

Wireless World

ELECTRONICS, RADIO, TELEVISION

Managing Editor: HUGH S. POCOCK, M.I.E.E.

Editor: F. L. DEVEREUX, B.Sc.

OCTOBER 1958

In This Issue

	459	Editorial Comment	
	460	Single Sideband Aircraft Communication	By G. L. Grisdale
	466	World of Wireless	
	469	Personalities	
	470	Chillerton Down	
	472	Apparent Saturation in F ₂ Layer	By T. W. Bennington
	474	Radio Show Review	
	484	B.B.C. Television Centre	
	486	A.G.C. for Television Receivers	By R. H. Skinner
	491	Farnborough, 1958	
	494	Letters to the Editor	
	496	Technical Notebook	
	497	On Understanding Transistors—2	By K. C. Johnson
	501	Short-Wave Conditions	
	502	Dispersion	By "Cathode Ray"
	507	Manufacturers' Products	
	508	News from the Industry	
	509	October Meetings	
	510	Random Radiations	By "Diallist"
	512	Unbiased	By "Free Grid"

VOLUME 64 No. 10

PRICE: TWO SHILLINGS

FORTY-EIGHTH YEAR
OF PUBLICATION

◆ ◆ ◆ ◆ ◆ ◆

Offices: Dorset House,
Stamford Street, London,
S.E.1

Please address to Editor,
Advertisement Manager or
Publisher, as appropriate.

Telephone:
WATERloo 3333 (60 lines)

Telegraphic Address:
"Ethaworld, Sedist, London."

PUBLISHED MONTHLY (4th Tuesday of preceding month) by ILIFFE & SONS LTD., Dorset House, Stamford Street, London, S.E.1.
Telephone: Waterloo 3333 (60 lines). Telegrams: "Iliffepres, Sedist, London." Annual Subscriptions: Home and Overseas, £1 15s. 0d.
Canada and U.S.A., \$5.00. Second-class mail privileges authorised at New York, N.Y. BRANCH OFFICES: BIRMINGHAM: King
Edward House, New Street, 2. Telephone: Midland 7191. COVENTRY: 8-10, Corporation Street. Telephone: Coventry 25210. GLASGOW:
26B, Renfield Street, C.2. Telephone: Central 1265. MANCHESTER: 260, Deansgate, 3. Telephone: Blackfriars 4412. NEW YORK
OFFICE: U.S.A.: 111, Broadway, 6. Telephone: Digby 9-1197.

Introducing an addition to the Mullard Technical Handbook

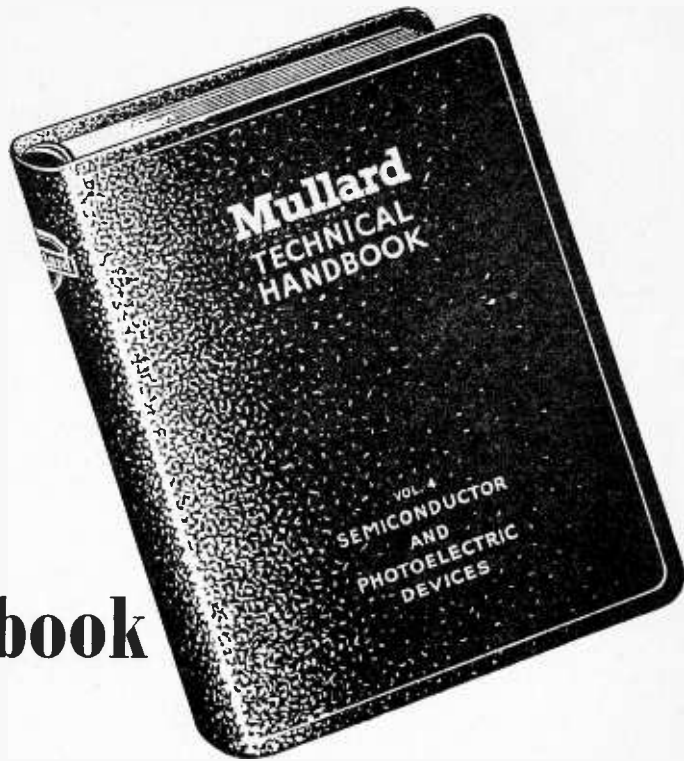

Data sheets on Mullard semiconductor and photoelectric devices are now available in a separate volume of the Mullard Technical Handbook. This addition to the Handbook Service enables circuit designers to be kept fully informed of the latest developments in semiconductor diodes, transistors and photocells.

The Mullard Technical Handbook is a loose-leaf publication, issued on a subscription basis and containing data sheets on Mullard valves, tubes and semiconductor devices in current production.

From one to twenty pages are devoted to each type, data including: standard ratings, recommended operating conditions and performance figures for various applications, limiting values, characteristic and performance curves.

Subscribers receive supplementary or revised sheets automatically as they are issued and thereby have early intimation of new introductions.

The Handbook now comprises five volumes with the following contents:—

VOLUMES I and IA

Data on current Receiving and Amplifying Valves. Cathode Ray Tubes. Special Quality Types. Voltage Stabiliser and Reference Tubes. Cold Cathode Tubes. Small Thyratrons. Miscellaneous Valves and Tubes.

VOLUME 2

Data on earlier type Receiving and Amplifying Valves and Cathode Ray Tubes still in limited production for the maintenance of existing equipment.

VOLUME 3

Data on Power Valves for Transmitting and Industrial Equipment. Power Rectifiers. Large Thyratrons. Microwave Devices.

VOLUME 4

Data on semiconductor diodes, transistors, Photoconductive Cells and Photoelectric Cells.

For full details of this service, including subscription rates and application form, will be supplied on request.

Mullard

Mullard Limited, T.S.D. Data and Publications Section,
Mullard House, Torrington Place, London, W.C.1.



MV 11 406

Show Fever

THE functions of showmanship are, first, to make us stand and stare; then, having riveted our attention, to astonish, mesmerize and generally to submerge our conscious thoughts so that we cheerfully acquiesce in the suggestions which the showman is trying to implant in our subconscious mind. It is no bad thing to be jolted occasionally out of the too familiar ruts of reasoning onto the wider verges of fantasy; so this year, after the serious business of putting together the factual reports which appear elsewhere in this issue, we took time off to mix with the crowds and submit to the full treatment, both at Earls Court and Farnborough.

We entered the Radio Show with a half-formed resolve to hear more stereo, but progress towards the Audio Hall in the gallery was seriously impeded by the simultaneous appearance of three very intriguing television programmes on scores of screens. In spite of reiterated newspaper statements that "Stereo Steals the Show" we found the compulsion of the television screen to be no less strong than in previous years. After trying to follow a documentary which too often persisted in changing to a skiffle group or a weather map and necessitated a quick run to a rival manufacturer's stand, we gratefully accepted the seating accommodation provided by Bush, whose knowledge of human nature has taught them that it takes more than a Radio Show to wean the addict from a good programme once it has taken hold of his imagination.

Having seen most of the sets in the Show we are prompted to ask why it is that line structure appears to be more obtrusive in 17-inch pictures than in smaller and larger sizes? Whatever reservations one may make about the overall luminosity and contrast of the 48-inch projected picture shown by Valradio there was no denying the appearance of much better than 405-line definition and the perfect interlace. Could it be that manufacturers of middle-of-the-road sets are not paying enough attention to the all-important factor of interlace? Until this is done we shall admit to a preference for smaller pictures—with or without proper interlace. The quality of the little picture in the Vidor battery portable gladdened the eye this year as did the 9-inch Ekco mains-battery portable (now unhappily no longer available on the home market) and the G.E.C. 6-inch "setting up" tube on previous occasions.

Full marks to all those firms who by skilful chassis design have tried to reduce the effort and cost of servicing television sets, and in particular to Philco for demonstrating and arguing the merits of their scheme on their main stand in full view of the public, rather than in the privacy of their demonstration rooms. Even if they did not understand the jargon, a small crowd of potential customers was

clearly impressed by the pointed questions put by an obviously experienced dealer, and the straight answers he got from the manufacturer's representative. More of this sort of thing should go far to dispel the widespread but often unjustified dissatisfaction with service methods and charges.

Progress in the Audio Hall was further checked by diversions to the B.B.C. and I.T.A. side shows, but the B.B.C.'s "Sounds Marvellous," an amusing exercise in sound subterfuge, proved to be an appropriate softening-up for the things we were eventually to hear. The Audio Hall was rather tucked away and although the purposeful "hi-fi" enthusiasts soon found their way there we had a feeling that many of the general public may have missed it altogether because of the stronger visual attractions of the broadcasting organizations' displays. Next year could we not have something like train noises emerging from the Audio Hall exit and disappearing into the entrance to catch the ear of the passing visitor? The sensation of movement would of itself be sufficiently arresting, and there would be no need to resort to high sound levels, which might embarrass other exhibitors. Stereo is undoubtedly a new aural experience—like "hi-fi" and singing in the bath—but it is just as likely to produce feelings of frustration as of exultation. At best it is still a synthesis and the smallest incongruity is sufficient to destroy the illusion in the mind of the listener which is the end product of any sound reproducing system. If the process of stereophonic recording "shows at the seams" we may well do better with a single-channel (not monaural, *please*), high-quality system, leaving the imagination to supply the illusion of the spatial displacements.

And so to Farnborough where processing and synthesizing was also very much to the fore this year in the handling of the increasing volume of radar and radio navigational data which must be presented to air traffic controllers. Much ingenuity is being exercised to eliminate redundant information from the "raw" radar display, by moving-target-indication techniques, auto-following, identification symbols, etc. Ultimately this will be all to the good, but we hope that the skills of interpreting an undocored display will not too soon be lost and that controllers may still be allowed access to the original if they want a check. After all, and in spite of a plethora of instruments, the best pilots still get the first indications of what an aircraft is doing "through the seats of their pants."

The flying display at Farnborough was magnificent, but we doubt if any of the aerobatics there could have matched the incredible performance of an oboe in one of the Earls Court "stereo" demonstrations as it flew from the left-hand to the right-hand loudspeaker and back again.

Single Sideband Aircraft

ADVANTAGES OF THE SYSTEM AND TECHNICAL PROBLEMS INVOLVED IN ITS

AIR traffic control systems require for their operation adequate communication between the controllers on the ground and the aircraft flying under their direction. Navigational systems supply information about the position of an aircraft, either to the navigator of the aircraft (as in the case of ADF, Decca Navigator, VOR, TACAN instrument landing system, and the recently described Doppler† systems) or to the observers on the ground (as for primary and secondary radar and ground d.f.). In either case the a.t.c. system can only operate if the

† "Airborne Dopple Navigation," G. E. Beck, *Wireless World*, May 1957, p.225.

Fig. 1, (a), (b) and (c). The amplitude modulated signal contains the carrier and two sidebands, which combine to form the modulated signal waveform at the detector. Removing the lower sideband results in a lower percentage modulation ((d), (e) and (f)); while reducing the carrier to equal the sidebands leads to a higher percentage modulation but produces distortion ((g), (h) and (k)).

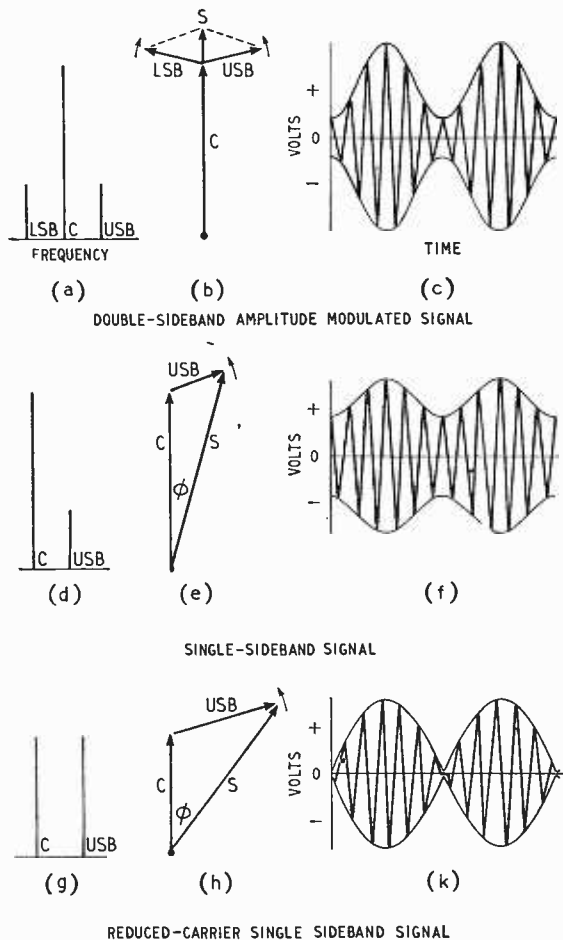

position information given by the navigational aids and the controllers' instructions can be passed rapidly in both directions between the aircraft and control centre. It is also necessary that control centres should be able to communicate with each other, so that flight plans may be transmitted and aircraft handed over during the flight from one authority to another, whether this be between London and Paris, or Prestwick and New York.

When the aircraft is within "line-of-sight distance" of the ground station, v.h.f. radio-telephone communication has proved satisfactory for passing a.t.c. messages; the range of communication, like that of radar, depends upon the height of the aircraft. Over Great Britain the coverage has been improved by using a group of transmitting and receiving stations distributed round the country, transmitting on closely spaced frequencies and modulated with the same telephony. But when the aircraft passes out of range of the v.h.f. stations, radio communication can be obtained only by using the h.f. band, in which the waves are bent round the curvature of the earth by the ionosphere; since the condition of the ionosphere depends upon natural causes beyond man's control, the quality of the radio signals which it passes on can be very variable. Signals can be too weak, or interference from distant stations too strong; fading can so distort the signals as to make them difficult to understand.

The routes demanding the use of h.f. communications are those passing over long stretches of sea or uninhabited land on which fixed stations cannot easily be installed and maintained. The north Atlantic is the most important of these areas for two reasons: first, the traffic control problem is severe because more aircraft fly here than on any other long-distance route in the world (about 50,000 crossings each year) and, secondly, the traffic passes through the area around north-east Canada and Greenland where the ionosphere is most disturbed by solar disturbances, making long-distance communication extremely difficult. Most of the discussion on long-distance aeronautical communication therefore centres around the north Atlantic problem, and a solution to this would solve many of the difficulties elsewhere in the world.

A few years ago most long-distance air-to-ground communication was by hand-speed morse code. The transmitters were not unduly complex, and this system provided the greatest range for a given transmitter power. Against that, the speed of transmission was slow and above all a wireless operator must be carried on the aircraft. Gradually many of the airlines have made more use of h.f. amplitude-modulated telephony, sometimes operated by the pilot, and this system is now generally accepted. Carrier powers up to 4kW are used on the ground and up to 400W in the aircraft. For a given power, telephony gives less range than c.w. and therefore the power of the aircraft transmitters has often been raised. Provision must also be made for working on many frequencies to cover world-wide frequency allocations and so that

Communication

INTRODUCTION TO CIVIL AIR ROUTES

By

G. L. GRISDALE,* B.Sc., Ph.D.

the best frequency for the required range can be used; if no radio operator is to be carried the adjustment of the transmitter and receiver for a new frequency must be automatic.

The number of aircraft in the air increases year by year, and their speed is increasing, so that more demands are placed on the air traffic control system to maintain safety standards. At the same time no more amplitude-modulation communication channels can be extracted from the band of frequencies available and interference is becoming serious at busy times. During the last thirty years single-sideband techniques have been developed for short-wave point-to-point telephone links, and for some years such methods have been considered for mobile operations. There are considerable technical difficulties to be overcome before such a system could be introduced.

When a radio-frequency carrier is amplitude-modulated with a single-tone frequency, two additional oscillations are produced, one above the carrier frequency and one below; these are the sidebands. When telephony is used to modulate the carrier, the telephone signal contains many frequencies and there are many sidebands. In Fig. 1 (a) a carrier, C, is shown with one sideband above and one below the carrier frequency; Fig. 1 (b) shows a vectorial representation, in which the carrier is shown stationary, the upper sideband rotates about it in a counter-clockwise direction and the lower sideband in a clockwise direction, the rate of rotation being equal to the modulation frequency. The carrier vector is actually rotating at the carrier frequency, but for ease of presentation has been shown stationary. This is the signal applied at the detector of the a.m. receiver, and adding the carrier and two sidebands gives a vector, S, which is the amplitude of the signal.

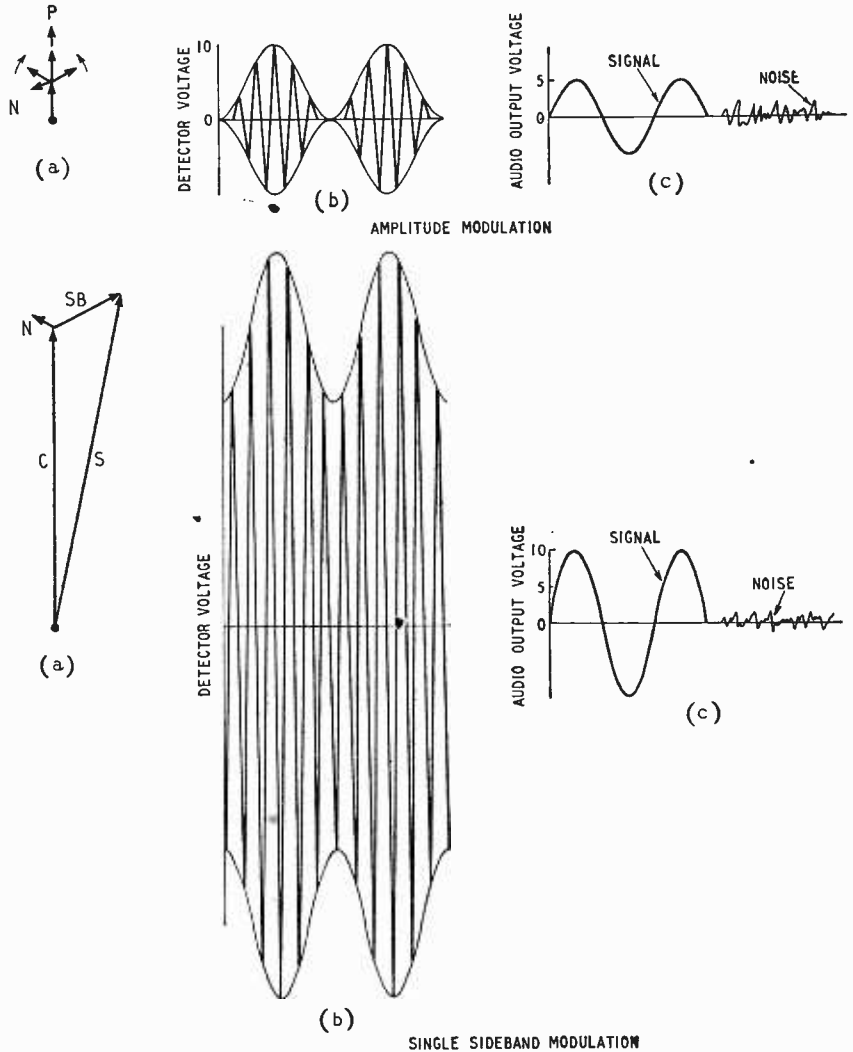

Fig. 2. Signal received at the detector from a.m. and s.s.b. transmitters having same peak power.

Fig. 1 (c) shows the actual waveform resulting at the detector, which is rectified and filtered to give the original modulation.

If the amplitude-modulated signal is passed through a filter which removes the lower sideband, it becomes as in Fig. 1 (d), (e) and (f). Cutting out one sideband has reduced the modulation percentage at the receiver, and has introduced a phase modulation, ϕ , into the signal; in the a.m. case the phase of the combined sidebands was the same as that of the carrier.

* Marconi's Wireless Telegraph Company, Ltd.

If the filter not only removes the lower sideband, but also reduces the carrier amplitude to equal the sideband amplitude, Fig. 1 (g), (h) and (k) illustrate the result. Now there is more phase-modulation of the signal, and the modulated waveform at the detector is very distorted. With only one sideband the carrier amplitude at the detector must be much greater than the maximum sideband amplitude for the distortion of the audio modulation to be small. S.s.b. receivers therefore include provision for amplifying the small transmitter carrier more than the sideband, or for injecting a locally-generated carrier at the correct frequency and amplitude, the local carrier replacing the suppressed carrier.

By suppressing the carrier, all available transmitter power is concentrated in the sideband. A comparison of a.m. and s.s.b. is often made by assuming that both transmitters can supply the same power peak, but this is not necessarily true; a 1-kW peak power s.s.b. transmitter will be somewhat more costly and will need bigger power supplies than a 1-kW peak

ESTIMATED PERFORMANCE OF A.M. AND S.S.B. TRANSMITTERS

A.M. Transmitter: Two 4-250A valves in class "C" power amplifier anode modulated by two 4-250A valves in class "B."
 S.S.B. Transmitter: Two 4-250A valves in class "B" linear radio-frequency power amplifier.

	A.M. Transmitter	S.S.B. Transmitter
Carrier power	1,000W	0
Peak power output to circuit ...	4,000W	1,000W
Power amplifier anode and screen efficiency	65%	65%
D.C. input to power amplifier ...	1,530W	1,550W*
Modulator power input	1,400W*	0
Anode and screen power for driver, modulator and power amplifier ...	2,945W*	1,565W*
Total a.c. input power for h.t., drive unit and filaments	4,095W*	2,276W*

*This is under condition of full modulation

The above s.s.b. transmitter would give a 6-dB better signal-to-noise ratio at the receiver, despite the fact that the power input has been almost halved and it uses fewer large valves.

power a.m. transmitter. The table compares the estimated performance of a 4-kW peak power a.m. transmitter with a 1-kW peak power s.s.b. transmitter.

For the airborne transmitter the peak power is often limited by the maximum voltage that the aerial can take without the surrounding air breaking down, particularly when operating at high altitudes. A comparison of the performance of a.m. and s.s.b. on the basis of equal peak power is therefore useful, and can be a basis for comparisons under other conditions. The vector diagrams and waveforms of Fig. 2 show the magnitude of the signals from transmitters having the same peak power on a.m. and s.s.b. The peak vector, P, for a.m. has the same length as the sideband vector, SB, in the s.s.b. case; the large carrier, C, for s.s.b. is assumed to be provided by a local oscillator at the receiver. The waveforms going into the receiver are shown at (b) and the detected audio signals at (c). The small vectors, N, represent the noise level; on s.s.b. the receiver bandwidth can be reduced to half, because it only has to include one sideband, and the s.s.b. noise is therefore reduced 3dB. It can be seen that the signal audio output has gained 6dB in the s.s.b. case, so the total gain in signal-to-noise ratio is 9dB, for equal peak transmitter power.

There is an additional improvement when using s.s.b. Transmission through the ionosphere produces unequal fading at different frequencies, even within a narrow frequency range. It therefore hap-

pens that the selective fading sometimes reduces the carrier of an a.m. signal at the same time leaving strong sidebands, and the received signal is then greatly distorted. Also, relative phase of the sidebands after passing the ionosphere is not always correct, and further distortion results. Experiment has shown that this distortion is equivalent in signal-to-noise ratio to at least 3dB in favour of s.s.b., in fact, if one sideband and the carrier are removed from a normal a.m. signal by means of a filter at the receiver, and a strong local carrier is inserted at the correct frequency, the resulting signal is usually slightly better than the double sideband signal.

The total improvement of signal-to-noise ratio at the receiver by using s.s.b. is therefore 12dB, provided the peak transmitted powers are equal. In the table the peak power of the a.m. transmitter (-6dB) is only one quarter that of the a.m. transmitter (-6dB) so the s.s.b. signal would be only 6dB better than the a.m. signal. This has been achieved with a transmitter with half the power consumption and half as many large valves. The s.s.b. transmitter and receiver have, however, more complex filtering circuits.

If the s.s.b. transmitter radiates a very small residual carrier, 14 to 24dB below the peak output power, this can be extracted at the receiver with a narrow-band filter having a curve as in Fig. 3 and after amplification can be re-inserted at the detector; block diagrams of the transmitter and receiver for this system are shown in Fig. 4. Both the carrier and the sidebands go through the same frequency changing processes and the frequency of the carrier has the correct frequency relationship to the carrier at the receiver detector. The detected audio frequencies are those applied to the transmitter. The a.f.c. system at the receiver keeps the carrier within the very narrow carrier-filter passband.

For aeronautical application this system has drawbacks. Many transmitters are using the same frequency allocation, but their carrier frequencies differ slightly. If two transmitters come on at the

Fig 3. Response curve of filters used for single sideband.

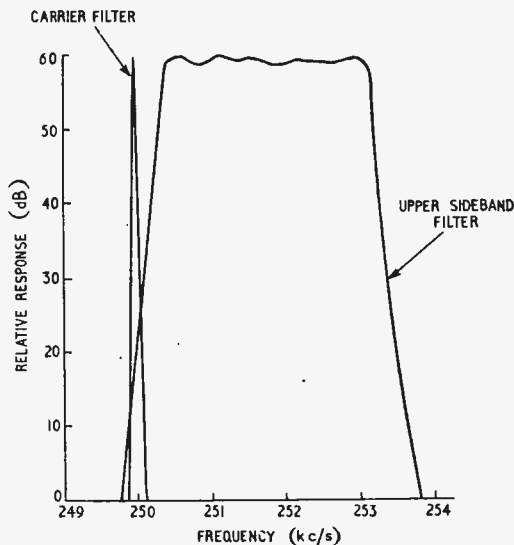

same time the carriers interfere at the receivers and the modulation probably becomes unintelligible. The a.f.c. system must respond so rapidly that the receiver is automatically tuned correctly before the message is passed. This demands either a very high stability oscillator, or a wider carrier filter than is desirable.

If, on the other hand, the correct carrier frequency can be supplied at the receiver detector from a local oscillator, and the carrier completely eliminated at the transmitter, all sidebands can be detected with the same carrier. The carrier frequency will never be exactly correct in relation to the sideband, and experiments show that an error of 30-50c/s is permissible before the speech signal becomes unintelligible. (On music an error of only 5c/s produces an unpleasant effect.) The carrier-frequency error is made up of the errors of all the oscillators in the transmitter and receiver; all must be crystal controlled and the highest frequency oscillators normally contribute most of the frequency error.

The frequency stability of suppressed-carrier s.s.b. transmitters and receivers must be about $\pm 10c/s$ each, and at 20Mc/s this means an oscillator stability of 5 parts in 10^7 . This is far higher than has been achieved in the past for aeronautical communications, and it may be assumed that the master oscillator will have to retain this stability for at least six months without readjustment; this will demand that a very good frequency standard be installed at the servicing base.

Airborne transmitters have to operate on a number of frequencies, in fact, well over 100 allocations have been made in different parts of the world. There is no simple relationship between the frequencies required, and some figures even include the odd 0.5kc/s. It is quite impractical to provide the numerous temperature-controlled crystals for all these frequencies with the 5 in 10^7 stability required for s.s.b., so attention is now being paid to systems which derive any frequency in the 2-30Mc/s band, at 0.5- or 1-kc/s intervals, from a single reference crystal oscillator. This apparatus is complicated, the oscillator source often including 40-50 valves. Such an oscillator could operate a trans-

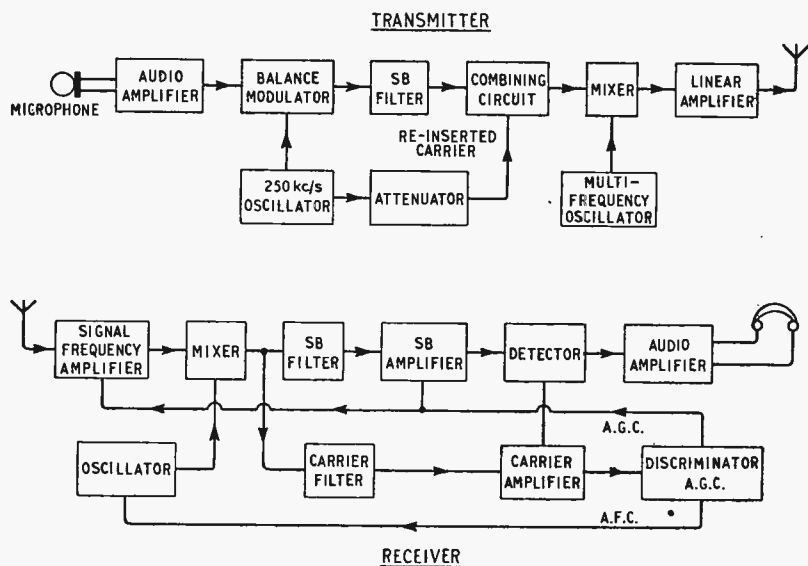

Fig. 4. Pilot-carrier s.s.b. transmitter and reconstituted-carrier receiver.

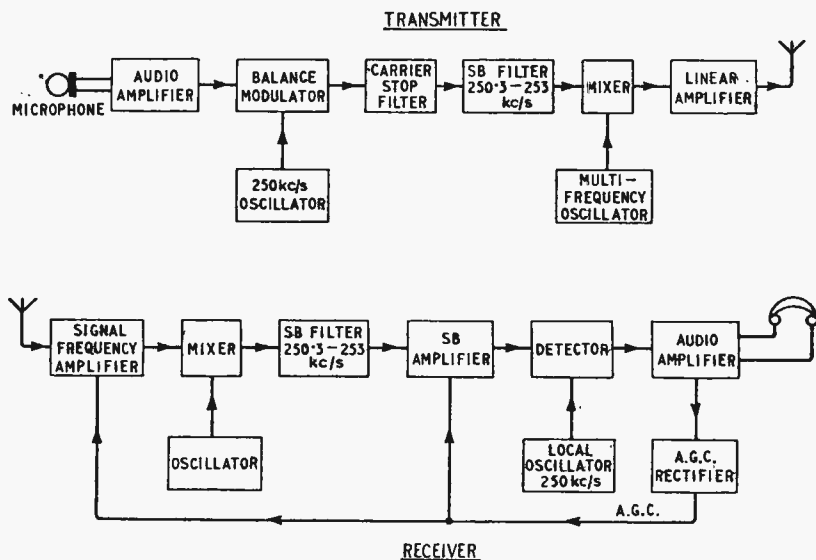

Fig. 5. Block diagram of transmitter and receiver for suppressed-carrier s.s.b. system.

mitter or receiver on any of 56,000 different frequencies, with an error of not more than 15c/s. Although it appears absurd to provide equipment with such a multitude of frequencies when only a few dozen may be required, it is in fact easier than providing a few frequencies scattered throughout the band, with the high stability demanded by s.s.b. The stability requirement is difficult to attain in an airborne equipment because the temperature changes very rapidly, and because the equipment has to be switched on and off at intervals. High-stability crystals do not maintain their stability so well after being switched on and off in this way.

When an aircraft flies away from a ground station at high speed, the frequency of the radio signal received is below that transmitted due to Doppler effect. At 330 miles per hour, on a frequency of 20Mc/s,

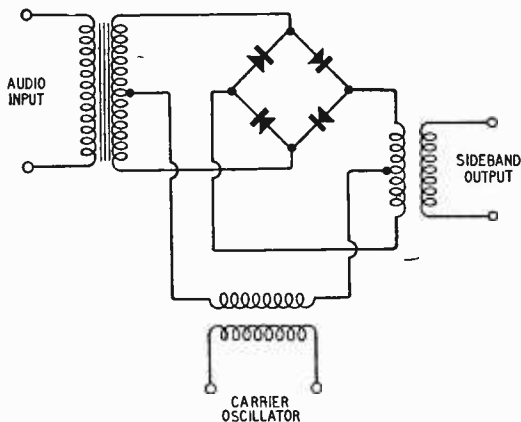

Fig. 6. Balanced modulator circuit.

the frequency error would be 10c/s, which is a considerable fraction of the permitted tolerance on s.s.b. The Doppler shift is unavoidable unless a.f.c. is used at the receiver, with the resulting disadvantage mentioned above; the Doppler frequency error must be included within the frequency tolerance. The effect is worse at higher speeds, on higher frequencies in the h.f. band, and when the aircraft course is in the direction of the ground radio station.

The s.s.b. transmitters which have been described use a modulator which produces both sidebands, and then pass the signal through a filter which leaves only one sideband. The modulator is usually a ring of four rectifiers, usually germanium or silicon diodes, known as a balanced modulator (Fig. 6). A useful property of the balanced modulator is that the carrier is balanced out and only a small residual carrier appears with the sidebands. In order to eliminate the carrier completely it is sometimes necessary to use a carrier-stop filter, as in Fig. 5.

Another way of producing a single-sideband signal was described by Norgaard¹ with two balanced modulators and 90° phase shifters. Each modulator produces two sidebands, but one is cancelled out by a phase-shifting technique. Barnes has used this kind of modulator in his pioneering work on aircraft s.s.b.² There is, however, a limit to the reliable suppression of the unwanted sideband, and although a partly suppressed "image" sideband may not affect the receiver tuned to the correct channel, it may interfere with communication on a neighbouring channel. For this reason it has been proposed to supplement the "phasing system" of s.s.b. generation with a sideband filter at the transmitter.

Barnes has also used the controlled carrier method of transmission, in which the full transmitter power is radiated at carrier frequency when there is no modulation, the carrier being reduced when modulation occurs. This provides a strong carrier when the transmitter is first switched on, and between periods of speaking, for frequency and gain control purposes at the receiver. This is one of the possible systems being considered for aeronautical s.s.b. communication.

S.s.b. transmitters and receivers in ground stations usually employ filters using quartz crystal resonators to give the sharp selectivity required, and very high performance is obtained with these units. In order to reduce size, however, airborne sets will probably use electro-mechanical filters,³ which give

an adequate performance in a smaller volume; the curves of Fig. 3 were obtained with filters only $3\frac{1}{2}$ in \times $1\frac{1}{4}$ in \times $1\frac{1}{4}$ in and weighing 7oz.

S.s.b. communication for civil aeronautics has been discussed at several meetings of the International Air Transport Association and proposals have been made about some features of the system. It was decided that as there is nothing to choose between upper or lower sideband selection there will be standardization in radiating the upper sideband.

If the same sideband is always used, the interference from a station on the adjacent channel is less, because the frequencies in the modulation of the unwanted station are inverted; the high energy low frequencies are transposed to the top of the audio band, where they cause less disturbance to the wanted speech.

It was also proposed that, apart from the Doppler effect, the frequency accuracy should be better than 45c/s from all causes. The ground transmitter alone, however, should be within 5c/s of nominal carrier frequency, permitting the maximum possible tolerance in the airborne equipment. When aircraft speeds become greater, increasing the Doppler frequency shift, it is proposed that the combined transmitter and receiver frequency tolerances should be reduced to 10c/s, the transmitter taking 3c/s.

Operating frequencies in the aeronautical mobile communication bands between 2 and 24Mc/s are spaced 7 to 10kc/s apart, some of the frequencies being on 0.5 kc/s values. However, the tolerance is relatively large, so that a transmitter accurately on the nearest 1-kc/s multiple would normally be within tolerance. High-stability multi-frequency drives could therefore be designed to give 1-kc/s instead of 0.5-kc/s frequency spacing, simplifying the design a little. With new allocations for s.s.b. it would be possible to make every frequency a multiple of 4kc/s, bringing a further simplification, but this is a matter for a future international conference when aeronautical s.s.b. communication is established.

The problem of introducing s.s.b. into the civil aviation service is more difficult than its use in military aviation. In the latter case, all the aircraft and ground stations are under a single organization. Civil aviation communications involve the administrations of all countries and many airlines, and it is not possible to introduce an entirely new system, involving new apparatus, at a settled date. The new system must therefore be made compatible with the old, and much attention has been given to the design of equipment referred to as "Bi-mode" equipment which will work with either a.m. or s.s.b.

The ground station transmitter will radiate a controlled carrier, whose amplitude will diminish as modulation level is increased. This will permit the use of a.f.c. in airborne receivers, if operators so wish. However, if the carrier is ultimately shown to be unnecessary, it can be suppressed completely at a later date.

The ground station s.s.b. receivers would be designed for suppressed carrier operation, and the airborne transmitters would not radiate a carrier when communicating with an s.s.b. ground station. However, provision has to be made for aircraft to transmit to ground stations not fitted with s.s.b. receivers, and for this aircraft transmitters will radiate a high amplitude carrier as well as one sideband. The effective signal on "full carrier" would be reduced at least 6dB compared with s.s.b. working,

but some provision for compatible s.s.b./a.m. working is essential for the changeover period.

The technical problems associated with the development of equipment suitable for s.s.b. communication in the aeronautical mobile service are considerable. The complexity of the high-stability multi-frequency oscillator demands a high standard of reliability in the airborne equipment. These problems are being overcome and the next few years should see the introduction of airborne s.s.b. communication into civil aviation. It will certainly not solve all the problems of long-distance communication, but there should be a considerable improve-

ment in the air-to-ground telephony link which is now an essential part of the aeronautical mobile service.

REFERENCES

- ¹ Norgaard, D. E., "The Phase-Shift Method of Single-Sideband Signal Reception." *Proc. I.R.E.* Vol. 44, No. 12, p. 1735.
- ² G. W. Barnes, "A Single-Sideband Controlled-carrier System for Aircraft Communication." *Proc. I.E.E.* Vol. 101. Pt. III, No. 71. May 1954. p. 121.
- ³ Lundgren, D. L., "Electro-mechanical Filters for Single-Sideband Applications." *Proc. I.R.E.* Vol. 44. No. 12. p. 1744.

Mechanism of Hearing

NEW KNOWLEDGE OF THE STRUCTURE OF THE EAR

OVER ONE thousand delegates attended the nine-day International Congress on the Modern Educational Treatment of Deafness held recently at Manchester University. The approach of *Wireless World* to this subject, that hearing is one possible part of the communication process, is naturally somewhat different from that of most of the contributors to the congress. It is because of this difference of approach that we report only Dr. H. Davis' paper on "Recent Developments in Knowledge about Hearing."

Recent developments reported were of the discovery of new details of the anatomical, electrical and chemical structure of the ear. One unexpected recent finding was the discovery of a bundle of nerves running from the brain stem to the ear. Galambos has shown that in cats these nerves are used to alter the sensitivity of the ear according to the size of the input signal. Further structural differences between the internal and external hair cells have been revealed by the electron microscope.

A number of other recent discoveries are thought to relate to the mechanism for achieving the maximum hearing sensitivity. At the threshold of hearing, the energy entering the ear is, surprisingly, not enough to

excite the nerves. Thus amplification must occur in some way; probably through modulation of the standing potential on the hair cells by bending them, as has been suggested by Guild. In addition to the potential on the hair cells themselves, the potential in the cochlear duct also probably provides an energy source for amplification to achieve the maximum sensitivity. This cochlear duct potential may be connected with the chemical composition of the endolymph fluid in this duct. Unlike other ear and body fluids, the endolymph contains a high concentration of potassium and low of sodium.

Another recent finding is that both direct and alternating currents flow from the hair cells: one type of current from each of the two kinds of cell. The a.c. output, which has a similar waveform to the sound input, is the usual cochlear microphonics, and comes from the external hair cells. The maximum sensitivity is probably fixed by these cells. The d.c. output, which is proportional to the sound energy input, comes from the internal hair cells. These cells probably determine the maximum discrimination between different levels. A similar difference with regard to sensitivity and discrimination exists between the rods and cones in the eye.

Books Received

Dilogarithms and Associated Functions by L. Lewin, A.M.I.E.E. Mathematical treatise on some little-known functions which have recently found application in quantum electrodynamics. Pp. 353; Figs. 6. Price 65s. Macdonald & Co. (Publishers), Ltd., 16 Maddox Street, London, W.1.

International Scientific Radio Union, Vol. XI, Part 5. Proceedings of the 12th general assembly at Boulder, Colorado, U.S.A. Commission V on radio astronomy. Pp. 148. Price 29s. General Secretariat, U.R.S.I., 7 Place Emile Danco, Uccle-Bruxelles, Belgium.

Radio Astronomy, Special Subject List No. 26, being a bibliography compiled by F. R. Taylor, F.L.A., of the Manchester Public Libraries. Pp. 15. Price 2s 6d. The Library Association, Chaucer House, Malet Place, London, W.C.1.

Rationalized and Unrationalized Formulæ in Electrical Engineering. British Standard BS 2990:1958 lists of symbols, an explanation of the relation of CGS and MKS systems of units and tables of examples of quantities affected and unaffected by rationalization. Pp. 15.

Price 4s 6d. British Standards Institution, 2 Park Street, London, W.1.

Beginners' Guide to Television, by F. J. Camm. Simple explanation of the basic elements of monochrome and colour television systems with a glossary of technical terms. Pp. 128; Figs. 61. Price 7s 6d. George Newnes, Ltd., Southampton Street, London, W.C.2.

Elementary Engineering Science, by A. Morley, O.B.E., D.Sc., Hon.M.I.Mech.E., and E. Hughes, D.Sc.(Eng.), Ph.D., M.I.E.E. Fourth edition of a textbook of mechanics, heat, electricity and magnetism, with numerous worked examples, covering the first year syllabus of courses for electrical technicians, and other engineering students. Pp. 381; Figs. 182. Price 11s 6d. Longmans, Green and Co., Ltd., 6 and 7 Clifford Street, London, W.1.

Bibliografia Marconiana, edited by Giovanni Di Benedetto. Chronological biography (in Italian) and 2,662 references to publications by or about Guglielmo Marconi. Pp. 243. Price 2,000 lire. Consiglio Nazionale delle Ricerche, Piazzale delle Scienze, 7. Rome.

WORLD OF WIRELESS

Stereophonic Broadcasting

A FURTHER series of experimental stereophonic transmissions are to be undertaken by the B.B.C. They will be radiated on alternate Saturday mornings from 10.15-11.15 beginning on October 18th. Both recorded and live programmes will be transmitted.

The Third Programme transmitters, both medium-wave and v.h.f., will be used for one channel and the B.B.C. television sound transmitters for the other (without interrupting the trade test transmissions on vision).

It is understood that the B.B.C. is also studying methods of stereophonic transmission from a single v.h.f. transmitter. In the States the F.C.C. has granted permission for the New York station WBAL-FM to operate experimentally an f.m. multiplex stereophonic system developed by Crosby Laboratories. According to *Electronic News* the system uses standard multiplex equipment on a 50kc/s sub-carrier with deviation up to 25kc/s modulating the main carrier from 15 to 50%. The system, which employs a recently developed "sum and difference" amplifier in the transmitter, is compatible, permitting non-stereo reception on normal f.m. equipment and stereo on receivers adapted to separate the two channels.

Air Radio Nav aids

IN an announcement restating the U.K. policy on short-range radio aids to air navigation the Ministry of Transport and Civil Aviation has come down heavily on the side of the Decca Navigator and Dectra systems.

Having outlined the requirements and examined the merits and demerits of various systems it states "Extensive flying experience over the past six years in many types of aircraft has clearly demonstrated that the Decca Navigator System best meets the requirements. . . . It provides vastly improved means for navigating all types of aircraft in the departure, en route, holding, descent and approach phases of flight. . . . Trials of the complementary long-range navigation system, Dectra, which are being carried out over the North Atlantic by jet and other aircraft have so far shown that the Decca and Dectra systems can be fully integrated to form a comprehensive navigational system using a unified airborne receiver. Accordingly, the Ministry intend to introduce new Decca procedures. . . ."

PUBLICATION DATE

Owing to a temporary rearrangement of our printing schedule the publication date of the November issue of *Wireless World* will be advanced to October 21st.

Transistor Convention

AS already announced the I.E.E. is organizing an international convention on transistors and associated semiconductors for next May. Because of the anticipated large attendance it has been decided not to hold the convention in the Institution building but at Earls Court. The dates are May 25th-29th.

Another departure from normal I.E.E. practice is that an exhibition is being organized with the convention. This international exhibition is sponsored by the Institution but is being arranged by Industrial Trade Fairs, Ltd., of Drury House, Russell Street, London, W.C.2.

Ship-shore Telephone

A NEW ship-shore radio-telephone service for vessels entering or leaving the Thames or passing between the North Sea and the Strait of Dover was inaugurated by the P.M.G. on September 5th. The inaugural ceremony, which was performed at the G.P.O. stand at the Earls Court Radio Show, included an exchange of messages between the P.M.G. and Viscount Simon, chairman of the Port of London Authority, who was on board the Marconi yacht *Elettra II* cruising in the Thames estuary.

The link between telephone subscribers and suitably equipped ships is provided by the North Foreland coast station. The frequency-modulated v.h.f. transmitters and receivers at North Foreland, supplied by Marconi's, provide two complete radio channels—a duplex working channel, and a simplex channel operating on the internationally agreed frequency of 156.8 Mc/s for calling and emergency working.

Subscribers wishing to make calls to ships in the area should ask the exchange for North Foreland Radio (Thanet 21303).

Further v.h.f. radio-telephone services are to be provided from the Niton (I.o.W.), Humber and Land's End coast stations during next year. There is already a similar service in the Firth of Clyde.

International Scientific Radio

IN each of the 26 member countries of the International Scientific Radio Union (U.R.S.I.), which was established nearly 40 years ago, a national committee is set up to sponsor scientific studies on particular radio problems brought before the meetings of the general assembly. In this country the committee is under the chairmanship of J. A. Ratcliffe, of the Cavendish Laboratory, Cambridge, with Dr. D. C. Martin, of the Royal Society, as secretary.

A list of members of the U.K. national committee for 1958/61 was recently given in the *Bulletin* of the Union. The Royal Society's four nominees are Prof. H. M. Barlow, Sir Charles Darwin, Prof. A. C. B. Lovell and J. A. Ratcliffe. Those from the Royal Society of Edinburgh are Professors E. G. Cullwick and R. V. Jones; from the I.E.E.

Sir Noel Ashbridge and Dr. R. L. Smith-Rose (who is also vice-president of the Union); and from the Physical Society Sir Edward Appleton and Prof. H. S. W. Massey. Other members are Dr. A. C. Best (Met. Office), Dr. W. J. G. Beynon (Radio Research Board), Dr. D. H. Black (Ministry of Supply), Col. E. J. C. Harrison (British Joint Communications-Electronics Board), Capt. C. F. Booth (Post Office), W. Proctor Wilson (B.B.C.) and Dr. L. Essen (N.P.L.).

C.I.R.M. Officers.—The new president of the International Maritime Radio Committee (C.I.R.M.) is W. D. P. Stenfert, managing director of Radio Holland, N.V. The new vice-presidents are H. Thorpe Woods, managing director of International Marine Radio Co. and W. E. Steidle, managing director of Deutsche Betriebsgesellschaft für drahtlose Telegrafie m.b.H. The C.I.R.M. is an international non-governmental organization set up for the improvement of the maritime radio communication and navigational services. The headquarters of the committee, of which Col. J. D. Parker is general secretary, is at Shipping Federation House, The Minories, London, E.C.3.

All India Radio, the national broadcasting organization in India, has introduced wire distribution in an endeavour "to make it possible for even the lowest income groups to listen to radio in their homes." Initially two of the blocks of "class IV quarters" in Sewa Nagar, New Delhi, are being wired. The rental of the installation is said to be very small.

Amateur 27-Mc/s Band.—Although allocated in the Atlantic City Plan to fixed and mobile services there is a proviso that the 26.96-27.23Mc/s band may be used by amateurs in certain countries in the southern hemisphere. However, for some time North American amateurs have also operated in this band but a recent re-allocation of frequencies by the Federal Communications Commission has deprived them of its use by allocating the band to the Citizens' Radio Service. In this country it is allocated for the radio control of models.

Radiation from portable receivers used by passengers in aircraft have been found to cause interference with the aircraft's radio-navigation equipment, such as VOR and ILS. In a notice to air crews the Ministry of Transport and Civil Aviation advises the "person in command" to "take such appropriate action as may be necessary to prevent any such risk."

I.T.A. in Northern Ireland.—The I.T.A. plans to build its tenth transmitter on the Black Mountains, near Belfast. It will operate in Channel 9 with a horizontally polarized directional aerial giving a maximum e.r.p. of 100kW. When the station is brought into service at the end of next year over 90% of the U.K. population will then be within the I.T.A.'s service areas.

Valve Bases.—Four new sections and one replacement section for the loose-leaf British Standard "Electronic-valve bases, caps and holders" (BS448) have recently been issued. The new sections are B7G/F, B8D, B8D/F and B9A/F. The replacement is for B5E. Each section costs 2s.

Magnetic Sound on Film.—A new British Standard (BS2981:1958) has been issued giving dimensional features of magnetic sound recording on perforated motion-picture film. Sections cover 8, 16, 17.5 and 35mm film. The specification costs 4s 6d.

Design Exhibition Bristol.—This is the first provincial design centre to be opened. Situated at Stonebridge House, Colston Avenue, The Centre, Bristol, 1, it covers almost all goods featured in the London Design Centre. Radio manufacturers interested in exhibiting their products should write direct to the above address.

Information Processing.—Further details of the proposed International Conference on Information Pro-

cessing, planned for next year, have now been announced. It will be held in Paris under the sponsorship of UNESCO from June 15th to 20th and will comprise six main sections covering methods of digital computing, logical design of digital computers, common symbolic language for computers, automatic translation of languages and the collection, storage and retrieval of information. An international exhibition will be held in conjunction with the conference. U.K. enquiries should be addressed to the British Conference on Automation and Computation (Group B—Computation and Automatic Control), c/o I.E.E., Savoy Place, London, W.C.2.

Electro-Medical Conference.—The Institute of Radio Engineers and two other American institutions are organizing the eleventh annual conference on electrical techniques in medicine and biology, to be held in Minneapolis from November 19th to 21st. The theme of the conference is biology and computers. Sessions will be devoted to the use of electronic computers in biological studies and, inversely, the application of the results of biological studies to the development of computers.

L.P. Conference.—Plans are being made by the Long Playing Record Library, of Squires Gate Station Approach, Blackpool, to hold a conference in the town next March. A hotel with a concert hall seating up to 800 people has been booked for the conference, which will include films and talks and a programme of live and recorded music. The cost of the weekend (March 13th-15th) including main meals will be 5½ gns. Further particulars and booking forms are obtainable from the organizers.

Computer Programming Courses.—Three types of programming course—covering the Pegasus, Mercury and Perseus computers—are now being conducted by Ferranti. In addition there is also a computer appreciation course. Each of the 12-day programming courses costs £30 and the 3-day appreciation course 15 gns. Further particulars of the courses, which are being held in London, are obtainable from Hollinwood, Lancs.

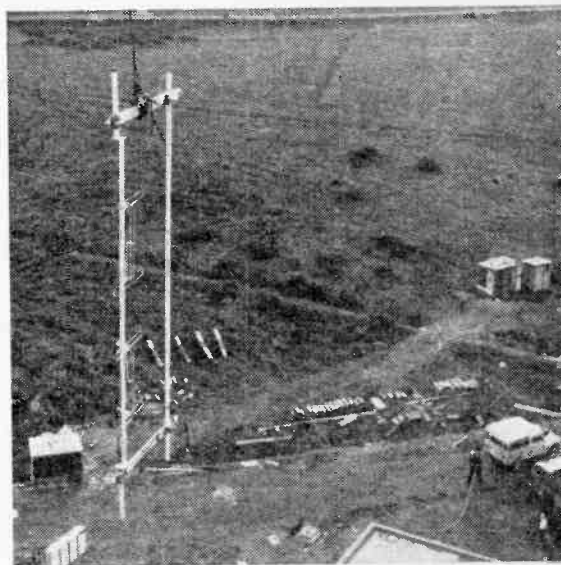

TEMPORARY AERIAL by Belling & Lee for the test transmissions from the I.T.A.'s new station at Burnhope, near Consett, Durham, being hoisted into position at approximately the 400ft level of the 750ft mast. Low-power test transmissions in Channel 8 began on September 15th, the station is scheduled to come into service on January 15th.

Receiving Licences.—Combined TV-sound licences in the U.K. outnumbered domestic sound-only licences by over two million at the end of July. The month's increase of 41,604 brought the number of combined TV-sound licences to 8,294,909. Domestic sound licences totalled 6,035,779 and those for car radio 351,146, giving an overall total of 14,681,834 broadcast receiving licences.

U.S. Audio Shows.—The annual convention and exhibition of the Audio Engineering Society of America will be held in New York from September 29th to October 3rd. The High-Fidelity Show organized by the Institute of High-Fidelity Manufacturers will be held in New York at the same time.

Scientific Films.—Among the 16 British films presented at the Twelfth Congress of the International Scientific Film Association in Moscow in September were: Mullard's "Conquest of the Atom"; "The Electron Microscope in Solid State Physics" from the Cavendish Laboratory; and "The Television Eyemarkers," which deals with the work undertaken by the Medical Research Council's applied psychology research unit into the electronic method of plotting eye movements as described in our May issue last year.

Factual Films.—An alphabetical directory of associations, industrial concerns and official bodies from whom 16-mm sound films can be borrowed was included in the August issue of *Film User*, published by Current Affairs, Ltd., of 319, High Holborn, London, W.C.1. This list, together with the subject index in the September issue, will be of considerable value to teachers and secretaries of societies and clubs.

Central Film Library.—Four Mullard films—"Particles Count," "The Transistor" and two on the junction transistor in radio receivers—are included in the latest list of films which can be borrowed free from the Central Film Library (Government Building, Bromyard Avenue, London, W.3).

Air Traffic Control.—In October International Aeradio, Ltd. will open an air traffic control training school at their premises in Hayes Road, Southall, Middx. The courses will provide training in all aspects of air traffic control, and a third of the time will be spent on practical training on an air traffic control synthetic trainer.

Advanced courses being held in 43 colleges in London and the Home Counties during the Autumn Term are listed in the "Bulletin of Special Courses in Higher Technology" issued by the Regional Advisory Council for Higher Technological Education. The 122-page booklet costs 3s and is obtainable from the Council at Tavistock Square, London, W.C.1.

Introduction to Electronics.—J. B. McMillan, director of studies at the E.M.I. College of Electronics, is giving a series of lectures on the principles and applications of electronics on Thursday evenings at Morley College, Westminster Bridge Road, London, S.E.1. The fee for the year's course, which commences on September 25th, is 26s 6d.

Liverpool College of Technology.—J. E. Macfarlane, head of the electrical engineering department of the College of Technology, Liverpool, has sent us particulars of two full-time courses—one a "transfer course" for Part III of the I.E.E. examination and the other an H.N.C. endorsement course in light-current engineering for the Brit.I.R.E. examination.

Twickenham Technical College, Middlesex, has arranged a course of 22 lectures on pulse circuit design for Thursday evenings beginning October 9th (fee £2). A course of 13 lectures on the principles of automatic control of machine tools will be given at the College on Monday evenings beginning October 13th (fee £1).

Battersea College of Technology.—A series of lectures and demonstrations on control engineering will be given at the Battersea College of Technology, London, S.W.11, during the 1958/59 session. Parallel evening lectures on industrial instrumentation (Thursdays) and mathematics of feedback control (Mondays) occupy the Autumn Term. These will be followed in the Spring Term by a series on automatic process control (Thursdays) and a further series on industrial instrumentation (Mondays). Fees are £1 for each of the first three courses and 10s for each of five specialized sections of the second industrial instrumentation course. The College is also conducting an evening course on linear servomechanisms on Mondays from January 5th (fee £2).

Northern Polytechnic.—The telecommunications section of the college prospectus for 1958/59 lists ten evening courses covering telecommunications, television engineering, colour television (see note in August issue), radio and TV servicing, radar engineering and microwave techniques, a.f. engineering and digital computers. There are, of course, also full-time and part-time day courses at this well-known North London College.

Borough Polytechnic, London, S.E.1, has planned a course of 20 lectures on transistors and allied devices, which will be given on Tuesday afternoons (from October 7th), and repeated in the evenings (fee 50s). A laboratory course in basic transistor measurements and applications will be conducted at the college on eight consecutive Wednesday evenings, from October 15th. The course will be repeated in the New Year from January 14th. (Fee £1).

Electric Circuit Theory.—Among the special courses being held at the South East London Technical College, Lewisham, during the coming session is one of about 20 lectures covering operational calculus with applications to electric circuit theory. It will be given on Tuesday evenings from October 21st. (Fee 26s.) The college is also conducting a course of six lectures on electronic switching on Tuesday evenings from October 21st. (Fee 10s.)

Bognor.—A radio amateurs' course is being conducted by E. J. Pearcey (G2JU) at the Bognor Regis Technical Institute on Monday evenings from September 22nd.

CLUB NEWS

Brighton.—At the meeting of the Brighton and District Radio Club on October 14th H. R. Henly will give the fourth in his series of talks on fundamentals, which will deal with valve amplifiers. The club meets every Tuesday at 8.0 at the Eagle Inn, Gloucester Road, Brighton, 1. Sec.: R. Purdy, 37 Bond Street, Brighton 1, Sussex.

Dorking.—Meetings of the Dorking & District Radio Society will be held on the second and fourth Tuesdays of each month at the Star and Garter Hotel, Dorking. Sec.: J. E. Greenwell (G3AEZ), Wigmore Lodge, Bear Green, Dorking.

Edinburgh.—Tape recording enthusiasts in the area may like to know that the Edinburgh Tape Recording Club meets on Sundays and Tuesdays in alternate weeks at 7.30 at 37, George Street, Edinburgh. Sec.: Alex. Whyte, 33, Tylers Acre Road, Edinburgh, 12.

Halifax.—The recently formed Halifax and District Amateur Radio Society meets on the first Tuesday of each month at the Sportsman Inn, Bradshaw, Halifax. Sec.: A. Robinson (G3MDW), Candy Cabin, Ogdon, Halifax.

Nottingham.—A new club for enthusiasts of sound recording and reproduction has been formed in Nottingham. Known as the Nottingham Audio Society it meets on Wednesdays at 7.30 at Woodthorpe House, Mansfield Road. Sec.: N. D. Littlewood, 129 Standhill Road, Nottingham.

Personalities

Kathleen A. Gough, B.Sc., F.Inst.P., chief physicist of the Dubilier Condenser Company, has gained the distinction of being the first woman for nearly sixty years to be elected a full corporate member of the Institution of Electrical Engineers (M.I.E.E.). Miss Gough, who was educated at the Wallington County School for Girls and read physics at University College, London, has for many years been responsible at Dubiliers for much development and experimental work on capacitors. She serves on several committees of the Electrical Research Association.



Ronald G. Griffith, the new vice-president of the Canadian Overseas Telecommunication Corporation, joined the corporation in 1954 as chief engineer. A native of London, he went to North America at the age of 25, returning to this country four years later (1929) to become assistant chief engineer of Creed & Co. In 1935 he joined Cable & Wireless and during the war was seconded to the Foreign Office to become chief engineer of the Inter-Services Cypher Policy Board and whilst there developed the first British error-detecting teleprinter multiplex system for radio. He returned to Cable & Wireless in 1946 and in 1951 went back to N. America and was for three years director of mechanical development of Radio Engineering Products Ltd., Montreal, where he produced the Griffith teleprinter.

Bernard F. Kane, O.B.E., B.Sc., M.I.E.E. has been appointed Marconi's sales and technical representative in Eastern Europe with headquarters in Vienna. He joined Marconi's in 1950 and after a period on v.h.f. research transferred to the installation engineering staff of the radar division and for the past year has been deputy chief of sales in that division. He was educated at Faraday House and received his technical training with Allgemeine Elektrizitäts Gesellschaft. Mr. Kane was for some years in the Far East and in 1945 was appointed Director of Signals, British Military Administration in Burma with the rank of Colonel. When Burma became an independent state he was appointed Adviser on Telecommunications to the Burmese Government.

Peter E. M. Sharp, A.C.G.I., B.Sc.(Eng.), A.M.I.E.E., who recently joined Troughton and Young, Ltd., as personal assistant to A. H. Young, joint managing director, has been awarded a Ford Foundation Grant by the English-Speaking Union for a two months' tour of the United States. During his visit next Spring he will spend two or three weeks at the Massachusetts Institute of Technology. He was at one time with the Telegraph Construction and Maintenance Co., and then joined China Engineers, Telcon's agents in the Far East. He returned from Hong Kong last year.

E. J. Seymour has joined Vandyke Engineering, Ltd., of Harlow, Essex, as manager of their recently formed Electronics Division. He was previously with A. C. Cossor, Ltd., for over eight years and was successively manager of the instrument division at Highbury, the marine radar factory at West Norwood and the radar scanner factory.

A. L. Sutherland, vice-chairman of the British Radio Equipment Manufacturers' Association, recently completed 25 years' service with Philips Electrical, Ltd. During the war he was a major in the Royal Artillery and held an appointment in the air branch of the General Staff. He returned to Philips in May, 1946, as manager of their tungsten lamp department and in 1950 became commercial manager of the television and radio division. He was appointed to the board in 1956.

W. Bruce Purslow, who retired from the B.B.C. engineering division two years ago, has gone back to sea as second radio officer in the General Steam Navigation Company's vessel *Empire Parkestone*. He was a sea-going radio operator before he joined the B.B.C. in 1926. In 1946 he was seconded to the Foreign Office for two years as chief engineer of the high-power broadcasting station in Singapore.

K. F. Crayford has been appointed sales manager of the Government and Industrial Valve Division of Mullard, which embraces the Communications and Industrial Valve Department and the Government Radio Valve Department. During the war he served operationally on radar.

W. G. Harrison, until recently in charge of sales in the components division of Salford Electrical Instruments, has joined Dynatron Radio as sales manager of their radio and television department.

OUR AUTHORS

G. L. Grisdale, B.Sc., Ph.D., author of the article on s.s.b. aircraft communication, is leader of an advanced development group of Marconi's at Writtle, near Chelmsford. After three years' research work on dielectric losses at London University, he joined the company in 1937, working on communication receiver design. Since 1951 Dr. Grisdale has been concerned with diversity reception and tropospheric scatter techniques.



R. H. Skinner, B.Sc., who writes on "Distributed A.G.C." in this issue, has been with Peto Scott Electrical Instruments since 1953 where he is concerned with the design and development of domestic television receivers. After studying at Guildford Technical College and Sir John Cass College, London, he obtained his degree in physics in 1951. He then did two years National Service in R.E.M.E. before joining Peto Scott.

OBITUARY

Dr. Ernest Lawrence, inventor of the cyclotron, died in Palo Alto, California, on August 28th at the age of 57. He had been on the staff of the University of California since 1927 and for the past 22 years had been director of its Radiation Laboratory. It was early in the 1930's that Dr. Lawrence constructed the first cyclotron at Berkeley, Cal. In 1939 he received the Nobel Prize for physics and he was also the recipient of the Hughes Medal of the Royal Society.

Professor Dr. H. Rukop died on August 3rd, aged 75. He took an active part in the development of Telefunken valves from 1914 until 1927, when he accepted the chair of applied physics at Cologne University. In 1933 he returned to Telefunken as a director. On retiring from that post in 1950 he became editor of *Telefunken Zeitung*.

Chillerton Down

I.T.A.'s MEDIUM-POWERED STATION FOR
THE SOUTH OF ENGLAND

ON 30th August a regular programme service started from this the seventh station to be operated by the Independent Television Authority. It is sited not far from the B.B.C.'s Rowridge transmitter on the Isle of Wight and its directional aerial covers the South of England from roughly Weymouth in the west through Newbury in the north to Brighton in the east—an area with a population of well over two million. It marks the beginning of the second stage of the I.T.A.'s programme to cover the whole country and is intended to provide programmes for one of the less densely populated areas not already served by the first six stations.

The aerial is a 16-stack array with a gain of 16dB in a semi-circle with a mid-bearing of 8° W. of N. With a vision output power of 4 kW the e.r.p. (effective radiated power) is 100 kW.

New types of vision transmitter (Type BD366) and sound transmitter (Type BD270A) have been installed by Marconi's. They are of "packaged" construction and are designed for installation on a flat floor, no underground ducting being required. The output stage of the vision transmitter consists of two CR 1100 tetrodes in push-pull and the tuned circuits are of the open-line type for ease of tuning and maintenance. The final tank circuit is combined with a vestigial sideband filter. Particular attention

has been paid to the design of the circuits linking the penultimate r.f. stage to the output valves to ensure a wide bandwidth, and the system is capable of handling black-and-white or colour signals on 405, 525 or 625 line standards. The vision carrier of the Isle of Wight station is on 204.75 Mc/s and the sound on 201.25 Mc/s.

Programme links for the I.T.A. national network from London and for local programmes originating from the Southern Television Plaza Studio at Southampton are provided and operated by the Post Office. The radio link from Museum Exchange in London

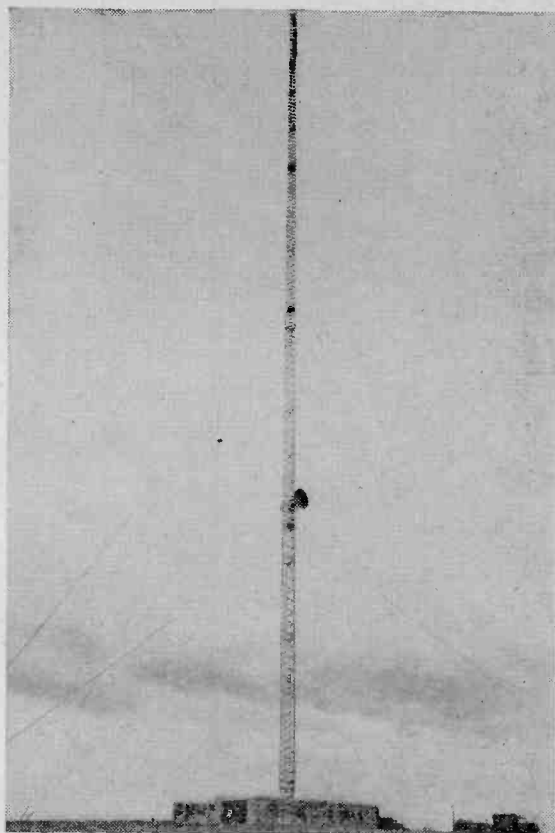

General view of the station buildings and 750-ft mast which also carries the dish for the Post Office radio relay link from Southampton. The transmitting aerial array is 1300 ft above sea level.

View from above of a part of the dipole structure, showing (left) the anti-icing shields.



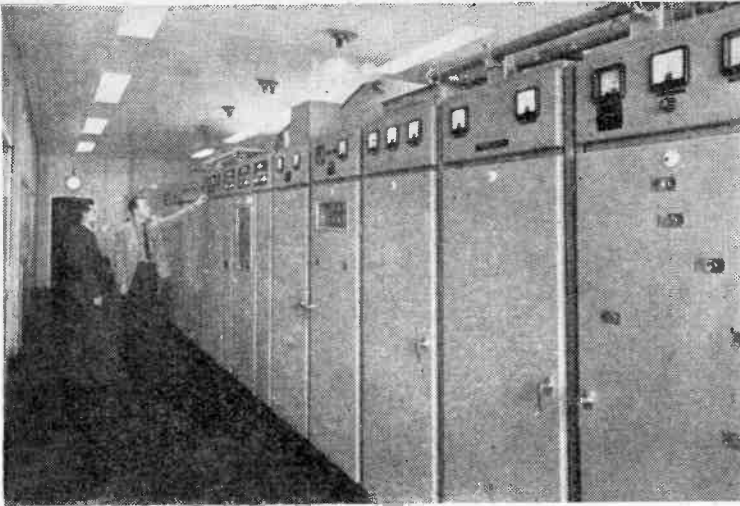

Marconi vision and sound transmitters are installed in duplicate for "main" and "stand-by" service.

Mast and dish on the Southampton Telephone Exchange for the 2 kMc/s radio link to Chillerton Down.

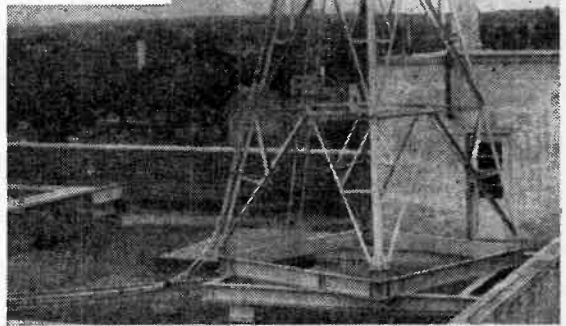

via a repeater at Golden Pot, Alton, to Rowridge works in the 4 kMc/s band. From Rowridge signals are conveyed by video cable to Chillerton Down. Video cables connect the Plaza Studio to a new microwave link station on the Southampton Telephone Exchange which provides two-way connection on 2 kMc/s with Chillerton Down.

The London Rowridge link, which was designed and installed by the Post Office Radio Experimental Branch, makes use of travelling-wave tubes, and waveguide-type branching filters enable both B.B.C. and I.T.A. programmes to be transmitted and re-

ceived without mutual interference on the same aerials. The link between Southampton and Chillerton Down was provided by the G.E.C., Coventry, and makes use of triodes at the lower frequency of 2 kMc/s. The feeders and launching units for transmission and reception from the same reflector are arranged to give polarization mutually at right angles to avoid interference.

Estimated coverage of the I.T.A.'s Isle of Wight station and (above) Post Office radio and cable links.

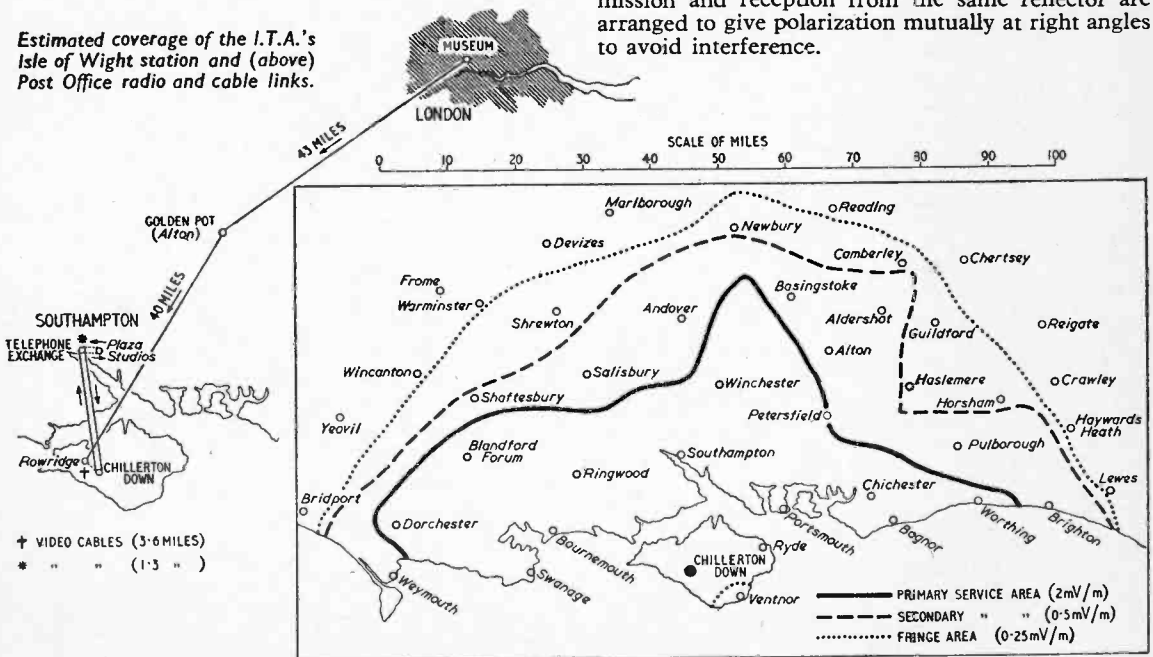

Apparent Saturation in F₂ Layer

Relationship Between F₂-layer Critical Frequency and Sunspot Number

By T. W. BENNINGTON*

FOR low values of sunspot number there is an approximately linear relationship between increasing sunspot number and increasing F₂-layer critical frequency, but for higher values of sunspot number departures from linearity occur. During the increasing phases of the sunspot cycles which began in 1933 and in 1944 it was noted that†, for places in the northern hemisphere, there was a decrease in the slope of the curve of running average critical frequency (f_{F_2}) with running average sunspot number (R) when the sunspot number was about 100, leading to the idea that at high values of sunspot number there was a "saturation" effect in the F₂ ionization. This can be seen from the two curves of Fig. 1. But it was also noted that this effect did not occur in the southern hemisphere, and the suggestion was made that the "saturation," besides being an effect of the high sunspot number, was connected with the northern hemisphere summer day-time minimum of F₂ ionization, and for this reason was not apparent in the southern hemisphere curves. That it is, in fact, connected with this summer minimum is strikingly shown by observations made during the present cycle, which started in 1954, and during which the sunspot number has risen to values far exceeding those for the previous two cycles, thus enabling the effects in both hemispheres to be more clearly distinguished.

In the curves of Fig. 1, which are for the critical frequency measurements made at Slough during the increasing phases of the 1933 and 1944 cycles, the points marked o are those which include the monthly mean critical frequency values for the first "summer" months after sunspot number 90 had been reached; namely, the months April to September inclusive. It is seen that the decreased slope of the curves occurred when the values for the summer months were included in the running average values. During the months April to September "winter" conditions prevail in the southern hemisphere, and for places there no decrease in the slope was apparent. Neither was there any in Slough curves for midnight. Curves for Washington for the cycle which started in 1944 display the same features as those for Slough.

The curves of Fig. 2 are for the present sunspot cycle, starting in 1954, and are, respectively, for Slough and for Christchurch, New Zealand, at noon. Curve (a) shows that for Slough, after sunspot number 100 was reached, there was no immediate decrease in the slope, the reason being that, at this time, winter conditions prevailed in the northern hemisphere. However, a decrease in the slope became apparent at a later time and with a higher sunspot number, namely when the values for the months April-September 1957 were included in the running

average, i.e. at the points marked o. During this cycle, as is seen from curve (b) there was a decreased slope in the southern hemisphere curve, i.e. around the points marked o, which are for the months October to March inclusive, when summer conditions prevail in the southern hemisphere. Curves for other places in the northern and southern hemispheres for the present cycle confirm these results, and lead to the idea that the "saturation" in F₂ ionization which occurs with high values of sunspot number is mainly a feature of local summer day-time conditions.

It will be clear therefore that, from the shortwave engineering point of view, it is not valid to make the simple assumption that, after sunspot number 100 has been reached, there will be a general decrease in the rate of increase of (f_{F_2}) with (R), and to carry this assumption into the operational planning of long-distance working frequencies. For it is apparent that, since the decreased slope is a feature of local summer daytime only, the slope of (f_{F_2}) curves with (R) will not be the same during each cycle, will be different in the two hemispheres during the same cycle, and will be different for any one place as between the increasing and decreasing sunspot phases. It is true that these considerations may not

* Research Department, British Broadcasting Corporation.

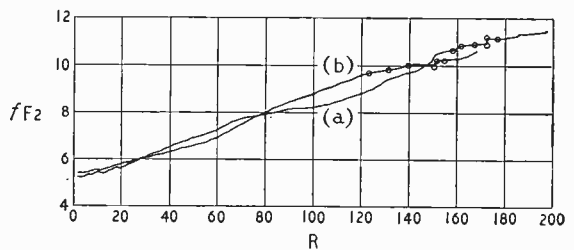

Fig. 1 Variations of running average critical frequency f_{F_2} with running average sunspot number R for Slough at noon. Curve (a) sunspot cycle commencing in 1933, (b) cycle starting in 1944.

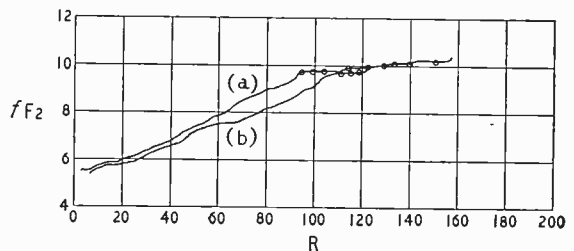

Fig. 2 Variations of f_{F_2} with R at noon during the present sunspot cycle. Curve (a) for Slough and (b) for Christchurch, New Zealand.

† Bennington, T. W.—"Critical Frequency Variations." *Wireless Engineer*, Vol. 30, No. 7, pp. 175-179, July 1953.

be of such prime importance as the linear increase in (f_{F_2}) for values of (R) below 100 owing to the fact that, by the time sunspot number 100 has been reached, most of the higher frequencies allocated for long-distance communication may already be in use. Nevertheless the nature of the effect has to be borne in mind.

What may be of greater interest are the physical

implications of this F_2 behaviour, for it is clear that the "saturation" in the ionization of the layer occurs only when the atmospheric region concerned expands under the influence of solar radiation, as occurs during the local summer day. However, these are considerations pertaining to the domain of the geophysicist, rather than to that of the radio engineer.

MOBILE U.H.F. RADIOTELEPHONE

More Details of the Elliott Equipment

WHEN the remaining television channels in Band III are cleared of the mobile R/T services using them at present, the already-difficult problem of providing new v.h.f. R/T channels will reach staggering proportions. One solution is to decrease the channel-width of existing allocations; but this provides only a temporary amelioration—another solution is to move to a higher frequency altogether. This is the answer suggested by Elliott Brothers (London), Ltd., with their E.B.L.303 u.h.f. mobile radiotelephone (announced in the July issue).

Recently *Wireless World* was invited to witness a demonstration of this equipment which operates in the 460 to 470 Mc/s band. About the same size as a conventional v.h.f. R/T equipment, this mobile transmitter/receiver produces 4 watts output for a power consumption of about 120 watts (which is only slightly higher than existing v.h.f. systems). On "receive" the current input is 7.5A and on "standby" 3.8A at 12V.

The gear was given a stiff test—instead of a base station with a high power output and a properly sited aerial an E.B.L.303, powered by a small petrol-electric set, was used. The aerial was a pair of stacked vertical $\lambda/2$ dipoles, so giving an e.r.p. of about 8 watts, and the site was just below the top of a 550-foot-high ridge near Rochester, Kent.

Using an end-fed dipole mounted at roof height on a saloon car, consistently good communication was achieved on a run through hilly country, built-up areas and, in some places, even where the road was cut down below ground level.

The demonstration run went out to 12 miles from the base station, and very strong signals were

received even at this range. Naturally, there were dead spots; but these seemed to be more sharply defined and, if anything, smaller than those experienced with v.h.f., using the same order of transmitter power. Some flutter was noticeable when passing through wooded or built-up areas; this was not surprising as amplitude modulation was employed; but it was rarely very bad.

The transmitter is crystal-controlled, using a QVO 6/20 valve and coaxial-line techniques in the output stage. The stability is of the order of one part in 105 and a provisional channel spacing of 66 kc/s has been awarded. The receiver is a double superhet using a grounded-grid r.f. stage and having i.f.s. of 50 Mc/s and 3.5 Mc/s. By using this arrangement an i.f. bandwidth of 22 kc/s and second-channel rejection of 45dB is achieved. A muting circuit (which can be switched out by a panel control) is provided, so that the receiver noise, in the absence of a carrier, can be suppressed.

The power for the mobile set is provided by a transistor converter powered by the vehicle electrical system (6 or 12V). This converter has an efficiency of about 85 per cent, and it contributes a great deal to the overall attractiveness of the equipment since it is naturally free from both electrical and mechanical noise.

For point-to-point working directional aerials can be supplied. These, and the end-fed dipoles used for the mobile demonstration, were made by J-Beam*.

* *Wireless World*, June, 1958, p. 272.

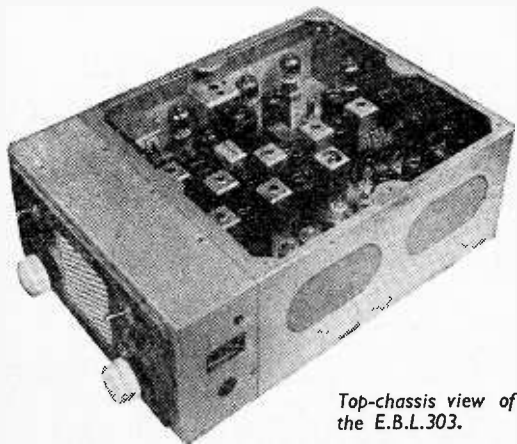

Top-chassis view of the E.B.L.303.

Television Engineering—4

A WIDE range of circuit techniques is covered in the fourth, and final, volume of "Television Engineering," by S. W. Amos, B.Sc. (Hons.), A.M.I.E.E., and D. C. Birkinshaw, M.B.E., M.A., M.I.E.E., which has recently been published. Like the previous three volumes of this comprehensive work on television theory and practice, the book has been written by members of the B.B.C. Engineering Division primarily for instruction of the Corporation's own staff. It is, however, of great interest to a wider technical public, including as it does such subjects as counter circuits, frequency dividers, delay lines, equalizers, d.c. clamping and restoration circuits, scan output stages, scanning coils, gamma control and shunt regulated amplifiers. Containing 268 pages with 175 diagrams and 2 pages of plates, Volume 4 can be obtained from booksellers at 35s or direct from our publishers, Iliffe & Sons Ltd., at 36s 2d by post.

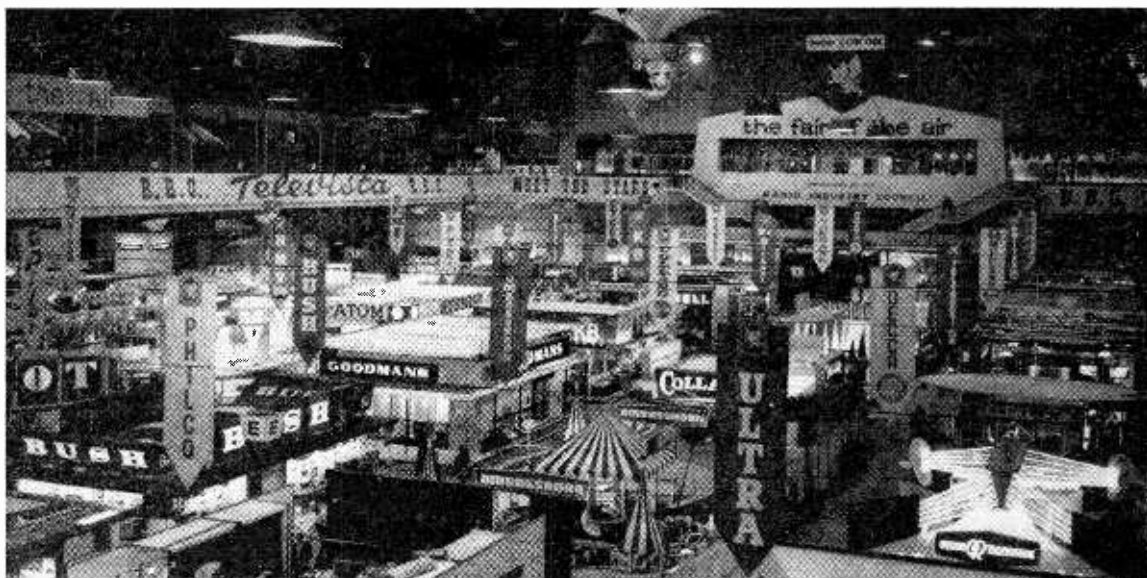

Radio Show Review

Trends as seen by *Wireless World* Technical Staff

AERIALS

THE past year seems to have been, in the main, an "improvement" year, with a general reduction in prices as the most important trend. How this reduction has been achieved differs between manufacturers—for instance, Aerialite and Antiference have decided that material (and money) was being wasted by using element and cross-arm sections of larger diameters and heavier gauges than was strictly necessary. Thus both these manufacturers have been able to reduce their prices by using smaller diameter and thickness tubes. Any doubts as to the ability of the new, lighter aerials to withstand adverse weather conditions should be dispelled by Antiference's introduction of a free-insurance scheme similar in outline to that offered by Belling-Lee for many years. Aerialite have named their new aerials the "Victory" range. They use high-density polythene, as do Wolsey, for some of the dipole insulators and the aerials have a very neat appearance brought about by "spinning-over" the ends of the elements instead of closing the tube with a bung. As an example of the reduction in weight—the "Victory" dipole (Band-I) and three-element (Band-III) aerial is about half the weight of the previous model. This firm's new Band-III broadside arrays are interesting because they use ordinary (not folded) dipoles as the driven elements with $3\lambda/4$ matching transformers of $35\text{-}\Omega$ cable.

Antiference have streamlined their "Clic-mec" spring-erection device for the lightweight Band-III range so that the parasitic elements are now mounted along the centre of the boom. This improved clip has cut manufacturing costs and should prove

a popular time-saving feature in aerial erection. Another improvement from Antiference is a folding chimney-lashing bracket—apart from packing into a smaller space from the previous types this presents a far larger contact area to the chimney. The lighter arrays and this feature should do much to alleviate fears of chimney damage during bad weather. Antiference are to be congratulated too on taking the courageous step of deciding to make nothing smaller than a 5-element Yagi for outside use on Band III. The price of the 5-element array has been reduced almost to that of the now-discontinued 3-element aerial.

J-Beam use a $\lambda/4$ collar on each half of the Band-I dipole of their combined Band-I/III aerials; but, unlike other manufacturers they connect the collar to the Band-I aerial at the outer end and insulate it at the inner. This prevents the Band-I section responding to Band-III signals, this function being left to the well-known skeleton-slot.

Another new development from J-Beam is the "Omnibeam 1"—a Band-I dipole combined with a broadband skeleton slot for Band III. This has two parasitic elements in the form of short-circuited folded dipoles—a configuration adopted to increase the effective diameter of the parasitics and hence the bandwidth. The Band-III section covers Channels 6 to 13. This, and another "broadband" aerial by Labgear would seem to suggest that the future lies with these, rather than "channeled" aerials, except for fringe areas.

Belling-Lee have extended their "Unit Plan" with three aerials for the Newcastle area, one of which is based on their successful "V" for Channels 4 and 8, and a new Band-I/III loft aerial. This latter has a telescopic Band-I top element, so that

it is immediately adjustable to any Band-I channel.

The "Double-Diamond" (Labgear) is, in effect, a 4-element Band-III aerial and it is a development from the "Quad" principle popular among American amateurs. A combined version of this uses a short coaxial stub to improve the performance on Band I; but the pickup on this band is still about 10dB less than that of a dipole. This, Labgear quite rightly point out, will save the cost of an attenuator.

One new indoor aerial, which looks just like a sheet of brown paper, is the Meadow-Dale "Banner." This is a 5-element Band-III Yagi made of aluminium foil and it sells at the extremely low price of 12s 6d. Another version includes a bent (as opposed to folded) Band-I dipole capacitively coupled to the Band-III section. Several suggestions are made for fixing, including pasting under the wallpaper! This should be a very popular aerial if the potentially high gain can be preserved under these conditions of mounting.

There has been an outcrop of "V's" at this year's Show, following the introduction of the Belling-Lee "Golden V" last year. These aerials vary in fixing facilities and styling; but most are straightforward "dipoles" (Antiference "Vantenna," Burwell "Floravision," Labgear "Tele-V" and Telerection "Twenty-20"). Two exceptions to this are the Aerialite "Viking" and the Wolsey "Topper," both of which incorporate a loading-coil to increase the Band-I pickup.

New items in the field of installation components are confined, in the main, to diplexers and triplexers. There seems to have been an extensive swing towards printed-circuit construction, but not for the capacitors, which are small close-tolerance wired-in components. Belling-Lee have introduced an extensive range, including waterproof types for outside use and Band-I/III diplexers which will pass Band-II signals through the Band-I sections, so enabling f.m. attachments to be used on a Band-I aerial. Another unit in this range is a TV/f.m. diplexer, and triplexers using printed coils are offered also by J-Beam, Labgear, Wolsey and Aerialite, who also

produce a "high-quality" unit for distribution systems.

Wolsey were showing a new, "solderless" coaxial plug for cables up to 1/8in diameter. This should find favour not only for r.f. use but in the audio field also, as it has a "chunky" body on which it is possible to get a really good grip. The connections are made by a pinch-screw and clamp system and the insulated body is a hard polythene moulding.

Communal Aerial Systems.—Five companies were exhibiting amplifiers for distribution systems, which are becoming more and more widespread as planning authorities refuse to accept angry-porcupine-like skylines in their new towns. There seem to be two types of system in common use: in one the amplified signal is distributed at low level on individual coaxial lines and the other in which the high-level signal is carried throughout the system and sets are connected through individual padder networks as close to the receiver as possible, in an effort to keep low-level line lengths to a minimum. The case against long, low-level lines is that they

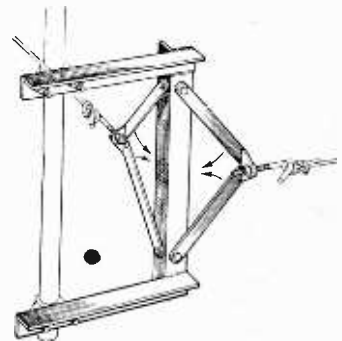

Antiference folding chimney-lashing bracket. Arrows denote direction of fold.

Belling-Lee 15C Band-I/III loft aerial with adjustable Band-I elements.

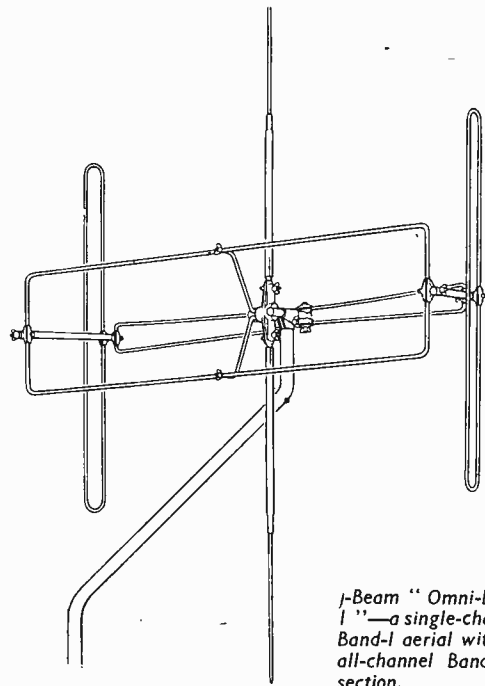
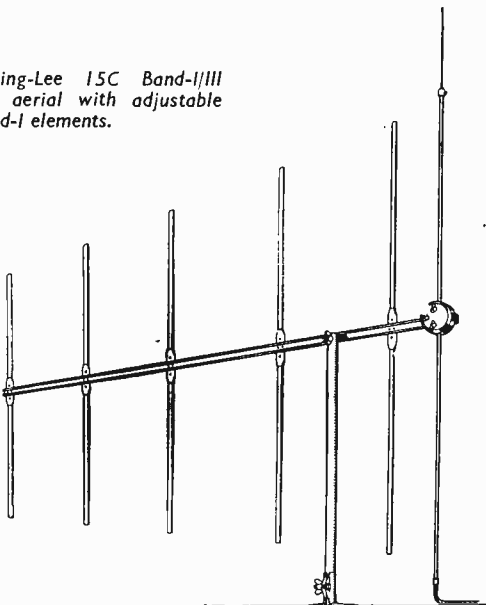

J-Beam "Omni-beam I"—a single-channel Band-I aerial with an all-channel Band-III section.

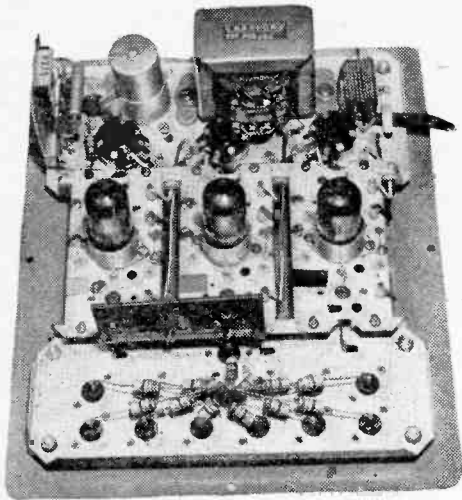

Distribution amplifier unit by Wolsey, including resistive splitting network.

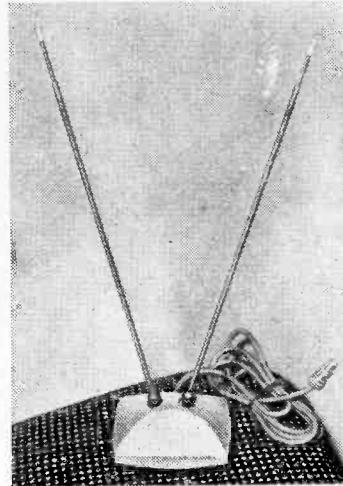

"Twenty-20"—a set-top "V" aerial by Telerection.

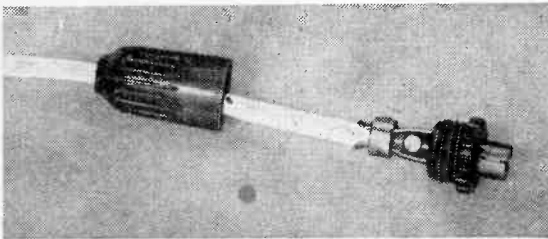

Wolsey's new "solderless" coaxial plug to R.E.C.M.F. draft specification, showing cable-fixing arrangements.

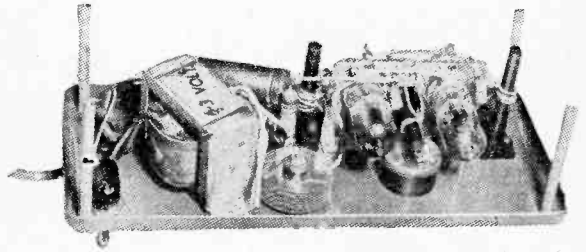

Aerialite PA2 distribution amplifier for communal aerial systems.

may pick up signals which will interfere with the "piped" one, and that cable costs are high. Against the high-level line must be set the danger of radiation from the system; but this should be small if it is properly designed. Belling-Lee distribute solely at high level, but Wolsey prefer the low-level system, and they provide their amplifiers complete with the resistive network to split up the amplified signal. Aerialite concede that both systems have their own advantages, and supply equipment for both types. The amplifier circuits are mainly cascode stages, cascaded to give more than single-stage gain, but

Belling-Lee and Labgear use pentode output stages. Wolsey have a particularly neat amplifier sub-chassis system and standard large and small cases fitted with a power supply. Into the large case may be fitted three r.f. amplifier sub-chassis, all of the same channel (to give about 50dB gain) or one each for Bands I, II and III, so giving a complete distribution system providing 20dB gain on each channel, and so on. Aerialite and Belling-Lee favour separate "boxes" for each amplifier and both of these companies manufacture a range of standard individual-channel amplifiers.

TELEVISION

ALTHOUGH television was supposedly taking a back seat at the Show this year, there were in fact some technical developments of more than usual interest to be seen. Outstanding amongst them was the advent of the completely transistorized television set, operating from batteries. Vidor were showing a small 8½-inch receiver while Mullard privately demonstrated a 17-inch model—both of them being very much in the experimental stage, of course. Readers will already be aware of the successful development of transistor circuits for timebase oscillators, sync separators and frame output amplifiers.* The really significant aspect of the Earls Court re-

ceivers, of course, is the achievement of transistor circuits for v.h.f. operation at the receiver front ends, for providing sufficient line scanning power and for generating e.h.t. supplies for the c.r. tubes.

The Mullard experimental receiver, as distinct from the Vidor, is not really intended to demonstrate the possibilities of portable battery-operated sets but to emphasize the power-saving abilities of the new magnetic "scan magnification" system invented by the firm. The r.f. and i.f. circuits of this set are based on an experimental alloy-diffused transistor while the Vidor receiver uses commercially-available micro-alloy and surface-barrier types. Band I only is catered for by the Vidor, which has a sensitivity of 40μV for

(Continued on page 477)

* "Transistor Television Circuits," by Barry and Secker, *Wireless World*, April and May, 1958, issues.

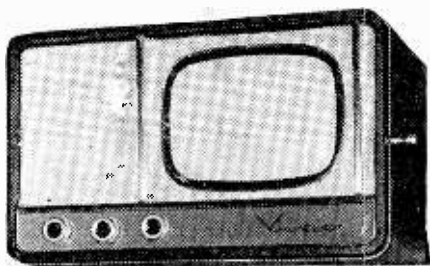

Vidor 8½-inch battery-operated transistor television set.

1 volt at the detector load, while the Mullard set incorporates an additional Band-III converter. Both receivers use a low i.f. of about 16Mc/s. They also use similar methods of generating e.h.t.—by transistor d.c. converters, the Vidor set requiring 7.5kV and the Mullard 18kV.

Power consumption of the Vidor receiver, which has 29 transistors, is 14 watts from the 18-V mercury battery. Of this 2 watts is taken by the c.r. tube heater and 5 watts by the direct-drive line output stage. The d.c. converter also produces voltage supplies of 50V and 300V as well as the e.h.t. Mullard's receiver has a comparable overall power consumption but because of "scan magnification" the total power required by all the scanning circuits is less than 1 watt.

These receivers, of course, represent no more than an exciting glimpse of a possible future trend in television. The design of the present commercially-available sets does not move quite so rapidly—though it is moving, none the less. Most immediately obvious this year was the advent of the 17-inch transportable where last year there were only 14-inch and smaller models. This larger screen seems to be taking us even farther away from the original idea of portable television sets, which started off looking rather like oscilloscopes. One assumes that the real justification for the design is not so much portability as the reduction in price made possible by the fibre, plastic or other non-wood type of case which is a characteristic feature of the transportable. The 17-inch screen is undoubtedly still the most popular size (a wise choice for 405 lines and small living rooms), and here is a way of manufacturing 17-inch sets at very competitive prices.

The cost of the receiver cabinet (always an expensive item) is being reduced even further by the new "slim" line (narrow from front to back) which is evident in quite a few of this year's models. Its attractiveness in saving space in the customer's living room is perhaps only a secondary advantage but is none the less real. The 90° c.r. tube (which, accompanied by electrostatic focusing, is becoming almost universal now) helps a great deal because of its reduced length, and when the neck is allowed to project a few inches out of the back of the set the saving in cabinet depth is quite considerable. Another expedient, giving an illusion of reduced depth, is to make the face of the tube project through the front of the set, enclosing it in a kind of picture frame.

A good many firms, incidentally, have adopted the so-called "push-through" presentation of the tube face, whereby the screen is not masked at the edges but the periphery of the glass envelope is visible. Not only does this help to reduce the depth of the

set, but it gives maximum picture size and also probably saves on the cost of masking.

An even greater reduction of cabinet depth will be achieved when the 110° c.r. tubes begin to appear in television receivers (a 21-inch tube being about three inches shorter than the 90° type of the same size). There were no 110° receivers on show to the public this year, but a few tubes and prototype chassis were nevertheless lurking in some of the manufacturers' private rooms. Mullard, incidentally, were demonstrating privately how it is possible to obtain the higher scanning power (about 40%) necessary for the 110° tube with the same types of valves used currently for 90° scanning. The secret is in an improved ferrite core material for the line output transformer, having lower losses and a higher saturation value.

The feature of including f.m. sound reception in television receivers is now very well known, and in spite of a widespread dislike of the idea it seems to be in more sets than ever this year. Originally the idea was to exploit the v.h.f. reception circuits already in existence in the television set, so that the extra facility could be provided at only a few pounds' extra cost. The f.m. sound was received either on one position of the turret station selector and the individual stations tuned in by the fine-tuner control, or on three separate positions (for Home, Light and Third) on the turret.

These methods are still being used in some current receivers. Unfortunately, it has been found that this general technique, using the existing television i.f., suffers from lack of selectivity (and sometimes gain) under certain reception conditions, and the f.m. reception does not compare at all well with that obtained from proper v.h.f. sound receivers. As a result we now see at this year's Radio Show the emergence of television sets with completely separate v.h.f./f.m. front ends, working on the correct i.f. of 10.7 Mc/s, as a means of combating the trouble.

Although one must commend the manufacturers for this development it seems a pity that, from the technical point of view, it is essentially a defensive move and is getting away from the original idea of exploiting the existing circuits in the television set. At least two firms, however, have tackled the problem in other ways. Murphy, in their new V330 17-inch set, use a double superhet circuit to improve the selectivity on the f.m. (and television) sound. The second sound i.f. has not been made 10.7 Mc/s (because of patterning difficulties), but 6.31 Mc/s, this being obtained with a second local oscillator frequency of 31.84 Mc/s from the first 38.15 Mc/s sound i.f. signal. Incidentally, Murphy still use their own four-position turret tuner for this receiver, and on the "FM" position the v.h.f. sound stations are selected by permeability tuning (no fine tuning is used on television). The mechanical arrangement is such that the permeability tuning plunger can be moved in the v.h.f. oscillator coil at all positions of the turret but only becomes effective when the station selector is switched to "FM."

Bush, in their new 17-inch model, TV77, use a separate v.h.f. sound tuner giving an i.f. output at 10.7 Mc/s, but they save valves in the i.f. section by an arrangement whereby the amplifier will work at either 10.7 Mc/s for f.m. sound or 38.15 Mc/s for television sound. This is all done by tuned circuits and so avoids switching. Referring to Fig. 1, the

two i.f. signals are applied in series to the grid of the first common i.f. amplifier (capacitor C_s being a short-circuit at 38.15 Mc/s). At 38.15 Mc/s L_1 with C_1 and L_2 in series act as a parallel tuned circuit and L_2 as a choke, passing on the signal by bottom capacitance coupling C_2 to the tuned circuit formed by L_3 , C_1 and the valve capacitance, while L_1 acts as a choke. At 10.7 Mc/s, L_2 with C_1 and C_2 in parallel form a tuned circuit and the signal is passed by top capacitance coupling C_3 through L_3 to the tuned circuit formed by L_4 in parallel with the valve capacitance. The second common i.f. amplifier has two transformers in series in its anode circuit, one supplying the television sound a.m. detector and the other the f.m. sound ratio detector. A gain of 30dB at 10.7 Mc/s is obtained between the grid of the first common i.f. valve and the anode of the second.

Whether it is the introduction of f.m. sound or the effect of "hi fi" in general, most of the latest television set designs seem to be paying greater attention to the quality of their sound reproduction. Loudspeakers* are tending to move to the front of receivers (elliptical types placed horizontally below the screen), while sometimes twin speakers are used, and in one notable example, a television radio-gram by Pam, there are facilities for stereophonic reproduction! Incidentally, one new Ultra set puts both sound i.f. and audio amplification into a single pentode by means of a reflex circuit.

At the r.f. end of the television receiver there were some interesting developments to be seen in tuner units. Most outstanding amongst these was the introduction of push-button station selection on the new Bush 14-inch transportable, TV80. Four buttons are provided, two of which can be arranged for selecting any two pre-set channels in Band I and the other two for any two pre-set channels in Band III. The tuner is a permeability/eddy-current type, and the interesting feature of the

mechanical design is that fine tuning or retuning can be done by the viewer by pulling out the push-buttons, which then become rotatable control knobs for adjusting the permeability plungers in the coils. When this rotary tuning has been done the button is pushed back and turned into its normal angular position, and the tuning plunger remains as set.

Most of the tuners in television sets are the conventional turret types, but some of the new receivers at the Show had a smaller and neater design based on a flat circular plate holding the coils in radial fashion instead of in the normal cylindrical arrangement. This is developed from the American tuner described in our June, 1957, issue (p. 269), but uses the well-known valve combination of double-triode cascode r.f. amplifier and triode-pentode frequency changer instead of the 2BN4 neutralized single triode and 5CG8 triode pentode in the original American version.

This flat plate construction is also a feature of a new design called a semi-incremental inductance tuner which appears in the latest Sobell and McMichael receivers. The conventional incremental inductance tuner is still very much in evidence, of course, and there have been some interesting comparisons drawn between it and the turret tuner.* The new Radio & Allied Industries design is a compromise between the two types in that it selects a fresh coil not at every position of the station selector switch, as in the turret tuner, but only at certain positions, and increments of inductance are added at the intermediate positions. Thus the design seeks to combine the superior electrical performance of the turret tuner (in oscillator drift, gain, etc.) with the lower cost of the incremental inductance type. Sound reception on f.m. is provided for on the final, 14th, position.

Vision a.g.c. circuits are divided between gated systems working on the black level and mean-level systems. Judging from the Show the mean-level system is used much more widely, presumably because of its lower cost, while the gated system is reserved for rather special receivers. In the actual control of the signal-frequency amplifier valves, several sets are utilizing a delayed or sequential system. Here the a.g.c. bias voltage operates on the common i.f. valve first and then, when the signal in-

* "A Comparison of Turret-Type and Switch-Type Television Tuners," by V. A. Jones, *Journal Brit. I.R.E.*, Vol. 18, No. 6, June 1958.

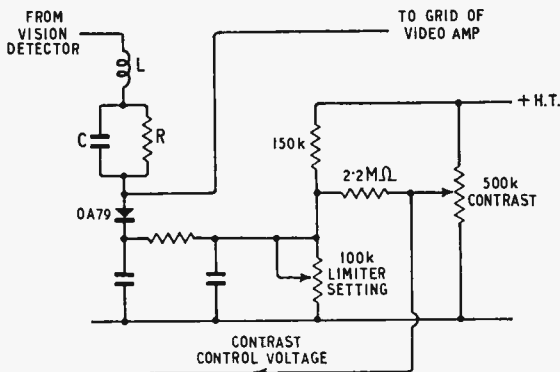

Above:—Fig. 2. Circuit of "resonant spot limiter" used in Ferguson and H.M.V. sets.

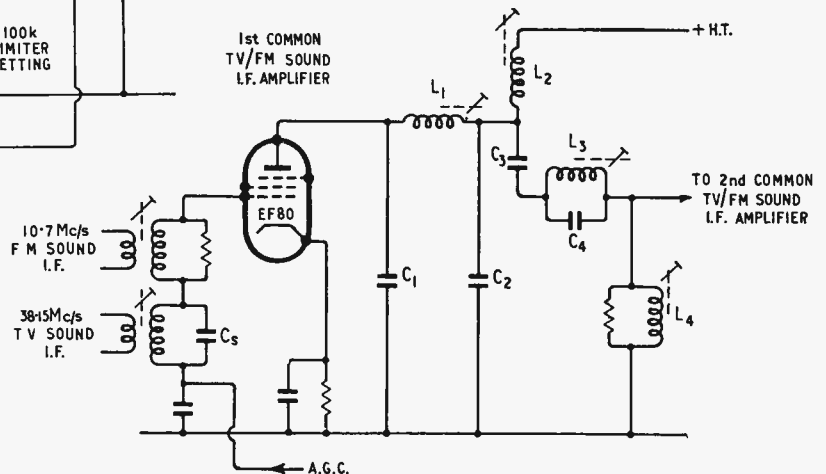

Right:—Fig. 1. Common i.f. amplifier circuits for f.m. and television sound in the Bush TV77 receiver.

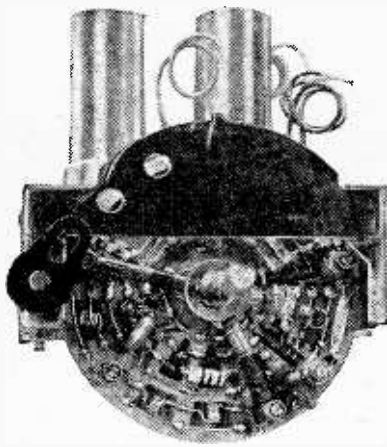

Semi-incremental inductance tuner used in Sobell and McMichael receivers.

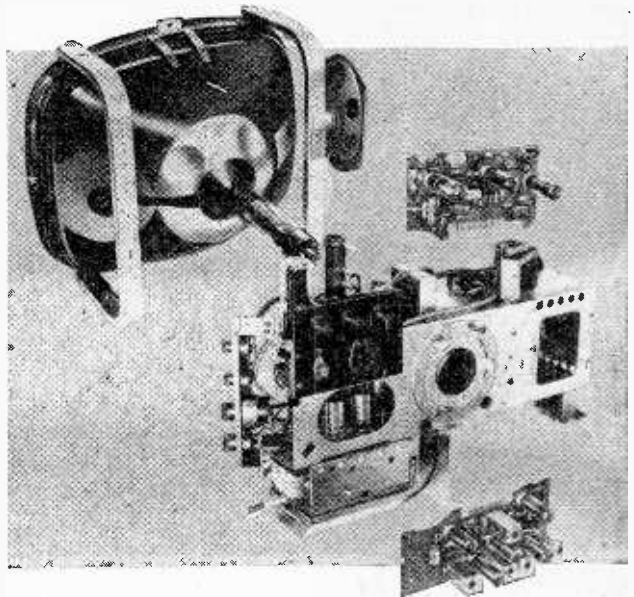

The four main parts of the Alca "packaged" television set. Two are plug-in replaceable printed circuits.

creases above a certain level, on the r.f. amplifier stage in the tuner. This ensures that at high signal strengths the common i.f. amplifier does not have to be biased to a point on its characteristic where non-linearity would cause cross-modulation between the vision and sound signals. At low signal strengths the r.f. stage gives maximum signal output and the a.g.c. bias is only applied to the i.f. valve so that the effect of mixer noise is minimized.

Ferguson and H.M.V. have a novel system working on this principle in their latest series of receivers. It is based on a rather complex arrangement of semiconductor diodes in the cathode circuit of the common i.f. amplifier. Some of these diodes provide different reference voltages which the other diodes use in their function of switching the a.g.c. bias voltage to the i.f. and r.f. valves at the appropriate levels. Incidentally, the a.g.c. bias voltage is used in several recent receivers as a means of automatically narrowing the bandwidth of the controlled i.f. stage with weak signals, so that under these conditions there is a reduction in noise power and a consequent improvement in signal/noise ratio. Manually-operated bandwidth control—for the same purpose—is a feature of the latest Pye receivers.

In the timebase section of the television set two small innovations were noted this year for improving synchronization. Ultra had an arrangement publicised as "vertical precision" for reducing the raggedness at the edge of the picture which occurs with weak signals. It is simply a pre-set wire-link switch, to be set by the dealer, for reducing the capacitive coupling from the sync separator to the line timebase. Thus on weak signals, when the edges of the line sync pulses are more distorted with noise and interference, the timebase is not so firmly locked to the fluctuating sync signal and so tends to run more evenly. Improved interlacing was the object of the second innovation, noticed in the circuits of the new Ferguson and H.M.V. sets. It is an arrangement in the frame oscillator (a multivibrator) for suppressing the effect of unwanted line pulses on the frame synchronization. Positive pulses from the cathode of the first multivibrator valve, occurring at the change-over point, are fed back to

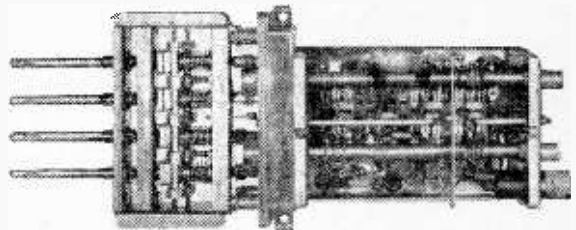

Details of the Bush push-button station selector and permeability tuner in the TV80 receiver. The control buttons are on the end of flat shafts (not shown) which couple with the rods on the left.

cut off a semiconductor diode in the grid of this valve, so that it cannot accept unwanted negative input pulses from the sync separator.

These Ferguson and H.M.V. receivers also contained another interesting circuit called a "resonant spot limiter." Looking like a normal diode interference limiter, as shown in Fig. 3, it has a tuned circuit in series. This tuned circuit is arranged to resonate at a frequency near to the residual i.f. signal which is present after the video detector. When an interference pulse occurs it passes a positive video pulse to the grid of the video amplifier through the LCR circuit. But, at the same time as this is happening, the tuned circuit is resonating with the accompanying burst of residual i.f. The diode rectifies the large current at resonance to produce a video pulse across R which is in phase opposition to the original positive interference pulse and so tends to suppress it. The level at which the diode conducts is set by the variable positive bias system shown, and this includes a compensating arrangement whereby any change in signal amplitude made by the contrast control does not affect the relative position of the limiter operating point to the video signal waveform.

In the sphere of mechanical design the two main trends are (a) making the servicing technician's job

easier by improving accessibility and simplifying disassembly, and (b) cutting costs by the extensive use of printed circuits. In one respect (b) runs counter to (a) in that printed circuits are generally execrated by the servicing fraternity, but one firm, Alba, have tackled the problem in a rather interesting way. They have designed their latest 17-inch receiver chassis on the "packaged" principle so that it can be easily separated into four main parts (see illustration). Of these, two are plug-in printed circuit panels which between them carry 90 per cent of the circuitry of the set. One has the vision i.f. strip, video amplifiers and audio section, while the other has the sync separator and timebase circuits. If a fault develops in one of these panels the servicing technician either replaces it with another one from stock or sends the faulty circuit back to the manufacturer, who returns a fresh one within 24 hours.

Cossor have a similar scheme for replacing the printed circuit panels of their latest 17-inch "slim line" receiver. In this set, though, there are six panels, arranged so that they can be easily unsoldered and unscrewed from the main chassis. A simplified fault-finding chart for the set displays 24 photographs of typical picture faults, and each one indicates which of the printed circuit panels or valves should be suspected and replaced if necessary.

Other receivers on view did not go as far as this but they often had facilities for detaching the printed-circuit panels easily. Sobell and McMichael chassis, for example, had a hinged frame at the rear, as an

aid to accessibility, from which two printed-circuit panels, i.f. and timebase, could be withdrawn. The hinging idea was also seen in other makes. Philco claim that their "Slender Seventeen" can be disassembled in three minutes, and this set, in common with several others, features a plug-in replaceable line output transformer. It also has a neat facility by which the oscillator trimmers in the tuner can be adjusted from outside the set through holes formed by the fine-tuning and station-selection knobs. On each position of the selector switch the hole is formed automatically at the right place when the fine tuner is rotated to its mid-point position.

The printed circuits of the Sobell and McMichael receiver are not of the conventional kind but are manufactured by an electroplating process. This technique allows the holes through the panels to be made larger because they are plated on their inside surfaces and so hold the solder round the inserted component wires more reliably than the same size of holes would do in conventional printed circuits. The reason for requiring larger-size holes is the strong economic one that it speeds up hand insertion of components. Further help in this direction is given by the use of small encapsulated units containing groups of wired-up resistors and capacitors.

Incidentally, as a final intriguing question, may we ask certain firms the precise reason why, in their new illuminated station selectors, they have chosen to represent B.B.C. by a green light and I.T.A. by a red light?

SOUND RECEIVERS AND REPRODUCERS

NO distinction will be made in this review between exhibits shown in the Audio Hall and those shown in the main body of the exhibition, because some manufacturers were showing in both places, and in these (and other) cases it would be difficult to divide exhibits into those which gave high-quality reproduction and those which were only "hi-fi."

Transistor receivers.—These are gradually taking their places as ordinary battery sets rather than curiosities which can be made very small. The trend is thus that small sets are getting bigger or, as one manufacturer put it, "No attempt has been made at excessive miniaturization."

This trend shows up most clearly in the now very common use of larger speakers (about 5in round or 7in x 4in elliptical): the largest we saw being a 9½ x 4½in elliptical unit in the Dynatron "Nomad." Of course, the advantages of a larger speaker are best realized if the output stage is push-pull, and such stages are also now very common.

With improvements in the high-frequency amplification capabilities of transistors, the use of intermediate frequencies considerably less than the standard 470 kc/s, to obtain sufficient gain, has now as far as we could tell completely ceased.

Another trend has been the addition of long wave-band reception. In some cases, however, this means only reception of the Light Programme at 200 kc/s. As a separate aerial coil is generally used to obtain sufficient sensitivity on this station (the oscillator coil being padded by a condenser switched across it) little saving in components seems to be effected by this restriction on full coverage of the long wave band.

Useful attachments available in the Perdio range

of receivers are aerial input sockets for use in cars to avoid directional effects with the internal ferrite-cored aerial as the car moves about (also seen on the K.B. "Rhapsody"), output sockets for feeding a tape recorder, and earpieces for private listening.

Transistorized Record Reproducers.—An interesting unit is the Camp Bird "Wondergram" shown in the photograph. By dispensing with the turntable, the whole unit can be made to occupy only 8½in x 4½in x 1½in. The record is driven by the rim of one of two rubber wheels (depending on whether the speed is 33½ or 45 r.p.m.) which rotate about a horizontal axis. The two speeds are selected automatically because 45 r.p.m. records, being only 7 inches in diameter, are not big enough to reach to the further of the two driving wheels from the

(Continued on page 481)

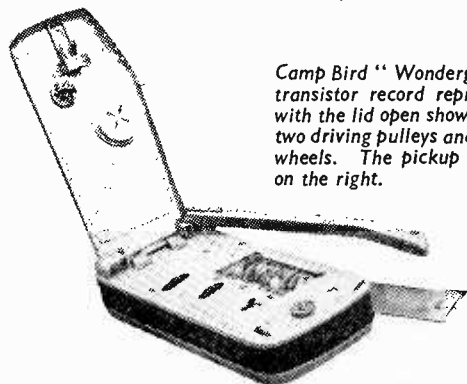

Camp Bird "Wondergram" transistor record reproducer with the lid open showing the two driving pulleys and idling wheels. The pickup arm is on the right.

**BELLING-LEE NOTES
HORIZONTAL BAND III**

After Chillerton Down I.O.W. comes Burnhope serving the N.E. with an I.T.V. signal, the first band III horizontally polarized transmission in this country.

We have given a lot of thought to the matter and readers of this column in the last number of "Wireless World" will remember what we said about stacking. Since writing, we have met over three

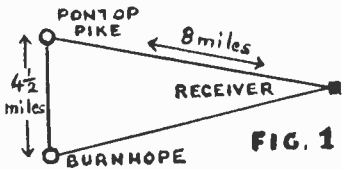

hundred members of the Trade in the N.E., and visited the Burnhope site where the mast was up to 600-ft. level (29th July). The small aerial will be mounted on the main mast about the 400-foot level, and by the time you read this, a pilot signal will be on the air from the small transmitter.

There should not be much trouble in the densely populated areas although there will be black spots. Generally the signal from the pilot transmitter covers the proposed service area thinly, and that does not mean that every site in the area will receive it, but it does allow those erecting aerials to assess possibilities. One real difficulty, about which little can be done, is in the case of a locked

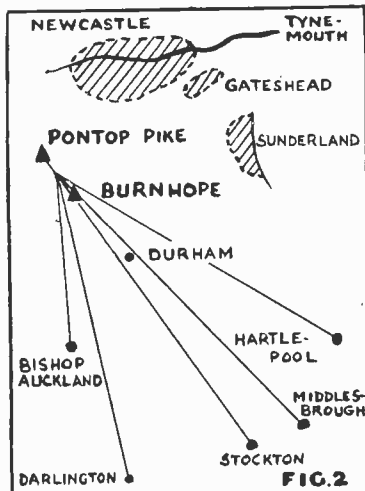

picture that is very noisy; the noise may hide one or more ghosts. When the station goes on high power, the noise will disappear leaving the ghost. If your business is erecting aerials, your estimate should allow for the

second visit of a rigger to swing the aerial in such cases.

In theory we would not expect much pick-up from the sides of a horizontal array, but ghosting has given trouble in some locations from Pontop Pike. For the reception of Burnhope on band III, we generally recommend four or six element arrays, or combined H+5. With an array of this kind, generally ghosting will not be bad.

There have been doubts as to the wisdom of erecting H+5, or adding the five element adaptor to an existing H because of the

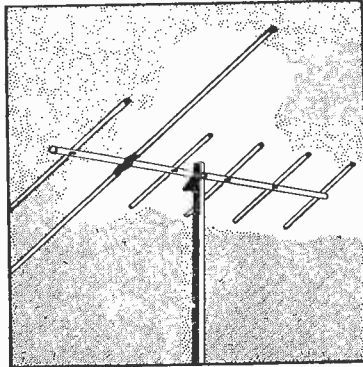

Showing a "Belling-Lee" 1+5 combined array. An H-5 is also available. A 5-element band III adaptor is also available for fixing to an existing horizontal H.

directivity, and the theoretical lack of pick-up from the sides. This has been very carefully considered, and it can be proved mathematically that, provided the receiving location is beyond eight miles, even if forming an isosceles triangle with the two transmitters (see Fig. 1) situated approximately 4 1/2 miles apart, if a combined array is lined up on the band III transmitter, there would be negligible loss of signal on band I. The broader acceptance angle of the band I H will look after it. The little map (see Fig. 2) shows that all the big centres of population are co-sited within the technical meaning of the word, and even for places twenty miles or more away, an array lined up on Pontop Pike would be satisfactory for Burnhope as the angular deviation would be negligible.

People living on the line Darlington-Middlesbrough, who now receive what they believe to be a good I.T.V. programme from Emley Moor, will be very surprised how good an I.T.V. signal can be when they change over to Burnhope.

Advertisement of
BELLING & LEE LTD.
Great Cambridge Rd., Enfield, Middx.
Written 8th August, 1958

**"BELLING-LEE"
Printed Circuit Connectors**

- L.1369 8-pole. L.1370 12-pole
- L.1372 18-pole. (0.15" Module)
- L.1355 8-pole. (0.1" Module)

These printed circuit connectors use the board as a plug-in member.

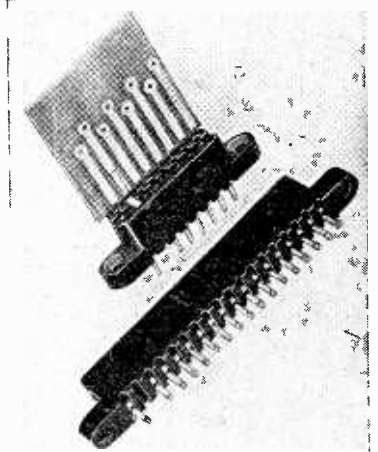

The unique contact spring construction ensures excellent contact with minimum wear on board and connector. Body in high-grade phenolic material carries the contact springs, formed with beryllium copper, heat-treated and gold-plated.

The "tag" ends of the contacts are suitable for dip soldering on printed circuit boards; and a solder bucket is incorporated for conventional wiring techniques. Suitable for printed circuit boards 0.0625in. ± 0.005in. thick, single or double sided.

Correct polarity of insertion can be arranged by removing a contact and replacing it with a polarizing pin (L.1381) which engages with a slot cut in the panel. More than one pin may be used to "code" boards in an assembly.

For maximum contact-life the board must enter the connector "square-on". This can be arranged by guides (L.1380), either mounted on the connector, or spaced from it, and these also support the panel when inserted. They are suitable for use with either 0.15in. or 0.1in. connectors.

- Breakdown voltage between pins:
0.15in. module—3.25 kV (sea-level)
550 V. (68,000 ft.)
0.1in. module—2.5 kV (sea-level)
450 V. (68,000 ft.)
- Insulation resistance: Greater than 100 megohms.
- Contact pressure: 0.15in. module—300 gms. approx.
0.1in. module—300 gms. approx.
- Contact resistance: Average 4.7 milliohms approx.
- Current rating: For a temperature rise of less than 30°C.—4 amps. per contact with conventional wiring. 3 amps. per contact with dip-soldering to a p.c. board.
- Endurance: A sample gave contact resistances in the range 5 to 15 milliohms after 3,000 insertions. Samples have survived more than 50,000 insertions without interruption of circuit continuity.

BELLING & LEE LTD
GREAT CAMBRIDGE RD., ENFIELD, MIDDX., ENGLAND
Telephone: Enfield 3322 : Telegrams: Radiosel Enfield



***Marconi
in
Electronics
for
Aviation***

**More than 50 Civil Airlines and 30 Air Forces
use Marconi radio, radar and navigational aids**

MARCONI

**AIRCRAFT AND AIRPORT SYSTEMS FOR
COMMUNICATIONS AND NAVIGATIONAL AIDS**

MARCONI'S WIRELESS TELEGRAPH COMPANY LIMITED, CHELMSFORD, ESSEX, ENGLAND
M.2

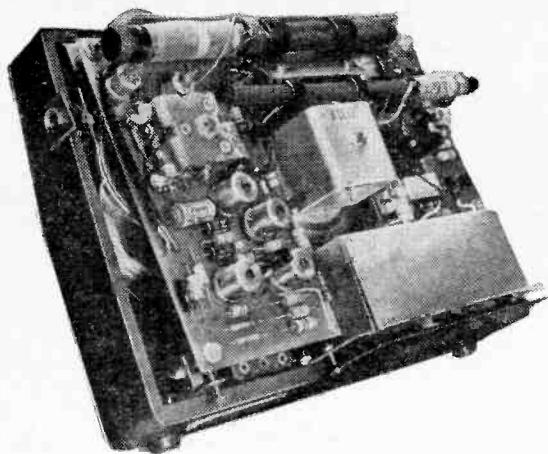

Dynatron "Nomad" transistor receiver with $9\frac{3}{4}$ in x $4\frac{1}{2}$ in elliptical loudspeaker.

record centre; and because $33\frac{1}{3}$ r.p.m. records, being 10 or 12 inches in diameter, are driven only by the further wheel since this is made slightly larger than the other driving wheel. The record is supported by a freely rotatable small disc at the centre spindle, and also by two idler wheels (one in the lower and one in the upper part of the "Wondergram") which play on the record label. The upper part (which is hinged near the edge furthest from the centre spindle) must thus be closed over the record to play it. The ceramic-element pickup arm is pivoted near one corner of the "Wondergram," and when not in use forms one of the edges of its upper part. The lower part contains the batteries, driving motor and wheels, and the push-pull transistor amplifier and 3-in speaker.

Sound Receivers.—Few basic changes were noted in this field. Car radios using the new ranges of valves which can operate with an h.t. supply of only 12V, and which can thus run directly from the car battery without the need for a vibrator supply, were shown by Pye, Masteradio and Ekco. Since, as yet, insufficient power output can be obtained from such valves, a power transistor is used in the output stage of this type of receiver. The transistor and its heat sink are generally separated from the rest of the receiver because of the higher operating temperature of the transistor. In the Ekco CR901 a "sliding bias" arrangement is used in which part of the output is rectified and fed back to adjust the bias so that the available output is increased from 2 to 4 watts although the quiescent current is relatively small (see *Wireless World*, October, 1957, p. 473).

"Turret tuning" as used in television receivers was seen in the Dynatron "Albany" a.m./f.m. radiogram and the Jason JTV v.h.f./f.m. and television sound tuner. The usual advantage of turret tuning, optimum placing of coils to allow short leads, of course still applies at v.h.f.

The total distortion in all stages of a new v.h.f./f.m. tuner shown by Scientific and Technical Developments is stated to be only 0.3% at 75 kc/s deviation. This low figure is obtained by a special negative feedback arrangement operating on the mixer, i.f. amplifier and ratio detector. This tuner is also available in the STD/447 on the same chassis as an electrically separate a.m. tuner, thus forming

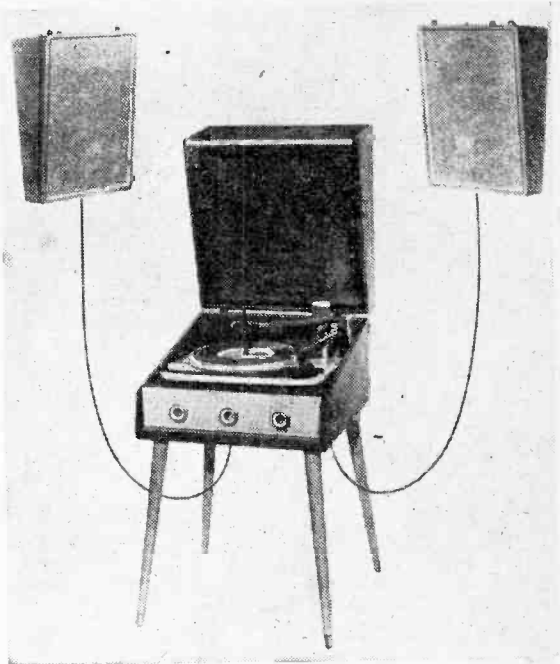

Margolin "Dansette Stereophonic" record reproducer with the loudspeakers detached from the sides.

a combined unit suitable for the reception of stereophonic broadcasts in which one channel can be received by the a.m. tuner and the other by the f.m.

Stereophonic Record Reproduction.—A very wide variety of arrangements were seen, sometimes even in equipment shown by the same manufacturer, so that at the moment it may be said that there are several trends running simultaneously. Indeed, if the almost universal use of the word monaural (or one-eared) to describe single-channel reproduction is any guide, one immediate and disastrous sudden trend has been the loss of one ear by anyone who does not own a stereophonic reproducer.

In considering the types of arrangements used, we shall follow the signals through the reproducing system. Starting then from the records themselves, as readers will probably already know, these have now been issued in this country by Pye, Decca and E.M.I.

Most of the pickups shown used twin crystal elements. These are often joined to the stylus by two long flexible links at right angles, so that stylus motion in either of the two recorded directions ideally only affects one of the elements owing to the flexing at right angles to its length of the link joining the stylus to the other element. In the Garrard GCS10, however, the two links from the elements are not joined to the stylus or each other, but cross over at right angles forming an X. The playing pressure forces the cantilever stylus support against the lower parts of the links where they cross over, so that stylus motion in either of the two recorded directions acts directly only on one of the elements and the cantilever slides along the link to the other.

In the Collaro twin ceramic "Studio" cartridge, the stylus is joined to one corner of a square slab which has an elliptical hole cut in it with its long axis vertical. This is roughly equivalent to two links,

but can be made much smaller, resulting in an improved high-frequency response.

In the Philips cartridge each link is bent at an acute angle so that both links form a W shape. In this way, pushing or pulling motion along the part of the links near the stylus is changed to twisting motion at the ends of the W, and is thus more suitable for acting on certain types of crystal element.

Twin variable reluctance pickups were demonstrated by E.M.I. in their RS 100 Capitol record reproducer, and also by Decca as a separate unit. The Decca pickup was originally developed for a "carrier" stereophonic system in which one stereophonic channel is frequency changed to supersonic frequencies to place it outside the frequency range of the other channel, the two channels being then laterally recorded in the usual way. Accurate tracing up to the highest recorded supersonic frequency (in this case 30 kc/s), is thus necessary for the reproducing pickup. The stereophonic version is claimed to have a very low effective stylus tip mass of only about 1 mgm in either the horizontal or vertical direction.

Although the recommended stylus tip radius (see *Wireless World* June 1958, p. 259) for stereophonic reproduction is $\frac{1}{2}$ thou (0.0005 in) many pickups used a $\frac{3}{4}$ thou stylus. When the stylus is also to be used for playing ordinary single channel microgroove records, the larger radius may be preferable to avoid playing on dirt which may have accumulated in the bottom of the groove, or even in some early or worn records with large bottom groove radii to avoid rattling in the bottom of the groove itself. The wear on the stylus with the larger tip radius is also likely to be less. To reduce the wear on such styli, which in any case have smaller tip radii than the 1 thou styli used for ordinary l.p. records, diamond is being

increasingly used as a stylus material even, for example, in the relatively inexpensive Margolin "Dansette Stereophonic" record reproducer.

Arrangements for balancing the output from the two stereophonic channels also varied widely. Some inexpensive record reproducers relied solely on matched amplifiers and speakers and the accuracy of two ganged volume controls. This arrangement cannot, of course, allow for any effective changes in sensitivity due to different acoustic conditions at the loudspeakers, for example an absorbing curtain near one of them. In "add-on" units, that is extension combined amplifiers and speakers for the easiest conversion of ordinary single channel reproducers, completely independent level controls are almost inevitable, and balancing may take some time. Separate but concentric volume controls are much easier to operate, as they can generally both be rotated together without much difficulty. This rotation is even easier in the H.M.V. 1635 radiogram because relative motion of the two knobs is made somewhat stiff. In the R.G.D. 161S record reproducer the two controls are normally rigidly connected, but one may be rotated relative to the other by first pushing it inwards. Where a balance control is provided in addition to ganged volume controls, a possible relative change of sensitivity between the two channels of up to about ± 6 dB or less is now almost universal. Facilities for making balancing easier were seen on the Pilot "Stereophonic 4" and Philips NG5076 record reproducers. In the Philips reproducer the inputs can be paralleled and the balance control adjusted until the apparent sound source is midway between the two speakers. In the Pilot reproducer either channel can be switched off by a push-button. The concentric volume controls can thus be adjusted till, on switching from one channel to the other, the two channels sound equally loud.

A surprising number of multi-speaker systems for each channel were seen, considering the often stated view that for the same overall impression of faith-

Hobday "Tri-Fi" stereophonic radiogram showing the two sliding panels carrying the loudspeakers in their maximum extension position.

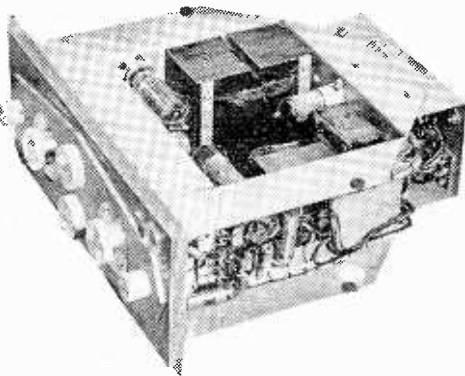

Scientific & Technical Developments stereophonic combined pre-amplifier and 2 x 4 watt amplifier STDJ444.



Compact Goodman's 6-in speaker for reproduction of frequencies above 300 c/s. A diffuser gives uniform horizontal sound dispersion.

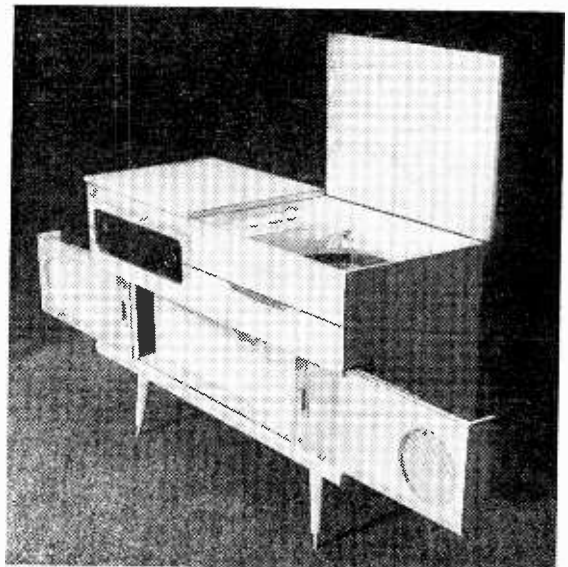

fulness to the original sound, the frequency response in a stereophonic system need not be nearly as wide as the response in a single-channel system. In most cases matched speakers or speaker systems were used for the two channels.

It was in loudspeaker mounting that the widest variety of methods was seen. In a number of cases both speakers were housed in the same cabinet spaced as far apart as possible (from about 3 to 4 feet) at the front. Forward rather than inwards angled facing of the speakers was generally favoured to increase the area in which a good stereophonic effect could be heard. With these arrangements, the apparent sound sources cannot extend beyond the line joining the two speakers. In the Hobday "Tri/Fi" a.m./f.m. radio-gram the two speakers are mounted (facing forwards as before) at the ends of two panels which can slide outwards so that the distance between the speakers may be increased from $3\frac{1}{2}$ to $5\frac{1}{2}$ feet.

In some of the E.A.R. reproducers the two speakers are mounted at the sides facing outwards (not upwards as incorrectly stated in our Show Guide). These are intended to be placed across a corner of the room so that the sound is reflected from the walls and the apparent sound field broadened. An obvious way to widen the sound field is to use a detached mounting for one or more of the speakers, though considerable space may be taken up and the leads to such speakers may become a nuisance. In record reproducers shown by Margolin, E.A.R. and Perdio, both speakers are detachable, but may also be used clipped to the sides of the record reproducer.

Completely detached speakers were shown in cabinets of practically all shapes and sizes. Several manufacturers suggested the use of the speaker in a television set.

A large cabinet volume in a small floor space can clearly be obtained by making the height much greater than the horizontal dimensions as in a column, and an increasing number of such column-shaped cabinets were shown. (Such cabinets should not be confused with columns of loudspeakers often used in sound reinforcement.) If the speaker is mounted near the top facing upwards onto a diffuser the uniform sound dispersion in a horizontal plane often advocated for stereophonic reproduction can be readily obtained. Horizontal sound dispersion uniform only through 180 degrees towards the front has also been advocated, and this type of dispersion is obtained in the Record Housing column by using a specially shaped diffuser. To modify the effect of air column and speaker resonances in the Expert column, there is a constriction half way down with some acoustic padding above it.

A number of small units were shown for hanging on walls, thus economizing on floor space still further!

According to Decca and Goodmans, directional effects in hearing are provided almost entirely by the higher frequencies (above about 3000 c/s Goodmans, 800 c/s Decca). On this theory, both channels can be fed to a single bass speaker which can be placed anywhere in the apparent sound field, and only two tweeters need be spaced apart, so that the separate speaker cabinets or baffles may be made very small without any acoustic disadvantages. Goodmans were showing a small direct-radiator loudspeaker (see photograph) for possible use in such

a system for the reproduction of frequencies above 300 c/s.

An interesting and relatively small loudspeaker system, the IB3, was also shown by Goodmans. This is similar to a pre-war model in that a bass speaker with a very low free-air resonant frequency (about 18 c/s) is used. This speaker can then be mounted in a small totally enclosed cabinet without the resonance being raised to a frequency where it is acoustically harmful. The enclosed air provides over 75 per cent of the total stiffness of the system so that distortion is lower than with a mechanical loudspeaker suspension. A large magnet is used to provide adequate sensitivity and damping; and because of the very heavy air loading, a very rigid cone must be used to avoid cone deformation and consequent distortion.

Tape Recording.—Again following the signals, we start first with microphones. A versatile stereophonic unit introduced by Lustraphone used two microphones similar to their VR64 mounted one on top of the other. The upper microphone may be rotated up to 100 degrees in one direction from the position in line with the lower to cover all the usual arrangements used in stereophonic recording with such close microphone pairs. Switches to reverse the phase of one microphone and/or to connect them in series are provided. By using the microphones out of phase and in series, a variety of different polar responses can be obtained according to their relative angular position. For example, when they are in line, only close sounds are responded to and ambient noise effects are considerably reduced.

A new range of pre-recorded single-channel and stereophonic tapes was introduced by Elizabethan.

The trends in tape recorders noted at the Audio Fair—the provision of 1½ in/sec as the slowest of 3 speeds, and the use of push-pull bias and erase oscillators with their low d.c. noise producing output—were, as might be expected, also seen in the new Radio Show models. Infrequently seen features provided in new models included, in the Veritone, "Venus", separate record and replay heads and amplifiers so that while recording, the signal actually recorded on the tape as distinct from the signal input to the tape may be monitored.

Transistors were seen in low noise input stages in the Jason JSM1 and JSM2 tape record and replay amplifiers. An optional feature in the Walter 505 and 303 recorders is a stroboscope attached to the capstan so that films can be synchronized to the tape using the light from the projector shutter.

Amplifiers and Pre-amplifiers.—Radically new design features are now seldom seen in these. As was to be expected, several new dual-channel units for stereophonic reproduction were shown. These included the Scientific and Technical Developments STD/444 combined 2×4-watt amplifier and pre-amplifier which had a particularly neat and economical component layout. A "sign of the times" is that the only control unit available from K.B. is for stereophonic reproduction.

An unusual feature seen in the single-channel B.T.H. control unit is the provision of continuous variation (from 5 to 15 kc/s) of the cut-off point in the 18dB per octave low-pass filter. Four-channel mixing facilities are incorporated in the new Dynatron TC20 single-channel pre-amplifier.

B.B.C. TELEVISION CENTRE

FEATURES OF EUROPE'S LARGEST
TV HEADQUARTERS



Colonnade approach to the Television Centre as visualized by Frank A. Weemys, whose perspective drawing was shown at the Royal Academy.

Model of the completed Centre, including the proposed "spur", viewed from the same angle as that from which the aerial photograph on page 485 was taken.

WHEN completed in 1961 the B.B.C. Television Centre will be the largest television headquarters in Europe. Standing on the White City site in West London used in 1908 for the Franco-British Exhibition, it will include seven studios, four of them larger than any at present in use in this country.

With the aid of the fold-out perspective drawing, reproduced by courtesy of the B.B.C., and our associate journal *The Architect and Building News*, readers will be able to gain some idea of the unique layout of the studios and technical facilities to be provided in the Centre. As can be seen in the upper inset in the drawing, the seven studios will radiate from the central circular building.

The first and second floors of the seven-storey building will be devoted to technical services. From the first floor the studio control rooms (vision, sound and lighting) look down into each of the seven studios, as shown (56, 57 and 58)* for Studio 1 in the drawing.

In the central wedge, between Studios 3 and 4 will be the central control room (24) which will be the focal point for all programmes whether originating within the building, from other studios or from outside broadcasting units. Also in this central wedge will be the Continental control point, at

* Key references to fold-out drawing.

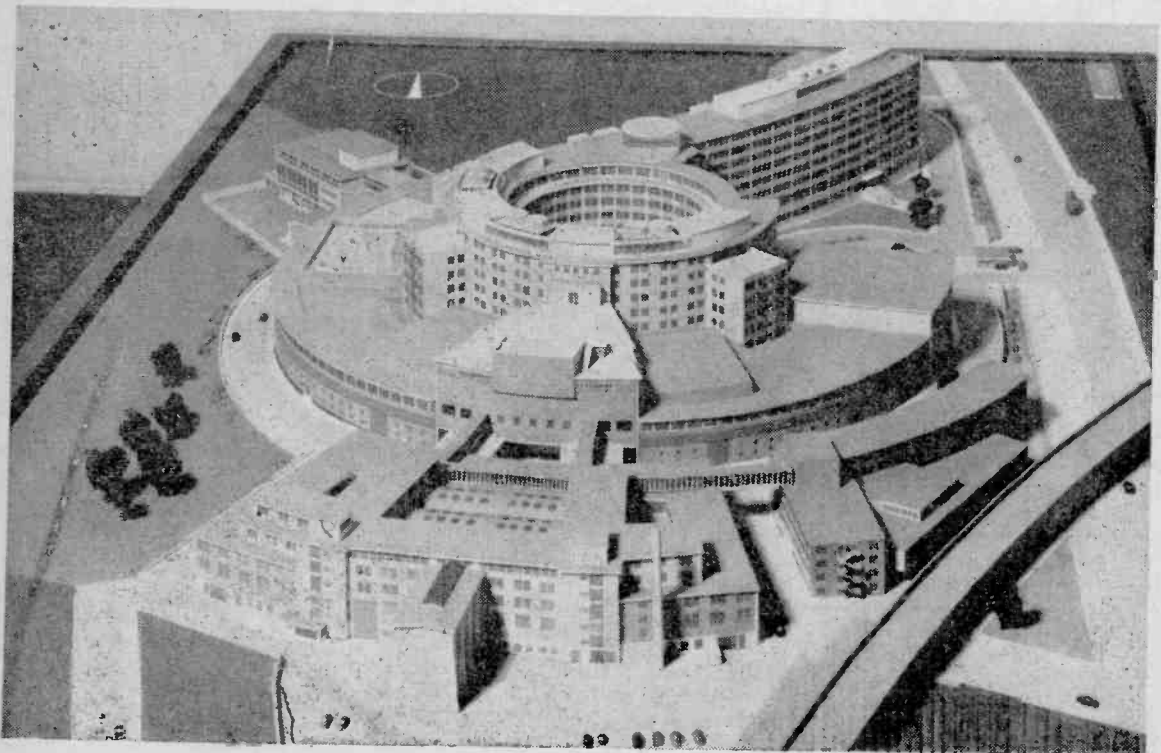

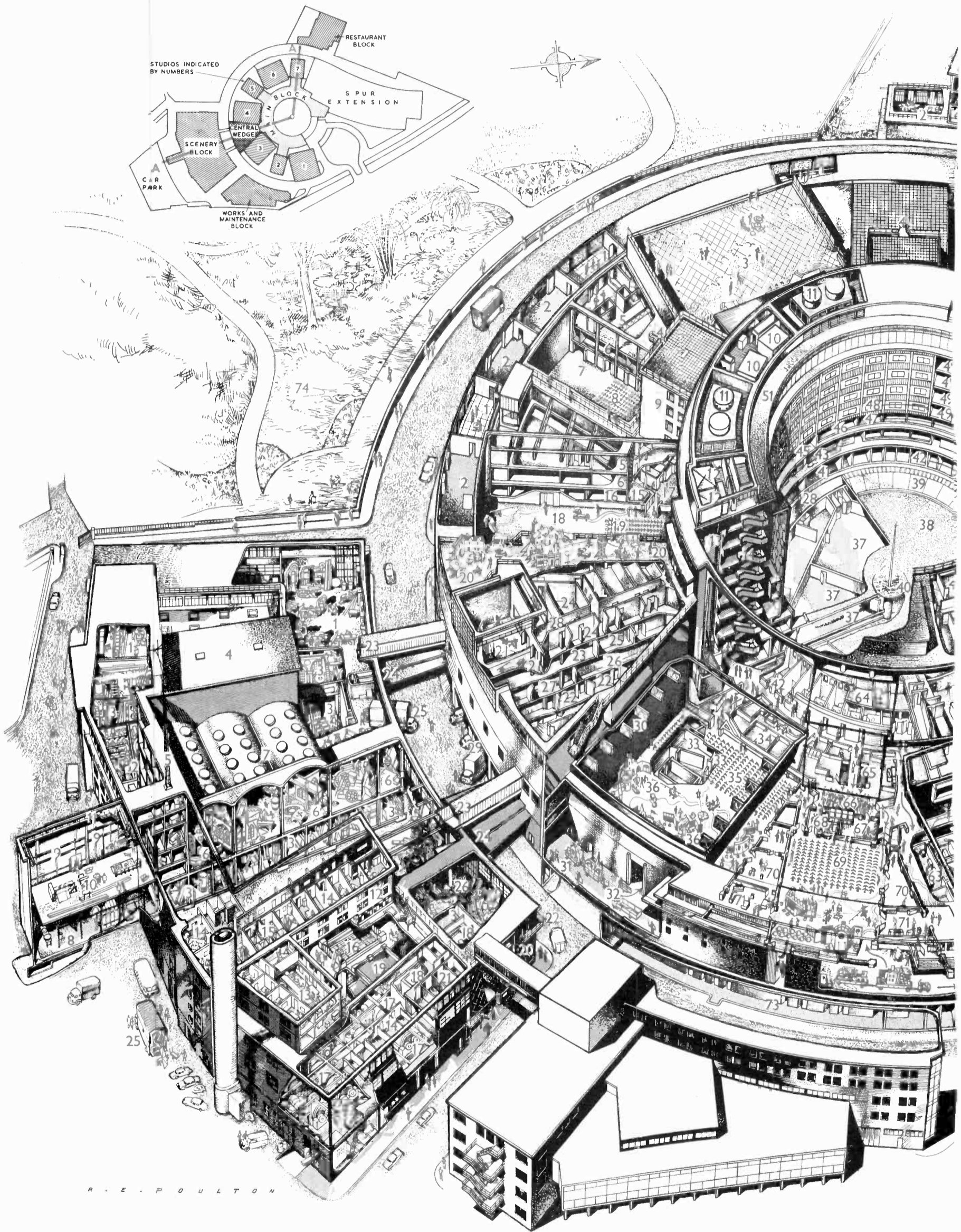

R. E. POULTON

COPYRIGHT B.B.C.

DRAWING PREPARED BY *THE ARCHITECT AND BUILDING NEWS* IN COLLABORATION WITH THE ARCHITECT FOR THE SCHEME GRAHAM DAWBARN C.B.E. (NORMAN & DAWBARN) AND M. T. TUDSBERY C.B.E. CONSULTING CIVIL ENGINEER TO THE B.B.C.

B.B.C. TELEVISION CENTRE

Impression of the buildings, now under construction in London

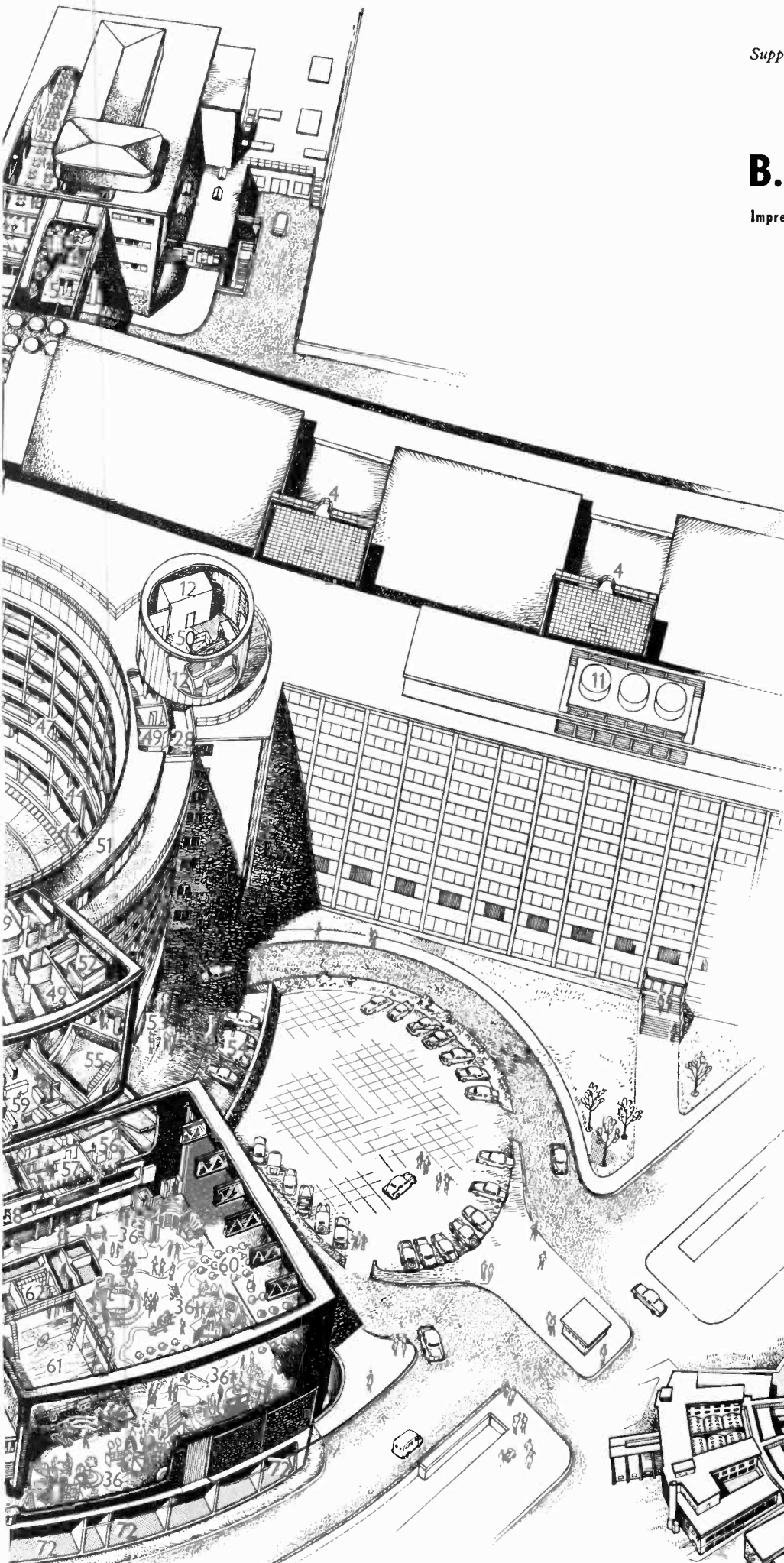

RESTAURANT BLOCK

- 1 Service for 750 diners on three floors
- 2 Foyer lounge
- 3 Bridge lounge
- 4 Passage below bridge lounge
- 5 Entrance from road

SCENERY BLOCK

- 1 Carpentry and machine shop (ground floor)
- 2 Property stores (basement)
- 3 Scenery storage (basement)
- 4 Office wing (west)
- 5 Aerial mast (receiving)
- 6 Set building space (ground floor)
- 7 Vaulted roof over setting space
- 8 Scene painting studio (60 feet high)
- 9 Electrically - operated painting frames (30 feet high)
- 10 Console controlling height of frames
- 11 Cat-walk
- 12 Office wing (east)
- 13 Temporary telephone exchange
- 14 Offices
- 15 Toilets
- 16 Scenery lift (basement to ground floor)
- 17 Boiler house (basement)
- 18 Fuel oil storage tanks (basement)
- 19 Papier maché workshop
- 20 Drapes and curtain store
- 21 Special effects section
- 22 Outside gallery along face of building
- 23 Bridge linking blocks
- 24 Protective hoods across roadway
- 25 Scenery and property vans
- 26 Scenery and properties (inward and outward)

- 19 Studio audience (400 persons)
- 20 Roof for outdoor filming and television
- 21 Presentation studios (2)
- 22 Film sequence area
- 23 Central apparatus room
- 24 Central control
- 25 Quality check
- 26 Telecine
- 27 Main film area, 35 mm.
- 28 Corridor
- 29 Loading dock
- 30 Roof trusses
- 31 Scenery runway serving all studios
- 32 Scenery entrance to studio
- 33 Echo effects rooms
- 34 Dressing rooms
- 35 Studio audience (400 persons)
- 36 Sets positioned on studio floor
- 37 Tele-recording suite
- 38 Central lawn
- 39 Paved way for fire engines
- 40 Fountain
- 41 Conference room
- 42 Stars' dressing rooms
- 43 Control area Studio 6
- 44 Entrance hall (ground and first floor)
- 45 Technical maintenance
- 46 Test room
- 47 Engineers' offices
- 48 Wardrobe, tailoring and stock-room
- 49 Offices
- 50 Ventilation plant
- 51 Roof walkway
- 52 Staircase
- 53 Main entrance colonnade
- 54 V.I.P. car park
- 55 Crowd dressing rooms (basement)
- 56 Lighting control room (Studio 1)
- 57 Vision control room (Studio 1)
- 58 Sound control room (Studio 1)
- 59 Vision apparatus room
- 60 Studio lighting grid
- 61 Pit in studio floor (can be water filled)
- 62 Make-up lockers
- 63 Repairs and maintenance
- 64 Advance maintenance room (first floor)
- 65 Stairs up—from basement
- 66 Assembly area
- 67 Green room
- 68 Quick change room
- 69 Studio audience (200 persons)
- 70 Studio equipment store
- 71 Studio production store
- 72 Subsidiary rooms—telephone system
- 73 Corridor (basement)
- 74 L.C.C. gardens

MAIN BLOCK

- 1 Open balconies
- 2 Electrical substations
- 3 B.B.C. Staff Club roof garden (over Studio 6)
- 4 Emergency stairs
- 5 Plant room
- 6 Contactor and dimmer room
- 7 Floor of Studio 5
- 8 Studio audience (200 persons)
- 9 Script libraries (4th and 5th floors)
- 10 Water tanks
- 11 Cooling towers (ventilation plant)
- 12 Lift motor rooms
- 13 Goods and passenger lift shafts
- 14 Main staircase (South Hall)
- 15 Ventilation ducts
- 16 Studio store
- 17 Access from assembly area to Studio 4 and 5
- 18 Floor of Studio 4

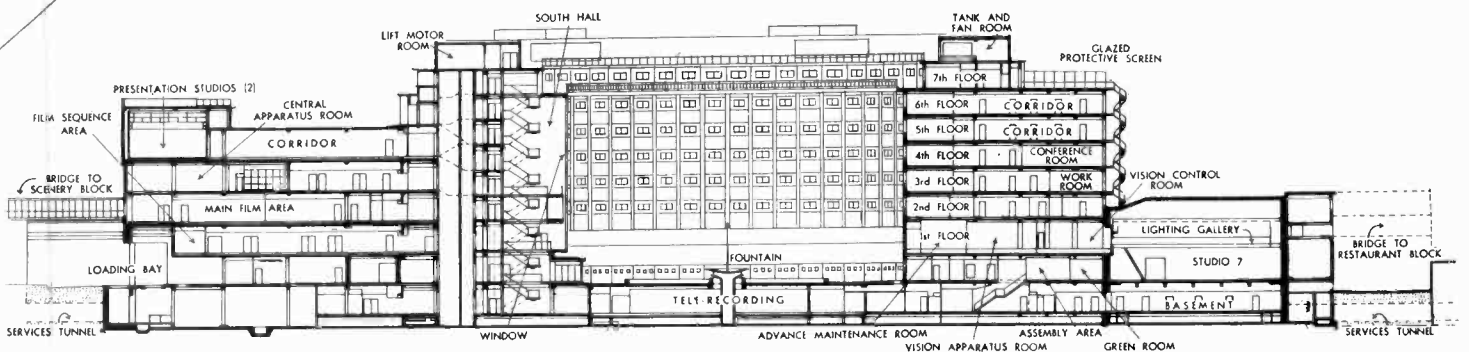
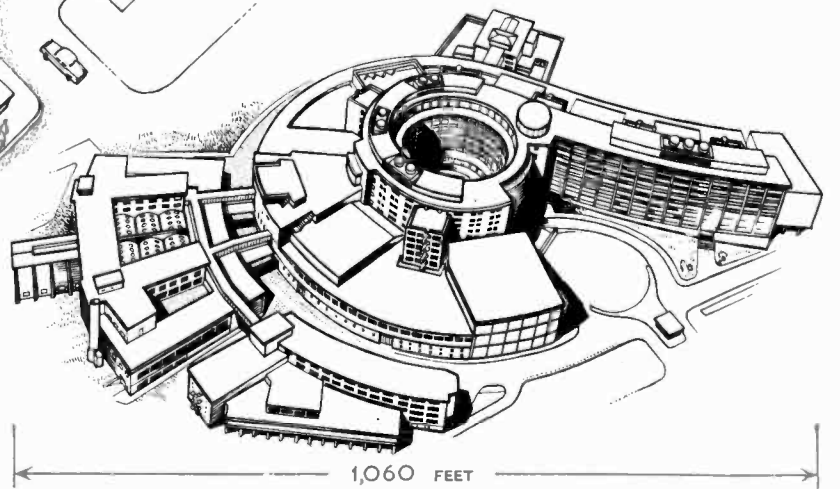

SECTION TAKEN ON A-A

present in Broadcasting House, through which pass the vision and sound signals for Eurovision programmes to and from this country.

A section of the first and second floors of the central wedge will be devoted to teleciné equipment (26). On the third floor of this wedge there will be a central apparatus room (23) containing all the equipment which can conveniently be accommodated in one central area. In this section is also the "quality check" rooms where the television pictures from the studios are finally checked for quality and passed on to the B.B.C. transmitters.

A major part of the area below the central lawn (38), which will be 150ft in diameter (about the size of Piccadilly Circus), is for tele-recording equipment (37). It consists of four main recording areas, each 32ft square, together with dark-rooms, viewing room and workshops.

On the second floor of the main building will be the base technical maintenance workshops (45), test rooms (46) and equipment stores. Here immediate repairs will be carried out on the television engineering equipment. Engineers' offices (47) are also on this floor.

The first section of the building to be completed is the scenery block, and it has been in use in conjunction with the nearby Lime Grove studios since 1954. The canteen block is also completed and has been adapted for temporary use as offices and

rehearsal rooms. It is expected that the first studio will be brought into service in 1960. Orders have been placed with Marconi's and E.M.I. for 30 cameras and associated equipment for use in these studios. It is understood that in planning the studios provision has been made for possible additional requirements which colour television may impose.

Round the outer periphery of the studios is a 20ft runway, along which properties and scenery will be conveyed direct from the scenery block to the studios.

A lighting gallery surrounds each studio at high level, and from these supplementary lights and backcloths will be operated. Provision is also made for a circular panorama in each studio. While on the subject of scenery, reference should be made to the scenery block already in use. It covers one acre and houses the Television Design Department where scenery is devised and made in the adjoining carpentry and plaster shops. There is a 65-ft-high scenic artists' studio for the painting of backcloths. Artists work on an intermediate platform some 25ft above the floor of the studio, and the screens are electrically moved up or down from a console.

The final development of the 13-acre site provides for the addition of a spur (see photograph of model), and although this forms a vital part of the original architectural concept, it is, as yet, planned in outline only.

This Aerofilms photo taken in July shows the progress made in building the Centre. In the foreground is the scenery block.

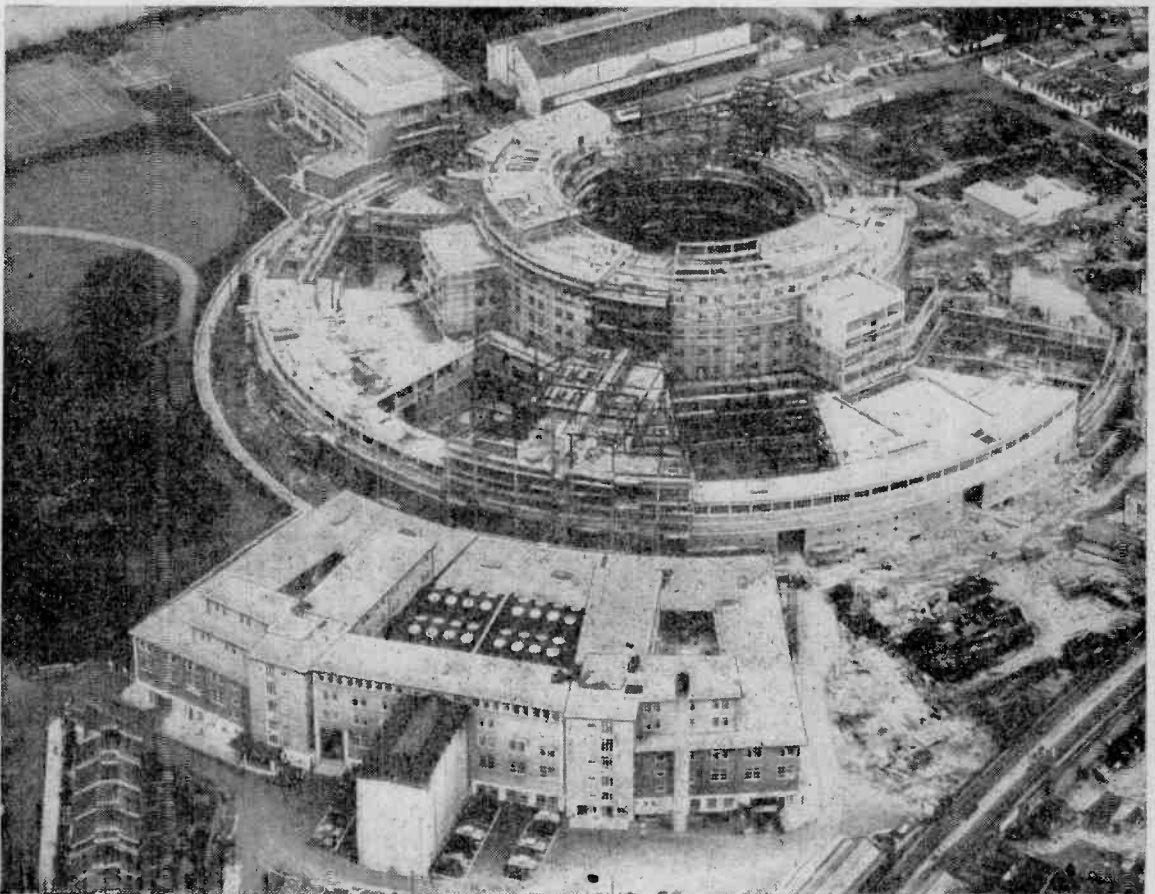

A.G.C. for Television Receivers

ASPECTS OF DISTRIBUTED AUTOMATIC GAIN CONTROL

By R. H. SKINNER,* B.Sc.

DUE to the wide diversity of amplitudes of television signals that can be received in different areas, the overall sensitivity of a television receiver needs to be variable between wide limits, e.g.: between say, $20\mu\text{V}$ and 200mV . This is achieved universally by the application of suitable bias potentials to a number of the stages of the receiver in order to vary the effective mutual conductances of the corresponding valves and, consequently, the gain of the stages. However, it is not sufficient to produce a single bias potential and apply it simultaneously to a suitable number of stages, because the potential that can be applied to a particular stage is subjected, in the light of required

much smaller than that to the i.f. stage, sound and vision signals will be of equal amplitude. Clearly, when all the controllable stages of the receiver reach their overload points, the overall gain of the receiver cannot be further reduced.

Consideration of the simplest practical case of a receiver containing one r.f. stage, mixer and two vision i.f. stages, with gain-control bias-potentials applied to the r.f. and first vision i.f. stages. We will assume that all the sound rejection (45-50 dB) is achieved between the mixer and the first i.f. stage.

Let us now make the following definitions: G_r and G_i are the relative gains of the r.f. and i.f. stages respectively, expressed in dB below their maximum values G_{mr} and G_{mi} .

S_{min} is the amplitude of the receiver input signal that is required to modulate the picture tube fully when the receiver is working at maximum overall gain.

S is the amplitude of signal required to give this this output when the relative stage gains are G_r and G_i .

Then, according to the above considerations, the ideal "gain/input" curves for the r.f. and i.f. stages are as shown in Fig. 1, with one provision—uncontrolled stages (e.g.: the mixer) must not be overloaded by the signal fed to them under these conditions.

Before the use of some form of vision a.g.c. became general practice the solution of the problem was to provide two variable positive bias-potentials from potentiometers across the h.t. supply and to apply these to suitable cathodes. Normally one would be applied to the r.f. stage and its adjustment would be by a pre-set potentiometer known as "Sensitivity" or "R.F. gain." The other would be applied to the cathode of the i.f. stage and its adjustment would be made accessible as a "user" control ("Contrast"). With this arrangement, it was always possible for a dealer, when installing a receiver, to set it up to give optimum performance, providing the above simple considerations were observed.

Application of Vision A.G.C. The advent of vision a.g.c. normally did not alter this state of affairs as the i.f. stages were then controlled by a negative a.g.c. potential applied to the grids and the "Contrast" control was used to vary the level of a.g.c. applied. In some cases some proportion of the a.g.c. voltage is applied to the r.f. stage in addition to a manual "Sensitivity" control.

When I.T.A. transmissions started most receivers were presented with two signals of widely differing strengths. It is obviously desirable to eliminate re-adjustment of the "Contrast" control each time

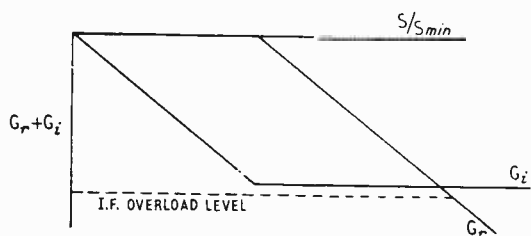

Fig. 1. Idealised gain/input curves for r.f. and i.f. stages.

overall receiver performance, to limitations depending upon the particular function of the stage in the receiver.

Let us consider the case of an r.f. amplifier. A considerable proportion of overall receiver noise arises in the mixer stage; therefore, to achieve optimum noise-performance, the gain of the r.f. stage should be as high as possible. Ideally, gain control should be applied to the r.f. stage only when no further control can be applied to later stages, i.e., vision i.f. stages.

The limit of control that can be applied to an i.f. stage is reached when the valve is biased to a point where the characteristic becomes appreciably non-linear over the excursion of the input signal. When this point is reached intermodulation between sound and vision signals occurs, usually manifesting itself as "sound-on-vision." The point at which this occurs depends, of course, on the characteristic of the type of valve used and the relative amplitudes of the sound and vision signals, i.e.: the amount of sound rejection that is introduced before the stage under consideration. A point of overload where intermodulation occurs will also exist for the "front-end" stages as, although the input level is

*Peto Scott Electrical Instruments Ltd.

the channel switch is moved; but this is not always possible. One solution used was to switch automatically between two manual r.f. gain controls when the channel switch is moved, while using a.g.c. on the i.f. stages. This system can be made to work quite satisfactorily; but it is still not ideal because the pre-set adjustment for each channel does not cover the full range of sensitivity variation of the receiver and it is possible to set the controls in such a way that the distribution of bias potentials does not allow optimum performance on one, or even both channels.

It is, however, possible to devise a system in which the sensitivity of a receiver may be varied between the widest possible limits by the adjustment of a single control, whilst the distribution of bias voltages is automatically arranged in a manner closely in accordance with Fig. 1.

This characteristic has two salient features:

(i) The control voltage applied to the r.f. stage must be delayed with respect to that of the i.f. stage by a suitable amount.

(ii) Beyond this point the balance of control must swing rapidly over to the r.f. stage and proceed to a condition where the gain of this stage is reduced relatively more than that of the i.f. stage.†

The basis of the circuit is a simple a.g.c. system

† *J. Brit. I.R.E.*, May 1958, "A.G.C. Circuits in Television Receivers for Negative Modulation" by P. L. Motherwell, *A.M. Brit. I.R.E.*

Fig. 2(a). Basic circuit for providing a.g.c. bias and "Contrast" control. (b) Method (I) for producing "distributed" a.g.c. (c) Method (II) for producing "distributed" a.g.c.

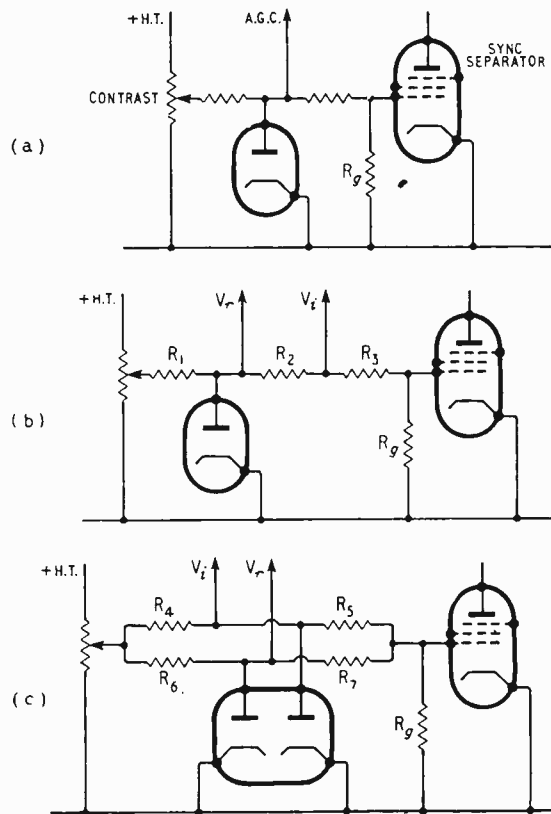

which has been in common use for a number of years, using the potential developed at the grid of the synchronizing-pulse separator. This is biased negatively by an amount dependent on the amplitude of the video signal and also, to some extent, upon picture content. A delay is applied to the a.g.c. potential by taking it, after the necessary smoothing from a suitable tap in a potentiometer chain between this grid and a relatively low impedance source of positive potential. The a.g.c. take-off point is prevented from going positive with respect to earth by the action of a diode. The source of positive potential is a variable potentiometer connected from the h.t. line to earth: this forms the contrast control. The basic circuit is shown in Fig. 1(a).

Before going further we must make some more definitions:

Let V_r and V_i be the bias potentials on the grids of r.f. and i.f. stages for relative gains G_r and G_i . For the sake of convenience we will refer these voltages to earth rather than cathode potential and we shall assume that cathode-bias resistors of 100Ω for the r.f. stage (cascode) and 150Ω for the i.f. stage (pentode) are used.

Let V_a be the potential developed at the sync separator grid when a suitable still picture (e.g.: a test card) is set up to modulate fully the picture tube and let V_b be the potential developed at the "contrast" potentiometer which, in conjunction with V_a , produces V_i and V_r . We may note, in passing, that V_a will always be negative and V_b positive; but we do not insert the signs at this stage to avoid confusion when dealing with the quantities algebraically. (When inequalities are introduced, they will be in the algebraic sense in which, for example $-2 < -1$.)

Methods of Providing Delay Characteristics

The first consideration is the problem of delaying the r.f. control potential with respect to that of the i.f.: two methods are apparent, to which we shall refer as (I) and (II).

(I) The potentiometer chain between V_a and V_b may be tapped at two points as in Fig. 2(b), V_i being taken from the tap nearer V_a . V_r is prevented from going positive by the action of a diode and thus the amplitude of V_i can never be less than

$$\frac{R_2}{R_2 + R_3} |V_a|$$

(II) V_r , V_i may be derived from two potentiometer chains in parallel between V_a and V_b as in Fig. 2(c). Both the take-off points of V_r and V_i must be clamped to earth by diodes. Then, if we make

$$\frac{R_4}{R_5} > \frac{R_6}{R_7}$$

V_r will be delayed with respect to V_i .

The swing of the balance of control from the i.f. stage to the r.f. can be obtained most readily by choosing valves of suitable control grid characteristics for these stages, in fact, a cascode amplifier (PCC84) for the r.f. stage and a variable- μ pentode (EF85) for the i.f. stage. For each of these valves, relative gain (G_r , G_i) is related to V_r , V_i as indicated in Fig. 3. From this we see, for example, that if $V_i = -12V$ and $V_r = -6V$, G_r is nevertheless reduced more than G_i .

An alternative method using valves of similar characteristics would be to apply only a fraction of the voltage developed at the junction of R_4 and R_5 (if we consider Case (II) to the i.f. stage. The fraction required can be selected by a suitable pair of series resistors between this point and earth. For example, if we assume normally that V_r and V_i are related to S as shown in Fig. 4, then if we apply half of V_i to the i.f. stage we obtain the required cross-over between G_i and G_r .

Due to the variation of valve parameters and characteristics it is possible for the sensitivities of similar receivers to vary by as much as 2:1 and so, in order to arrive at a simple assessment of a.g.c. distribution of a receiver, we will consider the relationship of V_r to V_i , which we will now derive for each of the two cases mentioned above.

We will assume the diode impedances to be zero or infinite according to whether they are conducting or not.

V_r/V_i Relationship Given by Method (I). For Case (I) we have

$$V_i = V_b - (V_b - V_a) \frac{(R_1 + R_2)}{R_1 + R_2 + R_3} = \frac{R_3 V_b + (R_1 + R_2) V_a}{R_1 + R_2 + R_3} \quad \dots \dots \dots (1)$$

and

$$V_r = V_b - (V_b - V_a) \frac{R_1}{R_1 + R_2 + R_3} = \frac{(R_1 + R_3) V_b + R_1 V_a}{R_1 + R_2 + R_3} \quad \dots \dots \dots (2)$$

Eliminating V_b we have

$$V_r = \frac{R_2 + R_3}{R_3} V_i - \frac{R_2 V_a}{R_3}$$

or putting $R_2/R_3 = x$,

$$V_r = (1 + x) V_i - x V_a \quad \dots \dots \dots (3)$$

Due to the action of the diode, this is only valid for V_i giving $V_r \leq 0$, i.e. for $V_i \leq \frac{x}{x+1} V_a$.

Conditions corresponding to values of V_i outside this range are not realisable physically and further reduction of input signal results in a reduction of video drive, making it impossible to maintain the voltage V_a at the sync. separator grid.

Thus we see that over its valid range, V_r is a linear function of V_i and it is delayed with respect to V_i by a voltage V_a where

$$V_a = \frac{x}{x+1} V_a$$

and is of the form shown in Fig. 5.

Let us now define m as the gradient of this line,

and also let $D = \frac{V_a}{V_a}$

Then we see from the equation above that

$$m = 1 + x \quad \dots \dots \dots (4)$$

and

$$D = \frac{x}{1+x} \quad \dots \dots \dots (5)$$

Thus m and D are both functions of x . Eliminating x from (4) and (5) we obtain the relationship

$$m = \frac{1}{1-D} \quad \dots \dots \dots (6)$$

We see also that, having chosen a suitable value for V_a , we can plot the $V_r + V_i$ relationship from the fact that the line must pass through the point $V_i = V_r = V_a$, which cannot normally be physically realised. We are only concerned with the values of V_r and V_i up to the overload points and when one of these is reached, the sensitivity of the receiver cannot usefully be further reduced. It is also clear that, in order to obtain the maximum possible reduction in sensitivity, we must arrange that V_r and V_i reach their overload levels together.

V_r/V_i Relationship for Method (II). We shall now turn our attention to Case (II) (Fig. 2(c)). We have

$$V_i = V_b - \frac{R_4}{R_4 + R_5} (V_b - V_a) = \frac{R_5}{R_4 + R_5} V_b + \frac{R_4}{R_4 + R_5} V_a \quad \dots \dots (7)$$

Similarly

$$V_r = \frac{R_7}{R_6 + R_7} V_b + \frac{R_6}{R_6 + R_7} V_a \quad \dots \dots (8)$$

Putting

$$\frac{R_4}{R_5} = y \text{ and } \frac{R_6}{R_7} = z$$

and eliminating V_b between (7) and (8) we have

$$V_r = \frac{1+y}{1+z} V_i - \frac{y-z}{1+z} V_a \quad \dots \dots \dots (9)$$

This is of the same form as (3) and we have

$$m = \frac{y+1}{z+1} \quad \dots \dots \dots (10)$$

and

$$D = \frac{y-z}{y+1} \quad \dots \dots \dots (11)$$

We may re-write (11) as

$$D = 1 - \frac{z+1}{y+1}$$

Thus m and D are both functions of the same variable $\frac{y+1}{z+1}$ and are once again related by equation (6).

Thus, from the point of view of distribution of

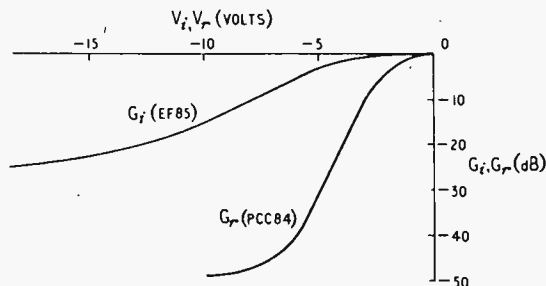

Fig. 3. Control-grid potential versus gain characteristic for PCC84 (r.f. amplifier) and EF85 (i.f. amplifier).

control voltages, the two systems can be made identical by a suitable choice of resistance values. However, returning to Method (I) we see that the maximum sensitivity for full video drive is reduced to the input level corresponding to the condition $V_i = V_a$. For lower values of input the video drive will be correspondingly reduced. For small values of V_a this may not be serious; but if it is required to increase it above a few volts, a certain amount of compromise must be tolerated. This is not the case in (II) where for $V_i > V_a$ equation (9) is replaced by $V_r = 0$ and there is no reduction in video drive until V_i is also zero.

“Contrast” Control Effects. Having compared the systems from the point of view of control distribution, for which purpose we regarded V_a as constant and V_b as the independent variable, we shall now compare the efficiencies as a.g.c. systems, where V_b now becomes constant and V_a the independent variable. We may say that the a.g.c. sensitivity referred to either stage will be greater,

the greater the quantities $\frac{dG_i}{dV_a}$ and $\frac{dG_r}{dV_a}$

We may also make the assumption that G_r, G_i are continuously increasing functions of V_r, V_i and thus the a.g.c. sensitivity for a particular stage is greater,

the greater the value of $\frac{dV_i}{dV_a}$ or $\frac{dV_r}{dV_a}$

for Case (I) we have from (1)

$$\frac{dV_i}{dV_a} = \frac{R_2 + R_3}{R_1 + R_2 + R_3} \dots \dots \dots (12)$$

and from (2)

$$\frac{dV_r}{dV_a} = \frac{R_1}{R_1 + R_2 + R_3} \dots \dots \dots (13)$$

and we observe that

$$\frac{dV_i}{dV_a} + \frac{dV_r}{dV_a} = 1 \dots \dots \dots (14)$$

For Case (II) we have from (7) and (8)

$$\frac{dV_i}{dV_a} = \frac{y}{y+1} \dots \dots \dots (15)$$

$$\text{and } \frac{dV_r}{dV_a} = \frac{z}{z+1} \dots \dots \dots (16)$$

(15) and (16) together with (10) give

$$\frac{dV_i}{dV_a} + \frac{dV_r}{dV_a} = \left(2 - \frac{m+1}{y+1}\right) \dots \dots \dots (17)$$

in each case V_i and V_r are linear functions of V_a and so we may consider finite changes. Thus for (I)

$$\Delta V_i + \Delta V_r = \Delta V_a$$

and for (II)

$$\Delta V_i + \Delta V_r = \left(2 - \frac{m+1}{y+1}\right) \Delta V_a$$

Thus we see that for given values of m and D if we choose y as large as possible and adjust z accordingly, the total change in the values of V_i and V_r for (II) may be in excess of, say, 1.5 times that for (I). The overall a.g.c. sensitivity depends, of course, on the distribution of these changes between the stages and the valve characteristics but it has been found that in practice, for similar distribution characteristics, (II) varies between being very slightly to

Fig. 4. Signal-strength plotted against a.g.c. bias showing the crossover between control given by V_r and V_i when half V_i is applied to the i.f. amplifier.

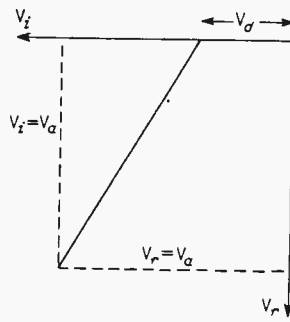
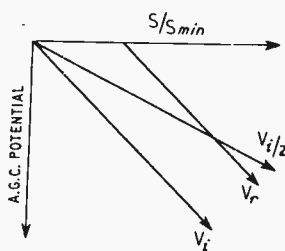
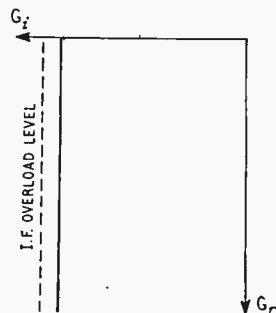

Fig. 5. Ideal relationship between a.g.c. bias applied to r.f. and i.f. stages.

Fig. 6. Idealised r.f. gain/i.f. gain characteristic.



considerably more sensitive than (I), depending upon the level of input to the receiver.

Practical Applications. From the above considerations we may compare the two systems by factors:

- (a) Distribution of control.
- (b) Efficiency as a.g.c.
- (c) Reduction in overall sensitivity (zero in (II)).

As a generalization we may say that if we make the two systems comparable in one of these factors, then (II) will exhibit some advantage in the other two. However, it should be mentioned that if an acceptable compromise can be reached with (I) this system is more economical in components, which is a major consideration to the designer of domestic TV receivers.

We shall now confine ourselves to Case (II) and consider some practical details. It has been stated above that for maximum a.g.c. efficiency y must be as large as possible. The limitation to this arises from the fact that we must always be able to bring the diodes to the point of conduction and, since V_b cannot be increased beyond the h.t. voltage, we have, assuming $V_a = 25V$ and h.t. voltage 175V

$$\frac{175}{R_4} > \frac{25}{R_5}, \text{ giving } y = \frac{R_4}{R_5} < 7$$

A further consideration influencing the choice of

resistance values is the limits which must be put on the resistance from the grid of the sync. separator to earth. Generally the manufacturer places an upper limit of about $1M\Omega$ under self-bias conditions and it is found that, for satisfactory sync. separation, at low signal levels, it must not fall below $500k\Omega$. It will be seen that the leak resistor R_g is shunted by the resistance to earth of the a.g.c. network which will depend upon the state of the two diodes.

With a system of this nature, there is a danger of the a.g.c. losing control on changing the channel or on a temporary interruption of the transmitted signal. This is due to the direct coupling of the video amplifier combined with positive detection which, on the reception of a very strong signal at maximum overall gain, may cause the video amplifier to draw grid current. This, in effect, puts a very low impedance across the video signal and prevents it from reaching the sync. separator and establishing an a.g.c. voltage. This effect may be overcome in a number of ways, three of which are mentioned below.

- (a) We may ensure that there is sufficient feedback at zero frequency in the video amplifier to eliminate the possibility of the grid reaching the cathode potential.
- (b) We may mix a small proportion of the sound a.g.c. into the vision a.g.c. circuit which, under ordinary operating conditions, has only a very slight effect. When the vision a.g.c. loses control, however, a large voltage is developed by the sound a.g.c. which depends on the r.f. carrier and not the modulation. This can be made to bias the r.f. and vision i.f. stages sufficiently to prevent an excessive level of detected signal.
- (c) We may insert a suitably bypassed resistor of the order of about $0.5M\Omega$ in the grid circuit of the last vision i.f. amplifier. Then, when the a.g.c. loses control, the input to this stage attains the order of several volts and develops a negative bias, by grid current, sufficient to reduce considerably the gain of this stage.

The V_r/V_i relationship was introduced above to eliminate differences in sensitivity and in the same

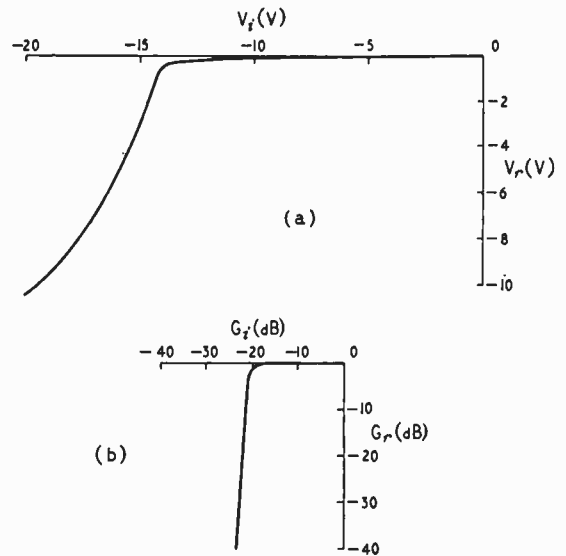
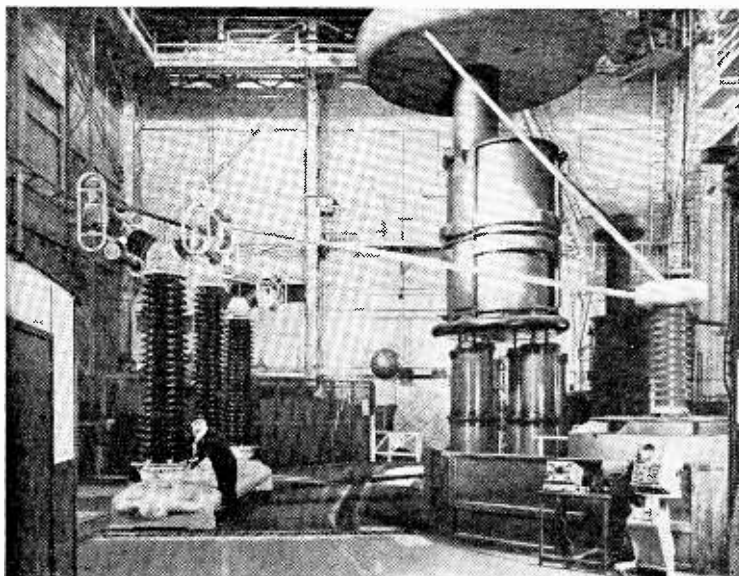

Fig. 7(a). R.F./i.f. a.g.c. bias relationship for Method (II).
 (b) R.F./i.f. gain characteristic achieved by Method (II).

way we may introduce the G_r/G_i relationship. From Fig. 1, we see that the ideal curve for this relationship consists of two straight lines along and perpendicular to the axis of G_i as shown in Fig. 6.

This system has been in use in production receivers for over a year using a PCC84 as the r.f. stage and an EF85 as the first vision i.f. A delay of $-12V$ was chosen for V_r corresponding to $G_i = -18dB$. The practical V_r/V_i curve is shown in Fig. 7(a) and this, together with the information contained in Fig. 3, enables us to obtain the G_r/G_i relationship as shown in Fig. 7(b). It will be seen that this compares quite favourably with Fig. 6.

Acknowledgement. The author wishes to acknowledge his indebtedness to R. C. Heath, A.M. Brit.-I.R.E. for the suggestion which initiated the work described above.



Radio Interference Suppression

High-voltage circuit breaker on test in the Metropolitan Vickers laboratory at Trafford Park. One test involves the measurement of r.f. generation by means of a standard G.P.O. interference measuring set, to see that an agreed level of $500\mu V$ at $200kV$ line to earth is not exceeded.

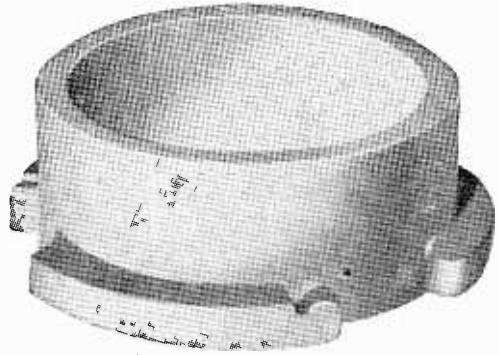
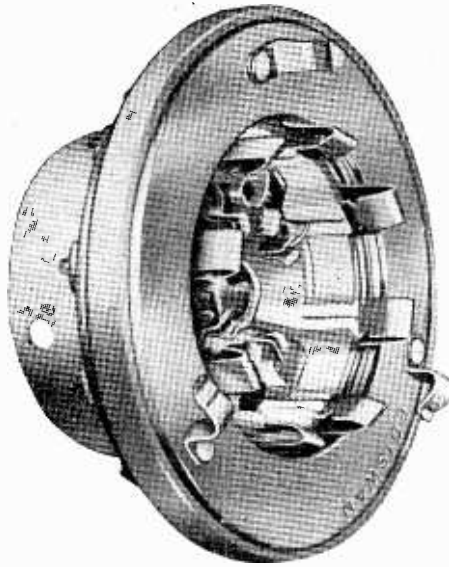

CLIX

B8F Air Spaced Valveholder

VH 88/801 Series (4X150A)

For Forced Air Cooling

Whichever way you look at this interesting valveholder (designed primarily for UHF transmitting valves) it adds up to a first class job. The body moulding in PTFE has exceptionally low R-F losses and high temperature characteristics while its low coefficient of friction reduces the air flow resistance and so promotes better cooling. It can be supplied with or without integral screen by-pass condenser. A detachable ceramic or PTFE chimney is available to concentrate the cooling air on the anode area. All metal parts are heavily silver plated and all contacts are of beryllium copper alloy.

You find the same attention to detail, the same care in selecting the right materials throughout the whole extensive Clix range of radio, television and electronic components. The list is too long to detail here, but if you are a set manufacturer or designer you ought to have all the particulars by you. Just drop us a request for the Clix components catalogue on your business notepaper.

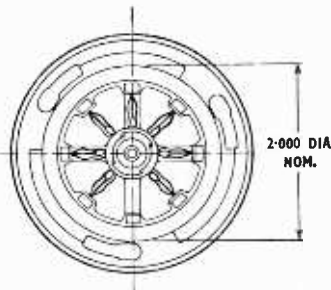
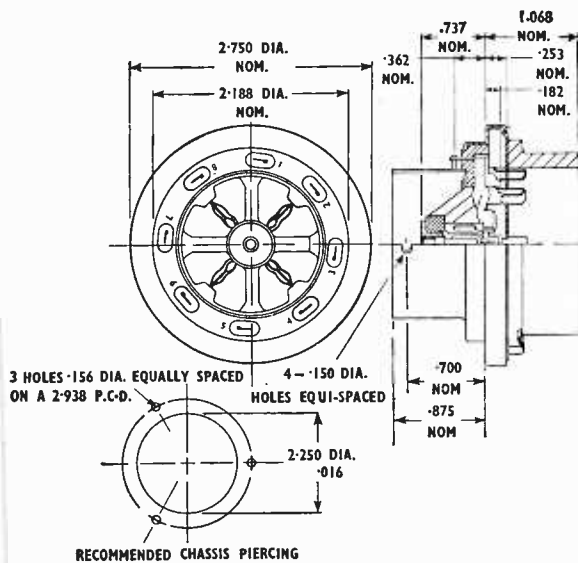

CLIX
Electronic
Components

SIEMENS EDISON SWAN LIMITED *An A.E.I. Company*
P.D.17. 155, Charing Cross Road, London, W.C.2. And branches.
CRC 17/9

EMI "HIS MASTER'S VOICE" MARCONIPHONE · COLUMBIA

Announce NEW PRACTICAL WAY OF LEARNING AT HOME

NEW — completely up-to-date methods of giving instruction in a wide range of technical subjects specially designed and arranged for self-study at home under the skilled guidance of our teaching staff.

NEW — experimental outfits and lesson manuals are despatched on enrolment and remain the student's property. A tutor is allotted to each student for personal and individual tuition throughout the course.

Radio and television courses, with which specially prepared components are supplied, teach the basic electronic circuits (amplifiers, oscillators, detectors, etc.) and lead, by easy stages, to the complete design and servicing of modern Radio and T/V equipments.

If you are studying for an examination, wanting a new hobby or interest, commencing a career in industry or running your own full-time or part-time business, these practical courses are ideal and may be yours for moderate cost. Send off the coupon to-day for a free Brochure giving full details. There is no obligation whatsoever.

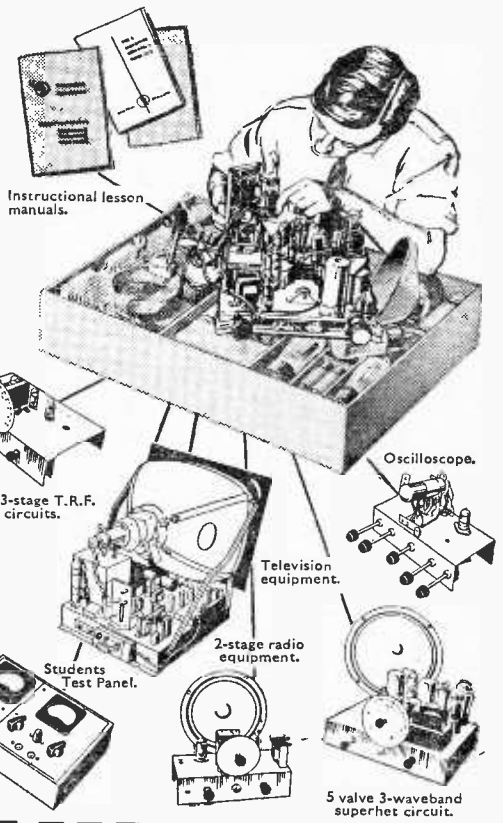

- Courses with Equipment**
- RADIO • SHORT WAVE RADIO
 - TELEVISION • MECHANICS
 - CHEMISTRY • PHOTOGRAPHY
 - ELECTRICITY • CARPENTRY
 - ELECTRICAL WIRING
 - DRAUGHTSMANSHIP • ART etc.

E.M.I. Factories at Hayes, England

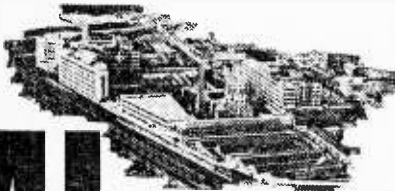

EMI INSTITUTES

Fill in for **FREE BROCHURE**
E.M.I. INSTITUTES, Dept. 127x, London, W.4.

Name _____
 Address _____
 Age (If under 21) _____

I am interested in the following subject(s) with/without equipment

OCT/58 (We shall not worry you with personal visits)



FREE
BLOCK
CAPS
PLEASE

IC107

The only Home Study College run by a World-wide industrial organisation.

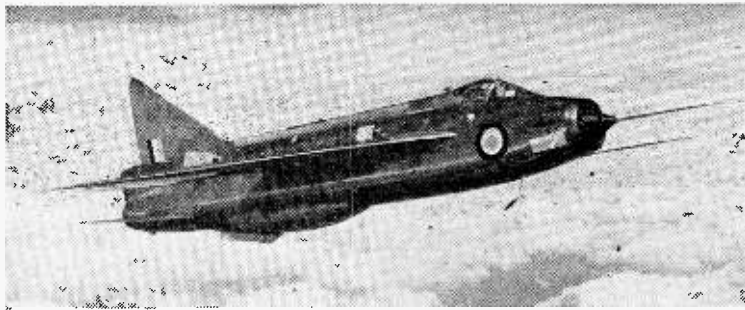

English Electric PIB fitted with Ferranti "Airpass" fire-control radar (inside conical radome in engine air intake).

REVIEW OF AVIATION ELECTRONICS AT THE S.B.A.C. EXHIBITION

Photograph: courtesy "Flight"

FARNBOROUGH, 1958

ON looking round the displays at Farnborough and the growing number of stands devoted to electronics, the major trend was obvious immediately—transistors. This was bound to come—nowhere are such demands made on the equipment designers to cut down power consumption, weight and size as in airborne equipment.

Some regret may be felt at the passing of a rackful of glowing valves, just as the passing of the obvious might of the spark transmitter must have caused a few sighs; but this year's show has given us an equally exciting glimpse into the future.

Data Handling and Processing. The numbers of aircraft using international airways and airports are so great that serious problems arise in "marshalling" them, even with the aid of radar. Last year Decca demonstrated a complete data sifting and projection display system, and this year Cossor and Marconi were showing air traffic data systems.

The Cossor CRD 23 system adds identification markers, video maps and c.r.d.f. information to the basic radar display on a number of 12-in repeater units which may be installed with cable runs of up to 2,000ft from a main unit, which may itself be up to 2 miles from the radar head.

In the Marconi system known as CADH (Civilian Aviation Data Handling) the Air Traffic Controller is presented only with a synthetic display consisting of a video map and geometrical symbols representing the positions of aircraft under his control. Thus the first complication of the A.T.C.'s job—that of selecting his "targets" from the noise, other aircraft and residual clutter—is obviated. The symbols are generated by scanning out their shapes during the flyback time of the radial p.p.i. scan; consequently they are very bright, which allows the A.T.C. to work under relatively high ambient lighting conditions. Another facility provided is an f.p.i.—future position indicator—which indicates the position of the aircraft, provided it maintains its present course, at up to 7½ minutes into the future. Obviously all this cannot be achieved by magic, so other people come into each a.t.c. chain—a tracking supervisor and trackers. The tracking supervisor identifies an aircraft echo on the "raw" radar display in front of him and places over it, using a "joystick" control, a ring marker. He then presses a button which feeds co-ordinate information into a vacant digital store. The next time the response appears he repeats the action, so giving the computer new co-ordinates separated in time from the first, so that the computer can obtain automatically the aircraft's speed and track.

Also in front of him the controller has a flight progress board of translucent material displaying normal flight information plus a symbol for each aircraft. Behind this is mounted a television camera, which feeds displays in front of the tracking team, who identify the aircraft and "mark" it with its symbol in the

system. It is then available to the A.T.C. who eventually hands it over to the approach controllers. Information from other sources such as v.h.f. d.f. and pilot's report can also be fed into the system and displayed alongside the symbol, together with an indication of the source of the information. If an echo is lost temporarily by, for instance, flying into a blind spot in the aerial polar diagram the system carries on and corrects any small errors when the echo reappears. A large error necessitates correction by a tracker.

Also under the heading of data-handling comes an automatic "direction-finder" plotter by Marconi, and the Decca DIAN navigation system. The d.f. plotter uses the well-known principle of feeding information from two or more sites to a central position. Here it is displayed on a common c.r.t. on which is placed a map transparency, so that each d.f. line originates at its station on the map, the intersection giving the position of the aircraft. A very useful adjunct to this equipment is a "free" line which can be moved to any point of the map, thus giving d.f. information for an airfield without d.f. facilities. Information is transmitted from the remote sites by microwave data-link or on land lines.

The DIAN system is an integration of Decca Navigator, Dectra and Decca Doppler, the output from which is recorded on a common flight-log chart. The Doppler tracker and computer are "transistorized".

E.M.I. were showing some of their latest telemetry equipment designed for use with missiles. This uses transistors as far as is possible (i.e., in all except the r.f. stages) and is a very good example of "ruggedized" construction to withstand high accelerations. Complete sub-assemblies are potted and fit together like building blocks: each sub-assembly is colour-coded so that servicing problems are cut to a minimum.

A most impressive demonstration of a projected radar "picture" was given by Kelvin-Hughes with their rapid-processing projector. This takes a photograph of the radar tube, develops, fixes, washes and dries it by a spray technique and projects the negative in six-second cycles. It is a continuous process so that every six seconds a new picture is projected. As the rotation speed of most radar aerials is about 12 r.p.m. the time delay is insignificant when compared with the advantage of having a large, bright display. Resolutions better than the original scan are achieved.

Airborne A.F. and Radio Equipment.—Here the use of transistors is widespread—the rotary-converter h.t. supply has given place almost completely to the transistor unit. Examples of this were shown by several manufacturers, including Elliott, Ultra and Ekco, who produce a range of units giving outputs of up to 200V, 3-phase, 500VA. Passenger "comfort" is catered for by Murphy and Ultra, who both have 40-W audio amplifiers for passenger-address purposes. The Murphy

amplifier has a matching tape-player giving two hours' continuous playing at the end of which time the tape motion is reversed by a light shining through a transparent "leader" strip onto a photo-transistor. The amplifier itself is 15in x 2½in x 7½in, consumes 70W d.c. at 40W output and has the output transistors mounted in a cooling "chimney" on the front panel. Transistors are, too, the choice of Ultra and S.T.C. for their crew intercommunication amplifiers. S.T.C. were showing also an altimeter (0-5,000ft), claimed to be accurate to within ±2ft (two!) or 3%, whichever is the greater. This uses the "classical" technique where the transmission (4,300Mc/s) is frequency-modulated and the signals reflected from the ground beat with this, the beat frequency being proportional to height. Again transistors are used in all but the r.f. stages, so enabling the equipment to be very small (transmitter/receiver 7in diameter x 7in deep, counter unit 3in x 3½in x 12in).

Most interesting as an example of the extent to which miniaturization can be carried was the Plessey "English" version of the Collins AN/ARC52 airborne u.h.f. transmitter receiver. This is contained in one "box" 21in x 10in x 7in, it weighs 48lb and provides operation on 1750 channels in the 225 to 390Mc/s band. Eighteen of these, plus the "guard" channel, are pre-set and can be selected by rotary switch, and any of the others can be set up by a system of four knobs

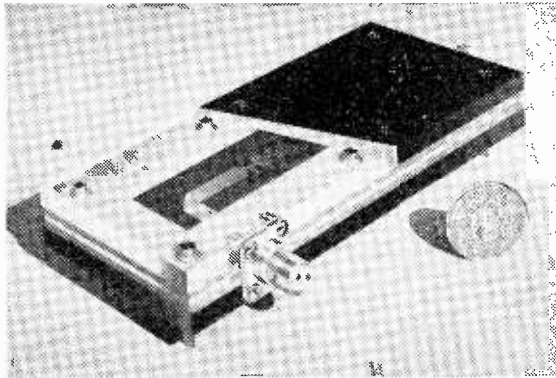

Cossor "printed-circuit" strip waveguide forming an S-band low-pass filter.

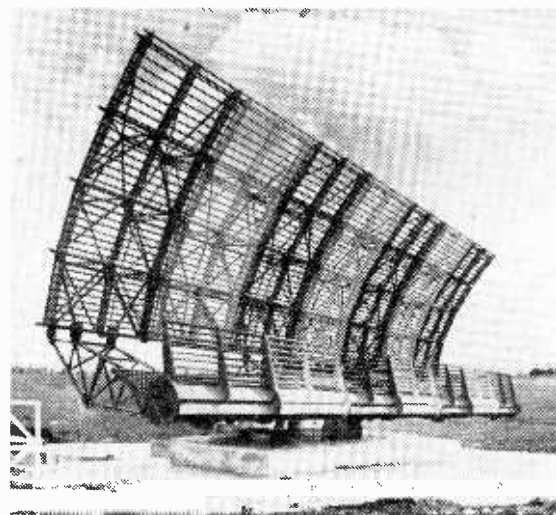

Aerial for Marconi S264 and S264A terminal area and airways surveillance radars.

indicating the digits of the frequency. The guard channel has a separate receiver and the transmitter output is 20W.

One of the items in the wide range of equipment produced by Elliott Bros. is a very small fully-automatic transistorized radio compass which weighs only 10lb and takes 1.2A at 27.5 d.c. The h.t. supply for the r.f. and i.f. stages, which use subminiature valves, is derived from the d.c. supply by a transistor converter. The receiver and servo and a.f. amplifiers are located in the control unit which is only 4½in x 5½in x 6½in. This is produced under licence from Air Equipement (France).

Airborne Radar.—It is natural that most recent developments in this field are on the secret list—one such is the Ferranti "Airpass" system and another is the G.E.C. Radar for the Sea Vixen. The "Airpass" is long-range search-and-track radar which includes a computer to work out the best course to fly to intercept targets. The most notable feature is that it is contained in a single bullet-shaped container which fits inside the air intake of the P1B fighter.

Two developments from Cossor strike interesting notes: a secondary radar transponder and a new receiver for the GEE installation. The transponder is contained in a single case 5in x 8in x 22in and it operates in the 1050Mc/s band. Again transistors are used except for the r.f. stages, and variations in the coding of the transmitted response can provide up to 64 possible replies to an interrogation.

The new GEE receiver has a reduced bandwidth and improved aerial system, so offering a gain of 24dB over the previous type. This naturally improves range performance greatly, a typical 30Mc/s Southern Chain maximum being 400 miles at 10,000ft. The MkIV receiver is directly interchangeable with the MkIII.

Marconi's have completed development on the com-

Water cooled chassis (R.R.E., Malvern) showing the water-ways formed in nickel-plated aluminium sheet.

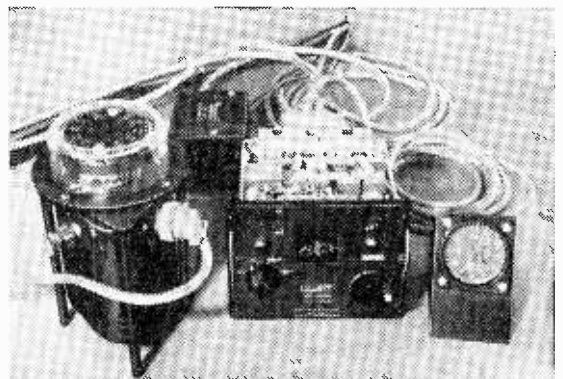
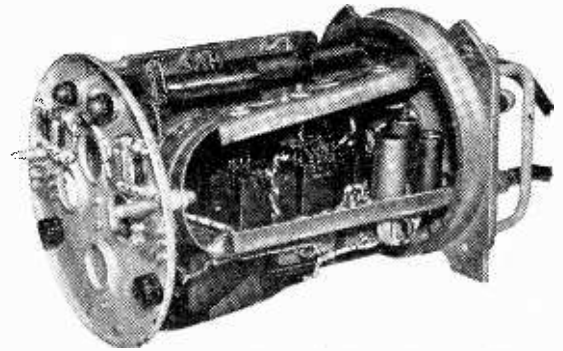

Elliott E-RCB-2 automatic radio compass using transistors.

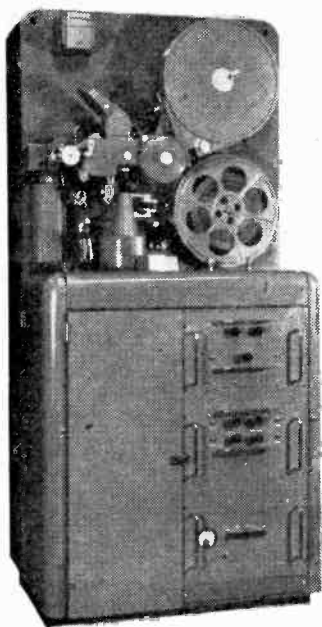

Rapid-processing photographic projector by Kelvin-Hughes. The radar c.r.t. is mounted vertically in the lower part of the machine and a prism is used to obtain horizontal projection.

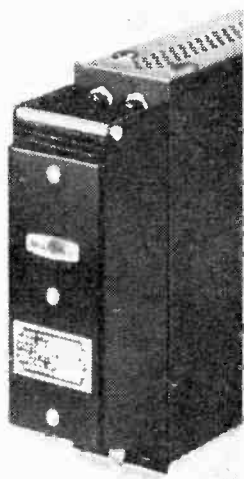

Front of Murphy 40-W. passenger address transistor amplifier weighing only 8lb. Note the transistor-cooling chimney.

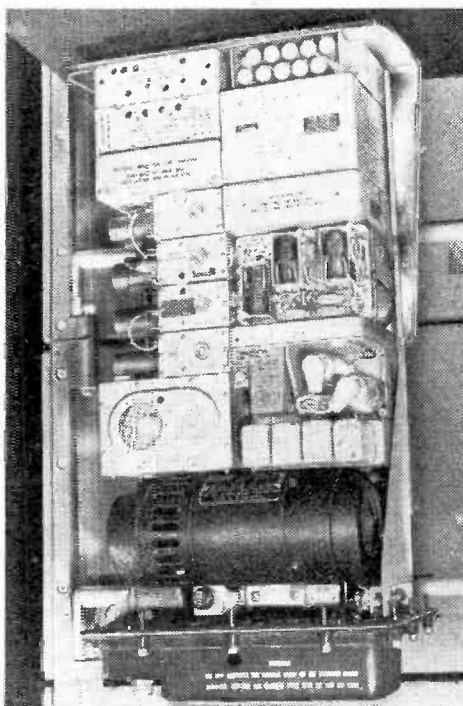

Top-chassis view of the Plessey AN/ARC52 airborne u.h.f. transmitter/receiver. Note the separate "guard"-channel receiver (top left "box").

puter for their Doppler System, and this was on show: it is a very small, neat unit.

Ground Radio Equipment.—A new v.h.f. direction finder from Ekco uses an end-fire aerial (Adcock system) which is rotated mechanically at 250 r.p.m. During each aerial revolution two nulls are apparent when the aerials are "broadside-on." This gives two possible bearings for an aircraft, so the output from an omni-directional aerial is mixed with the Adcock signal in such a phase that the nulls are moved together by about 10°, giving a 190° and a 170° sector. The rotational information is transferred from the aerial to the display tube by a magstrip and fixed-coil system and a bright radial trace is produced by gate circuits in the receiver after each long or 190° "signal-on" sector.

Redifon were showing a new frequency-shift spaced-diversity convertor which provides good signal copying when the signal itself is as much as 14dB below the noise level. Although primarily designed for spaced-diversity working, frequency diversity can be catered for by alternative plug-in units.

Ground Radar.—The radar used by Marconi to demonstrate their new data processing equipment was also new—the S264. It is a development from the S232, being a 50 cm, 50 kW terminal area radar. The transmitter frequency is crystal-controlled and a coherent m.t.i. system is used, as in the S232; but the most significant difference is in the aerial system, which is a 52ft long, single-curved reflector fed by an offset linear waveguide to produce the narrow horizontal beam-width (for a 50cm radar) of about 2.5°; the curved reflector produces the vertical shaping in conjunction with the reflection from the ground. The S264A is a ½MW version of the S264, and it is believed to be the only civilian radar using a klystron as the transmitter output stage with its attendant advantages in life and reduction in servicing.

Other Exhibits.—It is extremely difficult if not impossible to make some complicated waveguide assemblies by normal techniques and G.E.C. were showing a

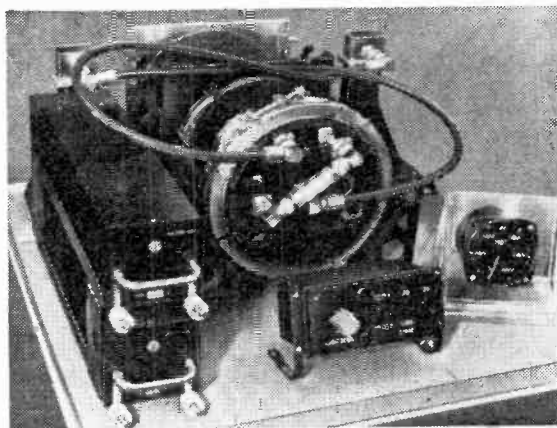

Altimeter by S.T.C. Two ranges are provided 0-500 and 0-5000 ft.

method using flat plates stamped out of a solder-coated aluminium alloy which fit together with small "twist-tabs", rather like tinplate toys. The whole assembly is made solid by a salt-bath dip-brazing process, and X-band waveguide has been made in this way to tolerances of 0.002in.

The Cossor exhibit featured an entirely new conception of waveguide. Copper strips on an insulating base (produced by the printed circuit process) are mounted between two parallel ground planes. This, in electrical appearance is rather like a coaxial cable, so no special wave-launching arrangements are required—just an end-feed from a coaxial socket. No E-lines pass through the insulator, so there is no additional dielectric loss. Also it is very easy to make up

complicated filters and matching sections by varying the width of the copper strip and so changing the impedance. Attenuation moving sideways from the strip is about 130dB/in, so different circuits can be placed quite close together. Normal bends, corners, rat-races, etc., work just as well as in rectangular guide.

The Ministry of Supply stand featured water-cooled chassis. This may seem unusual, but it must be remembered that there is a very great problem in getting rid of heat dissipated in electronic units in high-speed aircraft, and one method of doing this (evolved at the Royal Radar Establishment) is to cold-weld together two sheets of nickel-plated aluminium on which a water-flow pattern is printed. The printing inhibits the welding process, and inflation of the pattern at pressures of several thousand p.s.i. produces a tube-structure through which the cooling water is passed. The nickel plating makes it possible to solder directly to the chassis. The example shown was a stabilized power-pack dissipating about 200W in a case 8in diameter and 1ft long, giving 30°C temperature rise.

The realism of flight trainers has been further enhanced by the development, by the Instrument and Air Photography Dept., R.A.E., of a "pilot's view" simulator which presents a picture in accurate perspective of the ground being "flown" over in a simulated flight. The appropriate part of an air survey mosaic is projected through a zoom lens on to a screen, and moved according to information supplied by the speed and course outputs of the flight simulator. Height variations are reproduced by altering the scale of projection through the zoom lens. This ground plan projection is viewed

at a narrow angle by a small Pye industrial television camera mounted in gimbals and rotated in accordance with pitch and yaw information from the simulator. The picture as seen by the camera is then presented on a screen and viewed by the pilot through the wind-screen of the simulator cockpit. It is sufficiently realistic to have produced symptoms of airsickness in at least one spectator at the Show!

Computers have long since played an important part in the aircraft industry; but these are usually immense installations designed to do almost anything from totting up a pay-roll to a full-scale stress analysis. Consequently running time is very expensive and only large organizations can "waste" computer time by allowing it to be used for experimental purposes. Solartron have overcome this problem by producing a "desk-side" computer—the "Minispace"—providing ten analogue channels and a large, easily accessible patching-board. Another interesting function for a computer was shown by Bolton-Paul. This firm have been experimenting on man in an effort to find out his characteristics for inclusion into closed-circuit control systems. Their apparatus consists of a c.r.t. on which is presented a blip moving in a random manner. The subject has to keep the blip lined-up against a reference mark with a manual control. He therefore sees in the movement of the blip his error, which is squared and counted by the computer. One surprising result from the very limited amount of work that has been done is that a subject who is good initially seems to finish up with a worse score than one who is bad to start with, after they have both had the same amount of practice.

LETTERS TO THE EDITOR

The Editor does not necessarily endorse the opinions expressed by his correspondents

Medium Waves Only

WHAT I really want is an a.m. receiver *with an r.f. stage*, high selectivity and push-pull output to cover *only the medium-wave band* (200 to 500 metres). I therefore did a hook-up from the lumber shelf on these lines and like it much better than the conventional domestic set because:

(a) With the r.f. stage, sensitivity is sufficient to give me a choice of about 15 Continental music programmes all at enjoyable volume—instead of as backgrounds to carrier hiss and noise.

(b) With a quite simple outdoor aerial (instead of the usual piece of wire round the room) I got rid of most of the interference in and around the house at lower levels, and this in conjunction with a.v.c. applied to the r.f. valve gave me signal/noise ratio much higher than that with the ordinary domestic receiver.

(c) With the increased sensitivity available, I could afford high selectivity. Weakness of the higher a.f. response was easily compensated by including a simple high-pass a.f. filter.

(d) I did not miss either the long- or the short-wave bands. Several of the long-wave programmes are duplicated on medium-wave transmissions if one wants them. Like the rest of *hoi polloi*, I hardly ever switch to the short-wave band.

(e) Absence of the need for band switchery made design and construction much easier and cheaper. In the space left by the band switch, one could put in, say, a variable selectivity control, for use with very strong signals carrying programmes worthy of very wide a.f. response.

I am, of course, a Philistine. "Hi-fi" doesn't mean very much to me. I prefer listening to music I enjoy

even if it isn't perfectly rendered, to being bored by superb reproduction of stuff I don't much like; so wide choice at any time suits me better than waiting for what I like to come up on one or two transmissions. I fear that my kind of listener is in a majority. I have the notion that if one set out to sell sets of the kind I have described by putting them alongside conventional receivers and comparing "station-getting," one would be pretty successful in selling the simpler r.f. stage one-waveband variety. It might occur to the average housewife that three or more wavebands weren't, after all, any more necessary than that vestigial remnant of horse-carriage days, the "running board" on cars; and that noise background could be almost eliminated from "old-fashioned" sound receivers without resorting to v.h.f. or f.m.

London, E.17.

W. H. CAZALY.

567 Lines

WHILST P. T. Weston's article "567 Lines" is an interesting essay on how television systems obtain their seemingly "odd" numbers of lines, I submit that to draw the conclusions he does from recent determinations of the Kell factor is erroneous: as far as I know these determinations were made to establish the minimum standard of definition acceptable on a small-picture, low-line-number system of television. It is extremely doubtful, too, whether an increase from 405 to 567 lines would be of any significant benefit in reducing the visibility of the line-structure. I am sure that anyone who has seen a receiver giving the full three-megacycle bandwidth, good interlace and using spot-wobble or astigmatism would like a picture with more detail, not less. "Diallist" has, on several occasions, suggested that the

French 819-line system would provide the answer—it would; but it has two disadvantages: frame synchronization is not good, due to the single-frame sync. pulse, and the cost of receivers would be high. (The cost of changes in transmitting equipment is of little importance as the cost-per-viewer would be small.)

May I suggest, therefore, that the authorities start tests as soon as possible with a system of synchronized spot-wobble, as described some time ago in your pages. This would, as does any other system for increasing definition, demand additional bandwidth; but it would have the immense virtue that existing receivers need not be rendered obsolete, as they undoubtedly would be by any alteration from the present 10.125 kc/s line frequency. (Mr. Weston has forgotten that the modern line-time base output stage is designed around its operating frequency—a 40 per cent increase in this would almost certainly render most of them unusable.)

Surbiton, Surrey. E. MANSFIELD.

BEFORE increasing the number of scanning lines, may I suggest that the television authorities help the trade to obtain good interlace from the existing transmissions. Over the past year I have made a point of examining as many commercial receivers as I could see in dealers' shops, and in no single case did I find one giving better than about 60/40 interlace, some being 0/100!

The above suggestion is made because, in spite of many brave attempts made during the past 20 years to explain the reasons for non-interlace, no manufacturer seems to have discovered and applied a practical cure. What would be the point of changing to (say) an 819-line picture only to obtain the effect of about 40/5 lines?

Barnehurst, Kent. R. J. NEWMAN.

Flush-mounted Aerials

I WOULD like to venture some comments concerning your article "Flush-Mounted Aircraft Aerials" in the July issue. This seems to indicate the pressing need for a generally accepted criterion for aerials in the h.f. and v.h.f. bands, whether external or suppressed. The article itself does not deal with the quantitative issue of the subject to any degree. The h.f. and v.h.f. bands are generally those in which suppressed aerials have found their most widespread application.

Of recent years evidence has been mounting against these devices. In many cases suppressed aerials are not only unnecessary in an aerodynamic sense, but are also extraordinarily inefficient as collectors of r.f. energy.

To particularize, it has come to be accepted as a matter of general practice, that a figure in the region of 10 to 14dB down when compared to an isotropic source is a reasonable figure of gain for a suppressed aerial system in the region of 45Mc/s. If the aerial is vertically polarized, it will at this frequency perhaps have an effective height of 12in instead of 10ft.

The loss of available signal power entailed by the use of an aerial of such negative gain is large and causes a serious reduction in the service area of communications receivers and allied devices in the navigational field. In typical cases the v.s.w.r. over the band of such suppressed aerials, even when corrected by complicated matching circuits, can be in the region of 8:1, which seems an unnecessarily high figure even if the effective height were reasonable, which it is not. In many cases where the horizontal polar diagram should be omnidirectional, ratios of 4:1 between polar diagram minima and maxima are encountered. At quite small angles of elevation and depression in the vertical polar diagram similar ratios are found.

So far as aerodynamics are concerned, there appears to be no significant advantage in favour of suppressed aerials over the external type, apart from the purely æsthetic factor of an uncluttered aircraft line, and, anyway, this factor disappears if the aircraft is viewed from a distance of more than 20ft or so.

A certain amount of aerodynamic extremism has been

aired about the drag to be expected from external aerials, either whip or wire. If such aerials are intelligently mounted (and if vertical are given a moderate degree of initial rake) there seems to be no physical reason why they should introduce measurable drag at speeds up to 1,000 miles per hour.

A. C. MEARS.

Maidenhead.

"Walkie-Talkie" Licences

IT is apparent from enquiries received by the Post Office from persons wishing to use Government surplus transmission equipment, especially "Walkie-Talkie" sets, that there is uncertainty among both prospective users and radio dealers about the need for licences. I hope the information given below will be helpful to your readers.

Section 1 of the Wireless Telegraphy Act, 1949, provides that "no person shall establish or use any station for wireless telegraphy or install or use any apparatus for wireless telegraphy except under the authority of a licence in that behalf granted by the Postmaster General." Any person who does so is guilty of an offence under that Act.

Any person who intends to use Government surplus transmission equipment must, therefore, obtain a licence. I am afraid that in the majority of cases the technical characteristics of the equipment, including the frequency bands in which it works, are such that the Postmaster General would not be able to grant one.

J. EVANS,

Deputy Public Relations Officer, G.P.O.

London, E.C.1.

Tape Spools

WHAT an extraordinary attitude for John Weir (August issue) to take. I quote "but feel sure that most tape recordists would gladly pay a little extra..." Surely the proper approach is for the manufacturers of reels to put on the market products which are satisfactory to the public without "paying a little extra." The answer is not to buy what is unsatisfactory, and to make them realize that their goods are not up to requirements.

I agree that most reels are unsatisfactory in some way or another. The type quoted by Mr. Weir is very difficult to remove by a person with small hands, at least the 8¼-in reels are, and a plastic 8¼-in reel recently put on the market is just impossible and of stupid design.

London, S.W.1.

JOHN LAWN.

Elementary Particles

IN your July issue "Free Grid" rides once again his terminological hobby-horse and suggests that electrons be called "negatrons," principally, it would seem, to avoid any insult to these elementary particles that might be implied by the use of the term "positive electron." He knows very well that there is no such thing as a "positive electron" any more than there is a "negative positron," but equally one might suggest that it is improper to associate the positron with a negative charge! The unfortunate conjoining of the word "positive" with "electron" was made, no doubt, when physicists first propounded the existence of a positively charged particle having the same mass as an electron, but now that it has been detected and duly christened positron (or positon) it really matters little if some writers, as "Free Grid" found, irritatingly perpetuate the use of the original term.

What does matter, however, is that "F.G." is obviously unfamiliar with the "negative proton," sometimes called the anti-proton, but more generally the negatron! Incidentally, there is a four-electrode valve specifically designed for obtaining negative resistance and it, too, is called a negatron. Perhaps at this juncture he may be persuaded to dismount and withdraw from the Tron Handicap.

Blackpool.

P. S. REDFEARN.

Technical Notebook

Miniature Delay Lines.—The October issue of *Electronic & Radio Engineer* contains an article by Reinhold Gerharz on compact wire-wound distributed-constant delay lines of novel construction (see sketch). The lines consist of coils of thin insulated copper wire with earthed aluminium foil between layers. The foil shields the wire, and

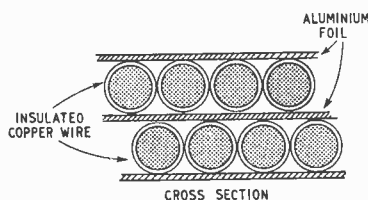

the arrangement behaves like a transmission line consisting of a single "line" conductor with two earth returns. Lines can also be made by winding a single insulated wire on a metal former. A typical line made with 34 metres of Neoprene-insulated wire, diameter 0.5mm, had a propagation velocity of 0.77 and an attenuation of 0.25dB per metre. The delay produced is temperature-sensitive, but the author estimates that with temperature compensation, lines could be used in pulse generators with stabilities approaching 1 part in 10^7 .

Electrolytic Transistor might be a suitable description for a new experimental semiconductor amplifier based on field-effect modulation at a semiconductor/electrolyte interface. Described recently by J. F. Dewald of Bell Telephone Laboratories, the device uses a hexagonal rod-like crystal of very pure zinc oxide as the semiconductor, immersed in a highly conducting electrolyte. A platinum electrode placed nearby serves as the field-effect modulating element. One end of the crystal is biased as a cathode with respect to the solution and the other end as an anode. Somewhere between is a neutral point which is unbiased, and this point shifts back and forth under the influence of input signal voltages applied to the modulating electrode. As a result, the resistance of the semiconductor changes, passing a current which follows the driving frequency very closely. A fairly large range of linear response is obtained. To make electrical contact to the zinc oxide

crystal, the two ends are first indium-plated to ensure good contact. They are then copper-plated to allow the soldering of copper wire leads. The platinum modulating electrode completes the assembly. After insulating all wires and connections except the modulator, the assembly is immersed in the electrolyte (5% sodium tetraborate and boric acid solution) and hermetically sealed in a small glass tube to avoid evaporation of the electrolyte. Small size is required to give high-frequency operation. The smallest units constructed so far use crystals about 0.3mm long and 0.15mm in diameter. It is expected that by utilizing a flat plate crystal instead of a rod, the present low-output power levels could be raised appreciably without any overall increase in size or any change in other operating characteristics.

Rotary Graphical Calculator introduced by the Kay Electric Company in America is a plotting and evaluation table for Smith and other circular charts which the firm supplies (covering radio propagation, field strength and radar calculations, and including a general purpose slide-rule and a "do-it-yourself" polar co-ordinate chart). The top of the table is reversible, so that any two charts can be mounted simultaneously and used interchangeably. The diametric scales have cursors, while the peripheral and radial scales can be rotated separately and are fitted with ball bearings for smooth operation. Known as the Rota-Graph, the calculator is available as

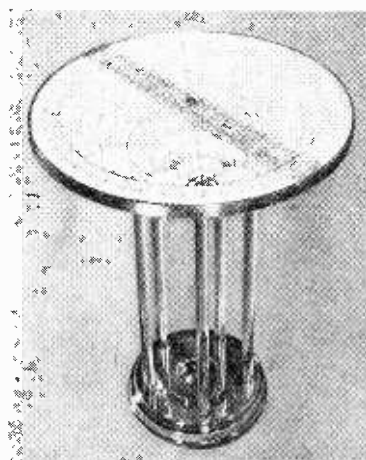

(noise equivalent power) is less than 4 milli-microwatts. The cell resistance is 75Ω and the maximum direct current 100mA. Apart from its speed of response, this semiconductor material is also notable for its wide spectral response in the infra-red region and its ability to detect temperatures within a few degrees of room temperature.

Map-Matching Guidance is used in a new guided missile called the Mace, developed by the Martin Company in America. The system is said to relate a film strip, actual or synthetic, to the terrain over which the missile is flying. If there is any deviation from the programmed route, the missile's flight is adjusted so that the terrain is once again matched with the film.

a wall or bench model, a standard pedestal model or as a special pedestal model with an indirectly illuminated chart area.

Indium Antimonide is coming into commercial use nowadays for magnetic-field and infra-red detectors, as we noted in the May, 1958, issue (p. 220). With infra-red applications this semiconductor is notable for its fast response time compared with thermal devices such as bolometers and thermopiles, and for this reason Mullard have used it in a new photoconductive cell intended for high-speed infra-red spectroscopy. The fast response is necessary to give satisfactory recording on a c.r. tube by repetitive coincident traces, and in fact the $<1\mu$ sec time constant of the cell is well within the practical c.r.t. scanning frequencies of 1kc/s to 10kc/s. Construction of the cell, designated ORP10, can be seen from the illustration, but the sensitive area is actually a narrow strip of semiconductor only 6mm long by 0.5mm wide. Its performance on monochromatic radiation at a wavelength of 6 microns, with a direct current of 50mA through the cell, is expressed as a signal-to-noise voltage ratio of 72, for an ambient temperature of 20°C . At this wavelength the minimum detectable power

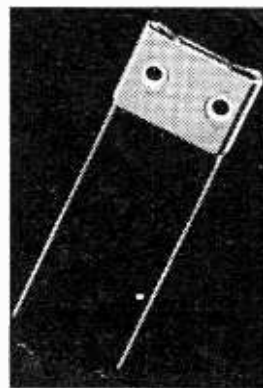

On Understanding Transistors

By K. C. JOHNSON, M.A.*

Concluded from page 432 of September issue

AN APPROACH FOR THOSE WHO HAVE
SUCCEEDED IN UNDERSTANDING VALVES

THE low-frequency equivalent circuit for a junction transistor shown in Fig. 2 is derived by surrounding the ideal valve described last month by various resistances to represent the different imperfections of the practical device. Convention is followed in that no account is taken of the d.c. conditions and it is also assumed that the transistor has been biased to a suitable Class A working point. The collector of a small transistor might typically be at $-6V$ with respect to the emitter and be carrying a current of $-1mA$. The circuit as it stands applies only for small signal levels, but the manner in which the impedance values change for larger variations will be indicated. The discussion will be qualitative rather than exactly quantitative and the intention is to indicate the physical nature of the various imperfections rather than to obtain exact values for quantities which in any case differ seriously between one transistor and another of the same variety.

This type of equivalent circuit may appear unconventional but it has proved very satisfactory in practical use. The ideal valve, when associated with R_1 , is really only the familiar current generator redrawn for readers who understand valves better than generators, whilst R_2 , R_3 , and R_4 are the usual three transistor resistances. These are drawn in "delta" form, rather than as a "star," because in any

practical circuit various external impedances will be connected between the three terminals of the transistor, and the total effective impedances are far easier to see when the internal and external impedances are simply in parallel.

R_5 is left separate as it has a real physical existence in transistors due to the thin piece of high resistivity material that must be used for the base. For this first low-frequency equivalent circuit R_5 could have been incorporated in the other resistances, since there are only four measurable parameters to be represented, but it will be seen that the picture is clearer if this is not done. In the interests of clarity, too, the value of R_5 will be neglected in much of the argument that follows in the sense that the voltage of the base material will be discussed although this is not really equal to the measurable voltage of the base terminal when finite base current is flowing.

Circuit Values

The most important parameter of any valve device is the measure of the effectiveness of the control voltage on the collector current at constant collector voltage. This is normally and conveniently expressed as the mutual conductance, g_m . A higher g_m clearly indicates a device in which a smaller cause may have a larger effect and which will therefore normally be more useful. In particular such a device will be able to charge circuit capacitances more rapidly and, other things being equal, will make faster circuits and wider bandwidth amplifiers.

In practice the g_m of all transistors, defined in terms of the voltage of the base material as already mentioned, is almost exactly proportional to emitter current over a wide range and is about $40mA/V$ for every milliamp of current flowing. There is little hope of improvement in this figure, except perhaps by cooling, as it is already very close to a limit set by fundamental physical constants which do not even depend on the semiconductor material used. Nevertheless it will be seen that this represents a considerable advantage over the best so far obtainable with thermionic valves. These are, as a matter of interest, subject to the same ultimate limit but are still far away from it after many years of development.

It must be noticed that all transistors necessarily have variable- g_m characteristics similar to the unfortunately named "variable μ " thermionic valves. Thus the value of R_1 in Fig. 2, which represents the mutual conductance by having the value $1/g_m$ must vary in inverse proportion to the emitter current

* Ferranti, Ltd.

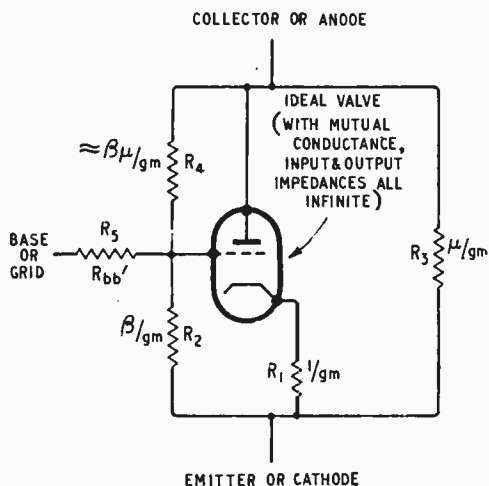

Fig. 2. Low-frequency equivalent circuit for a junction transistor.

when this equivalent circuit is stretched to cover large-amplitude signals. At -1mA R_1 may typically be 25 ohms, whilst at -5mA it would be about 5 ohms. This resistance, with its variation, provides a yardstick of impedance by which all the other quantities which vary in similar proportion to the current are most conveniently measured.

The first of these quantities is the resistance R_2 , which represents the finite a.c. input current taken by the base, due mainly to changes in the rate of re-combination of excess charge pairs within the base region. The current through R_4 is negligible if the collector voltage is held constant, so that the ratio of R_2 to R_1 is the familiar current gain β . This quantity is the differential ratio of the collector current to the base current at constant collector voltage and, other things being equal, a higher value will normally mean a better transistor. Expressed in this way as a pure number differential the value of β , unlike the g_m , stays reasonably constant over a wide working range of emitter current.

Most commercially available transistors have current gains in the range between 20 and 100, whereas the value for a normal thermionic receiving valve would be, perhaps, 100,000. This is a criterion, then, by which transistors are inferior. This inferiority, however, is largely an illusion, since few thermionic-valve circuits owe any real advantage to the very low grid currents, particularly where wide bandwidths or fast edges are required. Nevertheless this very neglect has meant that the current gain of thermionic valves is a concept which has seldom been considered in the literature and this unfamiliarity is one of the chief difficulties that newcomers find in transistor circuit design.

In the circuit of Fig. 2 a typical transistor at -1mA current would give R_2 a value of no more than 1,000 ohms. At first sight this appears impossibly low, but the g_m of transistors is so large that even this value can be high in comparison with the collector loads in a fast pulse circuit. As a general rule this base impedance limits the gain in the same sort of way as does the anode impedance of the familiar triode in, for example, RC-coupled amplifier circuits.

The quantity that strictly corresponds to the anode impedance is R_3 , the collector impedance, since R_4 is again negligible. This resistance represents the change of collector current with collector voltage at constant base material voltage, and is again best considered in terms of a differential, which in this case is that of R_3 to R_1 . This ratio is the voltage gain μ and, like β , it remains reasonably constant over a wide range as the collector impedance also varies approximately inversely with the emitter current. Needless to say the higher the value of this voltage gain then, in general, the better the transistor.

Unlike β , however, μ is advantageously high with transistors and 2,000 is a typical figure for a commercial device, while, of course, 100 is about the best available in thermionic triodes. Thus the collector impedance R_3 may typically be as high as $50\text{k}\Omega$ and is in any case far higher than the base impedance R_2 , which was $1\text{k}\Omega$.

In an RC-coupled amplifier, therefore, the total effective impedance of the coupling circuit will normally be determined primarily by the input impedance of the second stage, which is, of course, R_2 . This means that the stage gain, which equals the product of this impedance with the g_m , will be close to the current gain β , whereas it is well known that

with thermionic triodes R_3 is the smaller resistance and the stage gain therefore approaches μ . Both these quantities are adequately constant for good linear amplification to be obtained in either case but the gain per stage of the transistor amplifier is the current gain of the device, whereas that of the thermionic triode is the voltage gain. This fact may be partly responsible for the misleading idea that transistors are "current controlled devices" and therefore quite different from ordinary valves. This notion is unfortunately still being encouraged by the publication of characteristic curves and other data in which the base current is treated as if it were a primary variable.

The resistance R_4 of Fig. 2 represents the "back mutual conductance" whereby the collector voltage affects the current flowing at the base. In most transistors R_4 is found in practice to be close to $\beta\mu/g_m$, though there seems to be no simple theoretical reason to expect this value. The actual resistance is typically about $2\text{M}\Omega$, so that it will be seen that it is much larger than any of the other resistances and we were justified in neglecting it in the discussion of R_2 and R_3 .

The only circumstances in which the effect of R_4 is of real importance is in a voltage amplifier where the total collector load is so large that a stage gain of voltage approaching μ , that is 2,000, is being obtained. The Miller effect then magnifies the current through R_4 until it becomes roughly equal to that through R_2 and the effective input impedance is about halved. Such circuits are rare in practice, so that R_4 is almost always negligible in transistor circuits. It is, of course, entirely negligible with thermionic valves in all normal circuit arrangements and so will again be unfamiliar to the newcomer to transistors.

The last resistance of Fig. 2, that is R_5 , is called the "extrinsic base resistance" of a transistor. As already mentioned, it is drawn separately from the "delta" network because it has a real physical existence and hence, unlike the other resistances, a value which varies little with changes of the emitter current. It is R_5 which causes the difference in voltage between the actual effective base material and the base terminal accessible to the circuit designer and

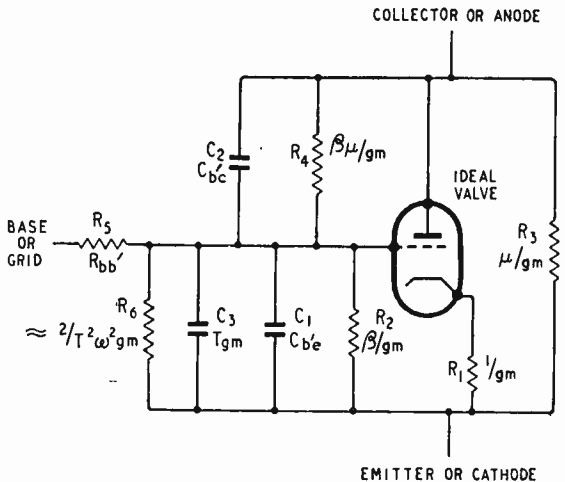

Fig. 3. High-frequency equivalent circuit for a junction transistor, also developed from the ideal valve concept.

which has hitherto been neglected in the discussion of g_m and μ .

The actual externally measurable values of these quantities in terms of the voltage at the base terminal are smaller than those described by a factor of the order of $R_s/R_e + R_s$ due to the potentiometer effect of the resistances. In a typical transistor R_s has a value of about 100 ohms, so that this ratio will be perhaps 90% at an emitter current of -1mA , falling to 70% at -5mA current. It will be seen later that R_s is far more important at higher frequencies when large transient base currents are flowing. Needless to say there is no significant resistance comparable to this in thermionic valves, as the grid assembly can be made of solid metal and the grid currents are so small that in any case a resistance as high even as 100 ohms would have only a trivial effect on the voltage except at the very highest frequencies.

High-Frequency Considerations

There are three main factors which begin to affect the performance at frequencies higher than those for which the equivalent circuit of Fig. 2 applies. The most important of these is the transit time for the charges passing through the base region, but the other two will be more familiar as they are the capacitances of the base electrode to the emitter and collector respectively. There are, of course, other small capacitances between various other points in the equivalent circuit which have a real physical existence, but these are normally unimportant and have been omitted for the sake of clarity.

All three of these effects have their exact counterparts in thermionic valve work, but the relative importances are rather different with transistors. In particular the transit times are much greater, as the charges must diffuse in a very weak field instead of flying free in a large one, while the inter-electrode capacitances are relatively less serious due to the high mutual conductance, although the actual values are in fact slightly larger. The ultimate limit to the time response of a valve amplifier in pulse circuits is normally governed very approximately by the sum of the transit time and the time-constant formed by the mutual conductance with the total capacitance of the valve electrodes and wiring. With thermionic valves the transit time has always contributed negligibly to this sum, whilst in early transistors the transit time was overwhelmingly long. With modern transistors these two limits on the speed are becoming comparable, particularly in computer circuits where the wiring capacitances are inevitably high, and they must, therefore, both be considered in detail.

Inter-Electrode Capacitance

The inter-electrode capacitances, represented by C_1 and C_2 in Fig. 3, are the more familiar and will consequently be considered first. It will be noticed that C_1 is directly in parallel with another capacitance C_3 , but this latter will be considered separately in due course as it is a representation of the transit time effects and is, for instance, proportional to the emitter current. C_1 and C_2 are the real inter-electrode capacitances, which remain even when the emitter current is negligible, and they have a very similar effect on the operation to the corresponding quantities in thermionic triodes. Naturally a transistor is

better if these capacitances are smaller, other things being equal.

In a typical good transistor C_2 is controlled carefully in manufacture to a value of perhaps 10pF at a collector-base voltage of -6V , while C_1 might be about 40pF when the base and emitter voltages are equal. The voltages are important here because each of these is a capacitance across a junction between two oppositely doped regions of a semiconductor and such capacitances reduce in value as the potential difference across them is increased. In an alloy-made junction, of the type now in large scale production, this variation is roughly proportional to the inverse square-root of the potential difference. Other kinds of junction show the same effect, but the exact law may differ if the manner in which the doping varies across the junction is different. In practice this variation in capacitance is rarely very important and merely provides a reason for keeping a fairly large voltage applied to the collector.

The reader may have been puzzled by the sudden change from the term "voltage" to the term "potential" in the paragraph above, and the statement that C_1 is quite finite even when the voltage across it is zero. Remember that the potential of a point refers to the energy of a unit charge which is hypothetically placed at rest at the point in question. In contrast to this the voltage is a measure of the total energy of a real charge at the same point. This latter includes an extra amount which can conveniently be thought of as the kinetic energy that the charge, which now consists of real electrons, must have to remain in its orbits. It is well known that this extra energy is different for different metals, giving rise to contact potential phenomena, and it is surely hardly surprising that it is also different for the two conduction modes in a semiconductor. This difference is called the "gap-width" and is about 0.72 volts in germanium and 1.12 volts in silicon.

Thus every point in a semiconductor has two different values of voltage, since it is always in principle possible to make electrical contact separately with either of the two conduction modes. These voltages, however, will always differ by a constant and known amount. There is, of course, only a single value for the potential at any point, but the potential difference between two points will only equal the voltage difference if the voltages are both measured in the same one of the two modes. In measuring the capacitance across a junction, such as that between the base and emitter of a transistor, the two leads naturally contact to the majority carriers in each region and hence to different modes. Thus the potential difference across the junction differs from the voltage difference by the gap-width. It will be seen therefore, that C_1 becomes theoretically infinite only at a large forward base-emitter voltage when an enormous current would flow and the equivalent circuit would no longer apply in any case as the transistor would be burning out.

It is interesting to notice in passing that it is this duplication of the voltage in semiconductors that makes it possible to "bottom" a transistor to a very low voltage indeed for a large emitter-collector current, while considerable forward voltage must be applied to drive the necessary emitter-base current to do it. In the one case there is no change of conduction mode involved, while for the other there is one. This explains why Eccles-Jordan circuits with direct collector-base cross connections function

comparatively well with transistors, but it is of no real fundamental importance in circuit design.

Transit Time

The other limitation to the speed that must be considered is the transit time, which will be represented by the symbol T . This can be defined as the average period for which each charge in transit from the emitter to the collector remains within the base layer. Since the progress of the charge depends primarily on diffusion the time varies little with changes of the voltage applied to the collector except that it increases sharply if "bottoming" is allowed to occur. This is because the charges are then no longer always captured completely by the collector when they diffuse to its junction. In general, if increased base current is forced to flow when the collector is bottomed it means that the time spent by each charge in the base layer must be a larger fraction of the lifetime, since the base current is largely determined by the number of charges that suffer recombination during transit. No account of "bottoming" phenomena is taken in this article as it is not difficult to arrange circuits in which it is prevented, and there seems little reason to believe that its use confers any advantage when fast operation is required.

A rough estimate of the transit time can be obtained from the figures for alpha cut-off frequency published by almost every transistor maker. This frequency is the one for which small signals of current fed to the emitter, with the transistor biased to a typical Class-A working point and with the base terminal earthed, are reduced to about 70% of their amplitude in the current flow at the collector. It is an easy measurement to make and provides a simple and useful comparison between different makes of transistor. The precise meaning of the result is a little more difficult to interpret. For the present we can assume without too serious an error that the transit time is roughly equal to one radial period of this alpha cut-off frequency. When the equivalent circuit has been developed, means for obtaining a more exact relationship and alternative methods of measuring the transit time will be apparent.

Assume then that we can define such a transit time and that it has roughly the value mentioned. During this time the electric charge of each carrier in transit must be neutralized by an extra charge of the opposite sign within the base layer, so as to prevent excessive space charge. As we have seen these charges of opposite sign can be present only in the other conduction mode of the material and are therefore able to enter and leave freely by means of the base terminal but only with difficulty by any other way.

Thus if the voltage of the base material is changed sharply by some means, so, let us say, as to increase the emitter current, the full value of extra current will start to leave the emitter with only an insignificant time lag. This new current will not flow at the collector terminal, though, until after the lapse of roughly one transit time. During this interval the extra current from the emitter is building up the charge in transit in the base layer and extra charges of opposite sign are flowing in at the base terminal to preserve neutrality and Kirchhoff's Law. Since the transit of the charges in the base layer of a transistor is primarily by diffusion, this transit time is only an average value for a spread of times and consequently the transfer of this extra current from the base to the collector at the end of the transient is

gradual rather than sharp. Needless to say a sudden change of base voltage which reduces the emitter current will be accompanied by a corresponding surge of base current in the other direction as the extra charge is being reduced. This may often be far greater than the steady d.c. current to the base and the circuit designer must remember and allow for the resulting reversed flow of current.

This transit time effect could clearly be described quite simply in terms of a graph showing the proportion of the carriers which cross in any given time. It is a difficult matter, though, to present this information satisfactorily in the form of an equivalent circuit. One solution proposed has included an actual delay-line, but although this may synthesize the effect fairly exactly it is difficult to believe that an equivalent of such complexity is of any more real use to the circuit designer than the fundamental theory it represents. Clearly some simpler representation is required, despite the fact that it will be less accurate and begin to fail at lower frequencies.

The approximation proposed here is the one customary in thermionic valve theory and appears in the equivalent circuit as two additional components only. These are susceptive and conductive terms in the input admittance and are represented by C_s and R_s respectively in Fig. 3. The effect of the collector voltage on the current is being ignored and so also is the fact that the transient base currents flow almost entirely at the expense of the collector current. Furthermore the values given here for C_s and R_s are merely the first two terms of a power series whose remaining terms become significant as the frequency is raised. For all these reasons this approximation is valid only for frequencies below perhaps half the alpha cut-off and for working at higher frequencies than this a more detailed equivalent circuit, or else a return to the fundamental theory, is essential.

The first of the two terms is an effective extra input capacitance and is represented by C_s . It can be seen from what has been said already that the value of this will be equal to the product Tg_m , since this is the charge that must flow in order to neutralize the extra carriers produced by a unit change of base voltage. Clearly the effect of this capacitance on the operation will be proportional to the frequency, in the usual way, whilst a transistor with a smaller T will, in general, show an advantage.

In a typical modern transistor with an alpha cut-off frequency of 6Mc/s the transit time T will be about 30m μ s. This means that every change of 1 mA in the emitter current requires a charge of 30 μ C to flow to or from the base. This is itself a useful figure to remember, but for convenience it can be combined with the g_m to give a value for C_s of 1,200pF at a -1mA emitter circuit. The corresponding figure for a typical thermionic valve is about 2pF at a normal value of current. Of this large factor of difference, 600 times, only about 60 is due to the increased transit time whilst the remainder is the improvement in the mutual conductance.

The resistance R_s represents the "input damping" due to the fact that the transient base current always lags behind the change of base voltage that causes it. The effective value of this resistance is inversely proportional to the square of the frequency and is roughly equal to $2/T^2\omega^2g_m$. Thus at half the alpha cut-off frequency this resistance will be no more than about eight times R_i and will form by far the largest

(Continued on page 501)

part of the total input conductance. For a typical transistor the value might be around 200 ohms at 3Mc/s, while, for comparison, the corresponding resistance in a thermionic valve might be $1M\Omega$ at this same frequency.

It must not be forgotten that the resistance R_s is still present and impedes the flow of current from the base terminal to the actual material as before. Clearly its effect will have become more serious as the frequency has been increased and the input currents have become larger. In particular, R_s prevents the efficient tuning-out of the input capacitance in narrow-band high-frequency applications, and can also make the emitter impedance inductive over a range of frequencies when the base terminal voltage is held constant.

It will be seen, then, that there are a variety of reasons why transistors rapidly become less effective as amplifiers as the frequency of operation approaches the alpha cut-off. It is for this reason that major advances in speed are likely to come only from reductions of the transit time, either by reduction of the width of the base layer or by some technique, such as the grading of the doping material through the base layer used in drift transistors, which allows a significant electric field to operate on the carriers in transit. It is unlikely that any device which depends on transit time for its operation will ever be successful with semiconductors owing to the time spread introduced by diffusion.

Conclusions

In practical pulse circuits where all voltage swings are kept to a minimum and where "bottoming," with its attendant vast increase of transit time, is never allowed to occur, it is found that a transistor such as the OC45 with an alpha cut-off frequency of 6Mc/s is substantially equivalent to a modern thermionic triode such as the ECC81. The slowing down due to the much greater transit time is roughly compensated by the improvement due to the high g_m . We, at Ferranti, have transistorized such circuits with very little redesign effort and have obtained not merely a similar performance but also similar tolerances in component values and supply voltages.

Where pentodes, such as the EF91, are necessary in such circuits two transistors of this type are required. This is reasonable since it is well known that two triodes can often be connected in cascade to reproduce the important performance features of a pentode. The two transistors, though, must be connected in tandem, that is where one emitter follows the input voltage and makes a low impedance version of it for use as the base input to the other, since, as we have seen, it is the input rather than the output of a transistor whose impedance is most in need of improvement. Such a tandem pair has the same mutual conductance as a single transistor and same voltage gain, but the current gain is squared and the Miller effect greatly reduced. It is probably true that the overall power gain of such a pair in a linear amplifier is less than can be obtained by an optimum design of two separate stages, but there seems little doubt that the tandem pair can often be the most economical arrangement particularly in pulse circuitry.

The equivalent circuits that have been derived here are not, of course, meant to be startlingly different from those that have been suggested previously and there is no question of their use starting a revolution in circuit design. It is, in fact, hoped that they will look fairly familiar and so encourage the reader to draw upon the vast resources of thermionic-valve experience by showing more clearly than before how familiar circuits must be modified for successful use with transistors. This is not to say for one moment that all previous transistor experience is to be dismissed as useless, but rather to suggest that the clever tricks that have been evolved may sometimes be directly applicable to thermionic-valve circuits with an almost exactly similar advantage. The real basic problems of circuit design are quite largely independent of the precise kind of valve being used and it is hoped that this report may have helped to make the fundamental limitations better understood.

The ideas put forward in these two articles have been developed in the Ferranti Computer Department with the assistance of colleagues and visitors too numerous for individual mention. The author wishes to thank them all.

SHORT-WAVE CONDITIONS

Prediction for October

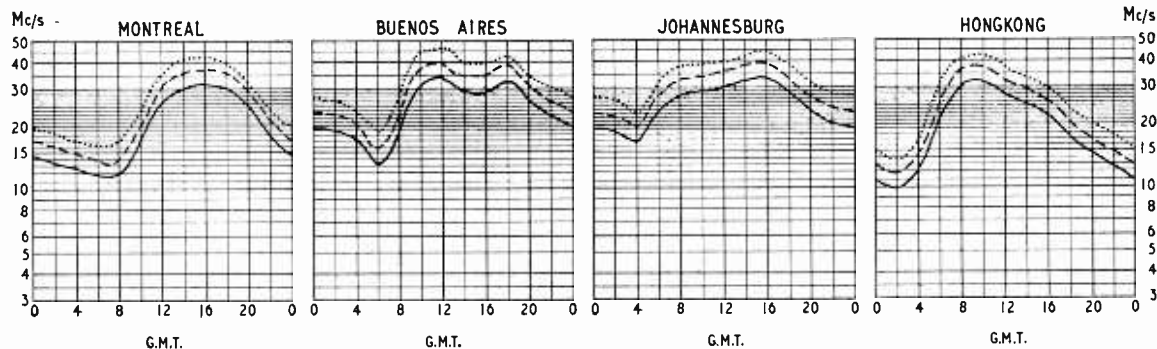

THE full curves given here indicate the highest frequencies likely to be usable at any time of the day or night for reliable communications over four long-distance paths from this country during October.

Broken-line curves give the highest frequencies that will sustain a partial service throughout the same period.

- FREQUENCY BELOW WHICH COMMUNICATION SHOULD BE POSSIBLE FOR 25% OF THE TOTAL TIME
- PREDICTED AVERAGE MAXIMUM USABLE FREQUENCY
- FREQUENCY BELOW WHICH COMMUNICATION SHOULD BE POSSIBLE ON ALL UNDISTURBED DAYS

Dispersion

By "CATHODE RAY"

WHEN VELOCITY VARIES WITH FREQUENCY

LAST month we made rather a remarkable and interesting discovery. We started with two entirely different lots of assumptions and arrived at the same results. The whole affair was perhaps a little involved for anyone who hadn't previously studied the subject, so even if you did follow it at the time you may be glad of a recap.

The basis for one of the arguments was that waves confined strictly (and I mean really strictly) to one frequency must have a pure sine waveform extending to infinity both in past and future. Directly starts and stops—necessary for signalling—are introduced there must be more than one frequency. Abrupt square-cut starts and stops necessitate a wide band of frequencies, difficult to handle by simple mathematics. Next to one frequency the simplest thing is two frequencies, and we know that two different

symbol β . (In most textbooks β is in radians— 2π times cycles—per unit distance, but that necessitates the frequency being in radians per sec.) If the differences are made infinitesimally small, the above result can be written as

$$v_g = \frac{df}{d\beta}$$

which means that the group velocity is equal to the slope of the graph of f against β (or the reciprocal slope of a β/f graph). We all know that the velocity of waves is equal to $f \times \lambda$, or f divided by $1/\lambda$, which is β . Since this is the velocity of a phase pattern it is called the phase velocity, v_p , so we have

$$v_p = \frac{f}{\beta}$$

If we compare these two equations we see that group velocity and phase velocity correspond respectively to a.c. and d.c. resistance in a current/voltage graph such as a valve characteristic curve. The equations prove that if v_p is the same for all frequencies then it is the same as v_g (but not *vice versa* as at least one textbook says!).

Before arriving at these results—which, let me emphasize again, were not tied to any particular kind of medium for the waves to travel in, but are quite general—we had found that the velocity of the phase pattern along a waveguide varies with its frequency. It is at least equal to the velocity of electromagnetic waves through open space (the well-known c , very nearly 300 million metres per sec) and is generally more. From the way we found it (as well as from a basic fact of Einstein's relativity) we know that actual energy doesn't travel at this faster-than-light speed, and we calculated that by whatever factor the phase velocity was greater than c the energy velocity would be c divided by that factor. We then drew a graph of β against f (Fig. 1) for the phase pattern (the resultant of assumed electromagnetic waves proceeding drunkenly from side to side along the guide at velocity c) and found that the group velocity, calculated on altogether different assumptions but which should be a velocity of energy, was equal to our waveguide energy velocity.

As tunnel engineers will agree, it is pleasant to meet at the same place from different starting points, but especially so in this case where we had

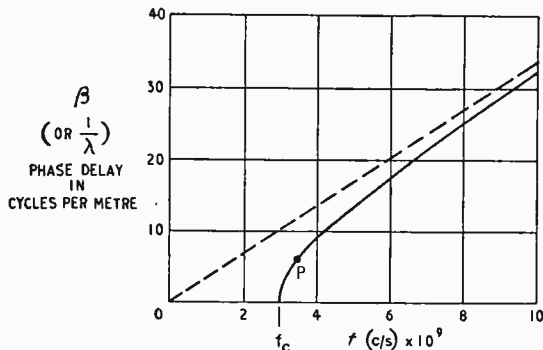

Fig. 1. Graph of phase delay per unit length of waveguide against frequency. The dotted line shows for comparison the characteristic of open space.

frequencies at once make groups of waves called beats. If the two frequencies travel at the same speed—as they do in space or along an ideal cable—the groups also travel at that speed. But if the higher frequency goes a little slower than the lower, the groups travel considerably slower still. This can be neatly demonstrated with a couple of combs having different tooth spacings*. We calculated this group velocity in terms of the frequencies and the velocities or wavelengths of the two lots of waves composing the groups, and concluded that it is equal to the difference in frequency divided by the difference in reciprocal wavelength. The reciprocal wavelength ($1/\lambda$), as we easily found, is the phase delay in cycles per unit distance, and is denoted by the

*When you try this trick you notice that moving the lower frequency teeth past the higher frequency ones makes the "groups" travel backward. Last month I commented that this didn't mean that the signals travelled along a waveguide backwards, because both sets of teeth were to be imagined as travelling fast in the first direction. Quite so. But while I was trying to expound the workings of the travelling-wave tube for "More Valves for Microwaves" in the October 1953 issue, there was already appearing a new development of it—the carcinotron or backward-wave tube, in which the energy actually does travel backwards with respect to the waves; i.e., the group velocity is negative!

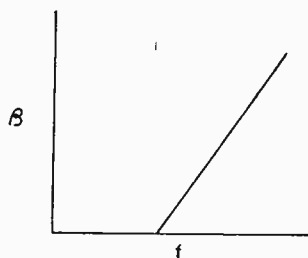

Fig. 2. This phase/frequency characteristic shows varying phase velocity ($=f/\beta$) yet constant group velocity ($=df/d\beta$).

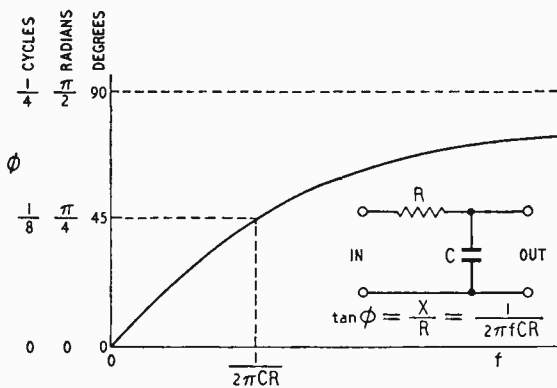

Fig. 3. Leaving out "per unit length," one can draw a phase/frequency curve for any tone-control or filter circuit, such as this simple RC arrangement. Like a waveguide, it is dispersive, causing waveform distortion.

only very general reasons for expecting that the velocity we believed energy would have along a waveguide might be the same as that of wave groups made up of two frequencies. The two calculations both made use of what mathematicians call an artifice—a word that sounds to more worldly ears like a bit of a fiddle. However, as regards v_g they led us to a perfect meeting.†

Before we go on to look at some other kinds of medium through which waves of different frequency travel at different speeds, let us consider the consequences of this peculiarity. Because even the simplest signal must include more than one frequency, the group velocity will differ from the phase velocity. If the group velocity also varies with frequency the signal will be distorted in transit. In its original form it can be likened to a group of racers leaving the starting line in close orderly formation, and in its received form to that same group strung out or dispersed around the course, for exactly the same reason.

It is easy to go wrong here by supposing that wherever the phase velocity varies with frequency the group velocity must inevitably do likewise and there will be distortion. This certainly does happen in a waveguide, as Fig. 1 shows; the slope of the continuous line, which is its graph, varies all the way (though only very slightly at frequencies higher than about twice the critical frequency). But suppose the characteristic had been as in Fig. 2. Here, as in Fig. 1, v_p varies all the way, so the Fourier components into which the signal could be analysed travel at different speeds; but v_g (as indicated by the constant slope of the line) is constant.

Readers who are more familiar with circuits than with waveguides or even transmission lines may feel more at home if they draw the graph for a simple RC "tone control circuit," as in Fig. 3. (The same shape applies if L is substituted for R and R for C.) We can't plot β , because that is phase shift per unit length, and R and C, being lumped, are supposed to have no length. However, β is only a particular case of phase shift, ϕ , so we plot ϕ , with scales to suit all tastes. The absence of length also rules out velocity in the usual sense, but the reciprocal of

velocity in the β/f graphs is time delay per unit length, so here it is just time delay. The group time delay at any frequency is equal to the slope of the curve at that frequency, and the phase time delay is equal to ϕ/f at that frequency. Fig. 3 shows us that both of these time delays decrease with rising frequency, and group delay is less than phase delay, in contrast to the waveguide, where phase time delay increases with frequency and group delay is greater. Also in contrast to the waveguide, over the lowest range of frequency ϕ is nearly proportional to f so there is least phase distortion. There is also least amplitude/frequency distortion, whereas in a waveguide this kind of distortion is very large at about f_c and very small well above it.

The easiest way of finding how a square wave, Fig. 4(a), is distorted by this kind of circuit is to make use of the simple theory of charging and discharging capacitors—exponential curves and all that. A typical voltage output is Fig. 4(b). But the same result is obtained by the more laborious way of analysing the square wave into its theoretically infinite number of sine-wave components, calculating the attenuation and phase shift of each one separately when passed through the RC combination, and then putting them all together again. An example of this up to the 15th harmonic was given in *Wireless World*, Dec., 1945, p. 358. Fig. 5 shows it for fundamental and third harmonic only, but even this is enough to reveal some resemblance to Fig. 4(b). This method enables one to see more clearly why tone control circuits can fitly be included among dispersive media.

Since in this particular circuit the group delay is less than that of the component sine waves (i.e., the group "velocity" is greater) the groups should gain on the components. Close scrutiny of Fig. 5 may show that they do, but one cannot be sure

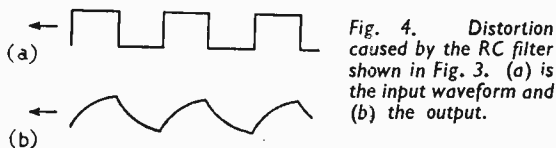

Fig. 4. Distortion caused by the RC filter shown in Fig. 3. (a) is the input waveform and (b) the output.

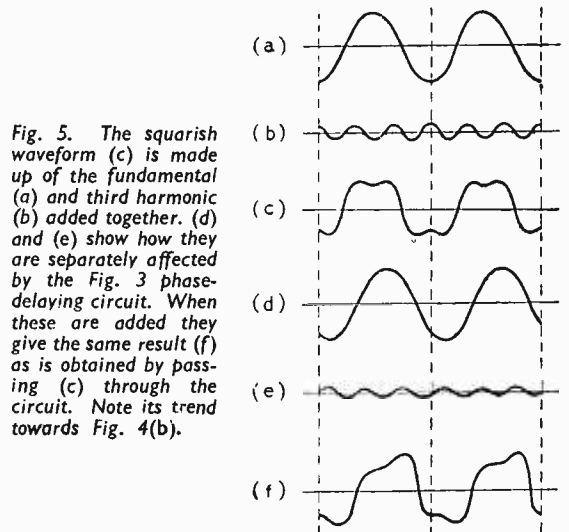

Fig. 5. The squarish waveform (c) is made up of the fundamental (a) and third harmonic (b) added together. (d) and (e) show how they are separately affected by the Fig. 3 phase-delaying circuit. When these are added they give the same result (f) as is obtained by passing (c) through the circuit. Note its trend towards Fig. 4(b).

† A proof that group velocity is the same thing as energy velocity is given in I. C. Staler's "Microwave Electronics," p. 41-42.

by how much, because of the distortion of the group waveform. This is as we would expect, for Fig. 3 shows that over the very wide frequency band of this signal the group delay varies considerably. So one cannot assign it a single value. As Thomas Roddam put it in a memorable metaphor, you cannot measure exactly the velocity of a pig through a sausage factory.

A perfect transmission line or cable, which means one that has inductance and capacitance but no series resistance or shunt leakage, is non-dispersive, so the difference between v_p and v_g doesn't arise, which is why in elementary courses transmission lines and cables are assumed to be perfect. The worst that can happen (apart from reflections) is that the material between the conductors may have a relative permittivity (ϵ_r) appreciably greater than 1, causing the velocity of the waves to be less than that in space (c) by the divisor $\sqrt{\epsilon_r}$. But it will be the same at all frequencies.

Real transmission lines and cables have both series resistance (R) and shunt leakage (G) per unit length, and β is an unpleasantly complicated function of f :

$$\beta = \sqrt{\frac{1}{2}[\omega^2 LC - RG + \sqrt{(RG - \omega^2 LC)^2 + \omega^2(LG + RC)^2}]}$$

(where as usual $\omega = 2\pi f$)

In general this does not vary linearly with f . But v.h.f. lines are usually short enough, and the ratio of maximum to minimum frequency small enough, for dispersion to be negligible. The same, incidentally, applies to waveguides, provided f_c is not approached too closely. In the exceptional case where waveguides were proposed for comparatively long-distance communication (*Wireless World*, April, 1955, p. 168) dispersion had to be seriously considered and was found to limit the usable signal bandwidth. Telephone and telegraph cables are often long, and the ratio of f_{max} to f_{min} is large, so the effect of R and G may be far from negligible. As an example I took what is known to army signalmen as field quad cable, having the following characteristics:

- L = 1.75 millihenries per mile
- C = 0.0945 microfarads per mile
- R = 78 Ω per mile
- G = 62 micromhos per mile

Substituting these values in the above equation for β gives, if I have done this rather tedious job without error, Fig. 6. The dotted line shows, for comparison, the result if R and G are omitted; the velocity, as you can check by dividing f by β anywhere along this line, is $0.42c$. An interesting thing about the real cable curve is that above about 2000c/s it is practically a straight line parallel to the dotted one. So although the phase velocity varies over this range of frequency the group velocity is practically constant, as in Fig. 2. But the ordinary telephone waveband is about 300-3000c/s, over which v_g varies considerably, with resulting distortion if the line as at all long.

R and G, especially R, can't be abolished, or even reduced to a satisfactory level without excessive expense. But if you put

$$\frac{L}{C} = \frac{R}{G}$$

you should find that β becomes directly proportional to f and all is well. However, for practical values

of R this necessitates either artificially increasing the leakage G (which increases the attenuation) or increasing the inductance L. Oliver Heaviside, who was the first to understand this, advocated increasing L, but was regarded by the telephone experts of the time as crazy. However, science won through in the end and it has become a standard practice to "load" long telephone cables with inductance, either by means of coils inserted at intervals or by wrapping the conductors around with high-permeability tape.

So much for signals travelling along lines under ground or water. Now for radio flying high, into the ionosphere. Empty space is a non-dispersive medium, and so fortunately is air under normal conditions. But at heights of the order of a hundred miles above the earth, where it is exposed to the ultra-violet radiation from the sun, it becomes ionized, for the reasons we went into in the last April issue. In other words, electrons become detached from their molecules and are no longer neutralized by them. So when radio waves come along their alternative electric field pushes the electrons to and fro in space, rather like it does when the waves strike an aerial, which also contains unbound electrons. These movements of electrons are, in effect, an electric current in space. How they modify the waves causing them depends on their phase relationship. If they were in phase with the electric field of the waves they would be like a current made to flow in a resistor, dissipating power. Actually there is some loss when radio waves travel through the ionosphere, but the greater part of the effect can be regarded as inductive, neutralizing or tuning out some of the capacitance of space and reducing ϵ_r below 1—a rather surprising state of affairs. The velocity of the waves consequently becomes greater than c .

That too would be a surprising thought had we not already come across it sufficiently often not to burst in with "Oh, but I thought nothing could travel faster than light!" It is, of course, only the velocity of a field pattern in space—a phase velocity. You couldn't measure the time taken by a wave to travel a given distance through the ionosphere unless you could identify it, and you could only do

Fig. 6. β/f graph for a typical telephone cable, showing dispersion. The dotted line is for the same cable if it had no resistance or leakage.

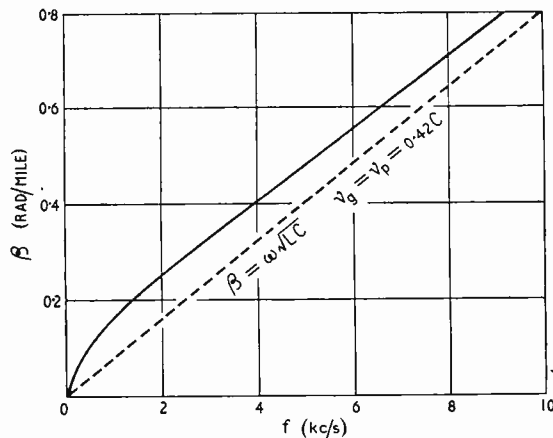

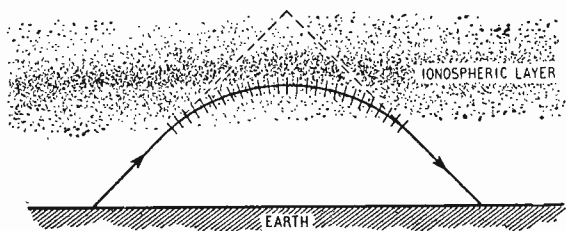

Fig. 7. An example of the refraction (bending) of radio waves by ionized layers in the upper atmosphere. Although the phase pattern is more spread out in the ionized region, indicating a higher phase velocity, wave groups actually take longer to pass through it—as long as they would if they took the dotted route at normal speed (c).

that by some such means as switching the transmitter on and off, which would inevitably give rise to sidebands. The effect of the free electrons depends on frequency, so the ionosphere is a dispersive medium. As with most dispersive media, the higher the frequency the lower the phase velocity, so the group velocity is less than c . A pulse from your transmitter, since it would travel at the group velocity and carry its energy at that rate, would break no law of Nature.

In discussing the propagation of radio waves through the ionosphere it is customary to forsake the term relative permittivity (ϵ_r) and to adopt instead a term used in optics—refractive index, denoted by n or μ . As μ is already grossly overworked I will use n . The relationship is $n = \sqrt{\epsilon_r}$, so v_p is inversely proportional to n . When $\epsilon_r = 1$ (as in empty space), $n = 1$, and $v_p = c$.

The reason for this terminological departure is understandable when we consider what the ionosphere does to us in practice. Fig. 7 shows an upward-inclined ray from a ground transmitter entering an ionized layer at an angle. The short transverse lines represent individual wave fronts, and one can see that the upper parts become affected by the layer first and more intensely. The greater velocity of these parts means that the ray is bent earthwards, just as when the outside men in a column of troops start to march faster. This is the behaviour known in optics as refraction, but the net result in this case is the same as if the layer had been a reflector, so the phenomenon is often called reflection. But refraction doesn't necessarily cause reflection; at some frequencies and ionospheric conditions (which, as is well known vary greatly with time of day year, and sunspot cycle) rays are bent but eventually pass right through.

When reflection does take place it may be a nuisance, causing distant transmissions to interfere with local ones, or useful, extending the range far beyond what would otherwise be possible. But, for the reason I have just mentioned, these useful results are rather chancy. What is more, the different treatment accorded different frequencies is liable to cause selective fading and distortion, especially if the signal waveband is wide. The poor pig again.

You may still be finding it hard to accept the idea of waves pushing through the ionosphere faster than c and permittivity and refractive index both less than 1, and I don't blame you. But we found that the velocity of the wave pattern in a waveguide was greater than c , and for that reason one could regard ϵ_r and n inside it as less than 1, absurd though

that may sound. But then, you may say, the wave pattern in the guide was really the resultant of ordinary well-behaved c -speed waves travelling in ordinary ϵ_r -equals-nearly-1 air. Passing over the question of what one means by "really," I would suggest that if it makes you any happier you can look at the ionosphere in the same way. It is a significant thing that the time taken by a wave group to follow the curved track in Fig. 7 is the same as if it had travelled at speed c along the straight dotted lines. Pause for reflection!

A frequency of 100 Mc/s is officially very high, 1,000 Mc/s is ultra high, 10,000 Mc/s is super high, and 100,000 Mc/s is extremely high. I don't know what, in this scale of superlatives, 500,000,000 Mc/s ought to be called, but it is a typical frequency of visible light. (I will probably get into trouble with Free Grid for implying that there is any such thing as invisible light.) Another thing I don't know is why optical people habitually specify light by wavelength rather than frequency, seeing that the wavelength depends on what medium it is passing through and doesn't definitely fix the colour and other properties, as frequency does. However, in elementary optics one learns that rays of light are bent or refracted where they pass into a medium of different refractive index, such as air into glass or vice versa. On this property

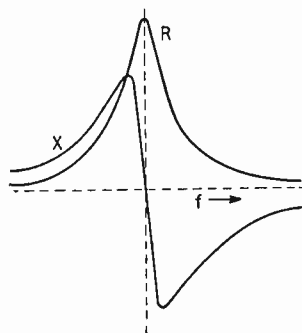

Fig. 8. Variation of resistance and reactance when frequency passes through resonance of a coupled circuit or of molecules, showing the slope of reactance at off-resonance frequencies—responsible for dispersion.

lenses depend. Usually the transition is abrupt, not gradual as in Fig. 7, so the bending is abrupt too, as we can see when we look at a stick dipping at a glancing angle into a tank of water. The relationship between the angle of incidence and angle of refraction depends on the refractive index, n . And this relationship is in accord with the supposition that the speed of the light is inversely proportional to n . Working in a very different frequency band, radio scientists found that the speed of their waves is inversely proportional to $\sqrt{\epsilon_r}$. It took some time to establish that n and $\sqrt{\epsilon_r}$ are identical. For one thing, the measured values are often widely different. But that is because the frequencies are so widely different, and the n or $\sqrt{\epsilon_r}$ is not constant; in other words, there is dispersion.

Why? Once again we must remember the excitation of atoms and molecules by radiation of certain frequencies. At those frequencies there is strong absorption and re-radiation, just as a tuned circuit behaves at its resonant frequency. Into any coupled circuit it introduces resistance which reaches a peak at the resonant frequency, as shown by the curve R in Fig. 8. It also introduces reactance which varies in the well-known manner shown by curve X. Light-carrying substances, because of resonant

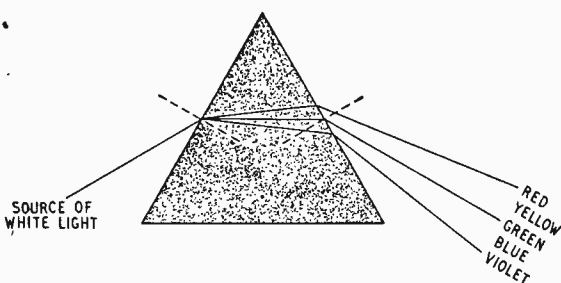

Fig. 9. Well-known diagram of how dispersion in glass can be used for obtaining light spectra.

excitation of their molecules, have analogous curves, the peaked one representing the absorption and the N-shaped one the refractive index, n . The resonant frequencies are usually in the ultra-violet, so the visible band comes where n is sloping gently upwards with frequency, and the velocity of the light gently downwards. (When it works this way it is called by the optical people normal dispersion. The reverse effect, close to a resonant frequency, they call anomalous dispersion.) This is rather like the effect of ionization in the atmosphere, except that the light does its own excitation whereas in the ionosphere the electrons have already been freed by radiation from the sun.

The familiar but none the less striking demonstration of this kind of dispersion is the production of the

rainbow colour spectrum by means of a prism (Fig. 9). The violet component of white light, having the highest frequency, is refracted most at the air-to-glass and glass-to-air transitions. The very elementary explanations of this phenomenon one reads as a child are apt to leave the impression that the pretty colours are a result of glass having a larger refractive index than air, so it may be advisable to emphasize that this alone is not enough; it is the variation of n with f that matters.

You will find that modern textbooks on light run remarkably parallel with those on telecommunications when they come to dispersion. Ditchburn's treatise, for example, has diagrams of Fourier analysis of pulse waveforms and the divergence of phase and group velocities, etc., that might easily belong to one on electrical lines and networks. After all, why not? There is only a difference in frequency.

Turning from electricity and light to sound, we find the same story, but fortunately only in a very brief version. Music would sound rather peculiar in the back seats if air was strongly dispersive to sound waves! It is only at supersonic frequencies, and especially in an atmosphere of carbon dioxide, that it is easily measurable; and so far even the fuggiest hi-fi addicts have failed to report.

If you wish to pursue the subject of dispersion with reference to ripples on the sunlit lake at eve you are free to do so, but without me (unless of course you are a sufficiently attractive young bluestocking). The next and final step is wave mechanics, in which group and phase velocity appear in circumstances of a very different scale of magnitude.

Commercial Literature

Hall-Effect Elements made by Siemens and Halske and mentioned in our report of the French Components Show (August issue) are available in this country through R. H. Cole (Overseas), who has issued a technical booklet on the devices from their office at 2 Caxton Street, Westminster, London, S.W.1.

Error-Correcting Telegraph Equipment of the multiplex type for h.f. and ionospheric scatter radio circuits. A descriptive booklet on their "Autoplex" equipment from Marconi's Wireless Telegraph Company, Marconi House, Chelmsford, Essex.

Silicon Half-Wave Rectifier with the exceptionally high p.i.v. of 750v for its small size of 7mm diameter \times 17mm long. Current rating: 400mA d.c. (capacitance load) or 500mA d.c. (resistance load). Technical data sheets from the manufacturers' (Siemens & Halske) agents, R. H. Cole (Overseas), 2 Caxton Street, Westminster, London, S.W.1.

Component and Network Bridge of the transformer ratio-arm type for two-, three- or four-terminal measurements, *in situ* if necessary. A full explanation of transformer ratio-arm techniques for different types of measurements is included in a leaflet from Wayne Kerr Laboratories, Roebuck Road, Chessington, Surrey.

High-Temperature Electronic Equipment is the title of a bulletin describing the operation of electronic equipment at ambient temperatures of -67°F to $+750^{\circ}\text{F}$ without the use of refrigerants. From the General Electric Company (U.S.A.), Missile and Ordnance Systems Department, Lakeside Avenue, Burlington, Vermont.

Stethoscope-Type Headsets, in which the electromagnetic earphone is housed in the jack plug and the sound is conveyed to the ears by acoustic transmission tubes, are described in leaflets from Amplivox, Industrial Division, 52-53 Margaret Street, London, W.1.

Communal Aerials and distribution systems for television and v.h.f. sound, designed for blocks of flats, housing estates, hotels, etc. Descriptions of equipments for up to 40 outlets

in a booklet from Belling & Lee, Great Cambridge Road, Enfield, Middlesex. Also a leaflet on **Band V Aerials**, with technical data on single, double and quadruple six-element Yagis and accessories.

Synchros; a leaflet giving brief tabular information (including Government designations) of the range of types made by Muirhead and Co., Beckenham, Kent.

V.H.F. Transmitter, 40-watt, intended for air-to-ground, ship-to-shore or point-to-point services. For a.m. operation on one or more closely spaced channels in the 50-200Mc/s frequency range. A leaflet from R.E.E. Telecommunications, 15a Market Square, Crewkerne, Somerset.

Unit Terminal Blocks, in black phenolic material, which can be built up into multi-way banks. A 30-amp type with 2 B.A. terminals is available in 4-way units and a 60-amp type with O B.A. terminals in 1-way units. Leaflet from Precision Components (Barnet), 13 Byng Road, Barnet, Herts.

Mobile Getter-Firing Induction Heater for thermionic vacuum devices. The 1-kW "Radyn" equipment is now available on a trolley fitted with a water tank and circulatory system for cooling. A hand coil for firing television c.r. tube getters is provided. Note from Radio Heaters, Eastheath Avenue, Wokingham, Berks.

P.M. Motors, international size 18, for 12V and 28V d.c. Speed: 5000 r.p.m.; torque: 4.2 oz.-ins. Leaflet of technical data on the range manufactured by R. B. Pullin and Company, Phoenix Works, Great West Road, Brentford, Middlesex.

Gramophone Tape Deck, a tape transport mechanism and recording/playback head called the "Gramdeck" which will operate from most 78-r.p.m. record players or radio-grams. A transistor control unit with self-contained battery provides the bias oscillator, pre-amplifier and tape characteristic equalisation. Literature from Stevenage Tools and Switches, Walkern Road, Stevenage, Herts.

Manufacturers' Products

NEW ELECTRONIC EQUIPMENT AND ACCESSORIES

Novel Cable Clip

A VERSATILE cable clip of novel design for securing cables of any size from $\frac{1}{8}$ in to $\frac{3}{8}$ in in diameter, or any combination of different sized cables having a total overall diameter not exceeding $\frac{3}{8}$ in, has been introduced by the Electronic Development Company, 17, Staines Road, Laleham, Middlesex.

As shown in the illustration, the method of fixing is to bend the flexible strip round the cable or cables, pass it under the specially shaped end boss and secure by means of a 6BA nut and bolt.

The clip is available in a variety of colours in either p.v.c. or polythene and it measures 3 in long, $\frac{3}{8}$ in wide and $\frac{3}{16}$ in thick approximately. Whilst the adjustable feature enables the one size of clip to serve for many purposes some larger sizes for securing cables up to 2 in in diameter are likely to be available shortly. The model illustrated on the right costs 12s per gross.

Valve Voltmeter

IN the new Advance 77 instrument full-scale deflections may be obtained with inputs from 1mV to 300V at frequencies between 10c/s and 5Mc/s. The scale is calibrated in r.m.s. volts corresponding to sine wave inputs, and also in dB with reference to 1mW as 0dB. The instrument may also be used as an amplifier with gain adjustable in 10dB steps up to 60dB, and a frequency

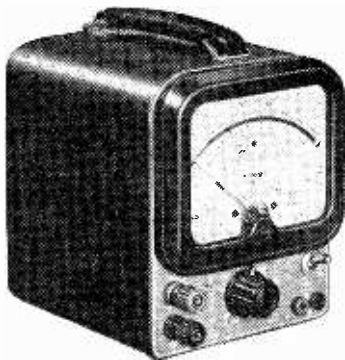

Advance 77 a.c. valve voltmeter.

response within ± 3 dB from 12c/s to 5Mc/s. Its input impedance is $10M\Omega$ across less than 5pF using the screened lead provided. The valve voltmeter costs £50, and is made by Advance Components Limited, Roebuck Road, Hainault, Ilford, Essex.

Sub-miniature Coils

A RANGE of sub-miniature tuning and oscillator coils for use in very small portable receivers has been introduced by Osmor Radio Products, Ltd., 418, Brighton Road, South Croydon, Surrey. They are wound on high-impact polystyrene formers measuring just under $\frac{1}{8}$ in in diameter, stand $\frac{1}{2}$ in high and have adjustable dust-iron cores of approximately $\frac{1}{4}$ in diameter. A moderately fine screw thread is used (about 36 t.p.i.) so that inductance adjustment should be relatively non-critical.

The Type QA8/SM illustrated is a medium-wave

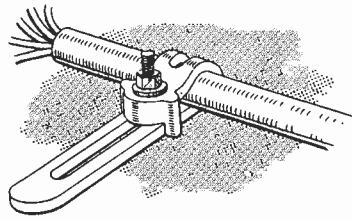

Left: — Adjustable cable clip (Electronic Development Company).

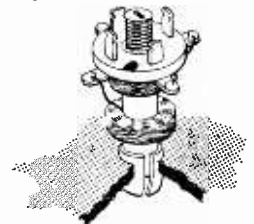

Right: — Osmor sub-miniature aerial coil Type QA8/SM.

aerial coil with a nominal inductance of 175 μ H, and a Q of 135 at 900kc/s, no mean achievement considering the small size of the coil.

Fixing is by means of a single hole and "Spire" clip. A feature of interest is the provision of a longitudinal slot extending the full length of the dust-iron core in place of the more usual shallow slot at each end. Chipped ends and jammed cores are far less likely with this type of slot.

The range includes aerial, r.f. and oscillator coils for long, medium and trawler wavebands and the price is 5s each.

Stereo Amplifier

TWO channels are available in the new Astronic combined amplifier and pre-amplifier Type 128. For each channel the sensitivity is 150mV for a peak output of about 4 watts with about 1 per cent distortion. Output impedances of 3 or 15 Ω are available, and the frequency response varies less than 1dB from 50c/s to 12kc/s. Ganged bass and treble controls are provided for the two channels. The volume controls are also ganged, but in addition, the gain of one channel relative to that of the other may be varied by up to ± 6 dB. The price of the Type 128 is 23 guineas with £1 8s 6d extra for a decorative cover. The maker's address is Associated Electronic Engineers, Ltd., Dalston Gardens, Stanmore, Middlesex.

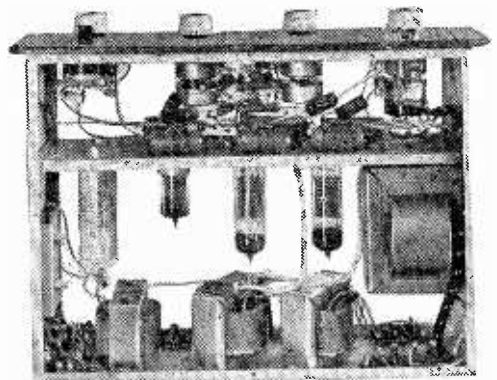

Underneath view of Astronic combine two-channel amplifier and pre-amplifier.

News from the Industry

Thorn.—The 1957-58 trading profit of the Thorn Electrical Industries group of companies, which includes the manufacturers of Champion, Ferguson, H.M.V. and Marconiphone sound and television receivers, totalled £2.343M. This is an increase of £222,000 on the previous year.

Beam-Echo.—Reference is made in the annual report of the Thorn Group to its recent acquisition of Beam-Echo, Ltd., of Witham, Essex, manufacturers of Avantic sound reproducing equipment.

Dubilier's trading profit during the year ended last March was £309,594. Although they sold larger quantities of capacitors and resistors to the radio and television industry than in the previous year, the profit was £80,411 less.

Cable & Wireless accounts for the year ended last March show a profit before taxation of £2,305,886, which is some £76,000 higher than the previous year.

Armstrong Amplifiers, Ltd., of Warlters Road, London, N.7, this year celebrate twenty-five years of manufacturing radio-gram chassis. To mark the occasion they have produced the Jubilee a.m./f.m. radiogramophone chassis.

Harvey Electronics Ltd., have formed a new subsidiary, Servo Units Limited, to handle all their servo-mechanism work. The address of the new company is 273 Farnborough Road, Farnborough, Hants. (Tel.: Farnborough 1120.)

Mills and Rockleys Ltd., screen process printers of Fretton House, Corporation Street, Coventry, are entering the field of printed circuits for which they have formed a subsidiary company, Mills and Rockleys (Production) Ltd. As mentioned in our August issue (page 367) D. L. Phillips, until recently with Technograph Electronic Products, has joined the company.

Radar Electronic Equipment Ltd. have formed a subsidiary company (Radar Electronic Engineering Limited) to conduct the business previously undertaken by the Pioneer Printed Circuits Division of the firm. The address is Colne-Way, Wraysbury Road, Staines, Middlesex (Tel.: Wraysbury 3194).

Hayward and Martin Ltd., industrial artists and consultants, of 34 High Street, Bromley, Kent (Tel.: Ravensbourne 6702), are prepared to undertake the complete production of technical publications and literature for manufacturers.

E.M.I. Electronics are supplying microwave television transmitting and receiving equipment to provide a link between the proposed B.B.C. stations at Wick and in the Orkneys. The equipment is designed for unattended operation on a frequency around 7,000 Mc/s.

Closed-Circuit 625-line television equipment developed by E.M.I. Electronics is being used at the Atomic Energy Authority's establishment at Harwell. The cylindrical camera unit, which measures only 3in diameter and is approximately 48in long, permits the remote inspection of many of the components without removal from the reactor thereby reducing radiation hazards.

British Communications Corporation are supplying a number of multi-channel recording installations for use in Radar Air Traffic Control Centres of the U.S. Air Force in the United Kingdom.

Standard Telephones and Cables installed the sound reproducing system in the recently rebuilt City Temple, London. Sound is distributed by four column line-source type loudspeakers. The installation also includes loudspeakers in the lower hall and in some of the smaller rooms.

Decca true-motion radar (TM46) is to be fitted in eight new tankers being constructed for the BP Tanker Company.

Schumann Microphones.—G. A. Stanley Palmer Ltd., of Maxwell House, Arundel Street, London, W.C.2, have been appointed the U.K. agents for the pickups, microphones and microphone inserts manufactured by F. & H. Schumann, of West Germany.

Japanese transistor receivers, marketed under the trade name of Shira, are to be imported by Winter Trading Company, of 6 Harrow Road, London, W.2. It was recently announced that the Government were to permit imports of Japanese transistor receivers to the total value of £20,000 a year.

Magnafon.—Record Housing Ltd., record cabinet manufacturers of Brook Road, London, N.22, have taken over the distribution and sales of Magnafon tape recorders made by Magnafon Ltd., of 99 Kensal Road, London, W.10.

Cawkell Research & Electronics, Ltd., formerly A. E. Cawkell, electronic engineers, recently moved to Scotts Road, Southall, Middx. The telephone number is unchanged (Southall 3702).

Truvox.—With the exception of the service department and the electric motor manufacturing section which are remaining at Harrow, all departments of Truvox are now at the new works at Neasden Lane, London, N.W.10. (Tel.: Gladstone 6455.)

BTH Electronics Group.—The headquarters of the BTH Electronics Group has been transferred from Rugby to New Parks Boulevard, Leicester (Tel.: Glenfield 531). The addresses of the following establishments are unchanged: Military Electronics and Radar, Blackbird Road, Leicester; Valves and Semiconductors, Carholme Road, Lincoln.

Kelvin & Hughes Ltd. have transferred their executive offices from Caxton Street, London, S.W.1, to Empire Way, Wembley, Middlesex. (Tel.: Wembley 8888.)

Daystrom Ltd., the recently formed U.K. subsidiary of the Heath Kits organization of America, has acquired accommodation at Glevum Hall, Southgate Street, Gloucester. (Tel.: Gloucester 20217.)

EXPORTS

Australian TV Stations.—Three of the four new government television stations to be built in Australia will be equipped with Marconi transmitters. These stations, which will be at Brisbane, Adelaide and Perth, will each have two 10-kW vision transmitters, two 2-kW sound transmitters, and a split 8-stack aerial array. Marconi's will also provide a considerable quantity of studio equipment for these stations, and the fourth to be built at Hobart.

Computers.—The Belgian Atomic Energy Authority has ordered from Ferranti a Mercury electronic digital computer. This is the fifth Mercury computer to be exported. The price of the machine is about £100,000.

Radar equipment to the value of approximately £1M has been ordered by the Norwegian Ministry of Defence from Marconi's, as part of the N.A.T.O. programme for a co-ordinated radar defence of member countries.

Marine Radar.—Twenty-six Kelvin Hughes marine radar sets (Type 14) have been ordered by the West German Ministry of Defence for installation in naval vessels.

An analogue computer for installation in the department of electrical engineering at McGill University, Montreal, is being supplied by Short Brothers & Harland, Ltd.

OCTOBER MEETINGS

Tickets may be required for some meetings; readers are advised therefore to communicate beforehand with the secretary of the society concerned.

LONDON

2nd. Television Society.—“Printed circuit techniques applied to a television tuner” by P. C. Ganderton (Sydney S. Bird & Sons) at 7.0 at the Cinematograph Exhibitors' Association, 164 Shaftesbury Avenue, W.C.2.

9th. I.E.E.—Presidential address by S. E. Goodall at 5.30 at Savoy Place, W.C.2

9th. Society of Instrument Technology.—“Aircraft flight simulators” by Dr. A. E. Cutler at 6.0 at Manson House, Portland Place, W.1.

10th. Physical Society.—“Vibrations and their measurement” by Dr. A. J. King at 5.30 at Imperial College, South Kensington.

13th. I.E.E.—Discussion on “The rationalization of the avenues of higher education for electrical engineers” opened by the President at 5.30 at Savoy Place, W.C.2.

17th. B.S.R.A.—“Use of white noise in audio testing” by J. Moir at 7.0 at the Royal Society of Arts, John Adam Street, Strand, W.C.2.

20th. I.E.E.—Discussion on “The presentation of electrical science in schools” opened by G. R. Noakes at 6.0 at Savoy Place, W.C.2.

22nd. I.E.E.—“Random thoughts of a propagation engineer” by G. Millington, Radio and Telecommunication Section chairman, at 5.30 at Savoy Place, W.C.2.

22nd. Radar and Electronics Association.—“Fatigue of metals” by Major P. L. Teed ((Vickers Armstrong) at 7.0 at the Royal Society of Arts, John Adam Street, W.C.2.

24th. Television Society.—“The present position of amateur television” by J. Royle at 7.0 at the Cinematograph Exhibitors' Association, 164 Shaftesbury Avenue, W.C.2.

27th. I.E.E.—“Rating of speech links and performances of telephone networks” and “Assessment of speech communication links” by Dr. J. Swaffield and D. L. Richards at 5.30 at Savoy Place, W.C.2.

28th. I.E.E.—Discussion on “Electronic control of machine tools” opened by D. T. N. Williamson at 5.30 at Savoy Place, W.C.2.

28th. Society of Instrument Technology.—“Basic measurements of time and frequency” by Dr. L. Essen at 6.0 at Manson House, Portland Place, W.1.

29th. Brit.I.R.E.—“Computers and ferro-electric storage” by Dr. M. Prutton at 6.30 at London School of Hygiene and Tropical Medicine, Keppel Street, Gower Street, W.C.1.

BRISTOL

2nd. Brit.I.R.E.—Inaugural meeting followed by “The scope and applications of the modern digital computer” by Dr. A. D. Booth at 7.0 at The School of Management Studies, Unity Street.

CARDIFF

15th. Brit.I.R.E.—“Principles of transistor circuitry” by B. R. A. Bettridge at 6.30 at the College of Advanced Technology.

CHELTENHAM

3rd. Brit.I.R.E.—“Nuclear instrumentation” by M. Thomas at 7.0 at North Gloucestershire Technical College.

CHESTER

27th. I.E.E.—“Recent developments in X-ray and electron microscopy with some applications to radio and electronics” by Dr. W. C. Nixon and C. W. Oatley at 6.30 at the Town Hall.

EDINBURGH

24th. Brit.I.R.E.—“Flight evaluation of airborne electronic equipment” by H. G. Hinkley at 7.0 at the Department of Natural Philosophy, Edinburgh University.

GLASGOW

23rd. Brit.I.R.E.—“Flight evaluation of airborne electronic equipment” by H. G. Hinkley at 7.0 at the Institution of Engineers and Shipbuilders, 39 Elmbank Crescent.

GRANGEMOUTH

30th. Society of Instrument Technology.—“Control instrumentation of nuclear reactors” by A. B. Gillespie at 7.0 at the Leapark Hotel.

LEICESTER

16th. Society of Instrument Technology.—“Semi-conductors and their applications” by G. M. Ettinger at the College of Technology and Commerce, The Newarke.

LIVERPOOL

15th. Brit.I.R.E.—“The manufacture of high-frequency surface barrier transistors” by P. A. Charman at 7.0 at the University Club.

20th. I.E.E.—Discussion on “Electronic control of machine tools” opened by D. T. N. Williamson at 6.30 at the Royal Institution, Colquitt Street.

MANCHESTER

7th. I.E.E.—Address by Professor F. C. Williams, chairman of the North-Western Centre, at 6.30 at The Engineers' Club, 17, Albert Square.

NEWCASTLE

8th. Brit.I.R.E.—“Electronic control systems for large astronomical telescopes” by G. H. Hickling and I. Paul at 6.0 at the Institution of Mining and Mechanical Engineers, Neville Hall, Westgate Road.

RUGBY

22nd. I.E.E.—“The atomic clock” by Dr. L. Essen at 6.30 at the College of Technology and Arts.

SHEFFIELD

15th. I.E.E.—“The origin and growth of electronics” by Dr. F. A. Benson, chairman of Sheffield Sub-centre, at 6.30 at the Grand Hotel.

STONE

10th. I.E.E.—“Electrical engineers and electronics” by R. W. Palmer, chairman, N. Staffordshire Sub-centre, at 7.0 at Duncan Hall.

WOLVERHAMPTON

8th. Brit.I.R.E.—“An introduction to colour television” by T. Jacobs at 7.15 at the College of Technology, Wulfruna Street.

LATE-SEPTEMBER MEETING

24th. Brit.I.R.E.—“Statistics in radio and television manufacture” by A. I. Godfrey at 6.30 at London School of Hygiene and Tropical Medicine, Keppel Street, Gower Street, London, W.C.1.

TRIX

60 watt AMPLIFIER

The power amplifier T664, illustrated below, has been developed to meet the need for a unit of relatively high output to be used in larger Sound installations. The T664 is primarily designed for mounting in our rack assemblies and has duplicated plug-and-socket facilities for inter-connecting a multiplicity of amplifiers.

It can also be made available as a self-contained unit, if required, with ventilated cover. The necessary mixers and pre-amplifiers can be chosen from our range according to requirements.

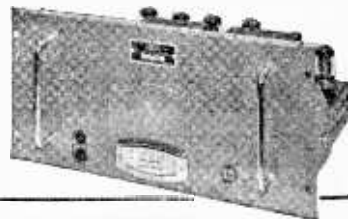

BRIEF SPECIFICATION:—

POWER OUTPUT

63 watts with total harmonic distortion not exceeding 1%.
73 watts with total harmonic distortion not exceeding 5%.

FREQUENCY RESPONSE

50-20,000 cps within ± 1 db.

OUTPUT STAGE

Four EL34 valves in parallel push-pull.

INPUT SENSITIVITY

0.85v. Resistance 470K ohms.

OUTPUT IMPEDANCE

165 ohms for 100v. line matching

FEEDBACK

16 db.

HUM and NOISE LEVEL

Below -65 db.

HT/LT SUPPLY

300 v. 30 mA., 6.3 v. 2 amp.

Please write for full details of our complete range of Sound Reproducing Equipment

TRIX ELECTRICAL COMPANY LTD.
1-5 Maple Place, Tottenham Court Road
London, W.1

Tel: MUSEum 5817 Grams: Trixadio Wesdo London

PP34

RANDOM RADIATIONS

By "DIALLIST"

A Hi-Fi Radio Show

TO MY mind the outstanding feature of this year's Radio show was the quality and the quantity of high-fidelity sound reproducing equipment to be seen. The Audio Hall was a brilliant inspiration and the numbers of people who visited it must have gladdened the hearts of those responsible. This country has lead the way in quality sound reproduction. The Williamson amplifier, for example, set and maintained a standard of performance which has been accorded world-wide recognition. Our export trade in sound reproducing equipment has gone up by leaps and bounds and the excellence of British apparatus is everywhere acknowledged. The rapid rise to popularity of stereophonic recordings came as a surprise to manufacturers. Pye, for instance, when they launched their first recordings last May estimated that the demand for them would be smallish. Recently the company stated that "what was anticipated as a small demand for stereo records by recorded sound specialists only, has proved, in fact to be a very considerable general market, with every evidence of expanding demand".

X-Rays and Wireless

WHEN, some months ago, I wrote in these notes that X-rays formed part of the sun's radiation several

readers expressed polite incredulity. Well, the presence of such radiation either on the outer fringes of the earth's atmosphere, or beyond it altogether, have been proved by measurements made by Explorers and Sputniks and signalled back to us. The latest view appears to be that there are zones of intense X-radiation and that the distance of these from the earth's surface varies. Isn't it possible that a belt of such sources of radiation nearer to us than usual may be partly responsible for some of the wireless blackouts that are apt to accompany, or rather to follow, great solar disturbances? Twice recently the Americans have exploded atomic missiles at great heights in the course of their tests. On each occasion there have been reports of complete breakdowns of wireless communication in areas some hundreds of miles from the point over which the explosion took place. The products of a nuclear explosion are radioactive and it seems likely that the radiation produced may have been responsible for the trouble.

Shooting the Moon

ONE thing that rather puzzles me is to know how, if a rocket is put into orbit round the moon, pictures of its dark side are to be transmitted to us on earth. Surely the dark side lives up to its name and is as much blacked out as those parts of this world where

it is night. Or nearly so, for since there is no atmosphere the light from stars and planets reaching its surface must be more intense than is the case with us. Even so, one would hardly think that the most sensitive of television apparatus could make much of the scenery. What seems more likely to be transmitted when the first lunar satellite gets to work is a series of measurements of temperatures and so on. Later on, perhaps, when we know more about putting our space projectiles where we want them to be, bigger and better instrument containers may be developed. These might be equipped with radar apparatus which could plot traces of the moon's surface beneath them, much as the echosounder used in ships plots traces of the sea bed.

Not so Easy

A QUESTION put to you, I expect, as often as it is to me by friends is: How long can one expect a TV tube to last? In the old days when there was only one service and programme hours were few, one could say with a certain amount of assurance that two or three years of service could be looked for on the average. But things are very different today when so many people have the choice of alternative and more extended programmes. On the day when this was written, for instance, an addict in the London area could have had his set in use for nearly seven hours. The life of any thermionic appliance such as the c.r.t. is normally a matter of the hours of use it has. A good many TV sets are probably worked now by various members of the family for at least double the number of hours that used to be the case. I'd put the average life expectation (barring accidents, or breakdown due to hidden defects) of a first-rate c.r.t. at something like 2,000-2,500 working hours. What are your views?

Needless Scrapping

IT IS much to be hoped that readers will tell their non-technical friends that a cathode-ray tube which has apparently "had it" can often be given a new lease of life. I wonder sometimes how many thousands of



"WIRELESS WORLD" PUBLICATIONS

	Net Price	By Post
LOW-COST HIGH-QUALITY AMPLIFIER. P. J. Baxandall, B.Sc.(Eng.)	3/6	4/-
GUIDE TO BROADCASTING STATIONS 1958-59. Compiled by "Wireless World"	2/6	2/11
THE OCILLOSCOPE AT WORK. A. Haas and R. W. Hallows, M. A. (Cantab.), M.I.E.E.	15/-	16/-
TELEVISION RECEIVING EQUIPMENT. W. T. Cocking, M.I.E.E. 4th Edition	30/-	31/9
TRANSISTOR A.F. AMPLIFIERS. D. D. Jones, M.Sc., D.I.C., and R. A. Hilbourne, B.Sc.	21/-	21/10
LONG-WAVE AND MEDIUM-WAVE PROPAGATION. H. E. Farrow, Grad. I.E.E.	4/6	4/10
RADIO LABORATORY HANDBOOK. M. G. Scroggie, B.Sc., M.I.E.E. 6th Edition	25/-	26/9
RADIO VALVE DATA. Compiled by "Wireless World." 6th Edition	5/-	5/9
TELEVISION ENGINEERING VOLUME IV: General Circuit Techniques. S. W. Amos, B.Sc.(Hons.), A.M.I.E.E. and D. C. Birkinshaw, M.B.E., M.A., M.I.E.E.	35/-	36/2

A complete list of books is available on application

Obtainable from all leading booksellers or from

ILIFFE & SONS LTD., Dorset House, Stamford Street, London, S.E.1

them are scrapped needlessly in the course of a year. The total must run to a pretty large figure. Everyone who knows anything about c.r.t.s is aware that the commonest of all faults, low emission, can usually be coped with (provided that the cathode is in reasonably good condition and that the TV set is worked off a.c. mains) by fitting a booster transformer for the heater. To cathode-heater shorts I've referred recently and letters continue to pour in from dealers who make a regular practice of using the method described, as well as from others who have successfully tried it out for the first time. It can't be too widely known, too, that apparently worn-out tubes can be re-gunned and this at much less than the cost of a replacement. There are now several excellent firms undertaking this work.

TV in Australia

TELEVISION seems to be coming along nicely in Australia, though for some time it's likely that the services will be confined chiefly to the six State capitals and their environs. So far only two cities—Sydney and Melbourne—have services, but each of them has government and commercial stations. What does surprise me after looking through the advertisements in a paper sent to me by an Australian friend is the much higher cost of receiving sets there than in this country. A 17-in set of the kind which sells here for about £75, including P.T., is offered, for example, for 215 Australian guineas. The Australian pound, one knows, is worth only about 16s of our money; but even so the price works out at something over £170. I suppose that heavy taxes of one kind or another must be partly responsible. And they must indeed be heavy for a £75 set would cost about £50 here, were it not for P.T.

Norwich in Fine Fettle

THE Norwich television transmitter has been working on full power since the second week in June and those who, like myself, are in its service area but over 20 miles away are finding an enormous improvement in the quality and steadiness of their pictures. Under international agreement the station had to reduce its output power considerably shortly after it first got going for it was found to be interfering seriously with Liege. The trouble seems now to have been overcome and here's hoping that the e.r.p. will be able to be maintained at its present level.

BULGIN
Micro-Switches

STAINLESS STEEL OR NYLON DRIVE-BUTTON
PURE SILVER INTERNAL CONTACTS
UNIQUE BERYLLIUM-COPPER ROLLING SPRING
TERMINAL SCREWS FITTED WITH SOLDERING-TAGS
SELECTED BERYLLIUM-COPPER BLADES
FIXING HOLES RAMPED TO FLAT SURFACE
TERMINAL BARRIERS

MOULDED BAKELITE CASE & BASE
EXTERNAL LEVER BLADES OF STAINLESS STEEL
FREELY-PIVOTED ROLLERS OF BRASS, STAINLESS STEEL, BAKELITE, GRAPHITE
THE NAME BULGIN (TRADE MARK) GUARANTEES GENUINENESS

...the best in the world!

The largest range of precision-made Micro-Switches manufactured; standard, miniature, open, lilliputian, ganged. Thousands & thousands in continuous use, everywhere, on all kinds of duties. Full details of scores of types in one complete catalogue, No. 199. (Free to Trade letterhead or order).

THE PRICE OF CRISIS

THE HOUSE OF
BULGIN components

A. F. BULGIN & CO. LTD., BARKING, ESSEX.
Telephone: RIPPleway 5588 (8 lines)

MANUFACTURERS OF RADIO AND ELECTRONIC COMPONENTS

Stereobatics

MANY radio shows of the past had a catchword summarizing some new development, and at this year's show the word "stereo" beat all records—except "television" at the 1936 Show.

These catchwords often pass into oblivion and sometimes the development which they describe perishes with them. An instance of this is push-button tuning which now survives mainly in the form of a method of waveband changing. In some instances, the word is forgotten but the principle survives, as in the case of "bandpass" which dominated the 1930 exhibition. Where now do you hear that word except in technical circles; and yet the principle of flat-topped tuning is a commonplace of all sets.

It is difficult to say into which of these two categories stereo is going to fall but if manufacturers want the public to buy stereo reproducing equipment I think they will have to alter their methods of demonstrating it. I am not criticizing them for their stereobatics with trains and ping-pong balls but for their failure at the Show to demonstrate the difference between stereo and non-stereo. I refuse to use the foolishly inaccurate word "monaural" to describe ordinary non-stereo reproduction, as surely monaural listening is impossible for a person with normal binaural hearing, unless, of course, he deliberately plugs one ear. The correct antonym for the Greek-derived word "stereo" is obviously "astero."

In my opinion each demonstration assembly should have been provided with a simple switching arrangement whereby the two loudspeakers could have been instantly connected in parallel to the output of one channel, and I hope that dealers will do this in their demonstrations. The only firm which adopted this method was one which was demonstrating stereo on earphones and the difference between "parallel" and "stereo" was very striking indeed.

One last word and that is a prophecy. In a few years' time the catchword of the show will be video. We shall then have available in the shops video recordings on magnetic tape (a domesticated VERA) and also on discs. These records will be played on units which we can connect to the video "pickup" terminals which our TV sets will then have. In this way we shall be able to have bottled plays and other things on our TV screens during non-broadcasting hours.

Our amateur ciné films will then be processed as reels of magnetic tape and they, too, will be shown in

this manner. Our radiogramophones will thus have their visual counterparts in these "radiogramoscopes."

The Triumphant Disc

ALMOST overnight the disc stereogram has arrived. A couple of years ago two channels on one disc was unknown except in the laboratory. The really surprising thing, however, is the popularity it has achieved compared with that of the tape stereogram which has been with us for quite a few years now.

There does not really seem to be much distinction between the two systems on the ground of cost. Each one uses its own special type of driving mechanism and pickup, and each uses a two-channel amplifier and output. Despite this, a tape stereogram seems to be a luxury and therefore only purchasable by the large pay packets of dukes, dustmen and other grades of unskilled labour. Ordinary people like you and me have to be content with twin-track discograms. I wonder why this is so? I wonder, too, why the tape stereogram, when it first came out, never received the wide publicity which the twin-track discogram is now getting?

"Pop" record availability is another thing in which the disc machine is already ahead despite the two or three years start of its tape counterpart. However, apart from questions of price, publicity and "pop" record availability I think one of the main reasons for the popularity of the disc compared with tape is the handiness of the former type of record when compared with the tedious threading-up needed by the latter. The amateur ciné world solved this

threading-up problem long ago with the handy film magazine.

There is in my opinion, only one respect in which the tape scores over the disc and that is in its non-mechanical method of picking the programme off the sound track. One day I feel sure that discs will be recorded and reproduced electromagnetically.

Stereo Radiograms

WE have presumably to get used to new words like "stereogram" to designate the new instruments capable of playing the new stereo discs. Some of these stereograms are combined with a radio set to form a radio-gram; in fact, these are ordinary radio-grams with a special pickup, and an extra amplifier and loudspeaker for the second channel. I have heard several people describe these as stereo radio-grams and the sooner this incorrect designation is quashed the better, for that is definitely what they are not. In a few years' time the B.B.C. regularly transmits stereo sound programmes we shall undoubtedly need the word "stereo-radio-gram" to describe the instruments we shall then be using.

It is obvious, I think, that a stereo-radio-gram when it arrives will be an instrument having not only two a.f. channels as in the present-day stereogram, but two r.f. channels also so that stereo broadcast transmissions could be received. It would be quite easy for a manufacturer to make a true stereo radio-gram with two r.f. channels now, but without B.B.C. stereo transmissions it would be as useless as the "16" speed is on our gramophones with no records available save talking books for the blind.

