

Wireless World

RADIO AND ELECTRONICS



JUNE 1946

1/6

Vol. LII, No. 6

IN THIS
ISSUE:

SUPER-REGENERATIVE RECEIVERS

**In the interests of Greater
Production in Loud Speakers
for the New Season**

Rola - CELESTION

make an Important Announcement to the Radio Industry

In order to meet the demand for Loudspeakers by the Radio Industry, BRITISH ROLA LIMITED have arranged to purchase the shares of CELESTION LIMITED as at the 31st July, 1946.

By pooling the resources of the two Companies they feel confident that *a substantial increase in deliveries by both Companies will be achieved.*

It must be emphasised that the Designs and Technical Development of both Companies will proceed Independently so that each will retain its Individuality under the New Arrangement.

BRITISH ROLA LTD.,
Georgian House, Bury St., St. James's, S.W.1.
Factories: Thames Ditton & Devises.

CELESTION LTD.,
Kingston-upon-Thames, Surrey.



Regd. Trade Mark

PRECISION

TESTING INSTRUMENTS

HIGH accuracy, simplicity, exceptional versatility and proven reliability have won for "AVO" Instruments a world-wide reputation for supremacy wherever rapid precision test work is demanded. There is an "AVO" Instrument for every essential electrical test.

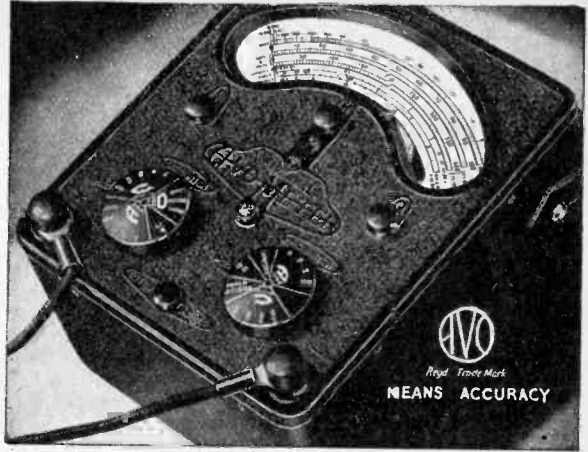

The MODEL 7 50-Range Universal

AVOMETER

Electrical Measuring Instrument

A self-contained, precision moving-coil instrument, conforming to B.S. 1st Grade accuracy requirements. Has 50 ranges, providing for measuring A.C. & D.C. volts, A.C. & D.C. amperes, resistance, capacity, audio-frequency power output and decibels. Direct readings. No external shunts or series resistances. Provided with automatic compensation for errors arising from variations in temperature, and is protected by an automatic cut-out against damage through overload.

Note Proprietors and Manufacturers

THE AUTOMATIC COIL WINDER & ELECTRICAL EQUIPMENT CO. LTD., Winder House Douglas Street, London, S.W.1. Phone: VICTORIA 3404/8

EQUIPPING A LABORATORY?

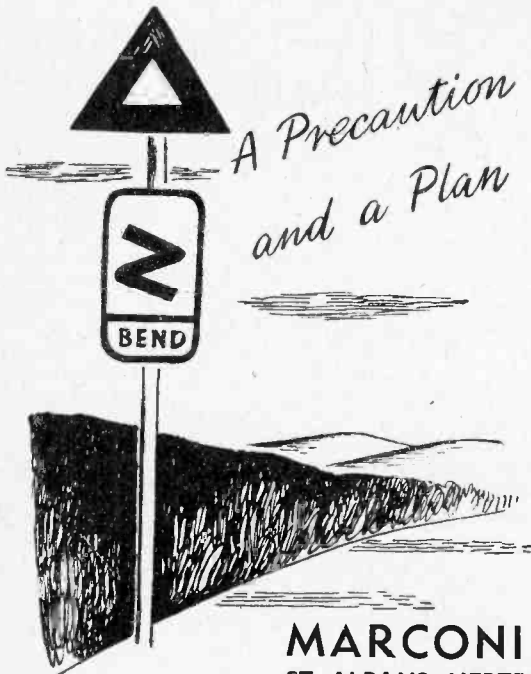

*A Precaution
and a Plan*

May we suggest a precaution before you decide on measuring apparatus for your laboratory? Consult our advisory staff and evolve thereby an instrumentation plan up-to-the-minute in technique and invention.

Over and over again a preliminary discussion has enabled us to show how the latest Marconi instrument can do the work of two existing models, or can reduce to simple terms an apparently intricate problem of measurement. Certainly by basing your requirements on the extensive range of Marconi apparatus you can be sure that to-morrow you will not discover something just a little

better, or a technique just a little more advanced than you knew existed. A Marconi instrumentation plan, therefore, means efficiency in your laboratory with the maximum saving of man-hours and money. Our advice costs nothing but nearly always proves to be rather more than worth while. Let us know your testing problems: we can most probably provide the answers.

MARCONI INSTRUMENTS LTD.

ST. ALBANS, HERTFORDSHIRE. Telephone: ST. ALBANS 4323/6

Northern Office: 30, ALBION STREET, HULL.

Telephone: HULL 16144



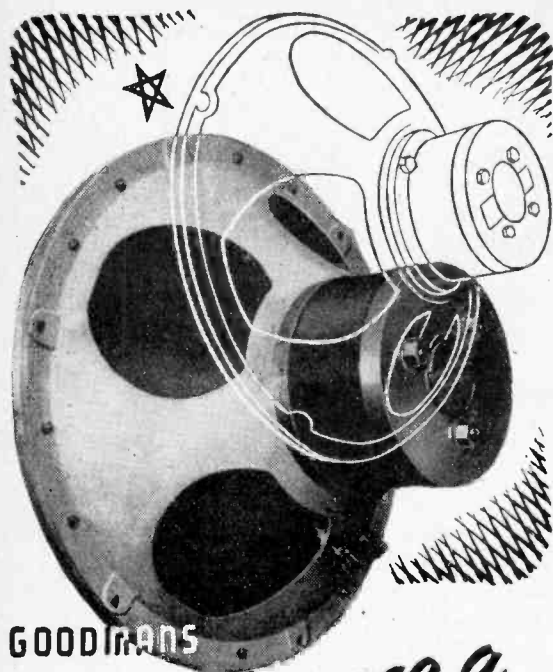

GOODMANS

Announce a
15 in
LOUDSPEAKER

The illustration shows the comparative sizes of a Goodmans 15 in. and 12 in. Loudspeaker. You already know the performance of the famous 12 in. Now consider the technical data of the new 15 in. model.

Overall Diam. 15 in.—
Overall Depth 8 in.
Fundamental Reso-
nance—55 c.p.s.
Voice Coil Diam—2 in.
Voice Coil Imped.—3.5
ohms at 400 c.p.s.
Flux Density — 15,000
gauss.
Max. Power Capacity—
25 W. peak A.C.
Net Weight—28lb. 6oz.

With an excellent re-
sponse up to 6,000 c.p.s.,
and an unusually high
power handling capacity,
this instrument sets a new
standard in Loudspeakers
for the Dance Hall, Rink,
Cinema and Heavy Duty
P.A. installations.

PRICE £18.10s. (subject)

The **GOODMANS** T10/1501/3-5
Loudspeaker

GOODMANS INDUSTRIES LTD., LANCELOT RD., WEMBLEY, MIDDX.
Telephone : Wembley 4001 (8 lines).

**Needle Impedance
causes Record wear**

Low Needle Impedance is obtained with light damping which, in turn, depends on low needle point pressure.

**The LEXINGTON
MOVING COIL PICK-UP**

SCIENTIFICALLY ENGINEERED
reduces these to a minimum by the introduction of pre-
cision watchmaking mechanics into the Radio Industry.



The new features are :

- Robust design. Accidental dropping on record will not damage Pick-up.
- Extreme low moment of inertia (80 milligrams total weight of movement).
- Pure sine wave with no harmonic distortion.
- Response curve flat from 30 c/s to 12 Kc/s.
- Automatic needle or sapphire changing opens new fidelity field to the amateur.
- Can be used with normal record changer without fear of damage.

Send stamp for illustrated pamphlet giving full technical details and price

COME AND HEAR IT !

Demonstrations Daily Monday to Friday 10 - 5 p.m.
Saturdays 2 - 4 p.m. Also Thursday Evenings 6.30 - 8 p.m.

COOPER MANUFACTURING CO.
134, Wardour Street, London, W.1 GERrard 7950



**FOR THE
RADIO SERVICEMAN
DEALER AND OWNER**

The man who enrolls for an I.C.S. Radio Course learns radio thoroughly, completely, practically. When he earns his Diploma, he will KNOW radio. We are not content merely to teach the principles of radio, we want to show our students how to apply that training in practical, every-day radio service work. We train them to be successful!

Special terms for members of H.M. Forces and discharged disabled members of H.M. Armed Forces

.....You may use this Coupon.....

INTERNATIONAL CORRESPONDENCE SCHOOLS Ltd.

DEPT. 38, INTERNATIONAL BUILDINGS, KINGSWAY, LONDON, W.C.2

Please explain fully about your Instruction in the subject marked X

Complete Radio Engineering. Radio Service Engineering.
Elementary Radio.

And the following Radio Examinations :-

British Institution of Radio Engineers.
P.M.G. Certificates for Wireless Operators.
City and Guilds Telecommunications.
Wireless Operator and Wireless Mechanic, R.A.F.

Name..... Age.....

Address.....

THE FINEST CORED SOLDER IN THE WORLD



Our claim is a simple one. We believe that Ersin Multicore is the finest cored solder in the world. If you are not already familiar with our product, we believe it can be of special assistance to you in your soldering processes whether you are manufacturing 10,000 radio receivers or repairing one. • Ersin Multicore is solder in the form of a wire containing 3 cores of non-corrosive Ersin Flux. • You get a guarantee of flux continuity. The Multicore construction gives you extra-rapid melting. Combined with a super active Ersin Flux—Exclusive with Multicore—you enjoy a speedy and consistently high standard of precision soldering. • Available in 5 alloys and 9 gauges. Please write for detailed technical information and samples.

ERSIN MULTICORE

Made in Britain by Multicore Solders Ltd., Mellier House, Albemarle St., London, W.1., England.
Telephone: Regent 7411 (P. B. X. 4 lines)

Sole U.S.A. Distributors: British Industries Sales Corp. (Dept. M) 401 Broadway, New York 13, N.Y.
Telephone: Canal 6-8876

Model
120a

Pocket Size TAYLOR JUNIOR



21 Ranges.

1,000 ohms
per volt
AC. and DC.

Weight 14 ozs.

Size $4\frac{7}{8}'' \times 3\frac{1}{8}'' \times 1\frac{15}{16}''$.

Price:—
£8 . 10 . 0 .

This Universal Taylor meter has self-contained ranges up to 5,000 volts DC. and AC. at 1,000 ohms per volt and up from 1 ma. to 500 ma. DC. full scale. Resistance ranges with self-contained battery cover from 0.5 ohms to 200,000 ohms and with external battery up to 20 megohms. All voltage resistors and shunts are adjusted to 1% giving a high degree of accuracy on all ranges. The moving coil meter has a sensitivity of 400 μ a. full scale and has a maximum scale length of 2½". Please write for illustrated technical leaflet.

Send enquiries to your usual factor or direct to:

Taylor Electrical Instruments Ltd.
419-424 MONTROSE AVENUE, SLOUGH, BUCKINGHAMSHIRE
Tel: Slough 21381 (4 lines) Grams: "Taylins" Slough



Now that Stentorian Extension Speakers are coming back to the shops the pleasure of listening again becomes complete. Just plug in one of these superb permanent magnet speakers to your set and you can enjoy its clean, pure tone anywhere in the house: sitting-room, kitchen, bedroom, wherever you happen to be. Supplies are still short, but a Stentorian is worth looking for. Ask your local dealer about them.

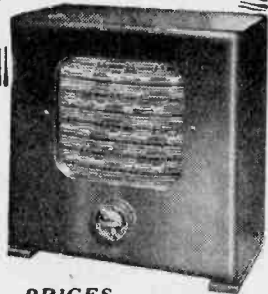

PRICES

Minor Type MX (for Low Impedance Extension)	29/6
Minor Type MC (with Universal Transformer)	35/6
Baby Type BX (for Low Impedance Extension)	43/6
Baby Type BC (with Universal Transformer)	49/6



Stentorian

THE PERFECT EXTRA SPEAKER FOR ANY SET

WHITELEY ELECTRICAL RADIO CO. LTD., MANSFIELD, NOTTS.

M.R. SUPPLIES

The business which handles only dependable Radio and Electrical material at the right price and effects immediate despatch from stock. All prices nett. All goods brand new.

Measuring Instruments of the highest grade. B.P.L. 3 1/2 in. flush mtg. precision M/Coil Instruments. 0/100 micro-amp., 75/-; 0/500 micro-amp., 85/-; 0/1 milliamp., 59/6; 0/100 milliamp., 55/- Also by same maker. Combined instrument in crash-proof bakelite portable case, 6 by 4 by 3 in., with carrying handle, 1,000 ohms/volt, universal A.C./D.C. Readings: 0/1, 0/10, 0/100 and 0/500 m.a., 0/10, 0/50, 0/100 and 0/500 volts. 0/10,000 ohms. Each range brought in by a positive contact, self-cleaning switch. Complete with cell, £8 15s. Also limited offer of Taylor 2 1/2 in. flush mtg., 0/500 milliamp m/coil meters (can be deslanted), brand new, at 35/-.

Insulation Testers. We now have the famous Evershed Wee-Meggers in stock. Pressure 500 volts. Range 0/20 megohms and inf. Supplied with pocket and log books, £9 10s.

Microphones, excellent range of reliable products. Rothermel D.104, original model in plated housing, with suspension rings, £5 5s. Same make BR28 Sound Cell Studio Model for serious work, £10 10s. Also Rothermel-Brush Miniature Inserts, 1 1/2 in. dia., 20/8 (all the foregoing are piezo-crystal. Gramplan Moving Coil type MCR (15 ohms), in square suspension frame, with lin. or 5/16 in. fitting, £4 4s. Same make, senior model, in alt-plated housing with internal switch. Response 60/5,000 c/s.—42 db., £7 8s. The new Resio VMC (12 ohms) in black and chrome with internal switch, for lin. mtg., £5 10s. Mu-metal Microphone Transformers to suit all above M/coil mics., 25/- Floor stands to suit all, all-chrom., collapsible, ext. to 5ft. 6in., 47/6. Chrom. cradles (for D.104 only), 8/6.

Loudspeakers.—High-fidelity models, by Vitavox. K12/10 (10 watt), 12in., 15 ohms coil, with 14,500 lines Ticonal perm. magnet, £7 (despatch, 5/-). Also R12/20 coil, with 42in. all-metal exponential horn, £9 10s. (despatch, 7/6) or with 42in. all-metal exponential horn, £10 10s. (despatch, 7/6). Also the Vitavox, (20 watt), same details, but 17,900 lines, £11 (despatch, 8/-). Also the Vitavox, with 12in. Unit and Tweeter, with 6-cell horn and filter in cabinet, 32in. x 17in. x 15in.—a challenge to any other high-fidelity reproducing system, £31 10s. despatch, 6/-). Note.—The Bitone is in very limited supply, and if we are out of stock on receipt of order, we will despatch within three weeks.

Projector Speakers for outdoor P.A. Obtain now before the seasonal rush Latest Vitavox P.M. 15 ohm Unit with 30in. all-metal horn, £9 10s. (despatch, 7/6) or with 42in. all-metal exponential horn, £10 10s. (despatch, 7/6). Also "A" type P.E.C. P.M. 15 ohm Unit, with line transformer incorporated, on 30in. horn, £11 (despatch, 7/6). On 42in. horn, £12 (despatch, 7/6). Immediate despatch. Battery Charging Equipment.—STC Metal Rectifiers. For charging up to 12 volts in conjunction with suitable transformers (see below). 3 amps., 22/6; 6 amps., 39/6; 10 amps., 49/6 (despatch, last two, 1/6).

Step-Down Mains Transformers.—All primes. tapped 200/250 v., Sec.: 8 and 14 v. 3/8; 4 mf., 1,000 v., 8/6; 8 mf., 1,000 v., 13/6; 10 mf., 400 v., 6/9; 5 mf., 1,000 v., 2/11; 0.1 mf., 1,000 v., 1/3 (12/6 doz.); 10 mf., 600 v., 8/6.

IN STOCK.—Vent-axia Extractor Fans, Pyrobrase Soldering and Brazing Equipment, Fuzit Wire Joints, Londex Relays, Stage Dimmers, Amplifiers, Headphones, Stuart Turner Centrifugal Pumps. Regret no lists at present. Please pay us a visit.

M.R. SUPPLIES, 68, New Oxford Street, London, W.C.1

Telephone: MUSeum 2958



Change of Address

Customers are requested to note that all works and administrative departments formerly at 12-22 Laystall Street, E.C.1., are now installed at our factory at Tolworth, Surbiton, Surrey. This move will involve no hold-up in the flow of deliveries. Henceforth, all communications should be sent to this new address.



UNITED INSULATOR CO., LTD
 Oakcroft Road,
 Tolworth,
 SURBITON, Surrey
 Tel: Elmbridge 5241 (6 Lines)

Unsurpassed In Ceramics

FOR **MODERN** SERVICE



ANOTHER
SERVICE FRIEND

Write for full details

Labgear Electronic Viewing Unit

LIST B/W/W/2014

CABINET SIZE
 $6\frac{1}{4} \times 5\frac{3}{8} \times 12$ inches

WEIGHT
 12 $\frac{1}{2}$ lbs.

SCREEN WIDTH
 2 $\frac{1}{4}$ inches

Labgear

WILLOW PLACE
 CAMBRIDGE

MANUFACTURERS OF HIGH CLASS TEST EQUIPMENT

**FLOATING
 ROTOR**

**DOUBLE
 CONTACT**

*Only in
 the famous*

**OAK
 SWITCH**

Other British N.F.S. Products Include: PAPER CAPACITORS, SILVERED MICA CAPACITORS, WIRE WOUND RESISTORS AND VOLUME CONTROLS—Write for full details.

Manufactured by

BRITISH N.F.S. CO. LTD.
 KEIGHLEY, YORKSHIRE

Phone: Keighley 4221/4. Grams: Enesef, Keighley

(Sole Licensees of OAK Manufacturing Co., Chicago)





NATIONAL SALES SERVICE



In the vital reconstruction task now facing the electrical industries this Company will play an important part. Our branch offices, located as above, are staffed and equipped to offer maximum sales service to customers.

BRITISH INSULATED CALLENDER'S CABLES LIMITED
 NORFOLK HOUSE, NORFOLK STREET, LONDON W.C.2

WEBB'S *Radio*

ALL COMPONENTS
CARRY WEBB'S UNCONDITIONAL
GUARANTEE OF SATISFACTION.

ENAMELLED COPPER WIRE s. d.
14 S.W.G. hard drawn (obviates corrosion
between strands)..... 100ft. 4 6

VARIABLE CONDENSERS
2-, 3- and 4-gang, .0005 mfd., 3- and 4-gang with
ceramic insulation. 2- and 3-gang 14 0
4-gang 17 6

Cyldon 500 pF. precision type—ceramic insula-
tion, removable spindle with extension for
ganging 15 0

NEUTRALISING CONDENSERS
Type "A," 6 pF. maximum—circular vanes—
mounted 2½" ceramic pillar—polystyrene insu-
lation. Minimum capacity approx. 1 pF. 9 6
Type "B," 8 pF. maximum—1½" circular vanes,
5,000 v.w. max. Minimum capacity 1.5 pF. 13 6

P.V.C. SLEEVING
2 mm. and 4 mm. 2 mm. ... per yd. 2
in 9 colours. 4 mm. ... per yd. 3

CO-AXIAL CABLE
0.45" dia. Polythene insulation, copper braided
with green P.V.C. outer covering. Impedance
80 ohms per yd. 1 6

EDDYSTONE
4-pin plug-in coil formers DL9 insulation,
ribbed but not threaded each 1 9

WESTINGHOUSE
Instrument Rectifiers—type MBS. 1, 1 ma.... 10 6

WEARITE
465 kc. iron-cored I.F. Transformers, new
improved type in aluminium cans each 7 6

WEBB'S I.F. TRANSFORMERS
1.6 mc.—ideal for high frequency receivers each 12 6

PUSHBACK WIRE
Single strand, good quality cotton insulation,
assorted colours. 250 yard rolls 15 0
(Not sold in small quantities)

FLEXIBLE DRIVING SHAFT
10" long—will drive through any angle. To fit
½" spindles each 5 0

WEBB'S RADIO
14, Soho Street, Oxford Street,
London, W.1
Telephone GERRARD 2089
Please note our SHOP HOURS—9 a.m. to 5 p.m.
(Saturdays, 9 a.m. to 1 p.m.)

THE STATIC CONDENSER Co. Ltd.

★ *Manufacturers of
STATIC
CONDENSERS*

TOUTLEY WORKS,
WOKINGHAM, Berks
Telephone: WOKINGHAM 708

THERE ARE TRIX
AMPLIFIERS FROM
5-500 WATTS. . . .

*Critical
users*

*Trust
TRIX*

Quality SOUND Equipment

THE TRIX ELECTRICAL CO. LTD.
1-5 MAPLE PLACE · TOTTENHAM COURT ROAD,
LONDON, W.1.
Incl. MUSEUM 5817 *Trux* a *Collins* TRIXRADIO-WESDO-LONDON.

TELEVISION AERIAL 'QUIZ'

Answers to some of the questions we are continually receiving by letter and telephone

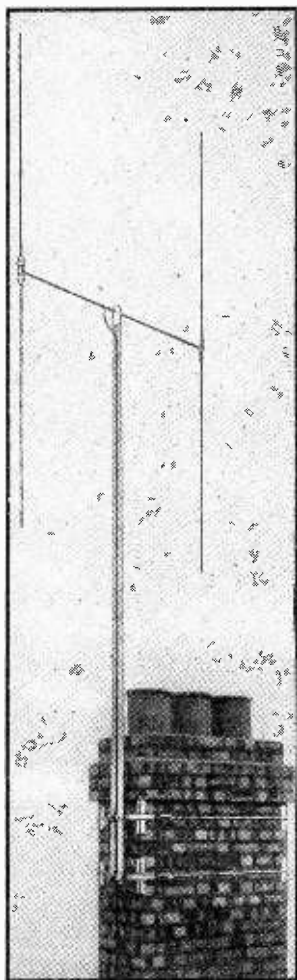

Television Aerial prices from 37/6 to 110/- with and without reflector.
Illustration shows L502L price 110/-
Cable L336 extra per yard 9d.

QUESTION 1. What are the advantages obtained when using a reflector with a dipole?

ANSWER. (a) It is necessary in areas of weak field strength to increase the signal input to the receiver.

(b) The directional properties can be utilised as a means of minimising interference, particularly so, if the aerial can be installed in such a position that the location of the source of interference is placed behind the reflector in relation to the transmitter.

(c) By rotating the aerial, ghost image can be reduced or eliminated.

Q. 2. Is it advantageous always to erect the aerial on the highest possible point of the building?

A. No, not always; sometimes a building can be used to screen against interference.

Q. 3. What type of feeder should be used with a dipole T.V. aerial?

A. T.V. Receiver designers still fall into three schools of thought:

(1) Coaxial feeder which needs complicated matching and balancing at the dipole end for best results and minimum interference.

(2) Unscreened twin which is the cheapest but needs a carefully balanced input circuit in the receiver for optimum results and does not provide a screened input to stabilise a super-sensitive receiver.

(3) Screened twin which gives the advantages of both but is a trifle dearer than coaxial.

If the receiver manufacturer makes a strong recommendation for his set it should be adhered to, but otherwise in most localities the cheapest, i.e. the twin unscreened feeder of 70 to 80 ohms impedance, will give no apparent loss even when connected to a coaxial input.

... TO BE CONTINUED

BELLING & LEE LTD
CAMBRIDGE ARTERIAL ROAD, ENFIELD, MIDDX

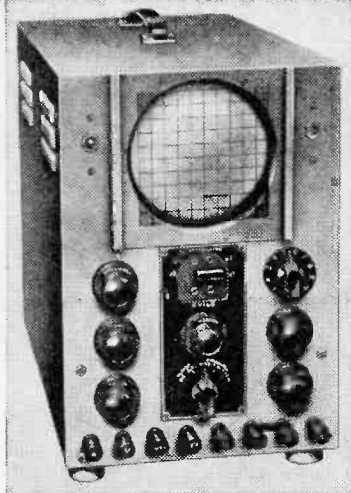

STATIC TWO-DIMENSIONAL
visual delineation of any recurrent law.

RELATIVE TIMING OF EVENTS
and other comparative measurements with extreme accuracy.

PHOTOGRAPHIC RECORDING
of transient phenomena.

SIMULTANEOUS INDICATION
of two variables on a common time axis.

INDUSTRIAL INDICATING and TESTING afford increasing scope for the Cathode Ray Tube as the only device with the above inherent features of which the last is unique in the Cossor DOUBLE BEAM Tube.

The Model 339 Cossor Oscillograph thus equipped is invaluable on all problems of research, production or operational testing, when the effect examined is applied as a voltage. When recurrent the traces are studied visually and when transient are recorded photographically, using Model 427 camera.

A. C. COSSOR LTD.,
INSTRUMENT DEPT.

Cossor House, London, N.5

*Phone: CANonbury 1234 (33 lines).
*Grams: Amplifiers Phone London.

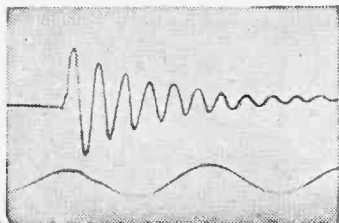

Constant Voltage

TRANSFORMERS
LINE VOLTAGE VARIATIONS OF $\pm 1\%$
 $\pm 15\%$ REDUCED TO $\pm 1\%$
TYPICAL SPECIFICATION
Input Voltage ... 190-260 v. 50 c/s.
Output Voltage ... 250 v. $\pm 1\%$
Max. load ... 150 watts.
Input power factor over 90%.
Prices on application. Write for details.

ADVANCE COMPONENTS LTD.
BACK RD., SHERNHALL ST., WALTHAMSTOW, E.17. PHONE: BARKSWOOD 43669

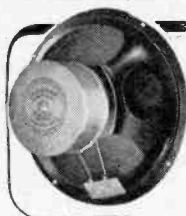

Here's

GRAMPIAN
QUALITY &
VALUE

The Gramphian P.M. Unit Speaker offers exceptional quality in return for a very modest capital outlay. It is fitted with a permanent magnet of nickel aluminium and the pole-piece has a non-ferrous locator to prevent dirt from reaching the "gap." A smooth response curve with gently rising characteristics gives superior clarity to speech and music. It is an ideal speaker for

Public Address and general-purpose work. Write to us.

38/-

List Price

Watts Handling: 7.

Chassis: 9".

Impedance: 2 or 15 ohms.

Flux Lines: 9,500



GRAMPIAN
LOUDSPEAKERS

GRAMPIAN REPRODUCERS LTD.,
Hampton Road, Hanworth, Middx. *Phone: Feltham 2657

INTRICATE PARTS

BUT NOT TOO INTRICATE FOR...

Bullers

Made in Three Principal Materials

FREQUELEX

An insulating material of Low Dielectric Loss, for Coil Formers, Aerial Insulators, Valve Holders, etc.

PERMALEX

A High Permittivity Material. For the construction of Condensers of the smallest possible dimensions.

TEMPLEX

A Condenser material of medium permittivity. For the construction of Condensers having a constant capacity at all temperatures.



BULLERS LOW LOSS CERAMICS

BULLERS LTD., 6, LAURENCE POUNTNEY HILL, LONDON, E.C.4
 Telephone: Mansion House 9971 (3 lines) Telegrams: "Bullers, Cannon, London" Manchester Office: 196, Deansgate, Manchester



PORTABLE
SUB-STANDARD
INSTRUMENTS
BY
PULLIN

THESE instruments have been primarily developed for use in Meter Test Rooms, Research Laboratories and Works Testing Departments. They are sufficiently robust to withstand severe industrial use.

The movements are of the iron-free dynamometer type or of the D'Arsonval moving coil type, and have a high torque to weight ratio. They are well damped, but will respond to minute changes of supply. They are effectively shielded from the influence of external magnetic fields, by means of double mu-metal shield.



MEASURING INSTRUMENTS
(PULLIN) LTD

Please address all correspondence to: Dept. J, Phoenix Works,
Great West Road, Brentford, Middlesex. Ealing 0011

FAMOUS FASTENERS

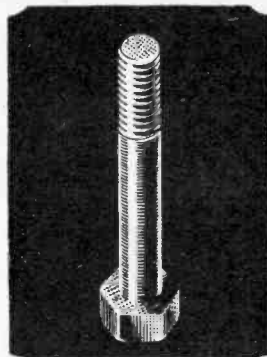

HIGH TENSILE HEXAGON BOLT

Three distinct tests ensure the standard of Linread Bolts. The first is checking of raw material, the second is specialised Quality Control during manufacture, and the third, inspection of finished products. Specialists in Cold Forging; Roll Threaded Screws; Solid and Tubular Rivets; Nuts and Bolts in all metals; Small Pressings; Auto and Caps-an-turned Parts.

LINREAD LTD., STIRLING WORKS, COX ST., BIRMINGHAM, 3.
TELEPHONE No.: GEN. 3851 P.B.X.
TELEGRAMS: "LINREAD BIRMINGHAM."
London Office: Clifton House, Euston Road, London, N.W.1.
Tele. No.: Euston 8261.

Linread
SPECIALISTS IN COLD FORGING

ADASTRA
GALVANISED SECTIONAL STEEL
RADIO MASTS
Send for Catalogue **W0330**
POLES LTD TYBURN RD EDDINGTON
BIRMINGHAM 24

METALLISED CERAMICS

for

Hermetic Seals and Soldered Assemblies

FREQUENTITE BUSHES

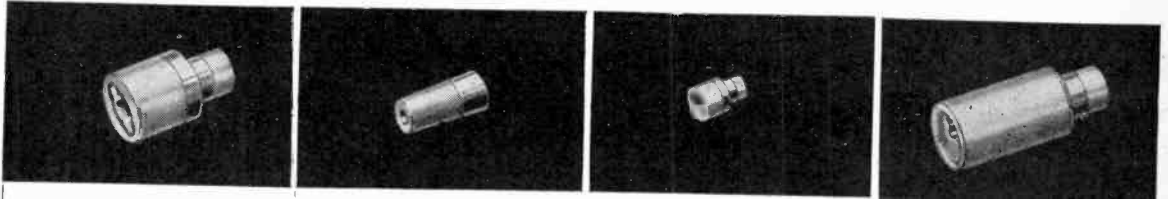

Photographs (above) actual size.
Drawings not to scale.

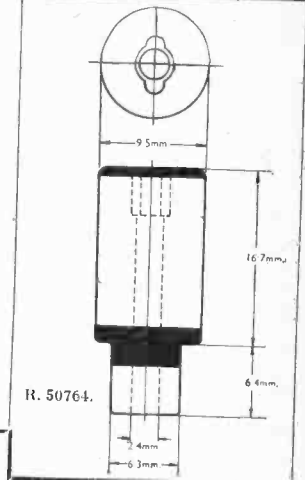
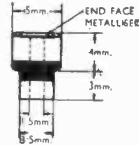
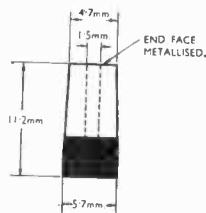
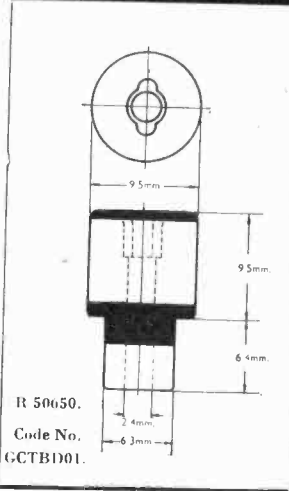

R. 50636.
Code No. GCTBA01.

R. 50728.

Code nos. are those used in I.S.C.Tech.C.
Specification No. R.C.L./330.11.

PORCELAIN BUSHES

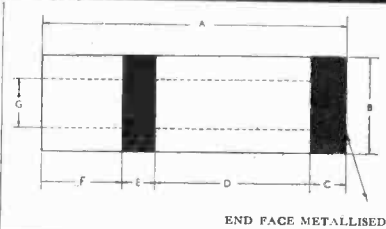
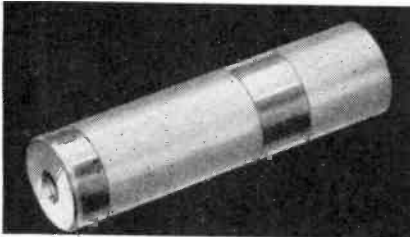

TYPE	CODE	A mms.	B mms.	C mms.	D mms.	E mms.	F mms.	G mms.
R. 50734	GCTBC01	20.3	7.6	3.8	6.4	4.6	5.5	3.0
R. 50768	GCTBC02	20.3	12.7	3.8	6.4	4.6	5.5	5.1
R. 50769	GCTBC03	20.3	15.2	3.8	6.4	4.6	5.5	6.4
R. 50770	GCTBC04	38.1	10.2	5.1	15.7	6.4	10.9	4.1
Q. 2092	GCTBC05	55.9	12.7	6.4	25.4	8.9	15.2	5.1
Q. 1982	GCTBC06	78.7	15.2	6.4	38.1	8.9	25.3	5.1

For full information and prices please write to:

STEATITE & PORCELAIN PRODUCTS LTD.

STOURPORT-ON-SEVERN, WORCS. T'phone: Stourport III. T'grams: Steatoin, Stourport.



S.S.W. TORSIONAL
REMOTE
CONTROL

and
**FLEXIBLE SHAFT
ASSEMBLIES**

DEFLECTIONLESS SLOW-SPEED
OPERATION ... *car radio*

POWER SHAFTS FOR HIGH-SPEED
OPERATION ... *speedometers*
... *tachometer*

PUSH-PULL OPERATION
... *chokes* ... *starters*

TENSION OPERATION ... *brakes*

THE S. S. WHITE COMPANY BRITANNIA WORKS
ST. PANCRAS WAY · CAMDEN TOWN · LONDON N.W.1.
Cable Address: WHICODENTA, WESDO, PHONE: LONDON
Telephone: EUSTON 4758-4759

Robert Sharp & Partners

WT 31

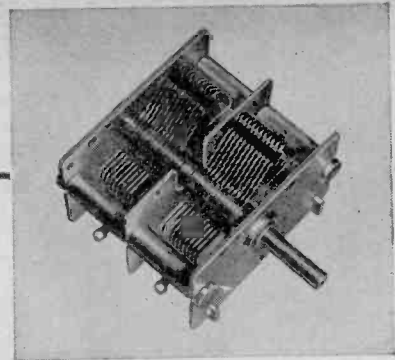

M.G. 1, 2 or 3 GANG CONDENSER

This small size condenser is of rigid construction, and is made in various capacities up to 540mmf. with tropical finish. It can be supplied with trimmers built in if required. The 2 Gang Frame is $2\frac{1}{2} \times 1\frac{1}{8} \times 2\frac{1}{8}$ over all.



JACKSON

BROS (LONDON) LIMITED

KINGSWAY · WADDON · SURREY

TELEPHONE: CROYDON 2754-5 TELEGRAMS: WALFILCO, PHONE, LONDON

LEAK

"POINT ONE" RANGE OF ALMOST DISTORTIONLESS AMPLIFIERS

Here are performance figures, inclusive of output transformer, for the type 15: —

TOTAL DISTORTION, including hum and noise, for 15 watts output: —

1,000 c.p.s. - 0.1% (one-tenth of one per cent)
60 c.p.s. - 0.2% (one-fifth of one per cent)

FREQUENCY RESPONSE: level within 0.25db. 20-20,000 c.p.s.

LOAD DAMPING FACTOR: 20 (10 times better than for average Class A triode).

GAIN: The basic amplifier requires 0.5v RMS at grid impedance. An additional two stages can be supplied built into the chassis, thus reducing the input to 0.005v R.M.S.

Full information on leaflet S.15

SPECIAL NOTE: The above figures establish such radically new standards that they may occasion some surprise. We therefore wish to stress that no error appears in this announcement. The circuits are original, and result from war-time research in our laboratory.

H. J. LEAK & COMPANY LIMITED
470 UXBRIDGE ROAD · LONDON · W.12
TELEPHONE: SHEPHERDS BUSH 5626

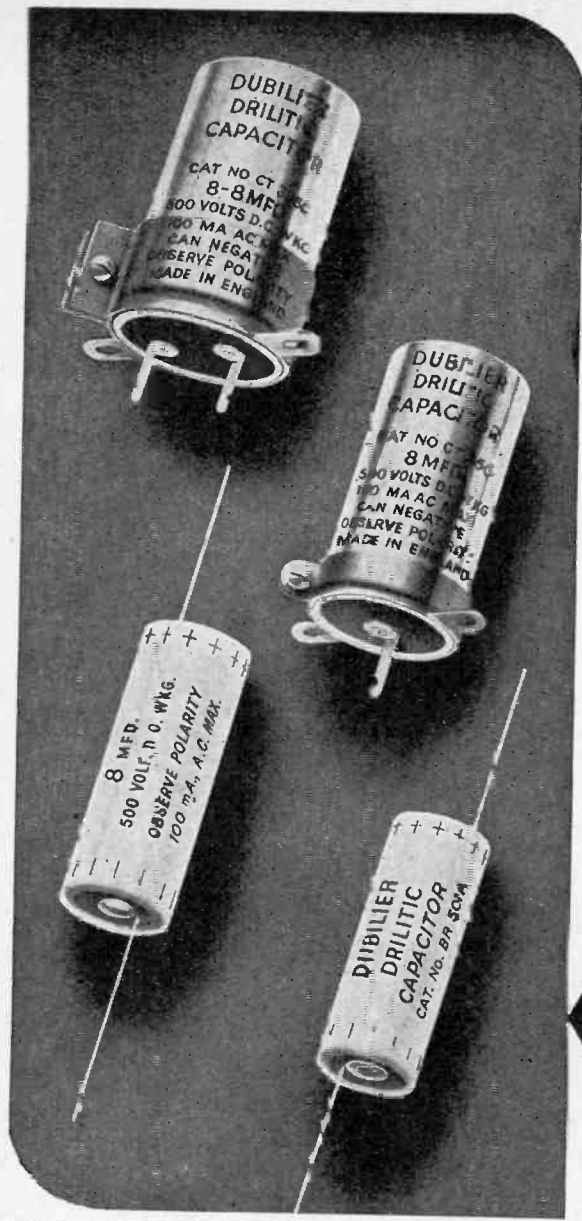

Now!
a full range

**"DRILITIC"
ELECTROLYTIC CAPACITORS**

Physically small, these B.R. and C.T. capacitors embody many technical advantages and their comprehensive coverage of every electrolytic requirement will be readily appreciated by users. The electrical characteristics of these capacitors are a marked advance in electrolytic design, the leakage current and equivalent series resistance are reduced, the audio and radio frequency impedance improved, breakdown voltage and life expectancy have been increased together with an improvement in temperature characteristics. They are contained in seamless drawn aluminium containers hermetically sealed and the container is always negative.

DUBILIER
CONDENSER CO. (1925) LTD
LONDON. W.3

" DRILITIC " CAPACITORS

Capacitance	MAXIMUM Working Voltage	SIZE INCHES		MAXIMUM Ripple Current mA.	TYPE Number	RETAIL PRICE EACH
		D.	L.			
50	12	1 1/2	1 1/2	55	BR501	2s. 6d.
25	25		1 1/2	75	BR252A	2s. 6d.
50	50		2	190	BR505	3s. 6d.
8	150		1 1/2	110	BR815	2s. 9d.
8	500		2	100	BR850	4s. 0d.
8	500	1	2	100	CT850	4s. 6d.
16	500	1	2	110	CT1650	6s. 6d.
8-8	500-500	1 1/2	2	*100-100	CT8850	6s. 6d.
16-8	500-500	1 1/2	2	*110-100	CT16850	8s. 6d.

Vertical mounting clips supplied with C.T. types. *The total max. ripple current for both sections must not exceed the larger figure.



Photo-Electric Cells



Manufacturers of over forty different types of Photo-electric cells, from standard ranges to "miniatures" and "specials" designed to meet all requirements in industry and the laboratory, with characteristics and physical dimensions over the widest possible range.

- Multiplier cells for amplification of the primary photo current.
- Quartz cells for use with ultra violet radiation.
- Guiger Muller tubes for Cosmic Ray research and other applications.
- Nitrogen Helium Discharge Lamps.

New Brochure and price list now available on application.

CINEMA - TELEVISION LTD.,

INCORPORATING BAIRD TELEVISION LIMITED
WORSLEY BRIDGE RD., LONDON, S.E.26
Telephone: Hither Green 4600

Suppliers to ADMIRALTY, MINISTRY OF AIRCRAFT PRODUCTION, MINISTRY OF SUPPLY, ARMAMENT RESEARCH, etc. Manufacturers of Scientific Instruments and Photo-electric cells.

NEW ROMAC RADIO & ORAL COMMUNICATION COMBINED

25 Watt, Model 25/HII.

Incorporated **Radio Tuning Unit**, Provision for **Moving Coil** or **Crystal Microphone** and High Impedance **Gramophone Pick-up** to meet the demand of the present day for High Grade Equipment.

Delivery Ex Stock

Also our Model 25/HI Amplifier for Microphone and Gramophone input only, also with high quality output of 25 watts.

Delivery Ex Stock.

Gramophone Playing Desk Unit in attractive case with lid available with either Amplifier.

ROMAC RADIO CORPN. LTD.

THE HYDE • HENDON • LONDON, N.W.9

consult us on your

PLASTIC PROBLEMS

COSMOCORD LTD · ENFIELD

MINIATURE or MIDGET

We specialise in their manufacture

HIVAC

THE SCIENTIFIC VALVE

BRITISH MADE

Originators, designers & manufacturers of Midget Valves

HARROW
HIVAC LIMITED, Greenhill Crescent, Harrow on the Hill, Middx. Phone: 0895

LINAGLOW LIMITED

ALL-WAVE COIL PACK

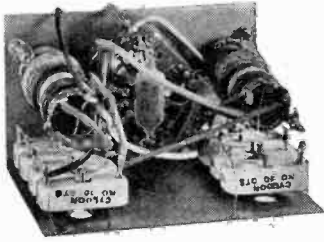

Ranges: 19-50, 200-550, and 1,000-2,000 metres. Simplifies the building of a superb set. Supplied complete with trimmer and padder condensers for use in standard 3-wave Superheterodyne circuit. One hole fixing to chassis. A fourth position is fitted to wave change switch for gramophone pick-up. For use with 465 K/C's, I.F. Transformers. Price complete with diagram of connections. **38/6**

METALAIR ELECTRIC CLOCKS. 7in. diameter, 4in. diameter dial, 200/250 volts, A.C. 50 cycles. Various colours sprayed steel. Price, 48/-, plus 10/8 purchase tax. Metal case finish to resemble plastic, in various colours. Price 52/6, plus 11/8 purchase tax.

CONDENSERS.—Brand new ex-G.P.O. fixed tubular paper aluminium can Sprague type .001 mfd. 1,000 v. D.C., .002 mfd. 1,000 v. D.C., .005 mfd. 1,000 v. D.C., .01 mfd. 1,000 v. D.C., .02 mfd. 750 v. D.C., .05 mfd. 500 v. D.C., .1 mfd. 500 v. D.C., .25 mfd. 500 v. D.C., .1 mfd. 350 v. D.C., .25 mfd. 350 v. D.C. Fixed paper moulded case (Micamold), .001 mfd. 600 v. D.C., .002 mfd. 600 v. D.C. Paper block .5 mfd. 1,000 v. D.C. with mounting brackets (Aerovox). Fixed paper block, .25 mfd. 800 v. D.C. and 400 v. D.C. (Solar). 8d. each.

ELECTROLYTIC CONDENSERS—tubular—6 mfd. 50 v., 1/8, 50 mfd. 12 v., 1/8, 25 mfd. 25 v., 1/8, 8 mfd. 500 v., 3/8. Tubular tag end, 8 x 3 mfd. 550 v., 5/8.

THE R.A.F. ELECTRIC HEATER.—Indispensible as a foot-warmer, pram alrer, clothes alrer, car anti-freezer, etc. Thermostatically controlled to provide a constant warmth. 200/250 v. 40 watts. 35/- plus purchase tax, 5/8. (Woolen covers available. 6/-, plus P.T. 1/6.)

VALVES.—American types at B.O.T. controlled retail prices, 12F5, 12J5, 1H5, 9/2, 1C5, 1N5, 3Q5, 35Z5, 11/-; 6Q7, 11/7; 1A7, 6F6, 6K6, 50L6, 12/10; 6A8, 6B8, 14/-.

British Manufacturers' Valves at List prices. 6X5, 6U6, 11/-; TDD4, 11/7; AC/V12, EF30, KTW61, PEN5, SP41, SP43, VP41, 12/10; 6CH3, X63, 14/-; AC/PEN, E135, PEN46, U21, 6L6, 18/3; D.1 diode, 1in. peanut valve, with valveholder, 8/- Prices include purchase tax. Please add 3d. per valve postage.

CHIME DOOR BELLS

American type. Ring with a mellow "ding-dong." Chimes 2ft. 10in. and 2ft. 6in. long. Striking mechanism, 7in. x 3in. Finished highly polished brass lacquered. **55/-**

8 to 10 volts bell transformer to suit the above, **17/6**



AMPLION ALL-DRY PORTABLE



£16.12.2

inc. Purchas Tax

SPECIFICATION:

DIAL: Full vision type. **CABINET:** Red or blue rexine. **CHASSIS:** Built in frame aerial attached to metal chassis. **VALVES:** Osram type X14, Z14, H014 and N14. **CALIBRATION:** Medium Wave, 190-550 metres. Long Wave, 700-2,500 metres. **IRON CORED COILS. BATTERY EMPLOYED:** Ever-Ready all-dry No. 3 or alternatively new B104 which is called Battery-max.

A Comprehensive Range of all types of Components are available at our Showrooms. We extend a welcome to all our customers.

(We regret owing to pressure of business, we are unable to handle C.O.D. trade).

FERRANTI TEST METERS

Complete in leather and velvet-lined case. Spec., 1,000 ohms per volt on all ranges; 600 volts A.C./D.C.; 0-750 milliamps, 0-50,000 ohms, without external batteries, up to 20 megohms, with external batteries. New and unused, complete with test prods, multipliers and instructions. **£8/16/6**



B.P.L. UNIVERSAL TEST SET

D.C. Volts.	D.C. Milliamps.	A.C. Volts
0-75 MV	0-1	0-10
0-10	0-10	0-50
0-50	0-100	0-100
0-100	0-500	0-500
0-500		

Resistance, 0-10,000 ohms. 1,000 ohms per volt on all voltage ranges. Accuracy, 2 per cent, except for lower values on the 10 volt A.C. range. Dimensions, 6in. x 4 1/2in. x 3 1/2in.

PRICE **£8. 17. 6**

VOLUME CONTROLS.—1 meg, 1 meg, 20,000 ohms, 10,000 ohms, without switch, 3/- each; 1 meg, 50,000 ohms, 100,000 ohms, with switch, 4/8.

TELEVISION LINES SCANNING OUTPUT TRANSFORMER. 12/6.

R.A.F. PORTABLE TRANSMITTERS

used but in good condition. Containing a wealth of valuable components, useful for the amateur or can easily be converted for use on amateur bands. Circuit diagrams and Parts List supplied with each instrument. Each Transmitter is complete with valves, crystal, Litz wound coils, Morse key, variable condenser, relays, portable aerial, resistors, chokes, condensers, etc. Limited quantity (approx. cost to manufacture, £39). Price, including postage and packing, **59/6**

CLAROSTATS

Genuine American Clarostats for use in American Midget Radios as means dropping resistance. Improved substitute line cord. 665 ohms, 445 ohms or 376 ohms .3 amp. **10/6**



● PLEASE NOTE ● **Dept. MO 64, 34, OSNABURGH STREET, Telephone: NEW ADDRESS: EUSTON ROAD, LONDON, N.W.1 EUS ton 8406 (4 lines)**

BRITISH PHYSICAL LABORATORIES 17 RANGE UNIVERSAL TEST SET

1,000 ohms per volt on A.C. and D.C. ranges. Toughened glass. Size 5 1/2" x 4 1/2" x 2 1/2". Ranges A.C. and D.C. volts 0/10, 0/50, 0/100, 0/500, 0/1,000. D.C. milliamps 0/1, 0/10, 0/100, 0/500. Resistance Ranges 0/1,000 and 0/100,000 ohms. Accuracy 2%. Rotary Range Selector.

Price **£8 17s. 6d.**

If unable to obtain this high grade instrument from your dealer, apply to U.K. Trade Distributors:—

RADIO AGENCIES LIMITED, 157, WARDOUR STREET, W.1. Phone: GERRARD 4456

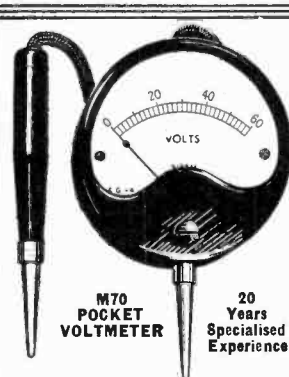

POCKET PRECISION

MODERN ROBUST CONSTRUCTION AND CONSTANT ACCURACY UNDER ALL CONDITIONS

SIFAM

ELECTRICAL INSTRUMENT COMPANY LIMITED TORQUAY · DEVON

Coil winding MACHINES

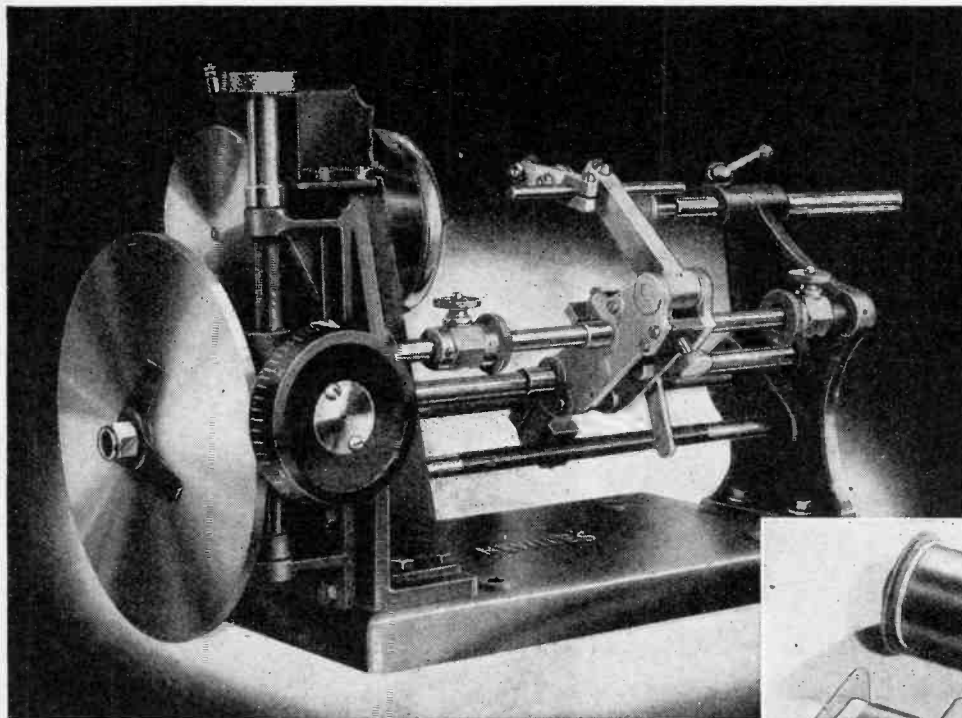

A typical selection of coils wound on the Neville's Pretoria Coil Winding Machine.

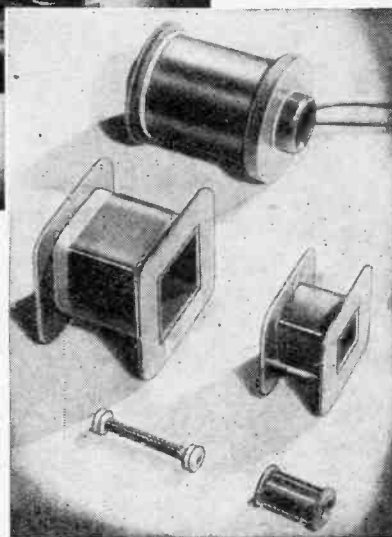

THE NEVILLE'S PRETORIA MODEL

For winding solenoid, transformer, choke and stator coils.

A bench-mounting universal automatic coil winder embodying many refinements hitherto only obtainable on expensive machines. A special foot-operated clutch gives smooth control of the winding spindle and it is possible to wind up to four coils simultaneously.

CAPACITY: Coils from 3/16" to 6" in length. Gauges of wire 22—48 S.W.G.

DIMENSIONS: The machine is 23 1/2" long, 10" wide and 12" high.

DRIVE: 1/4 H.P., 1425 R.P.M. Electric Motor.

SPINDLE SPEEDS: 400, 530, 800, 1250, 3000, R.P.M.

Write to department WD for full particulars. An experienced staff are available to give individual attention to any coil winding problems. Your enquiries are invited.

NEVILLE'S (LIVERPOOL) LTD

THE SIMMONDS TOWER · GREAT WEST ROAD · LONDON
A COMPANY OF THE SIMMONDS GROUP

Wireless World

Radio and Electronics

36th YEAR OF PUBLICATION

JUNE 1946

Proprietors:
ILIFFE & SONS LTD.

Managing Editor:
HUGH S. POCKOCK,
M.I.E.E.

Editor:
H. F. SMITH

Editorial, Advertising
and Publishing Offices:

DORSET HOUSE,
STAMFORD STREET,
LONDON, S.E.1.

Telephone:
Waterloo 3333 (50 lines).
Telegrams:
"Ethaworld, Sedist, London."



PUBLISHED
MONTHLY

Price: 1/6

(Publication date 26th
of preceding month)

Subscription Rate:
Home and Abroad
20/- per annum.

MONTHLY COMMENTARY	175
LINEAR SAW-TOOTH OSCILLATOR	
By W. T. Cocking	176
A NEW EARPIECE	
By C. M. R. Balbi	179
V-H-F COMMUNICATION EQUIPMENT	180
SUPER-REGENERATIVE RECEIVERS	
By "Cathode Ray"	182
MULTI-CHANNEL PULSE MODULATION	187
WORLD OF WIRELESS	192
THE GERMAN MAGNETOPHON	
By R. A. Power	195
INTERFERENCE PROBLEMS	198
DESIGN DATA (5).—Low-Frequency Correction	
Circuit	199
NAVIGATIONAL AIDS	201
PROPAGATION OF ULTRA-SHORT WAVES	202
LETTERS TO THE EDITOR	203
A SIMPLE OSCILLOSCOPE	
By F. P. Williams	206
SHORT-WAVE CONDITIONS	
By T. W. Bennington	207
RANDOM RADIATIONS	
By "Diallist"	208
RECENT INVENTIONS	210

Branch Offices:

COVENTRY:
8-10, Corporation Street.
Telephone: Coventry 5210.
Telegrams:
"Autocar, Coventry."

BIRMINGHAM:
King Edward House,
New Street.
Telephone:
Midland 7191 (7 lines).
Telegrams:
"Autopress, Birmingham."

MANCHESTER:
260, Deansgate, 3.
Telephone:
Blackfriars 4412 (4 lines).
Telegrams:
"Iliffe, Manchester."

GLASGOW:
25B, Renfield Street, C.2.
Telephone: Central 4857.
Telegrams: "Iliffe, Glasgow."



As many of the circuits and apparatus described in these pages are covered by patents, readers are advised, before making use of them, to satisfy themselves that they would not be infringing patents.

WE know HOW OUR SEALS WILL PERFORM



The first requirement of a seal is that it shall be a perfect seal. The second—that it shall continue to be a perfect seal for the period of its useful life.

The "STRATOSIL" sealing of Wright & Weaire VIBRATORS ensures effective operation in all situations irrespective of climatic conditions. Other principal features include: All-steel construction, Sponge-rubber lined metal can, Non-tarnishable precious metal driving contact, Contacts ground almost to optical limits, Mica and steel stack assembly.

"Wearite" Vibrators are available now for commercial purposes in both non-synchronous and self-rectifying types.

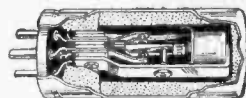

STRATOSIL Sealed VIBRATORS

W R I G H T & W E A I R E L I M I T E D
High Road, Tottenham, N.17. Telephone: TOTtenham 3847-8-9.



MULLARD

VALVES



FOR DOMESTIC RECEIVERS

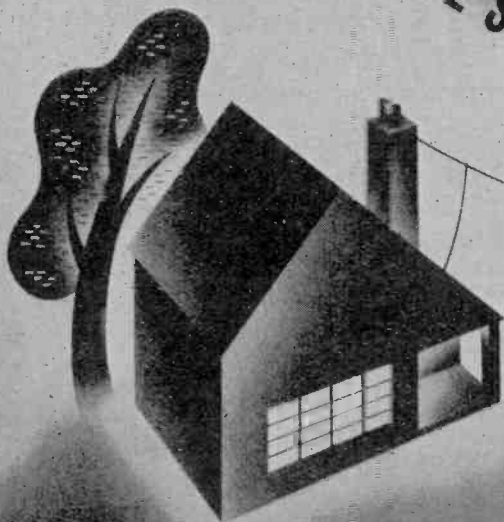

**Recommended Types for A.C./D.C.
Mains Operated Receiver.**

- CCH 35 Frequency changer.
- EF 39 Intermediate Frequency Amplifier.
- EBC 33 Detector L.F. Amplifier.
- CL 33 Output Pentode.
- CY 31 Rectifier.

Other recommended types are available for A.C., battery and portable receivers.

MULLARD THE DOMINANT NAME IN ELECTRONICS

Wireless World

Radio and Electronics

Vol. LII. No. 6

JUNE 1946

Price 1s. 6d.

Monthly Commentary

Gratitude to an Industry!

MANY warm tributes have been paid by Government spokesmen to the magnificent job which the Radio Industry did in meeting all the requirements of the Services in radar and radio equipment during the war years.

One special occasion for a formal statement of appreciation was when the President of the Board of Trade addressed representatives of the Radio Industry at a gathering held in London on the 31st August last year.

Tribute had previously been paid to the Service and Supply Departments, the Government Research establishments and the Universities, but this occasion was to make reference to the work of the many firms in the Radio Industry who had been responsible for production.

Appreciation

In the course of a survey of the fine work done by the industry, the President of the Board of Trade said:

"By the peak of the European war, a quarter of a million workers, men and women, were engaged on the production of radar and radio equipment. Some idea of the wonderful job which these men and women did can be realized when I tell you that, whereas before the war we produced in this country only a few million valves a year, in 1944—invasion year—we produced no less than 38 million valves, of 600 different types, for the three Services."

And again he said:

"As with valves, so with components. With each new development an entirely new range of components was demanded. Industry was responsible for its own development of these, and it is a great tribute to the innumerable firms concerned that even with the rapid changes in types and designs, requirements were always met."

And again:

"An industry with a wartime record such as

yours should turn to the tasks of peace with confidence."

Given confidence, the industry could tackle the changeover to peace conditions, but the confidence of the industry is being severely shaken by the conditions under which the changeover is having to be made.

Millions of radio components made during the war by the sweat and industry of those workers, to whom such tribute has been paid, are now being recklessly jettisoned by the Government on to the very market which the Radio Industry had hoped would absorb their current production and so provide full employment over the difficult period of transition to peace.

Particularly after their record of service during the war, those who earn their living in the Radio Industry ought not to be faced with a situation where the very products which earned for them such tributes should now be allowed to return, like a boomerang, and threaten their livelihood.

Nor are these components limited to British products, for quantities are of American manufacture obtained under lease-lend terms, and quite naturally our American friends decline to accept them back for disposal in their own markets.

Huge Quantities

It is only the vast quantities of these disposal components which create such a menace, for they represent in many cases the accumulation of stocks in anticipation of a long war in Europe and a still longer war in the Far East.

Is there not still time for the Government to reconsider policy in this matter and at least bring about the utilization of these components in some ordered manner over an extended period of time?

Tributes to war work of the Radio Industry have, of course, been appreciated, but what the workers of our industry look for to-day is a policy which will not deprive them of security and full employment now and in the future.

LINEAR SAW-TOOTH OSCILLATOR

Transitron Type Time-Base

ONE of the war-time radar developments^{1,2} having immediate application to both television and cathode-ray oscilloscopes is a single-valve linear saw-tooth oscillator. It is of particular interest because its performance is outstandingly good and it is at the same time both simple and economical.

In essence it is a modification of the transitron time-base which has its origins in the Numans oscillator³. After lying dormant for over a decade the principle was revived under the new name of transitron,^{4,5} but its applications were envisaged chiefly as a sine-wave oscillator using a tuned LC circuit. Its use as a saw-tooth generator⁶ was less widely realized, and it was not until 1940 that its capabilities appear to have been fully examined^{7,8}.

The war-time adaptation of it has resulted in an enormous improvement. In its present form it is really a combination of two things—the union of the pre-war transitron with the war-time Miller integrator—and although it still functions on transitron principles the details of its operation are very different.



Fig. 1. The basis of a time-base. A charged capacitor is allowed to discharge slowly through a resistor.

Since it is a combination of two circuits it is convenient to consider them separately as far as possible. The Miller integrator will be dealt with first, for this is the heart of the new circuit inasmuch as it is responsible for the linearity of the saw-tooth waveform. It is called the Miller integrator because it depends for its action upon the well-known Miller effect. That is, the effect which makes the input capacitance

By W. T. COCKING,
M.I.E.E.

of a valve ($\tau + A$) times its grid-anode capacitance, where A is the voltage amplification between the grid and anode circuits.

In the normal time-base a capacitance is charged slowly through a resistance from the H.T. supply, and then discharged rapidly through a valve. Alternatively, a capacitance is charged rapidly through a valve and then discharged slowly through a resistance. Considering this latter form, if C in Fig. 1 is charged to an initial voltage E and is allowed to discharge through R , the voltage e at any time t after the start of discharge is $e = Ee^{-t/T}$, where $T = CR$.

The voltage falls exponentially.

The slope $de/dt = \frac{E}{T}e^{-t/T}$. In

practice e is permitted to change only a small amount and for this small change the discharge is considered to be linear. Thus, if a change of slope during the discharge of 2 per cent is permissible $e^{-t/T} = 0.98$ as a minimum and $t/T = 0.02$ as a maximum. Therefore, the change of voltage across C is restricted to 2 per cent of the initial voltage on C .

For time-base purposes, a change of 40 volts across C is usually desirable, and this demands an initial voltage, and therefore an H.T. supply, of 2,000 volts. It is usually uneconomical to provide this.

The Miller integrator in the form adapted for a time-base is shown in Fig. 2; R_1 is usually very small compared with R , so that to a close approximation the valve and R_1 can be considered as a generator in series with R and C .

The action is most easily understood by starting with C charged to the full H.T. voltage and with the valve drawing some anode current, without bothering for the moment about how the capacitance is charged. The valve cur-

rent produces a voltage drop across R_1 so that the anode a is negative with respect to + H.T., — the point b . Therefore, the grid g is negative with respect to b by the sum of the drop across R_1 and the H.T. voltage. But the cathode c is negative with respect to b by the H.T. voltage. Consequently, g is negative with

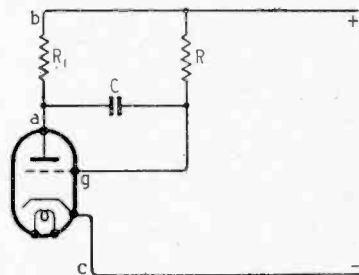

Fig. 2. The Miller integrator adapted for a time-base.

respect to c by the voltage drop along R_1 . Grid current, therefore, does not flow.

As C discharges the voltage across ag falls and so g becomes less negative with respect to c . This increases the anode current and so makes a more negative with respect to b . As V_{ag} falls V_{ba} increases (V_{ag} is the voltage by which a is more positive than g). If the two were equal the voltage V_{bg} would be constant and the current through R would be constant. This current, however, is the capacitance discharge current and a constant current flowing out of a capacitance means a linear fall of voltage across it.

This cannot be achieved for, if V_{bg} were constant, V_{gc} would also be constant and there would be no change of grid voltage to produce V_{ba} . However, by making the amplification large V_{ba} can be much larger than V_{gc} and the linearity can approach perfection.

It is not difficult to show that if A is the voltage amplification ($\approx g_m R_1$) the discharge current $i = \frac{E}{R}e^{-t/T}$ where $T = CR(\tau + A)$.

As far as current is concerned the

circuit behaves as if the capacitance were $(1 + A)$ times its actual value.

The anode voltage of the valve varies in the form

$$V_{a0} = E \{1 - A (1 - e^{-t/T})\}$$

It varies as if C were $(1 + A)$ times its actual value and E were A times the true voltage. With a screened pentode g_m may be 6 mA/V and R_1 may be 10 k Ω , making $A = 60$. Now A can easily be 250 volts, so that the effective voltage is 15,000 volts. For 2 per cent linearity, 0.02 of this or 300 volts, would be available as output but for one limitation. The maximum output must be less than the real H.T. voltage. A linear output is obtained only if the valve is acting as a linear amplifier. The maximum possible output is about 80 per cent of the real voltage, and to give a factor of safety it should be rather less than this figure.

When acting as a self-oscillator, the output obtainable is further restricted by the transitron action and is about 20 per cent of the H.T. voltage. For a 250-volt supply the output is about 50 volts, but for this 50 volts the linearity is as if 15,000 volts were acting in the circuit.

The distortion is therefore only $\frac{50 \times 100}{15,000} = 0.3$ per cent.

Using a pentode, only the control grid, cathode and anode are needed for this linearizing action and the screen and suppressor grids are available for other use.

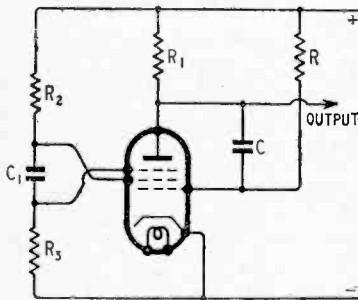

Fig. 3. The combination of the Miller integrator with a transitron gives a linear saw-tooth oscillator.

If they are resistance-capacitance coupled a transitron-type circuit is formed and a self-oscillating linear

time-base is obtained. The circuit is shown in Fig. 3.

The action depends upon the ability of the suppressor G_3 to control the ratio of the anode and screen currents. If the potential of G_3 is changed negatively from zero it reduces anode and increases screen current, slowly at first and then quite rapidly. At zero volts the anode current might be 10 mA and the screen current 2.5 mA. When G_3 is very negative, however, the anode current may be zero and the screen current 10–12 mA.

To a first approximation the cathode current is independent of the potential of G_3 and this electrode acts to control the division of the current between G_2 and anode.

Now consider Fig. 3 at an instant when C is fully charged and the valve is conducting. At this time G_3 is at or near cathode potential and the screen current is at its minimum. The voltage on G_2 is thus a maximum. The valve then functions more or less normally as an amplifier linearizing the discharge of C in the manner already described.

If the potentials of G_2 and G_3 were constant the action would be identical, but because the G_1 potential is changing positively, the G_2 current is increasing. This means the potential of G_2 is falling. The potential of G_3 does not follow this change of voltage of G_2 at all well, however, for the time-constant C_1R_3 is much less than $CR(1 + A)$.

The main effect, therefore, is rather like that of a pentode amplifier without a screen-grid by-pass capacitor, and a form of negative feedback occurs reducing the amplification somewhat.

As this process goes on the total cathode current is increasing as well as the individual anode and G_2 currents, but the ratio of anode to screen currents is substantially constant. Now R_1 and R_2 are of the same order of magnitude, therefore, the voltage change at the anode is greater than that at the screen and at length the anode potential drops to such a degree that its field acting through G_3 is no longer sufficient to collect the normal proportion of electrons passing G_2 . These consequently fall back to G_2 and

increase its current, thus dropping the G_2 voltage.

This change of voltage is passed to G_3 through C_1 and makes it negative. This further reduces anode and increases G_2 current, and so makes G_3 still more negative. The action is cumulative

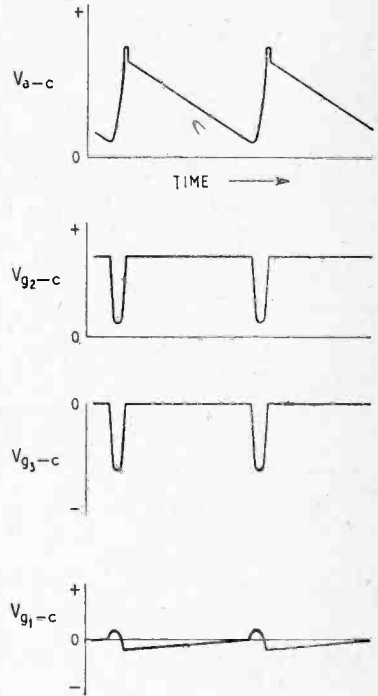

Fig. 4. Voltage waveforms on the various electrodes of the valve in the circuit of Fig. 3.

and there is a very rapid transition to the flyback state with anode current cut-off, the G_2 current a maximum and its voltage a minimum and G_3 highly negative.

As anode current is cut-off, there is no voltage drop across R_1 . The voltage across C is less than that of the H.T. supply, consequently G_1 is positive with respect to cathode and C now charges rapidly from the H.T. supply through R_1 and the G_1 -cathode path of the valve. This positive G_1 potential tends to increase the G_2 current and so reduce the G_2 potential further and make G_3 still more negative.

The time constant C_1R_3 is finite and G_3 cannot remain negative indefinitely. It is, however, larger than the discharge time

Linear Saw-tooth Oscillator— constant, comprising only C , R_1 and the grid-cathode resistance of the valve. When C is nearly fully charged the G_1 grid potential becomes nearly zero and reduces the G_2 current. There is a rise of G_2 potential and also of G_3 .

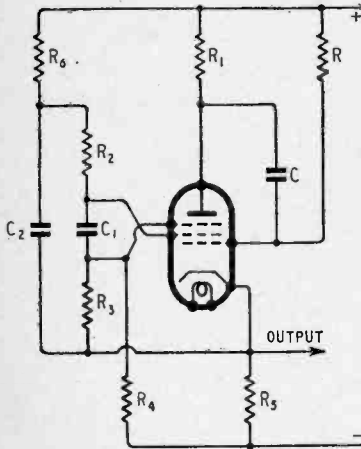

Fig. 5. Circuit giving a positive-going saw-tooth output at the cathode.

The anode potential is also substantially at the full H.T. voltage. The rising G_3 potential thus permits the anode to draw current again and so reduces the G_2 current. This makes the G_2 potential rise further and so G_3 goes still further in the positive direction. Again there is a cumulative action and a very rapid change-over to the initial condition of G_3 at about zero volts and G_2 at its maximum.

The various voltage waveforms are sketched in Fig. 4, and well illustrate the action. Synchronization can obviously be effected by applying a negative-going pulse to G_2 or G_3 at a time prior to that at which the discharge would naturally occur.

The writer has used the circuit of Fig. 3 at 50 c/s with a TSP4 valve. With a 220-volt H.T. supply an output at the anode of about 40 volts is obtainable with $C = 0.02 \mu\text{F}$; $C_1 = 0.01 \mu\text{F}$, $R = 4 \text{ M}\Omega$, $R_1 = R_2 = 10 \text{ k}\Omega$, and $R_3 = 0.5 \text{ M}\Omega$. R should be variable as a frequency control. A variable output can be secured at low-frequencies by making R_1 a potentiometer, and taking the output from the slider.

The fly-back time is governed mainly by the value of C and can be increased by reducing this capacitance while increasing R to keep the product constant. The above values give a scan-to-flyback ratio of the order of 10 : 1. The TSP4 is not essential and the EF50 should be equally suitable.

In many cases the fact that the output is a negative-going saw-tooth is a disadvantage of the circuit. A positive-going output can be obtained from the cathode, but only about one-half the output can be secured. In addition, the G_2 circuit must be decoupled to cathode.

The arrangement of Fig. 5 is satisfactory at 10 kc/s with $C = C_1 = 100 \text{ pF}$; $C = 0.1 \mu\text{F}$; $R = 4 \text{ M}\Omega$, $R_1 = R_2 = R_3 = 10 \text{ k}\Omega$; $R_4 = 0.5 \text{ M}\Omega$; $R_5 = 1 \text{ M}\Omega$; $R_6 = 20 \text{ k}\Omega$. A TSP4 was again used and an output of about 20 volts amplitude secured at the cathode.

The two grid leaks to G_3 may seem a little peculiar. This is really only a way of obtaining the effect of a single grid leak returned to a tapping on R_5 . It was found necessary in order to make the oscillator self-starting. With only R_3 present the circuit required an

initial kick to make it start, but once started it worked well. When R_4 was added, however, it started oscillating without difficulty.

The cathode output is limited by two factors. The first is that R_6 is virtually in parallel with R_5 as far as voltage changes are concerned, but they are in series for direct current. If the voltage on G_3 is to be high enough for satisfactory transitron action, therefore, the values of both R_5 and R_6 are limited. The second factor is R_1 ; at least one-half of the total output of the valve is developed across this resistance and must be if good linearity and transitron action are to be secured.

BIBLIOGRAPHY

- 1 "Radar Circuit Technique," *Wireless World*, May 1946. Vol. LII.
- 2 I.E.E. Radiolocation Convention Papers.
- 3 "The Numans Oscillator," by K. C. Van Ryn, *Experimental Wireless* (now *Wireless Engineer*), December 1924. Vol. 11, p.134.
- 4 "Negative Resistance and Devices for Obtaining it," by E. W. Herold, *Proc. Instn. Rad. Eng.*, October 1935. Vol. 23, p. 1201.
- 5 "The Transitron Oscillator," by C. Brunetti, *Proc. Instn. Rad. Eng.*, February 1939. Vol. 27, p. 88.
- 6 "Trigger Circuits," by H. J. Reich, *Electronics*, August 1939.
- 7 "Single-valve Time-base Circuit," by B. C. Fleming-Williams, *Wireless Engineer* April 1940. Vol. XVII, p. 161.
- 8 "Versatile Oscillator," by W. T. Cocking, *Wireless World*, September 1940. Vol. XLVI, p. 390.

BUSH EXPORT RECEIVER

NO fewer than eight wave-ranges are covered by this Bush export receiver, Model E.B.S. 84, which has band-spread tuning on the 13, 16, 19, 25, 31, and 41 metre bands. The usual medium - wave range is provided and there is an "intermediate" wave-range covering 48-150 metres. On the bandspread channels an R.F. amplifier precedes the frequency changer, the oscillator section of which includes negative temperature coefficient condensers to compensate for warming-up drift. The vertical illuminated scale is marked with station

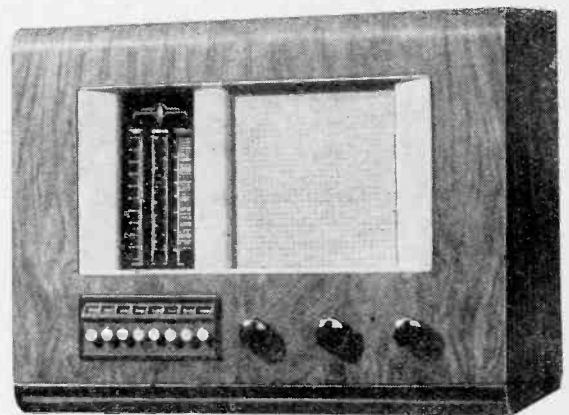

names on the medium-wave band, metres and megacycles in the "intermediate" band, and an arbitrary 100-division scale on the band-spread ranges. The output power is 3.5 watts from a pentode.

A NEW EARPIECE

Hermetically Sealed Crystal Drive with Inertia Control

By C. M. R. BALBI

THE miniature earpiece is an essential feature of hearing aids and "personal portable" radio receivers. The two simple requirements are:—

(1) That it shall be small, light and inconspicuous, and not need any support such as a headband; (2) it shall not be affected by conditions in the ear so that it cannot be clogged by moisture or wax.

A promising line of research for such a device offered itself in a method for the direct stimulation of the auditory nerve by direct electro-telephonic impulses,¹ but this was thoroughly investigated by the author in 1943 in conjunction with Dr. Craik at the Physiological Laboratories, Cambridge, and it was found that although the system required no more than a small electrode in the ear it was fundamentally impossible to transmit sounds of sufficient intensity without discomfort to be of any practical value.

The conclusion was that the only method available for the transmission of sound was by mechanical stimulation.

From this con-

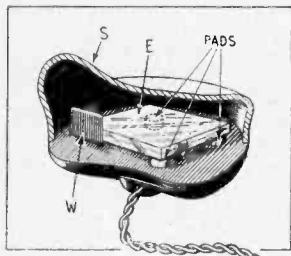

Fig. 1. Diagrammatic section of the "shell" earpiece.

clusion the author commenced to develop the "shell" earpiece which was to have the characteristics enumerated. The shell was made to fit the pinna of the ear, which is the part contained by the lobe, so that the device was seated within the ear in the manner of an ear plug. In this form there is no tendency for it to become dislodged.

The shell was made in plastic, in which no orifice occurred, and is therefore proof against moisture or wax, and can, if necessary, be washed and wiped clean with a handkerchief.

The next problem was to find a mechanism small enough to get it to work efficiently as a telephone. The author having also been responsible for bone conduction in 1919 chose the principle of inertia control and applied it to this air conduction receiver, the feature of which is that it has no diaphragm.

In the design shortly to be produced by Cosmo-cord, Ltd., of Enfield, the complete receiver weighs about 5 grams, and a piezo-electric crystal (E in Fig. 1) drives the shell S through rubber pads react-

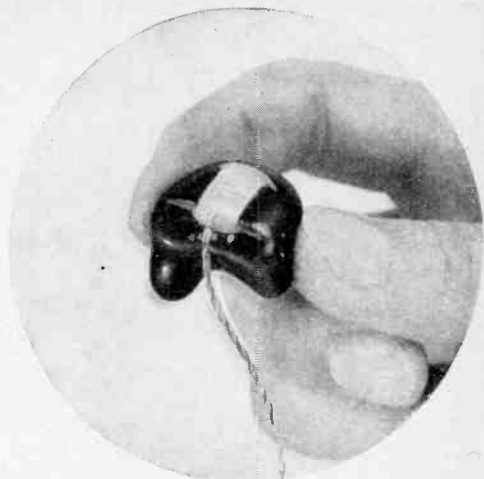

ing against the weight W. It can be shown theoretically that there are two main resonances in the system which are determined by the elasticity of the contact between the shell and the ear and the mass of the shell, and the other by the elasticity of the pads and the small weight attached to the crystal at one corner. The response of the earpiece may be varied considerably by the alteration of these several factors.

The efficiency of this new earpiece is high, although it may be lower by 10 or 15 db than a sensitive air-conduction earpiece many times its size,² and it is comparable in sensitivity with the miniature receivers now commonly used for hearing aids. The response characteristic of a shell earpiece in terms of frequency response in db above one bar per volt is shown in Fig. 2, as taken on an artificial ear, but it should be noted that in making such tests the compliance of the material supporting the shell must be comparable with that of human flesh, otherwise totally spurious results are obtained.

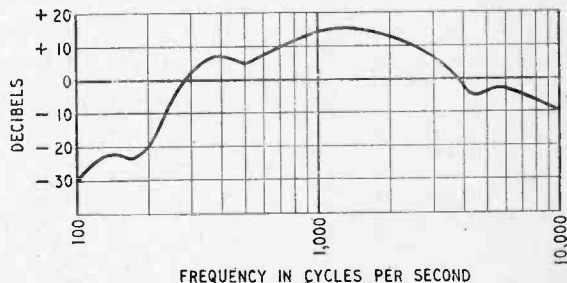

Fig. 2. Response curve measured electrically with an "artificial ear." Zero level corresponds to 1 bar per volt.

Because this receiver has a high upper frequency response, defects such as harmonic distortion are readily detected which would not be apparent to the ear when an inferior type of earpiece is used. Hence when a comparison of earpieces is being made, a high-grade amplifier should be used.

¹ *Electrical Review*, Oct. 28th, 1932, page 636.

² 15 volts gives a working level of 110 db above threshold; 25 volts is about the maximum safe voltage.

V-H-F COMMUNICATION EQUIPMENT

Transmitters and Receivers for Mobile and Fixed Stations

SOME details have now become available of the transmitters and receivers used in the multi-carrier system of communication described in our February, 1946, issue. All the equipment illustrated there was developed by the General Electric Company and those same transmitters and receivers are at present being used by police and fire services in many parts of the country for two-way telephone communication with patrol and staff cars. So far, however, these installations employ the more orthodox single transmitter.

In the diversity system described three different types of transmitters were used, these being rated at 7,30 and 100 watts power output respectively.

With the exception of the power supply arrangements all these transmitters are identical. For mobile work high tension is obtained from a rotary transformer and the whole installation draws its power from the car battery. At fixed stations, however, these voltages are more conveniently taken from the supply mains.

Low-power Transmitters

The mobile seven-watt transmitter, Type 7C, and its fixed-station counterpart, 7D, employ one type of valve only for all the radio-frequency stages—the Marconi-Osram DET19 twin triode. In the first stage one triode functions as a crystal oscillator with provision also for frequency doubling, while the companion triode gives a further doubling of the frequency. In the two following stages the valve is used with a push-pull input circuit and parallel output circuit and in each case it functions as a frequency doubler.

Transmitter Type 100A and a receiver assembled in adjacent racks for a headquarters station and for local control.

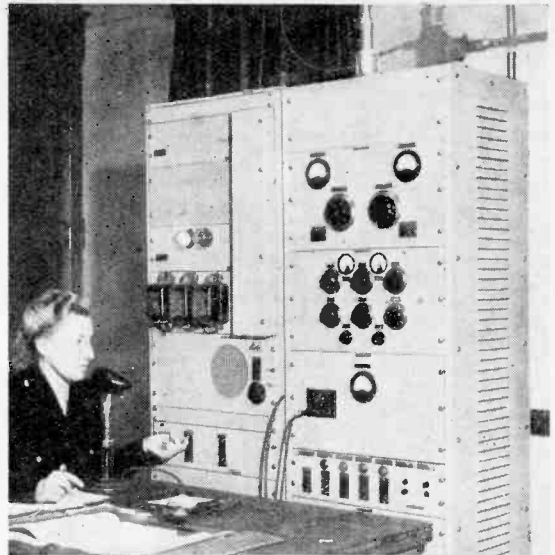

Up to this point the crystal frequency will normally have been multiplied sixteen times, being of the order of 100 Mc/s. The final stage, using another DET19, functions as a Class "C" push-pull R.F. amplifier anode modulated by a KT66 valve and a carbon microphone.

When operation between 30 and 64 Mc/s is required fewer doubling operations take place and the eighth harmonic of the crystal is employed. Under these conditions the oscillator section of the first DET19 does not double the frequency. From 64 to 131 Mc/s the output is on the sixteenth harmonic.

The Type 100A transmitter, supplying 100 watts of modulated R.F. power to the aerial, is installed at all the fixed sites in the multi-carrying system and at the majority of the headquarters stations in the single-carrier installations. It provides for operation on M.C.W. telegraphy, on telephony, or from a gramophone pick-up and it is fully equipped for remote control, either by line or by radio links if necessary. The modulating equipment is of sufficiently high gain to permit the use of a moving-coil microphone.

Built in rack form, it comprises six main units; the R.F. power amplifier, R.F. driver unit, modulator unit, control panel, modulator supply unit and the R.F. power supply unit.

The R.F. driver panel of the Type 100A can be employed as a 30-watt transmitter when used with scaled-down modulator and power supply units.

Pre-tuned Receivers

All the receivers used in the various installations have the same chassis and they differ only in the nature of the auxiliary equipment. For some headquarters stations the receiver chassis is assembled in a steel cabinet containing a mains-operated power unit and a loudspeaker. The same combination is also available in rack-mounting form, with or without the loudspeaker, whilst for mobile work the chassis, loudspeaker, and rotary supply units are separated.

The receiver is a 10-valve superheterodyne; as it is designed for pre-tuned operation, an extremely compact layout has been possible. The only controls are on-off switches, the H.T. and L.T. supplies having separate switches, and these can be located in the most convenient positions according to the type of installation. In the mobile equipment, for example, the receiver is generally in the luggage boot of the car, while the controls are grouped on a small dashboard panel.

The circuit consists of one signal frequency amplifier, in which is fitted a special V.H.F. pentode, the Z90. This valve is

used also in the mixer stage and for the second frequency multiplier of the two-valve crystal-controlled local oscillator.

Following the mixer is a three-stage I.F. amplifier operating at about 9Mc/s, and for normal pre-tuned radio telephony it is adjusted for a band-width of

approximately 100 kc/s. A twin-diode acts as a series-shunt noise limiter, while a double-diode-triode combines the functions of second detector, A.V.C. rectifier and first-stage audio amplifier. This is followed by a pentode output valve feeding a loudspeaker.

A receiver of this design is

capable of very high overall sensitivity, even at the high working frequency of 130 Mc/s, and the G.E.C. Model is no exception. Its test specification requires that for 50 milli-watts output the signal input must not exceed $5 \mu\text{V}$ at any frequency and with 30 per cent. modulation.

CORNER DEFLECTOR Baffles

THE problem of providing a baffle of adequate dimensions in the average living room has been solved in the "Dynamic Infinite Baffle Corner Deflector," made by Broadcast Acoustic Equipment Co., Tombland, Norwich, by using the walls of the room itself as elements in the combined horn and baffle system. The loudspeaker unit is contained in a rigid plaster casting shaped to give two outward radiating paths of logarithmically increasing section and a diffuser is incorporated to give even distribution of high frequencies. The back radiation from the cone is conducted to a small bass chamber inside the moulding, from which a small triangular hole in the angle of the walls gives access to the open air. A useful feature of this arrangement is the possibility of experiment with acoustic labyrinths of different length formed by the simple expedient of placing a stout board across the angle of the wall as indicated by dotted lines in the photograph.

The 12-inch loudspeaker units supplied with these baffles are of good quality with cast frames, detachable diaphragms and Ticonal magnets, and are available with single- or twin-cone diaphragms. The power handling capacity is 15 watts.

We have had an opportunity of hearing one of these baffles, and the results are very good. There is ample bass response, and the unit delivers its full rated power without any signs of overloading. It is also above the average in electro-acoustic efficiency. The single-diaphragm unit gives all the top necessary for gramophone reproduction and the majority of broadcast programmes, but the twin diaphragm would no doubt show to advantage on some local-station transmissions.

The price of the baffle is £6 10s, and the loudspeaker units cost £7 10s for the PM/15, and £8 15s for the PM/15/HiFi model with twin diaphragm.

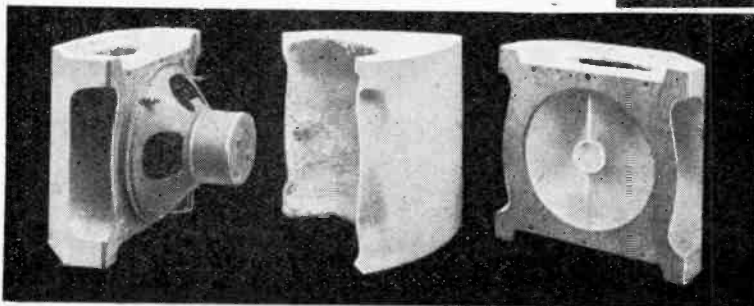
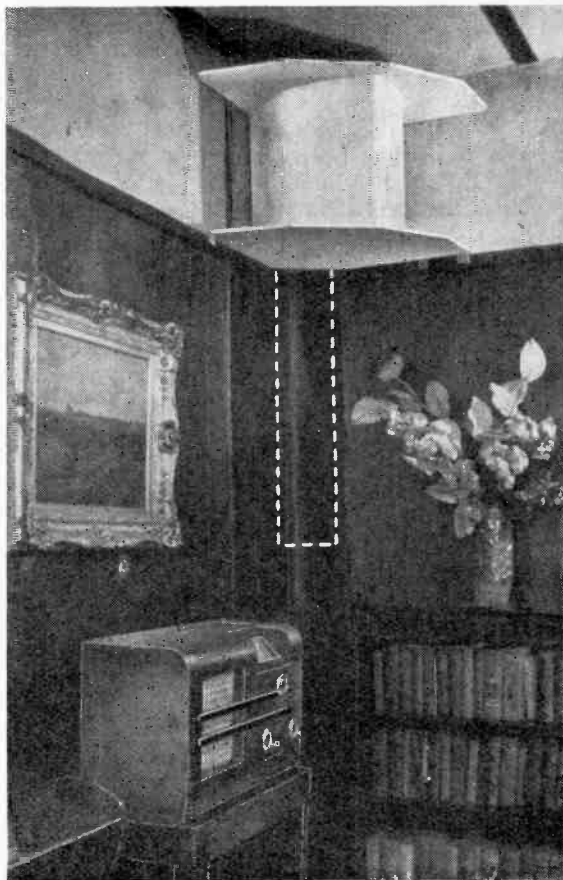

"Dynamic Infinite Baffle Corner Deflector" mounted in the corner of a room. The dotted lines indicate the possibility of extending the length of the air column behind the diaphragm by means of a board.

Component parts of the deflector showing diffuser for high frequencies and relief holes for the back radiation are shown on the left.

SUPER-REGENERATIVE RECEIVERS

A Re-assessment in the Light of Recent Developments

ONE can hardly expect anything, I suppose, to keep on being sensational for 24 years, but it does seem to me that the super-regenerative receiver deserves rather more publicity than it gets. Its performance really is sensational. A good single-valve super-regen is as sensitive as almost any receiver can be, regardless of the number of valves. So far from falling off at the ultra-high frequencies, it works better. It includes automatic gain control that would need a multi-valve superhet to equal. On top of all that, it deals effectively with interference of the motor ignition type that is so troublesome on the television waveband.

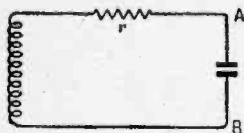

Fig. 1. Simple tuning circuit, in which r represents the effective resistance. In a super-regenerative receiver, r is made to alternate rapidly between positive and negative.

From the fact that the manufacture of all other types of receiver has not ceased, you are correct in deducing that the super-regen has snags. Those usually held up against it are (1) lack of selectivity, (2) noisiness, (3) radiation, and perhaps (4) uncertainty or freakishness of results. All of these can be largely or entirely overcome. The real objections, to my mind, are (a) that its performance, which is best at the very high frequencies (where other types of receiver tend to fail), falls off at the lower carrier frequencies, and (b) likewise at high modulation frequencies; and (c) that it distorts deep modulation rather badly. (a) and (c) knock it out for broadcast reception, and (b) for television. So to the man in the home the super-regen is not "news." It didn't even get much credit for its war service as

By "CATHODE RAY"

the heart of the most-produced radar equipment—I.F.F. and beacons—as well as in innumerable "walkie-talkies." Incidentally, its use for I.F.F., where the utmost stability and reliability was essential, disposes of objection (4) on the above charge sheet. There are many other jobs at which the super-regen could be usefully employed if it were better known and understood.

The trouble is that, although the super-regen circuit is simple in appearance and (up to a point) in theory, attempts to produce anything like a comprehensive theory of its action have invariably led to the most appalling mathematics, with each authority arriving at an entirely different and often contradictory result. So the practical man, finding it hopeless to think of designing a super-regen on a rational basis, has tackled it by trial and error, has unleashed a variety of noises and obscure effects unrivalled in any other branch of the art, and in disgust has made a superhet instead.

One reason for this state of things is that the super-regenerative receiver works in quite a different way from any other sort, superficial resemblances notwithstanding. Another reason is that its performance depends on so many variable quantities that it would be an endless job to give a complete account of all the possible combinations; so anyone who sets out to analyse it has to make some assumptions. Different authorities have made different assumptions; hence the conflicting results on record. This is not very encouraging for the ordinary reader, so what I am going to try to do is to give a reasonably simple account of how it works, the conditions that give the best results, and some practical suggestions.

We begin with a simple tuned circuit, Fig. 1. The resistance r is not usually there as a visible

component; it represents the unavoidable losses, chiefly in the coil. When a signal voltage arrives, Fig. 2(a), of the frequency to which the circuit is tuned, it builds up a comparatively much greater voltage, Fig. 2(b), across AB, which is then applied to the input of an amplifier, etc. The number of times greater is denoted by Q . For an average sort of tuned circuit by itself, Q is of the order of 100. When the signal stops, the voltage across AB dies away as shown.

Reducing r increases Q and also the amount of the build-up and the time taken to die away. By the use of reaction, r can be reduced to zero and even made negative. What happens then is that any voltage, however small or short-lived, starts oscillation at the natural frequency of the tuned circuit, and the oscillation continues to grow, in the manner shown at the left-hand side of Fig. 3(a), until something happens to reduce the negative r to zero. That something is generally the valve being driven to the limit of amplitude that it can handle. After that, the oscillation

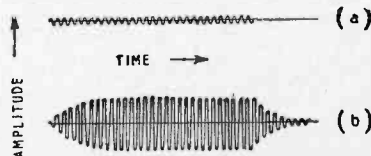

Fig. 2. If r in Fig. 1 is positive, the arrival of a signal voltage (a) in series with the coil causes a magnified voltage (b) to build up across AB. When (a) stops, (b) dies away gradually. This is the normal unassisted behaviour of a tuned circuit.

tion continues steadily at constant amplitude, as shown from the time marked l onward. In practice, of course, the pre- l and post- l phases are not so clear-cut, but merge into one another.

The way the oscillation grows while r is at a constant negative value is the same as that by which money grows when subject to compound interest; each cycle

is a certain percentage larger than the preceding one. The percentage depends on r ; the greater the negative r the greater the percentage growth, and the quicker the

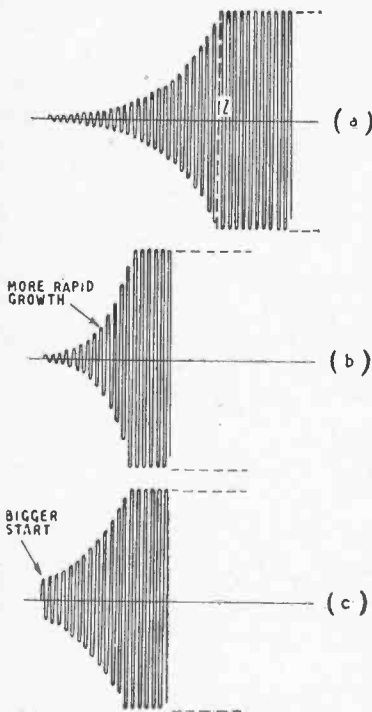

Fig. 3. When, with the aid of a valve and positive feedback, r in Fig. 1 is made negative, oscillation builds up (a) until, at l , it is checked by the valve reaching its limit. Either a greater negative r (b) or a bigger start (c) makes oscillation reach the limit sooner.

oscillation will reach its limit from a given start, Fig. 3(b). Another way by which the limit can be reached in a shorter time is by giving a bigger start, as in Fig. 3 (c) (which is just (a) with the first few cycles omitted). Relative to Fig. 3(a), (b) shows the result of a higher rate of interest, and (c) the result of investing a larger capital. Some numerical examples may help to make it clear:—

Percentage increase per cycle	Initial signal (microvolts)	Number of cycles to reach limit amplitude, say 5 volts
5	5	283
10	5	145
5	10	269
5	10,000	127

Fig. 3 is the key to super-regenerative action. Armed with it, we can tackle a receiver circuit, Fig. 4. Apart from the quench oscillator, this is a very simple 1-valve receiver with reaction. Assuming reaction is adjusted to the edge of oscillation (as it generally is in 1-valve receivers), r is almost zero, and a substantial increase in anode voltage will bring it well into the negative region, while an equal reduction will bring it well into the positive region. That is precisely what the quench oscillator does alternately, at a frequency which must be much less than that of the R.F. carrier wave, but greater than that of any modulation of the carrier. The precise frequency to adopt, within these limits, is one of the great super-regen controversies.

Another thing that has a profound effect on the performance (and accounts for many of the discrepancies between different treatises on the super-regen) is the waveform of the quench oscillator. Although not at all typical of actual practice, a square wave is the simplest for explanation. Consider, then, what happens when the quenching wave, Fig. 5(a), goes through its cycle, beginning with the negative half, which keeps the valve well off the oscillation point.

There is no incoming signal, shall we say; so the only voltages present in the tuned circuit

Fig. 4. Simple super-regenerative receiver circuit.

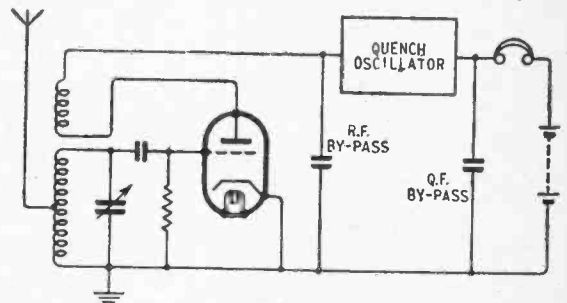

are the very small ones due to random motion of electrons, called inherent circuit "noise," of the

order of a microvolt. These are completely irregular, and only a very small proportion occur at the frequency of the tuned circuit, which consequently is very little excited by their presence. What we have, then, is a very small and very erratic oscillation in the tuned circuit.

When the quenching oscillator clicks over to its positive half-cycle, oscillations begin to build up, starting at the level at which by pure chance the noise voltage happens to be just then. Whether they will reach the limit during the half-cycle depends on (1) the noise voltage at the start; (2) the rate of growth (which in turn depends on the quenching amplitude and other circuit conditions); (3) the limit amplitude; and (4) the number of R.F. cycles in one Q.F. half-cycle (i.e., the ratio of radio frequency to quench frequency). This is where one begins to see that the problem may soon get out of hand; but there is no need to take fright just yet. In a given receiver, (2)-(4) are all fixed, and it is easy to see that in order to ensure even the smallest voltage building up to the limit in every quenching cycle it is only necessary to make the Q.F. low enough. Let us do that, then.

Oscillation continues at the limit for the rest of the half-cycle,

after which r is made positive again. Just as the rate of growth was proportional to the negative value of r , so the rate of die-away depends on the positive value. Assuming the two are roughly equal, the oscillation may be expected to have died down to noise level before the next de-quenching half-cycle begins. When it does, the noise voltage at that instant will in general be different from what it was at the

Super-regenerative Receivers— start of the previous (or any other) dequenching half-cycle; so the build-up will be quicker or slower accordingly.

Any sound that is heard in the phones is produced by the cur-

super-regenerating, regarded as programme material fails to grip the attention for long; so we next consider what happens when a carrier wave is tuned in. If this carrier wave is unmodulated, and much stronger than the noise, the

or roughly a lump of gold as big as the whole world for every 10 seconds through all those years. As the super-regen amplifies on the same principle, a phenomenal gain is only to be expected. Its voltage amplification is limited at one end by the size of the smallest possible voltage (i.e., noise) and at the other by the power-handling capability of the valve, and is of the order of a million. That is assuming the oscillations have time to build up to the limit. The lowest Q.F. that does not cut into speech frequencies is, say, 10,000 c/s, so half a cycle lasts 50 microseconds. Judging from the examples already worked out, it looks as if we ought to allow for several hundred R.F. cycles in this time; say 500. That puts the lowest R.F. for most effective performance at about 10 Mc/s (30 metres wavelength). The lower the R.F., the stronger should be the quench oscillation, in order to build up within the limited number of R.F. cycles.

On the other hand, if the R.F. is very high and/or the quench is very powerful, it is better to increase the Q.F., in order to get more build-ups into a given time. The Q.F. giving the most amplification is that which just allows time for full build-up and die-away in each of its cycles.

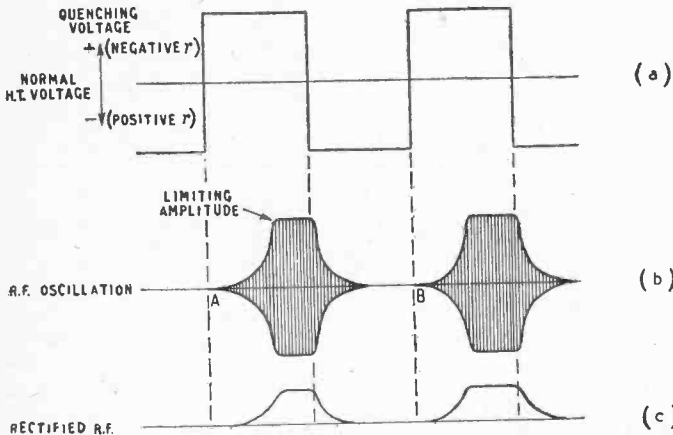

Fig. 5. Application of a square quenching wave (a) causes R.F. oscillations to build up and die away as at (b). The R.F. is rectified in the super-regen valve giving unidirectional pulses (c), and it is the variation in the size of these that is audible. For example, the second one shown here is larger than the first, indicating that the signal at B must have been stronger than at A.

rent, indicated in Fig. 5(c), due to rectification of the bursts of R.F. If these bursts occurred at an audible frequency they would, of course, produce a loud note of that frequency. But they occur at Q.F., which we have assumed (for one reason which is now clear) to be higher than audibility. The sizes of the bursts are varying, however, according to the noise voltages that happen to exist at the moments when the quench voltage goes from negative to positive. In Fig. 6, OADE represents a rectified burst following the least possible noise voltage, and OBDE one following the greatest noise voltage; so the maximum variation in size is as shown shaded. As the variations within this maximum are erratic, a completely formless sound, like gramophone record scratch, is heard. It indicates the enormous amplification of the super-regen, for there are few superhets, even, that amplify enough at very high frequencies to reveal circuit noise so strongly.

However, this sound, interesting theoretically, and useful for indicating that the super-regen is

starting voltage is practically the same at every quench cycle, so every burst is the same size (say, OCDE in Fig. 6) and no sound is heard. When the carrier wave is modulated, the sizes of the bursts are made to vary at audible frequency.

If you have read "Pulse Modulation" in the April issue you will agree that the super-regen process is remarkably like pulse length modulation. The super-regen valve generates R.F. oscillations; the quench oscillator generates fat pulses which modulate the R.F. into what I call wave pulses; the incoming signal modulates the effective length of the wave pulses; and the super-regen valve demodulates the modulated wave pulses, extracting the modulation frequency.

I hope the fog has now cleared away sufficiently to reveal the reasons for most of the peculiarities of the super-regen:—

(1) *Sensitivity.* If a tenth of a penny had been invested at 5 per cent per annum compound interest in the year 1 A.D. it would to-day have grown to

£100,000,000,000,000,000,000,000,000,000,000,000,000,000,000,

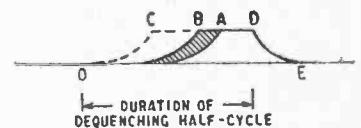

Fig. 6. When only "noise" is stimulating the receiver, the size of the rectified pulses varies to a certain extent, shown shaded. A relatively strong R.F. signal brings it, say, to C. Growth starts at O every time, but with a weak start is not big enough to show in a diagram until some way towards E.

(2) *A.G.C.* The numerical examples showed that a 1,000-fold increase in signal input only reduced the number of build-up cycles from 269 to 127. Let us elaborate this a little. It is the variations in signal strength, due to modulation, that are effective in producing audible output. Those variations can be measured

by the variations in the number of cycles necessary to build up to the limit. Let us suppose both signals in question are modulated 50 per cent, as follows:—

Modulated carrier wave voltage	Number of cycles to build up to 5 volts, at 5 per cent per cycle
Average $10\mu\text{V}$ { min. $5\mu\text{V}$ max. $15\mu\text{V}$	$\left. \begin{matrix} 283 \\ 260 \end{matrix} \right\}$ difference = 23 cycles.
Average $10,000\mu\text{V}$ { min. $5,000\mu\text{V}$ max. $15,000\mu\text{V}$	$\left. \begin{matrix} 142 \\ 119 \end{matrix} \right\}$ difference = 23 cycles.

So these signals of vastly different strength, when equally modulated, give exactly the same output! A.G.C. action is therefore theoretically perfect. In prac-

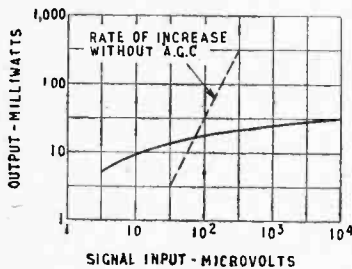

Fig. 7. Actual input/output curve of a typical super-regen receiver, showing A.G.C. characteristics with 30 per cent modulation. The dotted line, for comparison, shows the characteristic of a receiver without A.G.C.

tice it is not exactly so, because the non-linearity of the valve upsets the compound interest law slightly, and also very weak signals have to compete with noise. Fig. 7 is an actual measured input/output curve.

(3) *Noise*. The origin of the characteristic rushing sound of super-regeneration, and the reasons why it disappears when a relatively strong carrier wave is tuned in, are, I hope, now clear. But suppose the Q.F. is increased, or its amplitude on the negative side reduced, so that oscillations have not time to die away, but are still several times stronger than the noise voltage when the next positive Q.F. half-cycle is due to begin. Then the starting level will be this constant oscillation voltage rather than the erratic noise voltage; and the characteristic sound will be absent. That may be hailed as an advantage; on the

other hand, when the receiver is tuned through a carrier wave its self-oscillations will cause whistles by beating with the carrier. The situation is even more compli-

cated, because as the tuning is varied the oscillations produce audible stroboscopic effects with multiples of the quench frequency, rather like the strange behaviour of the wheels of moving vehicles seen in the cinema. Without going into all the gruesome details, you may be able to see that there is plenty of basis for the weird effects obtainable with super-regen receivers. The surest way to keep clear of them is to keep the R.F. high and the Q.F. low.

(4) *Interference Suppression*. Interference of the "click" type, caused chiefly by motor ignition systems, is generally the most prevalent on the V.H.F. waveband, for which the super-regen is most suitable; and electrically it consists of very intense but short-lived and isolated pulses. Looking at curve OCDE in Fig. 6, representing a quench cycle during reception, any clicks during the period CD find a receiver already saturated with oscillations of maximum intensity, and therefore practically dead to outside influences. During DE the oscillations are being suppressed. Just at O the receiver is extremely sensitive, but the chance of a click happening exactly then is very small. From O to C the effect produced by interference gets less and less. It is fair to say, then, that most of the interference is suppressed, and very few of the clicks get through with any serious strength.

(5) *Distortion*. Putting together figures we have already had, we see that a 10,000 microvolt signal growing at 5 per cent per cycle builds up to 5 volts in 127 cycles, and that when modulated to a depth of 50 per cent the positive peaks advance the build-up by 8 cycles while the negative peaks

retard it by 15 cycles. The output modulation wave will therefore be lopsided, and the distortion rapidly grows worse as the depth of modulation is increased. It is good enough for intelligible speech, however, if the modulation is kept within about 80 per cent, but rules the super-regen out for high-quality reproduction.

(6) *Selectivity*. With the square quenching wave we have been assuming, the build-up time is determined by the amplitude of whatever is in the input circuit at the moment of dequenching. The selectivity is therefore no better than that of the single tuning circuit under quench conditions; that is, it will be just about as poor as with one tuned circuit and no reaction. That may not be at all a bad idea in the V.H.F. or U.H.F. bands, where searching with a highly selective receiver is like looking for the proverbial hay-shrouded needle. But to refute the charge that this very low grade of selectivity is the best the super-regen can offer, it may be pointed out that there are other ways of organizing it. If the quenching voltage, after it has had time to suppress oscillation, is eased off so that for a little while before the dequench point the circuit is near the edge of oscillation, signals of exactly resonant frequency are built up by the ordinary reaction process and are all ready to kick off oscillation

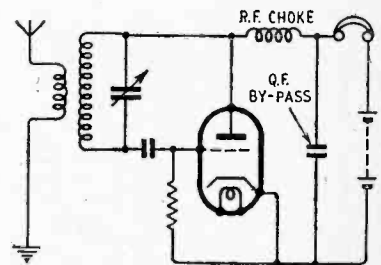

Fig. 8. Flewelling, or self-quenching, super-regen circuit.

with a flying start, whereas off-tune signals and noise are not thus pre-amplified. Selectivity and signal/noise ratio can be improved in this way by using a sine wave quench (which anyway is more natural than a square one) of the lowest possible Q.F. (already recommended), and the minimum quench voltage and

Super-regenerative Receivers— maximum reaction that will work properly. Instead of clicking suddenly over from high positive r to high negative r , as it does with a square quenching wave, the circuit spends more of its time with r near zero.

(7) *Radiation.* It is obvious that the Fig. 4 circuit will radiate furiously, a fact of which use is made in transceivers; if it is necessary to prevent it, a preliminary R.F. stage with proper screening is the remedy.*

(8) *Erratic Performance.* Some of the causes have appeared already; too high a Q.F. is about the commonest. Another is trying to make one valve do everything, including generating the quenching wave. In Fig. 4, the square box will normally contain a valve oscillating at Q.F., and appreciable power is needed to quench the super-regen valve in its anode circuit. But it is a good stable job. Economizing by quenching at the grid introduces complications, and a larger share

Q.F. depends mainly on the vigour of R.F. oscillation and on the values of grid condenser and leak. The grid voltage goes through working cycles rather as

no reaction! Nevertheless, it works, at V.H.F., because the effective cathode is somewhere between the visible cathode and the control grid, and stray capacit-

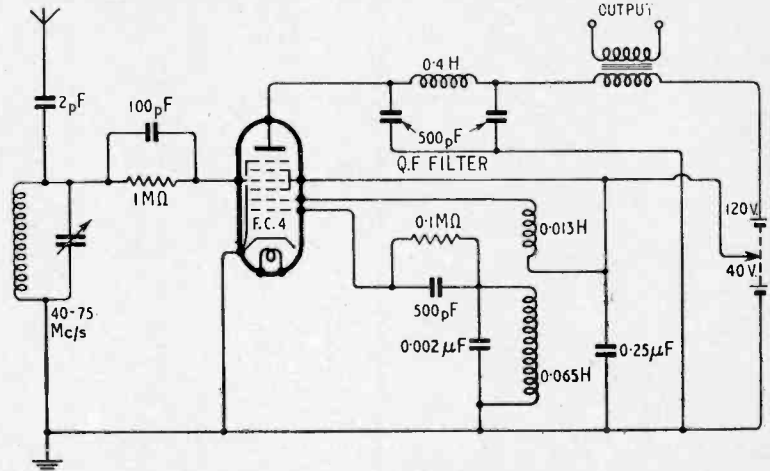

Fig. 10. Recommended super-regen circuit, using a frequency-changer valve.

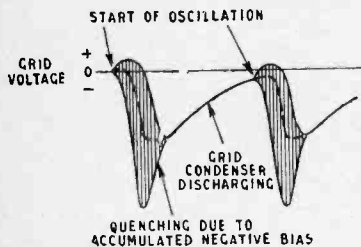

Fig. 9. Variation of grid voltage during two quenching cycles in the Flewelling circuit. The dotted line shows the average grid voltage during oscillation.

of skill or luck is needed to get good results.

Lastly, a few remarks on some special sorts of super-regen. What is called the Flewelling circuit (Fig. 8) is the ultimate in economy and simplicity. It is adjusted to oscillate so furiously that the accumulated negative bias chokes itself off, and it has to wait until the grid condenser has discharged before it can start again. If it does this a super-audible number of times per second, it combines the functions of R.F. oscillator and quenching oscillator. The

shown in Fig. 9; and they look almost ideal for encouraging selectivity. The Flewelling is not a very flexible circuit, but it is quite a good one for working on a fixed and very high radio frequency.

Personally, I think the most satisfactory 1-valve super-regen circuits are those using frequency-changer valves. Fig. 10 shows one built around an octode, but heptodes can be used, and no doubt triode-hexodes, too, with slight modifications. The first two grids, normally used for the local oscillator in a superhet, are employed to generate the Q.F.; and the R.F. goes in, also quite normally, at the control grid. At least, it looks normal for a superhet but quite abnormal for a super-regen, as there is apparently

ances cause the circuit to oscillate in the Colpitts manner.

Everything so far has been based on the assumption that oscillations are allowed to build up to the limit. If, on the other hand, the Q.F. is raised so high that they never have time to do so, the performance is quite different. In Fig. 11, if oscillation is started from, say, 10 microvolts at A and allowed to grow at compound interest, say, 5 per cent, until B, each cycle will be 1.05 times greater than the one before it. Suppose there are 150 cycles. Then the amplitude of the final one will be 10×1.05^{150} , which is 10×1440 . If the starting level had been, say, twice as great, the output would have been double, too. Output is exactly proportional to input. Working this way, there is less amplification per quench cycle, but more quench cycles, less selectivity, no A.G.C. action, and no distortion. In various ways this suits I.F.F. receivers, which have to respond to very brief pulses from radar stations, so they use super-regeneration of this second type.

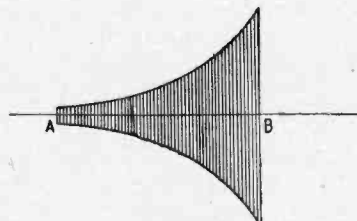

Fig. 11. In the non-limited or linear type of super-regeneration, the dequenching half-cycle, starting at A, stops at B, before the limiting amplitude has been reached.

If you want to study the first sort of super-regeneration more thoroughly, I can recommend F. R. W. Strafford's paper on the subject in the *Journal I.E.E.*, Part III, January 1946.

* See for example O. J. Russell, "Super-Regeneration," *Wireless World*, Dec. 1944.

MULTI-CHANNEL PULSE MODULATION

Details of Army Wireless Station No. 10

A BRIEF account of the operational use of the No. 10 set appeared in the December issue of *Wireless World*, and another article in the same issue described the principles of pulse-width modulation. Details are now available of the Signalling Equipment No. 10, the units in the 10 set which produce and demodulate width-modulated pulses. These pulses, once produced, are used to modulate in turn an ultra-high-frequency transmitter working in the 6-7 cm band. At the receiving end the width-modulated pulses appear in the output of the receiver and are then demodulated by the Signalling Equipment No. 10. The equipment is divided into two main units—the *pulser* and the *separator*.

The chief details of the circuit of the pulses are given in Fig. 3. Before discussing this, however, it may be as well to explain briefly the object of the apparatus. Narrow pulses recurrent at 9 kc/s are width-modulated by the A.F. signals which are to be transmitted. The pulses are narrow with an average duration of 3.5 μ sec. Each of the eight speech channels modulates a

separate train of pulses of the same recurrence frequency, but all the trains are staggered in time so that they can fit together without

be represented as in Fig. 1(b). The channel pulses are so-called because each one is width-modulated by one of the telephone lines

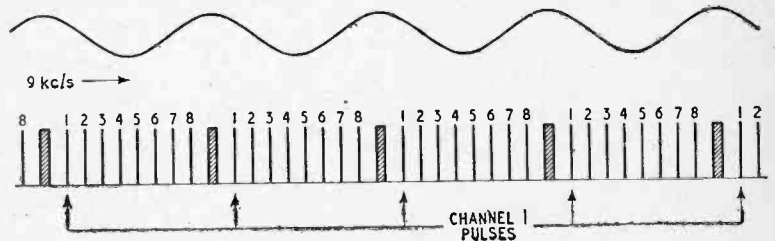

Fig. 2. This diagram shows essentially the same waves as Fig. 1, but to a reduced scale so that several cycles of the wave can be seen. Pulses numbered "1" convey intelligence for channel 1, "2" for channel 2 and so on.

interference. A synchronizing pulse is also included to control the receiving apparatus which sorts out the pulses, demodulates them and routes the A.F. signals to the proper output circuits.

The pulse starts with a 9-kc/s oscillator of sine waveform. Its output takes the form shown in Fig. 1(a). From this oscillator is derived a sequence of rectangular pulses which are repeated for every cycle of the 9-kc/s oscillator. This sequence consists of a synchronizing pulse followed by eight "channel" pulses and they may

coming into the station and thus provides a "channel" for conveying intelligence. The idea is easier to grasp from Fig. 2, which is Fig. 1(a) and (b) combined and reduced in scale. Here a number of pulse sequences is shown, and it will be seen that all the pulses marked "1" can be grouped to form a series of width-modulated pulses comprising the intelligence conveyed on channel 1, all those marked "2" can carry the intelligence conveyed on channel 2, and so on. It is by this system of interleaving pulses that a number of channels can be made to modulate a U.H.F. transmitter.

The method by which the various A.F. channels are recovered from these pulse sequences in the receiving part of the Signalling Equipment No. 10 is described later in this article. This operation is performed by the "separator." It is best at this point, however, to look at the pulser circuits in more detail.

Fig. 3 shows the circuit of the pulser. The inset rectangles show the shape of the wave-forms at particular points in the circuit, so that the way in which the final pulses are built up can be seen.

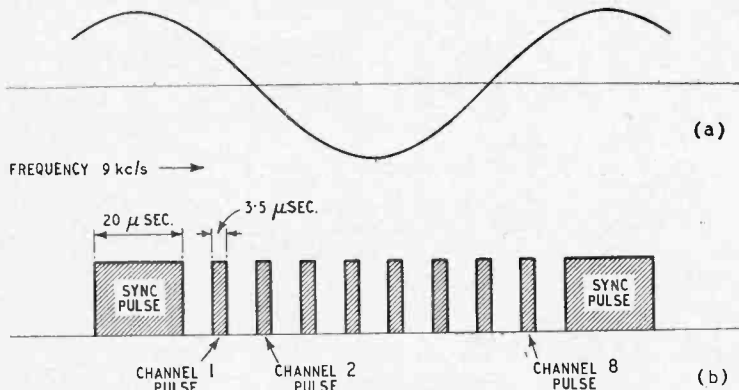

Fig. 1. The sine wave used to control the pulse generation is shown at (a) and the complete pulse sequence produced from it at (b).

Multi-channel Pulse Modulation—
They should be referred to as each stage in the circuit is described.

The 9-kc/s pulse-recurrence frequency, as it is termed, is generated by V_1 . It is a normal type of electron-coupled Hartley oscillator—the output being taken from the anode. This provides a certain buffering effect between the oscillator and later stages.

The saw-tooth generator is V_2 in which C_1 , R_1 , and R_2 have a time constant large compared with the period of 9-kc/s oscillator; therefore C_1 acquires a mean charge from the grid current of V_2 . The grid of V_2 is conse-

This process is continually repeated and thus a saw-tooth voltage is generated which is applied to the cathode-follower stage V_3 . This acts as a buffer and its output is distributed to eight channel units, each dealing with the input from one telephone line. We will deal with the channel unit concerned with channel 1, which is the only one shown in Fig. 3. The saw-tooth voltage in the output of V_3 is applied to the grid of the first valve V_7 in the channel unit. The action of the circuit can best

saw-tooth voltage on the grid becomes increasingly positive, however, a point is reached where the grid is more positive than the cathode and the valve suddenly conducts. This produces a steep fall in the potential of the anode and consequently in the potential of the junction between C_3 and R_3 . The latter potential will however, rapidly recover, the time taken to do so depending on the time constant of C_3 and R_3 . Thus a negative-going pulse is transmitted to the grid of V_8 .

It should be noted that the

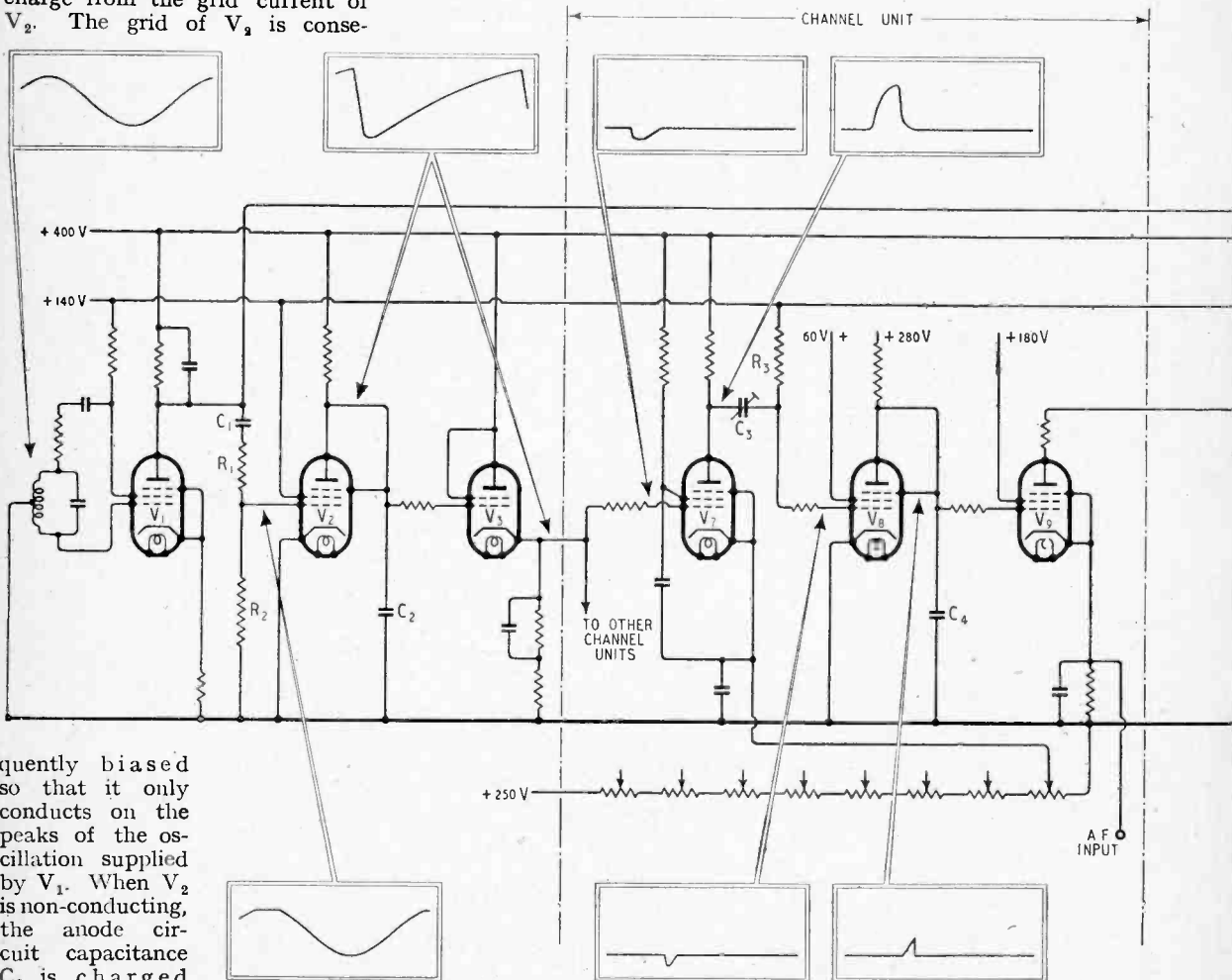

quently biased so that it only conducts on the peaks of the oscillation supplied by V_1 . When V_2 is non-conducting, the anode circuit capacitance C_2 is charged by the H.T. supply through the anode resistance. Before it has time to become completely charged, however, V_2 takes current and C_2 is rapidly discharged through the conducting path provided by the valve.

be understood by considering what happens when the saw-tooth voltage gradually rises from its lowest potential.

The cathode of V_7 is given a positive bias so that the valve will not conduct at first. As the

initial part of the pulse shown as the anode waveform of V_7 is positive-going. This is the recovery from the saw-tooth fly-back and remains the same for all channel units. In other units the voltage remains constant between

the end of this rise and the start of the fall when V_7 becomes conductive. This interval depends on the bias on V_7 and the greater the bias the more the voltage fall is delayed and the later the pulse on the grid of V_8 .

The grids of V_7 on the remaining seven channels are each biased positively, the bias increasing progressively on each channel. The application of the saw-tooth to all the channel units, therefore, results in a series of successive negative-going pulses, one at the grid of each valve V_8 . This latter valve constitutes a saw-tooth generator. Its grid is biased

is normally short-circuited through the conducting path provided by V_8 , is charged by the H.T. supply. Before it has time to become fully charged the valve V_8 conducts again and the capacitance is very rapidly discharged. Due to this action a saw-tooth voltage is applied to the grid of V_9 . This is the modulator and A.F. from the line corresponding to channel 1 is applied to its cathode. This valve produces width-modulated pulses of approximately rectangular shape at its anode.

In Fig. 4, "A" represents a saw-tooth voltage pulse on the

"t" when the voltage between grid and cathode is more than that required to cut off the anode current and thus a pulse is produced at the anode, of width

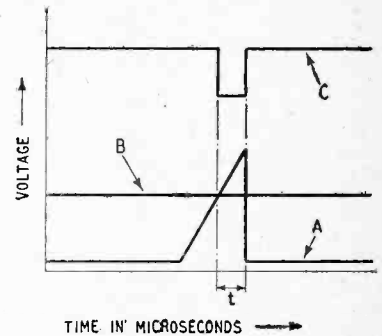

Fig. 4. The saw-tooth voltage on the grid of V_9 is shown at A, the cathode bias at B, and the pulse produced at the anode at C. The width of the pulse depends on the magnitude of B.

"t." This is represented by "C" in Fig. 4. When a modulating voltage is applied to the cathode the line "B" has the appearance shown in Fig. 5, and as a consequence the pulses at the anode vary in width. Since the trailing edge of the saw-tooth is vertical it is the leading edges of the pulses which are modulated.

The output of V_9 , in common with that of similar valves in the other channel units, is fed to the grid of V_5 , a synchronizing pulse being applied to the suppressor.

The synchronizing pulse is produced by the valve V_4 , the grid of which is fed with the 9-kc/s recurrence frequency from V_1 . The grid circuit is similar to that of V_2 , i.e. the grid having a negative potential so that the valve will only conduct on the peaks of the 9-kc/s sine wave. This produces negative-going pulses at the anode of V_4 and the valve is biased so that these are of 20 μ sec duration. This pulse occurs on the peak of the recurrence frequency and the channel pulses occur during the rest of the cycle. Consequently the output of V_5 consists of the synchronizing pulse followed by the eight channel pulses.

This series of positive-going pulses at the anode of V_5 is fed to V_6 which amplifies and squares the pulses and passes them to the

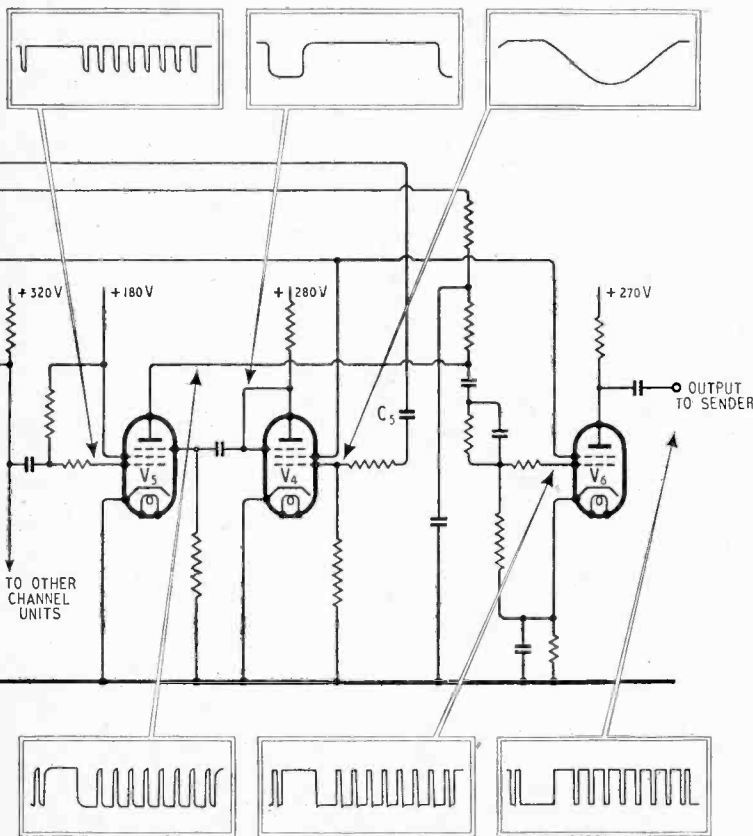

Fig. 3. The circuit diagram of the pulses, simplified by the omission of non-essential components such as test points. The wave forms at important points are indicated by miniature graphs enclosed in rectangles. The portion of the equipment between the vertical dash lines is repeated for each channel. As they are all identical only one of the eight is shown.

positively so that normally the valve is taking current. The application of the negative pulse to the grid, however, stops the current for a short time. During this time the capacitance C_4 , which

grid of V_6 . In the unmodulated state the cathode is given a certain positive bias represented by "B" in Fig. 5. It will be seen that the valve will only conduct during a certain time

Multi-channel Pulse Modulation—
U.H.F. sender. The output from V_6 will, of course, be negative-going pulses since the grid is

the eight channels (Fig. 7(c)). The output of the U.F.H. receiver is in the form of positive-going pulses corresponding to

fed to the diode V_1 in the separator unit (Fig. 6). The time constant of C_1 and R_1 is long compared with that of the pulses so that the potential of the junction between C_1 and R_1 follows that of the incoming pulses. On receipt of a pulse the cathode of V_1 is made more positive than the anode and the valve does not conduct. Therefore C_2 commences charging but does not have time to become fully charged before the end of the pulse has arrived. At this time C_2 discharges rapidly through the valve, the anode of which is now more positive than the cathode. The synchronizing pulse, being longer than the channel pulses, gives C_2 an opportunity to charge to a higher potential than the shorter channel pulses. Thus a series of saw-tooth pulses is passed to V_2 the pulse arising

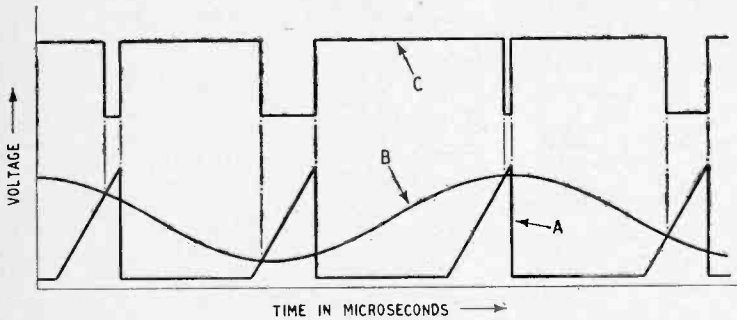

Fig. 5. This diagram illustrates the action of V_6 with an A.F. signal applied to its cathode. The cathode bias B varies with the signal and so the pulse width varies as shown by C.

fed with positive-going pulses.

At the receiving end the pulses corresponding to individual channels have to be separated from their fellows, demodulated and the resultant A.F. passed to the appropriate telephone line. This is done by a system of "gating" pulses. Fig. 7(a) represents the synchronizing pulse followed by two of the channel pulses.

These pulses are all applied to individual units, one for channel 1, one for channel 2, etc. The arrival of the synchronizing pulse causes gate pulses to be generated at certain intervals. The gate pulse is of longer duration than a fully-modulated channel pulse. That for channel 1 occurs at about the same time as the channel 1 pulse itself and similarly for channel 2, etc. Each channel unit will only admit a channel pulse during the brief period when a gate pulse is applied to it. Thus in the case of channel 1 unit, although all the channel pulses are applied to it in succession only the channel 1 pulse will be accepted since the gate is only open for long enough to allow the channel 1 pulse to go through (Fig. 7(b)). Immediately it has passed, the gate pulse ends and the unit is barred from accepting any more pulses until the next channel 1 pulse arrives. In the same way, immediately channel 1 gate is closed, channel 2 gate opens and admits the channel 2 pulse into the channel 2 unit and so on for the remainder of

the negative-going pulses produced by the pulser unit. These are

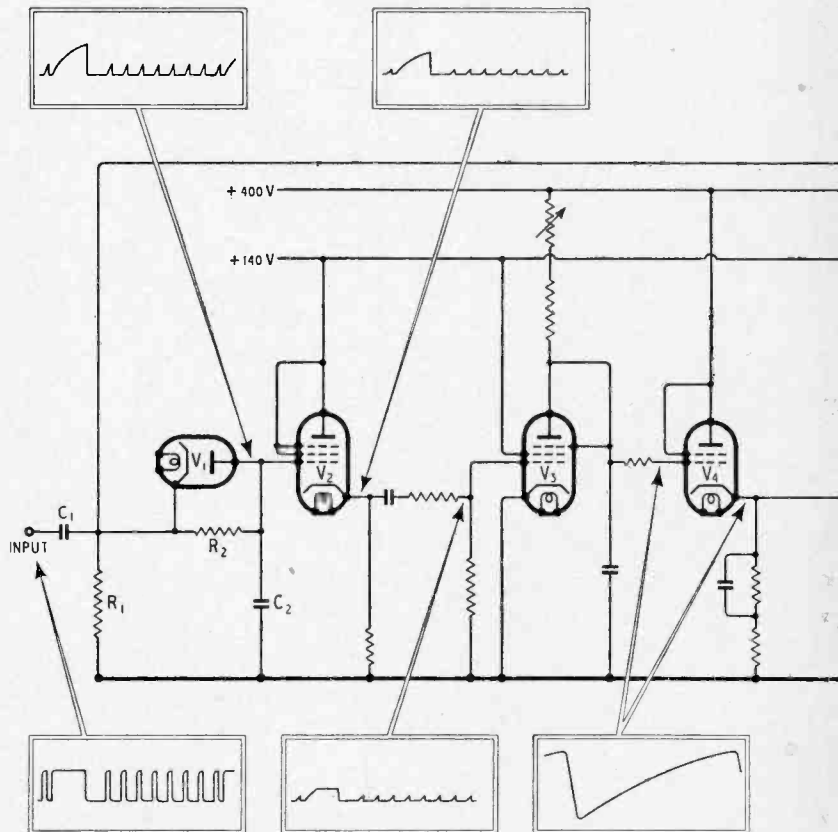

Fig. 6. The circuit diagram of the separator which, by generating gating pulses, separates the channel pulses and develops the A.F. outputs correctly routed to the proper output lines. V_1 is an integrator to separate the sync pulse which controls the saw-tooth generator V_3 . Equipment to the right of the dash line is provided for each of the eight channels.

from the synchronizing pulse being of much higher amplitude than the following channel pulses.

A cathode-follower buffer-stage V_2 is interposed between V_1 and V_3 because the grid circuit of V_3 takes current and would, therefore, interfere with the operation of V_1 if it were connected directly to it. V_3 is a saw-tooth generator and operates in a similar manner to V_2 in the pulser unit. The saw-tooth is triggered off by the synchronizing pulse (which rises to a higher potential than the main channel pulses) in the same way that the crest of the 9-kc/s oscillator V_1 triggers the saw-tooth generator V_2 in the pulser unit. The grid current produces a bias sufficiently large for the channel pulses to have no effect. The output from V_3 is applied to a cathode-follower V_4 which opera-

ates in a similar manner to V_3 in the pulser. From V_4 the saw-tooth is distributed to eight separator channel units. We will deal with the separator channel unit concerned with channel 1.

The circuit of V_6 works in the same way as V_7 in the pulser channel unit and produces a negative-going pulse at the grid of V_6 . The constants of the circuits are so chosen that this pulse is about $8 \mu\text{sec}$ in duration. By a system of biasing similar to that used in the pulser channel units it is arranged that the V_5 valves in the eight channel units produce their pulses in uniform succession following the reception by the separator of the synchronizing pulse. These pulses occur about the same time, relative to the synchronizing pulse, as the original channel pulses.

Reverting to channel 1, the valve V_6 produces at its anode a sharp positive pulse also of about $8 \mu\text{sec}$ duration. This comes about because the grid pulse is steep and the anode voltage is comparatively low. This is the gate pulse and is wide enough for the corresponding modulated pulse ($3.5 \mu\text{sec} \pm 2.33 \mu\text{sec}$) to fit inside. The gate pulse is applied to the control grid of the gate valve V_7 and the train of pulses from the U.H.F. receiver, to the suppressor grid. The control grid is normally biased so that the valve will not conduct. It reaches this condition after the first few gate pulses pass when the set is started up—the pulses causing the valve to draw grid current which charges up C_3 and thereafter keeps the grid negative. After this state has been reached,

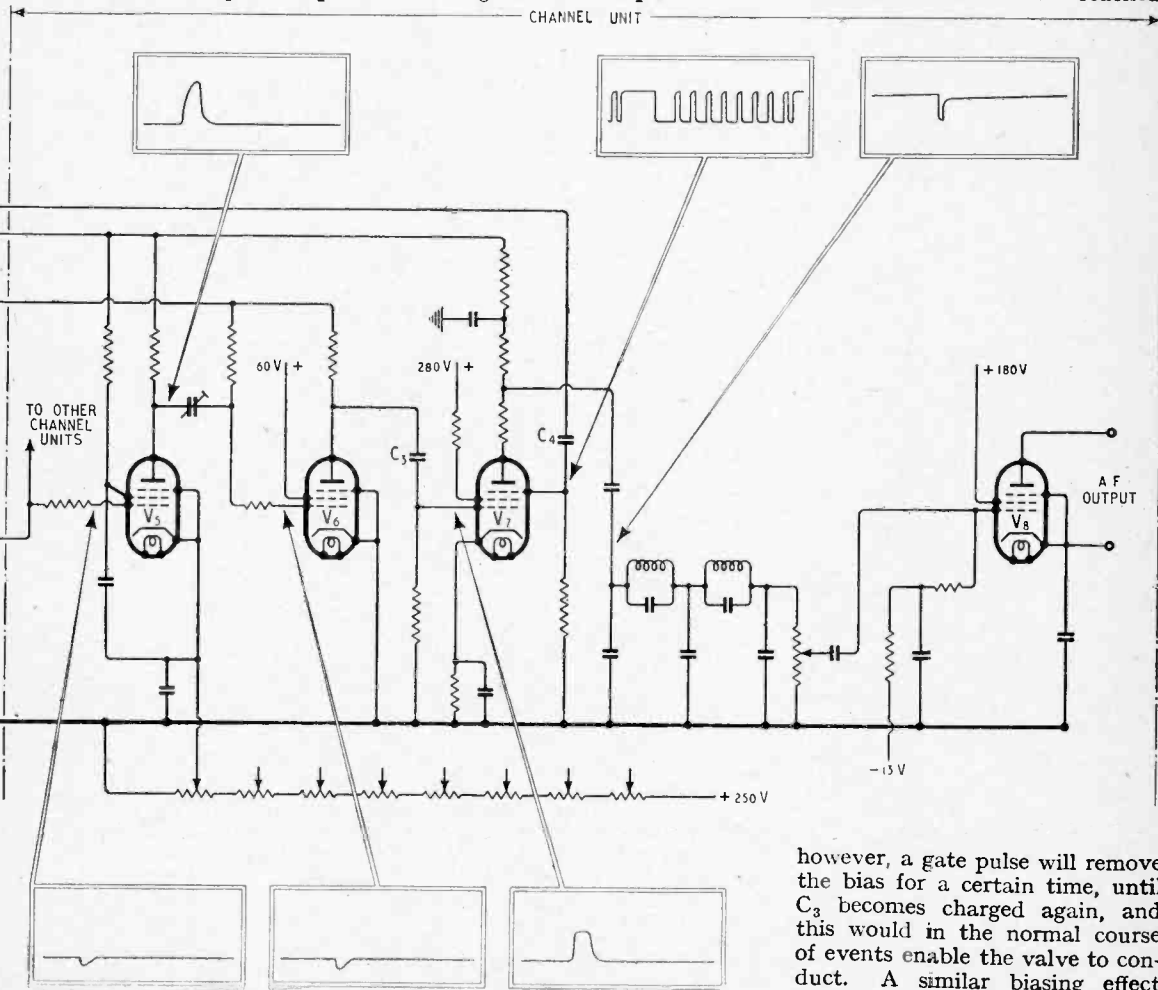

however, a gate pulse will remove the bias for a certain time, until C_3 becomes charged again, and this would in the normal course of events enable the valve to conduct. A similar biasing effect

Multi-channel Pulse Modulation—is associated with the suppressor grid of V_7 , the capacitor responsible being C_4 . Thus, unless a pulse is present at both grids, the valve will not conduct, but when two pulses are present at the same time it will conduct for the duration of the shorter pulse only. The V_7 (channel 1) will therefore pass the channel pulse associated with channel 1 since the gate pulse is only present on that particular valve for just

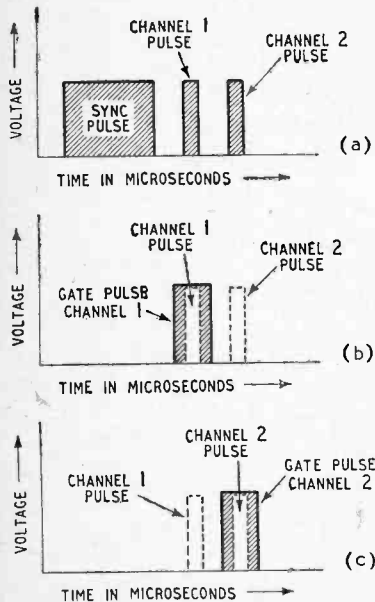

Fig. 7. The synchronizing pulse is shown at (a) followed by two channel pulses. It generates a series of gating pulses which permit channel pulses to pass only when channel and gating pulses are coincident. The two are shown at (b) for channel 1 and at (c) for channel 2.

sufficient time to allow the valve to conduct for the duration of the channel 1 pulse.

Similarly V_7 of channel 2 will "capture" the channel pulse associated with channel 2 and so on for the other channels. The output from each V_7 anode is thus a series of negative-going width-modulated pulses. On passing these through a suitable A.F. low-pass filter (cut-off 4 kc/s.) the modulation frequencies are recovered and amplified by V_8 before being passed to the appropriate telephone line.

WORLD OF WIRELESS

LONDON'S NEW MAST

IMPROVED reception of the B.B.C.'s London transmitter at Brookmans Park is promised for listeners in East Anglia, Kent and Sussex by the erection of a 500-foot anti-fading mast radiator.

In the past the Corporation has not been permitted to use masts higher than 200ft at this station, which has seriously restricted the service area after nightfall.

Details of the mast, which it is expected will be brought into service in the autumn, are not available.

GOVERNMENT SURPLUS

A CONSIDERABLE part of the annual report of the Radio Component Manufacturers' Federation is devoted to the question of the disposal of surplus Government stocks. It states that proposals were made for the purchase of all surplus stocks, at a nominal price per unit, all handling, storage, testing and subsequent disposals to be undertaken by the industry, and any profits arising from the resale of usable items to be shared with the Government. These proposals were rejected.

It appears, says the report, that the Government is pursuing a short-sighted policy of snatching at quick returns, presumably to satisfy Treasury demands, with complete disregard for the effect of unregulated disposals upon the industry.

POST OFFICE RESEARCH

REPLYING to a plea by Mr. Cobb, M.P. for Elland, for more fundamental research in telecommunications in this country, Mr. Burke, Assistant P.M.G., stated in the House on May 3rd that the Dollis Hill Research Station will shortly devote its whole resources to research and that new premises will be found in the Midlands for the section at present occupied with the training of engineers.

The Press were recently given the opportunity of seeing some of the activities of the station, which included demonstrations of the working of multi-channel coaxial lines, apparatus for producing synthetic fading signals and "Vocoder" speech analysis and synthesis.

At the request of the Medical Research Council the Dollis Hill Research Station recently undertook a series of tests to find the characteristics of a hearing aid which would

fulfil the needs of the majority of deaf people. They also designed a miniature hearing aid embodying the results, and this was shown. It includes a three-valve amplifier in a moulded case 3in x 2½in x 1in (the batteries are carried separately), and it is estimated that the cost of manufacture will be less than £10 and the running cost for batteries less than 1d per hour of continuous use.

Speaking of this development in the House, Mr. Burke said: "It is true to say that the Post Office in the past has been far too modest. It has just been successful, in working in association with the Medical Council, in bringing out an ear aid which, I hope, will not fall into the hands of private people to be exploited. I am sure it will be of benefit to thousands of deaf people in this country. It is one of the little things the Post Office does, as it were, in its stride, and which many people do not get to know about."

MARINE RADIO-NAVIGATION

AS a preliminary to the establishment of an international standard for marine radio-navigational systems a meeting opened in London on May 7th at which representatives of all the maritime countries of the world were present.

During the conference, which ended on May 22nd, papers were read and demonstrations given to inform other countries of the work done in this country in the field of radio aids to navigation and by means of informal discussion delegates were able to state what is being done in other countries.

Among the papers read were "Radio-wave Propagation in Relation to Marine Navigational Aids" by Dr. R. L. Smith-Rose and "Allocation of Frequencies" by A. H. Mumford. Sir Robert Watson-Watt was chairman.

A report on the demonstration in H.M.S. *Fleetwood* is given elsewhere in this issue.

RADAR—SIMPLY EXPLAINED

RADAR—what it is, what it does and how it works—is explained simply and lucidly with the aid of some 60 drawings and photographs in a book of 140 pages by R. W. Hallows, who is well known to *Wireless World* readers.

As Chief Instructor in A.A. Fire

Control at one of the Army's schools the author had to devise methods of training large numbers of men and women, most of whom had little or no knowledge of wireless, in the theory and use of radar. That he succeeded in his task of making an extremely difficult and abstruse subject appear simple is borne out in this book, which is based on the explanations given to operators. It contains no mathematics and calls for no previous knowledge of radio or electricity. It is, in fact, for the man-in-the-street.

Published by Chapman and Hall the book "Radar—Radiolocation Simply Explained," costs 7s 6d.

FIELD-DAY LICENCES

MANY of the recently re-formed radio clubs are planning field days but are in doubt as to the need for securing a licence for a portable transmitter as no official statement has been issued on the subject.

On enquiry it was learned that societies planning field days should get in touch with the G.P.O., giving details of the station, operator's name and the areas to be covered, asking for formal permission to operate a portable transmitter.

The application should be made to the Director of Telecommunications, G.P.O., St. Martin's le Grand, London, E.C.1.

WORDS INTO PLOUGHSHARES

SALVAGED German Army radio equipment is being used to manufacture 3-valve utility civilian sets at the rate of more than a hundred a week in a Hanover factory.

According to details given in the *British Zone Review* they are being sold at 250 RM and priority is given to schools, youth clubs and bombed-out families. Ten per cent of the factory's output goes to Army Welfare Services for distribution to British troops.

TELEVISION SETS

WITH the restarting of the B.B.C. television service on June 7th many people have been asking if sets will be available by then. The answer given by each of the manufacturers to whom the question has been put is, no.

Although production is well in hand and in some cases chassis are coming off the line, cabinets are non-existent—licences for wood being unobtainable.

The Government has licensed the production of 78,000 sets this year, but as C. O. Stanley stated recently "the industry has not yet got used to building houses without bricks!"

In addition to the production difficulties manufacturers are still awaiting a Government announce-

ment regarding purchase tax, which, if it is fixed at a high rate would kill the industry at birth.

PERSONALITIES

Sir Edward Appleton, F.R.S., lectured at the recent 60th anniversary conference of the Société Royale Belge des Ingénieurs in Brussels and also in Amsterdam.



LESLIE C. GAMAGE, M.A., joint-managing director and vice-chairman of the G.E.C., has been elected President for 1946-47 of the Radio Industries Club, which now has a membership of 601.

L. R. Batten, O.B.E., who served as a Wing Commander in the Second Tactical Air Force, has been appointed secretary of the Radio Communication and Electronic Engineering Association—one of the constituent associations of the Radio Industry Council. The Association is now at 59, Russell Square, London, W.C.1.

W. J. O'Brien has been awarded a Royal Society of Arts' prize of £50 for his invention of the Decca Navigator.

A. J. L. Collinson, B.Sc. (London), has been appointed Works Manager of the Radio Works of Allander Industries, Ltd., Milngavie, Glasgow.

W. A. Jackson, of the Telephone Manufacturing Company, was elected chairman of the Radio Component Manufacturers' Federation, and R. W. Merrick (Wright and Weaire) vice-chairman, at the recent annual meeting.

James K. A. Nicholson has retired from the post of Engineer-in-Charge at the B.B.C.'s Newcastle station which he has held since 1924.

Dr. A. T. Starr, M.A., has taken up an important appointment with Standard Telecommunication Laboratories, the new subsidiary of Standard Telephones and Cables.

E. O. Willoughby has resigned from the radio engineering staff of Standard Telephones and Cables to take up his appointment to the newly created Chair of Electrical Engineering at the University of Adelaide, Australia.

OBITUARY

It is with regret we record the death on May 5th of Dr. S. H. Long, O.B.E., Assistant Engineer-in-Chief in charge of development for the Marconi Company, at the age of 55. In 1929 he joined the Marconi International Marine Communication Co. as Technical Manager, and as Technical Adviser to the M.W.T. Co.

IN BRIEF

Batteries of not less than 15 volts and not more than 45 volts, specially designed for hearing aids and using layer-type cells not exceeding 6 millimetres in thickness, with zinc elements of which each face does not exceed 500 square millimetres, are now exempt from purchase tax.

Income Tax Allowances for expenditure on "scientific research undertaken by a trader," which is allowable under the new law in operation from April 6th, is explained in a pamphlet, No. 470, issued by the Board of Inland Revenue, Somerset House, London, W.C.2.

American Amateurs have been granted another band of frequencies. In addition to those given in last month's issue, they are now using the 3.7-4 Mc/s band.

French Amateurs have been granted permission to use the 14-14.4 Mc/s band in addition to the 5- and 10-metre bands.

Soviet Wireless Network.—Soviet News Agency announces that a network of wireless stations is to be opened in the Kara-Koum desert which is situated just north of the Persian frontier.

School Broadcasting.—Over 13,000 schools in England and Wales are registered as listening to school broadcasts. This is an increase of 1,300 over last year's figures and does not include the 1,684 schools registered in Scotland.



S. J. TYRRELL, Celestion's chief engineer for design and engineering, has been appointed a director of the company.

International Standards.—The American Radio Manufacturers' Association has decided to make the industry's engineering standards avail-

World of Wireless—

able to other countries in an endeavour to encourage some measure of international standardization in radio sets.

Interplanetary Communication is among the aims of the British Interplanetary Society, Albemarle House, Piccadilly, London, W.1. Details regarding membership and the local groups established at Manchester, Birmingham, Eccles and Farnborough are obtainable from the Secretary.

Back Numbers.—Our Publishers are anxious to obtain copies of our sister journal "Wireless Engineer" from 1941 to date for supplying to countries previously occupied by the enemy. Copies of "Wireless World" for July-December, 1939, and January-December, 1940, are also required. Readers wishing to dispose of their copies are asked to write to the Publisher, Dorset House, Stamford Street, London, S.E.1.

Publication Resumed.—Devoted to reporting the practical application of the results of the research work undertaken at the Philips Laboratories, Eindhoven, "Philips Technical Review," which ceased publication during the war, has reappeared.

Research Reports.—A new scientific journal devoted to the results of pure research work undertaken in the Philips Laboratories entitled "Philips Research Reports" is to be published bi-monthly. The first issue, dated October, 1945, appeared in April.

"R.C.A. Review," which suspended publication in 1942, has reappeared. It will be published quarterly by R.C.A. Laboratories, New Jersey.

"The Signal," the official organ of the Radio Officers' Union, celebrated its silver jubilee with the publication of the May issue. A. D. Crisp has been Editor throughout the 25 years.

COMPANY NEWS

Cossor Radar has been formed to take over A. C. Cossor's interests in the manufacture of radar equipment. It will operate from Cossor House, Highbury Grove, London, N.5.

Antiference Installations, a subsidiary of Antiference, Ltd., has been formed to handle the installation of the company's aerial equipment. The address is 1-3, Hale Lane, Mill Hill, London, N.W.7.

Electro-Acoustic Industries has been formed by E. H. Stoner and G. A. Barden, both of whom recently resigned from Goodmans Industries, to manufacture loudspeakers, microphones, transformers and chokes. Mr. Barden was chief engineer at Goodmans for 12 years. The company's address is Stamford Works, Broad Lane, Tottenham, London, N.15. (Tel.: Stamford Hill 5606.)

Marconi.—It is announced that the English Electric Co. has purchased the whole interest of Cable and Wireless in Marconi's Wireless Telegraph Company.

Belling and Lee ask us to state that their Arterial Road, Enfield, factory and offices will be closed for the annual holiday from June 22nd-30th inclusive.

Metro-Vick and Siemens have concluded an agreement regarding the marketing and servicing of radar and audio-type equipment for marine navigational purposes.

Société Anonyme Wild-Barfield has been formed to handle the sale and service of Wild-Barfield equipment, which includes R.F. heaters, in Belgium, Holland and Luxembourg. Enquiries should be addressed to S. A. Wild-Barfield, 165, Rue Belliard, Brussels, Belgium.

Johnson, Matthey and Co. are to hold an exhibition at Dorland Hall, Lower Regent Street, London, S.W.1, from June 13th to 26th, inclusive. Admission to the exhibition of the company's products will be by invitation card only, application for which should be made to the Exhibition Secretary, Johnson, Matthey and Co., 73-83, Hatton Garden, London, E.C.1.

Imperial Chemical Industries have organized an exhibition of chemical research which will open on June 5th at the Tea Centre, Lower Regent Street, London, S.W.1. In the section devoted to "The Chemist and Plastics" displays will show the contribution of polythene to radio and radar.

British Rola has acquired 97 per cent of the share capital of Celestion, but each company will continue to operate independently so far as research and development are concerned.

Cintel is the new trade name for products of Cinema-Television, Worsley Bridge Road, Lower Sydenham, London, S.E.26.

United Insulator Co. have removed to Oakcroft Road, Tolworth, Surbiton, Surrey. Tel.: Elmbridge 5241.

British Mechanical Productions state that orders for their Clix products should now be sent to 21, Bruton Street, London, W.1. Tel.: Mayfair 5543.

Electrothermal Engineering.—The postal district of the address of this firm was incorrectly given in our April issue—and should be E.7.

Delco-Remy and Hyatt, of 111, Grosvenor Road, London, S.W.1, inform us that in future their works and sales departments will work a five-day week and be closed on Saturday mornings.

TRADE ENQUIRIES

Belgium.—A radio engineer in Brussels desires exclusive agency for radio and television receivers, components and equipment. Letters addressed O.I.E.M., c/o The Editor, will be forwarded.

India.—The managing director of Electronics, Ltd., of New Delhi, is visiting this country this month and will be pleased to hear from component manufacturers regarding exports for set manufacture in India. Letters addressed to Mr. Sham Sundra will be forwarded.

Rumania.—Component manufacturers interested in exporting to Rumania are invited to write to the Bureau Electro-Technique, Bucharest. Letters addressed c/o The Editor will be forwarded.

CLUBS

Bolton and District Radio Society has resumed its activities and meetings are now held on the first Tuesday of each month at 7.30 at Gaskell House, 7a, Churchgate, Bolton. N. Moorcroft, 3, Beaconfield Street, Bolton, is secretary.

Ilford and District Radio Society has recommenced activities and is now meeting on alternate Thursdays at St. Albans Church Hall, Albert Road, Ilford, at 8.0. The next meeting is on June 6th. Secretary, C. E. Largen, 44, Trelawney Road, Barkingside.

Leicester.—"Industrial Electronic Instruments" is the subject of the lecture to be given by S. W. Burfitt, of the G.E.C., at the meeting of the Leicester Radio Society at the Charles Street United Baptist Church Hall on June 4th. Particulars of the club are obtainable from O. D. Knight, 16, Berners Street, Leicester.

Maidenhead.—A new club has been formed and meetings are held at 7.30 on the second Tuesday in the month at the Toc H Hall, Marlow Road, Maidenhead. The secretary is R. F. Woodruff, Maidenhead Amateur Radio Club, "Oaklands," College Road, Maidenhead, Berks.

Slade Radio.—The next meeting of Slade Radio will be held on June 28th at the headquarters, Broomfield Road, Slade Road, Erdington, when the subject for discussion will be direction finding. Secretary, L. A. Griffiths, 47, Welwyndale Road, Sutton Coldfield, Birmingham.

Surrey Radio Contact Club has resumed activities and now meets on the second Tuesday of each month at 7.30 at the Blacksmith's Arms, South End, Croydon. Details of membership are obtainable from the Secretary, L. C. B. Blanchard, 122, St. Andrew's Road, Coulsdon, Surrey.

West Bromwich.—A wireless society has been formed and now meets twice a month at The Gough Arms Hotel, Jovetts Lane, West Bromwich. The next meeting is on May 27th at 7.30. Secretary of the West Bromwich and District Radio Society is G. Johnson (G2BJY), 22, Lynton Avenue.

MEETINGS

Institution of Electrical Engineers

Favaday Lecture.—Dr. T. E. Allibone's lecture on "Atoms, Electrons and Engineers," which, illustrated by films and demonstrations, was originally given on May 9th, is to be repeated at the Central Hall, Westminster, on Wednesday, June 5th, at 6 p.m. As the lecture will be open to the public no tickets will be required.

Institute of Physics

Electronics Group.—A summer meeting will be held in the Research Laboratories of the General Electric Co., Wembley, at 2.30 on June 15th, when a series of papers will be given.

Radio Society of Great Britain

"Centimetric Radar for Precision Gun-laying," by H. A. M. Clark, B.Sc. (G6OT), at 6.30 on May 31st at the I.E.E., Savoy Place, London, W.C.2.

**FOR SHEER
DEPENDABILITY
AND
MAINTENANCE
OF
CHARACTERISTIC**

BRIMAR
(BVA)
VALVES

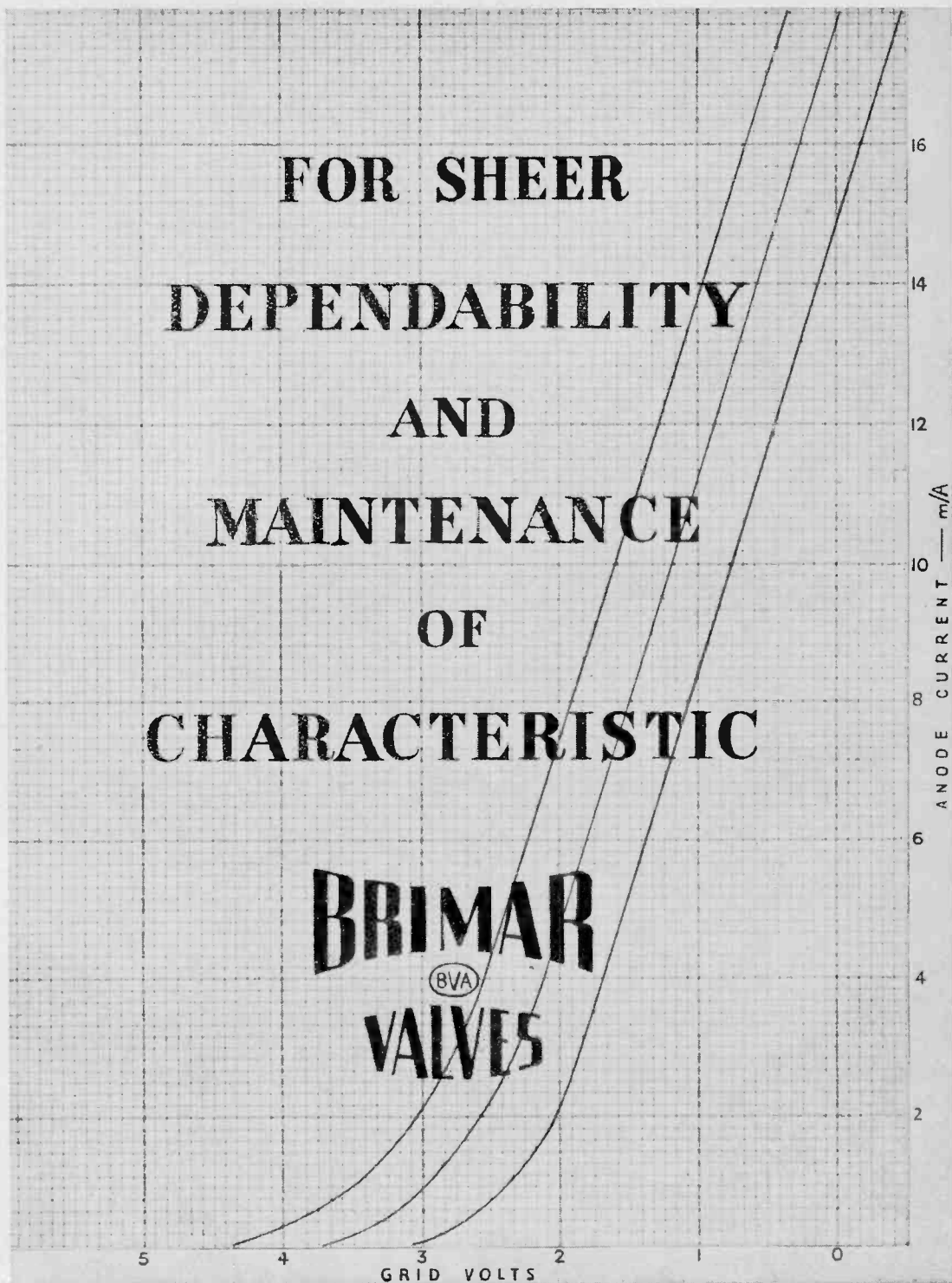

ADVERTISEMENT OF STANDARD TELEPHONES AND CABLES LIMITED FOOTSCRAY, SIDCUP, KENT

VORTEXION "SUPER FIFTY WATT" AMPLIFIER

This **AMPLIFIER** has a response of 30 cps. to 15,000 cps., within 1 db, under 2 per cent. distortion at 40 watts and 1 per cent. at 15 watts, including noise and distortion of pre-amplifier and microphone transformer. Electronic mixing for microphone and gramophone of either high or low impedance with top and bass controls. Output for 15/250 ohms with generous voice coil feedback to minimise speaker distortion. New style easy access steel case gives recessed controls, making transport safe and easy. Exceedingly well ventilated for long life. Amplifier complete in steel case, with built-in 15 ohm mu-metal shielded microphone transformer, tropical finish. As illustrated. Price 29½ Gns.



A.C.20 AMPLIFIER.—This well-known model has been retained, and has a response 30—15,000 cps., mixing arranged for crystal pick-up and microphone, large output transformer for 4—7.5 and 15 ohms to deliver 15 watts at less than 5 per cent. total harmonic distortion to the speakers. Price £15 15 0

RECORD REPRODUCER.—This is a development of the A.C.20 amplifier with special attention to low noise level, good response (30—18,000 cps.) and low harmonic distortion (1 per cent. at 10 watts). Suitable for any type of pick-up with switch for record compensation, double negative feedback circuit to minimise distortion generated by speaker. Has fitted plug to supply 6.3 v. 3 amp. L.T. and 300 v. 30 m/A. H.T. to a mixer or feeder unit Price £18 0 0

C.P.20A 15-WATT AMPLIFIER or 12 volt Battery and A.C. Mains operation. This improved version of the old C.P.20 has switch change-over from A.C. to D.C. and "stand by" positions and only consumes 5½ amperes from 12 volt battery.

Fitted mu-metal shielded microphone transformer for 15 ohm microphone, and provision for crystal or moving iron pick-up with tone control for bass and top and outputs for 7.5 and 15 ohms. Complete in steel case with valves. £22 0 0

DEALERS AND EXPORT AGENTS should write for special terms to:—

VORTEXION LTD.

257-261 THE BROADWAY,
WIMBLEDON, S.W.19.

Telephones: LIBerty 2814 and 6128

Telegrams: VORTEXION, WIMBL., LONDON

QUARTZ PLATES

REGD TRADE MARK

Standard Crystals cover 3.5/10 Mc/s, — but can be supplied for other frequencies and for a wide range of frequency-temperature characteristics.

Made in hundreds of thousands per annum for the services all over the world.

Made by

SALFORD ELECTRICAL INSTRUMENTS LTD.

PEEL WORKS, SALFORD, 3.

Proprietors: **THE GENERAL ELECTRIC Co. Ltd., of England**



*for
Communication
Equipment*

THE GERMAN MAGNETOPHON

Developments in Recording with Impregnated Plastic Tape

By R. A. POWER

IN 1930 a patent was taken out by Pfeumer for using a paper or plastic tape coated with iron dust to replace the steel wire or tape used with magnetic recorders. This development was taken up by Allgemeine Electricitäts-Gesellschaft (A.E.G.) and the I. G. Farben chemical company, with the idea of producing a general purpose recorder. I. G. Farben produced the tape, and A.E.G. undertook to produce the recording machine. Later these two companies combined to set up the Magnetophon Gesellschaft, Berlin.

The principle used for the recorder is as follows. A band of cellulose acetate covered with powdered magnetite runs tangentially past a gap in a toroidal electro-magnet head. If this toroid is energized by D.C. or A.C. with period large compared to the time a given particle spends near the gap, then this particle passing the gap will be left with a residual longitudinal magnetism, proportional to the energizing

A. E. G. Magnetophon high-quality tape recorder, Type H.T.S.

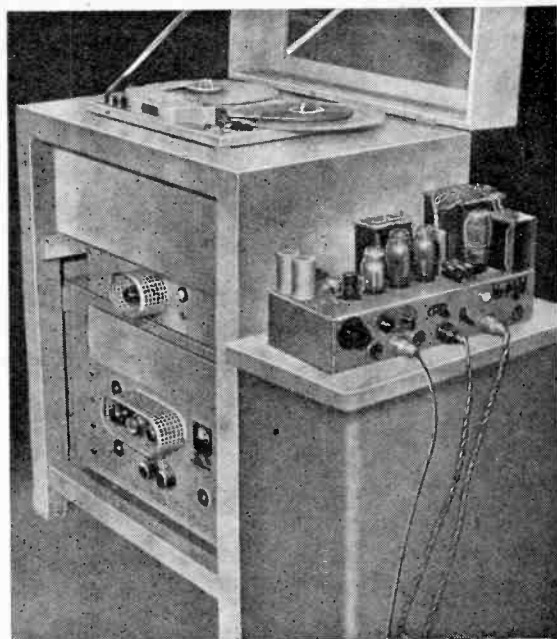

current. This follows for all the particles carried past the gap by the plastic film.

In practice three magnetic heads are used. The first is the erasing head. This ensures that any previous magnetic modulation is wiped off, and the tape is ready to receive the A.F. impressed on it by the second (recording) head. The third head is the "pick-up" or "play-back" head, and enables the recording to be monitored.

Early models use D.C. erasure. A direct current is passed through the coil of the erasing head, and its value is made large enough to create a field which will magnetically saturate the particles coming under the influence of the head. The recording head is fed with D.C., whose direction is such as to produce opposite magnetization to that of the eraser, and whose amplitude is such as to bring the particles back to magnetic neutral. The A.F. current is fed in series with this D.C., and the required recording is impressed on the tape by the erasing and recording heads are shown diagrammatically in Fig. 1.

It is believed that the D.C. applied at the recording head, besides its main purpose of returning the tape to magnetic neutral, serves to agitate the particles, reducing the inertia the A.F. has to overcome and the distortion this would cause.

The noise modulation in this D.C. system is fairly high, and this is one of the defects overcome in the latest model.

The erasing head is straightforward. It is made of soft iron

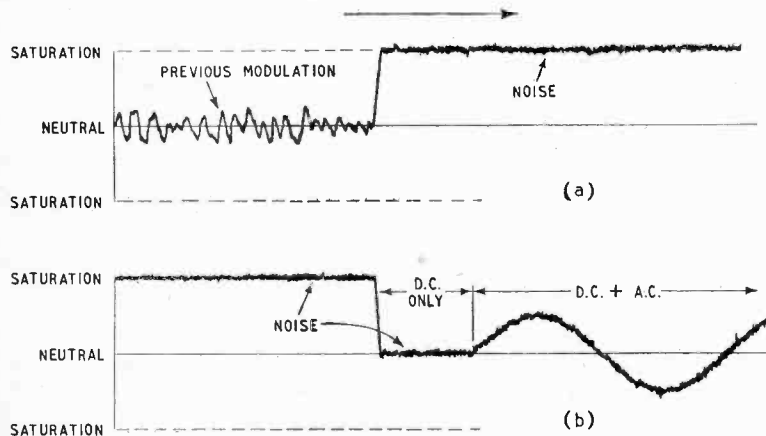

Fig. 1. Magnetization of tape in early models with D.C. bias (a) at erasing head (b), at recording head.

The German Magnetophon—

with negligible retentivity, and shaped to have maximum field strength at the gap.

The recording and pick-up heads are not so straightforward. It must be appreciated that they have to operate at A.F. and must have very small retentivity. They are made in the form of a ring in two halves, each half made up of very thin laminations of high permeability iron. Special bobbins fit over these laminations, and the winding is equally divided between the two halves. Besides a front air gap for recording (or pick-up) of approx. 0.02 mm, there is a larger air gap at the rear. This rear gap is to reduce the residual magnetism due to large current pulses, and is about 0.25 mm wide. Fig. 2 illustrates the construction of these heads. The two halves of the head are clamped together to make the finished job, leaving the air gaps as previously detailed. The erasing recording, and play-back heads are mounted side by side, with a cover over them so designed as to allow the tape to run past them, and to screen the heads from one another magnetically. The impedance of the heads varies in different models. The current required for recording is very low, of the order of 5 mA or so.

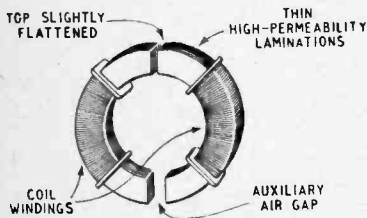

Fig. 2. Construction of recording and pick-up heads in the Magnetophon.

The field strength across the recording slit is proportional to the current in the coil, and the coil represents an inductive load. Because of this, the recording head is fed with A.F. current from a constant current source (pentode or beam tetrode). This gives an approximately flat response characteristic until the higher frequencies are reached. Then the time a particle spends under the influence of the magnetic field becomes an appreciable part of

the A.F. period. Under these conditions the phase of the magnetic force may change while the particle is under its influence, reducing the residual magnetism left on the tape. Taking an extreme case, if the particles are under the influence of the gap for a period equal to one cycle of A.F. the residual magnetism would be nil, owing to the fact that the particle would have been magnetized an equal amount in opposite directions.

This "slit loss" causes a falling off in reproduction at the higher audio frequencies, and from the foregoing analysis of this loss it is evident that, all other things equal, the highest frequency reproducible is proportional to the velocity of the tape (i.e., inversely proportional to the time a given particle spends under the influence of the recording head.) To equalize this loss, a top boost is given to the recording amplifier. The tape and amplifier noise is mostly at the higher audio frequencies, and for this reason it is usual to over-boost the top when recording, and attenuate the top when playing back.

At the play-back head, the voltage induced in the coil is proportional to the rate of change of flux—in other words the voltage output increases with frequency. To compensate for this and the over-boosting of the top, a simple capacity-resistance filter is included in the play-back amplifier.

A signal/noise ratio of about 38db was obtained with these early models, with a frequency range limited by the associated amplifiers to about 50-6,000 c/s, at a tape velocity of 77 cm/sec. The standard reel of tape is 1,000 metres long, and forms a reel about 10in in diameter. This, at 77 cm/sec, gives a playing time of 22 mins.

The tape is wound on metal hubs in self-supporting reels, which are placed on horizontally mounted discs. One disc is provided for the feeding reel, and one for the take-up reel. Each of the reels is driven by its own series-wound motor, and the tape is pulled past the heads at a constant velocity by a synchronous motor.

The feed reel motor is run at reduced power during recording

or play-back, and acts as a brake. The two reel motors serve to keep the tape under tension, while the speed is kept constant by the synchronous motor. For re-winding, the synchronous motor is disengaged from the tape, the power of the feed motor is increased, and that of the take-up motor decreased. Solenoid brakes are fitted to prevent tape slackness on switching off. The series-wound motors are fitted with governors to prevent runaway under "no-load" conditions.

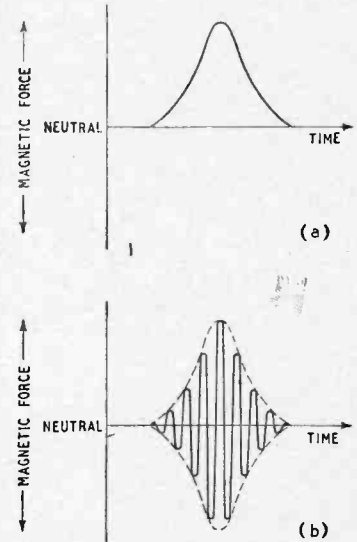

Fig. 3. Magnetic force on an element of the tape while passing over the gap; (a) with D.C. bias, (b) with supersonic excitation.

In designing the latest high-quality Magnetophon some minor modifications were made to the mechanical system to ensure constant tape velocity, and this side of the system was considered above reproach. The frequency range could be extended by suitable design of amplifiers. The biggest snag was the poor signal/noise ratio, caused by noise on the tape.

During 1941 came the development which enabled the Magnetophon to give a performance which places it among the foremost commercial recording systems in existence.

Whilst the Magnetophon was undergoing tests for broadcast transmission at the Reichrundfunkgesellschaft, Drs. Braummuhl

and Weber discovered that a great improvement in signal/noise ratio was obtained by using supersonic currents for erasing and "pre-magnetizing."

This system is now used and the D.C. erasing head of the early models is replaced by a head suitable for A.C. operation (similar to the recording and pick-up heads previously described, but with a larger gap). It is supplied by a 6-watt oscillator with a frequency of about 40 kc/s. The effect on particles coming under the influence of the field is shown in Fig. 3. Fig. 3 (a) shows the influence of the field on the particle with a D.C. system, in which the particle would be left with a residual magnetism. With the supersonic system the particle is subject to rapidly changing magnetic fields in both directions, Fig. 3 (b), and emerges magnetically neutral.

At the recording head a supersonic frequency is fed in as well as the A.F. It is derived from another 6-watt oscillator and has a frequency of about 100 kc/s. The action of this supersonic frequency is thought to be to agitate the particles and thus to reduce the inertia the A.F. field has to overcome. The residual magnetic modulation will be proportional to the A.F. current. The value of the supersonic pre-magnetizing current applied at the recording

head seems to have an optimum value, although it is not critical, nor are the frequencies of the supersonics critical.

The supersonic erasing and re-

cording process is illustrated graphically in Fig. 4.

The tape is about 6 mm wide and between 0.04 and 0.05 mm thick. The earlier tape consists

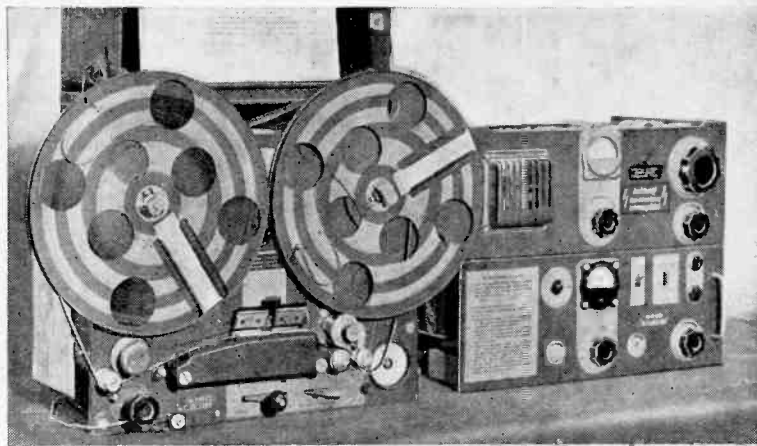

Tonschreiber B magnetic recorder used by the German Army.

cording process is illustrated graphically in Fig. 4. Comparing it with the representation of the D.C. system (Figs. 3a and 3b), it shows the noise modulation has been reduced to negligible proportions. This enables the latest type Magnetophon to have such a wide dynamic range. Several theories have been put forward as to why the use of supersonics should so reduce the noise, but up to the time of writing proofs as

of a film of cellulose acetate supporting the active layer of 0.01 to 0.02 mm thickness. This layer consists of 90 per cent. magnetite and 10 per cent. cement, the grain size when lying flat is about 0.002 mm. With this tape and the supersonic recording system, background noise is better than with D.C. bias but still limits the dynamic range to 50-55 db.

The latest tape has the magnetite impregnated in it. The band consists of a plastic carrier "Igelit PCU," a vinyl-chloride polymer into which an equal amount (by weight) of finely powdered magnetic Fe_2O_3 is mixed. The mixture is kneaded and thermoplastically laminated into a film 1,000 metres long. The Fe_2O_3 possesses the same crystal structure as natural magnetite Fe_3O_4 , the crystals measuring about one micron in size. The magnetic properties of this new form of Fe_2O_3 are stated to be due to its magnetic crystal form. With this impregnated tape and the supersonic system of recording, background noise is low enough to permit a dynamic range of 65-75 db. Under favourable conditions this can be increased to 80 db.

These tapes retain their magnetic properties indefinitely. The earlier tape tends to become brittle with ageing, but the im-

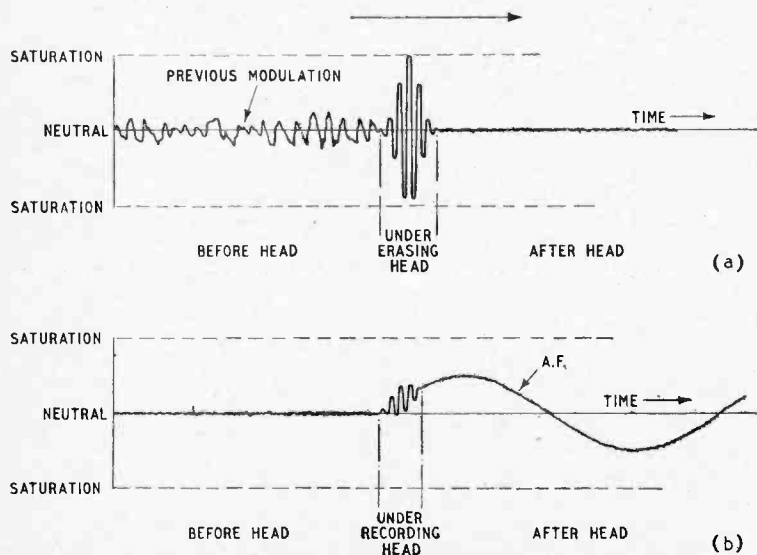

Fig. 4. Graphical presentation of magnetic state of tape with supersonic excitation (a) erasing, (b) recording.

The German Magnetophon—

pregnated tape overcomes this defect.

Conclusions.

Besides the high-quality, semi-fixed Magnetophon, portable models are made, and a series of lightweight models known as "Tonschreibers" was made for wartime purposes. By sacrificing top response in these models, the reel of tape can be run more slowly and longer playing time obtained (70 mins as against 22 mins for high quality).

In common with other tape or wire recording systems, the Magnetophon system enables records to be listened to directly after recording, no processing

being required, and the records may be played thousands of times without noticeable deterioration of quality.

In comparison with other tape or wire recorders, the Magnetophon has the following advantages:—

(a) Better quality is obtained (frequency range 25-10,000 c/s at tape speed of 77 cm/sec, dynamic range 65-75 db, distortion 2 per cent.).

(b) The plastic tape is lighter, cheaper, and wears better than the steel magnetic carriers.

(c) Tape may be cut and spliced at will, enabling editing, etc., as with cinematograph film.

(d) Notes, titles, etc., may be written along the roll—non-magnetic tape may be inserted for this purpose.

followed the difficulty of assessing interference in terms of field strength was emphasized and the need for further research to establish data upon which a code of practice could be formulated was stressed. A case might be made for arbitration in each individual case of interference as it arose, but this would require a host of inspectors armed only with their own judgment; it seemed better for a definite level to be specified though most speakers thought that this would be several orders of magnitude lower than the 1 mV/m put forward for debate.

Most speakers thought that the question should be settled without reference to the ambient interference from other industrial sources. Acceptance of this level as a permissible maximum for fresh sources of interference would lead to a cumulative rise in the aggregate level which would call for a corresponding rise in the power required by broadcast stations to give an adequate signal/noise ratio.

There was general agreement that effective screening rather than segregation of radio heating frequencies in restricted bands in which free radiation would be permitted was the more promising solution. For screening to be effective attention would have to be given to the maintenance of mechanical joints, interlocking mechanisms and the thorough filtering of power supply leads. Very efficient screening could be achieved by building factories underground. The problem of screening openings for doors, ventilators, etc., was discussed and it was suggested that instead of the usual wire mesh screen, a short corridor in the form of a waveguide might be used to give the necessary attenuation. It was stated that for a suitably proportioned corridor 6 ft high an attenuation of 10 db per metre was possible for a wavelength of 5 m.

The meeting showed the existence of a sincere desire on the part of both radio heating and communication engineers to collaborate to solve their common problems; as was perhaps to be expected the majority of the former had been trained originally in communications and fully appreciated their obligations.

INTERFERENCE FROM INDUSTRIAL ELECTRONIC APPARATUS

Discussion by the Radio Section of the I.E.E.

RADIO-FREQUENCY heating equipments with powers comparable to those used in broadcast stations are increasing in number and constitute a grave source of potential interference to communication channels. To establish a basis upon which a code of practice or, if need be, legislation could be formulated a discussion was held by the Radio Section of The Institution of Electrical Engineers on April 16th. It was opened by M. R. Gavin, M.B.E., M.A., B.Sc., who pointed out that most of the valve generators used in industry for heating purposes are self-oscillators and that considerable changes of frequency are experienced over each heating cycle due to changes in the electrical properties of substances under treatment. In some circumstances the variation might be as much as ± 5 per cent compared with the 0.05 per cent allowed for radio transmitters. To achieve a comparable stability in heating equipment, crystal control was essential and automatic tuning control would be necessary for the final stage of the power amplifier. This would increase the cost of high

power generators by about 50 per cent and considerably more on low powers. If a ± 1 per cent variation could be tolerated it might be possible to use a self-oscillator stabilised by a high Q circuit for such applications as thermoplastic sealing. Restriction of the amplitude of the power radiated by screening was the most hopeful method of combating interference.

If it were decided that a permitted level of interference should be fixed by law, then it was suggested that the level should be set at a relatively high value, e.g., 1 mV/m at the low frequency end of the radio band. Any equipment giving a level less than this should be approved unless it be found to cause interference. In that event the supervising authority should have the power to enforce further suppression, but before taking such action the case should be considered on its merits, taking full account of the relative importance of the heating application, the service being interfered with, and of the steps necessary to achieve the greater suppression.

In the discussion which

Now available in limited quantities for the Serious Experimenter . . the **TYPE 12 LIGHTWEIGHT PICK-UP**

(as used by the B.B.C.)



Pick-up - £2
(plus 8s. 8d. purchase tax)
Transformer
10s. 6d.

Specially designed for super quality reproduction and low record wear, the Type 12 Pick-up is a constant velocity device giving a flat response between 50 and 8,000 cycles per second.

The outstanding merits of the Type 12 Pick-up — now available to the serious experimenter — will readily be appreciated by the quality connoisseur from the following needle resonance table :

	Bass	Top
Silent Stylus	15 c.p.s. ...	9,000 c.p.s.
Miniature 99	15 c.p.s. ...	7-8,000 c.p.s.

Special needles as above should be used. For normal use we recommend the silent stylus, thereby ensuring long needle life and reduced record wear.

The total weight of the pick-up at needle point is 1½ oz.

A suitable matching transformer is also available. Type 12 Pick-up is for the genuine experimenter only, and when ordering, purchasers are requested to state that it is for their personal use. A certificate for completion to this effect will be supplied on request to E.M.I. Service Ltd., Radio Amateur Division, Sheraton Works, Hayes, Middlesex.

An Innovation in Needle Suspension

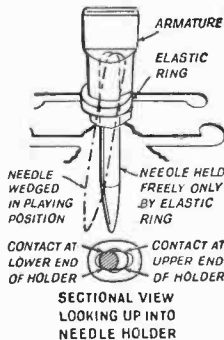

The new double V armature allows the needle to be fairly gripped without a needle screw, thereby reducing the total vibrating mass, and the weight on the needle point to give good tracking.

ELECTRIC & MUSICAL INDUSTRIES LIMITED

H A Y E S . M I D D L E S E X

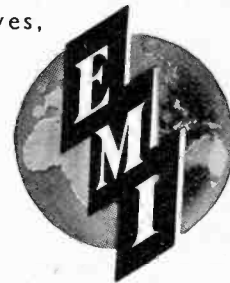

PREMIER RADIO Co.

MORRIS & CO. (RADIO) LTD.

Callers to 169 FLEET STREET, E.C.4. Phone: Central 2833

All Post Orders to 167 LOWER CLAPTON RD., E.5. Phone: Amherst 4723

ALL GOODS IN NEW CONDITION AND GUARANTEED.

TERMS OF BUSINESS, CASH WITH ORDER, OR C.O.D. OVER £1

Send 2½d. stamp for 1946 list.

5-WATT AMPLIFIERS. A/C/D operation, 3 stages, high gain, 3 ohm output, £8 8s.

ALUMINIUM CHASSIS. Substantially made of bright aluminium, with four sides, 10in. x 8in. x 2½in., 7/-; 12in. x 9in. x 2½in., 7/6; 16in. x 8in. x 2½in., 8/6; 20in. x 8in. x 2½in., 10/6

I.F. TRANSFORMERS. Iron core, Iltz wound, with or without flying lead. 460/465 K/c., 7/6.

MIDGET COILS. Unscreened Type, size 1½in. x ½in., designed for I.F. of 465 K/c Available in the types Osc. H.F. Tran. Aerial and in the following bands, 12-35-16-47, 34-100, 94-261, 200-557, 250-750, 700-2,000 metres. All types 2/3 each. Trimmers and Padders for all types, 8d. to 1/9. Also available, B.F.O. Coils, Aerial Filter, H.F. Filter. Same type and price as above.

YAXLEY TYPE SWITCHES. 2-pole 3-way 2-bank, 5/8; 2-pole 6-way 2-bank, 5/8; 2-pole 3-way 3-bank, 7/-; 2-pole 6-way 3-bank, 7/-. Any of the following types at 4/- ea. 1-pole 3-way, 1-pole 11-way, 2-pole 3-way, 2-pole 5-way, 3-pole 3-way.

S/W VARIABLE CONDENSERS. All Brass "Polyethylene Insulation," extended spindle for ganging. Noiseless. 15 mmd., 2/11; 25 mmd., 3/3; 40 mmd., 3/3; 100 mmd., 3/11; 160 mmd., 4/8; 250 mmd., 5/8.

FULL VISION S/M DRIVES. Calibrated 16-47, 200-557 and 700-2,000 with station names, 8-1 Escutcheon size, 7½in. x 4½in., 10/6. Junior Model. Calibrated 200-557 and 700-2,000 and station names. Escutcheon size, 5in. x 4in., 8-1, 10/6. Epicyclic Reduction Drives, 8-1, 2/9.

UTILITY MICRODIAL. Communication Type. Slow and Fast Motion Dual Knob and silver engraved, 4in. circular dial with hairline cursor 100-1 reduction. Fits entirely on front of panel, 8/6.

MAINS DROPPER RESISTANCES. Variable Type with sliding adjustment. 800 ohms, .3 amp., 5/6; 1,000 ohms, 2 amp., 5/6.

PREMIER MAINS TRANSFORMERS

All primaries are tapped for 200-230-250 v. mains 40-100 cycles. All primaries are screened. All LTS are centre tapped.

Output	Price	Output	Price
175-0-175 v. 50 m/a. 6.3 v. 2-3 a.	25/-	350-0-350 v. 150 m/a. 4 v. 1-2 a.	36/-
5 v. 2a.	25/-	4 v. 2-3 a. 4 v. 3-6 a.	36/-
175-0-175 v. 50 m/a. 4 v. 1 a. 4 v.	25/-	350-0-350 v. 150 m/a. 4 v. 2-3 a.	39/-
2-3 a.	25/-	4 v. 3-6 a. 4 v. 1-2 a. 4 v. 1-2 a.	39/-
250-0-250 v. 60 m/a. 6.3 v. 2-3 a.	25/-	350-0-350 v. 150 m/a. 5 v. 2-3 a.	36/-
5 v. 2 a.	25/-	6.3 v. 2-3 a. 6.3 v. 2-3 a.	36/-
250-0-250 v. 60 m/a. 4 v. 1-2 a.	25/-	425-0-425 v. 200 m/a. 4 v. 2-3 a.	47/-
4 v. 3-5 a.	25/-	4 v. 2-3 a. 4 v. 3-6 a.	47/-
300-0-300 v. 60 m/a. 6.3 v. 2-3 a.	25/-	425-0-425 v. 200 m/a. 6.3 v. 2-3 a.	47/-
5 v. 2 a.	25/-	6.3 v. 3-5 a. 5 v. 2-3 a.	47/-
300-0-300 v. 60 m/a. 4 v. 2-3 a. 4 v.	25/-	500-0-500 v. 150 m/a. 4 v. 2-3 a.	47/-
3.5 a. 4 v. 1-2 a.	25/-	4 v. 2-3 a. 4 v. 2-3 a. 4 v. 3-5 a.	47/-
350-0-350 v. 100 m/a. 5 v. 2-3 a.	29/-	500-0-500 v. 150 m/a. 5 v. 2-3 a.	47/-
6.3 v. 2-3 a.	29/-	6.3 v. 2-3 a. 6.3 v. 3-5 a.	47/-
350-0-350 v. 100 m/a. 4 v. 2-3 a.	29/-	500-0-500 v. 250 m/a. 5 v. 2-3 a.	65/-
4 v. 2-3 a. 4 v. 3-5 a.	29/-	6.3 v. 2-3 a. 6.3 v. 3-5 a.	65/-

PLAYING DESKS. A few only available. Consist of an Electrical Gramophone Motor with automatic stop and speed regulator, a quality magnetic Pick-up mounted on a strong metal frame. Price complete £8 17s. 6d.

MIDGET RADIO KITS. Complete with drilled chassis, valves and loud speaker, only cabinet required, medium and long wave T.R.F., size 10 x 6 x 6, 4 valves, inc. rect., tone control, A/O/D operation, 200/250 v. Circuit and constructional details supplied. Price, including tax, £9 17s. 6d.

AMAZING OFFER. We have purchased the following material which must be cleared. Special prices will be quoted for large quantities. Super Quality Lease-Lend Aerovox oil-filled Paper Condensers fitted with Staddock Insulators and vertical fixing clip, 2 mfd. 1,000 volts working, 2/6 each, or 20/- per dozen; 1 mfd. 600 volts working, 1/-, or 8/- per dozen, size 2in. x 1½in. x ½in. 0.1 mfd. 600 v. working, miniature aluminium can, wire ends, oil filled, insulation good as mica, 9d. each, or 7/6 per dozen.

MICAMOLD POSTAGE STAMP CONDENSERS. 0.01, 0.001, 0.002 mfd., 600 volts working, 9d. each, 7/6 per dozen.

CELESTION 10in. SPEAKERS. 2,100 ohms field, handle 8 watts. A super production with curved cone and dustproof voice coil, 50/-.

0005 CONDENSERS. Ceramic insulation, "Bar" Type. Single gang, 5/-; Twin gang, 8/6; three gang, 10/-; four gang, 10/-.

P.M. SPEAKERS. 5in., 21/6; 6in., 22/6; 8in., 24/-; 10in. 6 watt 15 ohm, 47/6; 12in. 15 ohms 15 watts, a high fidelity job, £8 15s.

Brand New GOVT. SURPLUS. Many Items at less THAN COST

ROTARY TRANSFORMERS. Input 15 v., output 180 v. 30 m/a. 4 v. 3 a. with 19 volts input, output is 50 per cent. higher. May be used on D/O mains as L.T. Charger. With small conversion could operate as D/O Motor. Original cost over £5. Employ powerful ring magnet. Price 10/- each.

ROTARY TRANSFORMERS. Input 6 v., 12 v. or 24 v. D.C., output 250 v., 560 v. or 1,200 v. 70 m/a. respectively, 40/-.

ELECTROLYTIC CONDENSERS. 8 mfd. 600 v.w., 3/-; 32 mf. 550 v.w., size 4 x 2 1/4, 5/-; 16 mf. 700 v.w., size 5 x 4 x 2, 7/6; 16 x 8 mf. 350 v.w., 7/6.

MAINS TRANSFORMERS. All 230 v. primary, 4 v. 1-2 amps., 7/6; 1,250+1,250 v. 250 m/a., £5; 6 v. 4 a. twice, 20/-; 4 v. 10 a. twice, 10/-.

CO-AXIAL CABLE. Super quality, consisting of a stranded centre core, a low-loss ribbed polyvinyl resin type insulator, a flexible screen, a weatherproof P.V.C. outer cover. Just the thing for Television Lead-in or Super Mike Cable, 6d. per foot.

TRANSFORMER CARCASES. Ideal for rewinding. All in perfect order with 230 v. primaries but odd type secondaries. 50 watt size, 7/6; 100 watt, 10/-; 150 watt, 12/6; 250 watt, 15/-.

FIRST GRADE MOVING COIL METERS

	Flash Mounting Bakelite Cases	100 microamp.
3½in. dia	1 milliamper.	£2 12 0
4½in. dia	1 milliamper.	£3 18 6
Internal Resistance	600 ohms	£3 8 3
	1,500 microamp.	£4 11 0
	600 ohms	£4 11 0

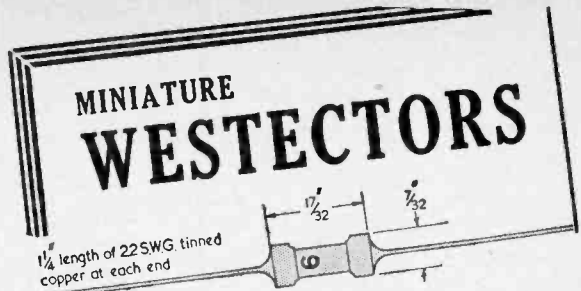

The Miniature Westector is designed to carry 1, 2, 3, 4 or 6 series elements protected from the outside atmosphere by compressing a neoprene ring between the metal end caps and the phenolic body to give a positive seal; this Westector is therefore suitable for tropical use and no reduction in the rating is necessary at ambient temperatures up to 55°C. (131°F).

WESTINGHOUSE

METAL RECTIFIERS

Write for Data Sheet No. 47

Westinghouse Brake & Signal Co. Ltd., Pew Hill House, Chippenham, Wilts.



IT is a fact that although VITAVOX K12/10 and K12/20 P.M. Speakers are not available in unlimited quantities, their quality is such that they are well worth waiting for.

It is a fact too that all specification figures are actual and not nominal.

VITAVOX LIMITED,
WESTMORELAND
RD., LONDON, N.W. 9.
Phone Colindale 8671/3

Design Data (5)

LOW-FREQUENCY CORRECTION CIRCUIT

Increasing Bass Response

THERE are many occasions on which it is necessary to give an A.F. amplifier a characteristic rising at the lower frequencies. Probably the most notable example is the case of an amplifier intended for reproducing gramophone records. Frequencies below some 250 c/s are attenuated in the recording process, and if the pick-up response curve is level, an equal increase in amplification is needed at such frequencies to correct for it.

One of the most satisfactory ways of achieving such correction is by means of the circuit shown in the diagram and it also gives some small amplification. This stage will normally be fed from the pick-up through the usual potentiometer-type volume control and its output will be fed to the grid of the first valve in the amplifier proper.

The stage can also be used as a low-frequency tone-control of the bass-lifting type by arranging a switch to change the value of C. The low-frequency response can then be varied without appreciably affecting the gain over the middle and higher audio-frequencies.

The design of a stage of this kind is based upon the fact that it is desirable for the valve to work into a load impedance of not less than twice its anode A.C. resistance. If the load is below this value it has only a small straightening effect on the valve characteristics, and the liability to amplitude distortion is increased. The values of components given by the appended design formulae are such that the load on the valve is twice its A.C. resistance at the higher frequencies and somewhat greater at low frequencies.

Example

The use of the equations is best illustrated by an example. Suppose that it is desired to determine circuit values to correct for a recording curve such as that shown dotted in Fig. 1, and that the valve has $R_a = 15,000 \Omega$ and $\mu = 40$. Correction below 50 c/s is usually unimportant and it is satisfactory to take this as the lower frequency f_1 ; the higher frequency f_2 should be chosen at a point where the attenuation is small, say, at 200 c/s.

The curve shows a response of -10 db at 50 c/s and -0.75 db at 200 c/s, therefore, $B_1 = +10$ db and $B_2 = +0.75$ db. Consequently, $y_1 = 10$, $y_2 = 1.19$ and $f_2/f_1 = 4$. Then carry out Step 1 in order to determine whether it is possible to obtain this degree of correction with this circuit. For the left-hand side of the inequality $y_1 = 10$. For the right-hand side, $1 + 16 \times 0.19 = 4.04$. The left-hand

side is greater than the right-hand and the required performance cannot be obtained.

Examination of the inequality shows that to obtain practical values it is necessary to reduce y_1 or increase y_2 or f_2/f_1 . Increases of y_2 and f_2/f_1 are virtually the same thing, for if f_2 is increased it means that the response at the old value of f_2 is greater.

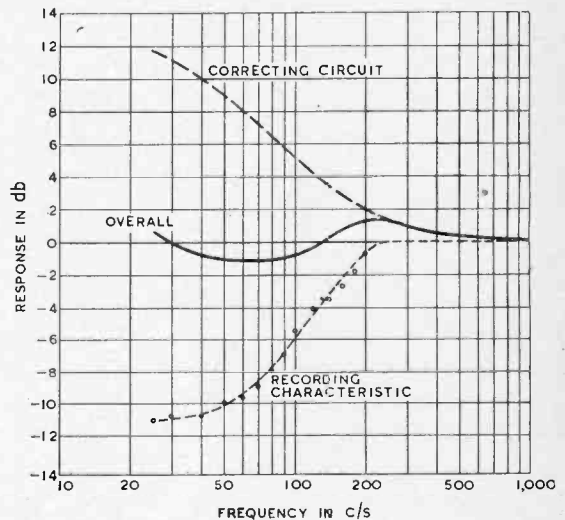

Fig. 1. Illustrating the application of the design data.

Now in practice small variations of response of the order of 1 or 2 db are negligible, for they are inaudible. The best way of obtaining a practical circuit, therefore, is to modify the requirements somewhat. Instead of demanding 10 db correction at 50 c/s, try 9 db, and instead of calling for a rise of only 0.75 db at 200 c/s, permit 2 db. The overall response will then be -1 db at 50 c/s and $+1.25$ db at 200 c/s, which is quite good.

With $B_1 = +9$ db, $y_1 = 7.95$ and with $B_2 = +2$ db, $y_2 = 1.59$. Now repeat Step 1. This gives, left-hand side = 7.95 and right-hand side = 10.44. The inequality is satisfied and the circuit is possible.

Step 2 comes next and gives $x = 0.211$ and $T = 0.00975$. Then comes Step 3, and the component values are: $R_1 = 45,000 \Omega$; $R = 21,400 \Omega$; $R_2 = 68,500 \Omega$; $C = 0.0456 \mu\text{F}$. The amplification E_o/E_{in} is 6.33 times.

Step 4 follows and $R \sqrt{1 + 1/\omega_1^2 T^2}$ is determined. Its value is $73,000 \Omega$ and R_3 must be much larger than

Low-frequency Correction Circuit

this. A value of 2 MΩ for R₃ is suitable and it will affect the response only to a small degree. Such a value will also usually be permissible for the grid leak of the following valve. Now C₁ must be very large compared with 0.00159 μF. A capacitance of 0.02 μF would be suitable.

A valve of the type selected for this example will usually need R₅ about 2,000 Ω; therefore, C₃ must be very large compared with 1.59 μF. A value of 25 μF or 50 μF will be satisfactory.

The response obtained from the circuit, neglecting the small effects caused by C₁R₃ and C₃R₅, is shown by the dashed curve of Fig. 1 and the solid curve shows the combination of this with the recording curve. Although no attempt has been made to obtain correction below 50 c/s, it so happens in this case that it is better below 50 c/s than at this frequency.

Design Data (5): Low-frequency Correction Circuit

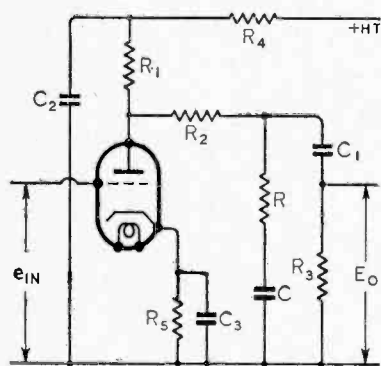

Given: R_a (ohms) = anode A.C. resistance of valve.

- μ = amplification factor of valve.
- B₁ (db) = increase of response required at a low frequency f₁ (c/s).
- B₂ (db) = increase of response required at a higher frequency f₂ (c/s).

Step 1

Check that the values of B₁ and B₂ are such that the required performance is possible with this circuit. It is necessary that

$$y_1 < 1 + (y_2 - 1) f_2^2 / f_1^2$$

where y₁ = antilog B₁/10 = power ratio corresponding to B₁ db.

y₂ = antilog B₂/10 = power ratio corresponding to B₂ db.

Step 2

Enumerate:—

$$x = \sqrt{\left[\frac{1}{y_1} \cdot \frac{(y_2 - 1) f_2^2 / f_1^2 - (y_1 - 1)}{(y_2 - 1) f_2^2 / f_1^2 - (y_1 - 1) y_2 / y_1} \right]}$$

$$T = \frac{1}{6.28f_1} \sqrt{\left[\frac{1 - x^2 y_1}{y_1 - 1} \right]}$$

Step 3

Determine component values:—

$$\begin{aligned} R_1 &= 3R_a \text{ (}\Omega\text{)} & C &= 10^6 T / R \text{ (}\mu\text{F)} \\ R &= \frac{27}{4} R_a x \text{ (}\Omega\text{)} & E_o / e_{in} &= \text{voltage amplification of stage at high frequencies} \\ R_2 &= 6R_a (1 - \frac{2}{3}x) \text{ (}\Omega\text{)} & &= \frac{3}{4} \mu x \end{aligned}$$

Step 4

Choose R₃ and C₃ in accordance with normal procedure for a resistance-capacitance coupled stage. This means usually

$$\begin{aligned} R_3 &\gg R \sqrt{1 + 1/\omega_1^2 T^2} \text{ (}\Omega\text{)} \\ C_1 &\gg 10^6 / \omega_1 R_3 \text{ (}\mu\text{F)} \text{ where } \omega_1 = 6.28f_1 \end{aligned}$$

Choose R₅ to give the required grid bias for the valve, and make C₃ >> 10⁶/ω₁R₅ (μF)

Make R₄ as large as possible consistent with obtaining an adequate anode voltage on the valve (50,000 Ω is usually of the right order). The value of C₂ depends on the amount of amplification following this stage and must be large enough to make feed-back effects negligible (8 μF is usually adequate).

If it is required to know the overall response, it may be calculated from the formula:—

$$B = 10 \log \frac{1 + \omega^2 T^2}{x^2 + \omega^2 T^2} \text{ db}$$

where ω = 6.28 times frequency in cycles per second.

FOR THE CONSTRUCTOR

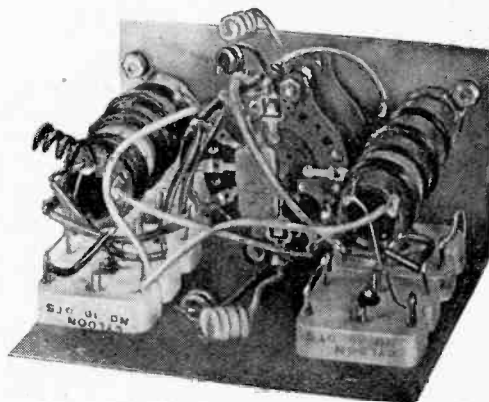

Three-waveband coil pack for superheterodynes made by Weymouth Radio Manufacturing Co., Crescent Street, Weymouth. The unit comprises aerial and oscillator coils with trimmers and waverange switch and covers 19-50, 200-550 and 1,000-2,000 metres.

NAVIGATIONAL AIDS

Demonstrations in H.M.S. "Fleetwood"

TO give delegates to the International Meeting on Radio Aids to Marine Navigation an opportunity of seeing some of many systems of radio position-finding in action, a series of sea trials were run last month in H.M.S. "Fleetwood."

The ship was fitted with radar and in addition to the standard wireless receiver which is all that is necessary to make use of shore rotating beacon stations such as Orfordness and the more modern multiple-lobe Consol, the ship carried a representative medium wave D/F receiver and special receivers for hyperbolic navigation with the continuous wave "Decca" and the pulse-operated "Gee" systems. Of course, no attempt was made to "sell" any particular system and in the descriptive programme prepared by the Admiralty Signal Establishment the advantages and limitations of each method were set out with scrupulous fairness.

The radar demonstration of pilotage in narrow waters followed the lines of the Thames Estuary experiments in H.M.S. "Pollux" already reported in the March issue of this journal. The equipment installed in H.M.S. "Fleetwood" has been "cleaned up" from the engineering point of view; detail improvements include a continuously variable range scale and an automatic reversing switch for the scanning motor so that when the chart comparison mirror is lowered to give direct vision, the optical reversal is automatically corrected.

Perhaps the most important development is the provision of automatic monitoring of the performance of both the transmitter and the receiver. This is essential if the ship is in fog in mid-ocean, when a blank display must mean that there is no other ship within range—and nothing else. The automatic monitor consists of a resonant cavity containing a crystal rectifier and a small spark transmitter and mounted a short distance behind the rotating aerial

reflector. Each time the beam sweeps past the monitoring box the received energy is integrated by a long time-constant circuit to give a D.C. meter reading. The received pulses are also given a suitable time delay and used to actuate the spark transmitter which sends a feeble pulse back to the aerial to test the receiving gear when it is not occupied with the main display. The rectified output from the receiver is added to the transmitter test output and if the combined current does not reach the required value a relay shuts down the display.

A second monitoring device enables the operator to put on the C.R. tube a number of vertical lines representing voltages in various parts of the equipment. These have been adjusted so that they are all of the same height under normal conditions and in the event of deterioration of performance the probable cause can be quickly located.

It has been suggested that a gyro compass to provide the repeater signals necessary to keep the display "right way up" on the screen might add prohibitively to the cost of the equipment. To meet this objection the Admiralty have produced a transmitting magnetic compass of simple and reliable design. The liquid in the compass bowl is made conducting by the addition of a trace of electrolyte and four electrodes are sealed into the sides of the bowl to form a wheatstone bridge. The compass card carries a light semi-circular metal strip on the underside which modifies the resistance of two arms of the bridge. It is arranged that the bridge is balanced when the lubber line coincides with north on the card and the metal strip is symmetrically placed between the arms of the bridge. The bridge is energised with A.C. and any out-of-balance current is amplified and applied to motors which cause the bowl to rotate until the balance is restored. The movement of the bowl is transmitted to repeaters by magstrip motors.

ONE LOUDSPEAKER —360° COVERAGE

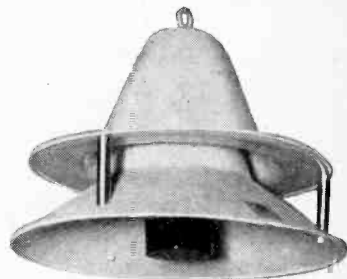

This new type, called the CIRCON, has horn-speaker efficiency together with completely uniform distribution throughout 360 deg.

Typical advantages:—ONE centrally placed will cover the whole of a medium-sized area: used on a moving vehicle results are equal approaching, passing or receding, thus ideal for street processions, elections, etc. Full details will be available shortly.

List price—Horn only £7 0 0.
Complete £14 5 0.



M.5
Moving Coil
MICROPHONE

No polarising current, adequate frequency response, low impedance, high output due to a very efficient magnet and careful design.

List price £5 15 0.

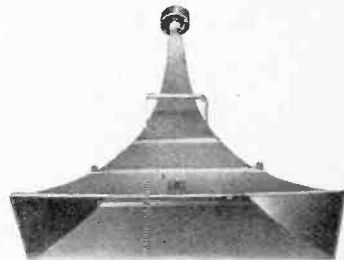

L.S.7 HORN LOUDSPEAKER
Maximum sensitivity and volume. Impedance 10 ohms: handles 12 watts 170-10,000 c.p.s. 40in. horn. List price £13 10 0.

F. I. for P. A.
FILM INDUSTRIES LTD.
60, PADDINGTON ST., W.1
Telephone: WELbeck 2385

PROPAGATION OF ULTRA-SHORT WAVES

Super-refraction Radio "Ducts" and Abnormal Radar Ranges

ON March 27th a session of the Radiolocation Convention being held at the Institution of Electrical Engineers was given over to the consideration of a number of papers on the propagation of waves used for radar. These are radio waves of the metre, decimetre and centimetre class, and, since such waves may be employed for numerous purposes other than radar, information about their propagation acquired during the war is likely to be of great general interest.

In a paper, "Elements of Radio Meteorology: How Weather and Climate Cause Unorthodox Radar Vision Beyond the Geometrical Horizon," Dr. H. G. Booker gave several examples of radar vision far beyond the optical horizon, i.e., of radar signals being returned from phenomenally long distances. One instance was that of radar vision of the low, flat coastline of Holland from a station in East Anglia. The author explained that radio rays in the atmosphere are normally not quite straight, but curve slightly downwards owing to the decrease of atmospheric density with height. Sometimes—generally in the body of air just above the surface—this curvature is much increased and there arises the case where a ray leaving horizontally from a transmitter at a certain height would curve to the same extent as the earth's surface. This gives rise to the formation of what is called a radio "duct," for rays leaving horizontally from transmitters situated lower down than that just specified would curve even more, and so would be propagated by successive hops around the earth's surface. They would, in fact, be "trapped" within the duct instead of going off into space as under normal conditions. These radio ducts are effective only for waves of the order of one metre or shorter, and longer waves are not affected because the rate of change of refractive index in the atmosphere is not such as to lead to the forma-

tion of such very large ducts as would be required to "guide" them.

The excessive curving effect is said to be due to "super-refraction" of the waves, and their successive hops lead to phenomenally long radar ranges. It occurs when there are unusual gradients of temperature and humidity in the atmosphere, and Dr. Booker went on to discuss the meteorological and climatic conditions which give rise to such gradients. The requirement is that the upper atmosphere should be exceptionally warm and dry in comparison with the air in contact with the earth's surface, and this most usually occurs when the weather is fine and calm. High winds or bad weather give rise to more orthodox propagation of the waves.

The details of the meteorological effects mentioned are too complex to deal with here, but there are distinct diurnal and seasonal effects, and in tropical climates the requirements for the formation of ducts are more often present than in temperate ones, and so super-refraction of ultra-short radio waves more frequently occurs.

Weather Conditions

A paper by E. C. S. Megaw, M.B.E., "Experimental Studies of the Propagation of Very Short Waves" dealt comprehensively with the results of wartime experiments on the propagation of ultra-short waves over certain land and sea paths. Striking evidence of the dependence of propagation under weather conditions was given in the results of an experiment between the Isle of Man and a ship at sea. When the weather was rough the field strength at a distance followed almost exactly that calculated for a standard atmosphere, but when fine weather set in there was a remarkable increase in the field at considerable distances. The author also dealt with the subjects of reflection and scattering from

sea and land, and with the effects of obstacles.

Interesting contributions to the subject under discussion were made by Lt. Cdr. F. L. Westwater, J. W. Kyde, Dr. R. L. Smith-Rose, Lt. B. S. Starnecki, J. M. C. Scott and T. L. Eckersley, F.R.S.

The concluding remarks by Sir Edward Appleton, F.R.S., dealt with the effects of extra-tropospheric phenomena upon the propagation of ultra-short waves. The normal ionosphere layers would not affect this, provided the waves used were below a certain wavelength. At least they would not affect it in these latitudes where we had sufficient data on the ionosphere to be sure about the matter, but there were parts of the world from which no data had yet been obtained, and it was possible that in some of these the ionisation might reach such values as to cause modification of the wavelengths used for certain purposes. There was, however, the phenomenon of "Sporadic E," and this might give rise to undesired refraction at times, whilst the "bursts" of signals on ultra-short wavelengths thought to be due to the ionisation caused by meteorites indicated another possible source of trouble. Finally, there was the radio noise coming from the Milky Way and from the Sun, which was of relatively considerable intensity on these wavelengths and which was therefore a factor which must be studied and taken into proper consideration.

T. W. B.

PYE 65a BATTERY RECEIVER

A BATTERY counterpart of the Pye 15A receiver reviewed in our January, 1946, issue has been introduced by Pye, Ltd., Radio Works, Cambridge. It employs a Q.P.P. output stage and has the quick chassis release, flywheel tuning and tone control features of the A.C. model. The price is £15 15s plus £3 7s 9d purchase tax.

Letters to the Editor

Tribute to Blumlein • B.B.C. Secretiveness • Servicing Troubles • Feedback Tone Control

Miller Integrator ?

A CIRCUIT device that ranks with the cathode follower among the most valuable of recent years is that called the Miller integrator. I suggest that this name is inappropriate and misleading, as although the circuit is related in principle to the Miller effect it is actually due to the late Mr. A. D. Blumlein. It would be some small recognition of the many contributions of Mr. Blumlein to circuit technique if this circuit were renamed the Blumlein integrator. As the present name has not yet been given much publicity it should not be too late to make the change, which I therefore strongly recommend for your consideration.

M. G. SCROGGIE.

B.B.C. Transmitters

INFORMATION as to how the B.B.C. distributes its programmes over its medium- and long-wave transmitters does not seem to be common knowledge at all and I would like to suggest that some information on this subject might be given. This could take the form of a map showing the location of the stations, together with a chart showing the programmes, wavelengths and power.

A. T. DRAKE.

Cheltenham.

Soldering v. Spot Welding

WITH reference to Richard Arbib's letter in your April issue, as ex-inspector of Admiralty radar equipment I would put the causes of poor or dry solder joints in the following order: First, incorrect iron temperature; second, careless or indifferent work by the operator.

I found in the course of my work that even with an iron of correct temperature, a good class solder and ample time to make a good job it was still hopeless to

expect some operatives to turn out a job free from bad or dry joints.

I consider that provided the requirements mentioned above are met with there is absolutely no excuse for bad soldering.

With regard to spot welding of joints, imperfect work could be still found here, and whatever the job, good or bad, in the main it always rests with the person performing it.

G. AUSTIN.

Haywards Heath.

Valve Metalizing

A COMMON fault experienced in servicing radio receivers is that caused by faulty valve metalizing. As is well known, instability and erratic behaviour go hand in hand with sets developing this particular trouble.

Surely, it is not beyond the wit of British valve manufacturers to design a contact to the metalizing that is well and truly anchored and at the same time will remain permanent during the life of the valve?

Ipswich.

A. ADCOCK.

Telephone Recorders

THE Federal Communications Commission, in Washington, D.C., recently started an enquiry on the use or abuse of sound recording devices in connection with telephone conversations. Witnesses for the telephone industry and the recording industry have given testimony, the former contending that some form of restriction which would assure positive notice to all parties of a telephone conversation that it was being recorded was essential, and the latter claiming that "a warning notice to the outside party is unnecessary because of the public acceptance of electronic or mechanical recording and of secretarial monitoring of telephone conversations. If any

NEW!



Tannoy are introducing many new features in their post-war range of products, and highly specialised equipment is now available. Illustrated is the latest pattern Tannoy Ribbon Velocity Microphone. Write for full details of the extensive range of Tannoy Sound Equipment.

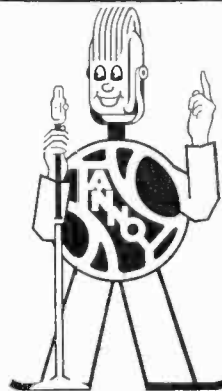

TANNOY

The Sound People

"TANNOY" is the registered trade mark of equipment manufactured by
GUY R. FOUNTAIN LTD.
 "THE SOUND PEOPLE"
 WEST NORWOOD, S.E.27. Gipsy Hill 1131
 and at Manchester, Belfast, Newcastle, Birmingham
 Bristol, Edinburgh, Glasgow, etc., etc.
 The largest organisation in Great Britain
 specialising SOLELY in Sound Equipment.

Letters to the Editor—

notice should be held desirable, a notation in connection with the subscriber's listing in the industry would suffice.

This matter may not seem to be of great import or urgency in Great Britain, but when magnetic wire or tape recorders, as well as long-playing disc reference recorders, become generally available here, this problem will have to be faced.

Telephone recording devices are already in use in this country,^{1,2} but their price has precluded widespread use so far. The G.P.O. has approved certain of these equipments and, for a nominal fee, permits a direct connection to their lines, but, of course, with induction coil coupling no actual physical contact with the telephone is needed, and it is possible to employ such a device without any indication to the persons telephonically linked or the G.P.O.

Space does not permit me to dilate on the legal, moral and technical pros and cons of employing recording devices on telephone circuits,³ but it is obvious to anyone with imagination that the use of such apparatus is fraught with many possibilities, and not all necessarily beneficial to the community.

As I am intimately connected with the recording profession I, naturally, am anxious to see an increasing use of sound recording devices for innumerable applications, but not by misuse to bring recording into disrepute. Therefore, with your kind co-operation, it would be interesting and helpful to have a few opinions of recording technicians and telephone subscribers on this question ventilated in your columns.

DONALD W. ALDOUS,

Tech. Secretary, British
Sound Recording Association,
London, W.C.1.

Tone Correction

A CIRCUIT I recently discovered while experimenting may prove of interest to those who wish to combine negative feedback with tone compensation

and simplicity of design. It is particularly applicable to the average battery set where bass and treble boost is missing. The circuit about to be described is found to give these benefits com-

of the speaker, which improves the tone, the positive feedback occurring at a considerably lower frequency.

When this system of feedback was added to a battery set, the

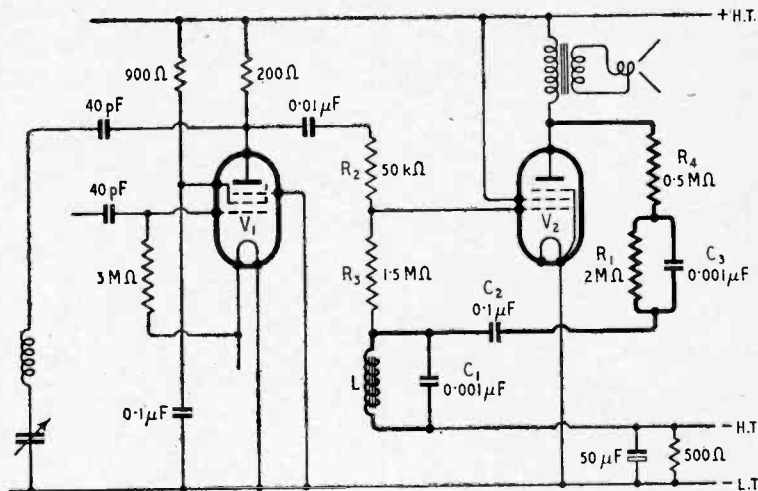

paratively cheaply. The diagram shows the detector pentode and output pentode of a typical battery set, and the additional feedback network is shown in heavy lines.

The inductance L is a 5:1 transformer and its approximate total inductance is 150 henrys. C_3 controls the frequency of the bass boost, and can be adjusted to suit the speaker and output transformer and personal requirements. The output transformer is of the average type with primary inductance 15 henrys. C_1 controls the frequency of the treble boost and C_2 is a blocking condenser. R_2 is inserted to reduce the effect of feedback on the anode of V_1 and R_1 is adjusted to reduce bass reverberation. R_3 and R_4 control the extent of feedback, and could be used to vary the extent of bass and treble boost.

The circuit can be analysed quite simply as follows. At low frequencies there is a complete phase reversal resulting in positive feedback. This phase reversal also takes place to a reduced extent at high frequencies. At medium frequencies, i.e. at the resonance of C_1L , negative feedback takes place. A certain amount of negative feedback also takes place at the bass resonance

tone was vastly improved, distortion was reduced and there was no appreciable loss in amplification.

L. GREGORY.

Upton, Cheshire.

MEASURING INTERFERENCE

WITH the increasing output of domestic electrical equipment there is considerable interest in the question of suppressing interference. There is, however, a dearth of equipment suitable for measuring the interference as prescribed in the British Standard No. 727.

In an endeavour to meet the need the G.P.O. is adapting a number of Army interception receivers Type R206 for the purpose, and they will be made available as cheaply as possible to manufacturers of electrical equipment.

As only a limited number of sets will be available it is probable that the demand will exceed the supply. The British Standards Institution has, therefore, been invited by the Post Office to advise as to their most useful allocation. All enquiries should be addressed to the Director, B.S.I., 28, Victoria Street, London, S.W.1, quoting the reference OC/1/3.

¹ *Wireless World*, July 5th, 1935, p. 5.

² *Wireless World*, June 29th, 1939, p. 611.

³ *Telephony*, August 11th, 1945, p. 13.

In advising as to the allocation, the B.S.I. will take into account the competence and willingness of the applicant to act, within reasonable and practicable limits, as an "approved testing station" for samples of the products of other manufacturers, as well as of his own, and the importance, from the radio interference point of view, of the range of products to be tested, particularly the applicant's own products.

The tolerable limits of interference are given in British Standard No. 800.

UNBIASED By FREE GRID

U.S.W. Telepathy

A KINDLY reader has sent me along a cutting from *Picture Post* in which a correspondent of the Editor of that journal points out how unnatural it is for us to dwell in two- or three-storied houses "situated," as the house agents say, many feet above Mother Earth. He has, so he says, solved the problems induced by this unnatural practice, by earthing his big toe, I cannot myself profess to know much about the nature cult, having rigidly eschewed it since they attempted to remove my bowler hat at the entrance gates of a nudist camp to which Mrs. Free Grid sent me in the vain hope of my doing a black-market deal in unwanted clothing coupons.



A nasty flash-over.

However, the whole affair reminds me very vividly of some researches which I made during the war into the vexed question of telepathy. As you know, the B.B.C. have tried it with very indifferent results, although few will deny that genuine cases of this irritatingly elusive mental faculty do exist. I had long supposed that this thought-transference business was done by U.S.W.,

B.B.C. YEAR BOOK

A WEALTH of information on the past year's broadcasting in all the services of the B.B.C. is contained in the "B.B.C. Year Book, 1946."

The Corporation's engineering developments during the war are outlined by the Chief Engineer, details are given of the underground headquarters built in the Clifton rocks, and some facts on the expansion of the engineering division are included in this 152-page book, priced 2s 6d.

The book is well illustrated and concludes with a useful reference section.

and only occurred in those comparatively rare instances where "transmitter" and "receiver," or, in other words, two minds happened to have the same natural wavelength.

It was but a step further for me to visualize that if this were true, as I had every reason to believe, it only remained for me to devise some method whereby the wavelength of each mind could be varied at will to bring about mutual sympathy. At first I went hopelessly astray and commenced very crudely by equipping Mrs. Free Grid and myself each with a metal cap like they use in the U.S.A. for electrocution purposes, attaching thereunto an ordinary aerial system. For Mrs. Free Grid's case I provided no earth connection, reckoning that the capacity of her body to earth would, ample as it was, be all that was needed and herein, of course, lay my undoing, as she accumulated a very considerable static charge which eventually resulted in a nasty flash-over, all of which would have been avoided had I only adopted the simple precautions advocated by the correspondent of *Picture Post*.

However, I had eventually to abandon my project entirely, as apart from a reluctance on the part of Mrs. Free Grid to co-operate further, I was legally advised that I was for all intents and purposes establishing a transmitter and as it was wartime the consequences were likely to be serious. I am hoping very shortly, however, to recommence my work in this matter as I am convinced that telepathy is just as much a question of U.S.W. as in rhabdomancy, concerning which one of *Wireless World's* most erudite contributors (D'Orsay Bell) wrote some weighty words of wisdom many years ago.

THE NEW MULTITONE UNIVERSAL pocket hearing aid

SPECIFICATION

Size: $5\frac{1}{2}'' \times 2\frac{1}{4}'' \times \frac{1}{4}''$ Weight: $9\frac{1}{2}$ ozs.
Three stage amplifier with crystal microphone. Button-base international valves. Low tension drain 90 m.a. High tension drain from $\frac{1}{4}$ to $2\frac{1}{2}$ m.a. Maximum voltage amplification 4,000. High tension battery 45 volts layer-built. Low tension $1\frac{1}{2}$ volts. All our aids may be had on a week's home trial free of charge. Write for the address of your nearest Multitone Agent.

The new Pocket Aid makes use of a cascade circuit (Patent applied for) which we have developed. Two valves only are used, a heptode as a two stage amplifier and a H.F. pentode as an output triode. The new circuit has enabled us to produce a hearing aid of outstanding performance, at the very moderate price of 12 gns.

The new instrument will give excellent hearing to all cases of deafness responsive to instrumental help. Its controls can be adjusted to make it equally helpful to those needing clarity of reproduction rather than great volume. It can be used without alteration with any type of earpiece, including crystal or bone-conductor.

The instrument incorporates many new features, one of which regulates the high tension current to the particular requirements of the individual user, thus ensuring longest possible life for high tension batteries. It is particularly economical—the cost of replacements for a severely deaf person being estimated at 1/6d. per week.

The batteries used are of the new layer built type and are all fitted with international connections and sockets—obtainable all over the world.

The Universal Pocket Aid is small and light enough to be easily worn on the person.

MULTITONE

ELECTRIC COMPANY LIMITED

92 New Cavendish Street London W1

A SIMPLE OSCILLOSCOPE

Using the Mains as a Time Base

BEING in need of a frequency comparator for calibrating a B.F.O. against 50-cycle mains, the writer purchased cheaply a 7in "magnetic" cathode-ray tube and resolved that the auxiliary apparatus should be on equally economical lines.

The resulting oscilloscope has proved very satisfactory in use, not only for its original purpose, but also for the examination of phenomena whose period of recurrence is, or can be adjusted to, an integral multiple of 50 c/s.

Deflecting and focusing coils, roughly following normal television practice, were quickly made up. No iron was used in the magnetic circuits, and the focusing coil was wound to suit a 2-volt D.C. supply which was available. The only other components required were a H.T. supply transformer of the small kind with a 2-volt filament winding (half a centre-tapped 4-volt winding), a

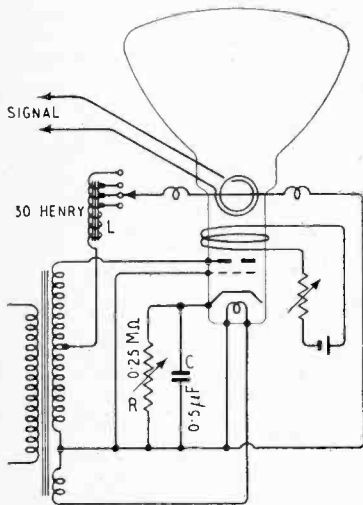

Fig. 1. Circuit diagram of oscilloscope. The anode is fed with raw A.C.

tapped choke and the variable resistances for focusing control and grid bias. The circuit arrangement, which could hardly be simpler, is shown in Fig. 1.

By F. P. WILLIAMS

The anode is fed with raw A.C. of about 700 volts peak, and the steady grid bias voltage developed across C is adjusted so that the spot is only visible on or near the positive peak of anode voltage. The idea is to use the straight "middle cut" of the sine wave for the time base and adjust the phase of this so that the middle of the base is reached at peak anode volts.

To this end a choke L is included in the horizontal deflecting coil circuit. The deflecting current, I_d , and therefore the field produced, lags behind the anode voltage V_a by nearly 90 degrees. The tapings on the choke serve to adjust the length of the time sweep. Fig. 2 shows the relation of anode voltage to deflecting current. An anode voltage, not dropping below 90 per cent. of the peak value, covers 50 degrees of the cycle; over this period the time sweep is as linear as makes no difference. 50 degrees of a 50-cycle wave is 2.8 milliseconds, which is long enough for one complete cycle at 350 c/s. The available length of base being about 12 cms, a 14,000 c/s wave is 3 mm from peak to peak. Higher frequencies may be observed by tapping down the choke so that the time sweep is well off the tube screen each end, the only limits being overheating of the deflection coils and progressive dimming of the trace as the writing speed gets higher.

For some purposes it is useful to know the "sense" of the time base and to have it writing from left to right, say. This may be done by disconnecting the time base deflecting coils and passing current from a 2-volt cell through them in such a direction that the spot is moved to the right. Note which coil terminal is connected to positive of the cell, and, when reconnecting for use, join this terminal to the choke.

It is worth noting that the use

of a condenser instead of a choke to obtain the phase shift is unsatisfactory, since this discriminates in favour of the harmonics present in the mains supply and spoils the linearity of the trace. One other point: with only 700 volts on the anode, the deflec-

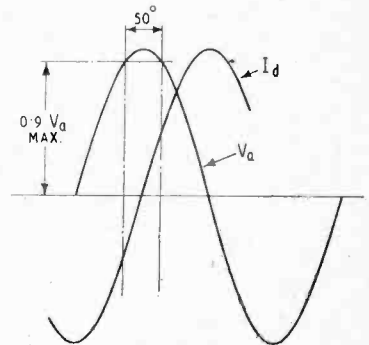

Fig. 2. With the correct phasing inductance the anode voltage remains practically constant over the straight portion of the deflecting current curve.

tional sensitivity of the tube is high (a useful feature), so that, unless a Mumetal screen is employed, the transformer and choke should be mounted not less than 2ft from the tube.

CATALOGUES RECEIVED

BOOKLET giving technical data on electrical resistance materials manufactured by Johnson, Matthey and Co., 73-83, Hatton Garden, London, E.C.1.

"Replacement Capacitors for the Service Engineer" (catalogue C.258) from A. H. Hunt, Ltd., Bendon Valley, Garratt Lane, London, S.W.18.

Leaflet describing solventless impregnating varnishes from Jenson and Nicholson, Ltd., Carpenters Road, Stratford, London, E.15.

Catalogue of mica and ceramic capacitors, hermetic seals and metallized bushes from the United Insulator Co., 12/22, Laystall Street, London, E.C.1.

List of sound recording and reproducing equipment from the Recordomat Co., 19, Exmouth Market, Rosebery Avenue, London, E.C.1.

SHORT-WAVE CONDITIONS

Expectations for June

By T. W. BENNINGTON
(Engineering Division, B.B.C.)

DURING April, the average daytime maximum usable frequencies for this latitude were about the same as during March, whilst due to the longer duration of daylight the night-time M.U.F.'s were considerably higher than during that month. Communication on the exceptionally high frequencies by way of the regular layers was, however, less frequently possible, particularly to the U.S.A., and it will probably become still rarer to that country as the summer approaches.

There was less ionosphere storminess during April than during the previous month. Nevertheless, storms did occur on the 9th, 14th-16th, and 23rd-26th. The latter was a disturbance of great intensity and during its course short-wave communication was greatly upset, whilst the aurora borealis was widely observed in this country. "Delinger" fadeouts were reported on the 3rd, 10th and 18th, and, on at least one of these occasions, the solar "hissing" noise was heard on the short wavelengths.

Forecast.—During June, the working frequencies for long-distance transmission should, generally speaking, be somewhat lower than during May in the daytime, but the night-time usable frequencies should continue to increase. Daytime frequencies will, on many circuits, remain of use for a longer period of time than during May—for example, 15 Mc/s should be regularly usable till well after midnight. For medium-distance transmission—up to about 2,000 miles—the E or F₁ layers will control transmission for considerable periods during the daytime, and, in this case, daytime as well as night-time frequencies should be higher than at present.

Sporadic E is likely to be particularly prevalent, and so, on frequent but unpredictable occasions, communication up to 1,400 miles may be possible by way of

this medium on frequencies far above those usable by way of the regular layers.

Below are given, in terms of the broadcast bands, the working frequencies which should be regularly usable during June, for four long-distance circuits running in different directions from this country. In addition, a figure in brackets is given, this indicating the highest frequency likely to be usable for about 25 per cent of the time during the month, for communication by way of the regular layers.

Montreal: 0000, 15 Mc/s (20 Mc/s); 0200, 11 Mc/s (18 Mc/s); 0900, 15 Mc/s (22 Mc/s); 1200, 17 Mc/s (25 Mc/s); 2300, 15 Mc/s (22 Mc/s).

Buenos Aires: 0000, 15 Mc/s (20 Mc/s); 0200, 11 or 9 Mc/s (15 Mc/s); 1000, 17 Mc/s (25 Mc/s); 1600, 21 Mc/s (27 Mc/s); 2000, 17 Mc/s (25 Mc/s); 2300, 15 Mc/s (20 Mc/s).

Capetown: 0000, 15 or 11 Mc/s (18 Mc/s); 0200, 11 Mc/s (15 Mc/s); 0600, 17 Mc/s (25 Mc/s); 0900, 21 Mc/s (32 Mc/s); 1400, 26 Mc/s (34 Mc/s); 1600, 21 Mc/s (31 Mc/s); 1900, 17 or 15 Mc/s (23 Mc/s); 2100, 15 or 11 Mc/s (18 Mc/s).

Chungking: 0000, 15 Mc/s (20 Mc/s); 0600, 17 Mc/s (24 Mc/s); 2000, 15 Mc/s (22 Mc/s).

Short-wave conditions are usually relatively undisturbed during June, and stable conditions may be expected, which is not to say that no disturbed periods at all will occur.

OUR COVER

THE cover picture illustrates a number of radar aerials. The two "telegraph poles" are 10-cm A.I. aerials. One is a dipole and reflector and the other a dipole with director and reflector. The reflector elements are longer, and the director shorter, than the dipoles and the arrays are used in conjunction with a mirror.

The skew-mounted array is used in automatic gun-laying turret equipment. It rotates at high speed and is provided with a counter-balance weight. The rotating joint is of the capacitive type.

The aerials shown are manufactured by B.I. Callenders Cables.

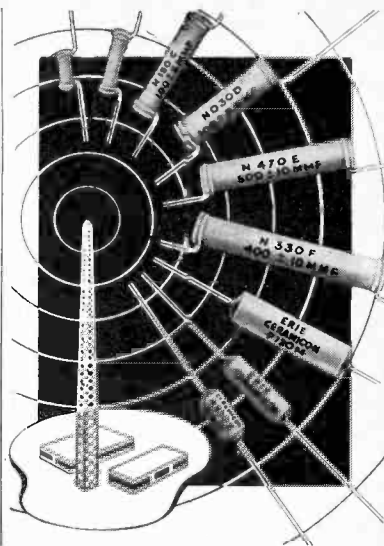

ERIE Ceramicon

**MAINTAIN SUPREMACY
IN THE FIELD OF COMMUNICATIONS
FOR TEMPERATURE COMPENSATING
& GENERAL PURPOSE CONDENSERS**

STYLE	CAPACITY RANGE		
	P080 P100 P120	N750	Hi-K
	MMF	MMF	MMF
A and K	1-9	1-51	56-560
B and L	10-18	52-110	560-1,500
C and M	19-63	111-360	1,500-4,700
D	64-93	361-510	4,700-6,800
E	94-150	511-820	6,800-12,000
F	151-200	821-1,100	12,000-15,000
G	—	—	15,000-22,000
H	—	—	22,000-33,000

Tolerance on Temperature Co-efficient is—30 parts/million/°C or ±15%, whichever is the greater.

Note: Styles A, B, C, D, E, F, G and H are non-insulated units. Styles K, L, and M are insulated.

**MAY WE SEND YOU SAMPLES
FOR TEST OR FOR PROTOTYPES?**

ERIE RESISTOR LIMITED

CARLISLE RD · THE HYDE · HENDON
LONDON · N.W.9
TELEPHONE · COLINDALE 8011
FACTORIES: LONDON · ENGLAND
TORONTO · CANADA · ERIE, PA. · U.S.A

RANDOM RADIATIONS

—By "DIALLIST"—

The "Smallweldpencil"

A KIND Danish reader, whose wartime activities as a member of the organization formed for sabotaging enemy activities in his country brought him literally into the closest contact with many German technical developments, sends me some particulars of the miniature spot-welding tool which was made by the Siemens-Halske Company. Despite its mouthful of a name—Smallweldpencil, all in one word—it seems from the illustrations sent to be a neat little tool. It was, I gather, largely used in the assembling of radio components such as transformers and resistors and my correspondent states that it made very effective connections with wires up to 0.5 mm diameter. One use suggested by the makers is for mending broken heater coils of electric fires. They claim that it replaces soldering for all kinds of fine electrical work and bid you use the Smallweldpencil and be free for evermore from *soldermentaluneasiness*. A pretty little word, that last!

□ □ □

Fair Do's!

IT is disconcerting to learn from an American technical writer that German radar was better than ours when the war began in September, 1939. The truth is that in radar we were always a long way ahead of the Germans. German gun-control radar never got beyond the decimetre-wavelength stage and then it must have given far from accurate results. The wavelength was actually of the order of 0.6

metre and the apparatus used half-wave dipoles with parabolic reflectors. You will see that the huge reflectors needed can hardly have been capable of smooth and steady movement in azimuth or in elevation, particularly if there was any wind. Our centimetre A.A. radar, using the cavity magnetron (developed in the first half of the previous year), was ready to go into production well before the end of 1941. The components, circuits and detailed layout which I saw in January, 1942, differed little from those of G.L.3 when it made its appearance in the field a short time later.

□ □ □

Must Be a Hard Life!

OFTEN have I thanked my lucky stars that Fate did not ordain that I should be a wireless dealer or a wireless serviceman. Being by nature one of those fools who do not suffer other fools gladly, I should long ago have been hanged by the neck for the murder of one or other of my more irritating clients. The other day as I waited in a small queue in an electrical and wireless shop, hoping misguidedly to be able to obtain certain small items such as soldering tags, a few yards of No. 30 Eureka and a couple of octal-base valveholders ("Sorry, we're expecting some next month"), there were in front of me two ladies, one frankly elderly and the other of similar years, but less frank about them with the doubtful aids of the beauty parlour, the hair-dresser and the wishfully thinking

□ □ □

What's in a Name?

DO you know how H₂S got its name? H₂S is an airborne type of radar by means of which a picture of the ground below is "painted" on the screen of a P.P.I. tube in the navigator's compartment by means of a radial revolving time base, which is synchronized with a revolving aerial. Most of the radar names have a meaning more or less appropriate to the applications of the systems to which they belong, though the connection between name and application is often of the vaguest for reasons of wartime security. G.L. (gunlaying), A.S.V. (aircraft-to-surface-vessel), A.I. (aircraft interception) and C.H.L. (chain home low-flying) are examples. Some names—Gee, Oboe, Rebecca-Eureka—were

Books issued in conjunction with "Wireless World"

	Net Price	By Post
FOUNDATIONS OF WIRELESS. Fourth Edition, by M. G. Scroggie	7/6	7/10
TELEVISION RECEIVING EQUIPMENT, by W. T. Cocking	10/6	10/10
RADIO LABORATORY HANDBOOK, by M. G. Scroggie. Third Edition	12/6	12/11
WIRELESS SERVICING MANUAL, by W. T. Cocking. Seventh Edition	10/6	10/10
HANDBOOK OF TECHNICAL INSTRUCTION FOR WIRELESS TELEGRAPHISTS, by H. M. Dowsett and L. E. O. Walker. Seventh Edition	30/-	30/7
BASIC MATHEMATICS FOR RADIO STUDENTS, by F. M. Colebrook	10/6	10/11
RADIO DATA CHARTS. Third Edition, Revised by J. McG. Sowerby	7/6	7/10
LEARNING MORSE. 335th thousand	6d.	7½d.
RADIO WAVES AND THE IONOSPHERE, by T. W. Bennington	6/-	6/3

Obtainable from leading booksellers or by post from
ILIFFE & SONS LTD., Dorset House, Stamford Street, London, S.E.1

pure fantasy. H₂S does not appear at first sight to belong to the latter class and for long I sought its meaning. No one whom I asked could tell me and until the very last lecture of the I.E.E. radar conference it remained a mystery. Then all was explained. The idea was a natural development from A.S.V., which was first demonstrated at fleet manoeuvres in 1938. When it was first put forward for the august consideration of a Very Important Person, he thought over for some time and then delivered the opinion: "It stinks." Actually, it was one of the outstanding successes of radar development and one with vast peacetime possibilities; but its malodorous name commemorates the chilly reception which, like so many other ideas that were later to prove pure gold, it received when it was originally mooted.

DYNATRON CONSOLE RECEIVER

THE specification of this receiver makes pleasant reading after so much austerity. Eleven valves, nine tuned circuits, four degrees of selectivity, 9 watts undistorted from push-pull triodes, 9kc/s whistle filter, 12in P.M. loudspeaker, four wavebands incorporated in two chassis housed in a walnut cabinet 38in high, 23in wide and 13in deep. The price is

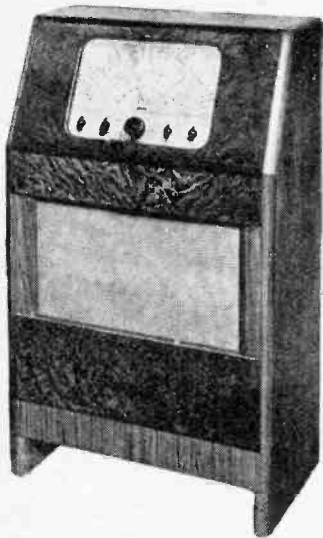

Dynatron "Merlin" Type B119 Console receiver.

£92 8s plus £22 6s 7d purchase tax, and the makers are Dynatron Radio, Ltd., Ray Lea Road, Maidenhead.

BATTLE-TESTED

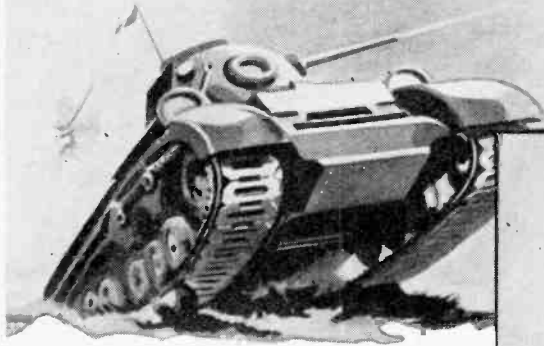

New BULGIN

TOGGLE SWITCHES

are ahead of every specification

WHY THE ARMY INSISTS ON A SEPARATE SWITCH

Bench tests, simulating actual combat conditions proved conclusively that separate switching gives 100% reliability. Wear was more rapid, faults developed nine times more quickly than where separate switching was used.

NINE TIMES LONGER LIFE with—

Battle-tested in British tanks, Bulgin Toggle Switches never let the Army down. One more reason why it is now standard practice to fit a Bulgin Switch to modern radio sets. A switch with Bulgin technicians behind it means radio performance at its best.

Keep Volume and Tone Controls Apart — Make Your Set 100% Efficient

Four out of five people prefer to switch on, leaving tone and volume unaltered. They prefer an on-off toggle-switch, built by Bulgin to last a lifetime. The Army can tell them why Bulgin is the radio man's first choice. In design and materials Bulgin keep ahead of the stiffest specifications, offering a selection of over 200 types, with swift certain make-and-break

BULGIN

TROUBLE FREE TOGGLE SWITCHES

OVER 200 TYPES AVAILABLE

Standard fitting is Nickelplated. They can also be had in Florentine Bronze or Gun metal finish to order.

A. F. BULGIN & CO., LTD., BYE-PASS RD., BARKING, ESSEX

RIPpleway 3474 (5 lines)

RECENT INVENTIONS

SHORT-WAVE CONVERTER

A MIXER valve which is used primarily as a short-wave converter is also arranged to act as an aperiodic amplifier when the set to which it is attached is receiving signals on the long- or medium-wave bands.

For receiving short waves, the switch S is in the position shown and the switches S₁ and S₂ are on one or other of their associated condensers. The input grid of the hexode section of the valve V is then tuned to the middle of the selected short-wave band, whilst the triode section of the valve generates oscillations to the receiver. When the switch S is moved to the right, and the switch S₁ is on the extreme right-hand contact, medium- or long-wave signals pass directly to the grid of the hexode, which then operates as an aperiodic amplifier, whilst the triode or local oscillator circuit is out of action.

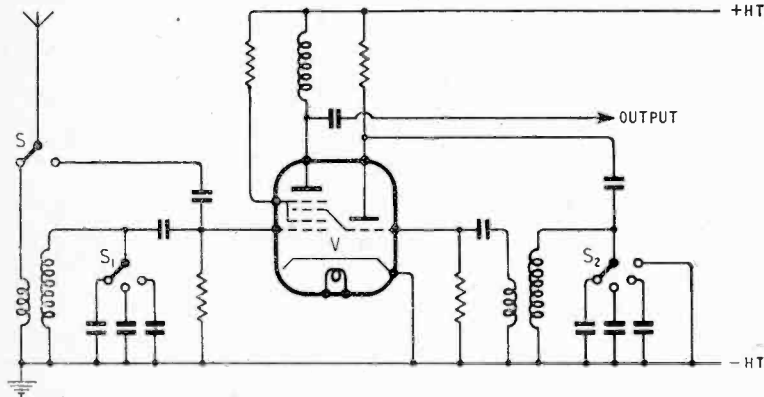

Combined frequency changer and aperiodic amplifier.

The inductance of the aerial coil is sufficiently small (a) to shunt long and medium-wave signals to earth, and (b) to damp the various tuned grid circuits to a degree which ensures an approximately uniform input for any selected setting of the switch S₁.

J. Lips. Convention date (Switzerland), November 10th, 1942. No. 571452.

SILENT INTER-STATION TUNING

IN a receiver for frequency-modulated signals, a pair of resistance-coupled valves, which normally serve to remove or limit amplitude variations, are automatically converted into a multivibrator unit, in order to eliminate disagreeable "noises" when tuning the set from one station to another.

A feedback circuit, including resistance and capacitance in series, connects the output of the second valve to the input of the first. So long as signal voltages are present, the relatively low amplification between the valves keeps the feedback link ineffective. But in the absence of a

A Selection of the More Interesting Radio Developments

signal, the prevailing biases are such as to allow any "noise" voltage that occurs during inter-station tuning to build up automatically between the two valves until the pair oscillate as a multivibrator unit. One or other of the valves is then non-conducting, so that the loudspeaker is mute. An incoming signal will at once develop biasing voltages sufficient to cut out the feedback effect, and restore the limiter stages to normal operation.

The British Thomson-Houston Co., Ltd. Convention date (U.S.A.), January 30th, 1943. No. 571404.

STATIC ELIMINATORS

A CIRCUIT for limiting the effect of static and like impulses is based on the theory that short disturbances of irregular phase and amplitude produce only positive or "outward" peaks of modulation on the carrier-wave, as distinct from the positive and negative variations produced by the more regular signal voltages.

The main signal rectifying diode is shunted by a reversely-connected diode, which is separately biased to short-circuit any "noise" in excess of a selected level. A second signal channel, closely coupled to the first, and including an auxiliary rectifier, supplies the threshold control bias. This is derived from the negative or inward peaks of the modulated carrier, so that the level at which the disturbances are cut out rises and falls with the prevailing signal strength. The arrangement is said to be free from the usual tendency of an eliminator circuit to "open-up" under the effect of large or repeated surges of interference.

The British Thomson-Houston Co., Ltd., Convention date (U.S.A.) October 5th, 1942. No. 570466.

SIGNALLING SYSTEMS

THE wave radiated from a telephony transmitter always includes a certain amount of surplus carrier energy, except during the comparatively rare periods when the modulation reaches 100 per cent.

In order to diminish this waste of power, the signals are sent out in intermittent pulses of waves of constant frequency and amplitude. Each pulse is of variable duration, but successive pulses are separated by an interval during which no energy is emitted. The length of each pulse, i.e., the number of waves contained in it, is determined by an electronic switch of the multivibrator type, under the conjoint control of the signal voltage and of an auxiliary oscillator of supersonic frequency.

The average power contained in a succession of pulses is thus always regulated by the prevailing intensity of the signal voltage. At the same time, the "silent" intervals represent a definite saving of energy, without affecting the apparent continuity of the received signals.

The Westinghouse Electric International Co. Convention date (U.S.A.), October 22nd, 1942. No. 571627.

REMOTE TUNING INDICATORS

THE tuning of a circuit to resonance is indicated at a remote point of control in a simple and inexpensive manner.

The tuning control shaft is made of one of the thermo-plastic materials that are known to have the property of "piping" or transmitting light rays without appreciable loss, and a small glow lamp of the "grain-of-wheat" type is placed near one end of it, and in the field of the distant circuit, so that the lamp will glow when the circuit is in resonance and carries a large circulating current. Light from the lamp then passes through the control shaft to illuminate the boss or centre of the tuning knob. In another arrangement, a copper tuning slug is mounted at the end of a control shaft of the push-pull type, so that it slides in and out the tuning inductance, which is in turn coupled to the flashing coil of the small indicator lamp.

Standard Telephones and Cables, Ltd. (assignees of H. R. Sherwood). Convention date (U.S.A.), February 13th, 1943. No. 571970.

The British abstracts published here are prepared with the permission of the Controller of H.M. Stationery Office, from specifications obtainable at the Patent Office, 25, Southampton Buildings, London, W.C.2, price 1/- each.

This
mathematical
symbol means
'not less
than'

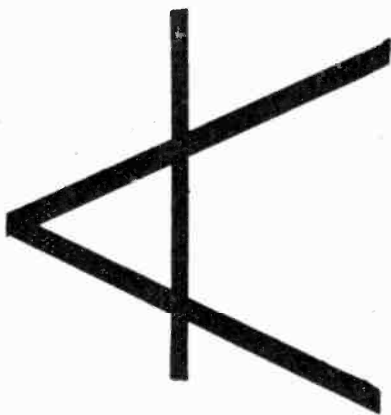

This
well-known
emblem
means
'not less than
the best'

PHILIPS

**LAMPS · RADIO · X-RAY · COMMUNICATIONS EQUIPMENT
 AND ALLIED ELECTRICAL PRODUCTS**

PHILIPS LAMPS LIMITED · CENTURY HOUSE · SHAFTESBURY AVENUE · LONDON · W.C.2

(125)

Rate 6/- for 2 lines or less and 3/- for every additional line or part thereof, average lines 5-6 words. Box Numbers 2 words, plus 1/-. Press Day: July 1946 issue, first post Thursday, June 6th. No responsibility accepted for errors.

NEW RECEIVERS AND AMPLIFIERS

AIRMASTER 5-valve 4-waveband (12-2000 metres) ac mains 200-240v superhet chassis with 6in R & A mains energised speaker and Mazda valves.

OUTPUT approx. 5watts, chassis size 14 1/2in x 8in x 3in, cream cellulose finish, illuminated glass dial 8in x 5in with coloured waveband scales and station names, pickup and extra L.S. sockets.

PRODUCT of one of the largest radio manufacturers, precision made to the highest standards; ideal for incorporating in radiogram or own cabinet; art photographs available to genuine enquiries; price £17/12, carriage paid per pass train; ready to switch on. WE are official agents for Pye, Eeco, Philips, Corsor, Philco, Ferguson, Ultra, Alba, R.G.D., etc., and new sets are available according to manufacturers' release schedules.

MAIL orders receive prompt attention. **COMPONENT parts**; we have good stocks of these and will be glad to forward our list on receipt of 2d stamp.

H.P. RADIO SERVICES, Ltd., 55, County Rd., Walkon, Liverpool, 4. Tel. Aintree 1445. Estab. 1935. [5198]

R.M.E.69 little used, best offer over £50; National H.R.O., power pack and 5 coils, good condition; offers—Box 7319. [5202]

T.R.F. ac/dc midget kit of parts: 200-250v wkg. 24 valves £29/6, speaker £1/7/6, cabinet £17/6, list prices; send for lists; cash with order or c.o.d.

HENRY'S, 5, Harrow Rd., Edgware Rd., W.2. **NEW** ac 4v T.R.F. 18-26mc receiver, and 2v 25w C.W. transmitter with valves and coils, a complete station; £28/10.—G3L2, 25, Clotherholme Rd., Ripon, Yorks. [5187]

AMPLIFIERS—Complete equipment for P.A. industrial, dance and stage installations and portable apparatus from 15 to 150w; early deliveries; illustrations and spec. on request.—Broadcast and Acoustic Equipment Co., Ltd., Broadcast House, Tombland, Norwich 26970. [2903]

ANELOY RADIO now offer improved set of components for med. and long wave semi-midget 4-valve a.c.-d.c. t.r.f. receiver, incl. striking cream cabinet, valves, drilled chassis. 6 1/2in speaker, screws, etc.; nothing more to buy. £8/10.—Aneloy Radio, 36, Hindmans Rd., E. Dulwich, S.E.22. [5020]

WHAT is the Moreton Cheyne receiver? It gives you the performance of the communications set and the quality of local station reception at will; a precision-built instrument of fine performance, with craftsmanship and reliability; do not miss this opportunity.—Send 2/4d. stamp for details to the Moreton Cheyne Company, 52a, Gaol Rd., Stafford. [5187]

BAKER'S—New 7-valve "Wireless World" Quality amplifier with tone control stage, 8 watts push-pull triode output, price includes super Quality triple cone, 12in permanent magnet speaker, with large output transformer and all valves; also as above but with 15 watts tetrode output, ideal for realistic reproduction for public address; 2/4d. stamp for particulars, prices, etc.—Baker, Selhurst Radio, 75, Sussex Rd., S. Croydon. Croydon 4226. [3680]

RECEIVERS, AMPLIFIERS—SECOND-HAND

R.M.E.69 DB20 spkr., £52/10; Fox modulator, 12w, £12.—Trewin, Exminster, Devon. [5339]

15-WATT Trix amplifier, mike, stand, 2 speakers, portable; £20.—Box 7392. [5287]

BRIERLEY 5-watt quality amplifier, used three weeks, surplus to requirements; £6/10.—Box 7758. [5287]

H.R.O. Senior power pack, full set coils, including band spread, perfect condition; best offer over £75.—Box 8119. [5339]

R.C.A. Communication receiver, model 88, R. 535-30,000 kc/s, condition as new, number spare valves.—Offers to Box 8052. [5325]

A.C.S. RADIO, 44, Widmore Rd., Bromley, Kent, offer small selection com. sets, radio receivers and amplifiers; list free.

HALLICRAFTER (S.27D) rkb VHF receiver, range 27.8 to 143 mc AM & FM, perfect condition; what offers?—Box 7358. [5287]

ARMSTRONG A.W.93 P.P. chassis ac 3-wave band 8v P.P. output, with matched Rola G.12, perfect condition; £16, or nearest offer.—Box 7393. [5232]

RADIOGRAM, ac, all mains, all wave, H.M.V. model 661, upright walnut cabinet, perfect order, overhauled; £55.—Tel. Reliance 2821. [5286]

COMMUNICATION receiver, Jng. Nikolaus Eitz, 7 valve, 110-220 ac, 24 dc, 3 band, 20-2 mc/s, B.F.O., manual and A.V.C. volume controls, 6 spare valves, as new, £35; Low ohmeter, Etched, 0.3-0.30 ohms, with case, £8; 954 R.C.A. valves, meters, coils, trans; send s.a.e. with requirements.—Box 7802. [5286]

Partridge News

INDIVIDUAL DESIGN

The process of reverting to peace-time production continues and we are able to manufacture special transformers and chokes to your own specification in about 28 days. We would, however, draw your attention to the fact that many components can now be despatched per return (see last paragraph).

TELEVISION COMPONENTS

Once again we are able to wind specially insulated high voltage transformers and chokes for television purposes. These are wound only to order and hence are suitable for use in new designs or as replacements in existing sets.

AVAILABLE STOCK

A comprehensive range of mains and audio components is now available from stock and we can despatch small quantities of these by return. We would stress that before ordering you send for our list detailing these components. Our stock range now covers almost all normal requirements and by availing yourself of this service you will save the inevitable delay in the production of a special component. We shall be pleased to send you our stock list upon receipt of your address.

Telephone:



Abbey 2244

PARTRIDGE TRANSFORMERS LTD

76-8, PETTY FRANCE, LONDON, S.W.1

Beautiful Cabinetwork

Gradually we are getting into our stride and soon shall be able to manufacture articles of the exquisite standard attained before the war. The timber problem is very difficult and we are fussy as to what we use, but good times will come again and we shall be ready... with very interesting cabinetwork, so in the meantime get your name on our lists to facilitate our planning for the future.

If you have Licences to manufacture we shall be pleased to receive your enquiries for Radio Cases, Instrument Cases, Baffles, Horns, etc., and in fact any articles in wood for Radio and Scientific Instruments.

Lockwood

& COMPANY

67, Lowlands Road, Harrow, Mdx.

Phone: BYRan 3704

NATIONAL Senior H.R.O. table model, 9 coils, power pack, 250 v dc, as new; £65; part exchange mains signal generator.—21, Golders Gdns., London, N.W.11. [5294]

G.B.R.G. selling complete transmitting station, 150 watt output, high power valves, G.E.C. milliamp metres, etc., H.R.O. receiver.—Apply G. Dee, Alderclose, Egham Hill, Egham, Surrey. Tel. Egham 202. [5278]

HALLICRAFTER SX-28, 500 kc/s to 45 Mc/s, 110-230 volts ac, 11 valves, with two 6V6 in push-pull, instruction book, some spare valves, stored 5 1/2 years, as new; view N. London area.—Offers to Box 8107. [5331]

SCOTT Phantom 16-valve radio receiver and S amplifier unit, complete with cabinet and 14in auditorium speaker, in excellent cond.; £50 or nearest offer.—Write or phone, 17, The Oval, Besaaccarr, Doncaster. Tel. Don. 55181.

G.E.C. De Luxe 14watt amplifier, 190-250v ac, supply, 40-100cycles, complete with microphone, G.E.C. make, with 3 loudspeakers, 2 in cabinets, 1 without; Philco-phon intercommunication complete with 4 speakers and cabinets.—Box 8255. [5146]

INTERNATIONAL Majestic 22 valve, 60 mgs. to 150 kc/s, 5 waveband, matched speakers, Rola G12, 2 pairs 6V6s p.p., pre-selector gain control, bass expander, treble attenuator, maintained as new, walnut cabinet; £135 or near offer.—Tel. Rav. 2375. [5320]

COMMUNICATION receiver, PX4 push-pull quality output, 10 valves plus magic eye, 16-100 and 200-4,000 metres, bass and treble tone controls with boost, h.f.o., gram unit, complete with Gramphon loudspeaker; £35.—8, Gladstone Rd., Wimbledon, S.W.19. [5192]

SOUND SALES super aud. enr. speaker £10; or in special acoustic cabinet, £13; field supply unit, £3; 4-band Super Six chassis, £26; h.t. unit, £3; kit of parts for 12-watt W.W. para. amplifier, with valves, £18; Motorola remote control a.c. set, £20; parts for battery electric clock, £25.—Particulars from Rockwood House, The Oaks, Bolton. [5286]

45 60 watt P.A. amplifier (D.A.50's, AB2), 12 Vitavox K.12/10 speakers, 3 first-class m.c. mikes and telescopic stands, gram unit, with Marconi p.u. amplifier, speakers and gram unit housed in strong joiner-made cabinets, complete with all cables and plugs, perfect working order; £70 or nearest offer.—Hall, 4, Whitfield Ave., Paddington, nr. Warrington. [5256]

GRAMPHONE AND SOUND EQUIPMENT

B.T.-H. Senior magnetic P.U., perfect condition; 60/- or offers.—Box 8106. [5330]

GERRARD 1946 mixed autochange, complete, unused; owner moving; offers.—Box 7806. [5295]

H.M.V. Universal auto gram, remote control, 20 records mixed, handsome cabinet, £35 or offer.—Box 7398. [5237]

H.M.V. Hypersensitive pick-up with trans., £5; Avco 40, £12/10; both perfect.—3, Hungerford Ave., Slough, Bucks. [5196]

B.T.-H. 16mm sound film projectors; limited quantity now available.—Enquiries, The British Thomson-Houston Co., Ltd., Rugby. [5286]

POLISHED walnut radiogram cabinet, £45/0; also Voigt M.C. pick-up, complete.—Phone (evenings) Barnet 6605. [5226]

H.M.V. autochanger, fitted latest Hypermotor with transformer, £20; wanted, Voigt speaker complete.—Solent Hotel, Ventnor. [5286]

COILS for "W.W." tone control and filter circuits (Brierley & Hartley spec.), high fidelity mic. line and output transformers; see full list.—R. Clark, 30, Langland Cres., Stanmore, Middx. Wor 5321. [5190]

PROFESSIONAL recording equipment, MSS recording machine, 20watt amplifier, complete, £100, new, from stock; blank discs, etc.; full range Sound Sales equipment available; Garrard transcription motors and playing desks.—Liverpool Sound Studios, 83a, Bold St., Liverpool. [5348]

AUTORADIOGRAM, entirely new 1346 R.G.D., finest ever made, magnificent, very limited production, rotational deliveries now commencing, post orders welcomed, safe delivery guaranteed, book yours now, £130 approx., plus tax.—Snell, Arcade, Swansea, Est. 1900. Tel. 3784. [5207]

To music lovers, £350; super-quality diogram auto-changer) and recording set, designed and built by owner regardless of cost; apparatus housed in large walnut cabinet; speaker in separate mobile cabinet; complete with pedestral mike, spares, accessories, etc.; also electric baking oven; demonstration any Sunday evening or by appointment; no dealers.—S. F., 224, Belsize Rd., West Hampstead, N.W.6. [5286]

TEST EQUIPMENT

SIMPLAX precision tracker, consider part ex, quality test gear.—Box 7391. [5230]

For sale, 83A Taylormeter, 4,000n per volt; what offers?—Box 7249. [5178]

ALL wave sig. gen., £7; Tayl. 90A, £7; A.C. bench grinder, £7.—Box 8105. [5279]

HICKOK multimeter model 133B, hardly used.—Offers to 188, Euston Grove, Morecambe. [5284]

OSCILLOSCOPE, professionally built, 4 1/2" time base, amplifier, used 20 hrs.; 149/5in. —Box 7536. [5258]

VOMETER, model 7, 56 range, complete in case with clips and prods, for sale.—Offers to Box 7317. [5200]

FOR sale, Weston analyzer, model 772, also voltohmmyst junior, as new, satisfaction assured.—Write Box 7612. [5272]

ULTRASCOPE mark II, new in makers' original packing, unused time base 7 to 130,000 c/s; price £30 or offers.—Summersby, 69, Fairfield Drive, Dorking, Surrey. [5245]

F. D. COSGROVE, radio and electrical equipment engineers, are now producing various types of radio and test equipment; details free on request.—185, Longley Rd., Slough, Bucks. [5369]

VOLTMETERS, pocket bakelite, 1st qual. moving coil, double range, 15v and 250v, second-hand, accurate, 20/- and 25/- ea (cost 55/-); also panel type, 2 1/2"mc 150v, 10/-; want list, model 7, Avo.—Box 7394. [5234]

TEST equipment, Universal Avometers, £8/10, c.w.o., immediate delivery. Avometers, valve testers, signal generators, bridges, short waiting period only, send for list "A"—Young, Radio Service, Southwick, Sussex. [5221]

FOR sale, Mullard G.M.3152 cathode ray oscilloscope, in perfect condition; also E.C.C. valve rectifier, model 1361 ac, input 440 volts, 3-phase 50 cycles, dc output 110 volts, 9.1 amps.—Offers to Box 7246. [5176]

COSSOR ganging oscillator with dummy aerial, amplitude, and frequency modulation, £30; 7 for more details, resistance and capacity bridge, £14; both above new and unused, ordered surplus to requirements.—Ramping, Downdney, Torpoint, Cornwall. [5261]

BRITISH Physical Laboratories 14-range Universal test set: 1,000 ohms per volt on ac and dc ranges; shock resisting bakelite case, toughened glass, size 4in x 4in x 5 1/2in, ranges ac and dc, volts 0/10, 0/50, 0/100, 0/500, dc milliamps 0/1, 0/10, 0/100, 0/500, resistance range 0/10,000 ohms, rotary range selector, accuracy 2%, retail £8/17/6; if unable to obtain this high-grade instrument from your dealer, apply to U.K. trade distributors: RADIO AGENCIES, Ltd., 157, Wardour st. W.1. Tel. Gerrard 4456. [5120]

TEST EQUIPMENT WANTED
COSSOR double beam oscillograph wanted, £30-£40, according to cond.—Box 7825.

NEW LOUDSPEAKERS
£5 118/6.—New Baker Super Quality 12in speaker. A superior permanent magnet speaker with triple cone, manufactured by Bakers Selhurst Radio, the pioneer manufacturers of moving coil speakers since 1925, wide frequency range, even response, ideal for quality reproduction, fitted with magnet, having exceptionally high flux density in the air gap suitable for public address equipment when quality reproduction is first consideration; send 2/6d. stamp for leaflet giving details of above and constructional details of a new acoustic chamber designed to extend loud speaker frequency range.

£8 19/6.—New Baker super power cinema permanent magnet speaker with 18in triple cone of new design, giving wide frequency response free from objectionable resonances; speech is clear and natural and music is reproduced with exceptional realism; fine engineering job, extremely sensitive; ideal for public address equipment when power handling capacity, plus realistic reproduction, is required; prompt delivery per pass train.—Bakers Selhurst Radio, 75, Sussex Rd., S. Croydon (Croydon 6813).

LOUDSPEAKERS, SECOND-HAND
VOIGT twin unit, perfect, 1,000mf field; £18.—Box 7843. [5305]

HAMMARLUND Comet pro crystal model speaker, £20.—Box 7395. [5233]

MAGNAVOX duode 2,500mf field, with trans. £20.—Box 6671. [5102]

MAGNAVOX duode, 2,500ohm field, with 1 unit trans., £5/10.—Box 7359. [5221]

SPEAKERS, energised, 12in 15ohm speech, R.K. 70/-; Baker's, 60/-; Baker's, 50/-; Epoch 18in, 60/-; Voigt straight 4ft horn, sectional, 60/-; faulty mains transformers, 6/-.—6, Beaufort Terr. Beaufort, Man. [5337]

COMPONENTS—SECOND-HAND, SURPLUS
G. W. SMITH & Co. (RADIO), Ltd., offers the following:—

CONDENSERS 2mf 250v wkg, 1/6; 2mf 400v wkg, 1/9; 0.1 mf 1,000v wkg, 3/6; 0.25mf 2,500v wkg, 3/6; 0.25mf 3,000v wkg, 0.1mf 3,000v wkg, 4/-; 0.25mf 8,000v wkg, 7/6; 0.1 mf 10,000v wkg, 0.02mf 10,000v wkg, 10/-.

G. W. SMITH & Co. (RADIO), Ltd., 2, Cecil Rd., Southgate, London, N.14. Tel. Enterprise 5463 [5323]

SMALL Ali can elec, 500v 8mf, 5/-; post extra under 12.—Coake, 25, Langdale Rd., Sheffield, 8. [5283]



OUR UNIT SYSTEM OF RADIO

See April issue for particulars

VARIABLE CONDENSERS. 25 pf. ceramic plate midget single—can be ganged 4/6. 0015 ceramic plate 2 gang, small, 12/6. 0015 ceramic insulation, 2 gang, small, 12/6. 00015 standard, 2 gang, S.W., 12/6. Reaction condensers, 0.003 mica dielectric, 3/-.

TRIMMERS. 3/30 ceramic base air spaced, new, 2/-; 40 pf. S.W. pre-set neutralising cond., 2/-; T.C.C. air spaced straight line, 5/35 pf., 1/-; ceramic postage stamp type, 30/80, 1/-; 50/120, 1/-; 150/250, 1/9.

MAINS TRANSFORMERS. 350-0-350 4 v. 4 a., 4 v. 2 a., 80 m.a., 30/-; also 6.3 v. 5 a., 5 v. 2 a., 30/-; 350-0-350 4 v. 4 a., 4 v. 2 a., 6.3 v. 5 a., 5 v. 2 a., 80 m.a., 35/-.

L.F. TRANSFORMERS. 3, 4, or 5-1 midget, 6/-; P.P. input 4-1 split sec. midget, 6/-; medium, 9/6; heavy, 12/6; Kola multi-ratio trans., 12/6; push-pull output trans. for 5, 7 1/2, 15 ohms, 4,000-0-4,000 v. (to suit 2 6v6 in push pull), 30/-.

CHASSIS. Alclad drilled for 7 or 10 valve set, 15/-; undrilled, polished, 12 1/2 x 7 1/2 x 4, 12/6.

L.F. TRANS. Iron-cored permeability tuned, 465 K/cs. screened, 15/-.

MIDGET PLUGS AND SOCKETS. 5-pin with plated cover, 1/-; banana plug and socket, red and black, 6d. each; standard plug, red and black, 3d. each; aluminium valve screen and base, 2/-.

COILS. 3 wave band on one former A. and H.F. Trans. with reaction, 16/50, 200/550, 900/2,000 m., 12/6; 3 wave band, A. and osc., 12/6; 3 wave band, A. H.F. and osc., 18/9; A. and H.F. med. and long, with reaction, 10/6; H.F. choke, all wave, 2/6; S.W., 2/-; 3 wave bands on one former A. H.F. and osc., 5/21, 20/54, 50/120 m., 6/3; 110/210, 200/540, 950/2,400, 6/3; colour coded. Diagrams of connections supplied.

SWITCHES. 4 pole 3 way midget single bank, 4/6; 3 bank 2 pole 6 way, standard type, with shorting plate, 8/6. We can supply switches to suit any combination of our coils.

KNOBBS. Communication type—black skirted brass insert 1 1/2in, skirt 2 1/2in, 1/6; black pointer knobs, 1/-.

Mains droppers, 2 A. 3,000 ohms, 6/-; 3 A. 750 ohms, 7/-; with mounting feet and variable sliders.

VALVE HOLDERS. 4, 5 and 8 pin English paxolin, 6d. each; 5, 6, 7 and 8UX, 6d. each; 9 pin ceramic (E.F. 50 valve), 2/6 each; Amphenol octal, 9d. each; ceramic octal, 2/6 each.

RESISTORS AND CONDENSERS of standard values in stock.

P.V.C. wire, six bright colours, 3d. per yd.; sleeving, highest grade, 2 mm., 4d. per yd. 1 mm., 3d. per yd.

TO OVERSEAS TRADERS
Wholesale and retail enquiries are invited.
Orders can be executed for B.A.O.R., C.M.F., and S.E.A.C. customers.

307, HIGH HOLBORN, LONDON W.C.1. Phone: HQLborn 4631.

VALUE! Matt has it.

SPECIAL offer, all new goods.
CONDENSERS (canned), all 500v working, 8mf 3/-, 16mf 3/6, 8+8 5/3, 0.1, 0.01, 0.002 6/- dozen.

RESISTORS: 1/2 watt, asstd. values, 4/- doz. **ROTHERMEL** pick-ups (crystal), de luxe, £2/16/3.

LINE cord, 0.3 amp (60 ohms per ft), 2-way 1/- per yd, 3-way 2/- per yd.

GLASS accumulators, 2 volt 45 amp, 12/6.

SPEAKERS, 6in p.m. Celestion, 1/trans., 16/6; 8in p.m. Celestion, 1/trans., 22/6.

LARGEST stock of B.V.A. and U.S. valves in England; list prices; let us have your enquiries.

MATT RADIO SERVICE, Kingston 4881, 152, Richmond Rd., Kingston-on-Thames, Surrey.

BUILD a super set; "Dorset" 5-valve 3-wave ac superhet.

THE finest drawings and instructions ever produced for the enthusiastic set builder; theoretical circuit, under chassis layout, above chassis layout, heater wiring, group board assembly and point to point wiring instructions, also parts list, price 5/-; this set can be made without previous radio experience and built in stages out of income; 3-wave coil pack specially designed for the job and group board assembly obtainable ready made; theoretical circuit and price list only 2/6d.; also available, "Wizard" 4-valve TRF ac d.c. m.w. circuit, with conversion for l.w., price 5/-; "Dorset" battery 3 m.w. circuit, with conversion for l.w., price 3/6; "Dorset" amplifier, ac/dc, 6-8 watts, 5/-—Write: **WELDONA RADIO ACCESSORIES, Ltd.**, 12, Gilbert Rd., Swanage, Dorset. [5346]

SOUTHERN RADIOS wireless bargains.
LATEST radio publications:
RADIO Valve Manual equivalent and alternative American and British types, with all data, 3/6; Radio Circuits, fully illustrated, receiver, power packs, etc., 2/-; Amplifiers, fully descriptive circuits, 2/-; Radio Coil and Transformer Manual, 2/-; Short Wave Handbook, 2/-; Manual of Direct Disc Recording, 2/-; Test Gear Construction Manual, 1/6; Radio Pocket Book, formulas, tables, colour code, etc., 1/-; Ten Hows for Radio Constructor, 1/-; Radio Reference Hand Book, comprehensive and up to date, covering all branches of radio, 10/6; American Service Manual, Sparton-Emerson, Crosley-Belmont (Part 1 & 2), Stewart-Warner-Pada, Emerson, 12/6 per vol.; Radio Resistor Chart (colour code values at a flick), 1/- each; Bulgin Radio Service Manual, 2/6; postage extra.

ACE "P.O." microphones, complete with transformer, usable with any receiver, 7/6; permanent crystal detector, 2/6; insulated push-back wire, 25 yards, 5/-; insulated sleeving, assorted sizes and colours, 3/6 per dozen 20" lengths; single screened wire, 7/6 per dozen yards; twin screened, 5/- per dozen yards; aluminium panels, undrilled, 16 gauge, 18 inches x 7 inches, 3/6; 18 inches x 9 inches, 4/6; ceramic and paxolin postage stamp trimmers, 30pf, single 1/3 each, double bank 2/-; reaction condensers, 0.0003, 0.0005, 4/- each; differential reaction, 4/6; tubular and mica condensers, 1/- each; knobs (pointer and round), 1/- each; valve holders, 1/- each; Cutler-Hammer power rheostats, 30 ohms, 4/6; power rheostats, 10 ohm, 1/6.

HUNDREDS more bargain lines; postage extra to be added.

SOUTHERN RADIO Supply Co., 46, Lisle St., London, W.C.1. Gerrard 6653. [4987]

RADIO CLEARANCE, Ltd., Museum 9188, R 27, Tottenham Ct. Rd., W.1.

MAINS trans., 300-0-300 10ma, 5v 2a, 6.3v 3a, 22/6; electrolytics, 8mf 250v, 2/6; 4-4, 450v, 3/6; 4mf 350v, 2/-; 4mf 500v, 2/11; 20mf 250v, 2/9; 50mf 50v, 2/6; 250mf 250v, 2/6; 200m 12v, 2/-; Manbridge condensers, 4mf 450v, 4/6; 2mf 400v, 1/6; 1mf 350v, 9d.; 0.5mf 4,000v wkg, 10/-; 0.5 400v, 6d.; silver mica, 50 to 5,000pf, 6d.; mica, 0.0001-0.0005, 4d.; 0.001-0.007, 5d.; 0.01, 6d. 0.01 2,200v test, 9d.; tubulars, 0.01, 0.02, 0.04, 6d.; 0.1 350v, 7d.; 0.25 375v, 11/-; switches, 4p 3-way, 3/-; 3p 4-way, 3/-; 1p 10-way, 3/-; 1p 12-way, 3/6; 1p 9-way, 3 banks, 5/6; resistors, 1/4w, 3d.; 1/2w, 4d.; 1w, 6d.; 2w, 10d.; 3w, 1/3; all values; bargain parcel 100 asstd. resistors, 1/4w to 3w, 17/6; all useful sizes; vitreous resistors, 500, 5000 c.t., 1,000n, 1,000p tapped, 250 and 500, 1,300mf tapped, 600n, 10w, 1/6; 20w, with clips, 120n, 200n, 2/-; 25w, 350n, 5,000n, 75,000n, 2/6; 40w, 14,000n tapped, 2,000n, 3/-; 50w, 50,000n, 20,000n, 3/6; toggle switches, single p, 2/-; double p, 2/11; screened octal top caps, 6d.; numerous other lines in stock; cash with order or c.o.d.; postage extra; post paid on orders over 7/6. [5065]

MALLORY 12v non-synchronous vibrators: 10/6 ea.—12, Nevcrn Place, S.W.5. [5209]

SURPLUS STOCKS

A word of Warning

'Bargains' in the form of surplus radio components are being offered to the radio trade and the public. Condensers made by T.C.C. are included. And it is concerning these that we issue this warning.

Such articles were generally made for special war purposes and may not have any safe peace-time application. Furthermore, many of them will have been in store for long periods and under adverse conditions.

They have not been re-tested by us and we accept no responsibility for their performance, nor—of course—for any consequential damage their failure may cause.

Our warning could apply equally well to the large quantities of components imported (but not used during the war), and now about to be dumped on this market—but it is with our own products that we are chiefly concerned. We know their origin from their markings.

Better be safe than sorry

Issued by the makers of



CAPACITORS

THE TELEGRAPH CONDENSER CO. LTD.

RADIO DIVISION

North Acton, London, W.3

Telephone: Acorn 0061

YOU can become a first-class RADIO ENGINEER

We are specialists in Home-Study Tuition in Radio, Television and Mathematics. Post coupon now for free booklet and learn how you can qualify for well-paid employment or profitable spare-time work.

T. & C. RADIO COLLEGE
North Road, Parkstone, Dorset

(Post in unsealed envelope, 1d. stamp)

Please send me free details of your Home-Study Mathematics and Radio courses.

NAME

ADDRESS

W.W.49.

METAL rectifiers, charger kits, eliminator kits, microphones.

METAL rectifier, 12v 1.5 amp type, with 50 watt transformer and ballast bulb for 2v to 12v charger, 35/-, post 10d; ditto with one amp rectifier, 29/6; ditto with 2 amp rectifier, 42/6; also sold for 2v, 6v only at 2 ampere, 35/-, post 10d.; metal rectifier, 2v 0.5 amp. with transformer, makes idle trickle charger for 2v cell, 13/6, post 7d.; de luxe type charger kits, 12v 3 amp rectifier, with transformer and ballast bulb, for 2v to 12v charger, gives low and high charging rate, 59/6, post 1/-; metal rectifier and transformer only for 12v at 3 amp, 50/-, post 1/-; ditto for 4 amp, 62/6.

METAL rectifier, 12v 4 amp type, with transformer and ballast bulb for 2v to 12v charger, 70/-; metal rectifiers, 12v 1.5 amp, 10/6, post 6d.; 12v 0.75 amp, 7/6; 12v 2.5 amp, 16/6; 12v 3 amp, 21/-, post 9d.; 12v 4 amp, 27/6; also large 12v 5 amp half-wave rectifiers for car battery chargers, 26/-, post 1/-; M.B.S.1 one milliamp instrument rectifiers, 18/6; also 5 ma type for Avo, Avominor, 18/6.

H.T. rect., selenium type, 250v 60ma, 120v 60ma, 11/9; 120v 25ma, for eliminators, 6/11; transformer, metal rectifier, 2.9 mids condensers for 120v 25ma eliminator, 32/6; ditto with 2v trickle charging, £2, post 8d.; Dubilier, Hunts 8 mids condensers, 450v wkg, 3/6; Rothermel "Bullet" microphones, for stand mounting, 59/6; D.104 mikes, £4/4; Lustraphone moving coil mikes, £4/4; Rothermel Senior bakelite pickups, 75/9—Champion, 43, Uplands Way, London, N.21. Tel. Lab. 4457.

SCOTLAND'S largest stockists.—Anything radio we have it.

EDDYSTONE—agents—Raymart. SEND for parts and kits list. BUCCLEUCH RADIO MANUFACTURERS, Melville Terr., Edinburgh. Tel. Edinburgh 42803. Grams, Therm. Edin. [5139

CHARLES BRITAIN (RADIO), Ltd., offer more bargains in radio spares.

SPEAKERS.—Midget type 5in P.M., fitted with new cones, complete with pentode trans., 12/6 ea.; mains transformers, standard replacement types, 4v and 6v, 350-0-350, £1; speaker transformers, multi-ratio type, heavy duty, £1; medium size 12/6, standard size 8/-.

ELECTROLYTIC condensers, TCC wet cans, 16 mfd, 440v wkg, 7/- ea.; 8 mfd dry cans with fixing base, 450v wkg, midget type, 4/6; 8 mfd dry cans TCC 350v wkg, 3/6; 8-8 mfd 450v wkg, with fixing base dry cans, 6/6 ea.; Hunts and B.I. blocks, 450v wkg, 4/-; Hunts tubulars 450v wkg, 3/6; 25-25, 50-12, 12-50, 75-12, 1/9 ea.; tubular condensers, Phillips, —1, 400v wkg, 5/6 dz; —05, —04, —03, —02, —01, 1,000v test, 5/- dz; —005, —004, —002, —001, 4/6 dz; mica condensers, —005, —002, —001, 4/6 dz; —0005, —0003, —0002, —0001, 4/- dz; resistances, 1 watt Erie and Morganite, most values in stock, 6/6 dz; ½ watt, 4/6 dz.

SPECIAL OFFERS: Small moving coil mikes, undamaged cones, 5/-; damaged, 1/6; parcel of new assorted tubular and mica condensers, including every size from —0001 to —15, 1 gross in each, £2/8; parcel of new assorted 1 watt, ½ watt and ¼ watt resistors, 1 gross in each, £2; band pass aerial coils, ex-Ekco, with disc gram, 2/6; wave-change switches for the above, 2/6; write for our new April list "W"; terms, cash or c.o.d. over £1.—Charles Britain (Radio), Ltd., Radio House, 2, Wilson St., London, E.C.2. Tel. Bis. 5985, ext. 7. [5399

A MATEUR wishes dispose part of large stock, s.a.e. for list.—Box 7531. [5254

A LIGNED INSTRUMENTS SERVICES, 25, Park Grove Rd., Leytonstone, E.11. Tel. Leytonstone 5601.

ALL-WAVE superhet kit, 16.47, 200-550, 800-2,000 metres, a.v.c. high "q" i.f.s. ext. i.a. and p.u. sockets, 8in spkr., uses model 20 coil pack, fully aligned and tested, ac model, £12, ac/dc, £12/10.

MODEL 20 coil pack, aligned and tested, only 5 connections, 39/6; i.f. trans. 465Kcs, high "q." aligned and tested for gain, 17/6 pair; model 20 tuning heart, fully assembled, with 3 valves, £6/15/10; handsome tuning scale, glass, etc., and s/motion drive for above, 12/6; amplifier kits, really well-designed, ac models, 6watt, £7, 12watt, £11; ac/dc, 5watt, £7, 15watt, £12; tuning units, 3w/band s/het type, assembled cpte. with valves, ac or ac/dc, £6/17/6; TRF type, two med. wave stations only, high fidelity design ac or ac/dc, £6; other kits available, send 1d. for lists, circuits and tech. desc. for any above, 2/6; post trade only at present, send c.w.o. if possible—saves clerical work, orders over £5 post free, no c.o.d. under £2.

EXHIBITION of modern radio components and amateur communication equipment, 9 a.m. to 5.30 p.m., every day except Thursday (9 a.m. to 1 p.m.); staffed by G3AD, G8ZD, SPIHH/SP2IHH.—Tele-London (1943), Ltd., 177, Edgware Rd., London, W.2. Tel. Paddington 6116. [5400

SOUND EQUIPMENT

PUBLIC ADDRESS AMPLIFIERS
READY FOR USE A.C. MAINS

Model A18. Approx. 18 watts, P.P. output suit 3, 5, 8, 15 ohm speakers, with high gain microphone stage, tone and mixer controls, complete in a steel carrying case. £11/15/-

Model A23. As above, uses 6V6's, larger model 23 watts, for all general dance hall and social work. £15/10/-

Model A18GRAM. For gram. enthusiasts, no mike stage. £9/18/-

Model A36 De Luxe, using 6L6 or KT66 in P.P. with feedback, 35 watts, electronic mixing tone, etc., stabilized voltage, in handsome case with recessed controls. Tropicalized components. £22/10/-

Speakers for use with above equipment.
TEN inch 15 ohm, recommended ... £1/17/6
TWELVE inch 15 ohm 12 watt units ... £6/10/-
Horn speakers and units from ... £13/10/-

Microphones and stands.
Chrom. stands, telescopic folding base ... £2/7/6
Moving Coil Microphones ... £5/5/-

Write for NEW lists (2½d.). Dealers—we are appointing district agents, apply for full details. If you are engaged in selling or using transformers, chokes, condensers, resistors, etc., we can be of service.

RADIO INSTRUMENT CO.



Radio Products
294, BROADWAY,
BEXLEYHEATH, KENT
Bexleyheath 3021

ANSWERS AT YOUR



ELECTRICAL AND RADIO ENGINEERS
OHM'S LAW CALCULATOR

Whether you are constructing or servicing a radio set, problems involving voltage, current and resistance can delay progress.

Flik-o-Disk will give the answer in a jiffy. For example, what resistance should you use to obtain a voltage drop of 100 v. when current equals 25 m.a.? A flick of the disk and there is your correct answer—4,000 ohms. The scales read from 1 millivolt to 1,000 volts. From 1 ohm to 1,000,000 ohms. From 1 milliamp to 10 amperes. From 1/10th of a milliwatt to 10,000 watts

The calculator is sold complete and with full instructions at Radio Stores and Stationers. If unable to obtain, write to IONIC LABORATORIES LTD., Dept. W., Cranborne Terrace, SALT HILL, SLOUGH, BUCKS, for name and address of your nearest stockist.

PRICE
6/6

G. A. RYALL, 65, Nightingale Lane, London, S.W.12. Mail order only. All prices extra; no C.O.D. under £1. please; postages sent; many new lines.

RELAYS, Standard telephone, etc.; 150ohm 2V 15ma, 2P M & B 1P CO, 6/-; also 200X 200ohm 4 1/2 or 9V 4P CO, small 4/6, larger type 7/6; all high-class insulation and finish, unused; well-made small buzzers 6v to 7v 20ma, 2/- each.

MOVING COIL No. 7 ex-Govt. hand microphones with moving-coil pair headphones, unused, 45ohms and 90ohms respectively, 45/- set, few only; power microphones, Hand type well-known make, unused, 30/-; stamp for particulars.

SPRAGUE 01 tubular wire and 500v condensers, 5/- dozen; also 0.5mfd, 3 for 2/-; both are metal cased; perfect insulation.

CONTROL boxes, ex-Govt. unused, 3 Mk 2, double type, containing 3 five-point sockets; No. 5a, 3 black pointer knobs, 6v bulb and holder, 3 four-way distribution boards, Yaxley type switches, 3P 3-way 3-bank, and 4P, 2-way, 3-bank; also 3P, 3-way 2-bank; few resistances and rubber grommets, size of metal case, 99 3/4 x 4 1/2 x 2 1/4 deep, 5/-; single control boxes, No. 1, Mk 2, with two 5P sockets, black pointer knob, 3 four-way distribution boards, 250ma glass fuse, Yaxley type switch, 3P, 3w 2-bank, rubber grommets box size, 4 1/2 x 4 1/2 x 2 1/4 deep, 2/6; all packed in original cartons, as manufactured.

RESISTANCES, 1,800ohm wire wound, 1 watt, 1/- dozen, 1,800 wire wound; Vitreous wire-wound 50ohm 3/- dozen; Erie insulated 1/2 watt, 22,000ohm, 2/- dozen; Erie non-insulated, 2,200ohm, 2/- dozen; heavy-duty 20-ohm Vitreous, 1/- each.

ERIE insulated 2.7meg, 2/- dozen; useful assortment of 1/2w, 1/4w, 1/10w, 1/4w, Erie, 1/8 doz. Ryall.

UNIVERSAL ELECTRONIC PRODUCTS (G5UQ) 36, Mablethorpe High St., London, W.V.I. Tel. Welbeck 4058.

LARGE selection of components, meters, polystyrene and paxolin sheet, etc.

MINIATURE metal rectifiers for bias supplies, relay operation, etc., 25volt 75ma, half-wave, 4/-; full-wave, bridge connection, 6/6.

CONDENSERS, Mausbridge type, 2ufd 350 volt, 1/9; 4ufd 450 volt, 4/9.

TERMS: Cash with order; postage paid on orders.

OUR workshops are now equipped to undertake the construction of all types of equipment, from an extension spindle or small chassis to a complete transmitter, and as practical people we welcome enquiries from amateur enthusiasts. 15375

FOR sale, resistors, 1/10w 1/6 doz, 1/4w 2/- doz, 1/2w 2/6 doz, 1w 3/- doz; 2w 15s 3/6 doz; 5w 27k 4/6 doz, 60w 300r 1/- doz.

VALVEHOLDERS, octal, internal, or Mazda, 3/6 doz, 30/- gross; Yaxley switches, 3 bank, 3 wavs, 3 levs, 15s doz; sleeving of all types, 1/- per doz yards; reduction for large quantities.—Ch. Wainrib, 14, Wessex Gdns, N.W.11.

HENRY'S, Radio and Electrical Components, 5, Harrow Rd., Edgware Rd., W.2. Pat. 2194. Hours, 9.30-6 o'clock Mon-Sat., half-day Thursday.

METAL rectifiers, input 200-600volts, output 300ma, 30/- each; 4mfd 1,000v wkg., 7/6 each, oil filled; 1mfd 1,000v wkg., 3/- each, oil filled; 3-gang, 0.0005 standard condenser with trimmers 12/6; 4-gang 0.0005 standard condenser, 10/-; Celestion amphenol valveholders, 4-, 5- and 7-pin, English and Mazda Octal, Int. Octal 4- and 5-pin, U.X., 9d each, 7/6 doz; Paxolin types, 5/- doz.; t.r.l. m. and l. wave with reaction, 8/6 pr., with circuit coils; t.r.l. med. wave coils, 5/- pr., with circuit; i.f. transformers, midget/cr iron core, 465k/cs, 10/6 each; standard 465k/cs iron core, 5/- pr.; standard 110cs small cases, air spaced trimmers, 12/6 pr.; large selection of cabinets in stock; callers only. 15409

CRYSTALS, a few ex-U.S. Army Xtals available, suitable for 5th harmonic operation in 28mc band; 17/6 each, post 21d.—Willetts, 71, Egerton St., Farnworth, Lancs.

A MATEUR selling out; large stock modern meters, components, etc., for third coprice; £90 to clear, or exchange photographic material; s.a.e. particulars.—Box 7874. 15310

FOR sale, all parts for Mazda television set, inc. 12ch. magnetic tube, power supply, 2 Pen. 45s, HL41, HL41D1, D1 and 4 SP41s; nearest offer to £10.—Box 7616.

TELEBRADIO.—Send 1d. stamp for the most comprehensive list of quality components, kits and sets yet offered; absolutely rock bottom prices and quick delivery.—157, Fore St., Edmonton N 18. 15281

COMPONENTS, clearance prices, numerous items; send s.a.e. for list; c.r.t.s 2 1/2in "E" type, 45/-; electrolytic cap type, best quality 24mf 50v 7/-; 8-8+8mf 45v 8/6; Lawrence & Co., 3, Slater Place, Liverpool, 1.

ELECTRADIX OFFERS

BATTERY CHARGERS. Lesdix Nitday Battery Charger Metal Rectification from 2 volt 1/2 amp for small wireless cells to large Chargers for car battery and garage use; several sizes in stock for immediate delivery. Send for special Battery Chargers leaflet. **DYNAMOS.** D.C. car type Dynamo 6 to 80 volts for charging and lighting. Send for special Dynamo leaflet.

CUTOUTS. Air Ministry enclosed type cut-out, 12 volt 40 amp, or 24 volt 40 amp, in bakelite case, 35/-; 6 or 12 volt triple auto. car type cutout, dynamo control box, armature field and battery, 21/-; 24/30 volt D.C., 30 amp contactors, 30/-; 12/24 volt D.C., 500amp/1C contactors, 50/-.

SOLENOIDS. 24 volt solenoids, massive type to lift 14 lbs., 15/-; small 12 volt solenoids, pull, 1 oz., 1 in., 6/6.

FIELD REGULATORS. F.O.B. and B.O.B. Regulators, all sizes to 15 kW. Ironclad. Send for special leaflet, "F.R.V."

AUTO PULSE PUMPS. 12 volts Petrol Pumps in new condition, 35/- each.

LABORATORY AND TEST GEAR. Gambrell Universal Shunt Box, 10,000 ohms, £5. Gambrell Resistance Box, 10-20-50-100-200-500 ohms, as new, £4. Tinsley Res Box, four 125-ohm coils with terminals, 45/-. We have a number of these resistances boxes, some less plugs, at special prices. Write for list. Wheatstone Bridges, 100 ohms to sub-divided ohms, £5 10s. P.O. pattern 10,000 ohms, £10. G.P.O. Resistance Box, 8,000 ohm by 10 ohm steps, switch and plug type, £4 15s.

RELAYS. We have just taken delivery of a consignment of new Siemens Relays, 500+1,000 ohms, 2 makes, 10/-; 2 makes, 1 S.P.C.O., 12/6; 3 makes 1 break, 12/6. 500-500 ohms S.P.C.O., 10/-; 200 ohms 1 break 1 S.P.C.O. studded, 12/6; 10,000 ohm S.P.C.O., 21/- Send for Special Leaflet. Relay Contact assembly, thermal contact, 12/6. Siemens' High-speed Relays in heavy brass case, £3 5s. Telephone type No. 6, 2-coil polarised, S.P.C.O., 6 volts 25 ma., 32s ohms, 8/6. No. 1A, S.P. on-off, 2 volts 40 ma., 5/-.

Relay movements 1,000 ohms, less blade and contact, 2/6. Moving-coil relays by Weston, Elliott and Sullivan.

FANS. D.C. 110 and 220 volt Desk Fans by G.E.C. Verity and other leading makers with 12in. blade and guard, new condition, 35/- each. Oscillating type, 45/-. Fan Motors only, 110 and 220 volts D.C. Bulkhead, 25/- each. 24 volt D.C. Table Fans with 6in. blade and guard, 25/-.

SPARK COILS. Ex-G.P.O. Spark Coils, 5in. to 1in. spark from 6 to 12 volt accumulator for model control, etc., 25/-. Spark gap, 3/6 each. Ex-G.P.O. Spark Transmitter with coil, gap and condenser, in canvas covered mahogany case with folding Morse Key, 65/-.

MICROPHONES. The Lesdix No. 11A Hand Mike is again available; a carbon inset in solid brass case, the sensitive diaphragm protected by a perforated metal panel, 8/6. Metal clad inset only, 5/-. Pedestal mikes for desk or pulpit, 25/-; High radio transformer, 4/6 extra. Recording and announcers' hand-mikes, multi-carbon, metal clad, service type, by Tannoy and Truvox, with neat switch in handle, 21/-. As illustrated. Special high ratio transformers, 7/6 each.

MAGNETS. AC/DC mains magnets, 2-pole 220 volts, 7/6 each. The wonder midget Magnet, alni perm. steel disc, weight only 1/2 oz., 3/4 in. dia., 3/4 in. thick with 3/16in. centre hole, 3/6 each. Large selection of horseshoe Magnets in stock. Send for leaflet "W."

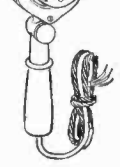

A VICTORY GIFT FOR YOUR BOY!

The Lesdix Bijou Crystal Set in bakelite case, condenser tuning, semi-perm. detector, 15/-. Pair of headphones, 12/6.



PARCELS. 7 lbs. of useful oddments for your junk box, all clean and dismantled from Government and other surplus apparatus, 7/6, post free.

ELECTRADIX RADIOS
214, QUEENSTOWN ROAD, LONDON, S.W.8
Telephone: MACaulay 2159

COULPHONE RADIO. Station Rd., New Longton, Nr. Preston.—The return of Post Mail Order Service. C.O.D. or cash with order. Orders over 5/- post free. Note the prices.

SPECIAL offer: ex-R.A.F. transmitters T1154, complete with valves; £5/5. ALL Tunggram and B.V.A. valves; list prices. FINE Cord .3 amp, 600 per foot, 2-way 1/6 yd., 3-way 1/9 yd.; mains droppers, Feet, 2 sliders, 2 amp 4/3, 3 amp 4/6.

GOODMANS T2/1205/15 12in P.M. quality speakers, £6/15; Goodmans T10/1501/3/5 15in P.M. super quality speakers to handle, 25 watts, weight 28 1/2 lb., £8/10.

1946 Airmaster 5v superhet chassis with 5in M.E. speaker, all ready to switch on; 13/30, 30/60, 200/550, 800/2,000 metres, high-class job, £16/10.

WEYMOUTH 3-waveband coil packs, completely wired and tested, for 465 kc, 38/6; matched pairs, iron-cored I.F. trans., 13/6.

MAINS transformers, highest quality, primaries tapped, 200/250 volts, 300/0/300, 60 m.a., 4v 3a, 4v 2a or 6.3v 2a, 5v 2a, 17/6; 350/0/350 100 m.a., 4v 6a, 4v 2.5a, or 6.3v 3a, 5v 2a, 24/-; bobbins 15/6; 450/0/450 200 m.a., 4v 8a, 4v 4a, 4v 4a, 6.3v 4a, 6.3v 4a, 5v 3a, 42/6; or 6.3v 6a, 4v 2a, 4v 2a, 5v 3a, 45/-.

EDDYSTONE short-wave components. **TUNING UNITS:** model A3, R.F. stage, 16/50. 200/550, 800/200, completely assembled and aligned with 3-gang condenser, drive scale and autotune, £5/15; model B3 as above, but with I.F. stage and D.D. stage, £8/15. Everything from a grid clip to a Vortexion 50-watt amplifier; send 2/6 stamp for new 12-page catalogue.

BUZZERS, 3/4; Morse keys, from 3/6; Partridge transformers, 250-0-250, 60 m.a., 4v 1-2a, 4v 2-4a or 5v 2a, 6.3v 2a, 19/6; 350-0-350 60 m.a., 4v 2 1/2a, 4v 2-4a, or 5v 2a 6.3v 4a, 23/3; Celestion 5in PM speakers, 23/6; Midget output trans, 6/6; list 1d, s.a.e.—Norris, 7, Kingshill Cres., St. Albans. 15332

PENWICK for sheet aluminium for cabinets, 18 gauges, screens, etc., 0.050in thick (18 gauge), 8in x 12in, 4/-; 18in x 6in, 2/6; 6in x 8in, 1/-; 18in x 6in, 2/-; also 8in x 12in 0.080in (14 gauge), 3/6; please enclose a few coppers to cover cost of post.—Penwick Dept. P, Brickkiln St., Wolverhampton. 15174

SERVICEMEN.—The following products are well designed and of high quality; volume controls, carbon type, all values, with or less switch, wire-wound resistors, 1 to 60watts; dropper resistors, 0.2 and 0.3 amp; line cords and razing resistors; terms and quotations on req.—Dagole Ltd., 5, Torrens St., London, E.C.4

GOVERNMENT surplus, 1000 ex R.A.F. throat mikes, 5/11 pair, post free; Post Office type mike insets, 1/- each, post free; new 4-way flexible telephone leads, tagged ends, 2 yds. long, 6d. each, postage 2d., 5/- per doz.; new 2ft. twin leads, tagged ends, 1/- doz., postage 4d.—Hay & Son, 129, North St., Brighton. 15267

REOPENED on the return of the technical R staff from war service.—Radiographic, Ltd., of Glasgow (B.R.S.12040), have now the opportunity of offering much in radio equipment of vital interest to the amateur and constructor; write or call for full particulars.—Radiographic, Ltd., 66, Osborne St., Glasgow, C.1. 15406

MALPINE BAKER RADIO. 54, Wellington Rd. South, Hounslow, Middx.—Mains trans. guar. 12 months; primaries, 200-250v, screened secondaries, c/t, 6v, same prices; 250-0-250 60ma, 4v 1/2a, 4v 2/4a, 19/6; 350-0-350 60ma, 4v 2a, 4v 2/4a, 23/6; 80ma, 4v 2 1/2a, 4v 2/4a, 4v 1a, 29/6; electrolytics, 450v 8mf, 3/-; 8x9, 5/6; 8x16, 6/6; 25mf 25v 1/9; resistor, 24 1/2 sizes, 7/6; post free, c.w.o. or c.o.d.; s.a.e. list. 15225

SANGAMO synchronous motors, self-starting, exceptionally good torque, rotor speed 200 rpm, 200-250v ac, 50c, consumption 2 1/2 watts, size 2 1/2", geared 1 rev 60 min, can be reset to zero by friction drive from front or back, shaft 5/16 x 1-10th to run clockwise, ideal movements for making electric clocks, time switches, etc., nickel-plated finish, price 22/6 ea, 12 to 1 dial trains to fit above spindle, per set 2/6.

CHAMBERLAIN and Hookham synchronous motors (enclosed type), self-starting, exceptionally good torque, rotor speed 200 rpm, 200-250v ac, 50c, consumption 3 watts, size 2 1/2", geared 1 rev 60 min, can be reset to zero by friction drive from front or back, shaft 5/16 x 1-10th to run clockwise, ideal movements for making electric clocks, time switches, etc., nickel-plated finish, price 25/- ea; 12 to 1 dial trains to fit above spindle, per set 2/6.

CASH with order post paid on all above goods. To callers only, a comprehensive stock of scientific instruments, meters, gears, relays, etc. H. FRANKS, Scientific Stores, 58, New Oxford St., W.C.1. Tel. Mus. 9594. 15206

ALL POWER
REGULATED H.T. SUPPLY UNITS

Model 101-A, 250-400 volts, 0-250 mA.
Stabilization Ratio : 100.
Output Ripple : Less than 2 mV.
Output Resistance : 1 ohm approx.
Model 102-A, 220-320 volts, 0-250 mA.
Stabilization Ratio : 20,000.
Output Ripple : Less than 1 mV.
Output Resistance : Less than 0.05 ohm.

Model 101-A is intended for general laboratory use, and Model 102-A for special applications demanding extraordinarily good stabilization. Both models are fitted with 4 1/2" scale output Voltmeter and Milliammeter.

HIGH VOLTAGE A.C. and D.C. TEST SETS

Model 301-A, 1-5 kv.
Model 302-A, 5-15 kv.

These instruments are designed for insulation tests on either AC or DC, and are therefore suitable for testing all types of components, including capacitors. Both models are fitted with high-grade Electrostatic Voltmeters, which are directly available for Voltage Measurements.

Please apply for Catalogue Sheets.

HIGH VOLTAGE TRANSFORMERS

We will be pleased to quote for your requirements.

Export enquiries invited

ALL POWER TRANSFORMERS LIMITED

8a, Gladstone Road, Wimbledon, S.W.19
Phone: L1Berty 3303

RADIO RECEIVER CIRCUITS HANDBOOK

By E. M. SQUIRE

A useful guide to circuits for members of the radio industry and radio amateurs. It covers all types of receivers by dealing with each stage or sub-stage in turn. The explanations are clear, and the book is freely illustrated with circuit diagrams and other useful material. *Wireless World* said of this book: "It is admirably suited to beginners."

CONTAINING PRACTICAL NOTES ON THE OPERATION OF BASIC MODERN CIRCUITS

6/- net

Order from your bookseller or direct from
SIR ISAAC PITMAN & SONS LTD
Fitman House, Parker Street
Kingsway, London, W.C.2.

SMALL "3-in-1" toggle switches, SP on and off SP changeover, or SPDT with one switch! Beautifully made, with wiper action contacts; post free, 2/3 each.—**Cannell**, 345, Purley Way, Waddon, Surrey. [5318]
AMERICAN condensers of finest quality. All metal cases; Sprague .001, .002, .01, 1,000v, 10/- doz.; .02, 750v, .05, 500v, 12/- doz.; .25, 500v, 18/- doz.; .25, 350v, 15/- doz.; .1, 1,000v, 15/- doz.; .25, 400v, 5, 600v, 18/- doz.; Micamoid, 5, 350v, 18/- doz. Aerovox fixed paper block, 5, 1,000v, 18/- doz., 2mfd, 350v, 18/- doz., 4mfd, 350v, 30/- doz.; 1 sample of each type, 15/-; cash or C.O.D.

TREGUNNA, 15, High Cross St., St. Austell.
METERS, moving coil, 2in scale, 60, 50, 40, 30, 15, 12, 10, 8, 6, 5, or 3mA, 23/- each; 2mA, 24/-; 1mA, 25/6; 500 microamps, scaled 0/15 and 0/600 volts, 26/-; thermocouple R.F. meters, 3.5 or 3amp, 35/-; 600mA, 36/-; 350mA, 37/6; AC voltmeter, high grade moving iron, 2 1/2" scale, 7.5 or 15volt, 20/- each; relays, ex-G.P.O., 2volt 10mA, 8/P.S.T., 7/6; Westinghouse meter rectifiers, 5mA, 7/6; 20amp vacuum mercury switches, 5/-; cash with order, post free.—**R. Massey**, 58, Wakefield Ave., Hull. [5212]

CABLE; VHF types, as used in A.M. radio and Radar equipment, surplus from A.M. contracts; suitable for internal wiring of radio receivers and transmitters and television equipment, and for screened aerial leads; the following quantities are available: Dumet 19, 28,988 yds; Uniplummet 1, 14,343 yds; P.1.9M., 3,445 yds; twin V.M. Low, 966 yds; Uniradio, 3,16,950 yds; cable form 2, 4,928 yds; cable form 38, 7,319 yds; cable form 41, 3,943 yds; Dusheth 4, 2,600 yds.—**Offers to**, Box 7984. [5316]

C.C. instrument wire, 1/4lb reels, 18, 20, 22, 24g, 1/6; 26, 28g, 1/9; 30, 32g, 2/-; 34g, 2/3; enamelled ditto same prices, including 36g, 2/3; 38, 40g, 2/6; S.C. ditto, 2oz, 24, 26, 28g, 1/6; 30, 32, 34, 36g, 1/9; 40, 42g, 2/-; 16g D.S.C., 1lb, 5/-; laminated bakelite papers, 1/4in thick, 6in x 4in, 1/3; 6in x 6in, 1/9; 8in x 6in, 2/3; 10in x 6in, 2/9; 10in x 8in, 3/6; 12in x 8in, 4/-; ditto, 1/16in thick, same sizes, 10d, 1/2, 1/6, 1/10, 2/4, 2/8; polished ebonite panels, 3/16in thick, sizes as above, 1/9, 2/9, 3/6, 4/6, 6/-, 7/-, respectively.

B.A. screws, gross useful sizes, 2/6; ditto nuts, 2/6 gr; assorted gross screws and nuts 2/6; ditto brass washers, 1/6 gr; fibre washers, 1/6 gr; assorted soldering tags, 2/-; assorted small eyelets and rivets, 1/3 gr; large stocks, state wants; finest quality stranded and single push-back wire, various colours, 12 yds, 2/3; resin-cored solder, 1 1/2 3/6; all postage extra; trade supplied.—**Post Radio Supplies**, 35, Bourne Gdns., London, E.4.
M.O.S., 24, New Rd., London, E.1. offer: 8mfd 500v tubular, cardboard electrolytics, 3/-; 2mfd 1,000v block condensers, 24/-; 24 carded crystalale knobs, all types, 24/-; D.P.D.T. toggle switches, 3/6; S.P.D.T., 2/2; 3-pole 4-way switches, 4-pole 3-way, 3/6; volume controls with switch, 3/8; less switch, 2/8; mains transformers, 350-0350v, 75 m/a, tropically impregnated, 30/-; instrument terminals, 4BA, 5d; Amphenol valveholders, octal and 4-pin, 7/6 dozen; trimmer kits, 30/-; Click extension plugs, red or black, 3d; crocodile clips, 2/9 dozen; I.P. transformers, alum. can, 465k/ea, 15/- pair; 3-pin plugs and sockets 8d, 4-pin 9d, 5-pin 10d, 6-pin 11/-; 1.5v dry batteries for portables, 2/-; 0-45-60v batteries for portables, 3/9; a new all-purpose transformer, can be used as auto-transformer, output transformer, bell transformer, to drive miniature trains, etc., 40/-, carriage 1/6; all types valves in stock; s.a.e. for lists; postage under 2s. [5164]

THE Simplex Hour, still the best, complete constructional details; Midget ac/dc (total cost of construction £9), theoretical and full-scale layout diagrams, with instructions, per copy 4/6; Midget polished wood cabinets, 35/-; Midget m. wave t.r.f. coils, high gain, 7/6; m.l. wave, with reaction circuit, 10/6; oil-filled paper condensers, high v. wkg. small size 4mfd 1,000v, 7/6; 8mfd 1,000v, 12/6; 8mfd 600v, 7/-; 10mfd 600v, 7/-; Midget electrolytic 8x16mfd 500v, 7/6; 15mfd 200v, 3/-; 16mfd 350v, 3/6; all-wave coil pack, wired, tested, 5 leads to receiver, boxed with ac/dc circuit, 40/-; Midget ivorine coloured dials, s.m.l. wave, 4x3 1/2, 2/6; coloured s.m.l. dials on glass, 9x4 1/2, 3/6; slow motion drives, 2-speed with driving disc, 3/6; ditto string drum drive, 1 speed, 2/6; epicycle drives, 3/-; miniature rotary switches, 4p 3w 5/-, 2p 6w 2/6; d.p.d.t., 3/-; chokes, midget, 50ma, 6/-; standard, 80ma, 8/6; heavy, 150ma, 12/6; Midget Simplex chassis, fully drilled with 4 valve holes etc., 11/4d, 2/-; 7/6; monthly comprehensive lists; 2/6d stamp with enquiries, postage all orders.
O. GREENLICK, Ltd., 34, Bancroft Rd., Cambridge Heath Rd., London, E.1. Ste. 1334.



SOLDER electrically with the SOLON

Designed by engineers for engineers, the Solon Electric Soldering Iron gives neater, cleaner, more efficient work in less time. The heating element is right inside the bit, giving constant heat at the point—where you want it. All internal connections housed at end of handle—away from heat and easy to get at. Complete with 6ft. of Henley 3-core flexible. Made for the following standard voltages:—100/110, 200/220, 230/250.

Made in England

Model shown is a standard 65 watt round pencil bit Solon. Other sizes and types available.



W. T. HENLEY'S TELEGRAPH WORKS CO. LTD.
51/53, HATTON GARDEN, LONDON, E.C.1.



W. BRYAN SAVAGE LTD.

Expert assistance in the solution of problems relating to

- TRANSFORMERS, CHOKES
- AMPLIFIERS
- POWER UNITS

and Specialised Equipment embodying

ELECTRONIC CONTROL

WESTMORELAND RD., N.W.9
COLINDALE 7131

TRANSFORMERS & CHOKES

To Special requirements 14 days
High Quality Vacuum Impregnated

AUSTIN MILLS LTD.

LOWER CARRS STOCKPORT

Telephone : STO. 3791 Established 20 years.

BATTERY CHARGERS & TRICKLE CHARGERS



Trouble-free Chargers fitted with selenium all-metal rectification. Good allowance on your old charger. Thirty years experience behind every Runbaken product. Booklet R.15, describes 12 Models, on request.

RUNBAKEN-MANCHESTER-1

Ex-ARMY No. 58 Mk. 1
Self-contained
SHORT-WAVE

TRANSMITTER & RECEIVER

Study this specification!

- 5-valve Superhet circuit ● A.V.C.
- Frequency range: 6 mc/s to 9 mc/s (50 to 33.3 metres).
- Working range: 5 miles with 12ft. rod aerial.
- Panel Test Meter for check on batteries and various parts of circuit.
- Chassis suspended in case by rubber shock mounts.
- Differential type noise-cancelling Mike.
- Head-phone assembly. ● Connecting Cables.
- Three aerials in carrier (12ft. rod, 8ft. Gins. Telescope, 25ft. wire).

BARGAIN OFFER (less Vibrator) £10

The above COMPLETE with
VIBRATOR POWER UNIT £22.10

—For Callers Only—

BAIRD TRANSFORMERS & TUBES

Electromagnetic Cathode Ray
Tubes. 15 inch. . . . £6 10 0
High Voltage Transformers for the
above. 6,500v. 3m/a. . . £1 0 0

INSTRUMENT METAL RECTIFIERS, 10 mA., 8/6.
SINGLE GANG CONDENSERS, .0005 mfd., 6/8.
SMALL FRACTIONAL H.P. MOTORS, 24 v. DC AC,
Universal and Reversible. Weight 20 ozs. Size
2 1/2" x 2 1/2" x 2 1/2". 2/8.

CONDENSERS, 2 mfd. 250 v. and 500 v. wkg., 1/3 each.
1 mfd., 5,000 v. wkg., 6/9 each. 1 mfd. 350 v. wkg.,
8d. each or 6/- doz. 1 mfd. metal cased, 1,000 v.
wkg., 2/6.

MOVING COIL INSERTS. Can be used as Head-
phones, Midget Speakers (without transformer),
Speech Mikes, or adapted for Pick-ups. In perfect
order but without grille. Coil, 30 ohms, 3/8.

In sound working order!

Ex-R.A.F. AIRBORNE G.P.
TRANSMITTERS

Type 1154. Complete with 4 valves. Frequency cover-
age: 500 kc/s, 200 kc/s, 10 mc/s, 3 mc/s, 2.45 mc/s,
8 mc/s, 2.5 mc/s. Power input 1,200 v., 200 mA. H.T.,
6 v. 4 amp. L.T. Chassis size 15in. x 13 1/2in. x 8 1/2in.
In metal cabinet. Supplied in strong wood case, with
metal bound corners and carrying handles, easily
adapted for Amateur use. Less 10 gns.
Power Pack.

R.A.F. Model 1155
COMMUNICATION RECEIVERS
Comparatively new

These receivers are made to the stringent specifica-
tion of the Air Ministry and are fitted with a large
scale dial calibrated from 7.5 mc/s to 1,500 kc/s.
Complete with 10 valves, including magic eye, they
are fitted in a strong metal cabinet, and supplied in
wood carrying case. They require only a power £15
pack to be ready for immediate operation. £15
You are invited to call and see the stocks of R.A.F.
gear we have for sale. It will pay you!

N.B. We do not issue lists and cannot deal with
correspondence on the goods we offer.

LONDON CENTRAL
RADIO STORES

Closed Thurs. 1 p.m. Open all day Sat.

23, LISLE STREET
LONDON GERrard 2969 W.C.2.

B. & H. RADIO offer all sizes of electro-
lytics, 2- and 3-core line cord, trans-
formers, chokes, volume controls, etc., trans-
formers, etc., made to specification; quality
amplifier components and design. Trade only.
Send for list, Huntley St., Darlington. [5195
SUPREME RADIO, 746, Romford Rd.,
Manor Park, London, E.12. Tel. III.
1260. For 15 years we have given service.
LINE cord 3-way 60-70v per foot, 1/6 yd;
ML coils, with circuit matched, 9/6 pr., MW
6/6; L.M.S. wave coils, A and O short 14-50
metres, M200-550L, 900-2,000, with circuit,
10/6 pr; I.F. 465 kc. 10/-; switches for same,
7/6; midget 2-gang 0005 condensers, 11/-,
3-gang 13/-; all-wave dials, 3 1/2in x 4in,
coloured 1/9; all-wave 5in, 2/6; glass 4 1/2in x
9in 3/6; L and M switches, 2/5.
SPEAKERS from 2 1/2in-10in; send for prices
valves, 6J5GT, new, boxed, 7/6; not BUA, 80,
5Y39, we have a quantity of odd valves, also
over 3,000 BVA valves at BOT prices; paper
and can condensers; send for prices; Airmaster
5-valve superhet chassis, 4-waveband pick-up
and extension speaker tappings, all Mazda
valves fitted, including PT, £15/10; also in
Console model, £29/10.
MANY other lines for the service engineer.
S.A.E. All enquiries, 6d extra for postage.
No c.o.d. [5333

DYNAMOS, MOTORS, ETC.
ROTARY converter, 250v ac/dc, constant
frequency governor; also rotary con-
verter, 250v ac/dc—Box 8067. [5328
CONVERTER, 200v dc to 230v ac, 521a,
smoothed and silenced, £10/10—3rd
Floor, 120, Drury Lane, W.C.2. [5322
VOIGT L.S. unit, £16; converter, 12v dc,
220 ac & 150 ah acc., £18; 6v dc, 240
60 m.a.d.c. & 150 ah acc., £6.—Box 7982.

VALVES
IR5, 184, 185, 174; 25/- each, all unused.—
Box 6489. [5061
AMERICAN G.T. valves at B.o.T. prices.—
1A5GT, 1A7GT, 1C5GT, 1H5GT,
1H5GT, 1N5GT, 3Q5GT, 6A8GT, 6P6GT,
6B6GT, 6K7GT, 12A7, 12Q7GT, 6P5GT,
6G7GT, 68A7GT, 12A7, 12Q7GT, 128A7GT,
128F5GT, 128Q7GT, 12Z3, 25L6GT,
25Z6GT, 27, 32L7GT, 83, 117Z6GT; cash or
c.o.d.

REPAIRS AND SERVICE
MAINS transformer rewound and con-
structed to any specification; prompt deli-
very.—Brown, 3, Bede Burn Rd., Jarro. [3460
ACCURATE radio rewinds, mains trans-
formers, fields, op. transformers, etc.—
Southern Trade Services, 297-299, High St.,
Croydon. [5158
LOUDSPEAKER repairs, British, American,
L any make; moderate prices.—Sinclair,
Speakers, 12, Pembroke St., London, N.1
Terminus 4355. [3308
TREGUNNA, High Cross St., St. Austell.
[5249

ELECTRICAL measuring instruments skil-
fully repaired and recalibrated.—Electrical
Instrument Repair Service, 329, Kilburn
Lane, London, W.9. [5344
RADIO repairs efficiently and speedily exe-
cuted by experts; comprehensive modern
test equipment.—Radio Maintenance Service,
139, Goldhurst Terrace, N.W.6. Mai. 6133.

REWINDS and conversions to mains and
output transformers, fields, etc. from 4/6.
PP equipment a speciality.—N. L. Rewinds, 4,
Brecknock Rd., N.7. Tel. Arnold 3390. [5185
RADIO repairs quickly executed to all
makes, English or American; lowest possi-
ble prices.—The Music Box, 89, London Rd.,
London, S.E.1 (Tel Waterloo 4460 and 6766.)

STURDY rewinds, mains transformers,
S chokes and fields; we give prompt delivery
and guarantee satisfaction; 14 years' experi-
ence; prices on request.—Sturdy Electric Co.,
Ltd., Dipton, Newcastle-upon-Tyne. [4316

REPAIRS to moving coil speaker, cones,
R coils fitted, field rewound or altered;
speaker transformers, clock coils rewound,
guaranteed satisfaction, prompt service.
I.S.S. REPAIR SERVICE, 49, Trinity Rd.,
Upper Tooting, London, S.W.17. [4819

LOUDSPEAKER repairs and mains trans-
former rewinds; we can now give prompt
service at reasonable prices to dealers and
service engineers; send 1d. for our latest list.
—A.W.F. Radio Products, Borough Mills,
Sharpe St., Bradford. [4495

TRANSFORMER rewinds or replacement
of coils, machine layer wound on bakelite
former, interleaved, impregnated and clearly
marked, rewinds, £1; standard windings to
70watts, coils. 15/6; extra secondaries and
larger types pro rata, new transformers or
chokes to specification, singly or in quantity;
trade list on application; delivery by return
of post most types; state model and iron sizes
when ordering coils, pick-ups, o/p trans, field
coil, etc., rewound, fully guaranteed.
—Radio Services, Field St. Works, Black-
pool, R.T.R.A. Serv. Members. Tel. 1250-1774.

GALPINS

GOV'T. SURPLUS ELECTRICAL STORES

408 High St., Lewisham, London, S.E.13
Telephone: Lee Green 0309. Near Lewisham Hospital

MAINS TRANSFORMERS, by well-known makers,
200/250 volts input, output 300/0/300, 100 m/a.
Price 21/-. Carriage paid.
Ditto, 275/0/275, 100 m/a. 5 volts 3 amps, 6.3 at
9 amps. Price 21/-. Carriage paid.

"EPOCH" CINEMA SPEAKERS, 15in. cone, 6volt
field, 15 ohm speech coil, handle 20 watts. Price
£6 15s.

LARGE TYPE RECTIFIERS, 12 volts 4 amps,
45/-; 12 volts 6/8 amps, 55/-; 6 volts 1 amp,
12/6; 50 volts at 2 amps, 42/6. All fully guaran-
teed.

MAINS TRANSFORMERS, to suit the above 12
volt rectifiers, with tapped output of 6, 12 and
24 volts at 6 to 8 amps., 40/-. Carriage, 2/-.

EX-GOV'T. R.A.F. Short-wave chassis, 10 valve,
suitable for components only, approx. 30 mixed
resistances, 28 condensers, 2 multi-contact relays,
and 9 Octal valve holders, price 17/6 each, postage
1/6, or in quantities of 3, 15/- each, 1/- postage
per chassis, in lots of one dozen or more, 12/6 each,
carriage and packing 7/6 per doz.

VOLTAGE CHANGER TRANSFORMERS. Auto-
wound, fully guaranteed, immediate delivery.
350 watts, 55/-; 500 watts, 70/-; 1,000 watts,
£5 15s.; 2,000 watts, £8 15s. All tapped
0, 110, 200, 220 and 240 volts.

EX-GOV'T. R.A.F. ROTARY CONVERTERS,
suitable for car radio, etc., all in new condition,
fitted with automatic switching and reduction
gearing operating 3 relays, complete with smooth-
ing, input 6 to 9 volts, output 450 volts at 50/80
m/amps, 37/6 each, carriage 2/6; or in quantities
of 3, 32/6 each, carriage 5/-; in lots not less than
12, 30/- each, carriage per dozen, 15/-.
Ditto, 12 to 18 volts, input same as above.

ELECTRIC LIGHT CHECK METERS, guaranteed
electrically 200/250 volts 50 cy., 1 phase, input
5-amp type, 12/6, 10 amp. type, 15/- each. Car-
riage 1/-.

D.C. MOTORS, approx. 1/4 h.p. series wound,
all guaranteed electrically for 110 or 250 volts
mains. Price 15/- each. Carriage 1/-. We
also have a few with **LAMINATED FIELDS**,
which are easily convertible to work off A.C.
mains. Price 20/-, C.F.

EX-R.A.F. ROTARY CONVERTERS, 20/24 volts
D.C. input, 450 volts 40/60 m/amps D.C., output
complete with smoothing, 25/- each. Carriage 2/-.

X-RAY TRANSFORMERS, by well-known makers
and fully guaranteed; input 120 volts, output
30,000 volts at 750 watts, £8 10s. Ditto, 110/250
volts, input 90,000 volts at 24 kw. with Coolidge
winding, £25. Ditto, 120 v., input 40,000 volts
at 80 watts, £15. Ditto, 120 volts, input 58,000
volts at 2 kva, £17 10s. Ditto, Dental type,
110/240 v., input 95,000 volts at 1 m/a., output
with Coolidge winding, £10.

HIGH-GRADE SWITCHBOARD TYPE AMP.
METERS, 5in. dial for A.C. or D.C. calibrated 50
cycles, 0 to 30 volts, 32/6 each. Amperimeters
moving coil, 3in. dial 0 to 10 amps., 20/- each.

THREE-PHASE ELECTRIC LIGHT CHECK
METERS, 400/400 volts, 50 cycle 3-phase load, 25
amps, 25/-.
SULLIVAN MOVING COIL VOLTMETERS, 0 to
10 volts, 2 1/2in. dial, new boxed, 35/-. T.C.C.
4 M.F. 300 v., A.C. wkg. condensers, 3/6 each.
Ditto, 2 M.F., 2/- each. Mult. contact relays,
ex-G.P.O., 5/- each.

T.C.C. ELECTROLYTIC CONDENSERS, 500
M.F. 25-v. wkg., 8/6 each, 2,000 M.F. 12-v.
wkg., 10/-, 2,000 M.F. 25-v. wkg., 15/-, 50 M.F.
50-v. wkg., 2/6, 50 M.F., 12-v. wkg., 1/6 each.

MAINS TRANSFORMERS, all by well-known
makers and fully guaranteed, input 200/250
volts, 50 cy. 1 phase; output 2,000/0/2,000 volts
at 250 m/amps with 2 L.T. tappings, 75/-. Ditto,
475/0/475 volts at 150 m/amps, with 3 L.T. tappings,
4v. and 6v., price 42/6. Ditto, 80, 100, 120, 140,
200, 220, 240 volts at 3,000 watts, £12 10s. Ditto,
6, 16 volts at 14/90 amps output, £15. Trans-
former cores, suitable for winding 2,000 watts,
27/6; 100 watts, 7/6 each.

EX-R.A.F. CHASSIS TYPE No. C2. Useful for
making your own oscillator. The components
consist of condensers, chokes, transformer, volume
controls, octal base, valve holders, tube holders,
and various other components. Price 27/6
each. Carriage 2/6.

RESULTS -

reported by Candler students who enrolled for the Junior Code course.

Ref. No. 3213. (Completed first two lessons.)
 "I am very pleased with your course. I am making more progress than I thought I would when I started. Thank you."

Ref. No. 2521. (Completed first five lessons.)
 "I commenced actively in January and seem to have progressed very satisfactorily since I took my G.P.O. Morse test on February 26th, and know I passed well. I made no errors in receiving at 12 words per minute, and sent at 14 words per minute... I found lesson five most helpful from the point of view of training the sub-conscious faculty for faster receiving and ease of receiving, too."

Ref. No. 2245. (Complete all ten lessons.)
 "I am glad to announce that I recently passed the P.M.G. Special Exam., and as you will see on my report, my speeds are now far ahead of the speeds needed in the examination. I therefore walked through the telegraphy part."

NOTE: Speeds were Sending 23 w.p.m., Receiving Code 19 and Plain language 24 w.p.m.

THERE ARE CANDLER MORSE CODE COURSES FOR BEGINNERS AND OPERATORS
 Full details are given in the Candler "BOOK OF FACTS," sent post free on request.

THE CANDLER SYSTEM CO. (Room 55W).
 121, Kingsway, London, W.C.2.

Candler System Co., Denver, Colorado, U.S.A. (645)

COVENTRY RADIO

COMPONENT SPECIALISTS since 1925

- Octal Valve Holders .. 6d. each .. 47/6 grs.
- A.E. Socket Strips .. 4d. .. 32/-
- Tag Strips—Insulated, 1 way, 1d. each. 8/- grs.
- Coil Formers, Bakelite, 3" x 3 1/2" dia. .. 4d.
- Coil Formers, Bakelite, 6" x 3d. .. 22/6
- Coil Formers, Bakelite, 3" x 1 1/2" .. 4d.
- Coil Formers, Bakelite, 3" x 1 1/2" .. 4d.
- Teicon Co-Ax Cable, 1/2" dia., very heavy, for television lead .. per foot 10d.

Send for Sample.

PROMPT DELIVERY, COMPLETE SATISFACTION

COVENTRY RADIO,
 191, DUNSTABLE ROAD, LUTON.

AMATEUR CHASSIS

An excellent range of sturdily-made Chassis for all requirements. Open ends make for easy access; stout steel straps (plated) give extra rigidity and are tapped 2 B.A. for cabinet fixing.

- STEEL (Plated)
 - 12in. x 9in. x 3in. deep .. 6/6
- ALUMINIUM
 - 7in. x 7in. x 2in. deep .. 3/9
 - 6 1/2in. x 9 1/2in. x 2in. .. 4/-
 - 11in. x 7in. x 2in. .. 4/9
 - 17in. x 10in. x 2in. .. 5/9

ALUMINIUM, punched for Midget Radio, 40 take 6 1/2in. Speaker and up to seven valveholders (or w/4 holders, can condensers, IF trans., etc., 10in. x 5 1/2in. x 2in. deep .. 5/-
 Packing and postage 1/- each extra. Any quantity despatched at once from stock. Note that the 5 1/2in. x 9 1/2in. model has been developed for unit construction of sets, power packs, etc., to butt together in 5 1/2in. widths.

WIRELESS SUPPLIES UNLIMITED,
 264-266, Old Christchurch Road, Bournemouth.

"SERVICE with a Smile."—Repairers of all types of British and American receivers; coil rewinds; American valves, spares, line cord.—F.R.I., Ltd., 22, Howland St., W.1. Museum 5675.

TESTGEAR REPAIR SERVICE specialists in repairs, recalibration, etc. of test equipment of every description for the radio industry.—2, Tower Bridge Rd., London S.E.1. Tel. Ber. 1669. [4506]

TELEVISION and radio receiver serviced by certified engineers; Murphy and Pye specialists; amplifiers rebuilt or repaired; sound repairs for 15 years.—T. E. Feyer. F.I.P.R.E., 50, Vine St., Uxbridge. [5266]

REWINDS, mains transformers, speaker field coil-chokes, high-grade workmanship, 7 day delivery; new transformers constructed to customers' specification, singly or in quantities.—Metropolitan Radio Service Co., 1021, Finchley Rd., N.W.11. Speedwell 3000. [3719]

24-HOUR service, 6 months' guarantee, any type transformer rewind, mains, outputs and i.f.s., etc., all types of new trans., etc., supplied to specification; business heading or service card for trade prices.—Majestic Wind-inz Co., 180, Windham Rd., Bournemouth.

ALL makes and kinds of electrical and radio instruments repaired by skilled technicians A.I.D. approved; over 60,000 instruments repaired for R.A.F.; all work quoted by return without charge.—C. Gertler, Dept. D, 29-31 Cowcross St., E.C.1. Cle. 6783. [4829]

LOUDSPEAKER repairs, any make, reasonable prices, prompt delivery, to the trade and quality fans; 25 years' combined experience with Rola, Magnavox, Goodmans, Celestion.—Sound Service Radio, 80, Richmond Rd., Kingston-on-Thames. Kin. 8008. [4977]

REWINDS, wax impregnated, O/P transformers, chokes, fields, clock coils, pick-ups, fractional hp motors, competitive prices; prompt delivery; guaranteed work.—W. Groves, Manufacturing Electrical Engineer, 154, Icknield Port Rd., Birmingham, 16. [4547]

DEGALLIER'S, Ltd.—"Service with a guarantee." If you cannot get your receiver serviced, let American specialists with proper test gear do the job; first-class workmanship only; we specialise in Air-King, Belmont, Challenger, Emerson, Ferguson, Gard, Allcraft, Hammerlund, McMurdo, Midwest, Majestic, Pilot, Scott, etc., also any British set; send s.a.e. with all enquiries. DEGALLIER'S, Ltd., 9, Westbourne Court, London, W.2. [5276]

MISCELLANEOUS

"W.W." 1940-45, 55 copies, 42/-—Smyth. Annalee House, Cavan. [5245]

SPARKS' data sheets—These data sheets provide complete constructional details, together with full-size prints, etc., of tested and guaranteed designs.

ELECTRIC guitar units (3rd edition), 5/-.

ELECTRONIC one-string fiddle, 3/6; 6-8watt ac/dc amplifier; phase inverter; push-pull output; neg. feedback; portable for use with above or mike, p.u., etc., 3/6.

A.C. two-valve, med. wave, coil details, 2/6; 3 1/2watt ac amplifier, 2/6.

SPARKS' DATA SHEETS (W.), 9, Pheobeth Rd., Brockley, London, S.E.4. [3622]

MIDGET polished wood cabinets, inside meas. 10 1/2in x 5 1/2in x 5 1/2in deep; plain or cut for speaker only 17/6, plus 1/- post and packing; cut to your requirements 2/- extra.—Morris, 9, Wicklow Av., Stockport. [5074]

IDEAS mean money!—If you have an idea, we can help you to make the most of it; write at once for full information on the technical, legal and financial services we offer to inventors.—Technico-Legal Services Bureau, 55, Rotheray St., Westminster, S.W.1. [4948]

THORNGOOD RADIO, Ltd., 44-45, Bamworth Rd., West Croydon (Tel. No. Croydon 7417-8), wish to announce they have reopened their retail business at this address, and will be pleased to receive literature, catalogues, etc., and to hear from suppliers of electrical, radio and lighting goods. [5269]

WANTED, EXCHANGE, ETC.

EKCO, a.c. 86 cabinet required.—Thompson, 69, Red Post Hill, S.E.24. [5228]

SET aerial h.t. det. bandpass coils.—Allday, Mill Lane, Nr. Aldridge, Staffs. [5229]

WANTED, round horn, take 12in unit.—130, High St., Braintree, Essex. [5257]

WTD, battery charger, metal rect, 2 circuit.—Matheson, Fishmarket, Aberdeen.

COMMUNICATION typewriter wanted.—20, Harold Ave., Belvedere, Kent. [5321]

WANTED, valve, Telefunken type UCL 11.—33, St. Marys Rd., Hayes, Middx.

WANTED, magnetic recording wire, tape, German Magnetophon tape.—Box 8120.

WANTED, communications rec.—Particulars to Owen, 12, Tivoli St., Cheltenham.

L-R-S Government Surplus POCKET WATCHES

Made for the R.A.F.

First-class Timekeepers

New, Helvetia brand, 15-jewel Swiss movement, luminous dial, Nickel Case. Reg. Postage 8d. Price

Also in Stock **£4-15**

STUART ELECTRIC PUMPS for Machine Tool cooling, fountains and all pumping purposes. List Id.

THE LONDON RADIO SUPPLY CO.

(Established 1925)

WINDEN, BALCOMBE, SUSSEX



Be WISE and PATIENT

WE APOLOGISE to those who have been waiting months for replies. Our post-war plans have been frustrated so far. Sorry!

VOIGT PATENTS LTD.

MIDLAND INSTRUMENT CO.

Offer brand new unused ex-R.A.F. Landing Lights, (Originally cost £15). Consists of ball-bearing, reversing, 12-24 volt AC/DC motors, (clearing, various automatic switch conditions, 8-in. dia. glass front reflector lamp. Easily adapted for many uses, 30/- each complete, carton, packing & postage 2/- extra. Avometers, Model 40, £17-10-0, carton, packing, postage & registration, 2/6 extra. Lewcos Instrument Wires & many other Radio & Electronic items new June lists, 2d. s.a.e. 18, Harborne Park Rd., Birmingham. 17. Tel. HAR. 1308 or 2664.

A.C.S. RADIO

FOR COMMUNICATION RECEIVERS, AMATEUR TRANSMITTING GEAR, ALL TELEVISION AND RADIO EQUIPMENT AND COMPONENTS.

Preliminary LIST NOW READY, but with new stocks constantly being added we suggest enquiry for definite items if not listed.

44, WIDMORE ROAD, BROMLEY, KENT

NON-MAGNETIC TURNTABLES

with STROMBOSCOPIC MARKING
 An essential accessory for serious PICK-UP DESIGN RESEARCH

SOUND SALES LIMITED
 West Street, Farnham, Surrey

PHOTO-ELECTRIC CELLS

SeTe on gold-alloy, super-sensitive to light, gas-filled, permanent, operate relay direct or with Valve Amplifier, perfect reproduction of Speech and Music from sound track of films; large tube 3 1/2in. from glass top to valve pin base, lin. diam., 38/-; same type 2 1/2in. long, 35/-; small tube, 2in. from top to terminal base, 1/2in. diam., 30/-; miniature cell, glass top to cap base, lin. overall, 1/2in. diam., thin flex leads, 28/-; all cells operate on 40-100 volts. Connections diagrams free.

PRECISION OPTICAL SYSTEM producing fine line of light from any car headlight bulb, for scanning film sound track direct into Photo-cell, metal tube 2in. long, 1/2in. diam., 1/2in. focus, 52/-, Instructions free. Goods by return.

GEFA INSTRUMENTS, 38a, York Street, TWICKENHAM, Middx. POPesgrove 6597

- +
J.B.ULLI

WOT! NO TROUBLE?
no trouble at all! It's a pleasure
(for us and our customers)

to select from
10,000 Popular and Rare Radio VALVES, exact type or suitable Replacement: ACHLDD, ACP, AC2RL, AOpen, AC2pen, AC2penDD, AC5pen, AC5penDD, AC0pen, AC0SG, AC5GVM, AOTP, ACVP2, ACVP2, AC044, APP4A, APP4B, APP4, AZ1, AZ11, AZ31, OL, O10, OBL31, COH35, OY10, D63, D430, DCF, DD13, DD41, DD207, DDT, D62, DH63, DL, DL63, DQ24, DW2, DW4/350, DW4/500, EA50, EB34, EB03, EB033, EB11, EOC31, BOH35, EF6, EF8, EF9, EF39, EF50, EL2, EL3, EL32, EL63, EL35, EMI, PC2, FC2A, F04, FC13, FC130, FW4/500, H63, H141D, H2, H224, H141, H12, H13, H12DD, H12, H12DD, H141DD, H13DD, H1120, H120, H12DD/120, IN5, IW4/350, KT2, KT24, KT32, KT30G, KT61, KT63, KT66, KTW61, KTW63, KT241, KT263, L63, LP2, MH4, MH41, MH1118, MH4105, MHD4, MHL4, MLL4, MS4B, MSP4, MSP6n, MSP6nB, MUI4, OM4, OM9, OM10, P2, P41, P215, P050, P420, P22A, PM2HL, PM2A, PM22D, PP3/250, PFG/400, PT2, P4, P32, P63B3, Pen4DD, Pen45DD, Pen4VA, Pen25, Pen45, Pen4DD, Pen46, Pen141, Pen428, PenA4, PenB4, PenDD402, QP22B, QP25, QP230, R4, B4VB, B2, SP13, SP130, SP1320, SP4, SP4B, SP41, SP42, TDD30, TDD34, TDD4, TH210, TH300, TH410, TH41, TH231, TH321, T22, T23, T226, T22690, TRXG, TV4A, T6D, U5, U10, U14, U16, U18, U31, U50, U52, U74, U403, U4090, UR10, UR30, UG2, UUG, UUG, V914, VHT4, VMP40, VMS4B, VP2, VP4, VP4A, VP4B, VP13A, VP130, VP23, VP41, VP133, W21, XH, X80, XE, XLO, X24, X41, X61A, X03, X63, Y63, Y01A, LA3, LA5, LA8, LA7, 1B4, 1C5, 107, 1D5, 1D6, 1D7, 1F4, 1F5, 1F6, 1F7, 1H4, 1H5, 1H6, 1J5, 1J6, 1L06, 1T5, 247, 2B7, 2D130, 2D4A, 2P, 5U4, 5V4, 5Y3, 5Z4, 6A4, 6A7, 6A8, 6A8E60, 6B5, 6B7, 6B8, 6C5, 6C6, 6C8, 6D5, 6D6, 6D7, 6F6, 6H4, 6J5, 6J7, 6J8, 6K5, 6K7, 6K8, 6L5, 6L6, 6L7, 6N7, 6P5, 6P7, 6P7, 6R7, 6SA7, 6SF7, 6T7, 6U5/6G5, 6U7, 6V6, 6X5, 6Y5, 6Z5, 6Z6, 7A7, 7A8, 7B5, 7B6, 7B7, 7B8, 7C5, 7C6, 7D3, 7D5, 7Y4, 8D2, 9D3, 10, 10D1, 11D5, 12A, 12A6, 12B5, 12J5, 12K8, 12Q7, 12SA7, 12SB7, 12SK7, 12S7, 12T3, 12Z5, 13A7A, 14, 15, 15D1, 18, 19, 20, 20D2, 22, 24, 25A6, 2Z24, 25Z8, 26, 29, 31, 32, 33, 34, 35, 35Z4, 3Z25, 37, 38, 40, 40SUA, 41MP, 41M7L, 418TH, 42, 42MPen, 43, 45, 45Z5, 46, 48, 49, 50, 53, 55, 56, 57, 58, 59, 71A, 74, 76, 77, 79, 80, 81, 82, 83, 85, 89, 99, 184V, 210DDT, 220TH, 301, 302, 303, 304, 354V, 500BU, 807, 804, 955, 1331, 2151, 9050, 9002, 9003, 9004, 9005, 86504, 86506, 86510, 86530,

All at list prices. Order C.O.D. Stamp with enquiries. Please send us also your enquiries for types not listed above.

EXPORT ORDERS safely packed and fully insured.

Forces and DEMOBILISED—Special Attention.

COMPONENTS
Full range of tested quality in stock.

J. BULL & SONS
(W.W.)
246, HIGH STREET,
HARLESDEN, N.W.10

BERRY'S (SHORT WAVE) LTD

ANNOUNCE A NEW—
6 VALVE SHORT-WAVE SUPERHET KIT for the discriminating Amateur

Brief Specification
ASW6. Low-loss plug-in Polystyrene coils: an d EF50 high gain low noise R.F. stage; 1.6 Mc/s I.F. giving complete freedom from second channel interference. Blueprint and details, 3/6.

20-PAGE CATALOGUE, 3d. Post Free
25, HIGH HOLBORN,
(Opposite Chancery Lane). **LONDON, W.C.1**

WTD, copies "Radio," "R.9," 1930 to 1942; "Radio Craft," "Radio News," 1937-1945.—Mitchell, "Flagstaff," Colwyn Bay. [5327]

WE offer cash for good modern communication and all-wave receivers.—A.C.S. Radio, 44, Widmore Rd., Bromley, Kent.

WANTED, R.C.A. AR.88 or SX.28 or later; good price paid for good receiver.—Will Rogers, G25Y, Drayton, Daventry. [5199]

URGENTLY wanted, cable flex P.V.C. and millimetre wire, all descriptions purchased for cash, any quantity.—Alec Davis, 8, Percy St., W.1. [5213]

G. W. SMITH & Co. (RADIO), Ltd., require the following: new or second-hand radio receivers and radiograms; all classes of radio test equipment; highest cash prices paid.
G. W. SMITH & Co. (RADIO), Ltd., 2, Cecil Rd., Southgate, London, N.14. Tel. Enterprise 5465. [5116]

WE buy for cash, new, used, radio, electrical equipment all types; especially wanted, radios, radiograms, test equipment, motors, chargers, recording gear, etc.—If you want to sell at the maximum price, call wire or 'phone to University Radio, Ltd., 22, Lisle St., Leicester Square, W.C.2. Gr. 4447.

SITUATIONS VACANT
FIRST class radio chief engineer wanted, with good experience, and excellent refs.—Reply Box 7844. [5304]

AIRCRAFT radio officers.—Vacancies for holders of Air Ministry wireless licences.—Application forms from Box 7523. [5251]

IMPROVER service engineer to work under specially skilled engineers; permanent position.—Kensington district.—Tel. Fireman 0444. [5275]

RADIO and television service engineer required, fully experienced, good position for right man; state experience and wage required; London, E.2.—Box 7566. [5262]

ASSISTANT record engineer wanted, one having some experience of amplifiers and test gear preferred.—Write Sound Recording Department, 9-11, Park Crescent, W.1. [5277]

E. K. COLE, Ltd., require fault-finders and testers for radio and television receivers.—Apply, giving full particulars of experience, to Personnel Manager, Ekco Works, South-end-on-Sea. [4939]

EXCEPTIONAL opportunity occurs for sergeant on eve of demobilisation to fill position as assistant works manager with progressive radio equipment manufacturer.
APPLICANTS must be fully experienced in all branches of radio development work, able to act on own initiative, preferably trained at Horton or Cranwell.—Reply in confidence, Box 7759. [5288]

DRAUGHTSMAN with experience in production drawing of radio apparatus, A.E.S.D. rates.—Applications in writing to Personnel Manager, E. K. Cole, Ltd., South-end-on-Sea, Essex. [4969]

DRAUGHTSMAN with experience in production drawing of radio apparatus; A.E.S.D. rates.—Applications in writing to Personnel Manager, E. K. Cole, Ltd., South-end-on-Sea, Essex. [5314]

FIRST class radio engineer having wide experience in design of radio receivers wanted; must have first class references; we offer good salary and high position.—Please write Box 7611. [5265]

WANTED, radio engineer, fully qualified; good position for right man.—Write, stating full particulars of experience and wages required, to A. B. White & Sons, Ltd., 132, High Rd., N.15. Sta. 2986. [5306]

RADIO development engineer required by Midlands radio manufacturer, experience of commercial radio design essential.—Write details of qualifications, experience and salary required, to Box 107, c/o Era, 166, Camden High St., London, N.W.1. [4972]

PRACTICAL designer and production supervisor required for E London radio factory producing receivers and amplifiers of all types.—Full details experience, age and salary, etc., to M.C.S. Mfg. Co., Ltd., 167, Lower Clapton Rd., London, E.5. [5427]

RADIO service engineer required, pre-war experience essential, television experience an advantage; comfortable and progressive post to man with capabilities.—Write, giving full details and salary required, Fancourt, Frogmore St., Tring, Herts. [5336]

SALES engineer required to take charge of service department, responsible for installation of television and broadcast reception aerials, investigation of interference problems and installation of suppression devices; work covers correspondence, consultation and control of riggers; must be A.M.I.E.E. or final City & Guilds in radio communication; age 27-35; salary £400 a year.—Please state age and give details of experience to Box 7613. [5271]

ARMSTRONG

Model EXP83

ALL-WAVE 8-VALVE SUPERHET

CHASSIS incorporating wave band expansion, large glass scale treble boost control. The latter together with tone and volume controls work on both radio and gram. High quality push-pull output gives 10 watts audio. For 100-250 v. A.C. mains.

Price 14 gns. plus tax.

Model EXP43

ALL-WAVE SUPERHET FEEDER UNIT

incorporating wave band expansion manual I.F. gain control, etc.

Price 11 gns. plus tax.

Model EXP63

ALL-WAVE 6-VALVE SUPERHET

CHASSIS incorporating wave band expansion on all bands, e.g. the 16-50 metre band covers just over 20 inches on the large illuminated glass scale. Tone and volume controls work on both radio and gram. R.C. coupled output. For 100-250 v. A.C. or D.C. mains.

Price 12 gns. plus tax.

The above chassis are of entirely new design and capable of a high performance. Demonstration Sets are now available for interested callers to hear and illustrated technical specifications are now ready.

Model AMP14

HIGH GRADE AMPLIFIER

in well finished metal instrument case. Two inputs, bass compensating circuit, treble boost control, 14 watts push-pull output preceded by 4 triodes.

Price 15 gns.

Model EXP53

ALL-WAVE 7-STAGE RADIOGRAM

CHASSIS 4 watts output with matched speaker. For A.C. mains.
Provisional price 13 gns. plus tax.

ARMSTRONG WIRELESS & TELEVISION CO. LTD.
WALTERS ROAD, HOLLOWAY, LONDON, N.7
'Phone : WORTH 3213

POST-WAR TELEVISION

The advance in Radio Technique offers unlimited opportunities of high pay and secure posts for those Radio Engineers who have had the foresight to become technically qualified. How you can do this quickly and easily in your spare time is fully explained in our unique handbook.

Full details are given of A.M.I.E.E., A.M.Brit.I.R.E. City & Guilds Exams., and particulars of up-to-date courses in Wireless Engineering, Radio Servicing, Short Waves, Television, Mathematics, etc., etc.

We Guarantee "NO PASS—NO FEE"
Prepare for to-morrow's opportunities and post-war competition by sending for your copy of this very informative 112-page guide NOW—FREE.

BRITISH INSTITUTE OF ENGINEERING TECHNOLOGY (Dept. 388)
17, Stratford Place, London, W.1



LUSTRAPHONE LTD

PATENT NO. 556137

"M.C." Microphones

- A Quality Product
- High Sensitivity
- Even Response
- Internal Shock Absorption

ASK FOR ONE AND TRY IT FOR YOURSELF!

84 BELSILE LAKE · LONDON · N.W.3
TEL. HAMPSTEAD 5389 and 5515

GROUP of wire broadcasting companies require the services of a research engineer conversant with carrier frequency technique.—Apply, giving full details of experience and qualifications, to Uni-Relays, Ltd., 57-59, Abbey St., Accrington, Lancashire, [5215]

LABORATORY assistant required for chemical section of electronics laboratory; knowledge of application of fluorescent screens, emission coating, etc., desirable; situation 50 miles from London.—Write, stating experience and salary required, Box 7614.

DRAUGHTSMAN-DESIGNER required, must have had previous experience in the design of commercial radio equipment and domestic appliances; applicants should write, stating age, experience, etc.; permanency and prospects for right man.—Write Box 7535.

DESIGNER and manager required to take charge of coil winding dept., must have full technical and practical experience in modern coil design and production.—Details experience, age, salary, etc., to M.C.S. Mig. Co., Ltd., 167, Lower Clapton Rd., London, E.5. [5426]

PRODUCTION manager required for transformer winding dept., must be capable of designing and supervising production of all types of radio transformers and chokes.—Full details of experience, age, salary, etc., to M.C.S. Mig. Co., Ltd., 167, Lower Clapton Rd., London E.5. [5425]

ELECTRONIC engineer, capable of designing and constructing audio frequency amplifiers, etc., for use with cathode ray tubes to measure mechanical strains, etc.; previous experience of mechanical engineering not essential, but an advantage; salary £300 to £350.—Write Box 7623. [5273]

DRAUGHTSMEN required with experience of design and layout of details and assemblies for commercial radio and television receivers and electronic instruments, for factory in West London.—Applications in writing, stating particulars of age, experience and salary required, to Box 7805. [5293]

TECHNICAL sales representative required to handle experimental and amateur transmitting gear; must hold transmitting licence, be prepared to travel whole country, and must own car.—State age, salary and commission required, past experience and qualifications, etc., to Labgear, Cambridge.

CHIEF draughtsman required by electrical instrument makers in South Midlands; essential, fully conversant with issuing of full manufacturing information, including drawings, specifications and electrical circuit diagrams, and have knowledge of manufacturing methods and tooling for small component parts; comm. salary £350-£400.—Box 8121.

MECHANICAL designer-draughtsman required with knowledge of light electro mechanical assemblies and vacuum cleaner design for progressive manufacturers of radio and domestic appliances in London area.—Write, giving full particulars of training, experience, age & salary req., to Box K2400, A.K. Adv., 212a, Shaftesbury Ave., W.C.2.

TELEPHONE RENTALS, Ltd., require an experienced engineer and also a draughtsman to assist in design and development work on telephone, audio amplifier and associated equipment.—Apply in writing, with full details of experience, age and salary required, to Telephone Rentals, Ltd., Eng. Dept., Kent House, Knightsbridge, S.W.7. [5197]

WIRELESS instructor wanted for residential college, must be able to undertake lectures in electricity and magnetism up to City and Guilds or 1st Class P.M.C. standard.—Write, giving full particulars of radio experience, stating salary required, in addition to living accommodation, which will be supplied, Principal, Wireless College, Colwyn Bay.

WIREMAN and service mechanic required for the construction and maintenance of test equipment; some knowledge of radio circuits and ac and dc bridges desirable; must be capable of wiring correctly from diagrammatic sketches; excellent prospects in large company for suitable applicant.—Write, with details of experience, to Box 5455, A.K. Adv., 212a, Shaftesbury Ave., W.C.2. [4964]

EXPERIMENTAL engineer, required to take charge of laboratory of well-known loudspeaker manufacturer; must be fully conversant with loudspeaker research, a.f. transformer, choke and amplifier design and also have ability to design and supervise the production of all works electrical and acoustical test apparatus; a degree is not essential, but applicants must have sound mathematical and electrical knowledge and not less than 5 years' experience in a similar position; good salary and excellent prospects for the right man, who must not be afraid of hard work and headaches.—Apply, with full details of education and situations held and copies only of references. Box 7803. [5292]

THESE ARE IN STOCK

- ELECTRONICS LABORATORY MANUAL.** By Ralph R. Wright. 6s. Postage 4d.
 - TELEVISION RECEIVING EQUIPMENT.** By W. T. Cocking. 10s. 6d. Postage 4d.
 - WIRELESS WORLD VALVE DATA.** 2s. Postage 2d.
 - THERMIONIC VACUUM TUBES.** By E. V. Appleton. 4s. 6d. Postage 8d.
 - THERMIONIC VALVE CIRCUITS.** By E. Williams. 12s. 6d. Postage 4d.
 - TIME BASES (SCANNING GENERATORS).** By O. S. Puckle. 16s. Postage 4d.
 - SHORT WAVE WIRELESS COMMUNICATION.** By A. W. Ladner and C. R. Stoner. 35s. Postage 6d.
 - PRACTICAL WIRELESS SERVICE MANUAL.** By F. J. Camm. 8s. 6d. Postage 4d.
 - RADIO COMMUNICATIONS.** By W. T. Perkins and R. W. Barton. 12s. 6d. Postage 4d.
 - RADIO DIRECTION FINDERS.** By Donald S. Bond. 18s. Postage 6d.
 - EVERYMAN'S WIRELESS BOOK.** By F. J. Camm. 6s. Postage 4d.
 - NEWNES' ELECTRICAL POCKET BOOK.** 6s. Postage 4d.
- WE HAVE THE FINEST STOCK OF RADIO BOOKS IN THE COUNTRY. WRITE OR CALL FOR COMPLETE LIST.**
- THE MODERN BOOK COMPANY**
(Dept. W.13), 19-23, PRAED STREET, LONDON, W.2.

"ENGINEERING OPPORTUNITIES"



This unique handbook shows the easy way to secure A.M.I.Mech.E., A.M.Brit.I.R.E., A.M.I.E.E., City and Guilds, etc.

WE GUARANTEE—

"NO PASS—NO FEE."

Details are given of over 150 Diploma Courses in all branches of Civil, Mech. Elec., Motor, Aero., Radio, Television and Production Engineering, Tracing, Building, Govt. Employment, R.A.F. Maths., Matriculation, etc.

Think of the future and send your copy at once—**FREE.**

B.I.E.T., 387, SHAKEPEARE HOUSE, 7, STRATFORD PLACE, LONDON, W.1.

THE INFINITE IMPEDANCE ADAPTOR.

An Ultra Modern Servicing Instrument, designed to facilitate simple and positive tests of Oscillator, circuits, detector circuits. A.V.C. components and voltages, etc., etc. With this instrument also many other special operations can be performed; for instance, alignment is possible without a Signal Generator. Price £6 17s. 6d. complete. Instruction manual, which is a text-book in itself. 5s. post free.

V.E.S. (W) RADIO HOUSE, RUISLIP, MIDDLESEX

LONDEX for RELAYS



AERIAL CHANGE-OVER RELAY

for Radio Frequency Type A.E.C.O. 4

3 V.A. Coil Consumption, especially designed for Transmitters, High Frequency Heating, Amateur Stations, experimental purposes, etc.

Ask for leaflet 112/WW

LONDEX · LTD

MANUFACTURERS OF RELAYS

207 ANERLEY ROAD · LONDON · S.E.20

REWINDS

Armatures, Fields, Transformers, Pick-ups, Vacuum Cleaners, Gram. Motors, Speakers Refitted New Cones & Speech Coils.

All Guaranteed and promptly executed. Valves, B.V.A. and American, good stocks. Send stamped addressed envelope for list of Radio Spares, and C.O.D. Service.

A.D.S. Co. 261-3-5, Lichfield Road, ASTON, BIRMINGHAM, 6

Representation

OFFERS for INDIA will be highly appreciated for GENUINE QUALITY RADIO SETS. CINEMATOGRAPHY-SOUND EQUIPMENT, TESTING INSTRUMENTS, COMPLETE KITS, COMPONENTS, etc., etc. MANUFACTURERS and EXPORTERS interested in INDIAN MARKET are requested to send full particulars with free or value-payable samples. Practical Books on above subjects also required.

COMRADE RADIOS, 1103-A, FASEEL ROAD OUTSIDE TEXALI GATE, LAHORE, INDIA.

RADIO BATTERY TESTER

Use "Quixo" method of battery testing. Reliable results. Guaranteed.

Send for interesting leaflet R115 on battery testing.



RUNBAKEN · MANCHESTER

WARD ROTARY CONVERTERS

For Radio, Neon Signs, Television, Fluorescent Lighting, X-ray, Cinema Equipment and innumerable other applications.

We also manufacture:—

Petrol Electric Generating Plants, H.T. Generators, D.C. Motors, Frequency Changers, etc., up to 25 K.V.A.

CHAS. F. WARD

37, WHITE POST LANE, HACKNEY WICK, E.9

Phone: Amherst 1393

LASKY'S RADIO

EVERYTHING FOR THE HOME SET
CONSTRUCTOR, AMATEUR RADIO
EXPERIMENTER, TRANSMITTER and
SERVICEMAN

**ELECTROLYTIC CONDENSERS OF
ALL TYPES**, 500 volts working, midget
cans: 8 mfd, 3/-; 16 mfd, 4/9; 8 x 8,
5/6; 8 x 16, 6/9.

**OIL FILLED, HIGH-VOLTAGE CON-
DENSERS.**

8 mfd 1,000 v.w. 12/6 8 mfd 600 v.w. 5/-
10 mfd 600 v.w. 7/- 10 mfd 400 v.w. 5/-
4 mfd 1,000 v.w. 7/- 2 mfd 1,000 v.w. 4/-
1 mfd 6,000 v.w. 10/- 5 mfd 6,000 v.w. 10/-
1 mfd 1,000 v.w. 4/- 1 mfd 750 v.w. 3/-

All with china stand-off insulators and fixing
clip (with feet)

**ALL SIZES P.M. and ENERGISED
LOUDSPEAKERS.** 2 1/2 in. P.M., 27/-; 3 1/2 in. P.M., 29/6; 5 in. P.M., 22/-; 6 1/2 in.,
23/6; 8 in., 21/-; 10 in. and 12 in. in stock.

TUNING CONDENSERS. 2-gang,
Ceramic insulation, .0005, 1 1/6; with
drum, drive dial, 14/6. .0005, 3-gang,
Ceramic insulation, 10/-.

**T.R.F. MEDIUM AND LONG-WAVE
COILS.** High gain, with reaction circuit
included, 8/6 per pair.

**LONG, MEDIUM AND SHORT F.E.
AND OSC. COILS,** with superhet
circuit, 10/6 per pair.

RADIO VALVES, 6,000 IN STOCK. Most
Types English and American Types at
B.O.T. prices.

MAINS TRANSFORMERS. 350-0-350,
120 m/a, 6.3 and 5 v. or 4 v. and 4 v., 29/6.

All Goods Sold by Us are Guaranteed.
Money refunded or goods exchanged if not
satisfactory.

Terms.—Cash with Order, C.O.D. or
Pro Forma. (No C.O.D. under £1.
Send 1d. for our Current List of Radio
and Electrical Components. (Now
being sent by return mail.)

LASKY'S RADIO

370, Harrow Road, Paddington, W.5.
(Opp. Paddington Hospital). Tele.: Cunningham 1979

SITUATIONS WANTED

PHYSICIST would undertake consulting
work; enquiries invited.—Box 7760. [5289]

FLY. LT. (ex W/O), 12 years R.A.F.,
wishes progressive position with radio
manufacturer or dealer; can commence im-
mediately.—Box 7694. [5282]

EX-R.E.M.E. wireless mechanic, 6 years
experience, pre-war amateur, age 26,
seeks radio servicing or similar situation;
Midlands preferred.—Box 8051. [5324]

R.A.F. officer, 6 years installation, mainten-
ance, supply and staff duties, 4 years
pre-war experience radio and television, test
and servicing, seeks progressive position with
reliable firm.—Box 8118. [5338]

PRODUCTION engineer, A.M. Brit. I.R.E., 10
years production manager, age 43, present
salary £2600 per annum and bonus; desires
responsible position; salary commensurate
with position.—Box 7524. [5247]

WARRANTY Officer wireless artificer,
R.E.M.E., age 25, 6 years' servicing and
test experience, seeks responsible position with
good prospects; manufacturer or dealer; avail-
able immediately.—Box 7826. [5300]

EX-R.A.F. wireless mechanic, 25, desires a
progressive post, preferably research or
experimental, experience with P.A. equipment;
hf & vhf ground transmitters & general main-
tenance & construction of radio equipment;
pre-war amateur experience.—Box 7530.

CPL. W.O.M., 24, release Group 44, 4 years
R.A.F., married, holds P.M.G. Special,
B.I.E.T. student, C. & G. radio communica-
tion, 18 months radio servicing prior to call-
up, desires progressive post radio industry;
Maidenhead or Home Counties pref.—Box 7808.

RADIO training.—P.M.G. exams and I.E.E.
Diploma; prospectus free.—Technical
College, Hull. [6011]

GENTLEMAN interested small radio repair
business requires personal practical
radio tuition; substantial fee offered; own
modern equipment and workshop; N.W. Lon-
don; congenial.—Mr. Davies write, address mis-
laid.—Box 7985. [5317]

**THE BRITISH NATIONAL RADIO
SCHOOL** is a long-established and highly
successful correspondence school, specialising
in transforming operators into engineers, and
in this chosen field it stands supreme. During
the war years we have been unable to accept
students other than radio officers serving in
the Merchant Navy; hence we have not adver-
tised, but now we are again free to enrol a
limited number of students from "Wireless
World" readers seeking personal tuition in
preparation for C. & G., Brit. I.R.E. and
I.E.E. examinations.

RADAR.—Our course is now ready.—Please
write fully to Director of Studies, B.N.R.S.,
66, Addiscombe Rd., Croydon. [5008]

TUITION

AGENCIES required by short-wave
stockists for agencies of experimental
amateur components and equipment.—Lab-
gear, Cambridge. [5280]

RADIO manufacturers specialising in high
quality radio chassis, amplifiers, and
transformers, cordially invite applications for
agencies from bona fide radio dealers; export
enquiries are specially welcome.—Box 7983.

**RADIO receivers, valves and radio acces-
sories;** established wholesale distributing
house with centrally situated office in Belfast
and six travellers covering Northern Ireland,
anxious to contact reputable manufacturers of
above lines with view to representations in
Northern Ireland.—Box 1393, Eason's Adver-
tising Service, Belfast. [5106]

PATENT AGENTS
A. E. HILL, chartered patent agent, 27
Chancery Lane, London, W.C.2. [4368]

PATENTS
THE proprietor of British patent No.
531965, entitled "Device for Producing
Vibrato in Sound-amplifying Systems and the
Like" offers same for licence or otherwise
to ensure practical working in Great Britain.
—Enquiries to Singer, Ehlert, Stern & Carl-
berg, Steger Buildings, Chicago, 4, Illinois,
U.S.A. [5263]

WORK WANTED
PICK-UPS of all makes, including crystals,
rebuilt, reconditioned and tuned.
EXPERT GRAMOPHONES, Ltd., Inger-
thorpe, Gt. North Rd., London, N.2. [5274]

WIRELESS cabinets made to order for
export.—Leipsy, 71, Killick St., Kings
Cross, N.1. [5208]

ENGRAVING; precision instrument firm in
West London can undertake specialised
machine engraving of knobs, dials, panels or
undry components; excellent delivery on small
quantities.—Box 6903. [5131]

DESIGN FOR P.A.

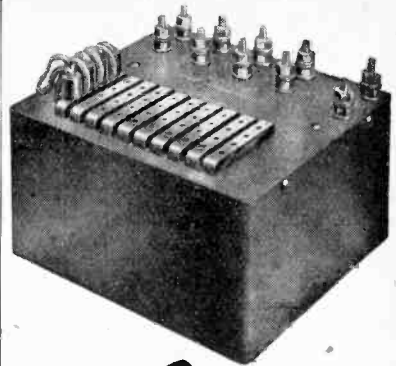

SOUND

WHERE YOU WANT IT!

The Acoustical matching unit enables up to
eight loudspeakers to be connected to a single
amplifier and the power output allocated in any
desired proportions. Individual loudspeaker
volume is instantly adjustable and correct
matching is maintained at all times.

Calibrated directly in watts, all impedance
calculations are eliminated.

The unit operates purely by transformer ratios
and delivers the full performance of the ampli-
fier at all settings.

Max output - 30 watts. Calibrated for 15 ohm
speakers. Price £8. 10. 0. each.



RADIO CORNER

(Proprietor, T. E. WILLIAMS)

138 GRAY'S INN RD., LONDON, W.C.1

Terminus 7937

MAIL ORDER. Delivery by return. **THE
BANNER CHARGER.** Type 1/1, 1 amp, ideal for
Motorists, a really first-class job. Input 240 v. A.C.
Output 2, 6 or 12 v. D.C., at £3. Designed for
the motorist who likes to keep his batteries in tip-
top condition.

RADIO VALVE MANUAL, giving American
and British Valve Equivalents and Data. Price 3/6.
Radio Constructors Manual. Price 3/-.

Radio Tuner Unit Manual. Price 2/6.
Engineers and Electricians Handbook. Price 1/-.

Cathode Ray Oscilloscope Manual. Price 2/-.

American Radio Valves. Types as under at
controlled prices. 45Z5GT, 5Y3G, 1A5GT,
1C5GT, 1Q5GT, 1T5GT, 80G, 35Z5, at 11/- each.
6J5GT, 12J5GT, 1H5GT, 12SF5GT, at 9/2 each.
6Q7GT, 12Q7GT, 12SQ7GT, 75G, at 11/7 each.
12S7GT, 12SK7GT, 6K7GT, 6K6GT, 6V6GT,
42G, 43G, at 12/10 each. 6A7G, 6AB7G, 6K8GT,
at 14/- each. Postage paid. Other types as they
become available for distribution.

AMERICAN RADIO SERVICE MANUALS

- Volume I. Spartan Emerson.
- II. Crosley Belmont. Part I.
- III. Crosley Belmont. Part II.
- IV. R.C.A. Victor G.E. Admiral
- V. Emerson. Part II.
- VI. Stewart Warren. FADA.

At 12/6 per Volume, or complete set of six
manuals £3 12s. 6d. These Manuals cover the
complete range of American Radio Receivers as
given and are invaluable and contain all the
technical data necessary.

Terms. Cash with Order only. We regret that
we are unable to send goods C.O.D.

FOR
**VACUUM
IMPREGNATION**
OF
**RADIO &
ELECTRICAL
COMPONENTS**
CONSULT
**GRIFFITHS BROS.
& Co., LONDON, LTD.**

VARNISH MANUFACTURERS
&
**SPECIALISTS IN
IMPREGNATION**
**MACKS RD., BERMONDSEY,
LONDON, S.E.16. BER. 1151**

HILL & CHURCHILL LTD
 BOOKSELLERS
SWANAGE DORSET

ENGLISH & AMERICAN
 BOOKS IN STOCK ON
**RADIO AND
 TELECOMMUNICATION**

CATALOGUE ON APPLICATION

CABINETS for wireless, television, etc., manufactured to customers' individual designs (trade only).—Enquiries to Birney Smallwood Products, Ltd., Swan Works, Fishers Lane, London, W.4. [5302]

CONSULTING electronic engineers with wide experience in both communication and non-communication electronic engineering are now able to undertake the design, development, work in these fields.—Box 7525.

ISTRUMENT cases, chassis and panels, of modern design and to specification, up-to-date finishes, specialists in short run sheet-metal work for radio and allied manufacturers.—Sea Rescue Equipment, Ltd., Chiltern Works, Clarendon, Rd., Watford. [5291]

RADIO and television trade service.—Enquiries invited for prompt and efficient servicing of radio and television receivers of all types, we have the latest television test gear, full staff of skilled engineers, complete stocks of all spare parts, prompt service, all enquiries promptly dealt with.—Write, telephone or call Thorogood Radio, Ltd., 44-45, Tamworth Rd., W. Croydon. Croydon 7417-8.

MATRICULATION
brings Success & Security

Whatever your age, you can now study for the all-important Matriculation Examination at home on "NO PASS—NO FEE" terms. "MATRIC" is the accepted passport to all careers, and opens up opportunities which would otherwise be completely closed to you. Ensure the success and security of you and yours through post war difficulties by writing for our valuable "Guide to Matriculation" immediately—**FREE**
B.T.I. (Dept. 114)
 356, Oxford Street, London, W.1.

R. A. ROTHERMEL LTD.
 are now in production for the well-known Piezo Electric Products.

- PICKUPS
- MICROPHONES
- HEADPHONES
- THE HUSHATONE
- DEAF AID MICROPHONES
- CONTACT MICROPHONES
- A.C. AMPLIFIERS

Send for informative literature.

NOW READY!

A specially designed A.C. Amplifier, Type V.R.2, rated at 4½ watts, is available from stock, for use in connection with all types of Crystal Microphone and Crystal Pickups. For many years R. A. ROTHERMEL Ltd. has made intensive research in Amplifier design, and we confidently present the V.R.2 as representing the ultimate in quality of reproduction, workmanship and material.
 Write for Bulletin.

R. A. ROTHERMEL LTD.
 ROTHERMEL HOUSE, CANTERBURY ROAD, KILBURN, N.W.6
 Telephone : Maida Vale 6066 (6 lines).

IF YOU USE WAX
 We Are At Your Service

THE WIDE RANGE OF **OKERIN DI-ELECTRICS** created in our own laboratories fulfils almost every need of the Electrical Industries. Grades have been designed for the most severe and varied conditions. Most are resistant to mould and fungus growth, whilst special types are evolved whenever new applications arise.

We invite technical discussion on difficult problems.

ASTOR BOISSELIER & LAWRENCE LTD.
 (Sales Dept.), Norfolk House, Norfolk Street, Strand, W.C.2
 Telephone : Temple Bar 5927.

Even a double load doesn't shorten the life of a **Welwyn Resistor**



"No property of the resistance presented any apparent alteration." Such is the independent report after testing a Welwyn Vitreous Resistor for 870 hours at continuous double load. (Normal load gives working temperature of 460°C.)
 Sizes:—1 w. to 300 w.
 New Trade catalogue available.
WELWYN ELECTRICAL LABS. LTD
 Welwyn Garden City, Herts. Ph: Wel. Gar. 3818

Remember-Walter

RADIO STAMPINGS • RADIO CHASSIS • RADIO PRESSINGS

FARM LANE, FULHAM, S.W.6. TELEPHONE : FULHAM 5234

C.R.C.A.

Printed in England for the Publishers, LIFFE AND SONS LTD., Dorset House, Stamford Street, London, S.E.1, by THE CORNWALL PRESS LTD., Paris Garden, Stamford Street, London, S.E.1. "Wireless World" can be obtained abroad from the following:—AUSTRALIA and NEW ZEALAND: Gordon & Gotch, Ltd. INDIA: A. H. Wheeler & Co. CANADA: Imperial News Co.; GORDON & GOTCH, Ltd. SOUTH AFRICA: Central News Agency Ltd; WILLIAM DAWSON & SONS (S.A.), Ltd. UNITED STATES: The International News Co.

TCC

CAPACITORS

PAPER
ELECTROLYTIC
MICA

SILVERED MICA
CERAMIC

*Capacitor
Specialists
for over
40 years*



THE TELEGRAPH CONDENSER CO., LTD.

RADIO DIVISION

NORTH ACTON · LONDON · W.3

TELEPHONE: ACORN 0061

THE MOST FAMOUS SET MAKERS ARE AGAIN FITTING

MAZDA

**RADIO VALVES AND
CATHODE RAY TUBES**

**because of their
PERFORMANCE AND
RELIABILITY**

**LOW
"I_f"**

**HIGH
"g_m"**



THE FILAMENT CURRENT OF THE MAZDA TP.25 IS EXCEPTIONALLY LOW; IT IS ONLY 200mA.

ITS MUTUAL CONDUCTANCES (g_m FOR TRIODE SECTION = 1.7mA/V; g_m FOR PENTODE SECTION = 1.0mA/V) ARE REMARKABLY HIGH FOR A VALVE HAVING SO LOW A FILAMENT CONSUMPTION.

THIS VALVE MAY BE USED AS A REPLACEMENT FOR THE BVA.172 IN THE CIVILIAN WAR-TIME RECEIVER.

THE EDISON SWAN ELECTRIC COMPANY LIMITED



155, CHARING CROSS ROAD, LONDON, W.C.2