

Wireless World

RADIO • ELECTRONICS • ELECTRO-ACOUSTICS



JUNE 1943

1/3

Vol. XLIX. No. 6

"SKIP DISTANCE" EXPLAINED



ELECTRO-MEDICAL
EQUIPMENT

DRAWING OFFICE
EQUIPMENT

H.F. ELECTRIC
FURNACES

SPECTROGRAPH
ANALYSIS EQUIPMENT

Interference created by above is suppressed by H.F. mains filters and screened rooms.
We supply screened rooms of any dimensions and H.F. mains filters 15 and 300 amperes maximum loadings.

**AERIAL SYSTEMS
DESIGNED & INSTALLED**

An Engineer with many years' experience in the work is available for consultation and practical assistance on all aspects of the subject of suppression on land or sea, either at the source of interference or at the receiver.

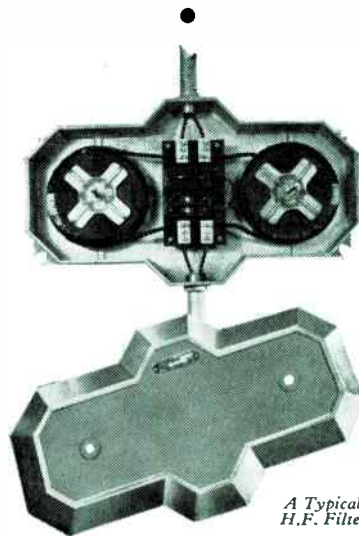

A Typical H.F. Filter

BELLING & LEE LTD
CAMBRIDGE ARTERIAL ROAD, ENFIELD, MIDDX



THE Model 7 Universal AvoMeter is the world's most widely used combination electrical measuring instrument. It provides 46 ranges of readings and is guaranteed accurate to B.S. first grade limits on D.C. and A.C. from 25 to 100 cycles. It is self-contained, compact and portable, simple to operate and almost impossible to damage electrically. It is protected by an automatic cut-out against damage through

severe overload, and is provided with automatic compensation for variations in ambient temperature.

The AvoMeter is one of a useful range of "Avo" electrical testing instruments which are maintaining on active service and in industry the "Avo" reputation for an unexcelled standard of accuracy and dependability—in fact, a standard by which other instruments are judged.

ONE INSTRUMENT

measures :—

- Current, A.C. and D.C. (0 to 10 amps.)
- Voltage, A.C. and D.C. (0 to 1,000 v.)
- Resistance (up to 40 megohms)
- Capacity (0 to 20 mfd.s.)
- Audio-frequency Power Output (0 to 4 watts)
- Decibels (- 10 Db. to + 15 Db.)

Some delay in delivery of Trade Orders is inevitable, but we shall continue to do our best to fulfil your requirements as promptly as possible.

Sole Proprietors and Manufacturers:

AUTOMATIC COIL WINDER & ELECTRICAL EQUIPMENT Co., Ltd., Winder House, Douglas St., London, S.W.1

Telephone: VICtoria 3404/7

WHY ERSIN MULTICORE

the Solder wire with 3 cores of non-corrosive ERSIN FLUX is preferred by the majority of firms manufacturing the best radio and electrical equipment under Government Contracts.



WHY THEY USE CORED SOLDER

Cored solder is in the form of a wire or tube containing one or more cores of flux. Its principal advantages over stick solder and a separate flux are:

- it obviates need for separate fluxing
- if the correct proportion of flux is contained in cored solder wire the correct amount is automatically applied to the joint when the solder wire is melted.

This is important in wartime when unskilled labour is employed.

WHY THEY PREFER MULTICORE SOLDER. 3 Cores—Easier Melting Multicore Solder wire contains 3 cores of flux to ensure flux continuity. In Multicore there is always sufficient proportion of flux to solder.

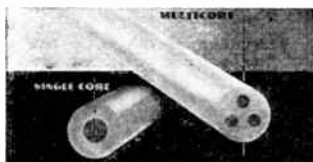

If only two cores were filled with flux, satisfactory joints are obtained. In practice, the care with which Multicore Solder is made means that there are always 3 cores of flux evenly distributed over the cross section of the solder,

so making thinner solder walls than single cored solder, thus giving more rapid melting and speeding up soldering.

ERSIN FLUX

For soldering radio and electrical equipment non-corrosive flux should be employed. For this reason either pure resin is specified by Government Departments as the flux to be used, or the flux residue must be pure resin. Resin is a comparatively non-active flux and gives poor results on oxidised, dirty or "difficult" surfaces such as nickel. The flux in the cores of Multicore is "Ersin"—a pure, high-grade resin subjected to chemical process to increase its fluxing action without impairing its non-corrosive and protective properties. The activating agent added by this process is dissipated during the soldering operation and the flux residue is pure resin. Ersin Multicore Solder is approved by A.I.D., G.P.O., and other Ministries where resin cored solder is specified.

PRACTICAL SOLDERING TEST OF FLUXES

The illustration shows the result of a practical test made using nickel-plated spade tags and bare copper braid. The parts were heated in air to 250° C. and to identical specimens were applied ½" lengths of 14 S.W.G. 40/60 solder. To

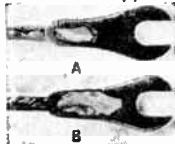

sample A, single cored solder with resin flux was applied. The solder fused only at point of contact without spreading. A dry joint resulted, having poor mechanical strength and high electrical resistance.

To sample B, Ersin Multicore Solder was applied, and the solder spread evenly over both nickel and copper surfaces, giving a sound mechanical and electrical joint.

ECONOMY OF USING ERSIN MULTICORE SOLDER

The initial cost of Ersin Multicore Solder per lb. or per cwt. when compared with stick solder is greater. Ordinary solder involves only melting and casting, whereas high chemical skill is required for the manufacture of the Ersin flux and engineering skill for the Multicore Solder incorporating the 3 cores of Ersin Flux. However, for the majority of soldering processes in electrical and radio equipment Multicore Solder will

show a considerable saving in cost, both in material and labour time, as compared either with stick solder or single cored solder. Cored solder ensures that the solder and flux are put just where they are required, and by choice of suitable gauge, economy in use of material is obtained. The quick wetting of the Ersin flux as compared with resin flux in single core resin solder ensures that with the correct temperature and reasonably clean surface, immediate alloying will be obtained, and no portions of solder will drop off the job and be wasted. Even an unskilled worker, provided with irons of correct temperature, is able to use every inch of Multicore Solder without waste.

ALLOYS

Soft solders are made in various alloys of tin and lead, the tin content usually being specified first, i.e. 40/60 alloy means an alloy containing 40% tin and 60% lead. The need for conserving tin has led the Government to restrict the proportion of tin in solders of all kinds. Thus, the highest tin content permitted for Government contracts without a special licence is 45/55 alloy. The radio and electrical industry previously used large quantities of 60/40 alloy, and lowering of tin content has meant that the melting point of the solder has risen. The chart below gives approximate melting points and recommended bit temperatures.

ALLOY Tin Lead	Equivalent B.S. Grade	Solidus C.°	Liquidus C.°	Recommended bit Temperature C.°
45/55	M	183°	227°	267°
40/60	C	183°	238°	278°
30/70	D	183°	257°	297°
18.5/81.5	N	187°	277°	317°

VIRGIN METALS—ANTIMONY FREE

The wider use of zinc plated components in radio and electrical equipment has made it advantageous to use solder which is antimony free, and thus Multicore Solder is now made from virgin metals to B.S. Specification 219/1942 but without the antimony content.

IMPORTANCE OF CORRECT GAUGE

Ersin Multicore Solder Wire is made in gauges from 10 S.W.G. (.128"—3.251 m/ms) to 22 S.W.G. (.028"—.711 m/ms). The choice of a suitable gauge for the majority of the soldering undertaken by a manufacturer results in considerable saving. Many firms previously using 14 S.W.G. have found they can save approximately 33 1/3%, or even more by using 16 S.W.G. The table gives the approximate lengths per lb. in feet of Ersin Multicore Solder in a representative alloy, 40/60.

S.W.G.	10	13	14	16	18	22
Feet per lb.	23	44.5	58.9	92.1	163.5	481

CORRECT SOLDERING TECHNIQUE

Ersin Multicore Solder Wire should be applied simultaneously with the iron, to the component. By this means maximum efficiency will be obtained from the Ersin flux contained in the 3 cores of the Ersin Multicore Solder Wire. It should only be applied directly to the iron to tin it. The iron should not be used as a means of carrying the solder to the joints. When possible, the solder wire should be applied to the component and the bit placed on top, the solder should not be "pushed in" to the side of the bit.



ERSIN MULTICORE SOLDER WIRE is now restricted to firms on Government Contracts and other essential Home Civil requirements. Firms not yet using Multicore Solder are invited to write for fuller technical information and samples.

MULTICORE SOLDERS LTD., BUSH HOUSE, W.C.2. 'Phone Temple Bar 5583/4

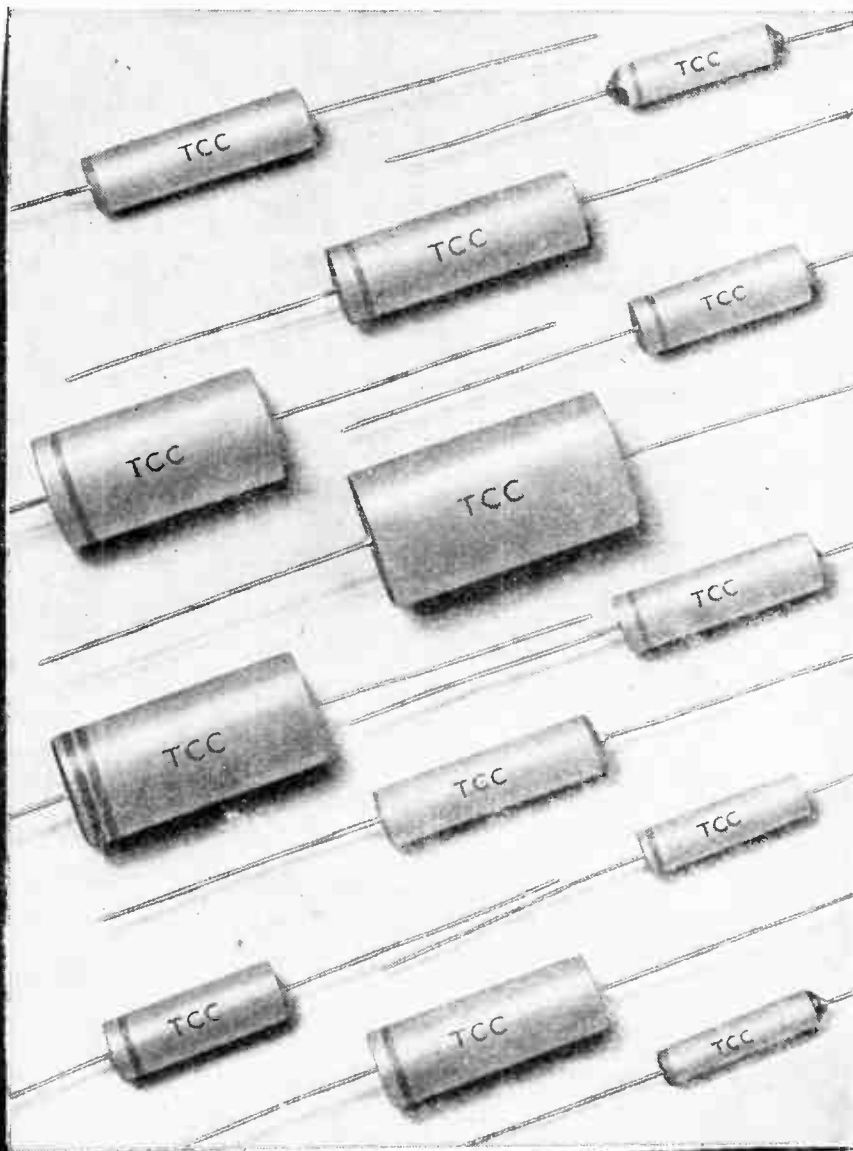

TCC

**PRE-EMINENT IN PEACE
INDISPENSABLE IN WAR**

ADVERTISEMENT OF THE TELEGRAPH CONDENSER CO., LTD.
G.P. 7704

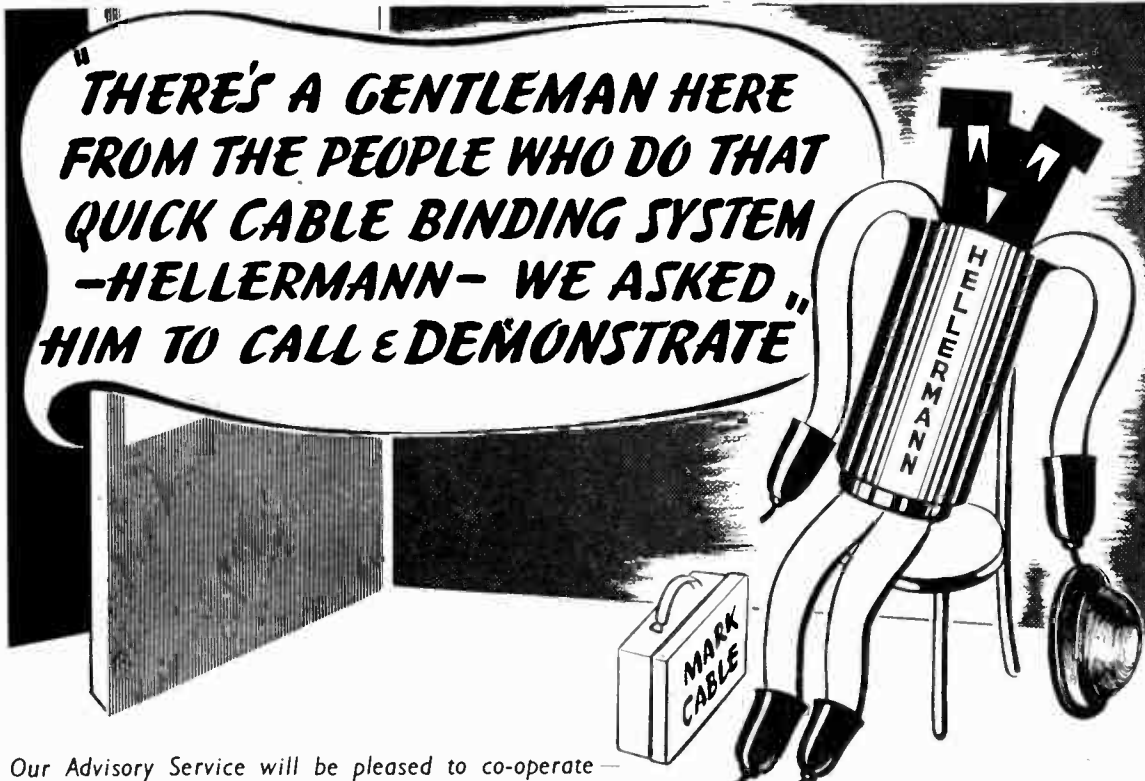

Our Advisory Service will be pleased to co-operate—
HELLERMANN ELECTRIC LTD. GOOTRIC WORKS, OXFORD. Oxford 2403

 An illustration of three men in suits, seen from behind, with their hands raised in a gesture of truth-telling. Above them is the text "NOTHING BUT THE TRUTH" written in an arch.

An electrical instrument may embody every assembled component necessary for an accurate measuring device. But it will remain ineffective for its purpose until its own individual performance has been checked and proved and calibrated. It is on the test bench that it finds itself: the inquisitor will be content with nothing less than the truth.

The testing of every measurement device produced by Marconi Instruments—and there are 60 of them in production—is as uncompromising as is every phase in its design and production. For these are instruments made for the measurement of very fine limits of performance. They apply the experience of a lifetime to the demands of a new technical age. In every requirement of to-day they live up to the traditions of accuracy and resource that have belonged for more than half a century to the name Marconi.

MARCONI Instruments Ltd
 ST. ALBANS · HERTS · TELEPHONE 4323

RUBBER-TO-METAL BONDING

The Problem of Insulating delicate instrument panels from vibration and shock by means of Flexilant Mountings

"FLEXILANT" Mountings : Examples from the SERIES.

The "Flexilant" Mounting of which several varieties are illustrated here is so accurately made that its displacement under load can be calculated to within .010" of requirements. The series is designed to carry loads of from 1 to 45 lbs. per mounting and these may be arranged with bolt axis at 90° to position, or the complete mounting may be inverted. The mountings can be supplied with or without holder and they can be arranged so that two utilize the same bolt.

We should appreciate the opportunity of helping with your vibration problems.

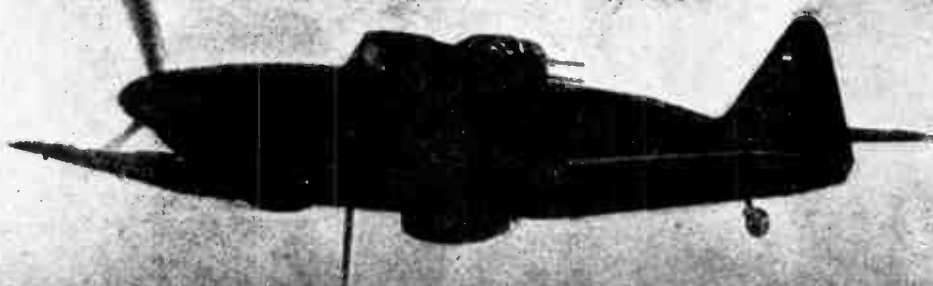
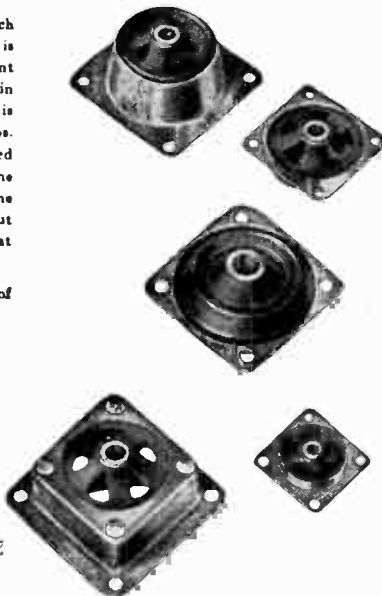
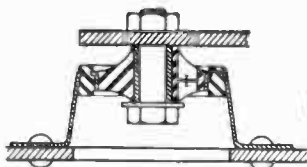

RUBBER BONDERS Ltd.
Engineers in Rubber bonded to metal

FLEXILANT WORKS · WATLING STREET · DUNSTABLE, BEDS.

TELEPHONE: DUNSTABLE 715

TELEGRAMS: FLEXILANT, DUNSTABLE

A Short Review of FLEXILANT Products is available on enquiry . . .



R 8 12

The glory of the future..



... when the tank gives pride of place to the "family 'bus" and engines of war to the instruments of peace, Goodmans will be able, once more, to give the connoisseur Loudspeakers that open up new possibilities in high fidelity reproduction.



GOODMANS

Makers of

HIGH GRADE LOUDSPEAKERS

Priority Orders only can be accepted

GOODMANS INDUSTRIES, LTD., LANCELOT ROAD, WEMBLEY, MIDDLESEX

STABILITY

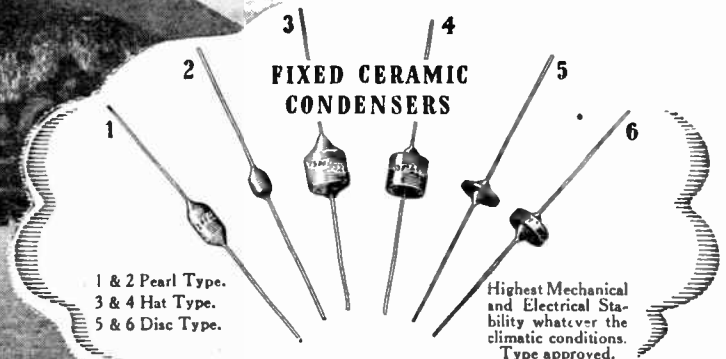
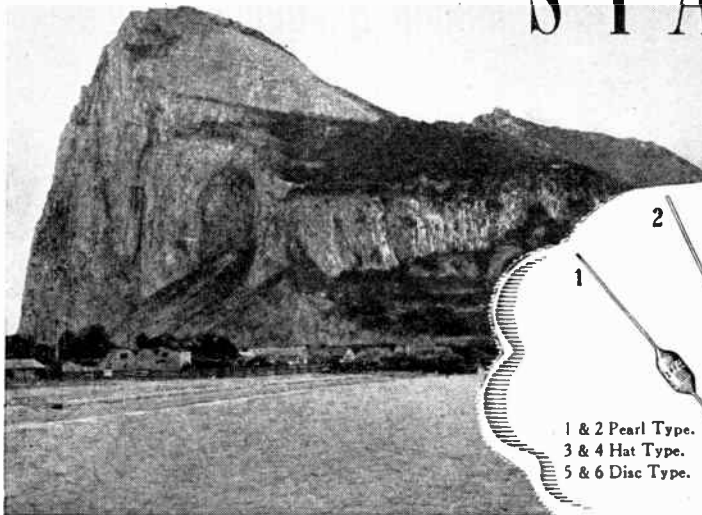

FIXED CERAMIC
CONDENSERS

1 & 2 Pearl Type.
3 & 4 Hat Type.
5 & 6 Disc Type.

Highest Mechanical
and Electrical Stability whatever the
climatic conditions.
Type approved.



UNITED INSULATOR CO. LTD.
12-20 LAYSTALL STREET, LONDON, E.C.1
Phone: TERminus 7383 Grams: Calanel, Phone, London

*The
Pioneers
of low-loss
Ceramics*

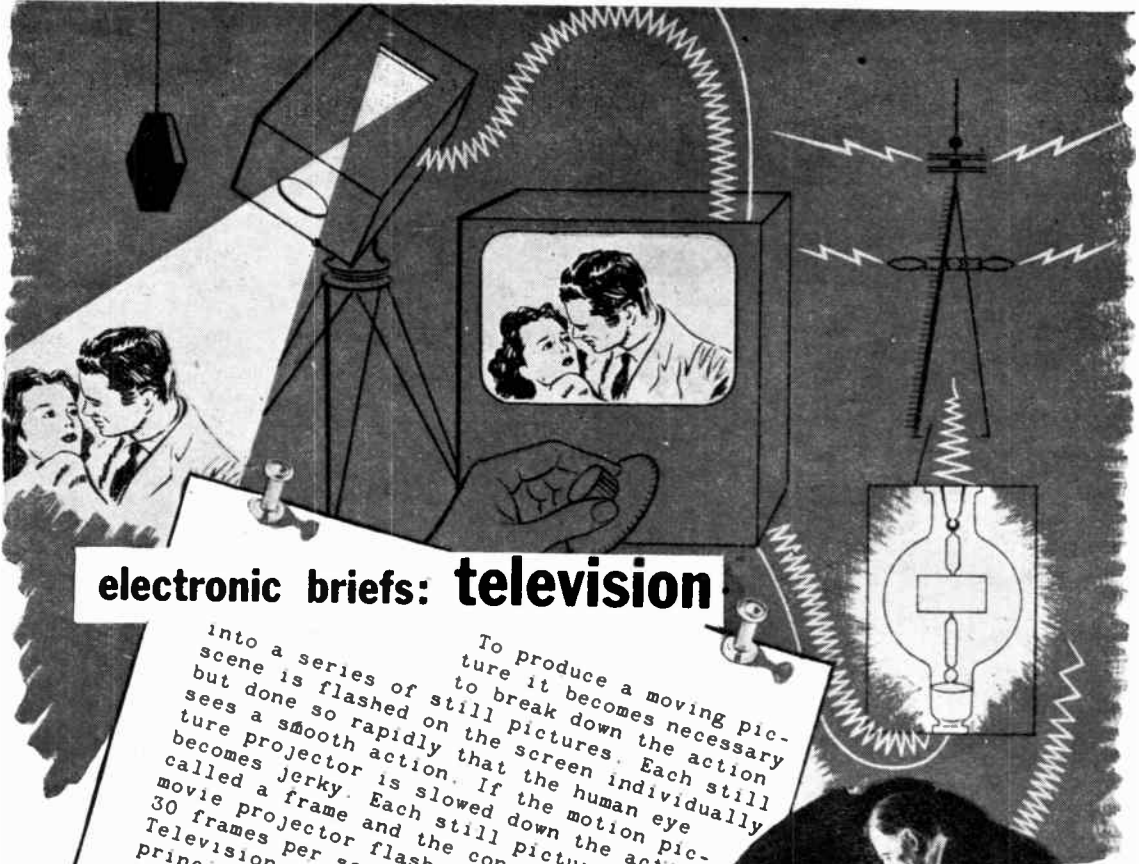

electronic briefs: television

into a series of still pictures but done so rapidly that the action seems a smooth action. If the motion picture projector is slowed down the action becomes jerky. Each still picture is called a frame and the conventional movie projector flashes between 24 and 30 frames per second on the screen. Television is based upon the same principle but the problems involved are much more complex.

Television, using the same basis for creating picture action as the movies, breaks down the picture or scene to be broadcast into a series of still pictures called frames. But each frame must also be broken down into approximately 200,000 tiny segments, each segment being broadcast separately and reassembled at the receiving end so rapidly that 30 frames can be flashed on the screen every second. Thus some 6,000,000 separate signals must be transmitted per second. Furthermore each of these signals starts as light, is converted into an electrical impulse, broadcast and then reconverted to light again. To make television talk, a conventional sound transmitter must be coordinated and synchronized with the picture broadcast.

As with all things in the field of electronics, vacuum valves are what make television possible. Remember; Eimac valves enjoy the enviable distinction of being first choice among leading electronic engineers throughout the world.



EITEL-McCULLOUGH, INC., SAN BRUNO, CALIFORNIA
EXPORT AGENTS: FRAZER & HANSEN, 301 CLAY ST. SAN FRANCISCO CALIF., U. S. A.

Follow the leaders to

Eimac
VALVES



Army Navy "E" flag awarded for high achievement in the production of war material

WEBB'S *Radio*

We can supply most things in **RADIO** including the **WEBB'S** tradition of technical guidance.

Useful Close Tolerance Silver-Mica Condensers. All 1/- each.

25 mmfd. Plus or Minus 10 per cent.	
50	10
77	2
100	1
200	10
305	2
500	5
1,000	5
1,505	1
2,000	1
3,750	5
5,000	5

Midget Mica Trimmers.

40 PF, 250 PF, 450 PF, 100 plus 100 PF ... all 1/- each

Tuning Condensers.

Wavemaster Ceramic End Plate .0001	all	5/-
.00016, .0002	...	3/6
Cyldon, Ceramic End Plate, .000025	...	3/6
Eddystone 15 mmfd. Microdenser	...	7/6
3-gang .00045, with Trimmers	...	7/6

All values 1/2 and 1 watt Resistors, 6d. and 1/-.

Baseboard, British Valveholders.

Skeleton low loss construction on pillars, 4, 5 and 7 pin ... 1/- each

L.F. Smoothing Chokes.

Ideal for initial smoothing for receivers, etc.
Inductance 70 h. at zero D.C., 45 h. at 10 m/a.,
28 h. at 25 m/a. D.C. ... 8/6 each

Additional charge of 1/- for postage and packing on orders below 10/-.

Visitors may inspect the famous

EDDYSTONE '358X'

communications receiver with the phenomenal range of 31,000 kc/s to 90 kc/s. All Eddystone Components generally available, though OFFICIAL requirements must take priority.

14 Soho Street, Oxford Street, London, W.1

Telephone: Gerrard 2089

Open 10 a.m. to 4 p.m. Saturdays, 10 a.m. to 12 noon



In our well-equipped chemical laboratories qualified chemists are constantly engaged in examination and analysis of materials used in WESTINGHOUSE PRODUCTS



Conditions to-day compel steady research and experiment towards improved rectifier design. While we regret that Westinghouse Rectifiers are not freely available, the day is drawing nearer when we shall offer to industry Rectifiers incorporating new, advanced features.

Westinghouse Rectifiers

WESTINGHOUSE BRAKE & SIGNAL CO., LTD.
PEW HILL HOUSE, CHIPPENHAM, WILTS.

TRANSFORMERS FOR THE TROPICS

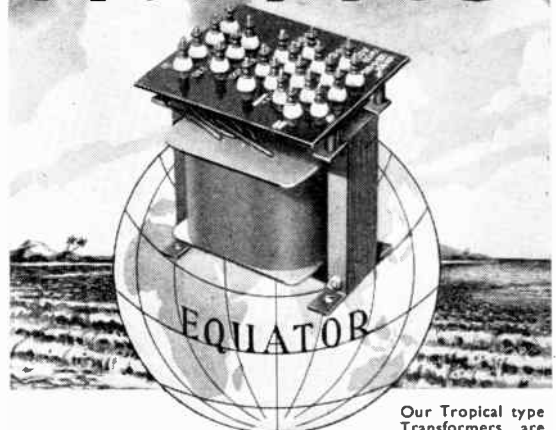

Our Tropical type Transformers are made to specifications D.T.D. 1000 or K. 110

Vacuum Impregnation ensures reliable service under most arduous conditions.

WODEN

TRANSFORMER CO.
Thornley Street, Wolverhampton
Tel.: Wolverhampton 22829

MAKERS OF TRANSFORMERS, POWER PACES, & SPECIAL RECOVERING & TRANSMITTING APPARATUS

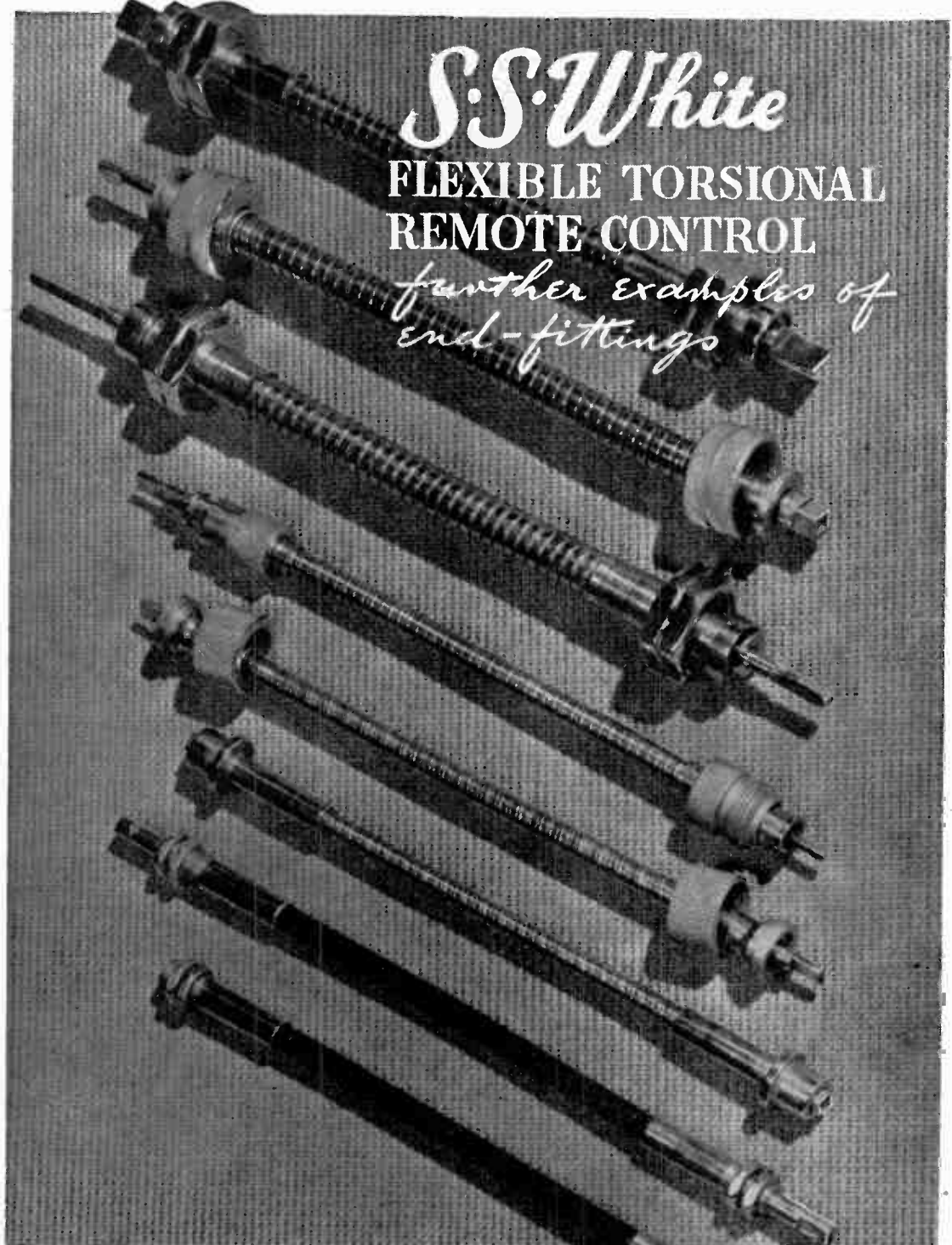

S.S. White

FLEXIBLE TORSIONAL REMOTE CONTROL

*further examples of
end-fittings*

THE S. S. WHITE COMPANY · BRITANNIA WORKS · ST. PANCRAS WAY · CAMDEN TOWN · LONDON N.W.1.
Cable Address: WHICODENTA, WESDO, PHONE, LONDON Telephone: EUSTON 4758-4759

W.T.J. Robert Sharp and Partners



On every battlefield

Condensers are at work

Perfect communication by radio is essential in all modern war operations, from grand strategy down to the smallest tactical manœuvre. Nothing but the very best of apparatus is good enough.

TRADE **HUNTS** MARK

The
Home of Condensers

Advt. of A. H. HUNT LTD., LONDON, S.W.18. EST. 1901

1916

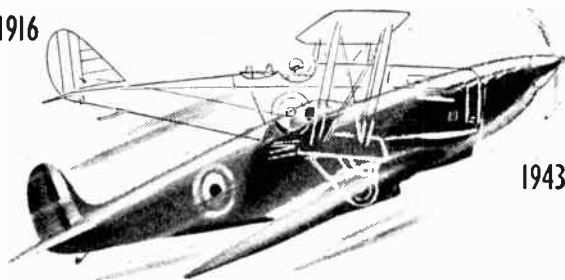

1943

It's happening in Radio, too!

Clear and tangible in the skies is the advance of aeronautical design in this war over the last. Not so apparent, but none the less definite is the war-time progress of radio. Co-operating in this, Masteradio will have interesting developments to offer listeners of the peace years. Register NOW without obligation for post-war priority stating home radio or car radio interest. Write: MASTERADIO, LTD., Watford, Herts.

Masteradio
IS LOOKING AHEAD

★ One of a series of Advertisements appearing in the National Press

MASTERADIO LTD., WATFORD, HERTS.

F·M Equipment
ARMSTRONG SYSTEM

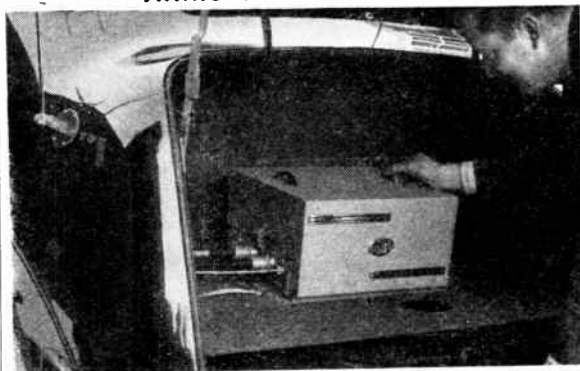

TWO-WAY MOBILE INSTALLATION
VICTORY SERIES 565Y.

F.M. insures minimum interference—compact single-unit design
100% crystal controlled. 25 30 watts.

NOW IN QUANTITY PRODUCTION BY
RADIO ENGINEERING LABORATORIES INC.
America's Pioneer F.M. Manufacturers.

Available on Priority Orders only.

Electronic Engineering Services, Ltd.

SOLE BRITISH DISTRIBUTORS



24, STANLEY ROAD, HEATON MOOR, STOCKPORT.
TELEPHONE: HEATON MOOR 3107

◆ LINAGLOW LIMITED ◆

SPECIAL OFFER of SERVICE KITS as follows

No. 1.—1 8x8 mfd. tubular can-type electrolytic condenser, 500 v.d.c.w., 25 assorted silver mica wire-end condensers, 25 assorted 1/2, 1/4 and 1 watt carbon wire-end resistors, 25 assorted 1-, 2- and 3-gang I.F. and aerial trimmers. **21 7 6** per kit.

No. 2.—3 8x8 mfd. tubular can-type electrolytic condensers, 500 v.d.c.w., 100 assorted silver mica wire-end condensers, 100 assorted 1/2, 1/4 and 1 watt carbon wire-end resistors, 50 assorted 1-, 2- and 3-gang I.F. and aerial trimmers, 50 assorted wire-end tubular paper condensers, 3 assorted volume and tone controls. **24 12 6** per kit.

No. 3.—6 8x8 mfd. tubular can-type electrolytic condensers, 500 v.d.c.w., 200 assorted silver mica wire-end condensers, 200 assorted 1/2, 1/4 and 1 watt carbon wire-end resistors, 100 assorted 1-, 2- and 3-gang I.F. and aerial trimmers, 100 assorted wire-end tubular paper condensers, 6 assorted volume and tone controls. **28 8 0** per kit.

No. 4.—**DE LUXE SERVICE ENGINEER'S KIT.** 15 8x8 mfd. tubular can-type electrolytic condensers, 500 v.d.c.w., 3 8 mfd. tubular can-type 500 v.d.c.w., 2 32 mfd. aluminium can-type, 350 v.d.c.w., 1 16 mfd. electrolytic condenser, 350 v.d.c.w., 3 32x32 tubular electrolytic condensers, 175 v.d.c.w., 1 50x50x2 block electrolytic condenser, 15/550 v.d.c.w., 1 50x50x12v. Mallory type condenser, 500 assorted silver mica wire-end condensers, 500 assorted 1/2, 1/4 and 1 watt carbon wire-end resistors, 250 assorted 1-, 2- and 3-gang I.F. and aerial trimmers, 100 assorted wire-end tubular paper condensers, 50 assorted wire-end wire wound resistors, 15 assorted volume and tone controls, with and without switch, 1 pentode output transformer, 1 multi-ratio output transformer, 1 push-pull output transformer, 3 rolls insulating tape, 6 assorted line cord replacement resistors. **229 10 0** per kit.

VALVES. Lease-Lend American types at B.O.T. controlled retail prices. For replacement only. 1A5, 1C5, 1H5, 1T5, 5Y3, 6A8, 6F5, 6F6, 6J5, 6J7, 6K7, 6Q7, 6SA7, 12A7, 12A8, 12F5, 12J7, 12K7, 12Q7, 12Z3, 12SA7, 12SJ7, 12SK7, 12SQ7, 25A6, 25A7, 25L6, 25Z6, 32L7, 35L6, 35Z4, 35Z5, 36, 47, 50L6, 70L7, 83.

Also British valves at manufacturers' list prices. AC/ME, AC/VP2, ACTP, CL4, ECH3, ELH3, EL35, EF30, FC13, KT39C, KTW61, TDD4, UU6, UV7, VP41, X63, X65.

FIXED CARBON RESISTORS. Wire assorted, assorted and useful values. 1/2-watt, 24/-; 1-watt, 36/-; 1-watt, 36/-; 2-watt, 55/- per 100. Minimum orders, 50 assorted. Assorted parcel for 2/3. Contains 25 1/2-watt, 50 1-watt, 50 1-watt, 25 2-watt, 10 3-watt.

ELECTROLYTIC CONDENSERS. We have many types and sizes in stock. Send us your requirements.

TUBULAR PAPER CONDENSERS, 350-500v., D.C. working. .00005, .0001, .0003, .0006 mfd., 4/- doz.; .001, .0015, .002, .003, .004, 6/- doz.; .01, .025, .03, .05 mfd., 7/- doz.; .08, .1 mfd., 12/- doz.; .15, .2, .25, .3 mfd., 15/6 doz.; .5 mfd., 18/- doz.; or assorted parcel of 50 for 27/6. Minimum orders, 1 doz. any type.

SILVER MICA CONDENSERS. Flat wire end. Assorted and useful values, 17/6 per 100 (not more than 5 alike).

LOUDSPEAKER FREQS. coppered brass, 8in. x 7in., 3/6; 10in. x 16in., 10/6.

I.F. AND AERIAL TRIMMERS. 12 assorted and useful values for 2/6.

HIGH FIDELITY M/C MICROPHONES, 20/25 ohm impedance, 60/4,500 cycles, ± 3 D.B. 20 6 0 each. Folding Chrome Stand 3-tier for above, 23 3 each.

LOUDSPEAKERS. Rola P.M., 3 ohm voice coil, without transformer, 5in., 21/-; 6in., 22/6; 8in., 25/6; with Pentode Output Transformer, 5in., 27/6; 6in., 29/6; 8in., 32/6. Celestion 8in. P.M., with transformer, 29/6. R.G.D. 10in. Energised Moving Coil, 250 or 500 ohm field, 2.5 ohm speech coil, corrugated cone, without transformer, 30/-; with heavy duty multi-ratio matching transformer, 42/-. Any of the above can be supplied with multi-ratio output transformer at 5/- extra per unit.

ROLA 10in. P.M. 3 ohm speech coil, corrugated cone, loudspeakers, without transformer, 27/-; with pentode output transformer, 35/-; with multi-ratio P/P output transformer, 39/6.

LOUDSPEAKER TRANSFORMERS. Philips Pentode 45 m.a., 5/6; Cossor Duty multi-ratio, 60 m.a., 10/6; Heavy Duty multi-ratio, 100 m.a., 12/6; Heavy Duty Pentode, 100 m.a., 10/6; ex-Heavy Duty Pentode, 150 m.a., 12/6; Universal Output and Pushpull, 100 m.a., 12/6; R.G.D. Pushpull Output, 120 m.a., 12/6.

MAINS TRANSFORMERS, 200/230/250, 300-0-300, 100 m.a., 6.3v., 3 amp., 5v., 2 amp., 35/-; 200/250, 350-0-350 4v., 6 amp., 4v., 3 amp., 120 m.a., 37/6 each.

AUTO TRANSFORMERS. Step up or down, 110/230v., 75 watt, 27/6; 110/210/220/240v., 100 watt, 32/6.

ELECTRIC IRON THERMOSTATS, 4-heat control, very heavy quality, easily fitted, brand new, 3/6 each.

EXTENSION LOUDSPEAKERS, in attractive Walnut Veneered Cabinet, complete with 8in. P.M. Loudspeaker, 55/- each.

BEDSIDE EXTENSION LEAD, complete with B.C. adapter, lamp holder and torpedo switch, 9ft. flex, 10/6 each.

AMERICAN YAXLEY, 6-way push-button controls, well below pre-war price, 3/6 each.

AMERICAN YAXLEY, 6-way push-button controls, with 2-gang .0003 variable condenser and drive, ready for chassis mounting, 12/6 each.

BRITISH-MADE CONVERTERS, 12v. input, 230v. output, 70 watt, in strong metal case, with heavy leads and smoothing unit, 27 15s. each.

VOLUME CONTROLS, 5,000, 10,000, 25,000, 50,000, 100,000 ohm; 1/2, 1 and 2 megohm, without switch, 4/9 each. As above, with switch, 6/9 each.

WALNUT VENEERED LOUDSPEAKER CABINETS. Modern design, fitted silk and baffle, suitable for 8in. speakers, 35/-.

DE LUXE WALNUT VENEERED CABINET. Suitable for American Midget sets. Overall dimensions, 14in. x 7in. x 6in., drilled three hole, 32/6 each.

OUR NEW SHOW ROOMS

are in the course of being fitted out and will be open early in June. We strongly recommend you to pay us a personal visit as, due to paper restrictions, advertising on a large scale is impossible. We have a number of useful lines in stock—to mention a few—many types of pre-war I.F. and Aerial Transformers, Chrome Escutcheons, Bakelite Strips, Knobs, Tuners and Meters, etc. All at very low prices.

◆ PLEASE NOTE ◆

When ordering replacement parts for American or British Radios, please state Model No. and, if possible, forward fully component with your order.

2/6 stamped addressed envelope must accompany all enquiries.

C.O.D. or CASH WITH ORDER.

VOLTAGE DROPPING RESISTORS AND LINE CORD REPLACEMENTS

Suitable for every make of radio receiver, comprehensive ranges mentioned below.

950 ohm .2 amp. Chassis mounting, heavy duty on porcelain former, 2 adjustable tappings, 8/6 each; as above, 800 ohm .3 amp., 8/6 each.

.2 amp. 675 ohm, tapped 100, 100, 425 and 50 ohms, suitable for Ekco and other makes, 4/- each.

.2 amp. 840 ohm, tapped 100, 100, 475, 115 and 50 ohms, for Ekco, etc., 4/-.

.2 amp. 945 ohm, tapped 100, 100, 545 and 100 ohms, for Halcyon, etc., 4/6.

.2 amp. 785 ohm, tapped 50, 50, 50, 50 and 535 ohms, for Pye, Hiscen, etc., 4/6.

.2 amp. 510 ohm, tapped 60, 105, 85 and 260 ohms, for Cossor, etc., 4/6.

.2 amp. 660 ohm, tapped 150, 360, 120 and 30 ohms, for Pilot Major Maestro, etc., 4/6.

.3 amp. 547 ohm, tapped 80, 80, 387 ohms, for Ferranti, etc., 7/6.

.3 amp. 1,014 ohm, tapped 82, 82, 320 and 530 ohms, for Double Decca, 7/6.

.3 amp. 781 ohm, tapped 45, 45, 352, 166 and 193, for Ferguson, etc., 9/6.

.3 amp. 823 ohm, tapped 45, 45, 290, 166 and 277 ohm, for Ferguson, etc., 9/6.

.3 amp. 660 ohm, tapped 150, 360, 120 and 30 ohms, for Pilot Little Maestro, etc. 8/6.

SPECIAL HEAVY DUTY RESISTORS, 5-watt, for bias, etc., all values from 25 to 2,000 ohm, with copper clips, 2/9 each. Similar to above, but 10-watt, 2/3.

SPECIAL 2.2 ohm Resistor, for converting dry battery sets for use with 2-volt accumulator, 2/6.

50 ohm centre-tapped Resistor, tapped at 25 ohm, for pilot lamps, 2/-.

SPECIAL VOLTAGE DROPPING RESISTANCE, for Electric Razors, 1,150 ohm, 2/6.

.3 amp. **LINE CORD RESISTOR,** 360 ohm, 6/6; .3 amp. **LINE CORD RESISTOR,** with slider, any resistance obtained up to 750 ohm, 7/9.

SPECIAL MULTI-LINE CORD RESISTOR, 5 tappings 50 ohm, 1 tapping 750 ohm, with slider, .2 amp., 8/6.

BARRETTER VALVES, TYPE C.1., .2 amp., 8/6 each.

BATTERY LEADS, 4-way, with Wander plugs, best quality, 1/3 each.

FLAT FLEX, 9-way, 14/36, 18/20ft. lengths, suitable for amplifiers, extension speakers, remote control and many other purposes. Finest quality pre-war manufacture, 7/6 per coil.

OSRAM TUBULAR PILOT BULBS, 6.2v., .3amp. MES or B.C., Round, 1/- each, including tax.

HUMDINGERS. 30, 25,000 and 50,000 ohm, 6d. each.

INSULATING TAPE. Best quality British and American manufacture, 1/2in., 1/4lb. reel, 9d.; 1/2in., 1/4lb. reel, 1/4; 2in., 1 lb. reel, 2/3.

AMPHENOL OCTAL CHASSIS MOUNTING VALVE HOLDERS, 1/3 each. 7-pin Chassis Mounting Valve Holders, 6d. each.

L.F. CHOKES. 20 hys., 100 m.a., brand new, 16/6.

EVER-READY QUICK-START CAR BATTERY, 6 volt, new, in metal container, with carrying handle, 12/6 each, plus tax.

DPDT SWITCHES, panel mounting, P.O. type, 2/6 each.

SCREENED INTERLACED FLEXIBLE MICROPHONE CABLE, pre-war quality, single, 1/3; triple, 1/9 per yard.

SPECIAL OFFER.—C.A.V., 60 volt H.T. Accumulators, type G.103, 5,000 m.a., at 1,000 hour rate, in strong carrying case, with handle, in used condition, as new, 25/- each.

◆ **CALLERS to Show Rooms,**
61 HIGHGATE HIGH ST., N.6

Phone: **MOUntriv 9432.**

◆ **POST ORDERS to Dept. M.O.7,**
3 HAMPSTEAD LANE, N.6.

*It's what's in between
that matters ...*

Especially between ENAMELLED WIRE WINDINGS

The HY-MEG process of impregnation offers many advantages to the radio and light component manufacturer. Its deeper penetration and more complete expulsion of air and moisture; its perfect through-drying qualities (although calling for as much as 50% less stoving time) commend it particularly for deep and complicated fine enamelled wire windings.

The enamel is unaffected by HY-MEG which sets plastic hard and stays hard under extreme working and tropical conditions—a fact clearly reflected in the general Government approval of components which are HY-MEG impregnated.

In short, HY-MEG sets new standards of quality and quantity in production and, because it is independent of materials in short supply, enables output to progress without risk of interruption.

INSULATE WITH
HY-MEG
TO BE SURE

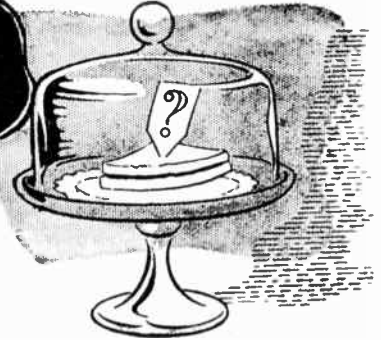

GIVE OUR 'BRAINS TRUST' YOUR PROBLEMS

The panel of experts whose experience and research created HY-MEG would be glad to have details of any insulation problem holding up your production; and to place their extensive laboratory facilities at your disposal.

HY-MEG IMPREGNATING VARNISH

V6934. Made specially for enamelled wire windings: but is equally suitable for Rayon and Glass covered wire.

L. EWIS BERGER & SONS, LTD. (Established 1760) LONDON, E.9. Phone: AMHerst 3321

MANUFACTURERS OF INSULATING VARNISHES AND ENAMELS

M.R. SUPPLIES

offer FROM STOCK the following brand new PUBLIC ADDRESS and ELECTRICAL MATERIAL of our usual dependable quality. All prices nett cash.

MINIATURE P.M. MOVING COIL UNITS. Only 3in. diameter, fitted weighty alnico magnets, Imp. 12 ohms. For use as microphone or speaker and ideal for intercom. systems. Very efficient, 25/-.

PIEZO-CRYSTAL MICROPHONES. As we are now without supplies of the 72/G model which we have frequently advertised we make a special offer of the original De Luxe (American) Rothermel D.104 Piezo-Crystal Microphone at £4/10/-. This is the well-known, expensively finished plated model with 6ft. screened lead, in makers' own boxes. Opportunity.

ROTHERMEL-BRUSH MINIATURE MICROPHONES (Piezo-Crystal). Only 1 1/4 in. dia. and capable of very high performance. In aluminium housing with short screened lead, but with no front grille. Although made for deaf-aids these instruments are suitable for all microphone duties and for cardiophone, etc. Useful in research depts., 27/6.

G.E.C. MOVING COIL MICROPHONES. Model 2283. Response level 50/9,500 c/s., sensitivity 50 db. In superior chromium housing with back terminals and mounting base. Imp. 15 ohms. A few left at £5/18/6 each.

MICROPHONE FLOOR STANDS. Chrom. collapsible model ext. to 5ft. 6in. and folding to 2ft., to suit all microphones above (except deaf-aid type), 37/6.

PUBLIC ADDRESS SPEAKERS. Brand new latest model G.E.C., comprising 10-watt P.M. McColl Projector Unit, with 42in. Round Metal Horn, £10/5/- (carr. 7/6 each, per pass. train). Please see below for other bargains in P.A. Speakers offered to callers only. Instant delivery—all models.

MEASURING INSTRUMENTS by Weston, Ferranti, Elliott, etc. (We cannot select particular maker, but will do our best). Housing 2 1/4 in. square flange, flush panel mtg., requiring 2in. mtg. hole, black bakelite with back terminals. **MICRO MILLIAMMETERS,** 0/160 millamps, 32/6. Also in same size and style Thermo-couple **MICRO COIL AMMETERS,** 0/21 amps. These have the advantage of reading accurately on D.C. and any frequency of A.C., 37/6. (NOTE:—These meters are ex-Govt., in excellent condition and lab. tested.)

ROTARY SWITCHES (Yaxley type). 2-bank 10 pos., 4/6. 4-bank 4 pos., and 5-bank 2 pos., either, 5/6. (We regret that we cannot briefly describe the various switching duties of these useful switches and cannot effect exchanges.)

RELAYS. Compact enclosed model, with 4/12 v. D.C. coil and single-pole 6-amp. "make" switch with fuse holder, 6/6.

INSPECTION LAMPS ("Gripper") Approved shockproof type, fitted B.C. holder and strong gripping tongue for attaching anywhere. The wire cage is supplied with a movable eye-shade, 18/6.

ELECTRIC SOLDERING IRONS. Best Industrial types from stock—trade quantity enquiries invited. S.T.C., all voltages, 75 watt with 4in. pointed bit, good all-purpose iron, 21/-. (Spare elements, 200/250 v., 6/-.) Same make, 150 watt, with massive flat bit, 32/6. Also ACBU bent model with interchangeable bit, 100 watt, 28/6. (Spare bits, our choice, 3/6 each.)

Please include sufficient for packing and post.

The following are offered to CALLERS ONLY:—**G.E.C. SEMI-PROJECTOR P.A. SPEAKERS,** 10 watt, with enamelled wood horn, large size, high quality, £5 15/-; **G.E.C. PROJECTOR SPEAKERS,** 10 watt Unit and 42in. Metal Horn, with fabric flare, £9 9/-; Same unit with 30in. diaphragm Horn, £8/17/6. **ROTARY CONVERTERS** (various).

M.R. SUPPLIES, 68, New Oxford Street, London, W.C.1.

(Telephone: MUScum 2958)

**IDENTIFICATION
LABELS FOR CABLES
& PIPELINES**
(M.A.P. APPROVED) A.I.D. APPROVAL N° 2583/A2

TRANSMITTER

Indelibly printed on white or coloured fabric for use in conjunction with transparent adhesive tape.

• Guaranteed 2/3 day delivery service.

P. P. PAYNE & SONS LTD

HAYDN ROAD NOTTINGHAM Phone: 64335

BUSH HOUSE LONDON Phone: TEMple Bar 6356

Callender

RADIO FREQUENCY CABLES

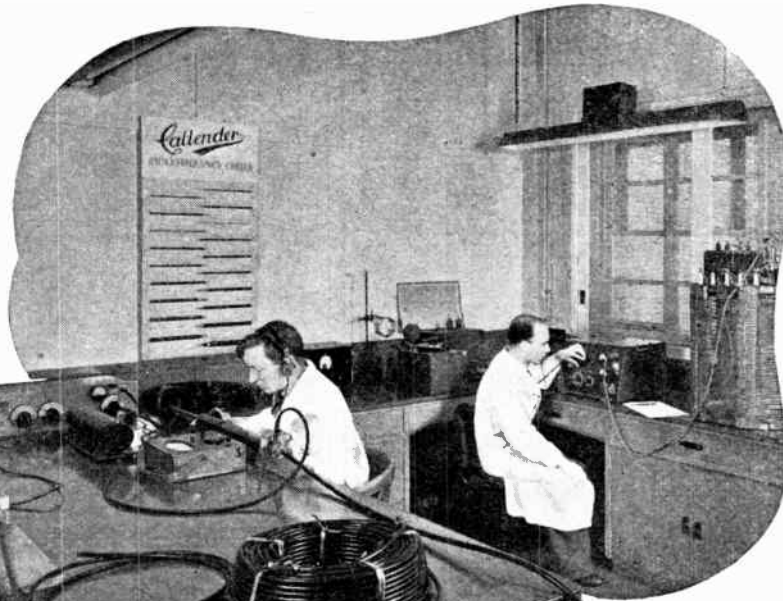

Part of our High Frequency Test Laboratories

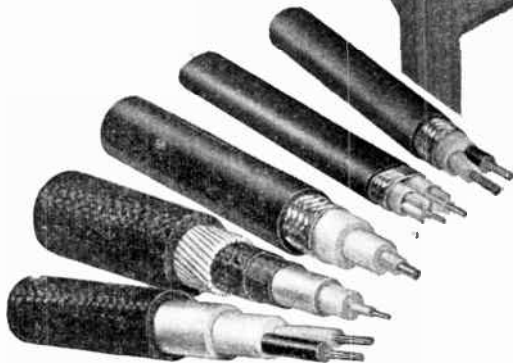

We are fully engaged on war production and are manufacturing all types of low loss and low capacity cables for use at high frequencies.

We shall be pleased to make available the experience of our extensive research and technical organisations in connection with special cable problems directly related to the war effort.

CALLENDER'S CABLE & CONSTRUCTION CO. LTD. HAMILTON HOUSE, VICTORIA EMBANKMENT, E.C.4

All over the World

LONDON CENTRAL RADIO STORES

HEAVY DUTY MAINS TRANSFORMERS

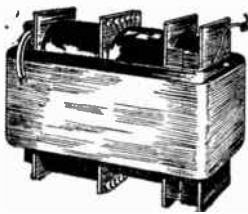

350-0-350 v., 120 m.a., 6.3 v. 5 amps., 4 v. 3 amps., 4 v. 1 amp. Input 100/250 v. Dimensions 5½ x 5½ x 4½ in. Free wiring diagram. **32/6** Post., etc., 2/-.

YAXLEY PATTERN SWITCHES

5-way, single-bank, with on-off mains switch, carrying 1 amp. at 250v., 2in. spindle with knob **5/6**
3-way, single-bank, 1in. spindle, with knob ... **2/9**
Post., etc., 6d. extra.

EX-GOVT. POTENTIOMETERS
Wire-wound. In bakelite case, 50,000 ohms. 2in. dia. x 1in. Without knob. Post., etc., **5/6** 6d.

OAK VIBRATOR UNITS — Synchronous

Input 6 volts. Output 250 volts 60 m.a. approx. These well-known units are fitted with 6-pin Am-erican bases... **15/6** Post., etc., 78d.



EX-GOVT. PLUGS & JACKS

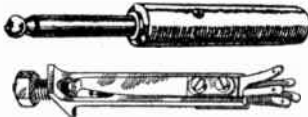

These **Jacks** have a powerful phosphor-bronze springs ensuring a perfect contact. Overall length, including ¼ in. threaded shank, ¾ in. Supplied complete with **Plug. 5/6** Price ... **5/6** Post., etc., 3d. extra.

ELECTRO-MAGNETIC COUNTERS

500 ohms coil. Counting up to 9,999. Operating from 25 v. to 50 v. D.C. Many industrial and domestic applications. (S.H., ex-G.P.O., all perfect.) Postage 9d. **5/6**

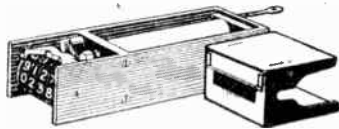

YAXLEY Type WAVE-CHANGE SWITCHES

4-way, 3-bank, with shielded oscillator section. Length from stop plate approx. 5 in., spindle 2in. **5/6**
5-way, 6-bank, with 3 screened sections, adaptable to many uses. Length from stop plate approx. 6½ in., spindle 2in. **8/6**
3-way, 3 double banks, without shields, 2in. spindle. Length 6½ in. **5/6**. Post., etc., 9d. each.

OAK SWITCHES



2½ in. spindle, complete with knob. 4-way, 2-bank, with connecting block ... **4/6**
4-way, 2-bank ... **3/9**
Post., etc., 6d.

PHILIPS Oil Filled CONDENSERS

0.1 mfd. 5,000 D.C. working. With porcelain insulated terminals. Size 2½ high x 3½ x 2in. Post., etc., 9d. **10/6**

See last month's advert. for other lines.

CHASSIS 11¼ x 9¼ x 2¼ in. and 11¼ x 7 x 2¼ in. ... **3/6**
Drilled for 9 valves, also rectangular hole 6½ x 2¼ in. Size 10½ x 9½ x 2in. ... **3/6**
12 x 9 x 3in., drilled for 10v. transformer, etc. ... **5/6**
Post., etc., 10d. extra.

EX-BAIRD High Voltage TELEVISION TRANSFORMERS

6,000 v. approx. Fitted with Porcelain insulated terminals, as illustrated. Size 3½ x 6½ x 3½. Post., etc., **20/-**
4,000 v. approx. Size 4in. x 3½ x 3½. Post., etc., 1/6 ... **10/6**

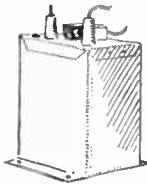

LOUDSPEAKERS

ROLA 5in. P.M. less transformer ... **22/6**
Post. and pkg., 1/6 extra.
ROLA, 8in., less transformer ... **24/-**
CELESTION 8in. P.M. Pentode Output. New ... **25/6**
Post., etc., on above, 2/- extra.



Targets, so efficiently popularised by the R.A.F., are an important feature of the National Effort, especially the Target of Production. Of course, we at R & S have a production target, too, and it tries hard to beat us. But close to it is our invisible target—the Target of Quality. It is a target that cannot be assessed in mundane figures or graphs, but every piece of R & S Sound Equipment is a visible and audible testimony to our success in consistently exceeding it. If you would like to learn about the range that we still have available in small quantities, a penny stamp will bring you a catalogue.

R & S

Amplifiers Limited

3-4, Highfield Rd., Shepperton, Middlesex. Tel.: Walton-on-Thames 1019

W.W. 6/43

ROLA

LOUD SPEAKERS
THE WORLD'S FINEST REPRODUCERS

TRANSFORMER LAMINATIONS

Core Widths ¼" to 1½" (E's and I's.)

EIGHT STOCK SIZES

A Comprehensive Bulletin together with details of Associated Covers and Clamps with design data will be sent to manufacturers on request.

BRITISH ROLA LIMITED

MINERVA ROAD · PARK ROYAL · N.W.10 · WILLOWDEN 4322

NO LISTS • NO PRO-FORMA INVOICES

23, LISLE STREET, LONDON, W.C.2.

Phone—GERrard 2969

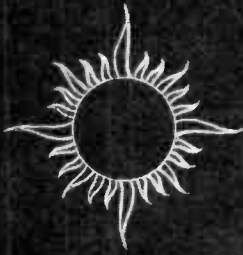

SYMBOLS OF PRECISION

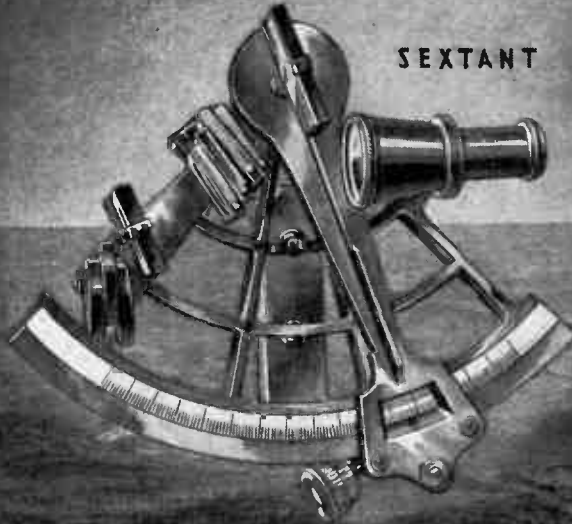

SEXTANT



MAZDA

RADIO
VALVES

THE EDISON SWAN ELECTRIC CO. LTD.



155, CHARING CROSS RD., LONDON, W.C.2

For full particulars write to Technical Service Department

Ensure the most successful results



USE

B.I.
CONDENSERS

BRITISH INSULATED CABLES LTD.
Head Office: PRESCOT, LANC. Telephone: PRESCOT 581.

P. R. MALLORY & CO. LTD.

MALLORY

Vibrators are always dependable



Along every front Mallory has pioneered in Vibrator design to ensure safety, dependability and long service.

Mallory offers synchronous and non-synchronous Vibrators for 6, 12 and 32 volt input, also a complete range of "STRATOSPHERE" Vibrators plus the world famous Mallory "VIBRAPACK" (Regd. Trade Mark).

Mallory engineers are at your disposal.

★ Vibrapack is a registered trade mark, the property of the P. R. Mallory & Co. Inc., Indianapolis, U.S.A. Units which do not bear this trade mark are not of genuine Mallory manufacture.

P. R. MALLORY & CO. INC.
INDIANAPOLIS, INDIANA, U.S.A.
RADIO AND ELECTRONICS DIVISION

Represented exclusively in Gt. Britain by

FRANK HEAVER LTD., Kingsley Road, Bideford, N. Devon, Eng.

Audio Amplifiers and Sub-assemblies to critical standards



In addition to Standard Amplifiers the activities of Acoustical include Special Amplifiers for Industrial Applications, Microphones, Transformers, Coil Winding, Sheet Metal Work, Stampings, Switch Assemblies, etc.

 **ACOUSTICAL**
MANUFACTURING Co. LTD.
HUNTINGDON - TEL: 361

HIVAC
THE SCIENTIFIC VALVE

BRITISH MADE



Specialists in
MIDGET VALVES

HIVAC LIMITED
Greenhill Crescent
Harrow on the Hill, Middx.
Telephone: Harrow 0895.

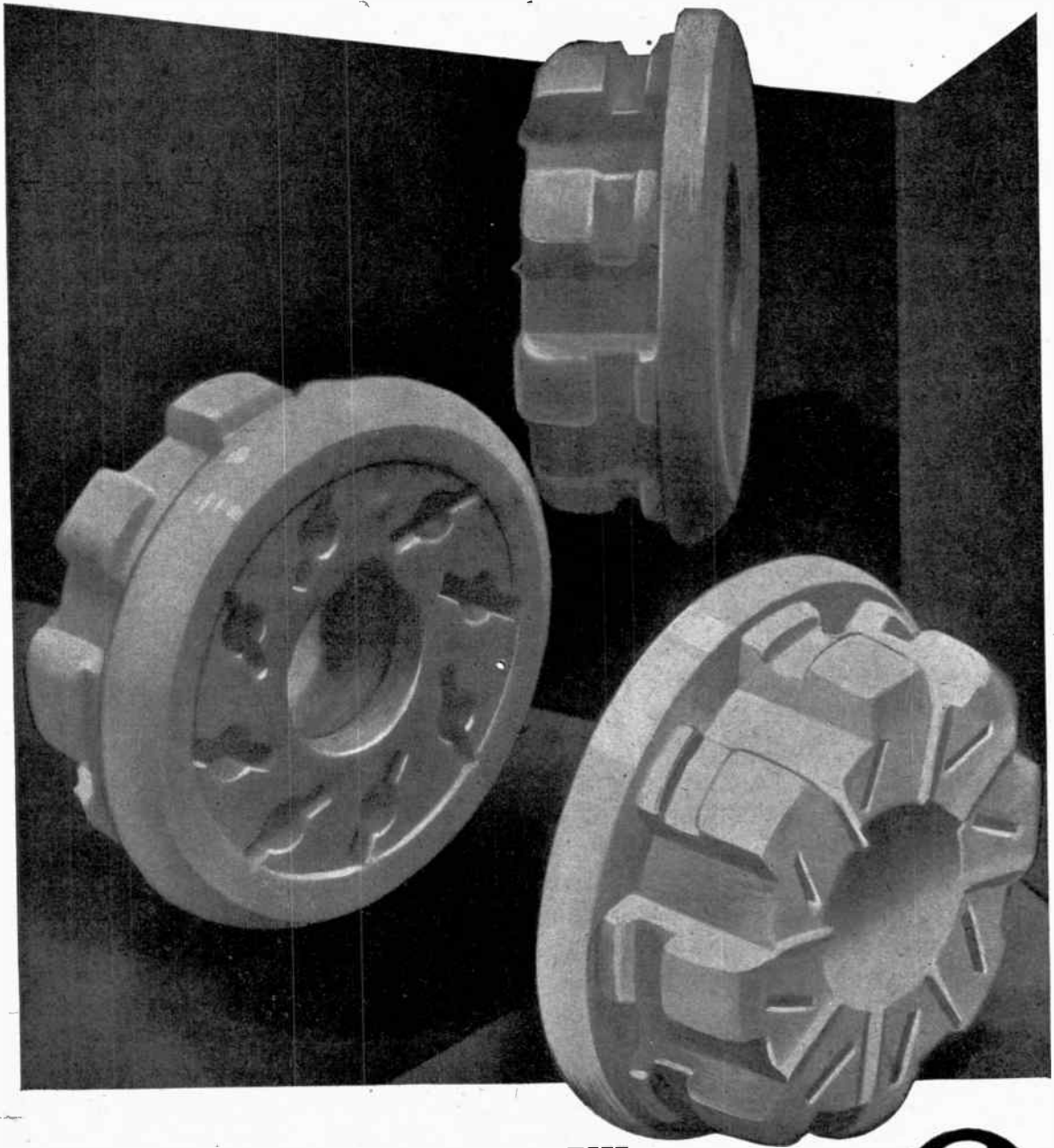

FROM EVERY POINT OF VIEW

Frequentite is the most suitable material for all high frequency applications. Ten years ago we introduced the first British-made low loss ceramic, and consultation with us before finalising the design of new components is a wise precaution.



STEATITE & PORCELAIN PRODUCTS LTD.

Head Office: Stourport-on-Severn. Worcester.

Telephone: Stourport 111.

Telegrams: Steatoin, Stourport.

SP20

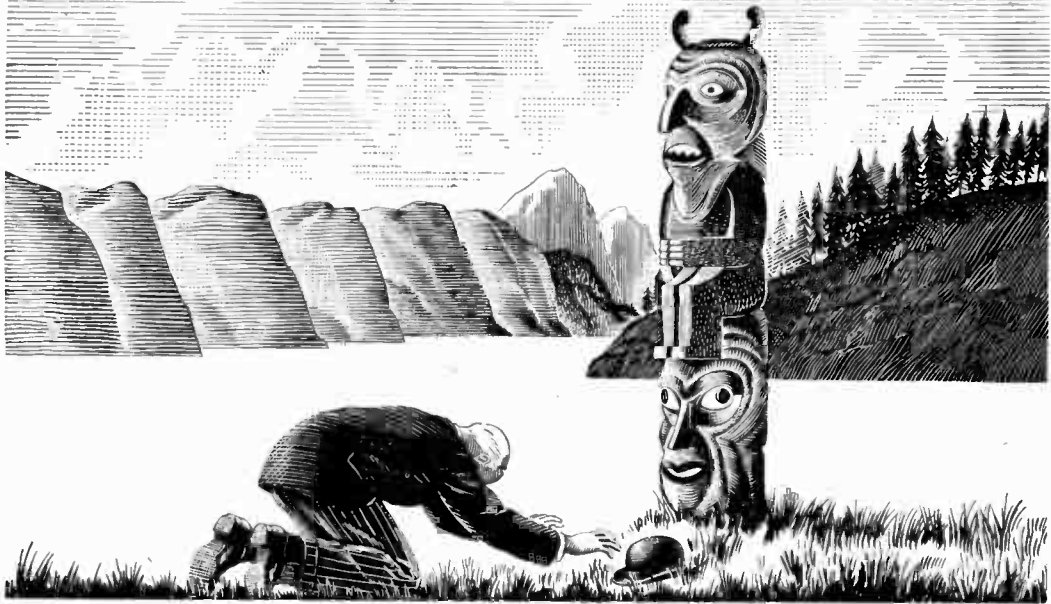

Taboo

PRODUCTION has its psychological as well as its physical problems, for some of us are by nature unduly impressed by the orthodox.

As greater inroads are made into the country's resources of labour and materials, improvements in technique will alone remain for further exploitation.

In this spirit the Simmonds Organization wrestles with convention. Its products are born of an imaginative approach to the problems of the hour and evidence abounds that they are effecting great national savings in time, labour and materials.

It is well that the AEROCESSORY came to challenge genuflexion.

S I M M O N D S

The Creative Impulse in
AERONAUTICAL, INDUSTRIAL & MARINE
Construction

THE SIMMONDS NUT · PINNACLE NUT · SPIRE NUT · SIMMONDS GAUGES,
INSTRUMENTS AND CONTROLS · FRAM OIL & ENGINE CLEANER

SIMMONDS AEROCESSORIES LTD.,
GREAT WEST ROAD, LONDON

A COMPANY OF THE SIMMONDS GROUP

LONDON, MELBOURNE, PARIS, NEW YORK.

Wireless World

Radio • Electronics • Electro-Acoustics

33rd YEAR OF PUBLICATION

JUNE 1943

Proprietors :
ILIFFE & SONS LTD.

Managing Editor :
HUGH S. POCOCK,
M.I.E.E.

Editor :
H. F. SMITH.

Editorial, Advertising
and Publishing Offices :
DORSET HOUSE,
STAMFORD STREET,
LONDON, S.E.1.

Telephone :
Waterloo 3333 (35 lines).
Telegrams :
"Ethaworld, Sedist, London."

△

PUBLISHED
MONTHLY

Price : 1/3

(Publication date 25th
of preceding month)

Subscription Rate
Home and Abroad
17/- per annum

EDITORIAL. Wireless and Defence Regulations ..	159
SKIP DISTANCE. By T. W. Bennington ..	160
DESIGNING SUPERHETS. By J. E. Haworth ..	163
AC VOLTAGE STABILISER. By T. A. Ledward, A.M.I.E.E.	166
FREQUENCY MODULATION.—VI : Future Applications of FM. By Christopher Tibbs, A.M.I.E.E.	168
UNBIASED. By Free Grid	172
RADIO DATA CHARTS.—8 : Power Dissipated by a Resistance. By J. McG. Sowerby, B.A., Grad.I.E.E.	173
NEWS IN ENGLISH FROM ABROAD	175
WORLD OF WIRELESS	176
ELECTROMAGNETIC FIELDS IN RADIO.—V : Waves in Dielectric Materials. By Martin Johnson, D.Sc.	178
EXPLORING THE IONOSPHERE	182
LETTERS TO THE EDITOR	184
" WIRELESS WORLD " BRAINS TRUST	186
RANDOM RADIATIONS. By " Diallist "	188
RECENT INVENTIONS	190

Branch Offices :

COVENTRY :

8-10, Corporation Street.
Telephone: Coventry 5210.
Telegrams :
" Autocar, Coventry."

BIRMINGHAM :

Guildhall Buildings,
Navigation Street, 2.
Telephone :
Midland 2971 (5 lines).
Telegrams :
" Autopress, Birmingham."

MANCHESTER :

260, Deansgate, 3.
Telephone :
Blackfriars 4412 (4 lines).
Telegrams :
" Iliffe, Manchester."

GLASGOW :

26B, Renfield Street, C.2.
Telephone : Central 4857.
Telegrams : " Iliffe, Glasgow."

△

As many of the circuits and
apparatus described in these
pages are covered by patents,
readers are advised before
making use of them, to satisfy
themselves that they would
not be infringing patents.

Exclusive features

of the
'STRATOSIL'
series of
**SEALED
VIBRATORS**
for use at all altitudes

- 1 All steel construction—even to the rivets—ensuring uniform expansion under extremes of temperature.
- 2 Reed driving coil—wound on a bakelite moulded bobbin to meet all climatic conditions.
- 3 Metal can, sponge rubber lined—Acoustically and electrically shielding the Vibrator.
- 4 Driving contact of non-tarnishable precious metal—ensuring starting under the lightest of pressures and voltages.
- 5 Contacts ground almost to optical limits.
- 6 Stack assembly. Mica and steel only are used.
- 7 International Octal base sealed by the WEARITE STRATOSIL process.

Embodying " Oak Manufacturing Co.'s " patents 460470, etc.

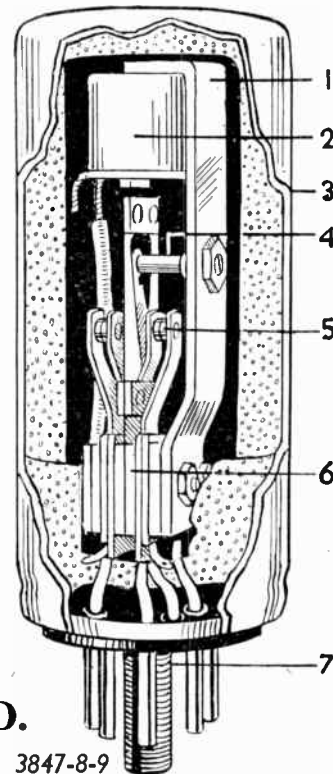

WRIGHT & WEAIRE LTD.

HIGH ROAD, TOTTENHAM, N.17. Telephones : TOTtenham 3847-8-9

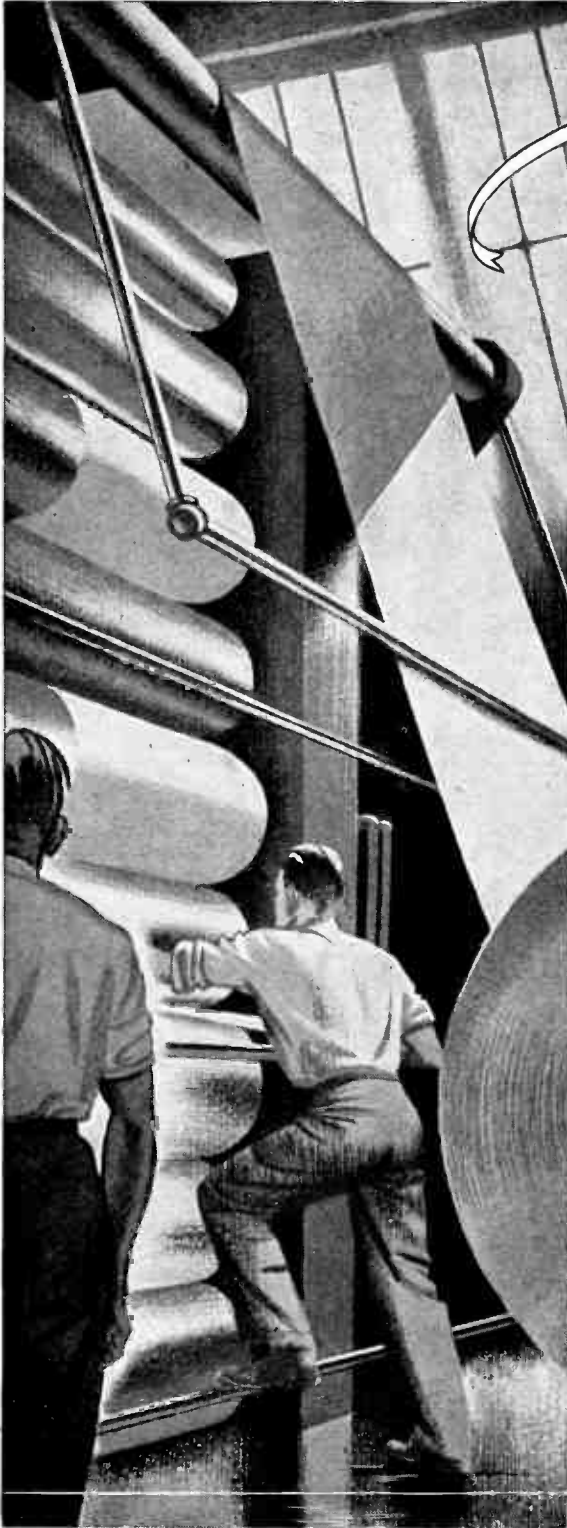

Valves and Paper

Paper is manufactured in the reel, and for many purposes it remains in reel form until it is finally printed and cut—as, for example, in the production of printed labels and wrappers. This method calls for a very high degree of accuracy in the final operation of cutting the paper to size, since the slightest error in timing when the reel is fed to the cutter means that the printed design will be out of register.

This is another typical instance where the Thermionic Valve can solve the problems of industry. By means of valves and light-sensitive cells in a suitably designed control system, the printed design itself can be used to regulate the speed of the paper through the rollers and determine its exact position under the cutters. This ensures a degree of precision unobtainable by mechanical methods; the accuracy is not affected even by a variation in the size of the design due to expansion or contraction of the paper.

MULLARD

THE MASTER VALVE

A Valve for Every Purpose

DOMESTIC · COMMERCIAL · INDUSTRIAL
SCIENTIFIC · MEDICAL · EXPERIMENTAL

THE MULLARD WIRELESS SERVICE CO. LTD.,
CENTURY HOUSE, SHAFTESBURY AVENUE, W.C.2 (52)

Wireless World

Radio • Electronics • Electro-Acoustics

Vol. XLIX. No. 6

JUNE 1943

Price 1s. 3d.

Wireless and Defence Regulations

1914 and 1943 Compared

LOOKING back through the volume of *Wireless World* covering the early part of the last war, we were interested to find how ardently the journal pleaded for a less rigorous interpretation of the Defence Regulations against those found in possession of apparatus which might be regarded as part of a wireless station. Severe penalties were imposed on persons found in possession of, say, a wire erected as a clothes line, because it might be intended for use as a wireless aerial. Anything might have happened to a person discovered with a morse key or a pair of headphones! The very severe treatment meted out by magistrates was criticised in *Wireless World*, and it was pointed out how very ineffective any wireless equipment was as a means of communication with the enemy unless it were so elaborate and obvious as to be easily detected. There were no valves available in those days and range was consequently very limited.

Lenient Treatment

But what of the position to-day, after nearly four years of war? When even doctors have for a time been deprived of their electrical equipment because it might radiate in such a way as to interfere with the sensitive apparatus used for our defence, it is amazing to learn that there are wilful or irresponsible people in this country who are actually using valve transmitting apparatus with no authority to do so and in direct contravention of the Defence Regulations. We are indeed surprised that when one such offender is caught red-handed and convicted the sentence he receives is limited to a short detention. The case is reported elsewhere in this issue.

Transmitting apparatus to-day, even of the simplest kind, is not only capable of being used for transmission over very great distances and certainly well into enemy country, but the radiation can play havoc with essential communications and with apparatus used for defence purposes. If any message is transmitted which might provide the enemy with information, then that is an aggravation of the offence.

We are convinced that no person capable of setting up and using a transmitter can, after all these years of war, pretend to be ignorant of the Defence Regulations on the subject and must be fully aware of the offence he is committing. It is possible that some of these offences are committed owing to misplaced enthusiasm on the part of members of the Home Guard, and others. This is no excuse. No transmitter may be used or operated except under direct authority from the Army, Navy or Air Force authorities, or the Post-master-General. In our view, the unauthorised use of a wireless transmitter may, no matter how low the power, do as much harm to our national defence as if it were being done deliberately at the instigation of the enemy.

To incur even the slightest risk of interfering with Service communications was bad enough during the period of more-or-less static war. It is particularly reprehensible at this crucial and more active stage of hostilities. Anyone capable of setting-up and operating a transmitter must know something of the vagaries of short waves, and even the most thoughtless and irresponsible person must have enough imagination to realise that, by working an illicit transmitter, he runs a risk of interfering with important operational messages.

We hope that we can count upon any reader of *Wireless World* who may be guilty of this offence or is aware that such an offence is being committed by others, however innocently, to see to it that the offence is not repeated and so help the authorities in the difficult task they have in tracking down those whose similar activities are by no means innocent. We expect both the police and the magistrates to be alive to the dangers, and hope that they will not be guilty of misplaced leniency in dealing with offenders. We understand that a number of offenders have been detected since the beginning of the war; in future, when the seriousness of such offences has been generally recognised, it is to be expected that the sentences meted out to offenders will take into account the fact that our national security has been endangered by their actions.

SKIP DISTANCE

Simple Explanation of the Effect

By T. W. BENNINGTON

ON the subject of skip distance—or “skipped” distance, as it might perhaps more properly be called—there seems to be, amongst those whose knowledge of short-wave transmission is in the elementary stage, a certain confusion of ideas, if not some complete misunderstanding.

the transmitter is called the “skip distance.”

Let us assume that the transmitting station radiates energy equally at all angles, both vertical and horizontal. The skip zone will then be roughly circular in shape, as shown in Fig. 1 (a), being bounded on its inner edge by the points at which the so-called “ground” wave becomes of negligible strength, and on its outer edge by points at which the first rays to be returned from the ionosphere reach the earth. Beyond this circle is the area which is covered by the energy which has been radiated in an upward direction—the area served by the so-called “sky” wave. Fig. 1 (a), it should be mentioned, is not drawn to scale.

outward with the wave in contact with the earth’s surface. It therefore sets up currents in the earth itself, and these represent a loss of energy from the wave, so that it becomes more and more attenuated as it advances. This ground absorption—besides depending upon the nature of the soil over which the wave is travelling—increases with frequency, so that on the high frequencies—or short waves—it is always relatively high. Because of the high ground absorption, therefore, the ground wave of a short-wave transmitter becomes negligible at points relatively close to the transmitter, as may be seen from Fig. 1 (b). The distance at which it does so will vary considerably with the nature of the terrain over which it is travelling, as well, of course, as upon the power radiated. For example, we might expect that a transmitter of 1 kW radiated power would provide some sort of ground-wave reception over land up to about 60 miles on 4 Mc/s and 40 miles on 20 Mc/s, while over salt water its ground-wave range might be up to 360 miles on 4 Mc/s and 160 miles on 20 Mc/s. But the ground wave is not usually of much importance in short-wave transmission—it is merely incidental to the radiation of a sky wave—and it is upon this latter that we mainly rely for communication by short waves.

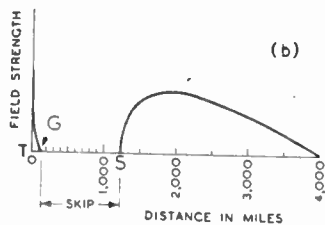
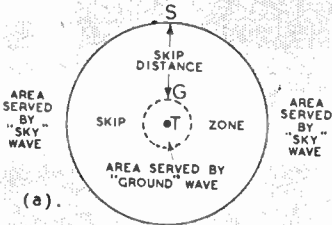

Fig. 1. Diagram (a) shows the extent of the skip zone, while (b) indicates the manner in which field strength varies with distance.

This article represents an attempt to explain the phenomenon, with the help of simple diagrams, in terms that will easily be understood.

The Skip Zone.—Round about a short-wave station there is usually a zone within which it is impossible to obtain steady and reliable reception of the station. Within this zone only weak and unreliable signals are normally obtainable, though, as we shall later see, there are occasions when the signals may become strong and steady, but only because of what must be regarded as abnormal conditions in the ionosphere. This zone is called the “skip” zone—because the radiated waves are pictured as “skipping” over it. The distance across it in any one direction from

If we proceeded outward from the station in any one direction, measuring the field strength as we went along, we should, on plotting our results, get a graph somewhat like that shown in Fig. 1 (b). In this, between the points T and G, we have plotted the field strength due to the ground wave decreasing towards the point G. Between G and S we are in the skip zone and no field is measurable. Beyond S there is a rapid increase in the measured field, because of the downcoming energy from the ionosphere, while farther out this gradually diminishes with increasing distance.

Cause of the Skip Zone.—The reason for the existence of a skip zone is illustrated in Fig. 2. The energy which is radiated from the transmitting aerial in hori-

This sky wave is made up of the energy which has been emitted from the transmitter in upward directions and which has been sent downwards to earth again by

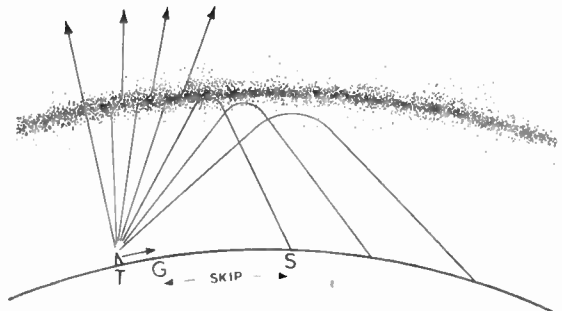

Fig. 2. Showing the reason for the existence of a skip zone.

zonal directions — that which forms the ground wave—travels refraction in the ionosphere. Now if the short-wave station were

working on a frequency *below the critical frequency* of the ionosphere refracting layer—usually the F layer — the upward-going rays would be returned to earth at no matter what angle they struck the layer. For the critical frequency is the highest frequency returned when the wave goes vertically upward, and if the working frequency is below this it will be returned at vertical incidence and for all other angles of incidence as well. In such a case there would not be a skip zone, for the surface of the earth all round the transmitter would be “illuminated” by the downcoming rays, even that part of it which was within the area covered by the ground wave. *None* of the upward-going rays would escape (as they are seen to do in Fig. 2)—*all* would return to earth at different points from the transmitter outwards.

But to work on a frequency as low as this is not good practice if we wish to transmit to long distances. For the absorption to which the waves are subject in the lower ionosphere increases inversely as the frequency, or, rather, as the square of the frequency. So that to work on a low frequency when a higher frequency could be used is to waste unnecessarily a great deal of power, the energy being dissipated in the ionosphere. If we wish to avoid this absorption so that the wave may persist and be receivable at long distances we must work on a relatively high frequency.

We are enabled to use such high frequencies—frequencies far above the critical frequency—by reason of the fact that when the wave strikes the refracting layer at a glancing angle, higher frequencies will be refracted than when the wave approaches the layer at right angles to its lower surface. And the more glancing the incidence of the ray the higher the frequency which will be refracted.

We cannot go into this matter in any detail, but it will be clear that the greater the transmission distance the more glancing is the angle which the incident ray must make to the layer boundary, and so the higher is the frequency which can be used. The highest frequency which is returned at any angle of incidence is called the “maximum usable frequency,” and there is thus a different “MUF” for every distance from

the transmitter, which will increase upwards from the critical frequency as the distance is increased. There is a limit to the distance that can be reached by one “hop,” depending on the height at which the refracting layer lies. Beyond the one hop, transmission is by alternate refractions at the ionosphere and reflections at the ground, as it is pictured in Fig. 3.

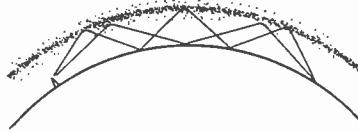

Fig. 3. Multi-hop transmission to distant points.

Now if, in order to transmit to long distances, we work on a frequency which is near the MUF for the rays with low angles of elevation, then it means that the high-angle rays will penetrate the ionosphere altogether. A glance at Fig. 2 should make this clear. The high-angle rays penetrate the refracting layer, then, because the frequency used is too high for refraction at their relatively small angle of incidence only the more oblique rays, which have a large angle of incidence, are sent back to earth. This is what gives rise to the skip zone. If, for example, the frequency used is such that the first ray to be returned to earth reaches the surface at a distance of 2,000 miles from the transmitter, and the ground wave is not usable beyond 100 miles, then the earth's surface in any direction from the transmitter between 100 and 2,000 miles distant is not being illuminated by any rays, either of the ground or sky wave. It is within the skip distance.

Extent of the Skip Zone.—

A question which often arises is this: “Why is not the skip distance again observed in the middle of the second and subsequent hops?” Well, it must be remembered that diagrams illustrating the mechanism of multi-hop transmission—such as Fig. 3—are usually very much simplified. They show only one or two rays of radio energy going up and down between the ionosphere and earth. In practice—even with narrow-beam aerial systems—there is

never one or two rays, but large numbers of them going up at slightly different elevation angles. All are being refracted at different angles in the layer, and returning to earth at different distances. Also we must remember that the ionosphere is hardly such a stable thing as a sheet of polished metal held suspended in the sky. Its electron density undergoes slight but constant changes, so that the height at which the waves are refracted is subject to considerable change. So for all practical purposes we can take it that, beyond the first zone where no refracted rays reach the earth, the whole surface is illuminated by rays coming down at different angles, and also perhaps having made different numbers of hops.

So far as we have gone then, we have agreed that the skip zone will surround any short-wave station working on a frequency above the critical frequency of the refracting layer, and that it will extend from the limits of the ground wave to the points where the first sky waves return to earth. In practice it may not be exactly circular in shape because the station may use a directive aerial system, which will concentrate the radiated energy at certain angles, both horizontal and vertical. It is important to note, however, that, while the “inside edge” of the skip zone will depend, generally speaking, only on the power radiated and the nature of the terrain, the position of the outside edge will be quite independent of power. With a given working frequency it will depend solely on the degree of ionisation in the refracting layer, and no increase or decrease in power will make any difference to its location. For it will be clear that increasing the power radiated at any elevation angle will not ensure better refraction—the ray will still escape through the layer if the frequency is above the MUF for the resulting angle of incidence—or for that transmission distance, if one prefers it that way.

How the Skip Zone Varies.—

Because the refraction of the wave is so dependent upon the degree of ionisation of the layer, the location of the outside edge of the skip zone will, however, vary markedly with the time of

Skip Distance—

day, season of the year and phase of the sunspot cycle, as well as upon the latitude of the station on the earth's surface. For, as we all know, the ionosphere is produced by the action of the sun's radiations, and its degree of ionisation will therefore vary—though not perhaps in a simple manner—with the intensity of the solar radiation affecting it.

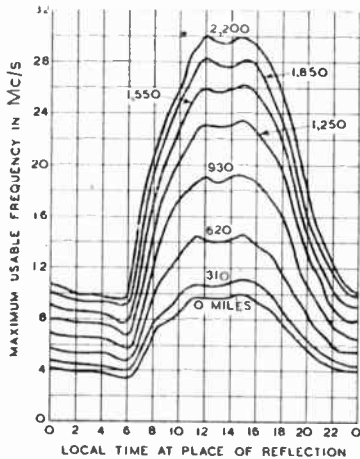

Fig. 4. Curves of MUF for various distances (Winter, 1941).

This will, of course, be determined by the conditions just enumerated. We need not bother to go into the details of this matter, however, but merely need to remember that the critical frequency of the layer is a measure of its ionisation, and that we can connect the skip distance with it. For in practical communication it is important, among other things, to see that the receiving location does not fall within the skip zone of the transmitter at any time, and we must ensure that the working frequency is such that this does not occur.

How to Estimate the Skip Distance.—Before the war a number of observatories were regularly engaged in measuring the critical frequencies and in publishing the results of their work. Nowadays, of course, such information would be of use to the enemy, and hence it is no longer published. But it is a safe prediction—and no secret—to say that after the war a vastly increased amount of ionosphere data will be made available for all who have occasion to use it.

So it may be useful to explain how such information can be used, in anticipation of the time when it is again available. Fig. 4 gives curves of MUF for different distances suitable for middle latitudes in the northern hemisphere during winter, and was published in 1941. These are calculated from the measured critical frequency, for the various angles of incidence appropriate for the various transmission distances shown. Since 1941 solar activity has decreased and the values would not be the same now.

Now the distance at which a given frequency is the MUF is also the skip distance for that frequency, for at the angle of incidence appropriate to that distance all higher frequencies will penetrate the refracting layer. The MUF and any lower frequency will be refracted so that the sky wave is receivable at the distance considered, though if the frequency is *much* below the MUF the attenuation due to ionosphere absorption will increase, and signal strength will therefore be reduced. So if we are interested primarily in skip distance we can for any time of the day read off from the curves—with a certain amount of interpolation—the skip distance appropriate to any frequency. This will, perhaps be more clearly shown if we plot the results in a curve of skip distance against frequency, as has been done for four times of day in Fig. 5. A study of Fig. 5 will yield quite a lot of information relating to skip distance. We see, for

Fig. 5. Skip distances for various frequencies at different times of day.

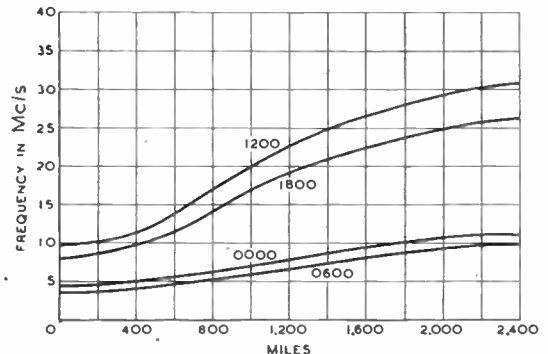

example, that at 1,000 miles 14 Mc/s would skip at 0000 and 0600 hours, but would be receivable at 1200 and 1800 local time at the centre of the transmission path. To avoid skipping we should have to use 7 Mc/s at midnight, and even this would be too high to avoid skipping at 0600. If, on the other hand, we are interested in the performance of only one

frequency—say 7 Mc/s—we see that at 0000 we should expect it to be usable at distances from 1,000 miles onward and at 0600 at distances of from 1,250 miles onward. At 1200 and 1800 it would not skip at all, but would probably be badly received at distances of from 400 miles onward, because it is so far below the MUF that the absorption would be high. In this way—and by interpolation for other times of day—we ought to be able to estimate the extent of the skip zone for any time of day.

Signals within the Skip Zone.

—Anyone who has operated a short-wave receiver within the skip zone of any particular station will realise that it is quite untrue to say that *no* signals at all are *normally* obtainable within that zone. Signals of a kind *are normally* obtainable, though they are usually weak and unreliable, are much subject to distortion and fading, and are generally not of a character suitable for reliable communication. They are due to "scattering" of some of the energy in the radio wave as it passes through the lower ionosphere. This scattering occurs generally at small, patches or "clouds" of ionisation in the E layer, or between the E and F layers, and the scattered energy may reach the earth within the skip zone directly from the scatter source, or by way of reflections

from other layers, or from the ground. Thus, the scattered energy may arrive at the receiver from any direction—not necessarily from the direction of the transmitting station. Generally speaking, scattered signals are less reliable on the higher short-wave frequencies than on the lower, though, as has been said, on no frequency is the scattered signal

DESIGNING SUPERHETS

Circuit Design Formulae for Minimum Tracking Errors

By J. E. HAWORTH

strength such as to be comparable with that due to the refracted wave.

Sometimes, however, there are obtained, within the skip distance, signals which are strong and steady, and comparable in every way to those due to the refracted wave. The causes of this occurrence have been dealt with in previous articles,¹ but it may here be said that they are almost always due to the prevalence of what is known as "sporadic E." This is due to the formation, within the E layer, of a thin layer of highly ionised air, such as will cause reflection of frequencies far higher than those which the normal E layer is capable of reflecting. This often results in very strong reception within the normal skip zone, and usually occurs most frequently in summer and during the late afternoon and evening. It does not, however, usually last for very long, nor, at any one time, extend over a very wide area. Its occurrence is quite unpredictable, and, as it is not to be relied upon, it cannot, as yet, be put to much practical use in short-wave communication.

Conclusions.—Summarising, we may say:—

(1) The skip zone of a short-wave station is the zone surrounding the station between the points where its ground wave becomes negligible and the points where the first sky waves are returned, and the skip distance is the distance across it in any direction.

(2) The position of the inside edge of the zone varies with the power radiated, the nature of the terrain and the frequency. It does not vary with time of day.

(3) The position of the outside edge is determined by the ionisation in the layer and therefore varies markedly with the frequency used and with time of day, season of year and phase of sunspot cycle. It is independent of the power radiated.

(4) Weak signals are normally receivable within the skip zone by scattering at the E layer, and strong signals are sometimes received at unpredictable times by reflection from the sporadic E.

IN a superheterodyne receiver it is desirable that the difference frequency between the oscillator frequency and the signal frequency should be exactly equal to the intermediate frequency over the whole of the tuning range. Plotting this on a graph would therefore give a straight line through the point f_i as shown in Fig. 1, where the difference frequency has been plotted against the signal frequency. This represents the ideal tracking curve.

In practice the radio-frequency input circuit and the oscillator circuit are generally as shown in Fig. 2, where L = inductance of radio frequency circuit; C_s = total stray capacitance + trimmer; L_o = inductance of oscillator circuit; C_o = total stray capacitance + trimmer; C_p = padding capacitance. The tuning condensers C in each circuit are assumed to be identical.

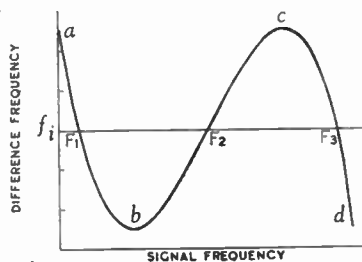

Fig. 1. Typical tracking curve for a superheterodyne receiver. The difference frequency only coincides exactly with the nominal intermediate frequency at three points.

With an oscillator circuit of this description the nearest approach to an ideal tracking curve is the curve *abcd* of Fig. 1, from which it will be seen that ideal tracking can only occur at three points in the range. The difference between the ideal curve and the curve *abcd* is generally known as the fault factor and gives an indication of the variation of the practical curve from the ideal. It is usual, therefore, to arrange the circuit constants so that although

the fault factor is zero at only three points over the range, it is not excessive at any point; and to achieve this the ganging frequencies must be determined.

Calling the ganging frequencies F_1 , F_2 , and F_3 , then if F_1 and F_3 are chosen too near to the ends of the range the fault factors at b and c are increased. Similarly

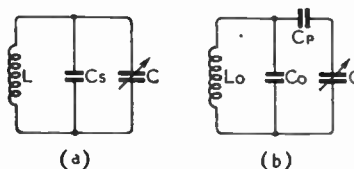

Fig. 2. Significant elements of the superheterodyne input (a) and oscillator (b) circuits.

if F_1 and F_3 are chosen too far from the ends of the range then the fault factors at b and c are reduced but the fault factors at a and d may be considerably increased. If only one ganging frequency is chosen incorrectly then the tracking curve will not be symmetrical, and the fault factor will be increased over a portion of the range. An optimum tracking curve is one in which the fault factors at a , b , c and d are equal. It is obvious therefore that there is a definite relationship between F_{min} , F_{max} , the limiting frequencies of the band, and F_1 , F_2 , and F_3 —a point rarely stressed in formulae relating to superhet design.

To determine the ganging frequencies F_1 , F_2 and F_3 , assume the frequency band to be divided into four equal parts as shown in Fig. 3, where α_0 , α_1 , α_2 , α_3 and α_4 are equidistant frequency steps. An analysis of tracking curves indicates that the fault factor will have maximum values at approximately α_1 and α_3 . As the curve is fairly flat over these portions we can state without great loss of accuracy that the optimum tracking curve is one in which the fault factors at α_0 , α_1 , α_3 and α_4 are equal.

¹ "Range of Ultra-Short-Waves," *Wireless World*, Sept., 1941, p. 228. "Short-Wave Phenomena," *Wireless World*, Jan., 1943, p. 30.

Designing Superhets—

Hence we can write :

When $x = \alpha_0$ $y = f_i + \Delta f$
 $x = \alpha_1$ $y = f_i - \Delta f$
 $x = \alpha_3$ $y = f_i + \Delta f$
 $x = \alpha_4$ $y = f_i - \Delta f$

and the most accurate general equation relating x and y will be given by

$$y_x = A(x-1)(x-3)(x-4) + B_x(x-3)(x-4) + C_x(x-1)(x-4) + D_x(x-1)(x-3) \dots \dots (1)$$

From this equation :

when

$$x = 0, y_0 = A(-1)(-3)(-4) = -12A = f_i + \Delta f \therefore A = -\frac{1}{12}(f_i + \Delta f)$$

$$x = 1, y_1 = B(1)(-2)(-3) = 6B = f_i - \Delta f \therefore B = \frac{1}{6}(f_i - \Delta f)$$

$$x = 3, y_3 = C(3)(2)(-1) = -6C = f_i + \Delta f \therefore C = -\frac{1}{6}(f_i + \Delta f)$$

$$x = 4, y_4 = D(4)(3)(1) = 12D = f_i - \Delta f \therefore D = \frac{1}{12}(f_i - \Delta f)$$

At the three ganging frequencies we know that the frequency difference between the oscillator frequency and the signal frequency is equal to the intermediate frequency, and therefore to satisfy this condition when $x = \alpha_n$ $y_n = f_i$. Therefore from (1)

$$y_n = -\frac{1}{12}(f_i + \Delta f)(n-1)(n-3)(n-4) + \frac{1}{6}(f_i - \Delta f)(n)(n-3)(n-4) + \frac{1}{6}(f_i + \Delta f)(n)(n-1)(n-4) + \frac{1}{12}(f_i - \Delta f)(n)(n-1)(n-3) = f_i$$

$$\therefore -\frac{1}{12}(f_i + \Delta f)(n^3 - 8n^2 + 19n - 12) + \frac{1}{6}(f_i - \Delta f)(n^3 - 7n^2 + 12n) + \frac{1}{6}(f_i + \Delta f)(n^3 - 5n^2 + 4n) + \frac{1}{12}(f_i - \Delta f)(n^3 - 4n^2 + 3n) = f_i$$

$$\therefore n^3 - 6n^2 + 9n - 2 = 0 \dots (2)$$

It is interesting to note that this solution is independent of the intermediate frequency f_i and the fault factor Δf . Solving for n in (2) gives three solutions $n = 0.2679$, $n = 2.0$ and $n = 3.732$. Dividing n by 4, the three ganging frequencies are therefore :

$$F_1 = F_{min} + 0.067(F_{max} - F_{min}) \dots \dots (3)$$

$$F_2 = F_{min} + 0.5(F_{max} - F_{min}) \dots \dots (4)$$

$$F_3 = F_{min} + 0.933(F_{max} - F_{min}) \dots \dots (5)$$

Determination of Circuit Constants

Having obtained the ganging frequencies it is a relatively simple matter to derive the circuit constants of Fig. 2. Let the desired frequency range be from F_{min} to F_{max} and the corresponding capacitance change of the condenser C be from C_{max} to C_{min} . Hence :

$$L = \frac{I}{4\pi^2 F_{min}^2 (Cs + C_{max})}$$

$$= \frac{I}{4\pi^2 F_{max}^2 (Cs + C_{max})}$$

$$\therefore Cs = \frac{F_{min}^2 C_{max} - F_{max}^2 C_{min}}{F_{max}^2 - F_{min}^2} \dots \dots (6)$$

$$L = \frac{I}{4\pi^2 F_{min}^2 (Cs + C_{max})} \dots (7)$$

Having obtained the values for L and C_s the capacitance of C at the ganging frequencies can easily be obtained from the relation

$$C = \frac{I}{4\pi^2 F^2 L} - C_s \dots \dots (8)$$

Therefore if the ganging frequencies are F_1, F_2 and F_3 let the capacitance of the tuning condensers at these frequencies be C_1, C_2 and C_3 , and let the corresponding oscillator frequencies be f_1, f_2 and f_3 , i.e., $f_1 = F_1 + f_i$,

where f_i is the intermediate frequency. Considering Fig. 2(b) we can write

$$4\pi^2 f_1^2 L_0 \left(Co + \frac{CpC_1}{Cp + C_1} \right) = I$$

$$4\pi^2 f_2^2 L_0 \left(Co + \frac{CpC_2}{Cp + C_2} \right) = I$$

$$4\pi^2 f_3^2 L_0 \left(Co + \frac{CpC_3}{Cp + C_3} \right) = I$$

and from these three equations we obtain :

$$Cp = \frac{-af_1^2 C_1 (C_2 + C_3) + (a+1)f_2^2 C_2 (C_1 + C_3) - f_3^2 C_3 (C_1 + C_2)}{af_1^2 C_1 - (a+1)f_2^2 C_2 + f_3^2 C_3} \dots (9)$$

where $a = \frac{f_3^2 - f_2^2}{f_2^2 - f_1^2}$

$$Co = \frac{I}{f_3^2 - f_2^2} \left\{ \frac{f_2^2 Cp C_2}{Cp + C_2} - \frac{f_3^2 Cp C_3}{Cp + C_3} \right\} \dots \dots (10)$$

$$Lo = \frac{I}{4\pi^2 f_2^2 \left(Co + \frac{CpC_2}{Cp + C_2} \right)} \dots \dots (11)$$

It will probably be of interest to amateur receiver designers to note that all the above formulæ can be evaluated by slide rule. The degree of error introduced by using a 10in. slide rule will be smaller than the constructional limits. All frequencies, inductances, and capacitances may be

stated in cycles per sec, henrys, and farads; or in megacycles per sec., henrys and micro-microfarads, respectively.

Practical Application

As an example of the practical application of the above formulæ consider the medium-wave band

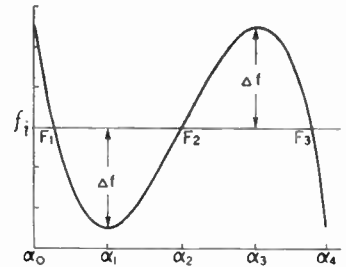

Fig. 3. For the purpose of deriving general equations for the ganging frequencies it is convenient to divide the signal-frequency band into four equal parts.

and let the required frequency range be from 550 kc/s to 1650 kc/s. The ganging frequencies will be :

$$F_1 = 550 + 73.7 = 623.7 \text{ kc/s.}$$

$$F_2 = 550 + 550 = 1100 \text{ kc/s.}$$

$$F_3 = 550 + 1026.3 = 1576.3 \text{ kc/s.}$$

Although it has been stated that for design purposes, a slide rule will give a high degree of accuracy, the results are given to a higher degree of accuracy in order to obtain an accurate tracking curve. This is essential as it will be appreciated that an error of only 1 per cent. in calculating the

oscillator frequency from the derived circuit constants will give an error of over 100 per cent. in the fault factor.

The tuning condenser used had a minimum value of 15 $\mu\mu F$ and a maximum value of 460 $\mu\mu F$.

Therefore from equation (6)

$$Cs = 40.625 \mu\mu F.$$

and from equation (7)

$$L = 167.26 \mu H.$$

From equation (8)

$$C_1 = 348.7, \quad C_2 = 84.5,$$

$$C_3 = 20.3 \mu\mu F.$$

and if $f_1 = 460$ kc/s

$$f_1 = 1083.7, f_2 = 1560, f_3 = 2,036.3 \text{ kc/s.}$$

The value of a will be 1.36.

Hence from equation (9)

$$C_P = 540.95 \mu\mu\text{F.}$$

from equation (10)

$$C_O = 56.45 \mu\mu\text{F.}$$

and from equation (11)

$$L_O = 80.34 \mu\text{H.}$$

The tracking curve calculated from these circuit values is shown in Fig. 4. It will be seen that this curve is not exactly the same as the optimum tracking curve of Fig. 3. This is due to the fact that the true equation for the tracking curve of Fig. 3 is not exactly the same as the assumed equation given by (1). The

$$C_P = \frac{(f_2^2 - f_1^2)(C_O + C_1)(C_O + C_2)}{f_1^2(C_O + C_1) - f_2^2(C_O + C_2)} \dots \dots \dots (12)$$

$$C_O = \frac{C_1(f_2^2 C_2 - f_3^2 C_3) - a C_3(f_1^2 C_1 - f_2^2 C_2)}{a(f_1^2 C_1 - f_2^2 C_2) - f_2^2(C_1 + C_2 - C_3) + f_3^2 C_1} \dots \dots (13)$$

discrepancy however is not sufficient to warrant the derivation

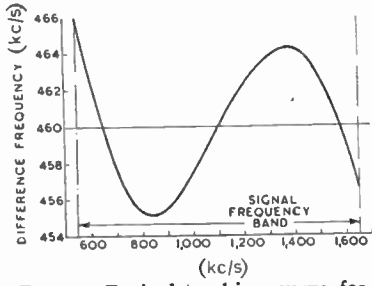
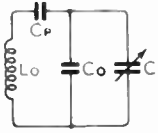

Fig. 4. Typical tracking curve for the medium-wave band.

of more accurate and more complicated formulae for equations (3), (4) and (5). Hence we can say that equations (3) to (11) give all the information required for the basic design of a super-heterodyne receiver.

Fig. 5. Alternative oscillator circuit arrangement in which the trimming capacity is connected across the tuning condenser.



In some circumstances the oscillator circuit may be arranged as shown in Fig. 5, in which case the circuit constants can be obtained from the following equations:

$$L_O = \frac{C_P + C_O + C_1}{4\pi^2 f_1 C_P (C_O + C_1)} \dots (14)$$

The values obtained when using the last three equations are only slightly different from the values obtained from equations (9), (10) and (11) provided the lowest frequency in the band is greater than the intermediate frequency. Consequently either set of equations may be used and if it is found to be advantageous to rearrange the circuit, only slight modifications to the trimming condensers will be required.

speak as pioneers, having been carrying out routine examinations of factory workers for eight years. Out of nearly 12,000 applicants for employment who were examined during 1936-1941, nearly 500 cases of tuberculous lung infection were detected.

With regard to the examination of Philips' employees it is stated that, as a result of early diagnosis made possible by the method, about 34 per cent. of cases were able to return to work after treatment; this figure relates to the company's parent factory in Holland.

BOOKS RECEIVED

The Technique of Radio Design. By E. E. Zepler, Ph.D. Details of receiver design, rather than broad principles, are dealt with at length. Although treatment is highly quantitative, "complicated mathematics are avoided and approximations suitable to the problem in hand have been made wherever possible." The book starts with a chapter on fundamentals, and then deals with such matters as aerial coupling, RF and AF amplification, detection, frequency changing, selectivity, screening and undesired feedback. The causes of such troubles as hum, parasitic resonances and distortion are explained, and the closing chapters describe methods of carrying out routine measurements (in receiver development) and fault finding. Pp. 305+X. Chapman and Hall, 11, Henrietta Street, London, W.C.2 Price 21s.

High Vacuum Technique. By J. Yarwood, B.Sc. (Hons.). Contains practical information on the creation of high vacua, as in valves and similar electronic devices. Pumps of the various kinds used for this purpose are described, and methods of measuring the vacuum obtained are given. "Gettering," the process of clearing the valve of occluded gases, is discussed, and the theory and practice of eddy-current heating is dealt with. Another chapter deals with applications of high vacua in industry. Pp. 102+XII; 62 diagrams. Chapman and Hall, 11, Henrietta Street, London, W.C.2. Price 10s. 6d.

Radio Goes to War. By Charles Rolo. A detailed account of the use of broadcasting for international propaganda purposes during the present war. Introductory chapters on "The Strategy of War by Radio" and "The Story of International Broadcasting" are followed by an account of the growth since 1933 of Germany's wireless propaganda service. Later chapters deal with the technique and methods of the other belligerents, especially Great Britain, America, Russia and Italy. The activities of the so-called "secret" or "freedom" stations are described. The author was formerly on the staff of the Princeton University "Listening Centre," where foreign broadcasts which give him much of his material were recorded. Pp. 238+VII. Faber and Faber, 24, Russell Square, London, W.C.1. Price 8s. 6d.

STATIC CHARGES ON RECORDS

DISC recordists have long known that the coating of a blank develops a charge of static electricity during cutting, thereby causing dust particles to adhere very firmly to the surface and increasing the abrasive action of the play-back needle, with accompanying rise of hiss in the reproduction. This static charge is also troublesome in the cutting process as it makes the removed thread of coating material hard to control, as it tends to fly up against the cutting-head.

Recent tests by N.B.C. in America revealed that rubbing a direct play-back disc with felt created potentials as high as 12,000 volts, and merely removing a disc from its envelope set up charges of the order of 5,000 volts! New glass-base priority blanks, now being used in the U.S.A., have a fibre insert in the centre-holes to counteract the building up of a charge. Some

recordists, before placing the disc on the turntable, pick it up by the edges and hold for a few moments to drain off the charge as much as possible! D. W. A.

MASS RADIOGRAPHY

RECENT pronouncements may have given the impression that the introduction of mass radiography in this country is by way of being an experiment, and that only time will show whether it can achieve the results expected of it. This application of X-ray technique is used mainly for the quick diagnosis of tuberculosis in routine medical examinations.

The makers of Philips radio point out that, so far as they are concerned, there is no longer anything experimental about the method of examination. In this matter Philips

AC VOLTAGE STABILISER

Constant Voltage Source for Laboratory and Test Instruments

THE voltage stabiliser to be described belongs to what may be termed the "variable series impedance" class. In Fig. 1, if the supply voltage varies, the voltage across the load

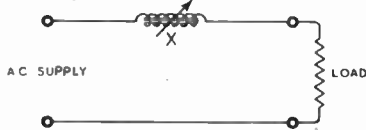
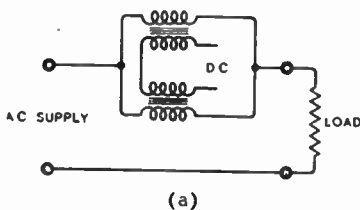

Fig. 1. Basic circuit of "variable series impedance" type of stabiliser.

may be kept constant by varying the reactance X . If, therefore, some means can be found to vary X automatically in sympathy with the variations of supply voltage, the voltage across the load will automatically remain constant.

It is well known that polarisation of the core of an iron-cored reactance or choke by means of DC in the winding will reduce the reactance value. This is the principle used in the present apparatus. A simple choke, however, is not the best form of reactance to use, as it is difficult to get sufficient variation by means of DC, and the AC voltage across the choke would be applied to the DC circuit. A very effective arrangement is to connect two chokes in parallel, and provide separate windings for the DC. The DC windings are then connected in series-opposition, and no AC voltage is applied to the DC circuit. This arrangement is shown in Fig. 2 (a). It is simplified in Fig. 2 (b) by using a single winding for the DC, embracing both cores. In this case, one of the AC windings must be reversed.



(a)

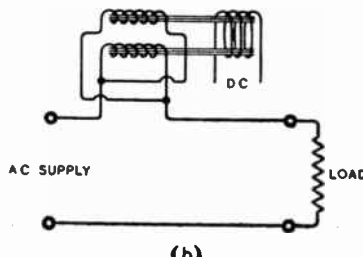

(b)

Fig. 2. Methods of eliminating AC from the DC windings of a polarised choke. (a) Separate chokes are connected in parallel with the DC windings in opposition. (b) A single winding is used for DC and the AC fluxes are in opposite phases.

By

T. A. LEDWARD,

A.M.I.E.E.

The single DC winding has the advantage that a large number of turns may be used without high values of AC voltage being induced in any part of the winding. Where separate DC windings are used, as in Fig. 2 (a), although there is no resultant AC when the two windings are connected in opposition, the induced voltages across the separate windings may be very high. The variation of react-

In arranging the DC supply it must be remembered that the reactance must be a minimum when the AC supply voltage is low, and must increase with increase of supply voltage. The DC must, therefore, be greatest when the supply voltage is low, and must decrease as the supply voltage rises. This requirement is readily met by utilising the anode current of a valve and arranging the negative grid volts to increase with increase of supply voltage. The complete circuit arrangement adopted is shown in Fig. 3. The resistance R_{10} , in parallel

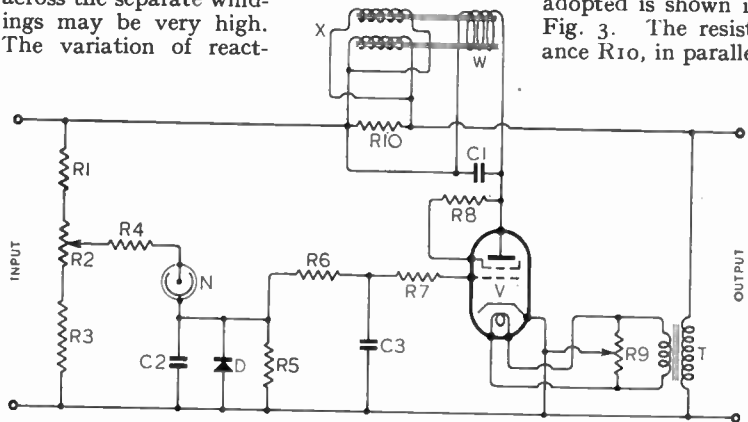

Fig. 3. Complete circuit diagram of AC stabiliser unit. R_1 , 7,000 ohms; R_2 , 1,000 ohms; R_3 , 12,000 ohms; R_4 , 20,000 ohms; R_5 , 0.03 megohm; R_6 , 0.15 megohm; R_7 , 0.25 megohm; R_8 , 200 ohms; R_9 , 50-0-50 ohms; R_{10} , 350 ohms. With the exception of R_3 , which should be rated at 2 watts, all resistances may be of the 1-watt type. C_1 , 8.0 μ F electrolytic; C_2 , 0.3 μ F paper; C_3 , 0.5 μ F paper; V , Osram KT41 tetrode, connected as triode; N , Philips 5-watt neon lamp with cap resistance removed; D , half-wave metal rectifier, rating 20 V, 5 mA.

ance obtainable with either of these twin-choke arrangements is much greater than that obtainable with a single choke.

with the choke, improves the performance by introducing a phase angle shift, and increases the power output.

Negative bias for the valve V is obtained by means of current through the neon tube N , the bias voltage being rectified and smoothed as shown. The anode current of V provides DC for the winding W on the reactance X . The DC is smoothed by the condenser C_1 . Heater current for the valve is supplied by the transformer T .

If the supply voltage variation is comparatively small, the primary winding of T may be connected across the input supply

instead of the output as shown. This would result in a little more current being available for the output load. On the other hand,

liser.* The conditions are not quite the same in the present case, where the supply is AC, and a condenser forms part of the cir-

desired by the aid of suitable output windings on the transformer T. The test was made with a purely resistive load of 255 ohms connected to the same terminals as the primary of the transformer T, the voltage being 165 volts. A heavier output load would require heavier cores and fewer AC turns for the reactance X, but the other details would remain the same.

Fig. 4. (a) Dimensions of Stalloy stampings used in variable reactance unit and (b) arrangement of windings. The spacing of the two cores is determined solely by the depth of the AC windings.

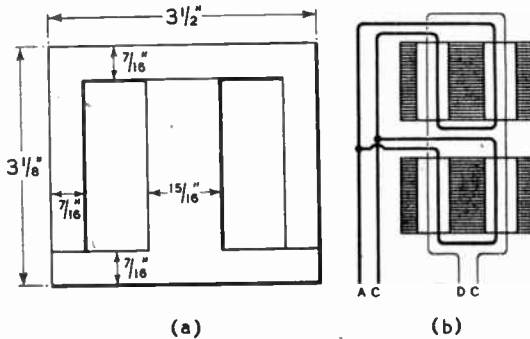

with the transformer connected as shown, it may be used as an output transformer with further secondary windings provided to give any value of constant output voltage required. It may be pointed out here, however, that the voltage will only remain constant with a definite value of watts loading. If different values of load are to be catered for, tapings may be provided on the reactance X, but a simpler alternative, when the connected load is less than that for which the apparatus is designed, is to add artificial loading to bring the total load up to the correct value. Such a method is not economical, of course, but that is usually of little consequence in the case of small test currents used for short periods.

Neon Control Circuit

The neon tube N is connected to a potential divider formed by the resistances R1, R2 and R3. R2 provides a fine adjustment of the neon tube voltage, and thus of the output volts. The resistance R4 limits the control exercised by the neon tube. If the value of R4 is too small, the neon control will be too great, and the output volts will fall appreciably as the supply volts rise; if R4 is too high, the reverse will be the case.

The potential divider is so proportioned that the neon tube just strikes when the supply voltage is a minimum. The operation of a neon tube in series with a resistance under conditions of varying voltage was described by the present writer in a previous article dealing with a DC voltage stabi-

liser, but the description mentioned will assist in understanding the operation.

The two cores of the reactance X were made of Stalloy stampings 0.014in. thick, of the form and

Fig. 5. Regulation curve of stabiliser with a load of 107 watts.

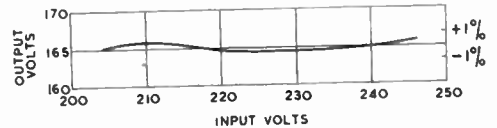

dimensions shown in Fig. 4 (a). Each core had an AC winding of 500 turns of 28 SWG enamelled copper wire, while the DC winding, embracing both cores, comprised 6,000 turns of 39 SWG double silk-covered copper wire. The windings were all on the centre limbs, the arrangement being shown diagrammatically in Fig. 4 (b). The cross-sectional area of each centre limb was 2 sq. in.

The voltage characteristic with an output load of 107 watts is shown in Fig. 5. It will be seen that the maximum variation from the mean output of 165 volts is less than ± 0.5 per cent. for an in-



Fig. 6. Waveform of output voltage for an approximately sine wave input.

put voltage varying from 205 to 245 volts. The output voltage may, of course, be altered as

* "Constant Voltage Supply," *Wireless World*, February, 1942.

Output Wave Form

The wave form of the output voltage when the input voltage approximates to a pure sine wave is shown in Fig. 6. This output wave form is the same at all values of input voltage. Distortion of the input voltage wave form will alter the value and form of the output voltage characteristic to some extent. It is important, therefore, in plotting the output characteristic, to vary the input voltage by means of trans-

former tapings and not by means of variable resistances or impedances.

THE WIRELESS INDUSTRY

TO assist in the selection of the appropriate resistance for any purpose from the table of "Standard Values" recently issued by the Inter-Service Component Manufacturers' Council, a coloured quick reference chart has been prepared, and is available to those engaged on work of national importance from manufacturers of fixed composition resistances. A charge of 3d. is made and this includes postage.

A number of service manuals relating to Emerson and Sparton receivers are available to servicemen from the Champion Electric Corporation, 84, Newman Street, London, W.1, to whom application should be made for further information.

A new London office has been opened by W. T. Henley's Telegraph Works Co., Ltd., at 51-53, Hatton Garden, E.C.1 (telephone: Chancery 6822), and the Advertising Department has moved there from Westerham. The office at Demby House, Wembley, has closed down.

Leslie Dixon and Company (Electradix) are now installed at larger premises at 214, Queenstown Road, Battersea, London, S.W.8, where callers will be welcomed. Telephone: Macaulay 2159.

Frequency Modulation—VI.

FUTURE APPLICATIONS OF FM

FREQUENCY modulation can, under certain conditions, offer tremendous advantages over amplitude modulation. A rational appreciation of its true worth has been shown in the planning of the Police Communication system installed on the recently opened Pennsylvania Turnpike². This 160-mile stretch of super highway has an elaborate system of both fixed and mobile transmitters and receivers. Although they all operate on the ultra-short-wave band, frequency modulation has only been used for communication with the patrol cars.

The system is based on a number of automatic relay stations situated on a series of hill tops. Amplitude-modulated transmitters working on the 116-119 Mc/s band have been used for this radio "trunk line," which can be tapped at any point over the whole length of the highway. More than half the receivers on the system are however fixed-tuned to the complementary FM transmitters, used for the actual radio link to the patrol cars.

Although these FM transmitters all operate on the same frequency (33.94 Mc/s) their carriers are not locked together. In spite of this, patrolmen are unable to tell from the received speech when they are passing from an area covered by one station to that of another. This is due to the way in which the weaker FM station is suppressed by the stronger. It would have been impossible to achieve this remarkably smooth transition from one station to the next with amplitude modulation. Reception between stations would have been marred by heterodynes, which could only have been overcome by locking all the transmitters to a common carrier.

This modern communication system exemplifies the probable future which lies ahead of frequency modulation in the communication field. While FM may be the only method of achieving a given set of results, other conditions may be better satisfied

By **CHRISTOPHER TIBBS,**
A.M.I.E.E.

In this concluding instalment the author surveys the future trend of development which the introduction of FM might bring about

by the use of amplitude modulation.

Post-war Broadcasting

The decision of when and where to introduce FM for broadcasting will be made in this country by the B.B.C. or perhaps by a Government "FM Committee." The question of whether or not FM should be introduced has to all intents and purposes already been answered in the affirmative by the system itself. In the long run nothing will hold down any system offering theoretically perfect reproduction with an interference level lower than was dreamed possible a few years ago.

Although there will naturally be a period of transition it is possible to look ahead for perhaps ten years, and forecast the changes which FM will have produced in the domestic broadcast receiver. The set of the future will almost certainly have three bands, or, if it is in the higher-priced class,

cast band, will comprise the second group available to the listener. These bands will be used by older or cheaper receivers, portables and midget sets. The listener with an FM receiver will only use the MW band for the reception of European or other stations which are too far away to be received on the FM band. While the quality obtained on the MW band will not be comparable with that from the local FM stations, it will still be considerably better than that obtained on the short-wave band. But, although quality may be inferior on the short-wave band, that is the only part of the frequency spectrum on which world-wide reception is possible, and so the distortion resulting from selective fading will have to be tolerated.

The receiver of the future will therefore have these three groups of bands. The FM band providing superb quality from local stations, the MW band offering good programme value over greater distances, and, lastly, the SW band giving world-wide reception at a low quality level.

Assume for the moment that here, as in America, a band of some 10 Mc/s is allocated for FM broadcasting. Even with a station

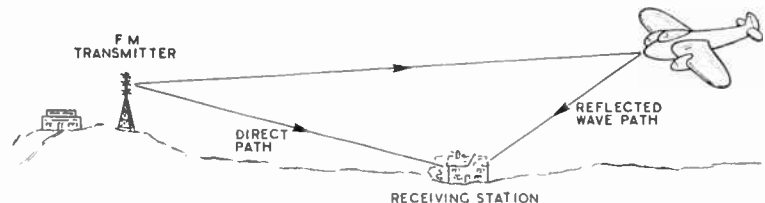

Fig. 1. Reflections from a moving aircraft are received at a slightly altered frequency. The resultant heterodyne with the direct path wave will usually be below the limit of audibility.

three groups of bands. The first will be the new FM broadcast band extending from perhaps 50 to 60 Mc/s. This band will have largely displaced the existing medium-wave band and will be used by the bulk of the listening public.

The medium-wave and, if it is still used, the long-wave broad-

separation of 250 kc/s there would be room for some 40 channels. At first sight these figures may not seem to be very interesting, but on further investigation it is found that they offer grounds for revising our entire system of home broadcasting. It has earlier been pointed out that the weaker FM station is suppressed by the

stronger and that the limit to the service area of each is sharply defined. In the light of these facts it is apparent that the whole 40 channels will be available for local stations. Where to-day there are only two programmes, the Forces and the Home Service, there could be 40 alternative programmes available. Two hundred miles or less from each station there could be another working on the same frequency but transmitting perhaps in another language. Apart from

sideband amplitude is serious enough with amplitude modulation. While it results in severe distortion on the short-wave band, reception is usually intelligible; under the same conditions a wide-band FM programme would, however, be almost, if not completely unintelligible.

The mechanism of selective fading is as follows. The direct and reflected waves are received simultaneously. At one particular frequency, say 15 Mc/s (20 metres), the two signals may

Mc/s. For practical purposes it is not unreasonable to ignore this form of distortion, due to its relative infrequency.

There is, however, another form of reflection due to "reflection boundaries" which becomes noticeable at roundabout these frequencies. This form of reflection differs radically from that due to the ionised layers. It would appear that it takes place at the boundary between two different air masses. Most of these boundary layer reflections take place below two kilometres, although they sometimes occur from air mass boundaries up to 5.5 kilometres.

In a paper⁴ dealing with this type of fading, it is found that the changes are always far slower than those due to the ionised layers on the short-wave band. Even under turbulent atmospheric conditions (high wind and convective instability) this form of fading is unlikely to exceed five cycles per minute. In the same paper it is deduced that for this type of reflection the difference in the reflected and direct path lengths was between 8 and 550 metres. These figures make it possible to assess the severity of any selective fading which may occur due to this cause. Taking the maximum difference in path length (550 metres), and assuming the carrier frequency to be 50 Mc/s (6 metres), and a FM peak-to-peak deviation of 150 kc/s; then at 50 Mc/s exactly there will be a difference in path length of

$\frac{550}{6} = 91.7$ cycles. At the maximum peak FM deviation of 50.15 Mc/s (5.98 metres) there will be a difference in path length of

$\frac{550}{5.98} = 91.9$ cycles. For this particular example, therefore, there is only a difference of 0.2 cycles between the relative path lengths (expressed in cycles), at the frequencies corresponding to maximum and minimum FM deviations. As this is an extreme case it is safe to draw the deduction that the difference in path length due to boundary layer reflections is not sufficient to cause selective fading to any marked extent. The limiter stage in the FM receiver is well able to cope with all the fading due to this cause.

There is still one further type

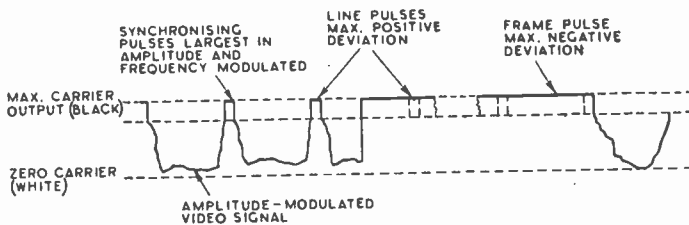

Fig. 2. It is suggested that FM could be used for the transmission of television synchronising pulses, while AM is used for the video component of the signal.

a very small zone of confusion there would be no interference between the two stations.

While the prospect of 40 local programmes may make the B.B.C. programme director shudder, there is no reason why they should not all be usefully employed. Some channels could be devoted to services run perhaps by the Board of Education or other authorities, others entirely to plays and vaudeville or perhaps news reviews and bulletins, while the possibility of commercial stations is not precluded.

Wide-band frequency modulation, with its wide frequency response and noise-free reception, offers a resounding challenge to certain projects that have been put forward for "wired wireless" broadcast distribution. It also places all relay systems at a serious disadvantage, as it does most existing methods of obtaining interference-free reception under difficult conditions.

FM and Fading

The most serious form of distortion which can be caused to an FM transmission results from selective fading, caused by interference between waves arriving by direct and reflected paths of different length. The effect of random variations in the received

add directly together. If it is assumed that the indirect path is 100,000 metres longer, there

will then be some $\frac{100,000}{20} = 5,000$

cycles extra along the reflected path. It will readily be seen that the two signals will be exactly out of phase if there are only 4999.5 cycles extra along the reflected path. This occurs at

$\frac{100,000}{4999.5} = 20.002$ Mc/s or only 2 kc/s away from the frequency at which the indirect and direct signals are exactly in phase.

Although in actual practice the position is considerably more complicated than this, it is not unusual for there to be a maximum and minimum fading amplitudes as close as 2 kc/s.

It has earlier been stated that FM transmission is impracticable on any band which employs the ionosphere as part of its transmission medium. Under normal conditions reflections due to this cause cease between 30 and 40 Mc/s. They can, however, under conditions of abnormal E layer reflections², extend in frequency up to between 50 and 60 Mc/s³. Selective fading due to ionised layer reflection can therefore be expected occasionally on the band between 40 and 60

Frequency Modulation—

of reflection which may well turn out to be the most troublesome. The reflections from a moving aircraft can cause serious distortion to an FM programme. By reasoning similar to that adopted for the boundary layer reflections it can be shown that the difference between the direct and the reflected path lengths can be great enough to result in selective fading.

In addition, aircraft reflections can produce detrimental results due to the shortening or lengthen-

length of the reflected path is being shortened by some 268 metres per second. If the carrier wavelength is 6 metres (50 Mc/s) the reflected signal frequency will be raised some 45 c/s. The difference frequency between the reflected and direct carriers will therefore result in a 45-cycle heterodyne. The following point should, however, be noted. The example taken is an extreme, and in the majority of cases the heterodyne would be lower in frequency and therefore in all probability below the limit of

following considerations. The lower limit is fixed as the lowest frequency which is free from ionised layer reflections. This has already been shown to be about 40 Mc/s. There are a number of factors which collectively place the upper limit at around 100 Mc/s. The principal difficulties which arise above this frequency are in connection with the receiver design. The calibration accuracy becomes increasingly difficult to hold as the frequency is raised. The tuning will also become more difficult as the ratio

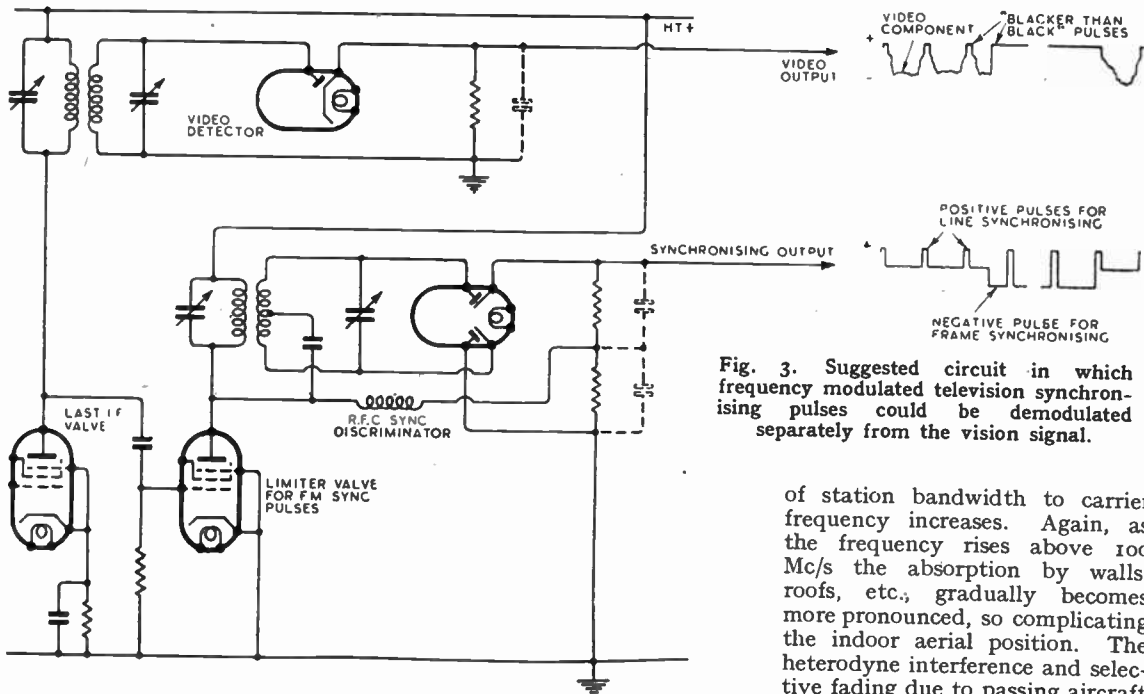

Fig. 3. Suggested circuit in which frequency modulated television synchronising pulses could be demodulated separately from the vision signal.

ing of the path taken by the reflected wave. Due to the Doppler Effect⁵, the reflected signal frequency will be increased by an amount determined by the rate at which the transmission path is being shortened, conversely the reflected signal frequency will be lowered while the reflection path is being increased. The result at the receiver is a heterodyne due to the frequency difference existing between the reflected and the direct waves. Taking the example shown in Fig. 1, the reflected path length is being shortened at a rate which is twice the speed of the approaching aircraft. Assume that it is travelling at 300 miles per hour (or 134 metres per second). The

audibility. It was this same effect which in pre-war days caused a television picture to "flutter" when an aircraft passed low overhead. The effect is also described in the paper referred to earlier⁴.

Summing up the position, low-frequency heterodynes accompanied by selective fading, due to moving aircraft reflections, may be expected under conditions of low ground field strength with high field strengths above the ground; as for instance in a valley near an aerodrome or any other point at which aircraft pass low overhead.

The Limits to the FM Band

The band suitable for FM broadcasting is limited by the

of station bandwidth to carrier frequency increases. Again, as the frequency rises above 100 Mc/s the absorption by walls, roofs, etc., gradually becomes more pronounced, so complicating the indoor aerial position. The heterodyne interference and selective fading due to passing aircraft will also become higher in frequency as the carrier frequency is increased—a small point, but worth considering. The above factors make it clear that the band between 40 Mc/s and 100 Mc/s is particularly suited to wide-band FM transmissions.

FM and Television

The advantages of FM may not be confined to sound broadcasting alone. It is more than probable that FM will first be introduced on the sound channel of any new television stations which are erected. Owing to the increased bandwidth (discussed in Part I), it is improbable that FM will be used for the actual transmission of video signals. There is, however, one way in which the advan-

tages of FM could be used to improve the received picture.

Although the synchronising of television sets used to receive the Alexandra Palace station was good, there was still a long way to go before it could be considered as completely satisfactory. Would the general public have accepted the everyday radio receiver so readily, if there had always been a possibility that the set, without any warning, might suddenly scramble the programme?

It is suggested that while AM is used for the transmission of the vision waveform, FM could be used for the transmission of the synchronising pulses. In order to do this the signal would have to be inverted, as shown in Fig. 2. As the Americans have already adopted a television standard⁶ which has a maximum carrier amplitude for the synchronising pulses, there is no reason why we should not do the same, if by so doing the received picture could be improved. It is in fact suggested that we might adopt a television standard similar to that used in America, with the exception that the synchronising pulses, in addition to being the

that the conventional vision output waveform is obtained, complete with the normal "blacker than black" pulses for the fly-back suppression. The frequency-modulated synchronising pulses pass through a special limiter before the discriminator stage. In this way they benefit to the full from the advantages of FM.

It will be noticed that the line pulses come out as positive signals while the frame pulses are negative. By suitable limiter working conditions, pulses of some 20 or 30 volts in amplitude could be developed. This would make it possible to use a driven time base. The old objections to the use of a television set in which the pulses from the transmitter actually drive the time bases would be very largely overcome by the use of FM synchronising pulses. These objections centred around the disruption to the smooth running of the time bases, which would have been caused by interference. The improved FM signal-to-noise ratio, coupled with the elimination of synchronising separator circuits and the very large pulse voltages possible, should ensure at least some measure of success

to experiments along these lines.

The author feels that the employment of FM television synchronising pulses would make a great improvement in the entertainment value of the received picture. A television set which cannot lose synchronism would become a practical proposition; interlacing difficulties and all allied faults would be removed in one operation. The cheapest receivers would probably benefit most. Such a development could quite fairly be regarded as one of the most important milestones in the history of high definition television; will FM make it possible? The use of a television standard in which black is a maximum amplitude would result in car ignition interference appearing as blank spots on the screen—a result which many elaborate interference inversion systems strive to obtain.

BIBLIOGRAPHY

- ¹ "The Pennsylvania Turnpike." *Electronics*, May, 1942.
- ² "Physics of the Earth." Volume VIII. Terrestrial Magnetism and Electricity. Edited by J. A. Fleming. McGraw Hill.
- ³ "56-Megacycle Reflections by Sporadic E-Layer Reflections." By E. H. Conklin. *Proc. I.R.E.* January, 1939.
- ⁴ "Ultra-Short-Wave Transmissions and Atmospheric Irregularities." By C. R. Englund, A. B. Crawford, and W. W. Mumford. *Bell System Technical Journal*, October, 1938.
- ⁵ "Classical and Modern Physics." Pages 194-5. By Harvey E. White. Chapman and Hall.
- ⁶ "Television." Page 468. By V. K. Zworykin and G. A. Morton. Chapman and Hall.

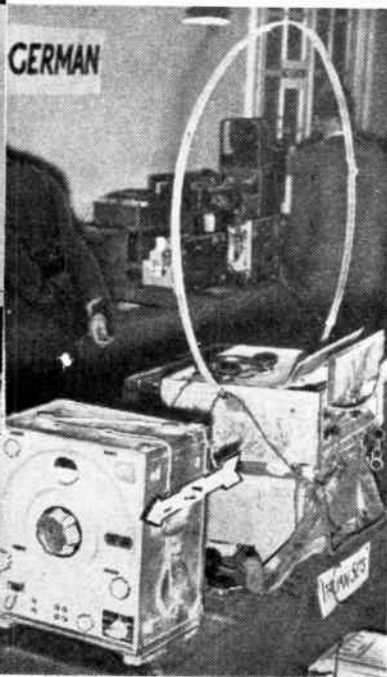

maximum carrier amplitude, are also frequency modulated. The line pulses could correspond to a maximum positive deviation and the frame pulses to a maximum negative deviation.

A television demodulator circuit arranged to receive a waveform of the type suggested is shown in Fig. 3. It will be noted

SPOILS OF WAR. Axis wireless gear captured during the North African campaigns was recently exhibited at G.H.Q. Middle East. German apparatus is shown in the photograph above and Italian on the right.

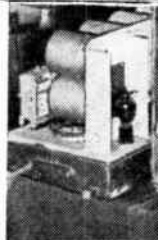

What the Sunspots Foretell

IT must always be a source of gratification to a great man of science, who has had the courage and the foresight to publish an opinion or take a course of action which might earn him naught but ridicule from his peers, when at long last his action is vindicated and his conclusions confirmed by slower-moving and more cautious fellow-scientists.

The Editor of this journal is in just such a gratifying position today, for in March, 1942, he extended the hospitality of his Correspondence columns to a reader who pointed out the strange and striking connection between solar activity and world politics and ventured the suggestion that 1944 might well see the end of Hitler. The Editor after consulting me on the matter, and being further fortified by a glass of static water at the Tune Inn, took his courage and his typewriter in both hands and adorned the latter with the attention-compelling headline, "What the Sunspots Foretell."

Criticism was not lacking—it seldom is—but he has not had long to wait for his action to be vindicated. We now find a Harley Street specialist, speaking to a learned assembly under the chairmanship of a prominent figure in the world of medicine, assuring his listeners that his researches had led him to the conclusion that not only certain diseases but various phases of human activity are influenced by solar activity. In particular it seems that artistic inspiration—and, of course, the vagaries of artistic behaviour—is traceable to certain solar activity recurring over a cycle of thirty-three years.

"A well-known
Harley Street
specialist."



No doubt some of you, by calculating the interval since the last one, will arrive at the conclusion that a first-class Editorial is due about now; but that, of course, is no concern of mine. The learned lecturer produced statistics concerning the writing of the world's greatest masterpieces, and it certainly is uncanny how neatly they dovetail into the peaks of these cycles of solar activity.

Frankly, however, I don't think

By FREE GRID

that either the lecturer or his audience realised the full significance of the data that had been collated and the conclusions that had quite correctly been drawn from them. The so-called solar activity to which the lecturer referred, no matter what its cause or origin on the sun, reaches us by means of ether waves and the production of these synthetically is surely right up our street; it should therefore be merely a matter of time for us wireless men to be able to produce the necessary apparatus to stimulate the brains of poets and politicians alike, and heaven knows some of them need it. I may say in fact that I have been actively engaged on this problem for some time past, and if any of you have noticed a change for the better in the technical level of contributions to *Wireless World* you will know to whom honour is due; at the same time, of course, I must admit that in certain cases I have been somewhat unfortunate in my choice of λ and crave your indulgence accordingly.

Receiverless Reception

I MUST confess that I have been not a little startled at some of the letters I have received as a result of my remarks concerning the DC valve famine. Several incensed AC users write to tell me that everything in the garden is *not* lovely with regard to AC supplies, as my words would seem to have implied. On the other side of the picture, others have written to chide me for my importunity concerning valve supplies for civilians when the country's needs in other directions are so pressing.

However, by far the most interesting letter I have received is from a man whose name, were I to reveal it, would cause what the old-time pressmen used to call "a flutter among the dovescotes of Downing Street." This valve shortage is, according to him, far more significant than I had thought, since it is part of the plot which I recently mentioned to swing the populace over to the idea of non-wireless reception. Obviously, if the obtain-

ing of a new valve means, as it usually does at present, a weary trek from shop to shop, people will soon be in the mood to listen to the blandishments of the wireless relay companies and take their programmes "via wire," and once this happens they will be loth to return to the ways of wireless after the war; in fact, adds my correspondent, this is exactly what the Government (or at least the P.M.G.) wants to happen.



"Receiverless communication."

The only argument against this, so far as I am aware, is that the relay companies are, like the Post Office Telephone Service, not in a position to take on any new business, owing to shortage of materials and labour. I must confess, however, that this letter has produced a nasty twinge of what the psychologists would call "guilty-conscience complex," since I am at the moment feeding from my home no fewer than six loudspeakers in different houses in my immediate neighbourhood, all of which have silent sets and voiceless valves. I am torn between regret at being compelled to encourage receiverless reception with a possibility of establishing a bad and unerasable habit, and anger at the thought of being used as a tool by the P.M.G. to promote his long-term ends.

Strangely enough, another correspondent in high places, who also suggests that the valve shortage is Government-inspired, advances a totally different reason for such an attitude on the part of the authorities. He points out that an ordinary receiving valve used as an oscillator in the simplest o—V—o receiver circuit has a transmitting range of several miles, and it could be an easy matter for enemy planes to fly at stratospheric height over the residences of fifth columnists each night and obtain vital information. This view certainly puts a very different complexion on the whole matter, and if it be true, I am prepared to range myself on the side of the authorities, much as it goes against the grain to do so.

Automatic Soldering

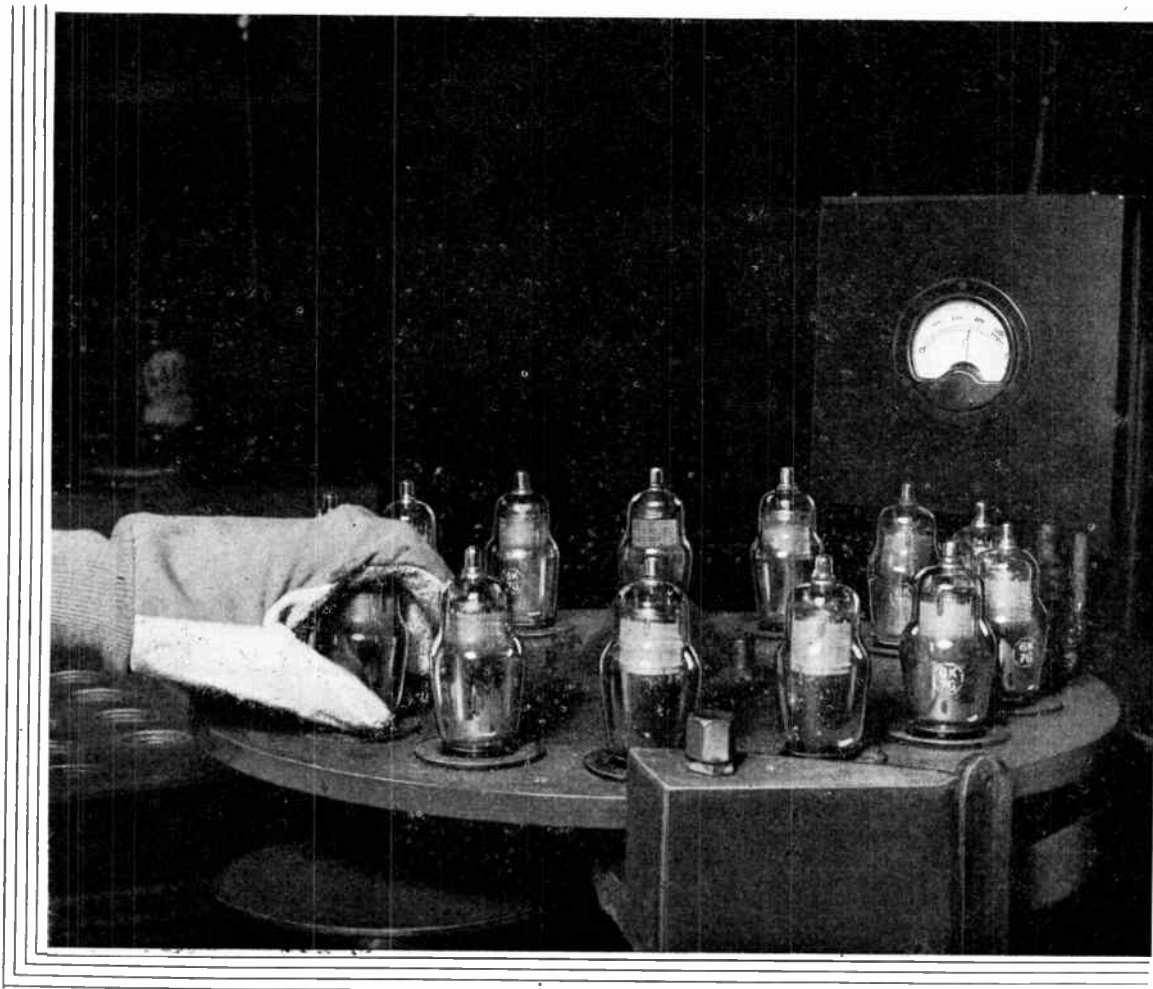

EFFICIENT electrical connection between electrodes and pins and top caps is assured by automatic soldering.

Our illustration shows a machine capable of making upwards of 13,000 joints per hour.

BRIMAR
BVA
VALVES

STANDARD TELEPHONES AND CABLES LIMITED, FOOTSCRAY, SIDCUP, KENT.

Rotary Cutting, Filing, Grinding and Polishing - *Economy and Accuracy*

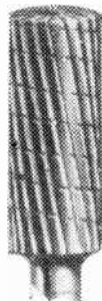

Use **MORRISFLEX** Flexible Shaft Equipment, and **REX** Rotary Files and Cutters for cutting, filing, grinding and polishing components of aluminium, Elektron, non-ferrous alloys and ferrous metals. For metal buffing and cleaning we supply **MORREX** Rotary Wire Brushes, and **MORRISFLEX** Rotary Polishing Mops and Felts, also Felt Cones. **MORRISFLEX** Rotary Rasps are ideal for woodworking, and attachments for **MORRISFLEX** machines include Sanders and Grinders.

MORRISFLEX machines are available in overhead suspension, bench and floor types. Their use ensures speed with accuracy, and a high degree of finish. Write for Lists.

B. O. MORRIS LTD.
SHIRLEY,
BIRMINGHAM.

Shirley 1237.

*Grams :

Morrisflex, Birmingham.

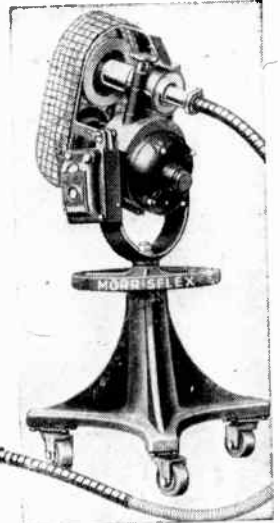

MORRISFLEX FLEXIBLE SHAFT EQUIPMENT

74 RANGE UNIVERSAL TAYLORMETER

Combining a very wide range of measurements with high sensitivity and accuracy.

Self-contained A.C. and D.C. Volt ranges available up to 5,000 volts.

A.C. and D.C. Current ranges from 50 μ A to 10 Amperes full scale.

Resistance measurements from 0.1 ohms to 50 Megohms with internal batteries.

Capacity and Inductance measurements can be made with special adaptor.

Some delay in delivery is unavoidable, but every effort is being made to meet Trade requirements.

Nett Price

MODEL 83A (4,000 ohms per volt A.C. and D.C.) 15 gns.

MODEL 83c (20,000 ohms per volt A.C. and D.C.) 19 gns.



TAYLOR METERS

Write for complete specification to:-

TAYLOR ELECTRICAL INSTRUMENTS LIMITED
MONTROSE AVENUE, SLOUGH, BUCKS SLOUGH 21381 (4 lines)

RADIO DATA CHARTS—8

Power Dissipated by a Resistance

THESE are two formulae for the power dissipated by a resistance, both of which are known to everyone. They are

$$W = I^2R \quad \dots \quad (1)$$

$$\text{and } W = E^2/R \quad \dots \quad (2)$$

An abac is presented which will perform calculations using either of these relations. A trial drawing showed that if the two charts necessary for the nomographical expression of these two equations were superimposed in the normal way (as for instance in No. 1 of the present series) the multiplicity of scales was very muddling. The two charts have therefore been inverted with respect to one

By

J. McG. SOWERBY,

B.A., Grad.I.E.E.

(By Permission of the Ministry of Supply)

another, and as printed, the normally readable scales represent (1). If the chart is now turned upside-down, the readable scales represent equation (2). Those who are accustomed to abacs will not need either key or examples to make the chart clear; it is only necessary to connect the required values of resistance and current (or resistance and voltage) together with a ruler, and the

required wattage dissipation is shown on the power scale.

It will be realised that very often simple problems arise which do not require an accurate answer. For example, suppose a general purpose triode has an anode load resistance of 65,000 ohms and an anode current of 3 mA, will a half-watt resistor do? To answer this it is only required to know whether the resistance will be called upon to dissipate more or less than half a watt—the exact answer to the problem is of next to no interest. To meet cases of this sort a simple chart has been constructed and is

(Continued on page 175)

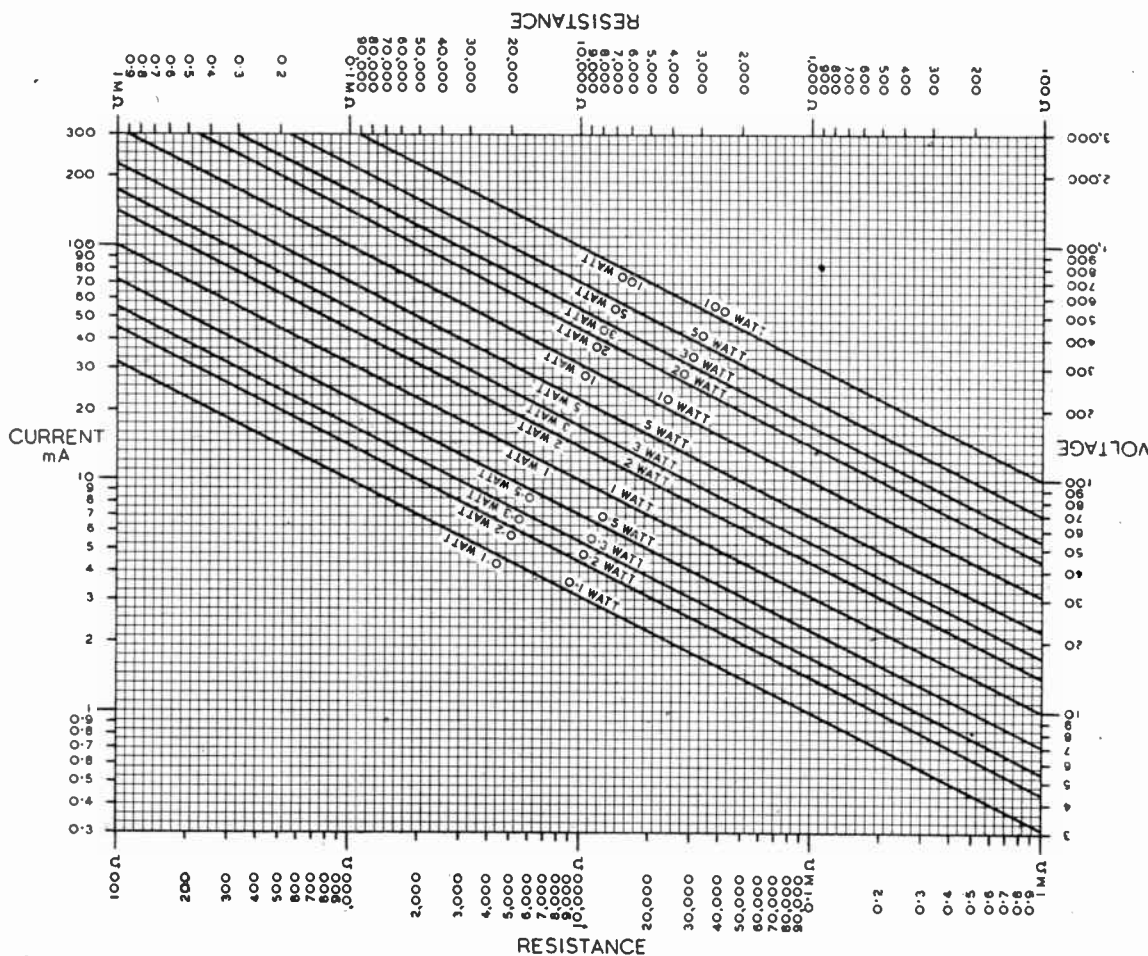
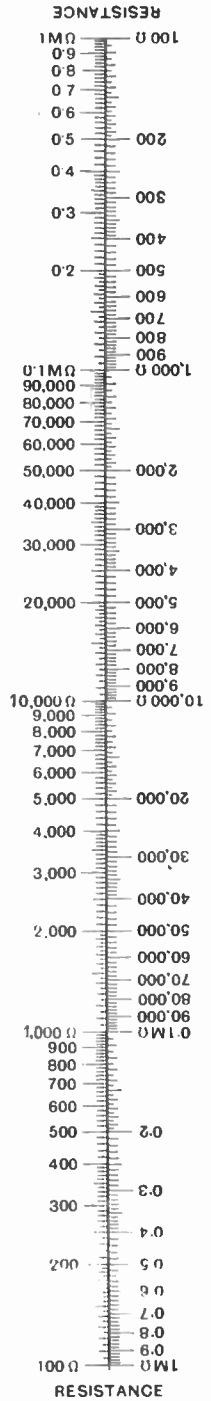
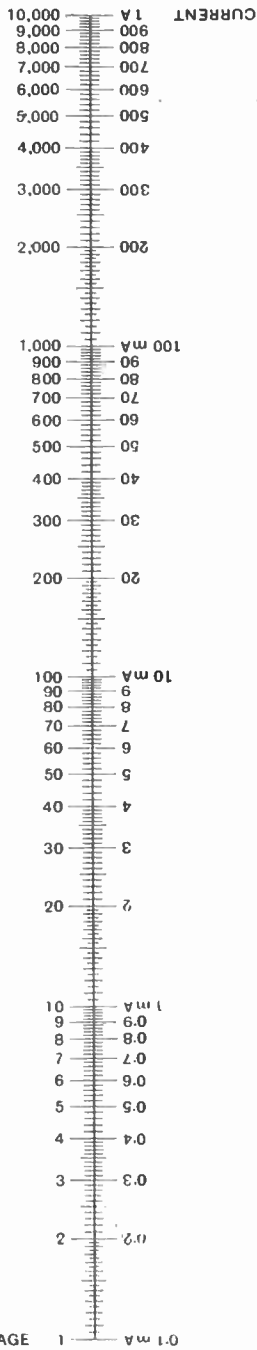
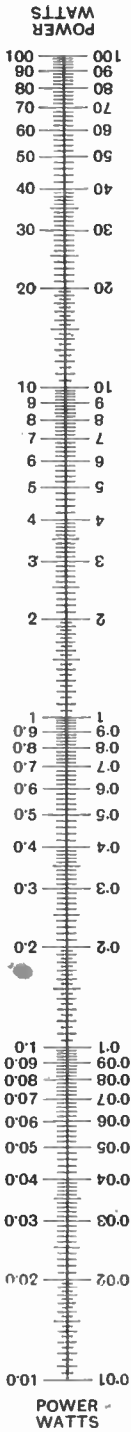

Fig. 1. Chart for rapid estimation of wattage rating of resistances.

POWER DISSIPATED BY A RESISTANCE



POWER DISSIPATED BY A RESISTANCE

Radio Data Charts—8—

shown in Fig. 1. It is, in reality, a simple graph using logarithmic scales. To find the answer to the above problem, project a vertical line from 65,000 ohms (by eye) and note where it crosses a horizontal line through 3 mA. If this point is above the line marked 0.5 watt then the dissipation is more than half a watt, and if below, less. In this case it is above—but only just: whether this represents a sufficiently serious overload to warrant a one-watt resistor being used in its place lies with the designer, and/or manufacturer of the resistor—it is no concern of the chart. Like the abac, Fig. 1 may be turned upside-down, when it then deals

with equation (2) in the same approximate fashion. Note that the order of the wattage lines is inverted: e.g. the 0.5 watt line is now above the 1-watt line instead of below. An example will make this clear. Suppose a 422 ohm resistor is connected across a 110-volt DC supply (to provide various voltages at several tapping points). What must be the wattage rating of the resistor? Find the point corresponding to 422 ohms and 110 volts. This is just above the 30-watt line. This is on the low side of the line, so a resistor rated at 30 watts would do. If the exact answer is required it can be found from the abac. It is 28.6 watts.

The reader will note that the lines within the scales on Fig. 1 have no meaning. They are there simply to guide the eye in straight lines. When using this chart, rough interpolations can, of course, be made between the wattage lines.

TEST INSTRUMENTS

Two new test instruments are described in a leaflet (No. 9563) issued by the General Electric Co., Ltd., Magnet House, Kingsway, London, W.C.2. One is a "Break Locator," comprising a high-frequency generator and exploring electrodes, with headphones designed to locate faults in un-screened flexible conductors. The other is a "Full Load Continuity Tester" for checking portable tools and appliances for faults which may not show up on light current continuity meters.

NEWS IN ENGLISH FROM ABROAD

REGULAR SHORT-WAVE TRANSMISSIONS

Country : Station	Mc/s	Metres	Daily Bulletins (BDST)	Country : Station	Mc/s	Metres	Daily Bulletins (BDST)
America				French Equatorial Africa			
WRUW (Boston) ..	6.040	49.67	0900	FZ1 (Brazzaville) ..	11.970	25.06	2145
WLWO (Cincinnati) ..	6.080	49.34	0700, 0800, 0900, 1000	India			
WBOS (Hull) ..	6.140	48.86	1000, 1100	VUD3 (Delhi) ..	7.290	41.15	0900, 1400, 1650
WCRC (Brentwood) ..	6.170	48.62	0700	VUD4 ..	9.590	31.28	0900, 1400, 1650
WGEA (Schenectady) ..	6.190	48.47	0700	VUD3 ..	15.290	19.62	0900, 1400
WBS ..	7.355	40.79	0700, 0800, 0900, 1000	Newfoundland			
WDJ ..	7.565	39.66	0200, 0300, 0400, 0600, 0800, 0900, 1000	VONH (St. John's) ..	5.970	50.25	0015, 2345
WJP ..	8.810	34.05	0200, 0300, 0400	Mozambique			
WGE0 (Schenectady) ..	9.530	31.48	2200, 2300	CR7BE (Lourenco Marques) ..	9.830	30.52	1255, 1812, 2015
WCBX (Brentwood) ..	9.650	31.09	0600, 0700	Switzerland			
WNBI (Bound Brook) ..	9.670	31.02	0100	HER3 (Schwarzenburg) ..	6.165	48.66	2250
WRUW (Boston) ..	9.700	30.93	0000, 2200	HER5 (Schwarzenburg) ..	11.865	25.28	2250
WDL ..	9.750	30.77	1100, 1400	Spain			
WKRX ..	9.897	30.32	0000, 1100, 1200	EAQ (Aranjuez) ..	9.860	30.43	1915
WRX ..	9.905	30.28	0700, 0900, 1000	Sweden			
WLWO (Cincinnati) ..	11.710	25.62	0000, 2300	SRU (Motala) ..	9.535	31.46	2320‡
WRUL (Boston) ..	11.790	25.45	0000, 2200	Syria			
WCDA (New York) ..	11.830	25.36	0000, 1200, 1300, 1400, 1630‡, 1630, 2200	Beirut ..	8.035	37.34	1920
WGEA (Schenectady) ..	11.847	25.33	1400, 1500, 1600, 1700, 1800, 1900, 2000	Turkey			
WBOS (Hull) ..	11.870	25.27	1300, 2000, 2200, 2300‡	TAP (Ankara) ..	9.465	31.70	1900
WKRD ..	13.442	22.32	1300, 1400, 1500, 1600, 1700, 1800, 1900, 2000, 2100, 2200	U.S.S.R.			
WDO ..	14.470	20.73	1500, 1800, 1900, 2100	Moscow ..	6.980	42.98	1900, 2300
WBOS (Hull) ..	15.210	19.72	1500, 1800	7.300	41.10	0000, 1800, 2100, 2200, 2300	
WLWO (Cincinnati) ..	15.250	19.67	2000, 2100, 2200	7.360	40.76	0000, 1900	
WCBX (Brentwood) ..	15.270	19.65	1630‡, 1830, 2200	7.560	39.68	2200	
WGE0 (Schenectady) ..	15.330	19.57	1500, 1800	9.480	31.65	0147, 1800	
WRUL (Boston) ..	15.350	19.54	1200, 1300, 1400, 1500, 1600	9.545	31.43	1330, 1615	
WCW (New York) ..	15.850	18.93	2000	10.445	28.72	1330	
WLWO (Cincinnati) ..	17.800	16.85	1600, 1700, 1800, 1900	11.830	25.36	1700	
WCRC (Brentwood) ..	17.830	16.83	1200, 1300, 1400, 1630‡, 1830, 2200	12.190	24.61	0147, 1330	
Australia				15.110	19.85	0147, 2315	
VLQ5 (Sydney) ..	9.680	30.99	0755	15.230	19.70	0147, 1330, 1615, 2315	
VLG3 (Melbourne) ..	11.710	25.62	0755, 0900	Vatican City			
VLI2 (Sydney) ..	11.872	25.27	0900	HVT ..	5.970	50.25	2015
VLG6 (Melbourne) ..	15.230	19.70	1615	MEDIUM-WAVE TRANSMISSIONS			
Brazil				Ireland			
PRL8 (Rio de Janeiro) ..	11.715	25.61	2130‡	Radio Eireann ..	565	531	1440‡, 1945, 2310
China				It should be noted that the times are BDST—two hours ahead of GMT. ‡ Sundays excepted.			
XGOY (Chungking) ..	11.900	25.21	1500, 1700, 1815, 2230				

WORLD OF WIRELESS

ILLEGAL TRANSMITTER GAOLED

PROSECUTED under the Defence Regulations on charges of possessing an illegal transmitting set and the theft of components from his employers, James Wilson (36), of Chorlton-cum-Hardy, was recently sent to prison for three months in the second division at Manchester City Police Court.

A War Office official, giving evidence, stated that such apparatus used by an unauthorised person constituted a grave danger to national security, as it might seriously interfere with official communications. It could, moreover, be used to communicate with the enemy, and might even act as a beacon for enemy aircraft.

Wilson was alleged to have said that he had only been using gramophone records for the transmissions.

The Stipendiary Magistrate said that while he did not think there was any suggestion that Wilson had any criminal idea of doing anything against the country, he could not possibly take other than a serious view of the case.

RADIO-MINDED U.S.

ALTHOUGH there is no licensing system in the U.S. whereby the total number of listeners in the country can be ascertained, it has always been considered one of the most radio-minded in the world. This is borne out by the census recently undertaken by the U.S. Bureau of Census, which revealed that 86.8 per cent. of the country's 30,721,944 white households have receivers. Of the 3,168,562 coloured households, however, only 43.3 per cent. are radio-equipped.

The District of Columbia is the most radio-minded of the forty-nine States, with a percentage of 97.4 of its 127,067 white households owning receivers.

New York is fifth in the list with 95.7 per cent. of its three million-odd white households possessing receivers. It has, however, the highest percentage of radio-equipped coloured homes—92.

RADIO INDUSTRIES CLUB

WHEN proposing the election of Sir Noel Ashbridge, B.B.C. Controller of Engineering, as president of the Radio Industries Club, Sir Louis Sterling remarked that for the first time the Club would have a president representative of the "sending" side of radio without which the "receiving" industry could not exist.

The membership of the Club, which was formed "to promote

mutual understanding and goodwill amongst those engaged in the radio and allied industries, by the holding of periodical luncheons and other meetings," has risen from 245 to 326 during the year. In his report the chairman, H. de A. Donisthorpe, analysed the membership, which showed that some 30 per cent. is representative of the set manufacturers, with the wholesalers and component makers following closely with their representations. Disappointment was, however, expressed at the support received from retailers.

The following five members were elected to the committee for the ensuing year: Guy R. Fountain (Tannoy), A. J. P. Hytch (B.B.C.), J. H. Williams (Cossor), A. G. Beaver (Sun Electrical), and W. E. Miller (*Wireless Trader*).

B.B.C. CONTROL

IN reply to a question in the House of Commons, Mr. Churchill stated that in no circumstances could he commit himself to the setting up of a select committee to consider the whole future of State broadcasting.

He had previously stated that it was not intended to make arrangements to enable B.B.C. Governors to answer questions in the House of Commons for that part of the activities of the British Broadcasting Corporation over which the Minister of Information had no control.

[There are two B.B.C. Governors who could answer in the House: Sir Ian Fraser, C.B.E., and the Hon. Harold Nicholson, C.M.G.]

Mr. Churchill further added that the present arrangements enabled Parliament to be informed as to any matters of general policy affecting the British Broadcasting Corporation; but it had never been contemplated that matters affecting the day-to-day administration of the Corporation should be the subject of question and answer in the House.

CANADIAN NETWORKS

OUR Canadian correspondent states that the Canadian Broadcasting Corporation is considering the establishment of a second network to provide alternative programmes. The present nation-wide network of the C.B.C. includes, in addition to the ten main transmitters ranging in power from 1 to 50 kW, ten 20-watt relay transmitters. These have been erected in British Columbia to provide a service for the isolated communities in this mountainous area of Western Canada.

WIRELESS OPERATORS DECORATED

THE Conspicuous Gallantry Medal has been awarded to Flt. Sgt. G. F. Keen, D.F.M., wireless operator, of the Royal Canadian Air Force, for "his courage and fortitude, which were of the very highest order," during an attack on Essen.

The citation of the order states that whilst over the target area the aircraft was hit by heavy anti-aircraft fire and the navigator was killed. Flt. Sgt. Keen, who was in the astrodome, had his right foot blown off, and received cuts on both legs. Disregarding his wounds, he regained his seat in the wireless cabin, and for over two hours he laboured to repair the damaged apparatus. He could not speak to other members of the crew owing to damage to the intercommunication apparatus. Another airman spoke to him, however, on at least a dozen occasions, and found him still conscious and working or directing the manipulation of various installations. He also offered assistance in navigating the aircraft, and dragged himself on two occasions to the navigator's compartment to obtain essential information.

A bar to the Distinguished Flying Medal has been awarded to Flt. Sgt. (now W/O.) E. Leavesley, D.F.M., who has been wireless operator on many sorties. "His technical ability and knowledge have been of the greatest assistance to his pilot and navigator, and not once has he had a wireless failure."

B.B.C. ENGINEERS

IT may come as a surprise to many to learn that the Engineering Division of the B.B.C. now has a staff of more than 3,000. This expansion from the pre-war total of 1,300 trained engineers has been necessitated by the rapidly expanding service—the transmitter-hours have been increased nearly sixfold. The increase is largely due to the expansion of the Oversea and European Services.

Whereas before the war no women were employed in the Engineering Division, other than in secretarial posts, there are now some 500 working as operators at studio centres, in recording rooms, and at transmitting stations.

Owing to the fact that only one in four of the present staff has had pre-war experience, it became necessary to start an Engineering School in 1941 for training purposes, and in its first year 700 recruits were passed into the service.

This and many other interesting

facts about the wartime operation of the B.B.C. are contained in the 128-page "B.B.C. Year Book, 1943," which has just been published at 2s. 6d.

750 KILOWATTS !

It will be recalled that the licence issued to the Crosley Corpn. of Cincinnati for the operation of the medium-wave experimental station W8XO with a power of 500 kW was cancelled by the U.S. Federal Communications Commission at the beginning of the year.

At the request of the Office of War Information, the station has now been granted permission to experiment with a power of 750 kW! According to our American contemporary, *Broadcasting*, it is thought that the tests are preparatory to the transmitter being sent abroad "as part of the psychological warfare."

RECORD SALVAGE

THE recent appeal for old gramophone records has not brought forth the response required to meet the needs of the manufacturers for the supply of new recordings.

Whereas only the nine brands marketed by E.M.I. and Decca were previously asked for, dealers will now receive all makes except Regal discs and flexible and cylindrical types. As previously mentioned, there are certain early issues of recordings made prior to the introduction of the solid stock system of manufacture in 1932 which are not re-usable. The following list gives the prefixes and the lowest numbers in the series which are acceptable:—

DB 762	Columbia	LB 8
FB 1000	DX 330	LX 163
	CB 416	
	Parlaphone	
RO 20175	R 20192	E 3950 to
F 100	R 1137	4500
OT 101	D 3000	E 11193
	Regal-Zonophone	
	MR 533	MF 200

Some dealers are paying as much as 5d. for 12in. and 3d. for 10in. discs.

OVERSEA RELAYS

DETAILS recently given by the Engineering Division of the B.B.C. disclosed some interesting facts regarding relays to and from this country.

Whilst in peacetime the number of relays from this country taken by oversea broadcasting organisations far surpassed those taken by the B.B.C. for rebroadcasting, last year's figures reveal that incoming relays increased almost threefold, whilst those emanating from this country were only a few in excess of the previous year. The comparative figures for incoming and outgoing relays for the last few years are: 1942, 3,217 and 2,259;

1941, 1,129 and 2,231; 1940, 502 and 1,836; 1939, 469 and 886.

Relays are classified in three groups by B.B.C. engineers. They are: Successful—those sufficiently satisfactory for immediate or delayed re-transmission; partially successful—those including short periods of distortion or severe interference, or of sufficient intelligibility for a script to be prepared for reading; and lastly, those unsuccessful.

Of last year's total of 3,217 incoming relays 2,880 were successful, 170 partially so, and 167 unsuccessful. Of the 2,259 outgoing transmissions 2,170 came in the first category, 35 in the second, and 54 in the third.

America supplied over half, actually 1,712, of last year's incoming relays and received 1,740 of the transmissions from this country taken by oversea organisations.

IN BRIEF

U.S. Warship "Fessenden."—By naming one of the new U.S. destroyer-escort vessels "Fessenden," an honour has been conferred upon a pioneer of wireless—the late Professor Reginald A. Fessenden. In 1900 he succeeded in transmitting speech by wireless over a distance of a mile at Cobb Point, Maryland, using a high-frequency alternator. He died about two years ago.

B.B.C. Short-wave News.—The following schedule of the times (BDST) of the B.B.C.'s short-wave transmissions of news in English and the wavelengths on which these are radiated will be operative when this issue of *Wireless World* is published:—

0306:	25.68, 30.53, 31.32, 48.43, 49.10.
0445:	25.68, 30.53, 30.96, 31.32, 41.96, 42.13, 42.46, 48.43.
0630:	25.68, 30.53, 30.96, 31.32, 42.13, 48.48, 49.10.
0815:	19.82, 25.53, 25.68, 30.53, 31.25, 31.55, 42.13.
0930:	16.84, 19.82, 25.47, 25.53, 25.68, 30.53, 31.55, 42.13.
1000:	25.53, 25.68, 30.96, 31.25, 31.32, 31.75, 31.88, 41.01, 41.75, 41.96, 49.10, 49.42, 49.59.
1300:	1500: 13.97, 16.64, 16.79, 16.84, 19.42, 19.50, 19.82, 25.53, 25.68.
1700:	13.97, 16.64, 16.79, 16.84, 19.42, 19.82, 25.68, 31.55.
1800:	16.59, 16.64, 16.84, 19.50, 19.66, 25.53, 25.68.
2000:	16.84, 16.94, 19.50, 19.66, 25.53.
2245:	19.66, 25.53, 30.96, 31.25, 31.88, 41.49, 48.43, 49.42, 49.59, 49.92.
2345*:	25.53, 25.68, 30.53, 31.32.

* Sundays excepted.

Books Wanted.—The librarian of a Signal Training Unit of the R.A., stationed in a somewhat isolated locality, appeals for the gift of books on wireless. Readers are asked to send any surplus volumes they may be able to spare to the Editor of this journal, marked "R.A. Signals," so that they may be forwarded to the right quarter.

No Licence!—A man who had had a wireless set for four years without a licence had the set confiscated at the Glasgow Sheriff Court recently. Fines varying from £1 to £5 were imposed in other cases, indicating that the authorities are taking a more serious view of set owners avoiding payment of licences.

Round the Clock.—According to the North American Director of the B.B.C., the U.S. Federal Communications Commission, by "surveillance of the whole radio spectrum 24 hours a day," prevents information from reaching the enemy by means of illegal broadcasts from the States.

Radio Artificers.—The Royal Canadian Navy has introduced the rating of radio artificer—a branch in which men will be employed on the maintenance of wireless telegraphy and radio direction-finding equipment ashore and afloat. Electrical artificers engaged in radio direction-finding duties, and ratings employed in wireless telegraphy maintenance work will, on recommendation, be transferred to the new branch.

Radio Relay Statistics.—The number of subscribers to radio relay exchanges increased by nearly 48,000 during the last nine months of 1942, although the number of exchanges has been reduced by one to 277. There were 435,073 subscribers at the end of December.

Apprenticeships.—It is understood that a Special Committee of the Radio and Television Retailers' Association is considering the question of training personnel for receiver maintenance and is drawing up a specimen form of indenture for apprenticeships.

Obituary.—The death was recently announced from Washington, D.C., of Brigadier Francis Wyville Home, R.M., at the age of 60. He was head of the Wireless Telegraphy Board of the three Services from 1923-1934, when he retired as colonel. For four or five years he held a post in the Engineering Division of the B.B.C., which he left after the outbreak of war to rejoin the Services, and was promoted acting colonel-commandant (temporary brigadier). He had specialised in wireless and had held various instructional and administrative posts in the Services.

Fifty Years' Service.—Mr. E. C. McKinnon, M.I.E.E., chief engineer of The Chloride Electrical Storage Co., has just completed fifty years' service with the company.

Brit.I.R.E.—The next meeting of the London Section of the British Institution of Radio Engineers will be held on Wednesday, May 26th, at 6.30 p.m., at the Institution of Structural Engineers, Upper Belgrave Street, London, S.W.1, when S. Hill, A.M.I.E.E., will deliver a paper on the "Application of Negative Feedback in Design Principles." The paper, "Microphones and Receivers—with Special Reference to Speech Communication," read by L. C. Pocock, M.Sc., A.M.I.E.E., before the London Section on April 30th, will be re-read before the North-Eastern Section at the Rutherford College, Newcastle-on-Tyne, on June 4th.

Institution of Electronics.—The next meeting of the N.W. England Section of the Institution will be held in Reynolds Hall, Manchester College of Technology, on May 28th, at 7 p.m. "Secondary Emission Tubes, Their Manufacture and Application," is the subject of the lecture to be given by Dr. Van den Bosch. Tickets are obtainable from the Secretary, Leslie F. Berry, 14, Heywood Avenue, Austerlands, nr. Oldham.

Electromagnetic Fields in Radio—V.

WAVES IN DIELECTRIC MATERIALS

By

MARTIN JOHNSON,
D.Sc.

THE account of travelling and stationary radio waves, in the previous articles of this series, has not dealt with the properties peculiar to particular materials, except in so far as we have supposed that "empty space" may terminate in some reflecting barrier with whose composition we have not yet needed to be concerned. We have also once mentioned that the lines of force for a wave "guided" by a conductor may suffer distortion, for instance at the surface of an aerial, since no material can be a perfectly conducting substance. But to replace empty space or the ideal reflecting barrier by a dielectric of particular insulating properties or by a mass of metal of given resistivity or by the partly ionised layers of the earth's upper atmosphere, forces us to enquire how waves travel through these media. This would be an exceedingly difficult subject, unless we were to see a way into it by making simple modifications for the "empty space" travel of radio already outlined in the earlier articles. We proceed first to classify the electrical properties which will introduce such modification.

Dielectric Constant, Conductivity, Magnetic Permeability.—Take the two Maxwell equations which we derived as containing in summarised form the laws of electromagnetism,

$$\frac{1}{c} \frac{\partial E}{\partial t} = \text{curl } H \quad \frac{1}{c} \frac{\partial H}{\partial t} = \text{curl } E$$

where c is the velocity of all electromagnetic waves in empty space, 3×10^{10} cm. per sec. (186,000 miles per sec.) and E and H are the vectors denoting electric and magnetic fields respectively. Now in the mechanical laws on which all our measurements are founded, the quantities kE and μH are of greater practical importance than E and H by themselves, since they allow actual materials to be judged. In the simplest system of units $k = 1$

and $\mu = 1$ for a vacuum, and very nearly so for air. k is the "dielectric constant" and μ the "magnetic permeability," and each may be defined in any of several ways. For instance, they modify the law of force varying with inverse square distance, according to the nature of the material through which charges or poles are attracting each other; or they can be defined through particular experimental facts, such as that a condenser filled with material of dielectric constant k has k times the capacity of the same condenser completely empty.

Besides thus introducing constants to denote the electrostatic and magnetic characteristics of materials, we need a term connected with the property of offering resistance to a flowing current if such can exist; for this we choose the conductivity, usually written σ , such that σE is a current density or current per unit cross-section of a conductor.

To transform the above "empty space" equations to suit all possible materials, these constants k , μ , σ , are inserted into them, making

$$k \frac{\partial E}{\partial t} + \frac{4\pi\sigma}{c} E = \text{curl } H$$

$$\frac{\mu}{c} \frac{\partial H}{\partial t} = \text{curl } E$$

What is the "Displacement Current" in a Dielectric?—We recall that these Maxwell equations represented the relations between electricity, magnetism, and motion. The first of them must therefore imply currents on the left-hand side of its equality. The new term involving σ which we have just introduced is obviously a current, but was this also true all along, was $k \partial E / \partial t$ a current also? This brings us to one of the essential features of the field theory which began with

Maxwell, namely, that even when σ is zero and the fields are oscillating in a perfect insulator, there is still some meaning to the notion of a current, though distinguished from that in a conductor and called the "displacement" current.

This is not to be regarded as a drift of free charges such as occurs in a metal where electrons migrate or in an electrolyte where positive and negative molecular and atomic ions migrate: but just as mechanical forces can exhibit themselves by strains or distortions as well as by accelerated motion, so we can regard a state of strain as being set up between the plates of the condenser C (Fig. 1). The displace-



Fig. 1. Conduction current where free electrons are available: displacement current in C even if no conductivity. Both kinds contribute to the magnetic "curl" in the Maxwell equation.

ment current may involve phase change and power loss and even heating, according to the composition of the dielectric, and so has many consequences analogous to those of the conduction currents which exist in the regions of finite σ such as R and L which might include electrolytic and gaseous as well as metallic loads. The form of the Maxwell equation shows that both kinds of current have magnetic consequences. We shall proceed under our next heading to picture some mechanisms underlying some of the losses when power is consumed by the displacement current in a material dielectric. But the term was invented before much was known about insulators and their molecular behaviour, and it still retains meaning for a perfect vacuum if we admit that any disturbance of the lines of force

has effects comparable with motion or with strain. In fact, the "aether" enthusiasts of an earlier age liked to picture this non-material medium as if it were traversed by elastic tubes of force which expanded and collapsed and jostled one another, though "dielectric losses" in the form of heat or leakage leading to breakdown could not occur until some trace of matter were present. The misleading suggestions associated with "aether," as if it were a kind of material substance, incline us to illustrate "displacement current" mechanisms from polarised materials such as the oil of an HT condenser, and to admit the extension of the idea to empty space by remembering that the appropriate term in the Maxwell equation is completely general and valid even when $k = 1$. We have thus avoided the term "induction" and the $kE/4\pi$ often called "the displacement" in conventional teaching, although electric intensity and displacement are often presented as useful analogies to mechanical stress and strain. The different behaviour of a condenser to DC and to AC or RF is, however, to be kept in mind, and may be considered as follows. One recognises the fact that a condenser is a complete barrier to DC but offers only a finite impedance to AC depending on its capacity and the frequency: in the case of DC the strain in the dielectric is established almost instantly when the potential is first applied, and no further work is done until the strain is momentarily reversed on removing the potential. For AC such momentary strains are repeated with the frequency of the applied potential so that energy continues to be consumed. When this is so, there is no more of a break in the circuit at C than at L or R, though there is no free flow of charge in C but only the periodic rebuilding of a system of lines of force. The displacement current is therefore "real," whether or not the condenser contains molecules to distort.

Dipole Molecules and Induced Polarisation of a Dielectric at Low and High Frequencies.—It was perhaps a logical continuity of ideas that required "current" in the perfectly empty condenser in Maxwell's day; but our more modern understanding

of what happens to the molecules of dielectric materials makes the effect of the displacement current easier to picture. Suppose the plates separated by an oil or wax. Two kinds of response to an alternating potential must be noticed, both contributing to the character denoted by k .

(a) The complex insulators synthesised for the radio industry by the organic chemist may include "polar" compounds. The centre of gravity of all the positive charges in the molecule does not exactly coincide with the centre of gravity of all the electronic or negative charges. The whole molecule must be pictured as elongated (Fig. 2), and characterised by a "dipole moment," product of either charge multiplied by distance separating the net charges. Since the whole molecule is neutral, the (+) which sums all the positives equals the (-) sum. The notion is analogous to the more familiar "magnetic moment." When material consisting of an assembly of such molecules in random orientation is situated between the condenser plates, and the potential applied, these molecular "dipoles" all start to orientate themselves in line with the field. The dielectric then presents the appearance of surface charge as in Fig. 3.

(b) Where there are no such "permanent" dipoles, the substance being of such chemical structure that the molecules are spherically symmetrical in all their charges, a distortion may

Fig. 2. Dipole molecule: the negative and positive charges of its electrons and ions neutralise each other, leaving the whole molecule uncharged, but are not centred at the same spot, so that the molecule has an electric moment and will orientate itself in a field.

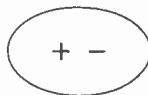

still occur under the influence of a field. Positives and negatives become slightly stretched apart, and the molecule becomes a "temporary" or "induced" dipole; it will return to normal when the field falls to zero.

These are simplified pictures of the "polarised" state of a dielectric, and it is unfortunate

that conventional language uses the same word to describe the confinement of a vector to a single direction in radiation.

With periodically reversing potential, and especially if the frequency of reversal becomes high, a great deal of energy may be expended in a form of loss comparable with friction, when interatomic and intermolecular forces

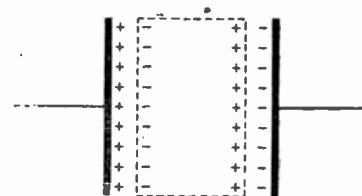

Fig. 3. Effect of polarisation in dielectric of condenser.

resist the tendency to swing into orientation. Since thermal agitation of the molecules will largely decide their freedom to swing round in the field, the portion of any dielectric constant k which involves "permanent" dipoles will vary with temperature. Any part of k involving the "induced or temporary" dipoles will be almost independent of temperature.

The frictional or elastic forces opposing swing or drag of the molecules will impose a slight time-lag in the full response to a field. At LF the time lag is negligible compared with the time for reversal of the field. At RF and especially at the highest modern frequencies of radio, the applied fields may reverse before the molecular adjustment in the "displacement" is completed.

From these considerations it may be realised that the molecular structure of any dielectric to be suitable for condensers must be scrutinised as to how k and therefore capacity will alter as temperature rises when the frictional losses lead to warming. A dielectric suitable for LF may be useless at frequencies which cause the effective k to depart from its DC value. The radio constructor's debt to the chemical inventor of dielectrics is well repaid when the latter uses a heterodyne beat circuit to discover the temperature coefficient of molecular polarisation, and so to investigate the structure of his newest compounds. Allow two valve circuits to heterodyne each other, each

Electromagnetic Fields—

depending for its frequency on a condenser, one of which contains the new substance—the smallest change in k alters C and the frequency, so that the beat frequency is heard to alter.

If we next turn to consider the speed of radio waves in material dielectrics, we shall notice that with k the "refractive index" alters, and both velocity of travel and bending of path, together with absorption and concentration as in an optical beam, can be controlled.

Slowing of Waves in Dielectric Media.—If we return to Maxwell's equations and remind ourselves how a velocity c was obtained for the wave motion when E and H travel together along the Poynting vector, the more complicated analysis of the equations modified to include k , μ , σ , show that the speed is no longer c , but $c/\sqrt{k\mu}$ if σ is negligible. It may be remembered that the wave equation was built by eliminating each variable in turn in Maxwell's equations and combining the results together, so that both k and μ are involved when an actual dielectric is traversed by the waves. In all but the "ferromagnetics" iron, nickel, etc., μ is nearly unity, so that the degree of non-agreement with c is mainly accounted for by k in dielectrics, and the speed approaches c as k approaches unity.

The following applications of this slowing of waves according to k suggest themselves.

(i) As before, we find it convenient that visible light is a particular waveband in the spectrum of electromagnetic waves, so that comparatively easy optical experiments afford useful information relevant to radio. Take the "rotating reflector" method which we described earlier for measuring the speed of light: by inserting a long tube containing water or other transparent dielectric between the mirrors, the speed of the light in each substance can be found. The ratio of the speeds in two media defines the "refractive index" which decides how a ray bends when passing from the one material to the other. But we have just seen that from Maxwell's equations the velocity changes with $1/\sqrt{k}$ for most

insulators; so refractive index ought to be equal to v_1/v_2 or $\sqrt{k_2/k_1}$. Discrepancies between refractive index as inferred from the bending of a ray, and speeds directly measured, are due to the former involving *wave velocity* while the latter involves *group velocity*, as we explained in a previous article. In a vacuum the two kinds of speed are equal, but in "dispersive" materials they diverge as the speed varies with the wavelength. This dispersion shows in the velocity experiment, the image in the eye-piece spreading into a colour band, for instance, if the dielectric is carbon disulphide.

(ii) In an earlier series of articles in *Wireless World*, we discussed the "critical frequency" of U-H-F wave guides; for wavelengths below this limit a hollow tube transmits power, but for longer waves transmission ceases. It is for this reason that the cross-section of a wave guide has to be of the same order of size as the wavelength used, and the device is only practicable below a metre. From the principle we have been discussing, we only have to fill the tube with dielectric of high k , and longer waves will come within the "permitted" region of quite a small tube. Unfortunately the chemists have not yet provided us with dielectrics which have no heat losses.

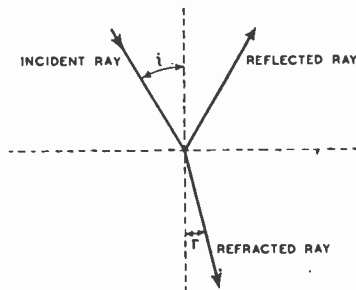

Fig. 4. Radiation striking a surface of separation between two media. Some is reflected, but the portion transmitted is bent in the direction implying that it is entering material in which it travels more slowly.

Refraction, Polarisation, Total Reflection, Dispersion.—We have suggested that dielectric constant decides the speed and the bending of radio waves in materials; under what conditions are they bent right out of a medium, for instance the upper atmosphere? Such

cases will become clear if we first see what happens if only k is involved.

(i) *Bending*: We defined refractive index (n) as a ratio of velocities, but it is also measured by $(\sin i/\sin r)$ where i and r are angles which the ray approaching a surface and the ray leaving a surface make with the "normal"

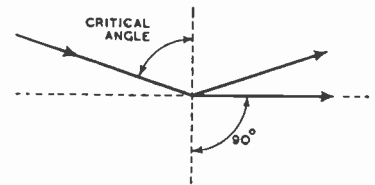

Fig. 5. Radiation striking surface at critical angle: the angle of refraction then becomes 90 deg., so that no energy penetrates the surface.

or perpendicular to the surface at that point (Fig. 4). By drawing the position of the wave-front at successive instants one is convinced that the two definitions are equivalent, so that

$$n = \frac{\sin i}{\sin r} = \frac{v_1}{v_2} = \sqrt{\frac{k_2}{k_1}}$$

Fig. 4 is a case where the wave is entering a "slower" material, n is greater than unity, so some of the radiant energy enters the second material, though some gets reflected at an angle equal to the incident angle. In a metal, where σ is no longer zero, the fraction entering is much smaller than for a dielectric.

(ii) *Total Reflection*: If n is less than unity, and the medium to be entered is "faster," there will be some angles i for which the angle r would exceed 90 degrees. In this case no ray succeeds in penetrating the boundary and only the reflected ray exists. Therefore if a radio beam impinges on a "faster" material, and we make it strike more and more obliquely, we reach a "critical angle" at which it ceases to penetrate and is "totally reflected," although the surface has otherwise no appearance of a mirror. In this case, the refractive index from "slower" to "faster" material is $\sin(\text{critical angle})/\sin 90$, the denominator being unity (Fig. 5).

(iii) *Polarisation by Reflection*: We have referred before to radio waves being polarised, or the E vector being confined to a single

direction instead of wandering all over the plane which faces the propagation line. Wherever E is, of course H follows it perpendicularly. In dealing with metals and the ionosphere later, we shall have to add "circular and elliptic" polarisation. Suppose any beam to be analysable into a mixture of two components, polarised in opposite planes. It is found that the reflection coefficient, or proportion of incident intensity which gets reflected, differs for the two components and also differs according to angle of incidence. At a particular obliquity of incidence (known as Brewster's angle) one of the two components has zero reflection coefficient, and the returning beam consists only of the other component. This is a practical means of reducing a beam to a single

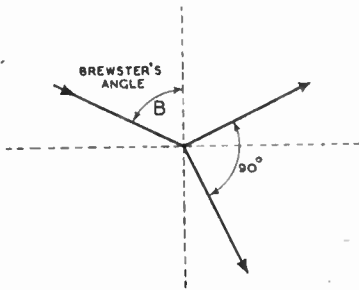

Fig. 6. Case of polarisation by reflection: the reflected and refracted rays are perpendicular to each other.

polarised component. Brewster's angle is such that the reflected ray is perpendicular to the refracted direction of onward travel. (Fig. 6). At this particular angle, $\tan B = \text{refractive index} = \sqrt{k_2/k_1}$. In optics of visible light, most refractive indices are about $1\frac{1}{2}$ to $1\frac{3}{4}$, for instance from air to water 1.33, so the angle at which light is polarised by reflection on a pond is about 53 degrees. But for radio waves, k for water may be as high as 80, and n therefore nearly 9, and the polarising angle 85 degrees, which means nearly "glancing incidence." Irregularities of radio transmission over the sea are partly due to this.

(iv) *Phase Change at Reflection* : The phase of the E vector becomes altered at the reflecting surface, according to the angle of incidence, and must in certain consequences be taken account of.

(v) *Dispersion* : We suggested that the orientation of dipole molecules takes time, and since this is one of the inevitable happenings when RF passes through a dielectric of certain composition, the k alters with frequency. This means the refractive index also alters. The bending of different wavelengths is not constant, and "deviation" turns into "dispersion." This becomes important at the highest radio frequencies and imposes a serious limitation on condenser material. The phenomenon becomes extreme in the "super-radio" wavebands where the electromagnetic spectrum merges into the infra-red heat waves and then into the optical band of visible light. We begin to see features in which the analogy between radio and light—so often vitally important—requires quantitative criticism. We again make contact with a topic stressed in a previous article, when we remember that "dispersion" means a growing divergence between wave velocity and group velocity. When conducting materials instead of dielectrics are considered, this divergence becomes even more important: in fact a recent article in *Wireless World* on the ionosphere has made much of it.

We defer "conducting materials and radio waves" to a final article, but include here a selected list showing the order of magnitude of dielectric constants. It

Air at ordinary temperature and pressure	1.0050
Air at 80 atmospheres pressure	1.0439
Air liquefied at the low temperature of -190 degrees Cent.	1.43
Distilled water	81.1
Glycerine	56.2
Methyl alcohol	31.2
Oils	2 to 5
Glasses	5 to 10
Rubber	2 to 4
Mica	5 to 6
Porcelain	4 to 7

must be remembered from our discussion that not only the direct meaning of k but also its indirect consequences are important in choosing condenser material: in fact, since few dielectrics are entirely without any conductivity, a useful ratio is that of "conduction current" over "displacement current," sometimes referred to as the "loss tangent," which is nearly equal to the "power factor" more familiar in judging coil windings.



**VARIABLE CONDENSERS
—DRIVES—
AUTOMATIC TUNERS**

THE manufacture of precision products by the volume production assembly line method is a speciality of the General Instruments Corporation. Radio receiver set manufacturers are more than familiar with General Instruments variable condensers, automatic tuners and precision drives. Although domestic set production has ceased for the time being, the time is rapidly approaching when it will once again be possible to proceed with this production. General Instruments will have new ideas based on the latest scientific research to offer the radio manufacturing industry.

Always remember General Instruments **VARIABLE CONDENSERS — DRIVES — AUTOMATIC TUNERS**

Register your name with our Representative now. He will forward you information on our products as soon as they become available.

THE GENERAL INSTRUMENT CORPORATION
ELIZABETH, N.J., U.S.A.

Exclusively Represented by
Frank Heaver Ltd. Kingsley Road, Bideford, N. Devon

OF OUR ABILITIES AND FACILITIES WE GIVE GLADLY



PARAMOUNT above all else is the necessity of meeting urgent and immediate demands for the protection of cherished liberty.

Astatic's engineering and manufacturing facilities are therefore first at the disposal of Allied Governments.

Astatic will be ready to serve you again with high quality piezo-electric devices when the "All Clear" of Victory sounds.

Register your name with our Representative for your future benefit.



THE ASTATIC CORPORATION
YOUNGSTOWN, OHIO, U.S.A.
TORONTO, CANADA.

Exclusively Represented by
Frank Heaver Ltd. Kingsley Road, Bideford, N. Devon

EXPLORING THE IONOSPHERE

Progress Over a Complete 11-year Cycle

SIR EDWARD APPLETON, K.C.B., F.R.S., in a lecture given before the Wireless Section of the Institution of Electrical Engineers on April 7th, made what he called a "progress report" on the ionospheric research work carried out by the Radio Research Board of the Department of Scientific and Industrial Research, of which body he is Secretary. No reader of this Journal will need reminding that it was Sir Edward who, in 1925, discovered the F or higher layer of the ionosphere. That region has since turned out to be the principal refracting medium for short waves; by its presence in the high atmosphere, long-distance communication by short waves is rendered possible.

Sir Edward recalled that his last talk to the Institution on his ionospheric work was given just eleven years ago, and said that this period of time has an important significance in ionospheric matters, the implication being, of course, that it represents approximately the course of a complete cycle of solar activity. This is a point of more than ordinary interest, for it means that Sir Edward and his colleagues have pursued their work throughout a complete period of ionospheric change, and should therefore be in a good position to apply its results to future short-wave problems.

Nature of the Ionosphere

In 1932 they had already developed the means—both theoretical and practical—for studying the structure of the ionosphere, and the way in which it varied with time. They found that the principal causative agent of the ionosphere layers is the ultra-violet sunlight, which liberates electrons from the gas molecules of the atmosphere, these free electrons being responsible for the reflection of the radio waves. Obviously, therefore, there is a greater electron population in the ionosphere by day than by night, though during summer in high latitudes—where

the night is very short—a fairly high electron concentration is maintained throughout the twenty-four hours.

Their experiments are conducted by sending "pulses" of radio waves up to the ionosphere and examining their characteristics when they return to earth. The higher the frequency used, the greater is the electron concentration necessary to return the pulses, and if they do not return, but go through the ionosphere altogether, then that itself is useful information. Facts learnt from the waves which do return yield information as to the distance of the reflecting surface, its properties as a reflector of radio waves and on the effect of the earth's magnetic field on the ionosphere.

Pulse Examination

Sir Edward showed a series of interesting slides illustrative of the methods of examination of the pulses, and of the way in which a curve of height against frequency is plotted for the various layers. It is by a study of such curves that knowledge of the structure of the ionosphere, and of the variations which occur within it, has steadily been acquired. A further slide gave details of some of these variations. The E and F₁ layers were seen to vary in their ionisation with the zenithal angle of the sun, this giving peak diurnal values at noon and peak seasonal values in mid-summer. The F₂, on the other hand, behaves in an anomalous manner, having lowest value of ionisation in summer and highest in winter. There is a steady increase in the ionisation of all layers towards the maximum of the solar cycle, as would be expected. This means that, while the range of available frequencies for short-wave communication is increased at the solar maximum, so also is the

amount of absorption to which the waves are subject in the E and D layer.

Calculations as to the variation in the ultra-violet sunlight necessary to produce the observed change of critical frequency between minimum and maximum of the solar cycle show that there must have been an increase of 120 per cent. during this period.

In 1932 an expedition—which included Sir Edward—went to Tromsø, Norway, to make a year's ionosphere observations at a location near to the auroral zone, in order to decide whether the ionosphere was indeed produced by ultra-violet sunlight, or by charged corpuscles ejected from the sun. The corpuscles are known to produce the Polar aurorae, and it was felt that if, during a visible aurora, the ionisation of the layers increased, then the corpuscles might be assumed to be the ionosphere-producing agency. The expedition's work proved that the F₂ layer ionisation did not increase—but actually decreased—during the auroral displays, which not only upheld the theory of ultra-violet sunlight being the producing agent, but also threw some light on the nature of ionosphere "storms." Evidence of a correlation between the aurorae, the magnetic and the ionosphere disturbances was obtained, showing the corpuscles to be the cause of all three phenomena. Since then, similar disturbances have been studied in lower latitudes and the same effects—decreases of the F₂ critical frequency and poor reflection of radio waves—have always been observed.

Short-wave Fade-outs

Sir Edward next described work which has been done in elucidating the nature of the other type of ionosphere disturbance—that usually called the "sudden" disturbance, to distinguish it from the ionosphere "storm." The history of its discovery was shown to begin in 1859, when the British astronomer Carrington observed a bright "flare" on the

sun, and, noting the time of its occurrence, later connected it with the time at which a small sharp disturbance to the earth's magnetic field took place. Then in 1929 Mögel noticed that a sharp "fade-out" of short-wave radio signals corresponded in time with a disturbance to the earth's magnetic field similar to that which had been observed by Carrington. So there were three things which appeared to have something in common: (1) the solar flare, (2) the magnetic disturbance, and (3) the short-wave fade out, but they had, up to that time, only been noticed two at a time—never all three together. But at the last sunspot maximum the Huancayo Observatory in Peru and the Mount Wilson Observatory in California succeeded between them in observing all three phenomena at the same time.

Solar Flares

The whole sequence of events is thus something like this. A solar flare takes place and a great increase in the sun's ultra-violet radiation occurs, which penetrates to the lower ionosphere and causes enhancement of the D layer ionisation. In this region short waves are absorbed and so a short-wave fade-out occurs,

whilst at the same time there is a disturbance to the earth's magnetic field. About a day later solar corpuscles—which left the sun with the ultra-violet radiation but travelled much slower—arrive at the earth and produce the ionospheric and magnetic "storms."

The lecturer next dealt with the behaviour of radio waves in the ionosphere when sent up obliquely—as in practical communication—mentioning the effect of the parabolic distribution of the ionisation in the layer, and illustrating the paths of rays having different angles of incidence. An important part of the work in this direction has been the establishment of the relation between the measured critical frequency at vertical incidence and the equivalent frequency (or MUF) for any angle of incidence. Finally the ionospheric "tide" which occurs in the E layer was described; this effect is due—like the tides of the ocean—to the influence of the moon.

Concluding, Sir Edward said he was very conscious that great gaps in our knowledge still existed, and he hoped, if the Council should again invite him to lecture in eleven years' time, to be able to report more progress and further problems solved.

T. W. B.

BUILT-IN RADIO.

An exceptionally neat method of installing a permanent broadcast receiver has been devised by G. S. Martin, of West Bromwich. The loudspeaker fret covers an aperture in the wall leading to a small larder in which the receiver chassis is situated. A simple straight circuit is employed with a push-button controlled RF stage, detector, first AF amplifier and push-pull triode output. Controls for station selection and volume are mounted in the lower edge of the loudspeaker framework and are coupled by mechanical links to the chassis.

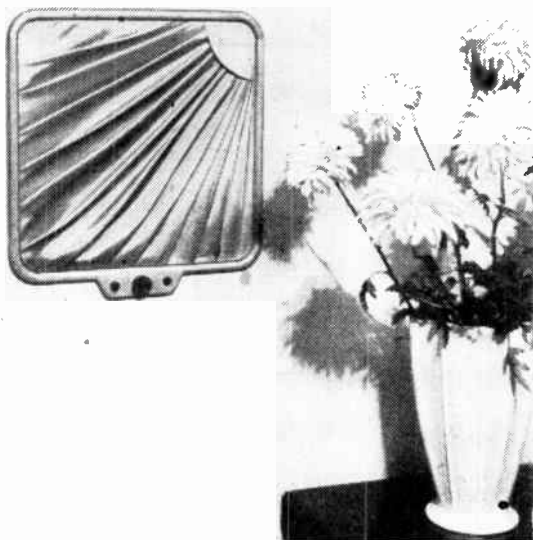

RAYTHEON

It is typically American to accomplish yesterday's impossibilities to-day. Raytheon research laboratory to-day and every day is delving into seemingly impossible Radio Electronic Tube problems . . . and solving them in an incredible space of time.

This unending scientific research carried on at Raytheon to aid the armed forces during the present conflict will, when we are once more on a peacetime basis, give Raytheon tubes the advantage of these newly-developed electronic principles. Your new Raytheons will be the product of the latest scientific research.

WORLD'S LARGEST EXCLUSIVE TUBE MANUFACTURERS

Register your name with our Representative now for your future benefit.

RAYTHEON PRODUCTION CORPORATION
NEWTON, MASS., U.S.A.

Exclusively Represented by
Frank Heaver Ltd. Kingsley Road, Bideford, N. Devon

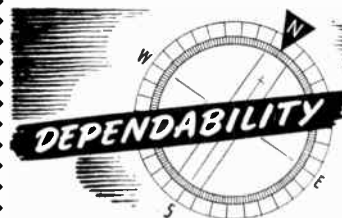

THE Crowe organisation is known to radio manufacturers throughout the world for dependable service and excellent quality of its many products.

Now devoted exclusively to production for Victory, with some items assisting directly in your Country's great efforts, we look forward to the time when our expanded facilities will be available for continuing our pleasant relationship with the British Radio manufacturing Industry.

CROWE
RADIO COMPONENTS

ESGUTCHEONS • TUNING CONTROLS
DIALS • REMOTE CONTROLS
POINTERS, ETC.

Crowe Name Plate & Manufacturing Co.
3701 Ravenswood Avenue
CHICAGO, ILL., U.S.A.

Exclusively Represented in Great Britain by
Frank Heaver Ltd. Kingsley Road, Bideford, N. Devon

Modifying the Transitron Pick-up Design

Transitron Oscillators

THERE are two remarks which I should like to make with reference to A. G. Chambers' articles in your March and April issues.

The first is theoretical, and concerns the operation of the transitron oscillator in the metre region. It was noticed by Herold that a circuit which was expected to oscillate at 10 Mc/s did not; the expectation was based on the knowledge that the negative resistance of the valve (at low frequencies) was less than the positive dynamic resistance of the tuned circuit at 10 Mc/s; and the failure was explained in terms of transit-time effects, although a more modern explanation would blame feedback due to lead inductances rendering the negative screen-cathode resistance too high for *transitron type* oscillation. I pointed out in a letter to *Wireless World* (Oct., 1940) how the unusually low negative resistance of an AC/SP1 valve could be used to extend the frequency range. Nevertheless, the figure of 60 Mc/s claimed by Chambers (and since verified by students of this Institute) appears excessive, especially as he does not claim a particularly high G_2 -to- G_3 transconductance. My doubts on this point were further increased by the second article, wherein feedback in the G_1 circuit was mentioned. I suggest that there is little likelihood of the transitron mechanism accounting entirely for oscillations at 60 Mc/s; it is more likely that some other mechanisms come into play, such as positive feedback from other electrodes, Barkhausen-Kurz electron oscillations, etc. This could be checked by strapping screen and suppressor earth return circuit (R_1) being disconnected.

Of greater practical importance may be a warning concerning frequency stability. While this is inherently high without question, Chambers' Fig. 2 (April *Wireless World*) shows the 1V output developed across a coil coupled to the tuned circuit L_1C_1 , presumably rather tightly as the RF volts

across L_1 are of the order of 10V. Hence the effective parameters of the tuned RF circuit will depend greatly on the load across the output, unless, of course, an attenuator of considerable step-down ratio is used; even then, the circuit would compare unfavourably with a more violently oscillating circuit, as an output of 0.1V at least would be required in practice and still give rise to far greater pulling than if it were taken from the tank circuit of a Hartley, say, with a PD of 100V RMS or so across it. Frequency modulation is another likely drawback of the circuit shown, especially at low values of dynamic resistance.

On the other hand, the absence of a high signal voltage is a good feature in a test oscillator, as less screening is called for. It is, therefore, suggested that the output be collected from a buffer stage, e.g., a cathode follower. Modulation could be carried out on that valve, e.g., by means of transitron action. The circuit suggested is shown in the figure; the values indicated are purely tentative, and the numbering follows Chambers' diagrams.

The RF output from V_1 is applied to the first grid of valve V_2 ; R_{12} is the self-bias resistor and the cathode load is $R_{12} + R_{14}$. Audio oscillation takes place in the circuit L_2C_2 which is in series with $R_{12} + R_{14}$; the audio

action is partly transitron type and partly positive feedback ($R_{12} + R_{14}$). R_{10} is made variable and controls the modulation depth. The voltage across R_{14} contains the modulated carrier plus some audio component which, however, may be blocked off by C_{12} , which feeds into the attenuator (not shown).

Another objection to the transitron oscillator has been mentioned to me. It concerns the effect of supply voltage changes on frequency stability. This is apparently very serious, rendering the performance of the transitron no better than that of the secondary emission (dynatron) type. The explanation is probably due to the effect of supply volts on the space charge near the suppressor grid, which is equivalent to a capacity between screen and earth.

T. J. REHFISCH.

Northampton Polytechnic,
London, E.C.1.

Needle Armature Pick-ups

THE article by Mr. G. A. Hay regarding high-quality pick-ups, published in your May issue, provokes the following comments:—

(1) Our own experiments along these lines using the same needles (H.M.V. Silent Stylus) show that the "springiness" of the needle itself alters the waveform at the higher frequencies.

(2) The output is very low as

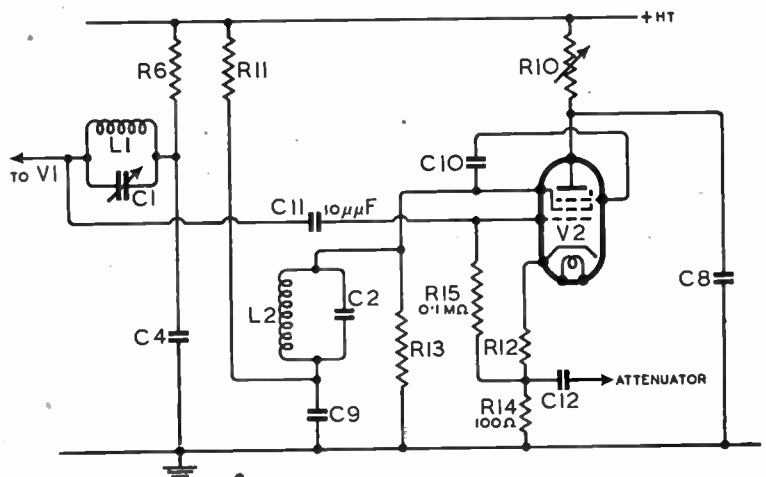

The circuit referred to by T. J. Rehfisch

the maximum needle movement occurs at the lower (record) end of the needle.

(3) The system of using a heavy pick-up and counterbalance causes bad wear on both needle and record unless the record is absolutely flat (a most unusual thing) and the turntable perfectly true. The groove jumping mentioned by Mr. Hay is just an extreme of the condition where the weight of the pick-up on the record is continually changing throughout each revolution of the turntable.

(4) The drag across the turntable causes wear on the outer side of the groove and corresponding wear on the needle, which can be seen after a few playings, with the aid of a microscope.

(5) It is almost impossible to eradicate electro-magnetically picked-up hum; not from the power transformers, which can be moved to a distance, but from the gramophone motor.

Points 1 and 2 can be cured by a rearrangement of the construction so that the pole pieces are at the lower end of the needle below the coil.

Our own pick-up follows the design used by Mr. Brierley (with all due acknowledgments to Mr. Voigt). The damping is light enough to permit a lower resonance of about 20 c/s, whilst keeping the total mass low. The HF resonance is about 12,000 c/s, which would be about the same as Mr. Hay's pick-up, as he can ascertain by speeding up the H.M.V. gliding tone record so that the starting frequency rises to about 14,000 c/s.

G. E. HORN,

R. H. THRUSSELL.

Oxford.

THE pick-up designs by Mr. J. Brierley, Dr. J. H. Mole, and Mr. G. A. Hay that have appeared recently in *Wireless World* have interested me greatly.

Regarding the descriptions of their pick-ups by the first and last authors, I would like to make a minor criticism of terminology. Both employ the commonly, yet erroneously, used word "tone-arm" when "carrying-arm" is the more accurate term. It has probably been forgotten that when the so-called tone-arm was invented, to enable the gramophone horn proper to remain at rest during the traverse of the

sound-box across the record, it was claimed that the tone of the reproduction was improved—hence its name, but I think that the perpetuation of this term, except in connection with sound-boxes, should be deprecated.

A point with reference to Mr. G. A. Hay's needle-armature design (May 1943 issue). Surely, the magnetic system could be modified to permit fitting pole pieces at the bottom as well as at the top of the coil, thus increasing the sensitivity of the pick-up?

I was pleased to see Mr. Hay's reference to the question of reducing tracking error by off-setting. The absolute and nuisance effects of tracking distortion are considerably greater than generally assumed, but these can be reduced to negligible magnitude by correct off-setting. A recommended rigorous analysis of this problem, with notes on optimal design, appeared in the *Journal of the Society of Motion Picture Engineers*, December, 1941.

DONALD W. ALDOUS.

Torquay, Devon.

MR. HAY'S article describing his needle armature pick-up raises several points worthy of comment.

The first point concerns the freedom of the needle. Mr. Hay's needle tip is as free to move longitudinally as transversely. With this arrangement, where the damping is the same for all directions of motion, increased buzz and noise should not result, but I have found freedom to move longitudinally usually results in noticeable "ironing out" of treble transients such as cymbal clashes and orchestral chimes.

On the matter of response curves, both Mr. Brierley and Mr. Hay, in their articles, show curves taken with gliding tone records. Tests made by myself on several pick-ups have been carried out using this type of record and also the set of H.M.V. standard frequency records. For my measurements I used a single valve amplifier and a Marconi-Ekco valve voltmeter. I found a marked difference between the gliding tone characteristic and that obtained on steady frequencies. The first was in every case very much smoother and lacked minor irregularities which were

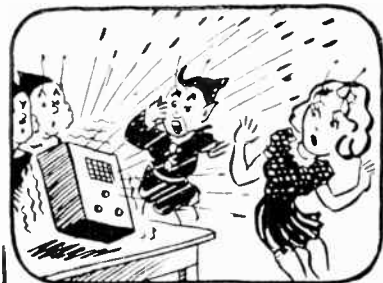

THE "FLUXITE QUINS" AT WORK

"Stick 'em up!" yelled the voice from the set.
"By gosh! It's real bullets, my pet!
Look out there!" OI cried.
"Something's busted inside—
That set'll need FLUXITE, I'll bet."

See that FLUXITE is always by you — in the house — garage — workshop — wherever speedy soldering is needed. Used for over 30 years in Government works and by leading engineers and manufacturers. Of all Ironmongers—in tins, 8d., 1/4 and 2/8.

Ask to see the FLUXITE SMALL-SPACE SOLDERING SET—compact but substantial—complete with full instructions, 7/6.

TO CYCLISTS! Your wheels will NOT keep round and true unless the spokes are tied with fine wire at the crossings AND SOLDERED. This makes a much stronger wheel. It's simple—with FLUXITE—but IMPORTANT.

The FLUXITE GUN puts FLUXITE where you want it by a simple pressure. Price 1/6, or filled, 2/6.



ALL MECHANICS WILL HAVE

FLUXITE

IT SIMPLIFIES ALL SOLDERING

Write for Book on the ART OF "SOFT" SOLDERING and for Leaflets on CASE-HARDENING STEEL and TEMPERING TOOLS with FLUXITE. Price 1s. each.

FLUXITE LTD.

(Dept. W.W.), Bermondsey Street, S.E.1

Letters to the Editor—

immediately apparent with the second system.

I attribute the difference in results to the transient nature of the frequency and inertia, either electrical or mechanical, in the valve volt-meter when using the first method.

Finally, as one of my pick-ups employs a more elastic and a adaptable moving system than either of those previously described, I will outline it here.

The pick-up has to be capable of reproducing very old and worn records of which I have some number, as well as many unworn ones.

It was decided to use Columbia Duragold needles for reproducing the old recordings, rejecting the needles, which are semi-permanent, after each playing. For the new records thorn needles were chosen and after some trials B.C.N. Emerald needles were selected as the most suitable.

The armature shown in the sketch is of extra special stalloy filed down and bent to shape. The pins, which are brass, are surrounded with rubber sleeves and form the pivot. The elastic nature of the armature allows many sizes of needle to be accommodated. With a flexible suspension no buzz is encountered.

With those needles the inertia is little in excess of that of the armature itself and treble response is dependent on the needle more than anything else. The full range of modern recordings is well within the limits of the system though considerable extreme treble lift is required.

With steel needles the inertia becomes very large and a pronounced resonance estimated at about 6,000-7,000 c/s takes place. This is not serious, however, as a 5,000 c/s cut-off is used on account of scratch being large on these records.

I am sorry more exact figures cannot yet be obtained. I only mentioned this armature because

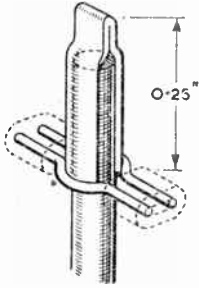

A. C. Robb's adjustable armature.

many people may find it possible to modify existing pick-ups to use such a system.

A. C. ROBB.

Upton, Cheshire.

Fog and Radiation

I WAS interested to read Mr. Forrest's article in your May issue on interference from power lines. Can it be explained why the attenuation of the interference as shown in figure 7 is so much greater in foggy than in dry weather? Is it because the radiation is differently polarised? Or is it because the ratio of inductive to radiation fields near the conductor varies according to the condition of the insulator?

Further information on this subject might enable the receiving aerial to be designed to favour wanted signals to an even greater extent than can be achieved by using a screened aerial feeder.

R. I. KINROSS.

London, S.W.3.

[The Author writes:—

“There seems to be no funda-

mental reason why the polarisation or the ratio of the induction to the radiation fields should vary with the condition of the insulators. The only effect of humid weather is to increase the intensity of the spark discharges; in other words, the power of the transmitter increases but the radiating system remains unchanged. Similarly it is difficult to see why the attenuation should be less in dry weather than in fog. A possible explanation of the observed results lies in the difficulty of measuring the weak noise fields in dry weather. It is clear from my Fig. 7 that if the general background of noise, due to causes other than the line, had a value of even $3 \mu\text{V/m}$, then the true attenuation law of the interfering field in dry weather would be masked, while the more intense interference in fog would only be slightly affected.

“Further investigations are required, however, in order to answer Major Kinross's question completely.”—ED.]

Wireless World Brains Trust**The Beginnings of Wireless : Marconi's Practical Contributions**

More Views on Question No. 11. (Who first conceived the idea of using electro-magnetic waves as a means of communication? . . .)

W. G. RICHARDS emphasises the part played by Marconi in applying Hertzian waves to a practical system of communication. He writes:—

IT is easy to be wise after the event, and, as everyone who has had anything to do with patents is aware, there may be many possible applications of a new discovery that never occur to the inventor, whose attention is focussed entirely on the one particular end he has in view. This plain fact accounts for many claims that are made by and on behalf of inventors and experimenters who have overlooked what, at a later date, may appear to be the logical outcome of their experiments. It is true that several scientists experimented with Hertzian waves, but the most sensible summing up on the question of who first conceived the

idea of using electromagnetic waves as a definite means of communication still seems to be that of Judge Townsend in the New York patent action in 1905. “It would seem to be a sufficient answer to the attempts to belittle Marconi's great invention,” he said, “that, with the whole scientific world awakened by the disclosures of Hertz in 1887 to the new and undeveloped possibilities of electric waves, nine years elapsed without a single practical or commercially successful result, and Marconi was the first to describe and the first to achieve the transmission of definite intelligible signals by means of these Hertzian waves.”

The same conclusion was voiced by a writer in *The Electrician* for October 14th, 1898:—“All the essential features of signalling by Hertzian waves were really outlined in scientific laboratories long before any idea of utilising them for commerce had occupied prominent attention. It is true that

the suggestion was cursorily thrown out by one or two leaders of science that Hertzian waves might be used for signalling; but this suggestion was never more than a bald idea conveying no practical directions as to its detailed working, and it was generally received with curiosity rather than with any serious idea of putting it into practical use. All honour is due to Signor Marconi for having been first to bring prominently forward the possibility and indeed the eminent practicability of using Hertzian waves for telegraphy between two places not connected by an electrical conductor."

In our last issue it was suggested that Nikola Tesla was one of the first to appreciate the possibilities of using Hertzian waves for communication. A. W. LADNER questions whether Tesla did, in fact, have in view what would now be described as radio telegraphy. He writes:—

IT is always difficult in these late post-mortems to weigh the evidence correctly since the material now available without an intensive search is already second, third, or even fourth hand; further, only part of the evidence is there and often is presented in such a way as to give a biased picture — biased in accordance with the writer's desire at the time.

Although there is no doubt that at the time people other than Marconi thought of Hertzian waves as a means of communication, authoritative quarters in all parts of the world have unquestionably given Marconi the credit for be-

ing the only one to see the commercial possibilities of communication by wireless and for having the initiative to produce the first practical system.

You quote Tesla's expression "through the earth," but apparently consider the Tesla experiments as evidence of wireless communication. I have always understood that Tesla's experiments (which were never carried out) were designed to prove the following theory:—

The earth being approximately a conducting sphere in space and therefore having inductance and capacitance and a natural frequency, Tesla's idea was that if one could in some way charge and discharge the earth at its natural frequency the influence would be world-wide. In other words, Tesla visualised the charging and discharging of the earth at its natural frequency as making it shake like a jelly, to put it crudely. Hence the reference to earth currents.

ELECTRICAL INDUSTRIES RED CROSS FUND

SUBSCRIPTIONS to this Fund, to which the wireless industry is giving its support, now amount to nearly £15,000. Among recent covenanted subscriptions from wireless firms are the following:—

Mullard Radio Valve Co., London	...	300
Mains Radio Gramophones, Bradford	...	50
Midland Counties Radio Services, Melton Mowbray	...	10

Information can be obtained from the Joint Secretaries of the Fund, c/o The E.D.A., 2, Savoy Hill, London, W.C.2. Contributions should be sent direct to the Electrical Industries Red Cross Fund, St. James's Palace, S.W.1.

Books issued in conjunction with "Wireless World"

	Net Price	By Post
FOUNDATIONS OF WIRELESS, by A. L. M. Sowerby. Third Edition revised by M. G. Scroggie	6/-	6/4
TELEVISION RECEIVING EQUIPMENT, by W. T. Cocking	10/6	10/10
RADIO LABORATORY HANDBOOK, by M. G. Scroggie. Second Edition	12/6	12/11
WIRELESS SERVICING MANUAL, by W. T. Cocking. Sixth Edition	7/6	7/10
HANDBOOK OF TECHNICAL INSTRUCTION FOR WIRELESS TELEGRAPHISTS, by H. M. Dowsett and L. E. Q. Walker. Seventh Edition	27/6	28/1
WIRELESS DIRECTION FINDING, by R. Keen. Third Edition	30/-	30/7
RADIO INTERFERENCE SUPPRESSION, by G. W. Ingram	5/-	5/4
LEARNING MORSE. 335th thousand	6d.	7½d.
INTRODUCTION TO VALVES, by F. E. Henderson	4/6	4/10
VALVE REPLACEMENT MANUAL, by A. C. Farnell and A. Woffenden	6/-	6/2

Obtainable from leading booksellers or by post from

ILIFFE & SONS LTD., Dorset House, Stamford Street, London, S.E.1

The Improved
VORTEXION
50 WATT
AMPLIFIER CHASSIS

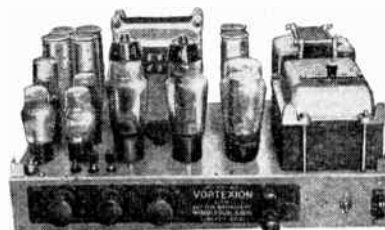

The new Vortexion 50 watt amplifier is the result of over seven years' development with valves of the 6L6 type. Every part of the circuit has been carefully developed, with the result that 50 watts is obtained after the output transformer at approximately 4% total distortion. Some idea of the efficiency of the output valves can be obtained from the fact that they draw only 60 ma. per pair no load, and 160 ma. full load anode current. Separate rectifiers are employed for anode and screen and a Westinghouse for bias.

The response curve is straight from 200 to 15,000 cycles. In the standard model the low frequency response has been purposely reduced to save damage to the speakers with which it may be used, due to excessive movement of the speech coil. Non-standard models should not be obtained unless used with special speakers loaded to three or four watts each.

A tone control is fitted, and the large eight-section output transformer is available in three types: 2-8-15-30 ohms; 4-15-30-60 ohms or 15-60-125-250 ohms. These output lines can be matched using all sections of windings and will deliver the full response to the loud speakers with extremely low overall harmonic distortion.

PRICE (with 807 etc. type valves) £18.10.0

Plus 25% War Increase

MANY HUNDREDS ALREADY IN USE

Supplied only against Government Contracts

VORTEXION LTD.

257, The Broadway, Wimbledon, S.W.19

Phone: LIBerty 2814

RANDOM RADIATIONS

By "DIALLIST"

Return to Simplicity?

IT would not surprise me greatly if when the war is over we found a growing tendency to discard the complex multi-electrode valve in favour of simpler types. Personally, I have never been very fond of the valve which, though it is a single component, is really two or three valves assembled in one and the same bulb. In making up sets for my own use, for instance, I have always preferred to have the local oscillator and the mixer separate entities rather than a combined unit of the triode-hexode type. The business of two-in-one and three-in-one valves started, if I remember right, with the German Löewe assemblies. Old readers will recall them. The basic idea was to reduce the length of grid wiring to a minimum and to achieve this the coupling condensers and resistances were actually within the bulb. The next development was to put RC-coupled RF and detector valves, with their condensers and resistances, into one envelope. Alternatively, the assembly might consist of a detector, resistance-capacity coupled to an AF valve. Wasn't there eventually a triple Löewe "valve"; RF-cum-detector-cum-output? I seem to remember that there was. These valves were large things and naturally they had to be treated with no small amount of care.

How it Started

But the Löewe valves, with their built-in condensers and resistances, hardly deserved to be classed as multi-electrode valves; they were really separate valve assemblies, with their associated couplings, made up in a large glass bulb. I can't recall which of the true two-in-one valves came first, but it was probably the diode-triode. It was a natural development. For years the triode reigned unopposed; it was the only valve. Then a second grid—the space charge grid—made its appearance and we had the first four-electrode valve, the tetrode. The screen grid valve, next in the direct line, is, of course, also a four-electrode valve, but the extra grid is differently employed. Some readers will remember the excitement caused by the appearance of the SG at the Radio Exhibition. What year was it? I've no reference books by me at my back-of-beyond station, but 1927 at a guess. It was a queer sausage-shaped double-ended affair. There was a

cap at either end, one containing the two pins for anode and screening grid and the other the three for control grid and filament. You mounted it in a hole cut in an earthed metal screen, which, you remember, had to be in the same plane as the internal screening grid.

Tetrode to Heptode

The pentode was first developed in Holland. I heard of it through a friend then living in that country and somehow managed to get a couple smuggled in here, some months before they were known in this country. I remember well the epistolary bricks heaved at my devoted head when I wrote a brief article forecasting the advent (the first pentodes were all of the AF type) of an output valve of enormous anode resistance and an amplification factor of a magnitude then undreamed of! The pentode soon came to stay, for once the RF type was developed and its little ways understood, it was found that there was hardly a limit to the purposes it could be made to serve. But once manufacturers had solved the problem of making valves with three grids the multi-electrode valve began to develop apace and further grids blossomed out. Then came the idea of a diode and a triode in one bulb and combinations, more and more complex, made their appearance. Set designers, seeing the possibilities of such valves, perhaps set the pace for the valve manufacturers.

Points of View

There is a lot to be said for and against the two-in-one and three-in-one valve, though my own view is that the "cons" outweigh the "pros." To the designer of moderate-priced broadcast receivers, who has to cut his making-up costs to the minimum reconcilable with decent performance, these valves certainly offer enormous help. Not only that, but they simplify wiring to some extent and also lend themselves to compactness in the receiver. But from the user's point of view—the broadcast listener, I mean, who is the most likely possessor of the kind of set I'm thinking of—they have one outstanding drawback: they're very expensive to replace. A double- or triple-duty valve is just as easily damaged as a triode—probably more easily—and it's no fun to find that the new one needed is going to cost several times as much as a simple valve.

The experimenter and the short-wave addict may use a certain number of complex valves; but most of us have the belief that you can get better performance from a liberal use of the simpler valves than from the employment of a few of the highly complex type. The wartime apparatus used by the Services makes enormous use of the two-, three-, four- and five-electrode valve and comparatively little of the complicated types. And I have a strong feeling that a return to this state of affairs may possibly be seen in receiving sets of post-war design.

Should We Gain?

We should, I believe, gain a great deal if such a return were made. Were manufacturers (who have learnt a great deal about mass-production methods during the war) free to concentrate their energies on just a few types of valve, none of these being more complex than, say, the pentode or the beam tetrode, production costs, and therefore retail prices, could come down with a run. I do not see why the cost of any of these valves should be more than seven or eight shillings. The public would not mind paying a little more for its receiving sets in the first instance if it felt that it was no longer haunted by the bogey of expensive replacements. Nor, I think, would it object to the cabinets of receiving sets being slightly larger, were this found necessary in order to house the extra valves. Performance could probably be improved and service men would certainly bless the wide use of the simpler types of valve.

□ □ □

Jamming

WHENEVER I listen, as I do quite often, to one of our broadcasts to foreign countries, I notice the enemy's efforts to jam it, and wonder how successful they are. They can't be completely effective; otherwise there would be no need for edicts threatening those who listen to London with frightful pains and penalties. Also we know that listening to our special bulletins is done on a large scale in enemy countries and those temporarily occupied by the enemy. The Hun is, of course, sitting rather pretty as regards facilities for jamming, for he or his willing or willy-nilly allies now control most European broadcasting stations, with few exceptions amongst those of noteworthy power

output. On the long waves alone Hilversum, Radio-Paris, the Deutschlandsender, Luxembourg, Oslo and Kalendborg must do what they are told, so there are always one or two available for the attempted jamming of Droitwich. Yet Droitwich we know does get through to a huge number of Continental listeners. We have too few stations to spare many for counter-jamming; though the Russians are pretty well off in that way even now, and one hears some remarkably successful work that is presumably theirs on German and Italian transmitters, I can't help wishing that some of our bombers might be briefed to deal with big enemy and enemy-controlled broadcasting stations as primary objectives. We could reach a far larger audience with some of the more powerful out of the way.

□ □ □

Protest Deductions

THE idea that certain listeners have conceived of withholding part of their broadcast licence fees as a protest against some of the aspects of the B.B.C.'s programme policy shows that an old misconception, often referred to by *Wireless World*, is by no means dead. The wireless receiving licence entitles its holder to establish and maintain apparatus for the reception of broadcast radio transmissions; no more and no less. In actual fact, a proportion of the licence fees goes to the B.B.C. for the purpose of running an entertainment service; but you will find nothing in the licence to the effect that entertainment is guaranteed to the purchaser—any more than a gun licence or game licence guarantees that its holder will find anything to shoot. They authorise you to carry and use a gun, or to kill game; part of the money received may go in the enforcement of game and wild-fowl laws; but if you have a poor season you cannot refuse to pay the full amount next time you want a licence. All that will happen to those who propose knocking something off the receiving licence fee is that they will not be able to buy licences and they will leave themselves wide open to a prosecution if they go on using their sets. The idea was a silly one and I hope it will end as all silly ideas should.

WASTE PAPER

IMPREGNATED paper is now being used for insulating purposes in various types of cables, including Admiralty power cables. Thousands of tons of paper are needed to cover the millions of miles of electric cabling used annually for war and other purposes.

COMMUNICATIONS DEPEND...

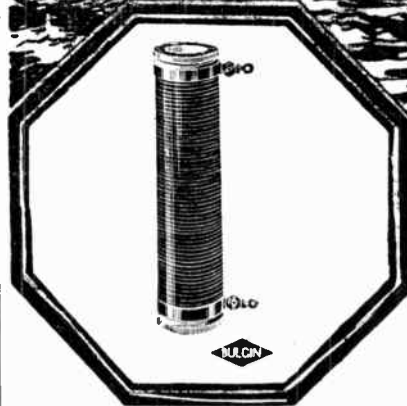
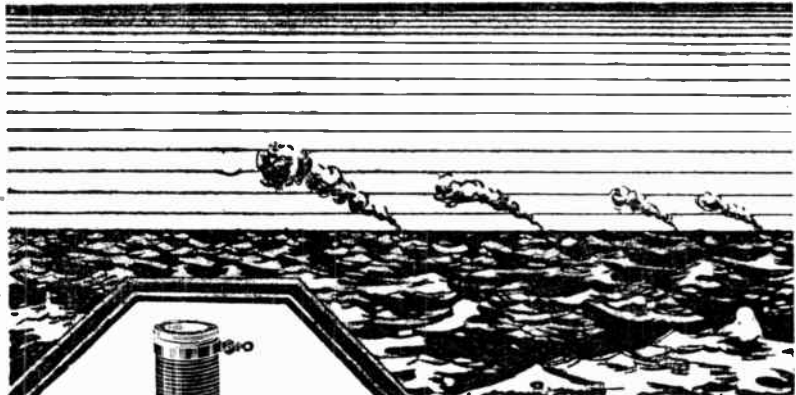

ON SMALL PARTS...

IN countless instances quite intricate pieces of apparatus are wholly dependent on the proved reputation and reliability of their component parts.

All products from the House of Bulgin are pre-eminent for superior design and workmanship and every article bearing our Trade Mark has to pass exacting and exhaustive tests during the course of its production.

We ask the kind indulgence of the Trade on delivery until peaceful conditions return.

The Choice of Critics

BULGIN FOR RESISTORS

The largest and most comprehensive range of Resistors. Values from 0.10 to 150,000Ω in wire-wound types, ratings from 2 to 100W. Solenoidal-wound and double-spiral models available. Special accuracies of $\pm 1\%$ to order, at special prices. Only the finest materials are used throughout.

"The Choice of Critics"

BULGIN

REGISTERED • TRADE • MARK

A. F. BULGIN & CO. LTD., BYE PASS RD., BARKING, ESSEX.
TEL. : RIPPLEWAY 3474 (4 lines).

RECENT INVENTIONS

PRODUCING MULTIPLE FREQUENCIES

THE electron stream of a cathode-ray tube is first flattened and is then traversed by an applied deflecting frequency over an anode which consists of a number of differently shaped conducting strips mounted separately on a concave sheet of glass. Each strip is connected to a different external circuit, and in each case is shaped so that the surface contacted by the electron stream varies from point to point of its traverse.

The result is that a number of currents of different frequency are produced simultaneously in the output circuits, each frequency being numerically related to that applied to the deflecting plates of the tube.

The arrangement may be used for multiplex signalling, for distorting speech in secret systems of telephony, or for generating musical sounds rich in harmonics from an applied fundamental frequency.

C. G. Galpin. Application date August 8th, 1941. No. 550,342.

DIPOLE ARRAYS

A NUMBER of coupled sets of dipoles, arranged as shown, are mounted one above the other on a single mast, at a high elevation, to give a uniform distribution of energy in the horizontal plane. Such an aerial array is particularly adapted for broadcasting television or frequency-modulated signals covering a wide band of frequencies.

Each dipole element is made of hollow tubing, and forms one link in a square or other closed-loop radiator. The two limbs A₁, A₂ are energised in anti-phase by crossed feed-lines, which pass up the centre shaft S and through the side supports 1, 2. The two other limbs A₃, A₄ are capacity-coupled to the first pair, so that the resulting current flows in phase around the outer periphery of the square or loop. As there will then be a voltage node at the centre of each limb, the assembly can be supported directly from the centre shaft, as shown, without insulation.

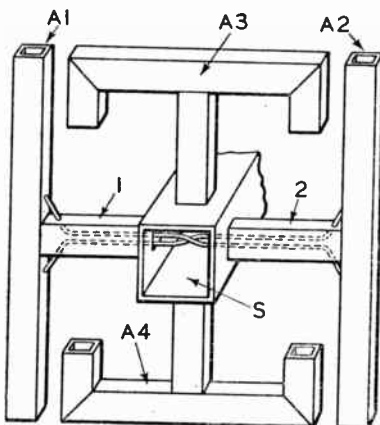

Wide-band dipole array.

A Selection of the More Interesting Radio Developments

For radiating on, say, 40 megacycles, the element is approximately 3 feet square, each hollow limb being 3 inches square in cross-section.

Standard Telephone and Cables, Ltd. (Assignees of A. Alford). Convention date (U.S.A.) September 25th, 1940. No. 550,009.

SHORT-WAVE OSCILLATORS

THE figure shows a pair of push-pull valves, with extended water-cooled anodes, for generating ultra-short waves at a high level of power. Normally the comparatively large surface of the anodes and water jackets will constitute a considerable capacity short to earth.

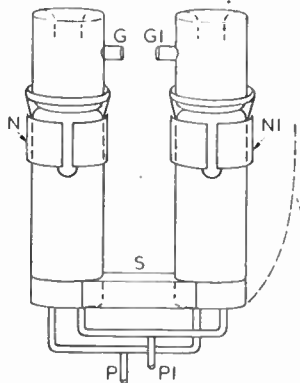

Push-pull USW generator.

In order to minimise this the tuned anode circuit is limited to the anodes and their associated cooling-jackets by bonding the two bases together by a metallic strap S. The metal-work then provides the distributed inductance and capacity required.

The inlet and outlet pipes P, Pi for the cooling fluid are connected to the lower ends of the anodes, and do not form part of the tuning inductance, the gradient of the high-frequency voltage along the anodes being indicated by the dotted line V. The neutralising condensers, in the case of triode oscillators, consist of cylindrical segments N, N₁, split to allow for adjustment, and connected to the opposite grids G, G. The bonding strap can also be adjusted along the axial length of the anodes.

Marconi's Wireless Telegraph Co., Ltd., and E. Green. Application date May 28th, 1940. No. 550,067.

The British abstracts published here are prepared with the permission of the Controller of H.M. Stationery Office, from specifications obtainable at the Patent Office, 25, Southampton Buildings, London, W.C. 2, price 1/- each.

MAGNETRONS

THE split-anode type of magnetron as used for generating centimetre waves normally requires a magnetic control field of high intensity and a correspondingly large magnetic superstructure. It is now pointed out that the magnetic field-strength can be reduced, for a wave of given frequency, if it is generated in a region which is occupied by a rotating space charge.

For this purpose a valve is described in which an axial filament is surrounded by a number of radial sheets or vanes, which are connected symmetrically to two end-discs, so as to form a cage-like structure about the filament. Adjacent pairs of vanes then form the two parts of a half-wave transmission line, which is shorted at both ends. This sets up a radial electric field, which spreads out from the filament to the anode, and, when subjected to the axial magnetic field from a pair of external coils, creates a rotating space-charge which is maintained by electrons from the filament.

The British Thomson-Houston Co., Ltd. Convention date (U.S.A.) July 27th, 1940. No. 550,081.

"SQUEGGING" ON CENTIMETRE WAVES

THE figure shows a valve circuit for generating centimetre waves in pulses having a predetermined repetition-frequency. The anode and grid are coupled through parallel Lecher wires L, L₁. These are terminated by a variable condenser C which is in series with a grid-leak resistance R adjustably tapped to the wire L₁. The HT supply is taken to a variable point P on the wire L, and the cathode is variably biased by a resistance R₁.

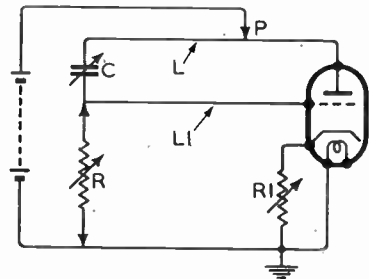

Centimetre wave oscillator.

The radio frequency is determined by the tuned Lecher circuit, whilst the pulsing or repetition-frequency depends mainly upon the time-constant of the grid resistance R and condenser C, but also, in part, upon the value of the high-tension and the point P at which it is applied, upon the contact position of the grid leak resistance R along the wire L₁, and upon the bias applied by the load resistance R₁ to the cathode. The pulsing period may be varied over a wide range for any value of C and R.

Marconi Wireless Telegraph Co., Ltd., and T. D. Parkin. Application date June 13th, 1941. No. 550,591.



LEADERSHIP

In the field of technical and scientific development – and still more in the stress of commercial competition—leadership is a position not easily earned or lightly held. Nor is the house of Philips unmindful of the obligations which leadership entails; the confidence of the public for over fifty years is a proud responsibility.

PHILIPS



INCANDESCENT AND DISCHARGE LAMPS · FLUORESCENT LIGHTING · RADIO RECEIVERS AND TRANSMITTERS · COMMUNICATIONS EQUIPMENT · THERMIONIC VALVES AND OTHER DEVICES · X-RAY EQUIPMENT FOR ALL PURPOSES · ELECTRO-MEDICAL APPARATUS · ARC AND RESISTANCE WELDING PLANT AND ELECTRODES · MAGNETS AND MAGNETIC DEVICES · SOUND AMPLIFYING INSTALLATIONS

PHILIPS LAMPS LIMITED, CENTURY HOUSE, SHAFTESBURY AVENUE, LONDON, W.C.2 (123B)

WHARFEDALE

THE manufacturers of the WHARFEDALE range of

TRANSFORMERS announce

with regret that Orders can be accepted for

PRIORITY PURPOSES ONLY

This applies to all INTERVALVE and OUTPUT TRANSFORMERS

WHARFEDALE WIRELESS WORKS
(SOLE PROPRIETOR: D. E. BRIGGS)

HUTCHINSON LANE, BRIGHOUSE

'Phone: Brighouse 50 'Grams: Wharfedale



FOR THE RADIO SERVICEMAN DEALER AND OWNER

The man who enrolls for an I.C.S. Radio Course learns radio thoroughly, completely, practically. When he earns his Diploma, he will KNOW radio. We are not content merely to teach the principles of radio, we want to show our students how to apply that training in practical, every-day radio service work. We train them to be *successful!*

Special terms for members of H.M. Forces.

-----You may use this Coupon-----

INTERNATIONAL CORRESPONDENCE SCHOOLS Ltd.

DEPT. 38, INTERNATIONAL BUILDINGS, KINGSWAY, LONDON, W.C.2

Please explain fully about your instruction in the subject marked X

Complete Radio Engineering. Radio Service Engineers.
Elementary Radio. Television.

And the following Radio Examinations:—

British Institution of Radio Engineers.
P.M.G. Certificate for Wireless Operators.
Provisional Certificate in Radio Telephony
and Telegraphy for Aircraft.

City and Guilds Telecommunications.
Wireless Operator and Wireless Mechanic, R.A.F.

Name..... Age.....

Address.....

THE KING'S BOUNTY

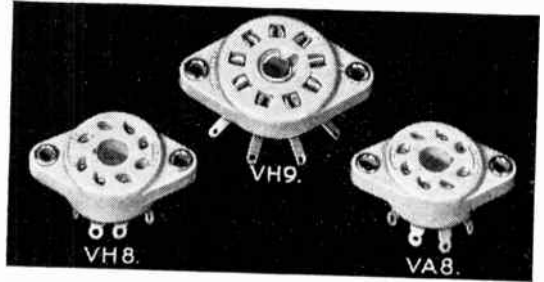

Unusual events are getting quite commonplace during the period we are passing through, in fact many take them for granted and never give a thought to the training or designing which has made them possible.

We have just contributed 3 new types of Valveholders which, with the others in our range, cover practically every present-day requirement. Naturally we are not applying for "The King's Bounty," but we will be perfectly content if you are sufficiently interested to write us for full details of these and our other types.

THE THREE NEW RAYMART VALVEHOLDERS

TYPE VH8, Mazda Octal. TYPE VA8, International Octal, 1/3 each.

TYPE VH9, for the new British "E" type valves, 1/9 each.

These three types have ribs between each contact to increase the effective distance between, and also to prevent tracking. Their Pierced solder tag connections protrude through base of Ceramic. Other features are standard with other types, viz.: Bases are of RMX low-loss Ceramic. Contacts, Resilient bronze alloy, sterling silver plated. Fixing. Floating nickel-plated eyelet (4BA clearance) fitted in strengthening boss in Ceramic.

Enquiries invited from Government Departments, Traders and Servicemen.

RAYMART 48 HOLLOWAY HEAD, BIRMINGHAM, 1
Telephone: Midland 3254.

BASICALLY BETTER...

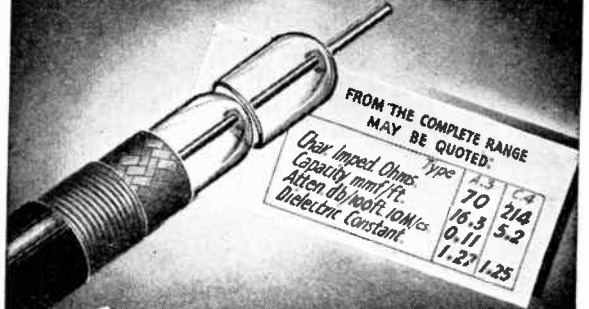

Air Insulation...

is the basic principle of

CO-AX CABLES
Unequalled H.F. Properties

There is a CO-AX Cable for every H.F. Purpose

TRANSRADIO LTD. Inc. TELEQUIPMENT CO. 16 HIGHWAY BEACONSFIELD

CLASSIFIED ADVERTISEMENTS. Rate 6/- for 2 lines or less and 3/- for every additional line or part thereof, average lines 5-6 words. Each paragraph charged separately. Press Day: July issue, first post Thursday, June 10th one day earlier at branch offices. Box Numbers: 5 words, plus 1-. Deposit System: particulars on request. No responsibility accepted for errors.

Ode
Partridge
No. 24

CARELESS TALK

Guard well thy tongue,
Lest it betray
The lives of those
For whom you pray,
And thinking not
You're overheard,
Could mar a plan
By one chance word.

'Tis not the spy
Who talks aloud,
But kindly folk
Who, feeling proud,
Relate with joy
A bit of news
That may bring death
To troops or crews.

Guard well thy tongue,
Lest it be said:
"Through your loose talk
Those lads are dead."

N. Partridge

Kings Buildings, Dean Stanley Street,
LONDON, S.W.1. Vic. 5035.

ARMSTRONG SERVICE

OUR Service Department is still at your service.

Despite the many changes caused by over three years of war, and the difficulties in material and valve supplies, we have managed to maintain a very large proportion of Armstrong Chassis in good working order.

IN ADDITION

to practically all Armstrong Chassis, including very old models, we can now undertake the repair and overhaul of many other makes of receivers, including American types.

ARMSTRONG MANUFACTURING CO.
WALTERS ROAD, HOLLOWAY, LONDON, N.7
Phone: NORth 3213

NEW RECEIVERS AND AMPLIFIERS

DEGALLIER'S, Ltd., will resume sales and service after war; owners of American sets in difficulty with service advised free; send s.a. envelope; just part of our service.—**Degallier's, Ltd.**, 9, Westbourne Court, London, W.2. [1741]

£22 World Quality amplifier, with tone control stage, 8 watts push-pull triode output, price includes Super Quality triple cone 12in permanent magnet speaker with large matched output transformer and all valves; as above but with 15-watt tetrode output, £24; ideal for quality reproduction; limited number available.—**Bakers Selhurst Radio**, 75, Sussex Rd., S. Croydon. [1698]

RECEIVERS, AMPLIFIERS—SECOND-HAND

FOR sale, Hallicrafter Diversity communication receiver, almost new.—**Box 2874, c/o Wireless World.** [1734]

W.W. Q.A., many refinements, 180ma for ex. use, 3 valves, tone control.—**Box 2876, c/o Wireless World.** [1754]

W.W. quality amplifier, £11; Goodman's infinite baffle speaker, £13; Murphy A56V television, £18, all perfect.—**Box 2880, c/o Wireless World.** [1771]

FOR sale, Baker's 10-valve 2H.F. receiver, S.Q. amplifier chassis; £15.—7, Westbourne Rd., Walton, Warrington. [1757]

SPECIAL variable selectivity superhet receiver and 10-watt Quality amplifier in oak cabinet, with separate Hartley Turner speaker; a first class outfit in perfect order; £40.—**Robinson, Berigem, Maresfield Park, Sussex.** [1756]

TEN-VALVE amplifier, without valves, suitable for factory, 60-100 watts output, 1,000v H.T. supply transformer and chokes, separate heater transformers, Mansbridge type condensers throughout, never used; worth £80.—**Offers to Headmaster, Wimbledon College, S.W.19.** [1768]

LISTS available under following sections: receivers, amplifiers, loud speakers, resistances, condensers, components, valves, electric lighting sets, batteries, dynamos, motors, converters, transformers, cinema and photo gear, domestic appliances, scientific instruments, miscellaneous (non-electric), switch and fuse gear; stamp, please, and state sections required.—**Harris, Strouds, Bradfield, Berks.**

Wanted

WANTED, A.C. communication receiver; parts.—12, Dare Rd., Erdington, Birmingham. [1744]

HALICRAFTER'S Skyrider Defiant, SX24, or Sky Champion.—**Avery, Downview, Tilehouse, Guildford.** [1740]

QUALITY tuner unit, power pack, 2 RF stages, for Q amplifier, complete or kit.—**Box 2873, c/o Wireless World.** [1733]

WE Offer Cash for Good Modern Communication and All-wave Receivers.—**A.C.S. Radio, 44, Widmore Rd., Bromley.** [1541]

URGENTLY required, first-class communication receiver, Hallicrafter SX28 or S27 pref.—**Box 2871, c/o Wireless World.** [1723]

WANTED, A.C. communication receiver, matched speaker; price, details.—**Read, 25, Cunningham Rd., Tottenham, N.15.**

W.W. Quality superhet unit or other "W.W." superhet; also communications receiver, pref. National or Comet Pro.—**Hardwicke, 29, Warwick Ave., Crosby, Lancs.**

NATIONAL H.R.O. Communications Receiver Required, 250 volts A.C.; must be late model, in good condition; state lowest cash price.—**Box 285a, 75-79, Farringdon St., London, E.C.4.** [1557]

COMMUNICATION receiver, W.W. preferred; high price given, or can offer Garrard Autochanger, Collaro record player, Mercano No. 8 and Trix railway, new, in part exchange.—**Box 2875, c/o Wireless World.**

RADIO set wanted, Bush PB.61, PB.63 or PB.65; also Pilot Little Maestro (recent model); best price given for set in good condition.—**Write, giving model No., age and price, to Rann, 18, Blanford Close, London, N.2.** [1725]

HALICRAFTER SX28 receiver, with matched speaker, or Hallicrafter SX29 Sky Traveller (battery model), or Hammarlund Super Pro, series 200, with matched speaker perfect condition.—**Box 93, Parris, 124, Kingsway, London, W.C.2.** [1732]

LONDON CENTRAL RADIO STORES will pay good prices for receivers, radiograms, amplifiers, dynamos, converters, test equipment, electric gramophone motors, and all radio and electrical accessories.—**London Central Radio Stores, 23, Lisle St., London, W.C.2. Gerrard 2969.** [9836]

NEW LOUDSPEAKERS

200 G.E.C., p.m. speakers with transformer in stock, complete in metal cabinets, £2/5 each, c.w.o. plus 1/- carriage and packing, brand new in maker's carton.—**A. Imhof, Ltd., 112, New Oxford St., W.C.1.**

Advertisers and buyers are reminded that under Defence Regulations 1939, Statutory Rules and Orders 1940, Number 1689, a permit (T 99 G) must be obtained before sale or purchase of certain electrical and wireless apparatus, particularly such valves and apparatus as are applicable to wireless transmission.



KURZ-KASCH RADIO KNOBS—DIALS INSTRUMENT KNOBS

NOT only are modern plastics materially helping to win the war, but they will also help in designing those better post-war days.

We patiently await the time when we shall once again be able to help equip your radio receivers and instruments with those well designed and good looking mouldings and, no doubt, with other items resulting from plant expansion and new developments.

Register your name with our Representative now. He will forward you information on our products as soon as they become available.

KURZ-KASCH INC.
Moulders of Plastics,
DAYTON, OHIO, U.S.A.

Exclusively Represented by
Frank Heaver Ltd. Kingsley Road, Bideford, N. Devon

L.R.S

STUART PUMPS

As supplied to Govt. Dep'ts. & County Councils.

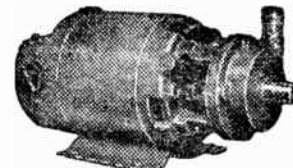

These Centrifugal Pumps are ideal for Machine Tool Cooling and all pumping purposes—hot or cold water. Supplied complete with foot-valve, strainer and hose union. Suitable rubber hose available from stock.

- No. 10. 100 gals. per hour. Carr. 2/- extra £5 2 6
 - No. 11. 280 gals. per hour. Carr. 2/- extra £8 6 0
 - No. 12. 560 gals. per hour. Carr. 3/- extra £7 12 0
- Please send 2/d. stamp for specification.

The STUART AUTOMATIC FLOAT SWITCH is the best method of controlling water. Post Paid level. Price complete with all fittings. .. £2 6 0

LONDON RADIO SUPPLY CO.
Est. 1925
Ardingly Road, Balcombe, Sussex.



A 65-watt SOLOON for general use

This 65-watt Industrial type SOLOON Electric Soldering Iron is fitted with an oval tapered bit—a shape which is suitable for most general work. For specialised work the pencil bit model is recommended, whilst bigger jobs call for the 125-watt or 240-watt models.

Supplies of these various models are only available for essential war work, of course, and due to heavy demands it is necessary to order well in advance to avoid disappointment in delivery.

Details of this and other models sent on request.



MADE FOR USUAL STANDARD VOLTAGES

W. T. HENLEY'S TELEGRAPH WORKS CO. LTD.
Engineering Dept., Milton Court, Westcott, Dorking, Surrey

BOOKS for wireless operators

RADIO RECEIVER CIRCUITS HANDBOOK

By E. M. Squire. A useful guide to circuits for members of the radio industry and radio amateurs. It contains practical notes on the operation of basic modern circuits, and the text is liberally illustrated with circuit drawings and other diagrams. Second Edition. 5s. net.

SHORT-WAVE RADIO

By J. H. Reynier, B.Sc., A.C.G.I., etc. This book gives an account of the tremendous progress which has been made in the field of short-wave radio-telegraphy during the last few years, and shows how many of the problems formerly regarded as insuperable have been overcome. 10s. 6d. net.

ELEMENTARY HANDBOOK FOR WIRELESS OPERATORS

By W. E. Crook, A.M.I.E.E., A.F.R.Ae.S. Written by an R.A.F. Instructor, this book is ideal for the man who wants to become a wireless operator. It gives you all the essential information you require in the first instance in a clear, easy-to-understand manner. You will be on the right lines if you read and study this book. 4s. net.

WIRELESS OPERATING SIMPLY EXPLAINED ("Simply Explained" Series)

By W. E. Crook. Gives a clear and interesting picture of the wireless operator in action—what he has to do and why he does it. 9d. net.

39, PARKER ST., KINGSWAY
PITMAN'S

£3/15 only.—Brand new Super Quality triple cone permanent magnet speaker, made by Bakers Selhurst Radio, the pioneer manufacturers of moving coil speakers since 1925; wide frequency range, even response; ideal for quality reproduction; limited number available under list price; send 2/6d. stamp for leaflet describing above and giving constructional details of infinite baffle cabinet; every music lover interested in realistic reproduction should write for leaflet now.—Bakers Selhurst Radio, 75, Sussex Rd., S. Croydon.

Wanted
GOODMAN'S or other really Hi-Fi 12in p.m. speaker.—1, Roe T.R.E., Malvern.
GOODMAN'S Infinite baffle speaker.—11, Hut 102, Copse Lane, Headington, Oxford.
WANTED, 2 G12S. Price and parties.—Windle, 337, Myrtle Rd., Sheffield.

NEW MAINS EQUIPMENT
VORTEXION mains transformers, chokes, etc., are supplied to G.P.O., B.B.C., L.R.T.B.; why not you? Imitated but unequalled; orders can only be accepted against Government contracts.
VORTEXION, Ltd., 257, The Broadway, Wimbledon, London, S.W.19. Tel. Lib. 2814. [9942]

MORSE EQUIPMENT
FULL range of transmitting keys, practice sets and equipment for Morse training.—Webb's Radio, 14, Soho St., London, W.1. Tel. Gerrard 2089. [9553]

TEST EQUIPMENT
WESTON output meter (A.C.), 5-range, £8/10; Ferranti 0-150ma, 37/6.—Box 2879, c/o Wireless World. [1766]

MULLARD GM3152 Oscilloscope, as new, £50 (pre-war price).—Particulars from Brewer, 15, Pearson St., Bury, Lancs. [1718]
RADIOMETER, Type U.V.T., "all valve R tester," in perfect working order, for A.C. mains only; what offers?—Box 2868, c/o Wireless World. [1717]
TESTSCOPE, used everywhere by radio service engineers, makes 20 important tests; send for interesting leaflet "R1."—Runbaken, Manchester, 1. [1074]

Wanted
C.R. tube, 1 to 6in, new or little used; also Midget receivers, any condition; good prices.—Ball, 240, Henvy Rd., Newquay, Cornwall. [1765]

SIGNAL generator or valve tester of good quality in exchange for Ediswan Tungar multi circuit battery charger cat. No. 68021, 5 circuit 60 cell model 200-250 volts 50-100 cycles a.c., unused.—Box 2866, c/o The Wireless World. [1712]

GRAMOPHONE EQUIPMENT
COMPONENTS for filter unit to J. Briereley's specification (W.W., April), see advert. in May issue; orders in rotation due to limitation of supplies; correction: your complete filter adjusted 10% post free. Enquiries invited for special coils.—R. Clark, 69, Longley Ave, Alperton, Middx. [1750]

Wanted
WANTED, dance records for fidelity working.—Box 2870, c/o Wireless World.

REQUIRED for important work, single or twin gramophone turn-table; highest price paid.—Full details to Wireless Services, Ltd., 246, Stanley Rd., Liverpool, 20. [1729]

COMPONENTS—SECOND HAND, SURPLUS
RADIO valves, components, quotations by return; 120ma mains transformer, 25/6.—Coventry Co., Dunstable Rd., Luton. [1763]

EXCHANGE Ferranti A.F.15C for Ferranti S.V.84 mains transformer or similar.—Johnson, 10d, South Mains St., Coatbridge.

LONDON CENTRAL RADIO STORES offer the finest radio and electrical bargains.

ELECTRIC soldering irons, 200-250v, 75 watts; post, etc., 8d. extra; 12/6.

PUSH-BUTTON mechanism only unit, complete with buttons; post, etc., 9d. extra; 4/6.

T.C.C. condensers, 0.1mfd 5,000v, dr wkg.; post, etc., 8d. extra; 9/6 each.

SCREENED cable, fine quality, heavy duty, 15 strand, 30 gauge, 5mm rubber covering, with two layers of Empire tape, 1/9 per yard.

RUBBER covered flexible wire, tinned copper, approx. 17 strands, 9ft lengths, 3d. per yard.

PILCO bleeder resistances, in metal cans, 100, 150, 250ohms; all 10w; post, etc., 3d. each; 2/6 extra.

TUBULAR condensers, 0.5mfd, 500v working; 2/6; post, etc., 4d.

MULLARD EA50 diodes, 60mmx12mm overall, 6.3v heater at 15amps; post and pkg. 3d. extra; 10/6 each.

PHILIPS potentiometers, carbon: 700,000 ohms, less switch, 3/6; 100,000ohms, with 2-pole m and b switch, 4/6; post and pkg. 6d. extra.

LONDON CENTRAL RADIO STORES, 23, Lisle St., London, W.C.2. Gerrard 2969.

"To paint the lily . . .

is wasteful and ridiculous excess," said Shakespeare. To that philosophy we heartily subscribe. At Gardners there is no attempt to "paint" or flatter a component, the intrinsic worth of which is apparent from its design and construction and proved by its performance. And nowhere in the Gardner range of quality transformers is "painting" more conspicuous by its absence than in the range of Small Power Transformers up to 4 kVA. When next you are in need of this type of transformer, and the specification taboos "painting," we'll be happy to co-operate with you.

We regret that at present Small Power Transformers are available for highest priority orders only.



GARDNERS RADIO LIMITED
SOMERFORD · CHRISTCHURCH · HANTS

He Learned CODE the CANDLER way!

If, as a result of reading this advertisement you send for a copy of the Candler "Book of Facts," you will also receive in the form of "extracts from letters" convincing proof of the excellence of Candler training.

Here is an extract from a letter sent in by Ref. No. 3171.—R.G.S.

"NOW IT'S THANKS TO 'CANDLER SYSTEM' THAT I'M WORKING WITH THE GREATEST OF EASE AND CONFIDENCE WITH SOME OF BRITAIN'S CRACK OPERATORS, AND I FEEL 'RIGHT AT HOME' AMONG THEM."

This Candler student has secured a Government post as a Wireless Telegraphy Operator.

In the "BOOK OF FACTS," which will be sent FREE on request, full information is given concerning the subjects covered by all Candler Courses.

JUNIOR Scientific Code Course for beginners. Teaches all the necessary code fundamentals scientifically.

ADVANCED High-speed Telegraphing for operators who want to increase their w.p.m. speed and improve their technique.

TELEGRAPH Touch-Typewriting Course for W/T operators who wish to become expert in using a typewriter for recording messages.

Code Courses on Cash or Monthly Payment terms.

COUPON

Please send me a Free Copy of Candler "Book of Facts."

NAME

ADDRESS

Post Coupon in 1d. unsealed envelope to
**THE CANDLER SYSTEM CO. (Room 55W),
121 Kingsway, London, W.C.2**
Candler System Co., Denver, Colorado, U.S.A. (643)

**PLEASE NOTE NEW ADDRESS
ELECTRADIX RADIOS**

We have moved from our temporary office in Broughton Street, to New Showrooms at 214, Queenstown Road, Battersea; close to Queens Road station on Waterloo line. No. 137 Bus (West End to Clapham) stops outside our door.

ALMOST NEW SWITCHBOARD EQUIPMENT. Enamelled slate panel with N.C.S. Battery Automatic cut-in and -out for 54 cell, 100 amp., only £3. Pair of 8-stud 100 amp. Battery Switches on similar slate panel, £4 10s. each. 200 amp. and 250 amp. S.P. overload trip switch-board type Circuit Breakers on slate panel, 13in. by 12in., £4 each. Nine double-pole 200 amp. ditto, £4 10s. each. 300 amp. D.P. Ellison on slate panel, 13in. by 16in., £5 each. 1,000 amp. Oil Switches, with overload trip, £6 each. All the above are worth more than double.

Bargains in Knife Switches, unmounted or on panel of enamelled slate, 24in. x 18in. Several 100 amp. size, each with porcelain handle, fuses fitted under. Bargain at 42/6 pair. Special Switch-panel, fitted 3 D.P. knife, 200 amp. switches with fuses and one pair of 60 amps., the whole panel, £6.

DYNAMOS, MOTORS AND MOTOR GENERATORS. We carry a large stock of serviceable machines, but can only list a few: Lucas-Rotax Aero, 6-12 volts 8 amps., high speed wind Dynamos, 3rd brush, 17/6, C.P. England and Wales. Slow speed type, 12 volts 12 amps., heavier type, 95/-. Charging Generators, Crypto 30 volts 5 amps., double shaft, 1,350 revs., 60/-. Then there are double voltage ex R.A.F. high speed G.E.C. Generators, 6 volts on one commutator and 600 volts 80 m/amps. on the other, 27/6 only. C.P. England and Wales. Motor Gens., D.C. 100 volts to 17 volts 5 amps., 87/6. 220 volts to 16 volts 5 amps., £5 8s. Holmes 3 h.p. 220 volts to 8 volts 250 amps., £35 10s. 220 volts to 9 volts 50 amps., Hobart, £18.

MOTORS, D.C. In almost all sizes. A.C., ½ h.p. and ¼ h.p. split-phase, 1,425 revs.; cheap. **MOTOR PUMPS.** We can give immediate delivery of the famous Stuart Turner 12 volt D.C. Motor Pumps; 120 gals. per hour, 84/-. Same type but for A.C. mains, 136/-. Pumps only: R type twin-piston rotary for ¼ h.p. motor drive, £3 5s.

ENGINES. For direct coupling. Twin-cyl. petrol air-cooled Douglas, with fuel and oil tanks, governor, mag. ign., 2½ h.p., £15; 1½ h.p., £12.

SMALL SWITCHGEAR. Automatic Circuit Breakers, 10 amps. upwards, open or ironclad, triple pole, thermal trip, from 25/-. Battery Cut-outs and Remote Control, D.C. contactors, 6-12 volts 8 amps., type L, 10/6. 10 volts, 240 volts and 230 volts, 10 to 40 amps., 35/-. Rotary Instrument Switches, 7-way by R.I., ebonite panel, 7 studs on teak box, 7/6 only. Low Voltage Switchgear. Lucas 8-way Aero enclosed, change-over and fuses. R.A.F. surplus, 3/6. 6-way R.A.F. push-button, 2/9.

MAGNETS. We have a large range of permanent magnets, all sizes from 2 ozs. to 4 lbs. Stamped envelope for illus. list. Electro-magnet Solenoids, for 12 volts D.C. with 2in. free plunger ½ in. dia., compound wound, 6/6.

The Wonder Midget 2-oz. Permanent Magnet Discs of Alni Steel. Tremendous magnetic force and only 1.3/16in. dia. x ½ in. thick, with soft centre for drilling. One leaps off the table to meet another. Uses: Any magnetic duty, metal separation, magnetic chucks and lifters. Cut-out core, polariser, solenoid cores, headphone re-magnetisers, etc., 2/6 each, or 4/6 pair. A.C./D.C. Mains Magnets, 2 wound poles, 110 or 220 volts, 7 lb. lift, 5/6.

COME TO US FOR:—Wavemeters, Direction-Finders, Mirror Galvos and Reflector Scales, Lab. Resistor Boxes and Wheatstone Bridges, Switchboard Meters, D.C. Eliminators, Blowers, Fans, Pumps A.C. or D.C., Motor Pumps for all purposes. Rheostats and Resistances, Slate Panels any size or thickness, to order. Headphones, House-phones, Portable phones and Microphones. For other Bargains see our advertisement in previous issue. Please add postage on Mail Orders, and send stamped envelope for replies to enquiries. Thank you! 137 Bus or 31 Tram to our New Showrooms.

NOTE NEW ADDRESS. CALL AND SEE US.

ELECTRADIX RADIOS

214, Queenstown Road, Battersea, London, S.W.8
Telephone: Maconway 2150



G. A. RYALL, 69, Wharfdale Gardens, Thornton Heath, Surrey.—Please note new temporary address; mail order only.

ERIE resistances.—¼ watt, 680 ohms and 33,000 ohms, 3/- dozen; Erie 2 watt, 150, 820, 3,900, 7,500, 140,000, 270,000, 3 1/6; Erie 3 watt, 700, 3,300, 6,800 ohms, 2 1/6. T.C.C.0.1 non-inductive tubular condensers, in paxolin tubes, type 330, 350v wkg., 6/6 dozen, 75/- gross.

SLOW motion (epicyclic) drives, in well-finished brass, ratio 8-1, shaft 1¼in long, ¼in dia., drilled to take pointer, 1/3 each.

DIAL plates.—Berners 4 wave band in 4 colours, brass stiffed edges, size 6¼x4 approx., 1/6 each; Burnsted 3-band, 3-colour on white ground, 5x3 approx., 1/3 each.

PAXOLIN strip, 2½in wide, 12in lengths, 3 1/6 or 100 25/-; short lengths cut group board size, 6 1/3.

K B wave traps, iron core, suitable medium and long wave, 1/3 each; thimble top caps, 24 1/3; insulating tape, black, 1/3 lb; Wenrite switches, ebonite with silver-plated contacts, for 2ht and band pass with dial lights, 1/6 each. [1747]

COULPHONE RADIO, New London, nr. Preston.—Brand new goods only; mains transfs., 350-350 120ma, 4v 6a, 4v 2.5a, 28/6; p.m. speakers with transfs., 8in. Celestion, 24/6; 5in. Rola, 22/6; Tungram valves; cored solder, 4/6 lb, Barretter resistors, 6/-; line cord replacement resistors, 800 ohm, 2 adjust. taps, 6/3; electrolytics, 50mfd, 50-volt, 3/3; 8r low-watt resistors, all values, 9s each; pushback wire, 100ft coil, 6/-; switch cleaner, 2/3 bottle; heavy pentode transformers, 7/6. S.A.E. for stock list. [1724]

BATTERY CHARGING.—Transformer, rectifier and ballast bulb for 6v 2amp charger, 42/6, post 10d; transformer and rectifier for 2v 0.5amp, 14/6, post 7d; metal rectifiers, 6v 0.5amp, 6/3, 12v 0.5amp 11/9, post 4d; 12v 3amp, 34/6, post 7d, all with circuit and instructions; instrument type rectifiers, latest type, very good make, 5ma, 10ma, 15/6; 50ma 12/6, 1ma 18/6, post 3d; H.T. rectifiers, 150v 25ma, 12/6; Rothermel Bakelite crystal pick-ups, 78/6; famous Bullet crystal microphones for stand mounting, best microphone value to-day, £3; D104 microphone, £4 15; miniature deaf and crystal mikes, 42/6; milliampmeter, 1ma, full scale, second-hand but perfect, 65/-; also 2 only 500 microamp, 70/-.—Champion, 42, Howitt Rd., London, N.W.3.

LASKY'S RADIO, 370, Harrow Rd., Paddington, W.9, offer for sale the following condensers: 0.15mfd 2,000v at 1/6 each, 0.02mfd 2,000v at 1/- each, 0.23mfd 2,000v at 1/6 each, 0.05mfd 2,000v at 1/- each, 0.002mfd 2,000v at 1/- each, 2mfd cond., 700v, at 2/6 each; 50mfd 12v tubular, 16/- doz, 25mfd 25v tubular, 18/- doz; 0.1mfd 350v tubular, 6/- doz; 10mfd 25v tubular, 1/6 each; speakers, speaker output transformers from 6/-; 6½in Rola speakers, less transformers, at 17/6, plus postage; 8in Rola speakers, less transformers, at 21/-, plus postage; 5in Rola speakers, less transformer, 17/6, plus postage; 8in Rola speakers, with transformers, 27/6; 10in Rola speaker, less trans., 31/6, plus postage; terms cash with order or c.o.d. Send us your requirements. [1737]

SOUTHERN RADIOS Wireless Bargains: 6/- gross assorted screws 6/-; 6/- gross soldering tags, including spade ends, 6/-; 7/6. Philco 3-point car aeriels. Make excellent short-wave and home aeriels. Complete with fixing bolts, etc., 7/6. 10/- limit tone arms. Universal fixing for all types of sound box and pick-up heads, 10/-; 7/-, Ace "P.O." microphones, complete with transformer. Ready for use with any receiver, 7/-; 30/- Erie resistances, 100 assorted resistances, ¼, ½, 1 and 2 watt; Sizes from 0.8 ohm upwards. Brand new, with wire ends, 100 for 30/-; 65/-, special assorted parcel for Servicemen. 100 Erie resistances, assorted sizes, from 0.8 ohms upward. ¼, ½, 1 and 2 watt; 24 assorted tubular condensers, 0.01, 0.05, 0.1, etc. up to 5 mfd. 50 volt; 6 reaction condensers; 12 lengths sleeving; 75ft. push-back wire; soldering tags, screws and wire. All brand new, 65/-; 1/6, powerful circular magnets, 1½in. diameter by ¼in. thick, 1/6 each, 15/- per dozen. Tungram H.R. 210 valves. General purpose battery type, 4/9; crystals (Dr. Cecil), 6d. each, 5/6 per dozen; with cats-whisker, 9d. each, 8/- dozen; complete crystal detectors, 2/6; 75ft. covered wire for aeriels, etc., 2/6; 25 yds. push-back wire, 5/-; crystals cups, 6d. each, 5/- dozen; Telsen reaction condensers (0.0001), 1/9 each, 18/- dozen; Telsen large disc drives, complete with escutcheon knob, etc. type W184, 3/- each, 30/- dozen; insulated sleeving, assorted yard lengths, 4/- per dozen; single screened wire, 12 yds., 10/-; M.E.S. holders (miniature screw bulb holders), metal, 7½d. each, 6/- per dozen. Many other bargains for callers.—Southern Radio Supply Co., 46, Lisle St., London, W.C. Gerrard 6653. [1599]

GALPINS
ELECTRICAL STORES
"FAIRVIEW,"
LONDON ROAD, WROTHAM,
KENT.

Please Note Change of Address!

This Business is now transferred permanently to the above address, where all Mail Orders will receive strict personal attention.

TERMS: Cash with Order. No C.O.D.

Regret Orders from Eire and Northern Ireland cannot be accepted.

ELECTRIC LIGHT CHECK METERS, well-known makers, first-class condition, electrically guaranteed, for A.C. mains, 200/250 volts 50 cy. 1 phase 5 amp. load, 10/- each; 10 amp. load, 12/6, carriage 1/-.

1 KW. FIRE ELEMENTS, mounted on fireproof porcelain, for 220 volts, as new, easily mounted. Price 6/6, post free.

1 KW. TRANSFORMER, input 100 volts at 100 cycles, single phase, output 10,500 volts, centre tapped to earth. Price £4 10s., carriage forward.

X-RAY TRANSFORMER, in oil-filled tank, medium size, input 120 volts, 50 cycles, 1 ph., output 45,000 volts at 2kV, intermittent rating, in perfect order. Price £20, carriage paid.

ROTARY CONVERTER, D.C. to D.C., input 48 volts, output 2,500 volts at 1 kW, condition as new and in perfect order. Price £10, carriage paid.

½ WATT WIRE END RESISTANCES, new and unused, assorted sizes (our assortment), 6/- per doz., post free.

SOLID BRASS LAMPS (wing type), one hole mounting, fitted double contact, S.B.C. holder, and 12 volt 16 watt bulb. Price 3/6 each, post free, or 30/- per doz., carriage paid.

HEADPHONES, 120 ohm, secondhand, complete with headband and cords, in perfect working order. Price 7/6 per pair, post free.

INSTRUMENT METAL RECTIFIERS, by famous makers, 10 M/A full load, connect your D.C. meter to A.C. working. Price 15/- each, post free.

TUNGSTEN CONTACTS, ¼ in. dia., a pair mounted on spring blades, also two high quality pure silver contacts ¼ in. dia., also on spring blades, fit for heavy duty, new and unused. There is enough base to remove for other work. Price the set of four contacts, 5/-, post free.

220 VOLT DYNAMO, 9 amp. output, by Lancaster Dynamo Co., shunt wound, speed 1,500 R.P.M., condition as new. Price £10, carriage paid.

POST OFFICE RELAYS, small type, high resistance, twin blade, very low milliamps operation, as new. Price 7/6 each, post free.

VOLTMETERS, 2½in. dia. panel mounting, moving coil, modern type, by famous makers, range 0-120 volts, F.S.D. very low. Price 32/6, post free.

AMPMETERS, description as above, range 0-1½ amps. Price 25/-, post free.

KLAXON MOTORS, 220v. D.C., 1/10th h.p., shunt wound, ball bearing, fitted reduction gear giving speed of 700 r.p.m., high grade job, condition as new. Price 50/-, carriage paid.

D.C. MOTOR, shunt wound, condition as new, high grade, ball bearing, ½ h.p., can be supplied in 110 or 220 volts as ordered. Price either voltage, 40/-, carriage paid.

ELECTROSTATIC VOLTMETER, by Everett-Edgcombe, 9in. dia., reading 10 to 4,000 volts, condition as new. Price £7 10s., carriage paid.

METAL RECTIFIER, output 6 volts at 2 amps., maker Westinghouse, in perfect order. Price 27/6, post free.

AUTO-TRANSFORMER, 2,000 watts, tapped 0-110-200-220-240 volts, as new. Price £9, carriage paid.

WESTECTORS, type WX6 30 M/A load. Price 7/6 each, post free.

SEXTON'S for SERVICE

AMERICAN LEASE-LEND RADIO VALVES
Types and prices as given below at Board of Trade Controlled Prices, inclusive of Purchase Tax—
1A5GT, 1C5GT, 1T5GT, 5Y3GT, 1Z23GT, 2Z23GT, 3Z24GT, 3Z25GT, at 11/- each. 1H5GT, 6F5GT, 12A5GT, 12S5GT, at 9/2 each. 6A8GT, 12A8GT, 12A57GT, 6S47GT, at 14/- each. 6F6GT, 12K7GT, 12J7GT, 12S7GT, 12S7GT, 25A6GT, 25L6GT, 35L6GT, 50L6GT, 6J7GT, 6K7GT, 36, 47, 6K6GT, at 12/10 each. 12A7G, 25A7GT, 32L7GT, 70L7GT, 12S8GT, 88, 15/3 each. 6Q7GT, 12Q7GT, 12S9GT, 45, at 11/7 each. Postage and Packing 4d.
These valves are sold only for immediate replacements and subject to the Radio Valve (Maximum Price) Order S.R. & O. No. 1934 of 1942.

Arcturus American Valves at standard Retail Prices incl. of Tax. 42, 43, at 10/8 each. 616, 606, at 10/4 each. 1N5GT, 1A7GT, at 21/8 each. 6K8GT, at 14/-, Postage and Packing, 4d.
Brivaron British-made Valves, equivalent to American type 80, 5-volt rectifier English type U.12 4-volt rectifier, at 13/7 each. Postage and Packing, 4d.

EXTENSION LOUD SPEAKERS
"Rola" 3 ohms voice coil, less Trans. Size 5in., at 20/6 each; size 6in., at 22/6 each; size 8in., at 24/- each; 10in., 26/- each; 12in., "Rola" Speakers with Trans., 29/- each.

Barretters, 2 amp., suitable for replacement of Philips' C1, at 8/6 each. Postage and Packing, 4d.
Electric Soldering Gun, best quality only. Universal voltage, at 14/6 and 17/6 each.

Spanners, Kit of wooden handled box spanners, sizes 2, 3, 4, 5, 6BA, at 16/6 per set.
Screw Drivers, Thin-bladed for Radio and Electrical work, 4in., at 9d. each; 6in., at 1/- each; 10in., at 1/4 each. Postage and Packing, 4d.

Electric Smoothing Irons, Super quality, 5-5 1/2 lbs. weight, strong hand, heavily-plated body, guard rest, ground and polished, note plate with heavy flex six foot long and 3-pin 5 amp. plug, at 32/6 each. Smaller model, 4 1/2 lbs., enamelled blue, plated guard and rest with 2-pin 5 amp. plug and flex, at 28/6 each.

Terms: Cash with order only. Owing to shortage of staff we regret that we are unable to despatch orders C.O.D. or send pro-forma invoices. All prices include purchase tax where applicable.

Send 1d. stamp and S.A.E. for latest list of all Valves, Radio Components, Electrical Fittings and Accessories, etc., which we have to offer.

J.E. SEXTON & CO. LTD.

164, Gray's Inn Road, London, W.C.1
Telephone: TER. 1304, 4842.

PLAN YOUR FUTURE NOW

Big developments in radio and television have been forecast. There will be splendid opportunities for technically trained men to secure well-paid positions. Hundreds of our students now doing important work owe their progress solely to our training. Our specialised method of Home-Study tuition is a proved success. Now is the time to prepare yourself for well-paid employment or profitable spare-time work. Post coupon for free details of our Home-Study Courses in Radio Reception, Transmission, Servicing, Radio Calculations, Television and Mathematics.

YOU MUST KNOW MATHS.
If you wish to make progress in any type of technical work, you must know maths. Our method of tuition makes maths really interesting and easy to understand.

T. & C. RADIO COLLEGE

2, THE MALL, EALING, W.5

★ Please note new address ★
(Post in unsealed envelope, 1d. stamp.)
Please send me free details of your Home-Study Mathematics and Radio Courses.
NAME
ADDRESS
W.W.18

4 MFD, 2,000 test, 10/6; B.T.H. R.K., 70/-; meters, components, Cossor 3343 oac; s.a.e.; list; wanted, 10.60 electric drill.—Febby, Bentham, Lancaster. [1772]
VOLUME controls, Plessey 1/2 and 1 meg d.p. switched, 6/6 ea., 70/- doz.; 8in. p.m., Rolas, 22/6; heavy o.p. trans., 7/6 ea., post pd., s.a.e.; write for lists.—Amtra, 76, King St., Belfast. [1707]

Wanted
VIBROPACK wanted, for working off 6-volt car battery, to give 150-200 ma at 220-230 volts.—Details and price to Box 92, Pairs, 121, Kingsway, London, W.C.2. [1720]

WANTED, moving coil or Piezo crystal headphones, also Varley or Eddystone air tuned 465ks i.f. transformers, must be good.—Box 2877, c/o Wireless World, [1759]
KINVA tunable type needle scratched filter. R-34a, Woodland Rd., Northfield, Birmingham. [1760]

DYNAMOS, MOTORS, ETC.
ALL types of rotary converters, electric motors, battery chargers, petrol electric generator sets, etc., in stock, new and second-hand.

WARD, 37, White Post Lane, Hackney Wick, E.9. Tel. Amherst 1393. [0518]
E.D.C. converter, 220 dc to 230 ac, 1.08 amps, in brown crackle cabinet and fitted with the manufacturer's suppressor.—138, Lewes Rd., Brighton. [1745]

L.T. dynamos for charging, Lucas-Rotax, 6-12v 8 amps dc, 3rd brush, weight 11lb, size 8 1/2 x 4 1/2 in. (unused ex W.11), cost £10, to clear 17/6 each; ht. and lt. (G.E.C. double current 6v and 600v, 17lb ditto, 27/6; all carr. paid England and Wales.—Electradix, 214, Queenstown Rd., Battersea, S.W.8. [1748]

VALVES
5000 valves, all types, outputs, rectifiers, etc., s.a.e.—Davies, 28, Mount Vernon Crescent, Barnsley. [1649]

VALVES—Large stock British and American types; retail price plus tax; send s.a.e. for list.—Napier, Woodfield House, 127, Prestwick Rd., Ayr. [1749]

WE have a large stock of new and boxed valves, all guaranteed, at retail prices, plus tax; also U.S.A. lease-lend types for replacement; send us your requirements.—Lasky's Radio, 370, Harrow Rd., Paddington, W.9. [1738]

1000 valves in stock; U05, U06, U07, AC/5PEN, PEN45, PEN45DD, TH4B, VP4A, PEN383, TP1340, AC/TP, QP22B, TP26, 35, 45, 80, 35Z4GT, 6Q6GT, 11Z26GT, 6K7G, 6L7G, KTW61, 5Y3G, 6C6G, 6D6G, 6V6G, 6F6G; send s.a.e. for valve and wireless parts lists, 2d.—Ransom, 9 and 34, Bond St., Brighton. [1697]

ENGLISH and American valves.—1A5, 106, E 1H5, 1T5, 6A5, 6A8, 6F5, 6E5, 6J5, 6F6, 6K6, 6K7, 6K8, 6Q7, 6W5, 6V5, 6J7, 6H6, 6C5, 5Z4, etc., 12A7, 12A8, 12B8, 12F5, 12I7, 12K7, 12Q7, 128A7, 12S7, 12S7, 12S7, 12S7, 12S7, 25A6, 25A7, 25L6, 25Z6, 32L7, 35L6, 35Z4, 35Z5, 45Z5, 50L6, 70L7, 41, 45, 43, 46, 47, 57, 58, 59, 79. 1/L valves are for replacement only; English valves in clude 1H2, 823, VP21, W21, MKT4, MX40, MH4, ML4, MS4B, H30, PX4, PX25, MU12, U31, U50, etc.; normal retail prices plus tax; enquiries s.a., please; r.o.d. or c.w.o.—Dale Electric Co., 13, Trelawn Gardens, London, N.W.7. [1770]

Wanted
VALVES wanted, any quantity from one upwards; also test equipment, service sheets and spares.—J. Bull, 246, High St., Harlesden, N.W.10. [9732]

VALVES, urgent, can you assist? 3 O P 25. 40 pen45D.D., 10 pen45D.D., 5 U403.—L.C.S. Radio Service, 54, Maryland St., London, E.15. Tel. Maryland 3954. [1709]

REPAIRS AND SERVICE
I.T.P. repair all mains transformers and chokes, prompt delivery.

LONDON TRANSFORMER PRODUCTS, Ltd., Willesden, N.W.10. Wil. 6486, (3 lines). [9552]

DEGALLIER'S, Ltd.—See page 25, under New Receivers. [1742]

MIDWEST etc., we are the American experts.—Bennett's, 4, Humberstone Drive, Leicester. [1683]

INSTRUMENTS of all types repaired and calibrated; work guaranteed.—McKissock, 9, Bruce St., Dunfermline. [1681]

TRANSFORMERS, motor rewinds, repairs of all descriptions to the wireless trade.—Marshall, 137, Windmill Lane, Nottingham.

METROPOLITAN RADIO SERVICE Co. guarantee repairs to American and British receivers.—1021, Finchley Rd., N.W.11. Spe. 3000. [9641]
ALL types of radio receivers serviced, Murphy and pilot specialist valves in stock, sound repairs for 13 years.—T. E. Foye, P.I.P.R.E., 50, Vine St., Uxbridge, Middx. [1735]



F.W.S.CO.
TRADE MARK
SINCE 1890

I.F. TRANSFORMERS
of all types
AERIAL & OSCILLATOR COILS
TRIMMER & PADDER
CONDENSERS
"SILVERCAP" CONDENSERS
COIL FORMS, etc.

Our increased manufacturing facilities, our added knowledge in the production of equipment for the Allied forces, will benefit you in due course.

We are making many specialised and intricate parts for the war effort, and we are happy to assist in winning that final unconditional surrender of the enemy forces.

Sickles transformers, coils, trimmers and many new parts will be ready for you again as soon as conditions permit.

Register your name with our Representative now. He will forward you information on our products as soon as they become available.

The F.W. SICKLES Co.
CHICOPEE,
MASS., U.S.A.

Exclusively Represented by
Frank Heaver Ltd. Kingsley Road,
Bideford, N. Devon

"SYSTEMATIC RADIO SERVICING"

A method for organising the repair-shop, devised and employed by J. Bull. Also a catalogue of many Radio Service Aids including "History of Faults," "Job Cards," which almost repair the sets, "Valve Base Data Cards," and perhaps most important, a Rectifier which will replace any of the popular Universal valves such as 1Z23, 25Z5, 1D5, U30, 40SUA, etc. Price 1/7 p.f.

V.E.S.,
(W) Radio House, Methone Drive, Ruislip, Mdx.

GECALLOY

N.F. ALLOY POWDER

THE LATEST DEVELOPMENT
IN MAGNETIC POWDER
METALLURGY

MAIN ADVANTAGES:

1. Higher Permeability.
2. Higher Particle Specific Resistance.
3. Low Eddy Current Loss.
4. Non-Rusting.

Salford Electrical Instruments Ltd.
PEEL WORKS, SILK STREET, SALFORD, 3
Telephones: BLAckfairs 6688 (6 lines)
Proprietors: The General Electric Co. Ltd., of England

PREMIER RADIO

I.F. TRANSFORMERS, IRON CORED

450-475 kos., plain and with flying lead, 5/8 each.
Premier 1-valve de Luxe Battery Model S.W. Receivers, complete with 2-volt valve, 4 coils covering 12-170 metres. Built on steel chassis and panel, 55/-, including tax.

PREMIER MICROPHONES

Transverse Current Mike. High-grade large output unit. Response 45-7,500 cycles. Low hiss level, 23/-.

Premier Super-Moving Coil Mike. Permanent Magnet model requiring no energising. Sensitivity 50db. Impedance 15 ohms. Excellent reproduction of speech and music. 25 5/-.
Microphone Transformers, 10/8 each.
Chromium Collapsible Type Microphone Stand, 52/6.

NEW PREMIER S.W. COILS

4- and 6-pin types, now have octal pin spacing and will fit International Octal valve holders.

4-PIN TYPE		6-PIN TYPE	
Type	Price	Type	Price
04	9-15 m. 2/6	06	9-15 m. 2/6
04A	12-26 m. 2/6	06A	12-26 m. 2/6
04B	22-47 m. 2/6	06B	22-47 m. 2/6
04C	41-94 m. 2/6	06C	41-94 m. 2/6
04D	76-170 m. 2/6	06D	76-170 m. 2/6
04E	150-350 m. 3/-	CHASSIS MOUNTING	
04F	255-550 m. 3/-		
04G	490-1,000 m. 4/-	OCTAL HOLDERS	
04H	1,000-2,000 m. 4/-		
New Premier 3-Band S.W. Coil, 11-25, 25-38, 35-86 m., 4/9.			

Rotary Wave Change Switch, to suit above, 1/6.
Bakelite Dielectric Reaction Condensers.
 0001 mf. 1/8 0003 mf. 2/6 0005 mf. 2/9 each
 0003 mf. Differential..... 2/11 each
 2-gang 0005 mf. Condensers, with trimmers 5/6 each

H.F. CHOKES

S.W. H.F. Choke, 10-100 m. 10jd.
 Standard H.F. Choke 1/-
 Binocular H.F. Choke 1/6

SHORT WAVE CONDENSERS

Troilful Insulation. Certified superior to ceramic. All-brass construction. Easily ganged.
 15 mmfd. .. 2/11 100 mmfd. .. 3/11
 25 mmfd. .. 3/3 160 mmfd. .. 4/8
 40 mmfd. .. 3/3 250 mmfd. .. 5/8
Brass Shaft Couplers, 1 in. bore .. 7jd each
Flexible Couplers, 1 in. bore .. 1/2 each
7-pin Ceramic Chassis mfg. English fitting Valve Holders, 1/6 each.

RESISTANCES

Mains Resistances, 660 ohms .3A Tapped. 360 x 180 x 80 x 60 ohms, 5/8 each.
 1,000 ohms, .2A Tapped. 900, 800, 700, 600, 500 ohms, 5/8 each.
 1 ohm ± 1%, suitable for Bridges, 5/-.
 1/2 watt all values, 5d. each.
 1 watt all values, 7d. each.
 4 watt from 50 to 2,500 ohms, 1/- each.
 8 watt from 100 to 2,500 ohms, 1/8 each.
 15 watt from 100 to 10,000 ohms, 2/- each.
 25 watt from 100 to 20,000 ohms, 2/9 each.
Valve Screens for International and U.S.A. types, 1/2 each.
Push-Back Connecting Wire, 2d. per yard.
Beam-Cored Solder, 7jd. per coil.
Spraflex Solder, 2 mm., 2/6 per doz. yards.
Waterproof Covered Cable, 3-way, 1/3 per yard; 5-way, 1/6 per yard.
Screened Braided Cable, Single, 1/3 per yard; Twin, 1/6 per yard. Maximum lengths 6 yards approx.

MOVING COIL SPEAKERS

Celestion 8 in. P.M. Speaker, 25/-.
 Above speaker is complete with output transformer.
Rola 5 in. P.M. Speaker, 3 ohms voice coil, 21/-.
Rola 6 1/2 in. P.M. Speaker, 3 ohms voice coil, 25/-.
Rola 8 in. P.M. Speaker, 3 ohms voice coil, 25/-.

Send for details of our Morse Equipment, Valves and other Radio Accessories available.

ALL ENQUIRIES MUST BE ACCOMPANIED BY A 2jd. STAMP.

PREMIER RADIO CO.

ALL POST ORDERS TO:

JUBILEE WORKS, 167, LOWER CLAPTON ROAD, LONDON, E.5. (A/nherst 4723.)

CALLERS to:

JUBILEE WORKS or 169, FLEET STREET, E.C.4. (Central 2833.)

ACCURATE radio rewinds, mains transformers, fields o.p. transformers, etc., and all loudspeaker repairs.—Southern Trade Services, 297-299, High St., Croydon. [1715]

MAINS transformers service, repairs, rewinds, or construction to specification of any type, competitive prices and prompt service.—Sturdy Electric Co., Ltd., Dipton, Newcastle-upon-Tyne. [9661]

"SERVICE with a Smile."—Repairers of all types of British and American receivers; coil rewinds; American valves, spares, line cords.—F.R.I., Ltd., 22, Howland St., W.I. Museum 5675. [1575]

RADIO repairs, American experts, reduced prices to the trade; send s.a.e. for enquiries; amplifiers made to order; bargain parcels 7/6 and 10/- inc. coils, chokes, cond. and trans., etc.; mains droppers, 3/6; 2-gang tuning condensers, 4/-, with slow motion 5/-; 3-gang 6/6, with slow motion 7/6; 0.00015 0.1 cond., 2/- doz., 0.1-2. 3/6; bell pushes, 8d.; LF chokes, 2/6. 1F trans., 1/6; 0.001-0.25, 1.000v, 8d. and 1/-.—Apply L. E. Healey, 36, Elm Grove, Clacton-on-Sea, Essex. [1719]

MISCELLANEOUS

USED torch bulbs wanted, any quantity; 1/- per lb. and carriage paid.—Hucleuch Radio Service, Melville Terrace, Edinburgh.

REPUTABLE firm of toy manufacturers and electrical engineers seek ideas for electrical and mechanical toys for post-war programme; generous terms.—Apply Box 2869, c/o Wireless World. [1719]

ELECTRICAL and mechanical engineer; have capacity available for the production of thermionic amplifiers, sound equipment, and small electro-mechanical apparatus essential work only.—Box 2865, c/o The Wireless World. [1708]

MAKE (and sell) your own torch battery cigarette, pipe and gas lighters; no awkward wheels, wicks, etc., to fix, lasts 6-7 months, well tested diagram and full instructions for easy home and mass production; 2/9, element included free.—Wm. Barham, Hilltop, Bradmore Green, Coulsdon, Surrey. [1714]

SITUATIONS VACANT

QUALIFIED radio engineer required by prominent factors now operating from North London area, 10/6 per hour offered to right man, part time 3 or 6 hours per week, evenings, Saturday afternoon or Sunday would be suitable.—Box 2867, c/o Wireless World. [1714]

ENGINEER with knowledge of electronics required in Worcester area; good grounding in radio engineering and; experience of servicing essential; responsible work, excellent prospects.—Apply, stating detailed qualifications and salary required to the Employment Exchange, Castle St., Worcester. [1714]

SITUATIONS WANTED

TECHNICIAN, wide experience, radio, television and u.s.w. work, with considerable production experience and ability, desires change; only executive or other responsible position considered.—Box 2878, Wireless World. [1714]

PATENT AGENTS

PATENT ADVICE AND SERVICE BUREAU.—Consultants and registered agents for British, foreign and Colonial patents, design and trade mark registrations, investigations and searches.—Thonet House, 251, Strand, W.C.2. Central 7330. [1609]

TECHNICAL TRAINING

GREAT possibilities exist for technically qualified engineers, key men in wartime and afterwards. Through the home-study courses of The T.I.G.B. take a recognised engineering qualification, such as A.M.I.Mech.E., A.M.I.E.E., A.F.R.Ae.S., A.M.I.Chem.E., C. and G., etc., in which examinations the T.I.G.B. students have gained 25 FIRST PLACES and hundreds of passes. Write today for "The Engineer's Guide to Success"—free—containing the world's widest choice of engineering courses covering all branches, including aeronautical, mechanical, electrical, wireless, chemical, etc.

THE TECHNOLOGICAL INSTITUTE OF GREAT BRITAIN, 82, Temple Bar House, London, E.C.4. [1403]

RADIO servicing, general wireless and television. These home-study courses are being taken by large numbers of radio men with the object not only of seizing to-day's opportunities, but preparing for the keen competition which will come with demobilisation. Our handbook, "Engineering Opportunities," describes over 200 courses of technical instruction, and explains the easiest method of passing the A.M.I.E.E., A.M.Brit.I.R.E., and all other examinations. A copy of this enlightening guide will be sent on request—free.—British Institute of Engineering Technology, 388a, Shakespear House, 17, Stratford Place, London, W.1. [1727]

TUITION

RADIO training.—P.M.G. exams. and I.E.E. Diploma; prospectus free.—Technical College, Hull. [0611]

WILSON

A.C. & BATTERY CONSTRUCTORS' KITS

3-V. T.R.F.

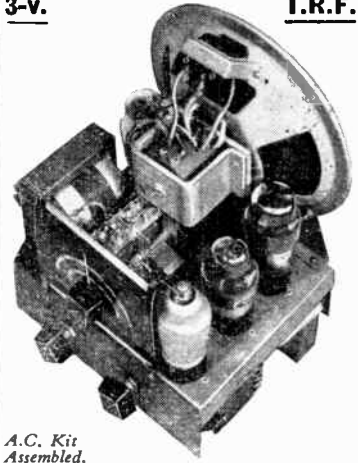

A.C. Kit Assembled.

When assembled these Kits give excellent reproduction on Medium and Long Waves. Supplied complete with chassis 8in. x 6 1/2in. x 2 1/2in., Valves, M.C. Speaker, and wiring diagram. (Regret, no cabinets.) 3 controls. **A.C. 3-V. (+RECTIFIER) KIT.** V.M.H.F. Pen., Triode, L.F. Pen., Rectifier, M.C. Speaker. Price £9 9s. Post 1/1, plus 3/6 packing (returnable).
BATTERY 3-V. KIT. V.M.H.F. Pen., Triode Detector and Output Tetrode, P.M. Speaker. Price £6 10s. Post 1/1, plus 3/6 packing (returnable).

Orders executed in rotation. Delivery approx. one month. No C.O.D.

CALL FOR DEMONSTRATION

OCTAL CABLE Plugs and Sockets, 2/- each.
SCREENED Valve Top Cap Connectors, English or Octal, 1/- each.
STANDARD 3-GANG Condenser, .0005 with trimmers and mounting bracket, 9/6.
BINOCULAR H.F. Chokes, 4/6.
NEW STEEL CHASSIS, Painted, 10 x 8 x 2 1/2, 7/6; and 8 x 6 x 2 1/2, 4/6 each.
10 WATT WIRE WOUND RESISTORS, 2,000, 500, 150 ohm., 2/6 each.
RESISTORS, 1/2 watt, 4d.; 1/4 watt, 6d.; 1 watt, 1/-.
MAINS VOLT DROPPING RESISTORS, 2-amp, 1,000 ohms., with two variable tappings 4/6 each. Also 3 amp. 750 ohms., one variable tapping, 6/- each.
MICA CONDENSERS, .001 2,200 v. test, 1/6; .0001 1/-; .01 1/6.
TWIN PADDERS, Ceramic 300-600 mmfd., 1/6.
VAXLEY type 3-bank, 2-pole, 4-way, with screening shield. Complete, new, 7/6.
VAXLEY type 2-bank, 2-pole, 2-way (shorting switch), 5/6.
OUTPUT SPEAKER TRANSFORMERS, heavy duty, aluminium shroud, chassis mounting, 10/-.
T.C.C. ELECTROLYTIC dry-can, 2 x 2 mfd., 300 volt working, 20 mfd. 30 volt working, 50 mfd. 25 volt working. Coloured wires chassis mounting, 9/6 each.
 Licence to export to Northern Ireland and Irish Free State. Please add postage for enquiries and mail orders.

51-52, CHANCERY LANE
 LONDON, W.C.2. Telephone HOLborn 4631

BULL for VALVES!

BRITISH VALVES
Mullard numbers generally quoted, but we may send B.V.A. equivalents. Prices quoted are current retail.
PM12 11/-, PM12M 11/-, SP2 11/-, VP2 11/-, VP2B 11/-, FC2 12/10, FC2A 12/10, PM1HL 5/10, PM2HL 5/10, PM2DX 5/10, PM2A 7/4, PM22A 11/-, PM22D 11/-, TDD2 9/2, also Marconi Osram P2 12/3, LP2 7/4.

4-VOLT A.C. MAINS TYPES
ACTP, TH4A, TH4B, FC4, MX40, 14/-; PM24M, AC5Pen, PenA4, Pen4VA, VP4, SP4, VP4B, SP4B, W42, 12/10; TDD4, MHD4, 11/7; H42, 354V, HL4, 9/2; PM24A, FW4/500 18/3; Pen4DD, 15/3; also Cossor MSPen, MVSpen, MSPenB, MVSpenB 12/10.

A.C./D.C. TYPES
FC13, FC13A, TH21C, TH30C, 15D2, 14/-; VP13C, SP13C, 9D2, 8D2, 12/10; HL13C, 2D13C, 2D13A, 9/2; TDD13C, 11/7; CL33, CL4, Pen26, 12/10; KTW61, KTW63, KT61, KT63, 12/10; also Cossor VP13A, SP13A, 12/10.

MAZDA OCTALS
ACTHIA 14/-, TH41 14/-, VP41 12/10, SP41 12/10, DD41 11/-, UU4 11/-, HL41DD 11/7, HL42DD 11/7, Pen45 12/10, Pen45DD 15/3, UU7 11/-, TH233 14/-, HL133DD 11/7, VP133 12/10, Pen25 11/-, HL23 5/10, QP25 15/3.

MULLARD E TYPES
EB4 12/10, EBC3 11/7, EBC33 11/7, EBF2 15/3, EBL1 15/3, EBL13 15/3, ECH2 14/-, ECH3 14/-, ECH33 14/-, ECH35 14/-, EFS 14/-, EFB 12/10, EFN 12/10, EFN3 12/10, EFN3 12/10, EK2 14/-, EK3 15/3, EL2 14/-, EL3 14/-, EL3 12/10, EL33 12/10, E22 12/10, AZ1 11/-, EM4 11/-, EF6 14/-, CBL1 15/3, CBL3 15/3, CL4 12/10.

AMERICAN VALVES
01A 11/-, OZ4 15/3, 1B4 15/-, 1B5 15/-, 1G5 15/-, 1I5 15/-, 2A6 14/-, 2A7 15/-, 2B7 15/-, 5Y3, 5Y4, 5Z4 14/6, 5Z3 18/3, 6A6 18/3, 6AG6 12/10, 6A7 14/-, 6AB 14/-, 6B6 13/-, 6B7 14/-, 6BB 15/3, 6C5 9/2, 6C6 12/10, 6D6 12/10, 6F5 9/2, 6F6 12/10, 6F8 18/3, 6H6 6/10, 6I7 12/10, 6I8 12/10, 6K8 14/-, 6K6 13/-, 6K7 12/10, 6L7 12/10, 6N6 18/3, 6Q7 11/7, 6R7 11/7, 6SA7 14/-, 6SC7 18/3, 6SK7 12/10, 6THB 14/-, 6V6 12/10, 6X5 11/-, 6Z3 18/3, 6Z5 18/3, 15 18/-, 19 18/-, 24 13/-, 25A6 12/10, 25L6 12/10, 25Z6 11/-, 27 9/2, 29 14/-, 30 12/-, 31 12/-, 32 15/-, 33 14/-, 34 15/-, 35 13/-, 36 12/10, 37 15/-, 38 15/-, 39 12/6, 41 12/10, 42 12/10, 46 15/-, 50 25/-, 52 23/-, 53 16/6, 55 13/6, 56 15/-, 57 14/-, 59 16/6, 75 14/6, 76 9/2, 77 12/10, 78 12/10, 79 18/3, 80 14/6, B1 21/-, 83 15/3, 84 14/-, 85 12/1, 89 18/3.

RECTIFIERS
Non-B.V.A. replacement types all at 14/6 each. Replacements for American 80, 5Y3, 5Z4, 5Y4; Marconi Osram U10, U12, MU12, U50; Mullard IW2, IW3, DW2, DW3; Cossor 442B, 4311U; Brimar R1, R2, R3; Phillips 1821; Mazda U03, U04, etc., etc.
S.A.E. must accompany all enquiries. Postage must be added on orders up to £3.
TO SAVE TIME ORDER VALVES C.O.D.

J. BULL & SONS
246, HIGH ST., HARLESDEAN, N.W.10

W. BRYAN SAVAGE LTD.
Expert assistance in the solution of problems relating to

- TRANSFORMERS, CHOKES
- AMPLIFIERS
- POWER UNITS

and Specialised Equipment embodying

ELECTRONIC CONTROL

WESTMORELAND RD., N.W.8.
COLINDALE 7131

LEARN Morse code the Candler way. See advertisement on page 26. [1292]
RADIO Engineering—Television and Wireless Telegraphy, comprehensive postal courses of instruction. Apply British School of Telegraphy, Ltd., 179, Clapham Rd., London, S.W.9 (Estd. 1906). Also instruction at school in wireless for H.M. Merchant Navy and R.A.F. [9349]

ENGINEERING Opportunities, free 112-page guide to training for A.M.I. Mech.E., A.M.I.E.E., and all branches of engineering and building. Full of advice for expert or novice. Write for free copy, and make your peacetime future secure.—B.I.E.T. (Dept. 387b), 17, Stratford Place, London, W.1. [1726]

POSTAL training in electrical engineering—power or radio; individual correspondence tuition by highly qualified engineers with wide teaching and technical experience. Elementary or advanced courses. Preparation for recognised examinations. Pre-service training specially arranged.—G. B., 18, Springfield Mount, Kingsbury, N.W.9. [1731]

THE Tuitionary Board of the Institute of Practical Radio Engineers have available home study courses covering elementary, theoretical, mathematical, practical, and laboratory tuition in radio and television engineering; the text is suitable coaching matter for I.P.R.E. Service-entry and progressive exams; tuitionary fees—at pre-war rates—are moderate.—The Syllabus of Instructional Text may be obtained post free from the Secretary, Bush House, Walton Avenue, Henley-on-Thames, Oxon. [1462]

BOOKS, INSTRUCTIONS, ETC.
WEBB'S radio map of the world locates any station heard, size 40x30in, 4/6, post 6d.; on linen, 10/6, post free.—Webb's Radio, 14, Soho St., London, W.1. Tel. Gerard 2089. [9947]

REQUIRED, service sheets, all types, good price paid.—Evans, 15, Church Rd., Shirley, Birmingham. [1763]

WANTED, service instructions and/or user instructions Baird Televisor T.26.—Mel drum, Stansted, Essex. [1713]

TEXT books by Wireless World, Scroggie, T. Sowerby, Terman, Camm, Rapsen, etc., urgently required by wireless college for students' use.—Particulars and prices to Box 2872, c/o Wireless World. [1730]

VOIGT For high quality loud speakers when the good times come again.

The Courts, Silverdale, London, S.E.26. 'Phone: SYD 6666.
VOIGT PATENTS LTD

KESSLERS, (London) LTD

For TURNING and MACHINING of PLASTIC MATERIAL
SIGNAL LAMP CAPS
SCREW CUTTING IN BAK. FABRIC
Albion House, 201-3, Church St., London, N.16
Tel.: Clissold 6247

SPEAKER REPAIRS by Specialists

Any make, British or American Best Service Moderate Charges

TRADE ONLY
Also Components for Service Men at keenest prices. List 1d.

A. W. F. RADIO PRODUCTS 'Phone: 11632
99, Duckworth Lane, Bradford

Rewinds Service

REWINDS. Transformers—Mains, 25/-, O.P., 6/-, Fields, Pick-ups, Coils, Chokes, Rewinds.

VALVES. We may have those you want.
S.A.E. to:
A.D.S. Co. 261/3/5, Lichfield Road, Aston, Birmingham, 6.

AN APOLOGY

We ask the kind indulgence of all engineers and dealers who have ordered Mains Transformers and the OP.12 type Output Transformer recently created, and have not yet had delivery.

The heavy demand caused by our advertisements in this journal, coupled with orders of a strictly priority nature, has overwhelmed our present factory.

Within the next few days we anticipate a considerable increase in production, as we have acquired additional premises which will enable the delivery of all types of transformers to be made with a minimum of delay.

We still have good stocks of Speakers, small Transformers and all other Service Components.

Please see last month's announcement, or write us for full details (enclose stamp).

SPEAKERS. Guaranteed brands only in stock. Rola, Celestion, R. and A., Goodman's, etc.

8 inch P.M. types, complete with transformers	25/-
10 .. P.M.	35/-
6 .. P.M. .. less trans., extension units ..	19/-
8 .. Energised, 2,000 ohm fields with trans.	24/-
10 1,000	30/-

RADIO INSTRUMENT SERVICE CO.
116, Littleheath Road, Bexleyheath, KENT.

WARD ROTARY CONVERTERS
Petrol Electric Generating Plants, H.T. Generators, D.C. Motors, Frequency Converters, etc., up to 25 K.V.A.

CHAS. F. WARD
37, WHITE POST LANE, HACKNEY WICK, E.9
'Phone: Amherst 1393

BATTERY-TRICKLE CHARGERS & CHARGERS
for all purposes
"QUICK-CHARGE" CHARGERS well known for reliability
Thousands already in use.
Send for interesting booklet "R.15"

Runbaken
MANCHESTER 1

ENGINEERING OPPORTUNITIES

This unique handbook shows the easy way to secure A.M.I. Mech.E., A.M. Brit. I.R.E., A.M.I.E.E., etc.

WE GUARANTEE— "NO PASS—NO FEE."

Details are given of over 150 Diploma Courses in all branches of Civil, Mech., Elec., Motor, Aero, Radio-Television and Production Engineering, Tracing, Building, Govt. Employment, R.A.F. Maths., Matric., etc.

Think of the future and send for your copy at once—FREE.

B.I.E.T., 3 /, SHAKESPEARE HOUSE
17, STRATFORD PLACE, LONDON, W.1

ROGERS

Postwar industry will be making wider use of industrial electronic technique developed during recent years. In this work Rogers Radio Tubes—the tubes which opened the way to all-mains wireless—have played and will play a recognised part. Rogers with an established reputation for quality, produce all standard types of radio receiving tubes, power tubes for radio transmission, audio frequency amplification and industrial electronic applications generally. At present engaged solely on official work, they look forward to future co-operation over a wide field of industry.

ROGERS RADIO TUBES LTD.

TORONTO (ONTARIO) CANADA

A subsidiary of BROADCAST RELAY SERVICE LIMITED
VICTORIA STATION HOUSE, VICTORIA ST, LONDON, S.W.1

BRIMAIN

POWER UNITS (Regd.)

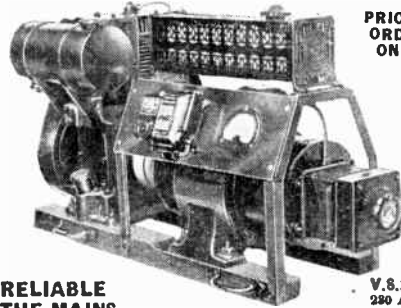

PRIORITY ORDERS ONLY.

AS RELIABLE AS THE MAINS

V.S.3
280 A.C.
1.25 K.V.A.

The V.S.3 is a compact, sturdily built Petrol Electric Generator, produced specially for 16mm. film projection where constant voltage must be maintained and light load surge eliminated. The output of 1.25 K.V.A. is amply sufficient for standard 16mm. projectors. Fitted with handles and spring bolts, the V.S.3 is instantly detachable and can be removed in a matter of seconds from the light van in which it would travel for mobile work.

UNITS BUILT TO SPECIAL REQUIREMENTS

Designers and constructors of
MOBILE CINEMAS for indoor and outdoor displays

BRITISH FILMS LIMITED

Head Office: 199 PICCADILLY, LONDON, Regent 2828
Works: 260 HIGH ROAD, BALHAM, LONDON. Battersea 8506

★ VALVES ★

MULLAED and equivalents, VP20, 12/8; TDD13C, TDD13, TDD4, 11/7; 2D18C, 5/6; P.M.E. PM202, PM252, 6/-; PM1A, PM1HL, 3/6; SP4B, SPVB, VP4A, SP4, VP13C, 12/10; TH21C, TH22C, 14/-; 354V, 994V, etc., 9/2. Barretters, types G1, C1C and 1941, 9/-.

MARCONI, Osram and Equivalents, X61M, X65, 14/-; Y63, Y64, 10/5; KT61, KTW63, 12/10.

AMERICAN Types, National Union, Philco, Tungernan, etc., 1A4, 1A4E, 1B4, 1B4E, 6/-; 1A6E, 10C, 12/10; 6U6, 6D5, 6H5, 6E5, 6U5G, 6U6G, 10/5; 6K7G, 6Y6V, 12/10; 6B7, 6A8, 6J8G, 6B8G, 14/-; 7C8, 11/7; 26, 27, 71A, 7/-; 01A, 49, 9/-; 33, 35, 01, 55, 15, 10/6.

Parcels of Assorted Components. Fixed and variable condensers, coils, valve-holders, resistors, trimmers, chokes, wire, insulators, transformers, switches, and other parts. Exceptional value. £1.

Philco. I.F. and R.F. transformers, aerial and oscillator coils for most models at pre-war prices.

No Lists. Please send stamp with enquiries.
Terms: Cash with order, Postage extra.

E. H. ROBINS TRADING CO. LTD.
44, Kyle Crescent South, Whitchurch, Glam.

HILL AND CHURCHILL BOOKSELLERS SWANAGE DORSET

ENGLISH & AMERICAN
BOOKS IN STOCK ON
RADIO AND
TELECOMMUNICATION

CATALOGUE ON APPLICATION

LONDEX for RELAYS

for A.C. and D.C.
TWO STEP RELAY LF/FS
(Heavy Silver Contacts)

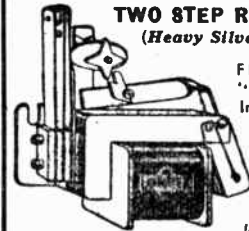

First Impulse "ON." Second Impulse "OFF."

Also Aerial Change-over Relays.

Ask for leaflet 88A/WW

LONDEX LTD
MANUFACTURERS OF RELAYS
207 ARLINE ROAD, LONDON S.E.20

M-O-R-S-E

COMPLETE PRACTICE UNIT

as supplied to many branches of H.M. Services No. 1281. Complete Morse Practice Unit. Heavy commercial Key with nickel silver contacts and sensitive triple adjustment. High-tone Buzzers with silver contacts, mounted on bakelite base with cover. Battery Holder, complete with 4.5 Ever

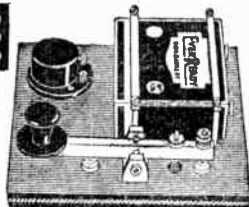

Ready battery. All metal parts heavily nickel plated, and the whole mtd. on polished Mahogany Base. 8 1/2 in. x 6 1/2 in. Post paid. **29/6**

Send 1d. stamp for Illustrated List

SIGNALLING EQUIPMENT LTD. (Dept. 8).

Merit House, Southgate Road, Potters Bar. 'Phone: Potters Bar 3133

from 32 to 10,000 cycles!!

IM Needles reproduce a far wider range of frequencies than are at present commercially recorded. You can make the test for yourself with frequency records and a first-class reproducer. And in spite of their marvellous top response they eliminate RECORD WEAR and NEEDLE SCRATCH.

Per "Top-hat" of TEN 2/- (Tax 1/4d.)

IM

LONG-PLAYING NEEDLES

Alfred Imhof, Ltd., 112-116, New Oxford Street, London, W.C.1. MUSEum 5944

WAX OKERIN

AND DIELECTRIC MATERIALS

Cable, Condenser, Coil, Transformer and Resistance Impregnating, dipping, sealing, filling and finishing.

A.I.D. and C.I.E.M.E. TYPE APPROVED WAXES to meet both **ARCTIC and TROPICAL** conditions.

TELEPHONE : WEST DRAYTON 2189

ASTOR BOISSELIER & LAWRENCE LTD

MIDDLESEX OIL & CHEMICAL WORKS

WEST DRAYTON, MIDDLESEX

When next you are considering the purchase of a good microphone in the High Fidelity class, may we suggest that you investigate the possibilities of a "MEICO" ?



MICRAMATIC ELECTRICAL INSTRUMENT CO.

360, Station Road, HARROW, Middlesex.
Telephone: HARrow 1064 and 1065.



Wartime installations show more conclusively than ever that

you can

trust

TRIX

30 watt Amplifier Model T633

Quality SOUND Equipment

There are TRIX Amplifiers from 5-500 watts
Send for details

To priority order only

TRIX ELECTRICAL CO. LTD., 65, Bolsover St., London, W.1.
Phone: EUS 5471/3. Grams: Trixado, Wasedo, London.

ON ALL
GOVERNMENT
LISTS

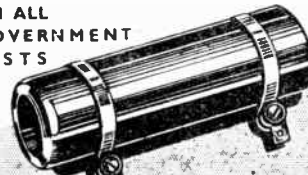

ERG

Trade Mark

Resistors

MANUFACTURED BY

ERG RESISTORS LIMITED
1021a, FINCHLEY ROAD, LONDON, N.W.11



INVENTORS

The world-wide Simmonds Organisation has established new methods and new products in many industries with great success. Simmonds Development Corporation seeks new ideas and inventions of brilliance and ingenuity to be developed by the technical resources and marketing knowledge of the Simmonds Group.

ALL COMMUNICATIONS MUST BE IN WRITING IN FIRST INSTANCE TO—

The **SIMMONDS GROUP**
LONDON
MELBOURNE
PARIS
NEW YORK
LOS ANGELES

SIMMONDS DEVELOPMENT CORPORATION LTD. 2-3 NORFOLK ST. W.C.2

Printed in England for the Publishers, ILLIFF AND SONS LTD., Dorset House, Stamford Street, London, S.E.1, by THE CORNWALL PRESS LTD., Paris Garden, Stamford Street, London, S.E.1. "The Wireless World" can be obtained abroad from the following: AUSTRALIA and NEW ZEALAND: Gordon & Gotch, Ltd. INDIA: A. H. Wheeler & Co. CANADA: Imperial News Co.; GORDON & GOTCH, Ltd. SOUTH AFRICA: Central News Agency, Ltd.; Wm. Dawson & Sons (S.A.), Ltd. UNITED STATES: The International News Co.



Going one better
IN COMMUNICATIONS



To-day, wherever Bullers Low Loss Ceramics are used, reception is clearer and better than ever before.

Years of research in Bullers Laboratories have developed these materials to such a high level of efficiency that Dielectric Loss is virtually eliminated. Bullers Ceramics are now playing a vital part in maintaining communications under all conditions.

BULLERS LIMITED
 THE HALL, OATLANDS DRIVE, WEYBRIDGE, SURREY
 Telephone : Walton-on Thames 2451
 Manchester Office : 196 Deansgate, Manchester

Bullers

LOW LOSS CERAMICS

Made in Three Principal Materials :

FREQUELEX. An Insulating Material of Low Dielectric Loss. For Coil Formers, Aerial Insulators, Valve Holders, etc.

PERMALEX. A High Permittivity Material. For the construction of Condensers of the smallest possible dimensions.

TEMPLEX. A Condenser material of medium permittivity. For the construction of Condensers having a constant capacity at all temperatures.





**T H E R E I S N O S U B S T I T U T E
F O R
E N G I N E E R I N G E X P E R I E N C E**

*

And this is obviously a matter of extent, intensity and time.

Take Electrical condensers for instance—simple in conception maybe—but demanding infinite experience and skill, to satisfy the exacting operating conditions of modern requirements. The fulfilment of these has meant the whole time occupation of highly skilled specialists, working at high pressure, in this way to earn, along with their countrymen in other spheres, the right of survival.

What a wealth of experience and technical excellence will be available to all, when happier times arrive ; and nowhere more than in Dubilier Condensers.

DUBILIER
CONDENSER CO. (1925) LTD.

