

The Wireless World

THE PRACTICAL RADIO JOURNAL
28th Year of Publication

No. 1005.

THURSDAY, DECEMBER 1ST, 1938.

VOL. XLIII. No. 22.

Proprietors : ILIFFE & SONS LTD.

Editor :
HUGH S. POCOCK.

Editorial,
Advertising and Publishing Offices :
DORSET HOUSE, STAMFORD STREET,
LONDON, S.E.1.

Telephone : Waterloo 3333 (50 lines).
Telegrams : "Ethaworld, Sedist, London."

COVENTRY : 8-10, Corporation Street.
Telegrams : Telephone :
"Autocar, Coventry." 5210 Coventry.

BIRMINGHAM :
Guildhall Buildings, Navigation Street, 2.
Telegrams : Telephone :
"Autopress, Birmingham." 2971 Midland (4 lines).

MANCHESTER : 260, Deansgate, 3.
Telegrams : Telephone :
"Iliffe, Manchester." Blackfriars 4412 (4 lines).

GLASGOW : 26B, Renfield Street, C.2.
Telegrams : "Iliffe, Glasgow." Telephone : Central 4857.

PUBLISHED WEEKLY. ENTERED AS SECOND CLASS MATTER AT NEW YORK, N.Y.

Subscription Rates :

Home and Canada, £1 10s. 4d. ; other countries, £1 12s. 6d. per annum.

As many of the circuits and apparatus described in these pages are covered by patents, readers are advised, before making use of them, to satisfy themselves that they would not be infringing patents.

CONTENTS

	Page
Editorial Comment	475
How the Valve Works : Adding Electrodes One by One	477
Television Topics : "Four-Way Interlacing"	480
Variable Resis.arces	481
Ultra-High-Frequency Superhet	484
News of the Week	487
The Tone Control Knob	489
Degallier Challenger "19"	490
Television Programmes	492
Readers' Problems	493
Unbiased	494
Crystal Band-Pass Filters, V	495
The New European Wavelengths	497
Letters to the Editor	498
Random Radiations	498
Recent Inventions	500

EDITORIAL COMMENT

Television Distribution

A Plan After All ?

IN our issue of November 17th we commented on this page on the difficulties which stand in the way of the development of television on a national scale with a number of stations, so that the whole country may be served. We referred to a recent lecture by Sir Noel Ashbridge, Chief Engineer of the B.B.C., in which these problems were discussed, alternative methods of distribution described and where it was pointed out that the greatest obstacle in the way of the expansion of the service at present was the costly nature of the technical means available for national distribution.

New Hope

Following close upon this rather pessimistic disclosure by Sir Noel Ashbridge comes a much more optimistic outlook from Mr. Alfred Clark, Chairman of Electrical and Musical Industries Ltd., in his speech at the general meeting of that concern. Mr. Clark, too, referred to the problem of the extension of television and said that there were two methods of accomplishing distribution ; one by means of special cables and the other by radio links working on wavelengths much shorter than those allotted for television broadcasting, and he continued :

" In an attempt to arrive at a decision the technical aspect of the problem will have to be faced, inasmuch as, besides the present state of the technique, the trend of future development will also have to be taken into account. We believe that our work has resulted

in a solution which, while permitting an immediate start for relaying television to the provinces, is, at the same time, economical and will not stand in the way of future progress. It can be incorporated and may become part of any relay system embodying future developments.

" A scheme embodying the results of our work has been submitted to the Television Advisory Committee and the Post Office, and we have every reason to believe it is being sympathetically considered by them at the present moment.

Importance of Research

" This work, as is, in fact, all television research work, is under the able guidance of Mr. Shoenberg, the head of our research laboratories. The importance of this department can better be understood if I add that the uses of television are expected eventually to go beyond entertainment for the public."

The fact that this scheme is now before the Television Advisory Committee and the Post Office precludes the publishing of any details of it at present, but it is extremely encouraging to learn that a scheme has been worked out and that it is possible to describe it as economical and of such a character that it will not stand in the way of future progress.

In our leader in the issue of September 29th, we asked whether there was yet a B.B.C. plan for television distribution. It would seem that the E.M.I. proposals may eventually prove to be this plan for which all of us are waiting before we can feel justified in looking upon television as having a national future of service to the whole community.

Equity on the Long Waves

The Brussels Suggestions

AT the time of going to press/official confirmation is lacking of the project for a new European wavelength plan, as published in our last week's issue. But, so far as the long broadcast band is concerned, the proposal that certain countries should relinquish their long-wave channels seems so eminently fair and equitable that we can only hope, not only that the project was correctly reported, but that it will receive sympathetic consideration at the Swiss Conference in the spring. Small and compact countries like Holland, Luxembourg and Lithuania, which can be easily and adequately served by medium-wave stations, can hardly establish a moral claim to monopolising a long-wave channel.

Valve Standardisation

Series-Parallel Heaters

IN our Correspondence columns a reader draws attention to the present lack of standardisation in valve heater ratings and suggests that a uniform rating of 13 volts be adopted for all types. We have ourselves often expressed the desire to see a greater degree of standardisation in the valve industry, and there are signs that the valve makers are endeavouring to improve matters in this respect.

We do not feel, however, that our corre-

spondent's suggestion of a 13-volt heater is likely to be adopted, and we ourselves favour the 6.3-volt rating. The advantage of this voltage over the 4-volt is that the heater current is lower, and there is consequently a lower voltage drop in connecting leads in AC sets, while the current is also low enough for economical operation of series-connected heaters in AC/DC sets. The rating suits car radio sets for cars with 6-volt batteries, and it is also suitable for 12-volt batteries, since the heaters can be series-connected in pairs. Moreover, the rating is in line with standard American and Continental practice.

In comparison, a 13-volt rating has the disadvantage of making car radio impossible for cars with 6-volt batteries and of leading to the possibility of rather more hum pick-up from the heater wiring in AC sets. Moreover, the heater power is greater, for up to the present 13-volt valves take as much current as 6.3-volt types. This means a more expensive mains transformer.

Whatever voltage is decided upon, complete standardisation can hardly be effected if general economy in consumption is to be retained. The present average 6.3-volt valve consumes 0.3 ampere, but certain valves, notably frequency-changers and output pentodes, require more heater power. This will necessitate the duplication of such valves. A valve taking 1.2 ampere at 6.3 volts is suitable for AC operation and car radio, but must have a heater rated for 0.3 ampere at

25 volts for AC/DC operation. It should be noted that this duplication would still be necessary if a 13-volt rating were adopted.

It should be noted, however, that much, if not all, of this duplication could be avoided by fitting certain valves with centre-tapped heaters and bringing out three heater leads to the base. The two halves of the heater could then be connected in series or parallel as required. With the two halves in parallel a valve might consume 0.6 ampere at 6.3 volts and be suitable for AC sets and 6-volt car radio. With the two halves in series it would take 0.3 ampere at 12.6 volts, and be suitable for AC/DC sets and 12-volt car radio.

There are at present one or two valves on the market in which this scheme is adopted, and if it were extended it would seem that a much greater degree of standardisation could be effected.

Post Office and Relays

Finding a New Excuse

THE Post Office appears to hold on to the idea of taking over the wireless relay services with a distressing tenacity. The latest argument we have heard put forward is that they ought to undertake the service in the national interest and see that every home is wired so as to be ready to replace the broadcasting system in case of emergency. Which, we would ask, in time of air raids, is likely to suffer first: a network of telephone wires to individual houses and distributed from central buildings, or a system such as broadcasting, where there are no destructible links between transmitter and individual receivers? If the Post Office has money to spend on relays let them rather devote it to a network of ultra-short wave stations coupled to the B.B.C. system which in time of emergency could be used for national purposes without much fear of eavesdropping beyond their service areas.

Amateur Transmitters

Room for More

IN recent issues we have pleaded for some relaxation (but always with proper safeguards) of the official attitude towards the granting of amateur transmitting licences. In making friendly reference to our proposals the *T. and R. Bulletin*, official organ of the Radio Society of Great Britain, suggests that there is not room in the ether for an appreciable number of newcomers.

While hesitating to express disagreement with a society that has rendered such valuable services to the British amateur, we feel that this is a statement that can hardly be allowed to stand unquestioned. In the U.S.A. over 40,000 amateurs manage to find elbow-room in a waveband allocation very little more generous than that at present occupied by a mere 2,600 stations in this country, or under 7,000 in the whole of Europe.

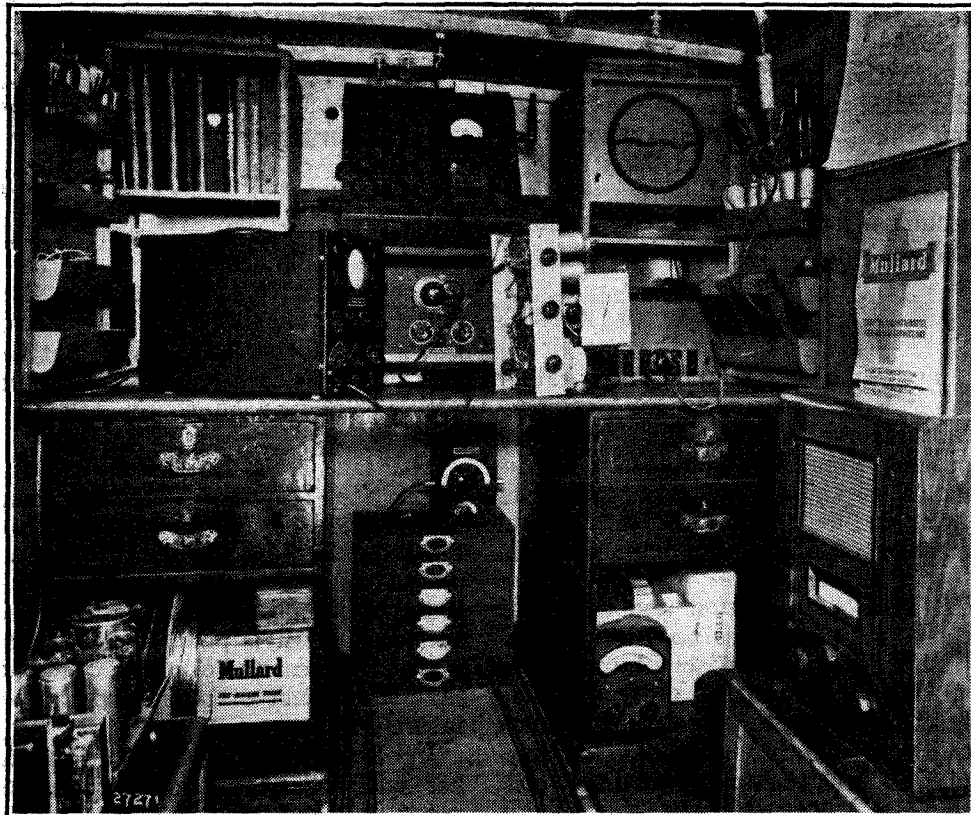

DOOR-TO-DOOR SERVICE. Universal Services, of "The Radiolab," Lyndhurst Avenue, North Finchley, London, N.12, have equipped a small motor van as a travelling service shop. The interior is shown in this photograph and is fully equipped, the apparatus including cathode-ray gear and all-wave test oscillator with "wobbling" facilities. A valve tester is provided and there are loud speaker, gramophone pick-up and turntable built in. An AC supply for the operation of receivers and test gear is obtained from a 12-volt accumulator and vibrator, this portion of the equipment being duplicated. A stock of spare valves and components is carried.

How the Valve Works

ADDING ELECTRODES ONE BY ONE

Part 1.—The Diode

MANY of the valves in common use to-day are highly complicated both in their structure and in their mode of operation. Ten years ago most valves were triodes, whereas now the electrodes range up to eight in number. It is consequently quite difficult to understand how some of these complex types function unless one is thoroughly acquainted with the simpler specimens.

In this series of articles, therefore, we shall start with simple types and work up gradually to the more complicated ones. In this way we shall not only trace the history of valve development, but by adding electrodes one at a time we shall clearly see their effect and how they alter the characteristics of a valve.

Now, the simplest valve of all and the first to be produced is the diode. As its name implies, it has only two electrodes—an anode and a cathode. It does not amplify, and is used mainly as a rectifier. Briefly, the cathode acts as a source of electrons which are attracted to the anode when this electrode is positive and repelled from it when it is negative.

The cathode is thus quite important, for it acts as the source of electrons; in modern valves it is one of two types—directly or indirectly heated. The directly heated cathode, and this applies to all valves, not merely to diodes, consists of a filament which is heated by the passage of current through it. At a certain temperature electrons are emitted in great quantity, and this is the normal operating condition. This normal temperature depends on the filament material and upon the emission required.

In the early days filaments were usually made of tungsten, and were operated at temperatures of the order of 2,000-2,500° K. Quite a large amount of power was necessary to raise the filament to this temperature, and a typical valve would consume about 0.8 ampere at 4.5 volts.

Thoriated tungsten filaments followed and gave much more emission for the same operating temperature. Usually, however, they were worked at a lower temperature, and the filament of a normal valve consumed about 0.25 ampere at 5 volts.

Coated filaments were also used. With

VALVE development has taken place rapidly in the last few years and many of the types now available are quite complex in their action. The set designer cannot get the best out of a valve and the service man cannot remedy faults unless they are familiar with the fundamental principles upon which the valve operates. In this series of articles the mode of operation of modern valves will be explained, starting with the diode and going on by easy stages to the complicated structures such as the octode and triode hexode.

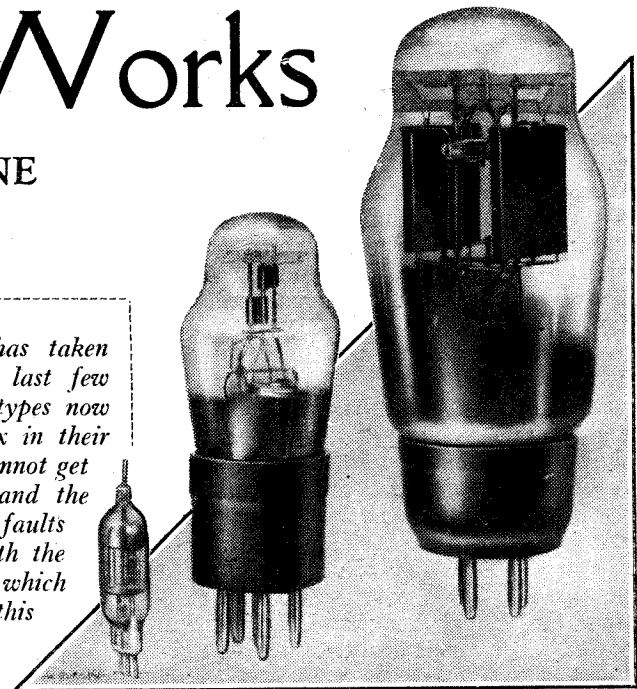

Types compared. A single diode detector for television, a duo-diode type, and right, a full-wave HT rectifier.

these the filament proper acts as a core, and there is deposited on its surface a coating which is often a mixture of barium and strontium. Such a filament can be operated at only 850° K., and needs only one-tenth the power of the tungsten type.

Directly heated cathodes of the filament type are still very widely used, being fitted to nearly all battery valves. They are also adopted for large-power triodes and for many diode rectifiers.

The indirectly heated cathode, as its name implies, is not raised to its working temperature by passing a current through it, but is heated by the conduction of heat from a nearby body at a higher temperature. In practice, the cathode consists of a tube which is coated on the outside by an emitting substance. Inside, but insulated from it, is a heater which often consists of a filament of tungsten or nickel. The passage of a current through the heater raises it to a high temperature, and it consequently brings the cathode to a suitable temperature for the emission of electrons.

The indirectly heated cathode has two advantages over the directly heated; there is no voltage drop along the cathode due to the heating current and its temperature can change only relatively slowly. The second advantage is the main reason for the use of indirectly heated cathodes, for

it permits the cathode to be heated from an AC supply without hum being introduced. Only in a few cases, such as an output valve or a rectifier, is it possible to run a directly heated valve from AC without serious hum.

The chief disadvantage of the indirectly heated valve is that the heater consumes more power than the filament of a directly heated valve. This is of little importance in mains-driven apparatus, but explains the retention of directly heated valves for battery-operated equipment. The separation of heater and cathode in the indirectly heated valve is, however, a great practical convenience, for it greatly simplifies automatic grid bias, and is often advantageous in other directions.

After this preliminary discussion of the cathode, it will be clear that this term applies to both the filament of a directly heated valve and to the heated element of an indirectly heated type. It is the electron-emitting electrode of a valve.

Let us now consider a heated cathode, naturally in vacuo, and suppose that there are no other electrodes. The cathode emits electrons which leave its surface with a certain initial velocity; their number depends on the cathode temperature and the material of which it is made. After traveling a short distance the electrons lose their velocity and fall back into the cathode. This electrode can thus be regarded as surrounded by a cloud of electrons.

The Anode-Cathode Space

Now, electrons have a negative charge, and tend to repel each other. The cloud of electrons surrounding the cathode thus tends to prevent further electrons being emitted by the cathode, and a state of equilibrium is reached at which the number of emitted electrons is equal to the number falling back on to the cathode.

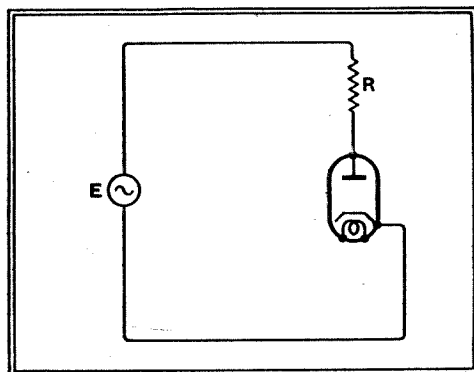

Fig. 1.—The basic circuit of a diode rectifier is shown here.

How the Valve Works—

This cloud of electrons is often referred to as the cathode space-charge.

Let us now consider a diode. The cathode is surrounded by an anode, which often consists of a metal cylinder. Suppose the anode is joined externally to the cathode, what happens? A few of the electrons emitted from the cathode will have sufficient velocity to reach the anode, and they will not fall back to the cathode but return through the external path and form a current.

If we now connect a battery between anode and cathode to make the anode potential negative with respect to cathode and gradually increase the voltage, we shall find that the number of electrons reaching the anode gets fewer and fewer, and eventually none do so. The negative anode repels the electrons, and only those of very high velocity can reach it; when the anode is sufficiently negative all electrons are turned back and the current ceases. The anode also exercises an elec-

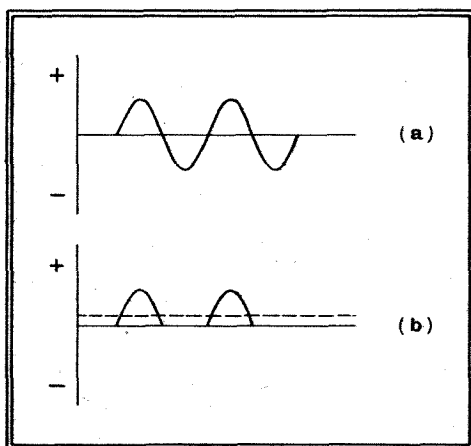

Fig. 2.—The waveform of the input voltage to the diode is shown at (a) and the rectified current at (b).

trostatic force on the space-charge and tends to move it nearer the cathode.

Now, if we reverse the polarity of the battery to make the anode positive with respect to the cathode, the anode will no longer repel electrons but will attract them. These electrons will at first be supplied by the cathode space-charge, for, instead of electrons falling back into the cathode, many of them will travel to the anode. If the potential is high enough all will go to the anode, and the normal space-charge will largely disappear, electrons emitted by the cathode passing straight to the anode.

Saturation

When this happens a further increase in anode voltage will not increase the anode current. All electrons emitted by the cathode are reaching the anode, and an increase in its voltage can attract no more. This is the saturation condition, and the anode current can be increased only by increasing the cathode temperature so that it emits more electrons. In practice, the saturation is not complete, or, rather, an increase of anode voltage above the saturation point does cause an increase in anode current, although only a small one.

This is because of a secondary effect. The anode gets hot through the work done by the electrons hitting it; the velocity of the

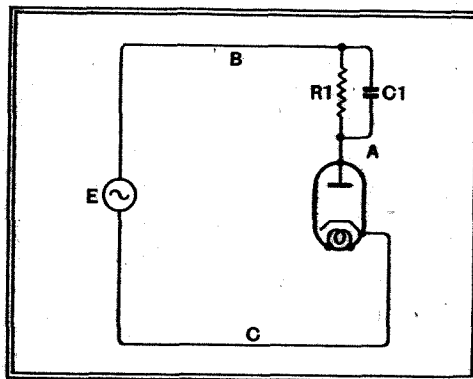

Fig. 3.—In practice, the load circuit R_1 usually has a condenser C_1 across it. The operation of the rectifier is then profoundly modified.

electrons, and hence the work done, increase with the anode voltage, and the anode temperature rises. By radiation the increase in anode temperature raises the cathode temperature and hence the emission.

With most modern diodes the saturation condition cannot be reached, because the cathode emission is so great that the cathode surface would be destroyed before saturation began.

The primary purpose of a diode is rectification. The valve is connected in series with a source of alternating voltage E and a load circuit R , as shown in Fig. 1. The applied voltage has a waveform such as that shown in Fig. 2 (a) and it swings the diode anode alternately positive and negative with respect to the cathode.

When the anode is positive the electrons are attracted to the anode and the current flows, but when the anode is negative electrons do not reach the anode and there is consequently no

Fig. 4.—When a reservoir condenser is used the action is as depicted in these diagrams, where (a) represents the input voltage waveform. The current through the diode is depicted at (b) and the voltage across the condenser at (c). The voltage between anode and cathode of the diode is shown at (d).

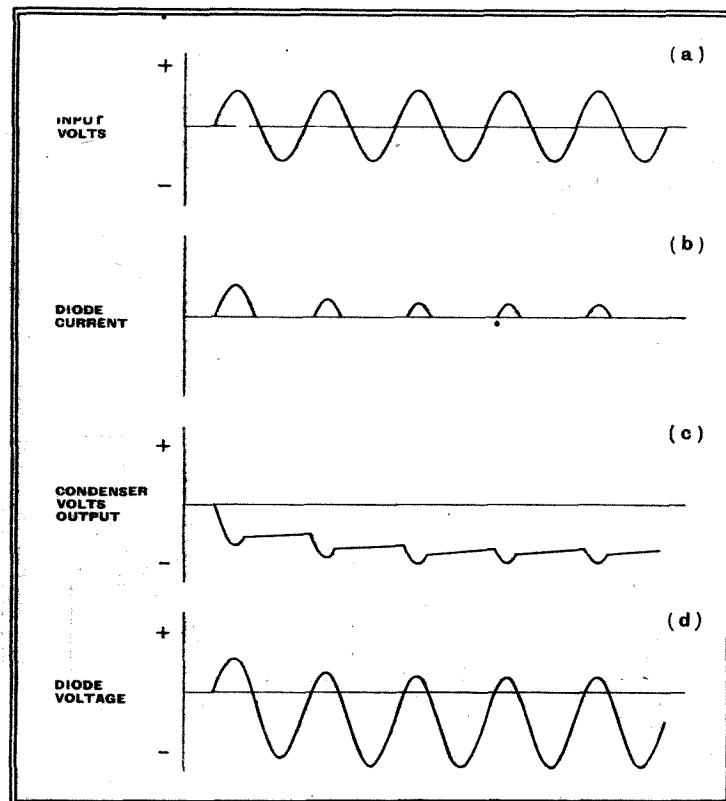

current. The current flow in the circuit is, therefore, as depicted in Fig. 2 (b); it flows in pulses on every positive half-cycle of the input voltage.

The current is pulsating and unidirectional, and it has a mean value, illustrated

by the dotted line, which will operate a direct current ammeter. The pulsating current can be regarded as a direct current with a superimposed alternating current of complex waveform. By means of smoothing circuits the latter can be removed and an output of nearly pure direct current can be secured.

In practice, the action of the rectifier is rather more complicated than this because the load resistance R_1 is shunted by a condenser C_1 , as in Fig. 3. The diode then conducts for a much shorter period than the whole of every positive half-cycle.

Consider what happens when the alternating voltage E is applied with the condenser C_1 uncharged. As soon as the anode becomes positive with respect to the cathode the valve is conducting and the electrons reaching the anode flow out into the external circuit. Very few flow through R_1 , for the majority flow into the condenser to charge it. The accumulation of electrons on the lower plate (in the diagram) of the condenser means that this plate is acquiring a negative potential with respect to the other plate.

Rectification

The voltage acting on the diode anode is thus reduced, for at the moment taken the point B is positive with respect to C by the input voltage and the point A is negative with respect to B. Consequently A is less positive than B with respect to C.

Current flows through the diode into C_1 and increases the potential across it as long as the positive input voltage is greater than the voltage across C_1 . When the peak of the positive half-cycle of input voltage is passed the voltage falls, and as

How the Valve Works—

soon as it equals the voltage on the condenser, there is no voltage applied between the diode anode and cathode and the anode current ceases.

The condenser then commences to discharge through R_1 and the voltage across it falls. The discharge is not completed by the time the next positive half-cycle of input comes along, and the diode again passes current when the positive input voltage exceeds the negative voltage on the condenser. After a few cycles a steady state is reached when the electrons leaving the condenser through R_1 during the non-conductive time of the diode are

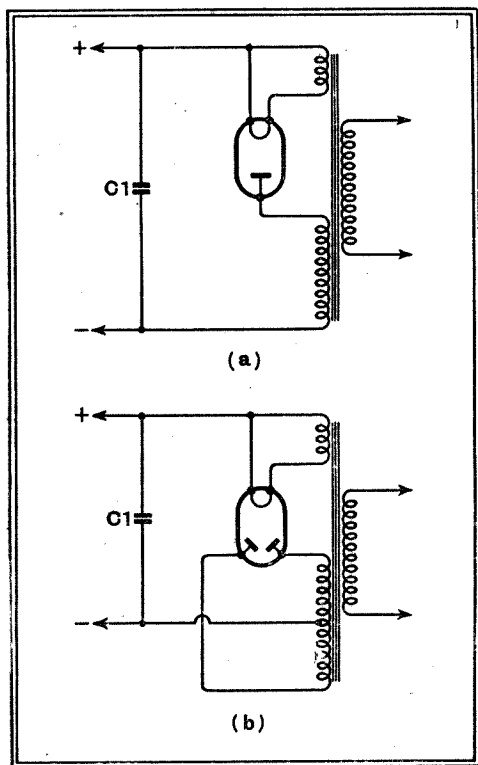
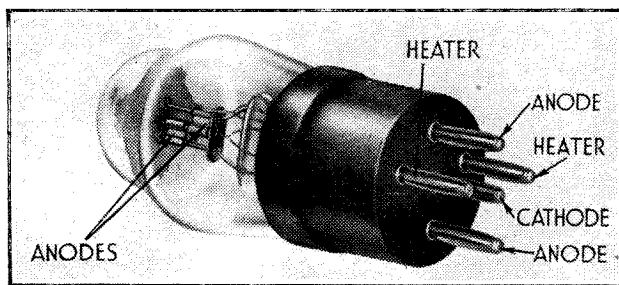

Fig. 5.—A typical half-wave rectifier suitable for a small HT supply unit takes the form shown at (a), while a full-wave rectifier is illustrated at (b).

equal to those entering it through the valve when the diode is conductive.

This state of affairs is sketched in Fig. 4, where (a) shows the input voltage E and (b) depicts the diode current. The condenser voltage is sketched at (c) and the voltage between the diode anode and cathode at (a). It will thus be clear that the ordinary rectifier conducts current for only a small portion of the

A typical duo-diode for use as a detector. Two diodes with a common indirectly heated cathode are fitted.



cycle of input voltage, and that this time decreases as the values of C_1 and R_1 increase. This is clear when it is remembered that the loss of voltage across C_1 during the non-conductive period of the valve increases as the product $C_1 R_1$ is reduced. In the limit, with $C_1 R_1$ equal to infinity, the voltage across C_1 would

not fall, and this condenser would charge up until the voltage across it equalled the peak input voltage. The condenser voltage would then always offset the input voltage, and the diode anode would never become positive with respect to its cathode, and so would not conduct.

This condition is never reached, of course, for we must have a current through R_1 , as it is to obtain this current that we use the rectifier. Nevertheless, for a given value of R_1 , the larger we make C_1 the more nearly will the mean voltage across it equal the peak input voltage, and the shorter will be the conductive time of the valve.

To come to practical values, a valve might be rated for 250 volts RMS input with a mean output current of 75 mA. The peak input is $250 \times 1.414 = 354$ volts, and on no load, that is, with R_1 removed, the output voltage across C_1 will rise to this value. With the full output current of 75 mA. flowing through R_1 the condenser voltage will fall to perhaps 265 volts when C_1 is some $8 \mu F$. Reducing the current to half this value by doubling R_1 will cause the voltage to rise to perhaps 300 volts. If the condenser capacity is doubled, the voltage will also rise.

The Peak Current

Now as the output current is continuous and nearly uniform, and the valve conducts for only a small portion of the total time, it is clear that when the valve does conduct the current through it must be very much greater than the output current. This peak current increases with the capacity of the condenser C_1 and, of course, with the load current, and forms the limit to the safe rectifier output. Users of small rectifiers rarely take much account of the peak current, for it is normal to use a condenser, and valve makers usually take a $4 \mu F$. condenser into account when specifying the load current. With very large rectifiers, however, it is usual for the maximum safe peak current to be specified rather than the output current to the load. In order to make the load current more nearly equal to the peak current, a condenser C_1 is not used

with such valves, and the operation follows more nearly the simple lines discussed earlier.

It should be noted that when a condenser is used, the maximum voltage across the valve on the negative half-cycles is equal to the peak input plus the condenser voltage. This is called the

peak inverse voltage, and can reach on open circuit 2.828 times the RMS input voltage. With high-voltage rectifiers, the maximum voltage input is usually specified in terms of the peak inverse. It should also be noted that with most of the usual circuits the peak inverse voltage

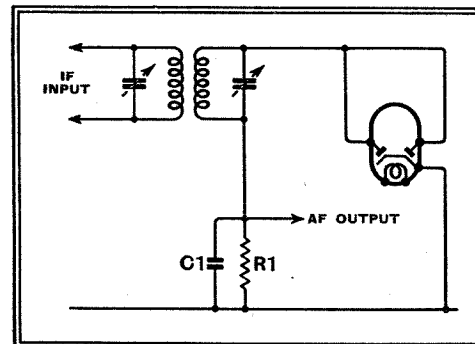

Fig. 6.—The half-wave rectifier is commonly used as a detector and the circuit often takes the form shown here.

appears between two windings on the input transformer.

A practical half-wave rectifier circuit is shown in Fig. 5 (a) using a directly heated type of diode rectifier. Such circuits are usually only used when low output current is required, as in small HT supply units and for high-voltage low-current supplies in television equipment. The resistance R_1 has disappeared, being, of course, replaced by the apparatus which is using the output of the rectifier. Smoothing equipment is interposed between the output shown and the load circuit to remove the ripple.

In order to avoid the considerable discharge of C_1 during the non-conductive time of the diode, it is common to use full-wave rectification. Two diodes are used to conduct on the opposite half-cycles of the input, and their outputs are taken in the same sense to the condenser C_1 , so that it is now charged twice as often. The arrangement is shown in Fig. 5 (b). The two diodes are usually separate electrode assemblies with separate filaments, but mounted in the same glass bulb.

Diodes of much smaller type but functioning in essentially the same way are often used as detectors. The most widely used circuit is fundamentally the same as that of Fig. 5 (a), and is shown in Fig. 6, where the similarity is readily apparent. The values of components are, of course, widely different. Instead of C_1 being $4-8 \mu F$. it is $0.0001-0.0005 \mu F$., and R_1 is of the order of $0.25 M\Omega$. The input is derived from an IF transformer.

In general, detector diodes are available as a pair in one glass envelope with a common cathode. Such a valve is shown in Fig. 6, and the two anodes are strapped together so that the two are used in parallel to form one diode of greater current handling capacity. In some applications they are used separately, and some of the latest duo-diodes have separate cathodes for the two sections, giving greater flexibility of use.

When used as a detector the rectified current rarely exceeds 1 mA., and is

How the Valve Works—

usually much less. Quite small cathode emission is needed, therefore, and the heater need consume only a small power. The whole electrode assembly can be quite small, and diodes are consequently often built into the same glass bulb as the electrode assemblies of other types of valve. The lower heater power also makes the diode one of the few valves which is available with an indirectly heated cathode in the types intended for

operation from a 2-volt accumulator.

Diodes are not only used for detection and rectification, they are also widely employed to simulate the action of a single-pole make-and-break switch! By changing the anode-cathode potential the valve can be arranged to short-circuit or open-circuit some connection as required. Used in this way a diode can give a delay on AVC action, can effect sync. separation in television, and can reduce certain types of ignition interference.

spectrum is like that sketched in the diagram.

The detector output of the sound receiver then contains the usual audio-frequencies and the 15 kc/s and 25 kc/s sub-carriers which are easily filtered out from the sound channel. The two sub-carriers are then separated by band-pass filters and applied to detectors, in the output of one of which appears the frame scan voltage and in the output of the other the line scan voltage. Amplifiers follow to bring the scanning signals to the correct level for applying to the deflecting plates or coils of the CR tube.

It will be seen that saw-tooth oscillators are not required in the receiver, for the actual saw-tooth voltages are present in the transmission and need only to be selected and amplified. There is consequently no possibility of a lack of synchronism between transmitter and receiver.

Another advantage of the scheme is that it is possible to change the scanning system at the transmitter without affecting the receiver. The number of lines or frames or method of interlacing can be changed as desired without necessitating any alteration to the receiver, since the whole process of synchronising is entirely automatic and does not depend on receiver characteristics.

It remains to be seen whether the system will be generally adopted or not. The use of separate carriers for vision and scanning raises the possibility of greater difficulty of good reception in districts where fading is severe, for the fading is unlikely to be the same on the two carriers. It is clear, too, that variations in signal strength would cause variations in the height and width of the picture. A good AVC system operating on the sound carrier will naturally help greatly.

Television Topics

"FOUR-WAY INTERLACING"

AMERICAN television methods are in general similar to the British, the chief differences in the proposed standards being the adoption of 441 lines and 60 frames. Negative modulation is also used. The 60 frames are interlaced to give 30 complete pictures a second.

A new method of considerable interest has been developed by the Du Mont Laboratories, however, in which interlacing is carried much farther. No fewer than four frames are needed for each picture. It is well known that with normal interlacing alternate lines are scanned in the first frame and in the next those missed in the first scan are covered. That is, if the lines are numbered downwards, lines 1, 3, 5, 7, etc., are scanned in frames 1, 3, 5, 7, etc., and lines 2, 4, 6, 8, etc., in frames 2, 4, 6, 8, etc.

The object of this interlacing is to reduce the frequency response range occupied by the transmission. A frame frequency of some 50 c/s is necessary to prevent flicker, but from the point of view of obtaining continuity of motion in the picture a much lower frequency would suffice.

The maximum modulation frequency is proportional to the number of lines and to the picture frequency. With the ordinary 2-1 interlacing there are two frames to every picture and the maximum frequency is consequently only one-half of what it would be if interlacing were not used, for without interlacing the picture frequency would have to be as high as the frame frequency to prevent flicker.

In the Du Mont system four-fold interlacing is used, so that the picture frequency is only one-quarter the frame frequency

and the maximum modulation frequency is only one-half of that with ordinary interlaced scanning. There are four frames to each picture. Lines 1, 5, 9, 13, etc., are scanned in frames 1, 5, 9, etc., lines 2, 6, 10, 14, etc., in frames 2, 6, 10, etc., lines 3, 7, 11, etc., in frames 3, 7, 11, etc., and lines 4, 8, 12, etc., in frames 4, 8, 12, etc.

The major difficulty in putting this quadruple interlaced system into operation lies in synchronising, for it has been found that ordinary methods are not accurate enough for such complex interlacing. The difficulty has been overcome by abandoning the use of synchronising pulses altogether. Instead the actual saw-tooth scanning waveforms are transmitted.

The Scanning Signals

The vision transmitter deals only with the picture signals and not with a mixture of picture signals and sync pulses as in other systems. The scanning signals are transmitted with the sound on another carrier.

The frame scanning voltages modulate

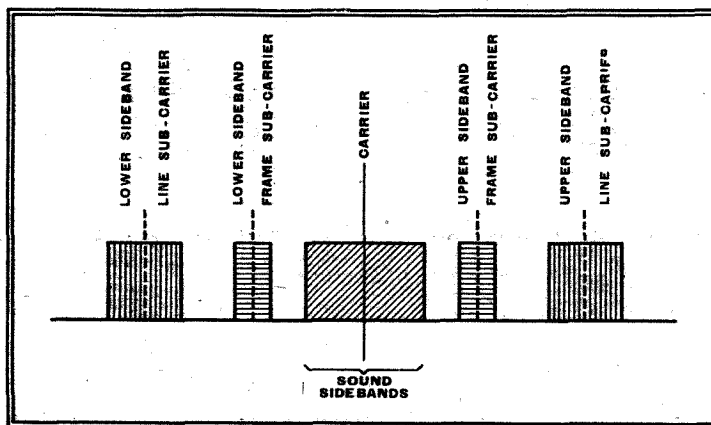

In this diagram the arrangement of sidebands on the sound carrier is illustrated. The scanning waveforms are carried by two sub-carriers which modulate the sound carrier.

a sub-carrier of 15 kc/s and the line scanning voltages another sub-carrier of 25 kc/s. The carrier of the sound transmitter is modulated by the sound and by the two sub-carriers, so that its frequency

SPRAYED SCREENING

New Process for Non-metallic Materials

CONSIDERABLE savings in manufacturing costs can be effected in components and complete receivers if the necessary metallic screening can be sprayed directly on to non-metallic materials such as bakelite, wood, etc. The difficulty is to find a composition which will not flake off under continual changes of temperature, but which at the same time will have a sufficiently high conductivity.

We learn that the problem has been solved and a method patented in Germany, where the process in question has been adopted by the A.E.G. company for use in their receivers. The mixture is sprayed on in the usual way and subsequently stoved at 150 deg. C. The cost of materials for completely treating an average broadcast receiver would be about eightpence.

The British Empire rights are for disposal, and those interested should apply to the agents, F. Arnold Best and Co., 21, Old Queen Street, London, S.W.1.

Variable Resistances

PROCESSES IN THE MANUFACTURE OF WIRE-WOUND AND COMPOSITION TYPES

WHEREVER a variable resistance is required, whether it be for volume control in a broadcast receiver or for use in laboratory measuring apparatus, a value running into many thousands of ohms will generally be called for. The higher the value the more difficult it is to ensure reliability of the wire or composition resistance element under the continual wear of the contact; but reliability there must be, for few faults in a wireless receiver are more

experience of the manufacturer that the future success or failure of the component will depend. The Reliance Manufacturing Co. (Southwark), Ltd., whose new works at Walthamstow we were recently able to inspect, have specialised for many years in the design of variable resistances both for instrument work and for broadcast receivers.

Their composition high-resistance type variable resistance and potentiometers consist of a homogeneous film of colloidal

ONE of the most important components in any broadcast receiver is the volume control. Reliability at this point is essential, and this article shows the methods by which it is achieved.

Contact with the resistance track is made by a small graphite block set in the end of a phosphor-bronze spring arm. The hardness of this graphite contact is important and its composition is adjusted so that it neither adds to nor subtracts from the thickness of the resistance film.

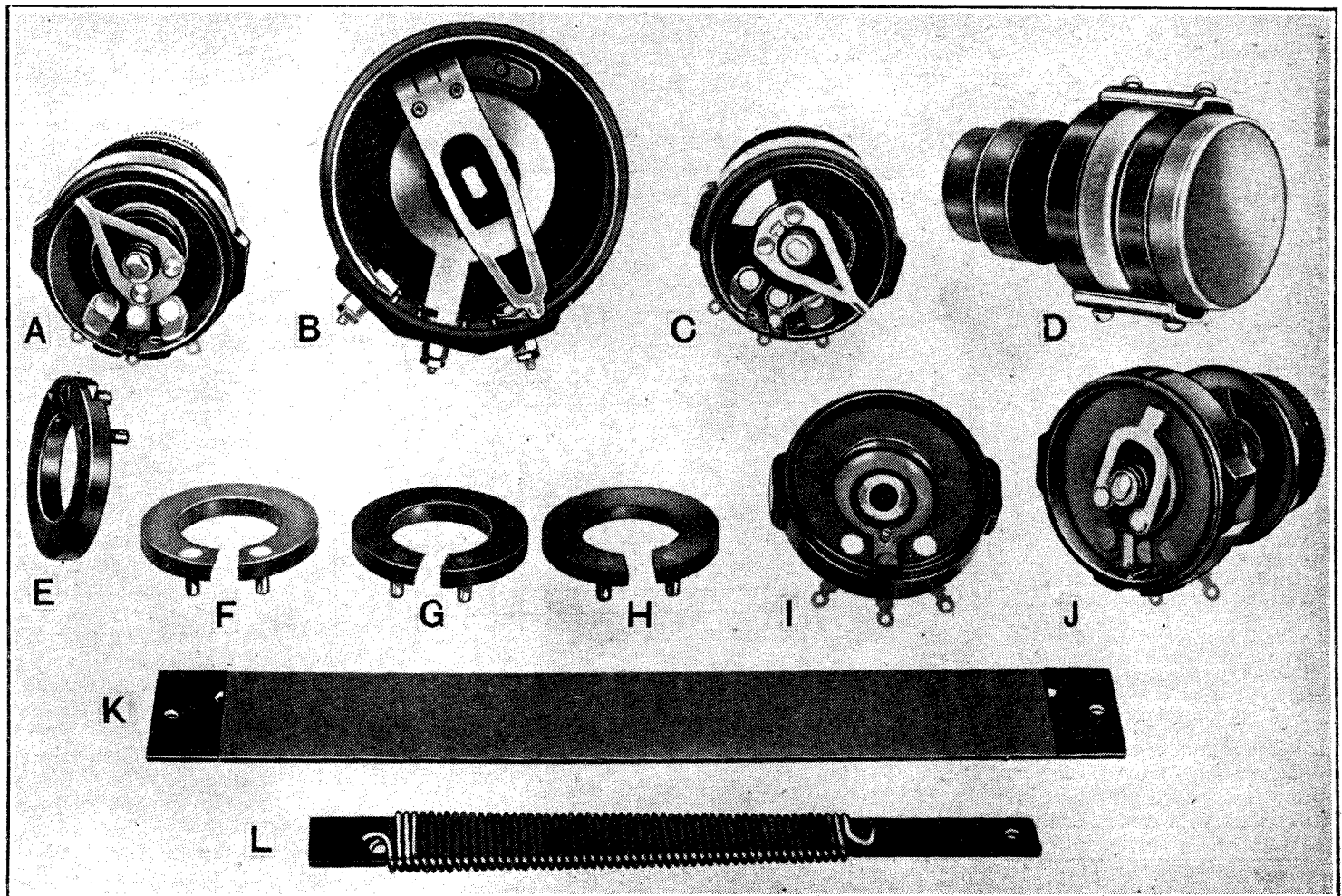

Representative resistance types and processes. A, standard Type T.W. 0.1 megohm wire-wound potentiometer. (Note thick phosphor-bronze spring end contacts.) B, Type P.I.W. 15-20 watt wire-wound resistance. C, Type T.W. with gold-silver alloy contact and pigtail centre connection. D, Type T.W.D. ganged potentiometers with independently operated spindles. E, bakelite ring for composition-type resistances with moulded inserts. F, surface machined and gap cleared. G, surface coated with graphite composition and aged. H, surface polished and resistance adjusted. I, resistance element assembled in housing with through contacts to soldering tags. J, potentiometer with insulated contact arm fitted. K, 0.5 megohm wire-wound resistance element containing 250 yards of wire. L (by way of contrast), 0.5-ohm Type T.W. element.

annoying than a noisy or "lumpy" volume control. A cheap component at this point is false economy, for the cost of replacement may well be greater than that of the potentiometer itself.

Superficially there is little to distinguish the good product from the bad; it is on the

graphite painted on a perfectly smooth and stable bakelite surface. The solution is not sprayed, as this has been found to introduce discontinuities in the surface, and the painting process has proved itself capable of giving a film which does not crack with age.

Standard values for composition resistances range from 1,000 ohms to 10 megohms, and they may be obtained with linear or logarithmic characteristics. The latter are suitable for volume controls and give approximately equal increments of loudness for equal angles of rotation.

Variable Resistances—

To obtain the required grading in the resistance of track the film is sometimes deposited by spraying, a progressive diminution in thickness being allowed for towards the maximum setting of the control. In Reliance resistances a simpler method has been found to give more consistent results. The film is painted on in three layers of different thicknesses, the first covering the full 300 degrees of the track, the second 200 degrees and the third 100 degrees starting from zero.

Final Grading

Skilful rubbing down produces a smooth track with a resistance curve closely approximating to a true logarithmic law. Even if the steps in the resistance were not smoothed off it is doubtful whether they would be noticed, for there is less than 2 db. difference from a true log. scale over 85 per cent. of the range of the control. The greatest deviation is towards the zero end, and this is in the right direction for it gives a lower minimum volume.

The foundation of the resistance track is a bakelite ring with brass contacts inserted during the moulding process. A diamond tool is used to machine the surface flat and to ensure that there will be no step at the boundary of the end contacts to damage the graphite-tipped sliding contact.

In the final polishing process the resistance is held in a special lathe equipped with slip rings and contact brushes by means of which "Megger" readings of resistance may be taken without removing the

Curve A represents a mathematically correct logarithmic volume control, and curve B shows that a close approximation is obtainable by dividing the resistance into three sections, each with a different linear variation. The greatest difference from the true log. law is in the first few degrees of rotation, and this is an advantage as it gives a better minimum.

bakelite ring or even stopping the machine.

Connection to the sliding arm is made through a second phosphor bronze spring in contact with a washer in the moulded

case of the resistance. The fixed contacts project through the back and are riveted directly to their soldering tags. Complete insulation between the spindle and the brushes is ensured by a bakelite boss moulded round the head of the spindle. If specially ordered a pigtail connection to the sliding arm can be supplied.

Composition resistances are aged for a period of at least three weeks before final grading, and the result is a stable and smooth-working control which has proved itself capable of standing up to hard wear.

Wire-wound resistances present their own special problems. They are wound on reinforced bakelised strips which are subsequently bent into a circle to fit inside their housings. The strips are clamped in a

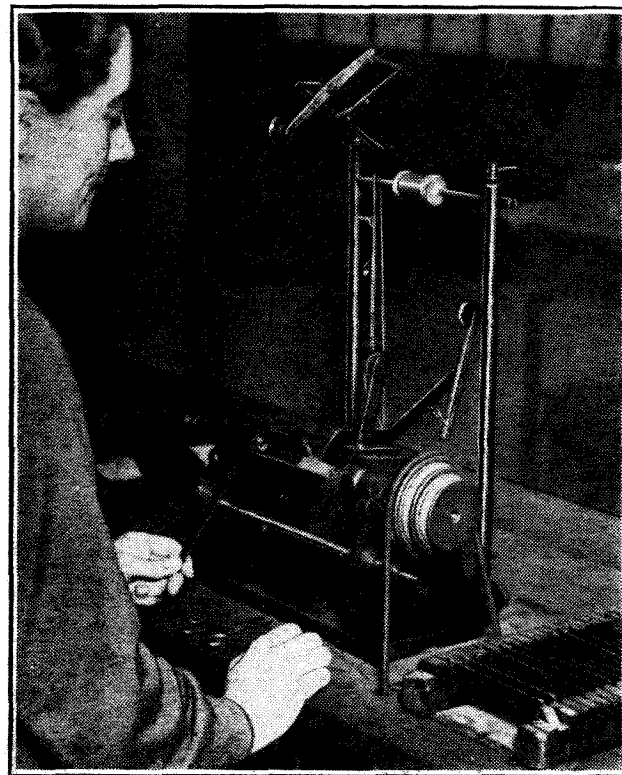

Wire-wound elements are handled by a machine fitted with coupled drives at each end. The mechanism for tensioning and guiding the wire has been perfected as the result of many years' experience of handling the finer gauges.

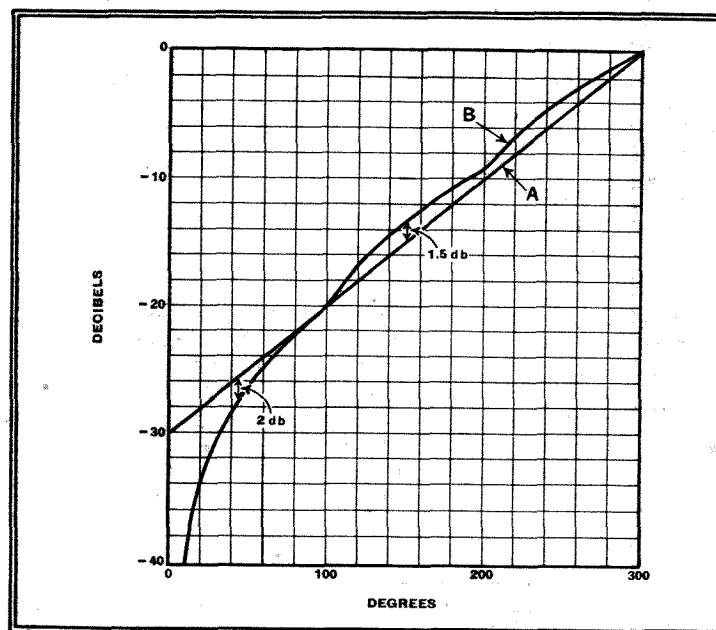

guides, the contours of which are more or less a trade secret. Obvious shapes, even if executed in the finest steel, would be worn through in a very short time by the hard alloys used for resistance wire. Any winding pitch can be arranged by changing the gears which drive the lead screw; the turns are always spaced to allow for the subsequent bending of the resistance when it is fitted in its case.

In the heavier gauges of wire used for low-resistance potentiometers enamelled insulation is generally specified, and in the finer gauges a thin oxide coating is employed. This coating is formed by passing the wire through an electric furnace in an atmosphere of oxygen.

Experience in the selection of wire and knowledge of the most reliable sources of supply are the finest essentials for success in this business. Not only must the resistance per yard remain constant, but the section must be perfectly circular and there must be no local variations of diameter. Breakages during winding are rare, and when they occur the whole resistance is scrapped, no attempt being made to join the wire. In the case of special resistances where more than one gauge of wire is used, the junctions are welded, not soldered. Freedom from traces of iron in the resistance alloy is also important, particularly for use in tropical climates. Incidentally, the tropical specification includes a copper

machine resembling a screw-cutting lathe with headstocks at each end. Gearing transmits the drive equally to both ends of the strip and the wire is fed through

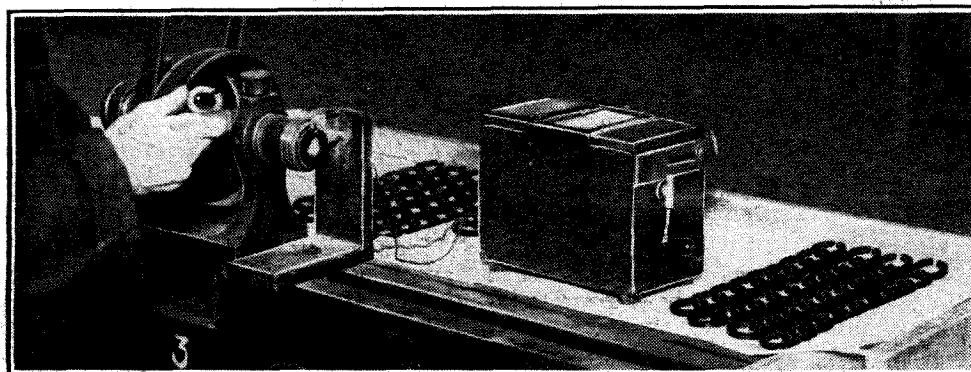

Polishing and adjustment of composition resistances on a special lathe fitted with slip rings which enable the resistance to be checked without stopping the machine.

Variable Resistances—

instead of aluminium dust cover and cadmium or nickel plating of all metal parts.

The range of wire-wound resistances and potentiometers is from 0.5 ohm to 0.5 megohm. For the latter nickel-chromium alloy wire 0.00075 inch in diameter—about one-third the thickness of human hair—is employed. The bakelite strip carrying this resistance is 1in. wide and 6½in. long; it holds 250 yards of wire and takes 15 minutes to wind at 300 r.p.m.

Stepped potentiometer resistance element designed to follow a special law with an accuracy within two per cent.

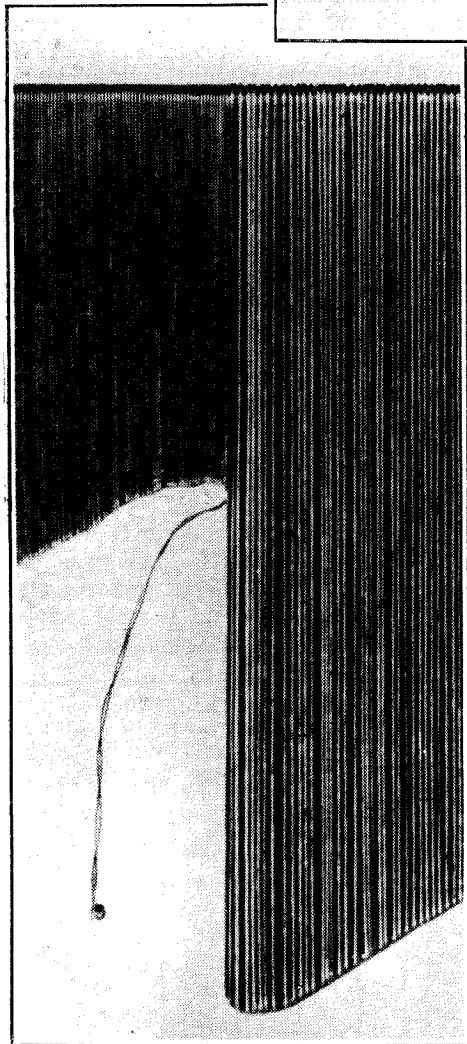
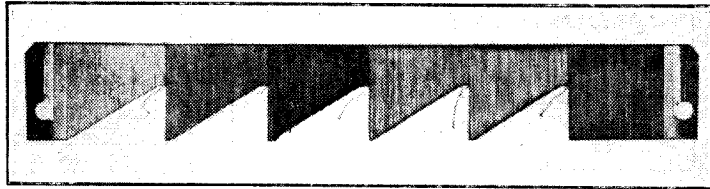

Enlarged photograph of junction between sections of a special "saw-tooth" resistance element. The maximum depth shown is actually 1 inch. Note the welded junction between twisted ends of the two wires.

Contact with the ends of the resistance is made by pressing the end turns by means of phosphor-bronze clips against soft foil bands previously cemented to the bakelite former. A firm contact is thus achieved without solder and without risk of cutting the fine wire.

The sliding arm works on the edge of the strip where the turns are in the firmest contact with bakelite strip. The whole element is treated with an adhesive

varnish to make quite sure that turns will not be displaced under the pressure of the contact.

Normally a phosphor-bronze contact arm is employed and the tip is "spooned" to reduce the contact to one or two turns. Where a specially low contact resistance is important gold-silver alloy tips are fitted, and for extreme reliability in remote parts of the world where servicing facilities may be non-existent a steel shoe may be specified. The reason for this is interesting. It is always the contact arm which wears

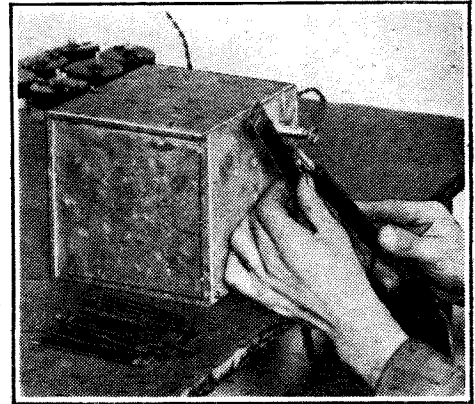

Spot-welding joints between sections of graded wire-wound potentiometer elements.

one type of resistance now being made to special order no fewer than five such changes of level have to be adjusted.

This resistance is typical of the high-grade instrument work which forms an important part of the firm's activities. The specification called for an overall accuracy of resistance of 1 per cent. and agreement with a special law within 2 per cent. at every 10 degrees of rotation from 0 to 300 degrees. The problem was solved by a saw-toothed former with six changes of wire. Another order recently executed was for a four-gang motor-driven resistance assembly to form a Wheatstone bridge which was required to remain in balance to within 0.1 per cent. at all settings.

Precisely the same technique is applied to the winding of resistances for special work of this kind as for the stock lines of broadcast receiver components. The new works at Sutherland Road, Walthamstow, are equipped with a complete modern moulding plant, and every process, with the exception of wire drawing, is carried on under one roof. No attempt is made to compete with cheap imported components, and on the score of quality the products of this factory are a credit to British industry.

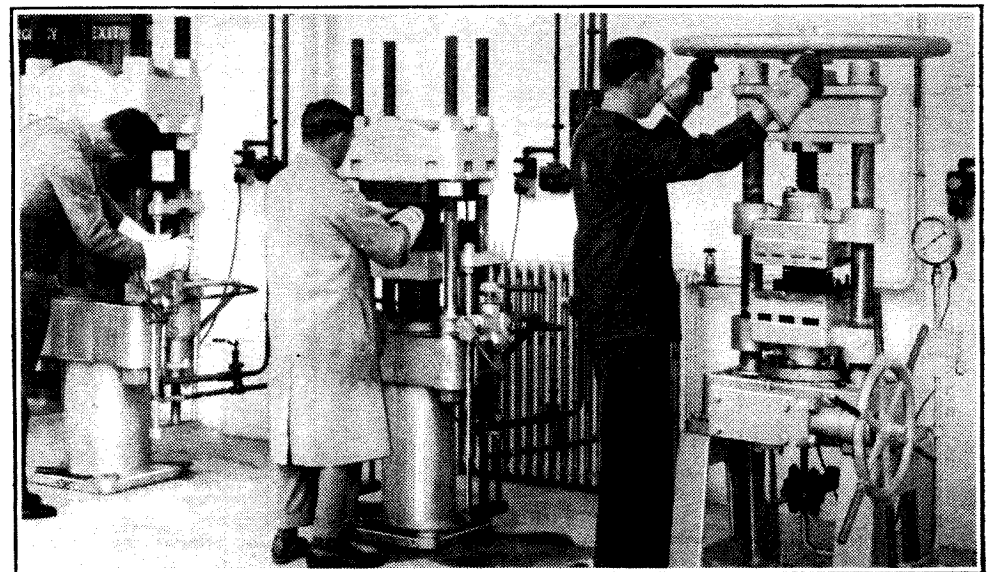

All processes, including moulding, are housed under one roof in the new Reliance factory. Electrically heated platens in the presses make for cleanliness and good insulation in the final product.

U-H-F Superhet

By D. W. HEIGHTMAN

SPECIALLY DESIGNED FOR
"SINGLE FIGURE" WAVELENGTHS

THE receiver about to be described was designed to give good stability, sensitivity and selectivity up to at least 65 Mc/s, i.e., to be capable of covering the 56-Mc/s amateur band, television sound and other UHF broadcasts, 28-Mc/s band, short-wave broadcasts and the 7 and 14-Mc/s amateur bands. It was required to be simple to construct, inexpensive as possible (consistent with good results), suitable for loud-speaker operation, have its own power supply for AC mains, and also provision for CW morse reception. In other words, to provide a good all-round receiver for the short-wave enthusiast.

While a carefully planned straight receiver, using one or more RF stages, modern valves, components, etc., is capable of giving good performance up to 60 Mc/s, it is extremely difficult to make such a receiver as stable and sensitive, over the wide band of frequencies generally covered, as one of the superhet type. Obviously one cannot hope to obtain optimum performance from RF stages which have to operate at any frequency between, say, 5 to 60 Mc/s compared with the superhet where the amplification is (or should be!) done by stages adjusted

ALTHOUGH the wavelength range of this receiver may be extended by means of plug-in coils up to some 60 metres, it is of particular interest for reception of wavelengths from below 5 metres up to some 10 metres.

for peak performance on one frequency. For a given number of stages the straight set cannot be made so selective. The superhet, then, has much in its favour for the reception of frequencies over 5 Mc/s.

Most superhet receivers of the class with which we are here concerned have one or two RF stages in order to avoid second channel interference and to increase sensitivity. This immediately involves constructional and other difficulties, especially if the receiver is to work on 60 Mc/s, since such stages must be very carefully laid out, screened, wired, ganged, etc., if satisfactory performance is to be obtained. In fact, one has most of the troubles of the straight set before one has even started on the main or super-

heterodyne portion! The ideal superhet, from the simplicity point of view, will not therefore use RF stages.

How can we overcome the two disadvantages usually considered inherent in superhets with no RF stages? First, second-channel interference. The usual IF is 465 kc/s, which means that the oscillator is working 465 kc/s higher than the desired signal and that a signal 930 kc/s higher than the desired signal will cause interference, because the selectivity of a single input circuit is insufficient to discriminate between two signals 930 kc/s apart at, say, 30 Mc/s. If, however, the IF is increased to between 2.5 and 3 Mc/s the separation between the desired and undesired signals is then 5 to 6 Mc/s, and even a single tuned circuit is capable of cutting out the undesired signal at such a separation. There are no disadvantages to having the IF amplifier working on 3 Mc/s, since with reasonable care good gain and stability can be obtained. Another advantage of the high IF is that there is no interaction between the signal and oscillator circuits—an important point at ultra-high frequencies.

Secondly, poor sensitivity can largely be overcome by reducing the losses in the input signal frequency circuit to a minimum and using a suitable valve as frequency changer. The present receiver

Complete circuit diagram of the receiver. Values and characteristics of the various components are given on the opposite page.

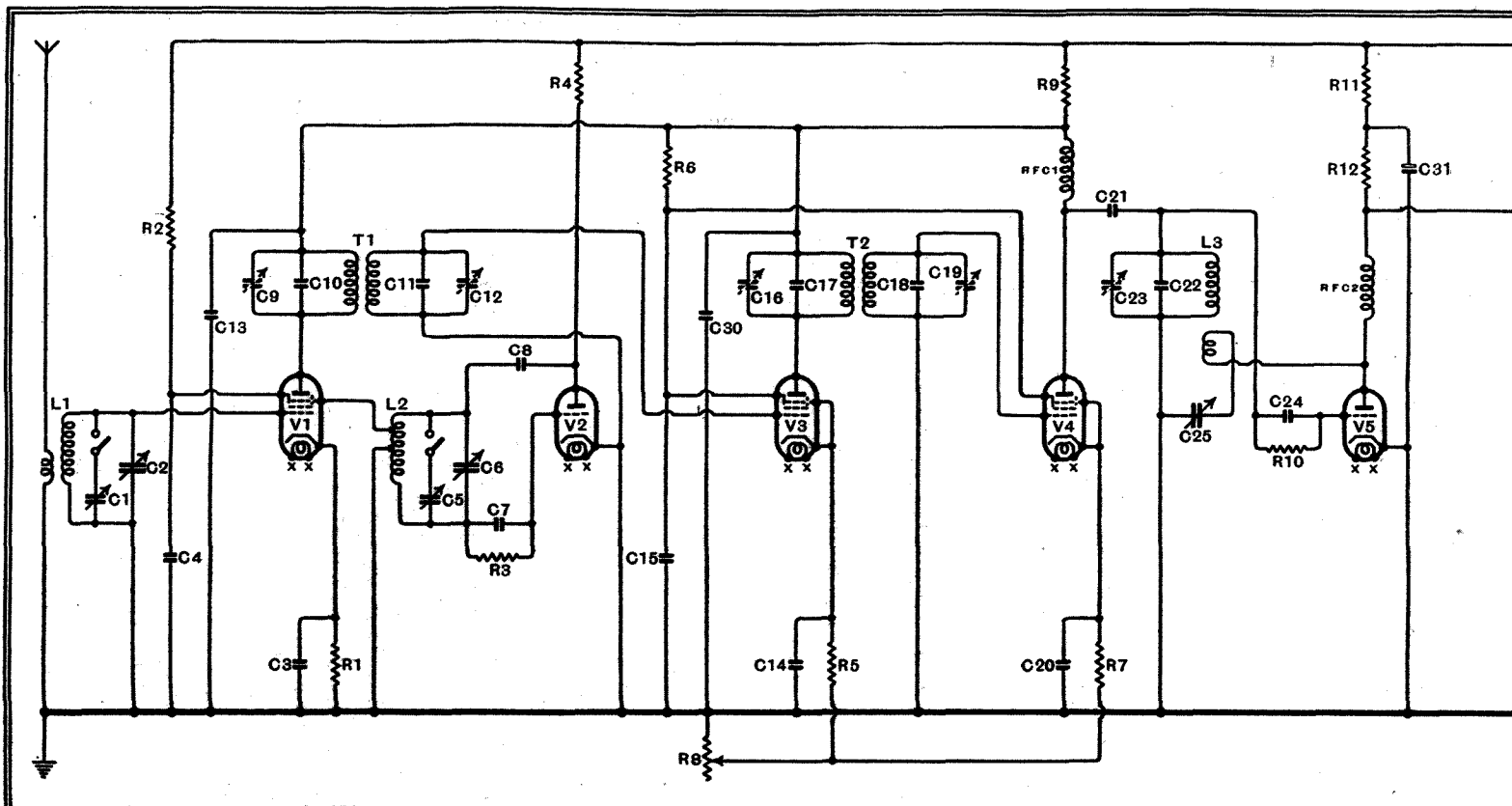

U-H-F Superhet—

has been designed on the above lines. The first valve is a 954 Acorn RF pentode functioning as mixer and first detector and chosen because its low input capacity and damping allows one to obtain an efficient input circuit even at 60 Mc/s or higher. The aerial is loosely aperiodically coupled by a few turns to the signal circuit in order that it does not damp the circuit too much. Provision is made that either Marconi or twin feed aerials can be used. The fairly high value cathode resistance provides for anode bend rectification in this stage. A 955 Acorn triode is used in a Hartley circuit as oscillator. The type of oscillator circuit used is relatively unimportant, the requirements of such a circuit being, of course, stability, freedom from drift and reasonably constant output over the tuning range. This particular circuit was adopted because of its simplicity and good performance.

Mixing is obtained by connecting the output of the oscillator to the suppressor

grid of the pentode. On frequencies over 15 Mc/s this connection is tapped down the anode side of the oscillator coil in order to improve stability and give freedom from modulation hum. On lower

sary for this position in the receiver. The 20-micro-microfarad tuning condensers used do not make tuning too critical and at the same time give a fairly large frequency coverage. With tuning con-

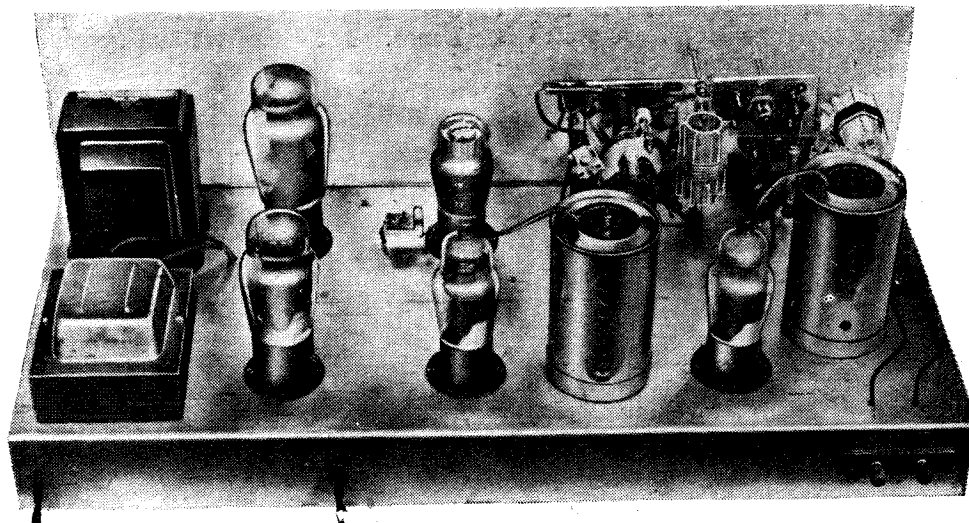

- C1 30 mmfds., pre-set.
- C2 20 mmfds., variable.
- C3 0.1 mfd., non-inductive.
- C4 0.1 mfd., non-inductive.
- C5 30 mmfds., pre-set.
- C6 50 mmfds., variable.
- C7 50 mmfds., fixed mica.
- C8 100 mmfds., fixed mica.
- C9 50 mmfds., pre-set.
- C10 50 mmfds., fixed mica.
- C11 50 mmfds., fixed mica.
- C12 50 mmfds., pre-set.
- C13 0.1 mfd., non-inductive.
- C14 0.1 mfd., non-inductive.
- C15 0.1 mfd., non-inductive.
- C16 50 mmfds., pre-set.
- C17 50 mmfds., fixed.
- C18 50 mmfds., fixed.
- C19 50 mmfds., pre-set.
- C20 0.1 mfd., non-inductive.
- C21 100 mmfds., fixed.
- C22 50 mmfds., fixed.
- C23 50 mmfds., pre-set.

- C24 100 mmfds., fixed.
 - C25 100 mmfds., variable.
 - C26 0.1 mfd., 400 volt working.
 - C27 25 mfd., 25 volt working.
 - C28 8 mfd., 400 volt working.
 - C29 8 mfd., 400 volt working.
 - C30 0.1 mfd., non-inductive.
 - C31 4 mfd., 400 volt working.
 - C32 500 mmfds., fixed, 300 volt A.C. working.
 - C33 500 mmfds., fixed, 300 volt A.C. working.
- (C28, 29 and 31 are electrolytic type and can be combined in one block (8-8-4).)
- R1 3,000 ohms.
 - R2 250,000 ohms.
 - R3 25,000 ohms. (½ watt).
 - R4 100,000 ohms low capacity.

- R5 500 ohms.
 - R6 50,000 ohms.
 - R7 500 ohms.
 - R8 10,000 ohms.
 - R9 5,000 ohms.
 - R10 500,000 ohms (½ watt).
 - R11 20,000 ohms.
 - R12 50,000 ohms.
 - R13 450 ohms.
- All resistances 1 watt, unless otherwise stated.
- T1, T2 3-Me/s IF transformers—see text.
 - T3, 5:1 audio transformer.
 - T4, Mains transformer—see text.
- SC 20-henry smoothing choke.
- RFC1, RFC2, section-wound short-wave choke.
- L1, L2—see text.
 - L3, second det. grid coil—see text.

densers of this value it was considered unnecessary to provide for further band spreading. When required, 20-mmfd. pre-set condensers can be included in parallel with the main tuning condensers to extend the tuning range of any particular set of coils. Five sets of coils can thus be made to give a coverage of 5 to 65 Mc/s without breaks. Both plates of the oscillator condenser are at radio frequency potential, and it is therefore necessary to operate this by a short insulating spindle and mount it on a Trolitul panel, mention of which is made later.

The frequency changer is coupled to the first of the IF valves (which are both 6K7 metal or glass type) by a specially designed IF transformer. These transformers have fixed condensers in parallel with their trimmers in order to minimise the detuning effect of temperature, etc., on trimmers if used alone. Loose coupling is used in the IF transformers so as to obtain a single peaked response curve. A similar transformer couples the first and second IF valves while coupling to the second detector tuned grid circuit is by means of a fixed condenser, the anode of the second IF valve being fed by an RF choke. The variable resistance R8 controls the gain (and consequently output) of the receiver by varying the bias to the two IF valves.

Regeneration is used in the second detector (6C5 triode) circuit to improve both selectivity and sensitivity and also, when necessary, to provide a beat-note for CW reception. In this way the necessity for a separate beat oscillator is avoided. AVC was not considered of much value in a receiver of this description but could, of course, be added at any time. The 6C5 second detector is resistance-transformer coupled to the 6F6 or 6L6 output valve.

A 5Y3 rectifier valve is used. Incidentally it will be noted that with the exception of the two Acorns all the valves are of the octal base type. The mains transformer, of the sunk-in chassis type, gives

frequencies the suppressor grid is taken to the anode end of the oscillator circuit.

Plug-in 4-pin coils were used in both the signal and oscillator circuits in order to improve and simplify construction and also to reduce cost. The type used, made by Messrs. Denco, have entirely Trolitul insulation, which reduces losses to a minimum. It is interesting to note that by substituting one of the Trolitul coils in the signal circuit for one using ebonite insulation, signals noticeably drop in strength and tuning becomes broader.

Tuning Controls

It was considered preferable not to gang the signal and oscillator tuning condensers. By so doing tuning would not be made materially easier, and much complication with padding, etc., would be introduced. Again, one is certain of obtaining maximum performance by being sure that the signal circuit is exactly in tune with the desired signal. In practice the signal circuit is roughly tuned to the required frequency. Tuning is then carried out on the slow-motion oscillator dial and when the signal is found the signal circuit is finally checked for resonance. Since the tuning of the signal circuit is not very sharp a slow-motion dial is unneces-

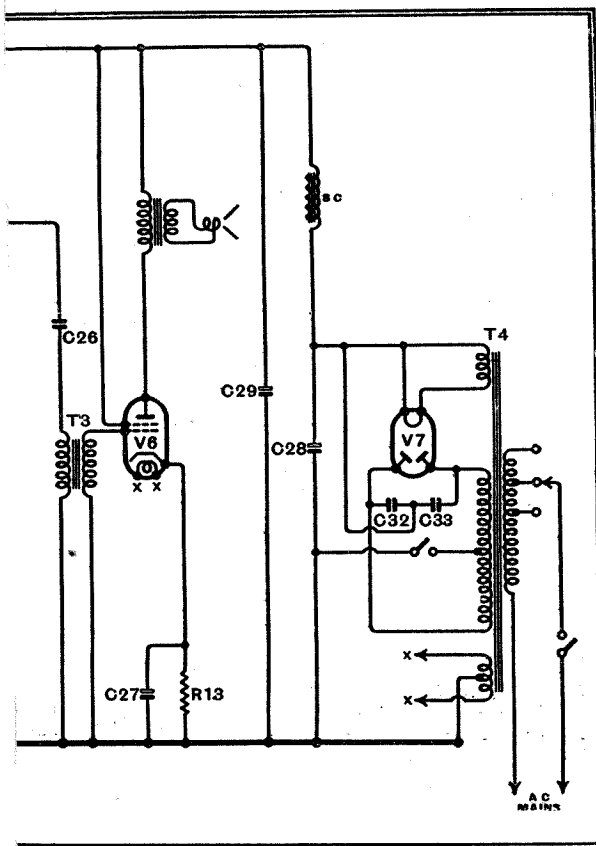

U-H-F Superhet—

secondary outputs of 500 volts (centre tapped) at 60 milliamperes or so, 6.3 volts (centre tapped) 3 amperes, and 5 volts 2 amps. The mica condensers connected between anodes and heater of the rectifier cut out the hum experienced on certain frequencies over 30 Mc/s. A switch is provided in the HT negative lead in addition to the mains switch, so that the receiver may be temporarily silenced for communication purposes. A 20-henry smoothing choke is used, but where desired this could be replaced by the field winding of a loud speaker.

The receiver was first put together experimentally, screening and decoupling being used only where obviously necessary. In this way construction was simplified, while under actual test the receiver was found to be perfectly stable and any additions proved unnecessary. The fact that there is no need for screen-

brackets at the bottom secured to the chassis. The Acorn pentode is mounted in a Trolitul valve-holder, and the signal coil socket is also of this material. All of these special components, including the IF transformers and second-detector grid coil, were made by Messrs. Denco. The IF valves and transformers are placed at the rear of the chassis and the power supply at the right-hand side looking from the front of the panel. The controls on the panel are, from left to right, signal tuning, IF gain control, main oscillator tuning, second detector reaction and two QMB on-and-off switches.

On completion, and before any results can be obtained, it will, of course, be necessary to line up the IF stages. For this purpose it is preferable to have a simple oscillator which tunes from about 2 to 3.5 Mc/s. If at hand, the oscillating detector in a straight receiver or the oscil-

lead. At this stage the 3 Mc/s oscillator can be dispensed with and the IF stages will be roughly in alignment. For final adjustment a steady signal at the input of the receiver is required. A small oscillator, working on, say, 14 Mc/s, is best for this, but if not available a fairly strong and steady short-wave signal should be tuned in and the IF trimmers then checked for complete resonance as indicated by the deflection on the meter.

Care should be taken to ascertain that the signal circuit is tuned lower in frequency than the oscillator, as on some parts of the tuning range it is possible to receive signals on both upper and lower beats.

As well as giving excellent results on the lower frequencies, the receiver has been tested on the television sound transmission for long periods and has been found very stable and free from creep after the initial heating-up period of ten minutes or so. Full loud-speaker output, with some reserve, is obtained at a distance of 70 miles with an ordinary broadcast aerial. Another interesting test was to compare the receiver with a good single-stage TRF receiver on the 56 Mc/s amateur band. A signal which was R4/5 on the loud speaker of the superhet was inaudible on the phones of the straight set.

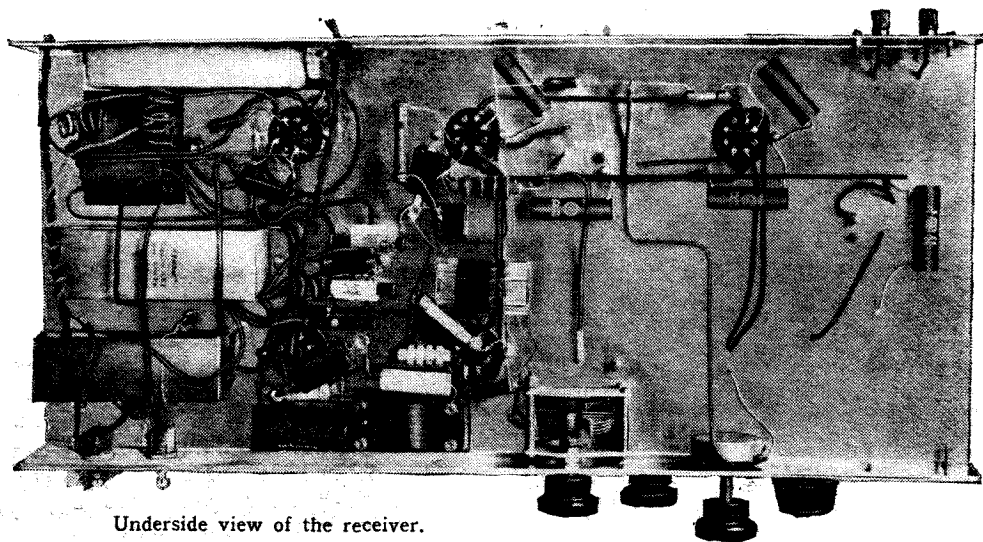

Underside view of the receiver.

ing between the signal and oscillator circuits lessens constructional difficulties to a very considerable extent. By using a well-spaced layout it was found unnecessary to provide extra screening for the IF valves (beyond their own internal screening) even when using the glass-type valves. The IF transformers are, of course, provided with their own screening cans. The second detector grid coil was not screened separately, but was placed under the chassis to avoid any unwanted couplings.

An aluminium panel measuring 7in. x 21in. and chassis 21in. x 9in. x 2in. deep are used. These dimensions give ample space for an uncrowded layout, but could be reduced somewhat.

It goes without saying that all leads in the signal and oscillator circuits are kept really short. The signal-frequency tuning condenser is mounted direct on the main panel with the Acorn pentode just above it. A Trolitul sub-panel measuring 3in. x 4in. serves as the oscillator coil socket, Acorn triode holder and oscillator tuning condenser mount. In fact, the whole of the oscillator is made up on this panel, which is mounted about 2in. behind the main panel and supported at the top by two pieces of screwed rod which are fixed to the main panel, also by two small

lator in a superhet will do the job satisfactorily. Having ascertained that the second detector oscillates, the trimmer tuning the grid coil of this stage is set about half-way in. An insulated lead is taken from the 3 Mc/s oscillator and loosely coupled to the grid of the second IF valve by lightly twisting the flex lead once or twice round the grid lead of that valve. The second detector is set oscillating, and then the frequency of the 3 Mc/s oscillator varied until it produces a beat note—i.e., is in tune with the second detector circuit. The reaction condenser is then turned out until the set stops oscillating. A high-resistance voltmeter is now connected from the detector anode circuit (resistance end of the RF choke) to chassis or, alternatively, a milliammeter is connected in series with the anode circuit, to indicate signal maxima. With the 3 Mc/s oscillator still coupled to the second IF, the grid trimmer of this stage is varied for maximum deflection on the meter.

The oscillator is next similarly coupled to the first IF grid, and the plate (primary) side of the IF transformer similarly lined up; the grid circuit of the second stage will also need slight readjustment. The process is repeated with the oscillator coupled to the frequency changer plate

New Insulator

A MICA SUBSTITUTE FROM CLAY

A POSSIBLE substitute for mica has been developed by Dr. Ernst A. Hauser, Associate Professor of Chemical Engineering at Massachusetts Institute of Technology. The material, derived from clay, is named "Alsifilm." The method is to submit a thin paste of fine-grained clay to the action of a high-speed centrifuge which separates the smallest particles from the others. This extremely fine-grained clay paste contains a relatively high proportion of water, but its important property is the tendency of the particles to align themselves into chains interlaced at random. The result is a felt-like structure, very easily disarranged, but becoming stable and strong when the water is removed by high heat and pressure. The resulting sheet material is not so painfully limited in size as is the natural mica sheet, nor does it have the same tendency to flake. It may be transparent like clear natural mica. With reasonable care in manufacture the film should excel mica in the matter of homogeneity—an important consideration at radio frequencies.

Alsifilm may be produced as a closely adherent layer coating or lining to various materials. It is therefore also a possible substitute for varnish or lacquer.

If the possibilities can be realised commercially the number of uses would appear to be large. At any rate, cost should be within reason, since suitable clays are abundant in several central and western districts of the United States.

NEWS OF THE WEEK

ELECTRICAL INTERFERENCE

Compulsory Suppression Abroad

WHEN in England recently our Italian correspondent was amazed at the interference with listening caused by electrical apparatus, and expressed surprise that there is no legislation to check this growing nuisance.

Things are very different in Italy, however. Here is an extract from the Royal Decree regarding electrical interference: "Whosoever constructs or uses in any way electrical apparatus or high power electrical transmission cables is expected to observe that the above-mentioned apparatus does not disturb wireless listeners' receivers. Should the necessary precautions not be observed, the Ministry of Public Works will take action and the owners are liable to a fine."

ONE SET TO EVERY FIVE PEOPLE

New Zealand Wireless Prospers

DESPITE the fact that a wireless receiving licence in New Zealand costs 25s. (£1 sterling), one in every five of the population owns a wireless set, according to the latest figure of 300,735 issued by the Dominion Government, and the number of licences has been more than doubled in the past three years.

Until the Ottawa agreement in 1933, America held the virtual monopoly for the export of wireless apparatus to New Zealand. Since 1934, however, the import of apparatus from Great Britain has been gradually ascending, and now with the issuing of the figures for the first six months of this year it is shown that some sixty per cent. is supplied from the Mother Country.

AMATEURS AND POLICE COLLABORATE

AMATEUR radio transmitters from the eastern counties are taking part in a series of tests at the request of the police authorities to ascertain what frequencies would be suitable for communication work in the event of a National emergency. Experiments are being conducted on the 3.5-, 7-, 28- and 56-Mc/s amateur bands. So far 7 Mc/s has proved unreliable owing to interference.

It is proposed to use multi-element beam aerials with reflectors, similar to those used at the Post Office ultra-short-wave telephone link stations, in the tests on 56 Mc/s.

LONDON TELEVISION RELAYED IN INDIA

Ultra-High-Frequency Experiments

THE Delhi broadcasting authorities recently relayed, with great success, from their local station the sound transmission from the London television station.

Our informant, an East Coast amateur, writes:—

"I keep a daily schedule on 28 Mc/s with VU₂AN, of Baluchistan, India, and I have got him to listen to the ultra-high frequencies, and he has heard the London television sound transmission on two or three occasions. He tells me that the Delhi broadcasting authorities recently relayed the television sound quite successfully over their local system, a double diamond aerial being used for reception. A similar schedule is kept with W₉ZHB, at Zearing, Illinois, with the object of a possible contact on 56 Mc/s. He has quite fre-

quently heard the sound transmissions, sometimes at excellent strength. These receptions coincide with the "F" layer peak, which occurs at the end of October and beginning of November. Unfortunately, the upper limit this year is definitely below that of last year, so that it would appear that we have passed the sun-spot maximum, and the possibility of transatlantic 56 Mc/s contact is very remote."

He further states that the transmissions on 41 Mc/s from W8XWJ, Detroit, have been received at excellent strength during the past three weeks. W₂XDG, Bound Brook, and W8XNT, Cleveland, on 38.6 Mc/s, are, however, much more frequently received. During the recent peak period the highest refracted signal heard was in the region of 48 Mc/s.

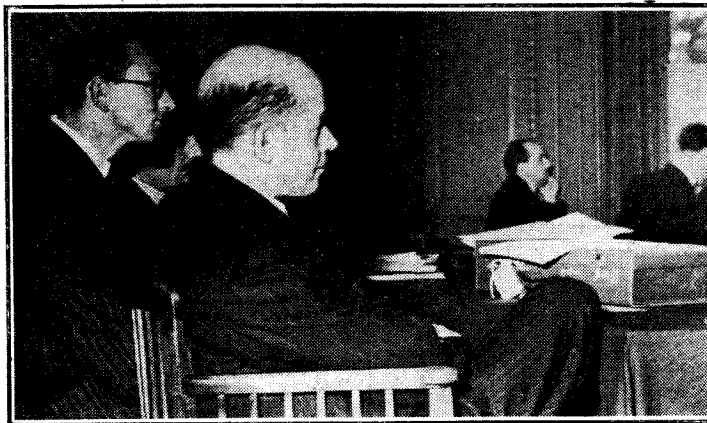

IN CONTEMPLATIVE MOOD. B.B.C. and G.P.O. representatives at the Brussels Wavelength Conference photographed by *The Wireless World* correspondent. Nearest the camera is Sir Noel Ashbridge, B.B.C. Chief Engineer, next to whom is his assistant Mr. L. W. Hayes. Seen between them is Colonel Angwin of the G.P.O.

DE-ICING AERIALS ON AIRCRAFT

Air Ministry Statements

METHODS of de-icing aerials on aircraft are explained in a pamphlet on "Ice Formation on Aircraft and its Prevention," just issued by the Air Ministry.

In the case of trailing aerials, the aerial fairlead—that is, the tube through which the aerial wire leaves the aircraft—should be protected from ice by means of a shield which deflects the air flow, states the pamphlet. Some fairleads are retractable and, therefore, may be drawn into the aircraft during ice conditions. A method of de-icing trailing aerials has been developed and has given promising results in the wind tunnel.

Spare trailing aerials should always be carried, in case ice conditions are so severe that an iced-up wire has to be cut away.

With regard to fixed aerials, it is stated that shrouds should be fitted over the aerial insulators to protect them from the direct air flow and keep them clear of ice. The point where the aerial downlead enters the aircraft—that is, the deck insulator—should also be shielded.

Modern practice, says the pamphlet, tends towards the increasing use of fore and aft aerials, and these do not appear to ice up to the same degree as aerial wires which run from the wing tips to the tail.

REGULAR SUNDAY AFTERNOON TELEVISION

Resolution for the New Year

HITHERTO television on Sunday afternoons has been confined to O.B.s spaced at increasingly wide intervals. We understand, however, that early in the New Year regular transmissions will be given on Sunday afternoons. Many of them will continue to be O.B.s, but when no suitable outside material is available recourse will be had to studio programmes. Except in the case of special O.B.s, it is expected that transmission will be from 3 to 4 p.m. as on weekdays.

E.M.I. CONFIDENCE IN TELEVISION

Its Progress and the Problem of Extending the Service

CONSIDERABLE enthusiasm was evinced at the seventh ordinary general meeting of Electric and Musical Industries, held in London last week, during Mr. Alfred Clark's report on television progress during the year.

He stressed the importance of the new emitron camera, which had made possible so many historical outside broadcasts, and remarked upon the distinct advance in the general quality of entertainment from Alexandra Palace.

While sales of television apparatus are still too small to be entirely satisfactory, the chairman pointed out that they are large enough to give a fair indication that television has become a permanent feature of broadcasting.

Extending the Service

Mr. Clark then raised the point which has been the subject of widespread speculation since the opening of the service in 1936.

"It seems clear (he said) that, in view of the experience of this first transmitting station at Alexandra Palace, the television committee presided over by Lord Selsdon will in the near future recommend the extension of the television broadcasting service so that a larger public can be reached. While we know that within a thirty-mile radius of London there is a great population, we should not forget that it is one which has at its door so much other entertainment that television is not as necessary to it as to those who live further removed from the larger centres."

Two relay methods are

News of the Week—

possible, one by means of special cables, and one by means of ultra-short-wave wireless links. The Chairman then stated that, as the result of E.M.I. research under the direction of Mr. Shoenberg, a solution had been found which, while permitting an immediate start for relaying television to the provinces, is at the same time economical and will not stand in the way of future progress. The scheme, which is discussed in the Editorial comment in this issue, has been placed before the television Advisory Committee and Post Office.

B.B.C. "TELEVISAPHONE"

Television Director to Answer 'Phone Queries Before the Cameras

MR. GERALD COCK, B.B.C. Director of Television, will try an interesting new experiment on December 23rd when, with a telephone by his side, he faces the television cameras to speak with individual viewers.

From his "witness box" he will invite queries concerning the television service from any viewers who are fortunate enough to have a telephone within sight of their televisions.

Calls will be limited to six, and each viewer will be limited to one question. Enquirers will be asked to give their names and addresses, although only their names and localities will be disclosed.

LIBYA'S NEW STATION

Interesting Aerial System

H. E. MARSHALL ITALO BALBO, Governor of Libya, opened the new E.I.A.R. 50-kW 271.7-metre transmitter at Zanzur, near Tripoli, on November 12th.

The radiating system of this station is of special interest, it being possible to direct the transmissions to the East or West or to make them omnidirectional. To accomplish this two aeriels are employed, each of which can be used as the radiator or as the reflector. The transmitter is connected to the studios at Tripoli by a six-pair cable.

TOURING LONDON BY MICROPHONE

HALF London will be "on tap" on December 30th when Michael Standing takes charge of "Entertainment Tour" for broadcasting. Staged on more ambitious lines than anything of the kind yet attempted, this feature will take listeners from one London entertainment to another at the flick of a switch. The programme will be directed from Broadcasting House, and a little army of commentators dotted about the Metropolis will be watching for their cue-lights.

TELEVISION REPORT

Statements by the Cinematograph Exhibitors' Association

AT the last meeting of the Television Committee of the C.E.A. it was pointed out that no novel developments have recently taken place in television, although some advance has been made in the luminosity of cathode-ray tubes. The latest tube of this type is capable of illuminating a six-foot picture at an intensity of 4-foot candles.

The C.E.A. Technical Department expressed the opinion that the optimum economic luminosity of cathode-ray tubes has been nearly reached, and that brilliantly lighted large-screen television reproduction is more likely to be achieved by the Diavisor method. This system employs an exterior light source, the beam of which passes through the cathode-ray tube picture, and is focused on the theatre screen.

The cathode-ray tube picture instead of being of various luminous intensities builds up the televised picture by rendering the otherwise opaque screen transparent.

The most serious difficulty to be surmounted is the manufacture of a compound which while opaque in its normal state will give a wide range of transparencies when subjected to varying electron beams.

ARE INTERNATIONAL RELAYS WANTED?

An Indian Commentary

AT a time when even the cheaper types of factory-made broadcast receivers pick up a large variety of foreign stations, it is being asked whether an elaborate system of international relays as envisaged by the International Broadcasting Union is really necessary.

An interesting commentary on the question comes from an unexpected quarter. According to the *Times of India*, technicians of All-India Radio have realised that relays of the B.B.C. Empire programmes from Daventry are by no means completely satisfactory. "A relay loses a good deal of its attraction," says the journal, "if a considerable proportion of listeners find it just as satisfactory to receive direct from the original."

If this is true of short-wave reception in India, where listeners are at the mercy of atmospheric vagaries and attenuation of signal strength, how much more so it must be where European reception is concerned.

ALBANIA'S FIRST BROADCASTING STATION

ALTHOUGH Albania's first broadcasting station was inaugurated on Monday, it will be of little use in the country itself, for it is operating on the short

waves in order to carry the voice of Albania into other countries.

This 3-kW station, with the call sign ZAA, is working on wavelengths in the 19-, 29- and 40-metre bands. As well as being used for broadcasting, it is equipped for radio-telegraphy and commercial radio-telephony.

**FROM ALL
QUARTERS****Radio for Small Ships**

At last week's inquiry by the Board of Trade into the loss of the steamer *Glanrhyd*, which foundered with seventeen men off the Gower coast in January, the assessors recommended that small coasting vessels should be fitted with radio-telephone apparatus.

£16,000 on Anti-interference

A TEN-MILLION-VOLT discharge between two metal spheres several feet apart will be a feature staged by the General Electric Company of America at the New York World's Fair next spring. £16,000 is to be spent on screening the building which is to house the demonstration, to prevent the diffusion of electrical interference.

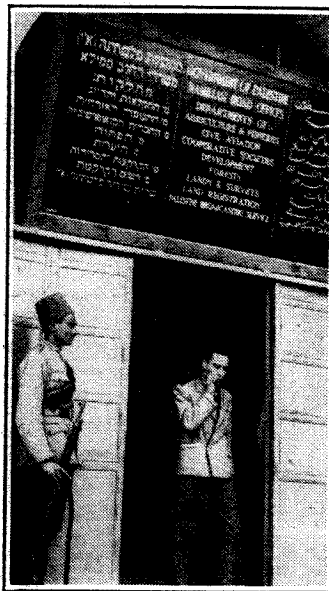

THE TRILINGUAL NOTICE outside the building in Jerusalem which houses, among other Palestine Government Departments, the Broadcasting Service reminds us of the three languages used in the service. The chief Arabic announcer, Mr. Hussein, on leaving the building passes a sentry.

Post Office Profits

THE Post Office net surplus for the year ended March 31st, 1938, was £10,169,524. Of this total £655,585 was derived from wireless licences.

Fresh Ground for Television

The first television transmission from a ballroom in a West-end Hotel will be given on New Year's Eve. The transmission will also be the first to be radiated up to and past midnight. Viewers will be taken into the Great Room at Grosvenor House, where some 1,500 visitors will be at the gala.

"Nature's" Editor Retires

SIR RICHARD GREGORY is retiring from the editorship of MacMillan's weekly scientific journal, *Nature*, with which he has been associated for forty-five years. It was in 1893 that he was invited by Sir Norman Lockyer, the foundation Editor, to become Assistant Editor, which position he held until 1919 on his appointment as Editor. *Nature* will in future be edited by Mr. E. G. W. Gale and Mr. J. F. Brimble, the present Assistant Editors, with Professor Alan Ferguson as Advisory Editor.

Companion I.E.E.

MR. CLAUDE LYONS, of the well-known firm of Claude Lyons, Limited, has been elected a Companion of the I.E.E. The total number of Companions is just over one hundred. Companionship is granted to those who have rendered important services to electrical engineering in the various fields of commerce, finance, law, and science.

Colombo Radio Exhibition

WHEN opening the Exhibition of Radio and Electrical Apparatus at Colombo, sponsored by the Radio Club of Ceylon, the Minister of Communications said that recent world events had forcibly brought to their notice the great value of an efficient broadcasting service in a time of crisis.

Another Italian Station

CATANIA'S three-kilowatt broadcasting station had been in full operation on 531 metres for some time prior to its official opening ceremony last Sunday, November 27th. It shares the same wavelength as Palermo.

Electro-Acoustics

At the joint meeting of the Physical Society and the Meter and Instrument Section of the I.E.E. at Savoy Place, Victoria Embankment, London, W.C.2, on Friday, December 9th, at 7 p.m., Dr. C. V. Drysdale will open the discussion on electro-acoustics.

Murderer Traced by Television

TELEVISION was successfully used for the first time for the unravelling of a mystery in Berlin recently. The raincoat belonging to the suspected murderer was brought before the television cameras, and its identification led to the arrest of a nineteen-year-old boy on the charge of murder.

German Lecture on Television Technique

IN addition to the meetings held hitherto at the Institution of Mechanical Engineers, one meeting of the Engineers' German Circle, which was formed in 1932, will be held each session at the Institutions of Civil Engineers and Electrical Engineers. The first meeting at the I.E.E., Savoy Place, London, W.C.2, to which visitors are invited, will be held on Monday, December 19th, at 6 p.m. The lecture on current problems in television technique, which will be illustrated by lantern slides, will be given in German by Herr Ministerialrat Gladenbeck, Head of the Research Department of the German Post Office.

The Tone Control Knob

By "CATHODE RAY"

RADIO dealers and servicemen will bear me out when I say that the majority of people who have sets provided with tone controls turn them round to the lowest tone possible and leave them there. I am talking about ordinary mass-produced sets, of course. This behaviour may not at first strike one as being very odd. But when one considers that owing to the need for selectivity the upper tones are already more or less drastically pruned even in the "High Tone" position, and that these high tones are necessary in order to reproduce anything resembling the original, the fact that most people take the trouble to cut them down even more thoroughly (see Fig. 1) does seem to need some explaining.

I used to put it down to the perversity and essential degradation of human nature, choosing the base things rather than the uplifting. But while this depressing view of mankind does not altogether lack evidence in these modern times, there is actually no necessity to fall back on it in this particular case. In fairness to Mr. and Mrs. Listener, charged with wilful mutilation of licence-holders' property (copyright reserved), they can plead quite a number of extenuating circumstances.

Some Reasons—

One of them is that Fig. 1 does not tell the whole story. It omits that very important character, the loud speaker. True, there is a tendency for the cheaper sorts of loud speaker to aggravate the offence by doing some high-note suppression on their own. But, on the other hand, they usually have some lofty peaks in the upper middle part of the scale. Also designers often make use of the characteristics of pentode output valves and loud speaker coils to obtain a rising curve, not shown in Fig. 1, which assumes a resistance load instead of a loud speaker. If the loud speaker were a really good one the high notes would stand a chance of being tolerated by listeners. But when they are presented in the form of one or more sharp loud speaker resonance peaks the effect (euphemistically referred to by the salesman as "brilliance") is not the clarity and naturalness that are conveyed by true high tones, but merely an unpleasant shrillness. If you want to hear how true sound is distorted in this way, next time

you are listening to a programme direct in a concert hall or some such place try putting your hollowed hand to your ear as if you were hard of hearing, but a little more closely so that the sound enters a comparatively small opening between hand and head and then swells out into the enclosed space. This introduces an acoustic resonance which makes the upper tones sound unpleasant. For the purposes of the experiment some smooth, hard cavity, such as a cup, would be more effective than the hand, but at the same time might attract unwelcome attention from other members of the audience or even lead to detention on suspicion of mental weakness.

Although the ordinary listener does not know exactly *why*, he or she does know that the high notes sound unpleasant, and proceeds to make use of the remedy provided. It is extremely difficult to avoid high-note resonances even in fairly expensive loud speakers, but it is found that as the faithfulness of the reproduction is improved so does the ability to listen willingly to the proper proportion of high tones.

Another thing is that in most situations, and except perhaps when listening to *very* local stations, reception is more or less noisy. There is receiver noise, interference from other stations, atmospherics,

noise from electrical appliances, and even with gramophone records there is scratch. All of these can be rendered very much less noticeable in relation to the programme by cutting off the high tones. And it is so much easier than going to the Post Office and filling in an anti-interference form, and easier still than

persuading everybody in the district (including oneself) to fit noise suppressors to everything. Even a high-fidelity enthusiast may be reluctant to put up with a barrage of mush in order to get "good" listening. And the ordinary slack listener is too lazy to turn back the control to "High" when conditions are favourable. Besides, there are still other reasons.

WHY IS IT
ALWAYS SET
AT "LOW"?



One is that, generally speaking, there is not enough depth of tone. This is partly because it is very expensive and cumbersome to achieve really true bass right down to the lowest. The ordinary table model cannot possibly do it. And it is partly because of our old friend "Scale Distortion,"

which causes a programme reproduced less loudly than the original to be relatively weak in the bass. For the benefit of readers who didn't follow the original controversy I must hasten to make clear that by "original" loudness I do *not* mean the result of cramming a military band (or whatever it may be) into your living room. I am talking about the intensity of sound at the ear. As I found some time ago by actual test¹ it may be possible to produce this intensity with a receiver of quite ordinary power; but not everybody always wants it as loud as that. Between one thing and the other, listeners often feel an urge for more bass, and as the ordinary set denies them the ability to satisfy it properly, they make do with a pretty poor second-best, by reducing the "top."

—and Some Excuses

We are now somewhere near the point where reasons degenerate into excuses. Anyway, if a result of civilisation is that people *must* do at least two things at once so as to get everything in, I suppose it is all right to use the radio as an accompaniment to conversation, meals, bridge, knitting, etc. As a result of careful research into this matter I have reached the conclusion that reproduction of the full range of tone, even at quite a low volume, is distracting; whereas reproduction of the low tones only forms a soothing background to these activities, and announcements, etc., being rendered practically unintelligible, do not intrude on the consciousness.

Whether this, or any of the other defences I have put into the mouths of the prisoners, Mr. and Mrs. Listener, ought to carry any weight with an impartial judge and jury, I leave you to discuss.

¹ "Loud Speaker v. Orchestra," March 10th, 1938.

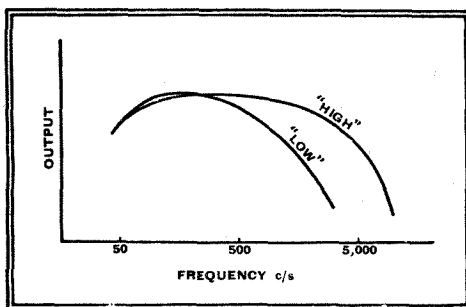
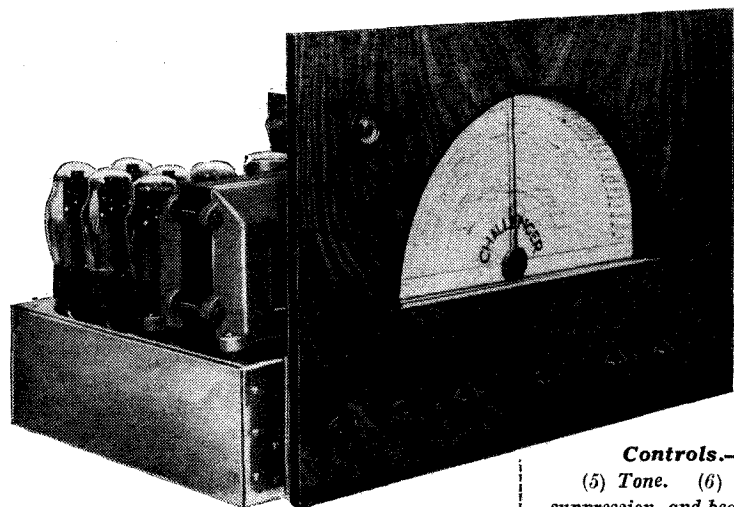

Fig. 1.—Even when the tone control of the average set is in the "high" position, there is considerable attenuation of the upper register.

Degallier Challenger "19"



A COMPREHENSIVE SPECIFICATION FOR LONG DISTANCE AND LOCAL STATION QUALITY RECEPTION

FEATURES. Waveranges.—(1) 5-10 metres. (2) 11-34 metres. (3) 35-95 metres. (4) 90-250 metres. (5) 200-550 metres. (6) 800-2,100 metres. **Circuit.**—RF ampl.—mixer—sep. osc.—1st IF ampl. (with band-pass input filter)—var. select. control valve—2nd IF ampl.—tuning indicator—2nd det. undelayed AVC rect. and vol. exp. rect.—delayed AVC rect., BFO and QAVC valve—vol. exp. control valve—1st AF ampl.—2nd AF ampl.—phase splitter—output stage (four tetrodes in Class A parallel push-pull). Full-wave power rectifiers.

Controls.—(1) Main tuning. (2) Band-spread tuning. (3) Volume. (4) Sensitivity. (5) Tone. (6) Variable selectivity. (7) Waverange. (8) Volume expansion. (9) Noise suppression, and beat oscillator switch. **Price.**—(including valves and two 12-inch loud speakers) £31 10s. **Makers.**—Degallier's Ltd., 32, Bathurst Mews, Lancaster Gate, London, W.2.

It is generally assumed that quality enthusiasts are interested chiefly in local station reception and that in a receiver which will be used primarily for long-distance communication work a large and expensive output stage is out of place. While this is quite a reasonable attitude to adopt when catering for specialists in one or other of these important branches of wireless activity, it must not be forgotten that there are many people who would like to possess and are prepared to pay for equipment which they

can demonstrate to their friends as the "last word" as far as present knowledge goes and which excels in both types of performance.

To meet this demand at a reasonable price, Degallier's have produced the Challenger "19," which is not only a very convincing performer as a long-distance communication set, but has a 30-watt output stage with negative feed-back capable

of giving high quality from the local station at a realistic volume level, even on the peaks of full orchestral items. Variable selectivity and volume expansion in the AF circuits are features which, when properly handled, are capable of giving a performance far in advance of that to which most broadcast listeners are accustomed.

There are ten stages in the direct line of amplification from aerial to loud speaker, four stages of what may be termed auxiliary services. The total number of

Circuit of the Challenger "19" in its latest form. Alternative use of one of the stages as a beat frequency oscillator for QAVC, and valve controlled variable selectivity are among the unusual features of this set.

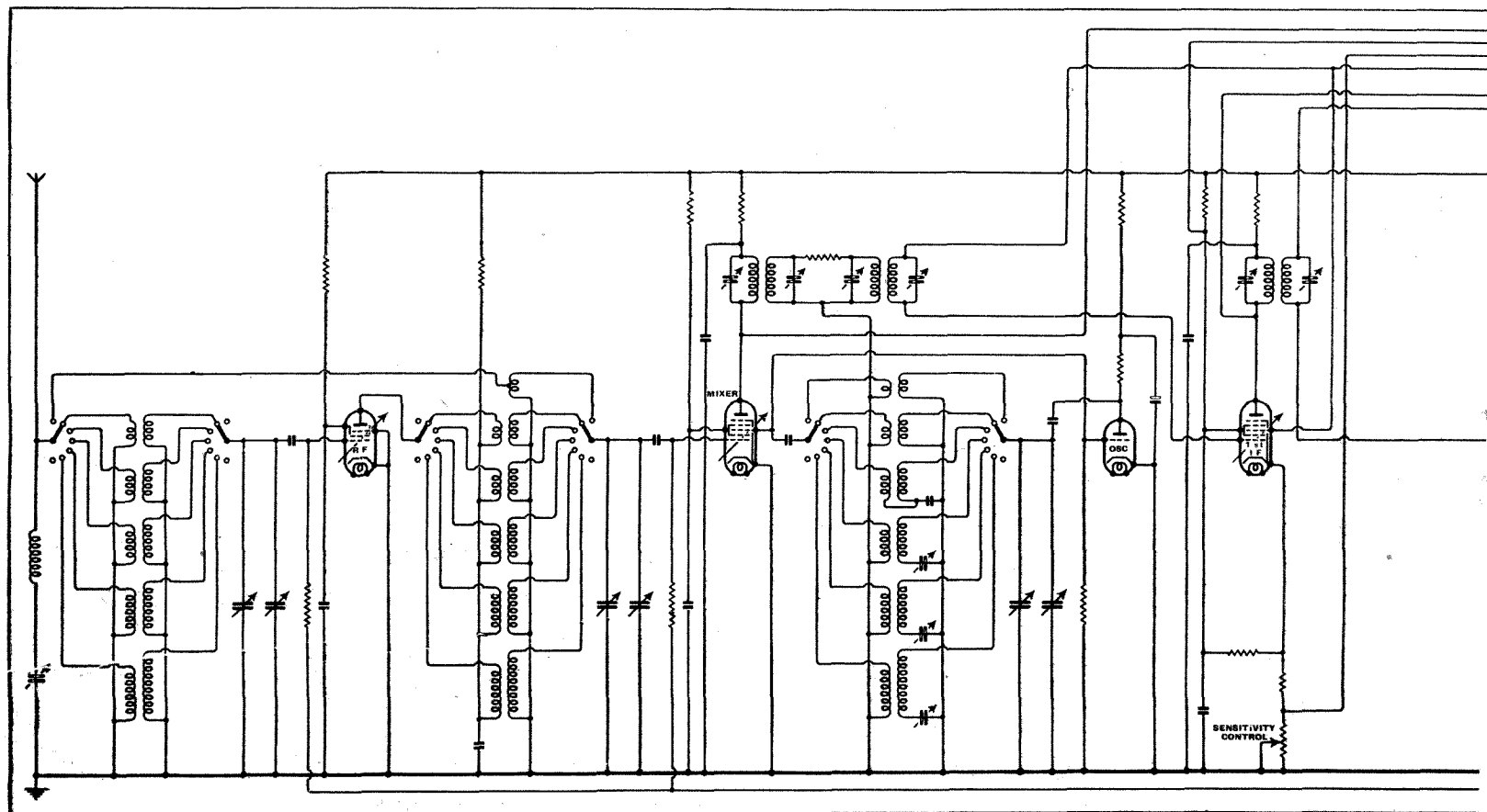

Degallier Challenger "19"—

valves, including twin rectifiers and four output tetrodes, is nineteen.

The RF amplifier functions on five out of the six waveranges and is transformer-coupled to a heptode mixing valve. Local oscillations are generated by a separate triode. The three-gang tuning condenser has a separate 30 mmfd. band-spread condenser with ceramic insulation connected in parallel on all wavebands. Ceramic insulation is also used in the RF valve holders and for the top grid connection of the metal 6K7 valve.

The intermediate frequency amplifier operating at 465 kc/s consists of two stages with eight tuned circuits. Four of these are included in the first band-pass transformer, the remaining two transformers being adjusted to single peak. An auxiliary valve is employed as a variable shunt to the band-pass transformer and the first IF valve. The control valve is operated both manually and from the AVC line in order that the widest bandwidth may be automatically available on strong signals. It is difficult to assess selectivity in a receiver of this type, but the makers state that the range of the control is 3 to 16 kc/s.

Undelayed AVC bias is supplied to the RF amplifier and mixed stages from the signal rectifier diode and a separate rectifier is used for the delayed bias applied to the IF stages. A double-diode triode valve is used for the latter function, and the triode portion serves alternatively as a beat frequency oscillator or to control the bias of the second AF amplifier for inter-station noise suppression.

Volume expansion is effected by a separate triode amplifier, the output of which is applied to the second diode in the signal rectifying stage. The resulting bias is used to control the amplification of the first AF stage.

The output stage is resistance-capacity coupled throughout and is preceded by a triode phase-splitting stage. Tone control is effected in the input circuit of this valve. There are four 6L6 valves rated to give a total output of 30 watts in the final stage.

The power rectifier stage makes use of two valves and the HT current is smoothed by the field windings in series with a separate choke which is mounted outside the chassis. The electrolytic smoothing condensers total 96 mfd.

The acoustic output available from the twin 12-inch loud speakers is far higher than would be tolerated in most living-rooms or small halls, but with the volume control well turned down the reserve of power-handling capacity gives much cleaner reproduction of occasional peaks, particularly when the volume expansion

is in operation on the local station. Careful adjustment of the volume expansion control in relation to the main volume control is, however, essential on weaker signals, otherwise the action is betrayed by a corresponding rise and fall of background noise.

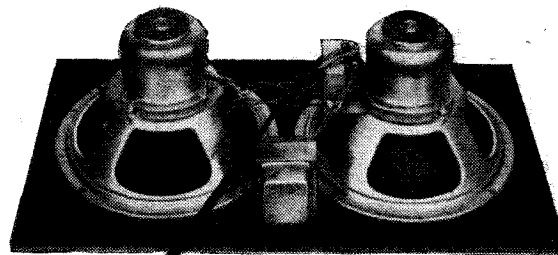

Dual 12-inch loud speakers are supplied on a temporary baffle together with the HT smoothing choke.

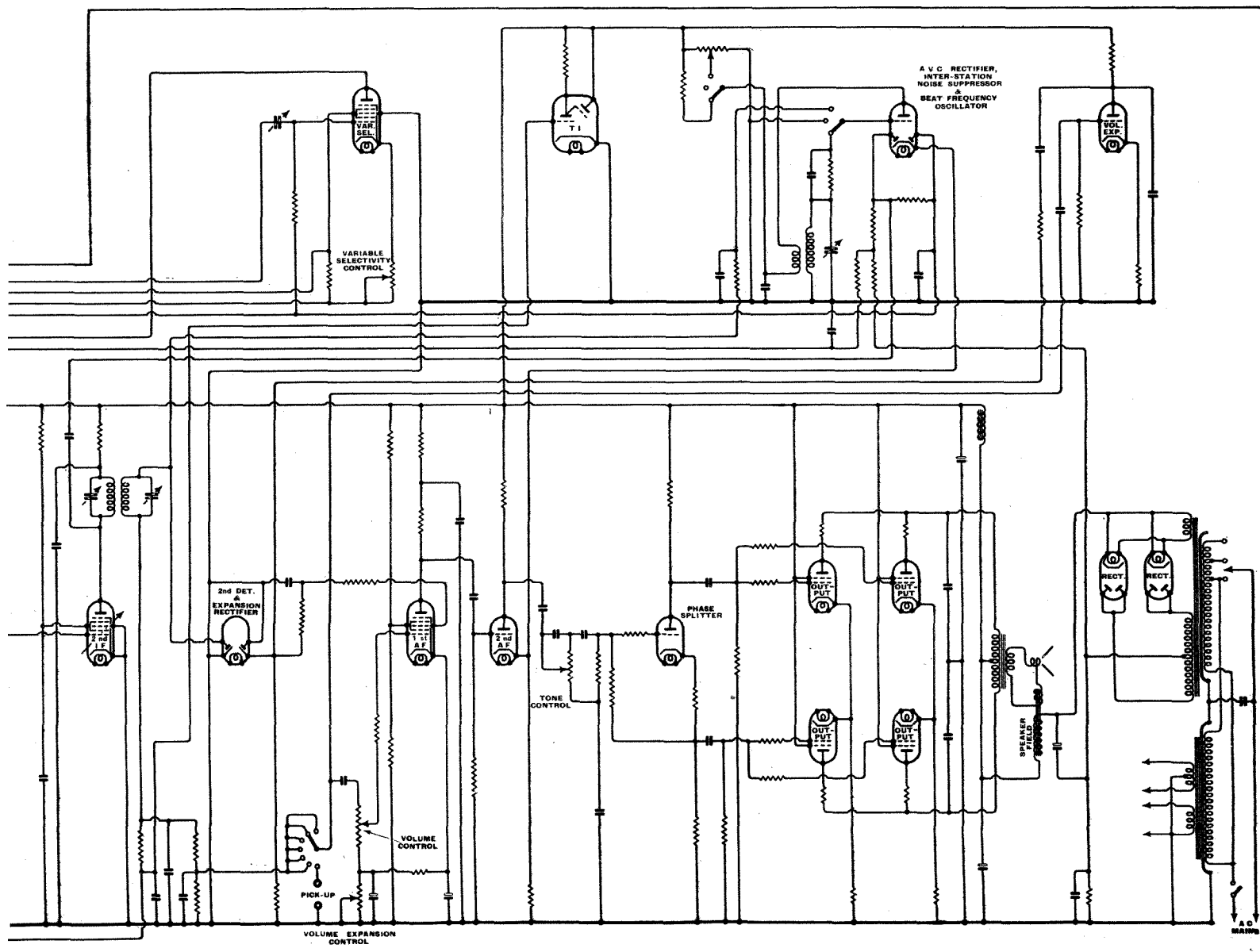

Degallier Challenger "19"—

The variable selectivity control is effective, though its action is most apparent in the first few degrees of movement from the "Broad" position, than in the remaining range of the control.

Background noise with the QAVC off

single aluminium chassis measuring 22in. x 13in. x 4in. There is a certain amount of flexibility, but this does not appear to affect the tuning circuits, the screening compartments of which are screwed directly to the underside of the chassis.

All trimmers are accessible, and there is

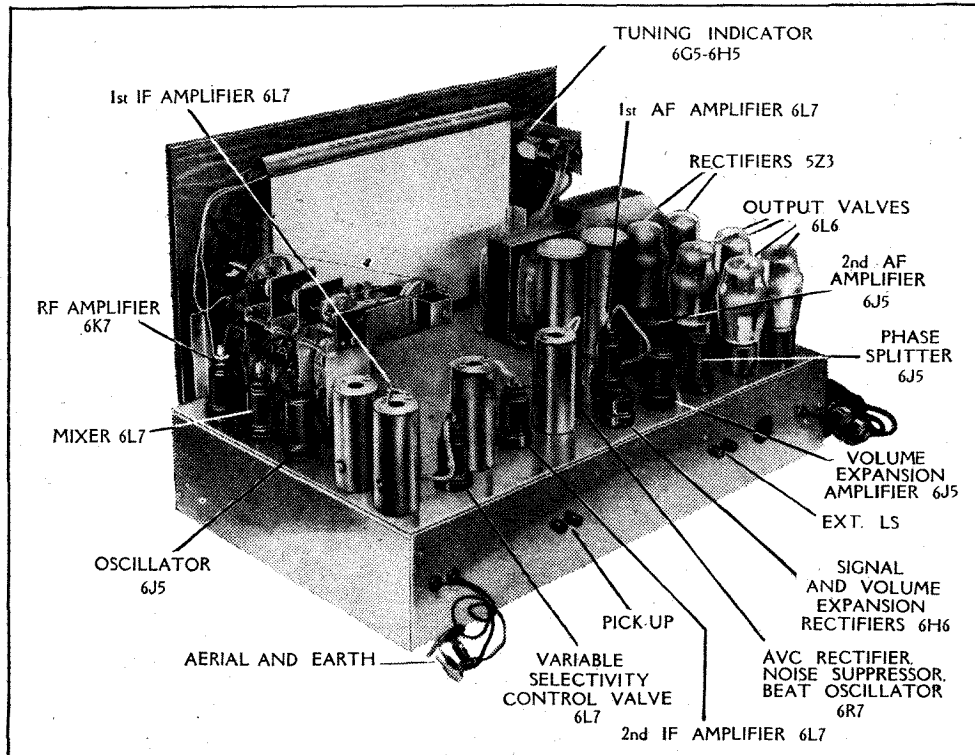

The chassis measures 22" x 13" x 4" and gives ample room for the nineteen valves and their associated components. Two mains transformers (below the tuning indicator) are fitted, one for HT supply and the other for the filament heaters. They are rubber mounted to minimise hum arising from mechanical vibration.

testifies eloquently to the high overall magnification of the circuit. The intrinsic signal-to-noise ratio is, however, good and with QAVC in action the set is very pleasant to handle. There is no need to wait for sunset to receive the two or three score of useful stations on the medium waveband, and on short waves the performance has all the earmarks of the thoroughbred communication receiver. Microphonic feed-back is negligible and remarkably low for such high amplification, self-generated whistles are absent, and frequency stability is excellent. From the communication set angle the only criticisms we have to offer are that the volts injected by the beat frequency oscillator were on the low side, and the mechanical drive of the band-spread condenser was less positive than that of the main drive. We understand that these matters are receiving attention.

The 12-inch diameter semi-circular tuning dial is well thought out as regards the arrangement of the various wavelength scales. Indication is provided by a sharply focused point of light which travels from scale to scale according to the position of the waverange switch. The pilot lights are contained in compartments of a channel-section box which swings behind the translucent scale.

All components, including the heavy mains transformer, are mounted on a

no local overcrowding of components. The layout is logical and the wiring neat and well soldered.

No reasonable expense has been spared to make this the complete wireless receiver. The specification is ambitious and the amplification formidable, but a little experience with the controls will suffice to show what proportion of this can be usefully employed. The significant point is that no matter in which direction one looks for performance this set is able to satisfy the most ambitious demands and yet to keep always something in reserve.

Television Programmes

Sound 41.5 Mc/s

Vision 45 Mc/s

An hour's special film transmission intended for demonstration purposes will be given from 10 to 11 a.m. each week-day.

THURSDAY, DECEMBER 1st.

3, Cabaret, with the Western Brothers and Harry Tate. 3.30, British Movietonews. 3.40, 195th edition of Picture Page.

9, Charles Heslop in "Fun and Games," a revue. 9.30, Gaumont-British News. 9.40, 196th edition of Picture Page. 10, Amateur Boxing from the Concert Hall at Alexandra Palace. 10.30, News.

FRIDAY, DECEMBER 2nd.

3, Jane Carr. 3.10, D'Anselmi, ventriloquist. 3.20, Gaumont-British News. 3.30, "St. Patrick's Day," a farce by Richard Brinsley Sheridan.

9, British Movietonews. 9.10, "Love from a Stranger," by Frank Vosper, from a story by Agatha Christie. 10.40, News.

SATURDAY, DECEMBER 3rd.

3, The John Carr Jacquard Puppets. 3.15, British Movietonews. 3.25, Cartoon Film. 3.30, "Fun and Games" (as on Thursday at 9 p.m.).

9, Cabaret (as on Thursday at 3 p.m.). 9.30, Gaumont-British News. 9.40, Cartoon Film. 9.45, "Doctor, My Book," a Doctor Abernethy play. 10.20, News.

SUNDAY, DECEMBER 4th.

8.50, News. 9.5, P. M. S. Blackett, F.R.S., Speaking Personally. 9.20-10.40, "An Elephant in Arcady," by Herbert and Eleanor Farjeon, with music adapted and conducted by Ernest Irving.

MONDAY, DECEMBER 5th.

3, Renee Houston in Cabaret, with Flotsam and Jetsam. 3.30, British Movietonews. 3.40, Parade of Fashion. 3.55, Cartoon Film.

9, Starlight. 9.10, Gaumont-British News. 9.20, Cartoon Film. 9.25, National Sporting Club Boxing from the Empress Hall, Earls Court. 10, "St. Patrick's Day" (as on Friday at 3.30 p.m.). 10.30, News.

TUESDAY, DECEMBER 6th.

2.15-4, Oxford v. Cambridge, Inter-Varsity Rugger O.B. from Twickenham.

9, News Map, VI—Poland. 9.20, Cartoon Film. 9.25, British Movietonews. 9.35, "The Bronze Lady and the Crystal Gentleman," translated from the Henri Duvernois original. 10, News.

WEDNESDAY, DECEMBER 7th.

3, Cabaret. 3.30, British Movietonews. 3.40, Parade of Fashions. 3.55, Cartoon Film.

9, Ian Hay, Speaking Personally. 9.10, Gaumont-British News. 9.20, Vic-Wells Ballet in Les Patineurs. 9.50, Cartoon Film. 9.55, Intimate Cabaret. 10.15, News.

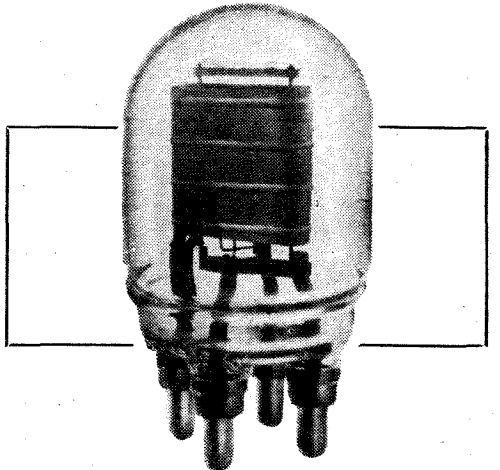

U-H-F TRANSMITTING VALVE. Designed for an anode dissipation of 160 watts, this American Westinghouse valve with a glass base employs a method of supporting the inner structure that makes for simplicity and low losses.

Motor Cycles and How to Manage Them.

Compiled by the Staff of *The Motor Cycle*. Pp. 274, with 143 diagrams and illustrations. Published by Iliffe and Sons Ltd., Dorset House, Stamford Street, London, S.E.1. Price 2s. 6d., or 2s. 9d. post free.

THE 27th edition of this well-known book, which has been thoroughly revised, has now made its appearance. In addition to the very comprehensive technical information which it contains, advice is given on how to choose a machine, and on the all-important subject of fulfilling the obligations of the law.

Readers' Problems

A Selection of Queries dealt with by the Information Bureau, and chosen for their more general interest, is published on this page.

Filament Supply

A READER wishes to build a receiver in which there are both directly and indirectly heated valves and the mains transformer available has only two LT windings. One has to be used for the HT rectifier and we are asked if there is any objection to connecting all the other valves to the remaining LT winding and not, as is customary, have a separate LT supply for the directly heated output valve.

Provided our enquirer is prepared to take a small risk, the arrangement suggested can be adopted. The only reason why operating indirectly and directly heated valves from a common winding is not advised is that, should, by any mischance, the heater-cathode insulation of one of the indirectly heated valves break down, then the grid bias resistance for the directly heated output valve will be short-circuited.

Should this happen grid bias will disappear and the output valve will almost certainly be damaged.

The possibility of a breakdown between cathode and heater is very remote, as variable- μ valves, for example, have to withstand quite a large difference in potential between these electrodes with certain forms of volume control, so that they should be quite safe with the amount of bias voltage used in an average case.

Long-wave Failure

A HOME-MADE battery set of early design in which separate tuning condensers are used for aerial and RF stages has developed a defect in its long-wave tuning. Dual-wave unscreened coils are used and the wave-change switches are ganged by a sleeve and grub screws.

The effect is that while long-wave stations tune in at the normal setting on the aerial-circuit condenser there is no apparent optimum setting on the RF circuit condenser, which has to be set to maximum capacity in order to obtain even a weak signal from Droitwich. The medium-waveband tuning is quite normal.

There can be little doubt that the cause of the trouble is that the long-wave winding on the RF coil is not coming into operation. If this coil is located behind the aerial coil and its wave-change switch operated through the ganging sleeve we would advise that this sleeve be examined for signs of looseness, as the switch may not be responding to rotation of the knob on the panel. If there is nothing wrong in this respect the next step would be to remove the RF coil and examine first for a faulty switch, as its contact may not open in the long-wave position, and then for any defect in the long-wave winding. The resistance of the various windings should be measured and compared with those of similar windings on the aerial coil.

Modulated Test Oscillator

A READER wishes to build the modulated test oscillator described in *The Wireless World* of May 10th, 1935, for AC operation, and asks our opinion of the suggestion and what alterations would be required.

Whilst there is no technical reason why

such a course should not be adopted, it is very doubtful if such modification would be worth while. Only 15 volts are needed for the anodes of the valves and as the total current is less than 1 mA a 16½-volt grid bias battery serves the purpose admirably.

No doubt the main reason for the conversion is to dispense with the 2-volt LT accumulator, but we think this can be effected in a far more economical way, namely, by the use of dry cells.

The parallel connection of the filaments could even be retained and the LT provided by two bell-type dry cells connected in series. A resistance of 0.5 ohms will be needed to absorb the surplus volt when the cells are new and with this form of HT and LT supply quite 12 months' service can be expected before replacement becomes necessary.

Aerial Coils

A READER who is building a set similar to *The Wireless World* Straight Three has a small unscreened dual-range coil for which no use can now be found, and he wishes to know if it can be employed for the untuned aerial coils L1 and L2 in the circuit reproduced here.

Unfortunately, the spare coil cannot be used for this purpose for the following reasons: Coils L1 and L2 are not standard tuning coils, as their inductances have to be very much greater than for coils of this kind. They are tuned by the aerial capacity to the top end, in wavelength, of the medium- and long-wave bands respectively. If it were possible to add sufficient turns to each in order to resonate them approximately at the right wavelengths, then, of course, they would be usable.

For the medium-wave coil L1 an inductance of about 400

Coils L1 and L2 in this circuit resonate with the aerial capacity at the upper end (in wavelength) of each range. Their inductances are accordingly much greater than those of standard tuning coils.

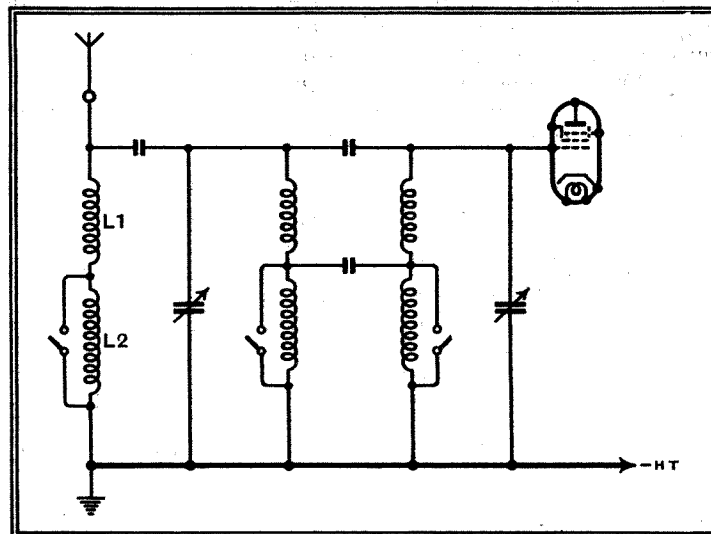

mH is required as compared with the 180 mH or so which is the probable inductance of our reader's coil. The long-wave loading section comprising coil L2 will require to have an inductance correspondingly larger than the long-wave winding of a standard coil.

Oscillator Failure

A FAULT has developed in a small superheterodyne that has had the following strange effects. Stations can be received only on a portion of the long- and the medium-wavebands, the set being abso-

lutely dead over the remainder of the scale.

The most likely explanation is that the oscillations generated by the frequency changer valve cease when the condenser passes a certain point on the scale. If it were due to a mechanical defect in the oscillator condenser, such as vanes touching, cessation of signals should be accompanied by a scratching noise. As no mention is made of this by our querist, we think that in this case the trouble is due to the emission of the triode section having become very poor. Though modern valves have a very long life they do not last indefinitely, and this seems a case where a replacement is indicated.

Poor Selectivity

WE are asked to find an explanation for a defect in a set which was hitherto quite selective but now seems to have lost its ability to discriminate between stations separated by as much as 30 or 40 kc/s. The trouble has been becoming progressively worse. The set is a superheterodyne.

In a receiver of this kind the selectivity is mainly dependent on the correct alignment of the IF amplifier, and we would feel inclined to look to this part of the set for the trouble.

Possibly some of the IF transformers have become detuned, in which case the response of the amplifier would be very broad. It could be brought about by vibration, though another likely explanation is that the capacity of the trimmers has changed owing to the spring tension on the moving vanes having weakened.

The defect will most likely be rectified by realignment of the IF amplifier, which should be done, if possible, with the help of a modulated test oscillator. It can, however, be carried out quite successfully by setting the pointer to the original tuning position on the scale of a familiar station and retrimming the IF transformers to produce

the best signal. A station of moderate strength should be used, as it will be very difficult to find the optimum setting for each trimmer if the signal is too strong.

Modernising New Monodial Super

THE circuit on page 451 in our issue of November 17th last, indicating where modifications can usefully be made to this set, shows the screen grid of the VMS4 valve joined to the main HT line, whereas it should terminate at the line immediately below. This line supplies the voltage for the screens in the RF and FC valves.

UNBIASED

By FREE GRID

Another Illusion Shattered

THERE comes a time in the lives of all of us when we realise that we are getting old, rusty and out of date, and to no class of the community does this apply so much as to us wireless men. Radio progress is so rapid that new discoveries become obsolete before we have time to assimilate them.

Notwithstanding this fact, however, there are certain wireless technical tenets which I have always regarded as being axiomatic and as unshakable as the Rock



Put it deep.

of Gibraltar. Among such tenets is the one which deals with the question of an earth connection. I don't know about you, but I have always been brought up in the belief that the rule for burying an earth plate was exactly the same as that for burying a dead cat, namely, put it deep, but for a different reason, of course.

This old belief has, however, been completely shattered by a writer in an electrical contemporary of unimpeachable integrity and I somehow feel that my whole world has come tumbling down about my ears and that the very foundations of the mountain of wireless knowledge which I have laboriously built up through the years have been undermined.

The argument which this iconoclastic writer advances is a perfectly logical one. If an earth plate is buried deep it will undoubtedly stand a much better chance of remaining moist than if it is buried near the surface as we all know; indeed, this is the very reason why we put it deep because moisture is a good conductor—or at least, so we have always believed. Unfortunately, however, this is just where we have erred, for, as the writer in question points out, the deeper the earth connection, the purer is the surrounding water, due to filtration, and pure water is, of course, a non-conductor.

Needless to say, my first act on reading these words was to proceed forthwith to the garden and dig up my carefully buried earth, for in spite of the fact that it had always seemed to me to give good results,

I know now that this has only been a delusion. Unfortunately, this leaves me in a quandary for if I bury my earth plate immediately underneath the soil it will not make good contact with it in dry weather.

There is one obvious solution to the problem and that is to restore the earth plate to its original position and to remove the top soil of the garden to a depth of several feet, replacing it by a few tons of salt, so that in the course of its filtering through it, the water will become more rather than less conductive.

Even here, however, there is a fly in the ointment, for Mrs. Free Grid, with the customary perversity of women, maintains that trees and flowers won't grow in salt, just as though such a trivial point as this counted when it is a question of getting a good earth connection. Mrs. Free Grid is adamant, however, and it looks as though the problem is one for Mr. Middleton.

Cabinet Reform Demanded

I SEE that certain very noisy self-styled artists of the ultra-modernistic school have been getting on their hind legs to moan about the increasing tendency to make the wireless and television set look like a thing of beauty, instead of the modernistic steel and chromium contraption which threatened to become popular a little while ago.

Personally speaking, I have never understood why it is that tremendous efforts are made to remove distortion from wireless receivers, or, in other words, to make them produce really beautiful sounds that entrance the ear, and yet no attempt is made, except in a very few cases, to continue the harmony of beauty by designing the exterior of the cabinet so that it is pleasing and lovely to the eye. I am perfectly willing to admit, of course, that the horrible sound output of a good many wireless sets is very aptly complemented by the cabinets into which they are built, but at the same time I could name several first-class reproducers which are housed in futuristic nightmares.

To be logical, I suppose, each set ought to be provided with a separate cabinet for each type of programme it is likely to be used for, as obviously a cabinet suitable for the fat stock prices would, aesthetically speaking, be impossible to harmonise with a Beethoven sonata. I daresay that it could be managed by having one cabinet with cunningly concealed floodlighting effects which could be varied so that they altered the whole appearance of the cabinet. The switch for operating these lights would, of course, be ganged with the tuning control, so that when tuning in Radio Luxembourg, for instance, the cabinet would take on a blaring, hard-boiled, modernistic appearance, while

tuning in to certain B.B.C. stations on Sunday would result in the set taking on an appearance of unctuous oiliness, and so on.

De Profundis

IT seems to be the fashion among certain modern writers to follow the lead of the poet, Lyte, and see nothing but degeneration and decay stalking rampant and unbridled throughout the land. I always think that a certain cure for this attitude of mind is to take a brief journey sitting on the hard stool of repentance provided in the average British railway train, or to spend a night in the morgue-like atmosphere of the average provincial hotel bedroom. The earnest enquirer after truth who does either of these two things will be very hard put to it to find any evidence of the luxury which ruined ancient Rome.

One of the most appalling instances of the mediævalism which still survives on our railways is the completeness with which the passengers in a train are cut off from communication with the rest of civilisation. Not the slightest attempt has been made by the railway authorities to connect trains up with the ordinary telephone service of the country and no really serious attempt has been made to provide broadcasting programmes to while away the tedium of the journey.

Now, I have always maintained that there should not be the least difficulty in providing both these services to add to the comfort and convenience of passengers by the simple expedient of employing wired wireless. There is, associated with every train, a continuous carrier cable for the necessary high-frequency energy, namely, the ordinary running rails.

It would be a far simpler problem than the fitting of similar facilities to motor coaches, where, of course, pure wireless would have to be employed. And yet, in spite of all this, a rumour has reached me that before very long we are to have these

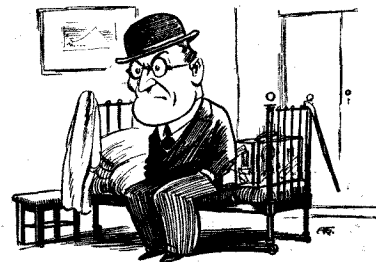

No evidence of luxury.

facilities on certain long-distance motor coaches if the permission and co-operation of the P.M.G. can be obtained. What are our railways doing to meet this new threat to their passenger traffic? Precisely nothing, so far as I can discover. Speaking as a railway shareholder who has held shares from the time when they were really worth having, I feel very bitter about it indeed.

Crystal Band-Pass Filters

Part V.—THE EFFECT OF IMPEDANCE MATCHING

By E. L. GARDINER, B.Sc.

IN the preceding discussion no attention has been paid to the load into which the crystal band-pass filter works. In order to simplify the treatment it has been assumed that a resistance is joined across the output, as shown in Fig. 7, and that its effect upon performance is not important. Practically, however, the behaviour of any filter is largely determined by the impedances between which it works, and the present case is no exception, since R is found to be a very important factor indeed.

The curve given in Fig. 8 was taken

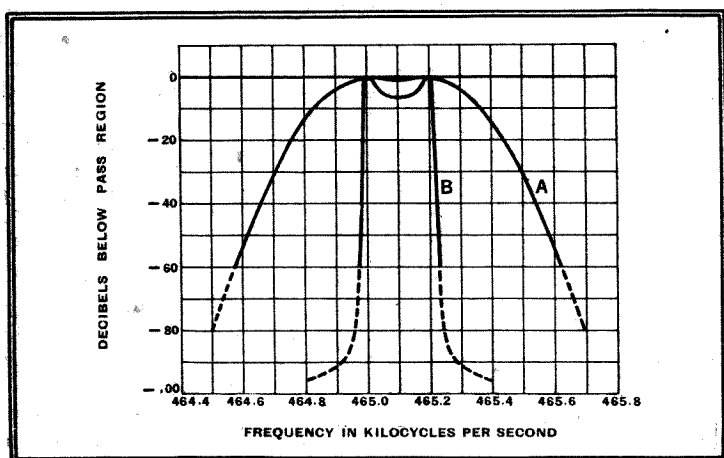

Fig. 12.—Curve B in this illustration is the curve reproduced as Fig. 8 in Part III. It is for a narrow-band filter terminated by a resistor. Curve A shows the effect of using a tuned circuit for the termination.

with an actual resistor in the position of R in Fig. 7, but a simple calculation will show that the effective load will not be a pure resistance, because the grid-cathode capacity of a valve acts in parallel with it. If R be taken as in the region of 100,000 ohms, and the capacitive reactance of typical valves is calculated, it becomes apparent that in the majority of cases this reactance is lower than 100,000 ohms, with the result that the effective load impedance will be mainly capacitive.

It has been shown by Colebrook¹ that a reactive load will result in high effective selectivity from the crystals. In other words, a quartz crystal working into a reactive load exhibits a very sharp resonance curve when this is measured by a voltmeter joined across that load. In consequence very selective curves are obtained, as in Fig. 8, where a marked dip occurs between the crystal frequencies, even when these differ by only a few hundred cycles, showing, of course, that the response of each crystal is falling very rapidly.

In the design of wider band-pass filters such high selectivity is not wanted, since it would make the levelling of the pass-band too difficult. It is therefore better to employ a truly resistive load, which will lead to apparently lower selectivity from each crystal, and a less pronounced

¹ Special report No. 12, by F. M. Colebrook, 1932.

dip between them. Unfortunately the resistance R is not effective, since it is "swamped" by unavoidable parallel capacity, and as might be expected it is found experimentally that values of R from 20,000 ohms up to several megohms make little difference to the measured curves. Lower values of resistance are

undesirable when working with high impedance crystals and filters, since they lead to mismatching and loss of output voltage.

The attenuation within the pass-band becomes high.

The effect of a pure resistive load can be attained by the well-known method of replacing R by a tuned circuit, as shown in Fig. 13, when the parallel capacity becomes part of the tuning capacity. At resonance (at the mid-frequency M) such a circuit will behave as a pure resistance, which can be accurately calculated, and which, for given values of inductance limited

Fig. 13.—A tuned circuit load to the band-pass filter is shown here; it is used as an auto-transformer of step-down ratio to feed the valve.

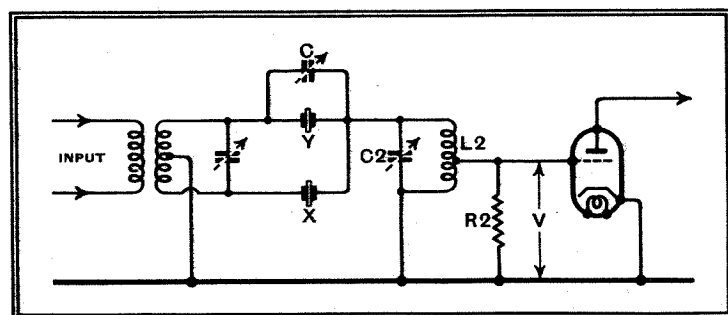

by the valve input capacity with which it must resonate to 465 Kc (approx.), will increase proportionately to the Q of the coil used.

The use of a tuned circuit to follow a crystal filter is not, of course, new, since it will be found as a common feature in communication receivers which employ the single "crystal gate." Such receivers frequently employ a step-up transformer to follow the crystal, the primary of which replaces the load resistance R of Fig. 1

(Part I), the secondary being tuned and connected between grid and cathode of the following valve. This transformer serves to match the comparatively low impedance of the crystal at resonance to the higher impedance of the grid circuit, and when the filter has been designed to employ a low-impedance crystal, may very materially increase the output voltage at resonance.

Impedance Matching

If a higher impedance bar-type crystal, such as has been advocated in these articles, is substituted for the low impedance crystal in such a receiver, there may be a noticeable loss in signal strength, due to incorrect impedance matching. Certain American receivers have the impedance matching developed to a high degree to suit the crystals for which they were designed, and employ a high transformer ratio, whilst others do not adopt this technique. It is advisable to examine the circuit diagram before attempting to fit a higher impedance crystal to such receivers, as if they are of the former class, results may be disappointing.

In the design of a single crystal filter employing a high impedance crystal, it will be found that the optimum transformer ratio does not differ widely from 1:1, and that a plain tuned circuit of moderate Q joined directly across the out-

put will probably be nearly as effective. This expedient lowers the selectivity of the filter, and much higher selectivity will result if a resistor or high impedance choke be substituted.

The single crystal gate differs fundamentally from the band-pass filters herein described, since it will be designed for the maximum output through the crystal at resonance, while in the band-pass case high output is required in the region between the crystal frequencies rather than

Crystal Band-Pass Filters—

at these frequencies, where the curves have shown that undesired peaks naturally tend to occur. Hence it is reasonable to design the output impedance to favour high efficiency near the central region M.

The use of a tuned circuit as load will assist in that direction, for since it reduces the sharpness of the resonance curve of each crystal, it leads to increased response at points a little off resonance, namely, at the central region M.

The effect of substituting a tuned circuit of moderate Q for the original resistance is illustrated by Fig. 9, in which it will be seen that the central region is depressed relative to the peaks by a factor of about three. Were the resistance (capacitive reactance load) retained, this depression would have been of the order of 20.

Curve A of Fig. 12 shows even more strikingly the effect of this alteration. It is a curve from the same pair of crystals used in the plotting of Fig. 8, which is reproduced here as curve B for ready comparison, no alteration to the circuit having been made except that of replacing the load resistance of 100,000 ohms by a resonant circuit, in this case having a Q of the order of 200. By such a simple change the effective band-width has been increased from about half a kilocycle to over one kilocycle, whilst the pass-band has been rendered flat to within 1 db. Had the crystals been separated by 200 or 300 cycles only, a change in band-width of about 4:1 would have resulted, thus suggesting a convenient method for varying the selectivity in telegraphic receivers. A single-pole two-way switch would enable the resistance to be changed for a tuned circuit very simply.

Wide-band Filters

Applying this principle to wider filters such as that of Fig. 9 it becomes necessary to go beyond the "filling up" of the pass-band produced by a high-Q circuit, and it has been found that the use of a transformer is surprisingly effective in doing this. Unlike the single crystal case, however, where a step-up ratio was found to improve response at resonance, we now wish to reduce this and to favour response near the mid-point M, which is considerably off resonance for both crystals. It would seem likely that a step-down ratio would be the better in this case.

The circuit adopted is shown in Fig. 13, in which the simple output circuit has been replaced by a tapped coil L_2 , tuned

to resonance by a small condenser C_2 . The tuning capacity should be a minimum, in order that the circuit impedance shall be high, while the tapped coil used should be of the best possible Q. The importance of high Q increases as the width of the

filter is increased and the problem of levelling the response becomes more exacting. The tapping point will lie between one-half and one-quarter turns from the earthed end of the winding, a typical ratio suitable for a bandpass of from 3 to 6 kc/s in width at 465 kc/s being one-third. The coil in such cases should possess a Q of about 150 for the narrow band-width, up to 250 for the wider.

The effect of this procedure in levelling the bandpass is almost magical, and is illustrated by the final curve of Fig. 14, which most readers will agree is a near approach to the ideal for general selective radio reception. This curve includes the effect of one additional IF transformer of average efficiency, and also of one pre-selector circuit at 1,000 kc/s (the effect of which is virtually negligible) since it is the response curve of a complete receiver fitted up and measured by a laboratory independent of the writer's.

The receiver was of a simple type, employing a 6A7 frequency-changer preceded by a single pre-selecting circuit. This was coupled by a normal IF transformer having air-cored primary and iron-cored secondary into the grid circuit of a 78 IF stage, as shown in Fig. 15. The crystal filter follows that stage, and works directly

into the diode detector. It was placed in that position in order that AVC could be taken from the input side of the filter, since it is undesirable for it to be taken off after such a selective coupling. To do so would result in complete lack of AVC action between stations, and lead to noisy operation unless some form of "inter-station noise suppression" were also fitted.

The Transformer

The strict analysis of the action of the step-down output transformer is not very simple, and, since it has been decided to present the subject in these articles without resort to mathematics, will not be attempted here. It is necessary for correct action that the transformer should work into a definite load, which is taken as a resistance of 100,000 ohms in parallel with the input capacity of a typical valve, and is therefore partly capacitive. A diode detector working into a load resistance of from 0.1 to 0.25 megohm behaves very satisfactorily. If an amplifying valve follows the filter it may be advantageous to connect a resistance of 100,000 ohms, or somewhat less, between grid and cathode.

Clearly, the use of a tapping point can be regarded as merely removing part of the valve load from the coil, thus enabling it to work at a higher effective Q, which will be a larger fraction of that of the coil itself. Were no tapping employed, the coil might be seriously damped by the following valve in many cases. However, the writer does not feel that this explanation is adequate, and suggests the following viewpoint as the simplest by which the function of the tapping can be appreciated.

The effective resistance of either crystal at resonance has been stated to be in the order of 10,000 ohms. This resistance becomes a reactance which rises very rapidly as the resonant frequency is departed from, and at the mid-point M the effective impedance of the filter looked at from the output coil is very high. A typical figure is of the order of one megohm. The prob-

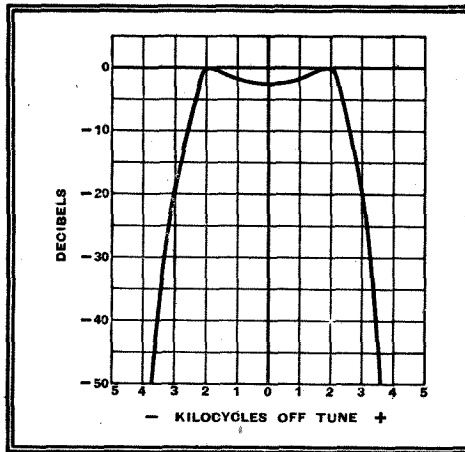

Fig. 14.—The overall resonance curve of the receiver of Fig. 15 well illustrates the performance obtainable with a correctly designed crystal band-pass filter.

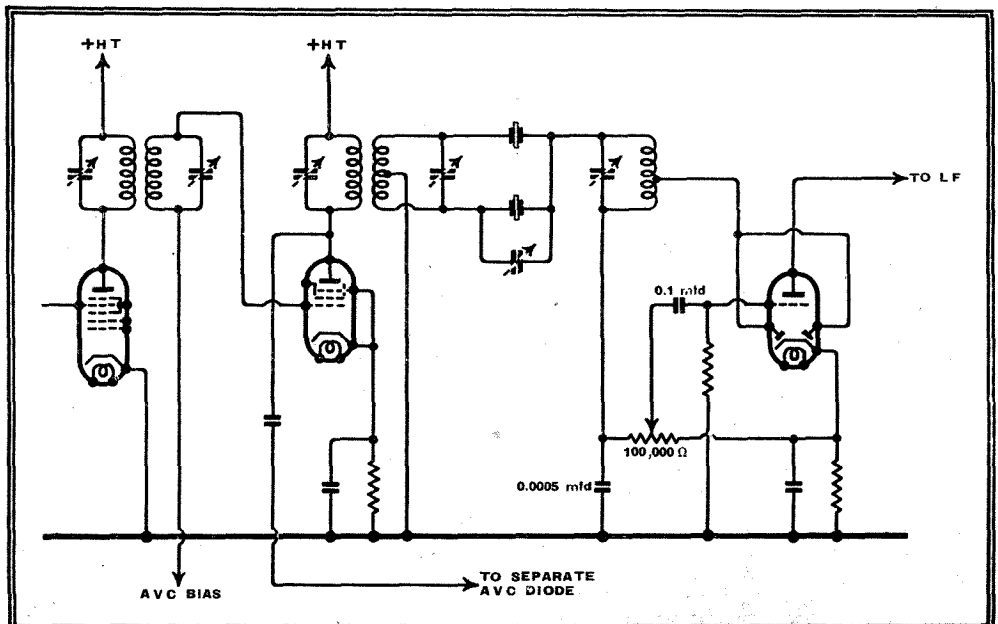

Fig. 15.—The circuit diagram of an experimental receiver including the crystal filter is shown here.

Crystal Band-Pass Filters—

lem, therefore, is to obtain the maximum voltage across the following valve grid-cathode circuit, namely, at V in Fig. 13, where the impedance may be taken as partly resistive and partly capacitive, and having a value of perhaps 50,000 ohms. Let us regard it as approximately equivalent to a resistance of that value.

Now, by analogy with such a well-known case as the matching of a power valve to a speaker speech coil through a transformer of correct step-down ratio, we can regard the problem as one of power transformation. Across the impedance at V it is desired to set up the maximum voltage, and, since this impedance is at least partly resistive, some current will flow through it in phase with the applied voltage. Power is, therefore, necessary to build up that voltage. The largest voltage can therefore be expected at the mid-point of the band-

pass when the impedance of the latter is matched to that of the effective load, which is the condition for maximum power transfer, namely, when a filter impedance of from half to one megohm is matched to a load of 50 to 100,000 ohms. This would suggest a transformer impedance ratio of 10 to 1, or a turns ratio of 3.3 to 1, which is very closely the figure that has proved in practice the most effective in levelling the band-pass.

On this assumption, the impedance matching at the peaks will be very poor, and the response at those frequencies will, therefore, be reduced while that between them is assisted. As a result, the pass region becomes comparatively level, and in the case of filters of the widths mentioned can be evened up to within 2 or 3 db by the use of the methods described above. Fig. 14 is an example of the results which are easily obtained in practice.

The New European Wavelengths

SOME PROVOCATIVE SUGGESTIONS

THE projected plan for rearranging the European broadcasting wavelengths, of which details were exclusively published in *The Wireless World* last week, is likely to be modified very drastically when it comes up for discussion at the European Radio Conference to be held in Switzerland next March. This proposed new plan was drawn up by a Technical Commission of the recent Brussels Conference of the Union Internationale de la Radio-diffusion, and it was not presented to the full assembly of delegates until towards the end of the meeting. It is not in itself intended to be in any way a definite plan, but merely to form the basis for discussion at the European Radio Conference, which is the final arbiter in these matters. Many of the 120-odd delegates to the Brussels Conference made strenuous objections when the proposals were placed before them by the Technical Commission.

The crux of the whole matter is that there has been a tremendous increase in the number of European broadcasting stations since the inauguration of the Lucerne Plan nearly five years ago, and these have to be fitted into wavebands which were augmented to an almost negligible extent at the Cairo International Telecommunications Conference last spring. It is the business of the Conference, which meets in Switzerland next spring, to fit the European broadcasting stations into the bands allotted at Cairo, taking the projected plan produced at Brussels as a basis for discussion.

The Technical Commission at Brussels, in its preparation of the preliminary plan, has already decided that some countries must lose their long-wave channels altogether. As compensation, such countries are to be offered accommodation in the best part of the medium-wave band, namely, at the top, but this in itself means that certain stations already established there must be dispossessed, a process to which their sponsors will hardly be likely to submit without a vigorous protest. There is already more than a hint of a certain liveliness to be

expected at the forthcoming conference in Switzerland, since certain delegates at Brussels demanded many times the wavelengths available for them. The U.S.S.R., for instance, which in the projected plan is allotted 10 exclusive long-wave channels, demanded no fewer than 18.

There are at present 27 long-wave stations operating on 22 wavelengths, and the Commission, it is said, proposes that these should be reduced to 17 stations working on 14 wavelengths, so that there can be wider frequency separation between them. They furthermore suggest, according to reports published last week, that Kaunas, Hilversum and Radio Luxembourg should be deprived of their long-wave channels. The extra elbow-room thus produced will allow for the putting into operation of their recommendation that there should be a full 9 kc/s separation between stations, and that 10 kc/s should be allowed at each side of Deutschlandsender and 9.5 kc/s between Droitwich and Warsaw. The existing congestion on the medium waveband will inevitably be made still worse by the intrusion of the erstwhile long-wave stations.

The Wireless Industry

AN accompanying photograph shows the new RKO Oscilloscope, recently introduced by Radiomart, of 44, Holloway Head, Birmingham, 1. This mains-driven instrument is especially suitable for amateur transmitters, as it provides much information on operating conditions. The price is £4 19s. 6d.

Recent public-address and community reception contracts carried out by Grampian include installations at Osborne Court, Cowes, Birmingham Municipal Airport, Buckfast Abbey, and the Romford Stadium.

The latest issue of the "Bulgin Bulletin," issued by A. F. Bulgin, Ltd., Abbey Road, Barking, Essex, announces two new anti-interference devices—a condenser-resistance switch click suppressor and a flex lead suppressor for unearthed portable appliances.

CLUB NEWS

Ilford and District Radio Society

Headquarters: St. Albans Church Room, Albert Road, Ilford.

Meetings: Thursdays at 8 p.m.

Hon. Sec.: Mr. C. E. Lergen, 44, Trelawney Road, Barking-side, Ilford.

An interesting evening was spent on October 27th when Mr. Lidbury demonstrated his three-valve short-wave receiver and Mr. Stott demonstrated his Fultograph receiving apparatus. Mr. Williamson, the society's operator, followed with an interesting and instructive talk on the uses of the valve voltmeter.

Exeter and District Wireless Society

Headquarters: Y.W.C.A., 3, Dix's Field, Southernhay, Exeter.

Meetings: Mondays at 8 p.m.

Hon. Sec.: Mr. W. J. Ching, 9, Sivell Place, Heavitree, Exeter.

An interesting lecture was given on November 14th by Mr. D. R. Barber, of the Norman Lockyer Observatory, his subject being "Radio and the Moon." During the course of the lecture graphs were shown compiled from lunar eclipse data sent to Mr. Barber by local members of the R.S.G.B.

Peckham District Short-wave Club

Headquarters: Windsor Castle Hotel, Cator Street, Peckham.

Meetings: Thursdays at 8 p.m.

Hon. Sec.: Mr. L. J. Orange, 11, Grenard Road, London, S.E.15.

This club, which was started in May of this year, has a membership of fifteen. At the weekly meetings Morse practice and also instruction in the practice and theory of transmission is given by licensed transmitting amateurs. Members are now engaged in building their own transmitter. There are competitions each month for those interested in DX listening, and during the present month it is hoped to arrange a team to meet other London clubs.

This is the only radio club in a very large district, and the secretary will be very pleased to give fuller information to those interested. Visitors to the club-rooms will be welcomed.

Croydon Radio Society

Headquarters: St. Peter's Hall, Ledbury Road, South Croydon.

Meetings: Tuesdays at 8 p.m.

Hon. Sec.: Mr. E. L. Cumbers, 14, Campden Road, South Croydon.

At the last meeting a question night was held in which the meeting was thrown open to a discussion of various technical topics raised by members. Phase reversal in push-pull amplifiers was discussed, and this led to a prolonged and interesting talk on tone compensation and testing for high quality.

Radio, Physical and Television Society

Headquarters: 72a, North End Road, London, W.14.

Meetings: Fridays at 8.15 p.m.

Hon. Sec.: Mr. C. W. Edmans, 72a, North End Road, London, W.14.

"Radio Activity in Medicine" was the title of a lecture given by Mr. Hamlett on November 18th. Modern methods of treating cancer were described, particular attention being paid to a new treatment which may possibly supersede the use of radium needles.

Golders Green and Hendon Radio Scientific Society

Headquarters: Regal Cinema, Finchley Road, London, N.W.2.

Meetings: Second and fourth Wednesdays of the month at 8 p.m.

Hon. Sec.: Lt.-Col. H. Ashley Scarlett, 60, Pattison Road, London, N.W.2.

On Wednesday, November 23rd, an interesting lecture on "Short-Wave Aerials" was given by E. L. Gardiner, B.Sc., before the Golders Green and Hendon Radio Physical Society. The results obtained with different types of aerial on wavelengths ranging from 160 metres to 5 metres were described, and a new form of compressed dipole with reflector that has been evolved by the lecturer for DF use on five metres was shown, and its construction explained. Polar curves of the many diverse types of aerial described were also shown.

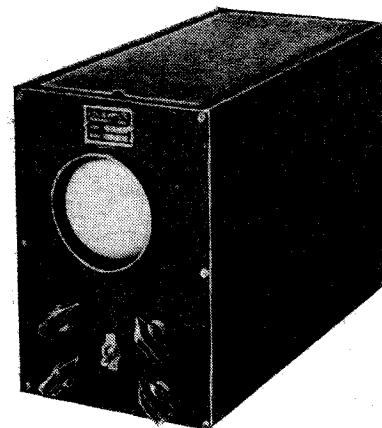

The Radiomart RKO Oscilloscope for transmitters.

Letters to the Editor

About Ourselves

MAY I congratulate you on your decision to increase the price of *The Wireless World* rather than impair its quality and technical interest. I can assure you of my continued support and trust your other readers hold the same views.

A. H. S. ROSEVEARE.

London, W.C.1.

IN favour—but why did you not make it 7d. when you were at it. Best wishes.

Glasgow. DEEDEN PATERSON.

IF raising price to 6d. will ensure our getting your paper, it's cheap at the price. Wishing you every success.

Newcastle, Staffs. W. G. WALKER.

YOU will probably be interested to know that your recommendations regarding biasing the deflector plates have been carried out and have effected a remarkable improvement in the general definition of the picture.

I thank you for the complete and very helpful advice you have always given me. I have been an enthusiastic reader of *The Wireless World* for the past twelve years and shall continue so even though you may raise the price beyond the 6d. about to be charged.

E. BINSTEAD.

South Ilford, Essex.

AS a regular reader of *The Wireless World* since the days of your *Everyman* Four, I should like to say that though naturally I regret the increase in price of the periodical I think you have taken the right course, and I shall, I hope, continue to look forward each week to its issue.

May I express a hope that we shall still be entertained by Free Grid's amusing contributions, with the clever sketches?

Falmouth. R. DE S. STAWELL.

THE question of raising the price of the paper to the public is, I think, a normal development, and I do not believe that this will in any way affect circulation, because most of the readers would want a *Wireless World* at any reasonable price.

The gesture will surely be appreciated by the industry as a body, and I feel sure that *The Wireless World* will continue on its progressive path, an example and an inspiration to contemporary journalism.

Enfield. W. DUNDAS BRYCE,
Belling & Lee, Ltd.

Sets for Seafarers

WHY does our radio industry neglect the market that undoubtedly exists among the thousands of officers and men of the British Merchant Navy? It is extremely difficult to buy a standard British broadcast receiver for the normal ship's voltage of 110 DC.

Surprising as it may seem, many men are buying sets in the States on hire purchase, forwarding the instalments whenever possible. This speaks highly for American trust in our national integrity, but the position is far from satisfactory.

Manchester.

"SEAFARER."

The Editor does not necessarily endorse the opinions of his correspondents

Extension Loud Speakers

IT does not seem to be generally realised by manufacturers that many set owners buy a separate speaker for the sole purpose of obtaining better reproduction than they get from the speaker already installed in their receivers, not necessarily because of any inferiority in the quality of the set speaker but simply because the position of the latter is frequently found to be unsuitable. Many radiograms, for instance, have their cabinets so constructed that the loud-speaker opening is very near the floor of the room in which they are installed. This is not only a bad thing in itself, but, in addition, there is a decided tendency for vibration arising from bass notes, and especially from drums, to be transmitted downwards, to the discomfort of anybody in the room underneath. Now, why do not manufacturers so construct and arrange their receivers that the internal speaker can be removed if desired (complete in its own cabinet) and be placed anywhere the listener wishes, within the limits of the extension cable supplied? Such a procedure should not entail anything more than the undoing of a couple of finger nuts. As things are now, it is often cheaper in the long run to buy another speaker altogether for this purpose!

Another point in this connection is that the extension speaker socket and switch should—especially in the case of big radiograms—be placed in a position more convenient than at the bottom and at the back of the cabinet. Why should it be so often necessary to move a heavy instrument away from the wall just in order to switch on or cut out the external or internal speaker? Such a switch should be placed on the control panel of the set. I consider, too, that

aerial and earth sockets could often be placed more conveniently than they are.

T. J. E. WARBURTON.

St. Leonards-on-Sea.

Valve Standardisation

I WONDER if any valve manufacturer in this country would be daring enough to let us know his intentions with regard to the 4-volt range of AC valves?

The future of this series, up till now the most important, appears definitely uncertain, and one cannot help wondering if it is going to suffer the same fate as that of the 6-volt range of battery valves some years ago. This is an important question to all experimenters, as most of us have comprehensive stocks of little-used valves in the 4-volt AC range. If these are all destined to become obsolete in the near future the sooner we know the better, as new designs based on obsolete valves are pretty useless.

It is easy to see the temptation to adopt the 6.3-volt type as standard, since it is the American standard "at present"; but this can be the only genuine reason, as for the British and Continental markets they have no advantage over the 4-volt valve. Most British and Continental cars use 12-volt batteries, so if the idea is to produce a more or less universal valve, suitable for AC, car radio and AC-DC sets, then obviously the 13-volt valve is the best compromise, as it is suitable for all three uses, whereas the 6.3-volt is not.

By all means produce the 6.3-volt range as a replacement range for American sets, but keep it for this purpose, and introduce all the latest improvements in whatever is to be the future standard British range.

It would be interesting to have your readers' views on this subject, as well as that of manufacturers, but I would earnestly ask the latter to agree together and decide which is to be the future standard, and stick to it.

If this is done we shall not need to use 4-volt output valves with 6.3 valves in the remainder of the set, several different types of valve-holders, and special mains transformers; as yet I find no output valves in the 6.3 volt range equivalent to the PX4.

Bolton.

CECIL HARPER.

Random Radiations

By "DIALLIST"

Power Increases Needed

SIR NOEL ASHBRIDGE, the B.B.C.'s Controller of Engineering, stated recently that though the plans for more powerful Regional transmitters were ready, nothing was to be done until after next year's European Wavelength Conference in Switzerland. One can quite understand the B.B.C.'s holding back for the time being, but it is to be hoped that the increases will be made as soon as possible after the end of the Conference. From those who travel about Europe I often hear complaints about the difficulty of receiving the home stations well. The German, the French and the Italian stations, they say, can be received well almost everywhere; but the medium-wave British stations give but a poor account of themselves in many places. As matters now stand, we have only one medium-wave station of 100 kilowatts; this

is Northern Ireland, which is not very well placed for reaching the Continent. Against this, France has seven medium-wave stations rated at between 100 and 120 kilowatts, Germany nine, Switzerland two, Czechoslovakia two and Italy, Hungary, Bulgaria and Sweden one apiece. Several of the Italian transmitters are, I believe, able to use much more than their nominal power when they want so to do.

Shortcomings

WHETHER or not we really get too much for our money in the wireless sets that we buy nowadays is a moot point. We certainly come down to pretty low price levels

for sets of what we may call standard types and I don't feel at all sure that we aren't actually doing ourselves a bad turn by expecting so much for so little money. What I am driving at is that low prices may tend on the one hand to retard genuine progress in receiver design, and on the other to lead us to put up with sets that are not so good as they ought to be. Certainly there are some pretty bad faults that one finds in far too many sets nowadays. One of these is break-through of medium-wave home stations on to the lower part of the long-wave band. This seems to be very common, for I find it in a large proportion of the sets that I try out. Sometimes it apparently isn't spotted by manufacturers themselves. One firm expressed horror and dismay when I told them that both National and Regional were breaking through; said that there must be something wrong with that particular set and sent down another in its stead. Number two was just as bad an offender as number one!

Points Worth Noting

Another defect that ought to receive much more attention than it does is second-channel interference. An IF of 450 kc/s, or thereabouts, should, in theory, keep the medium-wave band, at any rate, pretty clear of images. But often it doesn't and you're apt to find pretty strong squeals right on top of Berlin and of Brussels No. 1, to mention two good stations often affected in this way. In hardly any of the more moderately priced sets is any attempt made to suppress second channels, and it's true that they don't do much harm so long as the IF is reasonably high; they can, in fact, be an advantage by giving you two strings to your bow for each station, so that if one channel is unsatisfactory, there is always the other in reserve. But when a low IF is used, images are a real nuisance, for then the second channels may fall within the limits of the particular belt of short waves on which a station is working and so cause interference with other transmissions. Another nuisance on the short waves is due to the images caused by second harmonics of the oscillator. It doesn't seem to be quite sound to take a lot of trouble over making sets selective enough to cut out interference of one kind if you allow it to produce a different kind of interference of its own.

Can You Beat This?

ONE comes across some strange coincidences at times, but I don't think I have ever before met with one quite so strange as that which happened to me the other evening. I was writing an article on interference with radio reception and I had just started a paragraph about induction effects from telephone lines when my wife came into the room and asked whether I'd been using the telephone a minute or two before. I said that I'd answered a call and she then said, "A funny thing happened; there was a short interval in the London Regional programme and your voice came from the loud speaker." She then repeated word for word the reply that I'd given to a question over the phone. The most curious part of it is that though one wireless set or another is at work on most evenings of the week, and though the telephone is used a good deal, this was the first time that anything of the kind had happened. It takes some beating as a coincidence.

Still Going Strong

ONE reader has had a tilt at me for including references to batteries and battery sets in these notes. That kind of thing, he suggests, was all very well some years ago, but it is rather out of date nowadays. He forgets, I think, that there are still round about four-and-a-half million homes in this country without electric light or power. There are also considerable numbers of "wired" homes in which the current supplies are, for one reason or another, not suitable for working wireless sets. And what of the portable sets, which have been selling in large numbers for some little time now? Taking it all round, I should estimate the number of battery sets in use to-day at certainly not less than three million, and the figure may well be higher than that. Most wireless shops seem to regard accumulator charging as a not unimportant part of their business, and the sales of dry HTB's alone run to over ten million a year. The battery set is a long way from being a back number yet in this country and even in the United States

surprising numbers of them are in use to-day.

Surprising Efficiency

The up-to-date battery set, as a matter of fact, is a remarkably efficient instrument. It can't, of course, compare with the mains set for volume and quality of reproduction. But that's hardly to be expected: the designer of a small mains set can work to a load of 50 watts or so on his supply, whilst the designer of a similar battery set must work to something under 3 watts from both HTB and LTB together, for economy in running costs is a consideration of prime importance. Yet, so far as sensitivity and selectivity are concerned, there are many low-consumption battery sets which can hold their own pretty well with the average moderately priced mains receiver. Both the battery set designer and the battery valve designer have put in a great deal of useful work in the last few years, and the result of their combined efforts is a wonderfully efficient receiver with a remarkably small drain on the batteries.

Ceramic Insulators

WIDE
APPLICATIONS
IN
TRANSMISSION
AND
RECEPTION

Representative
"Calit" coil formers
and adjustable
inductances.

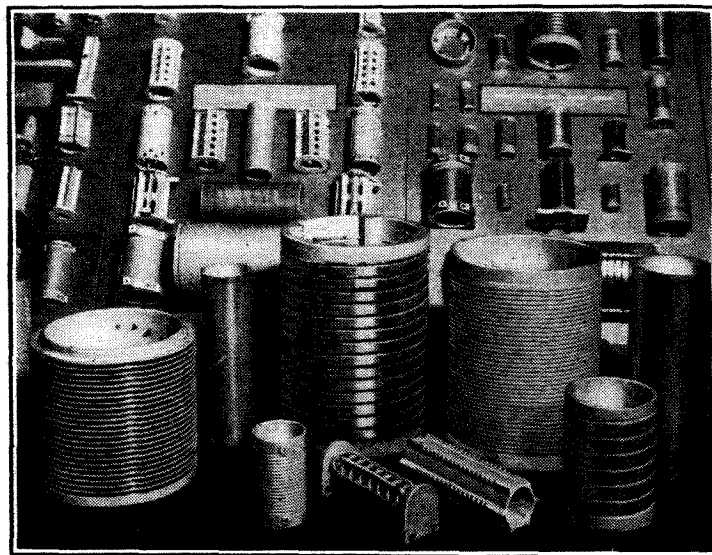

THE second annual exhibition of insulating materials arranged by the United Insulator Co., Ltd., 12-16, Laystall Street, London, E.C.1, was held at the Hotel Grand Central, Marylebone, from November 14th to November 18th.

This firm handles the products of the Hesco Company, of Hermsdorf, and hundreds of samples testified to the wide field of applications of "Calit" ceramic mouldings. These included spiral water-feed tubes for transmitting valves, disc-type fixed condensers for short-wave transmitters, and air-spaced variable inductances. In the two latter applications the electrodes and conductors are of silver or copper, and are fired directly into the surface of the insulator, thus ensuring high stability with changes of temperature. The inductances are cut in the form of a helix, and may be extended or compressed to adjust the inductance by means of an internal screw mechanism also moulded in "Calit."

A wide range of dielectrics with different properties included "Tempa S" with a loss factor of only 4×10^{-4} and "Condensa C" with a dielectric constant of 80. The latter

is employed in the "Hesco" temperature coefficient regulators in conjunction with "Calit." These resemble trimmers and have silver electrodes fired into the surface of the material. Rotation does not change the capacity, but the temperature coefficient of the condenser as a whole. "Calit" has a positive coefficient of 140×10^{-6} , and Condensa C a negative coefficient of 720×10^{-6} , and the thicknesses of the dielectrics are made proportional to their dielectric constants. The resulting condenser provides a linear variation of temperature coefficient from $+50 \times 10^{-6}$ to -500×10^{-6} , and can be set to compensate for changes in coils and trimmers in other parts of the circuit. There is also a wide range of high-grade tubular, disc and cup type fixed condensers for use in receiving sets, and a colour code has been devised to indicate the type of dielectric employed.

A new plastic material, "Peton," has been introduced by the company. It is lighter than aluminium and has a tensile strength which enables it to be used for nuts, bolts, etc. Easily machined, it can be nailed or screwed without splitting.

Recent Inventions

The British abstracts published here are prepared with the permission of the Controller of H.M. Stationery Office, from Specifications obtainable at the Patent Office, 25, Southampton Buildings, London, W.C.2, price 1/- each.

A TUNING PROBLEM

THERE is a tendency when receiving short-wave stations for the frequency of the local oscillator in a superhet to drift with the strength of the incoming signals. This is apparently due to the action of the AVC voltage applied to the grid of the mixing valve. The effect is more noticeable when a tuned RF stage precedes the mixer, assuming, of course, that the set is not provided with any of the known systems of automatic frequency control.

Any such drift is automatically corrected by the circuit shown in the drawing. This represents a triode-hexode mixing valve coupled to a tuned input circuit L, C and generating local oscillations in the circuit L₁, C₁, the two oscillations being combined in the IF circuit L₂, C₂. The circuit is a normal one except for the resistance R, and the fact that the resistance R₂ is of the order of 0.5 megohm (instead of perhaps 0.1 megohm) and is earthed instead of being taken to the cathode.

In the absence of signals, the grid G carries a minimum bias, which becomes more negative as an

Brief descriptions of the more interesting radio devices and improvements issued as patents will be included in this section.

electric cells when exposed to incident light. This, in turn, depends at least in part upon the capacity of the condenser formed between each cell and the metal backing-plate—from which the charges are released under the action of the scanning stream.

In practice the mosaic-cell electrode is made by depositing the photo-sensitive material in discrete particles upon an insulating layer placed over the metal backing-plate.

According to the invention, a coating of quartz, deposited by a process of evaporation, is used to form the insulating layer. In this way an extremely thin layer of dielectric is interposed between the sensitive material and the backing-plate, with a corresponding increase in electrical storage capacity. Further, since the heat-conductivity of quartz is four times that of the more usual mica

Miller effect, tend to introduce a reactive factor which will vary with the working frequency, but this is minimised by using relatively large condensers in the feed-back circuit. The arrangement is designed to keep the frequency constant in spite of fluctuations in the supply voltage. In addition, the circuit readily lends itself to be adjusted to any desired working frequency.

N. L. Yates-Fish; P. W. Willans; and Muirhead and Co., Ltd. Application date January 4th, 1937. No. 489849.

ELECTRON OPTICS

IT is well known that the electron stream inside a cathode-ray tube can be made to converge or diverge, or be brought to a given focus, by the application of transverse electrostatic and magnetic fields of force, which act upon it in a way somewhat similar to that in which a glass lens acts upon a ray of light. In practice this electron-optical control of the stream is effected by electrodes which, when once assembled, produce a focusing effect that cannot easily be varied.

According to the invention, an electrode system is so arranged and supplied with biasing voltages that it is possible to alter the focus of the stream, and therefore the magnification of the picture it produces, at will, and without giving rise to distortion. The control electrodes consist of a series of rings, or short cylinders (separately tapped to a biasing potentiometer) in combination with one or more discs pierced with apertures of different sizes.

Marconi's Wireless Telegraph Co., Ltd. Convention dates (U.S.A.), November 30th, December 24th and December 31st, 1935. No. 489846.

LIGHT VALVES

THE electrodes of a Kerr cell are usually placed close together in order to secure as strong an electrostatic field as possible from the applied signal voltage. This, however, renders it difficult to pass a ray of light between them without the risk of making a glancing contact sufficient to cause "scattering," which may adversely affect the emerging ray.

According to the invention, both the cell electrodes are made transparent, so that if the incident ray should strike against them, it will pass clean through and not be reflected or scattered in undesirable directions. The electrodes may, for instance, be made by depositing a layer of platinum or tungsten metal (sufficiently thin to be transparent to light) upon a plate of glass or mica.

Baird Television, Ltd., and J. L. Baird. Application date February 8th, 1937. No. 489964.

SHORT-WAVE AERIALS

THE figure shows an aerial suitable for broadcasting television signals. It consists of a vertical tube T one and three-quarter wavelengths long, the lower quarter being laid below the top of the supporting building, so

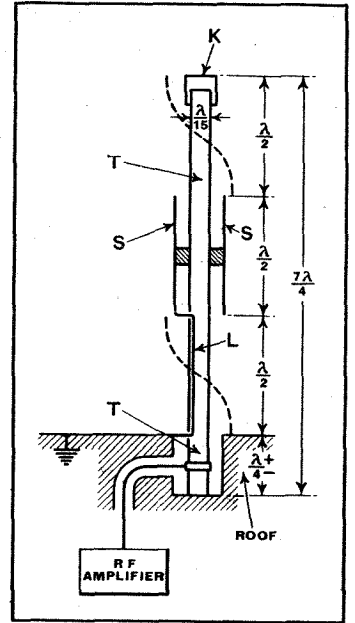

Partially shielded transmitting aerial.

that it does not radiate. A metal sleeve S surrounds the centre half-wave section, and is connected to ground by a lead L, which runs inside the main tube.

The sleeve S suppresses radiation from the centre part, so that the radiated field comes only from the upper and lower half-wave sections, which carry in-phase currents as shown by the dotted line curves. An adjustable cap K fits over the top of the aerial, and is used to regulate its effective electrical length. The tube itself is of substantial diameter, say, one fifteenth of the wave-length, in order to give the wide frequency response required in television.

Marconi's Wireless Telegraph Co., Ltd. (Assignees of C. W. Hansell and N. E. Lindenblad). Convention date (U.S.A.), February 3rd, 1936. No. 489775.

TELEVISION WITHOUT SCANNING

RELATES to a television system of the kind in which the picture to be transmitted is first focused on to a number of photo-electric cells. Each of these is connected, through a commutator switch, to a corresponding bank of neon lamps, by which the light-and-shade effects of the original picture are reproduced without the necessity of using any scanning device.

In this known type of arrangement, provision is now made for simultaneously transmitting sound signals, the two sets of signals being kept distinct by superposing them on two carrier-waves of different frequency.

Sir O. Stoll. Application date January 13th, 1937. No. 490523.

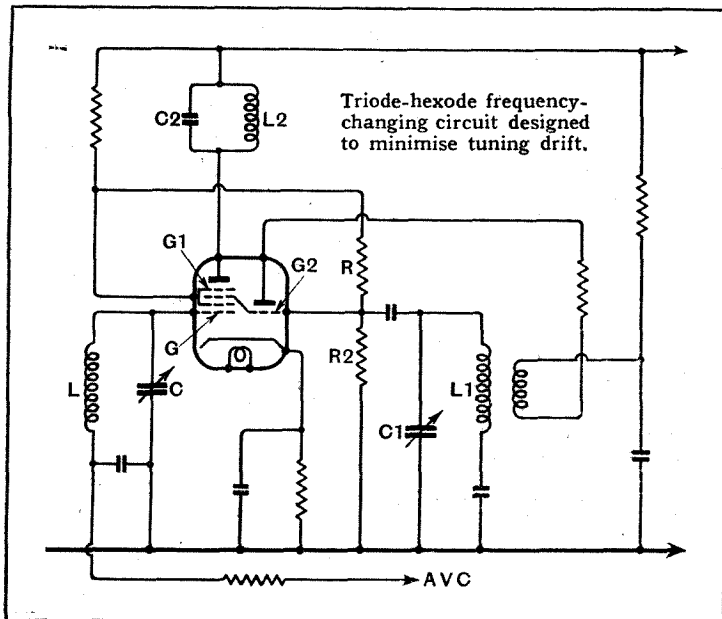

incoming signal causes AVC voltage to be applied. The negative bias on G causes the potential on the screening grid G₁ to rise, part of this rise in potential being applied, through the resistance R to the injector grid G₂ so as to force it further into the region of grid current. This, in turn, reduces the shunt effect of the valve impedance and so holds the frequency of the local oscillator circuit L₁, C₁ steady.

E. K. Cole, Ltd., and H. A. Brooke. Application date, March 10th, 1937. No. 490244.

MOSAIC-CELL ELECTRODES

THE efficiency of a mosaic-cell electrode, such as is used in the Iconoscope television transmitter, depends upon the magnitude of the elementary "charge" developed by each of the tiny photo-

insulation, the photo-sensitive material is able to cool more rapidly and will therefore have a longer life.

C. Lorenz Akt. Convention date (Germany), March 31st, 1937. No. 489270.

FEED-BACK CIRCUITS

A CROSS-COUPLED pair of valves, acting as a generator or amplifier, is provided with a non-reactive feed-back circuit (that is, one containing resistance and capacity elements only), which is designed to produce zero phase-displacement for the working frequency. For other frequencies the phase-displacement varies in opposite senses, according to whether they are above or below the desired frequency.

The interelectrode capacities, and in particular the so-called

The Wireless World

THE
PRACTICAL RADIO
JOURNAL
28th Year of Publication

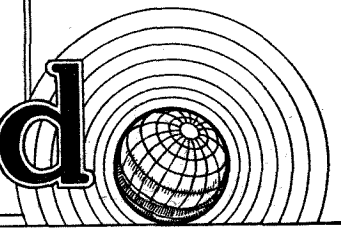
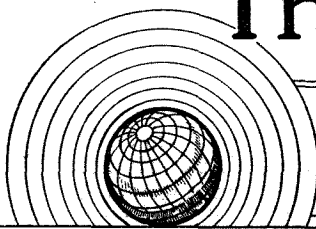

No. 1006.

THURSDAY, DECEMBER 8TH, 1938.

VOL. XLIII. No. 23

Proprietors : ILIFFE & SONS LTD.

Editor :
HUGH S. POCKOCK.

Editorial,

Advertising and Publishing Offices :
DORSET HOUSE, STAMFORD STREET,
LONDON, S.E.1.

Telephone : Waterloo 3333 (50 lines).
Telegrams : "Ethaworld, Sedist, London."

COVENTRY : 8-10, Corporation Street.
Telegrams : Telephone :
"Autocar, Coventry." 5210 Coventry.

BIRMINGHAM :

Guildhall Buildings, Navigation Street, 2.
Telegrams : Telephone :
"Autopress, Birmingham." 2971 Midland (4 lines).

MANCHESTER : 260, Deansgate, 3.

Telegrams : Telephone :
"Iliffe, Manchester." Blackfriars 4412 (4 lines).

GLASGOW : 26B, Renfield Street, C.2.

Telegrams : "Iliffe, Glasgow." Telephone : Central 4857.

PUBLISHED WEEKLY. ENTERED AS SECOND
CLASS MATTER AT NEW YORK, N.Y.

Subscription Rates :

Home and Canada, £1 10s. 4d. ; other
countries, £1 12s. 6d. per annum.

*As many of the circuits and apparatus described in these
pages are covered by patents, readers are advised, before
making use of them, to satisfy themselves that they would
not be infringing patents.*

CONTENTS

	Page
Editorial Comment	501
Wire for Receiving Aerials	503
Television Programmes	504
Amplification in the Theatre	505
New American Valves	509
How the Valve Works II—The Triode	511
Ferranti Model 515PB	514
Unbiased	516
MUSA—More Consistent Long- Distance Reception	517
News of the Week	519
Crystal Band-Pass Filters, VI	521
Letters to the Editor	523
Random Radiations	524
Recent Inventions	526

EDITORIAL COMMENT

Research and Invention

The Basis of All Progress

WHILST the radio industry has for years been considerably more sheltered than most industries from foreign competition, it is not safe to assume that that state of affairs will continue indefinitely. Future prosperity of the radio industry, too, will depend to an increasing extent on our ability to sell our wireless manufactures abroad.

At a recent gathering of electrical representatives the President of the Board of Trade laid special emphasis upon the importance of research to the electrical industry, and reminded us that the success of that industry in the export market was traceable not to keen competition in prices, but to the superiority of British electrical manufactures over those of most of our competitors.

Price Competition

British industries are not at their best when competing on price alone. There are many countries far better fitted to produce repetition articles cheaply than Britain and, in consequence, it seems that our aim must always be for our products to be better than those of our foreign competitors. It would be impossible to maintain such a position without intensive research, and it would, therefore, seem that in the wireless industry, as in all other British industries, research with a view to progress and improvement in production should be given first place in the minds of all our manufacturers in this industry. Every manufacturer should, we believe, find

means to finance a research department; but this is not enough. It is necessary that wireless research on a broad basis should be conducted in such a way that it benefits every wireless producer, whether concerned in production of apparatus for public use or for the Services.

Pooling Research

We know that at present one or two of the biggest concerns owning a large proportion of wireless patents license radio manufacturers and pool their patents for the benefit of the industry as a whole, reaping their reward in the form of royalties. Is the industry satisfied that the large concerns are conducting research on an adequate scale to ensure that the radio industry does not fall behind similar industries abroad?

Is there not room for still greater concentration on this problem of research? Might we not set up a central laboratory, supplying the results of its work to all those manufacturers or Government departments contributing to its maintenance? As things stand at present there must be an enormous wastage through overlapping in a vast number of research laboratories, great and small, run at the expense of the public or by private enterprise, throughout the country.

The Radio Corporation of America licenses most of the radio manufacturers in the U.S.A. to use its inventions in the field of domestic wireless, and that organisation conducts research on a large scale, deriving benefit therefrom only after the results of its work have been translated into production and services.

The "pool" licence to manufacturers in this country which we have referred

to above is conducted on similar lines, but we believe that there remains room for a far more comprehensive scheme of co-operation between the pool and its licensees than exists at present; and here is one direction in which we might hope to see progress made to the end that material for the technical perfection of our products in the future could be assured.

Are We Inhuman?

Functions of a Specialist Journal

NOBODY likes increases of price, and so it is all the more gratifying that so many readers have written not only to signify their acceptance of the sixpenny *Wireless World*, but actually to congratulate us on the steps taken to secure the economic future of the journal.

Of those few who have expressed dissent, it is perhaps only a coincidence that a large proportion—two individuals, to be precise—have referred to our "inhumanity." If by this expression they wish to imply that contributors are discouraged from attempts to project their personalities through our pages, at the expense of the matter in hand, we plead guilty. But we take it that the function of a journal like *The Wireless World* is to present facts rather than personalities, and in any case there can be nothing very inhuman—in the unpleasant sense—in a periodical that has inspired so many

letters written in such kindly, not to say affectionate, terms. We are at least human enough to be deeply appreciative of the warmth of feeling towards the paper expressed in many of the letters.

Better Aerials

New Kind of Mast Needed

IT is rightly urged that there is still no substitute for a good aerial, but where are we to find the right kind of mast on which to hang it? If we are satisfied with a purely utilitarian though inevitable unsightly erection, something can generally be devised, but not without considerable difficulty and the expenditure of much ingenuity.

The choice of ready-made metal masts of good appearance is distinctly limited, and so far as we know most of them require a network of supporting stays, which is bound to be unsightly. What is needed is a more or less self-supporting mast; recent advances in various branches of industry should make it possible to produce an attractive one at low cost.

Television Demonstrations

Inconvenient Transmission Times

DEALERS in the service area of the London Television Station are complaining of the difficulty of arranging demonstrations of televisors. It is pointed out that while women have taken it upon

themselves to choose sound broadcast sets, it is the man of the house that has the say in the purchase of a televisor.

The present film transmissions for demonstration purposes are given in the morning at a time when the average male customer is fully occupied. The same objection applies more or less to the afternoon programme. There is, of course, the evening transmission, from 9 to 10, but for intending purchasers to see this means that a special appointment has to be made after business hours. Would it not be possible for the B.B.C., as part of the proposed drive to popularise television, to give a transmission, even if it did consist of films, during the early evening, say from 6 till 7?

Offend None; Please None

Danger of Milk-and-Water Programmes

AT a recent function the B.B.C.'s Public Relations Officer for Television made it clear that the Corporation's policy is that no programme should offend the susceptibilities of any viewer.

But, as a subsequent speaker aptly put it, the programme that displeases nobody is unlikely to please anybody very much.

Here is a thought that the B.B.C. might take to its collective heart—always provided that it does not allow itself to be swung too far over in the opposite direction.

INDENTED SOUND TRACK

Recording on the Back of "Silent" Film

THE Filmograph—an apparatus for making "Home-Talkies" recently marketed in America—is interesting if only for its novelty. Essentially this instrument consists of an electro-magnetic pick-up, mounted in a special fitting that has a channel for holding the film while it runs

through, drawn by means of the projector drive, with which it is used. A sapphire stylus, placed in the pick-up (recording-head), indents a track about 0.002-in. deep and 0.001-in. wide in the celluloid base of the film, i.e., on the non-emulsion side. Pivoted weights provide the necessary pressure for recording. It is claimed that the fine grooves are not noticeable on the screen when the film is pro-

(Left) The Filmograph unit, for producing "home-talkies," as set up for play-back. Note position of weights and recording-head. (Right) A close-up of the recording-head, opened for threading the film. Weights are raised for play-back and lowered for recording.

jected and that the corrugations actually strengthen the film. The sapphire stylus performs the dual purpose of recording and playing-back, but for the latter function the weights are raised.

For economy it is intended that this device be used in conjunction with the AF section of a radio receiver, with the recording-head (any required impedance is available) replacing the loud speaker. When recording, a microphone is coupled to the pick-up

terminals of the receiver and the commentary spoken whilst watching the film flashed on the screen. The waveform is impressed on the film base at the same instant as a picture, which is 23 frames away, is projected; in this manner synchronisation is obtained. (See accompanying photographs, reproduced by kind permission of the Editor of *Radio-Craft*). Models are available to work with 8-, 16- and 35-mm. film. Straight recording on spoiled or blank film (up to 28 parallel tracks on 15 mm.) is possible.

D. W. A.

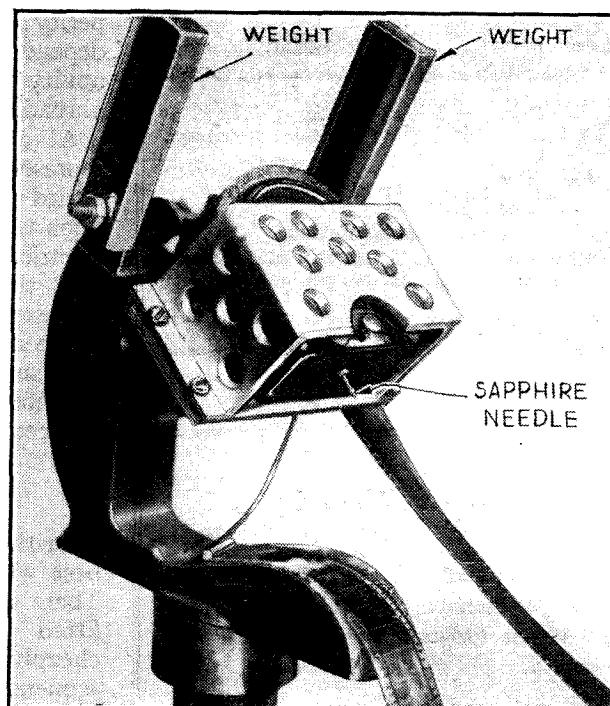
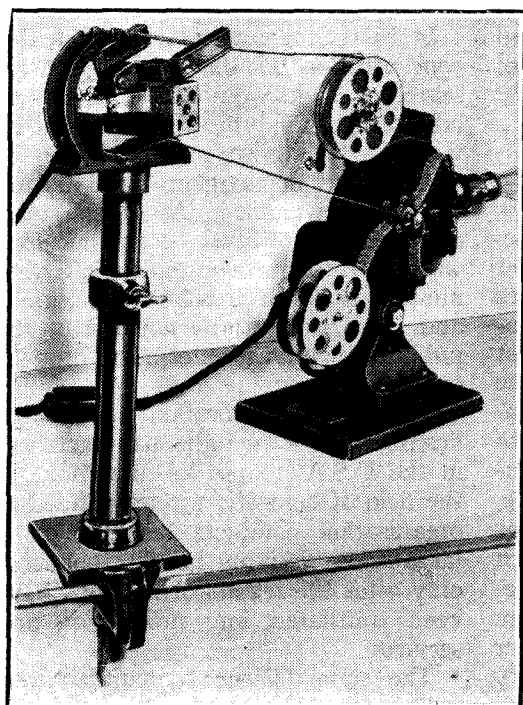

Wire for Receiving Aerials

IS THE GAUGE OR MATERIAL OF IMPORTANCE ?

IF one studies mathematically the properties of an average inverted "L" receiving aerial on the medium- and long-wave broadcast frequencies it becomes obvious, from certain of the relevant equations, that the resistance of the wire of which the aerial is composed is relatively unimportant under conditions of practical application; that is, for total lengths of wire not in excess of 120ft.

This is rather staggering when one thinks of certain special wires and corresponding claims for their receptive properties, and at first one wonders if the mathematical analysis may be incorrect.

Providing one applies correctly the fundamental principles of electricity and magnetism to the analysis of an electrical problem and does not make wild and illogical assumptions about the processes involved, it is certain that the correct solution will be obtained, and its correctness may be verified by experiment.

The manner in which the experiment is carried out, however, is very important, because extraneous effects are often introduced by a certain amount of thoughtlessness or carelessness during the preparation for the experiment.

For example, a crazy inventor erects a receiving aerial of, say, 20 SWG copper wire and listens to certain European broadcasts at midday and notes the results. He dismantles the aerial and coats it with some weird concoction which he chooses to call aetheric paint, re-erects the aerial and tests it out at 10 o'clock in the evening of the same day. European stations roll in at terrific strength, and our hero spends a sleepless night dreaming of Patent Office forms 1 and 2, and fat royalty fees!

Had our experimental friend left the original aerial erected and conducted the second test at 10 p.m., he would have observed exactly the same magnificent result; we folk who are familiar with the effects of the Heaviside layer know all about the increase in signal strength from distant stations attributable to its beneficent influence at night-time in this country.

Fools Step In . . .

The foregoing is but one illustration of the sort of thoughtless experiments that certain self-styled investigators make through assuming that "mathematics is eyewash," and gaily spend or waste their time careering up the path marked "Angels Only."

Any attempt to verify, for example, the

By F. R. W.
STRAFFORD

(Research Dept., Belling
and Lee, Ltd.)



mathematical elucidation of the unimportance of aerial resistance under certain practical conditions must be attended with care and precision and carried out by means of measuring apparatus of suitable characteristics and known performance.

We attempt by experiment to prove or disprove the question of the importance of the type of conductor used for aerials, and commence by erecting a pair of aerials the horizontal portions of which are

IT will perhaps come as a shock to some readers to learn that the mechanical properties of wire used for receiving aerials and its ability to withstand the weather are of more importance than its electrical characteristics. Within reasonable limits, the choice of gauge is unimportant.

parallel to one another and placed at a suitable distance so that their reaction one upon the other is negligible, as must of course be verified by experiment. Both aerials will be composed of the same material; for example, 18 SWG bare copper wire could be used, and it will further be essential that their total length and height and general disposition are identical.

The respective downloads of these two aerials are taken to a low-capacity single-pole double-throw switch, so wired that the aerials may be connected in turn to either a typical broadcast receiver or suitable measuring apparatus.

A casual listening test on various stations at various wavelengths indicates that the performance of each aerial is, so far as the ear can observe, identical, but here it must not be forgotten that any variations which are likely to exist will be masked by the effects of the AVC circuit of a typical receiver. Accordingly we disconnect the AVC circuit and connect a suitable measuring instrument, e.g., a microammeter, in series with the load resistance of the second detector, which is usually a diode. Providing that the input

signals are of insufficient magnitude to overload severely the early stages of the receiver, the microammeter will indicate the strength of the incoming signal in such a manner that its deflection is proportional thereto. Here we have a device which is capable of recording very small differences in the actual signal input available from each of the aerials, and enables us to settle without any doubt that the slightly different position of one aerial with respect to the other produces a negligible or unobservable change in signal intensity at the input of the receiver.

At this stage one of the aerials is directly connected to earth. Providing the spacing between the horizontal portion of the two aerials is not less than 20ft., it will be observed that the reduction in signal strength due to earthing one of the aerials is never greater than 2 db. over the wavelength range considered.

The second test is to remove the first aerial and in this case it will be found that the signal strength as received on the second aerial is in no way influenced, and is so far as can be measured the same as with the original aerial in position but unearthed.

The foregoing experiments are merely part of the precautionary measures which an investigator must take in this particular instance before he commences comparing aerials of different wire gauges, resistance, material, etc.

The Standard Aerial

In the actual experiment made by the writer the length of the horizontal roof of each aerial was 50ft., and the length of the download 17ft. The height of the two aerials above ground was 23ft. at both ends, and they were erected near the centre of a field of several acres in size. The standard aerial comprised a length of 18 SWG copper wire, and experiments were conducted by comparing the performance of this aerial with that of one of precisely the same dimensions as before stated, but in which the wire gauge was first reduced to 38 SWG, and then, finally, to 40 SWG Eureka resistance wire. Experiments could have been conducted with a greater variety of gauges and resistances of wire, but here again a logical assump-

Wire for Receiving Aerials—

tion was made to the effect that if negligible changes of performance were observed with these particular extremes of wire resistance and gauge, the need for experiments with intermediate gauges or material became unnecessary.

Two types of receiving apparatus were used in making these comparisons. Firstly, a typical broadcast receiver of the 15-guinea type was employed possessing an input impedance varying from about 3,000 to 8,000 ohms over the medium and long broadcast wavebands. Secondly, a carefully calibrated and well-screened measuring apparatus, which was fundamentally an elaborate form of superheterodyne receiver, was employed and the input impedance of this piece of apparatus was substantially independent of frequency, being of the order of 5,000 ohms throughout its entire frequency range.

The choice of two pieces of measuring apparatus rather than one was made in order that the effect of the variation of the input impedance of the receiver might be taken into account in making the measurements. It is obvious that the input impedance of the receiver will affect the results of a comparison, for if the said impedance is low an increase of the aerial resistance (by using a thinner wire, for example) will provide a greater reduction of the current through the receiver input impedance than if the receiver impedance were of a higher value.

The result of these comparisons are tabulated in Tables 1 and 2 for the typical broadcast receiver and the special receiver respectively.

It is at once apparent that the differences in either case are not large and that an experimenter could not possibly observe in the case of the 38 SWG copper wire aerial, without the most careful listening, the maximum indicated difference in the table.

TABLE I. (TYPICAL RECEIVER.)

Wavelength in Metres.	Measured Signal Loss in Decibels.	
	38 SWG Copper.	40 SWG Eureka.
1,875	0.0	2.0
1,620	0.5	1.0
1,500	0.5	1.0
1,300	0.0	0.5
500	3.0	4.5
480	0.0	3.5
370	0.5	5.5
260	0.5	2.5
213	1.0	5.0

TABLE II. (SPECIAL RECEIVER.)

Wavelength in Metres.	Measured Signal Loss in Decibels.	
	38 SWG Copper.	40 SWG Eureka.
1,875	0.0	1.0
1,620	0.0	1.5
1,500	0.0	1.75
1,300	0.25	2.0
500	0.5	2.5
480	0.7	3.0
370	0.75	4.0
260	1.0	4.5
213	1.5	5.5

In order to determine whether a covering over the wire of a material possessing a higher dielectric constant than air would affect the performance of an aerial, tests were carried out with a rubber-covered copper conductor of approximately 20 SWG. Here again, as can be imagined, the observable differences were negligibly small, since the change of the distributed

TABLE III.

Wavelength in Metres.	Estimated Signal Loss in Decibels.	
	38 SWG Copper.	40 SWG Eureka.
42	3.0	10.0
35	2.0	6.0
27	0.0	3.0
21	3.0	10.0
19	2.0	6.0
16	0.0	3.0

capacity due to the dielectric would be negligible unless the *whole space* between the wire and earth were filled with the dielectric material.

When we turn our attention to short-wave reception, however, we must study once again the relevant equations and determine whether aerial resistance plays an important part when the length of the aerial becomes comparable with the wavelength; and we find that the effect is by no means negligible under these special conditions.

The Aerial at Resonance

The total aerial length of 67ft. including the downlead is one half-wavelength long at approximately 42 metres, and one wavelength long at 21 metres, and so on. At these wavelengths the aerial is said to be in resonance, in fact, it is nothing more or less than an incompact tuning circuit containing inductance, capacity and resistance in distributed form.

Now it is a well-known fact that the voltage available from a tuned circuit in resonance is smaller if the resistance (i.e., the damping) of the circuit is increased. Hence an increase of the resistance of the aerial wire may, at certain wavelengths, for which the aerial is resonant, attenuate seriously the resultant input to the receiver.

Tests were accordingly carried out over the short-wave bands and Table 3 indicates the estimated results given by acoustic comparison on a typical broadcast receiver (the special receiver could not be used at these frequencies because it operated only between 200 and 2,000 metres).

It is at once apparent that differences exist, and that while these are negligible between the standard aerial and one employing 38 SWG copper (resistance 20 ohms), they are very serious when 40 SWG (1,000 ohms) is employed.

It is interesting to note that the differences are by no means so great when the length of the wire happens to be an odd integral multiple of a quarter-wavelength, as, for example, at 27 metres when the

length of the aerial is three-quarters of a wavelength, and at 16 metres when it is one and three-quarters of a wavelength.

Of course, no one would erect 40 SWG Eureka resistance wire for an aerial, or 38 SWG copper for that matter, so that it is obvious that even on the short wavelengths and for the particular frequencies at which the aerial is resonant, the choice of aerial wire within sane limits is unimportant.

Perhaps the only real claim which may be made for certain special types of aerial wire is their ability to stand adverse wind and weather.

In concluding it must be stated emphatically that the foregoing does not apply to aerials for transmission purposes when the conditions become somewhat different.

Television Programmes

Sound 41.5 Mc/s Vision 45 Mc/s

THURSDAY, DECEMBER 8th.

3, "A Break in the Journey," a play written for television by Anthony Bertram. 3.15, Gaumont-British News. 3.25, Cartoon Film. 3.30, 197th edition of Picture Page.

9, West End Cabaret. 9.25, British Movietonews. 9.35, 198th edition of Picture Page. 10.10, News.

FRIDAY, DECEMBER 9th.

3-4.30, Victoria Hopper and Wyndham Goldie in "Cornelius," a business affair in three transactions by J. B. Priestley.

9, "Proofs," a play by Frederick Burtwell. 9.15, British Movietonews. 9.25, Presents for the Children, No. I—Pictures suitable for nursery walls. 9.35, Film. 9.55, "Mushrooms," another play by Frederick Burtwell. 10.10, News.

SATURDAY, DECEMBER 10th.

3, C. H. Middleton. 3.10, Gaumont-British News. 3.20, Trudi Binar. 3.25, Cartoon Film. 3.30, "The Bronze Lady and the Crystal Gentleman," a play by Henri Duvernois.

9, Renée Houston in Cabaret, with Flotsam and Jetsam. 9.30, Ski-jumping and Racing. Viewers will see the second part of "Winter Cavalcade" from the snow slopes at Earls Court. 10, "This Cruising," talk by Reginald Arkell, with cartoons by Alan d'Egville. 10.10, Music Makers—Jean Norris. 10.20, News.

SUNDAY, DECEMBER 11th.

8.50, News. 9.5-10.40, "The Shoemaker's Holiday"—play by Thomas Dekker, from the Playhouse Theatre, London.

MONDAY, DECEMBER 12th.

3, Gaumont-British News. 3.10, Eastern Cabaret: a development of Cabaret Cruise 3.55, Cartoon Film.

9, Mr. Gillie Potter. 9.10, Cartoon Film. 9.15, "The Hunting of the Snark," a masque by H. D. C. Pepler, with music by Leighton Lucas and Fred Emery. 9.35, The Law To-day—talk. 9.55, British Movietonews. 10.5, Pas Seul. 10.15, News.

TUESDAY, DECEMBER 13th.

3, British Movietonews. 3.10, Cinderella. 3.55, Cartoon Film.

9, Gaumont-British News. 9.10, Priestley's play, "Cornelius" (as on Friday at 3 p.m.). 10.40, News.

WEDNESDAY, DECEMBER 14th.

3, The Roel Puppets. 3.10, Gaumont-British News. 3.20, "King of the Congo," an epic of the jungle, by Roger MacDougall and Allan MacKinnon.

9, Cabaret. 9.15, Speaking Personally. 9.25, British Movietonews. 9.35, "A Break in the Journey" (as on Thursday at 3 p.m.). 9.50, Cartoon Film. 9.55, Music Makers—Orloff. 10.5, News.

Amplification in the Theatre

SOUND amplifying equipment has proved itself of value in the theatre, not only for its more obvious function of helping the players to get their parts across to the audience, but for many other purposes. The nature of these applications is discussed in the present article.

II.—SOUND EFFECTS AND OTHER USES

By ALEXANDER BLACK (Alexander Black, Ltd.)

IN a previous article the writer dealt with amplifying equipment used solely for the reinforcement of sounds originating on the stage by means of microphones in the footlights and loud speakers in the auditorium (shown at A in the accompanying diagram). There are, however, several other important uses for microphone and gramophone amplifiers in the theatre; these may be classified as follows, the letter references being to the

diagram: B. Microphones (usually on the conventional floor stand) used on the stage as part of an artist's turn. C. Microphones in the orchestra to assist the stringed instruments in conjunction with loud speakers in the auditorium. D. Microphones used off-stage by artists or merely for sound effects. E. Gramophone records for interval music with loud speakers in the orchestra pit or for effects. F. Microphones in the orchestra pit in conjunction with loud speakers in the wings to assist a chorus singing off-stage to keep in time. G. Microphone in the Prompt Corner for the stage manager to communicate with operating departments

while the show is running. H. Microphones in stalls or dress circle to assist the producer in rehearsing a new production.

It will be appreciated that no single production is likely to make use of all the equipment shown in the diagram. Two of the shows of recent years to make the greatest use of amplifying equipment were Mr. C. B. Cochran's Revue, "Home and Beauty" at the Adelphi Theatre in 1937, and Eric Maschwitz's production "Paprika" at His Majesty's Theatre.

In "Home and Beauty" three amplifiers were used with microphones in classes A, B, D, G, and gramophone effects E.

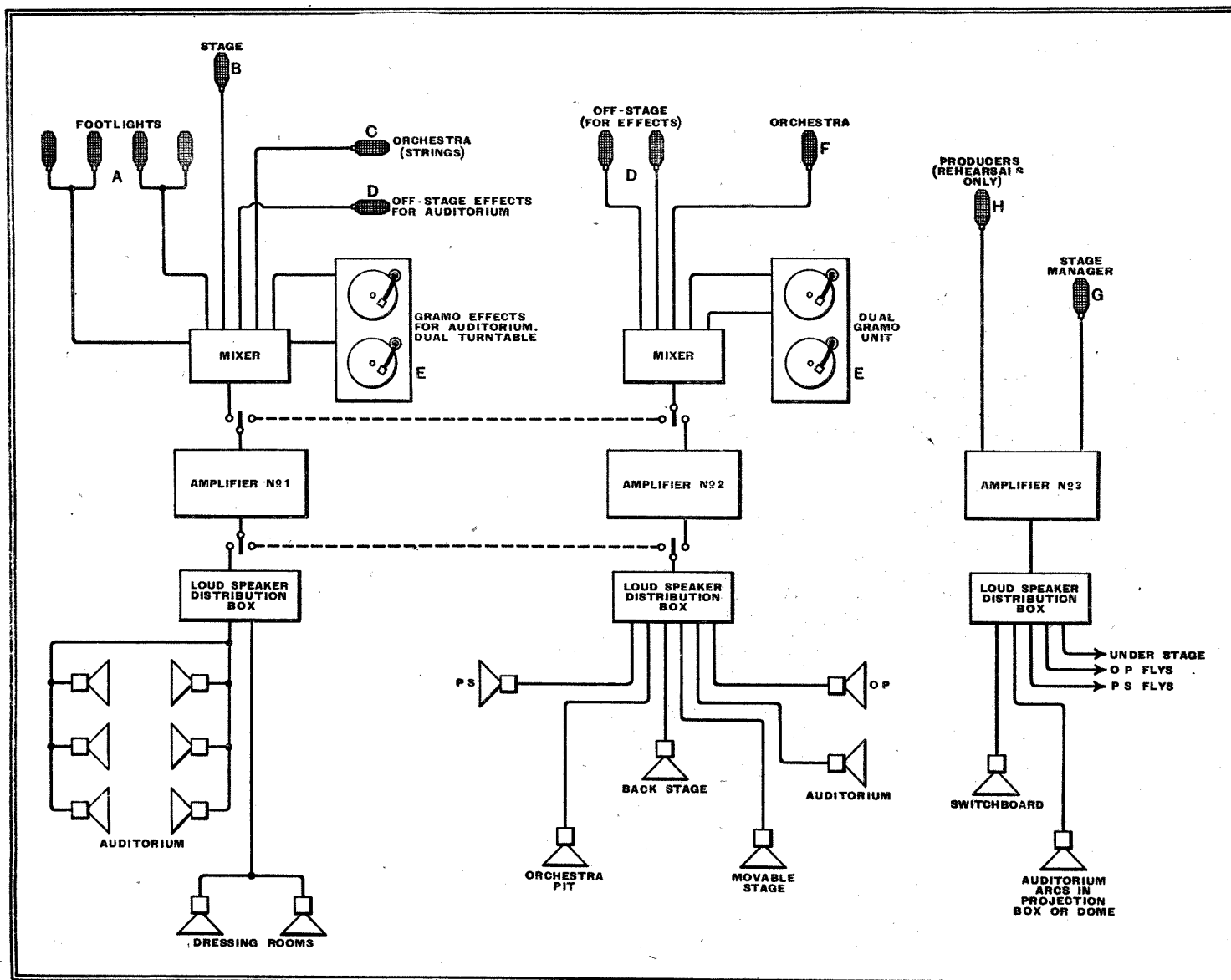

The more important applications of sound amplification in the theatre. The functions of the various microphones and speakers are described in the text.

Amplification in the Theatre—

Six loud speakers were installed in the auditorium and five back-stage. "Paprika" at His Majesty's used three amplifiers with six microphones in classes A, C, F, G, and gramophone effects E. Six loud speakers were used in the auditorium and eight back-stage.

The microphone for rehearsals (class H) is usually coupled to amplifier 3, but may equally well be used on amplifier 2, and is only of a temporary nature. Where effects are of great importance to the action

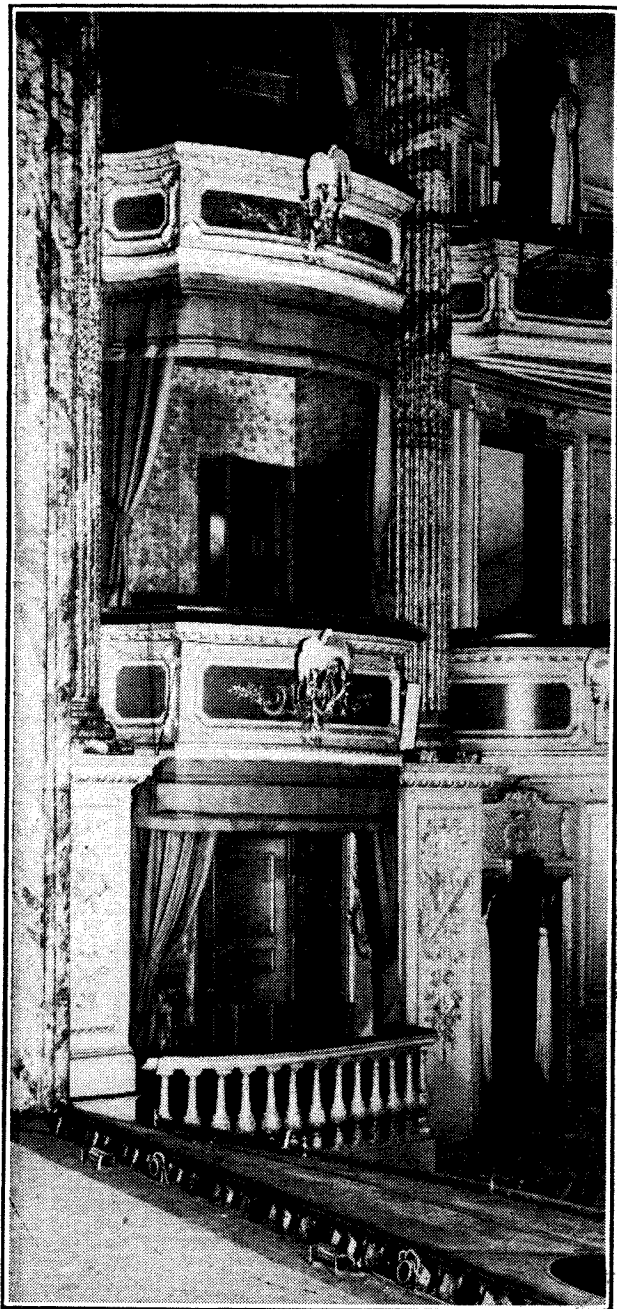

Footlight microphones at His Majesty's Theatre. One of the six loud speakers used in the auditorium will be seen mounted near the base of the fluted pillar. The smaller microphones close to the footlights are a permanent fixture for deaf-aid purposes.

of a play or revue it is desirable to have a duplicate amplifier to avoid risk of breakdown. In cases where there is an amplifier (1) for stage reinforcement this may be used as a standby to the effects amplifier (2); the connections are shown in dotted lines on the diagram. It will be noticed that the effects mixer may be switched either to amplifier 2 or 1; similarly the effects loud speaker distribution box may be coupled to amplifier 2 or 1. The change-over disconnects the footlight microphones but this is usually

not so important as getting the effects over; in any case, the effects are probably not used for more than a total of 10 or 15 minutes of the whole performance, and the footlight microphones can be brought into use for the rest of the show.

Referring again to the diagram, it will be noticed that although amplifier 1 is used primarily for stage reinforcement with loud speakers in the auditorium, additional speakers may be run from it into the principal dressing rooms, thereby dispensing with the services of a call boy, as the actors are able to follow the progress of the show without leaving their rooms. In a revue or musical show with a good deal of scenery and a large cast the performers get terribly in the way at the side of the stage whilst waiting their cue to make an entrance; it is usually impossible for the call boy to arrange for the chorus to be called at the last minute as he is fully occupied with the principals; also he is the first to get into trouble if one of the cast misses an entrance. It is surprising that more use is not made of this comparatively inexpensive installation. The writer only knows of one instance of its use, and that was in the principal's dressing room only, but he believes it is extensively used in the United States. No doubt our conservative theatre managers will realise the advantages of such an installation one of these days.

The writer has shown in the diagram four footlight microphones brought to the mixer in pairs; in some theatres three microphones are ample for satisfactory pick-up and all three may be coupled together and brought to the mixer as a

single input. It depends on the acoustics of the theatre to a certain extent, but more on the actual play, whether it is necessary to pick up from one side of the stage more than the other during any particular scene.

The mixer for amplifier 1 should also take charge of any microphones used by artists on the stage or off it for effects which require to go into the auditorium, also the output from a dual turntable for any gramophone effects which are to go "out front." These additional inputs to

amplifier 1 in no way interfere with the functioning of the footlight microphones in reinforcing the stage dialogue and singing.

Amplifier 2 has to be very flexible, as, in addition to having five different inputs,



Back-stage speaker at the Adelphi. One of the associated amplifiers is mounted on brackets on the wall.

it also has to have about six ways on the loud-speaker mixer; sometimes plain switches do, but at others many of the outputs require separate volume controls. The undistorted output should be normally about 20-30 watts. Only three loud speakers are required back-stage for general sound effects; Prompt Side, Opposite Prompt and Back-stage Centre. It does not make any difference when listening in the auditorium if the loud speakers are at stage level or up in the flies; the sound appears to come from the P.S. or O.P. or back, depending on which-ever LS is in circuit. In addition to these, provision must be made in some cases for one or two loud speakers in the orchestra pit. Further, many plays have a wireless receiver or radiogram as a stage property and frequently this is required to work at some time during the performance. For many reasons it is not practical to have the genuine article on the stage, so the radio or radiogram consists of an empty cabinet except for the loud speaker; this is connected to a suitable point in the wings coupled to the mixer of amplifier 2. When the sound has actually to come from an instrument on the stage it is not satisfactory to use one of the three loud speakers mentioned above as the scenery tends to spread the sound and destroy the illusion that it comes from an instrument on the stage. In the event of there being no stage reinforcement system with loud speakers in the auditorium, provision must be made for a loud speaker here. Very excellent aeroplane effects from gramophone records may be obtained by using two speakers back-stage P.S. and O.P. and one auditorium speaker, preferably as

Amplification in the Theatre—

high as possible; if each speaker is faded in and out in rotation an excellent imitation of aeroplanes circling overhead is obtained; by using different sequences on the mixer controls various evolutions can be simulated. "Idiot's Delight," when at the Apollo Theatre, provided an example of this system. A considerable amount of power is required to give realistic results; the amplifier at the Apollo gave some 180 watts on peaks.

"Canned Music" out of Place

One of the earliest applications of amplifying equipment in the theatre was for using gramophone records as interval music for non-musical plays, and it is still used extensively to-day for the purpose. In the opinion of the writer, no matter how excellent the quality of reproduction, it is definitely out of place in the living theatre, whereas it is taken as a matter of course in the cinema. No gramophone record yet made can give sufficient illusion of naturalness to deceive an audience that they are listening to living musicians in the orchestra pit. If music is required, however, as an off-stage effect, good records well reproduced are quite equal to living musicians; this is probably due to the fact that the music is farther away from the audience and is well diffused before reaching the auditorium.

In the living theatre amplifiers should only be used to assist the play and not be part of it.

We now come to amplifier 3, and the reasons for its usefulness in the modern theatre. People who are not actually connected with the stage probably have no conception of the activity that goes on behind the scenes of a heavy musical production or revue while it is being shown. The stage manager is in command in the Prompt Corner and from the switchboard

above his desk he gives light or buzzer cues to the electricians on their switchboard, the front-of-house arc men, and the flymen who control all scenery which is lowered into position. In some cases there are additional switchboards under the stage if the production is a heavy one from the lighting point of view. Normally this form of signalling is perfectly satisfactory. It must be remembered that scene changes in a revue or musical show are expected to take only 30 seconds or so and if a back cloth or piece of scenery gets caught up the delay is quite appreciable, and the stage manager must be in a position to give instant instructions to his flymen to assist in clearing the obstruction as the flymen themselves are usually unable to see the cause of obstruction. It is in these cases that a microphone (G), in the Prompt Corner is invaluable as there is no delay in giving orders and is far quicker than the telephone usually

Specially built sound-proof "effects" chamber showing the microphones.

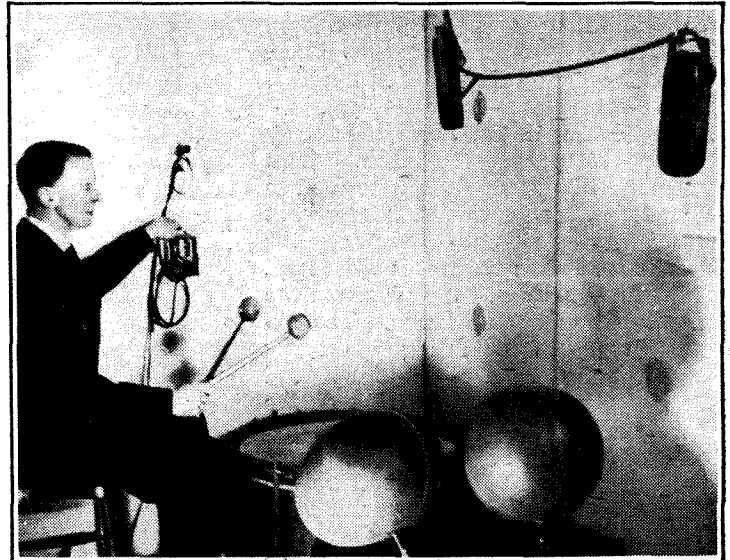

fitted. Also if the electrician on the board or the front-of-house arc men make a mistake this can be instantly corrected by the stage manager.

As regards the amplifier, this has about a 5-watt output and the loudspeakers are usually all in circuit all the time; the microphone is preferably a good carbon type which will stand up to three hours

sitting in the stalls or circle during rehearsals to give instructions to the stage manager in the corner as well as to the electricians and flymen. In these cases a temporary additional microphone is connected to amplifier 3 in parallel with the Prompt Corner microphone, and a loud speaker is fitted near the Prompt Corner, care being taken to avoid feed-back with the Prompt Corner microphone.

Microphone Fright

Let us now deal with the various classes of amplifier inputs individually. Probably one of the commonest uses of microphones in the theatre is when they are on the stage (B in the diagram). In the writer's opinion many artists would do far better if they dispensed with a microphone in front of their face during their turn, and if they have a weak voice and feel that they cannot get across without assistance, use sound reinforcement with the microphones hidden. A microphone in front of an artist, with a few exceptions, completely destroys their personality. One of the few exceptions is Larry Adler and his harmonica; he uses the microphone with great effect as part of his instrument. Some comedians are able to use the microphone in front of them very effectively in burlesques on broadcasting and crooners. The writer is convinced that, apart from these exceptions, microphones in the future will always be concealed on the stage. The audience will not then be disconcerted by the obvious mechanical

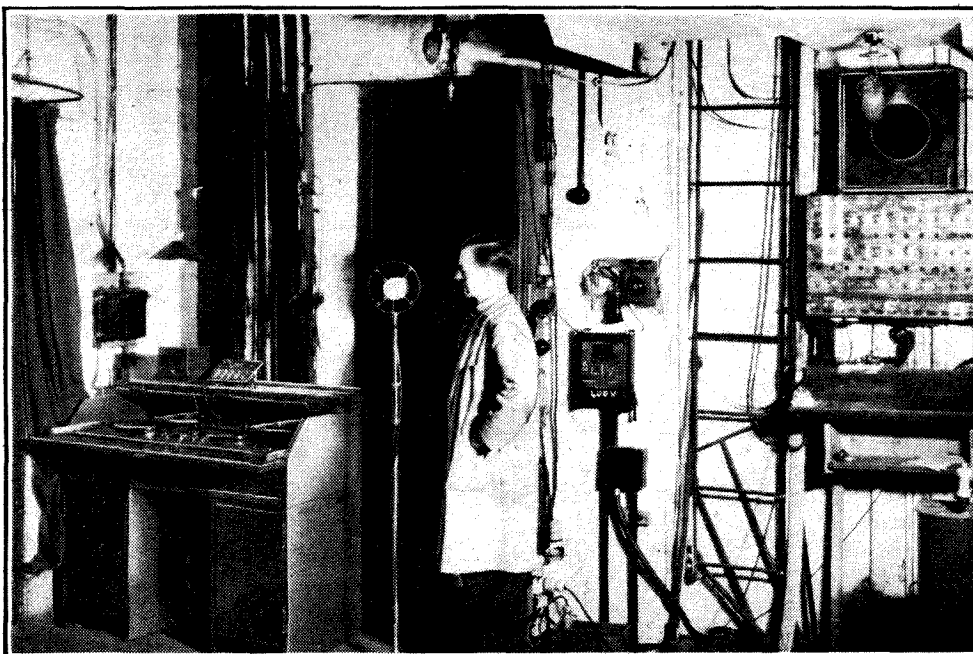

The control desk with twin turntables for gramophone effects at His Majesty's Theatre. The loud speaker distribution board is seen on top of the desk with a microphone mixer box on its left. The stand microphone can be used by the stage manager for giving instructions to electricians and flymen. Prompt side speaker is seen on the right.

Amplification in the Theatre—

assistance the microphone is giving to an artist's performance.

The next on the list is the microphone for the stringed instruments in the orchestra (C). We dealt briefly with this system in the previous article, i.e., the lapel type microphones used in the Trocadero Grill Room. The first use of a microphone for reinforcing the stringed instruments in the legitimate theatre was, as far as the writer is aware, at His Majesty's Theatre for "Paprika" and it was certainly effective. In this instance, one velocity microphone was suspended from the conductor's desk in front of the first and second violins, and was quite hidden from the audience; this microphone was mixed with the footlight ones and was left at a constant level throughout the show.

A variation of this system was recently used at St. James's Theatre. Two grand pianos by themselves were used in the orchestra pit for interval music, but as the stage tends to overhang the orchestra pit at this theatre, it was found that in many parts of the auditorium the pianos could hardly be heard. The expedient was tried of fitting a velocity microphone near each piano with a loud speaker concealed on either side of the proscenium arch; this was found to be most effective as a reinforcement; it was impossible to tell that the instruments were being amplified until the microphones were switched off, the drop in volume of sound being then most noticeable.

Effects Off-Stage

Turning now to the microphone off-stage for effects, etc. (D), quite a number of plays require as part of the effects a speech from a hidden announcer to appear from the house loud speakers or from one of those back-stage, or a speech to emanate from the dummy radio set on the stage. Originally this was done by means of special gramophone records, and to-day this method is still used in some cases, but it has been found far more effective to utilise one of the cast to make the speech in front of an off-stage microphone; for one reason it is easier to start at the exact cue, and secondly much better quality of reproduction can be obtained from a microphone. A very interesting use for off-stage effects microphones was in the play "You Can't Take It With You" at St. James's Theatre last year. In this play, fireworks had to appear to go off from the room under the stage room in which the action of the play took place. It will be realised that a considerable amount of noise was required to give the right atmosphere. In New York, when the play was first produced, a sound-proof room was used with a couple of microphones. To produce suitable sounds, a drum, two bladders filled with dried peas, a siren whistle, a couple of canes against a leather chair back were used. As there was no suitable room at St. James's Theatre a temporary sound-proof hut was built at the side of the stage; three men were required inside this erection for

working the effects, which were remarkably realistic; cues were given to them by means of signal lights from the stage manager, sound cues by means of a loud speaker being out of the question. The amplifier had a peak output of 180 watts which was fed into six large loud speakers in the orchestra pit. The necessity for a sound-proof room for the mikes will be understood, otherwise howl-back would have reduced the available amplification considerably. So far as the writer knows, this is the first time a sound-proof hut has been used for effects on the English stage.

For many other types of off-stage effects such as trains leaving stations, crowds cheering, weather effects, aeroplanes, etc., gramophone records are invaluable. The usual way of playing records is by a dual gramophone turntable so that two different records may be mixed together to produce a composite sound. On one or two occasions a triple turntable has been used for mixing purposes, but it is simpler now to prepare a special record with the required sounds ready mixed. The greatly improved results obtained by present-day

direct recording is probably responsible for this. Furthermore, should the effects, noise or music, have to continue longer than the playing time on the record, a second record may be faded in just before the finish of the first. For some effects it is often necessary to be able to drop the pick-up on a predetermined groove of the record; modern dual turntables are fitted with mechanical pick-up lifters, the pick-up arms having an engraved scale passing in front of a pointer which allows the pick-up to be pre-set and suspended over the right groove in the record until the cue to start is received.

In some musical shows a chorus is required to sing in the wings, and as the orchestra is never heard very clearly or loudly in this position, some way has to be found to help the singers keep in time; the most satisfactory way is by means of a concealed microphone in the orchestra pit (F), coupled to the effects amplifier 2, either the P.S. or O.P. loud speaker being brought into circuit.

[The Author is indebted to the Management of His Majesty's Theatre for facilities for taking some of the photographs used.]

Abnormal Five-Metre Conditions

LONG-DISTANCE SIGNALS DURING THE "INDIAN SUMMER"

FOR the past two years a regular watch has been kept on the five-metre amateur band with the view to investigating the potentialities of this wavelength for general communication purposes.

Daily listening has not been possible, but an hour or so during the evenings on three to four days of each week has been devoted to this band. From time to time signals have been picked up from stations working on 60 to 70 miles or so, but on the whole the distance covered by the average amateur five-metre transmitter, using between 25 and 50 watts input, seems to be of the order of 40 miles.

Occasionally conditions have deteriorated and signals over this distance have been so erratic that only portions of messages were decipherable.

During the early part of November last a very marked change was noticed and for a fortnight amateur stations located in the home counties were heard exchanging messages with G6DH in Clacton-on-Sea. The most active were G2OD, G5BY, G5RD, G5NF, and possibly others not logged by the writer. During the same period signals were being received by London amateurs from G6FO in Newport, Monmouth.

The behaviour of these distant signals pointed to the fact that bending was taking place in the upper atmosphere, since fading was often present. On one particular evening (Nov. 12th) G6FO's signals were accompanied by deep regular fading, signals rising to a good readable level then dying down to inaudibility; this took place at intervals of approximately two minutes.

Similar conditions obtained also on some

evenings while listening to the east-coast station G6DH.

A point of interest is that this form of fading, while apparently general when it was present, varied in degree in different localities, for while the signals were fading so badly at the writer's station as to be inaudible, the fading was apparently less severe elsewhere, since the complete messages were being received.

The amateur stations that were most notable for maintaining communication under these adverse conditions were G2OD and G5BY, the former in Ascot and the latter in Croydon.

The distances covered, though considerable for low-power five-metre equipment, could only be effected if bending took place in quite a low region of the upper atmosphere, and even the lowest known ionised layer would appear to be far too high to provide the bending medium.

It will be recalled that this period of November was very warm for the season; furthermore, as soon as the temperature reverted to more normal levels these distant stations ceased to be audible. The explanation for this sudden burst of five-metre signals over abnormally long distances for this country, and under quite ordinary conditions of reception, may lie in quite a different direction, but the facts remain that the one coincided with the other and there may be some connection.

Should we experience another out-of-season "heat wave" it will be interesting to see if it is accompanied by a repetition of these results, and amateurs interested in five metres might make a note to be extra vigilant should the occasion arise in the future.

H. B. D.

New American Valves

SINGLE-ENDED RADIO-FREQUENCY PENTODES

FROM their beginning screened tetrodes and pentodes have been of the double-ended type; that is, the anode or grid has been brought out to a connection at one end of the valve and the other electrodes to pins at the other end. The object of this has always been to keep grid and anode connections as far apart as possible in order to keep the grid-anode capacity at a minimum.

Departures from this practice are now being made both in Germany¹ and in America, and screened valves are now made with all connections brought out to the base pins.

Such single-ended types designed for ordinary receiver applications are now available in America under the type designations of 6SJ7 and 6SK7. In effect, these are single-ended forms of the common 6J7 and 6K7 pentodes. They differ from the Telefunken single-ended valves largely because the elements of the Telefunken tubes are placed horizontally, while those of RCA are vertical as usual. The relative advantages of the two arrangements as to

ally opposite to the anode pin in order to minimise capacity between the two. This alone is insufficient, and it is necessary to reduce these capacities both inside the valve and in the base and socket.

Reference to the cross-sectional drawing of Fig. 1 will make clear the method of capacity reduction. The grid-anode capacity in the base and socket is reduced by the "cylindrical base shield," which acts as a screen between grid and anode leads and base pins. This shield is connected to the metal shell, and is contained within the central spigot. This somewhat unconvincing device does what is desired. In a typical American "wafer" socket the capacity between diametrically opposite terminals is about 0.005 $\mu\mu\text{F}$., but when a 6SJ7 or 6SK7 valve is inserted this drops to the negligible value of 0.0001 $\mu\mu\text{F}$.. In another type of socket the capacity was 0.01 $\mu\mu\text{F}$. for the empty socket, dropping to 0.003 $\mu\mu\text{F}$. upon inserting the valve. Nearly the same effect is obtained by the use of a metallic locating pin instead of the hollow insulating pin containing the tubular base shield, but the capacities to frame are slightly higher.

Figures for these valves and for their double-ended counterparts are given in the table, and it is clear that the former are the better, providing undesired effects do not result in the associated circuits when they are all placed below the baseplate. That this possibility is not too serious has been shown by published discussions which may be summarised as follows: In using top-grid bottom-anode

Fig. 1.—This drawing, reproduced by courtesy of R.C.A., shows the internal screening arrangements of the new American valves.

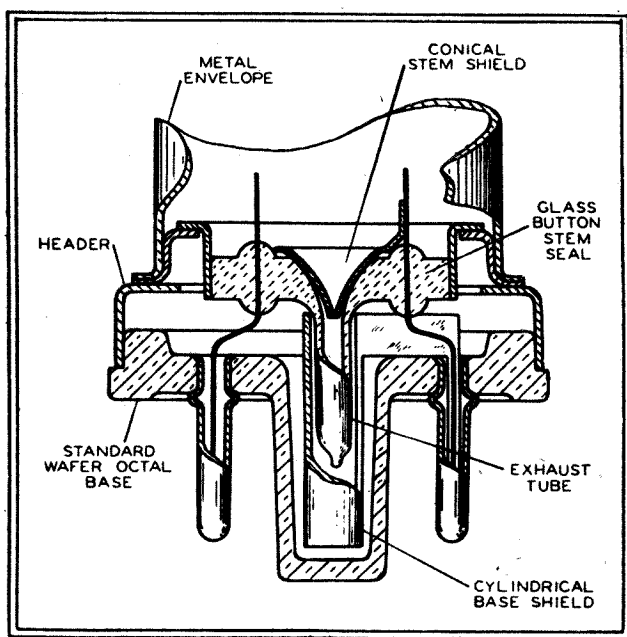

ease of manufacture and strength are controversial, but it is clear that they lead toward different placing of the lead-in wires. The Telefunken arrangement almost automatically produces two groups of wires which may conveniently be shielded from each other by a transverse metal partition.

The RCA valves have a different scheme of shielding, with no attempt to divide the space into compartments. The terminal pins are evenly spaced about the usual circle, with the input-grid pin diametric-

ally opposite to the anode pin in order to make possible a coupling to the next stage. This partially spoils the baseplate as a shield and introduces leads too long for good ultra-high-frequency amplification. Even at ordinary high frequencies the tuning may be disturbed by accidental displacement of the flexible lead to the top cap, especially where such a movement may introduce or alter regeneration.

It is, therefore, reasonable to abandon the baseplate altogether as an inter-valve

By Our New York Correspondent



The new valves all have the same external appearance and are of the metal type.

shield, retaining it merely as a mechanical foundation and an electrical return-circuit for the untuned circuits. Viewed in this way the single-ended pentode seems attractive rather than dangerous. Mechanically, the advantage is on the same side. Valves are exchanged more easily, the leads are shorter and stiffer, and, above all, it is easier to mount or to repair the interstage coupling devices, since the associated wiring does not pass through the baseplate.

The hum voltage induced into the grid circuit by the AC filament current depends partially upon the capacitive coupling of these circuits in the base of the valve. The pin arrangement chosen (Fig. 2) shields the grid pin from the heater pins.

This same form of construction has also been adopted for certain triodes, the 6SF5 or the 6SQ7, which have characteristics equivalent to the 6F5 and 6Q7.

Triodes

These triodes are commonly used in current American AF amplifiers. In the case of receivers the triode is, of course, often found in the same shell as a detector diode. In either case it has been customary to build the triode with a 6.3-volt heater, an amplification factor of 70 to 100, and a mutual conductance about 1.2 mA/v. The effective audio-frequency input capacity of such a valve is high because it is roughly equal to:—

$$C_{eff} = C_{gc} + (1 + A)C_{ga}$$

where C_{gc} is the grid-to-cathode capacity, C_{ga} is the grid-to-anode capacity, A is the amplification.

(The effect of the load is ignored for simplicity.)

TABLE OF CHARACTERISTICS

Type.	6J7	6SJ7	6K7	6SK7
Anode Volts ...	250	250	250	250
Screen Volts ...	100	100	100	100
Grid Volts ...	-3.0	-3.0	-3.0	-3.0
Anode Current (mA)	2.0	3.0	7.0	9.2
Screen Current (mA)	0.5	0.8	1.7	2.4
Mutual Conductance mA/v. ...	1.225	1.65	1.45	2.0
Input Capacity $\mu\mu\text{F}$.	7.0	6.0	7.0	6.0
Output Capacity $\mu\mu\text{F}$.	12.0	7.0	12.0	7.0
Grid Anode Capacity $\mu\mu\text{F}$	0.005	0.005	0.005	0.005

¹ The Wireless World, November 10th, 1938.

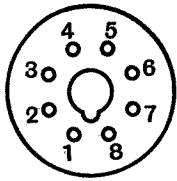

8 PIN (OCTAL)

Fig. 2.—BASE CONNECTIONS OF THE NEW VALVES.

	1	2	3	4	5	6	7	8
6SJ7 & 6SK7	Shield	Heater	Suppressor	Grid	Cathode	Screen Grid	Heater	Anode
6SF5 (Triode)	Shield	Cathode	Grid	Blank	Anode	Blank	Heater	Heater
6SQ7 (Duo-diode-triode)	Shield	Grid	Cathode	Diode Anode	Diode Anode	Anode	Heater	Heater

The tendency is, therefore, to short-circuit high-audio frequencies. In the effort to reduce this effect it was natural to employ a top-grid connection to reduce C_{gc} and C_{ga} , but the practical value of that construction is somewhat dubious. In high-fidelity audio amplifiers where high-frequency audio response is required the designer may discard the high- μ tube in favour of two stages of the more tractable moderate- μ variety. On the other hand, the designer of less costly PA equipment and of broadcast radio receivers is commonly so concerned with the reduction of hum pick-up that he provides liberal high-note shunting in the form of an input circuit enclosed in grounded metallic braid. It becomes doubtful whether the reduction of C_{gc} inside the tube warrants a top-grid connection. Thus, there remain only the questions whether the top grid offers lower C_{ga} and hum pick-up. As regards hum, the RCA single-ended high- μ triode 6SF5 introduces less than is picked up by the leads to the volume control of various radio receivers. A better view is obtained by considering the permissible hum level

quantitatively. The equivalent hum voltage on the grid of the single-ended 6SF5 is stated by RCA to be approximately 100 microvolts across $\frac{1}{2}$ megohm. Whether this is acceptable depends upon the impedance of the 6SF5 input circuit and the gain of the amplifier. In the two-stage audio systems used by radio receivers the hum output is well down. A 50-microwatt hum output is unobjectionable, and this level will not result for a normal 6SF5 unless the following amplifier gain is several times that of the usual loud speaker pentode and the grid impedance ahead of the 6SF5 is several times that normal to radio receivers. Hum outputs below 10 microwatts are probable.

As regards the capacities, C_{ga} is $2 \mu\mu\text{F}$. for the 6F5 and $2.6 \mu\mu\text{F}$. for the 6SF5, while the input and output capacities show a considerable reduction for the single-ended valve.

Some of the foregoing, especially the illustrative material, is from copyrighted engineering information of the RCA. It is used here by permission of RCA Manufacturing Co. Inc.

gain, and will actually load many single tetrodes and pentodes to their full power-handling capacity without a pre-amplifier. In view of the fact that with normal sets and amplifiers the volume control will have to be well turned down, a second curve was taken at half volume and found to have exactly the same shape as the curve at full output.

The price of the pick-up, complete with volume control, tone arm rest and needle cups, is 30s. and the makers are Cosmocord, Ltd., Enfield, Middlesex.

New G.E.C. Cathode-Ray Monitor Tube

A NEW miniature cathode-ray tube, type 4053, has been produced by the General Electric Co., Ltd. It is a $1\frac{1}{2}$ in. tube, similar to the older type 4051, but improved in sensitivity and focus.

The advantages of a cathode-ray tube of short overall length and low operating voltages are obvious, and there are innumerable cases where the need for such a tube arises. The new tube operates with the same anode, focusing and modulating voltages as the original 4051, and has identical external dimensions. The sensitivity is,

however, improved to the figure of $\frac{10}{V}$ mm.

per volt, where "V" is the voltage on the final anode. Considerable improvements in the screen also have resulted in a finer trace and greater freedom from burning.

This new cathode-ray tube is of the high-vacuum type, with a green screen, and is fitted with a standard British 9-pin base, so that connections are available to each of the four deflector plates separately. The price is 45s.; the original type 4051 is no longer available.

Cosmocord Crystal Pick-up

"SERIES 1"



The contrasting ivory and brown finish in the tone arm gives the Cosmocord "Series 1" crystal pick-up an attractive appearance. The head is rotatable to facilitate needle changing.

HOUSED in a moulded tone arm of similar design to that of the Model 25 magnetic pick-up, the "Series 1" crystal model is given a particularly attractive appearance by the ivory swivel head and volume control knob.

Special care has been given to the mounting of the crystal element, which is clamped in a featherweight needle holder, die-cast in magnesium alloy. This has a lower specific gravity than pure aluminium and consequently the inertia is exceptionally low. As a result, the high-frequency response of the pick-up is sustained up to at least 8,000 c/s, the upper limit of modern recordings.

Probably the most noteworthy feature of this pick-up is its phenomenally high output. At 50 cycles the voltage from the standard test record is a little over 20 volts RMS and from 2,000 to 8,000 cycles the out-

put is sensibly constant at nearly 2 volts RMS. It will be seen that the drop in the level of recording below 250 cycles is very generously over-corrected and gives a wide margin for experiment for those who favour a full bass response.

The "Series 1" pick-up should solve the problem of gramophone reproduction through receivers with a low overall AF

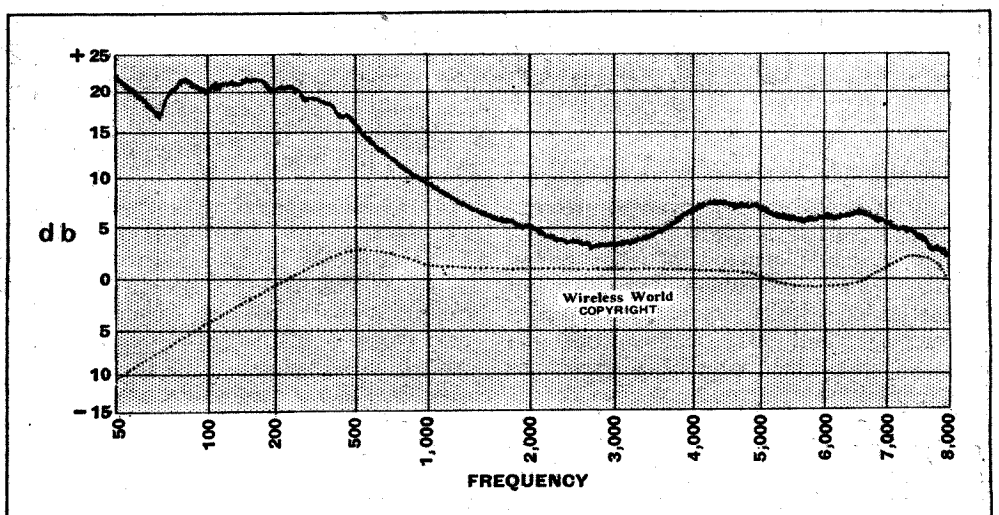

Output curve of Cosmocord "Series 1" crystal pick-up with H.M.V. High-Fidelity needle. Zero db is equivalent to 1 volt RMS and the dotted curve shows the characteristic of the test record.

How the Valve Works

ADDING ELECTRODES ONE BY ONE

Part II.—The Triode

FOLLOWING upon the discussion of the diode, a further electrode is now added so that the valve becomes a triode. In this article the internal operation is explained and some of the drawbacks which led to the development of more complex types are discussed.

WHEN discussing the diode in Part I it was shown that it gives no amplification and is in practice used chiefly as a rectifier. By introducing another electrode, so that it becomes a triode, amplification can be obtained. At one time nothing but triode amplifiers were used, but now this type of valve has been superseded for many applications by more complex structures. Nevertheless, the triode is still highly important and is the simplest amplifier.

We saw that the diode consists essentially of an electron emitting cathode, which may be directly or indirectly heated, surrounded by a metallic anode. The electrode structure of the triode is essentially the same, but between anode and cathode there is included a metal grid. This may consist merely of an open spiral of wire, or it may be a close mesh structure, depending on the type of valve. Before electrons emitted from the cathode can reach the anode, therefore, they have to pass through the spaces between the grid wires.

The action of anode and cathode is pretty much the same as in a diode, but the anode current is no longer dependent only on the anode voltage but also on the grid voltage. Under normal conditions the anode is maintained at a positive potential with respect to the cathode by the battery or other supply E_a ; the potential may be some 50-300 volts with ordinary receiving valves.

As shown in Fig. 7, the grid is normally maintained negative with respect to cathode by the battery E_g . The

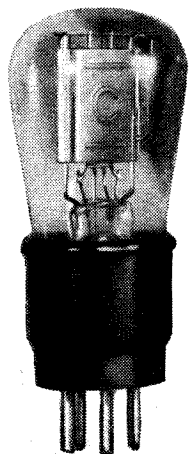

A battery triode is shown on the left and an indirectly-heated type above.



anode current measured by the meter depends on the anode and grid voltages and upon the electrode spacing and dimensions, and the mesh of the grid. With a given valve it depends on grid and anode voltages.

Just as with a diode, the cathode is surrounded by a cloud of electrons forming the space charge. The grid is negative and repels the electrons so that they do not pass to it. The anode is positive and acting through the interstices of the grid attracts the electrons. The electrostatic field acting on the electrons of the space charge is

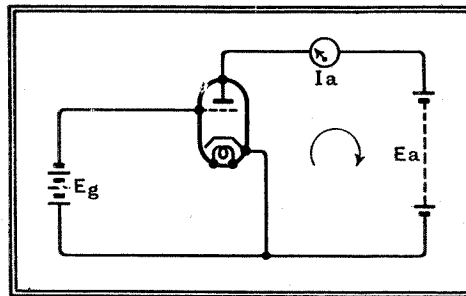

Fig. 7.—A triode valve is usually operated with a positive anode voltage E_a and a negative grid voltage E_g .

made up of the combined fields of grid and anode.

The grid, being the nearer to the cathode, exercises the greater influence, and a small voltage on the grid has as much effect as a large one on the anode. In practice a negative potential of 10 volts on the grid might just counterbalance 200 volts positive on the anode, so that the two electrodes together exercise little influence on the space charge.

If the grid is made a little less negative, the anode exercises some attractive force on the electrons of the space charge and they consequently move towards it. They do not fall on the grid because it is negative and repels them, but they pass through the gaps in its mesh. Once outside the grid they move much more readily to the anode, for not only is its full attraction exercised upon them but they are repelled by the negative grid behind them. Urged on by the pull of the anode and the push of the grid they fly rapidly to the former.

As the grid is made less negative the power of the anode on the space charge increases and more and more electrons pass through the grid to the anode. As long as

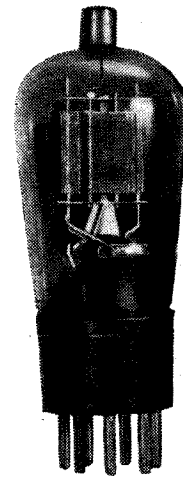

A large output triode is shown above and an indirectly-heated amplifier on the left.

the grid is negative with respect to the cathode (actually more negative than -1 volt with indirectly heated valves) electrons do not land on the grid wires and there is no grid current.

If the grid is allowed to become positive, however, the conditions change. Both grid and anode now attract electrons and they flow from the space charge in greater numbers. Some of them now land on the grid, for they are attracted to it, and flow back to cathode through the external grid circuit and so form a grid current.

As the grid becomes more positive both grid and anode currents increase, but the anode current increases less rapidly than the grid current. Electrons which have shot through the grid no longer have the same inducement to go on to the anode. This electrode still offers the same attraction to them, but it no longer has the help of a negative grid to push these electrons towards it. Instead, there is a positive grid trying to pull them back.

Because of this some of the electrons which pass through the grid are actually pulled back to it and go to increase the grid current instead of the anode current. At length, when the grid is sufficiently positive, the anode current ceases to rise and becomes nearly independent of the grid voltage.

Grid Volts—Anode Current

If we plot anode current against grid voltage we obtain a curve of the form shown in Fig. 8. The curve will be different for every value of anode voltage, and we can plot a whole family of such curves for a series of different anode voltages. The shape of the curve does not change much, however, and approximately the effect of increasing or reducing the anode voltage is to move the curve of Fig. 8 as a whole to the left or right respectively.

In most cases the grid is not allowed to become positive in use and the published valve curves do not as a rule extend beyond zero grid bias. Even when positive

How the Valve Works—

drive is adopted the grid is not usually allowed to go so positive that the upper bend in the curve is reached. Published curves, therefore, hardly ever show this upper bend, and this accounts for the unfamiliar aspect of Fig. 8. Incidentally, at high positive grid voltages secondary emission and grid emission play a part in determining the shape of the curve, but we shall consider these in more detail when dealing with more complex valves.

When the grid is negative there is no grid current and under ordinary circumstances the valve takes no current from the voltage source applied to the grid. The valve is consequently said to have an infinite input resistance. Actually, of course, the resistance is not infinite, for there are always a few odd electrons which manage to reach the grid and there are various leakages through defects in the insulating material. Nevertheless, the resistance is so high in comparison with the impedance of the circuits that in most cases it can be ignored.

Triode Constants

A triode has three "constants" which specify its behaviour in a circuit; these are amplification factor, anode AC resistance, and mutual conductance. The standard symbol for amplification factor is μ and it is defined as the ratio of the change of anode voltage to the change of grid voltage needed for constant anode current. That is, if a valve is set up with certain grid and anode voltages it will pass a certain anode current. If now the anode voltage is changed, the anode current changes also. It can, however, be brought back again to its previous value by altering the grid voltage, and the ratio of the voltage changes is the amplification factor. Thus, if we find that an increase of 20 volts in the anode potential makes it necessary to make the grid potential more negative by 1 volt to keep the anode current the same, then, $\mu = 20/1 = 20$.

The symbol for anode AC resistance is R_a , and it is defined as the ratio of a change of anode voltage to the resulting change of anode current, the grid voltage remaining constant and current being measured in amperes. Thus, if the anode voltage is altered by 20 volts and the resulting change is 2 mA., then R_a is $20/0.002 = 10,000$ ohms.

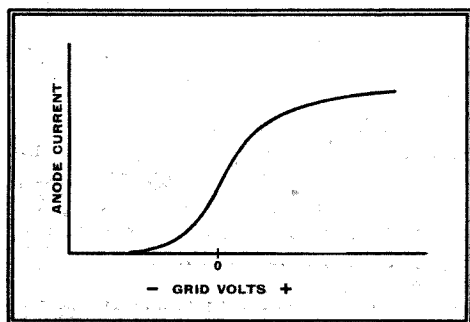
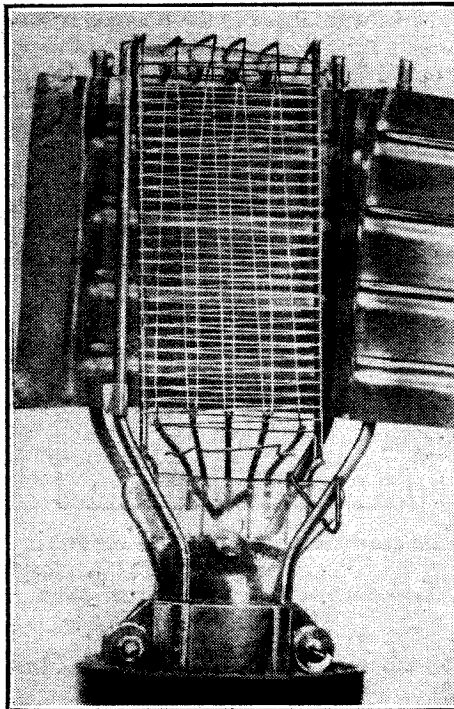

Fig. 8.—A typical triode characteristic carried well into the positive grid region is shown here.

Mutual conductance has the symbol g . In America it is often called transconductance or simply slope, and the symbol S is sometimes used. This is not a good symbol, however, because it is also the symbol for susceptance (the reciprocal of reactance) and is as widely used with this meaning as G is used for conductance. Mutual conductance is defined as the ratio of the change of anode current to the change of grid voltage needed to produce it, anode voltage remaining constant. Thus if a change of grid potential of 2 volts produces a change of anode current of 4 mA, then $g = 0.004/2 = 0.002$ A/V = 2 mA/V = 2,000 μ A/V.

In formulæ, g is always expressed in the fundamental unit amperes per volt (A/V), but in valve tables milliamperes per volt is the more usual unit. It is only occasionally in this country that microamperes



One side of the anode of an output triode cut away to expose the grid and filament assembly. The valve is directly heated and the filament can clearly be seen.

per volt is used. Sometimes *mho* is used for A/V, and micromho for μ A/V.

It should be clearly understood that these so-called constants are not actually constant, and the figures obtained depend on the operating conditions of a valve. The precise definitions of the terms thus include the statements that the changes of voltage and current must be infinitesimally small. In practice, measurements are made with grid voltage changes of the order of 0.1 volt or less, and anode voltage or current changes of equivalent magnitude. For triodes, too, it is standard practice to take measurements with 100 volts applied to the anode and with zero grid bias. Under normal operating conditions somewhat different figures are usually obtained.

Now, in most applications of a triode the change of anode current which results from changing the grid potential is of no

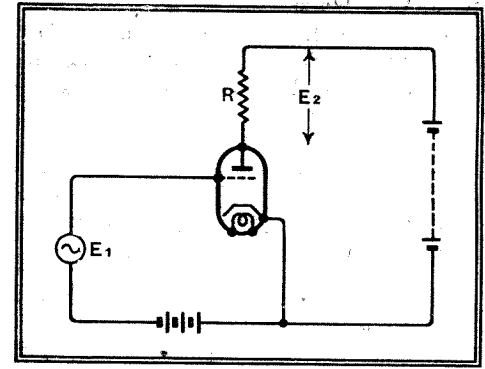

Fig. 9.—When the valve is used as an amplifier an impedance is connected in the anode circuit. In this diagram it takes the form of a resistance R .

direct use. We want the valve either to produce a larger voltage change than that on the grid (voltage amplification) or to develop power in a load. To obtain this result it is necessary to connect an impedance in the anode circuit. Actually, there is no basic difference in the circuit whether a voltage or a power output is required. There is always power developed. When power is wanted, conditions are chosen so that it is a maximum, but when voltage is wanted circuit values are picked accordingly, and the power may be quite small.

The simplest form of coupling is shown in Fig. 9, and it will be seen that a resistance R is included in the anode circuit. The steady anode current flows through this resistance and the anode voltage of the valve—that is, the voltage between anode and cathode is less than that of the HT supply by the drop in the resistance. Thus, if the HT supply is 200 volts and the valve passes 2 mA anode current, the anode potential is 100 volts when R is 50,000 ohms.

Now, suppose the grid potential swings more negative, the anode current falls just as it would do if R were not there, but it does not fall as much. The drop in anode current means that the voltage drop across R is less, with the result that the anode voltage is greater. The anode consequently attracts more electrons for the given grid potential than it would do if its potential remained fixed.

Amplification

When there is a load resistance and there is a change of grid potential, there is always a change of anode current and voltage. The ratio of the change of anode voltage to the change of grid voltage is the amplification, and the product of the changes of voltage and current is the power in the load. The higher the value of the load resistance R the greater is the voltage amplification, other things being equal, but there is always an optimum value for power. This optimum value occurs when the load resistance equals the internal resistance of the valve.

In practice this condition is not often used, because we are not as much interested in obtaining maximum power output as maximum undistorted power. This is usually obtained when the load resistance

How the Valve Works—

is about twice the valve resistance. The precise relation depends upon the amount of curvature of the valve characteristics and upon the degree of distortion considered permissible.

We are more concerned here with what goes on inside the valve than in the precise mode of operation, including the whole of the external circuit. The latter has been dealt with many times in the past in connection with different types of circuit, and it is sufficient here to show that the change of anode current consequent upon a change of grid voltage causes a change of anode voltage.

Now, in the valve and its base and internal connections there are inevitably small capacities between the various electrodes. There is one between grid and cathode, another between anode and cathode, and a third between grid and anode. The first two are not often of great importance because they are quite small— $3-15\mu\mu\text{F}$ —and only come in shunt with the input and output circuits. Under normal conditions only the grid-to-anode capacity is really of the first importance, and it is important because it allows a portion of the alternating anode voltage to be fed back to the grid, where it reinforces or reduces the grid voltage according to the phase.

In AF amplifiers the main effect is to make the valve behave as if it had a much higher input capacity than the true valve. Instead of being C_{gc} , the effective input capacity becomes $C_{gc} + C_{ga} (1 + A)$, where C_{gc} and C_{ga} are respectively the grid-cathode and grid-anode capacities and A is the amplification of the valve. The effective input capacity may become 100-200 $\mu\mu\text{F}$ or more, and exercises a shunting effect on the grid circuit of the valve.

At radio-frequency, tuned intervalve couplings are adopted, and the grid-anode capacity then results in feed-back, which normally causes instability. With both grid and anode circuits tuned there is some frequency at which the voltage fed back from anode to grid is greater in amplitude and of the same phase as the original grid voltage. It is easy to see that if the voltage fed back is equal to or greater than the original grid voltage, and is in the same phase, then the original grid voltage can be removed, and the valve will still have an adequate grid voltage, derived from the anode voltage, to maintain the anode current. It will be, of course, understood that these voltages and currents are alternating, and are not the steady grid and anode supplies.

In some cases such conditions are required, and the grid and anode circuits are deliberately coupled together, usually by means of coils. The stage is then an oscillator, and finds wide application in transmission, the superheterodyne receiver, and test apparatus. As an amplifier, however, the feed-back through the grid-anode capacity is unwanted, and in the early days many circuits were devised for avoiding its bad effects. As an RF amplifier the valve was usually employed in a neutralised circuit, the idea being to counteract the feed-

back by a voltage of equal and opposite phase fed back from another point on the circuit.

Many of these neutralised circuits were extremely successful, but have fallen out of use in receivers to-day because valves are now available with which the grid-anode capacity is exceedingly small. Needless to say, they are not triodes, and will be discussed later. Neutralising is still widely used in transmitters, however.

Interpreting Amateur Morse

THE new recruit to amateur radio often experiences difficulty in making sense out of morse messages picked up on the amateur wavelengths because so many abbreviations are employed. In addition to the recognised "Q" code it will be found that a form of phonetic spelling is adopted, while often vowels are omitted to save time.

Bearing this in mind the beginner can always rewrite the transcribed messages and fill in the omissions, but after a time one will become accustomed to this method of sending and be able to decipher messages quite easily.

When receiving only write down what is heard in the headphones and do not try to make good the deficiencies at the time, for this will almost certainly lead to confusion and the missing of large parts of the transmission.

H. B. D.

An Old-timer's Station

G8IG, Bromley, Kent, is a station with several unusual features; its layout and facilities should make for smart operating.

On the left of the accompanying photograph is seen the 50-watt transmitter which operates on 14 and 28 Mc/s; it comprises a "tritet" crystal-controlled oscillator, buffer stage and a T55 valve in the final stage.

Apparatus on the bench includes a field-strength meter, monitor and receiver, the last mentioned being a McMichael 362, modified by addition of a BF oscillator and

crystal gate, which works with a two-stage preselector unit mounted above the receiver.

The aerial system is particularly ambitious, comprising a two-section "8JK" beam, a three half-wave in-phase aerial, and, for 10-metre work, a half-wave vertical with director and reflector; a relay-operated system of aerial selection is included. The great-circle map above the bench shows at a glance the radiation directions of each aerial.

G8IG, which has worked all continents on CW and phone, is operated by Mr. C. G. Allen, who, in spite of his "8" call-sign, is actually an old-timer, having began his wireless career as a marine operator in 1917, first joining the amateur transmitting ranks in 1923. Mr. Allen is well known in wireless circles as sales manager of McMichael Radio, Ltd.

Photograms of the Year, 1939. Edited by F. J. Mortimer, Hon. F.R.P.S., Editor of *The Amateur Photographer and Cinematographer*. Published by Iliffe and Sons Ltd., Dorset House, Stamford Street, London, S.E.1. Price 5s. (paper covers), 7s. 6d. (cloth bound), postage 6d.

FOR the forty-fourth year in succession this well-known publication has made its appearance. In it are contained the best examples of modern pictorial photography, garnered from all quarters of the globe during the past twelve months. Included in its pages are also several important articles by photographic experts of world-wide reputation. Another valuable feature is a directory of over four hundred British photographic societies.

THE WIRELESS INDUSTRY

COPIES of the new Raymart catalogue, describing short-wave and transmitting components, are obtainable by sending a 1½d. stamp to Raymart, Ltd., 44, Holloway Head, Birmingham, 1.

Etablissements Elma, of 10, Rue Théophraste-Renaudot, Paris (XV), has sent us a leaflet (in English) giving full data on Elma H.F. transmission cable, the conductor of which is centred in a braided metal sheath by low-loss non-hygroscopic insulating thimbles.

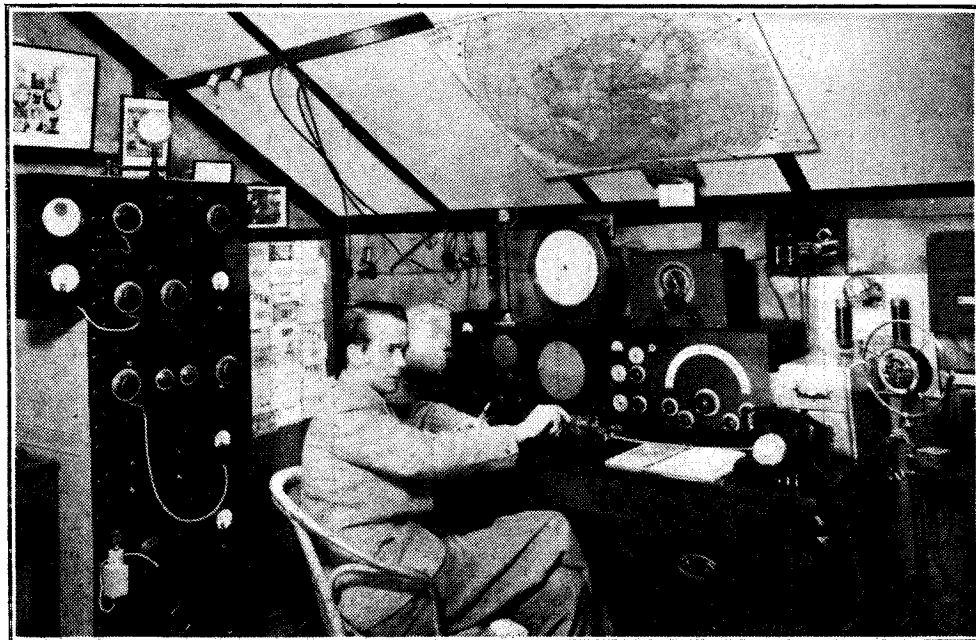

An elaborate system of directional aerals, with remotely controlled selector switching, is used at **G8IG**. Mr. C. G. Allen, the owner, is at the key.

Ferranti

A FOUR-VALVE SUPERHET

with a Well-designed
Automatic Tuning System

THE principle underlying the Ferranti "Prestune" system of automatic station selection is essentially simple. It is independent of the normal manual tuning circuits, and once the waverange switch has been turned to the position for press-button tuning one can select medium- or long-wave stations at will without further operation of the waverange switch.

Six alternative stations, chosen according to the locality in which the set is to be used, are selected by a row of push-buttons neatly arranged in a recess near the bottom of the cabinet. Station names are clearly indicated by translucent tablets above each button, and the complete separation between the manual and press-button circuits is emphasised by the extinguishing of the edgewise lighting of the main tuning dial and the lighting up of the push-button pilot lamps when the set is switched over.

All six pre-tuned circuits are based on

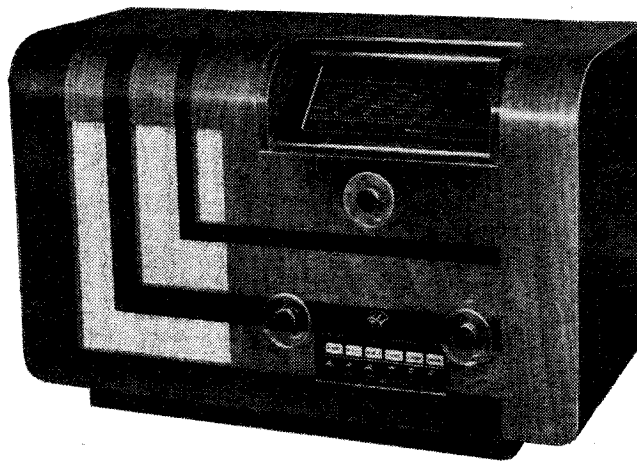

Model 515PB

FEATURES. Wave-ranges.—(1) 16.5-51 metres. (2) 200-560 metres. (3) 1,000-2,000 metres. **Circuit.**—Heptode frequency-changer—var. mu pentode IF amplifier—double-diode-triode 2nd det., AVC and 1st AF ampl.—pentode output valve. Full-wave valve rectifier. **Controls.**—(1) Tuning. (2)

Volume and on-off switch. (3) Waverange, push-button and gramo switch. (4) Station selector (six buttons). (5) Tone. **Price.**—15½ guineas. **Makers.**—Ferranti Ltd., Moston, Manchester, 10.

a single inductance of the same order as that used in the medium-wave range. Tuning is by capacity substitution, and the trimmers consist of small variables in parallel with fixed mica condensers. It will be obvious that a very small L/C ratio must be accepted for the long-wave stations, but the sensitivity of the receiver is well able to compensate for the consequent reduction of volts developed across the aerial-tuned circuit.

Considerable thought and care have been devoted to the elimination of frequency drift. The composite tuning capacities include fixed condensers with electrodes deposited directly on the mica and ceramic trimmers with silvered bases. In addition a temperature compensating condenser with a negative coefficient is included in parallel with the

oscillator circuits to neutralise any increase of temperature of the main tuning capacities in each case.

Another very good feature is to be found in the intermediate frequency stage. When the set is switched over to automatic tuning the bandwidth of the input IF transformer is expanded by an auxiliary circuit in series with the secondary. With reasonable care in the selection of alternative stations from the point of view of power and wavelength separation, it is obvious that a much lower selectivity can be tolerated than would be possible for general long-

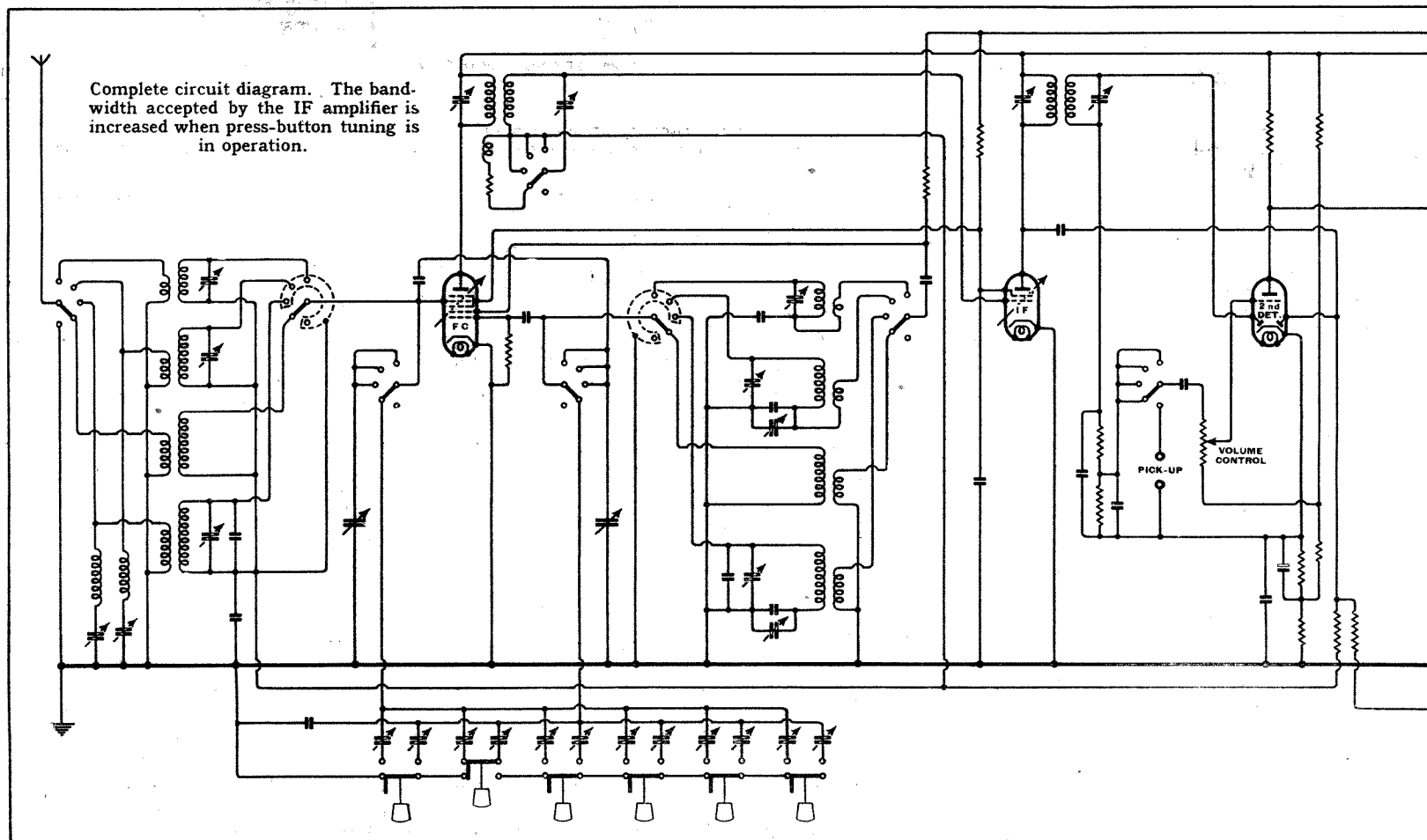

distance listening with the manual tuning control in operation. Consequently a much wider frequency response can be allowed, and has been provided for the push-button stations. Further, the increased bandwidth in the IF amplifier would be more tolerant towards any residual frequency drift in the oscillator, though it is not necessarily introduced with this object in view.

American-type valves of Ferranti manufacture with octal bases are employed throughout the circuit. The frequency-changer is a heptode. Together with the pentode variable- μ IF amplifier it is controlled by AVC bias derived from the third tuned IF circuit and rectified by one diode of the double-diode-triode second detector stage. Delay is provided by the volt drop in a small resistance in the negative HT return lead. Connections for a gramophone pick-up precede the triode portion of this valve, which is in turn resistance-coupled to a pentode output stage. A fixed degree of tone compensation is provided across the primary of the output transformer and an additional variable control bridges the anode circuit of the triode.

The main HT supply from the full-wave rectifier is smoothed by the loud

speaker field in conjunction with two 12 mfd. electrolytics, while the oscillator and screen feeds have a separate RC smoothing circuit with a total of 8 mfd.

A mains transformer of exceptionally generous specification is included and it is sent out from the works adjusted for 220-230 volt mains. Two other tapings on the primary are provided for 200-210 volt and 240-270 volt mains. The tapings terminate with soldering tags and presumably the dealer will make the necessary adjustment before the set is delivered.

A "hum-bucking" coil is included in series with the speech coil of the small

the 515PB is well above the average of its class on all three wavebands, and the amplification is well maintained at the ends of each range. Excellent reception of American broadcasting was obtained on the 16-metre band with very little second channel interference. No trace of any self-generated whistles was to be found on the medium- and long-wave ranges. The signal-to-noise ratio on short waves is particularly good.

Selectivity on medium waves is equivalent to the loss of slightly less than one channel on either side of London Regional at a distance of 15 miles, and on long

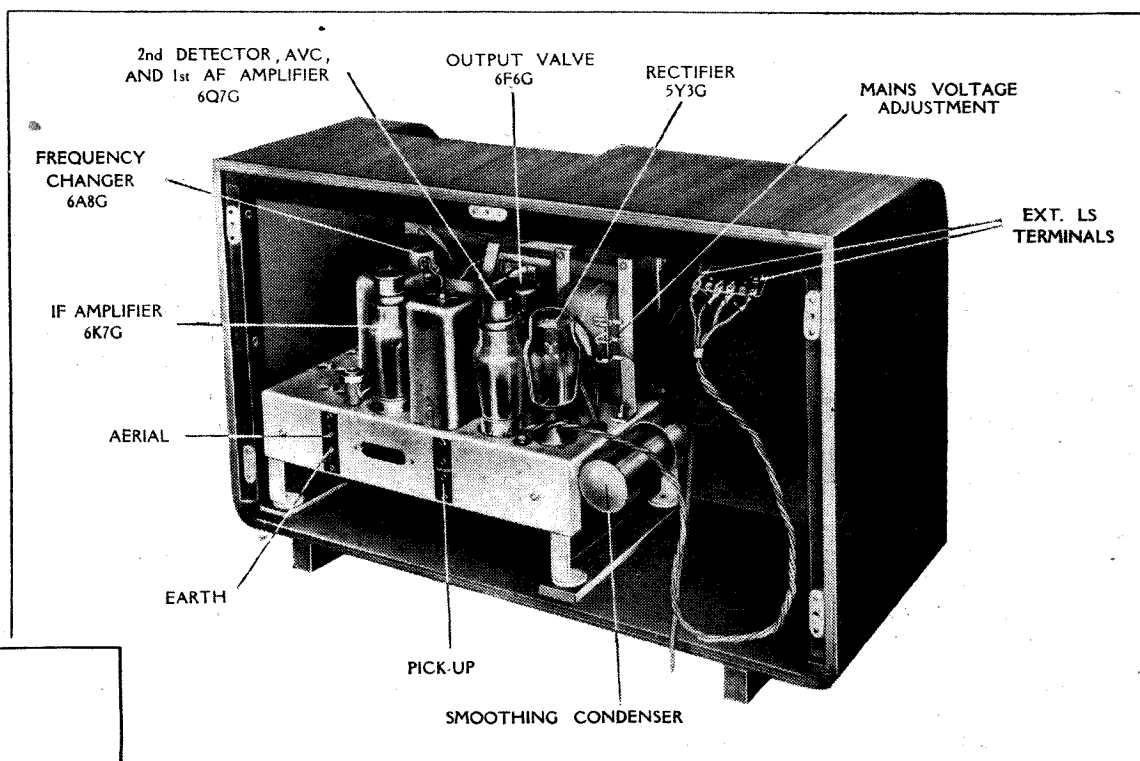

In the receiver tested American-type valves made by Ferranti were used. The frequency-changer, IF amplifier and second detector are completely enclosed in detachable metal shields.

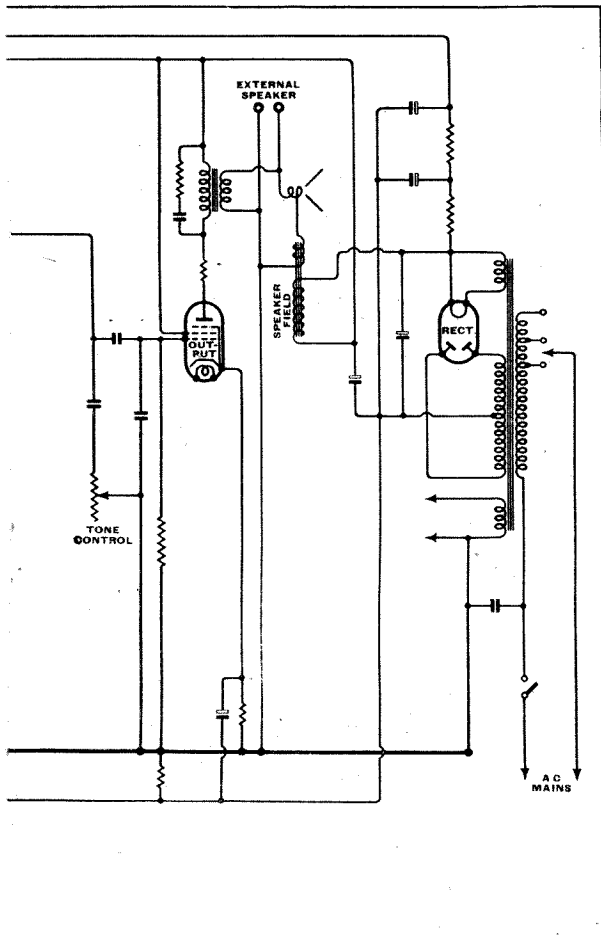

moving-coil loud speaker. Sockets are provided on the terminal panel of the loud speaker itself for the connection of a low-impedance external speaker.

The output of the final stage is rated at 4 watts, but it can be easily overloaded, and the limits of its power-handling capacity are soon made obvious if the volume control is advanced too far. There is no point in working at too high a volume level, however, as this only serves to emphasise a cabinet resonance at about 180 c/s and a diaphragm resonance at 3,500 c/s. The latter can be kept in check by the tone control, but it is better to accept a moderate volume level and take full advantage of the wide frequency response available with the press-button circuits in operation.

As was expected, there is an appreciable difference in signal strength between the long-wave stations when tuned-in on the main dial and on the press-buttons, but the reserve of overall amplification provided is ample, and it is only necessary to remember to turn down the volume control when returning to manual tuning.

From the point of view of sensitivity

waves there is more space than usual between the sideband interference from Droitwich and Radio-Paris, permitting clear reception of the Deutschlandsender.

The receiver is attractively turned out in a veneer walnut cabinet with transparent disc-type control knobs. The three-colour rectangular tuning scale is well illuminated and comfortable to read. Microphony on short waves has been eliminated by mounting the whole chassis on rubber feet, which results in a freedom of movement of the tuning dial and knob which is at first disconcerting, but to which one soon becomes accustomed. The two-speed drive, with slow-motion instantly available over a limited range of reversing the direction of rotation, solves the problem of moving rapidly from one extreme of the range to the other; it works smoothly and without backlash.

With the reservation that the volume and tone controls should be nursed intelligently in the interests of good quality, we can unhesitatingly recommend this receiver with very generous bonus marks for the simplicity and efficiency of the automatic tuning system.

UNBIASED

By
FREE GRID

Car Radio Revolutionised

QUITE a flutter among the technical doves—or perhaps I should say tigers' lairs—seems to have been caused by a recent very informative article on the subject of car aerials. The thing that has caused all the rumpus is the perfectly true statement that one of the best places for an aerial is to sling it under the chassis, a position which is highly convenient and leaves nothing to be desired from the signal pick-up point of view.

Nobody seems to deny the truth of this statement, but quite a lot of grey matter is being used up in arguing the question as to whether, in such a case, the car chassis is not the real aerial and the thing slung underneath it the earth. Personally, I can't see that it matters very much, but the article has had the effect of renewing my experimental interest in car radio, and I have been very busy carrying out a series of tests with a view to improving the efficiency and, therefore, the popularity of this branch of reception.

The first thing which strikes anybody who uses their head for other purposes than that of supporting a hat is that there is no proper earth connection in the case of car radio. Actually, this great thought struck me early one morning when I was driving Mrs. Free Grid and her mother back home from a night club whither they had been in connection with some wild-cat scheme of theirs to start milk bars in these places. No sooner had the idea flashed through my mind than I had stopped the

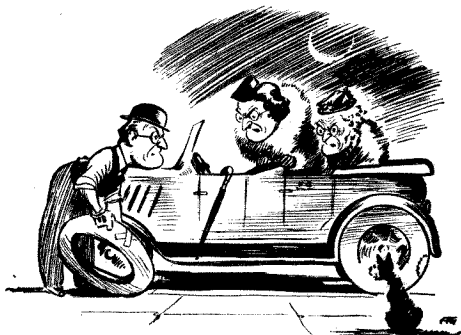

Running commentary.

car and found myself spending a perspiring half-hour removing the tyres to the accompaniment of a running commentary by my passengers on the dangers of alcoholic indulgence.

In the end I got the tyres off and was soon under way again, and, as I had anticipated, the earthing effect on the chassis of running on the rims increased signal strength a hundredfold. Unfortunately, our progress was arrested after a while by the police, and I had considerable difficulty in convincing them of my bona-fides. In the end they bade me a reluctant and suspicious farewell, but I could see quite well that the arrangement was one which could never become a permanency if I wished to avoid being stopped every few yards.

I thought at first of fitting a set of the newly developed anti-static tyres, which, as you know, are partially conductive, but an amazing idea struck me while I was in my bath one morning in that sudden and illuminating manner in which all great inventions come to the minds of their progenitors. Without further ado I at once rushed, all dripping wet, to my writing-desk and proceeded to work out a scheme whereby the design not only of car radio but of the car engine will be revolutionised. Briefly, the idea is to carry a tank of hydrogen instead of petrol and to inject into the cylinders a mixture of two parts of hydrogen and one of oxygen. Obviously, such an explosive mixture would be sufficient to propel the car along, but the crux of the whole idea is that the exhaust "gases" would, of course, consist of water which, if the exhaust pipe were directed towards the ground, would provide a sound and continuous link with earth for the wireless set. At present, however, the idea is not beyond the drawing-office stage.

A Misleading Misnomer

IN spite of the spread of popular education since the passing of the compulsory schooling Bill, or whatever it was called, in 1870, it is astonishing how abysmal is the ignorance of the average man about matters concerning which he might be expected to have some faint glimmering of knowledge. I have had a very striking instance of this lately, and I am beginning to wonder whether it is ignorance or lack of intelligence that is at the root of the trouble. If the latter, of course, there is, I fear, little that can be done about it.

The circumstances were perfectly ordinary. An acquaintance of mine asked me to recommend a small mains-driven portable which he could take with him when he visited the houses of his friends so that he might never be without the solace of wireless. He desired his own personal portable, he said, because he so often found that the programmes which were being churned out by his friends' sets were not to his taste, and he proposed, when

dining with them, to do what I do on such occasions and to place his set on the table and plug in to the nearest lamp socket rather than risk causing offence by asking for their set to be tuned to the station he wanted.



Never be without the solace of radio.

My choice fell on a very praiseworthy little universal mains portable which, to the everlasting shame of our manufacturers, is the only one of its kind made. I duly presented it to my friend with every confidence after waiting to see, of course, that his cheque had successfully passed the scrutiny of my bank manager.

I heard no more for a week, when the set was returned to me through the post together with a peremptory demand for his money back on the grounds that it would not "work from any electric light socket," as claimed by its makers. As it was a universal set I was considerably puzzled, and racked my brains to try and think if there could be any type of electric mains other than AC or DC which had escaped my memory. I even went so far as to ring up the Central Electricity Board and ask if they knew of any supplies other than AC or DC, but I am sorry to say I received no information at all but merely an abrupt demand for my name and address.

In the end I did what I suppose I ought to have done at first, namely, wrote to my friend and asked for details of the electric supply in the district where it had refused to function. Needless to say, I was very indignant when he told me that it had worked successfully indoors but that it was completely mute when plugged into one of the lamp sockets of his car, for which, he added indignantly, he had gone to the trouble of getting a special plug.

It was, I fear, of very little use my pointing out to him that 12 volts was totally inadequate for the set. He merely retaliated by saying that volts were no concern of his, and that the set's makers had no right to state that it would work from any electric light socket. In one sense I suppose my friend was correct, and yet, on the other hand, my sense of justice and right compels me to side with the manufacturer in this case, much as it goes against the grain for me to do so.

MORE CONSISTENT LONG-DISTANCE RECEPTION

IT is just as well for us sometimes to remember that we are not the only pebbles on the beach, and that in fact there are some quite substantial boulders. When we proudly install a super ten-valve receiver, or when we apply to the Post Office for a transmitting licence in order to carry out "important research on short waves," let us realise that they know something about this subject themselves, and, for example, are putting into service a 1,079-valve short-wave receiver that would probably take more than the regulation couple of pages if it were reviewed in *The Wireless World* in the usual manner. The circuit diagram might be difficult, too. I am not going to explain what each one of the thousand and seventy-nine valves does. To start with, I don't know. But the outstanding feature, bearing the cryptic name seen on this page, is of some general interest, even if for various reasons (among which is the need for about two miles of land) it would not be much use to most of you if I gave constructional details.

MUSA is one of a growing number of words formed, not by digging up Greek or Latin, but by using the initial letters of the full title. "Multiple Unit Steerable

unfavourable conditions by brute force, but besides being an uneconomical policy it would increase interference problems, and, anyway, would not overcome the perhaps most serious difficulty of distortion.

It is well known that the fading and distortion are mainly due to the varying routes by which radio waves travel from transmitter to receiver. In Fig. 1 (in which the height is greatly exaggerated) two such routes are shown, and it can be seen that the waves arrive at different angles, depending on the number of times they have been reflected by the ocean and the upper atmosphere. It may happen occasionally that the different waves—which, of course, have travelled different distances—cancel out and cause the net received signal practically to disappear. If part of the signal—say, the carrier wave—fades out, and the rest does not fade so much, there is severe distortion.

A hopeful way of tackling the problem

MUSA

By "CATHODE RAY"

of one ray, by which is not meant that A is skipped; by drawing a line, CA, at right angles to FB to represent the wavefront the state of the wave when it reaches A can be seen. It happens to be maximum positive at the instant being considered. After it travels a further distance of an exact number of wavelengths it reaches B, which therefore always receives maximum positive at the same instant as A. So if means are provided for combining the outputs of aerials A and B they add up together to produce a signal of double strength. Of course, in order to combine the outputs it is necessary to bring them to the same place by means of lines of some sort, and unless these are of equal length or differ by an exact number of wavelengths they do not add up properly; but it is quite easy to arrange that they do.

are provided for

combining the outputs of aerials A and B they add up together to produce a signal of double strength. Of course, in order to combine the outputs it is necessary to bring them to the same place by means of lines of some sort, and unless these are of equal length or differ by an exact number of wavelengths they do not add up properly; but it is quite easy to arrange that they do.

Signals Cancel Out

Now suppose a signal of the same wavelength comes down more steeply, as indicated by GB. The line at right angles, DA, shows that when the signal is a positive maximum at B it is a negative maximum at A, and vice versa. At all times the outputs from the two aerials cancel out and nothing is received.

Next, suppose that the line from A is shortened or lengthened by half a wavelength—in practice this would not be done literally, but the equivalent can be produced by means of an electrical circuit in the receiver. The results from the two rays would be reversed, for the half wavelength difference converts a positive maximum into a negative. At intermediate settings of the adjustment the direction of most effective reception would be between FB and GB.

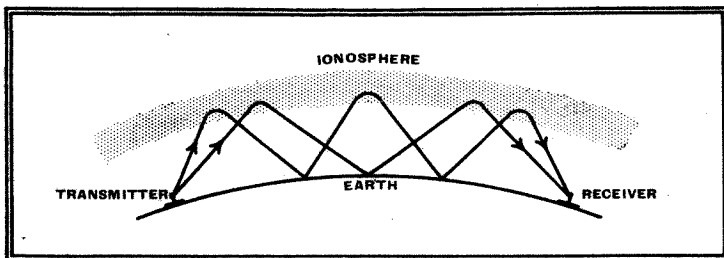

Fig. 1.—Depending on the number of "hops" it takes en route, a short-wave signal is liable to arrive at more than one distinct angle. These separate arrivals are liable to interfere with one another and cause fading and distortion.

Aerial" (or "Antenna," if you prefer it) is its name in full. Briefly, it is a sharply directional aerial that can be rapidly adjusted to any desired angle of elevation.

To understand what the sense of this is it is necessary to think for a moment about the difficulties of maintaining reliable communication over, say, the Atlantic. It is one thing to do it nine times out of ten, and quite a different thing to do it ten times out of ten. If it were merely a matter of increasing the sensitiveness of the receiver so that, however bad the fading, it would amplify the signal up to the necessary amount, it would be easy. But one snag is that fading is often accompanied by such bad distortion as to make the speech unintelligible however loud it might be, and another is that the amount of amplification that can be used is strictly limited because anything more merely increases amplifier noise, and that noise depends on the fundamental nature of matter and cannot be eliminated. Of course, the transmitter could be made enormously powerful, so as to get through

spherics from all except the direction of reception. An obvious difficulty is that as the strengths and angles of the rays are changeable it is like a game of blind-man's-buff trying to keep the aerial pointing in the best direction. A slight movement, and reception is missed altogether. Another difficulty is that such a sharply directive aerial is necessarily made up of a number of spaced unit aerials, and it is impracticable to swing the whole affair around as conditions change. The basic principle of directional aerials is illustrated in Fig. 2.

A and B are the locations of two aerials lying in the same direct line from the transmitter. Suppose FB is the direction

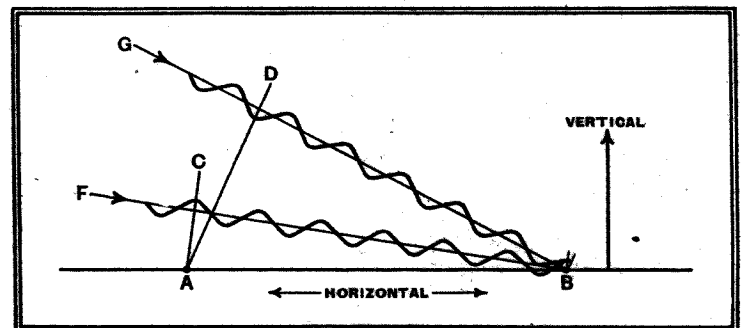

Fig. 2.—Illustrating the principle of directional aerial systems. The added effects of a wave signal at two or more aerial units depends on the angle of arrival.

To get a sharper directional response, as well as a stronger one, a larger number of aerial units is used; and the Post Office

MUSA—

has just set up a system of 16 units, stretching over two miles. And to avoid maximum responses from other directions outside the desired range of angles the individual units are of rhombic type, which is itself considerably directional.

The ability to steer the aerial system through a range of vertical angles that includes all the wanted signals, using a compact control at the receiving station, not only solves the problem of adjusting the angle without moving the aerial system itself, but also the other difficulty of finding the right angle to meet the wave ray. It is done by sweeping repeatedly over the whole range of adjustment and observing the strength of reception on a cathode-ray tube. In the original system, devised in America, the sweeping was done by means of a small motor continuously turning the condensers that adjusted the equivalent feeder line lengths—or wave phases—but

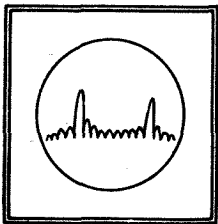

Fig. 3.—Typical cathode-ray figure showing strong reception at two separate angles when the aerial system is continuously swept through its whole range of angles.

in the latest equipment it is done electrically. The cathode-ray tube usually shows a diagram on its screen something like Fig. 3. This indicates two angles at which strong signals are arriving. Besides the connections from the 16 aerials to this exploring system, there are also parallel connections taken to two other phase adjusters which are not continuously varied, but are adjusted to coincide with the two major responses observed on the cathode-ray tube. The angles of these responses do not usually change very

rapidly, so it is not a very hectic business keeping the adjustments.

These two choice selected signals are applied to receivers, and the resulting speech outputs are combined so as to make the best of both. This is the well-known "diversity" principle, but applied in a new and more effective way.

Combining Speech Outputs

The above description gives little hint of the elaborateness of the equipment needed to carry out the idea effectively in practice. To mention one thing, the two speech outputs could not be combined simply by leading them into a common transformer or other simple device. They would, as likely as not, cancel out and produce as bad confusion as originally. A cathode-ray tube is needed to show the phase difference between them, and an adjustable delay circuit for eliminating any such difference. Then for various reasons the carrier wave of the transmission is practically suppressed, and has to be reintroduced. One sideband is also suppressed. And to use this expensive communication channel economically, more than one conversation is transmitted at once. And there are automatic frequency control circuits and other elaborations. So, bearing in mind the 16 aerials with all their associated preliminary valve-operated equipment, it is not so difficult to imagine how 1,079 valves can usefully be employed.

You may be wondering if the vast expense of equipping and maintaining such a receiver and aerial system is justified. It has been suggested that there is a "law" whereby the most economical way of distributing the total cost in order to obtain a given reliability of communication is to spend as much on the receiver as on the transmitter. Suppose the trans-

mitter costs £10,000 and the receiver £100—the sort of proportion one used to think reasonable. Then to double the ratio of received signal to unavoidable noise the power of the transmitter might be doubled, at, say, double the transmitter cost, raising the total cost from £10,100 to £20,100. Or the same thing might be accomplished by doubling the receiver cost, making the total £10,200—obviously a more economical policy. But if they cost £5,000 each, one would expect the halving of transmitter power to be much more than made up by the fifty-fold increase in receiver performance. Of course, performance does not depend on cost in the simple way assumed above, but even if the "law" is only very roughly true in practice it does show that it is reasonable to spend much more on the receiver in a point-to-point system than was done in the past. In broadcasting systems, on the other hand, the total cost of receivers has almost from the start been greater than the transmitter cost.

Club News

Bradford Experimental Radio Society

Headquarters: 66, Little Horton Lane, Bradford.
Hon. Sec.: Mr. S. Hartley, 7, Blakehill Avenue, Fagley, Bradford.

On December 6th a lecture entitled "High Quality Reproduction" was given by Mr. Briggs, of the Wharfedale Wireless Works. The Secretary desires to announce that the annual subscription to this society is 2s. 6d.

Radio, Physical and Television Society

Headquarters: 72a, North End Road, London, W.14.
Meetings: Fridays at 8.15 p.m.
Hon. Sec.: Mr. C. W. Edmans, 72a, North End Road, London, W.14.

Instead of the customary weekly meeting on November 25th, a party of members visited the main telegraph offices of Cable and Wireless, Ltd.

South London and District Radio Transmitters' Society

Headquarters: West Norwood Brotherhood Hall (opposite W. Norwood Bus Garage).

Meetings: First Wednesday in every month.
Hon. Sec.: Mr. H. D. Cullen, 164, West Hill, London, S.W.15.

At the November meeting an interesting talk was given entitled "Radio Conditions in South Africa," by a lecturer who at one time held a transmitting licence in that country. On December 7th, Mr. Stuart Davis, of the Davis Theatre, Croydon, gave a lecture and demonstration on "High Quality Reproduction."

Goldsmiths' Radio Society

Headquarters: The Goldsmiths' College, London, S.E.14.

Hon. Sec.: Mr. A. L. Beedle, 67, Hillcross Avenue, Morden.

Members have been very busy putting the finishing touches to the Club's transmitter and receiver. The transmitter consists of a 6AG crystal oscillator and frequency-doubler, a 59 buffer amplifier and two A3 valves in push-pull. The receiver, which is of the tuned radio frequency type, consists of a 6K7, a 6J7 and a 6C5, the modulator serving also the purpose of LF output from the receiver. The transmissions will be on 14,356 kc/s and not on 14,116 kc/s as previously announced.

Croydon Radio Society

Headquarters: St. Peter's Hall, Ledbury Road, South Croydon.

Meetings: Tuesdays at 8 p.m.
Hon. Sec.: Mr. E. L. Cumbers, 14, Campden Road, South Croydon.

At the November 22nd meeting of the Society, "Amphion" of *The Croydon Advertiser* lectured on the history and technique of orchestral conducting.

International Short Wave Club

Hon. Sec.: Mr. A. E. Bear, 100, Adams Gardens Estate, London, S.E.16.

At the recent Woman's Fair at Olympia there was a great deal of interest in the club's stand on which were exhibited two short-wave receivers which have been described in *The Wireless World*. Daily demonstrations were given of short-wave reception and of high-fidelity reproduction on 7 metres. The famous Boston station, W1XAL, broadcast special programmes for the benefit of visitors to the Fair, directional aerials being used for the purpose. Demonstrations of television were also given using a Pye receiver and Belling-Lee aerials.

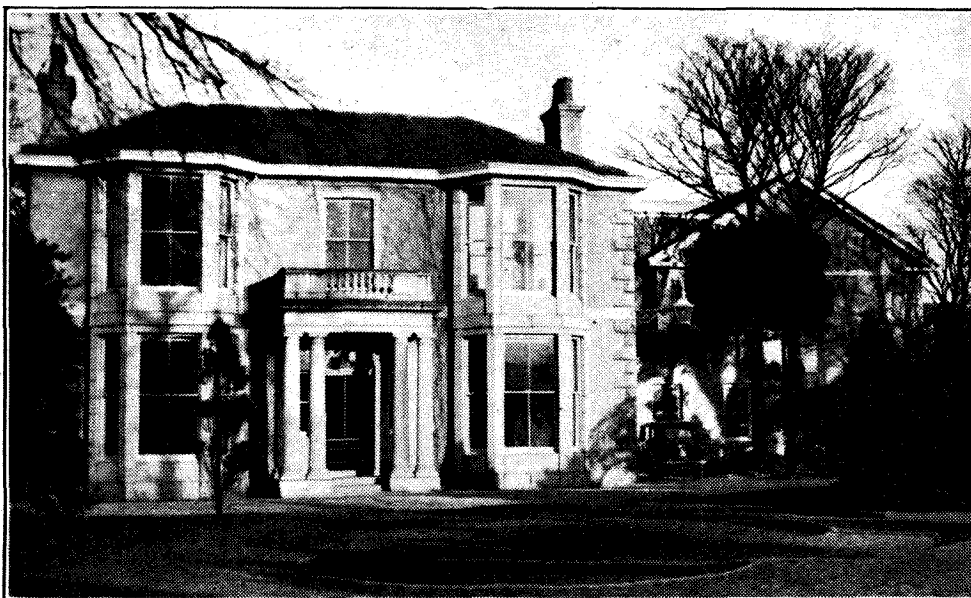

CONTRAST. When compared with the impression on the opposite page of what the B.B.C.'s headquarters in London will look like when completed, this picture of the Aberdeen Broadcasting House, to be officially opened to-morrow, December 9th, by the Marchioness of Aberdeen and Temair, carries with it an atmosphere of tranquillity. A passer-by would little guess that behind the unassuming face of the building are to be found four studios, a control room and offices. An extension, seen to the right of the original building, houses a large orchestral concert studio measuring 46 feet by 86 feet and 24 feet high.

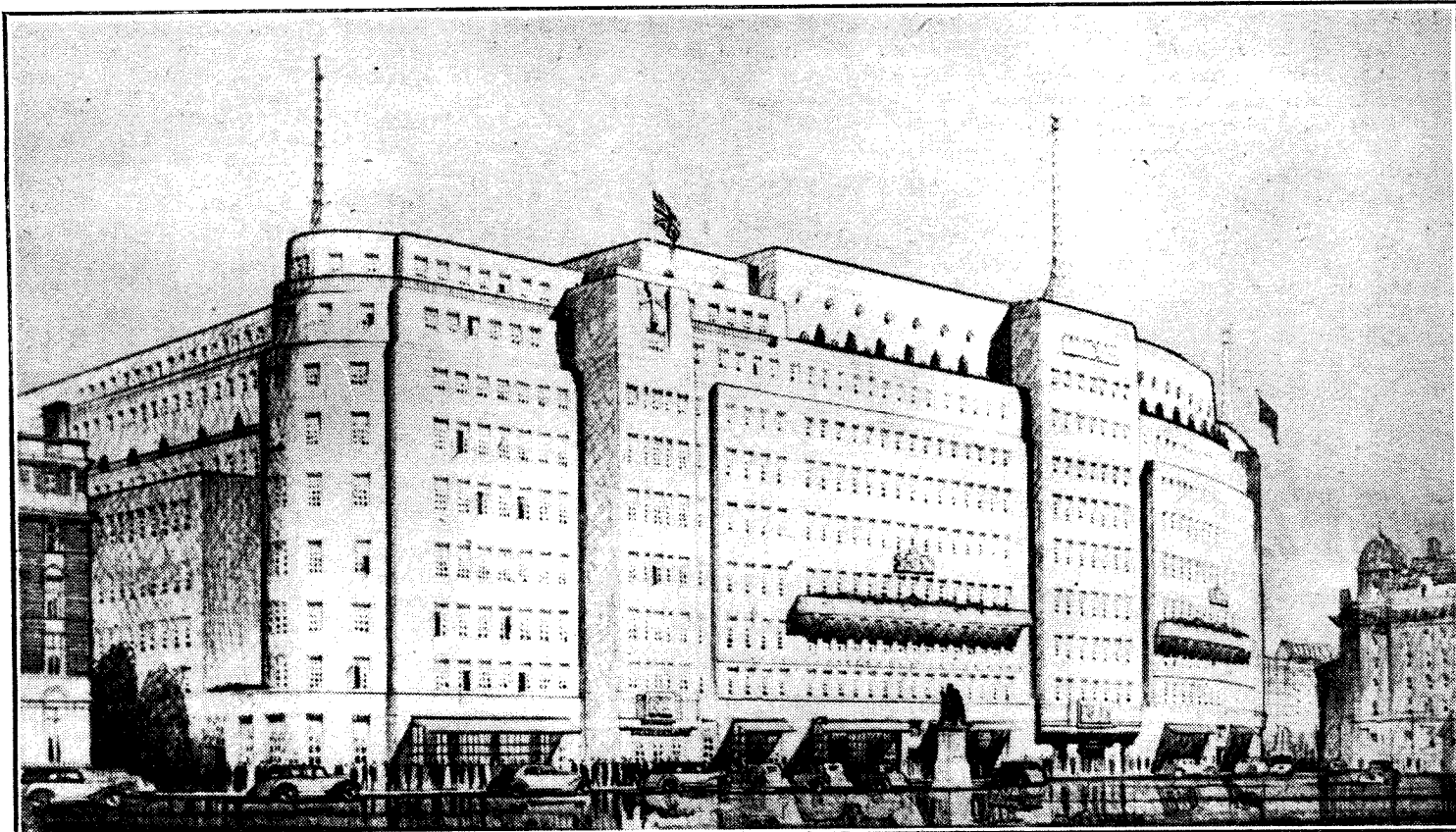

As the B.B.C. Headquarters should appear in 1940.

THE NEW BROADCASTING HOUSE

Mainly Devoted to Office Accommodation

EXCAVATORS employed by the B.B.C. are about to begin digging out one million or more cubic yards of earth in Portland Place, London, in preparation for the foundations and structure below ground level of the addition to Broadcasting House.

The excavations will go to a depth of 54 feet below ground level, and this preliminary work will continue until next June, when the construction of the new building will begin; and this work, in turn, should be completed by December, 1940.

Five "Studio Buildings"

The existing Broadcasting House covers an area of 17,390 square feet; the new building at ground level will cover an area of 20,950 square feet.

Rumours that the extension will contain eighteen or twenty additional studios with accommodation for television may be discounted. Only five studios are to be included, all built underground, but the method of construction will be different from the central tower arrangement which is adopted in the existing building. Each of the five studios in the extension will form a separate building within the main building and it will be cut off entirely from extraneous noises. Special precautions will be taken to exclude any vibration from the tube railway which runs in the vicinity.

In spite of the alleged danger

from enemy aircraft to the Control Room at the top of the building, the extension will have a separate Control Room on the seventh floor. The remainder of the building will be devoted almost entirely to offices.

The proposal to demolish the hotel at the rear of Broadcasting House and to erect a radio-theatre, to which audiences would be invited after the fashion of Radio City, New York, will not be proceeded with in the meantime, as the hotel premises are congested with B.B.C. staff who have been dispossessed from the houses in Portland Place to make way for the big extension.

INCREASING DIRECT RANGE

German Anti-Near-Fading Aerial

A NEW type of anti-near-fading aerial is being used by the new 5-kW transmitter at Stolp, which started regular transmissions last week on 225.6 metres—the North German common wavelength. The new aerial, which is known as a "Flächen-Antenne" and gives a considerably increased direct range, makes use of seven 150-foot masts. As the aerial is not quite complete the station will be closed from 8 a.m. till 5 p.m. local time each day until the work is completed.

COLONIAL WIRELESS LINK

A New Link in the Strengthening of the Imperial Chain

AN offer to the Government to establish a system of wireless telegraphic and telephonic communication throughout the Colonial Empire, without cost to the Administrations or the people concerned, was announced last week by Mr. Edward Wilshaw, chairman and managing director of Cable and Wireless Limited.

The scheme provides for the equipment of wireless receiving and transmitting facilities at each of the cable stations where no commercial wireless service is already in operation.

The use of such stations would bring additional revenue to the company, and in a strategic capacity they would provide a second line of defence in the event of any interruption of communications in war time. The system provides reasonable justification for the issue of non-restrictive licences, and it is reported that the Colonial Office has communicated with the various Colonial Governments recommending that such licences should be granted.

It is proposed to erect thirty-two stations at the beginning, and it is likely that the scheme will be launched in the West Indies.

START POINT

Novel Aerial System

START POINT, the B.B.C. transmitter for the West, will have the most modern form of aerial system in Britain, if not in Europe.

Two 470ft. masts will be used, but it is expected that they will give results normally obtainable only with masts of considerably greater height. Instead of using the capacity top employed with certain other B.B.C. aerials, the masts will be cut two-thirds of the distance from ground level for the insertion of an inductance coil across the gap. The extension of the service area along the South Coast is the objective.

One mast is already finished, and the other is nearing completion. The station will begin work next summer.

LIFEBOAT WIRELESS

Merchant Shipping Rules

REGULATIONS regarding life-saving appliances in Merchant Shipping, which come into force on January 1st, 1939, have just been issued by the Board of Trade. These rules, which are designated the Merchant Shipping (Life-saving Appliances) Rules, 1938, include regulations regarding the wireless equipment of lifeboats.

It is laid down that where the

News of the Week—

number of lifeboats carried by a passenger ship on international voyages is more than thirteen, one of these has to be a motor boat fitted with an approved wireless telegraphy installation, and where the number is more than nineteen two motor boats have to be so fitted.

Rule 34 details the type of wireless installation. It must be capable of transmission and reception on 500 kc/s (600 metres), and has to be provided with a source of power sufficient to give a minimum of 10 metre-amperes (the number of metre-amperes being determined by multiplying the current in amperes measured at the base of the aerial by the maximum height in metres of the aerial above the water-line). The power supply has to be capable of maintaining the installation in operation, allowing for intermittent use, for a total period of six running hours.

NEW DIRECTIONAL AERIALS FOR C.B.S.

W2XE and W3XAU Co-ordinate Service to South America and Europe

THE Columbia Broadcasting System will shortly be able to direct its short-wave broadcasts simultaneously to South America and Europe. This will be accomplished by combining the services of W2XE, New York and W3XAU, of the WCAU Broadcasting Company, a C.B.S. associate in Philadelphia.

W3XAU, at present operating with a non-directional aerial, is to have two new directional aerials. It will then be able to direct its broadcasts either to Latin America or Europe.

The new aerials for this 10-kW transmitter, which are being erected at Newtown Square, a suburb of Philadelphia, are of the horizontal "V" type. Each leg of the "V" will be approximately 500ft. long and the radiating portion of the aerial 110ft. above the ground.

The European beam, which will be directed on London, will cover the British Isles and the major part of Europe. The South American beam, directed on Buenos Aires, will give complete coverage of Latin American countries from the Atlantic to the Pacific.

INTERNATIONAL TELEVISION RELAYS

THE question of providing international circuits for the relay of television programmes from one country to another is being discussed at the International Conference of Telephone Experts, which was opened in London by Sir George Lee, Engineer-in-Chief of the Post Office, on December 5th. The conference is being attended by 100 delegates, representing

fourteen countries; it will continue until December 17th. Another of the problems to be discussed is the elimination of noise on long-distance lines.

PROGRAMME PRECISION**America's Latest Gadget**

THAT a very high standard of programme timing is maintained by the Columbia Broadcasting System is exemplified by a "programme failure alarm" which is being tested prior to installation in the Manhattan master control board where five and sometimes eight programmes are monitored simultaneously.

The alarm rings a bell and flashes a light whenever any of the programme channels into the

master control board are silenced for a predetermined length of time. A 20-second delay period has been chosen to avoid the alarm being given during the 10-second interval which is provided between programmes.

Surely such a hair-breadth margin of error in programme timing is worthy of commendation and might well be copied by the B.B.C., but, of course, time on the American stations is money.

CHECKING EUROPE'S WAVELENGTHS**The New Brussels Centre**

DURING the Union Internationale de Radio-diffusion wavelength conference in Brus-

sels, which ended on November 19th, the recently completed wavelength checking post of the U.I.R. at Uccle, Belgium, was officially opened in the presence of the delegates.

M. Raymond Braillard, Director of the Centre, pointed out that the precision with which the measurements are made has a margin of error of the order of two or three parts in ten million. It is interesting to note that in the original of the photograph reproduced here, the recorded deviation of Droitwich on that day was 6 c/s above its normal frequency.

POLICING THE ETHER. The new receiver for checking the long and medium waves.

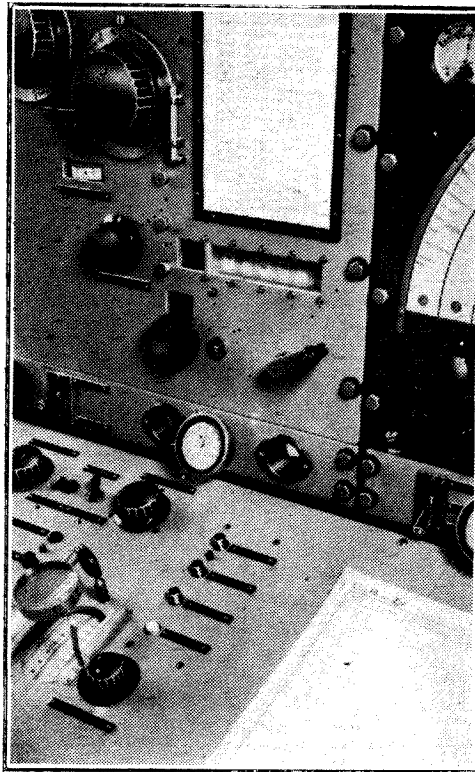
**FROM ALL****QUARTERS****Better Radio in Sweden**

WORK has just been commenced on the erection of a new 100-kW radio station near Borlange, in the Swedish Province of Dalarna. The Government has allocated 1,510,000 kroner (£77,800) to meet the cost of the station, the installation work of which is to be carried out by the Swedish Telegraph Office. This is part of a scheme for the development of the entire radio network, and extensions will next be undertaken at Gothenburg and Sundsvall in the North.

Indian Radio Directory

THE Indian Post Office has already issued over 1,800 wireless dealers' licences, and the number is steadily increasing every month. All who own licences, however, are not genuine radio dealers, and the All-India Radio Merchants' Association is therefore proposing to publish a Directory of the Radio and Allied Trades in India.

Ultra-short-wave Listeners

IN view of the large number of listeners in the London area who now pick up the sound transmissions from Alexandra Palace, television producers are forming the opening programme announcements in such a way that as much information as possible is given to listeners who cannot see the programme. "Vision" announcements, without sound, are discouraged.

Christmas Day Television

THE B.B.C. mobile television unit will, on Christmas Day at 3 p.m., return to within a few yards of the historic spot where on Coronation Day, 1937, it officially came into action. The occasion will be the televising of a genuine Christmas party in a Children's Ward at St. George's Hospital, Westminster. Among those at the party, which has been arranged by the B.B.C., will be Margaretta Scott, F. H. Grisewood, Uncle Mac, Leonard Henry, Eric Cardi (conjurer) and seven clowns from Bertram Mills' Circus.

Television-Telephone for Spain

THE German Government has given the Burgos Government a complete two-way television-telephone equipment similar to that used between Berlin and Leipzig, Nuremberg and Munich.

Broadcast Radio Technique

THE second section in the course of wireless instruction broadcast by the World Wide Broadcasting Foundation from its short-wave station W1XAL at the University Club, Boston, began on December 5th. Lectures, which run for about one hour, take place on Mondays at 1 a.m. G.M.T., and a recording for Europe is repeated on Fridays at 10 p.m. G.M.T. Booklets containing particulars of each course are available from the organisers at 1 dollar (4s. 4d.) each, post free.

A.W.A. Annual Report

A DIRECT wireless telephone service between Australia and the United States of America is foreshadowed by a statement in the annual report of Amalgamated Wireless (Australasia), Ltd., which was presented at the thirtieth ordinary general meeting on November 7th. The accounts for the financial year ended June 30th, 1938, which were also presented at this meeting, show a net profit for the year of £130,197.

Another Broadcasting House

A TWENTY-STUDIO Broadcasting House is to be erected at Copenhagen, and provision will be made for six independent programme channels. The equipment will be manufactured in the Copenhagen factory of Standard Electric A/S, with the exception of certain specialised units which will be furnished by Standard Telephones and Cables of London.

11 p.m. Radio Curfew

GODSTONE Rural District Council has decreed that no wireless set should be worked in any of its seven-hundred-odd houses after 11 p.m. or before 8 a.m. without written permission.

R.E. Reunion Dinner

AS many members of the R.E. Wireless Signals (1914-1919) Association were at some period of their service stationed at Worcester, the original war-time wireless training centre, the sixth annual reunion dinner will be held there on Saturday, February 18th, 1939. Further details are obtainable from Mr. C. R. Johnson, 288, St. Paul's Road, Smethwick, Staffs.

A.R.P. Communications

By a special change-over system each unit of the Ediswan Loud-speakerphone installation at the New Wortley Gasholder Station (Leeds) can be removed to various bomb-proof shelters, so permitting the work of the entire organisation to be carried on in safety during periods of emergency. The change-over has been timed to take three minutes.

Encouraging

It is reported from France that during next year four new television transmitters fed from the London Studios by cable will be erected at Birmingham, Manchester, Leeds and Glasgow—sounds good.

Crystal Band-Pass Filters

Part VI.—VARIABLE SELECTIVITY

By E. L. GARDINER, B.Sc.

THE application of crystal filters to variable selectivity is discussed in this article and it is shown that several degrees of selectivity can be obtained very simply. The question of AVC is also treated.

IN the preceding articles the production of band-pass filters of from a few hundred cycles to several kilocycles in width has been described. Up to 5 kc/s width no difficulty should be experienced in obtaining a sufficiently level pass-band by the impedance matching method. At widths of from 5 to 10 kc/s at an intermediate frequency between 400 and 500 kc/s, it may not be possible to reach that goal by matching alone; the use of transformer ratios of more than 3:1 or 4:1 tends to cause increasing loss of voltage within the pass-band, but makes it more level. In these cases resort should be made to the correcting effect of other resonant couplings which will form part of any practical amplifier.

Where two crystals differ in frequency by as much as 9 kc/s it will be possible to obtain a very considerable lift of the central region between them through the effect of a few circuits of reasonably high Q. The inclusion of these in the amplifying system can correct very amply for the originally concave shape of the crystal filter curve itself.

Having this range of band-widths available, it becomes necessary to select the appropriate filter for any given receiving conditions. Fortunately, the problem is simplified by the ease with which crystal filters can be switched to provide alternative band-widths. The method by which this can be done is illustrated in Fig. 16. In this example the crystal X is treated as a reference crystal, and chosen within perhaps two or three kc/s of the nominal intermediate frequency. Position 1 of the switch S can be used, if it should be so desired, to provide a simple "crystal gate" of the single crystal variety, X being the crystal in circuit and C₁ its balancing condenser. When not wanted this position of the switch can be omitted.

Position 2 will introduce into the other arm of the filter a second crystal, Y, differing by any desired frequency from X. Should the receiver be of the communication type it will probably be desirable to provide a band-width of a few hundred cycles for telegraphic reception, when Y will differ by that amount from X.

Position 3 of the switch can be used to introduce a third crystal, Z, differing by from 2 to 5 kc/s from X according to the views of the designer and the purpose of the receiver. In the event of the receiver being also used for high-quality broadcast or local station reception, position 4 will

remove the crystal filter entirely, giving substantially the selectivity of the remainder of the IF amplifier, which will be designed to provide an effective band width of perhaps 10 to 20 kc/s. The condenser C₄ is provided so that the optimum coupling between L₂ and L₃ can be selected in such a case. To dispense with the filter entirely for local station reception is the cheapest and most convenient expedient in a simple receiver. The alternative of a pair of widely spaced crystals will not yield any very striking improvement, for however steep its sides, a band-pass filter of 9 or 10 kc/s width is bound to accept considerable side-band splash from neighbouring stations, and its value is thus largely discounted. Moreover, it will not be easy to obtain a sufficiently level response for high-quality reproduction from a filter in which the crystals differ by more than some 6 kc/s unless the IF amplifier contains two other IF transformers. This generally implies the use of two stages, which may not be desired in an inexpensive type of receiver.

cities. In a broadcast receiver, where these condensers would probably be pre-set, the arrangement is ideal, but in the case of a communication receiver the balancing condenser can with advantage be a panel adjustment, so that interference can be exactly balanced out, and heterodynes eliminated. Since two panel adjustments may not be convenient, a useful modification will be to make C₂ and C₃ pre-set to slightly more than the correct value, and to provide C₅ across the reference crystal as a panel control which will provide exact balance. An increase of C₅ is equivalent to a decrease of C₃ or C₄ (according to the position of S) and if C₅ be of 2 or 3 $\mu\mu\text{F}$. only, it will be impossible to vary it too widely, and thus destroy the selective action of the filter. Operation is in this way rendered more "fool-proof."

The Load Circuit

A minor defect of the circuit shown in Fig. 16 is that only a single type of output impedance matching transformer can be used for all four positions of the switch. The transformer should be chosen for the widest filter used, and all circuits lined up to the central frequency of that band. They will then be quite near enough to the correct adjustment for narrower band-widths. In the case of a telegraphic filter of a few hundred cycles width however, it has been shown that best selectivity results from the use of a resistance as load. This is not

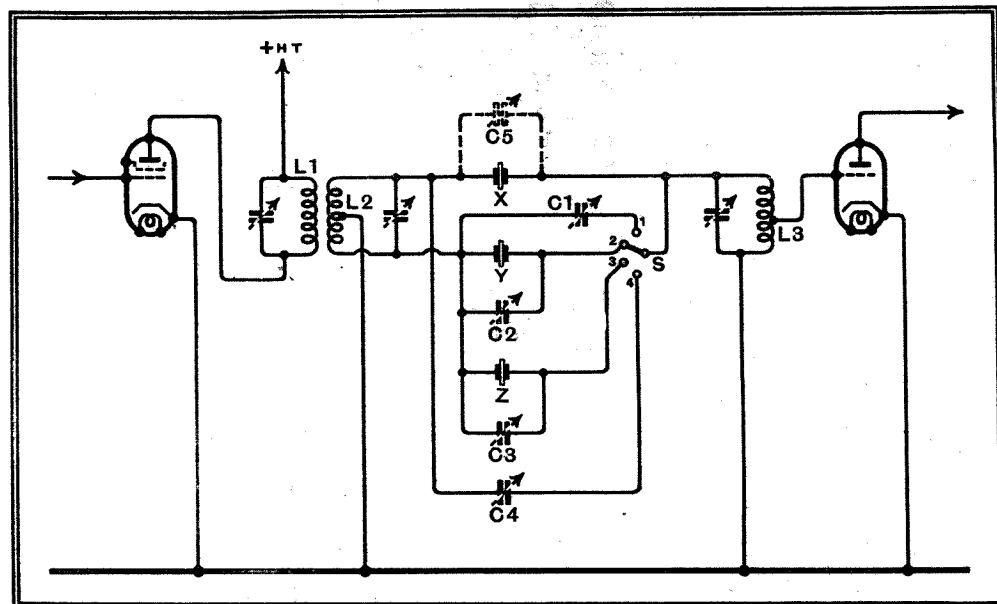

Fig. 16.—This diagram shows how four degrees of selectivity can be secured using four crystals and a single-pole four-way switch.

The circuit of Fig. 16 shows separate balancing condensers, C₂ and C₃ across each crystal, Y and Z, so that should these differ somewhat in total capacity, each filter can be separately balanced. A difference is almost certain to exist, owing to differences in wiring and stray capa-

possible in Fig. 16, unless additional ganged switching be added to the circuit so that the load can be changed to a resistance in positions 1 and 2.

Several improvements of this type will suggest themselves to the experienced designer, and so many variations are possible

Crystal Band-Pass Filters—

that it would be useless to enlarge upon them here. Care should be taken, however, over the screening of any switches used, and the switch S should be within the can which encloses the crystals. A possible design arrangement would employ a normal IF transformer can for L₁ and L₂, which must be screened thoroughly from L₃ and all following circuits. The crystals, switch S and L₃, with their associated condensers, might then be enclosed in a second can; S and C₅ would be mounted through the side of this, and provided with insulated extension spindles to the front panel.

A better circuit arrangement for some purposes is shown in Fig. 17. Here two independent pairs of crystals are used, the additional cost of four being little more in proportion than that of three, when the former are mounted in two pairs. A simple switch S now selects two independent filters, each with its appropriate output load, which in the illustration is shown as a resistance in one case. Clearly the arrangement can be extended to any desired number of band-widths, two only being shown for clarity. The system has a minor defect in that the crystals not in use remain connected to the input transformer, and will load this somewhat, producing narrow crevasses in the response curve as their respective frequencies are reached. These crevasses will be so narrow, however, that they will scarcely be audible except in the most exacting cases, when additional switching could be added to disconnect the crystals not in use at any moment.

Automatic Volume Control

The diagrams will suffice to show how simple the provision of true variable selectivity becomes when this factor is localised into a single crystal filter. The writer favours the arrangement of Fig. 16 for general use, and suggests that crystals X-Y should differ by about 250 c/s and X-Z by not less than 2.5 kc/s for a communication receiver, and not more than 5 kc/s for a selective broadcast receiver. There should be only a small change in amplification between the four positions, and it is possible to change instantly from one to another of the following band-widths:—

1. Single crystal-filter for stable telegraph signals.
2. Rather less than 1 kc/s effective width, for general morse reception of tone-modulated or slightly unstable transmissions, with very easy adjustment.
3. Three or 6 kc/s effective width for telephony, and broadcasting under serious interference.
4. Ten to 20 kc/s for local broadcast reception, or searching at very short wavelengths.

In selecting the best position for the crystal filter in an IF amplifier, a compromise must unfortunately be made on account of the requirements of automatic volume control. It is well known that the

latter should not be derived from too selective a point in the receiver, and should operate less "selectively" than the receiver as a whole. It should therefore not be taken from a point after the crystal filter, but the AVC diode should derive its input from a point before the filter. Nevertheless, sufficient amplification for the AVC control will not exist in a receiver using only one IF stage unless it be taken from a point after that stage. Conse-

Cross-modulation clearly reduces the value of high selectivity, and must be guarded against at any cost. Unfortunately the placing of the filter after an IF stage encourages it because, whereas the frequency-changer should be fairly free from this defect, the IF stage is handling stronger signals, and is likely to show it appreciably. The receiver shown in Fig. 15, and having the selectivity curve of Fig. 14, was a simple four-valve super-

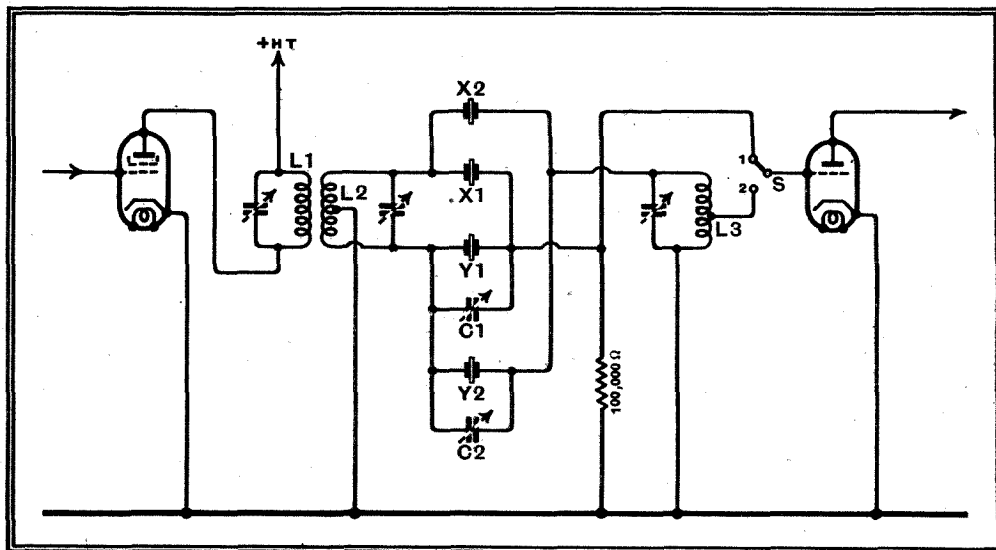

Fig. 17.—Two separate band-pass filters are used here and a change-over switch permits either to be selected at will.

quently it becomes necessary to place the crystal filter after the IF stage, and immediately preceding the second detector, as was shown in Fig. 15. AVC can now be taken from the primary of the filter input transformer.

In the case of receivers intended primarily to receive very weak signals, such perhaps as a communication receiver which is not fitted with broadcast wave-ranges, this is a very satisfactory position for the filter. It ensures that the signals which reach it are comparatively strong, and thus overcomes any traces of the threshold effect described in Part II. Also, it will be found easier to ensure that no stray signals leak past the filter if no IF amplifying stages follow it, with their possibilities of radiation from coils or wiring, etc.

Where a receiver is to deal with strong signals, however, and particularly when it is desired to receive weak telephony on a wavelength adjacent to a powerful local station, as in the case of most broadcast receivers, cross-modulation may be found troublesome. This is the valve defect which occurs when a strong and a weak signal pass together through a valve stage which is not strictly linear, and as a result of it the weaker signal becomes modulated to some extent by the programme of the stronger.

In most simple broadcast receivers the defect is masked by the still worse interference and side-band splash due to insufficient selectivity; but when a crystal filter is added the latter very largely disappear, while the effects of cross-modulation remain and become noticeable.

heterodyne. It was almost entirely free from direct interference between stations, being able, for example, to show a clear space between Droitwich and Deutschland-sender, apart from a little splash due to sidebands from these stations falling within the pass-band. On tuning to the latter station, however, the Droitwich programme became faintly audible through cross-modulation which occurred mainly within the type 78 IF valve, and this was by far the worst source of interference remaining in the receiver.

Avoiding Cross-modulation

Naturally the crystal filters will perform to best advantage in better class receivers, employing preferably an RF stage, and additional pre-selecting circuits which help to overcome cross-modulation. The most important step in its elimination is that of removing the crystal filter to the input of the IF system, so that it immediately follows the frequency-changer, since at this point minimum cross-modulation has occurred.

In so doing, however, it becomes necessary either to take AVC voltage after the filter, or to employ an additional AVC amplifying stage which derives its input directly from the frequency-changer. The former course is open to the objection that AVC vanishes as we tune past the edges of the band-pass, and when the latter is nearly perfect, little AVC action remains between stations. Consequently the receiver is working at high gain, and side-band splash becomes very noticeable whilst tuning. The second alternative remains as

Crystal Band-Pass Filters—

the ideal course, and one which would no doubt be employed in high-class equipment.

A minor point of importance which has been found out in testing the receiver of Fig. 15, is the need for a separate AVC diode. The original double-diode-triode was first connected in the usual manner, but it was found that since the signal diode followed the filter while the AVC diode

preceded it, and the two were in a single valve with closely adjacent pins, sufficient coupling occurred between them to by-pass the filter partially. The introduction of a Westector as AVC rectifier effectively removed this source of interaction, and the need for it illustrates the additional care which becomes necessary when the moderate selectivity of normal circuits is replaced by filters of much greater inherent effectiveness.

circuit to an RF stage is, I think, not fully realised, for enormous gains in sensitivity and selectivity can be achieved, but the circuits must be completely and effectively screened in separate metal boxes if stability is to be retained. The coupling between the circuits can be drastically reduced and a surprising degree of useful selectivity attained.
Birmingham. ERIC D. PRINCE.

Letters to the Editor

The Editor does not necessarily endorse the opinions of his correspondents

About Ourselves

From John Scott-Taggart, M.I.E.E., A.M.I.Mech.E., F.Inst.P., Fel.A.I.E.E., Fel.I.R.E.

YOU have frankly taken your readers into your confidence regarding the reasons for stabilising the price of your journal at 6d. It has always been a surprise to me, as a former editor and proprietor of radio periodicals, that this step has been so long delayed.

The new price is merely a return to the original one which was lowered during "boom" conditions. A readjustment to normal will deserve and obtain the loyal support of your readers and the industry.

The *Wireless World* kept the flag of radio flying before, during and immediately after the War, when radio interest was at a comparatively low ebb and greatly needed encouragement; it has remained an institution ever since. It has weathered every form of competition while maintaining a virile yet authoritative standard. You will retain all your readers because there has never been a journal in quite the same field.

It is regrettable that manufacturing interests should give any less support to what is practically their only technical organ, especially as their engineers without exception are among the strongest supporters of the *The Wireless World*. One by one, radio periodicals have given up the economic fight. One has only to think of the calamity of a great art and industry without a technical journal to realise how necessary it is that the radio industry should give *The Wireless World* every possible support.

Your periodical should be assured, if not of prosperity, at least of economic security to carry on its traditions of sound yet enterprising technical journalism.

London. JOHN SCOTT-TAGGART.

AS an old and regular reader of your highly valued journal, please accept my thanks for your decision to increase the price of *The Wireless World* rather than let the paper decline to a lower standard of quality.

Ever since the first appearance of this paper it has been, in my opinion, the only up-to-date and by far the most authentic weekly radio journal published, and I am sure that most of your readers who are interested in radio, either as amateur experimenters or commercially, would much rather pay double the modest price you ask than see the quality of the articles deteriorate.

Wishing you and your staff every success in the future.
T. JAQUES.

Doncaster.

The Communication Receiver

I FEEL it is only due to you to express my thanks for the very delightful "Communication Receiver" that was recently designed by your staff.

Although a "fan," I regret I am not technical enough to start an elaborate account of what it will do, but as this is "plenty" I should like to put on record the appreciation of, at any rate, one of your regular readers.
D. H. JOSEPH.

London, N.16.

Short-wave Reaction Control

I WAS very interested in the reaction system described by Mr. Hay in your issue of November 17th. May I submit a slight modification of the circuit given, as I believe it, too, will be useful to some readers?

For some time now I have been using electron-coupled reaction in place of the normal coil-condenser method, and I believe it has definite advantages over its predecessor. Up to the present I have not seen a battery circuit electron-coupled without a filament choke in the positive LT lead, but I have dispensed with that component

Reaction circuit described by Mr. Prince. Component values: C1, C2, C4, C5, 100 m-mfds.; C3, 0.5 mfd.; R1, 1-5 meg-ohms; R2, 10,000 ohms; R3, 50,000 ohms.

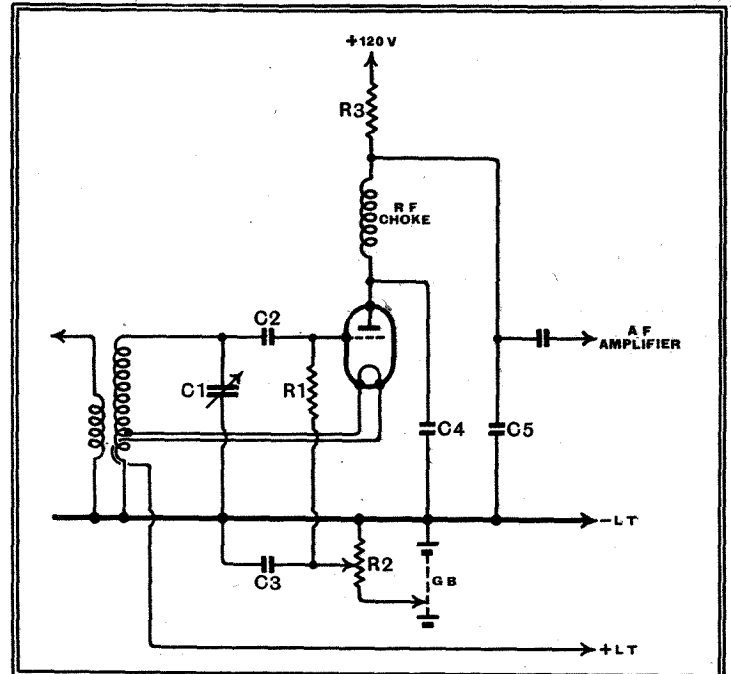

for some time by twisting the LT leads together at the valve-holder and running the usual number of turns round the dead-end of the grid coil, or tapping the LT negative lead to the coil and running the positive lead parallel to it and round the coil as in the accompanying diagram. But I agree with Mr. Hay that to control a regenerative circuit by the screen or anode potential must vary the amplifying power of the detector. In the AC version the bias can be obtained by shunting a potentiometer across one of the bias resistors in the AF circuits, the value of the potentiometer being four or five times the value of the bias resistor.

The advantage of applying a feed-back

5-metre DX is correct? Until they can, everything has not been found out, and the hams, by virtue of their numbers, are the only body equipped for this kind of work.

He then goes on to state that "the morse test at its present 12 W.P.M. is child's play," but that 3 W.P.M. more, "open the door to becoming an operator in the full sense of the word." He continues: "An examination of this character would deter any licensee from using telephony only for the whole of his radio career." How does an extra 3 W.P.M. justify this statement?

His remark that "a sliding scale of fees, varying according to the input used, is badly required," is the final folly of the article. It is, of course, already in force. As to his

Letters to the Editor—

idea of an extension of the amateur bands; well, as the W's would say, "Oh, yeah!"

If any drastic revision of licence regulations are to be made, I suggest something of a compromise between the American and our own. I agree with your editorial of October 13th that the ham should be allowed to transmit anything, barring commercial intelligence, providing no remuneration is received. Also, such restrictions as aerial length should be abolished.

That a desire to become a proficient operator is sufficient justification in these days for granting a licence I also agree, providing they are limited to 10 watts CW only. A simple technical examination and a test of the 'phone gear to be used before granting a 10-watt 'phone licence would probably stop some of the foul noises one hears on the air at present, i.e., on the assumption that a station is more likely to improve than deteriorate. With regard to the misuse of power it is not very difficult to curb that. A comparative field strength measurement by means of an ordinary commercial receiver with R meter from a van at the end of the street, then a call from the inspector with a request to operate the station in such a way that the R meter returned to the same reading would soon establish the power in use before the inspector's call.

I suggest a system of graded licences in accordance with the appended table. A scheme of official warnings and endorsements (for such offences as bad language, really

SUGGESTED LICENCE CONDITIONS

Grade.	Use.	Qualifications.
A	10 watts C.W. only, 40 and 20 metres.	Test 12 W.P.M. Morse Code.
B	10 watts C.W. and 'phone, 40 and 20 and 5 metres.	Above plus simple examination and satisfactory demonstration of apparatus.
C	100 watts C.E. and 'phone, 160, 40, 20, 10, 5 metres.	Holding of B licence for 1 year with no endorsements and passing of moderately stiff examination.
D	1 kW. C.W. and 'phone, 160, 80, 40, 20, 10, 5 metres.	Holding of C licence for at least 2 years with no endorsements.

bad-quality 'phone, impure note, excessive frequency drift, and gross misuse of any band, such as local communication on 20 metres) might well be instituted as part of the plan.

Huddersfield.

W. L.

Automatic Tone Compensation

THE authors of "Contrast Expansion and its Applications," published in your issue of September 22nd, are apparently surprised that little attention has so far been paid to the application of automatic tone compensation in conjunction with volume expansion (in order to correct for ear deficiencies when listening at low volume levels). The article opens with the statement that "the obvious aim of the receiver design engineer is to produce a set capable of giving as faithful and realistic a reproduction of whatever the microphone picks up as would be heard by a person standing alongside the microphone and picking up the same sound with the human ear." Such an aim includes the necessity for providing for stereophonic reproduction, which is necessarily omitted from the present argument.

If, apart from this, we have such a receiver, in which contrast expansion is exactly the inverse of the previous compression, then the sounds created by the loud speaker will be an exact replica of the sounds picked up by the microphone down to and including the smallest variation in volume

encountered, i.e., every sound from the softest to the loudest will be reproduced in true proportion, and at a sound intensity the same as that of the original at the microphone.

Now, it has not been suggested that the pair of ears one employs when listening via a loud speaker is in any way different from the pair one uses when listening to the actual rendering in the studio or concert hall. Since compensating for ear deficiencies in the concert hall has never been suggested, and since it is natural for them to be present, it would appear that to make such compensation in the reproducing chain otherwise accurate would introduce a most lamentable distortion.

It has been my experience that compensating for "ear curves" is only desirable when the sounds heard cannot be reproduced naturally and have to be "seasoned to taste." If the apparatus used is sufficiently perfect, however, the apparent loss of bass at low settings of the volume control is identical with that obtained when listening at a distance from the performers, except that the ratio of echo to direct sound may not be quite right.

In conclusion, I would add that, owing to the position of the mike, the sounds it "hears" are usually far too loud to be comfortable for listening. This sound intensity is desirable at the mouth of the reproducing loud speaker, but I doubt if any attempt to provide such a high volume level at the listener's ear would be appreciated.

Sydenham.

G. F. REDGRAVE
Voigt Patents, Ltd.

Ban Telephony for Beginners

I WOULD fain agree with the editorial in your issue of October 13th, and despite the fact that I wrote this letter after I had seen your second editorial in *The Wireless World* dated October 20th, I can truthfully say I was not biased thereby. Personally, I would ban telephony for new licensees for

at least two years. If our amateurs are to be of any use in an emergency, such as war, then they must be good telegraphists. The use of telephony is quite all right in flood emergency work, etc., but would be more than useless in war. Some amateurs and others I know would barely pass their 12 WPM test, because they have confined themselves so much to telephony. Although I have been an amateur transmitter for several years, I base my opinion rather on the fact that I served for some time during the Great War in charge of interception and direction-finding wireless stations in Palestine. The majority of our operators were trained telegraphists, mainly recruited from the British Post Office.

Singapore.

J. MACINTOSH.
(VSIAA.)

Short-wave Troubles

I HAVE recently experienced quite a large number of cases in which troubles of various kinds have been evident only on the short-wave band of all-wave receivers, although the troublesome circuits were common to all wavebands. It will often be found that although smoothing, screening and decoupling have an ample safety factor on the broadcast bands, the margin is quite small on the short waveband.

Here in Malta efficiency of short-wave reception is of first importance, and certain types of trouble experienced would suggest that many manufacturers still regard the higher frequencies as a novelty rather than a serious feature. Many new receivers I have handled recently have been troubled with very pronounced modulation hum on short-wave stations only, and this in spite of screened primary mains transformers. I was able to cure a recent case by connecting 0.01 mfd condensers from each side of the rectifier filament to earth. This was the only method which secured complete immunity.

Sliema, Malta.

L. P. DISMORE.

Random Radiations

S/W Broadcasting in Norway

YOU may recall that I wrote a week or two ago that I thought I remembered reading some time back that short-wave transmissions were used for internal broadcasting in Norway. I asked, then, if some Norwegian listener could verify. Sure enough, there comes a letter from Lamberseter, near Oslo (whose writer, incidentally, pays me a pretty compliment on the length of my memory), to say that four or five years ago the 1-kilowatt short-wave station at Jeløy was used to link the Oslo studios with a 10-kilowatt relay at Vardø, about 1,000 miles away.

A New Short-wave Station

This kind reader also tells me something of a new Jeløy transmitter, which came into action recently. The original transmitter, which still works on 6.13 Mc/s, is rated at one kilowatt. The new one, with an output of five kilowatts, uses omni-directional aerials and broadcasts on three channels. One of these, 9.53 Mc/s (or 31.48 metres), was shown in the recent *Wireless World* list; but the other two haven't appeared till now.

By "DIALLIST"

They are 11.735 Mc/s, or 25.56 metres, and 15.170 Mc/s, or 19.70 metres. Presumably there is a friendly arrangement with OZH of Skamleback, Denmark, about the last channel; if two Scandinavian stations used it simultaneously, it wouldn't be very valuable to either.

Czecho-Slovakian Stations

THE recent re-shuffle of Central European frontiers has meant a loss to Czecho-Slovakia of two rather valuable broadcasting stations. These are (or rather, were, for their names have now been changed) Kosice, on 1158 kilocycles, or 259.1 metres, and Moravska-Ostrava, on 1195 kilocycles, or 251 metres. Kosice has gone to Hungary and now broadcasts as Kassa, using the same channel. Moravska-Ostrava is completely unrecognisable under its new name, though it also retains its original channel. The station is now called Schönbrunn and belongs to Germany. Despite these losses, Czecho-Slovakia can still pride herself on having two transmitters that are outstanding

Random Radiations—

performers. These are Melnik, on 1113 kilocycles (or 269.5 metres), and the short-wave station at Podebrady which, under the call-signs OLR2A, OLR2B, OLR3A, OLR4B, OLR4A and OLR5A, has a full complement of channels on 6.01, 6.03, 9.55, 11.76, 11.84 and 15.23 megacycles respectively.

More of the Light Meter

A GOOD many readers seem to have been pressing their electric light meters into service as a rough means of finding the load of mains receiving sets. Some have sent me quite elaborate formulæ for discovering this or that. A correspondent hailing from West-Ferry, near Dundee, submits one for discovering in the twinkling of an eye the running cost per hour of a receiver. Here it is:—

$$\text{Pence per hour} = \frac{60P}{N \times T}$$

where P is the cost in pence per kilowatt hour and T the time of one revolution of the meter disc in minutes and fractions of a minute. Perhaps it might be more convenient to reverse the formula, writing:—

$$\frac{N \times T}{60P}$$

which gives the hours of use per penny. Other formulæ, some of them quite elaborate, have come in; but I think that we have enough now to go on with. I wonder how many meters were examined and timed by stop-watch as the result of my original note?

Instruction Books

SOME of the instruction books which accompany receiving sets are disappointing. If it's a battery set, the book of the words prattles gaily about pink, green and blue HT leads, whilst those attached to the set are brown, yellow and white. Or, it beseeches you, should certain undesirable things happen, to increase or decrease the screen potential by six volts, whereas the HTB supplied has 12-volt tappings and no others. "Be sure," writes a book of the words that I've just been studying, "to see that the mains leads are passed through the slot in the back provided for them." There is no slot. It's awfully jolly, again, after reading a warning printed in gigantic type, against using valves of any other kind than those listed in the booklet, to find one or two of an entirely different make sent with the receiver. Thinking that a mistake has been made, you take the trouble to write or telephone to the makers and learn that the different valves have now been adopted and that the booklet ought to have been altered, but wasn't. But perhaps the best bad joke of all on the part of the makers is to attach to the set a label suggesting that all kinds of awful things may occur if you try to bring it into operation without reading the instruction book, and then either to leave out the said book altogether or to send you one dealing fully with a completely different model.

Plugs and Sockets

WE are, it seems, further than ever from valve standardisation; we might, in fact, as well forget that the idea ever existed, save as a beautiful dream. But there are one or two things in receiving sets which I should like to see standardised, and one can't think of any sound arguments against such an obvious improvement. First of all, the aerial and earth sockets and the plugs that fit into them. As it is, some

plugs are fat, some are thin and some are betwixt and between. Nobody can possibly benefit from that kind of thing, and everyone who has to alter his plugs when changing over from one receiver to another cusses heartily. Also, if you happen to lose some queer-sized aerial or earth plug, it's ten to one that you can't find another to fit, no matter how hard you rummage through your collection of old tobacco tins filled with little wireless bits and pieces. Next, knobs. Why shouldn't the knob on the extreme left always be the volume control and main switch, and that on the extreme right always the wave-change switch? Why shouldn't there be recognised positions for the tone control and any other knobs that there may be? If makers could only agree on that point they'd simplify matters a good deal for all users.

B.B.C. Recordings

SOME people are inclined to lump all the recorded items sent out by the B.B.C. as "Blattnerphoned," though, as a matter of fact, three different methods are in regular use, the wax disc, the sensitised celluloid film, and the steel tape. An immense amount of recording has to be done for a variety of purposes. There is a huge collection of canned "effects," ready to meet the demands of any producer. These are mainly on discs. Discs are used also for short recordings of various kinds, and sometimes for long ones as well: the entire Coronation Day broadcast was cut on a series of 400-odd wax discs. The steel tape-recording system used is now known as the Marconi-Stille. It is employed chiefly for potting home programmes required for the Empire transmissions, and other items that are to be re-broadcast within a short time. Each spool holds one and three-quarter

miles of tape, and can record a half-hour programme. If a permanent record is not needed, the tape can be de-magnetised and used again and again. Film recording is the most faithful system of all, and is used for important musical programmes as well as for historic speeches. A 900-foot reel of film will hold a programme lasting for fifteen minutes. So extensive is the B.B.C.'s library of recordings that it occupies a corridor nearly a quarter of a mile long in the old Maida Vale Skating Rink.

Stormy Winds

THE gales that we've had of late seem to have wrought havoc amongst the ramshackle aerials that do the reverse of ornamenting so many folks' gardens. If only their owners knew it, the winds have done them a good turn. The old Heath-Robinson aerial that gave indifferent service for so many years has been laid flat, and there is now no excuse for not erecting something a trifle more up to date. It's long been a marvel to me how some of the aerials that one sees ever stand up to anything more than the gentlest zephyrs. But they do stand up—or, rather, they did in my part of the world—until one of those super-gusts smote them. It must be years now since I first began to wonder how long one comic affair that I pass most days would last. The house end was fixed to a gutter spout, and the free end to an alleged mast which started, reading from the ground upwards, with a slim and very crooked larch pole, continued with a length of curtain rod lashed on with string, and ended with a broom stick, similarly fixed. It has managed to weather many storms, but it came down right enough in the big gale, bringing several feet of gutter spout with it, and shedding the middle and top joints of its mast on to and through the roof of a greenhouse.

Salford Test Set

THE Miniature Multi-Range Test Set made by Salford Electrical Instruments, Ltd., of Peel Works, Silk Street, Salford, covers voltage and current measurements of both DC and AC. It is also an ohmmeter.

There are twenty-eight ranges covering 4 μ A. to 5 A., and 0.0012-500 volts DC. The lowest range reads 200 μ A. full scale. Except in the case of the lowest range, range-changing is by means of switches with recessed controls. As a DC voltmeter the resistance is 2,000 ohms per volt.

On AC a rectifier is

The Salford Test Set with battery container and carrying case.



included and for audio frequencies up to 2,000 c/s an accuracy of ± 3 per cent. is claimed. There are six current ranges, the lowest being 2.5 mA. full scale, and the highest 5 A., and there are six voltage ranges, from 1 volt to 500 volts full scale. The resistance is 400 ohms per volt.

For resistance measurements a separate battery is employed and it has a special holder which plugs into the end of the

tester. There is one range, indicating up to 500,000 ohms.

The meter itself has a scale measuring 2 $\frac{3}{4}$ in. across the arc and the overall measurements are 7 $\frac{1}{2}$ \times 3 $\frac{1}{2}$ \times 2 $\frac{1}{2}$ in. It is supplied with battery case and test leads in a leather carrying case, and costs £16 10s. DC current shunts and voltage multipliers for extending the range are available as extras, as also is a multi-range current transformer for AC.

Recent Inventions

Brief descriptions of the more interesting radio devices and improvements issued as patents will be included in this section.

ELECTRON MULTIPLIERS

IN diagram (a) is shown the usual arrangement of the target electrodes T in an electron multiplier. The biasing potentials increase from T₁ to T₂ and so on, so that the resulting electrostatic field is as indicated by the dotted lines. It will be seen that a large component of the field runs axially along the centre of the tube, and for this reason some of the electrons emitted from the targets follow that path straight through the tube. Since this prevents them from striking against succeeding targets they do not add their proper quota to the output current.

The remedy, as shown in diagram (b), is to insert between the targets T a pair of open-mesh or thin-foil electrodes P, P₁, which are transparent to the stream. They are so biased that the electrons are forced to pass through them, and so take a direct path from one target to the next, as shown by the arrows. In this way none of the electrons can escape, and thus make the full number of impacts. In addition, the open-mesh electrodes also serve to liberate secondary electrons, and

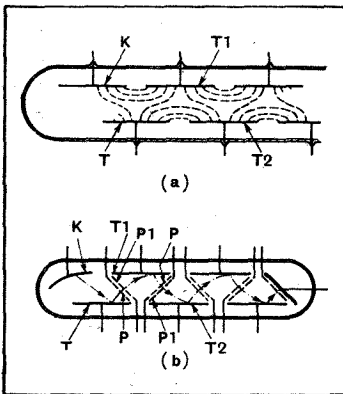

(a) Path of electrons through a normal electron multiplier and (b) effect of interposing guiding electrodes.

so help to increase the final value of the output current.

Baird Television, Ltd. (communicated by Fernseh Akt.). Application date, February 10th, 1937. No. 490230.

PIEZO-ELECTRIC TUNING CONTROL

AN initial error in the tuning of a superhet receiver is corrected—or alternatively the local oscillator is stabilised so as to prevent frequency "drift"—by the action of a piezo-electric crystal which has a natural frequency equal to that of the IF stages.

The crystal is coupled to part of the output from one of the IF stages, and, irrespective of whether there is a slight degree of mistuning or not, the crystal oscillates predominantly at its own natural frequency. This frequency is fed

to an auxiliary detector valve, which also receives part of the incoming signal energy. There must then be present, in the output circuit of the auxiliary detector, a beat frequency identical with that which should be produced by the main local-oscillator valve. This "control" frequency is fed to the grid of the LO valve, and serves to adjust the latter, if necessary, and thereafter to stabilise it at the frequency required to keep the circuits of the set accurately in tune.

J. Robinson. Application date, January 29th, 1937. No. 489571.

TELEVISION TRANSMITTERS

IN a cathode-ray transmitter, the presence of local interference, particularly when of a relatively low frequency, tends to give rise to what is known as "tilt" effect. This seems to produce a saw-toothed rise of voltage along each of the scanning lines, so that a spurious increase of brightness occurs towards one side of the picture, as seen in the receiver.

In order to correct for it, a grid is interposed between the original picture and the mosaic screen of the transmitter tube, which, in effect, divides the picture into vertical strips separated by black lines. The black lines are then utilised to create a series of control signals which automatically correct the "tilt" effect, though they are resolved by the scanning action and do not appear in the received picture. Preferably, the position of the grid is periodically shifted so that the position of the black lines on the mosaic screen is constantly altered or "interlaced."

A. D. Blumlein and C. O. Browne. Application dates, November 10th, 1936, and March 23rd, 1937. No. 490205.

TUNING ON THE S.W. BAND

TUNING on the short waves of an all-wave set is made "easy," and means are provided for "logging" any required station so that it can readily be found again when desired. For this purpose the wave-change switch brings into circuit a special short-wave unit, including an input-amplifier and frequency changer, which replaces the high-frequency circuits normally used for medium- and long-wave reception.

Tuning then takes place in two stages. A first adjustment sets the receiver to one or other of the fairly widely spaced regions in the short-wave band in which most of the available broadcasting stations are to be found. This is only an approximate setting, which is "arrested" at the appropriate parts of the scale by a detent which frictionally engages, but can be forced over, notches in a disc on the control shaft.

The short-wave unit is now feeding the signals into the fixed intermediate-frequency stages of the

set, so that final tuning is transferred to the normal medium- or long-wave controls, which being on an "open" scale can be rapidly and accurately adjusted.

Murphy Radio, Ltd.; L. A. Moxon; and J. D. A. Boyd. Application date, December 22nd, 1936. No. 489370.

SUPERHET RECEIVERS

IN an all-wave superhet set with an intermediate frequency of 450 cycles, the so-called "image" frequencies are particularly likely to be in evidence when receiving the ordinary long-wave programmes.

According to the invention, certain of the tuning coils in the input circuit of the set are made to serve a dual purpose in the sense that, on the long-wave side of the wave-change switch they form a series circuit which offers a low impedance to the image frequencies and so shunts them to earth. At the same time the input circuit offers a high impedance to the desired range of signal frequencies.

The attenuation circuit is automatically brought into action by the wave-change switch. Complete elimination occurs for frequencies in the middle of the image band, and substantial attenuation over the remainder.

G. W. Johnson (communicated by Philco Radio and Television Corp.). Application dates, January 9th and 25th, 1937. No. 490138.

TELEVISION RECEIVERS

IN one type of cathode-ray receiver, the picture is first formed at a high level of brilliance upon a comparatively small fluorescent screen, and is then projected on to a larger viewing-screen through a magnifying lens. In such arrangements, owing to the intense bombardment of the first screen, the ordinary fluorescent coating tends to burn out after a comparatively short life.

To avoid this, two sensitive screens are used. The one on which the picture is first formed is coated with a fluorescent material, such as calcium tungstate, which gives a brilliant radiation of too "blue" a colour to be pleasing. This picture is then passed through a magnifying lens on to a viewing screen which is coated with a zinc-cadmium-sulphide composition. This normally gives an orange-red response, but when subjected to the blue light from the first screen, produces a picture which appears approximately black and white.

The British Thomson-Houston Co., Ltd., and W. J. Scott. Application date February 4th, 1937. No. 490029.

TUNING INDICATORS

THE Figure shows the tuning scales for an all-wave set. The long-wave stations L, and medium-wave stations M are marked on the lower and upper halves of the central dial and are associated with a double-ended pointer P. The short-wave stations S are marked across a series of radial lines spreading out

from the centre of a semicircular disc D. The total length of these lines, e.g., the effective scale-length, may thus be made equal to several feet.

Mounted on the same centre as the pointer P, and lying behind the disc D, is an arm with a T-shaped end-piece. This is backed by a lamp so that it throws a slightly curved shadow K on the translucent disc D. This acts as a "cursor" and identifies the short-wave stations by intersecting the radial lines, one after the other in succession. As the point of intersection reaches the bottom of one radial line, the top of the

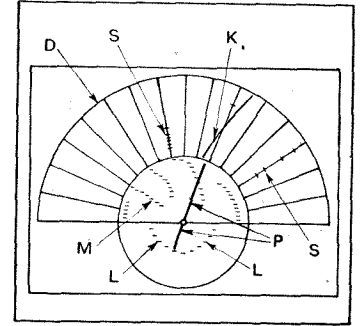

Three-band tuning dial in which a shadow acts as the cursor on the short-wave scale.

cursor begins to cross the top of the next radial line, and so on. In this way the scale reading is made continuous.

Marconi's Wireless Telegraph Co., Ltd., and J. D. Brailsford. Application date, February 20th, 1937. No. 490400.

SHORT-WAVE AERIALS

TO ensure a uniform radiation of energy in the horizontal plane, particularly when broadcasting television programmes, the ordinary dipole aerial is replaced by a series of loop aerials, which are "loaded" by series capacity, and vary in size according to a law which involves a Bessel function of the wavelength.

The loops may, for instance, be arranged concentrically, one inside the other, the smallest loop having a radius 0.29, the next 0.85, and the next 1.36 of the working wavelength, adjacent loops being energised in phase-opposition. The arrangement is stated to give an effective concentration of horizontally-polarised waves, uniformly distributed in the horizontal plane.

The aerials may also be arranged in tiers, i.e., one above the other. Each loop may be divided into segments, instead of being loaded with condensers, each segment then being energised through radial feed-lines from the centre of the loop.

Marconi's Wireless Telegraph Co., Ltd. (assignees of P. S. Carter). Convention date (U.S.A.) February 15th, 1936. No. 490383.

The British abstracts published here are prepared with the permission of the Controller of H.M. Stationery Office, from specifications obtainable at the Patent Office, 25, Southampton Buildings, London, W.C.2, price 1/- each

The Wireless World

THE PRACTICAL RADIO JOURNAL
28th Year of Publication

No. 1007.

THURSDAY, DECEMBER 15TH, 1938.

VOL. XLIII. No. 24.

Proprietors : ILIFFE & SONS LTD.

Editor :
HUGH S. POCOCK.

Editorial,
Advertising and Publishing Offices :
DORSET HOUSE, STAMFORD STREET,
LONDON, S.E.1.

Telephone : Waterloo 3333 (50 lines).
Telegrams : "Ethaworld, Sedist, London."

COVENTRY : 8-10, Corporation Street.
Telegrams : Telephone :
"Autocar, Coventry." 5210 Coventry.

BIRMINGHAM :
Guildhall Buildings, Navigation Street, 2.
Telegrams : Telephone :
"Autopress, Birmingham." 2971 Midland (4 lines).

MANCHESTER : 260, Deansgate, 3.
Telegrams : Telephone :
"Iliffe, Manchester." Blackfriars 4412 (4 lines).

GLASGOW : 26B, Renfield Street, C.2.
Telegrams : "Iliffe, Glasgow." Telephone : Central 4857.

PUBLISHED WEEKLY. ENTERED AS SECOND
CLASS MATTER AT NEW YORK, N.Y.

Subscription Rates :
Home and Canada, £1 10s. 4d. ; other
countries, £1 12s. 6d. per annum.

As many of the circuits and apparatus described in these
pages are covered by patents, readers are advised, before
making use of them, to satisfy themselves that they would
not be infringing patents.

CONTENTS

	Page
Editorial Comment	527
Current-Carrying Capacity	529
Radio Robots	530
Cathode-Coupled Circuits	531
"Evrizone" Magic Midget	533
How the Valve Works, III—The Tetrode	534
News of the Week	537
Which Way Does the Current Flow? Unbiased	539
Television Topics : Magnetic Scanning	541
Readers' Problems	542
Making Short-Wave Components	543
Letters to the Editor	544
Crystal Band-Pass Filters, VII	546
Random Radiations	548
Recent Inventions	550

EDITORIAL COMMENT

Wireless Licences

The Post Office Share

AT a time when the B.B.C. is generally credited with being hard put to it to fulfil its obligations on its present revenue, it is perhaps natural to examine more critically than would be permissible in more normal times the diversions from the B.B.C. exchequer of portions of the 10/- broadcast listeners' licence fee.

Let us make it plain first of all that the B.B.C. has never been entitled to the whole of the fee, or in fact to any part of it. It is a fee payable to the Postmaster General for a licence to use a wireless receiver, and it is only as a matter of convenience that the amount so raised has been used to finance the B.B.C. and it has been useful to keep grants to the B.B.C. within the revenue derived from licences. It would have been equally correct if the financing of the B.B.C. had been carried out by grants from the Government and the licences paid to the Post Office regarded as a thing apart. Having established by custom the idea that the listeners' licence fee goes to provide the programmes and to meet the other expenses of the B.B.C. organisation, it seems fair to enquire whether the Post Office ought to extract from the licence revenue more than a sum sufficient to cover the actual cost to the Post Office of issuing licences to the public and dealing with the incidental expenses associated therewith.

As matters stand at present the Post Office receives 10³/₄d. on every 10/- licence. Knowing, as we do, what an extraordinarily efficient organisa-

tion the Post Office is, it strikes us as quite impossible that the cost of issuing licences to the public should be anything approaching the figure of 10³/₄d. a head. It would be interesting to know (if the information could be disentangled) what actual increases in staff, if any, have been necessary at Post Offices to cope with the handling of wireless licences. We should not be surprised to find that neither increases in staff nor salary increases were necessary to enable the additional work to be carried out. This leaves the question of additional staff at the General Post Office, which it is certainly probable has been necessary for this purpose. But can this amount to a figure of as much as ¹/₂d. a head of the public taking out wireless licences? We do not think so.

A Question of Equity

It is necessary, of course, to consider expenditure which the Post Office has undertaken on research in certain directions and also work on the elimination of electrical interference with broadcast reception, but we would contend that most of the research work has been in connection with the development of telephone lines, which work would have been carried out even had there been no broadcasting.

The B.B.C. is by no means a small customer of the Post Office, and every time that special telephone lines are used by the B.B.C. they are hired from the Post Office at a figure which, we are entitled to assume, is not unremunerative to that Department.

We should like to feel satisfied that these points have been properly investigated so that, if the 10³/₄d. allocation to the Post Office is to stand, we can rest assured that it is an equitable arrangement.

Television Reception

Aerial Feeder Distortion

ON another page we publish a report of a recent meeting of the Institution of Electrical Engineers, at which the contributors of one of the papers drew attention to the possibilities of picture distortion caused through mismatching of the transmitting aerial feeder.

It seems worth while to point out that it is conceivable, though admittedly unlikely, that a similar form of distortion might occur at the receiving end. Fortunately, it is possible to obtain much closer matching between feeder and receiver than between transmitter and feeder, where the conditions must be chosen for optimum transference of power. Furthermore, the receiving feeder is almost invariably much shorter than its transmitting counterpart, and so, if the reflections that are responsible for the trouble do occur, the ghost image will probably be so near to the true image that it may be unnoticeable.

Examinations

Antiquated Questions

A RECENT study of representative papers set by examiners for students in wireless and light electrical engineering prompts us to ask whether there is not need for a general investigation into the mentality, not of the students, but of some of those responsible for setting the papers.

Many of the questions set might well have appeared in examinations of twenty years ago and strike us as extraordinarily demodé to-day in the light of modern knowledge and taking into consideration, too, the nature of the average modern syllabus.

We are aware that the purpose of an examination is to test the candidate's education rather than his instruction, by which we mean that it is to discover whether he is able to apply the instruction he has received to new problems. For this purpose it is desirable that the questions should search for weaknesses in his fundamental knowledge rather than check his up-to-dateness as regards recent progress. Nevertheless we believe it should be possible to probe the mind of the candidate just as effectively if not more effectively by modernising the questions to a considerable extent.

The Loud Speaker Problem

A Ready-made Solution

A CORRESPONDENT, whose letter was published in a recent issue of *The Wireless World*, suggested that the main reason why so many listeners nowadays buy an extension loud speaker for use with their sets is not so much because of any inferiority in the quality of reproduction given by the built-in loud speaker as because they find that the position of the latter is unsuitable. In the case of radiograms and console receivers the loud speaker is usually situated very near the

ground, which, as our correspondent rightly pointed out, is a bad thing from many points of view. In any case, the loud speaker is far too near the ear if, in the interests of tuning convenience, the set is stood near the listener's fireside armchair as it usually is.

A solution to this problem of loud speaker position would seem to be already to hand in the form of the motor tuning system with which so many sets are nowadays fitted. The logical development of this tuning system is that the controls should be mounted on a small unit which could be conveniently placed on the arm of a chair, and, if this were done, the whole set could be placed at the other end of the room. Furthermore, there would no longer be any reason for the built-in loud speaker of console receivers and radiograms to be placed near the floor, since it is only the necessity of having the tuning controls at the top of the set which at present relegates it to that position.

Car Radio Sets

Can the Amateur Build Them?

SEVERAL readers have recently enquired whether we intend to publish constructional details of a car radio receiver; pointing out that our articles on this type of set have hitherto been confined to design and installation problems, etc.

It has been our attitude that car sets are inherently unsuitable for amateur construction. The need for extreme compactness does not make for easy assembly, or wiring, and, more important still, there is an extremely limited choice of suitable components on the market. When so many efficient factory-built sets are obtainable at quite reasonable prices it seems that no useful purpose would be served by

devoting space to the subject. A set designed for amateur construction would almost inevitably suffer from certain limitations from which the ready-made product is free, and it is hard to see where any compensating advantages could be found.

Wire and Wireless

Co-operation Replaces Competition

THE report of the proposal to supplement Empire cable circuits by wireless links would, in the form in which it was published last week, have made strange reading in the pre-War numbers of this journal.

Those were the days of intense competition and jealousy between the two forms of telegraphic communication; no wireless man could ever find anything good to say of cables, which he stigmatised as out of date, costly, vulnerable and expensive to maintain. The wire and cable partisans, for their part, were not slow to retort that wireless communication was not dependable and was at the mercy of atmospherics, deliberate jamming and eavesdropping.

Lack of secrecy, a shortcoming of wireless that has long since been virtually overcome, was a strong card in the hands of the opposition. America, before it joined the International Convention, was wirelessly in a state of anarchy, and so in that country warfare was unrestrained; certain New York newspapers, no doubt inspired by competing interests, used to publish private telegrams of an intimate nature that had been intercepted over the Clifden-Glace Bay transatlantic system. The same newspapers gleefully reported interruptions in communication, and it became necessary to devise a secret code for such service instructions as "stand-by for . . . hours; atmospherics are too bad."

Nowadays, wire and wireless are used for the purposes for which each is best fitted. Rationalisation and elimination of wasteful competition is, of course, all to the good, but one may be permitted a sigh in memory of the combative spirit of the old days which, if it served no other purpose, at least accelerated the progress of wireless technique.



THE "MACHINE GUN" MICROPHONE. Designed for use in outside broadcasts where the level of extraneous noise may be high, this Western Electric microphone is fitted with a bundle of 55 aluminium tubes with lengths which increase in uniform steps from 1½ ins. to 5ft. Each tube is sensitive to one particular frequency, but the resonances are so close that they merge and the frequency response on the axis is not appreciably modified. Sounds with frequencies above 350 cycles are considerably attenuated outside angles of 60 degrees on either side of the axis and the microphone has also been successfully employed indoors to overcome the effects of excessive reverberation.

Current-Carrying Capacity

IT DEPENDS ON THE POSITION OF THE WIRE

By N. PARTRIDGE, B.Sc., A.M.I.E.E.

BEING associated with a branch of electrical engineering in which the use of copper wire is an everyday experience, I am often asked "What the maximum current so-and-so gauge will carry." It is usually apparent that the enquirer expects me to reply, "So many mA's," with no more thought than would be required to tell him the time.

Unfortunately, the current-carrying capacity of a wire is not so simple as that. There is no "so many mA's" associated with "so-and-so gauge." The wire manufacturers do not add a current-carrying ingredient when the various sizes of wire are made, neither do they specify what their wires will handle. The user must find out for himself. The reason is that the method of using the wire has as much to do with its safe current density as the wire itself has.

Ohms Law tells us that the voltage required to drive current through a piece of wire will be the product of the current (in amps.) multiplied by the resistance of the wire (in ohms). The watts expended will be the product of the volts multiplied by the current (in amps.) which according to the law just stated is the same as the square of the current multiplied by the resistance. This energy appears evenly distributed throughout the mass of the wire in the form of heat. Heat in itself is not particularly alarming, but an excess of it in an inconvenient place can cause a lot of trouble.

Heat Dissipation

The temperature to which a body will rise when continuously supplied with heat depends upon (1) the rate at which the heat is supplied and (2) the rate at which heat escapes by conduction, convection and radiation. The former condition can be calculated exactly in the case of a wire carrying current as mentioned in the previous paragraph, but the latter condition is very much more vague.

The rate of loss of heat from a body cannot be deduced with precision, but it follows certain fixed rules. It is determined principally by (1) the area of surface exposed to the air, (2) the ease with which heat can pass from the interior of the body to the cooling surface and (3) the difference of temperature between the cooling surface and surrounding air. These facts are used in everyday life, mostly as a result of experience rather than on theoretical grounds. It is impolite but very effective to pour tea into one's saucer to cool it because a large area is presented to the surrounding air. We put on overcoats and

thicker "undies" in the winter to prevent heat escaping from us so easily as it otherwise would. Lastly, on frosty nights we like our fires to be a nice bright red, knowing that they throw off more heat that way than when dull red or black.

These considerations would lead one to expect that our imaginary piece of wire would keep cooler if stretched out in free air than it would if rolled up into a ball and wrapped in asbestos. Expressed another way, the former arrangement would require a higher current to produce a given temperature rise than would the latter.

Valves, resistances, chokes and transformers all have to dissipate heat. The conduction of heat to the surface is generally fixed by the nature of the component, and the only factors over which the designer has very much control are the rate at which heat is generated and the area of the external cooling surface. Valves with high anode dissipations have larger bulbs, not always to accommodate the "works," but to aid cooling. Five-watt resistors are longer and fatter than one-watt resistors for the same reason. Transformers and chokes bring us back once more to the question of wires.

Imagine a quantity of, say, 36 SWG enamelled wire wound tightly so as to form a cube of 10in. x 10in. x 10in. The external area will be 10in. x 10in. x 6in. = 600 sq. in. and the volume 10in. x 10in. x 10in. = 1,000 cu. in. The surface per unit of volume is only 0.6 sq. in. In other words, the heat generated in each cubic

inch has only 0.6 sq. in. of surface from which it can escape. Now consider a similar cube of, say, 2in. x 2in. x 2in. This time the surface area is 2in. x 2in. x 6in. = 24 sq. in., and the volume 2in. x 2in. x 2in. = 8 cu. in. The area per unit of volume is no less than 3 sq. in. This bundle of wire is very much more fortunate because each separate cubic inch has three whole square inches with which to cool itself.

There is another reason why the small cube is better off than the big one. Heat is rather like water or electricity in that it requires something similar to pressure or potential before it will flow from one place to another. A cold poker remains equally cold all over, but if heated at one end and then left for a little while, the cold end becomes warm and the hot end cool. This is because the temperature gradient, which corresponds to pressure or potential gradient, causes the heat to flow from the hot

to the cold end. When both ends attain the same temperature there will be no temperature gradient and a state of equilibrium will be reached.

Going back to the 2in. cube of wire, the centre point is only 1in. from the nearest point on the surface, while the centre of the 10in. cube is 5in. away from the surface. It is reasonable to expect that since the heat has a longer distance to go in the latter case, it will require a greater temperature difference to drive it. In other words, it looks as though the centre of the large cube will be very much hotter than the surface, much more so than in the smaller cube. In practice this reasoning must be applied the other way round. The temperature at the centre is limited to a fixed maximum value and the surface temperature of a small component will, therefore, be higher than that of a large component.

Everything operates against the efficient cooling of large transformers and chokes. They have less surface per unit of volume and for a given maximum internal temperature this reduced surface must be cooler and therefore less effective as a radiator than is the case with small components. The safe current-carrying capacity of a given wire is, therefore, lower when it is employed in a large transformer than when used in a small one.

The accompanying table indicates the extent of this variation. Column "A" gives the current that may safely be carried by the various gauges when stretched out in a straight run as in electric light or bell

It is seldom appreciated how great is the difference between the safe current-carrying capacity of a wire freely suspended in air and another of the same gauge buried amidst the multiple windings of a mains transformer. This matter is explained in the present article, and helpful information is given on the choice of suitable wire gauges for different conditions.

S.W.G.	Approx. Current-Carrying Capacity in amps.		
	A	B	C
16	12.9	5.3	3.2
18	7.2	3.0	1.8
20	4.0	1.68	1.0
22	2.5	1.02	.62
24	1.54	.63	.38
26	1.03	.42	.254
28	.70	.285	.172
30	.49	.200	.120
32	.37	.150	.092
34	.27	.110	.066
36	.18	.075	.045
38	.115	.045	.028
40	.073	.030	.018

Current-Carrying Capacity—

wiring. The next column "B" shows the corresponding currents that would be safe in a small transformer weighing about 3 or 4 lb., while column "C" indicates a similar set of values for a larger transformer of about 20 or 30 lb.

The maximum safe temperature at which any electrical machine or device may work continuously is limited by the nature of the materials used in its construction. Certain insulators perish if kept very warm for long periods. There are two groups into which insulators may be roughly divided. The first is made up of organic materials and contains such things as cotton, silk, enamelled wire, etc., which should not be heated more than 55 deg. C. above normal air temperature. The second group is less sensitive to oxidation and embraces mica, asbestos and similar inorganic materials which can be allowed to rise to 75 deg. C. without harm.

It is the maximum temperature at the centre of the component with which we are concerned and neither its average temperature nor its external temperature. Fortunately, it is not difficult to estimate the temperature of any part of a bobbin wound with wire because the resistance of copper varies with temperature. Thus by measur-

time of the innermost winding of a mains transformer delivering 250-0-250V, 60 mA, 4V, 2 amps. and 4V 4 amps.² The weight of the component was 3½ lb. It will be noted that the rise is well within the limit of 55 deg. C. mentioned above, although the surface of the bobbin felt distinctly hot

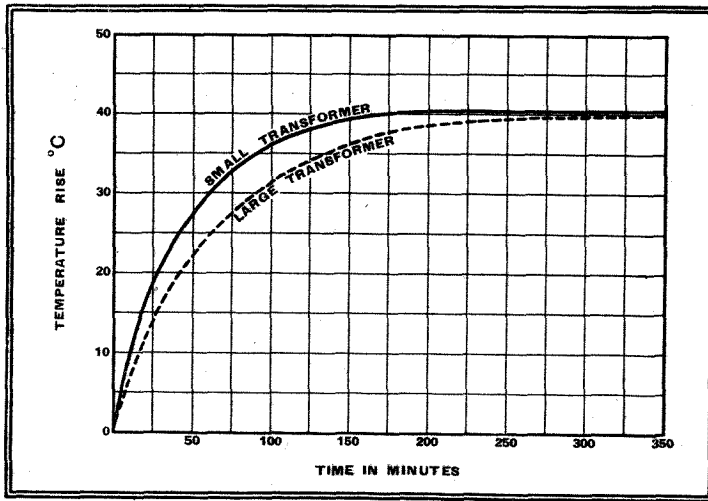

Fig. 1.—Showing the temperature rise that takes place in the innermost windings of typical mains transformers.

when touched by the hand.

The dotted line in Fig. 1 is a similar curve for a larger transformer. The same

² See Appendix, Note 2.

final temperature is attained, but in this case the exterior of the component felt quite cool to the hand. This was due to the greater difference of temperature between the interior and the surface which, as already explained, resulted from the greater distance from centre to surface.

It will be seen that the two curves do not rise together. Large components employ lower current densities and less heat is liberated per unit of volume in a given time. The natural result of this is slower heating.

APPENDIX.

1. The resistance of copper over the range of temperatures involved may be calculated from the following formula:—

$$\frac{R_2}{R_1} = \frac{T_2 C + 234.5}{T_1 C + 234.5}$$

where R_1 = resistance at T_1° C.
and R_2 = resistance at T_2° C.

2. The heating curve of a homogeneous body is an exponential following the law:—

$$t_r = T_r \left(1 - e^{-\frac{t}{T}} \right)$$

where T_r = maximum final temperature rise.

t_r = temperature rise after a time t .

T = time constant depending upon rate of supply of heat.

Transformers are not strictly homogeneous and do not follow the above law very closely and can be checked from the curves given.

Radio Robots

A TELEVISION-CONTROLLED UNDERSTUDY

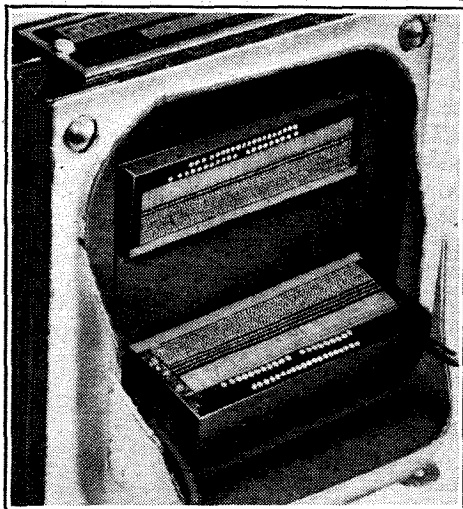

A typical mains transformer sawn through to expose a sectional view of the windings. It is obvious that the conditions for rapid heat dissipation cannot be favourable.

ing the resistance of the section of the winding under observation when cold and again when hot the change in temperature can be calculated from the change of resistance.¹

A typical heating curve is shown in Fig. 1. It indicates the temperature rise with

¹ See Appendix, Note 1.

TO-DAY'S wireless receiver is uncommonly—or shall we say uncannily—like a radio Robot. We are bluntly told to "press the button and the set will do the rest." Then if we have paid enough for our "box of tricks" it will proceed to counteract fading, control selectivity, mute the loud speaker as and when necessary, and bring the circuits precisely into tune with whatever station is wanted. It is all done automatically, and so smoothly and cleverly that it hardly gives the owner much chance of using any intelligence he may possess in his own right.

Next year, with the help of selective microphone relays, we shall probably be able to get any station we want simply by "calling" for it. In due course television sets will follow suit, and we shall have two radio Robots at our beck and call, one for seeing and the other for hearing.

Meanwhile F. von Okolicsanyi, a Hungarian television expert, proposes to take matters a stage farther. His idea (Patent No. 486604) is to enable an ordinary man to control, from a distance, the behaviour of an "artificial man—or what is called an Anthrophor"—in such a way that it is extremely difficult to distinguish "t'other from which." The human and the robot are linked together by television and speech channels, and by a system of electrical relays which are capable of "re-

peating" mechanical movements, with the result that the Anthrophor becomes, in effect, an animated counterpart or projection of its master.

Imagine, for instance, an important conference at which all the members except the chairman are actually present. For reasons best known to himself, the chairman prefers to be represented by his Anthrophor, who is duly installed at the head of the table. The conference starts, and Mr. Anthrophor is switched into circuit.

At that particular instant the Robot's eyes may happen to be directed towards a blank wall. This view is televised back to the absent chairman who, recognising the vista, moves his head to one side or other in search of something more interesting. The movement is automatically "repeated" by electric relays back to Mr. Anthrophor until the latter's television outfit picks out the face of a particular delegate. The real chairman then keeps his head firmly fixed in this direction (Mr. A., of course, following suit) and speaks words of solemn import, which are transmitted through a microphone and loud speaker so that they appear to issue direct from Mr. A.'s mouth. Should he wish to emphasise a point, the real, but remote, chairman can thump his own table, and the movement is faithfully relayed to, and repeated by, his robot substitute

Cathode-Coupled Circuits

THEIR PECULIARITIES AND APPLICATIONS

By W. T. COCKING

IT is by no means uncommon nowadays to include an impedance in the cathode circuit of a valve. In television, for instance, cathode-followers are quite commonly used. With a cathode-follower the load impedance of the valve is placed in the cathode instead of the anode circuit, and there is, consequently, very heavy negative feed-back. The stage does not amplify, but has a very low output impedance.

A similar arrangement is used for phase-splitting for feeding push-pull amplifiers. Here two equal loads are used and one is connected in the anode and the other in the cathode circuit. Tuned circuits are sometimes connected in the cathode circuit of an IF valve to give good band-pass characteristics through negative feed-back action,¹ and a detector has appeared which operates on the anode bend principle but with a cathode load giving negative feed-back.² This is the so-called infinite input impedance detector.

When the load is in the anode circuit of a valve the importance of feed-back through the grid-anode valve capacity is well recognised. It is not always realised, however, that a similar action involving the grid-cathode capacity takes place when a cathode load is used. The effect of the capacity is not as great as that of the grid-anode capacity, it is true, but it is suffi-

and if the cathode load Z is fairly large compared with the AC resistance R_a of the valve, the output volts e_2 are nearly equal to the input volts e_1 . In practice, e_2 is often 80-90 per cent. of e_1 . When this is the case it is often said that the grid-cathode capacity C_{gc} has a negligible effect, because the only voltage across it is the

difference of the input and output voltages. Actually, however, the voltage must be subtracted vectorially, for the output and input voltages are not necessarily in the same phase.

The grid-cathode capacity is by no means always negligible and with a suitable cathode load the input resistance of the valve can become negative.

If the valve is fed from a tuned circuit it will oscillate if the negative input resistance becomes lower than the dynamic resistance of the tuned circuit.

In the case of an anode circuit coupling, it is well known that a negative input resistance is obtained when the anode load is inductive and sufficiently high in value.

With cathode coupling an inductive load gives a positive input resistance, and it is necessary to use a capacitive load to obtain negative resistance effects.

Negative Input Resistance

With the arrangement of Fig. 2, which is actually the circuit of the so-called infinite input impedance detector, the input resistance is negative if gRC/C_{gc} is greater than $(1 + R/R_a)$ where g and R_a are the mutual conductance and AC resistance of the valve. Normal circuit values for the detector are $C = 100 \mu\text{F}$. and $R = 50,000$ ohms, while a valve of the 10,000 ohms class is usually recommended. Such a valve usually has a mutual conductance of 2.0 mA/v. Under working conditions, however, R_a may be 20,000 ohms and $g = 1$ mA/v only, while C_{gc} may be $7 \mu\text{F}$. Taking these values at 465 kc/s, the input resistance works out at $-209,000$ ohms.

A good IF transformer may well have circuits of higher dynamic resistance than this, and if it has the circuit will oscillate. In practice, it does oscillate quite readily even when the negative resistance is higher than this figure. This is because the detector is generally used after several stages of amplification and there is already some regeneration taking place, so that it

requires little more to make the circuit oscillate.

The remedy is, of course, to connect across the tuned circuit a resistance equal to the negative input resistance, so that regenerative effects are avoided. It should be noted that by making C variable it can be used as a control of regeneration, the negative resistance increasing as the capacity is increased. The input capacity also varies, however, so that the tuning is affected. It should be noted that the input capacity is always less than the grid-cathode capacity. This is, of course, apart from the grid-anode capacity which appears in shunt with the input.

The Colpitt's Oscillator

The input resistance is a minimum when C and C_{gc} are about equal in value and it rises as their capacity increases. If the circuit is to be used as an oscillator, therefore, the capacities should be made equal and large enough to ensure satisfactory oscillation with the tuned circuit adopted. When $C = C_{gc}$ the input capacity becomes approximately $C_{gc}/2$ and places a limit to the maximum value of capacity which can be used with a given coil.

It should be noted that the circuit is not a new oscillator, for it is nothing more than the Colpitt's oscillator. In the true Colpitt's circuit C and C_{gc} are both variable and of equal capacity since they are the two sections of a gang condenser; R is

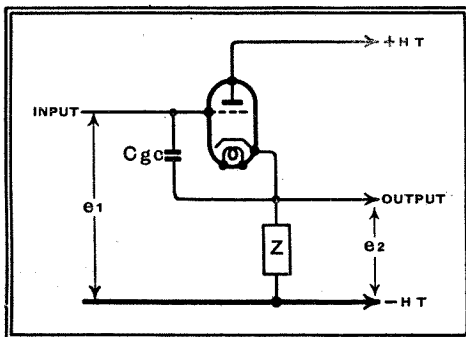

Fig. 1.—The basic cathode-coupled circuit is shown here.

cient profoundly to modify the action of some circuits.

The basic circuit is shown in Fig. 1.

¹ The Wireless World, April 30th, 1937.

² The Wireless World, January 1st, 1937.

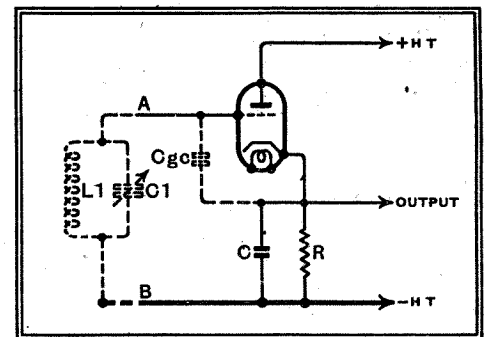

Fig. 2.—This diagram shows cathode-coupling applied to an anode bend detector.

usually replaced by an RF choke. In the form shown in Fig. 2 the circuit becomes the true Colpitt's oscillator only when the tuning capacity C_1 is small. In general it is satisfactory for capacities up to $100 \mu\text{F}$., but fixed values of C and C_{gc} are not very good for larger tuning capacities and it is then necessary to adopt the true Colpitt's oscillator with a two-gang condenser. The two sections being connected as C and C_{gc} ; C_1 being omitted.

It may be remarked that the circuit of Fig. 2 is liable to parasitic oscillation at about 75 Mc/s unless the circuit is carefully arranged. Such trouble normally occurs only when the tuning condenser C_1 is connected directly across L_1 and the

Cathode-Coupled Circuits—

leads to the valve are more than an inch or two in length. At the parasitic frequency the tuning capacities are C and C_{gc} and the inductance is that of the leads A and B. The condenser C₁ becomes no more than a blocking condenser, shunted by an RF choke made up of the coil L₁.

In general, the trouble occurs only when C₁ exceeds about 100 μF, and the frequency of oscillation is then largely independent of C₁ and L₁. All trouble can usually be avoided by reducing the lengths of the leads A and B; this reduces their inductance and so raises the possible oscillation frequency. When this is raised above 100 Mc/s or so no ordinary valve will oscillate and so no parasitic oscillation is found. This is a better remedy than the insertion of stopping resistances, since it leaves the normal operation of the circuit unaffected. To avoid trouble, there-

the circuit values are chosen so that R₁ + R₂ = R₃. The condenser C represents the stray capacity across the cathode load. Because of C_{gc} this will lead to a negative input resistance at very high frequencies, and if no other effect came into play could make a circuit connected to the input oscillate. Such a circuit might conceivably be formed by wiring inductance and capacity. In this particular application, however, there is also feed-back from the anode circuit through C_{ga} and this will give a positive input resistance component. The feed-back through C_{ga} will thus largely neutralise that through C_{gc} and the input resistance will be very high.

A major cause of distortion with a Class B₂ output stage is its low and variable input impedance; this can only be made unimportant by feeding it from a stage

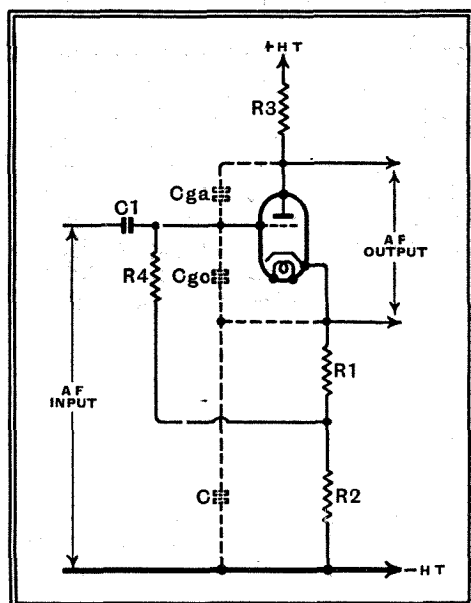

Fig. 3.—The well-known phase-splitter for resistance-coupled push-pull amplifiers is an example of cathode-coupling.

fore, the leads from the tuning condenser to the valve must be short. Long leads in the coil circuit are not important from this point of view.

Push-Pull Phase-Splitter

This possibility of parasitic oscillation must be borne in mind in other applications of cathode-coupled valves. In an AF circuit, for instance, the cathode-coupling resistance always has some capacity in shunt with it and it will often be of the same order as the grid-cathode capacity. The input resistance will consequently be negative and quite low at ultra-high frequencies. Consequently, if the grid circuit wiring can form a tuned circuit at these frequencies and its damping is not too high, parasitic oscillation will occur. No trouble is usually experienced because the wiring is generally very short in AF circuits and no suitable resonance circuit is formed.

The usual phase-splitting circuit for push-pull operation is shown in Fig. 3 and

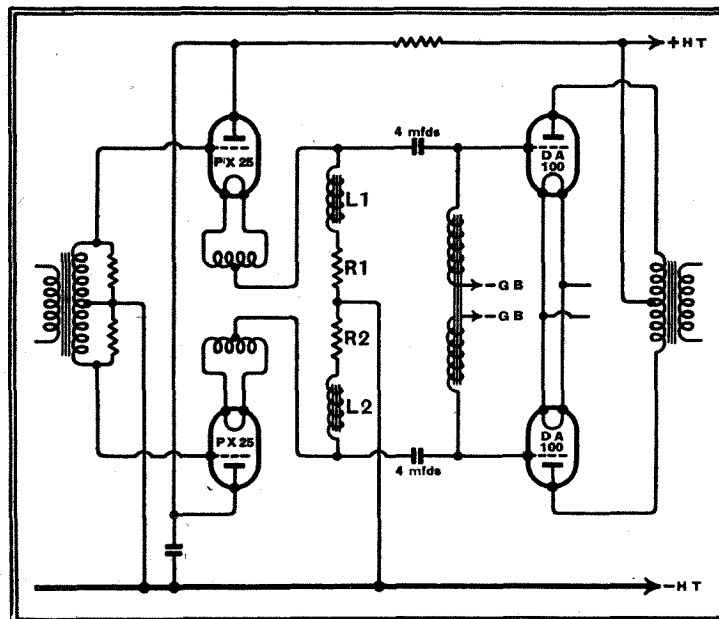

Fig. 4.—In the case of a large Class B₂ output stage cathode-coupling is adopted in the driver stage.

One of the main reasons for using a cathode-follower, so called because the cathode potential follows the grid potential, both being taken with respect to earth, is that it has a very low output impedance. The output impedance of the arrangement of Fig. 2 and ignoring capacity effects is nearly equal to 1/g. Quite an ordinary triode may have g = 2.0 mA/v. so that the output resistance is of the order of 500 ohms only.

Because of this low output resistance a cathode-follower is sometimes used as a driver stage before a large Class B₂ output stage. Choke or transformer coupling is used instead of a resistance, in order to obtain a coupling of low DC resistance, but the primary reason for using a cathode-follower is to reduce distortion.

having an output impedance low compared with the lowest value of input impedance. The cathode-follower is such a stage and an example of its application as a driver is shown in Fig. 4. The DA100 output valves are run in Class B₂ and are fed from a push-pull driver stage using PX25 valves as cathode-followers. Their output impedance is of the order of 70 ohms only!

The chokes L₁ and L₂ are of about 25 H. each and the DC resistance of the choke together with the series resistance R₁ (or R₂) should be 530 ohms to give the correct grid bias for the PX25.

In ordinary broadcast equipment the cathode-follower does not find much application, but there is one point at which its use may prove beneficial. This is imme-

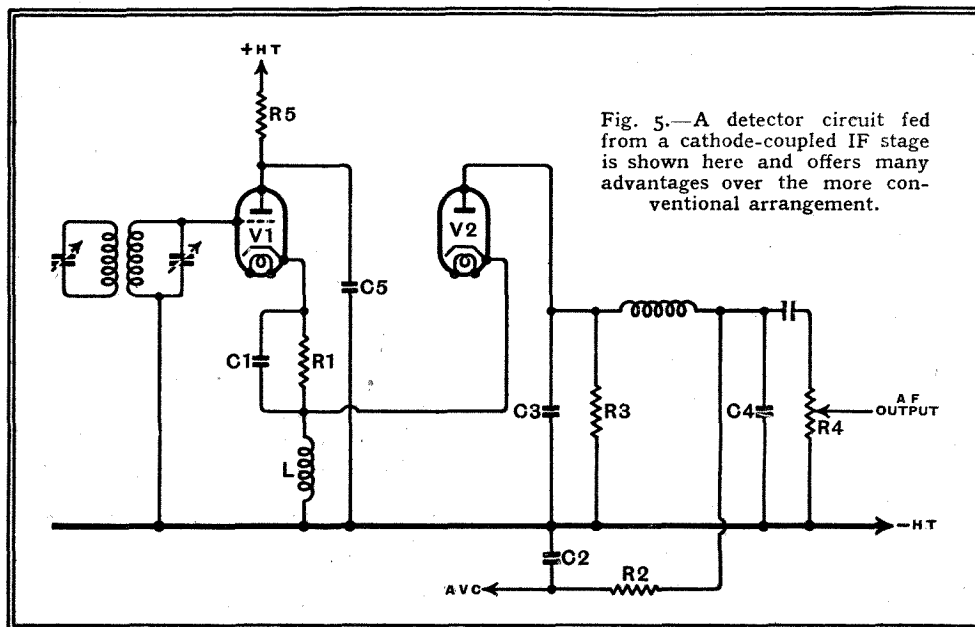

Fig. 5.—A detector circuit fed from a cathode-coupled IF stage is shown here and offers many advantages over the more conventional arrangement.

Cathode-Coupled Circuits—

diately before a diode detector. With such detectors the difficulty is that the ratio of the AC load impedance to the DC load resistance must be as near unity as possible if amplitude distortion is to be avoided on deep modulation. The ratio cannot, in practice, be made greater than about 0.7 unless the DC load is made quite low in value, say 100,000 ohms or less. If this is done the input impedance of the detector becomes low, usually less than 50,000 ohms, and damps the input tuned circuit heavily.

This damping reduces selectivity and amplification, and also limits the undistorted output of the last IF valve. Detector design is thus essentially a matter of compromise between a large number of conflicting factors. It was largely to avoid these troubles that the infinite input impedance detector was put forward. This detector has the disadvantage, however, that it cannot provide AVC and it is probably this more than any other factor which is responsible for its being so little used.

Pre-Detector Stage

All the difficulties can be overcome, however, by feeding a diode detector from a cathode-follower on the lines shown in Fig. 5. The output impedance of V_1 , measured across the coil L , will be of the order of 500 ohms only if a valve of the MHL4 class with a mutual conductance of 2.0 mA/v and an AC resistance of 10,000 ohms is used. The input resistance of the detector will, with any likely values of load impedance, be so much higher that it becomes unimportant.

The detector can thus be designed without reference to input impedance and the DC load R_3 can be made 50,000 ohms or even lower without affecting selectivity. If R_3 is made too low, of course, the detector efficiency will fall and the detector will be less linear, but even these effects can be overcome by using one of the low-impedance television diodes for V_2 instead of the ordinary kind.

Reasonable circuit values for the detector portion of Fig. 5 would be $R_2 = R_4 = 0.25 \text{ M}\Omega$, and $R_3 = 20,000\Omega$, giving a ratio of AC to DC load of 0.925, and $C_3 = C_4 = 0.0005 \mu\text{F}$. and $C_2 = 0.1 \mu\text{F}$. V_2 can be the two diodes of a valve such as the D41 strapped together, or, better, a D42.

For the cathode-follower a valve such as the MHL4 is suitable and R_5 and C_5 can be 500 ohms and $0.1 \mu\text{F}$. respectively. C_1 and R_1 provide grid bias and suitable values are $0.1 \mu\text{F}$. and 1,000 ohms. The coil L should, of course, be screened and of low DC resistance, otherwise the current through it will set up an appreciable voltage drop across it which will be applied to the diode as negative bias on the anode.

At an intermediate frequency of 465 kc/s an inductance of $1,000 \mu\text{H}$. is suitable, and the writer has used a Wearite Type P AF coil successfully. With the inductive cathode load, the input resistance of V_1 is positive and with the value quoted is of high value—several hundred

thousand ohms. The IF transformer is thus quite lightly damped and yet there is little danger of actual instability.

If L is shunted by a condenser of suitable value the input resistance does become infinite. If the condenser is larger than this, the input resistance becomes negative and the circuit may oscillate. In general, therefore, selectivity, and of course, sensitivity, can be increased by connecting a condenser across L . The correct value must be found by trial and if it is desired to try it, it is suggested that

a pre-set condenser of about $0.0002 \mu\text{F}$. capacity and with a low minimum capacity be used. Too large a capacity will usually make V_1 oscillate.

In a short-wave set the cathode of V_1 makes a very convenient point to which a beat-frequency oscillator can be coupled. A small condenser between the BFO tuned circuit and the cathode of V_1 will normally provide a suitable amplitude of injected voltage with a complete absence of pulling and other untoward effects. Large amplitude is hard to obtain, however.

“Evrizone” Magic Midget

NEW “OVERSEAS” MODEL WITH
THREE SHORT WAVEBANDS

THE circuit of this AC/DC transportable is the same as that of the standard model which we reviewed in our issue of February 10th, 1938. It is a superheterodyne consisting of a triode-hexode frequency-changer, variable-mu pentode IF amplifier, double-diode-triode second detector and pentode.

Frame aerials in conjunction with a certain amount of “vertical” pick-up are used on all four wavebands, which in the present case cover wavelengths from 13 to 555 metres without a break. There is provision for the attachment of a short external aerial, but the efficiency of the internal aerial system is such that the external aerial will be in most cases quite unnecessary.

The set was tested inside a steel-framed building 15 miles from Brookmans Park and again in a brick house at a distance of 5 miles. The latter situation is a severe test of selectivity on the medium-wave band, but the receiver was able to clear the London Regional transmitter completely when mistuned only $1\frac{1}{2}$ channels from its normal setting.

We were very favourably impressed by the quality of reproduction, particularly on speech, which is remarkably clear and natural. The full bass of the orchestra is, of course, missing in so small a set, but the reproduction suits smaller combinations such as quintets.

As on the previous occasion we were unable to tune in America, but all the principal European short-wave broadcast-

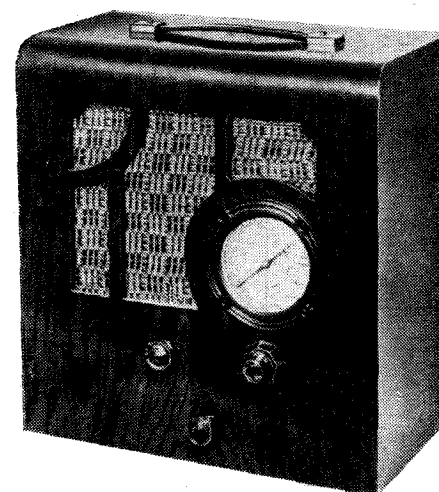

In the “Overseas” model of the Evrizone Magic Midget transportable an additional short-wave band (70-220 metres) takes the place of the long-wave range. The set covers 13-555 metres without a break.

ing stations were strongly received even inside the steel-framed building. The recently added “trawler” band is particularly sensitive and brings in many telephony transmissions of interest. There can be little doubt that the range of this set is sufficient to ensure an adequate choice of stations in any part of the world and the omission of the long-wave band in order to extend the range in the lower wavelengths where the frame aerials are more efficient is a logical step.

The price of the “Overseas” model is 9 guineas and the weight is between 14 lb. and 15 lb. The makers are Evrizone Radio and Television Co., Ltd., 2, Southlands Road, Bromley, Kent.

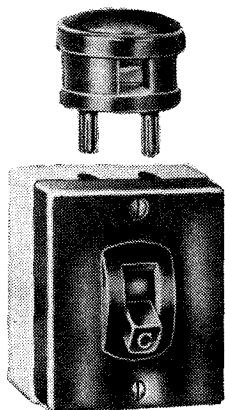

COMBINED LIGHT SWITCH AND POWER OUTLET. Wireless people will welcome this device, recently introduced by J. A. Crabtree and Company. It combines a switch for the room light with a 2-amp. unswitched outlet, and is little, if any, larger than a standard rectangular switch, though conveniently arranged for the extra wiring needed.

The Wireless Industry

NATIONAL RADIO AND TELEVISION SERVICE COMPANY announces that, to cope with the usual pre-Christmas rush of service and other work, the factory and order department will be kept open each day from 8 a.m. to 10 p.m. until December 23rd.

A comprehensive and informative catalogue of Rogers-Majestic receivers has just been issued by R.M. Electric, Ltd., Majestic Works, Oaklands Road, London, N.W.2.

The present range of McMichael receivers are described and illustrated in a new pocket-size catalogue issued by McMichael Radio, Ltd., Slough, Bucks.

How the Valve Works

Part III.—The Tetrode

FOLLOWING the triode we come to the tetrode or four-electrode valve. Briefly, a tetrode can be described as a valve with *two* concentric grids between anode and cathode. There are, however, several different kinds of tetrode. The earliest types were those known as bi-grids, and they were used in two ways. In one the outer grid was the control grid and the inner grid was kept at a fixed positive potential by a battery.

The result of this was a relatively high anode current for a low anode voltage and some types were produced that would function with an anode supply of no more than 6 volts. The performance, however, was generally inferior to that of the triode and they were not greatly used.

The other use of such valves was as a superheterodyne frequency-changer, the

It is clear that with such an arrangement if this extra grid is maintained at an unvarying potential with respect to cathode it will act as an electrostatic screen between grid and anode. The screening will not be perfect as the grid is a mesh structure, but it is actually fairly complete and reduces the grid-anode capacity to about 0.001-0.005 $\mu\mu\text{F}$. only. Naturally, this is obtained at the expense of increased input and output capacities, for the grid and anode each have a capacity to the screen. Notice also that the screening is only effective if the screen grid is maintained at a fixed potential relative to the cathode.

In practice, the anode has a potential of about 200-250 volts applied to it and the screen is kept positive with respect to cathode by about 60-100 volts. The con-

ADDING ELECTRODES ONE BY ONE

trol grid is kept negative, just as with a triode. In use the valve is connected up very much like a triode, the main difference being the necessity for providing the screen potential.

The internal action is rather different, however, and the characteristics obtained are quite different. Owing to the presence of the screen grid the anode voltage now has very little effect on the anode current, for it is very largely screened from the cathode by the screen grid.

The easiest way to understand what goes on is to picture the cathode, control grid and screen grid as the cathode, grid and anode of a triode, and ignore for the moment the anode proper. Electrons emitted from the cathode form the usual cloud around it which we call the cathode space charge, and many of them are attracted to the screen grid by its positive potential. In flying to it they pass through the meshes of the control grid, since this is negative and repels them. The number reaching the screen grid depends upon its potential and upon the control-grid potential, since the force acting on the space charge is a function of the potential of both electrodes.

The Screen-Anode Space

Now comes the difference from the triode. The electrons fly to the screen at high velocity, and since it is not solid, but a mesh structure, many fly through its interstices. Those that do so find themselves between two positive electrodes, the screen and the anode. The anode is the more positive of the two, but whether it exercises the greater attractive force on any individual electron depends on the position of that electron.

Electrons which only just succeed in passing the screen and so do not move far from it are attracted more by the screen than by the anode and so fall back into it. Higher velocity electrons passing through the meshes of the screen to a greater distance from it are attracted by the anode and so carry on their course to it. The anode can collect only those electrons which have sufficient velocity to carry them beyond the main influence of the screen and, within limits, it collects all these irrespective of its actual potential. Consequently, the anode current is not affected to any large extent by anode voltage.

An increase in screen potential, however, increases anode current for it attracts more electrons to itself as a whole and more consequently pass its meshes.

In this third article of the series, the screen-grid valve or tetrode is dealt with in detail. It will be followed by a discussion of the pentode and the latest kinkless tetrodes.

signal being applied to one grid and the other being used in conjunction with the anode for the oscillator. Even for this purpose the valves never had a very wide vogue.

Tetrodes, as they are understood to-day began with the screen-grid valve, and for some years were very widely used. They were then largely superseded by the pentode, for it was found that by the introduction of a third grid the characteristics could be considerably improved. Since then it has been possible to obtain the desired improvement without the third grid and the result is that the tetrode is now staging a come-back.

The Screen-Grid Tetrode

In view of this it will probably be confusing to adhere strictly to the principle of treating all tetrodes together and then going on to discuss pentodes. It will be simpler to deal with tetrodes and pentodes together, in the order of their actual development.

We start with the screen-grid valve. This was developed primarily to reduce the grid-anode capacity to a negligibly small figure and so to avoid the instability problems inherent with triodes in RF amplifiers. It was found, however, to possess, in addition, other desirable characteristics.

Essentially the valve consists of the cathode, grid and anode of a triode arranged in much the same way as in a triode, but with another close-mesh grid between the grid proper and the anode.

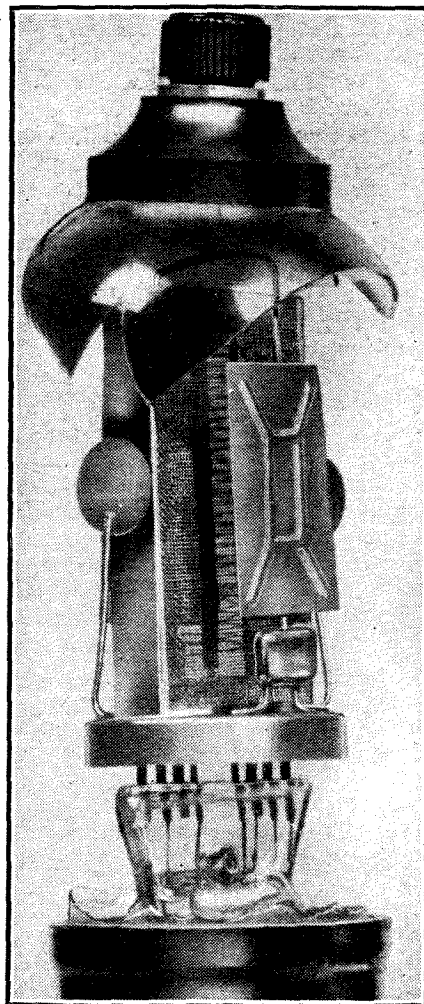

The glass envelope has been removed from this AC screen-grid valve to show the arrangement of the electrode assembly more clearly.

How the Valve Works—

Similarly, making the control grid less negative increases both screen and anode currents.

From the above it might be thought that the screen current would be much greater than the anode current. This is not so, however, for many more electrons pass the meshes than land on its wires, and in practice the screen current at the normal operating point is rarely greater than one-quarter of the anode current.

Now the grid-volts-anode-current curves of a tetrode are of much the same shape as those of a triode, but the anode-volts-anode-current curves are quite different. As the anode current is largely independent of anode voltage, the AC resistance is very high and the curves take the form of nearly horizontal lines.

The mutual conductance is of the same order as that of a triode, 1-4 mA/v., so that the amplification factor is also very high. A typical valve might have a mutual conductance of 2.0 mA/v. with an AC resistance of 250,000 ohms, giving an amplification factor of 500.

Now we know that with a triode the anode current falls gradually to zero as the anode voltage is reduced, in the way illustrated by curve A of Fig. 10, and we should naturally expect the same thing to happen with a

An anode displaced and one side of the screening grid torn open to show the grid and cathode elements in the same valve as that illustrated on preceding page.

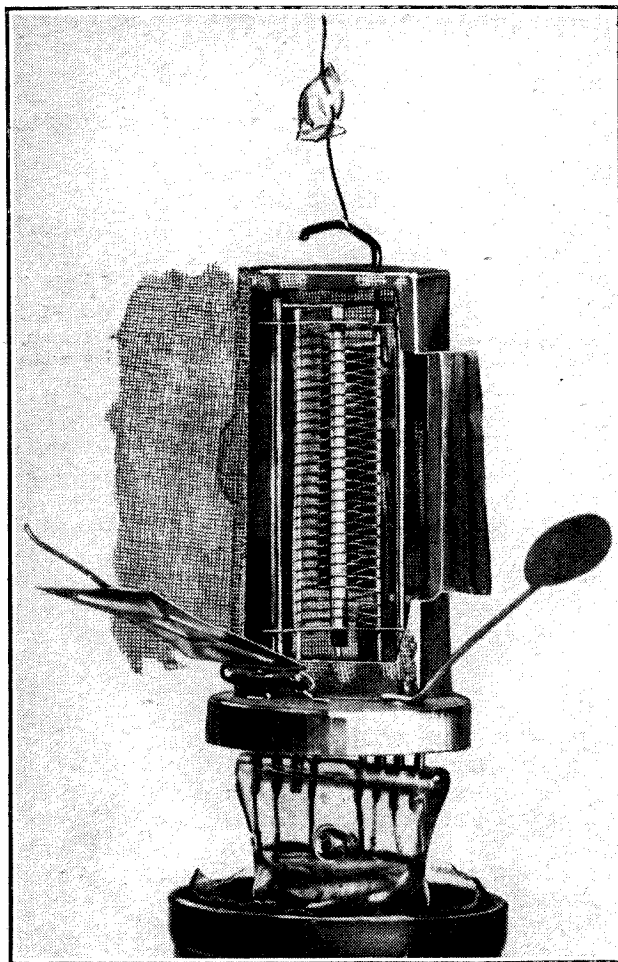

tetrode. Usually, however, it does not. As the anode voltage is lowered the anode current falls only very slowly at first until the anode potential becomes of the same order as the screen-grid voltage. For a further decrease in anode voltage the

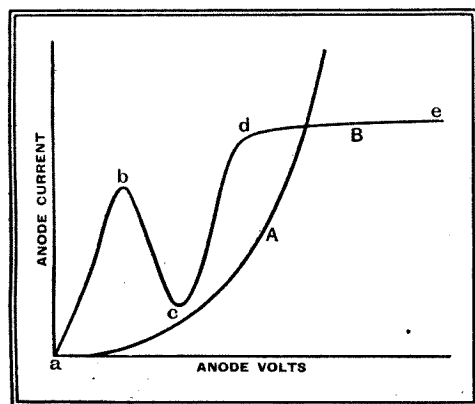

Fig. 10.—Curve A illustrates a typical triode characteristic and curve B that of a tetrode of the screen-grid type. Note the negative resistance portion *bc*.

anode current falls off rapidly. At another critical voltage, however, this falling-off ceases and a further drop in voltage makes the anode current rise! At a still lower voltage the rise ceases, and thereafter the current falls off steadily to zero at zero anode volts.

This state of affairs is depicted by curve B of Fig. 10. The first part considered is the flat top *de* over which normal operation takes place. At *d* the anode and screen potentials are of the same order,

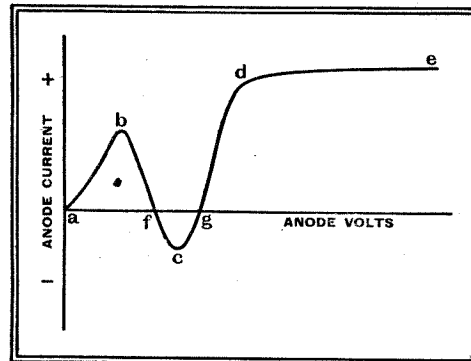

Fig. 11.—The tetrode curve may show negative values of anode current, as over the range *Feg*.

velocity. Although one primary electron may cause several secondary electrons to be emitted from the anode, these secondaries have a lower velocity than the primary.

In the case of a triode with negative grid, the secondary emission from the anode does little harm, for the electrons all fall back again into the anode. The same thing happens in the tetrode as long as the anode voltage is greater than the screen voltage, for then the anode attracts them to itself.

When the anode is at a lower potential than the screen, however, some of the secondaries may be more attracted by the screen than by the anode and so pass to this electrode, thus reducing the anode current.

Secondary Emission

Suppose we start from the point (*a*) with zero anode voltage. The anode current here is zero because it does not attract the electrons which pass the screen. These electrons consequently fall back into the screen and in passing through the screen and falling back to it they form a cloud outside the screen. There is consequently a space charge outside the screen and it is from this that the anode draws electrons to form the anode current when the anode potential is raised over the range (*ab*).

Over this small range the action between anode and screen space-charge is similar to that between the anode and the cathode space charge of a diode. As the point (*b*) is reached two things are happening. The anode is exercising sufficient attractive force to collect nearly all the electrons passed by the screen, so that the space charge is rapidly disappearing, and many of the electrons arriving at the anode do so with sufficient velocity to knock out secondary electrons.

At first these secondaries fall back to the anode, but as the anode voltage is raised and the primary electron velocity increased, the secondaries have a greater velocity and come within the attractive force of the screen. Over the range (*bc*) the anode current falls with increasing voltage because although an increase in voltage attracts a greater number of primary electrons to the anode, still more secondaries leave the anode and go to the screen.

and the current falls rapidly over *cd* as the anode voltage is further lowered. The rising current at still lower voltages is represented by *bc*, and the final fall in zero by *ab*.

The kink *bcd* in the curve represents a defect from most points of view, although on occasion it can be put to good use. The ideal tetrode curve would not have this kink, and can be obtained with pentodes and some of the latest tetrodes.

It is, however, instructive to see the reason for this kink. It is caused by secondary emission. Electron emission can be obtained not only by heating a suitable substance as in the case of the cathode, but also by bombarding a substance with sufficiently high-velocity projectiles. Electrons are such projectiles, and if they strike the anode with sufficient velocity each electron may knock out several others.

The number of electrons knocked out, or secondary electrons, depends on the material of the anode and upon its condition, apart from the primary electron

How the Valve Works—

This does not go on indefinitely, however, because the rising anode voltage at length begins to exercise a considerable attractive force on the secondaries, and so tends to prevent their passing to the screen. At the point (c) the tide turns and thereafter the anode regains control and secondaries pass to the screen in fewer and fewer numbers. The anode current consequently rises rapidly over (cd) and for higher voltages the anode not only collects nearly all the electrons passing the screen, but is powerful enough to prevent most of the secondaries from reaching the screen.

In some cases, the whole curve is lower than is shown in Fig. 10, and the anode current may be negative over a portion of it. Such a curve is given in Fig. 11, and over the range *fcg* the anode current is negative; that is, instead of flowing from the anode to the HT supply, it flows from HT to anode.

The action is the same as before, but at the points *f* and *g* there are as many secondary electrons leaving the anode and passing to the screen as there are primaries arriving at the anode. Consequently, the two balance and the external anode current is zero. Between *f* and *g*, more secondaries pass from anode to screen than primaries arrive at the anode and the current is negative. This negative current is not common, but is sometimes found. More often the curve is of the type shown in Fig. 10.

The chief disadvantage of this curiously shaped curve is that the output of the valve is restricted, for the instantaneous anode voltage cannot be allowed to swing below the point *d*. This is unlikely to happen in any case when the valve is used as an RF amplifier handling only weak signals, and it is for this purpose that the valve was first introduced and proved very successful.

With large signals, however, difficulties arose, and as an AF valve the kink in the curve seriously limited the power output and rendered this type of valve unsatisfactory in the output stage. The screened tetrodes were, of course, in any case unsuitable for power output owing to their low anode current, but types specially designed for output stage work were inferior to triodes on account of the kink in the curve. It should be noted that over the range *bc* where a fall in anode voltage causes an increase in anode current, the AC resistance of the valve is negative, and it will consequently make a tuned circuit connected to the anode oscillate. Used in this way the stage is a dynatron oscillator and has many applications.

While the dynatron oscillator is very useful, it is not very widely used because individual valves vary considerably in their characteristics over this portion of their curves. Secondary emission is rather difficult to control in manufacture, and in any case valve makers try to avoid it rather than to promote it in these valves. Consequently, when a dynatron oscillator is wanted, it is often necessary to pick the valve specially.

In Next Week's Issue**Three-Band AC Super****A Modern General Purpose Receiver**

FOR general broadcast reception a high standard of quality of reproduction, together with high sensitivity and good selectivity, are needed. The requirements are most easily satisfied with the superheterodyne and in the interests of a good signal-to-noise ratio the use of an RF stage is highly desirable.

The Three-Band AC Super incorporates such a stage with a low-noise hexode. There are two signal-frequency tuned circuits which, in view of the intermediate frequency of 465 kc/s, give very good rejection of superheterodyne whistle interference. The frequency-changer is a triode-hexode. In addition to the usual medium and long wavebands, a short waverange is included, and this covers some 16-45 metres.

One IF stage is used with four tuned circuits arranged as two coupled pairs. In one transformer, the coupling can be changed by means of a switch to give two degrees of selectivity. A duo-diode follows and one section acts as a detector and AVC source, while the other introduces delay and muting if required.

Following the detector comes the AF amplifier, which consists of a triode first stage followed by a large output pentode. In the interests of quality, negative feedback is applied across both stages.

The List of Parts**TUNER**

9 Coils, viz., 1 each: PA1, PA2, PA3, PHF1, PHF2, PHF3, PO1, PO2, PO214 Wearite

1 Variable Condenser, 3-gang, 0.0005 mfd. JB "L/B-N/T"

1 Dial, geared slow motion, with coupler $\frac{1}{4}$ in. shaft, $1\frac{1}{2}$ in. long Peto-Scott

Condensers:

2 0.05 mfd., tubular T.C.C. 341
5 0.1 mfd., tubular T.C.C. 341
1 0.0001 mfd., mica T.C.C. "M"
1 0.001 mfd., mica T.C.C. "M"
1 0.002 mfd., mica T.C.C. "M"

Resistances: All $\frac{1}{2}$ -watt, insulated type.

1 50 ohms Erie
1 150 ohms Erie
1 350 ohms Erie
1 1,200 ohms Erie
1 2,500 ohms Erie
1 5,000 ohms Erie
1 8,000 ohms Erie
2 30,000 ohms Erie
3 50,000 ohms Erie
1 100,000 ohms Erie

9 Trimmers, 60 mmfds. Polar 15/60
1 Trimmer, 300 mmfds. Bulgin CP3
1 Trimmer, 600 mmfds. Bulgin CP4
1 Trimmer, 3,000 mmfds. Bulgin CP7

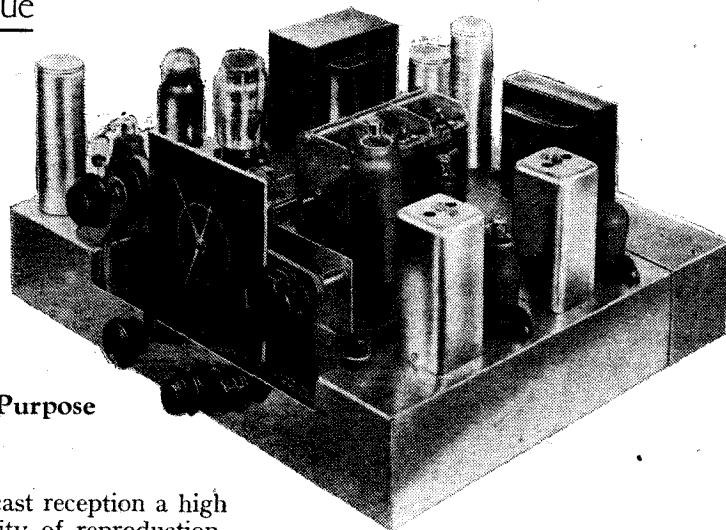

2 Valve Holders, 8-contact Bulgin VH24
1 Switch Assembly B.T.S. WW/3AC
2 Plug Top Valve Connectors

Belling-Lee 1175
Chassis, with terminal strips, complete with screws, etc. B.T.S.

Miscellaneous: Peto-Scott
4 lengths Systoflex, 2 oz. No. 20 tinned copper wire, etc.

Valves, 1 EF8, 1 ECH2 Mullard

RECEIVER

1 Mains Transformer with screened primary, 200-250 volts, 50 c/s.

Secondaries: 300-0-300 volts, 90 mA., 6.3 volts, 3 amps., 4 volts, 2 amps. Partridge WW/M5

1 Choke, 30H, 90 mA., 800 ohms.

Partridge WW/30

1 IF Transformer, 465 kc/s. Varley BP124

1 IF Transformer, 465 kc/s. Varley BP122

1 Switch, SPDT. Bulgin S92

1 Switch, DPDT. Bulgin S114

5 Valve Holders, 8-contact Bulgin VH24

2 Plug Top Valve Connectors Belling-Lee 1175

Condensers:

1 0.01 mfd., tubular T.C.C. 451
2 0.05 mfd., tubular T.C.C. 341
5 0.1 mfd., tubular T.C.C. 341
1 0.0002 mfd., mica T.C.C. "M"
1 0.0005 mfd., mica T.C.C. "M"
2 50 mfd., 12 volts, electrolytic T.C.C. "FT"
1 4 mfd., 440 volts, electrolytic T.C.C. 812
2 8 mfd., 440 volts, electrolytic T.C.C. 802

Resistances: $\frac{1}{2}$ watt insulated type.

1 50 ohms Erie
1 150 ohms Erie
1 350 ohms Erie
1 1,500 ohms Erie
1 2,000 ohms Erie
1 4,000 ohms Erie
1 10,000 ohms Erie
1 20,000 ohms Erie
1 50,000 ohms Erie
2 100,000 ohms Erie
1 0.25 megohm Erie
1 0.4 megohm Erie
1 1.5 megohm Erie
1 2 megohm Erie

Resistances: Other types.

1 10,000 ohms, 2 watts Erie
1 10,000 ohms, 3 watts Erie

1 Volume Control, 0.25 megohm, tapered Reliance "SG"

1 Fused Mains Input Connector with 1 amp. fuses Belling-Lee 1114

6 Terminals, ebonite shrouded, A, E, PU (2), LS (2) Belling-Lee "B"

2 lengths of screened sleeving Goltone

Chassis complete with screws, etc. B.T.S.

Miscellaneous:

6 lengths Systoflex, 2 oz. No. 20 tinned copper wire, etc. Peto-Scott

Valves: 1 EF9, 1 EB4, 1 EBC3, 1 EL3, 1 AZ3 Mullard

NEWS OF THE WEEK

NORTH SEA RADIO

Station for Ship-to-Shore Communication

THE Blaavand wireless station, Danish counterpart of the G.P.O.'s Humber station, was erected in 1901 to maintain communication between ships and the shore.

During the passing years it has been frequently renovated, but as the result of the tremendous increase in traffic the Danish Post Office decided to order an entirely new plant, which is now in operation.

The spacious site occupied by the new station, which is recognisable by the call-sign OXB, makes it possible for the five wooden receiving masts (three of 80 feet and two of 35 feet) to be located half a mile from the three 160-foot wooden transmitting masts.

The plant comprises four transmitters. The main WT transmitter operates on the 400-850 metre band with a power of 900 watts, and is supplemented by a stand-by WT transmitter of 500 watts. The telephony transmitter has an output of 500 watts, and is supplemented by a 60-watt stand-by transmitter.

Constant watch is maintained by two special receivers permanently tuned to the wavelengths of 600 metres (WT SOS messages) and 182 metres (Mayday distress calls).

The inauguration of this station marks another increase in the efficiency of the network of similar stations designed for the protection of vessels at sea by the speedy and efficient handling of telegraphic and telephonic ship-to-shore communications.

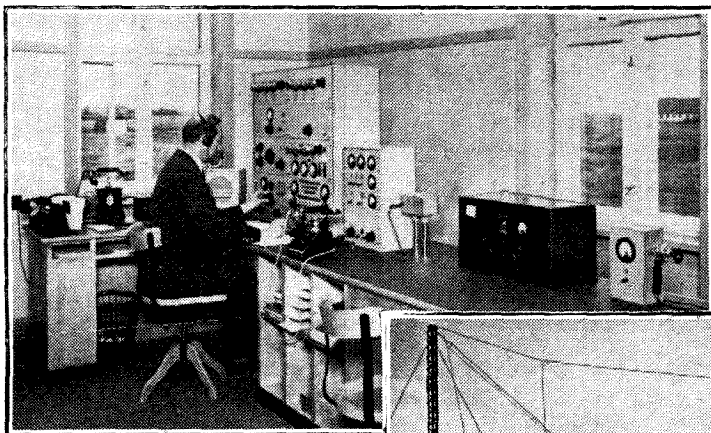

A REAL OLD TIMER RE-JUVENATED. The aerials and chief operator's room of the new Blaavand wireless station which is the Danish counterpart of the G.P.O.'s Humber Radio.

NO REPRIEVE FOR BOURNEMOUTH

Wavelength Needed for the New Clevedon Transmitter

AS previously announced, the B.B.C. 1-kW transmitter at Bournemouth is to close down with the opening of the new 100-kW Start Point transmitter. Some time ago Bournemouth Town Council made a request to its local authorities to make application to the B.B.C. for the retention of the Bournemouth transmitter, it being pointed out that Start Point is 86 miles away and from such a distance there might be frequent fading.

The B.B.C. have replied to this representation, stating that the new transmitter is expected to provide a satisfactory regional service from Land's End to Sussex. In addition to this, Bournemouth's wavelength, 203.5 metres, is required for Clevedon, which will give a regional service to Bristol and neighbourhood. It would, in fact, be impracticable to keep the Bournemouth transmitter in operation when these new transmitters are open.

The Council decided not to take any further action.

ANGLO-FRENCH U.S.W. RADIO-PHONE LINKS

AS a result of a year's continuous operation of the 9-channel ultra-short-wave radio link between Belfast and Stranraer, the British Post Office and French P.T.T. have placed an order with Standard Telephones and Cables and Le Matériel Téléphonique for a similar but improved system for communication across the English Channel.

QUESTIONS IN THE HOUSE

Wireless in the Hebrides—National Publicity—Post Office Detector Staff

IN reply to a question on the progress of wireless telephony and telegraphy in the Outer Hebrides, the Postmaster-General stated in the House of Commons last week that the work on the two wireless channels, which are to augment the existing cable telephone service between the islands of Lewis and Harris and the mainland, is now in its final stages and the service should soon be in use.

Replying to a question which amounted to a request for national publicity, he said that the inclusion of a series of appreciations of British health resorts in B.B.C. foreign broadcasts was left to the discretion of the Governors of the B.B.C., to whom he would, however, forward the suggestion.

In answer to another question, the Assistant Postmaster-General stated that enquiries into the detection of unlicensed radio sets were made by local postal and engineering staffs of the Post Office as the need arose. No staff was employed exclusively on this work.

RADIO IN THE FAR EAST

The Sino-Japanese War and Broadcasting in Japan

RECENT statistics, giving the total number of listeners in Japan at the end of August as 3,821,788, show that the increase since the commencement of the Sino-Japanese war has been considerable. In March, 1937, the two million mark was reached, and it is expected that the four million mark was reached, and probably passed, by the end of last month.

The remarkable average in-

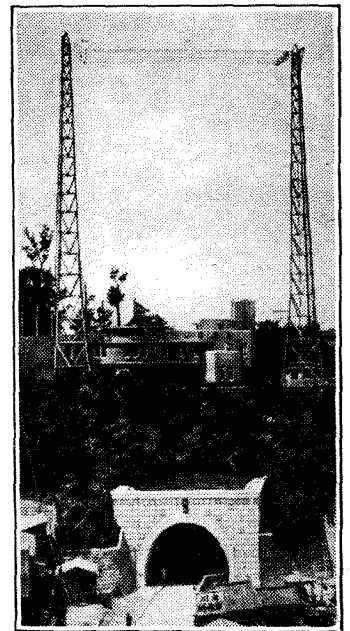

JOAK broadcasting station in Tokyo, the power of which has been increased to 150 kW.

crease of 55,000 per month, which was mainly in the rural areas, is largely accounted for by the fact that news from the war areas is a daily concern where so many of the men folk are in China. Furthermore, families with men in the fighting forces are exempt from paying tax, which probably accounts for the increase in the number of receivers.

International broadcasting has developed considerably, as is shown by comparing the total time occupied by such broadcasts in 1936 (183 hours), with the total of 684 hours in 1937. News is now broadcast to Europe in English, German, French, Dutch and Italian, and to South America in Spanish and Portuguese. The European transmissions are from JZJ on 25.42 metres and JZI on 31.46 metres, the time schedule being from 7.30 to 9 p.m., G.M.T.

During the last year four new

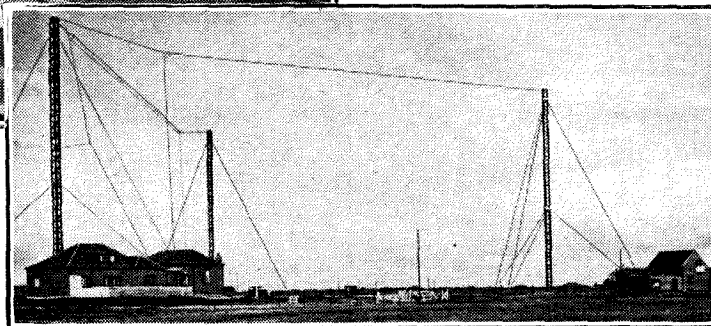

News of the Week—

broadcasting stations were erected at Miyazaki, Kofu, Kushiro and Hiroaki, bringing the total to thirty-six. A further advance was the addition of a new 150-kW transmitter to station JOAK in Tokyo.

R.M.A. BANQUET**D.G. Meets Radio Manufacturers**

MR. F. W. OGILVIE, Director-General of the B.B.C., was the guest of honour at the banquet and ball of the Radio Manufacturers' Association at Grosvenor House, London, last week. Lord Hirst of Witton, president of the Association, presided, and among the 580 guests were Mrs. Ogilvie, Lord Iliffe, Sir Frank and Lady Smith, Sir Stephen and Lady Tallents, Sir Louis and Lady Sterling, Sir Thomas and Lady Gardiner, Sir Noel and Lady Ashbridge, and Sir Ian and Lady Fraser.

In proposing the toast of "The Radio Industry," Mr. Ogilvie, after referring to the export market and short-wave and ultra-short-wave broadcasting, said: "Television at roughly the price of a radio-gramophone is now available to an area consisting of well over ten million people—that is, more than a fifth of the population of the country." Major L. H. Peter, chairman of the Association, in responding, said that it was the hope of the radio industry that every one of the eight million homes in this country which now enjoyed the B.B.C. programmes in sound might, in the not too far distant future, enjoy equally the vision programme.

Lord Iliffe, who responded to the toast of the guests, said: "The success of the B.B.C. must have had a profound effect on your own prosperity." He felt that the public should be full of admiration for the gigantic technical problems that the industry had solved in order to make television available on such favourable terms.

RADIO ECONOMY DRIVE**Relays to Reduce Indian Programme Expenses**

FINANCIAL difficulties and the possible methods of maintaining the radio service at its present standard were the principal subjects discussed at All-India Radio's Station Directors' Conference recently held in New Delhi. During the past three years broadcasting revenue has comfortably exceeded expenditure, but it is anticipated that next year's necessary expenditure of two million rupees could only just be met. Development and improvement costs, therefore, re-

main unprovided for financially, and since the Government have withdrawn the financial support promised for the erection of transmitters at Dacca and Trichinopoly, these towns will have to wait for their stations until 1940 at the earliest, although construction work has already begun.

It was decided that at the beginning of next year each station with a receiving centre should relay on one day a week programmes of a sister station. In addition, a number of talks should be relayed over groups of stations.

WHAT DOES THE LISTENER WANT?

AN extension of the scheme of listener research has been launched by the B.B.C. in the form of a house-to-house canvass. During next week a number of ladies will be calling at listeners' homes in London and will ask the occupants to supply a list of their listening for the previous three days. As the houses selected for this small test investigation will be chosen at random, it is hoped that the enquiry, although limited in area, will be representative of Londoners' predilections.

SPOKEN LETTERS**Greetings on a Gramophone Record**

THESE are now all the rage in Berlin, where two post offices and two big departmental stores are equipped with recording apparatus. These recordings, one of which was received

6½ in. in diameter, costs Rm.1.50 for a single-side recording or Rm.2.50 for both sides. About 130 words, speaking time one minute, can be recorded on each side. Double-sized discs costing

HEARING FROM YOUR FRIENDS can be a terminological exactitude in Berlin, where post offices are being equipped with apparatus for recording spoken letters. The posting packet, which is less than a quarter of an inch thick, measures 7½ inches square.

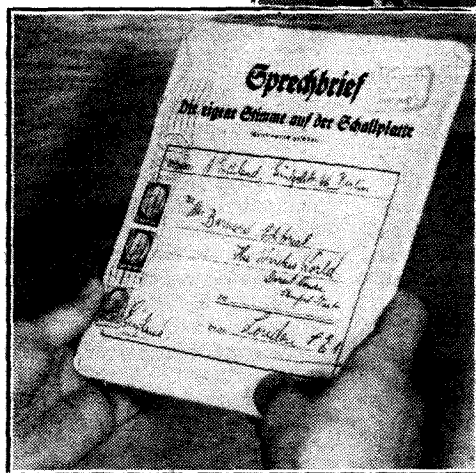

Rm.2.50 for single side or Rm.3.75 for both sides accommodate double the number of words. All these prices include the special envelope and trailing needles. Postage in Germany is only threepence.

The correspondent, having recorded his letter, can hear a playback if he wishes. A very

faithful reproduction of the voice is given by these recordings.

at *The Wireless World* offices last week, are available in two sizes. The smaller, measuring

FROM ALL**QUARTERS****Oxford Honours Dr. I. Langmuir**

DR. IRVING LANGMUIR, Director of the General Electric Company, Schenectady, New York, Nobel Prizeman 1932, pre-eminent among scientists for his research into insulin and into the behaviour of heated filaments in a vacuum, received the honorary degree of

D.Sc. at the Oxford Convocation on December 10th.

What Algeria Does Today . . .

WHEN will Great Britain follow the example of Algeria in suppressing interference with broadcast reception? The Algerian Post Office has taken delivery of four interference suppression units, each consisting of a car and directional receiving equipment for locating offenders. In 43 recent cases of interference 33 were eliminated.

A.R.P. Goes On

FOR the benefit of listeners who had not heard the A.R.P. siren practice in London, the B.B.C. recorded the sound of the warnings and subsequent broadcasts of the playbacks revealed the disturbingly low siren-to-traffic-noise ratio. Experiments are being carried out by the A.R.P. authorities in Manchester with a view to the remote control by wireless of that city's A.R.P. warning sirens.

Spanish Radio Journal

THE broadcasting authorities of the Spanish National Government have started publishing a weekly radio journal which includes the programmes of the Nationalist transmitters as well as general articles. The first issue of this paper, *Revista semanal de Radio-difusion*, was published on November 13th.

Free as the Air

FOUR pamphlets containing particulars of Germany's short-wave transmissions are published each month, and will be sent free on request to foreign listeners printed in their own language. About 65,000 copies are at present circulated.

Physical Society's Exhibition

THE twenty-ninth annual exhibition arranged by the Physical Society will be held at the Imperial College of Science and Technology, Imperial Institute Road, South Kensington, S.W.7, on January 3rd, 4th and 5th, 1939. The leading manufacturers of scientific instruments will be exhibiting their latest products in the Trade Section, whilst in the Research and Educational Section will be found contributions from research laboratories and experiments of educational interest. The work submitted for the craftsmanship and draughtsmanship competition by apprentices and learners will be on view. Admission to the exhibition, which opens at 2.30 p.m. on the first and last days and at 4 p.m. on the second day, is by ticket only. Tickets may be obtained from Institution Secretaries or from the Exhibition Secretary, 1, Lowther Gardens, Exhibition Road, London, S.W.7.

Component Manufacture in South Africa

IT is stated in the annual report of the South African Broadcasting Corporation that owing to the excessive delivery time for apparatus ordered from overseas, the Corporation has begun the manufacture of broadcasting apparatus on its own account. The control room apparatus (speech input equipment) for the Pretoria and Bloemfontein studios will be manufactured in the Corporation's workshops. The equipment already completed has proved equal in every respect to imported apparatus.

LS Signalling System

AS a temporary signalling system between Paddington and Ealing Broadway stations (a fire at the Paddington signalling box having destroyed the permanent system), Grampian Loudspeaker Equipment was used for directing gangs of men who are hand-operating points and signals.

Which Way Does the Current Flow?

By
"CATHODE RAY"

FREE GRID'S" recent assertion, in his usual uncompromising manner, that an electric current flows from the negative terminal of the supply to the positive, seems to have unsettled the minds of some readers. Though not daring to challenge publicly his claim to scientific infallibility, they confess that it would give them a greater feeling of assurance to have the matter placed before them calmly and dispassionately by "Cathode Ray."

Let Us Get This Straight

I have pleasure in responding to this invitation forthwith. To get a clear mental picture of how an electric current flows it is necessary to know the elementary facts about what everything in the material universe is made of. This is a good deal simpler than one would expect in view of the amazing variety of things that even this little corner that we call the Earth contains. I have been told that the number of known chemical substances is over a million. That is not counting innumerable variations, such as air and brass and paint, made by mixing together two or more distinct substances. Mixtures can be separated, theoretically if not practically, by a simple sorting process. When they are very finely mixed, our sight is not nearly good enough to separate the ingredients. Granting ourselves in imagination the ability to examine things far more minutely than the most powerful microscope, we can sort mixtures into single pure chemical substances—the million or more I referred to just now. We could go on pulling any one of these pure substances to pieces until we came across tiny fragments, called molecules, so small that they could not be broken up into anything smaller without destroying the very nature of that particular substance.

The Elements

That is not to say further analysis is impossible. By applying *chemical* processes the vast majority of the (let us say) one million different sorts of molecules can be divided into still smaller particles that have quite a different character when alone or grouped with others of their own kind. Apart from minor variations there are about ninety of these simpler substances, called elements—oxygen, hydro-

gen, carbon, iron, etc. Molecules can consist either of all one sort of element or of several combined in various definite ways. Some molecules are quite simple, and others—especially those that go to form living creatures—are relatively large and complicated. The parts of a molecule, which are the smallest possible portions of element substances, are called *atoms*, meaning something that cannot be divided. But the name soon became a misfit, for it was found that all the ninety different sorts of atoms were made up of

only two ingredients. At least, that is so if some of the latest scientific theories, which are not important for the present purpose, are ignored.

It is amazing that such diverse things as air and water and lead and pork chops and sunset clouds and petrol should be made essentially of only two sorts of components. These two are called electrons and protons. The remarkable differences in character between the ninety elements, and the still greater variety of the million compounds of elements, and the endless variety of mixtures of those compounds, result in some mysterious way from the number and arrangement of the electrons and protons that club together to form an atom and of the atoms that assemble into a molecule.

The only thing that modern science leads us to understand clearly about the precise nature of these things is that nobody is ever likely to be able to understand them clearly. On the other hand, if one is content with a sort of mechanical working model of them it is quite

easy to account for a lot of the otherwise mysterious behaviour of electricity and matter. Though scientists are quite certain that these two things—electrons and protons—are not just small lumps of stuff, like two sizes of billiard balls on an inconceivably small scale, yet it is helpful to picture them like that, just as it is helpful to have a circuit diagram of a receiver, though it bears no outward resemblance to it such as a photograph does.

Chemistry and Electricity

The simplest atomic society is, like matrimony, one of each. That constitutes the gas hydrogen, used for inflating balloons. Oxygen has a heavier and more complicated atom, consisting of sixteen of each. These are two typical elements. By combining two hydrogen atoms with one oxygen atom, totalling eighteen protons and as many electrons, we get one water molecule. Fig. 1 shows diagrammatically the respective stages in piecing together a single molecule of water.

All this may seem very much beside the point, more like a chemistry lesson than an explanation of electric currents. But instead of electricity being a sort of addition, like sauce on the goose, it is so much bound up with matter as to be indistinguishable. For electrons and protons are

not only the bricks with which the whole universe is built, but they are respectively the smallest possible negative and positive electric charges. Considering the hydrogen atom because of its sweet simplicity, its normal condition is one of ideal married bliss; each partner perfectly satisfies the other.

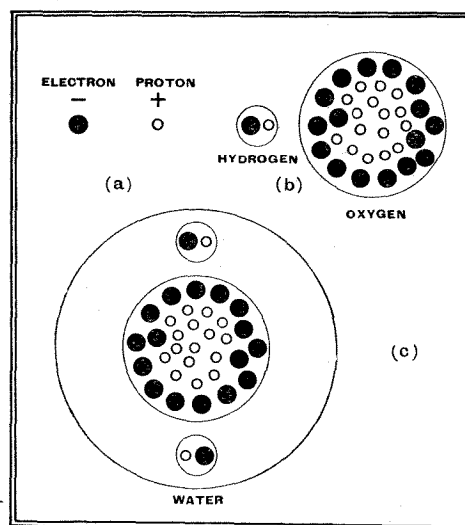

Fig. 1.—Diagrammatic representation of the stages in the building up of the smallest possible portion of a substance. (a) Shows the two units from which everything is made. They are both electrical, but the proton constitutes practically all the substance. (b) When grouped together, they form atoms, of which about 90 main sorts exist, most of them much more complicated than those shown. A more accurate diagram of an atom will appear later. (c) Atoms can unite into fixed groups called molecules. Two hydrogen atoms and one oxygen form one molecule of water. It is the smallest possible portion of water because (apart from loss of an odd electron or two) the split-up parts are not water at all. The atoms and molecule shown are electrically neutral, but if one or more electrons are detached the negative and positive electricities of the two portions become manifest.

Which Way Does the Current Flow ?

So, taken as a unit, it shows no electrical effects; the positive and negative halves cancel out. Under conditions of exceptional stress, however, this perfect partnership is broken up, leaving the separate electrons and protons to wander about alone. In this state they reveal their negative and positive electrical attractiveness; an electron repels any other solitary electron, but attracts any proton, and unless prevented from doing so by some outside influence they will rush together to form a union. When an electron is attracted by an exceptionally large collection of divorcées of the opposite kind (or repelled by a large number of its own) it can develop an astounding speed, comparable with that of light. If in this tearing haste it chances to bump into one or more married couples it may tear them apart, leaving behind a trail of broken romances.

Now let us see how this fits in with the world as we know it. Normally we are not conscious of electrical effects. In fact, there are still people in the obscurer parts of the world who go through their whole lives without ever noticing electrical effects (except for lightning, and that is considered by them to be so distinct from ordinary matter as to be a direct intervention of some deity). So the neutralised

state of matter, in which protons and electrons exactly balance one another, is the normal one. That does not necessarily mean they are all happily married; I shall deal with that point later. Coming now to the exceptional condition of matter, in which electrical effects *can* be observed, such a state is due to some influence—several kinds of which are known—causing an excess or a deficiency of electrons somewhere. A battery is one arrangement having the strange power of separating whole herds of electrons from their mates and confining them in a sort of concentration camp with a door called the negative terminal. Their mates are detained in a corresponding camp with a positive terminal. So long as the battery is in power it prevents any reunion through its own territory. But if you or some other beneficent authority provide an external passage between the positive and negative doors, the prisoners stream forth and reunite.

This is getting right to the crucial point in the argument. *WHICH prisoners stream forth?* Before I can reveal the answer it is necessary to study atoms a little more closely, so in the approved manner of the serial writer I shall at this important crisis in the dramatic story of the separated lovers direct readers' attention to the next instalment.

eyes happened to fall upon a well-filled wallet which had been dropped by some unfortunate fellow-citizen. I was exceedingly sorry to find, however, that it contained a plethora of pawn tickets as I realised that it probably belonged to some unfortunate wireless manufacturer, and this view was confirmed when I found also an invitation which he had evidently received to attend a demonstration of big-screen television in a West End cinema.

As the show was due to commence within half an hour of the time I made my find, I realised that it would be impossible to return it to its rightful owner in time, and, as waste is abhorrent to my nature, I determined to use it myself and



"My Lords and Gentlemen."

therefore duly abstracted the invitation card before handing over the remainder to the police as conscience and the law require.

Having arrived at the cinema, I found myself seated about forty or fifty feet away from a screen which a pamphlet handed to me at the door told me was 8ft. x 6ft. in dimensions. I was somewhat surprised when the proceedings were opened by a speech in which my fellow-guests and I were addressed as "My Lords and Gentlemen," and I at once proceeded to make sure that my own wallet was quite safe.

Quite frankly, I didn't expect to be very thrilled by the picture, and when it did appear it was a very pleasant surprise indeed. The television was an O.B. from the Alexandra Palace, and things were surprisingly clear—far more so, in fact, than in the far smaller "large" screen television sets at this year's Radiolympia, and I remarked upon this fact to my companion in the adjoining seat. I was rather staggered, however, when he pointed out that it was several weeks since Olympia had closed its doors and naturally a certain amount of technical progress must have been made since then.

A close examination of the "works" after the show revealed to me the fact that the screen being used was one of the crystal-beaded type such as I myself employ in conjunction with my own home cine projector. This type of screen gives much greater brilliance than any other sort and explained, to some extent, the excellent results obtained, although it was certainly not sufficient to account for it all. This type of screen could not, of course, be used for "large-screen" home receivers such as were exhibited at Radiolympia, since the screen employed in these is translucent owing to the use of back projection.

UNBIASED

Barmaids and Television

I WONDER how many of you read in your newspaper of the barmaid who was charged with causing wilful damage to her employer's television set? It appears that the set was duly installed by the benevolent brewers in the saloon bar of one of their pubs in an endeavour to divert the minds of their patrons when they were taking their daily dose. There is nothing new in this part of the story, of



"Counter attraction."

course, since television sets have been installed in pubs all over the London television area. Needless to say, there are certain malignant-minded persons who state that the benevolent and altruistic people who cause these sets to be put in pubs have an ulterior motive, namely, to attract more customers into the bar and thereby to sell more beer.

By Free Grid

To return, however, to the barmaid whom in our digression we have momentarily ignored. It appears that it was the very fact of her being ignored which led to her crime. The patrons of the pub were so interested in the new wonder of television that she no longer received the attention to which she was accustomed and had come to look upon as her right. As is the way of women the world over, she had naturally turned and vented her spite on her rival by putting her foot through the television screen.

This is an entirely new and unexpected menace to television, and if the B.B.C. don't do something about it quickly we shall have an orgy of television-set-smashing. I, for one, have no mind to be struck on the head by a flying bottle of Bass aimed at the television screen, and I hope that some genius of the B.B.C. staff will think of some scheme whereby barmaids are no longer left "out of the picture."

Cinevision Progress

WHILE walking along Piccadilly the other afternoon meditating profoundly on the follies of mankind, my

Television Topics

MAGNETIC SCANNING

WHEN magnetic deflection of the electron beam in the CR tube is adopted it is customary to use a transformer for coupling the time-base to the deflecting coils.

Owing to the leakage inductance of this transformer and the capacity between its windings, as well as the distributed capacity of the secondary winding and scanning coils, an oscillation is set up across the scanning coils at the end of the return stroke.

This is particularly true when the "resonant return" scanning circuit is used, the voltage wave-form across the coils being as in Fig. 1(a). It should be remembered that this voltage waveform is similar to the variation of velocity of the scanning spot with time, and during the working stroke BC this is required to be steady, so that the oscillations at B are a bad feature. They can be damped by a shunt resistance across the coils, but if this resistance is sufficiently low in value to provide critical damping of the leakage inductance-secondary capacity circuit, it provides excessive damping of the main shunt resonance which is used for the return stroke, and thus considerably reduces the amplitude.

The difficulty can be overcome by

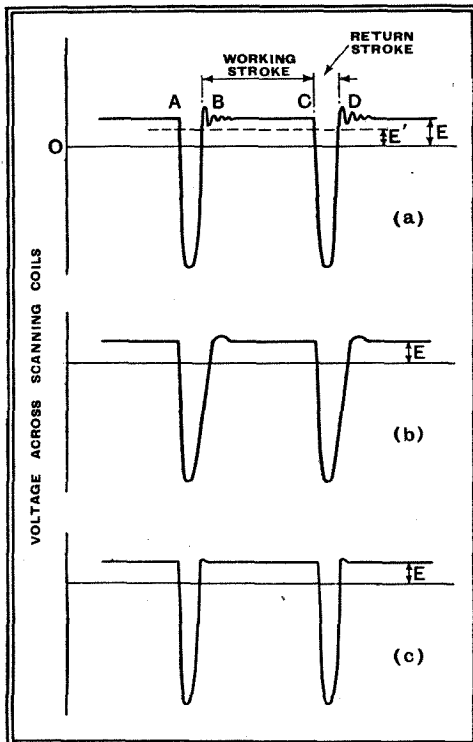
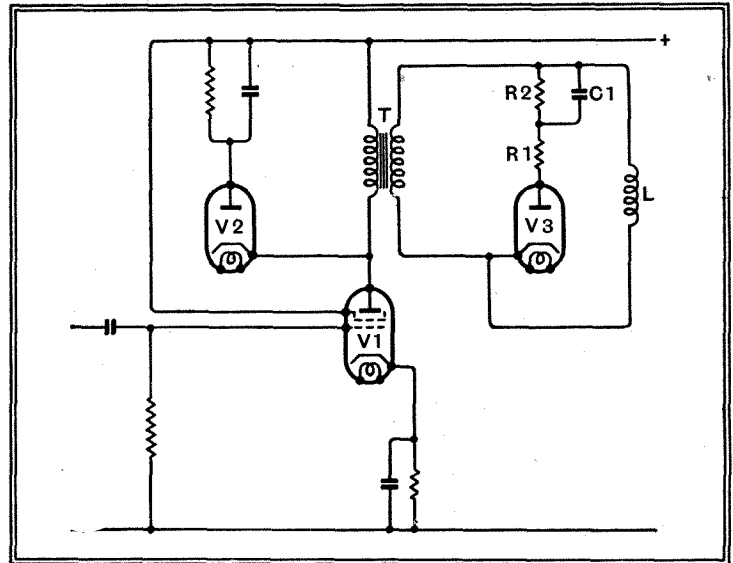

Fig. 1.—The waveform at (a) represents the voltage across the deflecting coil in a typical case. When a diode is used across the coil it becomes of the form (b) for a resonant return stroke and like (c) for a non-resonant return.

adopting the circuit of Fig. 2. During the scanning stroke the valve V1 allows a substantially uniformly increasing current to pass through the primary winding of the transformer T, the secondary of which has connected across it the scanning coils L. In this period the electromotive force developed in the scanning coils is substantially constant, as indicated in Fig. 1(a) by the portion of the curve marked C. At the end of the scanning stroke V1 is suddenly rendered non-conducting, and the

Fig. 2.—The output circuit of a magnetic time-base with diodes V2 and V3 for damping unwanted oscillation.



return stroke is effected by a half-cycle of oscillation corresponding to the surge of electromotive force developed in the scanning coils and shown in Fig. 1(a) by the portion of curve CD. The corresponding half-cycle of variation that appears across the primary is prevented from continuing as an oscillation by means of the diode V2 connected across the primary. In the circuit associated with the secondary winding there tends, however, to be set up an oscillation at the end of the return stroke such as that shown commencing at the point D in Fig. 1(a).

This oscillation can be prevented by connecting across the scanning coil L the diode V3, which is arranged to conduct during the period of the scanning stroke but not during the return stroke. The resistance R1 is connected in series with the diode in order that the amount of damping may be adjusted, and the resistance R2 shunted by the large condenser C1 is for the purpose of biasing the diode. Thus, by means of the charge accumulated on the condenser due to the rectifying action of the diode, the diode may be prevented from conducting until, as shown in Fig. 1(a), the potential difference across the coils has reached a level E', which is very nearly equal to the steady level E of potential attained during the working stroke. The resistance R1 and the resistance-capacitor combination R2 and C1 are not, however, essential, although it is desirable to employ some means of biasing the diode to avoid dissipating energy needlessly during the scanning stroke. A bat-

tery may, of course, be used as a source of bias potential, but the method described above in which the bias is supplied by means of the rectifying action of the diode is to be preferred.

The amount of power absorbed by the diode, especially when some form of biasing is employed, is very small, and is only of the order of $\frac{1}{100}$ of that dissipated by the diode V2 connected across the transformer primary. Because of this small-power dissipation metal rectifiers may be used with advantage in place of a diode. Thus, if the correct size and number of elements are chosen, the series resistance

may be dispensed with, as may also the source of bias potential.

When a resonant return stroke system is used, the waveform becomes like that sketched in Fig. 1(b) instead of as at (a), and a considerable improvement is evident. With a non-resonant return stroke the waveform tends to be more like that of Fig. 1(c).

Television at the I.E.E.

FEEDER DISTORTION : EMITRON OPERATION

THE difficulties encountered in the design of the aerial feeder system for the vision transmitter at Alexandra Palace were explained in a paper by E. C. Cork and J. L. Pawsey which was read at the Institute of Electrical Engineers on December 7th. Early experiment showed that quite small impedance irregularities along the feeder and a small degree of mismatching between feeder and aerial would cause serious distortion of the picture.

Mismatching or impedance irregularities cause reflection of the waves on the feeder. These reflected waves arrive back at the aerial after a time-delay and give rise to a ghost image at the receiver.

Close matching is needed for the avoidance of this effect. How close may be gauged from the fact that there is normally no visible trace of this distortion in the picture, but if one of the eight aerials is disconnected it becomes quite noticeable. The mismatch thus introduced is only about 12 per cent.

In order to achieve the necessary standard

Television Topics—

of performance it was found necessary to introduce adjustable correcting capacities at intervals along the feeder, usually in the right-angle junction boxes. To compensate for the impedance variations of the aerial itself, a parallel resonant circuit is included at a suitable point in the feeder.

The high standard of the work involved will be realised when it is said that over the band of 45-47 Mc/s the impedance measured at the transmitter does not vary more than ± 5 ohms.

A second paper, by J. D. McGee and H. G. Lubszynski, dealt with the Emitron. It was pointed out that the usual simple explanation of its operation is not strictly

correct and that the light storage action is much less than is usually supposed. The action is intimately bound up with secondary emission from the cells of the mosaic. In certain respects more satisfactory operating conditions exist in the Super-Emitron, owing to the separation of the photo-electric and mosaic surfaces, and the sensitivity of this tube is about 10-15 times as high as that of its forerunner.

In spite of this the Super-Emitron is confined chiefly to outdoor transmissions because of a certain distortion of the picture, which would be noticeable on a studio scene abounding in straight lines and rectangular objects. It passes unnoticed on the average outdoor scene, however.

minimum and maximum capacities must have a ratio of 1 to 7. If the stray capacities amount to 50 m-mfds. and the minimum of the condenser is 28 m-mfds., the ratio of minimum to maximum will be 78 to 550, or just 1 to 7, and the required tuning range will be obtained. If the stray capacities are much higher than the figure given while the maximum of the condenser is appreciably less, the coverage will be smaller.

READERS' PROBLEMS

A Selection of Queries dealt with by the Information Bureau, and chosen for their more general interest, is published on this page.

Simple Tone Control

WE are asked if a simple tone control could be fitted to a receiver, of which the circuit is submitted but not reproduced in full, in order to lessen the low-frequency response when listening to talks and other broadcast items in which speech predominates.

In this case the simplest form of control would be one which attenuates the bass, and this can conveniently be done in this particular case by inserting in series with the condenser coupling the DD triode to the output valve a further condenser shunted by a variable resistance as shown in the skeleton circuit at C, R. For condenser C any capacity between 0.0001 mfd. and 0.001 mfd. will suffice, while R should be not less than two megohms.

Ignoring R for the moment, condenser C and the following grid leak form a potentiometer in

Simple variable tone control for attenuating the low frequencies.

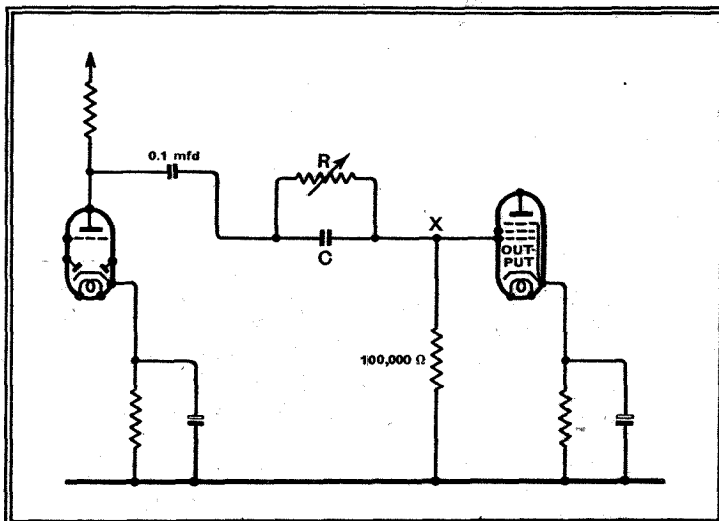

which the reactance or resistance of the upper part (C) varies inversely with frequency.

The effect may be likened to point X, the grid of the output valve being connected to the slider of a potentiometer and automatically travelled down towards the earth end and when a low-frequency signal came along, the amount of travel being dependent on the actual frequency. In this way the low audio frequencies are attenuated.

Resistance R is included to set a maximum limit to the upper half of the potentiometer, thus governing the degree of attenuation produced. When R is so small that C is virtually short-circuited, no attenuation takes place and the amplifier behaves as if C, R were removed.

Storing Accumulators

IT is desired to store a LT accumulator for several months, and as there will be no opportunity to give it attention during this period a reader asks if this can be done without damaging the battery.

The usual procedure in a case like this is to fully charge the accumulator, empty out the acid and flush out with distilled water. It should be carefully drained and examined to see that no particles of paste have become loose and lodged between the plates. Thoroughly drain and store in a dry place.

The battery can then be kept in good condition for a reasonable length of time.

Tuning Range

HAVING acquired an all-wave tuning unit from which the gang condenser had been removed, a three-gang condenser has been fitted, and it is found that the short-wave band only tunes up to 40 metres, whereas it was stated to have a coverage of 19 to 50 metres.

The query is, how can the full range be obtained?

A possible explanation is that the gang condenser fitted has a very high minimum capacity, and is possibly also slightly smaller at maximum than the value of 0.0005 mfd. stated.

In order to cover 19 to 50 metres the

Television Programmes

Vision 45 Mc/s

Sound 41.5 Mc/s

An hour's special film transmission intended for demonstration purposes will be given from 11 a.m. to 12 noon each week-day.

THURSDAY, DECEMBER 15th.

3, "The Hunting of the Snark," a masque by H. D. C. Peplar, with music by Leighton Lucas and Fred Emery. 3.20, British Movietonews. 3.30, 199th edition of Picture Page.

9, Jack Hylton and his Band. 9.30, Gaumont-British News. 9.40, 200th edition of Picture Page. 10.30, News.

FRIDAY, DECEMBER 16th.

3, "A Tune to Take Away." Scenes from this year's television revues, with Phyllis Monkman, Edward Cooper and Queenie Leonard. 3.50, Gaumont-British News.

9, "King of the Congo," an epic of the jungle, by Roger MacDougall and Alan MacKinnon. 9.30, Film. 9.40, 1938 Christmas Alphabet, with drawings and verses by Pearl Binder. 9.50, British Movietonews. 10, Bridge Demonstration. 10.20, News.

SATURDAY, DECEMBER 17th.

2.15, Rugby Football O.B. from Twickenham; Harlequins v. Cardiff. 3.30, Jack Hylton and his Band.

9, Eastern Cabaret, compered by Cyril Fletcher. 9.45, Music Makers—Frank Rayston, pianoforte. 9.55, Gaumont-British News. 10.5, Catch-as-Catch-Can Wrestling. 10.20, News.

SUNDAY, DECEMBER 18th.

8.50, News. 9.5-10.45, Gwen Ffrangcon-Davies in "Richard of Bordeaux," a play by Gordon Daviot.

MONDAY, DECEMBER 19th.

3-4.30, "The Knight of the Burning Pestle," a period pantomime, by Beaumont and Fletcher.

9, Guest Night 3: story-tellers, gathered together by A. G. Street, will endeavour to make your flesh creep. 9.30, Gaumont-British News. 9.40, "A Tune to Take Away" (as on Friday at 3 p.m.). 10.30, News.

TUESDAY, DECEMBER 20th.

3, Derek McCulloch and Eleanor Graham will show picture books for young children. 3.10, Cartoon Film. 3.15-4.0, Christmas Cabaret, including Jasper Maskelyne, Evelyn Dall and Afrique.

9, News Map 7—Poland. 9.20, Cartoon Film. 9.25, Eric Wild and his Band. 9.45, British Movietonews. 9.55, "Tactile Bee"—the naming of familiar things by touch alone. 10.25, News.

WEDNESDAY, DECEMBER 21st.

3, "Coffee Stall." 3.15-4.30, O.B. from Drury Lane of the dress rehearsal of Tom Arnold's Christmas Pantomime, "Babes in the Wood." Cast includes Fay Compton, G. S. Melvin and Greta Fayne.

9, Speaking Personally. 9.10, Gaumont-British News. 9.20, "Cinderella," a one-act opera by Spike Hughes with the B.B.C. Singers and Television Orchestra conducted by the composer. 10.5, News.

Making Short-wave Components

WHY SPECIAL PRECAUTIONS ARE NECESSARY

IT is not generally realised that the design and manufacture of short-wave components, at any rate of those intended to work at ultra-high frequencies, is quite a specialised business, calling for particular care in both mechanical and electrical details.

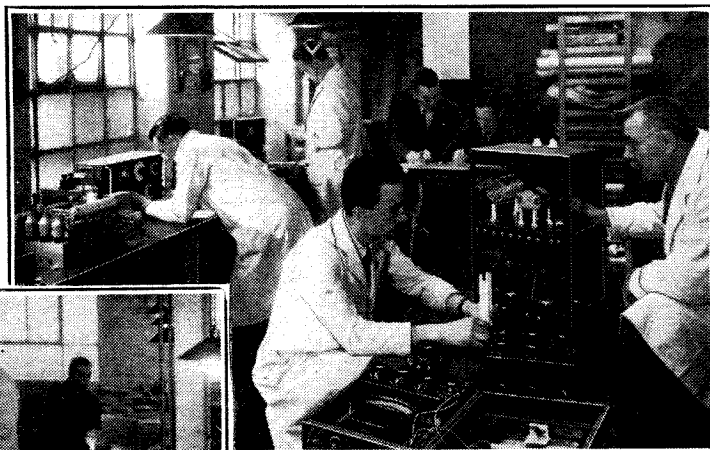

The Eddystone experimental section showing in the foreground a short-wave transmitter in course of assembly. The picture on the left shows a section of a coil-winding shop: RF chokes are in course of manufacture.

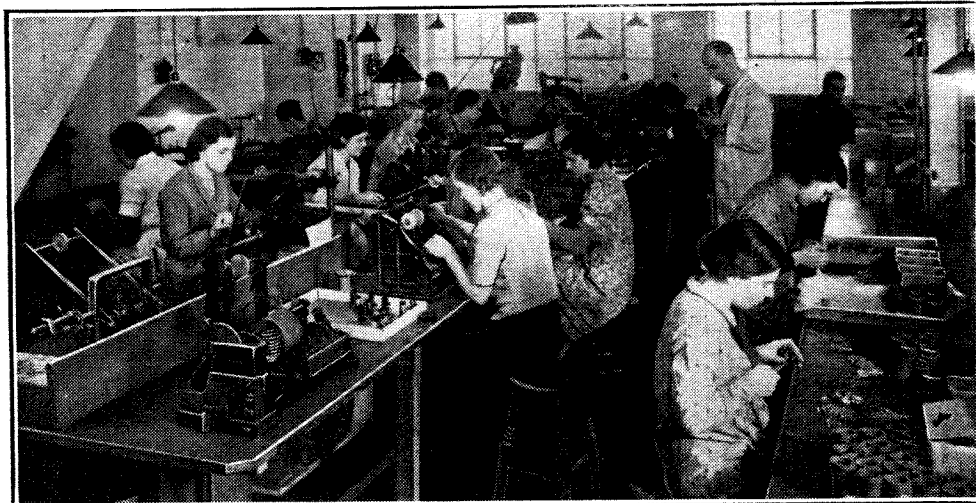

that ensures silence in operation. Condenser bearings, especially on the short waves, have been known to produce crackles and other undesirable noises when the condenser spindle is rotated.

How these and a host of other problems are tackled by one of our leading short-wave component manufacturers was explained to a member of our technical staff during a recent visit to the Birmingham factory of Stratton and Company.

Having seen the manufacturing processes adopted, the supervision exercised, and the tests to which all parts are subjected, one can well appreciate the reasons why Eddystone components enjoy such a high reputation for quality and workmanship.

NO better example could be found to illustrate the specialised nature of short-wave component manufacture than the apparently straightforward variable condenser. Quite apart from such obviously important working parts as stator, rotor and bearings, the design of the framework supporting both moving and fixed vanes plays an important part in the efficiency of the finished product.

If the frame of the condenser is of such size and nature that it forms a loop of metal in parallel with the moving and fixed vanes of the condenser, so constituting a tuned circuit independent of any external coils, it may, in certain types of short-wave oscillators, be responsible for the production of parasitic oscillations at a very high frequency.

The dielectric losses of most insulating materials increase as the frequency is

raised, so that for a short-wave condenser only those materials that exhibit a relatively small loss are really suitable. Since the condenser insulators are in parallel with the tuned circuit, it would be tantamount to joining a resistance of perhaps quite low value across the circuit if these losses were unduly high.

The bearing, or bearings, supporting the rotor of the condenser has to be taken into consideration and a design adopted

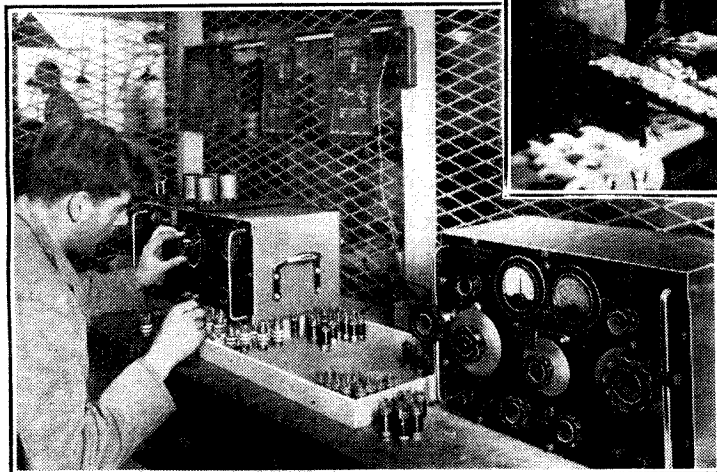
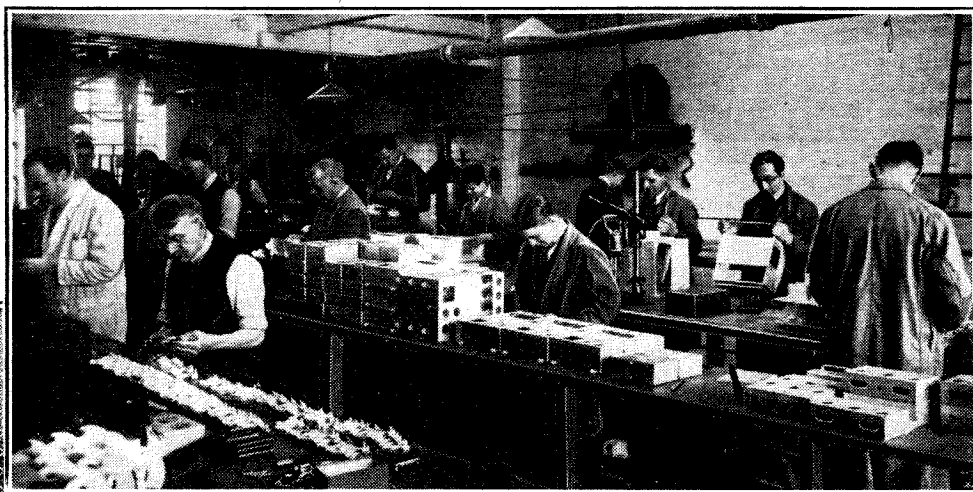

Receiver chassis being drilled and prepared before passing to the assembly shops. Every Eddystone component is tested as it leaves the production lines. One of the testing booths where the inductance of coils is measured is seen on the left.

Accurately made jigs are used in the assembly of receiving-type variable condensers, which ensures that any two selected at random will have almost identical minimum and maximum capacities. Considerable work has been done in connection with the design of the rotor bearing, both from the points of view of rigidity and silence in use. The special

Making Short-wave Components—

moulded material used for the end plates is prepared in the Eddystone factory, where the actual mouldings are also made.

Great attention to what might be regarded as insignificant points is paid in the manufacture of all the components. Any new design is withheld from production until very rigid tests have been carried out. For example, a certain new component soon to become generally available has been in the hands of the Eddystone research department for six months, and it was not definitely passed for production until they were absolutely sure it would satisfy the purpose for which it was designed.

In their receivers Eddystone cater for all classes of amateur experimenter. The practice of building up chassis from stamped metal parts does not hold favour, and, despite the cost entailed, the firm prefers to employ one-piece castings. And some of the chassis are quite intricate, with a number of completely screened

compartments, partitions, and the like.

We were informed that this is considered to be the only satisfactory way of ensuring complete screening, and that the practice adopted is justified by the enhanced performance thereby obtained.

Eddystone short-wave receivers are very largely hand-made sets—that is to say, they are assembled and completely wired by skilled workmen. All sets are subjected to a searching test, not only by means of signal generators and output meters, but also by actual performance on an aerial.

The executive staff of Stratton and Co. are all keenly interested in short-wave reception and transmission; consequently they are well equipped to appreciate the needs of the amateur. Though no specific mention has been made of their many components for short- and ultra-short-wave transmitters, it may be taken for granted that, in view of the staff's personal interest in this subject, they do not fall short either in design or in workmanship.

As an instance of the care required in design, we find it essential to connect an electrolytic condenser across the pilot lamps to ensure a long life, owing to the low resistance of the valve heaters when cold, and the fact that there is only a very low value of fixed series resistance when working on 110 volts.

REGENTONE PRODUCTS, LTD.
Isleworth.

ON reading "Seafarer's" letter in your issue of December 1st, one finds it a little difficult to believe that he can have looked very thoroughly for a standard British broadcast receiver that would operate from 110 volts DC.

For the last three seasons it has been the practice of this company to market DC converter units for use with a number of the standard Philips AC receivers, making the latter suitable for direct operation from either high- or low-voltage DC mains, the DC input ranges being 110-145 V and 200-250 V respectively.

In the range of Philips sets for the current season every AC model (excepting only the popular 8-guinea receiver) is available for operation from 110 volts DC.

Your correspondent might also be interested to know that we have available two specialised models giving continuous wave-band coverage from 9.5 to 570 metres and 5 to 580 metres respectively. These receivers have been specially developed to give exceptional short-wave sensitivity, low background noise, and high-quality output. Like our other models, they can also be operated on 110 volts DC.

London, W.C.2. JOHN DYER,
Philips Lamps Ltd.

Letters to the Editor

Interference from Baku

HERE in Ipswich I am getting quite definite interference from Baku as a background to the National transmission. We hear a good deal about interference from Jerusalem, but I have never heard the little 10 kW station on the shores of the distant Caspian cited as an offender.

Ipswich. R. GRAHAM PIPE.

Short-distance Fading

MY occupation leads me to visit well over 1,000 homes a year, mostly in or around London. In three—and only three—of these homes I have noticed that signals from London National have been subject to severe fading, such as one would expect from a distant transmission. The fading, which was carefully verified, was accompanied by severe distortion.

So far this effect has been observed only in certain parts of S.E. London, usually after 4 p.m. in the winter months. The effect seems to be extremely localised, as receivers in houses only 100 yards away were free from the trouble.

London, S.E.18. C. E. Le VERRIER.

Amateur Film Recording

AS I have had the pleasure of contributing to your columns on the topic of synchronised sound-on-disc films (July 30th, 1937), I would appreciate an opportunity to comment on Mr. Percy Harris' article (November 24th).

First, Mr. Harris refers to a letter from a Mr. Hamilton H. Pace. I imagine Mr. Harris was quoting from memory, for the gentleman's surname is Tait, and his letter appeared in *The Wireless World* for January 27th, 1938. As one might expect from Mr. Harris, his article shows a grasp of both film problems and photographic requirements in sound recording, and after following his carefully reasoned exposition, I feel one cannot but agree with his conclusion that when the sound track is separated from the picture all the advantages of disc recording can be

The Editor does not necessarily endorse the opinions of his correspondents

obtained with sub-standard sound-on-film, plus other advantages. In view of the general character of the article, Mr. Harris, of course, did not offer a practical design of his solution for the problem, but would any workable sound-on-film (separate) system be able to compete on the scores of (1) cheapness of purchase and running costs, and (2) simplicity of operation in recording, with a synchronised S.O.D. system?

Space limitations preclude giving detailed reasons for the following statement, but, in my opinion, the synchronised S.O.D. system has not yet outlived its usefulness for certain aspects of amateur "talkie" work, as it is comparatively inexpensive and easy to get high-quality sound, and with the aid of "dubbing" and post-recording excellent results are possible, especially when exact lip-synchronisation is not required.

Although no specific reference is made to it, I am sure Mr. Harris is aware that at least one practical system, working on the lines of his suggestion, has been in use for a considerable time, namely, the Sonodisc system, developed by my friend Mr. D. Roe. I wrote a short description of this method in *The Wireless World* for November 25th, 1937.

DONALD W. ALDOUS.

Ilford, Essex.

Sets for Seafarers

"SEAFARER" reproaches the British radio industry with neglecting the market for receivers suitable for working on 110 volts DC. We should like to point out that, although the market for this type of receiver is relatively small and that certain technical difficulties present themselves in the design of such a receiver, we have several types in our standard range for 100 to 120 volt working, and a fair proportion of these have actually been successfully installed on ships.

Push-pull Balancing Circuit

YOUR readers may be interested in a simple method of balancing the push-pull valves of an amplifier where a common bias resistor is used.

The bias resistor is replaced by a variable resistance (R in the accompanying diagram) of suitable value, which is connected

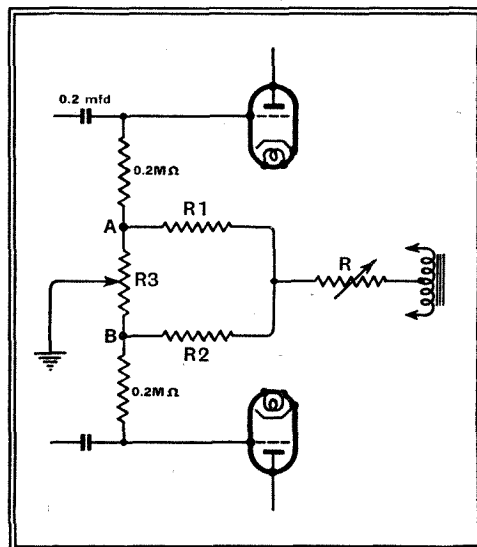

to two fixed resistances R1 and R2 of about 50 ohms each. R3 is a potentiometer of 200-250 ohms, with the slider earthed and the push-pull grid leaks connected to A and B, forming a simple bridge circuit. With the slider at end A, the grid B is a few volts positive. With the values given and a total current of 85 mA, B will be about 4 volts positive. As the slider is moved along to

wards B, the potential rises at A and falls at B. It is thus possible to vary the grids relative to one another by approximately 8 volts.

The resistance R is adjusted until the total current for the two valves is correct, and then the valves are matched for equal currents by the potentiometer. This adjustment may alter the total current slightly, and, if so, the resistance R should be reset.

A. W. GRAHAM.

Sanderstead, Surrey.

USW Reflections

FORGIVE me reiterating a subject that has, it appears, less interest than I think it merits, but I had hoped further reports would be made of cases of reflections similar to those I recently described, for I feel that, with some correlation of observed effects, some indication of the mechanism of propagation of ultra-short waves may possibly be gained. Therefore, with your permission, I will try once again.

Dealing first with Mr. Dawes' letter, published in your issue of November 3rd. I have not seen the article to which he refers, though I hope to do so. However, if Mr. Dawes quotes from this, and presumably he does, it would appear to be a résumé of reports of experiments conducted by Seeley and described in the *R.C.A. Review*, April, 1938. Seeley deals herein with reflections in some detail, and also refers to the effects of antenna and line mismatch; though he mentions the observed changes in phase, I am not sure that the same reason is the cause for the reversal to which I referred. In passing, a short article that appeared in that journal for March 10th, 1938, p. 215, shows how some of these effects are caused. When the modulation is high, however, another effect that can result in false deductions takes place.

An account of two simple tests recently conducted here will illustrate this point.

If, while the television equipment is normally working, an artificial signal consisting of a 45 Mc/s carrier (or thereabouts) modulated with a high and low frequency be fed to the equipment, the resulting pattern will be superimposed upon the picture and will be of such a form that the picture can still be observed. If the amplitude of this artificial signal be now increased, a point is reached where the original picture appears to be reversed in phase, though the detail remains perfectly clear.

A similar test using two separate aerials spaced by about 80ft. permitted a similar effect to be secured. It is considered, however, that these effects are probably due to over-modulation. A first-hand incorrect assumption could presumably arise from similar tests.

Concerning Mr. Dawes' suggestion that the reversal in phase is perhaps due to changes in the reflecting media, this is likely, though his further suggestion that the cause of the reflection may be attributed to a metal object or tree is not so probable.

A rough computation indicates the reflected wave to have travelled some 12½ miles farther than the original ray. And this is taking things at their face value, for the following possibility presumably should not be overlooked. It has in its support the fact that reflections have been observed here in which the "ghost" image has been displaced in the vertical direction by an appreciable number of lines. These cases are, however, relatively rare, and it is this oft-repeated phenomenon of the image dis-

placed by two-thirds of the picture width that is of interest.

The possibility I refer to is that the nature of the resolution of a ghost image is such as to permit this image to be displaced in the vertical sense for a few lines (more than three is likely to reveal itself), the correction then for the path distance is a simple multiple of the distance covered during a line traverse interval plus the distance covered during the horizontal displacement. A single horizontal traverse, i.e., one line occupies an interval of approximately 100 microsecs. During the interval a wave in free space travels 18.6 miles, so that, if there is any truth in this possibility, the path of the reflection could be 12.4 miles plus 18.6 miles, i.e., 31 miles, or perhaps 49.6 miles or very improbably 68.2 miles.

Perhaps those having a special acquaintance with reflecting layers may make something of this. I am about 100 miles from A.P.

Finally, the distances given are approximate only; they assume a line interval to be 100 microsecs., they assess the displacement in round figures and they take no account of the line sync. pulses margin. However, if anything is suggested by the above I shall be pleased to secure accurate data.

S. WEST.

Worlingham, Suffolk.

RF MEASUREMENTS

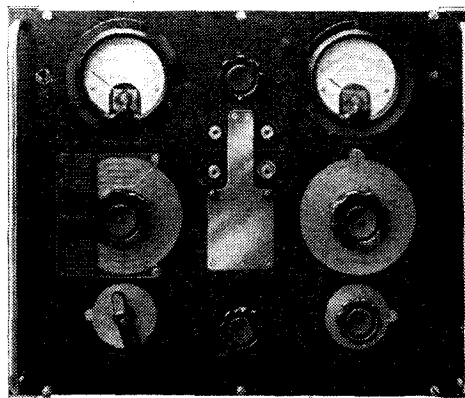

THE Marconi-Ekco Circuit Magnification Meter, TF.329, is an instrument which has an extremely wide range of applications in the measurement of power factor, magnification, dielectric losses, etc., at radio frequency.

The design comprises a triode oscillator which is used to inject a small known voltage into a tuned circuit consisting of the coil under test and a low-loss condenser integral to the instrument. The voltage developed across the condenser at resonance is indicated by the valve voltmeter.

The magnification range is 10 to 500 over the frequency range 50 kc/s to 50 Mc/s. Direct frequency calibration and mains operation are features.

The Amateur Radio Handbook. First edition, 1938. Published by The Incorporated Radio Society of Great Britain, 53, Victoria Street, London, S.W.1. Price 3s. in Great Britain and 3s. 6d. overseas, post free.

FIVE years ago the R.S.G.B. issued a booklet with the object of assisting the beginner to obtain a better understanding of short-wave receiving and transmitting

apparatus. Each following year an enlarged edition was produced until it eventually became apparent that *A Guide to Amateur Radio* was outgrowing its original conception.

The Amateur Radio Handbook thus came into being, and under the new title it takes the form of a comprehensive textbook of amateur radio as practised in this country. In the first chapter the fundamental principles of wireless are explained; then follows a chapter on the theory and operation of valves. Short-wave receivers and transmitters are discussed, which is followed by chapters on power supply units, audio equipment and aerials, and then a most useful discourse on the prevention of interference with broadcast reception by amateur transmitters.

In all there are twenty-five chapters, each dealing with a different subject and containing a wealth of useful information. Some idea of the scope of the handbook can be gauged by mentioning such subjects as television, ultra-high-frequency reception and transmission, measuring apparatus of all kinds, and the calculation of great circle distances.

This new R.S.G.B. handbook, which aims to cater for the needs of the British amateur experimenter, definitely achieves its object, and this is undoubtedly due to the fact that it is compiled by amateurs who have made a special study of the various subjects for which they are responsible. H. B. D.

Club News

Radio, Physical and Television Society

Headquarters: 72a, North End Road, London, W.14.

Meetings: Fridays at 8.15 p.m.

Hon. Sec.: Mr. C. W. Edmans, 72a, North End Road, London, W.14.

On December 2nd Mr. Royle delivered a lecture on "Crystal Controlled Oscillators," and gave some interesting particulars of frequency-stabilising devices. Details were given of the so-called rubber crystal control, which, in the opinion of the lecturer, will soon be a very popular arrangement with amateur transmitters.

Croydon Radio Society

Headquarters: St. Peter's Hall, Ledbury Road, South Croydon.

Meetings: Tuesdays at 8 p.m.

Hon. Pub. Sec.: Mr. E. L. Cumbers, 14, Campden Road, South Croydon.

At the meeting which was held on November 29th Mr. W. J. Bird lectured on "Sound in the Cinema." The lecturer had a complete sound-head with him with which to illustrate many of the points involved.

Ashton and District Amateur Radio Society

Headquarters: Commercial Hotel, 86, Old Street, Ash-ton-under-Lyne.

Meetings: Alternate Wednesdays.

Hon. Sec.: Mr. K. Gooding, 7, Broadbent Avenue, Ash-ton-under-Lyne.

It has been decided to hire a larger room for the club's headquarters owing to an increase of membership, which now totals 35. Several members are attending the Morse classes, and G3FF has been appointed official Morse instructor. It has been decided to hold a "hamfest" early in the New Year and to invite the Oldham and Rochdale Amateurs. It has also been agreed that the society shall be affiliated to the R.S.G.B.

Mr. Collinge, of Messrs. Ferranti, Ltd., will lecture on "Measuring Instruments" on January 25.

Exeter and District Wireless Society

Headquarters: Y.W.C.A., 3, Dix's Field, Southernhay, Exeter.

Meetings: Mondays at 8 p.m.

Hon. Sec.: Mr. W. J. Ching, 9, Sivel Place, Heavitree, Exeter.

On November 28th members received a lecture in the showrooms of the Exeter Gas, Light and Coke Co. The lecturer pointed out that units are now available commercially for operating wireless sets from the gas mains.

Southend and District Radio and Scientific Society

Headquarters: Strand Chambers, High St., Southend.

Hon. Sec.: Mr. J. M. S. Watson, 23, Eastwood Boulevard, Westcliff-on-Sea.

On December 2nd Mr. H. J. Walters, of Belling and Lee, Ltd., lectured on "Interference Suppression and Suppressors."

Crystal Band-Pass Filters

IN this concluding article of the series the author discusses the effect of the balancing condenser on the filter response and shows that by careful adjustment a more even response in the pass-band can be obtained. This is combined with increased selectivity close to the pass-band but reduced selectivity further away.

THROUGHOUT the preceding articles the balancing condenser has been treated as mainly useful in balancing the capacities of two crystals, so that no energy passes the crystal filter through a stray capacitive path. In the preceding circuits, however, it was suggested that the condenser might form a front panel control in certain cases, and with a knowledge of the results given by typical filters and the ways in which they can be used, it will now be helpful to examine more closely the changes in response which the balancing condenser can bring about at will. It will be seen to offer very valuable possibilities, and to provide a fourth method that can be used to level the response over the pass-band, or to reduce it at selected external points.

To understand the action of this condenser, suppose the crystals to be replaced by their recognised equivalent circuits, when a typical band-pass filter becomes as shown in Fig. 18. This has been drawn similarly to the preceding figures, such as Fig. 16, so that it will be easily recognised.

In discussing the filter it will be assumed that the three circuits L_1 , L_2 , L_3 , and their associated trimming condensers, are each tuned mid-way between the crystal frequencies, and that their resonance is so flat over the pass-band that they can be

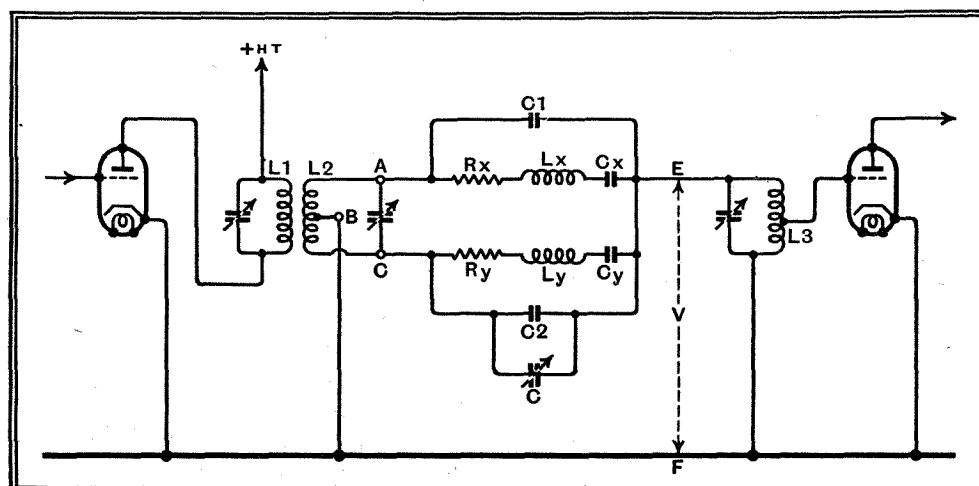

Fig. 18.—This diagram shows the equivalent circuit of the crystal band-pass filter.

Part VII.—THE BALANCING CONDENSER

By E. L. GARDINER, B.Sc.

regarded as pure fixed resistances over that range. While not strictly true, this assumption is very nearly so in the case of narrow filters of a few kc/s in width, and introduces very little error indeed into the discussion. On this assumption it can be said that no phase changes occur on account of these circuits, and that the filter is fed by oscillatory potentials across L_2 which are constant over the band concerned, and always opposite in phase at A to that at C, relative to the earthed centre-point B.

Now, the output from the filter is measured across a pure resistance at "V," between the points E and F or E and earth,

Fig. 19.—The normal crystal filter curve is shown at (a) and the change effected by an adjustment to the balancing condenser is illustrated at (b). A further change in its capacity gives the results of (c) and it is possible to modify this to the form of (d) by the use of additional circuits.

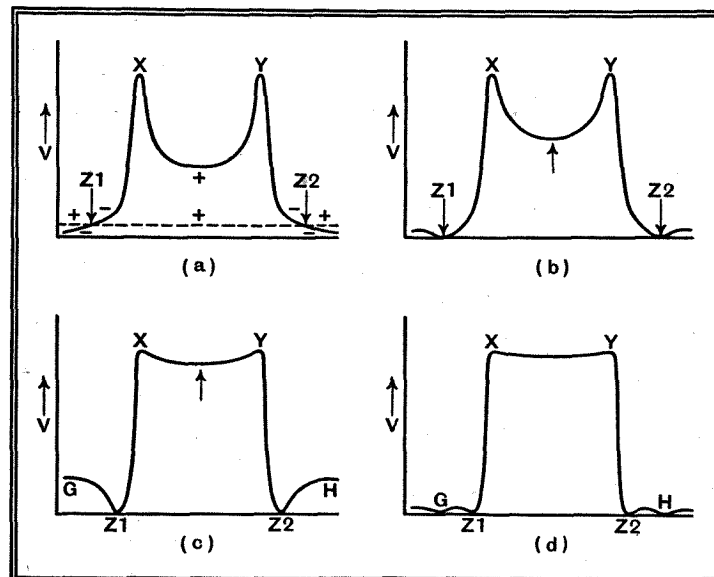

and we wish to know the influence of the balancing condenser C upon the potentials which reach E. The assumption that the circuit L_3 behaves as a pure resistance is not important, for whilst it simplifies the discussion, it has no profound effect upon the action of the balancing condenser.

Potentials set up in L_2 can reach E by

five parallel paths, namely, through:—

1. The series resonant circuit R_x , L_x , C_x , which represents the series component of the crystal X.

2. The series resonant circuit R_y , L_y , C_y , which represents the series component of the crystal Y.

3. The parallel capacity C_1 of the crystal X, which includes that of the crystal, its holder and associated wiring.

4. The parallel capacity C_2 of crystal Y, as above.

5. The balancing condenser C, acting in parallel with 4.

The potential at E will be the vector sum of these five components. Alternatively and more strictly, the potential at E will be due to the vector sum of the currents flowing through the five paths mentioned, across the load impedance. But since the latter is constant and resistive, current is proportional to potential, and the two can be referred to indiscriminately.

The Balance Condition

Considering now the current through the five paths listed. That through the first two causes the band-pass effect that was explained in general terms in the preliminary article, of September 15th, 1938. The current through C_1 will be equal in magnitude and opposite in phase to that through C_2 , if these two capacities are equal, since both are produced by equal potentials at A and B, which are in opposite phase. These two currents will set up equal potentials at V, which, since they are opposite in phase, will cancel, contributing nothing to the filter output. This is the condition that has been referred

Crystal Band-Pass Filters—

to as balance, or "balance at infinity," and the foregoing explanation shows that it can be correctly described as a balancing effect. It would be very simple to express the condition mathematically, but to do so would not add to the truth of the simple explanation just given.

No mention has yet been made of the current through the balancing condenser, C. This condenser acts in parallel with C₂, and can be regarded as part of that path. It will in practice be joined across C₁ or C₂, whichever is the lower in capacity, and adjusted so that C₂+C=C₁. In this way the balanced condition is arrived at experimentally. However, to investigate the effect of altering C to other values, it will be convenient to assume that C₁=C₂ already, when C equals zero for the balanced state, at which the curves given were taken. Alternatively, regard a part of C as employed to correct C₂ till it equals C₁. Then any departure of C from this value will be the figure referred to when discussing its effect upon the filter response.

Suppose, therefore, that C is zero, that the bridge is balanced for parallel capacities, and gives the curve sketched in Fig. 19 (a). What will happen if C is now increased? Clearly an additional current will flow through that arm, and will set up a potential at V of the same phase as that through C₂. This will be added (vectorially) to the curve of Fig. 19 (a), which was produced by the series arms (paths 1 and 2) alone.

Increasing the Balancing Condenser

Recalling the phase relationships of this curve given in the preliminary article, it is clear that since paths 1 and 2 behave as pure resistances at resonance, the potential at V at the two peaks X and Y of Fig. 19 (a) (due to the two crystals X and Y in Fig. 18) will be in the same phase as the potentials at the input points A and B respectively. They are thus equal and opposite. Now a phase change of approximately 90 deg. occurs in the

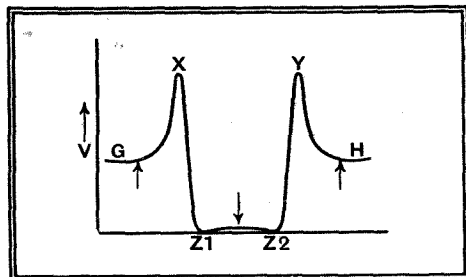

Fig. 20.—By the correct adjustment of the balancing condenser the filter can become of the band-stop type.

current through C, simply because the latter is a condenser, and so the potential which it sets up at V will lead that at X by 90 deg., or lag 90 deg. behind that at Y. In other words, the two are in quadrature, and so do not combine vectorially to modify the response at X or Y. This leads to the first practical conclusion, which is that varying the balancing condenser will have very little effect

upon the peaks of the filter curve.

Between these peaks, however, it has been shown that the phase is nearly uniform, and differs by 90 deg. from that

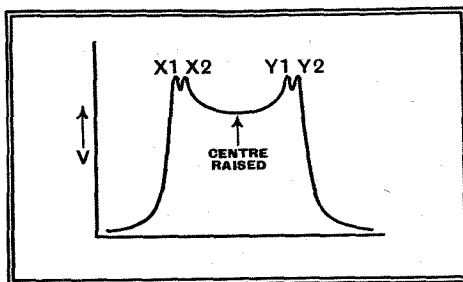

Fig. 21.—The peak height can be reduced by using pairs of crystals in each arm of the bridge, and a curve such as this is obtained.

through either crystal, because it is due to response at a relatively remote side-band of each crystal, in additive phase. Therefore a potential exists at V throughout the pass-band which is nearly in phase with that due to C, or else in opposite phase, according to which crystal is of higher frequency. It will be in phase if the crystal X is taken as the lower.

Increasing C, therefore, adds potential at V in phase with that already produced by the current through the crystals, and will so increase the response over the pass-band. Outside this band, however, the crystal currents result in a small potential in the reverse phase, and which is, therefore, opposed by that due to C. This condition is illustrated in Fig. 19 (a) where the dotted line represents the uniform potential due to C, the phase of which relative to the filter curve is shown by the arbitrary plus and minus signs. Between X and Y these two curves assist, while outside that region they oppose. At some point, therefore, they must be equal and opposite, giving zero potential across V. The result is shown in Fig. 19 (b), where Z₁ and Z₂ are two points at which the filter output has become zero.

Two "zeros," or "points of infinite attenuation," occur, one on each side of the band-pass. If the two crystals are of identical "Q," then the zeros will occur at practically the same frequency difference outside the peaks X and Y. Their production is most fully confirmed by experiment, and it is found that an attenuation exceeding 60 db occurs when the zeros are more than some 250 c/s outside X and Y at 465 kc/s. Generally, it is possible to obtain much better than 60 db attenuation provided that the whole filter is of low-loss construction. Clearly, since the production of zeros is a capacity balancing effect, the presence of any disturbing factors such as poor power-factor in the condensers, stray inductive coupling, etc., is likely to introduce phase changes which prevent a clean balance. In this respect the subject is very similar to bridge measurement work, and demands similar precautions.

The point Z₁ or Z₂ will occur where the potential due to C equals in magnitude that through the crystals. Therefore, as C is still further increased, Z₁ will move in towards X, whilst Z₂ moves sym-

metrically towards Y. At the same time the central region will be raised proportionately. It is found possible to progress continuously from a curve such as Fig. 19 (a), through 19 (b) to 19 (c), and to place the zeros at any desired position. This is clearly a most useful effect. Corresponding, as it does, to the better-known single crystal filter effect, it enables interference from telegraph transmissions or heterodyne beats to be eliminated, with the great advantage that whereas in a single crystal filter one side-band can only be depressed at the expense of the other, it is now possible to remove interference on both side-bands simultaneously.

At the same time the sides of the band-pass are steepened, and the pass region raised and levelled. It is very easy to obtain a nearly level band-pass through an increased value of the balancing condenser, and the separation X-Z₁ can be reduced to 200 or 300 c/s only at 465 kc/s, but a penalty is paid in the raised outside response near G and H. However, since other IF couplings will assist in the elimination of response at those points a limited use can often be made of the effect. It is of particular value in the case of filters wider than about 5 kc/s, and a possible method for designing these has been found in the increase of C to give a result similar to Fig. 19 (c) and the removal of the "lobes" at G and H by special methods. Coupled high Q absorption circuits tuned to those regions have been found very helpful in effecting this, and lead to a curve of the type shown in Fig. 19 (d), where the remaining external response can be removed by selectivity elsewhere in a receiver.

Band-Stop Filter

If instead of increasing the balancing condenser above the value necessary to produce balance it is reduced below that value, a different set of conditions occurs. The potential now transferred to V is in opposite phase to that in the pass-band, and in phase with that of the external regions. Therefore the filter response between X and Y is reduced at the expense of raised external response. If C be so adjusted that the potential transferred is equal to the mean potential within the pass-band the latter is reduced to zero, and the curve is similar to Fig. 20.

This has been found a very perfect method for obtaining band-rejection for purposes which require it. The cut-off is extremely sharp, while a very high degree of rejection is obtained from a simple circuit arrangement. In the design of a receiver having an exceptionally perfect band-pass characteristic, it would be quite possible to utilise a filter curve such as Fig. 19 (c), and to place two band-rejector filters similar to Fig. 20 at each side of it in order to suppress the regions G and H.

In concluding this review of crystal band-pass filters of the type invented by Dr. J. Robinson it will be interesting to mention a few special modifications, about which a great deal could be written.

Probably little improvement is necessary in the case of narrow filters, less than some

Crystal Band-Pass Filters—

5 kc/s in width. When, however, circumstances call for considerably greater widths, and as a result the response within the pass-band is from 6 to 15 db below that of the peaks, several alternative methods exist for improving the curve.

In some cases a moderately low, but level, response is satisfactory, and could be increased to a sufficient extent by simple amplification, provided that the peaks (X and Y) were less prominent. These can be reduced in such cases by the use of two additional crystals, identical within a few cycles with those forming the filter. The additional crystals are connected to produce the well-known "crevasse" effect, and might, for example, be joined across the input or output coils of the filter. They thus absorb the voltage across these coils at X and Y, and since the crevasse can be made very nearly complementary to the peaks of the original curve, the latter can be effectively removed. It is then only necessary to make up for the attenuation within the pass region by a stage of amplification to arrive at a satisfactory result.

An entirely different method of approach makes use of a pair of crystals in place of the single crystals at X and Y. That is to say, four crystals are used in all, arranged in two pairs. Each pair differs by a few cycles only, and are placed at each end of the pass-band as before. There is no objection other than cost to the use of three or more crystals grouped at each end of the band. Each crystal added in this manner contributes energy to the pass-band since the side-band responses of all are in additive phase throughout that region, while each pair provides energy in phase opposition outside the band as before, and tends to a small resultant. The use of two crystals at each end of the band-pass filter will approximately double the mid-band response, and is thus very useful in the case of wide-band filters. The effect is illustrated in Fig. 21, which shows the response curve to be expected if pairs of crystals were substituted for the single crystals used in the filter of Fig. 19 (a).

A number of other applications involving multiple crystals have been investigated by Dr. Robinson and the writer. Prominent amongst these has been the design of networks, including crystals which will have the desired band-pass characteristics quite independently of any associated thermionic valves. There are certain applications where such a device might be advantageous, for instance, in the construction of Multiple Telephony equipment for use over cable channels.

A filter network of this type will usually be designed to operate between very low impedances, and is considerably less simple than those described in these articles, both in construction and theory. In the case of radio receivers it is not of such great importance to separate the filter performance from that of the associated valves, and, in fact, it has been indicated that a simplification results from not doing so. A discussion of more conventional low impedance filter networks has, therefore, not been included here.

Random Radiations

Vision or Jamming?

A MARINE radio operator writes to tell me that he has been several times lately at Riga, in Latvia, and has had the greatest difficulty there in tuning in Droitwich, owing to very strong interference of a peculiar kind. He assumes that this was due to vision transmissions from a Russian station with a wavelength of about 1,400 metres. It is just possible that it was a low-definition vision transmission, but there is also a possibility that what was heard was the deliberate jamming by automatic apparatus of a station in Russia. I haven't heard such jamming on the long waves, though I've frequently come across it on the 31-metre and the 25-metre short wave bands. One can hardly imagine that Droitwich was being jammed, for even the most super-sensitive foreign governments couldn't find much to which to object in its news bulletins!



The Empire Radio Link

IT is much to be hoped that the Government will be able to accept the offer by Cables and Wireless, Ltd., to spend a million pounds in erecting a chain of radio stations to link up outlying parts of the Empire. At the moment, communications with places such as the West Indies are dependent mainly on submarine cables, which have the disadvantage of being extremely vulnerable in times of emergency. Further, as you will see by consulting the early pages of your telephone directory, only a few of the most important towns can be reached by the overseas telephone service. An Empire radio link would undoubtedly be of the very greatest value, not merely as a precaution for emergencies, but also in times of peace.



Television Ranges

IN a recent broadcast to the Empire the B.B.C.'s Chief Engineer, Sir Noel Ashbridge, had a good deal to say about the range of the Alexandra Palace television transmitter. I don't know whether you heard him, but this is the gist of what he said. The Television Committee anticipated that the service area would have a radius of 25 miles. Actually the London station has been received at places in this country up to 200 miles away on occasion; the sound portion of the programmes had been heard in India, South Africa and New York, and very vague television images have actually been reported from New York. But these things were, of course, freaks, and he would put down the average range for good reception from A.P. at 30 miles. Even that is, I think, a little under the mark. Except in some places which are notoriously bad, it seems possible to receive the A.P. programmes well enough in most localities up to at least 40 miles away, provided, of course, that the aerial is high, well designed and properly matched.



A Meter Difficulty

A SWINDON reader, who tried the "Diallist" method of using the household electric meter for checking the load imposed on the mains by a receiver, reports

By "DIALLIST"

that he encountered a strange difficulty. When everything else in the house was switched off, switching on the set didn't make the disk of his meter revolve at all. He could hardly, he says, summon the supply company to oil a rheumatic meter; but where was the difficulty? If the disk remains stationary the factor T is infinity, whence by the "Diallist" formula, the current consumption is nil. My recommendation would be to do as much listening as possible for nothing during daylight hours. The reader, however, was not so easily satisfied. He found that the disk could be started if the meter were tapped sharply, though it almost immediately came to rest again. A series of taps would keep it revolving and it occurred to him that a tap might be considered as the mechanical equivalent of an atmospheric, and so capable of resolution by a Fourier series into a series of impulses covering every periodicity. He was about to get down to this when wiser counsels prevailed. It was found that when a 60-watt lamp was also switched on the meter would do its stuff. This simplified matters immensely and he sends me a delightful formula, which appears to cover every eventuality. Much more valuable, I can't help feeling, would be a practical hint or two for worried householders on how to encourage sluggishness in the electric meter's disc!



Queer Interference

A BARROWFORD reader tells me that some time ago he had a somewhat similar experience of the picking up of a telephone conversation by a wireless set to that which I recounted in a recent issue of *The Wireless World*. He was then using a 1-V-1 straight receiver with reaction on to the aerial. One day he was changing over to another waveband and, with the set switched on, pulled out the aerial coil. Instantly he found himself listening to both sides of a telephone conversation, the purport of which made it clear that one, at any rate, of the speakers was in some business premises 70 yards or more away in a straight line. He found that directly he reinserted the aerial coil the loud speaker was silenced, coming into action again whenever the coil was removed. Very interested, he decided to see whether or not the effect would be repeated at a later time. For several weeks he left the receiver running for long periods minus its aerial coil, but never once found any recurrence.

Any Suggestions?

Like him, I've endeavoured without success to obtain a further demonstration of the cross-talk which occurred in my own home—you may remember that after I'd answered a telephone call my wife came into the room where I was and told me that during an interval in the London Regional programme she had heard my voice clearly from the loud speaker. A clue to my Barrowford reader's experience may possibly be found in the fact that it took place at the end of 1923. During the war we nearly always found that, when induction

between field telephone lines took place, it was caused by, and between, circuits with earth returns. I think I'm right in saying that in 1923 there were G.P.O. telephones with single wires and an earth return. If so, we have a possible solution of the mystery; it may have been that the circuit causing the effect was subsequently altered to a wire return, with the result that the cross-talk ceased. Alternatively, there may have been an insulation defect in the offending telephone circuit, which was set right shortly afterwards.

Reverse Effect

SOME years ago a friend of mine had a very strange experience of cross-talk; instead of hearing a telephone conversation reproduced by a loud speaker, he heard a wireless programme coming through on the telephone. One evening he lifted off the receiver of one of the old upright telephones to put through a call. On placing it to his ear he was surprised to hear loud sounds of music. The piece being played was one that was easily recognisable and he identified it as an item in the programme of 5XX, the old Daventry long-wave station. When the operator answered, he asked whether by any chance a wireless set was in use at the exchange, and found that this had not, of course, been so. The only explanation that I can think of it this. The telephone line from London to Daventry runs through the place where I live. Nowadays the link is the underground co-axial cable; but at that time there were overhead wires. Over these the National programmes would go from the London Studio to Daventry and there may have been induction between the line carrying the Daventry programme and that serving my friend's house. The G.P.O. people spent some little time in investigating the occurrence, but it never happened again and they were unable to find a completely satisfactory solution.

Slow Valves

DO you, I wonder, find it as irritating as I do that when you switch on your mains set an unconscionable time must elapse whilst the valves are warming up before the receiver comes into action? I can't say that I have put in any accurate stopwatch work, but my general impression is that the valves used in some modern sets, at any rate, are even slower in getting off the mark than those of a few years ago. I have just this moment timed two current models using valves of different makes. One takes 20 seconds to "cook"; the other, 24. There must, of course, be some delay with indirectly heated valves, but I can't help thinking that we might do a little better than that. Strange as it may seem, I know one household which has reverted to the battery set, with its almost instant response to the switch, because they found the wait after switching on a mains set so annoying.

U.S.A. Television

FROM the Director of the twin stations, W2XAD and W2XAF, at Schenectady, I've just had some news about television developments in the United States. The American G.E.C. has been conducting definite research and experimental work on television for eleven years now and intends to be in the forefront when American television gets into its stride. The Head of the G.E.C.'s television department expresses an opinion very similar to that which I've put

forward in these notes before now. In a nutshell, it is that though we now have the means of transmitting actual scenes and their accompanying sounds from place to place, we don't yet quite know what to do with this new acquisition. We've been experimenting with television programmes of various kinds for over two years now and our results have been carefully noted on the other side of the Atlantic. There are hints that American programmes, when they do begin, will strike out a new line of their own. If they do so, it will be all to the good and I am sure that our production people will be only too happy to avail themselves of any new ideas that may be evolved.

Why' the Fuss?

WHY all this pother about the programme specially for dogs? I think it's an utterly silly idea, but if it amuses some people, why worry? It was absurd for the R.S.P.C.A. to raise their voice in protest, for no dog owner need inflict such a programme upon animals of his that don't like it. No sensible dog owner would think of doing anything of the kind; he'd merely switch off or turn to some other station. My own golden Labrador takes absolutely no notice whatever of anything that comes from the loud speaker, having long ago decided for himself that wireless is just wireless. A broadcast gun-shot leaves him completely unmoved, despite the fact that he's a gun dog and that a genuine shot means, that he'll be called upon to do the job of work that he likes better than anything else in the world.

A Language for Radio

AN American scholar, Professor Carlo Spatari, has invented a new universal language for the special use of the wireless enthusiast. He calls the language Sirela. It is based on the names of the notes of the Continental Sol-fa scale—Do, Re, Mi, Fa, So, La, Si, Bo. These eight syllables and no others are used and by combinations of them you can ask almost any question you like of the man you're "working" and he can answer you. It doesn't matter in the least whether either of you knows the other's language or not. The idea is mag-

nificent, but it seems to me that misunderstandings might very easily occur owing to the similarity of some of the combinations which mean completely different things. For instance, Dobododo means "In answer to your request, the following is my opinion"; whilst Dobobodo means "I am situated in a wooded region." I tried to puzzle out some printed specimen messages and I must say that it took me a good long time to make head or tail of them.

Do We Need It?

Some of the South American and Central American broadcasting stations have already adopted Sirela and answer verification queries in that language. There is also a strong movement to popularise it amongst U.S.A. hams. I doubt, though, whether the language will attract a vast following, for radio already has a language that seems to answer pretty well—English. On a good many occasions amateurs, and, for that matter, professional operators, who don't understand each other's mother tongues often use English as a common language. After all, it's taught in the schools of most civilised countries nowadays and the number of people who have, at any rate, a smattering of it is amazingly large. I expect that most amateurs would rather expend their energies in learning a language that is going to be of use for other things besides radio.

The Young Idea

MY *Wireless World* correspondence makes me very popular with those youngsters of my acquaintance who are ardent stamp collectors, as most youngsters are at one time or another. I am always being asked for stamps and in most weeks I can produce a selection, from letters come in from readers living in almost every part of the world. In the past few months I have enriched several stamp albums by specimens from Guatemala (a queer little triangular stamp), Brazil, the United States, Canada, Mexico, India, Sarawak, Java, Kenya, Egypt, Palestine, Iraq, South Africa, Denmark, Norway, Sweden, Germany, France, Italy, Spain, Switzerland, and other countries that I can't remember off-hand.

Loud Speaker-Electrolier Combination

A PARTICULARLY interesting and functional solution to the problem of unobtrusively blending a loud speaker into the *décor* of a living-room is to be found in a loud speaker-cum-light pendant made by the German firm of Siemens.

As can be seen from the photographs, the loud speaker unit is fitted inside the 32in. diameter aluminium light reflector, the sound being emitted through a grille in the bottom of the bowl. This combination, which, incorporating a 6-watt loud speaker, weighs 17 lb., costs Rm.165 (approximately £14).

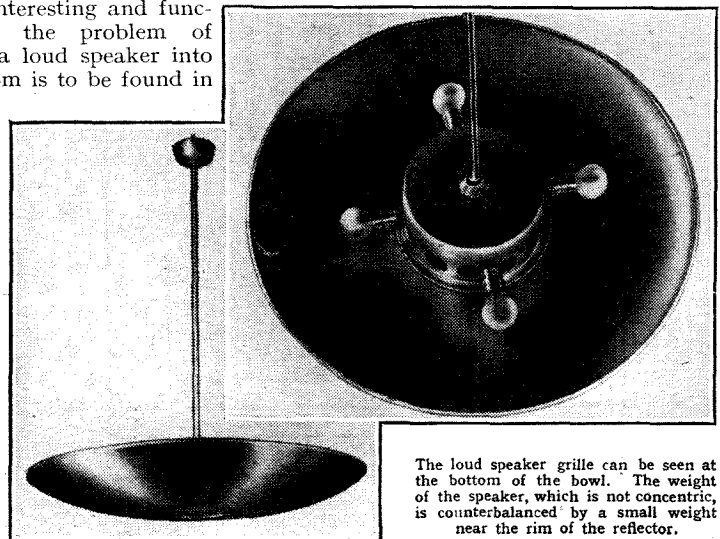

The loud speaker grille can be seen at the bottom of the bowl. The weight of the speaker, which is not concentric, is counterbalanced by a small weight near the rim of the reflector.

Recent Inventions

Brief descriptions of the more interesting radio devices and improvements issued as patents will be included in this section.

CORRECTING TELEVISION "TILT"

TELEVISION transmitters, of the type in which the picture is first projected on to a "mosaic" screen which is then scanned by an electron stream, are subject to a form of distortion known as "tilt." The effect, which is due to local interference of irregular wave-form and of comparatively low frequency, gives rise in the receiver to a progressive increase or "tilt" in the brightness of the picture towards one side of the screen; the dark areas of the picture are also sometimes filled with a white mist.

It has already been proposed to add a correcting voltage, of more or less saw-toothed form, in order to even-out the tilt, but if the average brightness of the scene changes fairly frequently, the necessary correcting voltage varies too, and it is found that the correction becomes too complicated to be practical.

According to the invention, a local source of light, such as an incandescent filament, is incorporated in the cathode-ray tube. This liberates a certain quantity of slow-moving electrons, which serve to stabilise whatever "tilt" is present and so enables it to be more easily corrected.

W. S. Percival; C. O. Browne; L. R. J. Johnson; and F. Blythen. Application date January 20th, 1937. No. 490845.

VOLUME EXPANDERS

VOLUME expansion is intended to increase the original "contrast" of sound, so that strong

signals are made stronger and weak ones still weaker. According to the invention, the non-linear resistance of an electric lamp filament is used to produce this effect.

The Figure shows a low-frequency amplifier consisting of two resistance-coupled pentodes V and V1. Shunted across the output transformer of the second valve is a small flashlamp L in series with a resistance R. The varying voltage at the junction point between the two is then applied, through a series condenser C, to the usual grid-biasing resistance R1 of the first valve V.

As the signal output increases, the resistance of the lamp filament increases with it, so that the feedback voltage decreases. As the feedback is negative, this means that the "gain" of the valve V1 is increased, so that the original signal strength is boosted. On the other hand, for a weak signal, the valve gain is diminished, so as to produce the desired effect at both ends of the audible range.

Pye Radio, Ltd., and M. V. Callendar. Application date February 9th, 1937. No. 490672.

o o o o

AUTOMATIC TUNING

THE two discriminator circuits, which are used (in known manner) to correct automatically for any slight mistuning of the set, are now further adapted to allow the listener to "shift" the incoming signals to one side or other of the centre of the intermediate-frequency pass-band, so as to select the side that is least subject to interference.

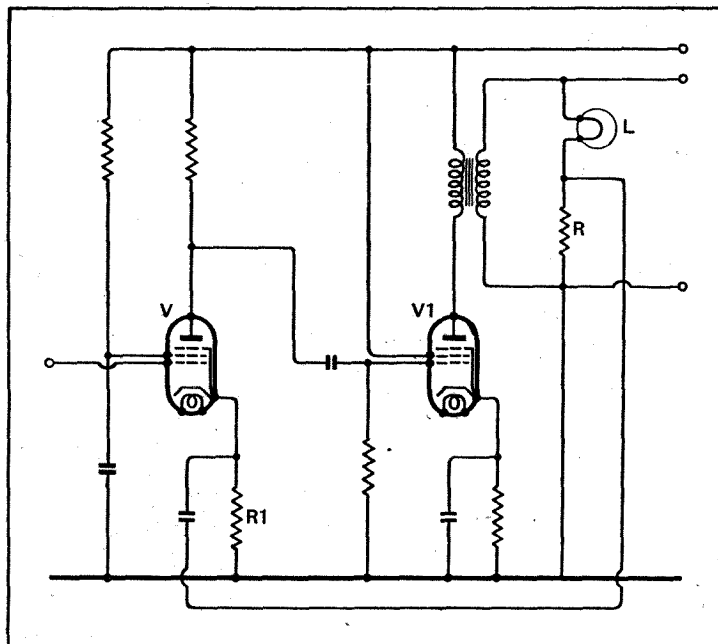

Volume expansion circuit using a lamp as the variable element of a feed-back potentiometer.

As shown in the drawing, the two "pull-in" or discriminator circuits D, D1 are coupled to the IF stage, and develop a voltage across the resistances R which is fed back to correct the frequency of the local oscillator in the usual way.

According to the invention, the two condensers C, C1 of the circuits D, D1 are each made vari-

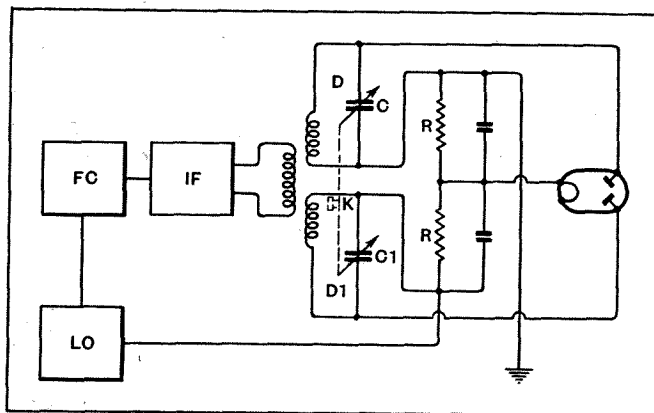

AFC circuit providing intermediate-frequency band discrimination.

able, and are preferably ganged to a common control knob K. This allows the frequency of the local oscillator circuit to be adjusted, at need, so that the desired signal is no longer overlapped by an interfering signal.

R. I. Kinross. Application date February 13th, 1937. No. 490597.

o o o o

SHORT-WAVE AERIALS

AN aerial for receiving television signals has an overall length of 50 or 60 feet, which is broken up by small series condensers inserted at intervals of about 15 inches. It is conveniently formed from a length of standard wire flex, which is stripped at the stated intervals. One of the wires is severed at one gap, and the other wire at the next gap, and so on, along the whole length of the flex. This is equivalent to inserting series capacity.

Owing to the capacity loading, the phase velocity of the currents induced in the aerial is greater than the velocity of the free signal-wave travelling in the ether. By arranging the aerial so that it is inclined to the advancing wave-front, the energy picked up at its "forward" end is augmented by the energy continually absorbed from the free wave by the "rear" parts of the aerial. In this way a gradual building-up of the aerial current takes place and is utilised to reinforce signals of the desired frequency.

E. C. Cork; M. Bowman-Manifold; and J. L. Pawsey. Application date February 9th, 1937. No. 490414.

SYNCHRONISING IN TELEVISION

RELATES to television receivers of the kind in which one or more mechanical scanning devices

are driven direct from AC mains, after the supply frequency has been suitably stepped-up, say, from 50 to 10,125 cycles a second. The use of valve frequency-changers for this purpose is said to be unsatisfactory (particularly in preventing the effect of sudden surges of voltage in the supply mains, such as occur when heavy loads are suddenly switched on or off). For this reason it is preferred to use a motor-generator set to obtain the required frequency.

In order to offset the effect of sudden surges, the final generating unit consists of a rotating toothed disc, acting as a condenser, in co-operation with two toothed

"stator" discs, all enclosed in an air-tight casing. As the rotor teeth pass between the teeth of the stators, the capacity between the latter is increased and a voltage impulse, of pure sine form, is generated and fed to the time-base circuit.

Scophony, Ltd.; G. Wikkenhauser; and A. F. H. Thomson. Application date, February 12th, 1937. No. 490294.

o o o o

"FADING-OUT" IN TELEVISION

A POTENTIOMETER control combined with a diode rectifier in such a way as to discriminate between picture signals and synchronising impulses, and to allow the amplitude of the former to be adjusted without affecting the latter.

The arrangement is particularly useful when it is desired to "fade-out" a scene during the transmission of a television programme. As one scene is faded out, a second scene from a different scanner gradually takes its place, and is locked to the same synchronising impulses, the complete change-over being effected by one control knob.

E. L. C. White and O. L. Ratsey. Application date February 18th, 1937. No. 490396.

The British abstracts published here are prepared with the permission of the Controller of H.M. Stationery Office, from specifications obtainable at the Patent Office, 25, Southampton Buildings, London, W.C.2, price 1/- each.

The **Wireless World** **6^d**

THE PRACTICAL RADIO & TELEVISION JOURNAL

Thursday, December 22nd, 1938.

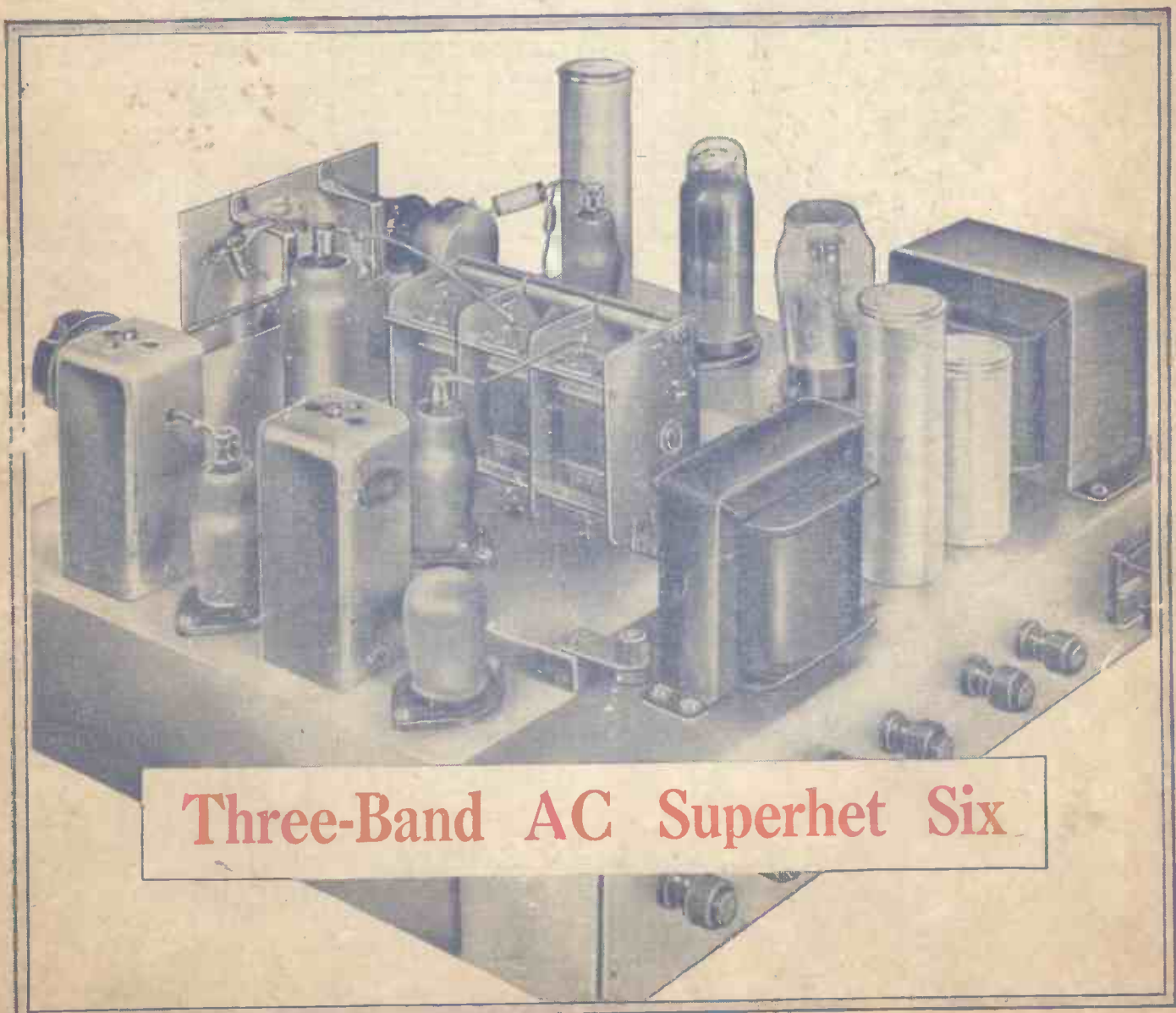

Three-Band AC Superhet Six

A FURTHER IMPORTANT ANNOUNCEMENT CONCERNING THE NEW MULLARD Red "E" VALVES

CONSTRUCTORS have been quick to grasp the interesting possibilities of these new Red "E" Valves, and the "Wireless World" has lost no time in catering for the demand revealed by our recent advertisement.

This issue contains a circuit specially designed

around some of the sensationally new types of the Mullard "E" Range. The skill of the "Wireless World" Laboratory plus the remarkable performance of the valves will surely make this one of the most successful circuits of recent years.

Outstanding features of the Red "E" Valves specified in the new "Wireless World" Circuit

E.F.8—R.F. PENTODE

In this variable- μ screened pentode the electron stream is beamed by the addition of an earthed grid aligned between the normal control grid and the screening grid. As a result, few electrons reach the screen and the noise level is reduced considerably. As an R.F. amplifier preceding the frequency changer, the E.F.8 effects a remarkable improvement in short-wave reception.

Heater Volts - - - - - 6.3 V.
Heater Current - - - - - 0.2 Amp.
Mutual Conductance at $V_{a2} 250, V_{g3} 250,$
 $I_a 8mA$ - - - - - 1.8 mA/V

PRICE 10/6

E.C.H. 2—TRIODE-HEXODE

The overall performance of a superheterodyne receiver is largely dependent upon the efficient operation of the frequency-changer stage, and with the E.C.H.2 Triode-Hexode a high standard of performance can be ensured. This is entirely due to its excellent characteristics. Not only does its conversion conductance of 0.75 mA/V provide high conversion gain but its other important characteristics (the mutual conductance of the triode oscillator section is 6.0 mA/V, whilst the optimum heterodyne voltage for maximum conversion gain is only 8 volts R.M.S.) greatly facilitate the actual design of frequency-changer circuits.

Heater Volts - - - - - 6.3 V.
Heater Current - - - - - 0.95 Amp.

PRICE 11/6

E.B.C. 3—DOUBLE-DIODE-TRIODE

The E.B.C.3 is a good example of the greater efficiency attained by the "E" construction and design even in valves of normal type. Its performance is equal to the older A.C. version despite the fact that its heater wattage has been reduced by fifty per cent. It has the additional advantage of a really compact, rigid electrode assembly.

Heater Volts - - - - - 6.3 V.
Heater Current - - - - - 0.2 Amp.
Mutual Conductance at $V_a 275, -V_{g1} 6.25,$
 $I_a 5mA$ - - - - - 2.0 mA/V

PRICE 9/6

E.F.9—R.F. PENTODE

This variable- μ screened pentode is primarily designed for use in the I.F. stages of superheterodyne receivers. By employing the "Sliding Screen" principle, the normal A.V.C. automatically adjusts the screen voltage to optimum conditions. Two important advantages result. First, the improved variable- μ characteristic reduces modulation distortion. Second, a high slope at a low anode current ensures maximum stage gain for minimum noise factor.

Heater Volts - - - - - 6.3 V.
Heater Current - - - - - 0.2 Amp.
Mutual Conductance at $V_a 250, V_{g2} 100,$
 $V_{g3} \text{ zero}, I_a 6mA$ - - - - - 2.2 mA/V

PRICE 10/6

E.B. 4—DOUBLE-DIODE

The two entirely separate anode-cathode systems embodied in this indirectly heated double-diode offer many advantages. In certain circuits the valve may be used for automatic frequency control or by joining the cathodes it can be used as a normal double-diode. Low diode-diode capacities guard against coupling between circuits.

Heater Volts - - - - - 6.3 V.
Heater Current - - - - - 0.2 Amp.

PRICE 5/6

E.L. 3—OUTPUT PENTODE

This new valve gives an audio output of 4.5 watts (9 watts dissipation) with an input voltage of 4.2 volts R.M.S.

Heater Volts - - - - - 6.3 V.
Heater Current - - - - - 1.2 Amp.
Mutual Conductance at $V_a 250, V_{g2} 250,$
 $-V_{g1} 6V, I_a 36mA$ - - - - - 9.0 mA/V

PRICE 10/6

A.Z. 3—FULL WAVE RECTIFIER

The A.Z.3 is a standard indirectly heated rectifier differing from other valves in the range in that it has a 4-volt heater.

Anode Voltage - - - - - 350-350 R.M.S.
D.C. Output - - - - - 120 mA

PRICE 9/-

To those readers of the "Wireless World" who are building this new receiver, we offer full technical and circuit data on all the valves specified.

Mullard

VALVE SALES DEPARTMENT

225 TOTTENHAM COURT ROAD, LONDON, W.1

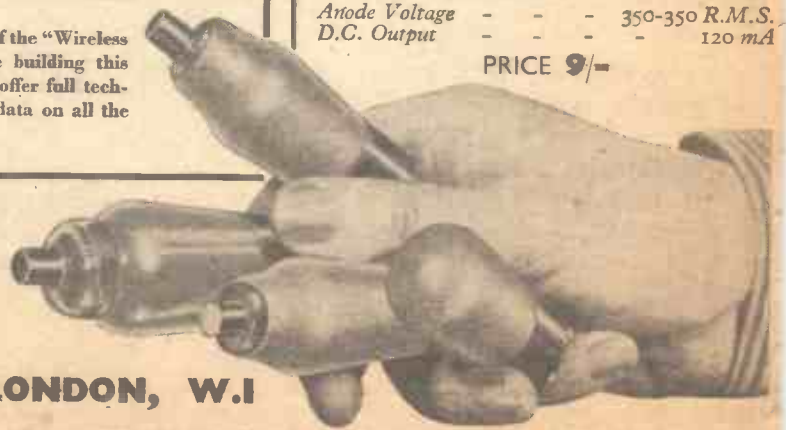

The Wireless World

THE
PRACTICAL RADIO
JOURNAL
28th Year of Publication

No. 1008.

THURSDAY, DECEMBER 22ND, 1938.

VOL. XLIII. No. 25.

Proprietors : ILIFFE & SONS LTD.

Editor :
HUGH S. POCOCK.

Editorial,
Advertising and Publishing Offices :
DORSET HOUSE, STAMFORD STREET,
LONDON, S.E.1.

Telephone : Waterloo 3333 (50 lines).
Telegrams : "Ethaworld, Sedist, London."

COVENTRY : 8-10, Corporation Street.
Telegrams : "Autocar, Coventry."
Telephone : 5210 Coventry.

BIRMINGHAM :
Guildhall Buildings, Navigation Street, 2.
Telegrams : "Autopress, Birmingham."
Telephone : 2971 Midland (4 lines).

MANCHESTER : 260, Deansgate, 3.
Telegrams : "Iliffe, Manchester."
Telephone : Blackfriars 4412 (4 lines).

GLASGOW : 26B, Renfield Street, C.2.
Telegrams : "Iliffe, Glasgow." Telephone : Central 4857.

PUBLISHED WEEKLY. ENTERED AS SECOND
CLASS MATTER AT NEW YORK, N.Y.

Subscription Rates :
Home and Canada, £1 10s. 4d. ; other
countries, £1 12s. 6d. per annum.

As many of the circuits and apparatus described in these
pages are covered by patents, readers are advised, before
making use of them, to satisfy themselves that they would
not be infringing patents.

CONTENTS

	Page
Editorial Comment	551
Vibrator Power Supplies.. ..	553
Educational Broadcasting	557
News of the Week	559
Unbiased	561
Three-Band AC Super	562
How the Valve Works, IV— Pentodes.. ..	566
Which Way does the Current Flow? II	568
McMurdo Silver "15-17" Re- ceiver	570
Letters to the Editor	572
Random Radiations	573
Recent Inventions.. ..	574

EDITORIAL COMMENT

Maintaining Receiver Performance

"Inevitability of Gradualness"

WHEN a wireless set is new, the average owner, having probably selected it as a result of comparing several different types in a showroom, has complete confidence in its performance and the quality which it gives.

Deterioration of a receiver, especially in the way of quality of reproduction from the local station, is a very gradual process ; so gradual, in fact, that those who listen to it in the home day after day are probably quite unconscious that any deterioration has set in at all. If, however, they could suddenly compare its performance after twelve months or so with what it was on the day on which it was installed, the contrast would probably be a shock to them.

The absence of any convenient means of comparison to enable the owner of a wireless receiver to judge its performance is one of the most unsatisfactory aspects of broadcast listening, because as a set tails off in performance with long use, the listener, if he notices anything at all, is very much inclined to imagine that it is the transmissions which are at fault and seldom suspects the set until an actual breakdown occurs.

Something is necessary to make the public appreciate that, to keep it up to proper pitch, a wireless set needs skilled attention from time to time. A piano is, by comparison with a wireless set, a very simple piece of apparatus, and yet nobody who appreciates music would think of using a piano year after year without regular visits from the piano-tuner. What we

need in wireless to-day is the equivalent of an army of piano-tuners, and for the public to be educated to accept the idea that periodic visits of inspection should be contracted for to ensure that receivers maintain a high standard of performance.

It is by no means an uncommon thing for the sets in use to-day to have so deteriorated as the result of neglect that speech is barely intelligible and musical reproduction is music only in name. No wonder then that popularity of the programmes seems to be waning and the public are reputed to be losing the habit of listening. We believe that neglect of receivers would be found to be a primary cause of the complaints against the programmes which are so frequently voiced.

Cannot something be done to organise service on the basis of regular visits rather than leaving matters so that the service engineer is only called in when the performance of the set has become quite unbearable ?

Television - Telephone

B.B.C. Experiment

ON the evening of December 23rd the B.B.C. Director of Television will try out an interesting experiment. Sitting at his desk at Alexandra Palace, we shall see him answering telephone calls from half a dozen fellow-viewers, who in turn will ring him up.

The experiment is a departure from broadcasting practice because it at once becomes a two-way communication instead of a broadcast transmission, and possibly special permission had to be obtained as the experiment is probably outside the terms of the B.B.C. licence from the Postmaster-General.

The experiment is one which we think should receive the special attention of the Post Office because, as we suggested on this page in our issue of July 23rd last, a means of seeing as well as hearing one's correspondent in a telephone conversation is an additional service which the Post Office might well consider introducing between certain fixed points where, by appointment, friends could converse with one another and enjoy the advantages of vision at the same time.

We suggested that such an innovation by the Post Office would be good propaganda for television and would encourage the public to take a keener interest in the service of television broadcasting.

Television Terms

Standardising the Vocabulary

IT is all to the good that the Radio Manufacturers Association is encouraging the adoption of standard technical terms in television. A sub-committee of the Association has recommended the adoption of terms as given in the British Standards Institution's "Glossary" (No. 205-1936; Sub-Sections 108 and 109) and has also agreed on uniform markings for the various control knobs of television receivers. These decisions have rightly been circulated to technical institutes and similar bodies, in the hope that the recommendations will be adopted by students as well as by those actively concerned with the development of the art.

As we have pointed out when discussing the general vocabulary of wireless and sound broadcasting, uniformity in these matters is of more importance than elegance or even strict academic accuracy. Confusion is likely to arise in any new and rapidly developing art if there is any ambiguity attaching to the terminology peculiar to that art.

It will be generally agreed that the terms recommended meet our present requirements fairly well, and most readers will be glad to see that the straightforward expres-

sion "vision frequency" is adopted in place of the hybrids "video" and "viseo" which have apparently been coined in a quite unnecessary attempt to link up with the analogous "radio" and "audio." "Blocking Oscillator" seems to be a rather less happy choice. As defined, this term covers all kinds of time-base generators, while in practice it is usually applied only to certain hard-valve types.

Christmas Greetings

From the Editor and Staff

WE take this opportunity of conveying to all our readers both at home and abroad our sincerest good wishes for Christmas and the New Year. No doubt wireless will, as usual, be used extensively for conveying good wishes to friends overseas, and broadcasting programmes, we may be sure, will figure largely in the family festivities.

Foreign Place Names

An Annoying B.B.C. Habit

ON another page attention is drawn—and not for the first time—to a custom of the B.B.C. that must puzzle or annoy countless listeners every time that a news bulletin is read. We refer to the Corporation's practice of pronouncing place names as they are pronounced—or, rather, as the announcer guesses they are pronounced—in their own countries. Even if announcers could be depended upon always to be right, the world is a long way from being well enough educated for the practice to be justified. As things are, no good purpose can be served by slavish adherence to "native pronunciation," which merely puzzles the great majority of listeners.

We still see no better solution of the problem than that suggested in our columns several years ago when it first came up for general discussion. Foreign

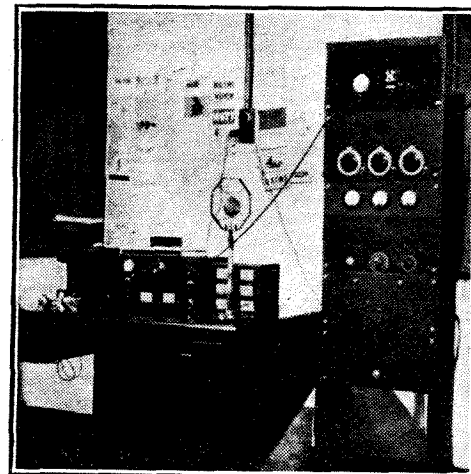

MALAYAN TRANSMITTER. VS2AR, situated at Batu Arang, Federated Malay States, is operated by Mr. J. W. Lucas. The transmitter employs a 47 oscillator valve with a 40-metre crystal, followed by a frequency doubler to 20 metres and a pair of push-pull RK25's in the final stage. Windom and diamond aerials have been tried, but the 2-half-wave-in-phase aerial at present in use proves more satisfactory.

place names occurring in news bulletins should be pronounced as they are spoken by an average well-educated and, perhaps, more than usually well-travelled Englishman. An English tongue may not take kindly to foreign intonations, but its owner, if of the type we have envisaged, has something of a genius for finding a compromise pronunciation that is sufficiently near to the original to be recognisable by a native and yet close enough to the spelling not to confuse his own countrymen. By all means let the B.B.C. accept rulings on spoken English from the learned Advisory Committee on which it now depends for advice on these matters, but keep the hands (or tongues) of the pedants off foreign words.

The Lighthouses

Better Communication Needed

RECENT happenings have drawn attention to the fact that comparatively few of the lighthouses surrounding our coasts are equipped with two-way wireless apparatus. This applies to many in positions so isolated that other forms of communication are liable to interruption through the elements.

Visual signalling, even if it could be depended upon in all weathers, is a hopelessly cumbersome and inadequate medium for conveying fine shades of meaning, as might be required in cases of sickness for discussions on symptoms and treatment between doctor and patient.

It has been proved that two-way radio telephony sets for operation by almost completely unskilled personnel can be produced quite cheaply. There seems to be now no reason why all outlying lighthouses and light vessels that cannot, for economic or technical reasons, be connected by a telephone line to the mainland should not be equipped with wireless transmitting apparatus.

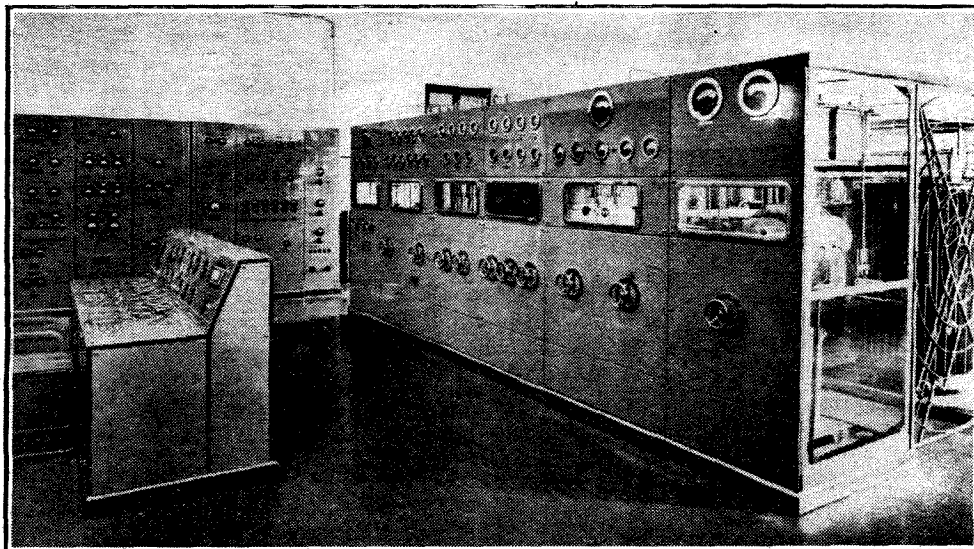

THE 30-KW TRANSMITTER of the new Turin I station which was recently put into operation together with two others of 5KW each. Operating on 263.2 metres, its original wavelength, this station broadcasts the second Italian programme.

Vibrator Power Supplies

By GRAHAM HALL, Dip.R.E., A.M.Inst.R.E. (Aust.), Assoc. I.R.E. (U.S.A.), Student I.E.E. (Eng.)

Theory and Operation of Synchronous and Non-synchronous Units

IN recent years vibrator-type power supply units have been used extensively for operating car radio receivers, but they are equally suitable for domestic broadcast sets in rural districts where a storage battery is available. This article describes the principle and operation of these units and shows by means of oscillograms the bad effects produced by the use of incorrect circuit values. It is based on a paper read at the recent World Radio Convention held in Sydney, N.S.W., by the Australian Institute of Radio Engineers.

IN the vibrator units described in this article a rapidly vibrating reed is used to interrupt the low-voltage current in order that a pulsating direct current may be produced. This pulsating direct current flows through the primary of a suitable power transformer, whence by transformation a high-voltage alternating current is available across the secondary. This voltage may be rectified by mechanical means within the vibrator unit itself, when it is known as a synchronous unit. In a non-synchronous unit the secondary voltage is rectified by a half- or full-wave valve rectifier or by rectifiers of the dry-contact type.

The ripple components in the rectifier output are removed by a low-pass filter, or smoothing circuit; but, in addition, a high-frequency filter is inserted to suppress the high-frequency transients produced by the make and break of the contacts.

The simplest type of arrangement, and which may be described as the series type,

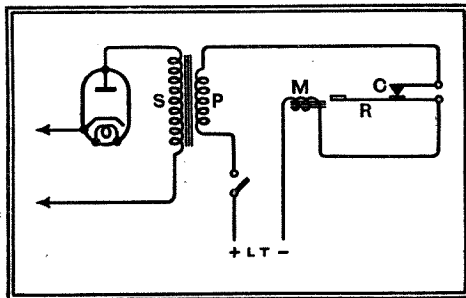

Fig. 1.—The operation of a vibrator can be best explained by a simple circuit of this kind.

is that shown in Fig. 1, and its operation is as follows:—

1 Contact C is normally held closed by virtue of the tension or springiness of the reed.

2 When the switch is closed, current flows from the positive of the LT battery through the magnet coil M and the primary P of the transformer. The change of current through the primary produces by transformer action a much higher voltage across the secondary. The primary current in passing through the magnet

coil M magnetises its core, which attracts the reed R, thereby opening the contacts C. This interrupts the primary current, and induces another high-voltage pulse in the secondary, but in the opposite direction to the previous one. Immediately the primary current is broken, the magnet coil M releases its hold on the reed, which automatically returns to its normal position. This closes contacts C, causing the primary current to flow again, re-establishing the complete cycle of the events. The high-voltage AC which appears across the secondary is rectified by the vacuum tube in the conventional manner, filtered, and applied to the load.

This arrangement, of course, suffers from all the disadvantages of single-wave rectification, and is very seldom used.

It is a long step from this first crude half-wave series type to the present-day highly efficient full-wave shunt vibrator, which we shall now consider.

Fig. 2.—Non-synchronous type vibrator showing (a) arrangement of the contacts, (b) and (c) the flow of primary and secondary currents as the reed vibrates.

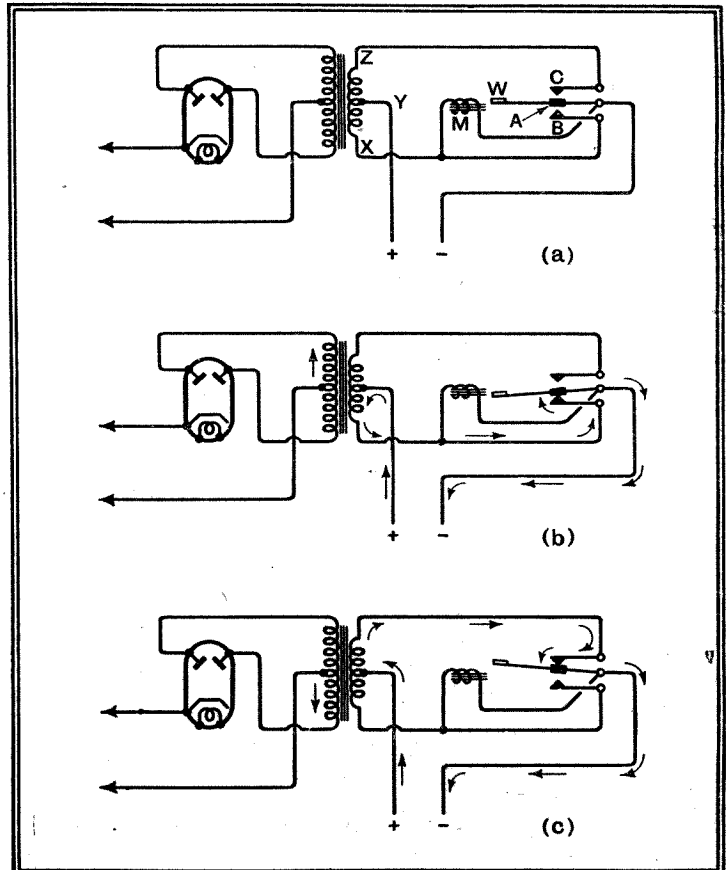

It will be seen from the circuit diagram of Fig. 2 (a) that this model has two contacts B and C, in addition to the reed contacts A. In modern vibrator units the reed carries a small counterweight, shown as W.

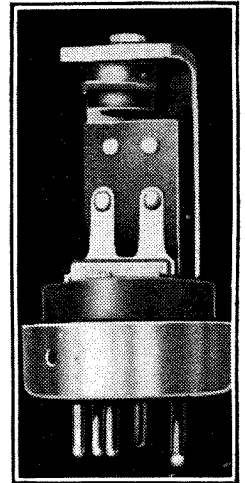
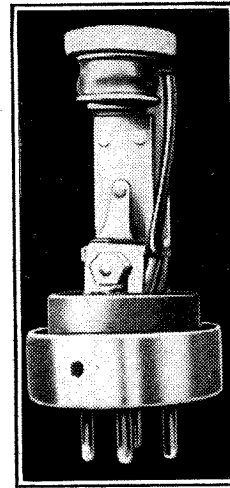

The above view shows one pair of the four contacts that are included in a synchronous vibrator. To the left is seen a non-synchronous vibrator which has one fixed contact on each side of the reed.

The magnet coil M is a shunt coil, and is internally connected to one of the side contacts. Unlike the series type the reed of this model, at the point of rest, is midway between contacts B and C, and not in contact with either. This is usually described as a non-synchronous type vibrator.

When the unit is in operation, current flows through the magnet coil M. This attracts the reed at W, causing the contacts A-B to close. A current thus flows from Y to X in the power transformer.

Vibrator Power Supplies—

This current flowing in the primary sets up an EMF in the secondary which is of opposite polarity, as shown by the arrows in Fig. 2 (b). When the contacts A-B close they short-circuit the magnet coil M, which loses its attraction for the reed W. This

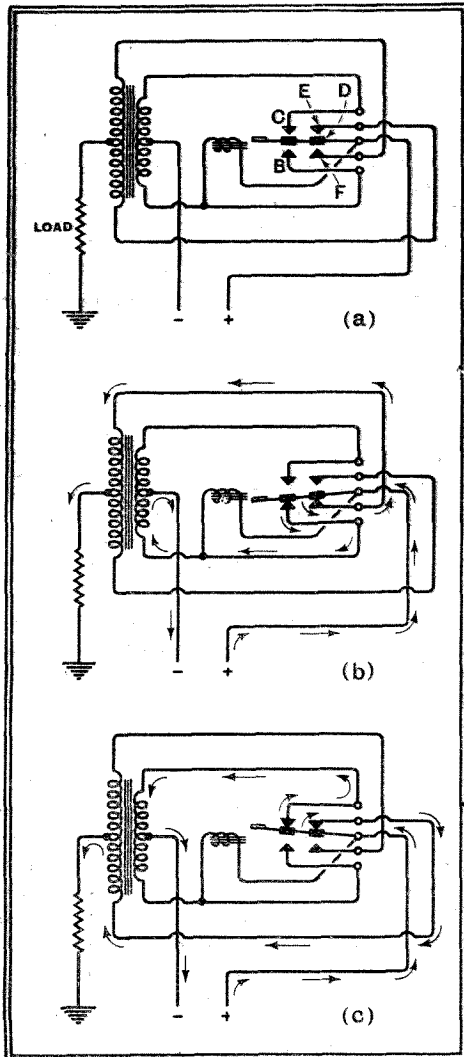

Fig. 3.—The self-rectifying, or synchronous-type, vibrator has two additional fixed contacts EF and one extra, D, on the reed as shown in (a). Note the phasing of the rectifier contacts in relation to the primary contacts; (b) and (c) show the direction of flow of current as the reed vibrates.

flies back, is carried by its momentum past the position of rest, and contacts A-C close. Current then flows from Y to Z in the power transformer. This sets up an EMF

in the secondary in the direction of the arrow in Fig. 2 (c).

Immediately contacts A-B are broken the magnet exerts an attraction on the reed. This attraction, however, is not sufficient to overcome the momentum of the reed and stop the closing of contacts A-C.

Upon passing the point of rest the influence of the magnet is again felt, and in this way the mechanism continues to function.

So far, we have only dealt with the non-synchronous type. The synchronous type is rapidly gaining favour because of the

is shown in Fig. 4, from which it is possible to see the purposes of the various filter circuits.

In the "live" primary lead, which in the case of a car starter battery may be either the positive or the negative, is a low-pass filter to prevent the "hash" from getting back into the heater supply. In the HT + lead is the filter system mentioned earlier in the article, while across the secondary winding is a resistive-capacitive network.

It can be proved that the insertion of resistors in a vibrator circuit reduces RF interference to a negligible quantity, and it

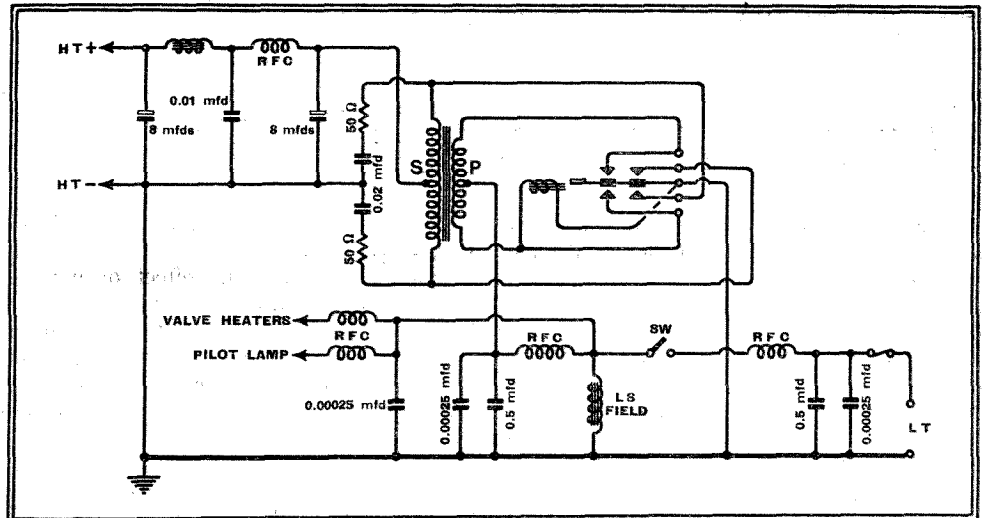

Fig. 4.—Complete circuit of an HT supply unit using a synchronous vibrator and which is suitable for use with a car radio receiver.

ability to dispense with the rectifying valve.

The construction of the synchronous type resembles that of the non-synchronous type with the addition of three contacts, DEF, in Fig. 3 (a).

Rectification is effected by these additional contacts. This can be clearly seen from Fig. 3 (b) and (c), which show the current flow for each position of the reed. It is important to note that correct phasing of the contacts is necessary.

As the contacts make and break inductive circuits it is very necessary to reduce the transient voltage produced at each make and break, in addition to reducing the arcing which would take place and ruin the contacts in a very short time. This is done by filtering.

A complete circuit of a power supply suitable for use with a car radio receiver

is not possible to insert resistors in any other place than that shown without affecting the load circuit. If the resistors are placed on the low potential side of the condensers, the RF by-passing of the condensers is affected. A single condenser connected across the secondary is not an effective RF by-pass, as there is no earth connection. The condensers tune the circuit so that it discharges while the vibrator reed moves from one contact to the other. The resistance has the effect of reducing the amplitude of any surge which may be caused by one side not discharging before contact with the other is made. If it were possible in mass production to keep the secondary winding and buffer condensers to very close limits of tolerance, the inclusion of resistors in the secondary circuit would be unnecessary.

In very obstinate cases it has been found

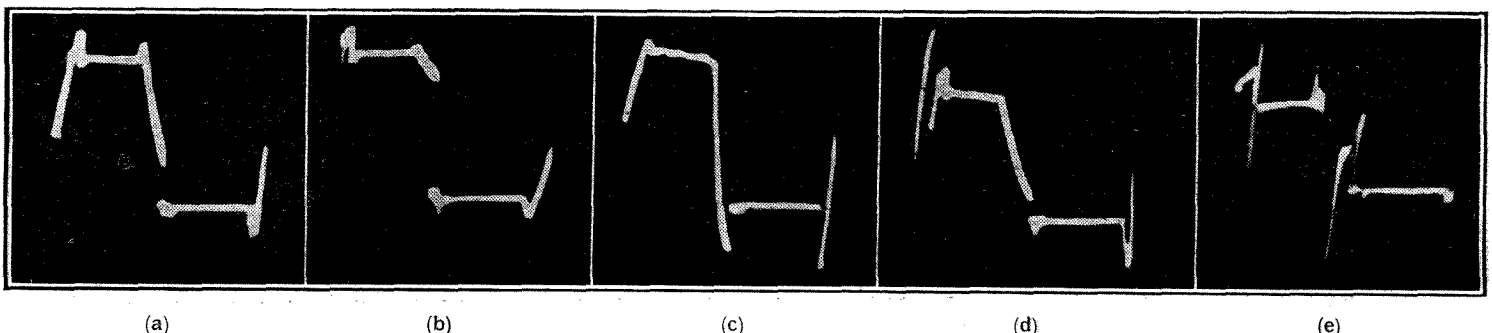

Fig. 5.—Oscillograms of the transformer primary and secondary voltages (a) with the buffer condenser values shown in Fig. 4, (b) for an increase in value of buffer condensers, (c) when one-half of the secondary winding is open-circuited, (d) with one-half of the primary open-circuited and (e) with output buffer condensers removed.

Vibrator Power Supplies—

advantageous to connect a resistance from each end of the primary winding to ground.

The cathode-ray oscillograph offers a very easy and simple method of investi-

information taken from an oscillograph.

$$E = \frac{L_1 + L_2}{L_3} \times 100 \text{ per cent.}$$

where "E" is the efficiency of the unit, L₁ is the length of the horizontal portion of the upper trace.

L₂ is the length of the horizontal portion of the lower trace.

L₃ is the distance between extremes of the wave shape.

In the case of the unit used for Fig. 5 (a), which is a photograph of the wave-shape of a production-type battery vibrator power unit, with a 16 milliamper load at 135 volts, the efficiency calculated by the above equals 52 per cent.,

whereas the actual measured efficiency was 50 per cent.

Fig. 5 (b) shows the effect of increasing the buffer condensers to 0.07 mfd. Note the increased gap. It was noticed that there was greater arcing at the contacts with this arrangement, apparently caused by the condensers not discharging fast enough.

The uneven wave-shape of Fig. 5 (c) is

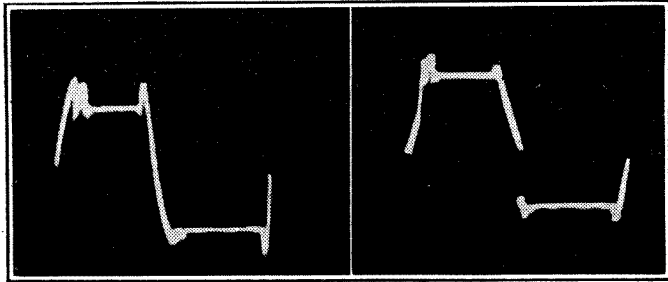

Fig. 6.—The oscillogram in (a) results when a single buffer condenser is joined across the whole secondary winding, while that in (b) is with optimum values for the particular vibrator used.

gating the performance of vibrators. It is particularly helpful in the study of contact spacing and the effects of transformer-buffer combinations, which are very important.

For long life and satisfactory performance a synchronous vibrator should have the secondary contacts spaced slightly wider than the primary contacts. This can be clearly seen from Fig. 5 (a), which

is an oscillogram of the voltage across one-half of the secondary winding of the power transformer. The top outer peak on this wave represents the primary voltage when the secondary contacts are open. Immediately the secondary contacts close, a load is placed on the vibrator, and the voltage drops to that represented by the horizontal lines. Because it is undesirable for the primary to break a heavy load, the secondary contacts open first and the voltage across the primary rises again. This is represented by the top inner peak.

The efficiency of a vibrator unit is dependent upon the "percentage time" during which the secondary contacts are closed, and is easily calculated from

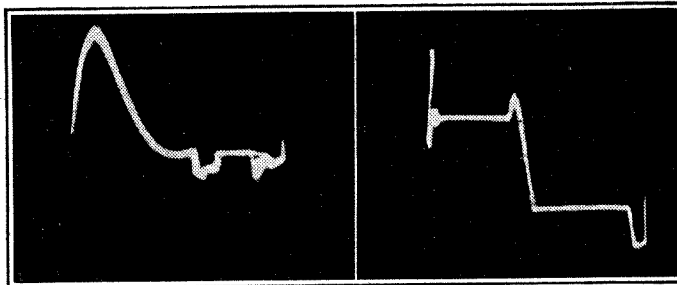

Fig. 7.—Of these oscillograms (a) portrays the effect of a vibrator working with a low primary voltage, while (b) shows the effect of heavily overloading the vibrator.

caused by one-half of the secondary winding being open-circuited. Notice the extremely high peak voltages generated on the half of the cycle which has the secondary in operation. These reduce to normal immediately the secondary contacts close and a load is placed upon the vibrator.

In Fig. 5 (d) is shown the result of one

side of the primary being open-circuited. Note particularly the uneven wave-shape, and the high peak voltages.

Fig. 5 (e) shows the effects of the buffer across the secondary being open-circuited. Notice here particularly the extremely high peak transient voltages, and blurred lines, due to RF voltages. It is due to these high peak transient voltages that the insulation of vibrator-power transformers has to be extremely good.

Importance of Filters

In Fig. 6 (a) is shown the effect of a buffer condenser connected across the full secondary winding. In this case there is no earth connection for the condenser, and its efficiency as an RF by-pass is greatly reduced. This was taken under the same load conditions as Fig. 5 (a). By comparing these figures, it will be noticed that, although the wave-shapes are similar, in general appearance they have several major differences. The first is that the condenser [Fig. 6 (a)] does not discharge at any time during the cycle, causing a "splash" at every "make" of the contacts. Secondly, it can be seen that the ability of the one condenser to absorb the transient voltages is not as great as the centre tapped arrangement. This is particularly noticeable at the top left corner of both traces. In addition to this, considerably more RF "hash" was noticeable with the arrangement of Fig. 6 (a).

We have in Fig. 6 (b) shown the effect of the best combination of load and buffer for this particular vibrator and transformer. As no two vibrators and transformers are exactly alike, it is impossible to attain optimum operating conditions for every unit. For this particular unit a load of 12 milliamperes and buffer condensers of 0.025 mfd. in conjunction with 50 ohms resistance was the best combination, giving an efficiency of 55 per cent.

In Fig. 7 (a) is portrayed the effect of a vibrator working on low primary voltage. The vibration was extremely weak and uneven because the exciting coil could not exert a pull strong enough to close the contacts properly. The high peak, distantly resembling a sine wave, represents the "percentage time" during which the contacts are closed, on the side away from the magnet coil. It can be seen that this practically equals zero. In viewing this with a stroboscope, details of which are

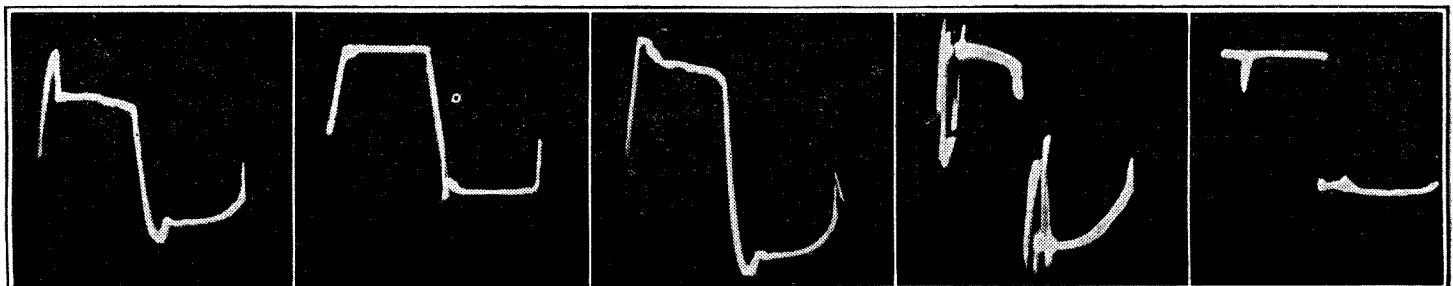

Fig. 8.—Oscillograms taken with a non-synchronous supply unit; (a) shows the wave shape on first switching on and (b) with the unit operating under correct load conditions.

Fig. 9.—These three traces show (a) a vibrator unit operating under very light load, (b) with buffer condensers removed and (c) without buffer but the unit on full load.

Vibrator Power Supplies—

given later, it was clearly seen that the contacts barely touched, and the reed did not have enough energy to move the fixed contact arm. On the side of the magnet coil there is a portion of the wave-shape flat. This is the time during which the contacts were closed and the vibrator was under load. Immediately the critical

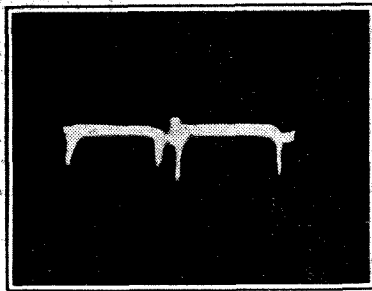

Fig. 10.—This oscillogram shows the pulses of voltage in the LT supply circuit of a vibrator unit working under optimum conditions of load.

operating voltage was reached the unit behaved in a normal manner.

Fig. 7(b) shows the effect of heavily overloading the unit. In this instance a load of 50 milliamperes was imposed upon a unit designed for 15 milliamperes. The high peak voltages are again noticeable in this case, showing that the transformer and buffer values are dependent upon the load and the vibrator with which they are used.

Fig. 8 is the wave-shape of a vibrator supply unit used for a well-known car radio receiver; (a) operating with no load, and (b) with the correct load of 50 milliamperes. Notice particularly in this case the lack of transients and the square topped wave. This unit gives an efficiency of 66 per cent., which is quite good for a vibrator power supply. It is of interest to note that in this case there is no actual break in the wave-form, as it is a non-synchronous unit, and there are no secondary contacts to reverse the polarity. The buffer constants are such that the secondary EMF is allowed to reach zero an instant before the contacts close again, thus keeping the arcing at the contacts to a negligible quantity. Under a stroboscope, it was noticed that this unit vibrated particularly strong and evenly. The energy of the reed was great enough to move the fixed contacts through a distance of $\frac{1}{16}$ in. This is the cause of the high "percentage time" during which the contacts are closed, and hence the high efficiency.

In Fig. 9(a) is shown the effect of very light load, consisting of the leakage current of the electrolytic condensers in the filter circuit, and the buffer of capacity and resistance. Compare this with

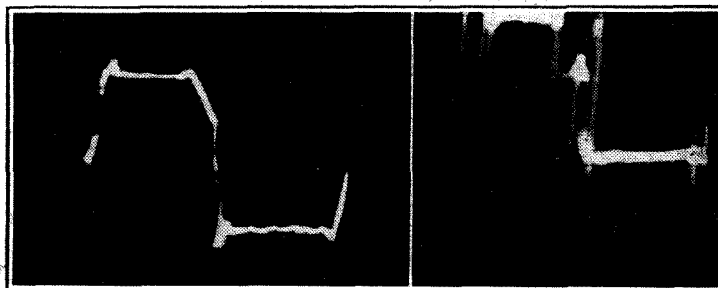

Fig. 11.—The photograph in (a) is that of the primary voltage of a vibrator unit with incorrect buffer values, while (b) is another example of completely removing the secondary condensers.

figure was missed, due to the end of the film being reached. The difference between this and the preceding figure can be clearly seen and appreciated.

Among the most useful pieces of apparatus in vibrator practice is the stroboscope. This instrument makes possible the slowing up of vibration and even holding it steady over a period. This is necessary if any serious investigation of vibrators is undertaken.

A simple stroboscope is shown in Fig. 12. The frequency of flash is controlled by R and C, and values found satisfactory in practice are:

$$R = 0 \text{ to } 10,000 \text{ ohms.}$$

$$C = 0.1 \text{ mfd. to } 1 \text{ mfd.}$$

From the foregoing it can be seen how

Fig. 9(b), which is identical except for the removal of the complete buffer circuit, and note the effect which the buffer circuit has on the wave-shape by absorbing all unwanted transient voltages.

Fig. 9(c) shows the result of removing the buffer and leaving the receiver at full load. The RF "hash" with this arrangement was particularly severe, as was the "splash" at every "make" of the contacts; as can be seen by the vertical "fingers" on the wave-form.

Fig. 10 is a most interesting photograph taken with the oscillograph connected across the low-tension supply to the vibrator. The four vertical "fingers" shown in the figure reading from left to right are: "Make, break, make, break," of the primary contacts. They are transient voltages, and it is these which cause most of the vibrator noise in battery vibrator units. With incorrect filtering these transients can assume large values. Increase in voltage in this case produces a downward movement of the trace, and it is of interest to note here how the primary voltage drops during the period "make to break," and increases during the period "break to make." This fluctuation in voltage, although only small, occurs at an audible rate, and is quite capable of modulating the emission from filament-type battery valves.

The trace of Fig. 11(a) was taken across the full primary winding of a vibrator power unit for a battery receiver, having incorrect buffer constants. This portrays more clearly the fall in primary voltage when the secondary contacts close, while in Fig. 11(b) is shown the voltage across the full primary with no buffer across the secondary. Unfortunately, a portion of this

important it is to design the power transformer-buffer combination to suit both the vibrator and working load.

For the transformer-buffer combination let us refer back to Fig. 5(c). The vertical distance between the horizontal portions of the wave-form represents 270 volts. From this can be clearly seen that the insulation of both transformer and buffer condensers needs to be of high value to withstand the transient peak volts. Practice has shown that condensers of the 400 volts rating are useless as buffer condensers. The working voltage must be at least 800 volts with a 2,000-volt test. Comparison of Figs. 5(a) and 6(b) shows the necessity of designing the transformer-

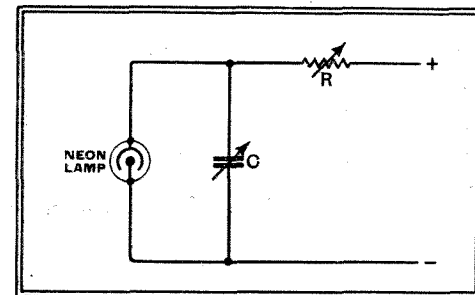

Fig. 12.—Circuit of simple stroboscope for visual examination of the vibrating reed.

buffer combination to suit the output load.

The power transformer is preferably designed to operate considerably below core saturation, to reduce the exciting current. It should, in any case, be of such a design as to allow relatively wide variation in primary voltage without saturation of the core. It will be appreciated that automobile receivers must operate from a supply varying in extremes between 4.5 volts for a discharged battery to nearly 8 volts for a fully charged battery, in the case of 6-volt equipment.

In addition to this operation on 8 volts, during the period until the receiver draws current, the vibrator is operating on no load. It is under this condition that improper design manifests itself, resulting in a heavy arc across the contacts and eventual failure of the unit.

The fact that the modern unit operates satisfactorily under such diverse conditions is a fine tribute to the vibrator manufacturers.

The Wireless Industry

VARIOUS accessories required for shielded aerial systems are described in a leaflet issued by Castelco (Great Britain), Ltd., 91-93, Southwark Street, London, S.E.1.

The high-fidelity sound-reproduction demonstrations given by the International Short Wave Club at the recent Woman's Fair, Olympia, were carried out with the help of receiving apparatus lent to the club by Lowther Manufacturing Co., Ltd., and a Voigt Corner Horn loud speaker.

At to-day's Christmas party given to ex-Service men at Buckingham Palace, under the auspices of the Not Forgotten Association, sound-amplifying equipment supplied by the British Thomson-Houston Co., Ltd., will be used.

Educational Broadcasting

By DR. ARNO HUTH

ALTHOUGH broadcasting in America is so largely concerned with publicity, special attention has nevertheless always been given to the question of education by radio. The large commercial companies, and particularly the National Broadcasting Company and the Columbia Broadcasting System, allocate quite a large proportion of their broadcasting time, which is usually sold at so high a price, to educational purposes. A still more interesting observation is that there are a large number of broadcasting stations actually owned by educational bodies.

These educational stations really owe their origin to amateur activities and were mostly used for morse transmission in the early days of their existence. Many of the colleges had experimental transmitting stations which were manned by amateurs, and as telephony and broadcasting came along so these stations started to function under the direction of the educational body to which they were attached.

These stations were in the past largely put up and run by the teaching staff and students themselves; later, former students presented broadcasting stations to the colleges or in some other way one college after another has acquired broadcasting

in importance and character. Some are of only 50 W., others are 5, 10 or even 20 kW. in power and their times of transmission vary from a few hours a week to twelve hours a day and, in some cases, they share transmission times with a number of others.

Some of the stations are exclusively used for educational purposes and others

Organisation of Special Stations in the U.S.A.

depend to some extent on advertising, which they accept as a means of covering the cost of running the

stations. Of those which are devoted entirely to education, one of the most important is WIXAL, of Boston, run by the World Wide Broadcasting Corporation. The station was started with funds from the Rockefeller Foundation and private gifts. Short waves are employed and the purpose of the station is to distribute educational programmes of high quality and to establish contacts between different nations.

The 5-kW. station WHA, belonging to the University of Wisconsin, claims to be America's oldest educational radio station. It started in 1917 and its first telephony transmitter, dating from 1922, was built entirely by the staff and students.

A number of these transmitters are used for experimental work in addition and undertake investigations of a technical nature. Many of these local educational

transmissions almost entirely to educational broadcasts to local farmers and workers. It even undertakes complete courses in agriculture.

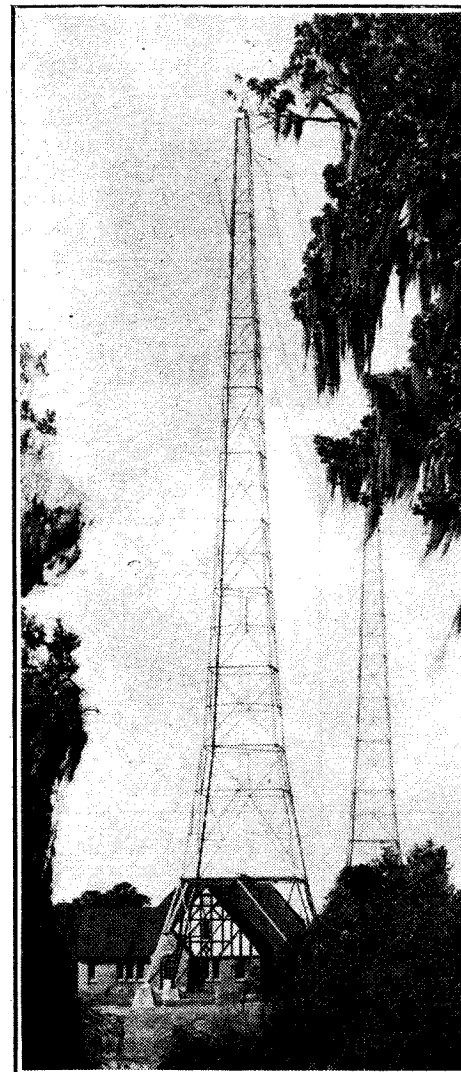

The aerials and station building of the 5kW. transmitter WRUF at the University of Florida, at Gainesville.

Some of the educational stations are owned by religious bodies and are immensely popular. They have been built and entirely maintained at the cost of religious organisations.

With regard to the type of programme radiated by the educational stations, it is significant that many of them, recognising that the big networks now include a good deal of educational matter of an elementary and general nature in their programmes, are inclined to devote most of their time to advanced and even specialised studies.

In a country so largely agricultural as the U.S.A. it is natural that the majority

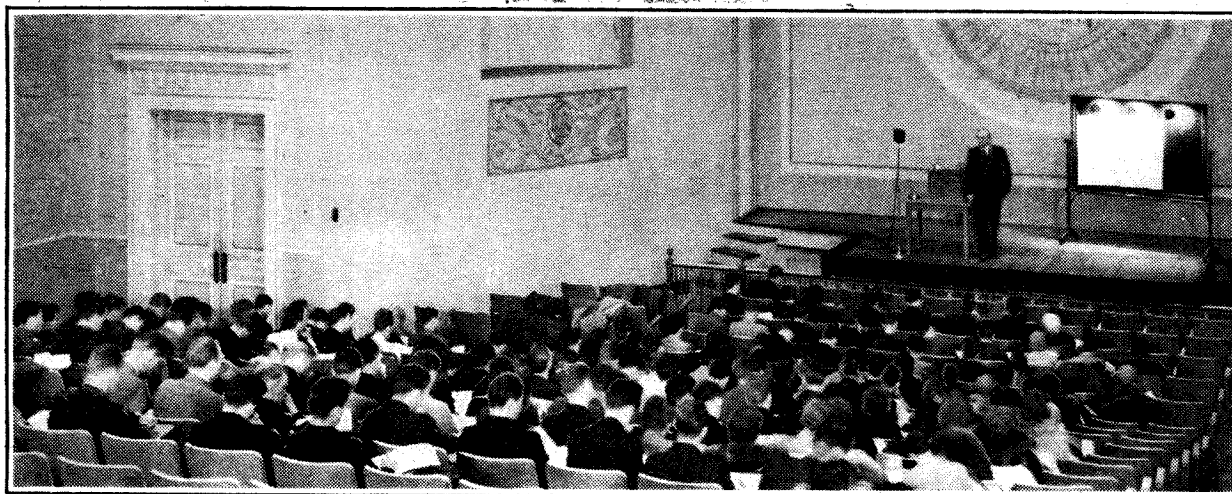

A lecture in progress at the University of Illinois. The microphone, which is linked with the college transmitter WILL, can be seen close to the speaker.

stations of varying power. There are at present 39 broadcasting stations in the U.S.A. controlled exclusively by educational authorities. They differ very much

stations suit their programmes to the districts in which they are located. A good example is WKAR, the East Lansing station, of only 1 kW., which devotes its

Educational Broadcasting—

of the educational stations should be devoted principally to the requirements of the farming community and talks are particularly directed to the needs of local farmers in the neighbourhood of any particular station. It is generally considered that the existence of so many stations

programme value to be really well received at all times by novice and expert alike, and without any readjustment of such controls as tone, selectivity, sensitivity—let alone tuning.

To be more explicit, it is suggested that a switch-tuned set might be constructed with a number of additional contacts

mitting equipment utilises comparatively high power, there is, nevertheless, a sufficiency of low-power apparatus to interest amateurs in this country.

It is the design and construction of a receiver or transmitter that contributes to its efficiency, and the means employed to achieve this end are just as applicable whether one uses 10 watts or 1 kilowatt.

The designs of short- and ultra-short-wave receivers exhibit the latest technique, and these chapters alone would justify its occupying a prominent place on the experimenter's book-shelves.

All the twenty chapters have been revised and new material added. For example, there are twenty pages of tabulated valve data providing a valuable reference to American valves both for receivers and for transmitters. Data on CR tubes are included this year. The schematic diagrams of valve base connections are also very useful.

The ultra-high-frequency section is particularly informative and will provide much food for thought to those interested in the 2½- and 1½-metre wavelengths. Some new designs of 5-metre transmitters combining crystal and line control are described.

The 1939 edition contains 454 pages with 815 illustrations and 50 charts and tables. It is obtainable from F. L. Postlethwaite, 41, Kinfauns Road, Goodmayes, Ilford, Essex, the price being 5s. 6d., post free.

H. B. D.

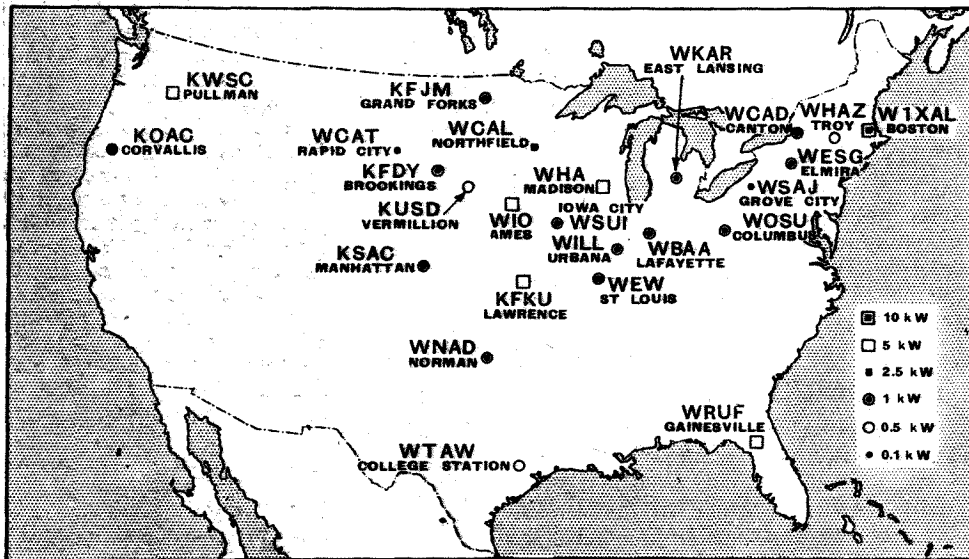

Distribution of educational broadcasting stations in the U.S.A. Authorised day-time powers (in some cases reduced at night) are shown.

devoted to educational work has served to remind the authorities continuously of the value of broadcasting when applied to this purpose.

The larger broadcasting organisations are, in consequence, paying far more attention to programmes designed to educate than they did in the past, even in spite of the fact that they could so easily sell the time which they give to these programmes for commercial purposes at a high figure. It is being recognised more and more that the inclusion of a fair proportion of material of this kind in the programmes creates good will amongst listeners, and so substantially increases the popularity of the stations themselves.

Push-button Systems

LOOKING AFTER SUBSIDIARY CONTROLS

THERE is one application of the push-button method of station selection which, although possessing certain advantages over the ordinary manual operation, does not seem to have received the attention it deserves. The general idea of an automatic tuning device seems to be something to save the set-owner the trouble of turning a knob round and round, and so would seem to have little appeal to the serious-minded amateur. There is no reason, however, why the push-button idea should not be employed to enable a selected few stations of known

ganged to the press-button tuning switches. These extra contacts would be arranged to make any adjustments to the volume, selectivity or tone as might be made necessary by such factors as field strength, geographical position or wavelength allocation of the station being received. For example, a person might wish to listen regularly to transmissions from the Deutschlandsender; assuming, first of all, that the set is capable of adjustment to the extent of receiving this difficult station intelligibly and without serious sideband interference, the switch contacts would be arranged to make the necessary adjustments automatically by opening or closing certain pre-set circuits. To attempt to receive London Regional with the same set of conditions in the receiver would obviously be absurd (and vice versa); in this case the extra contacts would either be left disconnected or arranged to bring about exactly the opposite effects.

The Radio Amateur's Handbook. Sixteenth edition. Published by The American Radio Relay League, Inc., West Hartford, Connecticut, U.S.A.

THIS handbook, which is compiled by the technical staff of the A.R.R.L., is a comprehensive and authoritative treatment of all branches of amateur wireless. Short- and ultra-short-wave receivers and transmitters are, of course, its main theme, but considerable space is devoted also to frequency measuring and testing equipment generally.

There is a section devoted to station layout and design, and while much of the trans-

Long-distance 5-Metre Signals

DOES WEATHER PLAY ANY PART?

ON Wednesday evening, December 14th last, after a somewhat dull period of listening on five metres with nothing out of the ordinary to record, the evening's vigil was rewarded at 11 p.m., G.M.T., by a faint signal calling "Test 56 Mc/s de G6FO." Though the transmitter switch was immediately thrown over, some disappointment was felt when no reply was forthcoming. G6FO is located in Newport, Monmouth, and the writer's station is in Pinner, Middlesex, the distance between these two places being about 110 miles.

By 11.20 p.m. the signals from G6FO had increased in intensity to RST 559, at which time he was in communication with G2JL, though the latter station was not audible.

How can we account for these long-distance five-metre signals? Do weather conditions have any bearing on it? An answer to this question may be forthcoming if a sufficient number of amateur stations can devote more time to regular listening and transmission on five metres. On the evening in question many parts of North London experienced either thick fog or heavy mist, and such conditions have, in the past, been noticed to favour long-distance signalling on the ultra-high frequencies.

Though there was no mistaking the origin of the signals, confirmation has not yet been had from G6FO. G2MC.

NEWS OF THE WEEK

PROGRESS IN SWITZERLAND

Extending the Country's Broadcast Service

GREAT efforts are being made in Switzerland to modernise and extend the technical facilities of the nation's broadcasting service. For example, the system of inter-town and inter-region land lines was extended during last year from 1,968 kilometres to 15,000 kilometres. The National transmitter at Beromunster has been equipped with a new aerial tower 700ft. high; it is hoped that this alteration will result in improved reception in the Grisons and in the Western districts of Switzerland.

The principal advance is the new 25-kW short-wave transmitter at Schwarzenburg, which is intended for the transmission of special programmes for Swiss people abroad and for the world-wide dissemination of national culture. It uses aerials directed towards North America and Africa, as well as a reversible aerial directional either to South America or Eastern Asia.

At present a temporary station, installed in a farmhouse, is conducting experimental transmissions on 31.46 metres (9,535 kc/s) from 1.10 to 2.10 a.m., 2.25 to 3.25 a.m., and 7.25 to 8.25 p.m., G.M.T.

Work on the permanent station is proceeding apace, and the official opening is expected to coincide with the opening of the National Exhibition at Zurich in May next year.

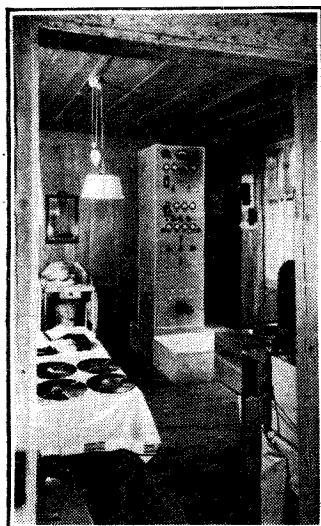

THE TEMPORARY HOME of the Schwarzenburg short-wave station. The experimental transmitter is housed in a ground floor room of a farm-house.

THE EIFFEL TOWER

50th Anniversary Celebrations

THE Eiffel Tower was built for the Universal Exhibition of 1889, and many years passed before familiarity with its gaunt outlines and the realisation of its scientific utility established it in the affections of the Parisian.

The famous radio-telegraphic station was installed in the tower in the early part of this century, and its service to pioneer wireless contributed greatly to French radio prestige. The transmissions, which included time signals and weather reports, could be received consistently over a great part of Europe on the crudest of crystal sets; during the Great War its services were recruited in the cause of national defence.

Becoming successively the home for sound and television stations, the famous edifice owes its continued existence to its great usefulness in these directions, and the Paris Comité des Fêtes is preparing a fitting celebration for Eiffel Tower's 50th anniversary next spring.

EUROPEAN BELLS BROADCAST

THE Union Internationale de Radiodiffusion has organised an all-Europe relay of New Year Greetings which will be heard at 6.30 p.m. on January 1st. The B.B.C. National transmitters are taking this interesting programme, which will consist of recorded greetings and chimes characteristic of the twenty or more countries contributing. Great Britain's contribution will be the bells of St. Clement Danes.

This programme suggests a development which would be welcomed by many listeners to Continental stations. The B.B.C. checking station at Tatsfield could make records of the interval signals of all the principal stations, and these could be embodied in a useful talk on station hunting and identification.

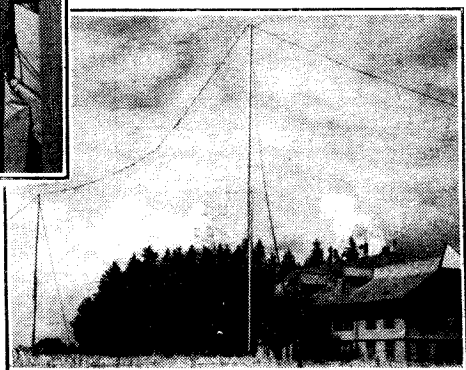

MARCONI'S YACHT

Experimental Apparatus Given to Italian Government

THERE have appeared many statements in the English Press recently regarding the disposal of the late Marchese Marconi's yacht, *Elettra*. It has now been verified from Italy that the yacht was purchased by the Fascist Government, but the apparatus on board, which included high-powered short-wave radio-telegraphic and radio-telephonic gear, as well as echo-sounding equipment, was partly the property of the Italian Marconi Company and partly the property of the Marconi Company of London.

The two companies concerned have, in memory of their president, presented the apparatus, which was valued at about £5,000, to the Fascist Government. The apparatus will eventually be handed over to the High Council of Research.

The *Elettra* has, since the death of her owner, been moored in Genoa harbour, with only a watchman on board. She will eventually come under the control of the Director-General of the Post and Telegraph Department.

REALLY SELF-CONTAINED

German Television O.B. Unit

SOMETHING of a feat of engineering has been achieved by German Post Office engineers in installing the complete equipment of the new television O.B. unit into one van with the power supply in a trailer. The obvious advantage of this really mobile outfit is that the van can readily be used to televise processions and the like.

The transmitters for sound and vision, which have an aerial power of 100 watts, work on a wavelength around 2 metres, and it is claimed that they have a range of up to five miles.

ITALY'S S.W. TRANSMISSIONS

THE recently opened Italian Imperial Short-wave Centre at Prato Smeraldo, which is at present working on two frequencies only, will eventually operate on ten wavelengths. On enquiry at E.I.A.R. it is learned that the following will be the call signs and frequencies:—

	Mc/s		Mc/s
2R01	6.085	2R05	15.17
2R02	6.98	2R10	15.19
2R03	9.63	2R06	15.3
2R09	9.67	2R07	17.77
2R04	11.81	2R08	17.82

It is expected that those in the first column will have a power of 100 kW, while those in the second will operate on 50 kW.

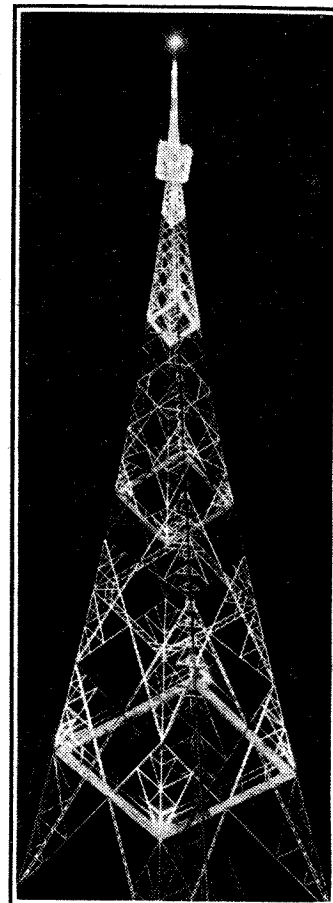

BEROMUNSTER'S new 700ft. aerial is located 1.5 kilometres from its 539.6 metre, 100-kW transmitter. As seen from this night-time picture, the mast is surmounted by a capacity ring.

QUESTIONS IN THE HOUSE

Transfer of P.O. Beam Stations—B.B.C. Finance

IN reply to a question in the House of Commons, Major Tryon, Postmaster-General, stated that the transfer of Post Office beam wireless stations to Cable and Wireless would take effect as from March 1st, 1938. The installations at Bodmin, Bridgwater, and Grimsby would in due course be transferred to existing stations at Dorchester, Somerton, and Ongar, respectively. He was assured by the Company that all members of the staff affected would be transferred to stations operated by the Company, with the exception of certain unestablished labourers. In these cases long notice and adequate compensation would be given.

In response to a suggestion that the B.B.C. should be provided with the necessary revenue to make early-morning physical fitness broadcasts possible, the Postmaster-General stated that, in accordance with the terms of the licence of the British Broadcasting Corporation, it rested with the Governors to initiate any application for an increase in the Corporation's percentage of the wireless licence revenue. It would be for the Governors to consider whether, having regard

News of the Week—

to the Corporation's other liabilities, such an application would be justified for the purposes suggested.

MALAYAN AMATEURS CLOSE DOWN

Government Criticised for Lack of Interest

THE Malayan Amateur Radio Society made its last broadcast from the Kuala Lumpur station on November 29th last, the service closing down from lack of support. The Society has criticised the Government for failure to establish broadcasting in the Federated Malay States.

It is understood (says the *Straits Times*) that the Government has not taken any action, but tests have been undertaken by the Posts and Telegraph Department with a portable transmitter, under a scheme to operate a series of medium-wave stations at several centres north of Singapore.

The British Malaya Broadcasting Corporation has worked ZHL, Singapore, under difficult conditions. According to Mr. R. C. Eiggins, who is retiring from the chairmanship of the Corporation, a statement of Malayan Government policy is to be expected this year.

BOMBAY RADIO CENTRE

New Studios for A.I.R.

THE new Bombay studios of All-India Radio represent the most advanced form of studio construction in India, their design having benefited from the builders' experience with the Lahore, Lucknow, and Madras stations.

The seven studios are located on the fourth floor of the new Central Government Building, and complementary offices occupy part of the floor below.

The arrangement of the aerial for picking up broadcasts from the mobile transmitter is of particular interest. It is erected on the roof of the building at right angles to the nearby electric railway in order to eliminate electrical interference from that source.

Double walls of light-weight material have been constructed around each studio, an air space of three to four inches having been allowed between the walls. This effectively cuts out extraneous noises.

TELEVISION IN AMERICA

ANOTHER U.S. television station, which will be at least 250ft. higher than the one on the top of the Empire State Building in New York, is being erected by the General Electric Company at Indian Ladder, in the Helderberg Hills, twelve miles from Schenectady. It is being constructed on the top of

a 1,500ft. hill, with the aerials on roof-towers.

A feature of this 10-kW transmitter, which will begin operation early in the coming year,

RADIO NORMANDIE

New Louvetot Transmitter in Operation

DIFFICULTIES of licensing which have kept Radio Normandie's new transmitter from active service since its completion last year have fortunately been overcome, and the station's 20-kW transmitter was brought into service with its change of wavelength from 212.6 to 274 metres last week. Situated at Louvetot, near the mouth of the Seine, the transmitter is of a modern design grossly belied by the appearance of the buildings from outside, which, as seen in this picture, follow the Norman style. The anti-fading aerial should level up reception of the station's transmissions in

THE NEW LOUVE-TOT transmitter of Radio Normandie is rather incongruously housed in a Norman style building. Reception reports are invited by the International Broadcasting Company at its London headquarters.

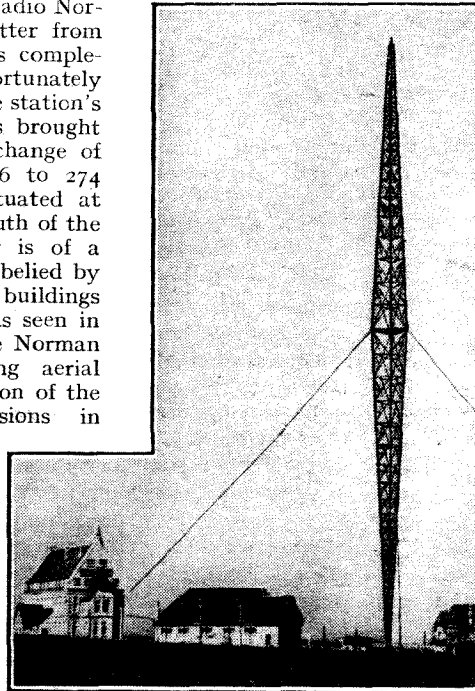

is that it will not employ a coaxial cable to link it with its New York studios, but will use an ultra-short-wave transmitter working on 1.4 metres.

hitherto poorly served areas. The studios are located in Caudebec, not far from the transmitter.

FROM ALL QUARTERS**Cross-Channel Phone Link**

THE wavelengths to be used by the new cross-Channel radiotelephone stations described in these pages last week will be 3.6 and 4.4 metres in one direction and 3.95 and 4.9 metres in the other.

Swedish Leader Beacon

A DIRECTIONAL wireless beacon has just been erected at Oregrund, on the Swedish Baltic Coast, to facilitate navigation in the channel to that port. The signals can be received on a simple wireless receiver. When a ship keeps the right course a constant tone is heard, but if the vessel goes too much to starboard or port the note changes. Two similar devices are also in use in Finland.

"Record" Circle

BECAUSE it is thought that many readers of the *Daily Sketch* have radio-gramophones and yet do not make the fullest use of them, what is to be called the Grid Leak Radio Circle has been formed. A short questionnaire has to be answered, the return of which, together with a 2d. stamp, enrolls the sender as a member. He then receives a stroboscope, a wallet of twenty long-life needles, and literature on records and record-making. Some of the facilities for members are: advice on record collecting, radio-gramophones and pick-ups, and advance information on record releases.

The Industry in Germany

THE number of sets sold in Germany during October was double that of any previous month. Of the 420,000 sold nearly 285,000 were fully paid sets, the remainder being People's receivers.

First General Listening Barometer

THE B.B.C. has started a new Listener Research scheme designed to show how many people listen to each programme. Four thousand listeners, who have volunteered for the job, are receiving every week for four months a printed list of the principal items of the evening in the National, Regional, Midland, North and West of England programmes. They are to indicate the items to which they have listened, and return the lists to the B.B.C.

For the Purpose of Continuity?

DURING the re-equipment of the Eiffel Tower television transmitter, necessitated by the change-over to the British E.M.I. system of transmission, the French television service has so far been maintained by a 1.5-kW transmitter at the rue Grenelle premises of the State Broadcasting Service.

R.A.F. Reunion

OFFICERS of the R.A.F., No. 1 "T" Wireless School are holding their reunion dinner at the R.A.F. Club, 128, Piccadilly, London, W.1, on Saturday, January 21st, at 7 p.m. Those who wish to attend and have not received a notification, should communicate with Flt. Lt. F. S. Wainscot, R.A.F., The Electrical and Wireless School, Cranwell, Lincs.

Radio Arrests

ARRESTS made possible by Scotland Yard's wireless transmitting station at West Wickham, Kent, now number approximately 4,000. The station was described in *The Wireless World* of October 29th, 1937, at its inauguration.

B.B.C. Exhibition for Nottingham

As previously stated in these pages, the exhibition of B.B.C. activities, which was shown at the Empire Exhibition, is to be taken to Nottingham. It is announced that it will be opened in the Central Library on February 2nd by the Lord Mayor in the presence of Sir Stephen Tallents, B.B.C. Controller of Public Relations. The exhibition will remain open until February 18th.

New Empire Announcer

LATEST addition to the ranks of Empire announcers at Broadcasting House is Mr. J. F. Sullivan, formerly chief announcer and manager of the English transmissions of Radio Normandie.

"Below the Scenes" at the B.B.C.?

THE B.B.C. would do well to copy the example of the Belgian broadcasting authorities in giving a series of talks on "Behind the Scenes in Broadcasting." The series will deal not only with the Belgian organisation, but with the broadcasting systems of the world, with "visits" to various broadcasting headquarters and transmitting stations. The B.B.C. might make a start by giving a running commentary on the new constructional work in Portland Place.

Rural Radio

ALL-INDIA RADIO has equipped twenty of the 381 villages in the Delhi Province with receiving sets for the purpose of testing the effectiveness and possibilities of rural radio.

Revised Licence Regulations

THE Swedish Post Office announces its intention of revising the existing rules appertaining to the issue of receiving licences. Additional payment for the use of more than one set will be demanded in the case of car radio only.

Wireless Reception at Croydon

IN order to avoid serious interference with wireless reception at Croydon Airport, the Air Ministry has had to pay special attention to the choosing of a site for the giant hangar which is to accommodate three of Imperial Airways' 22-ton Ensign liners.

Television: A New French Industry

THE plan for economic and financial recovery in France provides for the organisation of new industries. Television features amongst these, and accordingly it will be the subject of a tremendous publicity campaign in 1939.

Television from Phoenix Theatre

FOLLOWING upon the success of the recent transmission from St. Martin's Theatre, Shakespeare's "Twelfth Night" will be televised in its entirety from the Phoenix Theatre, Charing Cross Road, W.C.2, on January 2nd.



A Christmas Honeymoon

RADIO
RECOLLECTIONS
OF LONG AGO

THE unexpected appearance of several of the little Grid Leaks at the breakfast-table the other morning reminded me that the season of extravagance and highway robbery was hard upon us once more. Upon questioning them upon this point I found that this, indeed, was the case, and that they had arrived home from their respective scholastic establishments during the previous day. I at once proceeded to run over in my mind the presents which I knew that they would expect of me, and during my calculations I was puzzled to find that several of the little Grid Leaks appeared to be missing.

I at once made a re-count with no better success, and so I consulted Mrs.

Free Grid, Volta, Henry, Faradia, Mrs. Free Grid.



Free Grid upon the matter. She somewhat acidly informed me that, apart from those who had embarked upon the stormy seas of matrimony during the past year, there were several who were detained at their schools owing to various kinds of infectious illness which I was glad to learn would probably keep them there for a goodly part of the holidays. The little Grid Leaks are, of course, all named after various pioneers of wireless, and my daughters, Volta and Faradia, and my son Henry were, I learned, the sole remnant who would be with me this Christmas.

The Present Problem

This question of presents is always a vexing one, and does not, I find, grow any simpler with the passing years. Last year I recollect I decided to give Faradia a year's subscription to *The Wireless Engineer* with a view to improving her mathematics, which, like her mother's, is distinctly weak, as I found to my cost when she presented to me her personal expenses sheet, in which she had been endeavouring, very unsuccessfully, to strike a balance between the cost of her clothes and the amount of her dress allowance. I, therefore, made the necessary arrangements about *The Wireless Engineer* subscription with the local newsagent only to discover later in the year that he had permitted her to swop the subscription for one to some wretched film stars' magazine.

Thoughts of this nature carried me back to the early days of my married life before any of the little Grid Leaks had come upon the scene. In those days, of course, wireless really was wireless and not merely a matter of polished cabinets, as it is to-day. I remember quite well that on the evening of our wedding day Mrs. Free Grid and I sat until far into the night listening enthralled to the time signals and weather reports from the old Eiffel Tower spark station, using one of my earliest home-made receivers for the purpose. At that time, of course, crystal sets were but a dream of the future, and even the magnetic detector—dear old maggie, as we used to call it—was considered rather advanced and, although I have always been in the forefront of scientific progress, I had not actually installed one at that date.

Mrs. Free Grid was, of course, much younger in those days and, judged by the standards of those times, which were not very exacting, was quite passable looking. What particularly brings the scene back to me at this time of the year is the fact that it was Christmas Eve. The Eiffel Tower station, I recollect, gave out that a storm was brewing and that the further outlook was gloomy, which announcement turned out to be particularly appropriate to us, for late that night a matrimonial storm did spring up owing to the fact that I insisted on sitting up to try to receive the forerunner of the present "Five Hours Back" programme, namely, the American time signals and weather report from the old Arlington station. These were not due until 3 a.m. (Greenwich Time) and my insistence on waiting up in an effort to get them provoked Mrs. Free Grid to her first display of anger, for, as she rightly pointed out, with my technical qualifications I ought to have known better than to have tried to receive America with a coherer and an umbrella aerial. As I explained to her, however, Marconi himself had been jeered at in 1901 when he attempted to pick up the old Poldhu station in Newfoundland, and, had he not persisted in spite of the cold water thrown on his ideas by most of the leading scientists of the day, we should still have been in the dark ages.

Women are very illogical creatures, however, and in the end she cleared off to bed by herself, leaving me to keep my lonely vigil by the cold ashes of a long dead fire, my only company being the mournful hooting of the owls and the rustling of the rats in the wainscoting, with the occasional addition of the clacking of the morse inker when an exceptionally strong gust of atmospherics assailed the aerial. The whole atmosphere was, in fact, very eerie, and every time I was

By
FREE
GRID

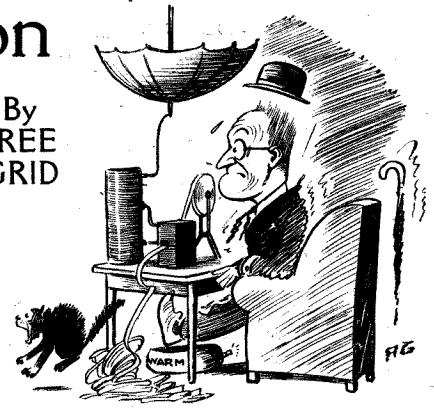

roused by a rat scuttling over my feet I half expected to see Father Christmas coming down the chimney and I seemed to hear Mrs. Free Grid's family ghost wailing woefully as it wended its weary way through the chilly chamber.

Engrossed as I was with these melancholy thoughts, I must have grown momentarily oblivious of my surroundings, for suddenly my ears were assailed by a ghastly gurgling and a few moments later, to my horror, the door slowly swung open on its hinges and an awful apparition advanced menacingly towards me, and the next instant I felt a cold, clammy hand on my face and with a soul-searing shriek I fell prostrate to the ground.

Came the Dawn

When I opened my eyes a little while later the blinds had been raised, the grey light of a winter's dawn filtered through the windows and I beheld Mrs. Free Grid in curlpapers and red flannelette dressing gown staring stonily at me. Needless to say, she was the apparition I had seen, darkness and my surroundings having been responsible for the rest. Before I had time to protest at the silent nature of her entry, she had commenced to rate me soundly for my conduct, telling me that it was the first time in all the years of her

The grey light of winter's dawn.



existence that her Christmas stocking had remained unfilled. In the end, I recollect, she took herself off to her mother, leaving me to spend Christmas Day alone amid my wireless bits and pieces, listening alternately to the Eiffel Tower and to Norddeich, with an occasional husky whisper from Poldhu's old fixed-gap transmitter.

Well, well, these reminiscences have not, I fear, got me any farther along the road to solving my Christmas presents problem. Perhaps some of you can help me by telegraphing suggestions?

Three-Band

A GENERAL-PURPOSE SIX-VALVE SUPERHETERODYNE

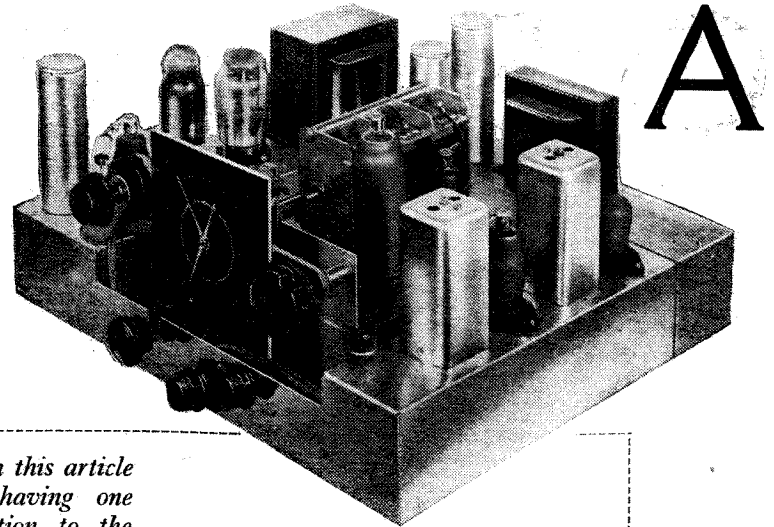

MODERN broadcasting requirements demand a high standard of performance from a receiver. The performance, however, does not only depend upon broadcasting conditions but also upon the requirements of the user. One man, for instance, wishes only to receive his local stations at the highest practicable quality, whereas another cares little for local reception and is much more interested in distant short-wave transmissions.

The best receivers for these widely different purposes are naturally very different, and are represented in general type by the Pre-Tuned Quality Receiver¹ and *The Wireless World* Communication Receiver.² Many people, however, require neither extreme in performance, and their needs can be summarised as follows:

¹ *The Wireless World*, Sept. 25th, and Oct. 2nd, 1936.
² *The Wireless World*, Aug. 18th and 25th, and Sept. 1st and 8th, 1938.

THE receiver described in this article is a superheterodyne having one short-wave range in addition to the usual medium and long wavebands. An RF stage is included to obtain high sensitivity with a good signal-noise ratio; there is variable selectivity and a distortionless AVC system. A large output is obtained from a pentode with negative feed-back.

High standard of reproduction from local stations, sensitivity and selectivity adequate for most Continental transmissions on the broadcast bands, low noise and hum levels, principal short-wave broadcast bands.

The requirements of a short-wave receiver conflict in some degree with those

of the broadcast set. This is chiefly because a tuning condenser of not less than 0.00035 mfd. capacity is necessary to tune over the medium and long wavebands, whereas for wavelengths below about 50 metres a smaller capacity is highly desirable.

It has been said with some truth that the design of a receiver should be carried out primarily for its shortest waveband. Unfortunately, this is not entirely practicable. In the case of a set tuning down to 5 metres, for instance, design on these lines would start by choosing a variable condenser of some 25-50 mmfds. capacity,

Fig. 1.—The complete circuit diagram of the receiver is shown here. AVC is obtained from the detector diode and delay is introduced by the other diode in conjunction with the voltage developed across R18. It is regretted that a tuned-grid oscillator is shown instead of a tuned-anode; S5 and C15 should be joined to C24 instead of C23 and S6 connected to C23.

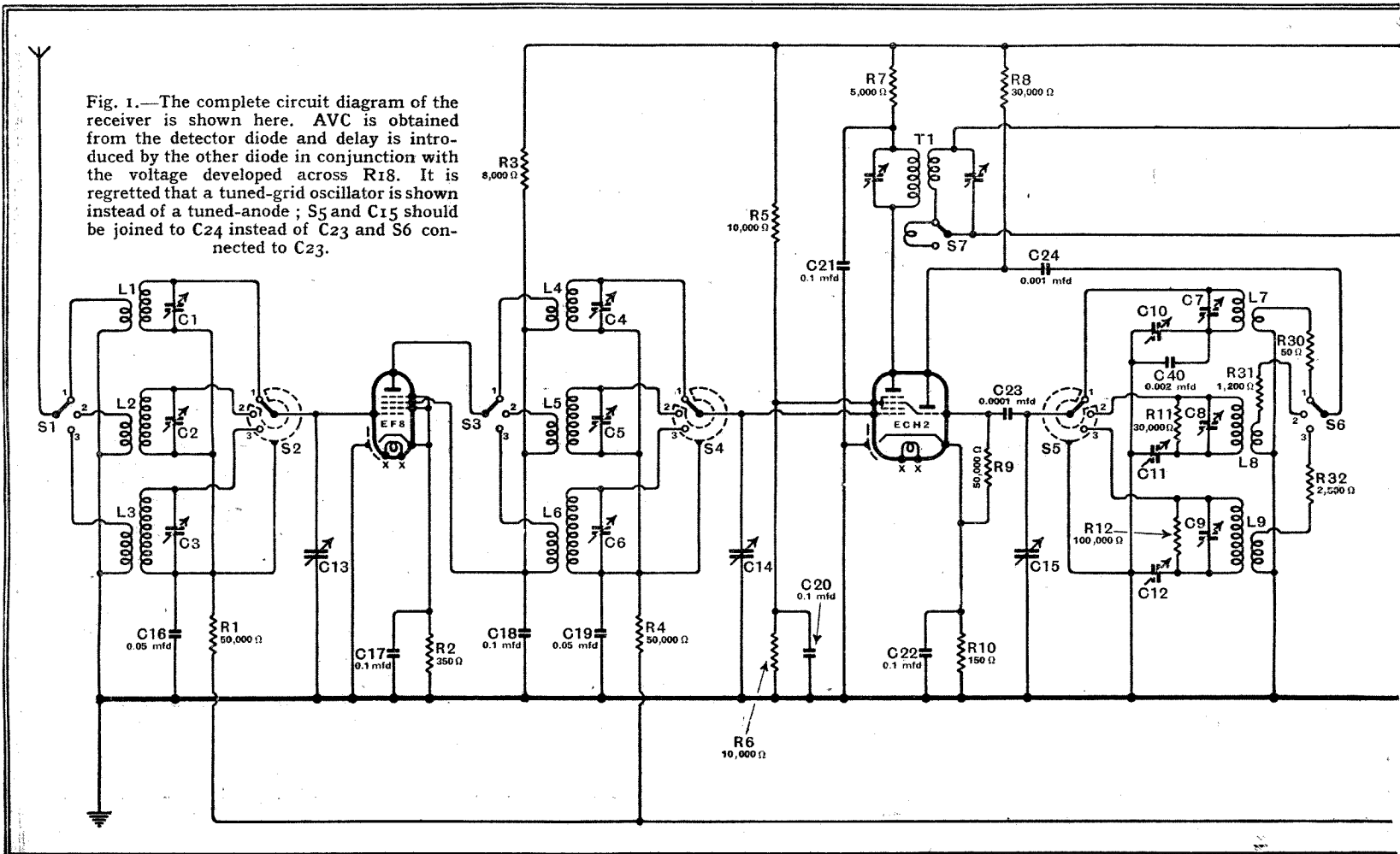

C Super

but this value would give a completely inadequate coverage at higher wavelengths. To cover 5-2,000 metres with such a capacity, it would be necessary to have something like eighteen wavebands!

The usual practice, therefore, is to adopt the smallest capacity practicable for covering the medium wave broadcast band in one step. This does, however, lead to difficulties below some 15 metres, and in *The Wireless World* Communication Receiver two separate variable condensers were included—one of 60 mmfds. for the ultra-short waves and the other of 500 mmfds. for higher wavelengths. In this way coverage was obtained in eight wavebands with a reasonable value of tuning capacity on all bands.

While measures of this nature are necessary for the highest standard of short-wave performance, their expense is unjustifiable for those who are only interested in broadcasting from the entertainment point of view. A weak and fading signal surrounded by interfering signals is of no interest to them, for with no receiver can it be made to give results of entertainment value.

Such a signal may be unreceivable with certain types of set and yet give an intelli-

gible output from a good communication receiver, hence the popularity of the latter type of set among those who are primarily interested in long-distance reception. While a first-class communication set is essential for reception under severe conditions, and is undoubtedly the equal or the superior of the broadcast set for general use, it is unnecessary for purely broadcast purposes.

The RF Stage

Experience shows that most broadcast requirements are met by a receiver having a first-class performance over the medium and long wavebands, and a good short-wave performance over a limited band. Such a receiver is used chiefly for reception above 200 metres where signals are fairly strong and fading is fairly small. On short waves, a tuning range of some 16-47 metres covers the majority of the short-wave broadcast bands and includes the American stations which are usually best received in this country. Designed to meet these requirements, therefore, the Three-Band AC Super has one short-wave range in addition to the medium and long-wave ranges. The circuit is shown in Fig. 1, and it will be seen that there is an RF stage with a triode-hexode frequency-changer, one IF stage and a duo-diode detector before the AF amplifier.

The use of an RF stage is important not only in short-wave reception but also on the medium and long-wave bands if valve

noise is to be kept at a minimum. A frequency-changer always introduces more hiss than an amplifier, usually about three times as much. If this hiss is to be negligible compared with the signal it is obviously necessary not to let the signal applied to the frequency-changer get too small. Equally obviously, this necessitates the use of an RF stage if the receiver is to give a good signal-noise ratio on weak signals.

On the broadcast bands the signal-noise ratio is then determined by the circuit noise of the first tuned circuit, provided that the RF valve is of a reasonably quiet type. On short waves, however, the dynamic resistance of the tuned circuits is so low that valve noise predominates over circuit noise and it becomes important to choose the quietest valve for the RF stage.

Accordingly the low-noise hexode EF8 has been selected for the RF stage. It has a tuned grid circuit and is coupled to the frequency-changer by a tuned transformer. There are thus two signal-frequency tuned circuits, so that second-channel rejection and the discrimination against other forms of superheterodyne whistles are very high. Even on short waves, where the image rejection inevitably falls off, quite good protection against such interference is secured.

The choice of the triode-hexode as a frequency-changer is dictated largely by the short-wave requirements, for with it, it is easier to secure freedom from serious

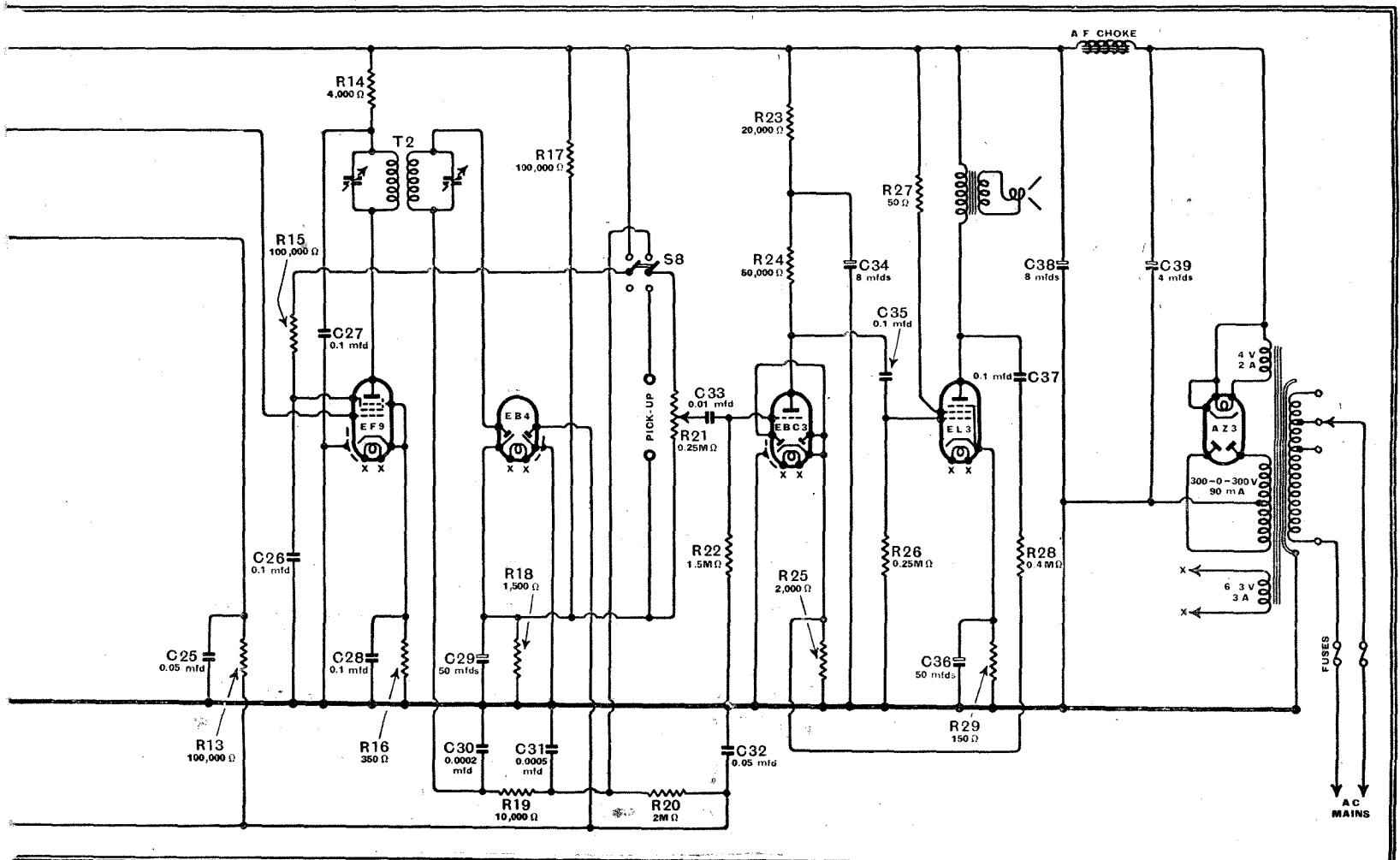

The Three-band AC Super—

interaction effects between the signal and oscillator circuits. Moreover, there is less chance of the oscillator frequency being affected by AVC voltage applied to the frequency-changer. To minimise any such effects, the oscillator circuit is of the tuned anode-type.

On each band a resistance is included in series with the reaction coil to help in maintaining even amplitude of oscillation over the waveband. On the medium and long wavebands shunt resistances to the oscillator tuned circuits are also included with the same object.

The RF and FC stages with all the tuning equipment are built on a rubber-mounted sub-chassis to reduce any tendency to microphony to a minimum. This chassis is also made of aluminium, since this material is a good conductor. The use of iron or steel is likely to cause difficulty on short waves, although it is entirely suitable for the main chassis, and is, indeed, to be preferred here on account of its greater rigidity.

Detector and AVC Systems

The IF valve is a variable-mu pentode and is fully controlled from the AVC system. The screen-feed, however, is by means of a series dropping resistance instead of the usual potentiometer. Consequently, the screen voltage rises as the negative grid voltage is increased and the grid base is greatly lengthened. This considerably reduces the possibility of distortion on strong signals.

The coupling between the FC and IF valves is by means of a transformer and the coupling between the coils of this transformer can be changed by means of a switch. Two degrees of selectivity are thus obtained. A similar transformer, but with fixed coupling, is used between

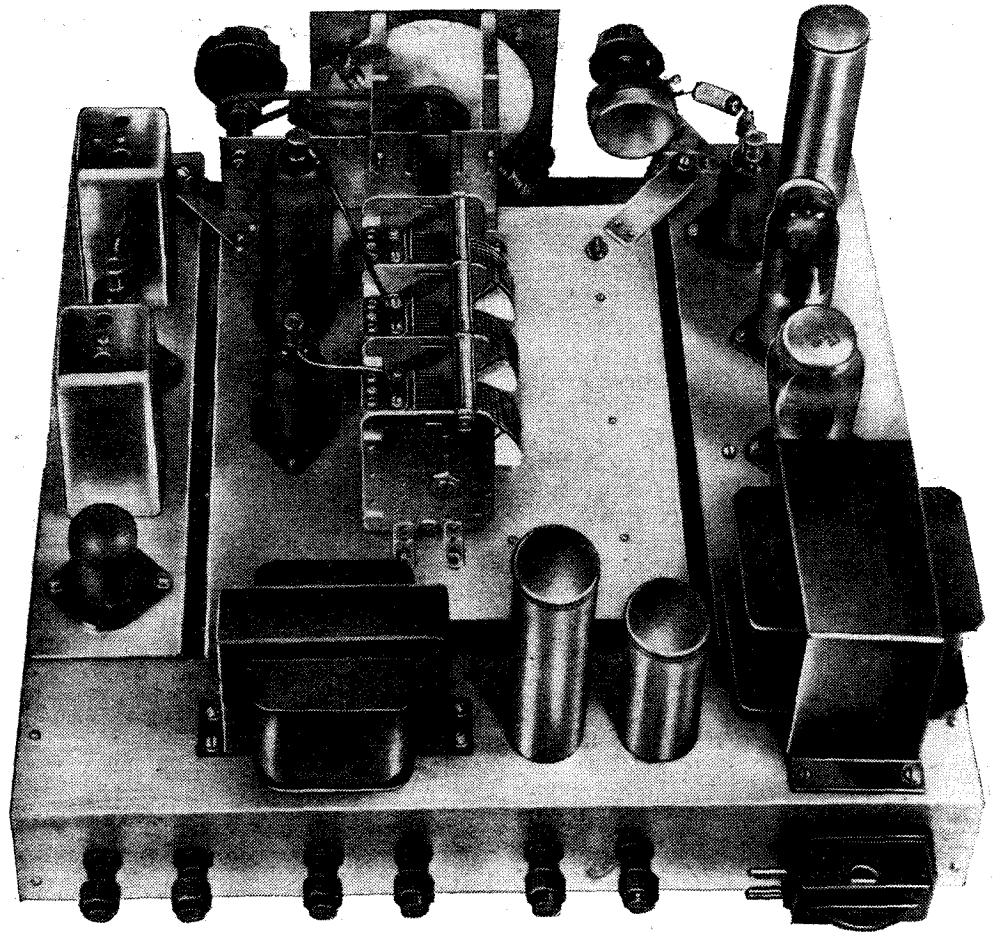

A rear view of the chassis showing the IF, AF, and mains equipment grouped around the tuner.

the IF stage and the diode detector.

The detector and AVC circuit is a little unusual and deserves explanation in detail. A duo-diode with separate cathodes is used, and one diode forms the detector, its load resistance being returned to cathode. R19 is the AF filter and R21 the DC load resistance and volume control. AVC is taken off in the usual way

through the filter comprising R20 and C32.

The detector circuit as a whole is biased positively with respect to negative HT by R17 and R18. If this were all, a positive bias would be applied to the controlled valves, but the second diode is shunted across C32 with its anode joined to the AVC line. In the absence of a signal

The List of Parts**TUNER**

- 9 Coils, viz., 1 each: PA1, PA2, PA3, PHF1, PHF2, PHF3, PO1, PO2, PO214 Wearite
1 Variable Condenser, 3-gang, 0.0005 mfd., C13, C14, C15 JB "L/B-N/T"
1 Dial, geared slow motion, with coupler $\frac{1}{4}$ in. shaft, $1\frac{1}{4}$ in. long Peto-Scott
Condensers:
2 0.05 mfd., tubular, C16, C19 T.C.C. 341
5 0.1 mfd., tubular, C17, C18, C20, C21, C22 T.C.C. 341
1 0.0001 mfd., mica, C23 T.C.C. "M"
1 0.001 mfd., mica, C24 T.C.C. "M"
1 0.002 mfd., mica, C40 T.C.C. "M"
Resistances: All $\frac{1}{2}$ -watt insulated type.
1 50 ohms, R30 Erie
1 150 ohms, R10 Erie
1 350 ohms, R2 Erie
1 1,200 ohms, R31 Erie
1 2,500 ohms, R32 Erie
1 5,000 ohms, R7 Erie
1 8,000 ohms, R3 Erie
2 30,000 ohms, R8, R11 Erie
3 50,000 ohms, R1, R4, R9 Erie
1 100,000 ohms, R12 Erie
9 Trimmers, 60 mmfds., C1, C2, C3, C4, C5, C6, C7, C8, C9 Polar 15/60
1 Trimmer, 300 mmfds., C12 Bulgin CP3
1 Trimmer, 600 mmfds., C11 Bulgin CP4
1 Trimmer, 3,000 mmfds., C10 Bulgin CP7
2 Valve Holders, 8-contact Bulgin VH24
1 Switch Assembly, S1, S2, S3, S4, S5, S6 B.T.S. WW/3AC

2 Plug Top Valve Connectors

- Belling-Lee 1175
Chassis, with terminal strips, complete with screws, etc. B.T.S.
Miscellaneous: Peto-Scott
4 lengths Systoflex, 2 oz. No. 20 tinned copper wire, etc.
Valves, 1 EF8, 1 ECH2 Mullard

RECEIVER

- 1 Mains Transformer with screened primary, 200-250 volts, 50 c/s.
Secondaries: 300-0-300 volts, 90 mA., 6.3 volts, 3 amps., 4 volts, 2 amps. Partridge WW/M5
1 Choke, 30H, 90 mA., 800 ohms. Partridge WW/30
1 IF Transformer, 465 kc/s., T1 Varley BP124
1 IF Transformer, 465 kc/s., T2 Varley BP122
1 Switch, SPDT., S7 Bulgin S92
1 Switch, DPDT., S8 Bulgin S114
5 Valve Holders, 8-contact Bulgin VH24
2 Plug Top Valve Connectors Belling-Lee 1175
Condensers:
1 0.01 mfd., tubular, C33 T.C.C. 451
2 0.05 mfd., tubular, C25, C32 T.C.C. 341
5 0.1 mfd., tubular, C26, C27, C28, C35, C37 T.C.C. 341
1 0.0002 mfd., mica, C30 T.C.C. "M"
1 0.0005 mfd., mica, C31 T.C.C. "M"
2 50 mfd., 12 volts, electrolytic, C29, C36 T.C.C. "FT"

- 1 4 mfd., 440 volts, electrolytic, C39 T.C.C. 812
2 8 mfd., 440 volts, electrolytic, C34, C38 T.C.C. 802

Resistances: $\frac{1}{2}$ -watt insulated type.

- 1 50 ohms, R27 Erie
1 150 ohms, R29 Erie
1 350 ohms, R16 Erie
1 1,500 ohms, R18 Erie
1 2,000 ohms, R25 Erie
1 4,000 ohms, R14 Erie
1 10,000 ohms, R19 Erie
1 20,000 ohms, R23 Erie
1 50,000 ohms, R24 Erie
3 100,000 ohms, R13, R15, R17 Erie
1 0.25 megohm, R26 Erie
1 0.4 megohm, R28 Erie
1 1.5 megohm, $\frac{1}{2}$ watt, R22 Erie
1 2 megohm, $\frac{1}{2}$ watt, R20 Erie
Resistances: Other types.
1 10,000 ohms, 2 watts, R5 Erie
1 10,000 ohms, 3 watts, R6 Erie
1 Volume Control, 0.25 megohm, tapered, R21 Reliance "SG"
1 Fused Mains Input Connector with 1 amp. fuses Belling-Lee 1114
6 Terminals, ebonite shrouded, A, E, PU(2), LS(2) Belling-Lee "B"
2 lengths of screened sleeving Goltone
Chassis, complete with screws, etc. B.T.S.
Miscellaneous:
6 lengths Systoflex, 2 oz. No. 20 tinned copper wire, etc. Peto-Scott
Valves: 1 EF9, 1 EB4, 1 EBC3, 1 EL3, 1 AZ3 Mullard

The Three-band AC Super—

this diode anode is held positive and it consequently conducts. Owing to the high value of R20 the voltage across the diode is only a very small fraction of the initial bias voltage across R18. Consequently, the bias of the controlled valves is only very slightly less negative than that developed by their own cathode bias resistances.

When a signal is received the negative voltage across R21 is applied to the AVC line in series with the positive voltage across R18. When the detector output voltage is about 1 volt greater than the positive voltage, it overcomes the latter and the sum total of the voltage applied to the AVC line is negative and the diode across C32 no longer conducts. The voltage on the AVC line is then applied fully to the controlled valves.

The simplest way of regarding the matter is to consider one diode as working normally as a detector and the other as short-circuiting the AVC line until the detector output equals the bias across R18.

When the second diode is conductive, the bias across R18 causes a current to flow through R21, R20 and the diode. The resulting voltage drop across R21 makes the detector anode negative with respect to its cathode. The detector thus has a small negative bias which gives a QAVC action. When the delay is overcome by the signal and AVC is functioning the bias disappears so that it causes no distortion under normal conditions.

The amount of AVC delay and silencing action are largely controlled by the value of R18. This has been chosen to give only a small delay and an amount of QAVC action which is barely perceptible. This has been done deliberately because QAVC is usually a nuisance on short waves, for it makes tuning much more difficult.

On short waves tuning is critical, and a muting system always requires a certain time to operate. Consequently, it usually happens that even a strong signal may be passed over unnoticed before the muting has had time to let it through.

Should anyone require a stronger muting action it is easily obtained by increasing R18 to, say, 10,000 ohms. This also increases the delay. Muting can be increased somewhat without affecting delay by reducing R20, but this is not advised, since it is likely to affect quality.

One of the main advantages of this method of obtaining delayed AVC is that the filter resistance R20 can be higher in value than with the more conventional system. This is because the grid circuits of the controlled valves are completed through the diode instead of through R20 when no AVC voltage is being developed.

As compared with the ordinary system there is also very much less risk of distortion, and it is practicable to use a simple delayed AVC circuit in high-quality apparatus.

Full constructional details and the operation of this receiver will be dealt with in next week's issue.

News from the Clubs**Exeter and District Wireless Society**

Headquarters: Y.W.C.A., 3, Dix's Field, Southernhay, Exeter.

Meetings: Mondays at 8 p.m.

Hon. Sec.: Mr. W. J. Ching, 9, Sivell Place, Heavitree, Exeter.

At the meeting on December 5th Mr. W. S. Pyrah lectured on "Electricity in Harness." Mr. Pyrah dealt with modern methods of electrical engineering, illustrating his remarks with many photographs and lantern slides. On December 12, Mr. F. S. Rumball lectured on "From Coal Stack to Consumer."

The programme for the second half of the winter session will be published shortly.

Croydon Radio Society

Headquarters: St. Peter's Hall, Ledbury Road, South Croydon.

Meetings: Tuesdays at 8 p.m.

Hon. Pub. Sec.: Mr. E. L. Cumbers, 14, Campden, South Croydon.

Great interest was taken at the lecture on recording given by Mr. Stuart Davis, of the Davis Theatre, Croydon. In the course of the demonstration which followed, the lecturer recorded the voices of a number of members.

Radio, Physical and Television Society

Headquarters: 72a, Northend Road, London, W.14.

Meetings: Fridays at 8.15 p.m.

Hon. Sec.: Mr. C. W. Edmans, 72a, Northend Road, London, W.14.

On December 9th a party of members visited the Kensington telephone exchange.

Wolverhampton Short-Wave Radio Society

Headquarters: 76, Darlington Street, Wolverhampton.

Meetings: Mondays at 8 p.m.

Hon. Sec.: Mr. V. C. Hague, 76, Darlington Street, Wolverhampton.

The Society's annual dinner was held at the Star and Garter Hotel on November 2nd and the annual general meeting was held on November 21st.

The Society was founded in 1935 and has fifty members, including nineteen fully licensed transmitters. It is affiliated to the R.S.G.B. Membership subscription is 5s. per annum; those between fourteen and sixteen years of age are charged 2s. 6d. per annum. Two field days have been arranged for the coming session. A special lecture on television, to which the public will be admitted, is being held at the public library during February. Club Headquarters are equipped with transmitter and receiver.

Romford and District Amateur Radio Society

Headquarters: Red Triangle Club, North Street, Romford.

Meetings: Tuesdays at 8.30 p.m.

Hon. Sec.: Mr. R. Beardow, 3, Geneva Gardens, Chadwell Heath, Romford.

Recent lectures have been given by Mr. D. Bradley on "The Relationship of Chemicals to Radio," and by Mr. Hollings, of Mullard's, on "Cathode-ray Tubes." A competition has been started for artificial aerial members, and an application is being made for a portable licence for the club in order to study propagation in its relationship to various local conditions. The Morse classes have now recommenced.

Eastbourne and District Radio Society

Headquarters: The Science Room, Cavendish Senior School, Eastbourne.

Hon. Sec.: Mr. T. G. R. Dowsett, 48, Grove Road, Eastbourne.

Mr. D. Ashby, of the Westinghouse Brake and Signal Company, recently gave a lantern lecture on Westinghouse battery chargers. After explaining the difference between the disc-type rectifier for low-wattage outputs and the plate type for high-wattage outputs, he went on to describe some of their industrial and commercial uses.

Edgware Short-Wave Society

Headquarters: Constitutional Club, Edgware.

Meetings: Wednesdays at 8 p.m.

Hon. Sec.: Mr. F. Bell, 118, Colin Crescent, London, N.W.9.

On December 7th Mr. Nixon, of the General Electric Co., gave a lantern lecture on "Sound Expansion Control and Amplifying Equipment." At the following meeting Mr. Menage, of R. A. Rothermel, lectured on "Piezo-electric Crystal Pick-ups and Microphones."

There were over sixty members and their friends present at the Society's first annual dinner on November 26th. On January 4th the Club's annual general meeting will be held. Messrs. Webb's McElroy automatic Morse sending equipment has now been hired for use at meetings on Wednesday at 7.30 p.m. and on Sundays from 11 a.m.-1 p.m.

North Manchester Radio Society

Headquarters: 14, Fairfax Road, Prestwich, nr. Manchester.

Hon. Sec.: Mr. R. Lawton, 10, Dalton Avenue, Thatch Leach Lane, Whitefield, nr. Manchester.

Owing to the increase in the membership of the Society, meetings are now being held every Sunday at 3.30 p.m. On January 8th and 22nd, February 5th and 19th, and March 5th and 19th the official business of the Society will be discussed, and on the intervening Sundays only important announcements will be given out, the Club room being open mainly for Morse practice and to construct receivers.

At the official meetings during January the B.T.S.

"Trophy 8" communication receiver will be demonstrated, other receivers being similarly dealt with from time to time. A few days ago members were taken on a conducted tour of Telephone House, Salford. Among future activities are visits to the Rochdale fire station, to some of the amateur transmitters in the district, to Broadcasting House, and to Moorside Edge.

Television Programmes

Sound, 41.5 Mc/s

Vision, 45 Mc/s

An hour's special film transmission intended for demonstration purposes will be given from 11 a.m. to 12 noon each week-day.

THURSDAY, DECEMBER 22nd.

3, "La Chauve-Souris" (The Bat Theatre) in selections from their repertoire, including Babi and The Parade of the Wooden Soldiers. 3.30, Gaumont-British News. 3.40, 201st edition of Picture Page.

9, Christmas Cabaret, including Jasper Maskeleyne, Evelyn Dall, and Afrique. 9.45, British Movietonews. 9.55, 202nd edition of Picture Page. 10.25, News.

FRIDAY, DECEMBER 23rd.

3-4.30, Cecil Parker, Gina Malo and Henry Oscar in Edgar Wallace's play "The Ringer."

9, "Grandfather's Follies"—cabaret from Grosvenor House. 9.25, Gaumont-British News. 9.35, The John Carr Jacquard Puppets. 9.50, Cartoon Film. 9.55, "The Gourmet's Christmas"—Marcel Boulestin. 10.10, The Director of Television in the Witness Box. Viewers are invited to ring him up in the studio, where they will see him answer any *bona fide* queries they wish to raise on television. 10.20, News.

SATURDAY, DECEMBER 24th.

3-4.30, "Charlie's Aunt," the world-famous farce by Brandon Thomas, first produced in London in 1892, subsequently in 1923 and 1933.

9, "La Chauve-Souris" (as on Thursday at 3 p.m.). 9.30, British Movietonews. 9.40, "Christmas Cards I Should Have Liked to Have Sent," by Nicolas Bentley. 9.55, Cartoon Film. 10, "Old-Time Music Hall," including Charles Coborn, Harry Champion, Vesta Victorie and Marie Lloyd, junior. 10.40, News.

SUNDAY, DECEMBER 25th.

2.30, "Moonshine," a fantasy by Laurence Housman for humans and puppets. Characters include Father Christmas, Pierrot, a Policeman and the Moon! 2.50, A Christmas Party from the children's ward of St. George's Hospital, London; those present include Freddie Grise-wood, Margaretta Scott, Derek McCulloch, Leonard Henry and Bertram Mills' Clowns. 3.45, "Puddings, Christmas," a slapstick sketch, with Richard Hearne and George Nelson.

8.50, News. 9.5, Noel Coward's comedy, "Hay Fever," with Kitty de Legh, Maurice Denham and a distinguished cast.

MONDAY, DECEMBER 26th.

3-4.30, "Once in a Lifetime," a comedy by George Kaufman and Moss Hart; cast includes Joan Miller and Charles Farrell.

9, Cabaret Cartoons, including Trudi Binar (Miss Czechoslovakia) and Stanelli. 9.30, British Movietonews. 9.40, "The Cab," a farce by John Taylor. 10.10, News.

TUESDAY, DECEMBER 27th.

3-4.30, Gwen Ffrangcon-Davies in "Richard of Bordeaux," a play by Gordon Daviot.

9, Jack Hylton and his Band. 9.30, Gaumont-British News. 9.40, "Snow and Ice," a Winter Sports feature. 10.10, Coffee Stall. 10.25, News.

WEDNESDAY, DECEMBER 28th.

3-4.30, "The Moon in the Yellow River," a comedy of modern Ireland by Denis Johnston. 9, "Charlie's Aunt" (as on Saturday at 3 p.m.). 10.50, News.

How the Valve Works

ADDING
ELECTRODES
ONE-BY-ONE

Part IV.—PENTODES

THE action of the pentode is discussed in some detail in this article and its advantages over the early tetrodes are explained. Following upon this the latest tetrodes, which are in some cases replacing pentodes, are dealt with.

IN the last article we saw that the main defect of the early tetrode was the presence of the negative resistance kink in its characteristic and that this kink was caused by secondary emission. In order to overcome the defect, which was of sufficient magnitude to prevent the tetrode from forming a useful output valve, an additional grid was introduced, thus making the valve into a pentode. This extra grid was introduced solely to suppress the effects of secondary emission and it was, and still is, called the suppressor grid.

The grid is placed between the screen-grid and the anode and is usually connected to cathode. Sometimes, especially with output valves, the grid is connected internally to cathode, but it is now often brought out to a separate base-pin so that it can be connected differently when required.

The general arrangement of the electrodes of a pentode is illustrated diagrammatically in Fig. 12 by a series of concentric rings. It will, of course, be understood that the actual structure does not necessarily consist of such cylindrical electrodes. Other shapes are often adopted, especially for directly heated valves where the cathode is a filament running in zig-zag fashion. The electrodes are then usually in the form of rectangular open-ended boxes.

In general, the control grid is wound with a moderate mesh and the screen-grid with a close mesh. The suppressor grid, however, has a very open mesh. Up to the screen-grid the action is the same as that of a tetrode. Outside the screen, some of the electrons hit the suppressor and return straight to cathode, but the

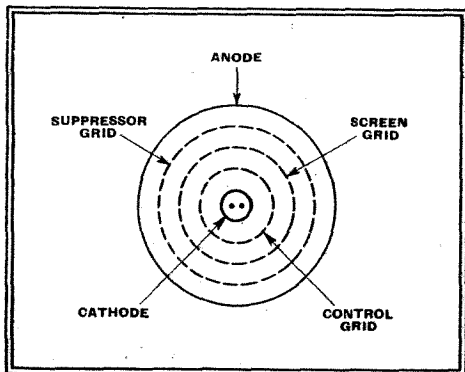

Fig. 12.—This diagram shows the general arrangement of the electrodes of a pentode.

majority continue to the anode just as in a tetrode.

Some of these primary electrons arrive at the anode with sufficient velocity to knock out lower velocity secondary electrons. This again is the same as in the tetrode. Here the resemblance ceases, however, for they no longer pass to the screen in any appreciable number.

Between screen and anode there is now the suppressor-grid at cathode potential and the distance between suppressor and anode is less than that between screen and anode. Consequently, the attractive force of the screen on the secondary electrons is largely overcome. The majority of the secondary electrons thus fall back into the anode and only a few can get to suppressor or screen.

Modern Tetrodes

The characteristic curve of a pentode is consequently of the form shown in Fig. 13 and exhibits no trace of any negative resistance kink. The anode voltage can be allowed to swing well below the screen voltage without trouble, with the result that the screen and anode can be operated at the same steady potential, instead of having to use an anode voltage of about double the screen voltage. This

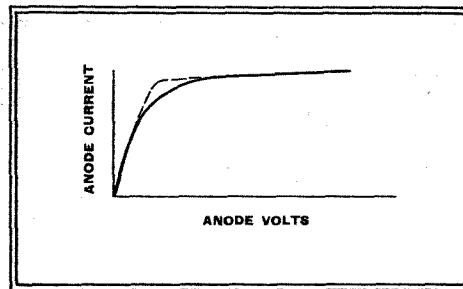

Fig. 13.—The solid-line curve shows a typical pentode characteristic and the dotted line the difference to be expected with one of the latest tetrodes.

results in a large increase in power output for the same power consumption from the HT supply, so that the efficiency is increased.

As applied to RF pentodes, this form of construction results in a considerable increase in the AC resistance for a similar or higher value of mutual conductance. This means both increased amplification and higher selectivity, and when coupled with the larger voltage handling capacity makes the pentode considerably better than the early tetrodes.

Quite recently there has been a swing back to tetrodes, because it has been found possible to avoid the negative resistance kink without introducing the suppressor-grid. These new tetrodes should not be confused with the older type, for

their characteristics are similar to, or better than, those of pentodes.

The obvious method of preventing the negative resistance kink in a tetrode is to tackle it at its source and stop the second-

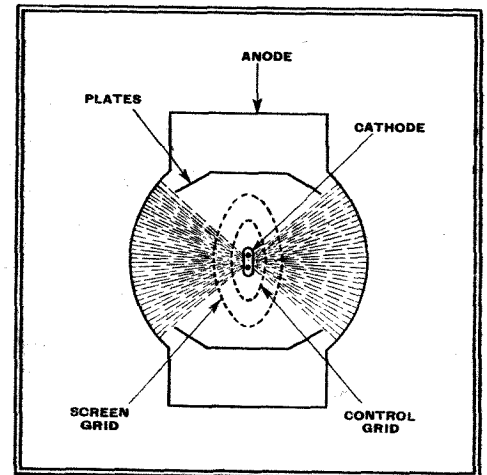

Fig. 14.—The electrode system of one modern tetrode is shown here.

ary emission from the anode. This is easier said than done, however, and it seems impracticable to effect a cure in this way, although secondary emission is naturally kept at a minimum by the suitable choice of the anode material.

One method of avoiding the negative resistance kink is to increase the anode-screen electrode spacing. As the spacing is increased the anode naturally exercises less attractive force on the primary electrons passing the screen. It consequently collects fewer of them and the anode AC resistance increases.

At the same time, the screen exercises less attractive force on the secondary electrons knocked out of the anode, so that fewer secondaries pass to the screen. At a certain critical distance between anode and screen, the negative resistance effects disappear, because the electrode spacing is such that at no anode potential can the screen gain control of the secondaries.

The characteristic curve of such a tetrode is very similar to that of a pentode, but is often somewhat straighter and with a more abrupt bend, as shown dotted in Fig. 13. This is an advantage since it reduces distortion and increases power output. It should be noted that with both tetrodes and pentodes, the negative resistance kink may appear again in some degree at a low anode voltage when the control grid is also very negative. The combination of a low anode voltage and a highly negative grid potential does not occur in normal operation, so this effect is unimportant in practice.

In some of the latest types of valve a rather more complex assembly is adopted.

How the Valve Works—

The valve is still a tetrode, but in addition to it four electrodes contain metal plates arranged to restrict the path of the electrons. These plates are not counted as electrodes because they are outside the path of the electrons.

The arrangement is shown in Fig. 14, and it is clear that as far as the screen the action is the same as in a triode. Outside the screen, however, the electrons are not free to follow any path to the anode, but are constrained by the plates to form beams with well-defined limits.

Beam-forming Plates

The electrostatic force of the anode on the electrons passing through the screen is exercised only through the gaps between the plates and consequently tends to make the electrons travel in beam formation. This tendency is accentuated by the effect of the plates themselves on the electrons. They are kept at cathode potential and as a result tend rather to repel electrons than to attract them.

One advantage of the beam formation of the electron stream is that the number of electrons per unit area is increased and hence the repelling force upon other electrons. The result is that the main electron stream itself repels secondary electrons emitted by the anode and prevents their passing to the screen.

Secondary electrons emitted at an angle, and which would normally take a long curved path to the screen, are prevented from doing so by the beam-forming plates. In other words, secondary electrons can only reach the screen through the gaps between the plates, and they are prevented from doing this by the repelling

force of the primary electron stream itself. The spacing of screen and anode and the shape and position of the plates naturally play a large part in the operation of the valve.

In addition to designs of this nature, the use of control and screen grids of the same pitch is becoming more usual. In the tetrode and pentode the screen current is really waste, and if it could be reduced to zero the efficiency of the valve would be higher. By efficiency is meant the ratio of output power to the power supplied by the HT system.

Now the electrons have to pass through the control grid and this splits up the stream into a series of flat beams. If the screen is wound with the same number of turns as the control grid and is placed so that its turns are in the same planes as those of the latter, the flat beams of electrons will tend to pass between the turns of the screen without hitting its wires. As a result, a great saving of

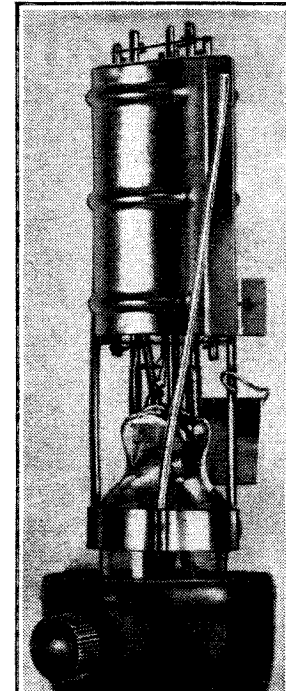
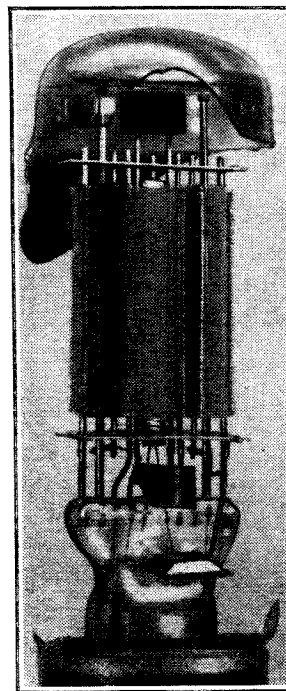

The electrodes of an early output pentode can be seen on the right, and on the left there is a modern large output pentode.

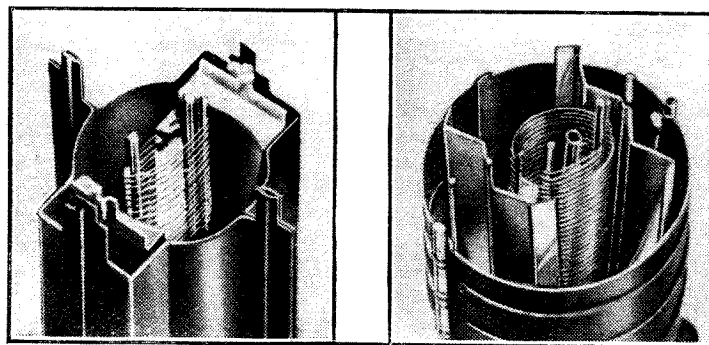

These views of the electrode assemblies of modern tetrodes clearly show the beam-forming plates. They are of the same valves as those illustrated below.

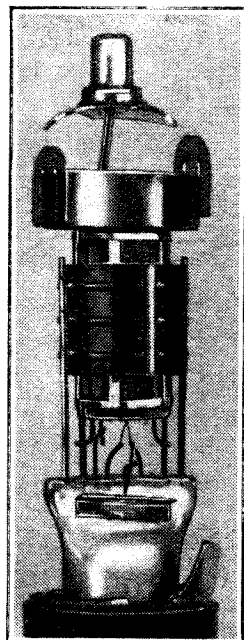
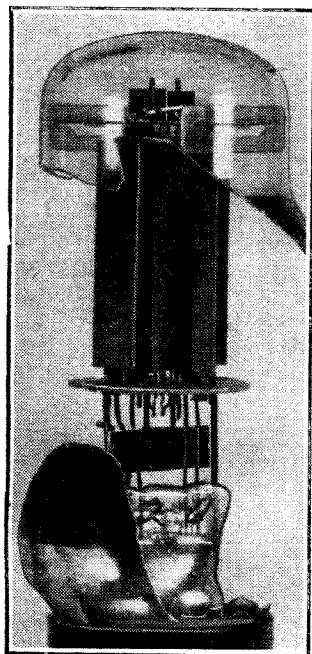

A typical modern RF tetrode is shown on the right, with an output tetrode on the left.

the screen current is effected.

This course is now often adopted for large output tetrodes where the saving in screen power is important. As it makes manufacture more difficult it is not adopted for smaller valves. It is also not used in RF tetrodes or pentodes because the screen must usually have many more turns than the control grid, or be of a fine mesh structure, if it is to screen grid and anode effectively.

Tetrodes and pentodes of the RF type are made in two classes, the straight and variable-mu types. The distinction is not inherent to tetrodes and pentodes, for variable-mu valves can be made with any number of electrodes from the triode upwards.

The main difference between a straight and a variable-mu valve is that the former has its control grid evenly wound, whereas the pitch of the grid turns in the latter changes along the length of the grid. As the control exercised by the grid depends upon the pitch of the winding, the amount of control exerted in the variable-mu valve varies along the length of the grid.

This means is adopted to obtain a valve with a long grid base and with a continuous change of mutual conductance with grid bias. The aim is to obtain a characteristic which at any point is straight enough to handle a reasonably large signal without distortion, and yet which is sufficiently curved to enable a large change of mutual conductance to be secured for a reasonable variation of bias voltage. The valve is used chiefly for volume control.

Potentiometers and Resistors
SOME RECENT ERIE DEVELOPMENTS

WITH the requirements of the serviceman especially in view, the Erie Resistor firm is now producing volume controls with long duralumin spindles which can easily be notched and broken off to any desired length.

To reduce risk of short circuits, the standard 1/2-watt and 1-watt Erie carbon resistors are now fitted in a ceramic case, while silvered ceramic and mica condensers have been added to the range of productions. Vitreous wire-wound resistors are available in all standard values.

A recently introduced price list shows many price reductions; Erie products are distributed direct from the works through official channels.

Which Way Does the Current Flow?

Concluded from page 540 of last week's issue.

BEFORE resuming this romantic story I must refresh your memories with a summary of how far we got in the first instalment.

Apart from innumerable mixtures there are at least a million different chemical substances that make up the whole material universe. The smallest possible pieces of these that can exist alone are called molecules. If molecules are divided up, we are left with only about ninety different sorts of stuff—the elements. The smallest possible pieces of these are called atoms. These in turn consist of two sorts of component, electrons and protons, which are electrically negative and positive respectively, but as normally they congregate in equal quantities they exactly neutralise one another and no electrical effects appear. A battery or dynamo or other electrical "generator" has the ability to separate electrons from their mates, confining them at opposite "poles," to which the terminals give access externally. Though the authority of the battery prevents reunion through itself, it is possible for the separated partners to be reunited if a path is provided between positive and negative terminals. *Do both parties use this path, or only one; and if one, which one?*

You may have noticed that although I have referred to one party of prisoners as electrons I have carefully avoided calling the opposite party protons. Why?

In the atom I described because of its simplicity, the hydrogen atom, there is only one electron and one proton. So if the electron is removed, what is left must be a proton. But that is actually quite an exceptional case. Take the next on the list, helium, also used for inflating balloons, but not so effective, owing to its greater weight. Each atom of it contains four electrons and four protons. But they are not just mixed together, like half-pennies and shillings in your pocket. Nobody has ever succeeded in removing more than two of the four electrons. On the other hand, it is possible for only one to be removed. So there are three possible states: no electrons removed, and therefore perfect neutrality, with no electrical properties; one electron removed, leaving behind a corresponding positive electrical charge; two electrons removed, leaving twice as much positive electrical charge per atom. Gold has no fewer than 197 pairs, of which 79 can be divorced, giving a maximum of 79 units of electrical charge per atom.

The diagrams of atoms and molecules given in Fig. 1 were, therefore, rather misleading. A better idea of them is shown here in Fig. 2, which illustrates a helium atom. (It is still not in line with the latest scientific theories, which complicate matters with neutrons and positrons, but these complications are unnecessary for the present purpose.) Four protons and two electrons form an inseparable group at the centre, and two spare electrons circle around it, like planets round the sun. They have to keep on revolving,

opposite kinds from causing them to be drawn in to the centre. It is these planetary electrons that can be dislodged. Incidentally, as the electrons and protons are, like sun and planets, extremely small compared with the orbits in which they revolve,

it can be seen that most of matter must be just empty space. It may be easy enough to realise that this is true of gases, which can be enormously compressed by applying sufficient pressure, but not so easy to realise that liquids and even solids like cast iron are as insubstantial as the vast tracts of astronomical space. It is rather like the way in which distant masses of cumulus cloud look at least as substantial and sharply defined as solid mountain peaks, yet an aeroplane can fly through them without appreciable resistance.

Except in the case of hydrogen, then, the positive particles are not lonely protons but are complete molecules except for the loss of one or more electrons. From a material standpoint this loss is surprisingly small, because, although electrons and protons are equal and opposite electrically, protons are nearly 2,000 times as heavy as electrons, so it is not far wrong to look on the units that include protons as the real substance, and the electrons as solely electrical in nature. Speaking of a "positively charged" molecule suggests that it is a molecule with positive electricity added, but it must be remembered that it is actually a neutral molecule with *negative* electricity subtracted. Incidentally, its name is an *ion*. Although this

name applies to negatively charged particles, too, it is seldom used in that connection.

Returning now to our battery, one does not observe a piling up of actual material on the positive terminal. (There is a visible piling up on the "poles" inside the battery, but that is a different matter.) It seems likely, therefore, that what happens is that the negative pole contains a preponderance of electrons (which, being inconceivably small and light, do not cause any visible change), this excess being extracted from molecules at the positive end. These robbed molecules merely have to stay where they are in order to constitute a positive charge. When a free path is provided outside the battery between positive and negative terminals it seems likely, too, that the relatively heavy, cumbersome structures, the positive ions, continue to stay where they are, while the nimble electrons nip along the path and rejoin their long-lost wives, or clubs as they now appear to be. The material of which the battery is composed would then resume its neutral, apparently non-electric, nature; were it not that so long as certain chemical processes are able to take place the arrest and transfer of electrons to the "negative pole" concentration camp continues at a rate sufficient to replace those that escape and return home.

An Unlucky Guess

The direction of the electric current, if words mean anything, is from negative to positive. Why, then, do the old books say that current flows from positive to negative? It was an unlucky guess, made in the days when the existence of electrons was unknown. People were beginning to use electricity a lot, though they knew nothing about it, and for convenience they had to label the two poles of a battery, so they decided to mark the carbon or

copper pole +, and daub a splash of red paint on it to make sure, and they marked the zinc pole - (and some black or blue paint), and agreed to say that current flowed from the + to the -. A bad guess, as it turned out.

So far our own conclusion is not a great deal better than guesswork. To be a little more sure of it,

consider the undefined "path" down which the electrons were supposed to have escaped. What is an electrical path? This is where our knowledge of molecules and atoms comes in useful. There are some substances, notably gases, in which

One-way and Two-way Traffic Through the Valve By "CATHODE RAY"

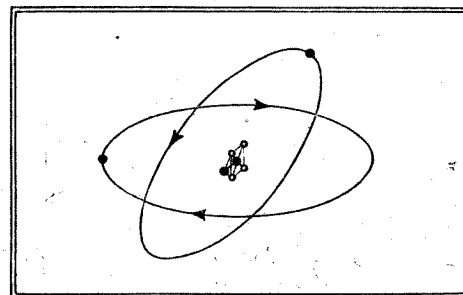

Fig. 2.—Diagram of an atom of helium. Four protons and two electrons are inseparably united at the centre, while two detachable electrons circle around them.

Which Way Does the Current Flow?

the club membership is very strict. Unless force is used, the molecules retain their normal quota of electrons. So there is none wandering round unattached. As long as all electrons are fixed in neutral clubs there can be no such thing as an electric current. In gases at atmospheric pressure, and oils, and ebonite and mica, the proportion of free electrons is almost negligible. They are, therefore, not electrical paths. But metals, particularly silver and copper, include a large proportion of electrons that have broken loose and are roaming around in the vast empty spaces between molecules. A crowd of aimless wanderers is not a current. But the former can be quickly converted into the latter by a shout of "Fire!" or "Food!" And a crowd of electrons can be urged in one direction by the chemical or magnetic influences acting in a battery or generator. Although the urge quickly spreads from end to end, the actual drift of electrons is relatively slow. When you turn on a tap, water almost instantly begins flowing in the pipes perhaps a mile away, but it may take a long time for that actual section of water to travel as far as the tap.

We now have a mental picture of what happens in a simple electrical circuit consisting of a battery with its terminals joined by a piece of wire. Directly the wire, with its abundance of loose electrons, is connected, the ions at the positive terminal start pulling them and the excess of electrons at the negative end start pushing, and at once there is a stream flowing towards the positive. Every electron that hops off at the positive is balanced by one that is heaved on at the negative.

Primary and Secondary Emission

Next suppose that an HT battery and a valve form part of the circuit. The cathode of the valve is a taking-off ground, at which electrons are persuaded to boil off by the application of heat. If it is connected to the positive terminal of the battery, the tendency is for them to be attracted back again and to refuse to leave. But if the battery connections are reversed, they are attracted over to the anode, and a current flows, negative to positive. There is not even air inside the valve, so no current at all in either direc-

tion is possible if the cathode is not heated to release a supply of electrons. On the other hand, if the valve is badly designed or overrun, so that the grid or anode gets

current flowing in both directions. There are other cases, such as currents through certain liquids. So the question of which way the current flows is not always a

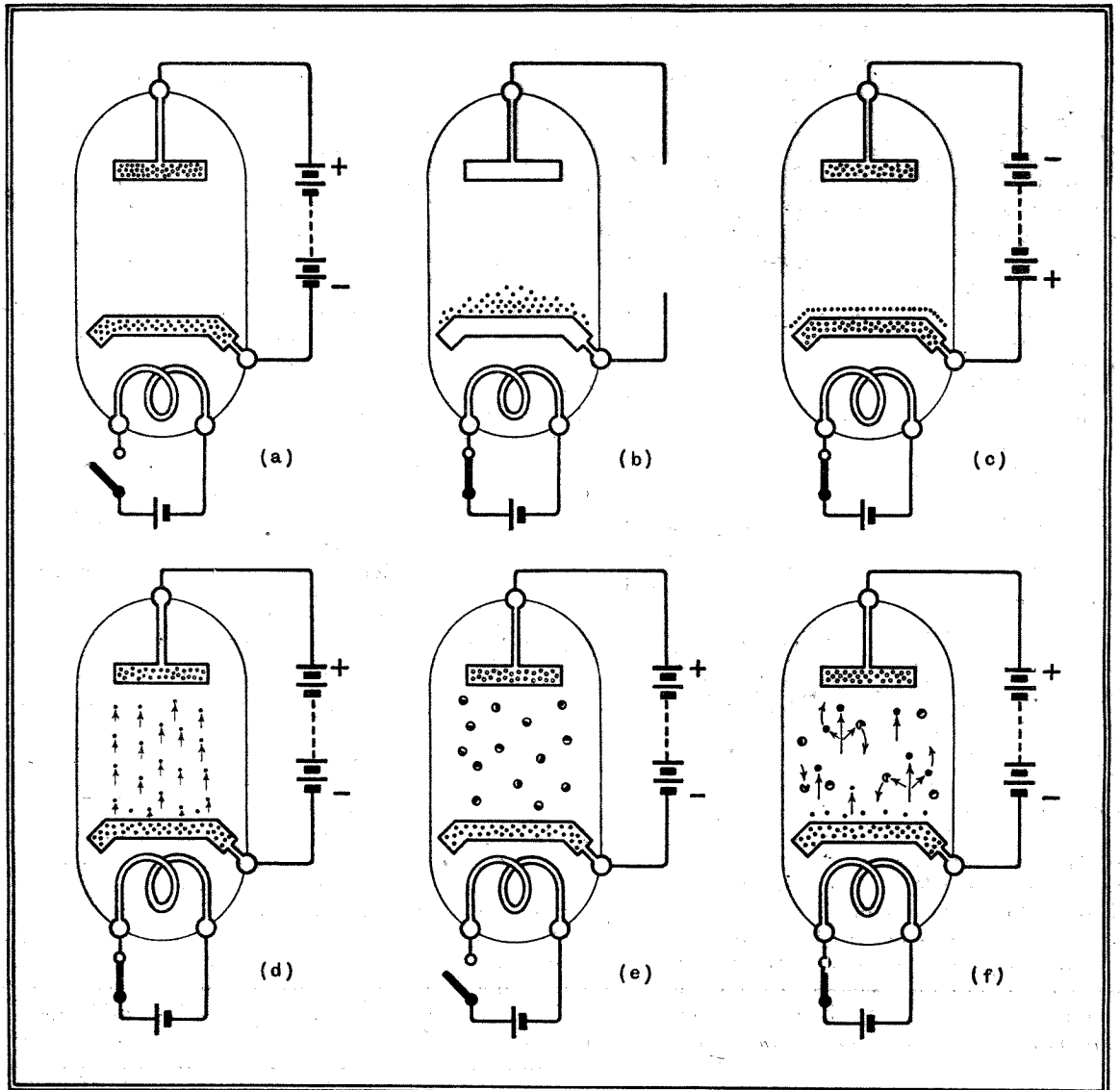

Fig. 3.—(a) A vacuum valve has practically nothing in it, so even the application of a HT battery fails to pass current. The positive and negative particles are in a majority on anode and cathode, but are unable to leave unless a destructively high voltage is applied. (b) If the cathode is heated, a cloud of electrons is ejected, but without a HT battery there is no inducement to go far. Still no current. (c) If the HT battery is connected the wrong way round, the ejected electrons are attracted back to the cathode by the excess of positive electricity there (and repelled by the negative on the anode). Still no current. (d) With HT battery properly connected and cathode heated, the loose electrons are pulled across and constitute an electric current. (e) If a small quantity of gas is present in the valve the HT battery (unless exceptionally high-voltage) is unable to influence the gas molecules because they are electrically neutral, having equal positive and negative portions. (f) When electrons are freed from the cathode and drawn across by the HT battery they collide with the gas molecules and break them up into negative electrons and predominantly positive groups (ions), which are attracted to anode and cathode respectively, augmenting the electric current by their two-way traffic.

hot, it, too, may release electrons and start a current in the wrong direction. Then some valves deliberately or accidentally have a small quantity of air or other gas in them. Last week I mentioned that a fast-travelling electron could break up otherwise closely bound combinations, releasing more electrons and positive ions. The process is called *ionisation*. The electrons and ions immediately start travelling in opposite directions according to their respective attractions, and the original current is greatly augmented. In fact, unless one is very careful the stream may grow into an uncontrollable torrent, with the result that the valve is destroyed. In particular the cathode suffers from the sudden shower of heavy ions.

Here, then, is a case of an electric

simple matter to decide. But as positive going one way is equivalent to negative going the opposite way, what does it matter? Do you mind whether a benevolent creditor withdraws from you a debit note for £10 or hands to you £10 in cash? The two transfers, though in opposite directions, come to the same thing.

Miscellaneous Advertisements and December 29th Issue

ADVERTISERS are reminded that owing to the Christmas holidays and the necessary alteration in our printing arrangements for December 29th issue, it was necessary to close the miscellaneous advertisement pages for press earlier than usual. No more copy can now be accepted for that number.

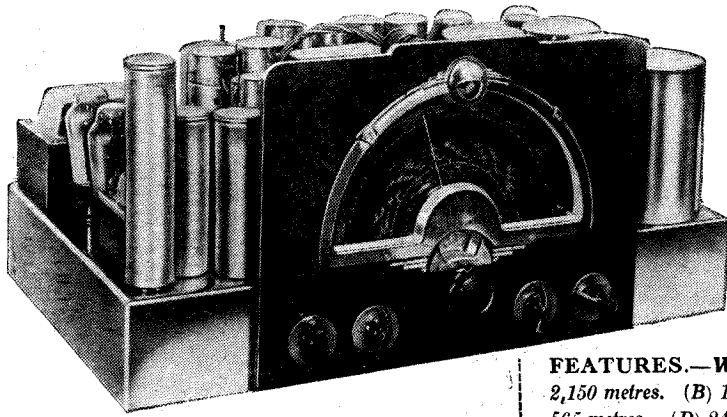

McMurdo "15-17" Silver

A Soundly Constructed
Receiver of Outstanding
Performance

SINCE this receiver was first introduced into this country more than a year ago it has undergone thorough revision and reconstruction in order that its characteristics shall be exactly suited to reception conditions on this side of the Atlantic. The products of this firm have already established for themselves a high place among quality receivers in the United States, and one can well understand the reason when one sees the amount of work which has evidently been put into the British version before its release to the public.

In these days of keen competition in long-distance performance it is safe to say that the short-wave ranges of a communication-type set will be made or marred by the RF stage preceding the frequency-changer, and it is here that special attention has been given to the design. The valve selected is the Mazda SP4T, which was introduced for television work and has a "g" of 8.4. It is in circuit on all

FEATURES.—Waveranges.—(A) 732-2,150 metres. (B) 181-565 metres. (C) 54.5-565 metres. (D) 24-56.6 metres. (E) 9.4-25 metres. (F) Television Sound. Circuit.—(Principal stages) RF ampl.—mixer—osc.—two IF stages with variable selectivity—2nd det.—1st AF ampl.—phase splitter—push-pull output stage. (Auxiliary stages) AVC rect. tuning indicator—beat osc.—two power rectifiers. Controls.—(1) Tuning. (2) Volume and on-off switch. (3) Selectivity and gramo. switch. (4) Waverange. (5) Tone and beat osc. switch. (6) "Local-Distance" switch. Price.—(Chassis and loud speaker) 39 guineas. Makers.—The British McMurdo Silver Co., 17, Hertford Street, Park Lane, London, W.1.

but the lowest of the six waveranges. Without the RF stage there is ample sensitivity for the television transmissions which are received with frequency stability and absence of microphony, but changing up to the next waverange (9.4 to 25 metres) is like switching in not one, but two or three extra stages. The addi-

tional sensitivity is maintained right down to 10 metres, and five American amateur transmitters on this wavelength were logged in as many minutes during the late afternoon. True, the background noise on this range was up to average, but reference to the familiar conditions on the 16-, 19- and 25-metre broadcast bands showed the signal strength to be very much above average and the actual signal-to-noise ratio therefore very good indeed.

American broadcasting stations, under reception conditions slightly below par, were received at full volume with the control advanced only one-fifth of its range from the minimum position. Selectivity, an increasingly important factor nowadays on short waves when so many of the European stations are increasing their power, was sufficient in the "sharp" position to give easy clearance of adjacent channel interference when listening to the American programmes.

Complete circuit diagram.
A separate diode is used to supply AVC bias to the mixer and the RF stage makes use of one of the latest types of television valve.

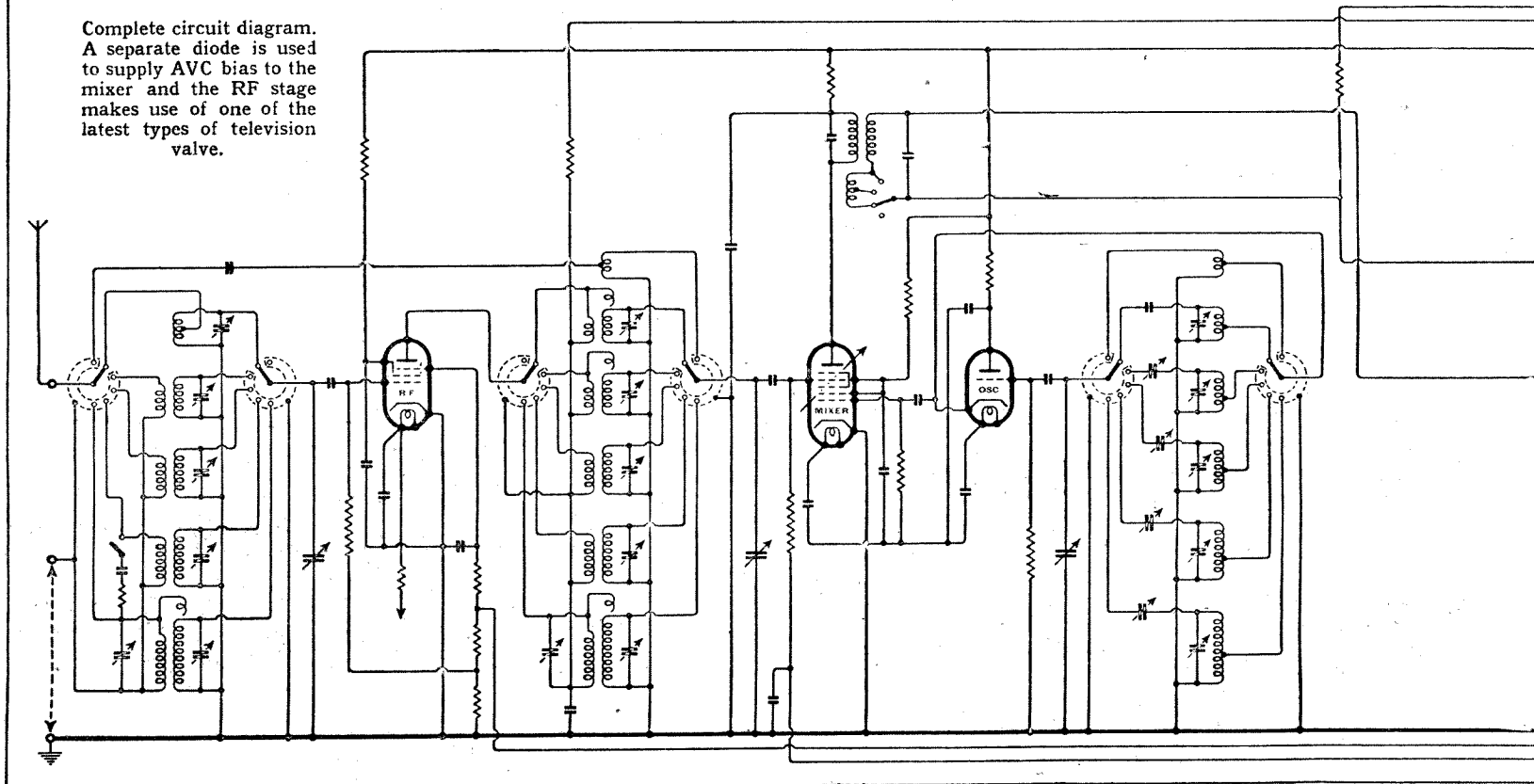

McMurdo Silver "15-17"—

The three degrees of selectivity provided are equivalent to bandwidths of 3, 9 and 16 kc/s, and with the switch in the position of maximum selectivity only half a channel is lost on either side of London Regional at 15 miles, while the Deutschlandsender is easily separated from Radio-Paris and Droitwich with but little use of the tone control.

Not a single self-generated whistle could be traced on any waveband when the set is properly handled. If any are found on medium or long waves they will almost certainly be due to overloading in the first stages of the set and are easily cleared by reducing sensitivity by means of the "Local-Distance" switch at the back of the chassis.

The tuning indicator is particularly sensitive, yet does not overload on strong signals. It is one of the many details which mark this as a finished set, not only in external appearance but also in the more important electrical essentials. Mechanically, too, the McMurdo Silver will appeal to those with an eye for such things. The controls are neat and are backed by engraved metal indicator plates. Two ratios of 16:1 and 80:1 are provided by the slow-motion tuning control and the higher ratio in particular is extremely light to the touch. A separate "degree" scale geared to the main drive passes 1,600 sub-divisions across its pointer as the main indicator traverses the length of each scale. Incidentally, the high wavelengths are to the left and the low to the right of the scale, the opposite to the convention in this country, but station names, broadcast bands, etc., are

so clearly marked that this is not a point for criticism.

The controls have been reduced in number by a system of combination which is rather unusual. Waverange has a control to itself and the gramophone switch is combined with the selectivity control. Volume control and mains on-off switch are associated in the usual way, but the beat oscillator switch comes into action at the "high" end of the tone control so that one is precluded from reducing background noise when receiving CW signals.

Clean Response

The quality of reproduction delivered by the output stage of this set is everything that it should be. Too often one finds valves with a high rating in sets of this calibre, which nevertheless carry a slight suggestion of harmonic distortion throughout the volume range or break down into hopeless overload distortion at some critical input level. In the McMurdo Silver the quality remains perfectly clear with good transient response and no aural evidence of harmonic distortion or cross-modulation up to levels which are far higher than are necessary for realistic results, even on a full orchestra.

At the other end of the volume range where the input to the push-pull stage is small, the reproduction was equally free from distortion and the balance between bass and treble was well maintained by the tone compensation associated with the volume control circuit.

Two loud speakers were tried out with the set, the first the standard McMurdo Silver "Giant" with 13½-inch diaphragm and the second a 9-inch diameter unit which is supplied to those who prefer the reproduction from a comparatively small diaphragm. Actually, we found nothing to choose between the two, since they were worked on baffles of different size which tended to equalise the response in the bass. Both possessed excellent qualities in the middle and upper registers with crispness and absence of cross-modulation as the predominant impressions. In conjunction with the bass-reinforcing baffle, which is generally built into the cabinets which use the "Giant," a very powerful low note response is achieved, and it is probably for this reason that the output from the small speaker is more to the taste of listeners in this country. Arrangements are being made in the near future to undertake non-standard installations from the acoustic point of view.

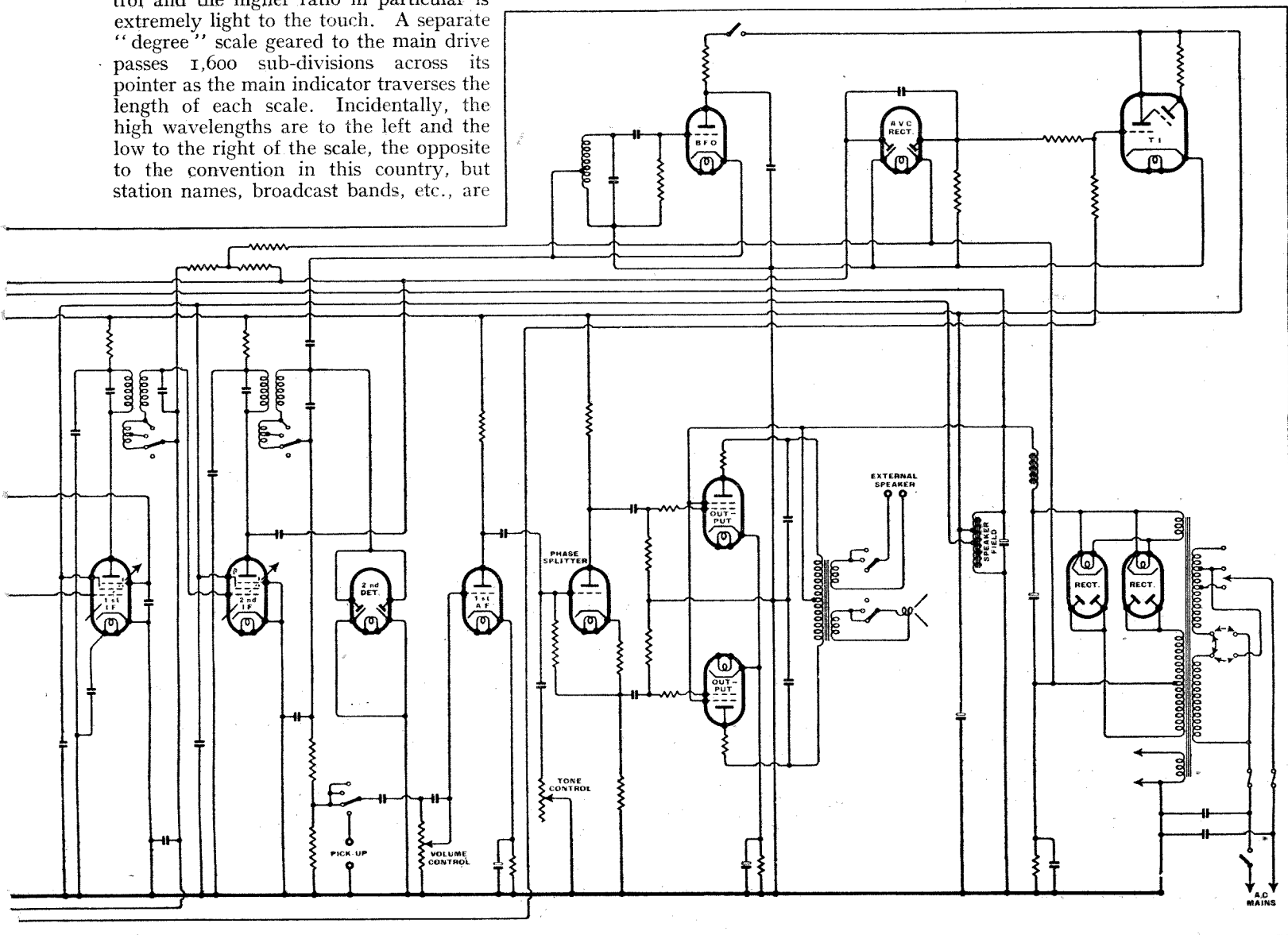

McMurdo Silver "15-17"

The circuit follows the best modern practice and the number of valves in the direct line from aerial to loud speaker provides just that excess of amplification which gives confidence that the best possible results are being extracted from a distant transmission without creating the impression that valves have been wastefully added only to increase inherent noise. A separate triode oscillator in conjunction with a heptode mixing valve follow the RF stage, and there are two stages of IF amplification with tertiary windings for controlling bandwidth in each of the three transformers.

Separate rectifiers are used for demodulating the

The chassis sets a high standard, not only for finish but in the mechanical and electrical soundness of its construction.

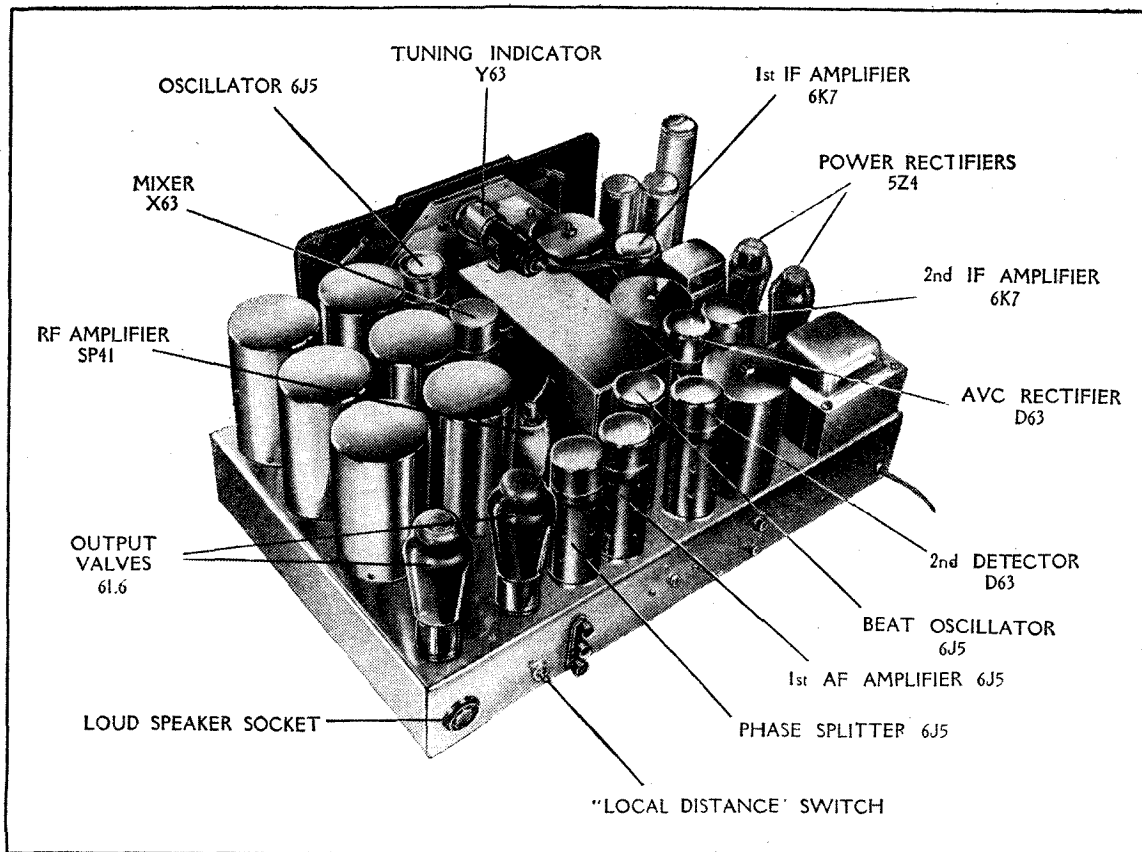

signal and for automatic volume control. Two diodes are allocated to the latter function, one for the RF and IF stages and the other for the mixing valve. By suitable adjustment of the initial bias it has thus been possible to arrange for the frequency-changer to operate with less delay than the other controlled valves. In the case of the RF amplifier most of the AVC voltage is applied to the suppressor grid, and only a small fraction to the control grid, a system which enables the gain to be varied without affecting the input capacity or resistance.

There is ample AF gain between the second detector and output stages. Volume is controlled in the first AF stage and tone in the input to the phase-splitting valve. The output valves are tetrodes working under conditions to give

a rated output of 20 watts undistorted. Two power rectifiers are employed and there is one stage of smoothing with a separate choke. The loud speaker field is across the HT supply and is used as a potential divider. There are terminals for a low-impedance external loud speaker which is fed from a separate winding on the output transformer. A three-way switch enables the internal, external or both loud speakers to be used.

The chassis is exceptionally well finished, all metal parts being highly polished and chromium-plated. Its performance lives up to its appearance, and it gives all the essentials of sensitivity, really sharp selectivity and good quality of reproduction without any of the minor blemishes which often accompany the use of a large number of valves.

for controlling the flow of a liquid or gas; it may be operated by hand or mechanically; it is generally used to permit a small force or flow to control a larger one; since this is precisely what the thermionic valve does with electron flow the term seems very appropriate for all types.

With regard to the other question as to whether the rectifier should be included in the number of valves used to describe a receiver I should say most emphatically not. What would anyone think if a dealer described a car as a "five-wheeler," including the steering wheel? If he tried to sell a tri-car as a four-wheeler by a similar subterfuge he would be regarded as guilty of gross misrepresentation. Yet no one is disputing the simple fact that the steering wheel is also a wheel. Just as one understands a car's description as pertaining to the number of road wheels, so, I contend, should the number of valves refer only to those definitely associated with the receiver performance and exclude any auxiliaries, such as tuning indicators, rectifiers, etc.

I plead for accuracy of description in things electrical by those who understand their subject; the layman has quite enough to confuse him without assistance from people who ought to know better. Why say "all-electric" when you mean "all-mains?" What is any receiver but all-electric? Why say battery when you mean cell? No one ever speaks of a single gun as a battery. These may be small things but if we wish to convey our thoughts clearly and concisely we must use correct and descriptive terms.

Glasgow. C. H. CAMPBELL GRAY.

Congestion on the Amateur Bands

I WAS very interested in your remarks in the last few issues regarding transmitting licences, and quite agree with you that more scope should be given to would-be holders. Although the *T. and R. Bulletin* this month

Letters to the Editor

The Editor does not necessarily endorse the opinions of his correspondents

U-S-W Quality

I AM constantly noting references, in various places, to the "superior quality" of the sound emitted by televisions. In my opinion this superiority is, in general, a myth.

That better quality is theoretically possible on ultra-short waves is undeniable, but is it not a fact that the AF side of the average television is sadly neglected, consisting usually of a pentode output driving a tiny loud speaker with an inadequate field (presumably to avoid magnetic interaction)? This seems hardly conducive to good reproduction, transient or otherwise, and such upper frequencies as are audible consist mainly of resonances.

It would be interesting to know what kind of broadcast receivers are used by those whose praise is loudest; or is it that the addition of vision renders the ear insensitive to distortion?—as witness the popular tolerance of the "quality" emitted at local cinemas, which very often have a 3 kc/s cut-off.

Wimbledon.

R. G. YOUNG.

Misleading Terms and Ratings

THE question of what shall rank as valve has again been raised by "Cathode Ray," who also suggests that the rectifier is more entitled to the term "valve" than the amplifiers, etc.

A valve in the mechanical sense is a device

says that there are enough amateur licences, I think that the reason the bands are overcrowded is due to the fact that there is a lot of senseless chatter between local stations.

In this district there are nightly gossips between three, four, and sometimes five stations, often lasting well over an hour. Break-in 'phone is used, and the subject-matter of the conversations is of no benefit to the hobby in which the speakers are all engaged.

Another type of "ham" who causes congestion is the man who virtually lives on the air. In the early part of this year I worked a G8, who, on his QSL card, proudly stated that in the first twelve months of holding a licence he had had 1,960 QSO's. During the 3½ years I have had my licence I have averaged around 300 per year, and I spend quite a lot of time in my shack, not necessarily on the air, as there are always rebuilding operations and other experiments to be carried out.

If more Morse were used instead of 'phone, conditions would be much better on the amateur bands.

EX-R. E. SIGNALS.

Valve Standardisation

I THINK Mr. Harper's suggestion that a 13-volt heater be adopted as standard is excellent and very practical. The 6.3-volt heater can hardly be justified on the ground of its use in car radio, as these will always be a very small proportion of the total

number of valves in use, and, again, how many 6-volt car batteries are there on the roads which can stand up to their normal job, especially in winter, even without the added drain of a receiver? My experience is that the number is very limited, and a 12-volt battery is bound to be more satisfactory when car radio is under consideration.

There may, as you say in your Editorial, be increased danger of hum pick-up with 13-volt heaters, but this need not be troublesome with careful design. I have recently handled one well-known commercial receiver using such valves in which hum is absolutely inaudible in spite of its 8-watt output.

When used in AC/DC sets the 13-volt valve leaves much less voltage to be dropped in the series voltage absorbers. Your suggestion that the 3-pin type of heater be used has much to commend it to prevent duplication when viewed from the 6.3-volt heater point of view, but it also has a great deal in its favour as applied to the 13-volt heater. It would be almost possible to devise valves with a truly universal application. The two halves of the heater could be connected in parallel where greater heater power was required in AC and car radio sets at 13 volts, and in series for AC/DC receivers, giving a 26-volt heater. Personally, I think the 6-volt battery valve should have been developed for 6-volt car radio.

J. W. TAYLOR.

Lower Ince, near Wigan.

Random Radiations

By "DIALLIST"

A Pious Hope

THE following statement, which I have just come across, may be of some interest: "The urgent necessity for standardisation has led all the set manufacturers in the United States to design their receivers to take the — type of valve for every part of the receiver except the output stage, for which special super-power valves, similar to our own, are available." News? I'm afraid not. When I say that I've just come across that paragraph I'm speaking the literal truth, but I did so when I was turning over the pages of an old wireless paper. Actually, it is from an article on American sets published in the year of grace 1928! Now, ten years later, we're further than ever from standardisation, and the odds are that each year will see longer and longer lists of different types of valve.

A Better Fate Deserved

In some ways one can't help wishing that that attempt on the part of the American manufacturer to standardise receiving valves didn't meet with a better fate. Actually it was doomed at the very outset to failure, for a variety of reasons. You may find it hard to believe, but that article on American sets, which covers all of the leading makes on the market, has no mention of any but battery-operated receivers. The indirectly heated mains valve had only just begun to make its appearance, and if you wanted to run a set from a wall socket you had to do so by means of a battery eliminator—which didn't, by the way, eliminate the LT accumulator. What upset the apple cart of valve standardisation was the coming

of all kinds of new valves, with characteristics and possibilities far in advance of anything then on the market. The screen-grid valve, though evolved some time previously by Dr. Hull, of the G.E.C., remained in the laboratories for some time after Captain Round had evolved a practical form of it in this country. The AF pentode made its bow to an astonished public at the 1928 Radio Exhibition, and crossed the Atlantic from east to west a little later. It was all very well to try to standardise valves when diodes and triodes were the only kinds available; the coming of a flood of new and better valves of all kinds entirely altered the situation.

Pros and Cons

In the past I've been an advocate of valve standardisation, but I don't think that I'm in favour of it now; certainly I'm against anything like *ruthless* standardisation. In some ways it would be a very great advantage if valve makers and set makers could get together, draw up a list of essential types and confine their energies to the production and use of these. Valves could become cheaper and one wouldn't have to consult books of the words to discover which pin was which when connecting them up. But anything of the kind might very easily cramp progress, and that would be all to the bad. Nevertheless, I can't help feeling that it would be a good thing if the lists of valves were severely pruned, for there must be scores upon scores of types that we could very well do without.

Interference Again

ANOTHER complaint that reaches me is concerned with interference in south-west London. I am taken to task for suggesting that anti-interference aerials are of much use, except in a few isolated cases. So far as my experience goes, anyway, I am inclined to think that instances of interference which can't be greatly ameliorated, if not completely cured by a properly erected anti-interference aerial, suitable for the job in hand, are comparatively rare. My correspondent says that I'd do a service to the cause of good listening if I could get some manufacturer to turn out an easily erected aerial mast from 50 feet to 75 feet high, "so that we could place our aerials where they would pick up more signals than noise." There are such masts available. There are anti-static aerials of the sky-rod type.



Dealers to Blame?

BEFORE now readers have advanced in proof of the incurability of interference in such and such a locality, the fact that even in the wireless shops reception is ruined by crackles and bangs. Honestly, that isn't proof at all. Often I've been astonished on going into radio shops to find that if any precautions at all have been taken against interference, they were of the most elementary and least effective kind. There are plenty of good dealers who have studied the question of interference elimination and have acted upon what they have learnt. But there are far too many others who seem neither to know nor to care anything about it. How they ever sell any sets is a puzzle to me, for the noisy demonstrations that they give on their premises would seem to be enough to put any prospective purchaser off. Listeners who can't get satisfaction from their dealers about interference suppression might do worse than get into touch direct with some of the firms who are recognised specialists in the manufacture of anti-static aerial equipment of various kinds.



Uniformity Wanted

THE pronunciation of foreign proper names by B.B.C. announcers has long been a source of heated argument. Some time ago Mr. Stewart Hibberd, the Chief Announcer, was reported to have said that there was no special rule on the subject; each pleased himself. Most of us, I think, would like to see a definite ruling laid down, for it's a little puzzling when you get the same proper name pronounced in two or three different ways by as many readers of the various news bulletins. The rule I'd like to see is: Always use the English names of foreign places, where they exist; if there are no English names, don't try to show off in pronouncing the foreign ones. Much the same would apply to the names of people. In ordinary conversation we don't try to do as the Romans do when pronouncing Bodoglio or Grandi or Gayda; we are content to make Ribbentrop rhyme with ribbon-shop, and we don't indulge in lingual or labial gymnastics when speaking of Daladier, Jéhaux and Maginot. No man can possibly pronounce all languages properly. The great thing is to make your hearers understand what you're saying and that should be the aim and object of everyone who is reading out the news bulletins.

Recent Inventions

The British abstracts published here are prepared with the permission of the Controller of H.M. Stationery Office, from Specifications obtainable at the Patent Office, 25, Southampton Buildings, London, W.C.2, price 1/- each.

AERIALS

AN aerial is designed to respond to a wide range of frequencies, and to operate either as a pure dipole or as a capacity (or T-type) aerial, according to the wavelength or field-strength of the signals being received, and to prevailing conditions of local interference.

The two horizontal limbs A, A1 (which may be of unequal length) are connected to a flex or similar two-wire down lead D, which terminates in a balanced transformer T. One coil of the transformer is in series with each wire, and the coils are reversely wound and tightly coupled. When the aerial is acting as a dipole, the signal currents flow in opposite directions through the down-lead wires, and in series through the transformer windings, as shown by the full-line

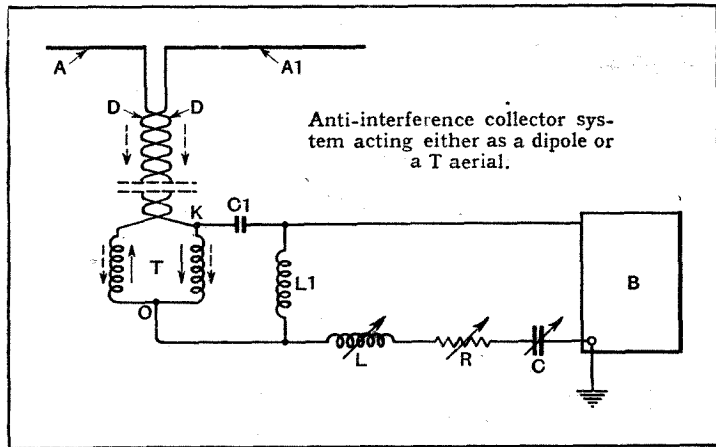

Anti-interference collector system acting either as a dipole or a T aerial.

arrow. Signal voltage is tapped off across the points K and O to the receiver B.

Any local interference picked up by the down-lead will flow down the flex in the same direction, as shown by the dotted-line arrows, and is therefore balanced-out across the points K, O. If there is any residual disturbance, it can be nullified by adjusting the impedances L, R, C. In a simpler form of aerial the condensers C, C1 and inductances L, L1 are omitted.

When the resistance R is cut out, the aerial acts as a true dipole, but if R is given a value of, say, 1,000 ohms, the limbs A, A1 will then act as an elevated capacity or T aerial and give a wider frequency response.

E. V. Amy and J. G. Aceves. Application date February 26th, 1937. No. 491220.

o o o o

CATHODES FOR CR TUBES

TO assist in producing a well-defined stream the emissive material of the cathode is usually pressed into a small round recess formed at the top of the indirectly heated element. It is found, however, that the pressing of the sensitive oxide material into the nickel support limits the "optical cathode" to a diameter of half a millimetre. Beyond that size the oxide tends to "warp," and to get so brittle that it begins to disintegrate and fall away. In this condition it produces only a frac-

tion of the calculated emission, owing in part to the high internal or "transverse" resistance of the broken oxide.

According to the invention these difficulties are overcome by first filling the recess with the sensitive oxide, and then holding the latter in place by a pair of fine nickel wires, about 50 microns thick. These are stretched across the top of the recess, at right-angles to each other, and then anchored to a pair of lugs at the base of the nickel holder. The wires are laid in electrical contact with the oxide,

and besides holding the material together, serve to stabilise its internal resistance.

Radio-Akt. D. S. Loewe. Convention date (Germany) March 12th, 1936. No. 491874.

o o o o

TIME-BASE CIRCUITS

A KNOWN method of transmitting synchronising pulses for television is by periodically interrupting the carrier wave as shown at T, in the left hand diagram, where the "black" datum line is indicated by the dotted line

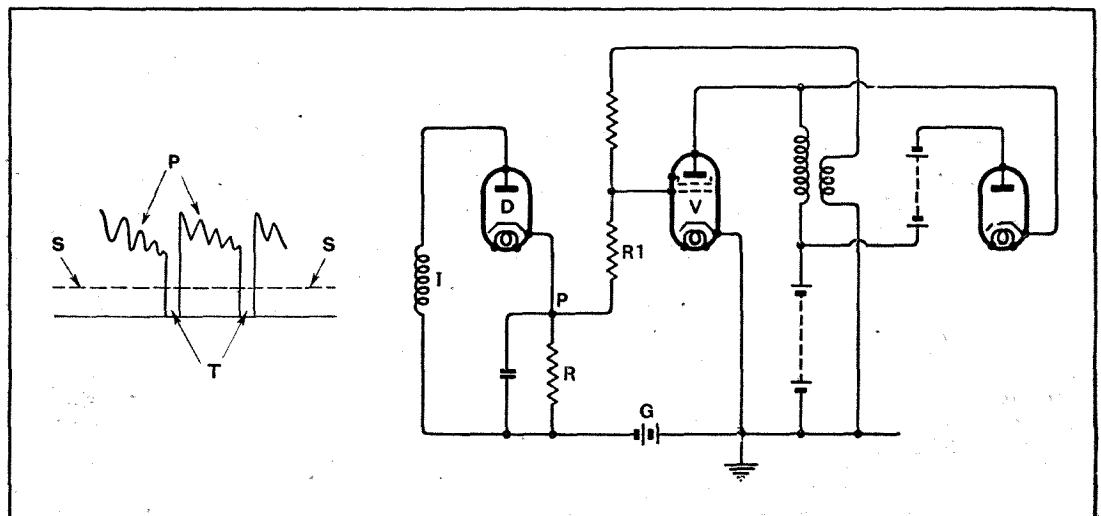

Isolating time-base circuits from the disturbing effects of incoming signals.

Brief descriptions of the more interesting radio devices and improvements issued as patents will be included in this section.

RECEIVING WIRELESS "ECHOES"

IT is possible to estimate distances, such as the height of an aeroplane above ground, by measuring the time taken for a pulse of energy radiated from the machine to get back after reflection from the ground. In such "echo" systems both the transmitting and receiving aerials are necessarily located close together, on the same machine, and the problem is to decouple the two so that whilst the receiving aerial is

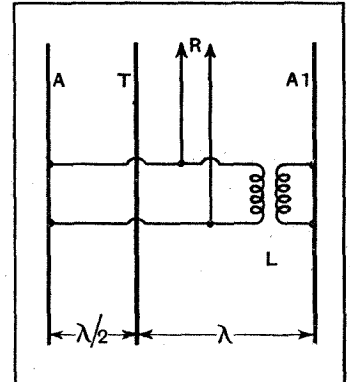

Isolating transmitting and receiving aerials in an echo altimeter device.

S, and the picture signals by P. The object of the invention is to prevent the increasing grid voltage produced by the rising picture-signals from affecting the proper operation of the saw-toothed oscillation-generator in the time-base circuit. For this purpose the signals are applied at I to the detector D in such a way that the rectified currents create a positive potential at the upper point P of the resistance R, this potential being opposed to one derived from a bias battery G, so that on the arrival of a synchronising impulse the back-coupled valve V is triggered into oscillation.

The connection from P to the grid of the valve V includes a resistance R1 which serves to "drop" any excessive positive bias developed during the picture-signal period, and so keeps the grid current flow in the valve V within desirable limits.

Telefunken Ges. für drahtlose Telegraphie mbh. Convention date (Germany) February 20th, 1936. No. 490760.

o o o o

CATHODE-RAY TUBES

THE whole of the electron-optical "lens" system, used to focus the electron stream inside a cathode-ray tube, is made as a single unit from a suitably shaped piece of insulating material. This is fitted in one operation to the glass stem of the tube, the parts of the lens structure which are to carry the biasing-voltages being metallised, either by spraying or by a plating process.

The inventor aims to simplify the construction and assembly of the electrode system, and so reduce the cost of manufacture of a cathode-ray tube.

E. Michaelis. Convention date (Germany) August 28th, 1936. No. 491050.

not affected by the outgoing waves it does respond to the "echo."

The diagram shows how this is done. The receiving aerial is divided into two parts A, A1 which are arranged on opposite sides of the transmitting aerial T, one half a wavelength and the other a full wavelength away. The outgoing energy will then induce phase-opposed voltages in the two parts A, A1, which mutually cancel in the receiver R, any difference in amplitude being balanced out by a transformer in the Lecher-wire coupling L. In the interval between successive pulses, the receiving aerial picks up the waves reflected back from the ground.

Siemens Apparate und Maschinen G.M.B.H. Convention date (Germany) July 27th, 1936. No. 491999.



Components of Merit



ALUMINIUM VALVE SHIELD.

For octal valves. Fits No. 1120 Eddystone valveholder. No. 1121 .. 1/3d.



FLEXIBLE DRIVING SHAFT.

For front panel control of awkwardly placed components. Drives through 90 degrees perfectly. Cable length 5 3/8 in. No. 1096 .. 3/6d.



INSULATED BRACKET

DL9 insulation and brass base. Fixing centre, height 1 3/8 in. No. 1116 .. 1/3d.

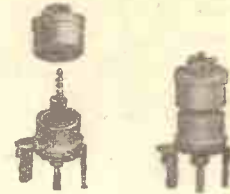

S.W. AIR TRIMMER.

A compact trimmer condenser with capacity variation of 1-30 mmfd. Finely graded control and constant setting. No. 1100, 1/3d.

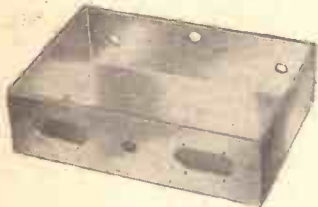

DIECAST ALUMINIUM CHASSIS.

Strong and rigid construction. Measures 8 1/2 in. x 5 3/4 in. x 2 3/8 in. deep. Two terminal panels provided. No. 1117 .. 5/6d. Undrilled metal panel, No. 1118 1/9d.



CONDENSER CRADLE.

Enables three microcondensers to be mounted as three gang condenser unit. Rotors and stators completely isolated. Brass division plates available for screening condenser units. No. 1114, 3/6d. Metal screens, No. 1125, 8d. pair.



BEAT FREQUENCY OSCILLATOR UNIT.

For 450/470 Kc/s. Aluminium can measures 2 3/8 in. high by 1 3/8 in. square. For use with 6J7 valve. No. 1119 .. 8/6d.

Write for illustrated 1939 Catalogue—
Free on request.

EDDYSTONE

Sole Manufacturers: Stratton & Co. Ltd.
Bromsgrove St., Birmingham.
London Service: Webbs, 14 Soho St., W.1



Speaker for the MAN who KNOWS

Exceptional strength of magnetic flux ensures complete freedom from "Boom" in bass. Extreme sensitivity, in direct comparison, 4 db. up on other speakers. Response curve shows maintained response level well into region of 10,000 c.p.s.

TELEFUNKEN PICK-UP "TO-1001"

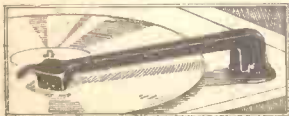

Permanent sapphire needle. Level response from 40 to 10,000 cycles. Weight of pick-up on record less than 1oz. Price £5.5.0
Matching transformer, £1.6.0.
Tone control unit, incorporating transformer, £4.4.0

SPEECH COIL IMPEDANCE 10 ohms @ 400 c.p.s.
SPEECH COIL DIAMETER - 2 inches.
SPEECH COIL TOTAL GAP CLEARANCE - - - - - 0.16 inch.
SPEECH COIL POWER HANDLING CAPACITY 20 watts, average.
MAGNETIC FLUX DENSITY 17,000 lines/sq. om.
TOTAL MAGNETIC FLUX- 260,000 lines.
FIELD COIL DISSIPATION - 40 watts.
DIAMETER OF DIAPHRAGM 16 inches.
TOTAL WEIGHT OF SPEAKER - - - - - 44 lbs.
FINISH : Cadmium plate and grey cellulose.
PRICES : Unit only, £8.14.0.
Rectifier Unit for 200-250 v. A.C. Mains, £2.12.6.



20,000 ohms per volt.

The HIGH RESISTANCE Avo MINOR

Regd. Trade Mark
ELECTRICAL MEASURING INSTRUMENT

CURRENT	
0- 50 microamps	0-250 microamps
VOLTAGE	
0- 2.5 volts	0- 10 volts
0- 50 volts	0- 100 volts
0-250 volts	0-1000 volts
RESISTANCE	
0- 5 megohms (with 10 V applied)	
0-50 megohms (with 100 V applied)	

(Adjustment provided for incorrect voltages)

An extremely sensitive D.C. moving-coil microammeter also calibrated as a multi-range voltmeter and megohmmeter. As a voltmeter its six ranges are all at 20,000 ohms per volt, the consumption at full scale deflection being 50 microamps. This extreme sensitivity permits precision readings with negligible loading on the circuit under test, and thus is eminently suitable for measuring grid, screen and anode voltages, and also for television. On the lower of its two current ranges, a deflection of approximately 1 mm. is produced by a current of 1 microamp, allowing accurate readings of grid current, etc. For resistance readings an external voltage is necessary, but adjustment is provided for incorrect voltage values.

Complete in case with special high-voltage leads, interchangeable crocodile clips and testing prods; and instruction booklet .. £3:10s.

Deferred Terms if desired.

BRITISH MADE.

Sole Proprietors and Manufacturers:
The AUTOMATIC COIL WINDER & ELECTRICAL EQUIPMENT CO., LTD.
Winder House, Douglas Street, London, S.W.1. Phone: Victoria 3404-7.

WRITE FOR FULL DETAILS.

Pamphonic

(Associated with P.Y. Ltd.)
Reproducers Limited
45, ST. PANCRAS WAY, LONDON, N.W.1. (Phone: EUSton 1727.)

Mention of "The Wireless World," when writing to advertisers, will ensure prompt attention.

MISCELLANEOUS ADVERTISEMENTS

NOTICES

THE CHARGE FOR ADVERTISEMENTS in these columns is

12 words or less, 3/- and 3d. for every additional word.

Each paragraph is charged separately and name and address must be counted.

SERIES DISCOUNTS are allowed to Trade Advertisers as follows on orders for consecutive insertions, provided a contract is placed in advance, and in the absence of fresh instructions the entire "copy" is repeated from the previous issue: 13 consecutive insertions 5%; 26 consecutive, 10%; 52 consecutive, 15%.

ADVERTISEMENTS for these columns are accepted up to **FIRST POST** on **MONDAY MORNING** (previous to date of issue) at the Head Offices of "The Wireless World," Dorset House, Stamford Street, London, S.E.1, or on **SATURDAY MORNING** at the Branch Offices, 8-10, Corporation Street, Coventry; Guildhall Buildings, Navigation Street, Birmingham, 2; 280, Deansgate, Manchester, 3; 26a, Renfield Street, Glasgow, C.2.

Advertisements that arrive too late for a particular issue will automatically be inserted in the following issue unless accompanied by instructions to the contrary. All advertisements in this section must be strictly prepaid.

The proprietors retain the right to refuse or withdraw advertisements at their discretion.

Postal Orders and Cheques sent in payment for advertisements should be made payable to **LILIFFE & SONS Ltd.**, and crossed **& Co.** Notes being untraceable if lost in transit should not be sent as remittances.

All letters relating to advertisements should quote the number which is printed at the end of each advertisement and the date of the issue in which it appeared.

The proprietors are not responsible for clerical or printers' errors, although every care is taken to avoid mistakes.

IMPORTANT NOTICE

Owing to the Christmas Holidays, next week's issue of "THE WIRELESS WORLD" (dated December 29th) has gone to press earlier than usual.

In accordance with the notice that appeared last week, only those Miscellaneous Advertisements which have already been received can be inserted in next week's issue.

NEW RECEIVERS AND AMPLIFIERS

ROYAL RADIO Co., Established 1908.

5-VALVE All-Mains Receivers, from £2/15; car radio, from £4/15; send 1/6d. stamp for catalogue.—Royal Radio Co., 5, Buckingham Rd., London, E.18. [7742]

SPARTON, Vidor, Ever Ready, Ambassador, Ferguson, Pilot; trade only.—Perseus Radio, Burton-on-Trent. [7594]

ALBA, Ferguson, Portadyne, Halcyon, Ever-Ready, Sparton-Spencer and other first class makes; wholesale only (write for lists).—Leonard Heys, 36, Henry St., Blackpool. [0610]

ARMSTRONG Company Have Nine New Radio Chassis of Outstanding Merit, from the press-button model at £7/18/6, to the large variable selectivity model at £17/17.

ARMSTRONG Manufacture a Range of High Fidelity L.F. Amplifiers and Radio Feeder Units; models include 6- and 12-watt output units, using P.X.4 and P.X.25s in push-pull respectively, with two stages of push-pull preceding; frequency response from 20-20,000 cycles. The 6-watt unit costs £9/9 and the 12-watt model £12/12; both of these units have current available to supply feeder unit.

ARMSTRONG Amplifiers Radio Feeder Units Include a Local Station Receiver, designed to give the widest possible frequency response, circuit consisting of a H.F. stage coupled to a linear law detector; this unit costs 3 gns. Full technical details are available free on request.

ARMSTRONG Co., 100, St. Pancras Way (formerly King's Rd.), Camden Town, N.W.1. [7410]

DEGALLIER'S Ltd. wish to convey their thanks and Seasonal Greetings to their many customers, past and present, whose support has enabled them to continue to supply the finest receivers made. [7790]

MCCARTHY

The Chassis Specialists

**THE MOST AMBITIOUS
BRITISH RECEIVER OF THE
YEAR
Model PP.1939.**

Built according to the most advanced theoretical practice, it combines the full specification of the large American receiver with the additional requirements of the British listener.

A Pentode RF stage, Hexode Mixer, and Triode Oscillator working under a new system of valve operation, proportionate AVC, copper-tube SW coils, air-spaced trimmers, low-loss insulation, and accurate alignment, all combine to give fractional microvolt sensitivity on all bands.

Four efficient IF transformers and two Hexode IF amplifiers with a valve-controlled shunt give progressively variable selectivity from 4.5 to 20 Kc., without peaking of the upper register, whilst, in the interests of signal-to-noise ratio, the gain of these stages is also variable.

The amplifier is of the direct-coupled push-pull variety with degeneration by negative feed-back, giving a substantially straight line response from 25 to 15,000 cycles and an output of 15 watts at two per cent. harmonic distortion.

The audio unit has been made as versatile as possible to suit the varied types of reception and the individual taste of the listener. To fulfil this purpose, such refinements as carrier-controlled volume-expansion, high and low-note tone control, inter-station-noise-suppression, and CW Beat Oscillator have been incorporated. Price 32 Gns. Loudspeaker equipment extra.

The two chassis, receiver and amplifier are of the most robust construction, and each instrument is laboratory tested after leaving the factory.

Here is the remainder of the 1939 range of McCarthy Chassis—truly all-wave—even the smallest, with continuous coverage from 13 to 550 metres.

RS639. 8 stages, 6 valves, 4 wavebands, for AC Mains £9 0 0

RS639U. As above, for AC/DC Mains.

RS739. 9 stages, 7 valves, 4 wavebands, for AC Mains £10 17 6

RS739U. As above, for AC/DC Mains.

PP739. 9 stages, 7 valves, 4 wavebands, push-pull output, providing 10 watts undistorted, AC £11 11 0

PP939. 11 stages, 9 valves, 4 wavebands, push-pull output, providing 12 watts undistorted. Noise suppression, variable selectivity, non-drift, IF transformers, permeability tuned. Wave range 10-2,200 metres, AC £14 14 0

PP939U. As above, for AC/DC Mains.

All McCarthy apparatus available on 7 days' approval against cash.

Hire purchase readily available.

For illustrated descriptive literature send 3d. in stamps. Abridged list free of charge.

All enquiries to be addressed to the sole manufacturers and distributors:

H. MCCARTHY LTD.
92, QUEENSWAY, BAYSWATER,
LONDON, W.2

Telephone: Bayswater 1102

NUMBERED ADDRESSES

For the convenience of private advertisers, letters may be addressed to numbers at "The Wireless World" Office. When this is desired, the sum of 6d. to defray the cost of registration and to cover postage on replies must be added to the advertisement charge, which must include the words Box 000, c/o "The Wireless World." All replies should be addressed to the Box number shown in the advertisement, c/o "The Wireless World," Dorset House, Stamford Street, London, S.E.1. Readers who reply to Box No. advertisements are warned against sending remittance through the post except in registered envelopes: in all such cases the use of the Deposit System is recommended, and the envelope should be clearly marked "Deposit Department."

DEPOSIT SYSTEM

Readers who hesitate to send money to advertisers in these columns may deal in perfect safety by availing themselves of our Deposit System. If the money be deposited with "The Wireless World," both parties are advised of its receipt.

The time allowed for decision is three days, counting from receipt of goods, after which period, if buyer decides not to retain goods, they must be returned to sender. If a sale is effected, buyer instructs us to remit amount to seller, but if not, seller instructs us to return amount to depositor. Carriage is paid by the buyer, but in the event of no sale, and subject to there being no different arrangement between buyer and seller, each pays carriage one way. The seller takes the risk of loss or damage in transit, for which we take no responsibility. For all transactions up to £10, a deposit fee of 1/- is charged; on transactions over £10 and under £50, the fee is 2/6; over £50, 5/-. All deposit matters are dealt with at Dorset House, Stamford Street, London, S.E.1, and cheques and money orders should be made payable to Liliff & Sons Limited.

SPECIAL NOTE.—Readers who reply to advertisements and receive no answer to their enquiries are requested to regard the silence as an indication that the goods advertised have already been disposed of. Advertisers often receive so many enquiries that it is quite impossible to reply to each one by post. When sending remittances direct to an advertiser, stamp for return should also be included for use in the event of the application proving unsuccessful.

RECEIVERS AND AMPLIFIERS

CLEARANCE, SURPLUS, ETC.

ANDERSON.

ALL-WAVE 5-valve Superhet. Chassis With Mazda Valves for A.C. Mains, separate power pack, 19.50 200-550, 800-2,000 metres, 465 k.c.s, energised speaker, limited quantity only, fully guaranteed; bargain price 75/-; also by supplied with Universal chassis, 75/-; above sets can be supplied in cabinets 10/- extra; no lists, stamp for all enquiries.

J. F. ANDERSON, 54, Wadham Avenue, Walthamstow, E.17. Larkwood 1574. [7678]

BANKRUPT Stock.—Brand new 1938 radio sets in makers' cartons with guarantees at less than half retail prices; send 1/6d. stamp for list bargains.—261-3, Lichfield Rd., Aston, Birmingham. [7687]

BATTERY CHARGING PLANT

LIMITED Number Reconditioned Second-hand Valve and Metal Rectifiers for Disposal.—British Rectifiers Engineering Company, Vernon Place, Cheltenham. [7669]

PUBLIC ADDRESS

V

VORTEXION P.A. Equipment.

IMITATED, but unequalled.

WE Invite You to a Demonstration.

8-10-WATT Dance Band Amplifier for A.C.-D.C.; complete in case with moving-coil microphone and speaker; £12/12.

15-20-WATT Amplifier (distortionless 14.7 watts) output, 30-18,000 cycles, independent mike and gram, inputs and controls, 0-57 volts required to full load, output for 4, 7.5 and 15 ohms speakers or to specification, inaudible hum level; 12-volt car battery and A.C. mains model, 12 gns.; A.C. only model, 8 1/2 gns., complete, as tested by "The Wireless World."

VENTILATED Steel Cases for Above; 12/6.

15-20 Watts Portable Amplifier, in case, with Collaro motor and Rothermel Piezo pick-up; £14.

35-40-WATT Output, 616's in negative feed back electronic mixing of mike and P.U. tone control, large output transformer; complete; £15.

ABOVE Model, complete in case with turntable, Piezo pick-up and microphone transformer; £20.

20-WATT Heavy Duty High Fidelity Model, as fitted to cinemas, dance halls, etc.; £15.

60-WATT Model, with negative feed back; £25, complete.

120-WATT Model, with negative feed back; £40, complete.

250-VOLT 250 m.a. Full Wave Speaker, field supply unit; 25/-, with valve.

ALL P.A. Accessories in Stock.

VORTEXION, Ltd., 182, The Broadway, Wimbledon, S.W.19. Phone: Lib. 2814. [7572]

PUBLIC ADDRESS

"**PARTRIDGE P.A. Manual**," free to trade, from N. Partridge, B.Sc., A.I.M.E.E., King's Buildings, Dean Stanley St., London, S.W.1. [0605]

ALEXANDER BLACK, Ltd., pioneers of hiring microphone amplifying equipment since 1938. Booklet on request.—55, Ebury St., S.W.1. Sloane 6129. [0598]

CAR RADIO

CAR Roof Aerials, improved type, chromium plated, 17/6 complete; vertical telescopic type, 12/6; American undercar aerials, single dipole, 9/6; De Luxe twins, rubber covered, 20/- pair; carriage paid.

WIRELESS SUPPLIES UNLIMITED, Essex House, Stratford, E.15. Maryland 3191. [0577]

IF You Own a Car Radio, it is bound to "go wrong" some time; be a good friend to it and get it repaired quickly, and at reasonable cost; all makes overhauled; free quotations.—Scott-Sessions Co., Car Radio Department, Exchange Works, Muswell Hill, N.10. Tudor 4101-2. [7498]

USED SETS FOR SALE

H.M.V.

H.M.V. 10-valve Radiogram, auto R.C., cost 70 gns., £12.—C. H. Brundle, "Ely Lodge," St. Faith's Rd., Dulwich. [7777]

MURPHY

MURPHY A40C 14-valve Console, cost £35; will sell for £20.—Comer, 15, Cloudesley Square, Barnsbury, N.1. [7875]

MISCELLANEOUS

ANY Offers? Kilomag Four (battery), Music Lover's battery set, original single span (A.C.), mostly complete; or would give to approved charity.—J. D. Davies, Lyth Hill, Shrewsbury. [7769]

EXCHANGE OR WANTED

W.W. "Straight Six," complete receiver or kit of parts, undamaged, cheap.—Johnson, 256, Alwoodley Lane, Leeds. [7786]

NEW MAINS EQUIPMENT

V.A.L.L. Transformers at Last Week's Prices.

VORTEXION, Ltd., 182, The Broadway, Wimbledon, S.W.19. Phone: Lib. 2814. [7792]

TANTALUM for A.C. Chargers, H.T. and L.T.—Blackwell's Metallurgical Works, Ltd., Garston, Liverpool. [7263]

CABINETS

A CABINET for Every Radio Purpose.

CONVERT Your Set into a Radiogram at Minimum Cost; surplus cabinets from noted makers under cost of manufacture (undrilled), 30/- upwards; motors at wholesale price.

"FIT-A-GRAM" Cabinet, 31x17x15; 21/-.

UNDRILLED Table, console and loud-speaker cabinets from 3/6.

INSPECTION invited, photos loaned to country customers.

H.L. SMITH and Co., Ltd., 289, Edgware Rd., W.2. Tel.: Pad. 5891. [0485]

DYNAMOS, MOTORS, ETC.

A.O. and D.C. Electrical Equipment Repair Specialists.—Esaco, 18w, Brixton Rd., S.W.9. [0558]

ALL Types of Rotary Converters, electric motors, battery chargers, petrol electric generator sets, etc., in stock, new and second-hand.

A.C./D.C. Conversion Units for Operating D.C. Receivers from A.C. Mains, 100 watts output, £2/10; 150 watts output, £3/10.

WARD, 46, Farringdon St., London, E.C.4. Tel.: Holborn 9703. [0518]

ELECTRIC Dry Shavers, A.C./D.C., 200/50 volts, "Minute Man," list price £2/10; our price £1/10, complete with leatherette case, one year's guarantee; send for details; trade supplied.

HENRY'S, 72, Wellington Av., Stamford Hill, N.15. Sta. 2907. [7708]

RECORDING EQUIPMENT

ALL Recording Discs and Materials in Stock; tracker units, £4/7/6; recording motors, £3/17/6.—Write for further details, Will Day, Ltd., 19, Lisle St., W.C.2. [0595]

PARMEKO Recording Plant, Piezo GZSZP microphone, cost £175, perfect; accept £75.—Box 8278, c/o The Wireless World. [7779]

RECORDER, Dennis Parish, list £14/10, complete, 15 ohm head, 12-in. turntable; heavy duty motor, unused; £10, or offer.—Kemp, 62, Wembley Park Drive, Wembley. [7772]

NEW LOUD-SPEAKERS

BAKER'S SELHURST RADIO.—New super quality speaker, £20; write for latest leaflet; music lovers requiring realistic reproduction at low cost can obtain the following brand new surplus speakers at half usual prices.

35/- Only, usual price £5.—Super power permanent magnet speaker with Alni magnet, fitted with latest triple cone comprising mancurved cone and dual Bakelite and duralumin cones combined, giving wide and even frequency response resulting in quality reproduction of speech and music; with multi-ratio output transformer, 39/6.

55/-, list £6.—Super power electro magnet speaker with triple cone as above, 1,000, 1,250, 1,500, 2,000 or 2,500 ohms field coil as required, this famous speaker was solely specified for the "Wireless World" Quality Straight Four receiver; with universal transformer, 59/6.

SURPLUS Speakers, cash with order or c.o.d.—Order now from Baker's Selhurst Radio, the Pioneer Manufacturers of Moving Coil Speakers, 1925-1938, 75, Sussex Rd., South Croydon. [7581]

PREMIER

1938-1939

RADIO

VALVES

AMERICAN VALVES. We hold the largest stocks of U.S.A. tubes in this country and are sole British Distributors for TRIAD High-grade American Valves. All types in stock. Standard types, 5/6 each. All the new Metal-Class Octal Base tubes at 6/6 each, 210 and 250, 8/6 each.

EUROPA MAINS VALVES, 4 v. A.C. Types, A.C./H.L. A.C./L., A.C./S.G., A.C./V.M.S.G., A.C./H.P., A.C./V.H.P., A.C./P., and 1 watt D.H. Pentodes, all 4/6 each. A.C./Pens., I.H., 5/6; A.C./P.X.4, 6/6; Oct. Freq. Chargers, 8/6; Double Diode Triodes, 7/6; Triode H. ex. Freq. Ch., 8/6; Tri. Grid Pen., 10/6; 3½-watt D.H. Triode, 7/6. 350 v. and 500 v. F.W. Rect., 5/6. 13 v. 2 amps. Gen. Purpose Triodes, 5/6; H.F. Pens. and Var.-Mu. H.F. Pens., Double Diode Triodes, Oct. Freq. Chargers, 7/6 each. Full-wave and Half-wave Rectifiers, 5/9 each.

Premier Short-Wave Kits

Complete to the last detail including all Valves and coils, as well as theoretical and wiring diagrams and lucid instructions for building and working. Each Kit is supplied with a steel Chassis and Panel and uses plug-in coils to tune from 13 to 170 metres.

1 Valve Short-Wave Receiver or Adaptor Kit	17/6
1 Valve Short-Wave Superhet Converter Kit	20/-
1 Valve Short-Wave A.C. Superhet Converter Kit	22/6
2 Valve Short-Wave Receiver Kit	25/-
3 Valve Short-Wave Screen Grid and Pentode Kit	58/6

PREMIER BATTERY CHARGERS. Westinghouse Rectification. Complete. Ready for use. To charge 2 volts at 1 amp., 10/-; 6 volts at 1 amp., 16/6; 6 volts at 2 amps., 19/6; 12 volts at 1 amp., 21/-; 6 volts at 2 amps., 32/6.

PREMIER 1939 HIGH FIDELITY AMPLIFIERS

A NEW COMPLETE RANGE OF 7 HIGH FIDELITY PA AMPLIFIERS FOR A.C. OR A.C./D.C. MAINS OPERATION.

With the exception of the 3-watt models, all Premier Amplifiers incorporate the new Premier Matchmaker Output Transformer, enabling any single or combination of speakers to be used. 6-, 8/10-, and 15-watt systems are provided with two separate input channels which can be mixed to any level. The 30- and 60-watt systems have 3 input channels. The built-in Pre-Amplifiers ensure that the gain is sufficient for any low-level crystal or velocity microphone. The actual gain of the 6-, 15-, 30- and 60-watt amplifiers is over 100 decibels. Tone controls are also incorporated.

	Kit of Parts with Valves.	Completely Wired and Tested.
3-watt A.C. Amplifier	£2 0 0	£2 15 0
3-watt A.C./D.C. "	£2 0 0	£2 15 0
6-watt A.C. "	£5 5 0	£6 0 0
8-10-watt A.C./D.C. "	£4 10 0	£5 5 0
15-watt A.C. "	£5 15 0	£7 0 0

Black Crackle Steel Cabinet 15/- extra.
30-60-watt A.C. Amplifiers or Modulators, completely wired and tested, in Black Crackle steel case. Power Pack in separate case to match. 30-watt, £12/12/- complete; 60-watt, £15/15/- complete.

MOVING COIL SPEAKERS. Magnavox 8in. P.M.s with Output Transformer, 10/6. Magnavox 8in. Energised, 2,500 ohm field with Transformer, 9/11. Rola 8in. P.M. with Transformer, 15/-. Rola 10in. P.M., 19/11. B.T.H. 10in. Energised L.S., 1,650 ohm field, less Transformer 9/11. Rola G-12 12in. High-Fidelity Speakers with Output Transformer, Energised, 1,250 or 2,500 ohm field, 59/6. P.M. model, 79/6. Premier Transverse Current Microphone, 20/-. Microphone Transformer, 6/-.

ELECTRIC GRAMO. MOTORS

COLLARO A.C. 37 MOTOR, 100-250 v. A.C., 12in. table and unit plate auto stop and start, 30/-.

COLLARO GRAMO. UNIT, comprising A.C. 37 motor, pick-up and vol. control, 45/-.

COLLARO U38 MOTOR, for A.C. or D.C., 100-250 v., 12in. table, auto stop and start, 45/-.

UTILITY Micro Cursor Dials, Direct and 100-1 Ratios, 3/9.

PREMIER Short-Wave Condensers, all-brass construction with Trolitol insulation. 15 mmf., 1/6; 25 mmf., 1/7; 40 mmf., 1/9; 100 mmf., 2/-; 100 mmf., 2/3; 250 mmf., 2/6.

PREMIER S.W. H.F. Chokes, 10-100 metres, 9d. each. Pie-wound, 1/6 each. Screened, 1/6 each.

SHORT-WAVE COILS, 4- and 6-pin types, 13-26, 22-47, 41-94, 78-170 metres, 1/9 each, with circuit. Special set of S.W. Coils, 14-150 metres, 4/- set, with circuit. Premier 3-band S.W. coil, 11-25, 19-43, 38-86 metres. Suitable any type circuit, 2/6.

COIL FORMERS; 4- or 6-pin low-loss, 1/- each.

Have you had our 1938 Catalogue, Handbook and Valve Manual? 90 pages of Radio Bargains and Interesting Data. Price 6d.

ALL POST ORDERS TO: Jubilee Works, 167, Lower Clapton Road, London, E.5. Amherst 4723.
CALLERS to:—Jubilee Works, or 165, Fleet Street, E.C.4. Central 2833, or 50, High Street, Clapham, S.W.4. Macaulay 2361.

LOUD-SPEAKERS

SECOND-HAND, CLEARANCE, SURPLUS, ETC.

V.AUXHALL.—Rola G12 P.M. speakers, 62/6; Rola G12, energised, 50/-; with transformers, all brand new.

V.AUXHALL UTILITIES, 163a, Strand, W.C.2. Over Denny's the Booksellers. Send for free list. [0603]

G.12 Rolas, brand new; P.M., 59/6; energised, 47/6; Rola 8in., energised, 6/11.—Shippers, 18, Corporation St., Manchester. [0606]

3,000 Speakers from 5/6 each, P.M. and energised 4in. to 14 in. including several Epoch 18in. —Sinclair Speakers, Alma Grove, Copenhagen St., N.1. [0590]

LOUD-SPEAKER CONVERSIONS

SINCLAIR SPEAKERS.—For conversions of all makes and types; advice given.—Alma Grove, Copenhagen St., N.1. [0593]

BAKER Conversions.—Whether your moving coil speaker has a permanent or electro-magnet and no matter what type or make you possess, you can considerably improve frequency response and quality of reproduction by having a triple cone assembly fitted, which comprises main curved cone and dual bakelite and duralumin cones combined, mounted in a 12in. die-cast aluminium frame. The price is 29/6 complete, including free fitting at our works.

BAKER'S SELHURST RADIO, 75-77, Sussex Rd., South Croydon. [7582]

TRANSMITTING APPARATUS

GET Our Quotation First for Your Transmitter; specify your requirements as accurately as possible; lowest prices, best workmanship, first grade components.

RADIOGRAPHIC, Ltd., 66, Osborne St., Glasgow, C.1. Telephone: Bell 848. [7778]

G5N1.—The recognised distributors for amateur equipment, National R.M.E., Thordarson, Hammarlund, McMurdo, Hallicrafters, etc.; send 1/4d. stamp for catalogue.—G5N1 (Birmingham), Ltd., 44, Holloway Head, Birmingham. [0531]

A.C.S. RADIO specialists in short-wave apparatus; communication receivers, including Hallicrafters, National and R.M.E. transmitting equipment, valves and components.—Send for free catalogue to A.C.S. Radio, 16, Gray's Inn Rd., W.C.1. Holborn 9894-5. G2NK, Technical Manager. [0550]

VALVES

ANDERSON.

ALL Types of American Valves, first grade only, Ken., Rad., Philco, Hytron, Raytheon, all tubes fully guaranteed, 5/- each; also line cords, resistances and electrolytic condensers for replacements. Stamp with all enquiries.

ANDERSON, 34, Wadham Avenue, Walthamstow, E.17. Larkwood 1574. [7291]

ALL Types of American Tubes in Stock of Impex and Areturus makes, at competitive prices.

WE Can Also Supply a Full Range of Guaranteed Replacement Valves for Any British, non-ring, American or Continental type at an appreciably lower price.

SEND for Lists of These, and also electrolytic condensers, line cords, resistances, etc.

CHAS. F. WARD, 46, Farringdon St., London, E.C.4. Tel.: Holborn 9703. [0452]

RAYTHEON, Iliac, Tungram, Trioiron; wholesale only.—Leonard Heys, 36, Henry St., Blackpool. [0609]

FULL Range Guaranteed American Valves, send for complete lists.—Cosmic Radio Services, Ltd., 23, Water St., Liverpool. [7445]

AMERICAN Valves, first grade, in all types; trade supplied.—Metropolitan Radio Service Co., 1021, Finchley Rd., N.W.11. Speedwell 3000. [0436]

2/9, American R.C.A.; popular types; guaranteed; 2,000 non-ring British; also National Union from less 50%; new lists free.—Shippers, 18, Corporation St., Manchester. [0607]

METERS, ETC.

A.V.O., Hunts, Triplett, Weston, Wearite, etc.; wholesale only.—Leonard Heys, 36, Henry St., Blackpool. [0608]

NEW COMPONENTS

ANGLO-AMERICAN RADIO (and MOTORS), Ltd.

MEISSNER 1939 Products.
JUST Arrived.

49/6—New 8-button push-button tuner can be affixed to any superhet or T.R.F. receiver, any make, 2 or 3-gang mains or battery, only three wires to connect to top of gang condensers; the best push-button tuner the United States have produced; order now for immediate delivery; full instructions in each carton; ten minutes to fix.

£12/10—Meissner signal shifter is completely assembled, wired and adjusted with one set of coils and has its own power supply, three provision switch providing "automatic stand-by," "continuous operation" and "manual stand-by"; in fact, makes your QSO's 100%.

£10/17/6—All-wave tuning unit.

THE Meissner All-wave Tuning Assembly is the Complete Heart of the Receiver, consisting of 5 band coil and switch assembly, 6.8 to 2.140 metres, individual coils for each band, low loss bakelite forms, align-airo trimmers, 6-gang shorting switch, Meissner quality precision 3-gang variable tuning condenser, illuminated oblong dial, fully calibrated 5-band scale, completely mounted on rigid crackled steel chassis, all components carefully mounted and including all resistors, by-pass condensers, coupling condensers and A.V.C. network associated with the R.F. mixer and oscillator circuits; every unit completely aligned and padded and laboratory tested; 2d. stamp brings complete illustrated lists of Meissner products by return post from sole distributing agents of Meissner Manufacturing Company of U.S.A.

ANGLO-AMERICAN RADIO (and MOTORS), Ltd. (Dept. D/19), Albion House, New Oxford St., London, W.C.1. [7643]

COMPONENTS

SECOND-HAND, CLEARANCE, SURPLUS, ETC.

R
R
R
AD
IO
C
L
E
A
R
C
E
A
N
C
E
ANCE, Ltd.
63 High Holborn, W.C.1. Holborn 4631.

ANOTHER Spectacular Purchase.

BRITISH Belmont 8-valve Plus Magic Eye All-wave A.C. Superhet Chassis, 4 wave bands, two short, medium and long, fitted latest Mullard Octal base American type valves; brief specification: Short wave, 6-18 metres (covers television sound), short wave 2, 18-50 metres, medium band, 200-550 metres, long wave band, 500-2,000 metres; valve combination, 6K7, Pre H.F., 6I7 oscillator, 6J7 mixer, 6K7 I.F., 6Q7 (D.D.T.), detection, A.V.C. and first L.F., two 6E6s parallel output, 5Y3 rectifier, plus 6G5 Magic Eye visual tuning; handsome dial, station names etched on glass; controls: 2-speed tuning, volume and on-off, combined variable tone control and selectivity switch, wave change plus gramophone switch; size of chassis: 13 1/2 in. x 10 in. x 3 in., supplied complete with valves, escutcheon, knobs and chassis bolts, but less speaker; £5/19/6; complete receiver in handsome walnut cabinet, details as above; £7/7 each.

ALL-WAVE Tuning Pack.

6 WAVE Bands, with Pre H.F. stage, product of a well-known manufacturer; tuning range: Short wave 1. television sound; short wave 2, 12 1/2 to 25 metres; short wave 3, 25-50 metres; short wave 4, 50-100 metres; medium wave, 190-550 metres; long wave band, 900-2,000 metres; intermediate frequency of I.F. stage 465 k/c; valve combination; I.F. VP4B, frequency changer TH4, or TH4A, or alternatively direct equivalents; supplied as tuning pack, only less valves, I.F.s and gang; £2/15 each.

PLESSEY 465 I.F. Transformer, complete with trimmers, fully screened, size 2 1/2 in. high, 2 1/2 sq.; 1/6 each.

RADIO-HEART Tuning Unit, with Pre H.F. stage, 3 bands, supplied complete as follows: Radio-Heart tuning unit, dial and escutcheon, 2 pilot lamps, 2 variable selectivity I.F. transformers, one switch; Radio-Heart tuning units are aligned at the factory, while operating in an actual set circuit; as above, but less valves (American types required); £2/12/6.

KEN-RAD American Valves, best yet, all types stocked, glass, glass G, and metal, 90-day guarantee; attractive prices.

FULL and Comprehensive Range of British Type Valves Stocked, product of well-known non-ring Continental manufacturer; battery valves from 2/6 each; mains valves from 3/9 each; 12-month guarantee.

DECCA 6-valve 3-waveband Battery Chassis, fitted complete with Mazda and Osram valves, OPP output, these chassis give a sparkling performance on all wave bands and are the product of a well-known manufacturer; 3 gns. each, complete with valves.

AMERICAN Valves, special offer, Majestic 6Z5 full wave rectifier, 6.3v., 250 volts, 60 m.a., 1/6 each; also 5Es and 6D7s, 1/6 each.

T.C.C. New Range of Compact Electrolytic Condensers, as follows:—

T.C.C. 8 mfd. Tubular Electrolytic, wire ends, 500-volt working, 600-volt surge; 1/6 each.

T.C.C. 8 Mfd. Midget, wire ends, size 2 1/2 in. x 1 1/4 in., 500-volt working, 600-volt surge; 1/6 each.

T.C.C. 8 plus 8, 4 lead Midget electrolytics, 500-volt working, 600-volt surge; 2/9 each.

T.C.C. 1 Mfd., tubular wire ends; 1/- each.

T.C.C. Bias Condensers.

50 Mfd. 12-volt; 4/-.
25 Mfd. 25-volt; 1/-.
25 Mfd. 50-volt; 1/3.
50 Mfd. 25-volt; 1/3.
50 Mfd. 50-volt; 1/6.

HUGE Purchase Lissen Valves, brand new, boxed, as follows: H2, L2 and ILL2, 2 each; B.B.220A, 3/11 each; B2, 3/3 each; S.G.V., S.G.215, P.T., 225, 3/11 each; A.C.S.G., 4/6 each; S.G.410, 2/-.

WEARITE Mains Transformers, standard for the season and exclusive to us, made to strict electrical standards, wire end type, all windings centre tapped, screened primaries, tapped inputs 200-250 volts, screw adjustment.

TYPE R.C.1 250-0-250, 80 m.a., 4 volts 2.5 amp., 4 volts 4.5 amp.; 9/6 each.

TYPE R.C.2 350-0-350, 120 m.a., 4 volts 2.5 amp., 4 volts 5 amp.; 11/- each.

TYPE R.C.3 350-0-350, 150 m.a., 4 volts 2.5 amp., 4 volts 2 map., 4 volts 5 amp.; 12/6 each.

TYPE R.C.4 500-0-500, 150 m.a., 4 volts 2 amp., 4 volts 2.5 amp., 4 volts 5-6 amp.; 19/6 each.

TYPES R.C.1 and R.C.2, drop through type, capped.
TYPES R.C.3 and R.C.4, upright mounting type, fully shrouded.

WEARITE Auto Transformers, type R.C.5, fully shrouded, input 100-110 volts, output 200-250 volts, 100 watts; 12/- each.

RADIO CLEARANCE Bargains Continued in Third Column.



apologise for the fact that they are unable to send everyone of their friends a personal Christmas Card, but trust that this advertisement space may be accepted as a substitute.

We take this opportunity of wishing you

E
V
e
r
y
H
a
p
p
y
C
h
r
i
s
t
m
a
s

and sincerely hope that your Radio will add pleasure to the Christmas festivities.

Marlborough Road,
Upper Holloway,
London — N.19.
Phone: ARCHway 1661/2/3

ARMSTRONG

NEW VARIABLE SELECTIVITY
MODEL A.W.125PP
12-V. 5-BAND ALL-WAVE
RADIOGRAM CHASSIS
12-550 continuous, 1600-2,000m.

with R.F. Pre-Amplifier, 2 I.F. stages with Variable Selectivity, Manual R.F. gain control and 10 watts R.C. coupled Triode P.P. Output.
£17.17.0

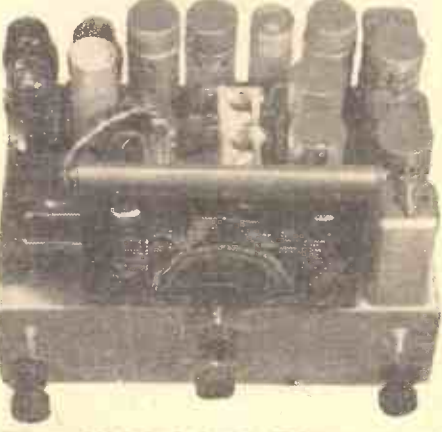

DEMONSTRATIONS
Extended hours for convenience of customers.
Engineer in attendance until 5.30 p.m. on Saturdays and 7.30 p.m. Monday to Friday.
All Models Gladly Demonstrated

ARMSTRONG MANFG. CO.
100 ST. PANCRAS WAY, CAMDEN TOWN, N.W.1
Phone: GULLiver 3105

COMPONENTS—SECOND-HAND,
CLEARANCE, SURPLUS, ETC.

RADIO CLEARANCE.—Continuing bargains in components.

CENTRALAB Volume Controls Available, as follows:—
WITH Switch, long spindle.

1,000, 5,000, 10,000, 25,000, 50,000, 100,000, 250,000, 500,000; 2/3 each.

2,500 Ohm Midget Energised Type Speakers, fitted pentode transformer; 4/6 each.

G.E.C. Relays, make and break type, 3,300 ohms; 4/- each.

100-WATT Auto Transformers, 100-250 volts reversible, wire end type; 7/6 each.

SPECIAL Offer Metal Chassis, 15in.x9in.x4in.; 1/6 each.

INDIRECTLY Heated Rectifiers, fitted octal base, well-known non-ring manufacturer, complete with octal base valveholder, 350-0-350, 120 m.a.; 4/- each.

SPECIAL Offer Erie Mixed Resistances, 1/2 and 1/4 watt; 4/6 gross.

ALL Orders 5/- or over Post Free; orders under 5/- must be accompanied by a reasonable amount for postage; e.o.d. orders under 5/- cannot be accepted. Hours of business 9 a.m. to 7 p.m. week-days, 9 a.m. to 1 p.m. Saturdays. Enquiries 1 1/2d. stamp if reply expected.

RADIO CLEARANCE, Ltd., 63, High Holborn, W.C.1. Holborn 4631. £7726

PREMIER SUPPLY STORES.
PLEASE See Our Displayed Advertisement on page 3. [0488]

RYALL'S RADIO, 280, High Holborn, London, W.C.1, offer new goods at knock-out prices. Note.—All post free.

TELEVISION Chassis, ex Ferranti, practically complete, no tubes available; £3/10; callers only; no postal, please.

VARIABLE Condensers.—J.B. Midget twin gang, with top trimmers, fully screened, 2/9; Plessey Midget, semi screened, twin gang, 2/9; Plessey fully screened top trimmers, 3-gang, small type, 4/-.

COLLARO A.C.37 Gramophone Motors and Pick-ups, on square unit plate with auto stop, 12in. turntable, needle cups, for A.C. 200-250v., all new in sealed cartons with instructions, with volume control, plate size 16x14; special price, 32/6.

SATOR Volume Controls, 1/2-meg., with switch, 50,000 ohm, with switch, 10,000 ohm., large base for tone control; all 1/3 each, or 7/9 dozen.

SPECIAL Offer of Iron Core Tuning Coils, ex "Burgoyne" made by Varleys, full details and coil connections supplied. Note.—All requests for information re these should be made to ourselves and not to Messrs. Varley, who are no longer responsible for same, the coils having been made for set manufacturers and not for resale. Pairs coils, for aerial and H.F. with reaction, 3/6; set three for 2H.F., 5/-; set five coils for R.F. superhet 465KC, 7/6; all chassis types, less switches.

K.B. Iron-core Wave Traps, for medium and long, very effective clearing L.W. interference, complete with variable padder, 1/3.

POLAR N.S.F. 0.15 Tubular Condensers, 350v. working, 1/3 per dozen; Sator 0.01 and 0.03 condensers, 1/3 per dozen, or (this item) 4/6 per half gross.

SPECIAL Offer 1-watt Carbon Resistors, colour coded, usual type, sizes 7,500 to 150,000 ohms, about 15 sizes at 2/6 per 50; good assortment given.

B.I. Electrolytic Blocks, 12x8x4x25x25mfd. 450v.-25v. wkg., 1/9, 15/- per dozen; B.I. 12x8x50 350v.-12v. wkg., 1/3; Ferranti midget 4x4 electrolytics, 450v. peak, size 2 1/2 in. x 1 1/4 x 1 1/4, 1/3 each, or 10/- per dozen.

FERRANTI Cardboard Electrolytics, 8x8 mfd., 500v. peak, size 4 1/2 in. long, 1 1/2 in. high, 1 1/2 in. deep; 1/9 each, or 15/- dozen.

POLAR/NSF Oak Type Low Loss Switches, air spaced banks, construction otherwise similar to Yaxleys, 4-bank, 2-pole, 4-way (8 4-way switches), effective length 9in., suitable for lowest wave lengths; 2/9 post free.

T.C.C. and Plessey Electrolytic Blocks, 30x8x2, 300v. working, 400v. surge, capacity guaranteed, upright mounting, 40mfd. for 1/4, or 9/6 dozen.

TUNING Eyes, 4v. with octal base, 3/6; 6.3v. type with medium American 6-pin base, 6g5, 3/6.

MAINS Transformers, 350-0-350, 70 m.a., 4v. 4.5a., C.T., 4v. 2 1/2a., input 200-250v., unused, guaranteed, 3/9 each.

ZENITH Wirewound Insulated Resistances, 550 ohms, tapped at 350-70-100; ex Ferranti, rating 0.3a., as used in A.C./D.C. sets, 1/4 each, or 9/6 per dozen.—Ryall's Radio, see above. [7789]

LONDON'S CENTRAL RADIO STORES.—Huge purchase enables us to offer the following amazing bargains.
B.I. Resin-oil Filled Rolled Foil Condensers, low loss stand off insulated soldering lugs, metal cased, tested at 1,500 volts. 450 volts working D.C., capacity 4 mfd., 1 1/2 in. x 2 in. x 3 1/2 in.; price 2/9 each.

As Above, but 0.1 mfd., 3,000 volts test, 1,000 volts working, size 1 1/2 in. x 1 in. x 3 1/2 in.; price 1/9 each.

PHILIPS Mains Transformers, 250v.-0-250v., 80 m.a., 100-250 volts primary, 4v. 2a., 4v. 5a. C.T., with fixing brackets; 4/3.
SPEAKER Transformers for Triode and Pentode, 2/3 each; special negative feed-back tone control chokes, with circuit, 2/- each.
LONDON'S CENTRAL RADIO STORES, 23, Lisle St., Leicester Sq., London, W.C.2. Phone: GERRard 2969. [7794]

COMPONENTS—SECOND-HAND, CLEARANCE, SURPLUS, ETC.

EXPERIMENTER'S Surplus; send 5/- for bargain parcel or state wants.—Cox, 47, Dawlish Drive, Ilford. [7770]

GARRARD A.C. 200/50 Record Changer, plays eight 10- or 12-in. records, model R.C.4A; £5/5, sealed cartons, carriage paid.

ELECTRIC Dry Shaver, A.C./D.C., 200/50. "Minute Man," list price £2/10; our price £1/10, complete with leatherette case, one year's guarantee; send for details; trade supplied.

HENRY'S, 72, Wellington Av., London, N.15. Stamford Hill 2907. [7707]

HEADPHONES, crystals, crystal sets, microphones, etc.; list, with diagrams, free.—Post Radio, 2, Copenhagen St., London, N.1. [7788]

VAUXHALL—T.C.C. condensers, tubular non-inductive, 0.1 mfd. 4d., 0.25 mfd., 50 mfd. 1/6, 50 mfd. 12v. 1/3 0.002, 0.001, 0.0002, 0.0001, 4d. each.

VAUXHALL—Hivac valves, entire range, new prices, full discounts, Polar horizontal, station scales; 1/-.

VAUXHALL—Iron-cored coils, on base, with switch, terminals, circuits; 2-gang, 11/3; 3-gang, 17/-. [7788]

VAUXHALL—Post paid 2/6 or over, cash on delivery, gang bar type, 6/8; Polar horizontal drives, 5/-.

VAUXHALL—Polar Midget 3-gang condensers, 8/9; 2-5/- minimum.

VAUXHALL UTILITIES, 163a, Strand, W.C.2. Over Denny's, the Booksellers. Send postcard for free list. [0602]

GRAMOTORS.—B.T.H., A.C., £1; Collaro Universal, £1/10; Garrard auto-change, used, £3/10; new, £4/10; carriage extra.—41, Glebe Avenue, Kenton, Middlesex. [7784]

MAINS RADIO DEVELOPMENT COMPANY Offer all Lines as Advertised last Week. We thank you for your splendid support during 1938, and assure you of our best attention in the coming year.

MAINS RADIO DEVELOPMENT COMPANY, 4-6, Muswell Hill Rd., London, N.6. Tudor 4046. [7780]

SOUTHERN RADIO, 46, Lisle St., London, W.C.2. Extend Seasonable Greetings to their many customers; all lines previously advertised still available; send for comprehensive lists, 2d. stamp.—Southern Radio, 46, Lisle St., London, W.C.2. Gerrard 6653. [7783]

Wanted

WE Buy for Cash All Types of Modern Second-hand Radio Sets and Accessories, test meters, parts, etc.; we pay more than any other dealer; part exchanges; bring, send, or will call.—University Radio, Ltd., 82, Hampstead Rd., London, N.W.1. Phone: Euston 3810. [7787]

MISCELLANEOUS

SEE Mother's "Illuminated Dial" when she slips into a warm bed under a Warm-Glow electric blanket.—Leaflet from Warmglow Co. Leigh-on-Sea, E. [7648]

EVERY Radio Dealer Who is Not a Regular Reader of "The Wireless and Electrical Trader" should send his trade card at once for a specimen copy and full details of the "Trader" Services. "The Wireless and Electrical Trader" has the widest influence, the largest weekly circulation, and is read by all the leading manufacturers and traders. Trade only, 10/6 per annum, post free.—Published at Dorset House, Stamford St., London, S.E.1.

EXCHANGE

I BUY, sell, exchange good quality receivers, accessories, components; H.P. facilities, promptness, efficiency.—Bostock, 1, Westbourne Terrace, S.E.23. Forest Hill 2236. [0529]

EXTENDED PAYMENTS

LONDON RADIO SUPPLY Co. (Established 1925) Supply, on convenient terms, components, accessories and sets, any make, 10% down, balance over 12 months; send for list of requirements.—11, Oat Lane, London, E.C.2. [0337]

MACHINERY, TOOLS, ETC.

COMPLETE Machinery and Equipment for the Manufacture of Radio Valves, including materials, processes, stock, etc.; written down balance-sheet figure of machinery approximately £2,000.—For full particulars apply to H. W. Vallance, Lodge and Co., Chartered Accountants, 25, Finsbury Sq., E.C.2. [7771]

PATENT AND TRADE MARK AGENTS

GEE and Co. (H. T. Gee, Mem. R.S.G.B., A.M.I.R.E. Estb. 1905), 51-52, Chancery Lane, London, W.C.2 (2 doors from Government Patent Office). Holborn 4547 (2 lines). Handbook free. [0001]

TUITION

GUARANTEED Posts.—Complete wireless training; ship and shore services. Television. Day, evening and postal. Boarders taken. Prosp. free.—W.K. London Radio College, Grove Park Rd., W.4. (Chiswick 3244.) [0580]

PETO-SCOTT Wireless World

3-Band A.C. SUPER RECEIVER KIT "A" CASH £7-12-9 or 13/9 deposit and 12 monthly payments of 13/2.

Comprising all components exact to Wireless World specification including Partridge Mains Transformer and Choke, Varley I.P. Transformers, B.T.S. ready-drilled and cadmium-plated chassis assembly, wire, sleeving and screws, but less valves.

5 Specified Valves.....Cash or C.O.D. £2-5-0 or add 3/8 to deposit and to each monthly payment.

TUNER KIT "A" CASH £6-3-9 or 11/3 deposit and 12 monthly payments of 10/8.

Comprising all parts for Tuner exact to specification including Wearite coils, Peto-Scott Geared Dial, B.T.S. Switch Assembly and ready-drilled Aluminium chassis and polished panel, wire, sleeving and screws, but less valves.

2 Specified Valves.....£1-2-0 or add 2/6 to deposit and 1/10 to each monthly payment.

FINISHED INSTRUMENT

Wireless World Three-Band A.C. Super Receiver and Tuner completely assembled exactly to Designer's specification with 7 specified valves. Less cabinet and speaker. Aerial tested before despatch.

CASH £21-0-0 YOURS FOR £4-0-0 DOWN balance in 12 monthly payments of 32/-.

Table listing KIT BITS and B.T.S. components with prices: B.T.S. ready-drilled Receiver Chassis Assembly £1-5-0, B.T.S. ready-drilled Tuner Chassis £1-1-0, B.T.S. Polished and Drilled Panel 4-0, B.T.S. special Switch Assembly 17-6, PETO-SCOTT Geared Dial with special coupler 12-6.

ALL-WORLD NEWS

Via the short-waves—the quickest and most thrilling way to ascertain all-world news and to follow current events. For the reception of all-world communications, there's nothing better than a TROPHY short-waver. The D.X. Ham now insists on an all-British TROPHY communication set and in most homes a TROPHY has proved to be the ideal second set. Send NOW for List W.W.9 covering the complete range of TROPHY'S. Most 3-valve models are available in addition to 5 and 8-valve types with and without incorporated speaker.

PETO-SCOTT Co. Ltd., Established 1919, 77 (W.W.9), City Road, London, E.C.1. New Showrooms: 41 (W.W.9), High Holborn, London, W.C.1. Clissold 9875-6-7, Clerkenwell 5911, Holborn 3248.

PARTRIDGE CHOKES AND TRANSFORMERS advertisement featuring a partridge logo and detailed text about product quality and availability.

REPAIRS AND SERVICE

"SERVICE with a Smile."

AMERICAN Valves, spares, line-cords, rewinds; repairs of all types of American and British receivers.—F.R.I. Ltd., 22, Howland St., W.1. Museum 5675. [0434]

METROPOLITAN RADIO SERVICE Co. for Guaranteed Repairs to American (Midget and Standard) and British Receivers.

CLARION and Majestic Service Depot.—I.F. and mains transformers rewound; American valves and parts; trade supplied.—Metropolitan Radio Service Co., 1021, Finchley Rd., London, N.W.11. Speedwell 3000. [0435]

LOUD-SPEAKER Repairs, British, American, any make, 24-hour service; moderate prices.—Sinclair Speakers, Alma Grove, Copenhagen St., N.1. [0590]

VALRADIO for Repairs and Rewindings to Vacuum Cleaners, converters, dynamos, motors, transformers, etc.—95, Leighton Rd., Kentish Town, N.W.5. Gulliver 5165. [7363]

GUARANTEED Repairs.—Any transformers, choke or motor armature, converter, dynamo, etc.; keenest prices, immediate quotation, prompt dependable service.—See below.

L.T.P. (LONDON TRANSFORMER PRODUCTS, Ltd.), Willesden, N.W.10. Willesden 6486 (3 lines). [6892]

MAINS Transformer Service, Repairs, rewinds, or construction to specification of any type, competitive prices and prompt service.—Sturdy Electric Co., Dip-ton, Newcastle-on-Tyne. [0516]

SCOTT-SESSIONS REPAIR SERVICE.—All types of receivers overhauled, rebuilt, repaired, including American communication sets, W.W. Monofals. All-wave Super-Seven. Variable Selectivity IV, etc.

SCOTT-SESSIONS REPAIR SERVICE, popular for 15 years from Land's End to John-o'-Groats; van collection London area; immediate, courteous and skilled attention to every instruction.

SCOTT-SESSIONS REPAIR SERVICE, Exchange Works, Muswell Hill, N.10. Tudor 4101-2. [7497]

GRAHAMS Rewinding Service, 24 hours' service guaranteed, loud speakers, L.F. and output transformers, chokes and mains transformers; conversions a speciality; quotations given; trade specially invited.

GRAHAMS SERVICES, Dept. W., 194, Tolworth Rise, Kingston By-pass, Surrey. Derwent 2060. [7679]

S.T. Receivers Serviced, rebuilt or modified by Clark and Randall (late of "Popular Wireless"). All other home constructed or commercial sets efficiently serviced.—15, Nimrod Rd., S.W.16. Phone: Streatham 4566. [7782]

REPAIRS to Moving Coil Speakers a Speciality; cones and coils fitted, fields altered; prices, including eliminators, quoted; loud speakers, 4/-; L.F. and output transformers, 4/-, post free; guaranteed satisfaction; trade invited, estimates free; prompt service.—Loud-Speaker Repair Works, 5, Balham Grove, London. Battersea 1321. [0594]

WANTED

WANTED, transformer winding machine, any make or condition; communication receiver with crystal gate.—Full details to EIBN, Longford, Eire. [7771]

BUSINESSES AND PROPERTY FOR SALE, TO BE LET, OR WANTED

"THE Wireless and Electrical Trader" is an essential part of the equipment of every Wireless Trader; its pages reflect the very latest turn of trade events, and it is read by all the leading dealers and manufacturers, for particulars of businesses offered or wanted. By subscription to the trade only, 10/6 per annum, post free.—Send your trade card for specimen copy to Dorset House, Stamford St., London, S.E.1.

SITUATIONS VACANT

AIR MINISTRY. A290—Applications are invited for a number of appointments as Technical Officer at the Air Ministry, the Royal Aircraft Establishment, South Farnborough, Hants, and other experimental establishments.

COMMENCING Salary up to £455 a Year (men), and £347 (women), according to qualifications and experience. Salary scales:—Men £275 by £18 annually to £455 and by £25 to £580; women £275 by £12 annually to £347 and by £18 to £464. Efficiency bar at £455 (men) and at £347 (women).

THE Qualifications Required are:—

- (1) A University Degree or Equivalent Technical Standing in a subject appropriate to the requirements specified below, and suitable practical experience.
(2) Experience in One or More of the Following Categories:—
(c) Radio or Communication Engineering, preferably with knowledge of design of small radio communication equipment.
(d) Design, development, testing and installation of aircraft instruments, optical instruments or similar apparatus.

CANDIDATES for Post "c" May be Required to Fly in Aircraft as Observers.

PROMOTION to the Higher Grade of Senior Technical Officer (£680-£800 men, £580-£680 women) and above is governed by merit as and when vacancies occur.

APPLICATIONS Should be Made on a Form to be Obtained from the Air Ministry (S2D) or Chief Superintendent, Royal Aircraft Establishment, South Farnborough, Hants. Request for forms should be made by postcard, quoting the reference number A290 and the posts for which it is desired to apply. [7774]

RADIOMART

G.S.N.I. (BHAM) LTD.

THE SHORT-WAVE SPECIALISTS

We are the oldest Distributors for BILLEY, THORNDARSON, TAYLOR TUBES, R.M.E. BASSETT CONCENTRIC CABLE, HOYT METERS, COLLINS, NATIONAL, ETC. Send us your enquiries. Large stocks carried.

HEAVY DUTY Mains Transformer, worth 45/- 350-350, 150 m.a. 4 v., 2.5 a., CT. 4 v., 6 a., CT. 12/6; 300-300 v., 80 m.a., 4 v. 2 a., CT. 4 v., 2 a., CT. 6/6. Speaker Transformers, 1/11.

SPEAKERS—We carry large stocks. Magnavox, 10in. energised, 1,000 or 2,000 ohms, 10/6. Energised 8in., 1,200 ohms with transformer, 6/11. I.T. Rectifiers, 4.5 v., 3 a., 7/6.

GANG CONDENSERS with Airplane dial, 8 and 80-1. Cost 35/-; few only, 4/11; 2-gang with Airplane dial, 3/11.

MICROVARIABLES.—All brass construction, latest ceramic insulation. The finest condensers made: 15 mmfd., 1/4; 40 mmfd., 1/7; 100 mmfd., 1/10. Transmitting Type—570in. spacing, 15 mmfd. (neutralising), 2/9; 40 mmfd. Tuning, 3/6. These are quality.

UTILITY 7/6 Famous Micro Dials, 3/9; Radiophone, 0.00016 Short-wave Condensers, 3/6. Shortwave HF Chokes, 5-100 metres, 9d. Centralab Pots, all sizes, 1/6; switched, 2/-; 20,000 ohm Pots, 1/-; Tubular Glass Fuses, 2d. Millimeters, 25 m.a. upwards, 5/9; super, 6/9.

W.B. 8in. Permanent Magnet Speakers at one-third Cost Extension Type (no Transformer) 7/6, Standard Type (with Transformer) 12/6.

AMERICAN Mains Transformers.—Heavy Duty 350-350 v. 150 m.a., 6.3 v. 4 a., 5 v. 3 a., 12/6. GE 350-350 v. 80 m.a., 2.5 v. 7 a., 5 v. 2 a., 6/11. Matic 250-250, 2.5 v. 5 v., 4/11; Pilot 250-250 v. 5 v. C.T., 3/11. Ceramic American Valveholders, including octal, 1/- each.

PUREBRACK Wire, 6 yds., 6d., heavy 9d. Resin-coated Solder, 6d., 6d.; Screened Flex, single, 6d. yd.; twin, 9d. yd. Assorted Solder Tags, 6d. packet. Humdimmers, 6d. each.

OUR NEW 66 PAGE MANUAL, packed full of valuable information. Post Free, 1/2d.

THE NEW RAYMART CATALOGUE shows dozens of New Short-wave Components and is yours for 1/2d. post free.

RECTIFIERS.—Westinghouse, in cabinet, input 230 v., output 110 v. 1 1/2 amps. Ideal for chargers, etc. Cost over £15. Our price, 59/6.

VALVES—We are now able to offer a complete range of replacements, including those for types PX25, PPS/490, PPS/250, PX4, AG2Pen., VP.4B., TDD4, etc. All types of Universal Valves, including side-contact, etc. All Guaranteed and showing a saving of over 50 per cent. Quotations on receipt of types required. Quantity Discounts to Service Engineers.

Asplendid range of short-wave components is always ready for immediate despatch. The right goods at the right prices.

RADIOMART Telephone: MIDland 3254.
G.S.N.I. (Birmingham) Ltd.
44, HOLLOWAY HEAD, BIRMINGHAM

ELECTRADIX RADIOS
Sends Christmas Greetings to all readers of this journal and invites them to send for their latest Bargain List
"W."

ELECTRADIX RADIOS,
218, Upper Thames Street, London, E.C.4.
Telephone: Central 4611.

HAYNES QUALITY
RECEIVERS and TELEVISION
Demonstrations Friday Evenings 7.30—10 p.m.
Lists free.

QUEENSWAY,
HAYNES RADIO Ltd. ENFIELD, MIDD.X.
Howard 1171.

Mains Transformer as specified for *The Wireless World* High Quality Communication Receiver Type WW5r-45/-.

W. BRYAN SAVAGE LTD.
Westmoreland Rd., London, N.W.9. Phone: Colindale 7131.

KINVA WHISTLE SUPPRESSOR

INDISPENSABLE TO ALL HIGH QUALITY SETS,
(1) OUR NEW PERFECTED WHISTLE RECTECTOR,
(2) OUR DE-LUXE SCRATCH FILTER for Pickup Circuit.
(No. 1. Special for Piezo Pickups; No. 2. For Electro-Magnetic do.)
Comprehensive details on Filtering. Graphs
Price, yours for 2s. stamp.
POSTLETHWAITE BROS., KILVER, STAFFS.

BOOKS on WIRELESS
Write for complete list to
ILIFFE & SONS LTD.
Dorset House, Stamford St., London, S.E.1. w.w.1

SITUATIONS VACANT

AIR MINISTRY.

APPLICATIONS are invited for the Following Appointments for Service in the first instance at Bawdsey Research Station, Woodbridge, Suffolk:—

SCIENTIFIC Officers (Ref. C.166).—Candidates should possess First or Second Class Honours Degree in Physics, Electrical Engineering or Mathematics, and have had extensive practical experience in research and experimental work on radio and line communication.

SALARY Scale £400 by £18-£454 by £25-£680 a year. There is an efficiency bar at £580 a year.

JUNIOR Scientific Officers (Ref. C.109).—Candidates should possess a First or Second Class Honours Degree in Physics, Electrical Engineering or Mathematics and experimental laboratory or works experience on radio and line communication. Post-graduate experience in radio research is desirable.

SALARY Scale £275 by £18-£347 a year.

SCIENTIFIC Officer Appointments will carry superannuation rights under the Federated Superannuation System for Universities, the Government contribution being approximately 10%, and the individual approximately 5% of salary. Junior Scientific Officer appointments will be brought under the scheme after two years' satisfactory service.

PROMOTION from Junior Scientific Officer to Scientific Officer and to the higher grades of Senior Scientific Officer (£680 by £25-£800) and Principal Scientific Officer (£850 by £30-£1,050) is governed by merit and when vacancies arise.

TECHNICAL Officers (Ref. C.617).—Candidates should have a technical training to the standard of an Honours Degree in Physics, Electrical Engineering or Mathematics, and have had extensive experience of experimental development work on radio and line communication.

SALARY Scale £275 by £18-£455 by £25-£580 a year. There is an efficiency bar at £455.

PROMOTION to the Higher Grades of Senior Technical Officer (£680 by £25-£800) and Principal Technical Officer (£850 by £30-£1,050) is governed by merit and when vacancies arise.

ASSISTANTS I and II (Ref. C.118).—Candidates should have had training to the standard of a University Degree in Physics or Electrical Engineering and experimental laboratory or works experience in communication engineering, preferably on the radio side.

ASSISTANT III (Ref. C.124).—Candidates should preferably have had training to the standard of a University Degree in Physics or Electrical Engineering and some experimental laboratory or works experience in communication engineering, preferably on the radio side.

SALARY Scales.
ASSISTANT I.—£400 by £18-£515 a year.

ASSISTANT II.—£315 by £12-£385 a year.

ASSISTANT III.—£130 by £12-£310 a year. (Efficiency bar at £214 a year.)

THE Commencing Salary for Assistants III may be up to £214 a year, and in exceptional cases above, according to qualifications and experience.

PROMOTION of Assistants from grade to grade is governed by merit and when vacancies arise. At the present time opportunities also exist for Assistants II to qualify for promotion to Technical Officer.

THE Technical Officer and Assistant appointments are non-pensionable, but entrants will be eligible for consideration for pensionable posts in the event of vacancies arising on the permanent establishment.

APPLICATION Should be Made on a Form to be obtained, by postcard, quoting the appropriate reference, from the Superintendent, Bawdsey Research Station, Bawdsey Manor, Woodbridge, Suffolk, to whom it should be returned not later than the 7th January, 1939.

AIR MINISTRY.

A LARGE Number of Assistants, Grade II and III, are required at the Air Ministry, the Royal Aircraft Establishment, South Farnborough, Hants, and other experimental establishments. The scales of salary are:—

A291—Assistant II: £315 by £12 to £385 a year (men); £265 by £12 to £315 a year (women).

A292—Assistants III: £130 a year (at age 19) by £12 a year to £310 (£260 women). There is an efficiency bar at £214. For candidates with suitable experience, and/or an education up to University degree standard, the commencing salary may be £214 a year.

THE Qualifications Required are:—

- (1) Good technical training, with workshops, drawing office or laboratory experience, or alternatively education to a degree standard.
- (2) Experience in either of the following categories is necessary for Assistant II appointments, and desirable but not essential for Assistants III.
 - (d) Development work on radio communications equipment.
 - (e) Experimental work on small mechanical apparatus, chiefly instruments.

PROMOTION from Assistant III to Assistant II, and from Assistant II to Assistant I (£400-£515) (£325-£415 women) is governed by merit as vacancies arise. Opportunities exist for Assistants II to qualify for promotion to Technical Officer £275-£455-efficiency bar-£580 a year, men; and £275-£347-efficiency bar-£464 women.

CANDIDATES May be Required to Fly in Aircraft as Observers.

APPLICATION Should be Made on a Form to be obtained from the Chief Superintendent, Royal Aircraft Establishment, South Farnborough, Hants. Request for forms should be made by postcard, quoting the appropriate reference number and the post for which it is desired to apply.

FOURTH EDITION—
Revised and Enlarged with 50
Additional Pages

WIRELESS SERVICING MANUAL

By W. T. COCKING

(of "The Wireless World")

The most complete book of reference of its kind. A reliable practical guide for amateur and professional.

The present Edition of the "Wireless Servicing Manual" brings the material of the book right up to date and includes an additional chapter on television receivers which is practically the only source of servicing information available on this subject.

Testing apparatus is fully dealt with and the methods of locating and curing faults in receiving equipment are explained in detail.

Ganging, Automatic Volume Control, Instability, Distortion, Mains Hum, Whistles, Local Interference and Aerials are all separately treated.

The reference material, including base-connections for British, Continental and American valves and the various colour codes for components, has been extended and revised.

BOUND IN CLOTH BOARDS
SIZE 7 1/2 ins. x 5 ins.
288 Pages

PRICE 5/- net
By post 5/5

issued in conjunction with
"THE WIRELESS WORLD" and
Published by the Proprietors:—

ILIFFE & SONS LTD.,
Dorset House, Stamford Street,
London, S.E.1

Third Edition of
**WIRELESS
 DIRECTION
 FINDING**

BY R. KEEN, B.Eng.

A BOOK OF INSTRUCTION AND REFERENCE FOR ENGINEERS, TECHNICIANS, TELEGRAPHISTS AND OTHERS ENGAGED OR INTERESTED IN THE USE OF DIRECTIVE WIRELESS TELEGRAPHY FOR THE NAVIGATION OF SHIPS AND AIRCRAFT.

The third edition of this well-known book deals with the principles of Wireless Direction Finding and gives an account of the circuits and apparatus used in its application to navigation. The Adcock Aerial has a separate chapter covering its principles together with much information on its installation and performance. Further chapters are included on Shore, Ship and Aircraft installations as well as a special section on the choice of a suitable site for the Aircraft Ground D.F., with Adcock Aerials.

Engineering students and research engineers will find useful references to a selected list of some 600 of the more important contributions to the literature of D.F.

800 pages 550 illustrations

PRICE:

25/- net. By post 25/9

ILIFFE & SONS LTD., DORSET HOUSE, STAMFORD STREET, LONDON, S.E.1

W.W. 60

SITUATIONS VACANT

ADMIRALTY.

DEPARTMENT of Scientific Research and Experiment.

APPLICATIONS are invited for Vacant Permanent and Temporary Posts for Assistants II and Assistants III in the Admiralty Technical Pool. The place of duty, in the first instance, will be an Admiralty Establishment in the South of England.

Every Candidate must be a Natural-born British subject, the child of a person who is or was at the time of death a British subject.

Candidates for these posts should possess qualifications up to the standard of the National Certificate in Electrical or Mechanical Engineering or Inter B.Sc. in Physics, and should have had experience of one of the following lines:—

- (i) Design of small mechanical and/or electrical components and apparatus. In certain cases experience of the design of high-voltage, high-frequency apparatus is required. In all cases candidates must be able to show an aptitude for and/or experience of genuine design work.
- (ii) Work in an experimental laboratory or commercial firm on the experimental development of small mechanical, electrical or optical apparatus.
- (iii) High vacuum technique, with some knowledge of glass and/or silica working and experience of supervision of staff.

The Salary Scales for Assistants II is £315 by £12 to £335 per annum; successful candidates will be required to enter at the minimum of the scale; candidates for Assistant II posts should preferably be over the age of 25.

The Salary Scale for Assistants III is £130 by £12 to £214 (efficiency barrier) by £12 to £310 per annum; successful candidates may be given a starting salary up to £214 according to age, qualifications and experience, and in exceptional cases a salary above this may be offered.

Candidates Appointed to Temporary Posts will be eligible for consideration for any vacancies which may occur on the Permanent Staff of the Department.

Applications, giving date of birth, particulars of qualifications and experience, and accompanied by copies of testimonials, should be forwarded to the Secretary of the Admiralty (C.E. Branch) not later than January 7th, 1939, quoting Reference Number C.E. 10970/38.

No application forms are required. [7776]

RADIO Manufacturers (West London District) Require Engineers with Experience and Design Ability in any of the following classes of work:—

- I.—Television receiver and time base design.
- II.—All-wave receiver development.
- III.—Power transformer and audio transformer design.

APPLICANTS Must Have Specialised in one of these Categories; only men with some years of practical experience will be considered; write, stating age, experience and salary required, to: Box 8219, c/o The Wireless World. [7751]

SENIOR Draughtsman Required, experience on radio chassis layout and component design an advantage, workshop experience essential.—Write, stating age and salary required, to Pye, Ltd., Radio Works, Cambridge. [7781]

BOOKS, INSTRUCTION, ETC.

AMERICAN Valve Data.—The new 200-page Raytheon valve data book gives full characteristics and applications of all types of American valves; invaluable to all servicemen; post free, 2/3; abroad 3/.—Leonard Heys, 36, Henry St., Blackpool. [0594]

FOUNDATIONS of Wireless.—By A. L. M. Soverby, M.Sc. Second edition. An elementary textbook on receivers. Deals fully with the construction of wireless sets, valves, and the process of detection. Price 4/6 net. By post 4/11, from Iliffe and Sons Ltd., Dorset House, Stamford Street, London, S.E.1.

ELEMENTARY Principles of Wireless Telegraphy and Telephony.—By R. D. Banguay. Revised by O. F. Brown B.Sc. Third edition (1930). The standard textbook for wireless students and beginners. Deals with the whole subject of wireless telegraphy and telephony, avoiding too technical a treatment of the problems involved. Well illustrated. Price 7/6 net. By post 8/1, from Iliffe and Sons Ltd., Dorset House, Stamford St., London, S.E.1.

RADIO Data Charts.—By R. T. Beatty, M.A., B.E., D.Sc. Second edition. A series of Abacs providing most of the essential data required in receiver design and enabling problems to be solved without having recourse to complicated mathematical formulae. Price 4/6 net. By post 4/10, from Iliffe and Sons Ltd., Dorset House, Stamford St., London, S.E.1.

THE Wireless World" Diary for 1939 contains 77 pages of facts, formulae and general information of the kind that is always wanted but is difficult to follow. Also a list of the most important European Broadcasting Stations and short-wave stations of the world. Twelve pages of circuit diagrams of receivers, amplifiers and units.—By post, 1/7 from Iliffe & Sons, Ltd., Dorset House, Stamford St., London, S.E.1.

SPECIFICATION. The 6778 Ambassador chassis is designed to give unparalleled short wave performance. The circuit is a 6 valve 4 wave band superhet. with R.F. stage on each wave band. Features include high speed AVC, permeability tuned I.F. transformers, large 10" Clair-audient speaker, separate mains power pack, wide spaced triple gang condenser, and 8 watts output. Mazda valves are used throughout.

Wholesale enquiries invited.

Manufactured in England at the

FREE!
 Send for illustrated leaflet fully describing this receiver and other Ambassador chassis, post free, from address below.

Ambassador
 RADIO WORKS,
 HUTCHINSON LANE, BRIGHOUSE, YORKS. Tel. 283 (3 lines).

TO CYCLISTS! Your wheels will NOT keep round and true unless the spokes are tied with fine wire at the crossings AND SOLDERED. This makes a much stronger wheel. It's simple—with FLUXITE—but IMPORTANT

THE FLUXITE GUN
 is always ready to put Fluxite on the soldering job instantly. A little pressure places the right quantity on the right spot and one charging lasts for ages. Price 1/6.

ALL MECHANICS WILL HAVE
FLUXITE
 IT SIMPLIFIES ALL SOLDERING
 FLUXITE LTD., Dept. W.W., DRAGON WORKS, BERMONDSEY ST., S.E.1

YOUR SAFE GUARD



Centralab
The Name which conveys a Universal Meaning

All over the world Radio Technical men insist on their Centralab Volume Controls being marked as shown in the above illustration, because "Centralab" is to them a guarantee of quality and reliability. Make sure, therefore, that the volume controls which you buy bear the name "Centralab." No other volume control provides resistance tapers so carefully adjusted for proper attenuation in each circuit as the Centralab Radiom. There is no direct rub on the resistance element as contact is made by a silver-plated band over the entire width of the resistance element which is nearly four inches long. There is a Centralab available (with or without switch) in resistance values from 500 ohms to 3 megohms. Write to-day for details.

The same prices apply to all resistance values irrespective of taper.

BRITISH CENTRALAB LTD.,
(Dept. B),
CANTERBURY ROAD, HIGH ROAD, KILBURN, N.W.6.
Phone: Maida Vale 6056.



The Sign of PRECISION INSTRUMENTS

Cur many years of practical experience in the design of Variable Condensers for use in any circuit where wide frequency variations are introduced, has been fully appreciated by the designers of receivers described in the "Wireless World."

The most critical attention to detail for the prevention of electrical and mechanical error is applied to all "JB" products.

The "JB" Bar Type Ganged Condenser as specified for the 3-band A.C. Super has low minimum capacity, low losses and is exceptionally rigid in construction.

J.B. Type. LB3/NT.
Minimum Capacity 10 mmf. Maximum 510 **17/6**

Exactly as Specified for the **THREE-BAND A.C. SUPER** described in this issue of the "Wireless World"

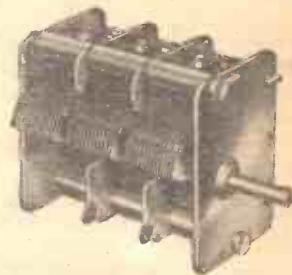

We invite you to send for our Complete Catalogue "W."

JACKSON Bros. (London) Ltd.
72, St. Thomas' Street, London, S.E.1

INDEX TO ADVERTISEMENTS

	PAGE
Ambassador Radio Works	7
Armstrong Manufacturing Co.	4
Automatic Coil Winder Co., Ltd.	1
Belling & Lee, Ltd.	
Birmingham Radiomart G5N1	6
British Centralab, Ltd.	8
British Institute of Engineering Technology	
British Insulated Cables, Ltd.	
Collins, Wm., & Co.	
Cosmocord, Ltd.	8
Edison Swan Electric Co., Ltd.	
Electradix Radios	6
Fluxite, Ltd.	7

	PAGE
General Electric Co., Ltd.	
Goodmans Industries, Ltd.	
Hartley Turner Radio, Ltd.	
Haynes Radio	6
Henley, W. T., Telegraph Works Co., Ltd.	
Institute of Wireless Technology	
Jackson Bros. (London), Ltd.	8
London Radio Supply Co.	
McCarthy, H., Ltd.	2
McClure, John, Ltd.	8
Mullard Wireless Service Co., Ltd.	Inside Front Cover

	PAGE
Pamphonic Reproducers, Ltd.	1
Partridge, N.	5
Perscus Mfg. Co.	
Peto Scott, Ltd.	5
Player's Cigarettes	
Postlethwaite Bros.	6
Premier Supply Stores	3
Savage, W. Bryan, Ltd.	6
Sound Sales, Ltd.	4
Stratton & Co., Ltd.	1
Varley, Ltd.	
Voigt Patents, Ltd.	
Ward, Charles F.	
Westinghouse Brake & Signal Co.	

JOHN McCLURE, BRITAIN'S BEST RADIO

Developed after 8 years of supplying the highest priced Quality Market. We are now in the position to supply all types of Radio Chassis, Power Amplifiers, Microphones, Recording Equipment and Quality Radio-Gramophones up to 300 Guineas.

WATCH THIS SPACE EACH WEEK



UTA W3 Universal 7-valve 3-waveband chassis

SUPER ALL-WAVE COMMUNICATION RECEIVER

Specially designed for the real short-wave enthusiast and the Amateur Transmitter.

Type A.C.7.A.W.6 for A.C.—Price £18-10-0

Type U.T.A.W.5 for Universal A.C./D.C.—Price £20-0-0

Syntoniser £1-10-0 extra.

These chassis incorporate our ACT6 and UT6 Tuning Units respectively. For details of the Tuning Units see this space in last week's "Wireless World."

Tuning range 41m.—2,000m, without gaps, complete with B.Y.A. Valves, Cathode Ray Tuning Indicator, readily effective A.V.C., Super-sprung chassis.

Entire chassis copper plated to give maximum HF conductivity and then protected by the very finest finish to prevent oxidation of the copper.

Excellent reproduction combined with ample sensitivity are features of McClure Hand-built Products.

Type A.C.7.A.W. 16-50, 200-550, 800-2,000m. Price £10-10-0

Type A.C.7.A.W.4, four bands, 12-35, 30-80, 200-550, 800-2,000 metres. Price £11-10-0

Type A.C.7.A.W.5, 12-2,000 metres without Gaps. Price £12-10-0

We specialise in Amateur Transmitters. FULL DETAILS ON REQUEST.

Dept. 10R, JOHN McCLURE LTD.

Offices and Showrooms: 163, Holland Park Avenue, W.11.

Works and Service: Warren House, Warren Road, Uxbridge, Middx. Phone: UXBIDGE 1234.

DO YOU KNOW ALL ABOUT THE BEST CRYSTAL PICK-UP ON THE MARKET?

See "The Wireless World" TEST REPORT, Dec. 8th issue.

PLEASE WRITE FOR FULL PARTICULARS TO

COSMOCORD LTD. ENFIELD, MIDDLESEX. ENF. 4022.
THE PICK-UP SPECIALISTS.

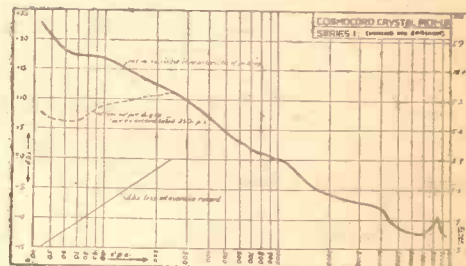

The Wireless World

THE PRACTICAL RADIO JOURNAL
28th Year of Publication

No. 1009.

THURSDAY, DECEMBER 29TH, 1938.

VOL. XLIII. No. 26.

Proprietors : ILIFFE & SONS LTD.

Editor :
HUGH S. POCOCK.

Editorial,
Advertising and Publishing Offices :
DORSET HOUSE, STAMFORD STREET,
LONDON, S.E.1.

Telephone : Waterloo 3333 (50 lines).
Telegrams : "Ethaworld, Sedist, London."

COVENTRY : 8-10, Corporation Street.
Telegrams : "Autocar, Coventry." Telephone : 5210 Coventry.

BIRMINGHAM :
Guildhall Buildings, Navigation Street, 2.
Telegrams : "Autopress, Birmingham." Telephone : 2971 Midland (4 lines).

MANCHESTER : 260, Deansgate, 3.
Telegrams : "Iliffe, Manchester." Telephone : Blackfriars 4412 (4 lines).

GLASGOW : 26B, Renfield Street, C.2.
Telegrams : "Iliffe, Glasgow." Telephone : Central 4857.

PUBLISHED WEEKLY. ENTERED AS SECOND CLASS MATTER AT NEW YORK, N.Y.

Subscription Rates :

Home and Canada, £1 10s. 4d. ; other countries, £1 12s. 6d. per annum.

As many of the circuits and apparatus described in these pages are covered by patents, readers are advised, before making use of them, to satisfy themselves that they would not be infringing patents.

CONTENTS

	Page
Editorial Comment	575
Wireless Communications	576
Civilian Wireless Reserve	578
Three-Band AC Super : Construction and Operation	579
Television Topics : Electron Lenses Unbiased	583
Balloon Transmitters	584
Sound-on-Disc Recording	585
News of the Week	588
How the Valve Works, V—Hexodes, Heptodes and Octodes	591
Letters to the Editor	593
Random Radiations	596
Recent Inventions	597
Principal Broadcasting Stations	598

EDITORIAL COMMENT

1939

What Lies Ahead?

AT the close of 1938 it is natural that we should look forward and try to forecast what may be the wireless developments of 1939. Both transmission and reception of sound broadcasting has been in a state almost of stagnation during the past year or so, and this is because of limitations imposed by the channels available for broadcasting, which means that little improvement can be effected in transmission quality nor can receivers be designed at present to give much improvement over the best of present standards. There have, it is true, been many improvements to receivers in the way of additions or devices for the convenience of the user, but the basic performance of the receiver has undergone little change. We hope that 1939 will not be so much an opportunity for adding extra devices to present broadcast receivers, but rather be used as an occasion for raising the standard of reproduction, of the cheapest sets, and at the same time increasing their reliability wherever possible.

Hitherto there has been some tendency both for reliability and quality to suffer when extra money has had to be found for incorporating new gadgets and then trying to sell the sets at the same price as before.

Television should pass through a very interesting stage during 1939, and we may anticipate marked progress. As 1938 comes to an end we look back to observe that much of the pioneering work has already been accomplished, and 1939 should see the establishment of the television service on permanent lines, with a definite policy. The production of receiving sets, too, should develop on sound lines.

Here we would take the opportunity of reminding our readers of a suggestion

we have made before, and which we still regard to be of importance. We refer to the desirability for manufacturers to adopt standardisation in television receiver design as far as possible, in order to facilitate both manufacture and the subsequent service. Standardisation, too, would reduce cost, particularly in the early stages, when it is so desirable that receivers should be put out at low prices, but still give the manufacturer a fair return.

It will be a disappointment if 1939 does not also see the introduction of legislation to control the troubles of interference. We know that a new wireless telegraphy Bill is being prepared, and that it will incorporate clauses to give the Postmaster-General wide legislative powers in the matter of electrical interference. It is to be hoped that this Bill will be presented early in 1939 and that by the end of the year we shall be well on the way to remedying this most distressing source of trouble to broadcast reception and particularly to television.

Autoocracy Versus Democracy

British and American Systems

WE are seldom impressed by arguments put forward to prove that the American system of broadcasting is superior to our own. When Mr. David Sarnoff, head of R.C.A. and N.B.C., claims that the free-for-all American system is a safeguard to democracy, we read into his remarks the natural inference that he considers a usurping dictatorship might more easily obtain control of a unified system such as the B.B.C. than of a diversified system like that of America. But is not public opinion the real protector of the B.B.C. against usurpation?

Wireless Communications

THE YEAR'S PROGRESS IN NON-BROADCAST FIELDS

By **LT.-COL. CHETWODE
CRAWLEY, O.B.E.**

THE International Telecommunications Conference, which takes place every five years, was held this year at Cairo during February and March. Seven hundred delegates from seventy-two countries took part, and there were also two hundred other representatives of interested parties. Over 1,600 formal proposals were considered.

So far as wireless communications are concerned, the most important matter dealt with was the distribution of frequencies amongst the various services. Thirty-eight meetings were devoted to this most difficult question, and the settlement eventually arrived at is generally regarded as satisfactory. As usual, all services followed the example of Oliver Twist, and this time the Air and Broadcasting got the best helpings. Apart from the ultra-short bands, air services were allotted exclusive use of 975 kilocycles (a gain of 905), and gained 2,367 kilocycles in shared bands. Broadcasting was allotted exclusive use of 3,355 kilocycles (a gain of 460), and gained 100 kilo-

IN this, the last issue of the year, we follow our usual custom by publishing a survey of the developments of 1938 in telegraphic and telephonic communications. Considerable increases in the use of radio by small craft and lifeboats are recorded, and the application of ultra-short waves for short-distance telephonic links has been extended.

of 11,115 kilocycles (a loss of 648), and lost 395 kilocycles in shared bands. Amateur services were allotted the exclusive use of 2,600 kilocycles (a loss of 100), with no alteration in shared bands (785 kilocycles).

It will be seen, therefore, that the fixed services lost most, but their total wavebands are much the greatest. Broadcasting gained a useful addition of channels. Amateurs, who are well provided with exclusive bands, suffered a very slight reduction. The Air and Marine had mixed bags, with Air on top, which will, in practice, confine ship services to the low-tolerance marine bands, and

air services to the exclusive aeronautical bands. Television, too, was allotted bands in the 10-to-1-metre section, which were allocated for the first time. These frequency allocations do not come into force until next September.

Other changes of interest made at Cairo were that spark waves from ships are reduced to three—600, 705 and 800 metres; a new restricted operator's certificate for touring aircraft, requiring a speed of only 16 words a minute, is introduced; broadcasting to the public direct from ships is prohibited; the 600-metre calling and distress wave is not to be used for traffic except from ships in congested areas (e.g., the Channel) for single short messages only; the 181.8-metre wave is to be the distress wave for small craft in the European region; regulations regarding the authority of the master of a ship and the secrecy of communications are strengthened; G.M.T. is to be used in operating logs all over the world; an additional series of operating signals is introduced for air services; and some additions and changes are made in the present list of operating signals.

Other changes of interest made at Cairo were that spark waves from ships are reduced to three—600, 705 and 800 metres; a new restricted operator's certificate for touring aircraft, requiring a speed of only 16 words a minute, is introduced; broadcasting to the public direct from ships is prohibited; the 600-metre calling and distress wave is not to be used for traffic except from ships in congested areas (e.g., the Channel) for single short messages only; the 181.8-metre wave is to be the distress wave for small craft in the European region; regulations regarding the authority of the master of a ship and the secrecy of communications are strengthened; G.M.T. is to be used in operating logs all over the world; an additional series of operating signals is introduced for air services; and some additions and changes are made in the present list of operating signals.

Other changes of interest made at Cairo were that spark waves from ships are reduced to three—600, 705 and 800 metres; a new restricted operator's certificate for touring aircraft, requiring a speed of only 16 words a minute, is introduced; broadcasting to the public direct from ships is prohibited; the 600-metre calling and distress wave is not to be used for traffic except from ships in congested areas (e.g., the Channel) for single short messages only; the 181.8-metre wave is to be the distress wave for small craft in the European region; regulations regarding the authority of the master of a ship and the secrecy of communications are strengthened; G.M.T. is to be used in operating logs all over the world; an additional series of operating signals is introduced for air services; and some additions and changes are made in the present list of operating signals.

Other Conferences

There were also held the international conferences for broadcasting and air services which take place every year; and in April a World Radio Convention at which 51 papers were presented was held in Sydney in connection with Australia's 150th anniversary celebrations. In November the countries bordering the North Sea had a conference to overhaul

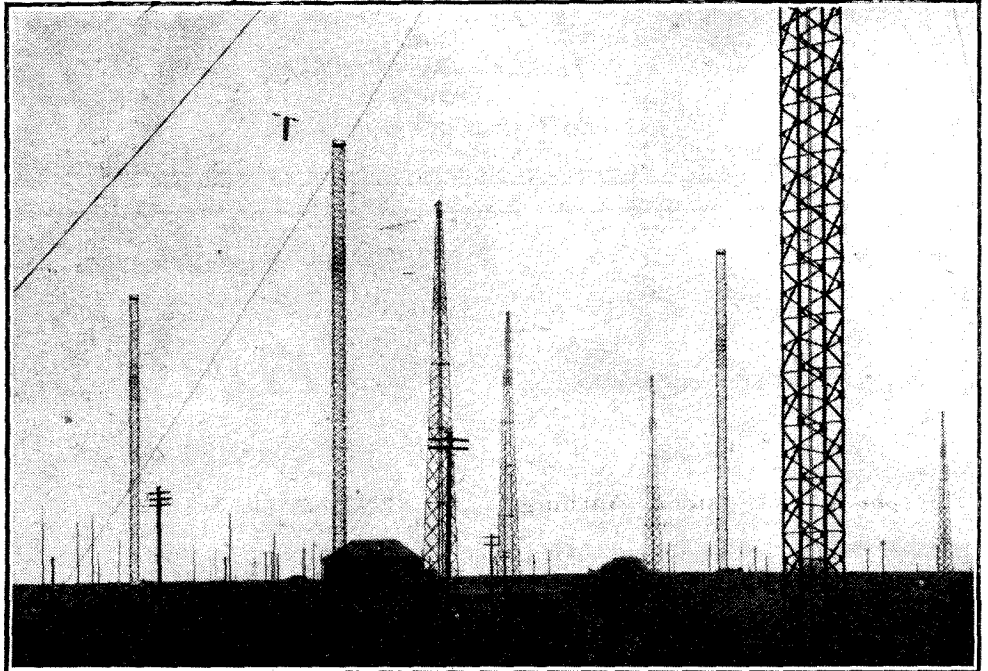

Part of the aerial system at Portishead Radio, which renders a truly impressive service to shipping by maintaining communication with vessels in all the Seven Seas.



Transmitting and receiving apparatus at North Foreland, the coastal station serving ships bound to or from the Port of London.

Wireless Communications—

the regulations regarding the communications of small craft, in view of some alterations made at Cairo in the waves available and other matters.

The number of these small ships fitted with telephone installations has increased rapidly in recent years, those in British small craft having doubled in the last five years. This has necessitated increasing the facilities for the communication of these small ships, mostly fishing craft, with our coast stations. A constant watch is now kept on the 181.8-metre wave by loud speaker at all stations whenever the station is not in actual communication with ships, and, in addition, special watch is kept by operators, which is, of course, better than loud-speaker watch, during scheduled periods at each station. The number of these periods has been increased during the year, and now averages 11 per station in the 24 hours.

Telephonic Navigational Warnings

This 181.8-metre wave is now being used also by our lifeboats for telephone communication with the coast stations, and 36 boats are already fitted. Owing to the increasing number of these telephone installations on board ship, arrangements were made last January to broadcast navigational and gale warnings from the coast stations by telephony, in addition to the broadcasting by telegraphy which has been in operation for many years.

The first British cross-Channel passenger ships to be fitted with telephony for communication through the coast stations

compulsorily. The latter number has not altered much in the last three years, whereas the former has doubled.

Great progress has been made in the collection of weather reports by wireless from ships at sea to form data for the weather forecasts with which we are all familiar. More than 10,000 of these reports were received at our coast stations from ships during this last year, which is about twice as many as were received three years ago.

As yet there is practically no passenger wireless traffic with aircraft, but the facilities for navigational and meteorological traffic have continued to expand during the year. The vital importance of the navigational service to aircraft may be judged by the fact that over 60,000 bearings were given in this country during the year to a total of little over 200 British aircraft; in fact, this navigational work is the primary function of the civil aviation wireless service. Its policy is to try out all possible systems and to use concurrently different systems which have each their own peculiar advantages, so that one may serve to a certain extent as a standby for another. Theoretically, ground DF's can work to an accuracy of two degrees, but in practice this requires the best conditions, including the use of Adcock aerial systems, which are often impracticable as presenting a serious obstruction to flying. Again, the use of ground DF's involves two-way communication, which leads to operational difficulties as the number of aircraft increases, and there is therefore a tendency to equip the aircraft with DF and use ground radio beacons of the track type, the omni-

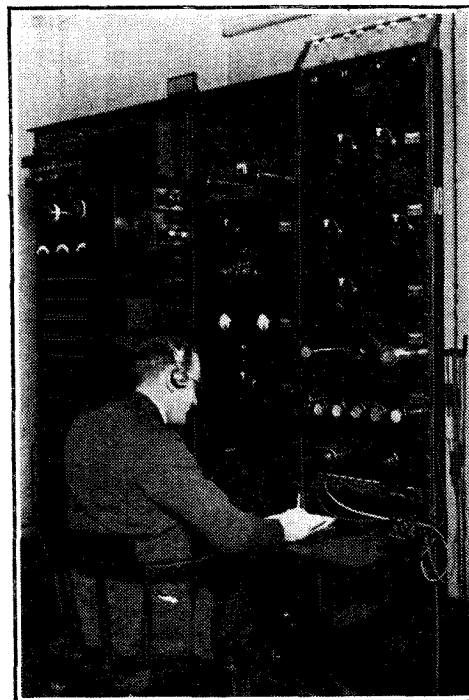

An operator on watch at Baldock, where long-distance radio-telephone traffic is received.

considerably expanded during the year, and, indeed, must go on expanding as more aircraft are fitted and more routes opened up.

The station at the Foynes air base on the Shannon has now been fully equipped to deal with the communications of the transatlantic air-mail service which is expected to make a start next year, and a conference was held in Dublin last spring

to arrange details of communication for the test flights which took place in the summer. Representatives from the U.S.A. and Canada attended, in addition to those from this country and Eire, and the arrangements made will hold good for the service next year.

The reduction in rates which has been such a striking feature in the progress of overseas telephone communication for the last few

Receivers at the Somerton beam telegraph station (Cable and Wireless, Ltd.).

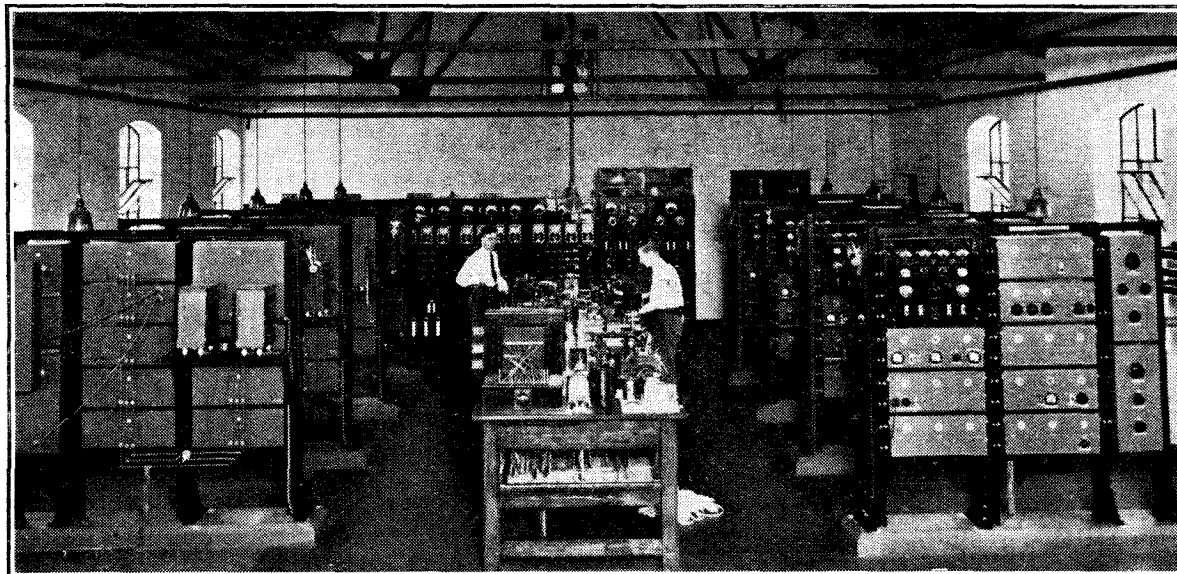

were the "Leinster" and "Munster," of the British and Irish Steam Packet Company. They were fitted early in the year, and in March demonstrated telephone communication when at sea, via the Seaforth coast station and thence by the Rugby-Baldock route, with the "Queen Mary," which was some hundreds of miles out on the Atlantic run.

The number of small British ships which are voluntarily fitted with wireless is now about 1,400, rather more than half the number of the larger ships which are fitted

directional type and the rotating type, according to circumstances. The problem of blind landing in bad visibility can hardly yet be considered as solved, but the employment of horizontally polarised waves of about 2 metres is expected to be useful for this purpose.

The wireless meteorological service for aircraft is also of the greatest importance, and there is a comprehensive system of collecting weather reports and distributing them by teleprinter land-line circuits and wireless broadcasts. This service was

years was much less marked this year, though there are still a few important reductions to record.

Perhaps, however, the most interesting telephone progress was in the realm of the ultra-short waves. About a dozen of these ultra-short-wave services are now in operation in this country, for communication with islands and across channels, e.g., Scotland-Ireland, six and nine circuits; Ardrossan-Arran, five circuits; Chaldon-Guernsey, four circuits; and Land's End-Scilly, four circuits, which was

Wireless Communications—

opened early this year. In these installations the transmitters utilise master oscillators with quartz crystals working at a tenth of the final frequency, and the receivers are of the superheterodyne type using an intermediate frequency of three megacycles with a similar crystal-controlled beating oscillator. They are extremely stable and require very little attention or maintenance.

Regarding rate reductions, in January, the rates to South American countries were substantially reduced, the new charges varying from £4 4s. to £4 16s. for three minutes' conversation, and £3 to £4 13s. on Saturdays; the Saturday rates to Egypt and neighbouring countries were reduced by 8s.; and the service with Portugal was extended to other circuits working through London. In May the hours of service with Malaya were extended so as to be available from 9 a.m. to 3.30 p.m.; and in November, the rate to New Zealand was reduced from £5 2s. to £4 10s.

As is well known, it is expected that the sunspot cycle which is due in 1940 will adversely affect these short-wave services, but especially those most distant from the earth's poles. The most important of these is the service with America, and during the year it was decided to erect a new receiving station in England which would incorporate special arrangements to combat the effects of this sunspot activity. These arrangements involve difficult conditions as regards the site, which had to be two miles long in the direction of America, and a quarter of a mile broad, the ground flat and reasonably damp, remote from roads carrying motor traffic, and fairly close to London so as to keep down the cost of the land lines. Eventually a suitable site was selected near Rochester, where there will be sixteen diamond-shaped aerials about 200 yards long and 60 yards broad, the receiver being at the end remote from America. It is hoped to have the station ready early next year.

On the telegraph side there were no new long-range services opened from this or other countries of the Empire, but several important services were opened between foreign countries: In January, between New York and Iceland. In March, between Shanghai and Tientsin. In May, between Peru on the one hand and Rome and Berlin on the other, between Lisbon on the one hand and Macao and Portuguese India on the other, and between Berlin and Columbia. In July, between Peking and Tokio, between Brussels and Warsaw, and between Amsterdam and Belgrade. In August, between Columbia and Brazil. In September, between Suva and Tahiti. In October, between Beyrouth and Saudi Arabia.

So far as the Empire is concerned, by far the most important development on the telegraph side during the year was the reduction in Empire rates, which was made in April. This was the result of an agreement between the Governments concerned and Cable and Wireless, Ltd., by which there were introduced flat rates per word

for all messages within the Empire. Broadly, the effect is an all-Empire rate of 5d. a word for letter telegrams, 7½d. for deferred, 10d. for code and 1s. 3d. for full rate plain language, but any existing rates that are lower remain unchanged, e.g., the plain language rate between the United Kingdom and Eastern Canada remains at 9d. a word. In most cases these new rates meant large reductions, e.g., the full plain language rates between Australia and India was 3s. 5d., between Great Britain and Hong Kong 4s. 7d., and between Great Britain and W. African Colonies 3s. It is hoped that these new rates, which were arrived at by concessions from the parties concerned, will prove of great value in encouraging closer relations between all parts of the Empire.

Civilian Wireless Reserve

AT the beginning of September last the Air Ministry announced its decision to form a Civilian Wireless Reserve consisting largely of amateur experimenters which would, if the need arose, provide a reserve of personnel experienced in the operating procedure of the Royal Air Force. The necessary qualifications and requirements were explained in *The Wireless World* at the time.

Up to the beginning of December nearly 1,000 had been enrolled in this new reserve, which has been organised so that the country is divided into four groups. Of these, two groups are now actively engaged in training exercises. There are 12 regional controllers in a group and each is responsible for the training of 20 reservists and a different frequency is allotted to each controller and his section. In addition, the controllers in any one group have allotted to them a common frequency on which communication is effected with the Air Ministry wireless station participating in these exercises. For example, all Group A controllers work on a common frequency of 2,583 kc/s (116.1 metres), while the Group B's frequency is 2,727 kc/s (110 metres).

Training exercises are carried out nightly between 7 and 9 p.m. at present, either between members of a group and their controllers or by transmissions from Cranwell, the R.A.F. Electrical and Wireless School, or from a new Air Ministry station erected near London and now almost ready for service.

Training is mainly undertaken by the members at their own homes and on their own sets; the transmission speed at the present time is moderately slow, being of the order of 12 words per minute.

The possession of a Post Office transmitting licence is not a necessary qualification for the Civilian Wireless Reserve, but a reasonably good knowledge of the Morse code seems to be essential, as the organisation does not enable instructions of this kind to be carried out.

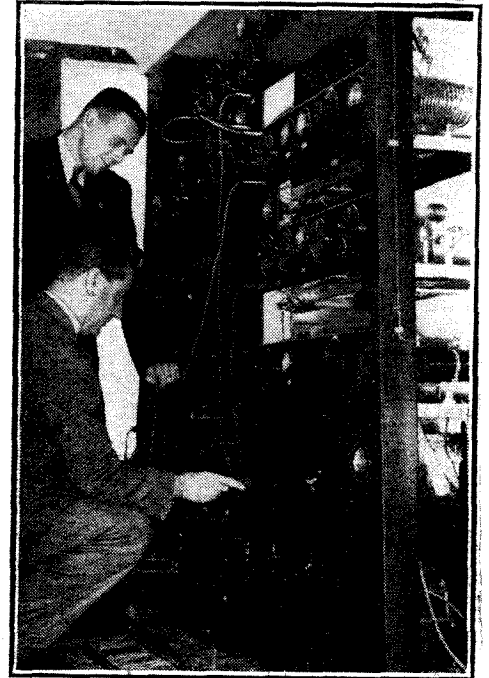

One of the Regional Controllers, Mr. J. W. Mathews, adjusting the transmitter at G6LL in the presence of the Chief Technical Instructor to the R.A.F. Civilian Wireless Reserve.

It was explained in our previous reference to the new reserve that the age limits are 18 to 54 years, so that in the event of the reserve being called on to augment the regular personnel of the Air Force Signal Branch those outside the age limit would most likely be allotted duties at ground stations and in connection with the various subsidiary signal services.

Those within the age limits of 18 to 30 years would have the opportunity of transfer to the R.A.F. Volunteer Reserve, which opens up to them all the activities of the Electrical and Wireless Section of the Air Force.

Training of members is not solely restricted to work at the reservist's home station, but arrangements are to be made for visits to Air Force wireless stations and other centres, while rallies will be organised during the coming year on somewhat similar lines to the field days held by radio societies.

The Civilian Wireless Reserve has its own Experimental Section, to which have been appointed experienced amateurs to deal with matters of design of transmitters, receivers and subsidiary apparatus based on the particular needs of this section. Several pieces of apparatus have already been produced and approved by the Director of Signals.

All members of the reserve have been issued with a button badge consisting of a shield surmounted by the eagle of the Royal Air Force. In the centre is a double-bladed axe with lightning radiating from it on a background of Air Force blue, with "R.A.F.C.W.R." beneath.

About 1,000 have already been issued and there are 500 more awaiting successful applicants, for the force is to be limited to 1,500. Candidates for the reserve should apply to the Under Secretary of State, Air Ministry (Signals C.W.R.), Kingsway, London, W.C.2.

Three-Band AC Super

CONSTRUCTION, OPERATION AND ADJUSTMENT

Concluded from page 565
of last week's issue.

A DISCUSSION of the early stages of this receiver up to and including the detector appeared in last week's issue, and it now remains to consider the AF amplifier. It can be seen from the circuit which appeared last week that this consists of a triode resistance-coupled to a pentode output valve, with negative feed-back over both stages.

The pentode is the EL3 and is rated to give an output of 4.5 watts into a load of 7,000 ohms with 10 per cent. total distortion. Of this about 9.5 per cent. is 3rd harmonic. For 5 per cent. total distortion the output is 3.2 watts. These figures are for the valve without negative feed-back, and when this is applied the distortion is considerably reduced. The output for really high quality can, therefore, be taken as about 4 watts.

The output valve requires a moderate input which is on the large side for direct feed from the detector and is certainly too great to be obtained directly from a pick-up. An AF stage is accordingly used and negative feed-back is obtained by injecting

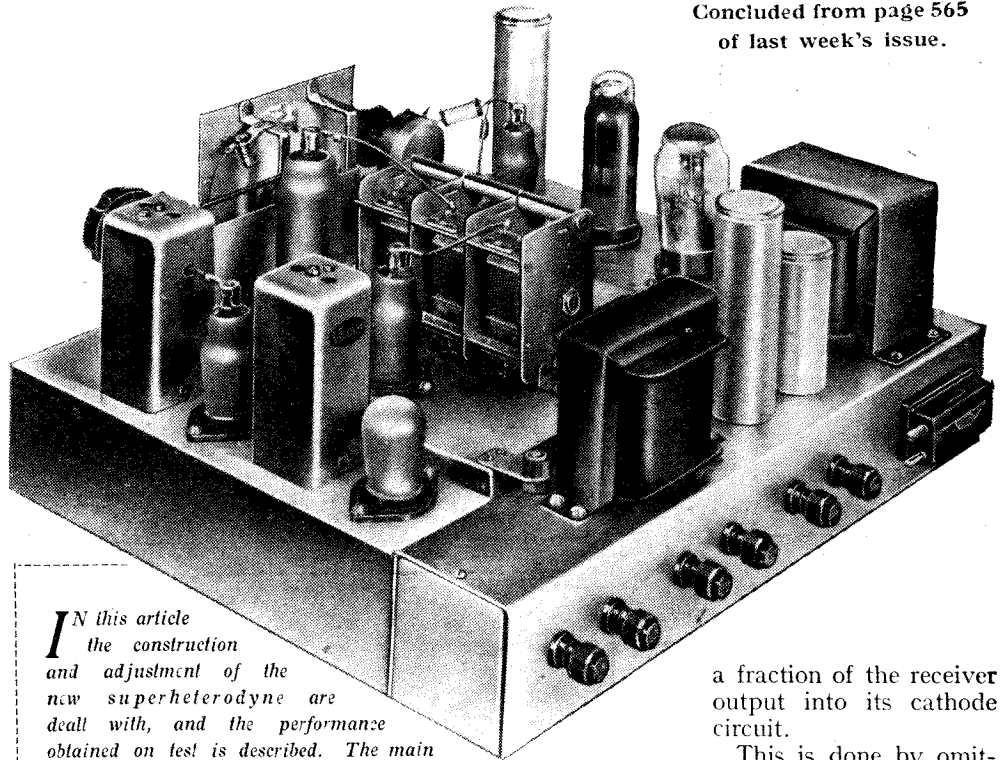

***I**N this article the construction and adjustment of the new superheterodyne are dealt with, and the performance obtained on test is described. The main features of the set are a high standard of performance with a straightforward design permitting ready initial adjustment.*

a fraction of the receiver output into its cathode circuit.

This is done by omitting a by-pass condenser to the bias resistance R25, and connecting the cathode to the pentode anode through the 0.4 megohm resistance R28 and the 0.1 μ F. condenser C37.

The valve used, the EBC3, is actually a duo-diode-triode. There is no simple triode in the "E" series of valves and when one is needed it is necessary to use the triode section of the EBC3 or to employ the EF6 with screen strapped to anode. The former is the more suitable in this case, and the two diode anodes are strapped to cathode and not used.

Diodes and Triode

It may at first seem strange that these diodes are not used in place of the separate duo-diode EB4. The reason is that for the circuit it is desired to use, which has many advantages, it is necessary for the two diodes and for the triode to have separate cathodes. If the EB4 were to be omitted, it would be necessary to adopt the conventional duo-diode-triode circuit giving delayed AVC. This would result in a considerable degree of distortion.

The mains equipment is straightforward and conventional. A full-wave rectifier, the AZ3, is used, and it is of the indirectly heated type. A single smoothing choke proves adequate in conjunction with high-capacity condensers.

No difficulty should be found in the construction if the drawings and photographs are carefully followed. With the exception of the leads to the IF transformer, the inter-chassis connections are bunched together and should be soldered to the tuner before it is dropped into the main

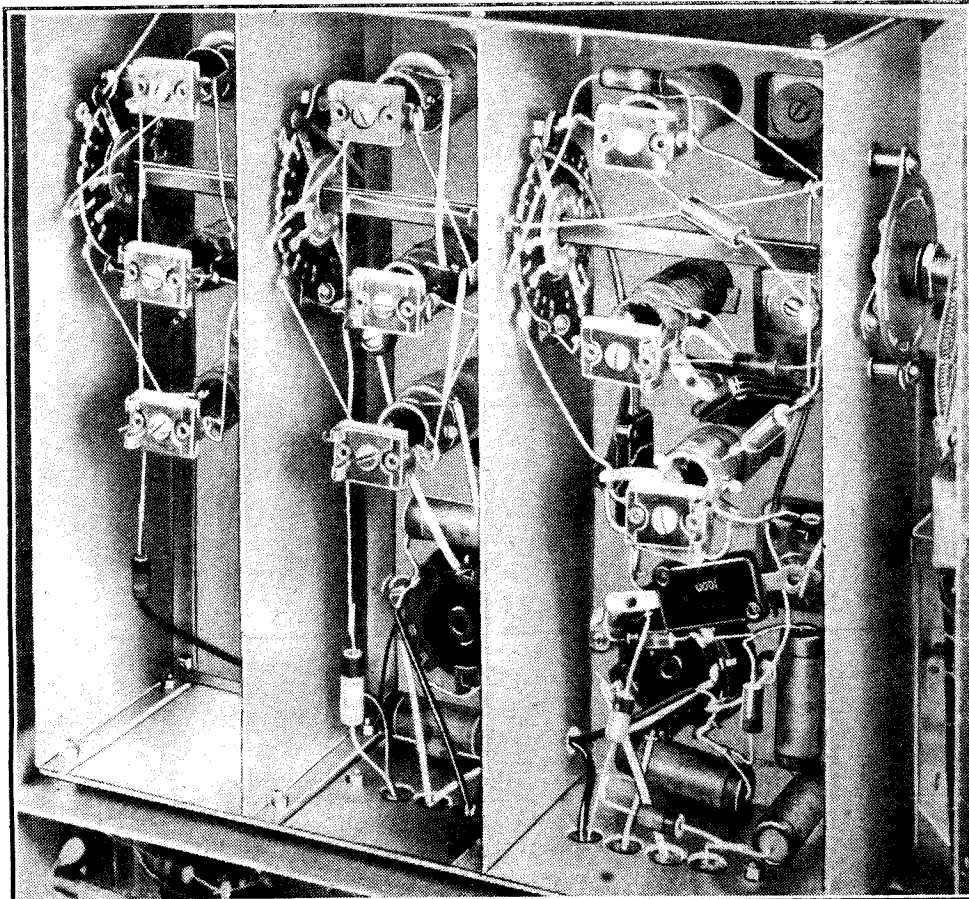

An underview of the tuner with the oscillator section on the right. From the top downwards the coils are, long, short, and medium wave.

THREE-BAND SIX VALVE AC SUPERHETERODYNE

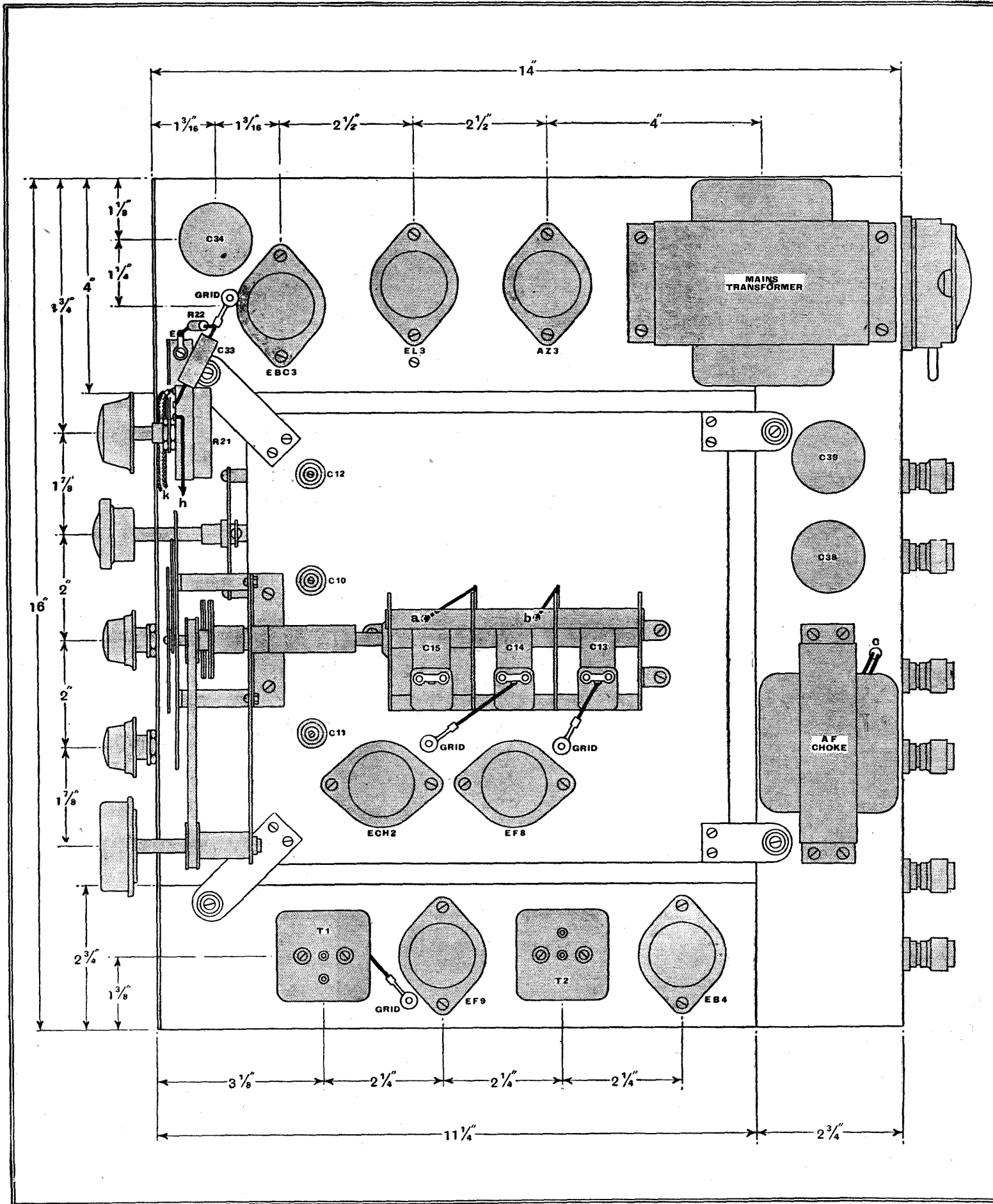

Assembly and Wiring Connections for the Complete Receiver Chassis

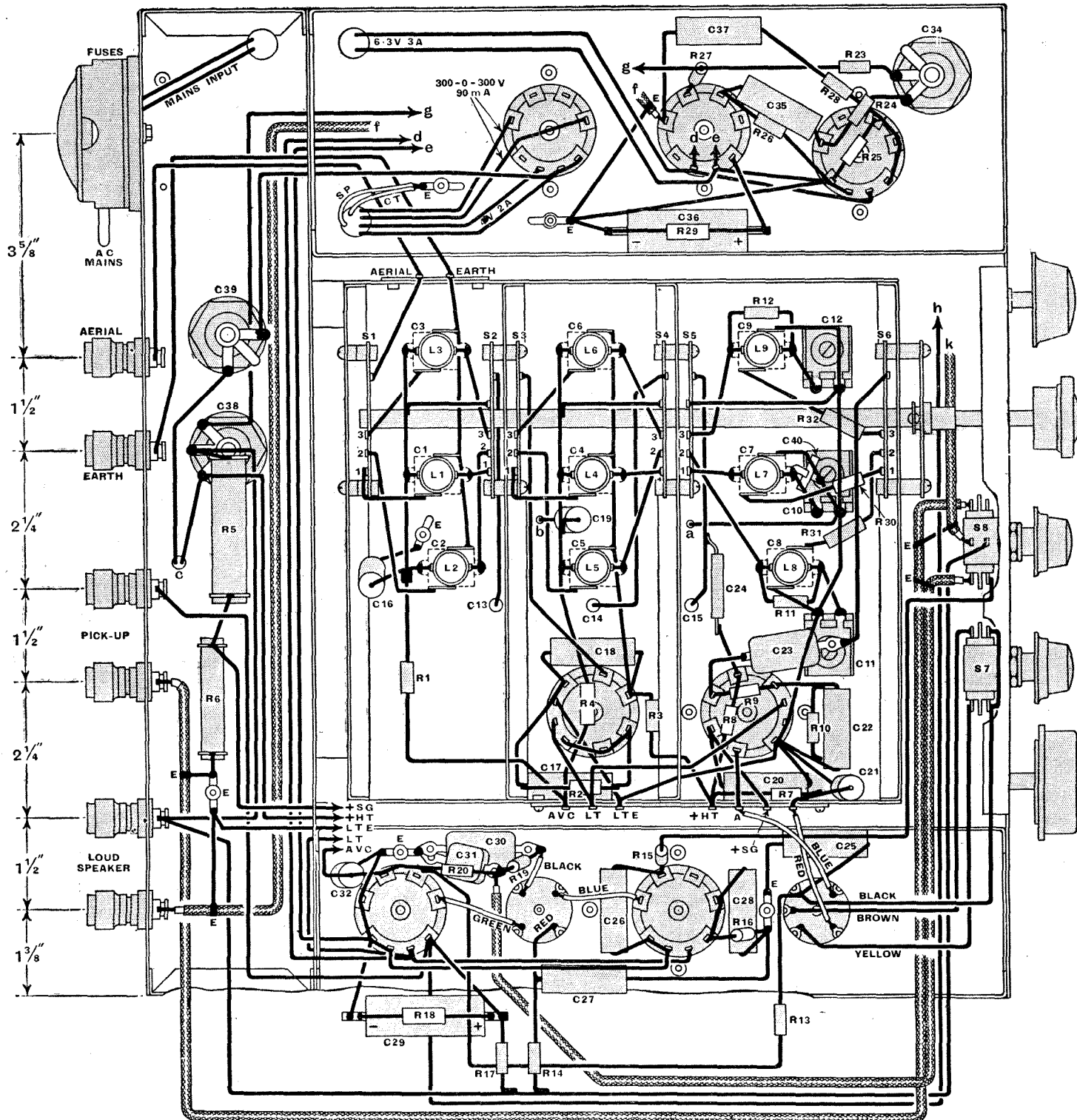

Three-Band AC Super—

chassis. The IF transformer connections can be made with the tuner nearly down to its final level, when the solder-tags are just accessible.

When setting up the receiver it is a good plan to start by checking the oscillator, since if it is not functioning nothing will be received and much time may be wasted. The oscillator is best checked by

For the initial adjustments a calibrated test oscillator is required. Set it to 465 kc/s and clip its output to the grid of the IF valve. Then adjust the two trimmers in the IF-det. transformer T2 for maximum response. The next step is to transfer the oscillator output to the grid of the frequency-changer, and to adjust the two trimmers in the FC-IF transformer T1 with the selectivity switch S7 at maximum.

than this should be used. Adjust the signal-circuit trimmers for minimum reading of the meter.

Set the test oscillator to 1,400 kc/s and tune the set to it by the main tuning control, using the meter as an indicator of resonance, and retrim the signal circuits. Then reduce the test oscillator output considerably and remove the short-circuit from the set oscillator. Now tune in the signal on the oscillator trimmer C8.

The next steps are to reapply the short-circuit to the set oscillator, to set the test oscillator to 600 kc/s with large output, and to tune the set to it by the main tuning control, using the meter as an indicator of resonance. Remove the short-circuit and reduce the oscillator output, and then adjust the oscillator padder C11. After this there is nothing to do but to go back to 1,400 kc/s and readjust the trimmers as before.

The procedure on the long waveband is the same, but the two frequencies of adjustment are 300 kc/s for the trimmers C3, C6 and C9, and 160 kc/s for the padder C12. It is best to start with the trimmers nearly fully screwed up and to tune in the 300 kc/s signal. Then adjust the trimmers carefully for maximum output. With the receiver oscillator short-circuited, the test oscillator set at 160 kc/s, and at large out-

In this photograph the whole of the underside of both receiver and tuner is clearly shown.

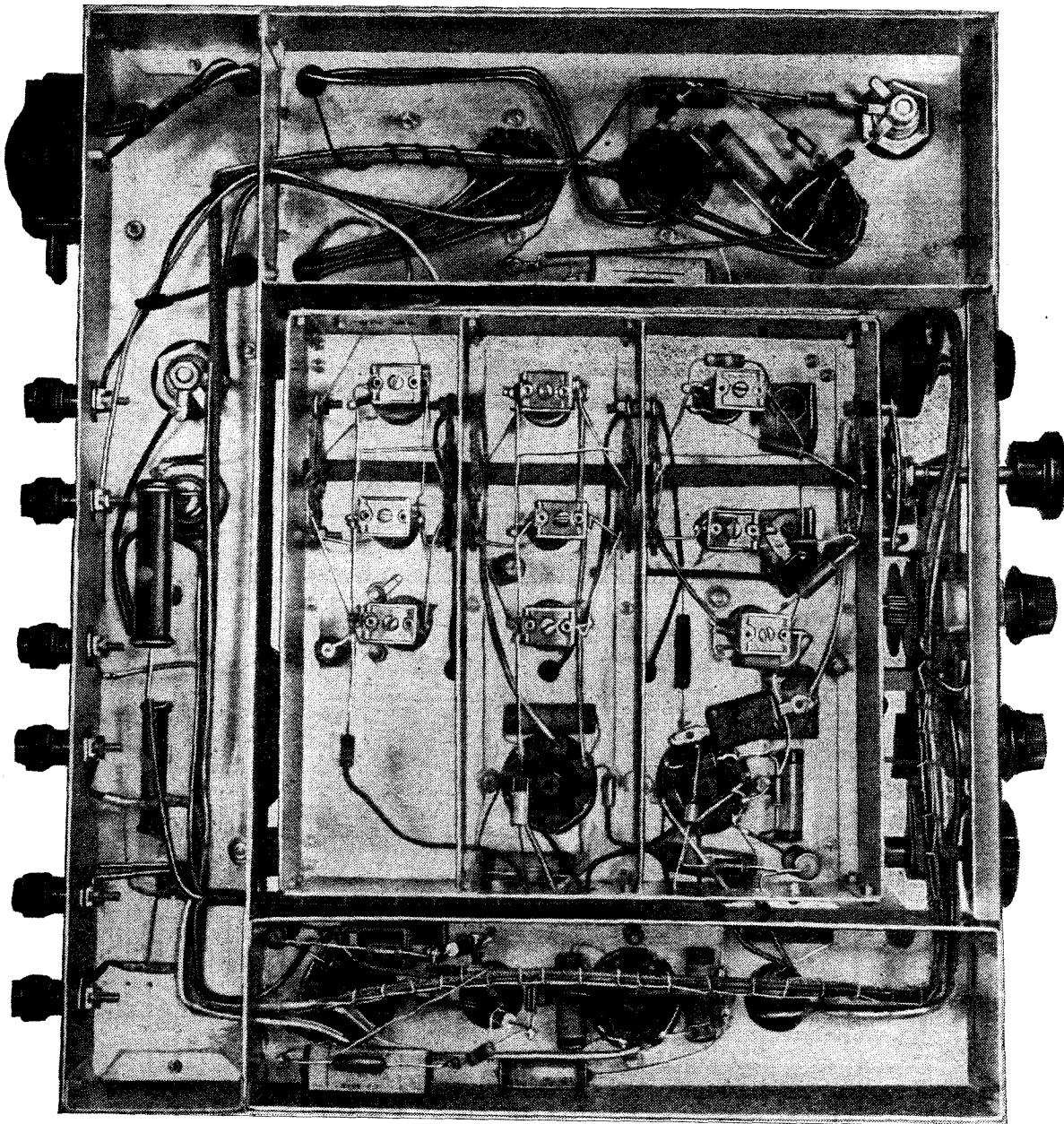

connecting a milliammeter in series with R9 and on the cathode side of it. On medium and long waves the current should be 0.2-0.3 mA., and will vary slightly with the tuning. On short waves the current will be lower and will normally be 0.15-0.2 mA. Efficiency is likely to fall off seriously if the current is less than 0.15 mA. and parasitic oscillation is highly probable if it is greater than 0.25 mA. on short waves.

Should the valve not oscillate, the current will be nearly zero and the most probable cause is that the coils are connected incorrectly. Check the wiring and, if all is in order, try reversing the leads to the reaction coil concerned; that is, the grid coil.

This completes the IF adjustments and the signal and oscillator circuits must now be done. Begin on the medium waveband with the test oscillator set at 1,500 kc/s (200 metres). With the tuning condenser at minimum capacity, tune in the signal on the oscillator trimmer C8 and then adjust the two signal-circuit trimmers C2 and C5 for maximum response.

Adjusting the Ganging

Now short-circuit the oscillator reaction coil by a short lead terminated in spring clips, and connect a voltmeter across the bias resistance R16 of the IF valve. As the output of the test oscillator is increased a point will be found at which the meter reading falls, and a little larger output

put, tune in this signal, remove the short-circuit, and adjust the padder C12.

On short waves the procedure is not so precise and the adjustments may consequently be a little more difficult. Set the tuning condenser at minimum and the test oscillator at 18.75 Mc/s (16 metres). Tune in this signal on the trimmers C1, C4 and C7. Then swing the test oscillator over a small range and note the frequencies of the two settings at which a signal is obtained. The signal for one setting will be much stronger than for the other. If this is the lower frequency (longer wavelength) of the two, all is well. If it is the higher frequency the set has been trimmed to the wrong oscillator beat. Set the test oscillator to the lower frequency and unscrew

Three-Band AC Super—

the set oscillator trimmer C7 to the lower capacity of the two settings which give the signal.

The next steps are to set the tuning condenser with the vanes about one-tenth the way in, to swing the test oscillator to tune with the set, again making sure that the lower frequency setting of the two possible ones is used, and then to readjust the two signal-circuit trimmers C1 and C4.

Now set the test oscillator to about 40 metres and tune the set to it. Adjust the padding condenser C10 while rocking the tuning control backwards and forwards over a few degrees until the optimum combination of settings is found. This completes the adjustments.

On test the receiver was found to give a highly satisfactory performance. The sensitivity is of a high order and ample for all ordinary requirements. The selectivity is quite high and adequate for general broadcast reception. While naturally lower than that of a communication receiver, it proved adequate for broadcast purposes and during the tests no case of serious interference on the more useful transmissions was noted.

Mains hum was inaudible during the test and the signal-noise ratio was good, being distinctly above the average. Quality of reproduction reached a very

high standard and would satisfy all but the hypercritical. The automatic volume control system functioned well and proved completely adequate for smoothing out all but the worst of the volume variations introduced by fading.

At the extreme bottom end of the long waveband signs of instability were found. They appeared below any broadcast station on this band and were due to the signal-frequency circuits becoming tuned to a frequency closely approaching the intermediate frequency.

The avoidance of this effect would entail either the adoption of a much higher degree of screening or a reduction of the amplification. Since the instability occurs at a part of the band which is normally never used, it was felt that neither course was justified and the tendency has been allowed to remain.

A very large number of signals can be obtained, and on short waves very distant transmissions are receivable under suitable conditions. The 16-, 19-, 25- and 31-metre broadcast bands are usually capable of providing some signals, and at suitable times there are plenty of stations on the 20- and 40-metre amateur bands.

Tuning is very sharp on this band, of course, and the control must be rotated slowly if stations are not to be passed over and missed.

is now a permanent magnet giving a field of about the right strength for focusing. A small winding W is provided, and according to the direction of winding and current flow its field will assist or oppose

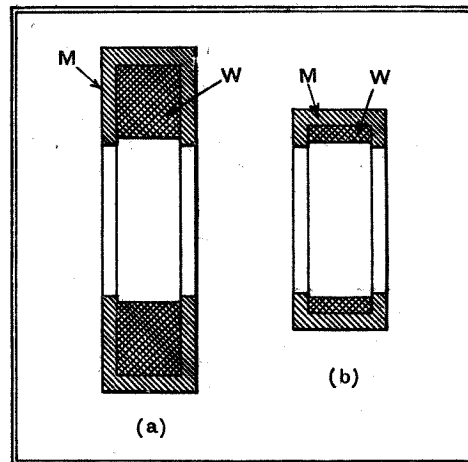

Fig. 2.—The relative sizes of an electromagnet (a) and a combination of permanent and electromagnets (b) are shown here.

that of the permanent magnet. Focusing can thus be controlled by varying the current through this coil.

About 90 per cent. of the weight of copper can be saved as compared with the electromagnet, and as the resulting winding occupies less space the iron dimensions can be reduced with a further saving.

Television Topics

ELECTRON LENSES

IN a cathode-ray tube the electron lens system by which focusing is achieved is open to most of the defects of an optical lens. Spherical aberration may exist, for instance, and it is usually necessary to shape the electrostatic field specially to avoid it. Various ways of doing this are available, but one which is especially interesting is illustrated in Fig. 1. Referring to the drawing, electrodes A and B form part of an electron gun and an electron lens is formed between the adjacent ends of these electrodes. A glass tube C, which is of sufficiently small diameter not to intercept the electron beam undesirably, is supported on the axis of A and B by a metal tube D which is itself supported by three radially disposed metal arms E. These arms, of which only

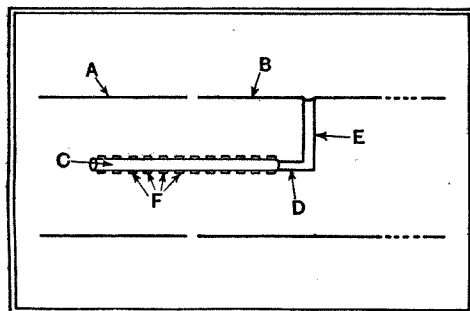

Fig. 1.—This diagram shows a sketch of an electron gun with a method of correcting for spherical aberrations.

one is shown, are fixed to the electrode B and are thus maintained, together with the tube D, at the same potential.

A number of metal rings F are mounted spaced apart along the glass tube and have potentials applied to them by conducting leads which pass through the glass tube C and its supports. These leads are shielded by the tube D and arm E, and the potentials applied to the rings are such that the field due to them is of the right shape to correct for spherical aberration due to the electron lens of the gun proper.

Magnetic Focusing

In many cases, of course, magnetic focusing is used instead of electrostatic, and the problems involved are then somewhat different. One is the chiefly mechanical drawback of the large size and weight of the electromagnet. Usually it is constructed on the lines sketched in Fig. 2 (a), where it is clear that the winding W is surrounded by an iron casing M.

The electromagnet could easily be replaced by a permanent magnet if it were not necessary to have an adjustment of the magnetic field for focusing purposes. The difficulty can be overcome, however, by using a combination of electro- and permanent magnets on the lines sketched in Fig. 2 (b).

It will be seen that the general arrangement is the same as that of the purely electromagnetic system, but the iron case

Club News

Southend and District Radio and Scientific Society

Headquarters: Strand Chambers, High St., Southend.
Hon. Sec.: Mr. J. M. S. Watson, 23, Eastwood Boulevard, Westcliff-on-Sea.

At the meeting held on December 16th Mr. J. Sewill gave a talk on "The Design and Development of PA Amplifiers." Later, he demonstrated one which he had constructed.

Stockport Amateur Short-wave Society

Hon. Sec.: Mr. S. Pearson, 89, Northcliffe Road, Offerton, Stockport.

The first meeting of this newly formed society was held on December 13th. The society's aim is to develop short-wave listening and amateur transmitting. Lectures on short-wave reception and transmission will be given and facilities will be provided for slow-morse practice. The next meeting will be held on January 4th and those interested are invited to communicate with the hon. secretary.

Surrey Radio Contact Club

Headquarters: The Alhambra, Wellesley Road, Croydon.
Meetings: First Tuesday in the month at 8 p.m.

Hon. Sec.: Mr. A. R. Willsher, 14, Lytton Gardens, Wallington.

The annual dinner was held at the Café Royal, Croydon, on December 8th. Thirty-five of the sixty members present were fully licensed transmitters. After the speeches, a lucky draw was held for prizes presented by leading manufacturers. Following this there was a musical entertainment and a spelling bee.

The next meeting will be held on January 3rd, when one of the oldest members will relate some experiences of his radio career.

Ashton and District Amateur Radio Socy.

Headquarters: Commercial Hotel, 86, Old Street, Ashton-under-Lyne.

Meetings: Alternate Wednesdays.

Hon. Sec.: Mr. K. Gooding, 7, Broadbent Avenue, Ashton-under-Lyne.

Twenty-four members attended the December 14th meeting when Mr. W. P. Green lectured on "Electrolytic Condensers." The morse classes have now been put on a proper basis and G3FF has been appointed official morse instructor. A beginners' class is held on Wednesdays, and an advanced class on Fridays. 2CDY has provided a mains-driven audio-oscillator and loud speaker, so there is no longer any need for members to bring 'phones.

A party of twenty visited the B.B.C. station at Moor-side Edge on December 17th. Mr. Collinge, of Ferranti, Ltd., is to lecture on "Electrical Measuring Instruments" on January 25th.

UNBIASED

De Hereticis Comburendis

By FREE GRID

I AM very glad to see that "Cathode Ray" has lent the full weight of his pen to my demand that the old error of asserting that the current flows from the positive to the negative of a battery instead of vice versa, should be duly acknowledged and corrected. If I had my way all the existing text-books would be burnt and new ones issued with the carbon pole of a dry cell boldly marked negative. After all, we no longer tolerate in our schools text-books which state that the earth is flat instead of round—at least, I presume we don't.

I am hoping that as a result of enlisting this valuable support in favour of polarity reform to be able to proceed still further with my campaign for cleansing radio and, indeed, electrical science generally of still greater heresies which cause such schism in our ranks and bring us all into grave discredit in the eyes of the thinking layman. I am particularly incensed at a statement I saw recently in an article I read which purported to instruct the uninitiated in the elements of wireless. The writer starts off very properly by an exposition of Ohm's Law, that work upon which the whole science of electricity is founded, but having done this he proceeds to go into detail about what he calls instances of where Ohm's Law fails.

This iconoclastic writer first deals with the question of the electric lamp, such as we use in our homes, and points out that if we use it on a higher voltage than that for which it is intended, "the current flow will be much greater than that which Ohm's Law indicates." As if this were not enough, he passes on swiftly into the realm of radio and tells us that "the



Suggested badge of the Ohm's Law Protection Society.

sudden increase of current on applying a critical voltage to a carborundum crystal is another obvious negation of Ohm's Law." Finally, he gives the clue to his own criminality by stating that in the case of selenium and of photo-electric cells generally, "it is owing to the alteration of their internal resistance, due to the action of light upon them, that they do not obey Ohm's Law."

I think that you will agree with me that this sort of thing requires very strong

action indeed, and I am taking steps to found forthwith a special society to protect the memory of Ohm and his great work. The first thing that all self-respecting societies must have, of course, is a suitable heraldic emblem, and I have, therefore, spent a considerable time evolving the one which I reproduce herewith.

The B.B.C. Scores

ONE of the hirelings of Broadcasting House, who is on the secret payroll of my Intelligence Service, tells me that while hidden in a clothes cupboard the other day he overheard two members of the staff discussing important matters of state, from which he gathered that it is by no means impossible that before very long the B.B.C. may unbend sufficiently to provide us music-lovers with some more quality concerts on the ultra-short-waveband. Apparently a real surprise may be in store for us. It is as obvious to you and me as it is to the great ones up at the Big House, that it is just as much trouble for the engineers at the Alexandra Palace to have to switch on the sound transmitter only, as to have to switch on both the sound and the vision gear. Why not, therefore, let them switch on the vision transmitter also?

Before you all reach for your pens, however, let me say at once that it is nothing so tame and inane as the sight of the B.B.C. Symphony Orchestra doing its stuff that we are to see on our screens. No, the big pots at Portland Place, knowing how fond we music-lovers are of following the score of a concerto when it is being churned out, propose to arrange that the aforementioned score should appear on the screens of our receivers.

This is surely a most excellent idea, and there is only one suggestion I have to make to improve it. When a recital of gramophone records is given, a picture of the record should be flashed on the screen in magnified form, for, as I mentioned once before, after a little practice it is no more difficult to read a musical score from a gramophone record than it is to read it from the ordinary musical notation; in fact, the only type of record on which it is normally impossible to follow the score is the steel tape of a Blattnerphone, but the difficulty can be got over even in this case by sprinkling some iron filings on it.

New Year's Resolutions and All That

NOW that the Yuletide yodellings of the younger generation and the organised orgies of the past few days are things of the past, we can pause awhile to take stock of our doings in the past

year before setting forth with renewed determination in the approaching New Year to raise radio to an altogether higher plane than it at present occupies in our national life.

At this time last year, I remember, I endeavoured, rather unsuccessfully, to express the customary New Year's wishes in proper scientific form, and I thereupon drew down upon myself the wrath of certain chemical purists on the grounds that I had used the wrong formula and was inciting certain of my readers to poison themselves with raw alcohol. I suppose that it never occurred to any of these critics that this is just what I might have meant to do. To forestall any further criticism I would like to add that this statement does not necessarily mean that this was my intention. With our libel and slander laws in the bewildering muddle that they are, you cannot be too careful these days what you say and write, and it is my invariable custom to have these weekly notes looked over by a barrister of



Legal Censorship.

the High Court before sending them to the Editor, and you would be surprised at the alterations he finds it necessary to make sometimes.

In the early days of broadcasting, one of the foremost New Year's resolutions of a broadcast listener was not to annoy other listeners any more by oscillating. This was a very worthy resolution, but in these days of superhets it is, of course, quite meaningless. I do think, however, that it might well be replaced by a resolution not to use any electrical apparatus without first taking steps to have it fitted with suppressors. In my opinion, however, a far more important thing than this is to resolve not to operate the loud speaker at such a volume level that it annoys others. Why I regard this as far more important is that, so far as listeners are concerned, they are not likely to break the "no interference" resolution, for if they do it will affect their own listening as well as that of others. The loud loud speaker fiend, however, is quite impervious to his own cacophonous manifestations, and I sincerely hope that if any legislation is ever passed against electrical interference—as may well happen in the times of our great-grandchildren—acoustic interference will also be included in the ban.

I can think of a large number of resolutions apart from the above, but I never let myself forget that this is a family journal which the children are allowed to read, and so if you want to know them you must write to me.

Balloon Transmitters

By I. M. HUNTER

A DESCRIPTION of an automatic transmitter designed for fitting in a balloon used in carrying out investigations on the electrical properties of the upper atmosphere.

THAT form of highly penetrating radiation known as "Cosmic Ray" has been studied very intensively in recent years, and it is believed that it is due to an ionising agency entering the atmosphere from outside. The detailed behaviour of the radiation is very complicated, first, because the nature of the radiation undergoes profound changes as it traverses the atmosphere, and, secondly, because the earth's magnetic field deviates any moving charged particles contained in the radiation. For the purpose of understanding the fundamental processes involved it is advantageous to take observations at different heights in the atmosphere and at different magnetic latitudes.

One of the aims of an expedition which went to West Greenland in the summer of 1937 was to study the intensity of cosmic radiation at great heights near the geomagnetic pole. This expedition was led by Mr. W. J. M. Wordie, and the physicists responsible for the methods of observation were E. G. Dymond and H. Carmichael. Two different methods of observation were used in the cosmic ray experiments, and in one of these apparatus was taken to a height of about 20 km. by a free balloon. The apparatus was arranged to register the "number" of cosmic rays at different heights and to transmit wireless signals to the ground in such a way that the rate of counting and the altitude of the apparatus could be recorded by an observer on the ground. It is the purpose of this article to give an account of the wireless apparatus developed for this purpose.

Recently several types of apparatus have been developed for the radio transmission of information from unmanned balloons, and a summary of the methods employed in meteorological work has been given by Wenstrom¹ and Lange.²

¹ *Monthly Weather Review* (Washington) Vol. 62, p. 221 (1934).

² *Bulletin of the American Meteorological Society*, Vol. 18, No. 3, March, 1937, pp. 99-126.

Before discussing the radio apparatus, it will be convenient to explain shortly the several methods which are used for registering cosmic rays at ground level and the technique which has been developed by various observers.

Such methods may be divided into two main groups: first, where the total effect of the radiation is observed over a given period of time, and, secondly, when the individual particles are recorded. Classical work with the first type of apparatus was done in the ionisation chamber experiments of Regener in Germany and Millikan in America. Each of these workers observed the leakage of charge through an ionisation chamber as the contained gases were rendered conducting when subjected to the influence of the highly penetrating radiation.

Signalling from the Balloon

Individual particles are conveniently recorded by the counters devised by Geiger. These consist of two-electrode vacuum tubes into which small quantities of various gases are introduced. The elec-

FOR
INVESTIGATING
COSMIC RADIATION
IN THE UPPER
ATMOSPHERE

caused to indicate the passage of the radiation.

The direction of travel of the rays detected is readily determined by using three counters in conjunction with a suitable discriminating circuit (see the accompanying diagram). The counters are arranged in a row, and it will be seen that only when all three counters are operated simultaneously is an appreciable voltage developed across the common anode load of the associated amplifying valves. Such an impulse will, in future, be referred to as a coincidence impulse. It was this type of apparatus which was employed and elaborated by Dymond in 1937; the output voltage being caused to modulate the radio transmitter.

In view of the altitudes at which flights were to be made, weight and size were of the greatest importance among those factors governing the design of the transmitter.

The frequency chosen was of the order of forty megacycles, which would reduce to a negligible value interference from long-distance radio transmissions without encountering the severe constructional difficulties experienced when extremely high frequencies are employed. At the same time atmospheric disturbances would be very small, and the transmitting aerial would be of manageable proportions.

The apparatus would have to function under extreme ranges of

temperature and under a range of pressure extending from one atmosphere to less than one centimetre of mercury. The latter limitation was of more importance when applied to the batteries than to the transmitting portion of the apparatus; but the high temperatures encountered were likely to play an important part in determining the frequency of oscillation.

Whenever a particle passes through the counter it ionises the gas and renders the tube momentarily conducting, with the sudden development of a potential across the resistance, which potential can be

Although it was hoped to recover some of the apparatus, all the actual informa-

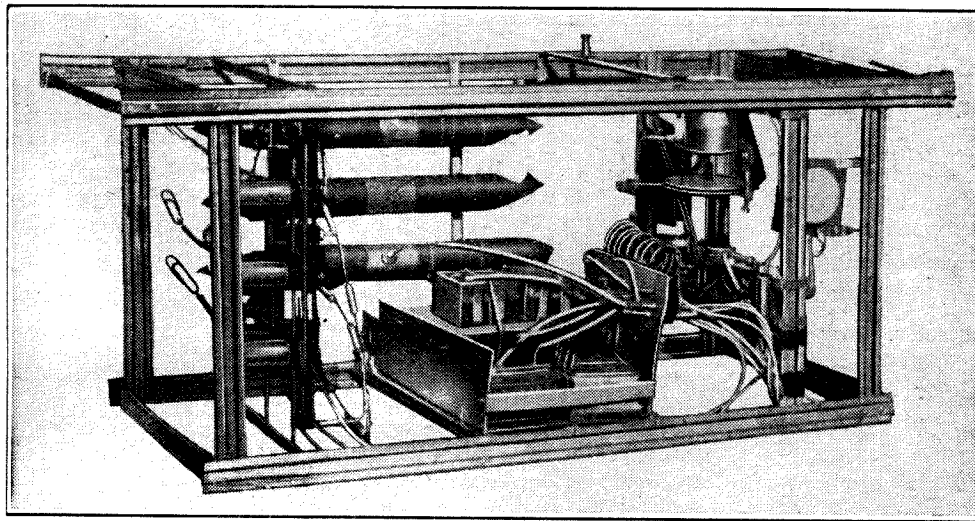

The complete transmitter, enclosed in a duralumin framework. Cosmic ray counters on the left, batteries in the centre and transmitting apparatus on the right.

Balloon Transmitters—

tion was obtained during the flight, and as this might last four hours the apparatus had to be extremely reliable. This reliability implied not only freedom from complete or partial breakdown but from errors introduced by the effects of temperature on the results transmitted. In addition, the apparatus had to be sufficiently robust to withstand transport by ship to Greenland without serious damage, and it was necessary for all parts to be conveniently replaceable or repaired with limited facilities. Launching the balloons was to be effected either from the ship, from the shore, or from ice floes, and here small size and robustness were of even greater importance than low weight. High winds were to be expected, subjecting the apparatus to continual buffeting, and there must, further, be no possibility of the aerial becoming entangled or short-circuiting against the metal gondola containing the apparatus.

Circuit diagram of the transmitter, including the cosmic ray "counters" and the automatic height signalling device, which is actuated by an aneroid (not shown).

It was also intended that signals from the transmitter should give an indication of the atmospheric pressure, and thus the altitude from which the transmissions were taking place. Accordingly a clock mechanism with an eight-minute cycle was fitted, which operated switches in the oscillator circuit, and thus caused a periodic signal to be sent out, from which the value of the pressure could be determined. Details of this switch are given later, but it should be mentioned here that each apparatus would have to be calibrated against pressure before each flight, this calibration being effected by means of a hand pump and a manometer.

Counter-Transmitter Unit

The complete circuit of one apparatus is shown in the figure. A, B and C represent the counters, each with a load of 10 megohms. Under "no signal" conditions, the three amplifying valves, V1, V2, V3, pass current, but the passage of a ray through any tube renders the appropriate valve grid negative (so that the corresponding anode current falls to zero). But only when all three valves are paralysed simultaneously is a large voltage applied to the grid of the modulator valve, V4.

The oscillator circuit is a conventional Franklin arrangement, which was found to work satisfactorily after a number of others had been tried. Under normal conditions, a paralysing bias is applied to the oscillator

valve V5 through the modulation transformer T, and the decoupling choke L2. The direction of the coincidence impulses is now arranged to be such that the change in current of V4 momentarily reduces the bias on the oscillator, and a short burst of oscillation takes place at a frequency determined by the oscillator inductance L and the condenser C1. When it is desired to transmit a signal indicating the value of atmospheric pressure, a switch S1 removes the fixed condenser C1 and replaces it by the variable condenser C2, the capacity of which is dependent upon the value of atmospheric pressure. This capacity change is effected by attaching one plate of

pletely cured by the insertion of a further resistance and capacity in series with the transformer. The only other difficulties encountered with the impulses appeared when a coincidence impulse caused the set to go off into continual oscillation and when modulator grid current damped out the impulses. The former was traced to the high impedance in the oscillator grid circuit, whereupon the inductance of the transformer was reduced by the permanent passage of 1 milliamp. through the primary winding: and the latter minimised by a permanent bias of 4½ volts on the modulator grid. Later a variable bias was applied through a potentiometer

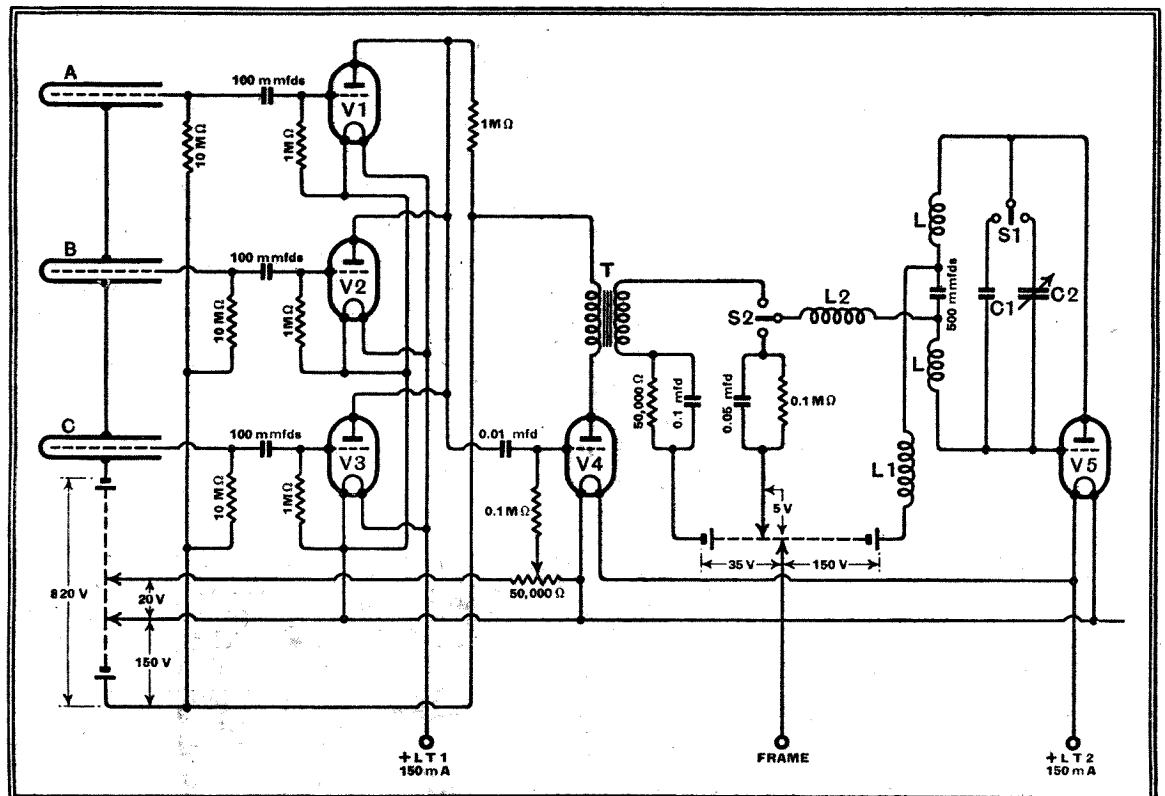

the condenser to an aneroid, so that alteration of the radio frequency transmitted is a measure of the atmospheric pressure.

As the intensity of cosmic radiation is very small at low altitudes, it was thought that it would be difficult to find the transmission while the frequency was varying. Accordingly, a further switch S2 changed the grid return lead to a different value of bias, which was applied through a resistance and condenser combination, which caused the valve to "squegg" and give bursts of oscillation at an audio frequency of the order of three cycles per second.

It will be noted that both on squeggs and coincidence pulses the average value of oscillator current was very low, current only being taken during the oscillatory period. Some care had, of course, to be taken to see that the direction of pulses was correct, and that the length of the pulse was not comparable with the shortest time likely to be encountered between successive pulses. Although pulses were very short when measured at the counter, some distortion inevitably took place in the transformer. This was almost com-

and proved invaluable during calibration, which was most conveniently carried out on single impulses.

The initial testing of the oscillator was carried out with continuous oscillation. Under these conditions the "midget" valves originally chosen for the sake of filament-current economy showed themselves insufficiently robust. Accordingly, the Mazda L2 was employed as an oscillator, the "midget" Mullard DA1 and DA2 being used as coincidence amplifiers and modulator respectively.

Aerial Current

The design of the oscillator and the arrangement of the aerial was largely governed by the necessity of transferring as much power as possible to the aerial over a considerable frequency range; and much time was spent in the measurement of aerial current obtained in different systems. The aerial finally chosen was a dipole of total length $\frac{3\lambda}{8}$, where λ is the shortest wavelength desired to be transmitted. Naturally, the aerial current did not remain constant over the frequency

Balloon Transmitters—

range employed (from about 30-45 Mc/s), but the optimum power transference was arranged to take place when the balloon was at its maximum height, and at this frequency the current obtained in the aerial (which was current-fed by direct tappings on the tuning coil) was of the order of 100 milliamperes.

The receiver was a 10-valve, commercially built AC set adapted to work from wet batteries. The output from this was fed to a "scale of two" vacuum tube counter designed by W. B. Lewis³ to reduce the number of coincidences to a value conveniently recorded by a thyratron counter. The reduction factor employed was eight, though intermediate numbers could be interpolated from "magic eye" tuning indicators, one of which was fitted to each stage of the reducing counter. This apparatus had a very high resolving power, and therefore care had to be taken to avoid its being fed with double-humped or distorted pulses. A cathode-ray tube was therefore connected across the receiver output as a monitor, both of waveform and amplitude.

In this form the apparatus was well tested. As the capacity of the batteries was such that a fall in voltage during the working period was anticipated, it was necessary to insure that the apparatus functioned over widely varying supply voltages. Some instability was traced to the common high-tension supply to the amplifiers and oscillator, but this was cured by the use of separate batteries. An apparatus tested at low pressure revealed no unexpected troubles. As a further test, a trial flight was made, and showed that ample signal strength was to be expected.

The batteries, which had been specially made by Väisälä in

The transmitter in its cellophane-covered gondola; photograph taken on board the Wordie Expedition's vessel.

Finland, were composed of accumulator positives and zinc negatives and developed a potential of 2.4 volts per cell. Four cells, of 0.3 ampere-hour capacity were employed for filament supply, and the high tension was obtained from eleven 90-volt units of 15 mA-hours. Each unit weighed about 150 grammes when filled with acid, and occupied 5 cm. x 2.5 cm. x 2.5 cm. (approx.).

The whole apparatus was supported in a frame of duralumin, and weighed 400 grammes complete. The counters were towards one end of the cage, together with their amplifying valves; and the modulator and oscillator were situated at the other end; at the centre of the cage was a presspahn tray containing the batteries.

³ W. B. Lewis, *Proc. Camb. Phil. Soc.*

The whole was inserted in a gondola composed of cellophane upon duralumin ribs, the gondola being suspended directly beneath the balloon. The accompanying photograph shows the gondola and apparatus ready for flight.

Twelve Miles Up

The apparatus worked satisfactorily up to a height of about 20 kilometres, and the results have been published elsewhere.⁴ Signal strength was ample, particularly in view of the very low background noise in Greenland. It is necessary, however, to record five difficulties which appeared.

(a) Some trouble was experienced with the clock switching mechanism, and in flight number three, therefore, the clock was removed and the apparatus set to count on variable carrier frequency all the time, and in spite of the extremely infrequent coincidences occurring at low altitudes, it was not found difficult to tune in the signals. This ease of tuning was helped by the fact that the aneroid-controlled condenser does not begin to move till a certain altitude is reached, and by the very great signal strength during the early part of the flight. A further advantage of the clockless method is that the observer can choose his own time to take readings of the counter instead of depending on the clock cycles, which may vary.

(b) Some trouble was encountered during transport from ship to shore where

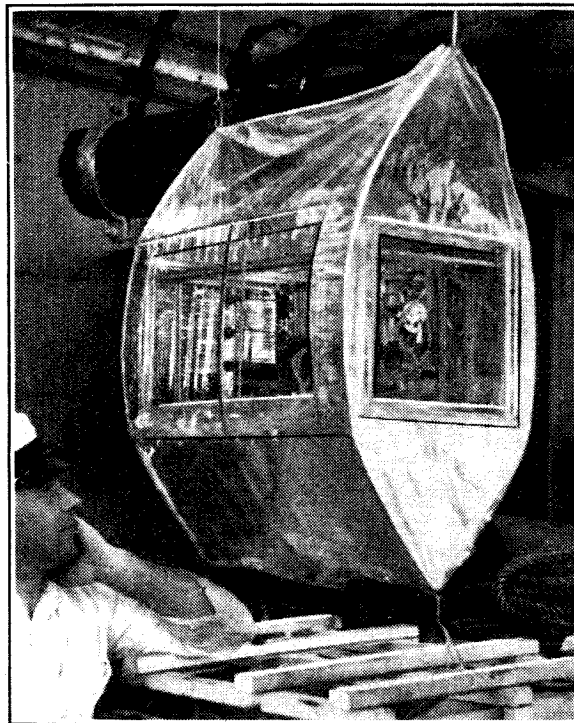

the release took place. During this process, the aerial had to be coiled up, and the apparatus subjected to a certain amount of rough handling, so that during this period irregularities tended to occur, from which the apparatus never properly recovered. In future flights it will be essential to ensure that the apparatus is working properly immediately before release.

⁴ Dymond and Carmichael, *Nature*, 21/5/38.

(c) At the altitudes reached, the temperature of the apparatus was almost completely governed by radiation, and could therefore be controlled by partially enclosing the apparatus in black paper. The area of the paper, however, could be only approximately forecast and considerable temperature change was to be expected. This change, which was made positive to avoid upsetting the Geiger counters, was found to have a serious effect on the frequency when transmission was taking place on the fixed frequency. This error is liable to be much less with the variable type capacity, but must be carefully watched.

(d) The winds in West Greenland were very slight and the apparatus often passed directly overhead. Some drop in signal strength, due to the directional properties of the transmitting aerial, was observed, but was not found likely to be serious unless occurring at maximum altitude, when signal strength was least.

(e) In the receiver employed, some trouble was experienced from harmonics, and second-channel images. These disappeared by the time the balloon had reached an altitude of 4 Km., but confusion was liable to arise at lower altitudes, unless care was taken.

In conclusion, it should be emphasised that no claim to finality in design is made for this apparatus. Developments of considerable importance were taking place up to the last flight, and a number of improvements have been made since the return of the expedition to England. Certainly not the least important result of the flight was the experience gained in design of the apparatus, and knowledge of the direction in which further experiment should proceed.

The Wireless Industry

FERRANTI car radio sets can now be obtained by a convenient instalment purchase plan through the usual agents. Enquiries from S.E. England regarding this plan should be addressed to Car and General Radio, Ltd., 35, Hugh Street, Eccleston Square, London, S.W.1, and from other parts of the country to Ferranti, Ltd., Moston, Lancs.

The "Astra" electrical gramophone reproducer, available in two-unit or self-contained form, is described in a booklet issued by The Gramophone Exchange, Ltd., 121/3, Shaftesbury Avenue, London, W.C.2.

Greenlee spiral screwdrivers, for which Gaston E. Marbaix, Ltd., Humglas House, 22, Carlisle Place, London, S.W.1, are agents, have the obvious advantage of an enclosed spiral. They are available with or without a spring return and in three sizes.

The 64-page 1938-39 catalogue issued by Leonard Heys, Faraday House, Henry Street, Blackpool, describes broadcast receivers as well as other electrical and mechanical apparatus. This publication is for trade circulation and copies will be sent post free on receipt of a card or letter heading.

Tungram has just issued a Comparison Chart dealing with large power and transmitting valves; free copies are obtainable for experimenters and traders. The chart shows the Tungram equivalents of various British, Continental and American makes.

Sound-on-Disc Recording

Methods and Processes in the Production of Pressed and "Direct" Recordings

THE recording machine used by manufacturers of pressed records is in reality an exceptionally high-grade precision lathe fitted with a horizontal face plate or turntable.

On the turntable a soft wax disc is placed and rotated under the cutting stylus, which moves across the face of the disc on a worm drive. By several means it is possible to control the number of grooves that are cut to the inch, the average number being 90. Most of the well-known gramophone companies build their own recording apparatus, and are most secretive concerning the details of its construction. The turntable is generally driven by a gravity motor, as fluctuations in angular velocity must be reduced to a minimum, and the gravity motor provides a simple, reliable and steady source of energy.

In certain types of equipment synchronous motors are employed, and in this case it is desirable that the motor be not located in the same framework that carries the turntable and cutting head. By a suitable distribution of the motor the shaft connecting motor and turntable may be broken up with a mechanical filter, thus preventing motor vibration reaching the delicate driving head and its associated stylus.

A modern recording system (in which are included microphones, amplifiers and cutting head) is designed faithfully to record all frequencies above 250. In actual practice the equipment is designed to accen-

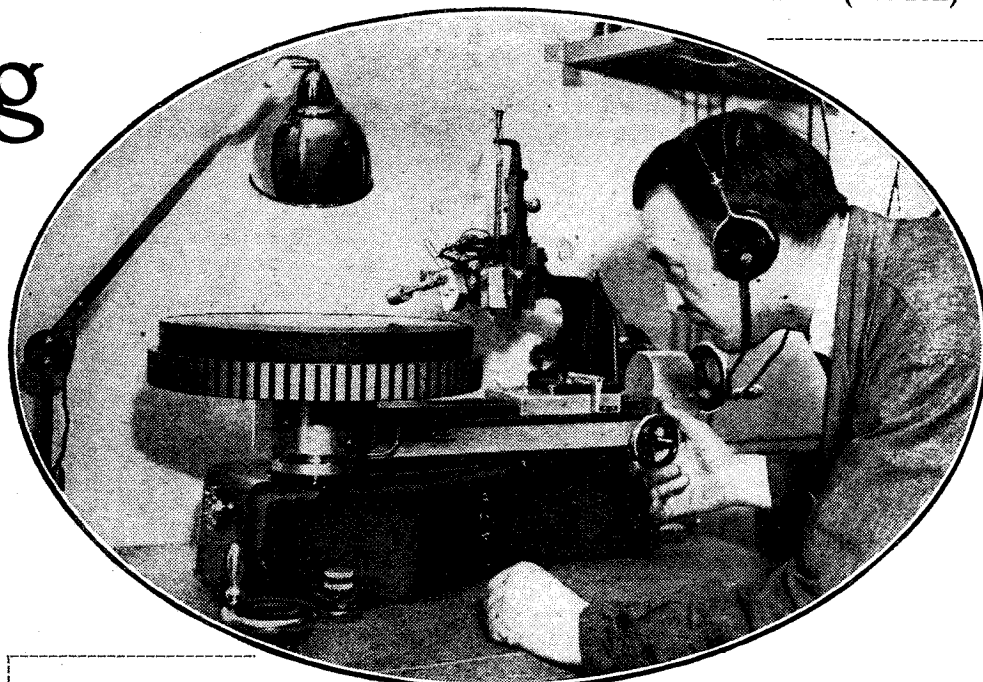

***T**HIS article, based on a paper read before the World Radio Convention, organised in Sydney by the Australian Institution of Radio Engineers, gives an excellent summary of modern practice in commercial, professional and amateur disc recording.*

master wax. A coating of the finest graphite is applied to its surface for the purpose of rendering it electrically conductive. It will be obvious that the surfacing of the wax master with graphite calls for the highest skill, otherwise the engravings might be distorted from their original position.

Plated Replicas

The wax master is now placed in an electrolytic bath and copper is deposited thereon until it is approximately 0.04 to 0.05 in. thick; this process usually takes about 10 to 14 hours. The process may be speeded up by adding, say, oxalic acid or ethyl sulphuric acid, but generally such a procedure is not resorted to by the better-class manufacturers.

The copper master, as it is now called, is stripped from the wax, cleaned and given a coat of iodine stripping fluid so that the copper master may be easily separated from the "mother," the manufacture of which is the next step to be taken. The copper master is placed in an electrolytic bath and nickel is deposited thereon to a thickness of 0.03 in. The copper and nickel plates are easily forced apart if the stripping solution has been carefully applied. Great care must be taken in handling the "mother," because this is a positive plate, and the slightest movement of a track towards an adjacent track due to unskilful handling will cause a distinct "echo" in the completed record. The process outlined in respect of the "mother" is now repeated for the purpose of producing what are known as "stampers." The "mother" may be used over and over again for production of stampers. These plates are now often

tuate the frequencies approaching the upper limit as this arrangement improves the quality of reproduction and substantially compensates for needle wear. Below 250 cycles the response falls off rapidly.

The greatest care must be taken in the manufacture of the wax and not less than 20 major conditions must be covered. Perhaps the most important requirements are as follows:—

- (1) It must be soft enough for the stylus to cut smoothly and cleanly without friction of the magnitude that will cause the stylus to chatter.
- (2) It must be homogeneous and of even density.
- (3) It must be unaffected by acid, metallic salts, or electrolysis.

Composition of Wax Masters

The greatest secrecy is maintained in the actual constituents of the wax blanks used by the major companies. There are, however, quite a number of well-known formulae available, one of which is made up as follows:—

Stearic acid, 37½ per cent.; lead peroxide, 7½ per cent.; caustic soda, 3 per cent.; vaseline, 8 per cent.; water, 9 per cent.; montan, 35 per cent.

After the wax disc has been engraved by the recording stylus it is described as the

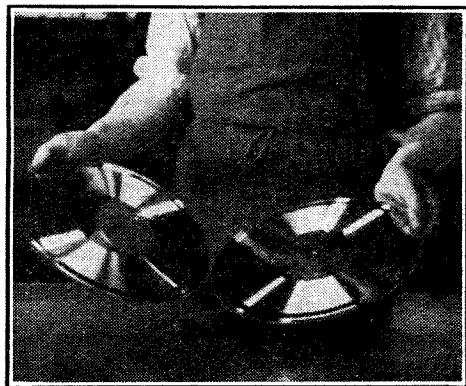

A nickel negative being separated from the copper master disc.

Sound-on-Disc Recording

made by forming a chromium layer on the "mother" of approximately 0.02in. thickness. The stamper is a negative plate and when this is locked to a hydraulic press and applied to the stock from which the gramophone disc is pressed the result is a positive disc, familiar to us all as the finished product.

At this stage it is of interest to comment on the extraordinary fidelity and accuracy that may be obtained by electrolytic deposition. It is possible to obtain an exact replica in nickel of lines only 0.00002 of an inch in width.

The exact composition of any given gramophone record is generally regarded as a trade secret. A typical formula, however, may consist of button lac 25 per cent., slate dust 65 per cent., carbon black 5 per cent., and cotton flock 5 per cent.

It is convenient at this stage to mention another type of commercial disc that has enjoyed wide popularity, namely, the laminated disc manufactured throughout the world under British patents. The laminated disc presents greater manufacturing problems than those produced from solid stock, but the finished product is superior. The method of manu-

ing costs, as the core of the disc is formed of the cheapest material, no shellac whatsoever being used in its manufacture. It is due to the fineness of the surface material that such excellent results are obtained with laminated records.

Radio broadcasting has demanded certain types of records to suit special circumstances. No doubt many of you have listened to recorded descriptions of events from broadcasting stations soon after the event had actually taken place. This means that a cheap and quick method of recording must be available. To achieve this end it is necessary that the actual disc on which the recording is done must be of a nature that permits it being used for reproduction purposes without any processing. Usually records of this type consist of an aluminium base carrying a coating 0.006 of an inch thick of nitro-cellulose

NEEDLE RESPONSE TABLE

Type of Needle	Frequency	Output Voltage
Loud tone steel needle.	20—4000	1.0
	4000—5000	0.9
	5000—6000	0.8
	6000—7000	0.4
Trailing needle...	50—400	1.0
	400—600	0.8
	600—1000	0.7
	1000—2000	0.5
	2000—3000	0.1
Soft tone needle	50—1000	1.0
	1000—2000	0.6
	2000—3000	0.4
	3000—4000	0.2
Fibre needle ...	40—1000	0.7
	1000—2000	0.4
	2000—3000	0.3
	3000—4000	0.1

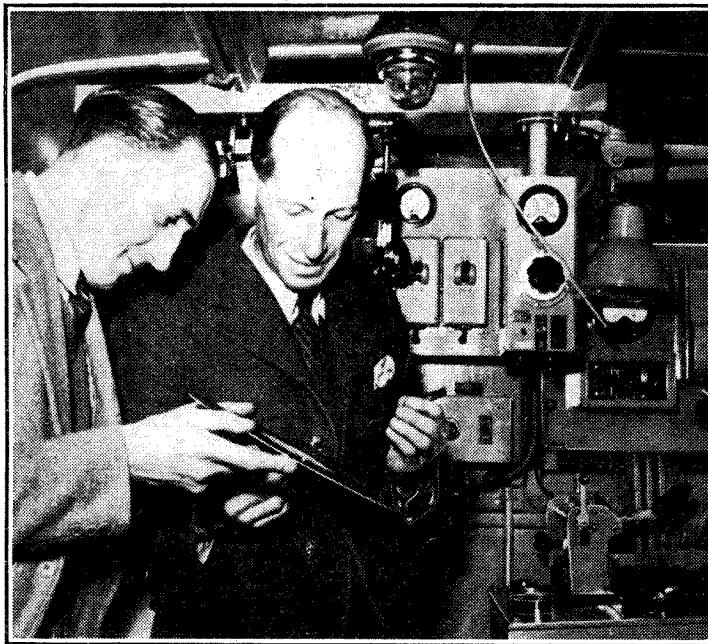

Examining a disc immediately after a direct recording had been made in one of the special vans used by the B.B.C. for outside work.

facture is to supply a core of plastic material consisting of barytes, silica, powdered mica and any of the several binders. Two discs of Kraft paper covered with a 0.025 mm. layer of fine thermoplastic powder (made up as follows: Carbon black 5 per cent., barytes 35 per cent., copal 2.5 per cent., shellac 22.5 per cent., aluminium silicate 35 per cent.) are pressed one on each side of the plastic core, the surface material taking the impressions from the two stampers. During the pressing period the surface material on the paper does not move outwards, whilst the core material is forced outwards. From the foregoing it will be readily seen that a very true impression of the stampers is obtained. The laminated record possesses a remarkably hard surface and consequently has a greater life, in addition to the fact that surface noise is lower than in other types of disc record. By using Kraft paper discs it is obvious that superior ingredients may be used in laminated records without unduly increas-

ing costs. This material is sufficiently plastic to be easily and cleanly cut by the recording stylus, yet hard enough to stand the pressure of a reproducing pick-up. It should be noted that the needle pressure on this type of record should not exceed three ounces.

Recording on celluloid is practical but is not a very satisfactory process, the noise level being unduly high owing to the granular structure of the material. In addition, celluloid becomes hard and brittle, with the result that the stylus does not make a clean cut, and the noise level is increased under these conditions still further. If the cutting stylus strikes a hard spot, the edge of the stylus usually becomes damaged and a noisy track is cut from then on. As celluloid is hygroscopic, it may be seriously affected by weather conditions, and under such circumstances the sound tracks will be distorted in such a manner that reliable reproduction cannot be obtained from the disc.

One of the chief difficulties in recording on cellulose-nitrate discs is that there is a tendency for the material to shrink with age, and to develop spots of unequal density. These spots are not readily ap-

parent and it is not until the recording is completed that their presence is known. The stylus cutting through the cellulose-nitrate and striking a hard patch will have its cutting surface damaged and the track cut thereafter becomes noisy as in the case of the celluloid disc.

At this stage a few figures will serve to illustrate how delicate are the engravings on a disc record and the strenuous conditions under which it is utilised. The width of the groove on the average English lateral-cut gramophone record is 0.006in. The distance between the grooves when the cutting stylus is receiving no impulses from its driving amplifier is usually of the order of 0.004in., and the depth of the groove is reasonably constant at 0.0025in. The groove wall has an angle of about 75 deg., whilst the radius at the bottom is approximately 0.0025in. The wall angle is, of course, controlled by the particular shape of the cutting stylus, which may vary between 60 deg. and 90 deg.

The length of the spiral groove on a 12in. disc may exceed 650 feet. This means that at the periphery the linear speed of the record under the reproducing needle is at the rate of 240 feet per minute, whilst at the end of the record the linear speed under the needle is down to approximately 86.7 feet per minute.

Consideration of the foregoing makes clear the difficulty experienced in recording and reproducing high frequencies towards the end of a record, assuming always that the recording commences from the periphery. With the standard gramophone record, the fall off in quality as the reproducing needle works towards the centre of the disc is readily apparent to the trained ear. Consider the problem from this angle. Assume that a recording commences from the periphery and works towards the centre, the last groove is cut two inches from the central spindle hole. At that diameter and at a speed of 78 r.p.m. approximately 16 inches of groove pass under the reproducing needle per second. Now, if the groove has been cut by a stylus that was being modulated by a frequency of 5,000 cycles per second, it will be seen that the wavelength engraved will be only

Sound-on-Disc Recording

0.0032in. in length. Now, when it is considered that the diameter of the ordinary needle is 0.003in. and its shape is being steadily distorted and its bearing surface increased as the needle wears, it will be readily appreciated that the needle experiences considerable difficulty in following faithfully the groove when high frequencies of the order of 5,000 cycles are being reproduced near the centre of the disc.

What actually happens in many cases is that the increased bearing surface of the needle causes it partially to ride on top of the groove, with the result that it cannot faithfully follow the small sinuosities, and as a consequence the output from the pick-up falls, resulting in what is termed "centre fading." If the recording were started from the centre we would have the advantage of a new and undistorted needlepoint that would be reasonably capable of following the closely packed sinuosities of a high frequency. As the wearing needle works out to the periphery the linear speed of the groove increases from 16 inches per second to 48 inches per second, resulting in increasing the wavelength of a recorded 5,000 cycle note from 0.0032in. to 0.0096in., thus affording the worn needle a better opportunity of following the groove sinuosities.

The question is often asked, "Why do some recordings commence from the periphery and work towards the centre, whilst others commence from the centre and work outwards, and does either system possess any advantages over the other?" The conventional gramophone record the world over commences from the periphery and works towards the centre. A habit has been established, and in spite of the now known disadvantages of the system the manufacturers are not prepared to ask the public to learn a new trick, simple though it may be. If the technician had the final say in such matters, all modern records would commence from the centre. Not the least significant point favouring a start from the periphery is the fact that the most valuable area of a disc is that at the outer edge. A recording that commences from the centre, no matter how carefully rehearsed, may conclude a half-minute before the planned time, with the result that the best portion of the disc remains unused.

Records for Broadcasting

The gramophone record has played an important part in the development of radio broadcasting the world over and it is difficult to imagine broadcasting without the aid of recorded music and speech. The wealth of talent available in recorded form has made possible the broadcasting of programmes of great merit by stations that otherwise could never finance entertainment on so grand a scale.

After a decade of commercial broadcasting, we find that records are being especially produced for broadcasting purposes. The best known of these special productions are called "electrical transcrip-

tions." Other types include the usual gramophone record, but carrying dramatic matter so arranged that record after record may be faded in to give the effect of an uninterrupted production of any length.

The so-called electrical transcription usually takes the form of a disc having a diameter of 16 inches and which is rotated at a constant speed of $33\frac{1}{3}$ r.p.m. Discs of this type are capable of carrying high-grade programme material of up to 30 minutes' duration on each side, still using the lateral-cut method of production.

At this stage a few remarks concerning reproducing needles will be of interest. In the first place, very few reproducing needles possess a sufficiently fine point to reach the bottom of the groove, but ride on the lower section of the groove walls. A badly shaped needle will ruin a record so far as high-class reproduction is concerned. It should not be taken for granted that every needle in a box is a good one, for this, unfortunately, is far from being the case. During the last four years shadowgraph needles have become very popular for reproducing electrical transcriptions or other valuable records. More often than not the owner of an electrical transcription will send a supply of needles with the record to avoid any chance of the record being damaged during reproduction. Shadowgraph needles are ordinary hard gramophone needles, but they have been individually inspected and their shadow projected on to a screen, when it is readily observed if they are distorted in any way. With the ordinary gramophone needle only an occasional needle is inspected, with the result that a number of distorted needles find their way on to the market, and many an excellent recording is damaged as a result.

Choice of Needles

Two important factors to be considered in connection with gramophone needles are the length and the compliance at the point. If a needle is over length when used with a conventional pick-up it has a tendency to whip, with the result that quality of reproduction is impaired and record wear is excessive.

The trailing needle, which is now quite a common sight in broadcasting stations, is used almost exclusively for reproduction of playback or positive-cut discs of the cellulose-acetate class. The trailing needle obviously presents a greater bearing surface to the record, with the result that the enormous pressure of 15 or 16 tons per square inch is reduced to 3 or 4 tons, resulting in less wear on the comparatively soft cellulose-acetate discs. It must, however, be borne in mind that high-fidelity reproduction is difficult to attain with needles of this type.

According to the type of needle used, so the output from an electromagnetic pick-up will vary. This is true when similar pick-ups are used and the material of which the records are made is identical. Another factor which would cause different

output voltages from identical reproducing pick-ups and needles would be the material of which the record was made. For instance, two similar pick-ups would deliver slightly different outputs if both were reproducing tone at 1,000 cycles from two discs, one being the usual hard-surfaced gramophone record and the other being a cellulose-acetate disc. This would be true even if a similar wattage were fed to the cutting heads whilst the two records mentioned above were being recorded. The reason for the two different outputs so obtained would be due to the fact that the elastic modulus of the acetate is far higher than that of the usual stock from which the orthodox gramophone record is made.

The variable outputs obtained by merely using different types of needles are shown in the table on the previous page.

"Hill and Dale" Recording

Previously all other references to records and recordings have been to the lateral-cut disc, which is now almost universal in its application. The vertical-cut disc, popularly referred to as the "Hill and Dale" method, possesses several advantages over the lateral-cut disc. It is possible to secure a slightly wider recorded frequency range than is permissible with a lateral-cut disc of similar dimensions. "Hill and Dale" discs may be safely cut with 200 grooves to the inch and, in addition, there is little difficulty in recording frequencies from 10,000 to 20 cycles per second. At the present time the extended available frequency range is not of great importance, as few receivers are capable of faithfully reproducing this range. It should also be borne in mind that unless broadcasting stations operating on adjacent channels are widely separated geographically, there would be undesirable "monkey chatter" if both stations were modulating 10,000 cycles simultaneously. In almost all countries, broadcasting stations are located in the broadcast spectrum 9 or 10 kc/s from carrier to carrier. In the vertical-cut disc the groove is cut to varying depths giving the appearance of a microscopic road crossing undulating country. The main factor limiting frequency in vertical-cut discs is the danger of the forces set up in the pick-up head exceeding the power that restores the needle to the bottom of the groove. It must not be thought that the restoring influence in this case is gravity, because records are made that have accelerations 800 times that due to gravity.

From the foregoing it will be seen that some mechanical restoring influence is employed to force the reproducing needle smartly down to the groove bottom after the needle passes the crest of a hill. As a matter of interest it might be mentioned that the Edison cylindrical records were cut on the "Hill and Dale" system. The Edison cylinder possessed one great advantage over all disc records, inasmuch as a constant linear speed is maintained throughout and such problems as centre fading were unknown.

NEWS OF THE WEEK

TELEVISION DRIVE

Co-operative Advertising Campaign for the New Year

AN extensive television drive for the New Year is planned by the Television Development Committee of the Radio Manufacturers' Association in collaboration with the B.B.C. As a part of the co-operative advertising campaign, Mr. Wolfe Murray, the B.B.C.'s new Public Relations Officer for Television, will next month give a series of television talks and demonstrations in different parts of London and the Home Counties. Efforts will probably be made to enlist the services of the Alexandra Palace transmitter in the radiation of brief propaganda talks by well-known people.

AN EXPERIMENT THAT FAILED

Television Audience Problem

"HOWL-BACK," bane of public-address systems, sounded a death knell to what promised to be an interesting experiment at Alexandra Palace last week for the televising of "Charley's Aunt." To encourage the actors in this evergreen farce, it was felt that an audience should be introduced, but there was no room for one in the studio. Then came the bright idea of placing the audience in an adjoining room, where they would see the performance on two or three television sets, and suspended over their heads would be a microphone which would take the laughter back to a loud speaker in the studio. Practical tests were carried out, but it was found impossible to avoid interaction between the speaker and microphones. The idea has not been entirely abandoned, however, and further tests may follow.

B.B.C. DEBATE ON SPONSORED PROGRAMMES

BROADCASTING will be the subject under discussion at the last of the series of debates in the Midland Regional programme under the title "Private Enterprise and Public Ownership." The speakers for private enterprise will be Mr. C. B. Cochran and Mr. H. G. Selfridge, Jun., who will take the view that "the show's the thing," and that sponsored programmes by competing commercial systems will provide the best entertainment for listeners. Mr. H. Wickham Steed and Mrs. Mary Agnes Hamilton, an ex-governor of the B.B.C., will speak for public ownership.

NEW SHORT-WAVE STATION

American Service for the Far East

A NEW 20-kW short-wave transmitter is to be erected by the G.E.C. on Treasure Island, site of San Francisco's World Fair, and will be ready for the opening of the Fair in the middle of February.

The station will operate on two frequencies, 9.53 Mc/s (31.48 metres) and 15.33 Mc/s (19.57 metres), which are duplicates of the wavelengths used for many years by the G.E.C. for its Schenectady stations, W2XAF and W2XAD. The sharing of wavelengths is made more practicable by the variation in time on the two sides of the continent. The station will be equipped with directional aerials to the Far East and to Latin America. The beams, concentrating the transmitter output within an angle of about thirty degrees, will considerably increase the effective carrier power, and reception in the Far East is expected to be far less "spotty" than Schenectady's broadcasts to the East, not only by reason of the station's construction, but because of its geographical position.

THEATRE TELEVISION.

An interior view of the scanning van of the television O.B. unit with the producer, Philip Dorté, in his shirt sleeves, during the televising of a theatre performance. The first television preview from a theatre was given last Wednesday when viewers saw an hour's dress rehearsal of the Drury Lane pantomime. The next theatre

visit of the O.B. unit will be on January 2nd when, from 8.30 to 11 p.m., the entire performance of Shakespeare's "Twelfth Night" will be televised by three cameras direct from the Phoenix Theatre. On this occasion the prices of admission will be reduced.

REGULAR FACSIMILE BROADCASTS

USING its new radio facsimile station, the *Post Despatch* of St. Louis, U.S.A., has started a regular broadcast service of a facsimile newspaper. The paper, which consists of nine four-column pages, each eight and a half inches deep, is transmitted every afternoon on a frequency

BROADCAST NEWS

State Control in France

M. DALADIER, the French Prime Minister, now has complete control over all news broadcasts from all French stations. M. Lohner has been appointed Chief Broadcast Control Officer under the authority of the Secretary-General of the Prime Minister's Office. According to the *Journal Officiel*, he has been instructed to control all news and talks dealing with home politics and foreign affairs and with economic and social questions broadcast from stations run by the State or from stations operating under a State licence.

The Control Officer is to have the assistance of two advisory committees set up in 1936 and 1938 respectively. His instructions to broadcasting stations will be delivered with the authority of the Prime Minister and the Minister of Posts and Telegraphs. M. Lohner's authority over private stations is to be exercised in the form of Departmental Orders signed by the Minister for Posts and Telegraphs, with the approval of the Prime Minister or the Minister for Foreign Affairs, or of the Interior.

SOUTH AMERICA IS INTERESTED

Plea for 16-metre Transmissions

SHORT-WAVE listeners in Buenos Aires are asking for more European transmissions on the 16-metre band. One experimenter refers to the excellent quality of Daventry's fourth transmission daily on this band, which is practically free from static, though this cannot be said of the other wavebands. The 31-metre wave is specially susceptible to atmospherics.

Another short-wave enthusiast suggests that the B.B.C. should install an aerial directional on South America, using the 16-metre band for Transmission 5.

REDISTRIBUTION OF WAVELENGTHS

How About the Manufacturer?

ACCORDING to present arrangements, the decisions which will be made at the forthcoming Wavelength Conference in February, 1939, will be applied in the following October. The Comité de liaison des Groupements Professionnels de la Radioélectricité (link between French radio manufacturers' unions) has drawn attention to the inadequacy of the time period placed at the disposal of manufacturers for such adaptation of their receivers as might be necessitated by the change. In order not to disturb the wireless market, it is requested that the date of application of the plan be October 1st, 1940.

SIXTEEN LANGUAGES FROM ITALY

THE foreign language services broadcast from Italy will be greatly extended in the New Year and will include transmissions in sixteen different languages: English, French, German, Russian, Hungarian, Spanish, Greek, Romanian, Bulgarian, Yugoslavian, Turkish, Italian, Swedish, Arabian, Albanian and Esperanto. This will, without doubt, be the most polyglot service in the world.

BLACK LIST OF PARTS

WHAT is the least reliable part in a wireless receiver? The doubtful distinction in America falls to the fixed condenser, according to service statistics published by our American contemporary, *Radio Retailing*.

It is revealed that condensers account for 33 per cent. of the



News of the Week—

faults normally encountered, resistors coming next with 27 per cent. Loud speaker fields, chokes and miscellaneous audio parts account for 17 per cent. of faults, and volume controls 15 per cent. Inductances and loud speaker cones cause surprisingly little trouble—only 5 per cent., and power transformers even less—3 per cent.

This computation significantly does not cover valves!

PART EXCHANGE**Fixing Prices for Second-hand Sets**

TOTALITARIANISM is entering the wireless industry in Italy, where the National Fascist Traders' Federation of Metal, Machinery and Allied Industries has, to use the words of our correspondent, decreed that all wireless traders must pay fixed part exchange prices for receivers.

The scale of allowances, which are based on the list price, is:—

1934-5	One wave-band sets,	20 per cent.
1934-5	Multi-wave sets,	25 per cent.
1935-6	Multi-wave sets,	30 per cent.
1936-7	Multi-wave sets,	40 per cent.
1937-8	Multi-wave sets,	50 per cent.

When exchanging a last season's model, the value of the new set must be not less than double the amount allowed on the one taken in part exchange.

VATICAN BROADCASTING

FIVE times a week, news and talks in English are transmitted from the Vatican City station, the opening signal of which is the ticking of a clock. Each transmission from this station opens and closes with the words "Laudetur Jesus Christus" and the bells of St. Peter's chime the hour.

The 25-kW transmitter uses seven different frequencies, the designation number of each being prefixed by the call sign HVJ.

The frequencies are:—

1. 17.84 Mc. s.	4. 96.6 or 95.5 Mc. s.
2. 15.12 Mc. s.	5. 61.9 or 60.3 Mc. s.
3. 11.74 Mc. s.	

The English transmissions are radiated on frequency number two on Sundays at 6 p.m. and Tuesdays at 3.30 p.m. and on one of the two frequencies of HVJ5 on Tuesday, Thursday and Friday evenings at 7 o'clock.

SERVICES' WIRELESS SCHOOL

THE German Army and Air Force School for radio operators is now equipped with two wireless transmitting vans, each having an aerial power of 1.5 kW. These transmitters, which, when the van is stationary, use a 75-foot aerial mast, have a range of about seven miles when operated whilst in motion. They have the unusual call signs of Liselotte and Gisela—two girls' names.

The school itself, which is

near Halle, is equipped with twelve transmitters, the weakest of which has an aerial power of 5 kW. Morse is taught by automatic transmissions, and a speed of from 70-110 characters (say, 16-22 words) per minute is required.

THE ANTI-INTERFERENCE PROBLEM

A WAVE of indignation at the inadequacy of the French Post Office facilities for the detection of the rapidly increasing number of cases of electrical in-

terference is voiced in the French Press.

It is suggested that the co-operation of the people should be obtained by adopting a method of postmarks which is at present being practised in German and French Switzerland. A Lausanne letter received here has the postmark: "N'utilisez que des appareils électriques déparasités."

A constant reminder such as this might help considerably in the international cause of interference suppression.

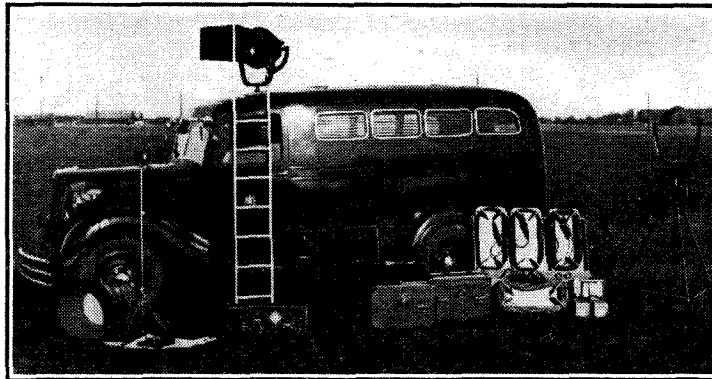

POLICE P.A. VAN equipped by Telefunken for use in Denmark's second largest city, Asarhus, is designed on the lines of the German Polizei-Kommandoanlage model. Denmark has no regular police radio service yet, but this vehicle is the first step at least in that direction.

FROM ALL QUARTERS**Another Short-wave Station**

A NEW Norwegian short-wave transmitter has been erected on a site at Lamberseter, near Oslo. Operating with an aerial output of 5 kW, the transmitter will radiate programmes as follows:—

20.60-9.00 (G.M.T.)	31.43 metres.
9.00-14.00 (G.M.T.)	25.56 metres.
14.00-20.00 (G.M.T.)	19.78 metres.

The existing 1-kW short-wave Jeløy transmitter, LKJ, will continue to operate on 6.13 Mc/s (48.94 metres).

How to Catch Listeners

CHEAPER wireless sets formed part of the campaign just completed in Switzerland for the popularisation of school broadcasting. By an arrangement between the Direction of Telegraphs and the Retailers' Association, schools purchasing receivers were allowed a discount of from 15 to 20 per cent. between November 21st and December 10th, with a further reduction of 3 per cent. for cash payment within a week of purchase. Licence fees were also reduced from 15 to 5 francs during the same period.

Components Exhibition

THE sixth annual exhibition of components will be held in Paris from January 31st to February 3rd, 1939. Organised by the Société Professionnelle et Industrielle Radiophonique, it will take place at the Centre Marcelin Berthelot, 28, bis rue Saint-Dominique, Paris.

Broadcast Drama Records for Sale

FOR the first time in America, the Columbia Broadcasting System has granted facilities for the recording, on discs for general sale, of a radio drama. Archibald MacLeish's poetic play, "Air Raid," which portrays the fate of a village bombed from the air, is available on three two-sided twelve-inch records.

Midget Receivers Again

ANOTHER wave of interest in the midget receiver is apparently sweeping the United States. The hope that these would be sold for stand-by receivers in homes already possessing standard models has been dashed by the fact that many purchasers are buying midget sets only and neglecting the better-class of receiver. Our American contemporary, *Radio Retailing*, points out that three to five midgets must be sold to provide the same profit as one standard model. The effect on trade returns is obvious.

B.B.C.'s Sunday Audience

ALTHOUGH the London Regional transmitter was out of action, due to frost trouble, all the morning of Sunday, December 18th, we are informed that very few enquiries were received at Broadcasting House. No doubt in these days of all-wave sets, when the humblest receivers have large numbers of stations from which to choose, the majority of listeners do not wait for more than a few seconds on a silent wavelength, and turn to another. This is the possible explanation for London listeners' apathy.

Jews and Radio

WIRELESS receivers, which may not be pawned or seized for debt from any Aryan members of the German community, may be seized from Jews in lieu of the payment of a debt. The question of depriving Jews in Germany of the privilege of listening-in has been discussed but rejected on the ground that the ever increasing number of laws against them are published by wireless.

Unlicensed Receivers

THE number of prosecutions for unlicensed wireless sets, undertaken by the Post Office during the past six months, is approximately 3,500.

The First Wireless Stamp

THE N.B.C. Philatelists' Club has a stand at the second National Stamp Exhibition, now being held in New York. Naturally there are to be seen on this stand all the stamps which have in any way referred to wireless, and the earliest in this category is of 1918. It depicts the Guatemalan Government station.

Alternating Currents and Electrical Oscillations

A COURSE of ten lectures, under the above heading, accompanied by practical demonstrations will be held on Tuesday evenings from 7 to 8.30 p.m., commencing January 17th, at the Sir John Cass Technical Institute, Jewry Street, Aldgate, London, E.C.3. The lectures, which will be given by Dr. D. Owen, Head of the Department of Physics and Mathematics, will deal with the properties of alternating currents over the whole range of frequencies, and are especially intended to elucidate the application of physical and electrical principles to wireless circuits and electric wave propagation. The fee for the course is ten shillings.

January Meetings

- Wednesday 4th, 6 p.m. I.E.E. Wireless Section,** Savoy Place, London, W.C.2. "Broadcasting and Television," Sir Noel Ashbridge, B.B.C. Chief Engineer.
- Friday 6th, 7 p.m. I.E.E. Meter and Instrument Section,** Savoy Place, London, W.C.2. "Instruments Incorporating Thermionic Valves, and their Characteristics," Dr. E. G. James, G. R. Polgreen and G. W. Warren.
- Friday, 13th, 5.15 p.m. The Physical Society,** Imperial College of Science and Technology, Imperial Institute Road, London, S.W.7. Distribution of Awards in the 10th Annual Competition in Craftsmanship and Draughtsmanship. Address by Sir J. Ambrose Fleming: "Physics and Physicists of the Eighteen-seventies."
- Tuesday, 17th, 7.30 p.m. Institution of Electronics (Telecommunications Section),** 75, Gloucester Place, London, W.1. "Constructing a Cathode-Ray Oscilloscope," G. T. Clack.
- Wednesday, 18th, 8.15 p.m. Royal Society of Arts,** John Street, Adelphi, London, W.C.2. "Recent Progress in Television," H. L. Kirke, head of the B.B.C.'s Research Department.
- Tuesday, 31st, 7.30 p.m. Institution of Electronics (Telecommunication Section),** 75, Gloucester Place, London, W.1. "The Evolution of Transmitting Valves," E. Grinstead.

How the Valve Works

ADDING ELECTRODES ONE-BY-ONE

Part V.—Hexodes, Heptodes and Octodes

ALTHOUGH the hexode follows the pentode in order of electrodes, it is only recently that it has become widely used, and the heptode preceded it in popularity. It will, therefore, be more convenient to take this seven-electrode valve first.

The heptode was developed as a frequency-changer and the general arrangement of the electrodes is shown in Fig. 15, and the conventional symbol is given in Fig. 16 with a typical circuit. Grids 1 and 2 are used with the cathode to form a triode oscillator and grid 4 is the control grid to which the input signal is applied. Grids 3 and 5 are screen-grids and are internally connected. The output at intermediate frequency is taken from the anode.

Electrons emitted by the cathode form the usual cathode space-charge. The grid 2 is a grid more in name than in fact, for it is not usually of the normal grid construction but consists often merely of two bars as shown in Fig. 15. It is maintained at a positive potential which is often somewhat higher than that of the screen G3.

In operation G2 and G3 pull electrons through the oscillator grid G1 and the majority pass to G3 or through its meshes. Some go to G2, however, and this electrode forms the anode of a triode.

The electrons which land on G3 form the inner screen-grid current; those which pass its meshes from a space-charge between G3 and G4. They do this because once they have passed G3 they come within the repelling influence of the negative grid G4.

The screen space-charge is essentially similar to the cathode space-charge, but its density depends on the number of electrons passing through G3 and hence upon

the potential of G1 and, to a lesser degree, upon the potential of G2.

Acting through the control grid G4, the positive screen G5 pulls electrons from the screen space-charge and the number depends upon the potential of G4 and upon the density of the space-charge itself. The number of electrons pulled to G5 thus depends primarily on the potentials of G1 and G4.

Some of these electrons land on G5 and constitute the outer screen-grid current;

In this concluding article, frequency-changers are dealt with in considerable detail. The action of such valves is extremely complex and is still the subject of intensive research. No attempt at a complete explanation of all the effects is made, therefore, and the second order effects, although important, are dealt with briefly. In conclusion, some effects common to most valves, whatever their number of electrodes, are discussed.

space-charge, the operation of these electrodes is essentially the same as that of a tetrode and the same secondary emission defects occur.

Taking this tetrode with the space-charge for cathode, it is easy to see that the electron stream to the anode can be

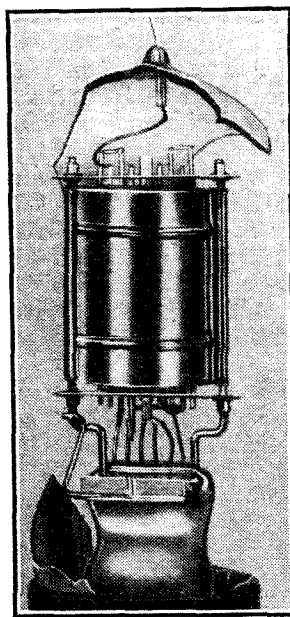

The electrode system of a typical heptode is shown in this photograph.

Fig. 16.—This diagram shows a typical circuit for a heptode frequency-changer.

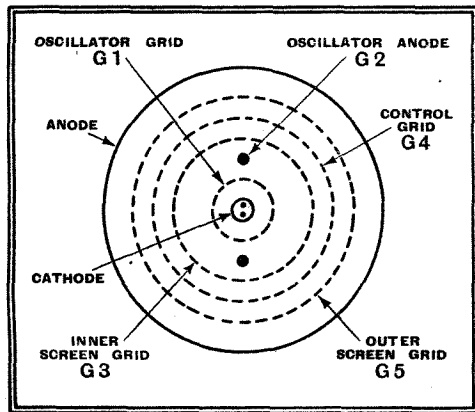
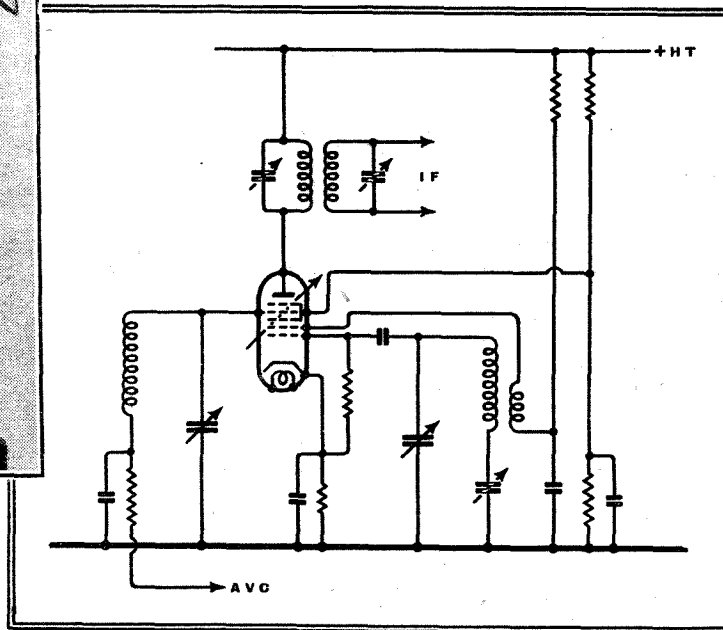

Fig. 15.—The general electrode assembly of a heptode valve is shown here.

the remainder are attracted to the more positive anode.

In normal operation the incoming signal is applied to G4 and the valve is oscillating between G1 and G2, so that there is an oscillator-frequency potential applied to G1. The anode current depends on the potential of both grids, and as the potentials are varying at different rates, beats are formed in the anode circuit. Thus, if the signal has a frequency of 1,000 kc/s, and the oscillator functions at 1,500 kc/s, the anode current will have components of 500 kc/s and 2,500 kc/s. The former is the one usually employed.

Perhaps the simplest way of regarding the operation is to consider G4, G5, and the anode as the electrodes of a conventional tetrode with the space-charge outside G3 as cathode. Given a constant

controlled by varying the space-charge density, and this is done by the inner electrodes. The space-charge is controlled by G1 and G3. The other elements, cathode, G1 and G2, form an ordinary triode oscillator.

As the outer electrodes are equivalent to a tetrode, this part of the valve suffers from the usual tetrode defect of a negative portion of the anode-volts—anode-current characteristic. This can be remedied in the same way as with a tetrode—by introducing a suppressor-grid G6 between G5 and anode. The valve is then an octode. The heptode is to the octode exactly as the tetrode is to the pentode, and it is consequently unnecessary to discuss the octode further.

Presumably, the heptode could be given octode characteristics in the same way

How the Valve Works—

that the latest tetrodes have pentode characteristics, by adopting a similar treatment. So far as the writer is aware, however, this has not been done, probably because the heptode has been largely displaced by the hexode.

The heptode was designed primarily to give an inexpensive frequency-changer with freedom from interaction between

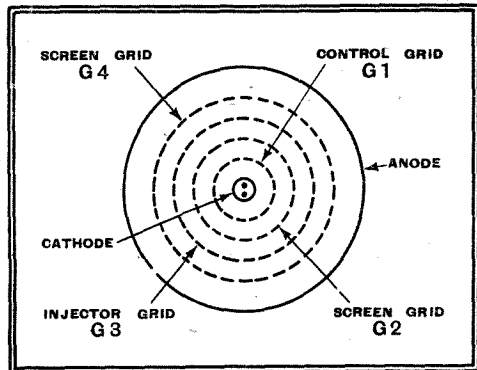

Fig. 17.—The hexode frequency-changer has an electrode arrangement of this form. It is usually included with a separate triode assembly in a common envelope.

the signal- and oscillator-frequency circuits. It does this in good measure on the broadcast bands, but on short waves various second order effects become important and the operation is seriously affected.

The interelectrode capacities, although small, are not negligible, and give coupling between G4 and G1 and between G4 and G2. Secondary electrons are emitted by G3 and collected by G2. One of the greatest drawbacks, however, is the effect of the screen space-charge on the signal grid. As this space-charge fluctuates at oscillator frequency it behaves as an elec-

trode of varying charge and by ordinary electrostatic action causes a current of oscillator frequency to flow in the circuit connected to G4.

As a result of these effects and some others, a considerable degree of interaction between the signal and oscillator circuits exists and the valve is not very suitable for short waves. Considerable development has recently taken place in the octode and some of the latest types are greatly superior. The splitting of the electron stream into definite beams and the adoption of a solid screen for G2 has led to a distinct improvement, while the use of a neutralising circuit between G1 and G4 still further reduces the coupling.¹ This neutralising circuit consists of a condenser and resistance in series and is built into the valve.

The Triode-Hexode

As an alternative to the heptode and octode, the hexode was developed and is now very widely used. It is usually known as the triode-hexode, because a hexode and a triode are built into the same glass envelope. The triode is used as the oscillator and the hexode as the mixer.

The electrode arrangement is sketched in Fig. 17, and it will be seen that the inner grid G1 is now the control grid to which the signal is applied. It is surrounded by a screen-grid G2 at a positive potential. Then comes a second control grid G3, usually called the injector grid because it is fed from the oscillator, and a second screen grid G4. Last of all, there is the anode.

The operation is at first sight not very different from that of the heptode, save that a separate oscillator is needed. However, most of the second order and undesirable effects of the heptode are absent.

The cathode, G1, and G2 together give the usual triode action and the electrons which pass G2 form a space-charge outside it because of the negative grid G3. This space-charge changes in density at signal-frequency. The oscillator amplitude applied to G3 is large and only permits electrons to pass this electrode during a portion of the positive half-cycles. At this time the positive screen G4 pulls the electrons through and those which pass its meshes are attracted by the anode.

Secondary emission from the anode can occur and give rise to a negative resistance kink in the characteristic. In some of the latest types this is overcome by the inclusion of a suppressor grid G5 between G4 and the anode. The valve then becomes a heptode, but of different kind from the ordinary heptode. Confusion does not arise as the valve

¹ *The Wireless World*, May 26th, and June 2nd, 1938.

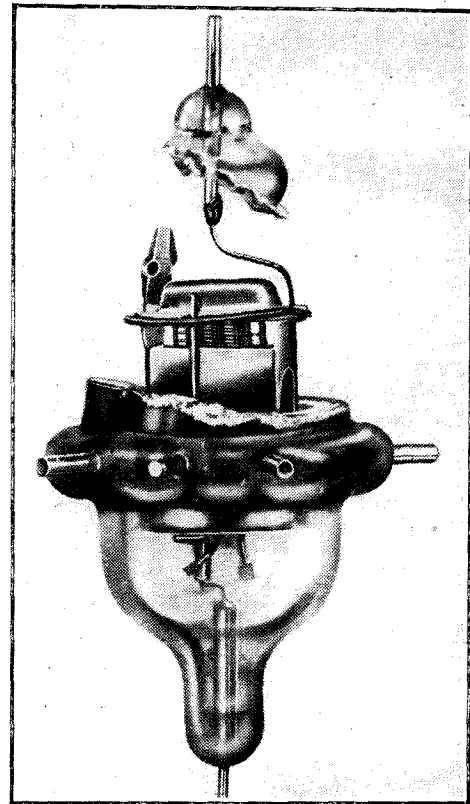

This illustration clearly shows the interior of an acorn pentode. It is shown here much larger than life!

nearly always has a triode section. As the tetrode is to the pentode, and as the heptode is to the octode, so is the triode-hexode to the triode-heptode.

A complete explanation of all the events in complex structures of this nature is beyond the scope of this series of articles. But sufficient has been said to show the general action, and in conclusion it will be sufficient to indicate some general effects common to most types of valve.

Before doing so, a few words about multiple valves may be advisable. These do not differ from the types discussed, save that the electrode assemblies of two or more valves are included in the same glass envelope. A duo-diode-triode, for instance, consists of two diodes and one triode. Each section functions independently of the others and follows the laws governing its own type. In practice, such a valve is not as flexible as the three separate valves which it replaces, for the cathodes are usually connected internally, and there is also the possibility of interaction between the sections through the small capacities existing between them.

Other multiple valves are the duo-triode or Class B valve (two triodes), the QPP valve (two pentodes), the duo-diode (two diodes), the triple-diode (three diodes), the triode-pentode (triode and pentode), the triode-hexode (triode and hexode), the triode-heptode (triode and heptode), duo-diode-pentode (two diodes and pentode), and triple-diode-triode (three diodes and triode).

Of the general effects common to all valves is a change of input capacity with grid bias. This is most important with tetrode and pentode RF and IF ampli-

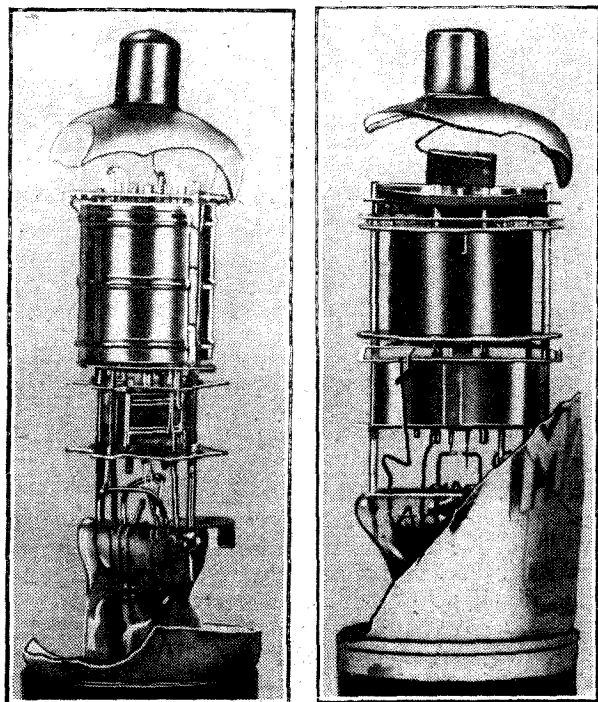

On the left is shown the interior of a triode-hexode; the triode section can be seen below the hexode assembly. A triode-heptode appears on the right.

How the Valve Works—

fiers. If the total capacity between control grid and earth is measured with the valve cold a certain value will be obtained. If it is measured again with the cathode hot, but with sufficient grid bias to cut off anode current, another higher value will be obtained. The increase is due in part to the expansion of the electrodes, but is also caused by the grid-cathode capacity being effectively between grid and the cathode space-charge instead of between the grid and cathode itself.

The cathode space-charge is nearer the grid than the cathode, and so the capacity is greater. If now the grid bias is reduced the input capacity increases because the cathode space-charge tends to move nearer the grid as the anode current increases. The change of capacity may be as much as 5 μF . and it naturally affects the tuning of the grid circuit of the valve. This is one reason why it is almost impossible to maintain symmetrical band-pass curves in practice. The grid bias is varied for volume control, either manually or automatically, and the tuning of the circuits consequently varies also to some degree.

A similar effect, but of rather more complicated nature, occurs in frequency-changers and is especially bad, since it causes a change in oscillator frequency. With some of the latest valves it is kept at a very low level.

On short waves an additional effect occurs. The time taken for electrons to pass through the valve is no longer negligible compared with one cycle of the input signal. The conditions in the valve are then rather different from those described earlier. If the grid voltage is changed there is a time lag before the resulting change of anode current takes place.

Suppose, for instance, that the grid voltage is changed negatively with extreme rapidity. The negative grid repels many of the electrons which were previously approaching it, and turns them back to the cathode. At the same time, the electrons which had just passed the grid are still receding from it, for they have not yet had time to reach the screen or anode. There are, therefore, more electrons receding from the grid than there are approaching it. Through ordinary electrostatic action this results in an electron flow or current to the grid in the external circuit. The action is just the reverse if the change of grid voltage is in the opposite direction.

The grid current absorbs power from the input circuit and the valve is said to have an input resistance. The value of this resistance is such that if connected across the input of a perfect valve it would absorb the same power as the practical and imperfect valve. The value of the resistance is proportional to the square of wavelength and can usually be ignored above some 20 metres. At 5 metres, however, it may be 2,000 ohms or less.

It seriously limits the performance of a valve on short waves, and it is possible

greatly to increase the input resistance by reducing the distance between the electrodes. The acorn valves are examples of such action and are very successful. They are not popular, however, because the clearances are so small that they are difficult to manufacture, and compared with ordinary valves they are rather fragile.

It has recently been found that the inductance of the internal connections of the valve also leads to a low input resistance at high frequencies. The low input resistance of the ordinary valve is thus not entirely due to electron transit time effects, but is partly caused by feed-back effects due to the impedance of its internal leads, particularly the cathode lead.

There is consequently a general tendency to adopt smaller valves with bases which lend themselves to the attainment of short internal connections. Some of the latest valves show a considerable improvement over the older types and have an input resistance which, while lower than that of the acorns, is high enough to permit the attainment of good results down to about 5 metres or even lower.

Remote Control Automatic Tuner

IN the "Melody-Radio" motor-driven automatic tuning system designed by M. Yardeny, separate selector discs are provided for seven stations. The discs are clamped to the main condenser spindle by a series of set-screws which are readily accessible from the front of the set. Any station can be assigned to any disc without observing any special sequence in wavelength.

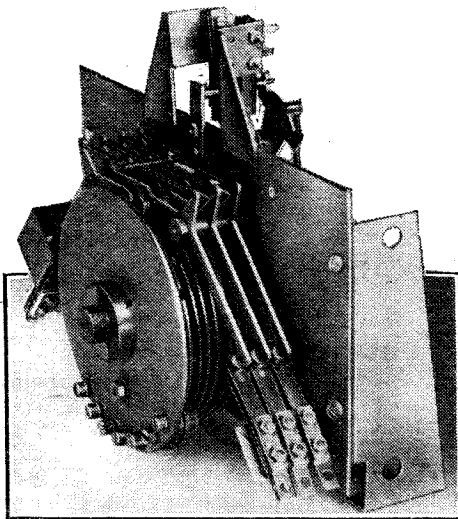

Accurate mechanical location of the tuning condenser is achieved by spring-loaded rockers in the "Melody-Radio" automatic tuner. The relay-type contacts are electrically independent of the selector discs.

The special feature of this system is the method of locating the discs. Spring-loaded rockers engage with slots in the discs and when the appropriate rocker falls into place the current to the motor is automatically cut by relay contacts at the opposite end of the rocker. Latitude is allowed for the overrun of the drive and the final location being of a mechanical nature is independent

of variations in the overrun. Since there are no electrical brushes on the discs themselves, wear due to burning at the edges of the discs on breaking the current is eliminated. The mechanism is not of the "homing" type and a separate trigger switch is incorporated to reverse the motor at each end of the scale.

The system is readily adaptable to remote control, and we have had an opportunity of trying a receiver incorporating this feature. It is reliable in operation and very simple to reset if a fresh group of stations is required. The agent for this mechanism in the United Kingdom is Mr. N. Barron, 35, Basinghall Street, London, E.C.2.

Television Programmes

Sound 41.5 Mc/s.

Vision 45 Mc/s.

An hour's special film transmission intended for demonstration purposes will be given from 11 a.m. to 12 noon each weekday.

THURSDAY, DECEMBER 29th.

3, Old Time Music Hall, including Charles Coburn, Harry Champion and Vesta Victoria. 3.40, 203rd edition of Picture Page.

9, Cabaret, including Robb Wilton in "Mr. Muddelcombe, J.P. at Home." 9.35, Gaumont-British News. 9.45, 204th edition of Picture Page. 10.15, News.

FRIDAY, DECEMBER 30th.

3-4.55, Noel Coward's comedy "Hay Fever," with Kitty de Lugh, Maurice Denham and a distinguished cast.

9, "The Knight of the Burning Pestle," a period panto by Beaumont and Fletcher. 10.30, News.

SATURDAY, DECEMBER 31st.

3, Cabaret (as on Thursday at 9 p.m.). 3.45-4.5, "The Cab," a farce by John Taylor.

9, Edgar Wallace's play "The Ringer," with Cecil Parker, Gina Malo and Henry Oscar. 10.30, Cyril Fletcher in Intimate Cabaret. 11, News. 11.20-12.5 a.m., Television will see the New Year in at the Grosvenor House Ballroom, where 1,500 revellers will be dancing to the music of Sydney Lipton's Band. Commentary will be given by Leslie Mitchell.

SUNDAY, JANUARY 1st.

3, Friends from the Zoo, presented by David Seth-Smith. 3.15, Irene Prador—Continental songs. 3.20, "In Search of Gold"—film. 3.30, "Snow and Ice"—a winter holiday in half-an-hour.

8.50, News. 9.5-10.30, "Mary Rose," by James Barrie.

MONDAY, JANUARY 2nd.

3, Jam Session, directed by Eric Wild. 3.20, British Movietone. 3.30, "Campbell of Kilmhor," by J. A. Ferguson. An incident in the pacification of the Highlands after the rebellion of 1745.

8.30-11, Theatre O.B. The entire performance of Shakespeare's "Twelfth Night" will be relayed from the Phoenix Theatre, London. 11, News.

TUESDAY, JANUARY 3rd.

3, Jack Hylton and his Band. 3.30, Gaumont-British News. 3.40, Cartoon Film. 3.45-4.5, "Moonshine," a fantasy by Laurence Housman.

9.5, "The Moon in the Yellow River," a comedy of modern Ireland by Denis Johnston. 10.35, News.

WEDNESDAY, JANUARY 4th.

3, Intimate Cabaret, including Trudi Binar and Bennet and Williams. 3.25, British Movietone. 3.35, "The Tell-Tale Heart," by Edgar Allan Poe.

9, Cherry Kearton—A Naturalist Among the Penguins. 9.10, "Once in a Life-time," a comedy by George Kaufman and Moss Hart. 10.40, News

Letters to the Editor

Indented Sound Track

IT was with great interest that I read of the "Indented Sound Track" apparatus, briefly but excellently described in this journal on December 8th.

During October, 1933, I applied for a provisional patent for this very idea, only to find after considerable searching that someone had already filed a full patent over three years before my application.

It seems strange that ideas having their birth in this country have to await recognition and presentation in other countries.

London, S.E.5. MARCUS GAMES.

I WAS particularly interested in the description of the "Filmograph" with its principle of an indented sound track, as published in the issue for December 8th, but were it not for the photographs shown I should be tempted to think that the whole idea was the product of the imagination of one just beginning to enjoy the fascination of sound recording.

Surely all recordists, at some time or another in their experience, have considered this system and there are probably many who, like myself, thought they had solved the "home talkie" problem until they actually got to grips with it in a practical manner.

I tried this idea some years ago and found that it is certainly possible to indent a playable track upon film stock, but it was necessary to run the film at "rewind" speed to obtain anything tolerable in the way of quality. There is also the problem of smoothing out the intermittent motion of the projected film.

Your contributor does not state how this very real problem of speed is overcome neither how the intermittent motion of the projected film is smoothed out.

A device such as this would not be marketed without it having achieved a certain amount of practical success, but I maintain that, unless the two problems which I have mentioned have been solved, the device would be useless.

I hope that information on these points will be forthcoming. If my doubts are without foundation we shall probably hear much more of this system, which should appeal to all who have attempted to make satisfactory "talkies."

Bromley, Kent. C. L. APPLEBY.

Short-range Fading

AS far back as December, 1934, I found similar conditions to those described by Mr. Le Verrier prevalent in S.W. London (Balham area).

The effect, aurally, is similar to the fading and distortion that accompanies, say, Radio Normandie when reception conditions are poor. There appears to be a sudden drop in field strength lasting for two to four seconds, accompanied by extreme distortion. My early notes on this phenomenon show that the fading occurred at much longer intervals than when I made my last tests in February last.

In 1934, after ascertaining that the trouble was external to the receiver in use, I telephoned to the B.B.C. and enquired if the programme radiated at that time was

relayed by line or short-wave radio to the Control Room. It appeared that the programme was local, and linked by landline. I mentioned the fading, and was told that my receiver was "undoubtedly faulty."

Confirming Mr. Le Verrier's observations, I also found the effect in patches. For instance, I arranged simultaneous tests between four listening posts (A and B) in Balham, (C) in Tooting, and (D) at Staines, Middlesex. It revealed that the fading was only experienced at A and C, sometimes together and sometimes singly, but never present at B or D. In all cases a mains-operated TRF receiver was used with both inside and outside aerials.

The writer has never experienced this type of fading in the North-West area of London.

The fading, characterised by a quick reduction in strength, together with distortion, well within the Service area of the medium wave National transmitter, requires explanation. I cannot recall such an occurrence on the Regional (342m.) transmission.

G. T. CLACK,

Wolsey Television, Ltd.

London, N.7.

I AM pleased to see mention of short-distance fading of the London National transmitter by your correspondent Mr. C. E. Le Verrier in his letter in December 15th issue.

Living as I do just outside London, I have experienced the same severe fading, together with distortion, from the London National transmitter on very many occasions during the winter months for some years past. I have also noticed fading, together with distortion, to a small degree on the London Regional transmitter for the first time last month.

I would mention that the receiver I use is a local station set with no form of AVC, but I have noticed the same distortion on sets fitted with AVC, which was unable to cope with a very bad fade.

I agree with Mr. Le Verrier that the fading is very localised, and that houses a few doors away may be quite free from the trouble and *vice versa*.

E. W. T. DRINKWATER.

W. Wickham, Kent.

Transients and Tone Correction

A NUMBER of recent articles on tone correction in *The Wireless World* have suggested that if transient response is to be preserved it is important to use a circuit which does not resonate. Now, this may turn out to be so in some cases, but it is not the fundamental factor. What is fundamental is the time required for a disturbance to die away, which is a very different thing and applies to non-resonant as well as to resonant circuits. Moreover, these articles have neglected the signal- and intermediate-frequency resonant circuits, although there seems to be no *a priori* reason for doing so.

Consider a few typical circuits. I will take as the time constant the time in seconds for a disturbance to fall to one-tenth of its original value. L is the inductance, R the resistance and Q the goodness. The figures given are approximate.

Signal Frequency Circuit at 1,000 kc/s.

The Editor does not necessarily endorse the opinions of his correspondents

L is 150 microhenrys; R, 10 ohms; Q, 100.
Time constant 8×10^{-5} sec.

IF Circuit at 450 kc/s.

L is 500 microhenrys; R, 15 ohms; Q, 100.
Time constant, 16×10^{-5} sec.

Tone Correction Circuits at 10,000 Cycles.

(a) Highly resonant.

L is 1 henry; R, 6,250 ohms; Q, 10.

Time constant, 80×10^{-5} sec.

(b) Just resonant.

L is 1 henry; R, 62,500 ohms; Q, 1.

Time constant, 8×10^{-5} sec.

The second tone correction circuit (b) would just about fulfil the requirements of one of the articles mentioned previously. But if its time constant of 8×10^{-5} sec. is significant, then so are those of the signal and IF circuits, and we should expect a straight set to have better transient response than a superhet, as it usually has. However, other factors, such as the customarily smaller frequency response of a superhet, may account for this. If, on the other hand, the time constants of the signal-frequency and IF circuits are unimportant, then a tone correction circuit of higher Q is permissible and more high-note boost can be thus obtained. This, I understand, was done in the Hartley Turner superhet, without, as far as I am aware, impairing the transient response.

However, whether the time constants of these circuits are important or not depends on how they compare with that of the ear (and also whether a high-fidelity loud speaker has one as good), of which measurements have probably been made. In the discussion on transient response that took place in *The Wireless World* a short time ago a figure of, if I remember correctly, 0.015 sec. was given. Perhaps some reader has further information on the subject.

London, S.E.3. DONALD McLEAN.

Urdox Resistances

IT is well known that the resistance of valve filaments is much lower when cold than when hot. This means a considerable rush of current when first switching on and is responsible, among other things, for the frequent failure of pilot lamps in AC/DC receivers.

Special protective resistances are now available which have an opposite characteristic to that of lamp and heater filaments, namely, a much higher resistance when in the cold state. They can be obtained in various types and ratings. A special model is available for protecting electrolytic smoothing condensers from high peak voltages. These resistances, which are known by the name of Urdox (or in combination with iron "barretter" resistances, as Neron-Urdox) are obtainable in this country from Erie Resistor, Ltd., and consist of a resistance element mounted in a glass bulb resembling a valve.

Neron barretter resistors designed to compensate for fluctuations of LT voltage (particularly in dry cells) are available for battery sets. These various devices are described in a leaflet issued by Erie Resistor, Ltd., Carlisle Road, The Hyde, London, N.W.9.

Random Radiations

Books of the Words

A YORKSHIRE reader sends me a glorious example of those errors in instruction books accompanying wireless receivers, to which I've referred previously in these notes. A battery set of a certain make produced no sounds whatever when connected up exactly in accordance with the instructions. Valves and so on having been carefully checked without result, a milliammeter was hooked into the HT negative lead to see what kind of a tale it had to tell. It had a surprising one; instead of about 10 milliamperes, it showed a reading of a full 50. Investigations proved that the QPP output valve was receiving a grid bias of 12 volts positive, which cannot have been exactly good for its health. The maker's explanation on receiving a letter of pained expostulation was that by mistake a combined high-tension and GB battery of out-of-date type had been sent.

A Strange Encounter

MY recent mention of GCC, the old Cullercoats spark station, prompts a Johannesburg correspondent to send me an account of a strange meeting that came his way not long ago. He was in a wireless shop one day and, whilst waiting to be served, toyed with a morse tapping key that was lying on the counter. Presently another customer came up behind him and asked: "What do you know about Cullercoats?" Quite unconsciously he had been tapping out the call-sign of that station. The enquirer turned out to be one of the first twelve operators employed by the then youthful Marconi Company and had been stationed for some time at Poldhu. Strange— isn't it?—that two old hands, who had never previously come across one another in the flesh, though they must often have heard one another's wireless messages in years gone by, should meet thus in Johannesburg.

New Use for Photo-cells

IT is reported that the Swedish Ericsson Telephone firm has taken out a patent for an anti-aircraft shell fuse operated by a photo-electric cell. Here's a rough idea of the way in which the device works. The shock of discharge sets light to a quantity of magnesium contained in the nose of the fuse. If and when the shell reaches a point within effective bursting range of the plane at which it is aimed, reflected light from the target strikes a photo-cell, which then operates a relay and fires the high-explosive charge. The photo-cell is, of course, so placed that light from the burning magnesium cannot reach it directly. The idea is certainly ingenious, but, having done a spot of anti-aircraft work in my time, I can see certain snags which may complicate matters considerably.

Will It Work?

In theory, this device gives the anti-aircraft gunner just what he has been looking for. One of the main difficulties of A-A gunnery is that it isn't sufficient by making intricate calculations (or having them made for you by instruments) and by correctly laying the gun to put your shell close to the target; to be effective it must burst during the tiny fraction of a second that it spends within the desired area. This is normally

By "DIALLIST"

done by means of a time fuse, but time fuses have the drawback that their rate of burning varies with the height that they reach owing to differences of atmospheric pressure. Hence a fuse which acted automatically when it reached the right spot would be magnificent. But can any photo-cell be so made or so mounted that it will stand the terrific jolt that must come its way when the gun is fired? And there's another rather knotty problem. In the interests of those on the ground, you would have to ensure that your shell either explodes in the air or doesn't explode at all. It might be awkward if shells with these photo-cell fuses missed the target and were detonated on their return journey by light reflected from the ground.

Casualties

IT was surprising that the frost should have put the London Regional transmitter out of action the other day by causing the pipes carrying its valve-cooling water to burst. Though it felt bitterly cold, the frost hadn't been really severe up to the time when the damage was done. You'd have thought that the routine precautions against freeze-ups would have been sufficient to prevent anything of the kind, but evidently they weren't. However, once bitten, the B.B.C. will certainly be twice shy and one can be sure that everything will be done to prevent similar mishaps at other stations. I wonder whether battery users have noticed any falling off in their results during the cold spell? Dry HTB's, particularly those that are not in their first youth, are apt to be affected considerably by low temperatures. Under their influence the depolariser is prone to become sluggish with the result that the e.m.f. falls more rapidly than normally it would.

About the Supply Meter

A BOROUGH Electrical Engineer is kind enough to send me some interesting facts about the electric supply meter, which, he says, can quite well be used to obtain approximate measurements of the loads imposed by AC mains receiving sets. He points out that the meter indicates the real load only if the voltage and the current are in step. In the ordinary domestic circuit used for lighting and heating, resistance predominates, and though current may lag or lead slightly, the amount is too small to be worth bothering about. A predominance of inductance, however, causes current to lag considerably, whilst a predominance of capacity has precisely the opposite effect. The supply meter registers in kilowatt-hours or Board of Trade units only; it takes no account of the power factor. In works where a big inductive load is imposed power factor correction plant is installed; but it certainly would not pay the user of, say, a small electric motor for driving a lathe to go to the expense of so doing.

Aerials and Interference

RATHER a good instance of the way in which a bad aerial accentuates interference presented itself the other day. One of my family was laid up and I installed in

the sick room a receiver which had been giving an excellent account of itself when used in another part of the house with a very good aerial. I had no means of connecting the set to this in its new position; nor was I able at the time to contrive anything better than a length of wire slung across the room. With this the set brought in just as many stations as before, but there was a vast difference in the quality and particularly in the background. Mine is not a locality where man-made interference is at all troublesome; in fact, though I have an anti-interference aerial of the "all-wave" type, I use a plain inverted L for most of my medium-wave and long-wave reception. Connected to that, the set had been noticeably free from nasty noises, but when I yoked it to the sick-room makeshift, affairs were very different. Its volume control had of course to be turned well up and in this condition it collected quite a bit of man-made interference which cannot have come from any very nearby source.

Don't You Believe Them

People often tell me that the aerial doesn't matter a bit nowadays; that any old bit of wire is good enough for the modern set. It certainly is so long as you don't mind having a strong background of man-made interference and a good deal more than your share of superhet hiss. But if you want a set to give you of its best there's no question that you must provide it with a first-rate aerial. I have also come across folk who maintain that the anti-interference aerial is no good. They've spent, they say, a lot of money on one and it doesn't make the least bit of difference. When you come to look at that expensive aerial you find as often as not that it's put up in such a way that it can't possibly do itself justice. I used to live in a place where interference was pretty bad and I certainly found that a properly put up anti-interference aerial made all the difference in the world to my reception.

Sliding Resistance

VARIOUS types of variable resistance are made by M.R. Supplies, of 68, New Oxford Street, London, W.C.1. The resistance is wire-wound on a slate former with a sliding contact adjustable through a slot in the metal case. This case, exclusive of the mounting feet, measures 6½ in. × 3 in. × 3½ in. high overall.

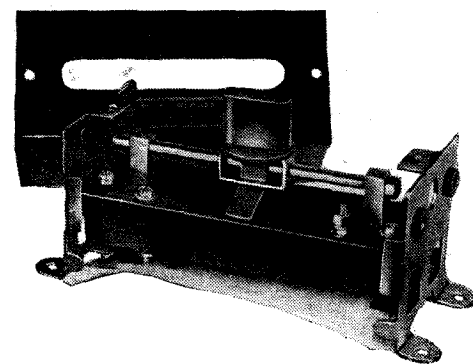

The standard values available are 580 ohms with a current-carrying capacity of 0.325 amp. and 400 ohms at 0.5 amp. These are priced at 10s. 6d. Other ratings are available at slightly higher prices.

The resistances are well made and appear able to stand up to their work indefinitely. They can confidently be recommended.

Recent Inventions

MODULATING SYSTEMS

A TRANSMITTER is so arranged that in the absence of any signals the carrier wave is suppressed, whilst during the signalling periods a constant percentage of modulation is maintained, irrespective of changes in the amplitude of the signalling currents.

As shown in the Figure, the first grid G₁ is supplied with a carrier frequency from a source S, whilst the grid G₄ is fed with signal currents from a source S₁. The grid G₂ is kept positive, relatively to the cathode, by a tapping from the source S₂, the positive end of which is connected to the mid-point tapping on a coil L branched across the anode A and grid G₃.

In the absence of signal currents applied to the grid G₄, the electron stream from the cathode divides equally between the anode A and grid G₃, so that the carrier frequency is balanced out in the

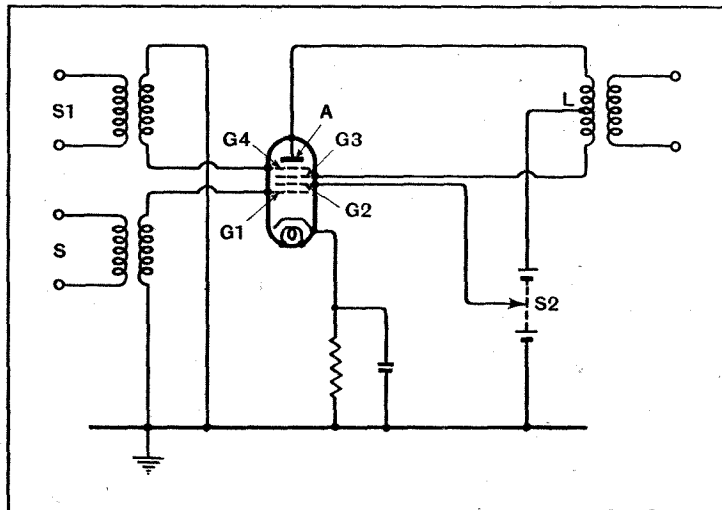

Telephony transmitting system in which the carrier is suppressed in the absence of modulation.

output coil L. As soon as signal currents are applied, the electron stream through the valve divides between the anode A and grid G₃ in the proportion required to maintain a constant percentage of modulated carrier-wave in the coil L at all time.

Fernseh Akt. Convention date (Germany), March 6th, 1936. No. 491805.

DIELECTRIC GUIDES

IT is known that very short waves can be propagated through a "guide-line" made of dielectric material. The waves are confined inside the guide instead of radiating in all directions, as they do through the ether, by

The British abstracts published here are prepared with the permission of the Controller of H.M. Stationery Office, from specifications obtainable at the Patent Office, 25, Southampton Buildings, London, W.C.2, price 1/- each

Brief descriptions of the more interesting radio devices and improvements issued as patents will be included in this section.

the reflecting action of the "boundary" between the particular dielectric used (which may either be a waxlike substance or a gas contained in a suitable tube) and the surrounding air. The "guiding" effect is comparable with that of the upper ionised layers of the atmosphere in reflecting wireless waves from a non-ionised region.

The dielectric guide may include an outer sheath or covering of metal, though even then the transfer of energy is not the ordinary go-and-return current through a conductor, but takes the form of a displacement wave travelling through the dielectric.

The type of displacement wave

automatically balance themselves out, thereby stabilising the operation of the device.

As shown in the Figure, electrons emitted from a photo-sensitive cathode C are made to impact in succession against target electrodes T, T₁, etc., under the guidance (a) of electrostatic charges on

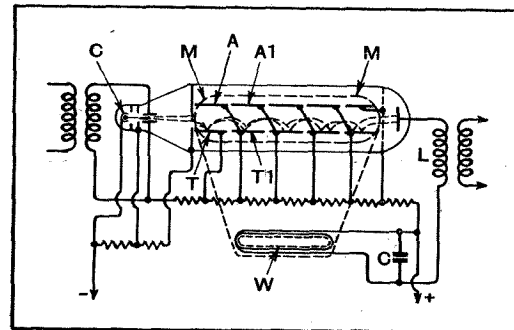

Stabilising the operation of an electron multiplier.

the anodes A, A₁, etc., and (b) of an external magnetic field applied by a magnet of which one pole-piece is shown in dotted lines at M. An auxiliary winding W on the magnet is included in series with the output coil L of the multiplier. Signal currents are by-passed through a condenser C, but slow variations in the output current pass through the winding W and by their focusing action on the electron stream tends to check any rise or fall, as the case may be.

Standard Telephones and Cables, Ltd. (assignees of A. M. Skellett). Convention date (U.S.A.), July 31st, 1936. No. 491773.

CENTIMETRE WAVES

THE Figure shows a valve designed to generate or amplify waves of the order of centimetres. It functions as an electron-oscillator in the Barkhausen-Kurz fashion, that is, with a highly positive grid G and a negative or "floating" anode A. The circuits are fine-tuned by means of discs D, D₁, D₂ attached to the

free positive ions leads to a great increase in efficiency.

The British Thomson-Houston Co., Ltd. Convention date (U.S.A.), January 29th, 1936. No. 491445.

A "WATCH-DOG" RECEIVER

FOR receiving short-wave signals an adaptor is often applied to heterodyne the incoming signals in such a way that the normal medium-wave input circuit can be used as an intermediate-frequency stage. This idea is now further developed to allow the same aerial to serve both for normal short-wave working and, at the same time, to form a constant "stand-by" for receiving emergency signals, such as the S O S call, which is sent out on a fixed frequency of, say, 600 metres.

The short-wave set is directly coupled to the aerial, with its IF stage tuned to the fixed frequency of 600 metres. The IF circuit is then separately and permanently coupled to the same aerial through a branched lead which includes a rejector circuit to prevent the short-wave signals from being fed back to the aerial. Should a distress call be made within range it will thus be received, even if the

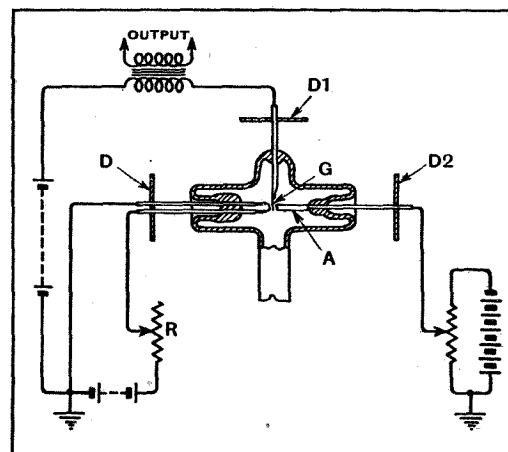

Valve generating "centimetric" wavelength.

electrode leads, though the frequency is chiefly determined by the interelectrode spacing.

According to the invention, the interelectrode spacing, and, there-

operator is listening-in on short waves at the time.

C. Lorenz Akt. Convention date (Germany), October 7th, 1936. No. 490485.

PRINCIPAL BROADCASTING STATIONS OF EUROPE

Arranged in Order of Frequency and Wavelength (Stations with an Aerial Power of 50 kW and above in heavy type)

Station.	kc/s.	Tuning Positions.	Metres.	kW.	Station.	kc/s.	Tuning Positions.	Metres.	kW.
Istanbul (Turkey)	152		1973.5	5	Bucharest (Romania)	823		364.5	12
Kaunas (Lithuania)	153		1961	7	Bodø (Norway)	823		364.5	10
Hilversum (No. 1) (Holland)	160		1875	10-150	Kiev (No. 2) (U.S.S.R.)	832		360.6	35
Radio Romania (Romania)	160		1875	150	Stavanger (Norway)	832		360.6	10
Lahti (Finland)	166		1807	150	Berlin (Germany)	841		356.7	100
Moscow (No. 1) (U.S.S.R.)	172		1744	500	Sofia (Bulgaria)	850		352.9	100
Paris (Radio Paris) (France)	182		1648	80	Valencia (Spain)	850		352.9	3
Ankara (Turkey)	183		1639	5	Simferopol (U.S.S.R.)	859		349.2	10
Irkutsk (U.S.S.R.)	187.5		1600	20	Strasbourg (France)	859		349.2	100
Deutschlandsender (Germany)	191		1571	60	Poznań (Poland)	868		345.6	50
National (Droitwich)	200		1500	150	London Regional (Brookmans Park)	877		342.1	70
Minsk (U.S.S.R.)	208		1442	35	Graz (Germany)	886		338.6	15
Reykjavik (Iceland)	208		1442	100	Linz (Germany)	886		338.6	15
Motala (Sweden)	216		1389	150	Helsinki (Finland)	895		335.2	10
Novosibirsk (U.S.S.R.)	217.5		1379	100	Hamburg (Germany)	904		331.9	100
Warsaw (No. 1) (Poland)	224		1339	120	Dnepropetrovsk (U.S.S.R.)	913		328.6	10
Luxembourg	232		1293	150	Toulouse (Radio Toulouse) (France)	913		328.6	60
Moscow (No. 2) (U.S.S.R.)	232		1293	100	Brno (Czechoslovakia)	922		325.4	32
Kalundborg (Denmark)	240		1250	60	Brussels (No. 2) (Belgium)	932		321.9	15
Kiev (No. 1) (U.S.S.R.)	248		1209.6	100	Algiers (Algeria)	941		318.8	12
Tashkent (U.S.S.R.)	256.4		1170	25	Göteborg (Sweden)	941		318.8	10
Bergen (Norway)	260		1153.8	20	Breslau (Germany)	950		315.8	100
Oslo (Norway)	260		1153.8	60	Paris (Poste Parisien) (France)	959		312.8	60
Vigra (Aalesund) (Norway)	260		1153.8	10	Odessa (U.S.S.R.)	968		309.9	10
Leningrad (No. 1) (U.S.S.R.)	271		1107	100	Northern Ireland Regional (Lisnagarvey)	977		307.1	100
Tromsø (Norway)	282		1065	10	Bologna (Radio Marconi) (Italy)	986		304.3	50
Tiflis (U.S.S.R.)	283		1060	35	Toruń (Poland)	986		304.3	60
Moscow (No. 3) (U.S.S.R.)	300		1000	100	Hilversum (No. 2) (Holland)	995		301.5	65
Saratov (U.S.S.R.)	340		882.3	20	Bratislava (Czechoslovakia)	1004		298.8	13.5
Finmark (Norway)	347		864	10	Chernigov (U.S.S.R.)	1013		296.2	4
Archangel (U.S.S.R.)	350		857.1	10	Midland Regional (Droitwich)	1013		296.2	70
Rostov-on-Don (U.S.S.R.)	355		845.1	20	Barcelona (EAJ15) (Spain)	1022		293.5	3
Budapest (No. 2) (Hungary)	359.5		834.5	18	Cracow (Poland)	1022		293.5	10
Sverdlovsk (U.S.S.R.)	375		800	40	Königsberg (No. 1) (Germany)	1031		291	100
Banská-Bystrica (Czechoslovakia)	392		765	15-30	Paredo (Portugal)	1031		291	5
Lulea (Sweden)	392		765	10	Leningrad (No. 2) (U.S.S.R.)	1040		288.5	10
Rostov-on-Don (U.S.S.R.)	395		759	20	Rennes-Bretagne (France)	1040		288.5	120
Voronezh (U.S.S.R.)	413.5		726	10	West of England Regional (Washford)	1050		285.7	50
Oulu (Uleaborg) (Finland)	431		696	10	Bari (No. 1) (Italy)	1059		283.3	20
Baranowice (Poland)	520		576	50	Tiraspol (U.S.S.R.)	1068		280.9	10
Ljubljana (Yugoslavia)	527		569.3	6.3	Bordeaux-Lafayette (France)	1077		278.6	60
Viipuri (Finland)	527		569.3	10	Radio Normandie (France)	1095		274	20
Bolzano (Italy)	536		559.7	10	Madrid (EAJ7) (Spain)	1095		274	5
Wilno (Poland)	536		559.7	50	Vinnitsa (U.S.S.R.)	1095		274	10
Budapest (No. 1) (Hungary)	546		549.5	120	Kuldiga (Latvia)	1104		271.7	25
Beromünster (Switzerland)	556		539.6	100	Tripoli (Libya)	1104		271.7	50
Klaipeda (Lithuania)	565		531	10	Melnik (Czechoslovakia)	1113		269.5	100
Catania (Italy)	565		531	3	Nyiregyhaza (Hungary)	1122		267.4	6.25
Palermo (Italy)	565		531	3	North-East Regional (Stagshaw)	1122		267.4	60
Radio Eireann (Ireland)	565		531	100	Hörby (Sweden)	1131		265.3	60-100
Stuttgart (Germany)	574		522.6	100	Genoa (No. 1) (Italy)	1140		263.2	10
Alpes-Grenoble, (P.T.T.) (France)	583		514.6	20	Trieste (Italy)	1140		263.2	10
Madona (Latvia)	583		514.6	50	Turin (No. 1) (Italy)	1140		263.2	100
Vienna (Germany)	592		506.8	100	London National (Brookmans Park)	1149		261.1	40
Athens (Greece)	601		499.2	15	North National (Slaithwaite)	1149		261.1	40
Rabat (Morocco)	601		499.2	20	Scottish National (Westerglen)	1149		261.1	50
Sundsvall (Sweden)	601		499.2	10	Kassa (Hungary)	1158		259.1	10
Florence (No. 1) (Italy)	610		491.8	20	Monte Ceneri (Switzerland)	1167		257.1	15
Brussels (No. 1) (Belgium)	620		483.9	15	Copenhagen (Denmark)	1176		255.1	10
Cairo (No. 1) (Egypt)	620		483.9	20	Nice-Côte d'Azur (France)	1185		253.2	60
Kouibyshev (U.S.S.R.)	625		480	10	Frankfurt (Germany)	1195		251	25
Christiansand (Norway)	629		476.9	20	Freiburg-im-Breisgau (Germany)	1195		251	5
Lisbon (Emissora Nacional) (Portugal)	629		476.9	20	Troppau (Germany)	1204		249.2	5
Trøndelag (Norway)	629		476.9	20	Lille (Radio P.T.T. Nord) (France)	1213		247.3	60
Prague (No. 1) (Czechoslovakia)	638		470.2	120	Rome (No. 2) (Italy)	1222		245.5	60
Lyons (P.T.T.) (France)	648		463	100	Gleiwitz (Germany)	1231		243.7	5
Petrozavodsk (U.S.S.R.)	648		463	10	Görlitz (Germany)	1231		243.7	5
Cologne (Germany)	658		455.9	100	Cork (Ireland)	1235		242.9	1
Jerusalem (Palestine)	668		449.1	20	Saarbrücken (Germany)	1249		240.2	17
North Regional (Slaithwaite)	668		449.1	70	Riga (Latvia)	1258		238.5	15
Sottens (Switzerland)	677		443.1	100	Salamanca (Spain)	1258		238.5	20
Belgrade (Yugoslavia)	686		437.3	20	Aberdeen	1285		233.5	5
Paris (P.T.T.) (France)	695		431.7	120	Klagenfurt (Germany)	1294		231.8	5
Stockholm (Sweden)	704		426.1	55	Vorarlberg (Germany)	1294		231.8	5
Rome (No. 1) (Italy)	713		420.8	120	Radio Méditerranée (France)	1303		230.2	27
Hilversum (Jaarsveld) (Holland)	722		415.4	17	Naples (No. 1) (Italy)	1303		230.2	10
Kharkov, (No. 1) (U.S.S.R.)	722		415.4	10	Malmö (Sweden)	1312		228.7	2.5
Madrid (EAJ2) (Spain)	731		410.4	3	Bremen (Germany)	1330		225.6	2
Seville (EAJ5) (Spain)	731		410.4	5	Dublin (Ireland)	1348		222.6	0.5
Turi (Estonia)	731		410.4	38	Genoa (No. 2) (Italy)	1357		221.1	5
Munich (Germany)	740		405.4	100	Turin (No. 2) (Italy)	1357		221.1	5
Marseilles (P.T.T.) (France)	749		400.5	100	Milan (No. 2) (Italy)	1357		221.1	4
Katowice (Poland)	758		395.8	12	Bordeaux-Sud-Ouest (France)	1366		219.6	25
Scottish Regional (Burghead)	767		391.1	60	Warsaw (No. 2) (Poland)	1384		216.8	7
Scottish Regional (Westerglen)	767		391.1	70	Lyons (Radio Lyons) (France)	1393		215.4	25
Stalino (U.S.S.R.)	776		386.6	10	Vaasa (Finland)	1420		211.3	10
Toulouse (P.T.T.) (France)	776		386.6	120	Kaiserlautern (Germany)	1429		209.9	2.5
Leipzig (Germany)	785		382.2	120	Turin (No. 3) (Italy)	1429		209.9	5
Barcelona (EAJ1) (Spain)	795		377.4	7.5	Burgos (Spain)	1447		207.3	6
Lwów (Poland)	795		377.4	50	Paris (Eiffel Tower) (France)	1456		206	7
Welsh Regional (Penmon) (Anglesey)	804		373.1	5	Bournemouth	1474		203.5	1
Welsh Regional (Washford)	804		373.1	70	Plymouth	1474		203.5	0.3
Milan (No. 1) (Italy)	814		368.6	60					

SHORT-WAVE STATIONS OF THE WORLD

Arranged in Order of Frequency and Wavelength (Stations with an Aerial Power of 20 kW and above in heavy type)

Station.	Call Sign.	mc/s.	Tuning Positions.	Metres.	kW.	Station.	Call Sign.	mc/s.	Tuning Positions.	Metres.	kW.
Amateurs		1.71		174.43	—	Warsaw (Poland)	SPD	11.53		26.01	0.7
		to		to		Motala (Sweden)	SBP	11.70		25.63	20-12
		2.00		150.00		Moscow (U.S.S.R.)	RIA	11.71		25.62	15
Amateurs		3.50		85.71	—	Winnipeg (Canada)	CJRX	11.72		25.60	2
		to		to		Paris (Radio-Mondial) (France) ...	TPA4	11.72		25.60	12
		4.00		75.00		Paris (Radio-Mondial) (France) ...	TPA6	11.72		25.60	25
Calcutta (India)	VUC2	4.88		61.48	10	Huizen (Holland)	PHI	11.73		25.57	25
Bombay (India)	VUB2	4.90		61.00	10	Boston (U.S.A.)	W1XAL	11.73		25.57	20
Madras (India)	VUM2	4.95		60.61	10	Daventry (Gt. Britain)	GSD	11.75		25.53	10-50
Delhi (No. 2) (India)	VUD2	4.99		60.06	10	Poděbrady (Prague) (Czechoslovakia)	OLR4B	11.76		25.51	30
Bandoeng (Java)	PMY	5.15		58.30	1	Zeesen (Germany)	DJD	11.77		25.49	5-40
Montevideo (Uruguay)	CXA2	6.00		49.96	5	Boston (U.S.A.)	W1XAL	11.79		25.45	20
Pretoria (South Africa)	ZRH	6.01		49.94	7	Tokio (Japan)	JZJ	11.80		25.42	50
Rangoon (Burma)	XYO	6.01		49.94	10	Zeesen (Germany)	DJO	11.80		25.42	5-40
Poděbrady (Prague) (Czechoslovakia)	OLR2A	6.01		49.94	30	Vienna (Germany)	DJZ	11.80		25.42	50
Zeesen (Germany)	DJC	6.02		49.83	5-40	Rome (Italy)	12R04	11.81		25.40	25
Moscow (U.S.S.R.)	RW96	6.03		49.75	100	Daventry (Gt. Britain)	GSN	11.82		25.38	10-50
Poděbrady (Prague) (Czechoslovakia)	OLR2B	6.03		49.75	30	Wayne (U.S.A.)	W2XE	11.83		25.36	10
Vatican City (Vatican State)	HVJ	6.03		49.75	25	Lisbon (Portugal)	CWN4	11.84		25.34	5
Boston (U.S.A.)	W1XAL	6.04		49.67	20	Poděbrady (Prague) (Czechoslovakia)	OLR4A	11.84		25.34	30
Tandjong Priok (Java)	YDA	6.04		49.67	10	Zeesen (Germany)	DJP	11.85		25.31	5-40
Miami (U.S.A.)	W4XB	6.04		49.67	5	Daventry (Gt. Britain)	GSE	11.86		25.29	10-50
Daventry (Gt. Britain)	GSA	6.05		49.59	10-50	Pittsburgh (U.S.A.)	W8XK	11.87		25.26	24
Cincinnati (U.S.A.)	W8XAL	6.06		49.50	10	Paris (Radio-Mondial) (France) ...	TPB7	11.88		25.24	25
Philadelphia (U.S.A.)	W3XAU	6.06		49.50	10	Paris (Radio-Mondial) (France) ...	TPA3	11.88		25.24	12
Motala (Sweden)	SBO	6.06		49.46	0.7-12	Moscow (U.S.S.R.)	RNE	12.00		25.00	20
Vienna (Germany)	DJY	6.07		49.40	50	Reykjavik (Iceland)	TFJ	12.23		24.52	7.5
Hong Kong (China)	ZBW2	6.09		49.26	2.5	Warsaw (Poland)	SPW	13.63		22.00	2
Lima (Peru)	OAX4Z	6.09		49.24	15	Amateurs		14.00		21.42	—
Capetown (South Africa)	ZRK	6.10		49.20	5			to		to	
Bound Brook (U.S.A.)	W3XAL	6.10		49.18	15-35			14.40		20.83	
Chicago (U.S.A.)	W9XF	6.10		49.18	10	Radio-Nations (Switzerland)	HBJ	14.53		20.64	20
Daventry (Gt. Britain)	G5L	6.11		49.10	10-50	Moscow (U.S.S.R.)	RKI	15.08		19.89	25
Mexico City (Mexico)	XEUZ	6.12		49.98	20	Zeesen (Germany)	DJL	15.11		19.85	5-40
Montevideo (Uruguay)	CXA4	6.12		48.98	10	Vatican City (Vatican State)	HVJ	15.12		19.84	25
Pittsburgh (U.S.A.)	W8XK	6.14		48.83	28	Paris (Radio-Mondial) (France) ...	TPB11	15.13		19.83	25
Winnipeg (Canada)	CJRO	6.15		48.78	2	Boston (U.S.A.)	W1XAL	15.13		19.83	20
Wayne (U.S.A.)	W2XE	6.17		48.62	10	Daventry (Gt. Britain)	G5F	15.14		19.82	10-50
Vatican City (Vatican State)	HVJ	6.19		48.47	25	Delhi (India)	VUD3	15.15		19.80	10
Riobamba (Ecuador)	PRADO	6.61		45.31	2	Guatemala City (Guatemala)		15.17		19.78	10
Radio-Nations (Switzerland)	HBQ	6.67		44.94	20	Skamleback (Denmark)	OZH	15.17		19.78	6
Amateurs		7.00		42.85	—	Daventry (Gt. Britain)	G5O	15.18		19.76	10-50
		to		to		Moscow (U.S.S.R.)	RW96	15.18		19.76	100
		7.30		41.09		Hong Kong (China)	ZBW4	15.19		19.75	2.5
Mexico City (Mexico)	XECR	7.38		40.65	20	Ankara (Turkey)	TA9	15.20		19.74	20
Radio-Nations (Switzerland)	HBP	7.80		38.48	20	Zeesen (Germany)	DJB	15.20		19.74	5-40
Budapest (Hungary)	HAT4	9.12		32.88	6	Pittsburgh (U.S.A.)	W8XK	15.21		19.72	18
Ankara (Turkey)	TAP	9.46		31.70	20	Huizen (Holland)	PCJ2	15.22		19.71	60
Madrid (Spain)	EAR	9.49		31.62	10	Poděbrady (Prague) (Czechoslovakia)	OLR5A	15.23		19.70	30
Rio de Janeiro (Brazil)	PRF5	9.50		31.58	12	Paris (Radio-Mondial) (France) ...	TPA2	15.24		19.68	12
Melbourne (Australia)	VK3ME	9.50		31.58	5	Boston (U.S.A.)	W1XAL	15.25		19.67	20
Bangkok (Siam)	H88PJ	9.50		31.58	5	Daventry (Gt. Britain)	G5I	15.26		19.66	10-50
Mexico City (Mexico)	XEWV	9.50		31.58	10	Wayne (U.S.A.)	W2XE	15.27		19.65	10
Daventry (Gt. Britain)	G5B	9.51		31.55	10-50	Zeesen (Germany)	DJQ	15.28		19.63	5-40
Montevideo (Uruguay)	CXA8	9.51		31.55	2.5	Buenos Aires (Argentine Republic) ...	LUR	15.29		19.62	7
Skamleback (Denmark)	OZF	9.52		31.51	6	Daventry (Gt. Britain)	G5P	15.31		19.60	10-50
Pretoria (South Africa)	ZRH	9.52		31.50	7	Schenectady (U.S.A.)	W2XAD	15.33		19.57	18
Hong Kong (China)	ZBW3	9.52		31.49	2.5	Zeesen (Germany)	DJR	15.34		19.56	5-40
Calcutta (India)	VUC2	9.53		31.48	10	Budapest (Szekesfehervar) (Hungary)	HAS3	15.37		19.52	6
Schenectady (U.S.A.)	W2XAF	9.53		31.48	25	Djibouti (Somaliland)		17.28		17.38	5
Tokio (Japan)	JZJ	9.54		31.46	50	Hicksville (U.S.A.)	W2XGB	17.31		17.33	10
Zeesen (Germany)	DJN	9.54		31.45	5-40	Hong Kong (China)	ZBW5	17.75		16.90	2.5
Poděbrady (Prague) (Czechoslovakia)	OLR3A	9.55		31.41	30	Zeesen (Germany)	DJE	17.76		16.89	5-40
Paris (Radio-Mondial) (France)	TPB11	9.55		31.41	25	Wayne (U.S.A.)	W2XE	17.76		16.89	10
Vatican City (Vatican State)	HVJ	9.55		31.41	25	Huizen (Holland)	PHI2	17.77		16.88	25
Bombay (India)	VUB2	9.55		31.40	10	Bound Brook (U.S.A.)	W3XL	17.78		16.87	15-35
Schenectady (U.S.A.)	W2XAD	9.55		31.40	18	Daventry (Gt. Britain)	G5G	17.79		16.86	10-50
Zeesen (Germany)	DJA	9.56		31.38	5-40	Rome (Italy)	12R08	17.81		16.84	25
Lima (Peru)	OAX4T	9.56		31.37	10	Paris (Radio-Mondial) (France) ...	TPB3	17.81		16.84	25
Millis (U.S.A.)	W1XK	9.57		31.35	10	Buenos Aires (Argentine Republic) ...	LSY3	18.11		16.56	5
Daventry (Gt. Britain)	G5C	9.58		31.32	10-50	Ankara (Turkey)	TAR	18.30		16.38	60
Melbourne (Australia)	VLR	9.58		31.32	1	Radio-Nations (Switzerland)	HBH	18.48		16.23	20
Delhi No. 2 (India)	VUD2	9.59		31.28	10	Bangkok (Siam)	H88PJ	19.02		15.77	5
Philadelphia (U.S.A.)	W3XAU	9.59		31.28	10	Zeesen (Germany)	DJS	21.45		13.99	5-40
Sydney (Australia)	VK2ME	9.59		31.28	20	Boston (U.S.A.)	W1XAL	21.46		14.00	20
Perth (Australia)	VK6ME	9.59		31.28	2	Daventry (Gt. Britain)	G5H	21.47		13.97	10-50
Huizen (Holland)	PCJ	9.59		31.28	60	Schenectady (U.S.A.)	W2XAD	21.50		13.95	18
Moscow (U.S.S.R.)	RW96	9.60		31.25	20	Wayne (U.S.A.)	W2XE	21.52		13.94	10
Capetown (South Africa)	ZRK	9.60		31.25	7	Daventry (Gt. Britain)	G5J	21.53		13.93	10-50
Rome (Italy)	12R03	9.63		31.13	25	Pittsburgh (U.S.A.)	W8XK	21.54		13.93	6
Lisbon (Portugal)	CS2WA	9.65		31.09	2	Daventry (Gt. Britain)	G5T	21.55		13.92	10-50
Buenos Aires (Argentine Republic) ...	LRX	9.66		31.06	7	Amateurs		28.00		10.71	—
Guatemala City (Guatemala)	TGWA	9.83		30.98	10			to		to	
Madrid (Spain)	EAQ	9.86		30.43	20			30.00		10.00	
Lisbon (Portugal)	CSW3	9.94		30.18	5	London Television (Sound)		41.50		7.22	3
Marapicú (Brazil)	PSH	10.22		29.35	12	London Television (Vision)		43.00		6.66	17
Ruyssedele (Belgium)	ORK	10.33		29.04	9	Amateurs		56.00		5.35	—
Buenos Aires (Argentine Republic) ...	LSX	10.35		28.99	12			to		to	
Kootwijk (Holland)	PDK	10.42		28.79	80			60.00		5.00	
Taihoku (Japan)	JIB	10.53		28.48	10	Amateurs		112.00		2.67	—
Lisbon (Portugal)	CSW2	11.04		27.17	5			to		to	
Radio-Nations (Switzerland)	HBO	11.40		26.31	20			120.00		2.50	