



4<sup>D</sup>

# The Wireless World

**THE PRACTICAL RADIO & TELEVISION JOURNAL**

Friday, January 1st, 1937

**Resolved!** JAN. 1<sup>st</sup>  
to maintain the acknowledged  
**SUPREMACY**  
of  
**Sound Sales Products.**  
Quality Amplifiers, Transformers and  
Chokes of all types.  
*Special Sound Equipment and Speakers.*



MARLBOROUGH ROAD, UPPER HOLLOWAY, LONDON, N.19. **SOUND SALES LIMITED.** (Contractors to the G.P.O., etc.)  
Tel.: Archway 1661/2/3.

## Have you had your Copy? **RADIO SERVICING SIMPLIFIED** FIFTH EDITION

● A comprehensive survey of radio testing. Describes the faults that can develop in receivers and radiograms. It sets forth multitudinous tests in a manner which makes them extremely straightforward. Explains the use of all testing instruments. Contains numerous diagrams and graphs. Acknowledged to be one of the most useful guides to servicing.

Contents include:—Standard Valve Tests, Resistance Tests, Standard Condenser Tests, Inductance and Capacity Tests for Receivers. Superheterodyne H.F. and I.F. circuits and Output Meter. Automatic Volume Control, Gramophone Pick-up arrangements, etc.

Obtainable only from us. Send **2/6** Postage 3d. a P.O. for your copy to-day.

The Automatic Coil Winder & Electrical Equipment Co., Ltd. WINDER HOUSE, DOUGLAS STREET, LONDON, S.W.1. 'Phone: Victoria 3404/7.

## HAYNES QUALITY RECEIVERS

*Demonstration night—every Friday, 7.30—9.30 p.m.*

*Originators of the Quality Receiver.*



Have you the Haynes Quality Booklet? 1936-37 Edition.

QUEENSWAY, ENFIELD, MIDDLESEX. Enfield 2726

Central London area Agent, London Radio Supply Company, 11, Oat Lane, E.C.2. Hire purchase arranged.

## CAV DRY BATTERIES



60 VOLTS 3'9  
99 VOLTS 6'3  
108 VOLTS 6'9  
120 VOLTS 7'6

*The Finest British Battery of Standard Capacity*

C. A. VANDERVELL LTD. WELL ST., BIRMINGHAM



## *All made to measure*

Personally we believe in standardisation of condensers. But it isn't much good our believing in it unless you agree with us.

So we have planned our design and production sections to supply any special type, size or shape of condenser in the minimum of time. Actually, we already produce so many different 'standard' types that special cases go through

practically as routine. Our laboratory under the direction of Mr. Coursey, spend their lives working with set manufacturers on these individual problems—perhaps you can make more use of them than you do at present.

But that still doesn't alter the fact that increased standardisation would be a good thing for everyone.



# DUBILIER

## CONDENSERS

DUBILIER CONDENSER CO. (1925) LTD., DUCON WORKS, VICTORIA ROAD, NORTH ACTON, LONDON, W.3

J. R. Casson 205

Mention of "The Wireless World," when writing to advertisers, will ensure prompt attention.

# The Wireless World

THE PRACTICAL RADIO JOURNAL  
26<sup>th</sup> Year of Publication

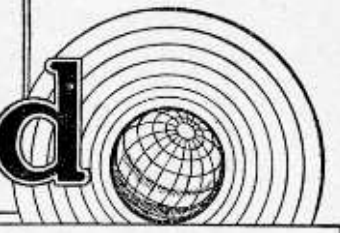
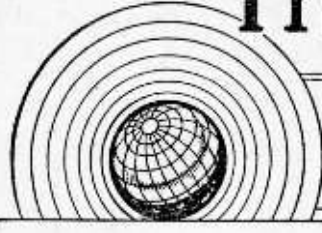

No. 905.

FRIDAY, JANUARY 1ST, 1937.

VOL. XL. No. 1.

Proprietors : ILIFFE & SONS LTD.

Editor :  
HUGH S. POCOCK.

Editorial,  
Advertising and Publishing Offices :  
DORSET HOUSE, STAMFORD STREET,  
LONDON, S.E.1.

Telephone: Waterloo 3333 (50 lines).  
Telegrams: "Ethaworld, Sedist, London."

COVENTRY: Hertford Street.  
Telegrams: "Autocar, Coventry." Telephone: 5210 Coventry.

BIRMINGHAM:  
Guildhall Buildings, Navigation Street, 2.  
Telegrams: "Autopress, Birmingham." Telephone: 2971 Midland (4 lines).

MANCHESTER: 260, Deansgate, 3.  
Telegrams: "Iliffe, Manchester." Telephone: Blackfriars 4412 (4 lines).

GLASGOW: 26B, Renfield Street, C.2.  
Telegrams: "Iliffe, Glasgow." Telephone: Central 4957.

PUBLISHED WEEKLY. ENTERED AS SECOND CLASS MATTER AT NEW YORK, N.Y.

Subscription Rates :  
Home, £1 1s. 8d. ; Canada, £1 1s. 8d. ; other countries, £1 3s. 10d. per annum.

As many of the circuits and apparatus described in these pages are covered by patents, readers are advised, before making use of them, to satisfy themselves that they would not be infringing patents.

## CONTENTS

	Page
Editorial Comment . . . . .	1
Microphones: Pressure and Velocity . . . . .	2
Broadcast Receiver Research . . . . .	5
A New Detector Circuit . . . . .	6
Broadcasting in the Balkans . . . . .	9
Current Topics . . . . .	11
Ferranti Arcadia Set Review . . . . .	12
Unbiased . . . . .	14
The Beam Power Tube . . . . .	15
Listeners' Guide for the Week . . . . .	16
Principal Broadcasting Stations . . . . .	18
Brilliant Television . . . . .	20
Broadcast Brevities . . . . .	22
Letters to the Editor . . . . .	23
Recent Inventions . . . . .	24

## The New Year

### Promise of Many Developments

IT might have been supposed that wireless being no longer in its infancy, and broadcasting having now been with us for some fifteen years, the year which we enter upon with this issue would show promise of no remarkable changes or developments of importance. Yet from all appearances the very reverse will apply, because at no time in the history of wireless have there been more positive indications of really important achievements in view.

Short-wave developments, both in the broadcasting and general communication fields, are being planned on a big scale in almost every country in the world and new services are promised for early in the New Year. The B.B.C. has several additional transmitters in preparation for an improvement in the Empire service, and these transmitters may be expected to be in operation during the year.

### Television Hopes

Television has passed through its earliest stage of development as a service with fair success, and if television is to provide a lasting service in the future, then it is certain that 1937 must see important programme changes in addition to improvements on both the transmitting and receiving side. If no means are found to improve the programmes of the television service out of present funds, then an alternative event of 1937 might be a new financing scheme.

With the commencement of the year the B.B.C. enters upon a new lease of ten years' renewal of its Charter.

1937 should show the introduction of the much-discussed legislation to control electrical interference, and this

should pave the way for conditions of reception, especially in large towns, better than anything which has hitherto been enjoyed. The probability exists, also, that changes in wavelength allocation in Europe may come about, resulting in an improvement, at least with the larger transmitters, of reception conditions as far as adjacent-channel interference is concerned.

Promises have been made that, in the broadcast programme field, 1937 will see an increase in the exchange of national programmes, thus helping to improve cultural relations as between one nation and another.

### Receiver Progress

In the sphere of reception it is difficult to anticipate how important may be the changes which may develop. Short-wave reception circuits will undoubtedly improve and many refinements which have already been disclosed in theory may be expected to find their way into practical application. The electron multiplier, the development of which in connection with television has been greatly stimulated, still holds promise of staging a revolution in amplifying circuits; whether or not progress in this direction will be sufficiently rapid to promise any radical changes in the nature of receivers during the year it would be unwise to anticipate, but that in the electron multiplier we have a potential revolutionary influence in receiver design will not be disputed.

*The Wireless World* enters this year upon its twenty-seventh year of publication, and we may hope that the record of events which its pages will chronicle will make this one of the most interesting years of its existence.

# Microphones: PRESSURE AND VELOCITY

## Main Characteristics and Applications of the Two Types

By F. N. G. LEEVERS, B.Sc., A.C.G.I.

IT has been frequently stated that of all the links in the broadcasting transmission and reception chain the microphone and the loud speaker are by far the weakest as regards both efficiency and fidelity. Although they occupy such extreme positions in the chain, the reasons for their shortcomings arise from the very similarity of their functions. they are both electro-acoustic devices, and while electrical measurements of a high order of accuracy can be made with comparatively simple and inexpensive apparatus, the same cannot be said of acoustic measurements. Further, acoustic conditions have a very important effect on the results obtained both in laboratory measurement and in practical use.

It is perhaps not surprising, therefore, that in the case of microphones the choice of types suitable for commercial use was, until a few years ago, very limited, being confined almost entirely to various types of carbon transmitter. In recent years, however, the rapid increase in the variety of uses to which the microphone is put, many of them involving very adverse conditions, has led to intense research, and this has resulted in the production of a number of new designs, in which good frequency and amplitude characteristics,

### EQUIVALENT MICROPHONES OF THE PRESSURE AND VELOCITY TYPES.

Electrical Characteristic.	Pressure Type.	Velocity Type.
Electro-Dynamic	1. Moving Coil 2. Inductor	Ribbon
Piezo-Electric Capacity	Sound Cell Non-directional Condenser	Differential Differential Condenser

together with low noise level, have been achieved. They include the "ribbon," the "inductor," the moving coil, the crystal, the differential crystal, the condenser, and the differential condenser microphones. These various types are usually regarded as belonging to categories determined by their method of converting acoustic to electrical energy—i.e., they belong to one or other of the electro-dynamic, piezo-electric, or capacity types.

In practice, however, it is far more useful to group them under the two main headings of pressure and velocity, according to whether they function by virtue of the pressure variation or the velocity of

*AN explanation of the essential difference between the two principal types of microphone and a discussion of the properties, particularly with regard to directional characteristics of examples in common use.*

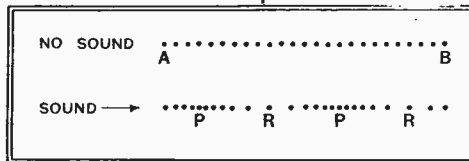

Fig. 1. — Displacement of air particles under the influence of sound waves.

the air particles. This re-grouping is shown in the accompanying table.

Reference to a suitable illustration of the propagation of sound in air will indicate the fundamental differences between the two types of microphones. In Fig. 1 the line of dots indicates the positions of air particles along a straight path radiating from a source of sound situated to the left. When no sound is emitted from the source the particles will be equally spaced, as indicated A B. When a sound of given frequency is emitted by the source, waves of high and low pressure will radiate from

below a mean value which is the atmospheric pressure. It is this alternating variation of pressure to which pressure microphones respond.

The air pressure at any point is indicated in the diagram by the density of the particles; hence variation of pressure due to sound waves involves the movement of the air particles towards or away from the source of sound. Particles cannot move in any other direction unless influenced by another source of sound, and they will only move about a mean position which remains constant. Except when very close to the sound source, the velocity of the displacement of the air particles is proportional to the variation of pressure.

From the last paragraph it can be seen that a microphone which responds to "particle velocity" will only indicate the component of this velocity which lies along its "major," or sensitive, axis. Since pressure microphones respond equally to

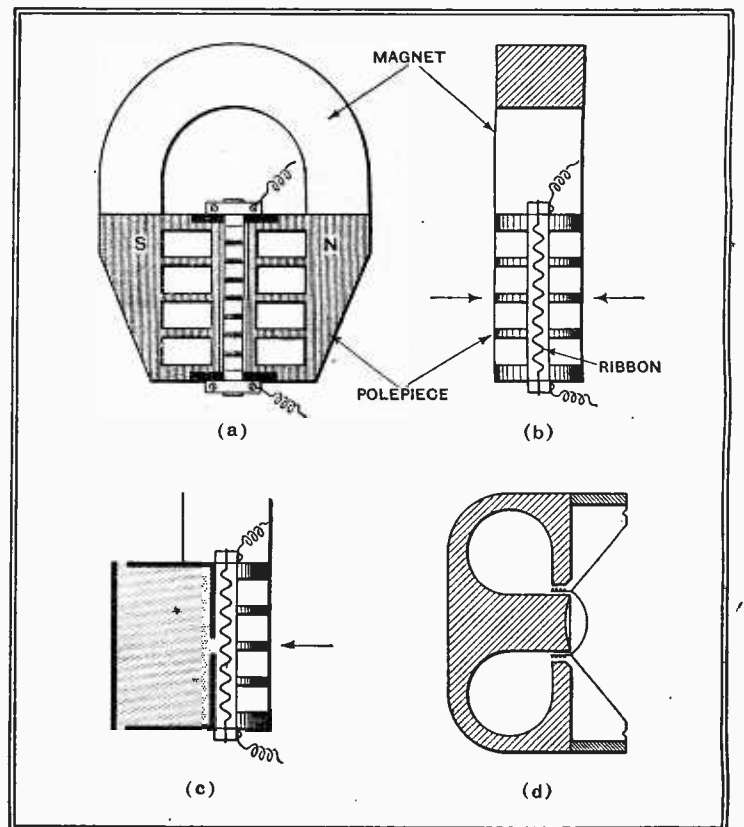

Fig. 2.—Diagrams a and b show a velocity ribbon microphone in front elevation and section, while c is a pressure ribbon microphone with enclosed back. A moving-coil type is shown in diagram d.

it—i.e., they will traverse our particular row of air particles from left to right, as indicated at P and R respectively. At a fixed point anywhere along our line of particles the pressure will appear merely to rise and fall as each wave passes. The pressure will actually alternate above and

sound waves arriving from any direction (neglecting special effects due to size and shape of the microphone itself), the directional characteristic, or "polar field," constitutes the major difference between the performances of the two types.

Having outlined the different acoustic

**Microphones—**

operations involved in the two types of microphone, let us return to the three main electrical categories, i.e., electro-dynamic, piezo-electric, and capacity, comparing the main constructional features of the velocity and pressure examples of each.

The main details of a ribbon (velocity) microphone are shown in Fig. 2a. A very thin light strip of aluminium is suspended by its two ends in an intense transverse magnetic field between the pole-pieces. The ribbon is corrugated concertina-fashion at right-angles to its length to give it sufficient flexibility to permit free movement in a backwards and forwards direction, while avoiding any danger of its moving sideways so as to touch the magnet pole-pieces. Both front and back of the ribbon are open to the air, as shown in the side view (Fig. 2b), and the adjacent magnet poles are shaped to give the minimum obstruction to sound waves. Since the ribbon, or at any rate most of it except for the ends, is free to move in sympathy with the vibration of the air, alternating voltages are induced in it. These voltages are very minute, and to avoid resistance loss in connecting cables a step-up transformer is usually fitted in the housing of the microphone above the magnet, thus keeping the leads to the ribbon very short.

**Pressure-type Microphone**

By enclosing one side of the ribbon while still leaving the other accessible to sound waves, as shown in Fig. 2c, the ribbon becomes sensitive, not to air-particle velocity as before but to the variation of pressure in front of the ribbon compared to the mean pressure on the enclosed side. This is usually called an "inductor," or pressure-ribbon microphone. Of course, the method of enclosing the back of the ribbon has a great effect on the results obtained. A solid backing cannot be placed very close to the ribbon, or no movement will result from changes of pressure, while a hollow air cavity cannot be used, since an enclosed quantity of air has mass and elasticity and therefore a natural frequency at which it will resonate. The interior of the cavity is therefore fitted with suitable baffles and damping material to avoid this. The arrangement sometimes takes the form of a long folded tube.

Increased efficiency may be obtained from the pressure-dynamic microphone by attaching a diaphragm to the moving element, when it is found convenient to use a coil of wire in a radial magnetic field instead of a ribbon. Fig. 2d shows the

construction of a typical moving-coil microphone, and a close resemblance to a small moving-coil loud speaker is evident. No baffle is used with the moving-coil microphone, but the back of the diaphragm is usually enclosed as in the case of the inductor type.

The moving coil may consist of many turns of thin wire instead of the single conductor of the ribbon type; hence the impedance is much higher, being usually in the neighbourhood of 20 ohms. The need for a matching transformer close to the microphone is thus avoided.

Turning to piezo-electric microphones, it was shown in a previous article<sup>1</sup> that voltages were produced by bending a certain type of crystal element. If such an element is sufficiently thin and flexible and is supported at one end, or at the two ends as indicated in Fig. 3a, the unsupported portion will be free to vibrate in sympathy with air vibrations, thus causing distortion of the laminations and setting up voltages across the electrodes. In this form, the crystal microphone is velocity-operated and is sometimes called a "differential" element. If two such elements are mounted back-to-back against spacers at the ends, closing the sides by a flexible seal will form a small air space between the elements as shown in Fig. 3b, and any variation in pressure of the surrounding air will cause both elements to bend inwards or outwards as the case may be, causing voltages to appear across both sets of electrodes. This constitutes a pressure-operated crystal microphone, which is usually called a sound cell. In commercial types the sound cell is mounted in a rectangular paxolin frame and enclosed by thin paper which is varnished to prevent the ingress of moisture which would disintegrate the crystals. The natural frequency of the sound cell is kept very high in the audio scale by using crystals of small dimensions. The most popular type at present in use employs crystals which are less than half an inch square, and the natural frequency is over 12,000 cycles per second.

The voltage output from single cells is

<sup>1</sup> Improved reproduction from discs, *The Wireless World*, April 24th, 1936.

very low, so that several cells are usually assembled in series-parallel to increase the output while keeping the impedance at a reasonably low value. The impedance is of a capacitive nature, so that, although capacity in the connecting cable will not affect frequency response, it will reduce the available output, as it does in the case of a condenser microphone.

In general, a condenser microphone consists of a small condenser in which one electrode is stationary while the other is free to vibrate under the influence of sound waves in such a manner that the spacing and therefore the capacity between the electrodes varies. Such a microphone does not generate voltage as the other types do, but if the condenser is charged from a battery through a high resistance, variation of the capacity of the condenser will cause charging and discharging currents to flow through this resistance, and the voltage drop across it will thus vary with the movement of the free electrode.

**Condenser Microphones**

An early form of electrostatic loud speaker consisted of a metallic diaphragm insulated from and mounted in close proximity to a perforated metal grille. A similar construction has been modified to form a condenser microphone of the velocity type as shown in Fig. 4a. In the more familiar pressure-operated type, however, the fixed electrode is solid and completely encloses the air dielectric as shown in Fig. 4b. Although a diaphragm of duralumin foil has been extensively used for many years, a new type made of gold leaf has proved successful. The design of the fixed electrode varies considerably with different makers. In some cases it is solid with shallow channels or slots cut

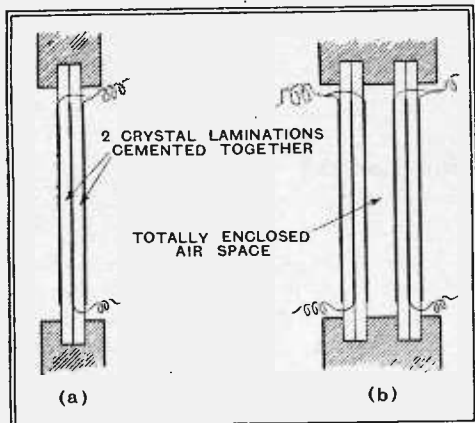

Fig. 3.—Diagrams a and b show, respectively, velocity and pressure crystal microphones.

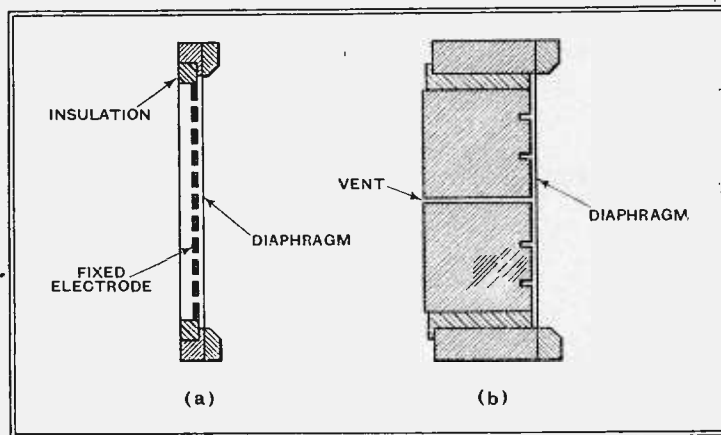

Fig. 4.—Velocity and pressure condenser microphones.

in it, while in others a small hole through the back communicates with the outer air, thus allowing the mean air pressure behind the diaphragm to remain at atmospheric level under all conditions. In one version a second smaller diaphragm, fitted in a compensating chamber behind the fixed electrode, can move to allow equalisation of pressure through the vent hole, while preventing the entry of moisture, dust, etc.

**Microphones—**

Although the velocity types of crystal and condenser microphone included in the above descriptions have not come into general use, the following practical observations, which refer to ribbon-velocity microphones, would also in general apply to them.

The polar response curve of a velocity microphone is of the cosine, or "figure eight," type as shown in Fig. 5. Here XX is the major axis and the response  $r$  to a wave arriving at an angle  $\theta$  to the major axis is:

$$r = OA \cos \theta$$

thus the response at right angles to the major axis is zero. The response to the "back" OX is similar, but opposite in phase. Fig. 6 shows polar curves for a commercial ribbon microphone taken in the open air, and the general shape can be appreciated although focusing at high frequencies is evident, and is probably due to the design of the field-pole-pieces.

Ribbon microphones have become increasingly popular for use in broadcast studios on account of this limited field of response. They are not liable to pick up unwanted sounds direct except at the back of the microphone, and the effects of studio reverberation and echo appear to be reduced considerably. The placing of artists is, however, rather critical, and more than one microphone is usually necessary to "cover" a number of artists. The author has seen as many as five used

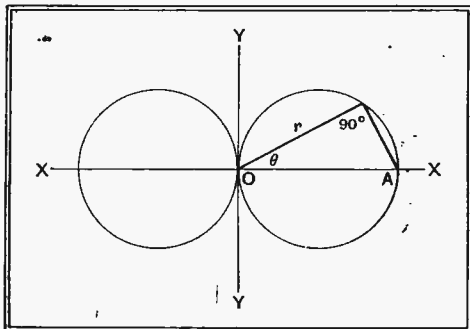

Fig. 5.—Theoretical polar response curve of a velocity microphone.

in balancing the various sections of a large orchestra.

Care has to be exercised when working near to a velocity microphone, since the particle velocity is no longer proportional to pressure close to the sound source. It is not advisable, therefore, to croon right into a ribbon microphone. But, who knows? It might be a blessing in disguise!

The velocity microphone was used for talking-film recording, but in this case its extremely directional characteristics turned out in practice to be rather a disadvantage. A broadcasting artist can be told where to stand, and how to speak, but a film artist must be allowed reasonable freedom of action. It is possible to follow an artist about a film set with the microphone, if this is suspended from a suitable boom, but if the microphone has to be rotated by remote control until it faces the artist each time he turns his head, the whole business becomes too

complicated for efficiency. The non-directional type of ribbon microphone which responds to pressure instead of velocity has largely superseded the velocity-ribbon in film work. In open air work, owing to the absence of walls and similar sound-reflecting surfaces, unwanted sounds can sometimes be "tuned out" by careful positioning of the velocity microphone, in the same way as unwanted stations can be "tuned out" by using a directional frame aerial with a radio set. Trouble, however, is usually experienced from wind noise, even when a wind baffle is used.

As stated previously, the pressure microphone should theoretically respond equally to sound waves arriving from all directions. Practical considerations, how-

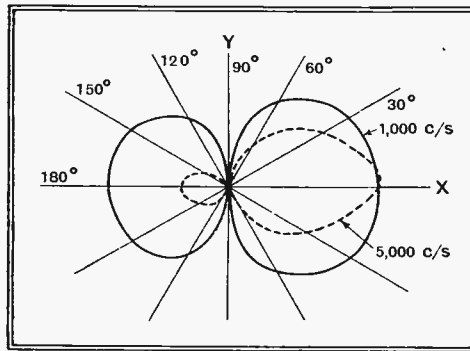

Fig. 6.—Polar response of ribbon-velocity microphone at 1,000 and 5,000 c/s.

ever, have usually prevented this being attained. Most types, particularly the inductor, the moving coil, and the older types of condenser microphone, are fairly large compared with the wavelength of the higher audio frequencies they are required to pick up. The bulk of the microphone therefore tends to cast an acoustic shadow to sound arriving from behind, and since this effect is only confined to the higher frequencies, good tonal balance is obtained to sounds arriving direct to the front of the microphone, but sound arriving by other paths due to echo, reverberation, etc., is decidedly boomy and unintelligible.

This effect is further increased by reflection of the sound waves by the diaphragm and its mounting. Since the reflected wave is in phase with the incoming wave at the diaphragm, the resultant pressure on the diaphragm is increased. This again only occurs at high frequencies where the wavelength is small, and when the sound source is in front of the microphone. Both these effects can be minimized by keeping the bulk small and streamlining the casing of the microphone.

Condenser microphones are commer-

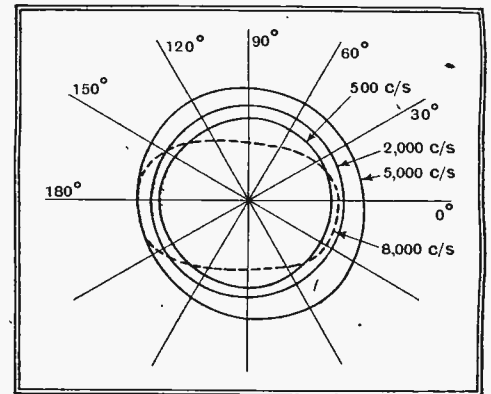

Fig. 7.—Polar response of radial type crystal microphone at various frequencies. Curves are taken at different sound levels for the sake of clarity.

cially available with transmitter elements little more than 1 in. in diameter, and they have proved to be non-directional up to relatively high frequencies. Piezo-crystal elements are usually even smaller than this. Fig. 7 shows the polar diagram of a crystal microphone incorporating two cells just over 1/2 in. square, and it will be seen that the field of response is extremely regular up to 8,000 cycles. The tendency for the diagram to become elliptical at high frequencies was due to a small felt mounting at the sides of the case.

**Studio Requirements**

In most forms of studio recording, the less polar response varies over the frequency range, the less complicated the microphone is to use. When acoustic conditions are bad, the most usual fault is excessive reverberation or boom at low frequencies, and the only method of reducing this electrically, is to attenuate bass. If, however, the microphone has a good polar response at high frequencies, there is obviously less need to attenuate bass. On the other hand, if conditions are good, the microphone will pick up reverberation

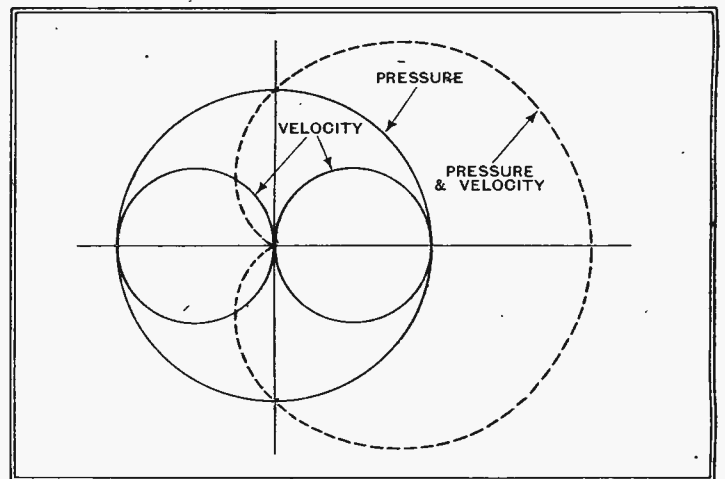

Fig. 8.—Theoretical polar field of combined pressure-velocity microphone.

and other indirect sound in its correct tonal balance.

When picking up sound from a number of artists, there is usually little to be gained by using more than one pressure

# Broadcast Receiver Research

NEW G.E.C. LABORATORY AT COVENTRY

## Microphones—

microphone, unless separate control is required, as in vocal items with music accompaniment. When two pressure microphones are used in one room, the effect of mixing the two will usually approximate to the pick-up from one microphone placed in an intermediate position. If sources of sound are widely separated, of course the position is different, and individual microphones are

**T**WO centres of radio investigation have hitherto been maintained by the General Electric Company; one for research proper at Wembley and the other for works development at Coventry. The growth of manufacturing activities has caused congestion of the space allotted to experimental work, and so it was decided early in the year to erect a separate building for the development of receivers.

The new radio laboratory at Coventry is divided into about twenty-four separate offices and laboratories, and it has been built in two floors, enabling

of electrical development is reasonably free from disturbances caused by his fellows, a number of small laboratories, each suitable for one or two engineers and an assistant, have been provided on the ground floor of the building. Each of these laboratories is provided with signal generators and standard testing equipment, while special equipment that is not so frequently employed is installed in other rooms.

## Isolation from Interference

Work requiring the total elimination of electrical interference is carried out in a screened room, in which special arrangements are made to prevent interference being brought in from the mains. Isolation proves so effective that it is impossible to receive even the most powerful transmitting station or locally generated interference without an external aerial.

Mechanical development work includes a life test where receivers and components are tested under every conceivable adverse condition of use; for instance, tropical conditions can be reproduced as an aid to development of receivers capable of withstanding overseas conditions. Another section is responsible for the maintenance of the testing apparatus throughout the laboratory and also for the design of special apparatus; in addition, it acts in an advisory capacity on any new tests that may be necessary in the final inspection department of the factory.

Finally, mention must be made of the circuit investigation section, for which four

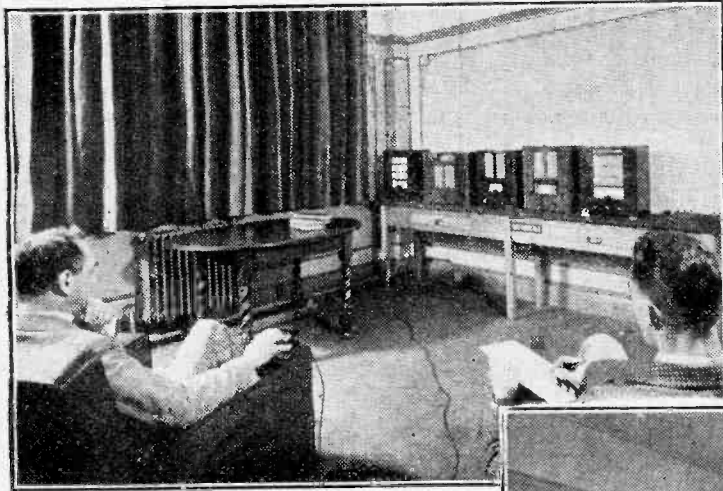

With the help of draping and furniture, domestic acoustic conditions are simulated in the listening room.

then almost essential to obtain the correct balance in the reproduction.

Pressure microphones of one form or another are widely used in film recording. As mentioned earlier, the straightforward technique involved in their use is a very important factor, particularly in view of the difficult situations frequently met with in this class of work.

The preceding notes have treated the pressure and velocity microphones as entirely separate types, but mention should be made of the possibility of combining the two in one instrument, and in so doing retaining the better features of each in a modified form. The full-line curves of Fig. 8 are theoretical polar diagrams of pressure and velocity transmitters. In the case of the velocity diagrams the two halves are opposite in sine. If the maximum output in the two cases be made equal as shown, at all frequencies, the result of combining the two will be the algebraic sum of the diagrams, as shown in dotted lines.

This heart-shaped diagram indicates a microphone having a relatively even response over a wide angle at the front while being practically dead at the back. This would seem to be an ideal characteristic in most types of work if it remains independent of frequency, and no doubt further developments will produce such a microphone in practical form.

In dealing with the various types of microphone, the question of frequency response has been deliberately avoided, since on this score there is little to choose between the best examples of each type, particularly when the appropriate equalising circuits are used.

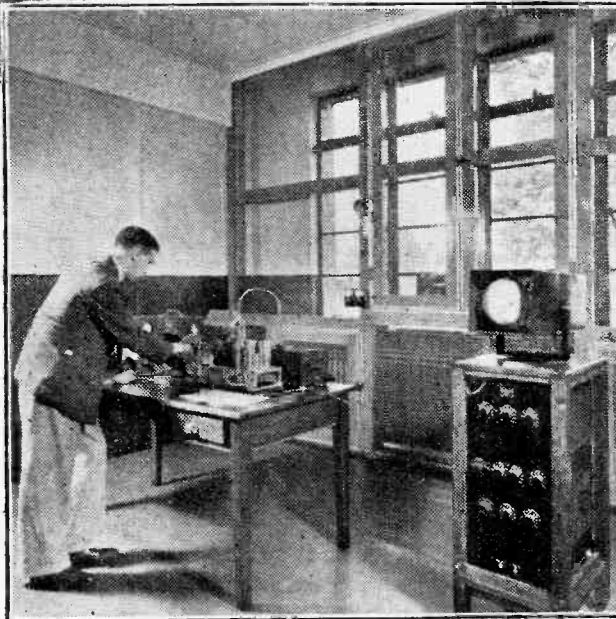

The screened room, from which all outside interference is excluded.

the ground floor rooms to be made reasonably sound-proof for work requiring silence and freedom from mutual interferences.

Laboratory work proper is supplemented by final listening tests on speakers and complete receivers. These tests are carried out in a room in which average acoustic conditions are simulated by furnishings and drapings, etc. Half a dozen receivers at a time can be tested and compared, remotely controlled relays being installed for rapidly changing from one to another.

To ensure that each worker in the field

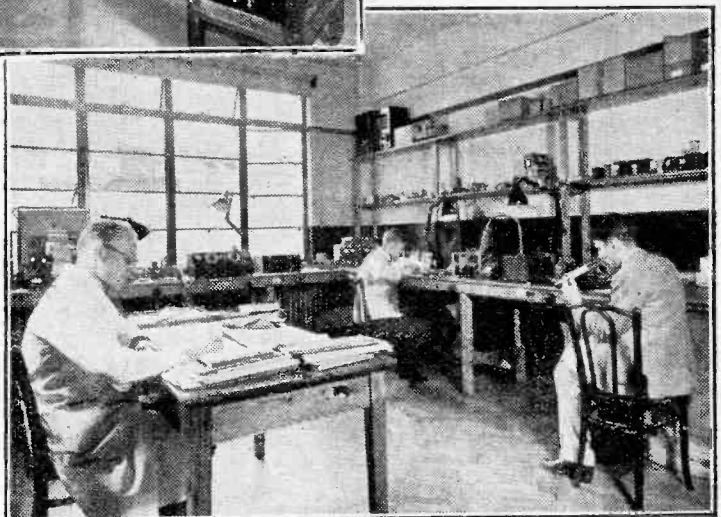

One of the small laboratories, fitted with equipment for electrical development work.

separate rooms are available. Here information from sources within or associated with the G.E.C. organisation is sorted out, classified, and examined to see how far it is applicable to present or future developments in radio receivers.

# New Detector Circuit

## APPLYING NEGATIVE FEED-BACK TO THE ANODE BEND RECTIFIER

WHILE the performance of the diode detector has been fully treated in past issues of *The Wireless World*, the several criteria for distortionless rectification are still a mystery to many. The realisation of a low level of distortion in the AF output of a diode detector subjected to deeply modulated signals depends largely on the magnitude of the ratio of the AC and DC output loads. The ideal condition is obtained when this ratio is unity, which can be realised only with direct coupling. If the AC load is appreciably lower than the DC load, the ability of the diode to handle a high percentage of modulation is limited.

The accompanying curves were furnished to the writer by the Hygrade Sylvania Corporation, in whose Application Laboratory they were made. These curves were plotted from data obtained by graphical methods involving the characteristics of the diode utilised in American duo-diode triode and pentode valves—both glass and metal—such as the 6Q7 and 85 valves. The diode characteristics were taken with conditions representing a generator impedance (circuit feeding diode) of approximately 100,000 ohms, which was considered as typical, and a signal of 30 volts peak was assumed.

In the preparation of this data, the conditions first considered were those where the diode load resistor  $R_1$  (Fig. 1) is a single unit and not tapped. Fig. 2 shows a typical case of the several shunting

resistances which give a resultant  $R_2$  composed of  $R_A$ ,  $R_B$  and  $R_C$  in parallel. The RF bypass condenser is neglected because its value is normally so low that the effect on audio frequencies is not applicable. Fig. 3 shows the general circuit for a tapped  $R_1$ . In this case,  $R_2$  is the resultant of the same components shown in Fig. 2. In each case the coupling capacitor  $C_1$  is considered as having negligible reactance at audio frequencies.

Figs. 4 and 5 show the modulation capability of a detector system for the cases where  $R_1$  is untapped and tapped respectively, the tapping being at the centre of  $R_1$ . It is evident that this arrangement increases the modulation capability of the detector at the sacrifice of AF output.

### Harmonic Distortion

Unfortunately, while this data shows that as low a value of  $R_1$  as possible is desirable, there are other factors (such as loading, limited power handling capacity of the last IF or RF stage, etc.), which must be considered in current design.

Figs. 6 and 7 indicate the harmonic distortion (2nd to 5th inclusive) of the AF output when a signal of 100 per cent. modulation is applied to a diode detector loaded for various modulation capabilities. These results are based on the assumption that the distortion is the effect of cutting off a portion of one half of the AF sine wave. The harmonic components given are those analysed in the cut-off portion of the wave. Although not absolutely

SOME causes of distortion with the diode detector are dealt with in this article and a new detector circuit is discussed which, by the application of negative feed-back, offers the possibility of a higher standard of quality. As the efficiency is higher than that of a diode, the system is an attractive one.

By W. N. WEEDEN

rigorous, the results are indicative of the magnitude of the distortion involved when a diode is not properly loaded.

In view of the serious distortion caused, it would seem advisable to make more use of the direct-coupled circuit, wherein the grid of the first AF tube is connected directly to the diode load (with no coupling condenser). For the best results, the AVC should be of the amplified and delayed type advocated by Cocking, not only to keep the input to the diode constant but to insure a constant DC or bias voltage being applied to the grid of the AF valve.

These defects of the diode are, of course, much smaller than those existing in other detectors, but a new type has just been developed which would appear to be even better than the diode. This new circuit was recently announced by the Hygrade Sylvania Corp., who kindly furnished the following curves to the writer, and it possesses several very real advantages. Although this announcement was made by Sylvania as part of their service to en-

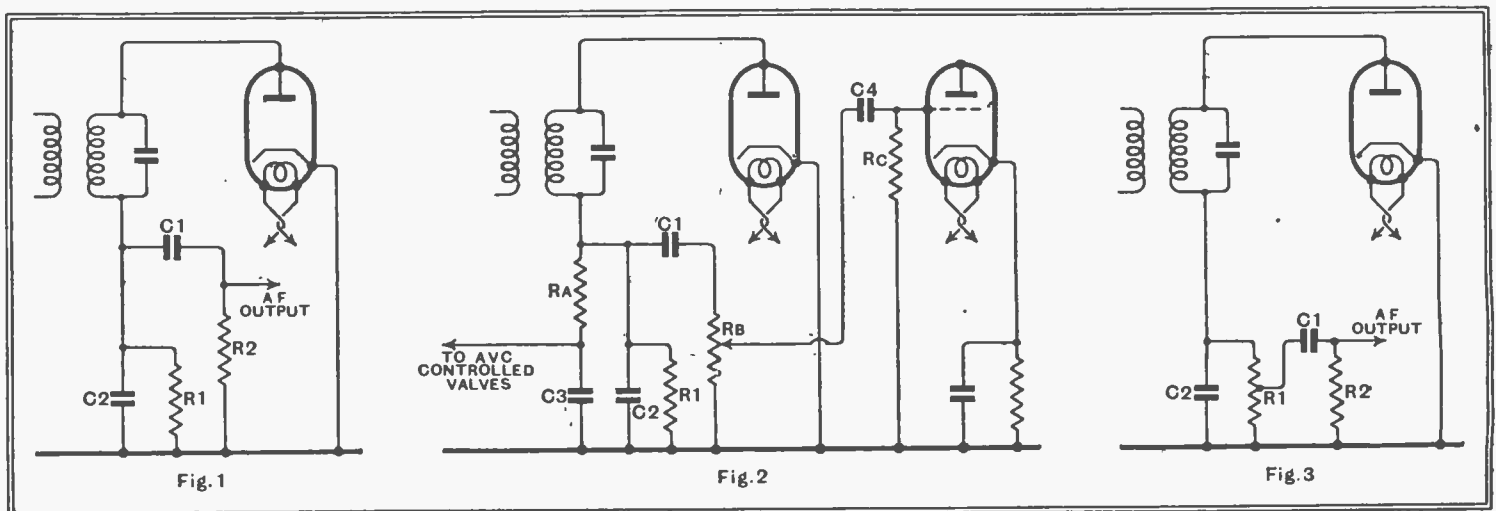

Fig. 1.—The conventional diode circuit in which the DC load is  $R_1$ , but the AC load  $R_1$  and  $R_2$  in parallel. Fig. 2.—In some cases more complex arrangements are used. Here  $R_A$ ,  $R_B$  and  $R_C$  all reduce the AC load resistance. Fig. 3.—The ratio of DC load to AC load can be made more nearly unity by tapping  $R_1$ , but at the expense of a loss of output voltage.



**Detector Circuit—**

gineers, the circuit was developed by the RCA Licensee Laboratories of New York City, and to them is due the credit.

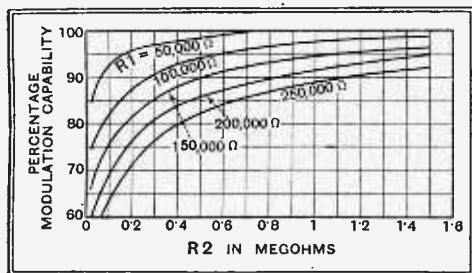

Fig. 4.—These curves show for a number of values of R1 the modulation depth with which the detector can deal without distortion; R2 is the total shunting value of the resistances following R1.

Considerable interest has been aroused by the development of this detector, partly because of its so-called "infinite input impedance." It is actually a triode anode-bend detector having a high resistance load in its cathode circuit. This load resistance is by-passed for carrier frequencies, and as it is common to both anode and grid circuits, degeneration or negative feed-back plays a large part in its freedom from harmonic distortion.

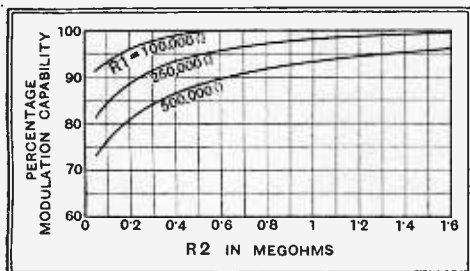

Fig. 5.—These curves give the same information as those of Fig. 4, but for the case when R1 is centre-tapped, as in Fig. 3.

Its input impedance is nearly a pure capacitive reactance which becomes a part of the tuned circuit without loading it, and this results in a considerable improvement in gain and selectivity, with simplification in design of coupling devices. From this point of view, the infinite impedance detector is a distinct advantage over the conventional diode. Likewise, its modulation capability is better than that of the diode, and it is the purpose of this article to present data on this characteristic in a form which can be compared with those already given for the conventional diode.

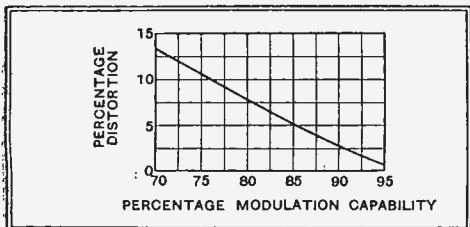

Fig. 6.—The amplitude distortion resulting when a 100 per cent. modulated signal is applied to a detector having the modulation capability shown is indicated by this curve.

The arrangement functions as a linear rather than square law detector, and in that respect is the same as the ordinary

diode. Fig. 8 shows the schematic circuit with the load resistors which were varied to obtain the data shown in the accompanying curves. It is to be noted that R1 represents the load resistance at DC, while R2 constitutes an AC load in parallel with R1, thus reducing the total AC load compared with the DC load.

In Fig. 9 is shown the percentage modulation which this detector system will handle with minimum inherent distortion when loaded with different ratios of AC to DC loads for various values of R1. Fig. 10 shows the same data on modulation capability plotted as a function of R2 for different common values of R1 to make the information more readily applicable to design work.

Fig. 11 is similar to Fig. 10, but gives the modulation capability of a system wherein R1 is mid-tapped so that R2 is across only

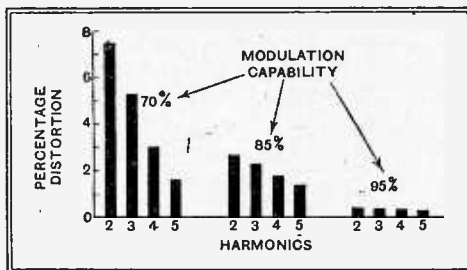

Fig. 7.—The distortion occurring when the modulation is 100 per cent. and so greater than the capability of the detector is here analysed.

half of the DC load. It is obvious that this arrangement increases the modulation capability of the detector, but reduces the AF voltage output by one-half.

While the new detector circuit has the very desirable features indicated above, it must be pointed out that a separate AVC channel is necessary, as AVC voltage cannot be obtained from this system. It has been found that regeneration is not a serious problem if care is used in the circuit design and layout.

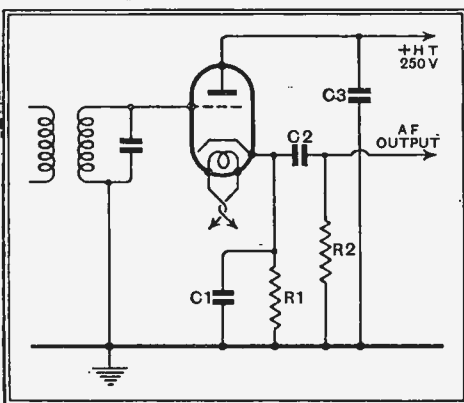

Fig. 8.—A new detector circuit embodying negative feed-back is shown here. It is an anode bend detector with the load resistance R1 in the cathode instead of the anode circuit.

While AVC voltage cannot be obtained directly from this detector as from a diode, it is entirely possible for the grid of the 'AVC amplifier described by Cocking' to be connected directly to some point on this cathode resistor or detector load. It would

<sup>1</sup> The Wireless World, June 12th, 1936.

be necessary to rearrange the circuit so that proper delay voltages could be provided not only for the purpose of preventing the functioning of the AVC circuit on weak signals, but also to avoid trouble due to the no-signal voltage across R1.

It is interesting to note that the signal voltage applied to the detector valve

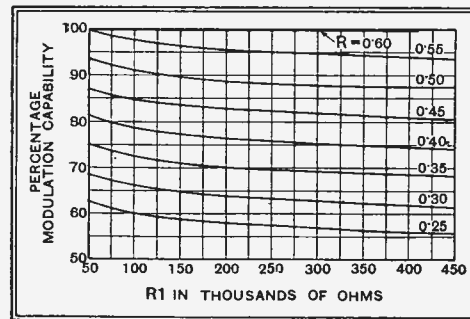

Fig. 9.—These curves show the modulation capabilities of the new detector for a 6C5 valve with 30 volts RMS input and 250 volts HT supply; R = R2/(R1 + R2).

in this new arrangement is equal to the voltage generated in the undamped secondary of the HF transformer as long as no grid current flows. In a conventional diode, however, the voltage is reduced by the damping of the detector.

The valve used for these tests is the Type 6C5, a metal valve with an AC resistance of approximately 10,000 ohms and an amplification factor of 20 at normal

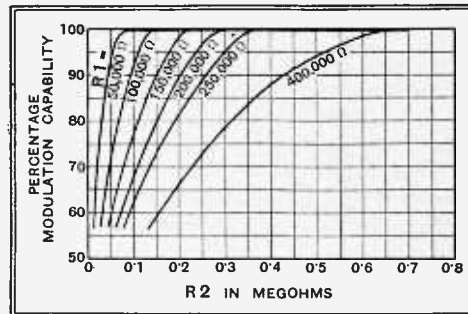

Fig. 10.—These curves give similar information to those of Fig. 9, but in a different form.

operating voltages. This valve was used as being indicative of characteristics suitable for this service, and an equivalent in the British range is the MHL4. Valves having amplification constants appreciably higher than this do not have as satisfactory modulation capabilities.

From limited personal experience with this device it would seem that its power sensitivity or efficiency is several times that of the diode, although not so great as that obtained from the same valve in a conventional circuit as anode detector.

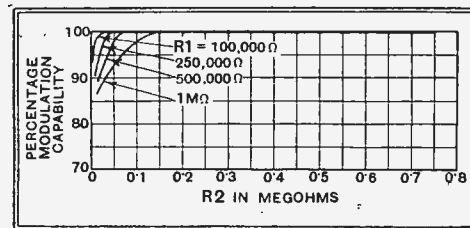

Fig. 11.—The modulation capability of the detector is shown here for the case when R1 is centre-tapped to feed R2 through C2.

**New Detector Circuit—**

This is explained by the negative feedback or degeneration, the use of which is always accompanied by decreased power sensitivity. The writer used the 56 valve for his experiments. This valve is an indirectly heated triode with an anode resistance of 10,000 ohms and  $\mu=14$ . With a load or cathode resistance of 50,000 ohms the output was four to five times that of a diode. The sensitivity would be still greater with larger values for  $R_1$ . This gain is not due entirely to the added efficiency of the detector, as the input to it, or output of the RF amplifier, increases with decreased loading, and it was not possible to isolate these effects in the limited time available.

In closing, the writer's views on the value of this new development may be of

interest to some readers. Low-cost receivers with a limited number of valves will undoubtedly continue to use the diode detector, as it is possible to utilise the DC output of such a detector with fair efficiency and almost no additional cost as the basis of a simple AVC circuit. Therefore the test of the new infinite impedance detector will come in its application and adaptation in the higher-priced receivers in which an extra valve would be of little significance. In such a circuit, the new detector should prove superior to any but the direct-coupled diode, and even then, it should win out because of the freedom from damping on its input circuit. However, time alone will tell, and we must await the release of the next few receiver models before judging its merits.

accurate; (5), short-wave scale too small and often a long way "out." The ideal dial would have none of these blots on its escutcheon. It would be a real indicator of the setting of the tuned circuits; it would be complete, it would be perfectly legible and it would mean what it said.

**Can It Be Done ?**

Must it remain an unattainable ideal? Or can it be worked out in practical form? I see no reason why it should not, at any rate in the "luxury" set. The scale itself would have to be large, and this at once raises the objection that it would spoil the look of the set. There are two ways out of this. One is to arrange for the dial to be covered when it is not actually in use. The second is to inscribe the scale on a long piece of non-stretching material mounted on rollers—only a portion of it is then seen at any time through a suitable aperture. To obtain reasonable accuracy the scale must be properly marked out in the first instance, and probably either it or the pointer must be capable of adjustment. For perfect accuracy hand calibration would be necessary, and I do not see why this should not be done, either as a regular thing or as an "extra," in big sets selling at largish prices. Well, these are some ideas which may help to start interested brains working.

# RANDOM RADIATIONS

**A Happy New Year**

A VERY happy New Year to all readers. May it be a good one for reception and crammed with interesting radio developments! I haven't much doubt that we are going to witness some big steps forward during the next twelve months, for in several departments of wireless we seem to be just on the verge of making real advances. Television, for instance, is full of possibilities. On the technical side we are likely to hear a good deal more of big-screen reception, probably by a variety of methods. And before the year is out we should know much more than we do now about the behaviour of the ultra-short waves of the order of seven metres. There may be some surprises in store there. Those who are responsible for the entertainment side of television should have had time to discover its most suitable applications and to work out a technique worthy of it. Television programmes, in a word, should reach the stage of providing real entertainment for all and not just material for the experimenter or a short-lived thrill for the man-in-the-street.

By "DIALLIST"

**Two Hobbies**

THE market for the smaller set would, of course, be enormous; but what of the big one costing real money? Provided that the public was properly educated up to its advantages, I believe it would soon sell readily. There's another hobby, photography, which has developed on much the same lines as wireless, though far more slowly. At first cameras for the amateur were expensive, difficult to operate, and not very efficient. Then came the era of the simple, compact camera at a moderate price. Such a camera is capable of taking reasonably good pictures of straightforward subjects in favourable circumstances, and it is still much the most widely used. But in the last few years highly efficient cameras intended for amateur use have made their appearance in both medium-sized and miniature form. They cost a great deal of money, for they have fine lenses, wonderful shutters and all kinds of fittings that make for first-rate results in all circumstances. Costly though they are, these cameras have big sales because they do produce the results. If people will pay £50 or more for a camera because they're not content with what a cheaper one can do, wouldn't they be equally willing to plunk down a good price for the very best in wireless sets? There's only one answer to that question, I think: they would.

**Identifying Announcers**

THE B.B.C. sprang a Christmas surprise on us by publishing not only the names of its announcers, but also their portraits and the times at which they would be at the microphone during the week. Myself, I've never been able to see why announcers should be anonymous any more than commentators or compères. I rather like the American system: their announcers tell you who they are at the beginning and at the end of the programme for which they are responsible. Broadcasting, after all, is, or should be, something rather intimate, for it brings the people in the studio right into our homes. For that reason my view is that anything like a cold, impersonal attitude should be avoided, particularly in the case of announcers, whom we hear so often that we look on them as old friends—even if we don't know their names. Possibly you won't agree with me, but will feel that matters are best left as they are.

**What of Receiving Sets ?**

THIS year will, I believe, see rather a change in the policy of many manufacturers. They are coming to realise that the public may be divided into two main classes from the wireless point of view: on the one hand there are those who neither demand nor appreciate high quality of reproduction and are prepared to pay only a modest price for their sets; on the other, we have those who want good quality combined with first-rate all-round performance, and are quite ready to pay handsomely for their receiving equipment. At present the tendency is rather to concentrate on the medium-priced set, which may be just a little too good and too expensive for the one class of listeners though not good enough for the other. I should not be surprised to find at the next exhibition two chief ranges of receivers: first, the small, simple superhet, priced at well under £10, and, secondly, the large superhet with all kinds of refinements and selling at from £20 to £30 or more.

**The Ideal Dial**

THERE should be a fortune awaiting the man who invents a first-class tuning dial. So far I've come across a good many that I like pretty well, but none that hasn't its shortcomings. Common defects are: (1) only a few of the receivable stations shown on medium and long wavebands; (2) names of stations sometimes not too easy to read; (3) marking so inaccurate that a wanted station does not come in when you turn the pointer to the setting indicated; (4) metre or kilocycle scales (if present) often too cramped and seldom sufficiently

**Corner Cabinets**

SOME time ago I suggested that a receiving set in a corner cabinet would be very popular in the homes of to-day, where space is often at a premium. A reader writes to tell me that he has built a set of the kind and that he finds it a boon and a blessing. He decided that sides for the cabinet were not necessary and made it to fit snugly into a special corner. The framework is simplicity itself—just three legs with a couple of triangular shelves for the mains unit and the set and a top of the same shape. He finds, as I thought would be the case, that the acoustic properties of a corner cabinet are particularly good, the walls acting as extensions of the baffle formed by the front and throwing the sound-waves from the loud speaker into the room in a very pleasing way. A radiogram can be made on the same lines, but the front-to-rear depth required for the turntable means that the cabinet has to be rather wide. Even so, it takes up less space than a rectangular cabinet.

# Broadcasting in the Balkans

By A. A. GULLILAND

FOR a long time past the Balkans have been by far the most backward part of Europe from the point of view of broadcasting, and although in certain parts of the peninsula there are big developments afoot it must still be considered as the most inarticulate part of the continent so long as two out of the six countries comprising it are without any organised broadcasting service.

hitherto been rather backward, there is a very definite movement afoot to come into line with the rest of Europe, and a 100-kilowatt station is now in course of erection at Vakarel, which is about 20 miles from Sofia, the capital. This station, as well as serving Bulgaria, is likely to be heard at very good strength, even at daylight hours, in the Southern part of Yugoslavia. Probably also it will be well received in parts of Rumania. The Bulgarian language is, of course, a Slavonic one not greatly dissimilar to Serbian, and the Vakarel station will therefore provide a good alternative programme for those Yugoslavs who are within range.

This will not

## EUROPE'S SILENT CORNER TO MAKE ITSELF HEARD

Bulgarian licence holders number only 20,000, this being but 0.3 per cent. of the population, which compares rather unfavourably with the 20 per cent. in the case of this country, but this is largely due to the absence of cheap receivers, a defect which it is said the Government are intending to remedy, possibly by the provision of a "people's" receiver.

In the neighbouring country of Yugoslavia broadcasting is in rather an unsatisfactory state owing to the fact that there is some uncertainty whether or not the Government is going to take over the service. The Government is particularly anxious for more stations of greater power to be built, partly in order to counteract

the broadcasts in various Yugoslav dialects which are coming from the other side of the Adriatic. The various companies which own most of the existing stations will not augment their power nor build additional ones until the Government agrees to extend their existing concessions—which have still some time to run—for a large number of years. At present the country has to put up with stations of



Bulgarian peasant musicians taking part in a broadcast from the present low-power Sofia station, which will shortly be replaced by a new 100 kW. transmitter now being built at Vakarel, about 20 miles outside the capital city. The partially finished station buildings are seen on the right.

These two countries are Greece and Albania, and while one can possibly understand the absence of broadcasting in the case of the latter country, it is astonishing to find that at Athens, the ancient centre of the civilised world, no attempt has been made to build a proper station. It is true that there are rumours to the effect that stations are being planned at Athens and at Tirana, the Albanian capital, but no official information is obtainable with regard to them. These two countries are the only ones of any size without a broadcasting service, as in the rest of Europe only the tiny states of Liechtenstein, Andorra, Monaco and San Marino remain without transmitters.

Of the remaining Balkan States, Rumania and Turkey have by far the best and most carefully organised broadcasting services. In Bulgaria, which has

apply in the case of Rumanian listeners.

Apart from Vakarel there are already in existence 2-kW stations at Varna and also at Stara Zagora, and it is interesting to note that these are supplied with programmes from Sofia by means of wired wireless, although in the case of Varna a fair amount of use is made of the local studio. The Bulgarian broadcasting service is run by the State and, apart from the building of the new high-powered station at Vakarel, the authorities are engaged in the erection of large new studios in Sofia and it is expected that these will be available sometime during 1938. They will be by far the largest and best in that part of Europe.

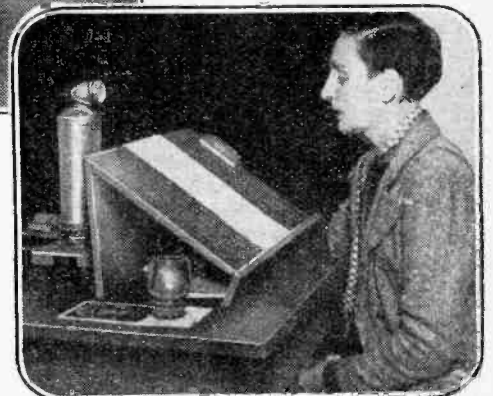
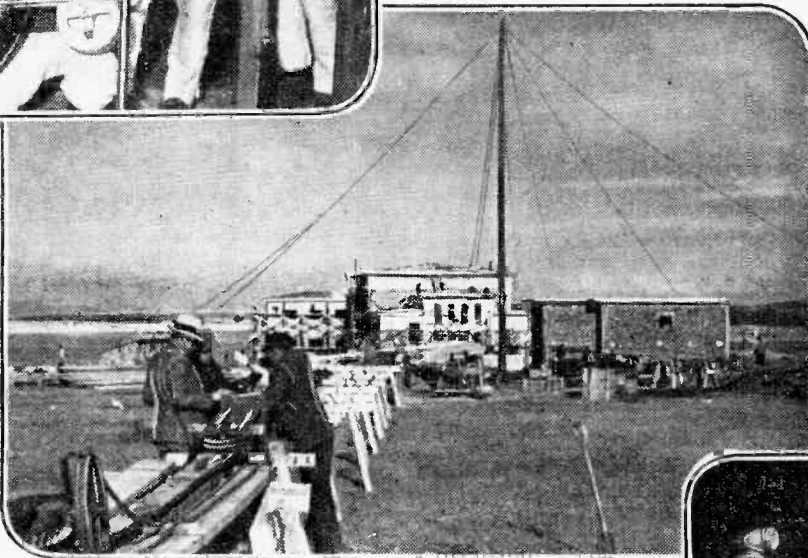

Broadcasts are made in eight languages from the Yugoslavian short-wave station in Belgrade. Mme. Bety Popovic makes all the English announcements.

relatively minor power, 5 kW. in the case of Ljubljana, 0.75 kW. for Zagreb, and 2.5 kilowatts for Belgrade, although the

**Broadcasting in the Balkans—**

Belgrade company are actually erecting a 20-kilowatt station in the capital.

There are plans to build a 100-kilowatt station in Belgrade, a 10-kilowatt station at Skoplje, and a 20-kilowatt one at Zagreb, together with a smaller one of about 3 kilowatts in Split. Until the Government grants the required long term of concessions, or takes over the whole of the broadcasting service themselves, however, these plans are not likely to be brought to fruition.

The Government has, however, realised the advantages of making Jugoslavia's voice heard in the world, and for this purpose is at present concentrating on the short waves. It was for this reason that the Belgrade short-wave station came into being some months ago. Its power is at present 1.5 kilowatts, but this is likely to be raised to 10 kilowatts or even 20 kilowatts at a fairly early date. This station,

like our own Daventry transmitter, employs various wavelengths to suit the time of the day and the particular locality at which the programme is aimed. At present programmes are broadcast in no less than eight languages. The total number

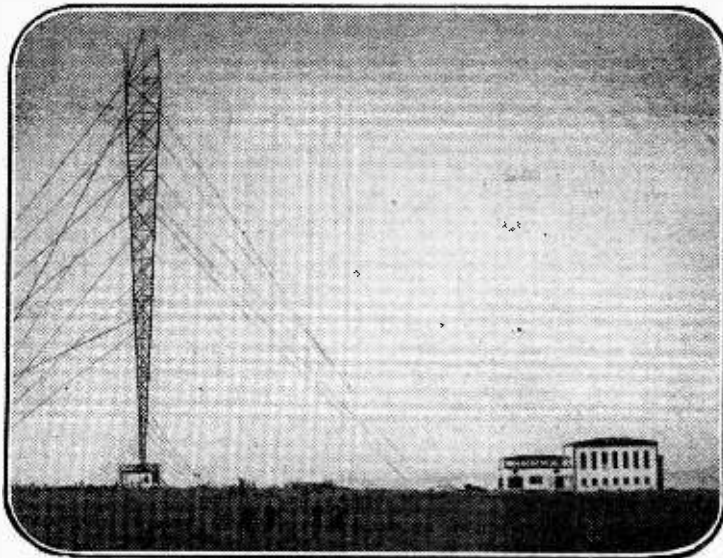

A later photograph showing the rapid progress being made in completing the Vakarel mast and station buildings. The mast is expected to be finished by the time this article is in print.

of listeners in Jugoslavia is at present about 100,000, the population being 14 millions, but this figure could undoubtedly be largely increased by the provision of more and better transmitters.

**DISTANT RECEPTION NOTES**

At any time within the next week or two a new big American station should come into operation. Or perhaps I should say that a big American will become bigger. The station in question is the Mexican XEAW, at present rated at rather over 50 kilowatts, which is shortly to blossom out as a "three-figure" transmitter with an output rating of 100 kilowatts. One would think off-hand that with this power XEAW should be well heard over here; but for some reason or other stations in Central America don't seem to reach us anything like so well as those in the United States or South America.

XERA, for example, is not often reported; yet this station has been working for some time with a power of between 300 and 400 kilowatts.

Mexico is a huge country—how big you don't realise until you use an atlas. Actually its area is only slightly less than that of France, Germany, Italy, Spain and Portugal all put together. It's not surprising, therefore, that it should have a good number of broadcasting stations, though its population is not much greater than that of Holland and Belgium. In the latest list that I have by me no less than 67 Mexican stations are shown. As some 20 of these are rated at 1 kilowatt or more, Mexico should provide good hunting for any D-X enthusiast who wants to break new ground.

At present there is only one station rated at 500 kilowatts in the United States. This is WLW, of Cincinnati, Ohio, whose licence to use such great power is still officially experimental. The station has, however, proved such a success owing to its enormous service area that half a dozen others have applied for permission to increase their power to the same figure. In the United States atmospherics are far worse than they are here, and one can well understand the importance of high power as an aid to obtaining a satisfactory signal-to-noise ratio at considerable ranges. It will not, therefore, be surprising if permits are granted to most of those who have applied for them, though so cautious are the Federal Communications Committee that the licences are likely to be provisional and subject to withdrawal at very short notice should the spread of the big stations at medium ranges be found unduly great.

There seems to have been a certain amount of reshuffling of the wavelengths of Norwegian stations, and so far as I can make out most of the published lists contain a few errors at the moment. Here is what I believe to be the correct list:—

Metres	Station	kW.
221.1	Nottoden	0.15
222.6	Rjukan	0.15
235.1	Stavanger	0.5
	Christiansand	0.5
245.5	Narvik	0.3
352.9	Bodø	10
	Porsgrund	1
386.6	Fredrikstad	1
415.4	Bergen	1
476.9	Trøndelag	20
578	Hamar	0.7
864	Finmark	10
1,064	Tromsø	10
1,186	Aalesund	10
1,153.8	Oslo	60

Some of the smaller fry should be interesting quarries for the sensitive and selective set in expert hands. D. EXER.

**TELEVISION PROGRAMMES**

Friday, January 1st, to Thursday, January 7th

The principal items only of each day's programmes are given. The system to be used each day is given below the date. Transmission times are from 3-4 and 9-10 daily.

Vision 6.67 m. (45 Mc/s). Sound 7.23 m. (41.5 Mc/s).

**FRIDAY, JANUARY 1st.**  
(Baird.)

3, British Movietonews. 3.15, Women's Interests—"Marine Parade"—a forecast of fashion. 3.30, Michaelson—topical quick-fire artist. 3.45, Cabaret.

9, Gaumont British News. 9.15, Demonstration by men of the R.A.F. Boxing Association. 9.30, Repetition of 3.30 and 3.15 programmes.

**SATURDAY, JANUARY 2nd.**  
(Baird.)

3, Gaumont British News. 3.10, Val Rosing and his Band with Anne Lenner. 3.25, Winter Sports—Ski-ing hints for beginners by Commander Jack Shirley, R.N. (retd.), illustrated by mannequins appropriately attired. 3.45, Val Rosing and his Band.

9, British Movietonews. 9.10, Repetition of 3.10, 3.25, and 3.45 programmes.

**MONDAY, JANUARY 4th.**  
(Marconi-E.M.I.)

3, New Styles in Hats. 3.15, Film. 3.25, "In Search of the Electron"—talk by Dr. H. Stafford Hatfield illustrated with experiments. 3.35, Gaumont British News. 3.45, Starlight—Billie Houston.

9, Repetition of 3 programme. 9.15, Film. 9.25, Repetition of 3.25 programme. 9.35, British Movietonews. 9.45, Cabaret, with The Television Orchestra.

**TUESDAY, JANUARY 5th.**  
(Marconi-E.M.I.)

3, The Orchestra and its Instruments: I—Strings. Philip Thornton will show with examples of old stringed instruments how the modern violin, etc., has been evolved. 3.20, British Movietonews. 3.30, Theatre Parade—scenes from the Whitehall Theatre production, "Anthony and Anna."

9, Repetition of 3 programme. 9.20, Gaumont British News. 9.30, B.E.C. Dance Orchestra.

**WEDNESDAY, JANUARY 6th.**  
(Marconi-E.M.I.)

3, Gaumont British News. 3.10, Record-breaking—Sir Malcolm Campbell with the "Bluebird" interviewed by Cecil Lewis, followed by a film of the Utah record. 3.30, Film. 3.40, Seventeenth Picture Page.

9, Repetition of 3.10 programme. 9.20, Film. 9.30, Eighteenth Picture Page. 9.50, British Movietonews.

**THURSDAY, JANUARY 7th.**  
(Marconi-E.M.I.)

3, British Movietonews. 3.10, Underneath London—Talk on Antiquary by G. F. Lawrence. 3.20, Film. 3.30, Scenes from The Old Vic production of "Hamlet."

9, Cabaret—The Television Orchestra. 9.30, Film. 9.40, Repetition of 3.10 programme. 9.50, Gaumont British News.

## News of the Week in Brief Review

### American Wireless Prosperity

THE past year has been one of the most prosperous ones known so far as the great U.S. broadcasting chains are concerned. Between them they have collected six million sterling in advertising fees, and one of them has increased its income by sixty per cent., compared with 1935.

### More SW Stations

NORTHERN Europe is soon likely to make its voice heard in the world to a far greater extent than at present, owing to the rapid extension of the SW broadcasting services which is taking place there. Work has been started on a 100-kw. station near the Icelandic capital, while Finland has a new 20-kilowatt station in course of construction. Several stations of power ratings from 10 to 20 kilowatts are planned for Scandinavia. The Swedish Government has granted a million kroner towards the cost of erecting new stations at Lulea, Karlskrona and Helsingborg.

### New High-powered Stations

IT is stated that the two Polish stations at Lwow and Wilno will shortly be radiating on 50-kW. The work of rebuilding these transmitters has been carried out entirely by Polish engineers. At the same time, it is stated that the Czechoslovakian Government has under consideration an extensive programme of station building. Two new 100-kilowatt stations are being planned, one at Neutra and the other near Brno. The Neutra station will probably take over the wavelength of Bratislava, the latter still continuing to work in some other part of the radio spectrum. The present Brno station is, however, likely to be closed down.

### New Test Apparatus

JUDGING from the advance information received, the interests of the wireless industry will be well represented at this year's Exhibition of the Physical Society. In the trade section most of the leading manufacturers of measuring apparatus have taken stands, and the research sections can be relied upon to provide demonstrations of the latest developments. The Exhibition opens at 2.30 p.m. on Tuesday next, January 5th, at

# CURRENT TOPICS

the Imperial College of Science and Technology, Imperial Institute Road, South Kensington, S.W.7, and closes at 9 p.m. on Thursday, January 7th.

### Australian Broadcasting Dispute

ALL hope of broadcasting running commentaries from the famous Victoria Park racecourse have been dashed to the ground. The broadcasting authorities were refused permission to broadcast from Victoria Park by the racing authorities. Accordingly they made arrangements to give a running commentary from a building overlooking the course. A legal injunction has now been obtained to stop even this.

### Wireless for Everybody

IN an effort to popularise radio still further, the Hungarian Government is to reduce licence fees and to take steps to enable valve sets to be used in remote villages not supplied with electricity. It is hardly likely that this will be done by extending electricity to these villages at present, but in all probability arrangements will be made for motor-vans to collect villagers' accumulators and take them to

the nearest town for charging. Meanwhile the Italian "People's Receiver" is to be reduced in price so that it will be available to a large class of people. Italian radio employees are reported to have had their salaries and wages raised by 8 per cent. in conformity with new financial arrangements made in other branches of industry.

### Oslo Police Adopt Radio

THE use of wireless patrol cars by the police authorities has now penetrated to Norway, and the Oslo police have acquired ten cars and have built a 10-metre transmitter in the middle of the city. The police authorities of the other Scandinavian countries are said to be still considering the question.

### Pioneer Announcer Dead

IT seems a little difficult to think of announcers before the era of broadcasting, and yet they did exist, as we are reminded by the death of Charles Scherz which has just occurred. Not only was he the very first announcer at the Budapest station, but in pre-broadcasting days he held the same office in connection with the original

Hungarian News-Broadcasting Service which sent its information over the ordinary landline to telephone subscribers at certain times of the day. This arrangement was very similar to the Electrophone system which used to be in vogue in this country before the days of broadcasting.

### International IF Channel?

THE American Federal Communications Commission is now considering a proposal already referred to in *Wireless World* that an international IF channel should be established. The idea is that all transmitters, throughout the world should be prevented from using a certain given channel, this being reserved for the IF amplifiers of receivers. By this means a good deal of interference would be cut out, and at the same time, owing to the standardisation of the intermediate frequency, the cost of superhets would be lessened.

### Wired Wireless in Sweden

EXPERIMENTS have been tried by the Post Office authorities at Karlshamn, in Sweden, with a view to radiating broadcast programmes over a telephone line simultaneously with three ordinary conversations. Very successful results have been obtained so far, and Post Office engineers from the neighbouring country of Norway have visited Karlshamn to study the system. It is quite likely that wired broadcasting may eventually play an important part in Scandinavian broadcasting, more especially in Norway, owing to the difficulties of reception due to the mountainous nature of the country.

### Anti-Interference Legislation?

THERE is a distinct possibility that now television has come upon the scene there will be early legislation to compel the fitting of suppressors to the ignition system of cars and other prolific radiators of ultra-short-waves. As is well known, the Government is still considering the report of the I.E.E. Committee, which recommended that statutory powers be sought to enforce the fitting of suppressors to eliminate interference to broadcasting. The coming of television is likely to hasten the Government's decision if one may be permitted to read between the lines of a recent statement made by the P.M.G.

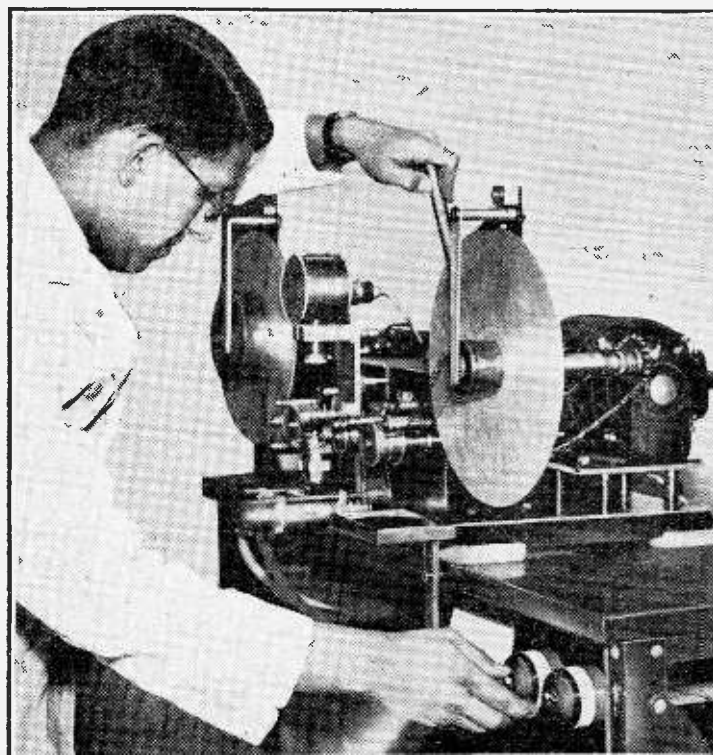

**MICKEY MOUSE MOVES HOUSE.**—As a result of a contract recently completed between Walt Disney-Mickey Mouse, Ltd., and "His Master's Voice," apparatus has now been installed at the "H.M.V." Recording Studios at St. John's Wood to transfer Mickey Mouse and Silly Symphony films from the sound track of the film to disc records. The apparatus constructed for "His Master's Voice" is believed to be the only one of its kind in the world, and incorporates intricate filters to obtain a constant speed with absence of jerkiness.

# Ferranti Arcadia

## AN ALL-WAVE SUPERHETERODYNE WITH VARIABLE SELECTIVITY

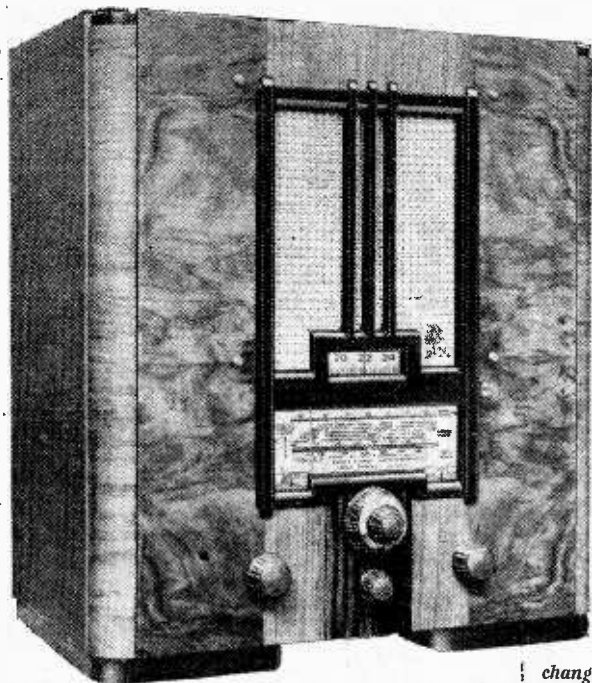

**FEATURES. Type.**—Table model superheterodyne for A.C. mains. **Waveranges.**—(1) 19-51 metres. (2) 200-550 metres. (3) 900-2,000 metres. **Circuit.**—Heptode frequency-changer—var.-mu pentode IF amplifier—double-diode-triode second detector—triode output valve. **Full-wave valve rectifier. Controls.**—(1) Tuning. (2) Volume and on-off switch. (3) Tone (variable selectivity). (4) Waverange. (5) Noise suppressor switch. **Price.**—15 guineas. **Makers.**—Ferranti, Ltd., Moston, Manchester.

long waves and inductive coupling for the short-wave range. The frequency-changer valve is a heptode, and special precautions have been taken to short-circuit oscillator coils not in use in order to avoid interference with the performance on the short-wave band. The variable-mu pentode IF amplifier functions at a frequency of 125 kc/s, and is fed with the output from the frequency-changer through an IF transformer in which the coupling between the primary and secondary windings is varied by the "Tone" control on the front panel.

COMPARED with last season's model, which we reviewed in the issue of February 15th, 1935, the 1936-7 "Arcadia" at the same price represents an appreciable advance in value for money. It has the same high-power triode output valve, but the earlier stages now include such additional refinements as variable selectivity, inter-station noise suppression, and a short-wave range. On the mechanical side the tuning scale has been improved—particularly from the point of view of short-wave working—by the addition of the "Magnascopic" optical device, and the loud speaker has been modified to improve the bass response.

leading place in the range of Ferranti table models, the circuit is full of detail refinements, and there is no indication whatever of any attempt to cut costs by introducing simplifications which might impair the performance. The aerial tuning circuit, for instance, is a well-thought-out design which incorporates an image rejector circuit. A band-pass filter with mixed coupling is used for medium and

The visual tuning indicator is common to the anode circuits of the frequency-changer and IF valves. A double-diode-triode fulfils the function of second detector, AVC rectifier, and first LF amplifier. A switch is included to alter the conditions of the control in the IF amplifier. Normally this valve is supplied with delayed AVC through a reducing potentiometer. To effect noise suppression between stations the switch changes over the AVC supply for the IF amplifier to the signal rectifying circuit, which is undelayed, and to compensate for the consequent change in initial bias the resistance

Complete circuit diagram. The coupling of the first IF transformer is variable and is actuated by the "Tone" control.

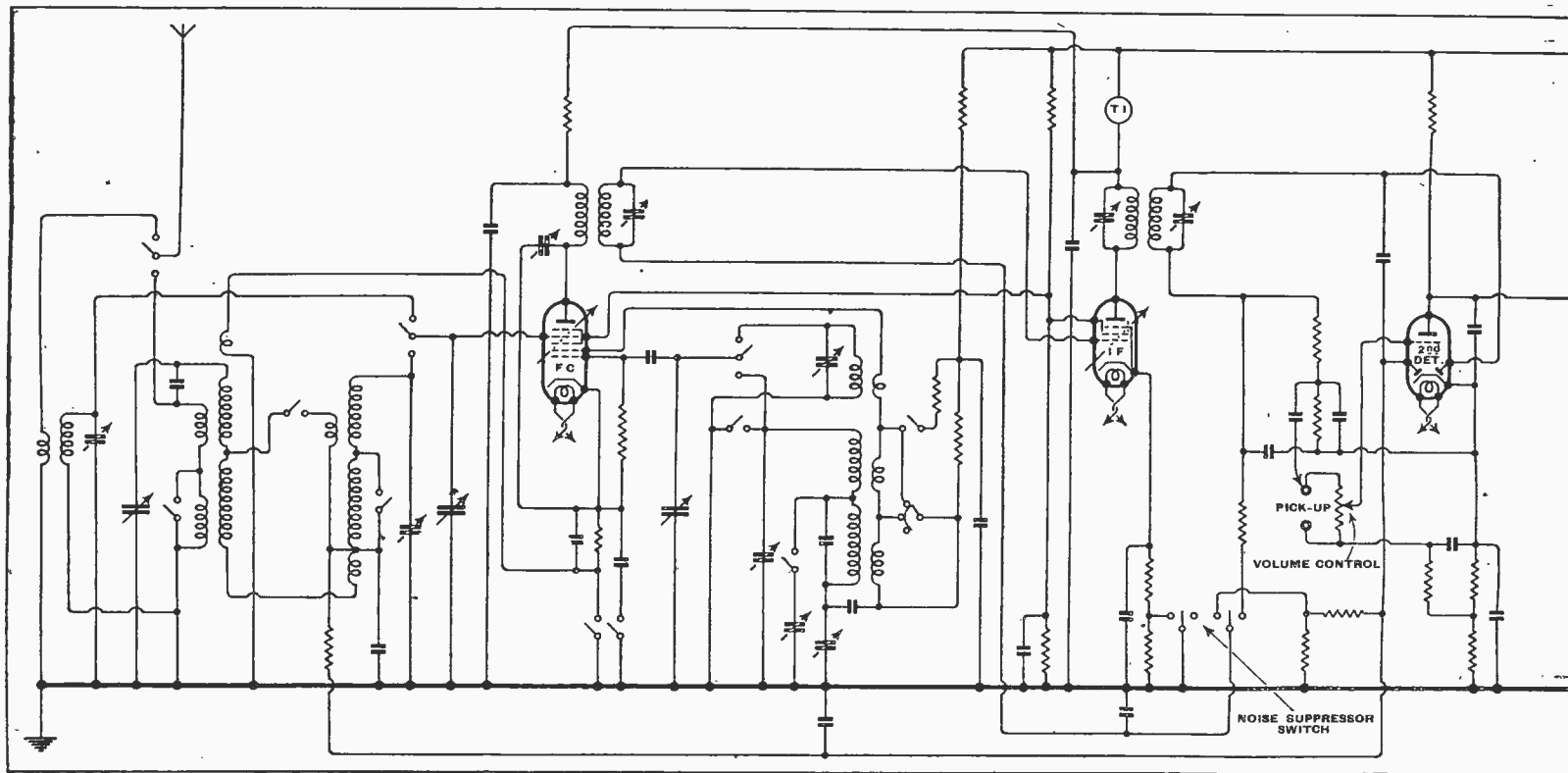

As befits a receiver which occupies a

in the return lead of the IF valve is increased. Resistance-capacity coupling is employed between the second detector and the triode output valve, the bias for which is derived from a potentiometer across the main HT supply.

The suspension of the cone in the moving-coil loud speaker fitted to the "Arcadia" receiver is given a greater degree of freedom than usual, and as a result the full and smooth bass response is perhaps the most pleasing aspect of the quality of reproduction. The high-note response is adequate, but does not extend to the point where local interference noises are accentuated. If the tone in the top register is a little hard, the use of a triode in the output stage ensures that it is free from any tendency to "peakiness."

**Selectivity**

When using the set in Central London with a considerable input from a full-sized outdoor aerial, the variable selectivity control was without much effect on the quality from London Regional. On the West, Midland and North Regionals, on the other hand, it behaved quite normally and gave as wide a choice of tonal balance as the ordinary resistance-capacity type of tone control. The variable selectivity aspect of the control was most convincingly demonstrated when the set was tuned to the Deutschlandsender. This station was badly interfered with by both Droitwich and Radio-Paris with the control in the "High" position, but the background cleared up progressively as the "Low" position was approached until finally there was only an occasional "splash" on deeply modulated passages. Unlike many variable selectivity controls, the signal strength of the wanted station is little affected by the setting of the control. By an ingenious mechanical device the set is automatically returned to the

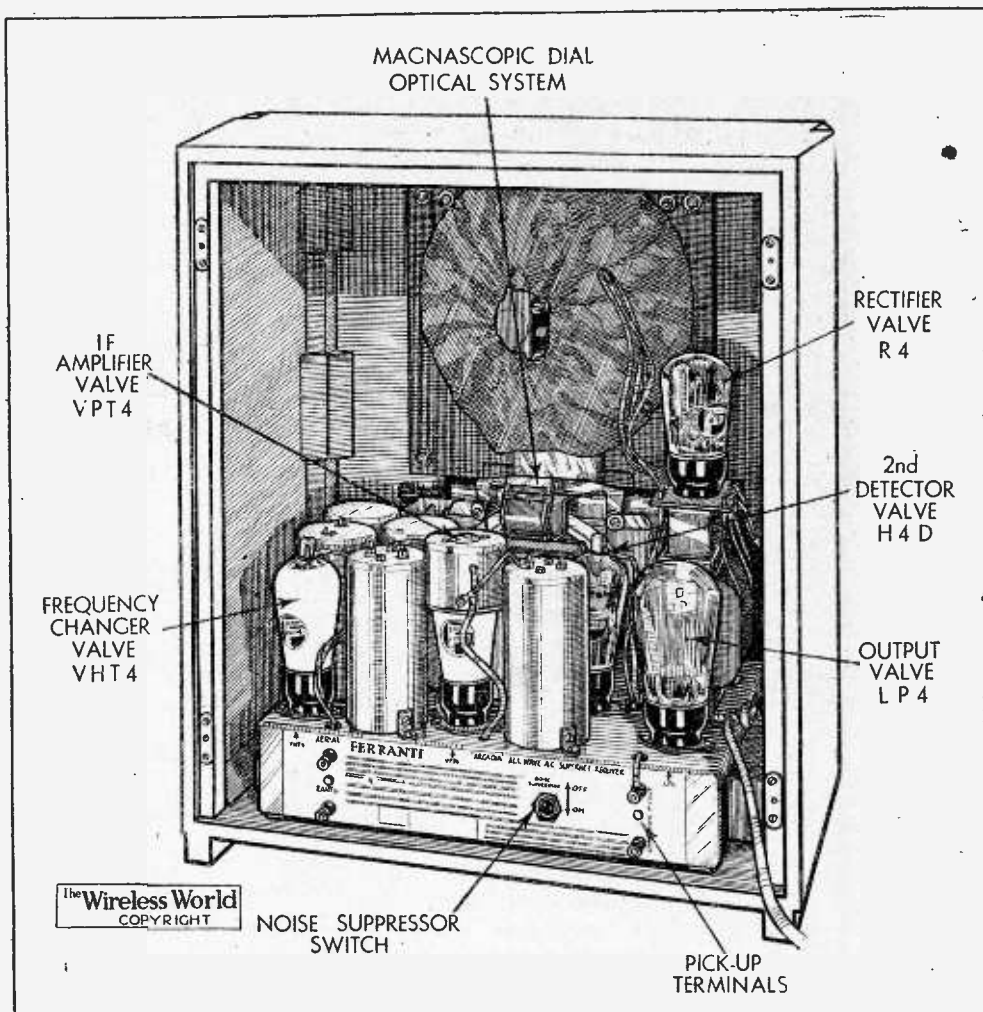

Extension loud speaker terminals are mounted on the loud speaker itself. A special type of suspension has been provided in this model.

condition of highest selectivity as soon as the tuning control is moved in search of another station.

On the medium-wave band only one channel was lost on each side of the London Regional and National transmitters, and elsewhere adjacent channel separation was possible when required. At least twenty stations were available at good programme strength during daylight on this range alone. There was a second channel whistle at about 465 metres on the medium-wave band and another at 1,200 metres on the long waves.

Reliable reception of American broadcasting was obtained on the short-wave band, but at a somewhat lower volume level than was at first expected having regard to the undoubtedly high intrinsic sensitivity on this range. The limiting factor was microphonic feed back at low frequency whenever a strong carrier was impressed on the aerial, and such was the strength of W2XAD that the maximum available setting of the volume control was not more than one-third of its range from the minimum position. This gave all the volume necessary for proper enjoyment of the programme, but not enough to let the neighbours know that one's set is capable of transatlantic reception!

Tuning on the short-wave range with the aid of the "Magnascopic" dial is as precise as one could possibly wish. The 180-degree translucent scale is divided into

individual degrees, and is magnified and projected on to a ground glass screen immediately above the main tuning dial. For fine tuning an effective scale length of over 6ft. is thus made available, and it is a tribute to the mechanical accuracy of the slow-motion drive that no trace of slip or backlash is revealed by this high magnification.

The cabinet measures 18in. high x 16in. wide x 10½in. deep, and is in walnut with macassar ebony inlays and ebonised feet.

**Club News**

**The Surrey Radio Contact Club**

At a recent meeting an instructive lecture entitled "Valves, Their Design and Use," was given by Mr. L. Grinstead, M.I.E.E., of the Mullard Co., who is a club member. On January 5th, at 8 p.m., a lecture on Electrical Measuring Instruments and their Uses will be given by a representative of Messrs. Everett, Edgumbe and Co., Ltd. The lecture will be held at the Alhambra, Wellesley Road, West Croydon. Hon. Secretary, Mr. E. C. Taylor, G5XW, 35, Grant Road, Addiscombe.

**The Radio, Physical and Television Socy.**

At a recent meeting Mr. J. G. Hobbs, A.M.I.R.E., lectured on short-wave transmitters. Methods of generating oscillations at radio frequency and of modulating them were dealt with. A low-powered transmitter was demonstrated. Meetings of the society are held on Fridays, at 8 p.m., at 72a, North End Road, W. Kensington, W.14. Those interested should write to Mr. V. R. Walker at 49, Fitz-James Avenue, West Kensington, W.14.

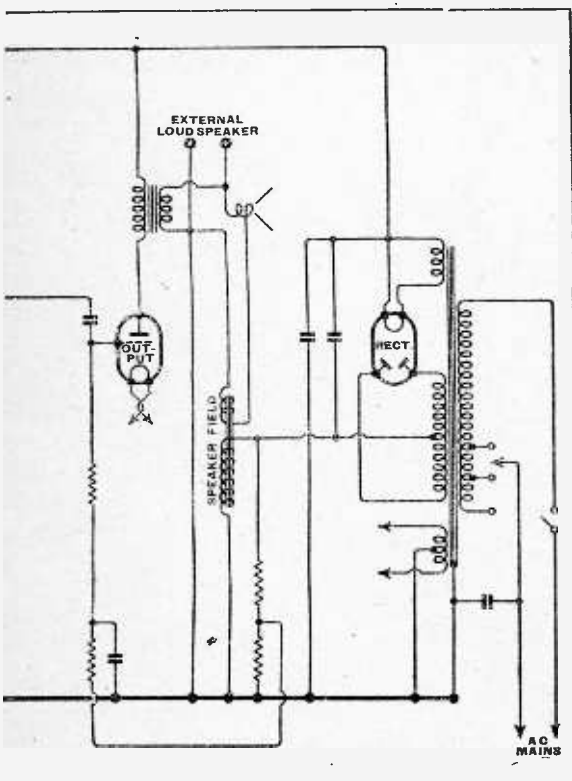

# UNBIASED

## A Boom in Midget Sets

I HAVE been very surprised at the interest which readers have taken in my scheme for remote control of tuning. What has astonished me most of all, however, is the enormous interest that there appears to be in the question of remote tuning control in general which our manufacturers neglect almost entirely.

My authority for stating that there is an enormous amount of interest in the subject is derived from dealers, several of whom have written to me about it. It appears that they know of this interest, not merely because of the number of enquiries they receive, but because of something far more convincing. This something is the growing number of midget sets of foreign origin which they are selling.

Now you might think, as I did, that this growing popularity of midgets merely showed that the public taste from the point of view of quality of reproduction was becoming more and more depraved, although, it is true, it might possibly be thought that an alternative reason for the purchase of these sets was that the average listener was getting more and more tired of having to keep on jumping up to change the programme and was prepared to put up with the inferior quality of midgets if he could be spared this Jack-in-the-box business; indeed, this was, I learn, the real cause of the great popularity which the midget achieved in America.

The reason why my correspondents know that the midgets they sell are bought for the convenience of remote tuning control, and definitely do *not* indicate any decline of musical taste on the part of their purchasers, is rather an unusual one. It appears that a large proportion of the purchasers of these sets nowadays buy also a separate loud speaker of normal proportions and ask the dealer to disconnect the internal loud speaker and provide terminals for connection to the extension instrument which they purchase.

Now a large proportion of the distortion in a midget set—but by no means all—is the miniature loud speaker, and this purchase of a separate one of normal proportions gets rid of this. But this fact does not merely prove that the public taste of quality is growing. It proves also that the public wants *real* remote control with the loud speaker on the other side of the room, and are not content to adopt the makeshift which many manufacturers so fatuously recommend, namely, to place a normal set by the side of the armchair and thus risk eventual deafness by having the loud speaker bellowing in their ear all the time. In every case, one dealer tells

me, when he has sold a midget plus an extension loud speaker, the customer has told him that he invariably installs the loud speaker on the other side of the room either on a flat baffle suspended from the picture rail or in a box baffle.

The above facts seem to me to be quite enough to prove that the public do want remote control, but not at the expense of poor quality, or of having a bulky set drawn up to their armchair, but there is more to come. In a very large number of cases the purchasers of these midgets ask that the absurd little loud speakers be taken out of the sets and space utilised for the installation of a better output stage for which they are willing to pay quite substantial sums. One dealer, in fact, mentions that he is going the whole hog and actually rebuilding midgets in this manner without any specific orders, for, he says, he has no difficulty in selling them when he points out that when this is done they form almost a perfect remote control unit without any sacrifice of quality.

Range is, of course, sacrificed, as it is



This Jack-in-the-box business

usually convenient only to employ a picture rail aerial, but even this difficulty can be overcome quite easily by using a transmission line to couple to an external aerial. I hope, therefore, that with this irrefutable evidence before them of a public demand for a remote control unit, our manufacturers will step on the gas and do something about it.

## Who Blundered?

I WAS very surprised to find that in their 1908 Scrapbook the B.B.C. had, by some strange oversight, got all their facts correct. I dare say, however, that some poor devil has got it in the neck for it by now. I must confess that hitherto I have never been able to understand the B.B.C.'s attitude in the matter of these scrapbooks. As they don't usually bother about accuracy, why not do things in style and

invent some really first-class incidents which would give us all a little excitement? As things are, the errors they usually make are duller even than the truth and, goodness knows, that's usually dull enough.

What would, I think, appeal to many people would be a scrapbook of 1940 or some other future year. The B.B.C. would then be able to give full rein to their

By

## FREE GRID

imagination without risk of contradiction by anyone while, if they secured the services of one of our tame astrologers, they would, I feel sure, be able to put out a really first-class programme. As for the pending 1919 scrapbook, I'll bet that they try to tell us that peace—as distinct from the Armistice—broke out officially on June 28th or July 19th.

## Wanted: An AC Battery

WE have all heard of the various arrangements adopted to prevent the electric light going out should the power supply fail. Such devices are usually adopted by hospitals in their operating theatres where a lighting failure might be fatal, and usually consist of a battery of accumulators operating in conjunction with a relay, so that it comes on automatically when the power supply fails.

These arrangements are, I believe, mostly designed and sponsored by the big accumulator manufacturing companies, but nobody seems to care two hoots about the predicament of the unfortunate "all-electric" householder when the supply fails during the night. He wakes up in the morning and either finds that all the clocks are stopped, or if they are of the self-starting type, they are all wrong. It is of little use, of course, trying to get the wretched accumulator companies to rig up an automatic "keep-going" arrangement to get over the difficulty, for, of course, all the clocks are AC ones, and as I have found out from personal experience, not a single manufacturer has bothered to turn his laboratory staff on to the problem of designing an AC battery. What some of them keep their costly research departments for I'm sure I don't know.

I certainly know one man who has solved the difficulty, but, then, he happens to have the good fortune to be on DC and has naturally installed a motor generator to operate his AC clocks. Obviously, it has been quite simple for him to arrange for the automatic switching on of a battery of accumulators to keep the DC motor going in the case of a supply power failure.



# The Beam Power Tube

IN America there are in widespread use many output systems which are employed comparatively rarely in this country. The Class "B" stage, it is true, is widely known, but rarely used except in battery-operated equipment. The American designer, however, has been rather fond of using this system in mains-driven apparatus where a large output is required, but owing to the distortion which it introduces there has been a tendency of late to discard it. Instead, a method of operation known as Class "AB" is becoming widely used.

A Class "AB" stage is one which operates under Class "A" conditions for moderate signal inputs, but under semi-Class "B" conditions with a large input. Class "A," of course, refers to the normal operation of an output valve with anode current flowing during the whole cycle of input voltage and no grid current. A Class "A" stage can contain one valve, or two in push-pull, and the latter introduces the least distortion of any system.

As the term is used in America, Class "B" refers to a state where two push-pull valves are used under such conditions that one valve handles one half of the input wave form and the other valve handles the other half. The valves are consequently biased at about the point of anode current cut-off. In this country such a stage is usually entitled QPP, and Class "B" refers to the particular case when grid current is permitted to flow. In America the term Class "B" covers both conditions.

With systems such as these, a very large signal input is required to secure full output when triodes are used, and this leads to difficulties in the preceding stage, which must supply a considerable amount of power if grid current is permitted. It so happens, therefore, that multi-electrode valves of high amplification factor are more convenient.

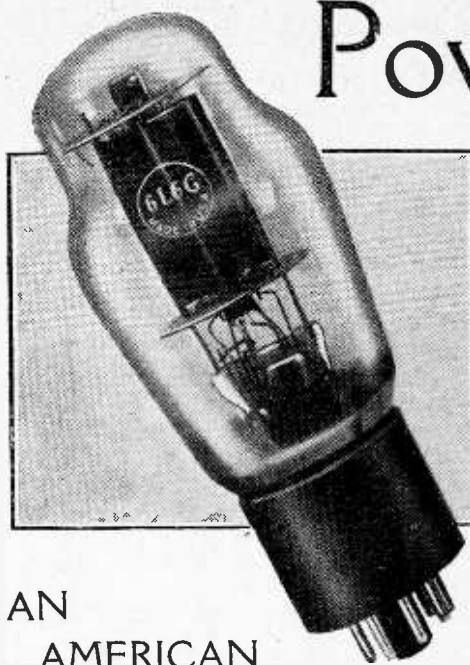

AN AMERICAN OUTPUT VALVE

the usual tetrode negative-resistance kink, however, special plates are included and internally connected to the cathode. These plates are not in the direct path of the electron flow, but act to confine it in the form of a beam, and it is from this feature that the valve takes its popular title of the "Beam Power Tube." The characteristics obtained are similar to those of a pentode.

It is an indirectly heated valve with a heater consuming 0.9 ampere at 6.3 volts. When used as a single-valve Class "A" output stage it needs 375 volts for the anode, 250 volts for the screen-grid, and -9.0 volts grid bias. The anode

should be 250 volts and the grid bias 16 volts, while the no-signal anode and screen currents are 120 mA. and 10 mA. The optimum load impedance is 5,000 ohms. With fixed bias the anode and screen currents increase to 140 mA. and 16 mA. with the maximum signal input, and the power output is 14.5 watts; with automatic bias, however, the currents rise to 130 mA. and 15 mA. respectively, and the output is 13.8 watts. The distortion is 2 per cent. and nearly all third harmonic.

Much greater output can be secured by operating under Class "AB" conditions, but without running into grid current. As the following table shows, as much as 34 watts can be obtained from a pair of 6L6 valves with only 2 per cent. distortion!

Even this is not the limit of output obtainable, for if grid current be permitted it is possible to obtain no less than 60 watts from two valves! For this output the anode and screen supplies must be 400 and 300 volts and -25 volts bias is needed with 80 volts peak AF input. With no-signal the anode and screen currents are 102 mA. and 6 mA., but rise to 230 mA. and 20 mA. upon the application of the full input. The optimum load is 3,800 ohms, and 350 milliwatts driving power is required in the grid circuit. The distortion introduced by this stage is only about 2 per cent., but the total distortion is likely to be much greater, since unless the driver stage is very well designed and operated it will introduce more than the output stage.

Like all valves of the pentode type, the 6L6 has a high AC resistance, and this is

TWO 6L6 VALVES IN CLASS "AB"

Anode volts	...	...	...	400	400	400	400
Screen volts	...	...	...	250	250	300	300
Fixed grid bias	...	...	...	-20	-20	-25	-25
Peak AF input volts (grid to grid)	...	...	...	40	40	50	50
No-signal anode current	...	...	...	88	88	100	102 mA.
Max.-signal anode current	...	...	...	126	124	152	156 mA.
No-signal screen current	...	...	...	4	4	5	5 mA.
Max.-signal screen current	...	...	...	9	12	17	12 mA.
Load resistance	...	...	...	6,000	8,500	6,600	3,800 ohms
Power output	...	...	...	20	26.5	34	23 watts
Distortion, 3rd harmonic	...	...	...	1	2	2	0.6 per cent.

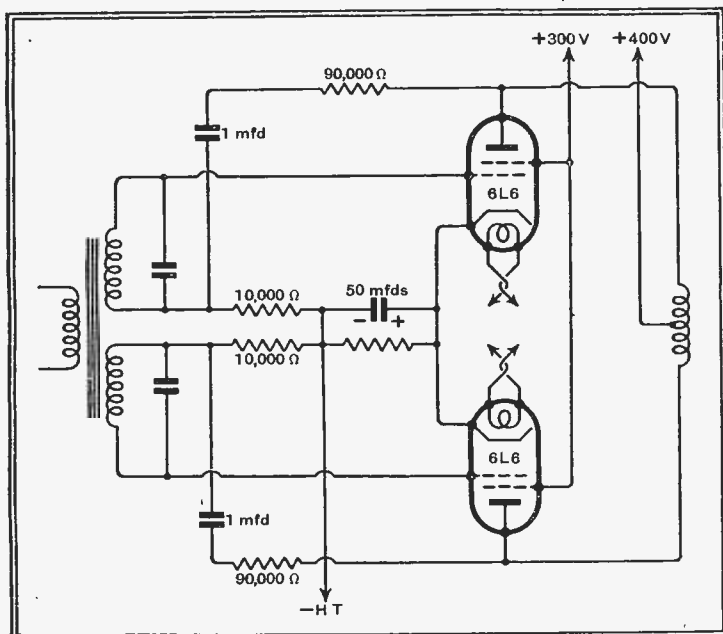

The American 6L6 is a valve which enables a very large output to be secured quite easily. It is actually a tetrode containing the usual cathode, control grid, space-charge grid and anode. In order to prevent the characteristics from containing

and screen currents are 24.0 mA. and 0.6 mA. respectively, and it will give an output of 4,200 milliwatts into a load of 14,000 ohms.

When a pair are used in push-pull under Class "A" conditions the

For the highest quality reproduction negative feedback is recommended.

disadvantageous for the highest standard of quality. The makers consequently recommend the use of negative feed-back<sup>1</sup> with the circuit of Fig. 1.<sup>2</sup> This reduces the effective output resistance so that the loud speaker is properly damped, and it also reduces amplitude distortion. A larger signal input is required, however. The values to be assigned to the condensers shunted across each half-secondary of the input transformer depend on the characteristics of that transformer and must be determined experimentally. In some cases resistances, or resistances in series with condensers, are better.

The 6L6 is a metal valve, but a glass-envelope counterpart, the 6L6G, having the same characteristics is also made. In this country it is obtainable from The Premier Supply Stores, Jubilee Works, 167, Lower Clapton Rd., London, E.5.

makers quote two sets of operating conditions, for fixed and for automatic grid bias. In both cases the anode and screen potentials

<sup>1</sup> The Wireless World, Nov. 6th, 1936.

<sup>2</sup> R.C.A. Review, July, 1936.



H.R.H. PRINCESS JULIANA with her fiancé, H.H. Prince Bernhard of Lippe-Biesterfeld. Their marriage will occasion special broadcasts from Hilversum I, and the wedding ceremony on January 7th will be heard by National listeners.

# Listeners' Guide

## Outstanding

described for listeners by S. J. de Lotbinière, the Director of Outside Broadcasts, who is going to Holland as commentator for the B.B.C.

The Royal wedding is bound to make itself felt in the programmes of Holland. Some of the special features from Hilversum I are: a radio play, "The Marriage of a Princess," at 8.55 on Sunday; relay at 9.40 on Tuesday from a special festival; the marriage ceremony and commentaries from 10.10 a.m. to 1.40 p.m. on Thursday, followed at 3.10 by

for violin and orchestra. Suk, who died last year, was a leading Czech composer, and the son-in-law of Dvorák.

The Special Recital series for this week comprises Tudor string music, which will be played by the Willoughby String Quartet. The recitals will be given in the National programme on Monday at 8.30, Tuesday at 7.10, Wednesday at 7.40 and Thursday at 9.20.

### THE GAY 'NINETIES

A PROGRAMME with the title, "The Eighteen-Nineties," has been prepared by M. H. Allen and Barbara Burnham, and will be broadcast at 9.30 to-night (Friday) in the National programme. This should provoke reminiscent chuckles and sighs among the elder generation and provide younger listeners with an interesting and colourful glimpse of a mode of life that has irrevocably vanished. The 'Nineties were a period of great artistic activity and also of an intense, in every sense of the word, Bohemianism.

The producers hope by judicious use of quotations, comment and music to present a sound picture that will catch the true spirit of those days.

"A HAPPY and Good New Year to all Peoples of the World" is the title given to the special half-hour programme arranged by the International Broadcasting Union for Sunday at 5, when twenty-three European countries will send messages of greeting. Actually it will be a recording, as the time of forty-five seconds allotted to each country does not allow for any delays. Germany has been accorded the privilege of making the technical arrangements for the transmission, which, having been already recorded, will be broadcast from Berlin and relayed by most European stations, including the London Regional.

Switzerland will start the programme, it being the home of the Union, and other countries, except Germany, which closes the programme, will follow according to the French alphabet. The only countries not participating are Spain, Greece, Bulgaria and Albania.

Some of the outstanding features of this varied programme will be a selection from Jean Sibelius's "The Melody of the Chimes" from Finland; greetings from village children in Belgium; a greetings "telegram" sung by "La Chanson Romande" from Switzerland; and a poem entitled "For the Wounded," recited by David Knudsen from the Oslo National Theatre, in which is expressed the wish

that all the peoples of the earth may live in perfect peace. The English contribution is very simple, just church bells from Westminster Abbey and a country church.

### IN RETROSPECT

It is quite a common occurrence at the beginning of the year to look back over the year that has just passed. We shall be given an opportunity of doing this in the National programme on Wednesday at 9.20, when Laurance Gilliam presents "Twelve Months Back," a retrospect of 1936.

### SHAKESPEARE

On four Sundays during the first quarter of this year full-dress productions of Shakespeare's plays will be broadcast. The first of these comes into the week under review, when Peter Cresswell will produce "Much Ado About Nothing" for National listeners at 5.35. This exquisite tragi-comedy was last broadcast ten years ago.

### DUTCH ROYAL WEDDING

The marriage of Her Royal Highness Princess Juliana, Crown Princess of Holland, with His Highness Prince Bernhard of Lippe-Biesterfeld, will be the occasion of an hour-and-twenty-minutes' broadcast for National listeners on Thursday morning at 11. The scenes outside the Church of St. Jacob at The Hague before and after the ceremony will be

a relay of the rejoicings from the Dutch East Indies.

### MUSIC

DURING last week the 100th anniversary of the birth of the Russian composer Balakirev (1837-1910) was celebrated in the Special Recital series, songs and piano music being broadcast, and on Saturday at 8.15 (Nat.) Constant Lambert will conduct a concert of Balakirev's orchestral works, including the incidental music for "King Lear." It is interesting to note that in this music the composer introduced two English folk tunes.

The first of the special orchestral concerts broadcast from a studio will take place on Sunday at 9.5 (Reg.) under the direction of Sir Henry J. Wood. The programme includes Vaughan Williams' "London Symphony," and Carl Flesch will be the soloist in Joseph Suk's "Fantasy"

GREETINGS from twenty-three European countries will be broadcast from Berlin, the main control room of which is seen in the centre, and relayed throughout Europe on



# or the Week

## roadcasts at Home and Abroad

### STERNE AND THOMSON

WITH such collaborators for a radio show as Ashley Sterne and A. A. Thomson one cannot but feel that it will be really funny. On Wednesday at 8 (Reg.) and Thursday at 9 (Nat.) listeners will be treated to "Snapdragon," which deals, in a way that only Sterne and Thomson can, with the age-old story of a princess rescued from a dragon by the prince. This should be well worth the time spent in listening.

### "MONEY WITH MENACES"

AFTER a lapse of over four years we are to have another play by Patrick Hamilton, whose "Rope" was such a success in 1932. From the scanty details available the best description one can give is that "Money with Menaces" is a study in suspense. Tune in, prepared for some thrills, on Monday at 9.35 (Nat.) or Tuesday at 8.15 (Reg.).

### SWING MUSIC

WE are to hear a relay from New York, in the first of a series of broadcasts by leading American dance bands headed "America Dances," on Wednesday at 8 (Reg.), when Benny Goodman and his Orchestra will play swing music.

Sunday. Below (left) is the choir of "La Chanson Romande," which will sing Switzerland's greeting, and (right) Tyrolean "star singers," whose song will be Austria's message.

### MORE VARIETY

A NEW series of mid-week music-hall shows starts on Tuesday at 9 (Reg.) with the title "Palace of Varieties," made up of short acts. To give the necessary atmosphere, two rather talkative members of the audience will discuss the show from the stalls of the imaginary music hall, and by so doing act as compères.

Among those billed for this first show are Ray Meux, Jackie Heller, and Vine, More and Nevard. After eighteen months' absence listeners will also hear the return of "The Disorderly Room," with Tommy Handley and Co.

### CRICKET

EACH day's play during the third Test Match between Australia and the M.C.C., at Melbourne, will be described by C. B. Fry for English listeners and broadcast at 8.30 a.m. (Nat.) on Friday, Saturday, Monday and Tuesday. A record of the commentary will also be broadcast at 1 p.m. each day.

### OPERA

TO-NIGHT (Friday) Turin and Milan give us the inestimable privilege of hearing a performance at the Scala, Milan, that home of grand opera and Mecca of every singer. At 8 we shall hear Thomas' "Mignon" — an opera which owes its popularity to the grace and charm and delicacy of its music. At 8.50 Stockholm relays from the Royal Opera House Act III of Wagner's "Mastersingers,"



LESLIE JEFFRIES, who will come to the microphone with the Grand Hotel, Eastbourne, Orchestra on Sunday at 5.30 (Reg.).

the act which includes the famous Dance of the Apprentices, as well as Walther's Prize Song and the Grand Finale.

The one transmission on Saturday which will be of double interest to English-speaking listeners comes at 7.5 from Berlin (Funkstunde), whence a studio interpretation of Nicolai's "Merry Wives of Windsor" is to be broadcast. The composer has followed very closely the amorous adventures of our own Sir John

Falstaff as presented by Shakespeare. Rome follows at 8 with another La Scala, Milan, relay, Pizzetti's three-act "Debora e Jaële." Radio-Paris at 8.45 transmits Massenet's "Cendrillon"—the French version of that darling of old and young alike, Cinderella.

On Tuesday at 7.10 Stuttgart and Deutschlandsender give a studio performance of Puccini's four-act "La Bohème" with Erna Berger in the rôle of Mimi.

THE AUDITOR.

### HIGHLIGHTS OF THE WEEK

#### FRIDAY, JANUARY 1st.

Nat., 7.30, The Air-do-Wells. 8.30, Viola Recital: Lionel Tertis. 9.30, "The Eighteen-Nineties."

Reg., 6.45, Talk: Car Upkeep—Buying a Car. 7.30, B.B.C. Orchestra (C) and Muriel Brunskill.

Abroad. Leipzig, 6.30, Concert from the Gewandhaus.

#### SATURDAY, JANUARY 2nd.

Nat., 9.20, Music Hall. 10.40, The B.B.C. Orchestra and May Busby.

Reg., 6.15, Band of His Majesty's Scots Guards. 8.15, Peter Yorke and his Orchestra. 9.20, "Sicilian Expedition." 10.25, Henry Hall's Hour.

Abroad. Vienna, 6.15, "The Gipsy Baron"—operetta (Strauss).

#### SUNDAY, JANUARY 3rd.

Nat., 5.35, "Much Ado About Nothing." Recital—Mary Jarred and Pouishnoff. 9.5, B.B.C. Theatre Orchestra and Revue Chorus.

Reg., 5, "A Happy New Year to All the World"—Continental Relay. 9.5, Symphony Concert: Carl Flesch (violin).

Abroad. Berlin, 7, "Love Songs Grave and Gay," songs from opera, operetta, singspiel and film.

#### MONDAY, JANUARY 4th.

Nat., 7.20, Music Shop.—7. 9.35, "Money with Menaces."

#### Monday, January 4th (cont.)

Reg., 6, The Luton Band. Recital: Henri Temianka. 8, The Two Leslies and Bertha Willmott.

Abroad. Leipzig, 7.10, Beethoven Concert from the Gewandhaus.

#### TUESDAY, JANUARY 5th.

Nat., 6.25, Reginald Foort at the Theatre Organ. Recital: The Shopping Public. Talk by Helen Simpson. 7.50, Carroll Levis and his Discoveries. Reg., 8.15, "Money with Menaces." 9, "Palace of Varieties."

Abroad. Stuttgart, 7.10, "La Bohème."

#### WEDNESDAY, JANUARY 6th.

Nat., 8, "Snapdragon." 9.20, "Twelve Months Back."

Reg., 6, Reginald King and his Orchestra. 8, "America Dances," relay from New York.

Abroad. Radio-Paris, 8.45, Gaubert concert from the Salle Gaveau, the composer conducting.

#### THURSDAY, JANUARY 7th.

Nat., 11 a.m., Marriage of Princess Juliana relayed from The Hague. 6.40, B.B.C. Military Band. 7.40, The Fol-de-Rols.

Reg., 6, From the London Theatre. B.B.C. Orchestra (C) and Antonio Brosa (violin). 9, "Snapdragon."

Abroad. Deutschlandsender, 7.30, The Great German Symphony Composers. No. 1—Beethoven.





Table of short-wave stations with columns: Station, kc/s., Tuning Positions., Metres., kW., Station, kc/s., Tuning Positions., Metres., kW.. Includes stations like German Relay Stations, Montpellier, Lodz, Dublin, etc.

SHORT-WAVE STATIONS OF THE WORLD

Main table of short-wave stations of the world with columns: Station, Call Sign, kc/s., Tuning Positions., Metres., kW., Station, Call Sign, kc/s., Tuning Positions., Metres., kW.. Includes stations like Ponta Delgada, Khabarovsk, Caracas, etc.

# Brilliant Television

## THE PRINCIPLE OF CUMULATIVE SCREEN ILLUMINATION

By "CATHODE RAY"

ONE may have one's doubts as to the ability of television to keep the great general public perpetually amused, or as to the source of enough money to spread the said amusement thickly over the whole of the British Isles; but even if television is a complete flop on one or both of these counts it will almost have been worth while, just for demonstrating how extraordinarily ingenious some people can be.

The experienced technician—amateur or professional—is the last to call attention to the extreme cleverness of his works; that is left to popular writers and greenhorns. Though obviously reluctant (having just said that) to indulge in the usual "wonder" and "amazing" language, I do think that some of the work that is being done in the cause of television is enough to force reluctant murmurs of admiration from between the ordinarily unemotional lips of even the hard-boiled technician. It is not necessarily undignified. There is a difference between the superficial flitting on the wings of the daily Press from one inaccurate and hysterical "wonder" to another and the real joy to be derived from intelligent admiration of some scientific problem beautifully solved.

There may be several ways in which a desired result can be achieved, and they may all work equally well in practice; yet one of them may give far more pleasure to contemplate than the others. To use an old-fashioned term, it is more "elegant."

The ordinary motor car gear box is an example of a practical solution that is *not* elegant. One of those Frenchmen who come out with pithy epigrams from time to time observed that "it is brutal, but it works"—or words to that effect. The Constantinesco gear, on the other hand, excels in elegance, but is never used.

Several ideas that have already appeared in the field of television are so beautiful that it is very surprising to find that they actually work—apparently quite well, too. One of them, the Iconoscope, has already received a fair measure of admiration. In this the layman, unfortunately, is unable to join, because some

technical knowledge is necessary in order to appreciate the terrific difficulty that is overcome.

If a 405-line system is considered, the number of "spots" that go to make up the picture is over 200,000. All of these are scanned every 25th of a second; so in the space of one five-millionth of a second an almost microscopic spot on the screen of the camera has to release enough energy to control 17 kilowatts! There is available for doing this no intense heat or other concentrated activity. No disruptive energy can be allowed to smite Miss Elizabeth Cowell's sensitive face; only the gentle force of light. And of this only

what is reflected can be used, and of this only a minute fraction strays through the small aperture of the camera lens; and of this less than one two-hundredth part impinges on any particular "spot." And this only for an infinitesimal fraction of a second. Photography has made wonderful strides. But the latest ultra-super-hypersensitive film needs thousands of

Enormously simplified diagram of several successive stages in the reconstruction on the receiving screen of an image by means of the Scophony light relay. The progress of the transmitting scanner over the object is shown at the left. At the receiver a constant source of light L shines through the relay cell C along which waves of extremely high frequency are propagated from left to right by a quartz oscillator. The intensity of the waves is controlled by the television signal and results in more or less light getting through on to the screen. The scanning mirror S projects on the screen not only the light being controlled at that instant, but also that which has been controlled during fifty previous instants, thus illuminating a much larger portion of the screen at any one time.

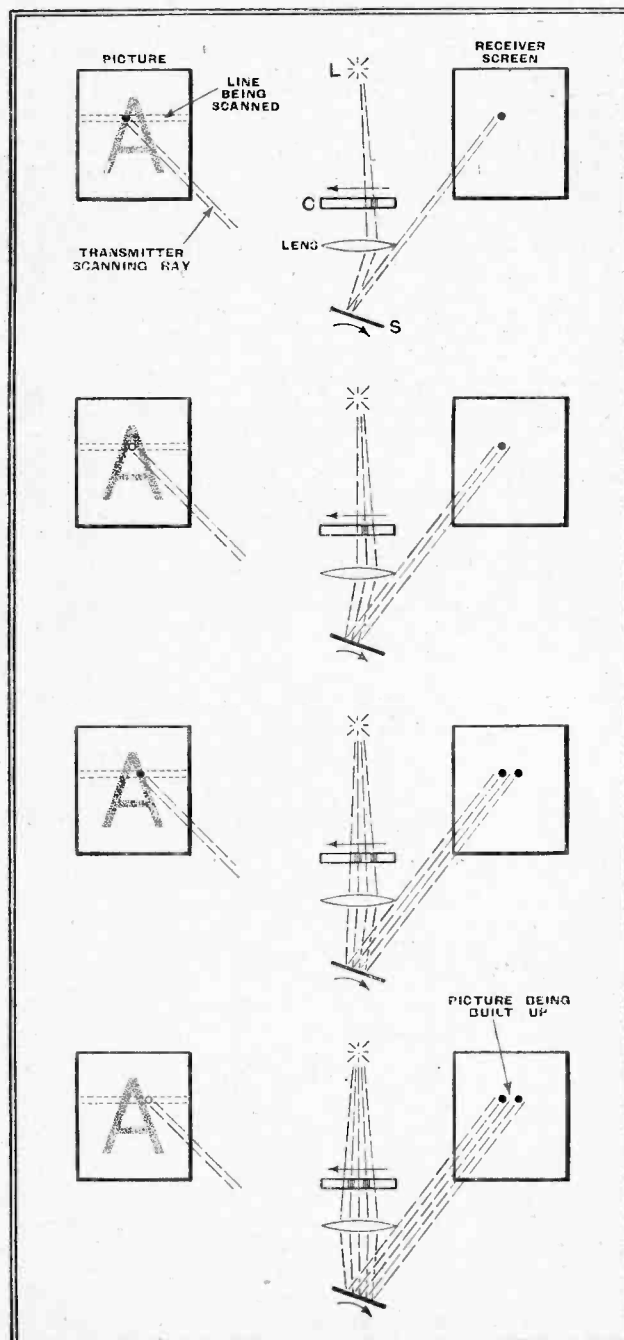

times this length of exposure to make a picture.

There you have some idea of the problem. The Iconoscope, in effect, lengthens the exposure to a twenty-fifth of a second—something with which photographers and electron engineers can do things.

Instead of using a simple light-sensitive cell to deal with each spot of the picture in turn, with no time to collect much of a "signal" from any of them, the Iconoscope ingeniously contains millions of cells, all working all the time to provide a nice fat signal for the scanning ray to collect each time it touches them. The ray, as it were, reaps the crop that has been steadily growing ever since it passed that way before. Theoretically there is 200,000 times as much time for the signal to develop, which helps quite a lot. But that such a pretty idea should really work is the most wonderful thing of all.

The Marconi-E.M.I. Company can scarcely be said to have been working in a blaze of publicity, but compared with it the Scophony system is still quite a dark horse. And at least one of the ideas that apparently has been made to work is even more wildly improbable than the Iconoscope. It is also considerably more difficult to understand. I

**Brilliant Television—**

am afraid the following venture may be an example of the blind leading the blind, but I trust that both will not altogether perish miserably.

The Iconoscope tackles a difficulty at the transmitting end; the Scophony light relay concerns the corresponding problem at the receiver. The television picture on which you gaze is an illusion. It is not a picture at all; it is only a single tiny spot of light. Because the human eye keeps on seeing after the object has moved away, a single spot of light moving rapidly about over the whole field is able to represent a complete picture. A single soldier might look to the enemy like a whole army if he appeared at different points in rapid succession.

If the "definition" of television comes into the "high" category, the spot must be very small and must move very rapidly. So even if it is extremely bright, the picture as a whole may look quite faint, because the light is distributed over (say) 200,000 times the area.

Hence the need for thousands of volts on a cathode-ray tube in the attempt to make the point of light so intense as to illuminate the whole area satisfactorily. The Scophony system dispenses with cathode-ray tubes and is faced with the problem of producing enough light through a device that can control the intensity at the requisite rate.

**The Comet's Tail**

A sort of opposite number to the Iconoscope would be a receiver that maintained the appropriate degree of light on every spot of the picture all the time, changing (if necessary) each time it was scanned. That would be very delightful, but so far as I am aware it remains to be invented. However, Scophony goes some way towards it by illuminating fifty or more spots simultaneously.

Now it is obvious that to constitute a picture these fifty spots must be prepared to consist of as many different intensities of light. It is also clear that fifty different signals cannot be broadcast simultaneously over one channel. At one instant a bald man's head is being scanned, resulting in a very intense light signal; a five-millionth of a second later the scanning ray has slipped off on to the black velvet gown of his companion, and if the head illumination on the receiving screen is to be sustained for a further period it must be done by something that has taken the imprint of the light that was shot forth some time earlier.

When a boat is being rowed across a still lake each stroke of the oars causes a whirlpool that remains visible for some distance in the wake. It is possible to imagine that the boatman might vary the strength of his strokes according to some recondite code. Every two seconds he would enact a different stroke, yet the scene of any one stroke would continue to register its intensity on the surface of the water, while a number of new ones were being created ahead of it.

This illustration may be somewhat fanciful, but the medium of a liquid is not selected at random, for the light relay consists of a liquid cell in which waves are propagated by a quartz crystal, the strength of waves at any instant being controlled by the television signal. Although the cell is not carried along bodily at scanning speed (obviously!) the same effect is obtained by passing a beam of light through it and then deflecting it by means of a mirror drum or other optical scanner. So, instead of the light whirled across the screen being in the form of a spot it is more like a comet with a long tail. The brightness of the light depends on the strength of the waves in the liquid through which the light has to pass (this is a result of a very subtle property of light which I have not time to explain).

Suppose a strong wave passes a bright light. Then when the transmitter is scanning Mr. Baldhead the cell is pushing out a series of strong waves which move from the head of the comet to the tail. Now (this is a clever part of the scheme) the backward velocity of the waves in the liquid is contrived to be equal to the forward velocity with which the scanner carries an image of the cell across the screen. So any particular wave continues to cast its influence on the same spot on the screen, just as the whirlpools set up by the moving boat are stationary on the water, or a man walking down a rising escalator at the same speed stays in the same place all the time.

As the transmitter ray moves off the bald head on to the black velvet the cell suddenly shuts down the wave intensity. The head of the comet lets through no light on the screen, though the rest of it is still busy pouring out light to give an adequate representation of the glistening pate. Gradually (if a scanning velocity of 10,000 miles an hour can be called gradual) the weak wave influence spreads down the cell, and a corresponding part of it is keeping the screen in a state of darkness. So the picture is built up, not only by the end of the cell that is responding from moment to moment to the signal from the transmitter, but also by a "tail," fifty spots long, that preserves the imprint of previous signals.

This account of the matter does not, of course, do justice to the full beauty of the invention, but it may perhaps give some idea of the ingenuity with which the problems are being tackled. It may also help to convince some of us would-be inventors that we might be more profitably occupied selling bootlaces.

**MAZDA TH2620**

THE heater characteristics of the Mazda TH2620 have been changed, and the valve now requires 23 volts at 0.2 ampere instead of 26 volts. When using the valve in a receiver designed for the older pattern, therefore, a resistance of 15 ohms must be inserted in the heater circuit. The new type will be designated by a different type number, and henceforth the valve will be known as the TH2320.

**MCCARTHY**

for the finest value in  
**All-Wave Receivers!**

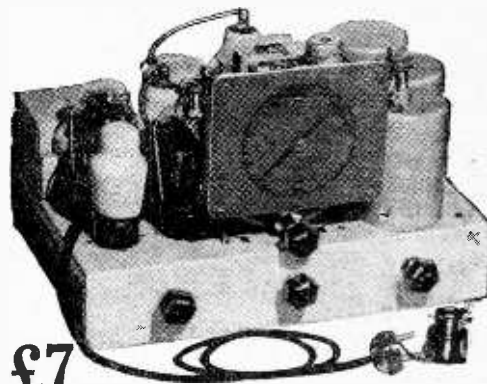

£7

**6 VALVE ALL-WAVE SUPERHETERODYNE**

(complete with B.V.A. Valves)

Improved edition of this popular receiver (praised "Wireless World" test reports). Heavier gauge cadmium-plated steel chassis. Iron-cored I.F. transformers give even better performance. No increase in price.

Brief Specification: 8-stage, all-wave band-pass superheterodyne, 7 tuned circuits. D.A.V.C. with "squelch" circuit valve for noise suppression. Illuminated "Airplane" dial. Octode frequency changer. 3.5 watts pentode. Switching for gramophone pick-up. Wave ranges: 16.5-50, 200-550, 800-2,000 metres.

**"De Luxe" Model**

**MCCARTHY ALL-WAVE SIX**

with  
radio frequency  
stage

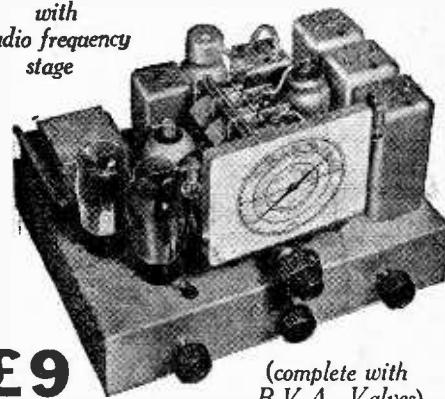

£9

(complete with  
B.V.A. Valves)

"De Luxe" 6 valve receiver with 8 valve performance (specially recommended for tropical and foreign reception conditions). Built on special cadmium-plated 16 gauge steel chassis. Varley iron-cored I.F. coils. Litz-wound tuning coils. 3 wave-ranges—16.5-2000 metres. Illuminated "Airplane" dial with principal station names. Micro-vernier 2-speed drive.

Circuit comprises: Pre-selector radio frequency amplifier (operative on all wavebands), triode-hexode frequency changer, double band-pass coupled I.F. amplifier, double diode-triode detector. D.A.V.C. applied to 3 preceding valves. L.F. amplifier and pentode output. Variable tone control and volume control operate on radio and gramophone.

All McCarthy receivers supplied complete with valves, knobs, pilot lamps, leads, mains cable and plug. 12 months' guarantee.

Deferred terms on application, or through London Radio Supply Co., 11, Oat Lane, E.C.2.

Cash with order on 7 days' approval. Also write for illustrated catalogue of complete range of all McCarthy receivers.

**MCCARTHY RADIO LTD.**  
44a, Westbourne Grove, London, W.2

Telephone: Bayswater 3201/2.

# BROADCAST BREVITIES

NEWS  
FROM  
PORTLAND  
PLACE

## Business as Usual in 1937

WHAT will the year 1937 bring for listeners in the way of programmes? So far as the main lines of policy are concerned there is not likely to be much change. Mr. Cecil Graves, Controller of Programmes, feels that the general ideas which he has worked out during the past year do not call for any extensive revision, but his aim will continue to be to shorten items with the idea of securing greater variation and contrast.

## Pickings for the Multitude

The New Year will be a trying one for the B.B.C. financially. Everyone looks like getting some extra pickings—the Performing Right Society, the Society of Authors and Playwrights, the dance band leaders, even the staff. In the latter case, however, increases will be given on a strictly graduated scale, and however good an official's work may be he will be limited to the maximum for his particular grade. Thus an increase of £25-£50 will be considered quite substantial. This is the first step in preparation for the coming of a staff association and the introduction of Civil Service conditions. As regards the extra payments to outside organisations, the listener naturally will not benefit, as he has already been receiving the best that they have to offer.

## A Growing Infant

THE library of recorded material at the B.B.C. now numbers some 4,000 items and includes examples of every phase of contemporary activity. If no more books were written, if the contemporary historian were enshrouded in impenetrable silence for evermore, posterity would still be able to get an accurate line on the political, religious and literary tendencies of the age by means of a "play-back" of the records preserved by the B.B.C. over the past few years.

## What They Want to Know

THE mailbag of the B.B.C. has contained during the past twelve months an aggregate of 160,000 letters from listeners on programme matters, and to that extent correspondence has helped towards a better understanding between the B.B.C. and its public. But the understanding is no doubt more fully developed on the part of the B.B.C. than on the part of some listeners; for the latter's demands are not always easy to satisfy—and inquirers are perforce "left

in mid-air." One writer, for instance, asked Broadcasting House for hints on how to keep bulldogs; another inquired what kind of work Shakespeare would be writing if he were alive today. This kind of letter scarcely comes within the sphere of constructive programme criticism, for which the B.B.C. hungers.

## That Co-axial Cable

ALTHOUGH the co-axial cable between Broadcasting House and Alexandra Palace has not yet been used for television, it has not been forgotten. High frequency measurements of quite an interesting kind have been carried out. With the installation of television cameras and necessary control apparatus at

more people are awakening to the fact that the sound transmission from Alexandra Palace is exceptionally good. Music and dramatic critics, after the first few minutes of watching a show, remark on the brilliance and depth of the sound accompaniment—and this without any preconceived notions as to the performance to be expected of ultra-short waves.

Actually the common sound transmitter at the television station is giving a nearly even response between 50 and 12,000 cycles.

## An "Ultra Short" Relay?

It has been suggested that the transmitter should be used for relaying the National or Regional programme when not required



BROADCAST ECONOMY. When the O.B. engineers in Sofia make a business trip they find the horse-cabs are not such a strain on the petty cash as the more modern taxi.

headquarters the coast would be clear for the first long-distance television experiments, but for a variety of reasons the engineers are not forcing matters in this direction.

## Ca'canny

Staff at Alexandra Palace are busy enough putting out a good signal on the spot. When a rock steady picture can always be relied upon it will be time to consider transmitting from studios at "B.H." The first television transmission from headquarters may be expected at about the middle of this year.

## Super-quality Transmission

NOW that the overwhelming novelty of television is beginning to pass off, more and

for television purposes, but official opinion is opposed to this for the very good reason that the transmitter is already called upon to operate for double the amount of time required of each television transmitter. Although at the moment actual transmission times are few, heavier demands are likely in the near future, and it is undesirable that the rate of depreciation of the sound transmitter should be disproportionately high.

## Ice Hockey Test Match

NOTHING in the "O.B." repertoire has been found to equal ice hockey matches in speed and excitement. Partly this is due to the inherent liveliness of the game and partly to the new spirit of verve and dash imported into the running commentaries by Bob Bowman, who

beat all records for high-speed description in his accounts of the Olympic Ice Hockey Games at Garmisch.

And now the tale is being taken up by David Miller, another keen commentator, who will accompany Tommy Woodroffe to the "O.B." box at Harringay Rink on January 14th to give Regional listeners an account of the Ice Hockey Test Match between England and the Resident Canadians.

London players have improved out of all knowledge in the last year, and it is expected that the home team will more than hold their own with their opponents. In any case, the commentary should be well worth listening to.

## O.B. Chief for Holland

TALKING of running commentaries, Mr. S. J. de Lotbinière, the B.B.C.'s outside broadcasts chief, has decided that he will himself visit Holland to give the running commentary on Princess Juliana's wedding on January 7th.

It was de Lotbinière who thrilled London with the late-night commentary on the Crystal Palace fire. When news of the disaster reached him at his North London home, he rushed to Sydenham by car and arranged the O.B. in record time.

## A Listener's Referendum

THE year 1937 may see the first determined effort on the part of the B.B.C. to discover the likes and dislikes of its thirty-odd million listeners. Mr. R. J. Silvey, the official most actively concerned, favours the questionnaire system, whereby listeners sufficiently interested to respond to a microphone appeal would be supplied with forms on which they could register their programme preferences.

A useful indication of the probable response may be had from the appeal which is now being made to televiewers. The form sent to those who respond, besides containing questions apropos height of aerial, ease of tuning-in sound and vision, interference, etc., will give ample space for programme eulogies or the ventilation of grievances.



# Letters to the Editor

The Editor does not hold himself responsible for the opinions of his correspondents.

## Service Prospects

AT the present time I am working as a radio tester at 1s. 1d. per hour. I have been at this job for six months, and find it a very monotonous and soul-destroying job. I have had no previous experience of radio, excepting a three months' course at a radio college. I have recently been wondering as to the prospects in this field. Perhaps you would be so kind as to enlighten me about this.

I have commenced studying for the A.I.W.T. and A.M.I.R.E. examinations. Would these be of any use in getting out of the rut and gaining a better position? Radio servicing would appear to be rather an attractive occupation, but how does one gain the experience to be able to service all makes of receivers?

As regards myself, I am twenty-eight years of age, and was educated at a public school. I feel I have reached the age when I should settle down to a career, and I am afraid at my present position I should always be somewhat of a "casual labourer," and be treated as a mere labourer replaceable at a moment's notice.

I should be very grateful for any helpful suggestions your readers may offer.

ENQUIRER.

## Contrast Amplification

ALTHOUGH the new method of volume expansion described by Mr. W. N. Weeden in your issue of December 18th seems to offer several advantages over previous methods, I would draw attention to a misconception. The writer says: "It will be seen that such a circuit should cause no distortion as the control valve is used only as a variable resistance, eliminating the effect of curvature of characteristics as encountered when the control valve is utilised as a variable-gain amplifier."

Now, it must be remembered that the anode voltage of the control valve is not constant, but varies over a small range proportional to the amplitude of the signal which it is desired to attenuate. If amplitude distortion is to be avoided, therefore, the AC resistance of the valve must be strictly constant over this range.

The quotation given above would seem to



The latest Western Electric studio microphone which has been specially designed not only to have equal sensitivity but also a uniform frequency response for sounds arriving from any direction.

imply that for a given grid voltage of the control valve ( $V_2$  in the original diagram) the anode voltage-anode current characteristic is a straight line. This is very nearly true for anode voltages in excess of about 75 V, but is by no means so at lower voltages.

If the operating conditions are so chosen that the anode voltage never falls below this figure reference to the curves of the 6D6 shows that the impedance is about 100,000 ohms at zero grid volts and 1 megohm at -20 volts. Under these conditions the fraction of the signal voltage applied to the grid of the amplifier valve  $V_3$  would vary between 0.5 and 0.91 respectively, giving an expansion range of less than 6 db.

In order to increase the upper limit of attenuation it is necessary to operate the control valve at low anode voltages. If distortion is to be avoided, therefore, it would seem necessary to restrict the applied signal amplitude to very small proportions—an argument which applies with hardly less force than in the case of the "variable- $\mu$ " method of control. B. D. CORBETT.

London, S.W.11.

## "W.W." Receivers

AS a satisfied user of Olympic S.S. and Quality amplifier, I am sending you particulars of my equipment, as it may possibly interest other users of this fine outfit. (1) Aperiodic input coil wound from data given by a contributor in "W.W." under heading "LF components in HF circuits." (2) Reaction winding removed from  $L_5$ , as it was found unnecessary. (3)  $R_{18}$  replaced by 400-megohms variable resistance and used as RF volume control, and in the output stage two 18-watt triodes feeding two B.T.H. speakers modified as follows: No. 1, spider removed and centring obtained with four silk threads stretched from outside of coil to four adjusting screws, cone doped with celluloid varnish for a distance of 3 inches from centre, leather surround impregnated with glycerine.

Speaker No. 2 used without alteration and mounted in a horizontal position in cabinet close to floor with resonator bars of different woods (no data for choosing these) arranged in Venetian blind form across the baffle. Speaker No. 1 is mounted in orthodox position on Celotex baffle 4ft. 6in. x 4ft. in cabinet, which is built throughout of  $\frac{3}{4}$ in. oak.

In conclusion I would say that, compared with any of the commercial HF jobs I have heard, the "W.W." Olympic S.S. sets a standard which would be difficult to equal and well-nigh impossible to better.

Thanking you for a superlative design.  
Belfast. G. McAULEY.

## Television Range

THE television sound transmissions are received here on an ordinary detector and 1 LF S.W. receiver.

This house is about 70 miles from the Alexandra Palace and in the shadow of the Downs on the southerly side.

W. W. WOODMAN.

Chichester, Sussex.

## POINTS OF IMPORTANCE in the Rola G.12



## OF STERLING WORTH

Used originally in connection with coinage of unvarying weight and fineness, the adjective sterling is now used to describe any article or quality of unvarying excellence. Just so the phrase "a G.12 equipped set" denotes a radio receiver the quality of which is beyond all doubt. Since the manufacturer who wishes to economise on components usually begins with the speaker it stands to reason that you can rely absolutely on any set in which this 12in., high fidelity, unit is installed. Manufacturers know from their sales this season that it pays to install G.12's. Listeners who arrange a demonstration at their dealers invariably come to the same conclusion!

G.12 D.C. (as illustrated) complete with Transformer, Mounting Stand, Handle and Base...	£5 5 0
G.12 D.C. with Mounting Stand, Handle and Base, but without Transformer ...	£4 16 0
G.12 D.C. Stripped, but with Transformer ...	£1 4 0
G.12 D.C. Stripped and without Transformer ...	£3 15 0
(When ordering please state Field Resistance and Impedance of Transformer required.)	
G.12 P.M. less Transformer ...	£4 16 0
G.12 P.M. with Transformer ...	£5 5 0

For Public Address work both the P.M. and Energised Models can be supplied with a 15 ohm Voice Coil at an additional charge of 3/-.

Write for Folder A.

OVER 7 MILLION IN USE

# ROLA

The World's Finest Reproducers

THE BRITISH ROLA CO., LTD.  
MINERVA ROAD, PARK ROYAL, N.W.10.  
PHONE: WILLESDEN 4322-3-4-5-6.

Brief descriptions of the more interesting radio devices and improvements issued as patents will be included in this section.

# Recent Inventions

## AUTOMATIC TUNING

**R**ELATES to automatic tuning and noise suppression circuits, in which an initial error in tuning is corrected by a pentode valve TC arranged to have a pronounced Miller effect, or variation of input capacity with slope.

The voltage applied from a diode D to the suppressor grid of TC alters the mutual conductance of that valve, and therefore its effective input capacity, which, in turn, controls the frequency of the local-oscillator circuit LO. To ensure automatic correction, the circuits F1, F2 of the diode D are

an initial muting-bias applied to the suppressor grid of the low frequency pentode VI, and brings the loud speaker into action. A switch S, ganged to the main tuning knob, cuts out the automatic tuning effect if and when the set is being operated manually.

*Murphy Radio, Ltd., and G. B. Baker. Application date March 19th, 1935. No. 453858.*

## SENSITISED "MOSAIC" SCREENS

**A** PHOTO-SENSITIVE screen of the "mosaic-cell" type, as used for transmitting television signals, consists of a very large number of photo-electric globules, mutually insulated from each other, and laid on a backing sheet of insulating material. It is desirable (a) that the distribution of the cells should be kept uniform, and

## ALL-WAVE RECEIVERS

**T**HE various tuning components of a multi-wave-band set are arranged inside compartments formed between the radial partitions and circular end walls of a supporting member, which is rotated about a shaft to bring them into operative relation with a set of stationary contacts. This couples the appropriate units at each position of the wave-band switch.

*The British Thomson-Houston Co., Ltd. Convention date (U.S.A.) October 31st, 1934. No. 454188.*

## LIGHT FOR LISTENERS

**I**T is stated that indirect lighting creates a favourable "atmosphere" for listening to a broadcast programme. The inventors

## MODULATING SYSTEMS

**I**N a class-B modulator two valves are used in push-pull, both as regards their anodes and grids, the latter being so biased that no anode current passes in the absence of a modulating signal. The arrangement is economical in power-output, but it necessitates the use of a push-pull transformer, which is not only expensive but also creates difficulties in securing a uniform response over a wide band of signal frequencies.

According to the invention the use of a transformer in such an installation is rendered unnecessary by arranging one modulator in shunt with the carrier-wave amplifier, and the other in series with it, so that the first modulates one half of each carrier wave, and the second the other half.

*Marconi's Wireless Telegraph Co., Ltd., and W. T. Ditcham. Application date March 27th, 1935. No. 454259.*

## D.C. AMPLIFIERS

**I**N certain cases, as for instance in television, it is desirable to use DC amplifiers rather than transformer-coupled circuits which cannot transmit the DC component necessary to keep step with changes in the average or overall brightness of the picture.

DC amplifiers are, of course, known, but they suffer from a tendency to "drift." That is to say, the output current is apt to increase or decrease gradually, even with no signal input, over a period of several minutes.

In order to overcome this tendency in a television system where the picture signals are separated by intermittent synchronising impulses, the latter are utilised to apply such a bias to the grid of the amplifier as will keep the output steady. The synchronising signals are applied to the grid of a valve initially biased below the cut-off point, and when drift occurs, they set up a potential drop in the output of that valve which is then applied to offset the drift.

*Marconi's Wireless Telegraph Co., Ltd. (communicated by A. W. Vance). Application date April 1st, 1935. No. 454511.*

## TELEVISION SYSTEMS

**F**ROM the standpoint of clearness in detail, the smaller the scanning aperture is made the better, but this finally reduces the sensitivity of the device to a point where it is difficult to ensure a satisfactory signal-to-noise ratio.

According to the invention, the first aperture over which the electron stream is swept includes a screen perforated by a smaller aperture. The small aperture determines the degree of detail, whilst the large aperture raises the amplitude of the signal well above the "noise" level.

*D. T. Farnsworth (assignor to Television Laboratories Inc.). No. 2037711. (U.S.A.)*

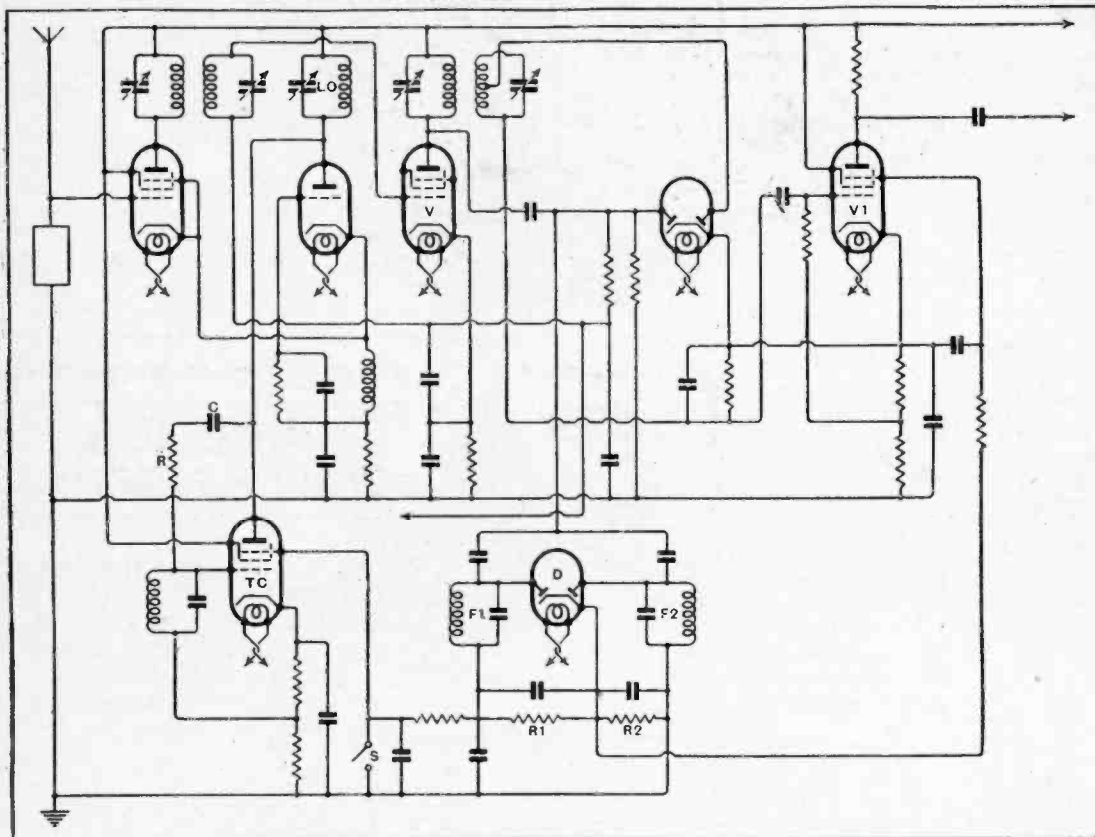

Arrangement of the circuit for automatic tuning correction and interstation noise suppression.

tuned, one a little above and the other a little below, the correct intermediate frequency. Both circuits are coupled to the output of the IF valve V, so that if the receiver has been left slightly "off-tune" one of the circuits F1, F2 builds up more energy than the other, thus producing an excess voltage in one of the load resistances R1, R2.

The excess voltage is fed to the suppressor grid of the pentode TC, and, by varying its mutual conductance, changes the frequency of the local-oscillator circuit LO until the initial error in tuning is automatically set right. Simultaneously the voltage produced across R1, R2 by a station of "worthwhile" strength removes

(b) that the ratio of the photo-sensitive area to the total area of the screen should be as near unity as possible. At the same time the leakage resistance between individual cells should be kept high.

To secure these results the screen is prepared by a photo-mechanical method which consists in applying to a backing sheet of mica a "resist" of bichromated glue on which a fine "mesh" pattern is printed. The "negative" is then developed and washed, and a coating of silver is applied by "sputtering" so that when the resist is removed the silver is left a regular pattern of separate elements.

*C. J. Whilems. Application date April 8th, 1935. No. 454937.*

accordingly fit one or more lamps inside a wireless cabinet which is provided with a translucent cover of frosted glass, so that when the set is switched on luminous rays are projected upwards from it. The upper part of the cabinet is ventilated to prevent excessive heat.

*Etablissements Victor. Convention date (France) December 12th, 1934. No. 454061.*

The British abstracts published here are prepared, with the permission of the Controller of H.M. Stationery Office, from Specifications obtainable at the Patent Office, 25, Southampton Buildings, London, W.C.2, price 1/- each. A selection of patents issued in U.S.A. is also included.



**FAULTLESS PERFORMANCE**

**MOBILE, OUTDOOR AND INDOOR EQUIPMENTS FOR EVERY PURPOSE.**

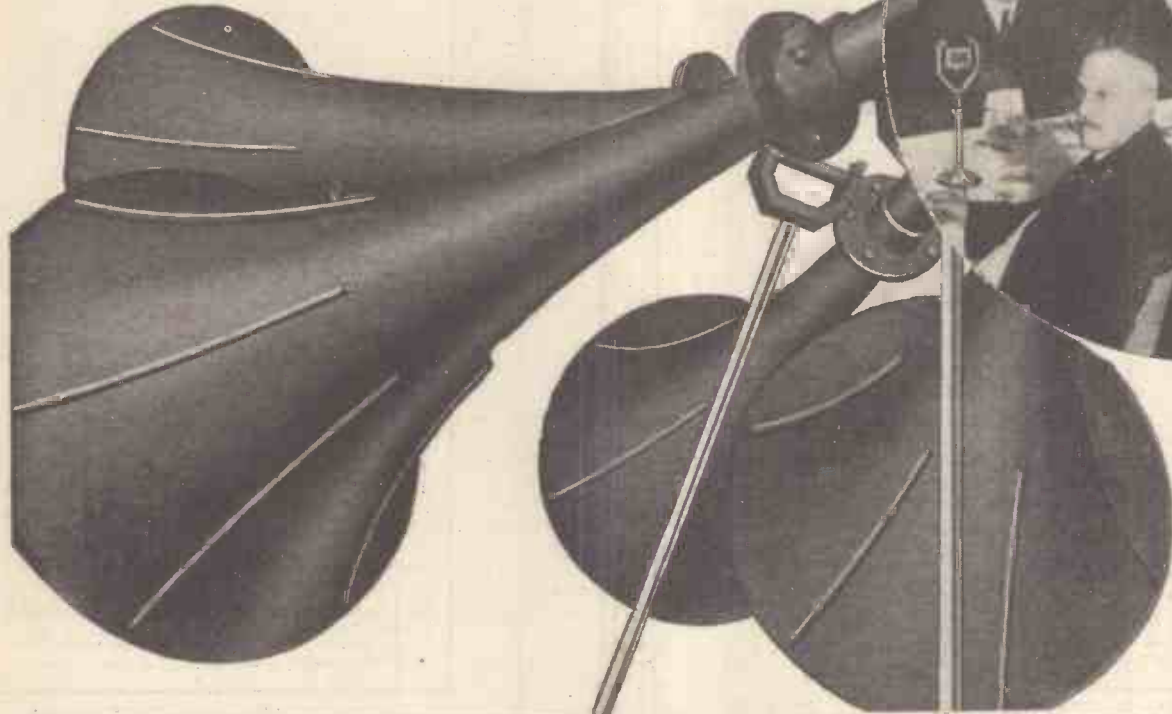

Amplifiers, 6 watts.. £18  
 " 12 " .. £37  
 " 30 " .. £40  
 " 45 " .. £69-10  
 Suitable for amplification from  
 Microphone, Pick-up and Radio.

P.A. Speakers,  
 rating 8 watts.. £12  
 " 12 " .. £20  
 Microphones .. from £3

Please write for full details and  
 trade terms.

**PARMEKO LTD.**  
 Aylestone Park, Leicester.

**1937 MIDWEST**

**THE ONLY ALL-WAVE RECEIVER  
 COVERING 4½ to 2,400 METRES**

Available in Chassis form  
 complete with matched  
 valves and 12" speaker or  
 in Console Cabinet.

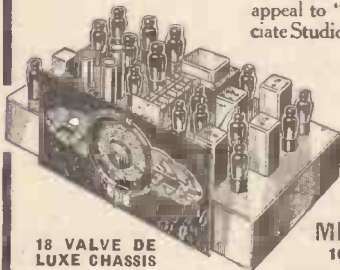

18 VALVE DE  
 LUXE CHASSIS

Magnificent alike in its conception, design and performance, this the latest Midwest Model X-18 High Fidelity Receiver brings the world to your fireside. With its 6 TUNING RANGES it gets "Everything on the Air." Its distinctive features in circuit design are not just "talking points," as a comparison will prove, but basic advantages which will assuredly appeal to "Wireless World" readers and all who appreciate Studio or Concert Hall quality of performance in home.

**FREE** Our fully descriptive 40  
 PAGE ILLUSTRATED ART  
 CATALOGUE giving particulars of  
 Midwest 11, 14, 16 and 18 valve models.

DEMONSTRATIONS at our showrooms Mondays  
 to Saturdays from 9 a.m. to 8 p.m.

DEFERRED PAYMENTS. The London Radio  
 Supply Co., 11, Oat Lane, Noble Street, London,  
 E.C.2, supply all models on Easy Terms.

**MIDWEST RADIO LTD.,** SHOWROOMS  
 & FACTORY:  
 16, OLD TOWN, CLAPHAM, LONDON, S.W.4.  
 Phone: MA Caulay 5005.

**B.I. WIRELESS  
 CONDENSERS**

**B.I. FIXED CAPACITY CON-  
 DENSERS** for Wireless Receivers,  
 Battery Eliminators, Smoothing  
 Circuits, etc., are made in several  
 different types to suit the various  
 uses for which Condensers are  
 required in connection with  
 Wireless circuits.



These Condensers are the result  
 of over 36 years' experience in  
 the manufacture of all kinds of  
 Condensers from the smallest  
 sizes up to Condensers weighing  
 more than 2 tons.

In addition to the Standard  
 Types, B.I. Condensers can be  
 supplied in special forms to suit  
 manufacturers' requirements.

**BRITISH INSULATED CABLES LTD.**

*Cable Makers and Electrical Engineers*  
**PRESCOT, LANCS.**

Telephone No. PRESCOT 6571

London Office: **SURREY HOUSE, EMBANKMENT, W.O.2**

Telephone No. Temple Bar 4793, 4, 5 & 6

**PERMAREC**

**HOME RECORDING UNIT  
 MAKES PERFECT RECORDS**

PRICE  
**£3.17.6**

A thoroughly sound  
 engineering job specially  
 designed for easy attach-  
 ment to any set or  
 Radiogram. Cutting your  
 own records is perfectly  
 simple with this unit.



Manufactured under British  
 Patent No. 433614.

Write to-day for Free Copy  
 of "The Wireless World"  
 Test Report and illustrated  
 leaflet fully describing this  
 and our larger professional  
 models.

**MUSIKON LTD.** RECORDING STUDIOS  
 Telephone: Gerrard 7105 and 3862.  
 19, LISLE STREET, LONDON, W.C.2.

# MISCELLANEOUS ADVERTISEMENTS

## NOTICES

THE CHARGE FOR ADVERTISEMENTS in these columns is

12 words or less, 3/- and 3d. for every additional word.

Each paragraph is charged separately and name and address must be counted.

**SERIES DISCOUNTS** are allowed to Trade Advertisers as follows on orders for consecutive insertions, provided a contract is placed in advance, and in the absence of fresh instructions the entire "copy" is repeated from the previous issue: 13 consecutive insertions 5%; 26 consecutive, 10%; 52 consecutive, 15%.

**ADVERTISEMENTS** for these columns are accepted up to **FIRST POST ON MONDAY MORNING** (previous to date of issue) at the Head Offices of "The Wireless World," Dorset House, Stamford Street, London, S.E.1, or on **SATURDAY MORNING** at the Branch Offices, 19, Hertford Street, Coventry; Guildhall Buildings, Navigation Street, Birmingham, 2; 260, Deansgate, Manchester, 3; 26a, Renfield Street, Glasgow, C.2.

Advertisements that arrive too late for a particular issue will automatically be inserted in the following issue, unless accompanied by instructions to the contrary. All advertisements in this section must be strictly prepaid.

The proprietors retain the right to refuse or withdraw advertisements at their discretion.

Postal Orders and Cheques sent in payment for advertisements should be made payable to **ILIFFE & SONS Ltd.**, and crossed **& Co.** Notes being untraceable if lost in transit should not be sent as remittances.

All letters relating to advertisements should quote the number which is printed at the end of each advertisement and the date of the issue in which it appeared.

The proprietors are not responsible for clerical or printers' errors, although every care is taken to avoid mistakes.

## NEW RECEIVERS AND AMPLIFIERS

**A. DEGALLIER'S, Ltd.**, the best firm for reliable fully guaranteed ultra short-wave radio, have on view in London without exception the largest selection of all-wave receivers, at very low prices. For instance, a 7-valve superhet., with 3 bands going down to 16 M, in A.C. or A.C./D.C., at £9. An 8-valve superhet., 4 bands going down to 11 meters, with push-pull output 7 watts undistorted, is only 13 guineas. Any known American valve for receivers 1925-1937, glass, glass counterparts, metal, and M.G. at 6/6 each, all firsts. They have range like this right up to a 24-valve Challenger twin-chassis, valves and two Auditorium speakers, 5-bands 5-2,050 meters, 60 watts undistorted at £50 (this is as supplied to the Navy, Army and Air Force canteens). They guarantee that every S.W. receiver will get stations on the low bands including the Americas, etc. Why not call and handle these receivers at your leisure. No obligation to purchase. Or send large S.A.E. for beautifully illustrated catalogues with actual photographs. Also in stock, Ferguson, Emerson, Belmont, Crosley, Garod, etc.

**DEGALLIER'S, Ltd.**, No. 18, Connaught St., Marble Arch, London, W.2. Paddington 2745. [3490]

**SPECIAL Offer.**  
25 Only, brand new receivers, British made, in handsome modern walnut cases; 5-valve superhets, universal mains, gram. p.u. extension speaker, A.V.C., Q.A.V.C.; list price 11½ guineas, in makers cartons, price to clear £5/17/6; satisfaction or money refunded.—P. Davis, 299, Upper Richmond Rd., Sheen, London, S.W.14. [3501]

**ROYAL RADIO Co.**  
**ESTABLISHED 1908.**  
ALL-WAVE Receivers, suitable for use on ships, as supplied to officers of many shipping lines.  
OUR 8 and 10 Metal Valve All-wave Receivers; 15-2,000 metres, acknowledged by the trade as the best for range, tone, and general performance.

LATEST 6-valve Car Radio, A.V.C., remote control, no suppressors required.  
A FULL Range of the World Famous Ferguson and Pilot Models Stocked.  
ALL Sets Fully Guaranteed by Ourselves.  
ALL Types of American Valves Stocked.  
ANY Make of Set Serviced by Our Qualified Radio Engineers at Reasonable Charges.  
PAY Us a Visit Any Time, or send for full range catalogue; 1½d. stamp will be appreciated.  
ROYAL RADIO Co., 5, Buckingham Rd., South Woodford, London, E.18. Phone: Buckhurst 2736. [3499]



"... why and wherefore in all things."

## THE DESIGN OF A.F. AMPLIFIERS

Why does our "12 watt" A.F. amplifier give nearly 18 watts in practice; and how do we get its response curve flat from 40 to 15,000 cycles? Clients have often asked us "how is it done?" when they see from the diagram that the circuit is absurdly simple, with no fancy devices or troublesome precautions.

Well, partly, of course, it is due to careful design of every little detail of the circuit. But largely, we must thank one special component—the

## HARTLEY-TURNER A.F. COUPLING UNIT

This comprises a parallel-fed Mumetal transformer, its coupling condenser, and a correcting network to give the required response curve. The whole assembly is compact, measuring 2½ ins. x 3½ ins. x 3½ ins. high in its bakelite case.

It is made in various modifications, as listed below, and these show minor differences in response; but they are all close to this surprising specification:

1 dB down at 30 c/s: flat from 50 to 9,000 c/s; rising slowly to 1 dB UP at 15,000 cycles, and then falling off gradually.

The transformer itself is 1 to 4 step-up; but the correcting network affects both input impedance and effective step-up; so we rate the unit as follows:—from the grid of the previous valve to the secondary of the unit, the gain is approximately twice the M of the valve.

**Standard types:** output up to 200 V swing overall; i.e. 100 V amplitude or 70 V r.m.s.

**P.P.A.—4-terminal—push-pull—bottom of primary and centre of secondary earthed.**

**P.P.B.—6-terminal—push-pull—secondary split and all four leads brought out.**

**S.A.—4-terminal—single valve.**

All at £1 10s. 0d. each.

**High power types:** output up to double the above.

**P.P.C. 4-terminal push-pull as P.P.A. but high-power.**

**P.P.D. 6-terminal push-pull as P.P.B. but high-power.**

**S.B. 4-terminal single-valves as S.A. but high-power.**

All at £2 5s. 0d.

Note that the high-power types do not include the coupling condenser; one of .5 mF must be connected externally.

In all cases, anti-oscillation resistors for the grid leads are provided within the case.



**HARTLEY TURNER RADIO LTD., THORBURY ROAD, ISLEWORTH, MIDDLESEX. Telephone: HOUnslow 4488**

## NUMBERED ADDRESSES

For the convenience of private advertisers, letters may be addressed to numbers at "The Wireless World" Office. When this is desired, the sum of 6d. to defray the cost of registration and to cover postage on replies must be added to the advertisement charge, which must include the words Box 000, c/o "The Wireless World." All replies should be addressed to the Box number shown in the advertisement, c/o "The Wireless World," Dorset House, Stamford Street, London, S.E.1. Readers who reply to Box No. advertisements are warned against sending remittance through the post except in registered envelopes: in all such cases the use of the Deposit System is recommended, and the envelope should be clearly marked "Deposit Department."

## DEPOSIT SYSTEM

Readers who hesitate to send money to advertisers in these columns may deal in perfect safety by availing themselves of our Deposit System. If the money be deposited with "The Wireless World," both parties are advised of its receipt.

The time allowed for decision is three days, counting from receipt of goods, after which period, if buyer decides not to retain goods, they must be returned to sender. If a sale is effected, buyer instructs us to remit amount to seller, but if not, seller instructs us to return amount to depositor. Carriage is paid by the buyer, but in the event of no sale, and subject to there being no different arrangement between buyer and seller, each pays carriage one way. The seller takes the risk of loss or damage in transit, for which we take no responsibility. For all transactions up to £10, a deposit fee of 1/- is charged; on transactions over £10 and under £50, the fee is 2/6; over £50, 5/-. All deposit matters are dealt with at Dorset House, Stamford Street, London, S.E.1, and cheques and money orders should be made payable to Iliffe & Sons Limited.

**SPECIAL NOTE.**—Readers who reply to advertisements and receive no answer to their enquiries are requested to regard the silence as an indication that the goods advertised have already been disposed of. Advertisers often receive so many enquiries that it is quite impossible to reply to each one by post. When sending remittances direct to an advertiser, stamp for return should also be included for use in the event of the application proving unsuccessful.

## NEW RECEIVERS AND AMPLIFIERS

**AIR KING.**  
**THE** Royalty of Radio.  
**MODEL** Empire 11-valve 4-band Supersonic Heterodyne Receiver for A.C. 100 to 250 Volts, incorporating every refinement known to modern radio technique, large illuminated dial, indicating each wave band separately marked in station names, wavelengths, and frequencies, with the famous exclusive beam tuning system, Magic Eye indicator for increased sensitivity and silent precision tuning, illuminated indicators to show high fidelity and gram. pick-up, high fidelity assured by two balanced speakers, one acting as special amplifier for high audio frequencies and one large concert type dynamic speaker for full range audio frequency range from 40 to 9,000 cycles, special band expansion intermediate frequency transformer on first stage, variable selectivity, full range variable tone control, A.V.C.  
**MODEL** Duchess 6-valve 3-band Superhet. Receiver for A.C. 100 to 250 Volts; this receiver is housed in an attractive lay down walnut cabinet.  
**MODEL** Envoy for A.C./D.C. Mains, 100 to 250 volts, no line cord used.  
**MODEL** Marquis 6-valve 3-band Superhet. Receiver for A.C. 100 to 250 Volts, in tastefully designed moulded one-piece bakelite cabinet, obtainable in ivory, red, walnut and ebony.  
**MODEL** Ermine 6-valve 3-band Superhet. Receiver for A.C./D.C. 100 to 250 Volts, no line cord used, a splendid set of proven popularity.  
**ALL** Models Feature Beam Tuning, Magic Eye indicator, gram. pick-up connections, and special output valves.  
**ALL** Sets Fully Guaranteed.  
**H.P.** Terms Available from 3/- per Week.  
**OUR** Technical Department is at Your Service.  
**ARCTURUS** Valves for Improved Radio Reception on All Types of Receivers.  
**ARCTURUS**, the only line made in 4 ranges, glass, metal, G type, and metal modernisers.  
**WRITE** for Lists o' These Famous Valves; prices from 4/9 each.  
**WHOLESALE** and Trade Enquiries Invited; generous terms.  
**AIR KING RADIO**, 115, Shaftesbury Av., Cambridge Circus, W.C.2 (1st floor above Barclay's Bank). Phone: Temple Bar 4875 (all lines). All receivers assembled in England. [3406]













**SUPER-CINEMA P.M. MODEL**



Designed to fill the demand for a speaker capable of handling very large inputs without using heavy field wattages, this reproducer has as great a sensitivity and power handling factor as the well-known Super-Cinema Energised range. It is most satisfactory for public address work where a number of speakers are employed, it being only necessary to run speech lines and not the usual combined speech and field lines. This obviates the necessity of expensive cable. Power handling factor 30 watts.

PRICE  
**£14.10.0**

INCLUDE  
**EPOCH REPRODUCERS & MICROPHONES**

in your P.A. EQUIPMENT for the  
**Coronation Ceremonies**

and your efforts will be  
**CROWNED WITH SUCCESS.**  
Complete catalogue upon request.

**RADIO DEVELOPMENT CO.**  
(Prop.: EPOCH Reproducers Ltd.)  
Aldwych House, Aldwych, London, W.C.2  
Telephone: Holborn 9111 (2 lines).

**MOVING COIL MICROPHONES**

Of robust construction our Model 55 can be used for all general purpose work. No local energised current required. Can be used on long microphone lines without loss of output, and the reduction of feedback is a very important point. Frequency response is from 70 to 5,000 cycles, and it responds very favourably up to 7,000. Output level is 85 db down.



Model 55 with Table Stand as illustrated **£5.5**  
Model 55 F with Standard Floor Stand **£6.6**

**INDEX TO ADVERTISEMENTS**

	PAGE
Anson, Henry, Ltd.	6
Armstrong Wig, Co.	6
Automatic Coil Winder & Electrical Equipment Co., Ltd.	Front cover
Belling-Lee, Ltd.	3
British Institute of Engineering Technology	8
British Insulated Cables, Ltd.	1
British Rola Co., Ltd.	Edit. 23
Cass, Sir John, Institute	7
C.A.V.	Front Cover
Dubilier Condenser Co.	Inside Front Cover
Electradix Radios	6

	PAGE
Exide, Ltd.	Back Cover
Forbat, Eugen, Ltd.	8
G.E.C.	Inside Back Cover
Hartley Turner Radio, Ltd.	2
Haynes Radio	Front Cover
Imhof, Alfred, Ltd.	7
Mains Radio Development Co.	6
McCarthy Radio, Ltd.	Edit. 21
Midwest Radio, Ltd.	1
Musikon, Ltd.	1
Parmeko, Ltd.	1
Premier Supply Stores	5

	PAGE
Prism Manufacturing Co.	6
Radio Industries Development Co.	4
Radio Development Co.	8
Radiomart (G5N1)	7
Record Radio	6
Savage, W. Bryan	8
Scientific Supply Stores (Wireless), Ltd.	4
Sound Sales, Ltd.	Front Cover
Tannoy Products	6
Universal Radio Distributors, Ltd.	6
Variety, Ltd.	8
Ward, C. F.	8

**SPECIAL OFFER FOR THE NEW YEAR**  
**NEW KITS FOR OLD AND NEW VALVES FOR OLD**

We suggest that Constructors seize the opportunity of trying out the Famous OSTAR-GANZ UNIVERSAL HIGH VOLTAGE VALVES, which are rapidly conquering the market. The advantages of using these valves will be proved soon after you accept our part exchange offer which we are backing with a six-months' guarantee, compared with the usual guarantee of three months, with 20% P.X. allowance. The same applies to our full range of Universal ALL-WAVE RECEIVERS, AMPLIFIERS, RADIOGRAMS AND TRANSMITTER KITS. Apply to:

**EUGEN J. FORBAT**

28-29, Southampton Street, Strand, London, W.C.2. Temple Bar 8608-4985.

WHY NOT BUY DIRECT FROM THE MANUFACTURER?  
WHY NOT EXCHANGE YOUR OLD SET FOR A NEW ONE?

**HYVOLTSTAR**

UNIVERSAL ALL-WAVES, ALL-MAINS, A.C.-D.C. SUPERS, RADIOGRAMS AND AMPLIFIERS.

"Wireless World" report says, re **THE REVOLUTIONARY NEW BATTERY-MAINS RECEIVER**—

"The set... should prove invaluable to people whose business takes them into unexpected places... There is a really sparkling performance on the medium wave-band... The quality of reproduction is admirably suited to the all-round usefulness of this receiver..."  
UNIVERSAL HIGH VOLTAGE RADIO LTD., 23-29, Southampton Street, Strand, W.C.2. Telephone: Temple Bar 4985 & 8608.



**Varley**

**THE DUO NICORE TRANSFORMER**

The B.P. 96 (465 K.C.) I.F. Transformer is a newly introduced type, with fixed coupling between coils. Litz-wound iron-cored coils are fitted, with mica di-electric trimming condensers. Selectivity obtainable almost equals that of a superhet. Particularly suited to all-wave receivers. Price 8/6.

OLIVER PELL CONTROL, LTD., BLOOMFIELD ROAD, WOOLWICH, S.E.18. WOOLWICH 2345

For really high-grade mains transformers and chokes—it's best to go to Savage!



★From our standard lists or to your specifications. We will gladly send you lists on request or quote to your particular requirements.

**W. BRYAN SAVAGE LTD.**

WESTMORELAND ROAD, LONDON, N.W.9  
PHONE: COLINDALE 7131 (3 LINES)

**JANETTE CONVERTERS AND PETROL ELECTRIC GENERATING PLANTS**

The generating plants are available with AC or DC outputs, suitable for operating amplifiers, radios, etc., whilst they have undoubted advantages over a rotary converter and batteries, where a large output is required for PA work.



**The JANETTE ROTARY CONVERTER**

These machines are in use throughout the world, and possess an unrivalled reputation for reliability and efficiency. We have practically every normal type in stock, with inputs from 32 volts upwards. They are available with all-wave filter, suitable for operating a radio receiver from 8 metres upwards.

Sole Distributor:

**CHAS. F. WARD**, 46, Farringdon Street, LONDON, E.C.4. Tel: Holborn 8703.

**ENGINEERS! ARE YOU EARNING LESS THAN £10 PER WEEK?**

If so, you cannot afford to carry on without reading our 268-page Handbook. The book explains clearly and definitely many ways of carving out a successful career. Among other things, it explains the Services of our unique Appointments Department, outlines Home-Study Courses in all branches of Civil, Mechanical, Electrical, Motor, Aero, Wireless, "Talkie" Engineering, Television, Building, Govt. Employment, etc., and gives details of B.Sc., A.M.I.C.E., A.M.I.A.E., A.M.I.E.E., A.M.I.W.T., G.P.O., Matric., and all Exams. We Guarantee—"No pass—No Fee." Whether you be an old hand or a budding apprentice, get this book to-day—FREE and POST FREE.



BRITISH INSTITUTE OF ENGINEERING TECHNOLOGY,  
387, Shakespeare House, 17/19, Stratford Place, London, W.1.

**"THE WIRELESS WORLD" DIARY for 1937**

76 pages of facts, formulae and general information for the wireless enthusiast.

1/6 net; by post 1/7

From bookstalls and stationers or direct from the Publishers

ILIFFE & SONS LTD.

Dorset House, Stamford Street, London, S.E.1



Osram Valve Type H42

W42	...	12/6
Variable $\mu$ screen pentode-Grid top cap		
X42	...	15/-
Improved Heptode frequency changer		
H42	...	9/6
High amplification Triode — Grid top cap. Low hum, non microphonic		
DH42	...	12/6
Double diode-Triode		
N42	...	13/6
High efficiency output Pentode		
Use Osram U12 Full wave Rectifier ... 10/6		

# Osram Valves

MADE IN ENGLAND

## A NEW RANGE OF A.C. MAINS VALVES

(INDIRECTLY HEATED, 4-volt heaters)

- 1 New manufacturing technique ensures **REAL UNIFORMITY** in characteristics and performance—invaluable to modern set design.
- 2 Reduced heater wattage makes for economy in set design and operation.
- 3 Low interelectrode capacities facilitate short wave reception.
- 4 Characteristics designed to meet the requirements of multi-valve high efficiency sets.
- 5 Complete range of 5 new types available.

★ Write for leaflets, giving full technical data and characteristic curves.

## BATTERY LIFE IS AFFECTED BY CHARGE LIFE

### *A fact not generally known*

Low tension batteries have undergone the same process of specialisation as most other things and are now produced in various types, each designed to work under certain conditions.

It is, however, not generally known that the life of the battery is adversely affected if it is not used under the conditions for which it is designed. For instance, 'Mass' type batteries containing a few thick plates, such as the popular Exide DTG or DFG, are designed for slow discharge with long periods between recharges. If that type of battery is subjected to cycles of charge and discharge of greater frequency than once a fortnight its life will be shortened. In any case, under those conditions it will not be giving the most economical service, for its full rated capacity will not be obtained.

This type of battery is excellent for small sets with a sufficiently low L.T. current consumption, but lately there has been a marked tendency to increase the size of sets. Over 90% of modern battery sets take 0.4 amperes or more owing to the use of more valves and of illuminated dials.

These loads are too high for the 'D' type of battery and so Exide have produced a new range of multi-plate batteries with characteristics suitable for these new



conditions. They are known as Exide 'Hycap' Batteries. The Exide 'Hycap' will give a higher capacity under these heavy discharges, so reducing the frequency of recharging. Listeners gain from 35% to 90% more listening hours per charge. Due not only to the reduced frequency of recharging, but also to the sturdy construction of the multi-plate assembly, 'Hycap' batteries are considerably more durable than thick-plate batteries operated under the same conditions. An additional advantage is that they can be recharged in about half the time required for thick-plate batteries. With these bigger sets the Exide 'Hycap' will therefore have a longer life and will reduce the cost of listening. Like the 'D' type battery, the Exide 'Hycap' is fitted with the invaluable Exide Indicator, which tells you in time when to recharge.

Sizes and Prices of Exide 'Hycap' Batteries

Type	Voltage	Capacity in ampere hours at the 20 hr. rate	Price (uncharged)
OCG3-C	2	15	8/6
GFG4-C	2	24	10/6
GKG5-C	2	36	12/6
CZG6-C	2	60	15/6

Obtainable from all reputable dealers and Exide Service Stations.

EXIDE BATTERIES • EXIDE WORKS • CLIFTON JUNCTION • NEAR MANCHESTER • ALSO AT LONDON • MANCHESTER  
BIRMINGHAM • BRISTOL • GLASGOW • DUBLIN AND BELFAST



4<sup>D</sup>

# The Wireless World

**THE PRACTICAL RADIO & TELEVISION JOURNAL**

Friday, January 8th, 1937

Before you decide—  
make this your guide!

A complete and comprehensive guide to the entire McCarthy range of radio chassis free!

Contains full technical specifications, complete circuit diagrams, and photographic illustrations of all McCarthy all-wave and other receivers, recommended loud speakers, cabinets, etc. More than 24 interesting and informative pages.



**McCarthy**  
RADIO LTD.

44a, Westbourne Grove, London, W.2.  
Telephone: Bayswater 3201.

SEE ALSO ADVERTISEMENT INSIDE →

**MOULDED MICA CONDENSERS**



CAPACITY $\mu$ F	PRICE EACH
.0005 - .0003	8d.
.0005	9d.
.001 and .002	1/-
350v. D.C. PEAK WORKING.	750v. A.C. TEST

You will find the wire terminals to these condensers a great help. They increase the speed and ease of assembly considerably.

**DUBILIER**

Dubilier Condenser Co. (1925) Ltd., Ducon Works, Victoria Rd., North Acton, London, W.3. O. R. Casson 10

Everything for

**QUALITY RECEPTION**



Everything for the

**TELEVISION CONSTRUCTOR**

Duophase amplifier 6-watt, Duophase amplifier 6-watt for P.M. speaker, Duophase amplifier 14-watt, Duophase amplifier 14-watt (constructor's model), Duophase amplifier circuits, Duophase Intervalve coupling, gramophone amplifier 6-watt, gramophone amplifier 14-watt, 1-H.F. tuner unit, 2-H.F. tuner unit, all-wave tuner unit, shortwave converter, table model receivers, radiogramophones, schools receivers, baffle boards, loud speakers, volume controls, mains transformers, smoothing and filter chokes, output transformers.

Originators of the Quality Receiver and Quality Radiogramophones.

Demonstration night every Friday, 7.30-9.30 p.m.

Time base transformers, time base units, H.T. transformers up to 6,000 volts, heater transformers, smoothing and voltage regulating equipment, high voltage rectifiers, cathode ray tubes and holders with protecting front screen, converter units for speech reception, complete apparatus for vision receiver construction, chassis and special baseplates.

The most attractive development ever presented to the radio enthusiast.

Have you the Haynes Quality Booklet? 1936-37 Edition. Free on request. Enfield 2726.

**HAYNES RADIO LIMITED, QUEENSWAY, ENFIELD, MIDDLESEX.**

You're always sure  
with Player's



Player's always please

10 for 6d.  
20 for 11½d.  
PLAIN or CORK-TIPPED

Notice how firm and round is a Player. Well-filled with good tobacco! Whether you prefer Plain or Cork-Tipped remember, Player's always Please because "It's the tobacco that counts."

IT'S THE TOBACCO THAT COUNTS

NCC 360A

## 1937 MIDWEST

**THE ONLY ALL-WAVE RECEIVER COVERING 4½ to 2,400 METRES**

Available in Chassis form complete with matched valves and 12" speaker or in Console Cabinet.

Magnificent alike in its conception, design and performance, this the latest Midwest Model X-18 High Fidelity Receiver brings the world to your fireside. With its 6 TUNING RANGES it gets "Everything on the Air." Its distinctive features in circuit design are not just "talking points," as a comparison will prove, but basic advantages which will assuredly appeal to "Wireless World" readers and all who appreciate Studio or Concert Hall quality of performance in home.

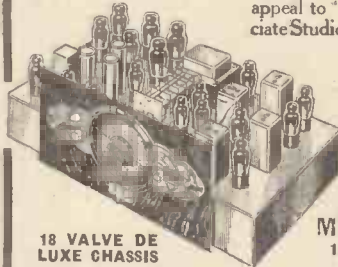

18 VALVE DE LUXE CHASSIS

**FREE** Our fully descriptive 40 PAGE ILLUSTRATED ART CATALOGUE giving particulars of Midwest 11, 14, 16 and 18 valve models.

DEMONSTRATIONS at our showrooms Mondays to Saturdays from 9 a.m. to 8 p.m.

DEFERRED PAYMENTS. The London Radio Supply Co., 11, Oat Lane, Noble Street, London, E.C.2, supply all models on Easy Terms.

**MIDWEST RADIO LTD.** SHOWROOM & FACTORY:  
16, OLD TOWN, CLAPHAM, LONDON, S.W.4.  
Phone: MACanlay 5005.

## PERMAREC HOME RECORDING UNIT MAKES PERFECT RECORDS

PRICE £3.17.6

A thoroughly sound engineering job specially designed for easy attachment to any set or Radiogram. Cutting your own records is perfectly simple with this unit.

Write to-day for Free Copy of "The Wireless World" Test Report and illustrated leaflet fully describing this and our larger professional models.



Manufactured under British Patent No. 433614.

**MUSIKON LTD.** RECORDING STUDIOS  
Telephone: Gerrard 7105 and 3862.  
19, LISLE STREET, LONDON, W.C.2.

# FOUNDATIONS of WIRELESS

A Book of  
First Principles  
for the  
Wireless  
Enthusiast

PRICE 4/6 NET

By Post 4/11

Issued in conjunction with  
"THE WIRELESS WORLD"  
and published by the Proprietors—

By A. L. M. SOWERBY, M.Sc.

An Elementary Text Book on Wireless Receivers

"Foundations of Wireless," based on a series of articles which appeared in "The Wireless World," covers the whole field of wireless from the simplest electrical phenomena to the construction of a modern set, and all the vital points in receiver-design are treated in full detail. Chapters are devoted to direct and alternating currents; typical circuits; the properties of inductance and capacity; the nature of high frequency currents; the tuned circuit; and amplification by the valve.

Eleven of the eighteen chapters of the book deal with the discussion of receivers in which the whole process of design is reviewed stage by stage to the finished article.

Special attention is paid to the important subject of tuned circuits and band-pass filters, on the correct design of which the performance of every type of set ultimately depends. Moreover the process of detection, so often imperfectly understood, is clearly explained.

ILLIFFE & SONS LTD., DORSET HOUSE, STAMFORD STREET, LONDON, S.E.1

Mention of "The Wireless World" when writing to advertisers, will ensure prompt attention.

# The Wireless World

THE  
PRACTICAL RADIO  
JOURNAL  
26<sup>th</sup> Year of Publication

No. 906.

FRIDAY, JANUARY 8TH, 1937.

VOL. XL. No. 2.

Proprietors : ILIFFE & SONS LTD.

Editor :  
HUGH S. POCOCK.

Editorial,  
Advertising and Publishing Offices :  
DORSET HOUSE, STAMFORD STREET,  
LONDON, S.E.1.

Telephone: Waterloo 3333 (50 lines).  
Telegrams: "Ethaworld, Sedist, London."

COVENTRY: Hertford Street.  
Telegrams: "Autocar, Coventry." Telephone: 5210 Coventry.

BIRMINGHAM:  
Guildhall Buildings, Navigation Street, 2.  
Telegrams: "Autopress, Birmingham." Telephone: 2971 Midland (4 lines).

MANCHESTER: 260, Deansgate, 3.  
Telegrams: "Iliffe, Manchester." Telephone: Blackfriars 4412 (4 lines).

GLASGOW: 26B, Renfield Street, C.2.  
Telegrams: "Iliffe, Glasgow." Telephone: Central 4857.

PUBLISHED WEEKLY. ENTERED AS SECOND  
CLASS MATTER AT NEW YORK, N.Y.

Subscription Rates:  
Home, £1 1s. 8d.; Canada, £1 1s. 8d.; other  
countries, £1 3s. 10d. per annum.

As many of the circuits and apparatus described in these pages are covered by patents, readers are advised, before making use of them, to satisfy themselves that they would not be infringing patents.

## CONTENTS

	Page
Editorial Comment . . . . .	25
Scanning in Television . . . . .	26
Wireless as Personal Luggage . . . . .	30
Transmission Lines . . . . .	32
Current Topics . . . . .	35
Unbiased . . . . .	36
New Osram Valves . . . . .	37
Random Radiations . . . . .	38
On the Short Waves . . . . .	39
Listeners' Guide for the Week . . . . .	40
Finding the Ultra-short Band . . . . .	42
Television Programmes . . . . .	43
Broadcast Brevities . . . . .	44
Dropping Filament Volts . . . . .	45
New Apparatus Reviewed . . . . .	46
Letters to the Editor . . . . .	47
Recent Inventions . . . . .	48

## EDITORIAL COMMENT

### Waveband Allocations Demand for Transmitter Efficiency

CONSTANTLY increasing demands on wavelengths for radio communication purposes have resulted in a tightening of regulations to ensure the efficiency of transmitters so that, whilst maintaining their allotted frequencies, they should interfere as little as possible with the proper working of their immediate neighbours in the wavebands which have been allotted to them. Crystal control of transmitters on many wavelengths, especially where congestion is serious, is becoming compulsory, and nowhere, perhaps, is more strict adherence to allotted frequencies so necessary as in the case of broadcasting. Broadcasting stations in America and in Europe can no longer deviate from their allotted frequencies without breaking in to the transmissions of other stations adjacent to them, and in the common cause it has become essential that deviation should not take place.

But whilst on certain wavebands these precautions are being taken, indignation is growing over the casual and obsolete methods adopted by transmitters in other wavebands at least as valuable for communication purposes. Wavelengths on a generous scale have been allotted for maritime wireless, and no one would question the necessity for maintaining an allocation adequate not only for marine traffic but more especially in the interests of safety of life at sea. The impression, however, is that the wavebands allotted for marine purposes are being abused because of the obsolete nature of much of the apparatus employed. There have been strong criticisms emanating from America

that ships' transmitters, with a few modern exceptions, are not yet employing any adequate frequency-controlling device, resulting not only in the occupation of a much wider band of frequencies than is necessary for transmission, but limiting also the potential efficiency of the receiver because it is required to be broadly tuned for the reception of an unsteady transmission.

Then, again, there is the question of the continuance of obsolete spark transmitters. Ultimately, we know, spark transmitters will disappear, but the question now raised is whether it is reasonable for the period of their disappearance to be so protracted.

### Menace to Communication

In an authoritative article in *The Wireless World* of December 25th dealing with the year's progress in commercial wireless it was pointed out that there are now about 15,000 ships fitted with wireless throughout the world, and that of these no less than 8,000 are still equipped with spark installations.

If it could be argued that for the purpose of safety of life at sea a wider band of frequencies is required by transmitters than in other radio communication services, then surely it could equally be suggested that where efficient communication, especially such as is required in cases of emergency, is to be effected it cannot well be done in wavebands which are cluttered up with spark transmissions or CW transmitters whose frequency is not suitably controlled.

When it is considered how extremely valuable every available band has become to-day it seems highly desirable that we should satisfy ourselves that the most efficient use is being made of every available transmission channel.

# Scanning in

*PRINCIPLES of scanning as employed in modern television are discussed in detail in this article. Scanning is shown to be the factor which is chiefly responsible for the greater complication of television receivers as compared with ordinary broadcast sets.*

By W. T. COCKING

THE mechanism of sound broadcasting is by now well known, and even the completely non-technical have some idea of the processes involved, how the sound waves in the studio are converted into electrical currents by the microphone, and how they modulate a radio-frequency carrier wave which is eventually radiated from the transmitting aerial. At the receiving end, too, it is understood that the aerial picks up the carrier of the desired station, and that this is amplified and selected from those of unwanted stations in the RF circuits; after detection AF currents are produced which operate the loud speaker and cause it to set up sound waves which are counterparts of those existing originally in the transmitting studio.

Many people who have quite a good knowledge of the principles of sound broadcasting, however, have little idea of the processes involved in television. It is either a complete mystery, or it is erroneously believed to be neither different in essence nor more difficult than telephony.

In many of its aspects television is exactly analogous to telephony, certain stages, in fact, differing only in degree but not in kind. There is, however, one fundamental difference, and it is one which makes television very much more complex than sound broadcasting. This difference is the necessity for scanning.

If it were necessary only to transmit changes in the intensity of light, no real difficulty would exist. Changes in light intensity can easily be converted into changes in an electric current, or can be made to produce a current which is proportional to the light, by allowing the light to fall on a suitable type of photo-cell. Once the current variations are secured, the process could follow the normal lines of sound transmission and cause the carrier amplitude to vary in sympathy.

## Variations in Light Intensity

On the receiving side, too, the apparatus would be similar to the ordinary broadcast set, but the output would be used to make the brilliancy of, say, a neon tube vary in accordance with the carrier modulation. Television would in these circumstances involve no more than replacing the microphone by a photo-cell and the loud speaker by a neon tube.

Unfortunately, a picture cannot be transmitted in any such simple manner. Light variations have to be transmitted,

it is true, and some process analogous to the above is actually adopted. It is necessary to transmit more than mere variations in light intensity, however, and it is just this something more which creates ninety-nine per cent. of the difficulties of television.

In order to see what is required, let us take one of the simplest possible cases. Suppose we wish to transmit a picture which is in the form of a transparency—that is, a piece of cinema film. If we place a lamp on one side of it and a screen on the other, and use a suitable combination of lenses, we can project the picture on to the screen as in the cinema or

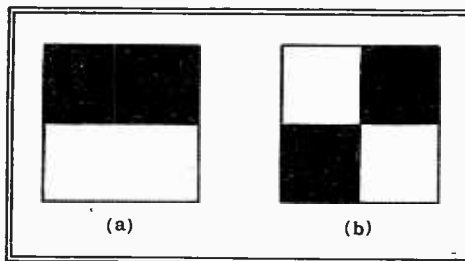

Fig. 1.—Two simple "pictures" for the transmission of which an elementary scanning system can be used.

"magic-lantern." With a different arrangement of lenses we can obviously reduce the size of the picture instead of enlarging it in the usual way, so that the image on the screen is much smaller than the transparency. It is obvious that it will still be a complete picture, and all the detail will be there.

Now, if we make this image small enough, we can substitute the sensitive surface of a photo-cell for the screen, and we have our picture on the end of the cell. The cell then causes a current to flow in the external electrical circuit which is proportional to the total amount of light falling on it, and to nothing else.

If our picture is of simple type, such as one black oblong and one white, as in Fig. 1 (a), each of half the picture size, it is clear that, as black is the absence of light, the light falling on the cell will be the amount passing through the white oblong. The current will be proportional to this amount of light. Now, suppose that the picture is of the form shown in Fig. 1 (b); it is of the same size, and the total area of the two black squares is the same as that of the black oblong in (a), while the area of the white squares is the same as that of the white oblong. The

amount of light passing and falling on the photo-cell will be the same in the two cases, and hence the current will be the same. There is nothing electrically to distinguish between the two pictures.

If a lamp be arranged to have its brilliancy controlled by the photo-cell current it can obviously illuminate a screen, and any shade between black and white can be obtained by varying the current, and hence by varying the light on the photo-cell. If the transparencies used at the transmitter are quite plain but of varying degrees of shade, perfect reproduction will be obtained. When a blank clear piece of celluloid is put in, the receiving screen will be brightly illuminated; when a blank grey transparency is used, the receiving screen will be grey, and when an opaque substance is inserted the receiving lamp will go out and the screen will be black.

## Elementary Scanning

Suppose we call half-illumination grey. Then, when either of the designs shown in Fig. 1 is put into the transmitter, the receiving screen will be blank but grey. It will be evenly illuminated to correspond with the total amount of light passing through the transparency, but there will be no detail at all.

Now, if we use four photo-cells at the transmitting end, and arrange that only the light passing through one-quarter of the picture falls on each, it is clear that we can have four lamps at the receiver, each illuminating one-quarter of the screen. If each photo-cell is connected to a lamp which is placed to illuminate the correct quarter of the screen, it is clear that such simple designs as those of Fig. 1 can be transmitted.

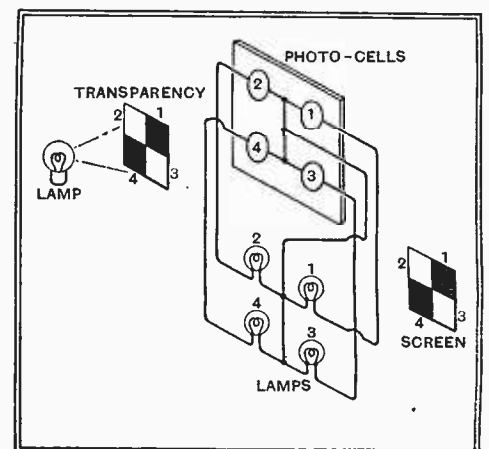

Fig. 2.—A method of transmitting and receiving extremely simple pictures. As explained in the text, only diagrams such as those of Fig. 1 can be dealt with.



# Television

## AN AUTOMATIC JIG-SAW PUZZLE

Suppose we insert the design in squares as in Fig. 2. The light from the lamp shines through the transparency, and the light passing through each of the four squares falls on its correspondingly numbered cell. The cells are connected to four lamps which glow in accordance with the photo-cell current. It is clear that no light passes through square 1, hence no current flows from cell 1, and lamp 1 is dark, and gives no illumination on square 1 of the receiving screen. Similarly with square 4, cell 4, and lamp 4. With squares 2 and 3, however, light passes and the cells pass current to lamps 2 and 3 and illuminate squares 2 and 3 of the receiving screen. It is clear also that the oblong design of

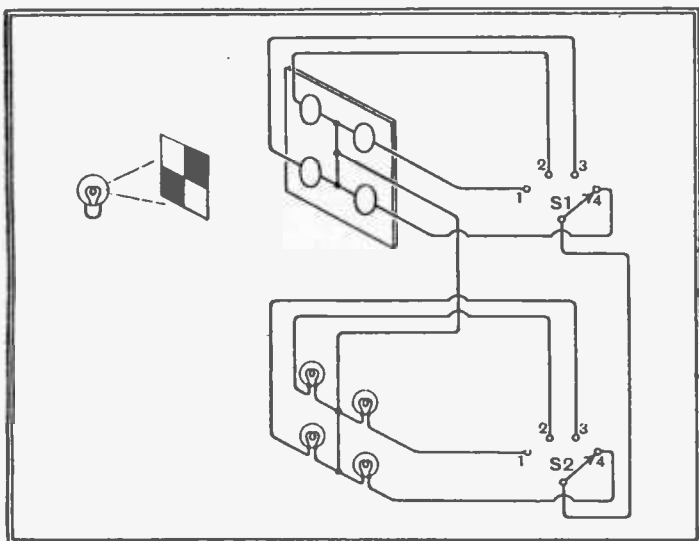

Fig. 1 (a) can also be reproduced by this means, and if it were inserted, squares 1 and 2 will be black and 3 and 4 light.

Now, it is not necessary that all cells be connected to their respective lamps the whole time, for, owing to the retentivity of the eye, it is possible for the current to any or all lamps to be interrupted without there being any visible effect, provided that the time of the interruption is sufficiently short. It is consequently possible to replace the multiple connections between the cells and lamps of Fig. 2 by the two wires of Fig. 3 if suitable switching is introduced. It can be seen that if contact 1 on S1 is closed when contact 1 on S2 is closed, and so on, each photo-cell is connected in turn to its appropriate lamp, and if the switches are rotated sufficiently rapidly and continue time after time to sweep over the contacts, the appearance of a continuous picture will be obtained.

This is at the base of scanning, which is an essential part of television. With the "magic-lantern" a picture is thrown on to the screen, and it remains there the whole time. In the cinema a series of pictures is thrown on the screen, each very

A raster photographed on the end of a cathode-ray tube. The individual lines cannot be seen, but the frame fly-back lines are apparent. These disappear when a picture is received.

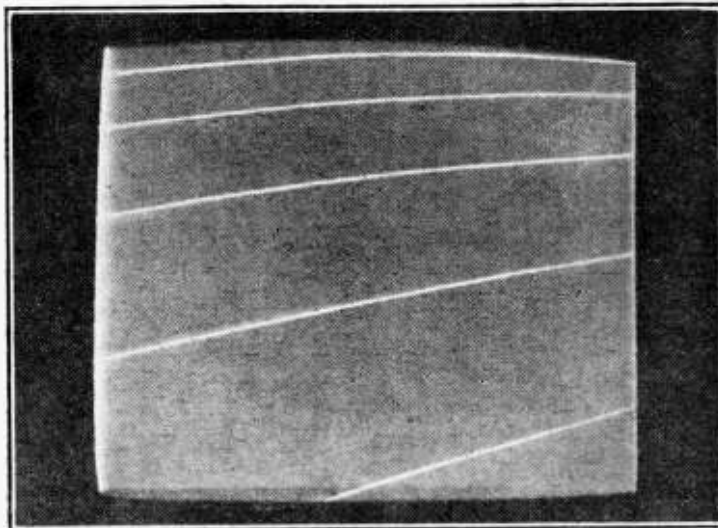

Fig. 3.—Owing to retentivity of vision, the number of connecting wires in the arrangement of Fig. 2 can be reduced to two only by adopting switching.

slightly different from its predecessor. Each picture is thrown on the screen as a whole, but there are slight gaps between successive pictures of which the eye is unaware if there are sufficient pictures a second. In general, at least twenty-five pictures a second are needed if the deception is to be complete and flicker avoided.

### Practical Television

In television we cannot even throw a complete picture on the screen instantaneously. We are only able to transmit changes in light intensity, so that we have to break up the picture in little bits, transmit the light intensity of each little bit in turn, and then reassemble them in their correct order at the receiver. All this must be done in one-twenty-fifth of a second!

Each little bit into which we break up the picture must be transmitted as a uniform shade corresponding to the average depth of this portion of the picture. If the picture over this area is also of a uniform shade, this is no drawback, but if it really involves a change of depth, as when the transition from black to white happens

to occur in one of these bits, then distortion is present, for this area is reproduced as a uniform shade between the two originally making it up. Because of this, sharp outlines in a picture tend to become blurred; instead of a sharp transition from black to white the one may merge into the other through a boundary of grey.

It is clear that the definition of the picture will depend upon the number of little bits, or elements, into which we can

break it up. With one element, that is, an attempt to transmit the picture as a whole, we obtain no detail at all nor any recognisable picture. With an infinite number of elements a perfect picture would be obtained and the received picture would be in no way inferior to the original.

In practice, we have to be content with a finite number of elements, which means that the picture must in some degree be imperfect. Whether the imperfections are visible as such to the eye or not depends largely upon the size of the picture. We all know that the ordinary half-tone illustration will not bear examination through a magnifying glass because it is actually made up of a large number of little dots. The eye does not see these in the normal size of the picture but readily detects them when an attempt at enlargement is made. In the same way, a larger number of elements are needed in television for a large picture than for a small if the apparent quality is to remain the same.

In practice, it is neither convenient nor necessary to break up the picture into a number of dots in the manner of a half-tone; it is sufficient to break it up into a series of parallel lines. One of the simplest of scanning methods to understand is one which is widely used in experimental apparatus and it employs the cathode-ray tube at both transmitter and receiver. This is not the place in which to describe the cathode-ray tube in any detail, and it is sufficient to say that it is in many respects analogous to the valve. Types employed in television have a high vacuum and the flattened end carries a fluorescent screen upon which the picture appears. The tube contains a number of electrodes to which suitable, and usually

**Scanning in Television—**

high, voltages are applied, and the result is that a thin pencil of electrons travels the length of the tube and strikes the fluorescent screen. The screen consequently fluoresces in the immediate vicinity of the impinging electrons and a

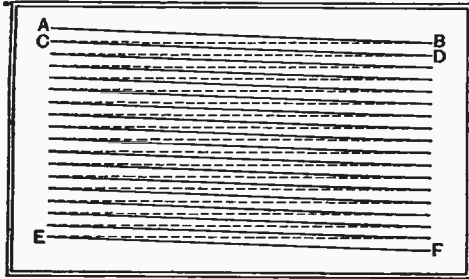

Fig. 4.—This diagram illustrates the way in which a raster is built up.

spot of light appears. The size and sharpness of this spot of light can be controlled by adjusting the voltages applied to the tube and its intensity can be regulated by varying the voltage applied to a control electrode which is usually termed the grid. Merely by varying this voltage the spot intensity can be varied continuously from full brightness until it is extinguished.

The screen of a tube may be 12in. or so in diameter, while the size of the spot may be no more than 0.025in. in diameter, so that at any instant it illuminates only a minute portion of the total area of screen. The position of the spot on the screen is readily controllable, for the electron beam can be deflected electro-statically by applying voltages to deflector plates built into the tube or electro-magnetically by passing currents through coils suitably mounted around the tube.

Now if we apply a voltage to the horizontal deflecting plates which increases linearly with time, it is easy to see that the spot will move steadily across the screen. If the voltage is then reduced to zero almost instantaneously, it will fly back to

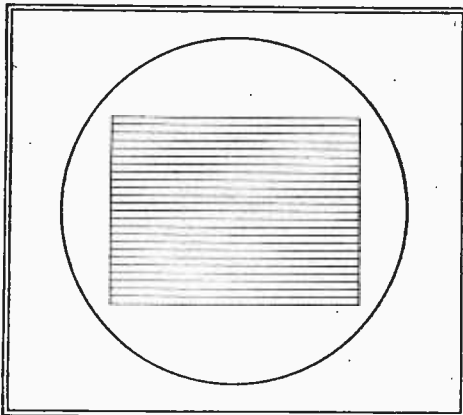

Fig. 5.—The complete raster appears very much as shown in this drawing, but the number of lines actually used is so much greater that they are barely visible.

its original starting point, and if the voltage again rises it will again move across the screen. It is easy to see that if this process is carried out sufficiently rapidly a luminous line of light will appear on the screen—a line which is actually merely a

moving spot, but which the eye cannot detect as such.

Now if in addition to this we apply a similar voltage, but one which rises in value more slowly, to the vertical deflecting plates, the path of the spot will be different. Referring to Fig. 4, the spot will now trace out a line AB which is slightly sloping and the rapid fly-back at the end will no longer return it to the start A, but to a point C immediately beneath it. The second line traced by the spot is consequently not coincident with the first, but is the new line CD immediately beneath it and parallel with it.

**Building up the Raster**

In this way, it is easy to see that the spot can be made to traverse a rectangle on the screen in a series of parallel lines and that if the speed of the spot is sufficiently rapid it will appear as though the whole rectangle were illuminated. When the last line EF has been traced, both the vertical and the horizontal voltages fall to zero and the spot returns to A to start tracing out a new series of lines coincident with the first.

In television terminology, the number of horizontal lines traced by the spot in the rectangle is known as the number of lines in the picture or frame. The number of times the rectangle is completely covered by the spot in one second is the picture or frame frequency, while the rectangle itself is called the raster.

A raster photographed on a tube. The number of lines has been greatly reduced so that the formation is clearly seen. The frame fly-back line can be seen, but the line fly-back is too rapid to show.

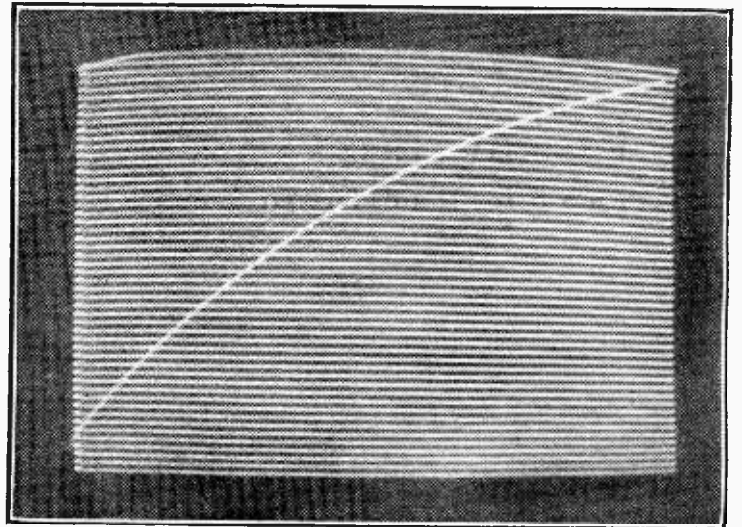

Whether or not the lines composing the raster are visible as such depends upon their number, upon the size of the frame and upon the distance from which it is viewed. Under average conditions they are barely detectable when there are more than 240 lines.

Let us now consider the case of transmission. We can set up a raster on the screen of a cathode-ray tube and it will appear somewhat as in Fig. 5. If we now place a cinema film in front of the screen we can obviously see the screen only through the film and we shall see the picture against the illuminated background of the raster. If we replace our eye by a photo-cell so that the arrangement of apparatus is that shown in Fig. 6, the light from the screen will, after passing through the film, fall upon the photo-cell and set up a current proportional to it in the electrical circuit.

Now the photo-cell differs from the eye in one particular: it sees the raster as it truly is—a flying spot of light—and not as the eye does as a solid evenly illuminated

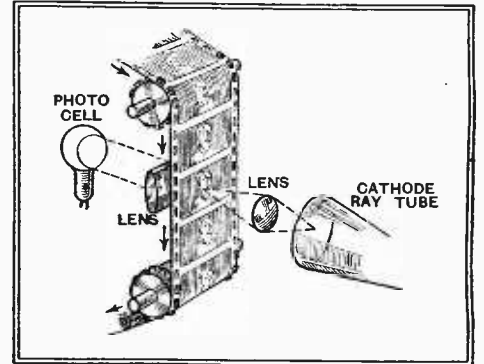

Fig. 6.—One method of scanning in transmission is shown here.

rectangle. As a result the amount of light reaching the photo-cell is continually varying. As the spot crosses the screen in its process of building up the raster, the light from the screen which passes through the film to the photo-cell is also moving across the picture on the film. On a light part of the film, nearly all the light passes and the photo-cell current is large; on a

dark part, hardly any passes and the photo-cell current is small.

In this way, the picture is divided up into strips and the varying light and shade in each strip is converted by the photo-cell into variations in an electric current. At the receiving end, this current sets up a voltage which modulates the beam of the cathode-ray tube, making the spot of light on the screen vary in intensity in accordance with the variations in the original picture. It is then easy to see that the picture will appear on the screen of the receiving tube provided that the spot of light is flying over the screen in exact accord with the spot of light in the transmitting tube. In other words, exact synchronisation of transmitter and receiver is essential. If synchronisation is not maintained, there will be no picture, for, although the spot of light will be brightening and darkening correctly in accordance

**Scanning in Television—**

with the dictates of the transmitter, the relative positions of the different points of lightness and darkness will be wrong.

In practice, other transmitting methods are often used, but the basic principle of scanning is the same as the method described here.

It is often convenient to think of the raster as a whole, for this way it is visible, but it must never be forgotten that it is never actually in existence. The raster is in reality nothing more than the visible result of a single small spot of light which is performing the complicated evolutions which have been described. It has to cover the whole picture in  $1/25=0.04$  second and one line in  $0.04/240=0.000166$  second; with a picture ratio of 4:3 and allowing as much detail in the horizontal as in the vertical direction the spot can be considered as lying on any point for only  $1/320$ th of a line, or  $0.000166/320=0.000,000,5$  second.

The flying spot of light which builds up the picture in the receiver and which causes the electric current to vary in sympathy with the detail of the picture in the transmitter thus rests on any point for no more than one-half of one-millionth of a second! It is consequently not surprising that one of the major difficulties in the past has been to obtain adequate illumination.

## Safety Precautions

### Specification for Mains-Driven Sets

**U**NDER the self-explanatory title of "British Standard Specification for Mains-Operated Apparatus for Radio, Acoustic and Visual Reproduction (Safety Requirements)," a booklet has just been issued by the British Standards Institution.

At the outset, it should be pointed out that these "Specifications," though often referred to loosely as "Regulations," do not carry the force of law. Nevertheless, they do carry considerable weight, and the present publication represents the labours of a committee on which there was direct representation of such bodies as the Post Office, the Home Office, the B.B.C., the Institution of Electrical Engineers, the R.M.A., and the R.S.G.B., etc.

Since the preparation of the last specification dealing with safety precautions in mains-operated apparatus, many important changes have taken place. In 1931, when B.S.S. 415 was issued, most mains-driven sets were worked through the intermediary of battery eliminators instead of by built-in power units, and high-definition television had not been developed commercially. These and other changes have all been taken into account, and the specification now deals with AC, DC and AC/DC apparatus of the types specified in the title.

Safety precautions are, of course, intimately linked up with the questions of enclosure and isolation. Rules for enclosure are comparatively simple, as they are more or less common to all types of apparatus, but the question of isolation is more compli-

cated, depending as it does on the nature of the supply mains. For instance, it is laid down that terminals for pick-ups, etc., in AC sets need not be isolated from the wiring if they are metallically connected to the earth terminals or if they are not live ("live" is defined as at a potential with respect to earth, but for the purposes of the specification, the object is not considered to be live if (a) its potential above the maximum of 50 volts is derived from a dry battery, or (b) if the maximum current which can flow in the event of a short-circuit to earth is limited to 5 milliamperes). In DC and AC/DC sets, pick-up terminals must be isolated by means of double-wound trans-

formers or by condensers of not more than 0.01 mfd. capacity.

Permissible temperature rise, which is expressed as a maximum rise above room temperature, depends on the material of the case, being highest for metal and non-ignitable substances.

In order to determine the accessibility of live parts, a special form of testing prod, described as a "Standard Finger," which simulates the shape and size of the human finger, has been devised.

Copies of the specification, which cost 2s. each (by post, 2s. 2d.), are obtainable from the British Standards Institution, 28, Victoria Street, London, S.W.1.

## Railway Signalling by Wireless

**T**HE development of ultra-short wave technique has led to a considerable increase in the number of special applications of radio for communication over short distances in cases where it would not be possible or convenient to use a wire link. One of the latest of these applications is in connection with railway shunting.

In large shunting yards, communication between the official in charge and the engine-driver has always been a matter of some difficulty, but the problem seems to have been completely solved by a wireless signalling system which has been installed at the shunting yards at Malmö in southern Sweden by the Aga-Baltic Co., of Stockholm.

The actual transmitter is installed alongside the track, and the ordinary overhead electrical distribution cables are used for an aerial. Control boxes are placed in different parts of the shunting yards so that the official in charge can direct the engine-driver from the position which happens to be the most convenient at the moment. There are four principal orders used in shunting work, and to save time these are given by means of

coloured lights in the cab of the engine.

There are four buttons at each control box and by means of these the audio-frequency modulation impressed upon the carrier-wave is varied to correspond with the constants of any one of the four signal-lamp circuits. There is a fifth circuit to enable ordinary spoken orders to be given when necessary via a control point and a loud speaker on the



The transmitter is installed in a special housing alongside the track. On the left the shunting official is seen using one of the special control boxes to communicate with the engine-driver.



engine. When any of the four signal lights are used, the engine-driver's attention is attracted by an audible note from the loud speaker.

The apparatus has been used in conjunction with steam locomotives and also electric ones, using the overhead type of energy connector. No difficulty has been experienced in eliminating electrical interference in the case of the latter. So far, the installation has been a pronounced success and its use is likely to be extended to other yards.

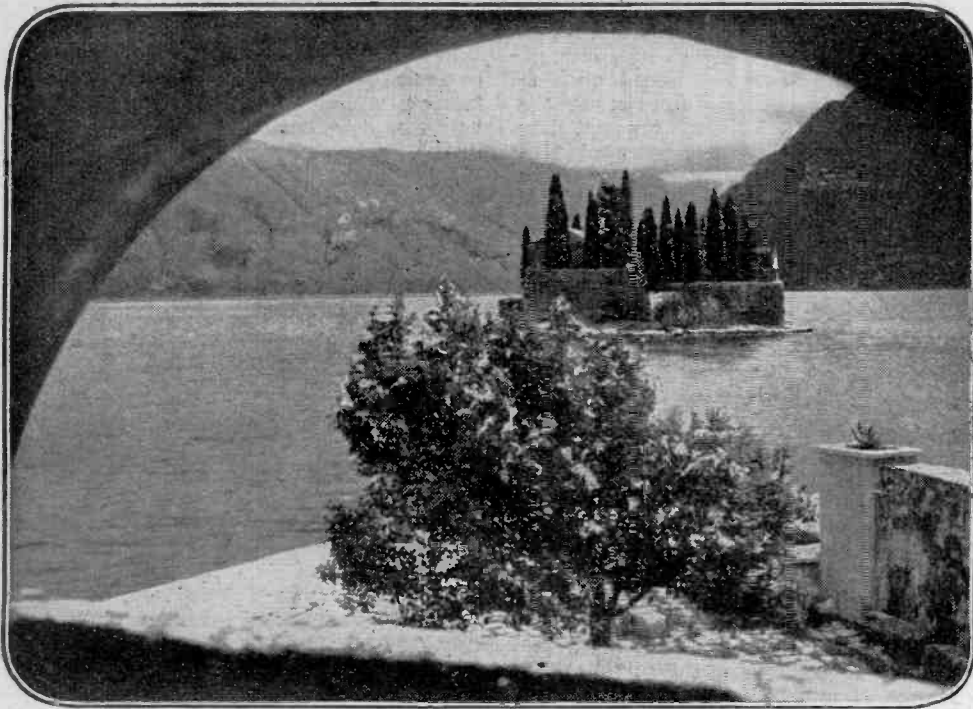

In the Bay of Kotor, Dalmatia.

**W**HEN I set out some time ago for a long journey through a number of European countries I had some misgivings that if I took a portable receiving set with me I should experience some exciting moments with strange-looking and foreign-speaking frontier guards. Previous requests for information about the treatment of travellers with portables at various Consulates and even Embassies mostly resulted in shrugs and the wise counsel that I had better leave the set at home if I wanted a pleasant trip, as some Customs officers might look upon the instrument as a bomb, or in any case there might be difficult formalities.

I already saw my set lying at some frontier station carefully tied with that special string Customs have and well sealed while I watched the tail end of my train vanish in the distance.

Looking back I smile. In some countries there are no regulations regarding portable sets. I may or may not have been the very first case. In one country I certainly was the very first portable user to come to the notice of the postal authorities, and here I really "blazed the trail," as travellers with portables will in future be handed a temporary licence, and will not have to go either as pirates or pay for listening for a period of three months. In another country where, according to regulations, the Customs ought to have demanded a deposit of the duty, and where the set should have been sealed until the arrival of a licence from the postal authorities, the officials were really human, turning an entirely deaf ear to my declaration that this was a radio receiver, and they abruptly turned their backs on me when I tried to insist. For obvious reasons I am unable to disclose the name of this country; it is unlikely that anybody would ever go there with a portable from Britain, and if they did they would no doubt be treated in the same friendly, if unofficial, manner.

But, in spite of my happy experiences, I should strongly advise getting really first-hand and up-to-date information regarding a portable or car receiver before starting on any extensive tour of Europe. Given time, the Consular authorities will write home and find out, or the central postal authorities will answer an enquiry very promptly. In Turkey, for instance, there are very stringent regulations, and the set will either be sealed or duty more than the value of the set must be paid. I have never been to Turkey, but from what I hear of their officials they are all

# Wireless

## BLAZING THE TRAIL FOR PORTABLES

By "WANDERING WAVE"

most painstaking, and not at all easy-going.

Yugoslavia, now a popular holiday country for Britishers, only requires a Customs certificate that the set has been brought in. One then goes to the post office, at the first stop, with this and registers the receiver—free of charge. Listening is then free for three months. If one stays longer, the duty must be paid and a proper licence taken out. In Austria, now famous for winter sports where many readers may be going this season, the Customs look upon your receiver as part of your personal baggage. Listening is allowed for one month after passing the frontier without further formality. It suffices to show your passport with the date stamp of the frontier station if the authorities should come to check. If one wishes to remain more than one month a short-term licence can be taken out for two or up to a period of three months. This costs the ordinary fee of two shillings per month and an extra



In a Hungarian wayside inn a portable set is really a novelty.

# s Personal Luggage

Austrian shilling for the licence. In Germany portable owners on a short stay and car receivers require a licence taken out at the first convenient post office. Price: Rm. 2 per month.

There are other countries in Central Europe with similar arrangements.

Why take a portable? I was often asked this question. The ordinary listener will probably never bother to carry a



"I logged Warsaw on the Fisherman's Bastion overlooking the Danube in Budapest."



Droitwich received in a wine-cellar in Vienna. Note the manner in which wine glasses are filled.

heavy receiver (and most portables are heavy) in addition to his other luggage, especially as hotels usually have some provision for listening-in nowadays. But there is the case of the car receiver, and also of the man who goes farther afield into a country where newspapers in an understandable language arrive too late to be of interest. With a portable one can tune in a home station at night and get the news quickly. I happened to be away at the time of the devaluation in France and Switzerland, and was grateful for the chance of listening to the news in a language I could understand, because even the best waiter or hall porter will not translate the essentials properly out of the local paper.

Reception results largely depend on the type of receiver. I chose the newly produced German "Olympia" portable, as I found it to have the most convenient shape and weight. It is flat like the old type of Remington portable typewriter, and not

caused interference. In Yugoslavia train reception was possible. My car was either fitted with anti-interference gadgets or else, perhaps, the dynamo did not operate in the daytime.

Using the metal bodywork as an earth and myself as an aerial I got excellent reception of Budapest in a car going at a speed of 60 miles an hour at a distance of about ten miles from the transmitter. As it was an open car I soon discontinued the experiment. At noon one day I logged Warsaw on the Fisherman's Bastion overlooking the Danube in Budapest, and got Droitzwich in the cellar of a "Heurigen" wine inn in Grinzing (Vienna).

Speaking generally of my reception experiences, I found that I could always rely on the German stations, and farther south-east down the Danube the Italian stations came in reliably. With the exception of Droitzwich, in Vienna I was unable to log a single B.B.C. station. Either they were blotted out by powerful

much larger, and weighs 8.5 kgs. with batteries. The inconvenience of having to lay out an aerial and use myself as an earth or any convenient body of metal nearby was outweighed by the strength of reception. The set has four valves, and is a straight two-circuit receiver with a tiny moving-coil speaker. In the trains in Germany reception was only possible at the stations, as the dynamo of the car

German or Italian stations or were inaudible. In Sofia, where I used a local receiver, Daventry came rolling in on the short waves. Scottish National and London Regional came in later on the same set, a powerful five-valve superhet. with special aerial, but they were badly marred by atmospherics, whereas Breslau and even Hamburg romped in like locals.

## Wireless Aids Aircraft

THE Air Ministry investigations into the various "blind" landing systems for aircraft have now reached the stage of practical tests, and three different systems have been installed at Croydon Aerodrome.

In broad outline the working of these "blind" landing systems is as follows: There are three different beams; the first, a horizontal one, gives a well-defined path of approach to the aerodrome from a distance of 10 to 15 miles. For this a wavelength of 9 metres is used. The second beam is a vertical fan-shaped one situated between 1½ and 2 miles from the aerodrome. Having passed this the aircraft continues to fly along the horizontal beam, until, at a distance of about 300 yards from the landing ground, a second vertical beam is passed. These vertical beams both operate on a wavelength of 7.89 metres.

The systems being tested are suitable for conditions in which the visibility is so poor that the ground cannot be seen at a height of 50ft. It is hoped that further developments will enable these systems to be employed under the very worst conditions. The Air Ministry emphasises that, at present, the three systems, supplied respectively by Standard Telephones and Cables, Ltd. (Lorenz), the Plessey Co., and Marconi's Wireless Telegraph Co., are being used for experimental purposes only.

# Transmission Lines

A FORM OF "TUNED CIRCUIT" WITH A NUMBER OF INTERESTING APPLICATIONS

**N**OW that general interest is turning more and more towards shorter and shorter waves, it is becoming really necessary to understand how they work. As waves change only in length and not in nature as they become shorter, the same principles apply to them as to any others. There is no definite boundary between long and short or very short waves. The reason why they appear to behave differently is that phenomena slight enough to be neglected at one wavelength are predominant at another. If a tuning coil and condenser for long waves are connected up by leads a foot long, one can reasonably regard the inductance and capacity of the circuit to be concentrated in the coil and

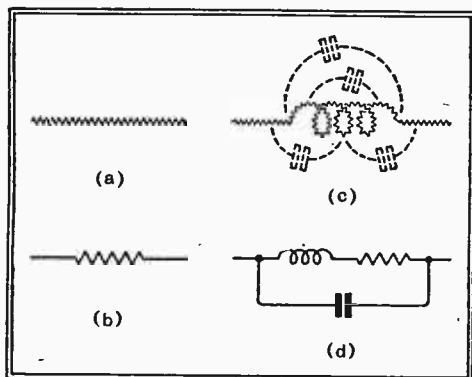

Fig. 1.—The resistance of a piece of wire is distributed throughout its length, as indicated by (a); but in a circuit diagram if any account were taken of the resistance at all it would be shown as a concentrated resistor connected by non-resistive wires (b). And any coil is a mixture of inductance, resistance, and capacity as suggested by (c); but can be considered more simply as a system of unmixed quantities (d).

condenser rather than in the leads. The coil is a lump of inductance and the condenser is a lump of capacity, to put it crudely. But when the wavelength is very short the inductance and capacity contributed by the leads can certainly not be neglected, nor can they be regarded as concentrated at any particular point. They are *distributed*.

How much more, then, is this so when still longer wires are used—for aerial and earth connections, say. It can be taken as a rule that a lead is "long," i.e., has important amounts of distributed capacity and inductance, when it is an appreciable fraction of the wavelength. A wavelength of 1,500 metres, for example, being approximately one mile, there is no need to worry about a few feet. But 5 metres is only about 16ft., so an aerial lead-in may even be several whole wavelengths.

At first sight it might not appear that distributed quantities introduce any great complications, because, after all, resistance is distributed throughout the length of a wire, and, nevertheless, the circuit diagram picture of a lump of resistance joined up by means of resistanceless wires is quite equivalent for purposes of reckoning. Even when the wire forms a coil, so that resistance and inductance are dis-

By

M. G. SCROGGIE, B.Sc.,  
A.M.I.E.E.

tributed among one another and completely mixed, it is perfectly allowable to think of them as a resistanceless coil in series with a non-inductive resistor. The thing is not quite so simple with the distributed capacity of a coil, but when (as in all practical examples) it is small, it can be assumed to be due to a fixed condenser in parallel with the coil (Fig. 1).

Things are not at all so easy when one considers a "long" wire. Every section of it, however small, has some inductance and some capacity to earth or to the return lead. Even if it is divided up into only two or three sections, each of which is looked upon as a "lumped" capacity and inductance (Fig. 2), it is obviously quite a difficult problem to calculate the single quantity that could be connected across the terminals AB so as to be equivalent.

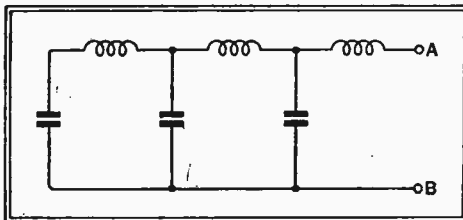

Fig. 2.—A very rough equivalent of a pair of parallel wires. The inductance and capacity are considered as concentrated in three separate sections.

And when you have done it, the result only holds good for one particular frequency.

If the wire is subdivided into a larger number of imaginary sections in order to get nearer to the actual thing, the calculation becomes still more perplexing. But when the number of sections is made infinitely large—which is exactly what we want for depicting real life—it is a relatively simple mathematical problem, but not quite simple enough to expound here. What is more important is to visualise the

*AS the author points out, ordinary lead-in wires are generally impracticable for certain types of short-wave aerials, as the length of the lead-in might well amount to several wavelengths. Transmission lines or "feeders" are necessary in order that the associated apparatus may be conveniently placed with respect to the aerial.*

action of such a system. Transmission lines or "feeders" are a practically necessary part of any short-wave station, for it is inconvenient to install the receiver (or transmitter) in mid-air, and inefficient to bring the aerial right down on to the apparatus. How do the connecting wires affect the circuit, apart from joining it to the aerial? Is there a likelihood of serious loss or mistuning?

The answer is that if things are properly arranged the feeder need have practically no effect on the circuit, but that if it is not properly arranged it can have most undesirable and disturbing effects.

## Parallel Feeder Wires

In order to be able to derive any simple general principles it is necessary to start by assuming that the there-and-back lines are parallel. Things become very much more complicated otherwise. There are two practical forms of the parallel line—two similar wires or rods mounted side by side, and a wire, rod, or tube mounted centrally inside a larger tube. The minor differences between these will be explained later; their fundamental principles are the same.

A few things fairly easy to see without any mathematical working. If the line has nothing connected at the far end, and is very short (compared with a wavelength), and particularly if the wires or tubes are close together, it forms a condenser. The leads to a component, if run closely parallel, have the effect of a small

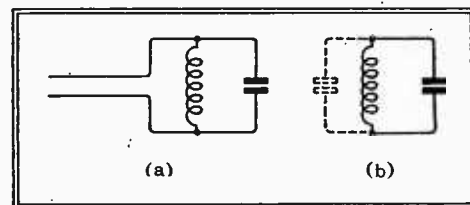

Fig. 3.—A short length of open parallel line connected to a circuit as at (a) is equivalent to a condenser (b).

capacity across the component (Fig. 3). But if the line is short-circuited at the far end, and particularly if it is widely

**Transmission Lines—**

spaced, it is equivalent to an inductance. It is, in fact, a single-turn frame aerial (Fig. 4).

The closer together, the more the capacity; the farther apart, the greater the inductance. Now, wavelength is closely related to inductance L, multiplied by capacity C. You know the famous formula:  $wavelength = 1,885 \sqrt{LC}$ . In a parallel line these two things, L and C, are

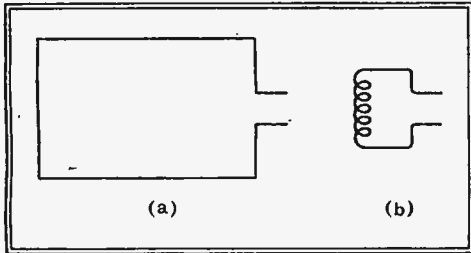

Fig. 4.—A short closed line (a) is equivalent to an inductance (b).

so related as to produce a result that is much simpler than one would have expected. It turns out that when the resistance and leakage are comparatively slight (which is what one naturally tries very hard to bring about), the product LC depends entirely on the length and not at all on the distance apart of the wires. When the wires are placed farther apart, the loss in capacity exactly balances the gain in inductance, and vice versa. It is familiar, of course, that one can tune to a given wavelength by using any one of an infinite number of combinations of L and C that make  $L \times C$  up to the right amount for that wavelength. It is necessary to find a combination by calculation, measurement, or trial, and sometimes it is quite a long job. But a transmission line ("transmission" does not imply distinction from reception, but is just the technical term for this sort of line) is actually far simpler, because one merely cuts off a length proportional to the wavelength.

The equivalents of a rejector circuit (L and C in parallel, giving a very high resistance at the wavelength of resonance), and an acceptor circuit (L and C in series, giving a very small resistance at resonance) for open and closed lines of various lengths, can easily be seen from Fig. 5. And it is also easy to see how to extend the scheme to longer lines.

**Direct Wavelength Measurements**

This information can be further illustrated by an example or two. Take the very first line shown. If you make an exaggerated wire hairpin, five feet long, you can substitute it for a parallel tuning coil and condenser, and it will resonate at  $4 \times 5ft.$ , which is 6.1 metres. In fact, this is the basis of a useful method of measuring wavelength. An oscillator is tuned until the "hairpin," when it is connected across a few turns of the tuning coil, makes no difference to the wavelength of the oscillator, which is then 6.1 metres. By short-circuiting the parallel wires at

other distances, other wavelengths can similarly be checked.

This otherwise delightful method is unfortunately subject to certain errors. If the wires are far apart they are liable to be influenced by other objects—or bodies, as the textbooks gruesomely delight to call them. None should be allowed within several line widths at least (Fig. 6). Then the simple calculation is also somewhat invalidated by the length of the shorting connection at the far end of the line being appreciable in comparison with the length of the line itself. On the other hand, it is essential for the wires to be very exactly parallel, and if they are close together it is difficult to make them so, because a small inadvertent displacement is then an appreciable fraction of the total spacing.

There are two important characteristics of a resonant circuit that we have not yet considered in relation to a transmission line. There is what is generally known as the "Q"—the ratio of reactance to resistance—which is a measure of the sharpness of resonance or the selectivity.

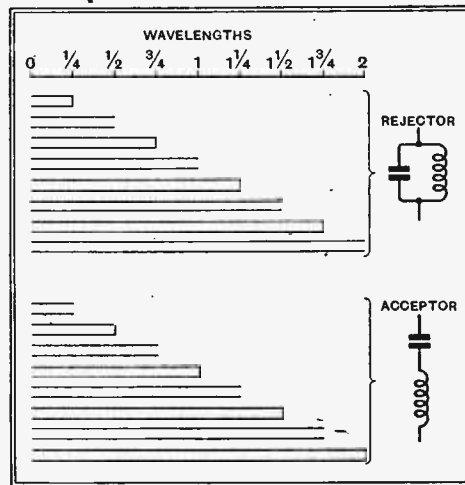

Fig. 5.—The various lengths of parallel line equivalent to acceptor and rejector resonant circuits. The diagram could be extended indefinitely to show longer lines, for the same conditions recur every half-wavelength.

In this respect a transmission line is similar to any other tuned circuit; but it is interesting to know that extraordinarily high values of Q can be reached. A good figure for the ordinary coil-and-condenser combination is 100, and 200 is exceptional. A graph given in a paper on "Frequency Control by Low Power-Factor Line Circuits" shows Q's up to 52,000! And these are for the very shortest wavelengths, at which great difficulty is experienced in minimising losses in the ordinary ways. To obtain anything like this it is necessary to adopt the concentric construction, with massive copper tubes of large diameter (Fig. 7). When one is exhorted to search for efficiency in short-wave work by keeping within small dimensions, it is interesting to observe that the ultra-efficient circuits compare in size with naval guns so large as to be prohibited by the Washington Treaty. This effort is worth while in cer-

<sup>1</sup> C. W. Hansell and P. S. Carter, Journal I.R.E., April 1936.

tain walks of life, because such extreme selectivity is most valuable for stabilising the frequency of ultra-short wave transmitters. Quartz crystals, commonly used for the purpose, become increasingly difficult to apply as the wavelength is

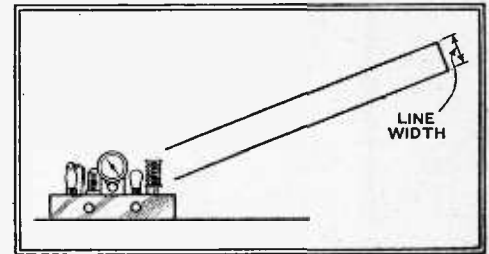

Fig. 6.—When the parallel wires of a resonant line are far apart it is difficult to keep everything, including the operator and other parts of the apparatus, outside a radius of several widths. Proximity of such objects introduces disturbing effects on the wavelength.

shortened; whereas the reverse is true of these cylindrical transmission lines.

Cylindrical "lines" have also been adapted recently by the American Bureau of Standards for receiver tuning. Using them as interval couplings in four stages an amplification at 200 Mc/s ( $1\frac{1}{2}$  metres) of no less than 200,000 has been obtained.

**"Metallic Insulators"**

Another rather startling application is the so-called "metallic insulator." The higher the Q the higher the resistance to which a circuit is equivalent at the wavelength of resonance (and the lower the resistance at other wave-lengths). The resistance of a suitable quarter-wave line is so high that it is actually superior to any ordinary sort of insulator, and is preferred for that purpose!<sup>2</sup> Insulating materials account for increasingly serious losses as the wavelength descends into the

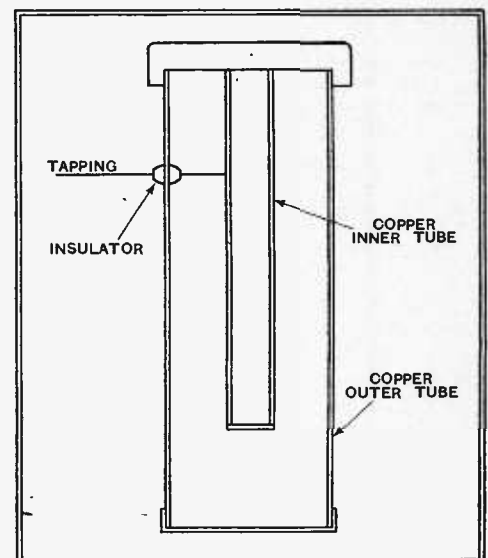

Fig. 7.—Section of tubular "line" of the type used for stabilising the frequency of ultra-short wave transmitters.

<sup>2</sup> "Development of Transmitters for Frequencies above 300 Megacycles," N. E. Lindenblad, Journal I.R.E., Sept. 1935.

**Transmission Lines—**

ultra-shorts. Another advantage (for fixed wavelength working) is that the line is insulated only for the desired wavelength; all others are short-circuited to earth.

The other variable factor that fixes the characteristics of a line is the width or spacing. It has already been explained that this is equivalent to the  $L/C$  ratio in an ordinary tuned circuit. Of the innumerable combinations of  $L$  and  $C$  that can be adopted for tuning to a given wavelength, the higher the ratio  $L/C$  the higher the impedance. A widely separated pair of wires corresponds to a large coil tuned by a small capacity. It is not purely a matter of spacing; it is obvious that for a given separation the concentric tubular type has a higher capacity than a pair of thin parallel wires.

In transmission line calculations a rather special quantity is used—the so-called characteristic impedance. It is equal to  $\sqrt{l/c}$ , where  $l$  and  $c$  are the inductance and capacity per unit length

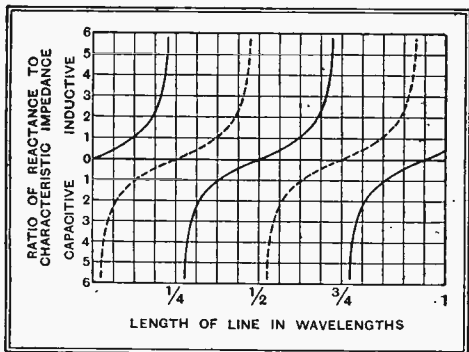

Fig. 8.—Curves showing the equivalent reactance of a short-circuited (full) or open (dotted) line of varying lengths.

(foot, metre, etc.). It is not the impedance of the line itself as might be supposed, for that depends on the length, but is the resistance of the load which it can be used to supply with maximum efficiency.

Before explaining this important point it would be advisable to finish considering the behaviour of the line itself. Examples have so far been confined to the first in Fig. 5—the closed quarter-wave type. At intervals of half a wavelength the same rejector resonance recurs. Half-way between these, and also at half-wave intervals, it becomes an acceptor. As the length is adjusted between one of these critical distances and the next, the line behaves as a capacity or inductance, covering all values from zero to infinity. Fig. 8 shows how these electrical characteristics are related to the length. When the curves go off the paper to infinity the line becomes a rejector, with very high resistance; when they cross the zero line it becomes an acceptor, with very low resistance. So a short-circuited line may sometimes play the part of an open circuit, and vice versa.

Now to deal with characteristic impedance. It is well known that if two pieces of electrical apparatus that are in any way related as generator and load are

to work efficiently together they must be *matched*. A 5,000-ohm power valve does not work to best advantage when it feeds a 5-ohm loud speaker. To obtain proper matching a step-down transformer is needed as a go-between. The same rules govern the connection of an aerial to a valve, or a telephone instrument to a cable. A transmission line, serving as a link between two units, ought to be matched at both ends. Generally it is advantageous to construct the best and most efficient line, as a line, regardless of impedance; and then match the terminal apparatus to it by means of transformers or otherwise. If the line were made to fit the tuned circuits and aerials at its ends, it would nearly always have to consist of widely separated wires. This is undesirable in several ways. It does not lend itself to low-loss construction. Among other sources of loss is a high radiation resistance. The object of using a line feeder for a transmitter is to avoid having the radiation from the aerial—which is usually a special directional array—upset by the lead-in doing some aerial business on its own. And similarly in a receiving station the object is to prevent the lead-in from picking up interference, which it readily does unless the wires are close together.

**Concentric Feeders**

In fact, the best form of line is the concentric. Besides enabling the resistance to be kept low—because tubes are particularly good in minimising “skin effect” at ultra-high frequencies—it has the very valuable advantage that the outer conductor can be earthed and it then completely screens the inner “live” wire, which is unable to radiate or to pick up. But obviously such construction is accompanied by low impedance, so some form of step-up is generally to be preferred to direct connection. Fig. 9 gives some idea of the impedances of both concentric and parallel wire lines.

Suppose an aerial having an impedance of 900 ohms is to be connected to an oscillator circuit of 1,600 ohms by means of a parallel wire feeder with a spacing of 20 wire diameters. The impedance, according to Fig. 9, is 360 ohms. By using a feeder-to-aerial transformer with a ratio of  $\sqrt{360 : 900}$ , or 1 : 1.6, the aerial is made to look like 360 ohms to the feeder, and therefore matches its characteristic impedance. This means that, apart from the slight feeder losses, things work as they would if the aerial were connected straight to the oscillator without any intervening line at all. Of course, another transformer, or its equivalent, with a ratio of  $\sqrt{1,600 : 360}$ , or 2.1 : 1, is needed between oscillator circuit and feeder.

And it is necessary to make the feeder of exactly the right length, which means any multiple of half a wavelength. It is not essential for it to be physically just so long; various electrical circuits can be arranged to adjust the equivalent length.

Our whole theory has been based on the

assumption that the resistance due to high-frequency losses is small. That is to be desired, not only to make theory simple, but to make practice effective. A conductor has

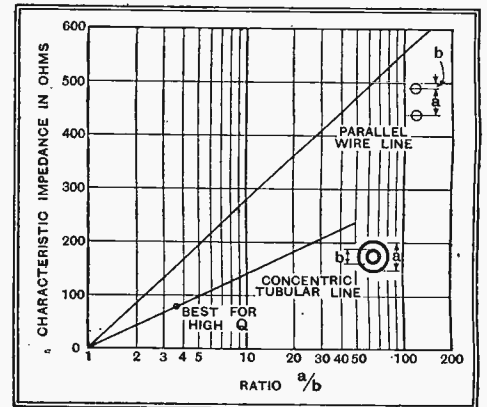

Fig. 9.—Characteristic impedance of parallel-wire and concentric feeders of various dimensions.

a lower high-frequency resistance in the form of tube than the same amount of metal as a rod or wire. And it would be very delightful if the metal could be supported in air alone. The necessity for supporting insulators, being unfortunate, leads one to work according to the principle “little and good.” Comparatively infrequent spacers of high-class material, such as the latest ceramic products, are adopted.

An incidental and likewise rather undesirable effect of these inevitable insulators is that where they are situated they cause a local increase of capacity; which mismatches the line, to an extent, however, that should not be important in any well-constructed specimen; and also results in the line being shorter than it should be according to simplified theory. This is always found to be so, to a greater or less extent, in practice.

**New Radio Factories Prohibited**

A RECENT decree issued by Berlin's Ministry of National Economy prohibits the opening of any new factories for the making of wireless sets or component parts. And it goes further than this: No factory at present turning out, say, condensers may extend its activities to include resistances, coils or any other components outside its own special line. Set makers may not manufacture parts save those that they use in their sets; component manufacturers are forbidden to market complete receivers. There appear to be two underlying intentions. The first is to prevent waste of raw materials by over-production; the second, to make the wireless industry as much of an all-the-year-round trade as possible. The decree certainly does not aim at reducing the production of wireless sets below the nation's requirements or at making them more expensive; the Government is far too conscious of the value of broadcasting to do anything of that kind. One fears, though, that it may have the effect of stifling that healthy competition which is the greatest stimulant to progress and development.



# Current Topics

## EVENTS OF THE WEEK IN BRIEF REVIEW

### Russian Television Received Here

EXPERIMENTAL television signals coming from Moscow are reported to have been picked up by a Birmingham amateur.

### USW Broadcasting

PROGRAMMES from American ultra-short wave broadcasting stations are beginning to be reported in this country. On a recent Sunday afternoon loud signals originating from Boston were heard on 7 metres.

### Turkish Radio Reorganisation

THE Ankara Government has appointed a German, Dr. Herzberg, to supervise the reorganisation of broadcasting throughout the country. Dr. Herzberg was formerly the director of the Deutsche Theatre in Berlin.

### Canadian Regional Scheme

THE regional scheme adopted by the B.B.C. ten years ago is to serve as a model for a new arrangement to be made by Canada in forming control centres for broadcasting. There are to be five regions in Canada, namely, Quebec, Ontario, British Columbia, the three prairie provinces, and the three maritime provinces.

### Japanese News

SIX hundred wireless sets have been presented to the lighthouse keepers around the Japanese coast by the Dowager Empress in order to relieve the monotony of their existence. Japan has now followed the example of many other countries in radiating multi-lingual broadcasts. English, French, German and Spanish are to be the languages used.

### Illicit Use of Call Signs

IT is reported that lately there has been a great increase in the undesirable habit of illegally using amateur transmitting call signs. In most cases this trouble is due to the activities of pirates, but, unfortunately, there is reason to believe that in some instances genuinely licensed transmitters, with a kink for practical joking, are concerned. In most cases these call-sign pirates represent themselves to be transmitters situated in Persia or some other out-of-the-way part of the world.

### Paris Exhibition

THE French P.M.G. recently laid the foundation stone of the Radio Pavilion in the great exhibition which is to be opened in Paris during the coming summer.

### North African Activities

THE number of listeners in the French possessions in N. Africa is now not far short of 100,000, and it is increasing daily. French Morocco accounts for 30,000 of these, Algeria for 50,000, the remainder being in Tunisia. The greater part of the population of these countries speaks Arabic, and an increasing demand is making itself felt for a larger number of talks in Arabic, and also for native music.

### R.A.F. Communications

THE radio station at Manchester airport has now been added to the list of those with which R.A.F. machines may communicate. Such communication is, however, limited to DF and emergency calls.

### Ideal Home Exhibition

EASTER Tuesday will see the opening of the 1937 *Daily Mail* Ideal Home Exhibition at Olympia. This famous annual show will remain open until April 24th.

### An Electrical Muezzin

MOST people who have dwelt in Moslem countries are familiar with the Call to Prayer uttered from the min-

arets of the local Mosque by the Muezzin. This picturesque Oriental figure has now, in the case of at least one Mosque, given place to the loud speaker. At Singapore the G.E.C. have just completed the installation of loud speakers in two of the minarets of the Masjid Sultan Mosque, two similar instruments being installed in the body of the building.

### Australian S.W. Transmissions

DURING January, Sydney VK2ME will transmit on Sundays from 0600 to 0800, and 1000 to 1600 G.M.T., using a frequency of 9,590 kc/s (31.28 metres). A transmission will also be given on Mondays from 1400 to 1600 G.M.T. Melbourne VK3ME will be heard from 0900 to 1200 G.M.T. daily, except Sundays, on a frequency of 9,510 kc/s (31.50 metres).

### Out-of-date American Sets

WHEN thinking of the average type of wireless receiver used by listeners in the U.S.A. we are apt to be critical of the quality of reproduction associated with it, but we have never supposed that any but the most up-to-date receivers were to be found in American homes. It is somewhat surprising to learn, therefore, that according to the Federal Communications Committee, which has just taken a census of the age of receivers used in rural areas in U.S.A., no less than twenty-five per cent. are of 1929 vintage or earlier.

### Horn-loaded Loud Speakers

ON January 13th next Mr. P. G. A. H. Voigt is giving a lecture to Golders Green and Hendon Radio Physical Society on horn-loaded loud speakers at Regal Cinema, Golders Green, commencing 8.15 p.m.

Anyone interested is invited.

### Institute of Wireless Technology

AT a special meeting held recently, certain amendments concerning fees and subscriptions were passed, the result of which will be of great benefit to the younger members of the industry wishing to become student members or associates of the Institute. Full details concerning the Institute may be obtained from the Secretary at 4, Vernon Place, Southampton Row, London, W.C.1.

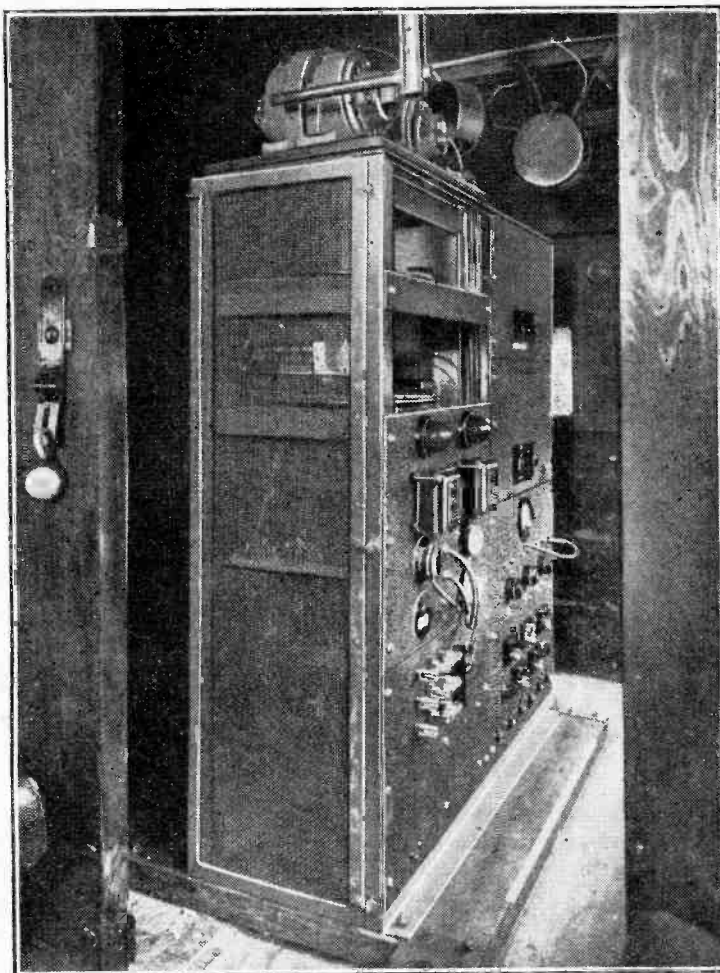

MOBILE AMPLIFYING EQUIPMENT installed in a motor-van and supplied by Ross & Robinson, Ltd., East Acton, London, for special public address use. Rack-type assembly is employed with battery chargers in the base and above them three 14-watt G.E.C. amplifiers. They can be used singly or collectively. Two gramophone turntables are included, also two DC-to-AC converters, which can be seen mounted on the top and adjacent to the units of the three large loud speakers. These have a range of seven miles. The equipment is so arranged that in the event of any single unit failing it can immediately be removed from the circuit by switches without affecting the operation of the remainder of the equipment.

# UNBIASED

## Wireless on the Stage

I SUPPOSE that most of you have, at some time or another, suffered at the hands of the various automatic cigarette lighters which infest the market. I do not refer to the all-mains variety which are sold for use at home, but to the type intended to be carried in the pocket. Usually either the petrol runs out at an awkward moment or else the flint arrangement which ignites it goes on strike—or, rather, refuses to do so.

Many laudable attempts have been made to produce an all-electric one in which a wire is made red hot by the passage of a current from a battery in the same manner as those which run from the mains. Unfortunately the current taken is so heavy that the battery soon wilts, and the device is really no better than the petrol variety. I have of late been devoting myself to the solution of this problem, and I flatter myself that I have succeeded and am hoping to get some manufacturer to take up my idea commercially. Needless to say, I have made up a model for myself, and its action is very, very simple. It consists merely of a miniature induction coil operated from a flash lamp battery through the usual make and break arrangement. The spark at the secondary is ample for lighting cigarettes, and the current taken from the battery is far smaller than by the hot wire method.



"Confided the whole story to a stage-door acquaintance."

Now it so happened that a few days after the completion of my invention I paid a visit to the theatre with a young lady from the country, as I had promised her mother, an old friend of mine, to keep a watchful eye on her daughter during her visit to London. During the course of an impassioned appeal of the hero to his lady love, in the middle of the first act, I drew out my cigarette case and, after handing it to my young friend, I offered her my lighter. We were rather surprised to hear the sweet voice of the heroine, who had just commenced a speech, drowned out by a raucous roaring which appeared to

emanate from her throat and that of the hero.

It was not until the next act, when the same thing occurred, that I began to connect the effect with my cigarette lighter. In this instance the interfering noise was much greater, since all the players seemed to be giving tongue to it. A few further experiments confirmed me in the view that my lighter was the cause of the trouble, but I entirely failed to see the reason for it. The lighter was obviously a transmitter—of limited range, of course—but how on earth it could affect the vocal chords of the actors I failed to see, until I confided the whole story to a stage-door acquaintance at the supper table that night.

The explanation proved astonishingly simple. It appeared that some time ago a well-known actor suddenly forgot his lines in the middle of an important play and was not able to proceed even with the help of the prompter, and had the mortification of being compelled to read his part from a script. This lapse of memory proved to be the result of shock following a recent motor accident. The theatrical world was so upset by this *contretemps* that all actors and actresses had been fitted with micro-wave receivers suitably disposed about their persons, the loud speaker being concealed in their headdress or just below the collar, according to the part they were playing.

Each receiver was tuned to a slightly different wave-length corresponding to the various transmitters in the wings, where sat both male and female prompters, who actually read the words from the script. The performers kept up the illusion that they were doing the talking by moving their lips in sympathy with the words coming from the loud speakers. To members of the audience the illusion was, in fact, far better than in the cinema, where the voices of the various characters on the screen appear to emanate from their lips although everybody knows full well that they come from one loud speaker common to all. My lighter, being nothing more nor less than a small flatly tuned ultra-short-wave transmitter, naturally upset the apple-cart.

## Murder Will Out

THERE is an old saying accredited to Dr. Johnson or George Robey—I forget which—to the effect that our education is never completed, and I must say that I have found more truth in it than is usually associated with these wisecracks.



Mrs. Free Grid's "At Home."

I happened to be paying a visit recently to a well-known Harley Street ear specialist in order to obtain his advice in the matter of a sprained ear drum from which I was suffering as a result of foolishly consenting to be present at one of Mrs. Free Grid's "At Homes," when she was entertaining a few of her lady friends. After giving me the necessary advice, the specialist decided that, owing to my fed-up appearance, I was probably suffering from gastric trouble also, and very kindly offered to conduct me in person to a fellow fee-snatcher down the street, who specialised in disorders of the alimentary tract.

Having arrived there, I was amazed at the number of dyspeptics of woebegone aspect whom I encountered in the waiting room, for, although I was fully aware that digestive troubles had increased enormously of late owing to the ever-increasing *tempo* of eating caused by the presence of jazz orchestras in our restaurants, I did not think that the number of victims of these synthetically produced alimentary irregularities was as great as I found it to be. I was so impressed that when at length I obtained admittance to the presence of the great man himself I could not refrain from commenting upon it.

I was greatly surprised when he blamed it all on to the effect of wireless, but my surprise turned to disgust when he expressed the view that my sympathy was wasted upon these unfortunates. Needless to say, I demanded to know in what way wireless caused digestive troubles, apart, of course, from the very obvious one of listening to some of the B.B.C. programmes which are frequently apt to produce feelings of nausea. Astonishment is scarcely the word to express my feelings when he trotted forth the old story about wireless waves affecting people's health. I protested that this old bogey had been exploded long ago, and that one would have to descend to wave-lengths far below the most ultra of ultra-shorts before any physiological effect was observed.

He pointed out that to a certain extent this was true, but that it had been found that even ordinary broadcasting wave-lengths could have a detrimental effect on the alimentary tract provided that the field strength was intense enough, and

**Unbiased—**

that it was for the purpose of protecting the public from this effect that the B.B.C. had built all its Regional stations well away from large centres of population, and not for the reasons usually given. I naturally pointed out that if this were really the case, the station engineers, spending long periods, as they did, within a few feet of the transmitting apparatus, would have suffered severely.

He surprised me still further by telling me that even this had been thought of by the all-wise B.B.C., who had suitably protected their engineers from such a calamity by means of metallic screening. To effect this, my friend explained, all the engineers had been compelled to wear pants and vests made of steel wool in place of the ordinary sheep's variety. It was due to the same cause, explained the specialist, that no lady engineers were to be found on the B.B.C. engineering staff. It appears that they absolutely refused to replace their pants and vests—or whatever it is that women wear in place of these garments—by ones made of steel wool.

With regard to the vast crowd of sufferers whom I met in the waiting room, their troubles were due, I learned, not to their living too near a wireless station, but to the fact that in the early years of broadcasting they had been persistent oscillators, and were now hoist with their own petard, and were therefore not deserving of any sympathy. The intensity of the etheric radiations within a few feet of an ordinary receiving valve in a state of oscillation is, as he rightly pointed out to me, far greater than that due to the radiations of a broadcasting station even at a spot only a few miles away.

**BOOKS RECEIVED**

**Two Hundred Metres and Down**, by Clinton B. De Soto, pp. 184. Published by the American Radio Relay League Inc., West Hartford, Connecticut, U.S.A. Price 1 dollar.

OF the many amateurs who to-day enjoy the facilities afforded for private experimental radio transmission, few can be fully cognisant of the difficulties the early amateur pioneers had to surmount, nor of the many signal achievements performed by amateurs in the face of discouragement by the radio engineers in the past.

These and many other matters of particular interest to the present-day amateur and, in particular, to the beginner, form the subject matter of *Two Hundred Metres and Down*.

It is the story of amateur radio, and though it deals with the subject from the American amateur's point of view, it is wide enough in its scope to take in account, and make due acknowledgment to, the valuable contributions in the short-wave fields made by private experimenters elsewhere.

The difficulties that have beset the amateur in the past are by no means over, so that an appreciation of the manner in which they were approached as and when they arose should prove invaluable were the amateur movement to find itself faced with similar problems in the future. H. B. D.

**Official Radio Service Handibook.** By J. T. Bernsley. Published by Gernsback Publications, Inc., 99, Hudson Street, New York, N.Y. Pp. 1,008. Price \$4.

THE first half of this book deals with servicing methods and types of circuits, while the second gives valuable information concerning American receivers. The book opens with a consideration of the basic circuits which in one form or another are employed in every receiver. The treatment is very elementary, however, and by no means free from errors. It is, for instance, stated on page 24 that "triodes have an internal plate to filament capacity which does not exist in multi-grid tubes, and which would serve to resonate any large inductance in the plate circuit to a particular frequency." A screen-grid valve may not have an appreciable direct anode-cathode capacity, but it most certainly has an output capacity at least as great as that of a triode. Whatever valve may be used, the inter-electrode capacities are important. Similarly, the later statement that reaction

between the grid and anode circuits of a screen-grid valve is impossible must not be taken literally.

While these points somewhat mar the book, judged as a whole it contains much of merit, and the whole field of modern receiving equipment is well surveyed. Although written from the American point of view, the general sections are naturally applicable also to British apparatus. The second half of the book, however, is of major interest only to those handling American sets, and to them it should prove very valuable indeed. It contains a vast quantity of information, including intermediate frequencies and component values, of a large number of receivers.

The book is well printed and bound; the circuit diagrams are rather small for legibility, however, and this is accentuated by the rather peculiar valve symbols adopted. These are intended to show the base pin connections as well as the symbol, but, unfortunately, the result is sometimes almost impossible to unravel. W. T. C.

**NEW OSRAM VALVES**

THE majority of AC indirectly heated valves consume 4 watts in the heater, but in the new Osram range most specimens consume only 2.4 watts. The standard 4-volt rating is adhered to, but the heater current has been reduced from 1 ampere to 0.6 ampere. In addition, it is claimed that the series can be made much more uniform in characteristics than has been possible with older types. In general, fairly wide tolerances in characteristics have to be permitted, but improved manufacturing methods have allowed them to be considerably tightened in these new valves.

This is quite important in practice because it permits the set designer to obtain a more consistent performance from his products. If the normal tolerance, for instance, is  $\pm 20$  per cent., on mutual conductance, the designer has to arrange for his set to be capable of giving adequate amplification with valves 20 per cent. below standard and at the same time for it still to be stable with valves 20 per cent. above standard. The importance of more uniform valves is thus greater than might at first appear, and should be a great help to the designer of broadcast receivers.

With the exception of the output pentode, the new valves all have top-grid connectors, even in the case of the triode. This leads to a reduction in the inter-electrode capacities and may, in certain circuits, reduce mains hum.

The first valve of the series is the W42 variable-mu RF pentode. Under normal operating conditions it takes 7.6 mA. anode and 1.9 mA. screen currents, with 250, 100 and -3 volts for the anode, screen, and grid respectively. The mutual conductance is 1.5 mA/V., but although this seems low it must be borne in mind that it is the figure effective under normal operating conditions.

The frequency-changer in this range is a

heptode, the X42, and this again requires -3 volts grid bias and has a conversion conductance of 0.49 mA/V. Owing to the short electrode assembly adopted, satisfactory operation is claimed on wavelengths as low as 15 metres.

The H42 is a triode of the high amplification factor type. Its AC resistance is 66,000 ohms, and the mutual conductance is 1.7 mA/v, so that the amplification factor is 112. At -2 volt grid potential the mutual conductance is 1.5 mA/V. and with a coupling resistance of 0.25 megohm a stage gain of over 50 times can be secured with sufficient

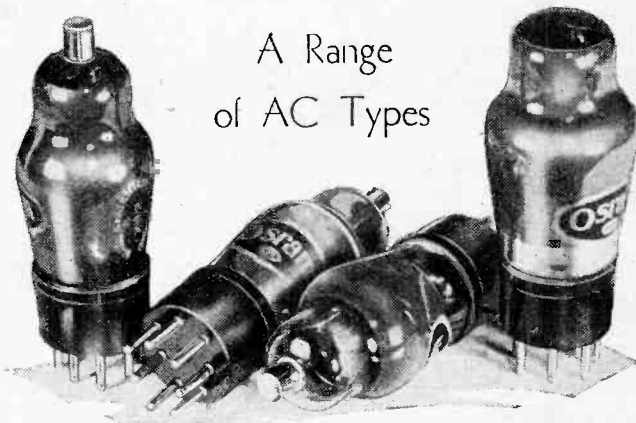

undistorted output to load a PX4 type valve.

A duo-diode-triode, the DH42, is also available, and the triode section has characteristics very similar to those of the H42, but a somewhat lower mutual conductance.

The remaining valve is the N42 output pentode. In this valve the heater consumes a rather greater current, 1 ampere, but is still low for a pentode. With 250 volts applied to screen and anode, the grid bias should be -16.5 volts and the screen and anode currents are 5.5 mA. and 34 mA. respectively. The output into the optimum load of 7,000 ohms is 3 watts for 7 per cent. distortion. Using two valves in Class "AB," however, 5.5 watts output can be secured for 4 per cent. distortion.

# Random Radiations

By  
"DIALLIST"

## Viewers' Views Wanted

I WAS interested to hear the B.B.C.'s recent request to owners of television sets and to viewers in public demonstration rooms to write in to say how they liked the programmes. The B.B.C., I'm sure, wants to make a success of the transmission, though it is working under considerable difficulties. There's not a great deal of money available, and some artists, at any rate, think that they should receive more for a televised turn than for one broadcast from the "sound" studio. Then it's something of a handicap to have two different methods of transmission, each of which demands its own special studio technique. That is a matter which seems likely to right itself, for it is suggested that in the near future the alternations may be monthly or at even longer intervals, those responsible for the system which is not in use at any time devoting their energies to research and development. Not a bad idea that, though I think that the suggestion made in these notes some weeks ago that one plant should be moved bodily to Birmingham is better still.

## Damage in Transit

A GOOD many radio sets are sent down for testing purposes each year to my home in the country, and the proportion which won't work when unpacked and connected up is quite remarkable. I presume that all are in working order when they are despatched and that the damage occurs *en route*. The packing is pretty good, and I don't often find that a carton shows signs of having been ill-treated on its journey. Yet here's the kind of thing that happens. An expensive set was received some ten days before Christmas. When plugged into the lighting mains and switched on it refused to do anything but howl. Clearly a breakdown in a decoupling circuit; after a long search a lead was found adrift and resoldered. The set then worked well for a few hours, after which it gave out once more. This time a "dis" in the output circuit was diagnosed, and examination disclosed another broken joint.

## Faulty Soldering

Both of the connections that caused trouble were badly made, one of them being a typical "dry joint." It seems to me that in factories more care is required in soldering or in testing joints after they have been made. Most amateur constructors make a practice of testing their joints by giving each lead a pull after the solder has set. Though it isn't infallible, this method does usually show up a dry joint. But prevention is better than cure, and the one certain way of ensuring against dry or otherwise faulty soldered joints is to see that the surfaces over which the solder is to flow are perfectly clean. If they aren't, a rickety junction is almost inevitable.

## Ingenious Tone Control

IN an American set I have recently come across a system of tone control which is new to me and may be also to many readers. The basis of the system is the use as first AF amplifier of a multi-electrode

valve containing two control grids, one with a high magnification factor and the other with a low. By means of suitable circuits the output of the second detector is divided, the upper and middle audio frequencies being passed to the low-mu grid and the low frequencies to that with the high mu. A potentiometer makes it possible to regulate the proportion of either part of the output that is applied to these grids.

The first AF valve acts both as an amplifier and as a re-combiner of the separated frequencies. With the tone-control potentiometer in its normal position there is a marked bass "lift" owing to the greater amplification given to the low audio frequencies. If desired this can be further accentuated by reducing the upper and middle audio-frequency input. Similarly, the bass can be toned down by reducing the input to the high-mu grid. It's an ingenious system which seems to have possibilities.

## For Easy Tuning

IF your set has a scale of metres or kilocycles the odds are that it won't be very accurate—unless, of course, you calibrated it yourself by hand. Sometimes, indeed, these scales are so inaccurate that the identification of stations is made a difficult matter. Here is a simple way of obtaining accurate readings—as accurate, at all events, as the size of the scale and the fineness or otherwise of the pointer will permit—which I have found so useful that I pass it on for the benefit of readers. Obtain a piece of graph paper and mark it off, if yours is a wavelength scale, from 200 metres at the left to 550 at the right along the bottom edge. Mark off the left-hand edge in exactly the same way from 200 metres at the bottom to 550 at the top. Thus the 200-metre point is common to both sets of markings. A kilocycle scale will run from 1,500 to 500, 1,500 being the common point at the left-hand bottom corner. Label the bottom scale "dial readings" and the other

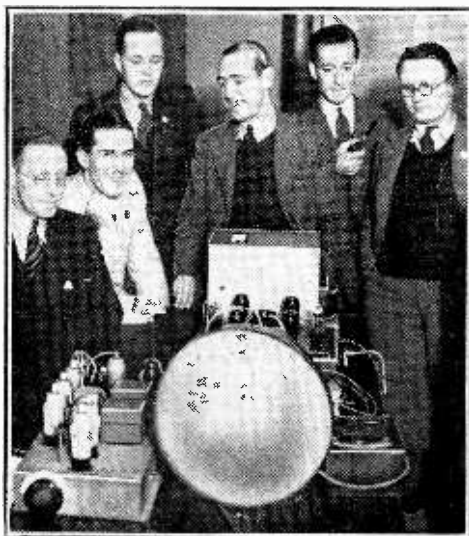

LECTURES ON TELEVISION are a regular feature in the programme provided for their members by the International Short-Wave Club (London Chapter) who hold meetings at 80 Theobald's Road, London, W.C.1, every Friday evening at 8 p.m.

"true readings." From stations known to be good wavelength keepers (British, German and Swedish stations are very reliable) it is now easy to plot a curve of dial readings against true readings, and from this you can read off the real wavelength or frequency, whatever untruths the pointer may be telling. Similar curves are plotted for the long waves and the short waves.

## Winged Words

JUDGE LILLEY had some caustic remarks to make about certain hire-purchase agreements the other day when dealing with various little bits of bother that had arisen from them. In one case a man was not satisfied with a set bought on hire-purchase and took it back to the dealer, who exchanged it. The manufacturers contended that the dealer had no authority to do so and sued the purchaser for a sum of money. The judge told the defendant that he had not a leg to stand on as a clause in the agreement stated that the dealer was not the maker's agent. He described it as "an absolutely iniquitous state of affairs," and I feel that he was entirely justified in so doing, for, clause or no clause, the man who sells the set, installs it and services it is definitely and understandably regarded by the public as the agent of the manufacturers. It is only natural that this should be so, since many set makers will not accept a returned set unless it comes through the dealer. And, as a rule, all complaints from purchasers are referred by them to the dealer who sold the set.

## Something Must Be Done About It

Judge Lilley did not remain content with the mere utterance of winged words. He translated them into action by making an order for payment at the rate of a few pence a month, which means that the plaintiffs will have recovered in full by about 1967. The whole question of radio hire-purchase undoubtedly needs straightening out. Manufacturers, I know, don't want to saddle the dealer with too heavy a burden of responsibility. Still, everyone must feel that they go a little too far in that direction when they make out that he is not their agent. A vast proportion of the public now buys its wireless sets on hire-purchase. Those who do so are the least able to withstand financial and other knocks, and it is only just that the whole position should be made completely fair to both buyer and seller.

## Talks from Tokio

THE Japanese Broadcasting Association has, I see, just started a series of special broadcasts in a good many European languages, including English. One has picked up transmissions in English before now from Japanese short-wave stations, but these new programmes from Tokio are to be on much more ambitious lines. The owner of a short-wave or "all-wave" receiver can't complain nowadays that there isn't much to be heard in English! Most

European countries with short-wave stations have regular English transmissions. In addition to the United States, Kenya, India and Australia, you can find news and talks coming in our own language from countries in many parts of the world. There's no need, therefore, to be a linguist to derive entertainment from the short waves—though I *have* heard talks in alleged English that were more difficult to follow than they would have been had the speakers kept to their own tongues!

### A Short-wave Idea

ON the tuning dial of any set that takes in a range of short waves there are large areas which the seeker after broadcasting draws blank so far as speech and music are concerned, since they are given over to ship and commercial stations. Unfortunately, they are far from blank in the matter of loud and nasty noises—and you generally seem to strike the most ear-piercing morse signals when the manual volume control is as full on as it will go. If any manufacturer wants a neat and attractive idea to work out here is one for him with my blessing. It consists in devising a tuning dial that will automatically silence the set, or very nearly so, whenever a portion of the band is reached which is untenanted by broadcasting stations or amateurs. It shouldn't be

hard to work this out (I've one or two shadowy schemes in my head already) and if it could be done it would add greatly to one's pleasure in using the short-wave range.

### Another Silencer

Talking of nasty noise elimination reminds me that some genius in the States has brought out a silencer, or rather a quietener for the too-loud loud speaker. Details are not disclosed, but it is said to work like a charm. I gather that the prime intention is that it shall be used voluntarily by those who receive complaints from their neighbours that they are overdoing it a bit in the decibel line. But it is said to be a tiny contraption, easily concealed in the hand, and there is something more than a hint that the victim may be able to slip it unobserved into the receiving set of his noise-loving neighbour. I know quite a few din addicts whose loud speakers I would willingly "spike" in this way could I but feel that the cure would be permanent. It seems to me, though, that the first act of the listener whose loud speaker's voice had been reduced from a lion's roar to the cooing of a sucking dove would be to take a look inside the set—or, if he wasn't expert enough himself, to send for the service man. In either event the silencer would soon be discovered and peace would be short-lived.

## On the Short Waves

I RECEIVE a number of reports of reception of my 30-watt 10-metre phone transmitter G5—from the U.S.A. and elsewhere when working on 28.26 or 29.16 Mc/s—but none has been more interesting than a recent note from my friend G2MV regarding the "anomalous" reception of it in Westerham, on the borders of Surrey and Kent. My transmitter is situated not far from Clapham Common, and normally, when in operation in the late evening, gives a weak and steady signal in Westerham, about R2/3 on the "R" of an RME69 receiver, but clearly audible.

During the daytime, however, and in particular during the afternoon of Boxing Day, the signal from G5—reaches much higher levels, and even surpasses G5BY of Croydon (250 watts?) in field strength at Westerham. (Croydon is also much nearer to Westerham.)

It is also reported by G2MV that a very interesting phenomenon is also observed in the case of the 56 Mc/s (5 metres) harmonics of certain London amateurs, which only become strongly audible round 10 a.m. and 4 p.m. at his location.

This variability in signal strength of the various ultra-high frequency transmissions is probably not confined to amateur transmissions, but can also probably be observed on the television transmissions from Alexandra Palace, though in this case it may probably be masked by the higher power which is in use. This fading is probably due to changes in the ionisation of the newly discovered C and D layers in the lower atmosphere, which were mentioned in these notes some months ago.

Whilst on this subject I should like to remark, if the Editor will permit me, that my 10-metre phone transmitter must be very nearly unique in this country, in that all its eleven valves are of British make and design! In fact, I am very proud of the DN 41 final doublet, which for an input of

470v. 40 mA gives 140 RF peak volts out on 28-29 Mc/s, providing adequate drive for the final choke-controlled amplifier, a DET5.

On the other side of the balance sheet, one is very sorry to report a very poor response to my request for correspondence on the subject of the amateur bands.

My suggestion that the 14.7-3.5 and 1.7 Mc/s bands might possibly be exchanged for the right to use powers up to 1 kW on



A RADIO GLOBE.—This 9-inch globe is designed to meet the needs of short-wave listeners. The rotatable discs on the base show standard time zones corresponding to any hour of the listener's local time, while the outer disc includes lists of stations in each zone. A curved rule for measuring Great Circle distances in either nautical or land miles is also provided. The globe is of American origin.

28 and 56 Mc/s apparently did not meet with favour; perhaps it might have met with a better response if the 14 Mc/s band had been added to those to be retained with higher power?

One would hate to feel that the height of the British amateur's ambition is to exchange Sunday afternoon pleasantries on 7 Mc/s (Oh, Boy, the QRM!) and to collect WAC with a signal that could just be copied!

My sympathies are with those who are building diamond arrays and 100-watt 56 Mc/s crystal-controlled transmitters in an endeavour to span the Atlantic once again.

There are, of course, some, or many, who will not agree, but that, perhaps, remains to be seen.

Turning now to reception conditions during the past fortnight, we find that the late evening results have, in general, been very poor, although the daylight frequencies have generally been good.

The outstanding signal on Thursday evening, December 17th, was W2XAD at 6.30 p.m., with W3XAL inaudible (possibly not working), and W2XAF fair at 9 p.m.

The Siamese transmitter Bangkok on 19 Mc/s was, however, fairly good during the afternoon.

Sunday afternoon provided excellent reception of many of the U.S. "apex" high-fidelity stations on 30-40 Mc/s. Among the outstanding stations was W3XES, a Columbia System Transmitter probably relaying WCAV on the very high frequency of 40 Mc/s (approx.), and reception was spoilt, however, by interference from a police transmitter W1XAO, Boston, Mass.

Conditions were good on Sunday evening (December 20th), too, and at 5 p.m. both W3XAL and W2XAD were very good; W2XAD was still very good at 6.30 p.m.

By 11 p.m. only the 6 Mc/s stations remained, the outstanding signal being W1XAL, Boston, on 6.04 Mc/s, who was practically 100 per cent. intelligible, in spite of heavy QRM from S. American transmitters.

Conditions remained fair during the Christmas week, but, as usual, W2XAD, the best signal, showed signs of failing before close-down at 8.45 p.m.

I did not do much listening on Christmas Day, but noted that W2XE was good on 21.52 Mc/s during the afternoon.

On Boxing Day the outstanding feature was the performance of the 10-metre (28 Mc/s) U.S. amateurs, some of them remaining good signals until 7.30 p.m.; and on December 27th, not only were conditions on 28 Mc/s good to the U.S., but also to Europe, in particular the Latvian station (YL2BB), working G5AU, was a good signal during the morning.

The outstanding 28 Mc/s signal, however, was W9BHT using 800 watts and diamond antenna directional on England, surpassing easily W2XE on 21 Mc/s. Strangely enough, as if to complete a day of queer conditions, W8XK appeared on 15.21 Mc/s at 11.20 p.m., and remained quite a fair signal for some time.

Conditions were very poor again on Monday, December 28th, but appear to be improving again at the time of writing; and, at 11.55 p.m. PMN Bandoeng on 10.26 Mc/s is coming through exceedingly well on the loud speaker, as it does most nights and afternoons. The signal is very stable and of high quality, but at present is suffering slight morse interference from a Russian station.

ETHACOMBER.

# Listeners' Guide for the



STOCKHOLM'S SKYLINE—showing the Town Hall (left-centre) and the spire of the Riddarm Church (right-centre). Sweden provides the European concert on Tuesday, which will be relayed by many Continental stations and the London Regional.

**E**ACH Friday evening for the next six weeks twenty minutes of the programme time will be taken up with what is called "European Exchange." Each programme will consist of an interview in a B.B.C. studio with a member of some trade or profession in this country and, immediately following, a man or woman in a similar trade or profession in one of six countries will be interviewed in a foreign studio by Moray McLaren, Assistant Director of Features and Drama. Mr. McLaren will spend a week in each of the following cities making the necessary arrangements—Paris, Rome, Vienna, Warsaw, Berlin, and The Hague. In the details of these broadcasts the B.B.C. are careful to state that they will be non-political and uncontroversial—just a straightforward presentation of types here and abroad. This week's programme will be given to-night at 9.20 (Nat.), when Moray McLaren interviews somebody in Paris.

## BROADCAST TALKS

MANY interesting series of talks are included in the synopses for the first quarter of this year. Some are continuances of series already running, others started last week, while some commence this week.

John Hilton, who gives another of his fortnightly talks entitled "This Way Out" on Thursday at 6.20 (Nat.), opens a series on gambling, on Sun-

day at 4 (Nat.). When it is realised that in 1929 the Race-course Betting Control Board estimated the probable annual turnover of betting to be about £230,000,000, this series of talks should be enlightening and controversial.

At the present time there is great diversity of opinion on the subject of the Church and its position in the world, and on Tuesdays from January 12th to February 16th at 9.20 (Nat.) well-known and authoritative speakers will give talks under the general heading of "Church, Community and State." This week's speaker will be Sir Walter Moberly, and his subject "The Present State of the World."

Topicality being the keynote of the new series of talks-cum-discussions which will be held each Monday evening in the National programme until March 15th no details will be available in advance. The theme, however, will be the social experiments taking place in this country at the present time. Howard Marshall will, on each occasion, be in the studio, and will ask the various people taking part in the talk—there may be as many as six at a time—questions about their work and its relative importance to the ordinary person. The series started last week, when, under the title of "It's Happening Now," the

subject was the Pioneer Health Centre at Peckham.

A pamphlet containing details of the talks to be broadcast during the first three months of this year can be obtained free on application to the B.B.C. Publishing Department, 35, High Street, Marylebone, London, W.1.

## EUROPEAN CONCERT

It is now Sweden's turn to provide the next European concert. This will be heard at 8 (Reg.) on Tuesday. The Swedish Broadcasting Orchestra will be conducted by Nils Grevillius, and the soloist will be Joel Berglund, baritone.

## FROM THE CHORUS

THE B.B.C. Talent Scout, Francis Bolton, has put forward the argument that most stage and film stars graduate from the chorus, and he has, therefore, changed his policy of search, and is now concentrating on this idea. He has asked theatres if they have any outstanding and promising youngsters in the front row. Some of these will be heard in "The Front Row," a programme featuring girls from the choruses of current London

G.B.S. as caricatured by Max Beerbohm. His light-hearted historic play, "The Man of Destiny," will be produced twice this week by Barbara Burnham.

productions, which will be produced by John Watt and Francis Bolton on Wednesday at 7 (Nat.).

Should this prove a success it will be the forerunner of a number of such programmes.

## ICE-HOCKEY

It needs a super-commentator to give a running commentary on an ice-hockey match. We all remember Bob Bowman's animated efforts. Now he has gone to Canada as "O.B." director for Canadian broadcasting, in his place we shall hear David Miller from Harringay Stadium on Thursday at 9.30 (Reg.). He will describe part of the match between Harringay and the Resident Canadians.

## OSCAR WILDE

"LADY WINDERMERE'S FAN," the melodramatic play by Oscar Wilde, will be broadcast for National listeners on Sunday at 9.5. Val Gielgud has secured a strong cast, which includes Lydia Sherwood as Lady Windermere, Austin Trevor as Lord Darlington, Ronald Simpson as Lord Windermere, and Carol Goodner as Mrs. Erlynne.



# Week

## Outstanding Broadcasts at Home and Abroad

### SADLER'S WELLS

THE second act of Mozart's "The Marriage of Figaro," which has its scene set in the Countess' boudoir in the Count's castle near Seville, will be heard in a relay from Sadler's Wells on Saturday at 8.55 (Reg.). As is customary, this will be preceded by a five-minute introductory talk.

### SHAVIAN

BERNARD SHAW wrote "The Man of Destiny" in 1895, and this was first performed two years later at Croydon and has twice been broadcast. It will again be heard on Monday and Tuesday of this week at 8.30 (Reg.) and 9.40 (Nat.) respectively. It provides an enter-

**SPEED AND EXCITEMENT** characterise commentaries on ice hockey matches. We shall be taken over to Harringay Stadium on Thursday to hear an account of part of the match between Harringay and the Resident Canadians.

tafing glimpse of that extraordinary person who was later to become Emperor of France while he was still a young man, and though a General, still obscure. The time is two days after the battle of Lodi, and Napoleon is lodged at an inn on the road to Milan. Listeners in general, apart from the large number who are undoubtedly convinced Shavian admirers already, will be well advised not to miss what happens to be a play which might well have been written specially for the microphone. A distinguished cast will be in the production, which is in the hands of Barbara Burnham.

### COMIC OPERA

TO-NIGHT we are to hear Joseph Lewis's concert version of the comic opera, "A

Princess of Kensington," by Basil Wood and Edward German. This will be broadcast from 6 to 7 (Reg.). Section C (forty players) of the B.B.C. Orchestra with Section B (twenty-eight voices) of the B.B.C. Chorus will support Elena Danieli (soprano) and Jan van der Gucht (tenor), the soloists. Joseph Lewis will himself conduct the orchestra.

### A LONG CONTRACT

ONE of the most popular of light orchestral programmes

since 1922, when the work to be heard to-night, "Don Gill of the Green Stockings," was performed in Rome.

Saturday's only real opera broadcast is Mulè's "Dafni" from Rome at 8. Mulè is a contemporary composer, born in 1885. He has written several operas, and also incidental music to the Greek tragedies performed at Syracuse. Sunday's performance of "Rigoletto" at the State Theatre, Weimar, to be relayed by Leipzig at 7, should be

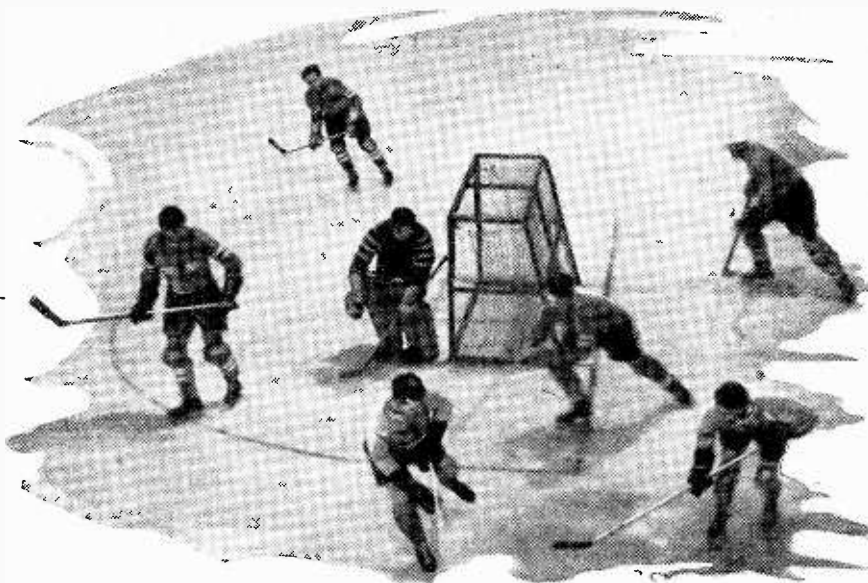

each week is that given by Van Phillips and his two orchestras, in which he alternates old and new numbers played by a small orchestra and a full band. He has just received another contract for a further period of thirteen consecutive weekly broadcasts, which now brings his contract to twenty-six successive programmes. I think this is the longest contract ever given by the B.B.C. to an outside orchestra. He will be heard this week on Tuesday at 8.30 (Nat.).

### OPERA AND OPERETTA

FROM Rome to-night (Friday) at 7.40 comes the work of a most interesting contemporary composer, Ezio Carabella, who has distinguished himself mainly as the composer of symphonic works performed at the Augusteo concerts. His success in a genre relatively new to Italian composers has been assured

worth tuning in. For the afternoon there is a concert version of Strauss' "Fledermaus" from Kalundborg at 2.25.

The late-night concert from Frankfurt and Stuttgart on Monday at 11 includes arias from "The Flying Dutchman," "The Mastersingers," and "The Valkyrie" by that fine bass-baritone Wagner singer, Rudolf Bockelmann.

Verdi's "A Masked Ball" will be heard from Milan on Sunday and from Rome on Tuesday. On both occasions the transmission commences at 8.

### BRITISH SEAMEN

A PROGRAMME of special interest to English listeners will be radiated by Hamburg from 9.30-10.15 on Monday. It will consist of part of an evening's entertainment from the British Seamen's Mission in Hamburg.

THE AUDITOR.

### HIGHLIGHTS OF THE WEEK

#### FRIDAY, JANUARY 8th.

Nat., 7.30, Symphony Concert.  
9.20, European Exchange—France. 10, B.B.C. Theatre Orchestra and Peter Dawson.  
Reg., 6, "A Princess of Kensington"—Comic Opera. 9, Recital, Pierre Fournier (cello) and John Wills (piano).

#### Abroad.

Warsaw, 7.15, "The Tales of Hoffman"—Offenbach.

#### SATURDAY, JANUARY 9th.

Nat., 6.45, Metropolitan Police Band. 9.20, Music Hall.  
Reg., 4, The Fol de Rols. 7.30, The Alfredo Campoli Trio. 8.55, Act II, of "The Marriage of Figaro," from Sadler's Wells.

#### Abroad.

Radio Paris, 8.45, Concert of the Société Nationale de Musique.

#### SUNDAY, JANUARY 10th.

Nat., 6.30, Victorian Melodies—XI. 7.55, Service from St. Martin-in-the-Fields. 9.5, "Lady Windermere's Fan" (Wilde).

Reg., 5, Enfield Central Band and Alleyne and Leonhardt (two pianos). 6, Shanties; B.B.C. Men's Chorus. 9.5, Hastings Municipal Orchestra and Jan van der Gucht.

#### Abroad.

Leipzig, 7, Verdi's "Rigoletto," from Weimar.

#### MONDAY, JANUARY 11th.

Nat., 6.40, B.B.C. Empire Orchestra. Entertainment Parade No. 8. 8, Social Experiments—2. 8.30, B.B.C. Dance Orchestra.

Reg., 6, Reginald King and his Orchestra. B.B.C. Orchestra (C) and Frank Manchester (piano). 8.30, "The Man of Destiny" (Shaw).

#### Abroad.

Hamburg, 9.30, A relay of part of entertainment evening from the British Seamen's Mission, Hamburg.

#### TUESDAY, JANUARY 12th.

Nat., 7.50, Songs You Might Never Have Heard—2. Van Phillips and his two Orchestras. 9.40, "The Man of Destiny."

Reg., 6, Cambridge Heath Salvation Army Band. 8, Swedish European Concert from Stockholm. 9.20, B.B.C. Theatre Orchestra.

#### Abroad.

Leipzig, 5-7, German Folk Songs and Dances.

#### WEDNESDAY, JANUARY 13th.

Nat., 7, "The Front Row"—artists from the chorus. 7.45, Bach Concert.

Reg., 7.30, Talk—The Cavalcade of the Thermometer. 9, Recital, Geza de Kresz (violin) and Nora Drewett (piano).

#### Abroad.

Strasbourg, 8.30, Fifth subscription concert from Palais des Fêtes.

#### THURSDAY, JANUARY 14th.

Nat., 7.40, The White Coons. 9.20, B.B.C. Theatre Orchestra.  
Reg., 6.20, the Victor Olof Sextet. 9, Al Collins and his Dance Orchestra. 9.30, Ice Hockey commentary.

#### Abroad.

Cologne, 7.10, Festival Concert celebrating the tenth anniversary of the forming of the Cologne Radio Orchestra.

Details of the week's Television programmes will be found on p. 43.

# Finding the Ultra-Short Bands

By B. W. F. MAINPRISE

**E**XPERIMENTERS who live at a distance from transmitting stations usually experience difficulty in finding ultra-high-frequency signals, and in many cases it is not easy to determine whether an unfamiliar receiver even tunes to the required frequency. The chief signals to be expected are the sound channels of the television stations, in the region of 40 megacycles, and the amateur experimental transmissions between 56 and 60 megacycles.

The professional method of determining frequency (or wavelength) is to couple a transmitter to a Lecher Wire system, and

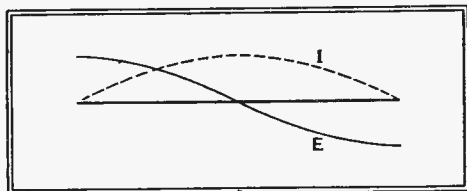

Fig. 1—Distribution of current and voltage in a half-wave aerial.

locate the positions of the voltage anti-nodes. At the same time an absorption wavemeter is calibrated from the transmitter for future use. The writer finds, however, that the erection and operation of the Lecher Wire system is tedious when working single-handed, and the following method has for some time past been employed with satisfactory results. It has the advantage of requiring only a length of supported wire, and a receiver tuning preferably to wavelengths around 20 metres. The details given apply to the amateur 56-60 megacycle band, as operation on this band is carried out in most parts of the country, whereas the television transmissions are chiefly limited to the London area. The values to be given can easily be changed to cover the 40 megacycle band, or other parts of the spectrum.

A given length of wire has a natural wavelength or frequency, and if supplied with energy will radiate a portion into space. Conversely, if the wire be suitably coupled to a source of energy of suitable frequency it will absorb a portion of the energy. The natural half-wavelength of a wire is given by the formula:

$$\text{Length (in feet)} = \frac{460,000}{\text{Freq. in kilocycles.}}$$

the constant in the numerator differing with various authorities and conditions. From this formula it will be seen that a wire 8ft. long resonates in the middle of the 56-60 megacycle band. If then, this wire be coupled to a receiver oscillating on

## GUIDANCE IN THE 5-METRE REGION

58 Mc/s, it will tend to pull the receiver out of oscillation. Coupling can be effected in several ways, but in our case the simplest and most convenient is to employ a small coupling coil in the centre of the wire, and to bring this coil close to the oscillating receiver. Reference to Fig. 1 will show the distribution of current and voltage in an excited  $\frac{1}{2}$ -wave aerial, and it will be seen that the current has a point of maximum value, or anti-node, at the centre of the length, while there are voltage anti-nodes at each end. Accordingly the coupling coil is inserted at the current anti-node, but its effect will be to load the aerial and decrease the natural frequency. The wire should, therefore, be shortened slightly.

The length of wire is best supported on midget stand-off insulators, mounted on, say, a roft. batten, one inch square in section. These battens are readily obtainable from the local timber yard, where they should at the time of purchase be planed to a smooth finish, as later they form excellent aerial or reflector supports if given a coat of waterproof varnish. In our case the extreme insulators are 8ft. apart, the wire being broken at the middle and secured to a pair of insulators each one inch from the centre. These two in-

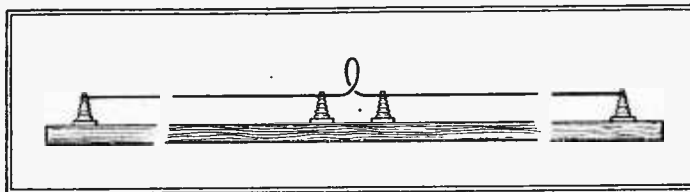

Fig. 2—Half-wave aerial with coupling coil; a length of 8 feet between outside insulators is suitable for the 5-metre band.

ulators are bridged by a wire some  $4\frac{1}{2}$  inches long (including the portions round the insulator terminals) which is bent to form a rough coil. (Fig. 2).

The ultra-short-wave receiver is made to oscillate, and the tuning condenser

rotated to show beforehand any "blind-spots" due to resonances in the chokes or in the wiring. If these are present, the dial readings must be noted. The wire on its supporting batten is now brought up close so that the coupling coil is in close proximity to the receiver tuning coil, and preferably near its earthed end. The tuning condenser is again rotated, and the receiver will be found to be pulled out of oscillation, probably over several degrees on the dial. The coupling coil is now gradually removed until its effect is barely perceptible, and the dial reading noted. The wire is resonating on some frequency which is probably a little below the 56 Mc/s end of the band, owing to the loading effect of the coupling coil, and it now remains to fix the band with greater accuracy.

**D**ESCRIBING a simple method of locating the 5-metre band with the help of a length of wire and an oscillating short-wave receiver. By an appropriate alteration in dimensions, any other ultra-short waveband may be found.

The short-wave receiver is now switched on, and made to oscillate weakly at the low-frequency end of the amateur 14 Mc/s band. The fourth harmonic on 56 Mc/s is looked for on the ultra-short-wave receiver, and will probably be found at a slightly lower dial reading than that marked as resonant with the wire. The SW receiver is slowly tuned to 15 Mc/s and the fourth harmonic followed on the USW receiver, thus marking the other end of the 56-60 Mc/s band.

In practice the whole operation can be carried out in a few moments, and has given very good results. The method is by no means novel, but it has seldom had attention drawn to it, as far as the writer is aware. The only point calling for mention is that if the SW receiver is oscillating too strongly, an excessive number of beat notes

will be heard on the USW receiver or a frequency-changing effect will become evident by the reception of short-wave broadcasting stations, as recently pointed out in *The Wireless World*. For picking up the beat notes, the USW receiver should



**Finding the Ultra-Short Bands—**

have the super-regenerative circuit cut out.

After the wire has been employed for determining frequency, it can readily be employed as an aerial or reflector. The coupling coil is now removed, and the wire can be coupled to the receiver by several methods, as shown in Fig. 3.

In (a) "voltage" coupling is employed. The feeders are first cut one-quarter wave in length, and run parallel, about two inches apart, by light spacers, the centre portion is bent into a single-turn coil, coupled to the receiver tuning coil, and, with no connections to the ends, these are equally cut down until resonance in the centre of the required frequency band is obtained. Resonance is indicated by the oscillation test as before. One feeder is then taken to an end of the 8-ft. wire, while the other feeder is left free of connections except to its securing stand-off insulator. The 8-ft. aerial has, of course, its centre insulators bridged by a straight wire.

In (b) "current" coupling is shown. The feeders are approximately of half a wavelength, and are coupled to the receiver as before, except that there is no bridging length across the centre of the 8ft. wire. The length of the feeders is cut to resonance when connected to the aerial so that the whole system resonates on the desired frequency.

A "matched impedance" system is shown in (c). The dimensions are for 58 Mc/s, using feeders of about 20-gauge wire, and the advantage of this system is

that the feeders can be of any reasonable length.

The feeders of the matched impedance aerial are clipped on to the tuned circuit

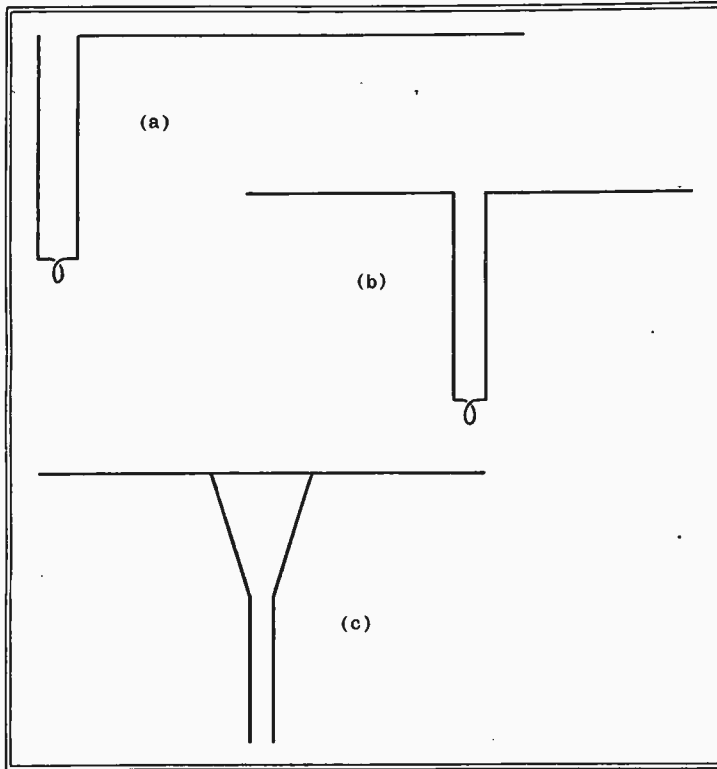

Fig. 3—After the half-wave aerial has served its purpose as a calibrating device, it can be coupled to a receiver by one of the methods shown here. In diagram (c) the "V" portions are each 2.6 ft. long, tapped 1 ft. on either side of the centre. Parallel downleads are 3.4 in. apart, and of any reasonable length.

of the receiver, symmetrically about the low-potential point, and about one-third the way up. In circuits of the split Hartley type, a condenser of 0.005 mfd. should be included in each feeder to isolate the HT voltage from the grid of the valve.

Considerable gain in signal strength can generally be obtained by erecting a reflector behind the aerial. The reflector is best mounted on a batten, in the same way as the aerial, and in the simplest form has no connections for feeders whatsoever. For 56-60 Mc/s it should be a couple of inches longer than the calculated half-wavelength, and spaced a couple of inches farther from the aerial than a quarter-wave, in general, but these dimensions are best determined by trial and error.

attend. There will be a special ISWC broadcast for short-wave listeners on Wednesday, January 27th, from 2330 to 0030 G.M.T. from the Rome 2RO station on 9,630 kc/s (31.13 m.).

**The Croydon Radio Society**

The second half of the winter session has now commenced, and a cordial invitation is extended to non-members to attend the meetings, held at the club's headquarters in St. Peter's Hall, Ledbury Road, South Croydon, full details of which can be obtained from Mr. E. L. Cumbers, 14, Campden Road, South Croydon.

**Television Programmes**

The principal items only of each day's programmes are given. The system to be used each day is given below the date. Transmission times are from 3-4 and 9-10 daily.

Vision	Sound
6.67 m. (45 Mc/s).	7.23 m. (41.5 Mc/s).

**FRIDAY, JANUARY 8th.**  
(Marconi-E.M.I.)

3, First Aid—I; Accidents in the Home. Surgeon-in-Chief of the St. John Ambulance Brigade. 3.15, Gaumont British News. 3.25, All-coloured cabaret.

9, First Aid—I; Accidents in the Home. Assistant Surgeon-in-Chief of the St. John Ambulance Brigade. 9.15, British Movietonews. 9.25, Repetition of 3.25 programme.

**SATURDAY, JANUARY 9th.**  
(Marconi-E.M.I.)

3, The Irish Players in "The Workhouse Ward"—Comedy. 3.25, Film. 3.35, Gillie Potter and Irene Prador. 3.50, British Movietonews.

9, Ord Hamilton, composer and entertainer, at the piano. 9.5, Stars and their directors—Anna Lee. 9.10, Film. 9.20, Repetition of 3 programme. 9.40, Gaumont British News. 9.50, Gillie Potter.

**MONDAY, JANUARY 11th.**  
(Baird.)

3, British Movietonews. 3.10, Scenes from the Arts Theatre production of "The Soul of Nicholas Snyder." 3.25, Film. 3.35, Leonard Henry. 3.45, Dancers and the Television Orchestra.

9, Repetition of 3.45 programme. 9.20, Film. 9.30, Cabaret including Gwen Farrar. 9.50, Gaumont British News.

**TUESDAY, JANUARY 12th.**  
(Baird.)

3, Sidonie Goossens (Harp). 3.10, Gaumont British News. 3.20, "The World of Women"—I, Setting a play. 3.35, Film. 3.45, Peggy Cochrane (Violin).

9, Repetition of 3 programme. 9.10, British Movietonews. 9.20, Repetition of 3.20 programme. 9.35, Film. 9.45, Repetition of 3.45 programme.

**WEDNESDAY, JANUARY 13th.**  
(Baird.)

3, London Galleries; Talk by John Piper. 3.15, Film. 3.25, Nineteenth Picture Page. 3.50, British Movietonews.

9, Gaumont British News. 9.10, Repetition of 3 programme. 9.25, Film. 9.35, Twentieth Picture Page.

**THURSDAY, JANUARY 14th.**  
(Baird.)

3, Home Affairs; discussion with photos and diagrams between the Rt. Hon. Herbert Morrison and John Hilton on London's Green Belt. 3.20, Gaumont British News. 3.30, Music Makers—Carroll Gibbons. 3.40, Scott Gordon's Marionettes in "Old-Time Music Hall." 3.50, Cabaret.

9, Repetition of 3.30 programme. 9.10, Repetition of 3.40 programme. 9.20, British Movietonews. 9.30, Repetition of 3 programme. 9.50, Cabaret.

**News from the Clubs**

**The Mid-Cornwall Short-Wave and Television Society**

This newly formed society is making steady progress, and a beginners' hour has been started. Morse instruction is another of the club's activities. Headquarters are at St. Austell, and full information will be given to those interested if they will write to Mr. P. O'Neill, 1, Warleigh Villas, Saltash, Cornwall.

**Bideford and District Short-Wave Society**

This society is making excellent progress. Premises have been obtained for a permanent club room and apparatus is being installed for power supply, reception and receiver testing. Two more artificial aerial call signs have been

issued to members and ultimately it is hoped to obtain a transmitting licence for the society. The Secretary, Mr. E. K. Jensen, 5, Furzebeam Terrace, Bideford, will be pleased to hear from prospective members.

**The International Short-Wave Club**

The London chapter of this club holds meetings every Friday at 8 p.m. at 80, Theobalds Road, Holborn, London, W.C.1. These meetings are open to all and there is a club room for the use of members, this being equipped with receiver, transmitter and library.

The Brighton chapter of the above club will be opened on Saturday, January 23rd, at 7 p.m. in the Brighton Technical College. All in the vicinity who are interested are invited to

# Broadcast Brevities

## Ultra-Short-Wave Relay

HERE is good news for lovers of quality reproduction. In all probability the B.B.C. will shortly establish an ultra-short-wave service for the relay of the National programmes, the transmitter being situated on the roof of Broadcasting House.

If and when the decision is made, probably in the next month or two, it will largely be due to the excellence of the sound transmitter at Alexandra Palace. Music critics—and not only music critics—have been able to forget the picture at times in their enjoyment of the sound reproduction. (This sounds too good to be true, but it is true.)

## Provinces Also ?

In this connection the B.B.C. also has its eye on the provinces, believing that, where possible, facilities accorded to the Metropolis should also be available to the Regions. The logical development would be to install ultra-short-wave transmitters at each of the provincial centres for relaying either the National or the Regional programmes to listeners who were prepared to go to the extra trouble and expense of picking up high-fidelity transmission.

Eventually, of course, these ultra-short-wave transmitters might be called upon to handle television, but that is another story.

## New Year Building Activity

IN addition to the start which is to be made in 1937 on the extension of Broadcasting House, the year will see the inauguration of other building schemes and the completion of various works which were in hand towards the end of last

year. These latter include the new studio premises in Glasgow, which may be ready by the autumn, when we shall see the return of Scottish broadcasting to its spiritual home. The new studio premises in Swansea will be complete and occupied by the spring, and a start will be made on new studio premises in Belfast.

## NEWS FROM PORTLAND PLACE

CHANGING SCENES. The wreckers will shortly be busy demolishing all these houses in Portland Place to make room for the extension of Broadcasting House. Seven of the houses are at present occupied by the B.B.C.

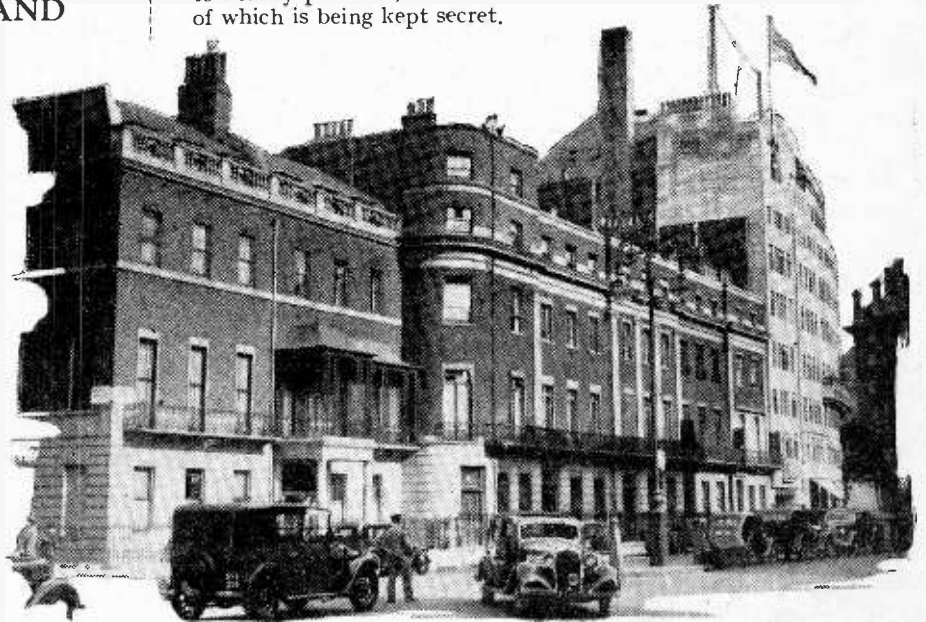

## New Transmitters

As regards transmitting stations, the three new Empire transmitters and aerial at Daventry will be completed in the early part of the year, so as to provide an improved service for listeners overseas in time for the Coronation. The transmitter at Beaumaris will be opened shortly, and the station at Stagshaw will be ready for

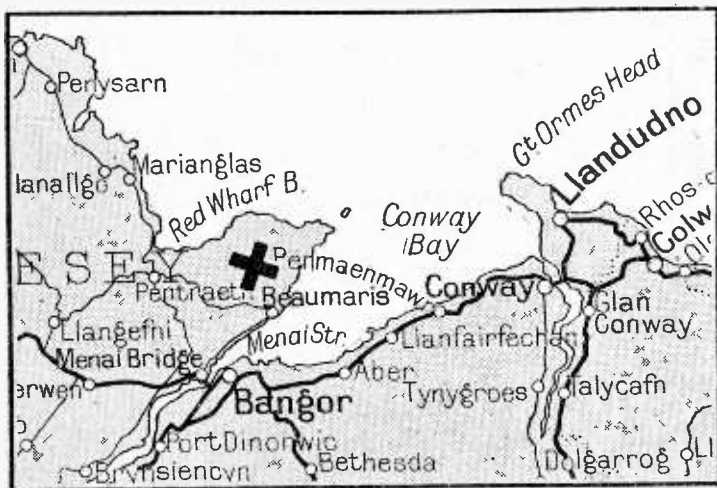

BEAUMARIS, in the Isle of Anglesey, is the site of the next B.B.C. station to take the air. Wales, Northern England, and Ireland will profit most from the new transmitter.

equipment in the early part of the year. Its completion will be followed by a start on the new transmitter for the south-west of England.

## Smashing-up Portland Place.

AN army of demolition men is about to get busy in Portland Place, and B.B.C. staff now occupying seven of the doomed houses are to be moved to nearby premises, the location of which is being kept secret.

would get it "in the neck" whichever way they voted. The suggestion is quite untrue.

The feeling now seems to be that the B.B.C., subject to its own prerogatives, treats its workers comparatively handsomely. Although a few cases of inequality of treatment may have cropped up here and there, appeal to higher authority almost invariably means that matters are righted.

## More Staff for Television

GRADUALLY the staff list at Alexandra Palace is enlarging to cope with television programme developments. Last

The Corporation has already had copious experience of pouring quarts into pint pots, and will, no doubt, find a temporary home for everybody. The only people in the block who must find accommodation elsewhere are the occupants of a Nurses' Institute. For them the Corporation has bought a building on the opposite side of Portland Place.

week Mr. Reginald Smith, fresh from the world of the theatre, joined up as Assistant Stage Manager. Unlike many of his tribe, "Reggie" is a stage manager who can also act; he was recently playing in Bernard Shaw's "The Millionairess," performed the other day for the first time at Bexhill. Mr. Smith was for years with André Charlot in revue production—an experience which should help considerably in the job of putting over "peppy" programmes in television.

## B.B.C. Staff Association ?

ONE of the first activities at "B.H." when the new Governors are settled in will be a close investigation of schemes presented by Mr. St. John Pym, Director of Staff Organisation, for the formation of a staff association.

Time marches on, however, and since the idea of such an association was first promulgated, desire for it on the part of the staff seems to have waned.

## Wrongs Righted

Critics of the B.B.C. have made much capital of the suggestion that the ballot for or against an association was a forced one, i.e., that numbers of the staff feared that they

## Installing the President

ONE of America's most spectacular "O.B.'s"—the inauguration of the President—comes to British listeners on January 20th. Particulars of the event—of the commentaries from airships and 'planes by ace announcers at strategic points along the processional route—appeared in these columns on December 11th.

A specialised anglicised commentary will be given by Felix Greene, the B.B.C. representative in New York.

The B.B.C. will pick up the ceremonies at Tatsfield, via 2XAD and 2XAF.

# Dropping Filament Volts

**M a k i n g  
R e s i s t a n c e s  
t o O p e r a t e F o u r - v o l t  
A C V a l v e s f r o m F i v e -  
v o l t o r S i x - v o l t L T  
S u p p l i e s**

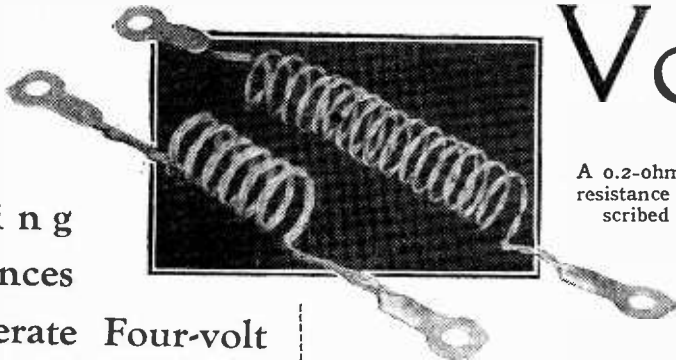

A 0.2-ohm and a 1-ohm resistance made as described in the text.

In order to make the resistances compact and easy to accommodate, they can be wound in the form of a loose coil using for a former a  $\frac{1}{4}$  in. rod or a pencil, though when made in this form it is advisable to employ enamelled or silk-covered wire.

### Resistance Values

If we take the case of a rectifier requiring 2.5 amps. at four volts and the valve is to be used on a five-volt supply, the total resistance will now be only 0.4 ohm, or 0.2 ohm for each filament lead. In this case five strands of wire are needed, each again 9in. long; for five one-ohm resistances in parallel gives 0.2 ohm. Twisted together and wound as a coil, this length of wire takes up only about  $\frac{5}{8}$  in. when the turns are slightly spaced.

It is not uncommon to find six-volt windings on some old pattern mains trans-

**T**HERE are occasions when it is required to employ a four-volt AC heated valve in place of one taking five volts or more, the replacement of an early-type five-volt HT rectifier by a modern one being a typical case.

In itself this is not a difficult problem, since the surplus volts can quite easily be dropped across a resistance, and the value of this resistance is easy to find from Ohm's Law. Thus, if one volt has to be lost and the valve takes one ampere, dividing volts by current we obtain a resistance value of one ohm.

The question now arises as to the best position for the resistance. It could, of course, be inserted in one of the filament leads, though a better plan would be to divide it into two equal parts and include half the total amount in each lead, as shown at R in Fig. 1, thereby preserving the symmetry of the circuit.

### Choice of Wire

The gauge of wire to use is of some importance, as it is always advisable to avoid an excessive rise in temperature whenever possible.

While there is considerable latitude in the choice of wire, it might be useful to know that No. 28 SWG Eureka will comfortably carry 0.5 amp. For currents greater than this, two or more strands twisted together can be used, the required number being the filament current in amps. divided by 0.5.

No. 28 SWG Eureka has a resistance of 3.914 ohms per yard, but for all practical purposes this may be taken as 4 ohms.

Where one volt has to be dropped and the current is one amp., the resistance should have two strands of wire, and, dividing it into two parts of 0.5 ohms each, simple calculation shows that each strand should be of one ohm. This is obtained with 9in. of No. 28 SWG Eureka.

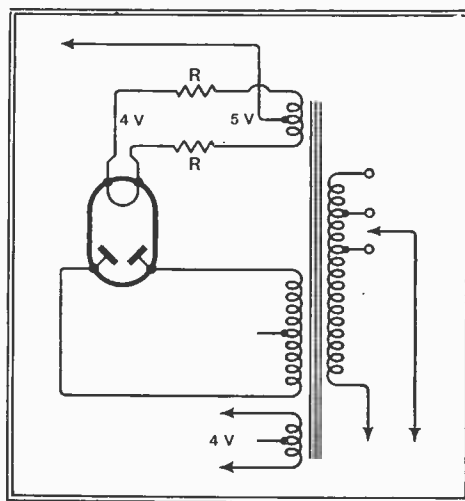
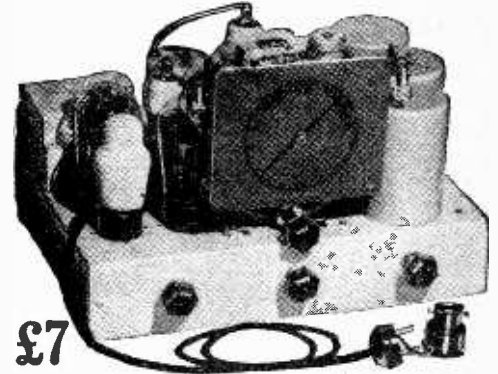

Fig. 1.—The voltage-dropping resistances are joined in the filament leads as shown above.

formers, and for a four-volt one-amp. valve a resistance of two ohms will be required. Two strands of the wire mentioned, each 18in. long, twisted together and coiled, will provide a one-ohm resistance capable of carrying one amp. Two such resistances are, of course, needed, and each takes up about  $1\frac{1}{4}$  in. only.

H. B. D.

**MCCARTHY**  
for the finest value in  
All-Wave Receivers!



**£7**  
**6 VALVE ALL-WAVE  
SUPERHETERODYNE**

(complete with B.V.A. Valves)

Most popular receiver with "Wireless World" readers. The "Wireless World" says: "Sensitivity of the set on all three wave bands cannot fail to give satisfaction . . . excellent results on the short-wave band."

Brief Specification: 8-stage, all-wave band-pass superheterodyne, 7 tuned circuits. D.A.V.C. with "squelch" circuit valve for noise suppression. Illuminated "Airplane" dial. Octode frequency changer. 3.5 watts pentode. Switching for gramophone pick-up. Wave ranges: 16.5-50, 200-550, 800-2,000 metres.

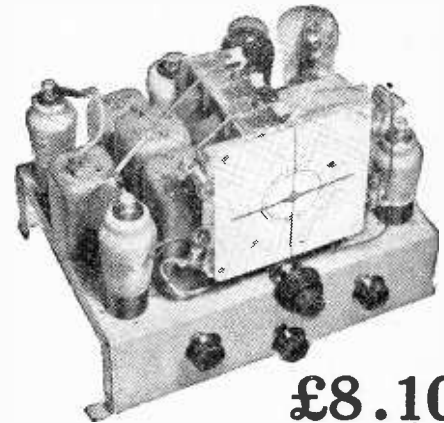

**£8.10**  
**6 VALVE ALL-WAVE  
SUPERHETERODYNE**

(with radio frequency stage)

Performance (made possible by use of multi-electrode valves) equal to that of many 8 valve receivers. 8 stages, 8 tuned circuits, covering 3 wavebands—16.5-2000 metres. Illuminated "Airplane" dial (different coloured lights automatically switched in for each wave range), giving principal station names, with micro-vernier 2-speed drive.

Circuit in brief: Pre-selector circuit, radio frequency amplifier (operative on all three wavebands), triode-hexode frequency changer, double bandpass I.F.T. coupled I.F. amplifier, double diode-triode detector and L.F. amplifier. D.A.V.C. applied to 3 preceding valves. 3 watt pentode output. Variable tone control and volume control operative on radio or gramophone.

All McCarthy receivers supplied complete with valves, knobs, pilot lamps, leads, mains cable and plug. 12 months' guarantee. Deferred terms on application, or through London Radio Supply Co., 11, Oat Lane, E.C.2. Cash with order on 7 days' approval. Also write for illustrated catalogue of complete range of all McCarthy receivers.

**MCCARTHY RADIO LTD.**

44a, Westbourne Grove, London, W.2

Telephone: Bayswater 3201/2.

# New Apparatus

## Recent Products of the Manufacturers

# Reviewed

### ROTHERMEL-BRUSH MICROPHONE MODEL B-1

CRYSTAL microphones of the "sound cell" type are widely used for calibration work and high quality reproduction, but their price has hitherto put them beyond the resources of many who are interested in experimental transmitting and public address work.

The new Model B-1 bridges the gap between the inexpensive diaphragm-actuated types and those with multiple cell construction. It employs a single cell which is mounted on a spring suspension inside an attractively finished dull chromium case.

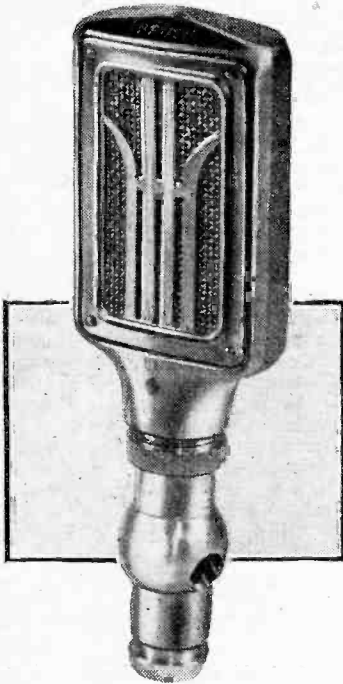

Rothermel-Brush Model B-1 sound cell piezo-electric microphone.

The characteristic is, of course, quite free from any resonances that might be associated with an auxiliary diaphragm, and the cavity resonance of the cell itself, probably in the region of 6,000 cycles, is so well damped that it causes no coloration. The sibilants are reproduced without emphasis and speech is remarkably natural. The only difference in quality between the B-1 and the more expensive G2S2P against which it was tested was in the extremely high frequencies associated with sounds such as the jingling of keys.

The output level of the B-1 is -72 db., i.e., an amplifier with a gain of 72 db. would be required to give an output of 1 volt RMS for a sound pressure of 1 dyne per sq. cm. The internal capacity is of the order of 0.01 mfd., so that the external capacity of leads, which are in any case without effect on the frequency response,

will make little reduction in the overall sensitivity.

Supplies are obtainable from R.A. Rothermel, Ltd., Canterbury Road, High Road, Kilburn, London, N.W.6, and the price is £6 10s. complete with mounting socket.

### SOUND SALES "SUPER AUDITORIUM" LOUD SPEAKER

THE strenuous conditions of PA work will soon reveal any weakness in the mechanical design of a loud speaker, and many types—even in the larger sizes—which have an adequate reserve of power-handling capacity for domestic use develop faults of various kinds if they are pressed into service for use with PA amplifiers.

For this reason Sound Sales, Ltd., have developed a special loud speaker for use with their power amplifiers, and although power-handling capacity and reliability have been given precedence, the frequency response is also outstandingly good. The output at 10,000 cycles is at the same level as that in the lower middle register, and there is a gradual rise, but no pronounced peak in the region between 1,000 and 5,000 cycles. The trough at 7,000 cycles was investigated and found to be solely a property of the axial response, and could not be detected in listening to the general radiation from the diaphragm.

One of the principal points of failure in highly stressed diaphragms is in the annular surround which is usually relied upon, together with the centring spider, for support. Parallel action is achieved in the Sound Sales speaker without any assistance from the surround, which is made of flexible woven material. The suspension is shared by a rear centring spider and a series of radial strips which permit an excursion of the coil of approximately  $\frac{1}{16}$  in. at low frequencies. It might be expected that the strips would develop appreciable amplitudes

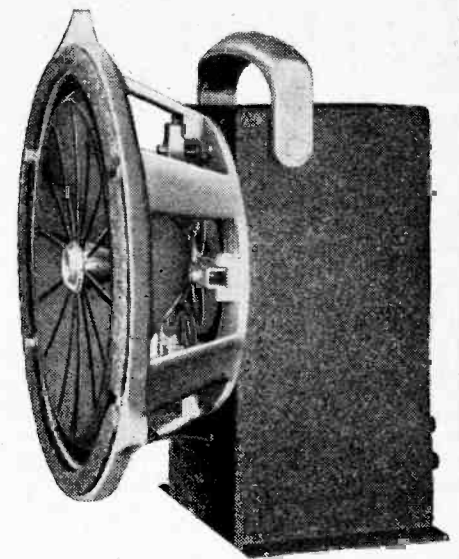

Sound Sales "Super Auditorium" loud speaker with dual suspension.

when the applied frequency resonates with their natural period of transverse vibration. This proved to be the case, but the results were entirely negligible as far as the general radiation from the loud speaker was concerned, as the area of the strips is only a small proportion of the radiating surface.

To make quite sure that damage will not occur as a result of the coil fouling the pole pieces, a gap of  $\frac{1}{16}$  in. has been provided, in which the massive magnet coil produces a field of no less than 12,000 lines per sq. cm.

The "Super Auditorium" is rated to handle 15 watts when fitted with a proper baffle, and the price is £12 complete with output transformer.

## The Radio Industry

THE Belling-Lee Set Lead Suppressor, Type 1256, has been discontinued in favour of an all-wave suppressor (Type 300, price 21s.) which is effective on wavelengths above 10 metres—and to some extent even below. The Type 300, which is rated at 1 amp., now becomes the standard suppressor for connection in the power supply lead.

Alumize, Ltd., of 34, North Street, Rugby, has developed a metallurgical process for joining together parts of aluminium and its alloys. Those who are interested in the applications of the process to wireless work are invited to apply for particulars.

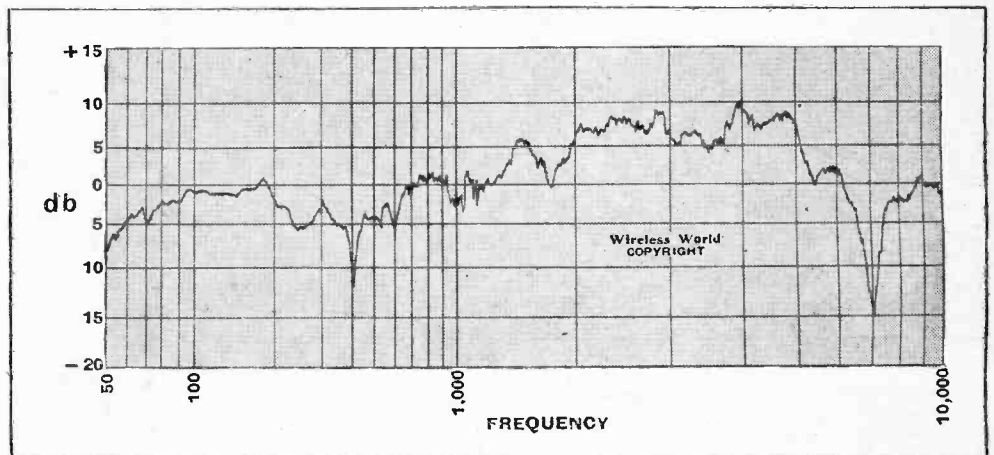

Axial response curve of Sound Sales "Super Auditorium" loud speaker on irregular baffle (area approx. 22 sq. ft.), microphone distance 4ft., power input 1 watt.

# Letters to the Editor

The Editor does not hold himself responsible for the opinions of his correspondents

## SW Fade Out

IT may be of interest to some of your readers to know of a remarkable effect which I observed on Thursday, December 3rd, 1936.

I was listening to GIA on approximately 15 metres at noon G.M.T., and was receiving him at about R5 as against his usual R7/8, when suddenly, at 12.15 p.m. G.M.T., he began to fade, and within three minutes had disappeared completely.

I promptly tuned in to Daventry (GSH) on 13.97 metres, bringing him in at R4 instead of his usual R7/8, and within a few seconds he had disappeared as well.

I then tried to tune in the numerous CW stations, which are always to be found working on wavelengths between 13 and 28 metres, but there was no sign of a single one of them and the ether seemed completely dead.

I tested the set in case any of the components or the batteries had failed, but all were in order, and the ignition systems of lorries passing on the road could be clearly heard, so the set was not to blame.

At 12.55 p.m. G.M.T. I tuned in again on 13.97 metres and found Daventry coming in at a strength of R8, and GIA about the same.

I happened to mention this complete "fade out" to a friend of mine at 2 p.m. G.M.T. the same day. He said that he also had experienced a similar complete fade out between the times mentioned by me, and could not pick up any stations at all between 13 and 50 metres on his eight-valve short-wave superheterodyne.

My set is a straight four-valve short-wave set with a pentode output, battery operated, with plug-in coils. The night of December 2nd had been very thundery, without a storm actually taking place, and the static

had been a good X9, so that listening was practically impossible. On the day of December 3rd there was practically no static.

I should be very interested to know whether any of your readers experienced a similar complete "fade out" on this date, and also whether any reason can be given for it.

P. F. M. BARRETT.

4th Dec., 1936.

Gold Coast Colony.

[This "fade out" was commented upon by Ethacomber in *The Wireless World* of December 25th, 1936, page 670.—ED.]

## Value Nomenclature

I HAVE read with interest a paragraph in the columns of "Diallist" in which he pleads for a more appropriate name to describe what we know as a "valve."

I notice that he considers the word valve is less apt for an amplifier than a rectifier. I think in this case he is thinking of some kind of non-return or safety valve for his mechanical analogy. The type of mechanical valve that I visualise in this connection is the type for controlling the flow of liquids or gases by means of a handle (what is known as a tap when on a small scale).

With this analogy one can consider the small energy required to turn the tap or valve to correspond to the grid potential and the powerful flow of fluid to correspond to the strong electron flow.

With this outlook I do not think the word valve is quite so inappropriate in describing amplifiers. (The flow of water in a small tube can actuate a valve of another tube carrying far more water.)

It seems a little difficult to find a more descriptive name applying in general to all radio valves. The only one I can think of is electron flow control tube, or electron-control tube.

I am afraid this would delight none but the Teutonic mind.

May I suggest that an entirely new word should be coined? I submit *electrol*, a shortened form of electron control.

This word, unfortunately, loses most of its descriptiveness. However, no word which is descriptive in one language can be fully descriptive in another.

In this case I may mention the standardisation of the names of the chemical elements. They are quite non-descriptive in any modern language, and yet they have been accepted by all countries.

London, W.C.1.

J. ARNOLD.

## Rejecting Whistles

I AM so sorry to see from your issue of December 25th that my previous letter had quite failed to soothe Mr. Baggally—perhaps his Christmas holiday has now succeeded in doing so.

It seems to me that the matter could only be fully argued out in a long and very high-brow letter, which I am certainly not going to write. After all, the proof of the pudding is in the eating. My whistle-filter suits me better than his, and I would not for the world quarrel with him if, in spite of that, he prefers his own.

P. K. TURNER.

Isleworth.

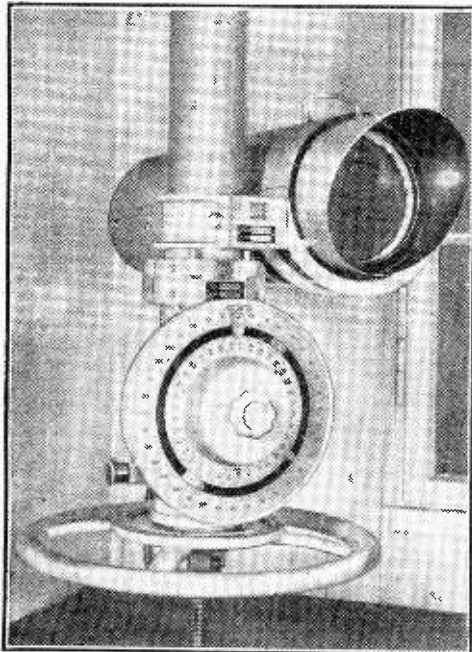

NEW GERMAN DIRECTION FINDING EQUIPMENT. To obtain the most accurate measurement possible the Telefunken Co. have made use of a cathode-ray tube mounted in the convenient manner shown in apparatus of recent design.

## POINTS OF IMPORTANCE in the Rola G.12



### THE "ROLLS-ROYCE" OF LOUDSPEAKERS

Used to denote perfection, the term Rolls-Royce has become part of the English language. When it comes to radio sets nothing denotes perfection so surely as the use of a Rola G.12. No manufacturer would use a speaker of the very highest quality unless he intended his whole set to be worthy of its reproduction. The Rola G.12 is a high fidelity 12" diameter unit of unsurpassed performance. Already manufacturers have found that it is the models with G.12 speakers that show the greatest sales increase. Be guided by their experience—install Rola G.12's in your receivers.

G.12 D.C. (as illustrated) Stripped and without Transformer ...	£3 15 0
G.12 D.C. Complete with Transformer, Mounting Stand, Handle and Base ...	£5 5 0
G.12 D.C. with Mounting Stand, Handle and Base, but without Transformer ...	£4 16 0
G.12 D.C. Stripped, but with Transformer ...	£4 4 0
(When ordering please state Field Resistance and Impedance of Transformer required.)	
G.12 P.M. less Transformer ...	£4 16 0
G.12 P.M. with Transformer ...	£5 5 0

For Public Address work both the P.M. and Energised Models can be supplied with a 15 ohm Voice Coil at an additional charge of 3/-.  
Write for Folder A.

OVER 7 MILLION IN USE

# ROLA

The World's Finest Reproducers

THE BRITISH ROLA CO., LTD.  
MINERVA ROAD, PARK ROYAL, N.W.10.  
PHONE: WILLESDEN 4322-3-4-5-6.

**Brief descriptions of the more interesting radio devices and improvements issued as patents will be included in this section.**

# Recent Inventions

## "IMPACT" AMPLIFIERS

A "cold" electron-amplifier consists of a series of open or network electrodes arranged, in increasing order of potential, along the axis of a series of concentric cylinders biased to a relatively higher potential. The first series of electrodes A . . . D are aligned inside the cylinders A1 . . . C1, the biasing voltages for each being tapped off from a common source of HT. The whole of the electrodes are enclosed in a cup-shaped collector K carrying the highest potential.

An electron entering the device at E strikes against the first open-work electrode A, and the secondary electrons so produced are accelerated and strike in part against the next plane electrode B and in part against the open-work cylinder A1. This process is repeated at the electrodes B and B1, until the amplified stream reaches the final stage D, from which it passes to the collector K and so to the out-

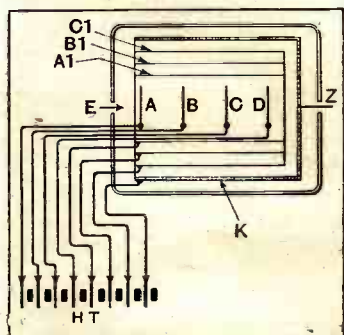

Electrode assembly in the cold cathode-ray-type amplifying valve.

put lead Z. The amplifier works without inertia and in a vacuum, without any gas-filling. The electrodes are preferably coated with caesium oxide to increase emission.

*The British Thomson-Houston Co., Ltd., Convention date (Germany), March 7th, 1935. No. 454133.*

## TUNING INDICATORS

THERE is a known type of tuning indicator in which the deflection of the spot of light on the fluorescent screen of a small cathode-ray tube shows when the circuits are accurately in resonance with the incoming signals.

According to the invention this idea is applied to a combined sound-and-picture receiver, the cathode-ray tube normally used to reproduce the televised picture being utilised to show also when the circuits are correctly tuned.

As shown in the Figure the cathode-ray tube C is arranged to be switched momentarily across a

resistance R in the anode circuit of the first detector valve V of a superhet receiver. When the switch S is moved to the upper pair of contacts the voltage across

## BROADCAST RELAYS

IN order to allow each subscriber in a wired relay system to control the tone response of his own loud speaker, without affect-

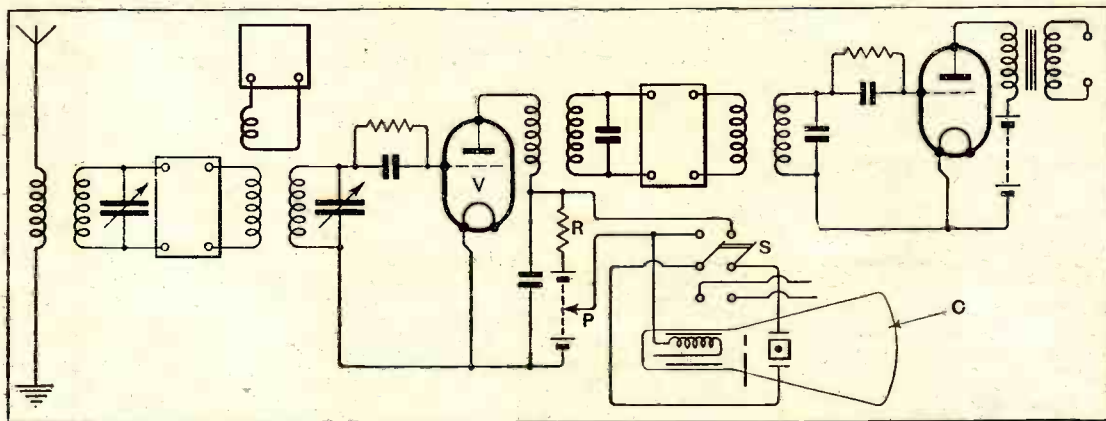

Arrangement of the circuit for using the cathode-ray tube in a television receiver as a tuning indicator.

R deflects the electron stream so as to indicate whether or not the tuning is correct. The degree of deflection that indicates resonance can be controlled by adjusting the tapping point P. On moving the switch S to the lower contacts scanning-voltages are applied to the deflecting plates of the cathode-ray tube from the usual time-base circuit (not shown).

*Marconi's Wireless Telegraph Co., Ltd., and A. A. Linsell. Application date March 11th, 1935. No. 453499.*

## BAND-PASS COUPLINGS

THE Figure shows a coupling suitable for handling television or other signals having a bandwidth greater than 20 k/cs. The coil A in the anode circuit, say of the first intermediate-frequency

ing other subscribers' instruments which may be connected in parallel, a variable resistance shunted by a fixed or variable choke is inserted, as a unit, in series with one of the supply leads. A switch allows the unit to be brought into operation or short-circuited, as required.

*G. A. Barden and Goodmans (Clerkenwell), Ltd. Application date January 17th, 1936. No. 454903.*

## DIRECTION-FINDING BY TELEVISION

THE bearings of a ship relative to a distant beacon-station are transmitted to it by television, so that the required information is shown directly in visual form. A picture of a compass scale, sur-

mounted by the name of the beacon station, is transmitted omnidirectionally. At the same time a directed "beam" is swung around the horizon from the same transmitter, and this is used at the receiving end to produce a sudden change in the overall illumination

of the received picture. The particular compass reading that occupies the centre of the receiver screen at the moment of the sudden change then indicates the required bearing.

One advantage is that only a single wavelength is required to transmit both the picture and the directed beam, whilst a second is that the critical bearing—indica-

tion is shown with sharp discrimination.

*Marconi's W. T. Co., Ltd.; R. K. Kemp and D. L. Plaistowe. Application date March 27th, 1935. No. 454256.*

## SHORT-WAVE RESONATORS

THE Figure shows a resonator or oscillatory unit used for ultra-short waves. It consists of a central conductor A fitted at each end with bell-shaped portions B

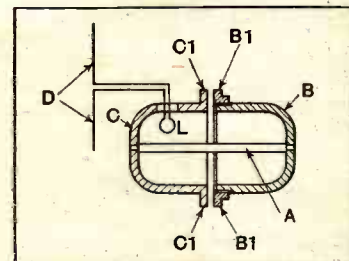

Method of coupling an ultra-short wave aerial to a high "Q" oscillatory circuit.

and C having flanges B1, C1 to increase the capacity between them. One of the flanges B1 is adjustable relatively to the other. The unit oscillates by virtue of its distributed inductance and capacity.

One advantage of the unit is that there is very little damping, so that the frequency is stable, whilst another is that it produces no external field. The part A is provided with an aperture to admit a single wire loop L which couples the resonator to a dipole aerial D.

*N. V. Philips' Gloeilampen-fabrieken. Convention date (Germany), March 18th, 1935. No. 454208.*

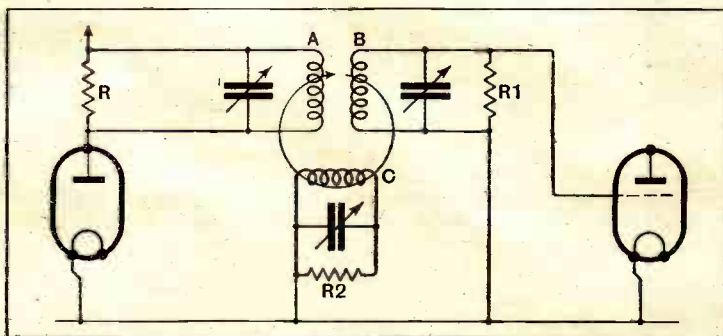

Wide-band inter-valve coupling circuit for television reception.

valve of a superhet receiver, is tuned approximately to the lower limit of the frequency band, whilst the coil B in the grid circuit of the next amplifier is tuned to the upper limit. A third coil C, coupled to the other two, is tuned substantially to the middle of the frequency band. Each circuit is damped by parallel resistances R, R1, R2, whilst the mutual coupling between the coils is adjustable.

*L. R. Meydler and Baird Television Ltd. Application date March 18th, 1935. No. 453847.*

The British abstracts published here are prepared, with the permission of the Controller of H.M. Stationery Office, from Specifications obtainable at the Patent Office, 25, Southampton Buildings, London, W.C.2, price 1/- each. A selection of patents issued in U.S.A. is also included.

# MISCELLANEOUS ADVERTISEMENTS

## NOTICES

**THE CHARGE FOR ADVERTISEMENTS** in these columns is

12 words or less, 3/- and 3d. for every additional word.

Each paragraph is charged separately and name and address must be counted.

**SERIES DISCOUNTS** are allowed to Trade Advertisers as follows on orders for consecutive insertions, provided a contract is placed in advance, and in the absence of fresh instructions the entire "copy" is repeated from the previous issue: 13 consecutive insertions 5%; 26 consecutive, 10%; 52 consecutive, 15%.

**ADVERTISEMENTS** for these columns are accepted up to **FIRST POST** on **MONDAY MORNING** (previous to date of issue) at the Head Offices of "The Wireless World," Dorset House, Stamford Street, London, S.E.1, or on **SATURDAY MORNING** at the Branch Offices, 19, Hertford Street, Coventry; Guildhall Buildings, Navigation Street, Birmingham, 2; 260, Deansgate, Manchester, 3; 26a, Renfield Street, Glasgow, C.2.

Advertisements that arrive too late for a particular issue will automatically be inserted in the following issue unless accompanied by instructions to the contrary. All advertisements in this section must be strictly prepaid.

The proprietors retain the right to refuse or withdraw advertisements at their discretion.

Postal Orders and Cheques sent in payment for advertisements should be made payable to **ILIFFE & SONS Ltd.**, and crossed **& Co.** Notes being untraceable if lost in transit should not be sent as remittances.

All letters relating to advertisements should quote the number which is printed at the end of each advertisement and the date of the issue in which it appeared.

The proprietors are not responsible for clerical or printers' errors, although every care is taken to avoid mistakes.



## DEMONSTRATION

*"The proof of the pudding . . . . ."*

A few days ago a new customer wrote to us, apparently almost in fear and trembling, to ask whether if he called on us he could actually hear our products.

So we want to make our views clear to you as we did by letter to him: *we infinitely prefer our clients to hear before they buy.*

No matter whether you are a skilled amateur or a non-technical lover of music—our staff will discuss your requirements intelligently, without trying to force a sale.

Open house is kept during our usual business hours (9 to 6 except on Saturdays, when they are 9 to 1) and during that time we try always to have a skilled demonstrator available.

We do even more: for those who cannot get here during business hours we are almost always ready to demonstrate at other times; but for this it is necessary to arrange an appointment. It is, in actual practice, always advantageous to make an appointment, for an unexpected caller may have to be kept waiting. There is always the possibility that the piece of apparatus he particularly wants to hear may not be connected up, or that the demonstration room may be engaged.

For the benefit of callers, here is a simple map showing our location. We give it, not because our office is hard to get to—it isn't: but because the postal address is rather misleading as to the best way to reach it.

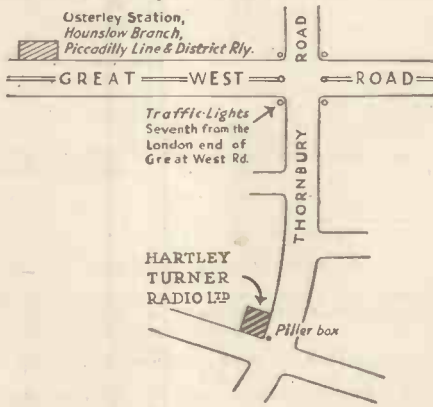

Here are a few further notes for those coming by road from more distant places.

From the West and South-West: make for the Great West Road, and then follow our map.

From North-West, North and North-East: get on to the North Circular Road, follow it to the Great West Road; and then follow our map.

From South-East and South: make for Richmond; there enquire for Isleworth, and then for Thornbury Road in Spring Grove.

Wherever you come from, we shall be glad to see you.



**HARTLEY TURNER RADIO LTD.,**  
**THORNBURY ROAD,**  
**ISLEWORTH, MIDDLESEX.**  
 Telephone: HOUnslow 4488

## NUMBERED ADDRESSES

For the convenience of private advertisers, letters may be addressed to numbers at "The Wireless World" Office. When this is desired, the sum of 6d. to defray the cost of registration and to cover postage on replies must be added to the advertisement charge, which must include the words **Box 000, c/o "The Wireless World."** All replies should be addressed to the **Box number** shown in the advertisement, *c/o "The Wireless World,"* Dorset House, Stamford Street, London, S.E.1. Readers who reply to **Box No.** advertisements are warned against sending remittance through the post except in registered envelopes: in all such cases the use of the **Deposit System** is recommended, and the envelope should be clearly marked "Deposit Department."

## DEPOSIT SYSTEM

Readers who hesitate to send money to advertisers in these columns may deal in perfect safety by availing themselves of our **Deposit System.** If the money be deposited with "The Wireless World," both parties are advised of its receipt.

The time allowed for decision is three days, counting from receipt of goods, after which period, if buyer decides not to retain goods, they must be returned to sender. If a sale is effected, buyer instructs us to remit amount to seller, but if not, seller instructs us to return amount to depositor. Carriage is paid by the buyer, but in the event of no sale, and subject to there being no different arrangement between buyer and seller, each pays carriage one way. The seller takes the risk of loss or damage in transit, for which we take no responsibility. For all transactions up to £10, a deposit fee of 1/- is charged; on transactions over £10 and under £50, the fee is 2/6; over £50, 5/-. All deposit matters are dealt with at Dorset House, Stamford Street, London, S.E.1, and cheques and money orders should be made payable to **Iliffe & Sons Limited.**

**SPECIAL NOTE.**—Readers who reply to advertisements and receive no answer to their enquiries are requested to regard the silence as an indication that the goods advertised have already been disposed of. Advertisers often receive so many enquiries that it is quite impossible to reply to each one by post. When sending remittances direct to an advertiser, stamp for return should also be included for use in the event of the application proving unsuccessful.

## NEW RECEIVERS AND AMPLIFIERS

(This advertisement continued from first column.)

tion, prizmatone high fidelity R.F. preselector stages on all bands, carriage, 6/-. for experimenters, less cabinet deduct 15/-. If public address Rola 12in. G.12 supplied in place of standard speaker, add £2.

**£17/17.**—Challenger 8 Console 800 C., height 3 feet 6 inches, width 24 inches, depth 12½ inches, chassis as incorporated in 800 model but incorporating the G.12 high fidelity 12in. speaker; carriage and crate 10/-.

**29** Guineas.—"Challenger 800 R.G." radiogram with automatic record changer; measurements, height 2 feet 8 inches, width 3 feet, depth 21 inches; this also incorporates the G.12 and tweeter; carriage and crate 15/-.

**NOTE.**—The Challenger 800 is available for A.C./D.C. 200-250 volts, employing 11 valves, at an additional cost of 20/- on each model.

**£16.**—Challenger 12 A.C./D.C. 200-250 volts, 4 bands 11-2,050 metres, the first time that D.C. users have been able to get 10 watts undistorted from their speaker, which is a large 12in. K. type Rola, triple parallel rectification, push-pull parallel four pentode output, carriage and crate 7/6.

**£50.**—Challenger "Model 5240" 24-valve superhet. twin chassis, valve and "2" Public address speaker, with 60 watts undistorted output, sensitivity ¼ microvolt absolute, tuned H.F. stages on all bands, 3 I.F. stages, the last one being used for selectivity only, frequency response at the speakers within 2db over whole range, wave band coverage 5-2,050 metres in 5 bands, Magic-eye tuning, variable selectivity, receiver chassis heavily shielded and chromium plated, Centro-Master automatic control unit, dual rectifier, signal channel separate from A.V.C. system, linear diode detection, separate rectifier to provide A.V.C. voltage, radio frequency pre-amplifier stages eliminate repeat points and whistles, and provide maximum signal to noise ratio, beam power output valves, polychromatic dial scale, prizmatone high fidelity, uni-control 2-speed free-wheeling tuning, band spread Magna dial and second-hand, automatic band indicator, automatic interstation noise suppression, separate bass boosting amplifier, automatic frequency control, iron core I.F. transformers, code interference filters, automatic volume control, beat frequency oscillator; carriage 18/-; also available in various gramophone and console cabinets.

**DEGALLIER'S Ltd.,** 18, Connaught St., Marble Arch, London, W.2. Paddington 2745. [3536]

## ALERT RADIO Co.

**ALL-WAVE** Receivers at £7/7, £9/9, and £13/13, A.C. or A.C./D.C.; Midget and other receivers up to 23 valves; for DX work we can supply the latest communication models.—21, East Rd., N.1. Clerkenwell 4871 [3220]

## HARMAUR RADIO 1937 Receivers.

**AMERICAN-BOSCH "Centromatic"** All-wave Sets. Freed-Eisemann compact portable receivers, Pierce Alro A.C./D.C. all-wave and car. radios, Raytheon valves; trade enquiries.

**THE HARMAUR RADIO Co., Ltd.,** 8, Clifford St., New Bond St., London, W.1. [0499]

## NEW RECEIVERS AND AMPLIFIERS

### A

**DEGALLIER'S Ltd.,** the Firm for Reliable Short Wave Radio (1937), have on show in London the largest selection of fully guaranteed brand new all-wave receivers; callers invited to handle all at their leisure without obligation to purchase; all S.W. receivers guaranteed to get stations on the low bands, including the Americas, etc. Hours of business, 11 a.m.-7 p.m., Saturdays 9 p.m. Early closing day Mondays. All goods cash with order or c.o.d.; handsomely illustrated catalogues available; send large stamped addressed envelope with all enquiries.

**WE** Guarantee to Receive the American Transmissions at full programme strength after 3 p.m. daily; those interested welcomed without obligation.

**6/6** Each.—Valves for American receivers, all guaranteed, each a first, no seconds or throw-outs; for every known set, from 1927-37; metal, metal glass, glass counterparts and glass; in ordering, just state type and number; we have it, even up to the latest 6L6; all post paid; line cords for all Midgets, 4/6.

**30/-**—"Doublet" Aerial Belden No. 8917, complete ready to erect; the most efficient made, having a variable coupling unit covering all bands.

**£9**—"Challenger" Table Grand Model 7-valve superhet, "Mono-vision" tuning control, A.C. 200-250 volts, 3 bands 17-55, 190-550, 800-2,000 metres, 5 watts output, tone control, delayed A.V.C.; carriage 4/6; (16½×16×8).

**£9**—"Challenger" Table Model 6-valve superhet, 3 bands, 16-52, 190-550, 900-2,000 metres, A.V.C. tone control, P.U. terminals (17×13×9), A.C./D.C., 200-250 volts; carriage 4/-; also available in A.C., same price.

**13** Guineas.—The new Challenger 8 (type 800) table model De Luxe, 22×18×12 high fidelity 8-valve superhet, A.C., 200-250 volts, wave-band coverage 11-2,050 metres, simplified centralised tuning, super Vernier, slow-fast tuning self-contained control panel, perfect tone quality at low volume, new type 10-inch M.C. speaker, from a whisper to 8 watts pure undistorted tone, no overloading at full volume oscillator fundamental without use of harmonics, persistent oscillator of highest output, isolating filters eliminate oscillation and motor-boating, fully delayed A.V.C. bias, absolute minimum of noise and sensitivity control for noise suppression, A.V.C. re-enforced capacitors prevent drift, pre-aged intermediate frequency transformers, I.F. barrier, discs, anchor coil leads, plug in loud-speaker, also provision for external speaker, moisture sealed out by tropical zone impregnation, self healing electrolytic condensers, one complete chassis of dreadnought construction, moderate voltages assure full valve life, economical to operate (consumption 65 watts), long life eliminates repairs, correct valve selection, no compromise, no hum, full weight transformers, true push-pull, stabilised high tension supply, stabilised biases, ceramic coil insulation, fully loaded plate coils give maximum gain, pre-balanced coil assembly, matched sets of individual coils, no taps, sealed insulation, thin laminations of special silico steel, 7 K.C. selectivity, fractional microvolt sensitivity, shielded switching, permits high-gain, positive silver-plated contacts, eliminates switch noises, audio frequency range 30-8,000 cycles, diode detec-

(This advertisement continued in third column.)

## NEW RECEIVERS AND AMPLIFIERS

**AIR KING.**

THE Royalty of Radio.

**MODEL Empire 11-valve 4-band Supersonic Heterodyne Receiver for A.C. 100 to 250 Volts, incorporating every refinement known to modern radio technique, large illuminated dial, indicating each wave band separately marked in station names, wavelengths, and frequencies, with the famous exclusive beam tuning system, Magic Eye indicator for increased sensitivity and silent precision tuning, illuminated indicators to show high fidelity and gram. pick-up, high fidelity assured by two balanced speakers, one acting as special amplifier for high audio frequencies and one large concert type dynamic speaker for full range. audio frequency range from 40 to 9,000 cycles, special band expansion intermediate frequency transformer on first stage, variable selectivity, full range variable tone control, A.V.C.**

**MODEL Duchess 6-valve 3-band Superhet. Receiver for A.C. 100 to 250 Volts; this receiver is housed in an attractive lay down walnut cabinet.**

**MODEL Envoy for A.C./D.C. Mains, 100 to 250 volts, no line cord used.**

**MODEL Marquis 6-valve 3-band Superhet. Receiver for A.C. 100 to 250 Volts, in tastefully designed moulded one-piece bakelite cabinet, obtainable in ivory, red, walnut and ebony.**

**MODEL Ermine 6-valve 3-band Superhet. Receiver for A.C./D.C. 100 to 250 Volts, no line cord used, a splendid set of proven popularity.**

**ALL Models Feature Beam Tuning, Magic Eye indicator, gram. pick-up connections, and special output valves.**

**ALL Sets Fully Guaranteed.**

**H.P. Terms Available from 3/- per Week.**

**OUR Technical Department is at Your Service.**

**RECTURUS Valves for Improved Radio Reception on All Types of Receivers.**

**RECTURUS, the only line made in 4 ranges, glass, metal, G type, and metal modernisers.**

**WRITE for Lists of These Famous Valves; prices from 4/9 each.**

**WHOLESALE and Trade Enquiries Invited; generous terms.**

**AIR KING RADIO, 115, Shaftesbury Av., Cambridge Circus, W.C.2 (1st floor above Barclay's Bank). Phone: Temple Bar 4875 (all lines). All receivers assembled in England. [3408**

**ROYAL RADIO Co.**

ESTABLISHED 1908.

**ALL-WAVE Receivers, suitable for use on ships, as supplied to officers of many shipping lines.**

**OUR 8 and 10 Metal Valve All-wave Receivers; 15-2,000 metres, acknowledged by the trade as the best for range, tone, and general performance.**

**LATEST 6-valve Car Radio, A.V.C., remote control, no suppressors required.**

**FULL Range of the World Famous Fergusson and Pilot Models Stocked.**

**ALL Sets Fully Guaranteed by Ourselves.**

**ALL Types of American Valves Stocked.**

**ANY Make of Set Serviced by Our Qualified Radio Engineers at Reasonable Charges.**

**PAY Us a Visit Any Time, or send for full range catalogue; 13½d. stamp will be appreciated.**

**ROYAL RADIO Co., 5, Buckingham Rd., South Woodford, London, E.18. Phone: Buckhurst 2736. [3499**

**"SERVICE With a Smile."**

**HENRY FORD RADIO, Ltd.,**

**ELECTRONIC House, 22, Howland St., Tottenham Court Rd., W.1. Museum 5675. [0511**

**£3 BUYS the Swellest Compact on the Market, 4 valves A.C./D.C. M.O. speaker, smart fabric covered case, good quality reproduction, plenty of stations.**

**£5/19/6 —6-valve all-wave superhet, A.C./D.C., National Union valves, 17/2,050 metres.**

**£9/9 —7-valve all-wave super, with cathode ray tuning eye, mono-vision dial, marvellous performance.**

**£10/10 —All-wave superhet, 1937 model with R.F. stags, Universal transformer, 100-250 volts A.C.**

**£13/13 —8-valve 4-band superhet, 12½/2-050 metres, 8 watts output, every, modern refinement, available in A.C. and A.C./D.C.**

**ALL Sets 100% Guarantee, set 12 months—valves 6 months; carriage free; satisfaction or money refunded.**

**RADIOGRAPHIC, Ltd., 66, Osborne St., Glasgow, C.1. [3495**

**TRANS-ATLANTIC RADIO Co., 15, Percy St., W.1. Museum 3096.—Splendid range of American A.C./D.C. Compacts from £3; all-wave consoles, etc.; Philcocks stocked.**

**TRANS-ATLANTIC for American and English Repairs; "Wireless World" sets a speciality (24 hours service). "The finest service at your disposal." [3513**

**CHASSIS, modern all-wave and two-band designs available; chassis and sets to your requirements; fourteen years' specialised experience.—Bercliff (Simmonds Bros.), 38, Rabon Lane, Smethwick. [3525**

**PILOT, Ferguson, Pegasus and Air King all-waves lead the field; our deliveries are prompt in original cartons with full guarantees; your trade card will bring our wholesale catalogue from the authorised distributors.—Leonard Heys, 36, Henry St., Blackpool. [0530**

**New Year Good Wishes and Bargains from****GALPINS ELECTRICAL STORES**

75, LEE HIGH RD., LEWISHAM, LONDON, S.E.13.

TERMS : CASH WITH ORDER OR C.O.D.

Telephone : Lee Green 5240.

**DYNAMO BY "CROMPTON,"** shunt wound, four pole, output 50/75 v. 25/20 amps, £4 10s.

**TRANSMITTING VARIABLE CONDENSERS,** .0005 m. glass case type, 12/6.

**FLOUORESCENT SCREEN,** 17x14in., framed, as new and complete with protected mounting frame, £3 10s. C/F.

**X-RAY TUBES,** new condition, with Tungsten Target, 15/-; with Platinum Target, 20/- C/F. Packing free.

**EX-R.A.F. MORSE KEYS,** fully adjustable, price 2/6. Post 6d.

**WESTERN ELECTRIC MICROPHONES,** solid back type, very sensitive, 2/6 each.

**MICROPHONE TRANSFORMERS,** high ratio, finest quality, 2/6 each.

**ELECTRIC LIGHT CHECK METERS,** Maker "Ferranti" 1 kilowatt-hour type, 200/250 v. single phase 50 cycle, for subletting, etc., 6/- each. Post 1/-.

**MULTIPLE SWITCH,** with sensitive actuating Relay, as new, ex. automatic Phones, 4/6 each.

**VARIABLE RESISTANCES,** 300 ohms 1/2 amp., 20 studs, small size, 12/6.

**DYNAMOS** for Lighting or Charging, all shunt wound, fully guaranteed, 150 v. 1 a., 17/6; 20 v. 5 a., compound, 30/-; all C/F.

**CHARGING RESISTANCES** or Shunt Regulators, Stud, switcharm type, 12/6 each, to suit your requirements.

**C.A.V. AUTOMATIC CHARGING CUT-OUTS,** suit any voltage, 7/6 each.

**ISENTIAL VARIABLE RESISTANCE,** to carry 10 to 15 amps., fitted 0 to 15 a/ampeter and Pilot Lamp, as new, 17/- C/F.

**G.P.O. GLASS TOP RELAYS,** Type B, highly sensitive, 7/6 each.

**DUPLEX TELEGRAPH MORSE KEYS,** send-and-receive type, 12/6.

**BRIDGE TYPE GALVOS.,** horizontal type, super sensitive, fully calibrated scale, price 7/6. Post 6d.

**BELLING ELECTRIC FIRES,** 200/250 volts 2 kW., 2- or 3-bar type, in good condition, 15/- C/F.

**EXIDE 2-volt 30/60 a.h. unspillable Accumulators,** type 3P23. Guaranteed sound. 2/6 each. Post 1/-.

**MOVING COIL METER Movements** for recalibrating into multirange meters, 5/6 each.

**FILAMENT TRANSFORMERS,** 220 v. input, 20 v. 32 amps. out, 35/- C/F.

**DIMMER SWITCH** for 12 volt control, suitable for regulating electric trams, 12 v. lighting, etc., 2/6 each.

**R.A.F. CHARGING CUT-OUTS,** also fitted voltage regulators, fully adjustable, suitable for 12 to 20 volt charging dynamo, price 2/- Post 6d.

**EX-R.A.F. SEARCHLIGHT,** 12in. dia., beam arc type, as new, power 2 kW., £3 10s. C/F.

**EX-R.A.F. TRANSMITTER,** 3 valve (no valves), in case 12x8x6, short wave approx. 10 to 50 metres, 10/- Post 1/-.

**EX-R.A.F. MICROPHONE TRANSFORMERS,** various ratios, high grade, 3/6; Ditto, without case, 2/6.

**VENNER TIME SWITCH,** 250 volt 20 amp., 45-day clock, £3.

**HIGH-VOLTAGE CONDENSERS,** 1 mf., 2,500 v. test, 2/6, post 6d.; 005, 30,000 volt, oil, 15/-; 1 mf., 2,000 v. working, 3/6.

**MAINS LIGHTING DIMMERS,** Slider type, Worm and Wheel drive, 1 kW., 25/-; 2 kW., 32/6.

**B.T.H. VARIABLE RESISTANCES,** 250 ohms, 1 to 3 amps. 15/- C/F.

**ZENITH VITREOUS RESISTANCES,** 3,000 ohms, 200 m/A, 2/-; 2,000 ohms, 100 m/A, 1/-; 30,000 ohms, 50 m/A, 1/6; 1,000 ohms, 200 m/A, 1/3; 120 ohms, 1/2 amp., 1/- Post 3d.

**EX-R.A.F. MARCONI R. VALVES,** 6 v. Bright Emmitta, suitable for small experimental transmitters, Morse practice, etc., 1/- Post free.

**TEAK BOXES,** size 10in. x 10in. x 10in., covered with waterproof canvas, fitted carrying strap and folding aluminium stand, condition new and unused, suitable for tool boxes, mounting all test meters, portable wireless sets, etc., etc., price 1/9. Post 6d.

**MAGNETIC KEY,** on base 3 1/2in. by 7in., triple contact, solenoid action, low voltage working, 2/6. Post 6d.

**MULTIRANGE METER,** moving coil, 3 1/2in. scale, reading 0-50 and 0-500 m/A, also 0-5 and 0-50 volts, 20/-.

**MORSE KEY and BUZZER** (high note), complete on mahogany base with terminals, long bar key, solid brass construction, not a toy, but a serious G.P.O. type-Morse practice set, price 5/- Post free.

**20-WATT AMPLIFIERS,** "Savage" Transformers and Chokes, "Mullard" and "Marconi" Valves, complete set wired ready for use, believed in perfect working order, but not guaranteed, 220 v. A.C. mains working, £4 15s. C/F.

**SAVAGE TRANSFORMERS,** 450-0-450, 250 m/A, 4 v.-7 a., 4 v.-4 a., 4 v.-4 a. and 4 v.-2 a., 22/6; Ditto, 1,000-0-1,000 v., 250 m/A, 25/-.

**SAVAGE CHOKES,** 40 Henry, 250 m/A, 15/-.

**VISUAL WAVE METERS,** 350 to 550 metres, 6/6.

**TWO-VALVE AMPLIFIERS,** with valves, suitable for Microphone or Gramophone, 7/6.

**P.M. LOUDSPEAKERS** by well-known makers, in Walnut cabinet, fitted volume tone control, 12/6 post free; Ditto, no cabinet, 10/- post free.

## NEW RECEIVERS AND AMPLIFIERS

**ARMSTRONG COMPANY** Manufacture 8 Radio Receivers in Chassis Form, briefly described hereunder.

**ARMSTRONG 6-valve All-wave Superheterodyne Radiogram Chassis,** for A.C. mains, complete with Rola speaker; £7/10.

**ARMSTRONG 8-valve 4 Wave-band Radiogram Chassis,** with phase reversed push-pull output; £9/17/6.

**ARMSTRONG 6-valve 4 Wave-band Radiogram Chassis,** with large triode output; £8/17/6.

**ARMSTRONG 8-valve 4 Wave-band Radiogram Chassis,** with radio-frequency stage and push-pull output; £11/11.

**ARMSTRONG 7-valve 4 Wave-band Radiogram Chassis,** with radio-frequency stage and single triode output; £10/10.

**ARMSTRONG 8-valve 2 Wave-band Radiogram Chassis,** with 8 watt push-pull output; £8/10.

**ARMSTRONG 6-valve 2 Wave-band Radiogram Chassis,** with single large triode output; £7/10.

**ARMSTRONG Chassis Carry 12 Months' Guarantee.**

**ARMSTRONG Chassis are Sent 7 Days' Trial,** carriage, packing, and crate free.

**ARMSTRONG MANUFACTURING Co.,** 100, King's Rd., Camden Town, N.W.1. [3460

## RECEIVERS AND AMPLIFIERS

## CLEARANCE, SURPLUS, ETC.

**ALL Regentone Sets,** advert. last week, still available.

**HENRY'S 72, Wellington Av., London, N.15. Stamford Hill 2907. [3545**

**CLEARANCE List (Trade Only).—Write Leonard Heys, 36, Henry St., Blackpool. [0527**

**SEND for Bargain List of Brand New Decontrolled Receivers; amazing prices.—P. A. O. Ltd., 54, Lamb's Conduit St., W.C.1. [2243**

## PUBLIC ADDRESS EQUIPMENT

**SPECIAL Offer!!!**

**81 Guineas Assembled; Vortexion 20 watt 4-stage P.A. amplifier,** in steel case, 8in. x 10in. x 9in., high, with carrying handle, input with controls for microphone and pick-up and tone control, output for 7 1/2" and 15 ohm speakers, weight 25lb.; only 8 1/2 guineas, with valves.

**4 Input Model,** with mixers; £10.

**HEAVY Duty Model,** as fitted to cinemas and dance halls; £15.

**CALL and Hear the Rumble of an Organ as Never Before on our Wide Frequency Range Models, the best yet.**

**VORTEXION, Ltd., 182, The Broadway, Wimbledon, S.W.19. See also New Mains Equipment. [3439**

**PARTRIDGE P.A. Manual,** free to trade. See "Partridge Transformers" under "New Mains Equipment." [3487

## USED SETS FOR SALE AND WANTED

## ADEY

**ADEY All-wave Battery Portable,** light, efficient; cost 12 guineas, accept £5/10; Wembley.—Box 378, c/o The Wireless World. [3530

## FERGUSON

**1937 Ferguson 8-valve All-wave Superhet A.C.,** recently purchased at 16 1/2 guineas, brand new; accept £11 or near offer, cash needed.—G., 7, Grove Rd., Folkestone. [3542

## IMPERIAL SHORT WAVE SIX

**IMPERIAL Short Wave Six,** brand new, just completed with all specified parts, valves and power pack, perfect working order, cost over £24 to build, must sell; price £12; approval deposit.—Humpidge, 6, Manilla Rd., Clifton, Bristol. [3507

## MAJESTIC

**MAJESTIC Model 260 A.C., 7-valve, perfect; £6, or offer.—C. Heys, 336, Central Drive, Blackpool. [3540**

## W.W. MONODIAL

**1936 Monodial Super, new feeder unit, 12 watt quality amplifier, £15, with all valves; new Avo oscillator, unused, £5; Avo Minor and Ayodapter, 30/-—Box 377, c/o The Wireless World. [3529**

## W.W. PRETUNED QUALITY RECEIVER

**"WIRELESS WORLD" Pretuned Quality Receiver,** unit only, to specification, perfect, whistle filter; cost £6/15. frst. £4/5.—148, Newarth Rd., Walkden, Manchester. [3524

## W.W. QUALITY AMPLIFIER

**Q.A. Receiver, push-pull quality amplifier, radiogram, walnut cabinet, Q.A. super chassis to work with amplifier, professional built; what offers the lot?—Grose, Stratton Terrace, Falmouth. [3533**

## EXCHANGE OR WANTED

**WANTED, Variable Selectivity IV or other "Wireless World" A.C. mains set; no objection to set requiring servicing or rewiring provided components are sound.—Box 379, c/o The Wireless World. [3531**



NEW MAINS EQUIPMENT

**V**  
**V**  
**V**ORTEXION Lead Again.

**V**ORTEXION Supply the B.B.C., G.P.O., L.P.T.B., and Borough Councils, etc., so why not you? **F**OR the Best Reproduction it is Possible to Obtain, see also advert. under Public Address Equipment.

**A**LL Fitted Screened Primaries and Tapped 200-250v., with centre tapped filaments, guaranteed one year.  
**250** 0-250 60 m.a., 4v. 1-2a., 4v. 2-4a.; 10/- open, 12/6 shrouded.  
**350** 0-350v. 60 m.a., 4v. 1-2a., 4v. 2-4a.; 12/6 open, 15/- shrouded.  
**350** 0-350v. 120 m.a., 4v. 1-2a., 4v. 2-4a., 4v. 2-5a.; 14/6 open, 16/6 shrouded.  
**425** 0-425v., 120-160 m.a., 4v. 5-10a., 4v. 2.5, 4v. 1-2, 4v. 1-2, supershrouded model, 2 1/2% regulation; 26/-.

**500** 0-500v. 120 m.a., L.T.'s. as above; 19/- open, 23/- shrouded; 400 or 450, same price.  
**500** 0-500v. 150 m.a., 3x, 4v. 2a., 4v. 2-5a., 4v. 4a., 26/- open, 30/- shrouded; 400 or 450, same price.

**C**HOKES, 30h. 60 m.a., 5/6; 7-13h., 10/6; 30h., 150 m.a., 12/6; regulation, 7/6.  
**O**UTPUT Transformers, 4-10 watt. W.W. Q.A., 17/6; 20-watt super shrouded, 30/-.  
**S**PECIAL Wide Frequency Range Model; £3/10.

**A**UTO Transformers, 100-120 to 200-240v., 60 watt, 9/-.; 120 watt, 12/6; 200 watt, 16/6; 500 watt, 30/-.  
**T**ELEVISION, 4,000v., 5-10 m.a., and 2.5-4v.; 27/-.

**Q**UOTATIONS for Specials by Return.

**V**ORTEXION, Ltd., 182, The Broadway, S.W.19. Tel.: Lib. 2814. [3438]

**A**LL **P**OWER

**T**RANSFORMERS, Ltd.—Transformers and chokes embodying all the best in design; no better value at any price; Radiolympia models; tapped and screened primaries, filaments, centre tapped.

**250** 0-250v. 60 m.a., 4v. 1-2a., 4v. 2-4a., 12/6, post 7d.; extra filament, 4v. 1a., 12/6.

**350** 0-350v. 60 m.a., 4v. 2-3a., 4v. 2-4a., 15/-, post 8d.; extra filament, 4v. 1a., 16/-.

**350** 0-350v. 120 m.a., 4v. 2-3a., 4v. 4-6a., 4v. 1-2a., 19/-, post 1/-; extra filament, 20/-.

**500** 0-500v. 140 m.a., 4v. 2-4a., 4v. 4-6a., 4v. 2a., 4v. 2a., 29/6, post 1/-.

**L**.T. Charger, charging rate 1a., 2, 6, or 12-volt, employing metal rectifier L.T.S.; 37/6, post 1/-.

**W**RITE for List; special quotations by return.

**A**LL **P**OWER **T**RANSFORMERS, Ltd., 8a, Gladstone Rd., Wimbledon, S.W.19. Tel.: Liberty 3303. [3383]

**P**ARAMOUNT Mains Transformers.

**P**ARAMOUNT in Quality, lowest in price; example: 250v. 60 m.a., 4v. 1a., 4v. 4a., open type 9/-, shrouded 11/-, post 9d.; 350v. 75 m.a., 4v. 2.5a., 4v. 4a., open type 12/-, shrouded 14/-, post 9d.

**W**RITE for List, "Paramount Mains Transformers."—R. H. Salter, 66, Hartfield Rd., Wimbledon, S.W.19. Phone: Liberty 3226. [2303]

**P**ARTIDGE Transformers, as supplied to B.B.C., Marconi's G.E.C., Mullards, I.C.I., Tungsram, etc.

**S**PECIALS Despatched Within 48 Hours; all standard types from stock. Specimen prices:—  
**350** 0-350v. 120 m.a., 4v. 2-3a., 4v. 3-6a., 4v. 1-2a., all C.T.; screened primary 200-250v., 18/6.

**425** 0-425v. 150 m.a., 4v. 2-4a., 4v. 4-8a., 4v. 1-2a., 4v. 1-2a., all C.T. (for W.W. circuits); 26/6.

**S**PECIAL Quotations to Manufacturers for Lots of 6 Upwards; hand wound, individually tested, immediate delivery, rock bottom prices.

**T**ELEVISION Transformers Insulated to 10,000v. A.C. expert knowledge of transmitting requirements (mains and modulation).

**H**IGH Fidelity (20 to 15,000 Cycles) Intervale and Output Transformers a Speciality.

**P**ARTIDGE P.A. Manual Free to Trade Only; contents includes constructional amplifiers, notes on microphone pre-amplifiers, lines, mixing, impedance matching, speakers, etc.

**P**ARTIDGE, N., B.Sc., A.M.I.E.E., King's Buildings, Dean Stanley St., London, S.W.1. Phone: Vic. 5035. [3486]

**T**ANTALUM for A.C. Chargers, H.T. and L.T.—Blackwell's Metallurgical Works, Ltd., Garston, Liverpool [2729]

CABINETS

**M**ANUFACTURER'S Clearance.

**H**ALCYON Radiogram Cabinets, rich, dark, figured walnut, 33 X 23 X 19 1/2, 45/-; many others, 30/- upwards; photos for selection sent on request.

**T**ABLE Radio Cabinets (undrilled); 6/6 upwards.

**S**PKAKER Cabinets; 4/6 upwards.

**S**END Particulars of Your Requirements (giving size of set, etc.), or call and make your choice from our stocks of over 100 different types; from 3/6 to £4/10.

**H**. L. SMITH and Co., Ltd., 287-9, Edgware Rd., London, W.2. Tel.: Padd. 5891. [0485]

DYNAMOS, MOTORS, ETC.

**A**LL Types of Rotary Converters in Stock, new and second-hand.

**W**ARD, 46, Farringdon St., London, E.C.4. Telephone: Holborn 9703. [0518]

1h.p. A.C. B.T.H. Motors, 1,425 revs., self starting, all 4 voltages; 53/-—Easco, 18, Brixton Rd., S.W.9. [0455]

Notes

on the Suppression of Electrical Interference with Broadcast Reception

Now that people are settling down after the seasonable disorganisations there must be many thousands who have purchased new radio receivers and who are wondering if they are much better off. Probably most of them find their new sets give them as much interference as programme, particularly if they are used for the reason many of them were bought, i.e., to listen to more distant stations.

Most *Wireless World* readers have numbers of less informed people depending upon them for advice and assistance on all matters relating to radio (including electric bells, etc.), and although most of what follows is already known to readers, we make no apology for repeating these facts.

These new receivers are invariably more sensitive than those which they replace. Most of them are superbets; many, real high gain jobs, and because they can bring in stations with an inferior aerial (or none at all) they are expected to give satisfaction. It is not realised that the more sensitive the receiver, the better should be the aerial system, because it is a fact that local electrical interference will come in to the serious detriment of the programme.

Generally the first thing to do to improve the noise-to-signal ratio is to ensure that the aerial system is at least reasonable. If it is, then it is generally worth while trying a mains filter. The most suitable one will probably be Type 300 (Belling-Lee all-wave 1-amp., 21/-) the one which also filters the earth lead. In most cases this will be found to effect a vast improvement, and you have the satisfaction of knowing that little or nothing else can be done beyond improving the aerial system. And this improvement can be made by the installation of an anti-interference aerial which, to be of any use with a modern all-wave receiver, must be satisfactory down to 10 metres, preferably without switching (because "Auntie" would never remember to switch the aerial).

If you want something which incorporates all these features, and is at the same time as easy to erect as an ordinary aerial, then you have no choice but must recommend the "Belling-Lee" "Eliminoise." You must insist that the unscreened part of the aerial is outside the field of interference and that there is sufficient top span, i.e., not less than 40ft.

\* Trade Mark.



Belling & Lee Ltd.  
Cambridge Arterial Road,  
Enfield, Middx.

No. 20

NEW LOUD-SPEAKERS

HULBERT for Quality Surplus Speakers.

**T**HE Following Genuine Bargains are Made by One of the Best-known Manufacturers of high-grade moving coil speakers. All are brand new and offered at considerably under half list prices. The Auditorium models are fitted with latest dual curved cones, giving remarkably wide and even frequency response, resulting in a quality reproduction of both speech and music.  
**37/6** Only, usual price £5; Auditorium permanent magnet speaker, with Alni magnet and die cast frame, large 12in. dual cone, comprising latest curved cone with auxiliary bakelite cone; complete with large 25 ratio transformer.

**59/6** Only, usual price £6; Auditorium electro-magnet speaker, 1,000, 1,250, 2,000 or 2,500 ohms field; exceptionally large magnet of high permeability steel, giving enormous flux density; 2in. moving coil; large dual cone, comprising latest curved cone with auxiliary bakelite cone, giving wide frequency response; complete with universal transformer; the ideal speaker for use with "Wireless World" and other quality amplifiers.

**75/-** Only, usual price £9; as above, but for use on A.C. mains; complete with Westinghouse rectifier and full smoothing equipment.

**24/-** Only; permanent magnet speaker, Alni magnet, die cast frame, 10in. cone, Universal transformer.

**15/6** Only; permanent magnet speaker, Alni magnet, 8in. cone, Universal transformer.

**12/6** Only; permanent magnet speaker, as above, with 7in. cone.

**11/6** Only; extension permanent magnet speaker, 8in. cone, complete with large cabinet, suitable for low impedance outputs.

**2/9** Only; brand new cabinets.

**8/6** Only; electro-magnet speakers, with 8in. cone, 6,500 ohms field, Universal transformer.

**I**F You are Requiring Quality Reproduction at Low Cost Order Now from:

**H**ULBERT, 6, Conduit St., W.1. Cash or c.o.d. [2895]

**V**AUXHALL—Best quality speakers; see other column. Vauxhall Utilities, 163a, Strand. [0520]

**S**INCLAIR SPEAKERS Have Quantity New Speakers, P.M. and energised, 8 and 10 inch, also P.A. 10 watt; to clear from 8/6 each; all guaranteed.—Alma Grove, Copenhagen St., London, N.1. Ter. 4355. [3528]

LOUD-SPEAKERS

**S**ECOND-HAND, CLEARANCE, SURPLUS, ETC.

**F**ERRANTI M1, as new, any trial; what offers?—Kaland, High St., Wellington, Som. [3519]

**V**AUXHALL—Magnavox mains energised, 2,500 or 6,500 ohms field, 10in. cone, 17/6; 7in. cone, 12/6.

**V**AUXHALL—Magnavox permanent magnets, universal, suitable for Class "B" power or pentode, 7in. cone, 16/6; 10in. cone, 22/-.

**V**AUXHALL—American Rolas 2,500, 8in. 15/-; 9 1/2in. 19/6; Permanent magnets, 8in. 19/6; 9 1/2in. 24/6.

**V**AUXHALL—Above, fully guaranteed, complete with humbucking coils; state power or pentode transformer; unused manufacturers' stock.

**V**AUXHALL—Immediate delivery, carriage paid; lists free; cash with order or c.o.d.—Vauxhall Utilities, 163a, Strand, W.C.2 Temple Bar 9338. [0456]

**M**AGNAVOX D.C. 152 (9in. cone), 22/6; Magnavox 154 (6 1/2in. cone), 16/3; all with humbucking coils, po. or pentode transformers, and 2,500 or 6,500-ohm fields; Magnavox P.M.254, 18/-; Magnavox P.M.252, 22/6.

**A**TENTION to All Orders Within 48 Hours; carriage paid; cash with order or c.o.d.; send for list.

**W**ARD, 46, Farringdon St., London, E.C.4. Tel.: Holborn 9703. [0451]

**S**TERN RADIO, 115, Fleet St., E.C.4, offer limited stock of 152 Magnavox Magna speakers, with push-pull output transformer, 6-watt output, 1,000 ohms field, list price 50/-, clearance price 27/6; also high fidelity B.E.A. microphones, original price £3, clearance price 27/6. [3532]

VALVES

**A**NDERSON.

**A**MERICAN Valves, all makes, first grade only; 5/- each.

**A**NDERSON 35, Lansdowne Rd., Walthamstow, E.17. Walthamstow 0827. [3551]

**B**EST Obtainable; six months' guarantee.

**A**.C. Valves, any type, 4/3; simply state equivalent; battery 2 volt Det., H.F., L.F., 2/-; power, 2/6; all others 4/9; American valves, any type, 3/3; state number.—See page 6.

**M**AUD TRADING and EXPORT Co., Dept. W.W., 6, Booth St., Manchester, 2. [3543]

**A**MERICAN Valves, first grade, in all types; trade supplied.—Metropolitan Radio Service Co., 1021, Finchley Rd., N.W.11. Speedwell 3000. [0436]

**3/-** Each—American valves, all popular types, 90-day guarantee; full range in stock, National Union, Hytron, Triad, metal, glass and M.G.; send for lists.

**R**ADIOGRAPHIC, Ltd., 66, Osborne St., Glasgow, C.1. [3494]

**A**LL Types of American Valves in Stock of Raytheon, Sylvania, and Arcturus makes, at competitive prices, guaranteed for six months; send for full list; 350 ohms line cords, 2/8.

**W**ARD, 46, Farringdon St., London, E.C.4. Tel.: Holborn 9703. [0452]

**N**OTHING Better Available—Six months' guarantee; complete range of battery, A.C. mains, rectifiers always in stock; 2-volt det., H.F., L.F., 2/3; power, 2/9; screen grid, pentode, H.F. pentode, 5/-; American types, fully guaranteed, 5/6 each, Nos. 18, 24A, 35, 42, 43, 45, 47, 56, 57, 58, 75, 77, 78, 80, 2A5, 2A6, 2A7, 6A7, 2B7, 6B7, 6C6, 6D6, 25Z5, 25Y5; write for other prices to Dulci Electrical Co., Ltd., Devonshire Works, Duke's Av., Chiswick, W.4. [0501]

# CONSISTENT DEMAND

Most people have an idea that the Radio Industry is terribly busy up till Christmas, and after that everyone is looking round for something to do. We agree that this may be so in the case of popular commercial receivers, but in our case we are still terribly busy taking fresh orders, since obviously real

**QUALITY AMPLIFIER EQUIPMENT APPEALS ALL THE YEAR ROUND.**

May we send YOU further particulars of **OUR 346 QUALITY AMPLIFIER WITH RADIO FEEDER UNIT AND AUDITORIUM SPEAKER AT AN ALL-IN PRICE OF £20?**

**ALTERNATIVELY, THE 4-12 WATT QUALITY AMPLIFIER PARAPHASE PUSH-PULL, COUPLED WITH S.S. ALL-WAVE SIX UNIT AND THE NEW SUPER AUDITORIUM SPEAKER.**

Superlatives are unnecessary with these equipments.



**MARLBOROUGH RD. UPPER HOLIOWAY LONDON, N.19. (Contractors to the G.P.O., etc.) LIMITED. Tel.: Archway 1661/2/3.**

## ARMSTRONG 6-Valve

THIS new chassis is designed to give a good all round performance with 31 watts output on both radio and gramophone. Short waveband is arranged to cover both the English and American amateur bands as well as the usual short wave broadcast. All the best English components are used throughout and the circuit incorporates the latest improvements such as three wavebands with band-pass input, full range volume and tone controls working on both radio and gramophone, large full view scale with station names marked on all wavebands, etc.

The price includes radiogram chassis complete with 6 British valves and 8" Rola moving coil speaker, matched to the chassis, mains leads, pilot lamps and everything ready for immediate use. Packing and carriage free.

7 days' trial, carriage paid.

ARMSTRONG 12 months' guarantee.

**SUPERHETERODYNE RADIOGRAM**

Chassis with

**ROLA F.6 SPEAKER**



Price **£7.10.0** Ready to switch on.



**ARMSTRONG MANUFACTURING CO. 100, KING'S ROAD, CAMDEN TOWN, N.W.1. 'Phone: GULLIVER 3108.**

## TESTING EQUIPMENT

STANDARD Telephones, modulated oscillator type 401, as new, less attenuator (complete); snip, £2.—(Young, South St., Corsham). [3510]

## METERS, ETC.

FERRANTI 0-1 m.a. A.C. Rectifier, 30/-; 250-0-250 microamps, 27/6; 200 v. D.C., 1,000 o.p.v., 25/-; Weston, 500 v. D.C., 1,000 o.p.v., 35/-; 300 v. D.C., 1,000 o.p.v., 27/6.—R.P.R. Radio, 112, Pentonville Rd., London. [3535]

## NEW COMPONENTS

TRANSVERSE Current Microphone Parts, complete, from 8/6.—A. Hinderlich, 2, Bridge Rd., London, N.W.10. [3539]

ENLARGED Catalogue for Home Constructors Now Ready, post free.—Lumen Electric Co, Litherland, Liverpool, 21. [3473]

## COMPONENTS

SECOND-HAND, CLEARANCE, SURPLUS, ETC.

**RADIO CLEARANCE,**

63, High Holborn, W.C.1. Holborn 4631.

**8-VALVE A.C. Mains Superhet. Receiver** by Well-known Manufacturer, incorporating many refinements, visual tuning, illuminated colour coded, volume control, local distance switch, etc., fitted in handsome bird's eye maple cabinet, size 12in. wide, 12in. deep, and 23in. high, comprising the following valves: A.C./V.P.1. F.C.4. A.C./V.P.1. A.C./V.P.1. A.C./H.L.D.D. V914. A.C.2Pen. I.W.3. Pre H.F. stage, 2 I.F. stages, full A.V.C., etc., a limited quantity; 27/15.

**LISSEN** 4-valve Universal A.C./D.C. Receiver, fitted in handsome upright walnut cabinet, clock face tuning, provision for extra speaker, etc., complete with ring valves; 24/15.

**BRUCE** Mains Transformers and Chokes, standard for the season, finest made British and guaranteed.

**250** 0-250, 80 m.a., 2-0-2 volts, 2.5 amp., 2-0-2 volts, 4 amp.; 8/6.

**350** 0-350, 120 m.a., 2-0-2 volts, 2.5 amp., 2-0-2 volts, 4 amp.; 10/6.

**350** 0-350, 150 m.a., 2-0-2 volts, 2.5 amp., 2-0-2 volts, 4 amp., 2-0-2 volts, 2 amp.; 12/6.

**500** 0-500, 150 m.a., 2-0-2 volts, 2.5 amp., 2-0-2 volts, 6 amp., 2-0-2 volts, 2 amp., 2-0-2 volts, 2 amp.; 17/6.

**H.T.8** Transformer, 250 volts 60 m.a.; 2-0-2 volts, 4 amp.; 8/6.

**DITTO** with H.T.8 Metal Rectifier; 17/6.

**ALL** Transformers are Fully Shrouded.

**BRUCE** Mains Chokes.

**40** m.a. 30 hys., 500 ohms; 4/6.

**60** m.a. 40 hys., 500 ohms; 6/-.  
150 m.a. 40 hys., 100 ohms; 10/6.

**250** m.a. 15 hys., 200 ohms; 21/-.

**60** m.a. 80 hys., 2,500 ohms, for speaker replacement, etc.; 6/-.  
**CENTRALAB** Volume Control with Switch, 5,000, 10,000, 25,000, 50,000; 2/6.

**LISSEN** All-wave Coils, complete with circuit, switching, etc., sent out in matched pairs covering 2 short bands, 1 medium and 1 long; 8/-.  
**DITTO** Single Coils; 4/6 each.

**8** mfd., 500 volt working, 550 volt surge, heavy duty electrolytic condenser, by well-known manufacturer; 2/11.

**8** mfd. and 4 mfd. Electrolytic, 450 volt working, 500 volt peak; 2/6.

**LISSEN** Class B 1-1 Hypnik Transformer, boxed, brand new as from the makers; 2/6.

**ENQUIRIES** 1/4d. Stamp if Reply Expected.

**HOURS** of Business 9 a.m. to 7 p.m., Saturdays 9 a.m. to 1 p.m.

**ALL** Orders Value 5/- or Over Post free; orders under 5/- must be accompanied by a reasonable amount for postage.

**C.O.D.** Orders Under 5/- Cannot be Accepted.

**RADIO CLEARANCE, 63, High Holborn, W.C.1. Holborn 4631. [3547]**

**HYAMS** RADIO.

**E**X-G.P.O. Galvos., in mahogany cases; 4/-.

**L**AST Few B.T.H. Universal Gramophone Motors, with mains resistance, for 100-250 volts, less turntable; 27/6.

**HYAMS** RADIO, 23, Lisle St., Leicester Sq., W.C. Gerrard 2969. [3502]

**ALL** Lines Advertised in Last Week's Issue Still Available.

**WARD**, 46, Farringdon St. Telephone: Holborn 9703. [0450]

**E**XPERIMENTERS' Surplus, all in good order, many unused; carriage extra under £1.

**B**AKERS' Triple Speaker, P.P. transformer, 1,250 w. field, £5/5; Marconi 95P.M., £1/7/6; W.B. 37s, £1/9/6; output transformers, O.P.M.4c. O.P.M.1c, 11/6.

**10-WATT** Amplifier Kit (A.C. mains), push-pull, complete with valves and output transformer, £5/19/6; modified "Wireless World" Q.A., complete, £9/18/6.

**R**OTHERMEL-BRUSH, soiled super piezo-pickup, cost £4/4, £1/12/6; Ferranti moving coil milliammeter, projecting, 0-50 m.a., 17/6.

**C**OLVERN K.B.L.C., K53, ganged, 8/11; Varley B.P.19, 8/11; Nicore I.F.S., 4/11; Colverdynes, 3/11; Wearite Unida, 4/11.

**6**D. Each, valveholders, 7-pin, Ceramic S.W.5, 7-pin, Yankee 4. 5. 6 and 7-pin; full lists for stamp.—Seradex, 48, Wake Green Rd., Birmingham. [3505]

A Radio mechanic named Hyde For a "fault-finder's" job once applied. "I'll be all right," he mused. "Where no FLUXITE'S been used I could always find fault if I tried."

See that FLUXITE is always by you—in the house—garage—workshop—wherever speedy soldering is needed. Used for 30 years in Government works and by leading engineers and manufacturers. Of Ironmongers—in tins, 4d., 8d., 1/4 and 2/8.

Ask to see the FLUXITE SMALL-SPACE SOLDERING SET—compact but substantial—Complete with full instructions, 7/6.

Write for Free Book on the art of "SOFT" SOLDERING—and ask for leaflet on CASE-HARDENING STEEL and TEMPERING TOOLS with FLUXITE.

**TO CYCLISTS!** Your wheels will NOT keep round and true unless the spokes are tied with fine wire at the crossings AND SOLDERED. This makes a much stronger wheel. It's simple—with FLUXITE—but IMPORTANT

## THE FLUXITE GUN

is always ready to put Fluxite on the soldering job instantly. A little pressure places the right quantity on the right spot and one charging lasts for ages. Price 1/3



ALL MECHANICS WILL HAVE  
**FLUXITE**  
IT SIMPLIFIES ALL SOLDERING  
FLUXITE LTD., Dept. W.W., DRAGON WORKS, BERMONDSEY ST., S.E.1

## ELECTRADIX

Motors! Motors! Motors!  
Tiny, Small and Medium. A large stock of really fractional horse-power motors have been released at bargain prices. 300 at 218 for immediate delivery.

**A.C. MAINS MOTORS**—Enclosed, self-start on load, A.C. regulator, 1/60 h.p. with pulley, Type 40, 1,500 revs., 18/6. Type 36, Ditto, 1,25 h.p., G.E.C., 3,500 revs., 27/6. Induction 1/10 h.p., 2,800 revs., 35/-; 4 h.p., self-starting, 1,425 revs., 49/-.  
**D.C. MAINS MOTORS**—1/40 h.p., Type 60, 220 v., K.B. series, 1,750 revs., 15/-; Ditto, 1/40 h.p., G.E.C., 230 v. series, 2,900 revs., 16/-; Ditto, 1/12 h.p., Craydon 110 and 230 v. shunt, 1,700 revs., 30/-; M.G. for A.C. 220 v. to 100 v., 1 amp., D.C. 60-, 100 v., 15/-; All fully guaranteed.  
**DOUBLE CURRENT DYNAMOS**—D.C. 600 volts 100 m.a., 32/6.  
**ROTARY CONVERTORS** for A.C. sets on D.C. mains, 7-watt, P.M. model, 35/-; 15-watt 220 D.O.220 A.C., ball bearings, lam. field, silent running, 65/-; 50 watt, 25; 90 watt, 27 10.  
**M.G. Sets** with filter, 6 v. to 170 v., 25 m.a., for H.T., 65/-; Dynamo and switchboard, 12 v., 12 amps., 47/6.

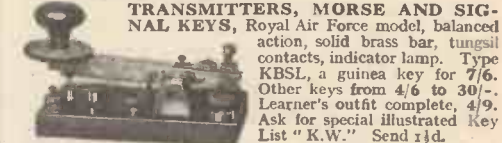

METERS—We carry large stocks of Meters, all ranges and sizes, from 2 1/2 in. dia. to 6 in., Laboratory apparatus a speciality.

Send for "Radio Electrical" Scientific Illus. List "W" Free.  
**ELECTRADIX RADIOS**  
218, Upper Thames Street, E.C.4.

Phone: Central 4611

Write to PRISM MANUFACTURING CO. CALIFORNIA WORKS, BELMONT, SURREY 'Phone: Sutton 5361/2

**TANNON THE SOUND PEOPLE**  
GUY B. FOUNTAIN LTD.  
FOR ALL CANTERBURY GROVE, WEST NORWOOD, LONDON, S.E.27. 'Phone: Str. 4122 (6 lines).  
SOUND AMPLIFYING EQUIPMENT

COMPONENTS—SECOND-HAND, CLEARANCE, SURPLUS, ETC.

**V. AUXHALL.**  
**V. AUXHALL.**—Polar Midget 3-gang condensers, straight or superhet., 8/9; Polar full vision, horizontal or Arcuate dial and drives, 5/-.  
**V. AUXHALL.**—J.B. drives with station-named scale, latest type, complete, 5/6; T.C.C. tubular, 0.25 mfd., 9d.  
**V. AUXHALL.**—Flat, sheet aluminium, hard rolled, 18 gauge 12in.x12in., 3/-; 18x18, 5/6; other sizes pro rata.  
**V. AUXHALL.**—Hivac, Tungstram valves, full range; full discounts allowed from new prices.  
**V. AUXHALL.**—Polar station-named scales, for horizontal dials, latest settings; 1/9 each.  
**V. AUXHALL.**—Polar 2-gang condenser, 6/8; Colvern twin-gang iron cored coils, on base with switch, 20/-.  
**V. AUXHALL.**—Colvern coils, G1, G2, G3, or G1, G2 and G3, superhet. type, 30/-; Colpaks, £2/4; Polar drives, 5/-.  
**V. AUXHALL.**—Iron-cored coils, 3-gang on base, with circuits, 17/-; B.T.H. Minor pickups, 15/3.  
**V. AUXHALL.**—All-wave tuning pack, 16.5 to 52 metres, medium and long waves; 87/6.  
**V. AUXHALL.**—Set manufacturers' surplus, skeleton type Westinghouse rectifiers, H.T.8, 9/6; H.T.9, H.T.10, 10/-; complete with fixing brackets.  
**V. AUXHALL.**—T.C.C. electrolytic condensers, 8 mfd. and 4 mfd., 550 volt, 5/-; 500 volt, 2/6; 450 volt, 2/5.  
**V. AUXHALL.**—T.C.C. condensers, tubular, non-inductive, 0.1, 6d.; 50 mfd., 50v. working, 1/6; 50 mfd., 15v., 1/3; 0.05, 6d.; 0.002, 0.0002, 0.001, 0.0001, 4d. each.  
**V. AUXHALL.**—T.C.C. mica, 0.002, 2,000 volt test, 1/-; 0.001, 4d.; 0.001, 1/-; 1 mfd. Mansbridge, 1/3.  
**V. AUXHALL.**—Resistances by well-known manufacturers, 1-watt type, 6d. each; all values.  
**V. AUXHALL.**—Centre tapped iron cored I.F. transformers, bases, terminals, 110 k/c; 6/6, guaranteed.  
**V. AUXHALL.**—Volume controls, Eric. Colvern, Centralab, 2/-; with switch, 3/-; all values, from 2,000 to 2 meg.  
**V. AUXHALL.**—Pushback wire, four colours, 6 yds. 6d.; 6B.A. screws or nuts, 4d. dozen.  
**V. AUXHALL.**—T.C.C. 200 mfd., 10v., dry, 2/6; 8 mfd., wet, 450v. working, 3/3; Westectors WX6, 4/-.  
**V. AUXHALL.**—Clix valve holders, terminals, 7-pin 9d., 5-pin 7d.; W.B. 5-pin 4/4d.; baseboard mounting, 6d.; post paid 2/6 or over or c.o.d.  
**V. AUXHALL.**—Collaro A.C. electric motors, boxed, 25/6; similar model complete pick-up and volume control, 41/6; Universal motors, 47/6.  
**V. AUXHALL UTILITIES.** 163a, Strand, W.C.2, over Denny's, the Booksellers, Temple Bar 9338. Send postcard for lists free. [0453]

**PREMIER SUPPLY STORES.**  
 PLEASE See Our Displayed Advertisement on this page.

ALL Post Orders Should be Addressed to Jubilee Works, 167, Lower Clapton Rd., London, E.5. Callers as usual to :-

20-22, High St., Clapham, S.W.4. Open till 9 p.m. Saturdays, Wednesdays, 1 p.m. Macaulay 2381.

165 and 165a, Fleet St., E.C.4 (next door to Anderson's Hotel). Early closing Saturday 1.30 p.m. Central 2833. [0488]

**SOUTHERN RADIO'S** Wireless Bargains.—All goods guaranteed and sent post paid.  
**G.E.C.** 3-Valve Battery Sets, "Battery Compact Three," with 5 Osram valves, moving coil speaker, in beautiful bakelite cabinet, brand new in sealed cartons, fully guaranteed, 50/- each (list 25/10).  
**BELMONT** 6-Valve Superhet. Receivers, complete in handsome cabinet for use on any mains, A.C.-D.C., 110-250 volts, with moving coil speaker and 6 valves, ready to plug in; £4 each.  
**GRAMOPHONE** Motors.—Garrard type "B" radiogram unit, consisting of A.C. motor, 100-250 volts, and pick-up, 45/-; Garrard motor, less pick-up, 30/-; in original sealed cartons.  
**RECORD** Changers.—Garrard model R.C.4, plays automatically and changes 8 10in. or 12in. records of any kind, sealed cartons; £6.  
**SPEAKERS.**—Celestion Soundex permanent magnet, 10/-; Telsen permanent magnet, with 10-ratio transformer to suit any receiver, 12/6; Telsen loud-speaker units, 2/6; all brand new and in sealed cartons.  
**COILS.**—Telsen, iron core, W349, Midget size, 4/-; type W478 (twin), 9/- pair; W477 (triple), 16/- set; type W476 (triple superhet. selector and oscillator), 16/- set, all ganged coils complete on base with switch; Telsen I.F. transformer coils, W482, 5/-; Telsen dual range aerial coils, with aerial series condenser incorporated, W76, 4/-; Telsen aerial series condensers with shunting switch, 2/-; all brand new, in sealed cartons.  
**MICROPHONES.**—Aco (P.O.) microphones, complete with transformer, ready for use with any receiver; 4/6 each.  
**RESISTANCES.**—Tru-ohm 1-watt, colour coded and marked; 36 assorted capacities on-card; 6/- per card.  
**AMERICAN** Valves.—A full range of valves for all American receivers; 6/- each.  
**HEADPHONES.**—Lightweight headphones, double pole type, 4,000 ohms each earpiece; 3/- pair.  
**TELSEN** A.C.-D.C. Multimeters, tests anything radio or electrical; 8/6.  
**CAR** Radio Aerials.—Ekco copper mesh aerials can be used on roof or floor of car; size 36in.x20in. 4/- each, 36in.x26in. 5/- each.  
**SOUTHERN RADIO.**—Branches at 271-275, High Rd., Willesden Green, N.W.10; 46, Lisle St., London, W.C.2. All mail orders to 323, Euston Rd., London, N.W.1.  
**SOUTHERN RADIO**, 323, Euston Rd., London, N.W.1 (near Warren St. Tube). Phone: Euston 3775. [3537]

# PREMIER SUPPLY STORES

## THE LARGEST RADIO MAIL ORDER HOUSE IN THE WORLD

Offer the following Set Manufacturers' Brand New Surplus Goods at a Fraction of the Original Cost; all goods guaranteed perfect; carr. paid over 5/-; under 5/- postage 6d. extra. Orders under 5/- cannot be sent C.O.D.

**ALL POST ORDERS TO JUBILEE WORKS, 167, LOWER CLAPTON RD., LONDON, E.5**

**CALLERS, AS USUAL, TO 20-22, HIGH ST., CLAPHAM, S.W.4 (Macaulay 2381) 'Phone: Amherst 4723**  
**And 165 & 165a, FLEET ST., E.C.4 (Next door to Anderson's Hotel.) Central 2833.**

### MAINS VALVES

**MAINS VALVES**, famous Europa 4 v. A.C. types, 4/6 each. H.L., L., S.G., Var.-Mu-S.G., H.F.-Pens., Var.-Mu-H.F. Pens. 1, 3 and 4-watt A.C. directly-heated output Pentodes. Full-wave rectifiers, 250 v. 60 m.a. A.C./D.C. types. 20-volt. 18 amp. S.G., Var.-Mu-S.G., H., H.L., Power. Following types all 5/6 each. Full-wave rectifiers, 350 v. 120 m.a. and 500 v. 120 m.a. 2-½ watt indirectly-heated Pentodes. Frequency Changers, Octodes and Heptodes. P.X.4 type, 6/6.  
**BATTERY VALVES.** 2 volts, H.F., L.F., 2/3. Power, Super-Power, 2/9. S.G., Var.-Mu-S.G., 4- or 5-pin Pentodes, H.F. Pens., V.-Mu-H.F. Pens., 5/- Class B, 3/6.  
**AMERICAN VALVES.** Genuine American HYTRON and TRIAD first-grade Valves. 3 months' guarantee. All types in stock, 5/6 each. 210 and 250, 8/6 each. New Metal-Glass Valves, all types, including 6L6 (see Wireless World review, Jan. 1st) 6/6 each. Genuine American DUOTRON Valves, all types, 3/6 each. Valve holders for all above types, 6d. each. Metal bases, 9d. each.

### SHORT WAVES

**SHORT-WAVE COILS.** 4 and 6-pin types, 13-26, 22-47, 41-94, 78-170 metres, 1/9 each, with circuit. Special set of 3 S.W. Coils, 14-150 metres, 4/- set, with circuit. Premier 3-band S.W. Coil, 11-25, 19-43, 38-86 metres. Simplifies S.W. receiver construction, suitable any type circuit, 2/6.  
**COIL FORMERS,** in finest plastic material, 1 1/2 in. low-loss ribbed, 4- or 6-pin, 1/- each.  
**SUPER CERAMIC CONDENSERS,** S.L.F. .00016, .0001, 2/9 each; double-spaced, .00005, .000025, .00015, 3/- each. All brass with integral slow motion, .00015 tuning, 3/9; .00015 reaction, 2/9. British Radiophone 2-gang .00016, 5/6.  
**H.F. CHOKES.** S.W. 10-200 metres, 9d.; S.W. screened, 1/6; standard screened 180-2,000 metres, 1/6.  
**CERAMIC S.W. VALVE HOLDERS,** 4-, 5- or 7-pin. Chassis type, 6d.; B.B. type, 8d.  
**GLASS AERIAL INSULATORS,** 4d. each.  
**BEEHIVE STAND-OFF,** 6d. each.  
**SCREENED FLEX,** single, 3d. yd.; twin, 4d. yd.

### PREMIER AMPLIFIER KITS

**3-WATT A.C. AMPLIFIER,** 2-stage, for mike or pick-up. Complete kit of parts with 3 valves, 40/-.  
**7-WATT A.C./D.C. AMPLIFIER.** 3-stage, high-gain, push-pull output. Complete kit of parts with 5 specially matched valves, £4 4s.  
**10-WATT 3-stage A.C. Amplifier Kit** with 5 valves, £5 5s.  
**20-WATT 3-stage A.C. Amplifier Kit** with 5 valves, £8 8s.  
**ELECTROLYTICS.** U.S.A., 4, 8 or 12 mfd. 530 v. peak, 1/9 each. Dusbilier, 4 or 8 mfd. 500 v., 3/-; 50 mfd. 50 v., 1/9; 10 mfd. 50 v., 6d.; 25 mfd. 25 v., 1/-. T.C.C. 4 or 8 mfd. 650 v., 4/-; 15 mfd. 50 or 100 v., 1/-; 50 mfd. 12 v., 1/-. Paper Condensers, W.E., 250 v. working 4 mf., 2/-; 2 mf., 1/6. Dusbilier 500 v. working 4 mf., 4/-; 800 v. 4 mf., 6/-; Wego 450 v. working 1 mf., 1/-; 2 mf., 1/9; 4 mf., 3/-; 700 v. working 2 mf., 2/-; 4 mf., 3/6.  
**COSMOCORD PICK-UPS,** with tonearm and volume control, 10/6 each.  
**PICK-UP HEADS** only, 4/6 each.

### MAINS TRANSFORMERS

**PREMIER** wire-end type with screened primaries, tapped 200-250 v. Centre-tapped Filaments. Guaranteed one year. H.T. 8 & 9 or H.T. 10 with 4 v. 4 a. C.T. and 4 v. 1 a. C.T., 8/6. 250-250 v. 60 m.a., 4 v. 1 a., 4 v. 2 a. and 4 v. 4 a., all C.T., 8/6. 350-350 v. 120 m.a., 4 v. 1 a., 4 v. 2 a. and 4 v. 4 a., all C.T., 10/6. Any of these transformers with engraved panel and N.P. terminals, 1/6 extra. 500-500 v. 150 m.a., 4 v. 2-3 a., 4 v. 2-3 a., 4 v. 2-3 a., 4 v. 3-4 a., all C.T., 17/6. Super Model, 19/6. **AUTO TRANSFORMERS**, step up or down, 60 watts, 7/8; 100 watts, 10/-. **FILAMENT TRANSFORMERS**, Tapped Primaries, 200-250 v. All secondaries C.T. 4 v. 3 a., 7/6; 4 v. 5 a., 8/6; 7.5 v. 3 a., 7/6; 6 v. 3 a., 7/6; 2.5 v. 8 a., 7/6; 6.3 v. 3 a., 7/6; 5 v. 3 a., 7/6. **SMOOTHING CHOKES**, 25 m.a., 2/9; 40 m.a., 4/-; 60 m.a., 5/6; 150 m.a., 10/6. 2,500 ohms, 60 m.a. Speaker Replacement Chokes, 5/6.  
**MILLIAMMETERS**, moving-iron, flush 2 1/2 in., all ranges from 0-10 m.a., 5/9. Visual tuning, 6 or 12 m.a., 5/9. Moving-coil meters, 2 1/2 in. 0-1 m.a., 18/6; 3 1/2 in. 0-1 m.a., 22/6. Multipliers, 1/- each.

**PREMIER (Reisz Pattern) Transverse-current MIKE, High Output, Straight Line Response, 30/-.** Transformer. 5/-.

**AMP METERS**, all ranges from 0-1 amp., 5/9. A.C./D.C. TELSEN Multi-meters, 3 and 30 m.a., 8, 16 and 240v., 8/6 each.  
**TRANSFORMERS**, latest type Telsen R.G.4 (list 12/0), 2/9 Lissen Hypernik Q.P.P. (list 12/0), 3/6.  
**OUTPUT TRANSFORMERS** for Power, Pentode and Push-Pull, 2/6; Multi-Ratio, 4/6; Push-Pull Input Transformers by prominent manufacturer, 4/6 each.  
**ELIMINATOR KITS** for A.C. mains. 120 v. 20 m.a., or 150 v. 25 m.a., 15/-, tapped S.G., det. and output. Complete Kit with long-life valve rectifier (replacement cost only 2/-).  
**PREMIER L.T. CHARGER KITS** for A.C. mains, including Westinghouse Rectifiers and Tapped Mains Transformers. 8 volts at 1 amp., 14/6; 8 volts 1 a., 17/6; 15 volts 1 a., 19/-; 15+15 volts 1 a., 37/6; 15+15+15 volts 1 a., 50/-; 8 volts 2 a., 29/6.  
**TELSEN** iron-cored screened coils, W.349, 4/- each.  
**Electric SOLDERING IRONS**, 200-250 v., A.C./D.C., 2/3. **LOTUS JACKS** (and Jack-switches), all types, 1/- each. Lotus Plugs, 1/- each.  
**PREMIER H.T. KITS**, all with Westinghouse rectifiers; tapped transformers and adequate smoothing. All Kits absolutely complete. 120 v. 20 m.a., 20/-; with 1/2 a. L.T. Charger, 28/-; 150 v. 30 m.a., 25/-; with 1/2 a. L.T. Charger, 31/6. 250 v. 60 m.a., with 4 v. 3 a. C.T., 30/-.

### SHORT WAVE KITS

**NEW 1937 1-Valve SHORT-WAVE ADAPTOR KIT** (can also be used as a 1-valve Receiver), 13-86 metres. Complete Kit and Circuit, 12/6. **VALVE GIVEN FREE! DE LUXE MODEL,** 17/6.  
**SUPERHET CONVERTER KIT,** 13/6.  
**S.W. SUPERHET CONVERTER**, for A.C. Mains Receivers, 20/-. A.C. Valve given FREE!  
**2-VALVE S.W. KIT, 19/6.** VALVES GIVEN FREE!  
**3-VALVE S.W. KIT, S.G. Det. and Pen., 42/-.** VALVES GIVEN FREE!  
**BAND-PASS TUNING PACK**, comprising set of Telsen 3-gang iron-cored coils with switching, mounted on steel chassis with 3-gang condenser, illuminated disc-drive and 4 valve holders, 25/- the lot. All Mains or Battery circuit. FREE!  
**LISSEN ALL-WAVE COILS,** 12-200 metres, complete with switching and wiring diagram, 12/6.  
**3 VALVE BAND-PASS KIT,** 200-2,000 metres. Complete kit of parts, including chassis, all components, valves, M.C. speaker and wiring diagram. Battery Model, 50/-. A.C. Mains Model, 70/-.

### MOVING COIL SPEAKERS

**MAGNAVOX.** Mains energised: '154', 7in. cone, 2,500 ohms 4 watts, 12/6; '152', 9in. cone, 2,500 ohms, 17/6; '152 Magna', 9in. cone, 2,500 ohms, 6 watts, 37/6. Magnavox P.M.s.—'254', 7in. cone, 16/6; '252', 9in. cone, 22/6. Reliable P.M.s, 10/6.  
**ROLA** latest type P.M.s, 18/6. KB 7in. mains energised, 1,500 or 2,500 ohms, 7/9. **GOODMANS'** 8in. mains energised, 1,000 ohms field, 10/6 each.  
**DIALS.**—Clarion Illuminated S.W. slow-motion Dial with 2in. knob, 2/-. Premier All-Wave 2-speed Dial, full vision straight-line, dual ratios 10-1 and 150-1, 6/6, with escutcheon.  
**Potentiometers** by well-known makers. All values up to 1 meg., 2/-; with switch, 2/6. **GRAMOPHONE MOTORS.** Collaro Gramophone Unit consisting of A.C. motor, 100-250 v. high quality pick-up and volume control, 45/-; Collaro motor only, 30/-; Collaro Universal Gramophone Motor, 100-250 v. A.C./D.C., with high quality pick-up and volume control, 67/6; Collaro Universal Motor only, 49/6; Edison Bell double-spring motors, including turntable and all fittings, 15/-; Cosmo-cord Gramo unit, comprising A.C. motor pick-up and volume control (list 55/-), 35/9.  
**TUBULAR CONDENSERS**, non-inductive, all values up to .5 mfd., 6d. each.  
**Wire-end RESISTORS**, any value, 1 watt, 6d.; 4 watts, 1/-; 8 watts, 1/6; 15 watts, 2/-; 25 watts, 2/6 each.  
**Reliable MORSE KEYS** with Morse Code engraved on bakelite base, 2/- each.  
**Bakelite case BUZZERS**, 1/6; Walnut case "Loud-tone," 2/6 each.  
**Super Quality lightweight HEADPHONES**, 3/9 pair.

**HAVE YOU HAD OUR LATEST GIANT ILLUSTRATED CATALOGUE AND VALVE LIST? IF NOT, SEND 4d. IN STAMPS FOR THIS AMAZING LIST OF BARGAINS!**

"Radio Receiver Measurements." Price 4/6 By post 4/9

**SCIENTIFIC  
8-VALVE, 4-BAND  
ALL-WAVE SUPERHET**  
RADIOGRAM CHASSIS. 12 Months' Guarantee.

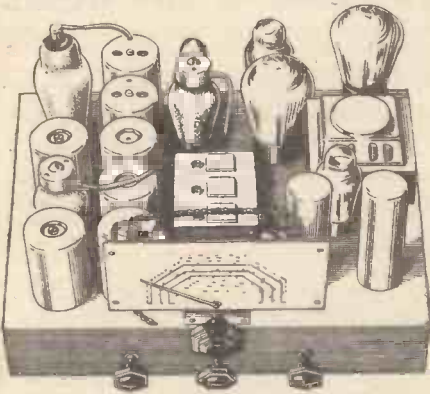

4 WAVEBANDS COVER 13-35; 35-81; 200-550 AND 800-2,000 m. OUTPUT 6 WATTS. DELAYED A.V.C. ILLUMINATED DIAL WITH STATION NAMES AND WAVELENGTHS.

This sensitive quality receiver incorporates band-pass input to a Triode hexode frequency-changer, band-pass coupled to an H.F. Pentode I.F. Amplifier. This is followed by a Duo-Diode giving distortionless rectification and A.V.C. voltage to the preceding valves. The rectified Diode output is amplified by an H.F. Pentode which is resistance-coupled to a Triode phase-changer feeding two large Triodes in push-pull. This ensures large output with exceptionally low phase and amplitude distortion. The full circuit, as described, is in use on all wavebands. Highest quality components and materials used throughout. Size 14 1/2" x 11 1/2" x 9" high. SUPPLIED ACCURATELY ALIGNED, FULLY TESTED AND READY TO SWITCH ON. COMPLETE WITH KNOBS, VALVES, PILOT LAMPS, ESCUTCHEON, ETC. WITH BRITISH £9-17-6

**6-VALVE, 4-BAND SUPERHET**  
Same as above but with single TRIODE output (and therefore phase-changer valve also omitted). Size 14 1/2" x 11 1/2" x 9" high. With British Valves £8-17-6

All chassis sent on approval against cash. ALL "WIRELESS WORLD" KITS SUPPLIED. SCIENTIFIC SUPPLY STORES (Wireless) LTD.

126, Newington Causeway, Elephant & Castle, S.E.1 Phone: HOP 1800.

33, St. Martin's Court, Charing Cross Road, W.C.2 (next to Leicester Square Station) Phone: TEMple Bar 1923.

**REALISTIC  
REPRODUCTION**

for 29/6!

The best speaker that money can buy is undoubtedly the

**BAKER Super-Quality TRIPLE SPEAKER** Prices from £7-7-0

The next best thing to this famous speaker is the

**BAKER TRIPLE CONE ASSEMBLY**

No matter what type or make of speaker you possess you can considerably improve frequency response and quality of reproduction by having a triple cone assembly fitted which comprises main curved cone and dual bakelite and duralumin cones combined, mounted in a 12" die-cast aluminium frame. The price complete including free fitting at Works is **ONLY 29/6**

There is a special Triple cone assembly for owners of Bakers Super Power speaker. Price 25/- including coil.

EXCHANGES. As an alternative to the above conversion we can allow you a good price for your old speaker in part exchange for a Baker Super Quality Triple speaker. Write now for quotation and our new leaflet—"Loud Speaker Tailoring"—Yours for the asking.

Get in touch now with the Pioneer Manufacturers of Moving Coil Speakers (1925-1936).

**Bakers Selhurst Radio Ltd.**  
75 Sussex Road, South Croydon  
PHONE: CROYDON 3441.

COMPONENTS—SECOND-HAND,  
CLEARANCE, SURPLUS, ETC.

**O**LVERS Offer Erie 1-watt Colour-coded Resistances, 3/2d. each, 3/- dozen, 2/6 dozen in 3-dozen lots.

**A**LUMINIUM Chassis, 18 gauge, 16in.x10in.x3in., undrilled, 5/-; ditto 16 gauge, 7/6.

**C**LIK Chassis Mounting Valve Holders, 5-pin 3d., 7-pin 4d.; tubular glass fuses, 1 amp., 150 m.a., 500 m.a., 3/2d. each.

**C**ENTRALAB Volume Controls, standard, with switch, 2/-; electric alarm clocks, 230v. 50 cycles, in walnut bakelite, 14/6.

**C**OLLARO Gramophone Motors, A.C. 110-250v. 50 cycles, Unitplate, Auto-strat and stop, turntable, regulator, etc., 24/6; Radiogram unit, ditto, but with rectangular unitplate, 14in.x16in., and complete with Collaro standard pick-up, with built-in volume control, complete, 38/-.

**R**OLA, manufacturer's type, speakers, energised, 2,000 and 2,500 ohms, brand new, with transformer, 10/6.

**H**UNTS Cardboard Case Electrolytics, 4 mfd. 1/6, 8 mfd. 1/9; 50 mfd. 50v. 1/6; 8 mfd. plus 4 mfd., 2/5; 8 mfd. plus 8 mfd., 2/9.

**M**ETAL Case Electrolytics, B.I. and T.C.C., 8 mfd. 2/4, 4 mfd. 2/1; Dubilier, 8 mfd., 2/6; B.L., 25 mfd. 25v., 1/1.

**A**LL Enquiries Invited, quotations per return; lists free.—Olivers, 676, Christchurch Rd., Boscombe, Hants. All orders under 5/6 postage 3d. extra. [3541]

**M**OVIING Coil Microphone, with table stand and amplifier, 50/- complete.—62, Worcester St., Stourbridge. [3517]

**P**HILCO Model O48, combined, all purpose (A.C./D.C.), test meter and oscillator, with full instructions and leads, in good condition; £5/10.

**F**ERRANTI A.C./D.C. Test Meter Rectifier, Model 1000 O.P.U., listed at £5/15, good condition; £3/2/6.

**G**ARRARD Record Changer, A.C./D.C. model, 100-250 volts, listed £10/17/6, in new condition; £6/10.

**H**ENRY'S, 72, Wellington Av., London, N.15. Stamford Hill 2907. [3546]

**H**EADPHONES.—5,000 guaranteed pairs to be cleared, Brown, G.E.C., B.T.H., Ericsson, Nesper, Western Electric, Siemens, Brandes, Sterling, etc., 2,000 ohms, 2/6; 4,000 ohms, 5/-; postage 6d.

**S**PECIAL.—Telefunken, adjustable, lightweight, 2,000, 4,000 ohms, 7/6; crystal sets, Burns-Jones, complete, guaranteed, 5/6; ditto, double circuit, 8/6; with permanent detector, 1/- extra; sensitive permanent detectors, 1/6; crystal detectors, complete parts, 1/-; crystals, 6d.—Post Radio, 183, Caledonian Rd., London, N.1. [3526]

**E**LIMINATORS.—Ferranti 250 volts 120 m.a., Ekco 150 volts 25 m.a. trickle charger, 6 watt 3 valve mains amplifier, all perfect condition; what offers?—Kallend, High St., Wellington, Somerset. [3520]

**M**AINS RADIO DEVELOPMENT COMPANY continue to Offer Exclusive Bargains. Unbeatable value, carriage paid. Stamp for new list. See displayed advert on this page for exclusive all-wave offer.

**K**NOBS.—Superb appearance, 1/4in., hexagonal, brown bakelite; satisfaction guaranteed; 2d. each; exclusive.

**C**HASSIS.—Three-valve, grey cellulosed, 12in.x6 1/2in.x3in., rigid metal, 1/-, brand new; Clix chassis mounting valve holders, 5-pin, 2/4; Plessey, 4-pin. 1 1/2d., 7-pin 4d.

**R**ESISTORS.—1-watt, colour coded, wire ends, very best make, unused, every value, 50 ohms to 4 megohms, 3 1/2d., 2/9 dozen; 2-watt ditto, 7d. each.

**C**ENTRALAB Unused 500,000 Ohm Potentiometers, 1/-; Corsor, 50,000 ohms, with switch, 1/6.

**T**ELSEN Latest Type Bakelite Reactions, coloured boxes, 0.0015 mfd., 4 1/2d., to clear; Ormond, 0.0003, 0.0005 mfd., 9d.

**S**TANDARD Telephones, brand new metal case condensers, 400 volt working, 2 mfd. 6d., 1 mfd. 4 1/2d., lowest ever; Formo unused tag condensers, 0.00005-0.002 mfd., 1 1/2d. each.

**T**UBULAR Condensers, brand new, non-inductive, 400 volt working, best make, 0.0001-0.002 mfd. 3d., 0.005-0.05 mfd. 5d., 0.1 mfd. 6d., 0.25, 0.5 mfd., 7d.

**O**RMOND Unused H.F. Chokes, very efficient, 6d.; short wave type, 4d.; B.I.C., 4mfd., 350 volt working condensers, 1/8; Lissen 0.1x0.1 mfd., 1,500 volt buffers, 9d.

**E**LECTROLYTES.—All unused, dry type, B.I.C., 8 mfd., 550 volt, one-hole fixing, 2/6 Plessey, 8 mfd., 550 volt, 1/8; 50 mfd., 50 volt, 1/8; 200 mfd., 15 volt, 2/3; 16 mfd., 525 volt, 2/2.

**T**ELSEN P.M.M.C. Speakers, 7 inch cone, ten ratio output transformer, massive magnet, new, boxed, 11/6 only; Telsen boxed disc drives, complete, 1/9.

**S**PAGHETTIS.—Lewcos, unused, sealed cartons, ten sizes, good assortment, absurd price to clear, 50 for 1/-; satisfaction guaranteed; 50 assorted half-watt resistors, wire ends, unused, good sizes, 2/6.

**M**AINS RADIO DEVELOPMENT COMPANY, 4-6, Muswell Hill Rd., London, N.6. Phone: Tudor 4046.

**F**ERRANTI Transformers, A.F.5c, 15/6; A.F.5 A.F.15c, O.P.M.11c, 12/6 each; A.F.3, 8/6; Ferranti trickle charger, 2-4-6v., 1/2 amp., A.C., 200-250, 15/-; Regentone eliminator, with trickle charger, Model W.5A, new condition, 25/-.—R.P.E. Radio, 112, Pentonville Rd., London. [3534]

**T**RANSMITTING APPARATUS

**G**5NL.—The recognised distributors for amateur equipment, National E.M.E., Thordarson, Hammarlund, McMurda, Halliwell, etc.; send 1/6d. stamp for catalogue.—Radiomart, 44, Holloway Head, Birmingham. [0531]

**C**INEMA EQUIPMENT

**M**OVIIE Cameras, projectors, screens, films; inspection invited.—Ilustra Enterprises, 159, Wardour St., London. [0486]

**MAUD EXPORT & TRADING Co.**

(Dept. W.W.)

**6, Booth Street, MANCHESTER, 2.**

**NEW STOCKS—NEW PRICES NO OLD JUNK!**

**OUR GUARANTEE—ALL GOODS ARE DESPATCHED IMMEDIATELY ON SEVEN DAYS APPROVAL: If not fully satisfied, return goods within this period in good condition and purchase price will be refunded in full.**

Orders 5/- and over, carriage paid, under 5/-, postage 6d. extra. Orders under 5/- cannot be sent C.O.D.

ALL-WAVE KITS: 3-valve, 6-2,000 metres	30/- each
SHORT-WAVE COILS, 4 or 6-pin	20/- " 1/9 " 6d. "
BASES, chassis mounting, for 6-pin coils	6d. "
BEEHIVE Porcelain Stand-offs	5d. "
BRITISH Radiophone Short-wave Two-gang Condenser, fixed pigtail connection, stentite base, .00016 each section	3/8 "
GLASS LEAD-IN TUBES	1/3 "
LIGHTWEIGHT HEADPHONES	2/8 pair
ELECTROLYTIC CONDENSERS, well-known British manufacturer, 500 v. working, 8 mfd., 1/9; 8 plus 4, 2/3; 8 plus 8, 2/9; 25 mfd. 25 v., 9d.	9d. each
WEBO, 1 mfd. Mainsbridge type, 700 v.	9d. each
TUBULAR CONDENSERS: .001-.05, 4d. each; .1-25, 5d. each; .5	9d. "
WIRE-WOUND RESISTANCES, all sizes	3d. "
VOLUME CONTROLS, replacements for any receivers, with switch, 2/6; without	2/- "
CLARION PICK-UPS, with tone arm, finest quality	9/3 "
TELEN 8in. P.M. SPEAKERS, with multi-ratio transformer	12/- "
SPEAKER TRANSFORMERS, 10-ratio, with terminals, match all sets and speakers	4/9 "
K.B. Mains Energised Speaker, 1,500 or 2,000 ohms	7/6 "
FINEST QUALITY B.A. Speaker, in smart wooden cabinet—as good as any M.C.	10/- "

**AMERICAN VALVES—ALL TYPES 3/3 "**

**BRITISH TYPE MAINS VALVES—famous Continental Manufacturer:**

Simply state equivalent—all types 4/3 each

BATTERY 2 v. valves: H.F., L.F., DET., 2/- each.	
POWER	2/6 "
All others incl. V.M.'s and 7 pins	4/9 "
ACE MICROPHONES on bakelite stand	3/9 "
ELECTRIC BELLS, all metal, 3in. gong	1/3 "
BELL TRANSFORMERS, 200/50 v. 2.5 amp., 3 v. 5 v.-8 v.	3/- "
ELECTRIC SOLDERING IRONS, AC DC 200/250 v.	2/- "
CYCLE DYAMO SETS, complete with head and rear lamp, chrome-plated	8/6 set
TELEGRAPH SIGNAL SETS, include MORSE KEY and 3-way switch for buzzer, taper and light flasher, complete with batteries	4/6 "
CAR-RADIO, 5 v. Super-het, the last word in American perfection (five-minute fixing), complete	£7 each
ALL-WAVE BATTERY RECEIVERS, 16-2,000 metres, H.F., Fan., DET. and Output Pen. M.C. Speaker, in very handsome horizontal cabinet	75/-
ELECTRIC VACUUM CLEANER, AC/DC, complete with all accessories, state voltage	48/6

**POWER RESISTORS**

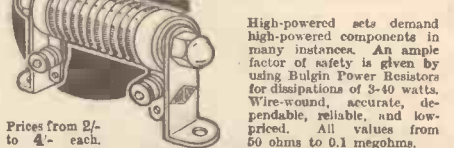

Prices from 2/- to 4/- each.

High-powered sets demand high-powered components in many instances. An ample factor of safety is given by using Bulgin Power Resistors for dissipations of 3-40 watts. Wire-wound, accurate, dependable, reliable, and low-priced. All values from 50 ohms to 0.1 megohms.

**A.F. BULGIN & Co. Ltd.** SHOWROOMS 64 HOLBORN VIADUCT, LONDON, E.C. ARBEY R. BARKING, ESSEX. TEL RIPLEYWAY 3474 (3 LINES).

**TRANSLANTIC All-Wave Tuning Pack**

A Complete Superhet. tuning unit, covering 15-50, 200-550 and 1,000-2,000 metres at the turn of a switch. Incorporating latest screened all-wave coils, two 465 K.C. I.F. transformers, latest Polar two-gang condenser and superb full-vision drive and 2 valveholders. Scale marked in station names, and degree on short wave band. Completely wired, aligned and tested, for A.C. or D.C. mains. EXCELLENT GREY CELLULOSE FINISH, SIX TERMINAL CONNECTIONS ONLY. Boxed 49/6 Carriage complete with circuit and instructions.

See also Miscellaneous advertisement on this page for other exclusive bargains.

**M**AINS RADIO DEVELOPMENT COMPANY, 4-6, MUSWELL HILL ROAD, LONDON, N.6. Tudor 4046.

MISCELLANEOUS

**HEAR** Printing.—1,000 billheads, 3/6; sample free; Gretnaway Press, 18, Buxted, Sussex. [3503]

**WARM** Bed this Winter for 1/2d. per week; the Warm-Glow Electric Blanket costs only 52/6.—Leaflet from Warmglow Co., Leigh-on-Sea. [0542]

**P.O. Engineering Dept.** (no experience required). Commencing £3/13 per week. Age 18-25. Excellent prospects.—Free details of entrance exam. from B.I.E.T. (Dept. 574), 17-19, Stratford Place, London, W.1. [3492]

**AMBITIOUS MEN**—Here's the way to better pay. Study at home with The T.I.G.B., the leading organization for engineering training. Write to-day for "The Engineer's Guide to Success"—free—which contains the world's widest choice of engineering courses—over 200—and which alone gives the regulations relating to qualifications such as A.M.I.E.E., A.M.I.W.T., A.Rad.A., etc. Extensive employment facilities for students. Hundreds of vacancies notified every year.—The Technological Institute of Great Britain, 82, Temple Bar House, London, E.C.4. (Founded 1917, 19,000 Successes.) [3506]

ELECTRIC CLOCKS

**SMITHS and Ferranti** Electric Clocks, Waltham and Russell watches and clocks; traders enquiries invited.—Leonard Heys, 36, Henry St., Blackpool. [0526]

EXTENDED PAYMENTS

**LONDON RADIO SUPPLY Co.** (Established 1925) supply on convenient terms, components, accessories and sets, any make; 10% down, balance over 12 months; send for list of requirements.—11, Oat Lane, London, E.C.2. [0337]

EXCHANGE

**COSMIO RADIO SERVICES, Ltd.**, 23, Water St., Liverpool, accept quality mains equipment, meters, components, etc., in part exchange. Meters purchased. [2490]

**I BUY**, sell, exchange good quality receivers, accessories, components; H.P. facilities; promptness, efficiency.—Bostock, 1, Westbourne Terrace, S.E.25. Forest Hill 2236. [0529]

PATENT AND TRADE MARK AGENTS

**H. N. and W. S. SKERRETT**, Chartered Patent Agents, 88-90, Chancery Lane, London, W.C.2. (Hol. 8837) and 24, Temple Row, Birmingham. [2461]

**CEE and Co.** (H. T. P. Gee, Mem. R.S.G.B., A.M.I.E.E., Estab. 1905), 51-52, Chancery Lane, London, W.C.2 (2 doors from Government Patent Office). Holborn 4547 (2 lines). Handbook free. [0001]

REPAIRS AND SERVICE

**GRAHAM'S**.  
**GRAHAM'S** Radio Repair and Rewinding Service; 24 hours' service guaranteed.—See below.

**ALL** Moving Iron Loud Speakers, L.F. transformers, or pick-ups, from 2/6; output transformers from 4/—; postage extra; mains transformers, moving coils, electric clocks quoted; trade discounts.—Graham's Repairs, 194, Tolworth Rise, Kingston-by-pass, Surrey. 'Phone: Derwent 2060. [3500]

**DISTAVOX SERVICE**.  
**TRADE** Service.—All makes of English and American receivers; quotation by return.

**REWINDING**—Mains, L.F. and output, transformers, speakers, headphones, etc.; keenest terms for contracts.

**DISTAVOX RADIO SERVICE Co.**, 119, Bunhill Row, London, E.C.1. 'Phone: National 8589. [3504]  
 "SERVICE With a Smile."

**HENRY FORD RADIO, Ltd.**,  
**LEADING** Service Specialists for American Receivers, also British; trade work particularly; estimates free.

**ELECTRONIC** House, 22, Howland St., Tottenham Court Rd., W.1. Museum 5675. [0434]

**METROPOLITAN RADIO SERVICE Co.** for Guaranteed Repairs to American (Midget and Standard) and British Receivers.

**CLARION** and Majestic Service Depot.—I.F. and mains transformers rewound, American valves and parts; trade supplied.—Metropolitan Radio Service Co., 1021, Finchley Rd., London, N.W.11. Speedwell 3000. [0435]

**DEGALLIER'S, Ltd.**, radio repairers on British and American receivers, 3 days' service, lowest prices with best workmanship, all repairs guaranteed.

**DEGALLIER'S, Ltd.**, 18, Connaught St., London, W.2. Paddington 2745. [3491]

**VALRADIO** for Repairs and Rewindings to Converters, Motors, transformers, vacuum cleaners, etc.—95, Leighton Rd., Kentish Town, N.W.5. Gulliver 5165. [3210]

**GUARANTEED** Repairs.—Any transformers, choke, motor, armature, converter, dynamo, etc.; keenest prices, immediate quotation; prompt, dependable service.—See below.

**L.T.P. (LONDON TRANSFORMER PRODUCTS, Ltd.)**, Willesden, N.W.10. Wil. 3568 and 7743. [3470]

**MAINS** Transformer Service.—Repairs, rewinds, or constructions to specification of any type; competitive prices and prompt service.—Sturdy Electric Co., Dip-ton, Newcastle-on-Tyne. [0516]

**F. E. GODFREY, A.M.I.E.E.**, qualified to build, repair and convert "Wireless World" sets, etc.; 25 years' experience; prompt service guaranteed.—30, Kemplay Rd., Hampstead, Hampstead 1104. [3509]

RADIOMART SHORTWAVE SPECIALISTS

**MICROVARIABLES**—All brass construction; latest ceramic insulation. The finest condensers made; 15 mmfd, 1/4; 40 mmfd, 1/7; 100 mmfd, 1/10. Transmitting Type.—070in. spacing 15 mmfd. (neutralising). 2/9. 40 mmfd. Tuning, 3/8. These are quality.

**SHORTWAVE COILS**—(RD4) CA 11-25, CB 20-45 metres 2/6. CC 44-100 metres, 2/9. Standard 6-pin types, CA6 CB6, 2/9 each, CC6, 3/-; same range as 4-pin.  
**COILFORMS**—Moulded in RD4 natural laloss material, hollow resilient pins 1 1/2 in. diameter ribbed; identification disc in top. Four types, 4-pin, 1/6; 6-pin (standard or to fit 7-pin valveholders), 1/9; 7-pin (for bandspread tap), 1/10; Machine threading, 2d. extra.

**AMERICAN Mains Transformers**, 230 v., fully shrouded, 350-350, 8.3 v., 5 v., 6/11; Majestic, 250-250, 2.5 v., 5 v., 4/11. Pilot 200-260, 2.5 VCT, 5 VCT, 5/11.  
**HEAVY DUTY Mains Transformer**, worth 35/-, 350-350, 150 m.a., 4 v., 2.5 ACT, 4 v., 6. ACT, 12/6.

**UTILITY 8/8**, Microdisc Dials, 3/11; Radiophone, 0.00016 Shortwave Condensers, 3/6; Series gap, twin, 3/9. Shortwave HF Chokes 5-100 metres, 9d.  
**465 KC** City Wound IFS, 3/11; Two-speed Slow Motion Knobs, 1/-; Telsen Ace Transformers, 1/11; Iron-cored HF Chokes, 1/-; Utility Straight Line Dials, 2/11; British Radiophone Straight or Superhet 3-gang Condensers, with trimmers fully screened, 4/11.

**LISSEN**, 3-gang Band Pass Kit, including switched coils, 3-gang Condenser with disc dial, 10/-.  
**ELECTROLYTICS**, Huge purchase 500 v. Aluminium Can, 4 mf., 1/6; 8 mf., 1/11; 16 mf., 2/6; 8+8 mf., 2/6; 8+8 mf. 450 v. + 8 mf. 250 v., 2/9; Block type, 500 v. peak, 4+4 mf., 1/6; 6+6+6 mf., 2/6; 8+8+4 mf., 3/-; 50 mf. 50 v., 1/3; 25 mf. 25 v., 1/-; 2 mf. 300 v., 9d.; 40+24 mf. 200 v., 1/6.

**FAMOUS CONTINENTAL A.C. Valves**, 4/6; Battery types from 2/3; American Duotron etc., all types, 3/6; All types of RCA Licensed first grade tubes, metal and glass, in stock from 5/6.

**FEATHERWEIGHT** Headphones, 2/6; Varley Bifocal Iron-cored Coils, 2/6; matched pair, 4/6.

**SMOOTHING CHOKES**, 20 hy., 120 m.a., 3/11; 40 m.a., 1/11; Centralab Pots, all sizes, 1/6; switched 2/-; 20,000 ohm Pots, 1/-; Tubular glass fuses, 2d.

**SPECIAL OFFERS**. Class B Kit worth 30/-, comprising Driver Transformer, Valve and Holder, 5/-; Dozen wire ended assorted resistors 1/6. Preset Condensers, 9d.

**TRADERS!** Monster Bargain Parcels value £4/10/0, for 10/-; also 5/- parcels. State battery or mains. Telsen Screened Dual Range Coils, 2/6; per pair, 4/6; Milliammeters 25 m.a. upwards, 5/9; super, 6/9.

**PUSHBACK** Wire, 6 yds. 6d.; heavy, 9d.; Resin cored Solder, 6ft. 6d.; Screened Flex, single, 6d. yd.; twin, 9d. yd.

**CONDENSERS**, 4 mf. 700 v. T., 2/6; 2 mf., 1/6; T.C.C. 1 mf., 6d.; Dabiller, 0.1 mf., 3d.; Tubular Condensers, 1,500 v. T., all sizes to 0.1 mf., 6d.; 0.2 to 0.5 mf., 8d.

**UTILITY 2-gang Uniknob**.0005 with Dial, 3/11. EDC Converters, new, 12 volt to 240 v. 40 m.a., 25/-; BTH ditto, 9 v., input fully smoothed, 39/6.

**CRYPTO** 500 watt 220 v. DC to 230 v. AC, as new, £10; Ditto, 1,000 watt, £15. One of each only.

**AMERICAN** latest Double Button Microphones, cost £2 in U.S.A., our price 35/- . Why buy junk?  
**SCOTT** All-wave Chassis, 15-550 metres, perfect order, separate push-pull output, chassis, twin speakers, £18; Silver Marshall 14 Valve ditto, single speaker, £10. One each only.

**ROLA**, used but perfect matched pairs, 2,500 ohms, 10in. and 7in., no transformer, 15/-; Ditto, Magnavox Magna, 25/-; Jensen 7in., new PM speakers, 12/6.

Order 5/- post free. Get our Bargain Catalogue, 1 1/2d. post free. All enquiries and requests for Catalogue must send 1 1/2d. stamp.

**RAYMART** 1936-7 EDITION  
 CRAFT A CREDIT  
**RAYMART SHORTWAVE MANUAL**

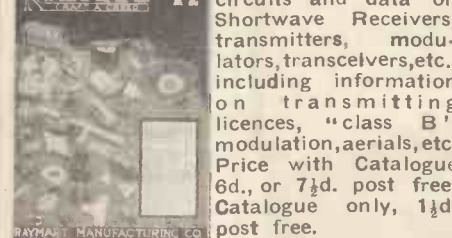

48 Pages of practical circuits and data on Shortwave Receivers, transmitters, modulators, transceivers, etc., including information on transmitting licences, "class B" modulation, aerials, etc. Price with Catalogue 6d., or 7 1/2d. post free. Catalogue only, 1 1/2d. post free.

**BIRMINGHAM RADIOMART (G5N1)**  
 19, John Bright Street and Dale End

MAIL ORDER DEPT. "W"  
**44 HOLLOWAY HEAD,**  
 BIRMINGHAM. TELE.: MID. 3254.

REPAIRS AND SERVICE

**LOUD** Speaker Repairs, all makes, English and American, 24 hour service; transformers made to specification; coils, transformers rewound.—Sinclair Speakers, Alma Grove, Copenhagen St., London, N.1. [3527]

**RADIO** Repairs and Constructional Service, receivers, transmitters, audio amplifiers, etc.; express radio repairs for Lancashire.—Harmony House Sound Service (G2IN, G5ZI), 116, Cambridge Rd., Southport. Tel.: 8621. [0536]

**REPAIRS** to Moving Coil Speakers a Speciality; cones and coils fitted, fields altered; prices, including eliminators, quoted, loud speakers, 4/-; L.F. and output transformers, 4/-, post free; guaranteed satisfaction; trade invited; estimates free; prompt service.—Loud-Speaker Repair Works, 5, Balham Grove, London, Battersea 1321. [0394]

TUITION

**RADIO** Training.—Marine, aircraft, broadcast; prospectus free.—Hull Municipal Technical College. [0523]

WANTED

**WANTED**, negative amplifier, less valves; state price.—J. Moxham, 41, College Rd., Epsom, Surrey. [3516]

**ROTARY** Converter Wanted, 120-200 watts, E.D.C. or similar.—Write Jones, 53, Barrington Rd., S.W.9. [3522]

**WANTED**, Burndepht no-flament type Ethotron rectifying valve.—Milward, Somersall Hall, Chesterfield. [3515]

**WANTED** for Cash.—Modern radio receivers; also meters, etc.—M. R. E. 6, Pentonville Rd., London, N.1. [3283]

**WE** Buy for Cash All Types of Modern Second-hand Radio Sets and Accessories, test meters, parts, etc.; we pay more than any other dealer; part exchanges; bring, send, or will call.—University Radio, Ltd., 82, Hampstead Rd., London, N.W.1. 'Phone: Euston 3810. [3484]

SITUATIONS VACANT

**CIVIL** Service Commission.

**FORTHCOMING** Examination: Male assistant superintendent of traffic (Class II) in the London Telephone Service and male assistant traffic superintendent in the Provinces, General Post Office (18-23, with extension for service in H.M. Forces).

**REGULATIONS** and Particulars, together with the forms on which applications must be made, will be sent in response to requests (preferably by post card) addressed to the Secretary, Civil Service Commission, Burlington Gardens, London, W.1, giving the title of the situation; the latest date for the receipt of application forms is March 4, 1937.

**WIRELESS** and Television.

**MARCONI'S** and Other Employers Require Hundreds of Trained Men This Year. We train students for all branches of Radio at our Residential Colleges in Southampton and Colwyn Bay, and guarantee appointments; licensed by Postmaster-General, recommended by Marconi's.—Write for free prospectus, The Wireless College, Colwyn Bay, or to London Office, 4, Winton Av., N.11. [0541]

**WANTED**, young man, public school or secondary, as radio improver for small business, well known radio surplus concern.

**ABLE** to Wire Up 3v. Chassis to Pattern, quickly and neatly, and study superhets with view to production all wave job.

**MUST** Be Willing to Accept Small Salary to Commence, 40 hour week, or would make suitable arrangement with student.

**OR** Qualified Radio Engineer, own tools, free lance part time, with view to full time at good salary, might suit.

**A** T London, W.C.1.—Reply to Box 381, c/o The Wireless World. [3538]

**FULLY** Experienced All-round Serviceman, East London, shop hours, good job with good pay for good man.—Box 376, c/o The Wireless World. [3523]

**ENGINEER** for Design and Manufacture of High Gain, L.F. amplifiers, will be required to take complete charge of production; London, S.W.8. 'Phone: Macaulay 4840. [3544]

**WANTED**—Qualified Radio Engineer, must be familiar with American All-Wave receivers; laboratory and production experience essential.—Write Box 33, "Pars", 121, Kingsway, London, W.C.2. [3508]

**YOUTH** Required for Wiring and Assembly of Amplifiers; experience in this or radio work essential; call 9-11 a.m. or 5-6 p.m.—Ardente Acoustic Laboratories, 11-12, Pollen St., Oxford Circus, W.1. [3514]

**GLASS** Expert Required for Radio Valve Factory; experience of glass machines for valves or lamps essential.—Write, stating age, experience and salary required, to Ferranti, Ltd., Moston, Manchester, 10. [3521]

**DRAUGHTSMAN** Required for Small Mechanical and Electrical Apparatus Design, outer Croydon area.—Apply, stating salary required, to Manager, Marconi's Aircraft Wireless Establishment, Wandle Rd., Hackbridge. [3518]

**RADIO** Testers with Full Technical Knowledge and Experience in Modern Superhet. Design, must have held previous position with reputable manufacturer and produce first class references.—Higgs Radio, Westbourne Place, Hove. [3481]

**A LIMITED** Number of Vacancies Occur Monthly for young men with secondary school education, to be trained in the Royal Air Force as Wireless Operators; age limits 17 1/2 to 32.—Apply: R.A.F. Recruiting Depot, Victory House, Kingsway, London, W.C.2, or any R.A.F. Recruiting Depot. [3512]

For really high-grade mains transformers and chokes—it's best to go to Savage!



★From our standard lists or to your specifications. We will gladly send you lists on request or quote to your particular requirements.

**W. BRYAN SAVAGE LTD.**



WESTMORELAND ROAD, LONDON, N.W.9  
PHONE: COLINDALE 7131 (3 LINES)

*The Autocar*

The Leading Motoring Paper  
EVERY FRIDAY 4d. W.W.16

## RADIO RECEIVER MEASUREMENTS

By Roy M. Barnard, B.Sc., A.M.I.R.E. (1934)

Although primarily designed for the benefit of the radio service engineer, this concise handbook is also of practical value to the amateur experimenter.

It describes the methods of measuring receiver performance and provides provisional standards as a basis for judging performance. Measurements of sensitivity, selectivity and fidelity are explained at length and the interpretation in estimating receiver performance is carefully set out.

Details are given of methods of receiver testing with full descriptions of commercial signal generators and their application to the adjustment of superheterodynes and "straight" receivers.

Complete with fifty-three illustrations and diagrams, summaries of method, four appendices and a general index.

PRICE 4/6 net

By post 4/9

From all booksellers or direct from the Publishers

ILIFFE & SONS LTD.

DORSET HOUSE, STAMFORD STREET, LONDON, S.E.1

W.W.19

## ENGINEERS! ARE YOU EARNING LESS THAN £10 PER WEEK?

If so, you cannot afford to carry on without reading our 268-page Handbook. The book explains clearly and definitely many ways of carving out a successful career. Among other things, it explains the Services of our unique Appointments Department; outlines Home-Study Courses in all branches of Civil, Mechanical, Electrical, Motor, Aero, Wireless, "Talkie" Engineering, Television, Building, Govt. Employment, etc., and gives details of B.Sc., A.M.I.C.E., A.M.I.A.E., A.M.I.R.E., A.M.I.W.E., G.P.O. Matric., and all Exams. We Guarantee—"No pass—No Fee." Whether you be an old hand or a budding apprentice, get this book to-day—FREE and POST FREE.



BRITISH INSTITUTE OF ENGINEERING TECHNOLOGY,  
387, Shakespeare House, 17/19, Stratford Place, London, W.1.

FOR P.A. AT ITS BEST



**GRAMPIAN**

GRAMPIAN REPRODUCERS LTD.  
Kew Gardens, Surrey.

## HIRE PURCHASE

We can supply any Radio and Electrical Apparatus on HIRE PURCHASE having a value of over £3 at convenient terms, including Midwest, Halcyon, Challenger, Armstrong and other receivers. Spartan Refrigerators, etc., etc.

CHAS. F. WARD, 46, Farringdon Street, LONDON, E.C.4. Tel.: Holborn 9703.

## BOOKS on WIRELESS

Write for complete list to  
ILIFFE & SONS LTD.

Dorset House, Stamford St., London, S.E.1 W.W.1

## INDEX TO ADVERTISEMENTS

	PAGE
Anson, Henry, Ltd.	4
Armstrong Mfg. Co.	4
Automatic Coil Winder & Electrical Equipment Co., Ltd.	4
Bakers Selhurst Radio	6
Belling-Lee, Ltd.	3
British Institute of Engineering Technology	8
British Insulated Cables, Ltd.	47
British Rola Co., Ltd.	Edit.
Bulgin, A. F., & Co., Ltd.	6
Cass, Sir John, Institute	4
C.A.V.	4
Dubilier Condenser Co.	Front Cover
Electradix Radios	4
Exide, Ltd.	4
Fluxite, Ltd.	4

	PAGE
Forbat, Eugen, Ltd.	2
Galpins	2
G.E.C.	8
Grampian Reproducers, Ltd.	1
Hartley Turner Radio, Ltd.	Front Cover
Haynes Radio	6
Imhof, Alfred, Ltd.	6
Mains Radio Development Co.	6
Maud Export & Trading Co.	6
McCarthy Radio, Ltd.	Front Cover, Edit. 45
Midwest Radio, Ltd.	Inside Front Cover
Musikon, Ltd.	Inside Front Cover
Parmeko, Ltd.	5
Players Cigarettes	Inside Front Cover
Premier Supply Stores	5

	PAGE
Prism Manufacturing Co.	4
Radio Development Co	4
Radio Industries Development Co.	7
Radiomart (G5NI)	7
Record Radio	8
Savage, W. Bryan	8
Scientific Supply Stores (Wireless), Ltd.	6
Silam Electrical Instrument Co.	8
Sound Sales, Ltd.	4
Tannoy Products	4
Universal Radio Distributors, Ltd.	4
Varley, Ltd.	8
Ward, C. F.	8



## VALVE EMISSION TESTER

A.C. MAINS OPERATED — FOR BRITISH AND AMERICAN VALVES

Price: £6 : 10 : 0 list

The new patented SIFAM VALVE TESTER is the most simple, efficient and quickest method of testing valves existing. No valve data or curves required, no measurements to worry about. Simply place valve in correct holder, move plug to correct filament socket, switch on and read "GOOD" or "BAD" on coloured dial of meter. Absolutely fool-proof—no technical knowledge required.



SIFAM ELECTRICAL INSTRUMENT CO. LTD.  
Hollydale Road, London, S.E.15. Phone: New Cross 2168.

SECOND EDITION

—Completely Revised

# RADIO DATA CHARTS

A SERIES OF ABACS

Providing most of the essential Data required in receiver design

By R. T. BEATTY, M.A., B.E., D.Sc.

PRICE 4/6 net

BY POST 4/10

From all leading booksellers, or direct from the Publishers. Published from the offices of "THE WIRELESS WORLD," DORSET HOUSE, STAMFORD STREET, LONDON, S.E.1

W.W.91

# TRADE & TECHNICAL Journals

*Influential and authoritative*

FOR TRADE DEVELOPMENT AND PROGRESS...

FOR FACTS OF PRODUCTION AND DISTRIBUTION.

FOR THE VERY LATEST NEWS AND INFORMATION

FOR AN INDEX TO GOODS USED AND SOLD....

**IF** you are seeking new markets, or desire to get first-hand information about a trade or industry, you cannot go to a surer or more authoritative source than the trade and technical journals serving it. The address of any paper in this list will be furnished on request.

Amateur Photographer and Cinematographer.  
Architects' Journal.  
Architectural Review.  
Autocar.  
Automobile Engineer, incorporating Motor Body Building.  
Boxmakers' Journal & Packaging Review.  
Brewers' Journal.  
British Baker.  
British Engineers' Export Journal.  
British Journal of Photography.  
British Printer.  
Bus & Coach.  
Chemist & Druggist.  
Cigar & Tobacco World.  
Confectioners' Union & Ice Cream & Soda Fountain Journal.

Drapers' Record.  
Dyer, Textile Printer, Bleacher & Finisher.  
Electrical Engineer.  
Electrical Review.  
Electrical Times.  
Electrical Trading & Electricity.  
Engineer.  
Engineering.  
Export Trader.  
Flight.  
Footwear Organiser.  
Furnishing Trades' Organiser.  
Grocer & Oil Trade Review.  
Grocers' Gazette & Provision Trades' News.  
Grocery & Branch Store Management.  
Hotel & Catering Management.

Confectionery Journal.  
Contractors' Record & Municipal Engineering.  
Dairyman,  
Drapers' Organiser.

India Rubber Journal.  
Ironmonger.  
Journal of Decorative Art.  
Laundry (The Power).  
Laundry Record & Dyeing & Cleaning Trades' Journal.  
Licensing World & Licensed Trade Review.  
Locomotive, Railway Carriage & Wagon Review.  
Machinery.  
Meat Trades' Journal.  
Mechanical World & Engineering Record.  
Men's Wear.  
Mining Journal, Railway & Commercial Gazette.  
Model Engineer & Practical Electrician.  
Modern Transport.  
Motor Cycle.  
Motor Cycle & Cycle Trader.  
Motor News.  
Motor Trader.  
Motor Transport.  
Motor World & Industrial Vehicle Review.  
Nursing Mirror.  
Oil & Colour Trades Journal.

Outfitter.  
Overseas Engineer.  
Packing Gazette.  
Photographic Dealer.  
Plumbing Trade Journal.  
Pottery Gazette & Glass Trade Review.  
Poultry.  
Printers', etc., Sales & Wants Advertiser.  
Silk Journal & Rayon World.  
Specification.  
Statist.  
Style for Men.  
Textile Manufacturer.  
Textile Recorder.  
Tobacco Trade Review.  
Waste Trade World.  
Watchmaker & Jeweller, Silversmith & Optician.  
Wine & Spirit Trade Review.  
Wireless & Gramophone Trader.  
Wireless Engineer.  
Wireless Retailer & Broadcaster.  
Wireless World.  
Yachting World & Motor Boating Journal.

Official Handbook, giving particulars of over 500 papers, post free 1/-

**PERIODICAL, TRADE PRESS AND WEEKLY NEWSPAPER PROPRIETORS' ASSOCIATION, LTD.**

Telephone: Central 2441

6, Bouverie Street, London, E.C.4

Telegrams: Weneppa, Fleet, London

*Make a Note of it—Now!*  
*Be sure to get your copy of*

The  
**Wireless  
 World**

## DIARY FOR 1937

Every wireless enthusiast should have this handy little diary. In addition to the usual pages—one week at an opening—it contains 76 pages of facts, formulæ and general information of the kind that is always wanted but is difficult to memorise.

There is a complete list of European Broadcasting Stations and Short-Wave Stations of the World. In addition an important section contains all the recognised codes relating to components, as well as useful tables of resistance ratings. There are also nine pages of base connections of British and American valves.

Sixteen pages of circuit diagrams of receivers, amplifiers and such units as whistle suppressors, tone controls and AVC systems are included. Valuable information is given on the prevention of mains interference and data for winding coils.



**NOW ON SALE**

Size 3½ by 4½ inches, 192 pages. Bound leather cloth, back loop with pencil.

**PRICE 1/6 net.**

By post 1/7

*From bookstalls and stationers,  
 or direct from the Publishers*

ILIFFE & SONS LTD., DORSET HOUSE, STAMFORD STREET, LONDON, S.E.1.

W.W.75

SECOND EDITION—THOROUGHLY REVISED

NOW READY

# WIRELESS SERVICING MANUAL

By W. T. COCKING

(of "The Wireless World")

The first complete book of reference of its kind. A reliable practical guide for amateur and professional.

The demand for this book was so great that the first edition was sold out in the short space of a very few months. A second edition containing additional material is now on sale.

The "Wireless Servicing Manual" deals fully with Testing Apparatus and explains the methods of locating and curing faults in receiving equipment.

Ganging, Automatic Volume Control, Instability, Distortion, Mains Hum, Whistles and Local Interference are all separately treated.

The new edition contains much additional information on short-wave receivers, and on methods of operating extension loud speakers, the reference material including base-connections for British, Continental and American Valves, and the various colour codes for components has been extended and brought up to date.

**BOUND IN CLOTH BOARDS**

SIZE 7½ ins. × 5 ins.

231 PAGES

**PRICE 5/- net. By post 5/4**

Issued in conjunction with "THE WIRELESS WORLD" and published by the Proprietors:—  
 ILIFFE & SONS LTD, DORSET HOUSE, STAMFORD STREET, LONDON, S.E.1

W.W.20



The

# Wireless World

4<sup>D</sup>

**THE PRACTICAL RADIO & TELEVISION JOURNAL**

Friday, January 15th, 1937



*Entirely New Range*



## 1937 R.K. SPEAKERS



**THE MINOR R.K. SPEAKER**  
(Cabinet Model)  
Price (Cat. No. 70772)  
£2. 18. 6

FLARE-SHAPED and variable density cones ensuring even response over a wide frequency range. Positive centring of the self-rigid coil former, eliminating fouling of the walls of the air gap. Improved metals for the construction of the field magnets, giving powerful, concentrated fields. These are some of the improvements embodied in the new R.K. Speakers which still further enhance the reputation gained by those pioneer moving-coil speakers introduced by B.T.H. Engineers some years ago.

Ideal for use as extension speakers, each model can be adjusted to suit the output of any receiver. The speakers are just out of the factory and are now available.



**THE SENIOR D.C. MODEL**  
Dimensions:—  
Height 13 1/8"; Width 12 1/8";  
Depth 8 1/2".  
Price (Cat. No. 70774)  
£5. 5. 0



**THE SENIOR PERMANENT MAGNET MODEL**  
Dimensions:—  
Height 12 3/8"; Width 12 1/8";  
Depth 6 1/2".  
Price (Cat. No. 70771)  
£5. 17. 6

# EDISWAN

**THE EDISON SWAN ELECTRIC CO. LTD.**  
155 Charing Cross Road, London, W.C.2

*Distributors for the British Thomson-Houston Co. Ltd., Rugby* RA 310.



**THE SENIOR A.C. MODEL**  
Dimensions:—  
Height 13 1/8"; Width 12 1/8";  
Depth 8 1/2".  
Price (Cat. No. 70773)  
£6. 17. 6

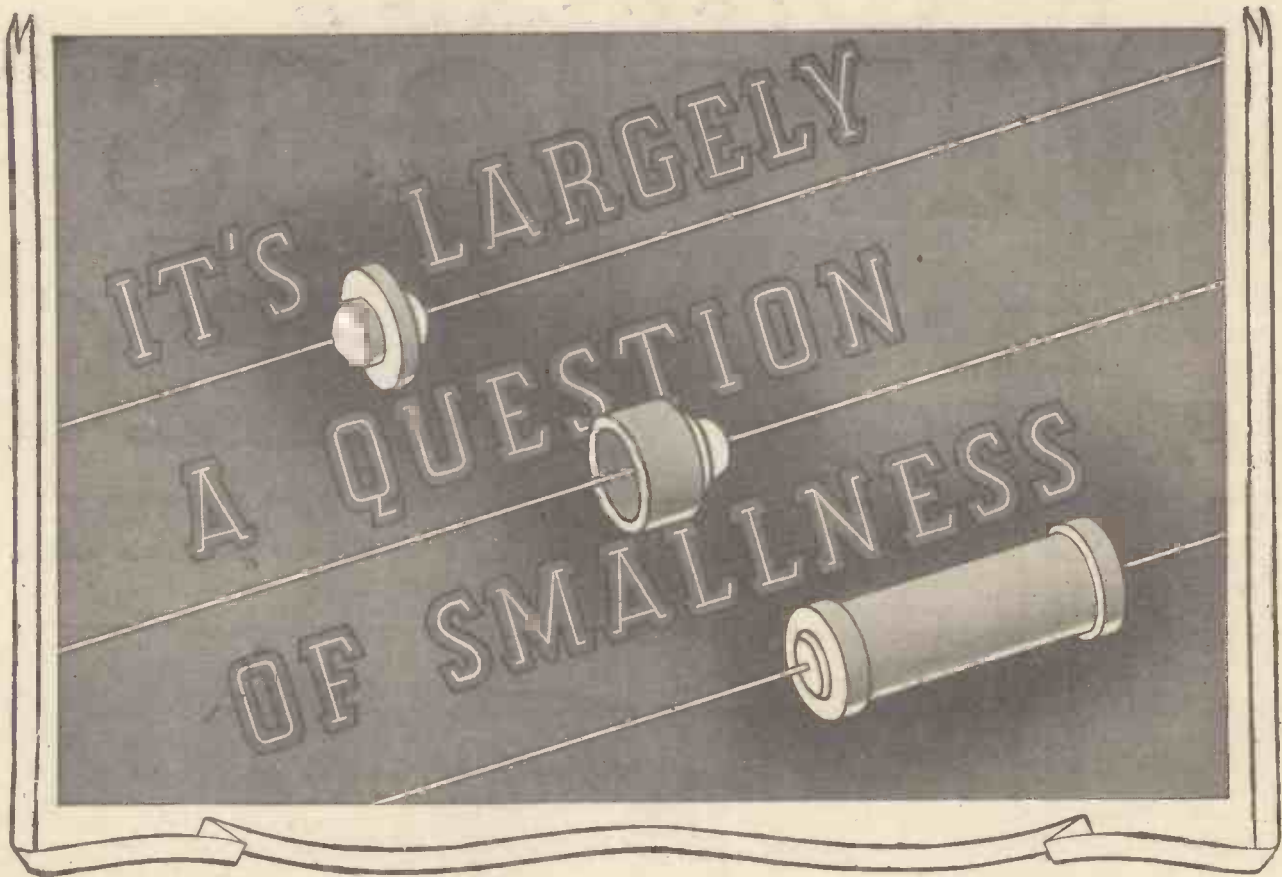

One of our chief considerations in designing these Ceramic Dielectric Condensers was to make them small, but that is by no means their principal quality. Above all, they are stable. Humidity or variation of temperature affect them little, if at all. They also have an extremely low-power factor and are non-inductive. You will find them ideal in any radio frequency apparatus where low loss, low temperature co-efficient, stability and predetermined accuracy are required, and particularly in short-wave receivers for sound and vision reception. Their smallness (and, incidentally, the 22 S.W.G. tinned copper and wire securely fixed to each condenser) will help you considerably in assembling them in the wiring or close to other apparatus. There are three types—the cup and disc type for capacities from 2 to  $100\mu\mu\text{F}$  and the tubular type from there up to  $1,200\mu\mu\text{F}$ . In both the cup and tube types an outer electrode coating provides an efficient electrostatic screen.

*Components in illustration are approximately  $1\frac{1}{2}$  times actual size.*

# DUBILIER

## CONDENSERS

DUBILIER CONDENSER CO. (1925) LTD., DUCON WORKS, VICTORIA ROAD, NORTH ACTON, LONDON, W.3



*C. R. Casson 117*

*Mention of "The Wireless World," when writing to advertisers, will ensure prompt attention.*

# The Wireless World

THE  
PRACTICAL RADIO  
JOURNAL  
26<sup>th</sup> Year of Publication

No. 907.

FRIDAY, JANUARY 15<sup>TH</sup>, 1937.

VOL. XL. No. 3.

Proprietors: ILIFFE & SONS LTD.

Editor:  
HUGH S. POCOCK.

Editorial,  
Advertising and Publishing Offices:  
DORSET HOUSE, STAMFORD STREET,  
LONDON, S.E.1.

Tekphone: Waterloo 3333 (50 lines).  
Telegrams: "Ethaworld, Sedist, London."

COVENTRY: Hertford Street.

Telegrams: "Autocar, Coventry." Telephone: 5210 Coventry.

BIRMINGHAM:

Guildhall Buildings, Navigation Street, 2.  
Telegrams: "Autopress, Birmingham." Telephone: 2971 Midland (4 lines).

MANCHESTER: 260, Deansgate, 3.

Telegrams: "Iliffe, Manchester." Telephone: Blackfriars 4412 (4 lines).

GLASGOW: 26B, Renfield Street, C.2.

Telegrams: "Iliffe, Glasgow." Telephone: Central 4857.

PUBLISHED WEEKLY. ENTERED AS SECOND  
CLASS MATTER AT NEW YORK, N.Y.

Subscription Rates:

Home, £1 1s. 8d.; Canada, £1 1s. 8d.; other  
countries, £1 3s. 10d. per annum.

*As many of the circuits and apparatus described in these  
pages are covered by patents, readers are advised, before  
making use of them, to satisfy themselves that they would  
not be infringing patents.*

## CONTENTS

	Page
Editorial Comment .. .. .	49
The Time-base in Television .. .. .	50
Noise: Some Notes about Radio	
Enemy No. 1 .. .. .	54
Programme Mixing .. .. .	56
Current Topics .. .. .	59
The Physical Society's Exhibition .. .. .	60
New Apparatus Reviewed .. .. .	63
Eddystone All-World Eight .. .. .	64
Listeners' Guide for the Week .. .. .	66
Improving the Simplified Volume	
Expander .. .. .	68
Random Radiations .. .. .	70
Broadcast Brevities .. .. .	71
Recent Inventions .. .. .	72

## EDITORIAL COMMENT

### Programme Distribution

#### Conditions Have Changed

**W**HAT has become of the rumour current a year ago that the B.B.C. was proposing to put programmes which were mainly of an educational character permanently on to one or two exclusive wavelengths? The idea at the time was hailed as a promising solution of the present unsatisfactory state of affairs where educational matter gets sandwiched in amongst lighter material programmes, spoiling the composition of both, and nearly always resulting in the broadcasts of an educational character being curtailed or compressed to a point where they cease to be of very much use as educational material.

There is room, we believe, in the planning of broadcasting for talks and lectures instead of being confined to a maximum of ten or fifteen minutes, to be extended, say, to half an hour, or even an hour, so as to deal more properly with the subject matter, provided that alternative material of a lighter character is always available on other wavelengths for the benefit of those listeners who prefer it.

#### Better Reception

We must not lose sight of the fact that transmitters have improved in efficiency and at the same time highly sensitive receivers have been brought down in price so that they now come within the reach of a very much greater proportion of the listening community. A few years ago it could be argued, with a good deal of evidence in support, that satisfactory reception of the B.B.C. stations other than the local transmitter was available only to persons of considerable means, but

to-day the cheapest of valve receivers (and crystal sets can be ruled out to-day) can rope in a choice of several B.B.C. programmes from nearly any part of the country.

This being so, the necessity for the B.B.C. to plan its programmes entirely on the assumption of local listening has disappeared, and whilst we are all agreed that for the very best quality in musical reproduction it is necessary to take the programme from the local station, the need for extremely high quality does not exist in the case of broadcast talks, or, in fact, for any type of transmission which does not call for the reception of a wide frequency range.

#### Service Area To-day

If it were possible to plan wavelengths in Europe on the basis of reserving certain stations for talks and other material not requiring a wide frequency band it might then be possible to find room for the extension of frequencies for special stations devoted to music.

It would be interesting if the B.B.C. Engineering Department would make available a map of the country indicating each transmitting station with the service area which is claimed for it, and see how far B.B.C. programme distribution policy on this basis fits in with the considered opinions of listeners in the areas concerned. We believe that the B.B.C. to-day is far too conservative in its estimation of service area, because it does not appear to have appreciated sufficiently the change in reception, as well as transmission, conditions which have taken place. Nor does it take into full consideration that probably fifty per cent. of the programme material is of such a nature that the highest quality of reception is not necessary to full enjoyment.

# The Time-base

## in Television

By W. T. COCKING

HOW SCANNING IS EFFECTED  
AT THE RECEIVER

**I**N television transmission the subject is scanned by a spot, which may be of light as in the Baird system, or may be the end of an electron beam as in the Emitron camera, which traces out a series of parallel lines. If the picture is to be reconstituted correctly on the screen of the cathode-ray tube, it is necessary for the spot caused by the impingement of the electron beam on the fluorescent screen to make exactly the same traversals as the spot in the transmitter.

Now the position of the spot on the screen can be altered by deflecting the electron beam either electrostatically or electro-magnetically. Both methods are used and are sometimes combined. Electrostatic deflection is probably the one more widely adopted, however, so that at first we shall consider only this.

The conventional cathode-ray tube has two pairs of deflecting plates built into it, and it is only necessary to apply suitable voltages to these plates to make the spot perform any gyrations we please. There is no figure or pattern which the spot cannot trace with suitable voltages applied to the plates. This is because there are two pairs of plates at right angles; with only one pair of plates, the movement of the spot is restricted to a straight line.

When there are two sets of plates, however, we can apply two forces at right angles to the electron beam, and so cause it to move in any direction.

For television purposes, the spot must build up a raster on the screen by tracing out a series of parallel lines. Referring to

*A*N essential part of all television receivers embodying cathode ray tubes is the time base, for it produces the voltages necessary for building up the raster. In this article, the method of operation of the conventional type including a gas-filled triode is described.

Fig. 1, the spot must start at the left-hand top corner (A) and move steadily across the screen to (B). It must then return to the left-hand side of the screen, but to a point (C) slightly below (A), and then trace out another line to (D), and so on until the full number of lines has been completed. The spot is then at the point (E) in the right-hand bottom corner, and it must now return to the original point (A) in order to trace out a second series of lines immediately over the first.

In television terminology, a line is one complete cross traversal of the screen and a frame is one complete vertical traversal *via* the whole series of lines. The raster is the resulting rectangle composed of parallel lines.

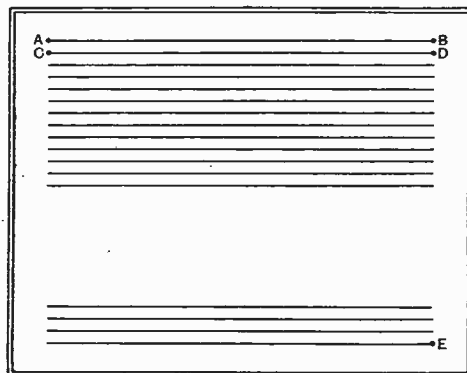

Fig. 1.—The raster is built up by the spot traversing a series of lines across the screen of the tube.

In actual fact the spot does not trace out a pattern exactly like that of Fig. 1, but one shown in greatly exaggerated form in Fig. 2. The spot moves steadily from (A) to (B) and traces out a line which is not quite horizontal. Having arrived at (B) it rapidly flies back to (C), tracing out the dotted line (BC); the next line (CD) is parallel to the first, and so on. The actual time taken for the traversal of each line must be a definite figure, depending on the transmission, and must be held constant within very close limits. The time taken by the fly-back would ideally be zero, but this is impossible; it must be very much less than the line time, however.

The correct pattern is obtained on the screen when the voltages on the deflecting plates are of saw-tooth wave-form with, of course, the correct frequency,

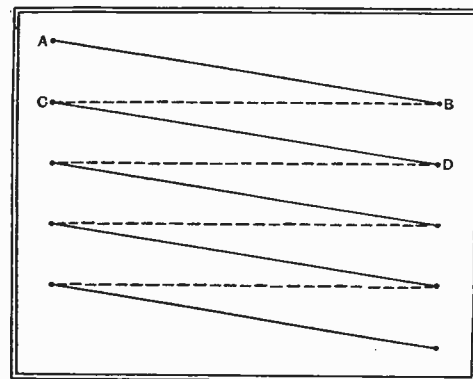

Fig. 2.—A section of a raster is shown here in greatly exaggerated form. The spot travels along AB to trace out a line and then flies-back along BC in preparation for the next.

phase, and amplitude. An ideal waveform is that shown at (a) in Fig. 3. The voltage rises linearly along (AB) with respect to time and then falls instantaneously to zero along (BC); in practice, zero fly-back time is impossible, and the waveform is more like that shown in (b). Here the rise of voltage along (AB) is the same as in (a), but the fly-back (BC) occupies a finite time. The time (AC) represents one complete period of the wave.

The waveform given by a poor time-base is shown in (c), and it will be seen that the voltage rise along (AB) is no longer linear. This will cause distortion of the picture by cramping the right-hand side. A perfectly linear time-base is probably impossible, and all types tend to give some curvature to the voltage wave. This is very small in a good time-base, however, but careful design is necessary.

The circuit of a simple time-base is shown in Fig. 4, the valve being a gas-filled triode. This kind of valve differs from ordinary hard valves in several ways. For our present purposes, its most important attributes are that it takes no anode current until the anode voltage

**The Time-base in Television—**

rises to a definite figure, which depends on the negative grid bias applied, and that once anode current starts to flow nothing will stop it but the removal of the anode voltage. For instance, if we gradually raise the anode potential there will be no anode current until the potential reaches, say, 100 volts. The valve will then strike and pass a very heavy current

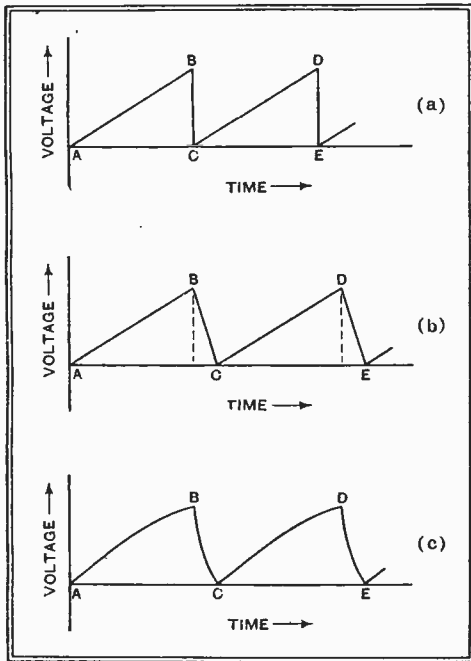

Fig. 3.—The ideal scanning waveform is shown at (a) and a more practical form at (b). A poor waveform appears in (c).

if the voltage is maintained. If the voltage is gradually reduced, the current continues until the voltage reaches a certain minimum of perhaps 20-40 volts, when it suddenly ceases. When the valve is conducting, the grid bias has no effect and the current cannot be stopped by increasing the bias. When the valve is not conducting, however, the anode potential at which it strikes depends on the grid potential, and the more negative the grid the higher the anode voltage required.

Referring now to Fig. 4, suppose the switch S is closed. Initially there is no voltage across the condenser C, and con-

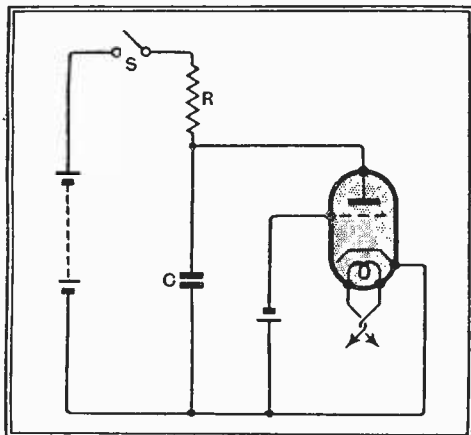

Fig. 4.—The fundamental time-base circuit using a gas-filled triode.

sequently none between anode and cathode of the valve, which is therefore non-conductive. As soon as S is closed, however, there is a current through the circuit, and the potential across C rises until it finally equals the battery potential if the valve does not strike. This is shown by the curve (AB) of Fig. 5.

**Generating the Saw-tooth Waveform**

Now let us start again, and assume this time that the valve is adjusted to strike at an anode voltage much less than the battery voltage. The voltage across the condenser rises along (AB) as before until it reaches the value of the point (C). At this point the valve strikes and discharges the condenser; its voltage consequently falls as shown by (CD), until the point (D) is reached and the valve again becomes non-conductive. The condenser voltage again starts to rise along (DE); when it reaches the valve (E), the valve again strikes and discharges the condenser until the voltage falls to (F), and so on.

It is easy to see that the rise in voltage during the charging stroke cannot be linear, for the rise in voltage across the condenser increases exponentially. It is, however, possible to replace the resistance R by a saturated diode, or, more usually, a pentode. With such a valve the AC resistance tends to infinity, which means that the current through it tends to be independent of the voltage. By using a pentode instead of a resistance in the

cases the high HT voltage will be needed for other purposes.

A practical time-base is usually much more complex than the simple circuit of Fig. 4, but this is not because the basic

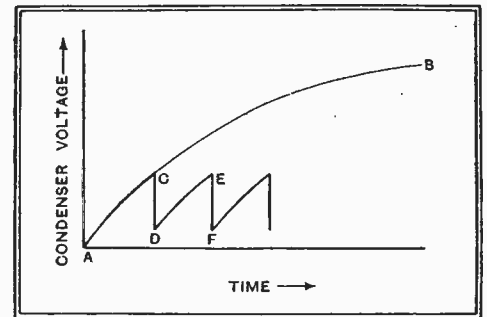
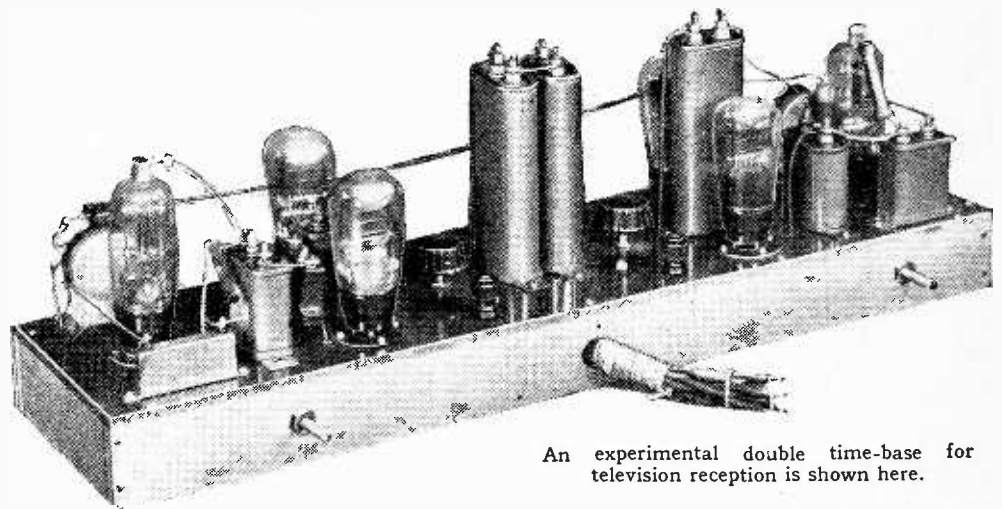

Fig. 5.—If the discharge valve failed to strike the condenser voltage would rise along AB. When it is operating it varies along ACDEF.

circuit is different but because a time-base generally includes a push-pull amplifier. Two time-bases are, of course, needed in a television receiver, one to produce the line scanning pulses and the other to produce the frame pulses. For reception of the Baird transmissions the frame frequency is 25 c/s and the line  $25 \times 240 = 6,000$  c/s, one cycle being reckoned as one charge and one discharge of the time-base condenser, or the time (DF) in Fig. 5. For the Marconi-E.M.I. transmissions, the frame frequency is 50 c/s and the line  $50 \times 202.5 = 10,125$  c/s.



An experimental double time-base for television reception is shown here.

charging circuit the condenser voltage rises very nearly linearly.

As an alternative, it is possible to retain the resistance, but to permit the condenser to charge to only a fraction of the battery voltage. Inspection of the charging curve (AB) of Fig. 5 shows that the initial rise of voltage is very nearly linear; we can have a linear time-base, therefore, by only utilising this portion of the curve.

Both methods are widely used, and which is the better depends very largely upon circumstances. As regards cost, we have to balance an extra valve on the one hand against four or five times the HT voltage on the other. This is not really a fair comparison, however, for in many

Now in the cathode-ray tube it is necessary for the mean potential of each pair of plates to be unchanging if interaction between the two sets of plates is to be avoided. Such interaction results in distortion of the raster. A constant mean potential can be obtained by feeding each pair of plates in push-pull. At the present time, push-pull working seems almost essential when double electrostatic deflection is used; it is not essential, but may be desirable, when electro-magnetic deflection is used for either or both of the scans.

The next thing we want to know is the output required from the time-base, and here those unfamiliar with cathode-

**The Time-base in Television—**

ray tubes will receive a shock. The actual figure depends on the tube and its operating voltages, but is generally about 1,000 volts! The sensitivity of a tube is expressed as so many millimetres deflection for 1 volt applied between the deflecting plates, and it is usually inversely proportional to the third anode voltage. With a tube of about 10in. diameter working at some 4,500 volts, the time-base output required is about 1,000 volts.

As a matter of fact, this is not quite as bad as it seems, for it is the total change of voltage required between the plates of the tube, or the voltage represented by (CD) (DE) (EF), etc., in Fig. 5. If we were using a sine instead of a saw-tooth waveform we should need an output of 500 volts peak or 350 volts RMS. The deflection with a sine-wave of 350 volts RMS applied to the plates will be the same as that with 1,000 volts amplitude of saw-tooth waveform, for the total swing of a sine-wave is twice the peak value, or 1,000 volts.

**A Modern Time-base**

The output circuits of the time-base, therefore, need not be designed to handle as large a voltage as one might at first suppose. If they will handle 350 volts RMS of sine waveform without amplitude distortion, they will also handle the 1,000 volts *total change* of the saw-tooth waveform. Moreover, if we use two

form shown in Fig. 6. The valve V<sub>1</sub> is a gasfilled triode, and functions with R<sub>1</sub> and C<sub>1</sub> in the manner already described in conjunction with Fig. 4. The resistance R<sub>2</sub> is included for the purpose of accelerating the fly-back; at first sight this seems impossible, but is actually true. Grid bias is secured from the resistance R<sub>11</sub>, which has a heavy current fed through it from the HT supply via R<sub>10</sub>.

The saw-tooth wave appears across C<sub>1</sub> R<sub>2</sub> as already explained, and is applied to the grid of the amplifier V<sub>2</sub> through the usual resistance-capacity coupling C<sub>2</sub> R<sub>3</sub>. Amplified potentials appear across the load resistance R<sub>7</sub>, and are taken off through C<sub>5</sub> to one of the pair of deflecting plates. A portion only of the anode voltage of V<sub>2</sub> is tapped off and fed through C<sub>3</sub> to the grid of V<sub>3</sub>, which thus provides across its anode load R<sub>8</sub> an equal and opposite output voltage which is communicated to the other of the pair of plates through C<sub>6</sub>.

This is all quite straightforward, but it must not be forgotten that if the saw-tooth waveform is to retain its original shape after amplification, the amplifier must be free from amplitude, frequency, and phase distortion. With resistance coupling the HT voltage must be greater than the total amplitude of the output of one valve. In this case it must be greater than 500 volts, and as the full voltage cannot be utilised, at least 700 volts would normally be needed; more often 1,000 volts is used.

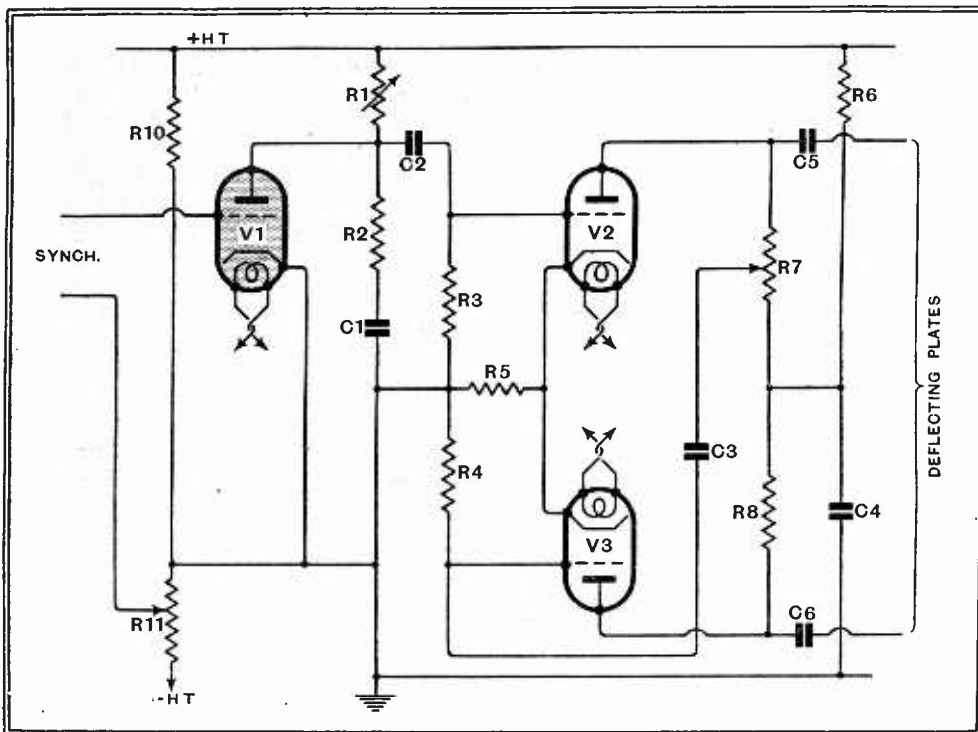

Fig. 6.—In practice a push-pull type amplifier must follow the relaxation oscillator of Fig. 4 in order to obtain adequate output for the deflection.

valves in push-pull for the output, each handles only one-half the output, so that each need give out the equivalent of only 175 volts RMS, 500 volts.

A practical time-base for television purposes with modern tubes thus takes the

The quiescent anode voltage of V<sub>2</sub> and V<sub>3</sub> is likely to be of the order of 350 volts, and when giving full output it may swing from 100 volts to 600 volts. It is the general practice to employ valves of the MH<sub>4</sub> or AC/P type, for

although the normal voltage rating is exceeded, the anode current is not large. Most specimens of this type of valve stand up to the work well, and with a valve such as the AC/P, a gain of the order of 10 can be obtained, so that a voltage change across C<sub>1</sub> of only about

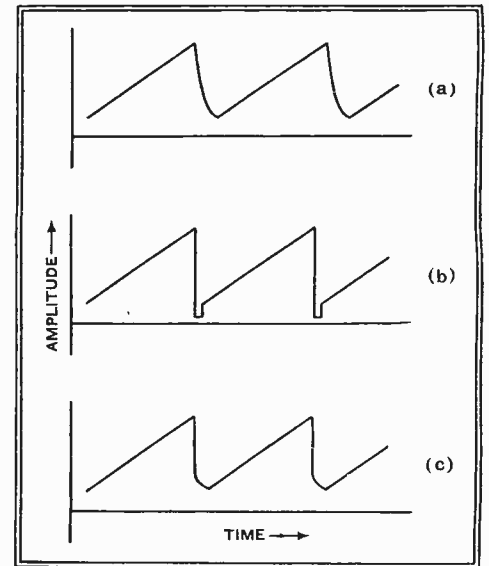

Fig. 7.—A practical saw-tooth waveform is shown at (a). As explained in the text, the fly-back can be accelerated by the insertion of resistance in series with the condenser. When the resistance is too high, the waveform is that shown in (b) but like that of (c) when the correct value is used.

50 volts is needed. When we have 700-1,000 volts HT available, we can easily obtain such a voltage with negligible departure from linearity, and we accordingly employ a charging resistance R<sub>1</sub>.

For the avoidance of frequency distortion it is necessary to make the coupling condensers and grid leaks large enough, and to keep stray capacities at a minimum. The frequency range required is greater than one would at first imagine, for it must extend from the fundamental time-base frequency to something like twenty times that value. Phase distortion is avoided by the same means as frequency distortion, but the requirements are much more stringent. One can safely say that if phase distortion is negligible, then frequency distortion is also negligible, but the converse is not necessarily true.

Before concluding, it may be remarked that the frequency is controlled by R<sub>1</sub> and C<sub>1</sub>, and the amplitude by R<sub>11</sub>. The controls are, however, greatly interdependent. Two time-bases are needed for television reception, of course, and need differ only in the values of components; a common HT supply can be used, but good smoothing and decoupling are required.

In practice, minor modifications are adopted in different cases. A fixed resistance of 0.5 MΩ is usually included in series with the variable R<sub>1</sub> of 2 MΩ in order to safeguard the valve. The condenser C<sub>1</sub> will usually have a capacity of 0.2 μF. for the frame scanning and 0.0005 μF.-0.0015 μF. for the line.

**The Time-base in Television—**

The value of the resistance R<sub>2</sub> is very important in the case of the frame scanning time-base. Its function is to increase the speed of the fly-back, and it does this in spite of the fact that it necessarily slows up the rate of discharge of the condenser! At first sight this appears to be a contradiction, but it can be seen that the voltage applied to the amplifier is actually that across C<sub>1</sub> and R<sub>1</sub> in series. At the instant when the fly-back commences there is no current through R<sub>1</sub>, and the voltage applied to the amplifier is equal to that across C<sub>1</sub>. If R<sub>1</sub> were not present this voltage would fall exponentially as C<sub>1</sub> discharges. When it is used, however, the discharge current sets up a voltage across R<sub>1</sub> which is in opposition to the voltage across C<sub>1</sub>, and it is the difference between these voltages which is applied to the amplifier.

If we examine the waveform of the generator we find that without resistance it is similar to that of Fig. 7(a). When R<sub>1</sub> is included the initial fly-back is very rapid, but if its value is too high the spot describes the loop shown in (b). When R<sub>1</sub> is correct the waveform is like that of (c). In the writer's experience R<sub>1</sub> is critical in the frame time-base and should be about 30 ohms. It is not always necessary, however, and it is generally better to omit it than to use too high a value. It is usually unnecessary if a 1,000-ohm resistance is included directly in the anode lead of the frame discharge valve, as is sometimes recommended by valve makers in order to limit the discharge current.

In the case of the line time-base, R<sub>1</sub> is much less critical and must be higher in value—1,000 ohms is satisfactory.

**Short-wave Manual**

**The Radio Amateur's Handbook.**—Fourteenth edition. 536 pages with over 500 illustrations and diagrams. Published by the American Radio Relay League Inc., West Hartford, Connecticut, U.S.A. Price 1 dollar in the U.S.A., 1 dollar 25 cents elsewhere.

IN order to include all the latest developments in amateur radio, the 1937 edition of the A.R.R.L.'s publication, *The Radio Amateur's Handbook*, has had to be considerably enlarged, and it now contains 424 pages of valuable information on short- and ultra-short-wave technique. Over 200 new illustrations have been added, and practically every chapter has been revised and brought up to date.

The design and construction of transmitting apparatus takes up a large share of the book, though the all-important matter of reception is, nevertheless, dealt with at adequate length.

The Handbook is essentially practical, and adequate data is provided to enable anyone to construct the apparatus so well described and illustrated in both the receiving and transmitting sections. Though comparatively high-power transmitters predominate, there are many designs suitable for operation with the limited power input customarily used in this country.

Aerials for the short and ultra-short waves have a chapter devoted to them, and some novel and interesting types of directional arrays are discussed and illustrated with diagrams giving constructional data.

"The Standard Manual of Amateur Radio

Communication," as it is described, is true in every sense of the word, for there is no aspect of the subject it does not deal with, and thus it forms a valuable handbook for both the beginner and the experienced short-wave experimenter. H. B. D.

TELEVISION  
IN ITALY

New Safar  
Receiving  
Equipment



THAT Italy is well to the fore in the design of television receivers is exemplified by the illustrations reproduced here of the latest Safar equipment which was shown at the Milan exhibition.

It consists of an ultra-short wave combined sound and vision superheterodyne receiver with a band width of 3 Mc/s and it employs seven valves. The time base, synchronising apparatus and power unit together account for eight more valves, making fifteen in all.

The receiver is designed for television systems of 375 lines and interlaced pictures giving fifty frames per second.

contrast control, sound output control and one for focusing the image. Apparently the tuning is pre-set, as there is no external adjustment provided for this.

As one of the illustrations shows, a very neat and compact assembly is adopted, the cathode-ray tube being mounted in a sturdy metal frame which serves also to support the loud speaker and control panel. The tube is not viewed direct, but the image is reflected in an inclined mirror mounted in the top of the cabinet.

Simplicity in operation is one of the principal features of the Safar receiver, as only three controls are provided. They are on/off switch, with which is combined a

This new Safar television receiver is a product of the Soc. An. Fabbricazione Apparecchi Radiofonic, of Milan, and the price is 9,000 lire, or approximately £100.

# Noise—Some Notes About

By "CATHODE RAY"

**I**N legal circles a "noisy" wireless set is one that is too loud, and which thereby constitutes a nuisance to the owner's neighbours. In the technical sense, however, noise is something for which possibly the neighbours are responsible and the wireless set is the victim, and it is not bound up with the volume of reproduction. Generally it is the programmes that cannot be reproduced loudly that are most affected by noise. Noise, briefly defined, is anything undesirable that is reproduced along with the desired programme or signals; except that other programmes or signals are generally distinguished as *interference* rather than noise.

When lay friends come to tell us of their noise troubles they report them all as "atmospherics," and think something of themselves for being so clever as to use the right word. Alas for them, it very seldom is right! When thunderstorms are in the immediate neighbourhood—usually only a few days a year—then atmospherics certainly are unmistakably present, even when listening to the local station; and in thundery weather generally they may provide a noticeable accompaniment at least to distant-station reception. The description of atmospherics as "coal-cellar loading" noises has not been bettered, I think. They are also rather like the sound of waves breaking on a beach, except that they do not occur at anything like regular intervals.

It is this irregularity, and also the prolonged tumbling nature of the "crash" or "grind," that distinguishes atmospherics from man-made (really machine-made) noises, or internal faults. The nearest thing to them is the rattle or clatter due to a bad contact, which may either be internal (in the set itself) or in the electric light or other wiring. The usual clue to this common type of noise is that it generally corresponds to a disturbing movement. Somebody walking about or banging a door may stir an electric house wiring fault to life; the wind disturbs a bad joint in aerial or lead-in; and the time-honoured procedure when an internal bad contact is suspected is to knock and thump the set and its parts individually and collectively.

Most other intermittent noises are sharper than atmospherics—more of the nature of clicks. Lifts and other machinery making and breaking current are of this type. Some sorts of electric signs cause clicks at very frequent intervals. And so we come by easy stages to continuous

Some of the possible sources of the various classes of noises described. Individual sources are denoted by reference numbers, which are explained in the accompanying key.



noises, of which there is a great variety—buzzes, hums, whines, hisses, rattles—almost as many sorts as there are electrical appliances. The domestic vacuum cleaner is a typical example.

Rather curious noises sometimes result from internal faults. Hum—low-pitched for AC and high for DC—are too familiar to need description. An open-circuited valve grid produces a characteristic "singing" usually composed of a mixture of low- and high-pitched hums. Various types of groans, whistles, "motor-boating," and "frying" may be caused by sundry receiver faults.

By the way, I need hardly mention that disconnecting the aerial is the standard method of distinguishing between internal and external noise causes. But it is just as well to remember that even a noise due to an internal cause may be modified, reduced, or (more rarely) even eliminated when the aerial is taken off.

## Technically Not Noise

The "monkey chatter" caused by the side-bands of an adjoining broadcast station may be classed either as noise or interference; and so may whistles. By calling them "interference" I can get out of having to say anything about them here!

Lastly we come to a type of noise which is different from all others in being unavoidable if very high amplification is used; at any rate, until somebody markets a convenient method of keeping certain parts of the receiver at the absolute zero of temperature (273 degrees below zero Centigrade), and then that wouldn't do for valve noise. This basic, fundamental

noise caused by the movements of electrons in conductors and valves appears as a hiss, familiar to every owner of a really sensitive superhet. A very valuable article on it by A. L. M. Sowerby was published recently.<sup>1</sup> More recently still one reads of the work of V. D. Landon, of the Radio Corporation of America, who has been investigating this class of noise.

Landon made up a pair of amplifiers on one chassis, each amplifier with five stages and a high gain per stage, so that the hiss due to the first valve was amplified until it more than fully loaded the last valve when running "all out." The exact frequency to which the amplifiers were tuned was not so very important—actually they were what would be called IF amplifiers, working on the American frequency of 150 kc/s—and both used band-pass couplings to give a fairly level response over a band of frequencies and a very sharp cut-off each side. They differed only in the fact that one amplifier was nearly sixteen times as broadly tuned as the other. The object was to check theoretical calculation of how the sharpness of tuning affects the amount of noise; or, what is more to the point, the ratio of noise to desired signal. This sort of noise being left over after all avoidable sources have been blocked up, it is important to know as much as possible about its haunts and habits.

These are the results of Landon's tests. He found that if both amplifiers were adjusted to the same signal gain the broadly tuned amplifier gave about four times the amplitude of noise, *whether the*

<sup>1</sup> *The Wireless World*, Oct. 9th and 16th, 1936.



# Radio Enemy No. 1

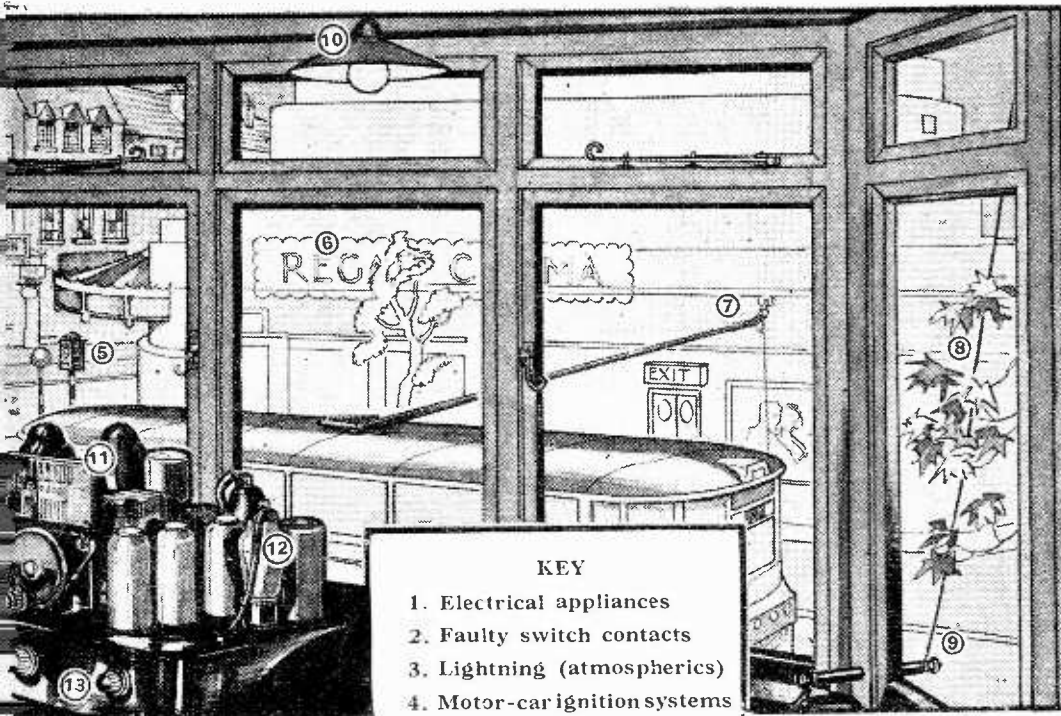

- KEY**
1. Electrical appliances
  2. Faulty switch contacts
  3. Lightning (atmospherics)
  4. Motor-car ignition systems
  5. Traffic signals
  6. Illuminated signs
  7. Trams and trolley-buses
  8. Aerial touching branches
  9. Defective aerial connection
  10. Arc across broken lamp filament
  11. Faulty valve; any stage
  12. Valve hiss; chiefly first stage
  13. Bad contact

peaks were measured or the root-mean-square values (i.e., the effective values used in AC measurements) were taken. As the broad amplifier covered nearly sixteen times the band of frequencies of the sharp one, this result confirms the well-known theory that the amplitude of this sort of noise—fundamental valve or circuit hiss—is proportional to the square root of the band width. But it was not previously known quite so definitely that the rule would apply to peaks. Incidentally, the highest peaks were about four times the RMS voltages in each case.

### Another Advantage of Selectivity

Landon also studied the effects of the type of noise coming in from outside and consisting of sharp clicks. The interesting result emerged that, whereas the RMS values of noise voltage at the output were still proportional to the square root of the band width, the peaks were directly proportional to the band width; in the apparatus described they were therefore some *sixteen times* greater with the broadly tuned amplifier. This shows the importance of making the amplifier as selective as possible, even apart from the question of interference from other stations.

These various sorts of noise are being tackled with considerable energy just now

on all (to use present-day terminology) fronts. Everybody knows about suppressors, Post Office forms and vans, anti-interference aerials, screened television feeders, and proposed legislation to compel electrical noise-producers to abate the nuisance. Where noises are, in the meantime at least, unabatable, it is possible to

design the receiver so that they are *limited* to a maximum equal to the signal. The "click" sorts of noise consist of a sharp peak lasting only a very brief moment but perhaps many times the amplitude of the signal or programme. So although it does not appear a very good achievement to reduce it no more drastically than to a condition of equality with the desired sound, yet the disparity in duration gives a better result than one might think.

I remember limiting systems being used fifteen years ago, consisting simply of dimming the filament of a valve; but the thing has been much better thought out and applied since then. Still, it only reckons to be useful for making Morse readable, and not for providing a background of complete silence for the aesthetic enjoyment of music.

For helping with that there is the "Q.S.T." system (described in *The Wireless World*, March 27th, 1936), which makes the "click" shut the door in its own face. The noises are lifted out of the programme by suppressing the amplifier

completely during their impact. The programme is suppressed, too, so the success of the scheme obviously depends on the noises being of a practically instantaneous character.

Then there is the very complicated but (we are told) very successful system invented by Armstrong, which necessitates an entirely different sort of transmitter as well as receiver. It is rather too involved to explain in detail at a tail-end like this, but the general idea is that, instead of making the radiation from the transmitter fluctuate in strength to correspond with the programme or signals being sent out, it is kept at full strength all the time and varied in frequency. The receiver must be designed to translate these frequency variations into amplitude variations again; and it is then found to be less responsive to noise than the orthodox type. But as this system takes up a much wider band of frequencies than ordinary broadcasting, it is perforce relegated to the ultra-short waves. Even here it will scarcely appeal to the domestic listener; but more is likely to be heard of it for commercial work.

The degrees of success that are being achieved in rendering receivers immune from noise must not be seized upon by owners of interfering apparatus as an excuse to roll the onus on to the listener, for not only do most of the methods necessitate a great increase in cost and complexity (which has to be multiplied by the number of receiving stations affected), but the cure is only partial. Still, it is a

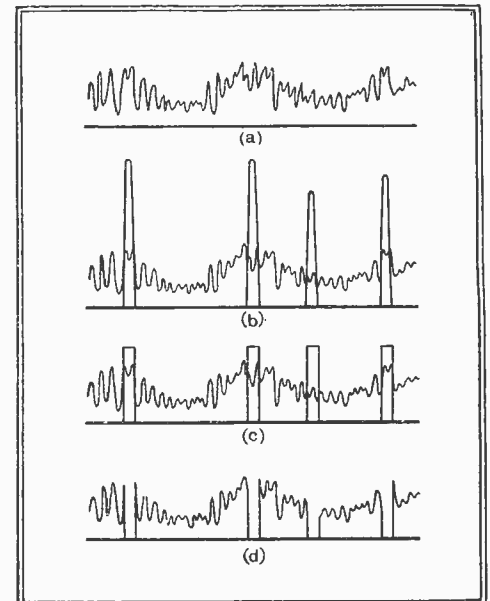

If the amplitude of a section of broadcast programme is represented by (a), the addition of interfering noise of the "click" type such as is caused by many sources might look like (b). Note the high amplitude but short duration. A "limiting" system is of some help but cannot do better than (c). A self-suppressing scheme which silences the receiver at the instant of the click leaves small holes in the programme (d), but this is less noticeable than either (b) or (c).

great thing that, when the need justifies, some impression can be made on the only remaining limitation to the range of radio communication.

# Programme Mixing

RECENT DEVELOPMENTS IN THE DESIGN OF  
DRAMATIC CONTROL UNITS

By

J. A. G. MITCHELL

Design Section, The British Broadcasting  
Corporation

*WHEN broadcast plays were first produced, what amounted virtually to a new medium of artistic expression was born, and the technique of control introduced many new problems, some of which are still in process of solution. When the B.B.C. recently introduced a new dramatic control unit it was decided to extend certain facilities and to incorporate two new ones in the revised design.*

COMPOSITE programmes, such as multi-studio broadcast plays, are produced by mixing the various studio outputs together. This mixing is done on a dramatic control unit by a producer or his assistant. The general features of a dramatic control unit have been frequently described in various publications and it is not proposed to repeat the description here, except where it is considered necessary to make clear the function of the recent additions.

In the early types of dramatic control units, when it was desired to superimpose artificially produced echo on the programme from any studio, it was necessary to use one echo room for every studio requiring echo. This arrangement had the obvious disadvantage that there were not always available a sufficient number of echo rooms for the programme commitments. When it became necessary to provide a new unit at Broadcasting House in 1934 the circuit was so arranged that only two echo rooms were necessary to give the full facilities required. In the provincial studio premises, however, this

would still mean a great strain on the available echo rooms, so it was decided to limit the number of echo rooms required to one.

When producing certain types of play,

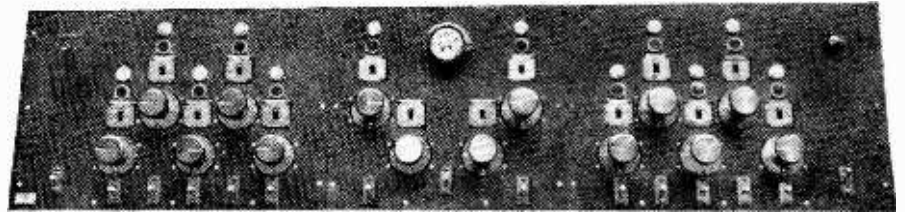

The front panel of the unit, showing right-hand and left-hand group controls. The independent channels and mixers are mounted on the centre panel.

like the recent adaptation of "The Thin Man," certain effects are obtained by abruptly cutting the programme, or part of it. Hitherto, this has been done on the fade potentiometers, and no matter how agile the producer may be, the effect obtained is a rapid fade and not a clean-cut break. It was, therefore, agreed that the new unit should incorporate a key in each channel potentiometer circuit to cut

the programme when instantaneous interruption becomes necessary.

The mixing arrangements normally employed in dramatic control units were such that each source of programme was separately controlled by a potentiometer, and the outputs from these control potentiometers were arranged in two groups and connected to a central mixer. It was then possible to fade out either group on the central mixer.

Usually an additional source was provided which was not associated with either group but which was combined with the output from the central mixer.

The circuit of this mixer originally was such that, while one of the groups was being faded out, the programme level from the other group remained constant, and vice versa. It was, therefore, not possible for a producer alone to fade one group out and the other in on the central mixer; when this was desired for a production in the past, other operators were employed to aid the producer by fading the individual channels of one of the groups. In order to overcome this difficulty it was proposed to divide the central mixer into two controls, one controlling all sources on the left-hand side of the panel while the other would control those on the right-hand side.

The methods by which the foregoing requirements have been met will now be described.

The system adopted for producing echo effects in the dramatic control unit supplied to Broadcasting House in 1934 is shown in Fig. 1. It will be seen that two echo rooms are necessary, one associated with the channels of group 1 and the other with the channels of group 2. As already explained, it was desirable, when designing the new unit, to arrange the circuits so that only one echo room would be required. The circuit was therefore, changed to that shown in Fig. 2. This diagram shows two sources connected to channels 1 and 4, while echo for these two sources is controlled *via* channels 2 and 5 respectively. It will be seen

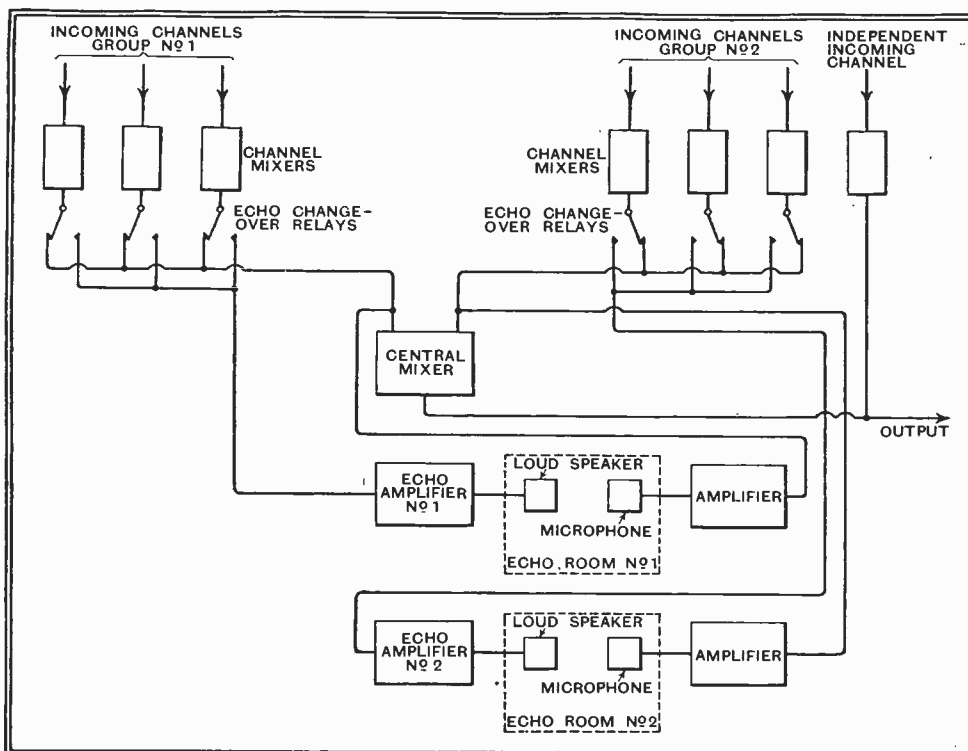

Fig. 1.—Schematic diagram of a dramatic control unit of 1934; two echo rooms are used.

**Programme Mixing—**

that the output from each channel potentiometer is taken to a change-over relay. When this relay is inoperative the channel potentiometer is connected *via* the central mixer to the output of the DC unit, but

In Fig. 2, channel 7 is shown as the independent channel. Similarly, the two outputs from the echo mixer are combined in an amplifier having two inputs. The output from this amplifier is taken to a loud speaker in the echo room, where a micro-

be connected to the same side of the mixer as that source. If this were not done when echo was being added on a programme and the central mixer was faded from one group to the other, it would mean that the source would be faded out while the echo remained at full strength.

The sources are connected to the dramatic control unit channels in the control room by connecting the amplifier output jacks to the input channel jacks of the unit with double-ended cords. Two sets of input channel jacks are provided; one set is labelled "DC Input Direct," while the other is designated "DC Input Echo." The programme contacts of these jacks—i.e., the tip and ring connections—are commoned, while the sleeve connections of the "DC Input Echo" jacks are wired to the negative winding of their respective echo change-over relays. By connecting the sleeve contacts of the amplifier output jacks to the negative of a battery and the positive winding of the echo change-over relays to the positive of the same battery, the particular channels desired may be connected to "echo" when the sources are connected to the input echo channels in the control room.

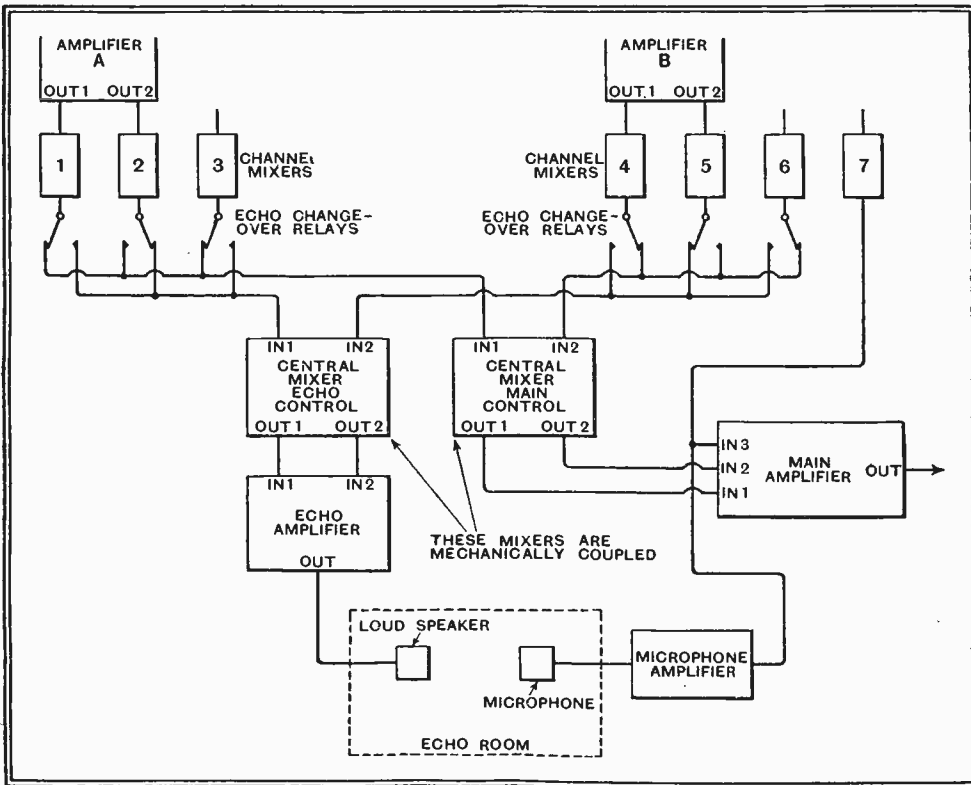

Fig. 2.—The new control system, with only one echo room.

when it is operated, the channel is connected *via* an auxiliary potentiometer associated with the central mixer to an echo amplifier and thence to the echo room.

The central mixer, which virtually consists of four potentiometers electrically separated but mechanically coupled together, is shown in Fig. 3. The four outputs from this mixer consist of two main and two echo outputs. In order to combine the outputs from the main mixer and the independent channel, an amplifier having three separate inputs is provided.

phone picks up the programme. The output from this microphone, amplified to a suitable extent, is connected to the same amplifier input as the independent channel. Thus, with the channels connected as shown in Fig. 2 the main output of amplifier "A" is controlled by channel 1 and the amount of echo required for this programme is controlled by channel 2. Similarly, the main output of amplifier "B" is controlled by channel 4 and the amount of echo by channel 5. If it should be required to add echo to the source connected to the independent channel, any channel on either side of the mixer may be used for this purpose.

If this is done, great care is necessary in operating the panel to ensure that the appropriate echo channel potentiometer is faded in and out at the same time as the independent channel.

It will therefore be seen that echo for these two sources is mixed in the echo amplifier and the mixture passed to the echo room. The strength of any constituent of the echo mixture may be related to that of its direct source by means of the associated fade controls on the DC unit. The fact that the DC unit is provided with a central mixer makes it essential that the echo for any source should

**Instantaneous Interruption**

In order to meet the conditions outlined in the introductory paragraphs, whereby a sudden break in the whole programme or a part of it is required, a "cut key" was introduced into the circuit immediately after each channel potentiometer and each half of the mixer. The method of connecting the key is shown in Fig. 4. A magnetic release has been fitted to the key, which operates when the associated channel potentiometer is faded out. The switching for this is arranged on an auxi-

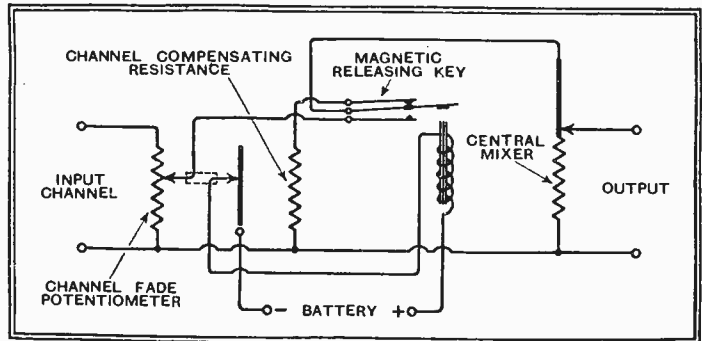

Fig. 4.—Circuit of one channel, showing the operation of the cut key.

liary row of contacts on the channel potentiometer. This facility has been provided so that the panel operator may avoid having to release the key manually if it is not desired to do so before the channel is faded out. It will also prevent mistakes occurring due to the operator forgetting to release the key. The keys associated with the central mixer differ from those associated with the individual channels because it is necessary to break the output from the echo mixer at the same time as the output from the mixer is broken. Thus the keys following the mixer have two sets of change-over con-

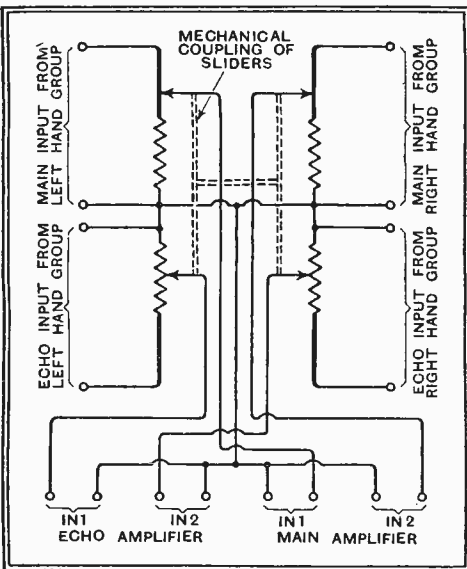
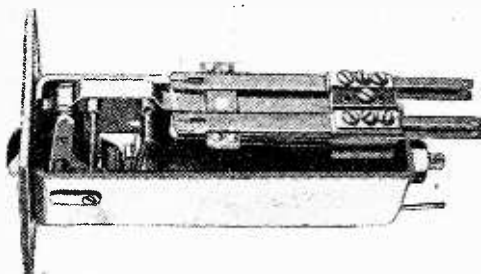

Fig. 3.—Circuit arrangement of the central mixer.

**Programme Mixing—**

tacts, while those connected to the channels have only one set.

The central mixer in all previous dramatic control units has consisted of two potentiometers on the one shaft, and they were so arranged that when one of these potentiometers was being faded out the other remained at maximum. In the revised design these two potentiometers have been mechanically separated so that they may be separately controlled. It will now be possible for a producer to mix the two groups of sources at whatever level



Details of the magnetic "cut key," which is here shown in the "operated" position.

he desires instead of being limited to a straight fade on one group only at a time.

This new dramatic control unit will not be so large as the fifteen-channel unit supplied to Broadcasting House in 1934, nor will it be equipped with the complicated switching circuits included in that unit for special overseas programmes. With these exceptions and the modifications described above, the new unit will be similar in all respects to its predecessors. The time is rapidly approaching when it will be impossible to add more facilities to this type of unit, otherwise the finished product will be too cumbersome for operation by one man.

**BOOK REVIEW**

**The Theory of Dimensions and its Application for Engineers.** By Dr. F. W. Lanchester, F.R.S. 314 + xxiv pp. Published by Crosby Lockwood and Co., Ltd., London, 1936. 12s. 6d. net.

THE appearance of this book is timely, since the International Electrical Commission of 1935 has "provisionally decided to adopt the M.K.S. (Giorgi) system of electrical units," as we read in the preface (p. xiii). It is not clear whether this is in addition to, or in place of, the C.G.S. "absolute" system, but in either event it is time to take stock and clarify our ideas. The reader of this book, unless he has a very exceptionally logical and tidy mind, will be surprised at the loose and inconsistent notions he has hitherto been content to entertain and the pitfalls whose existence he never realised. The author impartially reviews the many systems of physical units and entities which have been proposed from time to time, as used not only in electrical work, but also in mechanics and thermodynamics; "many views are expressed and ventilated, no positive conclusion is recorded" (p. xv). However, Dr. Lanchester has given Perry's "Engineers Unit of Mass" the *Slug*, a hard knock, and has scored a hit clean over the pavilion!

The confusion caused by the loose use of  $\mu$  for "specific permeability in terms of that of air as unity," and also as a dimensional symbol, is clearly pointed out (§92b), but has not the author fallen into an analogous error when he tacitly assumes that the specific heat of water is dimensionless? (§78). The dimensions which this assumption assigns to "Thermal Entities" will not be generally accepted without, at least, some opposition.

Useful tables of physical and engineering constants are given, many of the latter being the result of the author's own experience. Mention must also be made of the valuable collection of reprints of relevant matter from papers and articles by Rücker, Fitzgerald, Henderson, Heaviside, and Maxwell. C. R. C.

**Television Programmes**

The principal items only of each day's programmes are given. The system to be used each day is given below the date. Transmission times are from 3-4 and 9-10 daily.

Vision	Sound
6.67 m. (45 Mc/s).	7.23 m. (41.5 Mc/s).

**FRIDAY, JANUARY 15th.**  
(Baird.)

3, Friends from the Zoo introduced by David Seth-Smith. 3.15, British Movietonews. 3.25, Cabaret. 3.50, Film.

9, Gaumont British News. 9.10, Repetition of 3 programme. 9.25, Film. 9.35, Cabaret.

**SATURDAY, JANUARY 16th.**  
(Baird.)

3, In Your Garden—The Construction of a Small Lily Pond: by C. H. Middleton. 3.15, Gaumont British News. 3.25, Caricatures by "Goodenough." 3.35, Cabaret and the Television Orchestra.

9, Repetition of 3 programme. 9.15, British Movietonews. 9.25, Repetition of 3.25 and 3.35 programmes.

**MONDAY, JANUARY 18th.**  
(Marconi-E.M.I.)

3, Arts League of Service. 3.20, Gaumont British News. 3.30, Cabaret Cartoons.

9, Repetition of 3 programme. 9.20, British Movietonews. 9.30, Repetition of 3.30 programme.

**TUESDAY, JANUARY 19th.**  
(Marconi-E.M.I.)

3, Elisabeth Pollock—Impressions. 3.5, Musical Instruments—II. 3.20, British Movietonews. 3.30, Scenes from the Lyric Theatre production of "Charles the King."

9, Repetition of 3 and 3.5 programmes. 9.25, Gaumont British News. 9.35, Joan Luxton's Children's Theatre Company in "Cinderella" as presented at the Embassy Theatre.

**WEDNESDAY, JANUARY 20th.**  
(Marconi-E.M.I.)

3, Russell Swan—the Theory of Magic Expounded. 3.15, Film. 3.25, 21st Picture Page. 3.50, Gaumont British News.

9, Yvonne Arnaud at the piano. 9.15, Repetition of 3 programme. 9.25, British Movietonews. 9.35, 22nd Picture Page.

**THURSDAY, JANUARY 21st.**  
(Marconi-E.M.I.)

3, Fashions in Furs—A Display by Mannequins. 3.10, Masks and Mimes. 3.25, British Movietonews. 3.35, Geraldo and his Orchestra.

9, Repetition of 3 and 3.10 programmes. 9.25, Cook's Night Out. 9.40, Gaumont British News. 9.50, Eric Wild and his Teatimers with Ann Lenner.

**DISTANT  
RECEPTION NOTES**

AS it is exceedingly difficult at the present time to obtain information from Spain, I wonder whether any reader can help in solving a problem. Here it is: A friend who knows the country well gave me recently what he described as a complete official list of Spanish stations. From 410.4 down to 238.5 metres the list is in entire agreement with those published monthly in *The Wireless World*. But below this mark there is an astonishing difference.

On 201.1 metres, for instance, the published lists show only two stations, Albacete and Santiago, rated at 0.2 and 0.5 kilowatt respectively. In my friend's list there are no fewer than 33 small Spanish stations using this wavelength, nearly all with a rating between 0.1 and 0.2 kilowatt.\*

Then on 200 metres Radio-Alcala (0.2 kW) is the sole Spanish station appearing in the lists with which we are familiar, though my friend's contains a round couple of dozen. If his information is correct, Spain possesses—or did possess before the present troubles began—no fewer than 65 broadcasting stations, the great majority being small relays working on one of two common wavelengths.

It may perhaps assist investigators if I give the names of a sample half-dozen of the "unknown stations" stated to be occupying each wavelength. On 201.1 metres Malaga (0.2 kW), Melilla (0.2 kW), Cordoba (0.1 kW), Tarragona (0.2 kW), Gijon (0.2 kW), and Ceuta (0.2 kW); on 200 metres, Santander (0.2 kW), Toledo (0.2 kW), Algeciras (0.2 kW), Valencia (0.1 kW), Salamanca (0.2 kW), and Pontevedra (0.2 kW).

Anyone who has tried of late for medium-wave American stations will agree that conditions have been very patchy. On many nights there is very little to be heard from the United States. And then after perhaps a long period of disappointment one finds a night on which they are to be heard "all round the dial." On these good nights the strength of some U.S.A. stations is phenomenal. WBZ is generally the star, coming in at almost local-station strength. But it does not stand alone, for full loud speaker volume may be obtainable from WCAU, WOR, WPG, WHAM, WTIC, KDKA and several others.

If the U.S.A. stations are uncertain, those in South America are generally much more reliable. It is rather curious that the South Americans so often come in well when the North Americans are poor and *vice versa*. It is also very fortunate for the long-distance man, for heterodyne and jamming would otherwise ruin many transmissions.

Italy, in addition to building a new and much more powerful group of short-wave transmitters, is determined to increase the number of her medium-wave stations. There is to be a new station in Sicily and another at Ancona. Where the wavelengths are to come from it is rather hard to see unless the new stations are to be used as relays and to work in synchronisation with their parent transmitter. D. EXER.

\* [The small power of the transmissions and the inability to resolve any worth-while signal from many stations working on a common wavelength are reasons for the omission of these stations from the lists we publish at intervals.—ED.]

# CURRENT TOPICS

News of the Week in

Brief Review

## America's Wireless Tax

**A**LTHOUGH there is no licence fee for wireless users in the U.S.A. the Government gets money from listeners in an indirect manner, for it levies an excise tax of five per cent. on receivers, gramophones, and other domestic electrical equipment. In 1936 this revenue amounted to five million dollars.

## A Floating Service Station

**W**HAT is probably a unique depot for servicing wireless receivers exists in Alaska. It is housed in a yacht off the coast, and belongs to a Seattle radio firm. Apart from servicing radio receivers possessed by the scattered population of this part of the world, it also undertakes repairs to the transmitting and receiving apparatus installed on board various ships.

## New Tunis Station

**A**SUM of ten million francs has just been set aside by the French Government to build a high-powered broadcasting transmitter in the neighbourhood of Tunis. The station will be erected on high ground and will probably have a power of from 120 to 150 kilowatts. It is likely that it will be ready for preliminary tests by the end of the year.

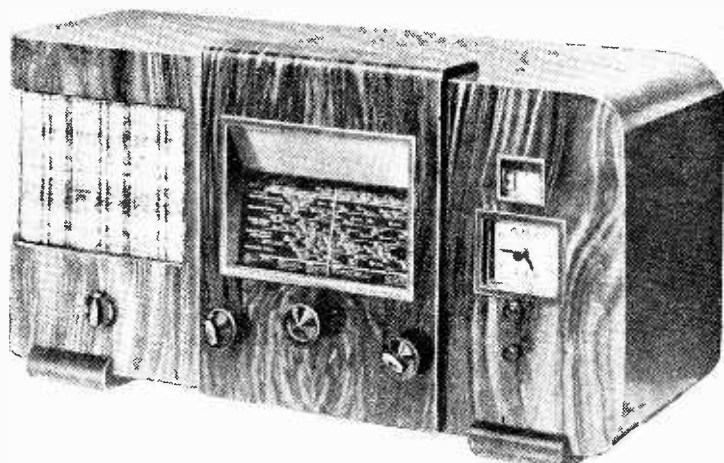

AN AUTOMATIC TIME SWITCH is fitted to this new German Telefunken receiver. The time at which the mechanism is set to switch on or off is shown by the indicator above the built-in clock.

## Preparing for 1941

**T**HE first stone of the building to house the great Italian exhibition, in which radio and television are to play a very prominent part, was laid recently by Mussolini. This exhibition, which will be held in Rome in 1941, is intended to exceed any so far held from the point of view of size and importance.

quarter of a million licence-holders in Norway, this shows very great confidence, although doubtless many visitors will come from the neighbouring country of Sweden.

## Indian Broadcasting

**M**R. C. W. GOYDER, the well-known chief engineer of the all-India radio ser-

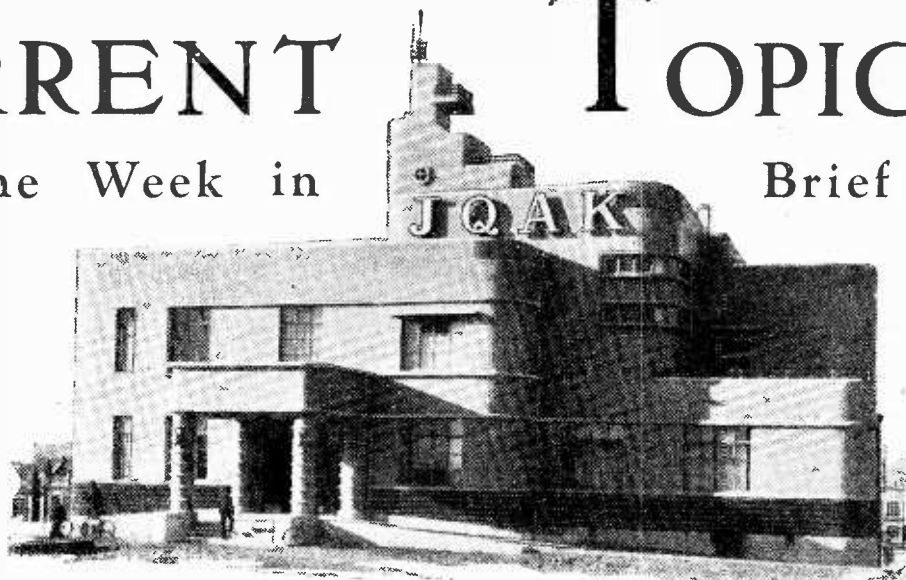

## New Radio Link

**A** NEW regular telephone service has been inaugurated between Rome and Addis Ababa.

## Oslo Radio Exhibition

**T**HE habit of holding wireless exhibitions seems to be on the increase. The latest country to join the ranks is Norway, and an exhibition is to be opened at Oslo to-day (January 15th), and will remain open for a fortnight. The leading feature of the exhibition will be a demonstration of television, using German apparatus with 375-line scanning. The exhibition authorities are consequently anticipating that at least 50,000 visitors will attend the show. In view of the fact that there are less than a

vice. has recently been on an aeroplane tour of India and the neighbouring Dutch East Indies in connection with plans to develop Indian broadcasting. The system in use in the Dutch East Indies is similar to that suggested for India. The proposed Indian system includes the provision of a first-class service over a restricted area by four medium-wave stations. The limited nature of the range as compared with broadcasting in this country is because of the heavy atmospheric interference in India. What is described as a second-class service is to be given by means of four short-wave stations.

## New French Scheme

**U**NDER the new system of grouping French broadcasting stations, the fourteen principal State transmitters are arranged together as follows:—

Group A: Radio-Paris, Bordeaux, Nice and Montpellier.

Group B: Paris (PTT), Marseilles and Grenoble.

Group C: Eiffel Tower and Lyons.

Group D: Strasbourg and Rennes.

Group E: Lille, Toulouse and Limoges.

No two of these station groups will have the same type of programme on the same evening, but one or other type of transmission may be repeated a second time within a week. It is hoped that the economy of talent and money thus achieved may result in a better standard of programmes.

## The Test Matches

**T**HE arrangements made for conveying news from Australia to this country in connection with the series of Test Matches now being played are said to be more elaborate than anything hitherto attempted. Special lines have been laid

The building of the new broadcasting station recently erected at Dairen, Manchukuo. A special radio exhibition, at which the G.E.C. has a stand, is being staged in the station buildings.

down from the various cricket grounds direct to the wireless

and cable headquarters, and the service has proved so effective that the fall of a wicket is known in London almost as soon as the dismissed batsman has arrived back at the pavilion.

## Coronation Illuminations

**E**LECTRIC lighting will naturally play an important part in the decorations for the Coronation in May. Floodlights, neon tubing and plain and coloured lamps will be employed on an unprecedented scale by local authorities, trade associations and other bodies, as well as by private individuals. To-day's special issue of the *Electrical Review* forms an illustrated guide to the products of over a hundred manufacturers of illuminating devices and equipment. It also contains special articles putting forward suggestions for decorative schemes.

## S.B. to All Stations

**A** WORLD-WIDE link-up of broadcasting stations is to take place on January 20th on the occasion of the inauguration of Franklin Roosevelt's new term of office as President.

## What is Your Wavelength?

**A**CCORDING to reports received from France, M. de Martini, a well-known scientist, has stated that the various cells of the human body radiate electro-magnetic waves which are in every respect similar to wireless ones, except that they are very much shorter than any so far used for wireless communication. The wavelength varies between 20 and 45 millimetres. In conditions of ill-health it has been noted that these radiations are altered in wavelength, although it is not yet clear whether this is a cause or an effect. It is said, however, that these discoveries open up an entirely new field of therapy.

# The Physical Society

## Many Important Developments in Radio Measuring Apparatus

FOR many years now the wireless industry has been represented by a steadily increasing proportion of the exhibits at the Annual Exhibition of Scientific Instruments and Apparatus at the Imperial College of Science and Technology, South Kensington. Those who were fortunate in being able to visit this year's Exhibition on January 5th, 6th and 7th will agree that the advance both in quality and variety of those instruments which may be regarded as the fine tools of the research worker and manufacturer was a stride where in previous years it had been a step. The accumulated experience in the use of signal generators has resulted in the development of vastly improved types, and the influence of television and short-wave reception is reflected not only in the cathode-ray tube

exhibits, but also in the extension of the frequency range of amplifiers, variable frequency oscillators and wavemeters.

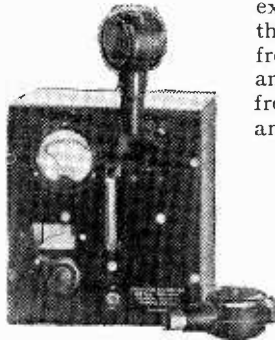

Claude Lyons G.R. precision wavemeter Type 724A. The interchangeable coils are rotatable.

There is little doubt that the wavemeter is the fundamental instrument for all branches of wireless activity, and the instruments shown ranged from laboratory sub-standards of phenomenal accuracy and stability to simple absorption instruments designed for rapid checking in the workshop or in the field.

The very beautiful Sullivan-Griffiths dynatron oscillating wavemeter (range: 100-30,000 kc/s), with its stable inductance standards and frequency stability of two parts in a million, is now provided with a direct-reading scale giving an accuracy of 0.01 per cent. for "rough" measurements where the ultimate accuracy of 0.003 per cent. by interpolation methods is not required. Direct-reading interchangeable scales are also fitted in the new Type R800 universal wavemeter (range: 30-15,000 kc/s), which can be used as an absorption or dynatron wavemeter without change of calibration. Of special interest, in view of the advent of television, is the new Sullivan sub-standard absorption wavemeter with a range of 5-42 metres. A valve voltmeter detector is provided, and a direct-reading accuracy of 0.01 per cent. and 0.03 per cent. by interpolation is possible.

Straight-line frequency variation is also a

feature of the Claude Lyons wavemeter Type 724A, so that increased accuracy by interpolation is possible from the readings given by the 270° scale. The indication is by valve voltmeter, and the range of 16-50,000 kc/s. is covered by seven interchangeable coils housed in robust bakelite mouldings.

In the Marconi-Ekco Type TF370 precision wavemeter the tuned circuit is connected in the anode of an RF pentode and coupled to a high-impedance valve voltmeter. Sensitivity control is provided which enables a high degree of frequency discrimination to be obtained. To eliminate temperature effects duralumin plays an important part in the construction of the condenser, which is driven from a worm reduction gear. The coils are self-contained, and are mounted on the turret principle, which is an important feature of many of this year's Marconi-Ekco instruments.

Standard signal generators may be regarded as developments of the fundamental wavemeter, and this year big improvements are to be noted in ease of handling and accuracy of calibration, particularly in the maintenance of modulation depth with change of audio-frequency. The new G.R. Type 605A standard signal generator shown by Claude Lyons is a very fine example of the latest practice. It has a range of 9.5 kc/s to 30 Mc/s in seven bands, which, instead of plug-in coils, are now selected by means of a switch. The instrument is entirely AC operated, but can be rapidly converted to battery operation if desired. The power supply unit is controlled by voltage regulators of the saturated core type, and the voltage output is constant within  $\pm 0.1$  microvolt below 3 Mc/s and not more than  $\pm 0.4$  microvolt at 30 Mc/s. The external modulation characteristic is flat within 1 db. from 30-15,000 cycles, and a further improvement is to be found in the provision of a buffer valve to prevent reaction of the attenuator setting on the carrier oscillator.

A very useful feature of the latest Type TF144 Marconi-Ekco standard signal generator is an auxiliary fine tuning control accurately calibrated and designed to facilitate the checking of selectivity curves. The frequency range of the instrument is 85 kc/s to 25 Mc/s covered by eight coils selected

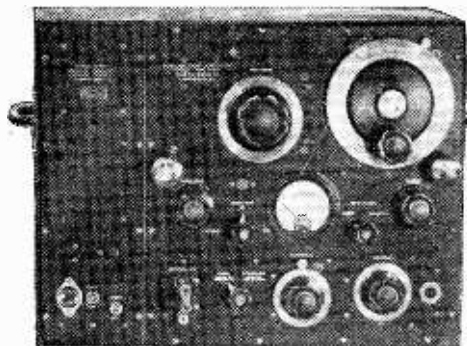

The new G.R. standard signal generator Type 605A is entirely AC operated and covers the range 9.5 kc/s to 30 Mc/s without the use of plug-in coils.

internally by a rotating turret. The RF screening has been considerably improved,

and mains or battery operation is now available by an internal change-over plug. An interesting feature is the provision of a spring stop on the attenuator to avoid accidental damage to the thermo-couple in the monitoring meter.

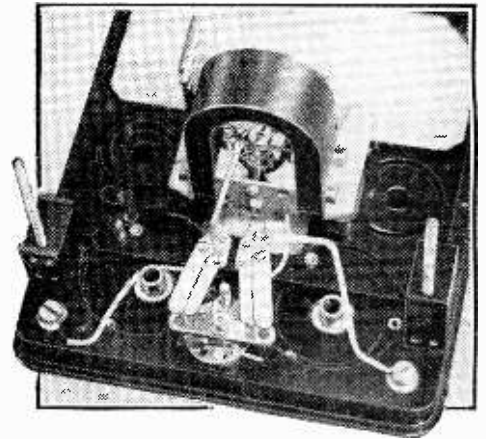

Protection from overload is afforded by a mechanically operated cut-out in the Model 7 Avometer.

The Marconi-Ekco TF390 is a good example of the new short-wave signal generators which are appearing as a result of the increased activity in the spheres of television and short-wave reception. The range is 20-100 Mc/s, and the output is brought out to terminals at the end of a flexible screened cable. Fundamentally, the arrangement of the circuit is the same as that of the standard signal generator, but the monitoring meter is in this case an acorn valve voltmeter. The output range of the instrument is from 1 microvolt to 0.1 volt.

Plug-in coils are used in the Claude Lyons Type 604B short-wave signal generator to cover a range from 3 to 100 Mc/s. A capacity attenuator is arranged to give continuous adjustment of output from 5 to 10,000 microvolts which appears at the end of a detachable screened lead. A useful adjunct is the rod antenna sectionalised into three lengths giving field strengths in the ratio of 1, 10 and 100 with a constant input of 1 volt.

Among the service test oscillators the Weston Model E692 is worthy of note. This compact oscillator is provided with a series of plug-in coils giving a range of fundamentals of 100 kc/s to 25 Mc/s.

Continuing our examination of what may be termed "sources" we come to audio-oscillators, in which a widely increased range is required for measurements of television apparatus. An example of the type of instrument which this new demand is likely to produce was provided by the Marconi-Ekco beat frequency microvolter Type TF336. The present frequency range of the instrument is 50-150,000 cycles, but we understand that it is hoped shortly to extend this range to 3 Mc/s. The output is 2.5 microvolts to 3 volts controlled by a twin unit attenuator.

For normal acoustic work the Claude Lyons Type 713A beat frequency oscillator has the very wide range of 10-20,000 cycles on a single scale. A subsidiary control gives

# Exhibition

incremental variations of  $\pm 50$  cycles at any part of the scale. The output is 130 volts on open circuit or 2 watts into 2,000 ohms. A balanced push-pull detector circuit is employed, and the harmonic content above 100 cycles is less than 1 per cent. Means are provided for checking the performance to ensure that unsuitable load conditions will not result in increased harmonic content.

Muirhead and Co., Ltd., have introduced a resistance-capacity controlled audio oscillator employing an improved type of circuit due to Dr. N. L. Yates-Fish. A frequency range of 10—1 is obtained by a single sweep of the variable air condenser and the instrument covers 20-20,000 cycles in three ranges. The oscillator is mains operated and has an output of 1 watt.

So much for calibrated sources of input. Valve voltmeters and other means of measuring the output as modified by the apparatus under test appear logically to come next for consideration. With few exceptions all modern valve voltmeters are mains operated, and in all cases it will be found that special precautions are taken to keep the input impedance high. In the re-designed Muirhead valve voltmeters for both mains and battery operation the grid terminal is mounted in a mica window and the window and the grid condenser is sulphur

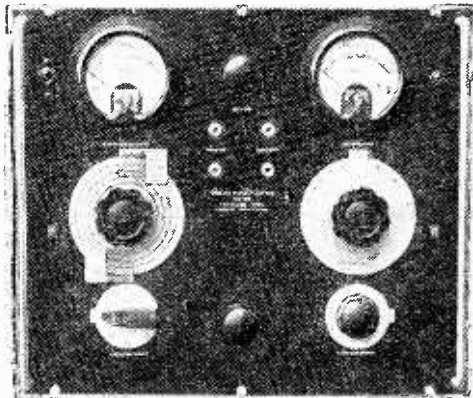

Marconi-Ekco coil magnification meter  
Type TF329.

insulated. An important feature of these instruments is that the meter scale is linear above 0.2 volt. The mains models have three ranges, viz., 0-2, 0-10 and 0-50 volt.

The Weston Model 669 is an AC operated instrument with six ranges, the lowest of which is 0-1.2 volt and the highest 0-16 volts. The calibration accuracy is stated to be within 3 per cent. from 40 cycles to 50 Mc/s and the input capacity has the exceptionally low value of 4 micro-mfds. Although the instrument was not available when we visited the stand, Claude Lyons now list an ultra-high-frequency valve voltmeter employing a "probe" containing an RCA micro-wave triode valve. The accuracy of this instrument is given as 1 per cent. from 20 cycles to 50 Mc/s.

With valve voltmeters we may include output power meters and in this category the Marconi-Ekco Type 340 is a good example. The input is variable from 2.5 to 20,000 ohms and the range is 0.1 to 5,000 milliwatts. In the Type 586 G.R. power level indicator shown by Claude Lyons, the high-

speed meter movement is calibrated directly in db. for a 500-ohm load and the correction chart is provided for other loads between 50 and 5,000 ohms.

Among DC and power frequency AC meters the Model 7 Avometer is of special interest. It has no fewer than 46 ranges which include scales for capacity measurement and power output, the latter with a db. scale referred to 50 milliwatts. Instead of the customary fuses this instrument is protected from overload by a cut-out which depends for its action on the inertia of the pointer. The latter is not rigidly connected to the moving coil but is held by a spring mechanism. Any abnormal acceleration of the coil causes a deflection relative to the needle, which releases a pawl and opens the circuit breaker. In general, the cut-out operates an overload before the needle has traversed more than one-third of the scale.

For many measurements dead-beat movements, which are at the same time quick in action, are required, and Ernest Turner Electrical Instruments, Ltd., were showing some fine examples of this type in 2½in. and 3½in. sizes. Zero to full scale occupies only 82 milliseconds and the over-swing does not exceed 1 millisecond.

Rectifier type AC meters with millivolt ranges and making use of suitable input transformers are now available, and examples of this type were shown by Elliott Bros. As regards the rectifiers themselves Westinghouse have introduced a new model in the 10mA instrument size, which is designed to permit the addition of extra elements if this is subsequently desired.

The Cambridge versatile galvanometer can now be supplied with special thermo-junctions, for addition or replacement, in which the sensitivity is adjusted at the works to conform with the scale of the instrument. Finally, Everett Edgcombe and Co. have developed an electrostatic voltmeter for testing the HT circuits associated with cathode-ray tubes. This instrument has ranges of 0-2,000, 0-4,000 and 0-8,000 volts and the instrument has been arranged to take a current of about 200 microamperes at full scale deflection on each range.

Both in the laboratory and test room bridges for measurement of fundamental electrical quantities are essential, and in this category the Type TF373 universal-impedance bridge shown by Marconi-Ekco is a good example. It is mains operated and makes use of the Maxwell circuit for inductance and the usual ratio arms for capacity-resistance measurements. The appropriate circuits are selected by a single switch, and for AC measurements a self-contained oscillator provides a frequency of 1,000 cycles. The overall ranges available are 0-100 henries, 0-100 mfd., and 0-1 megohm. The scales and range switches are calibrated directly in inductance, capacity, and resistance, and the bridge can also be used for the measurement of power factor and coil magnification.

Special meters for measuring coil magnification were shown by Marconi-Ekco and the Salford Electrical Instrument Co. In principle these depend upon the injection of a known voltage in series with the coil under test and a high-quality air condenser. A valve voltmeter indicating the volts developed across the tuning circuit is calibrated directly in coil magnification units ( $\omega L/R$ ). The

Marconi-Ekco Type TF329 indicates values of "Q" from 25 to 500 on a special open scale, and has a frequency range of 50 kc/s to 50 Mc/s—again provided by a turret of eight coils. The range of the Salford meter is 20-500 for "Q" and 100 kc/s to 5 Mc/s for frequency.

Special test sets for the direct measurement of capacity are no novelty, but the Sullivan-Griffiths logarithmic capacitance bridge is an instrument of unusual refinement. It makes use of the special form of condenser employed in the firm's beat oscillator and has a remarkably open scale for small capacities—of the order of ½in. between 1 micro-mfd. divisions near the zero end of the scale. The range is from 1 micro-mfd. to 200 mfd.—direct reading—with a uniform accuracy of 0.2 per cent. throughout. Another instrument deserving special mention is the Cambridge high-frequency capacity meter, which is also of the bridge type and is energised by a self-contained battery-driven oscillator with a frequency of the order of 200 kc/s. The scale is calibrated from 0 to 500 micro-mfd., and there is a range switch giving six multiplying factors from  $\times 0.1$  to  $\times 5$ . A centre zero galvanometer indicates balance, and the accuracy of scale reading is of the same order as that of the bridge dial. The overall accuracy is 0.5 per cent., and on the lowest range (50 micro-mfd.) capacities can be measured to 0.2 micro-mfd.

The routine testing of condensers should be greatly facilitated by the Tinsley Type 4595 RF capacitance and power-factor tester. In this instrument a direct reading of power factor is given on the scale of a self-contained reflecting galvanometer which forms parts of a valve voltmeter across a tuned circuit energised from a 1,000 kc/s oscillator. A measure of capacity is obtained by the reduction of the standard tuning condenser, the dial of which is provided with adjustable limit stops. The valve voltmeter deflection gives a measure of the "goodness" of the condenser and interchangeable scales carrying appropriate calibration curves, or a general scale with a series of curves for interpolation may be used.

Before leaving test gear the Marconi-Ekco Type TF339 inter-electrode capacity test

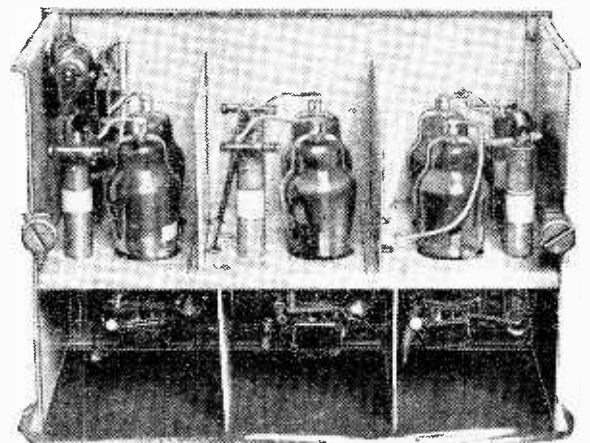

Cossor wide-range television line amplifier.

set should be mentioned. A known voltage from a 100 kc/s oscillator is applied through an attenuator and the capacity under test to a tuned circuit the dynamic resistance of which can be adjusted to a known value. The volts developed across the circuit are indicated by a meter preceded by an

**The Physical Society's Exhibition—**

amplifier, and for a standard deflection the attenuator is calibrated to read capacity. The range is from 0.0001 to 1 micro-mfd., and suitable valve adaptors are provided.

Valve bridges are important items of works equipment, and instruments incorporating bases for all current types of valve were shown by Automatic Coil Winder and Electrical Equipment Co., Ltd., Everett Edgcombe and Co., and Marconi-Ekco. A noteworthy feature of the latter instrument is that the valve sockets, which naturally come in for a good deal of hard wear, are replaceable.

Among new valves were noted the Mazda V312 and PA20 non-microphonic mains-operated triodes and the Mazda "acorns," applications of which were exhibited in the forms of a "probe" voltmeter and a low-powered 70 cm. transmitter.

Cathode-ray technique, as might be expected, was well to the fore, though the emphasis was on applications to engineering problems rather than to television. Apparatus in which a transient automatically brings up the beam to recording brilliance with a time lag of less than a micro-second was shown by Standard Telephones, and a similar principle was a feature of the Cambridge Instrument three-element oscillograph.

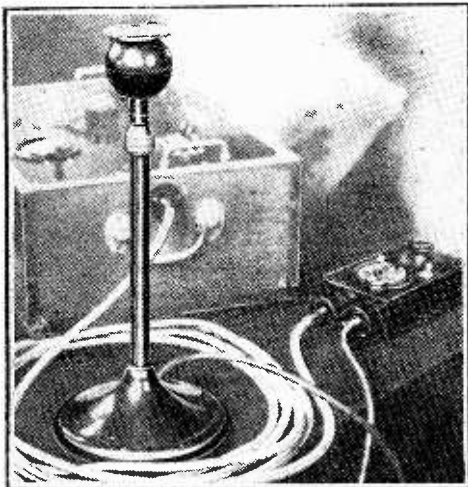

Non-directional moving coil microphone shown by Standard Telephones.

The Cossor stand was devoted exclusively to cathode-ray apparatus, and the exhibit included some newly designed film and drum cameras, single-stroke time bases, and a novel triple high-vacuum oscillograph employing cylindrical tubes housed in zinc diameter Mumetal screens. A link with television was established on this stand by the exhibition of a wide-range line amplifier, designed for battery operation, with an overall gain of 200 and a frequency range from 10 cycles to 5 Mc/s.

It was disappointing to find so little reference to work in conjunction with loud speakers, a very intriguing demonstration promised in the research section having failed to materialise at the last moment. Some really excellent earphone quality was heard, however, at the Standard Telephones stand, where a new moving-coil microphone and an earpiece constructed on parallel lines were demonstrated in conjunction with the Standard OB amplifier. The microphone (Type 4021A) is spherical, with an opening at the top surmounted by an acoustic screen in which the ratio of absorbed to transmitted

sound is controlled to give a non-directional characteristic. The earphone is of 35 ohms impedance, has a sensitivity of 1,000 bars

expansion incorporating a circuit due to Mr. C. E. Palmer Jones in which exact symmetry is achieved by using a negative feed-

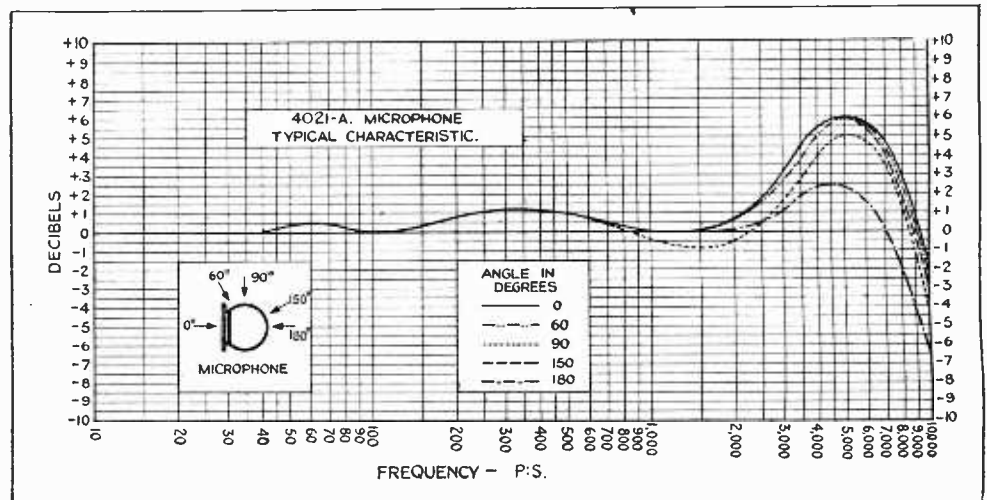

Response curves of Standard Telephones Type 4021A microphone for five angles of incidence. The maximum deviation between 40 and 10,000 cycles is 6 db.

per volt, and is flat within  $\pm 5$  db. from 10 to 10,000 cycles.

The sensitivity of the Muirhead-Williams microphone, in which the bulk of the microphone is removed from the sound field by the use of a long narrow conduit, has now been increased to 5 millivolts per bar, which is comparable with that of any high-fidelity microphone, and it should find wide application in work where it is desirable to avoid disturbance of the wave-front.

At this Exhibition on generally finds some instances of wireless technique being borrowed by other trades and professions. As an example, the Salford electric micrometer may be cited. This instrument was designed for keeping a check on thickness and/or alloy constitution in foil-rolling mills, and is, in effect, an application of the principles of screening. Pairs of coils mounted in a yoke are placed in opposite sides of the foil as it emerges from the mill, and one pair is supplied with constant current from an oscillator at about 12 kc/s. The other pair is connected to the rectifier and meter, and the DC is a measure of the thickness and resistivity of the foil.

Among subjects of allied interest deaf aids undoubtedly hold an important place, and on the Multitone Electric stand the

Salford electric micrometer for checking the thickness and composition of metal foils.

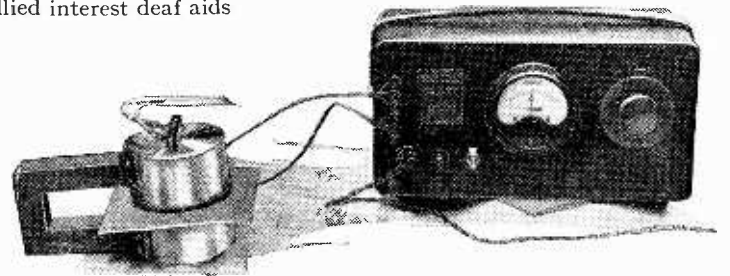

latest designs, incorporating automatic volume control and negative reaction for both tone and volume controls, were shown. Research into the type of characteristic required for different types of deafness is being carried out by a new form of optimum amplification meter in which the response and general level under actual listening conditions can be independently controlled for both ears.

If the exhibits in the Research Section did not prove this to be a vintage year for wireless enthusiasts they could have no reason to complain of less than their fair share of interest. The Post Office exhibits included a demonstration of volume compression and

back amplifier for the expander with the same constants in the feed-back circuit as those used in the volume-compression control. The idea was developed primarily to overcome line noise, but it could be extended to broadcasting or gramophone records if listeners were to adopt a standardised form of expansion control in their receivers or amplifiers.

The remaining exhibits dealt with cathode-ray research. The B.T.H. Research Laboratories showed a method of plotting potential lines in the electrode system by immersing a large-scale section of the elements in an electrolyte and following the equipotential lines with a probe electrode connected to a pantograph. Methods of measuring screen surface charges, and a special tube design for transient recording, working with voltages up to 15,000, were among the Edison Swan research exhibits. The G.E.C. Laboratories, Wembley, were showing special tubes with fluorescent screens illustrating the principles involved in the electron multiplier, and a really beautiful device known as the electron

microscope for viewing what might be termed the "emission texture" of a cathode surface. Two discs with 1 mm. apertures spaced 1 mm. apart are supplied with suitable potentials which give the electrical equivalent of a microscope immersion objective. The assembly is sealed into a tube at the appropriate distance from the cathode to be investigated and throws a magnified image of the emission on a fluorescent screen. Two tubes comprising different methods of depositing the oxide coating on a cathode were shown side by side, the images, resembling micro-photographs of metallurgical specimens, being of striking brilliance.



# New Apparatus

## Recent Products of the Manufacturers Reviewed

### M.R. PIEZO-CRYSTAL MICROPHONE

IN the construction of this microphone special precautions have been taken to design a case that will be non-resonant, so that the effect of enclosing the crystal unit will not alter its characteristics in any way.

The one used is cut from a special stone for which is claimed the required features. Apart from this, the stone employed has a most handsome grain, and in its finished and polished state gives the microphone a most distinguished appearance.



M.R. Crystal microphone mounted in dwarf-pattern table stand.

The microphone has an excellent characteristic, its output being well balanced throughout the entire audio scale of frequencies. Though it was subjected to a very searching test, and actually compared with a high-grade laboratory microphone, only one minor resonance could be detected. This is quite high up in the audio scale, and only has the effect of imparting a very slight sibilant accentuation, which might quite well pass undetected under normal conditions of use.

It is a microphone that can be confidently recommended for public address work, home recording, for amateur transmitting, and for any occasion where a microphone capable of giving very high quality of reproduction on speech or on music is required.

The makers are M.R. Supplies, 11, New Oxford Street, London, W.C.1, and the price is £5 10s. The stand shown in the illustration costs 15s., finished in chromium. Various alternative styles are also available.

### WEBB SHORT-WAVE CONDENSERS

A NEW range of condensers for use in short- and ultra-short-wave apparatus has recently been introduced by the Webb Condenser Co., Ltd., 34, Hatton Garden, London, E.C.1.

Known as the Type 92, they are assembled on a single end plate of an insulating material described as "Stealan."

Specially shaped brass vanes are used, also a brass spindle. The single bearing is of sufficient length to give rigidity to the rotor assembly.

Though a friction contact with the rotor

is employed, it does not give rise to noise in operation in ultrashort-wave sets, and from examination of its construction it should continue to prove satisfactory after prolonged use.

There are five different sizes in the series, viz., 15, 25, 45, 100, and 160 m-mfds. respectively, the first three mentioned having extra wide spacing between the plates.

A useful feature of these condensers is their small size, for the 160 m-mfds. model is not appreciably larger than the 15 m-mfds., since it is assembled on the same size end plate.

The capacities of several specimens have been measured, the results being tabulated below:—

TABLE.

Type.	Nominal Capacity m-mfds. (max.).	Measured Minimum Capacity (m-mfds).	Measured Maximum Capacity (m-mfds).
92	15 (0.000015 mfd)	3.2	13
92	25 (0.000025 " )	3.2	22
92	45 (0.000045 " )	3.5	42
92	100 (0.0001 " )	4.0	99
92	160 (0.00016 " )	5.0	157

The other condenser tested was a slow-motion reaction model of 0.0002 mfd. capacity. This has a built-in reduction drive having a ratio of 10½ to 1. It is known as the Type 87, and is made in three sizes, viz., 0.0001, 0.00015, and 0.0002 mfd.

It is made throughout of brass, and its minimum capacity was found to be 17.5

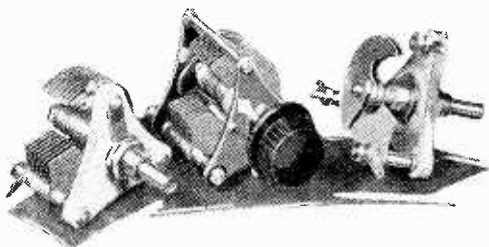

Selection of the new Webb short-wave condensers.

m-mfds., while the maximum value was 0.000202 mfd.

The Type 92 costs 4s. up to 45 m-mfds., and 4s. 6d. for the larger sizes. The 0.0001, 0.00015, and 0.0002 mfd., Type 87, reaction condensers cost 5s., 5s. 3d., and 5s. 6d. each respectively.

### VARLEY NICORE COIL UNITS

THE latest series of Nicore coil units made by Varley (Oliver Pell Control, Ltd.), Cambridge Place, Burrage Road, Woolwich, London, S.E.18, contains two models for use in superheterodyne sets. One is a three-coil assembly with band-pass input circuits for a 110 kc/s IF amplifier, while the other is for use with an IF of 465 kc/s, and has a single tuned input circuit, a band-pass input filter not being essential for good second-channel rejection with the higher IF.

Both these units have been tested and found satisfactory in every respect. The oscillator functions correctly on both medium and long waves, and the signal-circuit coils are closely matched in inductance so that good preselection can be obtained.

The inductances of both sections of the oscillator coils in the two- and three-gang models agree satisfactorily with the maker's figures, which are the correct ones for accurate tracking with condensers having shaped vanes in the oscillator section.

The coils are well made and the design is such that their assembly in a set is easily arranged. The wavechange switches are fitted with non-oxidising contacts and are of

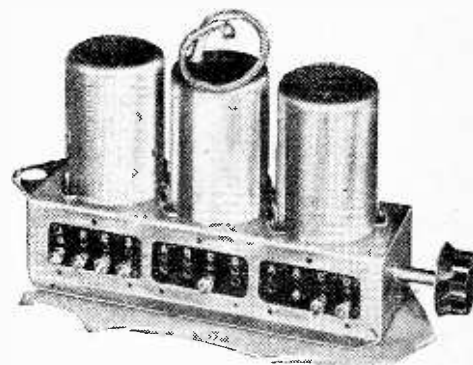

Varley three-gang Nicore coil unit, the Model BP111 for superheterodyne sets with 110 kc/s IF amplifier.

a pattern that should not give trouble, even after long use.

The two models tested are the BP112 and the BP111 and they cost 13s. 6d. and 21s. respectively.

### BULGIN BAYONET-CAP LAMP HOLDERS

THE screw-in type bulb generally used for illuminating the tuning scale does occasionally come loose, and may then give rise to annoying crackles in the loud speaker whenever the set is moved or touched. In order to eliminate one possible cause of interference, however remote, A. F. Bulgin and Co. have introduced a new range of lamp holders for use with midget bayonet-cap lamps.

These are made in the same wide variety of styles as the M.E.S. screw-type holders. Lamps for this new holder are also obtainable in the same range of sizes and filament consumption as the Bulgin M.E.S. bulbs.

So far, we have not been notified of the prices of these new fittings and lamps for them, but it is understood that this information will very shortly be available.

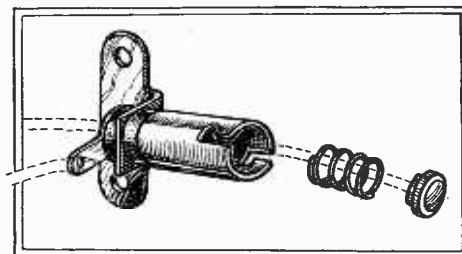

Bulgin new bayonet-cap lampholder.

### MOBILE AMPLIFYING EQUIPMENT

IN the caption accompanying the photograph of the PA van equipped by Ross and Robinson, and reproduced on Current Topics page in last week's issue, the range of the loud speakers should have been given as *several* miles, and not *seven* miles as stated.

# Eddystone All-World

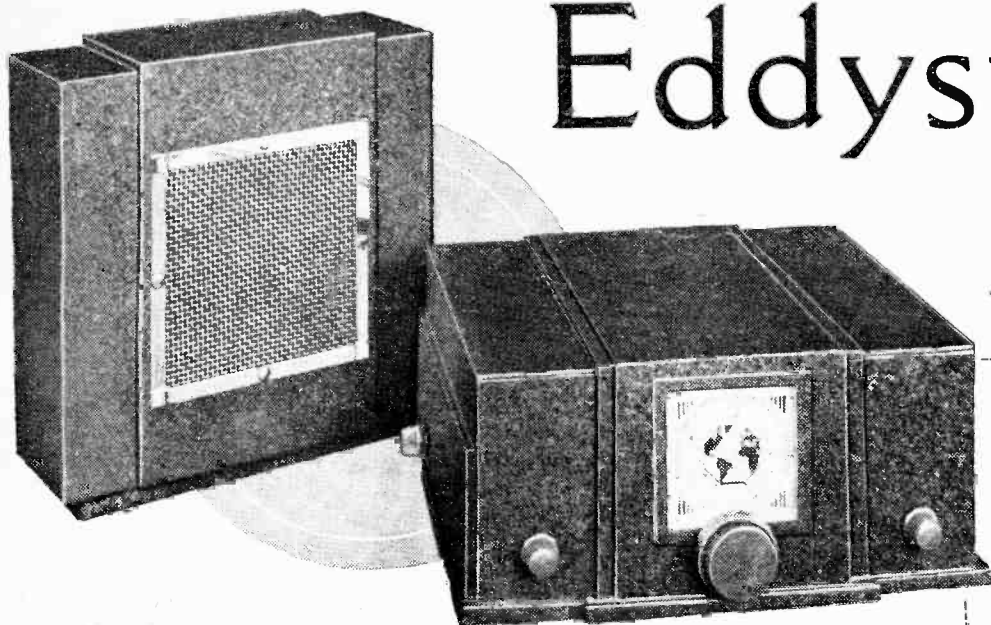

## A BATTERY SUPERHETERODYNE DESIGNED FOR USE IN THE TROPICS

THERE are many all-wave receivers which from the point of view of long-distance short-wave reception can be confidently recommended for use in any part of the world. For the most part, however, they follow domestic broadcast receiver practice in chassis design and layout, and although in a few details the construction may have been modified with an eye to the export market, there seems always to be an element of uncertainty regarding the time that will elapse before the wooden cabinet or even some vital part of the chassis will disintegrate in the hot and humid atmosphere of the Tropics.

No such uncertainty exists in the case of the "All-World Eight," for the designers have made a complete break with the constructional conventions of broadcast receivers and have built with an eye to permanence under any climatic con-

ditions which are likely to be found anywhere on the surface of the earth. Both the cabinet and the chassis are aluminium alloy castings, protected by a hard crystalline enamel. Valve holders, coil bases, etc., are of a special insulating compound known as DL9, which has a wide application in short-wave work. Porcelain pillars are used as anchorages for the wiring and for supporting small components, while every soldered joint is painted over to obviate subsequent deterioration from corrosion.

The decision to use a cast chassis has presented the designers with an excellent opportunity of improving the electric efficiency of the circuit by thorough screening. Both above and below the chassis is divided into cells by integrally cast webs, and the main tuning con-

**FEATURES.** *Type.*—Table model battery superheterodyne with interchangeable waverange units. *Waveranges* (supplied with receiver) (1) 13.4-31.6 metres. (2) 27.2-69.2 metres. (5) 240-573 metres. *Circuit.*—Var.mu pentode RF amplifier — pentode oscillator — pentode frequency-changer — two var.mu pentode IF amplifiers—double-diode-triode second detector—push-pull triode output valves. *Controls.*—(1) Tuning. (2) Volume. (3) Amplification. (4) Tone. (5) On-off switch. *Price.*—Receiver only, £27 10s. Loud speaker £3 10s. *Makers.*—Stratton & Co., Ltd, Eddystone Works, Bromsgrove Street, Birmingham, 5

denser, as well as the IF transformers, are totally enclosed in this way. In addition, all vital leads carrying HF currents are conducted through copper tubing, which, in the case of the valves, is taken to within a fraction of an inch of the caps.

### Trouble-free Wave-changing

In multi-range receivers the wave-change switch has always been one of the most vulnerable points, and although important improvements have recently been made in switch design, the makers have in this case wisely played for safety by providing interchangeable coil units housed in cast aluminium boxes, together with their trimmers. Three coil units are provided as part of the standard equipment of the receiver, and additional coils

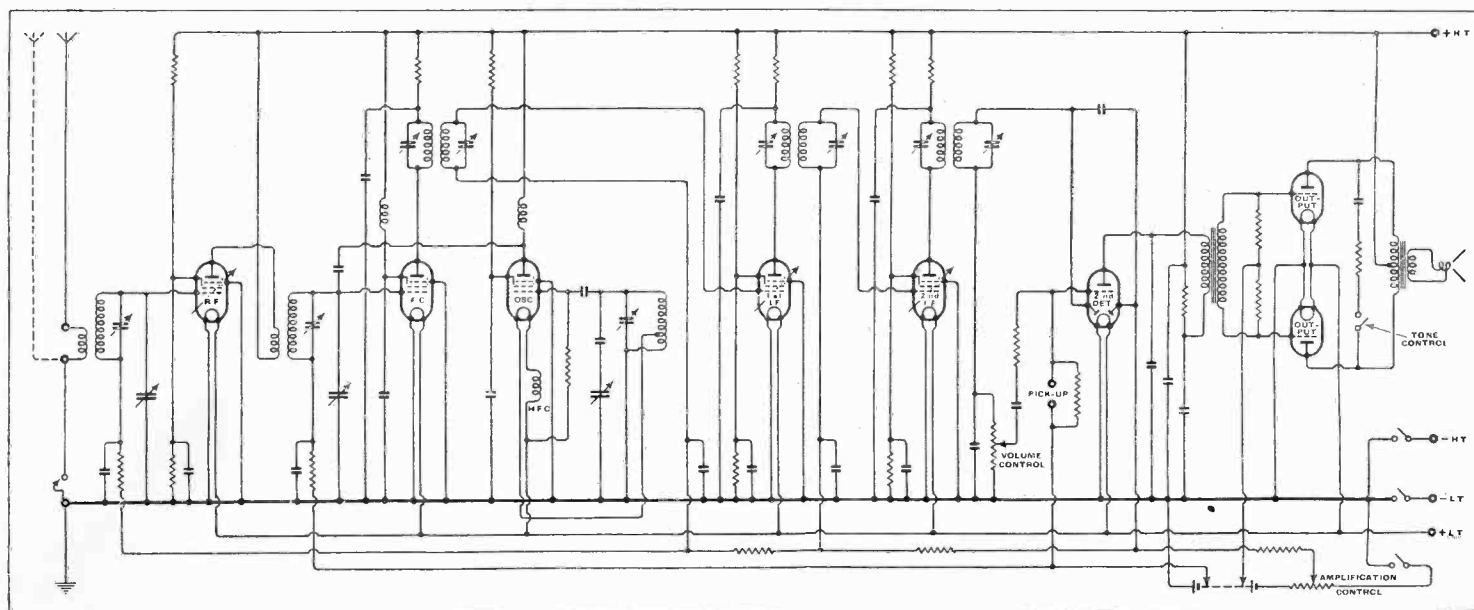

An input RF amplifier and two IF stages give good sensitivity and a push-pull output stage excellent volume for a total HT consumption of only 8 mA.

can be supplied to bridge the gaps between the standard ranges, thus giving a complete coverage from 13.4 to 2,000 metres.

performance on the short-wave ranges is really the result of an exceptionally good signal-to-noise ratio, and if the more powerful continental short-wave stations fail to rattle the loud speaker in the manner to which we have become accustomed, this is only because of the restraint exercised by the efficient AVC system. There is, in fact, very little difference in the signal strength and steadiness of the principal short-wave programmes from either side of the Atlantic, and we were particularly impressed with the excellence and reliability of the morning programme from Pittsburgh W8XK, on 13.9 metres.

The quality of reproduction from the permanent magnet loud speaker unit designed for use with this receiver is well suited to distant reception. It is true that on account of the small baffle area there is not much true bass, but, on the

which provides upwards of twenty or twenty-five continental transmissions in daylight, adjacent channel selectivity was possible with the exception of the two Brookmans Park stations, where one channel was lost on either side of their normal settings when using the set in Central London.

The tuning dial is driven by a two-speed reduction gear with ratios of 22:1 and 115:1. The calibrations for the three inductance units supplied with the set are engraved on a glass scale, behind which the pointer moves with the minimum of parallax error. There is also an arbitrary 0-100 scale, for which a calibration curve is supplied in the case of any extra inductance units which may be subsequently purchased. The tuning scale is backed by a white background which is spaced away from the glass panel, and we think it would have been an advantage, in view of the low current consumption of the set, if a dial light could have been provided. Our reason for making this suggestion is that on account of the low background noise there is every possibility that the receiver may be inadvertently left with the valves running. Actually the measured LT consumption was 0.52 amp. and the HT current consumed at 120 v. varied from 5-8 mA, depending upon the setting of the amplification control.

This is a receiver which provides reliable long-distance reception with unostentatious efficiency, and its construction and workmanship are such that it can be confidently recommended for use in any part of the world.

## News from the Clubs

### The Faraday Radio Society

A crystal-controlled transmitter and other apparatus has been placed at the disposal of this Society by the L.C.C. The club is run in conjunction with the Walworth Men's Institute and membership is restricted to men of 18 years of age or over who reside in the L.C.C. area. A very full programme of lectures and visits to places of radio interest has been arranged, and later in the season it is hoped to be able to carry out geophysical prospecting experiments as a change from the usual type of field-day. Morse classes and lectures are held every Tuesday and Wednesday at 8 p.m. at the club's headquarters at the Nelson School, Trafalgar Street, London, S.E. Full details of the society can be obtained from the Secretary, Mr. J. Sykes, 39, Wallington Road, Seven Kings, Essex.

### The Halifax Experimental Radio Society

This society holds meetings at 7 p.m. on Thursdays at their headquarters, Room No. 13, Friendly and Trades Club, St. James Road, Halifax. The entrance fee to the society is 1/-. Full details can be obtained from the Hon. Sec., Mr. W. Milner, "Ryburn Radio," Sowerby Bridge, Nr. Halifax.

### The Croydon Radio Society

A very interesting programme has been arranged for the second half of the winter session, and readers who are interested are advised to write for full particulars to Mr. E. L. Cumbers, 14, Campden Road, South Croydon. Next Tuesday, at 8 p.m. a lecture will be given on modern sound-film technique at the society's headquarters at St. Peter's Hall, Ledbury Road, South Croydon.

# d Eight

The circuit is designed for use either with a normal single wire aerial or with a doublet. There are eight valves in the circuit, the first of which is a variable-mu pentode RF amplifier. The oscillator is a separate valve and is coupled to the frequency-changer grid through a small

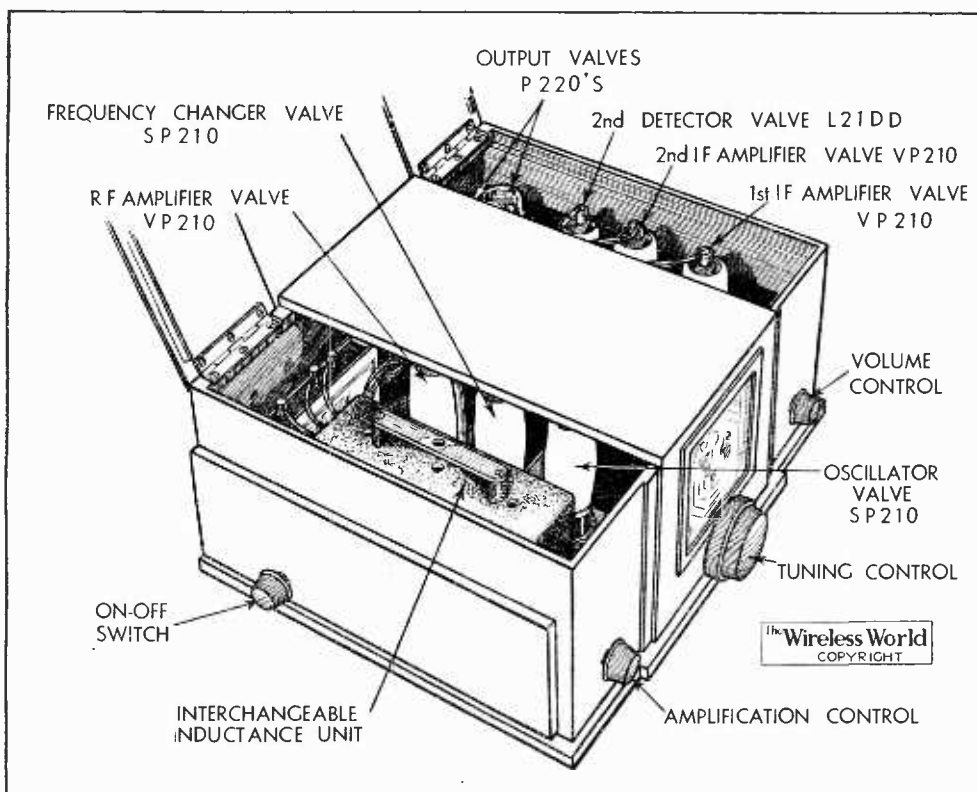

Both cabinet and chassis are aluminium alloy castings. Close-fitting lids give access to the valves and interchangeable coil units.

capacity. There are two stages of IF amplification, and the double-diode-triode which follows them performs the usual functions of signal rectification, AVC supply and first stage AF amplification. The RF amplifier and both IF valves are controlled, and there is a variable initial bias derived from a potentiometer across the grid bias battery. This provides a smooth and efficient control of over-all sensitivity and contributes materially to the ease of handling the receiver. The output stage consists of two triodes in push-pull, with a fixed tone control across the anodes which is brought into operation by means of a switch.

The performance of the receiver is at first somewhat deceptive, for it lacks the excess vitality which often passes for efficiency in many of the popular all-wave receivers. But its quiet and unobtrusive

other hand, there is complete absence of false resonance, and the top register is of the type which gives clarity without emphasising background noise. In fact, throughout the period of the tests no necessity was felt for making use of the tone control either on short waves or normal broadcast bands.

### On Medium and Long Waves

Although the receiver has been designed primarily for short-wave reception, the performance on the medium and long wave broadcast bands could not well be improved upon if the set had been designed from this point of view. On the long waves the selectivity gives clear reception of Deutschlandsender without the necessity of calling in the aid of the tone control, and on the medium waveband,

FOR the twelfth of their Scrapbook programmes, Charles Brewer and Leslie Baily have chosen the year 1922. From the point of view of listeners the main feature of that year

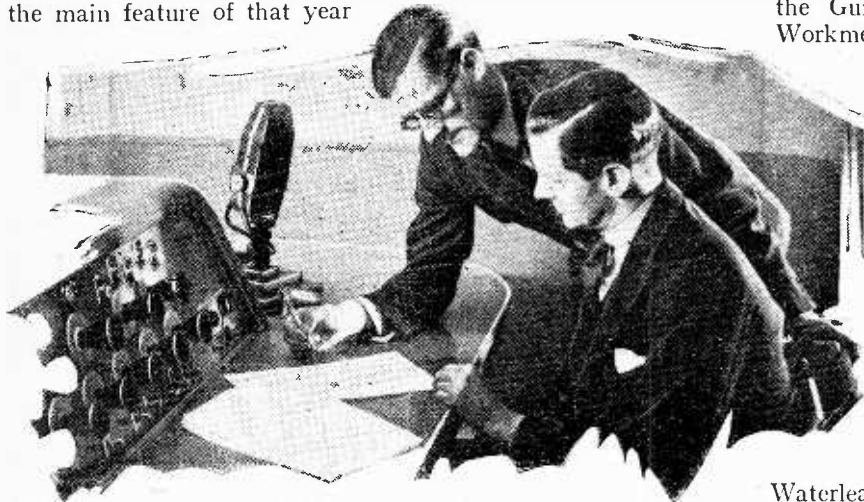

was probably that it marked the beginning of the organised activities of the B.B.C. The first regular broadcast of the British Broadcasting Company took place from 2LO on November 14th, and Mr. J. C. W. Reith was appointed General Manager on Boxing Day. Personalities connected with the early days of broadcasting will come to the microphone in this programme, and address their listeners on the changes that have taken place during the past fourteen years.

Outside the broadcasting sphere the year 1922 was a great one for light musical entertainment, and "Decameron Nights" at Drury Lane, Phyllis Dare as "The Lady of the Rose" at Daly's, and the "Cabaret Girl" at the Winter Garden were some of the successes which will be recalled. Another resounding theatrical success was "Tons of Money," the first of the famous Tom Walls-Ralph Lynn farces, which enjoyed a run of 737 performances.

Politics will, of course, be touched on, and other home and foreign affairs with which "Scrapbook for 1922" will be concerned will include the rise to power in Italy of Mussolini, the formation of the Irish Free State, Princess Mary's wedding, and the death of Lord Northcliffe. The programme will be heard on Thursday at 9 (Reg.) and again Nationally the following day.

#### SYMPHONY CONCERT

THE programme of the B.B.C. Symphony Concert from the Queen's Hall on Wednesday, the first to be

# Listeners' Guide for

the Guilds or Companies of Workmen whose calling had something in common with the subject of the play—for example, this pageant of the Deluge was first acted by the

#### CONTRASTS

A VARIETY trifle which may prove, through its presentation, quite amusing to listeners, is a little programme of contrasts called "Between Ourselves," which will be broadcast Regionally on Thursday at 8.40. Edward Cooper, who has now become famous for his sophisticated songs at the piano, will provide a contrast to Jimmy Rogers, American light pianist, who will play the piano and sing the "sweet" songs so popular in the United States. Archie Campbell, producer, has also enlisted Eileen Hunter and Elisabeth Welch, contrasting both in style and material. They will also give a glimpse of the divergence of artistes' material on each side of the Atlantic.

**SCRAPBOOK COLLABORATORS.** Charles Brewer and Leslie Baily (with spectacles), going over their script at one of the Dramatic Control panels.

Waterleaders and Drawers of the Dec. Clifford Lawson-Reece, a new recruit to the Drama and Features Department, will make his début as a producer with this broadcast of his own adaptation on Sunday at 4.30 (Reg.).

#### SPORTING COMMENTARIES

THREE sporting events will be commented upon for listeners during this week. On Saturday, from 2.20-4, Captain Wakelam will be at Twickenham to describe the play during the Rugby Union football match between England and Wales. This will be the forty-ninth Rugger match between these two countries.

Part of the snooker match between Joe Davis and Horace Lindrum at the Corn Exchange, Coventry, will be commented upon by Sidney Lee at 8.45 on Monday (Reg.).

Lionel Seccombe will be at the Empire Pool and Sports Arena, Wembley, on Tuesday for the contest between Benny Lynch and Small Montana (the holder) for the Fly-weight Championship of the World. At 9.40 he will give a round-by-round commentary for Regional listeners.

#### CORSICAN

FOR some months past Max Kester and Spike Hughes have been working on a musical play called "Bianca," which is a Corsican love tale based on a story by Anthony Hall. Max Kester will be producing this on Wednesday at 9 (Reg.), with Thea Holme, Arthur Gomez, Jan van der Gucht, Gabrielle Casartelli and Foster Carlin among the players.

#### MUSIC

THE Sunday evening orchestral concerts will be resumed this week at 9.5, when Kathleen Long will play Mendelssohn's Pianoforte Concerto in G Minor. The London Symphony Orchestra, under Clarence Raybould, will give Haydn's Symphony No. 22 ("The Philosopher") and Rimsky-Korsakov's "Scherzade."

Three new orchestral works by British composers will be



FELIX GREENE, the B.B.C. representative in New York, will be responsible for making all the arrangements for the relay by the National transmitter on Wednesday from 4.50 to 5.45 of the inauguration of President Roosevelt. Commentaries and sound pictures in the true American style will be heard from the processional route.

Details of the week's Television programmes will be found on p. 58.

# he Week Outstanding Broadcasts at Home and Abroad

broadcast for the first time in a programme on Saturday at 6.45 (Nat.) under the direction of Joseph Lewis. One of these is a "Saxo-rhapsody" by Eric Coates, which will be played by Sigurd Rascher and conducted by the composer. The other two works are William Lovelock's "Second Suite for Orchestra," and Benjamin Britten's "Soirées Musicales," a suite of movements on themes by Rossini. Benjamin Britten is a young East Anglian composer, and William Lovelock, a Doctor of Music on the staff of the Trinity College of Music, London.

## Musical Dramas

"Thais and Talmae," a music drama in one act by Colin McLeod Campbell, will be broadcast to-night at 7.20 (Nat.). The composer will conduct and the soloists will be Joan Cross and Edward Reach. It was first produced by the

Carl Rosa Opera Company at Manchester in 1921.

Another music drama, this time from the pen of the modernist French composer, Darius Milhaud, will be heard on Saturday evening. This will be the first performance in England of "Christopher Columbus," a musical drama in two parts and twenty-seven scenes. The story deals with the discovery of America by Columbus, but is treated throughout in a symbolic and semi-mystical vein, and great play is made of the symbolism contained in the name of Christopher Columbus—the "Christ bearer," and in French, the "Dove" or bringer of light. Just as Noah dispatched a dove from the Ark to find land, so was Columbus sent out from the Old World to discover the New. This performance will be given before an audience in a studio at Maida Vale and will be heard Regionally from 7.30 to 10.5 with a short interval at 8.50.

## HIGHLIGHTS OF THE WEEK

### FRIDAY, JANUARY 15th.

Nat., 7.20, "Thais and Talmae." 8, Music from the Movies—Louis Levy and his Symphony. 9.20, European Exchange—II, Italy. 9.40, "Invitation to the Waltz." Reg., 6.40, Car Upkeep—Inclusive Costs. 8, The Trial of Mrs. M'Lachlan. 9.30, The Rocky Mountaineers.

#### Abroad.

Milan, 8, Symphony Concert.

### SATURDAY, JANUARY 16th.

Nat., 4.20, Recital—Spencer Thomas (tenor) and Harriet Cohen. 6.45, Sigurd Rascher and the B.B.C. Orchestra (C). 8, Music Hall. Reg., 4, The White Coons. 7.30 and 9, "Christopher Columbus"—Milhaud.

#### Abroad.

Sottens, 7.30, Folk Songs of Italy. Spain, France and America.

### SUNDAY, JANUARY 17th.

Nat., 5, The Church of To-morrow—1, Kenneth Ingram. 7.20 "Edwin and Angelina." 7.55, Scottish Service from Glasgow Cathedral.

Reg., 4.30, "Noye's Fludde." 7.15, Fred Hartley and his Novelty Quintet. 9.5, The London Symphony Orchestra and Kathleen Long (piano).

#### Abroad.

Munich, 6.20, "Carmen" (Electrical recording).

### MONDAY, JANUARY 18th.

Nat., 7.20, "The Music Shop"—8. "It's Happening Now"—3. 9.35, Rhythm Music—Reginald Foort at the Theatre Organ.

Monday, January 18th (contd.).

Reg., 6.40, Organ Recital by Guy Weitz. 7.30, Eden Phillpotts' "The Runaways." 8.45, Snooker Commentary.

#### Abroad.

Radio-Paris, 8.45, Ex-Service Authors' and Composers' Concert.

### TUESDAY, JANUARY 19th.

Nat., 7.30, Discussion—A Nation of Shoppers. "Variety from Morecambe Winter Gardens. 9.40, "The Runaways."

Reg., 6.40, From the London Theatre. 7.45 and 8.55, The Liverpool Philharmonic Society's Concert. 9.40, Boxing Commentary.

#### Abroad.

Berlin, 7.10, Relay from the Philharmonic Hall, Berlin.

### WEDNESDAY, JANUARY 20th.

Nat., 7.30, Van Phillips and his Two Orchestras. 8.15, and 9.25, Symphony Concert from the Queen's Hall. "The Little Show"—Radio cabaret.

Reg., 8, "Bianca" by Max Kester. 9.40, Scottish Dance Music.

#### Abroad.

Strasbourg and Rennes, 8.30, Symphony Concert.

### THURSDAY, JANUARY 21st.

Nat., 6.40, B.B.C. Orchestra (E) and Tapia Caballero (piano-forte). 7.40, The Air-do-Wells. Reg., 6, Band of His Majesty's Coldstream Guards. 8.40, "Between Ourselves"—An Intimate Entertainment. 9, Scrapbook for 1922.

#### Abroad.

Hilversum, No. 1, 7.45, Symphony Concert from the Concertgebouw.

## SHOPS

THIS week's contribution on Tuesday at 7.30 (Nat.) to the series of programmes "A Nation of Shoppers" is a discussion on the relative merits of large- and small-scale retailing. The "big business" side will be sponsored by Sir George



**VALUABLE DIGITS.** Mantovani, who with his Tipica Orchestra will be heard again on Sunday afternoon, has, it is reported, insured his hands for ten thousand pounds.

Schuster and that of the "small shop-keeper" by W. Herman Kent and Captain Harold Balfour, M.P. The chair will be taken by Ronald Gartland, M.P.

## WELSH SONGS

THE Swedish choir Sangerkretsen have given themselves a very difficult task by learning a number of ancient Welsh songs for a special half-hour programme which will be broadcast over all Swedish stations on Thursday at 8.15. This programme comprises some of the best known Welsh songs from the seventeenth century and earlier.

## ICELANDIC

A Music programme of unusual interest will be heard from all Danish, Swedish, Norwegian, Finnish and Icelandic stations on Monday at 7. Icelandic and old Norse songs from the past 1,000 years, sung by the Reykjavik Y.M.C.A. choir and played by the Trocadero ensemble, will be relayed from Reykjavik, the capital of Iceland. The songs will be sung in the Norse tongue, which was spoken by the ferocious

Vikings. The concert will also be relayed by American stations.

## OPERA

SATURDAY's performance of Gluck's "Alceste," broadcast from Rome at 8, should be a rare treat. This classic was first produced in Vienna in 1767. Later, when produced in Paris, it was bitterly criticised by the Italian school, which accused the master of composing for the understanding and

not for the ear. The story follows Euripides' familiar play. For the less fastidious lover of opera, Radio-Toulouse at 10.15 on the same day offers one of its excellent "potted" versions. This time it is twenty-five minutes of Massenet's opera, "Werther," founded on that

romance of Goethe which is said to have caused an epidemic of suicides.

On Sunday Strecker's Singpiel, "Aennchen von Tharau," comes from Berlin (Deutschlandsender) at 7. This should please lovers of the modern in music.

That perennial Christmas-time favourite, "Hansel and Gretel," comes from Radio-Paris at 8.45 on Wednesday. First produced at Weimar two days before Christmas in 1893, it found its way the very next year to London. In England, of all operas it holds the record for the number of performances.

## DEDICATED TO THE FÜHRER

THE first part of a symphony dedicated to the German Chancellor, Adolf Hitler, will be heard during the relay by Berlin at 7.10 from the Philharmonic Hall in Berlin. The composer, Josef Reiter, will be 75 on the day of the broadcast. He was born in the same town as Hitler and has written numerous works, including ten oratorios and five operas. His Symphony has four movements and takes two hours to perform. THE AUDITOR.

# Improving the Simplified Volume Expander

By W. N. WEEDEN

## AVOIDING WASTAGE OF OUTPUT POWER

**A**LTHOUGH the lamp-bulb volume expander is ideal from several points of view, it unfortunately possesses several drawbacks, of which perhaps the most important is loss of efficiency through wastage of at least 50 per cent. of the output power. The next most serious shortcoming is the lack of flexibility through inability to control the degree of expansion, in addition to the fact that the expansion depends largely on the output level; if one listens at a level several db. below that for which the lamp bulbs were calculated but little expansion will result.

Coupled with the first objection is the fact that many amplifiers which can easily deliver sufficient undistorted power without the expander do not show up so well when called on to supply several additional watts to light two insignificant lamp bulbs. In America we use many amplifiers in which the power tubes are operated as Class AB<sub>1</sub> or even AB<sub>2</sub>. These amplifiers can usually supply 5 to 10 watts with but little distortion, as they are generally operating in straight Class A with such outputs, but when asked to double this output their harmonic distortion increases rapidly.

Although this form of expander possesses these shortcomings, it has several advantages, such as ease of maintaining valves in a balanced or matched condition and ready adaptability to any amplifier of fair power-handling capacity.

Recognising both the advantages and disadvantages, Mr. L. A. De Rosa, engineer of Electrad, Inc., leading manufacturer of volume controls in the U.S., set to work on the problem of eliminating its weak points while retaining its advantages.

The first change or improvement was

to move the expander ahead of the power stage, as it was determined that no appreciable amount of power should be lost. This change entailed the addition of two transformers, as shown in Fig. 1. The first is designed to couple the plate or plates of the intermediate AF amplifier to an impedance of a few ohms. The second transformer is used to match the output of the Wheatstone bridge formed by the two resistors and two bulbs to the grid or grids of the output stage or its driver.

This change adds greatly to flexibility, particularly if the volume control is inserted after the expander. In this case the degree of expansion is completely divorced from the output level at which one wishes to listen. It also permits of the substitution of variable resistors for the fixed units forming two arms of the bridge, which allows one to obtain almost any degree of expansion by the simple means of setting the degree of initial or no-signal unbalance. If the bridge is perfectly balanced under these conditions, any signal will cause an infinite ratio of increase. This method of control was not applicable to the expander as it was origin-

ally shown, when a bridge is operated near its balance point, only a small change in resistance of the opposite arms is required to cause a large increase in unbalance current. As the change in resistance of a lamp filament is limited by its temperature coefficient, it is obvious that, in order to secure a large increase in unbalance current by a minimum increase in input voltage, the bridge must be operated close to balance.

Still another advantage accruing from this low-level, near-balance operation is the increase in the time constant or lag

*I*N our issue of April 24th, 1936, the writer of this article explained a simple compensating circuit for restoring the original volume contrasts in reproduced music. He now describes a new way of using the same principle in such a manner that certain shortcomings of the original method are overcome,

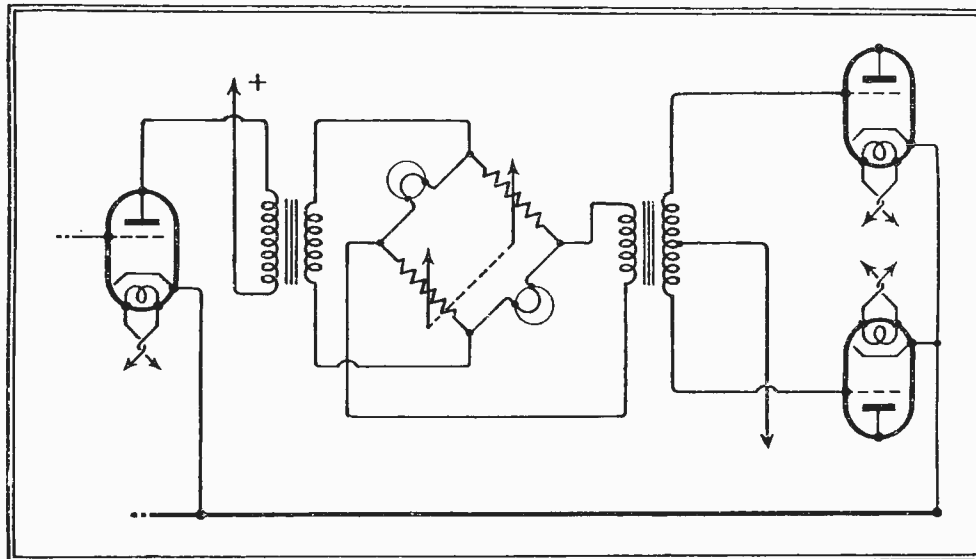

Fig. 1.—Illustrating the interposition of the volume expander in the AF amplifying circuit.

ally shown, because the power loss is a function of the unbalance, and with perfect balance far too much power would be lost for practical purposes. This may perhaps be explained more clearly by stating that a bridge operated with a large degree of unbalance must experience a large change in the two opposite resistance arms before an appreciable change in the unbalance current takes place. On the other

hand, which results from the fact that the thermal inertia of a filament is greater at lower temperatures than near incandescence. Not only is smoother and more pleasing operation secured from this increased delay, but there is also quite a decrease in third harmonic distortion. This distortion results from the rapid action of the expander, which may operate on the peaks of individual low-

frequency cycles, causing a serious change of wave-form. The delay caused by the increased thermal inertia causes the expansion to operate on the envelope instead of the individual wave.

Due to the great amount of expansion of which this circuit is capable, care must be exercised to use only a sufficient degree of expansion to restore the reproduction to something near its pristine or uncom-

**Improving the Simplified Volume Expander—** pressed state. More than this will cause music to become very unnatural and unpleasant. In operating, it will be found that a good balance (for a barely audible signal) will give tremendous expansion, while less expansion will result as the resistances opposite the lamps are made less than that of the cold lamp filament. If, on the other hand, the resistance arms are made greater than the filament resistance, output will decrease with increase in input, resulting in compression.

In closing, a few suggestions regarding the values of the parts may be in order. The amplifier feeding the expander should have an output of at least one watt, and may well be the driver stage of a QPP output stage, or of a Class AB or Class B output stage. In most cases one or two indirectly heated triodes, such as are nor-

pander. Of course, if a single valve is employed, it will be necessary to employ only a conventional single control of the type used in resistance-coupled amplifiers or for following a diode detector. Good transformers should be employed if the frequency response of the remainder of the equipment is good and if high-fidelity reproduction is desired.

In many cases where receivers or gramophone amplifiers are equipped with a driver stage, or with a stage from which one watt can be extracted, it will be possible to build the expander into the amplifier. Also, if the amplifier is not up to date from the viewpoint of power-handling capacity, the expander with a more modern output stage may be added to the amplifier externally.

Where transformer coupling of an inferior nature is employed in an older am-

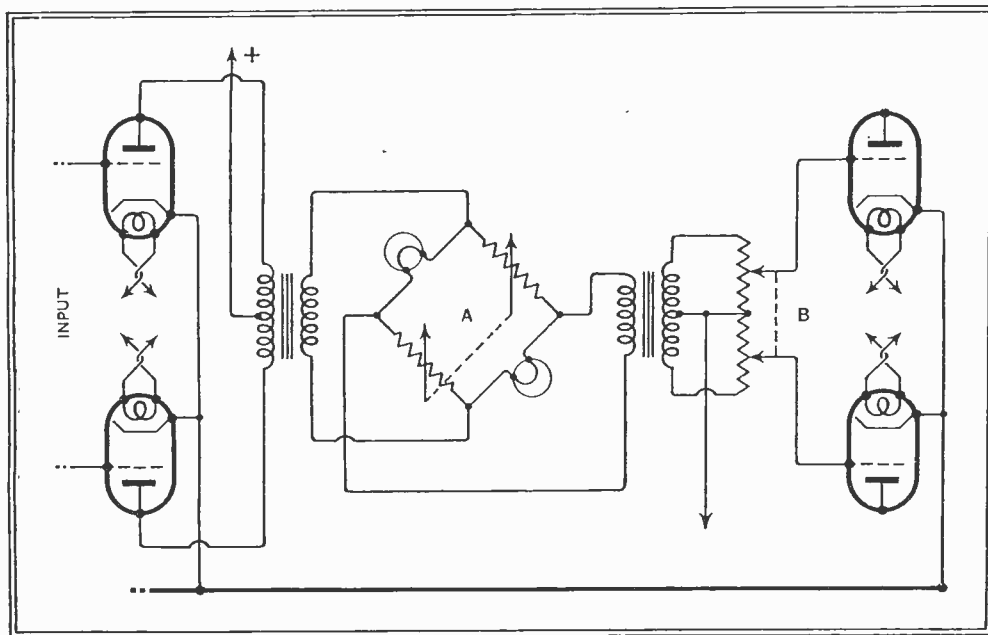

Fig. 2.—The improved volume expander in practical form. A, expansion control, comprising two 5-ohm ganged rheostats; B, volume control, comprising two potentiometers, 0.25 to 0.5 megohm, also ganged together.

mally used to feed an output stage, will suffice, provided that they are worked at maximum plate and grid voltages. They are coupled to the expander by means of an output transformer designed to couple such tubes to a very low-impedance speech coil—1 to 4 ohms. The lamps employed in this expander were of the automobile type—6-8 volts, 3 candle-power—while the two resistance arms are composed of a dual 5-ohm rheostat recently announced by Electrad under the type number 6608 (tandem control). If unable to secure such a control, two 5-10-ohm rheostats may be employed, although the balancing of the bridge and control of expansion will be much less convenient. The bridge output is coupled to the following tube through a transformer designed to couple a ribbon microphone to one or two grids. Both transformers should be capable of operating at about 20 db. levels without saturation. If possible, the main volume control should follow the expander, and might well consist of a dual potentiometer across the grids of the stage following the ex-

plifier, it might be desirable to replace the transformers by resistance couplings, substituting for the first- or second-stage valve one which can deliver the requisite power for operating the expander properly.

### The Radio Industry

**D**UE to the increased cost of raw material, it has been found necessary to increase the price of Belling-Lee "Eliminoise" screen cable (Type No. 1221) from 8d. to 10d. per yard. It is pointed out that this increase is in direct proportion to the rise in price of the raw material and that the cable, having copper braid screening, uses more metal than normal conductors.

An Everett, Edgcombe Visual Valve Tester has been supplied to the National Physical Laboratory for use at the Radio Research Station at Slough.

An unusual application of sound-amplifying technique has recently been put into effect by the G.E.C., which has installed an elaborate loud-speaker announcing system at the Heston and Isleworth Fire Station. All members of the brigade can be summoned immediately in cases of urgency.

## MCCARTHY

for the finest value in  
All-Wave Receivers!

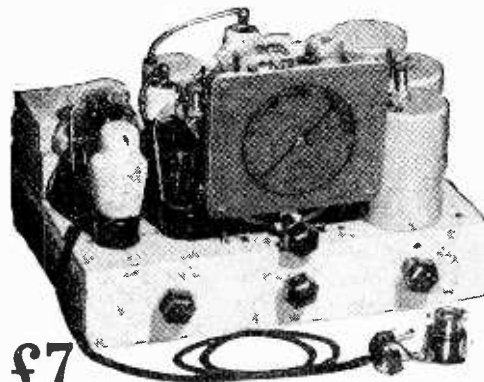

£7

### 6 VALVE ALL-WAVE SUPERHETERODYNE

(complete with B.V.A. Valves)

Improved edition of this popular receiver (praised "Wireless World" test reports). Heavier gauge cadmium-plated steel chassis. Iron-cored I.F. transformers give even better performance. No increase in price.

Brief Specification: 8-stage; all-wave band-pass superheterodyne, 7 tuned circuits, D.A.V.C. with "squelch" circuit valve for noise suppression. Illuminated "Airplane" dial. Octode frequency changer. 3.5 watts pentode. Switching for gramophone pick-up. Wave ranges: 16.5-50, 200-550, 800-2,000 metres.

### MCCARTHY ALL-WAVE SIX

with 6 watt  
push-pull  
output

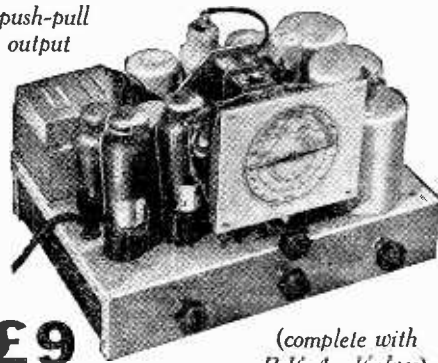

£9

(complete with  
B.V.A. Valves)

6 valve all-wave superheterodyne with similar specification, performance, etc., to above, but with large push-pull output giving 5½-6 watts.

Has illuminated "Airplane" dial with principal station names, tone control and volume control (both also operative on gramophone), full provision for gramophone reproduction.

A really high quality receiver, with exceptionally large undistorted output, and fine performance on all 3 wave ranges.

All McCarthy receivers supplied complete with valves, knobs, pilot lamps, leads, mains cable and plug. 12 months' guarantee.

Deferred terms on application, or through London Radio Supply Co., 11, Oat Lane, E.C.2.

Cash with order on 7 days' approval. Also write for illustrated catalogue of complete range of all McCarthy receivers.

**MCCARTHY RADIO LTD.**  
44a, Westbourne Grove, London, W.2

Telephone: Bayswater 3201/2.

# Random Radiations

By

"DIALLIST"

## Hollywood Bound

SO Cecil Lewis is to leave the Alexandra Palace and the production of television programmes, for some little time, at any rate. It's a pity, for with his wealth of ideas and happy knack of putting them into concrete form he would have been more and more invaluable as the scope of television expanded. Still, he couldn't very well refuse the offer to make a film scenario of his book "Sagittarius Rising," and the B.B.C., realising the importance of the opportunity, released him from his contract with them. He will be away for six months, anyhow, and possibly for two years beyond that. With Sir John Reith, Arthur Burrows, P. P. Eckersley, and Stanton Jeffreys, Cecil Lewis can claim to be a "founder-member" of the B.B.C. And now of that quartet only Sir John Reith remains with the Corporation.

## Small Beginnings

It seems almost incredible when one comes to look back that the B.B.C. can have grown so rapidly from its small beginnings just over fourteen years ago. At that time the entire staff, from programme builders to engineers, just nicely filled one very large room. The broadcasts—all given from a single studio in Marconi House—were quite informal affairs. Arthur Burrows combined the functions of programme director, announcer, producer and leader of the children's hour. He also did the work that was afterwards to be undertaken by the control room, which didn't then exist. Whilst an item was in progress he stood near the door wearing a pair of headphones connected to a small receiving set. If any performer was "blasting" a warning sign lit up to make him move farther from the microphone. Conversely, those who were coming over too faintly were moved nearer. Those waiting their turn to broadcast sat round the studio—and just occasionally someone failed to notice that the microphone had been switched on!

## Bigger Screens

ONE desirable improvement in television reception is an increase in the size of the viewing screen. I don't mean that we want real big-screen television in our homes; that, when it comes, will be for theatres and cine houses. But we do need some-

thing about the size of the screens used for home cine projection. The use of anything much smaller means that in scenes where a considerable number of people is shown the figures are too tiny for details to be brought out properly. I've no doubt that the bigger screen will be with us before so very long. Intensive work is being done, and some ideas seem very promising. But work of this kind can be very tantalising; so often when the goal seems in sight some unsuspected snag crops up that may mean starting all over again almost from the beginning.

## "Loud Speaker"

Future generations will probably be puzzled over the ways in which we came to coin the amazing collection of inappropriate wireless terms that we have handed down to them. Could anything, for instance, be much less descriptive than "pick-up" or "accumulator"? And the term "loud speaker" is no mean example of the ineptitude of our radio words. To say that a loud speaker reproduces music to perfection is almost as absurd as to claim that a violin has an Oxford accent! "Loud speaker" is actually a pre-wireless term. It's a shortened form of "loudspeaking telephone." Such contrivances were used in the Navy and for commercial purposes long before wireless reproductions had progressed beyond the headphone stage. And the earliest wireless loud speakers (you remember the old Brown Type H?) were literally loud-speaking telephones, since they consisted of nothing more than a large and sensitive telephone receiver provided with a horn.

## Sideband Splash

SOME time ago I predicted in the columns of *The Wireless World* that sideband splash, or sideband splutter, as some prefer to call it, would become one of the biggest interference problems as more and more high-powered broadcasting stations came into action within the limits of the medium-

Esagne or Fritto Misto No. 1. And there's nothing that you can do to make things any better. You've got to grin (with teeth-gnashing) and bear it, or tune in to something else—probably to find sooner or later that it also suffers in the same way. If stations on the medium-wave band are to continue to attract listeners at a distance, the authorities at their next conference will have to consider seriously ways and means of overcoming sideband splash. Possibly single-sideband transmission may provide the final solution.

## Could You Have Found This One ?

A GOOD many years ago, when loud speakers were rare and reception was mostly done by means of headphones, some of us were rather annoyed by the bragging of a youngster, who told us all what mutts we were at fault-finding (faults were pretty frequent in the receiving sets of those days), and undertook to run to earth any defect in a quarter of an hour at the outside. It was quite simple, he said, for anyone who had a voltmeter and a milliammeter and would use such brains as Heaven had given him. Would we care to put him to the test? I offered to put his set out of action in such a way that he wouldn't find the fault in twice the time he'd suggested, guaranteeing not to inflict permanent injury on any component. All I asked was that he should be out of the room for two minutes. He went. He came back. He produced the voltmeter and the milliammeter and presumably he used the brains of which he had told us. What he found was that the set was completely silent, though he obtained the correct readings with his instruments at every testing point. Don't read any further until you have thought it out and found your solution.

## Dirty Work !

Thought it out? Solved the problem? I wonder! Well, here's all that I had done. During the two minutes that he was out of the room I'd unscrewed the caps of the 'phone earpieces and removed their diaphragms. The victim pretty well had that set to pieces before his half-hour was up, but he didn't find the defect, and when I produced the missing diaphragms from my pocket his face was worth seeing.

A rather similar case very nearly proved my own undoing a little later on when loud speakers were in general use. Here again was a set that was completely silent. Here again correct voltage and current readings were obtained throughout the receiver. The loud speaker, when tested separately, proved to be all that it should be. What, then, had happened? Just a plain short-circuit across the jack into which the loud speaker was plugged. The plate current of the last valve was passing right enough, but it wasn't passing through the loud speaker. You may imagine that it took quite a while to spot that one!!

## SELF-FEEDING SOLDERING IRON

The special advantage of this new soldering "gun," recently introduced in America, is that one of the user's hands is always left free. Solder from a magazine contained within the body of the tool is fed to the heated tip of the iron by the action of pressing the trigger.

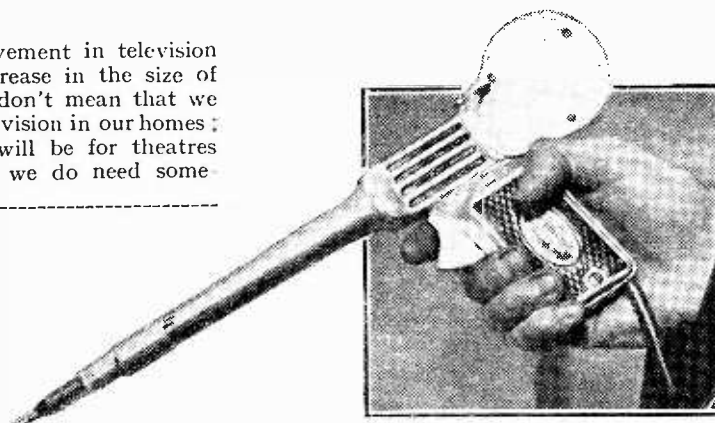

wave band. It is certainly one of the major annoyances of to-day in the reception of foreign stations. You tune in an enticing musical programme from Rad-Schmellburg and it is ruined by the "zit-zitt-zit-zit" of a speech from Château-en-



# Broadcast Brevities

## B.B.C. Station No. 2

THE Northern Ireland transmitter at Lisnagarvey is really the dark horse of the B.B.C. Isolated from its companions by a big strip of sea, enjoying a power second only to that of Droitwich, and boasting one of the most modern antenna systems in Western Europe, Lisnagarvey is a station to be reckoned with.

## Tests at Dawn

Just now there is unwonted activity in the early dawn at Lisnagarvey. Every Thursday morning this month, from 6.30 to 8, the station is radiating a special series of tests.

If you remember it, tune in on 307.1 metres on January 21st and 28th while the breakfast egg is boiling. You may make an interesting discovery.

## Beaumaris Warms Up

MEANWHILE, a new, though humbler, B.B.C. transmitter has been warming up in the past week or two. The new Welsh relay station at Beaumaris, which is synchronised with West Regional on 373.1 metres, began relaying the late dance music on January 2nd, and the engineers

## NEWS FROM PORTLAND PLACE

countries became available; for it was seen that Germany, with 7,937,907 licensed listeners, led Great Britain (7,897,518 licences) for the first time in broadcasting history. Investigation proved, however, that the position was not so unsatisfactory after all. Germany's figures included 550,185 free licences, whereas Great Britain has only 45,767 free licences, which are issued to the blind. Further, Germany's population is some 75 per cent. larger than Great Britain's, and by that token alone her licence figures should be higher.

## Televising the Moon?

A WELL-INTENTIONED televiewer made an interesting suggestion last week which cannot, alas! be carried out. He proposed a television tour of the moon.

Up to a point the method suggested was ingenious. It was that an Emitron camera be clamped to the eyepiece of a high-power telescope mounted on the terrace at Alexandra Palace. If the telescope were trained on the moon, televiewers would,

of course, obtain splendidly magnified views of the lunar mountains and craters; in fact, each television set would itself be a telescope.

N.E. REGION. Situated 17 miles west of Newcastle and 5 miles N.E. of Hexham the new high-powered transmitter at Stagshaw, indicated by the cross, will serve a large well-populated area. The station buildings are nearing completion and the transmitting gear will be installed in the course of a few weeks.

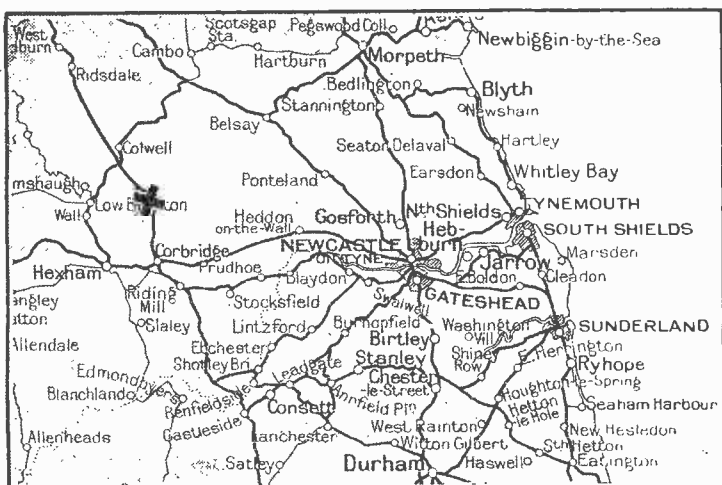

are perfectly satisfied with its performance. Although its power is only 5 kW., Beaumaris should give North Wales and Anglesey the first really reliable signal since the Liverpool relay station closed down.

## No Dance Band Auditions

ONE of the chief problems of the programme builders during the year 1937 will be to find enough regular work to make engagements for existing popular dance bands an economic possibility. In order to make the work go round, therefore, no dance band hunt like that of 1936 will take place. The results of the last one were, in general, very disappointing, although the experiment did introduce a few newcomers to the programmes. The B.B.C. has come to the conclusion that it was not altogether desirable to spend time and money in granting auditions to scores of dance bands just to find eleven fresh combinations, which was last year's experience.

## The Race in Licences

BROADCASTING HOUSE officials bowed their heads in shame when the latest licence figures for Great Britain and other

Unfortunately, the light reflected from the moon is not nearly strong enough to influence the sensitive Emitron. So that's that.

It should, however, be possible to get good television pictures of the sun by some such method as this; and if the sun happens to come out at all next summer, sunspots may enjoy a little less privacy than they normally do.

But the engineers, if they value their Emitrons, will first get in a good supply of smoked glass.

## Announcer's Car Crash

TELEVISION programmes came within an ace of losing their male announcer, Leslie Mitchell, when he was involved in a collision late one night recently near Lancaster Gate, Hyde Park. The small car which he was driving spun round after the impact with another car, and, after performing several complete circles, finally came to rest across the pavement. Both cars were considerably damaged, and Leslie Mitchell emerged with some bad bruises, which, he announces with a certain ferocity, will not be visible by television.

# POINTS OF IMPORTANCE

*in the Rola*  
**G.12**

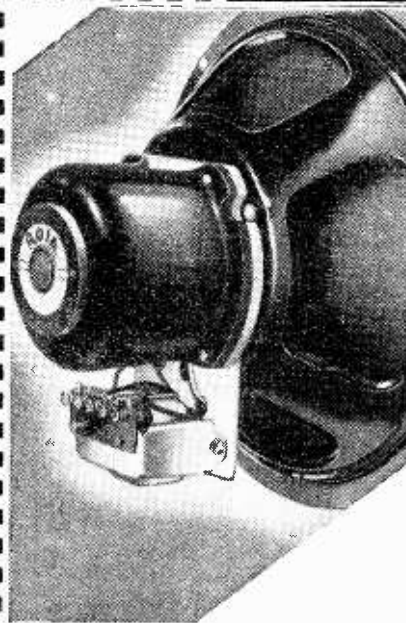

## THE BLUE RIBAND

As the possession of the Blue Riband marks the ship that is faster than all the vessels of her day, so the possession of a Rola G.12 marks the set that is ahead of contemporary models in design, construction and quality reproduction. Not only does a G.12 give you the finest reproduction that it is possible to obtain, but the mere fact of its being fitted in a receiver proves that the manufacturer has put quality first in selecting his components. That the public appreciate this is shown by the greatly increased sales of G.12 equipped models reported by radio set manufacturers all over the world. Get full particulars to-day.

- G.12 D.C. (as illustrated) Stripped, but with Transformer ... £4 4 0
  - G.12 D.C. Complete with Transformer, Mounting Stand, Handle and Base ... £5 5 0
  - G.12 D.C. with Mounting Stand, Handle and Base, but without Transformer ... £4 16 0
  - G.12 D.C. Stripped and without Transformer ... £3 15 0
- (When ordering please state Field Resistance and Impedance of Transformer required.)
- G.12 P.M. less Transformer ... £4 16 0
  - G.12 P.M. with Transformer ... £5 5 0

For Public Address work both the P.M. and Energised Models can be supplied with a 15 ohm Voice Coil at an additional charge of 3/-.

Write for Folder A.

OVER 7 MILLION IN USE

# ROLA

The World's Finest Reproducers

THE BRITISH ROLA CO., LTD.  
MINERVA ROAD, PARK ROYAL, N.W.10.  
PHONE: WILLESDEN 4322-3-4-5-6.

# Recent Inventions

The British abstracts published here are prepared with the permission of the Controller of H.M. Stationery Office, from Specifications obtainable at the Patent Office, 25, Southampton Buildings, London, W.C.2, price 1/- each. A selection of patents issued in U.S.A. is also included.

**Brief Descriptions of the more interesting radio devices and improvements issued as patents will be included in this section**

### TELEVISION "CAMERAS"

IN a television "camera," it is more convenient to focus the picture to be transmitted on to the surface of the sensitised electrode which faces away from the "gun" part of the cathode-ray tube rather than on to the surface which faces towards it, though the latter is the usual arrangement.

With the usual construction of mosaic-cell electrode, however, the former method reduces the efficiency of scanning, since the electron stream from the gun must first penetrate the aluminium backing-plate of the electrode before it can reach the layer of sensitive cells and discharge them.

According to the invention this difficulty is overcome by using a construction of electrode in which the usual minute globules of sensitised material are replaced by a large number of small metal "plugs" which extend through from one side to the other of the electrode, and are sensitised only at the ends which receive the image of the picture. This allows the electric charges built up by the action of the light rays from the picture to be scanned and discharged more effectively by the electron stream projected from the cathode or "gun" end of the tube. Also, since the parts of the electrode not occupied by the plugs are impervious to the passage of electrons, the new electrode serves to minimise the effects of both photo-electric and electronic "secondary" emission.

*Marconi's Wireless Telegraph Co., Ltd. (Assignees of L. E. Flory). Convention date (U.S.A.) February 28th, 1934. No. 454422.*

### RF AMPLIFIERS

IN order to ensure substantially uniform amplification over a definite band of frequencies, with a sharp cut-off outside this band, the anode and grid circuits of the valve are coupled through a variable resistance.

As shown in the figure, the variable resistance R is arranged in parallel with an inductance L across the tuned input and output

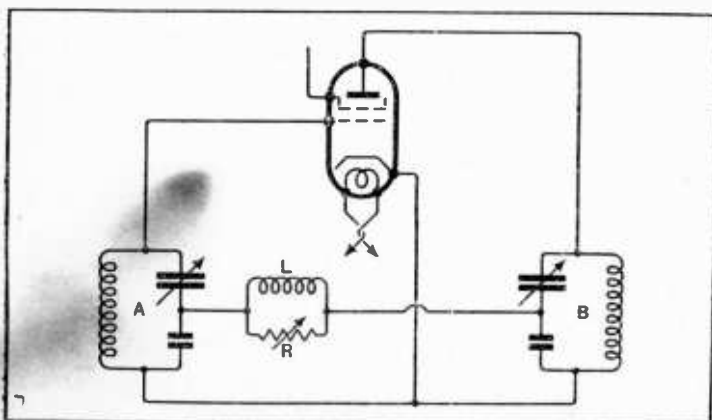

Method of obtaining uniform amplification over a band of frequencies.

circuits A, B. The point of connection is taken in each case from the midpoint of a variable tuning-condenser and a fixed condenser in series with it. It is stated that the inherent capacity of the resistance coupling-link does not affect the symmetry of the overall resonance curve of the amplifier, nor is the width of the curve affected by the tuning of the circuits.

*N. V. Philips Gloeilampenfabrieken. Convention date (Germany), June 12th, 1934. No. 454435.*

### DIODE RECTIFIERS

TWO diodes D, D1 are connected in series, so as to form a voltage-doubler, across the input of a push-pull amplifier. The out-

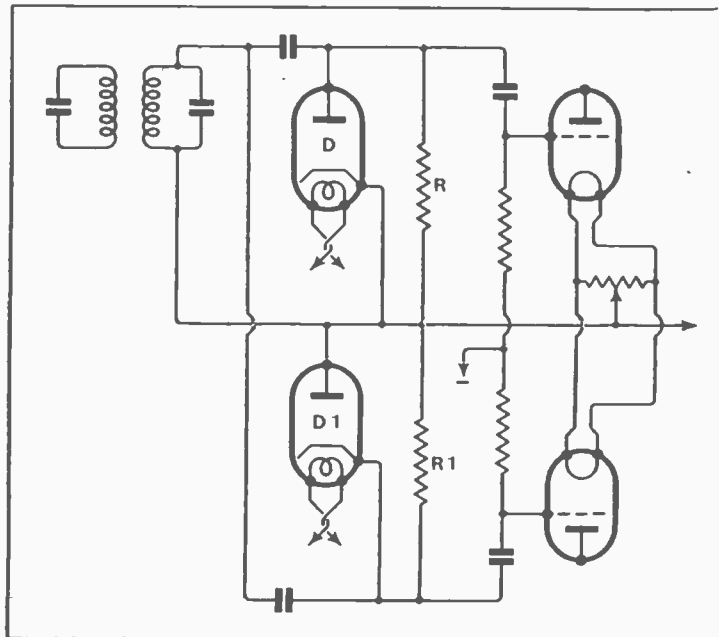

Detector circuit using two diodes followed by a push-pull amplifier.

put resistance is divided into two equal parts R, R1, connected on each side of the cathode line so as to make the arrangement symmetrical.

Since the variations of potential at the anode of D are in phase-opposition with those at the cathode of D1, the first diode always works one amplifier valve whilst the second always works the other. In this way the necessity for using an expensive push-pull input transformer is avoided. At the same time, since the diode voltage is approximately double that of the applied signal, the arrangement gives increased sensitivity.

*Magyar Wolframlampa. Convention date (Hungary), November 23rd, 1934. No. 454618.*

### FLUORESCENT SCREENS

IN order to prevent the so-called "tailing" effect or the drawing out of the spot of light into a comet-like patch, due to the gradual decay of the action of a fluorescent screen, the screen is maintained at a certain fixed tem-

perature in vertical sections requires a wave of the form shown in Fig. 2, comprising a normal saw-toothed oscillation and the

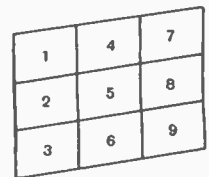

FIG 1



FIG 2

Television picture divided into sections (Fig. 1) and indicating order of scanning. Fig. 2.—Wave form of the scanning oscillations employed.

series of rectangular waves shown in dotted lines. The latter are produced by periodically "switching" the saw-toothed oscillator. One advantage of the method is that the individual scanning-lines in each zone or area are kept relatively short.

*J. L. Baird and Baird Television, Ltd. Application date April 4th, 1935. No. 454588.*

### SCANNING SYSTEM

THE picture to be televised is focused through a polariser upon an electrode surface built up of a large number of small bi-refringent light-cells. These cells are made active (in the sense that they are "opened" to the light) by the impact of the electron stream from the "gun" of a cathode-ray tube. The cell electrode is placed inside the cathode-ray tube, whilst the polariser is located outside it.

In operation the scanning stream from the gun, opens each cell in turn and so allows light to pass through from each corresponding small area of the picture in succession. The arrangement can be used either for transmission or reception.

*J. L. Baird and Baird Television, Ltd. Application date April 4th, 1935. No. 454589.*

### PERMANENT MAGNETS

AN alloy suitable for a permanent magnet is made from aluminium, iron, cobalt and nickel mixed together in such proportions as to represent a true chemical compound. That is, each element is present in proportion to its chemical valency. This is stated to increase both the molecular density of the alloy, and the intensity of its magnetic moment.

*T. Hamilton-Adams. Application date April 2nd, 1935. No. 454567.*

perature at which this undesired effect is found to be reduced to a minimum.

The temperature varies with the particular constituents used to make the screen, but it is kept at the desired level by making the end-wall of the cathode-ray tube double, and circulating a hot fluid inside the intervening space.

*J. C. Wilson and Baird Television, Ltd. Application date April 5th, 1935. No. 454601.*

### SCANNING SYSTEMS

INSTEAD of scanning the picture in a series of complete horizontal or vertical lines, the process is commenced first over the area marked 1, Fig. 1, which is one-third the overall width of the picture, and is scanned horizontally. Next the area 2 is similarly scanned, followed by the other areas in the sequence marked.

This combination of horizontal

# MISCELLANEOUS ADVERTISEMENTS

## NOTICES

THE CHARGE FOR ADVERTISEMENTS in these columns is

12 words or less, 3/- and 3d. for every additional word.

Each paragraph is charged separately and name and address must be counted.

**SERIES DISCOUNTS** are allowed to Trade Advertisers as follows on orders for consecutive insertions, provided a contract is placed in advance, and in the absence of fresh instructions the entire "copy" is repeated from the previous issue: 13 consecutive insertions 5%; 26 consecutive, 10%; 52 consecutive, 15%.

**ADVERTISEMENTS** for these columns are accepted up to **FIRST POST ON MONDAY MORNING** (previous to date of issue) at the Head Offices of "The Wireless World," Dorset House, Stamford Street, London, S.E.1, or on **SATURDAY MORNING** at the Branch Offices, 19, Hertford Street, Coventry; Guildhall Buildings, Navigation Street, Birmingham, 2; 260, Deansgate, Manchester, 3; 26a, Renfield Street, Glasgow, C.2.

Advertisements that arrive too late for a particular issue will automatically be inserted in the following issue unless accompanied by instructions to the contrary. All advertisements in this section must be strictly prepaid.

The proprietors retain the right to refuse or withdraw advertisements at their discretion.

Postal Orders and Cheques sent in payment for advertisements should be made payable to **ILIFFE & SONS Ltd.**, and crossed **& Co.** Notes being untraceable if lost in transit should not be sent as remittances.

All letters relating to advertisements should quote the number which is printed at the end of each advertisement and the date of the issue in which it appeared.

The proprietors are not responsible for clerical or printers' errors, although every care is taken to avoid mistakes.



## HANDY BILLY

Do you know him? He is not really "he" —it's the name that sailors gave years ago to one particular kind of "tackle" or pulley block assembly, because it was always being useful about the deck.

What Handy Billy is to the shellback, **HTG12S** is to the radio enthusiast. Its full name is the **Hartley-Turner G.A.12S A.F. amplifier.**

Not only is it likely to improve the quality of his radio reception, but it serves many other purposes. There are, of course, the obvious ones of:

- Record reproduction,
- Microphone work,
- Transmitter modulation;

but in measurement work it is much simpler to use a robust meter after an amplifier than a sensitive instrument on minute power.

It is, of course, essential that a general-purpose tool of this kind shall be reliable, steady, quiet and stable; and it must also have flat response.

That is why we recommend our

### G.A.12S (Model II).

It is a compact steel-chassis amplifier, 14in. wide, 7in. back to front, and about 9in. high over the valves.

It puts out 14 watts for less than 5 per cent. distortion, for an input of approximately 50 mV. to the first grid; and on music the distortion is quite unnoticeable on peaks at 20 watts.

It is completely mains-operated (A.C. 50 cycles, 200-250 v.), has a hum level 33 db. down on output, and is fitted with switch and volume control.

It is flat within  $\pm 2$  db. from 30 to 15,000 cycles, and is completely stable, earthed or unearthed.

It can provide up to 5 a. at 4 v. A.C., and up to 30 mA. D.C. at anything up to 500 v. for driving a receiver or pre-amplifier.

It has an output transformer to match loads of 3 to 20 ohms—other values can be matched specially if required (extra cost).

It costs **£15**, complete with valves—

less than the price of the "bits" if you build it yourself.

Make an appointment to come and hear it.



## HARTLEY TURNER

RADIO LTD.,

THORNBURY ROAD,

ISLEWORTH, MIDDLESEX.

Telephone: **HOUpslow 4488**

## NUMBERED ADDRESSES

For the convenience of private advertisers, letters may be addressed to numbers at "The Wireless World Office." When this is desired, the sum of 6d. to defray the cost of registration and to cover postage on replies must be added to the advertisement charge, which must include the words **Box 000, c/o "The Wireless World."** All replies should be addressed to the Box number shown in the advertisement, c/o "The Wireless World," Dorset House, Stamford Street, London, S.E.1. Readers who reply to Box No. advertisements are warned against sending remittance through the post except in registered envelopes; in all such cases the use of the Deposit System is recommended, and the envelope should be clearly marked "Deposit Department."

## DEPOSIT SYSTEM

Readers who hesitate to send money to advertisers in these columns may deal in perfect safety by availing themselves of our Deposit System. If the money be deposited with "The Wireless World," both parties are advised of its receipt.

The time allowed for decision is three days, counting from receipt of goods, after which period, if buyer decides not to retain goods, they must be returned to sender. If a sale is effected, buyer instructs us to remit amount to seller, but if not, seller instructs us to return amount to depositor. Carriage is paid by the buyer, but in the event of no sale, and subject to there being no different arrangement between buyer and seller, each pays carriage one way. The seller takes the risk of loss or damage in transit, for which we take no responsibility. For all transactions up to £10, a deposit fee of 1/- is charged; on transactions over £10 and under £50, the fee is 2/6; over £50, 5/-. All deposit matters are dealt with at Dorset House, Stamford Street, London, S.E.1, and cheques and money orders should be made payable to **Iliffe & Sons Limited.**

**SPECIAL NOTE.**—Readers who reply to advertisements and receive no answer to their enquiries are requested to regard the silence as an indication that the goods advertised have already been disposed of. Advertisers often receive so many enquiries that it is quite impossible to reply to each one by post. When sending remittances direct to an advertiser, stamp for return should also be included for use in the event of the application proving unsuccessful.

## NEW RECEIVERS AND AMPLIFIERS

**DEGALLIER'S, Ltd.**, the Firm for Reliable Short Wave Radio (1937), have on show in London the largest selection of fully guaranteed brand new all-wave receivers; callers invited to handle all at their leisure without obligation to purchase; all S.W. receivers guaranteed to get stations on the low bands, including the Americas, etc. Hours of business, 11 a.m.-7 p.m. Saturdays 9 p.m. Early closing day Mondays. All goods cash with order or c.o.d.; handsomely illustrated catalogues available; send large stamped addressed envelope with all enquiries.

**WE Guarantee** to Receive the American Transmissions at full programme strength after 3 p.m. daily; those interested welcomed without obligation.

**6/6** Each.—Valves for American receivers, all guaranteed, each a first, no seconds or throw-outs; for every known set, from 1927-37; metal, metal glass, glass counterparts and glass; in ordering, just state type and number; we have it, even up to the latest 6L6; all post paid; line cords for all Midgets, 4/6.

**30/-**—"Doublet" Aerial Belden No. 8917, complete ready to erect; the most efficient made, having a variable coupling unit covering all bands.

**£9**—"Challenger" Table Grand Model 7-valve superhet, "Mono-vision" tuning control, A.C. 200-250 volts, 3 bands 17-55, 190-550, 800-2,000 metres, 5 watts output, tone control, delayed A.V.C.; carriage 4/6; (16 1/2 x 16 x 8).

**£9**—"Challenger" Table Model 6-valve superhet, 3 bands, 16-52, 190-550, 900-2,000 metres, A.V.C. tone control, P.U. terminals (17 x 15 x 9), A.C./D.C., 200-250 volts; carriage 4/-; also available in A.C., same price.

**13** Guineas.—The new Challenger 8 (type 800) table model De Luxe, 22 x 18 x 12 high fidelity 8-valve superhet, A.C. 200-250 volts, wave-band coverage 11-2,050 metres, simplified centralised tuning, super Vernier, slow-fast tuning self-contained control panel, perfect tone quality at low volume, new type 10-inch M.C. speaker, from a whisper to 8 watts pure undistorted tone, no overloading at full volume, oscillator fundamental without use of harmonics, persistent oscillator of highest output, isolating filters eliminate oscillation and motor-boating, fully delayed A.V.C. bias, absolute minimum of noise and sensitivity control for noise suppression, A.V.C. re-enforced capacitors prevent drift, pre-aged intermediate frequency transformers, I.F. barrier, discs, anchor coil leads, plug in loud-speaker, also provision for external speaker, moisture sealed out by tropical zone impregnation, self-healing electrolytic condensers, one complete chassis of dreadnought construction, moderate voltages assure full valve life, economical to operate (consumption 65 watts), long life eliminates repairs, correct valve selection, no compromise, no hum, full weight transformers, true push-pull, stabilised high tension supply, stabilised biases, ceramic coil insulation, fully loaded plate coils give maximum gain, pre-balanced coil assembly, matched sets of individual coils, no taps, sealed insulation, thin laminations of special silico steel, 7 K.C. selectivity, fractional microvolt sensitivity, shielded switching, permits high gain, positive silver-plated contacts, eliminates switch noises, audio frequency range 30-8,000 cycles, diode detec-

(This advertisement continued in third column.)

## NEW RECEIVERS AND AMPLIFIERS

(This advertisement continued from first column.)

tion, prizmatone high fidelity R.F. preselector stages on all bands, carriage, 6/-; for experimenters, less cabinet deduct 15/-; if public address Rola 12in. G.12 included in place of standard speaker, add £2.

**£17/17**—Challenger 8 Console 800 C., height 3 feet 6 inches, width 24 inches, depth 12 1/2 inches, chassis as incorporated in 800 model but incorporating the G.12 high fidelity 12in. speaker; carriage and crate 10/-.

**29** Guineas.—"Challenger 800 R.G." radiogram with automatic record changer; measurements, height 2 feet 8 inches, width 3 feet, depth 21 inches; this also incorporates the G.12 and tweeter; carriage and crate 15/-.

**NOTE.**—The Challenger 800 is available for A.C./D.C. 200-250 volts, employing 11 valves, at an additional cost of 20/- on each model.

**£16**—Challenger 12 A.C./D.C. 200-250 volts, 4 bands 11-2,050 metres, the first time that D.C. users have been able to get 10 watts undistorted from their speaker, which is a large 12in. K type Rola, triple parallel rectification, push-pull parallel four pentode output, carriage and crate 7/6.

**£50**—Challenger "Model 5240" 24-valve superhet, twin chassis, valve and "2" Public address speaker, with 60 watts undistorted output, sensitivity 1/2 microvolt absolute, tuned H.F. stages on all bands, 3 I.F. stages, the last one being used for selectivity only, frequency response at the speakers within 2db over whole range, wave band coverage 5-2,050 metres in 5 bands, Magic-eye tuning, variable selectivity, receiver chassis heavily shielded and chromium plated, Centro-Master automatic control unit, dual rectifier, signal channel separate from A.V.C. system, linear diode detection, separate rectifier to provide A.V.C. voltage, radio frequency pre-amplifier stages eliminate repeat points and whistles, and provide maximum signal to noise ratio, beam power output valves, polychromatic dial scale, prizmatone high fidelity, uni-control 2-speed free-wheeling tuning, band spread Magna dial and second-hand, automatic band indicator, automatic interstation noise suppression, separate bass boosting amplifier, automatic frequency control, iron core I.F. transformers, code interference filters, automatic volume control, beat frequency oscillator; carriage 18/-; also available in various gramophone and console cabinets.

**DEGALLIER'S, Ltd.**, 18, Connaught St., Marble Arch, London, W.2 Paddington 2745. [3536]

## ALERT RADIO Co.

**ALL-WAVE** Receivers at £7/7, £9/9, and £13/13, A.C. or A.O./D.C.; Midget and other receivers up to 23 valves; for DX work we can supply the latest communication models.—21, East Rd., N.1. Clerkenwell 4871 [3220]

"SERVICE With a Smile."

**HENRY FORD RADIO, Ltd.**

**ELECTRONIC** House, 22, Howland St., Tottenham Court Rd., W.1. Museum 5675. [0511]

NEW RECEIVERS AND AMPLIFIERS

**AIR KING**  
THE Royalty of Radio.

**MODEL Empire** 11-valve 4-band Superonic Heterodyne Receiver for A.C. 100 to 250 Volts, incorporating every refinement known to modern radio technique, large illuminated dial, indicating each wave band separately marked in station names, wavelengths, and frequencies, with the famous exclusive beam tuning system, Magic Eye indicator for increased sensitivity and silent precision tuning, illuminated indicators to show high fidelity and gramo. pick-up, high fidelity assured by two balanced speakers, one acting as special amplifier for high audio frequencies and one large concert type dynamic speaker for full range audio frequency range from 40 to 3,000 cycles, special band expansion intermediate frequency transformer on first stage, variable selectivity, full range variable tone control, A.V.C.

**MODEL Duchess** 6-valve 3-band Superhet. Receiver for A.C. 100 to 250 Volts; this receiver is housed in an attractive lay down walnut cabinet.

**MODEL Envoy** for A.C./D.C. Mains, 100 to 250 volts, no line cord used.

**MODEL Marquis** 6-valve 3-band Superhet. Receiver for A.C. 100 to 250 Volts, in tastefully designed moulded one-piece bakelite cabinet, obtainable in Ivory, red, walnut and ebony.

**MODEL Ermine** 6-valve 3-band Superhet. Receiver for A.C./D.C. 100 to 250 Volts, no line cord used, a splendid set of proven popularity.

**ALL Models Feature** Beam Tuning, Magic Eye indicator, gramo. pick-up connections, and special output valves.

**ALL Sets Fully Guaranteed.**

**H.P. Terms Available** from 3/- per Week.

**OUR Technical Department** is at Your Service.

**RECTURUS Valves** for Improved Radio Reception on All Types of Receivers.

**RECTURUS**, the only line made in 4 ranges, glass, metal, G type, and metal modernisers.

**WRITE** for Lists of these Famous Valves; prices from 4/9 each.

**WHOLESALE** and Trade Enquiries Invited; generous terms.

**AIR KING RADIO**, 115, Shaftesbury Av., Cambridge Circus, W.C.2 (1st floor above Barclay's Bank). Phone: Temple Bar 4875 (all lines). All receivers assembled in England. [3406]

**PILOT**, Ferguson, Pegasus and Air King all-wavers lead the field; our deliveries are prompt in original cartons with full guarantees; your trade card will bring our wholesale catalogue from the authorised distributors.—Leonard Heys, 36, Henry St., Blackpool. [0530]

**YOU** Want Something Completely Different. If you have a nicely furnished home and the stereotyped models you see on every street corner do not appeal to you, you will delight in our superb range of exclusive quality models. We have radiograms with and without auto record changers, A.C. and A.C./D.C., which are a complete breakaway from the usual stuff in the local shops. If you prefer good furniture to boxes, if you want outstanding shortwave performance, and above all if you appreciate true quality of reproduction when you hear it, we have what you are looking for. Come and see. Come and listen. You will be agreeably surprised, not only to find that such splendid models exist, but that they can be sold at such very reasonable prices.

**WIRELESS SUPPLIES UNLIMITED**, 278-280-282, High St., Stratford, E.15. Maryland 3191. [3550]

**ROYAL RADIO Co.**

**ESTABLISHED 1908.**

**ALL-WAVE** Receivers, suitable for use on ships, as supplied to officers of many shipping lines.

**OUR** 8 and 10 Metal Valve All-wave Receivers; 15-2,000 metres, acknowledged by the trade as the best for range, tone, and generous performance.

**LATEST** 6-valve Car Radio, A.V.C., remote control, no suppressors required.

**A FULL** Range of the World Famous Fergusson and Pilot Models Stocked.

**ALL Sets Fully Guaranteed** by Ourselves.

**ALL Types of American Valves Stocked.**

**ANY** Make of Set Serviced by Our Qualified Radio Engineers at Reasonable Charges.

**PAY** Us a Visit Any Time, or send for full range catalogue; 1/4d. stamp will be appreciated.

**ROYAL RADIO Co.**, 5, Buckingham Rd., South Woodford, London, E.18. Phone: Buckhurst 2736. [3499]

**ENQUIRE** About Harmaur Radio 1937 Receivers.

**AMERICAN-BOSCH** "Centromatic" All-wave Sets.

**FREED-EISEMANN** Receivers as Bought by the B.B.C. and "The Wireless World."

**PIERCE AIRO AC/DC** All-wave and Car Radios.

**RAYTHEON** Valves. Trade enquiries.

**THE HARMAUR RADIO Co. Ltd.**, 8, Clifford St., New Bond St., London, W.1. [0499]

**£3/3**—4-valve Universal midgets, M.C. speaker, coloured fabric cabinets; 5-valve midgets from £3/15.

**£8/8**—6-valve Universal all-wave superhet., R.C.A. valves, new 25B5, in output stage, giving over 2 watts, in Class "A."

**£10/10**—6-valve all-wave superhet., 10in. Rola speaker, pre-H.F. stage, 100-250 volts A.C.

**£9/9**—6-valve car radio, A.V.C., remote control. R.C.A. valves.—E. Fellows, Ferney Rd., East Barnet, Herts. [3595]

FACTS *and* FIGURES

The "DUODE 33" includes unique patented features in its design.

The moving-coil system and method of driving are fundamentally different from any used previously.

The extended frequency range and absence of resonances are unobtainable from any moving-coil unit as is now generally used.

A large output stage is not necessary, as it takes less power to drive than the average speaker.

The inductance of the field coil is high, making it an efficient smoothing choke, and a hum neutralising coil is fitted.

The field power may be varied from 6 to 30 watts.

Twelve watts for the field coil is enough to provide maximum sensitivity.

An output valve rated at 2 watts undistorted output is adequate for normal domestic use, although the speaker will readily handle up to 7 watts.

The primary of the transformer will carry up to 65 milliamps for a single valve.

For push-pull two valves each drawing 65 milliamps can be used without saturation, as the current to each flows in opposite directions.

The voice-coil impedance is 15 ohms and the transformer is specially designed to match the characteristics of the speaker.

Send for illustrated technical booklet with copy of N.P.L. Chart and Report.



**BENJAMIN  
DUODE  
THIRTY-THREE**

MANUFACTURED UNDER MAGNAVOX PATENTS AND REGISTERED DESIGNS BY  
THE BENJAMIN ELECTRIC LTD.  
BRANTWOOD WORKS, TOTTENHAM, N.17

NEW RECEIVERS AND AMPLIFIERS

**ARMSTRONG COMPANY** Manufacture 8 Radio Receivers in Chassis Form, briefly described hereunder.

**ARMSTRONG** 6-valve All-wave Superheterodyne Radiogram Chassis, for A.C. mains, complete with Rola speaker; £7/10.

**ARMSTRONG** 8-valve 4 Wave-band Radiogram Chassis, with phase reversed push-pull output; £9/17/6.

**ARMSTRONG** 6-valve 4 Wave-band Radiogram Chassis, with large triode output; £8/17/6.

**ARMSTRONG** 8-valve 4 Wave-band Radiogram Chassis, with radio-frequency stage and push-pull output; £11/11.

**ARMSTRONG** 7-valve 4 Wave-band Radiogram Chassis, with radio-frequency stage and single triode output; £10/10.

**ARMSTRONG** 8-valve 2 Wave-band Radiogram Chassis, with 8 watt push-pull output; £8/10.

**ARMSTRONG** 6-valve 2 Wave-band Radiogram Chassis, with single large triode output; £7/10.

**ARMSTRONG** Chassis Carry 12 Months' Guarantee.

**ARMSTRONG** Chassis are Sent 7 Days' Trial, carriage, packing, and crate free.

**ARMSTRONG MANUFACTURING Co.**, 100, King's Rd., Camden Town, N.W.1. [3460]

**TRANS-ATLANTIC RADIO Co.**, 15, Percy St., W.1. Museum 3096.—Splendid range latest American A.C./D.C. compacts from 59/6; all-wave Consoles, etc.; "Philcos" stocked. [3578]

RECEIVERS AND AMPLIFIERS CLEARANCE, SURPLUS, ETC.

**CLEARANCE** List (Trade Only).—Write Leonard Heys, 36, Henry St., Blackpool. [0527]

**ALL** Regentone Sets Previously Advertised Still Available.

**HENRY'S**, 72, Wellington Av., London, N.15. Stamford Hill 2907. [3545]

**SEND** for Bargain List of Brand New Decontrolled Receivers; amazing prices—P. A. C., Ltd., 54, Lamb's Conduit St., W.C.1. [2243]

**DYNATRON** High-fidelity Radiogramophones and Receivers; a few recently obsolete models available at exceptional prices; 3 H.P. straight receivers of outstanding merit with 6 tuned circuits; also a few chassis and tuners; short-wave converter tuners, operate any receiver, pre-H.F. and triode-hexode, highly sensitive; originally £9/9; £3/15.—H. Hacker and Sons, Ray Lea Road, Maidenhead. [3575]

**BATTERY CHARGING PLANT**

**CARFAX** "Junior," 20/30 v., 5a., £5/5; guaranteed five years.—British Rectifiers, Vernon Place, Cheltenham. [3573]

**LANCASHIRE** Crypto Charger, good condition, cost £44/10; what offers?—Sussex Radio Service, 116, Cromwell Rd., S.W.7. [3549]

PUBLIC ADDRESS EQUIPMENT

**SPECIAL Offer!!!**

**81** Guinea Assembled: Vortexion 20 watt 4-stage P.A. amplifier, in steel case, 8in. x 10in. x 9in. high, with carrying handle, input with controls for microphone and pick-up and tone control, output for 7½ and 15 ohm speakers, weight 25lb.; only 8½ guineas, with valves.

**4** Input Model, with mixers; £10.

**HEAVY** Duty Model, as fitted to cinemas and dance halls; £15.

**CALL** and Hear the Rumble of an Organ as Never Before on our Wide Frequency Range Models, the best yet.

**VORTEXION, Ltd.**, 182, The Broadway, Wimbledon, S.W.19. See also New Mains Equipment. [3439]

**PARTRIDGE** P.A. Manual, free to trade. See "Part-ridge Transformers" under "New Mains Equipment." [3487]

**COLPHONE RADIO MANUFACTURING COMPANY**, Liverpool Rd., Hutton, near Preston, Lancs.—All British 12-watt amplifier, 12-inch P.A. speaker, transverse current microphone, 6-foot chromium telescopic floor stand; price £16; guaranteed 12 months, including valves.—Phone: Longton 196. [3563]

USED SETS FOR SALE AND WANTED

**CHALLENGER**

**1937** 8-valve Challenger 381 all-wave superhet, A.C., used few hours only; perfect; purchasing radiogram; listed £14/14; price £11.—Box 443, c/o The Wireless World. [3584]

**EKCO**

**£9**—Ekco A.C.97 mains receiver, used one month, cost 12½ guineas.—62, Ivy Avenue, Blackpool. [3552]

**HARTLEY-TURNER**

**HARTLEY-TURNER**—£35 Console, demonstration model; also Garrard auto changer, as new; offers or would consider exchange 3¼in. Drummond Lathe-Oscillograph, etc.—P. Paterson, 25, High St., Carlisle. [3571]

**H.M.V.**

**FOR** Sale.—Superb H.M.V. Magnavox; originally costing £400; suitable ship, hotel, private ballroom or club; also loud-speaking equipment, originally costing £70.—Box 447, c/o The Wireless World. [3582]

**PHILCO**

**PHILCO** Battery Major 238, perfect working condition, just overhauled; £4.—Box 452, c/o The Wireless World. [3588]

USED SETS FOR SALE AND WANTED

R.G.D.

RGD Model 1201 with Auto Changer, fitted special plate glass top on lid; best offer over £50 accepted, guaranteed perfect.—Beales, Radio House, Spalding. [3557]

W.W. SHORT-WAVE FOUR

JUNE, 1936, "Wireless World" Short Wave Battery Four, perfect condition, Peto Scott assembled, complete with valves, coils, batteries, as new; cost £9; selling for best offer.—Salt, "Pebbledash," Berrow, Burnham-on-Sea. [3565]

MISCELLANEOUS

THREE-VALVE American Shortwave Receiver, S.G., S.G., pen bandspread; £5.—G5NY, 48, Coles Lane, Hill Top, West Bromwich. [3577]

EXPERIMENTER Clearing Surplus, Haynes 2HF, spare valves, Piezo pick-up, Magnavox 33 and 6w. amplifier kit, many components; requirements, cash offers. Wanted, Super 7 H.F. unit.—Box 450, c/o The Wireless World. [3585]

EXCHANGE OR WANTED

WESTERN ELECTRIC 555w. Receiver, undamaged.—Parton, 4, Lower Rd., Beeston, Notts. [3564]

WANTED.—"W.W." P.A. amplifier feeder unit, Q.A. super or components.—82, Harnham Rd., Salisbury. [3568]

NEW MAINS EQUIPMENT

VORTEXION Lead Again.

VORTEXION Supply the B.B.C., G.P.O., L.P.T.B., and Borough Councils, etc., so why not you?

FOR THE Best Reproduction it is Possible to Obtain, see also advert, under Public Address Equipment.

ALL Fitted Screened Primaries and Tapped 200-250v., with centre tapped filaments, guaranteed one year.

SHROUDED Models, finished in elegant pressure die cast covers, will improve performance and appearance of any apparatus.

425 0-425v., 120-160 m.a., 4v. 5-10a., 4v. 2.5, 4v. 1-2, 4v. 1-2, supershrouded model, 2 1/2% regulation; 26/.

250 0-250 60 m.a., 4v. 1-2a., 4v. 2-4a.; 10/- open, 12/6 shrouded.

350 0-350v. 60 m.a., 4v. 1-2a., 4v. 2-4a.; 12/6 open 15/- shrouded.

350 0-350v. 120 m.a., 4v. 2.5a., 4v. 2-4a., 4v. 2-5a.; 14/6 open, 16/6 shrouded.

500 0-500v. 120 m.a., L.T.'s, as above; 19/- open, 23/- shrouded; 400 or 450, same price.

500 0-500v. 150 m.a., 3x, 4v. 2a., 4v. 2-5a., 4v. 4a., 26/- open, 30/- shrouded; 400 or 450, same price.

CHOKES, 30h. 60 m.a., 5/6; 7-13h., 10/6; 30h., 150 m.a., 12/6; regulation, 7/6.

OUTPUT Transformers, 4-10 watt, W.W. Q.A., 17/6; 20-watt super shrouded, 30/-.

SPECIAL Wide Frequency Range Model; £3/10.

AUTO Transformers, 100-120 to 200-240v., 60 watt, 9/-; 120 watt, 12/6; 200 watt, 16/6; 500 watt, 30/-.

TELEVISION, 4,000v., 5-10 m.a., and 2.5-4v.; 27/-.

QUOTATIONS for Specials by Return.

VORTEXION, Ltd., 182, The Broadway, S.W.19. Tel.: Lib. 2814. [3592]

ALL POWER TRANSFORMERS, Ltd.—Transformers and chokes embodying all the best in design; no better value at any price; Radiolympia models; tapped and screened primaries, filaments, centre tapped.

250 0-250v. 60 m.a., 4v. 1-2a., 4v. 2-4a., 12/6, post 7d., extra filament, 4v. 1a., 12/6.

350 0-350v. 60 m.a., 4v. 2-3a., 4v. 2-4a., 15/-, post 8d.; extra filament, 4v. 1a., 16/-.

350 0-350v. 120 m.a., 4v. 2-3a., 4v. 2-6a., 4v. 1-2a., 19/-, post 1/-; extra filament, 20/-.

500 0-500v. 140 m.a., 4v. 2-4a., 4v. 4-6a., 4v. 2a., 4v. 2a., 29/6, post 1/-.

L.T. Charger, charging rate 1a., 2, 6, or 12-volt, employing metal rectifier L.T.5; 37/6, post 1/-.

WRITE for List; special quotations by return.

ALL POWER TRANSFORMERS, Ltd., 8a, Gladstone Rd., Wimbledon, S.W.19. Tel.: Liberty 3303. [3383]

PARTRIDGE Transformers, as supplied to B.B.C., Marconi's, G.E.C., Mullards, I.C.I., Tungsram, etc.

SPECIALS Despatched Within 48 Hours; all standard types from stock. Specimen prices:—

350 0-350v. 120 m.a., 4v. 2-3a., 4v. 3-6a., 4v. 1-2a., all C.T.; screened primary 200-250v., 18/6.

425 0-425v. 150 m.a., 4v. 2-4a., 4v. 4-8a., 4v. 1-2a., 4v. 1-2a., all C.T. (for W.W. circuits); 26/6.

SPECIAL Quotations to Manufacturers for Lots of 6 Upwards; hand wound, individually tested, immediate delivery, rock bottom prices.

TELEVISION Transformers Insulated to 10,000v. A.C. expert knowledge of transmitting requirements (mains and modulation).

HIGH Fidelity (20 to 15,000 Cycles) Intervalve and Output Transformers a Speciality.

PARTRIDGE P.A. Manual Free to Trade Only; contents includes constructional amplifiers, notes on microphone pre-amplifiers, lines, mixing, impedance matching, speakers, etc.

PARTRIDGE, N., B.Sc., A.M.I.E.E., King's Buildings, Dean Stanley St., London, S.W.1. Phone: Vic. 5035. [3486]

TANTALUM for A.C. Chargers, H.T. and L.T.—Blackwell's Metallurgical Works, Ltd., Garston, Liverpool. [2729]

No. 21

Notes

on the Suppression of Electrical Interference with Broadcast Reception

We have had some very interesting correspondence with a gentleman holding an official position in a local Government Service. He happens to be an exceedingly well-informed radio listener using really high fidelity receivers, and has done everything possible to prevent interference from reaching his receiver. His interest in such matters has made him particularly critical regarding specifications of electric signs, traffic lights, etc., and in fact all electrical appliances over which his department has any control.

In his area they are the authority for electric supply, and he is happy in receiving the close co-operation of the engineers who deal at once with any complaints from consumers or the G.P.O. concerning the thousands of fittings, such as electric fans, hydro extractors, etc., under their control in conveniences, public baths, halls, etc. This is an ideal example of what can be done under present conditions, and it is a great pity that every authority has not a really enthusiastic radio man capable of giving a similar service in the course of his official duties.

Every reader of this journal should see to it that neither he nor his friends are responsible for any appliances which are unsuppressed. The influence of the "Wireless World" readers is such that a campaign of this kind would benefit enormous numbers of people. Flex Lead suppression is simple and effective, and can be applied to appliances wired with either two or three wires. For larger appliances use appliance plug suppression, suppressors immediately across brushes, or special choke and condenser units.

† "Eliminoise" Note

It may have been a coincidence, but last week one of our engineers investigated six cases of "Eliminoise" anti-interference aerials (all-wave) which were reported to be giving disappointing results. In five cases the transmission line conductors were crossed and connected to the wrong terminals, in spite of very detailed instructions given concerning the matter. In the sixth case the aerial was well within the field of interference and was too short.

Special Note

This same engineer (who has joined us recently) reports that in no case has he tried a type 300 Set Lead Suppressor (price 21/-) without obtaining a remarkable improvement. He admits that he is always surprised himself! He has not been with us long enough to believe it.

Send 1/2 for book "Interference Suppression" or for free copy of "Eliminoise System," and the literature relating to the subject.

† "Eliminoise" Trade Mark.



Belling & Lee Ltd. Cambridge Arterial Road, Enfield, Middx.

NEW MAINS EQUIPMENT

PARAMOUNT Mains Transformers.

PARAMOUNT in Quality, lowest in price; example: 250v. 60 m.a., 4v. 1a., 4v. 4a., open type 9/-; shrouded 11/-, post 9d.; 350v. 75 m.a., 4v. 2.5a., 4v. 4a., open type 12/-, shrouded 14/-, post 9d. WRITE for List, "Paramount Mains Transformers"—R. H. Salter, 66, Hartfield Rd., Wimbledon, S.W.19. Phone: Liberty 3226. [2303]

CABINETS

MANUFACTURER'S Clearance.

HALCYON Radiogram Cabinets, rich, dark, figured walnut, 33x23x19 1/2, 45/-; many others, 30/- upwards; photos for selection sent on request.

TABLE Radio Cabinets (undrilled); 6/6 upwards.

SPEAKER Cabinets; 4/6 upwards.

SEND Particulars of Your Requirements (giving size of set, etc.), or call and make your choice from our stocks of over 100 different types; from 3/6 to £4/10.

H. L. SMITH and Co., Ltd., 287-9, Edgware Rd., London, W.2. Tel.: Padd. 5891. [0485]

RADIOGRAM Cabinet, solid oak, 37x28x20, unused.—Phone: Riv. 1094 after 7 p.m. [3553]

HIGH Class Radio Cabinets Made to Order; competitive prices.—O. Mostyn, Ltd., Cabinet Manufacturers, 8-9, French Place, London, E.1. (Bishopsgate 8784.) [3554]

DYNAMOS, MOTORS, ETC.

ALL Types of Rotary Converters in Stock, new and second-hand.

WARD, 46, Farringdon St., London, E.C.4. Telephone: Holborn 9703. [0518]

A.C. 1/10h.p. Induction Motors, 2,750 revs., self-starting, all voltages; 35/-—Easco, 18, Brixton Rd., S.W.9. [0455]

CRYPTO Converter 200-250 D.C. to 230 A.C., 50 cycles, 100 watt, silence cabinet, smoothing, perfect condition; £3/15.—Box 451, c/o The Wireless World. [3587]

NEW LOUD-SPEAKERS

HULBERT for Quality Surplus Speakers.

THE Following Genuine Bargains are Made by One of the Best-known Manufacturers of high-grade moving coil speakers. All are brand new and offered at considerably under half list prices. The Auditorium models are fitted with latest dual curved cones, giving remarkably wide and even frequency response, resulting in quality reproduction of both speech and music.

37/6 Only, usual price £5; Auditorium permanent magnet speaker, with Alni magnet and die cast frame, large 12in. dual cone, comprising latest curved cone with auxiliary bakelite cone; complete with large 25 ratio transformer.

59/6 Only, usual price £6; Auditorium electro-magnet speaker, 1,000, 1,250, 2,000 or 2,500 ohms field; exceptionally large magnet of high permeability steel, giving enormous flux density; 2in. moving coil; large dual cone, comprising latest curved cone with auxiliary bakelite cone, giving wide frequency response; complete with universal transformer; the ideal speaker for use with "Wireless World" and other quality amplifiers.

75/- Only, usual price £9; as above, but for use on A.C. mains; complete with Westinghouse on rectifier and full smoothing equipment.

24/- Only; permanent magnet speaker, Alni magnet, die cast frame, 10in. cone, Universal transformer.

15/6 Only; permanent magnet speaker, Alni magnet, 8in. cone, Universal transformer.

12/6 Only; permanent magnet speaker, as above, with 7in. cone.

11/6 Only; extension permanent magnet speaker, 8in. cone, complete with large cabinet, suitable for low impedance outputs.

2/9 Only; brand new cabinets.

8/6 Only; electro-magnet speakers, with 8in. cone, 6,500 ohms field, Universal transformer.

IF You are Requiring Quality Reproduction at Low Cost Order Now from:

HULBERT, 6, Conduit St., W.1. Cash or c.o.d. [2895]

VAUXHALL.—Best quality speakers; see other column. Vauxhall Utilities, 163a, Strand. [0520]

SINCLAIR SPEAKERS Have Quantity New Speakers, P.M. and energised, 8 and 10 inch; also P.A. 10 watt; to clear from 8/6 each; all guaranteed.—Alma Grove, Copenhagen St., London, N.1. Ter. 4355. [3528]

LOUD-SPEAKERS

SECOND-HAND, CLEARANCE, SURPLUS, ETC.

VAUXHALL.—Magnavox mains energised, 2,500 or 6,500 field coil, 10in. cone, 17/6; 7in. cone, 12/6.

VAUXHALL.—Magnavox permanent magnets, universal, suitable for Class "B" power or pentode, 7in. cone, 16/6; 10in. cone, 22/-.

VAUXHALL.—American Rolas, 2,500, 8in. 15/-, 9 1/2in. 19/6; permanent magnets, 8in. 19/6, 9 1/2in. 24/6.

VAUXHALL.—Above fully guaranteed, complete with humbucking coils; state power or pentode transformer; unused manufacturers' stock.

VAUXHALL.—Immediate delivery, carriage paid; lists free; cash with order or c.o.d.—Vauxhall Utilities, 163a, Strand, W.C.2. Temple Bar 9338. [0456]

HARTLEY-TURNER Speaker, 6 volt pot., 30/-; transformer, 5/-.—Webb, New St., Dunmow, Essex. [3572]

DUODE Magnavox 33, 2,500 or 1,250 field, 15 ohm. voice coil, finest speaker obtainable; 55/-.—37, Rosehill Parkwest, Sutton. [3591]

**LOUD SPEAKERS—SECOND-HAND, CLEARANCE, SURPLUS, ETC.**

**MAGNAVOX** D.C. 152 (9in. cone), 22/6; Magnavox 154 (6 1/2in. cone), 16/3; all with humbucking coils, power or pentode transformers, and 2,500 or 6,500-ohm fields; Magnavox P.M.254, 18/-; Magnavox P.M.252, 22/6.

**ATTENTION** to All Orders Within 48 Hours; carriage paid; cash with order or c.o.d.; send for list. **WARD**, 46, Farringdon St., London, E.C.4. Tel.: Holborn 9703. [0451]

**VALVES**

**ANDERSON**. **AMERICAN** Valves, all makes, first grade only; 5/- each. **ANDERSON** 35, Lansdowne Rd., Walthamstow, E.17, Walthamstow O827. [3351] **AMERICAN** Valves, first grade, in all types; trade supplied.—Metropolitan Radio Service Co., 1021, Finchley Rd., N.W.11. Speedwell 3000. [0436] **AMERICAN** Valves, Siltotron, factory sealed, guaranteed, any type, glass, metal; 6/6 each.—4, Humberstone Drive, Leicester. [3570] **AMERICAN** Valves, popular types, 5/- each, all guaranteed; line cords, 2/6 each; write for lists.—E. Fellows, Ferney Rd., East Barnet, Herts. [3596]

**3/-** Each.—American valves, all popular types, 90-day guarantee; full range in stock, National Union, Hytron, Triad, metal, glass and M.G.; send for lists.

**RADIOGRAPHIC**, Ltd., 66, Osborne St., Glasgow, C.1. [3494]

**ALL** Types of American Valves in Stock of Raytheon, Sylvania, and Arcturus makes, at competitive prices, guaranteed for six months; send for full list; 350 ohms line cords, 2/8.

**WARD**, 46, Farringdon St., London, E.C.4. Tel.: Holborn 9703. [0452]

**NOTHING** Better Available.—Six months' guarantee; complete range of battery, A.C. mains, rectifiers always in stock; 2-volt det., H.F. L.F., 2/3; power, 2/9; screen grid, pentode, H.F. pentode, 5/-; American types, fully guaranteed, 5/6 each, Nos. 18, 24A, 35, 42, 43, 45, 47, 56, 57, 58, 75, 77, 78, 80, 2A5, 2A6, 2A7, 6A7, 2B7, 6B7, 6C6, 6D6, 25Z5, 25Y5; write for other prices to Dulci Electrical Co., Ltd., Devonshire Works, Dukes Av., Chiswick, W.4. [0501]

**AERIALS**

**SPIDER-WEB** All-wave Antenna System Designed to Cover the Extremely Wide Tuning Range of Modern Multi-wave Receivers; available assembled, ready for installation, it consists of a series of doublet antennas and an improved noise-free transmission line to the receiver; easily installed in any location which permits a span of 38ft. and a vertical clearance of 12ft.; eliminates man-made static, increases signal strength on all bands; improves selectivity; waterproof and weatherproof; cash with order, carriage paid; price 25/-.—Obtainable only at this address: W. F. Halliwell, The Villa, Wothorpe, Stamford. [3590]

**NEW COMPONENTS**

**TRANSVERSE** Current Microphone Parts, complete, from 8/6.—A. Hinderlich, 2, Bridge Rd., London, N.W.10. [3539]

**ENLARGED** Catalogue for Home Constructors Now Ready, post free.—Lumen Electric Co., Litherland, Liverpool, 21. [3473]

**OURS** is Now the Only Store in London Handling a Complete and Comprehensive Range of High Grade Components and Accessories, as distinct from clearance and surplus material. Everything from the smallest plug to the complete auto changer unit, finest makes, really keen prices, and personal and efficient service unexcelled by chain stores, clearance houses, department stores or by mail. Come and see.

**WIRELESS SUPPLIES UNLIMITED** 278-280-282, High St., Stratford, E.15. Maryland 3191. [3551]

**COMPONENTS**

**SECOND-HAND, CLEARANCE, SURPLUS, ETC.**

**VAUXHALL**. **ALL** Goods Previously Advertised are Standard Lines Available for Immediate Delivery.

**VAUXHALL UTILITIES**, 163a, Strand, W.C.2, over Denny's, the Booksellers, Temple Bar 9338. Send postcard for new lists, free. [0453]

**HYAMS RADIO**.

**EX-BAIRD** Television Receiver Chassis, consisting of mains transformer, 400-0-400 volt, condensers, chokes, resistances, etc., in cabinet; 15/-, a real bargain.

**MARCONI** 6-volt Energised Moving Coil Speakers, last few to clear; 15/-; 15 ohm speech coil.

**HYAMS RADIO**, 23, Lisle St., W.C.2. Ger. 2969. [3600]

**MERCURY** Switches Ensure Perfect Contact; best for automatic remote control or time switches.

**PHOTO-ELECTRIC** Cells, selenium and caesium, all types, for every purpose; illustrated lists.—Cela Products, 11, Ramsden Rd., London, S.W.12. [3602]

**TOBE** Tuner, 35h., new; £4/10, or offer.—Whitehouse, 54, Claremont Rd., Woodsmoor, Stockport. [3597]

**FERRANTI** A.F.5, 12/6; A.F.6, 12/6; cash or c.o.d.—Grigg, 70, Peel Rd., Wealdstone, Middlesex. [3569]

**MANUFACTURER'S** Surplus Components, stocktaking clearance; send list of your requirements; prices below bulk cost.—H. Hacker and Sons, Ray Lea Rd., Maidenhead. [3576]

**FERRANTI** Transformers, A.F.5c, O.P.3c, 10/-; B1 chokes, 5/-; B2, 10/-; Multitone, 10/-; experimenters guaranteed.—Bill, 38, Church Lane, Handsworth, Birmingham. [3598]

**DESIGNED EXPRESSLY FOR USE WITH "THE WIRELESS WORLD" AND SOUND SALES QUALITY AMPLIFIERS.**

**"OUTSTANDINGLY GOOD"**

Vide "Wireless World" Test Report, January 8th.

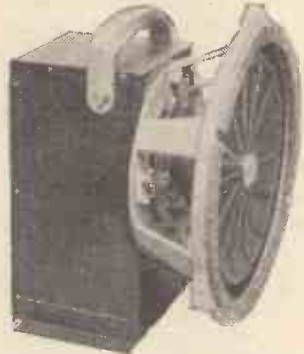

Quite a number of loud speakers sound fairly good. A selected few may put up a good performance with an input of about 3 watts; but we challenge you to find another speaker which will equal the **SOUND SALES SUPER AUDITORIUM MODEL** when working with a 12 watt input. Is there any point in owning an amplifier which will do justice to large peaks, unless you have a speaker worthy of the amplifier?

May we send you further particulars?

**SOUND SALES**  
  
**MARLBOROUGH RD. UPPER HOLLOWAY, LONDON, N.18.** (Contractors to the G.P.O., etc.)  
**LIMITED.** Tel.: Archway 1661/2/3.

**SAFETY**

Qualified Service Engineers

We use and recommend

**AVO**

You can recognise the genuine service engineer by this gold "AVO" Service Sign. It means that he is equipped with the most accurate and efficient instruments to provide prompt and competent service work. His charges will be more reasonable because he can locate and remedy faults in the shortest possible time. Look for the "AVO" Service Sign it is your safeguard.

Literature describing any of the "AVO" testing instruments free on request to:

**The AUTOMATIC COIL WINDER & ELECTRICAL EQUIPMENT CO., LTD.**  
 Winder House, Douglas St., London, S.W.1  
 Telephone: Victoria 3404-7.

**COMPONENTS—SECOND-HAND, CLEARANCE, SURPLUS, ETC.**

**RADIO CLEARANCE.**

**63.** High Holborn, W.C.1. Holborn 4631. **SPECIAL** Clearance Sale Now Taking Place at Our London Premises; the following bargains are offered to enable our mail order customers to participate in this eagerly awaited annual event.

**8-VALVE** A.C. Mains Superhet., by well-known manufacturer, fitted visual tuning, volume control, tone control, etc., handsome bird's eye maple cabinet, size 16in. wide, 12in. deep, 23in. high, valves as follows: A.C./VP1, FC4, AC/VP1, AC/VP1, AC/HLD, V914, AC 2 Pen., 1W3, pre H.F. stage, 2 I.F. stages, full A.V.C.; a super bargain at £6/10/6.

**LISSEN** 4-valve Universal A.C./D.C. Receiver, fitted in handsome dark finish, walnut cabinet of upright design, clock face tuning, volume control, reaction control, etc., a really fine receiver; £4/15.

**EXCLUSIVE** British Rights Held by Us for American Constructed Kits; during the sale, these kits are offered as follows:

- 1-VALVE Battery Kit, complete with valve; 21/-.
- 2-VALVE Battery Kit, complete with valves; 25/-.
- 1-VALVE A.C./D.C. Kit, complete with valve; 29/6.
- 2-VALVE A.C./D.C. Kit, complete with valves; 32/6.

**THESE** are Complete Sets (not Converters), covering a waveband of 15 to 600 metres by means of 5 interchangeable plug-in coils.

**8-VALVE** A.C. Superhet Chassis, complete with valves, details as above; £6/7/6.

**ROLA** 9in. Energised Type Moving Coil Speakers, 60C ohms or 1,000 ohms, field less transformer; 4/11 each.

**10,000-ohm** 7 1/2in. Cone, complete with transformer, Pentode type, 4/11 each.

**LISSEN** All-wave Coils, complete with circuit, switching, etc., in matched pairs, 8/- per pair.

**DITTO** Single Coils, 4/6 each.

**LISSEN** 126 I.F. Transformers, fully screened, 1/3.

**G.E.C.** 110 I.F. Transformers, Midget type, complete with trimmers, 1/3.

**WEARITE** 1/2-meg. Volume Controls, with switch, 1/- each.

**CENTRALAB** Volume Controls, with switch, 5,000, 10,000, 25,000, 50,000, 2/3.

**SPECIAL.** Special.

**JENSEN** 7 1/2in. 2,500 Field Pentode Type Moving Coil Speakers, 5/9 each; few only.

**HANDSOME** Straight Line Slow Motion Dial, complete with escutcheon, 2/3 each.

**THE** Following Condensers, by well-known manufacturer.

- 8 Plus 8 Plus 4 Electrolytics, wire end type, metal cases; 3/-.
- 14 Plus 8 Plus 4 Electrolytics, wire end type, metal cases; 2/-.
- 8 Plus 8 Plus 4 Electrolytics, wire end type, cardboard cases; 3/-.
- 8 mfd. 550 Surge 500-volt Working, metal can, 1-hole fixing; 2/11.
- 8 mfd. 500 Surge 450-volt Working, metal can, 1-hole fixing; 2/6.

**TUBULAR** Condensers, paper type, all sizes up to 0.1; 6d. each.

**50** mfd. 50-volt Working Condensers, well-known manufacture; 1/6.

**50** mfd. 25-volt working Condensers, well-known manufacture; 1/3.

**25** mfd. 50-volt Working Condensers, well-known manufacture; 1/-.

**50** mfd. 12-volt Working Condensers, well-known manufacture; 1/-.

**UTILITY** 3-gang Condenser, Superhet. type, 2 0.0005 sections, 1 110 k/c section, fully screened with top trimmers, 2/6.

**AMERICAN** Valves, special clearance, 3 types only; 12Z5, 6B7, 6A7, 1/9 each.

**AMERICAN** Valves; first class brand, Triad; following types: 34, 38, 47, 42, 43, 49, 6B7, 56, 58, 55, 6A7, 80, 75, 48, 41, 5Z3, 2A3, 12Z3, 45, 6C6, 6D6, 6F7, 30, 59; 4/6 each.

**ALL** These Valves Carry a 90-day Guarantee, and free replacement, provided that the filament or heater is intact and the glass not broken when returned to us.

**LISSEN** Class B Driver Transformers, ratio 1-1, brand new, boxed; 1/9 each.

**LISSEN** Intervolve Chokes, brand new, boxed, 1/-.

**BRYCE** Mains Transformers and Chokes, standard for the season, British and Guaranteed.

**250** 0-250, 80 m.a., 2-0-2 volts, 2.5 amp, 2-0-2 volts, 4 amp; 8/6.

**350** 0-350, 120 m.a., 2-0-2 volts, 2.5 amp, 2-0-2 volts, 4 amp; 10/6.

**350** 0-350, 150 m.a., 2-0-2 volts, 2.5 amp, 2-0-2 volts, 4 amp, 2-0-2 volts 2 amp., 11/6.

**500** 0-500, 150 m.a., 2-0-2 volts, 2.5 amp., 2-0-2 volts, 6 amp, 2-0-2 volts, 2 amp, 2-0-2 volts, 2 amp.; 16/6.

**H.T.8** Transformer, 250 volts, 60 m.a., 2-0-2 volts, 4 amp.; 8/6.

**DITTO** with H.T.8 Metal Rectifier, 16/6.

**ALL** Transformers are Fully Shrouded.

**BRYCE** Main Chokes.

**40** m.a., 30 hys., 500 ohms, 4/-; 60 m.a., 40 hys., 500 ohms, 5/6.

**150** m.a., 40 hys., 100 ohms 9/9; 250 m.a. 15 hys., 200 ohms, 18/6.

**60** m.a., 80 hys., 2,500 ohms, for speaker replacement, etc.; 5/6.

**ENQUIRIES** 1 1/2d. Stamp if Reply Expected.

**HOURS** of Business 9 a.m. to 7 p.m., Saturdays 9 a.m. to 1 p.m.

**ALL** Orders Value 5/- or Over Post Free; orders under 5/- must be accompanied by a reasonable amount for postage.

**C.O.D.** Orders Under 5/- Cannot be Accepted.

**RADIO CLEARANCE**, 63, High Holborn, W.C.1. Holborn 4631. [3567]

COMPONENTS—SECOND-HAND,

CLEARANCE, SURPLUS, ETC.

PREMIER SUPPLY STORES.

PLEASE See Our Displayed Advertisement on this page.

ALL Post Orders Should be Addressed to Jubilee Works, 167, Lower Clapton Rd., London, E.5. Callers as usual to:-

20-22, High St., Clapham, S.W.4. Open till 9 p.m. Saturdays, Wednesdays, 1 p.m. Macaulay 2381.

165 and 165a, Fleet St., E.C.4 (next door to Anderson's Hotel). Early closing Saturday 1.30 p.m. Central 2833. [0488]

SOUTHERN RADIO'S Wireless Bargains.—All goods guaranteed and sent post paid.

BELMONT 6-valve Superhet. Receivers, complete in handsome cabinet for use on any mains, A.C.-D.C., 110-250 volts, with moving coil speaker and 6 valves, ready to plug in; £4 each.

GRAMOPHONE Motors.—Garrard type "B" radiogram unit, consisting of A.C. motor, 100-250 volts, and pick-up, 45/-; Garrard motor, less pick-up, 30/-; in original sealed cartons.

RECORD Changers.—Garrard model R.C.4, plays automatically and changes 8 10in. or 12in. records of any kind, sealed cartons; 45.

SPEAKERS.—Celebration Soundex permanent magnet, 10/-; Telsen permanent magnet, with 10-ratio transformer 2/6; suit any receiver, 12/6; Telsen loud-speaker units, 2/6; all brand new and in sealed cartons.

COILS.—Telsen, iron core, W349, Midget size, 4/-; type W478 (twin), 9/- pair; W477 (triple), 16/- set; type W476 (triple superhet, selector and oscillator), 16/- set, all ganged coils complete on base with switch; Telsen I.F. transformer coils, W482, 5/-; Telsen dual range aerial coils, with aerial series condenser incorporated, W76, 4/-; Telsen aerial series condensers with shorting switch, 2/-; all brand new, in sealed cartons.

MICROPHONES.—Ace (P.O.) microphones, complete with transformer, ready for use with any receiver; 4/6 each.

RESISTANCES.—Tru-ohm 1-watt, colour coded and marked, 36 assorted capacities on card; 6/- per card.

AMERICAN Valves.—A full range of valves for all American receivers; 6/- each.

HEADPHONES.—Lightweight headphones, double pole type, 4,000 ohms each earpiece; 3/- pair.

TELSEN A.C.-D.C. Multimeters, tests anything radio or electrical; 8/6.

CAR Radio Aerials.—Ekco copper mesh aerials can be used on roof or floor of car; size 36in x 20in., 4/- each, 36in x 26in., 5/- each.

SOUTHERN RADIO.—Branches at 271-275, High Rd., Willesden Green, N.W.10; 46, Lisle St., London, W.C.2. All mail orders to 323, Euston Rd., London, N.W.1.

SOUTHERN RADIO, 323, Euston Rd., London, N.W.1 (near Warren St. Tube). Phone: Euston 3775. [5594]

OLIVERS, of Boscombe, offer Erie 1-watt colour coded resistances; 3/4d. each, 3/- dozen, 2/6 dozen in 3-dozen lots.

COLLARO Gramophone Motors, A.C. 110-250v., 50 cycles, Uniplate, Autostart and stop, regulator, turntable, etc., 24/6; radiogram unit with rectangular unit-plate, 14in. x 16in., and complete with Collaro standard pick-up with built-in volume control, 38/-.

CENTRALAB Volume Controls, standard type with switch, 2/-; Westinghouse rectifiers, H.T.8, 8/6; H.T.9, 9/6; H.T.10, 9/6.

CLIX Chassis Mounting Valve-holders, 7-pin 4d.; 5-pin 3d.; Rola energised speakers, manufacturer's type, 2,000 ohms and 2,500 ohms, 7in. cone, 10/6.

HUNTS Cardboard Case Condensers, 4 mfd. 1/6, 8 mfd. 1/9, 8 mfd. +4 mfd. 2/5, 8 mfd. +8 mfd. 2/9; 50 mfd. 50v., 1/6; T.C.C. 50 mfd. 50v., 2/-.

B.I. and T.C.C. Metal Electrolytics, 8 mfd. 2/4, 4 mfd. 2/1; Dubilier, 8 mfd. 2/7; 25 mfd. 25v., 1/-, B.I. TUNGSRAM and Non-ring Valves, all types, full discounts; write for lists.

OLIVERS, 676, Christchurch Rd., Boscombe, Hants.—All orders under 5/6 postage 3d.; no c.o.d. under 5/6. [3589]

WARD.—For unparalleled bargains in set manufacturers' surplus; all goods are guaranteed unused and perfect; immediate delivery.

BRITISH Radiophone Condensers, fully screened, superhet, or straight types, 3-gang and 2-gang; 7/6.

CENTRALAB Resistances, 1-watt type, 6d.; 2-watt type, 1/2; 3-watt type, 1/9; B.I.C. 8 mfd. and 4 mfd. 550 volts peak electrolytic condensers, 3/3.

3,000 Band New Wearite 110 kc. Pre-tune I.F. Transformers, type O.T.1, O.T.2 and O.T.2F; 1/6 each, or offer for quantity.

40 mfd. and 24 mfd. 200 Volts Peak Electrolytic Condensers; 3/6.

CLIX Chassis Type Valve Holders, 4- or 5-pin, 6d.; 7- or 9-pin, 6d.; R.C.A. American valve holders, 4s. 6. or 7-pin, 9d.

ASSORTED 1-gross Parcels of 1-watt and 1/2-watt Resistances by N.S.F.; 12/-.

MARCONI Model 25 Pick-ups; 25/-.

CONVERSION Units for Converting D.C. Receivers to A.C. Mains, operation up to 110 volts, improved full-wave type; 2/10.

WESTINGHOUSE Rectifiers, L.T.4 or L.T.5, with mains transformer and variable resistance, 22/6; Varley D.P.4 output transformers, 1-1 and 25-1, 9/-.

MAINS Transformers, 350-0-350v. 60 m.a., 4v. 3 amps., 4v. 25 amps., 12/-; 425-0-425v. 120 m.a., 4v. 1 amp., 4v. 1 amp., 4v. 7 amp., 4v. 25 amp., for "W.W." Quality Amplifier, 26/-; L.T. transformers, with two 4v. 3a. C.T. windings or 2.5v. 8a 5v. 2.5a. 8/6.

VOLUME Controls, with or without switch, by Rotor-ohm, Erie, Electrad, and other good makers, any value, 2/6; steel chassis, "Wireless World" Quality Amplifier, 8/6; Partridge 32-watt amplifier, 11/-.

WE Stock All Parts for "Wireless World" Quality Amplifier, Quality Amplifier Receiver, Imperial Short-wave Six, 1936 Monodial Q.A. Super, All-wave Super Seven, etc.

WE Can Supply Correct Equivalents for Any British Type of Valve, including side-contact Universals, H.F. pentodes, double diode triodes, 3.5 watt output pentodes, 500v. indirectly heated rectifiers, octodes, double diodes, single diode tetrodes, etc., at an appreciably lower price.

CARRIAGE Paid, cash with order or c.o.d.; send for list.

WARD, 46, Farringdon St., London, E.C.4. Tel.: Holborn 9703. [0450]

PREMIER SUPPLY STORES

THE LARGEST RADIO MAIL ORDER HOUSE IN THE WORLD

Offer the following Set Manufacturers' Brand New Surplus Goods at a Fraction of the Original Cost; all goods guaranteed perfect; carr. paid over 5/-; under 5/- postage 6d. extra. Orders under 5/- cannot be sent O.O.D.

ALL POST ORDERS TO JUBILEE WORKS, 167, LOWER CLAPTON RD., LONDON, E.5

CALLERS, AS USUAL, TO 20-22, HIGH ST., CLAPHAM, S.W.4 (Macaulay 2381) 'Phone: Amherst 4723

And 165 & 165a, FLEET ST., E.C.4 (Next door to Anderson's Hotel.) Central 2833.

MAINS VALVES

MAINS VALVES, famous Europa 4 v. A.C. types, 4/6 each. H.L., L., S.G., Var.-Mu-S.G., H.F.-Pens., Var.-Mu-H.F. Pens. 1, 3 and 4-watt A.C. directly-heated output Pentodes. Full-wave rectifiers, 250 v. 60 m.a. A.C./D.C. types. 20-volt. 1.8 amp. S.G., Var.-Mu-S.G., H., H.L., Power.

Following types all 5/6 each. Full-wave rectifiers, 350 v. 120 m.a. and 500 v. 120 m.a. 2 1/2 watt indirectly-heated Pentodes. Frequency Changers, Octodes and Heptodes. P.X.4 type, 6/6.

BATTERY VALVES. 2 volts, H.F., L.F., 2/3. Power, Super-Power, 2/9. S.G., Var.-Mu-S.G., 4- or 5-pin Pentodes, H.F. Pens., V.-Mu-H.F. Pens., 5/- Class B, 3/6.

AMERICAN VALVES. Genuine American HYTRON and TRIAD first-grade Valves. 3 months' guarantee. All types in stock, 5/6 each. 210 and 250, 8/6 each. New Metal-Glass Valves, all types, 6/6 each. Genuine American DUOTRON Valves, all types, 3/6 each. Valve holders for all above types, 6d. each. Metal bases, 9d. each.

SHORT WAVES

SHORT-WAVE COILS, 4- and 6-pin types, 13-26, 22-47, 41-94, 78-170 metres, 1/9 each, with circuit. Special set of 3 S.W. Coils, 14-150 metres, 4/- set, with circuit. Premier 3-band S.W. Coil, 11-25, 19-43, 38-86 metres. Simplifies S.W. receiver construction, suitable any type circuit, 2/6.

COIL FORMERS, in finest plastic material, 1 1/2in. low-loss ribbed, 4- or 6-pin, 1/- each.

SUPER CERAMIC CONDENSERS, S.I.F. 00010, 0001, 2/9 each; double-spaced, 00005, 000025, 000015, 3/- each. All brass with integral slow motion, 00015 tuning, 3/9; 00015 reaction, 2/9. British Radiophone 2-gang 00016, 5/6.

H.F. CHOKES. S.W. 10-200 metres, 9d.; S.W. screened, 1/6; standard screened 180-2,000 metres, 1/6.

CERAMIC S.W. VALVE HOLDERS, 4-, 5- or 7-pin. Chassis type, 6d.; B.B. type, 8d.

GLASS AERIAL INSULATORS, 4d. each. BEEHIVE STAND-OFF, 6d. each. SCREENED FLEX, single, 3d. yd.; twin, 4d. yd.

PREMIER AMPLIFIER KITS

3-WATT A.C. AMPLIFIER, 2-stage, for mike or pick-up. Complete kit of parts with 3 valves, 40/-.

7-WATT A.C./D.C. AMPLIFIER. 3-stage, high-gain, push-pull output. Complete kit of parts with 5 specially matched valves, 24 1/2s.

10-WATT 3-stage A.C. Amplifier Kit with 5 valves, £5 5s.

20-WATT 3-stage A.C. Amplifier Kit with 5 valves, £8 8s.

ELECTROLYTICS. U.S.A., 4, 8 or 16 mfd. 530 v. peak, 1/9 each. Dubilier, 4 or 8 mfd. 500 v., 3/-; 50 mfd. 50 v., 1/9; 10 mfd. 50 v., 6d.; 25 mfd. 25 v., 1/- T.C.C. 4 or 8 mfd. 650 v., 4/-; 15 mfd. 50 or 100 v., 1/-; 50 mfd. 12 v., 1/-.

Paper Condensers. W.E., 250 v. working 4 mf., 2/-; 2 mf. 1/-; 1 mf. 6d.; 350 v. working 4 mf., 2/6; 2 mf., 1/6. Dubilier 500 v. working 4 mf., 4/-; 800 v. 4 mf., 6/-.

COSMOCOD PICK-UPS, with tonearm and volume control, 10/6 each.

PICK-UP HEADS only, 4/6 each.

MAINS TRANSFORMERS

PREMIER wire-end type with screened primaries, tapped 200-250 v. Centre-tapped Filaments. Guaranteed one year. H.T. 8 & 9 or H.T. 10 with 4 v. 4 a. C.T. and 4 v. 1 a. C.T., 8/6. 250-250 v. 60 m.a., 4 v. 1 a., 4 v. 2 a. and 4 v. 4 a., all C.T., 8/6. 350-350 v. 120 m.a., 4 v. 1 a., 4 v. 2 a. and 4 v. 4 a., all C.T., 10/6.

Any of these transformers with engraved panel and N.P. terminals, 1/6 extra. 500-500 v. 150 m.a., 4 v. 2-3 a., 4 v. 2-3 a., 4 v. 2-3 a., 4 v. 3-4 a., all C.T., 17/6.

SUPER Model, 19/6. AUTO TRANSFORMERS, step up or down, 60 watts, 7/6; 100 watts, 10/-.

FILAMENT TRANSFORMERS, Tapped Primaries, 200-250 v. All secondaries C.T. 4 v. 3 a., 7/6; 4 v. 5 a., 8/6; 7.5 v. 3 a., 7/6; 6 v. 3 a., 7/6; 2.5 v. 8 a., 7/6; 6.3 v. 3 a., 7/6; 5 v. 3 a., 7/6.

SMOOTHING CHOKES, 25 m.a., 2/9; 40 m.a., 4/-; 60 m.a., 5/6; 150 m.a., 10/6. 2,500 ohms, 60 m.a. Speaker Replacement Chokes, 5/6.

WILLIAMMETERS, moving-iron, flush 2 1/2 in., all ranges from 0-10 m.m., 5/9. Visual tuning, 6 or 12 m.m., 5/9. Moving-coil meters, 2 1/2 in. 0-1 m.a., 18/6; 3 1/2 in. 0-1 m.a., 22/6. Multipliers, 1/- each.

AMP METERS, all ranges from 0-1 amp., 5/9. A.C./D.C. TELSEN Multi-meters, 3 and 30 m.a., 8, 16 and 8/6 each.

TRANSFORMERS, latest type Telsen R.G.4 (list 12/6), 2/9 Lissen Hypernik Q.P.P. (list 12/6), 3/6.

OUTPUT TRANSFORMERS for Power, Pentode and Push-Pull, 2/6; Multi-Ratio, 4/6; Push-Pull Input Transformers by prominent manufacturer, 4/6 each.

ELIMINATOR KITS for A.C. mains. 120 v. 20 m.a., or 150 v. 25 m.a., 15/-, tapped S.G., det. and output. Complete Kit with long-life valve rectifier (replacement cost only 2/-).

PREMIER L.T. CHARGER KITS for A.C. mains, including Westinghouse Rectifiers and Tapped Mains Transformers. 8 volts at 1/2 amp., 14/6; 8 volts 1 a., 17/6; 15 volts 1 a., 19/-; 15+15 volts 1 a., 37/6; 15+15+15 volts 1 a., 50/-; 8 volts 2 a., 29/6.

TELSEN iron-cored screened coils, W.349, 4/- each. Electric SOLDERING IRONS, 200-250 v., A.C./D.C., 2/3.

LOTUS JACKS (and Jack-switches), all types, 1/- each. Lotus Plugs, 1/- each.

PREMIER H.T. KITS, all with Westinghouse rectifiers; tapped transformers and adequate smoothing. All Kits absolutely complete. 120 v. 20 m.a., 20/-; with 1/2 a. L.T. Charger, 29/-; 150 v. 30 m.a., 25/-; with 1/2 a. L.T. Charger, 31/6. 250 v. 60 m.a., with 4 v. 3 a. C.T., 30/-.

SHORT WAVE KITS

NEW 1937 1-VALVE SHORT-WAVE RECEIVER OR ADAPTOR KIT 13 to 86 Metres without coil changing. Complete Kit and Circuit 12/6.

VALVE GIVEN FREE! DE LUXE MODEL 14 to 150 Metres, complete Kit with Chassis, 4 Coils and all parts 17/6.

SUPERHET CONVERTER KIT, 13/6.

S.W. SUPERHET CONVERTER, for A.C. Mains Receivers, 20/- A.C. Valve given FREE!

NEW 1937 2-VALVE S.W. KIT, 13 to 86 Metres without coil changing. Complete Kit and Circuit, 19/6. VALVES GIVEN FREE. DE LUXE MODEL, 14 to 150 Metres, complete Kit and Chassis, 4 Coils and all parts, 25/-. VALVES GIVEN FREE.

3-VALVE S.W. KIT, S.G. Det. and Pen., 42/- VALVES GIVEN FREE!

BAND-PASS TUNING PACK, comprising set of Telsen 3-gang iron-cored coils with switching, mounted on steel chassis with 3-gang condenser, illuminated disc-drive and 4 valve holders, 25/- the lot. All Mains or Battery circuit. FREE!

SPECIAL OFFER. LISSEN TWO GANG SCREENED ALL-WAVE COILS, 12 to 2,000 Metres, complete with switching and wiring diagram, 6/11 per set.

3 VALVE BAND-PASS KIT, 200-2,000 metres. Complete kit of parts, including chassis, all components, valves, M.C. speaker and wiring diagram. Battery Model, 50/- A.C. Mains Model, 70/-.

MOVING COIL SPEAKERS

MAGNAVOX. Mains energised. '154,' 7in. cone, 2,500 ohms 4 watts, 12/6; '152,' 9in. cone, 2,500 ohms, 17/6; '152 Magna,' 9in. cone, 2,500 ohms, 6 watts, 37/6. Magnavox P.M.s.—'254,' 7in. cone, 16/6; '252,' 9in. cone, 22/6. Reliable P.M.s., 10/6.

ROLA latest type P.M.s. 18/6. GOODMANS' 8in. mains energised, 1,000 ohms field, 10/6 each.

DIALS.—Clarion Illuminated S.W. slow-motion Dial with 2in. knob, 2/- Premier All-Wave 2-speed Dial, full vision straight-line, dual ratios 10-1 and 150-1, 6/6, with esutcheon.

Potentiometers by well-known makers. All values up to 1 meg., 2/- with switch, 2/6. GRAMOPHONE MOTORS. Collaro Gramophone Unit consisting of A.C. motor, 100-250 v. high quality pick-up and volume control, 45/-; Collaro motor only, 30/-; Collaro Universal Gramophone Motor, 100-250 v. A.C./D.C., with high quality pick-up and volume control, 67/6; Collaro Universal Motor only, 49/6; Edison Bell double-spring motors, including turntable and all fittings, 15/-; Cosmo-

cord Gramo unit, comprising A.C. motor pick-up and volume control (list 55/-), 35/9.

TUBULAR CONDENSERS, non-inductive, all values up to .5 mfd., 6d. each.

Wire-end RESISTORS, any value, 1 watt, 6d.; 4 watts, 1/-; 8 watts, 1/6; 15 watts, 2/-; 25 watts, 2/6 each.

Reliable MORSE KEYS with Morse Code engraved on bakelite base, 2/- each.

Bakelite case BUZZERS, 1/6; Walnut case "Loud-tone," 2/6 each.

Super Quality lightweight HEADPHONES, 3/9 pair.

PREMIER (Reisz Pattern) Transverse-current MIKE, High Output, Straight Line Response, 30/-. Transformer. 5/- Table Stand, 7/6.

HAVE YOU HAD OUR LATEST GIANT ILLUSTRATED CATALOGUE AND VALVE LIST? IF NOT, SEND 4d. IN STAMPS FOR THIS AMAZING LIST OF BARGAINS!

# ARMSTRONG 6-Valve

### SUPERHETERODYNE RADIOGRAM Chassis with ROLA F.6 SPEAKER

THIS new chassis is designed to give a good all round performance with 2 1/2 watts output on both radio and gramophone. Short wave band is arranged to cover both the English and American amateur bands as well as the usual short wave broadcast. All the best English components are used throughout and the circuit incorporates the latest improvements such as three wavebands with hand-pass input, full range volume and tone controls working on both radio and gramophone, large full vision scale with station names marked on all wavebands, etc.

The price includes radiogram chassis complete with 6 British valves and 8" Rola moving coil speaker, matched to the chassis, mains leads, pilot lamps and everything ready for immediate use. Packing and carriage free.

7 days' trial, carriage paid.

ARMSTRONG 12 months' guarantee.



Price  
**£7.10.0**  
Ready to switch on.



ARMSTRONG MANUFACTURING CO.  
100, KING'S ROAD, CAMDEN TOWN, N.W.1.  
Phone: GULLIVER 3105.

## For really high-grade mains transformers and chokes—it's best to go to Savage!



From our standard lists or to your specifications. We will gladly send you lists on request or quote to your particular requirements.

# W. BRYAN SAVAGE LTD.



WESTMORELAND ROAD, LONDON, N.W.9  
PHONE: COLINDALE 7131 (3 LINES)

### TRANSATLANTIC All-Wave Tuning Pack

A Complete Superhet. tuning unit, covering 15-50, 200-550 and 1,000-2,000 metres at the turn of a switch. Incorporating latest screened all-wave coils, two 465 K.C. I.F. transformers, latest Polar two-gang condenser and superb full-vision drive and 2 valve-holders. Scale marked in station names, and degrees on short wave band. Completely wired, including A.V.C., aligned and tested, for A.C. or D.C. mains. EXCELLENT GREY CELLULOSE FINISH. SIX TERMINAL CONNECTIONS ONLY. Boxed 49/6 Carriage complete with Circuit and instructions. . . . . paid.  
See also Miscellaneous advertisement on this page for other exclusive bargains.

MAINS RADIO DEVELOPMENT COMPANY,  
4-6, MUSWELL HILL ROAD, LONDON N.6. Tudor 4046.

### COMPONENTS—SECOND-HAND, CLEARANCE, SURPLUS, ETC.

MAINS RADIO DEVELOPMENT COMPANY Offer Exclusive Bargains; unbeatable value, carriage paid; stamp for bargain list; see displayed advert. on this page for exclusive all-wave offer.

**KNOBS**, 1/4in. spindle, hexagonal, brown bakelite, superb appearance, satisfaction guaranteed, exclusive; 2d. each.

**CHASSIS**, three-valve, grey cellulosed, 12in. x 6 1/2 in. x 3. rigid metal, brand new, 1/-; Clix unused chassis valve-holders, 5-pin, 2/6; Plessey 4-pin, 1 1/4d.; 7-pin, 4d.; all baseboards, 4d.

**RESISTORS**, very best make, one watt, colour coded. 1/8 wire ends, unused; every value 50 ohms to 4 megohms, 3 1/2d., 2/9 dozen; two watt, 7d.

**CENTRALAB** Unused 500,000 ohms Potentiometers, 1/-; Cossor 10,000 or 50,000 ohms, with switch, 1/6.

**ORMOND** Unused Efficient H.F. Chokes, 6d.; short-wave type, 4d.; B.I.C. 4 mfd., 350 volt working condensers, 1/8; Lissen 0.1 x 0.1 mfd., 1,500 volt condensers, 9d.

**TELSEN** Latest Boxed Bakelite Reactions, 0.00015 mfd. to clear, 4/4d.; Pye shrouded L.F. chokes, 20h. 120 m.a., boxed, 4/6.

**FINAL** Clearance—Standard telephones, brand new metal case condensers, 400 volt working, 2 mfd, 6d.; 1 mfd., 4/4d.; Formo unused tag condensers, 0.00005-0.002 mfd., 1 1/2d. each.

**ELECTROLYTICS**, all unused, dry type, B.I.C. metal case, one hole, 8 mfd., 550 volt, 2/6; Plessey 8 mfd. 550 volt, 1/8; 50 mfd., 50 volt, 1/8; 200 mfd., 15 volt, 2/3; 16 mfd., 525 volt, 2/-.

**TELSEN** P.M.M.C. Speakers, 7-inch cone, ten ratio output transformer, new, boxed, 11/6.

**HALF-WATT** Resistors, unused, wire ends, good marked sizes, 50 well assorted, 2/6; Lewcos spaghetts, sealed cartons, good assorted sizes, must be cleared, 4d. dozen, 50 for 1/-.

MAINS RADIO DEVELOPMENT COMPANY, 4-6, Muswell Hill Rd., London, N.6. Phone: Tudor 4046. [3558]

**HEADPHONES**—5,000 guaranteed pairs to be cleared. Brown, G.E.C., B.T.H., Ericsson, Nesper, Western Electric, Siemens, Brandes, Sterling, etc., 2,000 ohms, 2/6; 4,000 ohms, 5/-; postage 6d.

**SPECIAL**—Telefunken, adjustable, lightweight, 2,000, 4,000 ohms, 7/6; crystal sets, Burne-Jones, complete, guaranteed, 5/6; ditto, double circuit, 6/6; with permanent detector, 1/- extra; sensitive permanent detectors, 1/6; crystal detectors, complete parts, 1/-; crystals, 6d.—Post Radio, 183, Caledonian Rd., London, N.1. [3526]

**G.P.O.** Condensers, surplus: 1 mfd. 6d., 2 mfd. 1/2, 4 mfd. 1/10, 500-volt working; 1 mfd. 1/9, 2 mfd. 2/3, 4 mfd. 3/9, 800-volt working; 1 mfd. 2/9, 2 mfd. 3/3, 4 mfd. 4/9, 1,000-volt working; postage, 500 v.w. 3d., 800 v.w. 4d., 1,000 v.w. 5d., or c.o.d.—Mentone Radio Stores, 364, Fulham Rd., London, S.W.10. [3501]

### TRANSMITTING APPARATUS

**GENI**—The recognised distributors for amateur equipment, National R.M.E., Thordarson, Hammarlund, McMurda, Hallicrafters, etc.; send 1 1/4d. stamp for catalogue.—Radiomart, 44, Holloway Head, Birmingham. [0531]

### CINEMA EQUIPMENT

**99/-**—The "Illustra" 9.5 mm. super projector, which has the following features to fully recommend itself to you:

**S**PROCKET Feed, Maltese cross intermittent movement as used in motion picture theatres throughout the world.

**S**UPER Projection is Secured with a Lens of High Standard, will give a 6ft. picture from a 12-volt accumulator or any mains.

**F**ITTED for Super Reels of 300 and 400ft.—Prices: accumulator model, 99/-; projection mains model, £5/10; motor drive model, £7/7.

**I**N Short, these are new projectors at better prices than many second-hand offerings.

**A** 16-mm. Model is Also Available of Same Design and Appearance at Same Prices.

**A**LWAYS Available.—Projectors, projection bulbs, motors, screens, lanterns, resistances, dimmers, spotlights, etc.

**N**OT Merely a Shop, a warehouse packed with cine equipment; big selection of 35-mm. and 16mm. films; demonstrations daily from 12 noon.

**I**LLUSTRATED ENTERPRISES, 159, Wardour St., London W.1, Oxford St. end, facing Gaumont-British. Gerard 6889. Your inspection invited. [0486]

### MISCELLANEOUS

**C**HEAP Printing.—1,000 billheads, 3/6; sample free.—Creteway Press, 18, Buxted, Sussex. [3503]

**A** WARM Bed this Winter for 1/4d. per week; the Warm Glow Electric Blanket costs only 52/6.—Leaflet from Warmglow Co., Leigh-on-Sea. [0542]

**T**ELEPHONY, radio and motor engineering are expanding rapidly; there are lots of vacancies; our postal courses will make you eligible; advice on all careers free.—Dept. T92, The Bennett College, Ltd., Sheffield. [0543]

**G.P.O.** Engineering Dept. (no experience required). Commencing £3/13 per week. Age 18-23. Excellent prospects.—Free details of entrance exam. from B.I.E.T. (Dept. 573), 17-19, Stratford Place, London, W.1. [3492]

**A**MBITIOUS MEN.—Here's the way to better pay. Study at home with The T.I.G.B., the leading organisation for engineering training. Write to-day for "The Engineer's Guide to Success"—free—which contains the world's widest choice of engineering courses—over 200—and which alone gives the regulations relating to qualifications such as A.M.I.E.E., A.M.I.W.T., A.Rad.A., etc. Extensive employment facilities for students. Hundreds of vacancies notified every year.—The Technological Institute of Great Britain, 82, Temple Bar House, London, E.C.4. (Founded 1917. 19,000 Successes.) [3506]

## ELECTRADIX BARGAINS

**TRANSMITTERS, MORSE AND SIGNAL KEYS**, Royal Air Force model, balanced action, all solid brass bar, tungsten contacts indicator. Type KBSL, a guinea key for 7/6. Other keys from 4/6 to 30/-. Learner's outfit complete, 4/9. Ask for special illustrated Key List. Send 1 1/4d.

**ALL-WAVE CRYSTAL SETS** with plug-in coils, 2 tuning condensers, semi-perm. detector, 7/6.

**HEADPHONES**—Sullivan 120 ohms, 2/9. Ericsson, Lissen and others, 2,000 and 4,000 ohms, 4/6. Single high res. ear-pieces, 2/6.

**X-RAY VACUUM DISCHARGE TUBES**, 10/- New Government Hospital Surplus, 7" dia. Bulb. Big solid Tungsten electrodes. Emission guaranteed. COST £5. SALE 10/-, Packing, 2/6 extra.

**LIGHT AND RAY CELLS**. Selenium Raycraft, 21/-; Kingston, 15/-; Raycraft outfit with relay and amplifier, 45/-. **Photo-Cells**, for sound on Film, Television and Ray work, B.T.P., 15/-; R.C.A., 25/-; Beck, Angle Prisms, mounted in carrier, 5/6. Micrometer adjusters for lens, 1/-. Eyepieces with prism and lenses for photo-cell inspection, 12/6. Service Set Headlamps with Battery Holder, 7/6.

**MEGERS** as new. Direct Reading .001 ohms to 10 megs. Long scale dial for Resistance makers, 100, 250 and 500 volts, cheap.

**SILVERTOWN** Portable Tester. Combines Wheatstone Bridge, Galvo, shunts and ratios, as new, £8. G.P.O. Plug-in Bridge Resistance Boxes, to 8,000 ohms, 60/-.

**COMMUTATORS**. For Motors and Dynamos 5 to 500 volts. 2/- each. Fractional H.P. motors all sizes, cheap.

**H.T. TRANSFORMERS**—200 40 v. to 10,000 v. 25 m.a., 34/-; 5,000 volts 20 m.a., 19/6; 2,500 v. 15 m.a., 17/6. Large "Butterfly" Neon Signs, 4 ft. 2in. x 4 ft. 11 in. x 6 in., on glass panel, ready for use, £5.

**PUBLIC ADDRESS AMPLIFIERS**—We can supply from stock 3, 6, 10 or 20 watt Mains or Battery Amplifiers in portable or chassis form at lowest prices. Special Pro. Act or Dance Band Portable with mike and speaker, £12. 10 watt A.C. Mains Amplifier, 200/250 v., new, with valves, steel case, £9-10-0. Large Set for 16 watts output, with 4 speakers, £25. P.A. and Cinema Speakers, cheap.

**MICROPHONES, HAND AND STAND**—Transverse, Crystal, Condenser and Ribbon. Our Public Address Eisler-Reiss Transverse Current Microphones are far superior and all the best judges use them. Only 55/-.

**TABLE MODEL "W.W.11"**—Wonderful value, only 15/-.

Sole Bargain List "W" for 1 1/4d. stamp.  
**ELECTRADIX RADIOS**  
218, Upper Thames Street, London, E.C.4.  
Phone: Central 4611.

## ENGINEERS! ARE YOU EARNING LESS THAN £10 PER WEEK?

If so, you cannot afford to carry on without reading our 268-page Handbook. The book explains clearly and definitely many ways of carving out a successful career. Among other things, it explains the Services of our unique Appointments Department; outlines Home-Study Courses in all branches of Civil, Mechanical, Electrical, Motor, Aero, Wireless, "Talkie" Engineering, Television, Building, Gov. Employment, etc., and gives details of B.Sc., A.M.I.C.E., A.M.I.A.E., A.M.I.R.E., A.M.I.W.T., G.P.O., Matric., and all Exams. We Guarantee—"No pass—No Fee." Whether you be an old hand or a budding apprentice, get this book to-day—FREE and POST FREE.

BRITISH INSTITUTE OF ENGINEERING TECHNOLOGY,  
387, Shakespeare House, 17/19, Stratford Place, London, W.1.

## TANNOY

THE SOUND PEOPLE

GUY R. FOUNTAIN LTD.  
FOR CANTERBURY GROVE, WEST NORWOOD,  
ALL LONDON, S.E.27. Phone: Str. 4122 (6 lines).  
SOUND AMPLIFYING EQUIPMENT

### THE INSTITUTE OF WIRELESS TECHNOLOGY

(Incorporated)

4, VERNON PLACE, SOUTHAMPTON ROW, LONDON, W.C.1.  
**THE EXAMINATIONS, MAY, 1937**  
CANDIDATES for the May A.M.I.W.T. Examination must lodge their applications, on Form E, not later than the 30th of January.  
Full particulars of the Institute Examinations and Membership are contained in the new and revised Syllabus to be obtained from the Secretary.



ELECTRIC CLOCKS

SMITHS and Ferranti Electric Clocks, Waltham and Russell watches and clocks; traders' enquiries invited.—Leonard Heys, 36, Henry St., Blackpool. [0526

EXTENDED PAYMENTS

LONDON RADIO SUPPLY Co. (Established 1925) supply on convenient terms components, accessories and sets, any make; 10% down, balance over 12 months; send for list of requirements.—11, Oat Lane, London, E.C.2. [0337

HIRE-PURCHASE.—Prompt delivery of any radio apparatus on convenient terms. WARD, 46, Farringdon St., London, E.C.4. Tel.: Holborn 9705. [0539

EXCHANGE

COSMIC RADIO SERVICES, Ltd., 23, Water St., Liverpool, accept quality mains equipment, meters, components, etc., in part exchange. Meters purchased. [2490

I BUY, sell, exchange good quality receivers, accessories, components; H.P. facilities; promptness, efficiency.—Bostock, 1, Westbourne Terrace, S.E.23. Forest Hill 2236. [0529

PATENT AND TRADE MARK AGENTS

H. N. and W. S. SKERRETT, Chartered Patent Agents, 88-90, Chancery Lane, London, W.C.2 (Hol. 8837), and 24, Temple Row, Birmingham. [2461

GEE and Co. (H. T. P. Gee, Mem. R.S.G.B., A.M.I.R.E., Estab. 1905), 51-52, Chancery Lane, London, W.C.2 (2 doors from Government Patent Office). Holborn 4547 (2 lines). Handbook free. [0001

PATENTS

"PRACTICAL Hints on Patents," free on application.—The Imperial Patent Service, First Avenue House, High Holborn, W.C.1. Preliminary consultation free. [0481

REPAIRS AND SERVICE

GRAHAM'S.

GRAHAM'S Radio Repair and Rewinding Service; 24 hours' service guaranteed.—See below.

ALL Moving Iron Loud Speakers, L.F. transformers, or pick-ups, from 2/6; output transformers from 4/-; postage extra; main transformers, moving coils, electric clocks quoted; trade discounts.—Graham's Repairs, 194, Tolworth Rise, Kingston By-pass, Surrey. 'Phone: Derwent 2060. [3500

DISTAVOX SERVICE.

TRADE Service.—All makes of English and American receivers; quotation by return.

REWINDING.—Mains, L.F. and output, transformers, speakers, headphones, etc.; keenest terms for contracts.

DISTAVOX RADIO SERVICE Co., 119, Bunhill Row, London, E.C.1. 'Phone: National 8589. [3504

"SERVICE with a Smile."

HENRY FORD RADIO, Ltd.,

LEADING Service Specialists for American Receivers, also British; trade work particularly; estimates free. ELECTRONIC House, 22, Howland St., Tottenham Court Rd., W.1. Museum 5675. [0434

METROPOLITAN RADIO SERVICE Co. for Guaranteed Repairs to American (Midget and Standard) and British Receivers.

CLARION and Majestic Service Depot.—I.F. and mains transformers rewound, American valves and parts; trade supplied.—Metropolitan Radio Service Co., 1021, Finchley Rd., London, N.W.11. Speedwell 3000. [0435

SAUNDERS and Co., 15, Percy St., W.1. Museum 3036.—American and English repairs; "Wireless World" sets a speciality; estimates free. [3579

VALRADIO for Repairs and Rewindings to Converters, Motors, transformers, vacuum cleaners, etc.—95, Leighton Rd., Kentish Town, N.W.5. Gulliver 5165. [3210

HOLIDAY and HEMMERDINGER, Dolefield, Manchester, 3.—Free catalogue; amplifiers, microphones, speakers, recording equipment, American valves, books. [3297

GUARANTEED Repairs.—Any transformers, choke, motor, armature, converter, dynamo, etc.; keenest prices, immediate quotation; prompt, dependable service.—See below.

L.T.P. (LONDON TRANSFORMER PRODUCTS, Ltd.), Willesden, N.W.10. Wil. 3568 and 7743. [3470

MAINS Transformer Service.—Repairs, rewinds, or constructions to specification of any type; competitive prices and prompt service.—Sturdy Electric Co., Dip-ton, Newcastle-on-Tyne. [0516

F. E. GODFREY, A.M.I.R.E., qualified to build, repair and convert "Wireless World" sets, etc.; 25 years' experience; prompt service guaranteed.—30, Kemplay Rd., Hampstead, Hampstead 1104. [3509

LOUD Speaker Repairs, all makes, English and American, 24 hour service; transformers made to specification; coils, transformers rewound.—Sinclair Speakers, Alma Grove, Copenhagen St., London, N.1. [3527

RADIO Repairs and Constructional Service, receivers, transmitters, audio amplifiers, etc.; express radio repairs for Lancashire.—Harmony House Sound Service (G2N, G5ZI), 116, Cambridge Rd., Southport. Tel.: 8621. [0536

TRADE Service.—British and American receivers serviced at reasonable cost; estimates free; work guaranteed three months; American valves.—Majestic Service Co., 22-28, King St. West, Manchester, 5. 'Phone: Blackfriars 4951. [0544

RADIOMART SHORTWAVE SPECIALISTS

MICROVARIABLES.—All brass construction; latest ceramic insulation. The finest condensers made; 15 mmfd., 1/4; 40 mmfd., 1/7; 100 mmfd., 1/10. Transmitting Type.—.070in. spacing, 15 mmfd. (neutralising). 2/9. 40 mmfd. Tuning, 3/6. These are quality.

SHORTWAVE COILS.—(RD4) CA 11-25, CB 20-45 metres, 2/6. CC 44-100 metres, 2/9. Standard 6-pin types, CA6, CB6, 2/9 each, CC6, 3/-; same range as 4-pin.

COILFORMS.—Moulded in RD4 natural lous material, hollow resilient pins 1/4in. diameter ribbed; identification disc in top. Four types, 4-pin, 1/6; 6-pin (standard or to fit 7-pin valveholders), 1/9; 7-pin (for bandspread tap), 1/10; Machine threading, 2d. extra.

AMERICAN Mains Transformers, 230 v., fully shrouded, 350-350 6.3 v., 5 v. 6/11; Majestic, 250-250, 2.5 v., 5 v. 4/11. Pilot 260-260, 2.5 VCT, 5 VCT, 5/11.

HEAVY DUTY Mains Transformer, worth 35/-, 350-350, 150 m.a., 4 v., 2.5 ACT., 4 v., 6 ACT., 12/6.

UTILITY 8/6, Microdisc Dials, 3/11; Radiophone, 0.00016 Shortwave Condensers, 3/6; Series gap, twin, 3/9. Shortwave HF Chokes 5-100 metres, 9d.

465 KC Litz Wound IFS, 3/11; Two-speed Slow Motion Knobs, 1/-; Telsan Ace Transformers, 1/11; Iron-cored HF Chokes, 1/-; Utility Straight Line Dials, 2/11; British Radiophone Straight or Superbet 3-gang Condensers, with trimmers fully screened, 4/11.

ELECTROLYTICS. Huge purchase 500 v. Aluminium Can, 4 mf., 1/6; 8 mf., 1/11; 16 mf., 2/6; 8+8 mf., 2/6; 8+8 mf. 450 v. + 8 mf. 250 v., 2/9; Block type, 500 v. peak, 4+4 mf., 1/6; 8+8+4 mf., 3/-; 50 mf. 50 v., 1/3; 25 mf. 25 v., 1/-; 2 mf. 300 v., 9d.; 40+24 mf. 200 v., 1/6.

FAMOUS CONTINENTAL A.C. Valves, 4/6; Battery types from 2/3; American Duotron, etc., all types, 3/6; All types of RCA Licensed first grade tubes, metal and glass, in stock from 5/6.

FEATHERWEIGHT Headphones, 2/6; Varley Bifocal Iron-cored Coils, 2/6; matched pair, 4/6.

SMOOTHING CHOKES, 20 hy., 120 m.a., 3/11; 40 m.a., 1/11; Centralab Pots, all sizes, 1/6; switched, 2/-; 20,000 ohm Pots, 1/-; Tubular glass fuses, 2d.

SPECIAL OFFERS. Class B Kit, worth 30/-. comprising Driver Transformer, Valve and Holder, 5/-; Dozen wire ended assorted resistors, 1/6. Preset Condensers, 9d.

TRADERS! Monster Bargain Parcels value £4/10/0, for 10/-; also 5/- parcels. State battery or mains. Milliammeters 25 m.a. upwards, 5/9; super, 6/9.

PUSHBACK Wire, 6 yds. 6d.; heavy, 9d.; Resin cored Solder, 6ft. 6d.; Screened Flex, single, 6d. yd.; twin, 9d. yd.

CONDENSERS. 4 mf. 700 v. T., 2/6; 2 mf., 1/6; T.C.C. 1 mf., 6d.; Dubilier, 0.1 mf., 3d.; Tubular Condensers, 1,500 v. T., all sizes to 0.1 mf., 6d.; 0.2 to 0.5 mf., 8d.

UTILITY 2-gang Uniknob .0005 with Dial, 3/11. EDC Converters, new, 12 volt to 240 v. 40 m.a., 25/-; BTH ditto, 6 v., input fully smoothed, 39/6.

CRYPTO 500 watt 220 v. DC to 230 v. AC, as new, £10; Ditto, 1,000 watt, £15. One of each only.

AMERICAN latest Double Button Microphones, cost £2 in U.S.A., our price 25/- Why buy junk?

PHILLIPS Screened Ceramic and Brass All-wave .0003 Micro-Variables. Ideal experimenters, 10d. Visual Tuning Meters, 2/-.

SILVER MARSHALL 14-valve all-wave chassis with speaker, 15-550 metres, one only, 9 guineas.

ROLA, used but perfect matched pairs, 2,500 ohms, 10in. and 7in., no transformer, 15/-; Jensen 7in., new PM speakers, 12/6.

Order 5/- post free. Get our Bargain Catalogue, 1½d. post free. All enquiries and requests for Catalogue must send 1½d. stamp.

RAYMART 1936-7 EDITION RAYMART SHORTWAVE MANUAL



48 Pages of practical circuits and data on Shortwave Receivers, transmitters, modulators, transceivers, etc., including information on transmitting licences, "class B" modulation, aeriels, etc. Price with Catalogue 6d., or 7½d. post free. Catalogue only, 1½d. post free.

BIRMINGHAM RADIOMART (G5NI) 19, John Bright Street and Dale End

MAIL ORDER DEPT. "W" 44 HOLLOWAY HEAD, BIRMINGHAM. TELE.: MID. 3254.

REPAIRS AND SERVICE

REPAIRS to Moving Coil Speakers a Speciality; cones and coils fitted, fields altered; prices, including eliminators, quoted, loud speakers, 4/-; L.F. and output transformers, 4/-, post free; guaranteed satisfaction; trade invited; estimates free; prompt service.—Loud-Speaker Repair Works, 5, Balham Grove, London. Battersea 1321. [0394

TUITION

RADIO Training.—Marine, aircraft, broadcast; prospectus free.—Hull Municipal Technical College. [0523

WANTED

PETROL Generator for Mains Set, under 1 kW, anything suitable.—"Woodlands," Uley, Gloucester. [3548

TUNER for Hartley-Turner G.A.12S. Amplifier.—Somers, 205, Broadway, N.W.2. Gl. 1681. [3581

WANTED for Cash.—Modern radio receivers; also meters, etc.—M. R. E., 6, Pentonville Rd., London, N.1. [3283

WANTED, 200-volt A.C. Radiogram, high power, output 10-12-watt speech; must be cheap; age no disadvantage.—Box 436, c/o The Wireless World. [3561

READER Quality Enthusiast desires share house with person similar taste; no objection to occasional high outputs; Brixton, Clapham, Balham districts.—Box 463, c/o The Wireless World. [3599

WE Buy for Cash All Types of Modern Second-hand Radio Sets and Accessories, test meters, parts, etc.; we pay more than any other dealer; part exchanges; bring, send, or will call.—University Radio, Ltd., 82, Hampstead Rd., London, N.W.1. 'Phone: Euston 3810. [3484

SITUATIONS VACANT

WAR DEPARTMENT.

DESIGNER Draughtsmen (adult, male) Required for Signals Experimental Establishment at Woolwich. CANDIDATES must have at least 5 years' practical workshop experience; they must be capable of designing radio instruments from technical data, and should have had varied experience of radio mass-production methods, including moulding, press-tool and automatic machines.

PAY up to 140/- per week according to qualifications and experience; ex-service applicants given preference, other things being equal.

APPLICATIONS to be made in writing, giving full particulars of age, qualifications, and past experience, to The Superintendent, Signals Experimental Establishment, Woolwich Common, S.E.18. [3580

WIRELESS and Television.

MARCONI'S and Other Employers Require Hundreds of Trained Men This Year. We train students for all branches of Radio at our Residential Colleges in Southampton and Colwyn Bay, and guarantee appointments; licensed by Postmaster-General recommended by Marconi's.—Write for free prospectus, The Wireless College, Colwyn Bay, or to London Office, 4, Winton Av., N.11. [0541

SERVICE Engineer, actual experience E.M.I., Philco, etc.; good wage, overtime, commission; permanency right man.—Fullest details, references, to Chaitell, 40, High St. North, Dunstable. [3566

RADIO Service Engineer Required; permanency for fully competent man; must drive car.—Apply, state age, experience, and salary required, to T. Austin and Son, 122, Upper Richmond Rd., Putney, S.W.15. [3574

RADIO Engineer, with good practical experience of Cathode ray tube and time base technique, particularly as applied to television.—Write, stating age, experience, and salary required, to Box 437, c/o The Wireless World. [3562

LABORATORY Assistant, 22-26, design and development components, apparatus, television; experience essential; East London area.—Write full details; also vacancy Junior, with experience.—Box 448, c/o The Wireless World. [3583

ENGINEER Required by Factory near Nottingham, for design and test laboratory; knowledge of modern component assembly, also design of metal and sheet bakelite parts essential.—Forward usual particulars to Box 429, c/o The Wireless World. [3556

RADIO.—Wanted, first class men for fault diagnosis and accurate gauging of "all wave" superhets; experience in mass production methods desirable (in the Midlands); give full details of experience, age and salary required.—Box 426, c/o The Wireless World. [3555

DESIGNER-DRAUGHTSMAN.—Large Company has vacancy in department specialising in small and medium size radio transmitters for designer capable of initiating design of mechanisms, frameworks, switches, and similar component parts.—Box 461, c/o The Wireless World. [3593

A LIMITED Number of Vacancies Occur Monthly for young men with secondary school education, to be trained in the Royal Air Force as Wireless Operators; age limits 17½ to 32.—Apply: R.A.F. Recruiting Depot, Victory House, Kingsway, London, W.C.2, or any R.A.F. Recruiting Depot. [3512

WANTED for Radio Valve Factory North London, radio engineers, with experience of testing valves and receivers; also young men with University Degree and valve manufacturing experience; applicants with no previous experience may be considered for training.—Apply, giving full particulars, to Box 435, c/o The Wireless World. [3559

SITUATIONS WANTED

SERVICE Engineer and Salesman, R.M.S. member, require situation in South-west London or Surrey; has own test equipment.—Box 453, c/o The Wireless World. [3586

GENTLEMAN, aged 31, desires position as manufacturer's representative; good general travelling training; 16 years' wireless experience; own "P.A." and testing equipment; excellent driving record.—Box 438, c/o The Wireless World. [3564

INDEX TO ADVERTISEMENTS

	PAGE		PAGE		PAGE
Anson, Henry, Ltd.		Exide, Ltd.		Postlethwaite Bros.	8
Armstrong Mfg. Co.	6	Forbat, Eugen, Ltd.	8	Premier Supply Stores	5
Automatic Coil Winder & Electrical Equipment Co., Ltd.	4	Galpins		Prism Manufacturing Co.	8
Bakers Selhurst Radio		G.E.C.		Radio Development Co.	
Belling-Lee, Ltd.	3	Gramplan Reproducers, Ltd.	8	Radio Industries Development Co.	
Benjamin Electric, Ltd.	2	Hartley Turner Radio, Ltd.	1	Record Radio	8
Birmingham Radiomart (G.S.N.1)	7	Haynes Radio		R.G.D.	Back Cover
British Institute of Engineering Technology	6	Imhof, Alfred, Ltd.		Savage, W. Bryan	6
British Insulated Cables, Ltd.	Inside Back Cover	Institute of Wireless Technology	6	Scientific Supply Stores (Wireless), Ltd.	
British Rola Co., Ltd.	Edit. 71	Mains Radio Development Co.	6	Sifam Electrical Instrument Co.	
Bulgian, A. F., & Co., Ltd.		Marconi Wireless Telegram	Inside Back Cover	Sound Sales, Ltd.	4
Cass, Sir John, Institute		Maud Export & Trading Co.		Stratton & Co., Ltd.	Inside Back Cover
C.A.V.		McCarthy Radio, Ltd.	Edit. 69	Tannoy Products	6
Dubilier Condenser Co.	Inside Front Cover	Midwest Radio, Ltd.	Inside Back Cover	Universal Radio Distributors, Ltd.	
Ediswan, Ltd.	Front Cover	Musikon, Ltd.	Inside Back Cover	Varley, Ltd.	
Electradix Radios	6	Parneko, Ltd.		Ward, C. F.	8
		Players Cigarettes		Westinghouse Brake & Signal Co.	Back Cover

**SPECIAL OFFER FOR THE NEW YEAR**  
NEW KITS FOR OLD AND NEW VALVES FOR OLD

We suggest that Constructors seize the opportunity of trying out the Famous OSTAR-GANZ UNIVERSAL HIGH VOLTAGE VALVES, which are rapidly conquering the market. The advantages of using these valves will be proved soon after you accept our part exchange offer which we are backing with a six-months' guarantee, compared with the usual guarantee of three months, with 20% P.K. allowance. The same applies to our full range of Universal ALL-WAVE RECEIVERS, AMPLIFIERS, RADIOGRAMS AND TRANSMITTER KITS. Apply to:

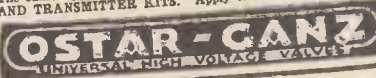

**EUGEN J. FORBAT**  
28-29, Southampton St., Strand, London, W.C.2. Temple Bar 8608-4985.

WHY NOT BUY DIRECT FROM THE MANUFACTURER?  
WHY NOT EXCHANGE YOUR OLD SET FOR A NEW ONE?

**HYVOLTSTAR**

UNIVERSAL ALL-WAVES, ALL-MAINS, A.C.-D.C. SUPERS, RADIOGRAMS AND AMPLIFIERS.

"Wireless World" report says, re **THE REVOLUTIONARY NEW BATTERY-MAINS RECEIVER**—

"The set... should prove invaluable to people whose business takes them into unexpected places... There is a really sparkling performance on the medium wave-band... The quality of reproduction is admirably suited to the all-round usefulness of this receiver..."

UNIVERSAL HIGH VOLTAGE RADIO LTD., 28-29, Southampton Street, Strand, W.C.2. Telephone: Temple Bar 4985 & 8698.



**PRISM**  
RADIOGRAMS AND P.A. EQUIPMENT



PRISM MANUFACTURING CO.  
CALIFORNIA WORKS, BELMONT, SURREY. Phone Sutton 53672

**RECORD**

The quality valve in the COMPLETE range

RECORD RADIO LTD., 2/3, Eldon Street, E.C.2

**HIRE PURCHASE**

We can supply any Radio and Electric Apparatus on HIRE PURCHASE having a value of over £3 at convenient terms, including Midwest, Halcyon, Challenger, Armstrong and other receivers. Sparton Refrigerators, etc., etc.

CHAS. F. WARD, 46, Farringdon Street, LONDON, E.C.4. Tel.: Holborn 8703.

**KINVA WHISTLE SUPPRESSOR**

Type A.5, for anode circuits, will cut out strong, high-pitched 9 Kc. whistles with negligible effect on quality. A neat two-coil unit, and simply switchable if required... 12/-  
V.2, tunable type, with switchable complete cut-off, for grid circuits, panel control, removes whistle and 'splash'... 17/6  
down to 4 Kc/s... 10/6  
Q.A.S. tunable, for Q.A. Super. 10/6

Details, Graphs, etc. for stamp.

POSTLETHWAITE BROS., KINVER, STAFFS.



**GRAMPIAN**

PUBLIC ADDRESS EQUIPMENT

P.A. at its Best

GRAMPIAN REPRODUCERS LTD.  
Kew Gardens, Surrey.

*The Autocar*

The Leading Motoring Paper  
EVERY FRIDAY 4d. W.W. 16

The **Wireless World**

**DIARY for 1937**

Size 3½ by 4½ inches, 192 pages. Bound leather cloth, back loop with pencil.

1/6 net.  
By post 1/7.

Contains 76 pages of facts, formulæ and general information, including a complete list of European Broadcasting Stations and Short-Wave Stations of the World. An important section contains all the recognised codes relating to components and there are nine pages of base connections of British and American valves. Sixteen pages of circuit diagrams of receivers, amplifiers and such units as whistle suppressors, tone controls and AVC systems are included.

From booksellers, bookstalls and stationers or direct from the Publishers

ILIFFE & SONS LTD., DORSET HOUSE, STAMFORD STREET, LONDON, S.E.1

W.W. 75.

**NOW READY!**

*Second Edition—Thoroughly Revised*

**WIRELESS SERVICING MANUAL**

By W. T. COCKING (of "The Wireless World")

The first complete book of reference of its kind, A reliable practical guide for amateur and professional. The first edition of this book was sold out in a very few months and a second edition, with additional material, is now on sale.

The "Wireless Servicing Manual" deals fully with Testing Apparatus, and explains the methods of locating and curing faults in receiving equipment. Ganging, Automatic Volume Control, Instability, Distortion, Mains Hum, Whistles and Local Interference are all separately treated.

Fresh information on short-wave receivers, and on methods of operating extension loud speakers, has been added. The reference material including base-connections for British, Continental and American valves, and the various colour codes for components has been extended and brought up to date.

Issued in conjunction with "THE WIRELESS WORLD" and Published by the Proprietors:—

ILIFFE & SONS LTD., DORSET HOUSE, STAMFORD STREET, LONDON, S.E.1

W.W.20

# B.I. RESINKOR SOLDER AND CORALINE PASTE



B.I. Resinkor Solder, which carries its own flux, is supplied in 9-in. sticks, in coils of 1 to 20 S.W.G. weighing up to 28 lbs., and all but the largest sizes can also be supplied on reels. For use with ordinary solder, B.I. Coraline Soldering Paste is excellent. It gives off no spray or fumes, does not run or dry, and is very economical, as only a trace is required. Sold in tins from 1 oz. to 7 lbs.

**BRITISH INSULATED CABLES LTD.**

*Cable Makers and Electrical Engineers*  
**PRESCOT, LANCS.**

Telephone No.: PRESCOT 6571

London Office: SURREY HOUSE, EMBANKMENT, W.C.2

Telephone No.: Temple Bar 7722.

## PERMAREC HOME RECORDING UNIT MAKES PERFECT RECORDS

PRICE  
**£3.17.6**

A thoroughly sound engineering job specially designed for easy attachment to any set or Radiogram. Cutting your own records is perfectly simple with this unit.

Write to-day for Free Copy of "The Wireless World" Test Report and illustrated leaflet fully describing this and our larger professional models.



Manufactured under British Patent No. 433614.

**MUSIKON LTD. RECORDING STUDIOS**  
Telephone: Gerard 7105 and 3862.  
19, LISLE STREET, LONDON, W.C.2.

## 1937 MIDWEST

**THE ONLY ALL-WAVE RECEIVER COVERING 4½ to 2,400 METRES**

Available in Chassis form complete with matched valves and 12" speaker or in Console Cabinet.

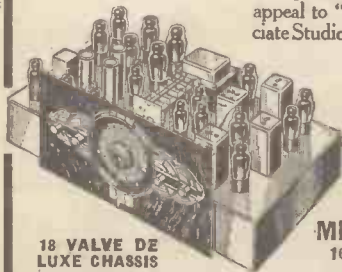

18 VALVE DE LUXE CHASSIS

Magnificent alike in its conception, design and performance, this the latest Midwest Model X-18 High Fidelity Receiver brings the world to your fireside. With its 6 TUNING RANGES it gets "Everything on the Air." Its distinctive features in circuit design are not just "talking points," as a comparison will prove, but basic advantages which will assuredly appeal to "Wireless World" readers and all who appreciate Studio or Concert Hall quality of performance in home.

**FREE** Our fully descriptive 40 PAGE ILLUSTRATED ART CATALOGUE giving particulars of Midwest 11, 14, 16 and 18 valve models.

DEMONSTRATIONS at our showrooms Mondays to Saturdays from 9 a.m. to 8 p.m.

DEFERRED PAYMENTS. The London Radio Supply Co., 11, Oat Lane, Noble Street, London, E.C.2, supply all models on Easy Terms.

**MIDWEST RADIO LTD., SHOWROOMS & FACTORY:**  
16, OLD TOWN, CLAPHAM, LONDON, S.W.4.  
Phone: MA Caulry 5005.

# ★ Incorporates the Best in DIAL DESIGN for MODERN Short Wave TUNING



No. 1070  
**8'9**

The movement can be mounted from panel or baseboard.

The dial is noiseless in operation even on the highest frequencies.

The open vision scale is clearly readable and divided in a new attractive manner into 100 divisions so that the indicating pointer has ample space for accurate settings.

The readings are arranged to increase as the frequency increases, which is in keeping with modern practice.

The movement is superbly smooth in action, without backlash on both the 20-1 and the 100-1 speeds.

The dial face fits on the front of the panel so that no large panel gap has to be cut unless it is desired to illuminate the scale from the back.

The dial can be used on panels up to ¼" thick and takes the standard ¼" spindle.

The escutcheon has a simple dignified appearance and is beautifully finished in oxidised silver relief.

## EDDYSTONE FULL VISION Dual Speed Dial

Sole Manufacturers: STRATTON & CO., LTD., EDDYSTONE WORKS, BIRMINGHAM  
London Service Depot: Webb's Radio, 14, Soho Street, Oxford Street, W.1

**STABILOVOLT**  
THE SOLUTION TO UNSTABLE SUPPLY VOLTAGE

The Stabilovolt tube is a voltage dividing potentiometer and voltage regulator. The voltages tapped are independent to a precision of about 1% from the supply voltage variations, 1-2% from the varying current intensities tapped, .01% from one another. Currents up to 200 mA, divided into parts of 70 volts each. Light in weight, small in size, simple and safe in operation.

**MARCONI'S**

Prices: Stabilovolt tubes from £1.16.0 to £62. Iron Barretters, for use with above, from 10s. to £1.7.6. Full particulars from:

MARCONI'S WIRELESS TELEGRAPH CO., LTD., Electra House, Victoria Embankment.

Mention of "The Wireless World," when writing to advertisers, will ensure prompt attention.

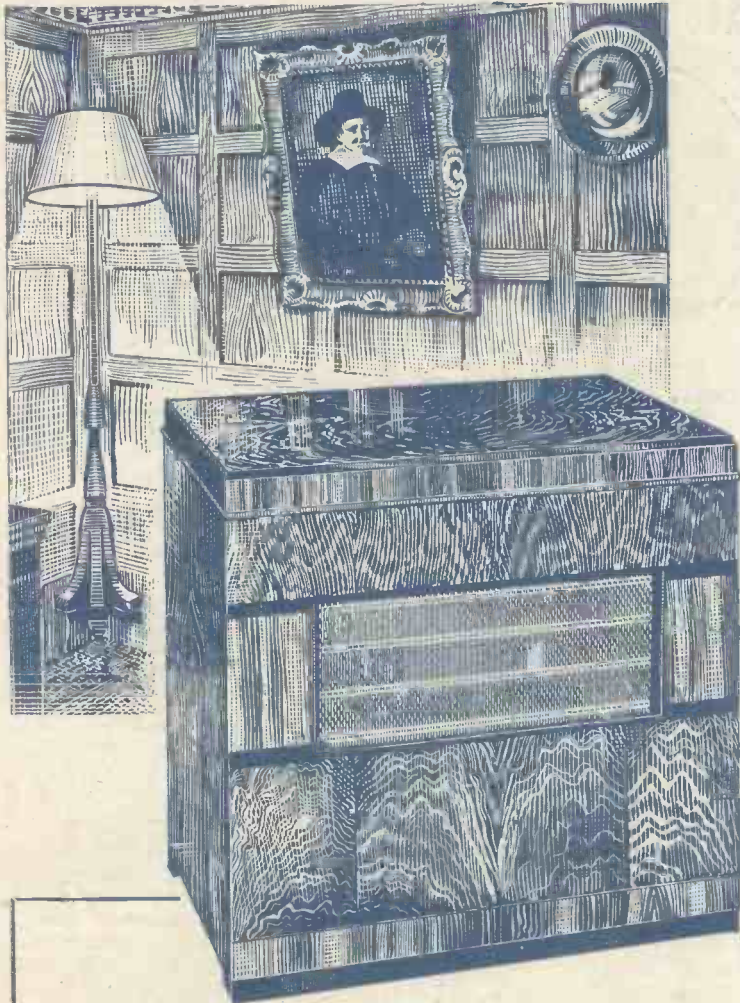

Instal an R.G.D. Radio Receiver or Radio Gramophone in your home and make 1937 a memorable year. Enjoy the finest attainable reproduction of broadcast speech and music . . . world-wide reception with freedom from interference . . . all-wave reception from the 5 continents.

In the R.G.D. range will be found an instrument to suit every requirement—every purse. Each embodies unique and revolutionary features which place R.G.D. in the forefront of radio receivers and radio gramophones.

Highest fidelity reproduction; controlled variable selectivity, simplicity of tuning, high and low tone balance control, Neon or "Mystic Ray" tuning indicators.—

Send a postcard for Illustrated descriptive literature and study the specifications. Ask any good class radio or musical instrument dealer to arrange a demonstration, without obligation, in your own home. Give R.G.D. any test you will and you will arrive at one conclusion, that it has overthrown all previous standards.

Radio Receiver 25 Gns. Console 30 Gns. and Automatic Radio Gramophones from 45 to 120 Gns. Cash or on Convenient Hire Purchase Terms.

Enjoy a new thrill in radio. Let R.G.D. give you the keenest enjoyment that radio can offer—enjoyment not for months, but years.

# R.G.D.

*"The Aristocrats of the Radio World."*

**RADIO GRAMOPHONE DEVELOPMENT CO. LTD.**  
**GLOBE WORKS - NEWTOWN ROW - BIRMINGHAM, 6.**  
 London: 40, DOUGHTY ST., W.C.1. Manchester: 17, BRIDGE ST.

Holdens

# ALL YOU WANT TO KNOW ABOUT A.C. MAINS RADIO, DETECTION & A.V.C.

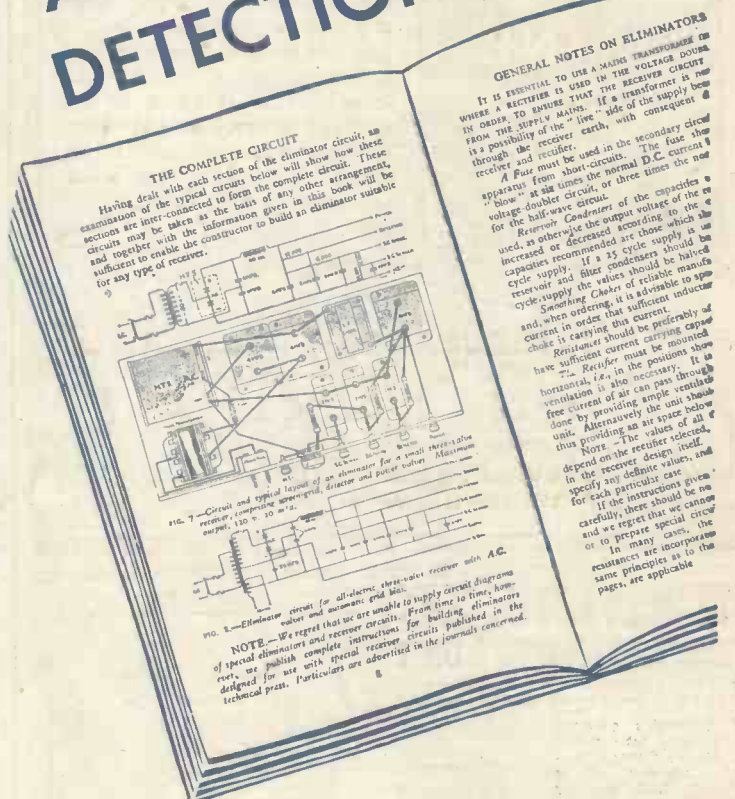

"The All-Metal Way, 1937," is more than a catalogue of Westinghouse Metal Rectifiers—it's a text book on A.C. mains radio, distortionless detection and automatic volume control. Every constructor will find it of great use . . . and it costs only 3d. post free. Get a copy to-day.

## WESTINGHOUSE METAL RECTIFIERS

**COUPON**

**WESTINGHOUSE BRAKE & SIGNAL CO. LTD.,**  
 82, York Road, King's Cross, London, N.1.

Please send me "THE ALL-METAL WAY, 1937" for which I enclose 3d. in stamps.

NAME .....

ADDRESS .....

W.W.15/1/37

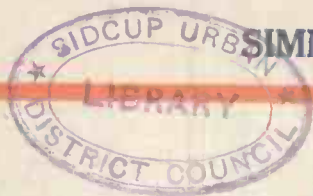

4<sup>D</sup>

# The Wireless World

## THE PRACTICAL RADIO & TELEVISION JOURNAL

Friday, January 22nd, 1937

### free!

### Blueprints of splendid sets



Colvern have specially designed two brilliant "up to the minute" sets and blueprints of them are being given away free (except for small postage charge). Using the new

## COLPAK

(Made under licence from patents, Hans Vogt) these sets offer the very latest in efficiency, precision and design. Send for blueprints to-day!  
To COLVERN LTD., Romford, COLPAK CLASS B Essex. Please send me full details and blueprint of the A.C. MAINS SET  
Stamps value 3d. to cover postage are enclosed.  
\* Strike out name of blueprint not required.

Name .....

Address .....

If you would like a copy of our Ferrocart booklet, please put a X here. ....

" .. but they MUST be **T.C.C. WET ELECTROLYTICS** "

The Telegraph Condenser Co. Ltd., Wales Farm Road, N. Acton, W.3.

763

Everything for

## QUALITY RECEPTION



Everything for the

## TELEVISION CONSTRUCTOR

Duophase amplifier 6-watt, Duophase amplifier 6-watt for P.M. speaker, Duophase amplifier 14-watt, Duophase amplifier 14-watt (constructor's model), Duophone amplifier circuits, Duophase intervalve coupling, gramophone amplifier 6-watt, gramophone amplifier 14-watt, 1-H.F. tuner unit, 2-H.F. tuner unit, all-wave tuner unit, shortwave converter, table model receivers, radiogramophones, schools receivers, baffle boards, loud speakers, volume controls, mains transformers, smoothing and filter chokes, output transformers.

Originators of the Quality Receiver and Quality Radiogramophones.

Demonstration night every Friday, 7.30-9.30 p.m.

Time base transformers, time base units, H.T. transformers up to 6,000 volts, heater transformers, smoothing and voltage regulating equipment, high voltage rectifiers, cathode ray tubes and holders with protecting front screen, converter units for speech reception, complete apparatus for vision receiver construction, chassis and special baseplates.

The most attractive development ever presented to the radio enthusiast.

Have you the Haynes Quality Booklet? 1936-37 Edition. Free on request.

Enfield 2726.

HAYNES RADIO LIMITED, QUEENSWAY, ENFIELD, MIDDLESEX.

# OF TECHNICAL IMPORTANCE

# NEGATIVE FEED-BACK AMPLIFICATION FOR D.C.-A.C. CIRCUITS

# Osram Valves

MADE IN ENGLAND

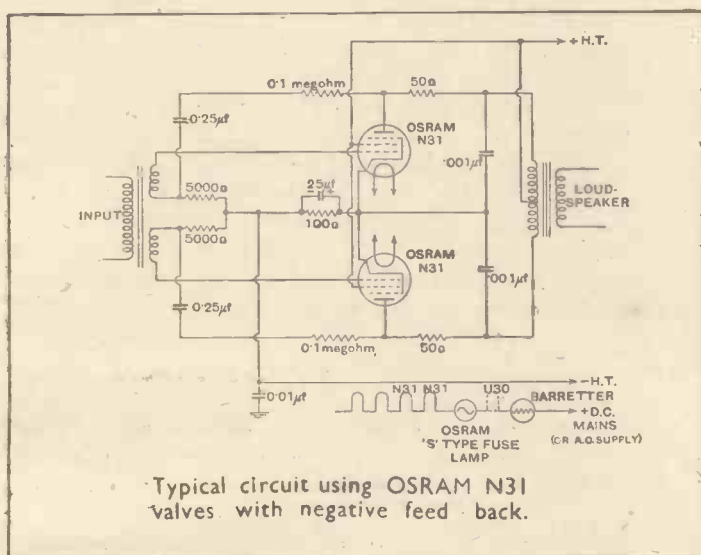

## TYPE N31 HIGH SENSITIVITY OUTPUT PENTODE

"The development of the negative feed-back principle has made it economically possible to build a D.C. Mains Amplifier which is strictly comparable from the point of view of quality with the best A.C. apparatus . . . ."

"The chief advantage of the arrangement is to give a pentode performance which approaches that of a triode as regards quality of amplification."

The ideal valve for negative feed-back circuits is the OSRAM N31.

### CHARACTERISTIC OF TYPE N31.

Heater Current	.....	0.3 amp or 0.6 amp.
Heater Volts	.....	26.0 or 13.0
Anode Volts	.....	200 max.
Screen Volts	.....	180 max.
Mutual Conductance	.....	10.0 mA/volt
Anode Current average	.....	40 mA
Screen Current average	.....	10.6 mA
Anode Dissipation	.....	8 watts
Normal Grid Bias	.....	-4.4 volts
Automatic Bias Resistance: each valve	.....	87 ohms
Optimum Load (single valve)	.....	5,500 ohms
Optimum Load (anode to anode, Low Loading Push-Pull)	.....	7,000 ohms

Price each : 13/6

### OTHER OSRAM 0.3 AMP. SERIES — RUN VALVES TO OPERATE WITH THE N31 ARE —

TYPE W31	Vari- $\mu$ Screen Pentode	12/6
TYPE X31	Triode-Hexode Frequency changer	15/-
TYPE H30	High ' $\mu$ ' Triode	9/6
TYPE D41	Double diode	5/6
TYPE DH30	Double-diode-Triode	12/6
TYPE U30	Rectifier	15/-

Technical data on application.

## OSRAM VALVES — DESIGNED TO ASSIST THE DESIGNER

Advt. of The General Electric Co., Ltd., Magnet House, Kingsway, London, W.C.2.

Mention of "The Wireless World," when writing to advertisers, will ensure prompt attention.

# The Wireless World

THE PRACTICAL RADIO JOURNAL  
26<sup>th</sup> Year of Publication

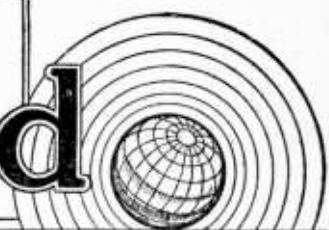
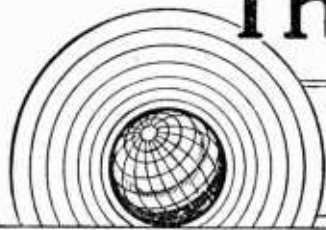

No. 908.

FRIDAY, JANUARY 22ND, 1937.

VOL. XL. No. 4.

Proprietors : ILIFFE & SONS LTD.

Editor :  
HUGH S. POCOCK.

Editorial,  
Advertising and Publishing Offices :  
DORSET HOUSE, STAMFORD STREET,  
LONDON, S.E.1.

Telephone: Waterloo 3333 (50 lines).  
Telegrams: "Ethaworld, Sedist, London."

COVENTRY: Hertford Street.

Telegrams: "Autocar, Coventry." Telephone: 5210 Coventry.

BIRMINGHAM:

Guildhall Buildings, Navigation Street, 2.  
Telegrams: "Autopress, Birmingham." Telephone: 2971 Midland (4 lines).

MANCHESTER: 260, Deansgate, 3.

Telegrams: "Iliffe, Manchester." Telephone: Blackfriars 4412 (4 lines).

GLASGOW: 26B, Renfield Street, C.2.

Telegrams: "Iliffe, Glasgow." Telephone: Central 4857.

PUBLISHED WEEKLY. ENTERED AS SECOND CLASS MATTER AT NEW YORK, N.Y.

Subscription Rates:

Home, £1 1s. 8d.; Canada, £1 1s. 8d.; other countries, £1 3s. 10d. per annum.

As many of the circuits and apparatus described in these pages are covered by patents, readers are advised, before making use of them, to satisfy themselves that they would not be infringing patents.

## CONTENTS

	Page
Editorial Comments .. ..	73
Synchronising in Television ..	71
Holland's New Broadcasting House	78
Current Topics .. ..	81
Simplifying the Beat Frequency Oscillator .. ..	82
Unbiased .. ..	85
Listeners' Guide for the Week ..	86
Random Radiations .. ..	88
Broadcast Brevities .. ..	89
The Loud Speaker and the Cabinet	90
Letters to the Editor .. ..	92
On the Short Waves .. ..	92
Recent Inventions .. ..	91

## EDITORIAL COMMENT

### Broadcasting on Ultra-Short Waves

#### Interesting Possibilities Opened Up

**T**HIS is not the first time that we have made reference to the possibilities of ultra-short-wave sound broadcasting, for as long ago as May, 1935, we were discussing on this page the potential importance of these wavelengths for high quality transmissions. We then said "although we seem to have settled down as the result of some years of experience to the idea that medium wavelengths are ideal for general broadcasting purposes, it is interesting to speculate as to whether this view will hold in the years to come.

"Quite obviously, any drastic or hasty change could not be contemplated, for the scrapping of medium-waveband transmitting stations, even if the advantages of so doing were immense, would render sets in universal use obsolete as well as the transmitting stations themselves, and such capital loss could not be entertained.

"But, nevertheless, the coming of television on ultra-short wavelengths does open up the possibility that sound broadcasting on these wavelengths may gradually achieve popularity amongst listeners to a point where regular listening as at present, on the medium wavelengths, may go out of fashion.

Earlier this month we published a note to the effect that in all probability the B.B.C. will shortly establish an ultra-short-wave service for the relay of national programmes, the transmitter being situated on the roof of Broadcasting House. There is every probability that this news will be confirmed in the very near future and the possibilities which this experiment opens up are extremely interesting.

Keen interest in the possibilities of

the new transmissions is already being shown, particularly by enthusiasts in London, who stand to reap the first-fruits of the scheme. A vast number of Metropolitan listeners may expect to be able to take advantage of the service with the help of extremely simple apparatus—at least so far as the radio-frequency side of the set is concerned.

That the use of ultra-short waves would enable very high quality sound reproduction to be achieved has long been recognised, but it is probably because of the extremely high standard of reproduction attained by the Alexandra Palace sound transmissions that attention has been focused on this matter in recent weeks.

#### An Opportunity

When these transmissions are started from Broadcasting House and extended, as we hope they may be, to other parts of the country, it is very desirable that the opportunities provided should be made use of to the very best possible advantage. In our view, it is a deplorable waste of opportunity to make use of the ultra-short waveband associated with television for the transmission of sound from film records or, in fact, to use it for any purpose other than those programme items which justify high quality. We would like to see these ultra-short wavelengths devoted exclusively to the transmission of music and other items where quality really matters.

Perhaps in the future more and more of the local broadcasting in this country will be done on wavelengths of this order, thus releasing other channels in the present broadcasting bands for the transmission of longer talks and other material so much needed for educational as well as for entertainment purposes, and for which high quality transmission is not essential.

*THE complete separation of the synchronising impulses from the vision signal is essential for stable pictures and some form of amplitude filter is necessary. The requirements are discussed in this article and various types of filter are described.*

# Synchronising in TYPES OF AMPLITUDE FILTERS

By W. T. COCKING

ONE of the greatest difficulties which arises in television receivers is the problem of synchronisation. It is well known that scanning is effected by causing a spot of light, or its equivalent, to traverse a series of parallel lines across the picture. In the receiver the picture is built up by a spot of light traversing an identical series of lines across the screen of the cathode-ray tube.

In most cases electrostatic deflection is used and the electron beam which causes the light spot by striking the screen is deflected by means of suitable voltages applied to the two pairs of deflecting plates. These plates are mounted at right angles and the horizontal deflection for producing the lines is obtained by applying a rapidly varying voltage to one set of plates while a slowly varying voltage applied to the other pair moves the spot vertically and so opens out the otherwise superimposed lines into a raster.

For distortionless reproduction of the picture it is necessary that at any and every instant the light spot be relatively in the same position as that in the transmitter. The permissible tolerances are very small indeed and quite small variations are sufficient to destroy any semblance to a recognisable picture.

secured in this way; indeed, it is usually possible to hold an intelligible picture for no more than a few seconds.

Something is required to force the time-bases to function with extreme regularity, and this is provided by the synchronising impulses in the transmission. At the end of every line traversal an impulse is provided which trips the line time-base at precisely the right moment and so forces it to operate in step with the transmission. Similarly, at the end of every frame a much longer pulse, or a long series of pulses, is provided for keeping the frame time-base in step.

Provided that the pulses actually applied to the time-bases are a faithful copy of those impressed upon the transmission, good synchronising is not difficult to secure. It is important, however, that the pulses should be as nearly the same as the original ones as possible, for if anything is added or subtracted the stability of the synchronising is likely to be greatly reduced.

Now both the Baird and E.M.I. transmissions include synchronising impulses of similar type. The intelligence necessary for the production of a picture is conveyed by variations in the amplitude of the carrier. The amplitude is varied between 30 per cent. and 100 per cent. of its maximum value for the picture signal proper and between zero and 30 per cent. for the synchronising impulses.

The carrier waveform thus takes the form shown at (a) in Fig. 1, and it will be seen that the synchronising pulses really consist of a complete cessation of the carrier. After rectification, the detector output takes the form shown in (b) and is applied directly to the cathode-ray tube for modulating the

the spot occurs. It is not possible to work with the spot brighter than this without a loss of detail.

This point of defocusing must correspond to white in the picture. The operating conditions must thus be adjusted so that when the carrier is modulated 100 per cent. the grid potential just reaches this point of defocusing, and when it is modulated 30 per cent. it is at the point of extinction of the spot; the difference between these two points is usually of the order of 20 volts. These conditions are shown in Fig. 2, and it will be seen that the synchronising impulses

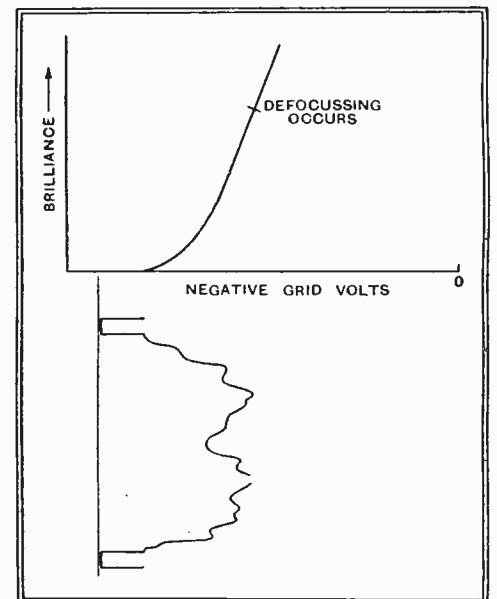

Fig. 2.—The characteristic curve of a CR tube is shown above with the applied waveform below. The picture signal is applied so that it sweeps over the useful part of the curve and the synch. pulses represent a signal which is "blacker than black."

fall upon a part of the tube characteristic where it is inoperative. They appear on the picture merely as a uniform black band at the edge.

The output of the detector is positive; that is, an increase in modulation depth causes the detector output voltage to increase in a positive direction with respect to earth. The change of detector output voltage during a synchronising impulse, however, is in a negative direction; in other words, there is a certain mean detector output, and during the synchronising pulse the output falls below this value. It is consequently in the wrong phase for operating the time-base.

A phase-reversal stage could be inter-

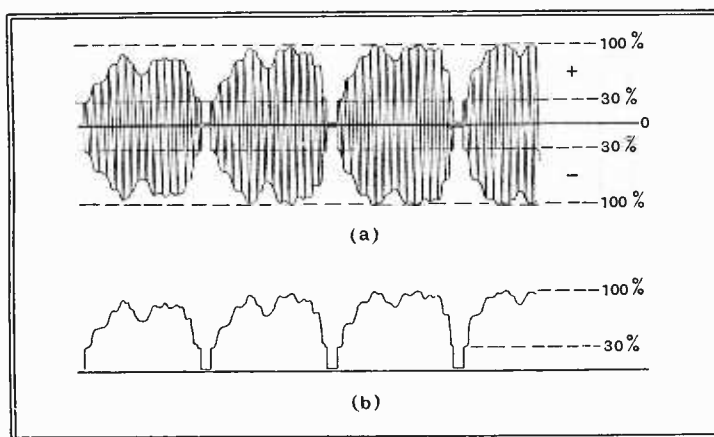

Fig. 1.—The IF waveform takes the form shown at (a) where the carrier is regularly interrupted for the synchronising pulse. After detection, the waveform is of the type shown at (b).

Self-running time-bases are usually employed for generating the scanning voltages, and it is theoretically possible to secure correct results merely by adjusting the controls so that they produce the correct frequencies. In practice, however, no time-base will operate sufficiently regularly for satisfactory results to be

electron beam. The tube has a characteristic like that of Fig. 2. At a certain negative grid voltage the light spot is extinguished and this voltage must naturally correspond to black in the picture. As the grid voltage is made less negative the spot gets brighter and brighter until a point is reached at which defocusing of



# Television

posed, but this alone would not be sufficient, for the effective amplitude of the synchronising pulses would no longer be independent of the picture signal. This would occur because of the necessity for using intervalve couplings which remove the DC component. If we have a series of pulses such as those of (a) in Fig. 3 developed across a resistance  $R_1$ , then the pulses developed across the resist-

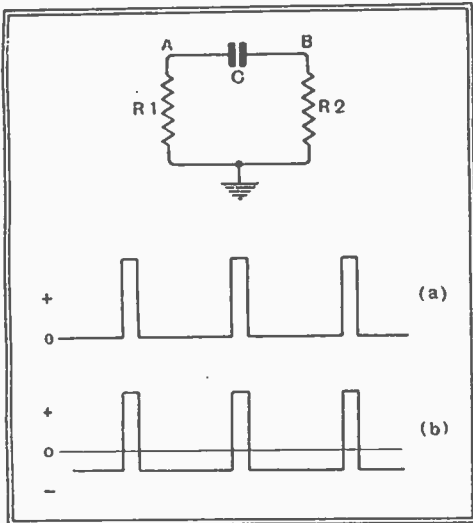

Fig. 3.—A resistance-condenser combination cannot deal faithfully with a waveform of the type shown at (a) for it removes the DC component. The waveform after the coupling is that of (b); only the changes of voltage are properly reproduced.

ance  $R_2$  are not identical. They can be very nearly the same in shape if the product  $C R_2$  is large enough, and the total change of voltage will be the same.

When the voltage at the point A moves as shown from zero to a positive value and back again to zero, that at the point B moves from a negative value through zero to a positive maximum less than that of point A and then back through zero to the original value negative with respect to earth. This is, of course, for the steady

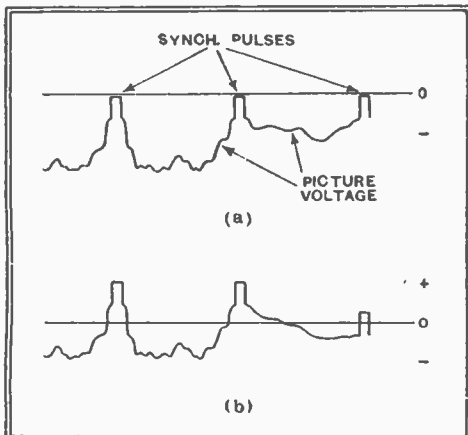

Fig. 4.—The effect of an RC coupling is to make the synch. pulses of different effective amplitudes when the picture content changes.

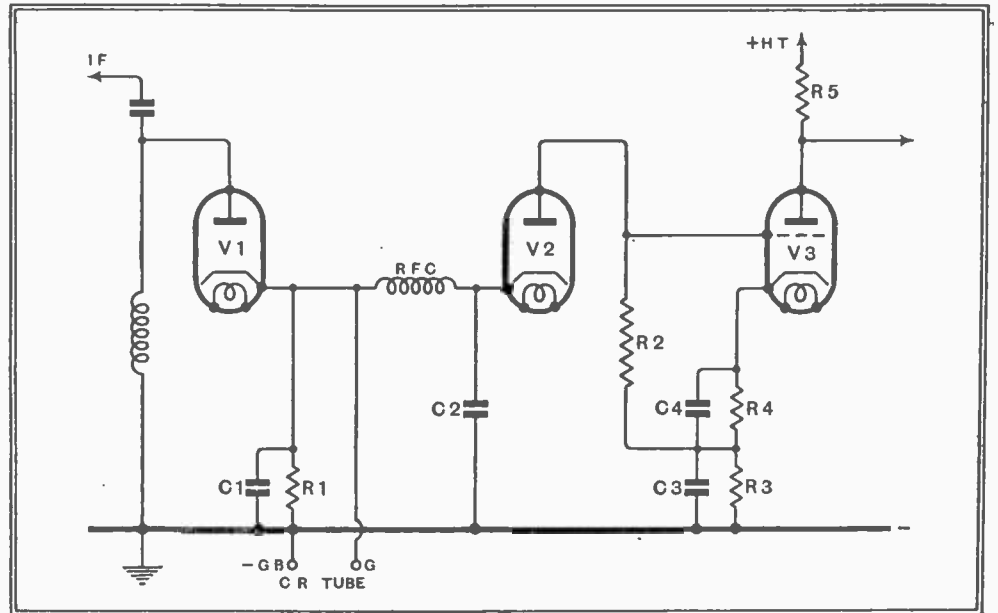

Fig. 5.—One method of synch. separation is shown above. The synch. separator is the diode  $V_2$  and the triode  $V_3$  is used as an amplifier and phase-reverser.

state after many cycles of such pulses. The amount by which B is negative between pulses depends upon how frequently the pulses occur and how long they are maintained. If their amplitudes vary, then the mean negative value between pulses will not be a constant and the positive amplitude of the pulses will vary.

Now suppose that we obtain a detector output voltage, such as that of Fig. 4 (a), in which the synchronising impulses are in the right phase. It is true that the picture signal is now in the wrong phase, but this need not worry us at the moment. If we use resistance-capacity coupling, the true output voltage will take the form shown in (b) in a greatly exaggerated manner. Two successive lines are shown as having a widely different picture content as evidenced by the different amplitudes of the picture voltages. When this is passed through a coupling which removes the DC component, the magnitudes of the voltage changes tend to remain unaltered, but near extremes of voltage tend to settle themselves at equal positive and negative values about the zero line. The tendency is for the sum of the positive and negative values over a period to be zero.

It is thus clear that the absolute positive amplitude of the synchronising pulses will vary with the picture content. The pulses will still occur at the right time to trip the time bases, it is true, but as the

length of the fly-back depends in some degree upon the amplitude of the pulses, the operation will be affected. Actually, the different lines will tend to start at different times, and so they will be slightly displaced and reduce the definition of the picture.

It is consequently necessary to filter out the picture voltages in such a way

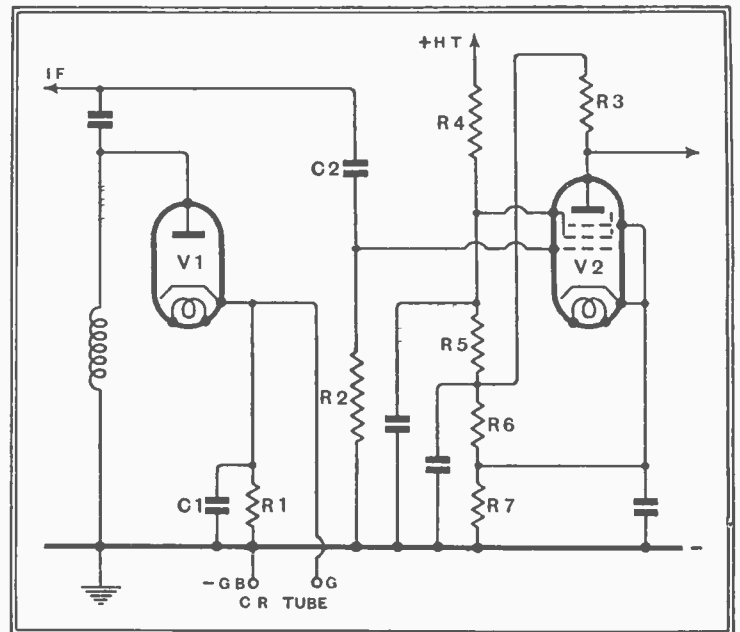

Fig. 6.—An amplitude filter which operates with an IF input gives extremely good results in practice. The RF pentode is operated with an anode supply of about 6 volts only.

that the amplitude of the synch. pulses is independent of the picture content. There are several ways of doing this, and one that has been used is shown in Fig. 5. The valve  $V_1$  is a diode detector of normal type and the voltage developed across its load resistance  $R_1$  is of the form shown in Fig. 1 (b), and is applied directly to the cathode-ray tube from the appropriate terminals. The valve  $V_2$  acts as a "synch.-separator," while  $V_3$  is an amplifier and phase-reverser.

**Synchronising in Television—**

When the picture output has a total swing of 20 volts on modulation changes from 30 per cent. to 100 per cent. the change of voltage across  $R_1$  due to the synch. pulse is  $20 \times 3/7 = 8.6$  volts. The anode of  $V_2$  is returned through  $R_2$  to a point about 5 volts positive, the voltage being conveniently obtained from a resistance  $R_3$  in the cathode circuit  $V_3$ .

Now, during the synch. pulse, there is no voltage across  $R_1$ , and the resistances  $R_1$  and  $R_2$  with  $V_2$  thus form a potentiometer across  $R_3$ . The voltage across this last resistance is in such a direction that the anode of  $V_2$  is positive with respect to its cathode, and this valve is consequently conductive and has a resistance  $R_a$ . The grid of  $V_3$  thus has a potential of  $5 \text{ volts} \times (R_a + R_1) / (R_a + R_1 + R_2)$  with respect to earth; the grid potential can be negative with respect to cathode, however, for an initial bias resistance  $R_4$  is included. With suitable values for the resistances the grid may be 3 volts above earth.

Now suppose that the synch. pulse ceases. The voltage across  $R_1$  returns to 8.6 volts and then rises higher during the picture signal. We now have two voltages in opposition acting on  $V_2$ ; there is

cathode and the diode ceases to conduct; the grid potential of  $V_3$  then becomes 5 volts above earth. No further increase in the voltage across  $R_1$  can affect the grid voltage of  $V_3$ , for the diode has become non-conductive.

The synch. pulse thus changes the grid potential of  $V_3$  from 5 volts above earth to about 3 volts, so that the grid potential changes by some 2 volts in a negative direction. The anode potential consequently rises by a greater amount and we obtain an output from  $V_3$  consisting of a positive pulse for each synch. pulse, all pulses being of the same amplitude, irrespective of the picture content. It is thus quite permissible to use resistancy-capacity coupling from the anode circuit of  $V_3$  to the time-bases.

Referring again to Fig. 5, it will be noted that an RF choke is included with a by-pass capacity  $C_2$ . These components are employed to prevent the application of IF potentials to  $V_2$ . Such potentials necessarily appear to some degree across  $R_1$ , and if applied to  $V_2$  the negative half-waves will render  $V_2$  conductive at the wrong moment. Care must be taken in the disposition of the choke, for it easily picks up mains hum which

volt. The mode of operation of the circuit is unaffected by this fact, but it must be taken into account when choosing values of components.

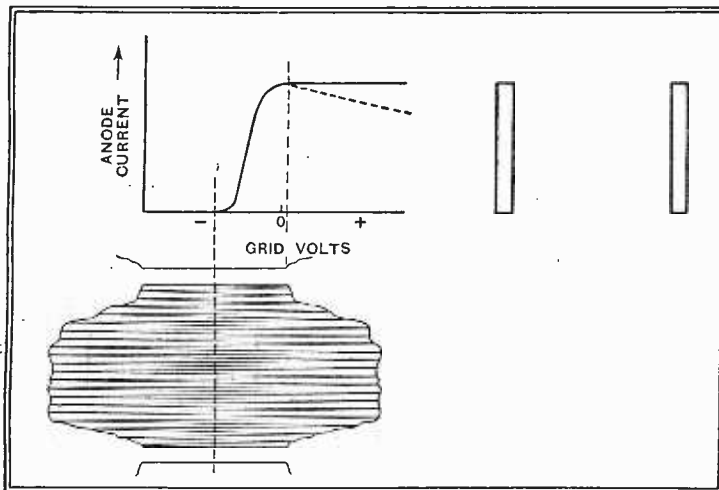

Fig. 7.—The operation of the filter of Fig. 6 can readily be seen from the characteristic curve, for the vision signal falls on the flat top and only the synch. pulses appear in the anode circuit.

the 5 volts across  $R_3$  tending to make the anode positive and the voltage across  $R_1$  tending to make the cathode positive or the anode negative. When the voltage across  $R_1$  exceeds that across  $R_3$ , the anode becomes more negative than the

will be superimposed on the line scanning. In the writer's experience even heater wiring must be kept well away from it! In addition, the anode-cathode capacity of  $V_2$  must be kept as small as possible, otherwise the picture frequencies will pass through it and reach  $V_3$  even when  $V_2$  is non-conductive.

The output obtainable depends on  $V_3$  and its operating conditions, and by suitable design can be made as much as 20-40 volts. The ordinary time-base, however, does not need more than a tenth of this amplitude, and in some cases it is possible to replace  $V_3$  by a transformer. It should be noted that in the foregoing explanation it has been tacitly assumed that a diode ceases to conduct as soon as its anode is negative with respect to its cathode. This is not the case in practice, and a diode usually conducts until the anode is more negative than about  $-1$

An alternative circuit is shown in Fig. 6; the detector remains as before, but no use is made of the synch. pulses in the detector output. Instead, they are derived directly from the intermediate frequency. The intermediate frequency is applied to the grid of  $V_2$  through  $C_2$ ; this valve has a characteristic with very sharp top and bottom bends of the type illustrated in Fig. 7, and the valve is biased just beyond anode current cut-off. The IF input waveform is drawn below the curve and it is easy to see what happens. The negative half-cycles of input cause no change in the current. Very small positive voltage changes also cause no current, but larger changes cause a rise in anode current. When they are large enough, however, they fall on the flat top of the characteristic and cause no further change in current.

**The IF Synch. Separator**

The operating conditions are adjusted so that with 30 per cent. modulation the crests of the positive half-cycles of input come well above the top bend, so that the changes of amplitude due to the picture modulation come on the flat top. At first sight this would appear to offer perfect separation of the synch. pulses, for it would seem that they should all be of the same amplitude.

This would be the case if the modulation envelope were solid. It must not be forgotten, however, that this envelope only indicates the peaks of the IF waveform. In effect, we are distorting this waveform by limiting the peak to a constant amplitude. Instead of the current waveform on each IF half-cycle being a half sine wave it will take the form shown in Fig. 8 (a) when the amplitude is only a little greater than the value needed to bring it to the top bend in the valve curve. When the input is much larger than this, however, it tends to the form

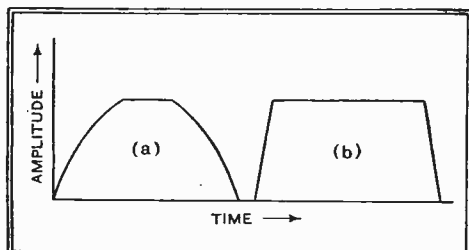

Fig. 8.—When the picture amplitude is small, a single IF half-cycle takes the form of (a) in the synch. separator, but when it is large it is more like (b). This results in the vision signal having some effect on the synchronisation.

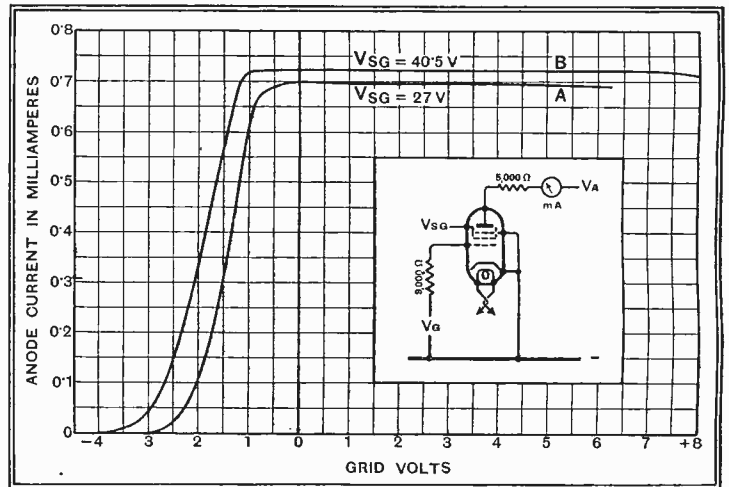

Fig. 9.—The characteristics of the Cossor MS Pen measured under the conditions indicated are shown here. For good operation at  $V_{SG} = 27$  volts, the input should not be less than 10 volts peak on 100 per cent. modulation.

**Synchronising in Television—**

of Fig. 8 (b), and it is easy to see that the area enclosed by the curve is greater.

In view of this the anode current of the valve will be greater when the picture amplitude is large than when it is small. This may not at first be clear, but it will be when it is remembered that the anode current with a large input is not equal to the value of the flat portion of the curve, but is less than this. The current is actually a kind of mean value of the instantaneous values during the RF half-cycles, and will obviously be constant only if all the RF half-cycles are constant.

It follows that this circuit cannot give perfect separation of the synch. pulses and that the amplitude of the pulses will depend in some degree on the picture content. An improvement is obtained if the characteristic does not have a flat top but one which falls with increasing voltage, as shown by the dotted curve of Fig. 7. With a curve of this nature the current tends to constancy with increasing input, for the falling characteristic tends to offset the increased area of the IF half-cycles effective over the main portion of the curve.

**Operating Conditions**

It is now pertinent to enquire how we can obtain such a characteristic. A close approximation to the ideal can be obtained from an RF pentode operated under suitable conditions, and the curves of Fig. 9 show the results with a Cossor MS Pen with 5.05 volts HT voltage. With this exceedingly small anode voltage a saturation effect soon sets in and gives a remarkably sharp upper bend to the curve, particularly with 40 volts screen-potential.

As grid current flows, it is important to take the characteristics with the resistances in circuit and for these curves R<sub>2</sub> and R<sub>3</sub> had values of 9,000 ohms and 5,000 ohms respectively. With 27 volts screen-potential the normal grid bias should be about -3.5 volts and the peak IF input during 100 per cent. modulation not less than about 10 volts. On 30 per cent. modulation, or more, the grid potential will be slightly positive and the envelope of the modulation will fall on the flat top. The small degree of over-biasing found with a grid potential of -3.5 volts reduces the effect of interference and valve noise on the synchronising.

With this circuit the output is positive in sign and has a maximum possible amplitude of 3.5 volts for the conditions quoted. Actually it will be slightly less. It is, however, sufficient to control time-bases of the type embodying gas-filled triodes, and gives excellent results.

Should a larger output be required at any time it is easy to add a stage of amplification. This will reverse the phase, so to obtain a positive output from the amplifier a negative output is needed from the synch. separator. This is readily obtained by biasing the valve on the top instead of the bottom bend, and for curve A, Fig. 9, we should use a bias of +0.5

volt instead of -3.5 volts. As a screen-grid valve is used, there is little risk of a leakage of the input to the output circuit

through the valve capacities, provided that reasonable precautions are taken in the layout.

**In Next Week's Issue**

*The Wireless World*

**EXPERIMENTER'S  
IF AMPLIFIER**

**I**N every class of experimental work it is often necessary to depart from the orthodox, and radio is no exception. New ideas frequently arise, and putting them into practical form usually entails considerable constructional preparations, though much of this work can be avoided by having available some standard units

**High-gain Selective Unit  
Embodying some  
Novel  
Features**

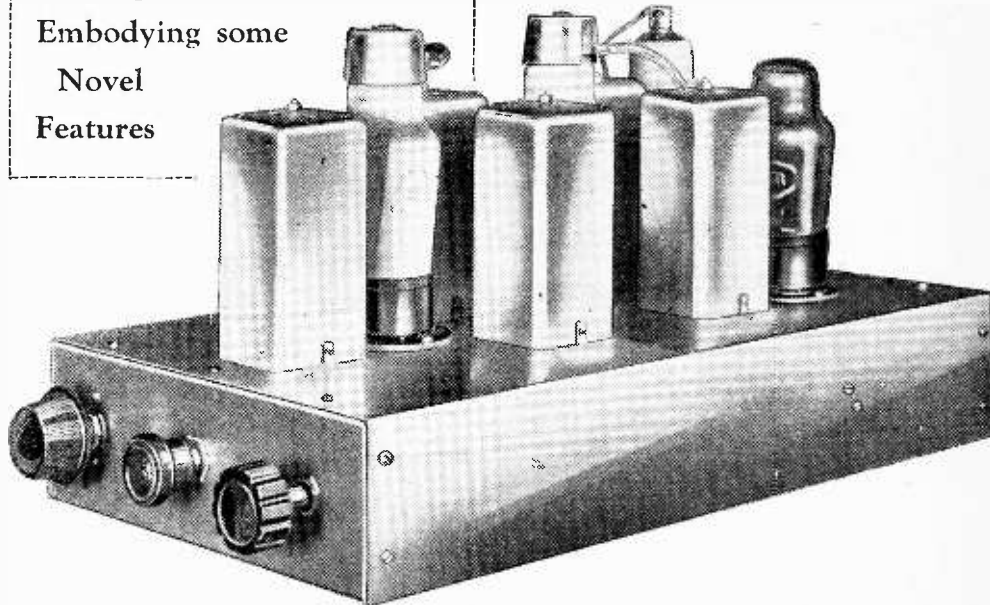

- THE LIST OF PARTS REQUIRED**  
*Certain components of other makes but of similar characteristics may be used as alternatives to those given in the following list*
- 2 IF transformers, 465 kc/s (special) **Varley BP97**
  - 2 IF transformers, 465 kc/s (special) **Varley BP98**
  - 1 IF oscillator unit, 465 kc/s (special) **B.T.S.**
  - 1 Volume control, 10,000 ohms, wire-round **Haynes**
  - 1 Volume control, 0.25 megohm, tapered, (without switch) **Polar-NSF V/4**
  - Condensers:**
    - 2 0.0001 mfd. mica **T.C.C. "M"**
    - 1 0.0005 mfd. mica **T.C.C. "M"**
    - 1 0.01 mfd. mica **T.C.C. "M"**
    - 10 0.1 mfd. tubular **T.C.C. 250**
    - 1 4 mfd., 450 volts, dry electrolytic **T.C.C. 502**
    - 1 50 mfd., 12 volts, dry electrolytic **T.C.C. "FT"**

- Resistances:**
  - 2 250 ohms ½ watt **Dubilier "F"**
  - 5 1,000 ohms ½ watt **Dubilier "F"**
  - 1 2,000 ohms ½ watt **Dubilier "F"**
  - 3 20,000 ohms ½ watt **Dubilier "F"**
  - 1 50,000 ohms ½ watt **Dubilier "F"**
  - 1 100,000 ohms ½ watt **Dubilier "F"**
  - 2 1 megohm ½ watt **Dubilier "F"**
  - 1 30,000 ohms 1 watt **Dubilier "F"**
  - 1 50,000 ohms 1 watt **Dubilier "F"**
  - 1 10,000 ohms 2 watts **Dubilier "F"**
  - 1 7,500 ohms 3-5 watts **Dubilier Spirohm**
- 1 Switch, double-pole, double-throw **Bulgin S114**
- 2 Screened valve top connectors **Bulgin P64**
- 1 Plug valve top connector **Belling-Lee 1175**
- 1 Five-way connector **Bryce**
- 3 Valve holders, 7-pin, chassis mounting, without terminals **Clix V2**
- 1 Valve holder, 5-pin, chassis mounting, without terminals **Clix V1**
- 1 Panel bush, ¼ in. bore **Bulgin Type C**
- 1 Shaft coupler, ¼ in. bore **Bulgin**
- 2 Stand-off insulators **Eddystone 1019**
- 1 Aluminium chassis, 14 x 8 x 2½ in. **B.T.S.**
- 1 Brass rod, 10 in. long, ¼ in. dia.
- Valves:**
  - 2 VMP4G (metallised), 1 MHD4 (metallised), 1 MH4 **Osram**

to which the experimental parts may be added.

An IF amplifier can be regarded as one such unit, since, by the addition of a frequency changer, a superheterodyne receiver is quickly assembled, and various arrangements of the signal circuits can be easily compared with the minimum of trouble. An IF amplifier has been designed mainly for this purpose, and, being self-contained, should be very useful to the amateur experimenter.

It consists of two 465 kc/s IF amplifying stages, with eight tuned circuits, a diode detector, AVC, IF beat oscillator, and one AF amplifier. Sensitivity and AF volume controls are embodied, also a switch which, when the beat oscillator is in use, renders AVC inoperative.

Its sensitivity is high, and the selectivity is adequate for the usual requirements of reception on all broadcast wavebands, including the short waves.

# Holland's New Broadcasting

*THE recently opened Dutch Broadcasting H.Q. is one of the most up-to-date in Europe and has excited favourable comment even in America. Our contributor has made a personal inspection of the building, as a result of which he is able to give a very detailed description of it.*

Holland is the listener's paradise. There are no licence fees and no publicity broadcasts. The Dutch listener joins, of his own free will, a listener's organisation and pays a voluntary annual subscription which goes to pay for his programmes. There are four great organisations in Holland, three of which are in some manner connected with political or religious parties, and one of which is entirely neutral. The first of these is the Avro which, incident-

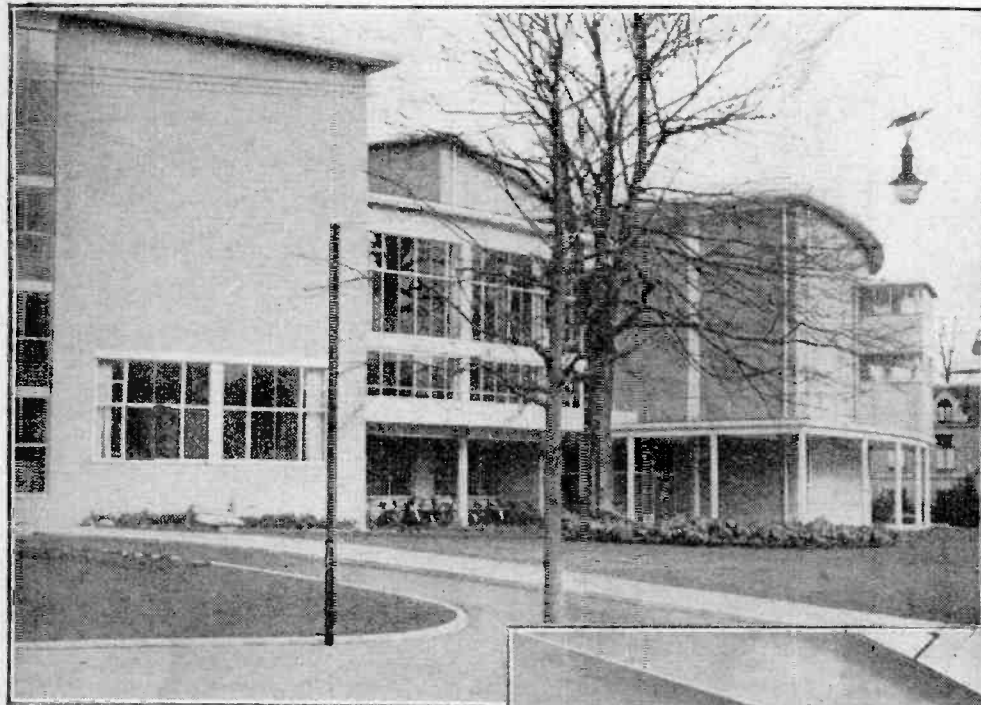

**T**HE new headquarters of the General Association for Wireless Broadcasting at Hilversum which was completed in July, 1936, may go down in history as the "house which impressed America" as an American was so intrigued by the Avro's new house that he desisted from his projected tour of other Continental broadcasting houses and even invited one of the two Dutch architects responsible for the Hilversum house to America to advise on the plans for various new studio centres which Columbia are building.

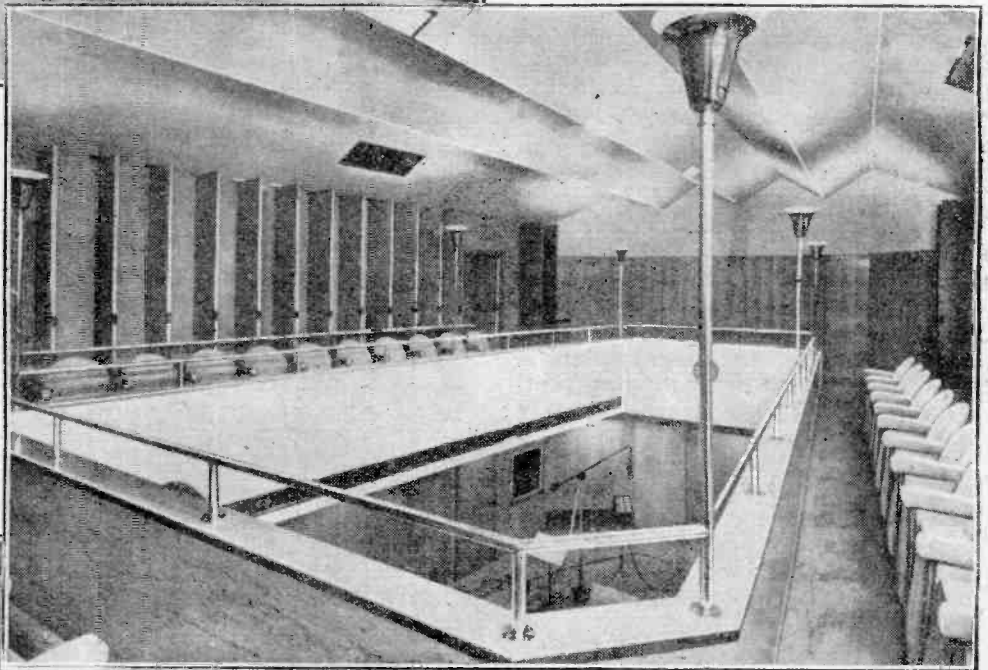

A distinctly modern note is struck by the architecture of the new A.V.R.O. building at Hilversum. The dance-music studio (above) is seen from a gallery provided for visitors. The large concert hall, which has seating accommodation for five hundred people.

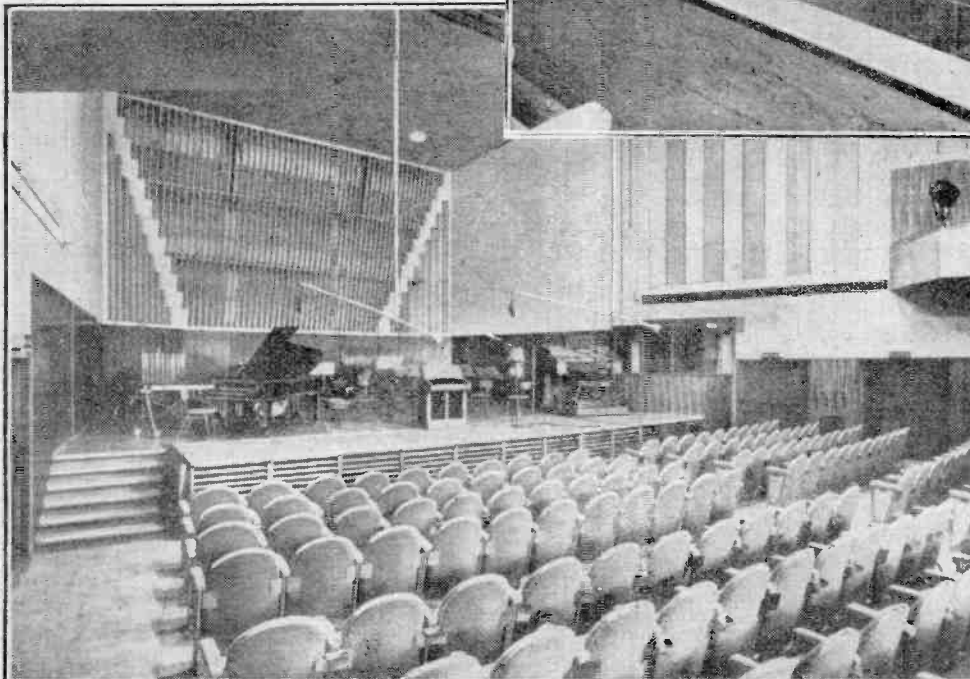

ally, has the largest number of members. Owing to the wavelength situation the four organisations have to share two transmitters so that each can only get half a week's broadcasting time.

Avro's new house is intended for a dual purpose, broadcasting and public entertainment in the non-broadcasting periods. As it may occasionally happen that the two may overlap, the house has been so constructed as to separate the public enter-

# House

## DESCRIPTION OF THE NEW A.V.R.O. BUILDING AT HILVERSUM

By "WANDERING WAVE"

tainment section from the actual broadcasting section. The house is semi-circular and is situated a few yards from Hilversum's ultra-modern Town Hall. As some readers may inquire why at Hilversum and not in The Hague or Amsterdam, I would like to explain that Hilversum is the traditional home of Dutch broadcasting and is only half an hour by express train from Amsterdam.

The broadcasting section contains seven

two "shells." This is bridged by special thresholds which prevent persons from stumbling over the gap in the doorways but which do not give mechanical connection. The doors are in steel frames and are of special construction. A bar closes them tightly at top, centre and bottom, and during my brief visit my guide felt a certain amount of fatigue after opening and closing them.

audience will not make too great a difference. In all the studios, except in the talks and chamber music ones, part of the walls have panels with two coatings, one absorbent and the other reflectant.

In the larger radio drama studio a small section of the far part of the floor has been raised and railed off to resemble a small stage. Two floor surfaces are provided, one stone, the other wood, to give actors the possibility of creating various effects when walking, possibly also for "stepping." Apart from the effects' studio, the big drama studio has a door built in, exactly similar to that in the Lausanne house, for effects use. It resembles a cupboard.

Large photos mounted under glass are a feature of the talks studio. The dance-band studio has a gallery with a number of seats for a small audience. The announcer's studio can hardly be called a

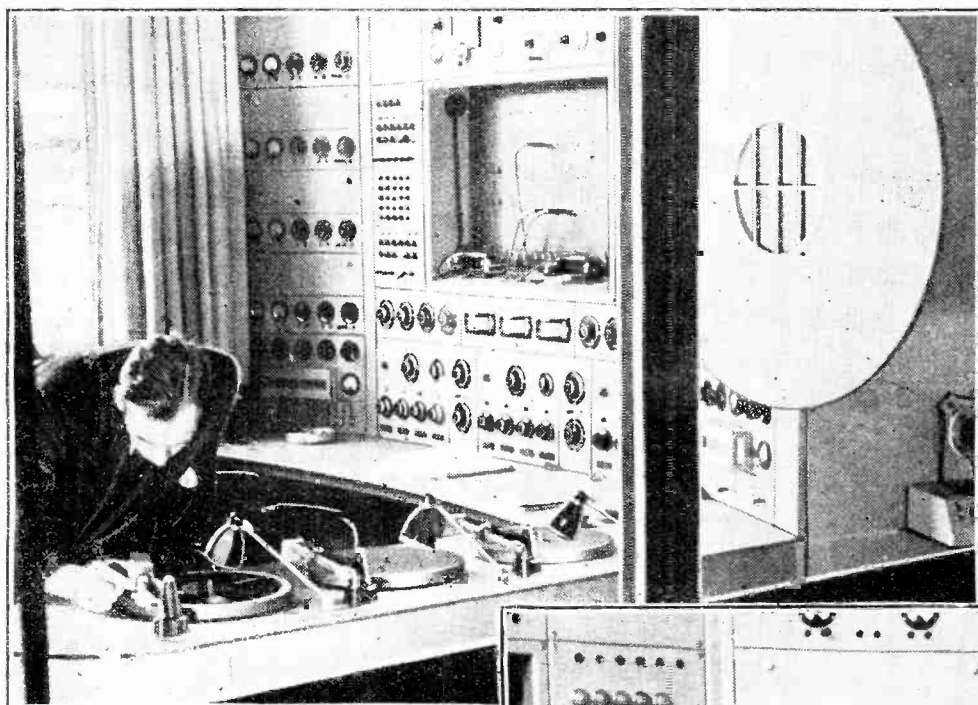

Inside one of the control rooms which contains a bank of gramophone turntables. The microphone (seen below) is for the use of the control engineer when it is necessary for him to make an announcement.

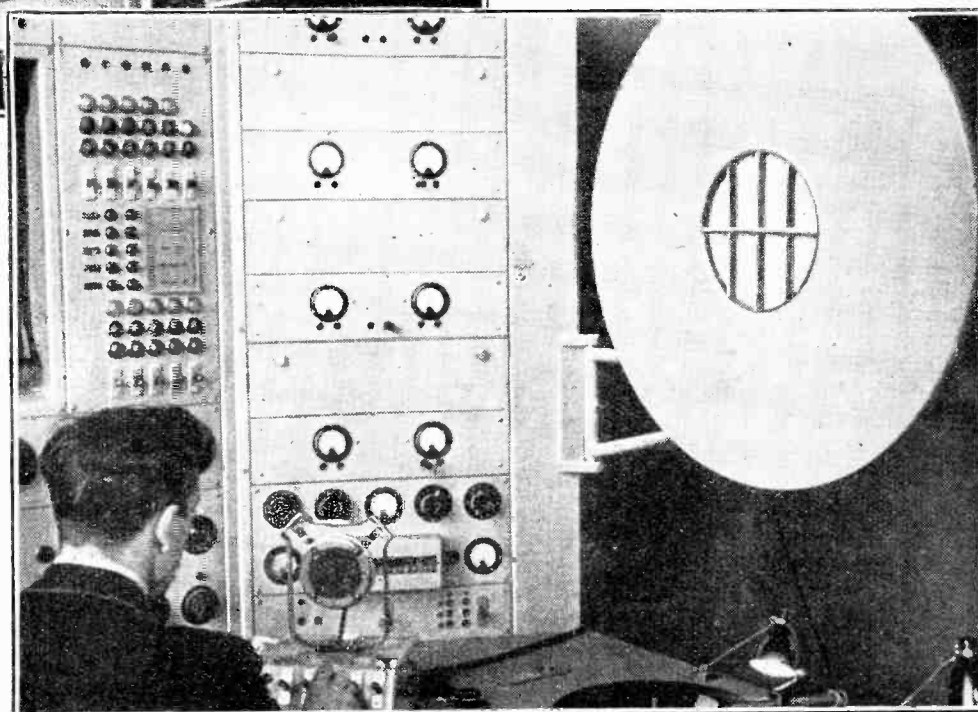

studios, two for drama and one each for talks, chamber music, dance music and effects, also one for the announcer. The "public" section contains a large concert hall with a seating capacity for an audience of 500 persons. The concert hall is constructed in the same manner as the other studios as it is also used for broadcasting. It can be converted into a theatre, complete with a fully equipped stage, orchestra pit, etc., or it can be used as a modern cinema. The two sections of the house are connected by a large restaurant with kitchens and other necessary offices.

The main feature of constructional importance is the complete separation of the inner studio from the outer "shell" of the building. Each studio is placed on independent foundations so that there can be no carriage of sound from one studio to the other. The architects have reverted to the age-old principle of pillar construction originally used by our heathen forefathers on the shores of Swiss lakes. Each studio is placed on pillars which pass through hollow sections of the outer shell, and end on their own foundations. A substantial air space is left between the

The walls in the concert-hall are subdivided by a long prismatical section with three different coatings; sound absorbent, semi-absorbent and reflectant, so that the acoustics of the hall can be suited to any form of broadcast. The seats are heavily padded so that the presence of an

studio at all. It is a semi-circular glass "cage" which juts out into the first-floor hall. Triple sound-proof windows are provided so that the announcer on duty can watch who enters or leaves.

In the large entrance hall on the ground floor the visitor is confronted by the

**Holland's New Broadcasting House—**

"Avro Clock." This clock gives the time-signal but the small microphone which is placed in front of it behind the glass panel is not actually used. A special "mike" is placed above the clock for the actual broadcasting of the signal. To the right of the large hall there is a small board room, and the house also contains

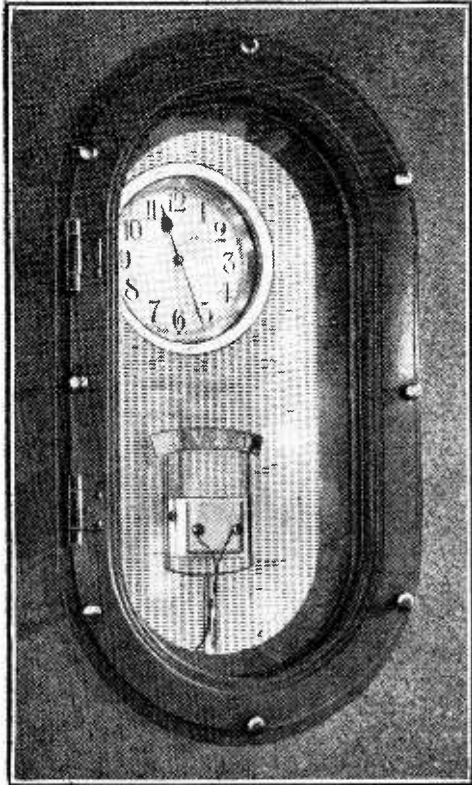

The time-signal clock in the entrance hall. The microphone shown, however, is not the one actually used for broadcasting the signal.

a small lecture hall for visiting listeners. Tuesday evening is the Avro's "at home" in Hilversum just now and special trains are occasionally run from various towns.

As each of the studios forms a hermetically sealed unit, suitable provision of fresh air presented a number of problems which provided food for study by two professors at the Delft Technical University for over a year. It was found that all precautions which were taken to prevent the actual air ducts from carrying sound were not sufficient to obviate it travelling in the actual air, notably from studio to studio. As it was not practicable to increase the length of the ducts, special baffle chambers were introduced which are coated with sound absorbent material, and which deadens possible air-borne sounds. By this means it should, theoretically, be possible for a hundred trumpets to blare in the dance-music studio without even a whisper of sound percolating out of it except through the microphone.

To cut the number of possible sources of electrical interference down to a minimum it was decided to cool the air in summer by means of water pumped up from a well 169ft deep (situated below the house) and not to use other means of refrigeration. The water in this well is

kept permanently at 10 deg. Centigrade.

Two control rooms and a sound-recording room are provided. Most of the control equipment was supplied from Germany; The organ in the concert hall, on the other hand, was built by a British firm. The control rooms are so fitted that the control engineer can operate three gramophone turntables for reproduction as well as watch the outgoing transmission. In the sound-recording room it is rather surprising that a German receiver, and not a Dutch one, is used for the recording of

foreign stations' programmes. The Avro, at present, use specially large records of glass which are coated with some kind of gelatine material. These records run much longer than the usual size.

From the above brief description, in which I have attempted to pick out the more salient features of the Avro's new house, readers will see that the general design and construction of broadcasting studios have greatly changed during the past years. It is no longer thought sufficient to place the studios as a whole on separate foundations, but they are individually isolated as well. The Ravag's new house in Vienna, which is nearing completion, follows the same principles.

## Television Programmes

The system to be used each day is given below the date. Transmission times are from 3-4 and 9-10 daily.

Vision	Sound
6.67 m. (45 Mc/s).	7.23 m. (41.5 Mc/s).

FRIDAY, JANUARY 22nd.  
(Marconi-E.M.I.)

3, Songs at the Piano: Nancy Logan. 3.10, First-Aid—II, Accidents on the Road. 3.25, Gaumont British News. 3.35, Television Gang Show: An All-Scout Revue.

9, Repetition of 3 and 3.10 programmes. 9.25, British Movietonews. 9.35, Repetition of 3.35 programme.

SATURDAY, JANUARY 23rd.  
(Marconi-E.M.I.)

3, Ballroom dancing; a novel method of instruction by Alex Moore and Pat Kilpatrick. 3.20, British Movietonews. 3.30, The White Coons Concert Party.

9, Music Makers: William Primrose (viola). 9.10, Stars and their Directors: Victoria Hopper and Basil Dean. 9.20, Gaumont British News. 9.30, Repetition of 3.30 programme.

MONDAY, JANUARY 25th.  
(Baird.)

3, Theatre Parade—Excerpts from Nancy Price's production of "Whiteoaks" from the Playhouse Theatre. 3.20, Sea Stories—Commander A. B. Campbell. 3.25, The World of Women—II. 3.40, British Movietonews.

9, Repetition of 3 programme. 9.20, Gaumont British News. 9.30, Repetition of 3.25 programme. 9.45, Cabaret.

TUESDAY, JANUARY 26th.  
(Baird.)

3, Billy Malony (comedian). 3.10, Gaumont British News. 3.20, Ice-hockey explained. 3.40, Film. 3.50, Togo—Japanese Juggler.

9, Music Makers: Helen Perkin. 9.10, Repetition of 3.20 programme. 9.30, Leslie Weston (comedian). 9.40, British Movietonews. 9.50, Starlight: Claire Luce, with William Walker.

WEDNESDAY, JANUARY 27th.  
(Baird.)

3, London Galleries: II. Discussion on "The Picture in the Modern Home." 3.15, Film. 3.25, Twenty-third Picture Page. 3.50, British Movietonews.

9, Jean Melville: Songs at the Piano. 9.10, Repetition of 3 programme. 9.25, Gaumont British News. 9.35, Twenty-fourth Picture Page.

THURSDAY, JANUARY 28th.  
(Baird.)

3, Syncopated Harp Solos by Mario Lorenzi. 3.10, Home Affairs: II. Discussion on the Future of Trade Unionism. 3.25, Gaumont British News. 3.35, Cabaret.

9, Cabaret. 9.10, Timber Building and Tourist Camps—Discussion. 9.25, British Movietonews. 9.35, Cabaret.

## The Radio Industry

READERS of our recent article on the "beam" power valve, Type 6L6, may be interested to know that American-made transformers to suit this valve are available from The Radio Mart, 19, John Bright Street, Birmingham, 1. Transformers for both RF and AF applications are supplied.

In the report on the Eddystone "All World Eight" which appeared in last week's issue, HT consumption was given, in error, as 5 to 8 mA. Actually the correct values for the particular set tested were 8 to 12 mA.

Certain increases have been made in the prices of Avo instruments; as examples, the DC Avominor now costs £2 5s. and the Universal Avometer 13 gns.

Among the Ediswan employees to whom presentations were recently made on the completion of fifty years or more of service with the company is Mr. William Hutt, whose job it is to attend to the pumping of large rectifying valves. Mr. Hutt, aged 67, has been with Ediswan for fifty-four years.

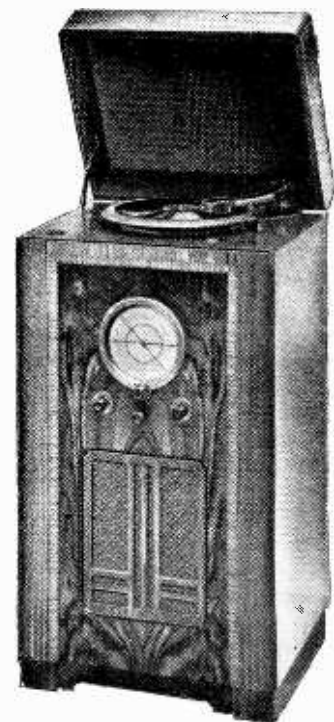

New Pilot Radiogramophone Model RU355 incorporating a superhet all-wave chassis covering 16-52 metres in addition to usual medium- and long-wave bands is designed for operation from AC mains and the price is 22 gns.; there is a universal model at 24 gns.

# CURRENT TOPICS

## EVENTS OF THE WEEK IN BRIEF REVIEW

### Siam Calling

A NEW short-wave station is to be erected in Siam by the Telefunken Co. It will be used for the dual purpose of handling traffic to ships and broadcasting musical programmes.

### American Programmes for Europe

IN answer to many demands from listeners on this side of the Atlantic the well-known short-wave station Boston WIXAL has advanced the time of its daily half-hour for European listeners by 1½ hours. It will now begin at 9.30 p.m. (G.M.T.), this being far more convenient for European listeners than the former time of 11 p.m.

### Wireless for the Blind

THE amount so far received by the British "Wireless for the Blind" Fund as the result of Mr. Christopher Stone's broadcast appeal on Christmas Day now amounts to £10,000, but it is hoped that this sum will be greatly increased as contributions are still continuing to arrive. The address of the Fund is 226, Great Portland Street, London, W.1.

### Indian Plans

CERTAIN modifications have been introduced into the All-India radio service scheme. It has been decided that Bombay, Delhi, Calcutta and Madras are to be provided with 10-kilowatt short-wave transmitters.

The medium-wave transmitters are intended to supply the needs of those actually dwelling in the large cities and their

neighbourhood. It is anticipated that although 5-kW transmitters will be employed, the useful range will only be about 35 miles owing to heavy atmospheric interference. These medium-wave transmitters will have only one aerial mast, an arrangement which has given very satisfactory results elsewhere. Furthermore, water-cooled valves will not be used, and it is anticipated that their

omission will result in a great saving owing to the high cost of auxiliary water-cooling.

### R.A.F. Dinner

THE Annual Reunion Dinner of the past and present officers of the Electrical and Wireless School, Royal Air Force, Cranwell, is to be held at 7 p.m. to-morrow (January 23rd) at the R.A.F. Club, Piccadilly.

### Special PA Number

THE issue of *The Wireless World* for February 5th will be primarily devoted to the subject of Public Address equipment and applications.

Recent developments in apparatus will be described and special articles will deal with various aspects of this subject, which is growing in importance so rapidly.

There are to-day uses for PA equipment of every category, ranging from domestic requirements to the extensive outfits used in connection with addressing large outdoor audiences.

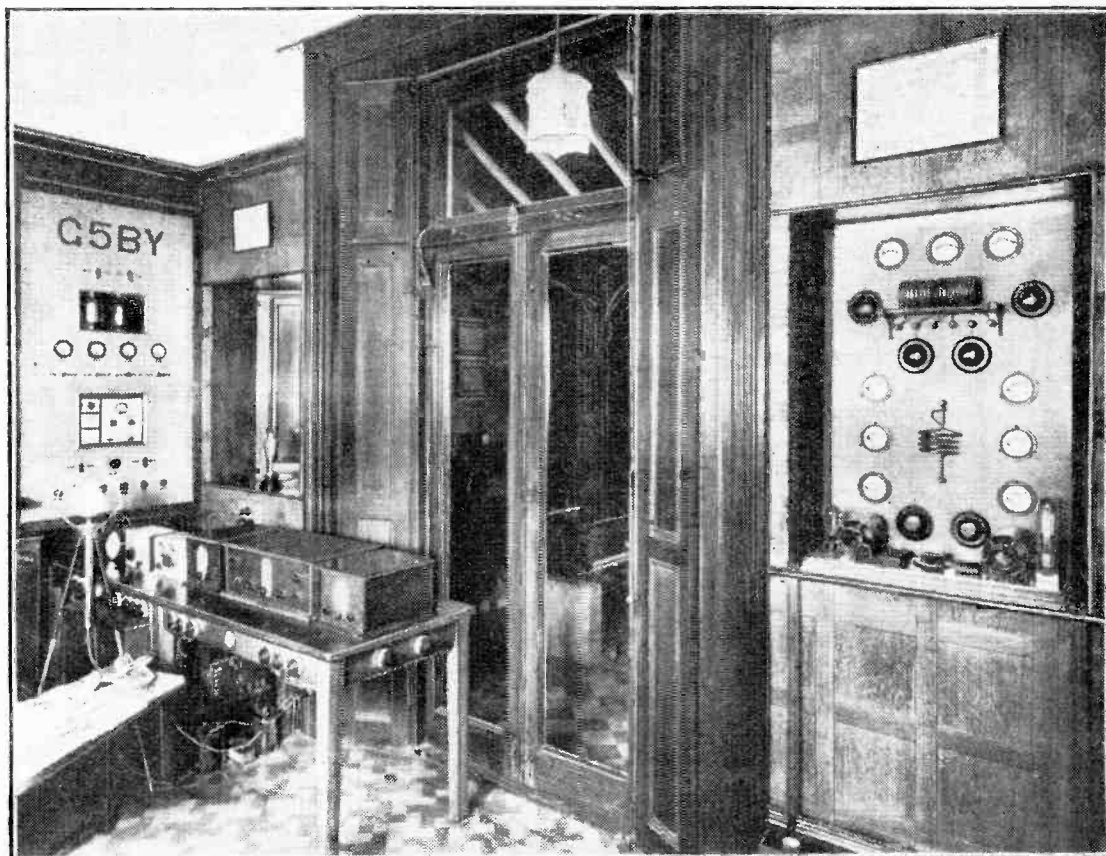

"FIVE-METRE" ATLANTIC SUCCESS. The crystal-controlled transmitter at G5BY, operated by H. L. O'Heffernan, which, as reported on the correspondence page, put the first five-metre signal across the Atlantic. It is remotely controlled and feeds a diamond aerial system, the power input to the final amplifier being between 100 and 250 watts. Above is shown a general view of the station with the receivers, monitors, modulation panel and controls for all transmitters on the left, while on the right is the 250-watt 20-, 40- and 80-metre transmitter. Below is seen the five-metre transmitter.

### Programmes for Danish Exiles

PLANS are being made in Denmark to supply programmes from the homeland to Danes who are living in various parts of America, and for this purpose a special 5-kW beam transmitter is to be put into operation. It will work simultaneously with the present SW transmitter at Skamlebaek. It is hoped that the new station will have a very considerable range.

### Index and Binding Case

THE Index for Volume XXXIX of *The Wireless World*, July to December, 1936, is now ready, and may be obtained from the publishers at Dorset House, Stamford Street, London, S.E.1, price 4d. post free, or with binding case 3s. 1d. post free.

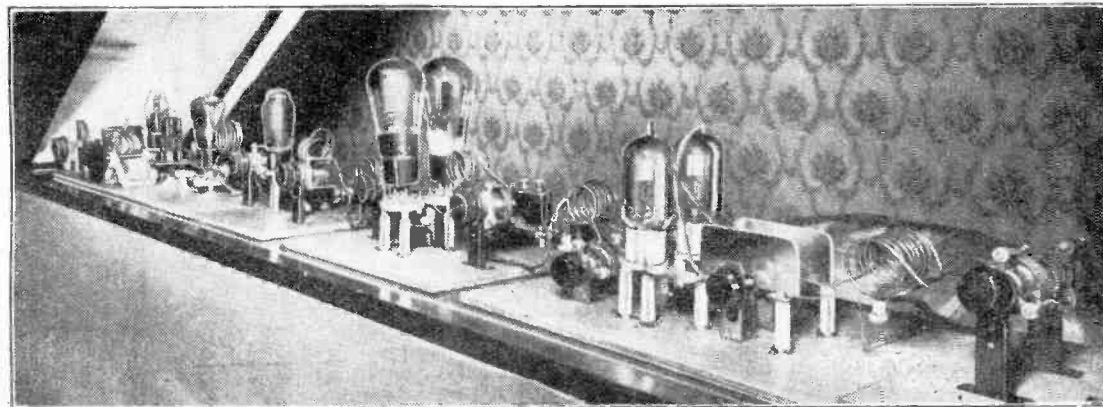

# Simplifying the Beat Frequency

## AN INEXPENSIVE AUDIO-FREQUENCY GENERATOR

By C. P. EDWARDS, M.Sc.Tech.

**M**OST quality enthusiasts will have felt at some time or other the desire to test their receiving gear for response over the whole range of useful audio frequencies. No matter how carefully one may calculate circuit values, it is generally true to say that several parts of a set affecting overall response are still rather doubtful, and an actual means of testing the fidelity of the electrical side is very valuable. Examples of these doubtful quantities are the high-note attenuation due to tuned circuits in RF and IF amplifiers, characteristics of tone compensation circuits, deficiencies of the output transformer, etc.

A variable audio-frequency source can by itself be used for measurements on the AF side of the set and by using such a generator for modulating a radio-frequency oscillator, one can include the

voltmeter. Readings of the voltmeter are plotted against audio frequency, taking care to keep constant the depth of modulation.

Regarding methods of obtaining various audio frequencies, consider first the use of standard frequency records, pick-up and amplifier. This is an expensive equipment and an AC voltmeter is almost essential for monitoring the output. One alternative to this is an audio oscillator of the straightforward tuned circuit type, but a very large number of coil changes is necessary to cover a range of 30 to 10,000 c/s, and the output varies considerably with frequency.

The heterodyne or beat-frequency oscillator gives a continuous change of frequency from zero to the required upper limit simply by turning a knob, the output remaining practically constant. The oscil-

*THE author describes an audio-frequency test oscillator in which the design has been simplified by using a triode-hexode as a mixing valve. This avoids troubles due to "pulling" between the two oscillators*

lated in a rectifier, and the audible "beat" or difference frequency is separated from the rectifier output by means of a low-pass filter.

Many commercial oscillators of this type contain up to nine valves, and may cost over £100, but much of the complication required to secure extreme stability of frequency and uniformity of output over the range can be dispensed with for the purposes under consideration. The oscillator described and illustrated here employs the circuit given in Fig. 1. It attains a high standard of performance

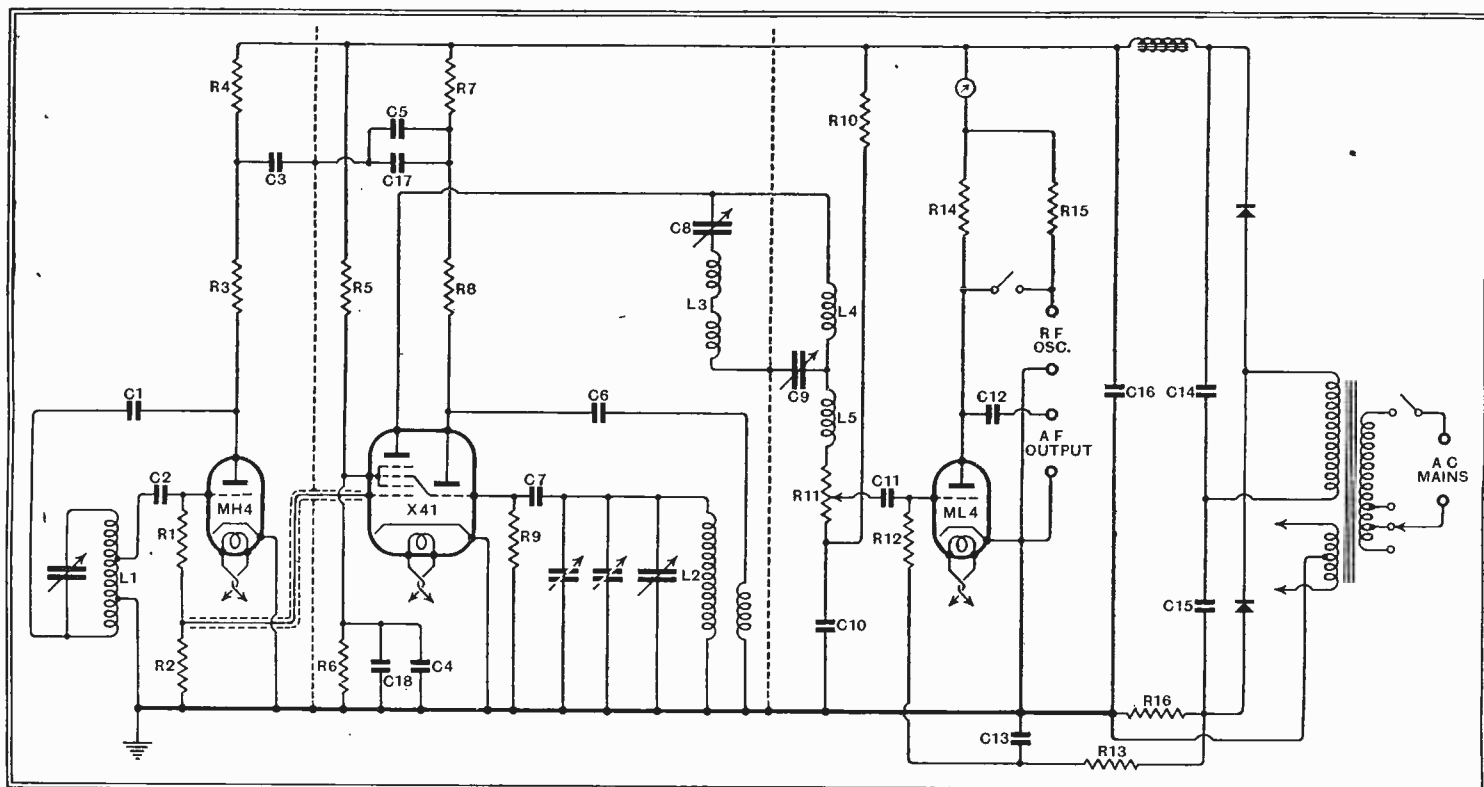

Fig. 1.—Complete circuit diagram of the oscillator, the positions of inter-stage screens are indicated. Values of components: C1, C6, 0.01 mfd; C2, C7, 0.0001 mfd; C3, C4, C5, C11, C13, 2 mfd; C8, C9, 0.0005 mfd; C10, C12, 4 mfd; C14, C15, C16, 8 mfd (electrolytic); C17, C18, 0.1 mfd; R1, 200,000 ohms; R2, R10, 10,000 ohms; R3, R14, 20,000 ohms; R4, R5, R7, R8, R11, 50,000 ohms; R6, R15, 30,000 ohms; R9, 100,000 ohms; R12, R13, 1 megohm; R16, 500 ohms. L1, L2, 17 millihenrys; L3, 34 millihenrys; L4, L5, 300 millihenrys.

signal-frequency portion of the set in an overall response test. The procedure is to connect a dummy resistance load in place of the loud-speaker speech coil and to connect across this a rectifier or thermionic

lator consists essentially of two high-frequency oscillators, the frequency of one of which can be varied by about 10,000 c/s by making a portion of its tuning capacity variable. The outputs are com-

with only three valves, the principal contribution to this notable simplification being the use of an electronic mixing valve, actually a triode-hexode, Type X41. This valve has very low capacity



# Oscillator

between the control grids in the mixing portion, and the oscillators can be coupled directly to these grids without trouble due to "pulling in" and wave-form distortion at low frequencies. This pulling into step of the oscillators has usually been combated by means of isolating amplifiers or a balanced bridge input system to the detector. Another great advantage of the hexode over the usual anode-bend triode is its ability to give a large output voltage at the difference frequency without distortion, thereby eliminating intermediate AF stages before the output stage. Heptodes do not appear satisfactory since pulling-in occurs at too high a frequency, and zero setting becomes inaccurate. The normal method of biasing the X41 by cathode resistance is also useless for the present purpose, for no matter how well this is decoupled it will give rise to serious "pulling" at low frequencies. Bias is obtained automatically by the grid rectification which occurs in the fixed oscillator.

The components are mounted on a chassis of aluminium  $12\frac{1}{2} \times 9\frac{3}{4} \times 1\frac{3}{4}$  inches, with a front panel of  $\frac{1}{8}$  in. aluminium 10 in. wide and  $7\frac{1}{2}$  in. high. The whole slides into a sheet metal box providing good screening from other apparatus. Screens above and below the chassis separate the variable oscillator components from those of the fixed oscillator and output stage.

The fixed oscillator is straightforward. The tuned coil L1, of approximately 17 mH in the model illustrated, is made from one coil of a G.E.C. Superhet Five IF transformer which was obtained through *The Wireless World* manufacturers' surplus columns. These are probably unobtainable now, and a suitable substitute coil is illustrated

in Fig. 2. It consists of 860 turns of No. 36 DSC wire on an ebonite bobbin of the dimensions shown, tapped at about one-third and two-thirds of the total turns. Flexible leading-out wires should be used for the ends and tappings. Failing a seamless screening can for this coil, a good alternative is a can built up from copper sheet with the seam carefully soldered. The coil is tuned to a frequency of approximately 70 kc/s by a 0.0005 mfd. compression type condenser, those illus-

proach to a logarithmic frequency calibration above 50 c/s will be obtained, i.e., a straight line graph on paper with the frequency scale logarithmic and condenser dial scale plain. The actual calibration curve of the oscillator described is shown in Fig. 4, together with the output curve. This straight line means also that a certain angular movement of the condenser will multiply the frequency by a constant factor at all parts of the scale, for instance on this model an octave is obtained by a movement of some 24 degrees, and piano scales can be obtained by turning the dial 3 degrees at a time at any part of the scale. Obviously a good condenser of brass construction and easily taken to pieces is desirable, and the one illustrated is an old Lotus component, square-law and of 0.0003 mfd. capacity before alteration. The AC voltage at the grid of this oscillator should be at least 10 volts, and a check by valve voltmeter is useful.

The detector output is filtered firstly by a tuned by-pass (L3, C8) for the fixed oscillator frequency. This is absolutely essential if serious "pulling" is to be avoided, for unless the anode is substantially shorted to cathode at this frequency, the voltage at the anode due to the fixed oscillator pulls the variable oscillator through the capacity from anode to outer control grid, which is not particularly small. The tuned by-pass consists of a low-loss coil L3 of about 34 mH and a screw-down condenser similar to those used in the oscillators. The coil consists of 1,300 turns of 36 DSC, on a bobbin of the same type as before (Fig. 2). Alternatively, two of the G.E.C. coils already mentioned may be used in series. The correct setting can be found instantly with a

cathode ray oscillograph, or a valve voltmeter across the coil or a rectifier milliammeter in series, or failing these, the correct setting is that which gives the lowest pull-in frequency. All other unwanted frequencies are cut down to a negligible

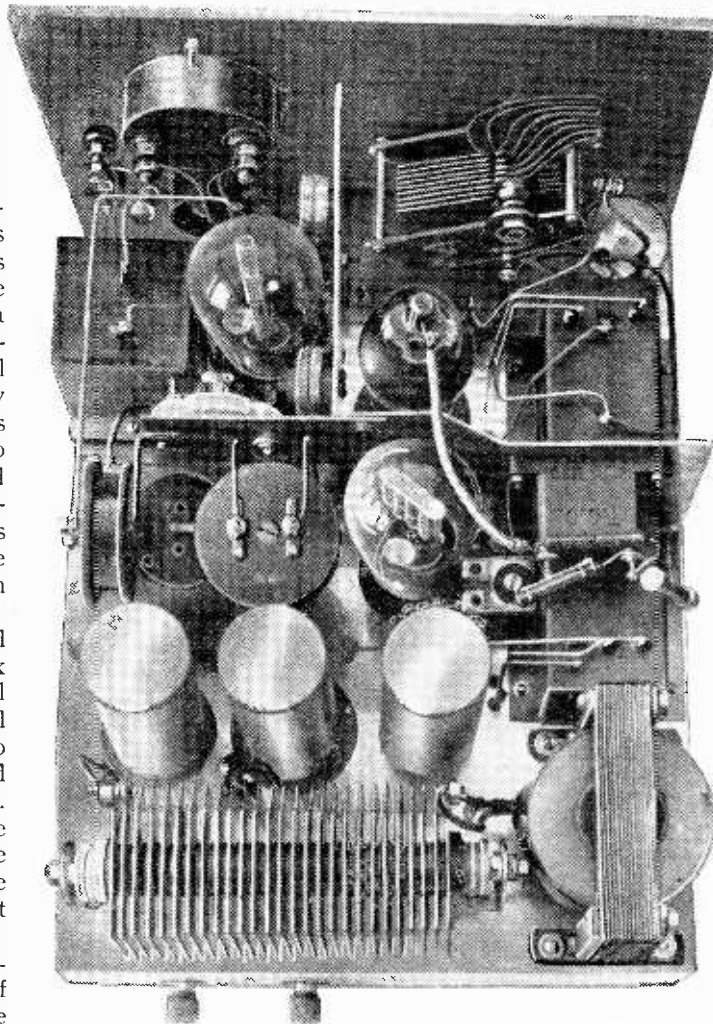

Disposition of the principal components and arrangements of the inter-stage screens are shown in this plan view.

trated being supplied with the IF transformers previously mentioned. About one-twentieth of the grid voltage developed is applied through a screened lead to the X41 control grid. Thorough anode decoupling is needed, or the tendency to pulling is increased.

The variable oscillator coil L2 has the same number of turns as the first, but is untapped and has a tightly coupled reaction coil of about one half the number of turns. Three condensers are connected across the tuned portion, a 0.0005 mfd. screw-down trimmer as before, a small neutralising condenser for zero adjustment and the main variable condenser. This condenser has to be free from slackness in the bearings and must have each vane cut away and filed to a different shape, copying as closely as possible the diagram, Fig. 3. If this is done carefully, a good ap-

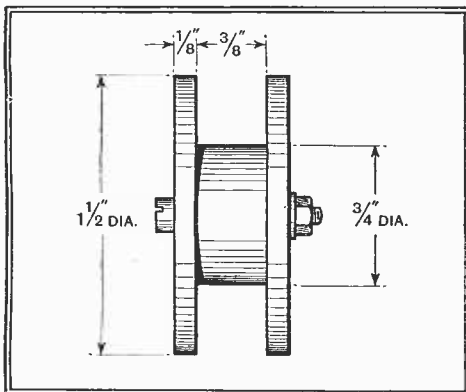

Fig. 2.—Dimensions of the ebonite former on which the oscillator and filter coils are wound.

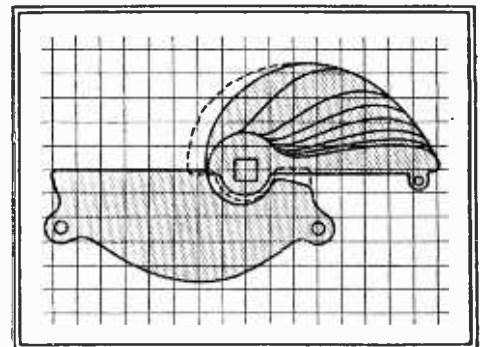

Fig. 3.—Shaping of the variable condenser rotor plates; original shape shown by dotted lines. The form of the largest plate is particularly important, as it determines the calibration up to 1,000 c/s.

**Simplifying the Beat Frequency Oscillator—**

amount by a low-pass filter, single T section, with two good coils of 0.3 henry, L<sub>4</sub>, L<sub>5</sub> (Postlethwaite "Kinva," 3s. 6d.) mounted at right angles, and a shunt condenser of 0.0004 mfd. theoretically, but which can be cut down to about 0.00025 mfd. to give slightly less attenuation at 10,000 c/s. The correct termination is supplied by the 50,000-ohm volume or output control R<sub>11</sub>.

Coupling to the output stage is by a good 2-mfd. condenser and 1-megohm leak. Bias is obtained by a resistance R<sub>16</sub> in the negative HT lead decoupled as shown. This is the only method, excluding battery or separate bias supply which will work down to frequencies below 10 c/s. No output transformer is fitted, but resistance coupling through a 4-mfd. condenser is suitable for high-impedance loads and powers up to 300 mW. Using choke or transformer output, nearly one watt could be obtained. In the interests of a well-maintained output at high frequencies, the metal cases of condensers C<sub>11</sub> and C<sub>12</sub> should be stood off from the chassis by blocks of ¼ in. ebonite and insulated. Power supply is from AC mains, using a Type HT8 Westinghouse metal rectifier and a smoothing choke of over 100 henrys, actually a speaker field replacement component of 2,500 ohms resistance. There should be no great difficulty in rearranging the supply circuits for battery operation.

**For Use as a Modulator**

The arrangements for supplying and modulating a radio-frequency oscillator are very simple. The HT supply is taken through a separate anode resistance which can be joined by a switch at its "live" end to the output valve anode when modulation is required. Practically any radio oscillator will be suitable provided that it contains no decoupling circuit in the anode, or by-pass condenser greater than say 0.0003 μF. The *Wireless World* Test Oscillator is a suitable type, and necessary modifications would be the use of an AC valve, type MH<sub>4</sub>, leaving out the modulator and taking out the "top" end of the feed RF choke to a terminal for connection to the heterodyne oscillator. Heater current for the valve is also supplied from the audio oscillator transformer.

The design of oscillator described, using the same coils and trimmers, requires the following approximate settings. Screw the fixed oscillator trimmer home and then back about half a turn. With neutralising condenser mid-way and main variable condenser set at zero, adjust the variable oscillator trimmer until the beat note heard in a pair of phones comes down to zero frequency. The very low frequencies

cause a visible vibration of the millimeter needle which becomes stationary at zero frequency. The neutralising condenser, operated from the front panel, is for finding this setting accurately. The range of the oscillator is increased by re-

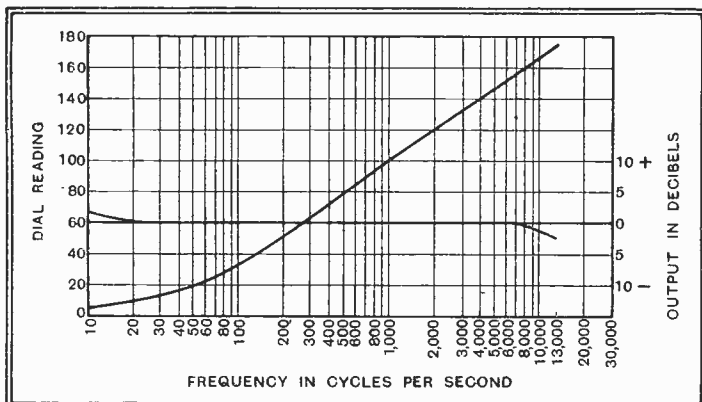

Fig. 4.—Calibration and output curves of the original model.

ducing the capacity of both trimmers. The tuned by-pass circuit should be adjusted at this stage.

A rough calibration and check on scale shape over the first part of the scale can be obtained by direct comparison with a piano, knowing middle C to be 256 c/s, the octave above 512, the octave below 128 and so on. If the graph so obtained on logarithmic paper is running straight, it can be produced to cover the top two octaves with fair accuracy, especially if the condenser has been carefully copied.

Complete calibration can be done very quickly from one good tuning fork, preferably of frequency 1,000 or 1,024 c/s, if access can be had to a small cathode ray oscillograph with linear time-base. The procedure is to let the oscillator warm up for half an hour, then set its zero and tune it to the fork frequency. Connecting



Pye cabinet-aid polishing kit.

it now to the oscillograph the time base is adjusted to one-eighth of this frequency, giving a stationary picture of 8 cycles. Synchronising should be only slight. The oscillator frequency can now be reduced to give pictures of 4, 2, 1, ½ and ¼ cycles, the frequencies being octaves below the fork, e.g., 512, 256, 128, etc. These points are noted, the oscillator is turned back to fork frequency, and the time base speeded up to give a picture of 1 cycle. Multiples of the fork frequency can now be obtained, e.g., 3 times fork frequency when 3 cycles appear on the screen, and so on up to 10 or 12,000 c/s.

Another solution of the problem of calibration is to be found if one can borrow a set of standard frequency records. These are played on the gramophone and the oscillator set to the frequency of each track in turn.

## Pye Polishing Outfit

FOR RENOVATING CELLULOSE  
FINISHED CABINETS

**D**URING the past few years considerable attention has been given to the design and construction of cabinets for radio receivers, and the modern version is indeed quite a handsome piece of furniture. Like many other articles that are in daily use, however, it is not always possible to avoid slight damage to the polished surface.

As the majority of radio cabinets are now cellulose finished, the surface cannot be renovated in the same way as french polished cabinets, so that those who might feel inclined to undertake the work themselves are debarred from doing so since the correct materials to use are not generally known.

Pye Radio, Ltd., have now come to the rescue by introducing a polishing outfit especially compiled for dealing with cellulose cabinets. Its purpose is for renovating and not for applying the polish to bare wood. Known as the Cabinet-aid Polishing Kit, it contains several bottles of solution, tins of special compound, brushes, cloths and all the necessary impedimenta for restoring the polished surface of a cabinet to its original appearance.

A perusal of the instruction book reveals that the work entailed is not difficult, nor is it beyond the skill of the average person; the methods of removing scratches, stains and other blemishes are all very clearly and fully explained.

The Kit is contained in a portable case, measuring 10½ x 10½ x 3¾ in., and it can be secured to a wall or the back of the work-bench, yet quickly removed whenever necessary.

Servicemen will find it a valuable adjunct to their equipment since after overhauling a receiver it can be returned to its owner, not only in good working order, but also with its external appearance greatly enhanced.

Considering the amount of material it contains, this polishing outfit is very reasonable in price, for it costs but 17s. 6d. complete.

# UNBIASED

## A Hint to the P.M.G.

BROADCASTING has a lot to answer for in adding to the sum total of human misery, for apart from the feeling of melancholy which is introduced into our homes by the solemn dirges of the B.B.C. on Sunday afternoons, to say nothing of the negroid noises of weekdays, we learn that thousands of actors and musicians who depended directly or indirectly upon the stage for their living



Certain advice to their patients.

have been reduced to the bread line owing to the unfortunate fact that former patrons of the theatre and concert hall now prefer to stay at home and listen in. But I digress. What I wanted to say was that in spite of all these base charges which certain vested interests are wont to levy against broadcasting, it is an ill wind that blows nobody any good, and I am constantly coming across instances of old-fashioned trades which owe the continuance of their existence to broadcasting.

A striking instance of the sort of thing I mean started soon after the war. Prior to the war, as you may know, one of the staple trades of this country was the very necessary hairpin industry. Came the war and women flocked in their thousands as near to the front line as they could get and found that, owing to the playful habits of *pulex irritans*, it was desirable that the hair should be kept short, and thus was a new fashion born and an old and honourable industry apparently doomed. Fortunately, however, the growing demands of home constructors for hedgehog transformers suggested an obvious use for the unwanted hairpin, and, although this type of component has long since disappeared, it gave the necessary breathing space to enable the industry to reorganise itself.

By far the most noteworthy case where broadcasting has proved to be the saviour of an industry, however, is one that has only just been brought to my notice. You have, I take it, all heard of those instruments known by various fancy names such as high-frequency vibrators and violet-ray generators. It appears that for

some considerable time past retailers of these infernal machines have been puzzled by a steady upward tendency in their sales curve, which has reached such alarming proportions of late that factories making them have had to work overtime. The base suggestion that doctors were getting a rake-off from the manufacturers in return for certain advice to their patients has proved to be quite groundless, and it appears that the whole trouble is due to the fact that since the coming of the all-wave set many people allow their loud speakers to drool away throughout the entire twenty-four hours, some set manufacturers actually encouraging this reprehensible habit by selling sets without a switch to turn them off.

Certain unscrupulous people, disturbed by this diurnal and nocturnal bellowing of their neighbours' loud speakers, and worried by the fact that it kept their children awake at night, have become so lost to all sense of decency that they have purchased these violet-ray instruments, not for the purpose of using them in a legitimate manner, but in order to induce their neighbours to silence their loud speakers by making their output intolerable even to them. Anybody who has lived within range—and it is a pretty extensive one—of a violet-ray machine will know very well what I mean. This regrettable habit has, I learn, gone on spreading until it has now reached such alarming proportions that in certain districts it is almost impossible to use a loud speaker after midnight.

## Justice for Motorists

I SUPPOSE that there are very few of my readers who, in common with myself, have not at one time or another stood in the dock at one of our police courts. I am not, of course, intending to cast any reflections on the honesty of *Wireless World* readers. They are, I suppose, as honest as the readers of any other journal; in fact, probably more so owing to the good example set them by this paper. There are, however, many crimes with which you may be charged nowadays without the slightest suggestion of dishonesty being imputed to you. Such crimes as mayhem and arson, for instance, to say nothing of murder and manslaughter, may be freely committed by a person whose word is his bond without damaging his reputation for honesty.

However, it is not these particular crimes that I have in mind at the moment so much as motoring offences. Although many of my readers, such as wireless manufacturers, may be far too poor to be car owners, there is still a goodly number, I feel sure, who are members of the honourable company of road hogs, and have oft-time, in answer to the clerk-of-

the court's stern question of Guilty or Not Guilty, been compelled to hang their heads in shame and murmur "I done it." There must also be a great number who, like myself, have stood unjustly accused before the Bench listening to the lying calumnies poured out by some witness for the prosecution, and it is to these unfortunates that I would speak so that I might

## By FREE GRID

pass on to them a tip which I have recently proved to be invaluable.

In the past I suffered so often at the hands of the Law and its pencil-licking satellites, who swore away my reputation as a car-driver as cheerfully as though I were their mother-in-law, that I determined to put a stop to it. I accordingly installed in my car the very latest thing in amplifiers and automatic home recording apparatus, and replaced my radiator cap with a microphone which was suitably disguised as a very ornate kind of mascot such as is fashionable nowadays.

Setting out one afternoon in search of my quarry, it did not take me long to run foul of a myrmidon of the law who began as usual to attribute to my car a speed which the manufacturers' catalogue did not claim for it even in its most moving passages. There ensued, of course, the usual exchange of pleasantries before I was permitted to move on after having my licence particulars taken just like any common felon out on ticket-of-leave. On the appointed day it did not surprise me to hear from the witness-box the usual distorted version given of my conversation with the constable, and I speedily asked permission to "put in" a gramophone record as evidence.

Sensation is a word I hate and detest, but I can honestly think of no other to describe the effect which the playing over

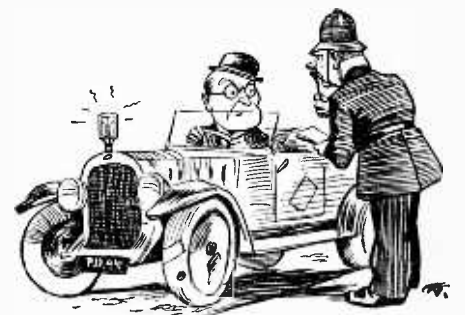

Like any common felon.

of my record had on the court. Even the principal witness against me stood amazed at the volley of abusive language about me which poured forth in his voice from the portable gramophone which I had brought to court with me. Needless to say, this, coupled with the meek and mild protests which the record irrefutably indicated as being my part in the discussion, immediately influenced the Bench in my favour; so much so in fact that they not only acquitted me but made a special order to the effect that all previous endorsements on my licence were to be wiped off forthwith.

# Listeners' Guide for the

**F**OUR distinguished Continental conductors are to appear in B.B.C. concerts this week.

To-night (Friday) at 9.40 in the National programme Dr. Heinz Unger, permanent conductor of the Leningrad Wireless Orchestra, will, for the first time, conduct Section D of the B.B.C. Orchestra. The programme will consist of Schubert's Overture "Rosamunde" and Mahler's "Fourth Symphony." This symphony, which lasts for over an hour, includes a soprano

He is well known as the composer of "Wild Violets," "Rise and Shine," and other light operatic successes. Maria Elsner and Jan van der Gucht will be principal vocalists. Stoltz' "Wild Violets" will, incidentally, be broadcast twice next week.

Werner Janssen will conduct the London Symphony Orchestra in a studio concert on Tuesday (Reg.). He has not yet conducted in England, but has given English works in America, where he has conducted the New York Philhar-

Boult will be conducting, and the soloists will be Astra Desmond and Roy Henderson. The Croydon Philharmonic Society, which has 158 members, will render the choral work.

## "TWENTY YEARS AFTER"

PETER CRESWELL, a producer in the Drama Department, has been puzzling as to how he was to keep up to the broadcast standard of "The Three Musketeers" with the broadcast version of "Twenty Years After," a sequel to this

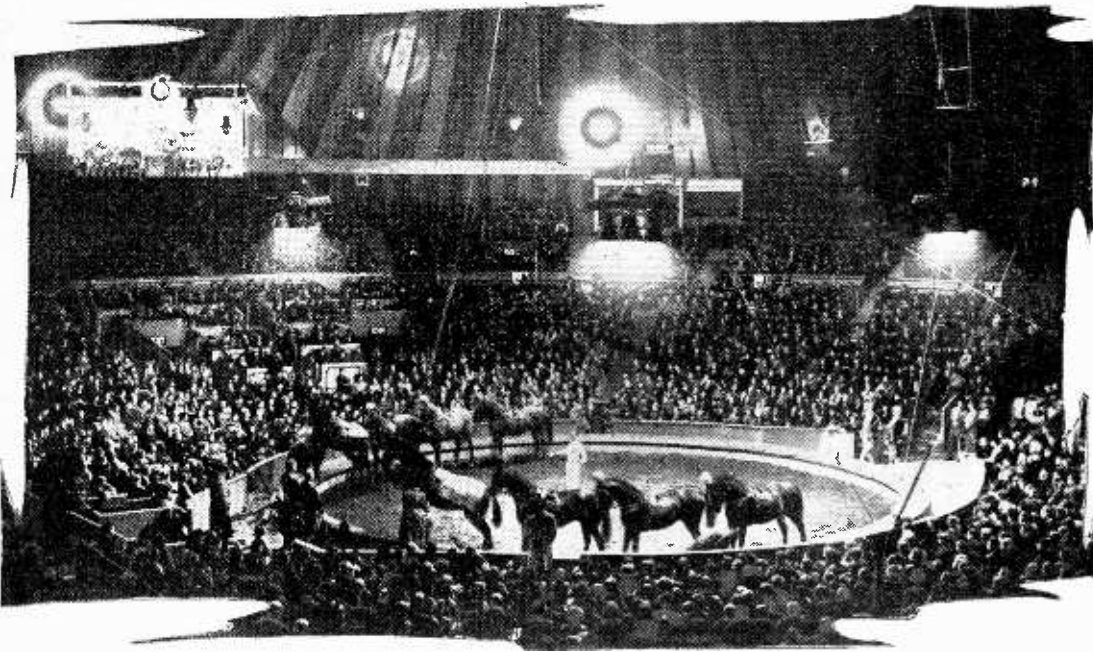

A WANDERING MICROPHONE will introduce clowns and performers at the Bertram Mills' Circus, Olympia, to Regional listeners on Tuesday at 7.30. The commentator will describe the waiting animals arranged for their turns and try to convey the expectant atmosphere behind the scenes.

solo, which will be sung by Elsie Suddaby.

On Sunday at 6.30 (Reg.) the Orchestra will be conducted by Volkmar Andreae, who will come specially from Zürich for the occasion. Professor Andreae is the permanent conductor at the Zürich Tonhalle, and will conduct a rhapsody of his own for violin and orchestra, in which the soloist will be Steffi Geyer.

Later in the evening, at 9.5 (Reg.), Robert Stoltz, from Vienna, will conduct the Theatre Orchestra in a programme of his own works.

monic Orchestra and the Chicago Symphony Orchestra. Werner Janssen has just been honoured by the Finnish Government in appreciation of his interpretations of Sibelius, whose Third Symphony he will conduct during this concert. Last Sunday he married Miss Ann Harding, the actress.

## FIRST BROADCAST

A NEW choral work by Vaughan Williams, entitled "Five Tudor Portraits," will be broadcast for the first time during the symphony concert at the Queen's Hall on Wednesday, which will be relayed Nationally from 8.15 to 10.35, with a twenty-minute break at 9.30, during which the news bulletin will be given. Adrian

book. "The Three Musketeers" possesses in itself an all-pervading rhythm and a speed which leaves the reader breathless. Patrick Riddell, who adapted it for broadcasting, added to this by the clever way in which he divided the dramatic scenes into short, staccato situations interspersed with effects and music.

The same method will be applied to "Twenty Years After," which, although not so well known as "The Three Musketeers," is nearly as absorbing and should make a first-class radio drama packed with thrills, romance, and history. It will be heard Nationally on Monday at 9.35 and again Regionally on Tuesday at 9.

## HIGHLIGHTS OF THE WEEK

### FRIDAY, JANUARY 22nd.

Nat., 6.25, Recital: The New English Singers. 8, Scrapbook for 1922. 9.20, European Exchange—3, Austria.  
Reg., 6, Reginald King and his Orchestra. 7.30, The Shepherds' Feast from Caldbeck.

### Abroad.

Warsaw, 7.15, Warsaw Philharmonic with Uminski (pianoforte).

### SATURDAY, JANUARY 23rd.

Nat., 4.35, Jeanne Dusseau (soprano) and Tom Jenkins (violin). 8, Music Hall, including Florrie Forde and Wilkie Bard.  
Reg., 4, The Air-do-Wells. 6, The Friary Brewery Band. 8, Discussion on the Tipping System.

### Abroad.

Brussels, I, "Rossini in Naples," three-act opéra-comique.

### SUNDAY, JANUARY 24th.

Nat., 6.30, The Richard Crea Orchestra. ¶Dr. Samuel Johnson: feature programme. 10, Piano-forte Recital: Jan Smetierlin.  
Reg., 5, B.B.C. Military Band and Arthur Fear. 6.30, Sunday Orchestral Concert. 7.55, Service from Romsey Abbey.

### Abroad.

Frankfurt, 7, Guila Bustabo (violin) in the Museum Society's Concert.

### MONDAY, JANUARY 25th.

Nat., 7.20, Ninth Entertainment Parade. 8, It's Happening Now: IV. 9.35, "Twenty Years After" (Dumas).  
Reg., 7.30, Recital: Alexander Kipnis (bass). ¶Van Phillips and his Two Orchestras. 8.30, Robert Burns' programme.

### Abroad.

Deutschlandsender, 7.10, Gala concert.

### TUESDAY, JANUARY 26th.

Nat., 8, "A Southern Maid." 9.20, Church, Community and State: III. 10, Music of John Ireland.  
Reg., 6, Band of His Majesty's Royal Marines (Chatham Division). 7.30, Relay from the Circus, Olympia. ¶Organ Recital: C. H. Trevor. 9, "Twenty Years After."

### Abroad.

Breslau, 7.10, "Land of a Thousand Lakes"—a radio trip to Finland.

### WEDNESDAY, JANUARY 27th.

Nat., 7.10, Palace of Varieties. 8.15 and 9.50, Symphony Concert.  
Reg., 7.45, The World Goes By. 9, "A Southern Maid."

### Abroad.

Strasbourg, 8.30, Municipal Orchestra from the Palais des Fêtes.

### THURSDAY, JANUARY 28th.

Nat., 6.20, This Way Out: John Hilton. 8.15, Music from the Movies. ¶Orchestre Raymonde.  
Reg., 7.30, "Songs you Might Never have Heard." 8.15 and 9.50, The Royal Philharmonic Society's Concert from the Queen's Hall.

### Abroad.

Kalundborg, 7, Tchaikovsky's and Berlioz' Versions of "Romeo and Juliet."

Details of the week's Television programmes will be found on p. 80.

# Week Outstanding Broadcasts at Home and Abroad

## BURNS' BIRTHDAY

THE 178th anniversary of the birth of Robert Burns will be celebrated in a special programme of his works on Monday at 8.30 (Reg.). Instead of inviting distinguished people to the microphone to tell listeners what Burns means to them and the poet's place in literature, the B.B.C. has decided to allow Burns on this occasion to speak for himself through his works.



## SHEPHERDS' FEAST

AN actuality broadcast from the Oddfellows' Inn, in the Lakeland village of Caldbeck, Cumberland, of a Shepherds' Meet will be heard to-night in the Regional programme at 7.30. It will be the occasion of a half-yearly "meet," when thirty or forty flockmasters and shepherds from the Skiddaw, Saddleback, and Caldbeck Fells gather together to identify stray sheep. These meets are essentially occasions of conviviality, for after the business side has been carried out there is a dinner, followed by songs and stories. The financing of these feasts comes from the sale of unidentified sheep.



## RHYTHM MUSIC

THE Norwegian broadcasting organisation, which has earned a reputation for quick response to listeners' wishes, has arranged a number of gramophone recitals of swing music to meet a public demand. One of these recitals will be broadcast on Thursday at 9.15 as a comparative programme of swing, hot, straight and soft music. None of the Scandinavian languages has words to describe these forms of rhythm

music, so the Northern people have adopted the Anglo-American words. Some of the world's most outstanding recordings by famous bands have been selected for this programme.



## DON JUAN

THE week's principal event in the Swedish programmes is a concert by the Berlin Philharmonic Orchestra, which is playing under the direction of Eugen Jochum the Don Juan Symphonic Poem by Richard Strauss, and Beethoven's Eroica Symphony. The concert will be relayed from Stockholm's Konsertforening on Monday at 7.10.



## OPERA

BUCHAREST commences the week's opera broadcasts with its usual relay of the Royal Romanian opera programme at 6.35 to-night (Friday). Transmissions by this station are of much greater general interest in these days, since all programmes are now relayed by the high-powered National transmitter, Radio-Romania (Brasov). At 7.10 to-night Königsberg reveals to us a little-known side of the eminent composer of German lieder, Hugo Wolf. This composer was responsible for only two operas during his lifetime, and of these the North German station has chosen the more familiar "Der Corregidor" (Spanish mayor). Post Parisien, too, offers at 8.40 a programme of the type usually bracketed with opera, in Delibes' charming ballet, "Sylvia," the concert version of which is arranged and presented by Paul Reboux.

Brussels I announces what is sure to be the draw of the week. At 8 on Saturday we are to hear the very latest opéra-comique, Paumgartner's "Rossini in Naples." As recently as January 3rd, Vienna was privi-

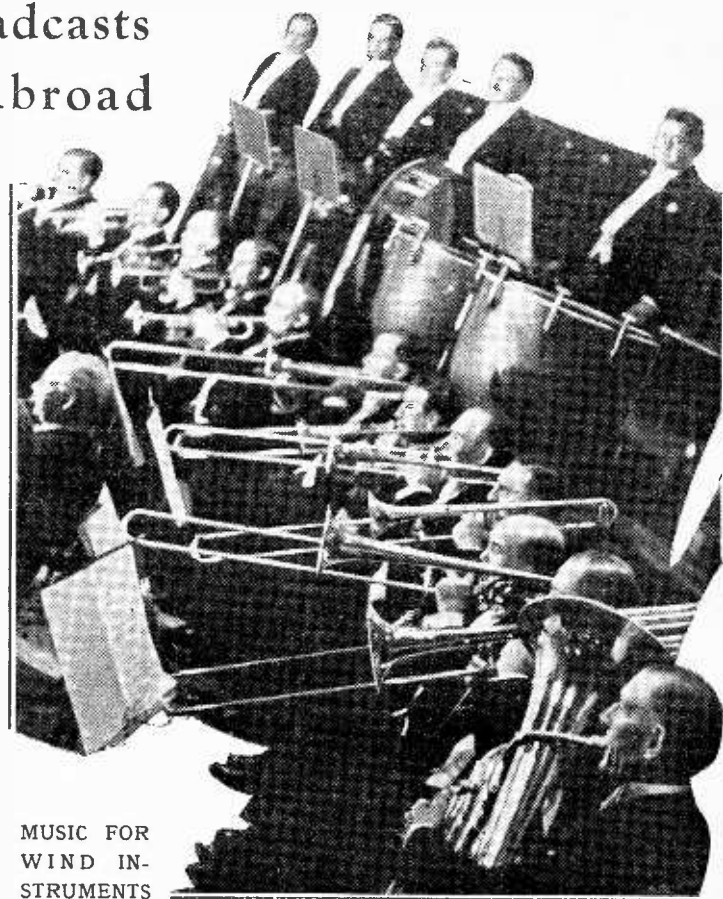

MUSIC FOR WIND INSTRUMENTS

will be played by the entire wind section of the Symphony Orchestra on Monday at 8.30 (Nat.). Part of the brass section is seen in this photograph.

leged to hear Tauber singing the title-rôle at the opera's première in that city, where it is enjoying almost staggering success.

Hamburg announces one of the less-familiar of Mozart's operas, "La finta giardiniera," for its 7.10 programme on Tuesday. Mozart lovers will welcome the opportunity of hearing their favourite's early attempts at opéra-bouffe. Luxembourg, too, promises an exceedingly interesting transmission for 9.15 on the same evening. For the third of a "History of Opera" cycle, Lully's "Acis and Galatea" is billed.

The centenary of the death of Pushkin, the great Russian poet, occurs this year, and as his work has so frequently inspired the composition of opera, this theme has been chosen for the programme from Paris PTT at 8.30 on Thursday.

## OPERETTA

A NEW operetta, "Die unsterbliche Sehnsucht" (Grothe), based on the ambition of a concert singer for the stage, an ambition which survived her retirement from the world of music on marriage,

will be heard from Hamburg at 7.10 on Sunday. It is highly probable that many of the song numbers of this operetta will prove to be popular hits, as Grothe's art is of the type that makes a very strong appeal to the man-in-the-street.



## MISCELLANY

NORWAY's first cinema organ, recently installed in a picture-house in Oslo, will have its broadcast début when Leif Nielsen gives a recital on it to be radiated by Oslo on Monday at 9.35.

The famous Dresden String Quartet, whilst visiting Norway, will give a broadcast recital of German chamber music from Oslo at 9.15 on Tuesday.

Guila Bustabo, the seventeen-year-old violinist, will be the soloist at the Museum Society's Fourth Sunday Concert which will be relayed from the Saalbau by Frankfurt at 7.

Paul Lincke, Berlin's popular composer, who recently celebrated his seventieth birthday, will conduct a concert of his own works in the Bürgerbräukeller, Munich, on Sunday at 7. This will be broadcast from Munich.

THE AUDITOR.

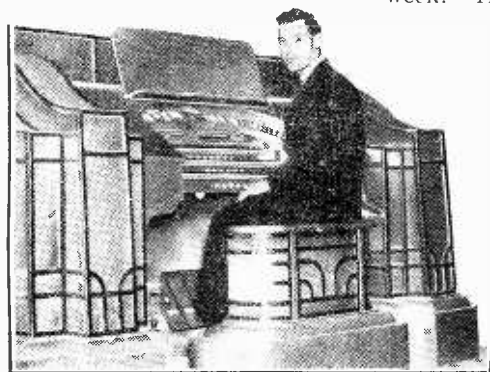

REGINALD NEW will give a twenty-five minute programme on the theatre organ on Monday at 6.40 (Nat.)

# RANDOM RADIATIONS

## An Automatic Dial

FROM an Isle of Wight reader I have received a particularly interesting letter on the subject of dials. "I have given the question of dials a lot of thought in the past," writes he, "and have come to the conclusion that the ideal method is one in which there is no need for skill or feats of memory. These conditions seem best satisfied by something on the automatic telephone principle." He tells me that he has almost completed such a dial for his own set, having picked up the necessary parts at junk shops for just over £1. To obtain any one of fifty stations, the first four letters of its name are dialled in the familiar way. Or, if he wants to play records, dialling GRAM causes the necessary switching to be done and brings the gramophone motor into action. A most ingenious idea, and one that seems to have great possibilities. One criticism, though, occurs to me: what happens if you dial HILV or BRUS or TOUL or LYON? Hilversum, Brussels, Toulouse and Lyons all have two stations apiece.

## Sports Models

An automatic dial covering fifty stations would probably be ideal for ordinary domestic use, but I am afraid that it would hardly satisfy the hard-bitten experimenter or the D-X enthusiast—at least not for his own personal use. Most of us who fall into either or both of those classes have two receivers. One is for the family; the other for ourselves alone. The sets we use ourselves bear much the same relation to domestic receivers as sports cars do to cars of the "family bus" type. But there's one big difference: the motorist who wants a sports car doesn't have to build it himself! Why shouldn't set manufacturers try sports models in wireless receivers? They ought to go pretty well, for the number of enthusiasts is large.

## What He'd Need

Here are my ideas about the "radio sports model." First of all, it should certainly be obtainable in two separate parts: the radio set proper (from the RF stage to the second detector) and the low-frequency amplifier. In this way both those who put sensitivity above all else, and those who regard high quality in reproduction as the most desirable of ends, would be able to satisfy their requirements. Also, either half of the set could be replaced as needed by something more up-to-date. In the radio half both sensitivity and selectivity of a high but widely variable order would be needed. We should also look for a large tuning dial either accurately calibrated or capable of such calibration. In low-frequency amplifiers the experimenter could make his own choice according to the amount of undistorted volume needed. Well, it's just an idea, and, of course, my notion of the sports receiver probably wouldn't be the same as yours, but I think there's something in it, don't you?

## The Agent Question

RECENTLY, I referred to some comments by Judge Lilley on hire-purchase agreements. If you remember, he was most scathing about a clause which stated that the retailer who sold the set was not the

By "DIALLIST"

agent of the manufacturers. When I picked up my local paper last week the first thing that struck my eye was a displayed advertisement by the owner of a radio shop, which ran: "XYZ IS YOUR LOCAL AGENT FOR . . ." and there followed a list of half a dozen well-known makes of receivers. I contend that the public does regard the man in the wireless shop as the maker's agent, and that it has every reason for doing so when this kind of advertisement appears. And haven't you seen, both outside shops and in their windows, signs reading: "Agent for such and such sets"? I also find frequently in the trade papers advertisements headed: "Agents wanted," put in by firms which require representatives in this district or that. The position certainly needs clearing up. I'm no lawyer, but I can't see how a man can be an agent and yet not an agent!

## Many Sets : Too Little Variety

JUST how many different sets there are on the market I don't know, but the number must run to a good many hundreds. Yet, when you come to examine catalogues or pay a visit to a big wireless showroom, you can't. I think, help being struck by the lack of variety. What I'm driving at is this: Most manufacturers have a three-valve battery set, and possibly a battery superhet with four or five valves. In the mains class they have three-valve straights, three-valve superhets, and here and there a set with five, six, or seven valves. It seems to me that we have too many sets capable of what one may term standard performance. By "standard performance" I mean that the receiver is sensitive and selective enough to bring in the majority of the higher-powered European stations working on individual channels, and that it has an output sufficient for the average room, the quality being satisfactory so long as one is not over-critical about the

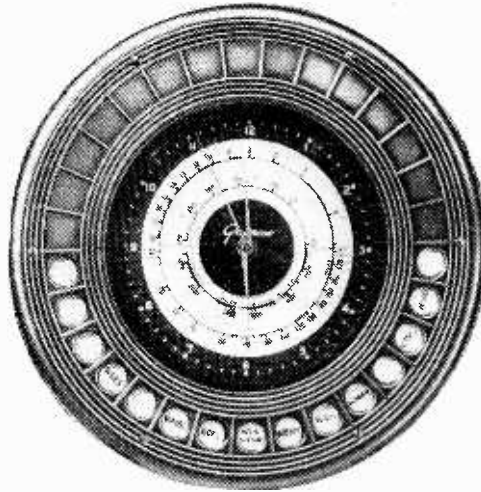

**AUTOMATIC DIAL.** From America comes a practical device on the lines being suggested in the columns of this page. By inserting a finger in the slot indicating the desired station by its call sign and rotating to the lower central position, the set is brought immediately into tune without noise from intervening stations. Ordinary knob control can also be used.

reproduction of genuine bass, the very high notes, transients, and so forth. If the set is of the "all-wave" type, it will give you a certain number of European stations and two or three of the more strongly received Americans in the ordinary way, and a somewhat wider selection when conditions are favourable.

## Why Not Specialise ?

What does seem to emerge from an examination of current receivers is that so few manufacturers try to specialise; the majority are content to produce the standard-performance set and to rely for variety upon cabinet design and gadgets connected mainly with tuning. There are well-known firms which specialise in particular lines in radio, but this kind of thing doesn't go nearly as far as it does in, for instance, cars, cameras, home cine apparatus, or such mundane things as furniture, clothes, and boots! I must say that I'd like to see more firms devoting their chief energies to battery sets, others getting a name for "all-wave" mains receivers of really fine long-distance performance, others concentrating on big undistorted (really undistorted!) volume, and so on.

## Guns and Wireless

You can't imagine any two things much more different than the shotgun and the wireless set. Yet there's a useful parallel to be drawn between them. If you're buying a gun you can purchase a machine-made weapon that bears the necessary proof marks for £5 or a little more. You can also pay a hundred guineas or more for a gun that is hand-made throughout of the very finest materials. Admittedly, a rabbit or a partridge or a pheasant isn't any more dead, whether it's shot by a five-pound or a hundred-guinea gun. Equally, a distant station can be chalked up in the log, whether it is received after miracles of tuning on a small, cheap set or with ease on one of many valves. But with the good gun—and with the good radio set—you do know that you have something that will enable you to do yourself justice. There are a good many firms which turn out first-rate and costly guns. They all specialise in something. It may be weight, or balance or barrel length, or fine finish. But all of these firms do pretty well. Wouldn't radio firms do just as well if they specialised on similar lines?

## Performing Rights

THE forebodings of strife between the B.B.C. and the Performing Right Society, the rumours that the Society might call a "strike" of its members, and so forth, appear to have been hatched in the mare's nest that is so frequently discovered by seekers after "sensations" when the B.B.C. has to come to any important decision. So far as one can see, the facts are that when the agreement between the two bodies came to an end on December 31st the Society was asking for more than the B.B.C. was prepared to offer. Both sides, however, consented to refer the matter to arbitration, and the matter will no doubt be settled amicably. Few listeners will feel that the P.R.S., whose members supply so much of our wireless entertainment, does not deserve to receive for distribution amongst them more than the £100,000 a year which it had under the old agreement. The Ullswater Committee, you may remember, recommended that the B.B.C. should be liberal in its treatment of composers and authors.

# Broadcast Brevities

## Engineers in Trouble

ON their own ground the B.B.C. engineers are supreme, but when it comes to choosing a name they suffer from the same mental agony that afflicted William Shakespeare. "As You Like It" and "Twelfth Night, or What You Will," were not worse efforts in the direction of titles than Lisnagarvey (which scarcely anybody had heard of till the Northern Ireland transmitter opened) or Moorside Edge—a pale euphemism beside Slaithwaite, the rightful name for the locality.

## No Prizes, but . . .

And now it appears that the new South-West of England transmitter is causing another pother on the upper floors of Broadcasting House. "Start Point"—a bold, vigorous description—will not do, apparently, as the transmitter may be more than a mile or two from the famous headland, and the Devonians being none too lavish in the use of place-names, there are no other likely titles that appeal to the engineering mind.

What is wanted is a really glamorous name which would comprehend the whole of "Lyonesse," this romantic land of Arthurian legend. No prizes are offered, but the listener who can think of a good name will unpucker many noble brows in the Engineering Department.

## "Penmon"

And not only the engineers are wrangling over place names. A dispute has been going on between North and South Wales as to whether Beaumaris (the new relay station) should be pronounced "Bewmaris" or "Bowmaris." The South favours the former, the North the latter. In the meantime, the B.B.C. has taken the wind out of everybody's sails by calling the station "Penmon," after a near-by village. Who shall say that the B.B.C. lacks a sense of humour?

## General Post in Wavelengths

And now for the intentions of the B.B.C. as regards wavelengths.

Next July the Scottish National programme transmitter, which at present works on a wavelength of 285.7 metres (1,050 kc/s), will be synchronised with the London and North National programme transmitters on 261.1 metres (1,149 kc/s). The wavelength thus released will be used temporarily by the present National programme transmitter at Wash-

ford to provide a separate West Regional programme to those listeners in the West of England who now take their Regional programme from the Washford transmitter on 373 metres (804 kc/s). The latter will then become the separate Welsh transmitter. Listeners who at present receive the National programme from the National programme transmitter at Washford will be asked to use Droitwich.

## Two New Transmitters

The construction of two additional transmitters to provide a Regional programme to the South coast and South-west of England on a permanent basis will be begun shortly. The first of these will work on high power and will be situated in South

RADIO  
DESK  
SET.—

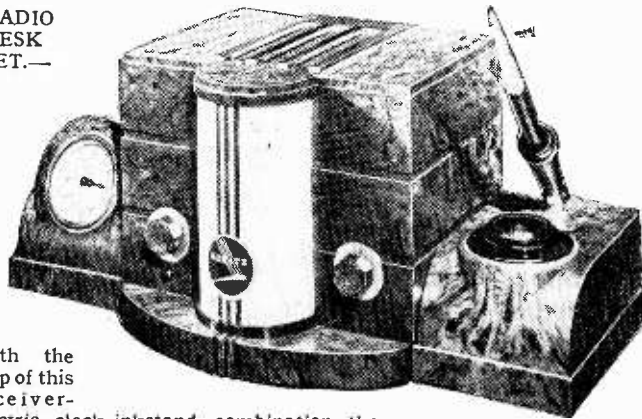

With the help of this receiver-electric clock-inkstand combination the American business man whiles away the time at his office quite pleasantly.

Devon, serving the South coast and the South-west of England, at the same time replacing Bournemouth and Plymouth. When ready for service it will take over the wavelength of 285.7 metres (1,050 kc/s), which, as already stated, is to be used temporarily to provide a West Regional programme from the Washford station. The location of the second new transmitter has not yet been definitely decided. This will be a medium-power relay station working on the wavelength at present used by Bournemouth and Plymouth, namely, 203.5 metres (1,474 kc/s). It will serve Bristol and certain areas in North Devon and Somerset not covered by the new transmitter to be built in South Devon.

## Beaumaris Next Month

From February 1st North Wales will be served by the new transmitter at Beaumaris, which will use the same wavelength (373 metres, 804 kc/s) as the Regional transmitter at Washford and radiate the same programme.

## NEWS FROM PORTLAND PLACE

From July until they close down on the opening of the new transmitter in South Devon the Bournemouth and Plymouth low-power transmitters will radiate the newly constituted West Regional programme.

## Nigg Calling

When Burghead was opened the Aberdonians put in a plea for more power at their local station, which operates on only 1 kW. Their hopes will be more than realised in the near future, for the B.B.C. has decided to erect an entirely new transmitter at Nigg, outside the city, which will have 5 kW. of aerial power.

writing his own script for variety shows as well as reading and adapting other people's—and here his long experience should stand him in good stead, for he was writing and producing radio dramas for the Leeds station way back in 1924. Few members of the B.B.C. staff can equal this record.

## Not So Dangerous

ALTHOUGH R. A. Rendall, the new Assistant Director of Television, finds his Alexandra Palace job full of thrills it lacks the spice of danger which entered into the job of setting broadcasting on its feet in Palestine. Soon after his arrival in Jerusalem in September, 1935, the riots began and there were times when the broadcasting station stood in danger of attack by malcontents.

Probably because the dissatisfied elements failed to realise the true value of broadcasting, the station escaped and Mr. Rendall and his associates were able to start the tri-lingual service—English, Hebrew and Arabic—in comparative quiet.

## The Village Set

IN fifteen months the number of listeners was trebled, the licence figures mounting from 6,000 to 18,000. Actually these figures are no true indication of the numbers listening, as many a village set provides entertainment for many hundreds.

## Television "O.B." Vans

NO fewer than three specially equipped television vans may be employed for "O.B.s" this summer. In addition to the much talked-of transmitter van, which is already under construction, there will be a vehicle containing the scanning equipment and another devoted solely to power plant.

It looks, therefore, as if a fleet of three vans, working in conjunction with each other, will always be necessary for television out-of-doors.

## The Coronation

Although no definite decision has been taken, it may be assumed that the Coronation procession will be televised. The opportunity is too good to be missed; in fact, the feeling at Alexandra Palace is that the Coronation should put television "on the map," just as the General Strike of 1926 finally established sound broadcasting as an indispensable adjunct in every modern home.

## Promotion for Empire News Chief

MR. C. A. L. CLIFFE, who has just been appointed Assistant Director of the Empire Broadcasting Service, knows more than most people about the special needs of the Colonies. He was an Assistant Principal in the Colonial Office in 1925 and served as a Permanent Under-Secretary in 1930 and 1931. He has worked in the Empire Broadcasting service since September, 1935, when he was appointed Empire News Editor—a post calling for unusual perception of news values and an almost 'pernickety' sense of proportion. The Empire news service has many formidable rivals all over the world, as owners of short-wave sets know only too well.

## Famous Partnership

LESLIE BAILY, of "Scrapbook" fame, is now assisting in the B.B.C. Variety Department in collaboration with Charles Brewer, and the famous partnership promises to become a permanency. Mr. Baily is

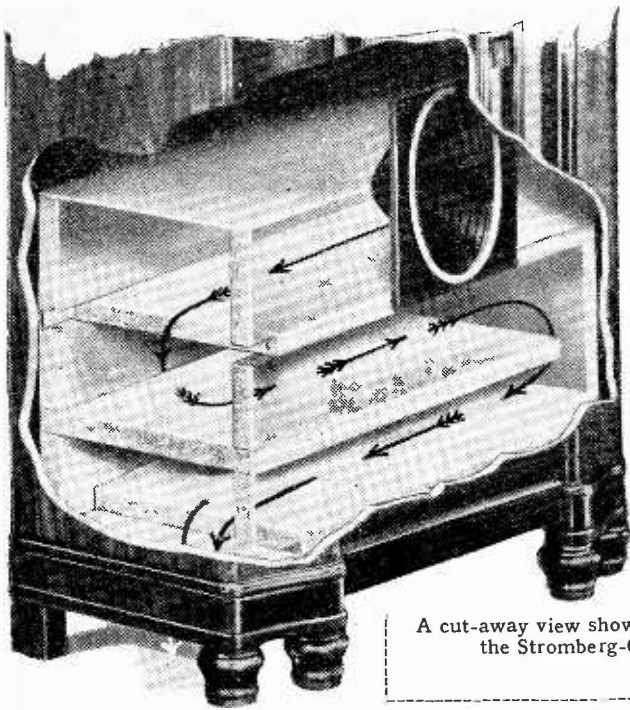

A cut-away view showing the general arrangement of the Stromberg-Carlson acoustic labyrinth.

# The Loud Speake

## IDEAS FOR IMPROVING QUALITY

By  
"CATHODE RAY"

**L**ISTENERS may be classified broadly into two sorts: first, those who go into a shop, buy a standard type of set consisting of a box (or, according to the catalogue, "a fine example of the cabinet-maker's craft") containing a receiver chassis and a moving-coil loud speaker, stick it in some convenient place in the house, and switch it on and off when they feel like it; secondly, those who realise that, in spite of the salesman's description, the standard type of set is not the ultimate in perfect reproduction, and who therefore go to one of the few specialist suppliers, or build or assemble carefully selected units into a system which is generally much less compact than the walnut masterpiece referred to above. It is almost certain to have the loud speaker separate from the receiver, and mounted in a door, bookcase, large baffle, or very special kind of box.

### Limitations of Mass Production

To give the mass-producers their due, they are always prepared to consider incorporating any advances made in the art of good reproduction so long as it does not make their products too (a) bulky, (b) heavy, (c) fragile, (d) unselective, (e) expensive. If they were to design up to the standard of their knowledge, there would always be some features that would conflict with these commercial requirements, and so the "standard set" is always rather less good than the best efforts of the specialist. The gap is not so wide as it once was; when, for example, the largest valve that could be used in a "popular" receiver had an output of about a third of a watt.

Where do imperfections still exist? At the high-note end of the scale there is a tendency to cut off altogether; but, assuming the price will run to a properly executed variable selectivity system, the limitation is imposed by the peaks and hollows of the cheap loud speaker. If

there is anything at all like full-level reproduction of the top notes, it is probably concentrated into one or more fearful peaks around 3,000-4,000 cycles. Even the specialist loud speakers are a bit shaky in the extreme top. I was interested to hear the designer of one of the best-known "quality" speakers confess that improvement at this part of the scale is almost pure cut-and-try. Then, when he has done all, the room plays a great part in determining the result.

But I am not concerned just now with the top end, which is very disputed territory. At the other extreme of the scale the problems are fairly clear, though it is by no means clear how they can be solved within the framework of the cabinet-maker's craft. The troubles are these: (1) The cabinet is like a short organ pipe, and resonates to some particular frequency, usually about 100-150 cycles—right in the middle of the bass. Result: The tubby, boomy effect familiar everywhere. (2) The loud speaker cone and coil as a whole resonates at some low frequency. Good care is taken to see that this peak does not hit the cabinet resonance, for that would be terrible; usually, it is somewhere around 90 cycles. The acoustic resistance at this frequency is low, so there is little to stop the resonance building up to a large amplitude, and the coil travels so far backwards and forwards that it comes out of the uniform magnetic field and causes distortion. It is possible to make the suspension floppy enough to put the resonance safely below the audible range, but this carries the practical objections that the coil must have a much wider gap in which to move without fear of fouling the magnet pole pieces, which, in turn, means bigger magnets, more energising power, lower sensitivity, or perhaps a combination of all three, to say nothing of the suspension being less easily manufactured and more easily damaged. The mechanical resonance in the bass is reflected in an electrical resonance whereby

the impedance of the coil may be many times higher than normal. The "standard" set drives the loud speaker with a pentode, of course; so not only is the bass peak emphasised, but also the distortion at full output rises much above the designed amount. Altogether, a bad business unless something is done about it.

(3) There is normally a falling-off in the bass, because a small cabinet is a poor sort of baffle. It might be possible to compensate for this by faking the amplifier circuits to give a rise; but, if successful, this would probably only magnify the evils resulting from (1) and (2).

One can compensate for a steady falling-off anywhere, but it is quite a different matter when there are sharp peaks, because it is impracticable to ensure that the compensation (if one is clever enough to produce it) corresponds exactly with the irregularities every time and all the time.

### Balancing Out a Resonance

That seems to be the reason why the acoustic resonator, proposed some time ago and actually fitted to some American broadcast receivers, hasn't come to anything. The idea was to close off part of the space inside the cabinet, leaving a narrow opening to form a cavity resonating equally and oppositely to the undesired resonance. Fig. 1 shows the general scheme, and Fig. 2 the results claimed. Whether it was possible to ensure these results without individual work on each receiver appears questionable.

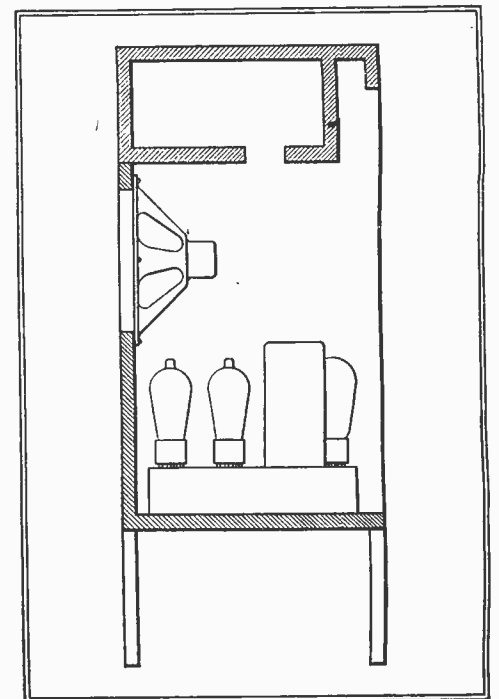

Fig. 1.—Outline of the method of opposing the cabinet resonance by means of a resonator built into the cabinet. (After Olson and Massa.)



# nd the Cabinet

More highly worked-out systems, designed not only to eliminate the evils of cabinet resonance but actually to convert the sound wave from the back of the loud speaker into an asset, have been marketed in America under the name of "The Magic Voice," and in this country under less fanciful descriptions by Voigt. I don't describe them in detail now, because this was done in *The Wireless World* of August 28th last. But another American system,<sup>1</sup> embodied in Stromberg-Carlson receivers, is also quite interesting. It is called the "acoustic labyrinth"; the name suggests its purpose, which is to make the sound from the back of the speaker lose itself.

The same device is familiar to motor cyclists and others; not, it is true, under the name "acoustic labyrinth," but as a

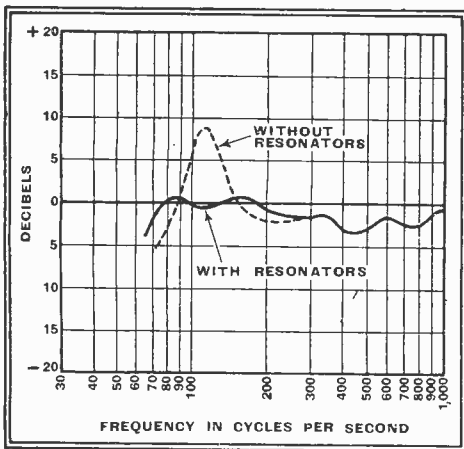

Fig. 2.—Result claimed for the resonator system. (After Olson and Massa.)

"silencer." The construction can be seen from the picture; instead of allowing the air at the back of the speaker to communicate with the inside of the cabinet, it is led through a pair of felt-lined covers—the space between is to prevent overheating of the magnet—into the lower part of the cabinet, which is divided by two horizontal partitions so as to treble the length before reaching the opening into the outer air. The total length of the tunnel is about 6ft., and the cross-section 4in. x 8in. The walls are everywhere lined with inch-thick rock wool—a material that is very effective in absorbing sound.

A closed air space with hard, reflecting walls is analogous to a low-loss tuned circuit; both respond sharply to a particular frequency, and, while this may be very good in a radio tuner, it is highly undesirable in a reproducer that is supposed to give "level" characteristics. The laby-

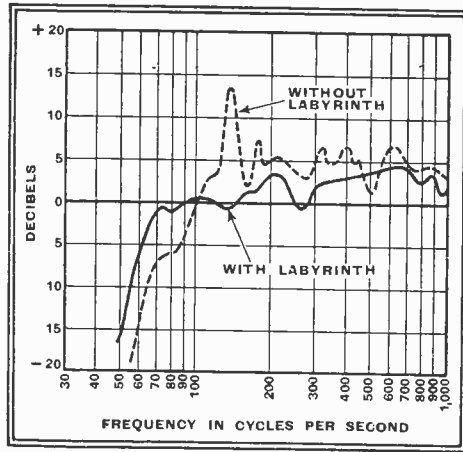

Fig. 3.—Curves showing effect of the acoustical labyrinth in eliminating cabinet resonance. (After E. Olney.)

rinth simply introduces a very high acoustic resistance into the "circuit," and flattens out the peak. Fig. 3 shows the extent to which it is effective. At higher frequencies there is no reason to suppose that the difference is appreciable.

Even more striking is the effect on the electrical impedance of the speech coil, which in the example tested was nominally 24 ohms. Without the labyrinth it jumps up to 200 ohms at one point; with the labyrinth this peak is reduced to about one-third (Fig. 4).

A test made with the labyrinth in position, but without the absorbent lining, showed simply appalling results. So it is not advisable to go half-measures in trying such a device.

The peak, by the way, is unusually low in the scale; in most loud speakers it would be much more harmfully placed.

It should be observed that this "silencer" is not equivalent to an ordinary baffle, which causes weakening and reinforcement of sound at certain frequencies depending on its dimensions. It may therefore sound a bit "down" in the bass when compared with other systems.

The method of bass control that one uses is decided by individual requirements or (more probably) by what involves the least unsightly appearance or the least effort to arrange. How many people really carry out for themselves half the things that they hold to be technically right?

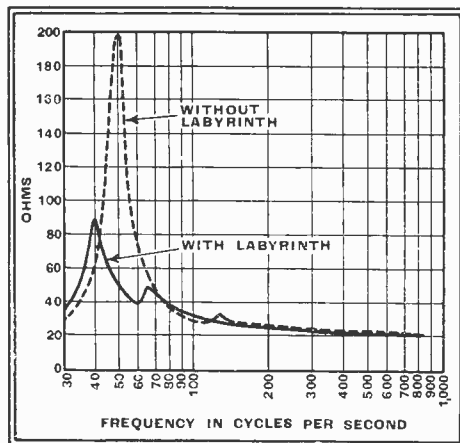
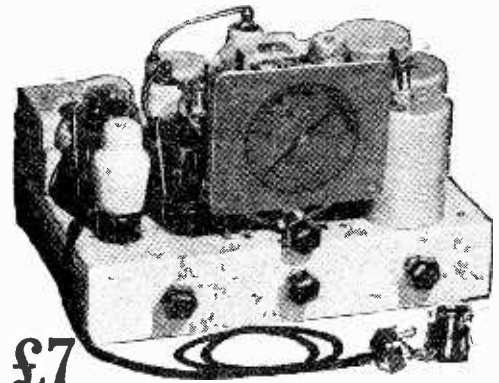

Fig. 4.—The labyrinth has also an indirect influence on the impedance of the moving coil, as shown here. (After E. Olney.)

## MCCARTHY

for the finest value in All-Wave Receivers!



### 6 VALVE ALL-WAVE SUPERHETERODYNE

(complete with B.V.A. Valves)

Improved edition of this popular receiver (praised "Wireless World" test reports). Heavier gauge cadmium-plated steel chassis. Iron-cored I.F. transformers give even better performance. No increase in price.

Brief Specification: 8-stage, all-wave band-pass superheterodyne, 7 tuned circuits. D.A.V.C. with "squelch" circuit valve for noise suppression. Illuminated "Airplane" dial. Octode frequency changer. 3.5 watts pentode. Switching for gramophone pick-up. Wave ranges: 16.5-50, 200-550, 800-2,000 metres.

### MCCARTHY ALL-WAVE SIX

with 6 watt push-pull output

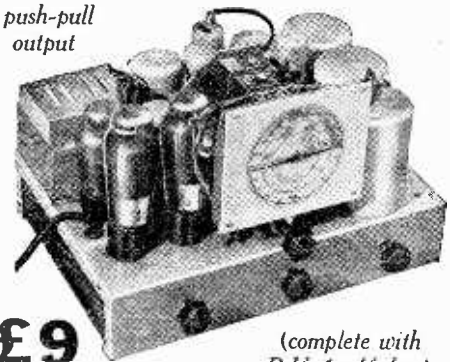

(complete with B.V.A. Valves)

6 valve all-wave superheterodyne with similar specification, performance, etc., to above, but with large push-pull output giving 5½-6 watts.

Has illuminated "Airplane" dial with principal station names, tone control and volume control (both also operative on gramophone), full provision for gramophone reproduction.

A really high quality receiver, with exceptionally large undistorted output, and fine performance on all 3 wave ranges.

All McCarthy receivers supplied complete with valves, knobs, pilot lamps, leads, mains cable and plug. 12 months' guarantee.

Deferred terms on application, or through London Radio Supply Co. 11, Oat Lane, E.C.2.

Cash with order on 7 days' approval. Also write for illustrated catalogue of complete range of all McCarthy receivers

MCCARTHY RADIO LTD., 44a, Westbourne Grove, London, W.2

Telephone: Bayswater 3201/2.

<sup>1</sup> Described by Benjamin Olney in *The Journal of the Acoustical Society of America*, October, 1936.

# Letters to the Editor

The Editor does not hold himself responsible for the opinions of his correspondents.

## Super-regenerative Receivers

IN his interesting article on the Super-regenerative Receiver in your issue of December 25th, Mr. E. L. Gardiner briefly describes some features of his practical circuit (Fig. 3) and then remarks that the remainder is self-explanatory. Personally I do not find it so, although I can follow him throughout the earlier stages of the article.

He refers to the hexode section of the multiple valve, although the valve specified is a triode-pentode and the modes of operation are not identical. However, that is a detail. But the fundamental principle of the circuit consists in the use of a quenching oscillation of sharply peaked waveform, and it is clearly explained how this is generated in the circuit of Fig. 1 by the overbiasing or "Class C" operation of an amplifying valve. In Fig. 3, however, all grids are returned to cathode, and the control R does not appear to function as in Fig. 1. How, then, is the overbiasing obtained? Also, as the space currents of both sections of the triode-pentode pass through the lower part of R the characteristics of the coupling to the detector appear to be decidedly complex, and the reasons underlying the choice of this system are not at all self-explanatory. Nor is it obvious how it is possible to employ positive or negative quenching as stated.

I feel that some amplification of this section of the article would be very valuable.

Incidentally, the author may be interested to note Fig. 4 in my article on the Super-regenerative Receiver in the November, 1936, issue of *The Wireless Engineer*, where the choice of a waveform bearing some resemblance to his is with the object of better selectivity. M. G. SCROGGIE.

Bromley, Kent.

## Service Prospects

WITH reference to "Enquirer's" letter in a recent issue of *The Wireless World*, I would like to state briefly my experience as a radio engineer.

I went straight from school to an engineering college at the age of 18, and after three years' study, at great expense to my parents (who fondly imagined that the profession was worth while), I graduated with the usual diplomas, etc. Armed with these—and six months' practical experience—I sallied forth, brimful of enthusiasm, to obtain a post. Soon, however, the wind was taken out of my sails, when I found that the best offer I could get was 11d. an hour (less than a common labourer), and no guarantee of a job beyond one hour! I do not think this needs further comment. Apparently, radio firms make a practice of engaging men (many with university degrees) just when they are busy, and then at an hour's notice consign them to the Labour Exchange! They appear to have no regard for the men, nor the profession. One would like to know what would happen in any other industry if highly trained technical men were treated in this manner. It certainly does not conduce to attracting the best brains, and it is impossible to enter the industry full of enthusiasm for

one's work, and desirous of putting the best into it, when one does not know whether or not he will be wanted on his job tomorrow! I would like to inform "Enquirer" that I have worked side by side with university men, with B.Sc. degrees, who were being paid 1s. 3d. an hour!

To any young man contemplating entering the radio branch of engineering, my advice is "don't." Take up a branch where ability is appreciated, even if it does mean the sacrifice of a subject you love.

"SADLY DISILLUSIONED."

Hampstead, N.W.6.

## Five Metres Spans Atlantic

I THINK you may be interested to know that my "5-metre" signals were received in the United States at 15.10 G.M.T. on 27th December, 1936, by Mr. Victor Ruebhausen, W2HXD, of Bronxville, New York.

His report checks exactly with: (a) What I sent, (b) the time of sending, (c) the frequency used, (d) the tone modulation frequency, and (e) the method of keying (carrier being keyed—not only the tone modulation).

I was transmitting modulated CW signals from a crystal controlled transmitter on 56,208 kc/s, operating with 100 watts input to the final amplifier and feeding a "Diamond" aerial system, beamed on the U.S. His receiver was a 7-valve superheterodyne.

This is, I believe, the first time ever that a "5-metre" signal has spanned the Atlantic, the previous best distances being around 1,200-1,400 miles between the central and eastern portions of the U.S. last May.

HILTON L. O'HEFFERNAN.

Croydon.

G5BY

# On The Short Waves

I MUST start by thanking all those amateurs and short-wave listeners who have so kindly written in response to my repeated request in my last notes.

From their letters it is clear that the British amateur is definitely wedded to the 7 Mc/s and lower frequency bands, and considers that 100-150 watts to be about the optimum power to use for all except short distance quasi-local communication.

I should like to make it clear that I have no quarrel with those who desire to use the short skip-distance channels; my point is rather that the use of these low-frequencies is too easy and should perhaps be reserved for those who have just obtained their licences, or who for other reasons are only occasionally able to transmit, although this point applies more particularly to 3.5 and 1.7 Mc/s than to 7 Mc/s, which is useful as a night frequency in the sunspot minimum years for long-distance communication, but could well be superseded by 28 or 56 Mc/s for direct-ray communication.

It must not be forgotten that 66ft. of wire at a given height is considerably more efficient on 28 Mc/s than on 7 Mc/s, and this fact, together with the lower noise level (except for car ignition), more often than not more than balances out the increased ground attenuation on 28 Mc/s, with the result that a greater local direct-ray range may be obtained on 28 Mc/s for a given power than on any of the lower frequencies.

My contention is that the job of the amateur is to pioneer the most difficult things in short-wave radio and not the easiest ones, and the first step towards doing this is to drop the use of jargon and start to use scientific terms, and so think scientifically whilst retaining the admirable "camaraderie" and good sportsmanship that already exist.

Frankly, I know some professional engineers graduated from the amateur ranks who still think that feeder lines should be cut to multiples of quarter or half wavelengths, and who presumably have never heard that it is desirable to terminate a feeder line in its own characteristic or surge impedance, for which purpose one quarter-wave matching transformer is often used.

I realise, of course, that when it is desired to use one piece of wire on a number of different bands it is almost impossible to use a correctly terminated feeder, but it is always desirable to use such a feeder if possible.

The most elegant and perhaps the only solution of this particular difficulty appears to have been made by the "Collins Company" with their 300-ohm twin tubular "feeder" and associated aerial, although there must be hundreds on the other hand who have reduced their signal by means of a "Collins Coupler," or whatever the thing is called!

Finally, I would welcome still further letters on this subject for a final discussion soon.

Leaving amateur affairs therefore for the time being, one turns to a recent statement by the Astronomer Royal, Dr. Spencer Jones, to the "Union Radio Scientifique Internationale," in which the following interesting table concerning Bright Solar Eruptions is given:—

Year.	No. of Bright Solar Eruptions.	No. of Radio Fadings.	Mean Daily Area of Spots.
1932	12	1	163
1933	5	0	88
1934	5	2	119
1935	25	8	624
1936 (Feb.-June)	28	20	1,200 (approx.)

It now seems fairly certain that the sudden severe "magnetic storms" of the sunspot maximum years are due to "Bright Hydrogen Eruptions," and not directly to sunspots as previously thought, and as I pointed out for the first time a number of years ago night-time fadeout (and magnetic storms) are generally due to a lack of sunspots.

Turning now to the conditions during the period now under review, signals were fairly good on Thursday, December 31st, but PMN Bandoeng was spoilt by a bad heterodyne during the late evening transmissions.

A high spot in the early hours of New Year's Day was W8XK on 11.87 Mc/s., at 3 a.m., broadcasting a news reel of the

"Twelve News Events of the Year"—the final scene, of course, dealing with the abdication of King Edward VIII, the characterisation being excellent.

At 7 p.m. Friday the best U.S. signal was W1HQN on 28 Mc/s, followed by W3XAL and W2XAD, the quality of the last named being a little low-toned.

Incidentally, I understand W2XAD changed from high-power to low-power modulation on December 27th, with a consequent two-fold increase in power, this station certainly provides an excellent signal until close-down every evening and is by far and away the most outstanding broadcaster heard on this side of the Atlantic.

Conditions were still good on Saturday, January 2nd, and solar activity was noted to be still high, but diminishing; signals on 28 Mc/s from the U.S. were still good at 7 p.m. or later, although it appears to be impossible to get a signal into the U.S. from this country on 28 Mc/s after 6 p.m. at the moment.

With the falling sunspot activity night conditions became distinctly poorer on Mon-

day, January 4th (although COCH, Cuba was good on 9.4 Mc/s at midnight), but recovered on Tuesday, the ultra-high frequencies being very good during daylight, W3XAL and W2XAD were excellent and 16 Mc/s stations were still audible at midnight!

On Wednesday evening, January 6th, an outstanding signal was W1XAL on 11.79 Mc/s at 11 p.m., but one must not forget to congratulate the B.B.C. on the excellent Dance Music relay at 8 p.m. from C.B.S. since, although the signal was fading badly to me, there was an almost complete absence of fading or noise on the relay.

The falling-off in signals was again noticeable by Friday, January 8th, and by Monday, January 11th, they were quite poor, which agreed with our estimate from the previous week, failing the appearance of new and unexpected sunspots.

Nevertheless, fairly strong signals were experienced from W2XE on 21.52 Mc/s during the earlier afternoons—and last week on 17.76 Mc/s from 5-6 p.m.

ETHACOMBER.

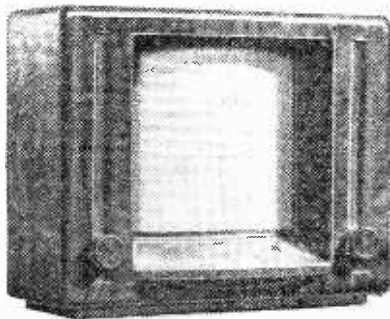

## THE LATEST PHILIPS PROGRAMME

Four Types, Including a Receiver of Unique Construction

Philips Type V5 all-wave superheterodyne for AC mains.

is used on DC supplies.

Finally we come to the Type V5, an all-wave super-

heterodyne for AC mains only, at 8 guineas. It employs the same valve arrangement as the Type 748, but there is no separate chassis, the components being fixed to lugs moulded on the back of the cabinet. The loud speaker is recessed, and the illuminated tuning scale slopes forward from the

ALL the new Philips sets are table model superheterodynes covering 16.7 to 51 metres in addition to the normal broadcast bands. Three are based on designs shown at Olympia and include the "Adaptor-visor" tilting tuning scale.

Type 794 is a development of the Type 797 and now has a cathode-ray tuning indicator, a new cabinet with larger dial, and an improved output stage. The AC model costs 15 guineas and the DC/AC 16 guineas. The battery receiver Type 714B continues unchanged at 14 guineas.

Type 748 employs a 4-valve circuit with an octode fre-

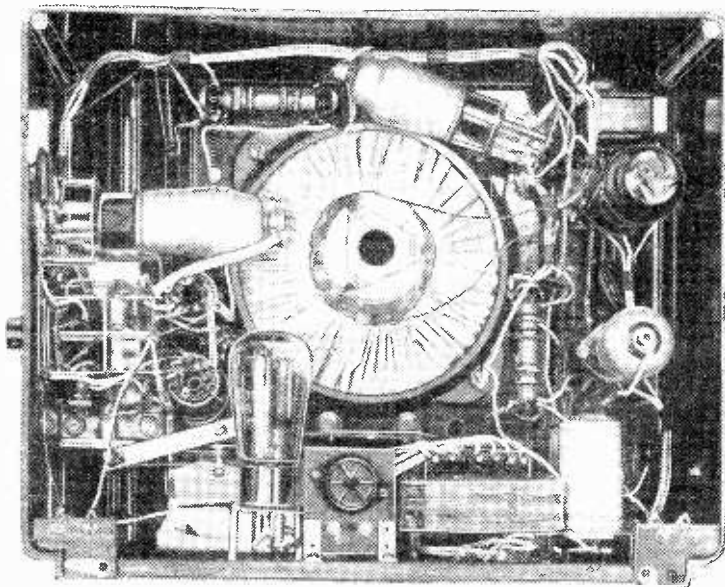

Rear view of Philips Type V5 receiver showing method of mounting of components directly in the moulded cabinet.

quency changer, pentode IF amplifier, double-diode-triode detector and high-slope pentode output valve, and costs 12½ guineas for AC and 13½ guineas for DC/AC mains. A built-in converter

base of the grille. The dimensions of the set are 16½ × 13½ × 6½ in., and altogether it is a very effective design. Only tuning and volume controls appear at the front, the waverange switch being mounted at the side.

## POINTS OF IMPORTANCE in the Rola G.12

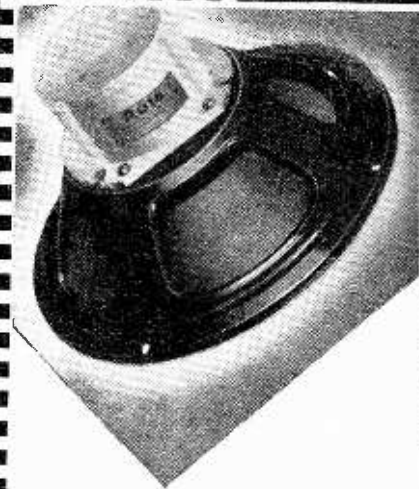

LIKE "SHEFFIELD" ON STEEL

People who want good cutlery look for the word "Sheffield." People who want a good radio set look first to see if it is G.12 equipped. For the Rola G.12 brings out the best that a set can give and no manufacturer would install such a speaker in a receiver that was not capable of securing the very highest quality reception. Ask your dealer to demonstrate a set with one of these 12" high fidelity units or if you are a manufacturer let us show you that even though the G.12 seems expensive it will assist in the sale of your product.

G.12 P.M. (as illustrated) less Transformer ... ..	£4 16 0
G.12 P.M. with Transformer ... ..	£5 5 0
G.12 D.C. Complete with Transformer, Mounting Stand, Handle and Base ... ..	£5 5 0
G.12 D.C. with Mounting Stand, Handle and Base, but without Transformer ... ..	£4 16 0
G.12 D.C. Stripped, but with Transformer ... ..	£4 4 0
G.12 D.C. Stripped and without Transformer ... ..	£3 15 0

(When ordering please state Field Resistance and Impedance of Transformer required.)

For Public Address work both the P.M. and Energised Models can be supplied with a 15 ohm Voice Coil at an additional charge of 3/.

Write for Folder A

OVER 7 MILLION IN USE

# ROLA

The World's Finest Reproducers

THE BRITISH ROLA CO. LTD.  
MINERVA ROAD, PARK ROYAL, N.W.10.  
PHONE: WILLESDEN 4322-3-4-5-E.

**Brief descriptions of the more interesting radio devices and improvements issued as patents will be included in this section.**

# Recent Inventions

## TELEVISION

IN transmission it is necessary to keep pace with and reproduce changes in the overall "brightness" or general illumination of a scene. Such changes occur comparatively slowly, as compared with the changes which reproduce the actual details of the picture, and special steps must be taken to reproduce them in the radiated signal.

According to the invention a cathode-ray transmitter is provided with a screen electrode which is covered on one side with a layer of photo-electric material, and on the other side with a coating of fluorescent material. The picture to be transmitted is focused on to the first layer, and the resulting emission of electrons is used to transmit the picture "detail" signals.

Meanwhile the fluorescent layer is being scanned by the electron stream from the cathode-ray tube. Each spot, as it is lit up, adds to the illumination, and therefore to the emission, from the corresponding spot on the photo-electric layer. The "extra" emission of electrons due to this cause is applied to regulate the amplitude of the radiated carrier-wave in accordance with the slow changes in brightness of the scene.

*Marconi's Wireless Telegraph Co., Ltd.; H. M. Dowsett; and L. E. Q. Walker. Application date April 18th, 1935. No. 455356.*

## DIRECTION-FINDING

THE so-called Adcock aerial consists of two pairs of antennae A, A1 and B, B1 which are spaced apart and coupled through horizontal transmission lines L to a central receiver R. Its advantage is that it does not respond to horizontally polarised waves, so that it is free, when used for taking the bearings of a distant transmitter, from any error caused by signals reflected from the Heaviside layer. Such

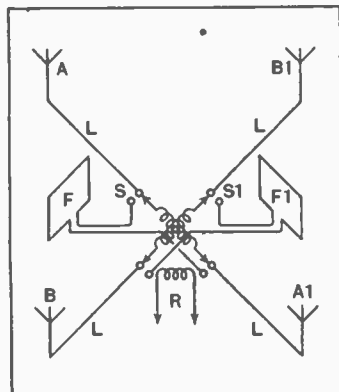

Modification of Adcock aerial system for direction-finding.

space-waves tend to become horizontally polarised in the process of reflection, and so give rise to false DF readings.

This property of the Adcock aerial may, at times, prove very inconvenient, for instance, during periods of intense "night effect," as it then prevents all reception and communication breaks down.

According to the invention this contingency is met by providing one or more frame aerials F, F1, which will receive horizontally polarised waves, and can be switched in at S, S1 in place of the aerials A-B, as and when the necessity arises.

*Marconi's Wireless Telegraph Co., Ltd., and S. B. Smith. Application date April 10th, 1935. No. 454955.*

## SUPER-REGENERATIVE RECEIVERS

TWO valves A and B receiving modulated carrier-waves of different frequency, such as the

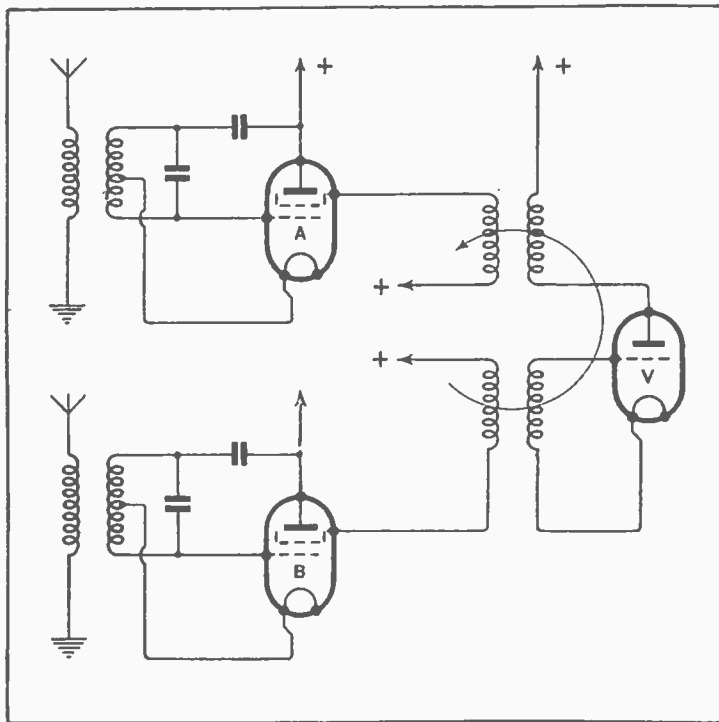

Receiving system for television using super-regeneration and a single quenching valve.

sound and picture signals of a television programme, are back-coupled to work as super-regenerators, and are both "quenched" from the same local oscillator V. It is stated that the arrangement is stable and overcomes the interference frequencies which arise when two separate oscillators are used to provide independent quenching. The amplifier A is quenched from the anode circuit, and B from the grid circuit of the common oscillator V, as shown. Preferably the connections are decoupled to prevent the risk of interaction.

*L. H. Merdler and Baird Television, Ltd. Application dates April 9th and July 5th, 1935. No. 454945.*

## HF COUPLINGS

A SERIES of tuned high-frequency circuits are reactively coupled together in such a way that the effective band-width can be varied, without moving the centre of the resonance curve either up or down the frequency scale. This allows the selectivity of the circuits to be altered, whilst keeping them symmetrically tuned about the centre of the received carrier-wave. The coupling system is particularly suited for the intermediate-frequency stages of a superhet. receiver.

*Hazeltine Corporation (Assignees of D. E. Harnett). Convention date (U.S.A.) May 31st, 1934. No. 455619.*

## SHORT-WAVE OSCILLATORS

A VALVE is used for generating oscillations, having a frequency of the same order as the transit time of the electrons from cathode to anode, with the aid of ordinary reaction as distinct from

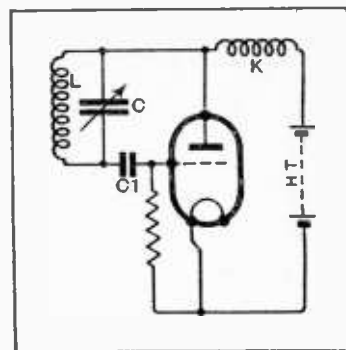

Colpitts oscillator for ultra short waves using a specially designed valve.

can reverse its phase and so tend to damp out the oscillations.

As shown in the figure the oscillatory circuit L, C is branched across the anode and grid, the valve then operating as a Colpitts oscillator. A blocking condenser C1 protects the grid from the HT source, whilst a choke K isolates the source from the oscillatory circuit.

*Standard Telephones and Cables, Ltd. (Assignees of R. A. Heising). Convention date (U.S.A.) April 25th, 1935. No. 454902.*

## COUPLING COILS

TWO coupling coils, provided with a common adjustable powdered-iron core, are mounted on a base-plate, and enclosed inside a screening "pot" to form a compact tuning-unit, which can be used either for an input circuit or as an intervalve coupling.

To ensure uniform "gain" over the usual broadcast range, one of the coils is designed to have a natural or inherent frequency lower than any frequency to which the other is intended to be tuned. The movable core enables the mutual coupling between the coils to be adjusted to an optimum value.

*Johnson Laboratories Inc. (assignees of A. Crossley and H. E. Meinema). Convention date (U.S.A.) April 10th, 1934. No. 454873.*

## LOUD SPEAKERS

A MOVING-COIL speaker is constructed with a number of diaphragms, each handling a different section of the audible band of frequencies. The diaphragms are arranged about a common centre-line, and are operated by the same magnetic movement but through independent speech-coils, which are all located in the same air-gap. The speech coils may be wired up in series or in parallel, and are set as close together as possible without obstructing each other. The arrangement presents a compact and inexpensive speaker unit, capable of giving a high output of sound.

*J. Sharp and J. McGrath. Application date January 15th, 1935. No. 455208.*

The British abstracts published here are prepared, with the permission of the Controller of H.M. Stationery Office, from Specifications obtainable at the Patent Office, 25, Southampton Buildings, London, W.C.2, price 1/- each. A selection of patents issued in U.S.A. is also included.

# Ilford & District Radio Society

Patron . . . . . Sir. GEORGE C. HAMILTON, M.P.  
 President . . . . . F. H. HAYNES, Esq.  
 Chairman . . . . . A. NEWMAN, Esq.

Past Presidents:  
 J. E. NICKLESS, A.I.E.E., 2KT. F. E. COLLINSON.

Vice-Presidents:  
 W. BRYAN SAVAGE.  
 P. K. TURNER, M.I.E.E.  
 H. A. HARTLEY.  
 A. F. BULGIN, M. INST. R.E.  
 G. PARR.  
 H. H. BURROWS.  
 H. O. CRISP.  
 W. H. DENNIS.  
 J. E. NOUET.



Founded 1922

Committee:  
 H. L. RANSON, A.M.I.R.E., A.M.I.W.T.  
 H. T. STOTT, A.M.I.R.E. H. BELBIN. E. ORROCK.  
 Hon. Auditors:  
 R. CLARKE. D. PATMORE.

Hon. Treasurer:  
 H. H. CARR.  
 39 LYNFORD GARDENS, GOODMAYES.  
 All Communications to Hon. Secretary  
**C. E. LARGEN,**  
 44 TRELAWNEY ROAD,  
 BARKINGSIDE, ILFORD.  
 Telephone ROYAL 4361. CHIGWELL 126.

Headquarters:  
 ST. ALBAN'S CHURCH ROOM,  
 ALBERT ROAD, ILFORD  
 (NEAR TOWN HALL)

29th. December 19 36

Messrs. Goodmans Industries Ltd.  
 Lancelot Road.  
 Wembley.Midd.

Dear Sirs,

Your ref. Mr. Stoner.

I wish to thank you for your courtesy in loaning us the 12" Auditorium speaker for trial on our club receiver.

The demonstration was very successful, and the members were very keen on the wide range of frequencies handled by the speaker.

A vote taken was unanimous on the proposal that your speaker was the best that this Society has ever heard demonstrated, only excepting a Voight which was in its cabinet kiosk and therefore could not be tried on a baffle. I might say that we have probably demonstrated well over 100 speakers in the last year or two.

I regret that we have to return this speaker, as funds will not permit the purchase of same by the Society. However I understand that two members immediately decided to purchase it's smaller counterpart, and the others will pass the word along in recommendation of an extremely good speaker.

I am despatching the speaker tomorrow.

Yours faithfully,

*[Signature]*  
 Hon. Secy.

**GOODMANS INDUSTRIES LTD.**  
 Lancelot Road, Wembley, Middx. Telephone: Wembley 4001-3.

**POST this COUPON**  
 to GOODMANS INDUSTRIES LTD., Lancelot Rd., Wembley, Middx.  
 Please send me Technical Bulletin describing GOODMANS High Fidelity Auditorium Reproducers and Response Curves, for which I attach 3d. in stamps.

Name .....

Address .....

v. v. 22-1-37

# MISCELLANEOUS ADVERTISEMENTS

## NOTICES

**THE CHARGE FOR ADVERTISEMENTS** in these columns is

12 words or less, 3/- and 3d. for every additional word.

Each paragraph is charged separately and name and address must be counted.

**SERIES DISCOUNTS** are allowed to Trade Advertisers as follows on orders for consecutive insertions, provided a contract is placed in advance, and in the absence of fresh instructions the entire "copy" is repeated from the previous issue: 13 consecutive insertions 5%; 26 consecutive, 10%; 52 consecutive, 15%.

**ADVERTISEMENTS** for these columns are accepted up to **FIRST POST on MONDAY MORNING** (previous to date of issue) at the **Head Offices** of "The Wireless World," Dorset House, Stamford Street, London, S.E.1, or on **SATURDAY MORNING** at the **Branch Offices**, 19, Hertford Street, Coventry; Guildhall Buildings, Navigation Street, Birmingham, 2; 260, Deansgate, Manchester, 3; 26a, Renfield Street, Glasgow, C.2.

Advertisements that arrive too late for a particular issue will automatically be inserted in the following issue unless accompanied by instructions to the contrary. All advertisements in this section must be strictly prepaid.

The proprietors retain the right to refuse or withdraw advertisements at their discretion.

Postal Orders and Cheques sent in payment for advertisements should be made payable to **LIFFE & SONS Ltd.**, and crossed **& Co.** Notes being untraceable if lost in transit should not be sent as remittances.

All letters relating to advertisements should quote the number which is printed at the end of each advertisement and the date of the issue in which it appeared.

The proprietors are not responsible for clerical or printers' errors, although every care is taken to avoid mistakes.

## NEW RECEIVERS AND AMPLIFIERS

A.  
A.

**DEGALLIER'S, Ltd.**, the best firm for reliable fully guaranteed ultra short-wave radio, have on offer in London without exception the largest selection of all-wave receivers, at very low prices. For instance, a 7-valve superhet., with 3 bands going down to 16 M. in A.C. or A.C./D.C., at £9. An 8-valve superhet., 4 bands going down to 11 metres, with push-pull output 7 watts undistorted, is only 13 guineas. Any known American valve for receivers 1925-1937, glass, glass counterparts, metal, and M.G. at 6/6 each, all firsts. They have range like this right up to a 24-valve Challenger twin-chassis, valves and two Auditorium speakers, 5-bands 5-2.050 meters, 60 watts undistorted at £50 (this is as supplied to the Navy, Army and Air Force canteens). They guarantee that every S.W. receiver will get stations on the low bands including the Americas, etc. Why not call and handle these receivers at your leisure? Demonstrations daily from 3.30 onwards on American transmissions. No obligation to purchase. Or send large S.A.E. for beautifully illustrated catalogues with actual photographs. Also in stock, Ferguson, Emerson, Belmont, Crosley, Garod, etc.

**DEGALLIER'S, Ltd.**, No. 18, Connaught St., Marble Arch, W.2. Paddington 2745. [3632]

**ALERT RADIO Co.**

**ALL-WAVE Receivers** at £7/7, £9/9, and £13/13, A.C. or A.C./D.C.; Midget and other receivers up to 23 valves; for DX work we can supply the latest communication models.—21, East Rd., N.1. Clerkenwell 4871. [3220]

"SERVICE With a Smile."

**HENRY FORD RADIO, Ltd.**

**ELECTRONIC House**, 22, Howland St., Tottenham Court Rd., W.1. Museum 5675. [0511]

**ROYAL RADIO Co.**

**ESTABLISHED 1908.**

**ALL-WAVE Receivers**, suitable for use on ships, as supplied to officers of many shipping lines.

**OUR 8 and 10 Metal Valve All-wave Receivers**; 15-2,000 metres, acknowledged by the trade as the best for range, tone, and generous performance.

**LATEST 6-valve Car Radio, A.V.C.**, remote control, no suppressors required.

**A FULL Range of the World Famous Ferguson and Pilot Models Stocked.**

**ALL Sets Fully Guaranteed by Ourselves.**

**ALL Types of American Valves Stocked.**

**ANY Make of Set Serviced by Our Qualified Radio Engineers at Reasonable Charges.**

**PAY Us a Visit Any Time, or send for full range catalogue; 14d. stamp will be appreciated.**

**ROYAL RADIO Co.**, 5, Buckingham Rd., South Woodford, London, E.18. 'Phone: Buckhurst 2736. [3499]



## HOW BIG IS A BAFFLE?

Thirty-six square feet. That is about the smallest baffle that does justice to a Hartley-Turner loud-speaker. Remember that our speakers have no bass resonance or boom. Hence their bass reproduction is directly dependent on proper baffling; and if 50-cycle notes are to be properly reproduced, six feet square is about the right size, or an equivalent area if the shape is not square.

Of course, the front area can be cut if sides are put on, but this needs care, or resonance may arise. So if you don't want a really large flat baffle, why not use the Hartley-Turner

### TRUE BASS BOFFLE BOX?

This is what we use in our own cabinet sets. It is a treated box, in which the treatment is so effective that a box 18in. square and 12in. deep has almost exactly the same response as a 3-foot flat baffle, an 18in. cube equals a 4-foot baffle, a 24in. cube equals a 6-foot baffle, and a 24in. cube an infinite baffle.

We can supply either the complete treated box, or if you prefer it can make "treatment" for your own box (provided the latter is so made that it can be fitted in).

The treatment is light in weight, and can be removed or replaced at will.

It can usually be arranged for other speakers, though of course it was designed for our own.

Price is quite low. Naturally it depends on size; we give just one example.

Standard treatment for 18in. cube £1.17.6  
Complete treated box, 18in. cube, in brown-stained multi-ply timber . . . £2.15.0

Full particulars and prices on request, and, as usual, it is best to

## COME AND HEAR IT



**HARTLEY TURNER RADIO LTD.,**

**THORNBURY ROAD,**

**ISLEWORTH, MIDDLESEX.**

Telephone: HOUNslow 4488

## NUMBERED ADDRESSES

For the convenience of private advertisers, letters may be addressed to numbers at "The Wireless World" Office. When this is desired, the sum of 6d. to defray the cost of registration and to cover postage on replies must be added to the advertisement charge, which must include the words Box 000, c/o "The Wireless World." All replies should be addressed to the Box number shown in the advertisement, c/o "The Wireless World," Dorset House, Stamford Street, London, S.E.1. Readers who reply to Box No. advertisements are warned against sending remittance through the post except in registered envelopes; in all such cases the use of the Deposit System is recommended, and the envelope should be clearly marked "Deposit Department."

### DEPOSIT SYSTEM

Readers who hesitate to send money to advertisers in these columns may deal in perfect safety by availing themselves of our Deposit System. If the money be deposited with "The Wireless World," both parties are advised of its receipt.

The time allowed for decision is three days, counting from receipt of goods, after which period, if buyer decides not to retain goods, they must be returned to sender. If a sale is effected, buyer instructs us to remit amount to seller, but if not, seller instructs us to return amount to depositor. Carriage is paid by the buyer, but in the event of no sale, and subject to there being no different arrangement between buyer and seller, each pays carriage one way. The seller takes the risk of loss or damage in transit, for which we take no responsibility. For all transactions up to £10, a deposit fee of 1/- is charged; on transactions over £10 and under £50, the fee is 2/6; over £50, 5/-. All deposit matters are dealt with at Dorset House, Stamford Street, London, S.E.1, and cheques and money orders should be made payable to Liffe & Sons Limited.

**SPECIAL NOTE.**—Readers who reply to advertisements and receive no answer to their enquiries are requested to regard the silence as an indication that the goods advertised have already been disposed of. Advertisers often receive so many enquiries that it is quite impossible to reply to each one by post. When sending remittances direct to an advertiser, stamp for return should also be included for use in the event of the application proving unsuccessful.

## NEW RECEIVERS AND AMPLIFIERS

A  
AIR KING,  
THE Royalty of Radio.

**MODEL Empire 11-valve 4-band Supersonic Heterodyne Receiver** for A.C. 100 to 250 Volts, incorporating every refinement known to modern radio technique, large illuminated dial, indicating each wave band separately marked in station names, wavelengths, and frequencies, with the famous exclusive beam tuning system, Magic Eye indicator for increased sensitivity and silent precision tuning, illuminated indicators to show high fidelity and gramophone pick-up, high fidelity assured by two balanced speakers, one acting as special amplifier for high audio frequencies and one large concert type dynamic speaker for full range audio frequency range from 40 to 9,000 cycles, special band expansion intermediate frequency transformer on first stage, variable selectivity, full range variable tone control, A.V.C.

**MODEL Duchess 6-valve 3-band Superhet. Receiver** for A.C. 100 to 250 Volts; this receiver is housed in an attractive lay down walnut cabinet.

**MODEL Envoy for A.C./D.C. Mains, 100 to 250 volts,** no line cord used.

**MODEL Marquis 6-valve 3-band Superhet. Receiver** for A.C. 100 to 250 Volts, no line cord used, a splendid set of proven popularity.

**MODEL Ermine 6-valve 3-band Superhet. Receiver** for A.C./D.C. 100 to 250 Volts, no line cord used, a splendid set of proven popularity.

**ALL Models Feature Beam Tuning, Magic Eye Indicator, gramophone pick-up connections, and special output valves.**

**ALL Sets Fully Guaranteed; H.P. terms available from 3/- per week; our technical department is at your service.**

**WHOLESALE and Trade Enquiries Invited; generous terms.**

**ARCTURUS Valves for Improved Radio Reception on All Types of Receivers.**

**ARCTURUS, the only line made in 4 ranges, glass, metal, G type, and metal modernisers.**

**WRITE for Lists of These Famous Valves; prices from 4/9 each.**

**AIR KING RADIO, 115, Shaftesbury Ave., Cambridge Circus, W.C.2 (1st floor above Barclay's Bank). 'Phone: Temple Bar 4875 (all lines). All receivers assembled in England. [3406]**

**ENQUIRE about Harmaur Radio 1937 Receivers.**

**AMERICAN-BOSCH "Centromatic" All-wave Sets.**

**FREED-EISEMANN Receivers as Bought by the B.B.C. and "The Wireless World."**

**PIERCE AIRO AC/DC All-wave and Car Radios.**

**RAYTHEON Valves. Trade enquiries.**

**THE HARMAUR RADIO Co., Ltd., 8, Clifford St., New Bond St., London, W.1. [0499]**

NEW RECEIVERS AND AMPLIFIERS.

**A**  
**N**  
**G**  
**C**ASH Offers.—Cabinets offered with chassis are of finest quality and finish, and as supplied by manufacturers with chassis; where cabinets are ordered with chassis these are despatched fitted as complete receivers.

**50/-**—Multi-band (7-2,000 metres) Junior Communications Outfit, special value; powerful 3v. battery chassis employing new 10-point tank and band-spread tuning system, 7in. pointer dial with short wave station names and world map tuning scale; complete with standard British type battery valves, metal cabinet, 5in. midget speaker and pair headphones, together with Free Gift 8in. world rotating globe on stand, enamelled in full colours with meridian scale, highly efficient, receives new Television sound programmes, world wide short wave, police, amateur, aircraft and all standard and long wave transmissions; supplied in kit form, with 8-page instruction and operation booklet, complete as above with all sundries, 50/-, or completely assembled and aerial tested, 20/- extra.

**67/6**—All-wave battery chassis, S.G. H.F. Pentode, 16-2,000 metres, 3 bands, latest all-wave slow motion dial calibrated in metres, P.U. and extra speaker sockets, an excellent home receiver; supplied direct from prominent British manufacturer, 8in. moving coil speaker, 10/6; horizontal type cabinet, 12/6.

**£5/19/6**—7-valve all-wave chassis 3 bands, 16½-2,000 metres, coloured tuning dial calibrated, visual cathode tuning, full A.V.C., A.C./D.C., 110-240v., exceptional performance; matched speaker, 10/6; cabinet, 12/6.

**£7/19/6**—8-valve all-wave chassis, 16-2,100 metres, new De Luxe 5½in. airplane multi-indication dial, A.V.C. tone control, calibrated all bands, 110-240v. A.C./D.C.; matched speaker, 12/6; cabinet, 14/6.

**£8/19/6**—8-valve all-wave chassis, 16-2,100 metres, visual cathode tuning, 7½in. super airplane multi-indication dial, 4 watts output, A.V.C., tone control, A.C. operation 110-240v.; matched speaker, 12/6; horizontal type cabinet, 15/6.

**£5/19/6**—Car Radio 5-valve superhet, highly efficient, A.V.C. tone control, illuminated dial, magnificent performance, complete with suppressors and sundries and complete operating and fixing instructions; demonstrations under London traffic conditions daily.

H.P. Terms Offered on the Following Models; the unsurpassed new Ferguson receivers.

**£1/0/6** with Order.—Model 378 all-wave 11-valve receiver, 4 wavebands, 12½-2,000 metres, 8 watts output, sensitivity and tone controls, A.V.C., Rola 10in. speaker, superb acoustically designed table model cabinet, 25x18½x12in., pick-up and extra speaker sockets, station names marked on all bands, 110-240v. A.C./D.C.; cash price 16½ guineas, or 20/6 with order and balance over 18 months; if required less cabinet and/or speaker, deduct for cabinet 25/-, speaker 15/-, but same initial deposit if required on deferred terms with balance over 18 months.

**18/-** with Order.—Model 366 all-wave superhet, cash price 10 guineas, 5 valves, 16½-2,000 metres, 3 bands, 8in. Rola speaker, high efficiency resistance capacity circuit with A.V.C., A.C./D.C. 110-240v.; 18/- with order, balance over 18 months.

**DEMONSTRATIONS** of All Models in Our Showrooms 9 a.m.-6.30 p.m., Saturday 1.30 p.m. (Nearest station, Tottenham Court Rd., Central London Railway.) If inconvenient to call, we will endeavour to arrange demonstrations to all requests within 30-mile radius of Central London; customers farther afield may order with every confidence that they will obtain the finest value and service in London; terms, cash with order or on delivery, or first payment only if desired, with Ferguson models; carriage and packing charge on all models, 2/-.

**ANGLO AMERICAN RADIO (AND MOTORS), Ltd.** (Dept. W.), Albion House, New Oxford St., London, W.C.1. (Telephone: Temple Bar 3231.) [3645]

**£3/3**—4-valve Universal midgets, M.C. speaker, coloured fabric cabinets; 5-valve midgets from 23/15.

**£8/8**—6-valve Universal all-wave superhet, R.C.A. valves, new 25B5, in output stage, giving over 2 watts, in Class "A."

**£10/10**—6-valve all-wave superhet, 10in. Rola speaker, pre-H.F. stage, 100-250 volts A.C.

**£9/9**—6-valve car radio, A.V.C., remote control, R.C.A. valves.—E. Fellows, Ferney Rd., East Barnet, Herts. [3595]

**COULPHONE RADIO MANUFACTURING COMPANY,** manufacturers of high class radio since 1923.

**STANDARD Range A.C. All-wave Super Hets.**, delayed A.V.C., Rola speakers, British Tungram valves, high class cabinets, 12 months' guarantee (including valves); 4-valve 3½-watt, £6/10; 6-valve, £10; super 6-valve, E.P. stage, £15; super 8-valve, R.F. stage, 4 wavebands, 4-watt reversed phase push-pull, Rola G.12, £20.—Liverpool Rd., Hutton, Nr. Preston, Lancs. Phone: Longton 196. [3641]

**1937 Radios**; save money by dealing with the actual importers; send 1½d. stamp for catalogues.—American Radio Distributing Co., 7, Grove Rd., Folkestone. [3635]

**TRANS-ATLANTIC RADIO Co.**, 15, Percy St., W.I. Museum 3096.—Splendid range latest American A.C./D.C. compacts from 59/6; all-wave Consoles, etc.; "Philcos" stocked. [3578]

**CHASSIS**; modern all-wave and two-band designs available, chassis and sets to your requirements; fourteen years' specialised experience.—Berclif, (Simmonds Bros.), 38, Rabone Lane, Smethwick. [3622]

**PILOT**, Ferguson, Pegasus and Air King all-waves lead the field; our deliveries are prompt in original cartons with full guarantees; your trade card will bring our wholesale catalogue from the authorised distributors.—Leonard Heys, 36, Henry St., Blackpool. [0530]

No. 22.

*Notes*

**on the Suppression of Electrical Interference with Broadcast Reception**

Let us devote this column to the ticklish problem of when, how, and why a customer should pay for suppression service other than the cost of the actual materials.

It is part of the service listeners obtain for their radio licence fees paid to the Post Office, that they obtain free advice as to what should be done about suppressing electrical interference which spoils reception of their nearest National and Regional B.B.C. programmes. Whenever possible, owners of offending apparatus are interviewed and efforts are made to persuade them to fit the recommended suppressors. The Post Office do not undertake to assist in the reception of distant programmes either of British or foreign origin, nor is it reasonable to expect them to do so. A local station cure, however, is often made sufficiently thorough to cover distant ones as well.

When an interference problem is outside the sphere of the Post Office the trade specialist must be called in and, let us say here and now, that every dealer in wireless sets is not a specialist in the suppression of interference, but if he is a good man, knowing his limitations, he will either seek the assistance of a colleague who knows, or he will write to us as the consulting engineers. If he says to you "really nothing can be done about it" then you write to us direct, and we will either help you direct or if possible give you the name of a specialist in your district.

Thousands of people think nothing of paying half-a-crown to have a fuse replaced by an electrician, but these same people seem to expect all radio service for nothing, even such highly specialised service as the diagnosis of difficult cases of interference. People write asking us to send an engineer to try out a suppressor that only requires to be plugged in. The price of suppressors does not include the cost of engineer's time (and as consultants we do employ engineers).

We charge half-a-guinea a visit or one guinea a day, and the charge is constant whether the customer is a member of the public, or a public institution.

When a manufacturer, a big store, or other organisation, including ships, consults us regarding suppression service, in effect we charge them for the specification of what is required (at the rate of one guinea per day for the engineer's time taken over the preparation thereof); whether or not our recommendations are carried out is a matter for the customer to decide.

If a manufacturer or a shipping company requires a specification for the suppression of electrical interference created by, or in, his wares we charge on a different scale by special arrangement.

Write to us for free literature on this subject, or send 1s. 2d. for technical book, "Interference Suppression."



**Belling & Lee Ltd.**  
Cambridge Arterial Road,  
Enfield, Middx.

NEW RECEIVERS AND AMPLIFIERS

**A** RMSTRONG COMPANY Manufacture 8 Radio Receivers in Chassis Form, briefly described hereunder.

**A** RMSTRONG 6-valve All-wave Superheterodyne Radiogram Chassis, for A.C. mains, complete with Rola speaker; £7/10.

**A** RMSTRONG 8-valve 4 Wave-band Radiogram Chassis, with phase reversed push-pull output; £9/17/6.

**A** RMSTRONG 6-valve 4 Wave-band Radiogram Chassis, with large triode output; £8/17/6.

**A** RMSTRONG 8-valve 4 Wave-band Radiogram Chassis, with radio-frequency stage and push-pull output; £11/11.

**A** RMSTRONG 7-valve 4 Wave-band Radiogram Chassis, with radio-frequency stage and single triode output; £10/10.

**A** RMSTRONG 8-valve 2 Wave-band Radiogram Chassis, with 8 watt push-pull output; £8/10.

**A** RMSTRONG 6-valve 2 Wave-band Radiogram Chassis, with single large triode output; £7/10.

**A** RMSTRONG Chassis Carry 12 Months' Guarantee.

**A** RMSTRONG Chassis are Sent 7 Days' Trial, carriage, packing, and crate-free.

**A** RMSTRONG MANUFACTURING Co., 100, King's Rd., Camden Town, N.W.1. [3460]

**YOU** Want Something Completely Different. If you have a nicely furnished home and the stereotyped models you see on every street corner do not appeal to you, you will delight in our superb range of exclusive quality models. We have radiograms with and without auto record changers, A.C. and A.C./D.C., which are a complete breakaway from the usual stuff in the local shops. If you prefer good furniture to boxes, if you want outstanding shortwave performance, and above all if you appreciate true quality of reproduction when you hear it, we have what you are looking for. Come and see. Come and listen. You will be agreeably surprised, not only to find that such splendid models exist, but that they can be sold at such very reasonable prices.

**WIRELESS SUPPLIES UNLIMITED**, 278-280-282, High St., Stratford, E.15. Maryland 3191. [3550]

**RECEIVERS AND AMPLIFIERS CLEARANCE, SURPLUS, ETC.**

**HYAMS RADIO.**

**SPECIAL Offer**; car radios, 6-valve superhet, A.V.C., etc., medium and long waves, no vibrator or rectifier, H.T. from "Gen. E. Motor," consumption only 3 amps. on 12 volt cars; list price 20 guineas, our price, brand new and complete, £7/10.

—All goods advertised in last issues still available.

**HYAMS RADIO**, 23, Lisie St., W.C.2. Ger. 2969. [3647]

**HENRY'S.**

**SHORT-WAVE Units** by Well-known Manufacturer, 13-70 metres, supplied in handsome walnut cabinet, complete with coils, adaptors and instructions, no alterations to your present set, one plug connection, for all A.C. mains or battery sets, listed at £3/3; our price 30/-, carr. pd., in sealed cartons.

**HENRY'S**, 72, Wellington Ave., London, N.15. Stamford Hill 2907. [3658]

**CLEARANCE List (Trade Only)**—Write Leonard Heys, 36, Henry St., Blackpool. [0527]

**SEND for Bargain List of Brand New Decontrolled Receivers**; amazing prices—P. A. C. Ltd., 54, Lamb's Conduit St., W.C.1. [2243]

**BUY a Ferranti Nova All-wave Receiver**; 12 guineas; 4 guineas; allowance on any old set.—Dunports, Adelaide Lane, Bournemouth. [3613]

**BATTERY CHARGING PLANT**

**NEWTON** 3-circuit 240v. A.C. Charger, 75 volts 10.3 amps., and H.T.; £8/10.—Wren, Kimpton, Herts. [3605]

**CARFAX "Junior"**, 20/30v., 5a., £5/5; guaranteed five years.—British Rectifiers, Vernon Place, Cheltenham. [3573]

**PUBLIC ADDRESS EQUIPMENT**

**SPECIAL Offer!!!**

**8½** Guineas Assembled: Vortexion 20 watt 4-stage P.A. amplifier, in steel case, 8in. x 10in. x 9in. high, with carrying handle, input with controls for microphone and pick-up and tone control, output for 7½ and 15 ohm speakers, weight 25lb.; only 8½ guineas, with valves.

**4** Input Model, with mixers; £10.

**HEAVY Duty Model**, as fitted to cinemas and dance halls; £15.

**CALL and Hear the Rumble of an Organ as Never Before** on our Wide Frequency Range Models, the best yet.

**VORTEXION, Ltd.**, 182, The Broadway, Wimbledon, S.W.19. See also New Mains Equipment. [3439]

**PARTIDGE P.A. Manual**, free to trade. See "Partidge Transformers" under "New Mains Equipment." [3487]

**USED SETS FOR SALE AND WANTED**

**AIR KING**

**1937 Air King 11-valve Empire A.C. All-wave Superhet.**, recently purchased at 26 guineas; accept £20; owner moving D.C. district.—Box 539, c/o The Wireless World. [3636]

**EVER-READY SUPER**

**1937 Ever-Ready Superhet**, 4-valve, cost 9½ guineas, practically unused; 7½ guineas.—Ealing 3777. [3619]

USED SETS FOR SALE AND WANTED

HAYNES

HAYNES Quality Receiver and Amplifier, A.C. mains, 6-watt undistorted output, dual Magnavox speakers, unused; for 10 guineas or nearest.—O'Rourke, 58, Whitehouse Way, N.14. [3625]

HOLLYWOOD

1937 Hollywood 9-valve All-wave A.C. Radio, 110-220 volts (Midget type), almost new; £10.—Box 540, c/o The Wireless World. [3637]

R.G.D.

FOR Sale, R.G.D. 1202 radiogram, 3 speakers, automatic record changing, 12 valves, perfect condition; cost £112 November, 1935, price £55 cash.—Vowles, Sadler St., Wells, Som. [3606]

W.W. MONODIAL

D.C. Monodial, 7-valve, as specified "Wireless World," without cabinet or speaker, needs slight adjustment; nearest offer to £5.—Partridge, 62, Pellerin Rd., N.16. [3643]

BEST Offer.—W.W. Monodial A.C. super chassis, pentode output, Rola G.12 speaker, meter tuning instead Neon light, six months old.—Write, call after 7 p.m., Wheeler, 38, Santley St., Clapham, S.W.4. [3648]

W.W. QUALITY AMPLIFIER

QUALITY AMPLIFIER, 12 watts (modified "Wireless World" design), complete with valves; £10/17/6; list of others for stamp.—48, Wake Green Rd., Birmingham. [3620]

EXCHANGE OR WANTED

WANTED, single-span or Q.A. and P.P.Q.A.; full particulars.—2, Eastham-locks, Cheshire. [3618]

MISCELLANEOUS

W.W. 4-12-watt Sound Sales Amplifier and Latest 2H.F. Radio Unit; details.—Jennings, "Ingledell," Flackwell, High Wycombe. [3621]

1937 12 Valves 6-2,100 Metres 100-275 V.A.C. Chassis, 15-inch speaker, and valves, 20 watts output, powerful set; £19/10.—Rayner, 94, Tooley St., S.E.1. [3639]

SCOTT XV, 12-2,000 metres, 15 valves, super speaker, new condition, cost £100, first £39; McMurdo Silver Masterpiece III, 13-2,000 metres, 12 valves, super speaker, complete, cost £95, first £37; R.C.A. Victor All-wave, table model, cost £35, first £15; Gambrell-Halford D.C. Radiogram, 7 valves, broadcast range, fine cabinet, cost £60, first £18; Eddystone Kildyone Four, built, with coils, valves and speaker, first £6; Eddystone Colonial 6 A.C. 13-2,000 metres, complete, cost £30, as new, £16.—A.C.S. Ltd., 52-4, Widmore Rd., Bromley, Kent. Ravensbourne 0156. [3610]

NEW MAINS EQUIPMENT

VORTEXION Lead Again.

VORTEXION Supply the B.B.C., G.P.O., L.P.T.B., and Borough Councils, etc., so why not you? Follow the Best Reproduction it is Possible to Obtain, see also advert under Public Address Equipment.

ALL Fitted Screened Primaries and Tapped 200-250v., with centre tapped filaments, guaranteed one year. SHROUDED Models, finished in elegant pressure die cast covers, will improve performance and appearance of any apparatus.

425 0-425v., 120-160 m.a., 4v. 5-10a., 4v. 2.5, 4v. 1-2, 4v. 1-2, supershrouded model, 2 1/2% regulation; 26/-

250 0-250 60 m.a., 4v. 1-2a., 4v. 2-4a.; 10/- open, 12/6 shrouded.

350 0-350v. 60 m.a., 4v. 1-2a., 4v. 2-4a.; 12/6 open 15/- shrouded.

350 0-350v. 120 m.a., 4v. 2-5a., 4v. 2-4a., 4v. 2-5a.; 14/6 open, 16/6 shrouded.

500 0-500v. 120 m.a., L.T.'s, as above; 19/- open, 23/- shrouded; 400 or 450, same price.

500 0-500v. 150 m.a., 3x, 4v. 2a., 4v. 2-5a., 4v. 4a., 26/- open, 30/- shrouded; 400 or 450, same price.

CHOKES 30h. 60 m.a., 5/6; 7-13h., 10/6; 30h., 150 m.a., 12/6; regulation, 7/6.

OUTPUT Transformers, 4-10 watt, W.W. Q.A., 17/6; 20-watt super shrouded, 30/-.

SPECIAL Wide Frequency Range Model; £3/10.

AUTO Transformers, 100-120 to 200-240v., 60 watt, 9/-; 120 watt, 12/6; 200 watt, 16/6; 500 watt, 30/-.

TELEVISION, 4,000v., 5-10 m.a., and 2.5-4v.; 27/-.

QUOTATIONS for Specials by Return.

VORTEXION, Ltd., 182, The Broadway, S.W.19. Tel.: Lib. 2814. [3592]

ALL POWER

TRANSFORMERS, Ltd.—Transformers and chokes embodying all the best in design; no better value at any price; Radiolympia models; tapped and screened primaries, filaments, centre tapped.

250 0-250v. 60 m.a., 4v. 1-2a., 4v. 2-4a., 12/6, post 7d.; extra filament, 4v. 1a., 12/6.

350 0-350v. 60 m.a., 4v. 2-3a., 4v. 2-4a., 15/-, post 8d.; extra filament, 4v. 1a., 16/-.

350 0-750v. 120 m.a., 4v. 2-3a., 4v. 4-6a., 4v. 1-2a., 19/-, post 1/-; extra filament, 20/-.

500 0-500v. 140 m.a., 4v. 2-4a., 4v. 4-6a., 4v. 2a., 4v. 2a., 29/6, post 1/-.

L.T. Charger, charging rate 1a., 2, 6, or 12-volt, employing metal rectifier L.T.5; 37/6, post 1/-.

WRITE for List; special quotations by return.

ALL POWER TRANSFORMERS, Ltd., 8a, Gladstone Rd., Wimbledon, S.W.19. Tel.: Liberty 3303. [3383]

TEST REPORT DISSECTED

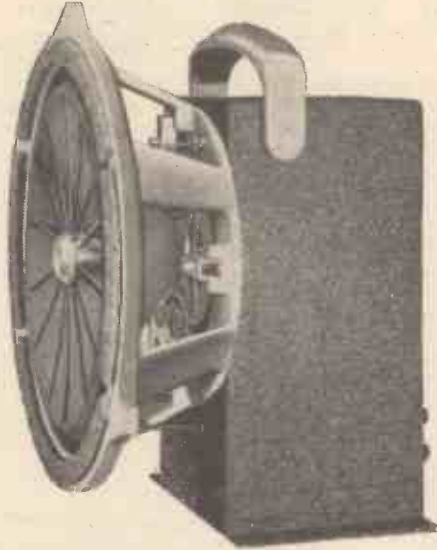

WE ATTACH GREAT SIGNIFICANCE TO THE TEST REPORT PUBLISHED IN THE JANUARY 8th ISSUE WHICH RELATES TO THE SOUND SALES SUPER AUDITORIUM SPEAKER SHOWN ABOVE. WE WOULD DRAW YOUR ATTENTION TO THE FOLLOWING POINTS.

- (1) The speaker has been especially designed for use with real Quality Amplifiers, such as the "Wireless World" and the S.S.4-12 watt and 30 watt models.
(2) It is the only speaker we have found which will really do justice to the capabilities of these Amplifiers.
(3) The "Wireless World" describe the performance as outstandingly good; they attach particular significance to the fact that the output at 10,000 cycles is at the same level as that in the lower middle register.
(4) There is another very significant point; most whistle filters are designed to attenuate sharply at 7,000 cycles. It will be noticed that the S.S. SUPER AUDITORIUM SPEAKER does this automatically to the extent of 15 D.B., therefore making the design of the whistle filter a simpler proposition.
(5) You do not have to add a whistle filter to correct a nasty 7,000 cycles peak with the SOUND SPEAKER.
(6) There is no peak at 100 and 200 cycles, which accounts for the amazing clarity of speech obtainable.
(7) The transformer fitted to the SUPER AUDITORIUM SPEAKER is our famous 036 model which has a flat response varying plus or minus 5 D.B. only from 20 to 10,000 cycles.
(8) Dual Suspension is the secret of the loud-speaker, there is no secondary "sound emission" due to special speech coils or additional cones.
(9) The Super Auditorium speaker is priced at £12 with transformer, £10 10s. less transformer. Permanent Magnet models £12 or £10 10s. less transformer. Special transformers supplied to suit without extra charge.

FINALLY TO APPRECIATE THE SOUND SPEAKER YOU MUST HEAR ONE WORKING ON A REALLY GOOD AMPLIFIER. WHY NOT DROP IN BETWEEN 9 AND 6 P.M. ANY WEEK DAY OR MAKE AN APPOINTMENT BETWEEN 6 AND 8.30 P.M. FRIDAY EVENINGS, THERE IS ABSOLUTELY NO OBLIGATION ON YOUR PART. YOU CAN BRING YOUR OWN RECORDS AND INCIDENTALLY YOU CAN HEAR ANY SOUND SALES EQUIPMENT WHICH MAY INTEREST YOU.

REAL QUALITY EQUIPMENTS ARE AVAILABLE FROM £20.

Agent for Scarborough: Mr. JOHN ELLIS, B.A. (Eng. Cantab). Prospect House, Scalby, Nr. Scarborough.

Deferred terms from London Radio Supply Co., 11, Oat Lane, E.C.2.

SOUND SALES logo with a speaker icon. Text: MARLBOROUGH RD. UPPER HOLLOWAY, LONDON, N.19. (Contractors to the G.P.O., etc.) LIMITED. Tel.: Archway 1661/2/3.

NEW MAINS EQUIPMENT

PARTRIDGE Transformers, as supplied to B.B.C., Marconi's, G.E.C., Mullards, I.C.I., Tungram, etc. SPECIALS Despatched Within 48 Hours; all standard types from stock. Specimen prices:—

350 0-350v. 120 m.a., 4v. 2-5a., 4v. 3-6a., 4v. 2a., all C.T.; screened primary 200-250v., 18/6.

425 0-425v. 150 m.a., 4v. 2-4a., 4v. 4-8a., 4v. 1-2a., 4v. 1-2a., all C.T. (for W.W. circuits); 26/6.

SPECIAL Quotations to Manufacturers for Lots of 6 Upwards; hand wound, individually tested, immediate delivery, rock bottom prices.

TELEVISION Transformers Insulated to 10,000v. A.C. expert knowledge of transmitting requirements (mains and modulation).

HIGH Fidelity (20 to 15,000 Cycles) Intervalve and Output Transformers a Speciality.

PARTRIDGE P.A. Manual Free to Trade Only; contents includes constructional amplifiers, notes on microphone pre-amplifiers, lines, mixing, impedance matching, speakers, etc.

PARTRIDGE, N., B.Sc., A.M.I.E.E., King's Buildings, Dean Stanley St., London, S.W.1. Phone: Vic. 5035. [3486]

PARAMOUNT Mains Transformers.

PARAMOUNT in Quality, lowest in price; example: 250v. 60 m.a., 4v. 1a., 4v. 4a., open type 9/-, shrouded 11/-, post 9d.; 350v. 75 m.a., 4v. 2-5a., 4v. 4a., open type 12/-, shrouded 14/-, post 9d.

WRITE for List, "Paramount Mains Transformers." R. H. Salter, 66, Hartfield Rd., Wimbledon, S.W.19. Phone: Liberty 3226. [2305]

TANTALUM for A.C. Chargers, H.T. and L.T.—Blackwell's Metallurgical Works, Ltd., Garston, Liverpool. [2729]

CABINETS

MANUFACTURER'S Clearance.

HALCYON Radiogram Cabinets, rich, dark, figured walnut, 33x23x19 1/2, 45/-; many others, 30/- upwards; photos for selection sent on request.

TABLE Radio Cabinets (undrilled); 6/6 upwards.

SPEAKER Cabinets; 4/6 upwards.

SEND Particulars of Your Requirements (giving size of set, etc.), or call and make your choice from our stocks of over 100 different types; from 3/6 to £4/10.

H. L. SMITH and Co., Ltd., 287-9, Edgware Rd., London, W.2. Tel.: Padd. 5891. [0485]

HIGH Class Radio Cabinets Made to Order; competitive prices.—C. Moslyn, Ltd., Cabinet Manufacturers, 8-9, French Place, London, E.1. (Bishopsgate 8784). [3554]

DYNAMOS, MOTORS, ETC.

ALL Types of Rotary Converters in Stock, new and second-hand.

WARD, 46, Farringdon St., London, E.C.4. Telephone: Holborn 9705. [0518]

A.C. 4hp. Induction Motors, 1,425 revs., self starting, all voltages; 49/9.—Easco, 18, Brixton Rd., S.W.9. [0455]

E.D.C. Rotary Converter, in silence cabinet with smoothing, 100-110 volts D.C. input, 230-250 volts A.C. output, 200 watts, as new; accept £8/17/6.—Johnson Engineering, 86, Great Portland St., W.1, Museum 7852. [3623]

NEW LOUD-SPEAKERS

HULBERT for Quality Surplus Speakers.

DURING the Last Two Years We Have Stocked and Advertised One Make of Surplus Moving Coil Speakers Only. These are made by Baker's Selhurst Radio, Ltd., the pioneer manufacturers of moving coil speakers. Although not current models, the following speakers are brand new and are offered at considerably under half list prices.

THE Auditorium Models are Fitted with Latest Triple Cone, comprising main curved cone and bakelite and duralumina cones combined, Prov. Pat., giving wide and even frequency response resulting in quality reproduction of both speech and music.

37/6 Only, usual price £5.—Auditorium permanent magnet speaker, with Alni magnet and die cast frame, large 12in. triple cone giving wide frequency range, complete with large 25 ratio transformer suitable for all outputs, including push-pull and Class B, etc.

59/6 Only, usual price £6.—Auditorium electro magnet speaker, 1,000, 1,250, 2,000 or 2,500 ohms field, exceptionally large magnet of high permeability steel giving enormous flux density, 2in. moving coil, large triple cone giving wide frequency range, complete with universal transformer, the ideal speaker for use with "Wireless World" and other quality amplifiers.

75/- Only, usual price £9.—As above, but for use on A.C. mains; complete with Westinghouse rectifier and full smoothing equipment.

24/- Only.—Permanent magnet speaker, Alni magnet, die cast frame, 10in. cone, Universal transformer.

15/6 Only.—Permanent magnet speaker, Alni magnet, 8in. cone, Universal transformer.

12/6 Only.—Permanent magnet speaker, as above, with 7in. cone.

11/6 Only.—Extension permanent magnet speaker, 8in. cone, complete with large cabinet, suitable for low impedance outputs.

2/9 Only.—Brand new cabinets.

8/6 Only.—Electro magnet speakers, with 8in. cone, 6,500 ohms field, Universal transformer.

IF You are Requiring Quality Reproduction at Low Cost Order Now; repeat orders coming in daily.

HULBERT, 6, Conduit St., W.1. Cash or c.o.d. [3631]



NEW LOUD-SPEAKERS

**VAUXHALL**—Best quality speakers; see other column. Vauxhall Utilities, 163a, Strand. [0520]  
**MANUFACTURERS' SURPLUS**—1937 brand new speakers, boxed, by noted British manufacturer; all types at half list prices, e.g., 12in. Super Auditorium model, list £4/4, our price £2/2, carriage paid; cash or c.o.d.—Spencer Radio, 318, Queen's Drive, Walton, Liverpool. [3617]

LOUD-SPEAKERS

**SECOND-HAND, CLEARANCE, SURPLUS, ETC.**  
**VAUXHALL**—Magnavox mains energised, 2,500 or 6,500 field coil, 10in. cone, 17/6; 7in. cone, 12/6.  
**VAUXHALL**—Magnavox permanent magnets, universal, suitable for Class "B" power or pentode, 7in. cone, 16/6; 10in. cone, 22/-.  
**VAUXHALL**—American Rolas, 2,500, 8in. 15/-, 9 1/2in. 19/6; permanent magnets, 8in. 19/6, 9 1/2in. 24/6.  
**VAUXHALL**—Above fully guaranteed, complete with humbucking coils; state power or pentode transformer; unused manufacturers' stock.  
**VAUXHALL**—Immediate delivery, carriage paid; lists free; cash with order or c.o.d.—Vauxhall Utilities, 163a, Strand, W.C.2. Temple Bar 9338. [0456]  
**DUODE** Magnavox 33, 2,500 or 1,250 field, 15 ohm voice coil, finest speaker obtainable; 55/-—37, Rosehill Parkwest, Sutton. [3591]  
**MAGNAVOX D.C.** 152 (9in. cone), 22/6; Magnavox 154 (6 1/2in. cone), 16/3; all with humbucking coils, power or pentode transformers, and 2,500 or 6,500-ohm fields; Magnavox P.M.254, 18/-; Magnavox P.M.252, 22/6.

**ATTENTION TO ALL Orders Within 48 Hours;** carriage paid; cash with order or c.o.d.; send for list.  
**WARD**, 46, Farringdon St., London, E.C.4. Tel.: Holborn 9703. [0451]

VALVES

**ANDERSON**.  
**AMERICAN** Valves, all makes, first grade only; 5/- each.  
**ANDERSON**, 35, Lansdowne Rd., Walthamstow, E.17. Walthamstow 0827. [3351]  
**3/-** Each, all popular types, American valves; 90-day guarantee  
**ALL** Types National Union in Stock, Hytron, Triad, etc.  
**TAYLOR** 866, with guaranteed hourage; 11/6.  
**TAYLOR** T54; 50/-  
**TAYLOR** T20, delivery 14 days.  
**R.C.A.** 50, 800, 801, 907, 913, etc.  
**RADIOGRAPHIC**, Ltd., 66, Osborne St., Glasgow, C.1. [3633]  
**AMERICAN** Valves, first grade, in all types; trade supplied—Metropolitan Radio Service Co., 1021, Finchley Rd., N.W.11. Speedwell 3000. [0436]  
**AMERICAN** Valves, popular types, 5/- each, all guaranteed; line cords, 2/6 each; write for lists.—E. Fellows, Ferney Rd., East Barnet, Herts. [3596]  
**ALL** Types of American Valves in Stock of Raytheon, Sylvania, and Arcturus makes, at competitive prices, guaranteed for six months; send for full list; 350 ohms line cords, 2/8.  
**WARD**, 46, Farringdon St., London, E.C.4. Tel.: Holborn 9703. [0452]  
**NOTHING** Better Available.—Six months' guarantee; complete range of battery, A.C. mains, rectifiers always in stock; 2-volt det., H.F., L.F., 2/3; power, 2/9; screen grid, pentode, H.F. pentode, 5/-; American types, fully guaranteed, 5/6 each, Nos. 18, 24A, 35, 42, 43, 45, 47, 56, 57, 58, 75, 77, 78, 80, 2A5, 2A6, 2A7, 6A7, 2B7, 6B7, 6C6, 6D6, 25Z5, 25Y5; write for other prices to Dulci Electrical Co., Ltd., Devonshire Works, Dukes Av., Chiswick, W.4. [0501]

METERS, ETC.

**UNUSED** Ferranti, 0-100 m.a., 0-15 m.a., 0-6 m.a., D.C. 0-750v., electrostatic, all nearly half price and indistinguishable from new.—Qualitex Radio, Short Heath, Wolverhampton. [3616]

NEW COMPONENTS

**TRANSVERSE** Current Microphone Parts, complete, from 8/6.—A. Hinderlich, 2, Bridge Rd., London, N.W.10. [3539]  
**ENLARGED** Catalogue for Home Constructors Now Ready, post free.—Lumen Electric Co., Litherland, Liverpool, 21. [3473]  
**OURS** is Now the Only Store in London Handling a Complete and Comprehensive Range of High Grade Components and Accessories, as distinct from clearance and surplus material. Everything from the smallest plug to the complete auto changer unit, finest makes, really keen prices, and personal and efficient service unexcelled by chain stores, clearance houses, department stores or by mail. Come and see.  
**WIRELESS SUPPLIES UNLIMITED**, 278-280-282, High St., Stratford, E.15. Maryland 3191. [3551]

COMPONENTS

**SECOND-HAND, CLEARANCE, SURPLUS, ETC.**  
**PREMIER SUPPLY STORES.**  
**PLEASE** See Our Displayed Advertisement on this page.  
**ALL** Post Orders Should be Addressed to Jubilee Works, 167, Lower Clapton Rd., London, E.5. Callers as usual to:—  
**20**—22, High St., Clapham, S.W.4. Open till 9 p.m. Saturdays, Wednesdays, 1 p.m. Macaulay 2381.  
**165** and 165a, Fleet St., E.C.4 (next door to Anderson's Hotel). Early closing Saturday 1.30 p.m. Central 2833. [0488]

PREMIER SUPPLY STORES

Offer the following Set Manufacturers' Brand New Surplus Goods at a Fraction of the Original Cost; all goods guaranteed perfect; carr. paid over 5/-; under 5/- postage 6d. extra. Orders under 5/- cannot be sent C.O.D.  
**ALL POST ORDERS TO JUBILEE WORKS, 167, LOWER CLAPTON RD., LONDON, E.5**  
**CALLERS, AS USUAL, TO 20-22, HIGH ST., CLAPHAM, S.W.4 (Macaulay 2381) Phone: Amherst 4723**  
**And 165 & 165a, FLEET ST., E.C.4 (Next door to Anderson's Hotel.) Central 2833.**  
**Have you had our GIANT ILLUSTRATED CATALOGUE AND VALVE LIST? Send 6d. IN STAMPS FOR THIS BARGAIN LIST.**

**MAINS VALVES**, famous Europa 4 v. A.C. types, 4/6 each. H.L., L., S.G., Var.-Mu-S.G., H.F.-Pens., Var.-Mu-H.F. Pens. 1, 3 and 4-watt A.C. directly heated output Pentodes. Full-wave rectifiers, 250 v. 60 m.a. A.C./D.C. types. 20-volt. 18 amp. S.G., Var.-Mu-S.G., H., H.L., Power and Pen. Following types all 5/6 each. Full-wave rectifiers, 350 v. 120 m.a. and 500 v. 120 m.a. 24 watt indirectly-heated Pentodes, Octodes, Frequency Changers.  
**BATTERY VALVES**, 2 volts, H.F., L.F., 2/3. Power, Super-Power, 2/9. S.G., Var.-Mu-S.G., 4- or 5-pin Pentodes, H.F. Pens., V.-Mu-H.F. Pens., 5/- Class B, 3/6.  
**AMERICAN VALVES**. Genuine American HYTRON and TRIAD first-grade Valves. 3 months' guarantee. All types in stock, 5/6 each. 210 and 250, 8/6 each. New Metal-Glass Valves, all types, 6/6 each. Genuine American DUOTRON Valves, all types, 3/6 each. Valve holders for all above types, 6d. each. Metal bases, 9d. each.  
**SHORT-WAVE COILS**, 4- and 6-pin types, 13-26, 22-47, 41-94, 78-170 metres, 1/9 each, with circuit. Special set of 3 S.W. Coils, 14-150 metres, 4/- set, with circuit. Premier 3-band S.W. Coil, 11-25, 19-43, 38-96 metres. Simplifies S.W. receiver construction, suitable any type circuit, 2/6.  
**COIL FORMERS**, in finest plastic material, 1 1/2in. low-loss ribbon, 4- or 6-pin, 1/- each.  
**SUPER CERAMIC CONDENSERS**, S.L.F., .00016, .0001, 2/9 each; double-spaced, .00005, .000025, .000015, 3/- each. All brass with integral slow motion, .00015 tuning, 3/9; .00015 reaction, 2/8.  
**H.F. CHOKES**, S.W. 10-200 metres, 9d.; S.W. screened, 1/6; standard screened 180-2,000 metres, 1/6.  
**3-WATT A.C. AMPLIFIER**, 2-stage, for mike or pick-up. Complete kit of parts with 3 valves, 40/-.  
**7-WATT A.C./D.C. AMPLIFIER**, 3-stage, high-gain, push-pull output. Complete kit of parts with 5 specially matched valves, 24 4s.  
**10-WATT 3-stage A.C. Amplifier Kit** with 5 valves, 25 5s.  
**20-WATT 3-stage A.C. Amplifier Kit** with 5 valves, 28 8s.  
**ELECTROLYTICS**. U.S.A., 4, 8 or 16 mfd. 530 v. peak, 1/9 each. Dubilier, 4 or 8 mfd. 500 v., 3/-; 50 mfd. 50 v., 1/6; 10 mfd. 50 v., 6d.; 25 mfd. 25 v., 1/-; T.C.C. 4 or 8 mfd. 650 v., 4/-; 15 mfd. 50 or 100 v., 1/-; 50 mfd. 12 v., 1/-.  
**Paper Condensers**. W.E., 250 v. working 4 mf., 2/-; 2 mf. 1/-, 1 mf. 6d.; 350 v. working 4 mf., 2/6; 2 mf., 1/6. Dubilier 500 v. working 4 mf., 4/-; 800 v. 4 mf., 6/-.  
**COSMOCORD PICK-UPS**, with tonearm and volume control, 10/6 each. **PICK-UP HEADS** only, 4/6 each.  
**PREMIER MAINS TRANSFORMERS**, wire-end type with screened primaries, tapped 200-250v. Centre-tapped Filaments. Guaranteed one year. H.T. 8 & 9 or H.T. 10 with 4 v. 4 a. C.T. and 4 v. 1 a. C.T., 2/6. 250-250 v. 60 m.a., 4 v. 1 a. 4 v. 2 a. and 4 v. 4 a., all C.T., 8/6. 350-350 v. 120 m.a., 4 v. 1 a., 4 v. 2 a. and 4 v. 4 a., all C.T., 10/6. Any of these transformers with engraved panel and N.P. terminals, 1/6 extra. 500-500 v. 150 m.a., 4 v. 2-3 a., 4 v. 2-3 a., 4 v. 3-4 a., all C.T., 17/6. Super Model 19/6. **AUTO TRANSFORMERS**, step up or down, 60 watts, 7/6; 100 watts, 10/-.  
**SMOOTHING CHOKES**, 25 m.a., 2/9; 40 m.a., 4/-; 60 m.a., 5/6; 150 m.a., 10/6. 2,500 ohms, 60 m.a. Speaker Replacement Chokes, 5/6.  
**MILLIAMMETERS**, moving-iron, flush 2 1/2in., all ranges from 0-10 m.a., 5/9. Visual tuning, 6 or 12 m.a., 5/9. Moving-coil meters, 2 1/2in. 0-1 m.a., 18/6; 3 1/2in. 0-1 m.a., 22/6. Multipliers, 1/- each. Ampmeters, 0-1, 3, 5, 10 or 20 a., 5/9. **TELSEN** Multi-meters, 3 and 30' m.a., 8, 16 and 240v., 8/6 each. Reads A.C. and D.C.  
**TRANSFORMERS**, latest type Telsen R.G.4 (list 12/6), 2/9 Lissen Hypermik Q.P.P. (list 12/6), 3/6.

**OUTPUT TRANSFORMERS** for Power or Pentode, 2/6; Multi-Ratio, 4/6; Push-Pull Input Transformers by prominent manufacturer, 4/6 each.  
**ELIMINATOR KITS** for A.C. mains. 120 v. 20 m.a., or 150 v. 25 m.a., 15/-, tapped S.G., det. and output. Complete Kit with long-life valve rectifier (replacement cost only 2/-).  
**PREMIER L.T. CHARGER KITS** for A.C. mains, including Westinghouse Rectifiers and Tapped Mains Transformers. 8 volts at 1 amp., 14/6; 8 volts 1 a., 17/6; 15 volts 1 a., 19/-; 8 volts 2 a., 29/6.  
**TELSEN** iron-cored screened coils, W.340, 4/- each. Electric Soldering Irons, 200-250 v., A.C./D.C., 2/3.  
**NEW 1937 1-VALVE SHORT-WAVE RECEIVER OR ADAPTOR KIT** 13 to 86 Metres without coil changing. Complete Kit and Circuit 12/6. **VALVE GIVEN FREE!**  
**DE LUXE MOEEL** 14 to 150 Metres, complete Kit with Chassis, 4 Coils and all parts, 17/6.  
**SUPERHET CONVERTER KIT, 13/6.** S.W. SUPERHET CONVERTER, for A.C. Mains Receivers, 20/-. A.C. Valve given FREE!  
**NEW 1937 2-VALVE S.W. KIT**, 13 to 86 Metres without coil changing. Complete Kit and Circuit, 19/6. **VALVES GIVEN FREE.** **DE LUXE MOEEL**, 14 to 150 Metres, complete Kit and Chassis, 4 Coils and all parts, 25/-. **VALVES GIVEN FREE.** **3-VALVE S.W. KIT**, S.G. Det. and Pen., 42/-. **VALVES GIVEN FREE!**  
**BAND-PASS TUNING PACK**, comprising set of Telsen 3-gang iron-cored coils with switching, mounted on steel chassis with 3-gang condenser, illuminated disc-drive and 4 valve holders, 25/- the lot. All Mains or Battery circuit. FREE!  
**SPECIAL OFFER. LISSSEN TWO GANG SCREENED ALL-WAVE COILS**, 12 to 2,000 Metres, complete with switching and wiring diagram, 6/11 per set.  
**3 VALVE BAND-PASS KIT**, 200-2,000 metres. Complete kit of parts, including chassis, all components, valves, M.C. speaker and wiring diagram. Battery Model, 50/-. A.C. Mains Model, 70/-.  
**MAGNAVOX**. Mains energised M.C. Speakers. '154', 7in. cone, 2,500 ohms, 12/6; '152', 9in. cone, 2,500 ohms, 17/6; '152 Magna', 9in. cone, 2,500 ohms, 37/6. Magnavox P.M.s.—'254', 7in. cone, 16/6; '252', 9in. cone, 22/6. Reliable P.M.s. 10/6.  
**ROLA** latest type P.M.s. 18 1/2. **GOODMANS'** 8in. mains energised, 1,000 ohms field, 10/6 each. Jensen P.M.s. 10/6.  
**DIALS**—Clarion illuminated S.W. slow-motion Dial with 2in. knob, 2/-. Premier All-Wave 2-speed Dial, full vision straight-line, dual ratios 10-1 and 150-1, 6/6, with escapement.  
**Potentiometers** by well-known makers. All values up to 1 meg., 2/-; with switch, 2/6. **GRAMOPHONE MOTORS**. Collaro Gramophone Unit consisting of A.C. motor, 100-250 v. high quality pick-up and volume control, 45/-; Collaro motor only 30/-; Collaro Universal Gramophone Motor, 100-250 v. A.C./D.C., with high quality pick-up and volume control, 67/6; Collaro Universal Motor only, 49/6; Edison-Bell double-spring motors, including turntable and all fittings, 15/-; Cosmocord Gramo. unit, comprising A.C. motor pick-up and volume control (list 55/-), 35/9.  
**TUBULAR CONDENSERS**, non-inductive, all values up to .5 mfd., 6d. each.  
**Wire-end RESISTORS**, any value, 1 watt, 6d.; 4 watts, 1/-; 8 watts, 1/6; 15 watts, 2/-; 25 watts, 2/6 each. Reliable **MORSE KEYS** with Morse Code engraved on bakelite base, 2/- each. Bakelite case **BUZZERS**, 1/6; Walnut case "Loud-tone," 2/6 each. Super Quality lightweight **HEADPHONES**, 3/9 pair.

**L.R.S.**

We are still specialising in

**QUALITY APPARATUS**

including

**SOUND SALES, HAYNES RADIO, McCARTHY RADIO, MIDWEST, and Kits for all Wireless World designs**

on

**CONVENIENT TERMS**

The BEST costs very little more on our generous terms—and the BEST QUALITY, purchased out of income, is better than indifferent quality for cash.

Please write for our quotation.

Estd. — 1925 Phone NATIONAL 1977

**THE LONDON RADIO SUPPLY COMPANY**

11 OAT-LANE · NOBLE ST · LONDON EC2

**EPOCH**

**NEW DOMINO DIAPHRAGM**

For those owners of Epoch Domino Speakers prior to August, 1936, a new diaphragm has been evolved using a specially improved surround manufactured of bakelised oiled silk, which improves the frequency response of the old models considerably. This new diaphragm can be fitted by anyone in ten minutes, and is well worth investing in, as it will bring the old Domino Speakers up to date. The price of this new diaphragm with 15 ohms speech coil, ready for fitting, is **£1**

Send for our complete catalogue—we fee sure it will interest you.

**RADIO DEVELOPMENT COMPANY**  
 (Proprietors: Epoch Reproducers Limited)  
 Aldwych House, Aldwych, London, W.C.2  
 Telephone: Holborn 9111.

**BOOKS on WIRELESS**

Write for complete list to  
**ILIFFE & SONS LTD.**  
 Dorset House, Stamford St., London, S.E.1 W.W.1.

# ARMSTRONG 6-Valve

THIS new chassis is designed to give a good all round performance with 31 watts output on both radio and gramophone. Short wave-band is arranged to cover both the English and American amateur bands as well as the usual short wave broadcast. All the best English components are used throughout and the circuit incorporates the latest improvements such as three wavebands with band-pass input, full range volume and tone controls working on both radio and gramophone, large full vision scale with station names marked on all wavebands, etc.

The price includes radiogram chassis complete with 6 British valves and 3" Rola moving coil speaker, matched to the chassis, mains leads, pilot lamps and everything ready for immediate use. Packing and carriage free.

7 days' trial, carriage paid.

ARMSTRONG 12 months' guarantee.

## SUPERHETERODYNE RADIOGRAM

Chassis with ROLA F.6 SPEAKER



Price £7.10.0

Ready to switch on.



ARMSTRONG MANUFACTURING CO. 100, KING'S ROAD, CAMDEN TOWN, N.W.1. Phone: GULLIVER 3105.

# ELECTRADIX BARGAINS

TRANSMITTERS, MORSE AND SIGNAL KEYS, Royal Air Force model, balanced action, all solid brass bar, tungoil contacts indicator. Type KBSL, a guinea key for 7/6. Other keys from 4/6 to 30/- Learner's outfit complete, 4/9. Ask for special illustrated Key List. Send 1/4d.

ALL-WAVE CRYSTAL SETS with plug-in coils, 2 tuning condensers, semi-perm. detector, 7/6. HEADPHONES.—Sullivan 120 ohms, 2/9. Ericsson, Lissen and others, 2,000 and 4,000 ohms, 4/6. Single high res. ear-pieces, 2/6.

X-RAY VACUUM DISCHARGE TUBES, 10/- New Government Hospital Surplus, 7" dia. bulb. Big solid Tungsten electrodes. Emission guaranteed. COST 25. SALE 10/- Packing, 2/6 extra.

LIGHT AND RAY CELLS. Selenium Raycraft, 21/-; Kingston, 15/- Raycraft outfit with relay and amplifier, 45/-. Photo-Cells, for sound on Film, Television and Ray work, B.T.P., 15/-; R.C.A., 25/-; Beck, Angle Prisms, mounted in carrier, 5/6. Micrometer adjusters for lens, 1/-. Eyepieces with prism and lenses for photo-cell inspection, 12/6. Service Set Headlamps with Battery Holder, 7/6.

MEGGERs as new. Direct Reading .001 ohms to 10 megs. Long scale dial for Resistance makers, 100, 250 and 500 volts, cheap. SILVERTOWN Portable Tester. Combines Wheatstone Bridge, Galvo, shunts and ratios, as new, £8. G.P.O. Plug-in Bridge Resistance Boxes, to 8,000 ohms, 60/-. Large Stock Lab. gear. COMMUTATORS. For Motors and Dynamos 5 to 500 volts. 2/- each. Fractional H.P. motors all sizes, cheap. See new list. H.T. TRANSFORMERS.—200 40 v. to 10,000 v. 25 m.a., 34/-; 5,000 volts 20 m.a., 19/8; 2,500 v. 15 m.a., 17/8. Large "Butterfly" Neon Signs, 4 ft. 2 in. x 4 ft. 11 in. x 6 in., on glass panel, ready for use, £5.

PUBLIC ADDRESS AMPLIFIERS.—We can supply from stock 3, 8, 10 or 20 watt Mains or Battery Amplifiers in portable or chassis form at lowest prices. Special Pro. Act or Dance Band Portable with mike and speaker, £12. 10 watt A.C. Mains Amplifier, 200/250 v., new, with valves, steel case, £9-10-0. Large Set for 18 watts output, with 4 speakers, £25. P.A. and Cinema Speakers, cheap.

MICROPHONES, HAND AND STAND.—Transverse, Crystal, Condenser and Mov. Coil. Our Public Address Eitel-Reisz Transverse Current Microphones are far superior and all the best judges use them. Only 55/-.

TABLE MODEL "W.W.11."—Wonderful value, only 15/-.

Sale Bargain List "W" for 1/4d. stamp.

ELECTRADIX RADIOS

218, Upper Thames Street, London, E.C.4.

Phone: Central 4611.

## COMPONENTS—SECOND-HAND, CLEARANCE, SURPLUS, ETC.

RADIO CLEARANCE, 63, High Holborn, W.C.1. Holborn 4631.

SPECIAL Clearance Sale Now Taking Place at Our London Premises; the following bargains are offered to enable our Mail Order customers to participate in this eagerly awaited annual event.

£6/19/6—8-valve A.C. mains superhet., by well-known manufacturer, fitted visual tuning, volume control, tone control, etc., handsome bird-eye maple cabinet, size 16in. wide, 12in. deep, 23in. high, valves as follows: A.C./V.P.1, F.C.4, A.C./V.P.1, A.C./V.P.1, A.C./H.L.D.D., V.916, A.C. 2 Fon., IW3, pre-H.F. stage, 2 I.F. stages, full A.V.C., a super bargain.

£4/15—Lissen 4-valve Universal A.C./D.C. receiver, fitted in handsome dark finish walnut cabinet of upright design, clock face tuning, volume control, reaction control, etc., a really fine receiver.

EXCLUSIVE British Rights Held by Us for American Constructrad Kits, during the sale these kits are offered as follows:—

21/-—1-valve battery kit, complete with valve.

25/-—2-valve battery kit, complete with valves.

29/6—1-valve A.C./D.C. kit, complete with valve.

32/6—2-valve A.C./D.C. kit, complete with valves.

THESE Are Complete Sets, not converters, covering a waveband of 15 to 600 meters by means of five interchangeable plug-in coils.

£6/7/6—8-valve A.C. superhet. chassis, complete with valves, details as above.

4/11—Rola 9in. energised type moving coil speakers, 600 ohms field, less transformer.

4/11—Rola 10,000 ohm 7 1/2 in. C.I. complete with transformer, Pentode type.

8/- Per Pair.—Lissen all-wave coils, complete with circuit, switching, etc., in matched pairs.

4/6—Ditto single coils.

1/3—Lissen 126 I.F. transformers, fully screened.

1/3—G.E.C. 110 I.F. transformers, Midget type, complete with trimmers.

1/-—Wearite 1/2-meg. volume controls, with switch.

2/3—Centralab volume controls, with switch, 5,000, 10,000, 25,000, 50,000.

SPECIAL. Special. Special.

5/9—Jensen 7 1/2 in. 2,50J field Pentode type moving coil speakers, few only.

2/3—Handsome straight line slow motion dial, complete with escutcheon.

THE Following Condensers, by well-known manufacturer.

3/-—8+8+4 electrolytics, wire end type, metal cases.

2/-—14+8 electrolytics, wire end type, metal cases.

3/-—8+8 electrolytics, wire end type, cardboard cases.

2/11—8 mid. 550 surge, 500-volt working, metal can, 1-hole fixing.

2/6—8 mid. 500 surge, 450 volt working, metal can, 1-hole fixing.

6D.—Tubular condensers, paper type, all sizes up to 0.1.

1/6—50 mid. 50 volt working condensers, well known manufacture.

1/3—50 mid. 25 volt working condensers, well known manufacture.

1/-—25 mid. 50 volt working condensers, well known manufacture.

1/-—5 mid. 12 volt working condensers, well known manufacture.

2/6—Utility 3-gang condenser, superhet. type, two 0.0005 sections, one 110 k.c. section, fully screened, with top trimmers.

1/9—American valves, special clearance, 3 types only, 1223, 6B7, 6A7.

AMERICAN Valves, first class brand, Triad. 4/6 following types: 34, 38, 47, 42, 43, 49, 6B7, 56, 58, 55, 6A7, 80, 75, 48, 41, 523, 2A3, 12Z3, 45, 6C6, 6D6, 6F7, 30, 59.

ALL These Valves Carry a 90-day Guarantee, and free replacement provided that the filament or heater is intact and the glass not broken when returned to us.

1/9—Lissen Class B driver transformers, ratio 1:1, brand new and boxed.

1/-—Lissen intervalve chokes, brand new and boxed.

BRYCE Mains Transformers and Chokes, standard for the season, British and guaranteed.

8/6—250-0-250, 80 m.a. 2-0-2 volts, 2.5 amp., 2-0-2 volts, 4 amp.

10/6—350-0-350, 120 m.a. 2-0-2 volts, 2.5 amp., 2-0-2 volts, 4 amp.

11/6—350-0-350, 150 m.a. 2-0-2 volts, 2.5 amp., 2-0-2 volts, 4 amp., 2-0-2 volts, 2 amp.

16/6—500-0-500, 150 m.a. 2-0-2 volts, 2.5, 2-0-2 volts 2 amp., 2-0-2 volts 2 amp., 2-0-2 volts 2 amp.

8/6—H.T.8 transformer, 250 volts 60 m.a., 2-0-2 volts 4 amp.

16/6—Ditto, with H.T.8 metal rectifier.

ALL Transformers are Fully Shrouded.

BRYCE Mains Chokes.

3/6—40 m.r. 30 hys. 500 ohms.

5/-—60 m.a. 40 hys. 500 ohms.

9/9—150 m.a. 40 hys. 100 ohms.

5/3—60 m.a. 80 hys. 2,500 ohms for speaker replacement, etc.

ENQUIRIES, 1/4d. stamp if reply expected.

HOURS of Business, 9 a.m. to 7 p.m.; Saturdays, 9 a.m. to 1 p.m.

ALL Orders Value 5/- or Over Post Free; orders under 5/- must be accompanied by a reasonable amount for postage.

C.O.D. Orders Under 5/- Cannot be Accepted.

RADIO CLEARANCE, 63, High Holborn, W.C.1. Holborn 4631.

For really high-grade mains transformers and chokes—it's best to go to Savage!



From our standard lists or to your specifications. We will gladly send you lists on request or quote to your particular requirements

# W. BRYAN SAVAGE LTD



WESTMORELAND ROAD, LONDON, N.W.9  
PHONE: COLINDALE 7131 (3 LINES)

## ENGINEERS! ARE YOU EARNING LESS THAN £10 PER WEEK?

If so, you cannot afford to carry on without reading our 268-page Handbook. The book explains clearly and definitely many ways of carving out a successful career. Among other things, it explains the Services of our unique Appointments Department; outlines Home-Study Courses in all branches of Civil, Mechanical, Electrical, Motor, Aero, Wireless, "Talkie" Engineering, Television, Building, Govt. Employment, etc., and gives details of B.Sc., A.M.I.C.E., A.M.I.A.E., A.M.I.R.E., A.M.I.W.T., G.P.O., Matric., and all Exams. We Guarantee—"No pass—No Fee." Whether you be an old hand or a budding apprentice, get this book to-day—FREE and POST FREE.

268 PAGES Free!

BRITISH INSTITUTE OF ENGINEERING TECHNOLOGY,  
387, Shakespeare House, 17/19, Stratford Place, London, W.1.

## PRISM RADIOGRAMS AND PUBLIC ADDRESS EQUIPMENT

PRISM MANUFACTURING CO. CALIFORNIA WORKS. BELMONT, SURREY. Phone: Sutton 5361/2

## P.A. at its Best GRAMPIAN

PUBLIC ADDRESS EQUIPMENT  
GRAMPIAN REPRODUCERS LTD.  
Kew Gardens Surrey

## TRANSATLANTIC All-Wave Tuning Pack

A Complete Superhet. tuning unit, covering 15-50, 200-550 and 1,000-2,000 metres at the turn of a switch. Incorporating latest screened all-wave coils, two 465 K.O. I.F. transformers, latest Polar two-gang condenser and superb full-vision drive and 2 valve-holders. Scale marked in station names, and degrees on short wave band. Completely wired, including A.V.C. aligned and tested for A.O. or D.C. mains. EXCELLENT GREY CELLULOSE FINISH. SIX TERMINAL CONNECTIONS ONLY. Boxed 49/6 Carriage paid.

See also Miscellaneous advertisement on page 7 for other exclusive bargains.

MAINS RADIO DEVELOPMENT COMPANY,  
4-6, MUSWELL HILL ROAD, LONDON, N.6. Tudor 4046.

COMPONENTS—SECOND-HAND,  
CLEARANCE, SURPLUS, ETC.

**VAUXHALL.**  
**VAUXHALL.**—Polar Midget 3-gang condensers, straight or superhet., 8/9; Polar full vision, horizontal or Arcuate dial and drives, 5/-.  
**VAUXHALL.**—J.B. drives with station-named scale, latest type, complete, 5/6; T.C.C. tubular, 0.25 mfd., 9d.  
**VAUXHALL.**—Flat, sheet aluminium, hard rolled, 18 gauge 12in.x12in., 3/-; 18x16, 5/6; other sizes pro rata.  
**VAUXHALL.**—Hivac, Tungram valves, full range; full discounts allowed from new prices.  
**VAUXHALL.**—Polar station-named scales, for horizontal dials, latest settings; 1/9 each.  
**VAUXHALL.**—Polar 2-gang condenser, 6/8; Colvern twin-gang iron cored coils, on base with switch, 20/-.  
**VAUXHALL.**—Colvern coils, G1, G2, G3, or G1, G2 and G3, superhet. type, 30/-; Colpaks, 2/4; Polar drives, 5/-.  
**VAUXHALL.**—Iron-cored coils, 3-gang on base, with circuits; 17/-; B.T.H. Minor pick-ups, 13/3.  
**VAUXHALL.**—All-wave tuning pack, 16.5 to 52 metres, medium and long waves; 87/6.  
**VAUXHALL.**—Set manufacturers' surplus, skeleton type Westinghouse rectifiers, H.T.8, 9/6; H.T.9, H.T.10, 10/-; complete with fixing brackets.  
**VAUXHALL.**—T.C.C. electrolytic condensers, 8 mfd. and 4 mfd., 550 volt, 3/-; 500 volt, 2/6; 450 volt, 2/5.  
**VAUXHALL.**—T.C.C. condensers, tubular, non-inductive, 0.1, 6d.; 50 mfd., 50v. working, 1/6; 50 mfd., 15v., 1/3; 0.05, 6d.; 0.002, 0.0002, 0.001, 0.0001, 4d. each.  
**VAUXHALL.**—T.C.C. mica, 0.002, 2,000 volt test, 1/-; 0.0001, 4d.; 0.001, 1/-; 1 mfd. Mansbridge, 1/3.  
**VAUXHALL.**—Resistances by well-known manufacturers, 1-watt type, 6d. each; all values.  
**VAUXHALL.**—Centre tapped iron cored I.F. transformers, bases, terminals, 110 k/c; 6/6, guaranteed.  
**VAUXHALL.**—Volume controls, Erie, Colvern, Centralab, 2/-; with switch, 3/-; all values, from 2,000 to 2 meg.  
**VAUXHALL.**—Pushback wire, four colours, 6 yds., 6d.; 6B.A. screws or nuts, 4d. dozen.  
**VAUXHALL.**—T.C.C. 200 mfd., 10v., dry, 2/6; 8 mfd., wet, 450v. working, 3/3; Westectors WX6, 4/-.  
**VAUXHALL.**—Clix valve holders, terminals, 7-pin 9d., 5-pin 7d.; W.B. 5-pin, 4½d.; baseboard mounting, 5d.; post paid 2/6 or over or c.o.d.  
**VAUXHALL.**—Collaro A.C. electric motors, boxed, 25/6; similar model complete pick-up and volume control, 11/6; Universal motors, 47/6.  
**VAUXHALL UTILITIES.** 163a, Strand, W.C.2, over Denny's, the Booksellers, Temple Bar 9338. Send postcard for lists free. [0453]  
**ALL Lines Advertised in Last Week's Issue Still Available.**  
**WARD, 46, Farringdon St. Telephone: Holborn 9703.** [0450]  
**RYALLS RADIO, 280, High Holborn, London, offer new goods at knock-out prices.**  
**T.C.C. Electrolytic cardboard, 8x12 mfd., 450v. working, 1/6; British N.S.F. 0.1 condensers, 2/6 dozen; N.S.F. 25 mfd. 25v. electrolytic wire ends, 6d.**  
**WEARITE Q.R.T. Coils, sets three, band-pass H.F. chassis type, 5/- set three; Wearite anti capacity switches for same, 1/6.**  
**3V. and Rectifier Chassis, complete, 200-250v. A.C. Varley iron-core coils, J.B. twin gang condenser with clock face, station name dial, pick-up sockets, with best make energised speaker, factory built; 50/- all complete, carriage 2/6, includes valves, etc. [3630]**  
**OLIVERS Offer Erie 1-watt Resistances, colour coded, 3½d. each, 3/- dozen; 2/6 dozen in 3-dozen lots.**  
**B.I. and T.C.C. Metal Electrolytics, 8 mfd., 2/4; 4 mfd., 2/1; Dubilier 8 mfd., 2/7, 25 mfd., 25v., 1/-, B.I.**  
**ROLA Energised Speakers, manufacturer's type, 2,000 ohms and 2,500 ohms, 7in. cone, 10/6; Plessey P.M., 11/-.**  
**LOTUS 2-gang 0.0005 mfd., 5/6; Plessey 3-gang, 6/-; Westinghouse rectifiers H.T.8, 8/6; H.T.9, 9/-; H.T.10, 9/6.**  
**HUNT'S Cardboard Electrolytics, 4 mfd., 1/6; 8 mfd., 1/9; 8 mfd.+4 mfd., 2/5; 8 mfd.+8 mfd., 2/9; 50 mfd. 50v., 1/6; T.C.C. 50 mfd. 50v., 2/-.**  
**CLIX Chassis Mounting Valve Holders, 5-pin, 3d.; 7-pin, 4d., L.F. chokes, 20 Hy., 100 m.a., 6/-.**  
**CENTRALAB Volume Controls, standard type with switch, 2/-; Collaro grammo motors, A.C. 110-250v. 50 cycles, Uniplate, auto-stop, regulator, turntable, etc., 24/6.**  
**ALL American and Non-ring Valves a Speciality, equivalents for every British type available; prices and details upon request; all valves guaranteed for various periods.**  
**OLIVERS, 676, Christchurch Rd., Boseombe, Hants. All orders under 5/6 postage 3d. extra. [3626]**  
**DOUGLAS No. 1 Coil Winder, equal new; £13, or nearest.—Qualitex Radio, Short Heath, Wolverhampton. [3615]**  
**PHOTO-ELECTRIC Cells, all types, Selenium, Calcium, Potassium, guaranteed; bargain list.—Cefa, 11, Ramsden Rd., S.W.12. [3646]**  
**FOSTER BROS.—Mains transformer and L.F. choke, primary 200-240 secondary's, 500-0-500v., 300 m.a., 4v. 7 amp., 4v. 5 amp., 4v. 5 amp., 4v. 2 amp., all C.T. choke, 50 Henry's 300 m.a., 65/- the two; Ferranti A.F.5s, 10/6; A.F.3s, 6/6; quantity in stock; Epoch Domino speaker, L.T. field, 45/-.—R. P. R. Radio, 112, Pentonville Rd., London. [3629]**

**RADIOMART**  
**SHORTWAVE SPECIALISTS**

**MICROVARIABLES.**—All brass construction; latest ceramic insulation. The finest condensers made; 15 mmfd., 1/4; 40 mmfd., 1/7; 100 mmfd., 1/10. **Transmuting Type.**—0.70in. spacing, 15 mfd. (neutralising), 2/9. 40 mmfd. Tuning, 3/6. These are quality.  
**SHORTWAVE COILS.**—(RD4) CA 11-25, CB 20-45 metres, 2/6. CC 44-100 metres, 2/9. Standard 6-pin types, CA6, CB6, 2/9 each, CC6, 3/-; same range as 4-pin.  
**COILFORMS.**—Moulded in RD4 natural loss material, hollow resilient pins 1¼in. diameter ribbed; identification disc in top. Four types 4-pin, 1/6; 6-pin (standard or to fit 7-pin valveholders), 1/9; 7-pin (for bandspread tap), 1/10; Machine threading, 2d. extra.  
**AMERICAN Mains Transformers, 280 v., fully shrouded, 350-350 6.3 v., 5 v. 6/11; Majestic, 250-250, 2.5 v., 5 v., 4/11. Pilot 260-260, 2.5 VCT, 5 VCT, 5/11.**  
**HEAVY DUTY Mains Transformer, worth 35/-, 350-350, 150 m.a., 4 v., 2.5 ACT, 4 v., 6 ACT, 12/6.**  
**UTILITY 8/6, Microdisc Dials, 3/11; Radiophone, 0.00016 Shortwave Condensers, 3/6; Series gap, twin, 3/9. Shortwave HF Chokes 5-100 metres, 9d.**  
**465 KC Litz Wound IFS, 3/11; Two-speed Slow Motion Knobs, 1/-; Telsen Ace Transformers, 1/11; Iron-cored HF Chokes, 1/-; Utility Straight Line Dials, 2/11; British Radiophone Straight or Superhet 3-gang Condensers, with trimmers fully screened, 4/11.**  
**ELECTROLYTICS.** Huge purchase 500 v. Aluminium Can, 4 mfd., 1/8; 8 mfd., 1/11; 16 mfd., 2/6; 8+8 mfd., 2/6; 8+8 mfd. 450 v. + 8 mfd. 250 v., 2/9; Block type, 500 v. peak, 4+4 mfd., 1/6; 8+8+4 mfd., 3/-; 50 mfd. 50 v., 1/3; 25 mfd. 25 v., 1/-; 2 mfd. 300 v., 9d.; 40+24 mfd. 200 v., 1/6.  
**FAMOUS CONTINENTAL A.C. Valves, 4/6; Battery types from 2/3; American Duotron, etc., all types, 3/6; All types of RCA Licensed first grade tubes, metal and glass, in stock from 5/8.**  
**FEATHERWEIGHT Headphones, 2/6; Varley Bifocal Iron-cored Coils, 2/6; matched pair, 4/6.**  
**SMOOTHING CHOKES, 20 Hy., 120 m.a., 3/11; 40 m.a., 1/11; Centralab Pots, all sizes, 1/6; switched, 2/-; 20,000 ohm Pots, 1/-; Tubular glass fuses, 2d.**  
**SPECIAL OFFERS.** Class B Kit, worth 30/-, comprising Driver Transformer, Valve and Holder, 5/-; Dozen wire ended assorted resistors, 1/6. Preset Condensers, 9d.  
**TRADERS! Monster Bargain Parcels value £4/10/0, for 10/-; also 5/- parcels. State battery or mains. Milliammeters 25 m.a. upwards, 5/9; super, 6/9.**  
**PUSHBACK Wire, 6 yds. 6d.; heavy, 9d.; Resin cored Solder, 6ft. 6d.; Screened Flex, single, 6d. yd.; twin, 9d. yd.**  
**CONDENSERS.** 4 mfd. 700 v. T., 2/6; 2 mfd., 1/6; T.C.C. 1 mfd., 6d.; Dubilier, 0.1 mfd., 3d.; Tubular Condensers, 1,500 v. T., all sizes to 0.1 mfd., 6d.; 0.2 to 0.5 mfd., 8d.  
**UTILITY 2-gang Uniknob .0005 with Dial, 3/11. EDC Converters, new, 12 volt to 240 v. 40 m.a., 25/-; BTH ditto, 6 v., input fully smoothed, 39/6.**  
**CRYPTO 500 watt 220 v. DC to 280 v. AC, as new, £10; Ditto, 1,000 watt, £15. One of each only.**  
**AMERICAN latest Double Button Microphones, cost £2 in U.S.A., our price 25/-. Why buy junk?**  
**PHILLIPS Screened Ceramic and Brass All-wave .0003 Micro-Variables. Ideal experimenters, 10d. Visual Tuning Meters, 2/-.**  
**SILVER MARSHALL 14-valve all-wave chassis with speaker, 15-550 metres, one only, 9 guineas.**  
**ROLA, used but perfect matched pairs, 2,500 ohms, 10in. and 7in., no transformer, 15/-; Jensen 7in., new PM speakers, 12/6.**

Order 5/- post free. Get our Bargain Catalogue, 1½d. post free. All enquiries and requests for Catalogue must send 1½d. stamp.

**RAYMART 1936-7**  
**EDITION**  
**RAYMART SHORTWAVE MANUAL**

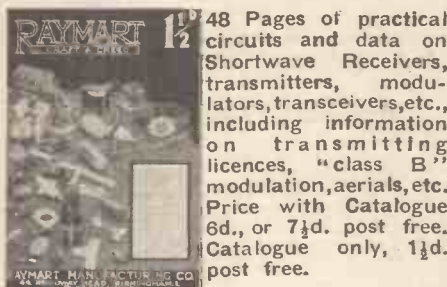

**BIRMINGHAM RADIOMART (65NI)**  
19, John Bright Street and Dale End

MAIL ORDER DEPT. "W"  
**44 HOLLOWAY HEAD,**  
BIRMINGHAM. TELE.: MID. 3254.

"Foundations of Wireless" Post free 4/11

COMPONENTS—SECOND-HAND,  
CLEARANCE, SURPLUS, ETC.

**SOUTHERN RADIO'S** Wireless Bargains.—All goods guaranteed and sent post paid.  
**RECEIVERS.**—Belmont 6-valve superhet. receivers, complete in handsome cabinet with moving coil speaker and six valves, for use on A.C.-D.C. mains, 100-250 volts, ready for use on any mains; 4s.  
**VIDOR.**—3-valve battery sets, model C.N.212, complete in attractive walnut cabinet, with three Mullard valves, moving coil speaker, batteries and accumulator, new, in sealed cartons; £3/17/6 (list 6½ guineas).  
**LUCILLE.**—5-valve American midget sets, complete with 5 valves, moving coil speaker, ready for use on any mains, 100-250 volts A.C.-D.C., long and medium waves; £3/15, new, in sealed cartons.  
**RECORD Changers.**—Garrard Model R.C.4, plays automatically and changes eight 10in. or 12in. records of any kind, new, in sealed cartons; £6.  
**GRAMOPHONE Motors.**—Collaro electric radiogram units, for A.C. or D.C. mains, 100-250 volts, fully auto stop, complete with pick-up, can be used on any mains, brand new, in sealed cartons; 57/6 each.  
**COLLARO Electric Radiogram Units, complete with pick-up and fully auto stop, for A.C. mains only; 37/6 each.**  
**COLLARO Single Spring Gramophone Motors, with 10in. turntables, complete with all accessories, 11/-; double spring motors, with 12in. turntable, 15/-.**  
**COLLARO Battery Radiogram Units, comprising double spring motor and pick-up, mounted on plate with all accessories; 35/- each; all Collaro motors are brand new in sealed cartons.**  
**SPEAKERS.**—Cestelon Soundex permanent magnet, 10/-; Telsen permanent magnet with 10-ratio transformers to suit any receiver, 12/6; Telsen loud speaker units, 2/6; all brand new and boxed.  
**COILS.**—Telsen iron core, W349 (midget size), 4/-; type W478 (twin), 9/- pair; type W477 (triple), 16/- per set; type W476 (triple superhet., selector and oscillator), 16/- per set; all ganged coils complete on base with switch; Telsen I.F. transformer coils, 110 kc., 5/-; Telsen dual range coils, with aerial series condenser incorporated, type W76, 4/-; Telsen aerial series condensers, with shunting switch, 2/-; all Telsen components brand new in sealed cartons.  
**CAR Radio Aerials.**—Ekco copper mesh aerials can be used on roof or floor of car; 36in. by 20in., 4/-; 36in. by 20in., 5/-.  
**AMERICAN Valves.**—A full range of valves for all American receivers, 6/- each.  
**MISCELLANEOUS Bargains.**—All brand new in original sealed cartons:  
**Telsen A.C.-D.C. Multimeters, tests anything radio or electrical, 8/6; Telsen 2-range voltmeters, 3/-; 3-range meters, including milliamps, 4/-; Ace (P.O.) microphones, with transformer, ready for use with any receiver, 4/6; 36 assorted Tru-ohm resistances, 1 watt, colour coded and marked, 36 on card, 6/- per card; bell transformers, 200-250 volts input, 3, 5 and 8 volts output, 3/6; Morse signal units, incorporating buzzer, tapper and flash, with international code, complete with batteries and bulb, 3/9 each; Varley square peak coils, BP5, 2/-; Marconi V24 and Q type valves (useful for short wave experiments), 1/6; glass insulators, 4d.; lightweight headphones, double pole, 4,000 ohms each earpiece, 3/- pair.  
**A.C. Trickle Chargers, for 2, 4 and 6 volts, 17/6.**  
**CAR and Radio Battery Chargers, incorporating Westinghouse metal rectifier, this charger will enable you to keep your car batteries fully charged, for use on 2, 6 and 12 volts; 45/- each.**  
**REGENTONE Eliminators, A.C. 200-250 volts, type W5a, with trickle charger; 37/6.**  
**SOUTHERN RADIO.—Branches at 271-275, High Rd., Willesden Green, N.W.10; 46, Lisle St., London, W.C.2. All mail orders to 323, Euston Rd., London, N.W.1.  
**SOUTHERN RADIO, 323, Euston Rd., London, N.W.1 (near Warren St., Tube). 'Phone: Euston 3775. [3634]**  
**MAINS RADIO DEVELOPMENT COMPANY Offer Exclusive Bargains; unbeatable value, carriage paid; stamp for bargain list; see displayed advert. on this page for exclusive all-wave offer.**  
**KNOBS, ¼in. spindle, hexagonal, brown bakelite, superb appearance, satisfaction guaranteed, exclusive; 2d. each.**  
**CHASSIS, three-valve, grey cellulosed, 12in.x6½in.x3, rigid metal, brand new, 1/-; Clix unused chassis, valve-holders, 5-pin., 2½d.; Plessey 4-pin, 1½d.; 7-pin, 4d.; all baseboards, 4d.**  
**RESISTORS, very best make, one watt, colour coded, 3½d. wire ends, unused; every value 50 ohms to 4 meg-ohms, 3½d., 2/9 dozen; two watt, 7d.**  
**CENTRALAB Unused 500,000 ohm Potentiometers, 1/-; Philips, 20,000 ohms, 1/-; 10,000 ohms with switch, 1s. 6d.**  
**TUBULAR Condensers, unused, best make, 400 volt working, 0.0001-0.002 mfd. 3d., 0.005-0.05 mfd. 5d., 0.1 mfd. 6d., 0.25 mfd. 7d.**  
**WEARITE H.F. Chokes, very efficient, 6d.; short-wave H.F. chokes, 4d.**  
**Telsen Latest Boxed Bakelite Reactions, 0.00015 mfd., to clear, 4½d.; Pye shrouded L.F. chokes, 20h. 120 m.a., boxed, 4/6.**  
**FINAL Clearance.—Standard telephones, brand new metal case condensers, 400 volt working, 2 mfd., 6d.; 1 mfd., 4½d.; Formo unused tag condensers, 0.00005-0.002 mfd., 1½d. each.**  
**PLESSEY Dry Electrolytics, 8 mfd., 550 volt, 1/8; 50 mfd., 50 volt, 1/8; 200 mfd., 15 volt, 2/3; 50 mfd., 12 volt, 8d.**  
**Telsen P.M.M.C. Speakers, 7-inch cone, ten ratio output transformer, new, boxed, 11/6.**  
**HALF-WATT Resistors, unused, wire ends, good marked sizes, 50 well assorted, 2/6; Lewcos spaghetts, sealed cartons, good assorted sizes, must be cleared, 4d. dozen, 50 for 1/-.**  
**MAINS RADIO DEVELOPMENT COMPANY, 4-6, Muswell Hill Rd., London, N.6. 'Phone: Tudor 4046. [3608]******

# AMERICAN SET OWNERS INSIST ON

## THE WORLD'S STANDARD VALVE



The Standard Valve for Standard Sets  
**FOR RELIABLE CONSISTENT PERFORMANCE**

UNIVERSAL RADIO DISTRIBUTORS LTD.  
 24, FITZROY SQUARE, LONDON, W.1.

You've paid your License  
 You've got your Set,  
 AND IF you've used  
**FLUXITE**—  
 You won't need a "VET."



See that **FLUXITE** is always by you—in the house—garage—workshop—wherever speedy soldering is needed. Used for 30 years in Government works and by leading engineers and manufacturers. Of Ironmongers—in tins, 4d., 8d., 1/4 and 2/8.

Ask to see the **FLUXITE SMALL-SPACE SOLDERING SET**—compact but substantial—Complete with full instructions, 7/6.

Write for Free Book on the art of "SOFT" SOLDERING—and ask for leaflet on CASE-HARDENING STEEL and TEMPERING TOOLS with **FLUXITE**.

TO CYCLISTS! Your wheels will NOT keep round and true unless the spokes are tied with fine wire at the crossings AND SOLDERED. This makes a much stronger wheel. It's simple—with **FLUXITE**—but IMPORTANT

## THE FLUXITE GUN

is always ready to put Fluxite on the soldering job instantly. A little pressure places the right quantity on the right spot and one charging lasts for ages.  
 Price 1/6.



ALL MECHANICS WILL HAVE

# FLUXITE

IT SIMPLIFIES ALL SOLDERING

FLUXITE LTD., Dept. W.W., DRAGON WORKS, BERNMONDSEY ST., S.E.1.

### COMPONENTS—SECOND-HAND, CLEARANCE, SURPLUS, ETC.

**H** EADPHONES.—5,000 guaranteed pairs to be cleared. Brown, G.E.C., B.T.H., Ericsson, Neper, Western Electric, Siemens, Brandes, Sterling, etc., 2,000 ohms; 2/6; 4,000 ohms, 5/-; postage 6d.

**S** PECIAL.—Telefunken, adjustable, lightweight, 2,000, 4,000 ohms, 7/6; crystal sets, Burne-Jones, complete, guaranteed, 5/6; ditto, double circuit, 8/6; with permanent detector, 1/- extra; sensitive permanent detectors, 1/6; crystal detectors, complete parts, 1/-; crystals, 6d.—Post Radio, 183, Caledonian Rd., London, N.1. [3526]

### TRANSMITTING APPARATUS

**G** 5NI.—The recognised distributors for amateur equipment, National R.M.E., Thordarson, Hammarlund, McMurda, Hallicrafters, etc.; send 1/4d. stamp for catalogue.—Radiomart, 44, Holloway Head, Birmingham. [0531]

### MISCELLANEOUS

**C** HEAP Printing.—1,000 billheads, 3/6; sample free.—Creteaway Press, 18, Buxted, Sussex. [3503]

**A** WARM Bed this Winter for 1/4d. per week; the Warm-Glow Electric Blanket costs only 52/6.—Leaflet from Warmglow Co., Leigh-on-Sea. [0542]

**H** OT Wire Ammeters, ex-Government, 7/6, postage 6d.; Wheatstone bridges, full range, high resistance, standard ohms, £5, carriage forward.—Beaton's Stores, 63a, Chalk Farm Rd., N.W.1. [3624]

**G** P.O. Engineering Dept. (no experience required). Commencing £3/13 per week. Age 18-23. Excellent prospects.—Free details of entrance exam. from B.I.E.T. (Dept. 574), 17-19, Stratford Place, London, W.1. [3492]

**A** MBITIOUS MEN.—Here's the way to better pay. Study at home with The T.I.G.B., the leading organisation for engineering training. Write to-day for "The Engineer's Guide to Success"—free—which contains the world's widest choice of engineering courses—over 200—and which alone gives the regulations relating to qualifications such as A.M.I.E.E., A.M.I.W.T., A.Rad.A., etc. Extensive employment facilities for students. Hundreds of vacancies notified every year.—The Technological Institute of Great Britain, 82, Temple Bar House, London, E.C.4. (Founded 1917. 19,000 Successes.) [3506]

### ELECTRIC CLOCKS

**S** MITHS and Ferranti Electric Clocks, Waltham and Russell watches and clocks; traders' enquiries invited.—Leonard Heys, 36, Henry St., Blackpool. [0526]

### EXTENDED PAYMENTS

**L** OONDON RADIO SUPPLY Co. (Established 1925) supply on convenient terms, components, accessories and sets, any make; 10% down, balance over 12 months; send for list of requirements.—11, Oat Lane, London, E.C.2. [0537]

**H** IRE-PURCHASE.—Prompt delivery of any radio apparatus on convenient terms.  
**W** ARD, 46, Farringdon St., London, E.C.4. Tel.: Holborn 9703. [0539]

### EXCHANGE

**C** OSMIC RADIO SERVICES, Ltd., 23, Water St., Liverpool, accept quality mains equipment, meters, components, etc., in part exchange. Meters purchased. [2490]

**I** BUY, sell, exchange good quality receivers, accessories, components; H.P. facilities; promptness, efficiency.—Bostock, 1, Westbourne Terrace, S.E.23. Forest Hill 2236. [0529]

### PATENT AND TRADE MARK AGENTS

**H.** N. and W. S. SKERRETT, Chartered Patent Agents, 88-90, Chancery Lane, London, W.C.2 (Hol. 8837), and 24, Temple Row, Birmingham. [2461]

**G** EE and Co. (H. T. P. Gee, Mem. R.S.G.B., A.M.I.E.E., Estab. 1905), 51-52, Chancery Lane, London, W.C.2 (2 doors from Government Patent Office). Holborn 4547 (2 lines). Handbook free. [0001]

### REPAIRS AND SERVICE

**G** RAHAM'S.  
**G** RAHAM'S Radio Repair and Rewinding Service; 24 hours' service guaranteed.—See below.

**A** LL Moving Iron Loud Speakers, L.F. transformers, or pick-ups, from 2/6; output transformers from 4/-; postage extra; mains transformers, moving coils, electric clocks quoted; trade discounts.—Graham's Repairs, 194, Tolworth Rise, Kingston By-pass, Surrey. 'Phone: Derwent 2060. [3500]

**D** IStAVOX SERVICE.  
**T** RADE Service.—All makes of English and American receivers; quotation by return.

**R** EWINDING.—Mains, L.F. and output, transformers, speakers, headphones, etc.; keenest terms for contracts.

**D** IStAVOX RADIO SERVICE Co., 119, Bunhill Row, London, E.C.1. 'Phone: National 8589. [3504]

"SERVICE With a Smile."  
**H** ENRY FORD RADIO, Ltd.,

**L** EADING Service Specialists for American Receivers, also British; trade work particularly; estimates free.  
**E** LECTRONIC House, 22, Howland St., Tottenham Court Rd., W.1. Museum 5675. [0434]

## IN STOCK FOR IMMEDIATE DELIVERY

Kits of parts for Wireless World Quality Amplifier, Imperial Short-Wave Six, Q.A. Super, All-Wave Super Seven, Variable Selectivity Four, Pre-Tune Receiver and Amplifier, Universal Gramophone Amplifier, Q.A. Receiver, and most other units.

We can also supply any of the individual components incorporated therein, and in addition stock a comprehensive range of resistances, condensers, valves, rheostats, transformers, rotary converters, speakers, receivers, motors, fans, service replacements, American tubes, bakelite fittings, A.C./D.C. conversion units, refrigerators, etc.

Hire-Purchase transactions undertaken.

Send for comprehensive lists to:—  
**CHAS. F. WARD**, 46, Farringdon Street, LONDON, E.C.4. Tel.: Holborn 9703.

### THE INSTITUTE OF WIRELESS TECHNOLOGY

(Incorporated)  
 4, VERNON PLACE, SOUTHAMPTON ROW, LONDON, W.C.1.

### THE EXAMINATIONS, MAY, 1937

**C** ANDIDATES for the May A.M.I.W.T. Examination must lodge their applications, on Form E, not later than the 30th of January.

Full particulars of the Institute Examinations and Membership are contained in the new and revised Syllabus to be obtained from the Secretary.

**TANNOY**  
 THE SOUND PEOPLE  
 GUY B. FOUNTAIN LTD.  
 FOR ALL SOUND AMPLIFYING EQUIPMENT  
 CANTERBURY GROVE, WEST NORWOOD, LONDON, S.E.27. 'Phone: Str. 4122 (6 lines).

**KINVA WHISTLE SUPPRESSOR**  
 Type A.5, for anode circuits, will cut out strong, high-pitched 9 Kc. whistles with negligible effect on quality. A neat two-coil unit, and simply switchable if required. 12/-  
 V.2. tunable type, with switchable complete cut-off, for grid circuits, panel control, removes whistle and 'splash' down to 4 Kc/s. 17/6  
 Q.A.S. tunable, for 'Q.A. Super.' 10/6  
 Details, Graphs, etc., for stamp.  
 POSTLETHWAITE BROS., KINVER, STAFFS.

*The Autocar*  
 The Leading Motoring Paper  
 EVERY FRIDAY 4d. W.W.16

THE  
**WIRELESS ENGINEER**  
 The Journal of  
 Radio Research and Progress  
 Monthly 2s 6d. net. W.W.2

REPAIRS AND SERVICE

**FOR** Good Repairs, rewinds and transformers, send to Dunports, Adelaide Lane, Bournemouth. Established 1925. [3614]

**METROPOLITAN RADIO SERVICE Co.** for Guaranteed Repairs to American (Midget and Standard) and British Receivers.

**CLARION** and Majestic Service Depot.—I.F. and mains transformers rewound, American valves and parts; trade supplied.—Metropolitan Radio Service Co., 1021, Finchley Rd., London, N.W.11. Speedwell 3000. [0435]

**SAUNDERS and Co.**, 15, Percy St., W.1. Museum 3096.—American and English repairs; "Wireless World" sets a speciality; estimates free. [3579]

**VALRADIO** for Repairs and Rewindings to Converters, Motors, transformers, vacuum cleaners, etc.—95, Leighton Rd., Kentish Town, N.W.5. Gulliver 5165. [3210]

**GUARANTEED Repairs.**—Any transformers, choke, motor, armature, converter, dynamo, etc.; keenest prices, immediate quotation; prompt, dependable service.—See below.

**L.T.P. (LONDON TRANSFORMER PRODUCTS, Ltd.)**, Willesden, N.W.10. Wil. 3568 and 7743. [3470]

**MAINS Transformer Service.**—Repairs, rewinds, or constructions to specification of any type; competitive prices and prompt service.—Sturdy Electric Co., Dip-ton, Newcastle-on-Tyne. [0516]

**F. E. GODFREY, A.M.I.R.E.**, qualified to build, repair and convert "Wireless World" sets, etc.; 25 years' experience; prompt service guaranteed.—30, Kemplay Rd., Hampstead. Hampstead 1104. [3509]

**RADIO Repairs and Constructional Service**, receivers, transmitters, audio amplifiers, etc.; express radio repairs for Lancashire.—Harmony House Sound Service (G2IN, G5ZI), 116, Cambridge Rd., Southport. Tel.: 8621. [0536]

**TRADE Service.**—British and American receivers serviced at reasonable cost; estimates free; work guaranteed three months; American valves.—Majestic Service Co., 22-28, King St. West, Manchester, 3. Phone: Blackfriars 4951. [0544]

**REPAIRS to Moving Coil Speakers** a Speciality; cones and coils fitted, fields altered; prices, including eliminators; quoted, loud speakers, 4/-; L.F. and output transformers, 4/-, post free; guaranteed satisfaction; trade invited; estimates free; prompt service.—Loud-Speaker Repair Works, 5, Balham Grove, London. Battersea 1321. [0394]

TUITION

**RADIO Training.**—Marine, aircraft, broadcast; prospectus free.—Hull Municipal Technical College. [0523]

WANTED

**WANTED**, Universal or Model 7 Avometer, good condition.—Box 534, c/o *The Wireless World*. [3628]

**WANTED** for Cash.—Modern radio receivers; also meters, etc.—M. R. E., 6, Pentonville Rd., London, N.1. [3283]

**WANTED**, Philco 048A Analyser, oscillator, or similar, good condition.—Box 525, c/o *The Wireless World*. [3612]

**WANTED**, P.A. speakers, P.M. type microphones, M.C. crystal or velocity.—Kntz's Music Warehouse, 88, High St., Lympington. [3611]

**WE Buy for Cash** All Types of Modern Second-hand Radio Sets and Accessories, test meters, parts, etc.; we pay more than any other dealer; part exchanges; bring, send, or will call.—University Radio, Ltd., 82, Hampstead Rd., London, N.W.1. Phone: Euston 3810. [3484]

AGENCIES

**GERMAN Firm Manufacturing High Quality A.F. Equipment** Seeks British Agent; kindly furnish explicit details.—Box 533, c/o *The Wireless World*. [3627]

SITUATIONS VACANT

**AIR MINISTRY.**

**AERONAUTICAL** Inspection Directorate.

**VACANCIES** exist for Examiners in the W/T and Instrument Sections. Salary £246 a year, rising by annual increments of £12 to £337 a year, except in the case of entrants below the age of 24 years, when the starting rate will be reduced by £12 for each year below that age. It is anticipated that, provided service is satisfactory, the appointments will be for at least two years. Candidates must not be more than 50 years of age on 1st February, 1937.

**APPLICANTS** for Posts in Instrument Section must have had good general education and theoretical training in Physics, Optics and Mathematics, and training in light engineering or instrument making. Preference given to candidates having good knowledge of Thermometry, precision pressure measuring and mechanical instruments as used on aircraft, and of materials from which they are manufactured.

**APPLICANTS** for Posts in W/T Section having the following qualifications will receive preference: Good general education, sound technical knowledge of high frequency engineering equal to City and Guilds final examination in communication engineering, practical knowledge of modern methods of production and testing of W/T transmitters, receivers, wavemeters, and associated equipment; also electrical equipment, such as generators, transformers, etc., and of the materials from which they are manufactured.

**APPLICATIONS**, stating qualifications, experience and date of birth, should be addressed to Secretary (S.2.d.), Air Ministry, Adastral House, Kingsway, W.C.2. [3644]

SITUATIONS VACANT

**WIRELESS** and Television.

**MARCONI'S** and Other Employers Require Hundreds of Trained Men This Year. We train students for all branches of Radio at our Residential Colleges in Southampton and Colwyn Bay, and guarantee appointments; licensed by Postmaster-General recommended by Marconi's.—Write for free prospectus, The Wireless College, Colwyn Bay, or to London Office, 4, Winton Av., N.11. [0541]

**EXPERIENCE** Service Engineer Required, able drive.—Henrys, 54, High St., Margate. [3640]

**RADIO Laboratory Assistants** Required, experienced H.F. and L.F. measurements; state qualifications and salary.—Box 506, c/o *The Wireless World*. [3604]

**JONES BROS. (HOLLOWAY), Ltd.**, Holloway Rd., N.7, require a thoroughly experienced service engineer for their enlarged radio service department; able to drive.—Apply Staff Manager. [3642]

**RADIO Engineer**, with good practical experience of Cathode ray tube and time base technique, particularly as applied to television.—Write, stating age, experience, and salary required, to Box 437, c/o *The Wireless World*. [3562]

**RADIO Engineer**, for laboratory work in large engineering works, London district, degree or equivalent, with some practical experience.—Write, stating age, education, experience and salary required, to Box 508, c/o *The Wireless World*. [3607]

**A LIMITED** Number of Vacancies Occur Monthly for young men with secondary school education, to be trained in the Royal Air Force as Wireless Operators; age limits 17½ to 32.—Apply: R.A.F. Recruiting Depot, Victory House, Kingsway, London, W.C.2. or any R.A.F. Recruiting Depot. [3512]

SITUATIONS WANTED

**MORE Business** Awaits Wireless or Electrical Firm Open to Consider Partnership; advertiser has had 17 years' technical experience with leading wireless company; willing to invest and co-operate to increase turnover; age 37 (single).—Write Box 313, c/o Dixons, 195, Oxford St., W.1. [3609]

BOOKS, INSTRUCTION, ETC.

**"WIRELESS World's,"** July, 1932, to date, 17/6, separately 2/6 volume; carriage paid.—Moffat, 19, Cateswell Rd., Birmingham, 11. [3603]

# FOUNDATIONS of WIRELESS

A Book of  
First Principles  
for the  
Wireless  
Enthusiast

PRICE 4/6 NET  
By Post 4/11

Issued in conjunction with  
"THE WIRELESS WORLD"  
and published by the Proprietors—

By A. L. M. SOWERBY, M.Sc.

An Elementary Text Book on Wireless Receivers

"Foundations of Wireless," based on a series of articles which appeared in "The Wireless World," covers the whole field of wireless from the simplest electrical phenomena to the construction of a modern set, and all the vital points in receiver-design are treated in full detail. Chapters are devoted to direct and alternating currents; typical circuits; the properties of inductance and capacity; the nature of high frequency currents; the tuned circuit; and amplification by the valve.

Eleven of the eighteen chapters of the book deal with the discussion of receivers in which the whole process of design is reviewed stage by stage to the finished article.

Special attention is paid to the important subject of tuned circuits and band-pass filters, on the correct design of which the performance of every type of set ultimately depends. Moreover the process of detection, so often imperfectly understood, is clearly explained.

ILIFFE & SONS LTD., DORSET HOUSE, STAMFORD STREET, LONDON, S.E.1

"The Wireless World Diary for 1937." Price 1/6 net By post 1/7

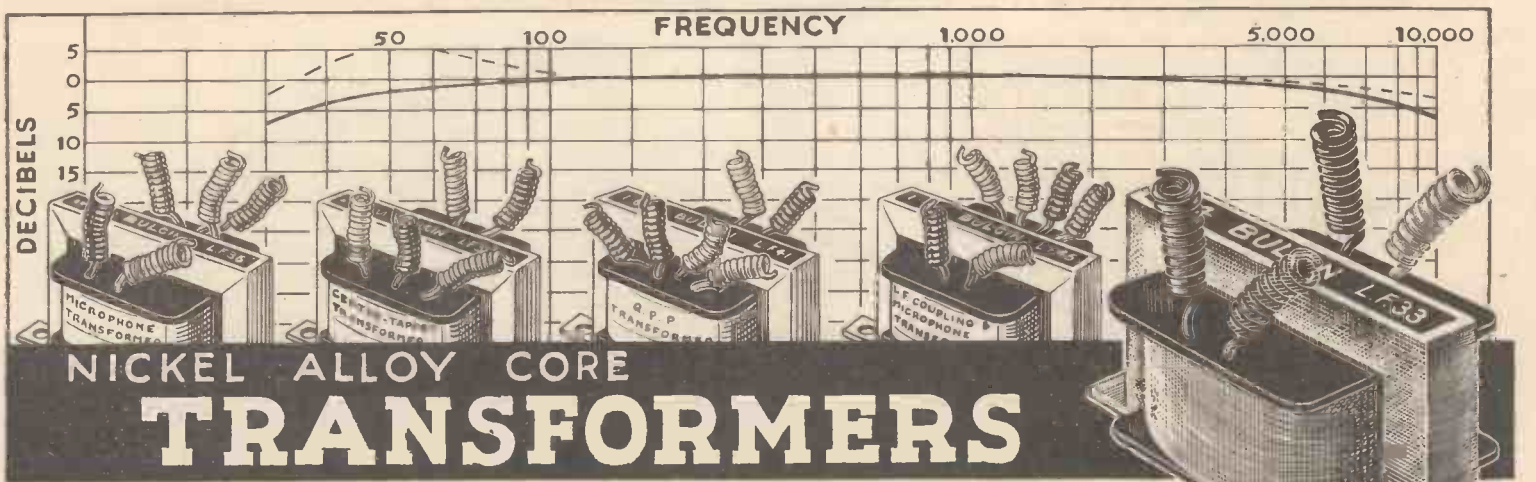

## NICKEL ALLOY CORE TRANSFORMERS

The Bulgin Midget Nickel-Alloy Core L.F. Transformers are famed for the even response they give and the high inductance they possess. The curve reproduced is of type L.F.33. Note the wide range obtained between limits of 5 db. variation.

The response curve can quite easily be varied according to requirements. A bass lift, for example, can be got with a coupling condenser of 0.05μF.

In quality amplifiers the treble response can be raised and strengthened by the use of an artificial C.T. for push-pull output (Class A) with two 0.25MΩ resistors. The primary L of L.F.33 is of the order of 75H.

We are always pleased to advise modes of use against specified requirements in the sacred cause of quality—quality *ne plus ultra!*

- L.F.35, midget "mike"-transformer, 1:35, 5/-
- 1:70, C.T., 65mA. max. d.c. ... each
- L.F.36, midget C.T. Secondary L.F.T., 1:2 + 4/9
- 1:2, for fed connection. 75H approx., each
- L.F.41, midget, C.T. (split) secondary L.F.T., 5/6
- 1:3+1:3, for fed use. 40H. approx., each
- L.F.45, midget L.F.T. (1:4) and "mike"-trans. (1:25), L.F. Primary, 6/-
- 1mA. max. or feed, as usual. Suitable for Transceivers ... each
- L.F.33, Popular 1:4 ratio, as curve above, for fed or straight (1mA. max.) connection. Pri. = 75-95 H. ... each 4/-



To Messrs. A. F. Bulgin & Co. Ltd., Abbey Road, Barking, Essex.  
Please send me a copy of your 116-pp. Complete Catalogue No. 156, with full details of all transformers. THIRD EDITION. PRICE 3d.

NAME.....  
ADDRESS.....

### INDEX TO ADVERTISEMENTS

Anson, Henry, Ltd. ....	PAGE 6	Exide, Ltd. ....	PAGE 8	Players Cigarettes .....	PAGE 8
Armstrong Mfg. Co. ....	6	Fluxite .....	8	Postlethwaite Bros. ....	8
Automatic Coil Winder & Electrical Equipment Co., Ltd. ....	6	Galpins .....	Inside Front Cover	Premier Supply Stores .....	5
Bakers Selhurst Radio .....	3	G.E.C. ....	6	Prism Manufacturing Co. ....	6
Belling-Lee, Ltd. ....	3	Goodman's Industries, Ltd. ....	1	Radio Development Co. ....	5
Benjamin Electric, Ltd. ....	7	Gramplan Reproducers, Ltd. ....	6	Radio Industries Development Co. ....	5
Birmingham Radiomart (GSM) .....	7	Hartley Turner Radio, Ltd. ....	2	Record Radio .....	6
British Institute of Engineering Technology .....	6	Imhof, Alfred, Ltd. ....	Front Cover	R.G.D. ....	6
British Insulated Cables, Ltd. ....	6	Institute of Wireless Technology .....	8	Savage, W. Bryan .....	6
British Rola Co., Ltd. ....	Edit. 93	London Radio Supply Company .....	5	Scientific Supply Stores (Wireless), Ltd. ....	5
Bulgin, A. F., & Co., Ltd. ....	10	Mains Radio Development Co. ....	6	Sifam Electrical Instrument Co. ....	4
Cass, Sir John, Institute .....	10	Marconi Wireless Telegram .....	6	Sound Sales, Ltd. ....	4
C.A.V. ....	10	Maud Export & Trading Co. ....	6	Stratton & Co., Ltd. ....	4
Colvern .....	Front Cover	McCarthy Radio, Ltd. ....	Edit. 91	Tannoy Products .....	8
Dubilier Condenser Co. ....	6	Midwest Radio, Ltd. ....	10	T.C.C. ....	Front Cover
Ediswan, Ltd. ....	6	Musikon, Ltd. ....	10	Universal Radio Distributors, Ltd. ....	8
Electradix Radios .....	6	Parneko, Ltd. ....	10	Varley, Ltd. ....	8
				Ward, C. F. ....	8

## 1937 MIDWEST

THE ONLY ALL-WAVE RECEIVER COVERING 4½ to 2,400 METRES

Available in Chassis form complete with matched valves and 12" speaker or in Console Cabinet.

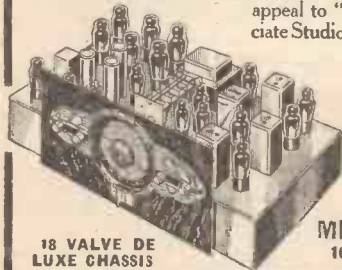

18 VALVE DE LUXE CHASSIS

Magnificent alike in its conception, design and performance, this the latest Midwest Model X-18 High Fidelity Receiver brings the world to your fireside. With its 6 TUNING RANGES it gets "Everything on the Air." Its distinctive features in circuit design are not just "talking points," as a comparison will prove, but basic advantages which will assuredly appeal to "Wireless World" readers and all who appreciate Studio or Concert Hall quality of performance in home.

**FREE** Our fully descriptive 40 PAGE ILLUSTRATED ART CATALOGUE giving particulars of Midwest 11, 14, 16 and 18 valve models.

DEMONSTRATIONS at our showrooms Mondays to Saturdays from 9 a.m. to 3 p.m.

DEFERRED PAYMENTS. The London Radio Supply Co., 11, Oat Lane, Noble Street, London, E.C.2, supply all models on Easy Terms.

**MIDWEST RADIO LTD.**, SHOWROOM & FACTORY: 16, OLD TOWN, CLAPHAM, LONDON, S.W.4. Phone: MACaulay 5005.

## RADIO RECEIVER MEASUREMENTS

By Roy M. Barnard, B.Sc., A.M.I.R.E. (1934)

Complete with fifty-three illustrations and diagrams, summaries of method, four appendices and a general index.

PRICE 4/6 net By post 4/9

From all booksellers or direct from the Publishers.

Of practical value to the radio service engineer and the amateur experimenter. Measurements of sensitivity, selectivity and fidelity are explained at length and the interpretation in estimating receiver performance is carefully set out.

Details are given of methods of receiver testing with full descriptions of commercial signal generators and their application to the adjustment of superheterodynes and "straight" receivers.

ILIFFE & SONS LTD., DORSET HOUSE, STAMFORD STREET, LONDON, S.E.1

W.W.19.

# TRADE & TECHNICAL *Journals*

*Influential  
and  
authoritative*

FOR TRADE DEVELOPMENT AND PROGRESS...

FOR FACTS OF PRODUCTION AND DISTRIBUTION..

FOR THE VERY LATEST NEWS AND INFORMATION

FOR AN INDEX TO GOODS USED AND SOLD.....

**I**f you are seeking new markets, or desire to get first-hand information about a trade or industry, you cannot go to a surer or more authoritative source than the trade and technical journals serving it. The address of any paper in this list will be furnished on request.

Amateur Photographer and Cinematographer.  
Architects' Journal.  
Architectural Review.  
Autocar.  
Automobile Engineer, Incorporating Motor Body Building.  
Boxmakers' Journal & Packaging Review.  
Brewers' Journal.  
British Baker.  
British Engineers' Export Journal.  
British Journal of Photography.  
British Printer.  
Bus & Coach.  
Chemist & Druggist.  
Cigar & Tobacco World.  
Confectioners' Union & Ice Cream & Soda Fountain Journal.

Confectionery Journal.  
Contractors' Record & Municipal Engineering.  
Dairyman.  
Drapers' Organiser.  
Drapers' Record.  
Dyer, Textile Printer, Bleacher & Finisher.  
Electrical Engineer.  
Electrical Review.  
Electrical Times.  
Electrical Trading & Electricity.  
Engineer.  
Engineering.  
Export Trader.  
Flight.  
Footwear Organiser.  
Furnishing Trades' Organiser.  
Grocer & Oil Trade Review.  
Grocers' Gazette & Provision Trades' News.  
Grocery & Branch Store Management.  
Hotel & Catering Management.

India Rubber Journal.  
Ironmonger.  
Journal of Decorative Art.  
Laundry (The Power).  
Laundry Record & Dyeing & Cleaning Trades' Journal.  
Licensing World & Licensed Trade Review.  
Locomotive, Railway Carriage & Wagon Review.  
Machinery.  
Meat Trades' Journal.  
Mechanical World & Engineering Record.  
Men's Wear.  
Mining Journal, Railway & Commercial Gazette.  
Model Engineer & Practical Electrician.  
Modern Transport.  
Motor Cycle.  
Motor Cycle & Cycle Trader.  
Motor News.  
Motor Trader.  
Motor Transport.  
Motor World & Industrial Vehicle Review.  
Nursing Mirror.  
Oil & Colour Trades Journal.

Outfitter.  
Overseas Engineer.  
Packing Gazette.  
Photographic Dealer.  
Plumbing Trade Journal.  
Pottery Gazette & Glass Trade Review.  
Poultry.  
Printers', etc., Sales & Wants Advertiser.  
Silk Journal & Rayon World.  
Specification.  
Statist.  
Style for Men.  
Textile Manufacturer.  
Textile Recorder.  
Tobacco Trade Review.  
Waste Trade World.  
Watchmaker & Jeweller, Silversmith & Optician.  
Wine & Spirit Trade Review.  
Wireless & Gramophone Trader.  
Wireless Engineer.  
Wireless Retailer & Broadcaster.  
Wireless World.  
Yachting World & Motor Boating Journal.

Official Handbook, giving particulars of over 500 papers, post free 1/-

**PERIODICAL, TRADE PRESS AND WEEKLY  
NEWSPAPER PROPRIETORS' ASSOCIATION, LTD.**

Telephone:  
Central 2441

6, Bouverie Street, London, E.C.4

Telegrams:  
Weneppa, Fleet, London

SECOND EDITION—THOROUGHLY REVISED

NOW READY

**WIRELESS SERVICING MANUAL**By **W. T. COCKING***(of "The Wireless World")*

The first complete book of reference of its kind. A reliable practical guide for amateur and professional.

The demand for this book was so great that the first edition was sold out in the short space of a very few months. A second edition containing additional material is now on sale. The "Wireless Servicing Manual" deals fully with Testing Apparatus and explains the methods of locating and curing faults in receiving equipment.

Ganging, Automatic Volume Control, Instability, Distortion, Mains Hum, Whistles and Local Interference are all separately treated.

The new edition contains much additional information on short-wave receivers, and on methods of operating extension loud speakers, the reference material including base-connections for British, Continental and American Valves, and the various colour codes for components has been extended and brought up to date.

**BOUND IN CLOTH BOARDS**SIZE  $7\frac{1}{2}$  ins.  $\times$  5 ins.

231 PAGES

PRICE 5/- net. By post 5/4

Issued in conjunction with "THE WIRELESS WORLD" and published by the Proprietors:—  
ILIFFE & SONS LTD, DORSET HOUSE, STAMFORD STREET, LONDON, S.E.1

W.W.20

*Make a Note of it—Now!*  
*Be sure to get your copy of*

The  
**Wireless  
World**

**DIARY FOR 1937**

Every wireless enthusiast should have this handy little diary. In addition to the usual pages—one week at an opening—it contains 76 pages of facts, formulæ and general information of the kind that is always wanted but is difficult to memorise.

There is a complete list of European Broadcasting Stations and Short-wave Stations of the World. In addition an important section contains all the recognised codes relating to components, as well as useful tables of resistance ratings. There are also nine pages of base connections of British and American valves.

Sixteen pages of circuit diagrams of receivers, amplifiers and such units as whistle suppressors, tone controls and AVC systems are included. Valuable information is given on the prevention of mains interference and data for winding coils.

**NOW ON SALE**

Size  $3\frac{1}{2}$  by  $4\frac{1}{2}$  inches, 192 pages. Bound leather cloth, back loop with pencil.

PRICE 1/6 net.

By post 1/7

From bookstalls and stationers,  
or direct from the Publishers

ILIFFE & SONS LTD., DORSET HOUSE, STAMFORD STREET, LONDON, S.E.1.

W.W.75.



SIDCUP PUBLIC LIBRARY

4<sup>D</sup>

# The Wireless World

## THE PRACTICAL RADIO & TELEVISION JOURNAL

Friday, January 29th, 1937

### "CATHODE RAY" WANTS A BETTER NAME FOR LOUD-SPEAKERS

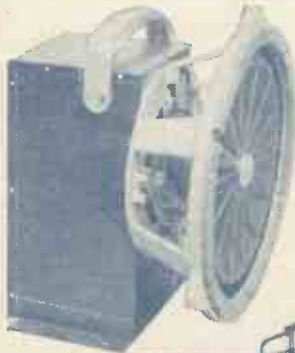

WE CANNOT SUGGEST A BETTER NAME; BUT WE CAN SUGGEST A HIGHER STANDARD OF REPRODUCTION VIA THE "S.S. AUDITORIUM SPEAKER," OR HAD WE BETTER SAY "S.S. REPRODUCER"? THIS IS DEFINITELY A CASE OF "HEARING IS BELIEVING." *DESIGNED FOR USE WITH QUALITY EQUIPMENT ONLY.*



MARLBOROUGH ROAD,  
UPPER HOLLOWAY,  
LONDON, N.19.

LIMITED.

(Contractors to the  
G.P.O., etc.)  
Tel.: Archway 1661/2/3.

### ● Unequalled facilities for Testing

The 46-range Universal

## AVOMETER

Model 7 *Regd. Trade Mark*

This latest development of the Avometer provides unique facilities for all radio tests on A.C. and D.C. It has 46 ranges. Thirty-eight are for measuring A.C. and D.C. amperes and volts. Five ohms ranges. Also Capacity, Power and Decibel ranges for output measurements. The current passed on all voltage ranges, except two, is 1mA or 2mA. The meter is protected against overload by an automatic cut-out. Also provided with a temperature compensator. Embodies all other Avometer features.

Write for descriptive pamphlet.

Price 16 Gns.

BRITISH MADE

Also the 36-range Universal Avometer, 13 gns.  
22-range D.C. Avometer, 9 gns.  
Leather Carrying Case, £1.



THE AUTOMATIC COIL WINDER & ELECTRICAL EQUIPMENT CO. LTD.,  
Winder House, Douglas Street, London, S.W.1. Telephone: Victoria 3404/7.

## HAYNES QUALITY RECEIVERS

Demonstration night—every Friday,  
7.30—9.30 p.m.

Originators of the Quality Receiver.



Have you the Haynes Quality Booklet?  
1936-37 Edition.

QUEENSWAY, ENFIELD, MIDDLESEX.  
Enfield 2726

Central London area Agent, London Radio Supply Company, 11, Oat Lane, E.C.2.  
Hire purchase arranged.

## CAV DRY BATTERIES



60 VOLTS 3/9

99 VOLTS 6/3

108 VOLTS 6/9

120 VOLTS 7/6

The Finest British  
Battery of Standard  
Capacity

C. A. VANDERVELL LTD. WELL ST., BIRMINGHAM



## Further outlook - Wet

There's no need to expound to you the qualities of a Wet Electrolytic Condenser at a point needing protection against voltage surge—it simply acts as a voltage regulator and passes greater current. But all wet electrolytic condensers evolve gas in the process. We have given this particular attention. Any gas evolved is disposed of through a most ingenious vent—without any loss of electrolyte. Leakage is further guarded against by a particularly efficient method of sealing the terminals.

Our long experience of electrolytics and the latest processes we use are of great advantage to us in the manufacture of these condensers. Amongst other things we have eliminated any chance of short circuiting between the anode and cathode—even if the condensers are roughly handled. We have also arranged for standard inverted mounting  $\frac{3}{4}$ " one-hole fixing with shake-proof washers and hexagon nuts. We normally supply these condensers in standard sized containers suitable to capacity and voltage rating.

# DUBILIER

## CONDENSERS

DUBILIER CONDENSER CO. (1925) LTD., DUCON WORKS, VICTORIA ROAD, NORTH ACTON, LONDON, W.3



C. R. Casson 118

Mention of "The Wireless World," when writing to advertisers, will ensure prompt attention.

# The Wireless World

THE  
PRACTICAL RADIO  
JOURNAL  
26<sup>th</sup> Year of Publication

No. 909.

FRIDAY, JANUARY 29TH, 1937.

VOL. XL. No. 5.

Proprietors : ILIFFE & SONS LTD.

Editor :  
HUGH S. POCOCK.

Editorial,  
Advertising and Publishing Offices :  
DORSET HOUSE, STAMFORD STREET,  
LONDON, S.E.1.

Telephone: Waterloo 3333 (50 lines).  
Telegrams: "Ethaworld, Sedist, London."

COVENTRY: Hertford Street.

Telegrams: "Autocar, Coventry." Telephone: 5210 Coventry.

BIRMINGHAM:

Goldhall Buildings, Navigation Street, 2.  
Telegrams: "Autopress, Birmingham." Telephone: 2971 Midland (4 lines).

MANCHESTER: 260, Deansgate, 3.

Telegrams: "Iliffe, Manchester." Blackfriars 4112 (4 lines).

GLASGOW: 26B, Renfield Street, C.2.

Telegrams: "Iliffe, Glasgow." Telephone: Central 4857.

PUBLISHED WEEKLY. ENTERED AS SECOND  
CLASS MATTER AT NEW YORK, N.Y.

Subscription Rates :

Home, £1 1s. 8d. ; Canada, £1 1s. 8d. ; other  
countries, £1 3s. 10d. per annum.

*As many of the circuits and apparatus described in these  
pages are covered by patents, readers are advised, before  
making use of them, to satisfy themselves that they would  
not be infringing patents.*

## CONTENTS

	Page
Editorial Comment .. ..	95
Experimenter's IF Amplifier ..	96
Synchronising Problems in Tele- vision .. ..	100
H.M.V. Television Receiver Re- viewed .. ..	102
Current Topics .. ..	105
Unbiased .. ..	106
New Apparatus Reviewed ..	107
Listeners' Guide for the Week ..	108
Fading: Vicissitudes of Waves in Space .. ..	110
Random Radiations .. ..	112
Broadcast Brevities .. ..	114
Letters to the Editor .. ..	115
Recent Inventions .. ..	116

## EDITORIAL COMMENT

### The Wireless Vocabulary

#### Glossary of Standard Terms

**T**O those who write *The Wire-  
less World* and to those who  
read it, the question of ter-  
minology is of equally vital  
importance. Unless some kind of code  
is used, writers on our subject cannot  
possibly convey their ideas without  
undue verbosity and circumlocution,  
and it is clearly essential that the  
code-words chosen should be generally  
accepted and understood among their  
readers.

It is for this reason that we welcome  
the newly published Glossary\* of elec-  
trical terms, of which the avowed  
object is "to standardise and co-ordinate  
the electro-technical terms used in the  
British Empire." The new edition  
deals not only with the terminology  
of radio communication in general but  
with television and cathode-ray tubes.  
It also defines the language of electrical  
fundamentals—the foundations of wire-  
less technique.

In general, the compilers of the  
Glossary have been animated by the  
same aims as those that influence the  
preparation of this journal: to "con-  
form to current usage, except where  
such usage appears to be erroneous  
or misleading." But perhaps we our-  
selves assign rather greater importance  
to usage, preferring a term that is  
universally accepted and understood  
even if it is inapt and inelegant, to an  
expression that may confuse the reader.  
It is realised, however, that, like the  
English language itself, the language  
of wireless is a living and growing

thing, and must always be in process  
of revision in order to cope with the  
changes in ways of thought and prac-  
tice. Consequently, old words must  
be abandoned or changed in meaning,  
or new ones introduced when they  
become necessary.

The compilers of the Glossary have  
accepted many terms that are doubt-  
less unpalatable, on the grounds that  
they have become firmly established,  
but a determined effort is made to  
displace "condenser" and "capacity"  
in favour of "capacitor" and "capa-  
cittance." The word "insulator" is  
deprecated, "insulant" (insulating  
material) being suggested in its  
place.

#### Defining Interference

A chance seems to have been missed  
for clearing up the confusion that so  
often arises when one is unduly  
economical with words in talking about  
the various kinds of interference to  
which reception is subject. "Jamming"  
is a word of such respectable antiquity  
that we sometimes hesitate to use it  
for fear of puzzling the newer genera-  
tion of readers. It is, however, re-  
tained in the Glossary, and, quite  
rightly, defined as interference due to  
unwanted signals. The word "inter-  
ference" itself is defined as applying  
to all kinds of disturbances. Surely  
much trouble could have been avoided  
by using "jamming" in the sense  
defined, "interference" for machine-  
made disturbance, and "atmospherics"  
(which also appears) for the efforts of  
Nature?

It is, perhaps, not surprising that  
no attempt has been made to define  
that invaluable word "signal" which  
may mean all sorts of things. It is  
noted, however, that the word itself  
is actually used in the definitions.

\* British Standard Glossary of Terms used in  
Electrical Engineering. The British Standards  
Institution, 28, Victoria Street, London, S.W.1.  
Price 7s. 6d.; by post, 8s.

# The Wireless World Experimenter's IF Amplifier

SUPERHETERODYNE  
UNIT EMBODYING AVC,  
BEAT OSCILLATOR  
AND ONE AF STAGE

IT may seem rather unusual to consider an IF amplifier as a separate self-contained unit as it is generally regarded as an integral part of a superheterodyne receiver. In experimental work, however, one does not always follow orthodox practice, and this applies particularly in the development of short-wave receiving apparatus.

The equipment in the average amateur station rarely retains for long the tidy appearance given it on first installing a short-wave set and possibly a transmitter, for the main object of the experimenter is to try out new ideas so that in a very short time the various chassis soon become not only an eyesore but absolutely unusable owing to the vast number of

*THE IF amplifier described in this article was evolved especially for investigating the relative merits of different styles of short-wave frequency-changers, and as it proved so useful it is possible that others also engaged in short-wave experiments might be interested in the arrangement employed. It provides a reasonably high degree of amplification, has good selectivity and embodies several features not usually included in the orthodox IF amplifier.*

holes of all sizes drilled in them as changes and alterations are made.

Rarely, however, does it become necessary to make any drastic changes in the IF amplifier of a short-wave superhet, provided, of course, a satisfactory design

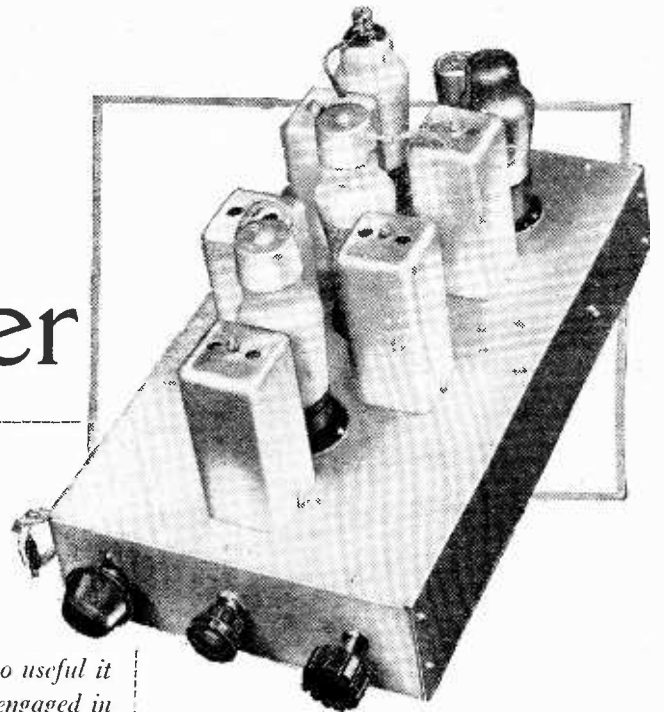

By H. B. DENT

has been adopted in the first place. Generally, it is the frequency-changer portion that suffers most; if an RF stage had not previously been incorporated its need may soon be felt and either a separate unit is added or, if space permits,

Fig. 1. Theoretical circuit diagram of the IF unit in which is included also one AF stage and a 465 kc/s oscillator. The two IF amplifiers are not operated at maximum sensitivity, but if more gain is required the bias resistances R5 and R12 can be changed for lower values.

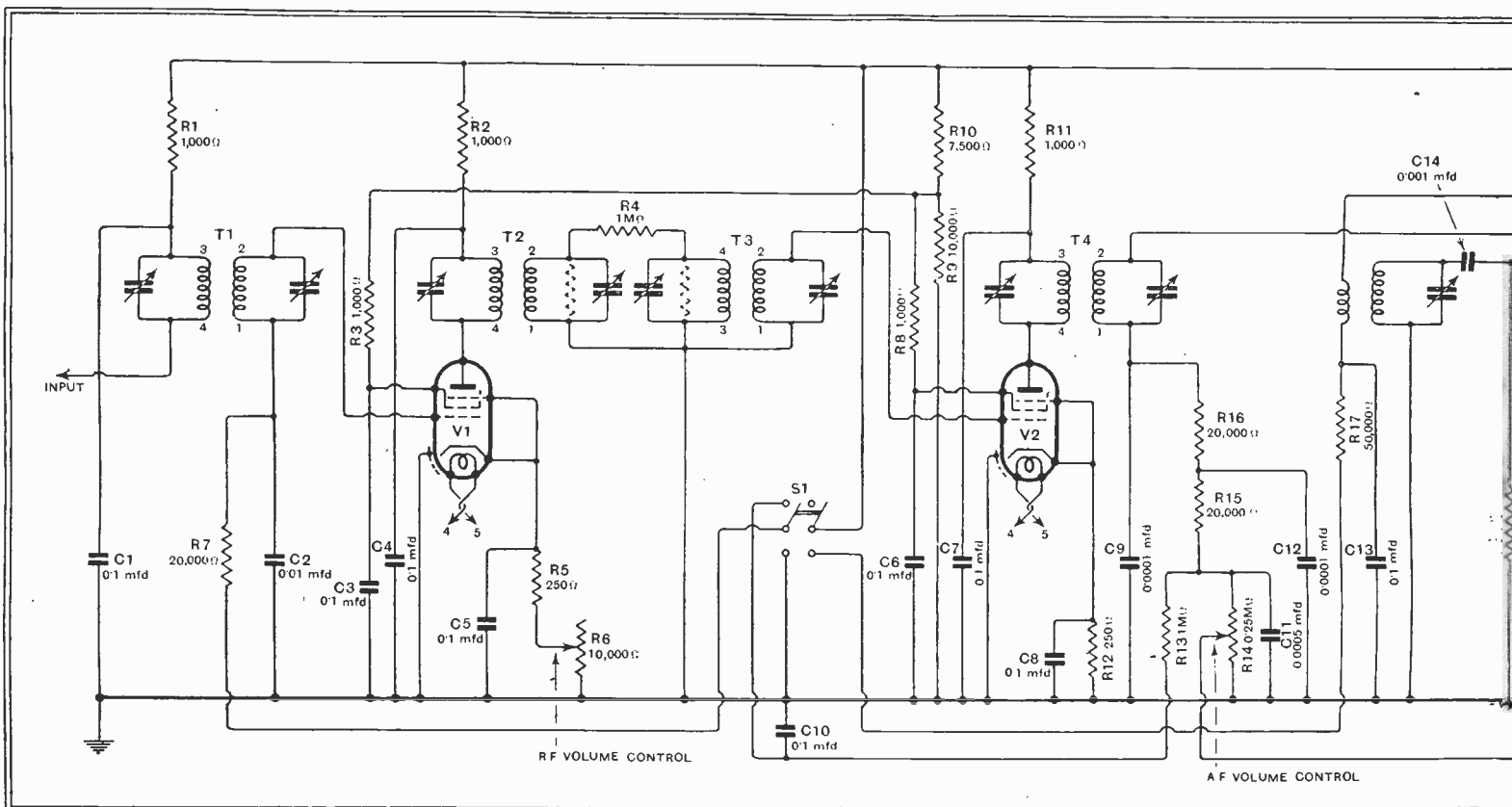

the additional parts are somehow accommodated on the main chassis.

Then again someone gives a glowing description of the results obtained with a certain type of frequency-changer or even an idea may suggest itself. Further alterations are contemplated and eventually things become so unsatisfactory that valuable time has to be devoted to completely rebuilding the set.

The writer has passed through all these

useful in practice and quite a number of different styles of frequency-changer, with and without an RF stage, have quickly been assembled and compared on the same IF amplifier with the minimum expenditure of work and time.

Possibly others interested in the short waves may find the idea attractive also!

The IF amplifier was designed to give a fairly high gain, be reasonably selective, embody AVC and also an IF beat-oscil-

of the frequency-changer while the other end of the winding is connected to the HT line.

After the first pair of coupled circuits is a variable-mu RF pentode which is joined to the AVC line and this is the only valve so controlled. The second IF stage, which feeds the detector, is best omitted from this circuit as the full sensitivity is needed to provide adequate bias voltage for the AVC line. When an RF stage is employed in the receiver unit this valve can with advantage be joined to the AVC line, but on the short waves it is not desirable to include the frequency-changer even though it be a variable-mu valve.

Between the first and second IF amplifiers are four tuned circuits arranged as two coupled pairs. As they are orthodox pattern IF transformers they could be coupled together by a small capacity between the high potential end of one secondary circuit and the high potential end of the other primary circuit.

The capacity needed for optimum or slightly sub-optimum coupling is, however, very small, being of the order of one m-mfd. or less. Such small capacities are not necessarily difficult to obtain in practice, but they are difficult to repeat unless

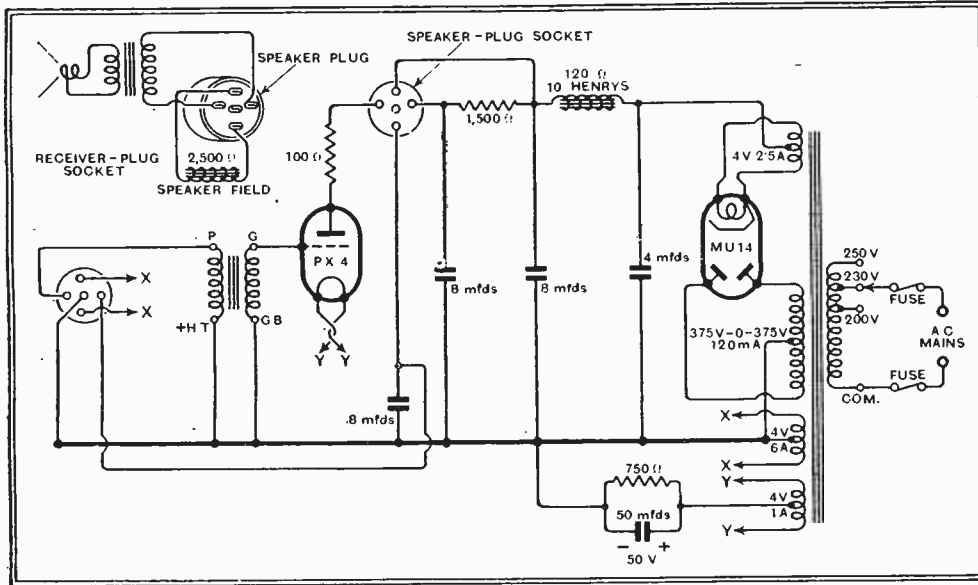

Fig. 2. A power supply unit embodying the output valve could be constructed to the circuit shown here.

stages and eventually decided to segregate the various parts of the set, making the frequency-changer, the IF amplifier and the power pack as separate units with the output stage incorporated in the power pack.

This scheme has so far proved very

lateral which could be brought into use by the turn of a switch for CW reception at the same time rendering AVC inoperative, as it is a hindrance rather than a help when receiving Morse. It embodies an IF sensitivity control as well as an AF volume control.

A good method of injecting the IF beat oscillations was found to be by using the triode section of a duo-diode-triode as the IF oscillator and the two diodes strapped together as the second detector. As the output valve employed was a PX4 some AF amplification was needed after the detector, and this is provided by a general-purpose triode with a parallel feed coupling to a 1 : 3 ratio AF transformer. This component is accommodated on the power pack, but the penultimate AF stage is in the IF unit.

If necessary, headphones can be used after the first AF stage, though it has not been found necessary to resort to them so far as all reception can be effected on the loud speaker.

Two IF stages are used operating at a frequency of 465 kc/s. In all, there are eight tuned circuits and these provide adequate selectivity for most of the short-wave bands. It is not too selective for good-quality reproduction of telephony, so that the amplifier is well suited for use on any of the short-wave broadcast bands and it gives good adjacent-channel selectivity. The complete circuit diagram of the unit is shown in Fig. 1.

The input is applied through a screened lead to the first IF transformer, and this lead will normally be joined to the anode

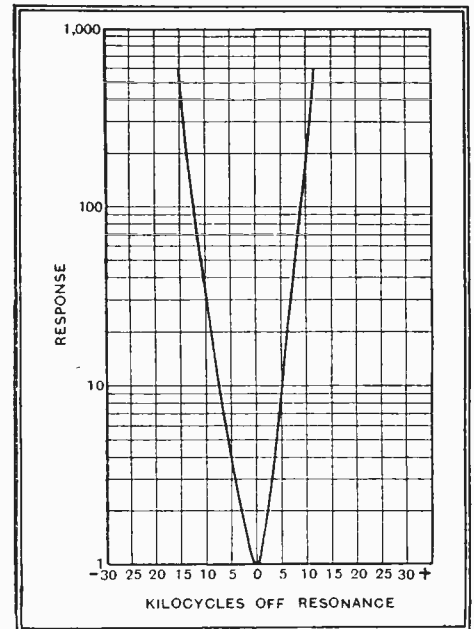
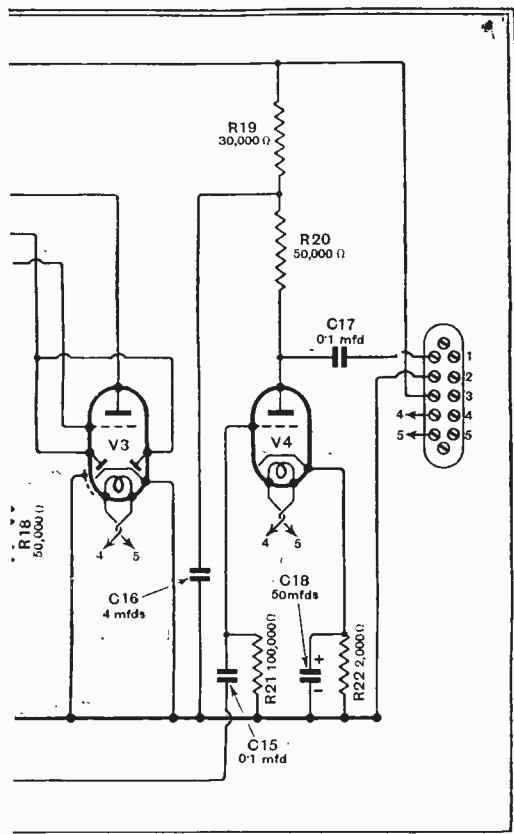

Fig. 3. Frequency response of the two IF stages including the eight tuned circuits. The intermediate frequency is 465 kc/s.

one has access to a signal generator and can measure the response of the amplifier with different coupling capacities. One way of obtaining the capacity is to join an insulated wire to each end of the circuits and run them parallel for a half-inch or so, but the capacity so derived will vary considerably with the thickness of the insulating sleeving and the closeness of the conductors.

An alternative method of coupling is to join the two circuits by a non-inductive resistance, and as this lends itself better to repetition it is adopted in the present case. The value used is one megohm.

In the circuit diagram the middle pair of the four coupled circuits are each shown



**Experimenter's IF Amplifier—**

shunted by a resistance in dotted lines. This is an optional addition, and may sometimes be helpful should it be desired to slightly "flatten" the response. As shown by the response curve in Fig. 3, the overall selectivity is not unduly high, and only in exceptional cases will these resistances be needed. Their values could be between 0.1 and 0.25 megohm each, while at the same time the coupling resistance R4 may be reduced to about 0.5 megohm.

Reference to the illustrations will show that two of the IF transformers are fitted with screened leads coming through the top of the cans, while the other two have all connections made below the chassis. The IF units with screened leads are the Varley Type BP98, the others are BP97.

The coil unit for the IF beat-oscillator has been made especially by B.T.S., and it also embodies the grid condenser C14 and grid leak R18, and accordingly these components, while shown in the theoretical diagram, are not visible in the illustrations, neither are they included in the list of parts. As supplied, this unit is tuned to 465 kc/s under similar working conditions, and it is essential to avoid upsetting the adjustment, because the oscillator can be utilised, as will be explained later, in lining up the IF circuits.

**Beat Oscillator**

When the IF oscillator is in use, AVC is rendered inoperative by disconnecting the grid return lead of the first IF trans-

former from the AVC line and joining it to the chassis.

The change is effected simultaneously with switching on its HT supply, and both these operations are effected by the double-pole, double-throw switch S1.

Neither the assembly of the components nor the wiring requires any lengthy description, as the work is quite straightforward and easily followed from the drawings and illustrations.

When mounting the IF transformers it is important that they be assembled in the correct positions and the right way round. Two of them have screened leads at the top, and their position on the chassis is readily found by reference to the illustrations. On the drawing of the underdeck wiring a figure is marked against each hole

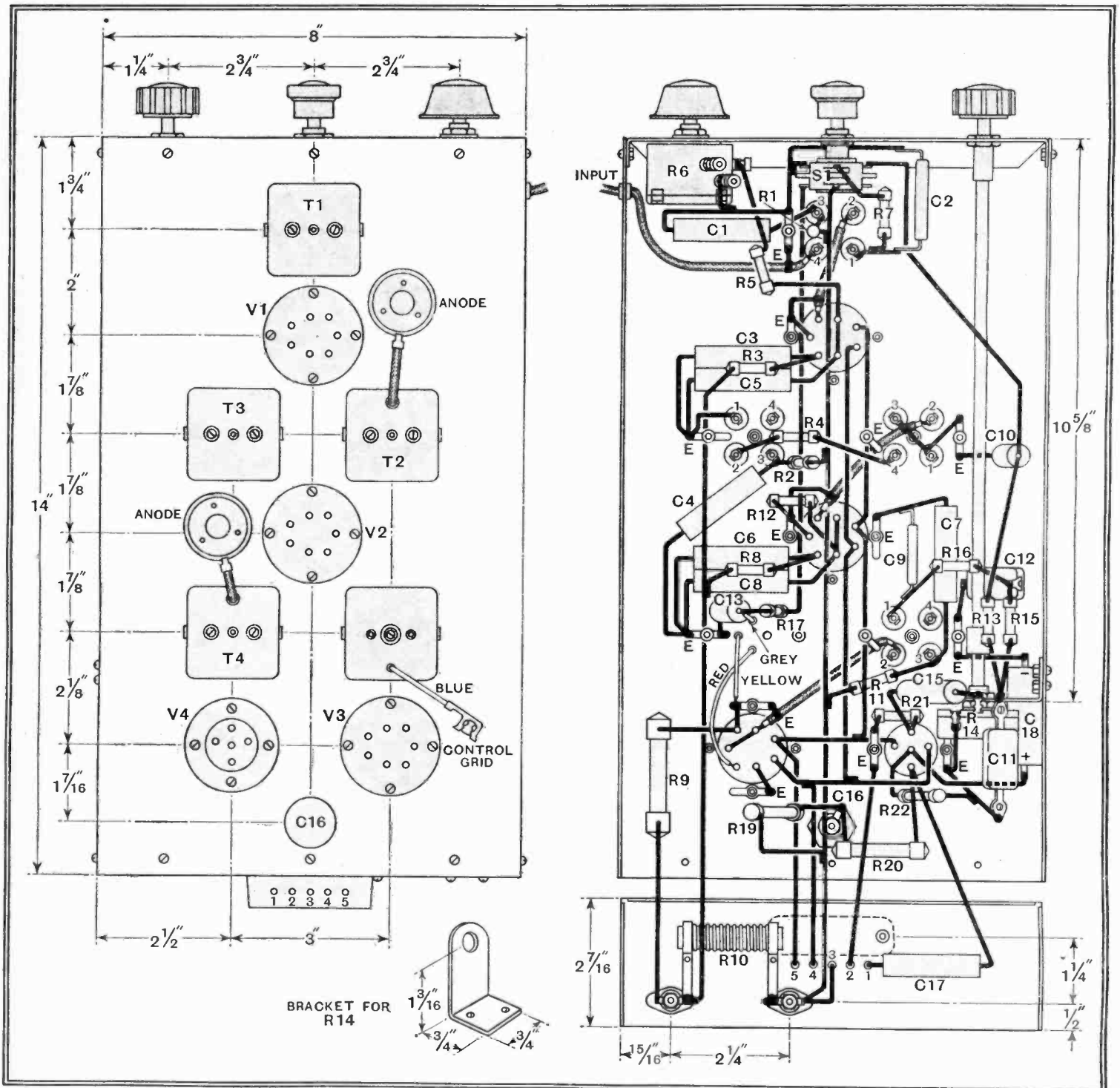

Fig. 4. Layout of the components and the practical wiring plan.

**Experimenter's IF Amplifier—**

through which the soldering tags of the transformers protrude, and these numbers are the same as those on the base plates of the IF transformers. When mounting them they should be orientated, so that the numbers agree in every case, for they are not all mounted with the figures in the same order of rotation for all four transformers. Another matter that requires attention is the connection of the leads from the base of the IF beat-oscillator coil unit. The red lead joins to the anode pin of the D-D-triode, the yellow lead to chassis, and the grey lead to HT position via resistance R17. The grid connection is on top of the screening can.

The sensitivity control which sets the minimum grid bias for the first IF valve is mounted direct on the end piece of

accurately marked in order to allow for easy rotation of the rod in the panel bush.

It has not been thought necessary at the present juncture to give a detailed description of the power pack, for some latitude is permissible, and possibly an existing unit can be made to serve the purpose. A suggested unit is shown in the theoretical circuit Fig. 2, which is very similar to that of the power pack designed for the

plifier has a slightly different input circuit, as the AF transformer is shown parallel-fed. The anode decoupling of the penultimate AF stage being contained in the IF unit, it is omitted from the power pack, so that one of the 8-mfd. electrolytic condensers and one resistance are not required, otherwise the construction and wiring can be the same.

Lining up the circuits of an IF amplifier

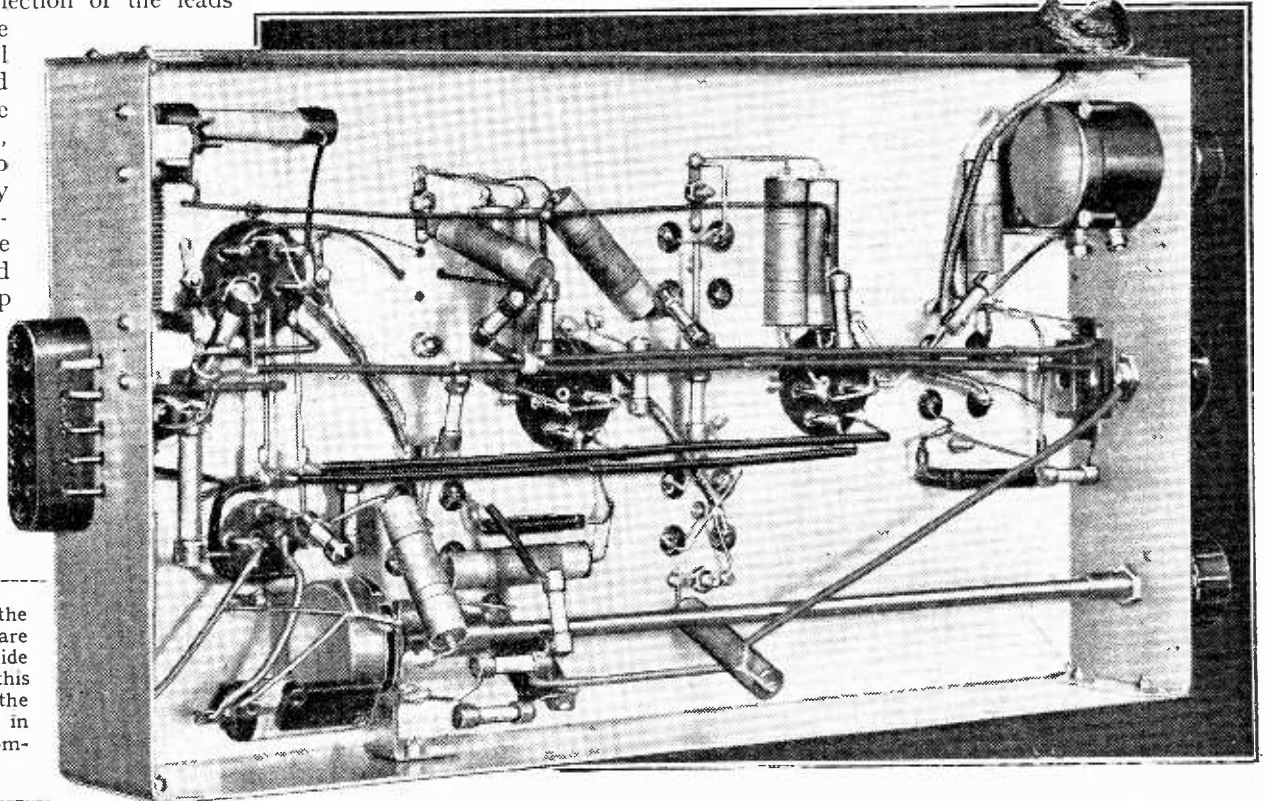

The wiring and all the small components are located on the underside of the chassis and this view shows clearly the position and manner in which they are accommodated.

the chassis, but the AF volume control is assembled close to the AF valve and operated by a long brass rod. It is positioned by a small bracket bolted to the side of the chassis, and its position should be

All-Wave Super Seven, described in *The Wireless World* of August 7th and 14th, 1936, constructional details of the power unit being given in the latter issue.

That suggested for use with the IF amplifier

at the correct frequency is not easily accomplished without the aid of a modulated test oscillator. In the present case a calibrated test set could be dispensed with, but an RF oscillator covering 465 kc/s will be needed. There are usually enough spare parts in the amateur's workshop for a temporary unit.

When the oscillator is rigged, a few turns of wire can be coupled to the coil and its ends clipped across the grid and chassis of the second IF valve.

With the IF beat-oscillator working, i.e., switch S1 turned clockwise, and the AF volume control set to maximum, an audible note will be heard in the loud speaker when the temporary oscillator approaches the frequency of the IF oscillator.

Adjusting the temporary one to give a note of about 400 c/s, the trimmers on the last IF transformer, T4, can be adjusted for strongest signals.

This process can then be repeated on the earlier stage without, of course, altering the tuning of the temporary oscillator.

As the various circuits come into resonance the coupling of the pick-up coil on the temporary oscillator will have to be loosened to avoid overloading.

Constructed as described, and with the valves mentioned, the amplification of the two IF stages alone is just under 1,000, and with 250 volts HT the consumption of the whole unit is 30 mA, or 32 mA with the IF beat-oscillator working.

**THE LIST OF PARTS REQUIRED**

*Certain components of other makes but of similar characteristics may be used as alternatives to those given in the following list*

- 2 IF transformers, 465 kc/s (special), T1, T3  
Varley BP97
- 2 IF transformers, 465 kc/s (special), T2, T4  
Varley BP98
- 1 IF oscillator unit, 465 kc/s (special),  
B.T.S.
- 1 Volume control, 10,000 ohms, wire-round, R6  
Haynes
- 1 Volume control, 0.25 megohm, R14, tapered  
(without switch) Polar-NSF V/4
- Condensers:**
  - 2 0.0001 mfd. mica, C9, C12  
T.C.C. "M"
  - 1 0.0005 mfd. mica, C11 T.C.C. "M"
  - 1 0.01 mfd. mica, C2 T.C.C. "M"
  - 11 0.1 mfd. tubular, C.1, C3, C4, C5,  
C6, C7, C8, C10, C13, C15, C17  
T.C.C. 250
  - 1 4 mfd., 450 volts, dry electrolytic, C16  
T.C.C. 502
  - 1 50 mfd., 12 volts, dry electrolytic, C18  
T.C.C. "FT"
- Resistances:**
  - 2 250 ohms ½ watt, R5, R12  
Dubilier "F"
  - 5 1,000 ohms ½ watt, R1, R2, R3, R8, R11  
Dubilier "F"
  - 1 2,000 ohms ½ watt, R22 Dubilier "F"
  - 3 20,000 ohms ½ watt, R7, R15, R16  
Dubilier "F"
  - 1 50,000 ohms ½ watt, R17  
Dubilier "F"
  - 1 100,000 ohms ½ watt, R21  
Dubilier "F"
  - 2 1 megohm ½ watt, R4, R13  
Dubilier "F"
  - 1 30,000 ohms 1 watt, R19  
Dubilier "F"
  - 1 50,000 ohms 1 watt, R20  
Dubilier "F"
  - 1 10,000 ohms 2 watts, R9  
Dubilier "F"
  - 1 7,500 ohms 3-5 watts, R10  
Dubilier Spirohlm
- 1 Switch, double-pole, double-throw, S1  
Bulgin S114
- 2 Screened valve top connectors Bulgin P64
- 1 Plug valve top connector Belling-Lee 1175
- 1 Five-way connector Bryce
- 3 Valve holders, 7-pin, chassis mounting, with-  
out terminals Clix V2
- 1 Valve holder, 5-pin, chassis mounting, with-  
out terminals Clix V1
- 1 Panel bush, ¼ in. bore Bulgin Type C
- 1 Shaft coupler, ¼ in. bore Bulgin
- 2 Stand-off insulators Eddystone 1019
- 1 chassis, 14 x 8 x 2 ½ in. B.T.S.
- 1 Brass rod, 10 in. long, ¼ in. dia.
- Valves:**
  - 2 VMP4G (metallised), 1 MHD4 (metal-  
lised), 1 MH4 Osram

# Synchronising Problems in

## OBTAINING STABLE PICTURES

By W. T. COCKING

THE method of operation of the usual form of time-base, embodying gas-filled triodes for generating the necessary saw-tooth waveforms for scanning, has been described in a recent article<sup>1</sup> in *The Wireless World*. The method of separating the synchronising impulses from the vision signal by means of an amplitude filter has also been treated.<sup>2</sup> The provision of a good time-base and amplitude filter, however, are not sufficient for the maintenance of perfect synchronisation over long periods. The line synchronisation is usually good, but it is difficult to prevent the frame from wandering.

The problems of synchronising were not discussed in the article referred to above dealing with the time-base, and it is necessary to understand how it is carried out before the difficulties can be appreciated. The basic circuit of a time-base

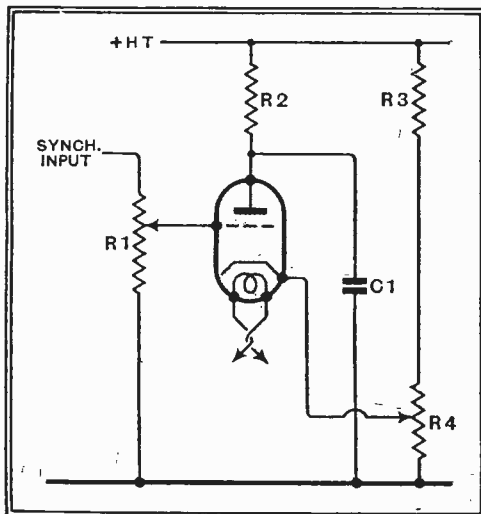

Fig. 1.—The basic circuit of a time-base embodying a gas-filled triode is shown here.

is shown in Fig. 1, and it will be remembered that the action is as follows: at the start, the valve is non-conductive and the condenser C1 charges through R2. When the voltage across C1, which is also the anode voltage of the valve, reaches a certain value, the valve suddenly becomes conductive and the condenser discharges through it. At a certain critical value of anode potential the valve again becomes non-conductive and the condenser again starts to charge and the whole cycle to repeat. The maximum voltage at which discharge takes place depends on the grid bias and increases as the negative grid bias is increased. The lower critical voltage at which the discharge ceases, however, depends chiefly on the design of the valve, and only to a minor degree on the bias.

Now a self-running time-base is not by itself sufficiently regular for television purposes, and synchronising pulses are provided in the transmission for the express purpose of keeping the time-base in regular operation. Matters are so arranged that just before the anode voltage of the valve has risen to the discharge value, a positive pulse is applied to the grid. The grid potential is lowered and the striking voltage so far reduced that the existing anode potential is sufficient to start the discharge.

The anode voltage is thus never allowed to reach the normal no-signal striking voltage, for the synchronising pulses arriving at regular intervals cause the valve regularly to become conductive at precisely the right moment. The times of discharge of the condenser are thus exactly controlled. There is, however, no control over the time of commencement of charge which follows every discharge and represents the start of each line or frame. It is assumed that the discharge is the same every time, so that at the commencement of each charging action the valve anode voltage is the same.

If the starting voltages are not the same, the lines will not be in perfect alignment but will be slightly displaced relatively to one another, and this will naturally reduce the definition to a serious degree.

thus easy to see that to ensure regular operation without displacement of the lines it is necessary to make certain that all the synchronising pulses have the same amplitude.

### The Synchronising Pulse

This can be done in the amplitude filter to a very close degree of perfection, and such a filter is essential to prevent the ever-changing amplitude of the vision signal from affecting the amplitude of the synchronising pulses. With such a filter, the amplitude is only likely to vary to an appreciable degree when interference is present. During the synchronising pulse the carrier amplitude falls to zero, but if interference is present the receiver output will not fall to zero but only to the interference level. As this will rarely be constant, we shall have a varying amplitude of synchronising pulse, and the interference will not only be evident by its appearance on the picture but also by upsetting the synchronising.

Fortunately, in cases where the interference level is low compared with the amplitude of the synchronising pulse in the carrier, its effects can be removed as far as synchronising is concerned by slightly over-biasing the valve used in the amplitude filter. In practice, it is possible to secure a synchronising output which is very constant in amplitude, and hence

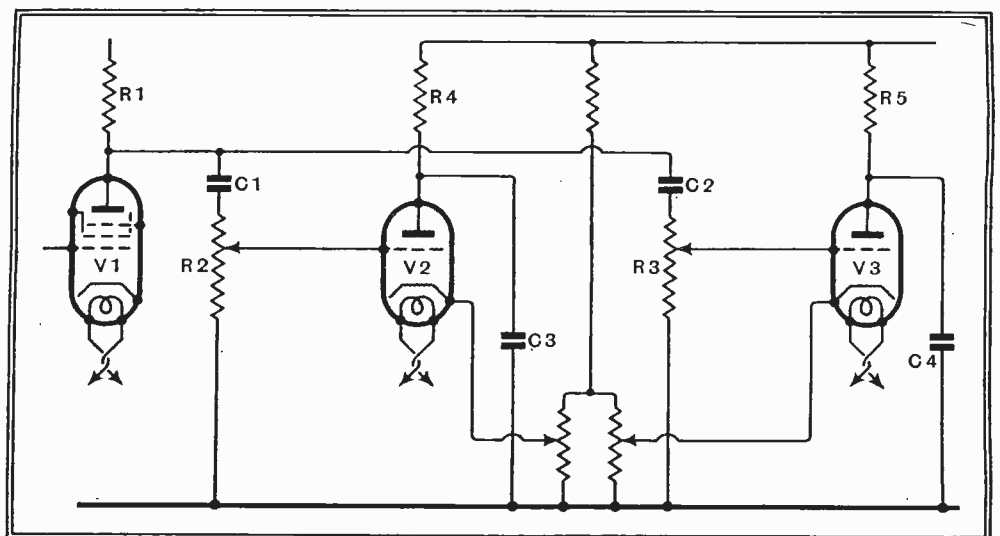

Fig. 2.—A commonly used method of feeding the synchronising pulses from the amplitude filter V1 to the frame and line discharge valves V2 and V3.

Now the final anode potential after the discharge depends in some degree upon the amplitude of the synchronising pulse which brought the discharge about. It is

very regular operation of the time-bases.

Now, in practice, we have two time-bases, one for the frame scanning and the other for the line. With Baird transmis-

<sup>1</sup> *The Wireless World*, January 15th, 1937.

<sup>2</sup> *The Wireless World*, January 22nd, 1937.



# Television

*THE separation of the synchronising pulses from the vision signal by means of an amplitude filter was dealt with recently in "The Wireless World." In this article the frequency separation of the line and frame pulses is treated*

sions, the one will be running at 25 c/s and the other at 6,000 c/s; at the end of every line a short synch. pulse is provided to trip the line time-base, and at the end of every frame a longer synch. pulse to trip the frame time-base. A circuit which one commonly sees recommended is shown in Fig. 2 in abridged form. The valve V1 is the amplitude filter, and it feeds only the synch. pulses to the gas-filled triodes V2 and V3.

It will be observed that both line and frame pulses are fed to both valves. As far as the line time-base is concerned there is little harm in this, for the long frame pulse merely means that it will hold the line time-base inoperative during this time. As this corresponds to a black edging on the picture, it is not visible. It does mean, however, that the discharge of the condenser is unusually complete during the frame pulse, with the result that the first few lines are displaced slightly when it again operates. This is evident by a slight displacement of lines at the extreme top of the picture.

This does not occur with the Marconi-E.M.I. transmissions, for with these the synch. pulses are different. There is no long framing pulse, but a long series of pulses and the line time-base is kept operating normally the whole time.

## The Synch. Pulses and the Time-base

Now let us look at the frame time-base; with the circuit of Fig. 2 the line pulses are applied to it as well as the frame pulses, and this seriously affects the operation. Instead of the voltage across the condenser growing to a definite figure and the frame synch. pulse then being applied to the triode, we find that the grid potential regularly changes at the end of every line while the anode voltage is growing.

Consider the case at the start of the first line of a frame. The anode voltage of the frame control valve is at its minimum and the grid at its maximum negative voltage. The anode voltage steadily rises, and after an interval the line synch. pulse arrives. It does not cause the valve to become conductive, however, for the anode potential is not high enough. The voltage still continues to rise, therefore, in spite of the line pulses, which thus have no adverse effect.

Now consider what happens when we get towards the bottom of the picture. The anode voltage is now getting close to the

value at which the valve will strike, but it should not do so until the frame pulse arrives. In practice, however, it very often happens that one of the last few line pulses of the frame trips the valve and so discharges the condenser a little

series with the grid of the frame control valve V2 while a condenser C3 is shunted from grid to the earth line. This resistance and condenser form a very simple and rather crude low-pass filter. Owing to the great difference in the frequencies to be separated, however, the filtering action proves adequate in practice and the writer has found suitable values to be 20,000 ohms and 0.003  $\mu$ F. for the resistance and capacity respectively.

In general, it is not necessary to filter out the frame synch. pulses from the line time-base, but it can readily be done by including a high-pass filter. Again a crude type suffices, and sufficient discrimination can be obtained with the aid of C2 and R4. By making these components of fairly low value, the frame pulses can be attenuated appreciably, and with R4 about 20,000 ohms, C2 can be 0.001  $\mu$ F. or even smaller.

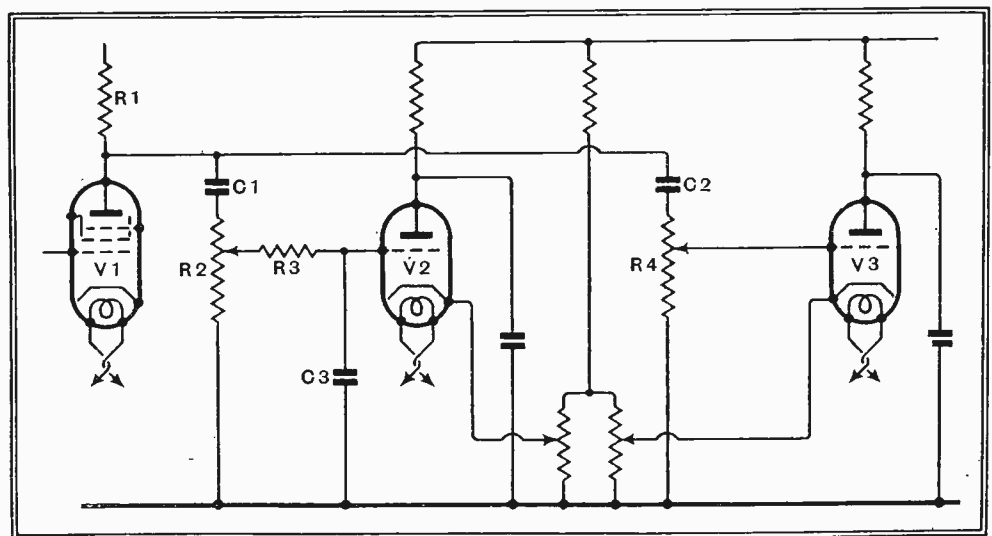

Fig. 3.—The inclusion of a simple low-pass filter R3 C3 in the grid circuit of the frame time-base greatly improves the stability of the synchronising.

earlier than it should. The result is that the picture cannot be held and moves as a whole in a vertical direction.

Apart altogether from the synch. pulses, there is a considerable degree of coupling between the two time-bases with the arrangement of Fig. 2. Gas-filled triodes pass a fairly heavy grid current when the condensers discharge, and voltages are set up across the grid resistances, and applied from one valve to the other. The coupling by this means is quite sufficient to interlock the two time-bases, and it is easily possible to obtain a steady raster in the absence of any synchronising signals. The effect is thus useful in development work on the time-base circuits themselves, but is undesirable during normal television reception.

In the writer's experience it is necessary to include a filter circuit to prevent the line synch. pulses from being applied to the frame time-base. Fortunately, quite a simple filter suffices in view of the widely differing frequencies and its use has the further merit of preventing interaction due to the grid current of the gas-filled triodes.

A circuit which experience has shown to be satisfactory is given in Fig. 3, and it will be seen that a resistance R3 is inserted in

It will, of course, be understood that the circuits given in this article are incomplete in the sense that the various decoupling and by-pass components have been omitted, and that the gas-filled triodes will, in practice, necessarily be followed by amplifiers. Various other methods of frequency separation are possible, but the simple filters indicated here appear to be all that is necessary. Certainly they permit stable synchronisation to be obtained over long periods, and this is not possible without them.

It should be pointed out that in the article "The Time-Base in Television" in *The Wireless World* for January 15th, 1937, the references to R1 in the three concluding paragraphs on page 53 are incorrect. Wherever R1 appears on this page read R2.

## SPECIAL PA NUMBER

Next Week's Issue will be primarily devoted to the subject of Public Address equipment, its problems and applications to both large and small requirements. A review of modern outfits and accessories, including microphones, loud speakers and valves, will be included. Special articles will deal with recent developments and various aspects of this subject.

# H.M.V. Television Receiver

## MODEL 901

STRAIGHT VISION  
AND SUPERHET  
SOUND RECEIVERS

**T**ELEVISION reception is still something of a novelty, and in all its aspects is full of interest. Unlike the usual sound receiver, there is as yet no hint of standardisation, and most television sets are quite different from one another in nearly all their details. To the technically minded this is but an additional attraction.

The H.M.V. television receiver is really two sets in one, for the vision and sound channels have only the initial circuits in common. The vision receiver is a straight set with six RF stages feeding a diode detector. The coupling between the last RF valve and the detector is a two-circuit band-pass filter, but single-circuit couplings are used elsewhere. The eight tuned circuits thus employed are not all tuned

**FEATURES.**—*Type.*—Ultra-short-wave sound and vision receivers with cathode-ray tube viewed through an inclined mirror. **Circuit:** (**Sound Receiver**) Superhet, with triode-hexode FC, RF pentode IF, duo-diode-triode detector, pentode output. (**Vision Receiver**) Straight set with 6 RF stages and diode detector. **Deflection:** Electromagnetic. **Controls:** (**Sound**) (1) Tuning. (2) Volume. (**Vision**) (1) Sensitivity. (2) Contrast. (3) Brilliance. (4) Line Hold. (5) Frame Hold.

(6) System selector switch. (7) On-off switch. **Subsidiary Controls.**—(**Vision**) (1) Form. (2) Focus. (3) Width. (4) Height. **Price.**—95 gns. **Makers.**—The Gramophone Co., Ltd., 98-108, Clerkenwell Road, London, E.C.1.

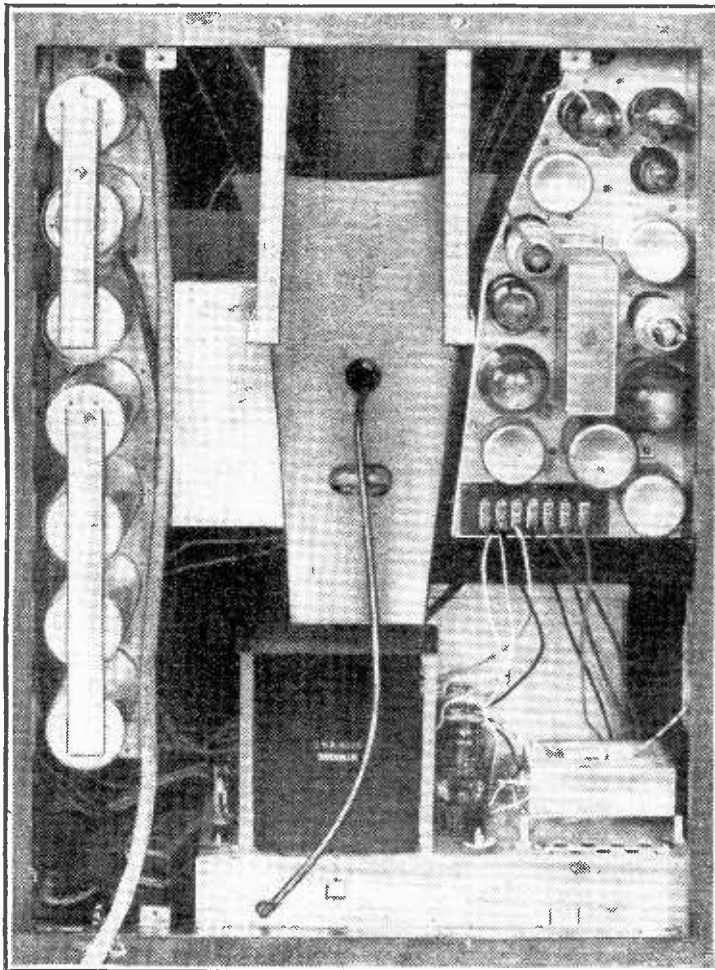
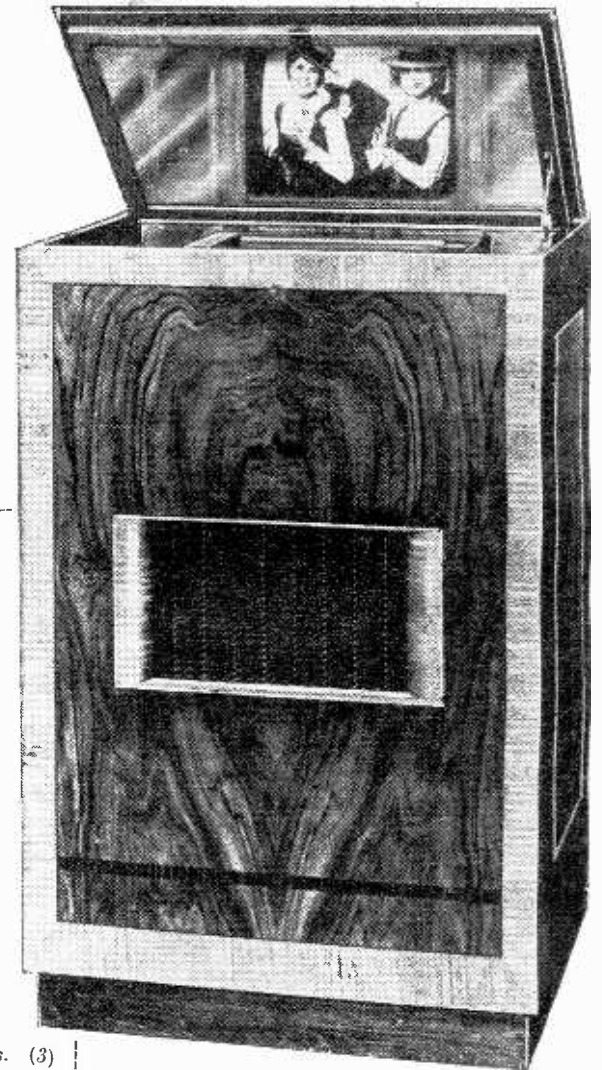

to the same frequency, but certain stages are staggered, so that an overall response curve is obtained which is sensibly flat over a wide range of frequencies on either side of 45.0 Mc/s.

In this rear view of the receiver the vision-receiver chassis can be seen at the left and the time-base chassis on the right. The tube is in the centre with the sound receiver behind it and the mains equipment at the bottom.

The first two stages are common to both vision and sound channels, for the frequency-changer of the sound receiver derives its input from the output of the second RF stage. Because of the RF amplification thus obtained, the triode-hexode frequency-changer operates with a reasonably large input, and one IF stage only is consequently em-

ployed. An economical sound receiver thus results, and the signal-noise ratio is maintained at a high level. The IF valve is followed by a duo-diode-triode which feeds the output pentode.

Returning to the vision equipment, the detector output is fed to the cathode-ray tube through a potentiometer which performs a function exactly analogous to the AF volume control of a sound receiver; it is, however, called the "Contrast Control." A sensitivity control operating on the early stages is fitted in addition.

It is interesting to note that RF pentodes are used throughout the RF amplifier, even in the last stage. This is, of course, only possible because of the special cathode-ray tube employed, for this can be fully modulated with an input of some 10 volts only. The tube contains no deflecting plates, for electromagnetic deflection is employed, the necessary currents of saw-tooth waveform being generated by the two time-bases.

Hard valves are used for generating the initial potentials; one screen-grid valve is used for the frame scan, and another for the line scan, and their outputs are amplified by means of output-type pentodes. Essentially, therefore, each time-base embodies only two valves, but a number of others are used in conjunction. Two RF pentodes are employed in order to separate the synchronising pulses from the vision

signal. These valves are fed from the detector output and with them is associated a diode in order to give more complete separation of the frame synchronising pulses.

The one and only triode in the vision circuits is employed in the time-base to ensure correct operation on both Baird and E.M.I. transmissions. The synchronising impulses are not the same in the two systems, and this valve enables the time-bases to function correctly on both. The power unit contains three rectifiers, of which one supplies the high voltage necessary for operating the CR tube.

It will thus be clear that the total of twenty-two valves is made up by a seven-valve vision receiver, a four-valve sound receiver, a four-valve double-time-base, and a three-valve power supply unit. In addition three valves are used for sync. separation and one for ensuring proper operation on both systems of transmission. All are hard valves of types readily obtainable.

As might be expected, the apparatus occupies a considerable amount of space, but this is much less than one might suppose, for great care has obviously been taken in the disposition of the different units. The tube is mounted vertically

and viewed through an inclined mirror mounted inside the lid of the cabinet. The overall dimensions are only 37½ in. high by 24½ in. wide by 16½ in. deep.

The controls are grouped around the CR tube and covered by the lid when this is closed. The vision circuits are pre-tuned and cannot be varied by the operator; a tuning control for the sound receiver is fitted, however, in addition to a volume control. The vision controls are the sensitivity and contrast controls, which are equivalent to pre- and post-detector volume controls respectively and are used in the same manner. In addition there is a Brightness control which varies the grid bias applied to the CR tube and hence the mean illumination of the picture.

Controls for varying the frame and line scanning frequencies are also included, and there is a switch to change over the circuits to suit either the Baird or the E.M.I. transmissions. There is also an on-off switch. This completes the controls proper, but a small panel covers four small knobs, which permit minor adjustments to be made at rare intervals to compensate for the ageing of valves.

Of these four, the first is the "Form Control," which permits any cramping of the left-hand side of the picture to be corrected. The second control is for focusing the spot on the CR tube, the third for varying the width of the picture, and the fourth for altering the height. Once set by the installing engineer, these controls require only occasional adjustment.

The operation of the equipment is extremely simple, and the instructions accompanying it are lucid. Since few are yet acquainted with the procedure, it may be as well to summarise here the details given in the H.M.V. operating instructions. These assume that initially none of the panel controls are correctly set. After setting the System Selector Switch for the appropriate transmission (Baird or E.M.I.), the steps are as follows:—

1. Turn the Brightness control fully to the left.
2. Switch on.
3. Turn the Sensitivity control fully to the left.
4. Turn the Contrast control fully to the right.
5. Slowly turn the Brightness control until a faint illumination appears on the screen. Then turn back until this just disappears.
6. Turn the Sensitivity control to the right until traces of the picture appear on the screen. Continue turning until a light and dark pattern appears on the screen.
7. Now slowly turn the Frame Hold control until the pattern formed on the screen, which will be moving from top to bottom or bottom to top of the screen, becomes stationary.
8. Turn the Line Hold control until a steady recognisable picture appears.
9. Bring up the half-tones if necessary by manipulating the Contrast control in conjunction with the Brightness control.

After this the sound is tuned in by the tuning control provided, and the volume adjusted to the required level.

In practice, once these controls have been properly set, they need only occasional adjustment. Experience with the receiver shows that not only does the synchronising hold throughout a transmission, but that if the controls are left set correctly the set can be switched on for a subsequent transmission without any adjustment being needed. When changing over from one type of transmission to the

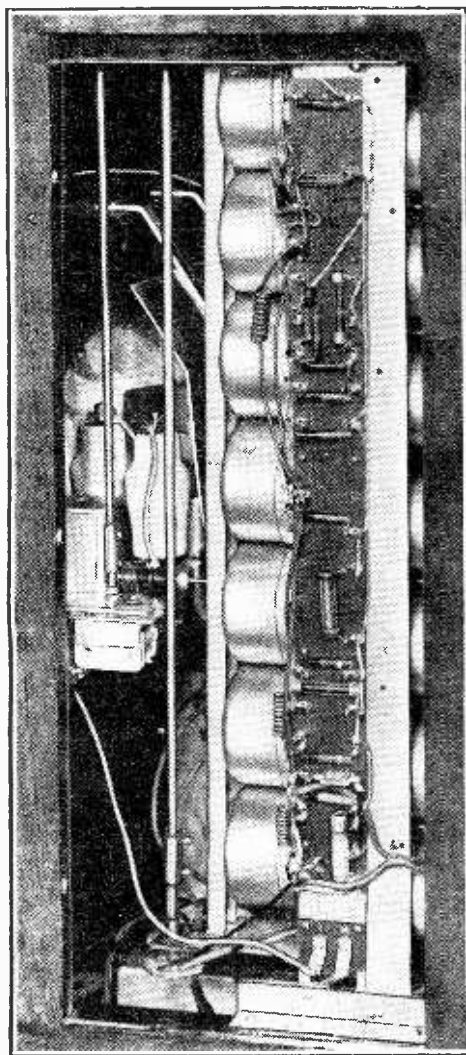

The removal of the left-hand side-panel of the cabinet exposes the side of the vision receiver and enables one end of the sound receiver to be seen.

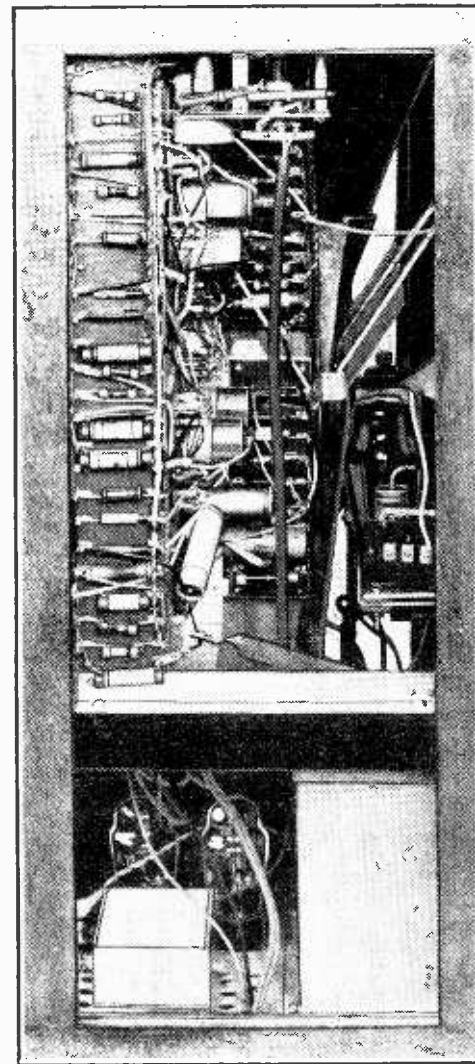

Upon removing the right-hand side-panel the under side of the time-base becomes accessible and also the output valve of the sound receiver and the rectifier valves in the mains unit.

other, however, some variation of the Line- and Frame-Hold controls may be needed. In the interests of tube life, it is advisable to turn down the Brightness control fully when switching off, and not to turn it up again until the set has been switched on for half a minute or so. Similarly, the Brightness control should be turned up no more than is necessary to give a good bright picture, for excessive brightness increases the wear and tear on the CR tube.

The receiver has been thoroughly tested for a considerable period in north-west London and used with the special resonant aerial and feeder supplied by the makers. It has given consistently good results, the picture being extremely bright and thus enabling entirely satisfactory results to be

**H.M.V. Television Receiver Model 901—**

secured without any darkening of the room. Normal illumination, daylight or artificial, can be retained and all details of the picture still seen.

The size of the picture is about 10in. by 8in., and the optimum viewing distance is about 6ft., the detail and contrast being extremely good. The synchronisation is practically perfect, and it is very rare indeed for a frame to slip or a few lines run out. Indeed, when this does occur it is a

sign that the controls are not properly set, and this is quite possible, in spite of apparently good synchronising being secured, for the synch. hold is so strong that considerable latitude in the setting of the controls can be tolerated. Unless the settings are correct, however, interference may cause momentary faults.

The testing site was close to a main road with a constant stream of traffic and also close to a bus-stop, so that the conditions were hardly ideal from the point of view

of freedom from ignition interference. In spite of this, however, interference was by no means troublesome; it had no apparent effect on the synchronising, and was only occasionally visible in the form of spots on the picture. This speaks well for the screening and the feeder system adopted.

Sound reception was equally satisfactory and of a really high standard of quality. The equipment is, of course, for AC operation, and it consumes 230 watts.

The receiver is supplied complete with a special resonant aerial and feeder and is priced at 95 guineas. This includes installation by the company's engineer of both aerial and set, and maintenance of receiver and cathode-ray tube for one year. The valves, of course, carry the usual three-months' guarantee.

## New Murphy Receivers

### First Four 1937 Sets all Table Models

**T**HREE of the four new models recently announced by Murphy Radio, Ltd., Welwyn Garden City, are fitted with a tuning scale of more than usual interest. Hitherto the firm has shown some reluctance to print station names on the dial, preferring to give a plain wavelength calibrated scale for use in conjunction with a separate station list. The usual "station calibrated" dial was not regarded as a satisfactory solution, for a knowledge of station wavelengths is necessary if a laborious search through a crowded list of

corresponding to the station wavelength. Having selected a station from the list, all that is necessary is to watch the corresponding leading line and tune until the terminating circle is bisected under the stationary index line. Wavelength scales are

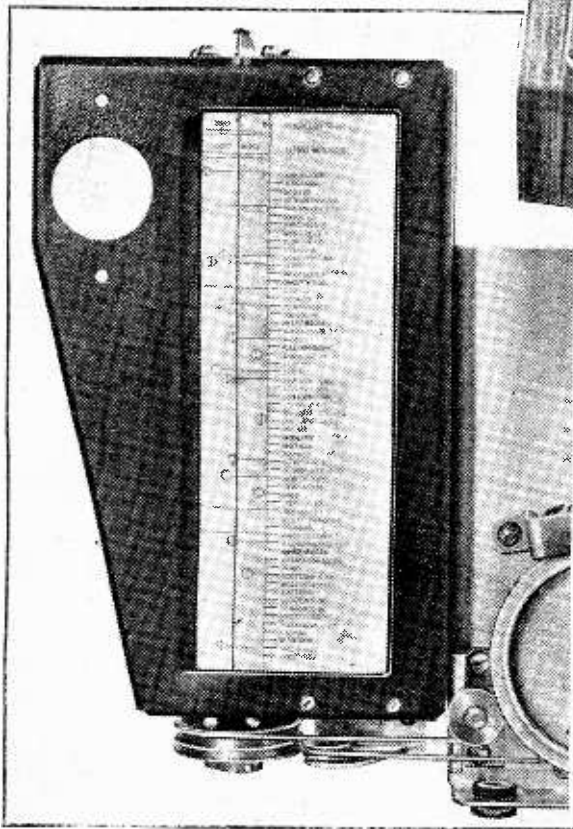

In the tuning scale fitted to the new Murphy B33, A34 and D34 receivers, the station names are arranged in alphabetical order.

names is to be avoided. A fundamental step forward is taken in the new Murphy dial, for the station names are arranged in alphabetical order with a suitable colour scheme to differentiate between medium- and long-wave stations.

The tuning "dial" consists of a rotating cylinder marked with a series of leading lines terminating in small circles at points

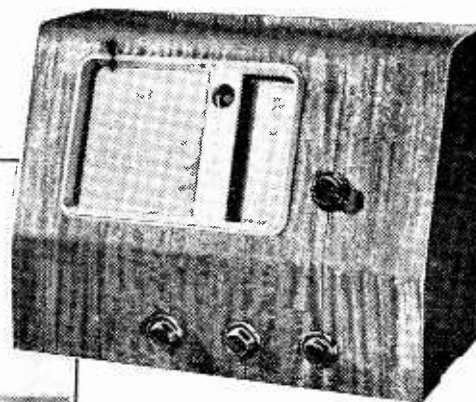

A cathode-ray tuning indicator, inter-station noise suppression and a new type whistle filter, are features of the new A34 Murphy superheterodyne.

also provided at the top of the drum to assist in finding stations not included in the list, which is confined to transmitters well within the range of the instrument.

The A34, a revised version of the previous A30 set for AC mains, has the new scale, and is fitted with a cathode-ray tuning indicator, a whistle filter and inter-station noise suppression. There is a DC/AC model (the D34), and the price in each case is £11 10s.

There are two battery receivers. The B33 is a development of the B27, with a triode-pentode frequency-changer, and a QPP pentode in the output stage. Automatic bias is provided, and there are only two HT leads. The alphabetical tuning scale is incorporated, and the price, without batteries, is £10 15s.

Finally, there is the B31, a "straight" HF-det-LF receiver, based on the B23, with automatic bias and a new high-slope pentode output valve. The cabinet has been redesigned, and a new full-vision tuning scale similar to that of the "28" series is now fitted. The price is £6 10s., without batteries.

## Television Programmes

The system to be used each day is given below the date. Transmission times are from 3-4 and 9-10 daily.

Vision	Sound
6.67 m. (45 Mc/s).	7.23 m. (41.5 Mc/s).

FRIDAY, JANUARY 29th.  
(Baird.)

3, British Movietone. 3.10, Friends from the Zoo—II, Animals introduced by David Seth-Smith. 3.25, Film. 3.35, Ord Hamilton and his Twentieth Century Melodians. 9, "Heard in Camera"—dramatic thriller in one scene with Tod Slaughter. 9.15, Gaumont British News. 9.25, Repetition of 3.10 and 3.35 programmes.

SATURDAY, JANUARY 30th.  
(Baird.)

3, Punch and Judy—Bruce McLeod. 3.10, Gaumont British News. 3.20, In Your Garden—II. C. H. Middleton demonstrates planting. 3.35, Film. 3.45, Cabaret. 9, Nancy Logan—songs at the piano. 9.10, British Movietone. 9.20, Repetition of 3.20 programme. 9.35, Cabaret.

MONDAY, FEBRUARY 1st.  
(Marconi-E.M.I.)

3, The Orchestra and Its Instruments—III, "Wind";—Philip Thornton. 3.20, Gaumont British News. 3.30, Light Entertainment with the Television Orchestra. 9, Repetition of 3 programme. 9.20, British Movietone. 9.30, Cabaret.

TUESDAY, FEBRUARY 2nd.  
(Marconi-E.M.I.)

3, Demonstration by the Women's League of Health and Beauty. 3.15, British Movietone. 3.25, Act II of "The Marriage of Figaro" by the Vic-Wells Company. 9, Light Entertainment. 9.20, Gaumont British News. 9.30, Act III of "The Marriage of Figaro" by the Vic-Wells Company.

WEDNESDAY, FEBRUARY 3rd.  
(Marconi-E.M.I.)

3, Patricia Rossborough: Syncopated Piano Songs, and Tony Raglan, Musical Chef. 3.20, Gaumont British News. 3.30, Twenty-fifth Picture Page. 9, Ballroom Dancing demonstrated by the English Amateur Dancing Team. 9.20, British Movietone. 9.30, Twenty-sixth Picture Page.

THURSDAY, FEBRUARY 4th.  
(Marconi-E.M.I.)

3, Children's Fashion Parade. 3.15, British Movietone. 3.25, Dancing Programme. 3.35, Film. 3.45, Starlight—Carroll Gibbons. 9, The Composer at the Piano—Norman Mack-forth. 9.10, Cook's Night Out—II, Marcel Boulestin's cooking demonstration. 9.25, Gaumont British News. 9.35, Boxing—England v. Ireland at the Alexandra Amateur Boxing Club Tournament televised from the Concert Hall, Alexandra Palace.

# CURRENT TOPICS

## EVENTS OF THE WEEK IN BRIEF REVIEW

### New SW Station Planned

THE present unofficial Swedish short-wave station which works on 25.63 metres with a power of 500 watts will shortly be replaced by a  $1\frac{1}{2}$ -kW station working in the neighbourhood of 19 metres.

### Portugal's SW Plans

SHORT waves are to be employed as a means of communication between Portugal and her African Colonies. Telefunken apparatus is to be used in the proposed stations. It is intended that the stations should be used for the relaying of broadcast programmes as well as for ordinary communication work.

### Kabul Calling

IT is anticipated that broadcasting will shortly be introduced into Afghanistan, and already plans are being made for the erection of a 20-kW station in Kabul, the capital. It is hoped that the station will be ready for service in the latter part of the year.

### New French Stations

A CERTAIN amount of dissatisfaction is being expressed in some quarters in France owing to slowness in getting on with the building of the new 100-kilowatt Radio Colonial transmitter near Paris. Comment has been so unfavourable that the authorities are seriously considering the installation of a 25-kW transmitter to allay public feeling until such time as the big transmitter is ready. The new Limoges station is to have an initial power of 100 kW, and arrangements are to be made so that it may be quickly raised to 200 kW if and when desired.

### An Indian Tatsfield

AN elaborate receiving station is being planned by the All-India radio service. It is to be erected in Delhi, and one of its principal functions will be to pick up S.W. broadcasts from Europe and America and pass them by landline to various Indian broadcasting stations for relaying. For this purpose an intricate system of directional aerials is to be used. In addition, the station will be employed for keeping a check on the wavelengths of Indian stations, and also for research work in connection with atmospheric

### Gold Medal for Television Pioneer

THIS morning (January 29th) Mr. John Logie Baird will be presented with the gold medal of the International Faculty of Sciences for his contributions to advancement in the science of television. The presentation will take place during the annual general meeting of the Faculty at the Central Hall, Westminster.

### Listening in Palestine

THERE was a considerable increase in the number of licensed listeners in Palestine during 1936. At the end of 1935 there were slightly more than 12,000 listeners. These had risen to nearly 19,000 by the end of October, 1936, the latest date for which official figures have been received.

### U.I.R. Meeting

THE new session of the International Broadcasting Union will take place in Berlin from February 22nd to March 3rd. At this session the precise date of the annual Congress, which will be held in Switzerland during June, will be settled.

### The Algiers Station

THOSE who make a practice of listening to foreign stations will have missed the familiar voice of the Algiers station during the past few days. The reason is that the transmitter has gone into dry dock for reconditioning. It is hoped to have the station working again on February 1st, and very greatly improved results are anticipated.

### Remarkable Amateur Feat

FOR the first time in history, according to a report received from the American Radio Relay League, amateur transmitters situated in each of the continents have established communication between themselves. In a little over twenty minutes each station had exchanged greetings with the others, and their voices were recorded by another amateur, and the record was immediately played back to them. The amateurs taking part were situated in the U.S.A., Colombia, England, Egypt, India, and Australia.

This feat was the result of careful planning, in which among other things, the most suitable hour of the day had to be chosen. This was exceptionally difficult, owing to the variation of time in these widely different parts of the world. On previous occasions one station

has worked stations in all other continents, but this is the first time that all continents have been able to communicate with each other simultaneously.

### A Malagasy Exhibition

A CONSIDERABLE amount of curiosity was recently aroused among the inhabitants of Madagascar by a wireless exhibition recently held there. It was the first of its kind and was very successful, judging by the attendance figures.

### French Amateurs' Year Book

THE 1937 edition of the yearly review issued by the French amateur organisation, "Réseau des Emetteurs Français," has just made its appearance. It gives a complete list of all French and French Colonial amateur stations, and other valuable data concerning the amateur movement in France and her Colonies. Its price is three francs, and it can be obtained from the headquarters of the organisation at 6, Square de la Dorlogne, Paris, 17.

### G6RG Destroyed by Fire

THE well-known amateur transmitting station owned by Mr. Bryan Groom, of The Hollies, Galashiels, has been gutted by fire. A new transmitter which was under construction has also been destroyed.

### Wireless for Mountaineers

IN order to lessen the risk of mountaineering in Austria a small portable SW transmitter has been designed by Professor Benz for installation in mountain huts so that calls for help may be sent out in case of accident. The transmitter will be fully automatic and when set into operation will send out its own call letters together with the distress call, so that no time will be lost in locating the particular hut concerned.

### French Broadcasts to Schools

AT the instigation of M. Jean Zay, French Minister of National Education, a regular programme of broadcasts to elementary and secondary schools has been inaugurated. These broadcasts are given through the Eiffel Tower Station.

### Below Five Metres

THE television experiments being carried out in the U.S.A. by the National Broadcasting Company are, in the case

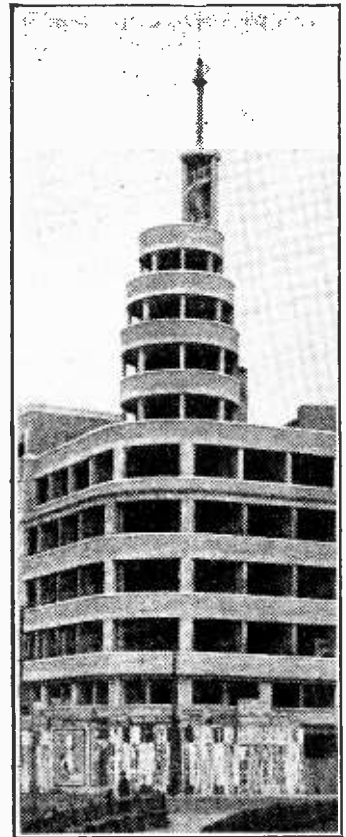

THE WORLD'S LARGEST STUDIO will be housed in the new Brussels Broadcasting House, now nearing completion. The tower of unusual design seen in the picture, which shows one corner of the new building, is reserved for the activities of the television department.

of both sound and vision, on a higher frequency than that adopted by the B.B.C. Sound is being sent out on 62 megacycles, thus taking it below the five-metre mark, while vision is on 52 megacycles. It will be noticed that the separation between sound and vision is ten megacycles instead of 3.5 as in the case of the Alexandra Palace, which transmits sound and vision on 41.5 and 45 megacycles respectively.

### World's Morse Speed Record

THERE appear to be many claimants for the speed record in the receiving of messages in morse. Most of them, however, appear to have received at a speed of only 50 or 60 words per minute. No recent claimant seems to have approached the speed achieved in 1935 by Mr. T. McElroy, of Boston, who, in open competition, set up a record of 69 words per minute, there being only one error in the message which he took down. In the case of these super-speed tests a typewriter is used for taking down the message, as it would be practically impossible to write at this speed with any pretence to legibility. An automatic transmitter is used for sending.

# UNBIASED

## B.B.C. Mangles History

STUDENTS of horse-racing and other vulgar pastimes of that nature are never tired of telling us always to stick like a limpet to the form book when making our investments, and not to be led astray by secret tips or information straight from the horse's mouth. The reason for this is that even if a good horse does occasionally let us down badly, it will always turn up trumps in the long run.

I must confess that I have never had much luck on the turf myself by following this system but, all the same, I am a firm believer that anything worth while will always be found to run true to form in the long run, and I am very pleased to say that I have found the B.B.C. to be in this category.

It was only a week or two ago that I was chiding the B.B.C.'s history-mangling department gently about letting us down rather badly over the 1908 Scrapbook which was broadcast without a single chronological error. It was, however, I am pleased to say, merely a momentary lapse on the B.B.C.'s part, and no doubt the member of the staff responsible for it has long since been hanged, drawn and quartered. I knew in my heart that such an out and out thoroughbred as the B.B.C. couldn't fail to return to proper form before long, and I was very pleased to see that the recent "Twelve Months Back" programme proved me correct.



The Intelligentsia of Portland Place.

They soon showed us that they had given up the delicate and thankless task of sticking meticulously to such an absurd thing as the truth, by giving us, with a challenging take-it-or-leave-it air, the wrong date for the commencement of the *Queen Mary's* maiden voyage. They reserved their master stroke for later on in the programme, however, and, believe me, it really was a master stroke worthy of the best traditions of Broadcasting House. Not content with getting all tangled up with ordinary historical dates, which I feel sure we one and all found so tiresome at school, the B.B.C. programme wallahs put the tin hat on everything by getting mixed up about the Corporation's own domestic history and telling us that the regular television service from the Alexandra Palace was inaugurated by the P.M.G. on November 1st. Tut! tut! And on the Sabbath, too!

## By FREE GRID

There is only one thing that is troubling me, and that is that I may be doing the B.B.C. less than justice, for Mrs. Free Grid, like all of her sex, is only too glad to rush, to the assistance of anybody or anything that looks orthodox and respectable, and she has given it as her firm opinion that it is my set which has developed a fault and is deliberately distorting the truth, for, as she rightly remarked to me, "You yourself have in the past had a lot to say about the distortion in certain sets." I can, therefore, only say that I am perfectly willing for the B.B.C. to send its technical experts to examine my set so that this reprehensible fault can be cleared up. While they are here they might also care to examine the record made on my home recording outfit, in case they thought, as I confess I did myself at first, that my ears had deceived me with regard to these chronological fantasies of the Intelligentsia(?) at Headquarters.

## Wireless Manufacturers Buy Pups

ON the face of it there would seem to be little connection between broadcasting and dogs, unless it be the manner in which the B.B.C. treats its listeners. However, it is not that sort of connection which I wish to talk about. It appears that nowadays animals play all sorts of unsuspected roles in the development of our wireless sets. Only the other week we were hearing about a firm which is using white ants to find out all about the proper material to use for the insulation of its tropical sets, and now it is dogs.

It was, as a matter of fact, purely by chance that I learnt about the dogs. I had happened to pay a visit to the works of a well-known set manufacturer in order to look into the method of making television sets, and as I emerged from one of the workshops I was surprised to hear a motley collection of barks, ranging from the deep baying of a St. Bernard to the shrill yapping of a wretched Pom. My guide, noticing my astonishment, informed me that the noise came from the kennels.

In order to satisfy my curiosity, he led me across to where the kennel maids were attending to the wants of as motley a collection of mongrels as it has ever been my fortune to see. I could not for the life of me see what part they played in set development, although I well recollect that many years ago certain prominent set manufacturers, in order to encourage sales, made a practice of selling, or rather giving away, a pup with every set they disposed of. Still, I thought those bad old days were happily gone for ever, and I hastily



A motley collection of mongrels.

put away the unworthy thoughts which had been welling up into my mind.

It appeared from the explanations that were given to me that the use of dogs for assisting in the design of wireless sets had come about in purely accidental manner. As most of us know, dogs appear to take absolutely no notice whatever of the sound of a wireless set, no matter whether music or voices are coming from the loud speaker. The explanation given by scientists for this is that it is due to the absence of the psychic link. Nobody, of course, knows exactly what is meant by the psychic link any more than do the scientists themselves, but, obviously, they are expected to say something in an attempt to explain the inexplicable, otherwise their reputations would suffer, and so, like the wireless experts in similar circumstances, they trot out some meaningless jargon.

Probably nothing more would have been heard about the affair had not a dog happened to be present during the testing of a television receiver, when the animal suddenly gave a low growl and committed hara-kiri by launching itself through the end of the cathode ray tube and collecting a few thousand volts. It was only after further experiments with other dogs had proved that it was not the vision which was the cause of this strange behaviour that some genius evolved the theory that it was the intense realism of the human voice which was the cause of the trouble, dogs simply not recognising the human voice as such when listening to ordinary medium or long-wave broadcasting with its restricted frequency range.

Further experiments revealed the fact that not only did various breeds of dog respond differently to the musical scale, but even different specimens of the same breed showed marked variations in their response curve. It was not very long before an ingenious laboratory worker thought of the idea of cutting production costs by doing away with costly laboratory gear and employing a collection of dogs "peaking" at different frequencies in order to test the high-quality amplifiers of television sets for undesirable resonances, and the result has been the springing-up of an entirely new industry, as dog-fanciers have already turned their attention to the breeding of special hand-calibrated dogs.

# New Apparatus

## Recent Products of the Manufacturers Reviewed

### KINVA WHISTLE FILTER

**POSTLETHWAITE BROS.**, Church Hill, Kinver, Stourbridge, Worcs, have for long specialised in whistle filters, and among their latest developments is a model described as the A5.

This is designed to give a sharp cut-off above 7 kc/s with maximum attenuation at about 9 kc/s. It is intended for use in sets having a comparatively wide frequency band for high quality of reproduction, and where heterodyne whistles from adjacent channel stations are sometimes very troublesome.

The standard A5 model is for connection in the anode circuit of an AF valve of between 7,000 and 20,000 ohms AC resistance and it will carry 10 mA. of DC. It thus serves for D-D triodes and most general-purpose triodes that would be used as penultimate AF amplifiers.

As the anode current flowing through the choke affects slightly the actual cut-off frequency, details of the valve that will be used and its anode current will enable the makers to supply the correct windings for the cut-off frequency wanted.

The whistle filter is, of course, only needed when this type of interference is present, and accordingly arrangements have been made to put it out of action when receiving the local station and other signals not subjected to interference. This is effected by a double-pole two-way switch that can be mounted accessibly on the panel of the set.

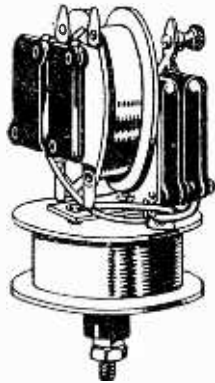

Kinva 9 kc/s whistle filter, Type A5.

The A5 9 kc/s whistle filter costs 12s., and a K81 type switch for use as described is available at 1s. 10d.

### PYE MAINS TRANSFORMER

**THE** modern production plant installed by Pye Radio for the manufacture of the mains transformers used in their receivers is now producing a model designed for home constructors' use.

One model only is available, but as it has the widest possible application, compatible with reasonable cost, it should satisfy the majority of requirements since it is suitable for use in any set or amplifier with a power output up to 3 watts.

The primary winding is tapped for supply voltages of 100 to 150 or 200 to 250 volts at 40 to 100 c/s, and with adjustment for voltages between these limits.

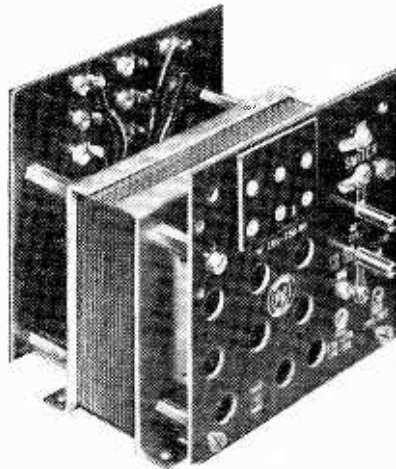

Universal type mains transformers made by Pye.

A clearly-marked plug board indicates whether the primary is adjusted for the 100- or the 200-volt range.

There is a static screen between the primary and the secondaries and two terminal points for including a mains on-off switch, while the windings are impregnated throughout.

The HT secondary is rated for 60 mA. after rectification and a DC output of either 250 or 350 volts can be obtained.

Three LT windings, each of 4 volts and giving 2, 3 and 4 amps. respectively, are included; all these have centre tappings.

Tested on full load and with a MU12 rectifier the smoothed DC output was 360 volts at 60 mA., while the LT windings gave, with their respective loads, 4.2 volts each. As short LT leads were used in the test assembly the slight excess in voltage is desirable as this allows for the voltage drop on the much longer leads that would be used in a set or amplifier.

The transformer is quite silent in operation and there is no trace of hum as is sometimes encountered if the core is not tightly clamped. It is also satisfactory in respect of its temperature, as the core and windings were only warm after a long period of operation on full load. Being a skeleton model there is, of course, ample opportunity for heat dissipation.

The price is 21s. and the makers are Pye Radio, Ltd., Cambridge.

### BELLING-LEE LOW-IMPEDANCE FEEDER

**BELLING AND LEE, LTD.**, Cambridge Arterial Road, Enfield, Middlesex, have introduced a low-impedance transmission line, or feeder, which is designed to match the impedance at the centre of a di-pole aerial. Its value is 72 ohms, and it is stated

to be suitable for use at radio frequencies as high as 44 Mc/s without introducing any appreciable loss.

The two conductors, which consist of No. 26 SWG enamel wire, are laid parallel and spaced about 1 mm. apart, the insulating material used being very tough and quite moisture proof; it will thus withstand the most severe climatic conditions.

It should find a useful application in amateur transmitting circuits, since the feeder is capable of carrying up to 1.5 amps. of RF. Thus it could be used in all cases where the input to the final amplifiers does not exceed 200 watts.

More than usual interest attaches to this cable, since for television reception resonant aerials with low-impedance feeders are generally the most satisfactory.

The Belling-Lee 72-ohm transmission line is obtainable in reels containing 65ft. and the price is 6s. 9d.

### BULGIN PRECISION RESISTANCES

**WIRE-WOUND** resistances with a high order of accuracy in regard to their ohmic values are now obtainable from A. F. Bulgin and Co., Ltd., Abbey Road, Barking, Essex, in values ranging from 0.1 ohm to 1 megohm.

Enamelled wire is employed, and it is wound on a slotted former with the direction of winding reversed in adjacent slots. Since the formers are of small diameter this method of construction results in a satisfactory non-inductive winding. The former is then enclosed in a tube of bakelised material for protection.

These resistances are rated at one watt and have an accuracy guaranteed to be better than 2 per cent. The sample tested, a 2-ohm model, measured 2 ohms on a laboratory Wheatstone bridge using a ratio giving

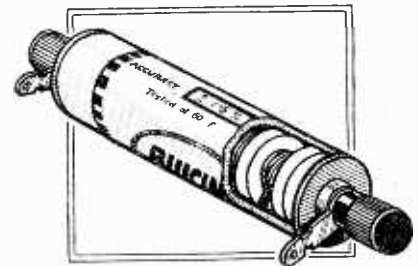

Bulgin wire-wound precision resistance, Model R15 of 2 ohms value.

measurements to the nearest 0.01 ohm. Its accuracy may thus be said to be better than 0.5 per cent.

These resistances will be found valuable for shunts and series resistances in multi-range meters as well as in the construction of test apparatus in which accurately adjusted resistances are needed.

Up to 5,000 ohms the price is 6s. each. Over this value the prices increase progressively to 24s. for one of one megohm.

### The Radio Industry

**L** EAFLETS describing several new Marconi-Ekco measuring instruments are now available. The most recent introductions are a Universal Impedance Bridge and two Inductance Comparators.

Tannoy sound-reproducing equipment will shortly be installed in the Leicester Municipal Cattle Market, where it will take the place of the runners who have hitherto been employed to take messages from one part of the market to another.

# Listeners' Guide for

## Outstanding Broadcasts at Home and Abroad

**T**HE first of a series of feature programmes which will deal with a subject of the greatest interest and importance to listeners—the actual work that is done behind the scenes before a programme goes out from Broadcasting House—will be given on Sunday at 9.5 (Nat.). The subject chosen to inaugurate this lifting of the veil is that of outside broadcasts. A typical programme will be followed throughout the various stages from the germination of the idea in the fertile brain of S. J. de Lotbinière or some member of his department to the end of the actual transmission.

The production of this first programme in the series "In the Making" will be in the hands of Felix Felton, who may subsequently enlighten listeners on how a Music Hall programme is built up; what happens each time a play is put on, or what arrangements have to be made in order to broadcast a symphony concert.

### GHOSTS OF LONDON

MARK LUBBOCK and Wilfrid Rooke-Ley combine on Sunday to present another of their programmes, "Ghosts of London," to be broadcast at 5.30 (Reg.). Music and dialogue are used to recall famous occasions in London's musical history, and in this programme famous visitors to the Metropolis whose works will be heard will include Wagner, Chopin and Berlioz.

### HALLÉ CONCERT

ON Thursday the Hallé Concert at Manchester will be heard in the Regional programme at 7.30 and 8.45. The orchestra will be conducted by John Barbirolli and Walter Gieseking will play the solo part in the Rachmaninoff Pianoforte Concerto No. 2. The main orchestral item will be Elgar's Second Symphony in E flat. This will be John Barbirolli's first broadcast since his return from the United States, where

he has just been appointed conductor of the New York Philharmonic in succession to Toscanini.

### "A DEEP DEPRESSION . . ."

A TEN-MINUTE insight into the preparations necessary for the compilation of the weather

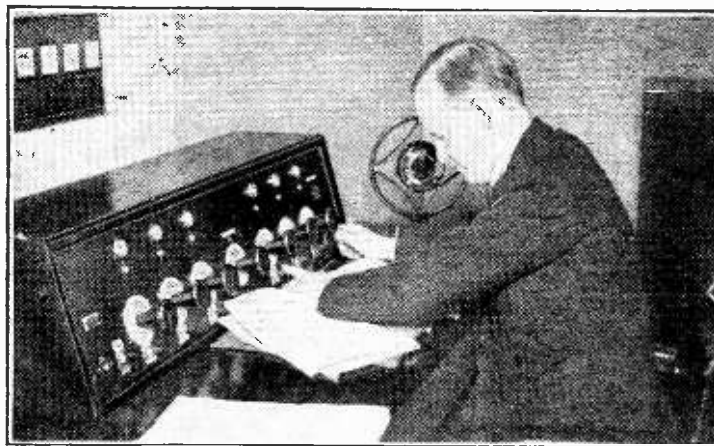

AT THE HELM. Martyn C. Webster, the producer, at the Midland Regional dramatic control panel. The production of "Wild Violets" on Monday and Tuesday of this week will be in his able hands.

reports which are issued from the Meteorological Office is to be broadcast at 6.50 on Wednesday. The microphone will visit the various offices at the Air Ministry, Adastral House, Kingsway, thereby giving listeners some idea of how weather reports are prepared from details provided by R.A.F. aerodromes, light-house keepers, coastguards, etc.

### SOUTH SEAS

SONNY MILLER, the American song writer, spent much of his life until five years ago in the South Sea Islands, with Hawaii as his base. He decided on leaving that something must be done with the colourful impressions he had gained from his life in the South Seas. Some six months ago in London he met Eric Maschwitz, the Variety Director, and outlined to him a series of broadcasts which would give a

musical impression of the South Seas and provide a programme which would appeal to the imagination.

He has himself written the book for these broadcasts, describing many of the scenes and the origins and reasons behind much of the folk music of the South Sea Islands. As far as is possible the music, which has been arranged by Eric Siday, who has also spent much time in the South Seas,

### TEST CRICKET

THE fourth Test Match between Australia and the M.C.C. at Adelaide being a very decisive one, reports on it will be eagerly awaited by listeners each morning. The B.B.C., with the co-operation of the Australian Broadcasting Commission, will, at 8.30 a.m. on Friday (to-day), Saturday, Monday and Tuesday, broadcast Nationally a ball-by-ball commentary on the last ten minutes of each day's play by Victor Richardson, followed by a résumé by Alan Kippax. An electrical recording of these commentaries will be broadcast at 1 p.m. each day.

### SHAKESPEARE

LOVERS of Shakespeare will be pleased to know that "The Merchant of Venice" is to be broadcast on Sunday. Although a shortened version for the microphone, lasting from 5.35 to 7.5 (Nat.), it will be well produced, for Barbara Burnham has it in hand. The part of Shylock will be played by Ernest Milton, who has many times taken the part in stage productions.

### "WILD VIOLETS"

THE book of this romantic operetta is by Bruno Hardt-Warden and the music by Stolz. There is, as many people will recall, a prologue of 1932 with the main action

will be played on genuine Hawaiian instruments. The vocal parts will be sung by the Three Admirals (a male trio) and the Three Dots—a feminine trio new to broadcasting.

This South Sea Island musical programme, "Paradise Isle," is to be broadcast to-night at 8.20 (Reg.)

### SWEDISH MUSIC

LISTENERS to the Regional programme on Sunday at 6.30 will hear a medley of Swedish songs, marches and dances relayed from Stockholm. The Swedish Broadcasting Orchestra and Choir will be conducted by Nils Grevillius and the principal soloists will be Kerstin Torlind and Set Svanholm.

The programme has been previously broadcast in Sweden and was originally devised for Swedes abroad with the idea of bringing back musical memories of their homeland. It should therefore provide English listeners with a kaleidoscopic picture of Sweden.



THE CELEBRATED CONDUCTOR, Boyd Neel, brings his string orchestra to the studio at 8 on Saturday to give an hour's programme from the National transmitter.

Details of the week's  
Television programmes  
will be found on p. 104.



# the Week

taking place thirty years earlier. It was produced at Drury Lane in 1932, and has had a long run recently in the provinces. For the broadcast on Monday at 8 (Reg.) and Tuesday at 7.50 (Nat.) the Revue Orchestra and Midland Revue Chorus will be conducted by Reginald Burston with Martyn C. Webster as producer.

## “COO-EE”

THE above is the title given to an all-Australian entertainment which will be broadcast on Wednesday at 8.15 in the Regional programme. The action for this entertainment takes place at the Bondi Surf Bathers' Life Saving Club, Sydney. Among those taking part are Albert Whelan, the Australian Boys, Nina Devitt and Billy Malony.

## MUSIC

AN attractive programme has been arranged for the Queen's Hall Symphony Concert on Wednesday, when Walter Gieseking will play the Grieg Pianoforte Concerto. The other works in the programme will be Symphonic Poem, Paris, by Delius; a Haydn Symphony, "The Swan of Tuonela"; and "The Return of Lemminkainen," by Sibelius. The concert will be broadcast at 8.15 and 9.30 (Nat.), and Sir Thomas Beecham will be conducting.

At the Sunday Orchestral Concert this week, to be broadcast at 9.5 (Reg.), Paul Beard, leader of the B.B.C. Symphony Orchestra, will be the soloist in the Tchaikovsky Violin Concerto.

On Thursday, from 10.20 to 11.15 (Nat.), Zoltan Székeley and Béla Bartók, the modernist Hungarian composer, will give a recital of violin and piano music. Bartók will play a group of his own piano solos and, with Székeley, Bach's Sonata in B Minor and his own Sonata No. 2 for violin and concerto.

## SATIRE

AN interesting retrospective programme will be broadcast from Copenhagen to-night at 7.20 under the heading "Satirical Revues Through the



LADY JANET CLERK, wife of the British Ambassador in Paris. A half-hour's programme of her music will be broadcast from Radio-Paris at 8.30 to-night (Friday).

Ages." It is the ancient but still popular process of presenting the truth swathed in a cloak of humour that will be illustrated by means of this broadcast.

## COMMUNITY SINGING

THE Danish broadcasting authorities are endeavouring to teach the listening public a number of popular old and new national songs. Listeners have been asked to join the Choir of Skaarup Seminarium in community singing. The event will take place on Monday night at 7, and will be the first of a series.

## OPERA

LISTENERS have two operas to choose from this evening (Friday). At 7 Stockholm offers Acts 1 and 2 of Verdi's "Othello" from the Royal Opera House, Stockholm, with the Swedish star, Martin Ohman in the name part, whilst at 7.10 "Der Freischütz" (Weber) comes from Breslau. On Saturday, Milan broadcasts Mussorgsky's opera, "Boris Godunov," evidently in Mussorgsky's original scoring with all its technical faults, in preference to Rimsky-Korsakov's improved arrangement.

Sunday brings a matinée performance of "The Tales of Hoffmann" from the Opéra-

## HIGHLIGHTS OF THE WEEK

### FRIDAY, JANUARY 29th.

Nat., 6.25, Pianoforte Recital: York Bowen. 7.20, Kentucky Minstrels. 8.20, National Lecture—Engineering, by Sir Alexander Gibbs. 9.20, European Exchange—IV, Poland. Reg., 6.45, Car Upkeep—Running In. 7.30, "Five Quid Pro Quo," radio play. 8.20, Paradise Isle. 9.20, Excerpt from "Humpty-Dumpty" at the Prince of Wales Theatre, Birmingham.

### Abroad.

Warsaw, 7.15, Warsaw Philharmonic Orchestra and W. Kampff (pianoforte).

### SATURDAY, JANUARY 30th.

Nat., 8, The Boyd Neel String Orchestra. 9.20, Music Hall. Reg., 6, Worthing Municipal Orchestra. 8.50, Act II of Rossini's "The Barber of Seville" from Sadler's Wells. 9.35, Pianoforte Recital: Marie Zoldesi.

### Abroad.

Strasbourg, 8.30, Operetta Evening.

### SUNDAY, JANUARY 31st.

Nat., 5.35, "The Merchant of Venice." B.B.C. Orchestra (C) and Yves Tinayre (tenor). 9.5, In the Making—I. Reg., 5.30, Ghosts of London—II. Musical Memories. 6.30, Swedish music, relayed from Stockholm. 7.10, The Bickershaw Colliery Band

### Abroad.

Leipzig, 7, "Euryanthe"—romantic opera (Weber).

### MONDAY, FEBRUARY 1st.

Nat., 7.20, Music Shop—9. "It's Happening Now—V. 8.30, Pianoforte Recital—Orloff. 10.45, The Little Show—radio cabaret. Reg., 8, "Wild Violets."

### Abroad.

Lyons PTT, 8.30, Symphony Concert.

### TUESDAY, FEBRUARY 2nd

Nat., 7.50, "Wild Violets." 9.20, "Church, Community and State"—IV. "The Edric Cundell Chamber Orchestra. Reg., 7.30, Phyllis Dare assisted by Arthur Klein. 8.10, Midland Parliament—"Profit Sharing in Industry."

### Abroad.

Frankfurt, 7.10, "Dancing Down the Centuries."—Classical dances, and dances of to-day.

### WEDNESDAY, FEBRUARY 3rd.

Nat., 7, Carroll Levis and His Discoveries. "Van Phillips and His Two Orchestras. 8.15 and 9.30, Symphony Concert from the Queen's Hall.

Reg., 8.15, "Coo-ee"—all-Australian entertainment. 8.40, "Broadway."

### Abroad.

Breslau, 7.45, Max Trapp conducts concert of his own works.

### THURSDAY, FEBRUARY 4th.

Nat., 7.40, The Fol-de-Rols. 10.20, Recital: Zoltan Székely (violin) and Béla Bartók (piano).

Reg., 7.30 and 8.45, Hallé Society's Concert from Manchester. 9.40, My Piano and I: Patricia Rossborough.

### Abroad.

Frankfurt, 7.10, "Carmen" (Bizet) from the Municipal Opera House.

comique, relayed by Paris PTT at 1.30. On Monday evening from Radio-Paris comes two hours of Terrasse's comic opera and operetta starting at 8.45. It is said of Terrasse, who died in 1923, that if his melodic imagination had been more varied he would have been one of the most remarkable composers of humorous music.

Tuesday brings "Othello" again, this time from the Strasbourg and Rennes stations at 8. From the Municipal Opera House on Thursday at 7.10 Frankfurt relays Bizet's "Carmen," with Marion Hunten in the name part. At 7.30 the same evening the second act of Wagner's immortal "Tristan and Isolde" will be relayed from the Royal Opera House by Stockholm.

## MISCELLANY

ON Saturday at 7 Swedish stations will relay excerpts from Stockholm's winter revue at the "Folkets Hus" Theatre.

Three orchestras combine to give a concert from Frankfurt on Sunday at 7.

Basque folk-lore will constitute the programme from Paris PTT on Wednesday at 8.30, when songs and dances



PERMANENT CONDUCTOR of the Berlin Station Symphony Orchestra. Heinrich Steiner will conduct the radio orchestra in a programme of works by Verdi and Puccini from Berlin on Sunday at 7 and 8.10.

of the sea and the mountains with modern Basque music will be heard.

At 7.10 on Thursday Deutschlandsender relays part of the Rhineland carnival from Cologne. This carnival continues until Shrove Tuesday, February 9th.

THE AUDITOR.



# Fading

## VICISSITUDES OF WAVES IN SPACE

By "CATHODE RAY"

**G**RADUALLY the problems that used to give us most of the fun in the old days are moving into the back seats. About twelve years ago I remember being rather amused at the suggestion of fitting a volume control. With the fractional-kilowatt transmitters and bright-emitter receiving valves (the famous "R" triodes!) of the period there was, in general, never any surplus volume to control. That is hardly our trouble now, when W2XAD overloads even a modern output stage unless the set is held down by AVC. As for the local station, only one ten-thousandth of the receiver's full amplification is actually brought into use.

In the early days nothing whatever had been devised for combating fading, and it was perfectly normal for reception to become more or less inaudible from time to time. This was accepted in the same spirit as "atmospherics," heterodyne whistles and income tax. Owing to the enormously greater strength of modern transmitters the first of these evils, though still present as before, is now relatively unimportant; and the necessity (if one can say so) for the second has been removed. The less said about the third the better.

Fading, like atmospherics, is still with us as a natural phenomenon; but the effect in the listening-room is largely neutralised by the automatic adjustment of amplification unobtrusively carried out in the receiver by AVC. It is important to realise that AVC cannot supply what is not there. So it would have been no use bringing it forward in the earliest days of broadcasting, when (as I have just recalled) there was no amplification or volume to spare. The height above sea level of the whole of England could not be brought to a uniform level of one thousand feet simply by cutting the hills down to this figure. But it could be done (theoretically) with Tibet, where the general level is upwards of 15,000 feet.

### Amplification to Spare

First, then, there must be plenty of amplification, so that even in the worst troughs of fading there is enough in hand to give adequate volume; then during the more favourable periods the surplus is thrown away to the correct extent by the AVC system. So successfully is this accomplished in modern receivers that programmes which appear quite steady may in fact be fading enough to render

themselves intolerable if handled by an old set.

Although this problem is therefore far less acute than it once was, it cannot be written off altogether just yet. I have emphasised that AVC acts in a purely negative sense; it cannot supply what isn't there. If fading is so severe as to bring the wave at the receiving aerial to zero, or at any rate beyond the maximum capabilities of the receiver to amplify to a useful volume, it is obvious that AVC is helpless to overcome the effect. And although there is practically no limit to the amplification that can be provided by modern technique, it is useless to apply more than the amount that brings up noise to enough volume to drown any programme. In "noisy" situations (e.g.,

next door to a man who runs an electric motor with a sparking commutator and refuses to do anything about it so long as the law can't compel him) the useful amplification may be very limited; but although Man may in this respect, as proverbially in others, be vile, Nature herself is not blameless and is responsible for an irreducible minimum of noise in the receiver itself<sup>1</sup> which is well within the range of moderately priced sets; to say nothing of atmospherics.

### The Limiting Factor

So although at first sight noise reduction appears to be a problem quite separate from fading it is actually the sole factor that decides how much fading can be eliminated by the receiver, now that

<sup>1</sup> Inherent Receiver Noise: *The Wireless World*, October 9th, 1936.

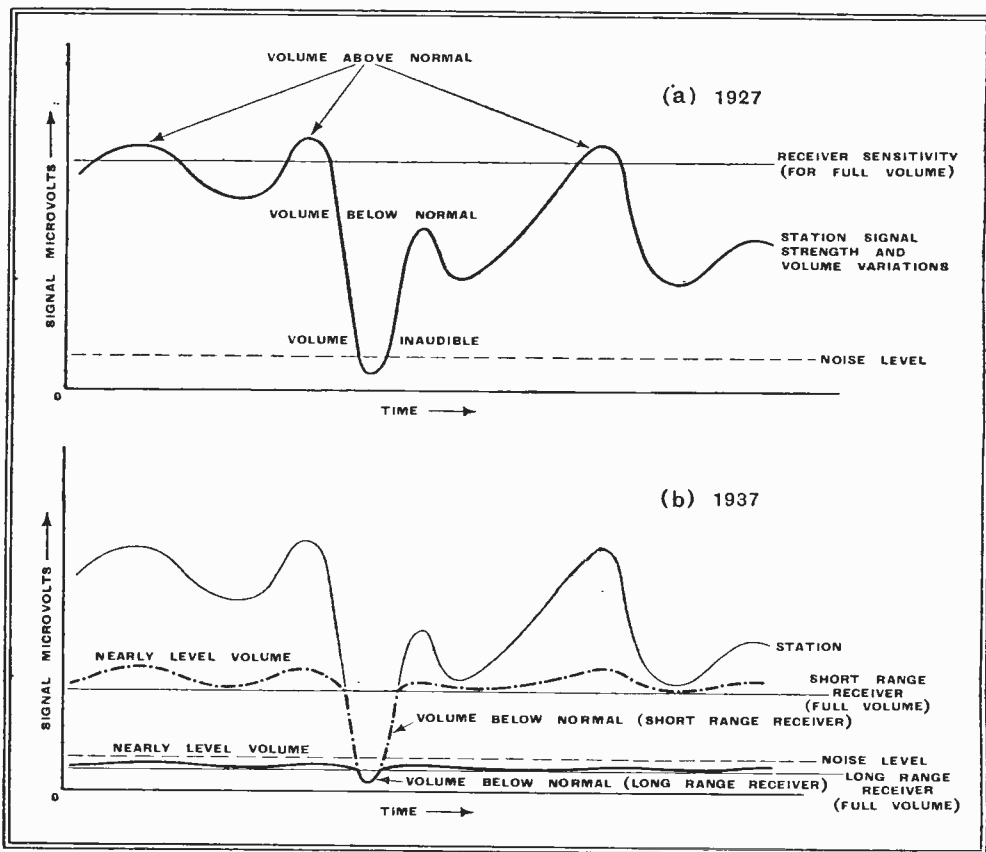

Fig. 1.—In the early days of broadcasting, receivers required a strong signal to give full output (see (a)) so the volume—suggested by the heavy line—corresponded with signal strength and faded with it. Although fading of signals still takes place now (see (b)) even a "short superhet" is sensitive to a much weaker signal and the surplus sensitivity is taken up by AVC, giving nearly constant volume (dash-dot line) except when the fading is very severe. A more sensitive receiver is then helpful (heavy full line) and the volume drops only when the signal is lost below the noise level in any case. (The "volume" lines suggest only the degree of constancy, and are not meant for comparing the volume given by different receivers).

**Fading—**

amplification and AVC can be made practically perfect without necessarily going off a commercial basis.

Now although in these days of hundreds of kilowatts it may have become the exception rather than the rule for otherwise good transmission to dive periodically below the noise level or even to dip their extremities in it, there is a tendency for listeners to make more use of the very distant stations. After all, *everybody* does not buy an "all-wave" set for prestige alone. So fading may even yet be the main restriction on foreign "travel." There is another thing: when fading is at all bad, though not necessarily so bad as to be out of control altogether, it is often accompanied by serious distortion. At the moment no simple method that could reasonably be applied to the ordinary broadcast receiver to cure such distortion is in sight.

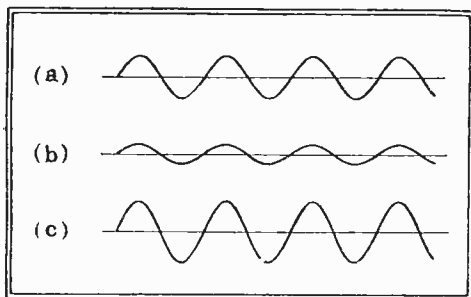

Fig. 2.—If two waves (a) and (b) arriving at the same place are of the same length (or frequency) and are in step (or phase) the combined result is a wave (c) stronger than either.

Various methods of combating fading have been developed for non-broadcasting services; of these the diversity reception method, described some time ago,<sup>2</sup> is perhaps just within the reach of very ambitious amateurs. But even if one is not in a position to take advantage of the more advanced methods, they are interesting for their own sake and as demonstrations of the truth of theories about radio communication in general and fading in particular. Which reminds me I

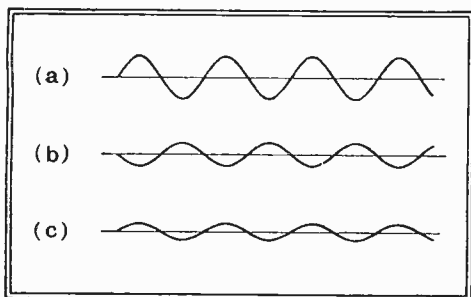

Fig. 3.—If the waves (a) and (b) are of the same length but arrive half a wave out of step the result is a wave weaker than either; or if (a) and (b) are of equal strength, a complete fade-out takes place.

have said nothing about what fading really is.

To understand it one needs a fairly clear

idea of how waves perform. Sea waves do not provide a good illustration of this unless they are at some distance from the shore, which unfortunately is not the most popular aspect for unemotional scientific contemplation of them. Their effect on some floating object, such as a buoy, is to move it alternatively above and below the

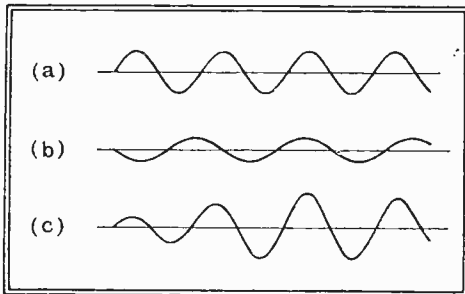

Fig. 4.—When waves (a) and (b) are not quite of the same length the result is a wave that alternately waxes and wanes—a beat note.

normal sea level. This corresponds to the voltage, alternately positive and negative, generated in an aerial when radio waves move past it. Unfortunately for the analogy, it is rare for two sets of waves of comparable magnitude to be set up on the surface of the ocean simultaneously. It sometimes happens in the wash of a large vessel; or it can be observed on a smaller scale in a pond by

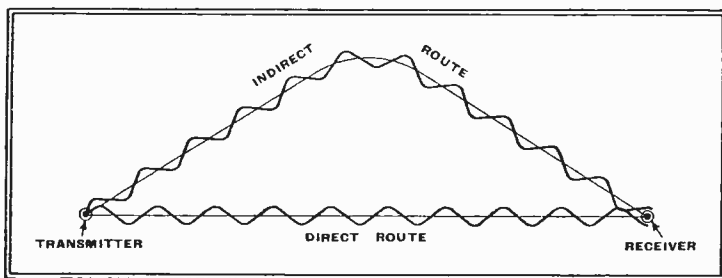

Fig. 5.—Showing how waves radiated in phase from the transmitter may arrive completely out of phase at the receiver owing to the greater distance of one route, thus giving zero signal at the receiver.

dropping stones therein. If at any point—the buoy, for instance—the two sets of waves are arriving in such a way that the crests of one lot always coincide with the crests of the other, and troughs likewise, the result is to increase the effect on the buoy. On the other hand, if they arrive so that crests always coincide with troughs they weaken one another, and, if they happen to be exactly equal, they cancel out completely and so far as the buoy is concerned there is a dead calm. The second set of waves causes the first to fade out.

The same principle applies to waves of other sorts—sound or radio, for example. A broadcasting station is a source of waves, which spread out and become weaker the farther they go. Other stations are putting out waves at the same time, but because they are of different frequencies they are not in step and there is no possibility of them either strengthening or cancelling one another continuously. The most they can do is to strengthen and cancel alternately, and if

they are close enough in frequency for this to occur less often than about 10,000 times a second the result is a heterodyne whistle. The number of waves emitted being of the order of a million per second—and many times more on the short wavebands—it is not very likely that two separate stations would send out *exactly* the same number even during as brief a period as one second without very special means being adopted for doing so. The B.B.C. work groups of stations (e.g., London, West and North Nationals) on the same frequency with very great accuracy, and unless the receiver is so close to one of them that the waves from the others are negligible in comparison they combine to give less or more than normal, and fading is probable.

**Helping or Hindering**

However, that is quite an exceptional case. But waves from any *one* station are invariably of the same frequency (or length) as themselves (obviously!) It will also be evident that if two waves from the same station travel to their destination by different but not-too-divergent routes there is at least a possibility that they will arrive at sensibly the same strength. Therefore, if anything happens to cause waves from a particular station to behave in such a way that some reach the receiver an odd number of half-wave-lengths behind others of the same strength, they cancel out completely. Fig. 5 shows this diagrammatically. If the indirect route were a little longer than that shown the waves would arrive by it a *whole* wavelength behind the other and the other and would therefore strengthen them; or, technically, be in phase with them. A

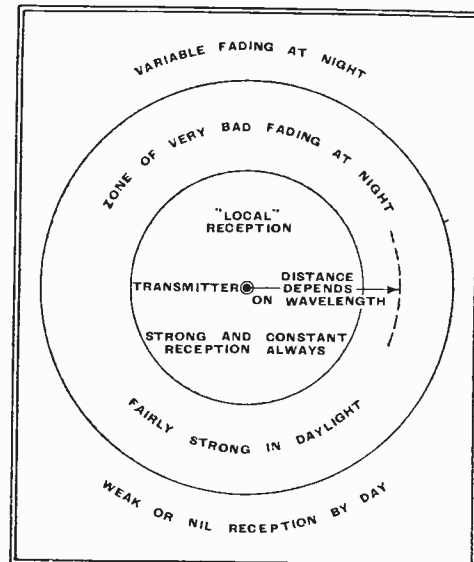

Fig. 6.—An imaginary "target" around a broadcasting transmitter. Explains itself.

<sup>2</sup> "How the B.B.C. Relays America," *The Wireless World*, May 1st, 1936.

**Fading—**

still greater lag would cause them to be out of phase again, and so on.

An indirect route might be produced by reflection. Ultra-short waves are reflected from wires, large metal structures, or the surface of the earth; and it is very easy to demonstrate the results by moving a portable ultra-short wave receiver about when the television transmitter is on. Within a movement of a few feet the signal may be completely extinguished. The longer waves need larger reflectors, and these are provided by Nature mainly during hours of darkness in the form of atmospheric layers at various heights above the ground—about 50 miles and more.

At very short distances from the transmitter the reflected waves, if any, are weaker than those received direct, and there is no fading at any time or on any wavelength. That may be called "local station reception."

At a greater distance—how much greater depends chiefly on the wavelength; it is less for short than for long waves, but a typical distance on the medium band is 70 miles—the direct wave has been weakened by being dragged over the surface of the ground. If conditions make a reflected wave possible, the greater distance it has to go is offset by the smoother travel by air, and it may easily happen that it arrives at practically the same strength as the ground wave. So it only has to be in the opposite phase for reception to be extinguished completely. As the reflecting layer is not a fixed mirror, but is more like the shifting surface of a ceiling of cloud, the strength and phase are usually constantly varying and so it is easy to imagine how the programme fades in and out in an entirely irregular manner. This reflection takes place on the ordinary broadcast waves only at night; so there is a zone around each station where reception is perfectly normal in daylight but fades badly after dark. Still farther away the direct wave is weaker than the indirect, so exact cancellation is impossible and fading is less violent. Abuse of the B.B.C. is still very violent, however, because the better reception of the more distant (foreign) stations convinces listeners that the home transmissions (which, unrealised by them, are at a disadvantage through their very nearness) are palpably inferior to those abroad.

**Sky - Waves Only**

These latter come into the third zone. Here the ground wave is nearly exhausted by its conflict with town and country, to say nothing of the pinpricks of countless receiving aerials, and daylight reception is poor or nil unless the magnification of the receiver is exceptional. After dark they come romping in, thanks to the reflection from the upper atmosphere. But there is still a likelihood of fading, though it is less likely to be of the very bad type characteristic of Zone 2. There are several possible causes. The ground

wave, though too weak to produce a complete fade, may yet be appreciable. Even if it is completely absent—and at great distances the curvature of the earth sees to that—the shifting and uncertain character of the reflector, on which one now depends entirely for reception, causes variability of results. Furthermore, there is the possibility of *two or more* sets of indirect waves conflicting among themselves. This is particularly so in long-distance short-wave reception.

Having already overstepped my usual bounds, I cannot take space to go into detail about how liability to fading depends on wavelength and time of day (and to some extent on other more obscure factors such as sunspots) and how one can thereby try for distant stations at the most auspicious times; but I hope shortly to go on to explain why fading is often accompanied by distortion; and how advantage is taken of the nature of fading in overcoming it.

# RANDOM RADIATIONS

By "DIALLIST"

**A Novel Way of Playing Records**

A CANADIAN reader sends me some interesting information about "radio-phonographs" and radio sets in the Dominion and the U.S.A. He confirms what I said some weeks ago about there being a revival of interest in recorded music. Very few radiograms are, however, in use, the tendency being to employ a turntable and pick-up in conjunction with the wireless set. Many of the latter have no pick-up terminals, and even if these are fitted subsequently there is often not sufficient AF amplification available for record playing. The difficulty has been overcome by the appearance of an ingenious little appliance in which a heptode oscillator is modulated by the pick-up. The output at about 1,500 kc/s is fed to the input terminals of the receiver and tuned in just as if it were a broadcasting station. Good, so far as it goes; but, as he says, "I hate to think of the possible effect of a flock of these rigs being used in, say, a large apartment building in a city!"

**Tuning Indicators**

My Canadian correspondent also comments on a paragraph which appeared some time ago in these notes criticising the use of a cheap and nasty moving-iron milliammeter as tuning indicator in an expensive receiving set. This instrument broke down and threw the set out of action. "Hasn't it occurred to you," he asks, "that a cheap meter, by virtue of its lack of a moving coil, must be more reliable than a more expensive type?" Frankly, I can't see eye to eye with him there. I've half a score of moving-coil meters of various kinds that have been in constant service for years, and I have never had any trouble with them—save once when an assistant in an absent-minded moment essayed to measure the EMF of a 150-volt battery with a 0.2 milliammeter! But I do agree with my correspondent when he says that the best of all indicators for general use is that of the "electron-ray" type. The man-in-the-street is apt to fight shy of meters, but he can't disregard a light that winks at him as he tunes.

**Télévision Ranges**

SOME time soon, I suppose, either the B.B.C. or some go-ahead manufacturer will publish a map showing the service area of the London television station. Such a map would be an immense help to the progress of television, for there is now ample

proof that good reception is possible at ranges greatly exceeding the original estimate of twenty-five miles. At such places as Bedford, Reading, Guildford, and Southend, for instance, good results are regularly obtained. Success with both sound and vision is also reported from Brighton, but I believe that in that case the aerial is a very high one standing on the crest of the Downs. In any event, the Alexandra Palace station covers a large and densely populated part of the country, and the number of people who are within range is greater by hundreds of thousands than was originally estimated. When the Birmingham transmitter gets going, about one-third of the population of the country may become potential televiewers.

**Portables for Football Fans ?**

NEXT time I go to Twickenham to see a big Rugger match I am firmly resolved to take with me a tiny portable set with a pair of headphones. No, dear reader, it is not that I want to listen whilst watching to the croonings of Henry Hall's sweetie-bereft vocalists or, indeed, to music of any kind. What I desire to hear is Captain Wakelam's comments on the game that I am watching. 'Flu and other things had compelled me until the day of the Welsh match to attend all my Rugger matches in spirit only this season, the body being at home and the ear, so to speak, glued to the loud speaker. And when at long last I was able to be a spectator in the flesh, I realised as never before that Nature has failed to endow me with the eagle eye of the expert commentator, who seems to see every minute point of the game and to be able to name any player unerringly, even though he (the player, that is) be covered in a solid sheet of mud from head to foot. The match-watcher's portable is a grand idea. It has another application, too. The real enthusiast, torn by conflicting loyalties, could watch one match and "hear" another with its aid!

**Worth Having**

OFTEN I've wondered why car radio doesn't catch on in this country to the same extent as in the United States. One reason is possibly that we need a second 10s. licence for the car set, whilst Americans don't have licences at all. It's queer how great a deterrent even small licence fees are to some people. I've heard of well-off folk who won't take on an extra manservant (whom they could perfectly well afford) because of the 15s. licence involved, though this represents but a minute percentage of the man's wages. I think we miss a good

deal by not being more car-radio minded. I don't mean that I want to have the wireless set on all the time that I am driving. I don't, but it is certainly a boon to be able to flick over the switch and to have music or other entertainment at will on long, lonely drives. A boon, too, to have the sporting commentaries, the news bulletins, and so on there for the switching when you drive out into the country in summer time. Once you've driven a wireless-fitted car you'll never want a "silent" one again.



**The Aerial Problem**

THOUGH there's not a little nonsense spoken and written about receiving aerial efficiency, I do think that many of us don't do our sets too well in the way of collectors, and for this I am rather disposed to blame the man who installs the set. When I say that there's a deal o' nonsense talked and written about aerials I have in mind this kind of thing. A man I know had what I should describe as a perfectly good aerial well above the average standard. A friend (?) who inspected it told him that if he could raise the far end another five feet he might expect wonderful results—though he wasn't doing too badly as it was. Wishing to have the very best, he had the alterations carried out at considerable expense, for there were certain difficulties. Result?

Well, no more stations and no noticeable increase in the volume from the weaker ones that he was already receiving.

**What is Needed**

The modern set undoubtedly deserves a good aerial, but if yours is of reasonable length, 25-30ft. in height, well insulated and unscreened by high trees or buildings, there's probably not very much wrong with it; an extra foot or two of height won't make all *that* much difference. What is bad, though, is when the service man who puts in the set tells those who don't know the ropes that an indoor aerial is just as good as one out of doors, or that the set will work perfectly well without an earth. I've come across one or two instances lately of this kind of thing, and some of them are enough to make one weep. One concerned an expensive mains set capable of first-rate performance. When I first heard it I was horrified at the amount of background noise. Investigation showed that there was no earth; the fellow who installed the set, having observed that it was going to be a bit of a job to make a good earth connection, had assured his victims that there was no need for it. And I've found before now a good existing outdoor aerial removed and the poorest of indoor aerials substituted to cover up lack of sensitivity in a dubious receiving set.

# Distant Reception Notes

SO many different figures are given for the total of U.S.A. broadcasting stations that I had the curiosity to tot it up when examining the other day the latest list sent to me by an American friend. I made it (E. and O.E.!) 663. This represents a very considerable drop from the total of some ten years ago, when there were about 800 stations broadcasting in the States. The reduction is probably accounted for chiefly in two ways.

First of all, many of the original stations who were very small fry started to advertise local business or scholastic or religious (yes, religious!) undertakings. They were swamped as bigger stations with more ambitious programmes came along. Next, many of the older stations could not conform to the Federal Communications Board's standards of frequency keeping. They therefore either relinquished voluntarily or forfeited involuntarily their licences to broadcast.

The surviving 663 stations include a very large number in the 0.1-0.5 kilowatt class; but all have brought their transmitting plants sufficiently up to date to be able to keep within the very narrow limits of wavelength wandering that are all that is allowed in that very enlightened country. Every station, whether it has an individual channel or works with anything up to a score or more of wavelength partners, has to submit to a monthly "solo" test by the central authority to ensure that it is capable of keeping, without undue deviation, to the straight and narrow path assigned to it.

Since the stations engaged in frequency checks work on cleared channels, some of them may be of interest to those D-X enthusiasts in this country who are wont to class any U.S.A. medium-wave station rated at 1 kilowatt and more as a "local." Here

are a few pre-breakfast time selections on frequencies of guaranteed accuracy: *First Monday in the month*, KTSA, San Antonio, Texas; 1.0 kilowatt, 550 kc/s, 6-6.15 a.m. *First Tuesday*, WRR, Dallas, Texas, 0.5 kW, 1,280 kc/s 6-6.15 a.m. *First Friday*, WACO, Waco, Texas, 0.1 kW, 1,420 kc/s, and KNOW, Austin, Texas, 0.1 kW, 1,500 kc/s, both 6.45-7.15 a.m. *Second Friday*, WJAG, Norfolk, Nebraska, 1.0 kW, 1,060 kc/s, 6.30-7 a.m. These transmissions are regular fixtures for some months to come. All times given are G.M.T.

From a kind correspondent I learn that the Greek broadcasting scheme, of which I gave details some time ago in these notes, is hanging fire to some extent. It may be quite a while before the 100-kilowatt Athens station materialises; but it has been arranged that a provisional 15-kW transmitter shall be put into action within a month or two, and this is now being constructed. As soon as the big station is completed, the 15-kW plant will be moved to some other centre in Greece. Greek listeners have for long been amongst the worst served in civilised countries. Their only station, at Salonica, has operated only every now and then (and more then than now, if I may so put it), with the result that those who possess receiving sets have to rely almost entirely upon foreign transmissions for their radio entertainment. And Greece herself has remained a country almost unheard outside her own frontiers. At any rate, I don't remember that I have ever come across anyone here who has succeeded in logging Salonica. If the new Athens station achieves an individual channel it should be receivable even with 15kW, and when the 100-kW transmitter gets to work good reception after dark should be regularly recorded.

D. EXER.

## MCCARTHY

for the finest value in  
All-Wave Receivers!

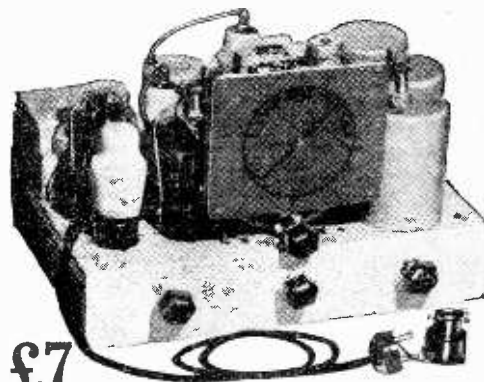

£7

### 6 VALVE ALL-WAVE SUPERHETERODYNE

(complete with B.V.A. Valves)

Improved edition of this popular receiver (praised "Wireless World" test reports). Heavier gauge cadmium-plated steel chassis. Iron-cored I.F. transformers give even better performance. No increase in price.

Brief Specification: 8-stage, all-wave band-pass superheterodyne, 7 tuned circuits. D.A.V.C. with "squench" circuit valve for noise suppression. Illuminated "Airplane" dial. Octode frequency changer. 3-5 watts pentode. Switching for gramophone pick-up. Wave ranges: 16.5-50, 200-550, 800-2,000 metres.

### MCCARTHY ALL-WAVE SIX

with 6 watt  
push-pull  
output

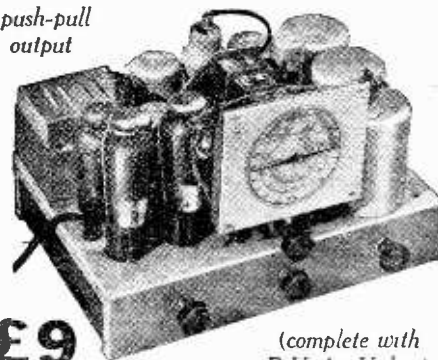

£9

(complete with  
B.V.A. Valves)

6 valve all-wave superheterodyne with similar specification, performance, etc., to above, but with large push-pull output giving 5½-6 watts.

Has illuminated "Airplane" dial with principal station names, tone control and volume control (both also operative on gramophone), full provision for gramophone reproduction.

A really high quality receiver, with exceptionally large undistorted output, and fine performance on all 3 wave ranges.

All McCarthy receivers supplied complete with valves, knobs, pilot lamps, leads, mains cable and plug. 12 months' guarantee.

Deferred terms on application, or through London Radio Supply Co., 11, Oat Lane, E.C.2.

Cash with order on 7 days approval. Also write for illustrated catalogue of complete range of all McCarthy receivers

**MCCARTHY RADIO LTD.**  
44a, Westbourne Grove, London, W.2

Telephone: Bayswater 3201/2.

# Broadcast Brevities

## Shut Your Eyes

NO B.B.C. department is more anxious than "Outside Broadcasts" to receive helpful suggestions from listeners. The trouble is that many well-meaning correspondents put forward the most impossible ideas.

Mr. Joly de Lotbinière has been compiling a number of acid tests which listeners might apply to their ideas before passing them on to the B.B.C. First he suggests that proposed "O.B.s" should be considered from the point of view of expense; secondly, news value; thirdly, atmosphere value; and fourthly, "commentability." To test for the last-named elusive quality, listeners are asked, before sending in their ideas, to shut their eyes and describe the proposed broadcast while their friends listen for entertainment value. (And people who would help in this way would be *real* friends.)

## Brighter "O.B.s"

Apart from the Coronation broadcasts, the O.B. Department has big ideas for infusing new blood into next summer's outdoor events. Probably more time will be devoted to County Cricket. Racing will receive new treatment, too. For instance, the Cheltenham Gold Cup will be relayed instead of the usual Hunt Cup, principally because Golden Miller is to attempt to win the Gold Cup for the sixth time in succession. It is also hoped to cover the Lincoln Handicap, which has never previously been broadcast.

The Derby and the Grand National will, of course, remain in the broadcast racing calendar.

## Wanted: A Word Painter

Amateur boxing will also receive more attention, and it is hoped to cover the national amateur championships, University boxing and the Army meetings.

Actually, of course, very little material has gone untapped by the O.B. Department in the last ten years, but a new source may be found in the "country scene." The microphones will be taken to ploughing matches, country fairs, horse shows, coaching meetings and cattle markets. And a search is now afoot for a "word-painter" who can describe landscapes. The post would have suited Mr. William Wordsworth.

## Television at the Ringside

THE forthcoming television broadcast of an amateur boxing match from Alexandra

## NEWS FROM PORTLAND PLACE

Palace Concert Hall on Thursday next, February 4, is giving the engineers cause for excitement. The Emitron camera will be placed on a platform some 11ft. from the ringside, and in order to determine camera angles, the amount of "panning" required, and necessary lighting, the television O.B. men have constructed a model boxing ring about 1ft. square. Even with an accurately designed model, however, there is a "snag" concerning the lighting; if 2,000 watts of light are used for the actual television transmission, one-tenth scale models of the lamps would require miniature bulbs of the flash-lamp type taking 20 watts. At the moment there is no such miniature bulb available.

Models are destined to play an increasingly important part in the devising of television programmes, and the boxing match

few days. The antiquated studios in Rosemount Terrace are to be scrapped in favour of more or less palatial headquarters at Beechgrove House, Beechgrove Terrace. Up till recently this was the residence of a respected town councillor. It is one more addition to the long list of buildings converted from their original state for the purpose of broadcasting.

## Strange Origins

The B.B.C.'s research building at Nightingale Square, Balham, was originally a convent, while Avenue House, Clapham, also a haunt of engineers, was the residence of a former Governor of Brixton prison. The original Cardiff transmitter was in a sub-station of the electricity supply adjoining the Great Western main line; the Leeds headquarters was formerly a Friends' Meeting House,

IF TELEVISION COMES to the Budapest studios Hungarian listeners who become "viewers" may have the added pleasure of seeing Lili Filotas (right) and Gitta Natter who are now announcers on the studio staff.

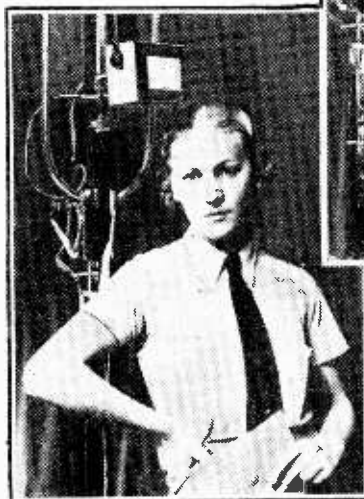

and private houses were taken over as B.B.C. premises in Bristol and for the new Penmon station.

But the most lowly origin could be claimed by the original Newcastle transmitter, which began life in a cowshed and was promoted to a stable yard.

## Battleship in "B.A."?

THAT the dummy forecastle of a battleship should be erected in BA studio, Broadcasting House, is one of the suggestions for imparting a realistic atmosphere to Mungo Dewar's fourth edition of "Eight Bells," to be broadcast regionally on February 10th. The orchestra and cast may be dressed in naval uniform.

Great rivalry exists at Broadcasting House between the producers of the various Services concert parties. So far listeners appear to favour "Flying High," the R.A.F. concert party produced by Charles Brewer.

## A Territorial Show

Continuing the "Services" tradition, a Territorial Forces concert party will probably be heard after the next "Eight Bells" broadcast, and then, some time in the summer, "Flying High" will return to the microphone. Charles Brewer is investigating all sorts of possibilities in extending these Service shows, which go with a swing and revive many old memories.

## The Eight Millionth

ON December 31st, 1936, licensed listeners in this country numbered 7,960,573, an increase of 579,145 in twelve months. Within the next week or two the eight millionth licence may be issued, and the occasion should merit a song and dance on the part of the Post Office and/or the B.B.C.

## North Wales Service

PROGRAMMES for broadcasting from Penmon, which comes into full service on February 1, will be received by land-line from Bangor, or via Bangor from Cardiff, or any other studio in the B.B.C. system. At the programme control desk the level can be controlled and quality checked. In addition, facilities for quality checking will be available in a room acoustically treated for this purpose. From the control desk the programme will go to the control room for preliminary amplification and thence to the transmitter, which is housed in a building sixty-eight feet long by forty-five feet wide.

## Synchronisation

The circuit of the transmitter resembles those of the two most recently built transmitters at Lisnagarvey and Burghead, in that the same system of series modulation is employed. The Penmon transmitter, however, is on a considerably smaller scale and as a result there are certain differences in layout.

As the programme will be identical with that put out by the Welsh transmitter, special care will have to be taken over synchronisation. The high-frequency input to the Penmon transmitter originates from a valve oscillator, the frequency of which is stabilised by a tuning fork. The frequency of this fork is itself controlled by a crystal at the Washford transmitter, the two being linked by land-line. Accurate synchronisation is thus ensured.

# Letters to the Editor

The Editor does not hold himself responsible for the opinions of his correspondents

## Sound Recording

THE publication of two articles on "Sound Recording" by S. R. Eade in the November 27th and December 4th, 1936, issues of *The Wireless World* once again exhibits your awareness of readers' requirements, and I beg the courtesy of your space to discuss several of the points and topics raised by these interesting articles.

To avoid confusion I will enumerate the points:—

(1) In Part 1 the author refers to the Blattnerphone magnetic recording system. The original equipment has been considerably developed, and with the metallurgical researches of Dr. Stille has evolved into a medium-quality apparatus. The latest example of this modern technique is the Marconi-Stille Recorder-Reproducer, Type M.S.R.I., as used by the B.B.C. It has an overall frequency response of from 70 to 5,000 c/s. within plus or minus 2 db. Incidentally, it may be observed that the total cost of the complete equipment is £1,435, and the price of 3,000 metres of special steel-tape, i.e., 30 minutes' run, is £19. (For a short survey of foreign methods of magnetic sound recording, see *Radio-Craft*, March, 1936.)

(2) In Part 2, page 594, column 2, paragraph 4, line 7, the word "positive" should be "negative." This will be apparent, for when the copper "master" is stripped off the recorded wax blank, which is positive, the grooves appear as ridges or in relief. The correct order in processing is as follows: recorded wax blank or "filled blank" (+), copper "master" (-), series of copper "mothers" (+), the necessary number of stampers, working matrices or dies (-), and so the final pressed disc (+).

(3) I agree with the author's conclusion that "in the light of home recording requirements . . . photographic methods are too expensive and require complicated apparatus operated with considerable technical skill. . . ." It would have been perhaps wise to have included in the foregoing the phrase "at present," because I have recently been informed of two firms in England which are experimenting to commercialise an amateur, or home, sound-film recording apparatus, together with cheap usable film stock. Therefore one may ask whether the sound-on-film system will ever wholly supplant the disc system.

(4) I disagree with the statements made in the three paragraphs preceding the last of Part 2; a sound quality of a high order is possible with certain disc recording equipments (e.g., the apparatus described by Mr. Bradford in *The Wireless World* for September 25th, 1936), and the difficulty is not even one of playing-time duration, but the chief problem is to devise an inexpensive and effective synchronising mechanism.

(5) I now give some information about two recent developments in the sound recording field, which I believe will interest readers.

The first is known as "ultra-violet exposure," which is a new R.C.A. Photophone method of obtaining improved emulsion resolution of the film and better definition of the images presented by the lens combi-

nation by recording and printing the sound-track with an ultra-violet light. This results in a more clearly defined wave-form at high frequencies, say, at 9,000 c/s, and consequent better sound-quality in the projected positive print. (For a full explanation see *The Journal of the Association of Cine-Technicians*, December, 1936-January, 1937.) One of the first films to employ this new method is "The Garden of Allah," now showing in London, although it must be confessed that the improvement is not very noticeable aurally.

The second development comes from America, and is a sub-standard sound film recording instrument. It consists of a 2,000 ft. reel of 16 mm. film which is "cut" or imprinted by a diamond-pointed stylus, and forty parallel sound tracks are produced across the entire width of film, except for the two sets of sprocket holes. As each track is cut and filled the stylus shifts automatically to the next adjacent space. The film record plays-back immediately, and one reel lasts approximately thirty-seven hours. (Cf. "The Phono-Reel" in *The Wireless World*, November 29th, 1935.)

Ilford, Essex. DONALD W. ALDOUS.

## Service Prospects

A POINT of great interest to me is raised by "Enquirer" in your issue of January 1. I am employed as service engineer by a fairly large firm of retailers, I work about twelve hours per day for five days, and four hours on the shop half-day closing. My wages, two guineas and sixpence, plus commission, is good pay as I am only just twenty one, the work is pleasant, and is better than the conditions in factories where the wage I was offered was twenty-eight shillings—thirty-five shillings when I was twenty-one.

If "Enquirer" can quickly diagnose the particular chassis he comes in contact with, experience will come quickly. If I were he I would obtain a good test meter and oscillator, and the *Wireless Service Manual*, digest this, and then go out for a service job at, say, two pounds per week.

There is a shortage of even moderate service men, and when experience is gained a man of thirty with his own gear should easily claim three fifteen to four pounds a week. Forget the letters for a while and get some experience in your own lab.

Manchester.

ENGINEER.

## The Croydon Radio Society

AN interesting lecture was recently given by Mr. P. G. A. H. Voigt, of loud speaker fame, who, of course, dealt with his own particular subject. The lecturer pointed out the striking effects which the acoustic properties of a room had on loud speaker reproduction and he deplored the modern style of room which imparted a harsh tone to the efforts of the B.B.C. Next Tuesday evening (February 2nd) is one of the club's loud speaker nights at which members bring their instruments for comparative tests to be made. This always arouses great interest, and anybody who desires to attend will be cordially welcomed. The meeting is at 8 p.m. at the Society's headquarters at St. Peter's Hall, Ledbury Road, South Croydon. Full particulars of the society may be obtained from the Hon. Pub. Secretary, Mr. E. L. Cumbers, 14, Campden Road, South Croydon.

## POINTS OF IMPORTANCE in the Rola G.12

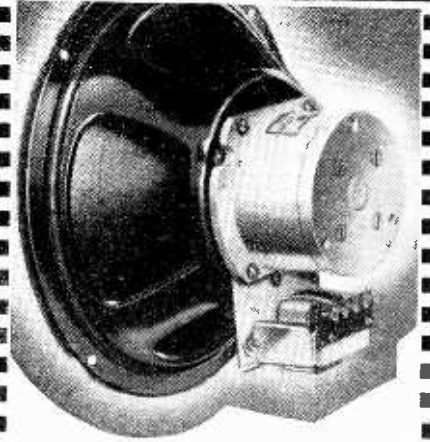

### OF THE FIRST WATER

A diamond of the first water is amongst the finest of the world's jewels. A radio receiver that is G.12 equipped is amongst the finest of the world's wireless sets. The fact that a Rola G.12 is fitted is a guarantee not only of the most faithful reproduction but of the high quality of every component in the set. For no set that is not thoroughly good throughout would be equipped with this outstanding speaker. Every listener should install a G.12 because it means better reproduction. Every manufacturer should install G.12's in their more expensive models, because they increase sales. In either case you will find that there is no better speaker made to-day.

G.12 P.M. (as illustrated) with Transformer . . . . .	£5 5 0
G.12 P.M. less Transformer . . . . .	£4 16 0
G.12 D.C. Complete with Transformer, Mounting Stand, Handle and Base . . . . .	£5 5 0
G.12 D.C. with Mounting Stand, Handle and Base, but without Transformer . . . . .	£4 16 0
G.12 D.C. Stripped but with Transformer . . . . .	£4 4 0
G.12 D.C. Stripped and without Transformer . . . . .	£3 15 0

(When ordering please state Field Resistance and Impedance of Transformer required.)

For Public Address work both the P.M. and Energised Models can be supplied with a 15 ohm Voice Coil at an additional charge of 3/-.

Write for Folder A.

OVER 8 MILLION IN USE

# ROLA

The World's Finest Reproducers

THE BRITISH ROLA CO., LTD.  
MINERVA ROAD, PARK ROYAL, N.W.10.  
PHONE WILLESDEN 4322-3-4-5-6.

# Recent Inventions

The British abstracts published here are prepared with the permission of the Controller of H.M. Stationery Office, from Specifications obtainable at the Patent Office, 25, Southampton Buildings, London, W.C.2, price 1/- each. A selection of patents issued in U.S.A. is also included.

## SUPER-REGENERATIVE CIRCUITS

A PENTODE valve is used as a local oscillator for quenching a super-regenerative circuit, the grid and screen-grid being back-coupled magnetically. Or the grid may be capacity-coupled to the anode, and the quenching oscillations applied to the screen grid, the pentode being shunted across the circuit to be damped.

As shown in the Figure, the pentode P is the super-regenerator. Its anode-cathode path is

**Brief Descriptions of the more interesting radio devices and improvements issued as patents will be included in this section.**

electron-emitting surface is covered with an insulating layer of artificial resin, on which is laid a perforated metal plate which acts as a control grid. The latter is covered with a layer of glue, to separate it from a second grid, which is also covered with an insulating layer to separate it from a third grid, and so on. Metal-foil leads are connected to the various

the condenser C through a resistor R by the action of the grids G, G1, a diode valve D being inserted, as shown, in order to prevent the voltage on the grid G1 from building-up much in excess of the cathode. The operation of the oscillator depends upon the fact that variations in the potential of the first grid causes corresponding variations in the potential of the second grid, within the limits allowed by the diode D.

E. L. C. White, Application date March 21st, 1935. No. 455497.

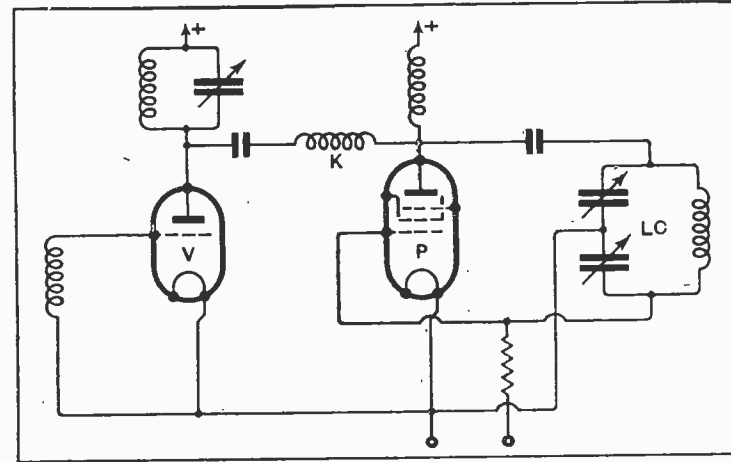

Super-regenerative circuit using a pentode as the quenching valve.

shunted by a choke coil K in series with a back-coupled oscillator valve V. The oscillations from the valve V periodically reduce the anode voltage of the pentode so that the latter is swung on to the low-impedance part of the curve. At these times it quenches the oscillations in the main circuit L, C, which is shunted across the anode and grid and connected between the two tuning-condensers shown to the cathode.

D. M. Johnstone and Baird Television, Ltd. Application date April 17th, 1935. No. 455298.

## DF AERIALS

A FRAME aerial used for direction-finding on an aeroplane is arranged so that when not in use it can be withdrawn into a recess in the fuselage, where it is protected from wind and weather, and adds nothing to the head resistance of the machine.

When required for taking bearings, the frame slides out of the recess on a yoke which is carried by guide-tubes, and is firmly locked in the fully retracted position. A centre spindle allows the frame to be orientated about a base-plate, which is marked with a compass scale.

Short Bros. (Rochester and Bedford), Ltd., and A. G. Parks. Application date August 1st, 1935. No. 455164.

## DRY-CONTACT AMPLIFIERS

A SERIES of dry-contact electrode-surfaces are arranged to act both as a detector and amplifier in much the same way as a thermionic valve. A cathode or

grids to allow the application of suitable biasing-potentials.

The upper or "plate" electrode consists of a metal of different electron-emitting properties to the first or cathode electrode, so that an electron discharge takes place across the assembly of electrodes, under the action, say, of a light-ray, and is controlled or amplified by the potentials on the various "grids."

N. V. Philips Gloeilampen-fabrieken. Convention date (Germany), March 9th, 1935. No. 454826.

## GENERATING "PEAKED" OSCILLATIONS

A FIVE-GRID valve V is used to generate a "peaked" or saw-toothed oscillation by discharging

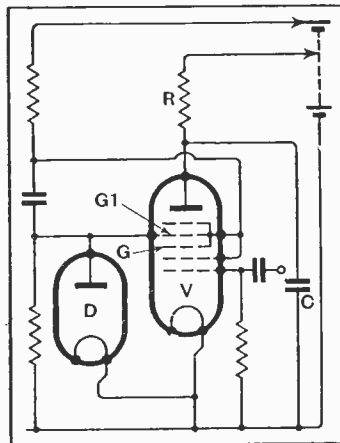

Circuit arrangement of saw-toothed oscillation generator.

## CONTROLLING ELECTRON EMISSION

THE rate at which electrons are liberated from a sensitised surface, either under the effect of an incident light-ray or as the result of bombardment by other electrons, depends to some extent upon temperature, of which there is an optimum value for different emissive surfaces.

Accordingly means are provided to control the temperature of the various electrodes, say, in a multi-grid electron-multiplier of the cold-cathode type. For instance, the electrodes may be made hollow and supplied with heating or cooling fluid through glass pipes sealed into the bulb of the amplifier.

E. E. Wright and Baird Television, Ltd. Application date April 15, 1935. No. 454973.

BROADLY speaking, the object is to produce an electron discharge device capable of high amplification and, in the case of

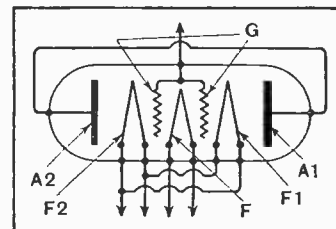

Electron discharge device embodying subsidiary cathodes to control the emission.

a thermionic valve, to secure a high degree of sensitivity by using electrodes which are spaced comparatively widely apart. Two electron-emitting elements are used in the same tube, the first acting as the cathode proper and the second acting to control the volume of emission from the first. In other words, the first emitter may be said to act as the anode of the second, since it collects electrons from it, and as a cathode so far as the main discharge through the stream is concerned.

Control is effected either by altering the potential-gradient between the two emitters, or by deflecting the electron stream passing through the space between them, also by varying the heating

of the second or control emitter. The principle can be applied to valves whether used as amplifiers or generators, and also to cathode-ray tubes.

As shown in the Figure, a central emitter F controls the emission from two other emitters F1, F2, which are located on opposite sides of it and co-operate with separate anodes A1, A2. Control grids G are inserted in the space between the centre and outer emitters. So far as the external circuits are concerned the emitters F1 and F2 are connected as a common cathode, the two grids G and the anodes A1, A2 being similarly treated.

P. Schwerin; Electronic Devices, Ltd., and H. C. Atkins. Application dates January 14th and March 9th, 1935. No. 455137.

## CATHODE-RAY TUBES

AS an alternative to the usual method of controlling the intensity of the light spot, the cathode K of a cathode-ray tube is so constructed that its emissivity is not uniform throughout, but varies from one end to the other of its length.

An electron image of the cathode is first focused by an ex-

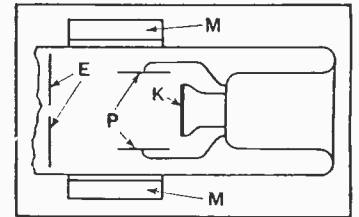

Electrode assembly of the cathode-ray tube described in Patent No. 455237.

ternal magnetic coil M on to a screening electrode E provided with a central aperture. Modulation is then effected by swinging the image to and fro, over the aperture, by means of the deflecting-field set up across two plates P. This causes the number of electrons passing through the aperture (and reaching the fluorescent screen) to vary in accordance with the strength of the signals applied to the plates P.

J. C. Wilson and Baird Television, Ltd. Application date April 15th, 1935. No. 455237.

TO minimise the danger of collapse, due to external air-pressure, it is desirable to make the glass envelope of a cathode-ray tube of uniform thickness throughout. Instead, therefore, of introducing the leads for the high-potential electrodes through a thickened stub, they are sealed-in at the junction between an upper and lower part of the tube, close to the electrodes in question. This allows the tube to be made in two parts, which are of uniform thickness and are butt-welded together.

Ferranti, Ltd., and M. K. Taylor. Application date April 16th, 1935. No. 455499.



# The attainment of Quality Reproduction



GOODMANS 12" High Fidelity Auditorium Reproducer.

Practical facts regarding the attainment of high quality reproduction usually remain the guarded secrets of technicians. We, however, have issued an interesting, lucid and concise Bulletin describing the technical development involved in the reproduction of our High Fidelity Auditorium Loudspeakers, which represent as high a standard of reproduction as present-day knowledge permits.

The problems encountered and their solutions are described. The causes of distortion are explained. The results of extensive experiments are recorded. The points dealt with include the following:—

- The attainment of level response and wide frequency range.
- Sub harmonics; their definition and cause.
- The elimination of sub-harmonic distortion.
- Efficient transient response.
- Bass modulation. Its cause and remedy.
- The theory of dual exponential cones.
- The necessary attributes in a high quality Receiver or Amplifier.

The scientific value of this Bulletin has already been widely acknowledged by Technical experts.

An appreciation reads:—

*"Thank you very much for the complete information on your Loudspeakers. The method of presentation and the fullness of information relating to the conditions of tests are worthy of real praise and the radio industry would do well to take note."* (Signed) E.D.

BULLETIN and Response curves will be sent to you for 3d. in stamps. Post this coupon for your copy.

DEMONSTRATIONS of Goodmans Loudspeakers held every Thursday Evening at the Wembley Works between 6 p.m. & 7 p.m. (5 mins. from Wembley L.M.S. & Bakerloo Stn., & Buses & Trams)

Other demonstrations by special appointment—  
Telephone: Wembley 4001.

## GOODMANS for Quality Reproduction

POST this COUPON to

GOODMANS INDUSTRIES LTD., LANCELOT RD., WEMBLEY MIDDX.

Please send me Technical Bulletin with response curves describing GOODMANS High Fidelity Auditorium Speakers, for which I enclose 3d. in stamps.

Name.....

Address.....

w.w. 29/1/37.

## IMPORTANT PRICE REDUCTION! MODEL D104



### PIEZO-ELECTRIC MICROPHONE

Reduced from £5.17.6 to **£4.10.0**

On February 1st.

The remarkable popularity of the Rothermel-Brush D104 Piezo-Electric Microphone has enabled us to reduce the price to the very attractive figure of £4.10. This change will come into force on February 1st. For Public Address equipment or Relay or Amateur Transmitter use the D104 is unquestionably the very finest instrument available. Clarity and sensitivity are unique, its frequency response up to 8,000 cycles is far superior to that of Carbon microphones and because of its high impedance it can be connected directly to the input grid without using transformers. No button-current or polarizing voltage is required. From every point of view the D104 is the ideal instrument for its particular purpose.

MODEL D104 complete with 6 feet shielded microphone cable **£4.10.0**

OVER 3,500 IN USE IN GREAT BRITAIN

*R.A.R. Rothermel LTD.*

Rothermel House, CANTERBURY ROAD, HIGH ROAD, KILBURN, LONDON, N.W.6.

Phone: Maida Vale 6066.

## CLIX

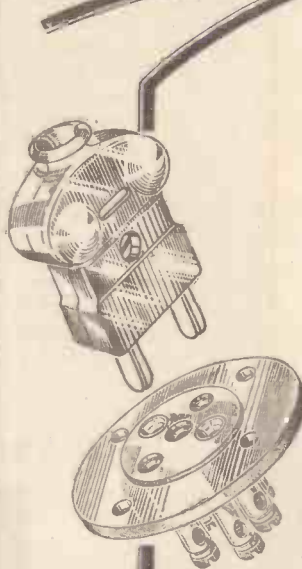

### FUSE PLUG

This Clix Fuse-Plug is supplied complete with two fuses of either 1-, 2- or 5-amp rating. When a fuse has to be replaced only one screw has to be removed and a new "Slip-in" fuse inserted. Simple—Speedy—Safe.

Complete with two fuses. **1/8d.**

### STANDARD VALVEHOLDERS

As specified for the Experimenters' **I. F. AMPLIFIER**

Type V1. 5-pin without terminals - **6d.**  
Type V2. 7-pin " " - **9d.**

Clix patent non-collapsible pins are used in Clix Fuse-plug. Clix Valveholders incorporate patented resilient sockets which give full surface contact. All Clix products give you long and faithful service.

If any difficulty in obtaining Clix products locally, please send us name and address of nearest dealer.

Folders "W" Free

*Yours faithfully*

LECTRO LINX LIMITED

79<sup>A</sup> ROCHESTER ROW. LONDON. S.W.1

# MISCELLANEOUS ADVERTISEMENTS

## NOTICES

THE CHARGE FOR ADVERTISEMENTS in these columns is

12 words or less, 3/- and 3d. for every additional word.

Each paragraph is charged separately and name and address must be counted.

SERIES DISCOUNTS are allowed to Trade Advertisers as follows on orders for consecutive insertions, provided a contract is placed in advance, and in the absence of fresh instructions the entire "copy" is repeated from the previous issue: 13 consecutive insertions 5%; 26 consecutive, 10%; 52 consecutive, 15%.

ADVERTISEMENTS for these columns are accepted up to FIRST POST on MONDAY MORNING (previous to date of issue) at the Head Offices of "The Wireless World," Dorset House, Stamford Street, London, S.E.1, or on SATURDAY MORNING at the Branch Offices, 19, Hertford Street, Coventry; Guildhall Buildings, Navigation Street, Birmingham, 2; 260, Deansgate, Manchester, 3; 26a, Renfield Street, Glasgow, C.2.

Advertisements that arrive too late for a particular issue will automatically be inserted in the following issue unless accompanied by instructions to the contrary. All advertisements in this section must be strictly prepaid.

The proprietors retain the right to refuse or withdraw advertisements at their discretion.

Postal Orders and Cheques sent in payment for advertisements should be made payable to LIFFE & SONS Ltd., and crossed **& Co.** Notes being untraceable if lost in transit should not be sent as remittances.

All letters relating to advertisements should quote the number which is printed at the end of each advertisement and the date of the issue in which it appeared.

The proprietors are not responsible for clerical or printers' errors, although every care is taken to avoid mistakes.

## NEW RECEIVERS AND AMPLIFIERS

**DEGALLIER'S, Ltd.**, the Firm for Reliable Short Wave Radio (1937), have on show in London the largest selection of fully guaranteed brand-new all-wave receivers; callers invited to handle all at their leisure without obligation to purchase; all S.W. receivers guaranteed to get stations on the low bands, including the Americas, etc. Hours of business, 11 a.m.-7 p.m., Saturdays 9 p.m. Early closing day Mondays. All goods cash with order or c.o.d.; handsomely illustrated catalogues available; send large stamped addressed envelope with all enquiries.

**WE Guarantee to Receive the American Transmissions** at full programme strength after 3 p.m. daily; those interested welcomed without obligation.

**6/6** Each.—Valves for American receivers, all guaranteed, each a first, no seconds or throw-outs; for every known set, from 1927-37; metal, metal glass, glass counterparts and glass; in ordering, just state type and number; we have it; all post paid; line cords for all Midgets, 4/6.

**30/-**—"Doublet" Aerial Belden No. 8917, complete ready to erect; the most efficient made, having a variable coupling unit covering all bands.

**£3/10**—T.R.F. Midget Receiver. "The smallest of its type in the world," medium and long wavebands, moving coil speaker, 2 watts undistorted, no earth, no aerial, compact and transportable, cloth covered, and obtainable in various colours; carriage 1/6.

**13 Guineas**—The new Challenger 8 (type 800) table model De Luxe, 22x18x12 high fidelity, 8-valve superhet, A.C. 200-250 volts, wave-band coverage 11-2,050 metres, simplified centralised tuning, super Vernier, slow-fast tuning self-contained control panel, perfect tone quality at low volume, new type 10-inch M.C. speaker, from a whisper to 8 watts pure undistorted tone, no overloading at full volume, oscillator fundamental without use of harmonics, persistent oscillator of highest output, isolating filters eliminate oscillation and motor-boating, fully delayed A.V.C. bias, absolute minimum of noise and sensitivity control for noise suppression, A.V.C. re-enforced capacitors prevent drift, pre-aged intermediate frequency transformers, I.F. barrier, discs, anchor coil leads, plug in loud-speaker, also provision for external speaker, moisture sealed out by tropical zone impregnation, self-healing electrolytic condensers, one complete chassis of dreadnought construction, moderate voltages assure full valve life, economical to operate (consumption 65 watts), long life eliminates repairs, correct valve selection, no compromise, no hum, full weight transformers, true push-pull, stabilised high tension supply, stabilised biases, ceramic coil insulation, fully loaded plate coils give maximum gain, pre-balanced coil assembly, matched sets of individual coils, no taps, sealed insulation, thin laminations of special silico steel, 7 K.C. selectivity, fractional microvolt sensitivity, shielded switching, permits high-gain, positive silver-plated contacts, eliminates switch noises, audio frequency range 30-8,000 cycles, diode detection, prismatone high fidelity R.F. preselector stages on all bands, carriage 6/-; for experimenters, less cabinet deduct 15/-; if public address Rola 12in. G.12 supplied in place of standard speaker, add 22.

(This advertisement continued in third column.)



## DOGGED DOES IT

Recently a gentleman called for a demonstration. He was much impressed, and bought a set. During our talk it came to light that for weeks he had been trying to hear our receivers. First he went to the nearest radio shop. They said, "Oh no—we won't touch H-T stuff—it's so complicated that no service man can repair it."

After a while he tried a large shop in a fair-sized town. They said, "Oh yes, we can get you one if you like, but we don't advise it. Their sets never get less than three stations at once. Why don't you have one of these lovely '—' superhets—only £15 complete and gets everything in Europe."

The persistent client tried a large music-dealer, who claims to be a specialist in high-quality radio. He said: "No! don't buy an H-T set. They sound awful unless they're turned full on. Try one of our '—' sets." The enquirer, a persistent man, instead of giving up the idea, got in touch with us direct . . . and is now a satisfied customer.

Not one of the three traders mentioned had ever heard our apparatus, as far as we know. Certainly none of them had ever bought any. Then why did they say what they said? We can guess. Here are some statements of fact on which we base our guess.

- 1.—Wireless retailers are in the business for their living.
- 2.—They get certain discounts to cover the cost of selling and service.
- 3.—If the trader is not a Hartley-Turner stockist he is concerned to sell something else; and it is almost too much to expect disinterested advice. Consequently, some may succumb to the temptation to suit their advice to their immediate profit.
- 4.—It therefore pays you—in terms of high quality reception—not to be put off, but to

COME AND HEAR IT



**HARTLEY TURNER  
RADIO LTD.,  
THORNBURY ROAD,  
ISLEWORTH, MIDDLESEX.  
Telephone: HOUnslow 4488**

## NUMBERED ADDRESSES

For the convenience of private advertisers, letters may be addressed to numbers at "The Wireless World" Office. When this is desired, the sum of 6d. to defray the cost of registration and to cover postage on replies must be added to the advertisement charge, which must include the words Box 000, c/o "The Wireless World." All replies should be addressed to the Box number shown in the advertisement, c/o "The Wireless World," Dorset House, Stamford Street, London, S.E.1. Readers who reply to Box No. advertisements are warned against sending remittance through the post except in registered envelopes: in all such cases the use of the Deposit System is recommended, and the envelope should be clearly marked "Deposit Department."

## DEPOSIT SYSTEM

Readers who hesitate to send money to advertisers in these columns may deal in perfect safety by availing themselves of our Deposit System. If the money be deposited with "The Wireless World," both parties are advised of its receipt.

The time allowed for decision is three days, counting from receipt of goods, after which period, if buyer decides not to retain goods, they must be returned to sender. If a sale is effected, buyer instructs us to remit amount to seller, but if not, seller instructs us to return amount to depositor. Carriage is paid by the buyer, but in the event of no sale, and subject to there being no different arrangement between buyer and seller, each pays carriage one way. The seller takes the risk of loss or damage in transit, for which we take no responsibility. For all transactions up to £10, a deposit fee of 1/- is charged; on transactions over £10 and under £50, the fee is 2/6; over £50, 5/-. All deposit matters are dealt with at Dorset House, Stamford Street, London, S.E.1, and cheques and money orders should be made payable to Liffe & Sons Limited.

**SPECIAL NOTE**—Readers who reply to advertisements and receive no answer to their enquiries are requested to regard the silence as an indication that the goods advertised have already been disposed of. Advertisers often receive so many enquiries that it is quite impossible to reply to each one by post. When sending remittances direct to an advertiser, stamp for return should also be included for use in the event of the application proving unsuccessful.

## NEW RECEIVERS AND AMPLIFIERS

(This advertisement continued from first column.)

**NOTE**—The Challenger 800 is available for A.C./D.C. 200-250 volts, employing 11 valves, at an additional cost of 20/- on each model.

**CHALLENGER Model 381**, with refinements over the 800 series, 8 valve, 13-2,060 metres. Polychromatic dial scale, improved vision master, beam power output valve, 10 watts undistorted, band spread Magna dials and second-hand, magic eye tuning, full range, tone control, automatic band indicator, high image frequency suppression, hair line selectivity, ultra sensitivity; the price will be: table model, 14 guineas; or in chassis form for the experimenter, chassis, dials and speaker, £13/18; the 381 is available in A.C. only; we would point out that this receiver does not in any way replace the 800 model.

**£16**—Challenger 12 A.C./D.C. 200-250 volts, 4 bands range, 11-2,050 metres, the first time that 12 C. users have been able to get 10 watts undistorted from their speaker, which is a large 12in. K. type Rola, triple parallel rectification, push-pull parallel four pentode output, carriage and crate 7/6.

**£17/17**—Challenger 8 Console 800C, height 3 feet 6 inches, width 24 inches, depth 12 1/2 inches, chassis as incorporated in 800 model but incorporating the G.12 high fidelity 12in. speaker; carriage and crate 10/-.

**£20**—Crosley High Fidelity Console De Luxe, 10-valve superhet., height 23 1/2 in., width 24 in., depth 13 in., 5 wavebands, 12-30, 30-75, 75-200, 200-600 and 750-2,000 metres, neon tuning, 12in. Magna "66" speaker, 12 watts undistorted output, separate oscillator valve, separate windings on I.F. transformers for improved selectivity, operates on A.C. 95-267 volts, 20-60 cycles, general specification as in 800 model; carriage and crate 10/-.

**£33**—Radiogram with auto charger, incorporating same chassis as above, carriage and crate, 14/-; £16 chassis, valves and speaker, with all knobs and esculcheons, etc., carriage 6/-.

**29 Guineas**—"Challenger 800 R.G." radiogram with automatic record changer; measurements, height 2 feet 8 inches, width 3 feet, depth 21 inches; this also incorporates the G.12 and tweeter; carriage and crate 15/-.

**£50**—Challenger "Model 5240" 24-valve superhet. twin chassis, valve and "2" Public address speaker, with 60 watts undistorted output, sensitivity 1/2 microvolt absolute, tuned I.F. stages on all bands, 3 I.F. stages, the last one being used for selectivity only, frequency response at the speakers within 2db over whole range, wave band coverage 5-2,050 metres in 5 bands, Magic-eye tuning, variable selectivity, receiver chassis heavily shielded and chromium plated, Centro-Master automatic control unit, dual rectifier, signal channel separate from A.V.C. system, linear, diode detection, separate rectifier to provide A.V.C. voltage, radio frequency pre-amplifier stages eliminate repeat points and whistles, and provide maximum signal to noise ratio, beam power output valves, polychromatic dial scale, prismatone high fidelity, uni-control 2-speed free-wheeling tuning, band spread Magna dial and second-hand, automatic band indicator, automatic interstation noise suppression, separate bass boosting amplifier, automatic frequency control, iron core I.F. transformers, code interference filters, automatic volume control, beat frequency oscillator; carriage 18/-; also available in various gramophone and console cabinets. **DEGALLIER'S, Ltd.**, 18, Connaught St., Marble Arch, London, W.2. Raddington 2745. [5678]

NEW RECEIVERS AND AMPLIFIERS

**AIR KING,**  
THE Royalty of Radio.

**MODEL Empire 11-valve 4-band Supersonic Heterodyne** Receiver for A.C. 100 to 250 Volts, incorporating every refinement known to modern radio technique, large illuminated dial, indicating each wave band separately marked in station names, wavelengths, and frequencies, with the famous exclusive beam tuning system, Magic Eye indicator for increased sensitivity and silent precision tuning, illuminated indicators to show high fidelity and grammo. pick-up, high fidelity assured by two balanced speakers, one acting as special amplifier for high audio frequencies and one large concert type dynamic speaker for full range audio frequency range from 40 to 9,000 cycles, special band expansion intermediate frequency transformer on first stage, variable selectivity, full range variable tone control, A.V.C.

**MODEL Duchess 6-valve 3-band Superhet.** Receiver for A.C. 100 to 250 Volts; this receiver is housed in an attractive lay down walnut cabinet.

**MODEL Envoy for A.C./D.C. Mains,** 100 to 250 volts, no line cord used.

**MODEL Marquis 6-valve 3-band Superhet.** Receiver for A.C. 100 to 250 Volts, in tastefully designed moulded one-piece bakelite cabinet, obtainable in ivory, red, walnut and ebony.

**MODEL Ermine 6-valve 3-band Superhet.** Receiver for A.C./D.C. 100 to 250 Volts, no line cord used, a splendid set of proven popularity.

**ALL Models Feature Beam Tuning, Magic Eye Indicator, grammo. pick-up connections, and special output valves.**

**ALL Sets Fully Guaranteed; H.P. terms available from 3/- per week; our technical department is at your service.**

**WHOLESALE and Trade Enquiries Invited; generous terms.**

**RECTURUS Valves for Improved Radio Reception on All Types of Receivers.**

**RECTURUS, the only line made in 4 ranges, glass, metal, G type, and metal modernisers.**

**WRITE for Lists of These Famous Valves; prices from 4/9 each.**

**AIR KING RADIO, 115, Shaftesbury Av., Cambridge Circus, W.C.2** (1st floor above Barclay's Bank). Phone: Temple Bar 4875 (all lines). All receivers assembled in England. [3406]

**ALERT RADIO Co.**

**ALL-WAVE Receivers at £7/7, £9/9, and £13/13.** A.C. or A.C./D.C.; Midget and other receivers up to 23 valves; for DX work we can supply the latest communication models.—21, East Rd., N.1. Clerkenwell 4871. [3220]

**ROYAL RADIO Co.**  
ESTABLISHED 1908.

**ALL-WAVE Receivers, suitable for use on ships, as supplied to officers of many shipping lines.**

**OUR 8 and 10 Metal Valve All-wave Receivers; 15-2,000 metres, acknowledged by the trade as the best for range, tone, and generous performance.**

**LATEST 6-valve Car Radio, A.V.C., remote control, no suppressors required.**

**FULL Range of the World Famous Fergusson and Pilot Models Stocked.**

**ALL Sets Fully Guaranteed by Ourselves.**

**ALL Types of American Valves Stocked.**

**ANY Make of Set Serviced by Our Qualified Radio Engineers at Reasonable Charges.**

**PAY Us a Visit Any Time, or send for full range catalogue; 1/4d. stamp will be appreciated.**

**ROYAL RADIO Co., 5, Buckingham Rd., South Woodford, London, E.18.** Phone: Buckhurst 2736. [3499]

**"SERVICE With a Smile."**

**HENRY FORD RADIO, Ltd.,**

**ELECTRONIC House, 22, Howland St., Tottenham Court Rd., W.1. Museum 5675.** [0511]

**£3/3**—4-valve Universal midgets, M.C. speaker, coloured fabric cabinets; 5-valve midgets from £3/15.

**£8/8**—6-valve Universal all-wave superhet., R.C.A. valves, new 25B5, in output stage, giving over 2 watts, in Class "A."

**£10/10**—6-valve all-wave superhet., 10in. Rola speaker, pre-H.F. stage, 100-250 volts A.C.

**£9/9**—6-valve car radio, A.V.C., remote control, R.C.A. valves.—E. Fellows, Ferney Rd., East Barnet, Herts. [3595]

**ENQUIRE About Harmaur Radio 1937 Receivers.**

**AMERICAN-BOSCH "Centromatic" All-wave Sets.**

**FREED-EISEMANN Receivers as Bought by the B.B.C. and "The Wireless World."**

**PIERCE AIRO AC/DC All-wave and Car Radios.**

**RAYTHEON Valves. Trade enquiries.**

**THE HARMAUR RADIO Co., Ltd., 8, Clifford St., New Bond St., London, W.1.** [0499]

**COULPHONE RADIO MANUFACTURING COMPANY,** manufacturers of high class radio since 1923.

**STANDARD Range A.C. All-wave Super Hets., delayed A.V.C., Rola speakers, British Tungram valves, high class cabinets, 12 months' guarantee (including valves); 4-valve 3½-watt, £6/10; 6-valve, £10; super 6-valve, R.F. stage, £15; super 8-valve, R.F. stage, 4 wavebands, 8-watt reversed phase push-pull, Rola G.12, £20.—Liverpool Rd., Hutton, Nr. Preston, Lancs. Phone: Longton 196. [3641]**

**CHASSIS, Peerless latest American 9-valve, 3-wave, £9/15; ditto, 11-valve, 5-wave, 12½in. speaker, 18-watts, £14/14.—Kay, 1, Old Church Lane, N.W.9. [0547]**

Notes  
No. 23.

**on the Suppression of Electrical Interference with Wireless Reception**

We still get letters asking if an "Eliminoise" aerial will be any good indoors. If the span is well up under the roof, it may be good enough, but remember that all the wiring to the ceiling lights of the rooms below, and all the water pipes and the guttering, are potential carriers of interference, and if you must put it under the roof, don't blame us or the "Eliminoise." It just cannot do its best unless it is right outside the field of interference, which is generally well away from the house.

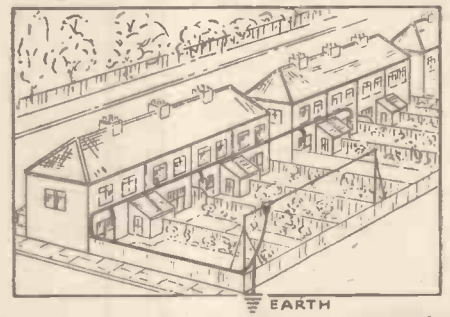

There is no earthly reason why three or four neighbours should not pool their resources and erect a common aerial with a good long span across the bottom of, say, three or more gardens, well away from houses, and each to feed in to separate set end transformers. In this way only one aerial "Eliminoise" would be required. Such an arrangement will probably give better results than any individual could obtain with a limited garden at his disposal. There would be no interaction between receivers tuned to the same or different stations, and although in the illustration the lead-in is made conspicuous, in practice it need never be seen and could be taken under floors, etc., to any room. If each of these people had a small aerial and wanted to get good results, each would have to fit a meterboard suppressor so that the total expenditure would be about equal to that of the community aerial idea.

Now, if an outdoor aerial is impossible, a Set Lead Suppressor may help. Type 300 is fitted at the plug point of a receiver operating from, say, a frame aerial. It will not cut out interference which is directly radiated from the source, but it will keep out that which is conducted along the mains to the set, and will help considerably to keep back that which is re-radiated from nearby electric wiring, e.g., when a Type 300 is in use, the mains lead approaching the receiver is free of interference; but without set lead suppression, the interference on the mains lead is re-radiated to the aerial and earth systems, and you may think it is coming down the aerial. Type 300 (21/-) filters the earth lead as well as the mains. A unique feature and patented.

† "Eliminoise" (Trade Mark), price 35/-, cable extra, per yard, rod.

Send 1s. 2d. for book, "Interference Suppression" or for free copy of "Eliminoise System" and other literature relating to the subject.

**BELLING-LEE SUPPRESSION SERVICE**

**Belling & Lee Ltd.**  
Cambridge Arterial Road,  
Enfield, Middx.

NEW RECEIVERS AND AMPLIFIERS

**ANGLO AMERICAN RADIO** Offer the Finest Range of Chassis and Receivers at London's Lowest Prices.

**50/-**—Multi-band (7-2,000 metres) Junior Communications Outfit, special value; powerful 3v. battery chassis employing new 10-point tank and bandspread tuning system, 7in. pointer dial with short wave station names and world map tuning scale; complete with standard British type battery valves, metal cabinet, 5in. midget speaker and pair headphones, together with Pres Gift 8in. world rotating globe on stand, enamelled in full colours with meridian scale, highly efficient, receives new Television sound programmes, world wide short wave, police, amateur, aircraft, and all standard and long wave transmissions; supplied in kit form, with 8-page instruction and operation booklet, complete as above with all sundries, 50/-, or completely assembled and aerial tested, 20/- extra.

**67/6**—All-wave battery chassis, S.G. H.F. Pentode, 16-2,000 metres, 3 bands, latest all-wave slow motion dial calibrated in metres, P.U. and extra speaker sockets, an excellent home receiver; supplied direct from prominent British manufacturer, 8in. moving coil speaker, 10/6; horizontal type cabinet, 12/6.

**£5/19/6**—7-valve all-wave chassis, 3 bands, 16½-2,000 metres coloured tuning dial calibrated, visual cathode tuning, full A.V.C. A.C./D.C., 110-240v., exceptional performance; matched speaker, 10/6; cabinet, 12/6.

**£7/19/6**—8-valve all-wave chassis, 16-2,100 metres, new De Luxe 5½in. airplane, multi-indication dial, A.V.C., tone control, calibrated all bands, 110-240v. A.C./D.C.; matched speaker, 12/6; cabinet 14/6.

**£8/19/6**—8-valve all-wave chassis, 16-2,100 metres, visual cathode tuning, 7½in. super airplane multi-indication dial, 4 watts output, A.V.C., tone control, A.C. operation, 110-240v.; matched speaker, 12/6; horizontal type cabinet, 15/6.

**£5/19/6**—Car Radio 5-valve superhet, highly efficient, A.V.C., tone control, illuminated dial, magnificent performance, complete with suppressors and sundries and complete operating and fixing instructions; demonstrations under London traffic conditions daily.

**CABINETS Offered With Chassis are of Finest Quality and Finish, and as supplied by manufacturers with chassis; where cabinets are ordered with chassis these are despatched fitted as complete receivers.**

**TERMS:** Cash with Order or on Delivery; 3d. stamp brings complete lists receivers, short-wave components, covering every radio need; London's lowest prices throughout.

**ANGLO AMERICAN RADIO (AND MOTORS), Ltd.** Dept. W.1, Albion House, New Oxford St., London, W.C.1. (Telephone: Temple Bar 3231.) [3625]

**ARMSTRONG COMPANY** Manufacture 8 Radio Receivers in Chassis Form, briefly described hereunder.

**ARMSTRONG 6-valve All-wave Superheterodyne Radiogram Chassis, for A.C. mains, complete with Rola speaker; £7/10.**

**ARMSTRONG 8-valve 4 Wave-band Radiogram Chassis, with phase reversed push-pull output; £9/17/6.**

**ARMSTRONG 6-valve 4 Wave-band Radiogram Chassis, with large triode output; £8/17/6.**

**ARMSTRONG 8-valve 4 Wave-band Radiogram Chassis, with radio-frequency stage and push-pull output; £11/11.**

**ARMSTRONG 7-valve 4 Wave-band Radiogram Chassis, with radio-frequency stage and single triode output; £10/10.**

**ARMSTRONG 8-valve 2 Wave-band Radiogram Chassis, with 8 watt push-pull output; £8/10.**

**ARMSTRONG 6-valve 2 Wave-band Radiogram Chassis, with single large triode output; £7/10.**

**ARMSTRONG Chassis Carry 12 Months' Guarantee.**

**ARMSTRONG Chassis are Sent 7 Days' Trial, carriage, packing, and crate free.**

**ARMSTRONG MANUFACTURING Co., 100, King's Rd., Camden Town, N.W.1.** [3460]

**TRANS-ATLANTIC RADIO Co., 15, Percy St., W.1. Museum 3096.**—Splendid range latest American A.C./D.C.; compacts from 59/6; all-wave consoles, etc.; "Philco's" stocked. [3681]

**PILOT, Fergusson, Pegasus and Air King all-waves lead the field; our deliveries are prompt in original cartons with full guarantees; your trade card will bring our wholesale catalogue from the authorised distributors—Leonard Heys, 36, Henry St., Blackpool. [0530]**

**YOU Want Something Completely Different. If you have a nicely furnished home and the stereotyped models you see on every street corner do not appeal to you, you will delight in our superb range of exclusive quality models. We have radiograms with and without auto record changers, A.C. and A.C./D.C. which are a complete breakaway from the usual stuff in the local shops. If you prefer good furniture to boxes, if you want outstanding shortwave performance, and above all if you appreciate true quality of reproduction when you hear it, we have what you are looking for. Come and see. Come and listen. You will be agreeably surprised, not only to find that such splendid models exist, but that they can be sold at such very reasonable prices.**

**WIRELESS SUPPLIES UNLIMITED, 278-280-282, High St., Stratford, E.15. Maryland 3191. [3550]**

**RECEIVERS AND AMPLIFIERS CLEARANCE, SURPLUS, ETC.**

**HENRY'S**

**SHORT-WAVE Units by Well-known Manufacturer, 13-70 metres, supplied in handsome walnut cabinet, complete with coils, adaptors and instructions, no alterations to your present set, one plug connection, for all A.C. mains or battery sets, listed at £3/3; our price 30/-, carr. pd., in sealed cartons.**

**HENRY'S, 72, Wellington Ave., London, N.15. Stamford Hill 2907. [3638]**

“...satisfactory in every respect”



	Price
BP 111 (3-gang)	£1 10
BP 112 (2-gang)	13 6
BP 113 (3-gang)	£1 10
BP 114 (2-gang)	13 6

★ — an extract from the *W. World Test Report on the Varley Nicore Coil Units*, published Jan. 15.

The Nicore Ganged Coil Unit has not been on the market a great while, but already it is firmly established. Test Reports and public alike have acclaimed it as one of the finest components in recent years. For your especial benefit we have published four circuit blueprints, which give excellent results with these ganged units, No. 1 (BP 111) Mains Superhet for 110 K/C.; No. 2 (BP 112) Battery Superhet for 465 K/C.; No. 3 (BP 113) 3-valve mains receiver with hand pass tuners; No. 4 (BP 114) S.G. Battery 3 with pentode. You can have one of these blueprints for 6d. (BP 111 is 3d.). The postage is free.

specified for . . .

During 1936 Varley were specified for every constructor receiver or apparatus of importance. Since 1922 when we first started making components, Varley have been pioneers of practically every technical advance in radio.

THE EXPERIMENTERS I.F. AMPLIFIER—FOUR VARLEY SPECIAL I.F. TRANSFORMERS. BP 97 AND BP 98 (WITH SCREENED LEAD). 465 K/C. each 8s. 0d.

Please send me, post free, the following blueprints. (Put list No. here). . . I enclose 6d. in stamps for either the BP 111, BP 112, BP 113 or 3d. in stamps for the BP 114.

Name . . . . .

Address . . . . . W.V. 291/37.

# Varley

OLIVER PELL CONTROL LIMITED,  
Bloomfield Road, Woolwich, S.E.18

**ELECTRADIX BARGAINS**

**MOTORS! MOTORS!**  
Tiny, Small and Medium horse-power. A large stock of really high-grade Motors and Convertors have been released at bargain prices. 300 at 21s for immediate delivery.

**A.C. MAINS MOTORS.**—Enclosed, self-start on load. A.C. repulsion, 150 h.p. with pulley, Type 40, 1,500 revs., 18/6. Type 36, ditto, 1.25 h.p., G.E.C., 3,500 revs., 27/6. Induction 1/10 h.p., 2,500 revs., 35/-. 1/4 h.p., self-starting, 1,425 revs., 49/-.  
**D.C. MAINS MOTORS.**—1/40 h.p., self-start on load. A.C. repulsion, 150 h.p. with pulley, Type 40, 1,500 revs., 18/6. Type 36, ditto, 1.25 h.p., G.E.C., 3,500 revs., 27/6. Induction 1/10 h.p., 2,500 revs., 35/-. 1/4 h.p., self-starting, 1,425 revs., 49/-.  
**D.C. MAINS MOTORS.**—1/40 h.p., self-start on load. A.C. repulsion, 150 h.p. with pulley, Type 40, 1,500 revs., 18/6. Type 36, ditto, 1.25 h.p., G.E.C., 3,500 revs., 27/6. Induction 1/10 h.p., 2,500 revs., 35/-. 1/4 h.p., self-starting, 1,425 revs., 49/-.  
**DOUBLE CURRENT DYNAMOS.**—D.C. 600 volts 100 m.a., 32/6.  
**ROTARY CONVERTORS** for A.C. sets on D.C. mains. 7-watt P.M. model, 35/-. 15-watt 220 D.C./220 A.C., ball bearings, lam. field, silent running, 65/-.  
M.G. Sets with filter, 6 v. to 170 v. 25 m.a., for H.T., 65/-. Dynamo and Switchboard, 12 v. 12 amps., 47/6.

**PUMPS AND COMPRESSORS, ETC.**  
Coronation Fountain Electric Pumps for A.C. or D.C. mains. Centrifugal, all-bronze pump, 3 ft. lift, 120 gals. per hour. For 6 ft. fountain, etc. With 50 yds. twin rubber cable and iron-clad D.P. switch, 67/6. Larger pumps quoted for. **AIR COMPRESSORS** for Fume Spraying, Set. Cleaning, Inflation, etc. Foot Operated, 37/6. Electric No. 1 size, 65/-. A few S.H. Plants in good order, cheap.

**MOTOR BLOWERS** or Exhausters. Strong iron body, 3 in. fan outlet, direct coupled to motor. A.C. 220 v., 65/-. D.C. 110 v., 45/-. D.C. 230 v., 55/-. For air conditioning.  
**A BARGAIN IN DYNAMOS.** Type “C.” Our latest for Bungalow, Yacht or Cell Charging. 140 watt. Enclosed Dynamo, 12-20 v. 12 amps. Ball Bearings, Vee Pulley, 25/-.  
Mains Type Switchboard with Ammeter, maximum and minimum Auto Cutout Mains Switch and Fuses. Field Regulator, 25/-.  
**BATTERY CHARGERS AND A.C. RECTIFIERS.** Sold all the 4-circuit DAVENSET Chargers as illustrated but have an A.C. to D.C. 3-circuit 28 guinea Davenset Charger which will charge 120 L.T. cells and a batch of H.T. as D.C. volts are 150 v. New model, H.T.3, fitted Ferranti meters. 3-current regulators, 4 switches and an automatic overload trip. As new, £12/10/-. Another Davenset, also new, Type S.P.G.L., with an output of 250 volts 250 m.a., also fitted Ferranti meter and wide range volt regulator. Sale, £7/10/-. A 3-phase Davenset, converting 1½ kw. 400 v. 460 v. to 220 v. 6 amps. D.C. This has 3-pole auto circuit-breaker and Phillips valve. Sale, £9/10/-. Several Tungars and Westinghouse, cheap. A.C. to D.C. Motor Chargers, all sizes in stock.  
**CORONATION ARC LAMP AND FLOOD LIGHTS,** Cable Resistances, etc. Porcelain Cords, 6d. pair. **ELECTRIC LIGHT,** 1,000 Porcelain Ceiling Roses with Ramie Junction Connectors, 5/- doz.  
**DYNAMOS, MOTORS, ALTERNATORS AND ROTARIES,** Big stock P.A. Sets, Amplifier Microphones and Speakers for outdoor use, 3 watts to 20 watts, at tempting prices.

Send for Electrical and Radio Lists “W.”

**ELECTRADIX RADIOS**  
218, UPPER THAMES STREET, LONDON, E.C.4  
Telephone: Central 4611

For really high-grade mains transformers and chokes—it's best to go to Savage!

★ From our standard lists or to your specifications. We will gladly send you lists on request or quote to your particular requirements.

**W. BRYAN SAVAGE LTD.**  
WESTMORELAND ROAD, LONDON, N.W.9  
PHONE: COLINDALE 7131 (3 LINES)

Sole Distributors of **JANETTE ROTARY CONVERTERS**

These Converters are manufactured by one of the most prominent manufacturers in the U.S.A. and are of the highest grade construction. Models available for P.A. or Domestic use. Of special interest will be the type with an All-Wave Filter to operate a Radio Receiver down to 10 metres without any interference.

FULL DETAILS UPON APPLICATION.  
**CHAS. F. WARD,** 46, Farringdon Street, LONDON, E.C.4. Tel.: Holborn 9703.

RECEIVERS AND AMPLIFIERS, CLEARANCE, SURPLUS, ETC.

**HYAMS RADIO.**  
SPECIAL Offer; car radios, 6-valve superhet, A.V.C., etc., medium and long waves, no vibrator or rectifier. I.T. from “Gen. E. Motor,” consumption only 3 amps. on 12 volt cars; list price 20 guineas, our price, brand new and complete, £7/10.  
—All goods advertised in last issues still available.

**HYAMS RADIO, 23, Lisie St., W.C.2. Ger. 2969.** [3647]

**CLEARANCE List (Trade Only).**—Write Leonard Heys, 36, Henry St., Blackpool. [0527]

**A BARGAIN List of New Sets from 75/-.**—Write Kay, 1, Old Church Lane, N.W.9. [0535]

**SEND for Bargain List of Brand New Decontrolled Receivers:** amazing prices—P. A. C. Ltd., 54, Lamb’s Conduit St., W.C.1. [2243]

**BATTERY CHARGING PLANT**

**CARFAX “Junior,”** 20/30v., 5a., £5/5; guaranteed five years.—British Rectifiers, Vernon Place, Cheltenham. [3573]

**PUBLIC ADDRESS EQUIPMENT**

**SPECIAL Offer!!!**

**8½** Guinea Assembled: Vortexion 20 watt 4-stage P.A. amplifier, in steel case, 8in. x 10in. x 9in. high, with carrying handle, input with controls for microphone and pick-up and tone control, output for 7½ and 15 ohm speakers, weight 25lb.; only 8½ guineas, with valves.

**4** Input Model, with mixers; £10.

**HEAVY** Duty Model, as fitted to cinemas and dance halls; £15.

**CALL** and Hear the Rumble of an Organ as Never Before on our Wide Frequency Range Models, the best yet.

**VORTEXION, Ltd.,** 182, The Broadway, Wimbledon, S.W.19. See also New Mains Equipment. [3439]

**PARTRIDGE P.A. Manual,** free to trade. See “Partridge Transformers” under “New Mains Equipment.” [3487]

**HARMONY HOUSE SOUND SERVICE,** Southport.—Beam power amplifiers, 14 watts output; £13/10 (subject); send for lists. [0546]

**PROFESSIONAL Direct Sound Recorder,** complete with 10-watt amplifier and fader panel; separate if desired.—Offers, Box 590, c/o *The Wireless World.* [3683]

**USED SETS FOR SALE AND WANTED**

**EDDYSTONE**

**EDDYSTONE “All-World Two.”** complete; £3.—John Curry, 37, King St., Peľaw-on-Tyne. [3684]

**EDDYSTONE All-world Four Battery Set.**—Smith, 284, Great Western Rd., Glasgow. [3654]

**MIDWEST**

**1937** Midwest 10-valve All-wave A.C./D.C. to 240 volts, 3 months old, near £10.—Blay, 43, White Hart Lane, N.22. [3667]

**MISCELLANEOUS**

**1937** All-wave S.T.800 Author’s Kit Complete, less loud-speaker; £2/10.—Box 575, c/o *The Wireless World.* [3651]

**“SOUND Sales”** Amplifier, 6-watt, and radiogram feeder unit, cost £16 month ago; accept £10; buying larger outfit.—Thompson, 8, Wharton St., Grimsby. [3674]

**A BARGAIN.**—3v. S.G. radiogram in solid walnut cabinet. M.C. speaker, electric motor, “Atlas” eliminator with trickle charger (A.C.), 90 a.h. accumulator, in perfect condition; £8; call after 8 p.m.—Langley, 39, Lyndhurst Avenue, Tolworth, Surbiton. [3686]

**EXCHANGE OR WANTED**

**FERGUSON** £11/11 Model 650 Battery Set for Cash.—Offers to S. Hall, 198, Whitehall Rd., Leeds, 12. [3680]

**WANTED** for Cash; H.M.V. battery portable Model 462 or mains 463, Marconiphone battery Model 269, or mains 279; state price.—Box 581, c/o *The Wireless World.* [3659]

**NEW MAINS EQUIPMENT**

**ALL POWER TRANSFORMERS, Ltd.**—Transformers and chokes embodying all the best in design; no better value at any price; Radiolympia models; tapped and screened primaries, filaments, centre tapped.

**250** 0-250v. 60 m.a., 4v. 1-2a, 4v. 2-4a., 12/6, post 7d.; extra filament, 4v. 1a., 12/6.

**350** 0-350v. 60 m.a., 4v. 2-3a., 4v. 2-4a., 15/6, post 8d.; extra filament, 4v. 1a., 16/6.

**350** 0-250v. 120 m.a., 4v. 2-3a., 4v. 4-6a., 4v. 1-2a., 19/6, post 1/6; extra filament, 20/6.

**500** 0-500v. 140 m.a., 4v. 2-4a., 4v. 4-6a., 4v. 2a., 4v. 2a., 29/6, post 1/6.

**L.T. Charger,** charging rate 1a., 2, 6, or 12-volt, employing metal rectifier L.T.5; 37/6, post 1/6.

**WRITE** for List; special quotations by return.

**ALL POWER TRANSFORMERS, Ltd.,** 8a, Gladstone Rd., Wimbledon, S.W.19. Tel.: Liberty 3303. [3383]

**TANTALUM** for A.C. Chargers, H.T. and L.T.—Blackwell’s Metallurgical Works, Ltd., Garston, Liverpool. [2729]

NEW MAINS EQUIPMENT

VORTEXION Lead Again.  
 VORTEXION Supply the B.B.C., G.P.O., L.P.T.B., and Borough Councils, etc., so why not you?  
**F**OR the Best Reproduction it is Possible to Obtain, see also advert, under Public Address Equipment.  
**A**LL Fitted Screened Primaries and Tapped 200-250v., with centre tapped filaments, guaranteed one year.  
**S**CREENED Models, finished in elegant pressure die cast covers, will improve performance and appearance of any apparatus.  
**425** 0-425v., 120-160 m.a., 4v. 5-10a., 4v. 2.5, 4v. 1-2, 4v. 1-2, supershrouded model, 2½% regulation; 26/-.  
**250** 0-250 60 m.a., 4v. 1-2a., 4v. 2-4a.; 10/- open, 12/6 shrouded.  
**350** 0-350v. 60 m.a., 4v. 1-2a., 4v. 2-4a.; 12/6 open 15/- shrouded.  
**350** 0-350v. 120 m.a., 4v. 2.5a., 4v. 2-4a., 4v. 2-5a.; 14/6 open, 16/6 shrouded.  
**500** 0-500v. 120 m.a., L.T.'s, as above; 19/- open, 23/- shrouded; 400 or 450, same price.  
**500** 0-500v. 150 m.a., 3x, 4v. 2a., 4v. 2-5a., 4v. 4a., 26/- open, 30/- shrouded; 400 or 450, same price.  
**C**HOKES, 30h. 60 m.a., 5/6; 7-13h. 10/6; 30h., 150 m.a., 12/6; regulation, 7/6.  
**O**UTPUT Transformers, 4-10 watt, W.W. Q.A., 17/6; 20-watt super, shrouded, 30/-.  
**S**PECIAL Wide Frequency Range Model; £3/10.  
**A**UTO Transformers, 100-120 to 200-240v., 60 watt, 9/-; 120 watt, 12/6; 200 watt, 16/6; 500 watt, 30/-.  
**T**ELEVISION, 4,000v., 5-10 m.a., and 2.5-4v.; 27/-.  
**Q**UOTATIONS for Specials by Return.  
 VORTEXION, Ltd., 182, The Broadway, S.W.19. Tel.: Lib. 2814. [3592]  
**P**ARAMOUNT Mains Transformers.  
**P**ARAMOUNT in Quality, lowest in price; example: 250v. 60 m.a., 4v. 1a., 4v. 4a., open type 9/-, shrouded 11/-, post 9d.; 350v. 75 m.a., 4v. 2.5a., 4v. 4a., open type 12/-, shrouded 14/-, post 9d.  
**W**RITE for List, "Paramount Mains Transformers."  
 -R. H. Salter, 66, Hartfield Rd., Wimbledon, S.W.19.  
 'Phone: Liberty 3226. [2303]  
**P**ARTRIDGE Transformers, as supplied to B.B.C., Marconi's, G.E.C., Mullards, I.C.I., Tungsram, etc.  
**S**PECIALS Despatched Within 48 Hours; all standard types from stock. Specimen prices:—  
**350** 0-350v. 120 m.a., 4v. 2-3a., 4v. 3-6a., 4v. 2a.-all C.T.; screened primary 200-250v., 18/6.  
**425** 0-425v. 150 m.a., 4v. 2-4a., 4v. 4-8a., 4v. 1-2a., 4v. 1-2a., all C.T. (for W.W. circuits); 26/6.  
**S**PECIAL Quotations to Manufacturers for Lots of 6  
**S**Upwards; hand wound, individually tested; immediate delivery, rock bottom prices.  
**T**ELEVISION Transformers Insulated to 10,000v. A.C., expert knowledge of transmitting requirements (mains and modulation).  
**H**IGH Fidelity (20 to 15,000 Cycles) Intervalve and Output Transformers a Speciality.  
**P**ARTRIDGE P.A. Manual Free to Trade Only; contents includes constructional amplifiers, notes on microphone pre-amplifiers, lines, mixing, impedance matching, speakers, etc.  
**P**ARTRIDGE, N., B.Sc., A.M.I.E.E., King's Buildings, Dean Stanley St., London, S.W.1. 'Phone: Vic. 5035. [3486]

CABINETS

**R**ADIOGRAM Cabinets, new designs, 30/- to £5/10; inspection invited or photos for selection sent on request.  
**T**ABLE Radio Cabinets, undrilled, 6/6 upwards.  
**S**PEAKER Cabinets, 4/6 upwards.  
**M**ANUFACTURERS Clearance.  
**K**.B. De Luxe Walnut Cabinets, undrilled, chromium plated edges and speaker grille, 25in. wide, 14½in. high, 10½in. deep, 18/6; Console model, 42in. high, 21½in. wide, 11½in. deep, 39/6.  
**H**ALCYON Radiogram Cabinets (Reconditioned), 33x 23x19, 35/-.  
**H**. L. SMITH and Co., Ltd., 287-9, Edgware Rd., London, W.2. Tel.: Pad. 5891. [0485]  
**H**IGH Class Radio Cabinets Made to Order; competitive prices.—C. Mostyn, Ltd., Cabinet Manufacturers, 8-9, French Place, London, E.1. (Bishopsgate 8784.) [3554]

DYNAMOS, MOTORS, ETC.

**A**LL Types of Rotary Converters in Stock, new and second-hand.  
**W**ARD, 46, Farringdon St., London, E.C.4. Telephone: Holborn 9703. [0518]  
**E**.D.C. Converter, 250 D.C., 250 A.C., 4 amp.—380, Garscube Rd., Glasgow. [3655]  
**A**.C. ¼hp. B.T.H. Motors, 1,425 revs., self starting, all voltages; 53/-—Easco, 18, Brixton Rd., S.W.9. [0455]  
**E**.D.C. 200-watt Motor Generator, 230v. D.C. to 2,000v. or 1,000v. D.C.; £10 or offers.—G.S.U.F., 14, Cliff Ave., Cromer. [3668]  
**E**.C.C. Rotary Converter, 24v. D.C., 250v. A.C., 90 watts, 50-60 cycles, as new and in perfect condition, or exchange two 30-watt P.A. loud-speakers.—M. White, 21, Broadway, Ripley, Derbs. [3663]  
**R**OTARY Converter, E.D.C., 150 watts, 50v. D.C. input, 400 volts D.C. output, new condition, £5/10; another E.D.C., 50-volt D.C. input, 250 D.C. output, 100 watts, £5; also M.L. 50-volt D.C. input, 400-volt D.C. output, 100 watts, £5.—Davis, The Lilacs, Downe, Kent. Tel.: Farnborough 22. [3661]

PREMIER SUPPLY STORES

Offer the following Set Manufacturers' Brand New Surplus Goods at a Fraction of the Original Cost; all goods guaranteed perfect; carr. paid over 5/-; under 5/- postage 6d. extra. Orders under 5/- cannot be sent C.O.D.  
**ALL POST ORDERS TO JUBILEE WORKS, 167, LOWER CLAPTON RD., LONDON, E.5**  
**CALLERS, AS USUAL, TO 20-22, HIGH ST., CLAPHAM, S.W.4 (Macaulay 2381) 'Phone: Amherst 4723**  
**And 165 & 165a, FLEET ST., E.C.4 (Next door to Anderton's Hotel.) Central 2833.**  
**Have you had our GIANT ILLUSTRATED CATALOGUE AND VALVE LIST? Send 4d. IN STAMPS FOR THIS BARGAIN LIST.**

**MAINS VALVES**, famous Europa 4 v. A.C. types, 4/6 each. HL., L., S.G., Var.-Mu-S.G., H.F.-Pens., Var.-Mu-H.F. Pens. 1, 3 and 4-watt A.C. directly heated output Pentodes. Full-wave rectifiers, 250 v. 60 m.a. A.C./D.C. types. 20-volt. 18 amp. S.G., Var.-Mu-S.G., H., HL., Power and Pen. Following types all 5/6 each. Full-wave rectifiers, 350 v. 120 m.a. and 500 v. 120 m.a. 2½ watt indirectly-heated Pentodes, Octodes, Frequency Changers.  
**BATTERY VALVES**, 2 volts, H.F., L.F. 2/3. Power Super-Power, 2/9. S.G., Var.-Mu-S.G., 4- or 5-pin Pentodes H.F. Pens., V.-Mu-H.F. Pens., 5/- Class B, 3/6.  
**AMERICAN VALVES**. Genuine American HYTRON and TRIAD first-grade Valves. 3 months' guarantee: All types in stock, 5/6 each. 210 and 250, 8/6 each. New Metal-Glass Valves, all types, 6/6 each. Genuine American DUOTRON Valves, all types, 3/6 each. Valve holders for all above types, 6d. each. Metal bases, 9d. each.  
**SHORT-WAVE COILS**, 4- and 6-pin types, 13-26, 22-47, 41-94, 78-170 metres, 1/9 each, with circuit. Special set of 3 S.W. Coils, 14-150 metres, 4/- set, with circuit. Premier 3-Band S.W. Coil, 11-25, 19-43, 38-86 metres. Simplifies S.W. receiver construction, suitable any type circuit, 2/6.  
**COIL FORMERS**, in finest plastic material, 1½in. low-loss ribbed, 4- or 6-pin, 1/- each.  
**SUPER CERAMIC CONDENSERS**, S.L.F., .00010, .0001, 2/9 each; double-spaced, .00005, .000025, .000015, 3/- each. All brass with integral slow motion, .00015 tuning, 3/9; .00015 reaction, 2/8.  
**H.F. CHOKES**, S.W. 10-200 metres, 9d.; S.W. screened, 1/6; standard screened 180-2,000 metres, 1/6.  
**3-WATT A.C. AMPLIFIER**, 2-stage, for mike or pick-up. Complete kit of parts with 3 valves, 40/-.  
**7-WATT A.C./D.C. AMPLIFIER**, 3-stage, high-gain, push-pull output. Complete kit of parts with 5 specially matched valves, £4 4s.  
**10-WATT 3-stage A.C. Amplifier Kit** with 5 valves, £5 5s.  
**20-WATT 3-stage A.C. Amplifier Kit** with 5 valves, £8 8s.  
**ELECTROLYTICS**. U.S.A., 4, 8 or 16 mfd. 50 v. peak, 1/9 each. Dubilier, 4 or 8 mfd. 500 v., 3/-; 50 mfd. 50 v., 1/9; 10 mfd. 50 v., 6d.; 25 mfd. 25 v., 1/-; T.C.C. 4 or 8 mfd. 650 v., 4/-; 15 mfd. 50 or 100 v., 1/-; 50 mfd. 12 v., 1/- Paper Condensers. W.E., 250 v. working 4 mf., 2/-; 2 mf. 1/-; 1 mf. 6d.; 350 v. working 4 mf., 2/6; 2 mf., 1/6. Dubilier 500 v. working 4 mf., 4/-; 800 v. 4 mf., 6/-.  
**COSMOCORD PICK-UPS**, with tonearm and volume control, 10/6 each. PICK-UP HEADS only, 4/6 each.  
**PREMIER MAINS TRANSFORMERS**, wire-end type with screened primaries, tapped 200-250v. Centre-tapped Filaments. Guaranteed one year. H.T. 8 & 9 or H.T. 10 with 4 v. 4 a. C.T. and 4 v. 1 a. C.T., 8/6. 250-250 v. 60 m.a., 4 v. 1 a. 4 v. 2 a. and 4 v. 4 a., all C.T., 8/6. 350-350 v. 120 m.a., 4 v. 1 a., 4 v. 2 a. and 4 v. 4 a., all C.T., 10/6. Any of these transformers with engraved panel and N.P. terminals, 1/6 extra. 500-500 v. 150 m.a., 4 v. 2-3 a., 4 v. 2-3 a., 4 v. 2-3 a., 4 v. 3-4 a., all C.T., 17/6. Super Model 19/6. **AUTO TRANSFORMERS**, step up or down, 60 watts, 7/6; 100 watts, 10/-.  
**SMOOTHING CHOKES**, 25 m.a., 2/9; 40 m.a., 4/-; 60 m.a., 5/6; 150 m.a., 10/6. 2,500 ohms, 60 m.a. Speaker Replacement Chokes, 5/6.  
**MILLIAMMETERS**, moving-iron, flush 2½in., all ranges from 0-10 m.a. 5/9. Visual tuning, 6 or 12 m.a., 5/9. Moving-coil meters, 2½in. 0-1 m.a., 18/6; 3½in. 0-1 m.a., 22/6. Multipliers 1/- each. Ampmeters, 0-1, 3, 5, 10 or 20 a., 5/9.  
**TELSEN** Multi-meters, 3 and 30 m.a., 8, 16 and 240v., 8/6 each. Reads A.C. and D.C.  
**TRANSFORMERS**, latest type Telsen R.G.4 (list 12/6), 2/9 Lissen Hypemnik Q.P.P. (list 12/6), 3/6.

**OUTPUT TRANSFORMERS** for Power or Pentode, 2/6; Multi-Ratio, 4/6; Push-Pull Input Transformers by prominent manufacturer, 4/6 each.  
**ELIMINATOR KITS** for A.C. mains. 120 v. 20 m.a., or 150 v. 25 m.a., 15/-, tapped S.G., det. and output. Complete Kit with long-life valve rectifier (replacement cost only 2/-).  
**PREMIER L.T. CHARGER KITS** for A.C. mains, including Westinghouse Rectifiers and Tapped Mains Transformers. 8 volts at ½ amp., 14/6; 8 volts 1 a., 17/6; 15 volts 1 a., 19/-; 8 volts 2 a., 29/6.  
**TELSEN** iron-cored screened coils, W.349, 4/- each. Electric SOLDERING IRONS, 200-250 v., A.C./D.C., 2/3.  
**NEW 1937 1-VALVE SHORT-WAVE RECEIVER OR ADAPTOR KIT** 13 to 86 Metres without coil changing; Complete Kit and Circuit 12/6. **VALVE GIVEN FREE!**  
**DE LUXE MODEL** 14 to 150 Metres, complete Kit with Chassis, 4 Coils and all parts, 17/6.  
**SUPERHET CONVERTER KIT**, 13/6.  
**S.W. SUPERHET CONVERTER**, for A.C. Mains Receivers, 20/- A.C. Valve given FREE!  
**NEW 1937 2-VALVE S.W. KIT**, 13 to 86 Meters without coil changing. Complete Kit and Circuit, 19/6. **VALVES GIVEN FREE.**  
**DE LUXE MODEL**, 14 to 150 Metres, complete Kit and Chassis, 4 Coils and all parts, 25/- **VALVES GIVEN FREE.**  
**3-VALVE S.W. KIT**, S.G. Det. and Pen., 42/- **VALVES GIVEN FREE!**  
**BAND-PASS TUNING PACK**, comprising set of Telsen 3-gang iron-cored coils with switching, mounted on steel chassis with 3-gang condenser, illuminated disc-drive and 4 valve holders, 25/- the lot. All Mains or Battery circuit, FREE!  
**SPECIAL OFFER. LISSEN TWO GANG SCREENED ALL-WAVE COILS**, 12 to 2,000 metres, complete with switching and wiring diagram, 6/11 per set.  
**3 VALVE BAND-PASS KIT**, 200-2,000 metres. Complete kit of parts, including chassis, all components, valves, M.C. speaker and wiring diagram. Battery Model, 50/- A.C. Mains Model, 70/-.  
**MAGNAVOX**. Mains energised M.C. Speakers. '154', 7in. cone, 2,500 ohms, 12/6; '152', 9in. cone, 2,500 ohms, 17/6; '152 Magna', 9in. cone, 2,500 ohms, 37/6. Magnavox P.M.s.—'254', 7in. cone, 16/6; '252', 9in. cone, 22/6. Reliable P.M.s., 10/6.  
**ROLA** latest type P.M.s., 18/6. **GOODMANS'** 8in. mains energised, 1,000 ohms field, 10/6 each. Jensen P.M.s., 10/6.  
**DIALS**.—Clarion Illuminated S.W. slow-motion Dial with 2in. knob, 2/- Premier All-Wave 2-speed Dial, full vision straight-line, dual ratios 10-1 and 150-1, 6/6, with escutcheon.  
**Potentiometers** by well-known makers. All values up to 1 meg., 2/-; with switch, 2/6. **GRAMOPHONE MOTORS**. Collaro Gramophone Unit consisting of A.C. motor, 100-250 v. high quality pick-up and volume control, 45/-; Collaro motor only 30/-; Collaro Universal Gramophone Motor, 100-250 v. A.C./D.C., with high quality pick-up and volume control, 67/6; Collaro Universal Motor only, 49/6; Edison Bell double-spring motors, including turntable and all fittings, 15/-; Cosmocord Gramo. unit, comprising A.C. motor pick-up and volume control (list 55/-), 35/9.  
**TUBULAR CONDENSERS**, non-inductive, all values up to .5 mfd., 6d. each.  
**Wire-end RESISTORS**, any value, 1 watt, 6d.; 4 watts, 1/-; 8 watts, 1/6; 15 watts, 2/-; 25 watts, 2/6 each. Reliable MORSE KEYS with Morse Code engraved on bakelite base, 2/- each.  
**Bakelite case BUZZERS**, 1/6; Walnut case "Loud-tone," 2/6 each.  
**Super Quality lightweight HEADPHONES**, 3/9 pair.

**EARN EXTRA MONEY** by hiring out the M.P.R. 8 Watt Amplifier to dances, socials, etc. Complete with Four Valves, Speaker, and Volume Control Push-Pull. Will reproduce Gramophone Recordings or Radio at full Band strength. Supplied ready for connecting to Pick-up or Microphone. For A.C. Mains only. Price £5-5-0 net, or 1/0-monthly.

Send for full particulars. 'Phone: Romford 338. M.P.R. ELECTRICAL CO., 252, Victoria Road, ROMFORD, Essex.



**TANNOY**  
 THE SOUND PEOPLE  
 GUY R. FOUNTAIN LTD.  
 FOR CANTERBURY GROVE, WEST NORWOOD, ALL LONDON, S.E.27. 'Phone: Str. 4122 (6 lines).  
**SOUND AMPLIFYING EQUIPMENT**

**BOOKS on WIRELESS**  
 Write for complete list to  
**ILIFFE & SONS LTD.**  
 Dorset House, Stamford St., London, S.E.1 w.w.1

**ENGINEERS! ARE YOU EARNING LESS THAN £10 PER WEEK?**

If so, you cannot afford to carry on without reading our 268-page Handbook. The book explains clearly and definitely many ways of carving out a successful career. Among other things, it explains the Services of our unique Appointments Department; outlines Home-Study Courses in all branches of Civil, Mechanical, Electrical, Motor, Aero, Wireless, "Talkie" Engineering, Television, Building, Govt. Employment, etc., and gives details of B.Sc., A.M.I.C.E., A.M.I.A.E., A.M.I.E.E., A.M.I.W.T., G.P.O., Matric., and all Exams. We Guarantee—"No pass—No Fee." Whether you be an old hand or a budding apprentice, get this book to-day—FREE and POST FREE.

BRITISH INSTITUTE OF ENGINEERING TECHNOLOGY,  
 387, Shakespeare House, 17/13, Stratford Place, London, W.1.



**THE MOTOR CYCLE** Every Thursday 3d. w.w.15

# WHY LOOK FURTHER?

The "DUODE 33" Loudspeaker relies solely on facts as to its quality—not on vague and unsupported statements and claims.

Briefly put, the "DUODE 33" has a published N.P.L. Curve of performance, is specified for the acknowledged best quality set of the season,\* will handle ample power, and is moderate in price.

When we've said that, we've said practically everything that matters to the searcher after truth.

And again we repeat—"Why Look Further?"

Send for latest technical booklet with copy of N.P.L. Curve and Report.

\* The "Wireless World" Pretuned QUALITY Receiver.



**BENJAMIN  
DUODE  
THIRTY-THREE**  
MANUFACTURED UNDER MAGNAVOX PATENTS AND REGISTERED DESIGNS BY THE BENJAMIN ELECTRIC LTD. BRANTWOOD WORKS, TOTTENHAM, N.17

## NEW LOUD-SPEAKERS

**H**ULBERT for Quality Surplus Speakers.  
**D**URING the Last Two Years We Have Stocked and Advertise One Make of Surplus Moving Coil Speakers Only. They are made by Baker's Selhurst Radio, Ltd., the pioneer manufacturers of moving coil speakers. Although not current models, the following speakers are brand new and are offered at considerably under half list prices.  
**T**HE Auditorium Models are Fitted with Latest Triple Cone, comprising main curved cone and bakelite and duralumin cones combined, Prov. Pat., giving wide and even frequency response resulting in quality reproduction of both speech and music.  
**37/6** Only, usual price £5.—Auditorium permanent magnet speaker, with Alni magnet and die cast frame, large 12in. triple cone giving wide frequency range, complete with large 25 ratio transformer suitable for all outputs, including push-pull and Class B, etc.  
**59/6** Only, usual price £6.—Auditorium electro magnet speaker, 1,000, 1,250, 2,000 or 2,500 ohms field, exceptionally large magnet of high permeability steel giving enormous flux density, 2in. moving coil, large triple cone giving wide frequency range, complete with universal transformer, the ideal speaker for use with "Wireless World" and other quality amplifiers.  
**75/-** Only, usual price £9.—As above, but for use on A.C. mains; complete with Westinghouse rectifier and full smoothing equipment.  
**24/-** Only.—Permanent magnet speaker, Alni magnet, die cast frame, 10in. cone, Universal transformer.  
**15/6** Only.—Permanent magnet speaker, Alni magnet, 8in. cone, Universal transformer.  
**12/6** Only.—Permanent magnet speaker, as above, with 7in. cone.  
**11/6** Only.—Extension permanent magnet speaker, 8in. cone, complete with large cabinet, suitable for low impedance outputs.  
**2/9** Only.—Brand new cabinets.  
**8/6** Only.—Electro magnet speakers, with 8in. cone, 6,500 ohms field, Universal transformer.

**I**F You are Requiring Quality Reproduction at Low Cost Order Now; repeat orders coming in daily.  
**H**ULBERT, 6, Conduit St., W.1. Cash or c.o.d. [3631]

**V**AUXHALL.—Best quality speakers; see other column. —Vauxhall Utilities, 163a, Strand. [0520]

## LOUD-SPEAKERS

**S**ECOND-HAND, CLEARANCE, SURPLUS, ETC.  
**V**AUXHALL.—Magnavox mains energised, 2,500 or 6,500 field coil, 10in. cone, 17/6; 7in. cone, 12/6.  
**V**AUXHALL.—Magnavox permanent magnets, universal, suitable for Class "B" power or pentode, 7in. cone, 16/6; 10in. cone, 22/-.  
**V**AUXHALL.—American Rolas, 2,500, 8in. 15/6, 9 1/2in. 19/6; permanent magnets, 8in. 19/6, 9 1/2in. 24/6.  
**V**AUXHALL.—Above fully guaranteed, complete with humbucking coils; state power or pentode transformer; unused manufacturers' stock.  
**V**AUXHALL.—Immediate delivery, carriage paid; lists free; cash with order or c.o.d.—Vauxhall Utilities, 163a, Strand, W.C.2. Temple Bar 9338. [0456]  
**H**ARTLEY-TURNER Standard Transformer Rectifier; £4.—Mackenzie, Palmerston Rd., West Croydon. [3671]

**M**AGNAVOX D.C. 152 (9in. cone), 22/6; Magnavox 154 (6 1/2in. cone), 16/3; all with humbucking coils, power or pentode transformers, and 2,500 or 6,500-ohm fields; Magnavox P.M.254, 18/-; Magnavox P.M.252, 22/6.  
**A**TENTION to All Orders Within 48 Hours; carriage paid; cash with order or c.o.d.; send for list.  
**W**ARD, 46, Farringdon St., London, E.C.4. Tel.: Holborn 9703. [0451]

## VALVES

**A**NDERSON.  
**A**MERICAN Valves, all makes, first grade only; 5/- each.  
**A**NDERSON, 35, Lansdowne Rd., Walthamstow, E.17. Walthamstow 0827. [3351]  
**3/-** Each, all popular types. American valves; 90-day guarantee  
**A**LL Types National Union in Stock, Hytron, Triad, etc.  
**T**AYLOR 866, with guaranteed hourage; 11/6.  
**T**AYLOR T51; 50/-.  
**T**AYLOR T20, delivery 14 days.  
**R**.C.A. 50, 800, 801, 907, 913, etc.  
**R**ADIOGRAPHIC, Ltd., 66, Osborne St., Glasgow, O.1. [3633]  
**A**MERICAN Valves, first grade, in all types; trade supplied.—Metropolitan Radio Service Co., 1021, Finchley Rd., N.W.11. Speedwell 3000. [0436]  
**A**MERICAN Valves, popular types, 5/- each, all guaranteed; line cords, 2/6 each; write for lists.—E. Fellows, Ferney Rd., East Barnet, Herts. [3596]  
**A**LL Types of American Valves in Stock of Raytheon, Sylvania, and Arceturus makes, at competitive prices, guaranteed for six months; send for full list; 350 ohms line cords, 2/8.  
**W**ARD, 46, Farringdon St., London, E.C.4. Tel.: Holborn 9703. [0452]

**N**OTHING Better Available.—Six months' guarantee; complete range of battery, A.O. mains, rectifiers always in stock; 2-volt det., H.F., L.F., 2/3; power, 2/9; screen grid, pentode, H.F. pentode, 5/-; American types, fully guaranteed. 5/6 each, Nos. 18, 24A, 35, 42, 43, 45, 47, 56, 57, 58, 75, 77, 78, 80, 2A5, 2A6, 2A7, 6A7, 2B7, 6B7, 6C6, 6D6, 25Z5, 25Y5; write for other prices to Dulci Electrical Co., Ltd., Devonshire Works, Dukes Av., Chiswick, W.4. [0501]



## RADIOGRAM CABINET

**I**n FIGURED WALNUT, Highly Polished. Thickness 2in., laminated wood heavily veneered, both sides.  
Size overall 36in. X 30in. X 18in. Motor Board 28in. X 16in. Headroom adjustable up to 8in. Loud speaker opening can be cut in any position or size for single or twin speakers. **£5-10-0** or without opening if required. Price £5-10-0 See our advertisement in Miscellaneous columns.

**H. L. SMITH & CO. LTD.,**  
287/289, EDGWARE ROAD, LONDON, W.2.



## RADIO RECEIVER MEASUREMENTS

By Roy M. Barnard, B.Sc., A.M.I.R.E. (1934)

Although primarily designed for the benefit of the radio service engineer, this concise handbook is also of practical value to the amateur experimenter.

It describes the methods of measuring receiver performance and provides provisional standards as a basis for judging performance. Measurements of sensitivity, selectivity and fidelity are explained at length and the interpretation in estimating receiver performance is carefully set out.

Details are given of methods of receiver testing with full descriptions of commercial signal generators and their application to the adjustment of superheterodynes and "straight" receivers.

Complete with fifty-three illustrations and diagrams, summaries of method, four appendices and a general index.

PRICE 4/6 net

By post 4/9

From all booksellers or direct from the Publisher.

ILIFFE & SONS LTD.

DORSET HOUSE, STAMFORD STREET, LONDON, S.E.1

W.W.19

METERS, ETC.

**PRECISION Instruments.**—Big discounts; send for list. from 8/6.—A. Hinderlich, 2, Bridge Rd., London, N.W.10. [3545]  
**VOMETER** £5 Model, 50/; Avominator, 21/-; both post paid, guaranteed perfect; stamp reply.—Bond, 121, Forest Rd., Nottingham. [3665]

NEW COMPONENTS

**TRANSVERSE Current Microphone Parts,** complete, from 8/6.—A. Hinderlich, 2, Bridge Rd., London, N.W.10 [3539]

**ENLARGED Catalogue for Home Constructors** Now Ready, post free.—Lumen Electric Co., Litherland, Liverpool, 21. [3473]

**OURS** is Now the Only Store in London Handling a Complete and Comprehensive Range of High Grade Components and Accessories, as distinct from clearance and surplus material. Everything from the smallest plug to the complete auto changer unit, finest makes, really kept prices, and personal and efficient service unexcelled by chain stores, clearance houses, department stores or by mail. Come and see.

**WIRELESS SUPPLIES UNLIMITED.** 278-280-282, High St., Stratford, E.15. Maryland 3191. [3551]

**SIEMENS and HALSKE 1/2-watt Wire Resistances,** each marked with value, new, 20 assorted sizes, 250 ohms to 2 megohms, 1/6, post free.

**SEE Our Next Week's Advert. for Further Bargains.**

**H. FRANKS, 81, New Oxford St., W.C.1. Temple Bar 2620.** [3684]

COMPONENTS

SECOND-HAND, CLEARANCE, SURPLUS, ETC.

RADIO CLEARANCE.

ALL Lines Advertised Last Week Still Available.

**RADIO CLEARANCE, 63, High Holborn, W.C.1. Holborn 4631.** [3683]

PREMIER SUPPLY STORES.

PLEASE See Our Displayed Advertisement on Page 5.

ALL Post Orders Should be Addressed to Jubilee Works, 167, Lower Clapton Rd., London, E.5. Callers as usual to:—

20—22, High St., Clapham, S.W.4. Open till 9 p.m. Saturdays, Wednesdays, 1 p.m. Macaulay 2381.

165 and 165a, Fleet St., E.C.4 (next door to Anderson's Hotel). Early closing Saturday 1.30 p.m. Central 2833. [0488]

**OLIVERS Offer Erie 1-watt Colour Coded Erie Resistances,** 3/4d. each, 3/- dozen, 2/6 dozen in 3-dozen lots.

**CENTRALAB Volume Controls,** standard with switch, 2/- each; Clix chassis mounting valve-holders, 5-pin 3d., 7-pin 4d.; aerial and earth socket strips, 4d. each.

**ALUMINIUM Chassis, 16in x 10in x 3in, 18-gauge, 5/3; 16-gauge, 7/6; "W.W." I.F. amplifier chassis, 18-gauge, 4/9; chassis, boxes, etc., built to any size or specifications; prices upon request.**

**WESTINGHOUSE Rectifiers, H.T.8, 8/6; H.T.9, 9/-; H.T.10, 9/6; special prices for quantities.**

**HUNT'S and B.I. Cardboard Electrolytics, 8 mfd., 1/9; 8 mfd.+4 mfd., 2/5; 8 mfd.+8 mfd., 2/9; 4 mfd., 1/6; 50 mfd. 50v., 1/6.**

**B.I. and T.C.C. Metal Electrolytics, 8 mfd., 2/4; 4 mfd., 2/1; 25 mfd., 25v., 1/1; Dubilier 8 mfd., 2/7.**

**ROLA Manufacturer's Type Energised Speakers, 2,000 Ohms and 2,500 Ohms, 7in. cone, 10/6; Plessey Jensen P.M.s, 11/-; all with universal transformers.**

ALL Goods Previously Advertised Available.—Olivers, 676, Christchurch Rd., Boscombe, Ilants. Orders under 5/6, postage extra. [3672]

**HENRY'S Offer Two Only, Garrard universal A.C./D.C. record changers,** in new condition; at £5/10 each; list £10/17/6.

**FERRANTI Universal Test Meter,** listed at £5/15, for £3/2/6; also Radiolab universal set analyser, in new condition, complete with all adaptors and signal generator, £7/15.

**HENRY'S, 72, Wellington Av., London, N.15. Stamford Hill 2907.** [3689]

**SELENIUM Rectifiers Inexpensively Convert Mains A.C. to any voltage D.C. for every purpose, outputs from 1/2 to 30 amps.; state requirements.**

**PHOTO-ELECTRIC Cells, Caesium, Selenium, all types, guaranteed bargains from 8/6; illustrated lists.—Cofa Products, 11, Ramsden Rd., London, S.W.12. [3688]**

**£12/10**—Eddystone All-wave Four, Eddystone moving-coil speaker, set of coils 13,500 metres, 2-volt accumulator, Atlas 10-30 mains eliminator.

**£5**—Ferranti M.1 moving-coil speaker, solid walnut screen baffle.

**£2/10**—Ferranti meter, 0-10 volts, 0-250 volts, 0-100 m.a.

**£2/10**—M.L. anode converter, input 60 volts, output 150 volts at 30 m.a., tappings at 120 and 60 volts.

**10/-**—Pair Brown A.2 headphones; all above very little used and in perfect condition.—Gross, "Mill Lodge," Lodge Lane, Salfords, Redhill, Surrey. [3670]

**RADIOMART SHORTWAVE SPECIALISTS**

**MICROVARIABLES.**—All brass construction; latest ceramic insulation. The finest condensers made; 15 mmfd., 1/4; 40 mmfd., 1/7; 100 mmfd., 1/10. Transmitting Type.—0.70in. spacing, 15 mmfd. (neutralising). 2/9. 40 mmfd. Tuning, 3/6. These are quality.  
**SHORTWAVE COILS.**—(RD4) CA 11-25, CB 20-45 metres, 2/6. CC 44-100 metres, 2/9. Standard 6-pin types, CA6, CB6, 2/9 each, CC6, 3/-; same range as 4-pin.  
**COILFORMS.**—Moulded in RD4 natural lobliss material, hollow resilient pins 1 1/4in. diameter ribbed; identification disc in top. Four types; 4-pin, 1/6; 6-pin (standard or to fit 7-pin valveholders), 1/9; 7-pin (for bandspread tap), 1/10; Machine threading, 2d. extra.  
**AMERICAN Mains Transformers, 230v. primary, fully shrouded, 350-0-350, 0.3v., 5v., 6/11; Ditto, heavy duty up to 10 valves 150m/A, weight 8 lbs., 12/6; Majestic, 250-250, 2.5v., 5v., 4/11; Pilot 260-260, 2.5v. CT., 5v. CT., 5/11.**

**HEAVY DUTY Mains Transformer, worth 35/-, 350-350, 150 m/A., 4v., 2.5 A., CT. 4v., 6A CT. 12/6; Philips 300-300, 120 m/A., same LT's, 6/6; Ditto, 300-300, 60 m/A., 4v., 2A., 4v., 4A., 4/11; Speaker Transformers, 2/6  
**UTILITY 8/6, Microdisc Dials, 3/11; Radiophone, 0.00016 Shortwave Condensers, 3/6; Series gap, twin, 3/9. Shortwave HF Chokes 5-100 metres, 9d. 465 KC Litz Wound IFS, 3/11; Two-speed Slow Motion Knobs, 1/-; Telsen Ace Transformers, 1/11; Iron-cored HF Chokes, 1/-; Utility Straight Line Dials, 2/11; British Radiophone Straight or Superhet 3-gang Condensers, with trimmers fully screened, 4/11.****

**ELECTROLYTICS.** Huge purchase 500 v. Aluminium Can, 4mf., 1/6; 8mf., 1/11; 16mf., 2/6; 8+8mf., 2/6; 8+8mf. 450 v. + 8mf. 250 v., 2/9; Block type, 500 v. peak, 4+4mf., 1/6; 8+8+4mf., 3/-; 50mf. 50v., 1/3; 25mf. 25v., 1/-; 2mf. 300v., 9d.; 40+24mf. 200v., 1/6.  
**FAMOUS CONTINENTAL A.C. Valves, 4/6; Battery types from 2/3; American Duotron, etc., all types, 3/6; All types of RCA Licensed first grade tubes, metal and glass, in stock from 5/6.**

**FEATHERWEIGHT Headphones, 2/6; Varley Bifocal Iron-cored Coils, 2/6; matched pair, 4/6. SMOOTHING CHOKES, 20 hy., 120 m.a., 3/11; 40 m.a., 1/11; Centralab Pots, all sizes, 1/6; switched, 2/7; 20,000 ohm Pots, 1/-; Tubular glass fuses, 2d.**

**SPECIAL OFFERS.** Class B Kit, worth 30/-, comprising Driver Transformer, Valve and Holder, 5/-; Dozen wire ended assorted resistors, 1/6. Preset Condensers, 9d. TELSEN switched Dual range coils (W216), 2/11.

**TRADERS:** Monster Bargain Parcel value £4/10/0, for 10/-; also 5/- parcels. State battery or mains. Milliammeters 25 m.a. upwards, 5/9; super, 6/9.

**PUSHBACK Wire, 6 yds. 6d.; heavy, 9d.; Resin cored Solder, 6d. 6d.; Screened Flex, single, 6d. yd.; twin, 9d. yd.**

**CONDENSERS.** 4 mf. 700 v. T., 2/6; 2 mf. 1/6; T.C.C. 1 mf., 6d.; Dubilier, 0.1 mf., 3d.; Tubular Condensers, 1,500 v. T., all sizes to 0.1 mf., 6d.; 0.2 to 0.5 mf., 8d.

**UTILITY 2-gang Uniknob .0005 with Dial, 3/11. EDC Converters, new, 12 volt to 240 v. 40 m.a., 25/-; BTH ditto, 6 v., input fully smoothed, 39/6.  
**CRYPTO 500 watt 220 v. DC to 230 v. AC, as new, £10; Ditto, 1,000 watt, £15. One of each only.****

**AMERICAN latest Double Button Microphones, cost £2 in U.S.A., our price 25/-.** Why buy junk?

**PHILIPS Screened Ceramic and Brass All-wave .0003 Micro-Variables.** Ideal experimenters, 10d. Visual Tuning Meters, 2/-.

**SILVER MARSHALL 14-valve all-wave chassis with speaker, 15-550 metres, one only, 9 guineas.**

Order 5/- post free. Get our Bargain Catalogue, 1 1/2d. post free. All enquiries and requests for Catalogue must send 1 1/2d. stamp.

**RAYMART 1936-7 EDITION**

**RAYMART SHORTWAVE MANUAL**

48 Pages of practical circuits and data on Shortwave Receivers, transmitters, modulators, transceivers, etc., including information on transmitting licences, "class B" modulation, aeriials, etc. Price with Catalogue 6d., or 7 1/2d. post free. Catalogue only, 1 1/2d. post free.

**BIRMINGHAM RADIOMART (G5NI)**

19, John Bright Street and Dale End

MAIL ORDER DEPT. "W"

**44 HOLLOWAY HEAD, BIRMINGHAM. TELE. MID. 3254.**

COMPONENTS—SECOND-HAND, CLEARANCE, SURPLUS, ETC.

**SOUTHERN RADIO'S Wireless Bargains.**—All goods guaranteed and sent post paid.

**RECEIVERS.**—Vidor 3-valve battery sets, model C.N.212, complete in attractive walnut cabinet, with three Mullard valves, moving coil speaker, batteries and accumulator, new, in sealed cartons; £3/17/6 (list 6 1/2 guineas).

**LUCILLE.**—5-valve American midget sets, complete with 5 valves, moving coil speaker, ready for use on any mains, 100-250 volts A.C.-D.C., long and medium waves; £3/15, new, in sealed cartons.

**RECORD Changers.**—Garrard Model R.C.4, plays automatically and changes eight 10in. or 12in. records of any kind, new, in sealed cartons; £6.

**GRAMOPHONE Motors.**—Collaro electric radiogram units, for A.C. or D.C. mains, 100-250 volts, fully auto stop, complete with pick-up, can be used on any mains, brand new, in sealed cartons; 5/7 6 each.

**COLLARO Electric Radiogram Units,** complete with pick-up and fully auto stop, for A.C. mains only; 3/7 6 each.

**COLLARO Single Spring Gramophone Motors,** with 10in. turntables, complete with all accessories, 11/-; double spring motors, with 12in. turntable, 15/-.

**COLLARO Battery Radiogram Units,** comprising double spring motor and pick-up, mounted on plate with all accessories; 35/- each; all Collaro motors are brand new in sealed cartons.

**SPEAKERS.**—Celestion Sohndex permanent magnet, 10/-; Telsen permanent magnet with 10-ratio transformers to suit any receiver, 12/6; Telsen loud speaker units, 2/6; all brand new and boxed.

**COILS.**—Telsen iron core, W349 (midget size, 4/-; type W478 (twin), 3/- pair; type W477 (triple), 16/- per set; type W476 (triple superhet, selector and oscillator), 15/- per set; all ganged coils complete on base with switch; Telsen I.F. transformer coils, 110 kc., 5/-; Telsen dual range coils, with aerial series condenser incorporated, type W76, 4/-; Telsen aerial series condensers, with shorting switch, 2/-; all Telsen components brand new in sealed cartons.

**AMERICAN Valves.**—A full range of valves for all American receivers, 6/- each.

**MISCELLANEOUS Bargains.**—All brand new in original sealed cartons:

**TELSEN A.C.-D.C. Multimeters,** tests anything radio or electrical, 8/6; Telsen 2-range voltmeters, 3/-; 3-range meters, including milliamps, 4/-; Ace (P.O.) microphones, with transformer, ready for use with any receiver, 4/6; 36 assorted Tru-ohm resistances, 1 watt, colour coded and marked, 36 on card, 6/- per card; bell transformers, 200-250 volts input, 3, 5 and 8 volts output, 3/6; Morse signal units, incorporating buzzer, tapper and flash, with international code, complete with batteries and bulb, 3/9 each; Varley-square peak coils, BPS, 2/-; Marconi V24 and Q type valves (useful for short wave experiments), 1/6; glass insulators, 4d.; lightweight headphones, double pole, 4,000 ohms each earpiece, 3/- pair.

A.C. Trickle Charger, for 2, 4 and 6 volts; 17/6.

**CAR and Radio Battery Chargers,** incorporating Westinghouse metal rectifier; this charger will enable you to keep your car batteries fully charged, for use on 2, 6 and 12 volts; 45/- each.

**REGENTONE Eliminators, A.C. 200-250 volts, type W5a, with trickle charger; 37/6.**

**SOUTHERN RADIO.**—Branches at 271-275, High Rd., Willesden Green, N.W.10; 46, Lisle St., London, W.C.2. All mail orders to 323, Euston Rd., London, N.W.1.

**SOUTHERN RADIO, 323, Euston Rd., London, N.W.1 (near Warren St. Tube). Phone: Euston 3775.** [3666]

**MAINS RADIO DEVELOPMENT COMPANY.** Offer Exclusive Bargains; unbeatable value, carriage paid; stamp for bargain list; see displayed advert. on this page for exclusive all-wave offer.

**CHASSIS,** three-valve, grey cellulosed, 12in. x 6 1/4in. x 3, rigid metal, brand new, 1/-; Clix unused chassis, valve holders, 5-pin, 2 1/2d.; Plessey 4-pin, 1 1/2d.; 7-pin, 4d.; all baseboards, 4d.

**RESISTORS,** very best make, one watt, colour coded, R wire ends, unused; every value 50 ohms to 4 meg-ohms, 3 1/2d., 2/9 dozen; two watt, 7d.

**CENTRALAB Unused 500-ohm Potentiometers, 1/-; Philips, 20,000 ohms 1/10; 10,000 ohms with switch, 1s. 6d.**

**TUBULAR Condensers,** unused, best make 400 volt working, 0.0001-0.002 mfd. 3d., 0.005-0.05 mfd. 5d., 0.1 mfd. 6d., 0.25 mfd. 7d.

**WEARITE H.F. Chokes,** very efficient, 6d.; short-wave H.F. chokes, 4d.

**TELSEN Latest Type Bakelite Reactions, 0.00015 mfd., 4 1/2d. to clear; Ormond 0.0005, 0.0005 mfd., 9d.**

**FINAL Clearance.**—Standard telephones, brand new metal case condensers, 400 volt working, 2 mfd., 6d.; 1 mfd., 4 1/2d.; Formo unused tag condensers, 0.00005-0.002 mfd., 1 1/2d. each.

**PLESSEY Dry Electrolytics, 8 mfd., 550 volt, 1/8; 50 mfd., 50 volt, 1/8; 200 mfd., 15 volt, 2/3; 50 mfd., 12 volt, 8d.**

**TELSEN P.M.M.C. Speakers, 7-inch cone, ten ratio output transformer, new, boxed, 11/6.**

**HALF-WATT Resistors,** unused, wire ends, good marked sizes, 50 well assorted, 2/6; Telsen spig-hettis, sealed cartons, good assorted sizes, must be cleared, 6d. dozen, 50 for 1/6.

**MAINS RADIO DEVELOPMENT COMPANY, 4-6, Muswell Hill Rd., London, N.6. Phone: Tudor 4046.** [3608]

AMAZING BARGAINS. OBTAINABLE ONLY FROM

GALPINS ELECTRICAL STORES

75, LEE HIGH RD., LEWISHAM, LONDON, S.E.13.

TERMS: CASH WITH ORDER OR C.O.D. Telephone: Lee Green 5240.

PERMANENT MAGNET MOVING COIL SPEAKERS by well-known makers, fitted volume tone control... GALPINS ELECTRICAL STORES... 75, LEE HIGH RD., LEWISHAM, LONDON, S.E.13.

COMPONENTS—SECOND-HAND, CLEARANCE, SURPLUS, ETC.

Vauxhall. ALL Goods previously Advertised are Standard Lines Available for Immediate Delivery. VAUXHALL UTILITIES, 163a, Strand, W.C.2, over Denny's, the Booksellers, Temple Bar 9358. Send postcard for new lists, free. [0453]

B.T.S. ACKNOWLEDGED THE BEST SPECIFIED for the "W.W." EXPERIMENTER'S I.F. AMPLIFIER... B.T.S. SPECIAL I.F. OSCILLATOR UNIT... B.T.S. READY DRILLED CHASSIS... B.T.S. MICA TUNED I.F. TRANSFORMER... B.T.S. TOGGLE SWITCH... B.T.S. Variable Selectivity I.F. TRANSFORMER... BRITISH TELEVISION SUPPLIES LTD.

TRANSATLANTIC All-Wave Tuning Pack A Complete Superhet. tuning unit, covering 15-50, 200-550 and 1,000-2,000 metres at the turn of a switch.

THE INSTITUTE OF WIRELESS TECHNOLOGY (Incorporated) 4, VERNON PLACE, SOUTHAMPTON ROW, LONDON, W.C.1. THE EXAMINATIONS, MAY, 1937

RECORD The quality valve in the COMPLETE range RECORD RADIO LTD., 1/3, Eldon Street, E.C.2

PRISM RADIOGRAMS Write to PRISM MANUFACTURING CO. CALIFORNIA WORKS, BELMONT, SURREY. Phone Sutton 5361/2.



MISCELLANEOUS

G.P.O. Engineering Dept. (no experience required). Commencing £3/13 per week. Age 18-23. Excellent prospects. Free details of entrance exam. from B.I.E.T. (Dept. 574), 17-19, Stratford Place, London, W.1. [3492]

ELECTRIC CLOCKS

SMITHS and Ferranti Electric Clocks, Waltham and Russell watches and clocks; traders' enquiries invited. Leonard, Reys, 36, Henry St., Blackpool. [0526]

EXTENDED PAYMENTS

LONDON RADIO SUPPLY Co. (Established 1925) supply on convenient terms, components, accessories and sets, any make; 10% down, balance over 12 months; send for list of requirements.—11, Oat Lane, London, E.C.2. [0337]

HIRE-PURCHASE.—Prompt delivery of any radio apparatus on convenient terms.

WARD, 46, Farringdon St., London, E.C.4. Tel.: Holborn 9703. [0559]

EXCHANGE

COSMIC RADIO SERVICES, Ltd., 23, Water St., Liverpool, accept quality mains equipment, meters, components, etc., in part exchange. Meters purchased. [2490]

I BUY, sell, exchange good quality receivers, accessories, components; H.P. facilities; promptness, efficiency.—Bostock, 1, Westbourne Terrace, S.E.23. Forest Hill 2236. [0529]

PATENT AND TRADE MARK AGENTS

GEE and Co. (H. T. P. Gee, Mem. R.S.G.B., A.M.I.R.E., Estab. 1905), 51-52, Chancery Lane, London, W.C.2 (2 doors from Government Patent Office). Holborn 4547 (2 lines). Handbook free. [0001]

PATENTS

PRACTICAL Hints on Patents, free on application. —The Imperial Patent Service, First Avenue House, High Holborn, W.C.1. Preliminary consultation free. [0481]

REPAIRS AND SERVICE

GRAHAM'S

GRAHAM'S Radio Repair and Rewinding Service; 24 hours' service guaranteed.—See below.

ALL Moving Iron Loud Speakers, L.F. transformers, or pick-ups, from 2/6; output transformers from 4/-; postage extra; mains transformers, moving coils, electric clocks quoted; trade discounts.—Graham's Repairs, 194, Tolworth Rise, Kingston By-pass, Surrey. Phone: Derwent 2060. [3500]

DISTAVOX SERVICE

TRADE Service.—All makes of English and American receivers; quotation by return.

REWINDING.—Mains, L.F. and output, transformers, speakers, headphones, etc.; keepest terms for contracts.

DISTAVOX RADIO SERVICE Co., 119, Bunhill Row, London, E.C.1. Phone: National 8589. [3504]

"SERVICE With a Smile."

HENRY FORD RADIO, Ltd.,

LEADING Service Specialists for American Receivers, also British; trade work particularly; estimates free.

ELECTRONIC House, 22, Howland St., Tottenham Court Rd., W.1. Museum 5675. [0434]

METROPOLITAN RADIO SERVICE Co. for Guaranteed Repairs to American (Midget and Standard) and British Receivers.

CLARION and Majestic Service Depot.—I.F. and mains transformers rewound. American valves and parts; trade supplied.—Metropolitan Radio Service Co., 1021, Finchley Rd., London, N.W.11. Speedwell 3000. [0435]

SAUNDERS and Co., 15, Percy St., W.1. Museum 3096. American and English repairs. Wireless World sets a speciality. Estimates free. [3682]

VALRADIO for Repairs and Rewindings to Converters, Motors, transformers, vacuum cleaners, etc.—95, Leighton Rd., Kentish Town, N.W.5. Gulliver 5165. [3210]

GUARANTEED Repairs.—Any transformers, choke, motor, armature, converter, dynamo, etc.; keenest prices, immediate quotation; prompt, dependable service. —See below.

L.T.P. (LONDON TRANSFORMER PRODUCTS, Ltd.), Willesden, N.W.10. Wil. 3568 and 7743. [3470]

MAINS Transformer Service.—Repairs, rewinds, or constructions to specification of any type; competitive prices and prompt service.—Sturdy Electric Co., Dip-ton, Newcastle-on Tyne. [0516]

F. E. GODFREY, A.M.I.R.E., qualified to build, repair and convert. "Wireless World" sets, etc.; 25 years' experience; prompt service guaranteed.—30, Kemplay Rd., Hampstead. Hampstead 1104. [3509]

RADIO Repairs and Constructional Service.—receivers, transmitters, audio amplifiers, etc.; express-radio repairs for Lancashire.—Harmony House Sound Service (G21N, G521), 116, Cambridge Rd., Southport. Tel.: 8621. [0536]

PETO-SCOTT The ONLY FIRM with 18 YEARS' EXPERIENCE supplying the specialised needs of the serious experimenter and constructor. W.W. EXPERIMENTER'S I. F. AMPLIFIER KIT "A" Cash or C.O.D. £5:13:6 COMPRISES The complete Kit of first specified parts exactly as used by the "Wireless World" research laboratory and includes every single part with Ready-Drilled B.T.S. Chassis and all necessary screws, wire and brass parts, but less valves. Cash or C.O.D., Carriage Paid, £5:13:6; or 10/6 down & 11 monthly payments of 10/6. Set of 4 Specified Valves £2:7:0 or add 4/3 to deposit and each monthly payment. B.T.S. CHASSIS as specified 7/6 B.T.S. Grey stove-enamelled steel chassis, ready drilled exactly to the "Wireless World" specification. Cash or C.O.D. Post 6d. extra. B.T.S. I.F. OSCILLATOR UNIT 9/6 B.T.S. Special I.F. Oscillator Unit, Type W.W. L.F.A., as exclusively specified. 465 K/c in aluminium screening can and complete with coloured leads for easy identification and wiring. Cash or C.O.D. Post 6d. extra. EXPERIMENTER'S I.F. AMPLIFIER ASSEMBLED AND TESTED. CASH or C.O.D. £9:9:0 YOURS FOR 17/6 DOWN Finished "Wireless World" Experimenter's I.F. Amplifier Assembled, Wired, Trimmed and Tested by Peto-Scott experienced technicians. Every part is exactly to W.W. first specification and each amplifier individually built and guaranteed to equal in performance the original model built by "Wireless World" Research Laboratories. Supplied complete with 4 specified valves but less cabinet. Cash or C.O.D., Carriage Paid, £9-9-0, or 17/6 down and 11 monthly payments of 17/3. Postal Orders should be crossed and made payable to Peto-Scott Co. Ltd. and currency registered. PETO-SCOTT CO. LTD. 77, (W.W.17) City Rd., London, E.C.1. Phone: City 9875/67. 62, (W.W.17) High Holborn, W.C.1.

DICTIONARY of WIRELESS TECHNICAL TERMS Compiled by S. O. PEARSON, B.Sc., A.M.I.E.E. and issued in conjunction with "THE WIRELESS WORLD" Second Edition. Completely revised and brought up to date This handy volume is very much more than a Dictionary. It not only takes the technical terms of wireless and explains their meaning, but in doing so it concentrates into a small space a large amount of information on wireless subjects. It has become, in fact, a compendium of wireless knowledge, and an invaluable handbook for all who are interested in wireless transmission and reception. Diagrams and illustrations are freely interspersed throughout the book to amplify the explanations of the text. 272 pp., bound in cloth boards Size 5 by 3 inches Price 2/- net. By post 2/2 From all leading booksellers or direct from Publishers. LILFFE & SONS LTD. Dorset House, Stamford Street, London, S.E.1 W.W.48

REPAIRS AND SERVICE

TRADE Service.—British and American receivers serviced at reasonable cost; estimates free; work guaranteed three months; American valves.—Majestic Service Co., 22-28, King St. West, Manchester, 5. Phone: Blackfriars 4951. [0544]

REPAIRS to Moving Coil Speakers a Speciality; cones and coils fitted, fields altered; prices, including eliminators, quoted, loud speakers, 4/-; L.F. and output transformers, 4/-, post free; guaranteed satisfaction; trade invited; estimates free; prompt service.—Loud-Speaker Repair Works, 5, Balham Grove, London, Battersea. [0394]

TUITION

RADIO Training.—Marine, aircraft, broadcast; prospectus free.—Hull Municipal Technical College. [0523]

WANTED

FERRANTI Transformers, D.C. Apynor; write details. —Grigg, 70, Peel Rd., Wealdstone, Middlesex. [3675]

WANTED, "Wireless World," June 22 and 29, 1932.—Stechert and Co., 2, Star Yard, Carey St., W.C.2. [3687]

WANTED for Cash.—Modern radio receivers; also meters, etc.—M. R. E., 6, Pentonville Rd., London, N.1. [3283]

COILS Wanted for G.E.C. Short-wave Superhet, "Overseas" model.—Wells, 94, Flass Lane, Barrow-in-Furness. [3673]

WE Buy for Cash All Types of Modern Second-hand Radio Sets and Accessories, test meters, parts, etc.; we pay more than any other dealer; part exchanges; bring, send, or will call.—University Radio, Ltd., 82, Hampstead Rd., London, N.W.1. Phone: Euston 3810. [3484]

SITUATIONS VACANT

AIR MINISTRY.

APPLICATIONS are Invited for the Post of Draughtsman, Grade 1, at Bawdsey Research Station, Bawdsey Manor, Woodbridge, Suffolk; applicants should be competent draughtsmen with experience of the design of radio transmitters and receivers from standardised parts; a knowledge of workshop and production practice is desirable; salary scale, £246-£12-£307.

APPLICATIONS Should be by Letter, quoting reference No. B.319, to the Superintendent, Bawdsey Research Station, Bawdsey Manor, Woodbridge, Suffolk, stating age, education, training and experience. Closing date for the receipt of applications is 12th February, 1937. [3676]

WIRELESS and Television

MARCONI'S and Other Employers Require Hundreds of Trained Men This Year. We train students for all branches of Radio at our Residential Colleges in Southampton and Colwyn Bay, and guarantee appointments; licensed by Postmaster-General recommended by Marconi's.—Write for free prospectus, The Wireless College, Colwyn Bay, or to London Office, 4, Winton Av., N.11. [0541]

TECHNICAL Translators Wanted by Internationales Uebersetzungs-Institut, Frankfurt/M.17. [3650]

SERVICE Engineer and Salesman (married), permanency for fully qualified and practical man, must drive, good wages and commission.—Box 60, Smith's Library, Cheam, Surrey. [3662]

RADIO Engineer, familiar with modern all-wave receivers, laboratory and production experience preferred.—Apply, Pilot Radio, Ltd., 87, Park Royal Rd., London, N.W.10. [3656]

LABORATORY Assistant Required for Routine and General Measurements, practical experience of radio-frequency measurements and knowledge of A.C. theory essential.—Box 604, c/o The Wireless World. [3677]

RADIO Testers Required with Good Technical Knowledge of Modern Receivers and Experience of Conveyor Belt System; applications should show clearly details of training, previous employers with dates, and work on which engaged.—Box 593, c/o The Wireless World. [3657]

A LIMITED Number of Vacancies Occur Monthly for young men with secondary school education, to be trained in the Royal Air Force as Wireless Operators; age limits 17½ to 32.—Apply: R.A.F. Recruiting Depot, Victory House, Kingsway, London, W.C.2. or any R.A.F. Recruiting Depot. [3512]

JNR. and Snr. Service Engineers, required immediately by well known South London radio manufacturers, paid holidays; weekly salaries and permanent full year situations for suitable applicants; give details of present and past situations and salary required.—Box 578, c/o The Wireless World. [3658]

MAN with Experience of Mains Transformer Construction Wanted to Take Charge of Small Factory.—Box 585, c/o The Wireless World. [3652]

WHOLE or Part Time Occupation, North, Midlands and South, for few responsible men who can obtain several sets per week for guaranteed repairs or modernisation by leading repair firm; exceptional opportunity for selected applicants.—Reply in confidence to Box 612, c/o The Wireless World. [3690]

SITUATIONS WANTED

PRODUCTION Engineer, Designer, sound systems, recording, reproduction, desires change.—Box 592, c/o The Wireless World. [3660]

INDEX TO ADVERTISEMENTS

	PAGE		PAGE		PAGE
Armstrong Mfg. Co.	3	Galpins	8	Premier Supply Stores	5
Automatic Coil Winder & Electrical Equipment Co. Ltd.	Front Cover	G.E.C.	1	Prism Manufacturing Co.	8
Bakers Selhurst Radio	3	Goodman's Industries, Ltd.	6	Radio Development Co.	2
Belling-Lee, Ltd.	6	Gramplan Reproducers, Ltd.	2	Radio Industries Development Co.	8
Benjamin Electric, Ltd.	7	Hartley Turner Radio, Ltd.	Front Cover	Record Radip	1
Birmingham Radiomart (G5N1)	5	Haynes Radio	8	R.G.D.	4
British Institute of Engineering Technology	5	Inhof. Alfred, Ltd.	1	Rothermel	1
British Insulated Cables, Ltd.	Inside Back Cover	Institute of Wireless Technology	8	Savage, W. Bryan	4
British Pix	10	Lectro Linx	1	Scientific Supply Stores (Wireless), Ltd.	6
British Rola Co., Ltd.	Edit. 115	London Radio Supply Company	8	Silam Electrical Instrument Co.	6
British Television Supplies	Front Cover	Mains Radio Development Co.	8	Smith, H. L., & Co., Ltd.	Front Cover
C.A.V.	8	McCarthy Radio, Ltd.	Edit. 113	Sound Sales, Ltd.	5
Dubilier Condenser Co.	Inside Front Cover	Midwest Radio, Ltd.	10	Tannoy Products	4
Ediswan, Ltd.	4	M.P.H. Electrical Co.	5	Varley, Ltd.	4
Electradix Radios	4	Musikon, Ltd.	Inside Back Cover	Ward, C. F.	4
Fluxite	4	Peto Scott, Ltd.	9	Wharfedale Wireless	Inside Back Cover
		Postlethwaite Bros.	9	Wingrove & Rogers, Ltd.	Inside Back Cover

# FOUNDATIONS of WIRELESS

A Book of  
First Principles  
for the  
Wireless  
Enthusiast

PRICE 4/6 NET  
By Post 4/11

Issued in conjunction with  
"THE WIRELESS WORLD"  
and published by the Proprietors—

By A. L. M. SOWERBY, M.Sc.  
An Elementary Text Book on Wireless Receivers

"Foundations of Wireless," based on a series of articles which appeared in "The Wireless World," covers the whole field of wireless from the simplest electrical phenomena to the construction of a modern set, and all the vital points in receiver-design are treated in full detail. Chapters are devoted to direct and alternating currents; typical circuits; the properties of inductance and capacity; the nature of high frequency currents; the tuned circuit; and amplification by the valve.

Eleven of the eighteen chapters of the book deal with the discussion of receivers in which the whole process of design is reviewed stage by stage to the finished article. Special attention is paid to the important subject of tuned circuits and band-pass filters, on the correct design of which the performance of every type of set ultimately depends. Moreover the process of detection, so often imperfectly understood, is clearly explained.

ILIFFE & SONS LTD., DORSET HOUSE, STAMFORD STREET, LONDON, S.E.1

## 1937 MIDWEST

THE ONLY ALL-WAVE RECEIVER  
COVERING 4½ to 2,400 METRES

Available in Chassis form complete with matched valves and 12" speaker or in Console Cabinet.

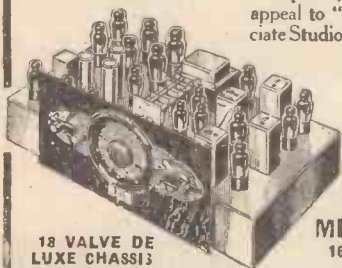

18 VALVE DE LUXE CHASSIS

Magnificent alike in its conception, design and performance, this the latest Midwest Model X-18 High Fidelity Receiver brings the world to your fireside. With its 6 TUNING RANGES

it gets "Everything on the Air." Its distinctive features in circuit design are not just "talking points," as a comparison will prove, but basic advantages which will assuredly appeal to "Wireless World" readers and all who appreciate Studio or Concert Hall quality of performance in home.

**FREE** Our fully descriptive 40 PAGE ILLUSTRATED ART CATALOGUE giving particulars of Midwest 11, 14, 16 and 18 valve models.

DEMONSTRATIONS at our showrooms Mondays to Saturdays from 9 a.m. to 8 p.m.

DEFERRED PAYMENTS. The London Radio Supply Co., 11, Oat Lane, Noble Street, London, E.C.2, supply all models on Easy Terms.

**MIDWEST RADIO LTD.,** SHOWROOM 1 & FACTORY:  
16, OLD TOWN, CLAPHAM, LONDON, S.W.4.  
Phone: MACanary 5005.

SECOND EDITION

—Completely Revised

# RADIO DATA CHARTS

A SERIES OF ABACS

Providing most of the essential Data required in receiver design

By R. T. BEATTY, M.A., B.E., D.Sc.

PRICE 4/6 net BY POST 4/10

From all leading booksellers, or direct from the Publishers. Published from the offices of "THE WIRELESS WORLD," DORSET HOUSE, STAMFORD STREET, LONDON, S.E.1

W.W. 1

THE ONE AERIAL FOR THE MODERN SET

# PIX INVISIBLE AERIAL

Pix, London, S.E.1.

Neat  
Efficient  
Blends with furnishings  
Self-Adhesive

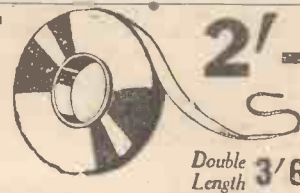

2' -  
Double Length 3'6

Printed in England for the Publishers, ILIFFE AND SONS LTD., Dorset House, Stamford Street, London, S.E.1, by The Cornwall Press Ltd., Paris Garden, Stamford Street, London, S.E.1. "The Wireless World" can be obtained abroad from the following: FRANCE: W. H. Smith & Son, 248, Rue Rivoli, Paris; Hachette et Cie, Réaumur, Paris, and branches. BELGIUM: W. H. Smith & Son, 74-75, Boulevard Adolphe Max, Brussels. AUSTRALIA: Gordon & Gotch, Ltd., Melbourne (Victoria), Sydney (N.S.W.), Brisbane (Queensland), Adelaide (S.A.), Perth (W.A.) and Launceston (Tasmania). NEW ZEALAND: Gordon & Gotch, Ltd., Wellington, Auckland, Christchurch and Dunedin. INDIA: A. H. Wheeler & Co., Bombay, Allahabad and Calcutta. CANADA: Imperial News Co., Toronto, Winnipeg and Vancouver; Benjamin News Co., Montreal; Gordon & Gotch, Ltd., Toronto. SOUTH AFRICA: Central News Agency, Ltd. UNITED STATES: The International News Co., New York.

# B.I. HIGH VOLTAGE CONDENSERS



for  
RADIO and TELEVISION

We can offer a complete range of High Voltage Condensers in all capacities and for all working conditions met with in Radio and Television Sets.

In accordance with our standard practice these are impregnated with a special Petroleum Jelly.

The insulated terminals have ample creeping surface, and we recommend these condensers with the utmost confidence.

**BRITISH INSULATED CABLES LTD.**

Cablemakers and Electrical Engineers

PRESCOT—Lancs.

Telephone No. : PRESCOT 6571

London Office : Surrey House, Embankment, W.C.2

Tel. No. : Temple Bar 7722

# POLAR & N.S.F. COMPONENTS

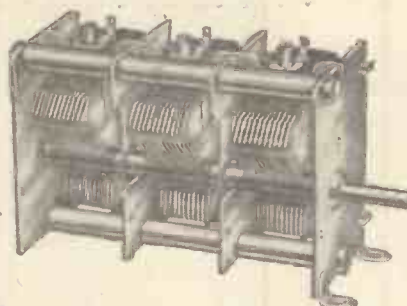

## POLAR BAR TYPE GANG CONDENSERS

Steel frame ensuring great rigidity. Low minimum capacity. Available with ceramic insulations .. 2/- 2-gang & 2/6 3-gang extra.

Two Gang or Superhet type .. .. 12/-  
Three Gang or Superhet type .. .. 17/6

## POLAR-N.S.F. VOLUME CONTROLS

Special Carbon element. Insulated spindle. Made in:—5,000 and 10,000 ohms, for H.F. circuits, 10,000 ohms straight law, 50,000, 100,000 ohms, 1/2, 1 and 2 megohms for LOW frequency circuits.

Without Switch .. .. 4/-  
With Switch .. .. 5/-



**SPECIFIED FOR THE EXPERIMENTERS I.F. AMPLIFIER**

One 1/2 Meg. (without switch) .. .. 4/-

## WHARFEDALE "GOLDEN" The Speaker of "more than average quality"

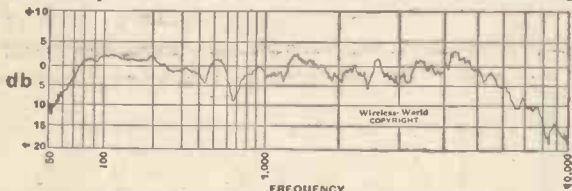

"Wireless World," 14/8/36, reports:—"a glance at the response curve shows that important improvements have been effected. The general flatness is remarkable. At the top end the output is much better sustained, while in the bass, the 80 cycle resonance has disappeared. The Unit is one which we can confidently recommend to those seeking a loudspeaker of more than average quality."

The Universal Model is fitted with large De Luxe Transformer.

WHARFEDALE WIRELESS WORKS, 62, LEEDS ROAD, BRADFORD, YORKS.

CHASSIS  
**55/-**  
UNIVERSAL  
**42/6**  
LESS TRANSF.

Cast aluminium chassis. Alni magnet. Handles up to 7 or 8 watts undistorted. Send for complete illustrated catalogue.

## PERMAREC HOME RECORDING UNIT MAKES PERFECT RECORDS

A thoroughly sound engineering job specially designed for easy attachment to any set or Radiogram. Cutting your own records is perfectly simple with this unit.

Write to-day for Free Copy of "The Wireless World" Test Report and illustrated leaflet fully describing this and our larger professional models.



Manufactured under British Patent No. 433614.

**MUSIKON LTD. RECORDING STUDIOS**  
Telephone: Gerrard 7105 and 3862  
19, LISLE STREET, LONDON, W.C.2.

PRICE  
**£3.17.6**

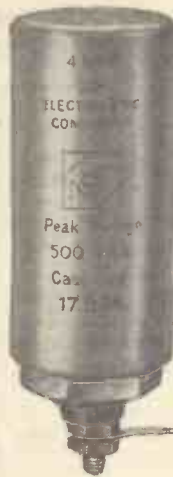

## POLAR-N.S.F. ELECTROLYTIC CONDENSERS

Highest Quality Materials. Peak voltage 500 v. D.C.

4 mfd. .. .. 4/6  
6 mfd. .. .. 5/-  
8 mfd. .. .. 5/6

## POLAR-N.S.F. TUBULAR CONDENSERS (not illustrated)

.0001	} 1/-	.02	} 1/4	Non-inductive Tested at 1,500 volts D.C. Working 350 volts D.C.
.0003		.05		
.0005		.1		
.001	} 1/3	.2	} 1/9	
.002		.5		
.005	} 1/3	5	} 2/-	
.01		10		

## POLAR-N.S.F. RESISTORS

Tolerance plus or minus 10%

1 watt 2 watt 3 watt

1/- 2/- 3/-



## WINGROVE & ROGERS, LTD. 188/189, STRAND, LONDON, W.C.2

Phone: Temple Bar 2244.

Works: Old Swan Liverpool.

907

*Make a Note of it—Now!  
Be sure to get your copy of*

**The  
Wireless  
World**

**DIARY FOR 1937**

Every wireless enthusiast should have this handy little diary. In addition to the usual pages—one week at an opening—it contains 76 pages of facts, formulæ and general information of the kind that is always wanted but is difficult to memorise.

There is a complete list of European Broadcasting Stations and Short-wave Stations of the World. In addition an important section contains all the recognised codes relating to components, as well as useful tables of resistance ratings. There are also nine pages of base connections of British and American valves.

Sixteen pages of circuit diagrams of receivers, amplifiers and such units as whistle suppressors, tone controls and AVC systems are included. Valuable information is given on the prevention of mains interference and data for winding coils.



*Size 3½ by 4½ inches, 192 pages. Bound leather cloth, back loop with pencil.*

**PRICE 1/6 net.**

By post 1/7

*From bookstalls and stationers, or direct from the Publishers*

ILIFFE & SONS LTD., DORSET HOUSE, STAMFORD STREET, LONDON, S.E.1.

W.W.75.

**SECOND EDITION—THOROUGHLY REVISED**

**NOW READY**

**WIRELESS SERVICING MANUAL**

**By W. T. COCKING**

*(of "The Wireless World")*

**The first complete book of reference of its kind. A reliable practical guide for amateur and professional.**

The demand for this book was so great that the first edition was sold out in the short space of a very few months. A second edition containing additional material is now on sale. The "Wireless Servicing Manual" deals fully with Testing Apparatus and explains the methods of locating and curing faults in receiving equipment. Gangung, Automatic Volume Control, Instability, Distortion, Mains Hum, Whistles and Local Interference are all separately treated.

The new edition contains much additional information on short-wave receivers, and on methods of operating extension loud speakers, the reference material including base-connections for British, Continental and American Valves, and the various colour codes for components has been extended and brought up to date.

**BOUND IN CLOTH BOARDS**

**SIZE 7½ ins. x 5 ins.**

**231 PAGES**

**PRICE 5/- net. By post 5/4**

Issued in conjunction with "THE WIRELESS WORLD" and published by the Proprietors:—

**ILIFFE & SONS LTD, DORSET HOUSE, STAMFORD STREET, LONDON, S.E.1**

W.W.20.