

The Wireless World

THE PRACTICAL RADIO JOURNAL
with Complete Foreign Programmes

4^D

Friday, July 7th, 1933.

**HIGH TENSION
FOR
NEXT TO
NOTHING**

Ask your dealer for BURTON All-Mains Units, or write for List to the makers—
C. F. & H. BURTON,
Progress Works,
WALSALL

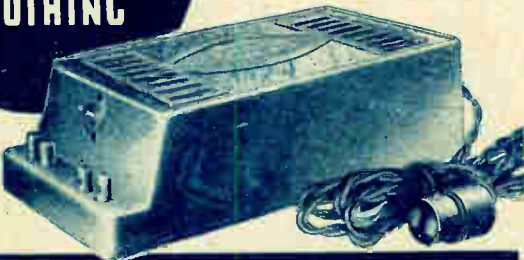

BURTON ALL-MAINS UNITS

Why spend money on H.T. Batteries when you can run your set through a Burton ALL-MAINS Unit with practically no increase in your Electric Supply account. No mains 'Hum' and your set permanently at peak of perfection. A.C. Models from £2-12-6. D.C. Models from £1-8-6. Trickle Charger £1-18-0.

TELSEN SUPERHET COILS

TYPE No. S.330

Specified for the W.W. Monodial Super Battery Receiver. The ideal coils for any superhet circuit. **25/6**

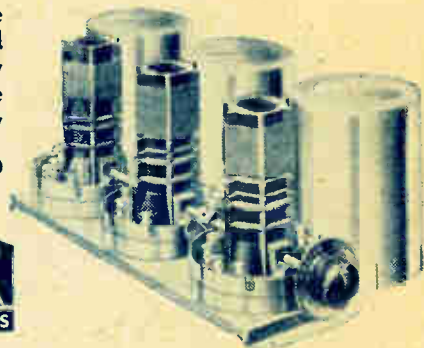

TELSEN
RADIO COMPONENTS

Announcement of the TELSEN ELECTRIC CO., LTD., ASTON, BIRMINGHAM

DC. AND A.C.
AMPS
VOLTS
OHMS

EVERY TEST WITH ONE COMPLETE INSTRUMENT

The Avometer is the only complete testing instrument which gives direct readings in amps, volts and ohms without the necessity for mathematical calculations. It is indispensable to the Service men of leading radio manufacturers as the only instrument that adequately meets their needs.

Two models, one for D.C. only, **8 GNS.** and the Universal Avometer giving both D.C. and A.C. readings (50 cycles) **12 GNS.** Deferred Terms if desired.

Illustrated Pamphlet post free.

The AVOMETER

BRITISH MADE

AUTOMATIC COIL WINDER & ELECTRICAL EQUIPMENT CO., LTD., Winder House, Douglas Street, London, S.W.1
Telephone: Victoria 3105-7.



COLVERN FERROCART COILS

FERROCART Coils are synonymous for outstanding selectivity, compactness and efficiency.

TYPES F1 F2 F3
For single S.G.H.F. stage receivers **37/6** per set

TYPES F10 F11 F12 F13
Suitable for 2 S.G.H.F. stage receivers **50/-** per set

Mounted on sub base with ganged wave change switches.

COLVERN LIMITED,
ROMFORD, ESSEX.
London Wholesale Depot,
150, King's Cross Rd., W.C.1.

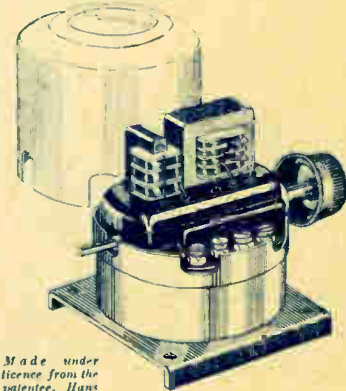

Made under licence from the patentee, Hans Vogt.



YOUR MAINS PROBLEMS! — this Book answers them all

T.C.C.
ALL-BRITISH
CONDENSERS

- What size Eliminator do I need? —
- How can I cut out Mains Hum? —
- How can I eliminate Interference? —
- When should I use an Electrolytic? —
- How do I build an A.C. PowerPack? —
- What special precautions for D.C.? —
- What resistance do I need? —

GET YOUR COPY

COUPON To The Publicity Dept., The Telegraph Condenser Co. Ltd., Wales Farm Rd., N. Acton, London, W.3.

Please send me a copy of your book "The Design and Construction of Radio Power Units," for which I enclose six penny stamps to cover cost and postage.

NAME.....

ADDRESS.....

W.W. 7/7/33. Please write in block letters

Keep the Week's Foreign Programmes handy for constant use

Listeners who habitually use the Foreign Station Programmes in "The Wireless World" will appreciate the value of the useful

READING CASE

for the weekly issue, which is now available.

It is an attractive cloth-board cover, gold lettered on front, and provided with silk holding cord for the current copy of "The Wireless World."

It has the merit of keeping the programmes immediately available for reference, and at the same time protecting them from damage by frequent use.

"The WIRELESS WORLD" READING CASE

Price 2/6 net
By post 2, 10

Now obtainable from the Publishers

ILIFFE & SONS LTD.
Dorset House, Stamford Street, London, S.E.1

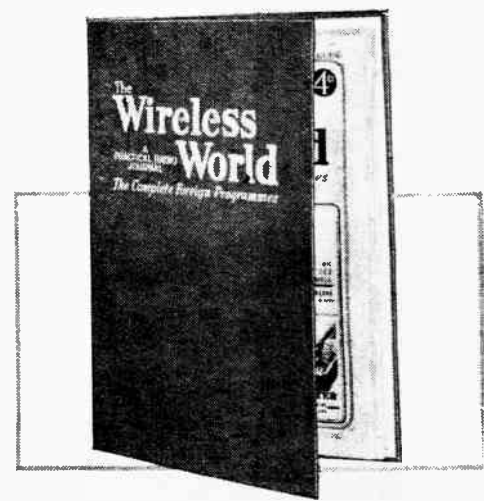

Mention of "The Wireless World," when writing to advertisers, will ensure prompt attention.

621,38405 W7482
v.33

The Wireless World

PROGRAMMES from ABROAD

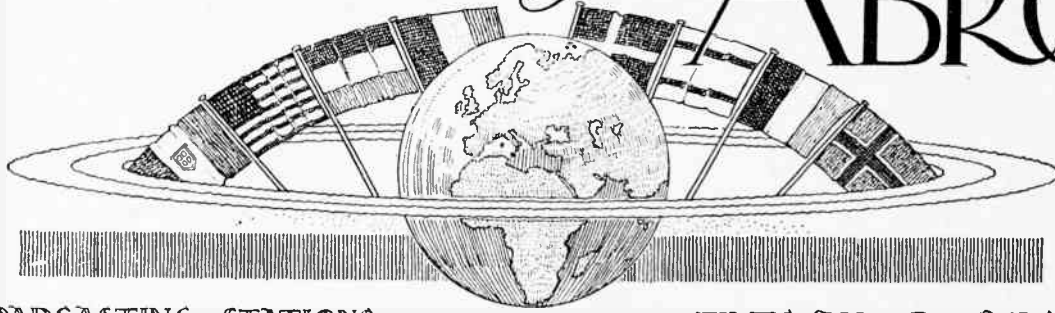

BROADCASTING STATIONS ARRANGED IN ORDER OF WAVELENGTH

TIMES AND DETAILS OF FULL WEEK'S FOREIGN TRANSMISSIONS

Metres.	kc s.	kW.	Station.	Tuning Positions.	Metres.	kc s.	kW.	Station.	Tuning Positions.
1935	155	7	Kaunas (Kovno) (Lithuania)		453.2	662	7	Milan (<i>Experimental Relays Rome</i>)	
1875	160	8.5	Huizen (Holland)		450.3	666	20	Madona (Latvia). (<i>Relays Riga</i>)	
1796	167	40	Lahti (Finland)		447.1	671		Paris, Ecole Supérieure, PTT (7.0 kW.);	
1725	174	75	Radio Paris, C.F.R.					Rjukan (0.15 kW.), Notodden (0.08 kW.)	
1635	183.5	60	Berlin (Deutschlandsender) (Germany). <i>(S.-W. Stn. DJA on 31.38 m., DJB on 19.73 m., DJC on 49.83 m., DJD on 25.51 m., DJE on 16.89 m.)</i>		441.2	680	50	Aalesund (0.35 kW.) (Norway) (<i>relays Oslo</i>).	
1554.4	193	30	Daventry National		435.4	689	55	Rome, IRO. (<i>S.-W. Station, 2 RO on 25.4 m.</i>)	
1538	195	7	Ankara (Angora) (Turkey)		430.4	697	2.5	Stockholm, SANA (Sweden)	
1481	202.5	100	Moscow, RVI (Old Komintern) (Russia)		424.3	707	2	Belgrade (Yugoslavia)	
1446	207.5	13	Eiffel Tower, FL, Paris		424.3	707	100	Madrid, EAJ7 (Union Radio). (<i>After 7.0 p.m.</i>)	
1412	212.5	120	Warsaw I (Poland)		419.5	715	1.5	Moscow, Imini Stalina (Russia)	
1380	217.5	100	Novosibirsk, RV6 (Russia)		416.4	720.5	5	Berlin, Witzleben (Germany)	
1354.4	221.5	30	Motala (Sweden). (<i>Relays Stockholm</i>)		413	725	60	Rabat (Morocco)	
1304	230	500	Moscow, WZSPS (Trade Union) (Russia)		408.7	734	16	Athlone (Irish Free State)	
1275	235	0.5	Tunis-Kasbah (Tunisia)		403.8	743	25	Katowitz (Poland)	
1230	244	0.6	Boden (Sweden). (<i>Relays Stockholm</i>)		398.9	752	25	Sottens (Radio Suisse Romande) (<i>Switzerland</i>)	
1200	250	5	Stamboul (Turkey)		394.2	761	12	Midland Regional. (Daventry)	
1200	250	21	Reykjavik (Iceland)		389.6	770	120	Bucharest (Roumania)	
1190	252	200	Luxembourg		385.1	779	8	Leipzig (Germany)	
1170	256	25	Tashkent, RV11 (Russia)		385.1	779	10	Toulouse (Radiophonie du Midi) (France)	
1154	260	7.5	Kalundborg (Denmark). (<i>Relays Copenhagen</i>)		381	788	16	Stalino, RV26 (Russia)	
1117	268.5	40	Moscow, Popoff RV58 (Russia)		376.4	797	50	Lwow (Lemberg) (Poland)	
1083	277	60	Oslo (Norway)		372.2	806	1.5	Scottish Regional (Falkirk)	
1071	280	35	Tiflis, RV7 (Russia)		370.1	810.5	0.8	Hamburg (Germany)	
1035	290	36	Kiev, RV9 (Russia)		368.1	815		Radio, L.L. Paris	
1000	300	100	Moscow (Russia) (<i>S.-W. Stn. on 50 m.</i>)					Seville, EAJ5 (Union Radio) (1.0 kW.);	
938	320	20	Kharkov, RV4 (Russia)		363.1	815	0.7	Galicja EAJ1 (0.2 kW.) (Spain); Bolzano	
857	350	100	Leningrad (Russia)		364.1	824	1	(1.0 kW.) (Italy); Helsinki (10 kW.) (Fin-	
840	357	18.5	Budapest (Hungary)		363.6	825	13	land) (<i>relays Lahti</i>); Kharkov, RV20 (10 kW.)	
825	363.6	50	Sverdlovsk, RV5 (Russia)		360.6	832	60	(Russia).	
760	395	1.3	Geneva (Switzerland). (<i>Relays Soltens</i>)		355.9	843	50	Fredriksstad (Norway). (<i>Relays Oslo</i>)	
720	416.6	15	Monte Ceneri (Switzerland). (<i>Testing</i>)		352.1	852	7	Bergen (Norway)	
720	416.6	20	Moscow, RV2 (Experimental) (Russia)		348.8	860	7.6	Algiers (Algeria)	
690	434.6	1.5	Oulu (Uleaborg) (Finland)		348.8	860	10	Mühlacker (Stuttgart) (Germany)	
680	441.2	0.6	Lausanne (Switzerland). (<i>Relays Soltens</i>)		345.2	869	11.5	London Regional (Brookmans Park) ..	
574.7	522	7	Ljubljana (Yugoslavia)		341.7	878	35	Graz (Austria). (<i>Relays Vienna</i>) ..	
569	527	0.25	Freilburg-im-Breisgau (Germany). (<i>Relay Stn.</i>)		338.2	887	15	Barcelona, EAJ1 (Spain)	
568.1	528	2	Grenoble (France)		335	896	5	Leningrad, RV70 (Russia)	
566	530	0.25	Hanover (Germany). (<i>Relays Hamburg</i>)		334.4	897	1.9	Strasbourg, PTT (France)	
563	533	16	Wilno (Poland). (<i>Relay Station</i>)		331.5	905	50	Brno (Brunn) (Czechoslovakia)	
560	536	0.25	Augsburg (Germany). (<i>Relays Munich</i>)		328.2	914	60	Brussels II, Velthem (Belgium). (<i>In Flemish</i>)	
560	536	1.5	Kaiserslautern (Germany). (<i>Relays Munich</i>)		325	923	60	Cadiz (Spain)	
550	545	18.5	Budapest No. 1 Lakihegy (Hungary)		321.9	932	10	Poznan (Poland)	
542	554	10	Andsval (Sweden). (<i>Relays Stockholm</i>)		318.8	941	0.25	Milan (Italy). (<i>Relays Turin</i>)	
537.6	558	3	Palermo (Italy)		318.8	941	1.5	Poste Parisien (France)	
533	563	60	Munich (Germany)		315.8	950	1.6	Breslau (Germany)	
525	571	15	Riga (Latvia)		312.8	959	0.7	Göteborg (Sweden). (<i>Relays Stockholm</i>)	
517.2	580	100	Vienna (Bisamberg) (Austria).		312.8	959	1.7	Dresden (Germany). (<i>Relays Leipzig</i>)	
509	589	15	Brussels No. 1, Velthem (Belgium). (<i>In French</i>)		312.8	959	10	Naples, INA (Italy). (<i>Relays Rome</i>) ..	
500.8	599	20	Florence, IF1 (Italy). (<i>Relays Turin</i>)		309.9	968	1	Marseilles, PTT (France)	
495.8	605	1.2	Trondheim (Norway)		309.9	968	50	Radio Vitus (Paris). (<i>S.-W. Stn. on 43.75 m.</i>)	
488.6	614	120	Prague, No. 1 (Czechoslovakia)		307	977	0.75	Cracow (Poland)	
480	625	50	North Regional (Manchester)		304	986	13	Genoa, IGE (Italy). (<i>Relays Turin</i>) ..	
472.4	635	60	Langenberg (Germany)		301.5	995	50	Trondheim (Norway)	
465.8	644	1.5	Lyons la Doua, PTT (France)		298.8	1004	11	Prague, No. 1 (Czechoslovakia)	
459.4	653	60	Beromünster (Schweizerischer Landessender) (Switzerland).		296.1	1013	20	North National (Manchester)	
453.2	662		San Sebastian, EAJ8 (0.6 kW.); Pori (1.0 kW.) (Finland); Danzig (0.5 kW.) (<i>relays Heilsberg</i>); Klagenfurt (0.5 kW.) (Austria) (<i>relays Vienna</i>); Porsgrund (0.7 kW.) (<i>relays Oslo</i>); Tromsø (0.1 kW.) Bodø (0.5 kW.) (Norway); Uppsala (0.15 kW.) (Sweden) (<i>relays Stockholm</i>).		293.5	1022	0.7	Tallinn (Esthonia)	
453.2	662	0.25	Agen (France)		293.5	1022	2.6	Hilversum (Holland). (<i>7 kW. before 4.40 p.m.</i>)	
					291	1051	13.2	Limoges, PTT (France)	
					288.3	1040	50	Kosice (Czechoslovakia)	
					288.3	1040	1	Viipuri (Viborg) (Finland). (<i>Relays Helsinki</i>)	
					286	1049	0.8	Scottish National (Falkirk)	
								Bournemouth (<i>Relay Station</i>)	
								Montpellier (France)	

BROADCASTING STATIONS ABROAD (In Order of Wavelength).

Table with columns: Metres, kc/s, kW, Station, Tuning Positions, Metres, kc/s, kW, Station, Tuning Positions. Lists various international broadcasting stations and their technical specifications.

PRINCIPAL SHORT-WAVE STATIONS.

(N.B.—Times of Transmission, given in parentheses, are approximate only and represent B.S.T.)

Table with columns: Metres, kc/s, Call Sign, Station, Tuning Positions, Metres, kc/s, Call Sign, Station, Tuning Positions. Lists principal short-wave stations with call signs and transmission times.

FOREIGN SUNDAY PROGRAMMES

JULY THE NINTH

ATHLONE

725 kc/s, 413 metres; 60 kW. Relayed by Cork, 1,337 kc/s, 244.4 metres.—8.30 p.m., Time Signal, 9.31, Amy Ellard's Instrumental Trio, 9.55, Money for Nothing, by the Minniners, 9.10, Soprano Solos by Josephine Curran, 9.55, Harp Solos by Annie Egan, 10.10, Baritone Solos by Matthew Dunleavy, 10.25, Pianoforte Solos by Fred Stone, 10.45, Instrumental Trio, 11.0, Time, News and Close Down.

BARCELONA

EAJ1; 860 kc/s, 348.8 metres; 8 kW.—12 Noon, Chimes from the Cathedral and Weather, 2.0 p.m., Gramophone Music, 2.30, Theatre Notes and Gramophone Music, 3.0, Film Review and Concert by the Radio Society, 4.0, Programme for Hospitals and other Benevolent Institutions, with Gramophone Records, 5.0 to 6.30, Interval, 6.30, Agricultural Talk and Gramophone Music, 7.0, Concert by the Station Orchestra, 7.30, Song Recital by Pascual (Tenor), 8.0, Concert by the Station Orchestra and Interpretation Callio (Songs), 10.0, Musical Comedy Music on Gramophone Records, 9.0, Dance Music from the Hollywood Bar, 11.45, Toss Lesson, 12 Midnight (approx.), Close Down.

BARI

112 kc/s, 269.8 metres; 20 kW.—10.45 a.m., Agricultural Talk, 11.5, Bible Reading, 11.30, Sacred Music relayed from the Church of an Domenico, 1.0 p.m., Giornale Radio, 1.10 to 2.15, Gramophone Music, In the interval at 1.55, Weather; and at 2.0, Time and Announcements, 5.30 to 6.30, Gramophone Music, 8.0, Sports Notes and Giornale Radio, 8.30, Time and Announcements, 8.35 (approx.), Concert of Operetta Music and songs, Soloists: Clara Dimitri (Soprano) and Michele Montanari (Tenor). In the interval: Art Notes, 10.30, Gramophone Music, 10.55, News.

ASLE.—See Schweizerischer Landessender.

BELGRADE

17 kc/s, 430.4 metres; 2.8 kW. 4.0 p.m., Gramophone Music, 4.30, National Songs, 0, Gramophone Music, 6.55, Time Signal and Programme Announcements, 7.0, Flute Solo, 7.30, National Songs, 8.10, Sports Notes, 8.20, Radio Play, followed by Orchestral Music, 10.35, Time Signal, News and Gramophone Music.

BERLIN

DEUTSCHLANDSENDER, 183 kc/s, 1,635 metres; 60 kW.—11.30 a.m., See Leipzig. Noon, See Heilsberg. In the interval at 1.55, Time, 1.30, Radio Report of the announcement of the Motor Cycle Grand Prix from the Avus Speedway; First-class motor Cycle Combinations, 2.0, See Hamburg, 3.0, Thor Gate reads from his own works, 3.30, Radio Report from the Avus Speedway (cont'd.), 4.0 (approx.), Concert (Chamber Music: Overture, Rosamunde chubert); Wagner Heitz (Derksen); Poturi of Strauss Operetta Music (Schlögel); ternozzo, Blumenpflüster (Blon); Selection from The Bird Fancier (Zeller), 4.40 (approx.), Final Report on the Motor Cycle and Prix from the Avus Speedway, 5.15, (k), The Protection of Animals, 5.45, (l) Report; The Theatre of the Harz contains, 6.15, Song Recital by Friedrich (Helm) Hezel, (Songs) (Schubert); (a) häfers Klageklid, (b) An die Musik, (c) r Bild, (d) Der Müselsohn; Songs (chumann); (a) Romanze, (b) In der ende, (c) Frühlingsnacht, (d) Freisinn, (ugs) (Brahms); (a) Wie bist du in die Königin, (b) Nicht mehr zu gehen, (c) Tambourlieder, (Songs) after Schütz); (a) Erinnerung, (b) Ein lnes Bild, (c) Und wehte auch an ien Matten, (d) Daheim, 6.45, Die icksritter—Radio Play (after the story iehendorf, with incidental music by usmaria Dobrowski), 8.0, Review of Day's Sport, 8.10, Concert of Dance sic and Light Music by Julius Tomson f his Orchestra, 9.0, Village Tales of Tyrol, 10.0, Weather and News, 10.45, after for Shipping, 11.0, Programme to announced, 12 Midnight, Close Down.

BERLIN

TZLEBEN, 715 kc/s, 419.5 metres; 1.5 kW. 1.30 a.m., See Leipzig. 12 Noon, See Heilsberg, 2.0, Talks for Garden City Dwellers, Radio Report of the Motor Cycle Grand x from the Avus Speedway, 3.45, Light sic and Dance Music from the Krollgarten, the interval from 4.30 to 5.15, Radio Re t of the Last Rounds of the Motor Cycle and Prix from the Avus Speedway, 6.30, Humorous Menu (arr. Munkepünke), 7.0, es about Flying, 7.30, Divertissement in flat for two Oboes, two Horns, and two sons (Mozart), 7.50, Sports Notes, 8.10, Hutmacher—Play (Gustav Quendenfeldt Theo Halton); Music by Josef Snaga,

PRINCIPAL EVENTS OF THE DAY:

AT HOME

- NATIONAL** Orchestral concert from Eastbourne.
- LONDON REGIONAL** Popular oratorio programme.
- MIDLAND REGIONAL** Band concert.
- WEST REGIONAL** Orchestral concert.

ABROAD

- BUDAPEST** 6.30 p.m. Johann Strauss concert by the Municipal Orchestra.
- EIFFEL TOWER** 1.30 p.m. Massenet concert by the Jean Bos Orchestra.
- HAMBURG** 8.0 p.m. The Philharmonic Orchestra, conducted by Adolf Secker.
- HEILSBURG** 4.0 p.m. The Königsberg Opera House Orchestra.
- HILVERSUM** 7.55 p.m. The Concertgebouw Orchestra, from Amsterdam.
- LANGENBERG** 8.45 p.m. Sacred concert from the Cathedral, Münster.
- MOSCOW** 6.30 p.m. Beethoven, Liszt and Verdi concert.
- ROME** 8.45 p.m. Operetta: "Bambù," by Carabella.
- STUTTGART** 12.0 noon. Orchestral concert from Glotterbad.
- TURIN** 8.30 p.m. Opera: "Sly," by Wolf-Ferrari.
- VIENNA** 11.25 a.m. Concert by the Symphony Orchestra, conducted by H. Winkler.
- WARSAW** 12.15 p.m. The Station Symphony Orchestra, conducted by S. Nawrot.

10.0, News, followed by Dance Music from the Zoological Gardens. In the interval at 11.10, Topical Talk, 1.0 a.m. (Monday), Close Down.

BERNE. See Schweizerischer Landessender.

BEROMUNSTER. — See Schweizerischer Landessender.

BODEN. See Stockholm.

BODÖ.—See Oslo.

BORDEAUX-LAFAYETTE

186 kc/s, 304 metres; 13 kW.—6.30 p.m., Radio Journal, 7.30, Sports Talk, 7.45, Report on the Cycling Tour of France, 8.5, Talk for Soldiers, 8.20, Lottery Results, 8.30, Concert of Gramophone Music, 9.0, Madame Caverlet—Comedy in Three Acts (E. Augier).

BRATISLAVA

7,076 kc/s, 279 metres; 11 kW.—11.0 a.m., Concert by the Municipal Orchestra, relayed from Piastany. 12 Noon, See Prague. 12.5 p.m., See Brno. 1.30, Agricultural Talk, relayed from Kosice, 1,022 kc/s, 293 metres. 1.45, Hydrographical Report, 1.50, Interval, 4.0, Concert relayed from Piastany, 5.30 (from Kosice). Relay from Uzhhorod, 7.0, See Prague. 8.50, See Brno. 10.0, See Prague. 11.0 (approx.), Close Down.

BREMEN. See Hamburg.

BRESLAU

923 kc/s, 325 metres; 60 kW. Relayed by Gleiwitz, 1,184 kc/s, 253 metres.—11.30 a.m., See Leipzig. 12 Noon, Orchestral Concert, conducted by Dr. Fritz Kuschinsky. Soloist: Hellmut Hallendorf (Tenor). 2.0, News, 2.10, Radio Report of the Unveiling of a Memorial to Two Murdered Nazis, Stanzki and Kometzki, relayed from Ohlau, 2.50, Talk on Bee-keeping, 3.10, Programme for Children, 3.50, Talk: The Hoheneibe Centenary Celebrations, 4.10, Concert of Donra and Balalaika Music, 5.0, A Radio Report: Schloss Sibyllenort, 5.25 (from Gleiwitz), Concert by a Nazi Band, 6.50, Reading, Heilige Heimat (Floriam Seidl), 7.20, German Folk Songs of Eight Centuries, by a Vocal Trio, 8.0, Weather, 8.5, Report of the Boat Race, from the Breslau Canal, 9.30, In the Woods and on the Moor—A Radio Potpourri, 10.0, Time and News, 10.30, Dance Music from Berlin (Witzleben), 12 Midnight, Close Down.

BRNO

879 kc/s, 342 metres; 35 kW.—11.0 a.m., Concert by the Municipal Orchestra, con-

ducted by Jan Elsnic, relayed from Luha-covice. 12 Noon, See Prague. 12.5 p.m., Concert by Moravian Village Bands, 1.30 to 1.45, Agricultural Talk, relayed from Kosice, 1,022 kc/s, 293 metres. 4.0, See Bratislava. 5.30, Pianoforte Recital by Liza Fuchssova; Polka (Jirk); Dance (Konjovitch); Tarentella (Jirk); Golliwog's Cake-Walk (Debussy); Spanish Dance (Falla); Brazilian Dance (Milhaud); Foxtrot (Castelnovo-Tedesco). 6.0, German Transmission: Variety Concert by K. Jirka (Songs), J. Lévy (Harpisichord) and J. Matzka (Pianoforte). 7.0, See Prague. 8.50, Talk, 9.0, Concert by the Station Orchestra, conducted by Jan Janota; Soloist, Josef Holub (Violin); Overture, A Night on Karlstein (Fibich); Concerto in D, Op. 35 (Tchaikovsky); Norwegian Dances, Op. 35, 10.0, See Prague. 11.0 (approx.), Close Down.

BRUSSELS (No. 1)

I.N.R., 590 kc/s, 509 metres; 15 kW.—10.0 a.m., Concert by the Small Station Orchestra, conducted by P. Lecmans. Soloist: Mme. Lady (Soprano). 11.0, Gramophone Concert, 12 Noon, Concert by the Station Symphony Orchestra, conducted by Jean Kumps; Overture, Le Cheval de bronze (Auber); Selection from Tannhäuser (Wagner); Two Sketches (Godard); Songs by Mme. Monlaert-Maes; Suite, Op. 16 (Saint-Saëns). 12.45 p.m., Running Commentary on the Races at Francorchamps, 1.5, Le Journal Parlé, 1.15, Concert by the Radio Orchestra, conducted by Franz André. Soloist: M. Albert (Baritone). In the interval at 1.30, Gramophone Records, 2.0, Running Commentary on the Races at Francorchamps (cont'd.), 2.10, Faust—Opera (Gounod), on Gramophone Records. In the intervals at 3.0 and 4.0, Running Commentary on the Races at Francorchamps, 5.0, Running Commentary on the Races at Francorchamps, 5.10, Dance Music, relayed from the Kursaal, Ostend, 5.30, Relay from Francorchamps, 6.15, Popular Hebrew Songs, 6.30, Gramophone Music, 6.45, Cambriolage à l'Amiable—Sketch (Lauville), 7.0, Extracts from the Suite in D (Bach) on Gramophone Records, 7.15, Religious Address, 7.30, Talk on Music, 8.0, Concert by the Station Orchestra, conducted by Franz André. Soloists: M. Béthune (Violin), M. Fischers (Cello), M. Durand (Tenor) and M. Steurs (Accordion); Dances and Tangos; Spanish Songs (Albeniz), 8.45, Reading of Poems dedicated to Harvest, 9.0, Concert (cont'd.), 10.0, Le Journal Parlé, 10.10, Dance Music relayed from the Casino, Knocke.

BRUSSELS (No. 2)

N.I.R., 887 kc/s, 338.2 metres; 15 kW. Programme in Flemish.—10.0 a.m., Gramo-

phone Records, 11.0, Concert by the Small Radio Orchestra, conducted by M. Lecmans, 12 Noon, Concert by the Radio Orchestra, conducted by M. Franz André, 1.0 p.m., Concert by the Station Symphony Orchestra, conducted by M. Kumps, 2.0, Gramophone Concert, 2.30, Flemish Choral Festival, relayed from Berchem, Antwerp. Conductor, Paul Van Nyon, 5.0, Dance Music from the Casino, Knocke, In the interval at 5.30, Sports Notes, 6.15, Gramophone Records: Liebestreu (Kreisler); Liebesleid (Kreisler); La fletta (Marchesi); Selection from Die Puppe (Bayer), 6.30, Recital of Light Music on Two Pianofortes, 7.0, Gramophone Music; Seville (Turina); Italian Serenade (Hugo Wolf), 7.15, Religious Address, 7.30, Music Review, 8.0, Concert by the Small Station Orchestra, conducted by M. Lecmans, 8.45, Recitations, 9.0, Concert from the Kursaal, Ostende, 10.30, Le Journal Parlé, 10.40, Dance Music from the Kursaal, Ostende.

BUCHAREST

761 kc/s, 394 metres; 12 kW.—4.0 p.m., Programme for Peasants, 5.0, Light Music and Romanian Music by the Marco Orchestra. In an interval at 6.0, Radio Journal, 7.0, Educational Talk, 7.20, Dance Music on Gramophone Records, 7.40, Reading, 8.0 to 9.45, Viennese Programme, 8.0, Music by the Krentzer Schrammel Quartet, 8.20, Concert by the Station Orchestra: Two Military Marches (Schubert); First Movement from the Serenade for Strings (Mozart); Overture, Die Fledermans (Joh. Strauss); Selection from The Land of Smiles (Lohar); Potpourri (Stolz), 9.10, Talk on Vienna, 9.25, Viennese Song Recital by Mme. Lizette Georgescu, 9.45, Radio Journal.

BUDAPEST

545 kc/s, 550.5 metres; 18.5 kW. Also relayed on 840 metres from 6.30 p.m. till Close Down, —11.0 a.m., Sacred Music and Address, followed by News, Tides Report and Concert by the Opera House Orchestra, conducted by Wilhelm Komor. In the interval: Wireless Review, 2.0 p.m., Gramophone Music, 3.0, Agricultural Talk, 3.35, Radio Report from the Province of Uszod, 4.45, Time and Concert of Cigany Music, 6.0, Talk: The Puszta, 6.30, Johann Strauss Concert by the Municipal Orchestra, conducted by Dr. Bor, relayed from the Municipal Park; Soloists, Ferike Bartok and Vince Imre; Overture, The Gipsy Baron; Intermezzo, The Arabian Nights; Polka; Waltzes; (a) The Blue Danube, (b) Frühlingsstimmen; Selection from A Carnival in Rome; Overture, Die Fledermans; Aja and Gondola Song from Eine Nacht in Venedig; Selection from Der lustige Krieg; Waltz, Künstlerleben; Selection from The Gipsy Baron; Selection from Die Fledermans; An Overture, 8.30, Humorous Talk, 9.0, Artists of the Comedy Theatre before the Microphone: Frau Göth, Ella Kertesz and Alexander Goth, 10.0, News, followed by Light Music and Dance Music from the Café Donankorso, 11.0, Cigany Music from the Café Bodo.

CASSEL.—See Frankfurt.

COPENHAGEN

1,067 kc/s, 281 metres; 0.75 kW. Relayed by Kalundborg, 260 kc/s, 1,153 metres.—8.30 a.m., Morning Gymnastics, 9.0, Educational Talk, 9.30, Interval, 10.0, Divine Service from the Aarhus Studio, 11.30, Weather Forecast, 11.40, News, 12 Noon, Time and Chimes from the Town Hall, 12.5 p.m., Concert by the Radio Orchestra, 1.0, Interval, 1.30, Accordion Recital by Henning Petersen, 2.0 (also relayed by Skamlabæk on 31.51 metres), Divine Service relayed from Holmens Kirke, 3.15, Programme arranged by the Workers' Radio Listeners' Association, relayed from a Park in Aarhus, 4.15 to 6.0, Orchestra Concert, relayed from a Park, 6.20, Talk: Queen Caroline Amalie, 6.50, Weather and News, 7.15, Time Signal, 7.30, Talk: William II and the East, 8.0, Town Hall Chimes, 8.2, Concert of Danish Music, 8.55, Recital of Songs, with Introductory Talk, 9.45, Violin Recital by Polyarp Andersen: Andante (Faure); Scherzo (Brahms); Nocturne (Hübner); Spanish Dance from La vida breve (Falla-Kreisler), 10.5, News, 10.15, Concert by the Radio Orchestra, 11.0, Dance Music from the Wivex Restaurant, In the interval at 12 Midnight, Town Hall Chimes, 12.30 a.m. (Monday), Close Down.

CORK.—See Athlone.

DANZIG.—See Heilsberg.

DRESDEN.—See Leipzig.

FECAMP

1,328 kc/s, 225.0 metres; 10 kW.—12 Noon, Variety Concert, 12.30 p.m., News, 12.45, Variety Concert (cont'd.), 2.0, Dance Music and Variety Items, 8.0, Opera and Operetta Music, 9.0 till Close Down, Concert by the I.B.C. In the interval at 12.5 a.m. (Monday),

News Bulletin in English. 1.0 (approx.).
Close Down.

FLENSBURG.—See Hamburg.

FLORENCE.—See Turin.

FRANKFURT

1,157 kc/s, 259.3 metres; 17 kW. Relayed by Cassel, 1,220 kc/s, 245.9 metres; and Trier, 1,157 kc/s, 259.3 metres.—11.30 a.m., See Leipzig. 12 Noon, See Stuttgart. 1.0 p.m., See Langenberg. 2.30, Talk arranged by the Wiesbaden Board of Agriculture. 2.40, Rural Programme—Two Talks. 3.30, See Stuttgart. 4.30, See Langenberg. 6.15, An Interlude (arr. Reinhold Freyberg). 6.45, Radio Report of the Motor Cycle Grand Prix, from the Avus Speedway, Berlin. 7.25, Sports Notes. 7.30, Everyday Dialogues (arr. Paul Laven). 8.15, Operetta Concert by the Station Orchestra, conducted by Hans Rosband, 10.30, Time and News. 11.6, See Munich. 12 Midnight, Close Down.

FREDRIKSSTAD.—See Oslo.

FREIBURG.—See Stuttgart.

GENEVA.—See Radio-Suisse Romande.

GENOA.—See Turin.

GLEIWITZ.—See Breslau.

GOTEBORG.—See Stockholm.

GRAZ.—See Vienna.

HAMAR.—See Oslo.

HAMBURG

Call ha (in Morse), 806 kc/s, 372 metres; 1.5 kW. Relayed by Bremen, 1,112 kc/s, 269.8 metres; Flensburg, 1,319 kc/s, 227.4 metres; Hanover, 530 kc/s, 566 metres; and Kiel, 1,292 kc/s, 232.2 metres. 11.30 a.m., See Leipzig. 12 Noon (from Hanover), Concert conducted by Richard Grille; Soloist: Wilhelm Gerecke. In the interval at 12.55, Time and Weather. 2.0 (from Kiel), Programme for Young Hitlerites conducted by Baldur von Schirach-Neumünster—a Town in Schleswig-Holstein. 3.0 (from Kiel), Reading of Modern Ballads (Hans Friedrich Blunck). 3.15, Radio Report of the Hamburg Rowing Regatta. 4.0, Programme for Children. 4.55, Motor Cycle Relay from Berlin (Deutschlandsender). 5.15, Wind Instrument Concert, conducted by R. Lücke. 6.15, From Island to Island—A Flight from Borkum to Westerland. 7.40, Sports Notes. 7.55, Weather. 8.0, Concert by the Hamburg Philharmonic Orchestra, conducted by Adolf Secker; Soloists: Hans Brinckmann (Flute) and Georg Schopenhauer (Bassoon). 10.0, News. 10.20, Hamburg, Bremen, and Lübeck—Report on Events in the Senates and Houses of Burgesses of the Hanseatic Free Cities. 10.35, Light Music and Dance Music from Berlin (Witzleben).

HANOVER.—See Hamburg.

HEILSBURG

1,085 kc/s, 276.5 metres; 60 kW. Relayed by Danzig, 662 kc/s, 453.2 metres.—11.30 a.m., See Leipzig. 12 Noon, Concert by the Zoppot Orchestra, relayed from the Kurgarten, Zoppot. 2.0, Talk: The Philippine Islands and their Inhabitants. 2.30, Programme for Young People. 3.0, Concert by the Thalia Male Voice Choir. 3.30, Ballad Recital by Herbert Menzel and Richard Helborn. 3.50, Horse-Racing Results. 4.0, Concert by the Königsberg Opera House Orchestra. In an interval at 4.40 (approx.), Motor Racing Report from Berlin (Deutschlandsender). 6.0, Paul Ernst Memorial Programme. 6.45, See Berlin (Deutschlandsender). 8.0, Sports Notes. 8.10, Dialogue: The Aims of the New Theatre. 8.30, Concert by the Königsberg Opera House Orchestra. 10.15, News and Sports Notes. 10.20 (approx.), Dance Music from Berlin (Witzleben). 12 Midnight (approx.), Close Down.

HILVERSUM

Announced HUIZEN, 1,013 kc/s, 296.1 metres; 20 kW. (7 kW. up to 4.40 p.m.).—8.10 to 9.10 a.m., Programme of the Christian Radio Society (N.C.R.V.). 8.10, Religious Programme, with Songs by Mme. V. van den Berg-Nun Lintgen. 9.10 to 4.40 p.m., Programme of the Catholic Radio Society (K.R.O.). 9.10, Gramophone Music. 9.40, High Mass, relayed from the Church of St. Nicholas, Venlo. 11.25, Gramophone Music. 11.40, Talk. 11.55, Concert by the K.R.O. Sextet: Unter freiem Himmel (Morena); In Camarosa (Grot); Waltz, Du und Du (Strauss); Cello Solos: Potpourri (Rubrecht); Serenade (Tareghini). 12.40, Talk. 1.0, Sextet (Concert (contd.)): Blumengeflüster (Blon); Campana a sera (Billi); Potpourri (Kozzak); Melody (Schiebek); Finale. 1.40, Talk. 2.10, Concert by the K.R.O. Orchestra. 3.55, Programme for Invalids. 4.40 to 7.25, N.C.R.V. Programme: Divine Service, relayed from the Halfweg Church, followed by Sacred Music on Gramophone Records. 7.25 till Close Down, K.R.O. Programme. 7.25, Talk. 7.45, Football Results. 7.50, Concert by the K.R.O. Boys.

JULY 9th

SUNDAY

continued

8.10, Song Recital by Mme. Riek Bouwens Leberto. 8.20, Concert (contd.). 8.40, News and Song Recital (contd.). 8.50, Concert (contd.). 9.10, Song Recital (contd.). 9.20, Concert by the Station Orchestra, conducted by J. Gerritsen; Overture, Rintan and Ludiella (Glinka); Andante cantabile (Tchaikovsky); Ballet Music from Raymond (Glazunov); Slav March (Tchaikovsky). 9.55, Press Review. 10.0, Concert (contd.): Wien-Berlin (Schrammel); The Canary (Poliakini); Waltz, Kiinslerleben (Strauss); March (Spiero). 10.20, Epilogue by the Small Station Choir. 10.40, Close Down.

HORBY.—See Stockholm.

HUIZEN

Announced HILVERSUM, 160 kc/s, 1,875 metres; 8.5 kW.—8.40 to 9.40 a.m., Programme of the Workers' Radio Society (V.A.R.A.). 8.40, Horticultural Talk. 9.10, Organ Recital. 10.10 to 11.40, Programme of the Liberal Protestant Radio Society (V.P.R.O.): Divine Service, from Baarn. 11.40 to 4.40 p.m., Programme of the Algemeene Vereeniging Radio Orchestre (A.V.R.O.). 11.40, Concert by the Wireless Orchestra, conducted by Nico Treep, with Interludes by a Children's Choir: March, Sempre avanti (Furik); Overture: Eine Nacht in Venedig (Joh. Strauss); Waltz, Tout Paris (Waldteufel); Poème (Pibich); Fünf-Uhr Tee in Populhaus (Rosen); Wiener Volksmusik (Lippold); Melody by a Children's Choir; Overture, The Bird-Fancier (Zeller); Hymn to the Sun, from The Golden Cockerel (Rinsky-Korsakovy); Fantasia of Mendelssohn Music (Fouls); Melodies by a Children's Choir; Tambourin chinois (Kreisler); Tales from the Vienna Woods (Joh. Strauss); Johann Strauss' Potpourri (Morena). 1.40 p.m., Weekly Book Talk. 2.10, Concert by a Mandolin Orchestra. 2.40, Marike—a Radio Play after the Book by C. Marxveld. 4.10, Gramophone Music. 4.40 to 7.40, Programme of the V.A.R.A. 4.40, Concert by the Kunst-en Strijd Choir. 5.40, Concert by the Amsterdam Chamber Orchestra, conducted by M. Kiekens; Overture, Der Bettelstudent (Müllers); Trauidealie (Furik); Two Arabesques (Debussy); Impressions of Madagascar (Landeron); Waltz, Wiener Blut (Joh. Strauss); Temple Dance (Profes). 6.30, The Adventures of Wakker and Trochobuit. 6.50, Concert (contd.): Selection from The Gipsy Baron (Joh. Strauss); Chant russe (Lalo); Spanish Dances (Moszkowsky); Potpourri of Mendelssohn Music (Urbach); Minuet in E (Mozart); Per aspera ad astra (Urbach). 7.40 till Close Down, Programme of the A.V.R.O. 7.40, Time and News. 7.55, Concert by the Concertgebouw Orchestra, conducted by Eduard van Beunin, relayed from the Concertgebouw, Amsterdam; Soloist: Joseph Penabauer (Pianoforte); Overture, Le Roi d'Ys (Lalo); Second Pianoforte Concerto in A (Liszt). 8.50, A Radio Play (Elizabeth Hingworth). 9.10, Concert by the Wireless Orchestra, conducted by Nico Treep; Soloist: Henk Viskil (Tenor); Le père la victoire (Ganne); Humoresque (Dvorak); Because (d'Hardelot); I hear you calling me (Marshall); Wine, Women and Song (Johann Strauss); Ein adtes Lied (Kreisler); Ah, sweet mystery of Life (Herbert); Lasciati amar (Leoncavallo); American Patrol (Meacham). 9.55, Gramophone Music. 10.10, Concert of Light Music by Bob Scholte. 11.40 (approx.), Close Down.

INNSBRUCK.—See Vienna.

JUAN LES PINS

1,205 kc/s, 249 metres; 0.8 kW.—8.0 p.m., Amusements' Guide and Sports Notes. 8.15, Press Review. 8.30, Radio Concert. 9.0, News. 9.15, Radio Concert. 10.0, The Listeners' Half-hour. 10.30 to 1.0 a.m. (Monday), Programme in English by the I.B.C. Miss L. Ballet Announcing. 10.30, Concert of Light Music: Waltz, Wiener Bouhous (Joh. Strauss); Serenade for Pianoforte and Celeste (Heykens); Song, Where Heaven Lies (German); Czardas and Mazurka from Coppelia (Delibes); The Fairies' Gavotte for Pianoforte and Celeste (Kohn); Song, Juanita (Norton); Jollity on the Mountains (Fetras). 11.0, Orchestral Concert with Songs: Just Once for All Time (Heymann); Trio, Loving Them All (Marks); Song, drifting Under a Summer Moon (Harding and Coningsby); Pianoforte Selection from Follow a Star (Billi); Trio, I Can't Write the Words (Marks); Song, Just for a Sigh, Just for a Kiss (Richardson); Gipsy Moon (Borzanov). 11.30, Down to the Sea; On the Quarter Deck (Alford); To-morrow, from Salt Water Ballads (Keel); How Deep is the Ocean? (Berlin); Selection from Mother of Pearl (O. Strauss); Hoist the Jib and Spanker (Layne); Dreams of the Ocean (Gungl); Naval Patrol (Williams). 12 midnight, Celebrity Gramophone Concert; Accordion Nights, Part 9, by Gerardo and his Accordion Band; Mighty Lak a Rose (Nevin); by Turner Layton; Look What You've Done (Kalmar and Ruby); by Ethel Levy; The Wedding of the Rose (Jessel); by Jack Hyflon and his Band; Roaldale Hounds (Cliff); by Gracie Fields; Seekin',

by Paul Robeson; Only a Bird in a Gilded Cage (von Tilzey); by Florrie Forde; Accordion Nights, Part 10, by Gerardo and his Accordion Band. 12.30 a.m. (Monday), Dance Music: Three's a Crowd (Dublin); Love Will Find a Way (Fraser-Simson); Song of Disappointed Love (Whidden); Butterflies in the Rain (Sherman Myers); Rum Tum Rhythm; Isn't it Romantic? (Hart); Do You Recall?; When You've Fallen in Love (Waller and Taurbridge). 12.57 I.B.C. Goodnight Melody. 1.0 (approx.), Close Down.

KALUNDBORG.—See Copenhagen.

KATOWICE

734 kc/s, 408 metres; 16 kW.—7.40 p.m., Announcements and Gramophone Music. 8.0 till Close Down, See Warsaw. In the interval at 9.5, Sports Notes.

KIEL.—See Hamburg.

KLAGENFURT.—See Vienna.

KOSICE.—See Prague.

LAHTI

167 kc/s, 1,796 metres; 40 kW. Relayed by Helsinki, 315 kc/s, 368.1 metres.—6.10 p.m., Talk. 6.35, Concert of Finnish Music by the Station Orchestra. 7.15, Dialogue. 7.40, Violin Recital. 8.0, Popular Concert by the Station Orchestra. 8.45, News in Finnish. 9.0, News in Swedish. 9.15, Concert from the Kappeli Restaurant. 10.0 (approx.), Close Down.

LANGENBERG

635 kc/s, 473 metres; 60 kW.—11.30 a.m., See Leipzig. 12 Noon, Programme by the Fröhliche Fünf—with two Dog Stories (Gottfried Köhnel). 1.0 p.m., Concert conducted by Wolf. 2.45, Talk in Dialect. 3.10, Talk: Music on the Stage. 3.35, Reading (Hans Heyek). 3.50, The Origin of Europe's National Anthems—a Sequence with Gramophone Illustrations. 4.10, Talk: East Prussia in Distress. 4.30, Sun-Souci Concert, relayed from Schloss Brühl, near Bonn. A Chamber Orchestra, conducted by Buschkötter, and the Cologne Viola Society. Soloists: Gertrude Becker (Soprano), Carl Hermann Pillney (Harpichord), and Paul Stolz (Flute). 6.20, Report of the Grand Prix Motor Cycle Races, relayed from Berlin (Deutschlandsender). 6.50, Sent home Blind—Adolf Hitler's last Vicissitude in the Great War. 7.10, Serenade relayed from Schloss Brühl (Mozart). 8.0, Sports Notes. 8.15, Variety Programme. 8.40, Topical Talk. 8.45, Sacred Concert, relayed from the Cathedral, Münster, on the Eve of the Great Procession. The Münster Municipal Choir and Wind Instrument Orchestra, conducted by Leiwering, and a Speaking Choir. 10.0, News. 10.45, Serenade conducted by Breuer. 12 Midnight, Close Down.

LAUSANNE.—See Radio-Suisse Romande.

LEIPZIG

769.9 kc/s, 389.6 metres; 120 kW.; and Dresden, 941 kc/s, 319 metres.—11.30 a.m., Barmherziges Herz der ewigen Liebe Cantata (Bach), by the Municipal and Gewandhaus Orchestra, the Choir of St. Thomas's, and Soloists. 12 Noon, Concert from Hamburg. 2.0, Weather and Time. 2.5, Programme Announcements. 2.25, Talk on Economics. 2.45, Agricultural Notes. 3.0, Choral Concert, conducted by Arno Richter; Sanctus from the German Mass (Schubert); Sturm- und Schwärzung (Bürner); Vaterland (Wohlgemuth); Ostwacht der Lausitz (Schöne); Mahnung (Heinrichs); Folk Song, Jetzt kommt die Zeit dass ich wandern muss (Hensel); Von Hause muss ich fort (Scheffler); Muss i denn (Sileher). 3.30, Reading (Zillich). 4.0, Military Band Concert, relayed from Gotha; Entry of the Guests into the Wartburg from Tannhäuser (Wagner); Overture (Theil); Der Prinzessin Lied (Clarens); Selection from Mignon (Thomas); Overture, The Bohemian Girl (Balfe); Serenade No. 1, Op. 15 (Moszkowsky); Neapolitan Sogng (Tchaikovsky); Edelweiss vom Semmering (Koch); Selection from The Gipsy Baron (Joh. Strauss); Overture, Poet and Peasant (Suppe); Waltz, Wiener Blut (Joh. Strauss); Intermezzo, Barbitona (Rhode); Potpourri, Klänge aus dem deutschen Liederhain (Curtis). In the interval, Address. 5.30, The Harz Mountains—Radio Sequence (Georgy Kamecke). 6.30, The Kreuzer Sonata in A, Op. 47, for Violin and Pianoforte (Beethoven). 7.5, Topical Programme. 8.0, Announcement. 8.5, Gipsy Love—Operetta (Lehár). 10.5, News. 10.15 (approx.), Dance Music. 12 Midnight, Close Down.

LINZ.—See Vienna.

LJUBLJANA

522 kc/s, 574.7 metres; 7 kW.—4.30 p.m., Dramatic Programme. 8.0, Song Recital. 8.45, Guitar Concert. 9.30, Weather and News. 9.45, Concert by the Station Orchestra. 11.0, (approx.), Close Down.

LUXEMBOURG

252 kc/s, 1,191 metres; 200 kW.—English Programme. 12.45 to 1.30 p.m., Report of the Start of the Motor Grand Prix, relayed from the Spa-Francorchamps Speedway. 5.0 to 5.45, Report of the Finish of the Motor Grand Prix. 7.45, Concert by the London Symphony Orchestra, conducted by Albert Coates, on Gramophone Records; Overture, Prince Igor (Borodin); March and Scherzo from The Loves of the Three Oranges (Prokofev); Waltz, Scherzo from The Loves of the Three Oranges (Prokofev); Dance of the Apprentices from The Mastersinger (Wagner); Extracts from The Valkyrie (Wagner); March from Tannhäuser (Wagner).

MALMO.—See Stockholm.

MILAN.—See Turin.

MORAVSKA-OSTRAVA

1,137 kc/s, 263.8 metres; 11 kW.—10.30 a.m. Reading. 11.0, See Brno. 12 Noon, See Prague. 12.5 p.m., See Brno. 1.30, Agricultural Talk from Kosice, 1,022 kc/s, 29 metres. 4.0, See Bratislava. 5.30, See Prague. 8.50, See Brno. 10.0, See Prague. 11.0 (approx.), Close Down.

MOSCOW

TRADES UNION, 230 kc/s, 1,304 metres; 11 kW.—2.45 p.m., Weather. 3.0, Concert of Music by Arseny Cul and Liapunov. 4.0, Talk: Agrrotechnics in U.S.S.R. 4.30, Literary and Dramatic Programme. 5.45, Talk: Mines. 6.30, Concert of Beethoven, Liszt and Verdi Music. 9.0, News. 9.30, Programme Announcements. 9.55, Chimes from the Kremlin Square. 10.5, Press Review and Talk in German.

MOTALA.—See Stockholm.

MUHLACKER.—See Stuttgart.

MUNICH

563 kc/s, 533 metres; 60 kW. Relayed by Augsburg and Kaiserslautern, 536 kc/s, 5 metres, and Nürnberg, 1,256 kc/s, 2 metres.—11.30 a.m., See Leipzig. 12.10 p.m. Orchestral Concert; Overture, Der Improvisator (d'Albert); Selection from Za (Leoncavallo); Melody (Tchaikovsky); Waltz, Hofballtänze (Lanner); Scherzo from Der Obersteiger (Zeller); Marc Weinmannsheil (Reckling). 1.0, Tim Weather and Programme Announcement. 1.10, Agricultural Talk. 1.30, Variety Music on Gramophone Records. 2.30, Talk: National Revolution. 2.50, Two and Two. Concert of Vocal Duets, Pianoforte Duet and Violin and Pianoforte Sonatas. 3.0, Radio Play from a Tale by Hans Christi Andersen (arr. Gertrud Funderger). 4.0, Orchestral Concert, conducted by Eric Kloss; Romantic Overture (Kéler-Béla Liebesromanz (Selmals-tiel); Selection from La Bohème (Puccini); Waltz, Jugenstrebte (Plank); Intermezzo, Rosenz (Manfred). 4.45, Radio Report of a Motor Cycle Races for the Grand Prix relayed from Berlin (Deutschlandsender). 5.15, Tales of Old Munich. 5.35, Zith Recital. 6.5, Programme from the Work of Peter Rosegger. 6.45, Choral Concert from Southofen. 7.20, Talk: The Painter Edmund Stepper, on his Sixtieth Birthday. 7.45, Weather and Sports Notes. 8.0, Concert by the Station Orchestra, conducted by Karl List; Soloists: Franz Ortz (Double Bass), and Hedda Dittmar (Soprano); Overture, Frau Aventure (Nötzke); Serenade in A (Glazunov); Concerto Bass Clarinet and Orchestra (Dragonetti); Scherzo (Schubert); Two Folk Songs; Wal Die Schönbrunner (Lanner); Two Pic (Kreyer); (a) Reigen, (b) Humoresque Selection from The Bartered Bride (Smetana); Italian Caprice (Tchaikovsky); Minnet (Bizet); Ingrid's Lament (Grieg); Polka (Dvorak); Waltz, Künstlerlieb (Joh. Strauss); Florentine March (Fnei) In the interval, Humorous Short Story (Franz). 10.20, Time and News. 11 Serenade by the Small Station Orchest conducted by Eric Kloss. 12 Midnight Close Down.

NAPLES.—See Rome.

NOTODDEN.—See Oslo.

OSLO

277 kc/s, 1,083 metres; 60 kW. Relayed Fredrikstad, 815 kc/s, 368.1 metres; Ham 522 kc/s, 574.7 metres, Notodden, 671 kc/s, 447.1 metres; Porsgrund, 662 kc/s, 45 metres; and Rjukan, 671 kc/s, 447.1 metres.—10.15 a.m., Road Report. 10.20, Chin 10.30, Service relayed from St. Saviour Church. 1.0 p.m., The Norwegian Yacht Societies' Jubilee—Report on the Rega relayed from Hanko. 5.0, Gramophone Records: Polonaise from Eugen One (Tchaikovsky); Le carnaval des anin (Saint-Saëns); Prelude in C Sharp, Mi (Rachmaninov); Gipsy Melodies (Sarasa). 5.15, Reading of Poems. 6.15, Sacred S Recital, relayed from Trondheim, 605 kW

JULY 9th

SUNDAY

continued

5.8 metres. 6.45, Parliamentary Notes. 15, Weather and News. 7.30, Relay from Shooting Range, Kristiansand. 8.0, me. 8.1, Concert by the Station Orchestra, conducted by Olvin Fjelstad: Overture, the Bartered Bride (Smetana); Mediterranean Suite (Jalowitz); Bavarian Dance (Lagar); Romance for String Orchestra (Jansen); Waltz from Der Bettelstudent (Müller); Frühlingswachen (E. Bach); reise (Fjelstad); Moroccan Patrol (essell). 9.0, Distribution of Prizes for selling, relayed from Hanko. 9.40, eather and News. 10.0, Topical Talk. 15, Recitations. 10.45, Dance Music on amophone Records.

TERSUND.—See Stockholm.

PALERMO

10.45, 537.6 metres; 3 kW.—10.25 a.m., de Reading. 10.40, Sacred Music. 11.5, ricultural Talk. 12.45 p.m., Giornale dio, 1.0 to 2.0, Concert of Light Music, e interval at 1.30, Time and News. 5.30 6.30, Gramophone Music. 8.0, Dopiovoro nouncements and Giornale Radio. 8.20, rts Notes. 8.25, Gramophone Music. In e interval at 8.30, Time and Announcem- . 8.45, Symphony Concert, conducted F. Russo. In the intervals, Talk and An- nouncements. 10.0, Gramophone Music. 10.55, ws.

PARIS

FFEL TOWER, Call FLE, 207.5 kc/s, 15.7 metres; 13 kW. Time Signals (on 10 metres) at 10.26 and 11.26 p.m. (Pre- nary and 6-dot Signals)—1.0 p.m., News l Weather Forecast. 1.30, Massenent Con- t by the Jean Ibis Orchestra; Selection in (a) La Navarraise, (b) Sapho, (c) is, (d) Werther, (e) Manon, (f) Don xote, and (g) Hérodiade. 6.45, Le Jour- alé. 7.45, Report of the Cycle Tour of ee. 8.5, Announcements. 8.30, Gramo- one Concert. Part I—Verdi Music; Sele- ct from (a) Sicilian Vespers, (b) Il yatore, (c) Othello, and (d) Falstaff. t II—Variety Music. 10.0 (approx.), se Down.

PARIS

STE PARIEN, 914 kc/s, 328.2 metres; kW.—10.0 a.m., Flourish of Trumpets and f of Drums. 10.20, Press Review. 10.30, mophone Concert. 12 Noon, Interlude 5 p.m., Sponsored Programme of Music n Sound Films. 12.45, Sponsored Pro- me. 12.50, Half an Hour of Fantasy Paul Weill. 1.20, Interlude. 1.30, Spou- ed Programme. 2.0 to 5.0, Interval. 5.0, ort on the Cycle Tour of France. 7.0, rnal Parle. 7.5, Sports Notes and Report the Cycle Tour of France. 7.30, Catholic ew. 8.0, Gramophone Music. 8.15, Inter- . 8.20, Gramophone Music. 8.40, Duet ital by M. and Mme. Adeline-Dangerville. Interlude. 9.15, Un caprice—Play (de sset). 9.45, Concert of Waltz Music of l. 10.30, Sponsored Programme. 11.0, es.

PARIS

DIO PARIS, Call CFR, 174 kc/s, 5 metres; 75 kW.—7.45 a.m., Light ie on Gramophone Records. 8.0, s. 8.30, Physical Culture. 12 Noon, gious Address by the Reverend her lhande. 12.20 p.m., Sacred Music; um ergo (de Vittoria); Toccata and ne in D Minor (Bach). 12.30, Bilbouquet e Balloon. 12.45, Running Commentary the European Motor Race at Spa. 1.30 to Programme in English by the I.B.C.; cert by Gramophone Records; Selection a La Gioconda (Ponchielli); Marche des s pierrrots (Bose); Aubade d'amour (nti); Shepherds' Song (Servanti and Ber- t); J'ai compris (Snoifer); La Mousméme); Divine Lady (Shikot); Les deux resses; La Godille (Van Hoorebecke). ning Commentary on the European or Race at Spa. 6.30, Popular Concert. Variety Concert. 8.45, Radio Paris ie Hall. 9.15, News. 9.30, Concert Light Music. 10.30 to 11.0, I.B.C. ramme; Light Music; March, Stars- Stripes (Soussa); Selection from zes from Vienna (Joh. Strauss); Potri, Dixieland; Shuffle eef to Buffalo ren); Selection from The Desert Song nberg); Barn Dance, the Coster's Woo- (Rimmer). 11.0 (approx.), Close Down.

PITTSBURGH

CA, 980 kc/s, 306 metres; 60 kW. Rel- yed by W8KK on 48.85 metres and 25.27 es.—5.15 to 6.15 p.m., Radio City Con- n from New York. 7.0, The Boys of eccastle. 7.15 to 9.30, New York Relay. World Economic Conference—William n from London. 7.30, Jan Garber and Orchestra. 8.0, National Opera Concert. Morton Gould and Bert Shefter. 9.15, phonette. 9.30, Vesper Services from lyside Presbyterian Church. 10.30, Pages Romance from New York. 11.0, Time al and Press News-Reeler. 11.5, Pro- me to be announced. 11.15, Weather rt. 11.15, Sport Review. 11.28, An- nouncement. 11.29, Temperature Report. l, L'Heure Exquise, from New York. 12 ight, Time Signal and Jack Pettis and

his Orchestra. 12.15 to 3.0 a.m. (Monday), New York Relay. 12.15, World Economic Conference—William Hard from London. 12.30, Great Moments in History. 1.0, Riesen- feld's Viennese Programme. 1.30, Don Hall Trio. 1.45, Floyd Gibbons. 2.0, Gulf Head- liners and Will Rogers and Orchestra. 2.30, Goldman Band. 3.0, Time Signal and Pro- gramme to be announced.

PORSGRUND.—See Oslo.

PRAGUE

614 kc/s, 488.6 metres; 120 kW.—10.5 a.m., Concert by a Sokol Women's Choir. 10.30, See Moravská-Ostrava. 11.0, See Brno. 12 Noon, Chimes. 12.5 p.m., See Brno. 1.20 to 1.45, Agricultural Talk from Kosice, 1,022 kc/s, 293 metres. 4.0, See Bratislava. 5.30, Gramophone Music. 6.0, German Trans- mission: Concert relayed from Kraslice. Conductor: Robert Manzor. Overture, Rienzi (Wagner); Selection from Aida (Verdi); Programme Review, followed by News in German. 7.0, Military Band Con- cert. 8.0, Humorous Programme. 8.50, See Brno. 10.0, Time and News. 10.20, Gramo- phone Dance Music. 11.0 (approx.), Close Down.

RADIO-SUISSE ROMANDE

SOTTENS, 743 kc/s, 403 metres; 25 kW.; and Geneva, 395 kc/s, 760 metres.—9.55 a.m., Chimes. 10.0 (from Geneva), Protestant Ser- vice. 11.0 (from Geneva), Gramophone Music. 12.30 p.m., News. 12.40 (from Geneva), Gramophone Music. 2.0 to 4.30, Inter- val. 4.30 (from Geneva), The Broadcasting Serenaders. 5.30 to 7.0, Interval. 7.0 (from Geneva), Catholic Address. 7.30 (from Geneva), News. 8.0 (from Geneva), Madensky Recital by M. Fryba (Double Bass). 8.30 (from Geneva), Les coteaux de Médoc— Play in One Act (Bernard). 8.45, Concert by the Radio-Suisse Romande Orchestra. 9.50, News. 10.0, Concert (contd.). 10.30 (approx.), Close Down.

REYKJAVIK

250 kc/s, 1,200 metres; 21 kW.—12.40 p.m., Weather. 1.0, Divine Service. 5.30, After- noon Concert. 8.45, Programme for Children. 9.30, Weather. 9.40, Musical Programme. 10.0, Chimes and News. 10.30, Reading. 11.0, Symphony No. 3 (Mendelssohn) and Arias on Gramophone Records. After the Concert, Dance Music. 2.0 a.m. (Monday), Close Down.

RJUKAN.—See Oslo.

ROME

1RO, 680 kc/s, 441 metres; 50 kW. Relay- ed by Naples, 941 kc/s, 319 metres; and 280, 11,810 kc/s, 25.4 metres, from 5.30 p.m.—10.10 a.m., Sports Notes and Amusement Guide. 10.30, Agricultural Report. 10.45, Bible Reading. 11.0 to 12 Noon and 12.30 to 2.15 p.m., See Turin. 1.30 to 2.30, Orchestral Concert. In the interval at 2.0, Time and Announcements. 4.45 (Naples), Programme for Children, Weather and Sports Notes. 5.0 to 6.15, Orchestral Concert. 6.15, Announce- ments. 7.30, Sports Notes and News. 8.0, Announcements. 8.30, Sports Report. 8.45, Bambù-Operetta in Three Acts (Carabella). In the intervals, Talk on Literature and Art, Science Review and Giornale Radio.

SALZBURG.—See Vienna.

SCHENECTADY

WGY, 790 kc/s, 379.5 metres; 50 kW. Rel- ayed at intervals by W2XAF, on 31.48 metres, and by W2XAD, on 19.56 metres.— 8.0 to 9.45 p.m. (approx.), New York Relay. 8.0, Wayne King's Orchestra. 8.30, Dr. Ralph W. Sockman in the Radio Pulpit. 9.0, Ficht- lers Three. 9.15, Wildroot Institute. 9.30, Temple of Song. 12.45 a.m. (Monday), Horse Sense Philosophy. 1.0 to 3.45, New York Re- lay. 1.0, Variety Programme. 2.0, Man- hattan Merry-Go-Round. 2.30, American Album of Familiar Music. 3.0, Popular Pro- gramme. 3.15, Highlights and Shadows. 3.45, Sunday at Seth Parker's, from New York, followed by Programme Re-sumé.

SCHWEIZERISCHER LANDESENDER

BEROMUNSTER, 653 kc/s, 459 metres; 60 kW.; Basle, 1,229 kc/s, 244.1 metres; and Berne, 1,220 kc/s, 245.9 metres.—10.0 a.m. (from Berne), Catholic Address. 10.45 (from Berne), Flute, Cello and Harp Recital. 11.30 (from Berne), Literary Programme. 12 Noon (from Berne), Concert of Marches. 12.30 p.m., Time and News. 12.40 (from Zürich), Concert by the Swiss Radio Orchestra. 1.30 (from Berne), Agricultural Programme. 1.50, German Folk Songs in New Settings—Concert by the Ostermün- digen Workers' Choir. 2.0 (from Berne), Talk. 2.30-5.0, Interval. 5.0 (from Berne), Light Music on Gramophone Records. 6.0-7.0, Interval. 7.0 (from Berne), Time and Sports Notes. 7.10 (from Berne), Con- cert by a Balalaika Orchestra. 7.35 (from

Berne), Programme to be announced. 8.0 (from Berne), Reading: The Letters of Famous Men and Women. 9.0, News. 9.10 (from Berne), Programme to be announced. 10.15 (from Berne), Sports Notes. 9.30 (approx.), Close Down.

SOTTENS.—See Radio-Suisse Romande.

STOCKHOLM

669 kc/s, 436 metres; 55 kW. Relay- ed by Boden, 244 kc/s, 1,229.5 metres; Göteborg, 932 kc/s, 322 metres; Hörby, 1,166 kc/s, 257 metres; Motala, 221.5 kc/s, 1,354.4 metres; Östersund, 389 kc/s, 770 metres; and Sundvall, 554 kc/s, 542 metres.—9.30 a.m., Rural Programme. 10.0 Gramophone Music. 11.0, Divine Service. 12.45 p.m., Weather Report. 3.0 p.m., Soloist Con- cert: Ingrid Fagerström (Harp), Lisa Tunell (Songs), Oluf Nielsen (Violin), Fritz Ahlberg (Violin), Roman Dukstulsky (Cello) and Anders Hansson (Flute). 4.0, Programme for Children. 4.30, Gramophone Music. 5.5, Talk. 5.30, Reading. 6.0, Military Band Concert conducted by Herman Nordström. 7.0, Pianoforte Recital of Music by Nordqvist with the Composer at the Pianoforte. 7.15, Weather and News. 7.35, Aren't we all?—Comedy (Frederick Lonsdale). 9.0, Song and Pianoforte Recital by the Lilly Erierson Vocal Quartet and Hans Almdal (Pianoforte). 9.45, Weather and News. 10.0, Concert by a Salvation Army Band, relayed from the Opera House. 11.0 (approx.), Close Down.

STRASBOURG

869 kc/s, 345 metres; 11.5 kW.—7.45 to 8.0 a.m., Radio Report of the Cycle Tour of France. 9.45, Protestant Service in French. 10.30, Catholic Service in German. 11.0, Radio Report in French of a Local Festival, relayed from Wangen. 12 Noon, Light Music on Gramophone Records. 12.15 p.m., Radio Re- port of the Cycle Tour of France. 12.30, Light Music on Gramophone Records. 12.45, News. 1.0, Variety Music on Gramophone Records. 3.0 to 3.30, Interval. 3.30, Orchestral Con- cert, relayed from the Casino, Vichy. Con- ductor, Bromilau. Overture, Phédre (Massenet); La voix des cloches (Luigini); Orches- tral Suite from Coppélia (Delibes); Serenade for Flute and Horn (Titl); symphonic Suite from Louise (Charpentier); Waltz, España (Waldteufel). 5.0, Gramophone Concert. In an interval at 5.15 (approx.), Radio Re- port of the Cycle Tour of France. 6.0, Medi- cal Talk. 6.15, Sports Talk. 6.30, Jazz Music, conducted by Roskann. 7.30, Time and News. 7.45, Radio Report of the Cycle Tour of France. 8.5, Press Review in French, Lot- tery Results, and Announcements. 8.45, Military Band Concert, relayed from Nancy; Sambre et Meuse (Planquette); Overture, Mirella (Gounod); March from Act IV of Hilda (Franck); Mimet in E Flat (Mozart); La statue (Reyer); Air from The Valkyries (Wagner); Quand Madelon (Bousquet- Robert). 10.30, Press Review in German. 10.40 (approx.), Dance Music from the Savoy. 12 Midnight (approx.), Close Down.

STUTTGART

MUHLACKER, 832 kc/s, 360.5 metres; 60 kW. Relay- ed by Freiburg, 527 kc/s, 570 metres.—11.30 a.m., See Leipzig. 12 Noon, Orchestral Concert from Glotterbad, March, Durch Kampf zum Sieg (Blou); Waltz, Kroils Balklänge (Lumbay); Overture, The Gipsy Baron (Joh. Strauss); Idyll, Gold- schmetterling (Siede); Wachtparade (Lincke); Potpourri, Von Wien durch die Welt (Hrubý); Army March. 1.0 p.m., Topical Talk. 1.15, Gramophone Concert of Light Music. 2.35 (from Karlsruhe), Talk: The Artisan Class and National Socialism. 3.0, Recital of Songs by the Prague Citizens' Choir. 3.30, Programme for Young People. 4.30, Running Comment- ary on the Final of the Motor Cycle Races from the Avus Speedway, Berlin. 5.15 (from Frei- burg), Mandoline and Guitar Concert, con- ducted by Emil Köhler. Soloist: Carl Jöken (Tenor); Festmarsch (Köhler); Pre- lude, Fostli he Weihe (Köhler); Tenor Solos: (a) Sicilienne from Cavalleria Rustic- ana (Massagni), (b) Aria from H Trova- tore (Verdi), (c) Aria from Martha (Flotow); Symphony in E Minor in One Movement (Wälki); Tenor Solos: (a) Volga Song from The Czarevitch (Lohár), (b) Tarantella from Gasparone (Müllbächer), (c) O Sole Mio (di Capua); In- termezzo from Mignon (Thomas Köhler); Kaiserwäzler (Strauss-Köhler). 6.15, See Hamburg. 7.40, Sports Notes. 7.50, PIANO- forte Recital with Commentary. 8.25, (ap- prox.), Concert from Frankfurt. 10.10 (ap- prox.), News. 10.13, Part-Relay of the South German Light Athletic Championship from the Hitler Stadium, on Gramophone Records. 11.0 to 12 Midnight, See Munich. 1.45 a.m. (Monday), Serenade by the Station Orchestra, conducted by Ferdinand Drost. Overture, Christlein (Pfitzner); Das Hex- entlied (Max von Schillings); Selection from

the Suite, Le Bourgeois Gentilhomme (R. Strauss).

SUNDSVALL.—See Stockholm.

TOULOUSE

779 kc/s, 385 metres; 8 kW. Transmission uncertain owing to recent fire.—5.30 to 7.0 p.m., Programme in English by the I.B.C. 6.30, Henlys Concert of Dance Music. 10.30 till Close Down, Programme in English by the I.B.C. 10.30, Fulford Bill Beans Con- cert. 11.0, Dance Music.

TRIESTE

1,211 kc/s, 247.7 metres; 10 kW.—9.40 a.m., See Turin. 11.0, Religious Address. 11.20 to 11.40, Agricultural Talk. 12 Noon till Close Down, See Turin.

TRONDHEIM.—See Oslo.

TURIN

1,096 kc/s, 273.7 metres; 7 kW. Relay- ed by Milan, 905 kc/s, 331.5 metres; Genoa, 959 kc/s, 312.8 metres; and Florence, 599 kc/s, 500.8 metres.—9.40 a.m., Giornale Radio. 10.40, Agricultural Report. 11.0, Mass from the Church of the Annunciation, Florence. 12 Noon, Bible Reading. 12.30 p.m., Concert by the Station Orchestra. In the interval at 1.0, Time and Announcements. 1.30, Spon- sored Music. 2.15, Gramophone Music. Orchestral Concert. 4.30, Variety Music. In the interval: Sports Notes. 6.15, Weather and Gramophone Music. 6.30, Giornale Radio and Sports Notes. 7.0, Time and Dovo- lavoro Announcements. 7.10, Gramophone Music. 8.0, Announcements, Giornale Radio and Sports Notes. 8.20, Talk on the Follow- ing Transmission. 8.30, Sly—Opera in Three Acts (Wolf-Ferrari). In the intervals: Talk and Theatre Notes. After the Opera: Gior- nale Radio.

VIENNA

581 kc/s, 517 metres; 100 kW. Relay- ed by Graz, 852 kc/s, 352.1 metres; Innsbruck, 1,058 kc/s, 283 metres; Klagenfurt, 662 kc/s, 453.2 metres; Linz, 1,220 kc/s, 245.9 metres; and Salzburg, 1,373 kc/s, 218.5 metres.— 10.10 a.m., Song Recital by Elemer von John (Baritone). 10.40, Sacred Music by the Vienna Boy's Choir. 11.25, Concert by the Vienna Symphony Orchestra, conducted by Herbert Winkler. Soloists: Christa Richter-Steiner (Violin) and Beatrice Reichert (Cello). 12.45 p.m., Orchestral Concert, con- ducted by Josef Holzer. 2.30, Agricultural Talk. 3.0, Time, Announcements and Weekly Review of the Press Association. 3.10, Re- view of Books. 3.35, Trio in F Minor for Pianoforte, Violin and Cello, Op. 65 (Dvorák). 4.15, Talk: The Latest Ex- cavations in Smyrna. 4.45, Orchestral Concert, conducted by Josef Holzer. 6.10, Reading from the Works of Paul Keller, on his Sixtieth Birthday. 5.40, Vari- ations and Fugue on a Theme by Handel (Brahms), with Commentary. 7.10, Time, Sports Notes and Programme Announce- ments. 7.20, Military Band Concert— Military Band Conductors as Composers. 8.45, I Pagliacci—Opera in Two Acts (Leon- cavalli) by the East of the Milan Scala, on Gramophone Records. 10.0, News. 10.15, Gáány Music, relayed from Budapest.

WARSAW

212.5 kc/s, 1,411 metres; 120 kW.—10.25 a.m., Programme Announcements. 10.30, Divine Service relayed from Lwów, 788 kc/s, 381 metres. 11.57, Time and Fanfare from St. Mary's Church, Cracow. 12.5 p.m., Programme Announcements. 12.10, Weather. 12.15, Concert by the Station Symphony Orchestra, conducted by S. Nawrot. 2.10, Talk: Balancing the Budget. 2.15, Weather. 2.20, Light Music on Gramo- phone Records. 2.45, Agricultural Talk. 3.5, Popular Concert relayed from Cracow, 959 kc/s, 312.8 metres. In the interval: News and Announcements. 4.0, Topical Talk for Young People. 4.15, Talk for Children. 4.30, Song Recital by Suzanne Karin. 5.0, Talk for Worker. 5.15, Concert of Polish Music by the Poznan Symphony Orchestra, conducted by B. Tyllia, relayed from Ciechocinek. 6.0, Vespers re- layed from the Bernardine Convent at Duka. 7.0, A Play (after a Novel by Chesterton). 7.40, Miscellaneous Items. 7.55, Programme Announcements. 8.0, Lehar Concert by the Station Orchestra, conducted by Z. Gorzyn- sky. Soloist: J. Poplawsky (Tenor). 10.0, Dance Music. 10.25, Sports Notes. 10.40, Aviation Weather Report and Police Notes. 10.45, Dance Music.

WILNO

533 kc/s, 563 metres; 16 kW.—7.40 p.m., Reading in Lithuanian. 7.55, Programme An- nouncements. 8.0, See Warsaw. 11.0 (ap- prox.), Close Down.

ZAGREB

977 kc/s, 307 metres; 0.75 kW.—8.10 p.m., Announcements. 8.30, Concert by the Station Orchestra. 9.30, Sports Talk. 9.40, Con- cert (contd.). 10.30, News, Weather, and Programme Announcements. 10.40, Dance Music. 11.30 (approx.), Close Down.

ZURICH.—See Schweizerischer Landessender.

ATHLONE

725 kc/s, 413 metres; 60 kW. Relayed by Cork, 1,337 kc/s, 244.4 metres.—1.30 to 2.30 p.m., Time, News and Gramophone Music. 6.0, Programme for Children. 6.45, News. 7.0, Talk in Gaelic. 7.15, Poetry Recital by May Pitchford. 7.30, Time. 7.31, String Quartet. 8.0, Soprano Solos by Lilian Swann. 8.15, The Station Orchestra. 8.30, Tenor Solos by J. Flood. 8.45, The Station Orchestra. 9.0, Further Adventures of Ellis Palmer. 9.45, Sponsored Programme. 10.30, Time. 10.45, News and Close Down.

BARCELONA

EAJ1, 860 kc/s, 348.8 metres; 8 kW.—7.0 p.m., Trio Concert: Selection from Werther (Massenet); Oriental Romance (Baines); Selection from The Valkyries (Wagner); Melody (Rubinstein); Intermezzo (Demaret); Polonaise militaire (Chopin). 8.0, Request Gramophone Records. 8.20, Sports Notes. 8.30, Exchange, followed by Talk in Catalan. 9.0, Gramophone Music and News. 10.0, Chimes, Weather, Exchange and Market Prices. 10.5, Humorous Review of the Week in Verse. 10.15, Concert of Sardanes. 11.10, Music by the Station Orchestra. 11.30, Topical Talk in Catalan. 12 Midnight, Piano-forte and Accordion Recital. 12.45 a.m. (Tuesday), Gramophone Music. 1.0 (approx.). Close Down.

BARI

1,112 kc/s, 269.8 metres; 20 kW.—8.0 p.m., Agricultural Notes, Tourist Talk and Dopolavoro Announcements. 8.20, Giornale Radio and Weather. 8.30, Time and Announcements. 8.35 (approx.), Othello—Opera in Four Acts (Verdi). In the intervals, Talk: Rome in the Time of Julius Caesar, Art Notes and News.

BASLE.—See Schweizerischer Landessender.

BELGRADE

697 kc/s, 430.4 metres; 2.8 kW.—6.0 p.m., Concert by the Station Orchestra. 6.50, Gramophone Music. 7.20, Talk. 7.50, Song Recital. 8.30, Programme relayed from Zagreb, 977 kc/s, 307 metres. 10.30, Time Signal, News and Gypsy Music, relayed from a Restaurant.

BERLIN

DEUTSCHLANDSENDER, 183.5 kc/s, 1,635 metres; 60 kW.—2.0 p.m., Gramophone Concert. 3.0, Talk for Women. 3.30, Weather and Exchange. 3.45, Review of Books on the Rights of Parents. 4.0, See Breslau. 5.0, Educational Talk. 5.25, Topical Talk. 5.35, Tanzrhythmen, Op. 14, 24 and 41, for Piano-forte Duet (Paul Juno), with the Composer and Rudolf Schmidt. 6.0, Poems. 6.5, Schumann Song Recital by Else Jörn: Widmung; Die Fenster-scheibe; Lied eines Schmiedes; Warum? Grillen; Schöne Wiege meiner Leiden; Schneeglöckchen; Röslein. 6.25, Dialogue on Gilding. 6.50, Weather Announcements. 7.0, Transmission for all German Stations, relayed from Breslau. 8.0, An Axiom. 8.5 (approx.), Concert of Historical Marches. 8.50, German Gardens in Song and Verse; a Radio Sequence (Martin Raschke). 10.0, News. 10.45, Weather Report. 11.0, Concert from Leipzig. 12 Midnight, Close Down.

BERLIN

WITZLIEBEN, 715 kc/s, 419.5 metres; 1.5 kW.—4.30 p.m., Orchestral Concert, relayed from the Tiergarten; Overture, Das Nachtlager von Granda (Kreutzer); Scherzo No. 1 (Schubert); Cradle Song (Järnefeldt); Rubin and Smaragd (Kick-Schmidt); Tango (Schulenburg); The Musical Clock (Blaauw); Selection from Dan Pasquale (Donizetti); Overture, Die Scheinhe (Kark); Gallop, Husarenritt (Spindler). 5.30, A Dialogue on Portrait Painting. 5.50, Ferdinand Schill reads from his Books: Adventures in Bolivia. 6.10, Old Love Songs—Recital by Max Meili (Tenor) and Heinz Grehner (Viola). 6.40, The Witzleben Station informs its Listeners. 6.45, Topical Talk. 7.0, Transmission for all German Stations, relayed from Breslau. 8.10, See Langenberg. 9.30, Hallo! London—Berlin calling—Radio Report from the Berlin office of a British International Newspaper. 10.0, News, followed by Dance Music from the Delphi-Palast. In the interval from 11.0 to 11.5, Talk: What they are talking about in Berlin. 12 Midnight, Close Down.

BERNE.—See Schweizerischer Landessender.

BEROMUNSTER.—See Schweizerischer Landessender.

BODEN.—See Stockholm.

BODO.—See Oslo.

BORDEAUX-LAFAYETTE

986 kc/s, 304 metres; 13 kW.—6.15 p.m., Radio Journal. 7.30, News, Market Prices and Lottery Results. 7.45, Report on the Cycling Tour of France. 8.5, Talk: Bordeaux a Century Ago. 8.20, Programme for Children. 8.35, Charades. 8.40, News. 8.45, Orchestral Concert relayed from the Casino, Vichy.

BRATISLAVA

1,076 kc/s, 279 metres; 11 kW.—2.50 p.m., Concert by the Station Orchestra, conducted by Dyk. 3.55 to 4.0, See Prague. 5.45, See Prague. 6.10, Four Trios for Violin, Cello and Piano-forte (Widor). 6.35, Talk on Tenis: The Davis Cup. 6.50, Gramophone

MONDAY

JULY THE TENTH

PRINCIPAL EVENTS OF THE DAY:

AT HOME

NATIONAL Chamber concert.
LONDON REGIONAL Orchestral concert from Scarborough. Military band.
MIDLAND REGIONAL From Spain and Portugal: orchestral concert.
NORTH REGIONAL Variety programme.
WEST REGIONAL Orchestral concert from the National Museum of Wales.
SCOTTISH REGIONAL Orchestral concert.
BELFAST Orchestral concert.

ABROAD

BARI 8.35 p.m. Opera: "Othello," by Verdi.
BERO-MUNSTER 9.10 p.m. Cello recital by J. Stutschewsky, from Zürich.
BRUSSELS (No. 1) 9.0 p.m. Concert from the Kursaal, Ostend.
HUIZEN 7.40 p.m. The Arnhem Orchestra, conducted by H. Manks.
OSLO 5.30 p.m. Concert by the Radio Ensemble.
STRASBOURG 8.45 p.m. Orchestral concert from the Casino, Vichy.
STUTTGART 9.30 p.m. Chamber music by Freiburg Composers, relayed from Freiburg.
WARSAW 8.0 p.m. Two operas: "Flys" and "Verbum Nobile," by Moniuszko.

Music. 6.55, Report for the Housewife. 7.0, See Prague. 7.40, Song Recital by Lúzi Bagrovini. 8.10, See Brno. 9.0, Concert of Operetta Music by the Station Orchestra, conducted by Dyk. Soloists: H. Slabejova and J. Sabota (Songs). Overture, Die geschiedene Frau (Fah); Volga Song from The Czarevitch (Lehar); Extracts from Paganini (Lehar); Two Duets (Kinel); Waltz from Polenbul (Nedbal); Two Songs (Benes); Operetta Song (Piskaekc); March Song (Benes). 10.0, See Prague. 10.15 (approx.), Close Down.

BREMEN.—See Hamburg.

BRESLAU

923 kc/s, 325 metres; 60 kW. Relayed by Gleiwitz, 1,184 kc/s, 253 metres. 1.0 p.m., Gramophone Concert of Ballet and Dance Music from Opera. 2.0, Time and News. 2.20, Gramophone Music: Overture, Die Zwillingenbruder (Schubert); Valse-serenade (Tchaikovsky); Hast du mich lieb? (Holm); Selection from Lilac Time (Schubert-Berte); Pastorale for Harpsichord (Searlatt); Waltz, Amoureuse (Berger); March Foxrot, So ein Jägermann (Lauder-Dehner); Waltz from Eva (Lehar); Kreuzritter-Fanfaren (Hennrich). 3.0, Market Prices. 3.40, Review of Books. 4.0, Orchestral Concert from Bad Hilsberg, conductor: Carl Waddow, March, Der eiserne Grenadier (Richter); Overture, La Traviata (Verdi); Procession of the Women to the Minister from Lohengrin (Wagner); Symphonic Poem from the Cycle, My Country (Smetana); Selection from Elektra (R. Strauss); Overture, Russian and Ludra (Glinka); Violin Solo, Faust-Fantasia (Sarasate); Waltz, Am Wörther See (Koschub); Selection from Eugen Onegin (Tchaikovsky). 5.30, Market Prices, followed by Talk on German Cultural Work. 5.55, Talk: The Organisation of the Nazi Movement. 6.20, Violin Recital: Prelude and Fugue in E Minor, Op. 117 (Bach); Sonata in D Minor, Op. 108, for Violin and Piano-forte (Brahms). 6.50, Weather and Market Prices. 7.0, Transmission for all German Stations; SA Kamerad, Tonne—Propaganda Radio Play for Workers (Peter Hagen). 8.0, Piano-forte Recital by Edo Dannert: Pictures from an Exhibition (Mussorgsky); Two Intermezzi, Op. 118 (Brahms). 8.40, Topical Talk. 9.0, News. 10.0, Das musikalische Schloss—a Radio Farce (Karl Theodor Haanen). 10.0, Time and News. 10.25, Wireless Technical Talk. 10.35, Talk: With the German Steamer Tuskanina to the Former German Colonies in South-West Africa. 10.55 (approx.), Close Down.

BRNO

878 kc/s, 342 metres; 35 kW.—6.25 p.m., German Transmission: News and Talk. 7.0, See Prague. 7.25, Yugoslavian Song Recital by Jozka Fadrusová. 7.40, See Prague. 8.10, Dramatic Programme. 9.0, See Bratislava.

Doek): Danes and Serenade from Mile (Block); La cloche du soir (de Taey Esquisses flamandes (Brussels); 5. Programme for Children. 6.30, Gramophone Music: Overture, Le Jeune Henri (Meli); Piano-forte Concerto No. 17 (Mozart); Overture, Abu-Hasan (Weber). 7.15, Program for Ex-Servicemen. 7.20, Wireless Revue. 7.30, Le Journal Parle. 8.0, Concert by Radio Orchestra, conducted by M. Wald Parle. 1—Massenet Music. Soloist: M. Jeanne Lauwers-Vandommerich (Song, Overture, Piéridé; Songs: (a) Eclési, Letter Aria from Werther; Gavotte Minuet from Manon; Selection from Erymides; Songs: (b) Pensée d'automne, Aria from The Cid; Scènes pittoresques. 8.45, Talk. 9.0, Concert (contd.). Part Overture, Chal Romano (Ketelbey); Selection from The Pearl Fishers (Bizet); Waltz, The Count of Luxembourg (Lehar); V. Solo, A Fete in Aranjuez (Demersson); Ballet égyptien (Loignin). 10.0, Le Jour Parle. 10.10, Dance Music on Gramophone Records (Flanagan); Foxrot, Wanda Valse des Baïers (Ganne); Tango, Sier (Bianco); Foxrot, Always in my H (Turk); Moss Rose (Rose); Foxrot, This a Crowd (Dubin); Waltz, Volupta (Leau); Foxrot, I can't believe it's (Newman); Tango (Losas); Foxrot, Sw hearts for ever (Friend); Spanish W Santiago (Corbin); Foxrot, Mother C Parade (Bream); Fiesta (Samuels); Fox Let's get friendly (Douglas); Teddy Be Plenie (Kennedy); Rumba, Wanna to Love (Rodriguez).

BUCHAREST

761 kc/s, 394 metres; 12 kW.—5.0 p.m., cert by the Station Orchestra; Soloist: Popesco (Flute); Marche solennelle (C. O Overture, Zampa (Herold); Flute: Idyll (Suppé); Fantasia on a Theme by (Arko); Selection from Cavalleria Rustica (Mascagni); Venetian Gondola Song (Delssohn); Chanson (Friml); Selection, Lilac Time (Schubert-Berte). In an interval at 6.0, Radio Journal. 7.0, Educational Quartet in D (Haydn) by the Theodo Quartet. 8.30, Concerto in F for Two P fortes (Gershwin), by MM. T. Sibiccano Koller. 9.0, Programme relayed from Restaurant. 9.45, Radio Journal.

BUDAPEST

545 kc/s, 550.5 metres; 18.5 kW. Also layed on 840 metres from 7.50 p.m. till Down. 5.0 p.m., Recital of Viennese Songs with Schrammel Music accompaniment Wiener Wald (Adolf Hirsch); Im Hirschen (Fall); Rosenstock and Holld Du guater Himmelvater (Krakauer); 5 tion from Die Schützenliesel (Ey. Galtzberglied; Selection from Fras (Lehar); Song from The Circus Princess (Méh). 5.30, Talk: Fashions for Men. Gramophone Music. 7.15, Exchange, Talk on the European Fencing Championship. 7.50, Concert of Gypsy Music, News. 9.10, Military Band Concert, ducted by R. Friesay; Horthy March (kas); Erzherzog Friedrich March (C. ka); Baron Fejervary March (Müller); nus (Scharohel); March of the Hinder Infantry (Friesay); Jetzt gehts los (Le die Bosnier Kommen (Wagner); 8 Horthy March (Hackl); Infantry A (Kocpekzy); Maria Theresia March (Fu Parade March (Friesay); Wagram (W mann); March (Krad); Deutsche marsch (Jurek); Seifertitz (Achleit Erzherzog Karl March (Schneider); garian March (Friesay); Rakoczy M 10.40, Weather, followed by Dance i from the Hotel Bellevue. 11.15, Ta French.

CASSEL.—See Frankfurt.

COPENHAGEN

1,067 kc/s, 281 metres; 0.75 kW. Re by Kalundborg, 260 kc/s, 1,153 met 12 Noon to 2.0 p.m., Concert from the d'Angleterre. 2.50, Talk for the Hous 3.0, Concert by the Radio Orchestra, ducted by Walter Meyer-Radon; Ove Agnes (Pærr); Ballet Suite (Grétry-Fra Selection from Aida (Verdi); Waltz The Arabian Nights (Joh. Strauss); ture, The Merry Wives of Windsor (Nie Reading; Overture, La belle Hélène (a bael); Ballet Music from The Cid (e net); Prelude to Susanna's Secret (Ferrari); Waltz, Estudiantina (Waldte Indian War Dance from Fiert fra Dan (Lumbye). 5.0, Gramophone Concert; Borgioli; Aria from La Traviata (V Dinsolina Giannini; Neapolitan Folk Mammella mia; Concert, Fantasia on C (Bizet-Sarasate); Sven-Olof Sandberg; (Sylvain); Josephine Baker; Ram-Pan (de Vita); Red Sam; Some of these (Brooks); The Three Ginx; Young Healthy (Warren). 5.55, Exchange Market Prices. 6.20 (from the A Studio), Gardening Talk. 6.50, Weathe News. 7.15, Time. 7.30, Talk: The 1 Fisheries. 8.0, Town Hall Chimes. Concert of Slav Opera Music; Ovi Polka, Puritan and Dance from The Ba Bride (Smetana); Selection from Godmow (Mussorgsky); Overture, R and Ludmilla (Glinka); Selection, Schwanda the Piper (Weinberger); from The Fair at Sorotchinsk (Mussor 9.0, Recital of West Jutland Songs Introductory Talk. 9.50, Saxophon

BRUSSELS (No. 2)

N.I.R., 887 kc/s, 338.2 metres; 15 kW.—12 Noon, Gramophone Music: Selection from L'Elisir d'amore (Donizetti); Overture, Patrie (Bizet). 1.0 p.m., News. 1.10, Concert by the Small Station Orchestra, conducted by M. Leemans: March of the Porcelain Statuettes (Tapp); Ballet Music from Philémon et Baucis (Gounod); Novalletta (Caldesi); Selection from Les Mousquetaires au Couvent (Varney); Rapsodie chinoise (Gabriel-Marie); Violin Solo: Souvenir (Drdla); Waltz, A Boy and a Girl were dancing; Foxrot, Fascination Vamp (Nussbaum). 5.0, Concert by the Radio Orchestra, conducted by M. Charles Walpot: Unité-Marche (Karel Walpot); Suite of Viennese Waltzes (Gilsen); Rapsodie dahoméenne (de

10.0, See Prague. 10.30 (approx.), Close Down.

BRUSSELS (No. 1)

I.N.R., 590 kc/s, 509 metres; 15 kW.—12.0 Noon, Concert by the Small Station Orchestra, conducted by P. Leemans: Overture, Boreaccio (Suppé); Extase (Ganne); Waltz (Waldteufel); Selection from The Student Prince (Romberg); Piano-forte Fantasia (Benoit); En badinant (d'Ambrosio); Selection from The Merry Widow (Lehar); Melodies from Une auto et pas d'argent (Grün). 1.0 p.m., Le Journal Parle. 1.10, Gramophone Concert, El capitán (Souza); Selection from The Desert Song (Romberg); Belgian Potpourri (Max Alexys); Oh, that Mitzi (O. Straus); Wedding of the Painted Doll (Brown); Mary Lou (Lyman); Waltz from The Arabian Nights (Joh. Strauss); Foxrot (MacKnight); Hylda (Reynaud); Viennese Potpourri (Leopold); Arabian March (Ganne). 5.0, Viola Recital by M. Broos: Adagio and allegro (Geminiani); Sonata (Ariosti); Four Pieces (Marais). 5.30, Gramophone Music: Selection from Maritona (Wallace-Blinncoe); Melody (Bizet-Delattre); Selection from: (a) Tamhäuser (Wagner-Middleton); (b) Lohengrin (Wagner-Middleton); Nuit d'Espagne (Massenet); Overture, The Wreckers (Ethel Smyth). 6.0, Talk: Cold Light. 6.15, Sonata in D Minor (Pierre de Bréville. 6.45, Une Annie d'enfance—Sketch (Rey). 7.0, Gramophone Music: Nocturne, Op. 9, No. 2 (Chopin); Two Pieces (Wolstenholme); Scandinavian Dance (Sven Rano); Melody (Borganov). 7.15, Talk: The Royal Belgian Library. 7.30, Film Review. 8.0, Trio Concert by Mme. Moulart (Soprano), Mme. Jeanne Maes (Mezzo-Soprano), and Mlle. Strelens (Contralto): Absence (Schumann); Nocturne; Berenice (Buffin); Serenade (Radoux); Le soir (Le Maître). 8.20, Il faut qu'une porte soit ouverte ou fermée—Play in One Act (de Mussot). 8.50, La Source—Ballet (Delibes), on Gramophone Records. 9.0, Concert, relayed from the Kursaal, Ostend. 10.30, Le Journal Parle. 10.40, Dance Music, relayed from the Kursaal, Ostend.

JULY 10th

MONDAY

continued

PARIS

POSTE PARISIEN, 914 kc/s, 228.2 metres; 60 kW.—5.45 p.m., Radio Report of the Cycle Tour of France. 7.0, Gramophone Music. 7.15, Journal Parle. 7.30, Radio Report of the Cycle Tour of France. 7.45, Hot Jazz on Gramophone Records. 8.15, Interlude. 8.30, Liszt Recital by Marguerite Liszt and Marcel Jacquinet. 9.0, Interlude. 9.20, Sponsored Concert. 10.20, News.

PARIS

RADIO PARIS, Call CFR, 174 kc/s, 1,725 metres; 75 kW.—7.30 a.m., Weather and Physical Culture. 7.45, Ballet Music from Coppélia (Delibes), on Gramophone Records. 8.0, News. 12 Noon, Chamber Music on Gramophone Records: Sonata for Flute and Strings (Searlatti); Largo for Violin (Viardot); Song (Bühm); Au bord de l'eau (Faure); Cortot Ballad in F for Pianoforte (Chopin); Trio in B Flat (Schubert); Danse macabre (Saint-Saëns); Dance of the Sylphs from The Damnation of Faust (Berlioz); Pianoforte Solo, Poissons d'or (Debussy); In the Steppes of Central Asia (Borodin); Ballet Music from Petroushka (Stravinsky). In the intervals at 1.0 p.m., Exchange and News, and at 1.30, Exchange. 2.0 to 3.35, Exchange. 7.0, News. 7.10, Book Review. 7.30, Gramophone Concert: Le p'tit quinquain (Desrousseaux); Evening Bells (Bill); Violin Solo, Marie Mari (di Capua); Selection from The Drum Major's Daughter (Offenbach). 7.50, Commercial Prices and News. 8.0, Gramophone Concert (cont'd.); Eine kleine Nachtmusik (Mozart); La Forêt (Caplet); Suite in F (Roussel). 8.30, News. 8.40, Review by Rehoux. 8.45, Symphony Concert, relayed from the Casino at Vichy (For details see Strasbourg). In the interval at 9.15, News.

PITTSBURGH

KDKA, 980 kc/s, 306 metres; 50 kW. Relayed by WEXK on 48.86 metres and 25.27 metres.—7.30 p.m., KDKA Home Forum. 8.0, Betty and Bob, from New York. 8.15, Monday Matinee, from New York. 8.45, Human Values. 8.58, Baseball Scores. 9.0, Radio Guild—Drama, from New York. 10.0, Rhythm Kings. 10.15, Tarzan of the Apes. 10.30, The Singing Lady, from New York. 10.45, Little Orphan Annie. 11.0, Time Signal and Press News-Reciter. 11.5, Sam Robbins and his Hotel McAlpin Orchestra, from New York. 11.15, Weather Report. 11.16, Sport Review. 11.23, I Bring a Song. 11.28, Announcement. 11.29, Temperature Report. 11.30, Pittsburgh Spotlights. 11.45, Today's News, by Lowell Thomas, from New York. 12 Midnight, Amos 'n' Andy, programme to be announced. 12.30, Rudy Vallee and his Hotel Pennsylvania Orchestra, from New York. 1.0, Chiquit Club Eskimos, from New York. 1.30, Potash and Perlmutter. 1.45 to 3.0, New York Relay. 1.45, Phil Cook and the Ingram Shavers. 2.0, Sinclair Minstrels. 2.30, Jack Frost Melody Moments. 3.0, The Silver Toppers.

PORSGRUND.—See Oslo.

POZNAN

896 kc/s, 335 metres; 1.9 kW.—6.0 p.m., Announcements. 6.15, See Warsaw. 7.20, Miscellaneous Items and News. 7.35, Theatre Notes and Programme Announcements. 7.40, See Warsaw. 7.58, Time Signal. 8.0, See Warsaw. 10.15, Time Signal, Sports and Police Notes. 10.30 (approx.), Close Down.

PRAGUE

614 kc/s, 488.6 metres; 120 kW.—2.50 p.m., See Bratislava. 3.55 to 4.0, Exchange. 5.45, Gramophone Music. 5.55, Talk. 6.5, Agricultural Report. 6.10, Gramophone Music. 6.15, Talk. 6.25, News in German. 6.30, German Transmission: Film Review and Talk on Finance. 7.0, Chimes. 7.1, News. 7.10, Talk: The Sky in Summer. 7.25, Slovak Folk Song Recital. 7.40, Concert of Light Music. 8.10, See Brno. 9.0, Time Signal. 9.1, See Bratislava. 10.0, Time and News. 10.15, News in German. 10.30 (approx.), Close Down.

RABAT

721.1 kc/s, 416 metres; 6 kW.—1.30 to 3.0 p.m., Concert of Gramophone Music. In an interval at 2.0, Talk: Hitler and his Attitude towards the Jews, Women, and the Church. 5.0 to 6.0 p.m., Gramophone Music. 8.30 to 9.0, Gramophone Music. 9.0 to 11.30, Concert of Gramophone Music.

RADIO-SUISSE ROMANDE

SOTTENS, 743 kc/s, 403 metres, 25 kW.; and Geneva, 395 kc/s, 760 metres.—3.28 p.m., Time Signal from Neuchâtel Observatory. 3.30 (from Lausanne), Concert by the Radio Lausanne Orchestra. 5.0 (from Lausanne), Programme for Children. 5.30 to 7.0, Interval. 7.0 (from Lausanne), Talk: The Harmony of Nature. 7.30, News. 7.35 (from Lausanne), Answers to Correspondence. 8.0 (from Lausanne), Saxophone and Pianoforte Duets, accompanied by the Radio Lausanne Orchestra. 9.0 (from Geneva), Variety Concert by the Broadcasting Serenaders. 9.50, News. 10.0 (from Geneva), Gramophone Music. 10.30 (approx.), Close Down.

REYKJAVIK

250 kc/s, 1,200 metres; 21 kW.—9.30 p.m., Weather. 9.40, Musical Programme and Announcements. 10.0, Chimes and News. 10.30, Reading. 11.0, Popular Concert by the Station Quartet, with Songs.

RIGA

572 kc/s, 525 metres; 15 kW.—6.0 p.m., Talk. 6.30, Talk: The Riviera. 7.0, Weather Report. 7.3, Choral Concert. 7.35, Humorous Programme. 8.5, News. 8.25, Chopin Pianoforte Recital. In the interval at 9.0, Weather and News. After the Recital, Dance Music. 10.0 (approx.), Close Down.

RJUKAN.—See Oslo.

ROME

1RO, 680 kc/s, 441 metres; 50 kW. Relayed by Naples, 541 kc/s, 319 metres; and 2RO, 11,810 kc/s, 25.4 metres.—1.0 to 2.15 p.m., Gramophone Music. In the interval from 1.30 to 1.45, Giornale Radio and Exchange. 4.45, Children's Radio Review. 5.10, Announcements. 5.15, Exchange and Giornale Radio. 5.30, Vocal and Instrumental Concert: Luigi Schiuna (Violin) and Hilba Gerunda (Soprano); Violin Solos: Baal Schem (Ernst Bloch); Three Songs (Schubert): (a) Gretchen am Spinnrade, (b) Heidenroslein, (c) Die Forelle; Aria and Duet from La Gioconda (Ponchielli); Violin Solos: (a) Hymn to the Sun from The Golden Cockerel (Rimsky-Korsakov-Kreisler), (b) Il Capitano Fracassa (Castelnuovo-Tedesco); Soprano Solos: (a) Romance from Le Vili (Puccini), (b) Venetian Song, Caro caro bello bambin (Guarnieri). 6.40 (Naples), Shipping and Sports Notes. 6.50, Agricultural and Dopolavoro Notes. 7.13, Tourist Report. 7.20, Announcements in Various Languages. 7.40, Giornale Radio. 8.0, Time and Announcements. 8.5, Gramophone Music. 8.30, Giornale Radio and Sports Notes. 8.45, Variety Programme. 9.45, Reading and Talk. 10.0, Concert of Light Music: Fantasia of Dances, Mascheronide (Mascheroni); Pierrot in marsina (di Ferdinando); Song (Abel); Piece (Egen); Amore all'erta sta (Tagliaferrri); Tango di Marilli (Mariotti); Fox-trot, Montagne russe (Mario); Pensa la mamma mia (Lama); When (Caslar); Mimosas (Abel); Roses (d'Anzi); Twostep (Boetz). 10.55, Giornale Radio.

SALZBURG.—See Vienna.

SCHENECTADY

WGY, 790 kc/s, 379.5 metres; 50 kW. Relayed at W2XAD on 19.56 metres.—9.0 p.m., Book News. 9.15 to 10.0 (approx.), New York Relay. 9.15, Winters and Weber (Organists). 9.30, Soloist. 9.45, Lady Next Door. 12.45 a.m. (Tuesday), Stock Reports. 1.0, Sonnyland Sketch, from New York. 1.30, Dramatised Penny. 1.45 to 3.30, New York Relay. 1.45, Ferde Grofé's Orchestra. 2.0, A and P Gipsies. 2.30, Musical Programme. 3.0, Contented Programme. 3.30, Ship of Joy, from New York, followed by Programme Résumé.

SCHWEIZERISCHER LANDESENDER

BEROMUNSTER, 653 kc/s, 459 metres; 60 kW.; Basle, 1,229 kc/s, 244.1 metres; and Berne, 1,220 kc/s, 245.9 metres.—6.15 to 6.35 a.m., Gymnastics. 11.59, Time Signal from Neuchâtel Observatory and Weather. 12 Noon (from Zürich), Gramophone Music. 12.30 p.m., Time and News. 12.40 (from Zürich), Gramophone Music. 1.25 (from Zürich), Exchange, Time and Weather. 1.45 to 5.0, Interval. 5.0 (from Zürich), Programme for Women. 5.30 (from Zürich), Gramophone Music. 6.30 (from Zürich), Programme for Children. 7.0, Time and Weather. 7.5 (from Zürich), Gramophone Music. 7.50 (from Zürich), Elementary English Lesson. 8.0 (from Zürich), Johann Strauss Concert. 9.0, Weather and News. 9.10 (from Zürich), 'Cello Recital by Joachim Stutschewsky. 10.15 (approx.), Close Down.

SOTTENS.—See Radio-Suisse Romande.

STOCKHOLM

689 kc/s, 436 metres; 55 kW. Relayed by Boden, 244 kc/s, 1,229.5 metres; Göteborg, 932 kc/s, 322 metres; Hörby, 1,166 kc/s, 257 metres; Motala, 221.5 kc/s, 1,354.4 metres; Östersund, 389 kc/s, 770 metres; and Sundsvall, 554 kc/s, 542 metres.—5.5 p.m., Historical Sketch with Incidental Music. 5.55, Gramophone Music. 6.55, Vocal Quartet Concert of Modern Songs, relayed from Malmö, 1,301 kc/s, 231 metres. 7.30, Cookery Talk. 8.0, Concert by the Station Orchestra. Soloist: Torsten Ralf (Songs). Overture, Tannhäuser (Wagner); Arias (Wagner), from: (a) Lohengrin, and (b) The Mastersingers; Les Préludes (Liszt); Ballad (Debussy); Aria from: (a) Rigoletto (Verdi), (b) Tosca (Puccini), (c) I Pagliacci (Leoncavallo); Italian Caprice (Tchaikovsky). 9.15 (from Göteborg), Talk. 10.0, 'Cello Solos by Alex Bergkvist. 10.15 (from Göteborg), Light Or-

chestral Concert, conducted by Karl Bornfors. 11.0 (approx.), Close Down.

STRASBOURG

869 kc/s, 345 metres; 11.5 kW.—7.45 to 8.0 a.m., Radio Report of the Cycle Tour of France. 11.30, Variety Music on Gramophone Records. 12 Noon, Radio Report on the Cycle Tour of France. 12.15 p.m., Gramophone Music (cont'd.). 12.45, News. 1.0, Time and Exchange. 1.5, Orchestral Concert, conducted by Maurice de Villers; Overture, Hamlet (E. Bach); Ballet Music from Faust (Gomod); Basque Rhapsody (Piercé); Selection from Paganini (Lehár); Défilé Tartare (Delmas). 2.0 to 3.30, Interval. 3.30, Orchestral Concert, relayed from the Casino, Vichy; Conductor: Brouillac; Overture, Les dragons de Villars (Maillart); Prelude to King Manfred (Reinecke); Habanera (Chabrier); Orchestral Suite from La source (Delibes); Cordoba (Albeniz); Selection from Dinorah (Meyerbeer); Waltz, Amour et printemps (Waldteufel). 5.0, Light Music on Gramophone Records. 5.40 (approx.), Radio Report on the Cycle Tour of France. 6.0, Literary Review in French. 6.15, Literary Talk in German: Die Stoeber (Levy). 6.30, Concert of Chamber Music; Soloist: Guth-Quénel (Soprano); Duets for Violin and Cello (Beethoven); Four Songs; L'apothéose de Lull (Conperin); 7.30, Time and News. 7.45, Radio Report on the Cycle Tour of France. 8.5, Press Review in French, Lottery Results, Announcements, and Gramophone Music. 8.45, Orchestral Concert, relayed from the Casino, Vichy; Conductor: Paul Paçay; Soloist: A. Radwan (Pianoforte); Faust-Symphonie (Liszt); Overture and Selection from Manfred (Schumann); Pianoforte Concerto in E (Chopin); Tshmachte Trio from L'enfance du Christ (Berlioz); Selection from Ronco and Juliet (Berlioz). After the Concert, Press Review in German. 11.15 (approx.), Close Down.

STUTTGART

MUHLACKER, 832 kc/s, 360.5 metres; 60 kW. Relayed by Freiburg, 527 kc/s, 570 metres.—12 Noon, Orchestral Concert, conducted by Karl Assmus, relayed from Baden-Baden. Overture, The Barber of Seville (Rossini); Slav Rhapsody No. 1 (Friedemann), German Waltz (Hill). Andante and Minuet from the Oxford Symphony (Haydn). Ein Morgen in Sanssouci (Kockert). Selection, from Hünsl and Gretel (Humperdinck). March, Friedensglocken (Urbach). 1.15 p.m., Time and News. 1.30, Concert from Langenberg. 2.0 to 2.15, Programme arranged by the Post Office, with Gramophone Records. 2.30, Spanish Lesson. 3.0 to 3.30, Elementary English Lesson. 4.30, See Munich. 5.45, Talk: Germany and her Leaders—Hugenberg, von Papen and Seldte. 6.15, Italian Lesson from Frankfurt. 6.45, Time and News. 7.0, Transmission for all German Stations, relayed from Breslau. 8.0 (from Karlsruhe), Police Band Concert. March, Deutsche Eiche (Heisig). Overture, Die schöne Galathée (Suppé). Triumphant March, from Aida (Verdi). Landsknechte (Berthelgen). Kolbinger Josiasmarsch. Unsere Marine (Thiele). 8.40 (from Mannheim), Programme in Palatinate Dialect. 9.30 (from Freiburg), Chamber Music by Freiburg Composers. Little Sonata for Pianoforte, Op. 51 (Julius Weismann). Serenade for Three Wind Instruments (Heinz Munkel). Sonata for Violin and Pianoforte, Op. 33 (Karl Peter). 10.20, Time and News. 10.45, Serenade on Gramophone Records. 12 Midnight, Close Down.

SUNDSVALL.—See Stockholm.

TOULOUSE

779 kc/s, 385 metres; 8 kW.—Transmissions uncertain owing to recent fire. 11.30 p.m. till Close Down, Programme in English by the I.B.C. 11.30, Light Music. 11.57, I.B.C. Goodnight Melody. 12 Midnight (approx.), Close Down.

TRIESTE

1,211 kc/s, 247.7 metres; 10 kW.—5.10 p.m. till Close Down, See Turin.

TRONDHEIM.—See Oslo.

TURIN

1,096 kc/s, 273.7 metres; 7 kW. Relayed by Milan, 905 kc/s, 331.5 metres; Genoa, 959 kc/s, 312.8 metres; and Florence, 559 kc/s, 500.8 metres.—5.10 p.m., Popular Concert by the Station Orchestra. 6.0, Weather. 6.35, Giornale Radio, Agricultural Report, and Dopolavoro Announcements. 7.0, Time, Tourist Talk, and Gramophone Records: Arrivederci (Marchetti-Bonavolontà); Caterinette (Ravasin); L'ultimo menestrello (Cerberini-Ruscini); Madama bruna (Lopez). 7.20, News in Foreign Languages. 7.40, Gramophone Music. 8.0, Announcements, Giornale Radio, Sports Notes, Weather, and Gramophone Music. 8.45, Art News. 9.0, Sponsored Concert. 10.0, One-Act Comedy. 10.30, Concert of Chamber Music; Nilde Prattini (Soprano) and Benedetto

Mazzaurati ('Cello); 'Cello Solos: (a) Cantilena (Goltermann), (b) Intermezzo (Lido); Soprano Solos: (a) Arietta (Salieri), (b) La promessa canzonetta (Rossini); 'Cello Solos: (a) Minuet (Ferrari Corti), (b) Canzonetta (d'Ambrosio); Soprano Solos: (a) Old Lullaby, (b) Popular Song (Magali), (c) Popular Savoyard Song (Marion); Spanish Dance (Granados-Kreisler); Bourrée (Silva); Soprano Solo, Theme with Variations (Parelli). 11.0, Giornale Radio.

VATICAN CITY

15,120 kc/s, 19.84 metres (Morning) and 5,969 kc/s, 50.26 metres (Evening); 10 kW.—11.0 to 11.15 a.m., Religious Information in Italian. 8.0 to 8.15 p.m., Religious Information in Italian.

VIENNA

581 kc/s, 517 metres; 15 kW. Relayed by Graz, 852 kc/s, 352.1 metres; Innsbruck, 1,058 kc/s, 283 metres; Klagenfurt, 662 kc/s, 453.2 metres; Linz, 1,220 kc/s, 245.9 metres; and Salzburg, 1,373 kc/s, 218.5 metres.—12 Noon, Concert by the Vienna Symphony Orchestra, conducted by Josef Holzer. 1.0 p.m., Time, Weather and News. 1.10, Concert (cont'd.). 2.0 to 3.0, Interval. 3.0, Time and News. 3.20, Talk: Smokeless and Sootless Fuel. 3.30, Programme for Voting People. 3.55, Gramophone Music. 4.35, Talk: Rescue from the South Wall of the Dachstein Mountains. 5.0, Talk: Anecdotes of Offenbach. 5.25, Pianoforte and Song Recital by Grate Weiss and Margarete Dragan. Song from Der Kubaer (Kienzl); Aria from La Juive (Halévy); Aria from L'Africaine (Meyerbeer); Songs (Bittner): (a) Der liebe Augustin, (b) Wer wird denn allweil aus Sterben denken; Fantasia in F Minor ('Chopin). Waltz in A Flat (Brahms); Etude in D (Liszt). 6.5, Talk: The Prater and its History. 6.25, Books and Publications in connection with the Week's Talks. 6.30, Talk with illustrations: A Social Journey in the Caucasus. 7.0, Elvcs, Spirits and Dreams—Concert by the Vienna Symphony Orchestra, conducted by Schönherr. Soloist: Arthur Fleischer (Baritone). Reigen seliger Geister (Gluck); L'apres-midi d'un faun (Debussy); Song: Die Heinkel-nämheln (Pfitzner); Queen Mab (Berlioz); Ballata delle gnomidi (Respighi); Songs from Robert le Diable (Meyerbeer); Song, Der Erlkönig (Löwe); A Night on the Bare Mountain (Mussorgsky); Aria from Der Vaupain (Marschner); Selection from Der Freischütz (Weber). 8.40, Topical Talk. 8.55, Old Viennese Music, by Isidore von Lätti, with the Composer at the Pianoforte. A Malv'cose Quartet, Blanka Glossy (Songs) and Ladislavs Kemenyi (Tenor). 9.55, News. 10.10, Talk in English: The Salzburg Festival. 10.20, Cigány Music by the Julius Horvath Band.

WARSAW

212.5 kc/s, 1,411 metres; 120 kW.—11.57 a.m. Time and Fanfare from St. Mary's Church (Craew). 12.5 p.m., Gramophone Music. 12.25 Polish Press Review. 12.33, Weather. 12.35 Jazz Music on Gramophone Records. 12.55 Radio Journal. 1.0 to 2.55, Interval. 2.55 Gramophone Music. 3.5, News. 3.10, Announcements. 3.15, Gramophone Music. 3.25 Economic Notes. 3.35, Gramophone Music. 3.45, Answers to Correspondence. 3.50 Gramophone Music. 4.0, Concert by the Poznan Symphony Orchestra, relayed from Ciechocinek; Conductor: B. Tyllja. 5.0, Tall in French. 5.15, Song Recital by Muc, Turs (Soprano) and G. Matjasiak (Baritone). Baritone Solos: (a) Ballad from L'Africain (Meyerbeer), (b) Recitative from Andr' Chénier (Giordano), (c) Air from Verbum Nobile (Montusko); Soprano Solos: (a) Song from La Gioconda (Ponchielli), (b) Air from Cavalleria Rusticana (Mascagni); Pion Baritone Solos; Soprano Solos: Five Songs. 6.15, Talk on Economics. 6.35, Pianoforte Recital by L. Burkath; Prelude in C (Bach); Fantasia in C Minor (Mozart); Piece (Chopin); (a) Nocturne in G, Op. 37, No. 1, (b) Mazurkas; Etude, Op. 4, No. 3 (Szymanowski); Melody (Rachmaninov); Le Lilas (Rachmaninov-Burkath); Nocturne in F Sharp, Op. 18 (Burkath); Two Sketches Op. 22 (Burkath). 7.20, Miscellaneous Items. 7.35, Programme Announcements. 7.40, Talk The Polish Novel. 8.0, Two Opera (Montusko): (a) Flys, (b) Verbum Nobile in the interval, Radio Journal and Agricutural Report. 10.15, Dance Music on Gramophone Records. 10.25, Sports Notes. 10.30 Aviation Weather Report and Police Note 10.40, Dance Music.

WILNO

533 kc/s, 563 metres; 16 kW.—7.20 p.m. Lithuanian Talk. 7.35, Programme Announcements. 7.40, See Warsaw. 9.0, Sport Notes. 9.10, Programme from Warsaw. 11 (approx.), Close Down.

ZAGREB

977 kc/s, 307 metres; 0.75 kW.—7.55 p.m. Book Review. 8.10, Announcements. 8.3 Pianoforte and Violin Recital. 9.30, Concert by the Station Orchestra. 10.30, News at Weather. 10.40, Dance Music. 11.30 (a prox.), Close Down.

ZURICH.—See Schweizerischer Landessender

TUESDAY

JULY THE ELEVENTH

PRINCIPAL EVENTS OF THE DAY:

AT HOME

- | | |
|----------------------------|--|
| NATIONAL LONDON | A Mabel Constanduros revue. Orchestral concert. Vocal and pianoforte recital. Choral concert. |
| REGIONAL MIDLAND | Military Band. |
| REGIONAL NORTH | "The Bouquets" Concert Party, from Scarborough. |
| REGIONAL WEST | Three short plays: "The Bad Lad," by T. R. Hughes; "Thomas' Play," by J. G. Williams, and "Soldier Harry," by R. H. Williams. |
| REGIONAL SCOTTISH | A Scottish concert of song and dance. |
| REGIONAL BELFAST | The first "Holiday Parade," a summer evening entertainment from Portrush. |
| ABROAD | |
| BRUSSELS (No. 1) | 8.0 p.m. Flemish music by the Radio Orchestra. |
| BRUSSELS (No. 2) | 8.0 p.m. The Station Symphony Orchestra, conducted by Meulemans. |
| HAMBURG PALERMO | 10.30 p.m. The Hamburg Philharmonic Orchestra. |
| PARISIEN STRASBOURG | 8.45 p.m. Opera: "I cavalieri di Ekebù," by Zandonai, conducted by the composer. |
| POSTE | 9.0 p.m. Musical and dramatic programme by Conservatoire prize winners of 1933. |
| STUTTGART | 8.30 p.m. Operetta: "The Count of Luxembourg," by Lehar. |
| WARSAW | 4.30 p.m. The New Philharmonic Orchestra, conducted by R. K. Guhr.
8.0 p.m. The Station Symphony Orchestra, conducted by S. Nawrot. |

BERNE.—See Schweizerischer Landessender.

BEROMUNSTER.—See Schweizerischer Landessender.

BODEN.—See Stockholm.

BODO.—See Oslo.

BORDEAUX-LAFAYETTE
936 kc/s, 304 metres; 13 kW.—6.15 p.m., Radio Journal, 7.15, News, 7.30, Programme for Women, 7.45, Report on the Cycling Tour of France, 8.5, Talk on Science, 8.20, News, 8.30, Programme to be announced.

BRATISLAVA
1,076 kc/s, 279 metres; 11 kW.—6.25 p.m., Summer Impressions, Op. 226, for Pianoforte (Suk), 6.40, Literary Talk, 6.55, Report for the Housewife, 7.0, See Prague, 7.10, See Brno, 7.25, The Bad—Comedy in One Act (Svoboda), 8.15, See Brno, 10.0, See Prague, 10.15, Dance Music by the Station Orchestra, conducted by Odchazel, 11.0 (approx.), Close Down.

BREMEN.—See Hamburg.

BRESLAU
923 kc/s, 325 metres; 60 kW.—Relayed by Clewitz, 1.184 kc/s, 253 metres.—2.0 p.m., Time, Weather, News and Exchange, 2.20, Love Scenes from Opera on Gramophone Records, 3.0, Agricultural Prices, 3.15, Programme for Children, 3.45, Concert by Elisabeth Piöffer (Contralto), Walther Dittrich (Violin), and Lotte Süß (Pianoforte), 4.45, Travel Talk: Down the Rhine where Three Countries meet, 5.5, The Nazi Poet Heinrich Anacker reads from his own Poems, 5.30, Agricultural Prices, 5.35, The Military Symphony in G (Haydn) on Gramophone Records, 6.10, Book Review, 6.30, Talk, relayed from the Rural Education Conference, from Würseldorf in Tannus, 6.50, News, 7.0, Transmission for all German Stations, relayed from Langenberg, 8.0, Community Singing, relayed from the Schloss Platz, 9.0, News, 9.10, Radio Reports from Silesian Labour Service Camps, 10.10, Time and News, 10.30, Political Press Review, 10.50, Talk: Holidays in the Tatras Mountains, 11.5, Light Music by the Maletzki Orchestra, relayed from the Café Vaterland, 12 Midnight, Close Down.

BRNO
878 kc/s, 342 metres; 35 kW.—2.50 p.m., Schrammel Quartet Concert, 3.55 to 4.0, See Prague, 5.45, Gramophone Music, 5.55, Boy Scouts' Report, 6.5, Gramophone Music, 6.25, German Transmission: News, Programme for Children and Agricultural Talk, 7.0, See Prague, 7.10, Talk: The Czecho-Moravian Highlands, 7.25, Mountain Songs by Marta

Haliřová, 7.40, See Prague, 8.0, Recitations, 8.15, A Comic Opera in Three Acts, 10.0, See Prague, 10.15, See Bratislava, 11.0 (approx.), Close Down.

BRUSSELS (No. 1)
I.N.R., 590 kc/s, 509 metres; 15 kW.—12 Noon, Offenbach Concert on Gramophone Records: Overture, Orphans in the Underworld; Selection from The Tales of Hoffmann; Barcarolle from The Tales of Hoffmann; Drinking Song and Finale from la Vie Parisienne; Overture, The Grand Duchess of Gerolstein, 12.25 p.m., Violin Solos by M. Borremans: Tambourin (Rameau); Andante from the Concerto No. 3 (Saint-Saëns); Prelude and Allegro (Pugnani-Kreisler), 12.45, Request Gramophone Records: Melody from Der Zwillingenbrüder (Schubert); Selection from La Gioconda (Ponchielli); Exotic Dance (Mascagni), 1.0, Le Journal Parlé, 1.10, Humorous Gramophone Concert: Pandor (Nadand); Pastiche musicale (Bérove); Elle était très bien (Xanoff); Tout va bien (Bach and Laverne); Groek in a Clarinet Quartet (Groek), 1.50, Saint-Saëns Concert: Danse macabre; Marche héroïque; Le rouet d'Omphale, 5.0, Concert by the Radio Orchestra, conducted by Franz André: Overtures (a) Masaniello (Auber), (b) Cavalleria rusticana (Mascagni), (c) La belle Hélène (Offenbach), 5.30, Programme for Children, 6.5, Talk, 6.15, Variety Programme, 6.30, Ballet Music from Isoline (Messenger) on Gramophone Records, 6.45, Organ Recital of Music by M. Plum: The Composer at the Organ; Grand Chorus in B Flat; Two Miniatures: (a) Andante pastorale, (b) Choral; Variations on Puer nobis nascitur; Elegie; Chorus angolorum; Melody in E Minor; Melody in D Minor; Improvisation on a Choral Theme, 7.15, Announcements and Film Review, 7.30, Art Notes and Talk for Women, 8.0, Concert of Flemish Music by the Radio Orchestra, conducted by Franz André: Marche des communiers brugeois (Dubois); Melody from Milenka (Bloekx); Au pays du lin (van der Meulen); Marche commémorative (Gilson); Flemish Dances (Bloekx); March from Klokke Rochand (Tinel); Mijn moederspraak (Benoit); Rubensmarsch (Benoit), 8.45, History Talk, 9.0, Concert, relayed from the Kursaal, Ostend, 10.30, Le Journal Parlé, 10.40, Suite in D (Bach) on Gramophone Records, 10.55, Christian Viniët (Liszt).

BRUSSELS (No. 2)
I.N.R., 887 kc/s, 338.2 metres; 15 kW.—Programme in Flemish, 12 Noon, Concert by the Little Station Orchestra, conducted by P. Lee-mans: Soloist: Mr. Van Aert (Baritone); Rubensmarsch (Benoit); Intermezzo from Pays du Lin (Vandermeulen); Selection from Princess d'Andeghe (Bloekx); Baritone Songs: Kermesse and Serenade from Milenka (Bloekx), 1.0 p.m., Le Journal Parlé, 1.10, Pianoforte Recital by Marinus

De Jong, with Songs by Mr. Borgers, 5.0, Concert by the Station Symphony Orchestra: Marche des communiers brugeois (Dubois); Songs: La Pacification de Gand (Benoit); De Vlaamsche leeuw (Miry), 6.0, Flemish Music on Gramophone Records, 6.30, Concert by the Small Station Orchestra, conducted by P. Lee-mans: Soloists: MM. Wigy and Michot (Violin); Overture, Carmen festum (Gilson); Thumelch (Schoemaker); Humoresque for Two Violins (Doblez); Procession flamande (Lee-mans); Pianoforte Solos: (a) Pastorale (Candaël); Waltz (Veremans); Esquisses flamandes (Brusselsmans), 7.30, Le Journal Parlé, 8.0, Concert by the Station Symphony Orchestra, conducted by A. Meulemans: Keringa-land (Roefs); Cantata, Alouette (Gevaert). In the interval at 8.45, Recitations, 10.0, Le Journal Parlé, 10.10, Sketch (Zyll), 10.30, Gramophone Concert of Flemish Music.

BUCHAREST

761 kc/s, 394 metres; 12 kW.—5.0 p.m., Light Music and Rumanian Music by the Motof Orchestra. In an interval at 6.0, Radio Journal, 7.0, Educational Talk, 7.20, Light Music, 7.40, Reading, 8.0, Concert by the Station Orchestra: Soloist, A. Pofmann (Baritone); Marche militaire (Saint-Saëns); Lehar Potpourri (Hrubý); Berceuse (Bour-nonville); Songs: Rumanian Potpourri; Floricela (Paschil); Tango (Leopold); Spanish Serenade (G. de Micheli), 9.45, Radio Journal

BUDAPEST

545 kc/s, 550.5 metres; 18.5 kW. Programme also relayed on 840 metres from 7.10 p.m. till Close Down.—5.30 p.m., Concert, 6.30, Talk, 7.0, Exchange, 7.10, Concert by the Budapest Concert Orchestra: Overture, The Thieving Magpie (Rossini); Waltz, Toujours on jamais (Waldteufel); Romantic Suite (Weinger); Poème (Füebli); Im Märchenwald (Ganglbauer); Selection from The Circus Princess (Kalman), 8.15, Dramatic Programme, 9.50, News, followed by Cigány Music from the Kovacssevy Restaurant, 11.15, Talk in German: Scoutmasters and the Jamboree.

CASSEL.—See Frankfurt.

COPENHAGEN

1,067 kc/s, 281 metres; 0.75 kW.—Relayed by Kalundborg, 260 kc/s, 1,153 metres.—12 Noon, Town Hall Chimes, 12.2 to 2.0 p.m., Concert from the Bellevue Strandhotel, 3.10, Recital of Songs by Gieda Sprüh, 3.30 to 5.0, Concert from the Wives' Restaurant, 5.35, Exchange and Fish Market Prices, 6.20 (from the Aarhus Studio), Talk: The Life of a Primitive Negro Race, 6.50, Weather and News, 7.15, Time, 7.30 (from the Randers Studio), Talk: Problems of Employment, 8.0, Town Hall Chimes, 8.2, Orchestral Concert from the Tivoli, 9.0, Reading (Rabindranth Tagore), 9.30, Concert from the Tivoli (contd.), 10.30, News, 10.45, Recital of Scandinavian Ballads, 11.0, Concert from the Tivoli (contd.), 12 Midnight, Town Hall Chimes and Close Down.

CORK.—See Athlone.

CRACOW

959 kc/s, 312.8 metres; 1.5 kW.—6.35 p.m., Gramophone Concert, 7.5, Talk: Old Cracow, 7.20, Miscellaneous Items and News, 7.35, Programme Announcements, 7.40, See Warsaw. In the interval at 10.25, Sports Notes, 11.0 (approx.), Close Down.

DANZIG.—See Heilsberg.

DRESDEN.—See Leipzig.

FECAMP

1,328 kc/s, 225.9 metres; 10 kW.—7.15 p.m., Local News, 7.30, The Listeners' Half Hour and News, 8.15, Talk, 8.30, Concert, relayed from Le Havre, 10.0 till Close Down, Concert by the I.B.C. In the interval at 12.5 a.m. (Wednesday), News Bulletin in English, 1.0 (approx.), Close Down.

FLENSBURG.—See Hamburg.

FLORENCE.—See Turin.

FRANKFURT

1,157 kc/s, 259.3 metres; 17 kW.—Relayed by Cassel, 1,220 kc/s, 245.9 metres, and Trier, 1,157 kc/s, 259.3 metres.—12 Noon, Concert by the Station Orchestra, conducted by Dr. Reinhold Merten, Soloist: Ilma Glaser (Soprano), 1.15 p.m., News and Weather, 1.30, See Stuttgart, 2.0, News, 2.20, Programme for Everyman, 3.0, Weather and Time, 3.10, Time and Exchange, 3.20, Talk: The Housewife and Recreation, 4.25, Economic Notes, 4.30, See Stuttgart, 5.45, Exchange, 6.0, See Berlin (Witzleben), 6.15, Talk: A Saxoth Village in Transylvania, 6.40, Politics in Verse, relayed from Trier, 6.45, Report of the Day's News, 6.50, Time and News, 7.0, Transmission for all German Stations relayed from Heilsberg, 8.0, See Hamburg, 9.0, Programme to be announced, 9.15, Concert by the Station Orchestra, conducted by Dr. Reinhold Merten, Soloist: Curt Friedrich (Cello), "Cello Concerto (Lalo); March, Jahrmarschtrummel (Lincke); Waltz, Erinnerung an Peterhof (Gungl); March (Nedbal); Spanish Comedy Overture (Keler-Bela); March, Blue Danube

ATHLONE
725 kc/s, 413 metres; 60 kW.—Relayed by Cork, 1,337 kc/s, 244.4 metres.—1.30 to 2.30 p.m., Time and Gramophone Music, 6.0, Programme for Children, 6.40, News, 7.0, Reading in Gaelic, 7.15, Talk on Dogs, 7.30, Time, 7.31, The Station Orchestra, 8.0, Irish Music by Mollie Flynn (Piceolo), 8.15, Fiddle Tunes by May Kavanagh, 8.50, Baritone Solos by Richard Browne, 8.45, Opera Music by the Station Orchestra, 9.0, Opera Songs by P. Black, 9.10, The Station Orchestra, 9.30, Talk by William Dawson: Is Dublin a Metropolis, 9.45, sponsored Programme, 10.30, Time, 10.45, News and Close Down.

BARCELONA
1,411, 860 kc/s, 348.8 metres; 8 kW.—7.0 p.m., Trio Concert: Selection from Sansón and Delilah (Saint-Saëns); Nocelette No. 2 (Ambrosio); Selection from The Tales of Hoffmann (Offenbach); Serenade, Mi amor Margutti; Tráameci (Schumann); Hungarian Dance No. 6 (Brahms), 7.45, Talk in Catalan on Hygiene, 8.0, Request Gramophone Records, 8.30, Exchange, 9.0, Gramophone Records and News, 10.0, Chimes, weather, Messages for Seamen, Exchange, Ad Market Prices, 10.5, Beauty Hints, 1.30, Concert by the Station Orchestra: Minuet (Beethoven); Intermezzo from La légende de bronze (Santillo and Vert); vettura, The Italian Girl in Algiers (Rossini), 11.0, Artistic, Agricultural, and Industrial Programme, relayed from the Igaia Theatre.

BARI
112 kc/s, 269.8 metres; 20 kW.—8.0 p.m., Agricultural Report, Tourist Talk, and Populoro Announcements, 8.20, Giornale Radio al Weather, 8.30, Time and Announcements, 8.35 (approx.), String Quartet Concert: Overture, Risorgimento italiano (Anelli); Intermezzo, Invocazione (Salvetti); Innet (Lecari); Selection from Turandot (Puccini); Overture, Im Reiche des Indra (Šteke); Pastorale (Boccherini-Vizzari); dttasia in Three Movements; Tramoto autunno (Mancusi); Wedding Procession (Rhode); Argentine Tango, Mendoza (Anadeli). In the interval, Agricultural Talk, 1.30, Gramophone Music, 10.55, News.

ASLE.—See Schweizerischer Landessender.

BELGRADE
7 kc/s, 430.4 metres; 2.8 kW.—6.0 p.m., Sordion Recital of National Music, 6.30, dk, 7.0, Gramophone Music, 7.30, Talk, 7.4, Violin Recital by Ludwig Nemecek: concerto for Violin (Dvorák); Polonaise (Bielh), 9.0, Concert by the Station Orchestra, 9.45, Time and News, 10.0 (approx.), National Songs, 10.30, Dance music, relayed from a Restaurant.

BERLIN
EUTSCHLANDSENDER, 183.5 kc/s, 1,635 metres; 60 kW.—2.0 p.m., Gramophone Music, 3, Programme for Children, 3.30, Weather and Exchange, 3.45, Reading (Friedrich Jese), 4.0, See Leipzig, 5.0, Talks for women: (a) Mothers throughout the Ages; (b) Books for Children and Young People, 5, Topical Talk: Preventing Road accidents in the Holidays, 5.35, String quartet, Op. 18, No. 5 (Beethoven), 6.0, ems, 6.5, Concert by the Station Chamber choir; Hunsbrück, ich muss dich lassen (Ade); Ade, ich muss mich scheiden (Friedrich); Es ritten drei Reiter zum Tore mus (Folk Melody); Ein Sträusschen an die (Folk Melody); Muss I denn zum idtlele hant (Folk Melody); Nua loh wohl, kleine Gasse (Süßner); Wanderlied (Folk Melody), 6.30, Political Press Review, 6.50, rather and Announcements, 7.0, Transmission for all German Stations, relayed from Heilsberg, 8.0, An Axiom, 8.5 (approx.), Orchestral Concert, conducted by Florenz-mer, relayed from Bad Reichenhaller; overture, The Merry Wives of Windsor (Nichols); rade for String Orchestra (Haydn); lian Caprice (Tchaikovsky); Intermezzo in The Arabian Nights (Joh. Strauss); dtz, Wenn der Flieder blüht (Paul awers); Hungarian Rhapsody in E, No. 1 (Sz); Upper Bavarian Clog Dance, Die chenhaller (Paul Schwes), 9.15, Dance 1 Light Music by the Glabe Band, 10.15, ws, 10.45, Weather, 11.0, Concert from mburg, 12 Midnight, Close Down.

BERLIN
TZLEBEN, 715 kc/s, 419.5 metres; 1.5 —6.0 p.m., Talk: Australia and Events, 1, Review of Books—In Praise of Gardens, 1, The Witzleben Station informs its teners, 6.45, Topical Talk, 7.0, nmission for all German Stations, red from Heilsberg, 8.10, Orchestral ont with Duets and Saxophone Solos, 9.20, hestral Concert, conducted by Dr. Hanns r. Soloist: Hedwig Fasbender-Rohr olin), Concerto in C for Violin and hestra (Haydn); Adagio in E for Violin hestra (Mozart); Rondo Concertant B Flat (Mozart), 10.0, News, 10.30 (prox.), See Hamburg. In the interval n 11.0 to 11.5, Talk: What they are say- in Berlin, 12 Midnight, Close Down.

JULY 11th

TUESDAY

continued

(Morawetz). 10.15, News. 10.40, Concert from Hamburg. 12 Midnight, Close Down.

FREDRIKSTAD.—See Oslo.

FREIBURG.—See Stuttgart.

GENEVA.—See Radio-Suisse Romande.

GENOA.—See Turin.

GLEIWITZ.—See Breslau.

GOTEBORG.—See Stockholm.

GRAZ.—See Vienna.

HAMAR.—See Oslo.

HAMBURG

Call ha (in Morse), 806 kc/s, 372 metres; 1.5 kW. Relayed by Bremen, 1,112 kc/s, 269.8 metres; Flensburg, 1,319 kc/s, 227.4 metres; Hanover, 530 kc/s, 566 metres; and Kiel, 1,292 kc/s, 232.2 metres.—5.50 p.m. (from Hanover). Variety Programme. 6.45, Frankfurt Exchange and Hamburg Market Prices. 6.50, Weather. 7.0, Transmission for all German Stations, relayed from Heilsberg. 8.0, Programme in North German Dialect: Martha Harms - Taugenmann (Songs), Richard Gerner (Songs to the Lute), Heinrich Andersen (Speaker), and the Station Choir. 9.0 (from Hanover). A Moorland Wedding—Play with Verse, Songs and Dances. 10.0, Time and News. 10.20, Topical Talk. 10.30, Concert by the Hamburg Philharmonic Orchestra, conducted by Gerhard Maas: Petite Suite de Ball-ét (Grétry-Franck); Serenata notturna (Mozart); Overture, The Merry Wives of Windsor (Niels); Ballet Music from Undine (Lortzing); Marche from the Serenade, Op. 48 (Tchaikovsky); Minuet (Grieg); Ballet Music from Eber allen Zauber Liebe (Lassen); Waltz, Neu-Wien (Joh. Strauss); Overture, Der Opernhall (Heinberger).

HANOVER.—See Hamburg.

HEILSBURG

1,085 kc/s, 276.5 metres; 60 kW. Relayed by Danzig, 662 kc/s, 453.2 metres.—11.30 a.m., Concert by the Königsberg Opera House Orchestra, conducted by Ludwig Leschitzky: Overture, Fidelio (Beethoven); Finale from the Surprise Symphony No. 91 (Haydn); Overture, Joan of Arc (Verdi); Symphonic Poem, Carnival (Dvorak); Melody; Potpourri, Ein Schubert-Abend in Alt-Wien (Raef); Overture, Morning, Noon and Night (Suppe); In the Fields and Groves of Bohemia (Smetana); Persian March (Joh. Strauss). 1.5 p.m., Gramophone Concert of Variety Music. In the intervals at 1.20 and 2.0, News. 2.30, Programme arranged by the Post Office, with Gramophone Records. 3.0, Agricultural Prices and Exchange. 3.30, Programme for Children. 4.10, See Langenberg. 4.30, Orchestral Concert, conducted by L. Karl Titein, relayed from the Kurgarten. Zoppot: Overture, Tannhäuser (Wagner); Gratulationsmuenett (Beethoven); Waltz from Polen Blut (Netbal); Slav Rhapsody No. 2 (Friedemann); Prelude to Act V of Die verkaufte Glocke (Zöllner); Selection from La Bohème (Puccini); Suite, Aus aller Herren Länder (Moszkowsky); March, Fredericus-Rex (Radek). In an interval at 5.0 (approx.), Book Review. 6.0, See Berlin (Deutschlandsender). 6.15, Agricultural Prices. 6.25, An Interview with a Docker. 6.50, Weather. 7.0, Transmission for all German Stations: Radio Picture of Marienburg—An East-German Frontier Fortress. 8.0, See Hamburg. 9.0, Political Notes, Weather and News. 9.15, Concert from Berlin (Witzleben). 10.0, Weather and News.

HILVERSUM

Announced HUIZEN, 1,013 kc/s, 296.1 metres; 20 kW. (7 kW. up to 4.40 p.m.)—7.40 a.m. till Close Down, Programme by the Catholic Radio Society. 7.40 a.m., Gramophone Music. 8.55, Interval. 9.40, Gramophone Music. 11.10, Religious Address. 11.40, Police Notes. 11.55, Concert by the Station Sextet: Sunshine and Roses (Nicholls); Serenade (Köln); Wiener Boubons (Strauss); Morgen geht's uns gut (Benzatzky); Schlager Potpourri (Dostal); Valse Berceuse (de Micheli); Gramophone Records; Spring Song (Mendelssohn); Potpourri (Nicholls); Selection from Fedora (Kalmán); Finale. 1.25 p.m., Interval. 1.40, Programme for Women. 2.40, Gramophone Music. 2.55, Song Recital by Mme. Nannie Passtoors Hansen. 3.10, Gramophone Music. 3.25, Song Recital (cont'd.). 3.40, Gramophone Music. 4.40, Concert by the K.R.O. Boys. Soloist: J. Mossic. 6.40, Police Notes. 6.55, Talk. 7.15, Gramophone Music. 7.25, Talk. 7.40, Concert by the K.R.O. Orchestra, conducted by J. Jerritsen. Soloist: S. Brill (Cello). Overture, Anaereon (Cherubini); Selection from Castor and Pollux (Rameau); Five German Dances (Mozart); Concerto in A Minor (Saint-Saëns). In the interval at 8.10, News. 8.40, Three Choral Songs by the Siedham Male Voice Choir; Selection from Aida (Verdi); Choir: (a) Tenebrae factae sunt (Vittoria), (b) Salve Regina (Schubert), (c) Serenade (Demény); Jägerlust (Ascholz); Cello Solos: (a) Après un reve (Faure), (b) Habanera (Ravel); Gramophone Records; Cello Solos: (a) Spanish Dance (Granados), (b) Asturian Melody (Nin), (c) Vito (Popper); Liberty Bell (Souza); Selection from The Geisha (Jones); Parade of the Tin Soldiers (Jessel). In the interval at 10.10,

News. 10.40, Gramophone Music. 11.40 (approx.), Close Down.

HORBY.—See Stockholm.

HUIZEN

Announced HILVERSUM, 160 kc/s, 1,875 metres; 8.5 kW. Programme of the Algemeene Vereeniging Radio Omroep (A.V.R.O.).—11.41 a.m., Concert of Light Music, with Gramophone Interludes. 1.55, Interval. 2.10, Gramophone Music. 2.40, Dressmaking Lesson. 3.40, Pianoforte Recital by Theja Schwarz: Sonata (Searlatt); Two Pieces for Flute (Haydn) Andante con variazione (Haydn); Tarantella (Chopin); Etosaises (Chopin); Scherzo (Brahms); Bohemian Dance (Debussy). 4.10, Concert by a Children's Choir, conducted by Jacob Hamel. 4.40, Programme for Children. 5.10, Concert by the Wireless Orchestra, conducted by Albert van Raalte: Military March (Schubert); Overture, The Magic Flute (Mozart); Meditation from Thais (Massenet); Serenade (Wolf-Ferrari); Suite No. 1 from Carmen (Bizet); Gramophone Music; Overture, Cagliostro in Wien (Joh. Strauss); Ballet Music from The Bartered Bride (Smetana); Piedmontese Dance No. 1 (Schiagaglia); Shepherd's Hey (German); Waltz, Roses from the South (Joh. Strauss). 6.40, Gramophone Music. 7.5, Talk: Oil Wells. 7.40, Time and News. 7.45, Variety Programme. 9.10, Gramophone Music. 9.25, Concert by the Wireless Orchestra, conducted by Albert van Raalte; Soloist: Andries Roodenburg (Violin); Overture, The Secret Marriage (Cimarosa); Violin Concerto (Vivaldi); Entr'acte and Ballet Music from Rosamunde (Schubert); Introduction and Ronde capriccioso (Saint-Saëns); Cortège de Bacchus (Delibes). 10.25, Gramophone Music. 11.40 (approx.), Close Down.

INNSBRUCK.—See Vienna.

KALUNDBORG.—See Copenhagen.

KATOWICE

734 kc/s, 408 metres; 16 kW.—6.35 p.m., Concert by the Halka Mandoline Orchestra: Polonaise (Faßl); Waltz, Traummelodei (Froek); Mazurka (Namyrowski); Chanson sans paroles (Tchaikovsky); Mazurka (Tymolski). 7.5, Talk: Silesian Writers of the Nineteenth Century. 7.20, Announcements and Gramophone Music. 7.35, Sports Notes. 7.40 till Close Down, See Warsaw.

KAUNAS

LITHUANIA, 155 kc/s, 1,935 metres; 7 kW.—8.40 p.m., Song Recital. 9.0, Talk: Clover Fields. 9.20, Talk. 9.40, Trio (Mendelssohn). 10.10, Sports Notes. 10.15, Concert of Russian Music: Overture, Russian and Ludmilla (Glinka); Suite, Caucasian Sketches (Prokofyev); Suite, In der Krim (Musorgsky). 11.0 (approx.), Close Down.

KIEL.—See Hamburg.

KLAGENFURT.—See Vienna.

KOSICE.—See Prague.

LAHTI

167 kc/s, 1,796 metres; 40 kW. Relayed by Helsinki, 815 kc/s, 368.1 metres.—6.15 p.m., Recitation. 6.40, Second Suite from L'Arlesienne (Bizet) by the Station Orchestra. 7.0, Talk. 7.25, Recital of Finnish Songs. 7.50, Talk. 8.10, Concert by the Station Orchestra: Overture, Ruy Blas (Abendsson); Melody from Sanson and Delilah (Rubin-stein); Torador et Andalouse (Sabin-stein). 8.45, News in Finnish. 9.0, News in Swedish. 9.15, Concert from the Kappeli Restaurant. 10.0 (approx.), Close Down.

LANGENBERG

635 kc/s, 473 metres; 60 kW.—1.0 p.m., Orchestral Concert, conducted by Wolf. Soloist: Erich Rummel (Pianoforte). Jubel-Ouverture (Bach); Pianoforte Solos: (a) Arabesque (Schumann), (b) Tarantella (Liszt); Ballet Suite from La Source (Debibes); Cavatina and Capriccio (Raff); Selection from Eugene Onegin (Tchaikovsky); Paraphrase on the Song, Es liegt eine Krone im grünen Rhein (Pacherberg); Waltz, Jungherrn-Tänze (Gungl); Heben-Marsch (Lübbert). 2.30 to 3.0, Interval. 3.0, Programme for Children. 3.30, Economic Notes and Time Signal. 3.50, A Plea for a Return to the Old Pre-Roman Germanic Culture. 4.10, Talk on Racial Culture. 4.30, Concert by the Station Chamber Orchestra, conducted by Breuer. Soloist: Kläre Hansen (Soprano). Overture, Phédre (Massenet); Suite, I Menestrelli (Amadei); Aria from Mazurka-Oberst (Lortzing); Aria from Der Wild-chitz (Lortzing); Rhapsody in C (Dobnanyi); Tambourin (Gossec); Gavotte (Gossec); Potpourri of Swabian Folk Music (Esterl); March, Der alte Fritz (Blon). In an interval, Political Talk. 5.45, A Radio Report from the Prehistoric Rhine Section of the Museum in Duisburg-Hamborn. 6.15, U-Boat Commander Rose and his Officer of the Watch discuss their War Experiences. 6.25, Italian Lesson. 6.45, Weather, Time and News. 7.0, Transmission for all German Stations, relayed from Heilsberg. 8.0, Announcements. 8.5, A Call to Arms—Concert by the Westphalian Nazi Band, relayed from Dortmund. 8.45, Sym-

phony Concert by the Station Choir and Orchestra, conducted by Buschköter. Hymns for Soprano, Choir, Orchestra and Organ (Heinz-Schubert); Serenade (Röger). 10.5, News. 10.25 (approx.), Close Down.

LAUSANNE.—See Radio-Suisse Romande.

LEIPZIG

769.9 kc/s, 389.6 metres; 120 kW.; and Dresden, 941 kc/s, 319 metres.—1.0 p.m., News. 1.15, Gramophone Music. 2.0, Second News. 2.10, Report for Workers. 2.25, Agricultural Notes. 2.35, Review of Books for Children. 3.0, Programme for Invalids. 3.35, Market Prices. 4.0, Concert by the Dresden Orchestra, conducted by Helmut Schäfer: The Clog Dance from Czar and Carpenter (Lortzing); Selection from The Hermit's Bell (Maillart); Norwegian Dances (Rode); Overture, Die Felsenmühle (Reissiger); Selection from the Waltzes, Op. 25 (Fuchs); Two Pieces (Schneider); (a) Berceuse, (b) Serenata pizzicato; March, Hurra!; Die schwere Artillerie (Jäpel); Selection from Don Cesar (Bellinger); Waltz, Hofballtänze (Lanner); Intermezzo, Das getauzte Festmahl (Schottler). 5.50, Market Prices, Weather and Time. 6.0, Talk: A Visit to the St. Thomas Choir—How They Live, Work and Sing. 6.25, Talk: The Historical Foundations of Particularism. 6.45, A Modern Dictionary. 7.0, Transmission for all German Stations, relayed from Heilsberg. 8.0, Talk: Building up the Nation. 8.25, Concert by the Station Orchestra, conducted by Hilmar Weber and Soloists. Overture, Am Rhein (Kamm); Am Rhein (Humperding); Am Rhein und beim Wein (Reis); Elisabeth's Hymn from the Suite, Thüringen (Raff); Air for Vocal Trio (Zilcher); Selection from Prangender Sommer (Epper); Four Pieces from Bilder am Chiemsee, Op. 131 (Niemann); Two Pieces from the Suite, From Baltic Lands (Kämpf); Mastoren (Hans Georg Buchholtz); Two Pieces from Wopswede for Violin, English Horn and Voice (Sehm-pflug); Three Folk Songs; Jagd-Ouverture (Künneke). In the interval at 9.10 (approx.), Economic Notes. 10.25, News. 10.30 (approx.), Wilhelm Rinkens Probergramm; Suite for Viola da Gamba and Harpsichord; Soprano and Baritone Duets from Briefe zweier Liebenden; Trio, Op. 21 (approx.), Close Down.

LINZ.—See Vienna.

LJUBLJANA

522 kc/s, 574.7 metres; 7 kW.—6.30 p.m., Concert by the Station Orchestra. 7.30, Talk on Religion. 8.0, Song Recital. 9.0, Gramophone Music. 9.30, Weather and News. 9.45, Concert by the Station Orchestra. 11.0 (approx.), Close Down.

LUXEMBOURG

252 kc/s, 1,191 metres; 200 kW. Belgian Programme. 7.45 p.m., Quintet in F Minor (César Franck), on Gramophone Records. 8.20, Talk in French. 9.15, Concert by the Luxembourg Municipal Orchestra, conducted by M. Stein, relayed from the Place d'Armes: Ballet Fantasia (Montagne); Ballet égyptien (Lugmijn); Selection from The Pearl Fishers (Bizet).

LWOW

788 kc/s, 381 metres; 16 kW.—6.35 p.m., Gramophone Music. 7.20, Miscellaneous Items. 7.40 to 10.40, See Warsaw. In the intervals at 7.55 and 9.0, News. 10.40, Gramophone Music. 11.0 (approx.), Close Down.

LYONS

LA DOUA, 644 kc/s, 465.8 metres; 1.5 kW.—7.30 p.m., Radio Gazette for Lyons and the South-East. 8.30, Dramatic Programme. After the Programme, News.

MADRID

EAJ7, 707 kc/s, 424.3 metres; 2 kW.—8.0 p.m., Chimes, Exchange and Request Gramophone Records. 8.30 (in the interval), Talk by Joaquin España Cantos. 9.15, News and Political Review. 9.30 to 11.0, Interval. 11.0, Chimes, Time and Political Review. 11.15 (approx.), Tannhäuser—Opera (Wagner), on Gramophone Records. 1.15 a.m. (Wednesday), News. 1.30, Chimes and Close Down.

MALMO.—See Stockholm.

MILAN.—See Turin.

MORAVSKA-OSTRAVA

1,137 kc/s, 263.8 metres; 11 kW.—6.25 p.m., See Brno. 7.0, See Prague. 7.10, See Brno. 7.40, See Prague. 8.0, See Brno. 10.0, See Prague. 10.15, See Bratislava. 11.0 (approx.), Close Down.

MOSCOW

TRADES UNION, 230 kc/s, 1,304 metres; 100 kW.—2.45 p.m., Weather Report. 3.0, Concert of Music by Lidov, Tchaikovsky, Gounod, Strauss, Schubert and Mozart. 4.0, Talk on Agrotechnics. 4.30, Reading. 5.45, Talk: The Chemical Industry in U.S.S.R. 6.30, Dance Music. 9.0, News. 9.30, Programme Announcements. 9.50, Chimes from the Red Square. 9.55, Press Review.

MOTALA.—See Stockholm.

MUHLACKER.—See Stuttgart.

MUNICH

563 kc/s, 533 metres; 60 kW. Relayed by Augsburg and Kaiserslautern, 536 kc/s, 566 metres; and Nürnberg, 1,256 kc/s, 239 metres.—12.45 p.m., Orchestral Concert, conducted by Erich Kloss: Overture, Die Felsenmühle (Reissiger); Allegretto from Symphony No. 7 (Beethoven); Waltz, Wiener Blut (Joh. Strauss). 1.15, Time, Weather and News. 1.30, Concert (cont'd.); Selection from Li-Tai-Po (Franckenstein); Venetian Barcarolle (T. Taeye); Hungarian Dances (Brahms). 2.0, Time and News. 3.0, Talks for the Housewife. 3.55, Weather and Market Prices. 4.5, Talk on Cycling. 4.30, Concert from Stuttgart. 5.45, Talk: The Universal Validity German Law. 6.5, Talk. 6.25, The German Minnesinger—Radio Sequence with Songs to the Lute. 6.45, Time, Weather and Market Prices. 7.0, Transmission for all German Stations, relayed from Heilsberg. 8.0 (from Nürnberg), Military Band Concert, conducted by Otto Böbereiner, with the Nürnberg Young People's Choir. 9.10, Ghost in the Funkhaus—Variety Programme. 9.40, Chamber Music by the Eilly Ney Trio: Sonata for Pianoforte, Violin and Cello (Schubert); Pianoforte Trio in G Minor, Op. 17 (Clara Schumann). 10.20, Time and News.

NAPLES.—See Rome.

NOTODDEN.—See Oslo.

OSLO

277 kc/s, 1,063 metres; 60 kW. Relayed by Fredrikstad, 815 kc/s, 368.1 metres; Hamar, 522 kc/s, 574.7 metres; Notodden, 671.1 kc/s, 447.1 metres; Porsgrund, 662 kc/s, 453.2 metres; and Rjukan, 671 kc/s, 447.1 metres. 5.30 p.m., Accordion and Violin Recital. Popular Music. 6.0, Talk for Housewives. 6.4, Accordion Solos by Karl Andersen. 7.0, Announcements, Weather and News. 7.3, Talk: The Small Republican State of Adorra. 8.0, Time. 8.1, Orchestral Concert conducted by Olvin Fjellstad. March (Gustrián); Overture, Le fils Mandarin (Cui Tarantelle (Raff); Spanish Serenade (Weser); Potpourri (Geisler); Romance from La Wally (Catalani); Meditation (Ranzato Melody (Slonov); Swedish Suite (Weinlander); Waltz, Künstlerleben (Strauss); Serenade (Jensen); Gavotte (Massenet); Exotic Suite (Lechner); Parade des poëtes de l'Éclair (Noiret); Baltic March (Gbert). 9.40, Weather and News. 10, Topical Talk. 10.15, Recitations. 10, (approx.), Close Down.

OSTERSUND.—See Stockholm.

PALERMO

558 kc/s, 537.6 metres; 3 kW.—3.0 p.m. Dopplavoro Notes, Tourist Talk, Agriculture Notes, and Giornale Radio. 8.20, Gramophone Music. 8.50, Time and Announcement. 8.45, I cavalieri di Ekebb—Opera in 3 Acts (Zandonai), conducted by the Composer. In the intervals, Talk, Announcements, and News.

PARIS

EIFFEL TOWER, Call FLE, 207.5 kc/s, 1,445.7 metres; 13 kW. Time Signal (on 2,650 metres) at 10.26 a.m. a 11.26 p.m. (Preliminary and 6-dot 8 mals).—6.45 p.m., Le Journal Parlé. In the interval at 7.45, Report of the Cycle Tour of France. 8.30, Pianoforte Recital, Marie-Antoinette Pradier with Comments by André Delacour. Prelude, Air vari Fantasia and Eigne (Handel); Sonata in (Haydn). 9.0, Quartet Concert, Quartet D Minor (Haydn); String Quartet No. (Mihaud). 10.0 (approx.), Close Down.

PARIS

POSTE PARISIEN; 914 kc/s, 328.2 metres; 10 kW.—7.0 p.m., Gramophone Music. 7, Journal Parlé. 7.30, Radio Report on the Cycle Tour of France. 7.45, Gramophone Music. 8.10, Interlude. 8.25, Gramophone Music. 8.45, Interlude. 9.0, Musical a Dramatic Programme by Conservatoire Pr Winners of 1933, relayed from the Paris Conservatoire.

PARIS

RADIO PARIS, Call CFR, 174 kc/s, 1, metres; 75 kW.—7.30 a.m., Weather; Physical Culture. 7.45, Gramophone Music. 8.0, News. 12 Noon, Gramophone Concert: Le Bal de la Reine (Paradis); Lorsque l'on vient (Mcraier); Selection from Le Grand Mogol (Andran); Melody (Fysher); Je salue la mode (Avignon); I love you (Sund Glow Warm Gavotte (Luzcke); Nelly (Bate Mado (Vacher); Au coulin (Gillet); A toi, tu la pas connu (Bousquet); Selection from The Three Musketeers (Friml); Le soir Madame la lune (Marinier); La Cinquième (Gabriel-Marie); Melody (Rubinstein); Singing in the Rain (Nacio-Brown); Se (Berlin); Pompes de Paris (Loyraux); Ch son (Friml); The Festival of the Gnom (Smidt-Hagen); Ambade à Cendrine (Aaby); Parlez (Yatove); Trio from Les Bains (Offenbach); Waltz Potpourri (Berli Marché tartare (Ganne). In the interval at 1.0, Exchange and News, and at 1.30, change. 2.0, News. 3.45, Exchange. News. 7.10, Gramophone Concert. La vides matelots (Loyraux); Song (Heyman Song (Benzatzky); Pense d'automne (Msenet); Ninon (Tosti); Waltz, Künstler (Joh. Strauss); Les fleurs ne meitent jan (Hermitte); Paysage (Hahn); Place blan (Mélé). 7.50, Commercial Prices and Ne

JULY 11th TUESDAY continued

.0, Dramatic Programme on Gramophone Records, Part I: La Voix Humaine—Scene (Coteau). Part II: Scenes from Acts III and IV of Marius (Pagnol). 8.30, News. 9.40, Review by Pierre Seize. 8.45, Russian songs on Gramophone Records. 9.0, Nineteen Years, Operetta in Three Acts (Bastin).

PITTSBURGH

DKA, 980 kc/s, 306 metres; 50 kW. Relayed by W8XK on 48.86 metres and 25.27 metres.—7.30 p.m., KDKA Home Forum, 0, Betty and Bob, from New York. 8.15, Radio Troubadours, from New York. 8.45, Congress of Clubs Period (subject to be announced). 8.58, Baseball Scores. 9.0, Gertrude Wilson's Orchestra, from New York. 9.30, Business News and Market Reports. 9.45, Sketch, from New York. 9.58, Baseball Scores. 10.0, Rhythm Kings. 10.15, arzan of the Apes. 10.30, The Singing Lily, from New York. 10.45, Little Orphan Annie. 11.0, Time Signal and Press Newsletter. 11.15, Weather Report. 11.30, Sport Review. 11.23, I Bring a Song. 11.28, announcement. 11.29, Temperature Report. 1.30, Pittsburgh Spotlights. 11.45, Today's News by Lowell Thomas, from New York. Midnight, Amos 'n' Andy, from New York. 1.15 a.m. (Wednesday), National Advisory Council on Radio in Education. 12.45 to 1.45, New York Relay. 12.45, Baritone Solos by W. Heatherstone. 1.0, Crime Clues. 1.30, Ventures in Health. 1.45, Floyd Gibbons, Lord's Fair Reporter. 2.0, Stadium Concert by Philharmonic Symphony Orchestra. 9, Time Signal. 3.0, Household Musical Memories, from New York.

IRSGRUND.—See Oslo.

POZNAN

kc/s, 335 metres; 1.9 kW.—6.15 p.m., See Warsaw. 7.20, Miscellaneous Items and News. 7.35, Theatre Notes and Programme Announcements. 7.40, See Warsaw. 7.58, No Signal. 8.0, Popular Concert. 8.50 (approx.). News from Warsaw. 9.0, Soprano and Violin Recital by Mme. Irena Wojciechowska and M. Mieczyslaw Paszkiet: Sonata aganini; Romance (Svendson); Aria from Bohème (Puccini); Berceuse (Chopin); Mazurka (Chopin-Kreisler); Songs (Spick); Tango (Albion); Fire Dance (Lilja). 10.0, Time Signal and News. 10.15, See Music relayed from the Esplanade (c). 11.50 (approx.), Close Down.

PRAGUE

kc/s, 488.6 metres; 120 kW.—2.50 p.m., Brno. 3.55 to 4.0, Exchange. 5.45, Gramophone Music. 5.55, Talk. 6.5, Agricultural Report. 6.15, Talk for Workers. 5, News in German. 6.30, German Translation: Talk on Music with Illustrations, Chimes and News. 7.10, See Brno. 7.40, National Poem. Mytava from the Cycle Mytavy (Smetana), by Konaševska Slavikova (op). 8.0, See Brno. 10.0, Time and News. 15, See Bratislava. 11.0 (approx.), Close Down.

RABAT

1 kc/s, 416 metres; 6 kW. 1.30 to 3.0 a.m., Concert: Marche Italienne (Roussseau); Deswalzer (Zichner); Concert; Overture (Berlioz); Song from The Drum Major's section (Offenbach); Pavane (Chaminade); section from La Vivandière (B. Godard); uson d'Amour (Hollmann and Grandgnin); Nocturne aragonais (Badènes); Instrumental Solo; suite variée (G. Pierné); 2: The Two Grenadiers (Schumann); Instrumental Solo; Divertissement on Russian tunes (H. Rabaud). 5.0 to 6.0, Gramophone Music. 8.0, Arab Programme; News Gramophone Music. 8.45, Journal Parlé, other and News. 9.0 to 11.0, Concert; ture, Turandot (Weber); Melody in F (Bisstein); Waltz, Morgenblätter (Joh. Brahms); Two Songs from Wilhelm Tell (Süss); Tränenregen (Schubert); Selection in Halka (Moniuszko); Chant Phydik (Pare); Cello Solo, Abendlied (Schumann); Triangles des Sœurs (Bizet); Suite from drillon (Massenet); Song from Boris unov (Mussorgsky); Der Abendstern (Munann); Spanish Dance (Fallá). 11.0, Gramophone Music.

RADIO-SUISSE ROMANDE

TENS, 743 kc/s, 403 metres; 25 kW.; and eva, 395 kc/s, 760 metres.—3.28 p.m., e Signal from Neuchâtel Observatory. (from Neuchâtel). Second Part of the ing Concert, relayed: Ballad in A Flat, 47 (Chopin); Songs (Faure); (a) Puisse e grandit, (b) La lune blanche (Faure); rzo in B Flat Minor, Op. 31 (Chopin); Colibri (Chausson); Theme with Varias, Op. 97 (Saint-Saëns); Trio from The ry Wives of Windsor (Nicolaï); Finale e the Concerto in A Minor for Cello (Lid); Paysage (Liszt); L'été joyeux (Mussorgsky). 4.45 (from Lausanne), Concert he Radio Lausanne Orchestra. 5.30 to 6.0 (from Geneva), Interval. 7.0, Talk. 7.30, s. 7.35 (from Geneva), Radio Inter- 8.0 (from Lausanne), Violin Recital by e Loew. 8.30 (from Lausanne), On dix-sept heures Comedy in One Act (aux). 9.0 (from Geneva), Orchestral ert, relayed from Berne; Soloist, Salva- i Salvati. 9.50, News. 10.0 (from va), Talk: The Work of the League of ons. 10.30 (approx.), Close Down.

REYKJAVIK

250 kc/s, 1,200 metres; 21 kW.—9.30 p.m., Weather. 9.40, Musical Programme and Announcements. 10.0, Chimes and News. 10.30, Reading. 11.0, 'Cello Solos by Thorhallur Arnason, followed by Pianoforte Concerto in C Minor No. 3 (Beethoven) on Gramophone Records.

RIGA

572 kc/s, 525 metres; 15 kW.—6.0 p.m., Literary Programme. 6.30, Talk. 7.0, Weather Report. 7.5, Concert relayed from Melluzi; Overture, Der Freischütz (Weber); Second Suite from L'Arlesienne (Bizet); Pied-montese Dances (Smignaglia); Waltz, Roses from the South (Joh. Strauss); The Moldau (Smetana); Polovitsian Dances from Prince Igor (Borodin); Slav Dances (Dvorak); Waltz, Wienerblut (Joh. Strauss). In the interval at 8.0, News. 9.0, Weather and News. 9.15 (approx.), Soloist Concert on Gramophone Records.

RJUKAN.—See Oslo.

ROME

1RO, 680 kc/s, 441 metres; 50 kW. Relayed by Naples, 941 kc/s, 319 metres; and 2RO, 11,810 kc/s, 25.4 metres.—1.0 to 2.15 p.m., Orchestral Concert. In the intervals at 1.30, Giornale Radio and Exchange, and at 2.0, Time and Announcements. 4.45, Children's Radio Review. 5.10, Weather Forecast. 5.15, Exchange and Giornale Radio. 5.30, Orchestral Concert: Foxtrot (Claret); Serenata di baci (De Micheli); Tambourino (Vallini); Slow Foxtrot, Mimosa (Abel); Selection from Suor Angelica (Puccini); Marietta (Brancucci); Tango del cuore (Restano); Foxtrot, In Waikiki (Lane). 6.15, Interval. 6.40 (Naples), Shipping and Sports Notes. 6.50, Agricultural Report and Populavore Announcements. 7.0, Tourist Report. 7.10, Lesson in Morse. 7.20, Announcements in Various Languages. 7.40, Giornale Radio. 8.0, Time and Announcements. 8.15, Sponsored Programme. 8.30, Sports Notes. 8.45, Concert: Quartet for Two Violins, Viola and 'Cello (Peruggino); Songs: Airs from (a) La Traviata (Verdi); (b) Fedora (Giordano); (c) Martha (Flotow); and (d) I Pagliacci (Leoncavallo); 'Cello Solos: (a) Réverie (Debussy); (b) Andalus (Granados); (c) Guitarre (Moszkowsky). 9.30, Addio Felicità—Comedy in One Act (François de Nion). 10.0, Concert (cont'd.); Ballet égyptien (Lugné). 10.20 (approx.), Dance Music. 10.55, Giornale Radio.

SALZBURG.—See Vienna.

SCHENECTADY

(WGY), 790 kc/s, 379.5 metres; 50 kW. Relayed at intervals by W2XAF on 31.48 metres, and by W2XAL on 19.55 metres.—12.45 a.m. (Wednesday), Stock Reports. 1.0 to 3.30, New York relay. 1.0, Blackstone Plantation. 1.30, Wayne King's Orchestra. 2.0, Ben Bernie's Blue Ribbon Orchestra. 2.30, Ed Wynn and the Fire Chief Band. 3.0, Lives at Stake. 3.30, National Radio Forum, from New York, followed by Programme Resume.

SCHWEIZERISCHER LANDESSENDER

REFORMUNSTER, 653 kc/s, 459 metres; 60 kW.; Basle, 1,229 kc/s, 244.1 metres, and Berne, 1,220 kc/s, 245.9 metres.—6.15 to 6.35 a.m. (from Berne), Gymnastics. 11.59, Time Signal from Neuchâtel Observatory, and Weather. 12 Noon (from Zürich), Concert of Light Music. 12.30 p.m., Time and News. 12.40 (from Zürich), Concert (cont'd.). 1.25 (from Zürich), Exchange, Time and Weather. 1.45 to 5.0, Interval. 5.0 (from Zürich), Concert by the Little Swiss Radio Orchestra, conducted by Max Scherbaum. 5.30 (from Berne), Marches and March Songs on Gramophone Records. 6.30 (from Berne), Talk: Animal and Plant Life. 7.0 (from Berne), Time and News. 7.10 (from Berne), Opera Music on Gramophone Records. 7.45, Ballet Music: from Sylvia (Delibes-Rhode) by the Swiss Radio Orchestra. 8.0 (from Berne), A Microphone Excursion into the Mountains. 8.30, Concert of Light Music by the Swiss Radio Orchestra. 9.0, News. 9.10 (from Berne), Symphony Concert by the Berne Municipal Orchestra, conducted by Luc Bahner. Soloist: Salvatore Salvini. 10.15 (approx.), Close Down.

SOTTENS.—See Radio-Suisse Romande.

STOCKHOLM

689 kc/s, 436 metres; 55 kW. Relayed by Boden, 244 kc/s, 1,229.5 metres; Göteborg, 932 kc/s, 322 metres; Hörby, 1,166 kc/s, 257 metres; Motala, 221.5 kc/s, 1,354.4 metres; Östersund, 389 kc/s, 770 metres, and Sundsvall, 554 kc/s, 542 metres.—5.5 p.m., Organ Recital by Fridtjof Staerke. 5.30, Song Recital by Dagmar Gustafson; Potpourri (Tchaikovsky); Song (Tchaikovsky); Berceuse (Tchaikovsky); Rheinlegendchen (Mahlber); We hat dies Liedl erdacht (Mahlber). 5.45, Microphone Report. 6.0, Rural Programme.

6.55, Talk: relayed from Jönköping, 1,490 kc/s (201.3 metres). 7.30 (from Boden), Talk. 8.0, Organ Recital with Sacred Songs, relayed from Lulea Cathedral; Fugue in E Minor for Organ (Pachelbel); Three Psalms (Olsson); Organ Solos: (a) Prelude in G (Bach); (b) Auf meinem lieben Gott (Händel); Two Hymns (Roman); Chaconne for Organ (Pachelbel). 8.30, Sonata in D minor, Op. 12, for Violin and Pianoforte (Aulin), by Carl Caraguly and Gertrud Lindström. 8.55, Variety Programme. 9.25, English Suite in G minor for Pianoforte (Bach) by Algot Raquinus. 10.0, Gramophone Music. 11.0 (approx.), Close Down.

STRASBOURG

869 kc/s, 345 metres; 11.5 kW.—7.45 to 8.0 a.m., Radio Report of the Cycle Tour of France. 11.30, Tenor Solos on Gramophone Records. 12 Noon, Trio Concert. Trio, Le voile du bonheur (Pons); Three Trios (Pierné); Two Trios (Huguet-Tagell); Trio from Sylvia (Delibes). 12.30 p.m., Radio Report of the Cycle Tour of France. 12.45, News. 1.0, Time and Exchange. 1.5, Orchestral Concert, conducted by Maurice de Villers. Selection from Etienne Marcel (Saint-Saëns); Jota Aragonesa (Saint-Saëns); Images d'opéra (Dupérier); Albumblatt (Wagner); Walter's Prize Song from The Mastersingers (Wagner); Divertissement on Russian Songs (Wagner). 2.0 to 4.0, Interval. 4.0 (approx.), Radio Report of the Cycle Tour of France. 5.0, Talk: French Colonies in Algeria. 5.15, Orchestral Concert, conducted by Roskam. Marche des Pandours (Léars); Waltz (May); Orchestral Suite, En terre celtique (Dulame); Overture, Le domino noir (Anber); Selection from A Waltz Dream (O. Strauss). 6.0, Historical Talk in French. 6.15, Topical Talk in French. 6.30, Gramophone Concert. Humides violettes; Speak to me of Love; Douceur d'aimer; Tu m'embras; Les yeux noirs; Les ombres du passé; Nuit joyeuse; Muletier de Tarragone; Vieux ruban Siamoise; Wacht Parade; Parade of the Tin Soldiers; Schön ist die Welt (Lehar). 7.30, Time and News. 7.45, Radio Report of the Cycle Tour of France. 8.5, Press Review in French, Lottery Results, Announcements and Gramophone Music. 8.30, The Count of Luxembourg-Operetta in Three Acts (Lehar). In an interval at 9.30 (approx.), Press Review in German. 10.30 (approx.), Close Down.

STUTTGART

MUHLACKER, 832 kc/s, 360.5 metres; 60 kW. Relayed by Freiburg, 527 kc/s, 570 metres.—7.30 p.m., Concert by the Station Orchestra, conducted by Otto Seyfert: Comedy Overture (Reznicek); Peer Gynt Suite (Grieg); Selection from Tiedland (d'Albert). 2.30-3.0, Advanced English Lesson. 3.30, Talk: Flowers. 4.0, Talk for Women: Travelling. 4.30 (from Karlsruhe), Concert by the New Philharmonic Orchestra, conducted by Rudolf Kurt Gühr: March, Deutschlands Ruhm (Schradler); Overture, Flotte Borsche (Suppé); Waltz, Traumdeale (Fück); Carnival Suite in Five Movements (Siede); Im Märchenwald (Ganglberger); Oriental Fanta-sia, Arabisches Gold (Rust); Potpourri, Zehn Minuten Schlager (Schneider). 5.45, Talk arranged by the National-Socialist Association for the War-Disabled. 6.10 (from Karlsruhe), Talk: The Artistic Possibilities of Wooden Buildings. 6.35, Time and News. 7.0, Transmission for all German Stations, relayed from Heilsberg. 8.0, Concert by the Station Orchestra, conducted by Gustav Gürlich, with Songs by a Soldiers' Choir: King Charles March (Unrat); Choir: (a) Wenn die Soldaten, (b) Muss ich denn; Potpourri of Marches, Wir marschieren (Weitschach); Choir: (a) Mein Regiment, mein Vaterland, (b) Kaiserjäger; Am Lagerfeuer (Siede); Choir: (a) Feldpostregt (Arnold), (b) Es klingt wie eine Sage (Simon); Erinnerung an Potsdam (Noack). 9.0, Radio Report from the Neckarzimmer Labour Service Camp. 9.30 (from Karlsruhe), Pianoforte Sonata in B Minor, Op. 35 (Chopin). 10.0, Time and News. 10.30, See Hamburg. 12 Midnight, Close Down.

SUNDSVALL.—See Stockholm.

TOULOUSE

779 kc/s, 385 metres; 8 kW. Transmissions uncertain owing to recent fire. 11.30 p.m. till Close Down, Programme in English by the I.B.C. 11.30, Military Band Music. 11.57, I.B.C. Goodnight Melody. 12 Midnight (approx.), Close Down.

TRIESTE

1,211 kc/s, 247.7 metres; 10 kW.—5.15 p.m. till Close Down. See Turin.

TRONDHEIM.—See Oslo.

TURIN

1,096 kc/s, 273.7 metres; 7 kW. Relayed by Milan, 905 kc/s, 331.5 metres; Genoa, 959 kc/s, 312.8 metres; and Florence, 590 kc/s, 500.8 metres.—5.15 p.m., Dance Music from the Savoia Dance Hall. 6.0, Weather. 6.35, Giornale Radio, Agricultural Report, and

Dopolavoro Announcements. 7.0, Time, Report of the Royal Geographical Society, and Songs on Gramophone Records. 7.20, News in Foreign Languages. 7.40, Gramophone Music. 8.0, Announcements, Giornale Radio, Sports Notes, Weather Forecast, and Gramophone Music. 8.30, An Operetta. In the intervals, Talk and Announcements. After the Operetta, Giornale Radio.

VATICAN CITY

15,120 kc/s, 19.84 metres (Morning), and 5,969 kc/s, 50.26 metres (Evening); 10 kW.—11.0 to 11.15 a.m., Religious Information in English. 8.0-8.15 p.m., Religious Information in Italian.

VIENNA

581 kc/s, 517 metres; 15 kW. Relayed by Graz, 852 kc/s, 352.1 metres; Innsbruck, 1,058 kc/s, 283 metres; Klagenfurt, 662 kc/s, 453.2 metres; Linz, 1,220 kc/s, 245.9 metres; and Salzburg, 1,373 kc/s, 218.5 metres.—12 Noon, Concert by the Vienna Symphony Orchestra, conducted by Josef Holzer. In the interval at 1.10 p.m., Time and News. 2.0 to 3.0, Interval. 3.0, Time and News. 3.20, Talk: Inculcating Generosity in the Child. 3.35, Programme for Young People: Mendelssohn Pianoforte Recital. 4.0, Gramophone Concert of Music from Sound Films. 4.35, Talk: Week-ends on the Water. 5.0, Talk: The Röntgen Rays in Technology, Art, and Criminology. 5.25, Song Recital by Helene Vothaler (Soprano) and Igor Gorin (Baritone). 6.5, Talk for Garden-Lovers. 6.20, Fourth Centenary Festival of the Croats in Transylvania. Talk and Music by a Tambourine Orchestra. 6.50, Talk: The Inadequacy of the Human Reason. 7.15, Concert by the Vienna Symphony Orchestra, conducted by Josef Holzer. Overture, Cagliostro (Strauss); Meditation (Bach-Gounod); Potpourri from Frederica (Lehar); Waltz, Dorf-schwalben aus Österreich (Jos. Strauss); Song from Lilar Time (Schubert-Berthe); Song, Hoch von Dachstein (Wagner); Waltz, Singen, lachen und tanzen (Zichner); Marching Song (Hollmeisberger); Potpourri of Old Viennese Songs (Muss). In the interval at 7.35, Time and News. 8.30, History Talk: The Turks before the Walls of Vienna. 9.0, Concert by the Vienna Symphony Orchestra, conducted by Reichwein. Soloist: Richard Krottschak (Viola da Gamba); Overture, Euryanthe (Weber); Concerto for Viola da Gamba and String Orchestra (Tartini); Symphony No. 4 in B Flat, Op. 60 (Beethoven). 10.15, News. 10.30, Dance Music on Gramophone Records.

WARSAW

212.5 kc/s, 1,411 metres; 120 kW.—11.57 a.m., Time and Fanfare from St. Mary's Church, Cracow. 12.5 p.m., Gramophone Music. 12.25, Polish Press Review. 12.33, Weather. 12.35, Gramophone Music. 12.55, Radio Journal. 1.0 to 2.55, Interval. 2.55, Gramophone Music. 3.5, News. 3.10, Announcements. 3.15, Gramophone Music. 3.25, Economic Notes. 3.35, Gramophone Music. 3.45, Aviation Report and Anti-Gas Drill. 3.50, Gramophone Music. 3.55, Announcements. 4.0, Concert by the Poznan Symphony Orchestra, relayed from Ciechocinek. 5.0, Talk: The Island of Majorca. 5.15, Song and Clarinet Recital by W. Waleska (Soprano) and Andrzej Kadynsky (Clarinet); Clarinet Solos: (a) Polonaise from the Concerto in E Flat (Weber), (b) Rondo (Avon), (c) Arabesque, Op. 24 (Taniec), (d) Rondo from Concerto, Op. 107 (Mozart), (e) Canzonetta (Ambrosio), (f) Berceuse, Op. 11 (M-beer); Soprano Solos: (a) Song from The Old (Massenet), (b) Air from Louise (Charpentier); Concerto in G Minor, Op. 47, for Clarinet and Pianoforte; Soprano Solos: (a) Song (Noskowski), (b) Air (Niewiadomsky), (c) Gretchen am Spinnrade (Schubert), (d) Serenade (R. Strauss). 6.15, Talk: Poland Today. 6.35, Light Music on Gramophone Records. 7.20, Miscellaneous Items. 7.35, Programme Announcements. 7.40, Topical Talk. 8.0, Concert by the Station Symphony Orchestra, conducted by S. Nawrot. Soloist: Stefan Frenklic (Violin). Overture, Der Freischütz (Weber); Monna Liza (Rozyccki); Violin and Orchestra: Suite (Frenklic); Symphony Poem, Phæton (Saint-Saëns); Suite, Life in Japan (Higgs); Violin Solos; Overture, The Count (Moniuszko). In the interval, Radio Journal and Agricultural Report. 10.0, Dance Music relayed from Ciechocinek. 10.25, Sports Notes. 10.35, Aviation Weather Report and Police Notes. 10.40, Dance Music relayed from Ciechocinek (cont'd.).

WILNO

533 kc/s, 563 metres; 16 kW.—6.35 p.m., Gramophone Music. 7.10, News. 7.20, Topical Talk in Lithuanian. 7.35, Programme Announcements. 7.40, See Warsaw. 8.0, Request Gramophone Music. 8.50, Programme from Warsaw. 11.0 (approx.), Close Down.

ZAGREB

977 kc/s, 307 metres; 0.75 kW.—8.10 p.m., Announcements. 8.30, Concert. 10.30, News and Weather. 10.40, Dance Music. 11.30 (approx.), Close Down.

ZURICH.—See Schweizerischer Landessender.

Are you taking full advantage of your electric light?

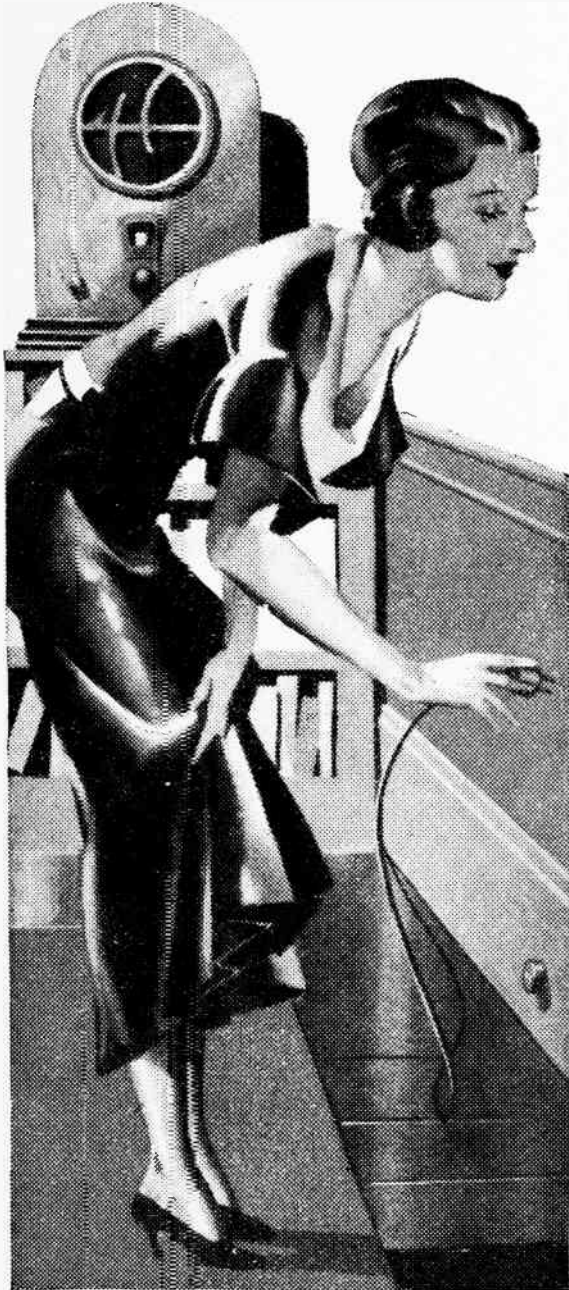

Radio reception now costs only 1/- a year!

★ Based on 3 hours daily use of an average 3-valve set. The equivalent cost of batteries is 50/-!

Do you still run your radio from batteries? If you do, you are behind the times—and paying a lot more than you need pay. Provided you have electric light you can reduce your set's costs to a negligible amount, and at the same time get constant unvarying power!

All you have to do is to connect the suitable EKCO Power Unit in place of the battery, plug into the electric light, and switch on—that's all! No alterations to set, valves or wiring. Consult your dealer or write for free illustrated literature.

Prices from 39/6, or by Easy Payments.

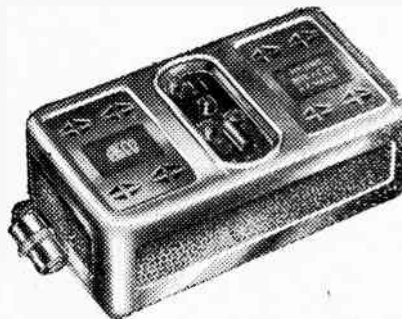

All Ekco units are similar in size and design. Size 9 ins. x 5 ins. x 3 1/4 ins.

To E. K. COLE, Ltd., Dept. W.16, Ekco Works, Southend-on-Sea.

Please send me full illustrated details of Ekco All-Electric Radio

Name.....

Address.....



RADIO POWER UNITS

Mention of "The Wireless World," when writing to advertisers, will ensure prompt attention.

The Wireless World

THE
PRACTICAL RADIO
JOURNAL
23rd Year of Publication

No. 723.

FRIDAY, JULY 7TH, 1933.

VOL. XXXIII. No. 1.

Proprietors: ILIFFE & SONS LTD.

Editor:
HUGH S. POCOCK.

Editorial,
Advertising and Publishing Offices:
DORSET HOUSE, STAMFORD STREET,
LONDON, S.E.1.

Telephone: Hop 3333 (50 lines).
Telegrams: "Ethaworld, Watloo, London."

COVENTRY: Hertford Street.

Telegrams: "Cyclist, Coventry."
Telephone: 5210 Coventry.

BIRMINGHAM:

Guildhall Buildings, Navigation Street, 2.

Telegrams: "Autopress, Birmingham."
Telephone: 2970 Midland (3 lines).

MANCHESTER: 260, Deansgate, 3.

Telegrams: "Iliffe, Manchester."
Telephone: Blackfriars 4412 (4 lines).

GLASGOW: 26b, Renfield Street, C.2.

Telegrams: "Iliffe, Glasgow." Telephone: Central 4857.

PUBLISHED WEEKLY. ENTERED AS SECOND
CLASS MATTER AT NEW YORK, N.Y.

Subscription Rates:

Home, £1 1s. 8d.; Canada, £1 1s. 8d.; other
countries abroad, £1 3s. 10d. per annum.

*As many of the circuits and apparatus described in these
pages are covered by patents, readers are advised, before
making use of them, to satisfy themselves that they would
not be infringing patents.*

CONTENTS

	Page
PROGRAMMES FROM ABROAD, pp. I—XXIV	
<i>Editorial Comment</i>	1
<i>Class "B" Economy is Two-fold</i> ..	2
<i>Avoidable Interference</i>	4
<i>Practical Hints and Tips</i>	6
<i>Single-dial Tuning</i>	8
<i>McMichael Duplex Super Five</i> ..	10
<i>News of the Week</i>	11
<i>Laboratory Tests</i>	12
<i>Broadcast Brevities</i>	13
<i>Letters to the Editor</i>	14
<i>Readers' Problems</i>	16

EDITORIAL COMMENT

Next Year's Sets *Midgets and Universal A.C.-D.C. Receivers*

WITH the Olympia Exhibition not much more than a month ahead of them, most manufacturers will already have decided on all the main details of their programme for next season. Valves have now an all-important influence on receiver design, and, if only for the reason that so many multi-electrode types have recently been introduced, we are bound to have an exhibition that will be full of technical interest.

Is the "midget" set, with a frontal area of about half the size of this page, and a depth no greater than that of a fair-sized book, to figure prominently on the programme? In spite of suggestions that this phase of development might well be short-circuited, so far as this country is concerned, many British manufacturers, influenced by the undoubted commercial success of this type of set in America, have gone to the length of developing experimental models.

Whether many of these "squeak-boxes," as they are now contemptuously called in the land of their origin, will finally get on the market is uncertain; if they are offered to the public purely as auxiliary sets, there will be little cause for complaint, but unless some genius manages to obtain better quality than that of the average specimen, the prestige of broadcast reproduction is bound to suffer in the long run.

There can, of course, be no valid objection to a set merely because it is small; on the contrary, compactness is obviously to be wished for. Uneasiness on this subject is felt only because hitherto it has been found impossible

to combine extreme compactness and quality. The permissible size of the loud speaker and its baffle area is too small, and is, indeed, the main limiting factor.

This naturally suggests the possibility of developing a real midget set—smaller even than existing types—to work with an external loud speaker. Such a plan overcomes all the more serious objections, and has its own special advantages. It is interesting to hear that at least one firm expects to produce a set on these lines.

Versatile Receivers

It so happens that midget sets are almost invariably of the "universal" type, working either on A.C. or D.C. mains. But none of the objections which have been urged against the midget set are of necessity applicable to a receiver merely because of its versatility in the matter of supply current. At the present time, when electrical undertakings are changing, or are expected to change, their system of supply, many possible buyers of sets are deterred by the possibility of finding themselves with a receiver which will be unsuitable for altered conditions, and it is certain that the new A.C.-D.C. sets which will appear will have a good reception. There is no technical reason why the standard of reproduction of such sets should not be as high as that of any but the more ambitious A.C. receivers which employ a much higher anode voltage than is obtainable from domestic D.C. mains.

Fears have been expressed that the new valves would be introduced into sets before their use was fully understood; it is reassuring to observe that, more than ever before, manufacturers are refusing to allow novelty, merely for its own sake, to influence their plans, and last-minute improvisations will be very much the exception.

Class "B" Economy is Two-fold

Some Measurements of Efficiency

By M. G. SCROGGIE, B.Sc., A.M.I.E.E.

IT is now well known that the quiescent output systems, to which Class "B" amplification belongs, afford a new measure of H.T. battery economy as the current consumed is proportional to the signal strength. It is probably not so well known, however, that these quiescent methods are in themselves much more efficient than the ordinary push-pull scheme with mid-point bias. The accompanying article sets forth some interesting results of efficiency measurements.

THE merits of the quiescent output stage (Q.P.P. or Class "B") have been widely expounded of late. But so far attention has been concentrated on only one of two respects in which it economises in battery power. It is now generally understood that a power valve worked in the ordinary manner might be compared to a car that consumes petrol just as fast when pottering along—or even standing still—as when going all out, whereas in the quiescent system the consumption is in proportion to the output at any instant. As in normal circumstances a receiver is "all out" for only fractions of a second, or at most seconds, at a time, and on the average is working at something like a tenth of full power, one contribution of quiescence to economical running is easy to apprehend.

Where the Waste Occurs

The impression has been gained, however, that when a quiescent stage is fully extended it is no more thrifty than other systems. This is incorrect. It confers a substantial benefit over and above that with which it is commonly credited.

The true measure of economy is *efficiency* in the engineering sense of the word, that is to say, the ratio between the useful power given out and the power

fed in. It can be shown mathematically that the greatest theoretical efficiency of the ordinary system is 50 per cent. So that however much valves are improved and sources of loss eliminated, at least another 50 per cent. of the power put into them from the H.T. battery (for it is battery users who are chiefly interested) is wasted. In actual practice 70 per cent. or 80 per cent. is usually wasted even when working at full power, and, of course, a much larger proportion when volume is reduced. But the theoretical efficiency of a perfect quiescent stage is π or 78.6 per cent. So the absolutely unavoidable waste is only a little over 20 per cent.



Showing the output circuit of "The Wireless World" Class "B" Ferrocart receiver, which delivers about 2 watts speech.

TABLES SHOWING EFFICIENCY TESTS RESULTS

	A.						B.					
	6,400	10,200	12,800	15,400	20,500	28,400	15,400	20,500	24,600	30,600	38,400	
Load resistance, ohms	6,400	10,200	12,800	15,400	20,500	28,400	15,400	20,500	24,600	30,600	38,400	
Output, voltage.....	107	154	180	194	197	203	195	206	216	221	211	
Output, watts.....	1.74	2.36	2.53	2.44	1.90	1.47	2.48	2.08	1.83	1.59	1.16	
Anode voltage.....	193	192	192	192	191	191	196	196	196	196	196	
Anode milliamps.....	49.0	47.5	45.5	44.5	43.0	42.0	21.4	17.9	15.8	13.8	11.2	
Anode input, watts..	9.45	9.10	8.75	8.55	8.25	8.05	4.20	3.50	3.10	2.70	2.20	
Anode circuit efficiency, per cent.	18.4	25.9	28.9	28.5	23.0	18.3	59.0	59.5	59.0	59.0	53.0	
Aux. grid, milliamps..	11.0	12.0	11.5	12.5	11.3	10.5	6.0	5.0	4.4	3.8	2.6	
Total input, watts....	11.6	11.4	11.0	10.9	10.4	10.0	5.37	4.50	3.96	3.45	2.7	
Total efficiency, per cent.	15.0	20.7	23.0	23.4	18.4	14.7	46.2	46.2	46.2	46.2	43.0	

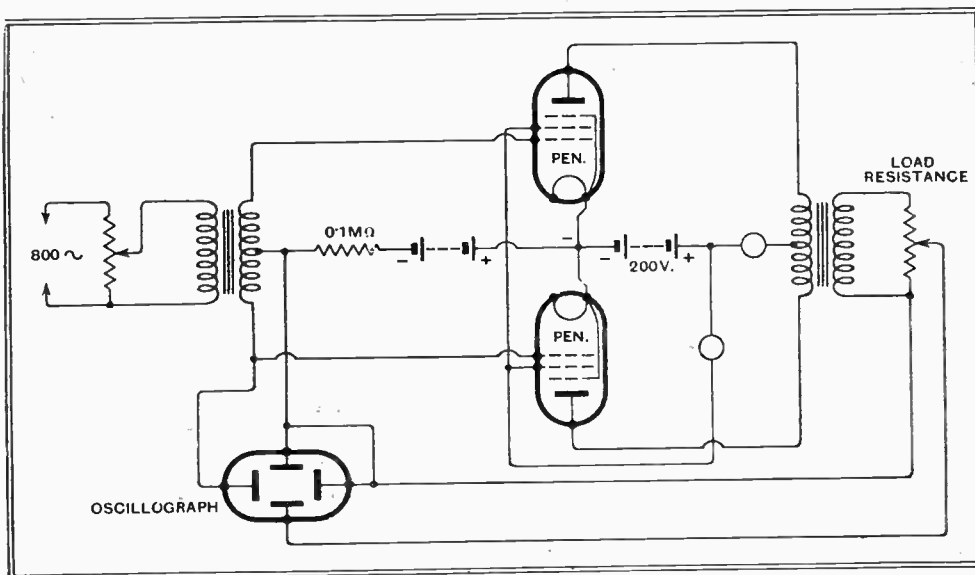

Fig. 1.—The circuit used for the measurement of efficiency of two pentodes in QPP.

Good though modern valves are, they fall short of the ideal assumed in these calculations, and the practical man is not greatly interested in something which cannot be put into effect. But the results of measurements on actual amplifiers confirm that quiescent operation is very substantially more efficient. The tests to be described were for convenience carried out on a pair of standard, separately heated, pentodes, but the general conclusions apply to other types, such, for example, as Class "B" valves, which resemble pentodes in characteristics rather than triodes.

An Interesting Experiment

The valves were connected up in the usual push-pull formation with suitable input and output transformers, and supplied with about 200 volts H.T. (Fig. 1). The grid bias for the first series of tests was 12 volts, giving true push-pull, here-

Class "B" Economy is Two-fold — in after called TPP, and for the second series 27 volts, giving quiescent operation. The anode current before applying a signal was 40 milliamps and 6 milliamps for TPP and QPP respectively. Instead of a loud speaker a pure resistance

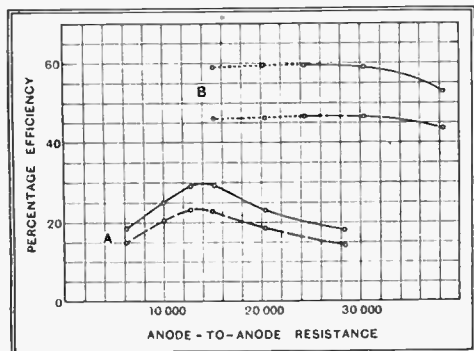

Fig. 2. — Efficiency plotted against load resistance. The solid lines represent anode circuit efficiency and the broken lines take into account power expended in the auxiliary grids.

was used, which could be varied. The signal came from an 800-cycle oscillator of pure waveform, connected to the input transformer. The output and input were visually compared by a cathode-ray oscillograph, and the current was increased until the distortion of the output was just clearly noticeable. Readings were then taken of the alternating voltage across the load resistance, the anode and screen currents, and the exact anode voltage. These data are sufficient for both input and output power in watts to be calculated, and hence the percentage efficiency. The particulars are shown in Table A for TPP and in Table B for QPP.

Advantages of Class "B"

The load resistances specified are the equivalents of those actually used when referred to a 1:1 transformer, and so are what is known as "anode-to-anode load." The figures given include the losses in the output transformer, but as a high grade component was used these would not amount to very much.

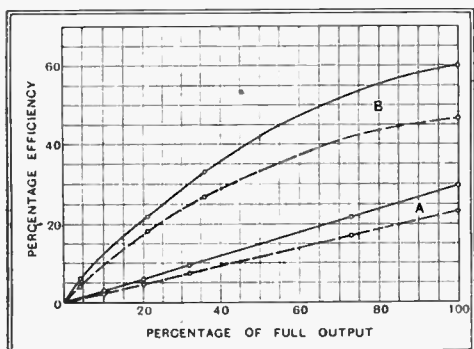

Fig. 3.—The relative efficiency of TPP(A) and QPP(B) can clearly be seen from these curves.

It will be noticed that two figures are given for efficiency in each case. The first takes no account of the power lost in the auxiliary grids of the valves, and is the figure generally quoted when valves are being discussed. It is the efficiency

of the anode circuit exclusively. From a practical point of view the other figure, which might be called the H.T. supply efficiency, is a fairer comparison with other types of valve which require no auxiliary current, because it is right that pentodes should be debited with this particular piece of wastefulness on their part. This is one respect in which Class "B" is superior to the older method, which requires pentodes to achieve the best results.

The results are shown more vividly in Fig. 2, where efficiency is plotted against load resistance. The solid lines represent the anode circuit efficiency, and the broken lines take into account the power expended in the auxiliary grids.

The most important fact to be derived is that the quiescent system has double the efficiency of the other. Remember, the results shown are for maximum "undistorted" output. If the output were

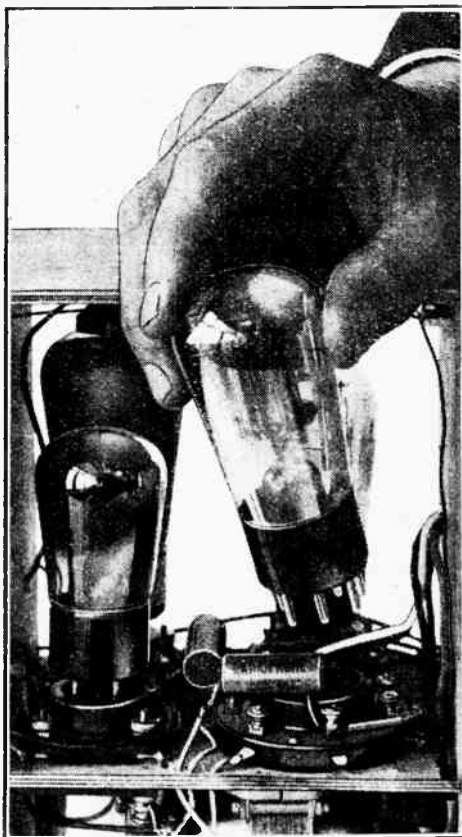

The Class "B" and driver stages of a recent "Wireless World" receiver—the Two-unit Portable.

to be reduced the QPP efficiency would drop slowly, but the TPP would rapidly have taken away from it even the small efficiency that it had. This effect is shown by the curves of Fig. 3, which bring home the two-fold economy conferred by quiescent operation. No special precautions were taken to match the valves or to reduce the quiescent current to a minimum, and better curves than those shown might be obtained with a little care.

Some interesting features of Fig. 2 remain to be pointed out. One is that TPP yields even its mediocre performance only when the load resistance is correctly

chosen. On each side the efficiency falls away rapidly. QPP gives a remarkably level curve over a wide range of load resistance. It is only fair, however, to call attention to the dotted portion, which is marked thus as a warning that over this part of the curve an appreciable amount of distortion was observable at quite small output levels, and that therefore it is better to err on the high side in load resistance.

The Optimum Load

Theory predicts that the optimum load resistance for QPP is just double that for TPP, and is confirmed by the results given, which point to a well-defined best choice of 14,000 ohms (7,000 ohms per valve) for TPP, and a less well-defined 28,000 for QPP. Very terrible distortion results from neglect of this principle.

As a matter of interest it may be noted that in the particular experimental conditions described, TPP was able to achieve 58 per cent. of the theoretical anode current efficiency open to its class, while QPP attained 76 per cent. of its much higher theoretical efficiency.

It is again emphasised that although the abbreviation QPP has been used for convenience, the results apply broadly to any system in which one valve amplifies the positive half waves and the other valve the negative half waves, by starting from the base line. Thus "Class B amplification" is not excluded from the meed of praise due to QPP. On the contrary, it may be expected to put up an even better show, other things being equal. There is, first, no auxiliary grid to side-track the precious milliamps. Another reason is that hitherto available Class B characteristics have suggested a closer approach to the theoretical ideal than is possible even with pentodes. There are, of course, other practical advantages which do not directly affect the efficiency in the strict sense of the word, such as absence of grid bias and need for matching. Class B is, therefore, the form of quiescent operation that finds most favour.

BLUE PRINTS

For the convenience of constructors full-sized blue prints are available of the following popular *Wireless World* sets that have been recently described, price 1s. 6d., post free.

- Monodial A.C. Super.** (Booklet, price 1s. 8d. post free.)
- Modern Straight Five.** (June 22nd and 29th, 1932.)
- Short Wave Two.** (November 4th and December 23rd, 1932.)
- Monodial D.C. Super.** (December 2nd and 9th, 1932.)
- Straight Three.** (December 16th, 1932.)
- Modern D.C. Thres.** (December 30th, 1932, and January 6th, 1933.)
- All-wave Monodial Super.** (January 27th and February 10th, 1933.)
- Modern A.C. Quality Amplifier.** (February 17th, 1933.)
- Ferrocart III.** (February 24th and March 3rd, 1933.)
- * A.V.C. Monodial Super.** (March 17th and 24th, 1933.) With 2.5 watt or 5 watt amplifier. State which is required when ordering.
- The Class "B" Ferrocart Receiver.** (April 17th, 1933.)
- Universal A.C. Short-wave Converter.** (April 24th, 1933.)

* Price of this blue print is 2/.

These can be obtained from the Publishers, Iliffe & Sons Ltd., Dorset House, Stamford Street, London, S.E.1.

AVOIDABLE INTERFERENCE

The Causes of Unwanted Radiation—and Its Cure

By ANDRÉ L. J. BERNAERT

AN informative article on "man-made static"—a topic very much in the limelight at present. The part played by electrical wiring in disseminating interference to points remote from its source may be proved by an interesting experiment which is described.

AS the amount of electrical machinery in use has increased considerably during the last few years, interference with radio reception is becoming more troublesome; a contributory cause is the greater average sensitivity of wireless receivers. Most of those who are responsible for the radiation of interference are still unaware of the existence of remedies which prevent radiation from their apparatus.

Almost every wireless user has observed that, when a lamp is switched on or off near a working wireless set, a click is heard in the speaker. What is the cause of it?

In switching the lamp on or off a spark occurs between the contacts of the switch. That spark causes vibrations in the ether; hence waves are radiated. The switch acts, in fact, as a small spark transmitter,

and, as represented in diagram *a*, radiates waves of different lengths in all directions. That explains why we can hear the noise in the speaker irrespective of the wavelength to which the set is tuned. The amplitude of these waves diminishes with the distance from the switch; they are heavily damped. Very little power is expended, and, theoretically, disturbances do not extend beyond a small area, of which the switch is the centre (diagram *b*).

But the impulses are propagated easily along the mains leads over much greater distances. Supposing we have an electric fan which is connected to the mains and causes interference in a nearby wireless set. If we operate the same fan from an accumulator battery little or no interference will be heard. Thus it is proved that the mains leads acted as an aerial for radiating the electrical disturbances.



Chokes, condensers and resistances can be brought into use to minimise interference from electric signs.

It is obvious that the cure consists in preventing the waves from being conveyed by the mains leads, and at the same time in reducing the size of the spark and consequently the intensity of radiation.

For that purpose we can use coils and condensers connected as shown in diagram *c*. The coils and condensers must be placed as close as possible to the point at which the spark occurs. By adding the condensers we reduce the size of the spark, therefore the interference is diminished, and as the condensers offer an easy path, they deflect the objectionable waves to earth. The coils to be used on A.C. mains have to be so designed that they do not impede to an appreciable extent the passage of A.C. of low frequency. For instance, a coil wound on a former of about 12 inches long and 6 inches diameter, having 150 turns of No. 18 D.C.C. copper wire, will be efficient on 50-cycle mains if the current through the windings does not exceed 6 amps. On A.C. the value of the condensers will be between 0.1 mfd. and 1 mfd. For D.C. supplies condensers of 1 or 2 mfd. are suitable.

Alternative Suppressor Circuits

There are numerous cases which will be dealt with satisfactorily if only condensers are used. Sometimes even one condenser without earth connection may be sufficient. The different methods are shown in diagrams *d*, *e*, *f*, and *g*. It may be observed that diagram *f* forms an oscillating circuit, and so, if the resonant frequency falls within the tuning range of the receiver, very strong interference will be heard. In this case a resistance of about 20 ohms

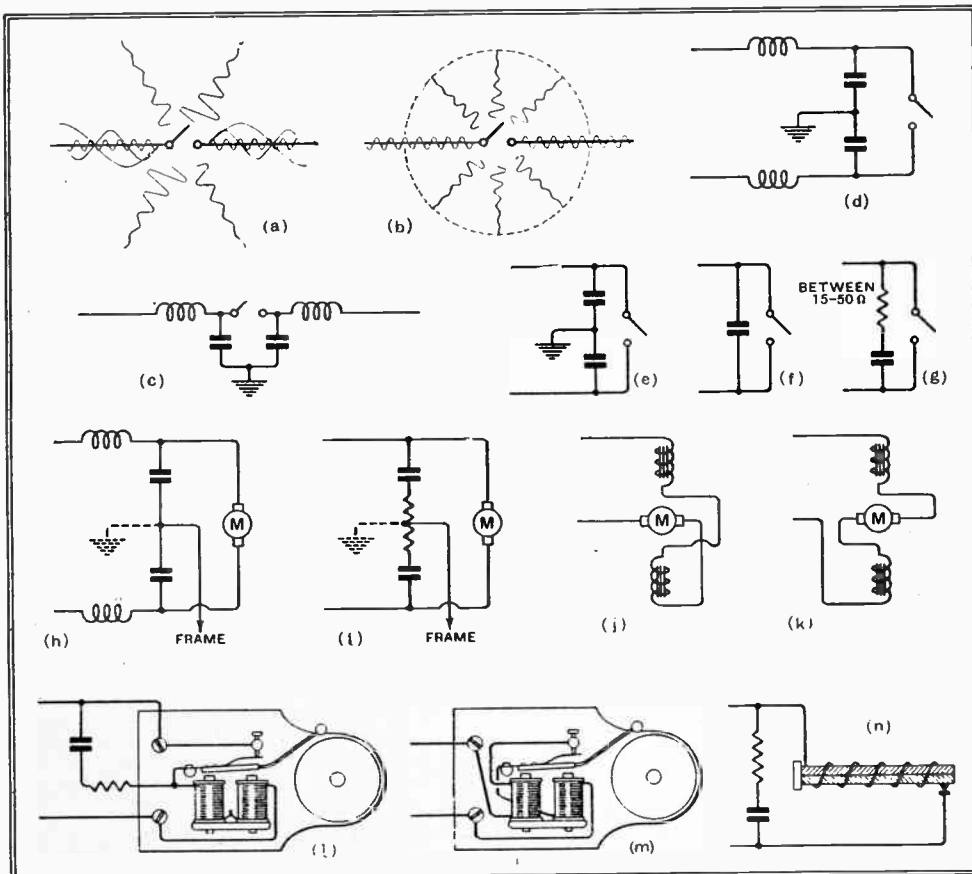

The nature of interfering radiation, and the appropriate remedies to apply under different conditions.

Avoidable Interference—

in series with the condenser (diagram g) will solve the problem. The four circuits are basically similar, but their efficiency in eliminating interference is different.

But not only the mains leads convey interference. The metal pipes or conduits through which they run do just the same thing. Earthing of the sheathing will stop this trouble. Sometimes, more especially if tubular metal conduit be used, there is a bad contact between successive lengths, and a wire bonding to connect them together will be advisable. Gaspipes also convey their share of disturbances; here again a good connection to earth should be made, and, if necessary, electrical bonding of the joints may be added.

Look to Your Aerial

Very strong interference is often caused by induction between the aerial or lead-in and conductors such as metal roofs, gutters, spouts, gaspipes, central-heating pipes, and so on. The aerial and lead-in should accordingly be kept as far as possible from them. As a further precaution the use of screened aerial down leads is coming into use. Special care must be taken to ensure high insulation between the lead-in and the earthed metal shield, and at the same time to keep the capacity between the two as low as possible. In addition, an alternative earth connection, which may be less affected by the interference, should be tried.

Small motors of all description are notorious offenders. The first thing to look for is excessive sparking. Brushes should be adjusted, and the commutators freed of dirt and metal particles. In most cases this alone will reduce the interference considerably. The metal motor frame should be earthed. If interference still persists the circuit given in diagram h should be adopted; the coils and condensers may be as already described. Sometimes either the coils or the condensers only will be sufficient, but where condensers only are used it is advisable to include a damping resistance of about 20 ohms, as otherwise very strong oscillations may be set up in the oscillating circuit formed by the coils inside the motor and the external condensers (see diagram i). By fitting two condensers of suitable value across the brushes of the motor of a domestic vacuum cleaner and connecting the centre point to the frame of the machine it will be electrically silent. Anti-interference coils and condensers, if properly designed to withstand the current and voltage used, do not affect the working of the motor and have no influence on the current consumption.

When an electric bell is the offending appliance a condenser of 2 mfd. in series with a resistance of 20 ohms, as shown in diagram l, will generally be sufficient. It is, however, interesting to try to use the magnet coils themselves as chokes by connecting one at each side of the interruptor as shown in diagram m. An analogous arrangement can be tried on a motor by rearranging the field coils (see j and k).

Most electric hot-plates are fitted with

an automatic device (diagram n) which prevents overheating by switching the mains off and on. A condenser in series with a resistance will, here again, reduce the interference.

with 26 S.W.G. D.C.C. wire to an inductance value of about 6,000 microhenrys. By using a mains transformer with an earthed screen between the primary and the other windings the same result will

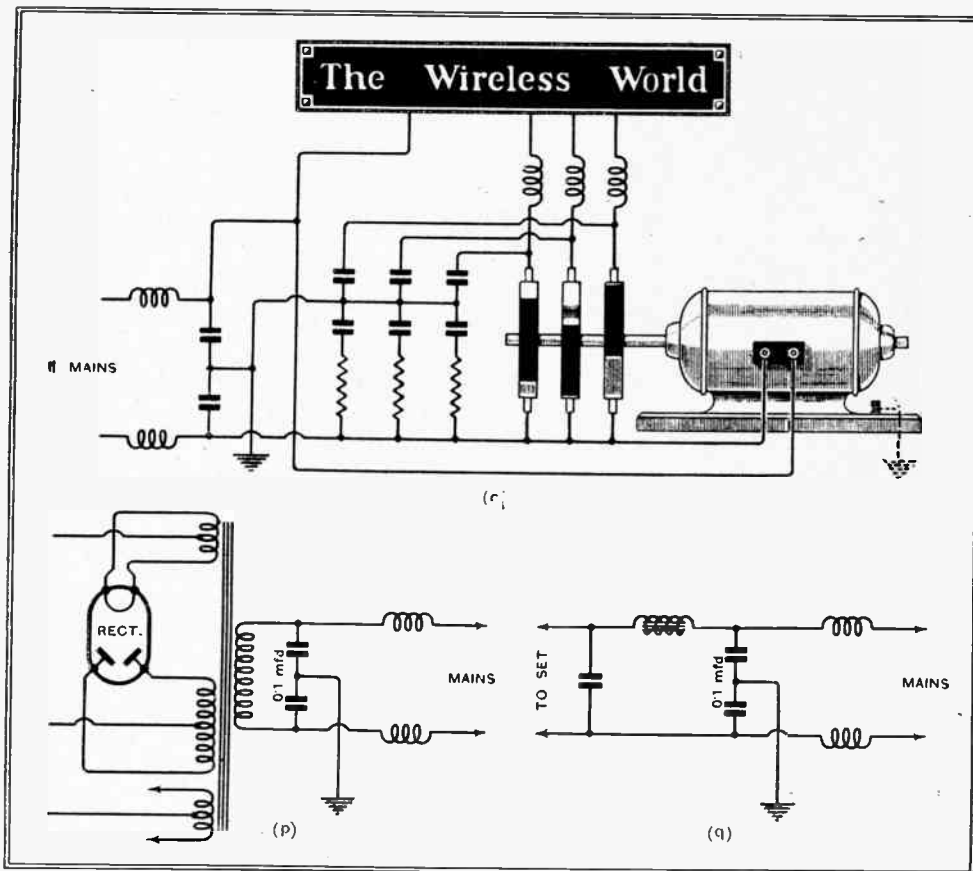

If *The Wireless World* used a flashing sign, it would certainly be "silenced": diagram (o) indicates the position of suppressor condensers, chokes and resistances. Below are shown input filter circuits for A.C. and D.C. mains sets.

In diagram o is represented an electric sign, in which use is made of coils, condensers and resistances which effectively reduce the background to bare audibility, even when the receiver is in close proximity to the apparatus. In general, all electric disturbances caused by switching mechanisms can be satisfactorily dealt with by including suitable coils in the mains leads and bridging the switch contacts with condensers and resistances.

To sum up, it should be remembered that:—

The anti-interference device should be placed as close as possible to the radiating apparatus. Care should be taken, however, that the condensers used in conjunction with apparatus developing considerable heat are placed at a safe distance, as they are likely to be affected by abnormally high temperatures.

If possible, the centre tap of the condenser block should be connected to the metal screen or frame. But it should be ascertained by trial whether earthing of the screen or frame has an adverse influence on the elimination of interference. In mains-operated receivers it is useful in some cases to include, between the set and the mains, two H.F. chokes and a centre-tapped condenser block to constitute a barrier to mains interference that may be introduced directly through this channel. Suitable coils may be wound

be obtained, or sometimes even a better one if the earth is rather long.

FOREIGN BROADCAST GUIDE

POSTE PARISIEN

(Paris, France).

Geographical position: 48° 53' N.; 2° 20' E.

Approximate air line from London: 220 miles.

Wavelength: 328.2 m. Frequency: 914 kc/s. Power 60 kW.

Standard time: Greenwich Mean Time (France adopts B.S.T.).

Standard Daily Transmissions

07.15 B.S.T., gramophone records, news, weather; 08.45; daily menus; 09.15, gramophone records (Sun.); 09.45, Bible reading (Sun.); 10.0, variety (Sun.); 12.10, concert; continuous broadcast until 14.00; 18.45, news, gramophone records, plays, talks; 21.20, main evening entertainment; 22.15, final news bulletin and details of following day's programme.

Opens with the playing of a fanfare of trumpets followed by *Marche Lorraine* or *Entre Sambre et Meuse* (gramophone record).

Announcer: Man.

Call: *Ici Poste Parisien*.

Interval Signal: Trumpet call (first six notes of a melody from Charpentier's Opera, *Louise*), as under:—



Closes down with conventional French good-night greetings followed by *La Marseillaise*.

Practical Hints and Tips

Simplified Aids to Better Reception

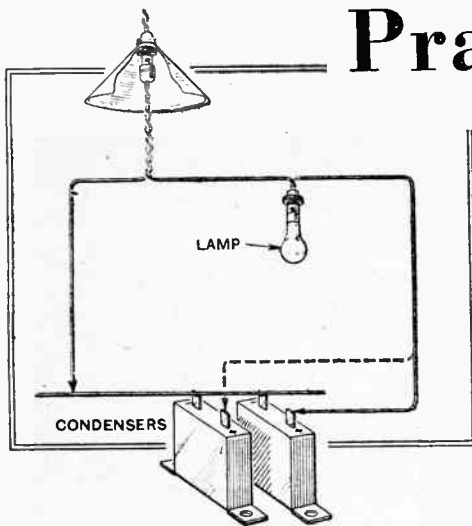

For testing condensers on A.C. mains.

VARIOUS methods of making exceptionally light fuses, "blowing" at a very few milliamperes, have recently been devised. These fuses are generally employed as a safeguard in the anode circuits of battery-operated sets, where they

Class "B" Anode Current

afford protection to the valve filaments, and, of even more importance, to the H.T. battery, in the event of a short-circuit.

When choosing a safety fuse for a Class "B" set, it should be remembered that, although the average current drawn by the output stage will be low, there will always be occasional heavy surges, corresponding to deep modulation at the transmitting end, and current may momentarily reach a value of from 40 to 60 milliamps. This peak or maximum value should be taken into account, rather than the "quiescent" current; otherwise it will be found that the fuses will need constant replacement.

WHEN dealing with a receiver or amplifier having a large number of high-capacity fixed condensers, it is anything but a simple matter to detect a faulty unit (or, in the case of a bank of condensers, the faulty section).

A Rapid Test for Condenser Defects

The following method allows a rapid and certain tracing of faulty condensers to be made *in situ*, without the necessity of disconnecting particular sections, and has the advantage of using apparatus which is certain to be at hand. The materials required are a low candle-power electric lamp, 15 watts preferably, of normal mains voltage, with holder and a length of twin flex, fitted with an adaptor at one end. As shown in the accompanying sketch, the tester connections are effected by wiring the lamp-holder in series with one lead of an adaptor flex; two free ends are left, one coming direct from the adaptor and another from the lamp-holder.

A word of caution at this point: remove earth, aerial, and mains leads from the set before starting to test. Now proceed to

attach, by means of a crocodile clip or in some other convenient way, one of the leads to H.T. negative or to the metal chassis. On applying the second lead from the lamp-holder to the "positive" terminals of each of the condensers in turn, the lamp will glow with varying degrees of brilliancy, depending upon the condenser capacity. Normal full light will indicate a short-circuited condenser which requires replacement, while total absence of glow will show an internal disconnection. This method will be found to be extremely rapid and certain, and will save considerable time.

IT may be welcome news to many of those readers who are without an A.C. mains supply to learn that the two-valve short-wave converter described in *The Wireless World* of April 28th is adaptable to battery operation. Although battery-operated valves are never quite as efficient as their "mains" counterparts, the behaviour of the converter, modified in this way, leaves little to be desired.

A complete circuit diagram, showing the necessary alterations for battery work, is

already fully loaded, there would be no objection to feeding the adaptor unit from separate sources.

With regard to components, the types specified for the original converter may be used, but, due to the somewhat lower efficiency of a battery type detector-oscillator valve, it may be necessary to tighten reaction coupling in order to maintain self-oscillation over the whole of the wavebands covered. This point is easily determined by trial, and if necessary a larger reaction winding or a larger fixed reaction condenser may be used. Alternatively, a variable reaction condenser may be substituted.

ALTHOUGH it may seem to be a terribly inefficient and extravagant procedure, often the best way of keeping down the output of a rectifier valve to the desired voltage is to shunt it with an absorbing resistance. This plan is generally adopted when the current to be drawn from the rectifier is considerably below its maximum rating. If no additional load were imposed a rise of voltage would take place, and the smoothing condensers might

Too Many Volts

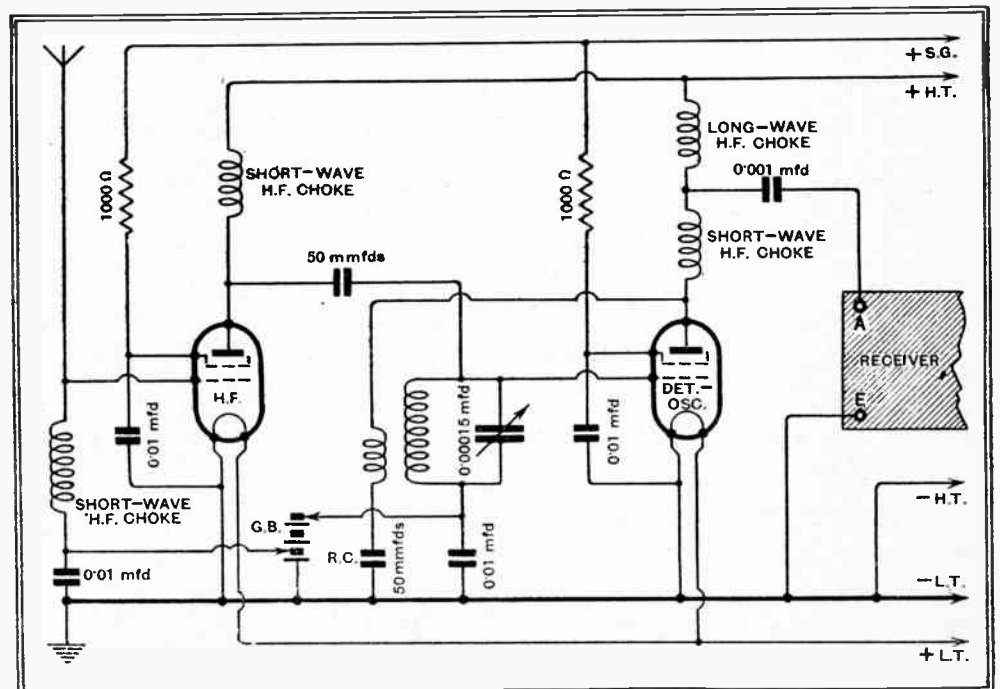

Fig. 1.—The "Universal A.C. Short-wave Converter," as recently described, may be modified for battery working.

given in Fig. 1, from which it will be observed that the unit is basically unchanged, but, instead of obtaining its H.T. and L.T. energy from a self-contained power unit, it is primarily intended for connection to the batteries which normally feed the set. Of course, where these batteries are

suffer; herein lies the real advantage, as the use of high-voltage condensers may be avoided by adopting this scheme. Further, the value of the parallel absorbing resistance may in most cases be estimated in a very simple way.

Take a case that is likely to arise in

Practical Hints and Tips—

practice—that of an "A" type rectifying valve designed to give about 250 volts at 60 mA., but to be used, in conjunction with a standard "A" transformer, to feed a set requiring only 20 mA. at 250 volts. At this relatively light loading voltage might rise to some 300 volts; this rise can be prevented only by ensuring that the total load will amount to 60 mA. What we need to know, therefore, is the value of shunt resistance which will absorb the surplus current—in this example, 40 mA.

The necessary resistance (in ohms) is here ascertained by dividing "voltage" by "surplus current," the latter expressed as a fraction of an ampere. In this case we get $250 \div 0.04$, equal to 6,250 ohms.

The voltage figure used in these calculations is not necessarily the maximum rated output, nor is the system of voltage regulation applicable only to a simple rectifier; an H.T. eliminator may be treated in the same way. Knowing the voltage output for a given consumption, it is easy to estimate the right value of absorbing resistance to maintain that voltage at any lesser consumption.

CERTAIN types of wire-wound potentiometer are prone to develop noisiness in operation, due to movement of adjacent turns of the resistance element as it is traversed by the rotating contact arm. It has been found that a potentiometer which gives trouble in this way can generally be put right by varnishing the windings with two or three coatings of celluloid cement. A clear day should be allowed for each coat to dry before the next is applied, and, of course, the actual contact surface should be kept free of varnish.

**Wire-wound
Potentiometers**

Celluloid cement is widely used for repairing accumulators, etc., and is obtainable fairly easily. It can be made by dissolving scrap celluloid in equal parts of acetone and amyl-acetate.

ALUMINIUM is in many respects a highly satisfactory metal for wireless work, and for many purposes it is almost irreplaceable. But, when using it, more than usual care must be taken to ensure good electrical contact.

**Contact
Resistance**

Metallurgists tell us that almost as soon as the tool leaves the surface of a piece of aluminium that is being worked, an invisible film of oxide is formed. The film is of high electrical resistance, and this is the reason why a wire to be joined to an aluminium chassis, condenser frame, etc., should always be forced into close and intimate contact with the metal.

The need for taking a certain amount of care in making electrical connections to aluminium is particularly likely to be noticed when carrying out experimental or testing work, when rough, temporary joins are usually made.

THE "VOLKSEMPFÄNGER"

More Details of the Hitler Set

GERMANY'S "Volksempfänger" — or national receiving set—is now an accomplished fact. It has been designed by Professor Leithäuser to the requirements of the German Ministry of Propaganda with the object of obtaining as big an audience as possible for the State talks and other ministerial propaganda.

In an interview with a correspondent of *The Wireless World*, Professor Leithäuser explained some of the problems set by the demand for a receiver of very high quality and very low price. It was necessary, he explained, that the set should be selective and powerful enough to guarantee loud speaker reception of the Königswusterhausen station and at least one German regional at all times of the day. At the same time, the receiver must not be "too good," otherwise the listener might hesitate to buy a more expensive receiver even if he had the money for it!



Professor Leithäuser

A two-valve all-mains set combined with loud speaker was found to be the best solution. Professor Leithäuser took one of the first trial models on a grand tour of Germany, in ten days he carried out reception tests in Central Germany, in Bavaria, in the Black Forest, in North Germany, and on the Rhine. Tests were also carried out in Eastern Prussia. Some curious effects were noticed in the Black Forest. In one village the long wave of the Königswusterhausen station seemed to come round a mountain on both sides, the two branches of the deflected ray causing mutual interference. At Castle Niedeggen, in the Eiffel district, it was possible to receive practically all European stations on a four-metre aerial.

The "Volksempfänger" is being manufactured on a generous scale; the first order is for 75,000 A.C. mains sets, 15,000 D.C. mains sets, and 10,000 battery sets, all of these to be ready by the time the German radio exhibition opens. Selectivity is secured by the use of a litz-wound coil and a special low-loss valve socket. The use of capacity reaction on the aerial will imply some tuition to the uninitiated, who would otherwise cause considerable interference.

Both A.C. and D.C. models employ two indirectly heated valves. In the A.C. model the popular RE 904 is used. This valve has a mutual conductance of 3.5 mA. per volt. The equally well-known RES 164d is a directly heated pentode with about three watts output. The two valves used in the D.C. mains set are both of the 20 volts indirectly heated type. The first, a RENS 1820 is a screened-grid detector valve. The second, REN 1823d, is a 20-volt pentode. The battery set has three valves, two RE 034's and one RE 174d.

The battery firms have decided to co-operate, and are producing special 2.5 amp. hour anode batteries at 6.90 marks. The loud speaker is selected from about forty

different types by different committees, which, curiously enough, were unanimous. It is a well-known moving-iron type.

Our correspondent asked Professor Leithäuser how it was possible for all the twenty-eight firms concerned to co-operate in the production of a uniform set. Professor Leithäuser replied that all drawings were supplied by the Central Office of the Manufacturers' Association, while each firm would furnish him at Heinrich Herz Institute with a test receiver which would have to be approved before going into production.

The price of 76 marks (approximately £3 16s.) has only been possible by mass production and the consent of the traders and manufacturers to large profit cuts.

MULTITONE CLASS "B" CONVERTER

CLASS "B" amplification offers such important advantages over other forms of output stage for battery sets that it is likely to find almost universal application in future. Not the least attractive feature of the new system is the ease with which an existing set can be changed to Class "B" by converting the normal output valve into the driver.

With the Multitone Class "B" Converter, which is illustrated herewith, not a single connection in the set or between the set and speaker need be interfered with, since the necessary change of connections is brought about by the use of a valve holder adaptor with a "split" anode. To put the converter into operation it is only necessary to remove the output valve from the set, insert into the adaptor and plug the whole back into the valve holder. This applies to either pentode or triode. The converter contains a driver transformer, a Class "B" valve holder, and an auto-transformer which was found to match any high-resistance speaker. There is no separate switch for the L.T. supply.

When tested the unit gave a good account of itself. The volume was far in excess of that obtainable from the ordinary single triode or pentode, and the quality of reproduction well balanced—there being a fixed tone correction circuit across the secondary of the driver transformer to prevent undue shrillness with a pentode driver.

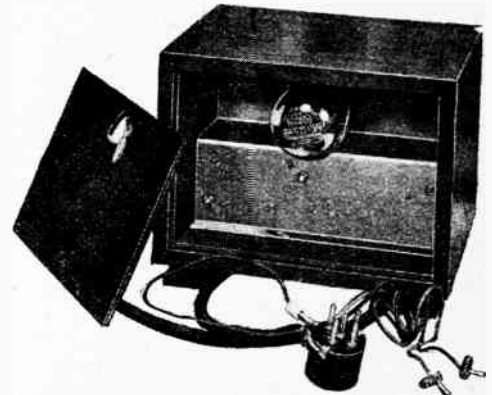

The Multitone Class "B" converter. No alteration to the wiring of the set is needed when using this unit.

The converter sells at 37s. 6d. without valve, and certainly represents good value for money; furthermore, it affords an extremely easy means of obtaining mains volume from a simple battery set.

How the Superhet Works. 7.

Single-Dial Tuning

The Alignment of the Oscillator Circuit

By W. T. COCKING

WHILE the superheterodyne is one of the most efficient types of receiver extant, certain adjustments are invariably necessary before it can yield its best. This article is of vital importance to the listener who desires that his superhet shall be tuned to give the highest performance. Most important among adjustments are those relating to the single-control tuning system.

IT has already been pointed out that the success of a superheterodyne depends upon two things—the soundness of the original design and the accuracy with which the various circuits are adjusted. From the point of view of the constructor the latter is more important, since it is he who must carry out the adjustments. All that he need do as regards the design is to satisfy himself that the receiver he chooses comes up to the required standard.

The most important adjustments are those connected with the single-control tuning system, for we have already seen that if the ganging is not accurate the advantages of the pre-selector in removing second-channel and kindred forms of interference are lost. It is as well, therefore, to examine the question in some detail, for there is no doubt that the adjustments necessary are rather more complex than those for a straight set.

In a set of this type, we assume that each section of the gang condenser has exactly the same capacity at every dial setting. Each circuit is required to be tuned to the same frequency, and this will be obtained if each coil has the same inductance, and the stray capacities on all the circuits are identical. This last requirement is achieved in practice by connecting

small-capacity condensers across each circuit, so that the stray capacities may be artificially equalised. Ganging, therefore, is carried out by the simple process of tuning-in a low wavelength station and adjusting each trimmer in turn for maximum signal strength. Provided that the final setting is such that an increase or decrease in the capacity of any trimmer reduces signal strength, the actual trimmer capacity does not matter at all, as far as ganging is concerned. If too much capacity be used, of course, the tuning range will be restricted, and it will no longer be possible to tune-in stations

on wavelengths as low as 200 metres; the ganging, however, will be quite accurate.

Now, in the superheterodyne it is only the pre-selector circuits which can be ganged in this simple manner, for the oscillator must not be tuned to the signal frequency, but to a frequency 110 kc. higher. In general, there are two practical methods by which this may be achieved. The first is the padding circuit, and it is almost universally employed in America and in many British commercial receivers; the second is the shaped-plate tracking system; it is quite rare in America, but fairly common in this country.

Let us first consider the padding circuit. With this the gang condenser can be of any ordinary type, with identical sections; in addition to the usual parallel trimmer, however, a padding condenser is connected in series with the oscillator section. The arrangement may be seen from Fig. 1; the circuit LC represents one of the pre-selector circuits, L being the tuning coil, C the variable condenser, and Ct the trimmer. The more complex network is the arrangement adopted for the oscillator, and L1 is the coil, C1 a section of the gang condenser identical with C, C1t the parallel trimmer, and C2 the padding condenser. At low dial settings the capacity of C2 is large compared with that of C1, so that the total capacity is nearly equal to that of C1 and Ct

together. The oscillator circuit capacity, therefore, at this end of the tuning range will be roughly the same as the capacity of one of the signal frequency circuits. The necessary frequency displacement between the circuits is thus obtained by choosing a lower value of inductance for L1 than for L.

Even with this lower inductance, however, the oscillator circuit would be tuned to too low a frequency at high dial settings if the padding condenser were not used. At this end of the range, therefore, this

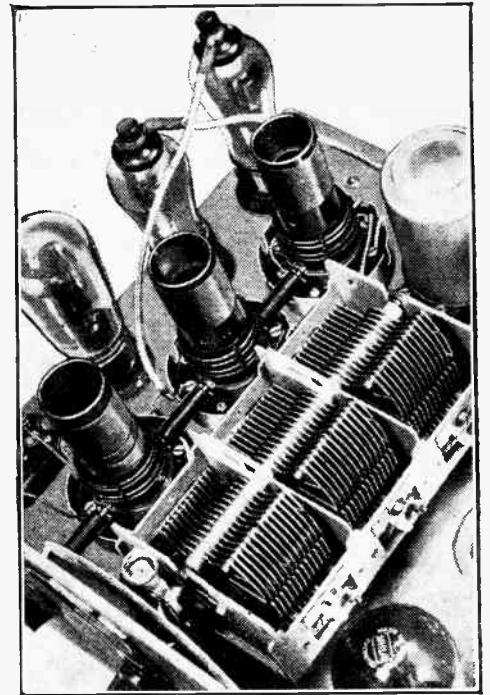

If the superhet is to give of its best, the alignment of the ganged circuits must be carried out with care.

condenser is adjusted to such a value that the oscillator circuit capacity is appreciably less than that of the other circuits. In theory, completely accurate ganging over the whole tuning range is impossible, and perfection can only be obtained at three points in the waveband; the maximum error, however, need be no more than 2 or 3 kc.

The Padding Condenser

In practice, the designer fixes the values of the coil inductances, the padding condenser capacity, and the minimum circuit capacities, and, for the ganging to hold, these must all be reproduced exactly in the receiver. A set of matched coils will usually be obtained, but the correct capacity values must normally be obtained by a system of trial and error. At the start, probable settings are assumed for C2 and C1t, a low wavelength station tuned in, and the pre-selector trimmers adjusted for maximum response. A station at the top of the medium waveband must then be found, and C2 adjusted while rocking the tuning dial backwards and forwards over a few degrees until the optimum combination of settings is found. This rocking of the tuning dial is necessary because an adjustment is being made to the oscillator circuit, and it is always this circuit which controls the dial settings in a superheterodyne.

Now the adjustment of the padding condenser throws out slightly the previous setting of the oscillator trimmer Ct, so that a return to the low wavelength station is necessary for the readjustment, not of this, but of the pre-selector trimmers. A further adjustment of the padding condenser may then be needed, and so on. After alternating several times between the different adjustments, correct ganging will be obtained at the two ends of the wave-

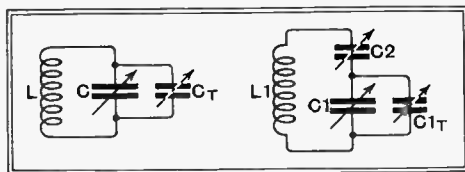

Fig. 1.—The tuning system when the padding circuit is used necessitates the insertion of an adjustable condenser C2 in the oscillator circuit.

How the Superhet Works—

band. The ganging at the middle of the range, however, will not be correct unless the pre-selector and oscillator stray capacities have their correct relative values.

It is therefore necessary to check the ganging at the middle of the range, and if it be found inaccurate, the capacity of C_T must be appropriately altered; the amount of the alteration needed will be largely based on guess-work. The whole process described above must then be gone through again and a further check made at the middle of the tuning range. If the ganging here is still inaccurate, C_T must be changed again and the circuits re-ganged at each end of the range, and still another check made at the middle.

It will be seen, therefore, that the process is quite complicated, and likely to take some time, particularly if one is without previous experience. It is not so difficult as it sounds, however, and the arrangement is perfectly feasible. In the case of a commercial receiver, of course, where suitable calibrated instruments are available, the process is much easier.

A Simplified System

With the shaped-plate ganging system, however, the adjustments are much simpler, and the arrangement is much more suitable for amateur use; furthermore, it can give more accurate ganging. With this system a special gang condenser is used in which the sections used for tuning the pre-selector circuits are of ordinary type, and identical in every respect, but in which the oscillator section has specially shaped plates to obviate the need for a padding condenser. The arrangement is illustrated in Fig. 2, where L , C , and C_T represent, as before, the inductance, tuning condenser, and trimmer, respectively, of the pre-selector circuit, and L_1 , C_1 , and C_{1T} are similar components in the oscillator.

As with the padding circuit, the frequency displacement at low dial settings is obtained by making L_1 smaller than L , but at high dial settings it is maintained by the special shape of the condenser vanes, and not by the introduction of an extra series condenser. It is merely necessary, therefore, that the coils should have their correct inductances, and the stray capacities be given their correct relative values. A matched set of coils will usually

be obtained, and the adjustments, therefore, are limited to the trimmers.

At the start a value is assumed for C_T , a low wavelength station is tuned in, and the pre-selector trimmers adjusted for maximum response. A station at the other end of the waveband is then found, and C_T is adjusted while rocking the tuning dial backwards and forwards until the optimum combination of settings is determined. A return is made to the low wavelength station and the pre-selector trimmers are re-adjusted. Usually this will complete the ganging for the medium waveband, but if the original choice of capacity for C_T was very widely out, it may be necessary to repeat the process.

It will be seen, therefore, that with this method of ganging not only is the adjustment to the padding condenser avoided, but the necessity for checking the ganging at the middle of the tuning range is obviated. The system thus represents a considerable simplification, and even the inexperienced need have no hesitation in tackling the adjustments; with a little practice the whole process can be carried out in less than five minutes.

Although the oscillator condenser vanes are specially shaped to avoid the necessity for a padding condenser, this can only apply to a single waveband. Even if we use this type of condenser, therefore, a padding condenser will still be necessary on the long waveband. This need occasion no difficulty, however, since the medium waveband adjustments determine the correct values for the stray capacities. On the long waveband, therefore, only the padding condenser needs adjustment. The complete arrangement is shown in Fig. 3, with the waveband switching. In the pre-selector, an additional coil is thrown into circuit on the long waveband, but there are no further adjustments.

In the oscillator circuit an additional coil, L_2 , and a padding condenser, C_2 , are inserted, and the correct capacity for C_2 is found by the simple process of tuning in a station on the upper end of the waveband and adjusting C_2 while rocking the tuning dial until the optimum combination of settings is found.

It will be seen, therefore, that the ganging is in no way difficult. It should be pointed out, however, that correct ganging is dependent upon the attainment of the proper relative stray circuit capacities, and if this cannot be obtained the ganging will be inaccurate. When building a

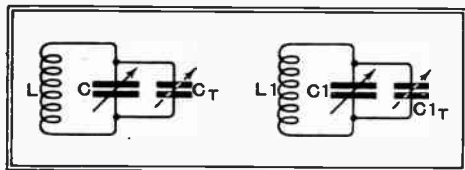
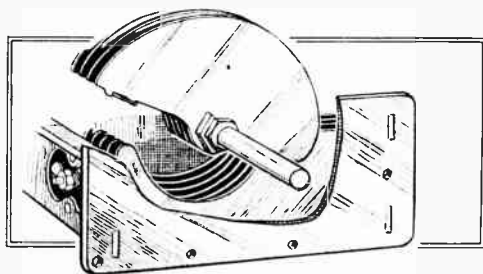

Fig. 2.—When the shaped-plate ganging system is employed, the oscillator circuit differs only in the value of components from the others.



The oscillator section of a shaped-plate gang condenser, showing how the fixed vanes are cut away to maintain the ganging.

Previous articles of this series have dealt with the following stages of the superheterodyne receiver; (1) The signal frequency stage; (2) the H.F. stage and the oscillator; (3) the frequency changer and the I.F. amplifier; (4) the second detector; (5) the first detector; (6) whistle interference.

receiver, therefore, it is important to keep the stray capacities, excluding the trimmer capacities, as nearly as possible to the values allowed for by the designer. The use of a different type of screened wire or valve-holder, for instance, may so increase the stray capacities that correct ganging is impossible. This would not occur in a straight set, for correct ganging would still be obtainable in spite of a general increase in capacity, and the only effect would then be to restrict the wavelength range.

The importance of correct ganging cannot be too highly stressed, for it is chiefly upon this that the designer relies for freedom from second-channel interference and whistles generally. In the removal of the latter much may be done by the correct adjustment of the operating conditions of the first detector, and by taking pains to avoid overloading the valves, but correct ganging is undoubtedly the chief safeguard.

We have now travelled through the superheterodyne, touching upon every portion of the apparatus peculiar to it, and going in some detail into the more important sections. Owing to limitations of space it has not been possible to deal exhaustively with any single portion of the receiver; a complete account of the operation of frequency-changing alone, for

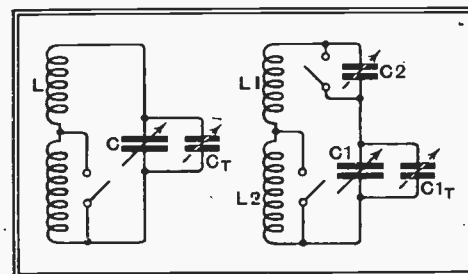

Fig. 3.—The shaped-plate circuit showing switching for two wavebands; a padding condenser C_2 is necessary for the long waveband, but its adjustment is easy.

instance, would occupy many more pages than have been devoted to the whole of this series of articles. It is hoped, therefore, to deal with certain of the more important questions which have been left untouched here, or only cursorily treated, in the future.

Radio International. A glossary of about 900 technical terms in 5 languages:—German, English, French, Spanish and Italian. In addition to the general list in which the various equivalent terms are arranged in parallel columns in the alphabetical order of the German words, each of the other languages has a separate alphabetical list of terms with reference numbers corresponding to those in the general list.

Compiled by Ernst A. Pariser and published by Union Deutsche Verlagsgesellschaft, Berlin. Price R.M. 3.50.

McMICHAEL Duplex Super Five



FEATURES

Type.—Frame aerial self-contained battery receiver with Class "B" output valve. Moving-coil loud speaker. Provision for external aerial, loud speaker and gramophone pick-up. **Circuit.**—Screen-grid H.F. with tuned grid coupling; grid detector with magnetic reaction; first L.F. stage; driver valve; Class "B" push-pull output valve. **Controls.**—(1) Tuning with "Duplex" dial calibrated in wavelengths. (2) Trimmer. (3) Volume control and on-off switch. (4) Reaction. (5) Waverange. **Price.**—19 guineas. **Makers.**—McMichael Radio, Ltd., Slough, Bucks.

An Economical Self-contained Battery Receiver

THE design of this table-model self-contained receiver is based on portable set practice of which this firm has an unrivalled experience. A frame aerial is fitted inside the cabinet, which stands on a ball-bearing turntable, and can be rotated to make use of the directional properties of the frame. The reproducer is of the moving coil type, and is fed by a Class "B" push-pull output valve which gives excellent volume and quality with a long battery life.

The early stages of the receiver do not differ greatly from those of the "Duplex Four" described in the issue of this journal for April 14th, 1933. The signals from the frame aerial pass through a screen-grid H.F. stage, in which volume is controlled by a filament resistance, to a leaky grid detector, and thence through parallel-fed transformers to an intermediate L.F. amplifier before reaching the special push-pull valve and its preceding driver valve. Cells incorporated in the H.T. battery supply the bias for the driver valve, and also for the H.F. and first L.F. stages through a potential divider which is automatically disconnected when the set is switched off.

The controls of the set are not difficult to operate, and the beginner should at once be able to obtain good results from his local stations. At the same time, the set is one which responds to skilful handling, and when the interdependence of the reaction and balancing controls are properly understood and full use is made of the directional properties of the frame aerial, a wide choice of foreign programmes is available. Sockets are provided for the addition of an external aerial and earth, but these should

be necessary only in districts where pronounced screening or absorption is evident.

The Duplex tuning dial, in which the pointer moves to the appropriate scale when the waverange switch is operated, is already a well-known feature of McMichael sets. Volume is controlled by reaction or, alternatively, by the filament resistance incorporated in the on-off switch at the right of the control panel. As the filament volume control is rather sluggish in action it is preferable to reserve its use for cases where the local station is too loud with reaction at minimum, and where it is inconvenient to turn the frame aerial in order to reduce volume.

The quality of reproduction is good, and considerably more volume is available without distortion than in the average battery receiver with a normal output stage. We were particularly impressed by the bass reproduction which goes down well below 100 cycles and is not coloured by any obvious resonance. From this point of view the performance is better than many mains receivers in which economy in the power supply is not a matter of importance.

In the "Super Five" the standing H.T. current when no signals are passing was found to be only 3.8 mA, and sustained loud passages drew about 25 mA. The average consumption at the maximum permissible volume may, therefore, be estimated at 8 to 10 mA., which is no more than that of a

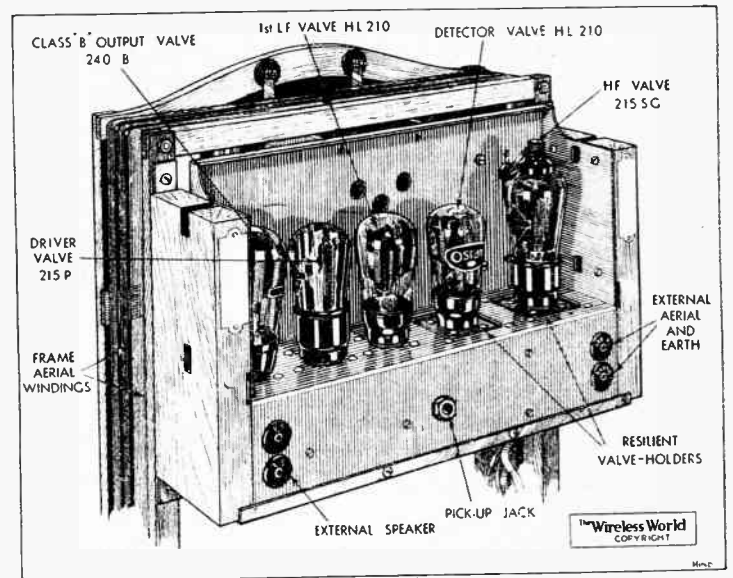

The chassis is mounted on the frame aerial unit above the battery compartment

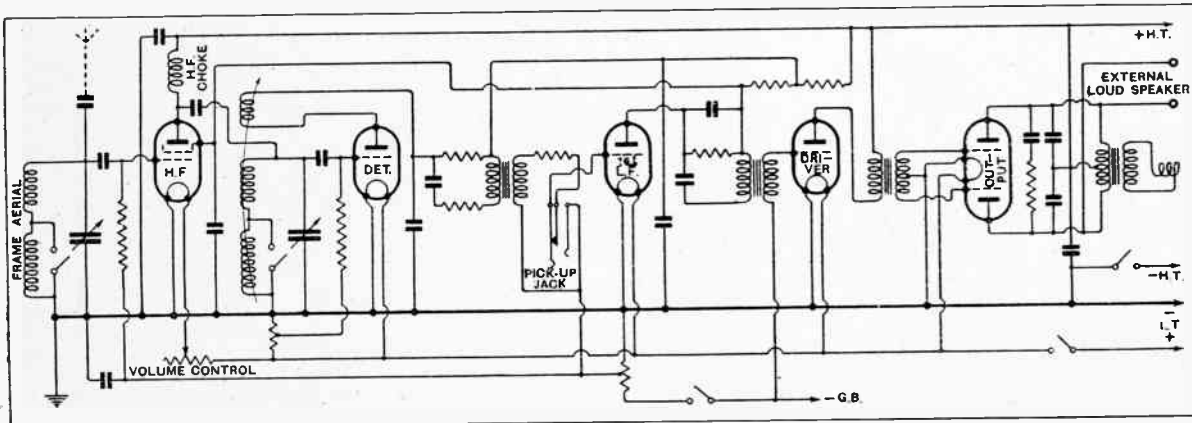

Circuit diagram showing connections of driver valve and Class "B" output stage.

portable with a normal output stage. For this expenditure of current a much greater volume with improved tone quality is obtained, while a much longer battery life is assured by the fact that the current is automatically reduced during intervals in the programme and when volume is low.

TRADE NOTES

F. C. Heayberd and Co., 10, Finsbury Street, London, E.C.2, have issued a leaflet dealing with Heayberd battery eliminators of constant voltage regulation for Class "B" and Q.P.P. receivers.

S. Smith and Sons (Motor Accessories), Ltd., Cricklewood Works, Cricklewood, London, N.W.2, have introduced a double-capacity 120-volt dry battery tapped at 10-volt intervals for use with Class "B" amplifiers. The price is 17s. 6d.

News of the Week

Events of the Week in Brief Review

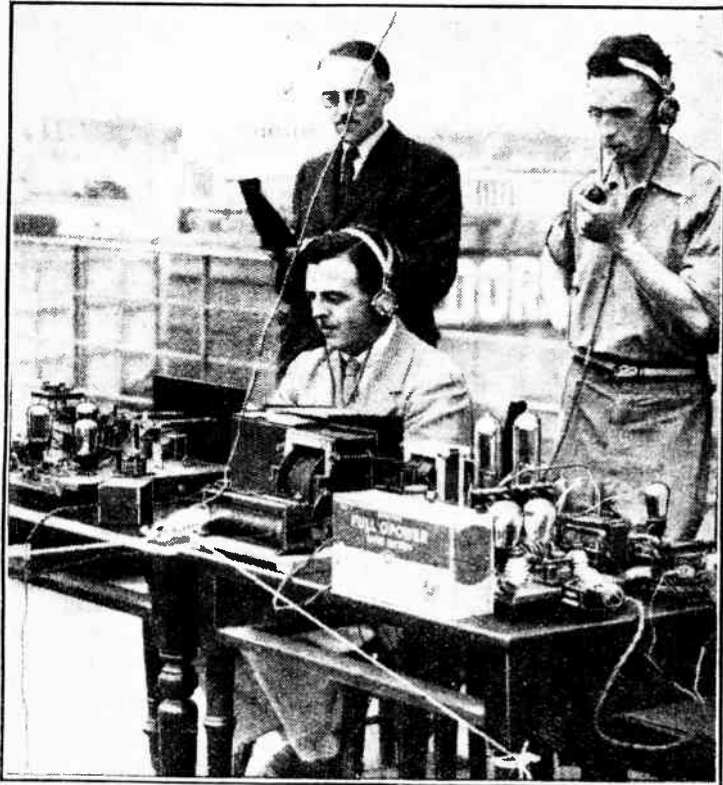

CALLING LONDON ON FIVE METRES. Mr. A. D. Gay (G6NF) transmitting test signals on 57 m.c. from the roof of *The Wireless World* offices on Sunday last. Many reports were received.

New Belgrade Station

A 40-kW Marconi broadcasting station is to be erected at Belgrade. This is the biggest item in the reorganisation of Yugo-Slavian broadcasting, which follows a redistribution of listeners' fees between the broadcasting organisations and the Post Office.

Demonstration Licences

THE Radio Traders' Federation and the Post Office in New Zealand are negotiating for the establishment of a system of free monthly demonstration licences, enabling prospective purchasers to test receivers without having to take out a licence for the whole year.

The R.N.W.A.R.

GOOD progress is being made with the Royal Naval Wireless Auxiliary Reserve, which was formed at the end of 1932 to provide a reserve of operators for service in the Navy in the event of a national emergency. The membership on January 1st last was one hundred, and has now risen to 175, seventy-five of whom are transmitters.

Instructional classes are held on Mondays and Thursdays at the Admiralty. A special short-wave transmitter has been designed by Mr. G. A. Exeter, and the sketches and drawings will shortly be ready for issue to members.

Those wishing for information regarding the Royal Naval Wireless Auxiliary Reserve should apply to: The Admiral Commanding Reserves, Queen Anne's Chambers, Tothill Street, London, S.W.1.

A Royal Visit

PRINCE GEORGE paid a visit to the works of the British General Manufacturing Co., Brockley, on Friday, June 23rd. He was shown over the factory where electrical and radio accessories are manufactured.

His Royal Highness displayed a sound knowledge of radio technique.

A Queen's Station

THE Queen of Bulgaria, the daughter of the King of Italy, has received a novel present in the shape of a 3-kW broadcasting station, given her by the City of Rome. It is understood that the Queen's own station will shortly be testing.

Sofia, the capital of Bulgaria, at present owns a station of only $\frac{1}{2}$ kW. When sufficient capital can be found a powerful 100-kW transmitter is to be erected near the city.

Broadcasting for All

UNION RADIO, Madrid, is inaugurating a new feature. In future anyone is to be given access to the microphone who has something of interest to say or to play. The studio is to be opened to musicians, authors, artists, writers, dramatists, and scientists. One fly in the ointment may stem the rush of applicants; everyone must consent to a reasonable preliminary process of selection, and they must give satisfactory evidence of the possession of the necessary talent.

This seems to be the usual requirement of broadcasting organisations.

Lucerne: The Non-Signatories

IT now appears that to the seven countries which abstained from signing the Lucerne Plan must be added Hungary, bringing the total of intransigents to eight. And what (writes a correspondent) was the reason for their objections? Poland, Finland, Holland, Sweden and Lithuania all objected to the treatment they received on the long-wave band; this, also, was the reason for the refusal of Luxembourg to sign. Greece may sign without delay. Hungary is probably sore at the fact of not getting a 700-800-metre wave for Budapest No. 2.

Whatever the objections, the Plan de Lucerne without all signatures is no Plan at all, and some powerful diplomacy on the part of the International Broadcasting Union will be necessary between now and January 15th, 1934, when the "Plan" is scheduled to come into effect. If the differences are not smoothed out by

then, it is difficult to see how long-wave listening, at least, will be possible. Probably the International Broadcasting Union, at its meeting in Holland this autumn, will effect certain compromises or 'glissements,' to use a diplomatic term.

Fortunately, certain of the stations in the Lucerne Plan are not yet constructed, and pending their completion, it may be possible to lend their wavelengths to more insistent transmitters.

Luxembourg

"IS Luxembourg free to do what she likes?" is the question arising out of the fact that while Luxembourg signed the Washington Radio Convention and ratified the Plan de Prague, she has signed and ratified neither the Madrid Convention nor the Lucerne Plan.

So disgusted were the Luxembourg representatives at losing their long-wave channel, that they left the Conference hall five days before the end.

FIVE-METRE 'PLANE TESTS

London-Liverpool-Hull Flight on Sunday

THE postponed five-metre 'plane tests are to take place, weather permitting, on Sunday next, July 8th, when, at 10 a.m., Mr. S. G. Morgan (G6SM) will begin his flight in a Gypsy Moth from Croydon and proceed to Liverpool, transmitting speech on 50 m.c. practically throughout the journey. At intervals the call sign G6SM and the 'plane's registration letters G-ACCY will be radiated in morse.

The approximate time-table will be as follows:—

London ..	10.0 a.m.
Aylesbury ..	10.30 a.m.
Daventry ..	11.0 a.m.
Birmingham ..	11.20 a.m.
Stafford ..	11.40 a.m.
Stoke ..	11.50 a.m.
Liverpool ..	12.15 p.m.

On the return journey the approximate localities and times should be as follows:—

Liverpool ..	3.0 p.m.
Manchester ..	3.30 p.m.
Leeds ..	3.50 p.m.
Hull ..	4.30 p.m.
Lincoln ..	4.55 p.m.
Stamford ..	5.30 p.m.
Bedford ..	6.0 p.m.
London ..	6.30 p.m.

Reports, which will be warmly welcomed from any district, should be in log form, mentioning time and nature of reception, signal strength, quality, presence or absence of fading, etc., etc. All communications should be addressed either to Mr. S. G. Morgan (G6SM), 3, High Street, Croydon, Surrey, or to the Editor, *The Wireless World*, Stamford Street, London, S.E.1.

Amateurs in the London area were given an opportunity to calibrate their five-metre receivers on Sunday last, July 2nd, when Mr. A. D. Gay (G6NF) transmitted almost continuous tests (speech

and I.C.W.) from 11 a.m. to 7 p.m. from the roof of *The Wireless World* offices in Stamford Street, S.E.1.

A number of reports were received from districts so far apart as New Southgate, Maida Vale, Victoria Park, Blackdown, Oxstead and Tatsfield. Once during the afternoon five-metre reception was picked up from a moving car "somewhere in Kent."

To enable listeners to the 'plane tests to calibrate their sets the following gentlemen have kindly undertaken to radiate 50 m.c. tests to-day and to-morrow (July 7th and 8th):—

G2IO.—J. Lees, 17, Trevoze Gardens, Sherwood, Nottingham; July 7th, 10.30 to 11 p.m.

G5TN.—, 87, Shaftesbury Road, Hammersmith, W.6, working duplex with

G5NR.—E. G. Nurse, 1, Cambridge Road Hammersmith, W.6; July 7th and 8th, 11.20 to 11.30 p.m., 11.40 to 11.50 p.m.

G6WJ.—V. Parker, 83, Mount Crescent, Thornes Road, Wakefield, Yorks; July 7th, 9 to 9.45 p.m. ('phone); July 8th, 10 to 10.30 p.m. ('phone), 11.30 to 12 midnight (I.C.W. and 'phone).

G2WD.—G. McLean Wilford, 33, Bibury Road, Hall Green, Birmingham ('phone: Springfield 2134); July 7th and 8th, 9 to 10 p.m. ('phone).

G5LS.—R. Bloxam, 12, St. Michael's Avenue, South Shields; July 7th, at 6, 7, 10 and 11 p.m.; July 8th, at 2, 3, 4, 5 and 11 p.m.

G6TW.—J. Noden, Coppice Road, Willaston, Nantwich, Cheshire; July 7th, 9.30 to 9.45 p.m.; July 8th, 4.15 to 4.30 p.m.; 9.30 to 9.45 p.m.

G2NH.—E. A. Dedman, 63a, Kingston Road, New Malden, Surrey; July 7th, 11 to 12 pm.

LABORATORY TESTS

New Radio Products Reviewed



Fluxite complete soldering outfit.

FLUXITE SOLDERING SET

MANY who are quite skilled in constructional work eschew soldering because of a mistaken idea that it is difficult to master. On the contrary, soldering is particularly easy provided a suitable equipment is employed; furthermore, having once acquired the art, considerable time can be saved in constructing a wireless receiver.

The Fluxite Soldering Kit provides all the necessary equipment, and enables anyone to tackle ordinary repair or constructional work entailing soldering. It is very compact and consists of a soldering iron, a tin of Fluxite soldering paste, several sticks of soft solder, and a small spirit lamp. This gives an intense flame which is thrown out horizontally, and is about four inches long. Its principal use is for heating the work to be soldered, but if other means of heating the iron are not available, it could be employed for this purpose.

The outfit includes, also, a small handbook giving a full description of how to solder, and much other useful information on soldering in general.

The makers are Fluxite, Ltd., West Lane Works, West Lane, Rotherhithe, London, S.E.16, and the price of the complete outfit is 7s. 6d.

PERCOLITE EARTH TUBE

MADE by Aerialite, Ltd., 10, Amber Street, Manchester 4, the Percolite earthing device consists of perforated copper tube 10½ in. long and one inch in diameter and filled with a special salt. When the protecting wrapper is removed and the tube sunk in the ground the chemical percolates the surrounding soil and results in a marked

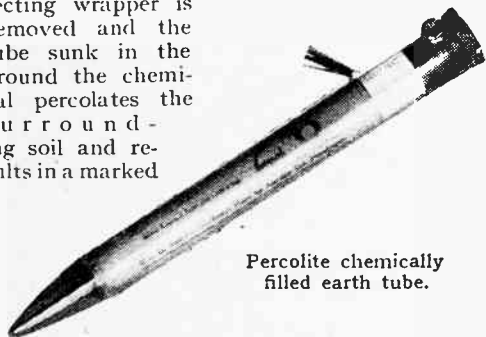

Percolite chemically filled earth tube.

reduction in its resistance over a wide area. The chemical does not appear to be of a hygroscopic nature and it would seem that it relies for its effect on the presence of moisture in the earth. Its action will, therefore, be accelerated if after the tube is in position the ground is thoroughly wetted in

the vicinity of the earth tube. A terminal is provided for connecting the earth lead and the price is 2s. 6d.

NEW RADIOPHONE CONDENSERS

TO the range of condensers made by the British Radiophone, Ltd., Aldwych House, Aldwych, London, W.C.2, has now been added two new models. One is a small two-gang unit totally enclosed and having the trimmers placed on the top. The style of construction adopted is similar to that of the condenser assembly embodied in their "Radiopak," and has the advantage that it requires the minimum baseboard space. Each section has a nominal capacity of 0.0005 mfd., and the price is 15s.

The two sections in the specimen tested were quite well matched throughout, but as this is the first sample of the new style we have examined, criticism on the accuracy of alignment of the two capacities will be deferred until production models become

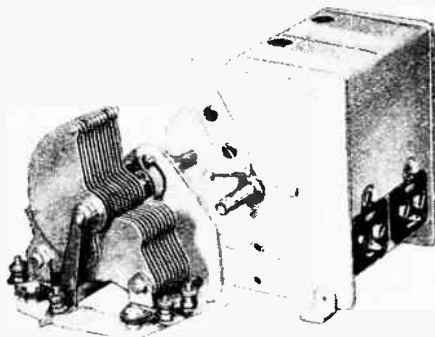

British Radiophone new model two-gang condenser and single unit embodying two small fixed condensers.

available for test. The style of construction, however, allows for very accurate adjustment, since each condenser is fitted with segmented end-vanes in the rotor sections.

The trimmers have a total capacity of 90 m-mfds. of which 64 m-mfds. represents the variable portion. The total change in capacity of each condenser is 482 m-mfds. (0.000482 mfd.) It is understood that for the present this new style will be made in the two-gang type only.

The other new model is a single 0.0005 mfd. condenser assembled on a stout bent metal frame and fitted with a single bearing for the rotor. It is fitted with a single hole fixing bush, and includes, also, two small fixed condensers, one plate of which is the supporting frame for the stator section. These condensers have mica dielectric and could be used one as a grid condenser and the other as an aerial series condenser in a single-tuned circuit receiver. There are, however, several other uses to which they could be put.

The measured minimum and maximum capacities are 17 m-mfds. and 492 m-mfds. (0.000492 mfd.). Each small fixed condenser was found to have a value of 102 m-mfds. (0.00012 mfd.). An enclosed pigtail is fitted for the electrical connection to the moving vanes, and the price is 8s.

RADIOLAB VALVE AND SET TESTER

THIS test set has been designed to enable the service engineer, the radio dealer, and the experimenter to undertake practically every test, whether this be of a complete wireless receiver, valves, or components, in a simple, straightforward manner. Each stage in a set can be checked separately by the simple process of removing each valve in turn, mounting it in the socket provided on the test set, and inserting a special adaptor in the vacant valve-holder in the receiver. All the voltages and currents can then be measured under working conditions, so enabling a faulty valve or a breakdown in any part of the receiver to be located in a few minutes.

Provision is made for dealing with three-electrode valves, screen-grid valves, and pentodes, either battery or mains-operated, the necessary alterations in the test set being effected by means of switches.

When checking the voltages and currents in certain types of mains receivers we were unable at first to obtain a true reading of grid bias voltages, since it was found that the presence of a grid leak or a grid decoupling resistance affected the reading. If the bias is derived from a resistance in the cathode lead, and these other resistances are included in the circuit, it will be necessary to join the grid of the valve to the earth line before taking a reading of grid bias.

Another precaution that should be observed in this case when checking the anode currents of H.F. or I.F. circuits, is to guard against H.F. instability when the valve is transferred to the test set. Should this take place, the anode current reading will not be a true one, and it will be necessary to short-circuit the grid circuit to suppress oscillation.

In addition to the applications mentioned above, the test set can be employed for measuring A.C. and D.C. voltages up to 1,000 volts, resistances up to 250,000 ohms, and it can be employed, also, as a signal generator for finally checking the working of the set.



Radiolab complete valve and set tester in portable carrying case.

The Radiolab Complete Valve and Set Tester is one of the most versatile instruments of this type we have examined; furthermore, it is particularly well made. The price is £12 12s., and the makers are the Radiolab Manufacturing Co., Sandridge Works, St. Albans, Herts.

Broadcast

The Belfast Mystery

SINCE the exclusive report in these columns that a site has been definitely chosen for the new B.B.C. high-power station in Northern Ireland, the air has been thick with the usual refutations. I can only repeat, possibly with a little more emphasis, the information previously given. The site has been selected, and although I must not name the exact locality, it is a few miles from the city in the centre of one of the most fertile potato-growing districts in Northern Ireland.

An announcement will shortly be made.

The New Organ: Strange Time-table

DESPITE the introduction of the new organ at Broadcasting House, it does not appear that we are to have a glut of organ music; indeed, it looks as if the ordinary evening listener will have few opportunities of hearing the new organ in the next few weeks.

A Quiet Hour

I hear that there will be a series of recitals from the Concert Hall on August 4th, 11th, 18th, and 25th, but these are to be given at the extraordinary hour of noon to 1 p.m., when probably 95 per cent. of listeners have their thoughts far removed from organ music. From 1 to 2 p.m. would be a more reasonable time, for then the jaded worker could at least steal a few moments from his lunch hour to pick up the strains outside a cut-price radio shop.

Small Audience

I am surprised that so eminent an organist as Sir W. G. Alcock should be engaged to play at a time when so few can listen.

Successful B.B.C. Test

CONGRATULATIONS to the B.B.C. engineers on the success so far achieved in synchronising West National and London National transmitters. I hear that "car radio" has been employed after midnight by some of the engineers who have roamed the Wiltshire countryside in the wee sma' hours trying to pick up the heterodyne that never came.

It seems that the two stations are synchronised in very fact. So far the B.B.C. has not dared to experiment before midnight, but I have no doubt that, judging by these results, listeners will have little to complain of when tests begin during programme hours.

Broadcasting Hall at Olympia

IT is good to have confirmation of the rumour, to which I was able to give first exclusive publication, that this year's Olympia Wireless Show will be notable for a huge Hall of Broadcasting, from which four or five concerts will be broadcast.

Listeners will not only be able to see how broadcasting is carried out in the studio, but they will be given an insight into the technical side; the Balance and Control Section will be present in force.

Twice Daily

In addition to the broadcast concerts, there will be other performances twice daily during the period of the Show.



DUKE ELLINGTON. The famous American jazz leader addressing one of the new condenser microphones during his recent broadcast from London.

By Our Special Correspondent

A Hot Place

THE comedy of the blinds promises to arouse considerable interest at Broadcasting House in the next three or four months.

Those who have surveyed that noble west façade will remember that no blinds or shutters mar its chaste whiteness. This spectacle is quite satisfying to one standing in the shadow of the Langham Hotel, but to the workers inside the building, half-blinded and half-roasted by the afternoon sun, other thoughts occur.

The other day green blinds were fitted inside the windows, and when it was discovered that these brought no relief (the glass conducting the heat just as much as ever), the more favoured officials were able to install grey silken curtains.

Not even these, however, helped "the green thought in the green shade," and now there is a campaign afoot to provide the whole of that western front with external green shutters.

Green Shutters

What Colonel Val Myer, the architect, says (or thinks, which may be worse) I do not know. Whatever is done must be uniform. Probably the staff will get their way, and the green shutters will be ordered and installed just before the November fogs begin.

U.I.R. and Interference

HOW fortunate it is that the International Broadcasting Union is not one of those bodies with a single idea, like the flat earth cranks or early-morning swimmers in the Serpentine. Although it has been up to its neck in wavelength problems, the Union has spared the time to consider the problem of interference, with the result that it is represented at the Electrotechnical Commission now meeting in Paris to consider man-made static from the international point of view.

Brevities

Selfishness

The Union realises only too well that the finest of wavelength schemes can be wrecked by the selfish thoughtlessness of the local static-maker.

New Gear at Brussels

Among other subjects which have occupied the attention of the International Broadcasting Union is the policing of Europe's wavelengths. New tuning-fork control as a secondary standard frequency has been obtained for Brussels, and other new equipment includes a thermostat for the tuning forks, and a heterodyne for obtaining beat notes.

There is also new short-wave measurement gear and apparatus for field-strength measurement.

Television from the Crystal Palace

IT has long been hoped that the B.B.C. would provide facilities for television transmission on the ultra-short waves from Broadcasting House. Just now, however, the B.B.C.'s ultra-short-wave transmitter is deserted, and possibly forgotten, in the excitement attaching to the Lucerne wavelength scheme.

In the meantime, I hear that the Baird Television Company is taking time by the forelock by installing ultra-short-wave gear on the top of one of the Crystal Palace towers.

Chance for 5-Metre Workers

It is understood that a contract has been signed which will involve experimentation over a number of weeks, and those readers of *The Wireless World* who have constructed the "Ultra-Short-Wave Two" may soon feel encouraged to construct simple television gear for operation therewith.

The New Scottish Director

NOT a few of the B.B.C.'s most successful henchmen have come from Aberdeen, and the Reverend Melville Dinwiddie, the new Scottish Regional Director, is in the same worthy tradition.

Mr. Dinwiddie, who was born in 1893, took his M.A. degree at Edinburgh in 1914, and served with distinction in the Gordon Highlanders throughout the war, being awarded the D.S.O., O.B.E., and M.C. He has been associated with St. Machar's Cathedral, Aberdeen, since 1924.

Payment in Kind

I HAVE just been regaled with another strong argument against sponsored programmes. Apparently, owing to the economic crisis, a number of French firms which had signed publicity contracts with broadcasting stations have been unable to pay the piper after the programmes have been broadcast. The stations have had no alternative but to accept payment in kind, with the result that the managerial offices of some studios are now replete with magnificent carpets, tablecloths, and other trimmings.

One station received a letter from a defaulter in these terms: "The state of my treasury compels me to ask you to accept 200 Yo-Yos and a number of dolls, each of which says 'Mamma' simply on being squeezed."

Correspondence

The Editor does not hold himself responsible for the opinions of his correspondents.

Correspondence should be addressed to the Editor, "The Wireless World," Dorset House, Stamford Street, S.E.1, and must be accompanied by the writer's name and address.

Location of the Speaker

I WAS very pleased indeed to read, under your "Editorial Comment" in the May 19th issue, the article on "Location of the Speaker," and hope to see this matter referred to again.

Rarely, if ever, is the best position for the speaker also the best position for the set, and for best results the speaker should not be built into the receiver.

Wireless World designers have offended in this matter in the past, and I am pleased to see that the "Ferrocart 3" was laid out with the idea of using the speaker apart from the set.

It is to be hoped that this practice will be continued in all future designs.

G. L. CANTRILL.

St. Helens, Lancs.

"Increasing Bass Response"

BOTH Mr. Willans and Mr. Pohn decry the practice of boosting the bass by means of mechanical resonance of the pick-up, and in this I concur generally.

I think that, as with many other things, it is a case for moderation. A pick-up with excessive resonant mechanical compensation is surely a bad pick-up, and I think this point was brought to light in the article, the purpose of which was to show that with a good pick-up having a *moderately* rising bass characteristic the output of the amplifier might yet be "down" on the lower frequencies, but that this defect might be made good to some extent by the careful application of the simple electrical resonance method described.

Precise application necessitates a study of the pick-up response, so that the electrical resonant frequency may be placed to the best advantage for the particular pick-up in use.

This point would obviously be where a pronounced "dip" occurred in the response curve above, say, 40 cycles. As pointed out in the article, very little compensation is obtainable below this region.

South Shields. R. BLOXAM.

Components

IN the issue of the *Wireless World* for May 26, 1933, I noticed in the Correspondence columns a letter from Mr. E. J. B. Curtis, of Bournemouth, the subject being "Prices." While not necessarily disagreeing with Mr. Curtis as regards the basic principles of his arguments, I should like to point out the inaccuracy of one or two of his remarks.

First, regarding the bakelite shrouding of modern interval transformers. Without having given the matter much thought I can immediately think of the following advantages to be gained from this shrouding, apart from the matter of appearance. Here are a few.

1. Exclusion of dust and damp. Dampness causes rusting of laminations and possibly corrosion of windings, with consequent electrical breakdowns.
2. Mechanical protection for transformer.
3. Cheapness of construction. This is the

very point Mr. Curtis has been aiming for. The bakelite moulding enables us to dispense with all terminal strips, clamps for the laminations, feet for mounting on base-board, etc. Also the transformer can be assembled rapidly owing to the absence of bolts and nuts, because in many cases the bakelite is shaped internally so as to form a clamp for the core. Assembly costs are then very low.

4. Better electrical efficiency in some cases due to the fact that no holes for clamping need be punched in the laminations. Admittedly, some non-shrouded transformers can also claim this advantage.

Later in his letter Mr. Curtis states "It is . . . fashion to cellulose with a nice grey 'paint.'" The use of the word "paint" when referring to "cellulose enamel" is hardly accurate and is certainly not complimentary to our manufacturers, especially in view of the splendid finish obtained by this means on many components. Might I point out the very, very obvious reason for using this finish, beyond adding to price? It is simply to prevent the steel chassis and covers, now commonly employed, from rusting under atmospheric action. Surely manufacturers can hardly be blamed for having this object in view.

In point of fact Mr. Curtis has little sense of proportion, and at the outset should realise that, of the total cost of a component, possibly as much as 50 per cent. is absorbed by advertising, retail and wholesale profits and research work, not to mention overhead expenses. There are many cases where the bare cost of production is only 10 per cent. of the selling price, so it is a poor policy to base all cost-cutting on that alone.

G. M. MEW.

Canterbury.

Automatic Volume Control

IN spite of the experiments quoted by Mr. Haynes in the *Wireless World* of June 9th, I am unwilling to believe that the signal of a weak transmission is partially demodulated before it reaches the second detector of a superheterodyne.

With a linear first detector, both E. B. Moullin (*Wireless Engineer*, Vol. 9, p. 378) and Aiken (*Proc. I.R.E.*, April, 1933, pp. 624-5) have shown that any such effect is negligible; and it is improbable that a square law detector would give a greater demodulation effect than a linear one. Moreover, since the local oscillator must provide an output appropriate to the strongest signal to be received, one would expect the demodulation effect to be noticeable over a fairly wide range of signal strength.

If the experimental result (a), "that very little signal voltage is developed at the second detector until a certain initial value of signal voltage is applied at the aerial terminal," refers to carrier voltage at the second detector, I must admit that I can offer no explanation; but neither can the demodulation hypothesis explain a reduction in carrier strength. It is difficult to judge without numerical data, but I would suggest that the lack of proportionality be-

tween the voltage across the output load and the second detector input on weak signals may be due to the behaviour of this detector. The signals may be so weak that the diode is no longer linear, or, alternatively, a small bias would give a delay effect, reducing the sensitivity to signals below a critical value. D. A. BELL.

Oxford.

Volume and Tone Controls

WHATEVER the technical advantages of A.V.C., from the listener's point of view, if there is to be a choice of one of the two I should say that *variable* tone control is of far greater importance.

In every set there is usually a manual volume control for use, but often and often one has to put up with uncomfortable and ear-rending reproduction because of the lack of a variable tone control. A few makes have a "fixed" tone control which enables one to go from one extreme to the other by means of a switch, but generally some intermediate point is most suitable, according to the type of matter broadcast.

Therefore, if manufacturers have to choose between the two, the variable tone control would be more useful, while the A.V.C. may be more "fashionable" next year. A set having both incorporated would naturally be more completely equipped.

A. A.

Liverpool.

DISTANT RECEPTION NOTES.

QUITE apart from the new wavelength plan to which it has given birth, the Lucerne Conference has been marked by several achievements of the highest importance to the listener. All of the countries whose representatives signed the Convention have agreed that none of their stations may make any change in its wavelength or its power except by common agreement. This in itself is one of the biggest steps yet made towards international co-operation in policing the ether. Of great importance, too, is the agreement to limit the power of stations working between 272.7 and 549.4 metres to 100 kilowatts, with a few exceptions; that of stations between 240 and 272.7 metres to 60 kilowatts and that of stations on lower wavelengths to 30 kilowatts. Then there is the undertaking to enforce "ten cycle exactitude" on most of the international common waves—at the present moment the *inexactitude* of these waves is often much nearer ten kilocycles!

I am afraid, though, that long-distance enthusiasts must wait a little before flinging up their hats to celebrate the coming of a wireless Utopia. There are still seven countries which have not yet signed the Convention and, though it is expected that they will fall into line, there is no guarantee that they will do so. Since the seven in-

Distant Reception Notes—

clude Holland, Sweden, Poland and Luxembourg, all of which own high-powered stations, it is obvious that if they do not agree the whole of the carefully worked out plan may be wrecked. Luxembourg is perhaps the biggest problem of all. She owns only one station, but this is a 200-kilowatt giant designed to work on a wavelength in the neighbourhood of 1,200 metres. Under the Lucerne Plan Luxembourg is assigned a wavelength of 240.2 metres and thus scrapes by 20 centimetres into the 60-kilowatt class. But to bring the power down to 60 kilowatts and to reduce the wavelength to 240.2 metres would entail something very like a complete reconstruction of the transmitting plant.

To the long-distance man the new plan may seem disappointing in some ways, for not a few of the stations that we now hear well are put down to share wavelengths and will therefore probably not be receivable after the middle of next January completely free from interference. To enable stations to cover their own service areas must always be the primary consideration of any well-thought out plan and this is the underlying idea of the Lucerne scheme. It seems to me, though, that the long-distance man is not too badly treated for he will still have a very large number of stations to provide him with genuine alternative programmes and with the increases in power that many of these will undergo during the next few months a wide choice of stations should be available for him all the year round.

Possibility of Improved Reception

As I write we are still going through a period of thundery weather which has already lasted for a fortnight without intermission. Atmospherics have therefore been a great nuisance at most times. The all-round field strength of stations, however, continues to be excellent and as soon as more stable weather conditions arrive first-rate reception should prevail once more.

On the long waves Radio-Paris, Zeesen, Warsaw and Luxembourg are still worthy of note, and on the medium band stations which show a consistently good record are Brussels No. 1 and No. 2, Prague, Langenberg, Lyons Doua, Berömunster, Paris Ecole Supérieure, Rome, Katowice, Leipzig, Hamburg, Strasbourg, Milan, the Poste Parisien, Breslau, Hilversum, Heilsberg, Turin and Trieste. Stations frequently well heard are Florence, Söttens, Brno, Göteborg, Gleiwitz and Fécamp.

D. EXER.

VIENNA VISITED

Inspecting the New 100 kW. Transmitter at Bisamberg

By DR. ADOLF ERDÖS

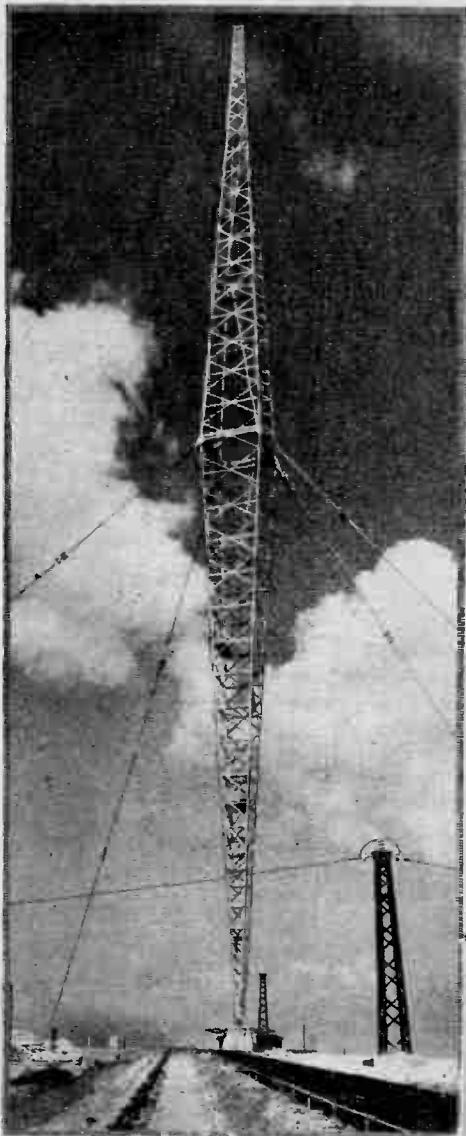

(Above) The 400-foot mast which actually forms the aerial. A portion of the counterpoise and one of its supports is seen in the foreground.

(Below) The control desk, from which the entire station can be operated. Safety switches permit of instant stoppage in case of emergency.

IN outward appearance the new 100 kW. broadcasting station at Bisamberg, near Vienna, resembles no other station in Europe. The transmitter building is the last word in modernity, while the 400ft. mast, which actually forms the aerial, gives the station a compact, self-contained look.

When the 100 kW. transmitter began its radiations on May 28th reports of good reception were received from all parts of the Continent, though the transmission during daylight, so the reports reveal, does not greatly exceed that of the old transmitter at Rosenhügel.

An engineer conducted me over the station. The Telefunken transmitter is served by three groups of Diesel engines supplying 1,400 h.p., and generating 3,308 volts at 50 cycles. The various voltages required are obtained from transformers and mercury arc rectifiers, and the total anode supply is 650 kW. In the final stage two 300 kW. valves are used. Each of these is 6ft. high, and requires a heating current of 1,800 amperes at 15 volts. The entire station can be operated from a central point, pressure on a single button being sufficient to start up the generators and radiate the carrier wave.

The weight of the aerial tower approaches sixty tons, and the whole is supported on a porcelain insulator, tested to take a strain of a hundred tons. At the earlier station trouble was experienced with the earthing

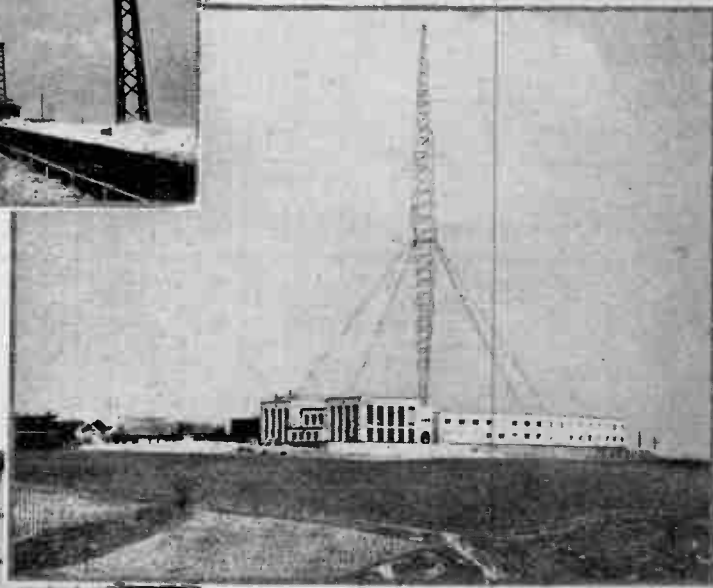

This general view of the station reveals its modern and efficient layout.

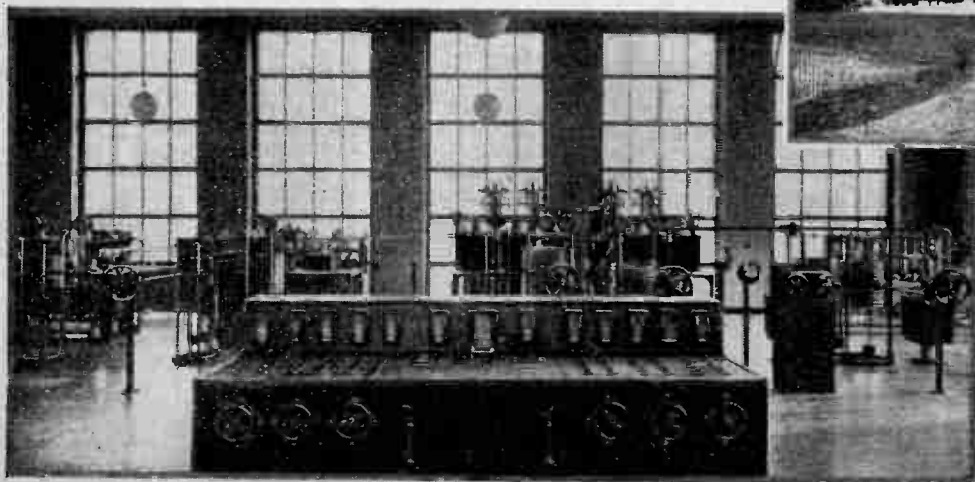

arrangements; consequently, Bisamberg dispenses with an earth, using a counterpoise mounted on a number of posts some 40ft. high and consisting of about ten miles of wire.

Two huge rotating light beams function after dark for the guidance of 'planes. For the safety of aircraft in daytime the aerial tower is painted alternately red and white, making it easily visible at a very great distance.

READERS' PROBLEMS

Erratic Reception

THE so-called mains aerial should be regarded rather as a makeshift device, likely to be uncertain in its action, and only to be used where nothing better is practicable. The behaviour of a mains aerial can never be foretold with confidence, as its efficiency as a collector is likely to be affected by circumstances beyond the control of the user.

A correspondent, who is using one of these aerials, complains of serious changes in signal strength which occur even during the day time; he therefore concludes, quite rightly, that true fading is not responsible. It has been confirmed by the use of a detector anode meter that the changes are real, and not imaginary. The set behaves quite normally when operated in another house with an outside aerial.

There can be little doubt that this variation in signal strength is caused by the switching on or off of various electrical appliances connected to the supply system

densers joined between each anode of the output valve and H.T.+) should be applied.

The "Sunbeam" Circuit

IN the circuit diagram of the "Sunbeam" Model U35 receiver, reviewed in our issue of June 23rd, there was a regrettable error in the connections of the valve heaters and H.T. supply. To those who are familiar with "Universal" A.C.-D.C. sets the correct connections will be obvious, but many readers who do not understand how a receiver, without any alteration, can work on either A.C. or D.C. supplies, were naturally puzzled. We tender to them our apologies, and reproduce in Fig. 2 a simplified diagram showing the correct arrangement of the feed circuits for both H.T. and heater current.

The rectifier is of course essential when the set is operated on A.C., but becomes a "passenger" on D.C. supplies, and offers

can only recommend that provision should be made for reducing the input to the receiver from the exceptionally large aerial which is in use.

A Class "B" Conversion

THE "All-Wave Monodial" was, of course, designed long before the days of Class "B" amplification, but there is no reason why it should not be altered to include this modern refinement.

Several readers have written to us for advice on this subject, and, as is usual when the question arises of modifying an existing receiver, it is recommended that the present output valve be converted into the driver, which in turn is linked to the added Class "B" valve by a special transformer.

The receiver in question includes an output pentode; in the interests of simplicity it may be preferred to replace this by a low-power three-electrode valve, but, provided suitable precautions are taken, the pentode may be retained as a driver. These precautions consist in using a Class "B" transformer of rather higher ratio than would otherwise be needed, and in taking extra measures against over-accentuation of high notes.

A Compensating Resistance

A CORRESPONDENT proposes to adopt for his new A.C. receiver a published design for an H.F.-det.-L.F. circuit, but, for the time being, wishes to omit the H.F. stage. It is realised that the omission of this valve will bring about a rise in H.T. voltage, and we are asked to say how this may be prevented.

The easiest, and generally the most satisfactory, way of maintaining the H.T. voltages intended by the designer is to connect, in place of the H.F. valve, a loading resistance across the source of H.T. supply.

To calculate the value of this resistance it will first be necessary to estimate the sum of the currents normally consumed in the H.F. valve anode circuit, the screening grid circuit, and by the associated S.G. potentiometer, if any. The necessary value of loading resistance (in ohms) is then found by dividing "H.T. voltage" by "total current," the latter being expressed as the fraction of an ampere.

The Wireless World

INFORMATION BUREAU

THE service is intended primarily for readers meeting with difficulties in the construction, adjustment, operation, or maintenance of wireless receivers described in *The Wireless World*, or those of commercial design which from time to time are reviewed in the pages of *The Wireless World*. Every endeavour will be made to deal with queries on all wireless matters, provided that they are of such a nature that they can be dealt with satisfactorily in a letter.

Communications should be addressed to *The Wireless World* Information Bureau, Dorset House, Stamford Street, London, S.E.1, and must be accompanied by a remittance of 5s. to cover the cost of the service. The enquirer's name and address should be written in block letters at the top of all communications.

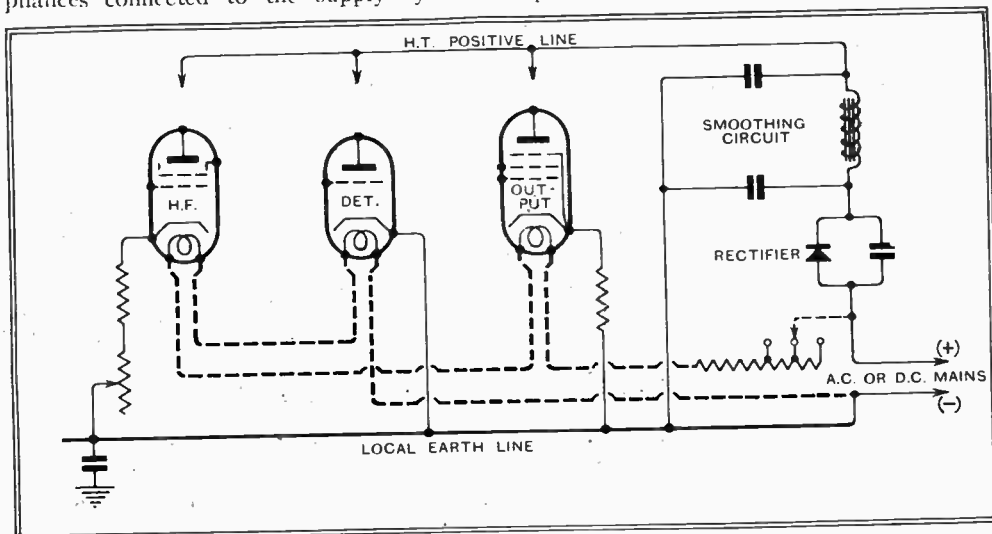

Power supply circuits of the "Sunbeam" "universal" receiver, which functions on either A.C. or D.C. supplies. This simplified diagram will help to explain the underlying principle of most A.C.-D.C. sets.

which our querist is using. The efficiency of a mains aerial often depends to a great extent on the nature of the devices connected to the wiring in the immediate vicinity of the set.

Spurious Oscillations

IT is not always easy to recognise the symptoms of parasitic oscillation in an output stage, but this trouble should always be suspected when, for no obvious reason, reproduction is not up to the standard expected.

A querist, who has added Class "B" amplification to his receiver, suspects that this form of oscillation may be present; he states that quality is poor, and that volume is disappointing.

We agree that self-oscillation may be taking place. If, in addition, measurement shows that anode current in the output stage is unduly high; this opinion will be confirmed almost beyond doubt. The usual remedy (a pair of 0.005 mfd. con-

an almost negligible resistance to the passage of anode current to the valves.

Overloaded First Detector

MOST users of superheterodynes know by now that, if the design be a good one, an excessive number of whistles can generally be attributed to incorrect "ganging" of the signal-frequency and oscillator circuits; another type of heterodyne whistle is caused by adjusting the L.F. amplifier in such a way that it embraces an unduly wide band of frequencies.

Still another possible cause of this trouble is an overloaded first detector; this trouble may occur over a relatively wide band of wavelengths when the set is operated in the immediate vicinity of a power station. From a description of operating conditions submitted by a correspondent, we are inclined to think that this is the cause of his own particular trouble. As the number of "pre-selector" tuned circuits already in use cannot, practically speaking, be increased, we

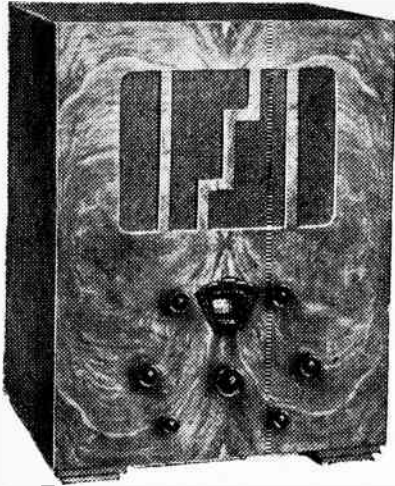

Important Notices to "W.W." Readers

On Monday next, the 10th inst, we are moving into our new freehold factory premises at 18-20, NORMAN'S BUILDINGS, CENTRAL STREET, E.C.1. These premises, comprising 13,000 square feet, have been equipped with the most up-to-date plant and machinery, which will place us in the position to supply the highest grade of Components and Receivers at fair and reasonable prices. Our Cabinet-making plant is second to none in the country, and we shall continue to cater for the individual requirements of our customers. Spacious demonstration and showrooms will enable visitors to inspect the very latest examples of Receiver design and Cabinet-making craftsmanship. Readers of the "Wireless World" will be interested to know that we have acquired the services of MR. W. I. G. PAGE, B.Sc., the designer of many Receivers of outstanding merit, who in future will act as Consultant and Technical Adviser to the Company. Our customers will thus be assured of the benefit of Mr. Page's many years' experience in Receiver design and technique. **COMPETITION DESIGNS.** We wish to thank the 3,753 readers who have submitted designs in the competition which closed on the 1st inst. The winning designs will be available for inspection at the forthcoming Radio Exhibition at Olympia.

Come and hear

"THE WIRELESS WORLD"

CLASS "B" FERROCART RECEIVER

The most outstanding Battery Set of the Year.

1. Every order for Kits of parts is delivered by our own vans direct to the forwarding London Terminus Station and placed on passenger train within two hours of receipt. Thus delivery to your address is effected within a few hours.
2. Every component is exactly of the designer's first choice, and is unconditionally guaranteed. Any Component found to be faulty will be instantly replaced without question or charge.
3. The Kits are complete down to the smallest detail. Every screw, nut and washer required is included.
4. The services of our technical staff are at the disposal of every customer. Our interest does not end with the sale of the Components and every assistance is available to the constructor in case of doubt or difficulty.
5. We will test free of charge any Receiver constructed from a "G.A.C." Kit of parts.

KITS AS SPECIFIED

(Designer's first Choice).

KIT 'A' Complete (less Valves, Batteries, Cabinet and Loud Speaker) £7-11-0

KIT 'B' Complete with Valves (less Batteries, Cabinet and Loud Speaker) £9-17-3

KIT 'C' Complete with Valves, Cabinet and Loud Speaker (less Batteries) £13-9-3

Cabinet, as illustrated £1 . 12 . 6



FREE. In view of the phenomenal interest taken in this wonderful circuit, we have reprinted 10,000 copies of the original article which appeared in the "Wireless World" of April 7th last and readers are invited to send for a copy, which will be forwarded gratis and post free on application.

THE CITY ACCUMULATOR CO., LTD.

18-20, NORMAN'S BUILDINGS, CENTRAL STREET, E.C.1.

(Nearest station, Old Street.)

Phones:

Clerkenwell 1038 and 6206.

NOTE THE NEW ADDRESS AND TELEPHONE NUMBERS

WEST END SHOWROOMS: 4, Surrey St., STRAND, W.C.2. Phone: Temple Bar 8620.

Give your Loudspeaker a chance— follow the B.B.C.

MOST loudspeaker cabinets spoil low notes and speech with "boom" or resonance, making perfect reproduction impossible. There is only one way to prevent this, the way the B.B.C. itself has chosen. Every loudspeaker in Broadcasting House is fitted with the Howe Box Baffle—and it does the job!

Why not make your existing speaker just as perfect? Easily, simply, economically. Why suffer from "boominess" any longer? It requires no technical knowledge, no skill to fit a Howe Box Baffle to your present loudspeaker. Here are a few enthusiastic extracts from unsolicited letters: "Astonished at the wonderful improvement." "Results are simply marvellous." "Almost incredible improvement." "Really Excellent." "Enormous improvement. I congratulate you." "Improvement of speech and music was wonderful." "The illusion is complete."

Follow the B.B.C. and you will find the results equally astonishing. You will fit a Howe Box Baffle sooner or later, so why not now?

Let us send you details FREE.

Let us send you full details of how you can fit a Howe Box Baffle to your own speaker. The Kit, complete with full instructions and every single item required, can be obtained as low as 20/-.



POST FOR FREE BOOKLET
To F. McNeill & Co. Ltd. (Radio Dept. 25)
Head Office: 52, Russell Square, London, W.C.1.
Please send me booklet on the Howe Box Baffle.
Name _____
Address _____

Instal EXTRA LOUDSPEAKERS

and have wireless all over the house

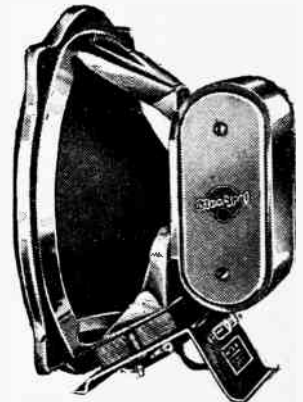

BLUE SPOT
Moving Coil
45 P.M. 45/-

Cabinet model 62 P.M. in walnut or mahogany 67 6. Other models to suit all pockets.

Blue Spot Loudspeakers can be used with your present set. Get one for the dining room, the nursery, the kitchen. Blue Spot is the best loudspeaker made. Accept nothing else.

TECHNICAL DETAILS.

High quality magnet—powerful and fluent energy. Transformer fitted with plugs and sockets for easy valve matching. Suitable for all output stages including Class B. Moisture proof cone and speech coil. No warping or fouling in the gap. Slide plates to exclude dust and foreign particles. Pure and lifelike reproduction.

BRITISH MADE



THE BRITISH BLUE SPOT COMPANY LTD.
BLUE SPOT HOUSE · 94/96 ROSOMAN STREET
ROSEBERY AVENUE · LONDON · E.C.1

Phone: Clerkenwell 3570. Grams: "Blue Spot, Isling, London."
Distributors for Northern England, Scotland and Wales: H. G. LEWIS & SONS (Sheffield and London) Ltd., 108, Leaton Rd., Sheffield; 22 St. Mary's Parsonage, Manchester; 177 Westgate Rd., Newcastle-upon-Tyne; 37, 38, 39 Clyde Place, Glasgow.

MISCELLANEOUS ADVERTISEMENTS

NOTICES.

THE CHARGE FOR ADVERTISEMENTS in these columns is

12 words or less, 3/- and 3d. for every additional word.

Each paragraph is charged separately and name and address must be counted.

SERIES DISCOUNTS are allowed to Trade Advertisers as follows on orders for consecutive insertions, provided a contract is placed in advance, and in the absence of fresh instructions the entire "copy" is repeated from the previous issue: 13 consecutive insertions 5%; 26 consecutive, 10%; 52 consecutive, 15%.

ADVERTISEMENTS for these columns are accepted up to **FIRST POST ON MONDAY MORNING** (previous to date of issue) at the Head Offices of "The Wireless World," Dorset House, Stamford Street, London, S.E.1. or on **SATURDAY MORNING** at the Branch Offices, 19, Hertford Street, Coventry; Guildhall Buildings, Navigation Street, Birmingham; 2; 260, Deansgate, Manchester; 3; 26, Renfield Street, Glasgow, C.2.

Advertisements that arrive too late for a particular issue will automatically be inserted in the following issue unless accompanied by instructions to the contrary. All advertisements in this section must be strictly prepaid.

The proprietors retain the right to refuse or withdraw advertisements at their discretion.

Postal Orders and Cheques sent in payment for advertisements should be made payable to **LILFLE & SONS Ltd., and crossed Notes being untraceable if lost in transit should not be sent as remittances.**

All letters relating to advertisements should quote the number which is printed at the end of each advertisement and the date of the issue in which it appeared.

The proprietors are not responsible for clerical or printers' errors, although every care is taken to avoid mistakes.

NUMBERED ADDRESSES.

For the convenience of private advertisers, letters may be addressed to numbers at "The Wireless World" Office. When this is desired, the sum of 6d. to defray the cost of registration and to cover postage on replies must be added to the advertisement charge, which must include the words Box 000, c/o "The Wireless World." All replies should be addressed to the Box number shown in the advertisement, c/o "The Wireless World," Dorset House, Stamford Street, London, S.E.1. Readers who reply to Box No. advertisements are warned against sending remittance through the post except in registered envelopes; in all such cases the use of the Deposit System is recommended, and the envelope should be clearly marked "Deposit Department."

DEPOSIT SYSTEM.

Readers who hesitate to send money to advertisers in these columns may deal in perfect safety by availing themselves of our Deposit System. If the money be deposited with "The Wireless World," both parties are advised of its receipt.

The time allowed for decision is three days, counting from receipt of goods, after which period, if buyer decides not to retain goods, they must be returned to sender. If a sale is effected, buyer instructs us to remit amount to seller, but if not, seller instructs us to return amount to depositor. Carriage is paid by the buyer, but in the event of no sale, and subject to there being no different arrangement between buyer and seller, each pays carriage one way. The seller takes the risk of loss or damage in transit, for which we take no responsibility. For all transactions up to £10, a deposit fee of 1/- is charged; on transactions over £10 and under £50, the fee is 2/6; over £50, 5/-. All deposit matters are dealt with at Dorset House, Stamford Street, London, S.E.1. and cheques and money orders should be made payable to Lilfle & Sons Limited.

SPECIAL NOTE.—Readers who reply to advertisements and receive no answer to their enquiries are requested to regard the silence as an indication that the goods advertised have already been disposed of. Advertisers often receive so many enquiries that it is quite impossible to reply to each one by post. When sending remittances direct to an advertiser, stamp for return should also be included for use in the event of the application proving unsuccessful.

2 FROM 150 WATTS
WATTS to 150 A.C.
UNDISTORTED OUTPUT

STANDARD POWER AMPLIFIER EQUIPMENT FOR ALL PURPOSES. AND FULL RANGE OF P.A. SPEAKERS AVAILABLE FOR:—

DANCE HALLS, SPORTS GROUNDS, HOTELS, FACTORIES, SHOPS, ETC.

TANNOY P.A. EQUIPMENT IS INDIVIDUALLY BUILT—NOT MASSED PRODUCED.

Write for full particulars and demonstration.

TANNOY PRODUCTS

(GUY R. FOUNTAIN LTD.)

DALTON STREET, W. NORWOOD, S.E.27. MANCHESTER, BIRMINGHAM, SCOTLAND, IRELAND.

RECEIVERS FOR SALE.

BETTER Part Exchange at Appleby's, 109, Edgware Rd., Hyde Park, London, W. [2650]

MONODIAL 21-watt Power Unit with Valves; offers—Box 7402, c/o The Wireless World. [3014]

"SPENODE" Radiogram, 5 watts output, for sale, £30, a bargain.—Box 7401, c/o The Wireless World. [3013]

S.T.400 Console cabinet, Mullard S.G. and Pen. valves, Inductor speaker, guaranteed new; cost £13, £8. Goddard, 16, Derby Rd., Watford. [3027]

PHILCO 5-valve Superhet. A.C. 1933. listed at 16 guineas, new and unused, in original packing; sacrifice, £12 10.—Wolsey, 274, High St., W.3. [3028]

MORE Part Exchange Receiver Bargains for Disposal; state approximate requirements for quotation.—Conntis, Wireless Engineers, Horley. [2613]

CLIMAX All-electric 200-250 A.C. Band Pass Three, in walnut cabinet, complete with valves and moving coil speaker; listed £16/16, unopened, £8/8, c.o.d., carriage paid.

OSTER-GANZ Combined A.C./D.C. All-electric Set, 3 valves and Magnavox moving coil speaker, in walnut cabinet; listed £11/11, our price £4/19/6, c.o.d., carriage paid.—Kay, 167, City Rd., Finsbury, E.C.1. [2635]

QUALITY Amplifier, all resistance coupled, 5 watt output, optional field supply, will work off needle armature pick-up, with valves; £14, or nearest.—Spottiswoode, Wellington, Berks. [2955]

PHILIPS Super 3-stage Portable Amplifier, cost approximately £90, our price £20; Philips drum type speaker, £4/10; Vitavox 6v. horn units, 50; also R.K. and Rola P.A. speakers, mains transformers, etc. Raymart, 44, Holloway Head, Birmingham. [3030]

ACCUMULATORS—BATTERIES.

EXIDE and Oldham H.T. Battery, 120 volts; 27 6.—19, Sternhold Av., Streatham Hill. [3031]

CHARGERS AND ELIMINATORS.

VORTEXION, Wimbledon, for the latest type transformers, all with screened primaries and

12 MONTHS Guarantee, absolute reliability (we supply talkie equipment); regulation guaranteed within 5% all models except snipers, which are 2½%; you cannot buy more reliable or better looking transformers, not a pre-set shrouding, but a substantial casing free from hum; fitted with detachable feet for mounting in any position.

VORTEXION—Specified for A.C., quality amplifier, 400 volts 110 m.a., 4v. 3, C.T.; 4v. 2, 4v. 1, C.T., terminals, 24; tagged leads, 20; shrouded, 24/-.

VORTEXION—Ferrocart III, 350-0-350, 60 m.a., 4v. 2.5, C.T., 4v. 3.5, C.T.; open type 13, 6, shrouded 16/-; post 9d.

VORTEXION—250-0-250, 4v. 1 to 2a., 4v. 2 to 4a.; open type 10 6, shrouded 12 6; post 9d.

VORTEXION—Super model for H.T. 8 or 9 or 10, 4v. 1 to 2, 4v. 2 to 4; open type 14, 6, shrouded 16, 6; post 1/-.

VORTEXION—2½-watt Monodial A.V.C. model; open type 14, 6, shrouded 16 6; post 1/-.

VORTEXION—5-watt Monodial A.V.C. model, 400-0-400, 120 m.a., 4v. 6a., 4v. 3½a., 4v. 2, 4v. 1a., super screened; 20/-, shrouded 24/-.

(This advertisement continued in third column.)

A definite advance IN AMPLIFIER DESIGN



This Savage type S220 Amplifier is just one of the new, redesigned Savage range. It delivers approximately 20 watt sound output and incorporates a number of innovations, including a vari-mu H.F. Pentode as first L.F. stage. Savage specialises in this class of work and can supply complete amplifier equipments to meet the requirements of any situation—race tracks, theatres, dance halls, etc. Send to-day for full particulars.

PRICES

Two stage, type S220, complete with valves £18 . 0 . 0
Three stage, type 320, complete with valves £19 . 10 . 0

Ask about the New Savage "M" Type Microphone.

SAVAGE

PUBLIC ADDRESS EQUIPMENT

W. BRYAN SAVAGE,
56 58, CLERKENWELL ROAD, LONDON, E.C.1



Chargers and Eliminators.—Contd.

(This advertisement continued from first column.)

VORTEXION, 350-0-350, 120 m.a., 4v. 2 to 5a., 4v. 2 to 4a., 4v. 2.5a.; open type 14 6, shrouded 16/6.

VORTEXION, 400 or 450 or 500v., 120 m.a., 4v. 2 to 5, 4v. 2 to 5, 4v. 2 to 5; open type, 19, shrouded 23/-.

VORTEXION, 400 or 450 or 500, 150 m.a., 4v. 4a., 4v. 2.5, 4v. 2, 4v. 2, 4v. 2, core size 2 in. x 1 in., a super job, 2% regulation; 35, shrouded, with terminals, less terminals, 30, open type 26; post 1/3.

VORTEXION Auto Transformer, to B.E.S.A. Specification, 100, 110, or 120v. to 200, 220 or 240 volts, 60 watts, 7 3, post 9d.; 120 watts, shrouded, 12 6, open type 10 6, post 1/-; 200 watts, open 14 6, shrouded 16/6, post 1/-; 500 watts 30, 2,000 watts £4 10.

VORTEXION 600-watt Transformers, £4/10, carriage free.

VORTEXION 30h. at 60 m.a. Chokes 5 6, 40h. at 60 m.a. 8 6, 50h. at 150 m.a., 200 ohms, 10 6 open type, 12 6 shrouded.

VORTEXION 200, 30 m.a. Eliminators, 110 or 220 input with 4v. 4a. winding, 37 6.

VORTEXION—Transformers made to your specification. All standards in stock. Phone; all hours.

VORTEXION (S. A. Brown), 182, The Broadway, W. M. Isledon. Tel.: Liberty 2814. [2694]

SERADEX Resistors. See test report, page 437, of issue dated June 16th of "The Wireless World."

WIRELESS World states: "Although an accuracy of 4% is claimed (for type M-150), the specimens tested showed a much closer agreement than this."

M-150 Resistors, 1½ watts rating, 8d. each, all values; **M-300** resistors, 3 watts rating, 1/3 each, all values; **SERADEX** G.125 Resistors, 25 ohms to 1,500 ohms, 9d.; 5,000 ohms, 1/-; 10,000 ohms, 1/3; intermediate sizes at next highest price.

SERADEX Glass-encased Resistors are Guaranteed Accuracy to within 2½%. "Wireless World" confirms this on page 437 of issue for June 16th.

SERADEX Filter Condensers, type B. "Wireless World" tested these and report that, tested at 800 volts, there was no sign of leakage.

SERADEX Type B Condensers, 1.0 mfd., 1/6; 2.0 mfd., 2 3; 4.0 mfd., 4 5; 4.24 mfd., 7 3; 8.8 mfd., 14 6.

FULL Illustrated Lists from Trevor Pepper, 48, Wakegreen Rd., Birmingham. [2616]

TANTALUM for A.C. Chargers, H.T. and L.T.—Blackwell's Metallurgical Works, Ltd., Garston, Liverpool. [2139]

180 Accumulator Chargers, ½ amp., 2-6v., in venetian (tinted metal case, with mains flex (Westinghouse rectifiers), 10 8; 1½ amp., 2½; 7 days' trial.—Arden Agency, Wollaston, Wellesborough. [2964]

N.P. for all Battery Chargers, A.C. mains; see display advertisement showing 105/- charger for L.T. and H.T. accumulators; a few slightly soiled instruments at bargain prices; trade lists.—Nash Products, Ltd., Stechford, Birmingham, 9. [3538]

HOYNE'S Transformers and Chokes the Best Obtainable, perfect insulation, regulation and reliability, used exclusively by discriminating set manufacturers, all fitted with tapped and screened primaries, filaments all centre tapped, stout cast aluminium clamps fitted to all models, also clearly marked terminal strips.

HOYNE'S Components are Guaranteed for One Year.

HOYNE'S Transformers Built to Your Specifications, at very competitive prices.

(This advertisement continued on next page.)

Mention of "The Wireless World," when writing to advertisers, will ensure prompt attention.

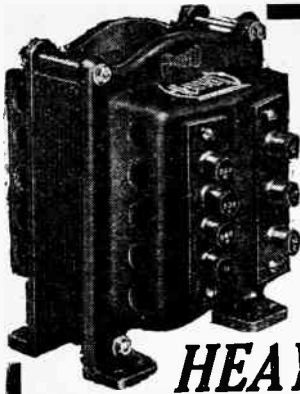

Some of the Latest Models from **HEAYBERD**

Recognised as Britain's leading Radio Transformer Manufacturers, Heayberd describe below three of their latest and best selling Transformers.

MODEL W.35
For use with Westinghouse H.T.11 Rectifier. Rectified Output 500 v. 120 ma. L.T. 4v. 5 amps. and 4v. 2 amps. Price 65/-

MODEL 803
Suitable for A Class Valves. Tappings 250 + 250v. 75 ma. 4v. 1 amp, 4v. 5 amps. Price 32/6

MODEL 723
Filament Transformer 4v. 3 amps. centre tapped. Price 12/6

Send 3d. stamps for 36 p. Book giving circuit diagrams for these Transformers



10, Finsbury Street, E.C.2. Phone: 7516-7-8 1 min. from Moorgate Stn.

MONARCH OF THE MAINS.

ANOTHER VALVE IN THE



UNIVERSAL HIGH VOLTAGE SERIES

D130 This new valve can be used as H.F. Detector, L.F. or last stage amplifier without any alteration in high voltage circuits and only slight alteration in others. Perfect for Resistance or Transformer coupling. Doubles volume, increases selectivity, reduces mains interference. It will work better than any detector valve previously offered here. Like all Ostar-Ganz high voltage valves it can be used on either A.C. or D.C. supply straight off the mains.

Characteristics: Impedance: 40,000 ohms. Amplification Factor: 100. Mutual Conductance: 2.6. Slope: 3.5 mA/V. Price 17/6. Write for complete List of Valves.



RECEIVER & AMPLIFIER KITS

British components. All instructions. Complete, ready for assembly. Highly efficient yet cheap, because the Ostar Universal High Voltage Valves cut out cost of transformers and breakdown resistances. Work on either A.C. or D.C.

2-VALVE RECEIVER £5. 15. 0 3-VALVE £8. 15. 0
2-VALVE AMPLIFIER £4. 4. 0 3-VALVE £5. 5. 0
3-VALVE RADIOGRAM KIT - £9. 15. 0

All prices include valves and resistors. Write for leaflet. EUGEN FORBAT, Sole Agent for Great Britain, 28-9, Southampton Street, Strand, W.C.2.

FIRST CLASS REPRODUCTION

AN UNREPEATABLE OPPORTUNITY TO SECURE A REAL B.T.H. **R. K. LOUDSPEAKER**



GUARANTEED NEW AT BARGAIN PRICES

Specification—6 in. diameter cone Moving Coil Loudspeaker giving full bass response and handling the output from the heaviest power valve. Far superior to many small modern moving coil speakers. Weight 30 lbs. Field winding to suit 6, 100, or 200 volts D.C. Send cash with order or C.O.D.

R. K. SPEAKER Originally listed at £6. 6. 0 Now offered for **30/-** A.C. MODELS £2. 10. 0

O. H. SEEKAMP, 46, FARRINGDON ST., E.C.4

Components, etc., for Sale.—Contd.

(This advertisement continued from previous page.)

PREMIER Chokes, 40 m.a., 25 hys., 4 -; 65 m.a., 30 hys., 6 -; 150 m.a., 30 hys., 10/6.

PYE Chokes, 20 or 32 hys., 4 -; Premier multi-ratio output transformers, giving 15 different ratios, 7/6.

PREMIER Eliminators, output 200-250 volt., 40-100 cycles, A.C., incorporating Westinghouse metal rectifiers, output 250v., 60 m.a., S.G. and 120v. taps, 42/6; with 4v. 4a. c.t. L.T., 7/6 extra.

PREMIER Eliminators, output 150v. at 30 m.a., S.G., and 100v. taps, with 4v. 3-4a. c.t. L.T., 37/6; or with trickle charger, 42/6.

PREMIER Eliminators, output 120v. at 20 m.a., S.G., and 100v. taps, 27/6; with L.T. trickle charger incorporated, 35/-.

PREMIER D.C. Eliminators, output 120v. at 20 m.a., S.G. and 100v. taps; 15/-.

ACCUMULATOR Chargers, 200-250 volts A.C., all incorporating Westinghouse metal rectifiers; 2, 4, and 6v. at 1/2 amp., 12/6; 2, 4, and 6v. at 1 amp., 17/6; 12v. 1a., 27/6; 6v. 2a., 35/-; 12v. 2a., 35/-; 12v. 1.5a., 30/-; 6v. 3a., 39/6; 12v. 3a., 42/6.

AMPHION High Inductance Chokes, resistance 2,500 ohms, 80 hys., 60 m.a.; 5/6.

WESTINGHOUSE Metal Rectifiers: 120v. at 20 m.a., 6/6; 180v. at 30 m.a., 8/6; 250v. at 60 m.a., 10/-; 300v. at 60 m.a., 11/-; 200v. at 100 m.a., 11/-; 8v. at 1/2 amp., 6/6; 6v. at 1 amp., 9/6; 12v. at 1a., 12/6; 6v. at 2a., 20/-.

KOLSTER BRANDES Electric Gramophone Motors, complete with turntables and automatic stop, 100-250v. A.C. and D.C.; list price 45, to clear 42.

B.T.H. Induction Type (A.C. only) Electric Gramophone Motors, 100-250v.; 30/- complete.

ROLA Type F6 Moving Coil Speakers, 2,000 or 6,500 ohms, with power or pentode output transformer, 17/6; A.C. conversion kit for this speaker, 10/- extra.

AMPHION Moving Coil Speakers, type E.M.644, dual fields, 2,500 and 5,000 ohms (100 and 200v.), with output transformer, 12/6; A.C. conversion kit for this speaker, 10/- extra.

WESTERN ELECTRIC Condensers, 250v. working, 1 mfd., 6d., 2 mfd., 1/-; 500v. working, 1 mfd., 1/-; 400v. working, 3 separate 4 mfd. condensers, 8/6.

T.C.C. Condensers, 250v. working, 4x4x1 mfd., 5/-; 300v. working, 4x4x2x2x2 mfd., 7/-; 300v. working, 4x4x2x1 mfd., 6/-.

SPECIAL Offer of Wire Wound Resistances—4 watts, any value up to 10,000 ohms, 1 -; 8 watts, any value up to 15,000 ohms, 1/6; 15 watts, any value up to 50,000 ohms, 2/-; 25 watts, any value up to 50,000 ohms, 2/6; 50 watts, any value up to 50,000 ohms, 3/6.

WIRE Wound Potentiometers, 15,000 ohms, 1/6; Centralab Potentiometer volume controls, 50,000 ohms, 2/-; wire wound Clorostat Potentiometer, 50,000 ohms, 2/6; Colerstats, logarithmically wound Potentiometers, 6,000 ohms, 1/9.

HEAVY Duty Variable Resistances, slider type, wound on porcelain, 2,000 ohms quarter-amp. and 500 ohms half-amp.; 5 - each.

FOR Callers Only.—The following valves, guaranteed as new: P.T.625, M.P., P.E.N., D.C.S.G., V.D.S., V.M.S., S.4V.A., A.C.S.G., A.C.S.G.V.M., V.M.S.G., 41M.S.G., V.M.S.4, M.S.4B, U.5, 904V., M.S.G.L.A., M.S.G.H.A., M.H.L.4, M.L.4, M.H.4, U.14, S.4V.B., D.W.3, P.T.4, D.S., D.S.B., M.S.4, 41M.L.F., M.V.S.G., A.C.H.L.; at half list price.

THE Last Few Western Electric 4211-D. Valves, 10v. 3a. filament, 750-1,000v. plate, 50-65 m.a., impedance 3,500 ohms, amplification factor 12; cost £5, to clear at 15/-.

500-VOLT 125-milliamp. Full Wave Rectifying Valves, 4v. 2 filament; 7/6.

PHILIPS 328 Valves for L.T. Charging, 5/6; 329 Barretter lamps, 2/-.

ALL the Following Lines 6d. each, or 5 - doz. as-sorted: Shielded S.G. or Pentode leads; 2ft. lengths of screened wire; 5-pin valve holders; Crabtree 5-amp. sunk switches; T.C.C. 0.1 mfd. condensers.

PREMIER SUPPLY STORES, 20-22, High St., Clapham, S.W.4. Macaulay 2188, Closed 6 o'clock Wednesdays, open to 9 o'clock Saturdays. Nearest Station, Clapham North Underground.

PREMIER, [3032]

MILDMAY RADIO EXCHANGE

OFFERS the Following, sound and perfect, all post paid.

FERRANTI A.F.5, 15/-; A.F.5c, 19/-; A.F.5cc, 20/-; A.F.7, 16/6; A.F.6, 16/6; B.I. chokes, 10/-.

POLAR 3-gang Condensers, 10/-; 2-gang ditto, 8/-; Jackson Unitone 2-gangs, complete with drive and screened, 10/-; Radiophone 3-gangs, fully screened, 16/-.

DIEHL Induction Motors, complete with auto. stop, listed at £4/15, each 35/-; Palliard induction motors, complete with fully automatic plate, brand new, 25/-.

RADIOPAN, complete, 35/-; Sonochorde 2,500, D.C., 17/6; pair Hola matched speakers, D.C., 35/-; Edison Bell De Luxe type P.M. speakers, 35/- each; Adaptogram, complete with Collaro Uniplate motor and pick-up, listed at £7/17/6, £3.

PHONE Clissold 5001. Open Thursday, closed Saturday 24, Midway Grove, London, N.1. [2971]

GILBERT INDUSTRIES Latest Offer:—

"D" Parcels, containing all the following high grade components:—One transformer, 350-0-350 at 60 m.a., 4v. 4 to 6a., C.T., 4v. 2a., one chassis and 3-valve holders, one H.M.V. 2-gang with trimmers, one 15 mfd. T.C.C. electrolytic, one 4+4 mfd. T.C.C. block, one volume control, 4 assorted resistances, 6 small assorted condensers, one Paxolin strip (10in.x4in.), one packet of "Varcos" insulating sleeving, 6 yds. heavy flex.

COMPLETE Parcel £1, post paid.—One "D" parcel and one A.C. Palliard motor, type 1504, universal input, complete with turntable, 42, post paid; also a few "A", "B" and "C" parcels still available. (See previous issues.)

TRADERS.—Do you realise that these parcels, when split up, will realise £3 to £4 in the shop?—Gilbert Industries, 519, London Rd., West-cliff-on-Sea. [3002]



MOVING COIL SPEAKERS

The Finest in The World in Each of Their Price-classes.

Ask your dealer or call for a demonstration at Exmouth House.

Send for New Booklet W.S.53. It is free.

EPOCH RADIO MANUFACTURING Co. Ltd. Exmouth House, Exmouth St., London, E.C.1 At the Junction of Rosbury Avenue and Farringdon Road.

Phone: Clerkenwell 6666 (4 lines).

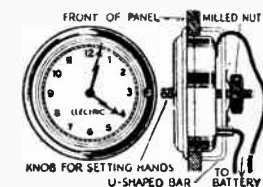

FIT THIS ELECTRIC CLOCK

TO YOUR SET! NO MAINS NEEDED! KEEPS CORRECT TIME! NO WINDING!

Works off small battery lasting 12 months, or can be plugged into G.B. Battery without affecting reception. Uses practically no current. Fits into hole 3 1/2" dia. in any panel up to 1/2" thick. Easy to fix—no screws required. Only 1" from front of panel to back of case. Swiss movement. Hands set from front. Nickel plated bezel. Useful addition to any set.



RIVERSIDE MFG. CO., LTD. COMPLETE WITH BATTERY POSTAGE 6D. Dept. 20, Crisp Rd., Hammersmith, W.6 Telephone: Riverside 6392.

ALL P.A. EQUIPMENT SHOULD INCORPORATE "SCIENTIFIC" EXPONENTIAL BAFFLES



Avoid wasted energy. Focus power over required area and save watts. Non-metallic material. Circular cross-section gives better forward tone.

Approx. 2' 6" long. MODELS FOR ALL TYPES OF EQUIPMENT. KEENEST PRICES. WE SOLICIT YOUR ENQUIRY. Lists on application.

SCIENTIFIC SUPPLY STORES (Wireless) Ltd. 126, Newington Causeway, London, S.E.1 Tel: Hop 4177.

PARIMA SELENIUM CELLS

FOR ALL PURPOSES.

Parima Light-Sensitive Resistances are constant, mechanically strong, moisture proof and exceedingly sensitive. Fully guaranteed for 12 months. 5/-

PARIMA MANUFACTURING CO. 21, BROMLEY ROAD, S.E.6. Hither Green 3629

WIRELESS DIRECTION FINDING

& Directional Reception By R. Keen, B.Eng. (Hon.) Second Edition (1927)

PRICE 21/- net. By Post 21/9

From leading Book-sellers or direct from

ILIFFE & SONS LIMITED Dorset House Stamford St., London, S.E.1 W.W.63

Components, etc., for Sale.—Contd.

GENUINE Manufacturers' Surplus by Leading Makers.

DOUBLE Smoothing Chokes Mounted, sound robust job, 120 m.a., 14.28 Henrys each; usual price 35/-, our price 6/6 each, 9d. postage; single ditto, 4/6 each, 6d. postage.

SMALL Iron Core Chokes, 2,000 ohms for output for choke coupling, 1/6 each, 5d. postage.

65 Only, massive twin gang, 0.0005 condensers with drum drive, change over switch and trimmers; original cost 45/-; our price 4/6 each, postage 9d.

14 Mfd. Block Condensers, 250v. A.C. working, 6:4+2+1-1, 2/6 each, 6d. postage.

WIRE wound resistances, finest quality at ridiculous prices: 3,000, 5,000, 8,000 ohms, 13,000, 15,000, 65,000 ohms; all 5 watt, worth 3/6 each; 6d. each, post 3d.; wire wound potential dividers, 60 watt wound 3 sections, 4,500 ohms+3,000 ohms+2,000 ohms, 1/6 each, post 4d.; 5 watt ditto, 20,000 ohms+20,000 ohms+20,000 ohms, 1/- each, 5d. post.

LIMITED Quantities of Bargain Parcels at 4/6 the lot, 1d. postage, containing: 1 1/2 mfd. Mansbridge type condenser, 250v. D.C. working; 1 4 mfd. Mansbridge type condenser, 250v. D.C. working, Mullard; 6 fixed condensers, various values; 2 grid leaks; 4 resistances; 1 Paxolin coil former; 3 Bakelite valve holders; 6 wander plugs; 1 bunch S.S. index cover-rod leads.

CASH with order, all orders despatched same day.

SURPLUS RADIO, 17b, Queensway, Ponders End, Enfield, Middlesex. [3019]

SOUTHERN RADIOS Wireless Bargains. Set manufacturers guaranteed surplus.—

VARIABLE Condensers.—British Radiophone 4-gang superhet type, fully screened and trimmers, 0.0005, 8/9 each (list 45/-); Cylon 3-gang fully screened and trimmers, 0.0005, 7/- each (list 32/-); Utility 2-gang, 0.0005, fully screened with trimmers, dial oscillexon and knob, 8/- each (list 39/6); Hydra block condensers, brand new, 16 mfd., 2:2+8:2+1:1, 1,000 volt test (made for Canadian Marconiphone Co.), 8/9 each; 20 mfd., 2:2+2+2+2, 2:2+2+1+1, 11/- each; 12 mfd., 2:2+2+2+2+1+1, 6/9 each; 10 mfd., 2+2+2+2+1+1, 6/3 each; all 1,500 volt test; 6 mfd., 2/6 each; 2 mfd., 1/9 each; 1 mfd., 1/- each; all 750 volt.

GRAMOPHONE Motors, Electric A.C., 110 volt to 250 volt, guaranteed dead silent; made Dr. Max Levy, of Berlin, and listed at £9 9/0; twelve only at 27/6 each, complete with turntable.

SPEAKERS, Celestion Soundex permanent magnet, 16/- (list 27/6); Rola P6 permanent magnet, 28/- (list 49/6); D.C. mains energised, 2,500 to 6,500 ohms, complete with humbucking coils and transformers, 16/6 (list 39/8); ultra permanent magnet speakers, 95P.M., complete with power pentode transformer, 47/6 (list £4 15/-).

CONSTRUCTORS' Kits.—Ready Radio "303" battery 3-valve kits, less valves, 18/- each, complete with 3 Mullard valves (P.M.11.E., P.M.2, 21X.N.), 33/- each (list 70/-); Ready Radio Motor screen grid 3-valve kit, less valves, 26/- with 3 Mullard valves (P.M.12a, P.M.21X.N., P.M.2a), 49/- (list £3 10/-).

READY RADIO Meteor Screen Grid 3-valve "A" Kit, complete with cabinet, permanent magnet speaker (less valves), £3 7/6, with 3 Mullard valves, £4 10 (list £8 17/6); Mullard Radio for Million 3-valve A.C. kit, complete with 3 Mullard A.C. valves (Pen.4V., 354V., 8.4V.), £3 10 (list £6 10/-); all kits brand new, in original sealed cartons.

SETS, 4-valve screen grid portables, brand new, complete with valve, batteries, etc., £3 15 (list £8 8/-); straight 5-valve portables, complete with valves, batteries, etc., £3 5 each (list £7 10/-).

All Goods Guaranteed Brand New and Perfect and Sent Carriage Paid.

SOUTHERN RADIO, 323, Euston Rd. (near Warren St. Tube), London, N.W.1. (Phone: Museum) 6524. [3033]

SHAFESBURY SUPPLIES Great Sale!! 224, Shaftesbury Avenue, London, W.C.2. See below.

SHAFESBURY SUPPLIES Great Sale!! Set manufacturers' surplus. All goods new and guaranteed; carr. paid. British Radiophone ganged condensers, latest types, 4-gang superhet 0.0005, 9/6; 3-gang 0.0005, disc drive, 9/11; 2-gang ditto, 7/6; P.C. and H.M.V. condenser packs 500 volt test, 4:4-1-1-0.5 (110.5) m.f., 3/14; 4:4 m.f., 600 volt test, 2/11; P.C. 3 m.f., 1,000 volt test, 3/-; 15 m.f. detrolux 100 v. working, 1/3; 1:2 m.f., 500 v. test, 1/-, 6 for 5/6; A.C. eliminators, London's finest bargain, for 200-250 volt A.C. mains (Westinghouse rectified) big output, 150/180 volts, 35 m.a., with S.G. and D.C. Tappings, 29/6; D.C. eliminators, output 120 volts 30 m.a., 12/6.

SHAFESBURY SUPPLIES Great Sale!! Mains transformers, Zenith for 100-250 v. mains, outputs 500 0-500, m.a., 4v. 6 amps, 6v. 4 amps, 7.5v. 3 amps, 32/6 carr. forward; Healybird, output 350-0-350, 80 m.a., 4v. 4 amps, 4v. 1 amp, 12/6; other makes, 350-0-350, 120 m.a., 4v. 4 amps, 4v. 2 1/2 amps, 4v. 2 amps, 17/6; transformers for H.T. 8 rectifier with 4v. 3 amps, 8/6; power chokes, 50 Henry 100 m.a., 5/-; 40 Henry 60 m.a., 3/9; Westinghouse rectifiers, H.T. 7, 200v. 30 m.a. output, 5/9.

SHAFESBURY SUPPLIES Great Sale!! Moving coil speakers, 150 New Epoch Senior 3-gigima perm. magnet with 3-ratio transformer to be cleared at 25/- each; Epoch energised, 2,500, 4,000 or 6,000 ohms field, with 3-ratio transformer, 14/6; Magnavox energised with 2-ratio transformer, 15/-; Rola energised, D.C. model, 12/6, or with rectifier, etc., for A.C., 22/6; Earl 39 6 P.M. model with 2-ratio transformer, 22/6; a low superincinema and auditorium models, send enquiries. Shaftesbury Supplies, 224, Shaftesbury Avenue, London, W.C.2. (Telephone Bar 4175.)

SHAFESBURY Supplies, above, Satisfaction or full price refunded; cash with order or credit; all goods carriage paid. Write for free catalogue. Shaftesbury Supplies, 224, Shaftesbury Avenue, London, W.C.2. [3033]

SHORT-WAVES!

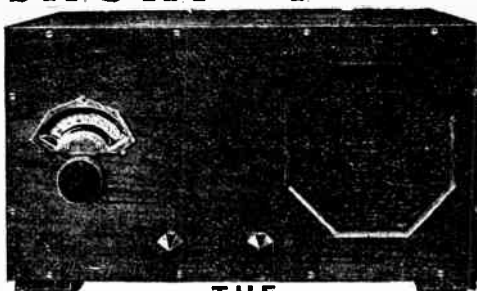

THE "EQUATOR-SUPER" (Battery Model)
FOR TROPICAL USE
and Empire Station Reception

PRICE £33 plus £1. 1. 0 Royalty (Overseas)
Incorporating Westinghouse Metal Oxide Detector and Automatic Volume Control. Write for full details

SCOTT SESSIONS & CO.
Radio Engineers
MUSWELL HILL, LONDON, N.10
Cables: "Tropiset, London."
Contractors to H.M. Government depts., &c.

BATTERY CHARGERS For A.C. Mains

THE SENIOR TWO TYPE N.P.
(Illustrated) will charge one to thirty batteries at once, 15-17 volts at 3 amps. Sliding Variable Resistance from small amperage—Westinghouse Metal Rectifiers. For H.T. and L.T. Cells.

Trade Price 105/-
Complete, delivered.
Other models up to £40
Send for 1933 trade list

NASH PRODUCTS LTD.
STECHFORD, BIRMINGHAM (9)

SILVER-GHOST
FARRAND
INDUCTOR 50%
DYNAMIC
PREFERRED BY MUSICIANS

"WIRELESS WORLD SAID 'WILL SUIT THE MOST HYPERCRITICAL EAR'"

LAMPLUGH RADIO
Silver Ghost Works, COVENTRY, ENGLAND
SEND FOR LITERATURE

Manufacturers' Surplus!

Astounding Offer LISSENOLA (LN890) 1933 COLOSSUS TWO-VALVE RECEIVERS

Listed by manufacturers at 57/6 (without valves or batteries)
A wonderful little set which will work a loud-speaker at full volume, perfect condition—worth more than the price for transformer and cabinet alone!

OUR PRICE 10/9
Carr. without valves Paid or batteries.

Mail Order Department,
CITY & GENERAL 199, Deansgate, MANCHESTER

Components, etc., for Sale.—Contd.

PEPPEER Offers the Following Under Usual Guarantee; 3 days' approval against cash; carriage paid over £2.
FKCO A.C.25 Eliminator, £1/13/6; Healybird ditto, £250v. 60 m.a., with 4v. 6 amps. L.T., listed £9, £3/10.

STRIPPED Type Mains Transformers, manufacturers' surplus, screened primaries, for mains, 200-230-250 volts 50 cycles.
300V. 550 m.a., for H.T.11, with 2-0-2v. 2 1/2a., 2-0-2v. 3-4a.; 22/6; carriage 1/6.

240V. tapped 200v. 200 m.a., for H.T.8 or 9, with 2-0-2v. 2a., 2-0-2v. 3-4a.; 12/11; carriage 1/3.

OWING to a Large Number of Customers Having Written Us Asking Us to Reprint Our Surplus Lists, we are issuing a new edition, which offers many remarkable bargains; free for stamp.

TREVOR PEPPER, 48, Wakegreen Rd., Birmingham, 13. [2915]

MAYFAIR RADIO offers Brand New Surplus Stock, all guaranteed; carriage paid; cash with order or credit.

AUTOMATIC Record Changers, complete with pick-up, A.C. 200-250, A.C. Garrard; listed at 10 guineas, at £7 10/6 only.

RADIOGRAMOPHONE Cabinets, solid walnut, Marconiphone type 535, overall 40", 19 1/2", 16 1/2", take chassis up to 19, 16, cost to make £8/10, at 50/-, or if collected 45/-; H.M.V. figured walnut type 531, as used in H.M.V. 70 guineas job, overall 40, 27, 20, take chassis up to 26", 19", cost £12, at £5, or 95/- if collected.

VARIABLE Condensers, British Radiophone 4-gang superhet, fully screened with trimmers, list 35/-, at 10/-; H.M.V. 3-gang semi screened, fitted trimmers and drum drive, cost 32/-, at 10/-; Utility 2-gang, complete with covers, trimmers, disc drive, etc., at 8/6.

MOVIING Coil Speakers, Rolas, F.6 (2,000 ohms and 2,500 ohms), list 35/-, at 18/- each; P.6 P.M., list 49/6, at 28/-; all fitted pentode transformer.

PICKUPS, Harlie, with volume control; list 27/6, at 15/-; Mayfair Radio, No. 31, George St., Hanover Sq., London, W.1. [3024]

COLVERN Ferronart Coils; set 25/-, post free.—Bilgood, 7, Cranbourne Rd., Chorlton-cum-Hardy, Manchester. [3039]

VARLEY Square Peak Coils, 2/9; intervalve ditto, 2/9; Colvern "T" type coils, 1/9; Colvern "K" type coils, 4/-.

READY Radio "P.W." Dual Range Coils, 1/6; Telson short wave coils, 9d.; Lewcos and Weaire superhet coils, intermediates, 2/6; oscillators, 2/6 and 5/6.

CYLDON Extenders, 3/6; Forum and Wavemaster slow motion extenders, 4/-; Ready Radio Diatune extenders, 2/6; Cylon double drum drive extenders, 10/-.

R.I. Transformers, Dux 4/9, Hypermu 7/6, Hypermite 4/6; Mullard Transformer, A.6/4; Telson Radiogrand (3-1, 5-1), 3/6.

FERRANT Transformers, 6/6 5/6, A.F.3 9/6, A.F.6 14/6, O.P.M.1(e), O.P.M.5(e) 12/6, O.P.2 (ratio 25-1) 6/6.

B.T.H. Pick-ups and Tone Arm: 1931 model (gilt), 15/-; 1932 (nickel), reversible head, 19/6; 1933, 25/-; 1933 Minor, 15/-.

HIS Master's Voice Playing Desk, A.C., 100-250 volts, hardly used; £3 10.

Some of the Second-hand Bargains from the North London Wireless Mart, 54, Malden Rd., N.W.5. Write for complete lists of speakers, pick-ups, sets, mains units, etc. [3025]

SERVICE RADIO, 46, Lisle St., London, W.C.2, offer the following amazing bargains in wireless components, etc.:

SMOOTHING Chokes, 20 Henrys 120 m.a., 9/- each; 50 Henrys 60 m.a., 7/3 each; 40 Henrys 40 m.a., 6/3 each; Mullard Radio for the Million A.C. kits, including 3 Mullard valves (Pen. 4v., 354v., 8.4V.), £3/10 each (listed £6 10/-); H.M.V. tone controls, 1/3 each (listed 12/6); Rola permanent magnet speakers, P.6, 28/- each (listed 49/6); mains energised D.C. speakers, 2,500 volts to 6,500 volts, complete with transformers, 16/6 each (listed 39/6); bargain parcels containing 6 chassis mounting 5-pin valve holders, 6 assorted fixed condensers (all useful capacities), 6 assorted Lewcos coils, 3 coils connecting wire, 6 assorted resistances, 7/6 per parcel (value £1 15/-); we invite callers to inspect our large stocks at our address: hundreds of bargains in mains transformers, valves, sets, kits, etc., etc.; every article guaranteed and carriage paid. Service Radio, 46, Lisle St., London, W.C.2. (Phone: Gerrard 6653.) [3023]

BARGAIN Bulletin, offering readers extraordinary radio component values sent post free.—Taylor, Macanby St., Huddersfield. [3000]

EPTON Leads Again!—Burgentone attractive walnut table cabinets, fully lined haffle, silk lined back, ideal for 3-valve battery or mains sets; 12/6.

POLAR Screened 2-gang 0.0005 Condensers, disc drive, etc., Uniknob model, 8/3; Utility screened 2-gang 0.0005, disc drive, trimmers, etc., boxed, 8/9; ditto, semi-screened, Uniknob model 9/6.

RADIOPAK 4-gang 0.0005 Superhet. Condensers, fully screened, trimmers (listed 45/-); 9/11.

VALVES, as new.—41M.P., 41M.S.G., A.C.P.1, D.U.2, 624B.U., 7/3; A.C.S.G./V.M., A.C.S.1 V.M., 10/-; 41M.H.F., 41M.L.F., 6/9; P.P.425, P.P.625, P.M.26, £11; P.M.256A, P.M.3, P.M.4, 8/10, P.625, 5/6.

EPTON, 93, New Rd., Chingford, E.4. Cash with order or credit. [3037]

SPECIAL Clearance Bargains.—Projectors (9, 16 and 35 mm.), 30 cameras from 20/-; everything for Movies, Walkies and Talkies; inspection invited.

ILLUSTRATED ENTERPRISES, 159, Wardour St. (facing Film House), London, W.1. (Phone: Gerrard 6889.) [3001]

MAJNS RADIOS Unique Offer of Two-valve Sets, with speaker and valves (Coscor and Marconi), in oak cabinets, space for batteries, new, £1, carriage paid.

SET Manufacturer's Surplus, carriage paid, T.C.C. blocks, 4:4 mfd., 250v. working, 2/11; 300v. ditto, 3/4; 4:4-1-1-0.5 mfd., 250v., 4/3.

UTILITY Two-gang Type W.312, complete, 9/-; Radiophone 10,000 vol. controls, with 3-point switch, 3/4.

VALVES, as new, A.C./S.G./V.M., 8/11; D.S., 5/4; V.M.S.4B, 6/4; M.S.A. 5/-; Mains Radio Development Co., 46, Muswell Hill Rd., London, N.6. [3041]

Components, etc., for Sale.—Contd.

5,000 Siemens Halske Condensers, rated test voltages, 10 mfd. 500 A.C., 6/-; 8 mfd. 1,500 D.C., 5/6; 8 mfd. 500 A.C., 5/-; 6 mfd. 500 A.C., 5/-.

4 mfd. 2,000 D.C., 6/-; 4 mfd. 1,500 A.C., 5/6; 4 1/4 mfd. 1,500 D.C., 5/6; 4 mfd. 500 A.C., 3/-.
 2 mfd. 2,500 D.C., 4/-; 2 mfd. 1,500 A.C., 3/6; 2 mfd. 500 A.C., 1/9; 2 mfd. 500 D.C., 1/3.

1.0.1 mfd. 3,500 A.C., 2/6; 0.1+0.1 mfd. 1,500 A.C., 1/6; 0.5 1,500 A.C., 1/6; 0.5 2,000 D.C., 1/6.

TRANSFORMING Type, 4 mfd. 3,500 A.C., 20/-; 6 mfd. 2,000 D.C., 12/6; 4 mfd. 2,000 D.C., 10/-; 2 mfd. 2,000 D.C., 5/6; Imfd. 2,000 D.C., 3/-.
 50 Siemens Halske M.C. Speakers, 12in. cone, 220v. D.C. rehl, 15 chms speech coil, packed in original cases; 22/6 each.

A.L. Prices Cash With Order or c.o.d., postage paid on all orders over £2, liberal discount for quantities.

H. FRANKS, 42a, St. George St., Cannon Street Rd., Commercial Rd., London, E.1. Phone: Royal 8546. [2959]

CHAL. ELECTRIC Offers Brand New Set Manufacturers' Boxed Surplus; all carriage paid; cash with order or c.o.d.; if not satisfied cash refunded without quibble.

VARIABLE Condensers.—Polar Star 3-gang, 1933, complete with disc drive, trimmers, covers, light, knob, etc., list 30/-, at 17/-; 2-gang Uniknob, fitted as above, at 10/-; J.B. Nu Gang 3-gang, fitted as above, at 15/-; 2-gang Nu Gang, as above, 9/6.

SMOOTHING Condensers, C.E.C. and Murphy, 800 test S.M.I., 1/1 2 mfd., 1/9; 4 mfd., 2/6; the following 1,500 test, 500 A.C. working, 800 peak, 1 mfd., 1/9; 2 mfd., 2/4; 4 mfd., 4/-; Multiple blocks (separate tapplings), 20 mfd., 2+2+2+2+2+2+2+2+1+1, at 11/-; 11 mfd. block, 4+2+2+2+1, at 6/9; 14 mfd. block, 4+4+4+1, at 7/6; 9 mfd. blocks, 4+4+1, at 5/3.—Chal Electric, No. 6, Conduit St., London, W.1. [2993]

RAYMART Milliameter, 2 1/2in. flush, 5/9; comprehensive list meters for stamp; Eric. H.M.V., etc., resistances, 100 to 50,000 ohms, 3/- doz., assorted, our selection.

CELESTION Model G Loud Speaker Units, 3/11; Amplion ditto, 2/3.—Radio Mart, 44, Holloway Head, Birmingham. [3029]

NEWPORT SURPLUS STORES Offers All Kinds of Components, also mains valves, guaranteed as new, at very low prices.—Call or write, 24a, Newport Court, W.C.2. [3010]

VALVES (mains and battery), coils, chokes, transformers (mains and inter-valve, condensers (fixed and variable), Westcoats, etc.; P.d. stamp lists.—Box 7414, c/o The Wireless World. [3022]

COSMIC RADIO SERVICE, 23, Water St., Liverpool.—Ormond Senior P.M. speaker, £1.15; Ultra pick-up, £1; 2 K.B.L.C., K.53 ganged, 12/-; O.P.M.10, 13/-; R.7, 10/-; O.P.M.6, 10/-; postage extra. [3006]

MOVING Coil Milli-Ammeters, 0-50, 10/6 each; 2 milliamps and 120v. 17/6 each; other ranges in stock; alterations, repairs of every description.—The Victoria Electrical Co., 47, High St., Battersea, S.W.11. [0355]

WIRELESS World Receivers Built to Specification, fully guaranteed; also supplied as kits; trade supplied.—Write for quotations.—London Radio Development Services, 56, Hazel Rd., Kensal Rise, N.W.10. [2937]

GARRARD Record Changer, £7; Varley superhet. G coils, 30/-; Colvern Ferricart coils, 30/-; Radiophone super 3-gang and dial, 25/-; Parmeko monodial transformer, £3.10.—Weller, 9, Walton Close, Cricklewood, N.W.2. [2985]

EBURY BRIDGE RADIO Offer You the Following Stupendous Bankrupt and Surplus Bargains: Electric hot plates, brand new, boxed, 240-250v., British made, guaranteed 2 years, special low price, 7/11, post 9d.; electric irons, brand new, nickel plated, all voltages, 6/11, post 1/-.

MANUFACTURERS' Cabinets, unused, Atlas Consolette, highly polished walnut finish, take speaker, set and batteries; 9/11, post 1/-.

BANKRUPT Stock, 3 only, G.E.C. Viking 4-valve sets, M. coil, Band Pass, Var. Mu, S.G. Det., 100-250 volts; list 23 guineas, our price, as new, £10/19/6 complete.

EX-MARCONI Radiogram Cabinets, model 535, solid walnut, cost to manufacture £8/10, 40/-; model 531, solid oak or walnut, cost to make £12, 4 guineas while they last.

R.I. Cosmic Triple Wave Coils, 3 ranges in 1, listed 12/6, our price 2/6, post 6d.; R. Rad. Duotons extensor condensers, 0.0005 mfd., 1/9, post 6d.; Tag condensers, 0.0001 mfd., 3d. each, post 1d.; valve holders, 4- and 5-pin, 3d. each, 2/6 dozen.

CALLARO A.C. Gram. Motor, with pick-up, listed 76/-, few only at 55/-; electrolytic condensers, T.C.C., 6 or 7 mfd., 450v., 4/6, post 4d.

MOVING Coil Speakers.—Celestion Soundex Per, Mag., new, boxed, 27/6 list, 14/6; energised Lamplough Silver Ghost, 2,200 ohms 10/6, 6,500 ohms 12/6; Rola P.6, 6,500 ohms, list 35/-, 14/-; A.C. rectification kit, 10/- extra; state Power or Pentode, post 1/-.

CLEARING Last of our Stock of Blue Spot 100U. inductor speakers, new, boxed, 39/6 list, special low price 12/11, post 1/-; Climax D.C. eliminators, 200-250v. output, 50 ma. and 12 ma. on small tapplings, 10 tapplings in all, list 34/-, bargain, 22/6, post 1/-.

READY RADIO Short Wave Coils, 1/6 each, post 6d.; 1 only, Igranic 7/1 transformer, 30/- list, 10/6, post 6d.; Deemark dual range coils, combined base, 1/9 each, post 6d.

D.C. Eliminators, 200-250v. input, output 150v. 30 m.a., 1 fixed, 1 variable positives, 10/6; 3 pos. tapplings for S.G., 12/6; Umello 120v. 20 m.a., 10/6, post 9d.; A.C. trickle chargers, 2-4-6 volts, 1 amp., Westinghouse, rectified, 11/6, post 6d.

WESTINGHOUSE Metal Rectifiers, 120v. 12 m.a., 2/6; 120v. 15 m.a., 3/-; 120v. 20 m.a., 3/3; 8v. 1/2 amp., 6/6, while they last, post 6d.

RESISTANCES, 1/2-watt wire wound Pye, 6,000, 10,000, 7,500, 750, 65 ohms, 4d. each, post 1d.; Pye Banks, 8-wire wound, total 50,000 ohms, 2/-, post 3d.; Glibar, 500 ohms, 2 watt, 56 m.a., for Auto. G.B., 5d., post 1d.; Franklin wire wound pots, 25,000 ohms, 1/9 each, new, post 2d.

CABLE, 7 mm., rubber covered, 100 yards 11/-, post 1/-; 12-yard hanks, 1/9, post 3d.

(This advertisement continued in third column.)

TRIX

PUBLIC ADDRESS EQUIPMENT

for sale or hire.

Unquestionably the finest value on the market. Users can be fully licensed for Public Performance of Records.

Let us quote for your next installation.

We also make the famous

EXPLORA SHORT-WAVE RECEIVER

We will gladly send you full details.

Eric J. Lever (TRIX) Ltd., 8-9, Clerkenwell Green, London, E.C.1.

Phones: Clerk 3014-6. Cable: Trixadio, Smith, London



The instruments which have made possible a re-creation of the original performance. There is a type for every output.

REPRODUCERS & AMPLIFIERS LTD. WOLVERHAMPTON.

FOR UNIFORM CHOKING,

MADE BY CHOKE SPECIALISTS.

THE "KINVA" STANDARD SCREENED H.F. CHOKE

for H.F. or DET. ANODE, 2/9 3/- post free.

"MAJOR" Type for "SUPERS", 5/6

POSTLETHWAITE BROS., KINVER, Nr. STOURBRIDGE.

Grippleshell Aerial Brackets

are simple and economical to install and avoid unsightly poles. Write for leaflet to:—

PARTRIDGE WILSON & CO., Dept. 29, Davenset Works, Leicester.

BAKER

WRITE NOW FOR OUR NEW BOOKLET & LEAFLETS

75-77 SUSSEX ROAD, CROYDON, SURREY

Phone: Croydon 3441-2

FOR QUALITY MOVING-COIL SPEAKERS.

Components, etc., for Sale.—Contd.

(This advertisement continued from first column.)

PHILIPS Mains Transformers, 200-250 volts input, outputs 200-0-200 volts 40 ma., 4v. 1a., 4v. 3a., 4/6 each, post 6d.

PYE Output Transformers for Power or Pentode, 17/6 list, 6/- each, post 6d.; Pye chokes (always useful), 20 or 32 heavy, new, boxed, listed 12 6, 4/6 each; rectifying valves, U.U.60 250, guaranteed, 8 6 each, post 6d.

BRAND New (not second-hand) Variable Eliminator Resistances, complete with knob and insulating washers, boxed, 7 watts; list price 4/6, 2 10, post 3d.

MICROPHONES, Reisz, Public Address, even response, for amplifiers up to 60 watts; 55/-, post free; watch our adverts.

ALL Above Goods 3 days' approval against cash, or c.o.d. Hours 9 a.m. to 8 p.m., Thursday 1 o'clock, Saturday 9 p.m.—Ebury Bridge Radio Co., Bankrupt and Surplus Dealers, 33, Ebury Bridge Rd., S.W.1 (near Victoria Station). Phone: Shams 8407. [3048]

RADIO CLEARANCE Co. Offer the Following:—Brand new manufacturer's surplus; 2v. all-electric receiver, M.C. speaker, 200 250 A.C., listed £8 10, at £3; Ekco R.S.2, £7; Ekco R.S.3, £9; Treatenit 4v. 2 S.G., M.C. speaker, 200 240 A.C., £7; Amplion 6w, £9; Crypto rotary converters, 220 D.C. or 220 A.C. 400 watt output, £6; all goods advertised in last week's issue still available.—Radio Clearance Co., 78, Commercial St., E.1. [2999]

MISCELLANEOUS.

MONEY Payments.—We supply, by easy payments, components, accessories, and sets, any make; 10% down, balance spread over 11 months. Send list of requirements to London Radio Supply Co., 11, Oat Lane, London, E.C.2. [0337]

ENGINEERS and Technical Workers of All Kinds.—A proper training by post in your spare time will take you through your right examination, then employment is waiting. Our advice on all careers free. Dept. 92, The Bennett College, Ltd., Sheffield. [0395]

AMBITIOUS Engineers Wanted to Apply for Our Free 250-page Handbook, gives details of A.M.I.Mech.E., I.E.E., A.M.I.A.E., G.P.O., etc., exams, outlines latest courses in mech., elec., motor, radio and aero. engineering, and shows clearly where first class vacancies occur each year.—Send P.C. for free handbook immediately to British Institute of Engineering Technology, 87, Shakespeare House, 29, Oxford St., W.1. [3012]

AMBITIOUS MEN.—Qualify for a well-paid post by studying at home with the T.I.G.B. Write today for "The Engineer's Guide to Success," 144 pages, free, which contains the widest selection of engineering and wireless courses in the world, and shows you how to become A.M.I.E.E., A.M.I.Mech.E., A.R.A., etc.—State Branch, post or qualification that interests you.—The Technological Institute of Great Britain, 82, Temple Bar House, London, E.C.4. (Founded 1917, 19,000 Successes.) [3008]

PATENT AGENTS.

PATENTS and Trade Marks, British and foreign.—Gee and Co. (H. T. P. Gee, Member R.S.G.B. and A.M.I.R.E.), 51-52, Chancery Lane, London, W.C.2. Phone: Holborn 1525. [0001]

REPAIRS.

REPAIRS to Loud-speakers, transformers and head-phones, 4/- each; Blue Spots or Wufas, 5/-; mains eliminators, etc., quoted for; prompt service; satisfaction guaranteed; terms to trade.—Loud-speaker Repair Works, 2, Shipka Rd., Balham, London, Streatham 6618. [0394]

GUARANTEED Repairs by Experts; specialists for repairs to S.G. Brown and Amplion radio apparatus, also loud-speakers, headphones, pick-ups, Blue Spots, any type rewound, remagnetised and adjusted; 4/-; post free; mains transformer repairs; terms to trade.—Howell, 91, Morley Hill, Enfield, Middlesex. [9716]

TUITION.

RADIO Engineering.—Day, evening, and postal courses. This school is fitted with most modern apparatus. Prospects free. Valuable recommendations given to qualified students.—Northern Counties Wireless School, Preston. [0399]

R.T.I. Training Methods are Recognised; write for particulars of home study for radio appointments; secure Certificate of Proficiency and become "A.M.R.T.I."—Radio Training Institute, 85, New Oxford St., London, W.C.1. [2947]

FINANCIAL PARTNERSHIPS.

ADVERTISER (London) Offers Keen Amateur Partnership spare time electrical business, develop full time later; very small investment—Box 7412, c/o The Wireless World. [3022]

RADIO Engineer, with University or equivalent degree, required by radio set manufacturers, to take charge of production dept.; invest £1,000 in limited Co.—Full particulars given in confidence, Box 7351, c/o The Wireless World. [2977]

EXCHANGE.

COSMIC RADIO SERVICE, 23, Water St., Liverpool, accept high class receivers and components in part exchange; no small parts or rubbish. [3007]

HIGH Allowance Made on Second-hand Goods in Part Payment for New Sets or Components; easy payments available; we have tremendous stocks tested, second-hand goods; send list of your requirements for quotation.—Hosock and Stonnill, 1, Westbourne Terrace, S.E.23. [3036]

WANTED.

SPOT Cash for Components, etc.—Economic Radio Co., 96-98, South Lambeth Rd., S.W.8. [2923]

WANTED, Avometer, perfect; state lowest cash.—A. Beer, 83, Devonshire Av., Southsea. [3042]

REQUIRED, small radio business, Epping Forest district preferred.—Box 7416, c/o The Wireless World. [3040]

SURPLUS Components and Electrical Goods Bought for Cash.—24a, Newport Court, Charing Cross Rd., W.C.2. [3011]

Wanted.—Contd.

HIGH Class Radio Sets and Parts Wanted for Cash. Midway Radio Exchange, 24, Midway Grove, London, N.1. [2972]

WANTED, a short wave receiver, 3 or 4 valves, A.C. preferred; state price for cash. Box 7403, c/o *The Wireless World*. [3015]

WANTED, new and second-hand valves; state what you have for sale and prices required. Box 7404, c/o *The Wireless World*. [3017]

AL.L. Types Second-hand Valves Required.—Send particulars and prices required by letter to Box 7396, c/o *The Wireless World*. [3016]

SITUATIONS VACANT.

IF You Wish to Enter the Wireless Profession with a Thorough Training, or if you wish to improve your present position, you will need the certificate issued by Britain's leading wireless college. This is not a correspondence college. Apparatus of all leading makes installed for instructional purposes. Boarders accepted. Training fees can be paid after appointment. Prospectus free.—Wireless College, Colwyn Bay. [10388]

SITUATIONS WANTED.

RADIO Engineer, 25, public school, 6 years radio and electrical engineering, seeks progressive situation. Box 7413, c/o *The Wireless World*. [3021]

BELLING-LEE PICK-UP



MODEL A.L. 1096.

Adjustable arm allows distance between needle point and centre of base to be varied from 7 1/2" to 9 1/2". The arm should be as long as cabinet space permits. Head angle is also adjustable to obtain minimum tracking error for different arm lengths.

LET YOUR EAR BE THE JUDGE! 27/6.

BELLING-LEE
Cambridge Arterial Road, Enfield, Middlesex.

Special Features.—Perfectly natural frequency response . . . minimises needle scratch while retaining high notes & brilliancy of reproduction. . . Minimum record wear. . . Copper screened flex.

FOR HIRE

RADIO, MICROPHONE & GRAMOPHONE AMPLIFIERS

ALEXANDER BLACK, LTD

WIRELESS CONSULTANTS

55, EBURY STREET, LONDON, S.W.1.

ESTABLISHED IN 1925. SLOANE 1655.

Trade Inquiries Invited.

SERVICE
SETS OF ALL TYPE 3

Supplied, Serviced and Visited in any district, or may be sent for Full Test and Report, at 2/- per valve-holder; portables, 1/6 per valve-holder.

PASSED WITH HONOURS
by "Wireless World"

See Full Report, Page 371, "W.W.," May 29th.

This Main Transformer is for receivers with maximum of 4 valves. Intended for use with "C" Class full wave rectifying valve. H.T. Winding gives 350-350 volts at nominal load of 80 ma. Two L.T. Windings rated at 4 v. 4a. and 4 v. 2.5a. Primary Tappings at 200, 250, 250 volts 50 cycles A.C. "WIRELESS WORLD" says:—"Coil is of generous dimensions . . . H.T. winding shows good regulation . . . both L.T. windings satisfactorily adjusted for respective loads. For example, on full load the 4 amp. winding gave 40 volts while the rectifier filament was operated at 3.75 volts."

PRICE, POST PAID **29/6**

The Small Intervalve Transformer has a step up ratio of 1 to 3, and primary inductance was found by measurement to be 13.7 henrys with no D.C. flowing, 10.0 henrys with 2 ma. and 8.0 henrys with 4 ma. passing through primary. Also available with 1 to 5 ratio.

PRICE, POST PAID **4/11**

Here are a few other examples—

but our complete list contains many more.

TRANSFORMERS FOR METAL RECTIFIERS (WESTINGHOUSE) with Combined Filament Windings.

M.F.S. 210 v. 150 ma. 1 v. 15a. 26/-

M.F.S. 240 v. 200 ma. 4 v. 3a. 1 v. 15a. 28/6

M.F.S. 120 v. 350 ma. 4 v. 3a. 1 v. 15a. 28/6

L.T. or 6 v. 1.5a. 35/-

SMOOTHING AND OUTPUT FILTER CHOKES.

Hrys.	Milliamps.	Approx. Res.	Price.
30	20	700	10/-
40	30	850	11/6
30	100	250	17/6

Also makers of L.F. Transformer.
SEND FOR DETAILED LIST.

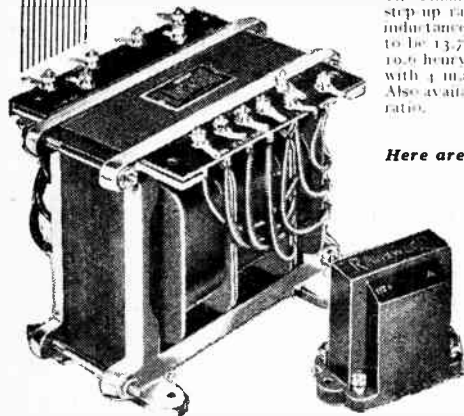

RAWSWOOD

RAWSWOOD ELECTRICAL CO., Preston New Road, BLACKPOOL.

Phone: Mutton 188. Grams: Rawswood, Blackpool.

No cheap materials—no cheap workmanship

OSBORN CABINETS

are recommended everywhere



MODEL No. 225. Radio-Gram. Cabinet 3' 6" high x 2' 2" wide x 1' 6" deep. Baffle behind fret, 24" x 17". Silk fabric for fret front included. Opening at top and back. Takes panel 24" x 13" or smaller. Accommodates any type of gramophone motor. **PRICES: Machined Ready to Assemble, Kit of Parts, Oak £3-5-0, Mahogany £3-10-0, Walnut £4-0-0. Assembled Ready to Polish, Oak £4-5-0, Mahogany £4-10-0, Walnut £5-0-0. Assembled and Polished, Oak £5-5-0, Mahogany £6-0-0, Walnut £6-15-0.**

OSBORN SUPER ACOUSTIC BAFFLE BOARD. Prevents 90° speaker worry. Guaranteed no vibration. Any size hole cut **FREE.** 18" x 18" 3/4", 24" x 24" 5/8", 30" x 30" 8/16", 36" x 36" 11/16". **SEND FOR FREE SAMPLE.**

SPECIAL QUOTATIONS FOR YOUR OWN DESIGN

CHAS. A. OSBORN, Regent Works, Arlington Street New North Road, London, N.1. Tel.: Clerkenwell 5095. Showrooms: 21, Essex Road, Islington, N.1. Tel.: Clerkenwell 5934.

RADIO DATA CHARTS A SERIES OF ABACS

Providing most of the essential Data required in receiver design

By R. T. BEATTY, M.A., B.E., D.Sc.

All keen amateurs will appreciate this book

PRICE 4/6 net

BY POST 4/10

From all leading booksellers, or direct from the Publishers. Published from the offices of "THE WIRELESS WORLD" DORSET HOUSE, STAMFORD STREET, LONDON, S.E.1 W.W.93

INDEX TO ADVERTISEMENTS.

	PAGE		PAGE		PAGE
Apollo Gramophone Co., Ltd.	Inside Back Cover	Electradix Radios	5	Picketts	PAGE
Automatic Coil Winder & Elec. Equipment Co., Ltd.	Front Cover	Epoch Radio Manf. Co., Ltd.	4	Pileo, Ltd.	6
Baker's "Solihull" Radio	6	Gambrell Bros., Ltd.	Inside Back Cover	Players	6
Belling & Lee, Ltd.	7	Garrard Engineering & Manufacturing Co., Ltd.	4	Postlethwaite Bros.	7
Birmingham Sound Reproducers, Ltd.	7	Hayward, F. C., & Co.	4	Rawswood Electrical Co.	7
Black, Alexander	7	Lampugh, Radio, Ltd.	5	Reproducers & Amplifiers, Ltd.	6
Bon Marché, Ltd.	7	Lectro Lins, Ltd.	6	R.L. Ltd.	6
Britannia Batteries, Ltd.	1	Lever, Eric J. (Triax), Ltd.	6	Riverside Manufacturing Co., Ltd.	4
British Blue Spot Co., Ltd.	1	McNiell, F., & Co., Ltd.	1	Rotax, Ltd. (M.L. Equipment)	4
British Radiophon, Ltd.	1	Miles Radio Co.	1	Savage, W. Bryan	2
Bulgin, A. F., & Co., Ltd.	1	Nash Products, Ltd.	5	Scientific Supply Stores (Wireless), Ltd.	4
Burton, C. F. & H.	Front Cover	Osborn, Chas. A.	7	Scott Sessions & Co.	5
City & General	5	Ostar Ganz (Eugen Forbat)	4	Seaton, O. H.	4
City Accumulator Co., Ltd.	1	Parina Manf. Co.	4	Tannoy Products	2
Cole, E. K., Ltd.	XII	Partridge, Wilson & Co.	6	Telegraph Condenser Co., Ltd.	Inside Front Cover
Colwyn, Ltd.	Front Cover	Partridge & Mee, Ltd.	Back Cover	Telsen Electric Co., Ltd.	Front Cover
Concordia Electric Wire Co., Ltd.	Inside Back Cover			Watmel Wireless Co., Ltd.	3
Coscor, A. C., Ltd.	8			Westinghouse Brake & Saxby Signal Co., Ltd.	Inside Back Cover
Dubilier Condenser Co. (1925), Ltd.	8			Wilburn & Co.	4

Modernise YOUR BATTERY SET convert to CLASS "B"

AND GET "MAINS VOLUME" WITHOUT
EXTRAVAGANT H.T. CONSUMPTION

You can easily convert your Battery Set into an up-to-date Receiver by fitting a Class "B" Output stage. By using a Cossor Class "B" Valve you can obtain "Mains Volume" with little, if any, increase in H.T. consumption. Send the coupon for Folder giving full details of this remarkable system of L.F. amplification.

COSSOR CLASS "B" VALVES



To A. C. COSSOR LTD.,
Melody Dept., Highbury Grove, London, N.5.

Please send me, free of charge, a copy of Folder No. L93,
which tells me how to use Class "B" Amplification.

Name.....

Address.....

W.W. 7733

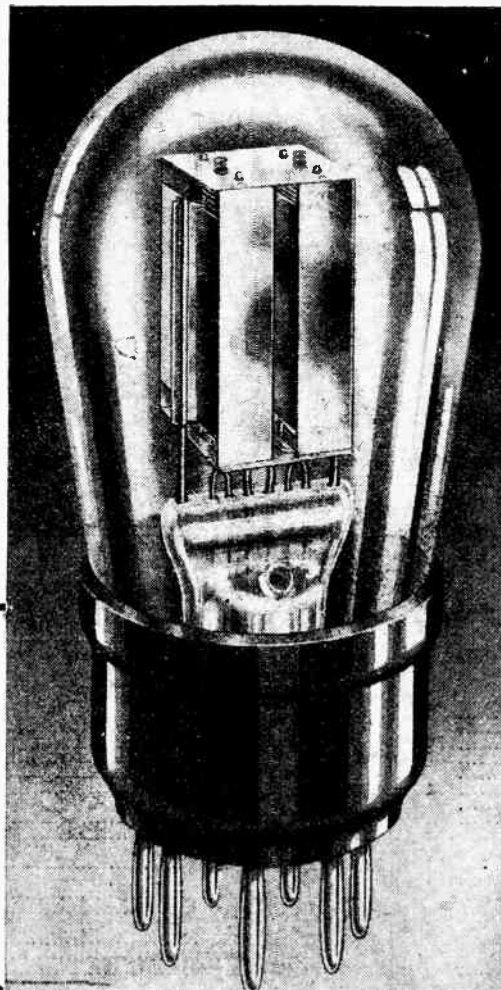

COSSOR 240 B.

Filament volts 2.0; Filament
amps 0.4; Anode volts 150
max.; Max. Anode Current
Swing 50 mA.; Max. Peak
Applied Signal (Grid to
Grid) 40 volts; Static
Anode Current at $V_a=100$,
 $V_g=0$ (each
half) 1.5 mA. Price **14/-**

COSSOR 220 B.

Filament volts 2.0; Filament
amps 0.2; Normal Anode
volts 120; Max. Anode Cur-
rent Swing 35 mA.; Max.
Peak Applied Signal (Grid
to Grid) 40 volts; Static
Anode Current at $V_a=100$,
 $V_g=0$ (each
half) 1.25 mA. Price **14/-**

3073.

Mention of "The Wireless World," when writing to advertisers, will ensure prompt attention.

ATHLONE

725 kc/s, 413 metres; 60 kW. Relayed by Cork, 1,337 kc/s, 244.4 metres.—1.30 to 2.30 p.m., Time and Gramophone Music. 6.0, Programme for Children. 6.45, News. 7.0, Gaelic Talk. 7.15, German Lesson. 7.30, Time. 7.31, Violin Solos by Nora Richardson. 7.45, Baritone Solos by John Lyonskey. 8.0, The Station Orchestra. 8.30, The Fly on the Wall—Play, by the Studio Players. 8.45, The Station Orchestra. 9.0, Mademoiselle—Play, by the Studio Players. 9.15, Soprano Solos by Edith Mirelson. 9.30, Accordion Solos by Terry Lane. 9.45, Sponsored Programme. 10.30, Time. 10.45, News and Close Down.

BARCELONA

EAJ1, 860 kc/s, 348.8 metres; 5 kW.—7.0 p.m., Trio Concert. 8.3, Request Gramophone Records. 8.50, Exchange. 9.0, Gramophone Music, followed by News. 10.0, Chimes, Weather, Exchange and Market Prices. 10.5, Concert by the Radio Orchestra. 11.0, Song Recital by Carmen Ramos Palazon. 11.30, Dance Music by the Solé Band, relayed from the Casa Libre. 12 Midnight (in an interval), News. 1.0 a.m. (Thursday), Close Down.

BARI

1,112 kc/s, 269.8 metres; 20 kW.—8.0 p.m., Agricultural Notes, Tourist Talk, and Depo-lavoro Announcements. 8.20, Giornale Radio and Weather. 8.30, Time and Announcements. 8.35 (approx.), Concert of Chamber Music. Soloists: M. de Santis Bruno (Soprano) and Donato Marrone (Pianoforte). Selection from Der Freischütz (Weber); Soprano Solo: Canzone di maggio (Pesce); Extracts from the Fantasie-Stücke for Pianoforte (Schumann); Melody (Respighi); Soprano Solo: L'assonido (Zandonai); Pianoforte Solo: Ballad, Op. 7 (Chopin); Selection from Gli-Gli (Lucca); Soprano Solo: Triste veglia (Gianini); Pianoforte Solo: Pezzi infantili (Casatola); Extracts from Il Re (Giordano); Soprano Solos: (a) Il cor più non me sento (Pischiello), (b) Chi vuol comprar la bella calandrina? (Donmelli); Pianoforte Solo: St. François d'Assise (Liszt). In the interval, Literary Notes. 10.30, Dance Music, relayed from the Gran Caffè di Levante. 10.55, News.

BASLE.—See Schweizerischer Landessender.

BELGRADE

697 kc/s, 430.4 metres; 2.5 kW.—6.0 p.m., Cigany Music by the Gramin Orchestra. 6.30, Talk. 7.0, Concert by the Station Orchestra. 8.0, Radio Play. 8.50, Faust Opera (Gomold) on Gramophone Records. In an interval at 10.5, Time and News.

BERLIN

DEUTSCHLANDSENDER, 183.5 kc/s, 1,635 metres; 60 kW.—12 Noon, Weather. 12.5 p.m. (approx.), Ballad Recital by Alfons Schlittendorfer, Einkör (Max Pfüddemann); Siegfrieds Schwert (Max Pfüddemann); Der Sänger (Hugo Wolf); Der gefangene Admiral (Carl Loewe); Hochzeitslied (Carl Loewe). 12.30 p.m., Gramophone Concert. Choral, So nimm denn meine Hände; Wo du hingehst (Reiss); Das ist der Tag des Herrn Kreuzer; Bridal Song from Lohengrin (Wagner); Hochzeitsstündchen (Kloster); Geburtstagsmarsch (Kühme). 12.55, Nature Time Signal. 1.45, News. 2.0, Gramophone Concert (contd.). Italian Opera Music. Melodies from La Traviata (Verdi); La Bohème (Puccini); I Faglicieri (Leoncavallo); Madame Butterfly (Puccini); Rigoleto (Verdi) and Tosca (Puccini). 3.0, Programme for Young People. 3.30, Weather and Exchange. 3.45, Reading from the Works of Hermann Stehr. 4.0, See Hamburg. 5.0, Talk: German Oratory I. 5.30, Humorous Song Recital by Hans Müller (Bass). Song from The Gipsy Baron (Joh. Strauss); Der Pfarrer von Onkenwitz (August Schellner); Der schlesische Zecher und der Teufel (Reissiger); Drei Weinkenner (Moritz Penschel); Im Rolandbogen (Paul Mania); Was ich hab' (Carl Bolau); Tavitus und die alten Deutschen. 6.0, Poems. 6.5, Address by the Rev. Müller. 6.55, Wireless Technical Talk. 6.50, Weather and Announcements. 7.0, Transmission for all German Stations. Scherbert Concert, conducted by Edwin Lindner. Ballet Music from Rosamunde; Symphony in C No. 7. 8.0, An Appeal for Funds for the National Labour Scheme. 8.5 (approx.), Kampf um Berlin: a Radio sequence after the Book by Dr. Joseph Goebbels, Minister for Propaganda (arr. Carl Franke). 9.35, Concert by a Young Hitlerites' Choir. 10.0, Weather and News, followed by Talk on Agriculture. 10.45, Weather for Farmers. 11.0, Programme from Langerberg. 12 Midnight, Close Down.

BERLIN

WITZLEBEN, 719 kc/s, 419.5 metres; 1.5 kW.—4.30 p.m., Concert from the Spreegarten: Germania-Marsch (Keil); March, Hoch Rheinland (Anzer); Overture, Zampa (Hérold); Waltz, O Frühling, wie bist du so schön (Lincke); German Prasant Dance (Hermann Niel); March, Deutschland ist erwacht (German); Potpourri, Jugendklänge aus Alt-Heidelberg (Rhode); Die türkische Scharwache (Michaelis); March, Potpourri (Michaelis); March, Potpourri, Jung Deutschland (Weniger). 5.30, A Dialogue on New Opera. 5.50, Recital of Contemporary Organ Music: Passacaglia in B Minor (Britten); Toccata and Fugue in F Minor (Johann Sebastian Bach). 6.10, Talk: Holidays on the Water. 6.30, Topical Talk. 6.40, The Witzleben Station informs its Listeners. 6.45, Topical Talk. 7.0, Transmission for all German Stations, relayed from Berlin (Deutschlandsender). 8.15, Homage to Stefan George; Reading from his Poems and Talk: Stefan George and National Movement. 8.45, Die Zwillingssel, Opera in Three Acts (Erwin Dressel), abridged for Radio by Theodor Müller. 10.5, News, followed by Dance Music from the Spreegarten, Treptow. In the interval from 11.0 to 11.5, Talk: What they are saying in Berlin. 12 Midnight, Close Down.

WEDNESDAY JULY THE TWELFTH

PRINCIPAL EVENTS OF THE DAY:

AT HOME

- NATIONAL: Symphony concert.
LONDON REGIONAL: A Mabel Constanduros revue.
MIDLAND REGIONAL: Old-time dance music.
NORTH REGIONAL: Running commentary on the Mammie Beg Motor Car Race, from the Isle of Man.
WEST REGIONAL: "Hullo, Washford, or Talking on Air," an unofficial communiqué.
SCOTTISH REGIONAL: "Frac a' the Airs," feature programme, from Strathdon.
BELFAST: Variety programme.

ABROAD

- BRUSSELS (No. 2): 8.30 p.m. Oratorio: "Lucifer," by Benoit, relayed from Antwerp.
BUDAPEST: 8.0 p.m. Concert by the Opera House Orchestra.
COPENHAGEN: 8.1 p.m. Grieg concert. 10.15 p.m. English music by the Station Orchestra.
EIFFEL TOWER: 8.30 p.m. Symphony concert, conducted by E. Flament.
HAMBURG: 8.0 p.m. Operetta: "The Cousin from Nowhere," by Kunnecke.
HUIZEN: 7.40 p.m. Festival concert from the Concertgebouw, Amsterdam.
MOSCOW: 3.0 p.m. Extracts from operetta: "Boccaccio," by Suppé.
STRASBOURG: 8.45 p.m. The Municipal Orchestra, conducted by Munch.

Waltz from Sleeping Beauty (Tchaikovsky); Songs; Tarantella, La danza (Rossini); Melody (Rubin-stein-d'Indy); Egyptian March (Joh. Strauss). 5.0, Dance Music from the Continental Palace Hotel, Blankenberg. 6.15, Talk: Prophecies about the End of the World. 6.30, Talk on Benoit's Oratorio, Lucifer, with Pianoforte Illustrations. 7.0, Gramophone Music: Gipsy Romance, Day and Night (Foinin); What good am I without you? (Ager); In a Chinese Temple Garden (Ketilbey); Malagena (Sarasate). 7.15, Koritars, 7.30, Gardening Talk. 8.0, Overture, The Bohemian Girl (Balle) on Gramophone Records. 8.10, Radio Play (Singers). 8.30, Lucifer—Oratorio (Benoit) relayed from the Zoological Gardens, Antwerp. 10.30, Le Journal Parlé. 10.40, Dance Music from the Continental Palace Hotel, Blankenberg.

BUCHAREST

751 kc/s, 294 metres; 12kW.—5 p.m., Concert by the Station Orchestra: Cadet March (Sonsa); Waltz, Wiener Boubons (Joh. Strauss); Overture, Chal Romano (Ketilbey); Selection from Don Giovanni (Mozart); Selection from The Geisha (Sidney); Dance Suite (Mairied); Slav Dances Nos. 8 and 9 (Dvorak); Selbstzufahrt (Jessel). In an interval at 6.0, Radio Journal. 7.0, Educational Talk. 7.20, Romanian Music on Gramophone Records. 7.50, Reading. 8.0, Pianoforte Recital by I. Arapov: Sonata in G Minor (Schumann); Etude No. 8 (Chopin); Waltz (Chopin). 8.30, Violin Solos by J. Thaler: Sonata, Op. 19 (Rachmaninov); Adoremus (Ravino-Thaler); Malagena (Albéniz-Thaler). 9.0, Flute Solos by V. Jann. 9.30, Programme relayed from a Restaurant. 10.3, Radio Journal.

BUDAPEST

545 kc/s, 550.5 metres; 18.5 kW. Also relayed on 840 metres from 8.0 p.m. till Close Down. 5.0 p.m., Concert of Cigany Music. 5.45, Talk. 6.15, Dance Music from the Luna Park. 7.0, Exchange. 7.10, Talk with Illustrations: Kruzszelied. 8.0, Concert by the Opera House Orchestra, conducted by Ernst Dohmann: Overture, Anacron (Cherubini); Serenade (Tchaikovsky); The Seventh Symphony (Beethoven). 9.30, News, followed by Gramophone Music. 10.10, Weather, followed by Cigany Music from the Café Baross.

CASSEL.—See Frankfurt.

COPENHAGEN

1,067 kc/s, 281 metres; 0.75 kW. Relayed by Kalundborg, 260 kc/s, 1,153 metres.—12 Noon, Time Signal and Chimes from the Town Hall. 12.2 p.m., Concert by the A. Bendix String Ensemble, relayed from the Wivex Restaurant. 2.0 to 3.0, Interval. 3.0, Gramophone Concert. 3.30, Concert by the Station Orchestra, conducted by Walter Meyer-Radon. In an interval at 4.15 (approx.), Talk for Women. 5.35, Exchange and Fish Market Prices. 6.50, Weather. 7.0, News. 7.15, Time Signal. 7.30, Agricultural Talk. 8.0, Time Signal from the Town Hall. 8.1, Grieg Concert by the Station Orchestra, conducted by Walter Meyer-Radon: Homage March from Sigurd Jorsalfar; Extracts from the Lyric Suite; A Wedding Day on Troldhaugen; Extracts from Peer Gynt; Norwegian Dances in D Minor. 8.45, Pianoforte Recital of Danish Music by Gudrun Seligmann: Sommerflugel (Hartmann); I Blomsterhaven (Gade); I Skoven (Gade); Two Character Pieces (Lange-Müller); (a) Moderato con moto, (b) Allegretto semplice; Ved-bend (Henriques); Sommerleg (Henriques). 9.35, Concert of Norwegian Music by the Brage Choir, conducted by Oskar Gylmark. 10.0, News. 10.15, Concert of English Music by the Station Orchestra, conducted by Walter Meyer-Radon: Children's Overture (Quilter); Suite, The Three Bears (Coates); Allegro di bravura and Tarantella, from the Gipsy Suite (Edward German). 11.0, Dance Music by Kai Julian and his Band, relayed from the National Scale. In an interval at 12 Midnight, Time Signal and Chimes from the Town Hall. 12.30 a.m. (Thursday), Close Down.

CORK.—See Athlone.

CRACOW

959 kc/s, 312.8 metres; 1.5 kW.—7.5 p.m., Talk: Mushrooms, poisonous and non-poisonous. 7.20, Miscellaneous Items and News. 7.35, Programme Announcements. 7.40, See Warsaw. 9.0, News. 9.10, See Warsaw. 10.0, Talk in Esperanto: Summer in Poland. 10.20, Gramophone Music. 10.25, Sports Notes. 10.35, See Warsaw. 11.0 (approx.), Close Down.

DANZIG.—See Heilsberg.

DRESDEN.—See Leipzig.

FECAMP

1,328 kc/s, 225.9 metres; 10 kW.—7.15 p.m., Local News. 7.30, The Listeners' Hour and News. 8.45, Concert relayed from Caen. 10.0 till Close Down, Concert by the I.B.C. in the interval at 12.5 a.m. (Thursday), News Bulletin in English. 1.0 (approx.), Close Down.

FLENSBURG.—See Hamburg.

FLORENCE.—See Turin.

BRNO: 8.0, See Berlin (Deutschlandsender). 8.10, See Langerberg. 9.10, Programme of German Student Songs, by the Leopoldina, Burgundia and Rheinfranken Choral Societies. 10.10, Time and News. 10.30, Talk: A Journey in the Balkans. 10.50, See Langerberg. 12 Midnight, Close Down.

BRNO

578 kc/s, 342 metres; 35 kW.—2.50 p.m., See Moravská-Ostrava. 3.55 to 4.0, See Prague. 5.45, Gramophone Music. 5.55, Talk on Gardening. 6.5, Gramophone Music. 6.25, German Transmission: News, Travelogue and Gramophone Music. 7.0, See Prague. 7.25, Humorous Song Recital. 7.50 till Close Down. See Prague. 10.30 (approx.), Close Down.

BRUSSELS (No. 1)

No. 1 I.N.R., 590 kc/s, 509 metres; 15 kW.—12 noon, Concert by the Station Symphony Orchestra, conducted by Jean Kumps: March, Jean de Nivelles (Delibes); Pête à Aranjuez (Dengresseman); Valse des Lotus (Gaine); Petite suite (Busser); Songs; Ballet Music (Massenet); Gothic Minuet for Wind Instruments (Bohmann); Persian Dance (Gürand). 1.0 p.m., Le Journal Parlé. 1.50, Acts I and II of La Bohème—Opera (Puccini) on Gramophone Records. 5.0, Concert by the Station Symphony Orchestra, conducted by J. Kumps: Symphony in C, No. 7 (Haydn); Serenade No. 2 (Glozman); Five Short Pieces (Ropartz); Dances from Prince Igor (Borodin). 6.0, Travel Talk: Italy. 6.15, Pianoforte Recital of Music by Peter Benoit. 6.30, Gramophone Concert: Overture, La princesse jaune (Saint-Saëns); Waltz, Künstlerleben (Joh. Strauss); Melody (Codini); Selection from Die Bayadere (Kálmán); In the Mystic Land of Egypt (Ketilbey); Mattinata (Leoncavallo); Phantom Brigade (Myddleton); Selection from Eldorado (Ritland-Clapham); The Clock and the Dresden Figures (Ketilbey). 7.15, Talk on Motor Racing. 7.30, Medical Talk. 8.0, Song Recital by Mme. Marthe Angelici: Se tu m'amai (Pergolesi); Se Florindo e fidele (Scarlatti); Caro mio ben (Giordani); Vittoria, Vittoria! (Carissimi). 8.15, Don Juan—Radio Play (Roger Avermaete). 8.55, March from The Prophet (Meyerbeer) on Gramophone Records. 9.0, Concert, relayed from the Kursaal, Ostend. 10.30, Le Journal Parlé. 10.40, Dance Music, relayed from the Kursaal, Ostend.

BRUSSELS (No. 2)

N.I.R., 887 kc/s, 338.2 metres; 15 kW.—12 Noon, Act II of Madame Butterfly—Opera (Puccini) on Gramophone Records. 1.0 p.m., Le Journal Parlé. 1.10, Concert by the Station Symphony Orchestra, conducted by J. Kumps: Selection from The Secret Marriage (Cimarosa); Le fibustier (Cui);

BRATISLAVA

1,076 kc/s, 276 metres; 14 kW.—5.55 p.m., Hungarian Transmission: Talk with Gramophone Illustrations: Impressions of Spain. 6.55, Report for Home-wives. 7.0, See Prague. 7.25, Recital on Two Pianofortes: Jazz Sonata, Op. 11 (Moyzes); Foxfoot Study, Op. 15 (Moyzes). 7.50, See Prague. 10.15 (approx.), Close Down.

BREMEN.—See Hamburg.

BRESLAU

923 kc/s, 325 metres; 60 kW. Relayed from Gleiwitz, 1,184 kc/s, 253 metres.—2.0 p.m., Time, Weather and Exchange. 2.20, Gramophone Concert of Rhenish Songs and Music. 3.0, Agricultural Prices. 3.30, Two Talks for Parents. 4.0, Book Review. 4.15, Carnival Suite (Schumann), by Margerete Shawik (Pianoforte). 4.45, Reading. 5.15, Agricultural Prices. 5.30, Song Recital by Hans Kaufmann (Baritone). 5.45, Talk: Hunting the Bird of Paradise. 6.5 (from Gleiwitz), Concert by the Glinka Orchestra: Overture, La fluta Giardiniera (Mozart); Overture, Bastien and Bastienne (Mozart); Waltz-Caprice (Raff); Minuet in G (Beethoven); Gavotte (Lemaire); Madrigal (Sinonetti); Turkish March (Mozart); Valse mignonne (Moszkowsky); Moment musical (Schubert); Waltz and Breakfast Scene from Der Rosenkavalier (Richard Strauss); Diavoletti (Lindemann); Tarantella (Hebe-Fassungen). 6.50, News. 7.0, Transmission for all German Stations, relayed from Berlin (Deutschlandsender).

ATHLONE

725 kc/s, 413 metres; 60 kW. Relayed by Cork, 1,337 kc/s, 244.4 metres.—1.30 to 2.30 p.m., Time, News and Gramophone Music. 6.0, Programme for Children. 6.40, News. 7.0, French Lesson. 7.15, Gaelic Talk. 7.30, Time. 7.31, Popular Music by the Station Orchestra. 8.0, Soprano Solos by Eva Trinder. 8.10, Violin Solos by P. Ward. 8.25, Tenor Solos by Hugh Davey. 8.45, Irish Music by the Station Orchestra. 9.15, Pipe Solos by S. MacAonghusa. 9.30, Gaelic Songs. 9.45, Sponsored Programme. 10.30, Time. 10.45, News and Close Down.

BARCELONA

EAJ1, 860 kc/s, 348.8 metres; 8 kW.—7.0 p.m., Trio Concert. 8.0, Request Gramophone Records. 8.30, Exchange. 9.0, Gramophone Records, followed by News. 10.0, Chimes, Weather, Market Prices and Exchange. 10.5, Concert by the Station Orchestra: Two step, Zobeida (Vila); Lullaby (Grieg); Serenade (Amadei). 10.30, Dance Music Relay. 11.0, Misteri de Dolor: Play in Three Acts (Adria Gual). 12.0 midnight (in the interval), News. 1.0 a.m. (Friday). Close Down.

BARI

1,112 kc/s, 269.8 metres; 20 kW.—8.0 p.m., Agricultural Notes, Tourist Talk and Dopolavor Announcements. 8.20, Giornale Radio and Weather. 8.30, Time and Announcements. 8.35 (approx.), Military Band Concert, conducted by Salvatore Rubino. Overture, The Siege of Corinth (Rossini); Duet from Matilde di Sabrau (Rossini); Corona d'Italia (Rossini); Selection and Second Finale from Aida (Verdi); Symphonic Prelude (Raudazzo); Bolero for Clarinets (Blemlant); Orchestral Suite, Sicilia canora (Mulé); Triumphant March (Mulé). In an interval, Agricultural Talk. 10.30, Gramophone Music. 10.55, News.

BASLE.—See *Schweizerischer Landessender*.

BELGRADE

697 kc/s, 430.4 metres; 2.8 kW.—6.0 p.m., Song Recital. 6.30, Cigany Music, relayed from the Kolarac Restaurant. 7.0, Talk. 7.30, Concert by the Station Orchestra. 8.30, Programme from Ljubljana. 522 kc/s, 547.7 metres. 10.30, Time and News. 10.45 (approx.), Dance Music from theinarski Brod Restaurant.

BERLIN

DEUTSCHLANDSENDER, 183.5 kc/s, 1,635 metres; 60 kW.—1.45 p.m., News. 2.0, Gramophone Music. 2.45, Programme for Children. 3.10, Talk by Willi Krause. 3.30, Weather and Exchange. 3.45, Reading (Max Petzold). 4.0, Concert from Heilsberg. 5.0, Talk for Women. 5.35, Felix Weyrsch Concert; Margarete Vogt-Gebhardt (Songs); Gita Wendt (Violin); and Werner Kirchhoff (Pianoforte); Songs: (a) Am Heiligenbild, (b) Der Mond als Liebespostillon, (c) Vorbeimarsch, (d) Getret, (e) Knabe Frühling, (f) Zwölf Fröier, (g) Abendwolk, Albumblatt for Violin and Pianoforte. 6.0, A Poem. 6.5, Lothar Windsperger Recital by Margarete Roll (Songs) and Willy Jaeger (Pianoforte); Songs: (a) Sommerbild, (b) Abendwolk, (c) Abbild, (d) Winternacht, (e) Schliesse mir die Augen beide; Short Pianoforte Sonata. 6.30, Talk: Colour Sense in Men and Animals. 6.50, Weather and Announcements. 7.0, Transmission for all German Stations, relayed from Leipzig. 8.0, Epigrams. 8.5, Concert by the Reddemann Orchestra. 9.0, Stefan George Programme. 10.15, News. 10.45, Weather for Shipping. 11.0, Relay of a Concert. 12 Midnight, Close Down.

BERLIN

WITZLEBEN, 715 kc/s, 419.5 metres; 1.5 kW.—4.30 p.m., Chamber Music: Sonata in E Minor for Violin and Pianoforte (Bach); Pianoforte Solos: (a) Allemande, Sarabande and Gigue (Lully); (b) March in C (Mozart). (c) Variations on a Theme from Gluck's *Amide* (Hummel), (d) Extract from Spaziergange eines Einsamen, Op. 78 (Heller), (e) Abendfantasie, Op. 11 (Loewe); Seven Variations in E flat for Cello and Pianoforte on a Theme from Mozart's Opera, The Magic Flute (Beethoven). 5.30, Reading. 5.50, Old and New Ballads by Oskar Jölli (Bartone). 6.10, Talk: Research Work in the Gobi Desert. 6.30, Talk on Pomerania. 6.40, The Witzleben Station informs its Listeners. . . . 6.45, Topical Talk. 7.0, Transmission for all German Stations, relayed from Leipzig. 8.5, Announcement. 8.10, Folk Songs. 8.40, Topical Programme. 8.50, Political Announcement. 9.0, Variety Concert by the Berlin Orchestra, conducted by Heinrich Steiner, Oscar Joost's Dance Band, Lotte Löring (Soprano), Eric Helgar (Tenor), Hans Lorenz (Speaker), The Five Merry Boys and the Station Choir. In the intervals at 10.0, News, and at 11.0 (approx.), Talk: What they are talking about in Berlin. 1.0 a.m. (Friday), Close Down.

BERNE.—See *Schweizerischer Landessender*.

BEROMÜNSTER. — See *Schweizerischer Landessender*.

BODEN.—See *Stockholm*.

BODO.—See *Oslo*.

THURSDAY
JULY THE THIRTEENTH

PRINCIPAL EVENTS OF THE DAY:

AT HOME

NATIONAL LONDON REGIONAL "Yorkshire Mummies" Concert Party.
LONDON REGIONAL "R.U.R.," a play by Karel Capek.
MIDLAND REGIONAL Light music.
NORTH REGIONAL Musical comedy selections, orchestral concert.
WEST REGIONAL Rhyll's Cabaret of 1933, from the Rhyll Pavilion and ballroom.
BELFAST The music of Eric Coates, orchestral concert.

ABROAD

BRUSSELS (No. 1) 6.30 p.m. Concert by the Small Station Orchestra.
HAMBURG 8.10 p.m. The Philharmonic Orchestra, conducted by A. Secur.
HILVERSUM 7.45 p.m. The Concertgebouw Orchestra, conducted by Oscar Strauss.
HUIZEN 7.40 p.m. Concert for the 700th Anniversary of the Town of Arnhem.
LAHTI 7.0 p.m. Popular concert by the Station Orchestra.
POSTE PARISIEN 9.40 p.m. Recital of Offenbach's lesser-known music.
RADIO PARIS 8.0 p.m. Concert in celebration of July 14th.
ROME 8.45 p.m. Orchestral concert.
TURIN 8.40 p.m. Opera: "Turandot," by Puccini.
WARSAW 6.35 p.m. Violin and pianoforte recital. 8.0 p.m. The Station Orchestra, conducted by S. Nawrot.

BORDEAUX-LAFAYETTE

986 kc/s, 304 metres; 13 kW.—6.15 p.m., Radio Journal. 7.25, Talk. 7.40, News and Lottery Results. 7.45, Report on the Cycling Tour of France. 8.5, Talk on Wine. 8.20, News. 8.30, Variety Programme.

BRATISLAVA

1,076 kc/s, 279 metres; 14 kW.—2.50 p.m., Concert of Italian Music by the Station Orchestra, conducted by Odclazel. Overture, Semiramide (Rossini); Selection from Rigoletto (Verdi); Selection from Madame Butterfly (Puccini). 3.55 to 4.0, See Prague. 5.25, See Prague. 5.55, Talk: Motoring in the Country. 6.5, See Prague. 6.25, Violin Recital by G. Pauliny, Sarabande from the Second Unaccompanied Sonata (Bach); Romance (Svendson); Canzonetta (d'Annunzio); Serenade (Pierce); Sicilienne and Rigodon (Francoeur-Kreisler); Ballet Music from Foscaund (Schubert-Kreisler). 6.45, G. Gerardini reads from his own Works. 6.55, Report for the Housewife. 7.0, See Prague. 7.35, Recital of Opera Arias by Greta Filipkova. 8.0, Military Band Concert, relayed from a Park. 8.45, See Prague. 9.0, See Brno. 10.0, See Prague. 11.0 (approx.), Close Down.

BREMEN.—See *Hamburg*.

BRESLAU

923 kc/s, 325 metres; 60 kW. Relayed by Gleiwitz, 1,184 kc/s, 253 metres.—2.0 p.m., Time, Weather, and News. 2.20, Sailors' Songs on Gramophone Records. 3.0, Agricultural Prices. 3.40, Book Review. 4.0, See Heilsberg. 5.25, Talk: The Fire Brigade. 5.30, Programme for Children. 6.0, Programme to be announced. 6.20, Talks by Workers and Labour Leaders. 7.0, Transmission for all German Stations, relayed from Leipzig. 8.0, Song Recital by Rudolf Watzke: Vom Dreissigjährigen Kriege (Selle); Der Unbestand ist ihr verwandt (Krieger); Songs (Schubert): (a) Der Wanderer, (b) Totengräbers Heimweh, (c) Wohin, (d) Geheimnis: Songs (Wolf): (a) Anakreons Grab, (b) Bitteroll, (c) Gesang Weylens, (d) Storchenhofschaff, (e) Der Tambour; Songs (Loewe): (a) Tom der Reimer, (b) Hochzeitlied, (c) Mädchen sind wie die Wind. 8.45, Johann Quantz Concert by the Station Orchestra: Soloists: Hermann Zanke (Flute) and Kurt Hattwig (Harpischord); Flute Concerto in G; Flute and Harpischord Sonata in D; Trio in D for Flute, Violin, and Harpischord. 9.30, Dance Music from Berlin (Witzleben). In the interval at 10.0, Time and News. 12 Midnight, Close Down.

BRNO

878 kc/s, 342 metres; 35 kW.—6.25 p.m., German Transmission: News and a Tragedy (Büchner), arranged for Broadcasting by

BRUSSELS (No. 2)

N.I.R.; 887 kc/s, 338.2 metres; 15 kW.—Programme in Flemish. 12 Noon, Gramophone Concert of Flemish Music. 1.0 p.m., Le Journal Parlé. 1.10, Concert of Flemish Music by the Little Station Orchestra, conducted by P. Leemans: Soloists: M.M. Wigy and Michot (Violin), and P. Douliez (Pianoforte); Overture, Carmen festium (Gilsou); Flemish Sketches (Brusselmans); Serenade from Milenka (Blockx); Aubade à Kiki (De Boeck); Humoresque for Two Violins (Douliez); Pastorale (Candael); Pianoforte Solo, Waltz (Verenians); Serenade (De Boeck); Fantastic March (Gilsou). 5.0, Concert by the Radio Orchestra, conducted by Franz André: Overture, Orpheus in the Underworld (Offenbach); Dance of the Hours from La Gioconda (Pouchelli); Waltz, Wiener Bonbons (Joh. Strauss); Waltz, La Houssarde (Ganne); Down South (Myddleton); Egyptian March (Joh. Strauss). 5.45, Programme for Children. 6.30, Programme for Young People. 7.15, Film Review and Book Review. 7.30, Programme for Women. 8.0, Concert of Flemish Music by the Radio Orchestra, conducted by Franz André: Soloists: M. Brenders (Pianoforte) and M. Tontenel (Baritone); K.V.R.O. Strijlde (Meulmans); Commemoration March (De Boeck); Rapsodie dahomeenne (De Boeck); Pianoforte Solo, Musiquette (Poot); Two Flemish Songs; Canadian Fantasia (Gilsou). 8.45, Legal Talk: 1302-1933. 9.0, Concert by the Station Orchestra, conducted by Arthur Meulmans: Soloist: M. Tontenel (Baritone); Festival March (Gilsou); Overture, Charlotte Corday (Benoit); Baritone Songs: Third Fantasia (Benoit); Waltz Suite (Gilsou); Flemish Dances (Blockx); De Vlaamsche Ieew (Miry). 9.55, Evening Prayer. 10.0, Le Journal Parlé. 10.10, Gramophone Concert: March, Heil und gruss (Kiersling); Waltz, Die Schönbrunner (Lammer); Selection from Viktoria and her Hussar (Abraham); Salut d'amour (Elzar); March, The Archduke Albert (Komzak); Viennese Waltzes (Korngold); Jota (Falla); Bereuse (Jarnefeld); Les ziganes (Serbian); March, Old Courades (Teike).

BUCHAREST

761 kc/s, 394 metres; 12 kW.—5.0 p.m., Concert by the Station Orchestra: March (Schindler); Waltz (Pachernegg); Overture, Figaro (Mozart); Suite, Bal constant (Rubinstein); Selection from The Rose of Stamboul (Fall); Suite, La fête chez Thérèse (Hahn); Selection from Tip-Top's (Gershwin). In an interval at 6.0, Radio Journal. 7.0, Educational Talk. 7.20, Reading. 7.40, Opera Music on Gramophone Records. In the intervals, Radio Journal.

BUDAPEST

545 kc/s, 550.5 metres; 18.5 kW. Also relayed on 840 metres from 8.15 p.m.—5.30 p.m., Concert, conducted by Wilhelm Roubal. 6.45, Humorous Talk. 7.10, Exchange. 7.20, Sonatas for Cello and Pianoforte. 8.0, Review of Foreign Affairs. 8.15, Talk. 8.45, Concert of Cigany Music. 10.15, News. 10.30, Concert of Light Music. The Gipsy King (Nagypal); Romantic Waltz (Heinecke); Selection from Rose Marie (Frind); Selection from Der Liebe Angustin (Fall); Overture, Der Erlenhügel (Kuhlan); Vergissmichnicht (Maebeth); Tango Song (Kalmán); Selection from The Geisha (Jones); Overture, Rind um die Liebe (Oscar Straus).

CASSEL.—See *Frankfurt*.

COPENHAGEN

1,067 kc/s, 281 metres; 0.75 kW. Relayed by Kalundborg, 260 kc/s, 1,153 metres.—12 Noon Town Hall Chimes. 12.2 to 2.0 p.m., Concert from the Hotel d'Angleterre. 3.30, Concert by the Copenhagen Wind Instrument Orchestra, conducted by Th. Dyring. Soloist: Holger Lund-Christiansen (Pianoforte). Radetzky March (Joh. Strauss); Overture, The Magic Flute (Mozart); Mazurka, La Czarine (Ganne); Selection from Faust (Gounod); Gallop, Vive Paris (Desormes). Pianoforte Solos: (a) Andante con moto from Forsaestoner, Op. 2 (Niels Gade), (b) Andante enuabile and Allegro vivace from Danse og Intermezzi Op. 49 (Lange-Müller), (c) Chaconne Op. 22 (Carl Nielsen). Hungarian March (Faurbach); Prelude to the Fourth Act of Tovelille (Asger Hammerich); Polka (E. Strauss); Waltz, Estudiantina (Waldteufel); Champagne Gallop (Wiegand). 5.35 (in an interval), Exchange and Fish Market Prices. 6.20, Talk. 6.50, Weather and News. 7.0 News. 7.15 Time Signal. 7.30, Talk: The Battle of the Marne, 1914. 8.0, Town Hall Chimes. 8.2, Concert of Danish Folk Music by the Station Orchestra, conducted by Lanny Gröndahl. Jutland Folk Dances of 1800 (arr. for Orchestra by Lanny Gröndahl). Amager Polka (Lumbye); North-West Jutland Folk Dance (arr. for Chamber Orchestra by Lanny Gröndahl); Elverhøj-Danish Folk Melody, arranged for String Orchestra (H. Sandby); Agnete og Havmanden—Danish Folk Melody arranged for String Orchestra (Emil Reesen); Danish Rhapsody (Otto Olsen). 8.50, Radio Pictures of Everyday Life—A Visit to a Chicken Farm. 9.20, Recital of Songs of Kay Rostgaard-Flöhe. 9.40, Reading (Edgar Wallace). 10.0, News. 10.15, Concert of Old Danish Music by the Station Symphony Or-

Erich Smutnik. 7.0, See Prague. 7.10, Instrumental Solos. 7.35, See Prague. 9.0, French Programme by the Station Orchestra, conducted by Jan Janota. Soloists: M. Fleischerova (Songs), T. Králová (Harp), H. Kaslik (Flute), and J. Bezdiček (Recitations); Gramophone Record: Song by a Breton Choir. Breton Rhapsody (Saint-Saëns); Recitations; Scènes alsaciennes (Massenet); Song with Harp Accompaniment (Caplet); Song with Flute Accompaniment (Roussel); Song (Honegger); Recitations; Symphonic Suite (Bert). 10.0, See Prague. 11.0 (approx.), Close Down.

BRUSSELS (No. 1)

I.N.R., 590 kc/s, 509 metres; 15 kW.—12 Noon, Concert by the Small Station Orchestra, conducted by P. Leemans: Overture, The Caliph of Bagdad (Boieldieu); Suite, Mascarade (Lacôme); Gopak (Mussorgsky); Selection from Le petit Duc (Lecocq); Berceuse (Renard); Violin Solo: Spanish Dance (Wigy); Selection from Show Boat (Kern); Melody (Gerbes). 1.0 p.m., Le Journal Parlé. 1.10, Gramophone Concert: Arab March (Ganne); Air from Le Petit Duc (Lecocq); Le cuisinier (Bach and Laverne); Tintoretto (Kockert-Zimmer); Selection from Countess Maritza (Kalmán-Göhl); Serenade (Caludi); Comme au plus beau jour (Popper); Selection from Hans, the Flute Player (Ganne); Eh ben, monlieux (Bonsquet); Selection from Ebevezmoi (Gaborche); Chanson d'Arlette (de Tugy); Songs from Lulu (Parés and Van Parys). 5.0, Concert by the Station Symphony Orchestra, conducted by Meulmans: Selection from Les Cloches de Corneville (Piaffatte); Entr'acte et Pas des Pierrots, from Joli gilles (Poise); Selection from Hérodiade (Massenet); Prelude and Sicilienne, from Cavalleria rusticana (Mascagni); March from The Prophet (Meyerbeer). 5.30, Literary Programme. 6.0, Talk on Cancer. 6.15, Gramophone Music: Recitative and Scherzocaprice (Kreisler); Gavotte du bouquet (Des-touche-Cs-adesus); Rhapsody for Clarinet and Orchestra (Debussy). 6.30, Concert by the Small Station Orchestra, conducted by P. Leemans: Overture, La belle Hélène (Offenbach); Symphonic Poem, Provence (Foutraud); Serenade (Godard); Potpourri, from Gluck to Wagner (Schreiner); Pianoforte Solo: Mouvements perpétuels (Poulenc); Ballet Music from Lakmé (Debès). 7.15, Talk for Workers. 7.30, Sports Review. 8.0, Concert by the Station Symphony Orchestra, conducted by Meulmans: Extracts from Le roi malgré lui (Chabrier); Ballet Music from: (a) Lakmé (Debès), (b) La Cigale (Massenet), (c) Samson and Delilah (Saint-Saëns); Selection from Hamlet (Thomas). 8.45, Talk. 9.0, Concert, relayed from the Kursaal, Ostend. 10.30, Le Journal Parlé. 10.40, Dance Music relayed from the Kursaal, Ostend.

ATHLONE

725 kc/s, 413 metres; 60 kW. Relayed by Cork, 1,337 kc/s, 244.4 metres.—1.30 to 2.30 p.m., Time, News and Gramophone Music. 6.0, Gramophone Music. 6.45, News. 7.0, Talk by Monica Traynor: Careers for Girls—Domestic Economy. 7.15, Gaelic Talk. 7.30, Time Signal. 7.31, Pianoforte and Flute Duets by Mary Roughan and W. Raebone. 7.55, Baritone Solos by H. Crowther. 8.10, The Station Orchestra. 8.35, Mezzo-Soprano Solos by Gertrude Mortimer. 8.50, The Emer Comedy Company. 9.20, Irish Music by the Station Orchestra. 9.30, Val Vonsden (Entertainer). 9.45, Sponsored Programme. 10.30, Time. 10.45, News and Close Down.

BARCELONA

EAJ1, 860 kc/s, 348.8 metres; 8 kW.—7.0 p.m., Trio Concert: Mimet (Paderewski); Selection from La Navarraise (Massenet); Erotika (Grieg); Serenata à Toscanini (Murrilli); Air (de Severac); Selection from Der Freischütz (Weber). 8.0, Request Gramophone Records. 8.30, Exchange. 9.0, Gramophone Music. 9.15, Talk on Disarmament, Gramophone Records (contd.), and News. 10.0, Chimes, Weather, Market Prices and Exchange. 10.5, Concert by the Station Orchestra. 11.0, Vicente Diaz de Tejada reads from his own Works. 11.15, An Opera on Gramophone Records. In the interval at 12 Midnight, News. 1.0 a.m. (Sunday), Close Down.

BARI

1,112 kc/s, 269.8 metres; 20 kW.—8.0 p.m., Agricultural Notes, Tourist Talk, and Dopolaro Announcements. 8.20, Giornale Radio and Weather. 8.30, Time and Announcements. 8.35 (approx.), Madame Butterfly—Opera (Puccini), on Gramophone Records. In the interval, Talk. After the Opera, News.

BASLE.—See Schweizerischer Landessender.

BELGRADE

697 kc/s, 420.4 metres; 2.8 kW.—6.0 p.m., Gramophone Music. 7.0, Talk. 7.30, National Songs. 8.0, Concert by the Station Orchestra. 9.0, Two Radio Plays. 9.30, Programme relayed from Tuzla. In an interval at 10.15, Time and News. After the Programme, Dance Music on Gramophone Records.

BERLIN

DEUTSCHLANDSENDER, 183.5 kc/s, 1,635 metres; 60 kW.—1.45 p.m., News. 2.0, Walzes on Gramophone Records. 3.0, Handwork for Children. 3.30, Weather and Exchange. 3.45, Reading (Adam Carillon). 4.0, Concert relayed from Hamburg. 5.0, Sports Review. 5.15, Weekly Report. 5.30, German Folk Songs for Soprano and Tenor by Martha and Karl Mims; Songs (arr. Weinreis); (a) Wie wird mir dann geschehen, (b) Tröst die Bedrängten, (c) Der Winter ist vergangen, (d) Mein G'sell, wie reich dein Haus so wohl; Songs (arr. Berger); (a) Hans und Liesel, (b) Schwefelhölzle, (c) Schmutzputzweibchen, (d) Du liegst mir im Herzen. 6.0, A Poem. 6.5, Music for Twelve French Horns. 6.30, Talk: The Position of Woman in Modern Germany. 6.50, Weather and Announcements. 7.0, Transmission for all German Stations, relayed from Langenberg. 8.0, Epigrams. 8.5, Programme from Breslau. 9.0, New German Dance Music. 10.0, News. 10.45, Weather Report for Shipping. 11.0, See Munich. 12 Midnight, Close Down.

BERLIN

WITZLEBEN, 715 kc/s, 419.5 metres; 1.5 kW.—4.0 p.m., Concert by the Alois Pachernegg Orchestra: Overture, Alfonso and Estrella (Schubert); Waltz, Freudengrüsse (Jos. Strauss); Potpourri of Alpine Songs. Die Berge hoch (Pachernegg); Volksliedchen (Kozzak); Märchen (Kozzak); Children's Song Suite (Inghelbrecht); Selection from Czar and Carpenter (Lortzing); Waltz, Flattergeister (Jos. Strauss); Overture, Der Landstreicher (Ziehrer); Bavarian Dances (Pachernegg); March, Barataria (Kozzak). In the interval at 4.55 (approx.), The Training of Light Athletes—a Radio Report. 5.30, Talk: Struggles in the Mark District against Swamps and Sand. 6.0, Song Recital by Johanna Egli (Contraalto): Songs (Manke); (a) Meine Flöte ist verstummt, (b) Mein Herze hat sich aufgetan, (c) Meeresleuchten, (d) Über den Wolken, Usterlicher; Songs (Wetzel); (a) Song, (b) An den Mond, (c) Hoffnung. 6.20, Talk: In the Zoological Gardens in Summer. 6.40, The Witzleben Station informs its Listeners... 6.45, Topical Talk. 7.0, Transmission for all German Stations relayed from Langenberg. 8.5, Announcement. 8.10, Humorous Stories. 8.20, Programme from Hamburg. 10.0, News. 10.15 (approx.), Dance Music relayed from the Europa Pavillon. In the interval at 11.0 (approx.), Talk: What they are talking about in Berlin. 1.0 a.m. (Sunday), Close Down.

BERNE.—See Schweizerischer Landessender.

BEROMUNSTER.— See Schweizerischer Landessender.

BODEN.—See Stockholm.

BODO.—See Oslo.

SATURDAY

JULY THE FIFTEENTH

PRINCIPAL EVENTS OF THE DAY:

AT HOME

- NATIONAL "Margate Memories" Concert Party.
LONDON Chamber music.
REGIONAL
MIDLAND The Masquerade Follies, from Leamington Spa.
REGIONAL
WEST "The Glanhowy" Concert Party.
REGIONAL
SCOTTISH Round the Stations, feature programme.
REGIONAL
BELFAST Military Band concert.

ABROAD

- BUDAPEST 8.0 p.m. Orchestral version of operetta: "Die Fledermaus," by Johann Strauss.
BERO-MUNSTER 8.30 p.m. Operetta: "The Merry Peasant," by Fall, relayed from Basle.
COPENHAGEN 8.30 p.m. Radio Ball for the Older Generation.
HILVERSUM 6.25 p.m. Strauss concert.
LANGENBERG 7.0 p.m. Opera: "Die Opernprobe," by Lortzing, relayed from Cologne.
POSTE 8.25 p.m. Schubert's Trio in B flat (Op. 99).
PARISIEN
STOCKHOLM 8.0 p.m. Variety programme by the Radio Orchestra.
RADIO PARIS 8.45 p.m. Opera: "The Land of Smiles," by Lehar, from the Theatre de la Gaite-Lyrique.
ROME 8.30 p.m. Opera: "Turandot," by Puccini.

BORDEAUX-LAFAYETTE

986 kc/s, 304 metres; 13 kW.—6.30 p.m., Radio Journal. 7.30, Sports Talk. 7.35, News. 7.45, Report on the Cycling Tour of France. 8.5, English Lesson. 8.20, News. 8.30, Catherine—Comedy in Four Acts (H Lavedan).

BRATISLAVA

1,076 kc/s, 279 metres; 14 kW.—6.25 p.m., Violin Concerto in B Minor, Op. 61 (Saint Saëns), played by Rudolf Doh. 6.55, Report for the Housewife. 7.0, See Prague. 7.25, See Brno. 8.5, See Prague. 8.50, See Brno. 10.0, See Prague. 11.30 (approx.), Close Down.

BREMEN.—See Hamburg.

BRESLAU

923 kc/s, 325 metres; 60 kW. Relayed by Gleiwitz, 1,184 kc/s, 253 metres.—1.0 p.m., Gramophone Music. In the interval at 2.0, Time and News. 3.0, Agricultural Prices. 3.29, Programme to be Announced. 3.40, Review of Joseph Wittig's Books. 4.0, Orchestral Concert, conducted by Rudolf Pietsch, March, Ein Maunneswort (Pollak); Overture, The Merry Wives of Windsor (Nicolai); Waltz, Wiener Bürger (Ziehrer); Rosenlieder (Ehlenburg); Indian Intermezzo, Aiska (Lindsay); Potpourri, Wiener Melodienstrauß (Klimert); Festival Overture (Lassen); Jagdlust-Quadrille (Lewe); Selection from Faust (Gounod); Graf Zeppelin March (Teike). 5.30, Film Review. 5.50, Programme Announcements. 6.0, Programme to be Announced. 6.20 (from Gleiwitz), Concert by a Male Voice Quartet. 6.50, Weather and News. 7.0, Transmission for all German Stations, relayed from Langenberg. 8.0, Variety Programme for Peasants. 9.0, See Berlin (Deutschlandsender). 10.0, Time and News. 10.30, Dance Music, relayed from Berlin (Witzleben). 12 Midnight, Close Down.

BRNO

878 kc/s, 342 metres; 35 kW.—5.55 p.m., Talk for Tourists. 6.5, Gramophone Music. 6.25, German Transmission: News and Pianoforte Duets by Rena Hawranek-Fischböck and Adele Weingärtner; (a) Fantasia in F Minor, Op. 130 (Schubert), (b) Legends (Dvorak). 7.0, See Prague. 7.25, A Slovakian Wedding—Folklore Scene with Music. 8.5, See Prague. 8.50, Variety Programme by the Station Orchestra, conducted by Jan Janota. Soloists: M. Bakalova (Songs) and Emil Brejsa (Zither). 10.0, See Prague. 11.30 (approx.), Close Down.

BRUSSELS (No. 1)

I.N.R., 590 kc/s, 509 metres; 15 kW.—12 Noon, Concert by the Station Symphony Orchestra, conducted by M. Meulemans: Jubel-Ouverture (Weber); Selection from Mignon (Thomas); Waltz, Wiener-Bonbons

(Joh. Strauss); Songs by Mme. Van Tiggelein; Three Short Pieces (Dubois); Extase (Ganne); Marche russe (Luigini). 1.0 p.m., Le Journal Parle. 1.10, Concert by the Radio Orchestra, conducted by Franz André; Soloist, Mr. Durand (Trumpet) and Mme. Dorine Pauwels (Songs); Walden Suite (Wangermée); Suite from La Fête chez Thérèse (Hahn); Trumpet Blues (Lindley); Songs: (a) Pensée d'automne (Massenet), (b) Air from La Vivandière (Godard); Arab Dances (Montagne Ring); Hungarian Rhapsody No. 12 (Liszt). 4.45, Talk: The Protection of Birds in Belgium. 5.0, Dance Music, relayed from the Continental Palace Hotel, Blankenberghe. 6.0, Talk: The Nervous Child. 6.15, Extracts from Pianoforte Concerto No. 2 (Liszt), on Gramophone Records. 6.30, Concert by the Small Station Orchestra, conducted by P. Leemans: Marche militaire française (Saint-Saëns); Waltz, La Doussarde (Ganne); Overture, La plus jolie fille de France (Fouadain); Violin Solo from Faust (Gounod-Sarasate); Fantasia on Limousin Airs (Roucheaud); Albanian Dances (Levadé); March, Sambre et Meuse (Planquette). 7.15, Talk: The Belgian Painter, Louis Dubois. 7.30, Le Journal Parle. 8.0, Song Recital by Mlle. Elisabeth Mly. 8.15, Monologues by Mme. Rose Denis, M.M. Gillain and Santerre. 8.30, Symphonic Suite from The Love for the Three Oranges (Prokofiev), on Gramophone Records. 8.50, Monsieur Badin—Play in One Act (Georges Courteline). 9.0, Concert relayed from the Kursaal, Ostend. 10.30, Le Journal Parle. 10.40, Dance Music, relayed from the Kursaal, Ostend.

BRUSSELS (No. 2)

N.I.R., 887 kc/s, 338.2 metres; 15 kW.—12 Noon, Concert by the Radio Orchestra, conducted by Fr. André. Soloists: Mme. Dorine Pauwels (Songs). Fête polonoise (Chabrier); Dance Suite (Godard); Suite (Zilka); Songs; Muziquette for Pianoforte (Pook); Boxing (Schoemaeker); English Scenes (Bantock); Suite algérienne (Saint-Saëns); Waltz, Wienerblut (Joh. Strauss). 1.0 p.m., Le Journal Parle. 1.10, Concert by the Station Symphony Orchestra, conducted by Mr. Meulemans: Cortège from Myrtis (Daneau); Carnaval from Princesse d'Auberge (Blockx); Dans la forêt (Fremolle); Entr'acte from Rigandin de Savière (Dubois); Songs by Mme. Dorine Pauwels; Aubade à Kiki (De Boeck); A Cypriis (De Taey); Waltz from Hoppes et Hoppes (Lauweryns). 4.45, Reading. 5.0, Concert by the Small Station Orchestra, conducted by P. Leemans: Operetta Overture (Lincke); Melody (Rubinstein); Waltz, La Barcarolle (Waldteufel); Selection from The Barber of Seville (Rossini); Liebesleid for Violin (Kreiser); Arabesque (Montagne-Phillips); Selection from Show Boat (Kern); Foxtrot, Dizzy Fingers (Confrey). 6.0, Symphony in G (Haydn) on Gramophone Records. 6.15, Technical Talk. 6.30, Gramo-

phone Concert: La Tourterelle (Damaré); Spanish Serenade, Cadix (Albeniz); Potpourri, Russian Souvenir (Mikhailovsky); Valse des as (Georges); Polka-Rondo, La Volière (Dunard); Fantasia-Mazurka (de Nattes); Polka, Myrto (Petit); Valse élégante (Holz); American March (Souza); Operetta Potpourri (Misraki); Selection from The Grand Mogul (Andran). 7.15, Talk on Basket Ball. 7.30, Agricultural Talk. 8.0, Concert by the Station Orchestra, conducted by F. André. Soloists: M. Toutenel (Baritone) and Boyarin (Songs and Balalaika Solos); Extracts from The Spanish Caprice (Rimsky-Korsakov); Hungarian Fantasia (Liszt); Items by M. Boyarin; Russian March (Ganne); Fantastic March (Gilson); Valse triste (Sibelius); Baritone Songs; Aragonaisa (Falla); A Wedding Day on Troldhaugen (Grieg); Baritone Songs; Four Viennese Pieces (Kreisler); Selection from Milenka (Blockx); Russian Potpourri (Bullerian). In the interval at 8.30, A Sketch. 10.0, Le Journal Parle. 10.10, Dance Music relayed from the Continental Palace Hotel, Blankenberghe.

BUCHAREST

761 kc/s, 394 metres; 12 kW.—5.0 p.m., Light Music and Romanian Music by the Sibicano Orchestra. In an interval at 6.0, Radio Journal. 7.0, Educational Talk. 7.20, Gramophone Music. 7.40, Reading. 8.0, Song Recital by Gabriel Popescu. 8.30, Dramatic Programme. 9.0, Romanian Music by the Fanica Luca Orchestra. 10.0, Radio Journal.

BUDAPEST

545 kc/s, 550.5 metres; 18.5 kW. Also relayed on 840 metres from 7.30 p.m. (approx.) till Close Down. 5.0 p.m., Popular Gramophone Music. 6.0, The Letter Box. 6.30, Hungarian Folk Songs, with Cigány Music accompaniment. 7.20, Exchange. 7.30, Humorous Programme. 8.0, Orchestral Version, Die Fledermaus—Operetta (Johann Strauss), by the Budapest Concert Orchestra, relayed from the Municipal Park. News in the interval. After the Relay, Dance Music from the Hotel Danapalota.

CASSEL.—See Frankfurt.

COPENHAGEN

1,067 kc/s, 281 metres; 0.75 kW. Relayed by Kalundborg, 260 kc/s, 1,153 metres.—12 Noon, Concert by the A. Bendix String Ensemble, relayed from the Restaurant Wivex, 1.0 to 3.0 p.m., Interval. 3.0, Symphonic Jazz, by Erik Tuxen and his Orchestra. In an interval at 3.45 (approx.), Reading. 5.0, Gramophone Concert. Elena Gerhardt; Romance from Rosamunde (Schubert); Joseph Hislop; Annie Laurie, Adolf Busch; Gigue from the Sonata in D Minor for Violin (Bach). Hans Kestenberg; Song from The Czarevitch (Lehar). Hilmer Borgeling; Café Rouge (White). Seger Ellis; Shine on Harvest Moon (Norworth). Layton and Johnston; A Broken Rosary (Klein and Dillon). The Harmonians; Love Tales (Pavis and Ager). 5.35, Exchange and Fish Market Prices. 6.20, Talk: The Joys and Pains of the Sailor's Life. 6.50, Weather. 7.0, News. 7.15, Time Signal. 7.30, Talk: June Political Review. 8.0, Time Signal from the Town Hall. 8.1, Reading. 8.30 till 12 Midnight, Radio Ball for the Older Generation. The Station Orchestra, conducted by Lanny Grundahl. Soloist: Aase Wallenstrom (Songs). 8.30, Concert of Light Music: War March (Moller); Augusta Waltz (Moller); Sovus Polka and Petra Mazurka (Jensen); Swedish Masquerade; Trippevals (Nielsen). 9.0, Four Songs (Boghiske). 9.15 Concert (contd.): Waltz, Morgenblätter (Joh. Strauss); Mazurka (Klinkwort); The Lancers (Mikel); Waltz, Children of Spring (Waldteufel); Polka; March, The Washington Post (Souza). 9.55, Four Old Danish Melodies. 10.10, Concert (contd.): Six Folk Dances for Clarinet and Strings; Columbine Mazurka (Lumbye); Nordlys Vals (Lumbye); Gallop, En Sommeraften paa Moens Klint (Lumbye). 10.50, News. 11.5, Pianoforte Solos: Sailor's Polka (Hornemann); Waltz, Echo an der Donau (Fahrbach); Maa jeg have den Fornjelse (Hornemann). 11.20, Concert (contd.): March, Wienerkünstler (Schrammel); Schottische, La petite Tonkinoise (Scott); Barcarolle (Waldteufel); Melody; Nyholer Polka (Jespersen); Helga Mazurka and Champagne Gallop (Lumbye). 12 Midnight, Time Signal and Chimes from the Town Hall.

CORK.—See Athlone.

CRACOW

959 kc/s, 312.8 metres; 1.5 kW.—7.0 p.m., Topical Talk. 7.15, Miscellaneous Items, News and Gramophone Music. 7.35, Programme Announcements. 7.40, See Warsaw. In the interval at 9.15, News. 10.0, Light Music, relayed from the Pavilion Restaurant. In the intervals at 10.25, Sports Notes, and at 11.30, News for Members of the Polish Polar Expedition, relayed from Lwów. 12 Midnight, Fanfare from St. Mary's Church.

DANZIG.—See Heilsberg.

DRESDEN.—See Leipzig.



"Overheads."

How much do you spend on H.T. batteries for your radio set? Whatever it is, you will appreciate that the upkeep costs of your receiver are far too high.

But—if you have A.C. Mains available, your H.T. costs need not be more than a shilling a year. Buy, or build, an eliminator incorporating a Westinghouse Metal Rectifier—plug into the mains and then switch on to a permanent, ample and constant power supply.



METAL RECTIFIERS

Westinghouse Metal Rectifiers are standardised by all the leading manufacturers of A.C. Mains apparatus; and tests have proved that their life is equivalent to at least 25 years' use with a radio set.

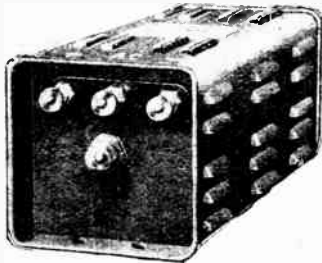

The WESTINGHOUSE BRAKE & SAXBY SIGNAL CO. LTD.,
82, York Rd., King's Cross, London, N.1.



A Satisfied User of the Ideal Aerial

"RECEPTICON"

INSULATED COPPER AERIAL

"Recepticon" can be used either as an indoor or outdoor aerial or as an earth. It is a seven-strand insulated aerial cable drawn from pure electrolytic copper and protected with a weatherproof covering, and is definitely non-corrosive. The conductivity of the aerial is, of course, extremely high, so that when "Recepticon" is fitted perfect satisfaction is assured. Obtainable from all wireless dealers or if in difficulty apply direct to the manufacturers.

THE CONCORDIA ELECTRIC WIRE CO. LTD.,
NEW SAWLEY, N. NOTTINGHAM.

PRICES.	
25 ft.	7½d.
50 ft.	1/3
75 ft.	1/10
100 ft.	2/6

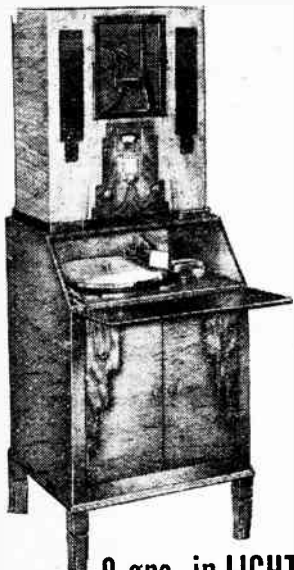

your present set

plus APOLLO Playing Desk

equals a fine Radio-Gram

8 gns. in LIGHT, MEDIUM or DARK WALNUT

TO MATCH VARIOUS SETS
Size of top, 18 x 11½ in

As illustrated, with Collaro Induction motor, and pickup, automatic current stop, volume control, Record cupboard—8 gns. or 12 payments of 15/6. Cabinet only, without motor or pickup, £3.15.0. Also supplied fitted with GARRARD AUTOMATIC RECORD CHANGER and volume control complete, £15 5.0. Table Models: Electric, £5.17.6; Spring, £4.4.0.

APOLLO PLAYING DESKS

Ask your Radio Shop, or write to—
APOLLO GRAMOPHONE CO., LTD.,
4-5, Bunhill Row, London, E.C.1.

ELECTRICAL TESTING INSTRUMENTS

Moving Coil Galvanometers —
Vibration Galvanometers —
Wheatstone Bridges — Standard Resistances — Microammeters — Millivoltmeters — Portable Galvanometers — Galvanometer Lamps and Scales — Universal Shunts — Standard Megohm Resistances — Standard Potentiometers — Standard Cells — Standard Condensers — Capacity Bridges — Ganging Bridges — Testing Keys and Switches.

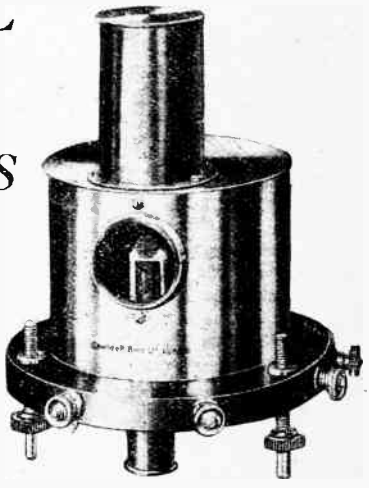

High Sensitivity Moving Coil Mirror Galvanometer.
Patent No. 3300.

Gambrells have been supplying for the past 35 years, testing equipment for the laboratories of the leading Electrical Manufacturing Companies, Government Departments, National Physical Laboratories, Universities, etc. Their knowledge of electrical testing problems is unique and they are continually being called upon to design apparatus to deal with the special requirements of their customers. If you require apparatus for carrying out electrical tests you will either find it listed in their catalogue, or they will design special apparatus to fit your requirements exactly.

GAMBRELL BROS. LTD.
ELECTRICAL ENGINEERS,
MERTON ROAD, SOUTHFIELDS, S.W.18.

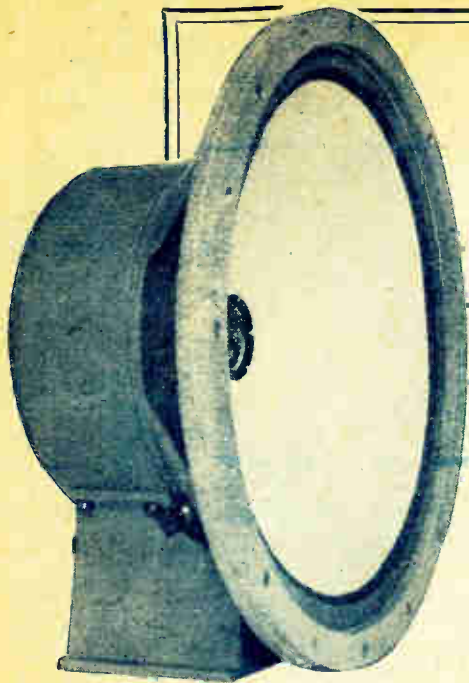

NEW "SENIOR" MODEL LOUD SPEAKER

In order to meet the demand of those who prefer a Loud Speaker of the large cone type, we have recently introduced our "SENIOR" MODEL. This speaker will be found similar in all respects to our "STANDARD" MODEL, with the exception that it has a 12" diameter diaphragm with a cone angle of 120°.

CATALOGUE AND FULL PARTICULARS FREE ON REQUEST

PARTRIDGE & MEE LTD.,

"Parmeko" Works,
Aylestone Park, LEICESTER.

74, New Oxford Street,
LONDON, W.C.1.
Mus. 5070.

It is capable of handling a large input without distortion. Supplied complete with Unit, Base and Transformer, giving Ratios of 11:1 and 22:1.

PRICE **£7**

DICTIONARY of WIRELESS TECHNICAL TERMS

Compiled by S. O. Pearson, B.Sc., A.M.I.E.E., and issued in conjunction with "THE WIRELESS WORLD." Second Edition. Completely revised and brought up to date.

This handy volume is very much more than a Dictionary. It not only takes the technical terms of wireless and explains their meaning, but in doing so it concentrates into a small space a large amount of information on wireless subjects. It has become, in fact, a compendium of current wireless knowledge, and an invaluable handbook for all who are interested in wireless transmission and reception. Diagrams and illustrations are freely interspersed throughout the book to amplify the explanations of the text.

272 pp., bound in clothboards
Size 5 by 3 inches

Price 2/- net. By post 2/2

From all leading booksellers or direct from the Publishers

ILIFFE & SONS LTD., DORSET HOUSE, STAMFORD STREET, LONDON, S.E.1

*Facsimile Page
from the
Second Edition*

Impulse Excitation. Method of starting high-frequency oscillations in an aerial system or oscillatory circuit by a sudden surge, e.g., a spark, and not by applying an oscillating voltage of the same frequency as that of the tuned circuit. Sometimes called "shock excitation."

In Phase. Two alternating quantities are said to be "in phase" if they have the same frequency and pass through their respective maximum and zero values at the same instants. The definition applies only where the two waves



are of the same shape. See PHASE DIFFERENCE.

Indirectly-heated Valve. The type of valve in which the cathode is indirectly heated by a separate heater resistance, the cathode being a hollow cylinder to accommodate the heater within it. The heater may be supplied with A.C. or D.C.

Induced Current. A current produced in a circuit by an induced E.M.F., i.e., by a changing of the magnetic flux linked with the circuit.

The Wireless World

4^D

THE PRACTICAL RADIO JOURNAL

with

Complete Foreign Programmes

Friday, July 14th, 1933.

COLVERN FERROCART COILS

FERROCART Coils are synonymous for outstanding selectivity, compactness and efficiency.

TYPES F1 F2 F3	TYPES F10 F11 F12 F13
For single S.G.H.F. stage receivers	Suitable for 2 S.G.H.F. stage receivers

37'6 per set
Mounted on sub base with ganged wave change switches.

COLVERN LIMITED, ROMFORD, ESSEX.

London Wholesale Depot, 150, King's Cross Rd., W.C.1.

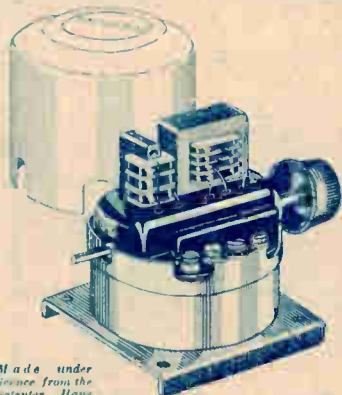

Made under license from the inventor, Hans Yott.

H.T. for ever for 1/- a year

Write to: E. K. Cole, Ltd., Dept. W.16, Ekco Works, Southend-on-Sea.

TELSEN SUPERHET COILS

TYPE No. S.330

Specified for the W. W. Monodial Super Battery Receiver. The ideal coils for any superhet circuit. 25'6

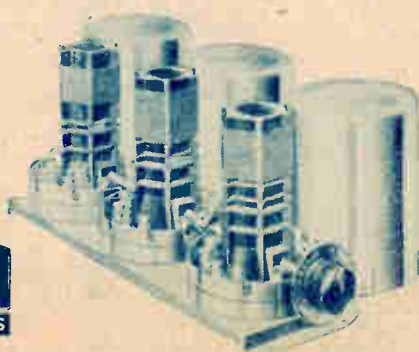

TELSEN
RADIO COMPONENTS

Announcement of the TELSEN ELECTRIC CO., LTD., ASTON, BIRMINGHAM

THE MEANING OF T.C.C. RESEARCH TO YOU



in a word DEPENDABILITY—the result of twenty-seven years' specialised research, of concentrated effort on the one product—condensers

Whatever the need—play Safe—use T.C.C.



T.C.C. build 2500 V.C. Condenser for WORKING at 250 V.D.C. (500 V. Test). Price 2s. 0d.

T.C.C.
ALL-BRITISH
CONDENSERS

The Telegraph Condenser Co., Ltd., Wales Farm Road, N. Acton, London, W.3.

3126

Keep the Week's Foreign Programmes handy for constant use

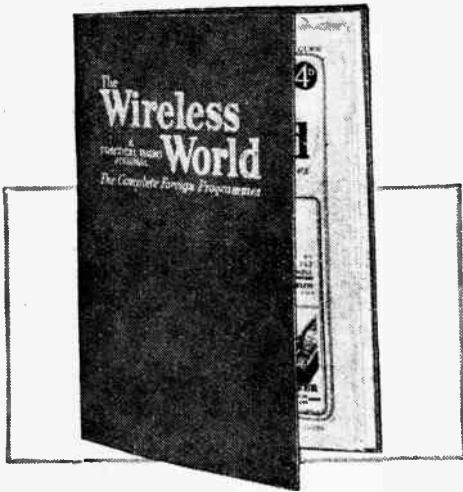

"The WIRELESS WORLD" READING CASE

Price 2/6 net. By post 2/10

Now obtainable from the publishers

ILIFFE & SONS LTD., DORSET HOUSE, STAMFORD STREET, LONDON, S.E.1

W.W.58

THE ELEMENTARY PRINCIPLES OF WIRELESS TELEGRAPHY AND TELEPHONY

By R. D. BANGAY

Third Edition. Revised by O. F. BROWN, B.Sc.

FOR many years this volume has been the standard book of instruction for wireless beginners and students. The progress of wireless during recent years has made necessary the New Edition, which covers the whole subject in a clear and simple style. Attention is given to the theoretical elements of electricity and magnetism, the dynamo and the properties of waves. Many new chapters have been added and descriptions of circuits have also been included.

A leaflet giving full particulars of the volume and a synopsis of chapters will be sent on request.

**THIRD
EDITION**

Price 7/6 net. By post 8/-

From all leading Booksellers or direct from the Publishers:

ILIFFE & SONS LIMITED, DORSET HOUSE, STAMFORD STREET, LONDON, S.E.1

W.W.97

Mention of "The Wireless World," when writing to advertisers, will ensure prompt attention.

The Wireless World

PROGRAMMES from ABROAD

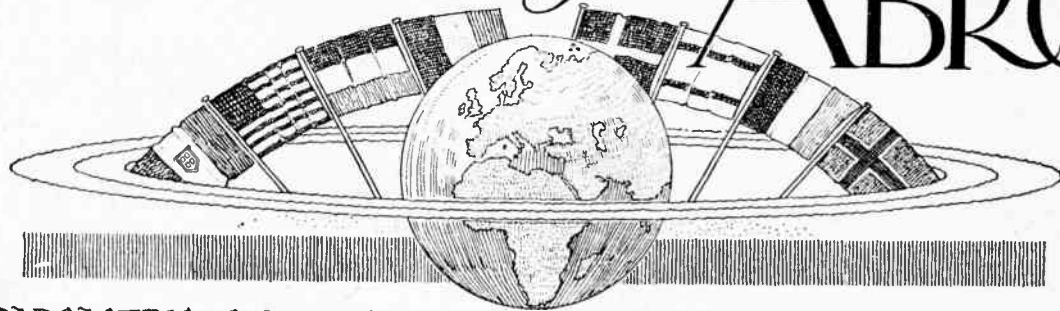

BROADCASTING STATIONS
ARRANGED IN ORDER
OF WAVELENGTH

TIMES AND DETAILS OF
FULL WEEK'S FOREIGN
TRANSMISSIONS

Metres.	kc s.	kW.	Station.	Tuning Positions.	Metres.	kc's.	kW.	Station.	Tuning Positions.
1935	155	7	Kaunas (Kovno) (Lithuania)		453.2	662	7	Milan (<i>Experimental Relays Rome</i>)	
1875	160	8.5	Huizen (Holland)		450.3	666	20	Madona (Latvia). (<i>Relays Riga</i>)	
1796	167	40	Lahti (Finland)		447.1	671		Paris, Ecole Supérieure, PTT (7.0 kW.); Rjukan (0.15 kW.); Notodden (0.08 kW.); Aalsund (0.35 kW.) (Norway) (<i>relays Oslo</i>).	
1725	174	75	Radio Paris, C.F.R.					Rome, IRO. (<i>S.-W. Station, 2 RO on 25.4 m.</i>)	
1635	183.5	60	Berlin (Deutschlandsender) (Germany). (<i>S.-W. Stn. DLA on 31.38 m., DJB on 19.73 m., DIC on 49.83 m., DJD on 25.51 m., DJE on 16.89 m.</i>)		441.2	680	50	Stockholm. SASA (Sweden)	
					435.4	689	55	Belgrade (Yugoslavia)	
1554.4	193	30	Daventry National		430.4	697	2.5	Madrid, EAJ7 (Union Radio). (<i>After 7.0 p.m.</i>)	
1538	195	7	Ankara (Angora) (Turkey)		424.3	707	2	Moscow, Imini Stalina (Russia)	
1481	202.5	100	Moscow, RVI (Old Komintern) (Russia)		424.3	707	100	Berlin, Witzleben (Germany)	
1446	207.5	13	Eiffel Tower, P.L., Paris		419.5	715	1.5	Rabat (Morocco)	
1412	212.5	120	Warsaw I (Poland)		416.4	720.5	5	Athlone (Irish Free State)	
1380	217.5	100	Novosibirsk, RV6 (Russia)		413	725	60	Katowitz (Poland)	
1354.4	221.5	30	Motala (Sweden). (<i>Relays Stockholm</i>)		408.7	734	16	Sottens (Radio Suisse Romande) (<i>Switzerland</i>)	
1304	230	500	Moscow, WZSPS (Trade Union) (Russia)		403.8	743	25	Midland Regional. (Daventry)	
1275	235	0.5	Tunis-Kasbah (Tunisia)		398.9	752	25	Bucharest (Roumania)	
1230	244	0.6	Boden (Sweden). (<i>Relays Stockholm</i>)		394.2	761	12	Leipzig (Germany)	
1200	250	5	Stamboul (Turkey)		389.6	770	120	Toulouse (Radiophonie du Midi) (France)	
1200	250	21	Reykjavik (Iceland)		385.1	779	8	Stalino, RV26 (Russia)	
1190	252	200	Luxembourg		381	779	10	Lwow (Lemberg) (Poland)	
1170	256	25	Tashkent, RV11 (Russia)		381	788	16	Scottish Regional (Falkirk)	
1154	260	7.5	Kalundborg (Denmark). (<i>Relays Copenhagen</i>)		376.4	797	50	Hamburg (Germany)	
1117	268.5	40	Moscow, Popoff RV58 (Russia)		372.2	806	1.5	Radio, L.L., Paris	
1083	277	60	Oslo (Norway)		370.1	810.5	0.8	Seville, EAJ5 (Union Radio) (1.0 kW.); Galicia EAJ1 (0.2 kW.) (Spain); Bolzano (1.0 kW.) (Italy); Helsinki (10 kW.) (Fin- land) (<i>relays Lahti</i>); Kharkov, RV20 (10 kW.) (Russia).	
1071	280	35	Tiflis, RV7 (Russia)		368.1	815		Fredrikstad (Norway). (<i>Relays Oslo</i>)	
1035	290	36	Kiev, RV9 (Russia)		363.1	815	0.7	Bergen (Norway)	
1000	300	100	Moscow (Russia) (<i>S.-W. Stn. on 50 m.</i>)		364.1	824	1	Algiers (Algeria)	
938	320	20	Kharkov, RV4 (Russia)		363.6	825	13	Mühlacker (Stuttgart) (Germany)	
857	350	100	Leningrad (Russia)		360.6	832	60	London Regional (Brookmans Park)	
840	357	18.5	Budapest (Hungary)		355.9	843	50	Graz (Austria). (<i>Relays Vienna</i>)	
825	363.6	50	Sverdlovsk, RV5 (Russia)		352.1	852	7	Barcelona, EAJ1 (Spain)	
760	395	1.3	Geneva (Switzerland). (<i>Relays Sottens</i>)		348.8	860	7.6	Leningrad, RV70 (Russia)	
720	416.6	15	Monte Ceneri (Switzerland). (<i>Testing</i>)		348.8	860	10	Strasbourg, PTT (France)	
720	416.6	20	Moscow, RV2 (Experimental) (Russia)		345.2	869	11.5	Brno (Brunn) (Czechoslovakia)	
690	434.6	1.5	Oulu (Ulenborg) (Finland)		341.7	878	35	Brussels II, Velthem (Belgium). (<i>In Flemish</i>)	
680	441.2	0.6	Lausanne (Switzerland). (<i>Relays Sottens</i>)		338.2	887	15	Cadiz (Spain)	
574.7	522	7	Ljubljana (Yugoslavia)		335	896	5	Poznan (Poland)	
569	527	0.25	Freiburg-im-Breisgau (Germany). (<i>Relay Stn.</i>)		334.4	897	1.9	Milan (Italy). (<i>Relays Turin</i>)	
568.1	528	2	Grenoble (France)		331.5	905	50	Poste Parisien (France)	
566	530	0.25	Hanover (Germany). (<i>Relays Hamburg</i>)		328.2	914	60	Breslau (Germany)	
563	533	16	Wilno (Poland). (<i>Relay Station</i>)		325	923	60	Göteborg (Sweden). (<i>Relays Stockholm</i>)	
560	536	0.25	Augsburg (Germany). (<i>Relays Munich</i>)		321.9	932	10	Dresden (Germany). (<i>Relays Leipzig</i>)	
560	536	1.5	Kaiserslautern (Germany). (<i>Relays Munich</i>)		318.8	941	0.25	Naples, INA (Italy). (<i>Relays Rome</i>)	
550	545	18.5	Budapest No. 1 (Lakihegy) (Hungary)		315.8	950	1.6	Marsilles, PTT (France)	
542	554	10	Sundsvall (Sweden). (<i>Relays Stockholm</i>)		312.8	959	0.7	Radio Vitus (Paris). (<i>S.-W. Stn. on 43.75 m.</i>)	
537.6	558	3	Palermo (Italy)		312.8	959	1.7	Cracow (Poland)	
533	563	60	Munich (Germany)		312.8	959	10	Genoa, IGE (Italy). (<i>Relays Turin</i>)	
525	571	15	Riga (Latvia)		309.9	968	1	Cardiff	
517.2	580	100	Vienna (Bisamberg) (Austria).		309.9	968	50	West Regional (Washford Cross)	
509	589	15	Brussels No. 1, Velthem (Belgium). (<i>In French</i>)		307	977	0.75	Zagreb (Yugoslavia)	
500.8	599	20	Florence, IF1 (Italy). (<i>Relays Turin</i>)		304	986	13	Bordeaux Lafayette, PTT (France)	
495.8	605	1.2	Trondheim (Norway)		301.5	995	50	North National (Manchester)	
488.6	614	120	Prague, No. 1 (Czechoslovakia)		298.8	1004	11	Tallinn (Estonia)	
480	625	50	North Regional (Manchester)		296.1	1013	20	Hilversum (Holland). (<i>7 kW. before 4.40 p.m.</i>)	
472.4	635	60	Langenberg (Germany)		293.5	1022	0.7	Limoges, PTT (France)	
465.8	644	15	Lyon la Doua, PTT (France)		293.5	1022	2.6	Kosice (Czechoslovakia)	
459.4	653	60	Beromünster (Schweizerischer Landessender) (Switzerland).		291	1031	13.2	Viipuri (Viborg) (Finland). (<i>Relays Helsinki</i>)	
			San Sebastian, EAJ8 (0.6 kW.); Pori (1.0 kW.) (Finland); Danzig (0.5 kW.) (<i>relays Heilsberg</i>); Klagenfurt (0.5 kW.) (Austria) (<i>relays Vienna</i>); Porsgrund (0.7 kW.) (<i>relays Oslo</i>); Trondheim (0.1 kW.) Bodö (0.5 kW.) (Norway); Uppsala (0.15 kW.) (Sweden) (<i>relays Stockholm</i>).		288.3	1040	50	Scottish National (Falkirk)	
453.2	662	0.25	Agen (France)		288.3	1040	1	Bournemouth (Relay Station)	
					286	1049	0.8	Montpellier (France)	

BROADCASTING STATIONS ABROAD (In Order of Wavelength).

Table with columns: Metres, kc/s, kW, Station, Tuning Positions, Metres, kc/s, kW, Station, Tuning Positions. Lists various international broadcasting stations and their technical specifications.

PRINCIPAL SHORT-WAVE STATIONS.

(N.B.—Times of Transmission, given in parentheses, are approximate only and represent B.S.T.)

Large table listing principal short-wave stations with columns: Metres, kc/s, Call Sign, Station, Tuning Positions, Metres, kc/s, Call Sign, Station, Tuning Positions. Includes stations like Radio Nations, Prague; Empire Broadcasting, Zones 2, 4, 5; and many others.

FOREIGN SUNDAY PROGRAMMES

JULY THE SIXTEENTH

ATHLONE

725 kc/s, 413 metres; 60 kW. Relayed by Cork, 1,337 kc/s, 224.4 metres.—8.30 p.m., Time Signal. 8.31, Lily Fagan's Instrumental Trio. 8.45, Anniversary—A Play by the Dublin Repertory Company. 9.20, Baritone Solos by John West. 9.35, Instrumental Trio (cont'd.). 9.55, Mezzo-Soprano Solos by Bridie Moloney. 10.10, Pianoforte Recital by Kitty Pyne. 10.25, Gaelic Song Recital by Aine Ni Oisín. 10.40, Pipes and Fiddle Music by S. MacAonghusa and F. O'Higgins. 11.0, Time, News, Sports Results, Weather Report and Close Down.

BARCELONA

EAJ1, 860 kc/s, 348.8 metres; 8 kW.—7.20 p.m., Concert by the Station Orchestra. March, Manhattan Beach (Souza); Waltz, Volga, Volga (Nocek); Selection from Don Gil de Alenla (Penella); El carro de la alegría (Campina and Corral); Ich liebe dich (Grieg). 7.30, Songs of José García Robles. Recital by Juan Barrabás (Tenor). 8.0, Concert by the Station Orchestra. Soloist: Carmen Gomban (Soprano). 9.0, Dance Music by the Demon Jazz Orchestra, relayed from the Hollywood Bar Dance Hall. 10.0, Extracts from Musical Comedies on Gramophone Records. 11.45, Chess Lesson. 12 Midnight, Close Down.

BARI

1,112 kc/s, 269.8 metres; 20 kW.—11.0 a.m., Agricultural Report. 11.5, Bible Reading. 11.55, Sacred Music from the Church of San Domenico. 1.0 p.m., Giornale Radio. 1.10 to 2.15, Gramophone Music. In the intervals at 1.55, Weather, and at 2.0, Time and Announcements. 5.30, Gramophone Music and Sports Notes. 8.0, Sports Notes and Giornale Radio. 8.30, Time and Announcements. 8.35, Concert of Operetta Music and Songs. Literary Notes in the interval. 10.30, Gramophone Music. 10.55, News.

BASLE.—See *Schweizerischer Landessender*.

BELGRADE

BEGRAD, 697 kc/s, 430.4 metres; 2.8 kW.—12.30 p.m., Orchestral Concert. 1.30, News and Time Signal. 3.0, Yugoslav Melodies by the Aranicki Orchestra. 4.0, Relay (to be announced). 6.55, Time and Programme Notes. 8.0, A Radio Play. 8.30, An Operetta (to be announced). In an interval at 10.15, Time and News. After the Operetta, Dance Music from the Ratnicki Dom Restaurant.

BERLIN

DEUTSCHLANDSENDER, 183.5 kc/s, 1,635 metres; 60 kW. 12 Noon, Orchestral Concert, relayed from Hamburg 12.55 p.m., Time. 1.0, Concert from Stuttgart. 2.0, See Hamburg. 3.0, Gramophone Records for Children. 3.40, Talk: Through Three Continents on a Motor Cycle. 4.0, Overture, Patria (Bizet), by the Municipal Orchestra, conducted by Herbert Albert, relayed from Wiesbaden. 4.15, See Frankfurt. 5.0, Siegfried von der French reads from his own Works. 5.30, Musical Saw Recital by Dr. Otto Fréderich, Meditation (Ba-h-Guomod); Caro mio ben (Giordano); Solvig's Song (Grieg); Hab' ich nur deine Liebe, from Bocaccio (Stappé). Folk Songs: (a) Amichen von Tharau, (b) Am Brunnen vor dem Tore, (c) Sah ein Knab' ein Röslein stehn, (d) Robin Adair. 5.0, Talk: The New Romanticism. 6.25, Talk: The International White-Slave Traffic. 6.45, Sea, Mountain and Forest—Musical and Literary Programme (arr. Fritz Junkisch) on Gramophone Records. 8.0, Sports Notes. 8.15, See Stuttgart. 9.30, Satirical Radio Sequence with Poccini. 10.15, News. 11.0, Dance Music from Berlin (Witzleben). 12.30 a.m., (Monday). Close Down.

BERLIN

VITZLEBEN, 715 kc/s, 419.5 metres; 1.5 W.—11.30 a.m., Sacred Concert by the Prætorius Choir; Hans Bastian (Violin); Theo chwoon (Viola), and Eugen Sinnich (organ); Choral, Partita; Jesu meine Freude Johann Walther); Cantata for Violin, Viola, horn and Organ; Meinen Jesum lass ich nicht (Regner); Gloria in excelsis (Regner). 2 noon, See Heilsberg. 2.0, Talks for arden City dwellers. 3.0, Interval. 3.30, Gramophone Music. 4.0, Military Band Concert relayed from the Zoological Gardens. 35 (approx.) (in an interval). Relay of the Berlin Grand Prix from the Grönwald Race course. 5.40, Radio Report from the Kaiser Wilhelm Stütze. 6.30, Festival Programme relayed from a Church in Nikolskoe. 7.0, agdeburg—a Programme by School Children. 7.20, The Hammer and Cog Wheel—a radio Sequence for Workers (Rolf Sievers). 55, Sports Notes. 8.10, Musik und Liebe—peretta in Three Acts (Johannes Müller), with the Composer conducting. 10.0, News. 11.25, Topical Talk. 10.30 (approx.). Concert relayed from the Traube Weinrestaurant. 12

PRINCIPAL EVENTS OF THE WEEK:

AT HOME

- NATIONAL** Orchestral concerts and a service in Welsh.
LONDON REGIONAL Band concert and chamber music.
MIDLAND REGIONAL Service from the Cathedral, Birmingham.
NORTH REGIONAL The Keswick Convention.

ABROAD

- BRUSSELS (No. 1)** 9.0 p.m. Concert from the Casino, Knocke.
HEILSBERG 6.30 p.m. Schubert and Schumann Recital, by Tina Zimmermann-Grassow (contralto).
HUIZEN (announced Hilversum) 9.10 p.m. Concert by the Wireless Orchestra.
LAHTI 6.35 p.m. Strauss concert.
LANGENBERG 10.30 p.m. "A Visit to Nottm'n," radio report (gramophone records) of the 550th Anniversary celebrations of the St. Martin Brotherhood.
PARIS (Poste Parisier) 8.30 p.m. Operatic favourites; soloist, Léonardo Aramesci (tenor).
PRAGUE 6.0 p.m. "Mozart in Prague," Music by Mozart and Czech composers of his period.
STRASBOURG 3.30 p.m. Gala concert from the Casino, Vichy.
TURIN 8.45 p.m. "Don Pasquale," opera, by Donizetti.
VIENNA 11.0 p.m. Operetta: "The Last Waltz," by O. Strauss.
WARSAW 8.25 p.m. Pianoforte recital by Roman Mieczwsky.

Midnight, Dance Music on Gramophone Records. 1.0 a.m. (Monday). Close Down.

BERNE.—See *Schweizerischer Landessender*.

BEROMUNSTER.—See *Schweizerischer Landessender*.

BODEN.—See *Stockholm*.

BODD.—See *Oslo*.

BRATISLAVA

1,076 kc/s, 279 metres; 11 kW.—11.20 a.m., Concert by the Municipal Orchestra, conducted by A. Motil, relayed from Trencsenke Toplice; Waltz (Leopold); Slav Dance No. 4 (Dvorak); Know'st thou the Land, from Mignon (Thomas); Potpourri, Offenbachiana (Conradi); March (Kostal). 12 Noon, See Prague. 12.5 p.m., Concert by the Station Orchestra. 1.30, See Prague. 1.45, Hydrographical Report. 1.50, Interval. 4.0 to 7.0, Programme relayed from Trencsenke Toplice. 4.0, Folk Lore. 5.30, Concert by the Slovak Teachers' Choral Society. 7.0, See Prague. 8.5, The Trial Marriage Operetta in Three Acts (Vleper). 10.0, See Prague. 11.0 (approx.). Close Down.

BREMEN.—See *Hamburg*.

BRESLAU

923 kc/s, 325 metres; 60 kW, and **Gleiwitz**, 1,184 kc/s, 253 metres.—10.0 a.m., Protestant Service. 11.30, Reading: Der blonde Jung (Jakob Schallner). 12 Noon, The Bicentenary of the great Silesian Architect, Langhans, Promenade Concert, relayed from Landeshut. 2.0 p.m., News. 2.10, Talk: The Silesian Landscape. 3.0, Programme for Children. 3.30, Talk: Our "Neighbour's" Aerial Fleets. 4.0, Promenade concert, relayed from Bad Leinerz. 5.40, See Berlin (Witzleben). 6.30, Silesian Folk Customs in Schreiberhan—a Radio Report. 7.15, Weather and Sports Notes. 7.45, Talk: Austria. 8.0, See Heilsberg. 9.0, The Stay-at-Home's Holidays—a Microphone Journey. 10.15, Time and News. 10.45, Concert from Berlin (Witzleben). 12 Midnight, Close Down.

BRNO

878 kc/s, 342 metres; 35 kW.—5.30 p.m., Recital of Yugoslav Songs. 6.0, German Transmission: Pianoforte Duet, A Viennese Idyll (H. Siegl). 7.0, See Prague. 8.5, See Bratislava. 10.0, See Prague. 11.0 (approx.). Close Down.

BRUSSELS (No. 1)

I.N.R., 590 kc/s, 509 metres; 15 kW.—10.0 a.m., Concert by the Small Station Orches-

tra, conducted by Pierre Leemans. 11.0, Gramophone Concert: Extracts from Iberia (Albeniz); Entr'acte from Messidor (Brucan); Song from Een Winternachtdroom (De Boeck); Habanera (Chabrier); Petite Suite (Debussy); Dances from Prince Igor (Borodin). 12 Noon, Concert by the Station Orchestra, conducted by C. Walpot. Soloists: René Durand (Tenor) and Mlle. Van Looy (Songs). 1.0 p.m., Le Journal Parlé. 1.10, Concert by the Station Symphony Orchestra, conducted by Arthur Meulemans. In the interval at 1.30, Monologues by Mlle. Daulboys. 5.0, Dance Music, relayed from the Casino, Knocke. 5.30, Football Results. 6.15, Cello Recital by M. de Noeker; Sonata in E minor (Vivaldi); Berceuse (Leemans); Flemish Song (Hondret); Waltz (Leclereq); Papillon (d'Herveyols). 6.45, Dialogue des Morts—Sketch (Leclereq). 7.0, Suite from Hansel and Gretel (Humperdinck), on Gramophone Records. 7.15, Religious Address. 7.30, Talk on Music. 8.0, Concert by the Station Orchestra, conducted by C. Walpot: Sambre et Messis (Planquette); Overture, Poet and Peasant (Suppé); Selection from The Merry Widow (Lehar); Waltz Potpourri (Robrecht); The Student passes by (Dañez). 8.45, Illustrated Talk on the Belgian Writer, Noël Ruet. 9.0, Concert, relayed from the Casino, Knocke. 10.30, Le Journal Parlé. 10.40, Dance Music relayed from the Casino, Knocke.

BRUSSELS (No. 2)

N.I.R., 887 kc/s, 338.2 metres; 15 kW.—10.0 a.m., Pianoforte Recital on Gramophone Records: Pieces (Chopin): (a) Fantasia in F Minor, (b) Etude, No. 6, Op. 10, (c) Mazurka No. 4, Op. 24, (d) Berceuse, (e) Ballad in F, Op. 38; Extract from La Boîte à Jouxoux (Debussy); Selection from El amor brujo (Fallá). 11.0, Concert by the Small Station Orchestra, conducted by P. Leemans: Overture, The Bohemian Girl (Balie); Plaisir d'amour (Martin); Minuet from the Cello Concerto (Saint-Saëns); Selection from Rigoletto (Verdi); Gramophone Records: Slav Rhapsody, No. 2 (Friedemann); International Suite (Tschaiakovsky). 12 Noon, Concert by the Station Symphony Orchestra, conducted by M. Meulemans. Soloist: Yvonne van Looy (Songs). Selection from Cavalleria rusticana (Mascagni); Selection from Manon (Massenet); Songs: (a) Ballad (Candael), (b) Shunueidjie (Meulemans), (c) May Song (Hubert); Waltz from Faust (Gounod); Extracts from Mignon (Thomas); Ballet Music from Samson and Delilah (Saint-Saëns); March from Tannhäuser (Wagner). 1.0 p.m., Le Journal Parlé. 1.10, Concert by the Radio Orchestra, conducted by Charles

Walpot. Soloist: M. Schell (Tenor). March from Aida (Verdi); Overture, The Italian Girl in Algiers (Rossini); Italian Songs; Selection from La Bohème (Puccini); Italian Songs; Waltz, Tesoro mio (Becucci). 5.0, Dance Music, relayed from the Kursaal, Ostend. 5.30, Sports Results. 6.0, Pianoforte Recital by Mme. Graudorger; Venice and Naples (Liszt); Sevilla (Albeniz). 6.15, Extracts from The Mastersingers, on Gramophone Records. 6.30, Saxophone Recital by M. Gasou: Serenade (Albeniz); Si mes vers avaient des ailes (Hahn); Barcarolle (Chopin); Bébé (Dorsey). 6.45, Concert of Gramophone Music: Sonata in C (Grieg); Solemn Melody (Walford Davies). 7.15, Religious Address. 7.30, Music Review. 8.0, Concert by the Symphony Orchestra, conducted by M. Meulemans: Carnaval à Paris (Svendson); Rhapsody, Midsommervaka (Alfvén); Norwegian Melodies for Strings (Grieg); Norwegian Dances (Grieg); Norwegian Rhapsody (Lalo). 8.45, Recitation from Harshheit (J. Simons). 9.0, Concert relayed from the Kursaal, Ostend. 10.30, Le Journal Parlé. 10.40, Dance Music, relayed from the Kursaal, Ostend.

BUCHAREST

761 kc/s, 394 metres; 12 kW.—5.0 p.m., Light Music and Romanian Music by the Marco Orchestra. In the interval at 6.0, Radio Journal. 7.0, Reading. 7.20, Dance Music on Gramophone Records. 7.40, Educational Talk. 8.0, Song Recital by Aurel Alexandrescu; Ich trage meine Minne (R. Strauss); Serenade (R. Strauss); Concert Aria (Mozart); Song (N. Patriche); Two Songs (Montia). 8.20, Concert by the Station Orchestra: Overture, Le Maschere (Mascagni); Waltz (Christoforo); Selection from La Wally (Catalani); Selection from Tip Toes (Gershwin); Algerian Melody (Kettley); Russian Dance (Bullerian). In an interval at 9.0, Reading. 9.45, Radio Journal.

BUDAPEST

345 kc/s, 550.5 metres; 18.5 kW.—9.15 a.m., News. 10.0, Catholic Service. 11.15, Evangelical Service, followed by News and Concert by the Royal Hungarian Opera House Orchestra. 2.0, Gramophone Music. 3.0, Agricultural Talk. 3.45, Concert by the Budapest Concert Orchestra. 4.50, Microphone Report from a Jamboree. 5.50, Concert (cont'd.). 6.40, Reading. 7.10, Cigány Music by the Bela Racz Band. 8.15, Talk, followed by News and Dance Music from the Restaurant Royal.

CASSEL.—See *Frankfurt*.

COPENHAGEN

1,067 kc/s, 281 metres; 0.75 kW. Relayed by **Kalundborg**, 250 kc/s, 1,153 metres.—8.30 a.m., Gymnastics. 9.0 to 9.30 (from the Esbjerg Studio), Religious Address. 10.0, Divine Service Relay. 11.30, Weather and News. 12 Noon, Town Hall Chimes. 12.2 p.m., Orchestral Concert. 1.30, Concert by a Children's Choir. 2.0 (also on Skamlebaek, 31.51 metres), Divine Service. 3.30, Reading (H. G. Wells). 4.0, Orchestral Concert, relayed from a Park. 5.45 to 6.20, Interval. 6.20, Talk. 6.50, News and Time. 7.30, A Radio Ball for Children. Reading in the interval. 9.30, Reading. 9.50, Concert of Light Music by Louis Preil and his Orchestra. 10.20, News. 10.30, Concert (cont'd.). 11.0, Dance Music from the Wixex Restaurant. In the interval at 12 Midnight, Town Hall Chimes. 12.30 a.m. (Monday), Close Down.

CORK.—See *Athlone*.

DANZIG.—See *Heilsberg*.

DRESDEN.—See *Leipzig*.

FECAMP

1,328 kc/s, 225.9 metres; 10 kW.—2.0 to 8.0 p.m., Programme in English by the I.B.C. 2.0, Light Orchestral Concert for South Coast Listeners: The Night by the Sea; The Way to the Heart (Lincke); Song, My Old Shako (Trotere); Serenade d'amour (Von Blom); Spring Blossoms awoke (Löhrl); Xylophone Solo, The Dripping Well (Abbey); Song, The Vagabond (Vaughan Williams); Romance (Löhrl); The Valley of the Poppies (Ancliffe). 2.30, Gramophone Concert: Bugle Call Rag (Pettis); Pianoforte Solo, He wanted Adventure, Parts 1 and 2 (Waller and Timbridge); Beautiful (Gillespie-Shay); Violin Solo: Waltz, Op. 39 (Brahms); Play Fiddle, play (Lawrence); The Doll's Song, from The Tales of Hoffmann (Offenbach); Dance of the Nymphs (Birch). 3.0, Light Music; Out of Breath; Mandoline Solo, Finger Tricks (Pietro); Some of these Days (Brooks); Chorus, The Old Refrain. Selection from Princess Pat (Herbert); Chorus, Japanese Sunset; Banjo Solo, Fashionette (Glogaw); Southern Rhapsody (Hosmer). 3.30, Military Band Music: Parade of the Tin Soldiers (Jessel); St. Patrick's Day (Brase); Song, Old Folks at Home (Foster); Wood Nymphs (Coates); Song, Marching through Georgia; General Mulcahy (Brase); Selection from

JULY 16th

SUNDAY

continued

The Belle of New York (Kerker); Naval Patrol (Williams); The Night by the Sea, 4.0, Judge Rutherford's Address. In the intervals, Report of the Races from Le Touquet. 4.15, Programme for Children. 4.30, Shredded Wheat Descriptive Adventure Story. 5.0, I.B.C. Members' Request Half Hour; Suite, Americana, Part 1 (Thurban); Paradise (Brown); Handsaw Solo, In a Monastery Garden (Kettelberg); On the Banks of Alban Water (Horn); Souvenir (Drdla); Hand me down my Walking Cane; Black Eyes (Ferraris); Suite, Americana, Part 2 (Thurban). 5.30, Organ Recital with Songs; Cathedral Chimes (Hawgill); Song, The Hills of Home (Fox); Selection from Les millions d'Arlequin (Drigo); Organ and Violin Duet, Because (d'Hardelot); Song, Poor Man's Garden (Russell); Song without Words (Tchaikovsky); Song, Love's Old Sweet Song (Molloy); Somewhere a Voice is calling (Tate). In the intervals, Sport Report. 6.0, Club Concert for Northampton Listeners. Part 1. Celebrity Concert on Gramophone Records: The Chum Song; Squire O'etel; Hungarian Dance in D (Brahms); Eddie Peabody; St. Louis Blues (Hardy); War Marching Songs, Part 1 (arr. Debroy Somers); Flanagan and Allen; The Sport of Kings; War Marching Songs, Part 2 (arr. Debroy Somers); George Robey; A Little Idea of my own; Marek Weber and his Orchestra; Les Sirènes (Waldfenfel). 6.30, Club Concert for Northampton Listeners. Part 2. Orchestral Music; Selection from Music in the Air. Part 1; Guitar Solo, Picking my Way (Lang-Kress); The Little Company (Ganglberger); Clarinetitis (Goodman); The Enchanted Forest (Ganglberger); Pianoforte Solo, Magic Notes (Steinberger); Selection from Music in the Air. Part 2. 7.0, Music from Spain; Spanish Serenade (Moscowsky); Pianoforte solo; Spanish Dance, No. 5 (Granados); Selection from "Carmen" (Bizet); La Paloma (Yradier); Flower Song from "Carmen" (Bizet); Violin Solo, Spanish Dance (Falba); Toreador Song from "Carmen" (Bizet); Old Spanish Song (Amberg). 7.30, Instrumental Music; In Vienna one Night (Bordin); Banjo Solo, Cracker Jack (Roser); Song, Deep Water (Brian); Hawaiian Love (Traditional); Waltz, Morella (Charlier); Song, Drifting under a Summer Moon (Coningsby); Banjo Solo, In the Moonlight (McElgh); The Blue Bird (Bordin). 8.0, Concert of Opera and Operetta Music. 9.0 till Close Down. Programme in English by the I.B.C. 9.0, Choral and Orchestral Music; Cœur Brisé (Gillet); Songs: (a) When the Dew is falling, (b) Lady Chloee; Spanish Gipsy Dance (Marquina); Songs: (a) The Old Refrain, (b) Kesako (Chapin), (c) When you and I were young, Maggie, (d) Barefoot Trail; Good-bye (Tosti). 9.30, Popular Concert: Selection from Chu Chin Chow. Part I (Norton); Song, You're still my Sweetheart (Yellen); Amina (Lincke); Violin Solo, An Old Viennese Dance (Voglein); Soprano Solo, It is only a Tiny Garden (Haydn Wood); The Valley of the Poppies (Ancliffe); Blaydon Races, from Tyneside Songs; Selection from Chu Chin Chow, Part 2 (Norton). 10.0, Sea Chanties; Nautical Moments (arr. Winter); One Dollar Fifty a Day; Blow the Man Down; The Merchant Ship; Under Heaven's Blue (Payton); One more day; Over the Waves (Kosas); Shenandoah (arr. Terry); More Nautical Moments (arr. Winter). 10.30, Dance Music; Waltzing in a Dream (Washington); You are too beautiful; I got a right to be blue; Drifting Down the Shalimar; I'll see you in the morning; You'll never get up to Heaven that way (Lerner); Two Buck Tim from Tinbucket (Heymann); The Grass is getting greener all the Time (Newman); Old Man Harlem; Here in my Heart. 11.0, Violin Recital; Overture, Die Fledermaus (Joh. Strauss); Meditation from Thaïs (Massenet); La Capricieuse (Elgar); Waltz from The Sleeping Beauty (Tchaikovsky); Moment Musical (Schubert); Slav Dance No. 10 (Dvorak); Larghetto (Weber); Selection from Swan Lake (Tchaikovsky). 11.30, Orchestral Concert; Signature Tune; Overture, Morning, Noon and Night (Suppé); Xylophone Solo, Snappy Sticks (Robbins); The Old Spinning Wheel (Hill) Song Mother Machree; Quartet, Homing (del Riego); Selection from The Mikado (Sullivan); The Minstrel Boy (Traditional); In the Valley where the Bluebirds sing (Salman). 12.5 a.m. (Monday), I.B.C. Late News Bulletin in English. 12.10 (approx.), Club Concert for Northampton Listeners. Part 1. Celebrity Concert of Gramophone Records: The Chum Song; Squire O'etel; Hungarian Dance in D (Brahms); Eddie Peabody; St. Louis Blues (Hardy); War Marching Songs, Part 1 (arr. Somers); Flanagan and Allen; The Sport of Kings; War Marching Songs, Part 2 (arr. Somers); George Robey; A Little Idea of my own; Marek Weber and his Orchestra; Les Sirènes (Waldfenfel). Part 2. Orchestral and Instrumental Music; Selection from Music in the Air. Part 1; Guitar Solo, Picking my Way (Lang-Kress); The Little Company (Ganglberger); Clarinetitis (Goodman); The Enchanted Forest (Ganglberger); Pianoforte Solo, Magic Notes (Steinberger); Selection from Music in the Air. Part 2. 12.57, I.B.C. Goodnight Melody. 1.0 (approx.), Close Down.

FLENSBURG.—See Hamburg.

FLORENCE.—See Turin.

FRANKFURT

1,157 kc/s, 259.3 metres; 17 kW. Relayed by Cassel, 1,220 kc/s, 245.9 metres; and Trier, 1,157 kc/s, 259.3 metres.—11.0 a.m., Concert of Light Music. 12 Noon to 2.15 p.m., See Stuttgart. 2.15, Talks arranged by the Wiesbaden Board of Agriculture. 2.25, Rural Programme—Two Talks. 3.15, Programme for Children. 4.15, Orchestral Concert relayed from the Kurhaus, Wiesbaden. Conductor: Herbert Albert. 6.0, Talk: The Eternal Philistine in German Literature. 6.25, Humorous Items by Karl Euber. 6.55, In a Bizzard's Ear. 7.15, Sports Notes. 7.25, Literary Programme. 8.0, See Heilsberg. 10.0, Light Music on Gramophone Records. 10.20, Time and News. 11.0 (approx.), See Munich. 12 Midnight, Close Down.

FREDRIKSSTAD.—See Oslo.

FREIBURG.—See Stuttgart.

GENÈVA.—See Radio-Suisse Romande.

GENOA.—See Turin.

GLEIWITZ.—See Breslau.

GOTEBORG.—See Stockholm.

GRAZ.—See Vienna.

HAMAR.—See Oslo.

HAMBURG

Call ha (in Morse), 806 kc/s, 372 metres; 1.5 kW. Relayed by Bremen, 1,112 kc/s, 269.8 metres; Flensburg, 1,319 kc/s, 227.4 metres; Hanover, 530 kc/s, 566 metres; and Kiel, 1,292 kc/s, 232.2 metres.—10.55 a.m., Divine Service from Guxhagen. 12.15 p.m., Concert by the Station Orchestra, conducted by Adolf Secker. Soloist: Paul Moth (Cello). In the interval at 12.55 p.m., Time and Weather. 2.0 (from Bremen), Report of the Nazi Parade and the Presentation of Ten New Storm Troop Standards, relayed from the Marienburg, near Nordstemmen. 2.30, Programme for Young Hitlerites, conducted by Baldur von Schirach. 3.30, Programme for Children. 3.50 (from Hanover), Concert by the Hannover Orchestra, conducted by Otto Ebel von Sosen. Soloist: Georg Capellen (Pianoforte). 5.15, Radio Report of the Meckleburg People's Festival, relayed from Büttow. 5.45, Reading: Strange Animals of South Chile. 6.0 (from Bremen), Wind Instrument Concert. 7.0, Poets and Knaves in Medieval German Drama. 7.40, Sports Notes and Weather. 8.0, See Heilsberg. 10.0, General News. 10.10, Hamburg, Bremen and Lübeck. Review of Political, Artistic and Social Events in the Three Hanseatic Free Cities. 10.25, Programme from Berlin (Witzleben).

HANOVER.—See Hamburg.

HEILSBURG

1,085 kc/s, 276.5 metres; 60 kW. Relayed by Danzig, 662 kc/s, 453.2 metres.—11.30 a.m., Organ Recital by Dr. Herbert Kolletat, relayed from the Albert University. 12 Noon, Orchestral Concert, conducted by Karl Tuteln, relayed from the Kurgarten. Zoplot. 2.0, Chess Lesson. 2.30 (from Danzig), Programme for Children. 3.0, Concert of Motets by a Mixed Choir, conducted by Dr. G. Linder. 3.30 (from Danzig), Talk: The Place of Trees in Folklore. 4.0, Concert, relayed from Wiesbaden. In the interval at 5.0, Sports Notes. 5.40, See Berlin (Witzleben). 6.30, Schubert and Schumann Recital by Tina Zimmermann-Grassow (Contralto); Part I—Schubert Songs: Death and the Maiden; Lachen und Weinen; Erster Verlust; Die Liebe hat gelogen; Die Rose; Part II—Schumann Songs: Der Nussbaum; Was will die einsame Träne; In der Fremde; Wehmut. 7.0, Talk: The Construction of the Fascist State. 7.30, Part Relay from the Ranschen Tournament. 7.50, Sports Notes. 8.0, Concert by the Municipal Orchestra, conducted by Karl Tuteln, relayed from Zoplot; Soloists: Maria Kießel, Herbert Klur and Fritz Kurt Wehner (Songs). 10.15, Nazi Report, followed by Dance Music from Berlin (Witzleben). 12 Midnight (approx.), Close Down.

HILVERSUM

Announced HUIZEN, 1,013 kc/s, 296.1 metres; 20 kW. (7 kW. up to 4.40 p.m.)—8.10 a.m., Religious Programme of the Catholic Radio Society (K.R.O.). 9.10, Programme of the Christian Radio Society (N.C.R.V.); Organ Recital and Divine Service, relayed from Amsterdam. 11.55 to 4.40 p.m., K.R.O. Programme. 11.55, Sextet Concert. In the interval at 12.40, Talk. 1.40, Religious Concert. 2.10, K.R.O. Report. 2.25, Orchestral Concert, conducted by J. Gerritsen. Overture, Jean de Paris (Boieldieu); Selection from The Cid (Massenet); Flirtation (Steck); Selection from The Nutcracker (Tchaikovsky); Gramophone Music. Overture, A Life for the Czar (Glinka); Brinka Potpourri (Frbach); Valse de concert (Glazounov). 3.55, Programme for Invalids. 4.40 to 7.25, N.C.R.V. Programme. 4.40, Sacred Music on Gramophone Records. 5.30, Divine Service, relayed from De Bilt, followed by Gramophone Music. 7.25 till Close Down, K.R.O.

Programme. 7.25, Gramophone Music. 7.45, Football Results. 7.50, Orchestral Concert, conducted by Heinrich Swoboda. Soloist: Alie Liza Frank (Songs). Overture, Fingal's Cave (Mendelssohn); Concert Aria (Mendelssohn); Serenade (Brahms). 8.40, News. 8.45, Gramophone Music. 9.10, Concert (contd.). Dance Suite (Bartok); Dances (Kodaly); Mein Lebenslauf ist Lieb und Lust (Strauss-Grosz); Overture, Die Fledermaus (Joh. Strauss). In the interval, News. 10.10, Gramophone Music. 10.20, Epilogue by the Small Choir. 10.40 (approx.), Close Down.

HORBY.—See Stockholm.

HUIZEN

Announced HILVERSUM, 160 kc/s, 1,875 metres; 8.5 kW.—8.40 to 11.40 a.m., Programme of the Workers' Radio Society (V.A.R.A.). 8.40 a.m., Horticultural Talk. 9.10, Concert by the V.A.R.A. Orchestra, conducted by H. de Groot. 9.55, Organ Recital by J. Jong. 10.10, Cinema Talk. 10.25, Organ Recital (contd.). 10.40, Orchestral Concert (contd.). 11.10, Address 11.40 to 4.40 p.m., Programme of the Algemeene Vereniging Radio Omroep (A.V.R.O.). 11.40, Time. 11.41, Concert by the Wilhelms Orchestra, conducted by Nico Treep. 1.40, Book Review. 2.10, Concert by a Male Voice Choir, conducted by P. Kellebach. 2.40, Orchestral Concert, conducted by Ignaz Neumark, relayed from the Kurhaus. Scheveningen. Soloist: Louis Rosor (Cello). 4.10, Gramophone Music. 4.40 to 7.40, V.A.R.A. Programme. 4.40, Choral Concert, conducted by D. Jongbloed. 5.40, Book Review. 6.25, Divine Service. 7.40 till Close Down, A.V.R.O. Programme. 7.40, Time, News and Sports Results. 7.55, Popular Concert by Kovacs Ladis and his Dance Band. 8.50, No Betting allowed—One-Arks Play (Neche). 9.10, Concert by the Wireless Orchestra, conducted by Nico Treep. Soloist: J. van Kempen (Tenor). In the interval at 9.55, Gramophone Music. 10.40 (approx.), Close Down.

INNSBRUCK.—See Vienna.

JUAN LES PINS

1,205 kc/s, 249 metres; 10 kW.—8.0 p.m., Amusements Guide and Sports Notes. 8.30, Radio Concert. 9.0, News. 9.15, Radio Concert. 10.0, The Listeners' Half Hour. 10.30 till Close Down, Programme in English by the I.B.C. Announcer: Miss L. Ballet. 10.30, Military Band Concert: Military March (Schubert). Song: Ho Jolly Jenkin. Pomp and Circumstance (Elgar); Naval Patrol (Williams). Xylophone Solo: The Skaters' Waltz (Waldfenfel); Parade of the Tin Soldiers (Jessel). Song: A Jovial Monk and I (Andran); Gaity Echoes. 11.0, Gramophone Concert, London Symphony Orchestra; Czardas from Coppelia (Delibes). Kreister; Dance of the Marionettes (Winterhitz). George Metaxa; New love is Old (Kern). Edward O'Henry; Medley of Wilfred Sanderson's Songs. The Pickens Sisters; Too Many Tears (Dubin-Warren); Maria Sandra; I got a Home in dat Rock (arr. Lawrence Brown). Raie da Costa; Selection from Follow a Star (Ellis). London Symphony Orchestra; Mazurka from Coppelia (Delibes). 11.30, Orchestral Concert: Sasehinka (Schumann); Waltz, Tris jolie (Waldfenfel); Violin Solo; Le Balcon (St. Denis); Dreams on the Ocean (Gungl); Song: Juanita (Norton); The Cossack's Wedding Fete (Krier); Violin Solo; Waltz, Dolores (Waldfenfel); Potpourri of Russian Gipsy Songs and Dances (Schumann). 12.0 Midnight, Half an Hour in Vienna—Concert: Waltz, Tales from the Vienna Woods (Strauss); Waltz, Wiener Zugvögel (Strauss); Song: Vienna, City of my Dreams (Lockton); Viennese Waltz, Song: Waltzing time in Old Vienna (Evans). Wiener Bonbons (Strauss); Song: Goodnight Vienna (Posford); Waltz, The Blue Danube (Joh. Strauss). 12.30 a.m. (Monday), Dance Music: What a Perfect Combination; A Letter to my Mother; Look what you've done; Standing on the Corner; Sittin' in the Dark; My Heart's to let; I'm playing with Fire; When you've fallen in love. 12.57, I.B.C. Goodnight Melody. 1.0 (approx.), Close Down.

KALUNDBORG.—See Copenhagen.

KIEL.—See Hamburg.

KLAGENFURT.—See Vienna.

KOSICE.—See Prague.

LAHTI

167 kc/s, 1,796 metres; 40 kW. Relayed by Helsinki, 815 kc/s, 366.1 metres.—5.0 p.m., Gramophone Music. 5.59, Time and Weather. 6.10, Talk. 6.35, Strauss Concert by the Station Orchestra; Overture, Die Fledermaus; Czardas from Ritter Pausan; Lagunen-Walzer, Persian March. 7.10, Talk. 7.30, Song Recital by Sylvi Nikula. 7.55, Popular Music by the Station Orchestra. 8.45, News in Finnish. 9.0, News in Swedish. 9.15, Light Music, relayed from the Restaurant Kappeli. 10.0 (approx.), Close Down.

LANGENBERG

635 kc/s, 473 metres; 60 kW.—11.10 a.m., Talk: What the Ideal Town of the Future will look like. 11.30, Talk: The Towns of Rhineland and Westphalia-Zulpich. 12.10, Schubert Music on Gramophone Records. 1.0 p.m., Concert, conducted by Wolf. 2.30, Chess Lesson. 3.0, Dialect Reading. 3.25, Talk with Gramophone Illustrations: The National Anthems of Europe. 3.45, Agricultural Talk. 4.5, Political Talk. 4.15, Concert by the Fröliche Fünf. 5.10, Report on the West-German Swimming Championship, relayed from Elberfeld. 5.30, Concert by the Söfingen Choral Society, relayed from Levern. 5.0, Orchestral Music. 5.10, Radio Report from the Kaiser Wilhelm Institute at Berlin on Gramophone Records. 7.0, Variety Concert by the Fröliche Fünf. 7.30, Reading (Hans Friedrich Blunck). 7.45, Sports Report. 8.0, Concert by the Station Orchestra, conducted by Kilim; Selection (Mozart); (a) Overture, Der Schauspielerdirektor; (b) Aria from The Magic Flute; (c) Minuet. (d) Bass Aria from Don Giovanni; Serenade for Strings (Volkman); Selection (Verdi); (a) Overture, The Force of Destiny; (b) Bass Aria from Don Carlos; (c) Prelude to Rigoletto; (d) Gilda's Aria from Rigoletto; Ballet Music from The Merry Wives of Windsor (Nicola); Monologue from The Mastersingers (Wagner); Overture, Rienzi (Wagner). In an interval, The German's Catechism. 10.0, News and Sports Notes. 10.30, A Visit to Nottulm—Radio Report of the 55th Anniversary Celebrations of the St. Martin Brotherhood (on Gramophone Records). 11.0, Concert from Berlin (Witzleben). 12 Midnight (approx.), Close Down.

LAUSANNE.—See Radio-Suisse Romande.

LEIPZIG

769.9 kc/s, 389.6 metres; 120 kW. Relayed by Dresden, 941 kc/s, 319 metres.—12 Noon, Concert by the Station Orchestra, conducted by Hilmar Weber. In the interval, Reading (Moeller van den Bruck). 2.0 p.m., Weather and Time. 2.5, Talk: The Programme for the Coming Week. 2.25, Review of World Politics. 2.45, Agricultural Talk. 3.0, Vocal and Instrumental Concert. 4.0, Report on Gramophone Records; With the Short Wave Transmitter on a Trip down the Elbe through Saxon Switzerland. 5.0, Concert by the Leipzig Symphony Orchestra, conducted by Otto Findeisen. In the intervals from 5.30 to 5.40 and from 6.10 to 6.20, Radio Report of the Four Races in Dresden for the German Rowing Championship. 6.50, Kämpfende Jugend—Radio Play (Fischer). 7.30, Prof. Fritz von Bose in a Recital of his own Music; Suite No. 2 for Pianoforte. Op. 20; Intermezzo and Rhapsody. 8.0, Dialogue: The Harz Theatre. 8.25, Government Announcements. 8.30, Military Band Concert. 10.5, News. 10.15, Dance Music and Light Music by the Endé Orchestra. 12 Midnight, Close Down.

LINZ.—See Vienna.

LUXEMBOURG

252 kc/s, 1,191 metres; 200 kW. English Programme.—7.0 p.m., Concert by the Station Orchestra. 7.40, Weather Report. 7.45, Concert of English Music. 8.25, Recital of English Songs. 8.50, News in French. 9.15 Variety Concert. 9.45, News in German. 9.55 Concert (contd.). 10.25, Dance Music on Gramophone Records.

LWOW

788 kc/s, 381 metres; 16 kW.—6.40 p.m. Miscellaneous Items. 7.0, See Warsaw. 9.0 Humorous Programme. 10.0, See Warsaw. 10.45, Gramophone Music. 11.0 (approx.), Close Down.

MADRID

EAJ7. 707 kc/s, 424.3 metres; 2 kW.—9.10 to 10.0 a.m., Topical Review. 3.0 p.m. (Chimes, Time and Announcements. 3. (approx.), Concert of Popular Music. 5. to 8.0, Interval. 8.0 to 9.30, Chimes, Radi Journal and Dance Music. 9.30 to 11.1 Interval. 11.0, Chimes, Time and Scienc Talk. 11.30, Municipal Band Concert, relayed from Rosales. 1.30 a.m. (Monday), Close Down.

MALMO.—See Stockholm.

MILAN.—See Turin.

MORAVSKA-OSTRAVA

1,137 kc/s, 263.8 metres; 11 kW.—6.0 p.m. See Prague. 8.5, See Bratislava. 10. See Prague. 11.0 (approx.), Close Down.

MOTALA.—See Stockholm.

MUHLACKER.—See Stuttgart.

MUNICH

536 kc/s, 533 metres; 60 kW. Relayed Augsburg and Kaiserlautern, 536 kc/s, 5 metres; and Nürnberg, 1,256 kc/s, 5 metres.—12 Noon, Concert by a Milita Band. 1.0 p.m., Time, Weather and Programme Announcements. 1.10, Agricultural Talk. 1.30, Song Recital on Gramophone Records. 2.30, Talk on the Nation Revolution. 2.50, Zither and Mandoli

Concert. 3.30, Programme for Children.
 4.0, Orchestral Concert, conducted by Erich Kloss. 5.10. In Honour of the Soil—Programme of Talks and Music, relayed from the Town Hall, Trostberg. 6.0, Recital of Humorous Songs. 6.15, Music and Environment—Radio Sketch of the Time of Mozart (Scheller). 7.0, Poets of the New Germany—Werner Beumelburg. 7.20, Choral Concert of German Folk Songs. 7.45, Talk on Austria. 8.5, Concert by the Station Orchestra, conducted by Hans Winter. Soloist: Kurt Rodick (Tenor). In the interval at 8.45, Weather and Sports Notes. 9.45, Siebenkais—Radio Play from the Novel by Jean Paul Richter (Bringolf). 10.20, Time and News. 11.0, Serenade, conducted by Erich Kloss. 12 Midnight (approx.), Close Down.

NAPLES. See Rome.

NOTODDEN. See Oslo.

OSLO

277 kc/s, 1,083 metres; 60 kW. Relayed by Fredrikstad, 815 kc/s, 368.1 metres; Hamar, 522 kc/s, 574.7 metres; Notodden, 671 kc/s, 447.1 metres; Porsgrund, 662 kc/s, 453.2 metres; and Rjukan, 671 kc/s, 447.1 metres. —5.0 p.m., Gramophone Music. 6.15, Agricultural Talk. 6.45, Song Recital by Henry Alf. 7.15, Weather and News. 7.30, Talk. 8.0, Time. 8.1, Orchestral Concert, conducted by Olvin Fjeldstad. Soloists: Ernst Glaser (Violin), and Bjørne Brustad (Viola). Overture, Rosamunde (Schubert); Symphonie concertante (Mozart); Sæpherd's hey (Grainger); Romance in C (Sibelius); Symphonie Intermezzo (Halvorsen); Chant russe (Lalo); Rhapsody No. 2 in G Minor (Brahms); Suite, Javotte (Saint-Saëns); Esquisse ecossaise (Godard). 9.38, Agricultural Notes. 9.40, Weather and News. 10.0, Topical Talk. 10.15, Concert, relayed from Stavanger, 1,247 kc/s, 240.6 metres. 10.45, Dance Music, relayed from Stavanger.

OSTERSUND. See Stockholm.

PALERMO

558 kc/s, 537.6 metres; 3 kW.—10.25 a.m., Bible Reading. 10.40, Sacred Music. 11.5, Agricultural Talk. 12.45 p.m., Giornale Radio. 1.0 to 2.0, Concert of Light Music. In the interval at 1.30, Time and News. 5.30 to 6.50, Gramophone Music. 8.0, Dopolyvoro Announcements, Giornale Radio and Sports Notes. 8.20, Gramophone Music. In the interval at 8.29, Time and Announcements. 8.45, Symphony Concert, conducted by F. Russo. In the intervals, Talk and Gramophone Music. 10.55, News.

PARIS

2,650 metres; 13 kW. Time Signals (on 2,650 metres) at 10.25 a.m., and 11.26 p.m. (Preliminary and 6-dot Signals). 1.0 p.m., News. 1.15, Weather. 1.30, Concert by the Jean Hus Orchestra, Part I. Old Music, Part II. Modern Music. 6.45, Le Journal Parlé. In the interval at 7.45, Report of the Cycle Tour of France. 8.30, Gramophone Concert of Light Music. 10.0 (approx.), Close Down.

PARIS

POSTE PARISIEN, 914 kc/s, 328.2 metres; 10 kW.—10.0 a.m., Fanfare of Trumpets and Roll of Drums. 10.20, Press Review. 10.30, Concert. 11.0, Gramophone Music. 12 Noon, Interval. 12.15 p.m., Sound Film Music. 12.45, Sponsored Programme. 12.50, Half an Hour of Fantasy by Paul Weill and Mlle. Matina. 1.20, Interval. 1.30, Sponsored Programme. 2.0, Interval. 3.0 (approx.), Radio Report of the Cycle Tour of France. 7.0, Le Journal Parlé. 7.5, Sports Notes. 7.30, Catholic Review. 8.0, Gramophone Music. 8.15, Interval. 8.30, Concert. Soloist: Leonardo Araucoso (Tenor). Torna a Surriento (Curtis); Mattinata (Leonavallo); Air from Fedora (Giordano); Air from Mimi Pinson (Leonavallo); Air from La Bohème (Puccini); Ridi Pagliacci, from I Pagliacci (Leonavallo); La Donna e mobile (Verdi); Air from Paganini (Lehar); Tell me to-night (Spogliansky). 9.0, Interval. 9.15, The Châneur—Play (Max Maurey). 9.45, Pianoforte recital: La Prière d'une Vierge; La Filleule (Lemaire); Au clair de la lune (Lambert); Avenue; Serenade (Pierné); Les Cloches du Donastère (Lefebvre); Réveries de Marnette (Yung); Stephanie Gavotte (Czibulka); Waltz (Durand). 10.30, News.

PARIS

RADIO PARIS. Call CFR, 174 kc/s, 1,725 metres; 75 kW.—7.45 a.m., Gramophone Music: Brise Argentine (Dequin); Misa de ave (Giuchaudin); Raffle (Bertraux); Jujn ava (Caconcelli). 8.0, Review of the Tess and Weather. 8.30, Physical Culture. 12 Noon, Religious Address. 12.20 a.m., Sacred Music: St. Anne Fugue (Bach); Inale from the Second Symphony (Widor). 2.30, Bilboquet. 12.45, Gramophone Concert. 2.0 to 5.30, Interval. 5.30, Gramophone Concert. 6.0, Popular Concert. 7.0, concert of Variety Music. 8.0, Programme of Light Music and Recitations. 8.30, cws, Sports Notes and Weather. 8.45, Music and Recitations (contd.): Mou cœur à resté pres du tien (Aubrey-Delannay); aissons l'amour (Lenoir); Ballad (De-

lette-Jambin); Minute exquise; Toe-toc (Zac Nam); Landerinette (Deletre); La valse viennoise (Luxeu). 9.15, Press Review and News. 9.30, Recitations: (a) Complications (Duard), (b) Le pain du menage (Renard). 10.0, Gramophone Music: Overture, The Caliph of Bagdad (Boieldieu); Algerian Nights (Grieg); Selection from H. Guirany (Gomez). 10.30, Programme in English by the I.B.C.: Clarke's Atlas Concert; Blaze away (Holzmann); Selection from The Desert Song (Romberg); Selection from Gay Nineties; Of Man River (Kern); Selection from The Mikado (Sullivan).

PITTSBURGH

KDKA, 980 kc/s, 306 metres; 50 kW. Relayed by W3XK on 48.86 metres and 25.27 metres.—5.15 to 6.15 p.m., Radio City Concert, from New York. 7.0, The Boys of Wynnecau. 7.15 to 9.30, New York Relay. 7.15, World Economic Conference William Hard from London. 7.30, Jan Garber and his Orchestra. 8.0, National Opera Concert. 9.0, Milton Gould and Bert Shefter. 9.15, Symphony (te). 9.30, Vesper Services from Shady-side Presbyterian Church. 10.30 Programme to be announced. 11.0, Time Signal and Press News-Reader. 11.5, Beethoven Chamber Music, from New York. 11.15, Weather Report. 11.16, Sport Review. 11.28, Announcement. 11.29, Temperature Report. 11.30, L'Heure Exquise, from New York. 12 Midnight, Time Signal and Jack Pettis and his Orchestra. 12.15 to 3.0 a.m. (Monday), New York Relay. 12.15, World Economic Conference William Hard from London. 12.30, Great Moments in History. 1.0, Riesensfeld's Viennese Programme. 1.30, Don Hall Trio. 1.45, Floyd Gibbons. 2.0, Gulf Headliners and Arthur Brisbane and Walter C. Kelly. 2.30, Goldman Band. 3.0, Time Signal and Phil Ducey and his Fireside Songs.

PORSGRUND. See Oslo.

PRAGUE

614 kc/s, 488.5 metres; 120 kW. 12 Noon, Chimes. 12.5 p.m., See Bratislava. 1.30 to 1.45, Talk. 4.0, See Bratislava. 5.30, Gramophone Music. 6.0, Gorman Transmission: Mozart in Prague—Concert of Music by Mozart and Czech Composers of the Period. After the Programme, News in German. 7.0, Military Band Concert, relayed from Královská Ohra. 7.50, Talk by Dr. K. Hujer: Impressions of my Tour round the World. 8.5, See Bratislava. 10.0, Time and News. 10.20, Popular Songs by Czech Composers, arranged for Two Pianofortes. 11.0 (approx.), Close Down.

RADIO-SUISSE ROMANDE

SOTTENS, 743 kc/s, 403 metres; 25 kW.; and Geneva, 595 kc/s, 760 metres.—9.55 a.m., Chimes. 10.0, Protestant Service relay. 11.0, Gramophone Music. 12 Noon, Report from the Military Parade in the Place Neuve, Geneva. 12.30 p.m., News. 12.40, Gramophone Concert. 2.0 to 2.30, Interval. 2.50, Report of the Military Display, relayed from the Champalais, Geneva. 3.0 to 7.0, Interval. 7.0, Catholic Address. 7.30 News. 8.0, Recital of Old Music by Mlle. Tatianov (Songs), and Charles Koller (Harpisichord). 8.30, Les sincères—Play (Mariyauz). 9.0, Concert of French Music by the Radio Suisse Romande Orchestra, conducted by Robert Echenard. 9.50, News. 10.0, Concert of Light Music by the Radio Suisse Romande Orchestra, conducted by Robert Echenard. 10.30 (approx.), Close Down.

RJUKAN. See Oslo.

ROME

2RO, 680 kc/s, 441 metres; 50 kW. Relayed by Naples, 941 kc/s, 319 metres and 2RO, 11,819 kc/s, 25.4 metres.—10.10 a.m., News, Sports Notes and Amusement Guide. 10.30, Agricultural Report. 10.45, Bible Reading. 11.0 to 12 (Noon) and 12.30 to 1.30 p.m., See Turin. 1.30 to 2.30, Programme to be announced. In the interval at 2.0, Time and Announcements. 4.45 (Naples), Children's Radio Revue, Weather and Sports Notes. 5.0 to 6.15, Orchestral Concert. Sports Notes in the interval. 6.15, Announcements. 7.30, News. 7.45, Time and Announcements. 8.0, See Vienna. After the Relay, Dance Music. 10.55, Giornale Radio.

SALZBURG. See Vienna.

SCHENECTADY

WCY, 790 kc/s, 379.5 metres; 50 kW. Relayed at intervals by W2XAF on 31.48 metres and by W2XAD on 19.56 metres.—8.5-9.45 p.m. (approx.), New York relay. 8.0, Wayne King's Orchestra. 8.50, Dr. Ralph Sockman in the Radio Pulpit. 9.0, Fiddlers Three. 9.15, Wildroot Institute. 9.30-9.45, Temple of Song. 12.45 a.m. (Monday), Horse Sense Philology. 1.0-3.45, New York Relay. 10, Popular Programme. 2.0, Manhattan Merry-Go-Round. 3.0, American Album of Familiar Music. 3.30, Variety Programme. 3.15, Highlights and Showdowns. 3.45, Sunday at Seth Parker's, from New York, followed by Programme Resumé.

SCHWEIZERISCHER LANDESENDER

BEROMUNSTER, 653 kc/s, 459 metres; 60 kW. Basle, 1,229 kc/s, 244.1 metres and Berne, 1,220 kc/s, 245.9 metres.—10.0 a.m., (from Berne), Protestant Address. 10.45 (from Berne), Concert of Chamber Music. 11.30 (from Berne), Literary Programme. 12 Noon (from Berne), Programme to be announced. 12.30 p.m., Time, Weather and News. 12.40 (from Berne), Programme to be announced. 1.20 (from Berne), Concert of Yodels and Ländler Music. 2.0 (from Berne), Talk in Berne Dialect. 2.30-5.0, Interval. 5.0 (from Berne), Famous Conductors on Gramophone Records. 6.0 (from Berne), Talk on Chess. 6.30 (from Berne), Talk on Louis Duplain. 7.0 (from Berne), Time and Sports Notes. 7.10 (from Berne), Variety Concert by the Berne Mandoline Orchestra. 7.50 (from Berne), Programme to be announced. 9.0, Weather and News. 9.10 (from Geneva), Programme to be announced. 9.50 (from Berne), Dance Music. 10.15 (from Berne), Sports Notes. 10.30 (approx.), Close Down.

SOTTENS. See Radio-Suisse Romande.

STOCKHOLM

680 kc/s, 436 metres; 55 kW. Relayed by Boden, 244 kc/s, 1,229.5 metres; Göteborg, 932 kc/s, 322 metres; Hörby, 1,166 kc/s, 257 metres; Motala, 221.5 kc/s, 1,354.4 metres; Östersund, 389 kc/s, 770 metres; and Sundsvall, 554 kc/s, 542 metres.—9.30 p.m., Rural Programme. 10.0, Gramophone Music. 11.0, Mass, relayed from Harnösand. 12.45 p.m., Weather Report. 2.30 (from Sundsvall), Provincial Programme. 4.0, Gramophone Music. 5.5, Programme for Children. 5.30 (from Sundsvall), Reading. 6.30 (from Sundsvall), Evensong. 7.15, Weather and News. 7.35 (from Göteborg), The Musical Box: Radio Play in One Act (Eugenie Rivkin-Søderberg). 8.10, Orchestral Concert, conducted by Adolf Wiklund: Piecola sinfonia (Atterberg); Romance (Sinding); Die Moldau (Smetana). 8.50, Cello Solos by Roman Dukstulsky: Adagio and Allegro (Bocherini); Song without Words (Mendelssohn); Die Biene (Schubert); Chanson villageoise (Popper). 9.5, Concert (contd.): Pomp and Circumstance (Elgar); Selection from Aida (Verdi); Pizzicato Polka (Joh. Strauss); Waltz, Wienerblut (Joh. Strauss). 10.0 (from Göteborg), Reading. 10.15 (from Göteborg), Military Band Concert. 11.0 (approx.), Close Down.

STRASBOURG

869 kc/s, 345 metres; 11.5 kW.—7.45 a.m., Radio Report of the Cycle Tour of France. 9.30, Divine Service Relay. 10.20, Centenary Concert by the Municipal Band, relayed from Cernay. 11.30, Catholic Service. 12 Noon, Gramophone Concert. 12.45 p.m., News. 1.0, Time and Gramophone Dance Music. 2.0, Gramophone Concert. 3.30, Gala Concert, conducted by M. Brouillat, relayed from the Casino, Vichy. Overture, Gwendoline (Chabrier); Norwegian Dances, Nos. 2 and 3 (Grieg); Suite from Sylvia (Delibes); Contemplation (J. Maczeller); Selection from Hérodiade (Massenet); Amorettentänze (Gungl). In an interval at 4.15 (approx.), Report of the Cycle Tour of France. 5.0, Gramophone Music. 5.15, Dance Music. 6.0, Medical Talk in German. 6.15, Sports Notes in French. 6.50, Concert of Chamber Music: Quintet in E Flat for Pianoforte, Oboe, Clarinet, Bassoon and Horn (Beethoven); Fantasies for Clarinet and Pianoforte, Op. 73 (Schumann); Andante for Horn and Pianoforte (Monteillard); Pastourelle for Oboe and Pianoforte (Lamy). 7.30, Time and News. 7.45, Report of the Cycle Tour of France. 8.5, News in French. 8.50, Alsatian Programme: D'r Luftbüts—Farce in Three Acts (G. Stoskopf). 10.20 (approx.), News in German, followed by Dance Music from the Savoy. 12 Midnight (approx.), Close Down.

STUTTGART

MUHLACKER; 832 kc/s, 360.5 metres; 60 kW. Relayed by Freiburg, 527 kc/s, 570 metres.—11.30 a.m., Recital of Songs by M. Sommay (Baritone). 12 Noon (from Mannheim), Concert by the Philharmonic Orchestra, conducted by Hans Leger. 1.0 p.m., Gramophone Music. In the intervals: Reports on the International Automobile Races (from Freiburg). 2.15, Agricultural Talk. 2.40, Street Singers (Schütz and Albrecht). Gramophone Music in the intervals. 3.30 (approx.) to 5.30, Programme from Frankfurt. 5.40, See Berlin (Witzleben). 6.30, Sports Notes. 6.45, Swabian Programme: Songs and Recitations. 7.25, Märke Programme: Songs, Letters and Poems (arr. Martin Lauze). 8.15, Concert of Waltzes and Polkas by the Municipal Orchestra, conducted by Karl Assmus, relayed from Baden-Baden. 9.30, Baron Mucki: Gramophone Sequence (Werner Bergold). 10.15, Time and News. 10.40, Programme to be announced. 11.0, See Munich. 12 Midnight (approx.), Close Down.

SUNDSVALL. See Stockholm.

TOULOUSE

779 kc/s, 385 metres; 8 kW.—Transmissions irregular owing to fire. 6.20 to 7.0 p.m., Programme in English by the I.B.C. 6.30 to 7.0 p.m., Concert of Dance Music. 10.30 to 12 Midnight, Programme in English by the I.B.C. 10.30, Concert. 11.0, Dance Music. 12 Midnight, Close Down.

TRIESTE

ENTE ITALIANO AUDIZIONI RADIO-FONICHE, 1,211 kc/s, 331.5 metres; 10 kW. 9.40 a.m., See Turin. 9.55, Mass from the Cathedral of San Giusto. 11.0, Religious Address. 11.20 to 11.40, Agricultural Talk. 12.30 (approx.) till 8 p.m., See Turin. See Vienna.

TRONDHEIM. See Oslo.

TURIN

1,006 kc/s, 273.7 metres; 7 kW. Relayed by Milan, 905 kc/s, 331.5 metres. Genoa, 959 kc/s, 312.8 metres; and Florence, 599 kc/s, 500.8 metres.—9.40 to 9.55 a.m., Giornale Radio. 10.40, Agricultural Talk. 11.0, Mass from the Church of the Annunciation, Florence. 12 Noon to 12.15 p.m., Religious Address. 12.30, Orchestral Concert. In the interval at 1.0, Time and Announcements. 1.45 (approx.), Sponsored Gramophone Music. 2.30 to 4.30, Interval. 4.30, Orchestral Concert of Light Music. Sports Notes in the interval. 6.15, Announcements and Gramophone Music. 6.20 to 6.45, Giornale Radio and Sports Notes. 7.0, Time and Announcements. 7.10, Gramophone Concert. 8.0 (Florence only), See Vienna. 8.20, Talk on the following Trans-mission. 8.30, Don Pasquale—Opera (Donizetti). In the intervals, Talk, Theatre Notes and Giornale Radio.

VIENNA

581 kc/s, 517 metres; 100 kW. Relayed by Graz, 852 kc/s, 352.1 metres; Innsbruck, 1,058 kc/s, 283 metres; Klagenfurt, 662 kc/s, 453.2 metres; Linz, 1,220 kc/s, 245.9 metres; and Salzburg, 1,373 kc/s, 218.5 metres.—10.15 a.m., Mass in C Minor (Oscar Störz). 11.0, Peter Rozsger Memorial Programme, relayed from Alpi. 11.30, Concert by the Vienna Symphony Orchestra, conducted by Dr. Erwin Leuchter. Soloists: Margarete Alt (Pianoforte). Overture, Iphigenia in Aulis (Gluck); Concerto in G Minor, Op. 25, for Pianoforte and Orchestra (Mendelssohn); Symphony (Paul Josef Frank). 12.45 to 2.0 p.m., Concert of Light Music. 2.15, Time and News. 2.20, Agricultural Talk. 2.40, The Blessing of Motor Cars and Coaches by His Eminence the Cardinal-Archbishop, Dr. Theodor Innitzer, relayed from Christofen. 3.10, Review of Books. 3.35, Brahms Chamber Music by the Sedlak-Winkler Quartet. Quintet in F Minor for Pianoforte, Two Violins, Viola and Cello; Sonata in D Minor, Op. 108, for Violin and Pianoforte. 4.40, Travel Talk with Gramophone Record Illustrations. 5.5, Talk: In a Small French Town. 5.30, Wind Instrument Concert. 6.45, Dora Stockert-Meyner reads from her own Works. 7.15, Time and Sports Notes. 7.25, Variations and Fugue on a Theme by Bach, Op. 81 (Beger). 8.0, The Last Waltz—Opera in Three Acts (Oscar Straus). In an interval at 9.40, News. 10.15, Dance Music on Gramophone Records.

WARSAW

212.5 kc/s, 1,411 metres, 120 kW.—10.0 a.m., Programme Announcements. 10.5, Divine Service from Poznan. 11.57, Time Signal and Fanfare from the Tower of St. Mary's Church, Cracow. 12.5 p.m., Programme Announcements. 12.10, Weather Forecast. 12.15, Concert by the Station Orchestra, conducted by S. Nawrot. Soloist, A. Slezminska (soprano). 2.0, Agricultural Talk. 2.15, Weather for Farmers. 2.20, Concert by a Male Voice Choir. 2.45, Veterinary Talk. 3.5, Concert of Light Music by the Station Orchestra. 4.0, Talk for Young People. 4.15, Programme for Children. 4.30, Concert by the Poznan Opera House Orchestra, relayed from Ciecchocinek. 5.0, Talk: Workers' Colonies in the Suburbs. 5.15, Dramatic Programme from Cracow. 5.59 kc/s, 312.8 metres. 6.0, Song Recital by Mme. Szczęsowska. 6.35, Programme Announcements. 6.40, Miscellaneous Items. 7.0, The Battle of the Marne—Radio Play (André Obey, arranged Mme. Dehndt). 7.40, Answers to Technical Correspondence. 8.0, Song Recital by A. Michalowski (Bass) In questa tomba oscura (Beethoven). Three songs (Schubert). Prayer (Moniuszko). Angelus (Zelenski). Le Platane (Niewiadomski). Berceuse (Milanowski). 8.25, Pianoforte Recital by Roman Mieczewski: La fille au cheveux de lin (Debussy); Gollywog's Cake Walk (Debussy); Old Vienn (Godovsky); Dispositions Parodoxales (Gólowsky); Frelude (Prokofiev); Gavotte (Prokofiev); The Musical Box (Sauer); Staercot-Elude (Sauer); Waltz, Op. 34, No. 2 (Michalowski); Oberek (Marczewski). 8.50, Radio Journal. 9.0, Humorous Programme, relayed from Lwow, 788 kc/s, 281 metres. 10.0, Dance Music. 10.25, Sports Notes. 10.40, Aviation, Weather Report and Police Notes. 10.45, Dance Music.

ZURICH. See Schweizerischer Landessender.

JULY 17th **MONDAY** continued

inary and 6-dot Signals).—6.45 p.m., Le Journal Parlé. In the interval at 7.45, Report of the Cycle Tour of France. 8.45, Concert relayed from the Casino, Vichy (for Details, see Strasbourg). 11.15, (approx.). Close Down.

PARIS

POSTE PARISIEN, 914 kc/s, 328.2 metres; 60 kW.—7.0 p.m., Gramophone Music. 7.15, Le Journal Parlé. 7.30, Report of the Cycle Tour of France. 7.45, Hot Jazz on Gramophone Records. 8.15, Interval. 8.30, Song Recital by Edmée Querey. 9.0, Interval. 9.15, Concert. 10.15, News.

PARIS

RADIO PARIS, Call CFR, 174 kc/s, 1,725 metres; 75 kW.—7.30 a.m., Weather and Physical Culture. 7.45, Gramophone Music. Selection from Dédé (Christins); Selection from Enleve-moi (Gaborche). 8.0, Weather and Press Review. 12 Noon, Concert of Request Gramophone Records. Kreisler: Violin Concerto (Beethoven); L'invitation au voyage (Dupare); Soir (Fauré); Selection from Ramuntcho (Pierné); Duet from Romeo and Juliet (Gounod); Ballet Music from The Old (Massenet); Song from Le Jongleur de Notre Dame (Massenet); Aria from Benvenuto Cellini (Diaz); Selection from Scheherazade (Rimsky-Korsakov). In the intervals at 1.0 p.m. and 1.30, News and Exchange. 2.0, Exchange. 3.45, Exchange and Market Prices. 4.45, Concert by the Pierre Reitlinger Quartet, relayed from the American Conservatoire. Fontainebleau. Quartet (Verdi); Quartet (Debussy); Nocturnes (Glazunov). 7.0, Exchange and Racing Results. 7.10, Gramophone Music. Norwegian Dances (Grieg); Two Songs (Grieg); (a) Ich liebe dich, (b) Ein Traum; Romance (Svendsen); Finlandia (Sibelius). 7.50, Market Prices and News. 8.0, Recitations on Gramophone Records; Les vieux (Daudet); Le jet d'eau (Baudelaire); Les chapeaux du ler Janvier (Franc-Nohain); Rupture (Bataille); Maman Colibri. Scene 6 (Bataille); Naissance du poème (Divoire). 8.30, News. Weather and Sports Notes. 8.45, Pianoforte Recital by Mlle. Wackmann; Ballad in G Minor (Chopin); Concert Etude No. 2 (Liszt); Waltz (Brahms); Sixth Barcarolle (Fauré). 9.15, Press Review and News. 9.30, Song Recital by Mme. Barbreau (Soprano), and Gramophone Music. Minnet and Allegro from the Third Flute Sonata (Haendel); Polonaise (Bach); Songs: (a) Pamina's Aria from the Magic Flute (Mozart), (b) Quand je dors (Liszt), (c) Old Spanish Song (Aubert), (d) Cette fille, elle est morte (Gre-court), (e) Ständchen (Strauss); Gramophone Records of the Lener Quartet: Quartet in G (Beethoven). In the interval at 10.40, Review by Paul Reboux.

PITTSBURGH

KDKA, 980 kc/s, 306 metres; 50 kW. Relayed by **W8XK** on 48.86 metres and 25.27 metres.—7.30 p.m., KDKA Home Forum. 8.0, Betty and Bob, from New York. 8.15, Words and Music, from New York. 8.45, Human Values, Summer Camps for Undernourished Children, by John C. Weaver, Kingsley Association. 8.58, Baseball Scores. 9.0, Radio Guild—Drama, from New York. 10.0, Rhythm Kings. 10.15, Tarzan of the Apes. 10.30, The Singing Lady, from New York. 10.45, Little Orphan Annie. 11.0, Time Signal and Press News-Review. 11.5, Sam Robbins and his Hotel McAlpin Orchestra, from New York. 11.15, Weather Report. 11.16, Sport Review. 11.23, I Bring a Song. 11.28, Announcement. 11.29, Temperature Report. 11.30, Pittsburgh Spotlights. 11.45 to 1.30 a.m. (Tuesday), New York Relay. 11.45, To-day's News by Lowell Thomas. 12 Midnight, Amos 'n' Andy. 12.15, Kolleickers. 12.30, Rudy Vallee and his Hotel Pennsylvania Orchestra. 1.0, Chiquet Club Eskimos. 1.30, Potash and Perlmutter. 1.45 to 3.0, New York Relay. 1.45, Phil Cook and the Ingram Shavers. 2.0, Sinclair Minstrels. 2.30, Jack Frost Melody Moments. 3.0, The Silver Toppers.

PORSGRUND.—See Oslo.

POZNAN

896 kc/s, 335 metres; 1.0 kW.—6.0 p.m. Miscellaneous Items. 6.15 to 7.20, See Warsaw. 7.20, Miscellaneous Items. 7.35, Theatre Notes and Programme Announcements. 7.40, See Warsaw. 7.58, Time Signal. 8.0, See Warsaw. 10.30 (approx.), Time and Sports Notes. 10.45 (approx.), Close Down.

PRAGUE

614 kc/s, 488.6 metres; 120 kW.—2.50 p.m., See Bratislava. 3.55 to 4.0, Exchange. 5.45, Gramophone Music. 5.55, Talk. 6.5, Agricultural Report. 6.10, Gramophone Music. 6.15, Talk. 6.25, News in German. 6.30, German Transmission; Two Talks. 7.0, Chimes and News. 7.10, See Brno. 8.10, See Moravská-Ostava. 8.25, See Brno. 9.0, See Bratislava. 10.0, Time and News. 10.15, Talk in German: German Libraries in Czechoslovakia. 10.30 (approx.), Close Down.

RADIO-SUISSE ROMANDE

SOTTENS, 743 kc/s, 403 metres; 25 kW.; and Geneva, 395 kc/s, 760 metres.—12.28 a.m., Time Signal from Neuchâtel Observatory. 12.30, News. 12.40, Gramophone Con-

cert. In the interval at 1.0, Financial Report. 2.0 to 3.28, Interval. 3.28, Time Signal from Neuchâtel Observatory. 3.30, Interval. 4.0, Concert by the Radio-Suisse Romande Quintet. 5.30, Interval. 7.0, Talk: Here and There. 7.25, Radio Interview. 7.45, Results of the Cycle Tour of France. 7.50, Il Seraglio—Opera in Three Acts (Mozart) relayed from Berne. In the intervals at 8.40 and 9.45, News. 10.15 (approx.). Close Down.

REYKJAVIK

250 kc/s, 1,200 metres; 21 kW.—9.5 p.m., Musical Programme. 9.30, Weather Report. 9.40, Musical Programme and Announcements. 10.0, Chimes and News. 10.30, Reading. 11.0, Popular Music by the Radio Quartet and Songs.

RIGA

572 kc/s, 525 metres; 15 kW.—6.0 p.m., Literary Programme. 6.30, Talk on Swimming. 7.0, Weather Report. 7.3, Gramophone Music. 7.30, Reading. 8.0, News. 8.15, Concert of Old Time Dance Music. 9.0, Weather and News. 9.15 (approx.), Concert of Meyerbeer Opera Music: Coronation March from The Prophet; Air from L'Africaine; Shadow Dance from Dinorah; Selection from The Huguenots; Air from The Huguenots; Overture, Ein Feldlager in Silesien; Torch Dance No. 1.

RJUKAN.—See Oslo.

ROME

Call **1R0**, 680 kc/s, 441 metres; 50 kW. Relayed by **Naples**, 941 kc/s, 319 metres; and **2R0**, 11,810 kc/s, 25.4 metres.—1.0 to 2.15 p.m., Gramophone Music. In the interval at 1.30 to 1.45, Giornale Radio and Exchange, and at 2.0, Time and Announcements. 4.45, Children's Radio Review. 5.10, Weather. 5.15, Exchange and Giornale Radio. 5.30, Voed and Instrumental Concert: Germano Arnaldi (Pianoforte), Augusta Quaranta (Soprano) and Luisa Carecarvini (Violin). Pianoforte Solos: (a) Ritmi di marcia (Labroca), (b) Toccata in D (Veretti); Soprano Solos: (a) Sotto il cielo (Sibilla), (b) Perduta ho la speranza (Donaudy), (c) Aria from Francesca da Rimini (Zandonai); Violin Solos: (a) German Waltz (Reger), (b) Melody (Gershwin), (c) Gipsy Dance (Rachmaninov); Soprano Solos: (a) Solveig's Song (Grieg), (b) Song (Benedict), (c) Waltz Song Frühlingstimen (Joh. Strauss); Second Polonaise in E Minor for Pianoforte (Liszt). 6.40 (Naples), Shipping and Sports Notes. 6.50, Agricultural and Dopolavoro Notes. 7.10, Tourist Report. 7.20, Announcements in Foreign Languages. 7.40, Giornale Radio. 8.0, Time and Announcements. 8.5, Gramophone Music. 8.30, Giornale Radio and Sports Notes. 8.45, Variety Programme. 9.45, Humorous Programme. 10.0, Concert of Light Music. 10.55, Giornale Radio.

SALZBURG. See Vienna.

SCHENECTADY

WGY, 790 kc/s, 319.5 metres; 50 kW. Relayed at intervals by **W2XAF** on 31.48 metres and by **W2XAD** on 19.56 metres.—9.5 p.m., Book News by Lever Fuller. 9.15, Winters and Weber, Organists. 9.30, Soloist, from New York. 9.45-10.0 (approx.), Talk by S. W. Ashe: What's New in the Berkshires. 12.45 a.m. (Tuesday), Stock Reports. 1.0, Socranoyland Sketch, from New York. 1.30, Dramatized Penny. 1.45-3.30, New York Relay. 1.45, Ferdie Grofe's Orchestra. 2.0, A. and P. Gypsies. 2.30, Musical Programme. 3.0, Contented Programme. 3.30, Ship of Joy, from New York, followed by Programme Resumé.

SCHWEIZERISCHER LANDESENDER

BEROMUNSTER, 653 kc/s, 459 metres; 60 kW. Basle, 1,229 kc/s, 244.1 metres and Berne, 1,220 kc/s, 245.9 metres.—6.15-6.36 a.m., (from Berne). Gymnastics. 11.59, Time Signal from Neuchâtel Observatory and Weather. 12 Noon (from Basle), Organ Music on Gramophone Records. 12.30 p.m., Time, Weather and News. 12.40 (from Basle), Popular Swiss Music on Gramophone Records. 1.25 (from Basle), Time, Weather and Exchange. 1.45-3.45, Interval. 3.45, Choral Concert relayed from Frauenfeld. 5.0 (from Berne), Programme for Young People. 5.30 (from Berne), Berlin Folk Music on Gramophone Records. 6.30 (from Berne), Talk: Mountaineering Accidents. 7.0, Time and Weather. 7.30 (from Zürich), Elementary English Lesson. 8.0, Concert by the Swiss Radio Orchestra. 9.0, Weather and News. 9.10 (from Berne). A Comedy in Dialect. 10.15 (approx.), Close Down.

SOTTENS.—See Radio-Suisse Romande.

STOCKHOLM

689 kc/s, 436 metres; 55 kW. Relayed by **Boden**, 244 kc/s, 1,229.5 metres; Göteborg,

932 kc/s, 322 metres; Hörby, 1,166 kc/s, 257 metres; Motala, 221.5 kc/s, 1,354.4 metres; Osterund, 389 kc/s, 770 metres; and Sundsvall, 554 kc/s, 542 metres.—5.5 p.m. (from Sundsvall), Accordion Music. 5.25 (from Sundsvall), Talk on Old Härnösand. 5.45, Gramophone Music. 6.45 (from Sundsvall), Provincial Programme. 7.15, Weather and News. 7.50, Song Recital by Calle Hagman and Emy Hagman. 8.0 (from Sundsvall), Agricultural Talk. 8.30 (from Sundsvall), Concert of Light Music by Naima Lindgren (Songs) and Holger Aberg (Harp), with Readings by Olga Appellöf. 9.15 (from Sundsvall), Talk: The Annual and Vegetable Kingdom. 9.45, Weather and News. 10.0, Dance Music on Gramophone Records. 11.0 (approx.), Close Down.

STRASBOURG

859 kc/s, 345 metres; 11.5 kW.—7.45 a.m., Report of the Cycle Tour of France. 8.0 to 11.30, Interval. 11.30, Gramophone Concert. 12.45 p.m., News and Exchange. 1.0, Time Signal, and Report of the Cycle Tour of France. 1.15, Concert by the Station Orchestra, conducted by M. Roskam. 2.0 to 2.0, Interval. 3.0, Report of the Cycle Tour of France. 3.15, Gramophone Music. 3.30, Concert conducted by M. Brouillard, relayed from the Casino, Vichy. 4.50 (approx.), Report of the Cycle Tour of France. 5.15, Dance Music. 6.0, Talk in French: The Cinema. 6.15, Topical Talk in German. 6.30, Louis Dumas Concert by the Radio Orchestra, conducted by M. de Villers and Soloists. 7.30, Time Signal and News. 7.45, Report of the Cycle Tour of France. 8.5, Press Review, in French. 8.20 (approx.), Gramophone Music. 8.45, Beethoven Concert of Choral and Orchestral Music, relayed from the Casino, Vichy. Conductor: Paul Paray. Overture, Coriolanus; The Pastoral Symphony; Ballet Suite from Prometheus; The Ninth Symphony. 11.15 (approx.), News in German.

STUTTGART

MUHLACKER, 832 kc/s, 360.5 metres; 60 kW. Relayed by **Freiburg**, 527 kc/s, 570 metres. 12 Noon, Orchestral Concert, conducted by Karl Assmus, relayed from Baden-Baden: Badenweiler March (Fürst); Overture, Franz Schubert (Suppe); Suite from Sigurd Jorsalfar (Grieg); Rondo from Titus (Mozart); Potpourri from Schön ist die Welt (Lehar); Three Dances from Henry VIII (Saint-Saëns); Waltz, Morgenblätter (Joh. Strauss). 1.15 to 1.30 p.m., Overtures on Gramophone Records: Zampa (Hérold); Si j'étais roi (Adam); Benvenuto Cellini (Bellini). 2.0, Programme arranged by the Post Office, with Gramophone Records. 2.30, Spanish Lesson. 3.0 to 3.30, Elementary English Lesson. 4.30, See Langenberg. 5.45, Talk: Leaders and Personalities in the Nazi Movement. 6.15, See Frankfurt. 6.45, Time and News. 7.0, Transmission for all German Stations, relayed from Munich. 8.0, See Munich. 8.25, From Heilbronn to Heidelberg—a Musical Steamer Trip down the Neckar. 9.10, You must know... 9.30 (from Karlsruhe), Variety Programme. 10.15, Time and News. 10.45, Concert by the Station Orchestra, conducted by Gustav Görlich. Soloist: Gerda Hansi (Soprano), Selection from Bastien and Bastienne (Mozart); Andante from the Drum-Roll Symphony (Haydn); Minuet (Dittersdorf); Arietta from Oberon (Weber); Overture, Ailhouse and Estrella (Schubert); Albumblatt (Wagner); March (Glück); Recitative and Aria from Der Walfenngelänger (Lortzing). 12 Midnight to 1.0 a.m. (Tuesday), Dialogue: Swabians the World over. 1.15 (also on Zeesen), Love, Betrothed and Married—A Programme of Swabian Folk Songs (arr. Martin Lang). 2.0 (approx.), Close Down.

SUNDSVALL. See Stockholm.

TOULOUSE

779 kc/s, 385 metres; 8 kW. Transmission irregular owing to fire.—11.30 to 12 Midnight, Programme in English by the I.B.C. 11.30, Light Music. 11.57, I.B.C. Goodnight Melody. 12 Midnight, Close Down.

TRIESTE

1,211 kc/s, 247.7 metres; 10 kW.—5.10 p.m. till Close Down. See Turin.

TRONDHEIM.—See Oslo.

TURIN

1,096 kc/s, 273.7 metres; 7 kW. Relayed by Milan, 905 kc/s, 331.5 metres; Genoa, 959 kc/s, 312.8 metres; and Florence, 599 kc/s, 500.8 metres.—5.10 p.m., Orchestral Concert: Barcelona (d'Anzi); Melody (Stone); Danze dei maragatos (Azzoni); Selection from Viktoria and her Hussar (Abraham); Melody (Stolz); Serenata giordiana (Luttuada); Legenda (Mascaroni); Madame (Goldwyn); Com'è bella la vita (Bixio). 6.0 to 6.5, Weather. 6.35, News. 7.0, Time, Tourist Report and Gramophone Music. 7.20, News in

Foreign Languages. 7.40, Gramophone Music. 8.0, News and Weather. 8.15, Sponsored Gramophone Music. 9.15, Concert of Chamber Music. 10.15, Mandoline Concert. 11.0, Giornale Radio.

VATICAN CITY

15,123 kc/s, 19.84 metres (Morning) and 5,969 kc/s, 50.26 metres (Evening); 10 kW.—11.0-11.15 a.m., Religious Information in Italian. 8.0-8.15 p.m., Religious Information in Italian.

VIENNA

581 kc/s, 517 metres; 100 kW. Relayed by Graz, 852 kc/s, 352.1 metres; Innsbruck, 1,058 kc/s, 283 metres; Klagenfurt, 662 kc/s, 453.2 metres; Linz, 1,220 kc/s, 245.9 metres; and Salzburg, 1,373 kc/s, 218.5 metres.—12 Noon, Orchestral Concert, conducted by Josef Holzer: Overture, Das Nachtlager von Granada (Kreutzer); Song, Gern hab ich ich die Frau'n geküsst (Lehar); Selection from Marietta (Oscar Straus); Two Pieces (Del-brück): (a) Schummerlied, (b) Schalkel-pferd; The Vision of Fuji-San (Ketelbey); Waltz, Unsere Wiener Herzen (Dominic Ertl); Melody (Drda); Gesellen-Marsch (Eysler); Overture, Der Schatzmeister (Zieler); Wiener Lied, Drum in der Lohau (Heinrich Ströcker); Beim Burgtor am Michaelerplatz (Ernst Arnold); Waltz, Promotinen (Joh. Strauss); Symphonie Piece, Das Herz des Pierrot (Clémens); Selection from A Kiss in Spring (Kalmann); March, Tiroler Holz-hacker (Wagner). In the interval at 1.0 p.m., Time and News. 3.0, Time and News. 3.20, Talk: Thirty Years of the Prevention of Smoke and Dust in Austria. 3.40, Programme for Young People. 4.5, Folk Songs on Gramophone Records. 4.35, Talk: Experiences of a Photographer-Reporter. 5.0, Talk on Music. 5.25, Soloist Concert: Ivo Spritta (Baritone) and Dr. Mercedes Janetzky (Pianoforte): Prelude, Aria and Finale (Frank); Pianoforte Solo, Jeux d'eau (Ravel); Lolita (Buzzi-Beccia); Mattinata (Leoncavallo); Santa Lucia (Gordigiani); Baritone Solos: (a) Aria from I due Foscari (Verdi), (b) Aria from Macbeth (Verdi). 6.5, Talk: The Streets of Vienna—the Maria-hilferstrasse. 6.25, Books and Publications in connection with the week's Talks. 6.30, Talk. 7.0, Concert by the Vienna Symphony Orchestra, conducted by Anton Kourath: Overture, King Stephen; The Second Symphony in D, Op. 36. 7.35, Time and News. 7.40, Concert (contd.). Symphonie Poem, From the Fields and Groves of Bohemia (Smetana); In a Summer Garden (Delius); Romantic Suite (Eugen Müller). 8.30, Topical Talk. 8.45, Orchestral Concert, conducted by Josef Holzer: Overture, Man lebt nur einmal (Wagner); Waltz, Mein Lebens-lauf ist Lieb' und Lust (Joh. Strauss); March, Es lebe das Leben (Adolf Iselpold); Song from Rund um die Liebe (Oscar Strauss); Polka, Sängerlust (Jos. Straus); Potpourri, Für lustige Lent' (Komzak); Song from Liebesrausch (Buttykyay); March from Plebnit (Nedbal); Waltz, Freut euch des Lebens (Joh. Strauss); Polka, Fronsium (Jos. Strauss); Overture, Der lustige Krieg (Joh. Strauss); Polka Mazurka from Die arme Jonathan (Lehar); Selection from The Merry Widow (Lehar); Gallop, Leben heiss geniessen (Zieler). 10.15 (approx.), News 10.30, Dance Music from the Grabencafé.

WARSAW

212.5 kc/s, 1,411 metres; 120 kW.—11.57 a.m. Time Signal and Fanfare from the Tower of St. Mary's Church, Cracow. 12.5 p.m.—Violin Solos on Gramophone Records. 12.2 Polish Press Review. 12.33, Weather. 12.35, Jazz Music on Gramophone Record. 12.55, Radio Journal. 1.0 to 2.55, Interval. 2.55, Gramophone Music. 3.5, News. 3.0, Announcements. 3.15, Gramophone Music. 3.25, Economic Notes. 3.35, Gramophone Music. 3.45, Traffic Report. 3.50, Gramophone Music. 4.0, Concert by the Pozna Opera House Orchestra, conducted by Tylli relayed from Ciechocinek. 5.0, Talk French. 5.15, Pianoforte and Violin Recit by Stella Dobryszczyka and Mme Baeewie Pianoforte Sonata in D (Mozart); Spanish Suite for Violin (Albeniz). Pianoforte Solos: Two Impromptus Op. 142, in B flat and A flat (Schubert). Violin Solos: (a) Minuet (Porpora-Kreisler), (b) Perpetuum Mobile (Novacek), (c) Ballet Music for Rosamunde (Schubert-Kreisler). 6.1 Habanera (Ravel), (c) Presto (Benda). 6.1 Library Talk. 6.35, Gramophone Music. 6.55, Programme for Soldiers. 7.20, Miscellaneous Items. 7.35, Programme Announcements. 7.40, Talk on French Literature. 8.0, Polenblut—Operetta (Nedbal). In t intervals, Answers to Agricultural Correspondence and Radio Journal. 10.0, Dai Music from the Europe Café, Ciechocin. 10.25, Sports Notes. 10.35, Aviation Weather Report and Police Notes. 10, Dance Music Relay (contd.).

WILNO

533 kc/s, 563 metres; 16 kW.—6.35 p.m. Gramophone Music. 6.50, Announcements. 6.55, Talk in Lithuanian. 7.35, Program Announcements. 7.40 to 11.0, See Warsaw in the interval from 9.0 to 9.10, Sports Not 11.0 (approx.), Close Down.

ZURICH.—See Schweizerischer Landessender

TUESDAY

JULY THE EIGHTEENTH

PRINCIPAL EVENTS OF THE WEEK:

AT HOME

- | | |
|------------------------|---|
| NATIONAL | Sailors' shanties, gramophone and instrumental concerts. |
| LONDON REGIONAL | "Morning, Noon and Night." |
| NORTH REGIONAL | Three plays: "Last Man Out" (L. D. Dawson); "Adventure of the Blue Carbuncle" (Conan Doyle); "Ernie's Big Double" (Whittie Kerr). |
| BELFAST | Speeches at luncheon given at the Opening of Craigavon Bridge, from the Guildhall, Londonderry. |
- ABROAD**
- | | |
|-------------------------|---|
| BARCELONA | 7.0 p.m., Trio concert. |
| BRUSSELS (No. 1) | 8.0 p.m., Brahms Centenary Concert by the Station Orchestra. |
| COPENHAGEN | 8.15 p.m., "The Three Musketeers," a musical play, by Benatzky. |
| HAMBURG | 10.50 p.m., Concert by the Station Orchestra. |
| LANGENBERG | 9.0 p.m., Concert of Viennese music by the Station Orchestra. |
| RADIO PARIS | 9.30 p.m., Opera-comique: "Les Noces de Jeanette" (Masse). |
| ROME | 8.45 p.m., Opera: "Don Pasquale" by Donizetti. |
| STOCKHOLM | 9.15 p.m., Song recital by Mavis Bennett. |
| STRASBOURG | 8.30 p.m., Concert by the Société des Amis du Pays Messin, relayed from Metz. |

BUCHAREST

761 kc/s, 394 metres; 12 kW.—5.0 p.m., Light Music and Romanian Music by the Motoi Journal. In an interval at 6.0, Radio Journal. 7.0, Reading. 7.20, Gramophone Music. 7.40, Educational Talk. 8.0, Song Recital by Mme. Humphris: Aria from Figaro (Mozart); Die Krähe (Schubert); Die Fanelle (Schubert); Das verlassene Mädchen (Schumann); Der Nussbaum (Schumann); Die Nacht (R. Strauss). 8.20, Concert by the Station Orchestra: March, Carpathengröße (Stelzig); Blue Danube Waltz (Strauss); Overture, Don Pasquale (Donizetti); Selection from La Traviata (Verdi); Ballet Suite from Die Puppenfee (Bayer); Suite, Ballet égyptien (Luigini); Tristesse d'amour (Tallier); Scherzo (Brunetti). In an interval at 9.0, Talk. 9.45, Radio Journal.

BUDAPEST

545 kc/s, 550.5 metres; 18.5 kW.—4.0 p.m., Music by a Gypsy Band, 4.45, News. 5.0, Reading. 5.30, Piano forte and Violin Recital. 6.30, Reading. 8.15, Opera Programme. Part I: The Nuremberg Doll—Comic Opera (Adam). Part II: Der Schauspielerdirektor—Opera (Mozart). After the Programme, News and Gypsy Music by the Bura Sander Band. CASSEL.—See Frankfurt.

COPENHAGEN

1,067 kc/s, 281 metres; 0.75 kW.—Relayed by Kalundborg, 250 kc/s, 1,153 metres.—12.0 Noon, Town Hall Chimes. 12.5 p.m., Concert from the Bellevue Strandhotel. 3.30, Concert by the Station Orchestra, conducted by Emil Reesen: Overture, Raymond (Thomas); Waltz, Frühlingsstimmen (Joh. Strauss); Selection from Rigoletto (Verdi); March from The Queen of Sheba (Gounod); Polka (Borodin); Polonaise from Les Millions d'Arlequin (Drigo); Spanish Comedy Overture (Keler Bela); Berceuse (Järnefelt); Extracts from The Nutcracker Suite (Tchaikovsky); Melody (Gillet); Ratzky March (Joh. Strauss). In the interval at 4.15 (approx.), Reading. 5.35, Exchange and Market Prices. 6.20, Talk on Architecture. 6.50, Weather. 7.0, Press Review. 7.15, Time 7.30, Review of Foreign Politics. 8.0, Time. 8.1, Talk on the following Transmission. 8.15 (approx.), The Three Musketeers—Musical Play (Benatzky). In the interval at 10.5, News. 11.10, Dance Music, relayed from the Nimb Restaurant. In the interval at 12.0 Midnight, Time and Chimes from the Town Hall. 12.30 a.m. (Wednesday), Close Down.

CORK.—See Athlone.

CRACOW

959 kc/s, 312.8 metres; 1.5 kW.—7.20 p.m., Talk: Old Cracow. 7.35, Miscellaneous Items and News. 7.40, See Warsaw. 7.55, Programme Announcements. 8.0 to 11.0, See Warsaw. In the interval at 10.25, Sports Notes. 11.0 (approx.), Close Down.

DANZIG.—See Heilsberg.

DRESDEN.—See Leipzig.

FECAMP

1,328 kc/s, 225.9 metres; 10 kW.—4.30 to 6.0 p.m., Programme in English by the I.B.C. 4.30, Programme for Children. 5.0, Concert of Light Music for Torquay and Exeter Listeners: The Night by the Sea; Selection from Wild Violets, Part 1 (Stolz); Le Java de Doudone (Padilla); When work is through (Sherman); Song: Wayside Rose (Lehár); Amine (Lincke); Only Brokenhearted me (Farrell); Song: Lolita (Puccini); Selection from Wild Violets, Part 2 (Stolz). 5.30, Concert of Old Songs for Plymouth and Devonport Listeners. Old Music Hall Memories: Part 1: Two lovely Black Eyes; When Father papered the Parlour; After the Ball (Harris); The Old Rustic Bridge by the Mill (arr. Wood); The Man who broke the Bank at Monte Carlo; The Galloping Major. Old Music Hall Memories, Part 2: The Night by the Sea. 6.0, Programme in French. 10.0 till Close Down, Programme in English by the I.B.C. 10.0, Dance Music by the Blue Mountaineers (Electrical Transcriptions): Bells of Normandy (Evans); Lovable; Gettin' Sentimental; When we're alone; Sailing on the Robert E. Lee; There's another empty Saddle; I got Rhythm (Gershwin); Can't we talk it over?; Love, you funny thing (Turk); Too many Tears (Warren); Rumba, Bahama Mama (Gilbert); We all wanna know why (Hargreaves); If you were only mine (Newman); Mad about the boy; You're my Everything (Warren); The Younger Generation; Moonlight, the Danube and you (Towers); Bells of Normandy (Evans). 11.0, Club Concert for St. Ives Listeners. Part I, Orchestral Music. The Chum Song; Overture, Masaniello (Auber); Room for the Factotum; from The Barber of Seville (Rossini); The Moon and I, from The Mikado (Sullivan); Violin Solo: Hymn to the Sun (Rimsky-Korsakov); Pompée valse (Poldini); Dance of the Clown (Smetana); Aria (Verdi); Chinese fantaisie (Deppen). Part 2, Celebrity Concert of Gramophone Records: Piano forte Solo, He Wanted Adventure, Part 1 (Waller and Tunbridge); Dance of the Nymphs (Birch); One Little Drink, from Song of the Flame (Clarke-Akst); Jim at the Bank; The Clatter of the Clogs (Flynn, arr. Flight);

ATHLONE

725 kc/s, 413 metres; 60 kW., Relayed by Cork, 1,337 kc/s, 224.4 metres.—1.30 to 2.20 p.m., Time Signal, Stock Exchange Quotations, Weather Report and Gramophone Music. 6.0, Programme for Children. 6.40, News. 7.0, Gaelic Reading. 7.15, Talk. 7.30, The Station Orchestra. 8.0, Bass Solos by H. J. McCormick. 8.15, Violin Solos by E. Kiernan. 8.20, Soprano Solos by Letitia Ennis. 8.50, The Station Orchestra. 9.10, Variety Programme by T. C. Earls and A. J. Thornton. 9.30, Talk by William Dawson. 9.45, Sponsored Programme. 10.30, Time Signal. 10.45, News, Weather Report and Close Down.

BARCELONA

EAJ1, 866 kc/s, 348.8 metres; 8 kW., 7.0 p.m., Trio Concert. Selection from Tlais (Massenet): A Song of Autumn (Elgar); Serenade (Rachmaninov); Intermezzo (R. Strauss); Berceuse (Debussy); Selection from The Pearl Fishers (Bizet). 8.0, Request Gramophone Records. 8.30, Exchange and Art Notes. 9.0, Gramophone Records. 9.15, Football Notes, Gramophone Records and News. 10.0, Chimes, Weather, Messages for Seamen, Exchange and Market Prices. 10.5, Sponsored Programme. 10.30, Concert by the Station Orchestra, Ronde des Lutins (d'Ambrosio); Serenade (Fernandez); Idyll (Février); Gavotte (Mahy). 11.0, Artists, Agricultural and Industrial Programme, relayed from the Vigna Theatre. In the interval at 12 Midnight, News.

BARI

1,112 kc/s, 259.8 metres; 20 kW.—8.0 p.m., Agricultural Report, Tourist Talk and Dopolavoro Announcements. 8.20, Giornale Radio and Weather. 8.30, Time and Announcements. 8.35, Gramophone Concert. 9.30, Miscellaneous Notes. 9.35, Concert by the Bari Mandoline Quartet: Overture, Der Sehnsuchtsdirektor (Mozart); Poem, Improviso (Gentile); Minuet Op. 49 (Beethoven); Selection from La Bohème (Puccini); Intermezzo, Idillio appassionato (Del Buono); Sul Lido (Bottacchiari); Fantasia Tramonto d'autunno (Manente); Serenata (Viterbini); Ecossaise (Schubert); Flémimino (Del Buono); Popular Spanish Dance (de Jerez). In the interval, Talk. 10.55, News.

BASEL.—See Schweizerischer Landessender.

BELGRADE

BEGRAD, 697 kc/s, 430.4 metres; 2.8 kW.—5.55 p.m., Time and Programme Notes. 6.0 Yugoslav Melodies. 6.30, Talk. 7.0, Orchestral Concert. 7.50, Gramophone Music. 8.0, Recital on Two Piano-fortes: Andante with Variations, Op. 46 (Schumann); Variations on a Theme of Haydn, Op. 56 (Brahms); Romance, Op. 51 (Greig). 8.0, Military Band Concert. 10.30, Time, News and Gypsy Music, from the Potrosacks Zadraga Restaurant.

BERLIN

DEUTSCHLANDSENDER, 183.5 kc/s, 1,635 metres; 60 kW., 2.0 p.m., Gramophone Concert of Pianoforte Music: Improvimpromptu in G, Op. 90 (Schubert); Moment Musical in F (Schubert); Waltz in E Flat Minor (Chopin); Berceuse (Chopin); Polonaise in A Flat (Chopin); Serenade in B Flat (Schubert-Liszt); An den Frühling (Grieg). 2.40, Violin Recital by Gerda Reichert. 3.0, Programme for Young People. 3.30, Weather and Exchange. 3.45, Reading (Karl Maerztin). 4.0, See Leipzig. 5.0, Agricultural Talks. 5.25, Topical Talk. 5.35, Bach recital by Albert Hufeld (Pianoforte); Prelude and Fugue in E Flat Minor from Das Wohltemperiertes Klavier; Italian Concerto. 6.0, Poems. 6.5, Schubert Song Recital by Wilhelm Winterberg: Der Sieg; Der ersühtete Orest; Fahrt zum Hades; Der Wanderer an den Mond; Totengräbers Hummel; An den Tod; Verklärung. 6.30, Political Press Review. 6.50, Weather and Announcements. 7.0, Transmission for all German Stations, relayed from Frankfurt. 8.0, Epigrams. 8.5 (approx.), Das heiderliche Kleeblatt—A Sketch (Johann Nestroy) (Music by Adolf Müller). 9.30, Radio Report from a Young Hitlerites' Camp. 10.0, Weather and News, followed by Talk: By Car from Lake Victoria to Lake Chad. 10.45, Weather. 11.0, Concert from Hamburg. 12 Midnight, Close Down.

BERLIN

WITZLEBEN, 715 kc/s, 419.5 metres; 1.5 kW.—6.15 p.m., Book Review. 6.40, The Witzleben Station informs its Listeners. . . . 6.45, Topical Talk. 7.0, Transmission for all German Stations, relayed from Frankfurt. 8.10, Beethoven Concert relayed from the Kurhaus, Swinemünde; The Orchestra, conducted by Paul Scheimpflug; Soloist, Fred Drissen (Baritone); Overture, Die Geschöpfe les Prometheus; Two Songs: (a) Prüfung des Küssens, (b) Mit Mädchen sich vertragen; Symphony No. 8 in E. Op. 93. 9.0, Fritzische Rebellion—Play (Geyer). 10.0, News. 10.30 (approx.), See Hamburg. In the interval at 11.0 (approx.), Talk: What they are saying in Berlin. 12 Midnight, Close Down.

BERNE.—See Schweizerischer Landessender.

BEROMÜNSTER.—See Schweizerischer Landessender.

BODEN.—See Stockholm.

BODO.—See Oslo.

BORDEAUX-LAFAYETTE

526 kc/s, 304 metres; 13 kW.—6.15 p.m., Radio Journal. 7.30, News and Lottery Results. 7.45, Report of the Cycle Tour of France. 8.5, Topical Talk. 8.20, News. 8.30, Programme to be announced, relayed from Paris (Ecole Supérieure), 671 kc/s, 447.1 metres.

BRATISLAVA

1,076 kc/s, 279 metres; 14 kW.—7.10 p.m., Recital of Slav songs by Jana Kamasova. 7.25, Talk on Economics. 7.35, See Prague. 7.50, See Brno. 8.15, See Prague. 9.0, See Brno. 10.0, See Prague. 11.0 (approx.), Close Down.

BRESLAU

923 kc/s, 325 metres; 60 kW.; and Gleiwitz, 1,184 kc/s, 253 metres.—1.0 p.m., German Folk Songs on Gramophone Records. 2.0, Time and News. 2.20, Chamber Music on Gramophone Records. 3.0, Agricultural Prices. 3.15, Talk for Children: What to do in the Holidays. 3.45, Robert Franz Song Recital by Lotte Wessel (Soprano); Gute Nacht; Ein Friedhof; Auf dem Meere; Im Herbst; Denk ich dein; Das Meer hat seine Perlen; Lieben ist da; Der Schmetterling ist in die Rose verliebt; Tanzend im Mai; Mein Schatz ist auf der Wanderschaft. 4.15, Sonata in A for Violin and Piano forte (Beethoven). 4.45, Reading of Transylvanian Tales. 5.20, Agricultural Prices. 5.25, Zither Recital by S. Joneczko. 5.50, Book Review. 6.5, Programme to be announced. 6.25, Talk: The Lümburger Heide. 6.50, News. 7.0, Transmission for all German Stations, relayed from Frankfurt. 8.0, Das Stauwerk—Propaganda Radio Play for Workers (Gerhard Menzel), with Incidental Music. 9.0, News. 9.10, Viola and Piano forte Recital. 10.0, Time and News. 10.10, Wireless Notes. 10.30, Political Press Review. 10.50, Orchestral Concert from the Kaffee Vaterland. 12 Midnight, Close Down.

BRNO

878 kc/s, 342 metres; 35 kW.—6.25 p.m., German Transmissions: News and Talks. 7.0, See Prague. 7.10, Song Recital. 7.35, See Prague. 7.50, Haydn Music: Four Pieces for Flute; Quartet in D for Lute, Violin, Viola and Cello. 8.15, See Prague. 9.0, Military Band Concert: Overture, Masaniello (Auber); Jubilee March (Zita); Selection from Tosca (Puccini); Selection from The Bartered Bride (Smetana); Potpourri, Gay Prague (Leopold); Song and Tango (Kovarik); Polka (Dudek). 10.0, See Prague. 11.0 (approx.), Close Down.

BRUSSELS (No. 1)

N.I.R., 590 kc/s, 509 metres; 15 kW.—12 Noon, Concert by the Small Station Orchestra, conducted by Pierre Leemans: National Dances; Old Czech Polka (Hilmar); Tarantella, Martina (Canteloube); Oriental Dance (Glazunov); Tango (Albeniz); La Berriehonne (Wachs); Hindü Dance (Bernard); Old Boer Dance (Sieg); Insalah (d'Agreves); Congo Dance (Rouffosse); Spanish Rondo (Cassado); Romanian Dance (Bareh); Habanera (Turina); Slav Dance No. 6 (Dvorak); Hungarian Peasant Dance (Pachernegg); German Dances (Schubert). 1.0 p.m., Request Gramophone Concert. 1.30, Liszt, Piano forte solos: (a) Mephisto Walzer, (b) Consolations. 5.0, Dvorak Concert by the Station Symphony Orchestra, conducted by Arthur Meulemans: Legend, No. 10; Bacchanale; Piece; Humoresque. 5.30, Programme for Children. 6.5, Literary Talk. 6.15, Clarinet Solos by Zephyr Raudour. 6.45, Ici l'Asile—Radio Sketch (Schiaffer). 7.15, Dialogue: The First Eucharistic Congress in the Belgian Congo. 7.30, Art Notes and Talk for Women. 8.0, Brahms Centenary Concert by the Station Symphony Orchestra, conducted by Arthur Meulemans. Soloists: M. Lykondi (Violin) and M. Wetzel, (Cello), Liebeswalzer, Suites 1 and 2. Double Violin Concerto. 8.45, Religious Address. 9.0, Concert relayed from the Kurhaus, Ostend. 10.30, Le Journal Paris. 10.46, Poemes (Chausson), on Gramophone Records. 10.55, Christus Vincit (Liszt).

BRUSSELS (No. 2)

N.I.R., 887 kc/s, 338.2 metres; 15 kW.—12 Noon, Light Music on Gramophone Records. 1.0 p.m., Le Journal Paris. 1.10, Concert by the Small Station Orchestra, conducted by P. Leemans: Overture; Sicilian Vespers (Verdi); Four Pieces for Orchestra (d'Ambrosio); (a) Andante; (b) Paysanne; (c) Ronde des Lutins; (d) Tarantella; Selection from Le Jongleur de Notre Dame (Massenet); Improvimpromptu for Piano forte (Brenta); Casades No. 5 (Michiels). 5.0, Opera Music on Gramophone Records: Selection from (a) Manon (Massenet); (b) The Fair Maid of Perth, (c) Lakmé (Delibes); (d) Carmen (Bizet). 5.45, Programme for Children. 6.30, Light Music on Gramophone Records. 7.15, Talk. 7.30, Tourist Talk. 8.0, Concert of Gramophone Music, with Joanne Weyer (Songs) and Lion Contran (Piano forte). 9.0, Talk: The Flemish Question and Socialism. 9.15, Concert by the Symphony Orchestra; Soloists: Mme. Weyer-Verhoeven (Songs) and Lion Contran (Piano forte); Schiller March (Meyerbeer); Songs (Grieg); (a) Vom Monte Pincio; (b) Solvejg's Song; (c) Im Kalmu; Spanish Dance (Lacôme); Piano forte Solos: (a) Le Pas des Fleurs (Delibes-Dolmányi); (b) Paraphrase on Rigoletto (Verdi-Liszt); March (Berlioz). 10.0, Le Journal Paris. 10.10, Light Music on Gramophone Records.

JULY 18th

TUESDAY

continued

Song: Nirvana (Adams); A Little Bit of Chinese Music; Pianoforte Solo, He wanted Adventure, Part 2 (Waller and Tunbridge). 12.5 a.m. (Wednesday), I.B.C. News Bulletin in English. 12.10 (approx.). Instrumental Music: Let us Waltz through the Night (Miller); Mandoline Solo: Czardas (Monti); Accordion Nights; Mandoline (Thomé); My South Sea Home (Camillo). 12.30, Dance Music by Jack Payne and his Band; Belles of Normandy (Evans); When the Band goes marching by; Oh! that kiss; To-day's the Day; Masquerade; Underneath the Arches; Lullaby of the Leaves; The Clouds will soon roll by; Paradise; Belles of Normandy. 12.57, I.B.C. Goodnight Melody. 1.0 (approx.). Close Down.

FLENSBURG.—See Hamburg. FLORENCE.—See Turin.

FRANKFURT

1,157 kc/s, 259.3 metres; 17 kW. Relayed by Cassel, 1,220 kc/s, 245.9 metres; and Trier, 1,157 kc/s, 259.3 metres.—4.30 p.m., See Munich. 5.45, Exchange. 6.0, Clearing the Book Case—Family Discussion. 6.25, Talk: Problems of Education in the Country. 6.45, Review of the Day's Events. 6.50, Time and News. 7.0, Transmission for all German Stations. Jugend auf Fahrt—a Sequence of Radio Pictures and Songs of German Youth. 8.0, Concert by the Station Orchestra, conducted by Reinhold Mertens: Two Marches from Die Landstreicher (Zielner); Polka-Mazurka, Frohsinn (Keller-Bohm); Die Das Modell (Suppé); March from The Bird Fancier (Zeller); Waltz, Mädchenherzen (Lanner); Polka, Zuckerhut (Bayer); Waltz, Lese muntere Lieder (Lincke); Kinderliebe der-Marsch (Zielner); Three Pieces (Holmesberger); (a) Spanish Waltz, (b) Heine's Ballade, (c) Die Traumtänzerin; Heinzelmännchen, (a) Die Traumtänzerin, (b) Gallop, Reise (Joh. Strauss, Sen.), 9.0, Programme to be announced. 9.15, Poems in Dialect. 9.30, Organ Recital: Prelude and Fugue on an original Theme; Introduction and Passacaglia on a given Theme; Fugue on a given Theme; Fantasia on a Choral. 10.15, Time and News. 10.50, See Stuttgart. 12 Midnight, Close Down.

FREDRIKSSTAD.—See Oslo. FREIBURG.—See Stuttgart. GENEVA.—See Radio-Suisse Romande. GENOA.—See Turin. GLEIWITZ.—See Breslau. GÖTEBORG.—See Stockholm. GRAZ.—See Vienna. HAMAR.—See Oslo.

HAMBURG

Call ha (in Morse), 803 kc/s, 372 metres; 1.5 kW. Relayed by Bremen, 1,112 kc/s, 269.8 metres; Flensburg, 1,319 kc/s, 227.4 metres; Hanover, 530 kc/s, 566 metres; and Kiel, 1,292 kc/s, 232.2 metres.—6.0 p.m., Recital of German Folk Songs of the past Five Centuries. 6.45, Exchange and Weather. 7.0, Transmission for all German Stations, relayed from Frankfurt. 8.0, Talk: The National Socialist Movement. 8.10, Concert by the Station Orchestra, conducted by Adolf Secker. Soloists: Erna Kröll-Lange (Songs); Overture, Il Seraglio (Mozart); Aria from the Second Act of Don Giovanni (Mozart); Waltz, Hofballtänze (Lanner); Selection from Der Waffen-Schmidt (Lortzing); Aria from Der Wildschütz (Lortzing); Die Mär von tapferen Schneiderlein (Zimmer); Overture, Light Cavalry (Suppé); Selection from The Bird Fancier (Zeller); Waltz, Donausagen (Fueki). 9.30, Ernst J. Brenner, Pianoforte Recital for four hands: Hanna Fiedler (The Blind Pianist) and the Composer; Suite in D Minor; Dance Suite. 10.0, Time and News. 10.20, Concert by the Station Orchestra, conducted by Adolf Secker: Overture, The Italian Girl in Algiers (Rossini); Polonaise in E (Liszt); Peer Gynt Suite No. 2 (Grieg); Humoresque (Humperdinck); Musik am Abend (Graener); Prelude to the Fourth Act of Maritahoff (Scheffler); Selection from Madame Butterfly (Puccini); Overture, The Merry Wives of Windsor (Nicolaï).

HANOVER.—See Hamburg.

HEILSBURG

1,085 kc/s, 276.5 metres; 60 kW. Relayed by Danzig, 662 kc/s, 453.2 metres.—1.5 p.m., Gramophone Concert. In the intervals at 1.20 and 2.0, News. 2.30, Programme arranged by the Post Office, with Gramophone Records. 3.0, Market Report. 3.30, Programme for Children. 4.0, Concert by the Königsberg Opera House Orchestra, conducted by Karl Hrubetz: Overture, Die schöne Galathée (Suppé); Marien-Walzer (Bayer); Suite (Bullerian); Overture to a Revue (Lincke); Waltz, Die Rosen von Shiras (Sieber); Selection from Der lustige Krieg (Joh. Strauss); The Tea-House with a Hundred Steps (Yoshitomo); Fächer-Polonaise (Zielner); Gavotte, Die Lautenschlägerin (Kozak); March, Heil Deutschland, Heil (Wehrman). In the interval, Book Review: The Men Around Hitler. 5.45, Programme for Young Hitlerites. 6.15, Agricultural Report. 6.25, Talk: The Königsberg-Pillau Pilot Service. 6.50,

Weather. 7.0, Transmission for all German Stations, relayed from Frankfurt. 8.0, Political Talk and Weather. 8.5, See Berlin (Deutschlandsender). 9.35, Concert of Handel Chamber Music: Chamber Trio No. 1; Arias for Contralto; Chamber Trio No. 3. 10.10, News.

HILVERSUM

Announced HUIZEN, 1,013 kc/s, 296.1 metres; 20 kW. (7 kW. up to 4.40 p.m.).—11.55 a.m. to 3.40 p.m., Programme by the Catholic Radio Society (K.R.O.). 11.55 a.m., Concert by the K.R.O. Sextet; Tempo, tempo (Schindlauer); Gavotte (Gossec); Waltz, Tout Paris (Waldteufel); Wiegenlied (Schumann); Suite, Ein Sommerabendfest (Sieber); Murmurande (Racho); Gramophone Records; Quand Madelon (Bousquet-Hale) ; Melody (Maldoren); Potpourri (Urbach); Mystery Waltz (Baynes); Salem Al-bakum (Haber). 1.25 to 1.40 p.m., Interval. 1.40, Programme for Women. 2.40, Gramophone Music. 3.40, H.I.R.O. Programme. 4.50, Concert by the K.R.O. Boys, conducted by P. Lustenhöwer. 5.40, Talk. 6.0, Concert by the K.R.O. Orchestra, conducted by J. Gerritsen: Onze jonkzens (van Leeuwen); Waltz, Manöverklänge (Fétis); Selection from The Dram Major's Daughter (Offenbach); Selection from The Daughter of the Regiment (Donizetti). 6.40, Police Messages. 6.55, Tourist Talk. 7.15, Concert (cont'd): Zivill und Militär (Schrammel); Selection from The Love Parade (Scherzinger); Military March (Schubert). 7.25, Talk. 7.40, Concert (cont'd): Rakoczy Overture (Köler Bela); Parade of the Tin Soldiers (Jessel); Potpourri, Bei Lied und Wein (Armaudola). 8.10, News. 8.15, Recitations and Songs by M. Koevoets. 8.25, Concert (cont'd): Overture, Light Cavalry (Suppé); Schweitzer Schützengilde (Zimmer); Concert by the Sambre et Meuse. 9.10, Concert by the K.R.O. Boys, conducted by P. Lustenhöwer. 9.50, Gramophone Music. 10.10, News. 10.15, Cabaret Programme for the Seven Hundredth Anniversary of the Town of Arnhem. 11.40 (approx.), Close Down.

HOBBY.—See Stockholm.

HUIZEN

Announced HILVERSUM, 160 kc/s, 1,875 metres; 8.5 kW. Programme of the Allgemeine Vereinigung Radio Omroep (A.V.R.O.).—12.10 p.m., Concert by the Station Orchestra, conducted by Nico Treep, with Interludes by the Hollandia Three; Overture, Light Cavalry (Suppé); Waltz, Tänzchen m'cht' ich (Kretler); Selection from Les Dragons de Villars (Maillart); Indian Suite (Löhling); Un soir de fête à la Havane (Filipucci); Sérénade florentine (Godard); Lagunenwäizer (Joh. Strauss); By the Swanee River (Myddleton); March (Schrammel). 1.55 to 2.10, Interval. 2.10, Song Recital. 2.40, Gramophone Music. 3.40, Pianoforte Recital by J. Rodrigues Lopes; Sonata in D (Haydn); Scherzo in E Minor, Op. 16, No. 2 (Mendelssohn); Polonaise No. 1 in C Minor (Liszt). 4.10, Songs by a Children's Choir. 4.40, Programme for Children. 5.10, Organ, Violin and Song Recital. 6.40, Talk. 7.10, Gramophone Music. 7.40, Time, Weather and News. 7.45, Concert by the Station Orchestra, conducted by Nico Treep. Soloists: Helen van Vliet (Soprano), Bert van Bloem (Tenor). Overture, A Night in Venice (Joh. Strauss); Tenor Aria from A Night in Venice (Joh. Strauss); Tenor Aria from Liliæ Time (Schubert-Berté); Soprano Solo; Romance and Waltz from Das Lied der Liebe (Joh. Strauss-Korngold); Overture, Rind und die Liebe (O. Strauss); Tenor Aria from Fräusquita (Lehár); Tenor Song from Schön ist die Welt (Lehár); Duet from Boergerie (Suppé); Soprano Song from Eva (Lehár); Duet from The Gipsy Princess (Kálmán). 8.55, A Play. 9.25, Popular Music by Kovacs Lajos and his Dance Band. 10.40, Weather and News. 10.50, Gramophone Music. 11.40 (approx.), Close Down.

INNSBRUCK.—See Vienna.

KALUNDBORG.—See Copenhagen.

KATOWICE

734 kc/s, 408 metres; 16 kW.—7.20 p.m., Announcements and Gramophone Music. 7.35, Sports Notes. 7.40 till Close Down, See Warsaw.

KIEL.—See Hamburg.

KLAGENFURT.—See Vienna.

KOSICE.—See Prague.

LANGENBERG

635 kc/s, 473 metres; 60 kW.—12 Noon, Concert by the Fröhliche Fünf. 12.50 p.m., Weather and News. 1.0, Orchestral Concert, conducted by Wolf; Soloist: Gerd Nielsen (Violin); Overture, Preciosa (Weber); Violin Solos: (a) Legend, Op. 17 (Wieniawsky), (b) Czardas (Monti); Entr'acte Music from Rosamunde (Schubert); Selection from Die toten Augen

(d'Albert); Elegy (Suk); Spanish Rhapsody, España (Chabrier); Selection from Die Fledermaus (J. Strauss); Der lustige Zweivierteltakt (Geissler). In an interval at 2.0 (approx.), News. 3.0, Programme for Children. 3.30, Exchange and Time. 3.50, Talk: Life-Saving as a part of Swimming Instruction. 4.10, Talk on Rural Education, by Dr. Johann Dietz. 4.30, Talk: Liberalism or Nationalism in Economics? 6.10, The Miracle of Hiltens, a Saga of the Lower Rhine. 6.30, Song Recital by Heinrich Selbmann on Gramophone Records. 6.45, Weather and News. 7.0, Transmission for all German Stations, relayed from Frankfurt. 8.0, News. 8.5, Concert of Viennese Music by the Station Orchestra, conducted by Kühn: Dance Suite (Schubert); The Clock Symphony (Haydn); Tänze aus Oesterreich (Bittner); Waltz, Alt-Wien (Kremsner). In the interval, Political Talk. 9.40, Weekly Programme Review. 10.10, News.

LAUSANNE.—See Radio-Suisse Romande.

LEIPZIG

769.9 kc/s, 369.6 metres; 120 kW. Relayed by Dresden, 941 kc/s, 319 metres. 1.15 p.m., Soloist Concert. Käte Grundmann (Soprano), Toni Scholtz (Contralto), and Friedbert Sommer (Pianoforte); Pianoforte Solos from Wanderbilder, Op. 17 (Adolf Jensen); Four Folk Duets (Paul Geisdorf) (a) Wach auf, (b) Es taget vor dem Walde, (c) Es ist der Morgen (d) Es liel ein Sterne; Pianoforte Solos from Wanderbilder, Op. 17 (Adolf Jensen); Four Duets (Brahms); (a) Am Strand, (b) Jägerlied, (c) Klänge, (d) Hüt Du Dich. 2.10, News. 3.0, Concert: Song, Gebet (Hugo Wolf); Andante cantabile from the String Quartet, Op. 3, No. 5 (Haydn); Larghetto from the Clarinet Quintet in A (Mozart); Allegretto scherzando from the Eighth Symphony (Beethoven). Reading in the interval. 3.35, Exchange Quotations. 4.0, Orchestral Concert, conducted by Friedrich Brunn: Selection from L'Amico Fritz (Mascagni); Waltz, Lotusblumen (Emil Ohlsen); Military March (Schubert); Selection from Der Tenor der Herzogin (Künneke); Hungarian Rhapsody (Alfred Brendel); Schmetterling (Karl Schölk); March, Mutig voran! (Laurenz Korb). 5.50, Exchange, Weather, and Time. 6.0, Talk on the Bayreuth Festival. 6.20, Talk on Agricultural Policy. 6.40, Talk on Queen Louise of Prussia. 6.50, Review of the Day's Events. 7.0, Transmission for all German Stations, relayed from Frankfurt. 8.0, Government Announcements. 8.5, Sound Film Music on Gramophone Records. 9.5, Economic Questions of the Day. 9.15, Programme for Young People. 10.5, News. 10.15 (approx.), Concert by the Dresden Soloist Ensemble: Overture, Hungaria (Bela Nagy); Two Pieces (Leopold Wenzinger); (a) Winter, (b) Abendlied; An Evening in St. Petersburg (Meyer-Helmund); Galop chromatique (Liszt); Selection from Maskerade (Carl Nielsen); Meditation (Blon); Romance, Liebesgespräch (Selma Stein); Spanish Rhapsody (Emil Kronke); Selection from Eva (Lehár); Lieschenpolka (Lincke); Selection from Die Tante aus Wien (Ernst Steffan); Selection from Gasparone (Millocker); March Potpourri, Alle mit uns (Robrecht); Waltz, Amorettenränze (Gungl). 12 Midnight, Close Down.

LINZ.—See Vienna.

LUXEMBOURG

252 kc/s, 1,911 metres; 200 kW. Belgian Programme. 7.0 p.m., Concert of Variety Music by the Station Orchestra. 7.40, Weather Report. 7.45, Concert of Belgian Music by the Station Orchestra. 8.50, News in French. 9.15, Symphony No. 1 (Brahms) on Gramophone Records. 9.45, News in German. 9.55, Concert by the Station Orchestra. 10.25, Dance Music on Gramophone Records. Exchange and News in the intervals.

LYONS

LA DOUA, 644 kc/s, 465.8 metres; 1.5 kW.—6.30 p.m., See Strasbourg. 7.30, Radio Gazette for Lyons and the South-East. 7.40, News. 7.45, Report of the Cycle Tour of France. 8.10, Medical Talk. 8.20, Humorous Review. 8.30, Programme relayed from Paris. After the Programme, News.

MADRID

EADJ, 707 kc/s, 424.3 metres; 2 kW.—8.0 p.m., Chimes, Exchange, Radio Journal and Request Gramophone Records. In the interval at 8.30, Talk by Joaquin España Cantos. 9.15, News and Political Review. 9.30 to 11.0, Interval. 11.0, Chimes, Time and Political Review. 11.15 (approx.), Lucia di Lammermoor—Opera (Donizetti) on Gramophone Records. 1.15 a.m. (Wednesday), News. 1.30, Chimes and Close Down.

MALMO.—See Stockholm.

MILAN.—See Turin.

MORAVSKA-OSTRAVA

1,137 kc/s, 263.8 metres; 11 kW.—5.0 p.m., Concert by the Municipal Orchestra, relayed from Radhost. 6.5, See Prague. 6.25, See

Brno. 7.0, See Prague. 7.10, Song Recital relayed from the National Theatre, Moravsko-Ostrava. 7.35, See Prague. 7.50, See Brno. 8.15, See Prague. 9.0, See Brno. 10.0, See Prague. 11.0 (approx.), Close Down.

MOSCOW

TRADES UNION, 230 kc/s, 1,304 metres; 160 kW.—2.45 p.m., Weather. 3.0, Popular Concert. 4.0, Radio Report. 4.50, Reading. 5.30, Dramatic Programme for Young People. 6.30, Lecceq, Joh. Strauss, and Saint-Saëns—Concert by Alexandrijskaya (Mezzo-Soprano), M. Sledkopectzern (Tenor), and Mlle. Turzajewa (Soprano). 9.0, News. 9.30, Programme Announcements. 9.55, Chimes from the Red Square. 10.5, Press Review.

MOTALA.—See Stockholm.

MUHLACKER.—See Stuttgart.

MUNICH

563 kc/s, 533 metres; 60 kW. Relayed by Augsburg and Kaiserslautern, 536 kc/s, 239 metres, and Nürnberg, 1,256 kc/s, 239 metres.—4.20 p.m., Concert, conducted by Erich Kloss. Prelude and Liebestod from Tristan und Isolde (Wagner); Sérénade, Op. 25 (Beethoven); Selection from Königskünder (Humperdinck); Florentine Intermezzo (Godard); Old Russian Melodies (Lenseher); Waltz, Quand l'Amour meurt (Cremieux); Valse bleu (Marsiz); The Flight of the Bumble-Bee (Rimsky-Korsakov); Stahelhelm March (Fawertowski). 5.45, Palatinat Programme Talk: Die Kaiserstrasse. 6.5, Talk. 6.25, Toccata for Two Pianofortes (Höller). 6.45, Time and News. 7.0, Transmission for all German Stations, relayed from Frankfurt. 8.0, White Coal in Bavaria—Radio Sequence about Water-Power (Gail-Kühne-Helwensen). 9.0, Concert by the Josef Schwarz Orchestra. Soloist: Karl Kröll (Tenor). Overture, Peter Schmitt (Weber); Waltz, Wiener Bonbons (Strauss); Goldkäferschens Brautwerbung (Lautenschläger); Two Songs: (a) Dass nur kein Blatt herunterfällt (Leonard), (b) Song from The Bird-fancier (Zeller); An Evening in Toledo (Hellmuth); Waltz, Weiner Praterleben (Trautlatour); The Coekelafers' Tea Party (Noack); Two Songs: March (Seyfried). In the interval, Humorous Interludes. 10.20, Time and News.

NAPLES.—See Rome.

NOTODDEN.—See Oslo.

OSLO

277 kc/s, 1,083 metres; 60 kW. Relayed by Fredrikstad, 815 kc/s, 368.1 metres; Hamar, 522 kc/s, 574.7 metres; Notodden, 671 kc/s, 447.1 metres; Porsgrund, 662 kc/s, 453.2 metres; and Rjukan, 671 kc/s, 447.1 metres.—5.0 p.m., Popular Concert, relayed from the Theatre Restaurant. 6.0, Programme for Women. 6.45, Hawaiian Music. 7.0, Advertising Notes. 7.15, Weather and News. 7.30, Recitations. 8.0, Time. 8.1, Orchestral Concert, conducted by Olvin Fieldstad. Overture, Prinz Methusalem (Joh. Strauss); Waltz from The Desert Song (Romberg); Tango from A Kiss in Spring (Kálmán); Melody (Schrüder); Selection from The Lull of Sniles (Lehár); Two Arias from Turandot (Puccini); Humorous Variations (Suppé); Melody (Klin); Pieces (Backer-Grøndahl); March (Andersen-Wingar). 9.10, Talk. 9.40, Weather and News. 10.0, Topical Talk. 10.15, Concert by the Espana Mandoline Quartet.

OSTERSUND.—See Stockholm.

PALERMO

558 kc/s, 537.6 metres; 3 kW.—8.0 p.m. Dopplavoro Announcements, Tourist Report, Agricultural Notes and Giornale Radio. 8.20, Gramophone Music. In the interval a 8.30, Time and News. 8.45, Sly—Opera in Three Acts (Wolf-Ferrari). In the intervals, Talk and Announcements. After the Opera, News.

PARIS

EIFFEL TOWER, Call FLE, 207.5 kc/s, 1,445.7 metres; 13 kW. Time Signals (6 2,650 metres) at 10.26 a.m. and 11.26 p.m. (Preliminary and 6-dot Signals).—6.45 p.m. Le Journal Paris. In the interval at 7.41, Report of the Cycle Tour of France. 8.30, Concert by the Symphony Orchestra, conducted by Eclair Flament: Part I—Hall Programme; March, Les jeunes Lauriers Selection from Chouquette; Songs, Part II—Messenger Programme; Suite fuamblesque Selection from L'amour masqué; Balka Music from Isolde; Ballet Music from La deux pigeons. 10.0 (approx.), Close Down.

PARIS

POSTE PARISIEN, 914 kc/s, 328.2 metre; 60 kW.—7.0 p.m., Gramophone Music. 7.1 Le Journal Paris. 7.30, Report of the Cycle Tour of France. 7.45, Gramophone Music 8.15, Interval. 8.35, Orchestral Concert soloist: André Gaudin (Songs); Prelude, chants d'Espagne (Albeniz); Valse viennoise (Delmas); Gaby (Coolis); Three Sou Esquisses (Gaubert); Selection fro François les Bas Bleus (Messager); Scher (Brun); Suite albanaise (Pouget); Airs fro

JULY 18th

TUESDAY

continued

VATICAN CITY

15,120 kc/s., 19.84 metres (Morning) and 5,969 kc/s., 50.26 metres (Evening); 10 kW. 11.0-11.15 a.m., Religious Information in English. 8.0-8.15 p.m., Religious Information in Italian.

VIENNA

591 kc/s., 517 metres; 100 kW. Relayed by Graz, 852 kc/s., 352.1 metres; Innsbruck, 1,058 kc/s., 283 metres; Klagenfurt, 662 kc/s., 453.2 metres; Linz, 1,220 kc/s., 245.9 metres; and Salzburg, 1,373 kc/s., 218.5 metres.—12 Noon, Orchestral Concert, conducted by Josef Holzer: Overture, Edelweiss (Komzak); Selection from Tiedland (d'Albert); Waltz, Accelerationen (Joh. Strauss); Two Songs (Eysler); (a) Song from Schützenlied, (b) Kommt's wir fuhr'n nach Neuwaldegg; Die kleine Kompagnie (Ganglbauer); Violin Solos: (a) Liebeslied, (b) Liebesfreud (Kreisler); Intermezzo, Appalachian (Max Wichtl); Egeländer Marsch (Kopetzky); Potpourri of Lohr Music; The Old Musical Clock (Hampfers); Romance from Don Sebastian (Duničetti); Waltz from The Arabian Nights (Joh. Strauss); Intermezzo, Die Lotobohne (Lincke); Song and Tango (Flemming); Song, Die Stadt der Lieder (Hoffmann); Overture, Orpheus in the Underworld (Offenbach). In the interval at 1.0 p.m., Time and News. 3.0, Time and News. 3.20, Talk on Poultry Keeping. 3.30, Gramophone Records of Operatic Music. 4.36, Talk for Women. 4.55, Talk: Simple Means of Preserving Vegetables. 5.10, Talk. 5.25 Song and Pianoforte Recital by Arthur Preuss (Tenor) and Frederic Ogonse: Song from Louise (Charpentier); Song from Diamleth (Bizet); Aria from Figaro (Mozart); Song from The Mastersingers (Wagner); Sonata in F Sharp, Op. 30 (Schubert); Three Preludes (Rachmaninov); Third Sonata in A Minor (Prokofiev). 6.5, Talk. 6.35, Talk. 7.0, Concert of Light Orchestral Music: Wiener Marsch (Fitzmaurer); Overture, Carneval in Rom (Joh. Strauss); Dance Humoresque from Baby (Heuberger); Harfers Abendgongang (Kienzl); Selection from The Merry Peasant (Fall); Waltz, Auf den Bergen wohnt die Freiheit (Komzak); Flute Solo: Idyll, Il primo Amore (Suppe); Studenten aus Alt-Heidelberg (Klimsch); Alt-Wien (O. Strauss); Czardas (Miska); Menschen, Menschen (Lorenz); Overture, Der Bettelstudent (Milköcker). In the interval at 7.35, Time and News. 8.30, Concert by the Vienna Chamber Orchestra, conducted by Karl Auerlieth: Symphony in D (Haydn); Serenade in D, Op. 9 (Robert Fuchs); Scandinavian Melodies (Grieg); Slovak Suite (Vitězslav Novak); Comedy Overture (Marco Fratti). 9.45, News. 10.0, Gramophone Concert of Light Music.

WARSAW

212.5 kc/s., 1,411 metres; 120 kW.—11.57 a.m., Time Signal and Fanfare from the Tower of St. Mary's Church, Cracow. 12.5 p.m., Gramophone Music. 12.25, Polish Press Review. 12.35, Weather. 12.35, Gramophone Music. 12.55, Radio Journal. 1.0 to 2.55 Interval. 2.55, Gramophone Music. 3.5, News. 3.10, Announcements. 3.15, Gramophone Music. 3.25, Economic Notes. 3.35, Gramophone Music. 3.45, Aviation Report and Anti-Gas Drill. 4.0, Popular Concert by the Poznan Opera House Orchestra, relayed from Cichocinek. 5.0, Geographical Talk, relayed from Lwow, 788 kc/s., 381 metres. 5.15, Concert by a Mandoline orchestra, conducted by Szezoglow: Overture (Wiche); Blumenfächer (Blon); Waltz, Snowdrop (Fucky); Intermezzo, Frühlingserwachen (Bach); Owerk (Wiche); Waltz (Bakalajczyk); Intermezzo (Stiede); Russian Potpourri, March, Fraternity (Wiche). 6.15, Talk: Modern Poland. 6.35, 'Cello Recital by Albert Katz, relayed from Wilno, 533 kc/s., 563 metres.—Sonata (Brevat); Après un rêve (Fauré); Malagena (Albeniz); Adagio con variazioni (Respighi); Hungarian Rhapsody (Popper). 7.20, Miscellaneous Items. 7.35, Programme Announcements. 7.40, Topical Talk. 8.0, Concert by the Station Orchestra, conducted by Nawrot, Soloists: Ignace Dygas (Tenor). Overture, A Midsummer Night's Dream (Mendelssohn); Mountaineers' Dances from Mann (Paderewski); Songs, Carnival Suite (Gabriel-Marie). 8.50, Radio Journal. 9.0, Agricultural Notes. 9.10, Concert (cont.): Rhapsody (Sokolowski); Songs, Spanish Dance from Monte Cristo (Moniusko); Minuet (Bolton); Waltz-Fantasia (Glinka); Berensene die Jeselyn (Godard); Mazurka (Namisowski). 10.0, Dance Music. 10.25, Sports Notes. 10.35, Aviation, Weather Report and Police Notes. 10.40, Dance Music.

WILNO

533 kc/s., 563 metres; 16 kW.—6.35 p.m., 'Cello Recital: Sonata (Brevat); Après un rêve (Fauré); Malagena (Albeniz); Adagio with Variations (Respighi); Rhapsody (Popper). 7.20, Talk in Lithuanian. 7.35, Programme Announcements. 8.0, Request Gramophone Music. 8.50 to 11.0, See Warsaw. 11.0 (approx.), Close Down.

ZURICH.—See Schweizerischer Landessender.

White Horse Inn (Stolz-Benatzky); Selection from Callirhoe (Chaminade); Pastorale for Clarinet and Strings (Piercé); Melody (Turina); Promenade militaire (Gillet). 10.30, News.

PARIS

RADIO PARIS, Call CFR, 174 kc/s., 1,725 metres; 75 kW.—7.30 a.m., Weather and Physical Culture. 7.45, Gramophone Concert: Demande et Réponse (Cofelidge-Taylor); Zephyr (Habay); Song (Friml); Waltz, Inspiration (Hazlett). 8.0, Weather and Press Review. 12 Noon, Concert of Light Music on Gramophone Records Tesoro mio (Berger); Spanish Serenade (Chaminade-Kreisler); Waltz Suite from Die geschiedene Frau (Fall); Mi madre (Cazes); Selection from Le petit duc (Leocq); La complainte du fromage (Billand); Souvenir des bois d'Avron Mon ami Pierrot (Zimmermann); Les plaisirs champêtres (Montclair); Mon cœur est à vous (Valère); Moorish Serenade (Chapi); Enchantment (Massenet); Blonde amie (Carcel); Recitation; The Wedding of the Rose (Dessle); Vers toi (Chapon-Rodot); Douce tendresse (Paradis); L'Amore a la campagne; Le retour du marin (Tiersot); Selection from The Geisha (Jones); Dinah (Lewis and Young); Caucasian Sketches (Ippolitov-Ivanov); The Donkeys of Cairo (Nerini); Bells across the Meadow (Ketelbey); Waltz, Estudiantina (Waldteufel); Ballet Music from Faust (Gounod). In the intervals at 1.0 p.m. and 1.30, Exchange, News, and Weather. 2.0, Exchange. 3.45, Exchange. 7.0, Market Prices and Raring Results. 7.10, Gramophone Concert: Selection from Garde-moi (Cyvain); La croix du chemin (Goulbier); Etincelles (Waldteufel); Waltz from The Desert Song (Romberg); Liebesfreud (Kreisler); Melody (Spencer); Etude in G flat (Zoubalov); Cheri (Monteux Wilwite); Pierre (Kongnell). 7.50, Commercial Prices and News. 8.0, Gramophone Concert: Overture, Masaniello (Auber); Le jardin des amours Moutret-Casadesus); Navarra (Albéniz); Innamorata (Albéniz); Rhapsody in Blue (Gershwin). 8.30, Concert by the Radio Paris Orchestra, conducted by Raoul Labis: Selection from The Barber of Seville (Rossini); Au bois d'amour (Labis); La légende dujoint d'Argentan (Fourdrain-Delsaux); Waltzes Nos. 1 and 4 (Dvorak). 9.30, Les Voies de Jeannette—Opéra-Comique (Masse).

PITTSBURGH

KDKA, 980 kc/s., 306 metres; 50 kW. Relayed by W8XK on 48.86 metres and 25.27 metres.—7.30 p.m., KDKA Home Forum. .0, Betty and Bob, from New York. 8.15, News and Music, from New York. 8.45, Congress of Clubs Period. 8.58, Baseball scores. 9.0, Meredith Wilson's Orchestra, from New York. 9.30, Business News and Market Reports. 9.45, Sketch, from New York. 9.58, Baseball Scores. 10.0, Rhythm Kings. 10.15, Tarzan of the Apes. 10.30, The Singing Lady, from New York. 10.45, Little Orphan Annie. 11.0, Time Signal and Press News-Reeler. 11.5, Hotel McAlpin Orchestra. 11.15, Weather Report. 11.16, port Review. 11.23, I Bring a Song. 11.28, announcement. 11.29, Temperature Report. 1.30, Pittsburgh Spotlights. 12 Midnight to 4.5 a.m. (Wednesday), New York Relay. 12 Midnight, Amos 'n' Andy. 12.15, National Advisory Council on Radio in Education: r. Taxpayer versus Mr. Taxpayer, byaniel W. Hoan, Mayor of Milwaukee, andouis Brownlow, Director of Public Administration, Clearing House. 12.45, Baritone Solos by Ray Heatherstone. 1.0, rime Chases. 1.30, Adventures in Health. 4.5, Floyd Gibbons, World's Fair Reporter. 0, Concert by Philharmonic Symphonychestra. 2.59, Time Signal. 3.0, Household Musical Memories, from New York.

DRSGRUND.—See Oslo.

POZNAN

6 kc/s., 335 metres; 1.9 kW.—6.0 p.m., Talk. 15 to 7.20, See Warsaw. 7.20, Miscellaneous Announcements. 7.35, Theatre Notes and Gramophone Announcements. 7.40, See Warsaw. 7.58, Time Signal. 8.0, Orchestral Concert, conducted by Steralski: Polonaise in (Steralski); Waltz from Casanova (Zyckey); Nibelungenmarsch (Wagner); sssini and Kosecki Music. 8.40, Recital of ars by Z. Wisniewski (Soprano). 8.50, See arshaw. 9.0, Recital by Mme. Janowska-apezynska (Soprano) and Mme. Nadjicjadowska (Pianoforte); Pianoforte Solos:) Prelude in E flat (Mendelner), (b) Cradle ng (Bakalajew), (c) Prelude in C Minor achmaninov), (d) Variations in F Sharp ur, Op. 72 (Glazunov); Songs. 10.0, Time, orts, and Police Notes. 10.15, Dance Music on the Café Esplanade. 11.50 (approx.), se Down.

PRAGUE

kc/s., 488.6 metres; 120 kW.—2.50 p.m., ncert of Light Music. 3.55 to 4.0, Exange. 5.45, Gramophone Music. 5.55, lk: A Tour through Italy and France. , Market Prices. 6.15, Talk for Workers. 5, News in German. 6.30, German Transmision: Love Songs—Recital by Prof. ebat: Liebesbotschaft (Schubert); Song endelssolm); Mit Myrthen und Rosen umann); Wiegenlied (Brahms); Ewige

Liebe (Brahms); Maimacht (Brahms). 7.0, Chimes and News. 7.10, Song Recital by Jarmila Winklerova. 7.35, Talk: Unfamiliar Parts of Bohemia. 7.50, See Brno. 8.15, The Poet in the Train—Radio Sketch (Vrchelica). 9.0, See Brno. 10.0, Time and News. 10.15, Gramophone Music. 11.0 (approx.), Close Down.

RADIO-SUISSE ROMANDE

SOTTENS, 743 kc/s., 403 metres; 25 kW. and Geneva, 395 kc/s., 760 metres.—12.28 a.m., Time Signal from Neuchâtel Observatory. 12.30, News. 12.40, Gramophone Concert. In the interval at 1.0, Financial Report. 2.0, Interval. 3.28, Time Signal from Neuchâtel Observatory. 3.30, Reading. 4.0, Dance Music by the Broadcasting Serenaders. 5.30, Interval. 7.0, Newly-released Gramophone Records. 7.55, Results of the Cycle Tour of France. 8.0, Talk: Love Letters and Business Letters of Negroes. 8.20, Pianoforte Recital by Jeanne Jaspas. Pastoral and capriccio (Searlatti); Mouvemnts perpétuels (Poulenc); Prelude in D (Chopin); Mazurka (Chopin); Tarantella (Hilfer). 8.45, Concert by the Radio-Suisse Romande Orchestra, conducted by Robert Echenard. 9.50, News. 10.0, Concert (cont.). 10.30 (approx.), Close Down.

REYKJAVIK

250 kc/s., 1,200 metres; 21 kW.—9.5 p.m., Musical Programme. 9.30, Weather Report. 9.40, Musical Programme and Announcements. 10.0, Chimes and News. 10.30, Reading. 11.0, Pianoforte Recital by Emil Thoroddson, followed by Arias and Il Trillo del Diavolo (Tartini), on Gramophone Records.

RIGA

572 kc/s., 525 metres; 15 kW.—6.30 p.m., Talk. 7.0, Weather Report. 7.3, Concert of Waltzes and Operetta Music. 9.0, Weather and News. 9.15 (approx.), Gramophone Concert of Chamber Music.

RJUKAN.—See Oslo.

ROME

Call 1R0, 650 kc/s., 441 metres; 50 kW. Relayed by Naples, 951 kc/s., 319 metres; and 2R0, 11,810 kc/s., 25.4 metres.—1.0 to 2.15 p.m., Concert from Turin. In the interval from 1.30 to 1.45, Giornale Radio and Exchange, and at 2.0, Time and Announcements. 4.45, Children's Radio Review. 5.10, Announcements. 5.15, Exchange and Giornale Radio. 5.30 to 6.15, Orchestral Concert of Light Music. 6.40 (Naples), Shipping and Sports Notes. 6.50, Agricultural and Dopulavory Announcements. 7.0, Tourist Report. 7.10, News in Foreign Languages. 7.40, Giornale Radio. 8.0, Time and Announcements. 8.15, Sponsored Gramophone Music. 8.30, Sports Notes. 8.45, Don Pasqual—Opera (Donizetti). In the intervals, Talk and News. Giornale Radio after the Opera.

SALZBURG.—See Vienna.

SCHENECTADY

WCY, 790 kc/s., 379.5 metres; 50 kW. Relayed at intervals by W2XAF on 31.48 metres and by W2XAD on 19.56 metres.—12.45 a.m. (Wednesday), Stock Reports and Police Notices. 1.0-3.30, New York Relay. 1.0, Blackstone Plantation. 1.30, Wayne King's Orchestra. 2.0, Ben Bernie's Orchestra. 2.30, Ed Wynn and the Fire Chief Orchestra. 3.0, Lives at Stake. 3.30, National Radio Forum, from New York, followed by Programme Resumé.

SCHWEIZERISCHER LANDESENDER

BEROMUNSTER, 653 kc/s., 459 metres; 60 kW. Basle, 1,229 kc/s., 244.1 metres and Berne, 1,220 kc/s., 245.9 metres.—6.15-6.35 a.m., (from Berne), Gymnastics. 11.59, Time Signal from Neuchâtel Observatory and Weather. 12 Noon (from Basle), Waltzes on Gramophone Records. 12.30 p.m., Time, Weather and News. 12.40 (from Basle), Concert and Jazz Music. 1.25 (from Basle), Time, Weather and Exchange. 1.45-5.0, Interval. 5.0 (from Basle), Concert of Modern Italian Chamber Music on Gramophone Records. 5.30 (from Basle), Variety Concert on Gramophone Records. 6.30 (from Berne), Programme to be announced. 7.0 (from Berne), Time, Weather and Notes on the Broadcasts to Schools. 7.10 (from Berne), Concert of German Symphony Music on Gramophone Records. 8.0 (from Berne), Talk on Jazz Music. 9.0, Weather and News. 9.10 (from Zürich), Organ Recital. 10.15 (approx.), Close Down.

SOTTENS.—See Radio-Suisse Romande.

STOCKHOLM

680 kc/s., 436 metres; 55 kW. Relayed by Boden, 244 kc/s., 1,229.5 metres; Göteborg, 932 kc/s., 322 metres; Hörby, 1,166 kc/s., 237 metres; Motala, 221.5 kc/s., 1,354.4 metres; Ostersed, 389 kc/s., 770 metres; and Sundsvall, 554 kc/s., 542 metres.—

5.5 p.m. (from Sundsvall), Folk Music. 5.50 (from Sundsvall), Provincial Programme. 5.45, Radio Report. 6.15, Gramophone Music. 7.15, Weather and News. 7.30 (from Sundsvall), Talk: Norway's Physicians. 8.0, (from Sundsvall), Band Concert, conducted by M. G. Leijld. 8.45 p.m., Talk: Bussener Steel. 9.15, Song Recital by Mavis Bennett: Aria from Hamlet (Thomas); A Song in the Night (Longborough); La Rondine (Dell'Acqua); Down in the Forest (Landon Ronald); Folk Song, Ack, hör du lilla flicka; Folk Song (Merikanto); Song (Faubert). 9.45, Weather and News. 10.0, Concert of Light Music. 11.0 (approx.), Close Down.

STRASBOURG

859 kc/s., 345 metres; 11.5 kW.—11.30 a.m., Gramophone Music. 12 Noon, Orchestral Concert, conducted by Maurice de Villers. 12.45 p.m., News. 1.0, Time and Exchange. 1.5, Orchestral Concert (cont.). 2.0 to 5.0, Interval. 5.0, Talk in French: The Villages of Tongking. 5.15, Dance Music. 6.0, History Talk in French. 6.15, Topical Talk in French. 6.30, Orchestral Concert, conducted by M. Roskam. 7.30, Time and News. 7.45, Report of the Cycle Tour of France. 8.5, News in French. 8.30, Concert by the Société des Amis du Pays Messin, relayed from Metz; Pianoforte, Violin, Viola, and Cello (Beethoven); Two Pieces for Violin and Pianoforte (a) Sonata (Handel), (b) Intermezzo, Goyescas (Granados-Casaldá); Two Melodies (Daniel Caillé); (a) Au crépuscule, (b) Automne sur l'Esplanade; Two Pieces for Violin and Pianoforte; (a) Molto appassionato (René Delany), (b) Fantasia Impromptu (Gabriel Pierné); Sonata for Flute and Pianoforte (Gaubert); Trio for Flute, Violin, and Cello (Haydn); Barentse (Chopin); Waltz in A (G. Pierné); Prelude (Rachmaninov); Two Melodies (D. Caillé); Two Quartets (René de Boislaiff); (a) Au bord d'un ruisseau, (b) Au bord de la Moselle. In the interval, Talk and Press Review in German. 10.30 (approx.), Close Down.

STUTTART

MUHLACKER, 332 kc/s., 360.5 metres; 60 kW.—Relayed by Freiburg, 527 kc/s., 570 metres.—1.30 p.m., Concert from Frankfurt. 2.0, Programme arranged by the Post Office, with Gramophone Records. 2.30 to 3.0, Advanced English Lesson. 3.30, Horticultural Talk. 4.0, Talk for Women: Queen Louise of Prussia. 4.30, Concert by the Station Orchestra, conducted by Hermann Eschrich, relayed from Wildbad. Overture, Leidenschaft (Otto Lehmann); Prelude and Scherzo (Bach-Abert); Waltz Fantasia, Bal paré; Two Descriptive Pieces (Edgar Hansen); Selection from Boris Godunov (Musorgsky); Suite from Carmen (Bizet). 5.45 (from Freiburg), Talk: Cheap Holidays through Heidelberg to the Black Forest. 6.10, Talk on Alfred Rethel. 6.35, Time and News. 7.0, Transmission for all German Stations, relayed from Frankfurt. 8.0, Musical Life in Old Vienna—Radio Pictures by Karl Köstlin, with Lutzer and Strauss Music by the Station Orchestra. 9.20 (from Freiburg), A Leisure Hour in a Dog-out. 9.50, Recital of Old Time Pianoforte Music by Arthur Haagen. Tocatta in D Minor (Froberger); Suite (Lully); German Aria with Variations; The Empress Eleonora Magdalena Theresia (Poglietti); Two Pieces (Comperin); (a) Les charmes, (b) Les papillons; Two pieces (Rameau); (c) La ponte, (d) Le rapelle des oiseaux; Rondo, Le concert (Daquin). 10.20, Time and News. 10.50, Serenade by the Station Orchestra, conducted by Gustav Görlich, with Songs by a Nazi Choir. 12 Midnight, Close Down.

SUNDSVALL.—See Stockholm.

TOULOUSE

779 kc/s., 385 metres; 8 kW. Transmissions irregular owing to fire.—11.30 p.m. to 12 Midnight, Programme in English by the I.B.C. 11.30, Military Band Concert. 11.57, I.B.C. Goodnight Melody. 12 Midnight, Close Down.

TRIESTE

1,211 kc/s., 247.7 metres; 10 kW.—5.0 to 8.30 p.m., See Turin. 8.45 (approx.). See Rome. 11.0, Giornale Radio.

TRONDHEIM.—See Oslo.

TURIN

1,096 kc/s., 273.7 metres; 7 kW. Relayed by Milan, 905 kc/s., 331.5 metres; Genoa, 959 kc/s., 312.8 metres; and Florence, 599 kc/s., 500.8 metres.—5.0 p.m., Dance Music from the Savoia. 6.0 to 6.5, Announcements. 6.35, News. 7.0, Time, Report of the Royal Geographical Society and Songs on Gramophone Records. 7.20, News in Foreign Languages. 7.40, Gramophone Music. 8.0, News. 8.15, Sponsored Music. 8.30, A Comedy in Three Acts, followed by Programme of Light Orchestral Music. 11.0, Giornale Radio.

SUPERHET and MOVING COIL SPEAKER

IN A PORTABLE RADIO

... by "HIS MASTER'S VOICE"



For your convenience, this new "His Master's Voice" set is a Portable. But in tone, range, reception, it has the performance of a six valve superhet receiver *with moving-coil speaker*.

"His Master's Voice" have produced the Superhet Portable Six M.C. to demonstrate conclusively that portability need imply no limitations — either in range, selectivity, or in tone! It needed "His Master's Voice" to give such a convincing demonstration—"His Master's Voice" with thirty years of experience in designing instruments acoustically; experience which enables them even in a portable instrument to see that chassis, moving coil speaker, and cabinet, are all *perfectly matched* from an acoustic standpoint.

The result is a Portable set which gives pleasure to the music lover anywhere and at any time, simple to control, commanding extensive range without overlap, *and with the famous "His Master's Voice" 'true-to-life' tone!* Hear it at your nearest dealer's.

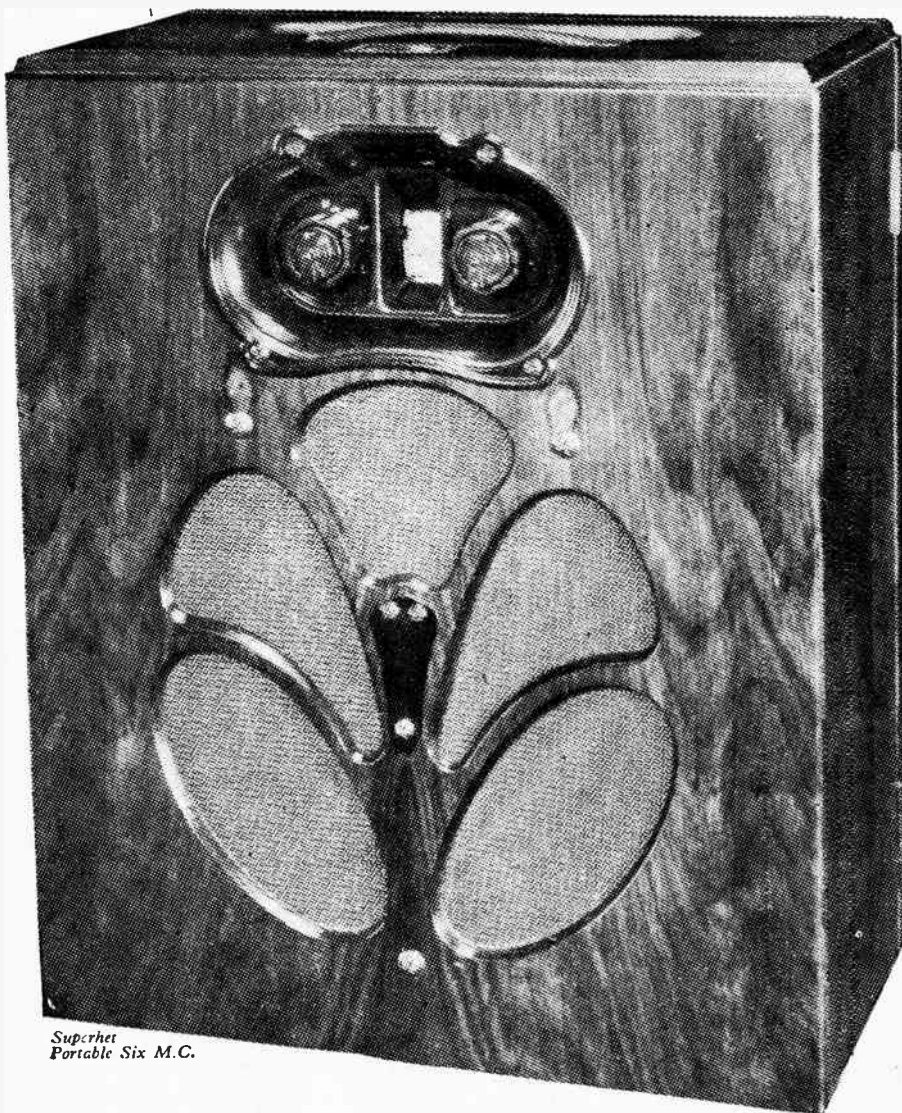

Superhet
Portable Six M.C.

OUTSTANDING FEATURES: Great range of reception. Selectivity to match. Moving coil loud-speaker. Low battery consumption. Connection for gramophone pick-up. Neatness and simplicity of controls arrangement. Figured walnut cabinet.

14 GNS.
or by hire purchase

"HIS MASTER'S VOICE"

The Gramophone Co., Ltd., 98-108 Clerkenwell Road, London, E.C.1.

(Price does not apply in I.F.S.)

Mention of "The Wireless World," when writing to advertisers, will ensure prompt attention.

The Wireless World

THE
PRACTICAL RADIO
JOURNAL
23rd Year of Publication

No. 724.

FRIDAY, JULY 14TH, 1933.

VOL. XXXIII. No. 2.

Proprietors: ILIFFE & SONS LTD.

Editor:
HUGH S. POCOCK.

Editorial,
Advertising and Publishing Offices:
DORSET HOUSE, STAMFORD STREET,
LONDON, S.E.1.

Telephone: Hop 3333 (50 lines).
Telegrams: "Ethaworld, Watloo, London."

COVENTRY: Hertford Street.
Telegrams: "Cyclist, Coventry." Telephone: 5210 Coventry.

BIRMINGHAM:
Guildhall Buildings, Navigation Street, 2.
Telegrams: "Autopress, Birmingham." Telephone: 2970 Midland (3 lines).

MANCHESTER: 260, Deansgate, 3.
Telegrams: "Hilite, Manchester." Telephone: Blackfriars 4412 (4 lines).

GLASGOW: 26B, Renfield Street, C.2.
Telegrams: "Hilite, Glasgow." Telephone: Central 4857.

PUBLISHED WEEKLY. ENTERED AS SECOND
CLASS MATTER AT NEW YORK, N.Y.

Subscription Rates:
Home, £1 1s. 8d.; Canada, £1 1s. 8d.; other
countries abroad, £1 3s. 10d. per annum.

*As many of the circuits and apparatus described in these
pages are covered by patents, readers are advised, before
making use of them, to satisfy themselves that they would
not be infringing patents.*

CONTENTS

	Page
PROGRAMMES FROM	
<i>ABROAD, pp. I--XXIV</i>	
Editorial Comment.. ..	17
Wireless Under Way	18
New Ideas for the Superheterodyne	20
Practical Hints and Tips.. ..	22
News of the Week	23
Simplified "Science Museum" Re- ceiver	24
Scott Sessions "Equator-Supcr" ..	26
Laboratory Tests	28
Unbiased Opinions.. ..	30
Broadcast Brevities.. ..	31
Readers' Problems	32

EDITORIAL COMMENT

Electricity and Wireless Need for a Better Understanding

WE learn on good authority that the electricity interests are about to embark upon a publicity campaign on a big scale to bring home the advantages of electricity for domestic purposes.

The development of the Grid Scheme has brought electricity within the reach of vast areas of the country where formerly electricity was only available if generated on the premises.

We think it is an opportune moment to draw the attention of those who will be responsible for this publicity campaign to the many irksome and unnecessary restrictions which have been placed on the use of electricity for operating wireless receivers by many distributors of electricity throughout the country.

Surely it is time that valves ceased to be confused with lamps for illumination purposes, and that insistence on the current for wireless sets being charged for on the same basis as lamps for illumination was discontinued.

We have, on several occasions in the past, drawn attention to the irritating and inexcusable attitude adopted by certain suppliers of electricity on this point, yet again and again the question crops up and leads to publicity for electricity of a kind likely to do considerable damage to the cause of extended popularity, and calculated to neutralise any collective efforts which may be made.

It has been clearly laid down that the special charge known as the "lighting rate" is to apply only where electricity is used for purposes of illumination, yet once more an electricity supply authority, this time in Surrey, is at present exasperating consumers by attempting to insist

upon current for wireless sets being taken through the lighting meter.

It is all very ridiculous, and it is high time that the Central Electricity Board recommended a uniform policy to distributors of electricity.

One of the first considerations in endeavouring to popularise the use of electricity should, in our view, be to emphasise the simplicity and convenience of this source of energy and even if we cannot, for the moment, expect uniform charges for electricity throughout the country, at least we may expect the abolition of petty restrictions to the use of wireless receivers now that they are sufficiently commonplace to be regarded as ordinary articles of domestic equipment.

The "New Monodial"

A Receiver of Outstanding Performance

IN this issue we announce the introduction of a new constructional set.

The original "Monodial Super," as our readers are well aware, has earned for itself an incomparable reputation, and has been very generally described as a set having the finest performance of any receiver which has yet appeared in this country.

We now have the opportunity of presenting to our readers, with the "New Monodial," a design which, although based upon the original receiver, surpasses it in performance in every way. Every new development in receiver technique which could be put to a useful purpose in superheterodyne design has been incorporated in this set. A list of parts employed and a preliminary reference to the set appears in this issue, whilst the full description with details of construction will be included in our issues of July 21st and 28th.



A wireless-equipped car beside Loch Chon.

Wireless Under Way

Suppressing Radiation from Car Electrical Systems

IF a wireless set is to be operated successfully in a car while the vehicle is in motion, or even while the engine is running, it is essential that the electrical equipment should be "silenced"; in other words, anti-interference devices must be fitted in much the same way as when dealing with other apparatus of similar type. It has been proved that the

***E**VEN an ordinary portable set may be operated satisfactorily in a stationary car, but the electrical equipment of the vehicle must receive special attention if signals are to be received, on any set, without serious interference while the engine is running. This article describes, in the simplest possible terms, the fitting of anti-interference devices, and the electrical system of a typical modern car is taken as an example.*

suppression of interference is seldom a particularly difficult matter, in spite of the fact that the ignition system, with its sparking plugs and high voltages, is obviously akin to a spark transmitter, which, if unchecked, will radiate strongly. The radiation is bound to affect adversely a sensitive receiver mounted only a few feet away, unless effective means are found to stop it.

Interference with reception is not confined entirely to the high-tension side of the ignition system. Heavy surges are produced by arcing at the low-tension make-and-break contacts, and the dynamo also produces interference by

sparkling at the brushes. Auxiliary apparatus, such as electrical screen-wipers and petrol gauges, all contribute their share, and finally we have to contend with the fact that almost all forms of interference are propagated along the car wiring, some of which is certain to run in close proximity to the set and aerial.

High-tension ignition interference, although it is so strong, is fortunately the easiest to prevent, and, by fitting suitable "stoppers," it is almost always possible to obtain virtually complete immunity from its effects. In practice, radiation is prevented by inserting a resistor of about 25,000 ohms in series with each sparking plug, and another of the same value in series with the common high-tension lead from the coil secondary to the distributor. The position of these various resistors is clearly shown in the accompanying circuit diagram, which relates to the ignition system of a typical modern four-cylinder car with coil ignition.

Heavy-duty Resistors

All this sounds simple enough, but the design of a resistor to stand up to the work is not entirely straightforward. It will be subjected to extremes of heat and cold, humidity and dryness, and is likely to become coated with oil. Although the steady current passing will amount only to a few milliamperes, heavy surges take place, and—perhaps most important of all—the high-frequency resistance of the suppressors, as opposed to their D.C. resistance, must be well maintained. This postulates a low self-capacity, and so composition-type resistors are usually

employed. It is claimed by some manufacturers that, by taking special precautions in design, it is possible to use a considerably lower value of resistance than that stated above, with consequently less chance of impairing the electrical efficiency of the ignition system.

In any case, it cannot be guaranteed that any resistor will last indefinitely, and few makers claim that their products will last longer than for 50,000 miles of driving. From this it will be gathered that specially made resistors are almost essential; amongst the firms making or distributing suitable types in this country may be mentioned the Dubilier, Erie, Rothermel, and Varley concerns. In all cases suitable precautions are taken to protect the

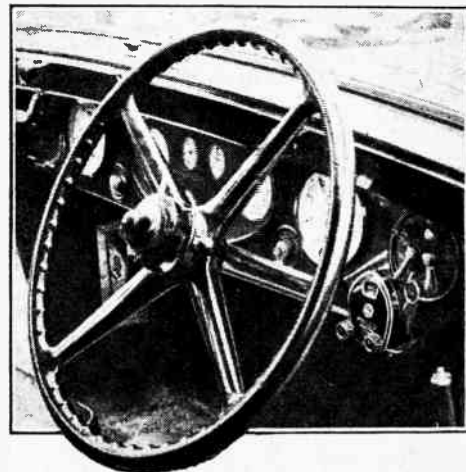

Almost all motor-car sets are remotely controlled on the "Bowden wire" principle. This photograph shows the control-box of a Philco "Transitone" mounted on the dash, to the right of the steering wheel.

Wireless Under Way—

resistance elements by enclosing them in a cover of vitreous or similar material.

It should be emphasised that the suppressor resistances should always be mounted as closely as possible to the source of interference. Sparking plug suppressors are so made that they may be connected directly to the plugs, while the distributor resistance is usually of such a type that it may be easily inserted in the high-tension cable.

Care of the Sparking Plugs

In order that these measures may be entirely effective, it is worth while to clean the plugs and to adjust the spark gaps to the length recommended by the manufacturers with rather more care than usual.

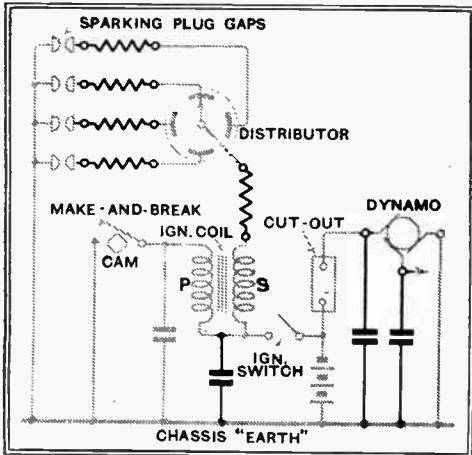

A simplified circuit diagram, drawn "wireless fashion," to show the addition of suppressor resistances and by-pass condensers. Additions are shown in full lines.

As a general rule, wide gaps tend to provoke interference, and so minimum clearances should be employed. But at least one manufacturer of car radio sets recommends that, if the idling of the engine is adversely affected by the fitting of suppressors, the sparking plug gap should be increased by a few thousandths of an inch.

Turning to the low-tension equipment, several condensers are bound to be required for the complete suppression of interference. These condensers, for which a capacity of about one mfd. will generally be right, should preferably be made specially for car use, as, like the resistances, they have to work under much more trying conditions than in a wireless receiver. A specially designed condenser, enclosed in a copper case, and with a heavy fixing bracket which also acts as the earthing connection, is illustrated in an accompanying photograph. Electrically speaking, the demands made on a car "suppressor" condenser are not heavy, but heat and dampness are the principal enemies. It has been found that, where an ordinary wireless condenser can be mounted in a position where it will be fairly cool, it stands up to its work quite well, but the position cannot always be chosen from this point of view, as the connecting leads should be short.

With regard to interference from the

make-and-break, the usual preventive measure is the connection of a condenser between the primary of the coil and earth, as shown in the diagram. It has been found that in a few instances a residue of interference may be minimised, without noticeably impairing engine performance, by adding to the capacity of the existing built-in condenser (shown in faded lines), which is normally shunted across the make-and-break contacts, and which is usually built into the lower part of the casing which encloses the mechanism. In one case where interference from this source was particularly troublesome, the connection of a 20-ohm resistance in series with the shunt condenser proved to be entirely effective.

Interference from the Generator

Radiation produced by sparking at the dynamo brushes may always be recognised, as it is heard in the loud speaker as a whining sound, of which the pitch depends upon engine speed. Except in particularly difficult cases, or where an exceptionally silent background is needed, it will be sufficient to connect a condenser between the positive dynamo terminal and earth. As a refinement, or where it seems to be especially necessary, an extra condenser may be connected between the third brush (the so-called control brush) and earth in the manner shown.

For obvious reasons, it is hardly necessary to trouble about the starter motor; it usually produces heavy radiation, but as it is used so intermittently it does not cause annoyance.

Auxiliary apparatus is generally silenced quite easily by connecting a shunt con-

one of the electrodes. This casing should be directly earthed, or at any rate joined to the "earth" terminal of the device, while the insulated connection is, of course, joined to the positive or "live" terminal.

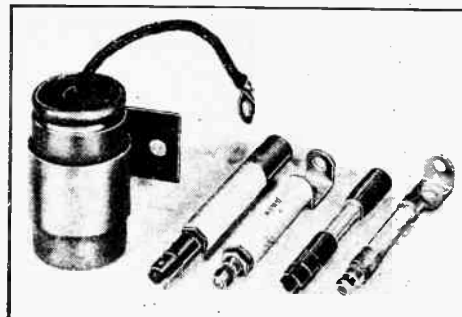

A special T.C.C. condenser, and suppressor resistances made by Erie and Centralab (Rothermel).

It should also be mentioned that when the addition of a shunt condenser fails to have the expected results the expedient of connecting a 20-ohm resistance in series with it, as already mentioned, should always be tried. By making this addition, H.F. oscillations in an "accidental" circuit will be damped out.

Although this article deals with the suppression of interference rather than with the installation of car sets, it should be mentioned that the car aerial is, more often than not, installed in the roof, and so is particularly likely to be affected by H.F. impulses propagated along the wiring of the roof-light. The aerial should accordingly be spaced as far as is practicable from this light; its leads should be also kept clear, and, if possible, screened in metal-braided coverings. The roof-light wiring may also be by-passed to

earth by a condenser, and the wiring of the ignition switch may be screened.

In order to minimise the pick-up of interference by the aerial down-lead, which is usually run to the set down one of the front pillars, it is as well to enclose it in a low-capacity metal shield, which should extend all the way to the aerial terminal of the receiver. The latter, of course, should be totally enclosed in a metal case, carefully earthed to the chassis; similar remarks apply to

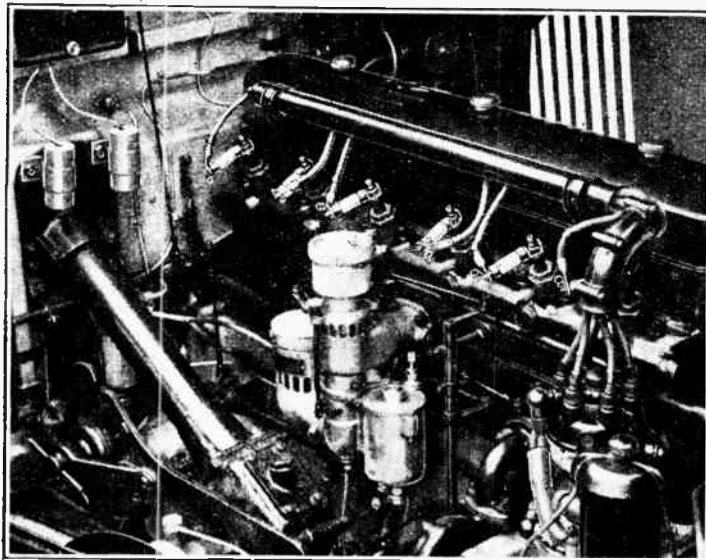

Under the bonnet of a Rolls-Royce. Suppressor resistances mounted directly on the plugs, and two by-pass condensers are shown; the distributor resistance is enclosed in a length of rubber tubing.

denser. Most cars are wired on the earth-return system, and so it is necessary to take certain precautions when connecting condensers, especially if these be of the special "car" type, of which the external metal casing is joined internally to

the H.T. generator, and all external connections to the loud speaker, etc., should be made with metal-braided wire.

Finally, it should be remembered that clean contacts and good insulation will help to ensure a silent back-ground.

New Ideas for the Superheterodyne

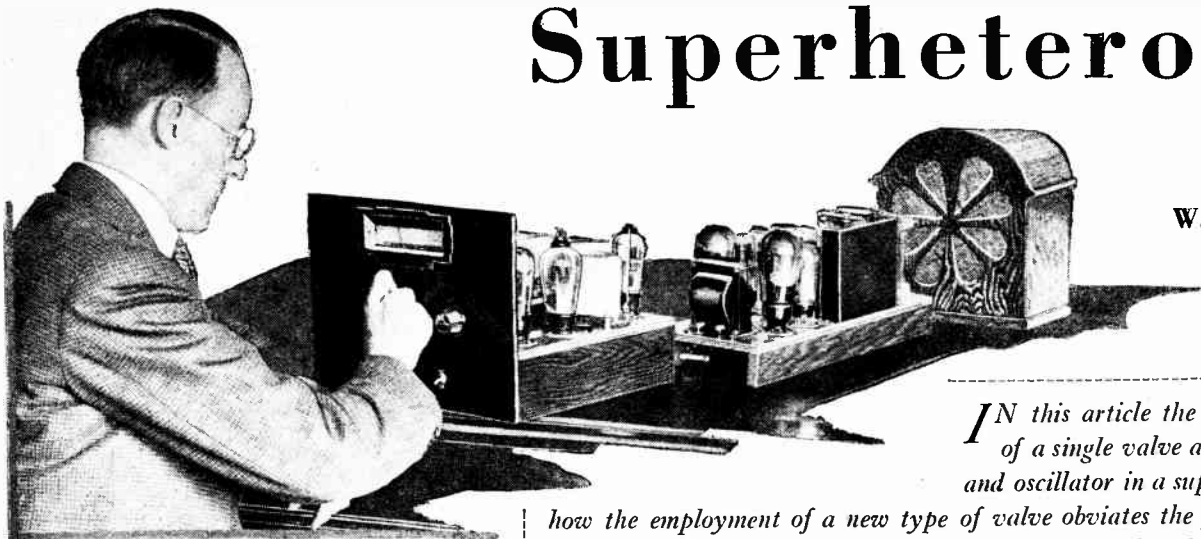

By

W. T. COCKING

IN this article the author discusses the use of a single valve as combined first detector and oscillator in a superheterodyne and shows how the employment of a new type of valve obviates the former disadvantages of a single valve and at the same time permits delayed A.V.C. to be used on the first detector. Other new features in superhet design are also discussed.

MANY attempts have been made in the past to carry out the functions of the first detector and oscillator of the superheterodyne with a single valve, but none has proved to be entirely free from drawbacks. Until recently the self-neutralised pentode, which was introduced by *The Wireless World*, was one of the few satisfactory single-valve frequency changers, but even this suffered on the grounds of low efficiency and critical operation when compared with the conventional two-valve circuit.

It seems that the two functions of rectification and oscillation cannot be carried out with complete satisfaction when the same electrodes of a valve are used for both purposes. A valve with more electrodes than usual would appear to be necessary. Even the two-valve frequency changer is not without its defects, however, and these are of two kinds—a tendency to the formation of whistles and difficulties connected with the coupling of the oscillator to the first detector.

Why Whistles Occur

Whistles are produced in the frequency changer if the first detector is not effectively linear, and theory indicates that a square law valve with a long grid-base is desirable. Such a valve, however, is likely to prove inefficient, and in practice a particular type of variable- μ valve is the most satisfactory. Practical tests show the importance of the grid volts-anode current curve being of smooth shape without any sudden change of slope, and this usually means a valve with a maximum mutual conductance of about 1 mA/V. and a grid-base of some 50 volts. Unfortunately, there are now few such valves available.

The coupling between oscillator and first detector may result in interaction between the oscillator and signal frequency tuning controls, and hence to ganging difficulties. Moreover, the oscillator potential

developed on the first detector grid will usually change considerably with frequency unless special precautions are taken, and the overall efficiency of the frequency changer will consequently vary over the waveband. If the oscillator coupling is not so tight that overloading of the first detector occurs at low wavelengths, the efficiency may be low at low

The Latest Tendencies in Design

wavelengths, and background hiss become prominent. Conversely, if the coupling be made tight enough at a low wavelength, the first detector may overload at a high wavelength, and then whistles will occur.

A new valve has recently been developed in America which overcomes these defects. The Pentagrid is really two valves in one, for it contains the electrodes of a variable- μ valve and of a triode. The latter are used for the oscillator, and are screened from the tetrode electrodes which form the first detector. The characteristics of the latter are of the type which we have already seen to be desirable, so that on this score there is no difficulty.

Advantages of the Pentagrid

As the two sets of electrodes are screened from one another, and no external coupling between the oscillator and first detector circuits is used, there is no interaction between the controls. The necessary coupling is neither capacitive, inductive, nor resistive, but electronic. The tetrode has no proper cathode, and its place is taken by a cloud of electrons sur-

rounding the screen placed between the triode and tetrode. The density of this electron cloud varies with the instantaneous oscillator potentials, with the result that the electron stream through the tetrode is modulated by the oscillator. Provided that the oscillation is sufficiently vigorous, the efficiency of this frequency changer is independent of the actual oscillation strength, so that full efficiency can be maintained without special circuits.

As a result, we have not merely a single-valve frequency changer which is as satisfactory as the two-valve circuit, but one which is definitely better, and which would merit use on this score alone. As compared with the conventional arrangement, the efficiency is considerably higher, back-

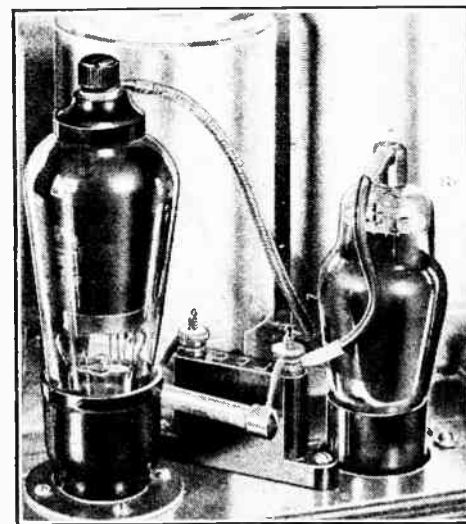

The Pentagrid valve incorporated in the design of the "New Monodial Super" to be described next week.

ground hiss is less, the efficiency is more evenly maintained over the waveband, and whistles are absent.

Development has not proceeded only in

New Ideas for the Superheterodyne—

the frequency changer, however, and no part of the superheterodyne is completely free from change. The use of critically coupled I.F. circuits has resulted in increased simplicity of adjustment with improved selectivity and efficiency, but has necessitated an increase in the amount of tone correction necessary for high-quality reproduction. High audible frequencies must be amplified some thirty times as much as low notes, and it has proved difficult to obtain the requisite performance with a triode tone-corrector valve. A screen-grid type of valve or, better, a screened pentode, has thus become necessary in the L.F. circuits, for its high internal resistance does not have the effect of

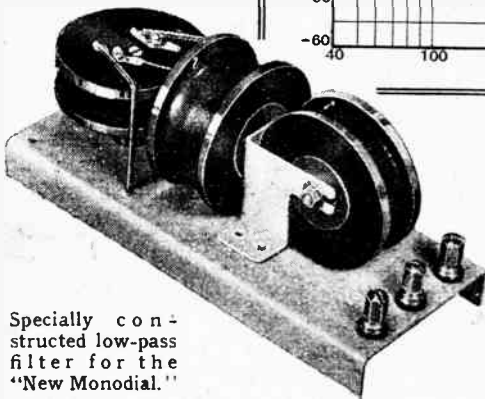

Specially constructed low-pass filter for the "New Monodial."

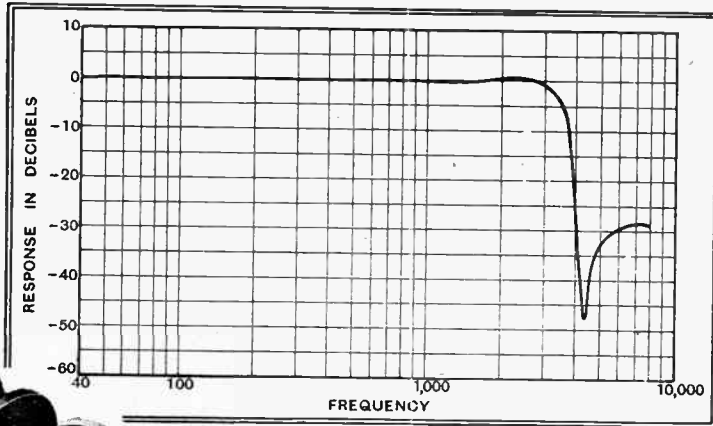

Fig. 1.—The measured response curve of a low-pass filter designed to eliminate sideband splash. The attenuation does not exceed 4.5 db. below 3,500 cycles, but reaches the high figure of 50 db. at 4,500 cycles. At higher frequencies the attenuation is less, but it is still sufficient.

but the usual methods of tone control are likely to prove unsatisfactory owing to their gradual cut-off. A properly designed low-pass filter is necessary to prevent sideband splash with a minimum of deterioration in quality.

Importance of the New Features

A suitable filter would have a cut-off frequency of 3,500 cycles, and would attenuate very greatly all frequencies higher than that without affecting lower frequencies. The measured curve of an experimental filter is shown in Fig. 1, and practical tests showed that it would entirely remove sideband splash under normal conditions. Since the stations upon which the filter need be used are usually weak and accompanied by a background of atmospherics and local interference, the deterioration in quality is not very noticeable. Indeed, the lower standard of quality with complete freedom from sideband splash is definitely more pleasing than perfect quality accompanied by interference. When conditions are suitable, of course, the filter can be thrown out of circuit by a switch and the full benefit of the upper register obtained.

It will thus be seen that considerable development has recently taken place in superheterodyne design and that an up-to-date set would employ two fewer valves, be more sensitive and selective, give better quality, less background hiss, and fewer whistles than an A.V.C. receiver of only a few months ago. In addition, the inclusion of a low-pass filter enables sideband splash to be eliminated

at will. The reduction of valves, of course, lies in the receiver proper, and it is particularly important in that it permits the use of an additional output valve without the total number of valves becoming excessive. The use of a push-pull output stage, with its attendant advantages of reduced amplitude distortion and feed-back effects, thus becomes permissible.

BOOK REVIEW

The Cult of Invention

Dr. Hatfield treats his subject in wide perspective, as might perhaps be expected from the son of a former Chief Examiner in the Patent Office. He is concerned not so much with the prosaic details and formalities of patent law and practice as with the peculiar qualities that go to distinguish the inventor—and his activities—from the rest of *homo sapiens*.

Special consideration is given to the practice of invention as a profession, to the art of directing the creative urge in the most promising direction, and to the still more difficult task of financing the invention when made. There is also an interesting and detailed survey of the mechanical, chemical, electrical, and biological aspects of the inventive faculty.

In a final chapter on patent law the author tackles some of the admitted weaknesses of the present system with considerable point, and goes on to develop an alternative scheme designed to give the inventor a financial return based definitely on his practical value to the industry of the country.

"The Inventor and his World," by H. Stafford Hatfield, Ph.D. Kegan Paul, pp. 269, price 6s.

FOREIGN BROADCAST GUIDE

BRESLAU (Germany).

Geographical position : 51° 5' N. ; 17° E.
Approximate air line from London : 745 miles.
Wavelength : 325 m. Frequency, 923 kc/s. Power : 60 kW.
Standard time : Central European (coincides with B.S.T.).

Standard Daily Transmissions.

06.15 B.S.T., Physical exercises and concert ; 07.00, military band (Sun.) ; 07.30, news, weather ; then continuous broadcast until 11.15, weather, news, concert ; 16.20, concert, talks ; 19.00, National programme ; 20.00, main evening entertainment ; 22.00, weather, news, etc. ; light concert.

Announcer : Man.

Call : *Achtung! Achtung! Hier die Schlesische Rundfunksender Breslau und Gleiwitz.*

Interval signal : Metronome (200 beats per minute), and when of long duration, first bars of *Hohenfriedberger March* as under.



Closes down as other German stations with a patriotic song or alternately, with the *Horst Wessel lied* (Nazi Hymn) and National Anthem (*Deutschland ueber Alles*).
Relay : Gleiwitz, 253 m. (1,184 kc/s), 5 kW.

greatly damping a tuned correction circuit.

The introduction of duo-diode triode and duo-diode pentode valves has rendered the use of separate valve A.V.C. systems unnecessary, and has greatly added to the number of methods of obtaining automatic volume control. The choice of method depends largely upon the receiver design, and not upon the merits of the system in itself, the amount of L.F. amplification employed being one of the chief factors. The simple delayed diode control is hardly possible when only a small detector output is needed, since it can give good control only when the detector input is large. If the control be arranged to operate on the first L.F. stage as well as the early stages, however, this system becomes possible with a moderate detector input, and it has the supreme merit of simplicity.

Choice of First L.F. Valve

A variable-mu valve is then necessary for the first L.F. stage, and as we already require this valve to be of the pentode type for tone correction purposes, the Cossor duo-diode pentode becomes ideal. A single valve of this kind will provide diode second detection, delayed diode A.V.C. on the H.F., first detector, I.F., and first L.F. stages, and act as the first L.F. valve giving tone correction. It thus takes the place of two ordinary valves.

Practical HINTS and TIPS

ONE of the greatest advantages conferred by the variable-mu H.F. valve is that volume may be controlled in an extremely satisfactory manner by variation of its grid bias voltage. In order that signal strength may be reduced to a sufficient extent, arrangements are usually made for varying the bias progressively from the optimum value of a volt or so to anything up to some 30 volts negative.

Out of Control

But even when the maximum available bias is high it is not always possible to reduce signals from a powerful nearby station to inaudibility, or even to a comfortable strength. Insufficient control is particularly likely to manifest itself in sets with only one controlled stage, and also in battery receivers where it may be inconvenient to use a sufficiently large bias battery.

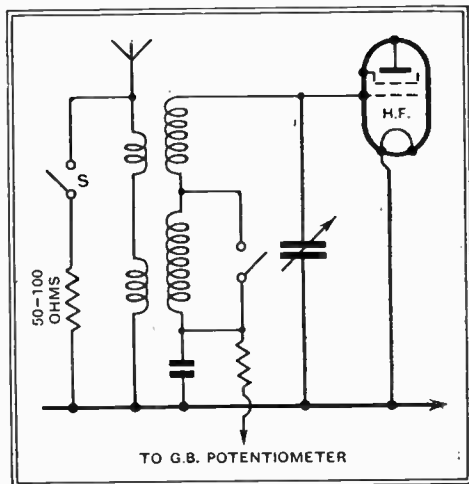

Fig. 1.—By closing the "local-distance" switch S the aerial input is almost completely short-circuited by a resistance of low value.

As a supplementary control, to be used only when receiving a local station for which grid bias adjustment may be inadequate, it is a good plan to fit some form of desensitising device which may be thrown into operation at will. Such a device is generally known as a "local-distance switch," and, of course, must be capable of bringing about a drastic reduction in overall sensitivity.

Of all the methods that have been suggested for the purpose it is doubtful if any are greatly superior for all-round use to the simple expedient of shunting the aerial-earth circuit by a resistance of 50 to 100 ohms. This resistance, of course, is connected across the circuit at will by means of a switch, as shown in Fig. 1.

The only disadvantage of a local-distance switch is that one is apt to forget its existence, and to attempt to tune in distant stations when the switch is closed!

AIDS TO BETTER RECEPTION

THERE is no royal road to real selectivity, and the only way to obtain exceptional freedom from interference from unwanted stations is to use plenty of tuned circuits, which, unfortunately, add to cost and complexity. Of course, the superheterodyne principle in itself helps towards the attainment of this ideal, but its success is largely due to the fact that the number of circuits actually employed may be increased very simply and cheaply by putting some of them into the I.F. amplifier, where they do not need retuning for each station.

Tuned Circuits for Selectivity

From a practical point of view the selectivity obtainable from a set in which the modern iron-powder-cored coils are used is high, but a small number of exceptionally good circuits is not a complete substitute for a larger number of less ambitious ones.

To give a quantitative idea of the true position, it may be stated that two of the best circuits that it is practicable to include in a receiver at the present time would not provide as much real overall selectivity as three circuits in which coils of average efficiency were employed.

WHEN the usual remedies for mains hum in an A.C. set have been tried and found to be ineffective it may be remembered that a misplaced centre-tap on one of the L.T. windings of a power transformer is not unknown, and may be largely responsible for the trouble. To unwind the transformer, and then to experiment with another position for the tapping, is a laborious task, not to be recommended to the amateur, but, fortunately, the use of an adjustable potentiometer, whereby an artificial centre point may be located accurately, provides a solution of the difficulty.

An Artificial Centre-tap

The connection of a potentiometer in place of the existing centre-tapping is quite simple, and, indeed, is only the work of a moment. The ends of the resistance winding are joined across the transformer winding, and the wire which was originally connected to the centre point is transferred to the potentiometer slider terminal.

A suitable value of resistance is about 20 ohms, and is by no means critical. Ready-made potentiometers, specially in-

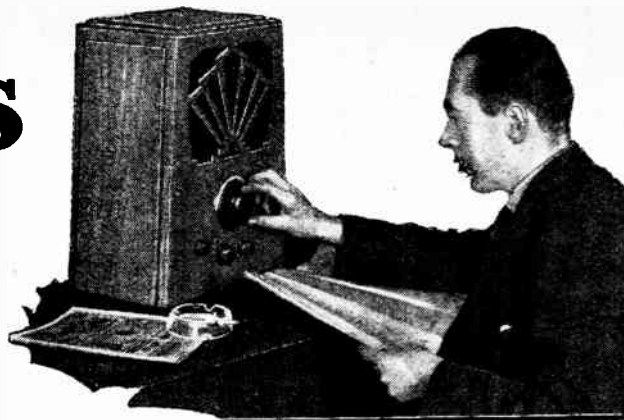

tended for this purpose, and which occupy very little space, are available commercially.

ALTHOUGH the components associated with a Class "B" output stage do not take up very much space, it is not always possible to find room for them in an existing set of fairly compact design. In such circumstances the obvious thing to do is to mount the extra components in a separate container, which will be treated as an external adjunct to the receiver. As a rule the original output valve will be converted into a driver valve; it will generally be possible to economise in anode currents by over-biasing the grid of this valve.

Class "B" Unit

As will be seen from Fig. 2, which shows such an "add-on" unit, the internal wiring and also the interconnections to the existing receiver are quite simple. Little or no alterations to the set itself will be required, although some form of tone control must be provided in order to prevent over-accentuation of high notes. This control could be embodied in the Class "B" unit, but it is perhaps more usual to include it in an earlier stage.

As a rule, the simple plan of shunting the primary of the existing L.F. transformer with a condenser of 0.01 mfd. in series with a variable resistance of 20,000 ohms or so will be found satisfactory.

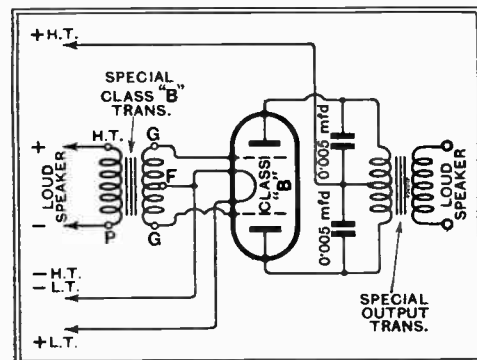

Fig. 2.—An "add-on" unit for converting an existing set to Class "B" amplification. Connections to the receiver terminals are indicated.

In addition, if there are any signs of instability, or if quality is poor, it may be necessary to provide extra decoupling in the set. Occasionally this decoupling will be desirable in the driver circuit.

News of the Week

Current Events in Brief Review

2RN Testing

THE Irish Free State Minister of Posts and Telegraphs states that the Dublin station (2RN) is now broadcasting the Dublin studio programmes for test purposes. The wavelength has been altered from 413 to 217 metres.

Sir Ambrose Fleming

THE gold medal of honour of the Institute of Radio Engineers of New York has been awarded to Sir Ambrose Fleming, the well-known radio research worker and inventor of the first thermionic valve.

One-way Traffic at Olympia ?

TO relieve the tremendous crush at the Olympia Radio Show this year, it is suggested that visitors should be marshalled along gangways in one direction only. "Test walks" made last year proved that it was impossible to cover all the Show in less than three hours.

Safeguarding the Buyer

ACCORDING to new regulations in Germany, the sale of wireless sets and installation of aerials is restricted to firms who are registered as wireless dealers. Licences are granted only if the owners and employees of the firm have passed a test in radio theory and practice.

Two-way Police 'Phone

LORD TRENCHARD, Commissioner of the Metropolitan Police, hopes that secret daily changes of wavelength will enable him to obtain privacy with the new two-way wireless telephone installation in his house near Barnet. This apparatus is to be used to maintain direct communication with Scotland Yard.

Soldiers as Set Builders

THE Chilean army is now fighting—the foreign radio manufacturer. With the restoration of peace in Chile, the army is concentrating on the manufacture of multi-valve sets which, the Government hopes, will reduce the present outflowing of more than £80,000 annually spent on foreign receivers.

Respite for French Listeners

THE order to all French possessors of sets to have these licensed by June 30th caused a lot of worry and embarrassment, not only to the "pigs of payers" (*cochons de payants*), as the tax-paying public calls itself, but also to postal officials, who had not been supplied with the necessary instructions. The result, according to our Paris correspondent, was that many people had to copy out in detail the forms displayed in their local Post Offices. This entailed queues, delays, bad temper, and universal grumbling. In the end the permissible registration time has been indefinitely extended.

Athlone Nearly Paid For

LAST year the Irish Free State spent £87,945 on the broadcasting service, this including £46,100 for the high-power station. Mr. Boland, Minister of Posts and Telegraphs, secured a

Human Wavelength Scheme ?

IT is predicted in Paris that the forthcoming "Who's Who" will take the form of a wireless annual containing the individual wavelengths of everybody who is

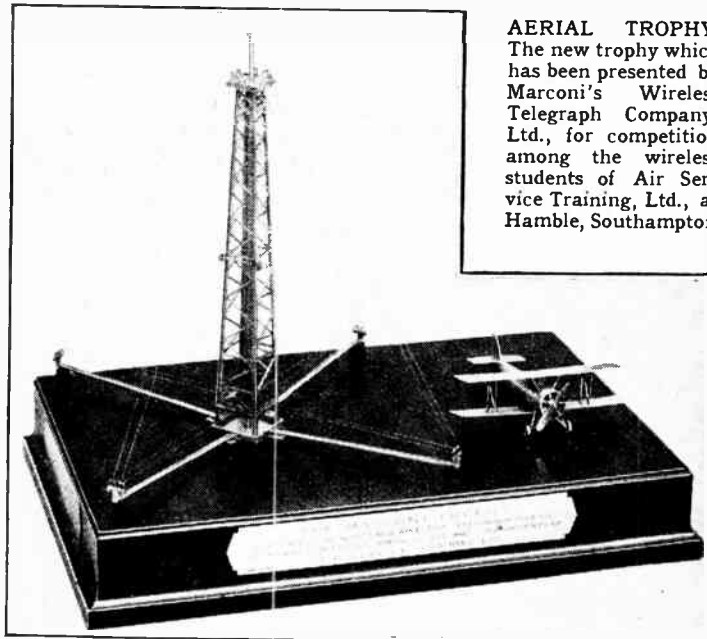

AERIAL TROPHY. The new trophy which has been presented by Marconi's Wireless Telegraph Company, Ltd., for competition among the wireless students of Air Service Training, Ltd., at Hamble, Southampton.

vote of £43,530 for the broadcasting service for the current year, as compared with £60,310 for last year. The decrease was due to the fact that the cost of the high-power station had almost been cleared.

Last year the revenue from wireless receiving licences was £17,296. The total number of licences last year was 33,883, an increase of 4,438.

New Interval Signals

AS a new interval signal, Bavarian stations are now using the famous tune from the opera "Parsifal," portraying the bells of the Holy Grail, the notes being C—G—A—E.

An automatic vibraplane is used, operated by small hammers driven by an electric motor, and striking steel plates fixed to tubes of varying lengths.

Nürnberg, when transmitting from its own studio, employs a similar signal, but consisting of a few bars from the "Meistersingers."

How The Money Goes

GERMAN listeners' licence fees, which are to be reapportioned during the budget year 1933-34, will be distributed between the Post Office and the Ministry of Propaganda in the proportion of 55 per cent. and 45 per cent. respectively. The Post Office proportion covers the cost of the new high-power stations and their operation, together with the cost of collection. The Ministry of Propaganda retains ten millions of marks, or about 9 per cent., passing on the remainder to the Reichs Rundfunk Gesellschaft.

anybody. It seems that personal wavelengths are now being taken very seriously by the psychotherapists, hypnotists, and psychologists who met in Paris last week under the chairmanship of Professor d'Arsonval.

The greater part of the proceed-

ings was devoted to human radiations. Dr. Vachet, a prominent Paris psychologist, stated that the "animal organism plunged in a magnetic field acts exactly as any other object," and he traced an analogy between the "electric wave" and the "nervous wave."

If there is any truth in this, many unpleasantnesses might be avoided with the creation of a kind of human Lucerne Plan to prevent individual "jamming."

The Lucerne Plan

IT is regretted that in the necessary haste to secure publication of the Lucerne Wavelength Plan before any other journal in Britain or abroad, we allowed two or three slight errors to creep in. The wavelength of 274 metres is allocated to Vinnitsa, not Venice. The 309.9 metre wavelength applies to Odessa, not Vinnitsa.

A Whisper from Spain

THE magnificent project of a 500 kW. broadcasting station in Madrid seems to have collapsed, but we learn that it has been decided to build a "provisional" station with the comparatively modest power of 100 kW., according to a communication of the Spanish Home Office.

The Sound Film

IN the caption to an illustration of a Vinten tracking camera on page 427 of our issue of June 16th it was erroneously stated that the truck was designed to transport the microphone boom, whereas, as explained in Mr. Dallas Bower's article, the illustration is of the machine on which the camera is placed for moving-camera shots.

A Chequered Journey

First Reports on the Five-metre Tests

DESPITE a chequered journey, interrupted by severe storms and temporary breakdowns of his apparatus, Mr. S. G. Morgan (G6SM) secured a number of reports on his transmissions during his flights between London and Liverpool on Sunday last.

At the time of going to press reports are still being received from Liverpool, Southgate, Sidecup, and other points, and it is evident that the range of reception was only limited by the fact that the 'plane was unable, owing to unfavourable weather conditions, to rise above a maximum height of 4,000 feet. Clear signals were heard at Firth Beacon on the South Downs, near Lewes, by Mr. H. L. O'Heffernan (G5BY), when the 'plane was eighty miles away.

After a delayed start at 10.30 a.m. the 'plane flew over London at a height of 3,000 feet. A slight mechanical breakdown necessitated a landing at Heston, but after ten minutes the 'plane got away and test signals were transmitted continuously until the oscillator valve broke down when G6SM was over Halton Aerodrome, North Bucks. A quick landing was made to effect

an adjustment, and the 'plane took off for the North at noon.

The weather broke up after leaving Halton, and terrific rainstorms and "bumps" threatened to incapacitate the apparatus. However, all went well until the modulator failed to function near Birmingham, but the necessary adjustment was made in the air. Liverpool was reached at 4 p.m.

The return journey from Liverpool was begun at 5.15 p.m., and the city was encircled before the 'plane started off for Manchester, which was reached at 6 p.m. The Pennines were crossed at 4,000 feet, and the course then followed Sheffield, Derby, Northampton, Leicester, St. Albans, and London. It was found necessary to descend for petrol near Leicester and also near St. Albans. Croydon Aerodrome was reached at 9.11 p.m.

On the southward journey the wireless apparatus functioned perfectly. At the time of going to press it is too early to have received reports from the various districts in the North.

Next week we hope to collate reports and to publish Mr. Morgan's own story of the test.

Simplified "Science Museum" Receiver

A Reader's Experience with Resistance-coupled Push-pull

INSPIRED by the description of the Science Museum receiver in *The Wireless World* of July 30 and August 6, 1930, the writer decided to build a local-station receiver and gramophone amplifier, the L.F. side being designed on the same lines. The following notes may be of interest to anyone attempting this form of amplification without previous experience.

The accompanying diagram shows the general arrangement of the set; it is not proposed to deal with the eliminator, as this unit follows convention and gives an output of 350 volts smoothed D.C.

The detector arrangements are also quite normal, and the radio side is designed to receive only the two local stations; a single-circuit tuner was used, this being desirable because the receiver was designed for fixed tuning, switching from one station to the other being accomplished by relays which switch in fixed condensers (see later remarks).

Switching from "gramophone" to "radio" is done by a relay which changes over the grid of the first amplifying MH4 valve to the pick-up. A resistance, R11, is fitted to prevent the grid circuit of this

It is often thought that the resistance-coupled push-pull amplifier, as used in the famous Science Museum demonstration receiver, is too complex for amateur use. Many of our readers have expressed disagreement with this view, and here one of them describes a successful "paraphase" amplifier of his own construction.

By C. C. INGLIS

valve from being "opened" during switching operations.

In order to obtain push-pull working from a pair of output valves, it is necessary to introduce an opposition in phase between their grid voltages. With the usual transformer coupling, this is easily obtained by using a centre-tapped transformer, but, where resistance coupling is used, this can be effected by taking advantage of the principle that the A.C. voltage component on the plate of an am-

plifying valve is 180° out of phase with that on the grid.

The input voltage is applied, therefore, to the grid of one valve, say, to point Y in the diagram, and a portion (in this case about 4 per cent.) of the amplified voltage, which is now 180° out of phase, is injected into the grid of the second chain of amplifying valves. This is done by tapping off a portion of the voltage difference between the anodes of the first stage by means of the potentiometer S.

The success of the operation of the amplifier depends on the correct balancing of the circuits—that is to say, considering the first stage, the L.F. voltage on the grid of one MH4 must be equal and opposite to the L.F. grid voltage on the other MH4. If this is done, the L.F. voltages on the plates of these valves will be equal and opposite in phase, provided that the amplification of each MH4 with its associated resistances and condensers is the same.

Similar remarks, of course, apply to the output valves. If this correct balance is attained, there should be no audio-frequency currents in the common positive feed to any stage or in the common nega-

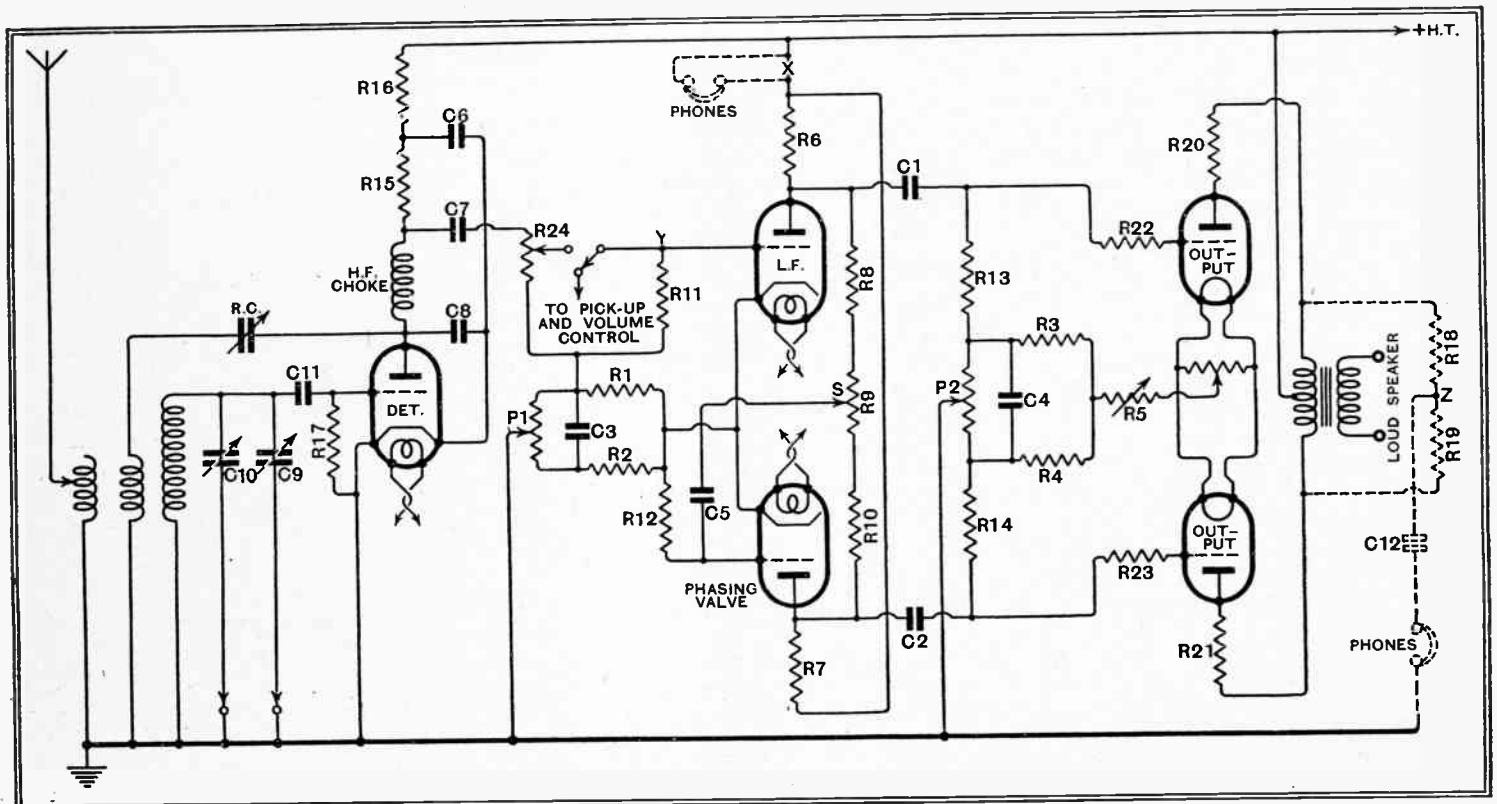

Short-range radio-gramophone set with resistance-capacity-coupled push-pull amplification. Valves: MH4's in early stages, with PX4 output valves. Values of components: P1, P2, 50-ohm potentiometers; R1, R2, 600 ohms; R3, 250 ohms; R4, 300 ohms; R5, 400 ohms; R6, R7, 30,000 ohms; R8, R10, 0.25 megohm; R9, 50,000 ohms; R11, 2 megohms; R12, R13, R14, 0.25 megohm; R15, 30,000 ohms; R16, 20,000 ohms; R17, 0.25 megohm; R18, R19, 10,000 ohms; R20, R21, 100 ohms; R22, R23, 10,000 ohms; R24, 0.25 megohm; C1, C2, 0.012 mfd.; C3, C4, C6, 2 mfd.; C5, 0.01 mfd.; C7, 0.05 mfd.; C8, 0.0003 mfd.; C9, C10, 0.0005 mfd.; C11, 0.0001 mfd.; C12, 0.01 mfd.

Simplified "Science Museum" Receiver.—

tive feed from the stage. This is easily tested in the first stage by the insertion of a pair of phones, at the point X, and the potentiometer S is moved so that a minimum signal is heard in the phones, the PX₄'s having been temporarily removed from their holders. If, now, the PX₄'s be replaced, and if each PX₄ and its associated components amplify the signal to the same extent, there should be

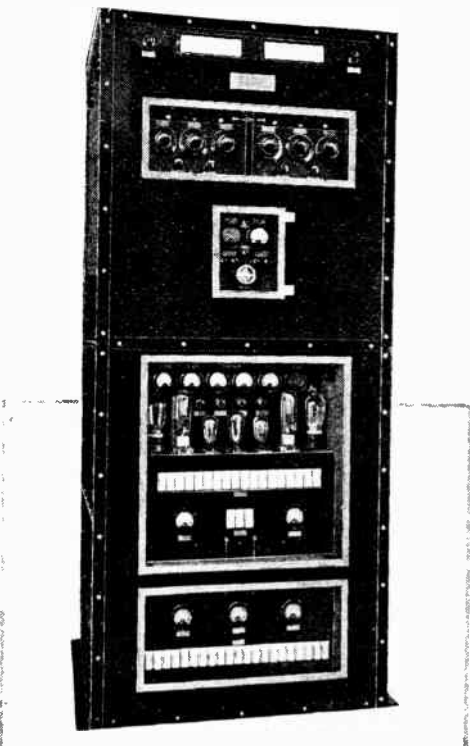

Courtesy Science Museum.

Quality at all costs! The mammoth demonstration receiver installed at the South Kensington Science Museum.

no signals heard in a pair of phones connected (as shown in dotted lines) across the output transformer. This arrangement is virtually the same as that for the first stage, except that the heavy anode current of the output stage is prevented from flowing through the phones, the point Z being at the same L.F. potential (if any) as the centre tap of the primary of the output transformer.

Balancing the Amplifier

In practice it has been found that, in order to obtain a minimum signal in the phones when connected in the latter manner, the setting of S is slightly different when compared with the setting when the first stage was balanced; and this can only be due to slightly different conductances of the PX₄'s and other circuit differences. The difference of the settings of S in the two cases is small, however, and the final setting is that which gives a balance when the phones are connected to the output transformer.

The balancing of the first stage is done only as a check on the correct functioning of the first stage, and to prove that, while the value of amplification of each chain was the same, such amplification was properly divided between each valve in each stage

It is interesting to note that if S is varied, so that an out-of-balance of, say, 20 per cent. is produced (a guess), instability is noticed in its effect on the quality of reproduction, and if this value is considerably exceeded motor-boating will set in, especially when the amplifier is working as a local-station receiver. Decoupling is unnecessary in the amplifier, as each stage is self-contained as regards L.F. energy, there being at most only a trace in the common positive feed to each pair of valves, and in the negative feed from the cathodes. This absence of decoupling enables a lower H.T. voltage to be used, with a consequent saving in cost of condensers and resistances, mains transformers, etc., this saving more than compensating for the cost of the extra phase-reversing valve where push-pull output is required.

Matching Anode Currents

The 2-mfd. condensers C₃ and C₄ might be regarded as a form of grid decoupling, but as they shunt a 50-ohm potentiometer, they obviously do not play any useful part except as convenient terminal points—which actually was the reason for their inclusion.

The grid-bias arrangements look unusual, but they only serve to enable the

valves to be matched, as regards anode current. The arrangement used can vary the anode currents of the PX₄'s by 4 mA. each, so that valves with anode currents differing by 8 mA. can be matched by a turn of the potentiometer P₂.

In practice it was found that the PX₄'s differed by more than 8 mA., so that the greater portion of the out-of-balance was catered for by the unequal values of the two main bias resistances (300 and 250 ohms).

Similar arrangements were made for the first stage, but the out-of-balance was not so severe, and could be allowed for by the potentiometer P₁.

Hum is negligible, and the smoothing is simplified by reason of the balanced nature of the stages. It is possible to apply unsmoothed D.C. to the output stage with very little resultant hum, and when this is applied to the first stage as well, the consequent hum is not so great as one would expect.

The PX₄'s require about 300 volts, including grid bias and drop in the output transformer, and the surplus 50 volts is absorbed by relays in series, which switch in fixed tuning condensers for remote control of tuning.

These relays are operated by the anode current of the last stage, but details of these are outside the scope of this article.

ELECTRONIC MUSIC IN LONDON

Theremin Principle in a New Instrument

WE understand that a series of concerts will be given in London in the near future to enable the public to judge the standard now reached in what is generally known as "electrical music." At a recent demonstration of an improved Theremin instrument at the Connaught Rooms by the Electronic Music Development Co., Ltd., of Purley, Surrey, it was evident that this electronic music instrument must be accepted as a serious effort towards the creation of a new musical art.

The principle of the Theremin is familiar to the majority of readers of *The Wireless World*. Briefly, the unit consists of two valve-driven, high-frequency tuned circuits. The frequency of the one circuit is fixed and that of the other is varied by the player. The combination of the two generated frequencies produces a heterodyne or beat note which, after rectification and low-frequency amplification, operates the loud speaker in the usual manner. A compass of about nine octaves can be covered.

Avoiding Glissando Effect

The instrument is essentially an adjunct for use with any existing radio receiver, mains or battery operated, but preferably employing a high-frequency stage or stages before the detector valve. The normal aerial lead is removed from the set, being replaced by the screened cable from the control gear of the instrument. The receiver is then tuned to about 1,100 metres, the wavelength upon which the new instrument operates.

The instrument is played usually by bringing the right hand nearer or farther from the brass rod, thus creating a capacity effect

which varies the note. Perhaps the most important feature of this model is the device for permitting interruption of the notes by a contact held in the left hand. The player is thus able, if desired, to avoid the *glissando* effect in passing from one note to another. The volume of sound can be controlled by means of a pedal.

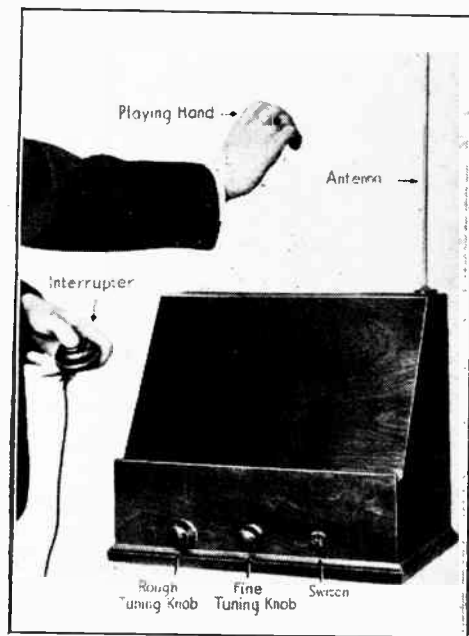

ELECTRONIC MUSIC. The new musical instrument, based on the Theremin principle, which has been developed by the Electronic Music Development Co., Ltd. Public concerts are shortly to be given in London.

Scott Sessions "Equator-Super"

A Short- and Medium-wave Battery Superheterodyne with Automatic Volume Control

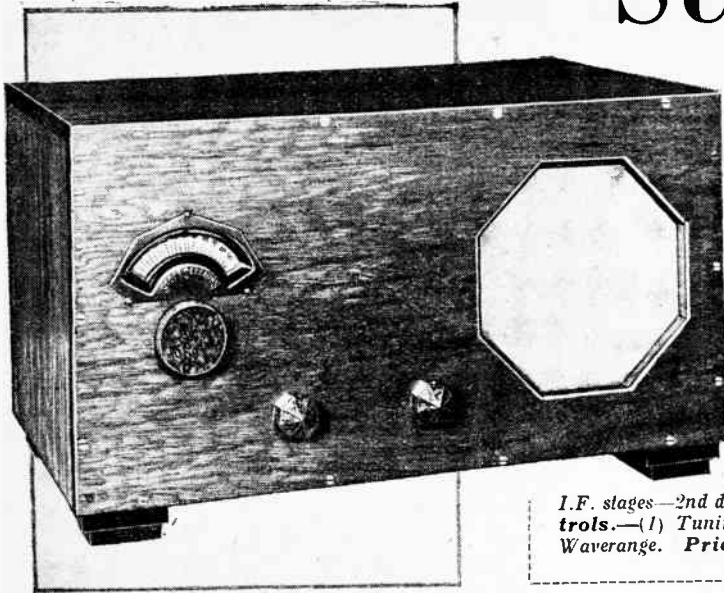

FEATURES

Type.—Short- and medium-wave battery superheterodyne for tropical use. Automatic volume control, Class "B" output and moving-coil loud speaker. **Circuit.**—Signal-frequency variable-mu H.F.—1st detector (autodyne on short waves)—separate oscillator (medium waves only)—two variable-mu

I.F. stages—2nd detector (metal oxide "Westector")—driver valve—Class "B" output valve. **Controls.**—(1) Tuning, with illuminated dial. (2) Manual volume control and on-off switch. (3) Waverange. **Price.**—£33. **Makers.**—G. Scott Sessions and Co., Muswell Hill, London, N.10.

IN view of the fact that short-wave receivers are in great demand in tropical countries where supply mains are not always available and where climatic conditions are severe, the makers have designed this set for battery operation, and housed it in a dust- and insect-proof cabinet.

The circuit is thoroughly up to date, and contains many features of special interest from a technical point of view. There are, in all, eight stages, with a "Westector" metal oxide rectifier taking the place of a valve in the second detector stage. The set covers the medium broadcast band, in addition to three short-wave ranges, and the wavelengths covered are approximately as follows: *Medium-wave*, 220-550 metres. *Short-wave Range (1)* 80-55 metres. *Range (2)* 60-28 metres. *Range (3)* 30-12 metres. All four ranges are controlled by a single switch, and the user is not called upon to interchange coils on the short-wave ranges. The control switch, in addition to altering the wave range, also modifies the circuit in the earlier stages in the following manner:—

On the medium-wave broadcast band the aerial circuit includes a tuned input trans-

former, and the signals after amplification at radio frequency by the first screen grid variable-mu valve are heterodyned in the first detector stage by a separate oscillator before passing to the intermediate frequency stages. On the short-wave ranges the detector, which is the second valve from the left in the circuit diagram, functions on the autodyne principle and is self-oscillating, while the third valve—the medium-wave separate oscillator—is put out of action by short-circuiting the reaction coil and opening the filament circuit. At the same time the tuned aerial circuit is replaced by a high resistance, and the tuned grid circuit preceding the detector is changed over to the short-wave coils and the special short-wave condenser coupled to the spindle of the medium-wave triple gang condenser. Only two sets of coils are used on short waves, and the three ranges are covered by short-circuiting or paralleling sections.

Westector and A.V.C.

The two intermediate frequency stages employ variable-mu screen-grid valves, and are

tuned to 110 kc/s. The full-wave metal oxide rectifier which performs the function of second secondary of the second I.F. stage. This type of rectifier is well suited to deal with the comparatively high output from the I.F. stages, and also provides a convenient means of obtaining automatic volume control. In the Scott Sessions set the D.C. component of the rectifier output is used to bias back the variable-mu radio frequency amplifier. A measure of automatic volume control is thus obtained which appreciably reduces fading effects on short waves.

The automatic volume control is supplemented by a manual control, which performs the dual function of reducing the aerial input and biasing back the I.F. valves. The two potentiometers are ganged, and when the set is switched off the potentiometer across the grid bias battery is disconnected.

The remaining two valves deal with the low-frequency component of the "Westector," and comprise the driver and push-pull valve of a Class "B" amplifier feeding into the permanent magnet moving-coil loud speaker. This arrangement ensures

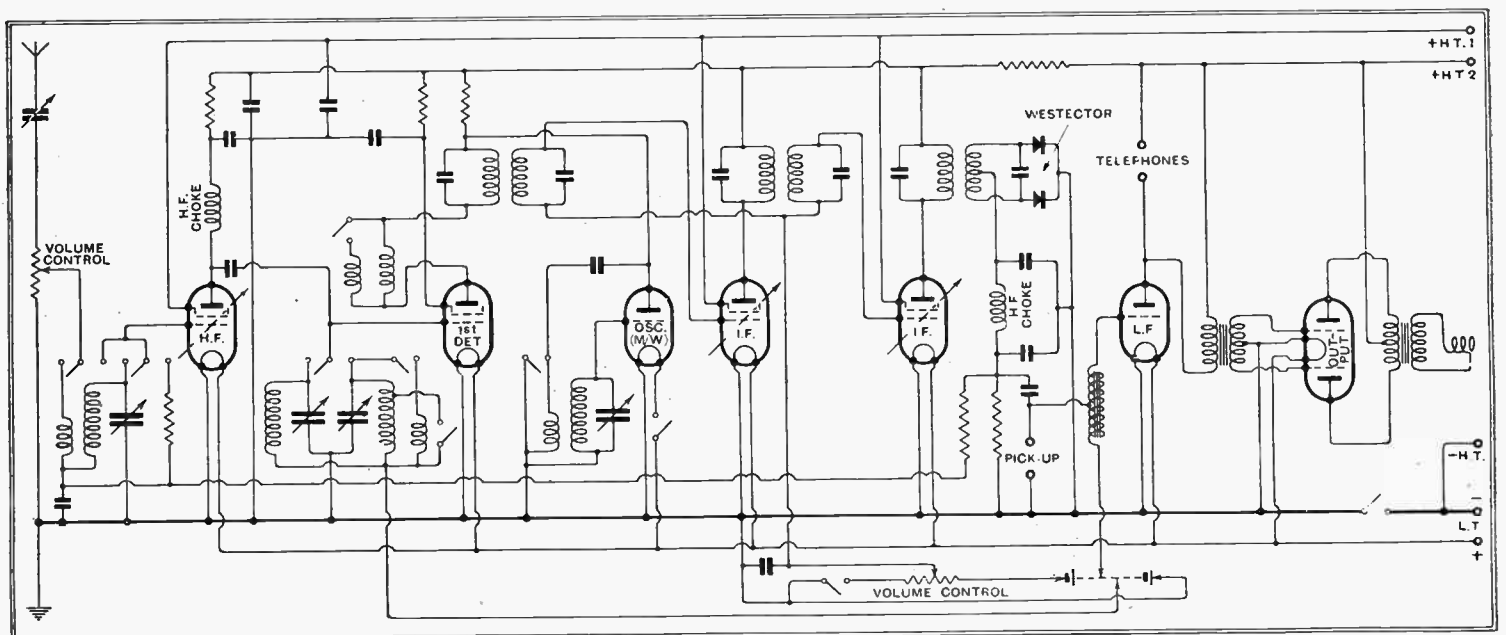

Complete circuit diagram. The two volume-control potentiometers are ganged, and in the latest models a tone compensation circuit is incorporated in the output stage.

Scott Sessions "Equator Super"

efficient utilisation of the battery current expended in the output stage—an important consideration to users who may be many miles from a source of supplies.

The construction of the chassis is well suited to tropical conditions, and careful consideration has been given to insulation resistance. Ample spacing is provided between the contact springs of the waverange switch, and paxolin insulation is used

of the latest models in which a tone-control circuit is associated with the Class "B" output transformer. In this case the quality was well balanced, and a power output estimated at 600 to 750 milliwatts was obtained without overloading. Four Continental short-wave transmissions were received at this level, and an opera from one of the Italian S/W stations was enjoyed without once having to touch the controls, a slight rise and fall in the background noise being

louse problem by the list of wavelengths under the Lucerne Plan. Examine it carefully and you will find no channel assigned to Toulouse Midi, though on 386.6 metres (77.6 kc/s) you will find Toulouse PTT. This wavelength is very close to that at present used by the Midi station, and it would seem that what I suggested some months ago as likely to happen will actually take place with regard to the St. Agnan station. It will most likely be taken over by the French Government lock, stock and barrel, and when it does start to give a regular broadcasting service it will do so as Toulouse PTT. The Government want a high-powered station at Toulouse; Toulouse Midi has one. But the station cannot be used until the Government gives permission, and this permission is being withheld. The choice for the owners thus lies between handing over the station at a reasonable valuation, or reserving it as the only silent transmitter in the world!

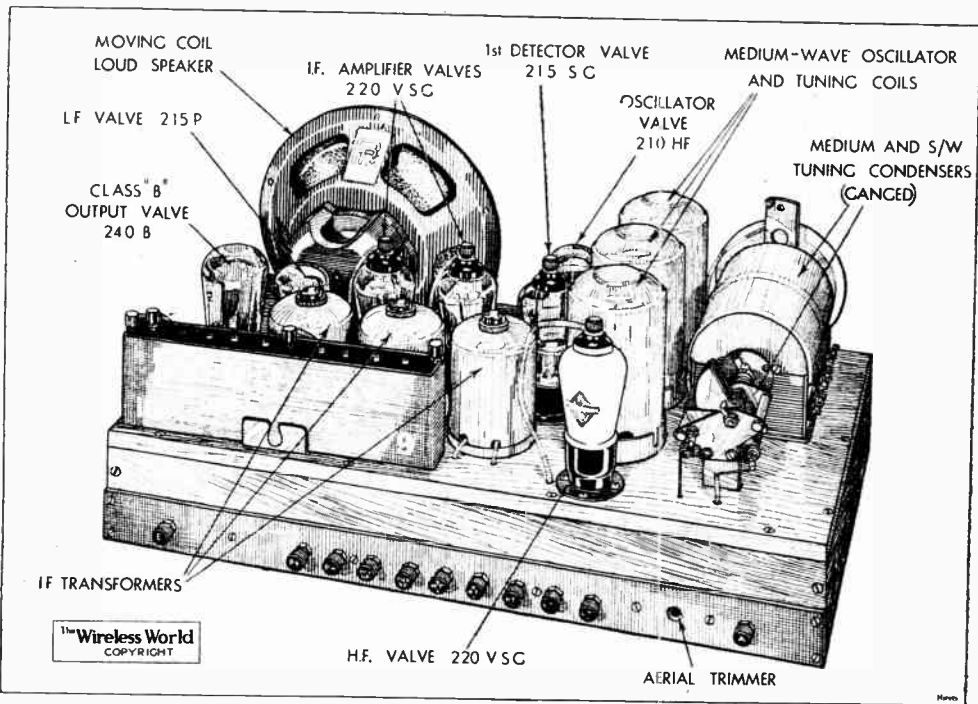

A teak baseboard forms the foundation of the chassis, which is designed to withstand tropical climates.

wherever possible. The frame of the set is made of teak, the underside of the baseboard being covered by an earthed metal screen.

The Manual Volume Control

To get the best results from the set, careful attention must be given to the adjustment of the manual volume control. Just above the half-way mark the I.F. stages go into oscillation, and there is an appreciable angle of zero near the lower end, so that the range is rather restricted. The efficiency of the I.F. stages is rather dependent on the correct adjustment of this control, which must therefore be handled as a reaction control.

The range of automatic volume control is sufficiently wide to be effective in cutting down background noise on strong signals, and the levelling effect on the relative strength of medium-wave broadcasting stations is at once noticeable. At first the set gives the impression of being insensitive in relation to the number of valves used, but further acquaintance soon reveals that the number of distant stations received is in keeping with the advanced character of the circuit. While the automatic volume control is helpful, its range is not sufficient entirely to cope with short-wave fading, and for those who prefer the crispness and "punch" of a normal sensitive receiver, and do not object to frequent manipulation of the manual volume control, the makers are willing to supply the set without automatic volume control.

In the original set tested the quality was somewhat high-pitched, but we have subsequently had the opportunity of hearing one

the only evidence that fading was present.

The standing H.T. current is of the order of 12 mA., and on loud passages the average current was estimated at 18 to 20 mA. Large-capacity dry batteries are recommended, and the H.T. voltage required is 120, with provision for a tapping at 45 volts. We understand that a special rotary converter will shortly be available in order that the power for the H.T. circuits may be derived from the L.T. accumulator.

Provision is made for the reproduction of gramophone records, and telephones may be connected in the driver valve stage for very weak signals.

Distant Reception Notes

What Lucerne Really Means

WHAT exactly did Luxembourg do or omit to do at Lucerne? In his broadcast talk on the Conference transmitted from the B.B.C. National stations, Mr. F. W. Phillips, Assistant Secretary of the G.P.O., stated that eight countries had not signed the Convention, namely, Holland, Sweden, Poland, Finland, Hungary, Greece, Lithuania, and Luxembourg. Yet a pronouncement by the B.B.C. says that only seven countries failed to sign, and does not mention the name of Luxembourg. Since manuscripts of all talks have to be sent in for scrutiny before they are passed for broadcasting, this one presumably received official approval for the correctness of its statements. But the B.B.C.'s own pronouncement must also have received that approval.

Light appears to be thrown upon the Tou-

Posers for Set Designers

Have you noticed how small is the separation between channels on the band provided under the new plan on the long waves? Radio-Paris is only 7 kc/s above Brasov and 8 kc/s below the 500-kilowatt Moscow I. The latter station is separated by 8 kc/s again from a wavelength shared by four stations, and there is another 8 kc/s separation between this group and Zeesen. Daven-try is 9 kc/s above Zeesen, and 8 kc/s above is Minsk. Kalundborg, besides having to share a wavelength with Portugal, is 8 kc/s from Warsaw on the one side and only 7 kc/s from Leningrad on the other. Designers of receiving sets will have some pretty little problems to deal with so far as the long waves are concerned in the matter of providing adequate selectivity combined with reasonably good quality. Radio-Paris is at present about the easiest of all foreign stations to receive clear of interference; after January next it may well be one of the most difficult.

Reception conditions continue to be extraordinarily good, and now that a welcome change has occurred in the weather, atmospheric conditions are almost if not entirely absent. We had a bad spell of them during June as a result of seventeen days of thundery weather on end.

With the exception of Kalundborg, Oslo and Motala, the long-wave stations can be relied upon for good reception at any time. Motala has been below par for some weeks now, while both Kalundborg and Oslo have almost disappeared.

Brussels No. 1, though usually wonderfully good and generally receivable in the daytime, has had occasional rather poor days of late. Possibly this station is coming under the influence of the adverse seasonal effects which manifest themselves on transmissions near the top of the medium wave-band. Florence, Prague, and Langenberg have all been excellent. The Lucerne list shows that the present power of Lyons Doua is actually 15 kilowatts, and not 1.5 as most lists show it. Readers may remember that I suggested some time ago that the indications were that the decimal point had been moved one place to the right.

Stockholm is temporarily on the weak side, but Rome is first-rate. Katowice, Söttens, Leipzig, Hamburg and Strasbourg are all quite reliable. Other stations always to be found when required are Brussels No. 2, Milan, the Poste Parisien, Breslau, Göteborg, Bordeaux-Lafayette, Hilversum, Heilsberg, Turin, Gleiwitz and Nürnberg.

D. EXER.

LABORATORY TESTS

NEW RADIO PRODUCTS REVIEWED

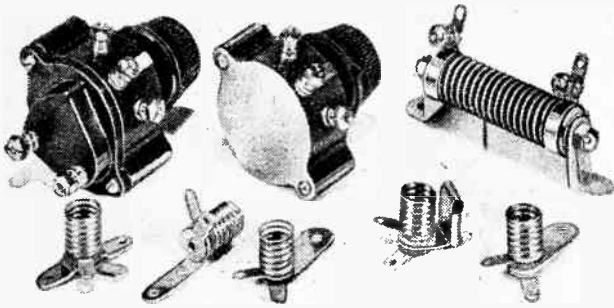

Selection of new Bulgin components consisting of Compact volume control with switch, power resistances and M.E.S. lamp holders.

BENJAMIN CLASS "B" OUTPUT CHOKE

A TAPPED output choke giving the choice of seven different ratios, and developed especially for use with Class "B" valves, has been introduced by the Benjamin Electric, Ltd., Brantwood Works, Tariff Road, Tottenham, London, N.17. Known as the Class "B" Universal Output Choke, its function is to provide the medium for matching the valve to the loud speaker, but it does not replace the transformer fitted to present-day loud speakers, nor is it suitable for use with low impedance models. The ratios provided are 1/1.2, 1/1.6, 1/1.9, 1/1, 1.2/1, 1.6/1, and 1.9/1. It has a total resistance of 400 ohms, and with no D.C. flowing shows a total inductance of the order of 60 henrys. The core is of ample size to ensure that a satisfactory power output at the lower audible frequencies is obtained when one-half of the winding is carrying the normal working current of one valve.

The winding is completely screened, and the overall dimensions are 3½ in. x 2½ in. x 2 in. The price is 11s.

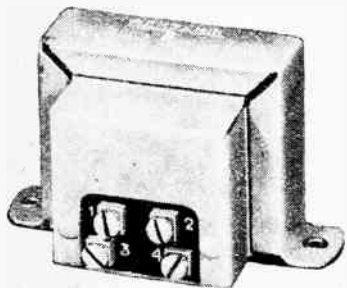

Benjamin Class "B" Universal output choke.

NEW BULGIN COMPONENTS

THE new Compact volume controls, which have a maximum rated dissipation of 3 watts, contain a resistance element wound with special nickel chrome alloy resistance wire totally enclosed in a moulded bakelite case finished in mottled green, a colour scheme that is adopted for many of this firm's products. A single hole fixing bush is fitted, and as this is electrically "live" to the moving arm, insulating washers can be obtained for mounting the component on a metal panel.

Contact between the centre terminal and the resistance is made by a small squash plate, a system which is both silent in operation and imposes the minimum of mechanical strain on the wire. These new resistances are made in all the usual values from 500 ohms to 100,000 ohms, the prices of the volume controls range from 3s. 6d. to 4s. 6d.,

and fitted with a built-in mains switch rated to handle 3 amps. at 250 volts, from 5s. to 6s.

We have tested some specimen volume controls, and find them perfectly silent and smooth in operation, and the measured resistances agree very well indeed with

the marked values.

Recent improvements effected in the manufacture of Bulgin 20-watt power resistances have resulted in a higher degree of accuracy and reliability than hitherto. The nickel chrome resistance wire employed is spirally wound on a heat-resisting core, and this, in turn, is wound on a spirally grooved porcelain former. The tapping bands, which carry the terminal, are not employed to anchor the wire, so that they can be loosened and readjusted if a non-standard resistance value is required. Alternatively, extra tapping clips are available at an additional charge of 6d. each.

These resistances will dissipate their rated watts, but naturally a certain amount of heat is generated so that care should be taken to mount them in well-ventilated positions and not too close to other components. Resistances up to 5,000 ohms in value cost 3s. 6d. each; from 7,500 ohms to 40,000 ohms the price is 3s. 9d. Between 50,000 ohms and 100,000 ohms the prices range from 4s. to 6s. Among other new items is a series of small M.E.S. lamp-holders for illuminating condenser scales, etc. They are fitted with fixing lugs and soldering tags, and the prices range from 2d. to 3d.

The makers are A. F. Bulgin and Co., Ltd., Abbey Road, Barking.

ORMOND THREE-GANG CONDENSER

KNOWN as the No. 7 Screened Gang Condenser, this latest Ormond product incorporates the most up-to-date features and principles of condenser construction, for it is assembled on a stout steel frame rigidly supported and well braced. The rotors are mounted on a hollow shaft carried in two large bearings, which preclude any form of end-play. The spindle is positioned by small grub screws, it is adjustable for length, and can be inserted at either end for clockwise or counter-clockwise drive. Constancy of initial adjustment is ensured, first, by employing stout gauge aluminium for the vanes, and, secondly, by securely bonding the free ends of the rotor vanes in each section.

Contact is made with the rotors at two points, in addition to that afforded by the end-bearing, thereby enabling the wiring to be arranged so as to avoid connections common to two or more circuits. Each section is fitted with a small trimmer, the adjusting screws for which will be at the top when the condenser is secured to the baseboard by the fixing lugs provided. Provision is made, also, for mounting the condenser on its side, but this entails removing the dust cover.

Matching of the three sections in the specimen tested was very satisfactory, the largest discrepancy in the capacities was of the order of one per cent. only, while over the major part of the scale the average deviation was considerably less. The trimmers gave a variation of approximately 74 micro-mfds., and the minimum capacities of the three sections were 25, 26, and 25

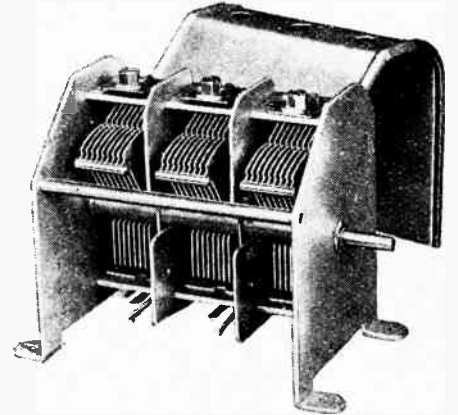

Ormond No. 7 screened gang condenser.

micro-mfds. respectively. The maximum change in capacity of a section was found to be 480 micro-mfds. (0.00048 mfd.), and the full capacity, with the trimmer set to minimum, was 0.000505 mfd.

To sum up, this latest Ormond gang condenser is a thoroughly sound component, both mechanically and electrically, and at the price of 21s. represents good value for money. The makers are the Ormond Engineering Co., Ltd., Ormond House, Rosebery Avenue, London, E.C.1.

NEW BRITISH RADIOPHONE DIALS

BRITISH RADIOPHONE, Ltd., Aldwych House, Aldwych, London, W.C.2, have introduced two new condenser dials of the type usually described as full-vision scales. Known as the models 582A and 583A respectively, they incorporate the same mechanical principles, and the only difference is in the shape of the scales employed. The slow-motion drive gives a ten-to-one reduction, and will drive a large gang

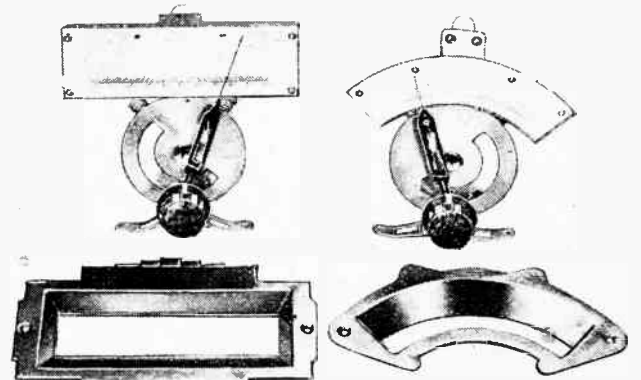

British Radiophone new type full-vision scales.

condenser without the slightest trace of slip or backlash.

Easily detachable dual-lampholders are fitted at the back of the translucent scale so as to give even illumination. The dial

is particularly robust, and will withstand very hard wear, being made almost entirely of steel. It is secured by screwing to the baseboard, for which purpose feet made of a pliable material are fitted, so that they can be easily bent to raise the dial to the height desired.

The model 582A has a straight horizontal scale divided into one hundred divisions, but on the companion model this is replaced by one having a slight curve, arranged so that the engravings are on the arc swept by the pointer. Either style will greatly enhance the appearance of the set, and, furthermore, they offer a welcome change to the orthodox semi-circular type.

These new dials fit condensers having $\frac{1}{4}$ in. shafts, and the drive spindle is left sufficiently long to pass through the wood front of a cabinet and protrude sufficiently to take a standard knob with a $\frac{1}{4}$ in. hole. Model 582A costs 8s. 6d., and the companion style (model 583A) 8s., including a bronzed-finished escutcheon of appropriate design.

EELIX DUPLEX COIL

UNLESS particular care is taken, switching in short-wave circuits may introduce quite serious losses, yet so far as practical considerations allow, the duplication of coil formers should be avoided, since coils not in use may be mislaid or suffer damage. In order to comply with both these conditions J. J. Eastick and Sons, Eelix House, 118, Bunhill Row, London, E.C.1, have developed a short-wave coil covering a range of 15 to 60 metres nominal without the need for switching or using a tuning condenser of abnormal size. Known as the Duplex coil,

it is wound with two separate sets of windings, and the required wave-band is selected by the simple expedient of reversing the coil

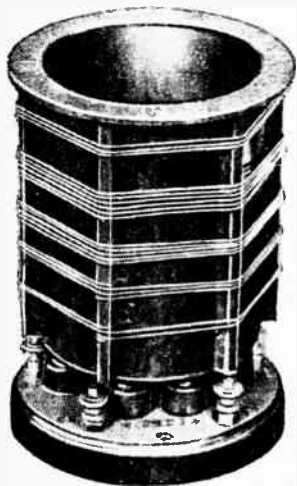

Eelix Duplex short-wave coil and base. Wave-change is effected by reversing the coil.

in its holder. A special base with sockets arranged to facilitate this is supplied. Tests made with a specimen coil proved entirely satisfactory. Used either in a straight det.-L.F. receiver or in a superheterodyne adaptor reaction was perfectly smooth and easily controllable over the whole range covered. No "blind spots" were encountered. We found it advisable, however, to include a small condenser in series with the aerial coil, since without it the effect of aerial damping was very marked at some parts of the wave band.

The top of the coil former is marked to indicate the short and long positions, their respective wave ranges being 15.25 to 31.7 metres and 27.6 to 55 metres using a 0.00015 mfd. tuning condenser and a 0.0003 mfd. reaction condenser.

To cover the 60-metre wavelength a 0.0002 mfd. tuning condenser is required.

The price of the Duplex short-wave coil is 7s. 6d., and this includes the special base.

In Next Week's Issue:—

The New Monodial Super

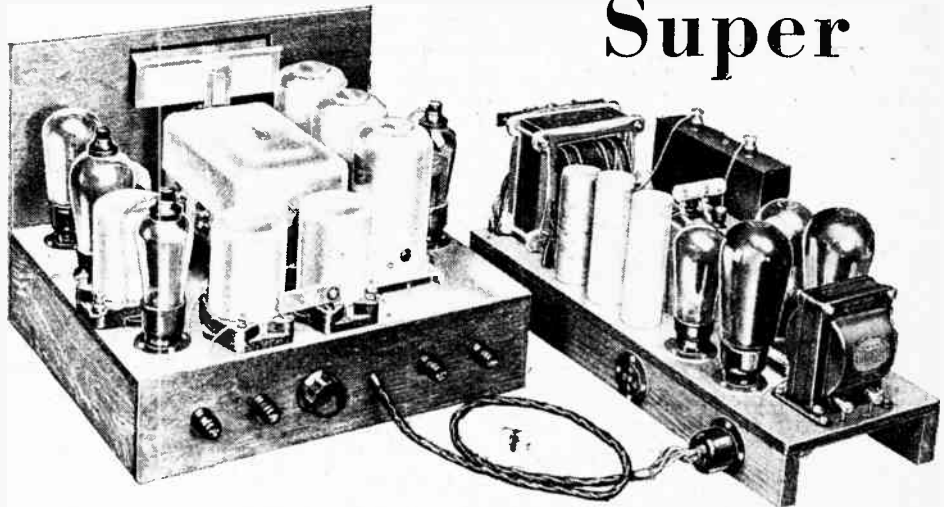

A successor to the original *Wireless World* Monodial, this receiver incorporates every practical new development in superheterodyne technique

THE New Monodial Super is designed on similar lines to the original Monodial, but incorporates those refinements and improvements which eighteen months of research have made possible. Among the features of the new receiver are a Pentagrid single valve frequency-changer, which reduces the possibility of whistle production, a duo-diode-pentode second detector giving delayed A.V.C. for eliminating fading, and a 6-watt push-pull output stage. The set is A.C. operated.

The performance is exceptional in every way. The sensitivity is sufficiently high to permit consistent distant listening even under poor conditions, and background hiss is very low. The selectivity prevents interference of the intelligible type from all stations spaced by 9 kc/s, and a filter permits sideband splash to be cut out at will. The quality of reproduction is better than that given by many local station "quality" receivers, and the volume is adequate for a small hall, but is under complete control. The A.V.C. system eliminates most of the effects of fading and also keeps the volume level constant on all stations.

LIST OF PARTS

After the particular make of component used in the author's model, suitable alternative products are given in some instances.

Receiver Unit.

- 1 3-gang Superhet. condenser with right-hand trimmers (Polar.) **British Radiophone**
- 1 Slow motion dial **British Radiophone No. 582A**
- 1 Set Superhet. coils **Varley BP19**
- 3 I.F. transformers, 110 kc. **Telsen**
(Colvern.)
- 3 5-pin Valve holders **Clix chassis mounting type**
- 1 7-pin Valve holder **Clix chassis mounting type**
(Goltone, W.B.)
- 1 7-pin Valve holder for 2A7 valve **Claude Lyons**
- 1 5-pin Plug **Bulgin P3**
(Keystone.)
- 1 5-way Battery cable with twin 70/36 leads **Harbros**
- 1 Tapered volume control, 250,000 ohms **Centralab**
(Claude Lyons.)
- 2 Toggle switches **Bulgin S.98**
- 1 Toggle switch, make and break **Bulgin S.80**
(British Radiophone, Claude Lyons.)
- 1 Potentiometer, 5,000 ohms, wire wound **Watmel No. 1**
(Haynes Radio, Claude Lyons.)
- 1 Fixed condenser, 12 mfd. **Eddystone No. 929**
- 4 Terminals, A. E. Pickup (2) **Belling-Lee Type "B"**
- 1 Compression condenser, 0.002 mfd. **R.I.**
- 1 Heterodyne filter, 3,500 cycles **Wearite W.M.3**
- 2 Screened H.F. chokes **Wearite Type H.F.P.**
- 2 Fixed condensers, 2 mfd., 400 v. D.C. test **T.C.C. Type 50**

- 1 Fixed condenser, 1 mfd. 400 v. D.C. test **T.C.C. Type 50**
- 5 Fixed condensers, 0.1 mfd. 400 v. D.C. test **T.C.C. Type 50**
- 1 Fixed condenser, 0.02 mfd. mica, 500 v. D.C. test **T.C.C. Type 25A**
- 1 Fixed condenser, 0.0001 mfd. **T.C.C. Type 34**
- 1 Fixed condenser, 0.01 mfd. **T.C.C. Type 34**
- 5 Fixed condensers, 0.0001 mfd. **T.C.C. Type "M"**
- 1 Fixed condenser, 0.002 mfd. **T.C.C. Type "M"**
(Dubilier, Peak, Telsen.)
- 1 Electrolytic condenser, 50 mfd. **T.C.C. Type 501**
- 2 Dial lamps, 6 volts **Bulgin Type O.B.**
- 2 Metallised resistances, 10,000 ohms 2 watts **Dubilier**
- 1 Metallised resistance, 1,000 ohms 1 watt **Dubilier**
- 1 Metallised resistance, 2,000 ohms 1 watt **Dubilier**
- 3 Metallised resistances, 20,000 ohms 1 watt **Dubilier**
- 3 Metallised resistances, 100 ohms 1 watt **Dubilier**
- 3 Metallised resistances, 2 megohms **Dubilier**
- 2 Metallised resistances, 0.1 megohm **Dubilier**
- 2 Metallised resistances, 0.25 megohm **Dubilier**
- 1 Metallised resistance, 0.5 megohm **Dubilier**
(Eric, Claude Lyons, Seradex.)
- 1 Resistance, 2 ohms **Claude Lyons**
- 1 5-way Connector **Wilburn**
- 2 lengths Screened sleeving **Harbros**
(Goltone, Leweos.)
- 10 lengths Systoflex, 2 ozs. No. 20 Tinned Copper Wire. Wood, etc.
- Plymax Baseboard, 14in. x 12in. x $\frac{1}{2}$ in. **Peto-Scott**
- Wood Panel, 14in. x 10in. 3-ply
- Screws: 12 $\frac{1}{2}$ in. No. 4 R/hd.; 30 $\frac{1}{2}$ in. No. 1 R/hd.; 16 $\frac{1}{2}$ in. No. 4 R/hd.; 2 $\frac{1}{2}$ in. No. 4 R/hd.
- Valves: 2 Marconi or Osram VMS4 (plain, metallised, or Catkin); 1 Osram or Marconi MHL4; 1 Cossor DD Pen; 1 Claude Lyons 2A7 with grid clip.

Power Unit.

- 1 Fixed condenser, 4 mfd. 1,500 v. D.C. test **T.C.C. Type 101**
(Dubilier.)
- 1 Dry Electrolytic condenser, 8 mfd. 500 v. D.C. working **T.C.C. Type 902**
(Dubilier.)
- 2 Dry Electrolytic condensers, 50 mfd. **T.C.C. Type 521**
- 2 Wet Electrolytic condensers, 8 mfd. 440 v. D.C. working **T.C.C. Type 802**
- 2 Metallised resistances, 1,000 ohms 2 watts **Dubilier**
- 2 Metallised resistances, 100 ohms 1 watt **Dubilier**
- 1 Metallised resistance, 10,000 ohms 1 watt **Dubilier**
- 1 Metallised resistance, 30,000 ohms 1 watt **Dubilier**
(Eric, Claude Lyons, Seradex.)
- 1 Resistance, 2,500 ohms, tapped at 1,000 ohms, 5 watts **Dubilier "Spirchm"**
(Electrad.)
- 1 10 henry choke **Sound Sales No. 10 D.C.**
- 1 20 henry choke **Bulgin LF14**
- 1 L.F. Transformer, push-pull **Ferranti A.F.5c**
- 1 Mains transformer, Primary 200 volts 50 cycles, Secondaries, 425-0-425 v. 120 mA., 4v.C.T.3A., 4v.C.T.1A, 4v.C.T.1A, 4v.C.T.6A., Screened Primary **Claude Lyons**
- 6 5-pin Valve holders **Clix Chassis Mounting Type**
(Goltone, W.B.)
- 1 5-pin Plug **Bulgin F3**
(Keystone.)
- Plymax Baseboard, 18in. x 6 $\frac{1}{2}$ in. with 2 runners 18in. x $\frac{1}{2}$ in. **Peto-Scott**
- 2 lengths Systoflex, etc.
- Screws: 36 $\frac{1}{2}$ in. No. 4 R/hd.; 8 $\frac{1}{2}$ in. No. 6 R/hd.
- Valves: 2 Osram or Marconi PX4 or Mullard AC044 or Mazda PP3/250; 1 Osram or Marconi F14, or Mullard DW4, or Mazda UU200, 500, or Cossor 400BU; 1 Ediswan DLS1 (Delay Switch).

UNBIASED

BY FREE GRID

They Trust Me

I HAVE been extremely gratified by the very considerable amount of correspondence received apropos of my recent note re automatic record changers for gramophones. Some of the missives from the silent sufferers who write to thank me for once more championing the cause of the under-dog are sufficiently poignant to make even a gramophone manufacturer cry like a human being.

Apart from these, however, I have had considerable correspondence from inventors who write and complain of the scurvy treatment which they have received at the hands of manufacturers. One man who possesses a record-changer with many invaluable features, including the ability to play either side of some twenty records, states that it has been hawked round all the various companies without a sale of the patent being effected.

Specially do I desire to thank all the many trusting inventors who have sent in for my inspection full details and all necessary working drawings of their brain-children without even observing the precaution of taking out a provisional patent.



Implicit trust in my integrity.

Their implicit trust in my integrity is very moving, and has done much to restore my fast waning faith in the inherent goodness and guilelessness of human nature.

This Must Stop

I HAVE had a pathetic appeal from a Novocastrian concerning the adoption of A.V.C. on the pleasure steamers which ply up and down the Tyne. According to my Tyneside correspondent, the B.B.C. programme received and fed to the various loud speakers on board is often completely ruined by a complete fade-out every time the ship passes under the high level bridge at Newcastle. "Often," writes my Northern friend, "I have been the unwilling spectator of the heartrending disappointment of a little child who has missed its birthday greeting owing to the wretched bridge intervening at the critical moment.

Now, personally, I have no sympathy with the bridge in question, having been mulcted of a halfpenny when passing over it some years ago, but, to give it its due, I am afraid that if it causes a complete blot-out, no ordinary system of A.V.C. will do, and a special one will have to be devised in its honour.

The only thing I can think of for the moment is that the steamer should rig up a spare aerial on a small boat, which should be towed behind it at a suitable distance, so that when the ship's aerial is momentarily screened the cessation of aerial current will release a delicate relay, which will bring the spare aerial into circuit. If any of you can think of anything better pray bear in mind the pathetic spectacle of little Tyneside children being robbed of their birthright, and communicate with me accordingly.

The Choir Boy Problem

A NOVEL experiment which is being tried in a church in one of the northern countries of Europe interested me so much that I paid a special visit there last week. Briefly, the customary choir-boys have been displaced by loud speakers, and in a chat with the local priest, aided by an interpreter, I learnt exactly why this course had been adopted.

Choir boys in that Northern latitude, it appears, are no better behaved than their cousins over here, and complaints from the congregation finally decided him upon this drastic step.

Into each choir stall had been built a cunningly concealed loud speaker, and these were all connected up to an amplifier fed by a gramophone pick-up and turntable under the control of the organist. Records had been obtained of the singing of most of the well-known hymns and psalms by choirs of world renown. The organist, therefore, had merely to keep in time with the singing. The whole thing had proved remarkably successful in leading the congregation in their choral efforts, except in the case of those newcomers who were put off their note in their efforts to probe the secret of the "ghost choir."

Although interested, I pointed out through the interpreter that the priest had undertaken needless expense in having a loud speaker built into every choir stall when two would have done the job much better, and more cheaply.

Furthermore, I stressed the fact that instead of taking pains to obtain records of unaccompanied singing it would have been better to have got hold of records with an organ accompaniment. He could then have dispensed with his organ and organist. He could also dispense with church bells, as the amplifier leads could

be switched through to a speaker in the belfry.

He was, I could see, quite fired by my idea, but wished to extend it further by having microphones fitted in the large cathedrals of his country, thus enabling



Hastily recanted.

him to obtain the whole service *en bloc*. I pointed out to him, however, that by so doing he would abolish himself, and he hastily recanted.

A Falling Commentary

THE B.B.C. are always seeking novel broadcasts to titillate the jaded palates of their listeners, but almost everything seems to have been done, ranging from broadcasts in the air to those from the bottom of the sea. I have just heard, however, of a new surprise item with which they are proposing to edify us, and, as the stunt does seem to me to possess the merit of real novelty, I tender them my warmest congratulations.

Briefly, the stunt is to broadcast the impressions of a parachutist descending from a height of between three and four miles. It is intended that he shall give a few preliminary observations from the aeroplane, and, as he leaps and trails his aerial after him, he is to give us a running, or perhaps I should say a falling, commentary on his impressions.

The transmitter will be a special low-power short-wave instrument strapped on his back, the whole apparatus having been developed by a well-known commercial wireless company for the purpose. Its signals will be picked up by a short-wave ground station, and the whole relay carried out after the manner of the usual boat-race broadcast. Well-known aeronautical experts tell me that the broadcast should last for about a minute and a half.

I cannot help thinking that this idea is worthy of further development, and the B.B.C. could with advantages arrange a similar broadcast by Professor Piccard the next time he ascends into the stratosphere.

Broadcast Brevities

By Our Special Correspondent

Hot Ideas

THE hot weather does not stem the flow of ideas in Broadcasting House, and I was amazed last week, when visiting that noble pile, to note the cascade of suggestions for brightening the programmes during the "dog days."

Ideas emanating from the staff rarely reach fruition, but this fact does not detract from the intrinsic value of the ideas themselves.

Sunday Evening "Proms" ?

"Why not give the public Sunday evening 'Proms'?" demanded one zealous creature. "And what," cried another, "is the objection to talks in public in the Concert Hall—talks that would have a snap about them which is totally lacking in the refrigerated stuff from the Talks Studio?"—or words to that effect.

Argument Against

The former suggestion has definitely been turned down by those in authority, who hate the thought of public audiences (other than church congregations) on a Sunday. It is no use to argue that the "Proms" need not start till 9 p.m. Presumably the trouble then would be that the audience would not get home in time to hear the Epilogue.

All-day Transmissions on Sunday

The Board of Governors met on Wednesday last, July 12th, to decide whether Sunday broadcasting should be continuous from mid-day till 10.30 p.m. By the time these lines are read an announcement may have been made. It seems pretty evident that the 6.30 to 8 p.m. period will be filled, possibly with alternative programmes.

Charity Appeals in the Studio

THE financial depression is having its effect on the "Week's Good Cause" appeals. There has been a considerable falling-off in contributions of late, though charitable bodies still recognise the microphone as the finest possible medium for appealing to the public purse.

Song Plugging to be Stopped

And, while on the subject of appealing to the public purse via the "mike," I have some interesting news apropos of song plugging. Dance-band leaders, not less than hospital secretaries, know the potency of the microphone, and anyone with any aural discernment must be aware that certain tunes are played more often than others. Why?

A Drastic Move

Well, it seems the B.B.C. is at last beginning to smell a rat, and I am able to state that a drastic move towards the suppression of this evil of "song plugging" will be made before the trees turn brown.

Even if additional expenditure is involved, the Corporation is determined to stop the subsidising of band leaders by the music publishers. At present the B.B.C. does not pay hotels and restaurants from which dance music is broadcast, but, remembering that "he who pays the piper calls the tune," the Corporation may shortly change its policy.

Henry Hall on Saturday Nights

ON his return from his American holiday Henry Hall will be faced with a slightly different régime. The B.B.C. Dance Band is to be heard on Saturday nights instead of Thursdays, as at present. This arrangement is no doubt due in some measure to the departure of Ambrose from the May Fair Hotel.

In the meantime, although big changes are imminent in the broadcasting of outside dance bands, the B.B.C. is definitely not appointing an outside band leader as "Controller-in-Charge" of broadcast dance music.

Scrapping the Nationals

BY the time these lines are read, West National should be testing during programme hours.

The synchronisation experiment has proved remarkably satisfactory, but, lest it should have failed, the engineers were previously comforting themselves with the reflection that the measure was only a temporary one. It is common knowledge that West National, in common with London National and North National, will be scrapped or at least suspended from service when the 100 kW. long-wave station at Droitwich is opened towards the end of next year. Scotland will probably retain its National transmitter, but the whole of England, it seems, will obtain its National programmes from the new high-power station.

Regrettable

In many ways this drastic step will be regrettable, for no one would pretend that a long-wave station, however powerful, can give such good modulation and be consis-

tently good over long ranges as a medium-wave transmitter covering a reasonably small service area.

National Programme as Standby ?

It certainly looks as if the National programmes will have to consist of talks and scraps, the Regional wavelength being reserved for serious musical efforts.

Wasted Transmitters

There is another aspect of the case. The London, Northern and West Nationals have not long been completed; indeed, West National was not on the air before sentence of death was passed upon it. How can the B.B.C. square up this with its ideals of economy and efficiency?

The answer, if any, will be given next week.

From the Crystal Palace

A CHOIR of four thousand voices, drawn from two hundred and twenty choirs of cathedrals, town and village churches affiliated to the School of English Church Music, will be heard by London Regional listeners on July 21st, when they take part in the Festival of English Church Music at the Crystal Palace. Organ accompaniments will be played by Dr. Ernest Bullock, and organ solos by Dr. Stanley Marchant. The conductor is Dr. Sydney H. Nicholson.

Re-arranging the Acoustics

The Crystal Palace holds no terrors for the B.B.C. engineers from the acoustical point of view, although admittedly only two previous relays have been given from this vast glass house on Sydenham heights. For the relay on July 21st, draperies will be fixed behind the organ, and the whole of the centre transept will be enclosed by movable draperies from roof to floor. In addition to the singing of the magnificent choir, an address by the Archbishop of Canterbury will be broadcast.



COATS OFF IN THE "EFFECTS" ROOM. A tense scene during the transmission of a play over the Columbia Broadcasting System of America. Radio drama in the U.S. is usually linked up with the products of the firm sponsoring the programme.

READERS' PROBLEMS

THESE columns are reserved for the publication of matter of general interest arising out of problems submitted by our readers. Readers requiring an individual reply to their technical questions by post are referred to "The Wireless World" Information Bureau, of which brief particulars, with the fee charged, are to be found at the foot of this page.

The "A.V.C. Monodial" Control Valve

IT is quite impossible by ordinary means to make an accurate measurement of the voltage applied to the control valve of the "A.V.C. Monodial" receiver. This is because the valve includes in its anode circuit a resistance of 1 megohm, and even when the best of meters is used for measuring the loss of voltage in this resistance is so great that the reading will be altogether misleading. Several querists who are apparently using low-resistance meters have found hardly any indication of voltage on the anode.

The published figure with regard to voltage relates to the measured difference of potential between the receiver chassis and the power chassis; this, in effect, is the true voltage applied to the A.V.C. valve under "no-signal" conditions, when no current is flowing through the valve.

Gramophone Volume Control

A QUERIST, who is about to convert his A.C. mains receiver for gramophone reproduction, asks whether it is better to fit the volume control potentiometer in the receiver itself, or at the end of the extension leads by means of which the pick-up will be connected.

Although this is often a matter of indifference, it is safest to install the potentiometer in the set, as indicated in

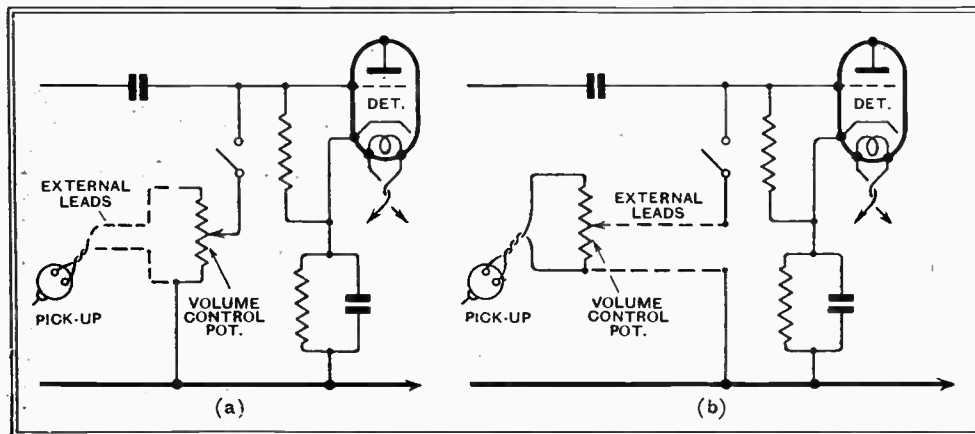

Fig. 1.—It is safer to install a gramophone volume control potentiometer at the receiver end of the pick-up leads (a) than at the remote end (b).

Fig. 1 (a). The alternative arrangement is illustrated in diagram (b).

Incidentally, it is worth while pointing out that when hum, instability, or any other untoward effect is produced by adding a pick-up to a receiver which originally worked satisfactorily without it, this detail should be borne in mind, and, if possible, the effect of changing the position of the potentiometer should be tried.

A.C. to D.C.

A READER, who has recently moved to a locality where the electrical supply is D.C., asks us to explain, as simply as possible, how his A.C. eliminator may be converted for operating on the new supply.

Full-wave valve rectification is employed, and the eliminator is of conventional design.

Theoretically, it should be a very easy matter to make the necessary changes. The two leads originally joined to the centre tapings of the filament-heating and H.T. windings of the power transformer should be disconnected from these points, and then connected, respectively, to the positive and negative mains leads, preferably through safety fuses.

Most eliminators are intended to give, on normal load, a voltage in the order of 150 volts, but the voltage of the ordinary domestic D.C. supply is considerably greater than the output of the rectifier normally included in commercial eliminators. It may therefore be necessary to add a resistance for absorbing the surplus voltage.

It is as well to remember that the amount of smoothing included in the average A.C. eliminator may be insufficient to cope with exceptionally "rough" D.C. mains.

Bias Volts for Nothing

AS the supply voltage of a correspondent who writes on the subject of a three-valve D.C. mains set is 200 volts only, it is realised that, in order to obtain the best possible performance, it will be necessary

the slider of a potentiometer which is connected across the choke.

By adopting this plan, the additional loss

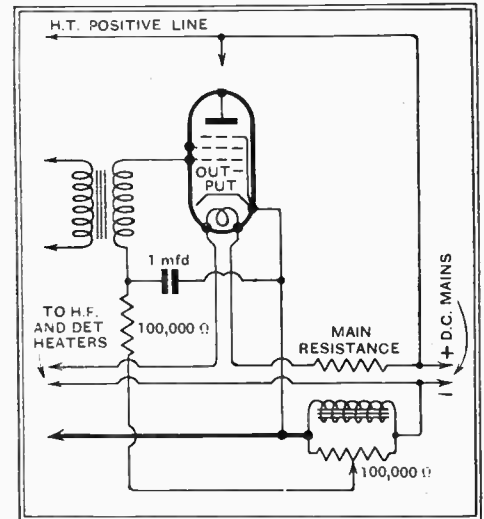

Fig. 2.—How to save ten volts: Grid bias scheme applicable to a D.C. mains set.

of H.T. voltage that would normally occur is entirely avoided. As the positive side of our correspondent's mains is earthed, the connection of the choke in the negative H.T. lead is quite permissible.

Impaired Smoothing Properties

ANOTHER question on a topic similar to that treated in the preceding reply deals with the ohmic value of a potentiometer which is to be shunted across a smoothing choke. To quote from the letter: "Would it not be permissible to use almost any resistance value, provided that it is several times greater than the D.C. resistance of the choke?"

In this connection, the D.C. resistance of a choke is of minor importance; what we are mainly concerned with is its reactance at the ripple frequency with which it will have to deal. By shunting the choke with a resistance of 1,000 ohms, as our correspondent proposes to do, its smoothing efficiency would be greatly impaired. A value of at least 50,000 ohms, and preferably higher, is to be recommended.

The Wireless World INFORMATION BUREAU

THE service is intended primarily for readers meeting with difficulties in the construction, adjustment, operation, or maintenance of wireless receivers described in *The Wireless World*, or those of commercial design which from time to time are reviewed in the pages of *The Wireless World*. Every endeavour will be made to deal with queries on all wireless matters, provided that they are of such a nature that they can be dealt with satisfactorily in a letter.

Communications should be addressed to *The Wireless World* Information Bureau, Dorset House, Stamford Street, London, S.E.1, and must be accompanied by a remittance of 5s. to cover the cost of the service. The enquirer's name and address should be written in block letters at the top of all communications.

to take exceptional care that there is no unnecessary waste of precious H.T. volts.

In order to obtain satisfactory smoothing without undue loss, it is intended to use a smoothing choke of high efficiency and low D.C. resistance. We are asked to say whether the voltage developed across this choke could be used for bias purposes if it were connected in the negative supply lead, and if so, to give a circuit diagram.

It is practically certain that voltage developed by the flow of H.T. current through the choke will be more than enough for biasing the output pentode that is to be employed, and we suggest that the circuit should be arranged as in Fig. 2, from which it will be seen that any desired proportion of this voltage may be "picked up" from

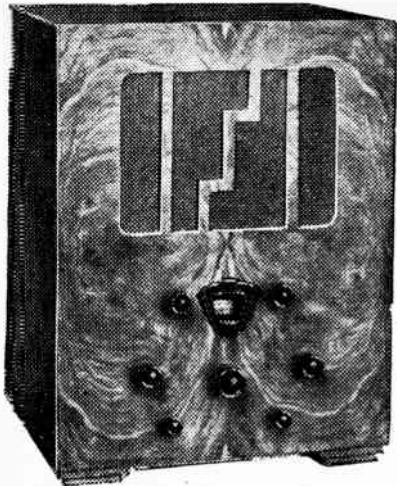

FREE. In view of the phenomenal interest taken in this wonderful circuit, we have reprinted 10,000 copies of the original article which appeared in the "Wireless World" of April 7th last and readers are invited to send for a copy, which will be forwarded gratis and post free on application.

NOTE THE NEW ADDRESS AND TELEPHONE NUMBERS

Important Notices to "W.W." Readers

On Monday last, the 10th inst., we moved into our new freehold factory premises at 18-20, NORMAN'S BUILDINGS, CENTRAL STREET, E.C.1.

These premises, comprising 13,000 square feet, are equipped with the most up-to-date plant and machinery, which place us in the position to supply the highest grade of Components and Receivers at fair and reasonable prices.

Our Cabinet-making plant is second to none in the country and we shall continue to cater for the individual requirements of our customers. Spacious demonstration and showrooms enable visitors to inspect the very latest examples of Receiver design and Cabinet-making craftsmanship.

Readers of the "Wireless World" will be interested to know that we have acquired the services of MR. W. I. G. PAGE, B.Sc., the designer of many Receivers of outstanding merit, who in future will act as Consultant and Technical Adviser to the Company. Our customers will thus be assured of the benefit of Mr. Page's many years' experience in Receiver design and technique.

Come and hear

"THE WIRELESS WORLD"

CLASS "B" FERROCART RECEIVER

The most outstanding Battery Set of the Year.

1. Every order for Kits of parts is delivered by our own vans direct to the forwarding London Terminus Station and placed on passenger train within two hours of receipt. Thus delivery to your address is effected within a few hours.
2. Every component is exactly of the designer's first choice, and is unconditionally guaranteed. Any component found to be faulty will be instantly replaced without question or charge.
3. The Kits are complete down to the smallest detail. Every screw, nut and washer required is included.
4. The services of our technical staff are at the disposal of every customer. Our interest does not end with the sale of the Components and every assistance is available to the constructor in case of doubt or difficulty.
5. We will test free of charge any Receiver constructed from a "G.A.C." Kit of parts.

KITS AS SPECIFIED
(Designer's first Choice).

KIT 'A' Complete (less Valves, Batteries, Cabinet and Loud Speaker) £7-11-0

KIT 'B' Complete with Valves (less Batteries, Cabinet and Loud Speaker) £9-17-3

KIT 'C' Complete with Valves, Cabinet and Loud Speaker (less Batteries) £13-9-3

Cabinet, as illustrated £1 . 12 . 6

THE CITY ACCUMULATOR CO., LTD.

18-20, NORMAN'S BUILDINGS,

CENTRAL STREET, E.C.1.

(Nearest station, Old Street.)

Phones:

Clerkenwell 1038 and 6206.

WEST END SHOWROOMS:

4, Surrey St., STRAND, W.C.2.

Phone: Temple Bar 8620.

WIRELESS DIRECTION FINDING

and DIRECTIONAL
RECEPTION

(1927)

By R. KEEN, B.Eng. (Hons.)

Second Edition

THIS volume deals with the principles of the subject and the constructional details of direction-finding installations, and includes some information concerning aircraft equipment. It describes the principles of Direction and Position Finding in such a way that the subject may be grasped easily by engineers tackling this field of wireless work for the first time. Numerous photographs and diagrams are included.

Price 21/- net. By post 21/9

From leading booksellers or direct from the Publishers:

ILIFFE & SONS LIMITED

Dorset House, Stamford Street, London, S.E.1

w.w.68

DAVENSET TRANSFORMERS

Home constructors will find no more reliable components than DAVENSET Transformers. Their specification in many well-known sets is evidence of the high opinion accorded them by the acknowledged experts in radio set design.

Write for a copy of "Mains Transformers & Power Smoothing Chokes for Radio & Industrial Purposes."

PARTRIDGE, WILSON & CO.
Dept. 29, Davenset Works, Leicester.

Scottish Branch: 200, St. Vincent Street, Glasgow, C.2.

MISCELLANEOUS ADVERTISEMENTS

NOTICES.

THE CHARGE FOR ADVERTISEMENTS in these columns is 12 words or less, 3/- and 3d. for every additional word.

Each paragraph is charged separately and name and address must be counted.

SERIES DISCOUNTS are allowed to Trade Advertisers as follows on orders for consecutive insertions, provided a contract is placed in advance, and in the absence of fresh instructions the entire "copy" is repeated from the previous issue: 13 consecutive insertions 5%; 26 consecutive, 10%; 52 consecutive, 15%.

ADVERTISEMENTS for these columns are accepted up to **FIRST POST** on **MONDAY MORNING** (previous to date of issue) at the Head Offices of "The Wireless World," Dorset House, Stamford Street, London, S.E.1, or on **SATURDAY MORNING** at the Branch Offices, 19, Hertford Street, Coventry; Guildhall Buildings, Navigation Street, Birmingham, 2; 260, Deansgate, Manchester, 3; 26a, Renfield Street, Glasgow, C.2.

Advertisements that arrive too late for a particular issue will automatically be inserted in the following issue unless accompanied by instructions to the contrary. All advertisements in this section must be strictly prepaid.

The proprietors retain the right to refuse or withdraw advertisements at their discretion.

Postal Orders and Cheques sent in payment for advertisements should be made payable to **ILIFFE & SONS Ltd.**, and crossed & Co. Notes being untraceable if lost in transit should not be sent as remittances.

All letters relating to advertisements should quote the number which is printed at the end of each advertisement and the date of the issue in which it appeared.

The proprietors are not responsible for clerical or printers' errors, although every care is taken to avoid mistakes.

NUMBERED ADDRESSES.

For the convenience of private advertisers, letters may be addressed to numbers at "The Wireless World" Office. When this is desired, the sum of 6d. to defray the cost of registration and to cover postage on replies must be added to the advertisement charge, which must include the words Box 000, c/o "The Wireless World." All replies should be addressed to the Box number shown in the advertisement, c/o "The Wireless World," Dorset House, Stamford Street, London, S.E.1. Readers who reply to Box No. advertisements are warned against sending remittance through the post except in registered envelopes; in all such cases the use of the Deposit System is recommended, and the envelope should be clearly marked "Deposit Department."

DEPOSIT SYSTEM.

Readers who hesitate to send money to advertisers in these columns may deal in perfect safety by availing themselves of our Deposit System. If the money be deposited with "The Wireless World," both parties are advised of its receipt.

The time allowed for decision is three days, counting from receipt of goods, after which period, if buyer decides not to retain goods, they must be returned to sender. If a sale is effected, buyer instructs us to remit amount to seller, but if not, seller instructs us to return amount to depositor. Carriage is paid by the buyer, but in the event of no sale, and subject to there being no different arrangement between buyer and seller, each pays carriage one way. The seller takes the risk of loss or damage in transit, for which we take no responsibility. For all transactions up to £10, a deposit fee of 1/- is charged; on transactions over £10 and under £50, the fee is 5/6; over £50, 5/-. All deposit matters are dealt with at Dorset House, Stamford Street, London, S.E.1, and cheques and money orders should be made payable to Iliffe & Sons Limited.

SPECIAL NOTE.—Readers who reply to advertisements and receive no answer to their enquiries are requested to regard the silence as an indication that the goods advertised have already been disposed of. Advertisers often receive so many enquiries that it is quite impossible to reply to each one by post. When sending remittances direct to an advertiser, stamp for return should also be included for use in the event of the application proving unsuccessful.

PILOT AUTHOR KITS

Exact to Specification

TWO UNIT PORTABLE

KIT "A" Author's Kit of **FIRST SPECIFIED** Components less Panel, Baseboard, Valves, Speaker, Batteries and Cabinet. **£4 - 16 - 3** or **12 monthly payments of 8/10.**

ESSENTIAL ACCESSORIES	
UTILITY Two-Gang Condenser, type 311.....	19 6
1 OLDHAM 2 volt unspillable L.T. Accumulator, type P.Z.F.3.....	13 0
1 PENTRIX 130 volt H.T. battery, type No. 312.....	16 6
1 SIEMENS 4 volt G. bias battery, type G.1.....	1 0
4 BLUE SPOT 25 P.M. "Class B" Loudspeaker.....	£1 12 6
4 VALVES as specified.....	£2 3 6
TWO UNIT PORTABLE CABINET to specification £1 - 15 - 0	

CLASS "B" FERROCART

OUR PRICE **£7-7-0** **KIT "A"** Cash or C.O.D. Carriage Paid. Or by 12 monthly payments of **13/6**

Comprising Author's Kit of **FIRST SPECIFIED** Components including Peto-Scott **PLYMAX** Baseboard, as specified by the Designer, Ready Assembled and Drilled, Not Metal Paper Covered, but less Valves, Cabinet and Speaker. **9/6**

PETO-SCOTT Genuine "Plymax" Baseboard 10" x 14" x 1/2" ready drilled with battens and brass strips. **AS SPECIFIED BY THE AUTHOR. NOT METAL PAPER COVERED.**

● **DELIVERY PER RETURN GUARANTEED.** Finished instrument as illustrated above. Ready assembled with Valves, Cabinet and Speaker exact to Designer's Specification and Broadcast Tested. **£14-7-6.** Your old set taken in **PART EXCHANGE.** H.P. Terms on application.

● We invite your enquiries for Kits, Part Kits, or Separate Components for all "Wireless World" Sets, including Finished Instruments. We specialise in and have the largest stocks of "Wireless World" Components in the Country. Write to-day. No obligation.

CASH. — C.O.D. — H.P. **FOREIGN ORDERS.** Send one-third value of goods with order. Balance (including forwarding charges) payable to our forwarding agents on delivery. Insurance effected if desired. All orders carefully executed and expertly packed by special export staff.

PETO-SCOTT CO. LTD.
77, CITY ROAD, LONDON, E.C.1.
West End Showrooms: 62, High Holborn, London, W.C.1
● **TRADE SUPPLIED—BEST DISCOUNTS.**

Mr. EXPERIMENTER—

Follow the lead of the manufacturers and make your connections and nuts positively secure with—

"SHAKEPROOF" LOCK WASHERS

AND LOCKING TERMINALS.

British Patent 194937.
The twisted teeth bite into the metal and prevent "slacking off." The more the vibration, the tighter they grip.

ASK YOUR DEALER FOR "SHAKEPROOF"

Manufactured by **BARBER & COLMAN Ltd., Brooklands, Manchester**
Dealers and factors' enquiries to—
W.M. CLARK (Spare Parts) Ltd., 5, Marshalsea Rd., London, S.E.1.

PARIMA SELENIUM CELLS

FOR ALL PURPOSES.

Parima Light-Sensitive Resistances are constant, mechanically strong, moisture proof and exceedingly sensitive. Fully guaranteed for 12 months. **5/-** Prices from

PARIMA MANUFACTURING CO.
21, BROMLEY ROAD, S.E.6. *Hither Green 3829*

RECEIVERS FOR SALE.

MILD MAY RADIO EXCHANGE
OFFERS the Following Mains Receivers, sound and perfect, all with English valves.
CLIMAX Table Type Radiograms, brand new, with Rola moving coil speaker, Collaro A.C. motor, and Harlie pick-up, 200-250 volt A.C.; listed at £23/2, £8 10 each.
AMPLION Six A.C. Mains Receivers, complete with built-in moving coil speaker, 2 screen grid with push-pull output; £9 each.
PHILLIPS 730A 6-valve Superhet, complete with built-in moving coil speaker; listed at £25/4, £9 10.
G.E.C. Compact 3-valve, complete with built-in speaker; listed at £18/18, £8; A.C. mains.
R.G.D.D.C. Mains Radiogram, listed at £48, unpacked, 2 screen grid circuit, in walnut cabinet; £20.
A.L. the Above Carriage Paid.
PHONE: Clissold 5001. 24, Mildmay Grove, London, N.1. [3065]

SHORT-WAVE Two, perfect results; real bargain, 65%.—7445, c/o *The Wireless World*. [3044]

"**WIRELESS WORLD**" A.C. Three, complete kit and valves, £5, or separate.—Box 7466, c.o. *The Wireless World*. [3051]

1933 Consor 5-Valve All-Electric a.c. Mains Set for Sale, £9; perfect condition.—Box 7471, c.o. *The Wireless World*. [3059]

1933 Philco 5-valve Superhet A.C., 60 stations; list £16/16, accept £8/8.—"Cranleigh," Farnborough Crescent, Addington, Surrey. [3046]

MAINS RADIO'S Offer of Guaranteed Super Receivers, all complete in table cabinets, internal loud-speaker, ring valves; carriage paid.

2-VALVE Battery Sets, oak cabinet, room for batteries, £1; 3-valve ditto, S.G., Det., power, walnut cabinets, £2.

MAINS Sets, all with moving coil speaker, walnut cabinets, 2-valve D.C., £3/17/6; ditto, A.C., £3/15; 3-valve D.C. (S.G., Det., Pentode), £5; ditto, A.C., £4/17/6.

A.L. Sets Give Performances Equal to Any Other Make; all brand new.—Mains Radio Development Co., 4-6, Muswell Hill Rd., London, N.10. [3070]

MORE Part Exchange Receiver Bargains for Disposal; state approximate requirements for quotation.—Coutts, Wireless Engineers, Horley. [2613]

"**MARCONIPHONE** 536" 7-v. Superhet. Radiogram, record changer, just new, must sell, leaving; cost £50, accept £35.—19, Old Ford Rd., Shoreham-by-Sea. [3047]

CLIMAX All-electric 200-250 A.C. Band Pass Three, in walnut cabinet, complete with valves and moving coil speaker; listed £16/16, unopened, £8/8, c.o.d., carriage paid.

OSTER-GANZ Combined A.C./D.C. All-electric Set, 3 valves and Magnavox moving coil speaker, in walnut cabinet; listed £11/11, our price £4/19/6, c.o.d., carriage paid.—Kay, 167, City Rd., Finsbury, E.C.1. [2835]

Receivers for Sale.—Contd.

TWIN Turntable Reproducer, B.T.H. Universal motors, oak cabinet, mains speaker separate cabinet, new valves, complete, suit cinema; £10.—14, Victoria Rd., Colchester. [3067]

"**WIRELESS WORLD**" Receivers Built to Specification, fully guaranteed; also supplied as kits; trade supplied; write for quotations.—London Radio Development Services, 56, Hazel Rd., Kensal Rise, N.W.10. [2987]

CHARGERS AND ELIMINATORS.

VORTEXION, Wimbledon, for 99.9% reliable transformers.

IF You Haven't Tried Them Yet Ask Someone who has, or call and inspect complimentary letters.

ALL Standard Models Delivery by Return; all secondaries centre tapped

GUARANTEED 12 Months, and within 5% normal and 2 1/2% super models, neat shrouding, with detachable feet, as used by Government Departments, etc., etc.

VORTEXION.—Specified for A.C., quality amplifier, 400 volts 110 m.a., 4v. 3, C.T., 4v. 2, 4v. 1, C.T., terminals, 24-; tagged leads, 20-; shrouded, 24/-.

VORTEXION.—Ferrocart III, 350-0-350, 60 m.a., 4v. 2.5, C.T., 4v. 3.5, C.T.; open type 13/6, shrouded 16/-; post 9d.

VORTEXION.—250-0-250, 4v. 1 to 2a., 4v. 2 to 4a.; open type 10/6, shrouded 12/6; post 9d.

VORTEXION.—Super model for H.T.B. or 9 or 10, 4v. 1 to 2, 4v. 2 to 4; open type 14/6, shrouded 16/6; post 1/-.

VORTEXION.—2 1/2-watt Monodial A.V.C. model; open type 14/6, shrouded 16/6; post 1/-.

VORTEXION.—5-watt Monodial A.V.C. model 400-0-400, 120 m.a., 4v. 6a., 4v. 3 1/2a., 4v. 2, 4v. 1a., super screened; 20/-, shrouded 24/-.

VORTEXION.—350-0-350, 120 m.a., 4v. 2 to 5a., 4v. 2 to 4a., 4v. 2.5a.; open type 14/6, shrouded 16/6.

VORTEXION.—400 or 450 or 500v., 120 m.a., 4v. 2 to 5, 4v. 2 to 5, 4v. 2 to 5; open type, 19/-, shrouded 23/-.

VORTEXION.—400 or 450 or 500, 150 m.a., 4v. 4a., 4v. 2.5, 4v. 2, 4v. 2, core size 2 1/2 in. x 1 1/2 in., a super job, 2% regulation; 35/- shrouded, with terminals, less terminals, 30/-, open type 26/-; post 1/3.

VORTEXION Auto Transformers to B.E.S.A. Specification, 100, 110, or 120v. to 200, 220 or 240 volts, 60 watts, 7 3/4, post 9d.; 120 watts, shrouded, 12/6, open type 10/6, post 1/-; 200 watts, open 14/6, shrouded 16/6, post 1/-; 500 watts 30/-, 2,000 watts £4/10.

VORTEXION 600-watt Transformers; £4/10, carriage free.

VORTEXION 30h. at 60 m.a. Chokes 5/6, 40h. at 60 m.a. 8/6, 30h. at 150 m.a., 200 ohms, 10/6 open type, 12/6 shrouded.

VORTEXION 200v. 30 m.a. Eliminators, 110 or 220 input with 4v. 4a. winding, 37/6.

VORTEXION.—Transformers made to your specification. All standards in stock. Phone: all hours.

VORTEXION (S. A. Brown), 182, The Broadway, Wimbledon. Tel.: Liberty 2814. [3079]

Mention of "The Wireless World," when writing to advertisers, will ensure prompt attention.

Chargers and Eliminators.—Contd.

- E**KCO 3E.20 A.C. Eliminator, 1930 type as new; 35/-; or offers. Gates, 14, Mayfield St., Halifax. [3049]
- T**ANTALUM for A.C. Chargers, H.T. and L.T.—Blackwell's Metallurgical Works, Ltd., Garston, Liverpool. [2139]
- C**RYPTO Converter, 110 D.C., 240 A.C., 400 watts; per foot; bargain, £6/10; list £25.—Martin, 43, Tophill St., Ebbw Vale. [3054]
- 180** Accumulator Chargers, 1½ amp., 2.6v., in ventilated metal case, with mains flex (Westinghouse rectifiers), 10/8; 1½ amp., 21/-; 7 days' trial.—Arden Agency, Wellington, Wellingborough. [2964]
- A**.C. or D.C. Chargers for 2 to 200 Cells at Low Prices; state requirements; dynamos and rotaries in stock, all sizes; Brown's Generator, battery superseder for H.T. for 2v. or 6v. input, 37.6 and 52.6; television and sewing machine universal motors, 25/-; lists.—Electradix Radios, 218, Upper Thames St., E.C.4. [3038]
- H**OYNE'S Transformers and Chokes, the Best Obtainable, perfect insulation, regulation and reliability, used exclusively by discriminating set manufacturers, all fitted with tapped and screened primaries, filaments all centre tapped, stout cast aluminium clamps fitted to all models, also clearly marked terminal strips.
- H**OYNE'S Components are Guaranteed for One Year.
- H**OYNE'S Transformers Built to Your Specifications, at very competitive prices.
- H**OYNE'S Supply the Trade.
- H**OYNE'S.—250-0-250v. 60 m.a., 4v. 1-2a., 4v. 2-4a.; 10/7, post 9d.
- H**OYNE'S.—250-0-250v. 60 m.a., 4v. 1-2a., 4v. 2-4a.; 4v. 1a.; 12/6, post 1/-.
- H**OYNE'S.—350-0-350v. 60-70 m.a., 4v. 2-3a., 4v. 3-4a.; 12/6, post 1/-.
- H**OYNE'S.—350-0-350v. 70-80 m.a., 4v. 2-3a., 4v. 3-4a., 4v. 1-2a.; 15/6, post 1/-.
- H**OYNE'S.—350-0-350v. 120 m.a., 4v. 2-3a., 4v. 4-6a., 4v. 1-2a.; 16/-, post 1/3.
- H**OYNE'S.—500-0-500v. 140 m.a., 4v. 2-4a., 4v. 4-6a., 4v. 2a., 4v. 2a.; 27/6, carriage 1/6, weight 12lb.
- H**OYNE'S.—0-110-135v. 90 m.a., 4v. 2-4a., suitable for H.T. 6 or 7; 10/7, post 9d.
- H**OYNE'S.—200v. 200 m.a., 4v. 2-4a., 4v. 1-2a., suitable for H.T.8; 15/6, post 1/-.
- H**OYNE'S 0-200-240v. 200 m.a., 4v. 2-4a., 4v. 1-2a., suitable for H.T.8 or 9; 14/6, post 1/3.
- H**OYNE'S.—Line transformers and chokes always in stock; we can also supply all components.
- M.** J. HOYNE, Offices and Works, 8a, Gladstone Rd., Wimbledon, S.W.19. Tel.: Liberty 5303. Open every day, including Wednesday and Saturday, till 7 p.m. [2771]

CABINETS.

RADIOGRAM Cabinets: fully illustrated list free; remarkable values.—Gilbert, Cabinet Maker, Swindon. [1686]

DYNAMOS, ETC.

ROTARY Converters, 220 volts D.C. to 200 volts A.C., capacities up to 0.44 K.V.A., cheap.—Milo Engineering Works, Milo Rd., East Dulwich, S.E.22. Sydenham 4422. [2907]

LOUD-SPEAKERS.

R. & A. Victor Speaker, as new; 50/-.—Corby, 47, Ivydale Rd., S.E.15. [3083]

B.T.H. R.K. Moving Coil Speakers, guaranteed new, unused, manufacturers' surplus, original price.

6 Guineas, highly sensitive and wonderful tone response, will handle up to 10 watts output, available for 6v., 100v., 200v. D.C.; 30/-; also A.C. models.

£2/10; carriage paid, cash, or cash with order; the best value in speakers obtainable to-day. Seakamp, 46, Farringdon St., London, E.C.4. Telephone: Holborn 0129. [1425]

PPETER GRASSMANN Moving Coil Speakers, 9in. cone, 7 watts, dis-in-pion, 220 volts D.C. type; 20/- each.—Rotor Electric, Ltd., 4, Robert St., N.W.1. [3075]

OPPORTUNITY!—"Magna" D.C.142, 2,500 megohms, 39/-; mains primu-static, with 13 6 matcher, 22/-; Challis Univers (list 47/6); 23/-; brand new, boxed.—Particulars, 151, Wellington Rd., Northampton. [3074]

30/-—B.T.H. R.K. moving coil speakers, 6in. cone, new and unused, guaranteed; these speakers are type as used in cinema sound equipments; suitable for public address work; weight 3 lb., and are vastly superior to cheap speakers now on the market, 100 volts, 150 volts, and 200 volts D.C.

27/6—11/6 D.C. speaker, as above; £2/7/6, speaker as above, for 103-250 A.C.; carriage paid; cash with order, or c.o.d.

B.T.H. Brand New Public Address Amplifiers, 4-stage, including microphone stage, 2 types, 12 watts and 6 watts outputs, 12-watt type has 2 P.P.5 400s in output, 6-watt type has 2 P.P.5 425s in output, 12-watt type price £15, 6-watt type £12 10/-; B.T.H. cinema type pick-ups, brand new, 17/6.—Ward, 12, Tredgar Rd., Bow, E.3. Advance 3668. [3082]

PICTURE RECEIVER APPARATUS.

TELEVISION Constructors' guides, disc receiver, 1/10; screen television, 2/8; we supply used or new components. A.C.R. Co., 270, High St., Camden Town. [3053]

TELEVISION.—All components supplied direct from the actual manufacturer.—Send your enquiries to John Salter, Member Television Society, Featherstone Buildings, High Holborn, W.C. [3003]

For PERFECT VOLUME CONTROL — WATMEL POTENTIOMETERS

Our Policy this year is to specialise in Potentiometers. You can, therefore, be certain when purchasing a Watmel Potentiometer that you are obtaining the very best from a firm that is concentrating on this type of component. This resistance meets with the requirements for a volume control which will have an equal variation of volume for the rotation of the knob. This is specially important for the control of the grid bias of the new variable- μ valves.

Here is illustrated the Watmel Type 2 Potentiometer with mains switch.

Price. Square Law Winding 8/6 Without Mains Switch 6/6 Type 1. Standard Winding 5/-

Please write for the interesting Watmel book on volume control. Free.

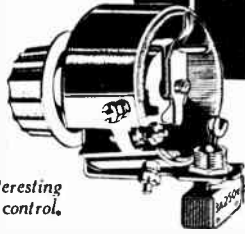

WATMEL WIRELESS Co., Ltd., Imperial Works, High Street, EDGWARE. Telephone: Edgware 0323

TRANSMITTERS.

- Q**UARTZ Oscillating Lenses 2/6.—Smith, Bryn Rodyn, Colwyn Bay. [3057]
- U**UNUSED Parts of 1½ kW. Transmitter, accept half cost price or best reasonable offer, would consider splitting. Mullard V.O. 350, cost £11; 2 Mullard V.U. 150s, cost £5 10 each; 3 Mullard supports for above, cost £3 10 each; 2 rheostats, 2 ohms 10 amps., insulated 6,000v. to earth, cost £3 1 each; 2 T.C.C. condensers, 1 mfd., 5,000v. working, 10,000v. test, cost £4 15 each; 3 2½-in. Dial A.C. voltmeters, 0-24v., cost £1 12 each; also D.C. voltmeter, 0-6,000v., takes 3 m.a., requires 2 meg. 6,000v. resistance, 2 AKW, 53, Church Rd., S.E.19. [3045]

VALVES.

THE Following Valves are Guaranteed as New, and any valve differing from the makers' characteristics will be exchanged, all latest types.

AC Pens., P.T.4s, G.U.1s, A.C.S.G. V.M.s, Pen. 4V.s, M.V.S.G.s, P.T.625s, V.M.S.4s, D.C.2/Pens., D.P.T.s, M.P.T.4s, V.M.4V.s, A.C.S.1 V.M.s, P.M.24B.s, D.C.28.G., V.M.s, 11/-; M.S.4s, M.S.4B.s, A.C.S.G.s, S.4V.A.s, S.4V.B.s, M.S.C. L.A.s, D.S.B.s, A.C.S. 2s, P.X.4s, D.C.28G.s, 9/6; U.14s, 10/-.

ML.4s, A.C. P.s, 41M.P.s, P.M.24s, 8/-; A.C. H.L.s, 164V.s, 354 V.s, A.C.2 H.L.s, 41M.H.L.s, U.10s, U.C.60 250s, M.H.4s, M.H.L.4s, 7/6; V.S.2s, 215S.G.s, 220S.G.s, P.M.12s, P.M.12A.s, 9/-; 442B.U.s, D.W.3s, 8/6; 215P.s, 220 P.s, L.P.2s, 4/9; P.2s, 6/6; P.T.2s, P.M.22A.s, 9/-; H.L. 210s, H.210s, L.210s, 3/9.

ALL Types of Brand New American Valves in Stock, first class makes; 247s, 235s, 224s, 236s, 237s, 235s, 245s, 244s, 12/-; 227s, 226s, 280, 245, 9/6; 242s, 252s, 11/-; U.N.210s, 15/-.

UX.250s, 7 watts output, 16/-; 281s, 14/6; for quickest delivery send telegraph money order.

OVER 5,000 Valves Always in Stock for Immediate Delivery; carriage paid; cash with order or c.o.d.—Ward, 12, Tredgar Rd., Bow, E.3. Advance 3668. [3081]

AND Another Large Purchase of Set Manufacturers' Stock, guaranteed as new, and any valve differing from the makers' characteristics will be exchanged free; all latest types.

HL.210s, H.210s, L.210s, 210H.L.s, 210H.F.s, P.M.1H.F.s, 3/9; P.M.2s, P.M.2As, L.P.2s, 220P.s, 215P.s, 4/9; D.H.s, 41M.H.L.s, M.H.4s, A.C./H.L.s, A.C./2H.L.s, 354V.s, D.C./3H.L.s, 1821s, 7/-; M.L.4s, A.C./P.s, 164V.s, 104V.s, P.M./24s, 442B.U.s, 1807s, 7/6; S.4V.B.s, S.4V.s, M.S.4Bs, M.S.G./H.A.s, A.C./S.4s, A.C./S.2, 41M.S.G.s, D.S.B.s, 215 S.G.s, P.M.12s, P.M.12A.s, 9/-; Pen.4Vs, V.M.S.4s, M.M.4Vs, P.T.41s, P.T.41Bs, D.P.T.s, A.C./Pens., 11/-; 620T.s, 680P.s, 10/-.

OVER 4,500 Valves Always in Stock for Immediate despatch; carriage paid for cash or c.o.d.; prompt delivery.

NEWMAN, 309, Roman Rd., E.3. [2892]

COMPONENTS, ETC., FOR SALE.

PREMIER Summer Sale.

10% Discount on All Orders of £1 or Over.

MANY Prices Reduced Apart from Discount.

PREMIER SUPPLY STORES Offer the Following Set Manufacturers' Surplus Brand New Goods at a Fraction of the Original Cost; all goods guaranteed perfect; carriage paid over 5/-; under 5/-, postage 6d. extra. (Ireland carriage forward.)

ELIMINATOR Kits, including Transformer, Westinghouse metal rectifier, Pye choke, T.C.C. condensers, resistances, and diagram; 250 volts at 60 m.a., 30/-; 150 volts at 30 m.a., 25/-; 120 volts at 20 m.a., 20/-.

FLUXITE Sheets for Charging Boards, 24in. x 24in. x 5/16in., 3/- each.

T.C.C. Condensers.—2 mfd., 750v. working, 4/-; 4 mfd., 6/-; 4 mfd., 490v. D.C. working (300v. A.C.), 4/-.

IMF., 500v. working, 1/6; 4 mfd., 200v. working, 2/6; 0.5 mfd., 1,500v. working, 2/-; 0.25 mfd. mica, 2/6; 4 mfd. Electrolytic (aqueous type), 440v. working, 3/-; 8 mfd., 3/6.

DUBILIER Condensers, 0.01 mica, 6d.; 0.01 mica, 1,000v. working, 1/6.

DOLAR 3gang 0.0005 Condensers, split end vanes, totally screened, disc drive, 6/11.

AMSCO Triple-gang 0.0005 Condensers, with trimmers; 4/11.

ORMOND 0.0005 Condensers, 1/3; 2 gang semi shielded, 2/6.

WESTERN ELECTRIC Mains Transformers, input 200-250 volt, output 500-0-500 volt, at 150 milliamps; 4v. 4a., 4v. 2.5a., 4v. 2a., 4v. 1a., 4v. 1a., massive job; 19/6.

T.C.C. Electrolytic Condensers, 10 mfd., 100 volts working 1/-; 15 mfd., 1/3.

SPPECIAL Offer of Mains Transformers, manufactured by Philips, input 100-115v. or 200-250v., output 180-0-180 volts, 4) m.a., 4v. 1a. and 4v. 3a., 4/6; 200-0-200v., 4v. 1a., 4v. 3a., 4/6.

ALL Premier Guaranteed Mains Transformers have engraved terminal strips with terminal connections, input 200-250 volts, 40-100 cycles, all windings paper interleaved.

PREMIER H.T.8 Transformer, 250v. 60 m.a., rectified, with 4v. 3.5a. c.t. L.T. and screened primary, 15/-; with Westinghouse rectifier, 25/-.

PREMIER H.T.9 Transformer, 300v. 60 m.a., rectified, with 4v. 3.5a. c.t. L.T. and screened primary, 15/-; with Westinghouse rectifier, 26/-.

(This advertisement continued on next page.)

"We're Fluxite and Solder —the reliable pair; Famous for Soldering—known everywhere!"

Take your RADIO with you —without any qualms: For if WE are near you—Music still hath her charms!"

See that Fluxite and Solder are always by you—in the house—garage—workshop—anywhere where simple, speedy soldering is needed.

ALL MECHANICS WILL HAVE FLUXITE IT SIMPLIFIES ALL SOLDERING

All Ironmongers sell Fluxite in tins: 4d., 8d., 1s. 4d., and 2s. 8d. Ask to see the FLUXITE POCKET SOLDERING SET—complete with full instructions—7s. 6d. Ask also for our leaflet on HARDENING STEEL with Fluxite.

FLUXITE LTD., (Dept. W.W.), ROTHERHITHE, S.E.16

FOR ALL REPAIRS!

ELIX

"MASTER" WALL PLUGS

PERFECT CONTACT IN ANY SOCKET.
NO ANNOYING CRACKLES.
SELF-CENTERING. SELF-ADJUSTING.
NON-COLLAPSIBLE PINS.
WIRED IN A MINUTE.
NO TOOLS REQUIRED.

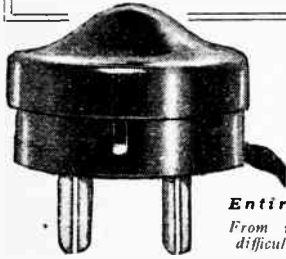

5 AMP. TWIN PLUG
Supplied Black or Bronze **9d.**

Entirely British Made
From most dealers. If any difficulty, send us 1/- P.O.

LECTRO LINX, Ltd., 79a, Rochester Row, London, S.W.1.

IF YOUR RECEPTION IS BAD

THE AERIAL WHICH MADE BROADCASTING POPULAR
SUPERIAL
ELECTRON'S SUPER-AERIAL

WILL IMPROVE IT



Whether it is a bad set or a bad locality SUPERIAL will make your reception definitely better because it is the most efficient and powerful aerial ever devised. The extra heavy rubber insulation stops interference and noises, abolishes maats, insulators and separate leads-in and increases the signal strength. The only efficient indoor or invisible aerial. Lightning proof too—get your £100 Free Insurance to-day. From all dealers.

100 ft 3/6; 75 ft 2/6; 50 ft 1/9; 25 ft 1/4
THE NEW LONDON ELECTRON WORKS LTD EAST HAM LONDON E.6

RICH & BUNDY

MAINS TRANSFORMER AND POWER CHOKES

Well known to amateur and professional radio engineers for nearly ten years.

For a reliable job of sound design and robust construction, specify

RICH & BUNDY

First in the field, imitated, but never equalled.

Transformers designed to your exact specification. Chokes which do the job without excessive losses. Highest grade British workmanship and Materials only. No mass production methods.

Every item built as an individual unit. Built to give long service and satisfaction.

"RICH & BUNDY FOR RELIABILITY."

Write to-day for descriptive Art Catalogue.

RICH & BUNDY LTD., Transformer Manufacturers, New Road, Ponders End, Middx.

Phone: Enfield 0777.
Sole Distributors: I.E.S.: KELLY & SIBBEL, Ltd., 47, Fleet St., Dublin, C.4

BAKER

WRITE NOW FOR OUR NEW BOOKLET & LEAFLETS

75-77 SUBSEX ROAD, CROYDON, SURREY

Phone: Croydon 2441-2

FOR QUALITY MOVING-COIL SPEAKERS.

Components, etc., for Sale.—Contd.

(This advertisement continued from previous page.)

PREMIER H.T.10 Transformer, 200v. 100 m.a., rectified, with 4v. 3-5a. c.t. L.T., and screened primary, 15/-; with Westinghouse rectifier, 26/-.

PREMIER Mains Transformer, output 135v. 80 m.a., for voltage doubling, 8/6; 4v. 3-4a. c.t. L.T., 2/- extra; Westinghouse rectifier for above, giving 180v. 30 m.a., 8/6.

PREMIER Mains Transformers, output 250-0-250 volts, 60 m.a., 4v. 1-2a., 4v. 2-3a., 4v. 3-4a. (all c.t.), with screened primary, 15/-.

PREMIER Mains Transformers, output 350-0-350 volts, 90 m.a., 4v. 3-5a., 4v. 2-3a. (both c.t.), with screened primary, 15/-.

PREMIER Mains Transformers, output 400-0-400 volts, 100 m.a., 4v. 4-5a., 4v. 2-3a. (both c.t.), with screened primary, 15/-.

PREMIER Auto Transformers, 100-110 200-250 volts or vice versa, 60-watt, 7/9; 100-watt, 10/-.

SPECIAL Offer of Manufacturers' Type Transformers, any input, output 250-0-250 volts, 60 m.a., 4v. 1a., 4v. 3a. (both c.t.), 8/6; H.T.8 transformer, with 4v. 3-4a. (c.t.), 8/6; with rectifier, 18/6.

AMPLION Mains Transformers, input 100-250 volts, A output 350-0-350 volts, 120 m.a., 4v. 5a., 4v. 2a., 6v. 1a. (all c.t.), 17/6.

FILAMENT Transformers, polished and engraved terminal boards, N.P. terminals, 4v. 3-4a., 5/6; 10v. 3a., 6/6; 12v. 1a., 5/6; 4v. 4-6a., 6/6; 14v. 4a., 6/6; 22v. 1a., 6/6; 6v. 2a., 5/6; 9v. 1a., 5/6.

PREMIER Chokes, 40 m.a., 25 hys., 4/6; 65 m.a., 30 hys., 6/6; 150 m.a., 30 hys., 10/6.

PYE Chokes, 20 or 32 hys., 4/6; Premier multi-ratio output transformers, giving 15 different ratios, 7/6.

PREMIER Eliminators, output 200-250 volts, 40-100 cycles, A.C., incorporating Westinghouse metal rectifiers, output 250v. 60 m.a., S.G. and 120v. taps, 42/6; with 4v. 4a. c.t. L.T., 7/6 extra.

PREMIER Eliminators, output 150v. at 30 m.a., S.G., and 100v. taps, with 4v. 3-4a. c.t. L.T., 37/6; or with trickle charger, 42/6.

PREMIER Eliminators, output 120v. at 20 m.a., S.G., and 100v. taps, 27/6; with L.T. trickle charger incorporated, 35/-.

PREMIER D.C. Eliminators, output 120v. at 20 m.a., S.G., and 100v. taps, 15/-.

ACCUMULATOR Chargers, 200-250 volts A.C., all incorporating Westinghouse metal rectifiers; 2, 4, and 6v. at 1/2 amp., 12/6; 2, 4, and 6v. at 1 amp., 17/6; 12v. 1a., 27/6; 6v. 2a., 35/6; 12v. 2a., 35/6; 12v. 1.5a., 30/6; 6v. 3a., 39/6; 12v. 3a., 42/6.

AMPLION High Inductance Chokes, resistance 2,500 ohms, 80 hys., 60 m.a.; 5/6.

WESTINGHOUSE Metal Rectifiers; 120v. at 20 m.a., 6/6; 180v. at 30 m.a., 8/6; 8v. at 1/2 amp., 6/6; 6v. at 1 amp., 9/6.

KOLSTER BRANDES Electric Gramophone Motors, complete with turntables and auto-matic stop, 100-250v. A.C. and D.C.; list price £5, to clear £2.

B.P.H. Induction Type (A.C. only) Electric Gramophone Motors, 100-250v.; 30/- complete.

ROLA Type F6 Moving Coil Speakers, 2,000 or 6,500 ohms, with power or pentode output transformers, 17/6; A.C. conversion kit for this speaker, 10/- extra.

AMPLION Moving Coil Speakers, type E.M.643, dual fields, 2,500 and 5,000 ohms (100 and 200v.), with output transformer, 12/6; A.C. conversion kit for this speaker, 10/- extra.

WESTERN ELECTRIC Condensers, 250v. working, 1 mfd. 6d., 2 mfd. 1/-; 500v. working, 1 mfd. 1/-; 400v. working, 3 separate 4 mfd. condensers, 8/6.

T.C.C. Condensers, 250v. working, 4x4x1 mfd., 3/6; 300v. working, 4x4x2x2x2 mfd., 6/-; 300v. working, 4x4x2x1 mfd., 6/-; 6x4x2x2x2 mfd., 375v. working, 6/11.

SPECIAL Offer of Wire Wound Resistances,—4 watts, any value up to 10,000 ohms, 1/-; 8 watts, any value up to 15,000 ohms, 1/6; 15 watts, any value up to 50,000 ohms, 2/-; 25 watts, any value up to 50,000 ohms, 2/6; 50 watts, any value up to 50,000 ohms, 3/6.

WIRE Wound Potentiometers, 15,000 ohms, 1/6; Centralab Potentiometer volume controls, 50,000 ohms, 2/-; wire wound Climatostat Potentiometer, 50,000 ohms, 2/6; Colverstats, logarithmically wound Potentiometers, 6,000 ohms, 1/9.

HEAVY Duty Variable Resistances, slider type, wound on porcelain, 2,000 ohms quarter-amp. and 500 ohms half-amp.; 5/- each.

FOR Callers Only.—The following valves, guaranteed as new: P.T.625, M.P., P.E.N., D.C.S.G., V.D.S., V.M.S., S.4V.A., A.C.S.G., A.C.S.G.V.M., V.M.S.G., 41M.S.G., V.M.S.4, M.S.4B., U.5, 904V., M.S.G.L.A., M.S.G.H.A., M.H.L.4, M.L.4, M.H.4, P.14, S.4V.D., D.W.3, P.T.4, D.S., D.S.B., M.S.4, 41M.L.F., P.E.N.4V., M.V.S.G., A.C.H.L.; at half list price.

THE Last Few Western Electric 4211-D Valves, 10v. 3a. filament, 750-1,000v. plate, 50-65 m.a., impedance 3,500 ohms, amplification factor 12; cost £5, to clear at 15/-.

500-VOLT 125-milliamp. Full Wave Rectifying Valves, v. 2a. filament; 7/6.

PHILIPS 328 Valves for L.T. Charging, 5/6; 329 Barrier lamps, 2/6.

ALL the Following Lines 6d. each, or 5/- doz. assorted: A Shielded S.G. or Pentode leads; 2ft. lengths of screened wire; 5-pin valve holders; Crabtree 5-amp. sunk switches; T.C.C. 0.1 mfd. condensers.

PREMIER SUPPLY STORES, 20-22, High St., Clapham, S.W.4, Macaulay 2188. Closed 1 o'clock Wednesdays, open to 9 o'clock Saturdays. Nearest Station, Clapham North Underground.

PREMIER.

RADIO DATA CHARTS

A SERIES OF ABACS

providing most of the essential Data required in Receiver Design

By

R. T. BEATTY, M.A., B.E., D.Sc.

Reprinted from "The Wireless World"

(1930)

"Radio Data Charts" provide designers of wireless apparatus with a ready and convenient means of solving problems without having recourse to complicated formulæ and mathematics.

By the use of the charts it is possible to tackle all the more familiar problems in radio receiver design; such as, for example, finding the relationship between inductance capacity and frequency, and working out the design of high frequency transformers. All keen amateurs will appreciate this helpful book.

(39 CHARTS and more than 50 Diagrams)

Price 4/6 net

By post 4/10

Published from the Offices of "THE WIRELESS WORLD"

From all leading booksellers or direct from the Publishers

ILIFFE & SONS LTD.
Dorset House,
Stamford St., London, S.E.1

W.W. 93

Components, etc., for Sale.—Contd.

R.
SELECTED Parts for Sale, as new, any equal, or "Wireless World" deposit system, which we recommend if in doubt as to the splendid value offered; we take risk of damage in transit to customers; goods tested for callers and guaranteed.

RYALL'S Mains Transformers, 250v. 60mA. 4v. lamp, 4v. 3amp, 10/6, 350v. 12.9. H.T. 7 10/6, H.T. 8 12/9, 4v. 3-5a L.T. 8/9, chokes, 20/11, 120mA. 8/9, 25H. at 60mA. 6/9, resistance 260 ohms, 40H. at 100mA. 600 ohms 10/6; all other models available.

TC.C., type 84, 1 mfd., 350v. working, 1/3; T.C.C., 2 mfd., 350 working, 1/6.

SIMPSON'S A.C. turntable, 21/6; B.T.H. Universal motor, Senior model, complete without auto stop, 40/-; pair Polar twin S.M. thumb drive, 0.0005, 12/6; pair Wearite Binowave coils, 12/6.

VARLEY heavy duty interval transformer, 10/6; pair Varley P.P. transformers, separate G.B., 22/6.

POLAR Star 3-gang Condensers, 16/6; with drive, 18/6; Radiophone 3-gang condensers, fully screened, with trimmers, Radiopack type, 9/-; post 9/-; Polar Uniknob 2 gangs, with drive, 7/6; Radiophone 4 gangs, 12/6; with cover and drive, 16/-; Radiophone 4-gang superhet, type, screened, with trimmers, Radiopack, type, 9/-, post 9d.

TC.C. Block Condensers, 2-4 mfd., 250v., working, 3/6; ditto, 2-4 mfd., 2-2 mfd., 4/-; Ryall's condenser block, 2-4 mfd., 2-2 mfd., 400v. working, 8/-; Ryall's S.T. 300-400 coils, 4/- pair, to clear; Lotus new 4 gangs, 17/6.

VALVES, all guaranteed as new, full emission, A.C./P.1. 8/6; A.C. H.L., 7/6; M.H.F., 7/-; A.C. S.2, 9/-; S.V. A., 12/-; Mazda S.G.V.M., 9/6; A.C. P., 8/-; A.C./P.E.N., 10/6; 904V., 7/6; 110, 7/6; 164V., 7/6. Following callers only: P625, 5/-.

RYALL'S RADIO, 33, Chancery Lane, London, W.C.2 (nearest Tube, Chancery Lane; bus 67 passes door, or tram to Savoy St.). Holborn 3529. Open Saturday afternoon. Close 7 p.m., Saturday 6 p.m., Thursday closed all day.

R. [3061]

GILBERT INDUSTRIES Latest Offer:—
"D" Parcels, containing all the following high grade components:—One transformer, 350-0-350 at 60 m.a., 4v. 4 to 6v., C.T., 4v. 2a., one chassis and 3-valve holders, one H.M.V. 2-gang with trimmers, one 15 mfd. T.C.C. electrolytic, one 4-4 mfd. T.C.C. block, one volume control, 4 assorted resistances, 6 small assorted condensers, one Paxolin strip (10in. x 3in.), one packet of "Varcos" insulating sleeving, 6 yds. heavy flex.

COMPLETE Parcel £1, post paid.—One "D" parcel and one A.C. Paillard motor, type 1604, universal input, complete with turntable, £2, post paid; also a few "A," "B" and "C" parcels still available. (See previous issues.)

TRADERS.—Do you realise that these parcels, when split up, will realise £3 to £4 in the shop?—Gilbert Industries, 519, London Rd., Westcliff-on-Sea. [3002]

SOUTHERN RADIOS Wireless Bargains.—Set manufacturers guaranteed surplus:—
VARIABLE Condensers.—British Radiophone 4-gang superhet type, fully screened and trimmers, 0.0005, 8/9 each (list 45/-); Cyclon 3-gang fully screened and trimmers, 0.0005, 7/- each (list 32/-); Utility 2-gang 0.0005, fully screened with trimmers, chat escutcheon and knob, 8/- each (list 39/6); Hydra block condensers, brand new, 16 mfd., 2-2; 8+2-1+1, 1,000 volt test (made for Canadian Marconiphone Co.), 8/9 each; 4 mfd., 2/6 each; 2 mfd., 1/9 each; 1 mfd., 1/- each; all 750 volt.

GRAMOPHONE Motors.—Electric A.C., 110 volt to 250 volt, guaranteed dead silent; made Dr. Max Levy, of Berlin, and listed at £9/9 0; 12 only at 27/6 each, complete with turntable.

SPEAKERS.—Celestion Soundex permanent magnet, 16/- (list 27/6); Rola F6 permanent magnet, 28/- (list 49/6); D.C. mains energised, 2,500 to 6,500 ohms, complete with humbucking coils and transformers, 16/6 (list 39/6); ultra permanent magnet speakers, 95P.M., complete with power pentode transformer, 47/6 (list £4/15).

CONSTRUCTORS' Kits.—Ready Radio "303" battery 3-valve kits, less valves, 18/- each; complete with 3 Mullard valves (P.M.H.F., P.M.2, 2D.X.), 33/- each (list 70/-); Ready Radio Meteor screen grid 3-valve kit, less valves, 26/-, with 3 Mullard valves (P.M.12A, P.M.2D.X., P.M.2a), 49/- (list £3/10).

READY RADIO Meteor Screen Grid 3-valve "A" Kit, complete with cabinet, permanent magnet speaker (less valves), £3/7/6, with 3 Mullard valves, £4/10 (list £8/17/6); Mullard Radio for Million 3-valve A.C. kit, complete with 3 Mullard A.C. valves (Pen.4V., 35A.V., 84V.), £3/10 (list £6/10); all kits brand new, in original sealed cartons.

ALL Goods Guaranteed Brand New and Perfect and Sent Carriage Paid.

SOUTHERN RADIO, 323, Euston Rd. (near Warren St. Tube), London, N.W.1. Phone: Museum 6324. [3069]

SERVICE RADIO, 46, Lisle St., London, W.C.2, offer set manufacturers guaranteed surplus:—
SMOOTHING Chokes, 20 Henries 120 m.a., 9/- each; 50 Henries 60 m.a., 7/3 each; 40 Henries 40 m.a., 5/9 each; Weston manufacturers, flush type, model 354, 30-0-30, 4/9 each (list 25/-), brand new and boxed; H.M.V. tone controls, 1/3 each (list 12/6); Rola P.M. speakers, F.6, 28/- each (list 49/6); Mains energised D.C. speakers, 2,500 ohms to 6,500 ohms, complete with Universal transformers and humbucking coils, 16/6 each (list 39/6); F.7 mains energised D.C. speakers, with Universal transformers and humbucking coils, 23/6 each (list 42/-); Plico All-in-one Radiometer, latest type with bakelite case, 6 only at 9/6 each (list 12/6).

WE Have Purchased a Large Stock of Marconiphone High Power Amplifiers, generators and converters, etc., etc.; this stock is too large and varied to be enumerated in this advertisement; we cordially invite readers of *The Wireless World* to call and inspect our stock, and can guarantee a saving of pounds on any goods purchased; all goods are brand new and guaranteed, and sent carriage paid.—Service Radio, 46, Lisle St., London, W.C.2. Phone: Gerrard 6653. [3068]

SHORT- WAVES!

THE "EQUATOR-SUPER" (BATTERY MODEL)

is specially designed and constructed for Tropical Use, particularly for Empire Station Reception.

Many unique features, including Automatic Volume Control and Westector Second Detector and Celestion Moving Coil Speaker. Handsome Teak Cabinet. Extreme simplicity of operation.

PRICE £33 plus £1.1.0 Royalty (Overseas) F.O.B. LONDON.

Send for List.

SCOTT SESSIONS

RADIO ENGINEERS,

MUSWELL HILL, LONDON, N.10

Cables: "Tropiset, London."

Contractors to H.M. Government Depts. etc.

Electradix Bargains

W.W. "Measurements with a Photocell"

We have some £5 Photo Cells for Talkies, Light Tests, Timing Controls, etc. at bargain prices. Response to light 50 microamps per lumen, 40 watt lamp, 75 c.m. King B.T.P., 15/-; R.C.A., 25/-; Holders, 1/-; Beck Prisms, 5/6; Focus Lens, 3/6. SELENIUM CELLS. Light sensitive resistance, gold grids, moisture-proof. L to D ratio 5 to 1, 5/- each. Mounted in Bakelite. 7/6. Super Model in Oxy-brass body with window, 10/-.

MICROPHONES 1-

Microphone Buttons for all purposes, 1/-; Booklet free. Announcers No. 11 Mikes, 5/6; Pedestal type 18/6. Microphone Carbon Granules. In glass capsule, enough for four buttons, Grade No. 1. 8d.; No. 2. Medium. 1/-; No. 3. Fine. 1/6; Carbon, solid back, blocks, 3d.; Mouthpieces, curved or straight, 10d. Carbon diaphragm, 55 mm., 4d. Panel brackets, pivoted, 5/-; Reed Receiver Unit for Amplifier making, 3/-; Headphones, 2/9 pair.

View-Cameras, Brown's Double Lens, 2-. Set Builders. All-metal chassis **Brownie**, fitted 2-valve holders, all drilled for Brownie components. 3/6. **Loud Speaker** Fret Silk, 12in., 10in., 1/-; 24in., 24in., 3/-. **35 gau. enam. Cop. Wire**, 2/6 lb. Switches, all types. Radio to 1,000 amps. cheap. **TELESCOPES**, Cooke monocular prism R.F., with 9-mile distance scale, 7in. long, weight 3½ lb., sale 17/6. **Naval Gun Sighting Telescopes**, internal focus ring, 24in. long, 2in. dia., weight 6 lb., magnification 6, for short and long range. Cost £25. Sale, 17/6. **Spotting Telescopes**, 17in. x 14in., by Watson, 25/-.

The GENEROMETER BATTERY SUPERSEDER makes H.T. from your L.T. 2-volt battery, rectified and smoothed. Gives 3 tappings with output exactly suited to Class B Amplification and lasts indefinitely. A boon to those who are not on the mains. Reduced from £3 15/- New and Guaranteed, 37/6.

Double Current DYNAMOS, cost Govt. £15. Two comms. D.C., 6-8-volt., 3-5 ams, and H.T. 400, 600-volt., 100 m.m., 5½in. dia., 12in. long, 17 lb., 4,000 revs., ball bearings. Guaranteed 12 months. Sacrificed at 22/6. Carriage 2/6.

MOTOR GENERATORS. For Battery Charging and Amplifiers.

R.C.A. 220 volt to 500 volt 200 m.a., £5; 3-phase 380 volts to 12 volts 10 amps. and 320 volts 300 m.a., £6. S.M.D. Co., 12 volts to 800 volts m.a., £4. D.C. 7½ H.P. 400 volts 12 amps. to 100 volts 66 amps., 1,700 revs. by E.C.C. £15. D.C. 115 volts 3 H.P. 23 amps. Motor coupled to 110 volts 14 amp. 50 cycle ½ K.W. A.C. Gen., £12. 220 D.C. to 310 volt 300 m.a. and 12 volts 10 amps., £6. Ditto to 480 volts 200 m.a. and 18 volts 20 amps., £6 10/- The best bargains ever offered in A.C.-D.C. sets. A quarter original cost.

ELECTRADIX RADIOS 218, UPPER THAMES STREET, LONDON, E.C.4.

Components, etc., for Sale.—Contd.

MAYFAIR RADIO Offers Brand New Surplus Stock, all guaranteed, carriage paid, cash with order or c.o.d.

AUTOMATIC Record Changers, complete with pick-up, A.C. 200-250, A.C. Carrard; listed at £10/10, at £7/10/6 (6 only).

RADIO-GRAMOPHONE Cabinets, solid walnut, Marconiphone type 535, overall 40in. x 19in. x 16in., take chassis up to 19in. 16, cost to make £8/10, at 45/-; carriage and packing 7/6 extra; H.M.V. figured walnut, type 531, as used in H.M.V. 70 guinea job, overall 40x27x20, take chassis up to 26in. x 19in., cost to make £12, at £4/15, carriage and packing 7/6 extra.

VARIABLE Condensers, British Radiophone, 4-gang Superhet, fully screened, with trimmers, listed 35/-, at 10/-; H.M.V. 3-gang, semi screened, fitted trimmers and drum drive, listed 32/-, at 10/-; Utility, 2-gang, complete with covers, trimmers, disc drive, etc., at 8/-.

MOVIING Coil Speakers, Rola's F.6 (2,000 and 2,500 ohms), listed 35/-, at 18/- each; F.7 voltages as above, listed 49/6, at 28/- each. All incorporate humbucking coils.

PICK-UPS: B.T.H. Senior, 1933, complete with volume control, listed £2/2, at 28/- each; Harlie, with volume control, listed 27/6, at 15/- each.

SMOOTHING Condensers, G.E.C. and Murphy, 800 test. 1 mfd. 1 l., 1 mfd. 1/9, 4 mfd. 2/6; the following 1,500 test, 500 A.C. working 800 peak, 1 mfd. 1/9, 2 mfd. 2/4, 4 mfd. 4/-; multiple blocks (separate tappings), 20 mfd., 2+2+2+2+2+2+2+2+1+1, at 11/-; 11 mfd., 4+2+2+2+1, at 6/9; 14 mfd. block, 4+4+4+1+1, at 7/6; 9 mfd. block, 4+4+1, at 5/3.

ASK for special quotations for all your requirements.

MAYFAIR RADIO, 31, George St., Hanover Sq., W.1. [3066]

PEPPIER. Closed from July 13th to July 30th, for holidays and reorganisation.—See this column, July 28th. [3083]

CHAL-ELECTRIC offers Brand New Set Manufacturers Boxed Surplus, all carriage paid, cash with order or c.o.d.

VARIABLE Condensers, Rola Star 3-gang, 1933, complete with disc drive, trimmers, covers, light, escutcheon, knob, etc., listed 30/6, at 17/-; Polar 2-gang Uniknob, complete as above, 10/-; J. B. Nugang 3-gang, complete as above, 15/-; 2-gang Nugang, 9/6; J. B. Utility 2-gang, complete as above, 8/6.

MOVIING Coil Speakers, last batch only.—Rola's F.6, 90/130 volts (2,500 ohms), 200/250 volts (6,500 ohms) listed 35/-, at 18/- each; F.7 voltages as above, listed 47/6, at 25/- state if power or pentode transformer. All incorporate humbuckers.

PERMANENT Magnets.—F.6 P.M., listed 49/6, at 28/-; F.7 P.M., listed 60/-, at 33/-.

AREAL Hefty Job.—Ultra 95 P.M., with Multi Ratio Transformer, listed £4/15, at 47/6.—Chal-Electric, 6, Conduit St., London, W.1. [3064]

FERRANTI New A.P.6, 25/-; A.P.5, 25/-; A.P.5c, 22/6; O.P.M.3, 15/-.—Jackson, Glenoran, Helensburgh. [3072]

RADIO Clearance.—Callers only, no lists; surplus stocks being cleared at bargain prices.—53, Newton St., Birmingham. [3084]

BARGAIN Bulletin, offering readers extraordinary radio component values sent post free.—Taylor, Macaulay St., Huddersfield. [3000]

LARGE Stock Second-hand Sets, components, valves, all perfect; cheap; write for list.—Zenith Radio-Service, 17, Park St., Guildford. [3063]

SPECIAL Clearance Bargains.—Projectors (9, 16 and 35 mm.), 30/-. Cameras from 20/-; everything for Movies, Walkies and Talkies; inspection invited.

ILLUSTRATED ENTERPRISES, 159, Wardour St. (facing Film House), London, W.1. Phone: Gerrard 6889. [3004]

SALE GRC Type 558 amateur band wavemeter, £4/15; GRC decade resistance box, 102K, £7/15; Sullivan calibrated variable condenser, 0.0005 mfd., £3/10. Box 74E5, c/o The Wireless World. [3050]

MOVIING Coil Milli-Ammeters, 0-50, 10/6 each; 2 milliamps and 120v. 17/6 each; other ranges in stock; alterations, repairs of every description.—The Victra Electrical Co., 47, High St., Battersea, S.W.11. [0355]

BARGAINS.—Garrard record changer, £7; Rola F.6 speaker, 2,500, 16/6; Colvern Ferrocat coils, 30/-; Ferranti A.P.5c transformer, 17/-; Colvern I.F., 9/6 each; Radiophone 3-gang, 25/-; Weller, 9, Walton (close, Cucklewood, N.W.2). [3071]

BT.H. Universal Gramophone Motor, 17/6; A.F.6, 15/-; Mazda P.P.3/250, 10/-; Osram P.N.4, 10/-; U.S.B., 8/6; Pye 20 and 32 Henry Chokes, 4/6 each; all above perfect; postage extra.—H. Thornley, 153, Somerville Rd., Small Heath, Birmingham. [3060]

FERRANTI A.F.3, 9/6; A.F.4, 8/-; A.F.6, 18/6; A.F.7, 18/6; A.P.3c, 12/6; A.P.5c, 17/6; A.P.5c, 20/-; A.F.7c, 20/-; A.F.11c, 21/-; O.P.M.1, 12/6; O.P.M.1c, 15/-; O.P.M.2c, 15/-; B2 choke, 9/6; set lowcos superhet coils, 18/6.—Bostock and Stonhill, 1, Westbourne Terrace, S.E.23. [3078]

EPTON First Again!—All valve prices reduced! Valves (as new): A.C.S.G./V.M., A.C.S.I./V.A., 9/6; P.M.22A, P.T.2, 12/-; 41M.P., 41M.S.G., D.U.2, 624B.U., 7/2; 41M.L.F., 1821, A.C.H.L., A.C.2H.L., 6/9; A.S.4, 84V.A., V.S.2, P.F.625, P.M.26, 8/9; P.M.256A, P.M.3, P.M.4, 8410, P.625, 5/3.

POLAR Screened 2-gang 0.0005 Condensers, tub type, disc drive, etc., 7/9; ditto, Uniknob model, 8/3; Utility 2-gang 0.0005, disc drive, trimmers, etc., 7/9.

EPTON, 93, New Rd., Chingford, E.4. Cash with order or c.o.d. [3076]

MISCELLANEOUS.

EASY Payments.—We supply, by easy payments, components, accessories, and sets, any make; 10% down, balance spread over 11 months.—Send list of requirements to London Radio Supply Co., 11, Oat Lane, London, E.C.2. [0337]

ENGINEERS and Technical Workers of All Kinds.—A proper training by post in your spare time will take you through your right examination, then employment is waiting. Our advice on all careers free. Dept. 92, The Bennett College, Ltd., Sheffield. [0395]

AMBITIOUS Engineers Wanted to Apply for Our Free 250-page Handbook, gives details of A.M.I.Mech.E., I.E.E., A.M.I.A.E., G.P.O., etc. exams, outlines latest courses in mech., elec., motor, radio and aero. engineering, and shows clearly where first class vacancies occur each year.—Send P.C. for free handbook immediately to British Institute of Engineering Technology, 87, Shakespeare House, 29, Oxford St., W.1. [3012]

AMBITIOUS MEN.—Qualify for a well-paid post by studying at home with the T.I.G.B. Write to-day for "The Engineer's Guide to Success," 144 pages, free, which contains the widest selection of engineering and wireless courses in the world, and shows you how to become A.M.I.E.E., A.M.I.Mech.E., A.Rad.A., etc. State Branch, post or qualification that interests you.—The Technological Institute of Great Britain, 82, Temple Bar House, London, E.C.4. (Founded 1917. 19,000 Successes.) [3008]

PATENT AGENTS.

PATENTS and Trade Marks, British and foreign.—Geo and Co. (H. T. P. Gee, Member R.S.G.B. and A.M.I.R.E.), 51-52, Chancery Lane, London, W.C.2. Phone: Holborn 1525. [0001]

REPAIRS.

IF you are in Trouble with Your Radio Set, write or phone to us.

WE are Service Specialists and Consultants for all A.C. and D.C. Mains and Battery Sets.—Helson Electric Co., 641a, Fulham Rd., S.W.6. Phone: Fulham 7217. [3073]

REPAIRS to Loud-speakers, transformers and headphones, 4/- each; Blue Spots or Wufis, 5/-; mains eliminators, etc., quoted for; prompt service; satisfaction guaranteed; terms to trade.—Loud-speaker Repair Works, 2, Shipka Rd., Balham, London. Streatham 6618. [0394]

REPAIRS.—Rebuilding to any set; highest quality work only; lowest charges; estimates given free; distance no object.—L. Eastwood, Radio Manufacturers' Consultant, Late of His Master's Voice and Marconi Wireless Telegraph Co. Telephone: Clerkenwell 4520. Address: 60, Horder Rd., Fulham, S.W.6. [3085]

GUARANTEED Repairs by Experts; specialists for repairs to S. G. Brown and Amphion radio apparatus, also loud-speakers, headphones, pick-ups, Blue Spots, any type rewound, remagnetised and adjusted; 4/- post free; mains transformer repairs; terms to trade.—Howell, 91, Morley Hill, Enfield, Middlesex. [19716]

TUITION.

RADIO Engineering.—Day, evening, and postal courses. This school is fitted with most modern apparatus. Prospectus free. Valuable recommendations given to qualified students.—Northern Counties Wireless School, Preston. [0359]

R.T.I. Training Methods are Recognised; write for particulars of home study for radio appointments; secure "Certificate of Proficiency" and become "A.M.R.T.I."—Radio Training Institute, 85, New Oxford St., London, W.C.1. [2947]

IF You Wish to Enter the Wireless Profession with a Thorough Training, or if you wish to improve your present position, you will need the certificate issued by Britain's leading wireless college. This is not a correspondence college. Apparatus of all leading makes installed for instructional purposes. Boarders accepted. Training fees can be paid after appointment. Prospectus free.—Wireless College, Colwyn Bay. [0388]

EXCHANGE.

HIGH Allowances Made on Second-hand Goods in Part Payment for New Sets or Components; easy payments available; we have tremendous stocks tested second-hand goods; send list of your requirements for quotation.—Bostock and Stonnill, 1, Westbourne Terrace, S.E.23. [3077]

FINANCIAL PARTNERSHIPS.

RADIO Engineer, with University or equivalent degree, required by radio set manufacturers, to take charge of production dept.; invest £1,000 in limited Co. Full particulars given in confidence, Box 7351, c/o The Wireless World. [2977]

WANTED.

CRYPTO Charger Wanted, a.c.; state particulars.—9, Leuham Rd., Thornton Heath. [3053]

SPOT Cash for Components, etc.—Economic Radio Co., 96-98, South Lambeth Rd., S.W.8. [2923]

HIGH Class Radio Sets and Parts Wanted for Cash, Mildmay Radio Exchange, 24, Mildmay Grove, London, N.1. [2972]

E.D.C.C. or M.I. Rotary Transformer, 12v. in, 50 or 100 watts out.—Holiday and Hemmerdinger, 2, Dalefield, Manchester. [3048]

ROTARY Converter, input 200 D.C., output 200-250 volts, 80 watts; complete smoothing, etc.; good condition.—Box 7487, c/o The Wireless World. [3052]

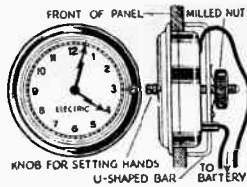

FIT THIS ELECTRIC CLOCK TO YOUR SET! NO MAINS NEEDED! KEEPS CORRECT TIME! NO WINDING!

Works off small battery lasting 12 months, or can be plugged into G.B. Battery without affecting reception. Uses practically no current. Fits into hole 3 1/2" dia. in any panel up to 1/2" thick. Easy to fix—no screws required. Only 1 1/2" from front of panel to back of case. Swiss movement. Hands set from front. Nickel plated bezel. Useful addition to any set.



RIVERSIDE MFG. CO., LTD., Dept. 20, Crisp Rd., Hammersmith, W.6 Telephone: Riverside 6392. COMPLETE WITH BATTERY POSTAGE 6D

EPOCH MOVING COIL SPEAKERS

The Finest in The World in Each of Their Price-classes. Ask your dealer or call for a demonstration at Exmouth House.

Send for New Booklet W.S.5a. It is free. EPOCH RADIO MANUFACTURING CO. Ltd. Exmouth House, Exmouth St., London, E.C.1. At the Junction of Rosbury Avenue and Farringdon Road. Phone: Clerkwell 9956 (4 lines).

Write for illustrated Catalogue of RADIO - GRAMPHONE CABINETS

of exclusive modern design, made by craftsmen, in highly figured Oak, Walnut or Mahogany, post free. REMARKABLE VALUES. Cabinets made to order a speciality. Maker, under license, of the HOWE BOX BAFFLE. Recommended by the B.B.C. Full details on request. GILBERT Cabinet Maker - SWINDON Est. 1886 Estimates Free.

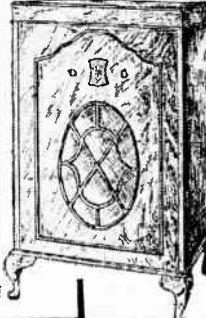

SAVAGE for AMPLIFIERS

Write for leaflet to W. Bryan Savage, 56 8, Clerkenwell Road, London, E.C.1.

HAVE YOU HAD? particulars of the "Magnum" Slow Motion Dial with the smooth non-slipping drive. Pilot Lampholder for rear illumination. Adaptable to all Air-spaced and solid Dielectric condensers. Retail price 3/-

BURNE-JONES & CO. LTD. 296, BOROUGH HIGH STREET, LONDON, S.E.1

Lamplugh RADIO LTD. COVENTRY Silver Ghost INDUCTOR MOVING COIL Dynamics SEND FOR LISTS

Wanted.—Contd.

ALL-ELECTRIC 3-Valve Bandpass Receiver, 200-250 A.C., console cabinet; complete £4 10 offered, deposit system.—Lincolt, Sudbury Rd., Halkstead, Essex. [3056]

WANTED, all types of A.C., D.C and battery valves, receivers and any other new components in quantities.—Ward, 12, Tredegar Rd., Bow, E.3. Advance 3668. [3080]

CASH Paid for Sets and Components, new or second-hand; best prices allowed in part exchange; S.G. valves, 2V., perfect, 9/-, or 3/- down, 2/- fortnightly; immediate delivery. R. Wigfield, Furlong Rd., Goldthorpe, Yorks. [3086]

SITUATIONS VACANT.

PROGRESSIVE Radio Manufacturers Have Vacancy for Production Manager Able to Make Small Investment; excellent opportunity for keen worker; directorship available later; bankers' and solicitors' references given.—Box 7482, c/o The Wireless World. [3083]

PERMANENT Magnets.—Old-established manufacturers have vacancy on technical staff for a man with thorough knowledge of all permanent magnet applications. Experience in design of speakers and pick-ups preferred. Send full particulars of qualifications, age, and salary required to: James Neill & Co. (Sheffield), Ltd., Napier St., Sheffield. [3055]

SITUATIONS WANTED.

ENGINEER, EXECUTIVE A.M.I.R.E., five years wireless, public address and acoustic experience, has progressive ideas of sales, management and display. Would reorganise shop or department for coming season for increased sales and decreased overhead.—Box 7473, c/o The Wireless World. [3062]

BOOKS, INSTRUCTIONS, ETC.

"MOTOR Racing," by S. C. H. Davis ("Casque" of "The Autocar"). A book of speed and thrills by a racing driver of international repute who secured notable successes at Le Mans in 1927, and in the 500 miles race in 1930. Demy 8vo., 320 pages, 6 maps, numerous illustrations from photographs, and pen sketches by the Author. Price 7/6 net, by post 8/-, from the Publishers, Illife and Sons Ltd., Dorset House, Stamford St., London, S.E.1.

AUCTION SALES.

JULY MONTHLY RADIO AUCTION.

By order of the Receiver and Manager—WITHOUT RESERVE. ENTIRE CONTENTS OF CITY WAREHOUSE together with Shop Fittings, Office Furniture and Motor Van. All new boxed and cartoned Goods, 1,600 sound boxes, 637 tone arms, 471 coils aerial wire, 18 doz. record cleaning pads, 89 assorted condensers, 169 Tunigram valves (power and battery), 54 ETA ditto, 1,200 various condensers, qts. of grid leaks, resistances, coils, chokes, moving coil and other speakers, voltmeters, hydrometers, 1,263 Piecedilly records, 304 earth tubes, bowl fires, torch cases, bulbs and batteries, oak, mahogany and walnut pedestal and console radiograms and other cabinets, 50 portable and table model gramophones and other articles too numerous to mention. 37 RADIOGRAM ALL-MAINS AND BATTERY RECEIVERS by Cifel, Kolster Brandes, E.R.P., Clarendon, Portman, Aeonic, Pembroke, Stamford, Apollo, Ediswan, Umfello, etc., etc. Catalogues of GODDARD & SMITH, 70, Seymour Place, W.1. Tel: 0277-3 and 5805.

Famous Maker's Offer! £5 Radio-Gram. CABINET for 65/- 7 DAYS' FREE TRIAL (OR 10/- MONTHLY). Piano built (Pat. 8123), the acoustic tone brings a fine thrill (Piano Oak). (Radio-Press, B.B.C., 3,000 clientele.) Models from 35/- to £15. List FREE. Send for photographs, detail drawings. Piano-Tone Cabinet, Albion Rd. (w.w.) Beesleyheath, Kent. Picketts £8-15-0

Cage Birds THE WEEKLY JOURNAL for all who keep Canaries, British Hybrids or Foreign Pet Birds. EVERY FRIDAY 2d. W.W.98 Specimen copy of recent issue free on request from The Publisher (W.W.), Dorset House, Stamford St., London, S.E.1.

FOR HIRE RADIO, MICROPHONE & GRAMPHONE AMPLIFIERS giving exceptional quality and volume, suitable for Dances, Sports Meetings, Fêtes, etc., from 15/- per day. McMichael Portable Sets 15/- a week: £2-12-6 a month. WIRELESS CONSULTANTS 55, EBURY STREET, LONDON, S.W.1. ESTABLISHED IN 1925. SLOANE 1653. Trade Inquiries Invited. SERVICE SETS OF ALL TYPES Supplied, Serviced and Visited in any district, or may be sent for Full Test and Report, at 2/- per valve-holder; portables, 1/6 per valve-holder.

PEAK CONDENSERS

The Electrolytic condenser illustrated here epitomises the Peak policy—highest quality at the lowest possible prices. Since its introduction, this condenser has won golden opinions from all sections of the trade, by its sterling performance under most arduous conditions, and altogether has worthily upheld that reputation for quality and unrivalled value always associated with the name PEAK.

ELECTROLYTIC CONDENSER TYPE W
450 Volt D.C. Peak working.

8 mfd 4/9 each



HOLDER FOR PEAK ELECTROLYTIC CONDENSERS



6d. each

The new illustrated price list of Peak Fixed Condensers is now ready and will be supplied free on request.

Wheatheaf House,
Carmelite Street,
Northern Distributors

WILBURN & COMPANY

London, E.C.4
Phone: CENTRAL 0810

W. Andrew Bryce & Co., Bury, Lancs.



The World's Best Reproducers
A type for every output 15 - to 70 -
Ask your dealer to demonstrate.

REPRODUCERS & AMPLIFIERS LTD., WOLVERHAMPTON.

COLLARO COMBINED PICK-UP AND MOTOR UNIT

A complete self-contained unit comprising "32" model Induction Motor, suitable for 100-130 Volts and 200-260 Volts, 40-60 Cycles. (Can also be supplied for 25-40 and 60-100 Cycles.)

Automatic start and stop, combined with "Collaro" Pick-up; all that is required for the Gramophone side of a Radio-gram.

The "Collaro" Pick-up can be used in conjunction with all receiving sets and amplifiers. The built-in wire wound Volume Control will show no signs of deterioration or cracking in use.

The Pick-up base head and arm are Bakelite mouldings and the general outline is designed to harmonise with the clean lines of the modern Radio-Gramophone.

Obtainable from all Radio Factors and Dealers.

COLLARO LIMITED.

Culmore Works, Culmore Rd., Peckham, London, S.E.15



PRICE 76/-
WITH BUILT-IN VOLUME CONTROL
80/-

Starts automatically
Stops automatically

THE WIRELESS ENGINEER

AND

EXPERIMENTAL WIRELESS

The Journal for Professional Engineers and Advanced Wireless Experimenters

Monthly 2/6 net

Annual Subscription 32/- post free

LIFFE & SONS LTD., Dorset House, Stamford Street, London, S.E.1

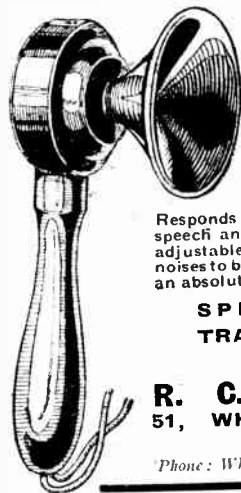

The R.C. ALL-PURPOSE ADJUSTABLE MICROPHONE

A scientifically made instrument suitable for Public Address, Home Recording, Transmitting, House and Factory Telephone and many other uses.

CAN BE USED ON ANY WIRELESS RECEIVER

Responds evenly to all sound-frequencies, giving crystal-clear speech and music at any power of amplification. Sensitivity is adjustable to suit output volume, a great advance enabling parasitic noises to be eliminated, thereby ensuring an absolutely silent background.

NEW LOW PRICE **7/6** Post Free

SPECIAL MICROPHONE TRANSFORMER, Ratio 100-1. Price **6/-**

OF ALL GOOD DEALERS.

R. C. & WILSON ELECTRIC Ltd.,
51, WHITCOMB STREET, LEICESTER SQ.,
LONDON, W.C.2

Phone: Whitehall 8877/6.

"Grams" & "Loudsigs," London.

INDEX TO ADVERTISEMENTS.

	PAGE		PAGE		PAGE
Baker's Solihurst Radio	4	Edison Swan Electric Co., Ltd.	5	Peto-Scott Co., Ltd.	2
Barber & Colman, Ltd.	2	Electradix Radios	5	Picketts	6
Belling & Lee, Ltd.		Epoch Radio Manuf. Co., Ltd.	6	Players	Inside Back Cover
Birmingham Sound Reproducers, Ltd.	Inside Back Cover	Fluxite, Ltd.	3	Postlethwaite Bros.	
Black, Alex., Ltd.	C	Garland Engineering & Manufacturing Co., Ltd.		R. C. Wilson Electric, Ltd.	7
Britannia Batteries, Ltd.		General Electric Co., Ltd.		Rawswood Electrical Co.	Inside Back Cover
British Radiophone Co., Ltd.		Gilbert, J. G.	6	Reproducers & Amplifiers, Ltd.	7
British Rola Co., Ltd.		Gramophone Co., Ltd.	xii.	Rich & Ruddy, Ltd.	4
British Thomson-Houston Co.		Hayberd, F. C., & Co.		Riverside Manufacturing Co., Ltd.	6
Bryce, W. Andrew, & Co.		Jackson Bros.		Rotax, Ltd. (M-L. Equipment)	
Bulgin, A. E., & Co., Ltd.		Lamplugh Radio, Ltd.	6	Savage, W. Bryan	6
Burne-Jones & Co., Ltd. (Magnum)	6	Lectro Lux, Ltd.	4	Scott Sessions & Co.	5
Burton, C. F., & H.		Lever, Eric J. (Trix), Ltd.		Seekamp, O. H.	
Carrington Manuf. Co., Ltd.		London Radio Supply Co.		Siemens Electric Lamps & Supplies, Ltd.	
Celestion, Ltd.		Lyons, Claude, Ltd.		Tannoy Products	
City Accumulator Co., Ltd.	1	Marconiophone Co., Ltd.		Telegraph Condenser Co., Ltd.	Front Cover
Clarke, H., & Co. (M. cr.), Ltd.		Multitone Electric Co., Ltd.		Telsen Electric Co., Ltd.	Front Cover
Cole, E. K., Ltd.	Front Cover	New London Electron Works, Ltd.	4	Varley (Oliver Pell Control, Ltd.)	Back Cover
Collaro, Ltd.	7	Parina Manuf. Co.	2	Watnet Wireless Co., Ltd.	3
Columbia Graphophone Co., Ltd.	Front Cover	Partridge & Mee, Ltd.		Westinghouse Brake & Saxby Signal Co., Ltd.	Inside Back Cover
Colvern, Ltd.	Front Cover	Partridge, Wilson & Co.	1	Wilburn & Co.	7
Coscor, A. Co., Ltd.				Wilkins & Wright, Ltd.	
Darwins, Ltd.	Back Cover				
Dubilier Condenser Co. (1925), Ltd.					



Complete Constructional Details of

The
Wireless
THE
PRACTICAL RADIO
JOURNAL
World

MONODIAL A.C. SUPER

A SEVEN-VALVE SUPERHETERODYNE RECEIVER OF OUTSTANDING PERFORMANCE

By W. T. COCKING

This booklet contains in a compact form the original articles which appeared in "The Wireless World"

It describes at length, with full explanations and illustrations, a superheterodyne receiver for A.C. Mains which is still unchallenged for faithful reproduction and exclusive selectivity.

Since the Monodial A.C. Super was first described, many thousands have been built, and no single instance of failure or disappointment

with the performance due to difficulties of construction, has come to light. The Receiver is an ambitious one, but the design is straightforward, and a simplified method of construction has been adopted.

For quality, range and selectivity, the performance is unsurpassed by any known receiver.

Crown 4to. 2; p. In attractive coloured cover.

PRICE 1/6 net. By post 1/8

From all book-sellers, or direct from the Publishers

ILIFFE & SONS LIMITED, DORSET HOUSE, STAMFORD STREET, LONDON, S.E.1



W.W.38

DICTIONARY of WIRELESS TECHNICAL TERMS

Compiled by S. O. Pearson, B.Sc., A.M.I.E.E., and issued in conjunction with "THE WIRELESS WORLD." Second Edition. Completely revised and brought up to date.

This handy volume is very much more than a Dictionary. It not only takes the technical terms of wireless and explains their meaning, but in doing so it concentrates into a small space a large amount of information on wireless subjects. It has become, in fact, a compendium of current wireless knowledge, and an invaluable handbook for all who are interested in wireless transmission and reception. Diagrams and illustrations are freely interspersed throughout the book to amplify the explanations of the text.

272 pp., bound in clothboards
Size 5 by 3 inches

Price 2/- net. By post 2/2

From all leading booksellers or direct from the Publishers

ILIFFE & SONS LTD., DORSET HOUSE, STAMFORD STREET, LONDON, S.E.1

Facsimile Page
from the
Second Edition

Impulse Excitation. Method of starting *high-frequency oscillations* in an aerial system or *oscillatory circuit* by a sudden surge, e.g., a spark, and not by applying an oscillating voltage of the same frequency as that of the tuned circuit. Sometimes called "shock excitation."

In Phase. Two alternating quantities are said to be "in phase" if they have the same frequency and pass through their respective maximum and zero values at the same instants. The definition applies only where the two waves

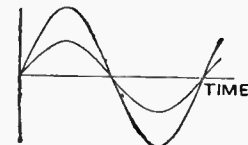

Sine waves in phase.

are of the same shape. See PHASE DIFFERENCE.

Indirectly-heated Valve. The type of valve in which the cathode is indirectly heated by a separate heater resistance, the cathode being a hollow cylinder to accommodate the heater within it. The heater may be supplied with A.C. or D.C.

Induced Current. A current produced in a circuit by an *induced E.M.F.*, i.e., by a changing of the magnetic flux linked with the circuit.

W.W.48

WEDNESDAY

JULY THE NINETEENTH

PRINCIPAL EVENTS OF THE WEEK:

AT HOME

- NATIONAL** Relay from Manchester Hippodrome.
LONDON REGIONAL Songs from Rudyard Kipling's Just-so Stories.
MIDLAND REGIONAL Variety programme.
SCOTTISH REGIONAL "Non-Stop," an engine driver's description of "The Flying Scotsman's" journey between Edinburgh and London, by Mr. Robert Shedden.

ABROAD

- BRATISLAVA** 5.55 p.m. Pianoforte recital of Hungarian music.
BRUSSELS (No. 1) 10.40 p.m. Dance music from the Continental Palace Hotel, Blankenberghe.
HAMBURG 10.30 p.m. "The Haunted Midnight Hour," a programme of characteristic music.
HEILSBURG 8.40 p.m. Summer songs of the Baroque Period.
HILVERSUM (announced Huizen) 9.25 p.m. Organ recital.
RADIO PARIS 8.45 p.m. Vocal and instrumental concert.
ROME 9.50 p.m. Concert by the Angusto Orchestra, from the Basilica di Massenzio.
STOCKHOLM 7.30 p.m. Orchestral concert, conducted by Adolf Wiklund, relayed from Skansen.
WARSAW 8.0 p.m. Songs and music for two pianofortes.

lin, Harpsichord and Strings (Bach), 9.30, Radio Report of the Fishing Festival from Putbus, 10.0, News, 10.15 (approx.), Dance Music, relayed from Treptow. In the interval at 11.0 (approx.), Talk: What they are saying in Berlin, 12 Midnight, Close Down.

BERNE.—See Schweizerischer Landessender.
BEROMUNSTER.—See Schweizerischer Landessender.

BODEN.—See Stockholm.

BODO.—See Oslo.

BORDEAUX-LAFAYETTE

986 kc/s, 334 metres; 13 kW. 6.15 p.m., Radio Journal, 7.15, News, 7.30, Tourist Talk, 7.45, Report of the Cycle Tour of France, 8.5, Agricultural Talk, 8.20, News, 8.30, Symphony Concert.

BRATISLAVA

1,076 kc/s, 279 metres; 11 kW. 5.55 p.m., Pianoforte Recital of Hungarian Music, with Introductory Talk; Etude in A flat, Op. 25 (Chopin); Rhapsody No. 2 in G minor, Op. 79 (Brahms); Polonaise in E flat, Op. 6.55, Report for the Housewife, 7.0, See Prague, 10.15 (approx.), Close Down.

BREMEN.—See Hamburg.

BRESLAU

923 kc/s, 325 metres; 60 kW.; and Gleiwitz, 1,184 kc/s, 253 metres.—2.0 p.m., Time and News, 2.20, Gramophone Music, 3.0, Agricultural Prices, 3.20, Talk: Travelling in China during the Revolution, 3.40, Talk: The German Gymnastic Festival in Stuttgart, 3.55, Talk: Luther's Views on Authority, 4.15, Pianoforte Recital by Gertrud Marks: Eight Variations on the Song, Ein Weib ist das herrlichste Ding (Mozart); Variations on the Name, Abegg, Op. 1 (Schumann); Variations on a Theme of Puccini (Hoyer), 4.45, Review of Periodicals, 5.5, Recital of Upper Silesian Folk Songs, 5.35, Talk: The Study of Heredity, 5.55, Acordion Concert: Erzherzog Albrecht-Marsch (Komzak); Overture, Light Cavalry (Suppé); Waltz, Heimatliebe (Pöhlner); The Mill in the Black Forest (Eilenberg); Potpourri, All Deutschland (Richter); Mazurka, Liebesglück (Schmidt); Fantasia on Verdi's Opera, La Traviata (Pries); Ein Vöglein sang im Lindenbaum (Eberle); Froedrichs Rex March (Radek); King Frederick March (Friedemann); March, My Regiment (Blankenburg), 6.50, News, 7.0, Transmission for all German Stations: A Call from the East—Propaganda Programme on the Siberian Frontier Problem, 8.0, See Berlin (Deutschlandsender), 8.5, Talk: The Political Struggle in Austria, 8.25, Love in the Ranks—Military Band Concert with Readings, 10.10, Time and News, 10.30, Talk: Locust Swarms in Silesia, 10.45,

Dance Music from Berlin (Witzleben), 12 Midnight, Close Down.

BRNO

878 kc/s, 342 metres; 35 kW. 2.50 p.m., Concert by the Station Orchestra, 3.55, See Prague, 4.0 to 5.45, Interval, 5.45, Recital of Folk Songs, 6.20, Gramophone Music, 6.25, German Transmission: News and Talk: The Medieval Castles of Moravia and Silesia, and Programme for Workers, 7.0, See Prague, 7.10, Reading, 7.20, Moravian and Slav Songs and Dances by Pista Berka and his Band, 7.45, Reading, 8.0, See Prague, 10.30 (approx.), Close Down.

BRUSSELS (No. 1)

I.N.R., 590 kc/s, 509 metres; 15 kW.—12.0 Noon, Concert by the Station Orchestra, conducted by Franz André; Soloist, Mme. Germaine Marville (Songs): Two Tickets to Georgia (Voung); Suite Africaine (Lacôme); Songs: Four Indian Love Lyrics (Woodford-Finden); Finale for the Violin Concerto (Mendelssohn); Two Old Dances (Razigade); Foxtrot, Please handle with care (Strider); Dances (Gervais-Sauis); Songs: (a) Goodbye (Tosti), (b) Si petite (Claret) (c) Confidence (Sykes); Selection from La Trompette de M. le Prince (Bazin); Summer Days (Coates), 1.0 p.m., Le Journal Parlé, 1.10, Concert by the Small Station Orchestra, conducted by Pierre Lecmans: March, Washington Post (Souza); Waltz (Waldteufel); Neapolitan Song (Bonincontro); Selection from Tip Toes (Gershwin); Pianoforte Solo, Barcarolle (d'Agreves); Torcedor et Andalouse (Rubinstein); Selection from Mademoiselle sourire (Lachaux), 5.0, Dance Music relayed from the Continental Palace Hotel, Blankenberghe, 6.0, Talk on the Belgian Musician, Wambach, 6.15, English Rhapsody; Brigg Fair (Delius), on Gramophone Records, 6.30, Sonata (Mendelssohn), by Mme. Michaux (Pianoforte) and M. Frenx (Cello), 7.0, Peer Gynt Suite, No. 2 (Grieg), on Gramophone Records, 7.15, Sight-seeing in Belgium: Danne in Flanders, 7.30, Medical Talk, 8.0, Concert by the Station Orchestra, conducted by Franz André: Military March (Schubert); I wake up smiling (Leslie); Pianoforte Solo: Allegro appassionato (Saint-Saëns); Selection from Comp de ronlis (Messager); Selection from Les Femmes d'Alger (Modigliani); Hindu Scenes (Missa), 9.0, Concert relayed from the Continental Palace Hotel, Blankenberghe, 10.30, Le Journal Parlé, 10.40, Dance Music relayed from the Continental Palace Hotel, Blankenberghe.

BRUSSELS (No. 2)

N.I.R., 887 kc/s, 338.2 metres; 15 kW.—Programme in Flemish.—12.0 Noon, Concert by the Small Station Orchestra, conducted by P. Lecmans: Overture, Maritana (Wallace); Henry VIIIth (Fields); Humoresque

(Montagu Phillips); Hornpipe (O'Neill); Fantasia on Popular British Songs (Humphries); Salut d'amour (Elgar).—Pianoforte Solo: Waltz Caprice (Newland); Dance from Tom Jones (German), 1.0 p.m., Le Journal Parlé, 1.10, Gramophone Concert: March from Prince Igor (Borodin); Berceuse (Gretchaninov); Dans l'église (Tchaikovsky); Song: Doubi (Glinka); Barcarolle (Rachmaninov); Melody (Karnovich); Waltz from The Sleeping Beauty (Tchaikovsky); Meditation (Glazunov); Song of the Volga Boatmen; The Fair at Sorochinsk (Mussorgsky); Wedding Procession (Rinsky-Korsakov); Two Popular Russian Songs; Selection from The Loves of the Three Oranges (Prokofiev); Melody (Bortniansky); Orfeural Dance (Glazunov); March of the Sirdar (Ippolitav-Ivanov), 5.0, Concert by the Station Symphony Orchestra, conducted by Meulemans: Overture, Le Roi d'Ys (Lalo); Selection from Les Bynes (Massenet); Pavane pour une infante defunte (Ravel); Air from Mors et Vita (Gounod); Ballet Music from Faust (Gounod), 5.45 p.m., Programme for Children, 6.30, Concert by the Small Station Orchestra, conducted by P. Lecmans: Overture, Les Hirondelles (Hirschmann); Waltz, Frühlingsstimmen (Joh. Strauss); Intermezzo and Barcarolle from The Tales of Hoffmann (Offenbach); Violin Solo: Hymn to the Sun (Rinsky-Korsakov); Old Dance Melodies: (a) Gavotte (Gossec), (b) Gavotte (Martini), (c) Minuet (Mozart), (d) Minuet from Le Bourgeois Gentilhomme (Lully); Dance of the Merry Jascots (Ketelhey), 7.15, Talk, 7.30, Le Journal Parlé, 8.0, Concert by the Station Symphony Orchestra, conducted by Meulemans, Soloist: M. de Decker (Bass) and Mme. Grainbeige (Pianoforte), Symphonie Poem, The Moldau (Smetana); Concerto in D—the Coronation (Mozart); Festival March (Busser); Symphonie Poem, Le chasseur harpiste (César Franck); Bass Solo: (a) Mijn moeder-spraak (Benoit), (b) Tronstliedeken (J. Van der Meulen), (c) De wiedeende mijnwerker (Hillebroeck); Tarantella for Flute and Orchestra (Saint-Saëns); Pianoforte Solos (Meulemans): (a) Lentewandeling, (b) Fête, (c) Danse exotique; Napoli (Chapentier); Waltz from Der Rosenkavalier (R. Strauss); In the interval, Religious Talk, 9.55, Evening Prayer, 10.0, Le Journal Parlé, 10.10, Extracts from Madame Butterfly—Opera (Puccini) on Gramophone Records.

BUCHAREST

761 kc/s, 394 metres; 12 kW.—5.0 p.m., Dance Music by the Syncop Accorders Jazz Band, relayed from the Lido. In an interval at 6.0, Radio Journal, 7.0, Reading, 7.20, Romaniote Music on Gramophone Records, 7.40, Educational Talk, 8.0, Violin Recital by M. Edin, Elmore; Sonata in G (Brahms); Tambourin chinois (Kreisler); Gavotte (Bach); Melody (Tchaikovsky); Percussion mobile (Ris), 8.20, Talk, 8.45, Pianoforte Recital by M. E. Stein: Sonata Op. 50 (Beethoven); Nocturne (Chopin); Dance (Friedmann); Aragonese (Albeniz); Paraphrase (Strauss-Grünfeld), 9.15, Cello Solo, by M. N. Papazoglu; Sonata in E Minor (Vivaldi); Arioso (Bach); Habanera (Lalo); Intermezzo from Goyescas (Granados), 9.45, Programme relayed from a Restaurant, 10.0, Radio Journal.

BUDAPEST

545 kc/s, 550.5 metres; 18.5 kW.—5.0 p.m., Dance Music, 6.0, Talk, 6.30, Orchestral Concert of Grieg Music, 8.0, Reading, 8.30, Song Recital, 9.20, Cigany Music by the Vercs Lajos Band from the Café Ostend. After the programme, English Talk, 10.45, Gramophone Music.

CASSEL.—See Frankfurt.

COPENHAGEN

1,067 kc/s, 281 metres; 0.75 kW. Relayed by Kalundborg, 260 kc/s, 1,153 metres.—12 Noon, Time and Chimes from the Town Hall, 12.5 p.m., String Ensemble Concert, relayed from the Wivex Restaurant, 2.0, Interval, 3.0, Gramophone Music, 3.30, Concert by Carl Radahl's String Orchestra: Overture, Maritana (Wallace); Selection from The Little Mermaid (F. Henriques); Waltz, Les Fleurs (Waldteufel); Sover sødt i hellig Fred (Nielsen); Norwegian Bridal Procession (Grieg); Minuet in E flat (Mozart); Overture, Der Gæstegætte (Lehár); Laengsel (Skovgaard); Waltz, Amelie (Lundbye); Selection from cavalleria rusticana (Mascagni); Vuggevis (Danning); Minuet (Paderewsky); March, Berliner Luft (Lincke). In the interval at 4.15 (approx.), Programme for Children, 5.35, Exchange and Fish Market Prices, 6.20, Talk: Peder Larsen skraeparket, 6.50, Weather Forecast, 7.0, News, 7.15, Time Signal, 7.30, Agricultural Talk, 8.0, Chimes from the Town Hall, 8.5, Concert of Danish Music by the Station Orchestra, conducted by Emil Reesen: Overture, Little Christie (J. P. E. Hartmann); Extracts from the Noctettes for Strings (Gade); Concert Overture, Nordisk Saeterreise (Gade); Romance for Violin and Orchestra (Lange-Müller); Selection from Ved Bosphorus (Lange-Müller); Dance from Maskerade (Nielsen), 8.50, Topical Talk, 9.20, Guitar Recital by Kurt Gudian, 9.50, News, 10.5, Orchestral Concert, conducted by Emil Reesen: Overture, Robinson Crusoe (Offenbach); Selection from Orpheus in the Underworld (Offenbach);

ATHLONE

725 kc/s, 413 metres; 60 kW. Relayed by Cork, 1,337 kc/s, 224.4 metres.—1.30 to 2.30 p.m., Time Signal, Stock Exchange Quotations, Weather Report and Gramophone Music, 6.0, Programme for Children, 6.45, News, 7.0, Gaelic Talk, 7.15, German Lesson, 7.30, Time Signal, 7.31, Recital of Duets for Two Pianofortes by A. Duff and Mrs. Atkinson, 7.55, Vocal Duets by P. J. Byrne and W. J. Hobbs, 8.15, The Station Orchestra, 8.35, Soprano Solos by Mollie Phillips, 8.50, Irish Music by the Station Orchestra, 9.0, Gaelic Song Recital by Denis Cox, 9.10, Uilleann Pipe Solos by Liam Andrews, 9.20, Songs (contd.), 9.30, Talk by Miss E. Jones: Eggs from the Farmer to the Consumer, 9.45, Sponsored Programme, 10.30, Time Signal, 10.45, News, Weather Report and Close Down.

BARCELONA

EAJI, 860 kc/s, 348.8 metres; 8 kW.—7.0 p.m., Trio Concert: Selection from The Barber of Seville (Rossini); Aria from Louise (Chapentier); Minuet (Ganne); Song from The Valkyries (Wagner); Wedding Day on Trollhaugen (Grieg); Selection from Mignon (Thomas), 8.0, Request Gramophone Records, 8.30, Exchange, 9.0, Gramophone Records and News, 10.0, Chimes, Weather and Market Prices, 10.5, Concert by the Station Orchestra, 11.15, Recitations (Ventura Ruiz Aguilera), with Introductory Talk, 11.30, Dance Music from the Casa Llibre. In the interval at 12 Midnight, News, 1.0 a.m. (Thursday), Close Down.

BARI

1,112 kc/s, 269.8 metres; 20 kW.—8.0 p.m., Agricultural Report, Tourist Talk and Dopolavoro Announcement, 8.20, Giornale Radio and Weather, 8.30, Time and Announcements, 8.35, Chamber Music Concert, Soloists: Milena Barberio (Soprano) and Franco Ruggiero (Pianoforte), Ballet Overture (Lincke); Soprano Solos: (a) Mi par eh'io sappia (Napoli), (b) Sgomento (Napoli); Sonata for Pianoforte (Ravel); First Swedish Suite (Wesslander); Soprano Solo, Canto di primavera (Cimara); Pianoforte Solos: (a) Danza (Napoli), (b) Intermezzo (Jachino); Overture, Silverya (Silverya); Soprano Solo, Nebbia (Respighi); Pianoforte Solos (Chopin): (a) Nocturne, Op. 15, (b) Etude No. 2, Op. 25; Adagio (Zucchi); Soprano Solo, Piano antico (Mile); Pianoforte Solo, Kullersenen (Schumann), Talk in the interval, 10.30, Music from the Gran Caffè del Levante, 10.55, News.

BASLE.—See Schweizerischer Landessender.

BELGRADE

BEograd, 697 kc/s, 430.4 metres; 2.8 kW.—5.55 p.m., Time Signal and Programme Notes, 6.0, Orchestral Concert, 7.0, Popular Song Recital, 7.30, Talk, 8.0, Aida—Opera (Verdi) on Gramophone Records. In an interval at 9.30, Time and News, After the Opera, Dance Music from the Ratnicki Dom Restaurant.

BERLIN

DEUTSCHLANDSENDER, 183.5 kc/s, 1,635 metres; 60 kW.—2.0 p.m., A Trip round the World—a Gramophone Concert, 3.0, Talk: The Protection of Animals and Food-stuffs against Poisonous Gases, 3.30, Weather and Exchange, 3.45, Reading (Felix Timmermans), 4.0, See Hamburg, 5.0, Talk: Style in German Speeches, 5.30, Suite for Viola da Gamba and Harpsichord (Rinken), 6.0, Poems, 6.5, Religious Address by the Rev. Müller, 6.35, Wireless Technical Talk, 6.50, Weather and Announcements, 7.0, Transmission for all German Stations, relayed from Breslau, 8.0, An Appeal for Funds for the National Labour Scheme, 8.5 (approx.), Symphony Concert by the Deutschlandsender Orchestra, conducted by Dr. Hans Hörner, Soloist: Prof. Kurt Schubert (Pianoforte); Overture, Der Schanpieldirektor (Mozart); Pianoforte Concerto in C Minor (Ph. E. Bach); The Oxford Symphony (Haydn), 9.0, Dance Music, 10.10, Weather and News, 10.45, Weather, 11.0, See Munich, 12 Midnight, Close Down.

BERLIN

WITZLEBEN, 715 kc/s, 419.5 metres; 1.5 kW.—4.30 p.m., Military Band Concert, relayed from Treptow, 5.25, Talk: Youth and the State, 5.45, Soprano Song Recital by Ilse Jörn: Songs (Franz): (a) Ein Ständlein wohnt vor Tag, (b) Mutter, o sing mich zur Ruh, (c) Für Musik, (d) Es hat die Rose sich beklagt, (e) Rosmarie; Songs (Cornelius): (a) Auf ein schlummerndes Kind, (b) Veilchen, (c) Three Songs from Brandtlieder—Ein Mäntchen; Vorabend, and Erfüllung, 6.5, See Berlin (Deutschlandsender), 6.40, The Witzleben Station informs its Listeners, . . . 6.45, Topical Talk, 7.0, Transmission for all German Stations, relayed from Breslau, 8.0, See Berlin (Deutschlandsender), 8.15, Handel and Bach Concert: The Chamber Orchestra, conducted by Eigel Krüttge, Soloists: Max Strub (Violin), Paul Luthier (Flute), Peter Herbert Lehmann (Cello) and Eigel Krüttge (Harpsichord), Concerto grosso in E minor for Strings (Handel); Trio in C minor for Flute, Violin, Cello and Harpsichord (Handel); Concerto in A minor for Violin and Strings (Bach); The Fifth Brandenburg Concerto in D for Flute, Violin,

Suite, The Four Ways (E. Coates); Selection from Frederica (Lehar); Russian March (Ganne). 11.0, Dance Music, relayed from the National Scala. In the interval at 12 Midnight, Time and Chimes from the Town Hall. 12.30 a.m. (Thursday), Close Down.

CORK.—See Athlone.

CRACOW

959 kc/s, 312.8 metres; 1.5 kW.—7.20 p.m., Miscellaneous Items and Announcements. 7.35, Programme Announcements. 7.40 to 9.10, See Warsaw. 9.10, Gramophone Music. 10.15 to 11.0, See Warsaw. In the interval at 10.25, Sports Notes. 11.0 (approx.), Close Down.

DANZIG.—See Heilsberg.

DRESDEN.—See Leipzig.

FECAMP

1,328 kc/s, 225.9 metres; 10 kW.—4.30 to 6.0 p.m., Programme in English by the I.B.C. 4.30, The Nursery Corner; Music, Stories, and Birthday Greetings. 5.0, Quartet Concert for Portsmouth and Southsea Listeners: The Night by the Sea; Dreams on the Ocean (Gungl); When the Convent Bell is ringing (Clifford); Song, The Blackbird in the Apple-Tree (Lubbeck); Pan and the Wood Goblins (Rathke); In Tudor Time beside the Water Mill (Albott); Song, Fairy Tales of Ireland (Coates); I do like to be beside the Seaside (Glover); Stephanie Gavotte (Czibulka). 5.30, Gramophone Concert from The Student Prince (Romberg); Selection from The Whirl of Golden Dawn (Kalmár); Piano Solo, The Futurist Rag (Bloom); Song, Mountain Lovers (Squire); Organ Solo, Rain on the Roof (Ronell); Piano Solo, When Love Day is done (de Sylva); The Porter's Love Song (Johnson); Selection from The Student Prince, Part 2 (Romberg); The Night by the Sea. 6.0, Programme in French. 10.0 till Close Down, Programme in English by the I.B.C. 10.0, Dance Music by the Rhythmic Rascals (Electrical Transcriptions); The Suit has got his Hat on; Let that be a Lesson to you; Singing in the Moonlight; Let me be your Carmen for to-night; Pagan Moon; The Old Kitchen Kettle; Leave the Rest to Old Man Moon; At Eventide; Speedway Sam; Sing a New Song; Dance of the Cuckoos; Strangers; When the Band goes marching by; Through that open Window; It's that extra little something; Same Old Moon; Bells of Normandy. 11.0, Piano Solo and Songs; Medley, Words and Music, Part 1 (Coward); Song, Seven Veils (de Sylva); Night aboard the Saucy Sue; A Fo'c'sle; Just humming along (Ewing); Everyone says "I love you" (Kalmár); Song, Dear Old-fashioned Thing (Harrington); Song, Serenade (Toselli); Medley, Words and Music, Part 2 (Coward). 11.30, Orchestral Concert: Signature Tune; Pool Butterfly (Hubell); Song, Sign no more (Aiken); The Fortune Teller (Herbert); Violin Solo, Tambourin chinois (Kreiser); London-derry Air (arr. Grainger); Song, Take a Pair of Sparkling Eyes (Sullivan); Serenade (Herbert); Waltzes from "A Waltz Dream" (O. Straus). 12.5 a.m. (Thursday), The I.B.C. Late News Bulletin. 12.10, (Club) Concert for Godmanchester Listeners. Part 1, Tango Band; The Chum Song; There was a poor Musician; I kiss your little Hand, Madame; Song, Loving them all; Marion, Part II; Dance Music; Dreaming; When we're alone; Wanderer; Somebody loves you; Wheezy Anna; Just an Echo in the Valley; Night after Night; A little Street where old Friends meet. 12.57, I.B.C. Goodnight Melody (Woods). 1.0 (approx.), Close Down.

FLENSBURG.—See Hamburg.

FLORENCE.—See Turin.

FRANKFURT

1,157 kc/s, 259.3 metres; 17 kW. Relayd by Cassel, 1,220 kc/s, 245.9 metres, and Trier, 1,157 kc/s, 259.3 metres.—4.30 p.m., Concert by the Station Orchestra, conducted by Reinhold Merten. Soloist: Cyrill Kopatschka (Violin). Part I: Violin Concerto in A Minor, Op. 55 (Dvorák). Part II: Old Dance Music. 5.45, Exchange. 6.0, Talk on Eugenics. 6.25, Topical Talk 6.45, Review of the Day's Events. 6.50, Time and News. 7.0, Transmission for all German Stations relayed from Breslau. 8.0, See Berlin (Deutschlandsender). 8.5, See Stuttgart. 9.20, Zaidé—Musical Play in Two Acts (Mozart). 10.20, Time and News. 11.0 (approx.), See Munich. 12 Midnight, Close Down.

FREDRIKSSTAD.—See Oslo.

FREIBURG.—See Stuttgart.

GENEVA.—See Radio-Suisse Romande.

GENOA.—See Turin.

GLEWITZ.—See Breslau.

GÖTEBORG.—See Stockholm.

GRAZ.—See Vienna.

HAMAR.—See Oslo.

HAMBURG

Call ha (in Morse), 806 kc/s, 372 metres; 1.5 kW. Relayd by Bremen, 1,112 kc/s, 269.8 metres; Flensburg, 1,319 kc/s, 227.4

JULY 19th **WEDNESDAY** continued

metres; Hanover, 530 kc/s, 566 metres, and Kiel, 1,292 kc/s, 232.2 metres.—4.0 p.m. (from Bremen), Orchestral Concert, conducted by Franz Koennecker, relayed from the Lüneburg-Bremen; Overture, Liebendes Leben (Rust); Selection from The Miracle (Humperdinck); Waltz, Hochzeitsreigen (Lincke); Metropolis, a Fantasy in Blue (Grofé); Two Pieces (Alter): (a) Manhattan Moonlight, (b) Manhattan Serenade; Selection from The Desert Song (Romberg). 5.0, Humorous Recitations and Talk: Hanover thirty Years ago. 5.30, Hamburg, Bremen and Lübeck—Report on Events in the Senates and Houses of Burgesses in the Hanseatic Free Cities. 6.0, Talk: Armies of other Countries. 6.20, From the City Archives—Radio Report from the Hamburg Town Hall. 6.45, Exchange and Weather. 7.0, Transmission for all German Stations, relayed from Breslau. 8.0, See Berlin (Deutschlandsender). 8.5 (approx.), Hohenzieritz—a Radio Sequence about Mecklenburg's Noblest Daughter, Queen Louisa of Prussia. 9.0, Concert from the Hohenzieritz Castle Park. 10.0, News. 10.20, Topical Talk. 10.30 (from Bremen), The Haunted Midnight Hour—Concert by the Bremen Stadtmusikanten, conducted by Reinhold Krug; Overture, Hokusokus (Leuschner); The singing Wind (Yoshitoku); Waltz, Fische Geister (Vollstedt); Heinkel der Gnommen (Metter); Moonlight Serenade (Moret); Fantasia, Dream Pictures (Linnhy); Mischkätzchens Nachtparade (Watzliff); Pantomime (Thomas); Gespenster-Parade (Köhler); Waltz, Nachtschwärmer (Zieher); The Clock is playing (Blaauw); Wenn die Nacht kommt (Korkert); Magic Moon (Humphries); Bari al buio (Michele); Mitternachtsspek (Rhode).

HANOVER.—See Hamburg.

HEILSBURG

1,085 kc/s, 276.5 metres; 60 kW. Relayd from Danzig, 662 kc/s, 453.2 metres.—1.5 p.m., Gramophone Music. In the intervals at 1.20 and 2.0, News. 2.30, Programme arranged by the Post Office with Gramophone Records. 3.0, Exchange and Market Prices. 3.20, Hints for the Housewife. 3.30, Programme for Children. 4.0 (from Danzig), Talk for Parents. 4.30, Concert by the Königsberg Opera House Orchestra, conducted by Ludwig Leschetizky, relayed from Königsberg; Overture, Der Wildschütz (Lortzing); Old Vienna in Song and Dance (Pachernegg); Es beat eine Krone im grünen Rhein (Pachernegg); Russian Dances (Bullerian); Fête villageoise (Godard); Overture, In der Natur (Dvorak); Army March. In the interval at 5.0, Review of Books on Broadcasting and the Cinema. 5.45, Programme in Commemoration of Queen Louise of Prussia. 6.15, Market Prices. 6.25, A Warehouse Fire in Königsberg (related from old Documents). 6.50, Weather. 7.0, Transmission for all German Stations, relayed from Breslau. 8.0, See Berlin (Deutschlandsender). 8.10, Talk: German Colonisation in Eastern Europe in the Middle Ages. 8.40, Summer Songs of the Baroque Period; Introduction by Prof. Müller-Blatzau; Songs from the Waldliederlein Cycle (Joh. Hermann Schein); Die Königsberger musikalische Kürbis-Hütte (Heinrich Albert); Der Streit zwischen Kuckuck und Nachtigall (Jakob Regnart). 9.40, Weather and News, followed by Dance Music from the Strandhotel. Cranz. 11.0, Programme from Berlin (Witzleben). 12 Midnight (approx.), Close Down.

HILVERSUM

Announced HUIZEN, 1,013 kc/s, 296.1 metres; 20 kW (7 kW, up to 4.40 p.m.).—Programme of the Christian Radio Society (N.C.R.V.). 11.55 a.m., Gramophone Music. 12.10 p.m., Instrumental Concert: Overture, Undine (Lortzing); Dreams on the Ocean (Gungl); Melody (Petras); Czardas (Nieklas-Kempner); Gramophone Music; Hungarian Comedy Overture (Kéler-Béla); Selection from Polenblut (Nedbal); Selection from Il Trovatore (Verdi); El Tria (Granados); Le Régiment de Sambre et Meuse (Planquette-Turlet). 1.40, Interval. 2.10, Talk for Stamp Collectors. 2.40, Gramophone Music. 3.40, Choral Concert and Gramophone Music. 4.40, Programme for Children. 5.40, Talk: Touring in Holland. 6.10, Talk. 6.40, Police Announcements. 6.55, Religious Information. 7.10, Talk. 7.40, Concert arranged by the Salvation Army. 9.10, Talk. 9.25, Organ Recital. In the interval at 9.40, News. 10.25, Gramophone Music. 11.10 (approx.), Close Down.

HORBY.—See Stockholm.

HUIZEN

Announced HILVERSUM, 160 kc/s, 1,875 metres; 8.5 kW.—11.40 a.m. till Close Down, Programme of the Workers' Radio Society (V.A.R.A.). 11.40 a.m., Concert by De Notenkrakers Orchestra, conducted by D. Wils. 1.25 p.m. to 1.40, Interval. 1.40, Programme for Women. 2.40, Programme for Children. 5.10, Concert by De Fliedruiters Orchestra, conducted by Horst. 6.10, Talk. 6.40, Topical Talk. 7.0, Concert by a Children's Choir. 7.20, Talk. 7.40, S.O.S. Announcements. 7.42, Concert by the V.A.R.A. Orchestra, conducted by de Groot. Soloist:

C. v. Munster (Tenor). In an interval at 8.10, News and Announcements. 8.50, Dramatic Programme. 9.10, Concert by the V.A.R.A. Orchestra, conducted by de Groot; Melody (Leopold); Wiener Walzer (Benatzky); In a Pagoda (Bratton); Dorrischens Brautfahrt (Rhode); Banditeingalopp (Strauss); Arab Dance (Tchaikovsky); Córdoba (Lozano). 9.40, Gramophone Music. 9.55, Orchestral Concert (cont'd.): March (Cicere); Mein Baden (Komzak); Schubert Potpourri (Urbaei); Plaisir d'amour (Martini); La Fanciulla del Mare (Toselli); Die Welt im Lied (Intrater). 10.40, Gramophone Music. 11.40 (approx.), Close Down.

INNSBRUCK.—See Vienna.

KALUNDBORG.—See Copenhagen.

KATOWICE

734 kc/s, 408 metres; 16 kW.—7.10 p.m., Talk for Housewives. 7.25, Announcements and Gramophone Music. 7.40, See Warsaw. 8.40, Light Music. 8.50, See Warsaw. 11.0, The Letter Box in French.

KIEL.—See Hamburg.

KLAGENFURT.—See Vienna.

KOSICE.—See Prague.

LANGENBERG

635 kc/s, 473 metres; 60 kW.—12 Noon, See Munich. 1.0 p.m., Concert by the Station Chamber Orchestra, conducted by Josef Breuer. Soloist: Erna Schröder (Soprano). Overture, Die Matrosen (Flotow); Soprano Songs: (a) Avelänten (Chelius), (b) Mondschein (Chelin); Geständnis (Brüggemann); International Suite (Tchaikovsky); Waltz, Dreams on the Ocean (Gungl); Selection from Boris Godunov (Musorgsky); Second Little Suite (Michele); Waltz, Winterstürme (Fucik); Riechhofen Marsch (Bransky). In an interval at 2.0 (approx.), News. 3.0, Literary Talk: Hans Jakob von Grimmelshausen. 3.30, Exchange and Time. 3.50, The Mountain Fortresses of Germany—Radio Sequence for Young People. 4.30, Orchestral Concert, conducted by Wolf; Overture, The Daughter of the Regiment (Donizetti); Selection from Der Rosenkavalier (R. Strauss); Two Pieces for Mixed Five-Part Choir (Robert Ziegler): (a) Im Wald, (b) Das Gericht; Ständchen (Graener); Liebeswalzer (Rger); Suite from The Sleeping Beauty (Tchaikovsky); Rhapsodie Fantasia (Urban). 5.50, Talk for Women: The Joys of Motherhood. 6.10, Variety Programme. 6.30, Italian Lesson. 6.45, Weather and Sports Notes. 7.0, Transmission for all German Stations, relayed from Breslau. 8.0, See Berlin (Deutschlandsender). 8.5, News. 8.10, German Dancing in Music and Literature—a Sequence by the Fröhliche Fünf and Else Pfaff (Recitations). 9.0, Dance Music from Berlin (Deutschlandsender). 10.15, News and Sports Notes. 10.35, Topical Talk. 11.0, Serenade from Munich. 12 Midnight (approx.), Close Down.

LAUSANNE.—See Radio-Suisse Romande.

LEIPZIG

769.9 kc/s, 389.6 metres; 120 kW. Relayd by Dresden, 941 kc/s, 319 metres.—12 Noon, Weather. 12.5 p.m. (approx.), Concert by the Leipzig Symphony Orchestra, conducted by Theodor Wünschmann. In the interval at 1.0 and after the Concert, News. 2.10 (approx.) to 2.20, Talk on Hermann Bahr, on his Seventieth Birthday. 3.0, Song Recital by Gerda Pönitz (Soprano); Two Arias from Der Freischütz (Weber); Two Arias from Figaro (Mozart). 3.35, Exchange Quotations. 4.0, Programme for Young People. 5.50, Exchange, Weather and Time. 6.0, Review of Books on German Musicians. 6.30, Talk: Adolf Hitler and Bayreuth. 6.50, Review of the Day's Events. 7.0, Transmission for all German Stations, relayed from Breslau. 8.0, See Berlin (Deutschlandsender). 8.5, Choral Concert. 8.40, Concert. 9.0, Agricultural Talk. 9.10, Datterich—Comedy (Elias Niebergall). 10.25, News. 10.40 (approx.), Orchestral Concert, conducted by Hilmar Weber; Champagner-Ouverture (von Baussner); Er und Sie—a Dance Comedy in Six Scenes (Georg Kießig); Selection from Christelflein (Hans Pfitzner); Rhapsody in C, Op. 7 (Birk Schäfer); Two Pieces (Grieg): (a) Im Volkston, (b) Kuhnreigen und Bauerntanz; Waltz, Künstlerball (Fritz Blüher). 12 Midnight, Close Down.

LINZ.—See Vienna.

LJUBLJANA

522 kc/s, 574.7 metres; 7 kW.—5.30 to 6.0 p.m., Programme in English by the I.B.C. International Broadcasting Club Concert: Someone to care for; This is no dream; Play Fiddle play; I'll never have to dream again; The Night was made for Love; To-morrow Night we'll meet again; How are you?; When they're on the Love Parade; Ooh, that kiss; My donna Rita. 6.0, Readings. 6.30, Gramophone Music. 7.30, Literary Talk. 8.0, Song Recital. 8.45, Guitar Solos. 9.30, Weather and News. 9.45 (approx.), Gramophone Music. 11.0 (approx.), Close Down.

LUXEMBOURG

252 kc/s, 1,191 metres; 200 kW. Luxembourg Programme.—7.0 p.m., Orchestral Concert. 7.45, Weather Report. 7.45, Scottish Symphony (Mendelssohn) on Gramophone Records. 8.15, Talk on Nicholas Ries, the Luxembourg Author. 8.25, Recital of Luxembourg Songs. 8.50, News in French. 9.15, Choral Concert Relay. 9.45, News in German. 9.55, Concert of Light Music by the Station Orchestra. 10.25, Dance Music on Gramophone Records. Exchange and News in the intervals.

LWOW

788 kc/s, 381 metres; 16 kW.—6.35 p.m., Song Recital relayed from Wilno, 533 kc/s, 563 metres. 7.20, Miscellaneous Items. 7.40, See Warsaw. 8.40, Gramophone Music. 8.50, See Warsaw. In an interval at 9.0, News. 10.0, Answers to Correspondence. 10.15, See Warsaw. 10.40, Gramophone Music. 11.0 (approx.), Close Down.

LYONS

LA DOUA, 465.8 metres; 1.5 kW.—7.30 p.m., Radio Gazette for Lyons and the South-East. 7.40, News. 7.45, Report of the Cycle Tour of France. 8.10, Talk on Dentistry. 8.20, Book Review. 8.30, Variety Concert. After the Concert, News.

MADRID

EAJ7, 707 kc/s, 424.3 metres; 2 kW.—8.0 p.m., Chimes, Exchange, Radio Journal, Programme for Women and Dance Music. 9.25, News and Political Review. 9.30 to 11.0, Interval. 11.0 (Chimes, Time and Political Review. 11.15 (approx.), Two Plays: (a) La Gitanilla (Cabrero); (b) El Alcalde de Zalamea (Calderón de la Barca). 1.15 a.m. (Thursday), News, 1.30, Chimes and Close Down.

MALMO.—See Stockholm.

MILAN.—See Turin.

MORAVSKA-OSTRAVA

1,137 kc/s, 263.8 metres; 11 kW.—6.25 p.m., Orchestral Concert relayed from Hulváky. 7.0, See Prague. 10.15 (approx.), Close Down.

MOSCOW

TRADES UNION, 230 kc/s, 1,304 metres; 100 kW.—2.45 p.m., Weather. 3.0, Concert of Music by Schubert, Bizet and Mendelssohn. 4.0, Talk on Agronomy. 4.30, Extracts from the Works of Maxim Gorky. 5.45, Talk. 9.0, News. 9.30, Programme Announcements. 9.55, Chimes from the Red Square. 10.5, Press Review.

MOTALA.—See Stockholm.

MUHLACKER.—See Stuttgart.

MUNICH

563 kc/s, 533 metres; 60 kW. Relayd by Augsburg and Kaiserlautern, 536 kc/s, 239 metres, and Nürnberg, 1,256 kc/s, 239 metres.—4.30 p.m., Concert of Chamber Music by Munich Composers: Polonaise (Huber-Anderach); Munich Comedy Overture (Closser); Two Pieces from the Ballet Der Zauberbeiger (H. Grimm); Minuet and Gavotte from Als der Grossvater die Grossmutter nahm (Rüdingen); Extracte from the Rocooco Suite (Haas); Barcarolle from the Romantic Ballet (Reuss); March, Sturmzeichen (Fritag). 5.45, Programme to be announced. 6.5, The Kreutzer Sonata for Violin and Piano (Op. 47 (Beethoven)). 6.45, Time, Weather and Agricultural Notes. 7.0, Transmission for all German Stations, relayed from Breslau. 8.0, See Berlin (Deutschlandsender). 8.5, Talk: The Political Struggle in Austria. 8.30, Verdi Concert by the Small Station Orchestra and Soloists. 9.10, Variety Concert. 9.40, Dance Music by the Small Station Band. 10.20, Time and News. 11.0, Serenade by the Bavarian Schrammel Ensemble and Soloists.

NAPLES.—See Rome.

NOTODDEN.—See Oslo.

OSLO

277 kc/s, 1,083 metres; 60 kW. Relayd by Fredrikstad, 815 kc/s, 368.1 metres; Hamar, 522 kc/s, 574.7 metres; Notodden, 671 kc/s, 447.1 metres; Porsgrunn, 662 kc/s, 453.2 metres; and Rjukan, 671 kc/s, 447.1 metres.—6.0 p.m., Cello Recital by Gunnar Groth-Hansen; Hymn to the Sun (Rinsky-Korsakov); Gavotte (Lully); Mazurka (Popper); Song (Halvaksen); Rondo (Bocherini); Berceuse (Hannikainen); Guitar (Moszkowsky); Sonata in A Minor (Marcello). 6.30, Programme for Young Boys. 7.0, Advertising Notes. 7.15, Weather and News. 7.30, Talk. 8.0, Time. 8.1, Orchestral Concert of Norwegian Music. 9.10, Recitations. 9.30, Agricultural Report. 9.40, Weather and News. 10.0, Topical Talk.

OSTERSUND.—See Stockholm.

PALERMO

558 kc/s, 537.6 metres; 3 kW.—8.0 p.m., Dopolavor Announcements. Tourist Report, Agricultural Notes and Giornale radio. 8.20, Gramophone Music. In the interval at 8.30, Time and Announcements. 8.45, Concert.

JULY 19th

WEDNESDAY

continued

TRIESTE

1,211 kc/s, 247.7 metres; 10 kW.—5.10 p.m., Chamber Music: Nives Franck (Violin) and Dora Franco (Pianoforte): Adagio and Allegro from the Violin Sonata in E (Handel); Pianoforte Solos (Chopin): (a) Etude in F, (b) Etude in E, (c) Waltz in E Minor; Violin Concerto in A Minor (Goldmark); Pianoforte Solos (Smaraglia): (a) Selection from Ippolito Hamminghi, (b) Song from Oceana. 6.0 till Close Down, See Turin.

TRONDHEIM.—See Oslo.

TURIN

1,096 kc/s, 273.7 metres; 7 kW. Relayed by Milan, 905 kc/s, 331.5 metres; Canoa, 959 kc/s, 312.8 metres; and Florence, 599 kc/s, 500.8 metres. 5.10 p.m., Song Recital. 6.0 to 6.5, Weather. 6.35, News. 7.0, Time, Tourist Report, and Songs on Gramophone Records. 7.20, News in Foreign Languages. 7.40, Gramophone Music. 8.0, News. 8.15, Medical Talk. 8.30, An Operetta in Three Acts. In the intervals, Talk and News. Giornale Radio after the Operetta.

VATICAN CITY

15,120 kc/s, 19.84 metres (Morning) and 5,969 kc/s, 50.26 metres (Evening); 10 kW.—11.0-11.16 a.m., Religious Information in Spanish. 8.0-8.15 p.m., Religious Information in Italian.

VIENNA

581 kc/s, 517 metres; 15 kW. Relayed by Graz, 852 kc/s, 352.1 metres; Innsbruck, 1,058 kc/s, 283 metres; Klagenfurt, 662 kc/s, 453.2 metres; Linz, 1,220 kc/s, 245.9 metres; and Salzburg, 1,373 kc/s, 218.5 metres.—12 Noon, Concert by the Vienna Symphony Orchestra, conducted by Josef Holzner. In the interval at 1.0, Time and News. 2.0, Interval. 3.0, Time and Announcements. 3.20, Notes on Photography. 3.30, Talk: Children's Characters. 3.55, Operetta Music on Gramophone Records. 4.40, Talk for Young People. 5.0, Talk. 5.25, Instrumental Concert. 6.15, Legal Talk. 6.40, Talk: Viennese Handicrafts Two Hundred and Fifty Years Ago. 7.5, Time and Announcements. 7.15, Reading from the Works of Hermann Bahr. 8.15, Topical Talk. 8.30, Pictures from the East—Concert by the Vienna Symphony Orchestra, conducted by Josef Holzner; Soloist: Gerda Redlich (Contralto); Overture, *Il Seraglio* (Mozart); Turkish March (Mozart-Herzbein); Aria from Oberon (Weber); Song, *The Asra* (Rubinstein); Overture, *The Caliph of Bagdad* (Boieldieu); Selection from *The Wizard of the Nile* (Victor Herbert); Two Songs from Sussan and Delilah (Saint-Saëns); Waltz, *Märchen aus dem Orient* (Joh. Strauss); Egyptian March (Joh. Strauss); Two Songs from Djamilah (Bizet); Orientalischer Aufzug (Leemanns); *The Sultan* (Lanciani); Selection from *The Arabian Nights* (Joh. Strauss); Persian March (Joh. Strauss). 10.0, News. 10.15, Talk in Esperanto on Austria. 10.25, Dance Music on Gramophone Records.

WARSAW

212.5 kc/s, 1,411 metres; 120 kW.—11.57 a.m., Time and Fanfare from the Tower of St. Mary's Church, Cracow. 12.5 p.m., Gramophone Music. 12.25, Polish Press Review. 12.33, Weather. 12.35, Gramophone Records. 12.55, Radio Journal. 1.0 to 2.55, Interval. 2.55, Gramophone Music. 3.5, News. 3.10, Announcements. 3.15, Gramophone Music. 3.25, Economic Notes. 3.35, Gramophone Music. 3.45, Announcements. 4.0, Popular Concert by the Poznan Opera House Orchestra, conducted by Tyllia, relayed from Ciechocinek. 5.0, Topical Talk. 5.15, Song Recital by Cécile Otley, relayed from Lwów, 788 kc/s, 381 metres; Aria from *The Countess* (Moussizsko); Prayer from Beatrix Cenci (Rozycy); Aria (Solty's); Prelude (Friedmann); Silence (Lipski); *Maggiolata* (Solty's); Mignon's Song (Schubert); Song (Brahms). 5.40, Programme to be announced. 5.55, Concert from Ciechocinek (cont'd.). 6.15, Talk: Sport and Physical Training. 6.35, Song Recital by R. Peter, relayed from Wilno, 533 kc/s, 563 metres; Aria from Eugene Onegin (Tchaikovsky); Aria from Luisa Miller (Verdi); Two Spanish Songs; *The Arrival* (Wielhorski); Neapolitan Song (Curtis); Song (Kratzer). 7.20, Miscellaneous Items. 7.35, Programme Announcements. 7.40, Reading. 8.0, Recital of Songs and Music for Two Pianofortes. 8.40, Gramophone Music. 8.50, Radio Journal. 9.0, Answers to Agricultural Correspondence. 9.10, Light Music. 10.0, Talk in Norwegian: Polish Ports. 10.15, Dance Music from the Café Europe, Ciechocinek. 10.25, Sports Notes. 10.35, Aviation Weather Report and Police Notes. 10.40, Dance Music Relay (cont'd.).

WILNO

533 kc/s, 563 metres; 16 kW.—6.35 p.m., Song Recital. 7.20, Talk in Lithuanian. 7.35, Programme Announcements. 7.40 to 8.40, See Warsaw. 8.40, Announcements. 8.50, See Warsaw. 9.0, Talk on Contemporary Lithuanian Literature. 9.0 to 10.0, See Warsaw. 10.0, Talk. 10.15 to 11.0, See Warsaw. 11.0 (approx.), Close Down.

ZURICH.—See Schweizerischer Landessender.

SCHWEIZERISCHER LANDESENDER

BEROMUNSTER, 653 kc/s, 459 metres; 60 kW.—Basle, 1,229 kc/s, 244.1 metres; and Bern, 1,220 kc/s, 245.9 metres.—6.15-6.35 a.m. (from Bern), Gymnastics. 11.59, Time Signal from Neuchâtel Observatory and Weather. 12 noon (from Bern), Orchestral Concert. 12.30 p.m., Time, Weather and News. 12.40 (from Bern), Weber, Strauss, Schubert and Millöcker Music on Gramophone Records. 1.20, Exchange, Time and Weather. 1.35 to 5.0, Interval. 5.0 (from Bern), Programme for Children. 5.30 (from Bern), Variety Concert on Gramophone Records. 6.30 (from Basle), Talk: Adventures in the Ukraine. 7.0 (from Basle), Time, Weather and Market Prices. 7.15 (from Basle), Concert of Oriental Music by European Composers on Gramophone Records. 8.0 (from Basle), Reading from the Works of Karl Spitteler. 8.30, Gramophone Concert. 9.0, Weather and News. 9.10 (from Basle), Bach and Handel Concert. 10.15 (approx.), Close Down.

SOTTENS.—See Radio-Suisse Romande.

STOCKHOLM

689 kc/s, 436 metres; 55 kW. Relayed by Boden, 244 kc/s, 1,229.5 metres; Göteborg, 932 kc/s, 322 metres; Hörby, 1,166 kc/s, 257 metres; Motala, 221.5 kc/s, 1,354.4 metres; Östersund, 389 kc/s, 770 metres; and Sundsvall, 554 kc/s, 542 metres.—5.5 p.m. (from Sundsvall), Programme for Children. 5.30 (from Sundsvall), Provincial Programme. 6.0, The Practical Corner. 6.15, Gramophone Music. 7.15, Weather and News. 7.30, Orchestral Concert, conducted by Adolf Wiklund, relayed from Skansen. Soloist: Signe Lundqvist (Songs). Symphony No. 4 in E minor (Brahms). Songs (R. Strauss): (a) Traum durch die Dämmerung, (b) Die Nacht, (c) Aller Seelen, (d) Heuliche Anforderung; Petite Suite (Debussy); Le Chasseur mandit (César Franck); Cello Solo: Le Cygne (Saint-Saëns); Overture, *The Mastersingers* (Wagner). 9.15, Talk: Norwegian Towns. 9.45, Weather and News. 10.0 (from Göteborg), Modern Dance Music. 11.0 (approx.), Close Down.

STRASBOURG

869 kc/s, 345 metres; 11.5 kW.—7.45 to 8.0 a.m., Report on the Cycle Tour of France. 11.30, Operetta Music on Gramophone Records. In an interval at 12 Noon, Report on the Cycle Tour of France. 12.45 p.m., News. 1.0, Time and Exchange. 1.5 to 2.0, Gramophone Music. 3.30, Concert by the Casino Orchestra, conducted by M. Broullac, relayed from the Casino, Vichy; Overture, *Mignon* (Thomas); Canzonetta No. 1 (d'Ambrosio); Neapolitan Song (d'Ambrosio); Ballet Suite from *Le Cid* (Massenet); Scherzina (Raff); Canzona (Raff); Introduction to the Third Act of *The Mastersingers* (Wagner); Waltz, *Je l'aime* (Waldteufel). 5.0, Talk in French on Electricity. 5.15, Dance Music. 6.0 (approx.), Report of the Cycle Tour of France. 6.15, Concert by the Station Trio, relayed from Lille, 1,130 kc/s, 265.4 metres. 7.0, Legal Talk in French. 7.15, Gramophone Music. 7.30, Time and News. 7.45, Report of the Cycle Tour of France. 8.5, Press Review in French, Lottery Results, Announcements and Gramophone Music. 8.45, Concert by the Municipal Orchestra, conducted by M. E. G. Munch, relayed from the Orangery: Four Pieces (Joh. Strauss): (a) Overture, *The Gipsy Baron*, (b) Waltz, *Wiener Blut*, (c) Perpetuum mobile, (d) Czardas from Ritter Putschman; Fantasia (E. Mawet); Ballet Suite Op. 130 (Max Reger). In the interval, Press Review in German. 10.30, Dance Music from the Savoy. 12 Midnight (approx.), Close Down.

STUTTGART

MUHLACKER, 832 kc/s, 360.5 metres; 60 kW. Relayed by Freiburg, 527 kc/s, 570 metres.—1.30 p.m., Gramophone Music. 2.0, Concert arranged by the Post Office. 2.30 to 3.15, Interval. 3.15, Reading of Fairy Tales. 3.30 (from Freiburg), Programme for Children. 4.30, See Frankfurt. 5.45, Talk: Hungarian Swamps. 6.10, Talk: The Impressions of a Frenchman in Germany. 6.35, Time and News. 7.0, Transmission for all German Stations, relayed from Breslau. 8.0, See Berlin (Deutschlandsender). 8.5 (from Karlsruhe), Choral Concert, relayed from the Academy of Music. 9.20, Horribiliferifax—Comedy (Gryphius). 10.5, Time and News. 10.35, Programme to be announced. 11.0, See Munich. 12 Midnight (approx.), Close Down.

SUNDSVALL.—See Stockholm.

TOULOUSE

779 kc/s, 385 metres; 8 kW.—Transmissions irregular owing to recent fire. 11.30 p.m. till Close Down, Programme in English by the I.B.C. 11.30, Old-Time Dance Memories. 11.57, I.B.C. Goodnight Melody. 12.0 Midnight (approx.), Close Down.

kc/s, 563 metres. 7.20, Miscellaneous Items. 7.35, Theatre Notes and Programme Announcements. 7.40, See Warsaw. 7.58, Time Signal. 8.0 to 10.0, See Warsaw. 10.0, Time, Sports and Police Notes. 10.15, Dance Music on Gramophone Records. 12 Midnight, Close Down.

PRAGUE

614 kc/s, 488.6 metres; 120 kW.—2.50 p.m., See Brno. 3.55 to 4.0, Exchange. 5.45, Gramophone Music. 5.55, Talk: Perils of Mountaineering. 6.5, Agricultural Report. 6.10, Gramophone Music. 6.25, News in German. 6.30, German Transmission: Talk: Country Excursions and Talk for Workers. 7.0, Chimes and News. 7.10, Concert by the Mandoline and Guitar Club. 7.45, Astronomical Talk. 8.0, Violin Recital by Peter Rylar; Sonata in G for Violin and Piano (Op. 100 (Dvorak)); Rondo capriccioso (Saint-Saëns); La Ronde des lutins (Bazzini). 8.30, Variety Programme. 10.0, Time and News. 10.15, News for Foreign Countries in French. 10.30 (approx.), Close Down.

RADIO-SUISSE ROMANDE

SOTTENS, 733 kc/s, 403 metres, 25 kW.; and Geneva, 395 kc/s, 760 metres.—12.28 p.m., Time Signal from Neuchâtel Observatory. 12.30, News. 12.40, Gramophone Concert. In the interval at 1.0, Financial Report. 2.0, Interval. 3.30, Talk by a Journalist. 4.0, Concert by the Radio Suisse Romande Quintet. 5.30, Interval. 7.0, Travel Impressions. 7.30, Radio Interview. 7.55, Results of the Cycle Tour of France. 8.0, Cabaret Programme. 8.50, Concert by the Radio Suisse Romande Orchestra, conducted by Robert Echehard. 9.50, News. 10.0, Gramophone Dance Music. 10.30 (approx.), Close Down.

REYKJAVIK

250 kc/s, 1,200 metres; 21 kW.—9.30 p.m., Weather Report. 9.40, Musical Programme and Announcements. 10.0, Chimes and News. 10.30, Reading. 11.0, Septet Op. 20 (Beethoven) on Gramophone Records.

RIGA

572 kc/s, 525 metres; 15 kW.—6.0 p.m., Review of Foreign Affairs. 6.30, Concert of Viennese Music. 7.0, Weather Report. 7.3, Agricultural Talk. 7.30, Orchestral Concert, conducted by E. Mehlisch; Soloist, Stefan Frenkel (Violin); Overture, *Der Improvisator* (d'Albert); *Siegfried Idyll* (Wagner); Till Eulenspiegel (R. Strauss); Spanish Symphony for Violin and Orchestra, Op. 21 (Lalo); Overture, *William Tell* (Rossini). In the intervals at 8.15 and 9.0, News and Weather. 9.30, News, followed by the Comedian Harmonists on Gramophone Records.

RJUKAN.—See Oslo.

ROME

Call IRO, 680 kc/s, 441 metres; 50 kW. Relayed by Naples, 941 kc/s, 319 metres, and RIO, 11,810 kc/s, 25.4 metres.—1.0 to 2.15 p.m., Orchestral Concert: A Neapolitan in London (Zecca); Un po' d'amore (Carabella); Tarentella a Capri (Tagliaferr); Spanish Dance (Granados); Strampellata (Negri); Waltz, *Nel verde* (Perné); Selection from *Manon Lescaut* (Puccini); Notte in mare (Dada); Silyana (Hamud); Sempre allegri (Ansaldo). In the interval from 1.30 to 1.45, Exchange and Giornale Radio, and at 2.0, Time and Announcements. 4.45, Children's Radio Review. 5.10, Weather. 5.15, Exchange, Report of the Royal Geographical Society and Giornale Radio. 5.30 to 6.15, Orchestral Concert: Non so cos'è (Ranzato); Impressioni d'Oriente (Amadei); Meriggio d'autunno (Mariotti); Danza amantina (Mink); Intermezzo, *Alvez* (Annat); Ragazze scozzesi (Cattolica); Mimose (Abel); Antilla (Beauregard). 6.40 (Naples), Shipping and Sports Notes. 6.57, Report of the International Institute of Agriculture (in Italian and English). 7.10, Tourist Report. 7.20, Giornale Radio. 7.40, News in Foreign Languages. 8.0, Time, Announcements and Gramophone Music. 8.15, Medical Talk. 8.25, Giornale Radio and Sports Notes. 8.30, Sponsored Gramophone Music. 9.30, Concert by the Augusteo Orchestra from the Basilica di Massenzio, Monologue in the interval. 10.55, Giornale Radio.

SALZBURG.—See Vienna.

SCHENECTADY

WGY, 790 kc/s, 379.5 metres; 50 kW. Relayed at intervals by W2XAF on 31.48 metres and by W2XAD on 19.56 metres.—9.0-10.0 p.m. (approx.), New York Relay. 9.0, Pop Concert. 9.30, Texas Cowgirl. 9.45, Lady Next Door. 12.45 a.m. (Thursday), Stock Reports. 1.0-2.15, New York Relay. 1.0, Variety Programme. 1.30, Musical Programme. 2.0, Ferde Grofé's Orchestra. 2.15, Outdoor Girl. 2.30, Popular Programme. 3.0, Variety Programme, from New York. 3.30, Musical Programme, from New York, followed by Programme Resumé.

Soloists: V. Palmieri (Tenor) and R. Alfano (Barr). March from *Cendrillon* (Massenet); Harp Solo: *L'autunno* (Tomas); Mennet et Tambourin (Rameau); Tenor Solos: (a) *The Stars were Shining*, from *Tosca* (Puccini), (b) *Ballad from Rigoletto* (Verdi); Harp Solos: (a) *Minuet* (Rameau), (b) *La Gitana* (Masselemans); Nocturne (Mendelssohn); Tenor Solos: (a) *Una furtiva lacrima*, from *L'Elisir d'amore* (Donizetti), (b) *Spring Song from The Valkyries* (Wagner); Selection from *Médée* (Cherubini). In the interval, Talk. 10.0, Variety Songs. 10.55, News.

PARIS

EIFFEL TOWER, Call FLE, 207.5 kc/s, 1,445.7 metres; 13 kW. Time Signals (on 2,650 metres) at 10.26 and 11.26 p.m. (Preliminary and 6-dot Signals).—6.45 p.m., *Le Journal Parlé*. In the interval at 7.45, Report of the Cycle Tour of France. 8.30, Concert by the Symphony Orchestra, conducted by Edouard Flament. Soloist: Germaine Gendron (Pianoforte). *The Jupiter Symphony* (Mozart); *Symphonic Poem, Vlatava* (Smetana); *Pianoforte Concerto in C minor* (Piercé); *Pastels chantants* (Flament); Selection from *The Flying Dutchman* (Wagner). 10.0 (approx.), Close Down.

PARIS

POSTE PARISIEN, 914 kc/s, 328.2 metres; 60 kW.—6.0 p.m., Report of the Cycle Tour of France. 7.0, Gramophone Music. 7.15, *Le Journal Parlé*. 7.30, Report of the Cycle Tour of France. 7.45, Gramophone Music. 8.0, Assurance Societies' Report. 8.5, Talk on Radio Interference. 8.15, Interval. 8.30, *La Chienne aux yeux de femme*—Play (Yvan Noé). 10.30, Dance Music from the Lido. 11.0, News.

PARIS

RADIO PARIS. Call GFR, 174 kc/s, 1,725 metres; 75 kW.—7.50 a.m., Weather and Physical Culture. 7.45, Light Gramophone Music. 8.0, News. 12 Noon, Educational Talk. 12.15 p.m., Gramophone Records: *Sarabande* (Ducasse); *L'Isle joyeuse* (Debussy). 12.30, Organ Recital from the Gammont Palace. 1.0, Exchange and News. 1.5, Gramophone Concert: *Complet de la Bournoisaise* and *L'Éclat de rire* from *Manon Lescaut* (Auber); *Amour sacré et Cavatine du Sommeil* from *Masaniello* (Auber); *Fille des rois* and *O Paradis* from *L'Africain* (Meyerbeer); Selection from *The Huguenots* (Meyerbeer): (a) *Cavatine du page*, (b) *O beau pays*, (c) *Pif, paf, pouf*, (d) *Recitativo and Choral*; *Cavatina* and *Ah! mon fils* from *The Prophet* (Meyerbeer); *Bass Aria* from *Robert le Diable* (Meyerbeer); *Cavatina* and *Aria* from *Norma* (Bellini); *Aria* from *I Puritani* (Bellini); *Arias* from *La sonnambula* (Bellini). 2.0, Exchange and Announcements. 3.45, Exchange and Market Prices. 7.0, News and Racing Results. 7.10, Gramophone Concert: *La ronde des saisons* (Büsser); *Les Fauvettes* (Bousquet); *Extase* (Ganne); Selection from *Enlevez-moi* (Gabaroche); Selection from *The Three Musketeers* (Priuli); *March* (François). 7.50, Commercial Prices and News. 8.0, Gramophone Concert for Young People: *Slav Songs*; *Humorous Scenes* (Leonard); *Cadet Roussel La Bonne Hétesse* (Chepfer); *Popular Song* (Leontovitch); *Christmas Carol* (Leontovitch); Selection from *Das Nachtlager in Granada* (Kreutzer). 8.30, News. 8.40, Fashion Review. 8.45, Vocal and Instrumental Concert. Soloists: Lina Falk (Songs), G. Tzipine (Violin), and J. Tzipine (Cello). *Frauenliebe und Leben*—Song Cycle (Schumann). Violin and Cello Duets: (a) *La voluptueuse* (Conprin), (b) *Minuet* (Rameau). Songs (de la Presle). Quintet (Franck). In the interval at 9.15, News.

PITTSBURGH

KDKA, 980 kc/s, 306 metres; 50 kW. Relayed by W8XK on 48.86 metres and 25.27 metres. (See Short-Wave List.) 7.30 p.m., KDKA Home Forum. 8.0 to 8.58, New York Relay. 8.0, Betty and Bob. 8.15, Words and Music. 8.30, Happy Days in Dixie. 8.58, Baseball Scores. 9.0, Southern Symphonies, from New York. 9.30, Business News and Market Reports. 9.45, Sketch, from New York. 9.58, Baseball Scores. 10.0, Rhythm Kings. 10.15, Tarzan of the Apes. 10.30, The Singing Lady. 10.45, Little Orphan Annie, from New York. 11.0, Time Signal and Press News Reeler. 11.5, Essex House Ensemble. 11.15, Weather Report. 11.16, Sport Review. 11.23, I Bring a Song. 11.28, Announcement. 11.29, Temperature Report. 11.30, Pittsburgh Spotlight. 11.45 to 1.30 a.m. (Thursday), New York Relay. 11.45, Today's News by Lowell Thomas. 12 Midnight, *Amos 'n' Andy*. 12.15, *Annie, Judy and Zeke*. 12.30, String Symphony. 1.0, Crime (Ches. 1.30, Potash and Perlmutter. 1.45, Phil Cook and the Ingram Shavers, from New York. 2.0, Programme to be announced. 2.15, Rocking Chair Memories, from New York. 2.30, Century of Progress Festival Orchestra, from New York. 3.30, Around the Cracker Barrel.

PORSGRUND.—See Oslo.

POZNAN

896 kc/s, 335 metres; 1.9 kW.—6.15 p.m., See Warsaw. 6.35, Song Recital from Wilno, 533

ATHLONE

725 kc/s, 413 metres; 60 kW. Relayed by Cork, 1,337 kc/s, 224.4 metres.—1.30 to 2.30 p.m., Time Signal, Stock Exchange Quotations, Weather Report and Gramophone Music. 6.0, Programme for Children. 6.40, News. 7.0, French Lesson. 7.15, Talk for Women Drivers by A. D. Whelan. 7.30, Time Signal. 7.31, Pianoforte Duets by Claire O'Beirne and Miss Lenahan. 7.50, Baritone Solos by Peter Howard. 8.5, The Station Orchestra. 8.20, St. John's Eve—a Play, by Gabriel Fallon and Company. 8.50, Soprano Solos by May Doyle. 9.5, The Station Orchestra. 9.20, Lecture Recital by Dr. Annie Patterson. 9.45, Sponsored Programme. 10.30, Time Signal. 10.45, News, Weather Report and Close Down.

BARCELONA

EAD 1, 860 kc/s, 348.8 metres; 8 kW.—7.0 p.m., Trio Concert. In the interval, Talk. 8.0, Request Gramophone Records. 8.30, Exchange. 9.0, Gramophone Records and News. 10.0, Chimes, Weather and Market Prices. 10.5, Concert by the Station Orchestra. March (Heber); Waltz, Leicht wie Schaum (Fetras); In a Monastery Garden (Ketelbey); Melody (Courtions); Oriental Dance (Perez Moya). 10.45, The Legion of Honour—Musical Comedy (Valls). In the interval at 12 Midnight News. 1.0 a.m. (Friday), Close Down.

BARI

1,112 kc/s, 269.8 metres; 20 kW.—8.0 p.m., Agricultural Report, Tourist Talk and Popolavoro Announcements. 8.20, Giornale Radio and Weather. 8.30, Time and Announcements. 8.35, Concert by the Philharmonic Mandoline Orchestra: Overture, William Tell (Rossini); Suite marinesca (Amadei); Overture, Sicilian Vespers (Verdi); Dance of the Hours from La Gioconda (Ponchielli); Overture, Figaro (Mozart); Nocturne, Chiaro di luna (Rusi); Mareia dei Titani (Nozzetti). In the intervals, Notes on Art. After the Concert, Gramophone Music. 10.55, News.

BASLE.—See Schweizerischer Landessender.

BELGRADE

BEOGRAD, 697 kc/s, 430.4 metres; 2.8 kW.—5.55 p.m., Time and Programme Notes. 6.0, Talk on Physical Culture. 6.30, Yugoslav Songs. 7.0, Talk. 7.30, Orchestral Concert. 8.30 to 10.30, Programme from Ljubljana, 522 kc/s, 574.7 metres. 10.30, Time, News and Cigany Music from the Rudnicain Restaurant.

BERLIN

DEUTSCHLANDSENDER, 183.5 kc/s, 1,635 metres; 60 kW.—2.0 p.m., Gramophone Concert: Largo (Handel); Ave Maria (Bach-Gounod); Ave Maria (Schubert); Träume (Wagner); Alhambra (Wagner); Moment musical (Schubert); Salut d'amour (Elgar); Liebestraum (Liszt); Nocturne in E Flat (Chopin); Gavotte tendre (Ganne); Sérénade (Pierné); Potpourri of Opera Melodies. 2.45, Programme for Children. 3.10, Talk: A Trip along the Rhine on a Motor Bicycle. 3.30, Weather and Exchange. 3.45, Carl von Brehren reads from his own Works. 4.0, Programme to be announced. 4.30, See Heilsberg. 5.0, Talk for Women. 5.35, Suite in G for two Clarinets and Bassoon (Kurt Rasch). 6.0, Poems. 6.5, Programme by Werner Fink. 6.30, Agricultural Talk. 6.50, Weather and Announcements. 7.0, Transmission for all German Stations, relayed from Hamburg. 8.0, An Axiom. 8.5 (approx.), Gramophone Records, with Commentary. 9.0, Talk: Through East Prussia with a Young Hitlerite. 9.25, Bunte Stunde. 10.0, News. 10.45, Weather. 11.0, Concert from the Nationale Gaststätte. 12.30 a.m. (Friday), Close Down.

BERLIN

WITZLEBEN, 715 kc/s, 419.5 metres; 1.5 kW.—4.30 p.m., Concert of Old and New Operetta Music, relayed from Swinemünde. The Orchestra, conducted by Bruno Eckhardt. Soloist: Friedel Eckhardt (Soprano). Prelude, Chorus, Ballad and Dance from Das Pensionat (Suppé); Selection from Der Bettelstudent (Millöcker); Song; Czardas of the Die Fledermas (Joh. Strauss); Lehrar Potpourri; Selection from Tango um Mitternacht (Komjati). 5.30, Prussian Coinage—Literary Programme. 5.50, Flute and Violin Duets by Heinz Breiden and Siegfried Borries; Duet in G (Telemann); Two Duets (C. P. E. Bach): (a) Duet in E Minor from Musikalisches Vielerlei, (b) Duet in C. 6.10, Talk with Illustrations on Gramophone Records: The Dance as an expression of National Character. 6.30, Talk on Pomerania. 6.40, The Witzleben Station informs its Listeners. . . . 6.45, Topical Talk. 7.0, Transmission for all German Stations, relayed from Hamburg. 8.10, Recital of Folk Songs. 8.40, Radio Report from the Naval Training School, Deutschland. 9.0, A Summer Festival in Neufelchen. The Orchestra, conducted by Heinrich Steine. The Ging-gang-gingeli Male Voice Choral Society and Soloists. In the intervals at 10.0 (approx.), News, and at 11.0 (approx.),

THURSDAY JULY THE TWENTIETH

PRINCIPAL EVENTS OF THE WEEK:

AT HOME

NATIONAL Gentlemen v. Players: An eye-witness account by Mr. Howard Marshall.
LONDON REGIONAL Variety Programme.
MIDLAND REGIONAL "In Summer-time," an orchestral concert.
WEST REGIONAL Concert by Winners at the Urdd Eisteddfod, Caerphilly, 1933.

ABROAD

BRUSSELS (No. 1) 8.0 p.m. Saint-Saëns concert.
COPENHAGEN HAMBURG 8.1 p.m. French opera music.
8.10 p.m. "Merry Men of Brunswick," a variety programme.
HEILSBURG 8.10 p.m. Opera: "La Combiiale di Matrimonio," by Rossini.
HILVERSUM (announced Huizen) 8.40 p.m. Carillon recital, relayed from the Royal Palace, Amsterdam.
PARIS (Poste Parisien) 8.45 p.m. Wind-instrument concert.
PRAGUE 8.15 p.m. Concert by the Karlsbad Municipal Orchestra, from Karlsbad.
8.45 p.m. Opera: "Stentorello," by Alfred Cuxina.
ROME STRASBOURG 8.30 p.m. Wagner concert, conducted by Maurice de Villers.
TURIN 8.45 p.m. Opera: "Turandot," by Puccini.

Talk: What they are saying in Berlin. 1.0 a.m. (Friday), Close Down.

BERNE.—See Schweizerischer Landessender.

BEROMUNSTER.—See Schweizerischer Landessender.

BODEN.—See Stockholm.

BODO.—See Oslo.

BORDEAUX-LAFAYETTE

986 kc/s, 304 metres; 13 kW. 6.15 p.m., Radio Journal. 7.25, Talk on Bull-Fighting. 7.40, Lottery Results. 7.45, Report of the Cycle Tour of France. 8.5, Talk on Aine. 8.20, News. 8.30, L'Etrangère—Comedy (A. Dumas, fils).

BRATISLAVA

1,076 kc/s, 279 metres; 14 kW.—7.0 p.m., See Prague. 7.45, See Brno. 8.15, See Prague. 11.0 (approx.), Close Down.

BREMEN.—See Hamburg.

BRESLAU

923 kc/s, 325 metres; 60 kW. Relayed by Gleiwitz, 1,184 kc/s, 253 metres.—12 Noon, Concert by the Silesian Symphony Orchestra, conducted by Gerhard Ewald Rischka: Overture, Die Landstreichler (Ziehrer); Waltz, Zeller-Abende (Tieleke); Piazza del Popolo (Juel-Frederiksen); Selection from Rigoletto (Verdi); Comedy Overture (Lincke); Selection from Die Abenteuer einer Ballnacht (Heuberger); Two Pieces (Herfurth): (a) Abentfriele, (b) Am See; Potpourri, Klänge aus Arkadien (Morena); Gailthaler Jägermarsch (Koschat). 2.20, Gramophone Music. 3.0, Market Prices. 3.40, Talk: Bad Charlottenbrunn. 3.50, Reviv of Books. 4.30 (approx.), See Heilsberg. 5.10, Legal Talk. 5.20, (from Glewitz), Market Prices, followed by Talk: Training the Small Child. 5.35, Programme for Children. 6.0, Programme to be announced. 6.20, A Discussion between Workers and their Leaders. 6.50, Weather and News. 7.0, Transmission for all German Stations, relayed from Hamburg. 8.0, Shepherd Songs: Cycle (B. Müller) by Bruno Jagielski and a Symphony String Quartet. 8.30 (from Glewitz), The Mining Industry on the Frontier: Radio Report from an Upper Silesian Coal Mine. 9.0, See Berlin (Witzleben). 10.0, Time and News. In the interval at 10.25, Talk: Impressions of a Trip to Norway. 11.0 (approx), Close Down.

BRNO

878 kc/s, 342 metres; 35 kW.—5.25 p.m., National Dance Music by the Station Orchestra, conducted by B. Bakala. 5.45, Talk. 5.55, Talk on Yachting. 6.5, Gramophone Music. 6.25, German Transmission: News,

Commercial German, and Readings. 7.0, See Prague. 7.30, Talk. 7.45, A Farce in Dialect. 8.15, Gramophone Music. 8.30, Animal Life—a Gramophone Concert. Soloists: Marta Halilova (Songs), J. Polasek (Violin); On hearing the first Cuckoo in the Spring (Delius); Songs (Bendl); (a) Violin Lark, (b) The Cuckoo, (c) The Owl; Violin Solo, Die Biene (Schubert); Three Songs (Krieka); Carnival des Animaux (Saint-Saëns). 9.15, Humorous Programme. 9.35, Pianoforte Recital by A. Skaticka: Nocturne No. 1 in C sharp minor, Op. 27 (Chopin); Rondo (Dusik); Scherzo No. 2 in E minor, Op. 16 (Mendelssohn). 10.0, See Prague. 11.0 (approx.), Close Down.

BRUSSELS (No. 1)

I.N.R., 590 kc/s, 509 metres; 15 kW.—12.0 Noon, Gramophone Concert: Le tram (Mongot); Aria from Hérodiade (Massenet); Potpourri, Traveller (Maufred); French Songs (arr. Misraki); Wagner Potpourri (Doucet); Waltz (Aubry); Aria from Don Quixote (Massenet); Franz Liszt Potpourri (Morena); Melody (Pallemaerts); Pas des patineurs (Jouve); Selection from White Horse Inn (Benatzky); Phantom Brigade (Myddleton). 1.0 p.m., Le Journal Parlé. 1.10, Concert by the Small Station Orchestra, conducted by Pierre Leemans: Pasodoble, Cordoba (Lolano); Overture, Le Caid (Thomas); La mia serenata (Staffelli); Ballet égyptien (Luigini); Pianoforte Solos; Russian Melodies, Nitechevo (Volpatti); Arabian Patrol (Maufred). 5.0, Concert, Louis Ganne, by the Station Orchestra, conducted by Charles Walpot; Russian March; Selection from Cocorico; Extase; Mazurka naturaliste; Valse des blondes. 5.30, Programme for Children. 6.0, Cooking Lesson. 6.15, Gramophone Concert: The Jupiter Symphony (Mozart); Concerto in D, Op. 3, No. 9 (Vivaldi); Toccata (Pasquini); Romance (Wieniawsky); Impromptu No. 3, Op. 142 (Schubert); Waltz, The Blue Danube (Joh. Strauss-de Rille); Parlez-moi d'amour (Lenoir); Extracts from P.P.I. (Gray-Zimmer); Waltz, Gold and Silver (Lehár-Daris). 7.15, Talk for Workers. 7.30, Sports Bulletin. 8.0, Saint-Saëns Concert by the Station Orchestra, conducted by Charles Walpot; March héroïque; Overture, La Princesse jaune; Réverie du soir; Gramophone Records: (a) Le Solitaire, (b) Le pas d'armes du roi Jean; Danse macabre; Vello Solo; Le Cygne; French Military March. 8.45, Talk. 9.0, Concert relayed from the Kursaal, Ostend. 10.30, Le Journal Parlé. 10.40, Dance Music relayed from the Kursaal, Ostend.

BRUSSELS (No. 2)

N.I.R., 887 kc/s, 338.2 metres; 15 kW.—Programme in Flemish. 12 Noon, Concert by the Small Station Orchestra, conducted by Pierre Leemans. Overture, Lieutenant du Roi (Titl); Waltz (Vollstedt); Ideale

(Tosti); Selection from The Drum-Major's Daughter (Offenbach); Flute Solo: L'oiseau tapageur (Balleron); Intermezzo, Manuela (Lottler); Selection from The Desert Song (Romberg); Waltz (O. Strauss); Fox Trot, Tiger Rag (La Rocca). 1.0 p.m., Le Journal Parlé. 1.10, Gramophone Music. Overture, Anacronon (Cherubini); Légende naïve (Jonen); Selection from Lohengrin (Wagner). 5.0, Dance Music relayed from the Kursaal, Ostend. 6.15, Recitation. 6.30, Concert by the Small Station Orchestra, conducted by Pierre Leemans. Cortège oriental (Leemans); Enchantement (de Taeye); Berceuse (Wigy). Flute Solo: Impromptu (Sarly). Selection from Lilac Time (Schubert-Berté); Verzichtung (Opsoner); Oriental Dance (Douliez); Cramignon (Gillon). 7.15, Religious Talk. 7.30, for Housewives. 8.0, Harp Recital by Mlle. Mireille Flour. La source (Zabel); Barcarolle (Gillon); Les fibres (Dandrieu); Der Nussbaum (Schumann); Rhapsody (Vierni); Negro Spirituals (Tournier). 8.30, Humorous Programme by M. Contran with Recitations by Mme. R. Verschuere. 9.0, Concert, relayed from the Kursaal, Knocke. 10.30, Le Journal Parlé. 10.40, Dance Music relayed from the Kasino, Knocke.

BUCHAREST

761 kc/s, 394 metres; 12 kW.—5.0 p.m., Light Music and Romanian Music by the Dinico Orchestra. In an interval at 6.0, Radio Journal. 7.0, Reading. 7.20, Gramophone Music. 7.40, Educational Talk. 8.0, Tenor Solo. 8.20, Symphony Concert on Gramophone Records: Overture, Don Giovanni (Mozart); In the Steppes of Central Asia (Borodin); Bourrée fantastique (Chabrier); The Ninth Symphony in D Minor (Beethoven). In an interval at 9.0, Talk. 9.45, Radio Journal.

BUDAPEST

545 kc/s, 550.5 metres; 18.5 kW.—5.30 p.m., Cigany Music. 6.30, Microphone Report. 7.30, Talk. 8.0, Pianoforte Recital by Annie Fischer: Sonata in D minor (Beethoven); Scherzo in C sharp minor (Chopin); Etude in D flat (Liszt); Wedding March (Liszt-Mendelssohn). 8.40, Review of Foreign Politics. 9.0, Sea Studies on Gramophone Records. 10.0, Concert by the Royal Hungarian Opera House Orchestra, conducted by E. Dohnanyi. After the Concert, Cigany Music from the Café Patria.

CASSEL.—See Frankfurt.

COPENHAGEN

1,067 kc/s, 281 metres; 0.75 kW. Relayed by Kalundborg, 260 kc/s, 1,153 metres.—12 Noon, Time and Chimes from the Town Hall. 12.1 p.m., Music by the Max Skaika String Ensemble from the Hotel d'Angleterre. 2.0 to 3.30, Interval. 3.30, Concert by Teddy Petersen and his Orchestra from the Wivex Restaurant. 5.0, Pianoforte Solos by Palle Alstelt: Two Mazurkas (Leschetizky); Phitination (Friedmann); Danza d'Olaf (Piek-Mangialli). 5.35, Exchange and Market Prices. 6.20, Talk. 6.50, Weather. 7.0, News. 7.15, Time. 7.30, Talk: The Battle of the Marne, September, 1914. 8.0, Time Signal. 8.1, Concert of French Opera Music by the Radio Orchestra, conducted by Walter Meyer-Radon: Overture, Zampa (Hérold); Suite No. 1 from Carmen (Bizet); Selection from Samson and Delilah (Saint-Saëns); Prelude and Waltz from Faust (Gounod); March from The Queen of Sheba (Gounod). 9.0, Microphone Report: A Visit to a Physical Training School. 9.30, Schumann Song Recital by Jörgen Bendix: Provenzalisches Lied; Knabe mit dem Wunderhorn; Hidalgo; Frühlingsnacht; Wanderlied; The Two Grenadiers. 9.55, News. 10.10, Russian Concert by the Radio Symphony Orchestra, conducted by Walter Meyer-Radon: Overture, May Night (Rimsky-Korsakov); Introductor to The Fair at Sorotchinsk (Mussorgsky); Moderato assai and Scherzo from The Third Symphony in A Minor (Borodin-Glazunov) 11.0 (approx.), Close Down.

CORK.—See Athlone.

CRACOW

959 kc/s, 312.8 metres; 1.5 kW.—7.20 p.m. The Letter Box. 7.35, Miscellaneous Item and Announcements. 7.40, See Warsaw 7.55, Programme Announcements. 8.0 to 10.0, See Warsaw. 10.0, Light Music from the Pavilion Restaurant. In the interval at 10.25, Sports Notes. 11.0, Fanfare from the Tower of St. Mary's Church.

DANZIG.—See Heilsberg.

DRESDEN.—See Leipzig.

FECAMP

1,328 kc/s, 225.9 metres; 10 kW.—4.30 p.m. to 6.0 p.m. till Close Down. Programme in English by the I.B.C. 4.30, The Nurse Corner; Music, Stories, and Birthday Greetings. 5.0, Orchestral Concert for Warthin and Littlehampton Listeners: The Night by the Sea; Waltz, Wiener Blut (Joh. Strauss); Violin Solo, Poème (Fibich); Xylophon

JULY 20th

THURSDAY

continued

Duet, Dance of the Nymphs; Song, Crystal Spring; The Old Spinning Wheel; The Way to the Heart (Lincke); Song, The Wrangle Taggle Gipsies O; Song, Hares on the Mountains; Serenade of Love (von Blon). 5.30, Concert for Brighton and Love Listeners; Xylophone Solo, Snappy Sticks, Part I; Russian Rhapsody (Nussbaum); The Clouds will soon roll by; The Little Company (Ganglberger); Just a Photograph signed by you; Beautiful; Brother, can you spare a Dime; Xylophone Solo, Snappy Sticks, Part II; The Night by the Sea, 6.0 to 10.0, French Programme, 10.0 till Close Down, Programme in English by the I.B.C., 10.0, Dance Music by Jack Hylton and his Band (Electrical Transcriptions); Bells of Normandy; Farewell to Arms; Live, Love and Laugh; Her Name is Mary; Today I feel so happy; I sign for you, Rio Rita; Ich liebe dich, my dear; Lover come back to me, from New Moon (Romberg); Just an Echo in the Valley; Moon Song; Marry Me; Pickaninies' Heaven; After to-night we say Good-bye; Good-bye, Blues; Rock your cares away; Same Old Moon; A Bedtime Story; Bells of Normandy, 11.0, Club Concert for Ramsay Listeners, Part I. Organ Solos and Songs: The Chum Song; Just humming along; Song, Ich liebe dich, my dear; Rain on the Roof; Song, Drifting under a Summer Moon; Song, Twilight Reveries of you; Ca'ci'st Madrid; Song, Big Ben's saying "Good-night"; Nola. Part II: Selection from Music in the Air, Part I; Pianoforte Solo, Wasps; Veterans of Variety, Part II; I kiss your Lips; Amoureuse; Marching through Georgia; Pianoforte Solo, Where are you?; Selection, Music in the Air, Part II, 12.5 a.m. (Friday), The I.B.C., Late News Bulletin, 12.10, The Midnight Waltz; The Ghost Walk; The Devil Dance; Moonlight at Sanssouci; Midnight Waltz (Spoliansky), 12.30, Dance Music; Bells of Normandy; Under my Umbrella; You've got me crying again; And so I married the Girl; Stormy Weather; Body and Soul; Sylvia; Chansonette (Friml); I wake up smiling; Bells of Normandy, 12.57, I.B.C., Goodnight Melody, 1.0 (approx.), Close Down.

FLENSBURG.—See Hamburg.

FLORENCE.—See Turin.

FRANKFURT

1,157 kc/s, 259.3 metres; 17 kW. Relayed by Cassel, 1,220 kc/s, 245.9 metres and Trier, 1,157 kc/s, 259.3 metres.—3.30 p.m., Programme for Children, 4.25, Market Prices, 4.30, See Munich, 5.45, Market Prices, 6.0, Wireless Notes, 6.25 (from Cassel) Talk on the Painter, Louis Corinth, 6.45, Today's News, 6.50, Time and Announcements, 7.0, Transmission for all German Stations relayed from Hamburg, 8.0, Haydn Cello and Pianoforte Recital by Ludwig Hoelscher and Hans Rosband; Dialogue; The Modern Technique of Cello Playing; Overture in D; Cello Concerto in D; Symphony in G, 9.15, Radio Report of the German Skittle Club, 10.0, Time and News.

FREDRIKSSTAD.—See Oslo.

FREIBURG.—See Stuttgart.

GENEVA.—See Radio-Suisse Romande.

GENOA.—See Turin.

GLEWITZ.—See Breslau.

COTEBOURG.—See Stockholm.

GRAZ.—See Vienna.

HAMAR.—See Oslo.

HAMBURG

Call ha (in Morse), 806 kc/s, 372 metres; 1.5 kW. Relayed by Bremen, 1,112 kc/s, 269.8 metres; Flensburg, 1,319 kc/s, 227.4 metres; Hanover, 530 kc/s, 566 metres; and Kiel, 1,292 kc/s, 232.2 metres.—6.20 p.m., Review of Books—Reminiscences and Autobiographies, 6.45, Exchange and Weather, 7.0, Transmission for all German Stations; The Dogger Bank, 8.0, Talk: The Nazi Movement, 8.10 (from Hanover), Merry Men from Brunswick—A Variety Programme, 9.10, Concert of Dances relayed from Berlin (Witzleben), 10.0, News, 10.20, Topical Talk, 10.30, Dance Music from Berlin (Witzleben) (cont'd).

HANOVER.—See Hamburg.

HEILSBURG

1,085 kc/s, 276.5 metres; 60 kW. Relayed by Danzig, 662 kc/s, 453.2 metres.—1.5 p.m., Gramophone Music. In the intervals at 1.20 and 2.0. News, 2.30 (from Danzig), Exchange and Market Prices, 3.0, Agricultural Prices and Exchange Rates, 3.30, Talk for Young People: Adolf Hitler and the Young Hitlerites, 4.0, Book Review, 4.20, Interval, 4.30, Orchestral Concert, conducted by Karl Tutin, relayed from the Kirgarden, Zoppot; Overture, The Caliph of Bagdad (Boieldieu); Kaiserwalzer (Joh. Strauss); Spanish Dance from Le Tribut de Zamora (Gounod); Selection from Hérodiade (Massenet); Overture, Banditenstreich (Suppé), 5.20, Baritone Song and Pianoforte Recital by Hans Eggert

and Hildegard Sehnarick; Songs: (a) Wach' auf, mein Herzensschöne (Brahms), (b) Weis' mir ein schönes Röselin (Plüddemann), (c) All mein Gedanken (Brahms), (d) Mir ist ein schön's braun's Mädelein (Brahms); (e) Mein Schatz ist nicht da, (f) Des Abends kann ich nicht schlafen gehn, (g) Das Schwäbtle ziehet fort, (h) So wünsch' ich ihr ein' gute Nacht, 6.0, Reading, 6.15, Agricultural Prices, 6.25, Agricultural Talk, 6.50, Weather, 7.0, Transmission for all German Stations, relayed from Hamburg, 8.0, News, 8.10, La Cambiale di matrimonio—Opera in One Act (Rossini), 9.25 (from Danzig), Reading of a Short Story by Wilhelm Hauff, 10.5, News.

HILVERSUM

Announced HUIZEN; 1,013 kc/s, 296.1 metres; 20 kW. (7 kW. up to 4.40 p.m.).—11.40 a.m. to 1.40 p.m., Programme of the Catholic Radio Society (K.R.O.), 11.40, Police Announcements, 11.55, Orchestral Concert, conducted by J. Gerritsen, 1.40 till Close Down, Programme of the Christian Radio Society (S.C.R.V.), 1.40, Handwork Lesson, 2.40, Gramophone Music, 3.10, Interval, 3.40, Hilde Reading, Song and Organ Recital; Talk for Amateur Photographers, 4.40, Handwork Lesson, 5.10, Trio Concert by K. Hartvelt (Violin), R. Bresser (Cello) and G. Seale (Pianoforte); Concerto No. 2 in G (Rameau), Concerto No. 2 in D (Copernic), Trio (Hijnman); Gramophone Music; Trio in D Minor, Op. 63, No. 1 (Schumann), 6.25, Dressmaking Lesson, 6.40, Police Announcements, 7.10, Press Review, 7.40, Choral Concert, 8.40, Carillon Recital, relayed from the Royal Palace, Amsterdam; Variations on Wilhelmus (Vincent); Five Pieces (Frey); Tonstück (W. F. Bach); Minnet (Bach); Three Pieces (Viotti); Rondo (Tetterode); Tanz auf der Tenne (Parlow); Selection from Il Trovatore (Verdi); Minnet (Pleyel); Rondo (Pleyel); Chanson néerlandaise (Smits); March (deon Hertog); Naar buiten (Stantz); My Heart is in the Highlands; Schifflied Melody, 9.40, News, 9.50, Gramophone Music, 11.10 (approx.), Close Down.

HORBY.—See Stockholm.

HUIZEN

Announced HILVERSUM; 160 kc/s, 1,875 metres; 8.5 kW.—Programme of the Algemeene Vereeniging Radio Omroep (A.V.R.A.), 11.40 a.m., Time Signal, 11.41, Concert by the Station Orchestra, conducted by Nico Gerharz; March, King Cotton (Souza); Overture, The Barber of Seville (Rossini); Waltz, Pomona (Waldteufel); Ballade and Rigaudon (Ganne); In Adam's Paradise (Urbach); Gramophone Records; Overture, The Arabian Nights (Joh. Strauss); Spanish Serenade, La Manola (Eilenberg); Canary (Gerharz); Potpourri, Was die Donau erzählt (Morena); Gramophone Records, 1.55 p.m., Interval 2.10, Concert (cont'd), Island Dances (Leifs); Minnet (Paderewski); Invitation to the Dance (Weber), 2.40, Gramophone Music, 3.40, Programme for Hospitals, 4.10, Gramophone Music, 4.40, Play for Children, 5.20, Concert by Kayos Lajos and his Orchestra, with Songs by Bob Scholte, 6.10, Sports Talk, 6.40, Concert (cont'd), 7.10, Gramophone Music, 7.40, Time, 7.41, News, 7.45, Gramophone Music, 7.55, Concert by the Concertgebouw Orchestra, conducted by Nico Trepp, relayed from the Concertgebouw, Amsterdam; Soloists, Ruth Posselt (Violin) and Helene Cals (Soprano); Overture, Rosamunde (Schubert); Songs: (a) No che non sei capace (Mozart), (b) Ariette (Trepp), (c) Prayer (Trepp), A Night on the Bare Mountain (Mussorgsky); Songs: (a) Cavatina from The Barber of Seville (Rossini), (b) The Blue Danube (Strauss); Gramophone Music; Violin Concerto, Op. 35 (Tchaikovsky); Overture, 1812 (Tchaikovsky), 10.10, Gramophone Music, 10.40, News, 10.50, Gramophone Music, 11.40 (approx.), Close Down.

INNSBRUCK.—See Vienna.

KALUNDBORG.—See Copenhagen.

KATOWICE

734 kc/s, 408 metres; 16 kW.—7.10 p.m., Sports Talk, 7.25, Announcements and Gramophone Music, 7.40 till Close Down, See Warsaw.

KIEL.—See Hamburg.

KLAGENFURT.—See Vienna.

KOSICE.—See Prague.

LAHTI

167 kc/s, 1,796 metres; 40 kW. Relayed by Helsinki, 815 kc/s, 368.1 metres.—6.15 p.m., Concerto No. 3 in E-Flat for Hunting Horn (Mozart), 6.35, Talk, 7.0, Recital of Old Arias by Margherita Violanti-Schauman, 7.25, Talk, 7.45, Concert by the Station Orchestra, 8.45, News in Finnish, 9.0, News in Swedish, 9.15, Light Music, relayed

from the Restaurant Kappeli, 10.0 (approx.), Close Down.

LANGENBERG

635 kc/s, 473 metres; 60 kW.—1.0 p.m., Orchestral Concert, conducted by Wolf, Soloist: Johanna Voss (Soprano), Overture, The Thieving Magpie (Rossini); Love Songs, Op. 83 (Dvorak); Mephisto Waltz, No. 1 (Liszt); Scenes from Martha (Flotow); Serenade from Les Millions d'Arlequin (Drigo); Scandinavian Suite (Frederiksen); Minuet and Scherzo (Schubert); Styrian Dances (Lanner). In an interval at 2.0 (approx.), News, 3.0, Programme for Children, 3.30, Exchange and Time, 3.50, A Wespallian Saga, 4.0, Talk: The Colonisation Ideal in the Education of the Young, 4.30, See Munich, 5.50, Some Advice on the Choice of Books to Read, 6.15, Song Recital by Caruso on Gramophone Records, 6.30, Legal Talk, 6.45, Weather and Announcements, 7.0, Transmission for all German Stations, relayed from Hamburg, 8.0, News, 8.5, See Berlin (Deutschlandsender), 9.0, Concert by Die Fröhliche Fünf, 9.30, Political Talk, 10.0, News, 10.20, Radio Report of the German Skittle Club on Gramophone Records, 10.35, Symphony Concert by the Station Orchestra, Soloist: Robert Grote (Cello), 12 Midnight (approx.), Close Down.

LAUSANNE.—See Radio-Suisse Romande.

LEIPZIG

769.9 kc/s, 389.6 metres; 120 kW., and Dresden, 941 kc/s, 319 metres.—12.5 p.m., Gramophone Concert, 1.0, News, 1.15, Old and New Dance Music on Gramophone Records, After the Programme, News, 2.10, Art and Film Review, 2.40, Fantasia, Op. 116 (Brahms), by Helmut Meyer, 3.0, Programme for Children, 3.35, Market Prices, 4.0, Concert by the Leipzig Symphony Orchestra, conducted by Fritz Schröder; Overture, Der Wallenstein (Lortzing); Haydn Potpourri (Urbach); Procession to the Münster from Lohengrin (Wagner); Salut d'amour (Elgar); Waltz, Etincelles (Waldteufel); Suite from The Queen of Spades (Tchaikovsky); Two Songs from The Queen's Kerehief (Joh. Strauss); Waltz, Gold and Silver (Lehár); Selection from Die Puppenfee (Bayer), 5.40, Talk on Taxation, 5.50, News, 6.0, Religious Address, 6.25, Talk: The Idea and the Development of Trades Unions, 6.50, Topical Talk, 7.0, Transmission for all German Stations relayed from Hamburg, 8.0, Government Announcement, 8.5, Festival Concert by the Plauen Municipal Orchestra, conducted by Dr. Otto Warisch, relayed from Bad Elster; Soloist: Gerda Heuer (Soprano), Comedietta (Graener); Concert Aria (v. Westermann); Partita for Orchestra (Wartelsch), 9.5, Agricultural Talk, 9.15, Talk: Building up the New Constitution, 9.35, Folk Music Concert by a Mandoline Orchestra, conducted by Franz Günther; Overture (Liprandi); Aus Vogtlands Wäldern (Pöhlhlands); Romance (Ritter), 10.5, News, 10.20 (approx.), Dance Music by the Emdé Orchestra, In the interval, Humorous Talks, 12 Midnight (approx.), Close Down.

LINZ.—See Vienna.

LUXEMBOURG

252 kc/s, 1,191 metres; 200 kW. German Programme.—7.0 p.m., Concert by the Station Orchestra, 7.40, Weather Report, 7.45, Concert of German Music by the Station Orchestra, 8.20, Recital of German Songs, 8.30, Talk in German: Interior Decoration of the Modern House, 8.40, Songs (cont'd), 8.50, News in French, 9.15, Orchestral Concert, In the interval at 9.45, News in German, 10.25, Dance Music on Gramophone Records, Exchange and News in the intervals.

LWOW

788 kc/s, 381 metres; 16 kW.—6.15 p.m., Talk, relayed from Wilno, 533 kc/s, 563 metres, 6.35, See Warsaw, 7.20, Miscellaneous Items, 7.40, See Warsaw, 9.0, Topical Talk, 9.10, See Warsaw, 10.40, Gramophone Music, 11.0 (approx.), Close Down.

LYONS

LA DOUA, 644 kc/s, 465.8 metres; 1.5 kW.—6.30 p.m., See Strasbourg, 7.30, Radio Gazette for Lyons and the South-East, 7.40, News, 7.45, Report of the Cycle Tour of France, 8.10, Charades, 8.20, Talk, 8.30, Announcements, 8.40, Concert.

MADRID

EAJ 7, 707 kc/s, 424.3 metres; 2 kW.—8.0 p.m., Chimes, Exchange Radio Journal and Programme for Children, 9.15 News and Political Review, 9.30 to 11.0, Interval, 11.0, Chimes, Time and Political Review.

11.15 (approx.), Asturian Song Recital by Manuel Azarate, 11.30, Municipal Band Concert, relayed from Rosales, 1.15 a.m. (Friday) News, 1.30, Chimes and Close Down.

MALMO.—See Stockholm.

MILAN.—See Turin.

MORAVSKA-OSTRAVA

1,137 kc/s, 263.8 metres; 11 kW.—7.45 p.m., See Brno, 10.0, See Prague, 11.0 (approx.), Close Down.

MOSCOW

TRADES UNION, 230 kc/s, 1,304 metres; 100 kW.—2.45 p.m., Weather, 3.0, Extracts from The Fair at Sorochinsk—Opera (Mussorgsky), 4.0, Talk, 4.30, Programme of Russian Literature, 5.30, Talk, 6.30, Concert of Music by Vivaldi, Liszt, Busoni and Rimsky-Korsakov, 9.0, News, 9.30, Programme Announcements, 9.55, Chimes from the Red Square, 10.5, Press Review.

MOTALA.—See Stockholm.

MUHLACKER.—See Stuttgart.

MUNICH

563 kc/s, 533 metres; 60 kW. Relayed by Augsburg and Kaiserlautern, 536 kc/s, 239 metres; and Nürnberg, 1,256 kc/s, 239 metres.—4.30 p.m., Orchestral Concert, conducted by Erich Kloss; Overture, Die drei Pintos (Weber); Frühlingstraube (Schubert); Das Meer (Schubert); Selection from Jessonda (Spohr); Suite, L'enfant prodigue (Debussy); Russian Dance (Bortkiewicz); Mazurka (Wieniawsky); Melody (Vescey); Stephanie Gavotte (Czibulka), 5.45, Agricultural Talk, 6.5, Talk: Mussolini and the Problem of Home Grown Corn, 6.25, Talk: Schiller and the National Revolution, 6.45, Time, Weather and Agricultural Notes, 7.0, Transmission for all German Stations relayed from Hamburg, 8.5, The Flying Dutchman—Opera in Three Acts (Wagner), relayed from the Richard Wagner Festival in the Prinzregent Theatre, In the interval at 9.5-9.45, News, 11.15, Time, Weather, News and Sports Notes.

NAPLES.—See Rome.

NOTODDEN.—See Oslo.

OSLO

277 kc/s, 1,083 metres; 60 kW. Relayed by Fredrikstad, 815 kc/s, 368.1 metres; Hamar, 522 kc/s, 574.7 metres; Notodden, 671 kc/s, 447.1 metres; Porsgrund, 662 kc/s, 453.2 metres; and Rjukan, 671 kc/s, 447.1 metres.—5.30 p.m., Gramophone Concert, 6.30, Divine Service, 7.0, Advertising Notes, 7.15, Weather and News, 7.30, Song Recital by Ragna Nielsen, 8.0, Time, 8.1, Agricultural Talk, 8.30, Variety Concert, 9.38, Agricultural Notes, 9.40, Weather and News, 10.0, Topical Talk, 10.15, Talk.

OSTERSUND.—See Stockholm.

PALERMO

558 kc/s, 537.6 metres; 3 kW.—8.0 p.m., Popolavoro Announcements, Agricultural Report and Giornale Radio, 8.20, Gramophone Music, In the interval at 8.30, Time and Announcements, 8.45, Extracts from Italian Operettas, In the interval at 9.30, In portineria—Comedy in One Act (Verga), 10.55, News.

PARIS

EIFFEL TOWER, Call FLE; 207.5 kc/s, 1,445.7 metres; 13 kW. Time Signals (on 2,655 metres) at 10.26 a.m. and 11.26 p.m. (Preliminary and 6-dot Signals).—6.45 p.m., Le Journal Parlé. In the interval at 7.45, Report of the Cycle Tour of France, 8.30, Gramophone Concert, 10.0 (approx.), Close Down.

PARIS

POST PARISIEN, 914 kc/s, 328.2 metres; 60 kW.—6.45 p.m., Programme for Children, 7.15, Le Journal Parlé, 7.30, Report of the Cycle Tour of France, 7.45, Gramophone Music, 7.50, Talk, 8.40, Variety Programme, 8.30, Interval, 8.45, Wind Instrument Concert, Two Pieces for Flute, Oboe, Clarinet, Bassoon and Horn (Ropartz); Chanson (d'Indy); Dance (d'Indy); Symphony (Gounod), 10.30, News.

PARIS

RADIO PARIS, Call CFR, 174 kc/s, 1,725 metres; 75 kW.—7.30 a.m., Weather and Physical Culture, 7.45, Potpourri of Johann Strauss Operetta Music (Selhlogel), on Gramophone Records, 8.0, Weather and Press Review, 12 Noon, Protestant Address, 12.30 p.m., Concert of Famous Soloists on Gramophone Records, Cortot; Symphonie

JULY 20th

THURSDAY

continued

Studies (Schumann). Chaliapine: Two Songs from Mephistopheles (Boito); Two Songs from Boris (Godeunov (Mussorgsky)). Kreisler: Two Violin Solos (Dvorak): (a) Innuoresque, (b) Caprice viennois. Di Mazzei: Three Songs: (a) Lusina (de Curtis), (b) Caro mio ben (Giordano), (c) Song from Tosca (Puccini). Menuhin: (a) Rigaudin (Monsigny), (b) Perpetuum Mobile (Novacek). Andre: Bange; Figaro's Aria from 'The Barber of Seville (Rossini). Yvonne Printemps: (a) Song from The Grand Duchess of Gerolstein (Offenbach), (b) Song from L'Amour masqué (Messager). Boyer: Song, Prenez mes roses (Fugazo). Marie Dubas: Les bousards de la garde. In the intervals at 1.0 and at 1.30, Exchange, News and Weather. 2.0, Exchange. 3.45, Exchange. 7.0, Market Prices and Racing Results. 7.10, Gramophone Concert. Hungarian Dances Nos. 5 and 6 (Brahms). La tourterelle (Denare); J'veux pas dire bonjour a la dame (Baer). Violin Solo: La jolie fille; Melody (di Capua); Selection from Die Fledermaus (Joh. Strauss). 7.50, Market Prices and News. 8.0, Tristan and Isolde—Opera (Wagner) on Gramophone Records. In the intervals at 8.30, News, Weather and Sports Notes, at 8.40, Review by Christophe and at 9.15, Press Review and News.

PITTSBURGH

KDKA, 980 kc/s, 306 metres; 50 kW. Relayed by W8XK on 48.86 metres; and 25.27 metres.—7.0 p.m., Hotel Pierre Concert Ensemble, from New York. 7.30, The Pioneers, from New York. 7.45, KDKA Home Forum. 8.0, Betty and Bob, from New York. 8.15, Words and Music, from New York. 8.45, State Federation of Pennsylvania Women. 8.58, Baseball Scores. 9.0, Thursday Special, from New York. 9.30, Business News and Market Reports. 9.45, Thursday Special (cont'd.), from New York. 9.58, Baseball Scores. 10.15, Tarzan of the Apes. 10.30, The Singing Lady, from New York. 10.45, Little Orphan Annie. 11.0, Time Signal and Press News-Reeler. 11.5, Bert Lown and his Park Central Hotel Orchestra. 11.15, Weather Report. 11.16, Sport Review. 11.23, I Bring a Song. 11.28, Announcement. 11.29, Temperature Report. 11.30, Pittsburgh Spotlight. 11.45, Today's News by Lowell Thomas, from New York. 12 Midnight, Amos 'n' Andy, from New York. 12.15 a.m. (Friday), Concert Footlights. 12.45 to 4.0, New York relay. 12.45, Tunc Detective. 1.0, Captain Diamond's Adventures. 1.30, Aldo Ricci and his Phantom Strings. 1.45, Floyd Gibbons, World's Fair Reporter. 2.0, Death Valley Days. 2.30, Wayne King's Orchestra with Lady Esther. 3.0, Century of Progress Festival Orchestra.

PORSGRUND.—See Oslo.

POZNAN

896 kc/s, 335 metres; 1.0 kW.—6.0 p.m., Answers to Agricultural Correspondence. 6.15, Talk from Wilno, 533 kc/s, 563 metres. 6.35, See Warsaw. 7.20, Miscellaneous Announcements. 7.35, Theatre Notes and Programme Announcements. 7.40, See Warsaw. 7.58, Time Signal. 8.0, Recital of Polish Songs. 8.25, Double Bass Solos. 8.50, See Warsaw. 9.0, Recital of Brahms and Rachmaninov Songs. 9.30, Sonata in C Minor for Violin and Pianoforte (Grieg). 10.0, Topical Talk. 10.15, Time, Sport and Police Notes. 10.30 (approx.), Close Down.

PRAGUE

614 kc/s, 488.6 metres; 120 kW.—5.25 p.m., See Brno. 5.45, Gramophone Music. 5.55, See Brno. 6.5, Agricultural Report. 6.10, Gramophone Music. 6.15, Talk for Workers. 6.25, News in German. 6.30, German Transmission: Agricultural Report. 7.0, Chimes and News. 7.10, Popular Songs. 7.30, Talk: Modern Literature. 7.45, See Brno. 8.15, Concert by the Karlsbad Municipal Orchestra, relayed from Karlsbad. Conductor: Robert Manzer. 10.0, Time and News. 10.15, Concert of Light Music. 11.0 (approx.). Close Down.

RABAT

MOROCCO, 721.1 kc/s, 416 metres; 6 kW.—1.30 to 3.0 p.m., Concert of Popular Music: Foxtrot, Blue River (Meyer Wood); Over-Louisiana Moon (Donaldson-Wood); Overture, Casanova (Lineke); Song, (Baer); Trois jours de vendanges (Lahn-Mouton); Selection from Herodiade (Massenet-Tayan); Song (Shilkret); Violin Solo: Ancient Melody (Ballet Régence (Mesquita); Les deux sérénades (Leonevallo); Cydalise (Pierne-Mouton); Oriental Fantasia (Wieniawsky-Salabert). 5.0 to 6.0 p.m., Gramophone Music. 8.0, Arab Programme. 8.45, Le Journal Parlé and Weather. 9.0, Concert: Waltz (Stroble); Désespérance (Levadé-Charnettes); Overture, La petite Bohème (Hirschmann); Song (Massenet); Selection from Roma (Massenet-Mouton); Selection from La Juive (Halévy-Tavan); Selection from Lucia di Lammermoor (Donizetti); Violin Solo: Rondo (Mozart-Kreisler); Song from Galathée (Massé); Suite from Namouna (Lalo); Song from The Damnation of Faust (Berlioz); Hungarian Dance, No. 8 (Brahms-Malkine). In the interval: Polyphème—Play in Two Acts (Albert Samain). 11.0, Gramophone Music.

RADIO-SUISSE ROMANDE

SOTTENS, 743 kc/s, 403 metres; 25 kW.; and Geneva, 395 kc/s, 760 metres.—12.28 p.m., Time Signal from Neuchâtel Observatory. 12.30, News. 12.40, Gramophone Concert. In the interval at 1.0, Financial Report. 2.0, Interval. 3.28, Time Signal from Neuchâtel Observatory. 3.30, Concert by the Radio-Suisse Romande Quintet. 5.0, Programme for Children. 5.30, Interval. 7.0, Programme for Mountain Lovers. 7.30, News. 7.35, Talk on Optimism. 7.55, Report of the Cycle Tour of France. 8.0, Grand duo concertant for Clarinet and Pianoforte (Weber). 8.20, Talk. 8.35, Violin Concerto in A Minor (Bach) by Lidus Klein and the Radio-Suisse Romande Orchestra, conducted by Robert Echenard; Soloist: Lidus Klein. 9.50, News. 10.0, Popular Programme. 10.30 (approx.). Close Down.

REYKJAVIK

250 kc/s, 1,200 metres; 21 kW.—9.30 p.m., Weather Report. 9.40, Musical Programme and Announcements. 10.0, Chimes and News. 10.30, Reading. 11.0, Concert by the Station Trio, followed by Arias and Popular Music on Gramophone Records.

RIGA

572 kc/s, 525 metres; 15 kW.—6.30 p.m., Concert of Opera Music. 7.0, Weather Report. 7.3, Legal Talk. 7.30, Symphony Concert by the Station Orchestra, conducted by Verner Janssen: Fire-work Music (Handel); Fourth Symphony (Sibelius); Suite, Gli Uccelli (Respighi); New Year's Eve in New York (Janssen). In the intervals at 8.30 and 9.0, News and Weather. 9.30, News and English Dance Music.

RJUKAN.—See Oslo.

ROME

Call IRO, 680 kc/s, 441 metres; 50 kW. Relayed by Naples, 941 kc/s, 319 metres; and 2R0, 11,810 kc/s, 25.4 metres, from 5.30 p.m.—1.5 to 2.15 p.m., Orchestral Concert. In the interval from 1.30 to 1.45, Giornale Radio and Exchange, and at 2.0, Time and Announcements. 4.45, Children's Radio Review. 5.10, Weather. 5.15, Exchange and Giornale Radio. 5.30 to 6.30, Vocal and Instrumental Concert. Luigi Biondi (Violin), Maria Romano (Soprano), and Lina Borghi (Mezzo-Soprano). Violin Solos: (a) Minuet (Porpora-Kreisler), (b) Canzonetta (Vieuxtemps), (c) Serenade (Aloy); Mezzo-Soprano Solos: (a) Bella porta di rubini (Respighi), (b) Le lucciole (Broggi), (c) Terra adorata degli avi miei (Donizetti); Violin Solos: (a) Andalusian Romance, (b) Playera (Saracate); Soprano Solos: (a) Enigma (Zanella), (b) Aria from Suor Angelica (Puccini), (c) Aria from Il Trovatore (Verdi); Violin Solo, Pasquinade (Tirindelli). 6.40, (Naples), Shipping and Sports Notes. 6.50, Agricultural and Dopolavoro Notes. 7.10, Tourist Report. 7.20, News in Foreign Languages. 7.40, Giornale Radio. 8.0, Time and Announcements. 8.2, Talk: In the Churches of Rome. 8.15, Gramophone Music. 8.30, Giornale Radio and Sports Notes. 8.45, Stenterello-Operetta in Three Acts (Alfredo Cusina). Talk and Announcements in the intervals. Giornale Radio after the Operetta.

SALZBURG.—See Vienna.

SCHENECTADY

WCY, 790 kc/s, 379.5 metres; 50 kW. Relayed at intervals by W2XAF on 31.48 metres and by W2XAD on 19.56 metres.—12.45 a.m. (Friday), Stock Reports. 1.0 to 3.0, New York Relay. 1.0, Variety Programme. 2.0, Captain Henry's Show Boat. 3.0, Musical Programme, from New York, followed by Programme Resumé.

SCHWEIZERISCHER LANDESENDER

BEROMUNSTER, 653 kc/s, 459 metres; 60 kW.; Basle, 1,229 kc/s, 244.1 metres; and Berne, 1,220 kc/s, 245.9 metres.—6.15-6.35 a.m. (from Berne), Gymnastics. 11.59, Time Signal from Neuchâtel Observatory and Weather. 12 noon (from Basle), Zither and Guitar Recital on Gramophone Records. 12.30 p.m., Time and News. 12.40 (from Basle), Opera Music on Gramophone Records. 1.25 (from Basle), Time, Weather and Exchange. 1.35 to 5.0, Interval. 5.0 (from Berne), Programme to be announced. 6.30 (from Basle), Talk on Emile Jaques-Dalozero. 7.0 (from Basle), Time, Weather and Traffic Report. 7.10 (from Basle), French Music on Gramophone Records. 7.30 (from Basle), Talk on the Opera, Il Seraglio (Mozart), with Gramophone Illustrations. 8.30 (from Basle), Duets from Opera. 9.0, Weather and News. 9.10 (from Basle), One Act Comedy in Dialect. 9.50 (from Basle), Variety Concert on Gramophone Records. 10.15 (approx.), Close Down.

SOTTENS.—See Radio-Suisse Romande.

STOCKHOLM

689 kc/s, 436 metres; 55 kW. Relayed by Boden, 244 kc/s, 1,229.5 metres; Göteborg, 932 kc/s, 322 metres; Hörby, 1,166 kc/s, 257 metres; Motala, 221.5 kc/s, 1,354.4 metres; Östersund, 389 kc/s, 770 metres; and Sundsvall, 554 kc/s, 542 metres.—5.5 p.m., Divine Service, relayed from Uppsala, 662 kc/s (453.2 metres). 5.30 (from Sundsvall), Dialogue: Songs to the Lute by Sigurd Rödström. 6.20, Gramophone Music. 7.15, Weather and News. 7.30, Talk: Norwegian Towns. 8.0, Hansen—Comedy in Three Acts (Anstinsen). 9.15 (from Sundsvall), Choral Concert, conducted by Emil Anberg. 9.45, Weather and News. 10.0 (from Göteborg), Light Orchestral Concert. 11.0 (approx.). Close Down.

STRASBOURG

869 kc/s, 345 metres; 111.5 kW.—7.45 to 8.0 a.m., Report on the Cycle Tour of France. 11.30, Light Music on Gramophone Records. 12.30 p.m., Report on the Cycle Tour of France. 12.45, News. 1.0, Time and Exchange. 1.5, Orchestral Concert, conducted by Maurice de Villers. Overture, Le Pré aux Cleres (Hérold); Suite, Fête galante (Lacôme); Selection from Hérodiate (Massenet); Gavotte, Ballet Suite and Fantasia (Saint-Saëns); Petite Suite (Debussy). 2.0 to 3.0, Programme for Children. 4.0, French Elocution Lesson. 4.15 (approx.). Report on the Cycle Tour of France. 4.30, Programme for Children, relayed from Bordeaux-Lafayette, 986 kc/s, 304 metres. 6.0, Talk in German. 6.15, Programme for Women. 6.30, Orchestral Concert, conducted by M. Roskam. Overture, Boccaccio (Suppé); Waltz, Die Hydrophatien (Gungl); Minuet, Gracieux Page (Delannay); Gavotte En pensant à Watteau (Delannay); Trio, Elegiac Poem (Delannay); Selection from La Faussette du temple (Messager); Mattinata (Leonevallo); Sérénade royale (van Hèrek); Selection from The Gelsia (Jones). 7.30, Time and News. 7.45, Report of the Cycle Tour of France. 8.5, Press Review in French, Lottery Results and Announcements. 8.30, Wagner Concert, conducted by Maurice de Villers. Soloists: Mlle. Grunenwald (Soprano), M. Faniard (Tenor), Mlle. Genya-Marat (Mezzo-Soprano), M. Wimmer (Baritone), Forest Mürmers. Two Poems: (a) Schmerzen, (b) Trümmerei. The Ride of the Valkyries; Selection from Lohengrin. In the interval, Press Review in German.

STUTTGART

MUHLACKER 832 kc/s, 360.5 metres; 60 kW. Relayed by Freiburg, 527 kc/s, 570 metres.—1.30 p.m., Concert by the Radio Orchestra, conducted by Gustav Görlich: Overture, The Princess with the Golden Slippers (Hust); Selection from Der Obersteiger (Zeller); Elegy for Strings and Harp (Hartmann); Bassoon Solo: Polka, The Teddy Bear (Ganglberger); Waltz, Traumideale (Fueick); Russian March (Ohlsen). 2.0, Interval. 2.30, Spanish Lesson. 3.0, English Lesson. 3.30, See Frankfurt. 4.30, See Munich. 5.45, Topical Talk. 6.10 (from Freiburg), The Colonisation of East and South East Germany—Radio Picture, with Scenes from Und deutsch sei die Erde and Burg im Osten (Kotzke-Kottenrodt). 6.35, Time and News. 7.0, Transmission for all German Stations, relayed from Hamburg. 8.0, Extracts from The Merry Wives of Windsor—Operetta (Nicola) on Gramophone Records. 8.45, A Talk with our Neighbours across the Border. 9.0, Dance Music from Berlin (Deutschlandsender). 10.0 (from Freiburg), Dialogue: The Travel Bureau. 10.15, Time and News.

SUNDSVALL.—See Stockholm.

TOULOUSE

779 kc/s, 385 metres; 8 kW. Transmissions irregular owing to Recent Fire. 11.30 p.m. till Close Down. Programme in English by the I.B.C. 11.30, Dance Music. 11.57, I.B.C. (Goodnight Melody). 12.0 Midnight (approx.), Close Down.

TRIESTE

1,211 kc/s, 247.7 metres; 10 kW.—5.10 p.m. till Close Down, See Turin.

TRONDHEIM.—See Oslo.

TURIN

1,096 kc/s, 273.7 metres; 7 kW. Relayed by Milan, 905 kc/s, 331.5 metres; Genoa, 959 kc/s, 312.8 metres; and Florence, 599 kc/s, 500.8 metres.—5.10 p.m., Orchestral Concert of Light Music. 6.0 to 6.5, Weather. 6.35, News. 7.0, Time and Announcements. 7.20,

News in Foreign Languages. 7.45, Medical Talk. 8.0, News. 8.15, Sponsored Gramophone Music. 8.30, Talk on the following Transmission. 8.45, Turandot—Opera in Three Acts (Puccini). In the intervals, Talk and Literary Notes. Giornale Radio after the Programme.

VATICAN CITY

15,120 kc/s, 19.84 metres (Morning), and 5,969 kc/s, 50.26 metres (Evening); 10 kW.—11.0 to 11.15 a.m., Religious Information in French. 8.0 to 8.15 p.m., Religious Information in Italian.

VIENNA

581 kc/s, 517 metres; 100 kW. Relayed by Graz, 852 kc/s, 352.1 metres; Innsbruck, 1,058 kc/s, 283 metres; Klagenfurt, 662 kc/s, 453.2 metres; Linz, 1,220 kc/s, 245.9 metres; and Salzburg, 1,373 kc/s, 218.5 metres.—12 Noon, Orchestral Concert, conducted by Josef Holzer: International Sport March (Benedikt); Overture, St. Hubertus (Fueick); Selection from Carmen (Bizet); Harfen-Serenade from Carmen (Bizet); Aquarellen (Joh. Strauss); Viennese Song, Das Glück ist ein Vogel (Kratzl); Austrian Peasant Dances (Pacherregg); Piccolo solo, Vogelsang (Wilhelm Popp); 'Zardas (Marie); Ballet Overture (Kremsler); Variations on the Folk Song, 's kommt ein Vogel geflogen (Ochs); Song from Das süsse Mädel (Reinhardt); Waltz, Grubelheiter (Zeller); Selection from The Gipsy Princess (Kálmán); March, Tausendkünstler (Blankenburg). In the interval at 1.0, Time and News. 3.0, Time and News. 3.20, Talk for the Housewife. 3.30, Programme for Children. 3.55, Famous Orchestras on Gramophone Records: The Concertgebouw Orchestra, conducted by Dr. Willem Mengelberg; Overture, Oberon (Weber); The Milan Symphony Orchestra: Intermezzo from William Ratcliff (Mascagni); The New York Philharmonic Orchestra, conducted by Arturo Toscanini; L'Apprenti Sorcier (Dukas); The Budapest Philharmonic Orchestra, conducted by Ernst von Dohnanyi; Hungarian Rhapsody No. 1 (Liszt); The Philadelphia Symphony Orchestra, conducted by Leopold Stokowsky; Corpus Christi Festival in Seville (Albeniz). 4.40, Talk: 5.5, Talk: Dangers and Technique of Mountaineering. 5.25, Song and Pianoforte Recital by Anny Kummelmann and Jose Löseher (Pianoforte): Toccata and Fugue (Bach-Taussig); Ballad in A Flat (Chopin); Two Pieces (Liszt): (a) Liebeslied, (b) Gnonouenreigen; Evening Prayer (Mussorgsky); Cradle Song (Gretchaninov); Heimkehr vom Feste (Blech); Mutter an der Wiege (Löwe); Two Pieces (Wilhelm Grosz): (a) Der verwandelte Spatz, (b) Das Zebra. (c) Zwölf kleine Negerlein. 6.5, Talk: The Exploration of Caves. 6.30, Music Talk with Gramophone Illustrations. 7.0, Lehar Recital by Franz André (Pianoforte): Melodies from The Czardas; The Land of Smiles and Schön ist die Welt; Waltz, Gold and Silver; Melodies from Frasnitz, Frederica, Paganini and The Land of Smiles. 7.30, Time and News. 7.40, Topical Talk. 7.55, Talk: A Visit to Troy. 8.30, See Turin. In the intervals at 9.15 (approx.), and at 10.30 (approx.), News.

WARSAW

212.5 kc/s, 1,411 metres; 120 kW.—11.57 a.m., Time and Fantasy from the Tower of St. Mary's Church, Cracow. 12.5 p.m., Choral Music on Gramophone Records. 12.25, Polish Press Review. 12.35, Weather. 12.40, Gramophone Music. 12.55, Radio Journal. 1.0, Interval. 2.55, Gramophone Music. 3.5, News. 3.10, Announcements. 3.15, Gramophone Music. 3.25, Economic Notes. 3.35, Gramophone Music. 3.45, Scouts Report. 3.50, Gramophone Records. 4.0, Programme for Children, relayed from Lwow, 788 kc/s, 381 metres. 4.30, Jazz Music on Gramophone Records. 5.0, Talk on Children, relayed from Wilno, 533 kc/s, 563 metres. 5.15, Concert by the Poznan Opera House Orchestra, relayed from Ciechoeimek. 6.15, Talk: A Visit to North Poland, relayed from Wilno. 6.35, Concert by the Warsaw Quartet. Quartet in E flat (Mozart); Quartet in A minor Op. 64 (Glazunov). 7.20, Miscellaneous Items. 7.35, Programme Announcements. 7.40, Talk. 8.0, Concert by the Station Orchestra, conducted by Nawrot. Soloist: Lipowska (Soprano). Overture Janek (Zelenski); Nocturne (Tolwinski-Pajek). Two Songs: (a) Sophie's Aria from Janek (Zelenski), (b) Aria from La Juive (Halévy); Petite Suite (Bizet); Mountain Fantasia (Noskowski). 8.50, Radio Journal. 9.0, Talk: Linen and Wool. 9.10, Concert (cont'd.). 10.0, Dance Music. 10.25, Sport Notes. 10.35, Aviation Weather Forecasts and Police Notes. 10.40, Dance Music.

WILNO

533 kc/s, 563 metres; 16 kW.—6.15 p.m. Talk: North Poland. 6.35 to 7.20, See Warsaw. 7.20, The Letter Box. 7.40, Pre programme Announcements. 7.45, Announcements. 7.55 to 9.0, See Warsaw. 9.0 (Topical Talk. 8.10 to 11.0, See Warsaw 11.0 (approx.), Close Down.

ZURICH.—See Schweizerischer Landessender

FRIDAY

JULY THE TWENTY-FIRST

PRINCIPAL EVENTS OF THE WEEK:

AT HOME

- NATIONAL** Festival of English Church Music at Crystal Palace.
- LONDON REGIONAL** Symphony concert.
- NORTH REGIONAL** Tom Vernon's Royal Follies, Central Pier, Blackpool.
- SCOTTISH REGIONAL** The Rothesay Entertainers.

ABROAD

- BARCELONA** 10.10 p.m. Concert by the Station Orchestra.
- BRNO** 8.0 p.m. Popular concert by the Station Orchestra.
- BRUSSELS** 9.0 p.m. Concert, relayed from the Kursaal, Ostend.
- (No. 2)**
- HILVERSUM (announced Huizen)** 7.40 p.m. Beethoven concert, by the Anhem Orchestra.
- PARIS (Poste Parisien)** 8.35 p.m. Orchestral concert.
- PRAGUE** 9.30 p.m. Pianoforte recital by Notbert Goldbaum.
- ROME** 9.15 p.m. Music by Umberto Giordano.
- STOCKHOLM** 8.0 p.m. Concert by the Symphony Orchestra.
- STRASBOURG** 8.30 p.m. Gala concert from the Casino, Vichy.
- WARSAW** 8.0 p.m. Concert by the Station Orchestra, conducted by Wolfstal.

phone Records; Walloon Melodies (de Tave); Pianoforte Solo: Fantastic Rhapsody (Dobez); Petite suite (Jongen); Phrygian Suite (Brusseman). 7.15, Gramophone Music. 7.30, Wireless Talk. 8.0, Concert by the Station Symphony Orchestra, conducted by Arthur Meulemans: March (Gillon); Suite in G (de Greef); Feestklanken (Verheyden); Serenade (Waelput); Selection from Milenka (Bloeky). 8.45, Readings. 9.0, Concert, relayed from the Kursaal, Ostend. 10.30, Le Journal Parlé. 10.40, Dance Music relayed from the Kursaal, Ostend.

BUCHAREST

761 kc/s, 394 metres; 12 kW.—5.0 p.m., Dance Music by the Syncop Accorders Jazz Band, relayed from the Lido. In an interval at 6.0, Radio Journal. 7.0, Reading. 7.20, Educational Talk. 7.40, Manon Lescaut—Opera (Puccini) on Gramophone Records. In the intervals, Radio Journal.

BUDAPEST

545 kc/s, 550.5 metres; 18.5 kW.—5.0 p.m., Hungarian Songs for Pianoforte. 5.30, Talk. 6.0, Concert by the Gutenberg Orchestra. 6.40, Poetry Recital. 7.30, Gramophone Concert. 8.30, Musical Play. After the Programme, Cigány Music by the Kiss Lajos Band.

CASSEL.—See Frankfurt.

COPENHAGEN

1,067 kc/s, 281 metres; 0.75 kW. Relayd by Kalundborg, 260 kc/s, 1,153 metres.—12 Noon, Town Hall Chimes. 12.5 p.m., Concert, relayed from the Bellevue Strandhotel. 3.0, Concert by the Louis Prells' Instrumental Ensemble. Soloists: Anna Schou Ibsen (Songs) and Carl Schneider-Meyer (Pianoforte). March, Vivat Hungaria (Kálmán); Mattinata (Martiniengo); Viennese Potpourri, Servus Wien (Dostal); The Lark (Glinka); Melody (Gillet); Selection from Ball in Savoy (Abraham); Pasodoble (Gandolfo); Five Songs; Metropolis (Grofe); Waltz (Gyldmark); Spanish Serenade (Weber); Fantasia (Stohart); Pizzicato (Morena); Melody (Bargy); Mignonette (Pozy); Pianoforte Novelty (Kappusch). 5.0, Reading. 5.35, Exchange and Fish Market Prices. 6.20, Literary Talk: Emil Aarstrup. 6.50, Weather. 7.0, News. 7.15, Time Signal. 7.30, Talk: Handicrafts and Legislation. 8.0, Time from the Town Hall. 8.1, A Play in Three Acts (Wengel) with Music. 9.30, Concert by Poul Strobeek Kische (Saxophone) and Richard Stangerup (Marimba). Saxophone Solos: (a) Little Grey Home in the West (Lühr), (b) Enlèvement (Bilmand); Marimba Solos: (a) On the Woodpile (Breyer), (b) Melody (Rubinstein), (c) The Squirrel (Smith); Saxophone Solos: (a) Andante (Goltermann), Selection from The Merry Widow (Lehar). 9.55, News. 10.10, Orchestral Concert of Swedish Music. Conductor: Emil Rescen. Suite (Atterberg); Four Swedish Dances (Aulin); Rhapsody on Swedish Folk Songs (Lindberg). 10.50, Dance Music, relayed from the Arena. In the interval at 12 Midnight, Time and Chimes from the Town Hall 12.30 a.m. (Saturday), Close Down.

CORK.—See Athlone.

CRACOW

959 kc/s, 312.8 metres; 1.5 kW.—6.35 p.m., Gramophone Music. 7.5, Talk. 7.20, Miscellaneous Items and Announcements. 7.35, Programme Announcements. 7.40 to 11.0, See Warsaw. In the interval at 10.25, Sports Notes. 11.0 (approx.), Close Down.

DANZIG.—See Heilsberg.

DRESDEN.—See Leipzig.

FECAMP

1,328 kc/s, 225.9 metres; 10 kW.—4.0 to 6.0 p.m., Programme in English by the I.B.C. 4.30, Programme for Children. 5.0, Concert of Musical Comedy Music for Southampton and Winchester Listeners: The Night by the Sea; Selection from The Belle of New York (Kerker); Love will find a way, from The Maid of the Mountains (Fraser-Stinson); Violin Solo: Indian Love Call, from Rose Marie (Friml); My Hero, from The Chocolate Soldier (O. Strauss); Song: One Alone, from The Desert Song (Romberg); Waltzes, from A Waltz Dream (O. Strauss); I give my heart, from The Dubarry (Müllbacher-Jones); Selection from The Geisha (Jones). 5.30, Octet Concert for Bourne-mouth and Weymouth Listeners: Ballet Music from Rosamunde (Schubert); Mock Morris (Grainger); Take a Pair of Sparkling Eyes (Sullivan); Valse caprice; Waltz from Der Rosenkavalier (R. Strauss); The English Rose (Germann); Au der Wäge (Grieg); Golliwog's Cakewalk (Debussy); The Night by the Sea. 6.0, Programme in French. 10.0 till Close Down, Programme in English by the I.B.C. 10.0, Dance Music by Jay Wilbur and his Band (Electrical Transcriptions); Bells of Normandy (Evans); Looking on the Bright Side (Flynn); Marta (Simons); Please don't mention it (Wysse); Shadows on the Window (Washington); When the rest of the Crowd goes home (Dublin); Hoch Carolin; Long ago (Meisel); Sing Brothers; Hummin' to myself; We will always be Sweethearts (Robin); Night shall be filled

ATHLONE
725 kc/s, 413 metres; 60 kW. Relayd by Gork, 1,337 kc/s, 224.4 metres.—1.30 to 2.30 p.m., Time Signal, Stock Exchange Quotations. Weather Report and Gramophone Music. 6.0, Programme for Children. 6.45, News. 7.0, Gardening Talk by G. O. Sheppard. 7.15, Literary and Dramatic Talk by Aodh de Blacum. 7.30, Time Signal. 7.31, Novelty Programme by the Station Orchestra. 8.0, Variety Concert by Eva Brennan and Company. 8.40, Tenor Solos by Simon Whyte. 8.55, Pianoforte Solos by G. Shanahan. 9.10, The Station Orchestra. 9.30, Soprano Solos by Eileen Deiseoll. 9.45, Sponsored Programme. 10.30, Time Signal. 10.45, News, Weather Report and Close Down.

BARCELONA

EAJ1, 860 kc/s, 348.8 metres; 8 kW.—7.0 p.m., Trio Concert: Selection from Fidelio (Beethoven); Hymn to the Sun (Rimsky-Korsakov); Canabile (Lefebvre); Selection from Rheingold (Wagner); Romance sans paroles (von Goens); Selection from Un Ballo in maschera (Verdi). 8.0, Request Gramophone Records. 8.30, Exchange. 9.0, Gramophone Records and News. 10.0, Chimes. Weather, Messages for Seamen, and Market Prices. 10.10, Concert by the Station Orchestra. 11.0, Baritone Song Recital by Ricardo Fusté. 11.30, Dance Music by the Sohré Band, relayed from the Casa Llibre. In the interval at 12 Midnight, News. 1.0 a.m. (Saturday), Close Down.

BARI

1,112 kc/s, 269.8 metres; 20 kW.—8.0 p.m., Agricultural Report, Tourist Talk and Populavore Announcements. 8.20, Giornale Radio and Weather. 8.30, Time and Announcements. 8.35, Concert of Opera Music: Selection from Berliner Luft (Lübeck); Soprano Song from La rondine (Puccini); Bass Song from The Force of Destiny (Verdi); Selection from Il Re (Giordano); Soprano Song from Don Pasquale (Donizetti); Bass Song from Figaro (Mozart); Selection from Gloria (Cilea); Overture, Elsie (Frontini); Soprano Song from La Bohème (Puccini); Aria from The Italian Girl in Algiers (Rossini); Prelude to Educa (Catalani); Soprano Song from The Barber of Seville (Rossini); Bass Solo from Napoli di carnevale (De Giosa); Selection from Cavalleria rusticana (Mascagni). In the interval, Theatre Notes. 10.30, Dance Music from the Gran Caffè del Levante. 10.55, News.

BASEL.—See Schweizerischer Landessender.

BELGRADE

BEGRAD, 697 kc/s, 430.4 metres; 2.5 kW.—5.55 p.m., Time and Programme Notes. 6.0, Yugoslav Melodies. 6.30, Talk. 7.0, Gramophone Music. 7.10 to 8.0, See Prague. 8.0, Concert. Talk, Songs, Violin Solos and Orchestral Music. 10.30, Time, News and Cigany Music from the Petrovacka Zadruga Restaurant.

BERLIN

DEUTSCHLANDSENDER, 183.5 kc/s, 1,635 metres; 60 kW.—2.0 p.m., Gramophone Records of German Chorus. 3.0, Discussion: In a Film Studio. 3.30, Weather and Exchange. 3.45, Reading (Paul Ernst). 4.0, See Leipzig. 5.0, Educational Talk. 5.25, Topical Talk. 5.35, Beethoven Pianoforte Recital by Hans Heltz; Rondo in G; Sonata. 6.0, Poems. 6.5, Violin Recital by Prof. Hans Basser-mann; Minuet (Mozart); Hungarian Dance (Brahms); Waltz (Reger); Spanish Dance (Fallá); Jota navarra (Sarasate); Tambourin ainois (Sarasate). 6.30, Talk: State Leadership and Party Politics. 6.50, Weather and Announcements. 7.0, Transmission for all German Stations, relayed from Heilsberg. 8.0, An Axiom. 8.5 (approx.), Das Schweineschächtchen—Peasant Comedy (August Hinrichs), on Gramophone Records. 9.20, Mit uns zieht die neue Zeit Radio Play (Karl Terff). 9.45, Recital of Workers' Songs. 10.0, News. 10.45, Weather. 11.0, Concert from Frankfurt. 12 Midnight, Close Down.

BERLIN

WITZLEBEN, 715 kc/s, 419.5 metres; 1.5 W.—4.30 p.m., Orchestral Concert, relayed from the Tiergarten. 4.50, Talk: Trips by Water. 5.10, Recital of Folk Songs by Martha Mirus (Soprano) and Karl Mirus (Tenor). Songs (arr. Wilhelm Berger): (a) S' steht ein Lind', (b) Zwei Königskinder, (c) Vallyöglein, (d) Kein Feuer, keine Kohle, (e) Schwewelhölzle, (f) Schmitzelpützhausel, (g) Sandmännchen. 5.30, Variety Programme. 6.0, Talk: Small Pleasures. 6.15, Radio Report from Heringsdorf. 6.40, The Witzleben Station informs its Listeners. . . . 7.45, Topical Talk. 7.0, Transmission for all German Stations, relayed from Heilsberg. 10. Life in the Beehive—a Chronicle of (natural History (Georg Rendl). 9.0, Government Announcement. 9.10, A Radio Report with Folk Songs, from Brandenburg. 10.0, News. 10.15 (approx.), Dance Music, relayed from the Zoological Gardens. In the interval at 11.0 (approx.), Talk: What they are saying in Berlin. 12 Midnight, Close Down.

ERNE.—See Schweizerischer Landessender.

EROMUNSTER.—See Schweizerischer Landessender.

ODEN.—See Stockholm.

ODO.—See Oslo.

BORDEAUX-LAFAYETTE

986 kc/s, 304 metres; 13 kW.—6.15 p.m., Radio Journal. 7.15, News. 7.30, Film Review. 7.45, Report of the Cycle Tour of France. 8.5, Spanish Lesson. 8.20, News. 8.30, Symphony Concert.

BRATISLAVA

1,076 kc/s, 279 metres; 14 kW.—6.0 p.m., Cello Recital by Greta Halmová: Sonata in G (Sammartini); Caro mio ben (Giordano); Star of Eve, from Tannhäuser (Wagner); Songs my Mother taught me (Dvorak-Grünfeld); Gavotte No. 2, Op. 23 (Popper). 6.45, Talk on Hypnotism. 6.55, Report for the Housewife. 7.0, See Prague. 7.45, Talk: The Castles of Czechoslovakia, relayed from Kosice, 1,022 kc/s, 293 metres. 8.0, See Brno. 8.50, See Prague. 10.15 (approx.), Close Down.

BREMEN.—See Hamburg.

BRESLAU

923 kc/s, 325 metres; 60 kW. Relayd by Gleiwitz, 1,184 kc/s, 253 metres. 1.0 p.m., Gramophone Concert of German Dance Music. 2.0, Time and News. 2.20, Gramophone Concert of Opera Music: Overture, Le Macon (Auber); Tenor Solo from La dame blanche (Boieldieu); Selection from Czar and Carpenter (Lortzing); Soprano Solo from The Merry Wives of Windsor (Nichols); Overture, The Caliph of Bagdad (Boieldieu). 3.0, Market Prices. 3.30, Programme for Young People. 4.0, Song Recital by Elli Weidlich (Soprano); Three Songs (Mascagni); Two Songs (Loewe): (a) Odins Meereritt, (b) Der Mönch zu Pisa; Three Songs (Mascagni): (a) Spirito santo, (b) Canzone d'amore di Luisa, (c) Piaceva d'amore; Traum durch die Dämmerung (R. Strauss); Seeher, sieben oder acht (Brüll). 4.45, Talk on Handel. 5.10, Concert of Light Music, relayed from Hindenburg. 6.10, Reading: Der Weg nach Innen—the Story of a War Disabled Man (Johann Luzian). 6.30, Talk: Everyday Forgeries. 6.50, Weather, News and Market Prices. 7.0, Transmission for all German Stations, relayed from Heilsberg. 8.0, Request Concert by the Symphony Orchestra, conducted by Rischka. Soloist: Helmut Hallendorf (Tenor). In the interval at 9.20, Topical Review of Germany and Austria. 10.10, Time and News. 10.30, Talk: Lesser-known Characters of German Legend. 10.45, Dance Music from Berlin (Witzleben). 12 Midnight (approx.), Close Down.

BRNO

878 kc/s, 342 metres; 35 kW.—2.50 p.m., Concert by the Station Orchestra, conducted by B. Bakala: Wedding March (Kapral); Selection from The Jacobin (Dvorak); Overture (Hrimaly); Ballet Music from The Indian Princess (Beidl); Suite on Themes of Job,

Strass (Morena); Slav Rhapsody No. 2 (Friedemann); Polonaise from Eugene Onegin (Tchaikovsky). 3.55 to 4.0, See Prague. 5.45, Gramophone Music. 5.55, Programme for Women. 6.5, Gramophone Music. 6.15, Programme for Workers. 6.25, German Transmission: News, Sports Notes and Humorous Talk. 7.0, See Prague. 7.45, Talk: Castles of Yugoslavia, relayed from Kosice, 1,022 kc/s, 293 metres. 8.0, Popular Concert by the Station Orchestra, conducted by J. Janota: Overture, The Kiss (Smetana); Idyll, Op. 39 (Fibich); Humoresque (Dvorak). Selection from Poleň Blit (Nedbal); Polka—Furiant from the Czech Suite (Moor). 8.50, See Prague. 10.15 (approx.), Close Down.

BRUSSELS (No. 1)

I.N.R., 590 kc/s, 509 metres; 15 kW.—12 Noon, Military Band Concert. 1.0 p.m., Le Journal Parlé. 1.10, Gramophone Concert: Patria Belgica (Labory); Oriental Melody (Poet); Miroir (Bernier); Le bleu est blond (Bernier); Au ruisseau (Goeyens); Bal de fleurs (Jongen); Chanson d'Arlette (de Tave); Song from Kaatje (Buffin); Réve d'enfant (Ysaye); Chevauchée à Laube (Brenta); Prelude in F Sharp minor (Goeyens); L'église paysanne (de Boeck); Petite Suite (Jongen). 5.0, Concert by the Station Symphony Orchestra, conducted by Arthur Meulemans: Wedding March (Tinel); Poeme (Radoux-Rogier); Waltz (de Boeck); Interlude (Vreulx); Melody (Poet); Adoration (Layge); Rhapsody (Delcroix); Walloon Rondo (Jongen). 6.0, Flemish Poems. 6.10, Song Recital by Mlle. Marguerite Thijs: Rondo (Lekou); Nocturne (Lekou); Ma soeur la pluie (Herberigs); La fleur de pêcheur (Stekke); Chant d'amour (Stekke); Chant sans paroles (Jongen). 6.30, Quartet (César Franck) on Gramophone Records. 7.20, Recitation of Walloon Poems. 7.30, Legal Talk and Literary Review. 8.0, Concert by the Station Orchestra, conducted by Franz Andri. In the intervals: Recitations from Emile Verhaeren's and Marcel Paycoot's Poems. 9.0, Concert relayed from the Casino, Knoeke. 10.30, Le Journal Parlé. 10.40, Dance Music, relayed from the Casino, Knoeke.

BRUSSELS (No. 2)

N.I.R., 887 kc/s, 338.2 metres; 15 kW. Programme in Flemish.—10.0 a.m. to 1.0 p.m., Military Music. 1.0, Le Journal Parlé. 1.10, Concert by the Small Station Orchestra, conducted by Pierre Leemans: Rubens March (Beaot); Symphonie Prelude 1920 (Leemans); Peasant Melodies (De Tave); Violin Concerto, No. 5 (Viouxtemp); Scenes dramatiques (Sarly). 5.0, Dance Music relayed from the Casino, Knoeke. 6.15, Song Recital by M. Tontenel (Baritone). 6.30, Concert by the Small Station Orchestra, conducted by Pierre Leemans: Marche de l'industrie (van Oost); Scherzo for Flute (Gillon); Marche funèbre d'un hanneton (Dubois); Gramo-

JULY 21st

FRIDAY

continued

with music (Marks); What would you do? (Robin); By the fireside (Connelly); Moonlight on the River (Green); Good-night little girl, Good-night (Ege); Song of the Harp; Bells of Normandy (Evans). 11.0, Club Concert for Warboys Listeners. Part I—Orchestral Concert: The Chum Song; Classical Selection, Part II (arr. Ewing); Torch Dance from Henry VIII (German); Violin Solo: Hymn to the Sun (Rimsky-Korsakov); March from Taubhäuser (Wagner); 'Cello Solo: Abendlied (Schumann); In the Hall of the Mountain King, from the Peer Gynt Suite (Grieg); Violin Solo: Air on the G String (Bach); Air de Ballet (Drigo). Part II—Concert of Gramophone Records: Selection, The Dubarry, Part I (Müllöcker-Mackeben). Making a Talkie, Part I and II, by Clapham and Dwyer; Rose Mousse (Bose); Old Folks at Home (Foster); Loin du bal (Gillet); Veterans of Variety, Part I; Selection, The Dubarry, Part II (Müllöcker-Mackeben). 12.5 a.m. (Saturday), Late News Bulletin in English. 12.10 (approx.), Choral Selections; John Peel (Traditional); Vienna, Vienna (Foss); Pretty Flowers (Perkins); When the Lilac Blooms again (Rotter); Song of the Vagabonds (Friml). 12.30, Dance Music: Bells of Normandy (Evans); You're getting to be a habit with me (Dublin); Sharing (Lombardo); You're beautiful to-night, my dear (Young); With Summer coming on (Ahler); We just couldn't say Good-bye (Wood); No more love (Friend); I'll never be the same (Kahn); Waltzing in a dream (Crosby); Bells of Normandy (Evans). 12.57, I.B.C. Good-night Melody. 1.0 a.m., Close Down.

FLENSBURG.—See Hamburg.

FLORENCE.—See Turin.

FRANKFURT

1,157 kc/s, 259.3 metres; 17 kW. Relayed by Cassell, 1,220 kc/s, 245.9 metres; and Trier, 1,157 kc/s, 259.3 metres.—4.30 p.m., See Stuttgart. 5.45, Market Prices. 6.0, Medical Talk. 6.25, Topical Talk. 6.45, Today's News. 6.50, Time and Announcements. 7.0, Transmission for all German Stations, relayed from Heilsberg. 8.5, See Langenberg. 10.0, Variety Items. 10.15, Time and News. 10.45, Orchestral Concert, conducted by Hans Rosband. Soloist Johannes Strauss (Pianoforte). Part I—Paul Graener Programme. Symphonic Prelude to Schirin and Gertrud, Pianoforte Concerto in G, Op. 72. Part II—Operetta Music: Selection from (a) La Fille de Mme. Angot (Lecocq); Liselott (Künneke). 12 Midnight, Close Down.

FREDRIKSTAD.—See Oslo.

FREIBURG.—See Stuttgart.

GENEVA.—See Radio-Suisse Romande.

GENOA.—See Turin.

GLEIWITZ.—See Breslau.

GOTEBORG.—See Stockholm.

GRAZ.—See Vienna.

HAMAR.—See Oslo.

HAMBURG

Call ha (in Morse), 806 kc/s, 372 metres; 1.5 kW. Relayed by Bremen, 1,112 kc/s, 269.8 metres; Flensburg, 1,319 kc/s, 227.4 metres; Hanover, 530 kc/s, 566 metres; and Kiel, 1,292 kc/s, 232.2 metres.—6.0 p.m., Act I from Agnes Bernauer—Play (Heibel), by a Company of Unemployed Actors. 6.45, Frankfurt Exchange and Hamburg Market Prices. 6.50, Weather. 7.0, Transmission for all German Stations, relayed from Heilsberg. 8.0, Political Announcements. 8.10, See Berlin (Witzleben). 9.0, Concert by the Gömmer Ensemble, with Interludes by the Gömmer Ensemble. 10.10, Time and News. 10.30, Topical Talk. 10.40, Dance Music from the Hans Sietger.

HANOVER.—See Hamburg.

HEILSBERG

1,085 kc/s, 276.5 metres; 60 kW. Relayed by Danzig, 662 kc/s, 453.2 metres.—1.5 p.m., Gramophone Concert. In the intervals at 1.20 and 2.0, News. 2.30, Programme arranged by the Post Office, with Gramophone Records. 3.0, Agricultural Prices and Exchange Rates. 3.30, Programme for Children. 4.0, Talk for Women. 4.20, Orchestral Concert, conducted by Karl Tuteln, relayed from the Kurgarten. Zopott: Festival Overture (Lortzing); Der Erlkönig (Schubert); Norwegian Rhapsody No. 2 (Svendsen); Selection from Eugene Onegin (Tchaikovsky); Symphonic Prelude to Tiefland (d'Albert); German Dances (Schubert); Overture, William Tell (Rossini). In the interval at 5.0 (approx.), Where shall we go for our next Excursion? 5.45, Talk: The German Gymnastic Festival in Stuttgart. 6.0, Recitations. 6.15, Agricultural Prices. 6.20, Pianoforte Sonata in F Sharp Minor, Op. 11 (Schumann), played by Rudolf Winkler. 6.50, Weather. 7.0, Transmission for all German Stations: A Concert at the Court of Queen Louise in 1809. The Chamber Orchestra and Station Choir, conducted by Ludwig Leschetizky. Soloists: Adelheid Arnold (Soprano), Dr. Erwin Ross (Bass), Margarete Schuchmann (Pianoforte). Introductory Talk; Psalm No. 146 for Soloist, Choir and Orchestra (Himmel); Two Songs (Himmel-Zelter): (a) Ich denke dein, (b) An den Mond; Nocturne for Pianoforte, Flute,

String Trio for Two Horns (Prince Louis Ferdinand); Songs for Soprano and Bass (Reichardt): (a) Wer nie sein Brot, (b) An den Türen will ich schleichen, (c) Nur wer die Sehnsucht kennt; Cantata for Soloist, Choir and Orchestra, Die Günst des Augenblicks (Zelter). 8.0, News. 8.5, Reading from Der zerbrochene Krug (Heinrich Kleist). 9.20, Talk by Dr. Giuseppe La Verde: The Organisation of Fascism. 9.45 (from Danzig), Pianoforte and Viola Recital by Winfried Wolf and Reinhard Wolf; Thirty-Two Variations in C Minor for Pianoforte (Beethoven); Sonata in F Minor for Pianoforte and Viola (Brahms). 10.30, News.

HILVERSUM

Announced HUIZEN, 1,013 kc/s, 296.1 metres, 20 kW. (7 kW. up to 4.40 p.m.).—Programme of the Christian Radio Society (N.C.R.V.). 12.10 p.m., Quintet Concert: Deutschemeister-Regimentsmarsch (Jurek); La Houssarde (Ganne); Selection from La Gioconda (Ponchielli); La Serenata (Braga); Selection from The Bird Fancy (Zeller); Gramophone Music: Aubade printanière (Lacombe); Ballet égyptien (Luigini); Overture, The Bohemian Girl (Halpe). 1.40 to 2.10, Interval. 2.10, Reading. 2.40, Gramophone Music. 3.10, Song Recital by Mme. de Zweenw-Slierecht (Soprano): O del mio dolce ardor (Gluck); Vittoria mio core (Carissimi); Care selye (Handel); Pianoforte Solo: Partita in C Minor (Bach); Songs (Grieg): (a) Ein Schwan, (b) Hoffnung; Three Songs (R. Strauss): (a) Die Georgine, (b) Die Nacht, (c) Ständchen; Pianoforte Solos: (a) La cathédrale engloutie (Debussy), (b) Delft in avondscherming (Voormlolen), (c) Het huishouden van Jan Steen (Voormlolen); Two Songs (Nogardere); Schermerliedje (Bruckner Fock); Two Songs (Zagwijn): (a) De Nachtergaal, (b) 't Meezeken; Song (Wagonaar). 4.10, Talk for Young Photographers. 4.40, Vocal and Instrumental Concert; Novelletten (Gade); Three Soprano Solos (Grieg): (a) Ich liebe dich, (b) Im kabine, (c) Zickeltanz; Sonata, Op. 45 (Grieg); Gramophone Music; Two Intermezzi (Brahms): (a) In E Flat Minor, Op. 118, No. 6, (b) In E Flat, Op. 117, No. 1; Villanelle (dell'Acqua); Cradle Song (Praag); Scherzando (Praag); Two Songs (Vladarcken); Frühlingsstimmen (Strauss). 6.10, Talk on Horticulture. 6.40, Police Notes. 6.55, Gramophone Records. 6.55, Gramophone Music. 7.10, Literary Talk. 7.40, Beethoven Concert by the Arnhem Orchestra, conducted by M. H. J. Mauks; Soloist, M. Hecker (Violin); Overture, Die Weihe des Hauses; Two Romances for Violin and Orchestra; Symphony No. 8 in F. 8.40, Recitations. 9.10, Concert (contd.): Overture, Patrie (Bizet); Suite, Les Erynnies (Massenet); Symphonic Poem, Phaëton (Saint-Saëns); Hungarian March (Berlioz). In the interval at 9.45, News. 10.10, Gramophone Music. 11.10 (approx.), Close Down.

HORBY.—See Stockholm.

HUIZEN

Announced HILVERSUM, 160 kc/s, 1,875 metres; 8.5 kW.—11.40 a.m. to 3.40 p.m., Programme of the Algemeene Vereeniging Radio Omroep (A.V.R.O.). 11.40, Time. 11.41, Gramophone Music. 12.10, Concert of Light Music by Kovacs Lajos and his Orchestra; Soloist, Bob Scholte (Songs). 1.40, Talk. 2.10, Gramophone Music. 2.40, Song Recital by A. Walters: Voi che sapete, from Figaro (Mozart); Garden of Happiness (Wood); Because (d'Hardelot); Pano Murciano (Nin); Jota (Falla); Mein (Schubert); Liebe schwärmt auf allen Wegen (Schubert). 3.10, Gramophone Music. 3.40 to 10.40, Programme of the Workers' Radio Society (V.A.R.A.). 3.40, Concert by De Notenkraakers, conducted by D. Wins. 4.10, Programme for Children. 4.40, Concert (contd.). 5.10, Concert by the Little V.A.R.A. Orchestra, conducted by H. de Groot. 6.20, Talk. 6.40, Concert by De Filiefluiters, conducted by J.v.d. Horst. 7.40, Talk arranged by the Liberal Protestant Radio Society (V.P.R.O.). 8.10 (approx.) to 10.10, A.V.R.O. Programme. Concert, conducted by Carl Schuricht, relayed from the Kurhaus, Scheveningen. In the intervals, Talks arranged by the V.P.R.O. 10.0 (approx.) to 10.40, V.P.R.O. Programme. 10.0, Recitations. 10.25, Gramophone Music. 10.40, V.A.R.A. Programme. Gramophone Music. 11.40 (approx.), Close Down.

INNSBRUCK.—See Vienna.

KALUNDBORG.—See Copenhagen.

KATOWICE

734 kc/s, 403 metres; 16 kW.—6.35 p.m., Military Band Concert. 7.5, Talk on Palestine. 7.20, Announcements and Gramophone Music. 7.35, Sports Notes. 7.50, See Warsaw. 11.0, The Letter Box in French.

KIEL.—See Hamburg.

KLAGENFURT.—See Vienna.

KOSICE.—See Prague.

LAHTI

167 kc/s, 1,796 metres; 10 kW. Relayed by Helsinki, 815 kc/s, 368.1 metres.—6.15 p.m., Programme for Children in Swedish. 6.40 (from Helsinki), Pianoforte Recital by Martti Paavola. 7.5, Talk in Swedish. 7.25 (from Helsinki), Concert by the Station Orchestra: Ballet égyptien (Luigini); Tesoro mio (Beatrice); Serenata (Toselli); Czardas (Monte). 8.0, Humorous Programme in Swedish. 8.20 (from Helsinki), Gramophone Concert. 8.45, News in Finnish. 9.0, News in Swedish. 9.15, Light Music, relayed from the Restaurant Kappeli. 10.0 (approx.), Close Down.

LANGENBERG

635 kc/s, 473 metres; 60 kW.—12 Noon, Concert by the Station Chamber Orchestra, conducted by Josef Breuer. Soloist: Erdmütte Fiebiger (Contralto). Overture, The Nutcracker (Tchaikovsky); Suite, Jeux d'enfants. (Bizet); Spanish Fantasia, A Fête in Aranjuez (Demerssenau); Songs: (a) Tre Giorni (Pergolesi), (b) Dido's Aria from Dido and Aeneas (Purcell), (c) Plaisir d'amour (Martini); Selection from Gianni Schicchi (Puccini); Polovtsian Dances from Prince Igor (Borodin); Song Potpourri (Körke). 12.50 p.m., News. 1.15, Concert conducted by Wolf. Soloist: Isabella Schmitz (Violin); Overture, Britannicus (Scassola); Violin Solos: (a) Spanish Dance (Sarasate), (b) Spanish Dance (Falla), (c) Canzonetta (d'Ambrósio), (d) Irish Folk Dance (Grainger); Delirien-Walzer (Strauss); Selection from Hansel and Gretel (Humperdinck); Ballet Suite from Die Liebesprobe (Mozart); Selection from Wenn Liebe erwacht (Künneke). In the interval at 2.0, News. 2.30, Interval. 3.0, Talk: Fascism and the Housing Question. 3.20, Announcements. 3.30, News. 3.50, Talk for Young People: Former German Colonies. 4.30, Rhenish and Westphalian Music—Concert by the Station Orchestra, conducted by Breuer, the Station Choir and String Quartet and Soloists: Ferdinand Böger (Mezzo-Soprano), and Egbert Grape (Pianoforte); Concert Piece for Flute and Pianoforte (Ginger); Duet for Flute and Pianoforte (Fährles); Songs (Höcker): (a) Nach dem Regen, (b) Abendzug, (c) So ist's auf Erden, (d) Mond über einer alten Stadt, (e) Kleine Artie, (f) Ica wand're, (g) Des Kindes Dank; String Quartet in F Minor, Op. 16 (Nolt); Four Songs for Choir (Leinacher): (a) Fülle, Op. 18, No. 5, (b) Gluck Datum, Op. 68, No. 6, (c) Rosen, Op. 66, No. 2, (d) Wildwidewum, Op. 88. In the interval, Topical Talk. 5.45, Talk: A Soldier's Memories of Fifteen Years Ago. 6.15, Folk Music. 6.30, Talk in Dialect. 6.45, Weather. 7.0, Transmission for all German Stations, relayed from Heilsberg. 8.0, News. 8.5, The Rhenish People—Stories and Music. 8.45, Humorous Dialect Programme with Music. 10.0, News. 10.20, A Radio Report from the Institution for the Blind at Suest. 10.40, See Frankfurt. 11.39 (approx.), Close Down.

LAUSANNE.—See Radio-Suisse Romande.

LEIPZIG

769.9 kc/s, 389.6 metres; 120 kW., and Dresden, 941 kc/s, 319 metres.—12 Noon, Weather and Time. 12.5 p.m., Concert by a Nazi Band. 1.0 p.m., News. 1.15, Wagner Concert on Gramophone Records. 2.0, News. 2.10, Art Report. 2.30, Reading from the Lyrics of Fritz Wolke. 2.45, Violin Recital on Gramophone Records. 3.15, Talk for the County Woman. 3.35, Market Prices. 4.0, Concert by the Leipzig Symphony Orchestra, conducted by Hilmar Weber. Soloists: Oskar Jölli (Tenor); Overture in C in Italian Style (Schubert); Melody; Suite, Op. 22 (Schumann); Melody; Waltz from Der Rosenkavalier (R. Strauss); Selection from Die Königs-kinder (Humperdinck); Intermezzo from Mona Lisa (von Schillings); Hungarian Dances Nos. 11 to 16 (Brahms). 5.0, Book Review. 5.20, Interval. 5.50, Market Prices, Weather and Time. 6.0, Talk: The Press Stenographer. 6.25, Talk: How to check National Deradence. 6.50, Today's News. 7.0, Transmission for all German Stations, relayed from Heilsberg. 8.0, Government Announcements. 8.5, The Prussian Spirit—Radio Play (Paul Ernst). 9.15, News. 9.25 (from Dresden), Concert by the Dresden Orchestra, conducted by Ernst Schickeltanz; Overture, Die Frau Meisterin (supple); Selection from Ritter Pasman (Joh. Strauss); Selection from Irre Excellenz (Heibeger); Waltz from Der arme Jonathan (Müllöcker); Maikäferlied from Jaluwiga (Dellinger); March from Where the Lark sings (Lohar); Overture, Casanova (Lincke); Barcarolle from Liebeswalzer (Zehrer); Selection from Und dennoch König (Schickeltanz). 10.45, News.

LINZ.—See Vienna.

LUXEMBOURG

252 kc/s, 1,191 metres; 200 kW.—Dutch Programme. 7.0 p.m., Concert of Light Music by the Station Orchestra. 7.40, Weather Report. 7.45, Sixth Symphony (Tchaikovsky)

by the Concertgebouw Orchestra, conducted by Willem Mengelberg, on Gramophone Records. 8.25, Song Recital. 8.50, News in French. 9.15, Talk in Dutch. 9.25, Orchestral Music. 9.50, News in German. 10.0, Concert of Variety Music and Dance Music, relayed from the Hotel National and the Station Hotel. Exchange and News in the intervals.

LWOW

788 kc/s, 381 metres; 16 kW.—6.15 p.m., See Warsaw. 6.35, Gramophone Music. 7.40, See Warsaw. 10.40, Gramophone Music. 11.0 (approx.), Close Down.

LYONS

LA DOUA, 644 kc/s, 465.8 metres; 1.5 kW.—6.15 p.m., Radio Journal. 7.30, Radio Gazette for Lyons and the South East. 7.40, News. 7.45, Report of the Cycle Tour of France. 8.10, Talk on Birds. 8.20, Talk on Aeronautics. 8.30, Talk. 8.40, Concert of Songs and Instrumental Music: Sonata (Beethoven); Three Ballads (Debussy); Suite (Sammartini); Le parfum impérisable (Fauré); En sourdine (Fauré); Concerto for Three Violins (Vivaldi); Nocturne in A Flat (Fauré); Etude de concert (Pierne); Le promenoir des deux amants (Debussy); Quintet (Franck). After the Concert, News.

MADRID

EAJ7, 707 kc/s, 424.3 metres; 2 kW.—8.0 p.m., Chimes, Exchange, Radio Journal, and Request Gramophone Concert. 9.15, News and Political Review. 9.30 to 11.0, Interval. 11.0, Chimes, Time, and Political Review. 11.15 (approx.), Symphony Music on Gramophone Records: Overture, Figaro (Mozart); Intermezzo from Goyescas (Granados); Le Chasseur maudit (César Franck); Second Symphony in D (Brahms); Pianoforte Concerto in F minor (Chopin). 1.15 a.m. (Saturday), News and Programme Announcements for Listeners Abroad. 1.30, Chimes and Close Down.

MALMO.—See Stockholm.

MILAN.—See Turin.

MORAVSKA-OSTRAVA

1,137 kc/s, 263.8 metres; 11 kW.—7.45 p.m., Talk: Show of Castles, relayed from Kosice, 1,022 kc/s (293 metres). 8.0, See Brno. 8.50, See Prague. 10.15 (approx.), Close Down.

MOSCOW

TRADES UNION, 230 kc/s, 1,304 metres; 100 kW.—2.45 a.m., Weather. 3.0, Strauss and Pianquette Concert on Gramophone Records. 4.0, Talk. 4.20, Programme of Soiree Literaire. 5.45, Talk. 6.30, Concert of Music by Borodin, Medtner, Dawidenko, and Schubert. 9.0, News. 9.30, Programme Announcements. 9.55, Chimes from the Red Square. 10.5, Press Review.

MOTALA.—See Stockholm.

MUHLACKER.—See Stuttgart.

MUNICH

563 kc/s, 533 metres; 60 kW. Relayed by Augsburg and Kaiserlautern, 536 kc/s, 239 metres, and Nürnberg, 256 kc/s, 239 metres.—4.30 p.m., Orchestral Concert, conducted by Erich Kloss; Overture, Cagliostro in Wien (Joh. Strauss); Hungarian Rhapsody No. 5 (Liszt); Selection from I Pagliacci (Leoncavallo); Spanish Waltz (Seiberger); Ballet Suite (Karkk); Waltz (Reinl); Kiss Serenade (Miechli); Polka, Frauenherzen (Jos. Strauss); 5.45, Programme for Young People. 6.6, Programme to be announced. 6.25, Talk: Experiences with Animals. 6.45, Time, Weather, and Agricultural Notes. 7.0, Transmission for all German Stations, relayed from Heilsberg. 8.0, The Last Waltz—Folk Play in Three Acts (Schleier). 9.20, Topical Review of Germany and Austria. 9.40, Minstrel—Concert by the Small Station Orchestra, conducted by Erich Kloss; Soloist: Hugo Becker (Violin); Little Overture (Tchaikovsky); Old Dances (Ama-de); Ich liebe dich (Grieg); Minuet (Bolzoni); Rose Mousse (Bose); Violin Solo: Serenade (d'Ambrósio); Tango (Gade); Lullaby (Godeard); Perpetuum mobile (Larsen); Birthday Serenade (Lincke); Nigger Lullaby (Clusam); A Box of Soldiers' (Schleier). 10.20, Time and News.

NAPLES.—See Rome.

NOTODDEN.—See Oslo.

OSLO

277 kc/s, 1,083 metres; 60 kW. Relayed by Fredrikstad, 815 kc/s, 368.1 metres; Hamar 522 kc/s, 574.7 metres; Notodden, 671 kc/s, 447.1 metres; Porsgrund, 662 kc/s, 453. metres; and Rjukan, 671 kc/s, 447.1 metres.—6.30 p.m., Pianoforte Recital by Id. Björset. 7.0, Advertising Notes. 7.15 Weather and News. 7.50, Talk. 8.0, Time 8.1, Dramatic Programme. 9.30, Foreign Agricultural Report. 9.40, Weather and News. 10.0, Topical Talk. 10.15, Song Recita by Alf Størseth.

OSTERSUND.—See Stockholm.

JULY 21st

FRIDAY

continued

PALERMO

558 kc/s, 537.6 metres; 3 kW.—8.0 p.m., Dopplavoro Announcements, Tourist Report, Agricultural Notes, Report of the Royal Geographical Society and Giornale Radio. 8.20, Gramophone Music. In the interval at 8.30, Time and Announcements. 8.45, Concert of Opera Music, conducted by F. Russo. In the intervals, Talk and Announcements. 10.55, News.

PARIS

EFFEL TOWER, Call FLE, 207.5 kc/s, 1,445.7 metres; 13 kW.—Time Signals (on 2,650 metres) at 10.26 a.m. and 11.26 p.m. (Preliminary and 6-dot Signals).—6.45 p.m., Le Journal Parlé. In the interval at 7.45, Report of the Cycle Tour of France. 8.30, Literary and Musical Programme for Young People. 9.15, Concert of English Music by the Symphony Orchestra, conducted by Eduard Flament: I pitch my lonely Caravan (Coates); Bird Songs at Eventide (Coates); Roses of Picardy (Wood); Where my Caravan has rested (Lohr); Symphonic Poem (Fog); A Sunday Promenade (Sadun); In a Chinese Temple Garden (Ketchell); First Suite for Strings (Scott); Petite Suite de Concert (Coleridge Taylor). 10.0 (approx.), Close Down.

PARIS

POSTE PARISIEN, 914 kc/s, 328.2 metres; 40 kW.—7.0 p.m., Gramophone Music. 7.5, Talk. 7.15, Le Journal Parlé. 7.30, Report of the Cycle Tour of France. 7.45, Gramophone Music. 8.15, Interval. 8.35, Orchestral Concert. Soloist: Mlle. Deva Dassy (Songs). Prelude and Chœur de l'Inne from Werther (Massenet); Waltz, Dolores (Waldteufel); Air from Madrilène (Infante); Selection from Le Petit Faust (Hervé); Scènes antiques (Larrieu); La Brise est douce (Fili-pucci); Selection from Aida (Verdi); Melody (Simou); Spanish Song, Caramba (Franggi); Song: Carta a una española (Laparra); Romance for Violin and Piano (Beethoven); Suite from Fortunio (Messager); Marche funèbre d'une marioulette (Gounod). 10.30, News.

PARIS

RADIO PARIS, Call CFR, 174 kc/s, 1,725 metres; 75 kW.—7.30 a.m., Weather and Physical Culture. 7.45, Gramophone Music; Serenade (Toselli); Los Banderilleros (Volpati); Hylde (Reynaud); Fantasia on a Neapolitan Melody (Gemin). 8.0, Weather and Press Review. 12 Noon, Jewish Address. 12.30, Spain in Music—Gramophone Concert. Suite, Iberia (Albeniz); Spanish Dance No. 6 (Granados); Selection from La Vida breve (Fallá); Spanish Serenade (Borodin); Spanish Caprice (Rimsky-Korsakov); Suite, La Feria (Lacome); Seguidillas from Carmen (Bizet); España (Chabrier); La Soirée dans Grenade (Debussy); Prelude (Laparra); Alborada del Gracioso (Ravel). In the interval at 1.0 p.m., Exchange, News and Weather, and at 1.30, Exchange. 2.0, Exchange. 3.45, Exchange and Market Prices. 7.0, Market Prices, Weather, Agricultural Notes, and Racing Results. 7.10, Social Insurance Report. 7.20, Gramophone Music. 7.50, Commercial Prices and News. 8.0, Pianoforte Recital by Mlle. Simone Lamié: Sospeso (Liszt); Scherzo in B minor (Chopin); Jardins sous la pluie (Debussy); La Campanella (Liszt); The Flight of the Bumble Bee (Rimsky-Korsakov-Strimen). 8.30, News, Weather and Sports Notes. 8.40, Astronomic Review. 8.45, Paul et Virginie—Play (Beissier), with Music by Lucas. 9.15, Press Review and News. 9.30, Gramophone records.

PITTSBURGH

CDKA, 980 kc/s, 306 metres; 40 kW. Relayed by W8XK on 48.85 metres and 25.27 metres. 4.0 to 4.59 p.m., U.S. Marine Band, from New York. 7.30, KDKA Home Forum. 8.0, Betty and Bob, from New York. 8.15, International Sunday School Lesson by Rev. S. S. Appin. 8.30, Tenor Solos by John Dunlap. 8.45, Happy Jack, from New York. 8.58, Baseball Scores. 9.0, Gene Quaw and his Hotel Metropolitan Orchestra, from New York. 9.30, Business News and Market Reports. 9.45, Arcadians, from New York. 9.58, Baseball Scores. 10.0, Rhythm Kings. 10.15, Caravan of the Apes. 10.30, The Singing Lady, from New York. 10.45, Little Orphan Annie. 1.0, Time Signal and Press News-Reader. 1.15, Weather Report. 11.16, Sport Review. 1.23, I Bring a Song. 11.28, Announcement. 1.29, Temperature Report. 11.30, Pittsburgh spotlight. 11.45, Today's News, by Lowell Thomas, from New York. 12 Midnight, Amos 'n' Andy, from New York. 12.15 a.m. (Saturday), Rondoliers. 12.30, Pastoral, from New York. 1.0, Manchester Arms-KDKA Players. 1.15, The Silver Toppers. 1.30, Potash and Crumutter. 1.45 to 3.45, New York Relay. 4.5, Phil Cook and his Ingram Shavers. 2.0, et's Listen to Harris. 2.30, Variety Programme. 3.0, First Nighter.

ORSGRUND.—See Oslo.

POZNAN

16 kc/s, 335 metres; 1.9 kW.—6.0 p.m., Talk. 15 to 7.20, See Warsaw. 7.20, Miscellaneous items. 7.35, Programme Announcements and Theatre Notes. 7.40, See Warsaw. 7.58, Time Signal. 8.0 to 10.0, See Warsaw. 10.0, Time, Sports and Police Notes. 10.15, Dance music from the Café Polonia. 11.50 (approx.), Close Down.

PRAGUE

614 kc/s, 488.6 metres; 120 kW.—2.50 p.m., See Brno. 3.55, Exchange. 4.0 to 5.45, interval. 5.45, Gramophone Music. 5.55, Educational Programme. 6.5, Market Prices. 6.15, Gramophone Music. 6.25, News in German. 6.30, German Transmission: Two Talks. 7.0, Chimes and News. 7.10, Paganini Recital by V. Frait (Violin) and Professor Maudr (Guitar); The Witches' Dance; Two Capriccios, Nos. 21 and 9; Variazioni di bravura; Variations on the G String. 7.45, Talk: Slovak Castles, relayed from Kosice, 1,022 kc/s, 293 metres. 8.0, See Brno. 8.50, King of the Romans—Play (Palovic). 9.30, Pianoforte Recital by Norbert Goldbaum; Impressions, Op. 73, No. 6 (Foerster); Serenade, Op. 30 (Kricka); Scherzo from the Suite, Op. 5 (Mastaler); Gavotte (Ridky); Overture (Finke); Two Pieces (Prochaska); Descriptive Pieces, Op. 12, No. 3 (Suk). 10.0, Time and News.

RADIO-SUISSE ROMANDE

SOTTENS, 743 kc/s, 403 metres; 25 kW.; and Geneva, 395 kc/s, 760 metres.—12.28 p.m., Time Signal from Neuchâtel Observatory. 12.30, News. 12.40, Gramophone Concert. In the interval at 1.0, Financial Report. 2.0, Interval. 3.28, Time Signal from Neuchâtel Observatory. 3.30, Dance Music by the Broadcasting Serenaders. 4.30, Programme for Women. 5.30, Interval. 7.0, Sports Talk. 7.20, News. 7.30, Political Review. 7.55, Results of the Cycle Tour of France. 8.0, Concert by the Geneva Mandoline Club. 8.30, Programme to be announced. 8.45, Vibraphone Recital by Charles Peschier. 9.0, Concert by a Yodelling and Zither Club. 9.50, News. 10.0, Gramophone Concert. 10.30 (approx.), Close Down.

REYKJAVIK

250 kc/s, 1,200 metres; 21 kW.—9.30 p.m., Weather Report. 9.40, Musical Programme and Announcements. 10.0, Chimes and News. 10.30, Reading. 11.0, The Fifth Symphony (Tchaikovsky) on Gramophone Records.

RIGA

572 kc/s, 525 metres, 15 kW.—6.0 p.m., The Kreuzer Sonata for Violin and Pianoforte (Beethoven), played by Isold Meiges (Violin) and Arthur de Graf (Pianoforte). 6.30, Medical Talk. 7.0, Weather Report. 7.30, Concert of Opera Music, by the Station Orchestra, conducted by Ernst Mehlisch, relayed from Molluzi; Soloist, Vera Krampé (Songs); Overture, Mignon (Thomas); Selection from Faust (Gounod); Waltz from Eugene Onegin (Tchaikovsky); Suite from The Tale of Zar Saltana (Rimsky-Korsakov); Overture, The Barber of Seville (Rossini); Arias, Meditation from Thaïs (Massenet); Waltz from Der Rosenkavalier (R. Strauss); Overture, The Bartered Bride (Smetana). In the interval at 8.0, News. After the Concert, News, followed by Dance Music on Gramophone Records.

RJUKAN.—See Oslo.

ROME

Call 1RO, 680 kc/s, 441 metres; 60 kW. Relayed by Naples, 941 kc/s, 319 metres; and 2RO, 11,810 kc/s, 25.4 metres.—1.0 to 2.15 p.m., Orchestral Concert of Light Music. In the intervals from 1.30 to 1.45, Giornale Radio and Exchange, and at 2.0, Time and Announcements. 4.45, Children's Radio Review. 5.10, Weather. 5.15, Exchange and Giornale Radio. 5.30, Vocal and Instrumental Concert. 6.40 (Naples), Shipping and Sports Notes. 6.50, Agricultural and Dopplavoro Notes. 6.57, Report of the International Institute of Agriculture (in Spanish, German, and French). 7.10, Tourist Report. 7.20, News in Foreign Languages. 7.30, Sports Notes. 7.40, Giornale Radio. 8.0, Time and Announcements. 8.15, Sponsored Gramophone Music. 9.15, Concert of Music by Umberto Giordano: Duet, Prelude to the Third Act and Finale from Marella; Intermezzo from Il voto; Selection from Il Re; Duet from the Second Act of La cena delle beffe. 10.10 (approx.), A Comedy in One Act (Quintero Brothers). 10.30, Dance Music. In the interval at 10.55, Giornale Radio. 11.30 (approx.), Close Down.

SALZBURG.—See Vienna.

SCHENECTADY

WGY, 790 kc/s, 379.5 metres; 50 kW. Relayed at intervals by W2XAF on 31.48 metres and by W2XAD on 19.56 metres.—9.0 p.m. May We Present, from New York. 9.15, Popular Programme, from New York. 9.30, Talk: The Mind Age. 9.35 to 10.0 (approx.), South Sea Islanders, from New York. 10.15, See Brno. 10.45, Stock Reports. 1.0, Cities Service Concert, from New York. 1.30, WGY Farm Forum. 2.0, Variety Programme, from New York. 2.30, Popular Programme, from New York. 3.0, WGY Players in Red Adams. 3.30, Musical Programme, from New York, followed by Programme Resumé.

SCHWEIZERISCHER LANDESSENDER

BEROMUNSTER, 653 kc/s, 459 metres; 60 kW.; Basle, 1,229 kc/s, 244.1 metres; and Berne, 1,220 kc/s, 245.9 metres.—6.15-6.35 a.m. (from Berne), Gymnastics. 11.59, Time Signal from Neuchâtel Observatory and Weather. 12 noon (from Berne), Hungarian Folk Music on Gramophone Records. 12.30 p.m., Time, Weather and News. 12.40 (from Berne), Variety Concert on Gramophone Records. 1.25 (from Berne), Time, Weather and Exchange. 1.35 to 5.0, Interval. 5.0 (from Basle), Programme for Children. 5.30 (from Basle), Variety Concert on Gramophone Records. 6.30 (from Berne), Talk on the Early Years of Airships. 7.5 (from Zürich), Concert by the Swiss Radio Orchestra. 8.0 (from Berne), Talk on Psychology. 9.0, Weather and News. 9.10 (from Berne), Extracts from Der Freischütz—Opera. (Weber). 10.15 (approx.), Close Down.

SOTTENS.—See Radio-Suisse Romande.

STOCKHOLM

689 kc/s, 436 metres; 55 kW. Relayed by Boden, 244 kc/s, 1,229.5 metres; Göteborg, 932 kc/s, 322 metres; Hårbj, 1,166 kc/s, 257 metres; Motala, 221.5 kc/s, 1,354.4 metres; Östersund, 389 kc/s, 770 metres; and Sundsvall, 554 kc/s, 542 metres.—5.5 p.m. (from Sundsvall), Reading (Oscar Rydqvist). 5.30, Gramophone Music. 6.15 (from Sundsvall), Provincial Programme. 7.15, Weather and News. 7.30, Talk: From Wood to Artificial Silk. 8.0, Concert by the Symphony Orchestra, conducted by John Kahrmann: Rakoczy March (Berlioz); Concert Overture (Ottosen); Selection from Lila Time (Schubert-Berté); Swedish Suite (Weslander); Valse des Brunes (Ganne); March, Escamillo (Kahrmann). 9.0, Talk. 9.30, Song Recital by Greta Torpaldie-Bratt. 9.45, Weather and News. 10.0 (from Göteborg), Chamber Music: Pianoforte Quartet in E Flat, Op. 47 (Schumann); Trio in C Minor, Op. 3, No. 9 (Beethoven). 11.0 (approx.), Close Down.

STRASBOURG

869 kc/s, 345 metres; 11.5 kW.—7.45 to 8.0 a.m., Report of the Cycle Tour of France. 11.30, Variety Music on Gramophone Records. In an interval at 12.15 p.m., Report of the Cycle Tour of France. 12.45, News. 1.0, Time and Exchange. 1.5, Belgian National Festival Concert, conducted by Maurice de Villers. Soloist: M. Faniard (Tenor). Suite dans le style ancien (Jean Blockx); Five Old Songs for Tenor (F. Brunagne); Suite Phrygienne (Brusselsians); Songs: (a) Nuit de Juin (François Rasse). (b) L'Eglise Paysanne (Aug. de Boeck). (c) Bal de Fleurs (Jos. Jongen); Song with Cello Accompaniment; Réveil (René Barbier). 2.0 to 3.30, Interval. 3.30, Gala Concert, conducted by M. Brouillat, relayed from the Casino, Vichy; Overture, La Dame blanche (Boieldieu); An den Frühling (Grieg); Solveig's Song (Grieg); Première suite d'orchestre (G. Pierné); Carmosine (Henri Février); Three Pieces (Massenet): (a) Prélude du Réve, (b) Danses Siciliennes, (c) Selection from Manon; Waltz, La Vague (Olivier Métra). In an interval at 4.0, Report of the Cycle Tour of France. 5.0, Literary Talk in French: Maurice de Saxe and Adrienne Lecouvreur. 5.15, Dance Music. 6.0, Chamber Music by the Station Trio, relayed from Lille, 1,130 kc/s, 265.4 metres. 7.0, Topical Talk in German. 7.15, Talk in German: The International Labour Conference. 7.30, Time and News. 7.45, Report of the Cycle Tour of France. 8.5, Press Review in French, Lottery Results and Announcements. 8.30, Gala Concert, conducted by Paul Paray, relayed from the Casino, Vichy; Overture, Gwendoline (Chabrier); Symphonic Poem, Orpheus (Liszt); Symphonic fantastique (Berlioz). 10.0, Press Review in German.

STUTTGART

MUHLACKER, 832 kc/s, 360.5 metres; 60 kW. Relayed by Freiburg, 527 kc/s, 570 metres.—12.50 p.m., Gramophone Music. 1.15, Time and News. 1.30, Folk Music on Gramophone Records. 2.0, Concert arranged by the Post Office. 2.30, Advanced English Lesson. 3.0, Interval. 3.45, Talk: Sunday Walks. 4.0 (from Mannheim), Pianoforte and Soprano Song Recital of Music by Heinrich Seal: Five Pieces for Pianoforte, Tröstungen, Op. 70; Songs: (a) Wasserrosen, (b) O dürrt ich kättnpfen doch, (c) Ballstene. 4.30, Orchestral Concert, conducted by Albert Hitzig, relayed from Badenweiler; Overture, Das Nachtlager von Granada (Kreutzer); Waltz from Das süsse Mädel (Reinhardt); Selection from Paganini (Lehár); Fantasia, Durch Webers Zauberwald (Friedrich); Am Meer (Schubert); Ständchen (Schubert); Intermezzo, Gnomenschnliche (Rhode); March, Hoch Heideckburg (Herzer). 5.45, Talk on Christianity. 6.10, Legal Talk. 6.35, Time and News. 7.0, Transmission for all German Stations, relayed from Heilsberg. 8.5, See Heilsberg. 9.15, Concert of Swabian Music. The Station Orchestra, conducted by Ferdinand Drost. Soloist: Katharina Bosch.

Möckel (Violin); Suite (Herrmann); Violin Concerto (Reutter); Kleine Suite (Ade); Dance of the Gnomes (Bleyle). 10.0, Talk: Poisson Gas. 10.20, Time and News. 10.45, See Munich. 11.5, See Frankfurt. 12 Midnight, Close Down.

SUNDSVALL.—See Stockholm.

TOULOUSE

779 kc/s, 385 metres; 8 kW.—Transmissions irregular owing to recent fire. 11.30 p.m. till (Close Down, Programme in English by the I.B.C.). 11.30, Organ Recital. 11.57, I.B.C. Good-night Melody. 12 Midnight (approx.), Close Down.

TRIESTE

1,211 kc/s, 247.7 metres; 10 kW.—5.0 p.m. till Close Down. See Turin.

TRONDHEIM.—See Oslo.

TURIN

1,096 kc/s, 273.7 metres; 7 kW. Relayed by Milan, 905 kc/s, 331.5 metres; Genoa, 959 kc/s, 312.8 metres; and Florence, 599 kc/s, 506.8 metres.—5.0 p.m., Chamber Music. 6.0 to 6.5, Weather. 6.35, News. 7.0, Time, Announcements and Songs on Gramophone Records. 7.20, News in Foreign Languages. 7.40, Gramophone Music. 8.0, News. 8.15, Sponsored Gramophone Music. 8.30, Variety Programme. 9.30, A One Act Comedy. 10.0, Dance Music. 11.0, Giornale Radio.

VATICAN CITY

15,120 kc/s, 19.84 metres (Morning), and 5,969 kc/s, 50.26 metres (Evening); 10 kW.—11.0 to 11.15 a.m., Religious Information in German. 8.0 to 8.15 p.m., Religious Information in Italian.

VIENNA

581 kc/s, 517 metres; 15 kW. Relayed by Graz, 852 kc/s, 352.1 metres; Innsbruck, 1,058 kc/s, 283 metres; Klagenfurt, 662 kc/s, 453.2 metres; Linz, 1,220 kc/s, 245.9 metres; and Salzburg, 1,373 kc/s, 218.5 metres.—12 Noon, Concert by the Vienna Symphony Orchestra, conducted by Josef Holzer. 1.0 p.m., Time and News. 1.10, Concert (cont'd.). 3.0, Time and News. 3.20, Talk. 3.35, Programme for Children. 4.0, Gramophone Concert of Sound Film Music. 4.40, Programme for Women. 5.5, Talk. 5.30, Recital by Georg Funtz (Bass) and Dr. Robert Friedmann (Pianoforte). 6.5, Tourist Talk. 6.20, Talk: Cycle Tours. 6.35, Sports Notes. 6.45, Talk: Cycle Tours. 6.55, Vienna Symphony Orchestra, conducted by Josef Holzer: Dufay-Marsch (Strömer); Overture, The Arabian Nights (Johann Strauss); Norwegian Folk Melodies (Sveendson); Waltz from Das Fürstentum (Lehár); Selection from Polenblut (Nedbal); March, Mit Eichenlaub und Schwert (v. Blom); Kleines Trompeterlied (Stolz); Serenata (Welser); Overture, Rund um die Liebe (O. Straus); Viennese Song, Beim Agnesbrunn in Sievering (Alföldi-Raxler); Waltz, Faschingskinder (Ziehrer); Viennese Song Potpourri, Wien bei Nacht (Kozzak). In the interval at 7.45, Time and News. 8.30, Talk: The Austrian Countryside in the Summer. 8.50, Symphony concert, conducted by Dr. Anton Webern. Soloist: Wolfgang Schneiderhan (Violin). 10.15, News. 10.30, Gramophone Dance Music.

WARSAW

212.5 kc/s, 1,411 metres; 120 kW.—11.57 a.m., Time Signal and Fanfare from the Tower of St. Mary's Church, Cracow. 12.5 p.m.: Light Music and Dance Music by the Station Orchestra. 12.25, Polish Press Review. 12.33, Weather. 12.35, Light Music and Dance Music (cont'd.). 12.65, Radio Journal. 1.0, Interval. 2.55, Gramophone Music. 3.5, News. 3.10, Announcements. 3.15, Gramophone Music. 3.25, Economic Notes. 3.35, Gramophone Music. 3.45, Aviation Notes and Anti-Gas Drill. 3.50, Gramophone Music. 3.55, Naval and Colonial Report. 4.0, Popular Concert by the Poznan Opera House Orchestra, conducted by Tyllia, relayed from Ciechocinek. 5.0, Talk: Photography in Summer. 5.15, Soprano and Pianoforte Recital relayed from Lwów, 788 kc/s, 381 metres. 6.15, Talk: Modern Poland. 6.35, Light Music on Gramophone Records. 7.20, Miscellaneous Items. 7.35, Programme Announcements. 7.40, Topical Talk. 8.0, Concert by the Station Symphony Orchestra, conducted by Wolfstall; Soloist: Holcman (Violin); Secular Songs (Karłowicz); Violin Concerto in G minor, Op. 26 (Brahms). 8.50, Radio Journal. 9.0, Hints for the Week-end. 9.10, Concert (cont'd.); The New World Symphony (Dvorák); Symphonic Poem, L'Apprenti Sorcier (Dukas). 10.0, Dance Music from the Europe Café, Ciechocinek. 10.25, Sports Notes. 10.35, Aviation Weather Report and Police Notes. 10.40, Dance Music.

WILNO

533 kc/s, 563 metres; 16 kW.—6.35 p.m., Dance Music on Gramophone Records. 7.10, Announcements. 7.20, Lithuanian Review. 7.40 to 9.0, See Warsaw. 9.0, Talk: The Week End. 9.10 to 11.0, See Warsaw. 11.0 (approx.), Close Down.

ZURICH.—See Schweizerischer Landesender.

SATURDAY

JULY THE TWENTY-SECOND

PRINCIPAL EVENTS OF THE WEEK:

AT HOME

- NATIONAL** King's Prize at Bisle; running commentary on final stage by Capt. E. H. Robinson.
 "Across the Moon," a play by Holt Marvell.
- LONDON REGIONAL** Orchestral Concert from Whithy.
- NORTH REGIONAL** Orchestral Concert from Whithy.
- WEST REGIONAL** An Account of Cardiff Air Pageant by Mr. J. C. Griffith-Jones.

ABROAD

- ATHLONE** 8.35 p.m. Concert of opera music.
- BRUSSELS (No. 1)** 6.15 p.m. Brahms song recital.
- BUCHAREST** 9.15 p.m. Romanian music by the Fanica Luca Orchestra.
- COPENHAGEN** 10.50 p.m. Dance music from the Lodberg Restaurant.
- HUIZEN (announced Hilversum)** 7.55 p.m. "Come and Look!" a revue, relayed from Amsterdam.
- ROME** 8.30 p.m. Opera: "Turandot," by Puccini.
- STOCKHOLM** 9.0 p.m. Old-time dance music from Sundsvaal.
 10.0 p.m. Modern dance music from Göteborg.
- STRASBOURG** 10.10 p.m. (approx.) Orchestral concert, relayed from the Grand Kléber Tavern.
- WARSAW** 9.30 p.m. Chopin recital, by L. Robowska.

BORDEAUX-LAFAYETTE

986 kc/s, 304 metres; 13 kW.—6.15 p.m., Radio Journal. 7.30, Sports Talk. 7.35, News. 7.45, Report of the Cycle Tour of France. 8.5, English Lesson. 8.20, News. 8.30, Two One-Act Plays: (a) L'Évasion (Villiers de L'Isle-Adam), (b) Vive Bouillabaisse (Regis-Gignoux).

BRATISLAVA

1,076 kc/s, 279 metres; 14 kW.—6.25 p.m., Talk. 6.40, Gramophone Music. 6.55, Report for the Housewife. 7.0, See Prague. 8.40, Variety Concert by the Station Orchestra, conducted by F. Dyk. 10.0, See Prague. 10.15, See Brno. 11.30 (approx.), Close Down.

BREMEN.—See Hamburg.

BRESLAU

923 kc/s, 325 metres; 60 kW. Relayed by Gleiwitz, 1,184 kc/s, 253 metres.—1.0 p.m., Gramophone Music. 2.0, Time and News. 2.20, Gramophone Music (contd.). 3.0, First Market Prices. 3.30, Talk: The Meaning of History for the Younger Generation. 3.50, Review of Books on Political Geography. 4.10, Dialogue: The Films of the Week. 4.30, Concert conducted by Max Kaden, relayed from Bad Salzbrunn. March, Unter deutscher Flagge (Dünter), Deutschlands Erwachen 1933 (Kieslich); Harp Aria from Esther (Handel); Waltz, Aus guten alten Zeiten (Jos. Strauss); Overture, Stilleho (Verdi); Nocturne, Op. 76, No. 2 (Fug. Kamm); Selection from The Arabian Nights (Joh. Strauss); March, Heil Hitler (Kleiner). 5.50, Programme Announcements. 6.0, Programme to be announced. 6.20, Talk with Gramophone Illustrations: A Visit to the Cave Dwellers. 6.50, Weather, News and Market Prices. 7.0, Transmission for all German Stations, relayed from Berlin (Deutschlandsender). 8.0, A Humorous Tyroler Programme. 9.0, See Langenberg. 10.5, Time and News. 10.30, Dance Music from Berlin (Witzleben). 12 Midnight (approx.), Close Down.

BRNO

878 kc/s, 342 metres; 35 kW.—2.50 p.m., Concert by the Post Office Orchestra. 4.0 to 5.45, Interval. 5.45, Gramophone Music. 5.55, Tourist Talk and Report. 6.10, Gramophone Music. 6.25 to 7.0, German Transmission. 6.25, News. 6.40 (approx.), Concert by a Mandoline Orchestra, conducted by K. Julinek: Moment musical (Schubert); Intermezzo, In a Persian Market (Kubelbey); Glow-worm Idyll (Lincke); Japanese Lantern Dance (Yoshitomo); Waltz, Künstlerleben (Joh. Strauss). 7.0, See Prague. 7.10, Dialogue. 7.30, See Prague. 8.40, See Bratislava. 10.0, See Prague. 10.15, Concert by the Station Orchestra. 11.30 (approx.), Close Down.

BRUSSELS (No. 1)

I.N.R., 590 kc/s, 509 metres; 15 kW.—12 Noon, Concert by the Station Symphony Orchestra, conducted by Arthur Meulemans: Overture, Raymond (Thomas); Ramuntcho (Piericé); Rhapsody on Two Popular Themes (Gaubert); Songs; Three little Pieces (Dubois); Selection from Don César de Bazan (Massenet); Waltz, Dolores (Waldteufel). 1.0 p.m., Le Journal Parlé. 1.10, Concert by the Sykes Orchestra, relayed from the Scala, Ostend. 1.45, Talk. 5.0, Concert by the Station Orchestra, conducted by Charles Walpot: Overture, Die Fledermaus (Joh. Strauss); Waltz, Fin de siècle (Waldteufel); Selection from Lakmé (Delibes); Largo religieux (Crabbé); En sourdine (Crabbé); Caprice on a Popular German Theme (Ochs); Hymn to St Cecilia (Gounod); Selection from Ta bouche (Yvain). 6.0, Talk on Home-crafts: Glazing. 6.15, Brahms Song Recital by Frédéric Anspach (Tenor): Die Mainacht; Dämm'ung senkte sich von oben; Feldinsamkeit; Ständchen; Dein blaues Auge; Alte Liebe; Vergebliches Ständchen; Von ewiger Liebe. 6.45, Gramophone Concert: Overture, Rosamund (Schubert); Louis XIII (Chanson and Pavane (Couperin-Kreisler); Popular New Zealand Songs; Melody (Bazzini); Miniature Suite (Coates). 7.15, Agricultural Talk. 7.30, Le Journal Parlé. 8.0, Concert by the Station Symphony Orchestra, conducted by Arthur Meulemans: Overture, Les Pêcheurs de Saint Jean (Widor); Alla Marcia (Gilsou); Suite for Small Orchestra (Ducasse); Romantic Waltzes (Chabrier). 8.45, Reading of Poems. 9.0, Concert, relayed from the Kursaal. Ostend. 10.30, Le Journal Parlé. 10.40, Dance Music, relayed from the Kursaal, Ostend.

BRUSSELS (No. 2)

I.N.R., 887 kc/s, 338.2 metres; 15 kW. Programme in Flemish.—12.0 Noon, Concert by the Sykes Orchestra, relayed from the Scala, Ostend. 1.0 p.m., Le Journal Parlé. 1.10, Concert by the Station Symphony Orchestra, conducted by Arthur Meulemans: Overture, Sakuntala (Goldmark); Selection from The Master Singers (Wagner); Songs; Rhapsody, Piet Hein (Van Aroy); Waltz, In Lauscher (Ziehrer). 4.45, Book Review. 5.0, Dance Music relayed from the Continental Palace Hotel, Blankenburghe. 6.15, Gramophone Concert: Selection from Aida (Verdi); Waltz from The Dollar Princess (Fall); Donausagen (Fueick); Selection from La Vie Parisienne (Offenbach); March, Pax (Van Hemmel); Overture, Morning, Noon and Night (Suppé); Heintzelmann's Wacht-parade (Soack); Serenade (Braga); Cœur brisé (Gillet); Variations (Proch); Ballet Music from Hamlet (Thomas). 7.15, Reading. 7.30, Film Review. 8.0, Concert by the Radio Orchestra, conducted by Charles Walpot, and a Vocal Quartet: Overture, The Gipsy Barot (Joh. Strauss); Suppé Pot-pourri (Michalčlov); Songs by the Quartet;

ATHLONE

725 kc/s, 413 metres; 60 kW. Relayed by Cork, 1,337 kc/s, 224.4 metres.—1.30 to 2.30 p.m., Time Signal, Stock Exchange Quotations, Weather Report and Gramophone Music. 6.0, Gramophone Concert. 6.45, News. 7.0, Talk by Claire Scully; Pearl Fishing in Irish Waters. 7.15, Gaelic Talk. 7.30, Time Signal. 7.31, Pipe and Fiddle Music by T. J. Small and T. Brazil. 7.45, Anglo-Irish Songs by Nora Finn (Contralto). 8.0, Irish Music by the Station String Orchestra. 8.20, Pianoforte Recital of Irish Music by Lillian Conolly. 8.35, Concert of Opera Music. 9.5, The Station Orchestra. 9.25, Humorous Programme by Jack MacGarvey. 9.45, Sponsored Programme. 10.30, Time Signal. 10.45, News, Weather Report and Close Down.

BARCELONA

EAJ1; 860 kc/s, 248.8 metres; 8 kW.—7.0 p.m., Trio Concert: Selection from Tristan and Isolde (Wagner); Moment musical (Schubert); Symphonie Entracte (Desprez); Violin Solo from the Ballet Sylvia (Delibes); Selection from Ariane (Massenet); Spanish Serenade (Chaminade). 8.0, Request Gramophone Records. 8.30, Exchange. 9.0, Gramophone Records. In the interval at 9.15, Talk on Disarmament and News. 10.0, Chimes, Weather and Market Prices. 10.5, Concert by the Station Orchestra. 11.30, An Opera on Gramophone Records. In the interval at 12 Midnight, News. 1.0 a.m. (Sunday), Close Down.

BARI

1,112 kc/s, 269.8 metres; 20 kW.—8.0 p.m., Agricultural Report, Tourist Talk and Dopo lavoro Announcements. 8.20, Giornale Radio and Weather. 8.30, Time and Announcements. 8.35, Madame Butterfly—Opera (Puccini) on Gramophone Records. In the intervals, Talk and Reading. After the Opera, News.

BASLE.—See Schweizerischer Landessender.

BELGRADE

BEograd, 697 kc/s, 430.4 metres; 2.5 kW.—5.55 p.m., Time and Programme Announcements. 6.0, Gramophone Music. 7.0, Talk. 7.30, Clarinet Recital. 8.10, Concert by a Russian Choir. 8.55, A Radio Play. 9.30, Time, News, and Orchestral Concert. 10.50, Dance Music on Gramophone Records.

BERLIN

DEUTSCHLANDSENDER, 183.5 kc/s, 1,635 metres; 60 kW.—2.0 p.m., Gramophone Concert: Spanish Serenade (Margutti); Song without Words (Dubey); Old Love Song (Molloy); Three Little Words (Rube); Der Sonnenstrahl (Seitz); Gavotte, Alfonsina (Taraffo); Tyroler Echo (Stehl); Der Traum der Semmerin (Labitzky); Aube of the Birds (Peguri); Programme of Marches. 3.0, Programme for Children. 3.30, Weather. 3.45, Reading (Gottfried Keller). 4.0, See Hamburg. 5.0, Sports Review. 5.15, Review of the Week. 5.30, Talk: The Song of the Birds, with Gramophone Illustrations. 6.0, Poems. 6.5, Franz and Grieg Song Recital by Günter Stenzel. Six Songs (Robert Franz): (a) O säh' ich auf der Heide dort, (b) Abendlich schon rauscht der Wald, (c) Es hat die Rose sich beklagt, (d) Lieber Schatz, sei wieder gut, (e) Gute Nacht, (f) Widmung; Five Songs (Grieg); (a) Mit einer Wassermilch, (b) An das Vaterland, (c) Mit einer Primula veris, (d) Zur Johannesnacht, (e) Der Jäger. 6.30, Radio Report: The German Storm Troops. 6.50, Weather and Announcements. 7.0, Transmission for all German Stations. The Turnpike—Play (Heinrich Lepp), arranged for Radio by Bruno Wellenkamp. Music by Victor Gorkzillus. 8.0, An Axiom. 8.5 (approx.), Summer Evening Programme. 9.0, In the interval, Radio Report of the Automobile Races from the Avus. 10.0, News. 10.45, Weather. 11.0, Concert of Light Music. 12.30 a.m. (Sunday), Close Down.

BERLIN

WITZLEBEN, 715 kc/s, 419.5 metres; 1.5 kW.—4.0 p.m., Orchestral Concert conducted by Peter Schmitz: Overture, Liebesfrühling (Gesic Schumann); Two Pieces for Strings (Ehrenberg); Frieden-Scherzo; Serenade, Op. 15 (Fiedler); Suite in Dance Form (Kienzl); March, Op. 57 (R. Strauss). In the interval at 5.0 (approx.), Sports Notes. 5.20, A Radio Report from Jershöft. 5.50, Violin Recital by Marta Lutz: Romance in F, Op. 50 (Beethoven); Ave Maria (Beethoven); Rondo brilliant in B Minor, Op. 70 (Schubert). 6.10, Riddles (Walter Georg Hartmann). 6.40, The Witzleben Station informs its Listeners. . . . 6.45, Topical Talk. 7.0, Transmission for all German Stations, relayed from Berlin (Deutschlandsender). 8.10, Humorous Stories. 8.20, Variety Programme. 10.0, News. 10.15 (approx.), Dance Music. Soloist: Käte König (Soprano). In the interval at 11.0 (approx.), Talk: What they are saying in Berlin, and Sports Report. 1.0 a.m. (Sunday), Close Down.

BERNE.—See Schweizerischer Landessender.

BEROMUNSTER.—See Schweizerischer Landessender.

BODEN.—See Stockholm.

BODO.—See Oslo.

Fantasia on Flemish Melodies (Walpot). 8.45, Recitations. 9.0, Choral Concert, conducted by Jef Van Hoef. 10.0, Le Journal Parlé. 10.10, Dance Music from the Continental Palace Hotel.

BUCHAREST

761 kc/s, 394 metres; 12 kW.—5.0 p.m., Light Music and Romanian Music by the Siliceanu Orchestra. In an interval at 6.0, Radio Journal. 7.0, Reading. 7.20, Gramophone Music. 7.40, Educational Talk. 8.0, Concert by the Station Orchestra: March from Bocaccio (Suppé); Waltz from Eva (Lehat); Overture, Nebuchadnezzar (Verdi); Suite, In the Bay of Naples (Ehrenberg); Mandolinata (Drigo); Selection from The Circus Princess (Kalmán); Hinton Song (Rimsky-Korsakov); Russian Dance (Tchaikovsky). In an interval at 8.30, Talk. 9.15, Romanian Music by the Fanica Luca Orchestra. 9.45, Radio Journal.

BUDAPEST

545 kc/s, 550.5 metres; 18.5 kW.—5.0 p.m., Orchestral Concert. 6.0, Reading. 6.30, Gramophone Concert. 7.40, Wireless Notes. 8.20, Gramophone Concert. 9.35, Light Music. 10.45, Dance Music.

CASSEL.—See Frankfurt.

COPENHAGEN

1,067 kc/s, 281 metres; 0.75 kW. Relayed by Kalundborg, 260 kc/s, 1,153 metres.—12 Noon, Time and Chimes from the Town Hall. 12.5 p.m., String Ensemble Concert, relayed from the Wivex Restaurant. 2.0, Interval. 3.0, Concert by the Radio Orchestra, conducted by Walter Meyer-Radon: Overture, Tancred (Rossini); Ballet Music from Elverhøj (Kuhlau); Lyric Suite (Brahms); Selection from La Bohème (Puccini); Invitation to the Dance (Weber); Readings; Overture, La Grande Duchesse de Gérolstein (Offenbach); Troika from The Seasons (Tchaikovsky); Four Pieces for Strings (Jokel); Selection from Bocaccio (Suppé); Waltz (Waldteufel); Marche Lorraine (Ganne). 5.0, Gramophone Music. 5.35, Exchange and Fish Market Prices. 6.20, Talk. 6.50, Weather Forecast. 7.0, News. 7.15, Time Signal. 7.30, Talk: The Modern Fire Station. 8.0, Chimes from the Town Hall. 8.5, Sullivan Concert by the Station Orchestra, conducted by Walter Meyer-Radon: Overture, The Mikado; Selection from Ivanhoe; Barcarolle, Dance and Finale from The Merchant of Venice. 8.35, Recital of Jullian Songs. 8.55, Reading (Anatole France). 9.15, Bellman's Songs to the Lute. 9.35, Violin Recital of Music by Fini Henriques: Romance in G, Op. 50; Erotik, Op. 20, No. 6; Nikke dukker Op. 20, No. 3. 9.50, News. 10.5 Orchestral Concert, conducted by Walter Meyer-Radon: Overture, Martha (Flotow); Waltz, Wiener Frauen (Joh. Strauss); Variations on the German Folk Song, 's komm' ein Vogel geflogen (Bach, Haydn, Mozart, Joh. Strauss, Verdi, Gounod, Wagner, Beet hoven, Selmann, Brahms and Meyerbeer); March, Two Swedish Folk Melodies (Svend sen); Arab March (Ganne). 10.50, Dance Music, relayed from the Lodberg Restaurant. In the interval at 12 Midnight, Time and Chimes from the Town Hall. 12.15 a.m. (Sunday), Close Down.

CORK.—See Athlone.

CRACOW

959 kc/s, 312.8 metres; 1.5 kW.—7.20 p.m. Topical Talk. 7.35, Miscellaneous Items and Announcements. 7.40, See Warsaw. 7.55, Programme Announcements. 8.0 to 9.15, See Warsaw. 9.15, Agricultural Press Review from Wilno, 533 kc/s, 563 metres. 9.30, See Warsaw. 10.0, Gramophone Music. 10.2: Sports Notes and Weather. 10.40, Light Music from the Pavilion Restaurant. In the interval at 11.30, News for Members of the Polish Polar Expedition, from Warsaw. 1 Midnight, Fanfare from the St. Mary Church.

DANZIG.—See Heilsberg.

DRESDEN.—See Leipzig.

FECAMP

1,328 kc/s, 225.9 metres; 10 kW.—4.30 to 6.0 p.m., Programme in English by the I.B.C. 4.30 to 5.0, Programme for children. 4.31 Music and Story. 4.45, Birthday Greetings. 5.0, Concert for Timbridge Wells an Isle of Wight Listeners: The Night by the Sea; Even-ong (Esthope-Martin); Pien o'mine (Sanderson); Song of the Cloc (Burchell); Un peu d'amour (Silesu); Love old sweet song (Molloy); Up from Somers (Sanderson); Narelsius (Nevin); Cevant (Raff). 5.30, Orchestral Concert for Dove and Folkestone Listeners: The Kiss Waltz (Burke); Song: Try a little tendere; (Woods); It seems to be Spring; Pianoforte Solo: The King of Jazz (Whiteman); G! Happy; Song: West Wind (Robinson); Ti Moon is low; The Japanese Sandman; Ti Night by the Sea. 6.0 to 11.0, Programme in French. 11.0, Special Will Eyfe Regue Programme: Round Scotland with W. Fyffe, Part I. Orchestra: Animal Anté (Wark); He's been on the bottle since baby (Bell and Fyffe); Pianoforte at Xylophone Duet: The Match Para (Wchle); I'm the landlord of the Inn Aberfoyle (Roberts-Fyffe); Orchestra; Amin

JULY 22nd

SATURDAY

continued

(Lincke); Pianoforte Solo: Still I love her (Gaskill). Round Scotland with Will Fyffe, Part II. 11.30, Orchestral Concert: Signature Tune; Selection from Wild Violets, Part I (Stolz); Song: Live for To-day (Tate); Gipsy Moon (Borganov); Vienna, City of my dreams (arr. Revere); A Good Old Irish Stew, Part I; Pale Volga Moon (O'Hagan); Song: Lily of Laguna (Stuart); Selection, Wild Violets, Part II (Stolz). 12.5 a.m. (Sunday), Late News Bulletin in English. 12.10 (approx.), Club Concert for Stilton Listeners, Part I—Guitar Band: The Chum Song; Aloma (Bowers); That little lock of hair (Vernill); Julien (Donata); That's my love song (Colville); Tomi Tomi (Traditional). Part II—Dance Music: I'm sure of everything but you (Wendling); Paradise (Clifford); Just a little home for the old folks (Aulert); My extra-ordinary gal (Shand); Young and Healthy (Dubin); Maybe I love you too much (Berlin); I guess I'll have to change my plans; I wake up smiling (Leslie). 12.57, I.B.C. Goodnight Melody. 1.0 a.m., Close Down.

FLensburg.—See Hamburg.

Florence.—See Turin.

FRANKFURT

1,157 kc/s, 259.3 metres; 17 kW. Relayed by Cassel, 1,220 kc/s, 245.9 metres; and Trier, 1,157 kc/s, 259.3 metres.—6.0 p.m., Herbert Volck reads from his book, Rebellen im Ehere. 6.25, Time and Announcements. 6.30, Weekly Review. 6.50, To-day's News. 7.0, Transmission for all German Stations, relayed from Berlin (Deutschlandsender). 8.0, (Glückliche Reise—Operetta in Three Acts (Künzele). 10.15, Time and News. 10.45, Dance Music from Berlin (Witzleben). 12 Midnight, Close Down.

FREDRIKSSTAD.—See Oslo.

Freiburg.—See Stuttgart.

Geneva.—See Radio-Suisse Romande.

Genoa.—See Turin.

Leipzig.—See Breslau.

Gotteburg.—See Stockholm.

Graz.—See Vienna.

Hamar.—See Oslo.

HAMBURG

all ha (in Morse), 806 kc/s, 372 metres; 1.5 W. Relayed by Bremen, 1,112 kc/s, 269.8 metres; Flensburg, 1,319 kc/s, 227.4 metres; Hanover, 530 kc/s, 566 metres; and Kiel, 1,292 c/s, 232.2 metres.—4.0 p.m. (from Hanover), concert by the Orchestra of Unemployed Musicians, conducted by Otto Ebel von Osen. Soloist: Kurt Brünmann (Violin); verture, Zaide (Mozart); Violin Concerto in E Flat (Mozart); Viennese Dances (Beethoven); Hungarian Rondo (Haydn); Overture in Italian Style (Schubert). 5.0 (from Hanover), Talk: The Hunting Peoples of the Arctic Regions and the Steppes. 5.30 (from Hanover), Concert by the Station Orchestra, conducted by Otto Ebel von Osen. Soloist: Walter Carmuth (Tenor); verture, Il Scraglio (Mozart); Songs (Johann): (a) Wenn der Freude Tränen essern, (b) Frisch zum Kampf; Serenade, p. 7; Aria from Der Rosenkavalier (R. Strauss); Intermezzo from Suor Angelica (Puccini); Aires (Puccini) from (a) The Girl in the Golden West, (b) Manon Lescaut; duction from Madame Butterfly (Puccini). 10. (from Kiel), Talk. 6.50, Weather. 7.0, Transmission for all German Stations, relayed from Berlin (Deutschlandsender). 8.0, e Leipzig. In the interval at 10.0, Time and News. 10.20, Topical Talk. 10.30, e Leipzig.

Anover.—See Hamburg.

HEILSBURG

185 kc/s 276.5 metres; 60 kW. Relayed by Kiel, 662 kc/s, 453.2 metres.—11.30 a.m., concert by the Königsberg Opera House Orchestra, conducted by Karl Hubertz; arch, Stramm und schneidig (Bartelshaus); verture, An mein Vaterland (Alibont); altz, Seid unschuldigen Millionen (J. Strauss); Potpourri, From A to Z (Geiger); medly, Overture (Lincke); Reklamatizer (Roth); Potpourri, Pretiosendemann); Der Eremit (Schmalzlicht); eal Tango (Dauber); March (Kronegger). 1.0 p.m., Gramophone Concert. In the intervals at 1.20 and 2.0, News. 2.30, Programme arranged by the Post Office, with amophone Records. 3.0, Market Prices. 4.0, Military Band Concert. In the interval at 5.0 (approx.), Report on the A.D.A.C. ad Race. 5.50, Programme for Workers, , Programme Announcements. 6.15, ricultural Notes. 6.25, Talk: Socialism Eighteenth Century Prussia. 6.50, eather. 7.0, Transmission for all Geru Stations relayed from Berlin (Deutschlandsender). 8.0, Weather and News. 8.5, eital of Old Soldiers' Songs to the Lute. 9.0, Wilhelm von Humbold Memorial Programme. 9.0, Military Talk. 10.0, News, eather and Sports Notes. 10.15 (approx.), ece Music from Berlin (Witzleben). 12.30 a. (Sunday), Close Down.

HILVERSUM

Announced HUIZEN, 1,013 kc/s, 296.1 metres; 20 kW (7 kW. up to 4.40 p.m.).—Programme of the Catholic Radio Society (K.R.O.). 11.55 a.m., Sextet Concert: Student March (Arsenius); Au den Frühling (Grieg); Waltz (Lander); Why (Valerio); Dubinushka (Schirrmann); Clog Dance (Frederiksen); Gramophone Music: La lettre de Manon (Gillet); Spanish Dances (Moszkovsky); Serenata (Costi); Wieneriana (Algra); Finale. 1.25-1.40, Interval. 1.40, Programme for Young People. 2.10, Programme for Children. 3.40, Gramophone Music. 5.10, Concert by the K.R.O. Boys. 6.0, Talk on Journalism. 6.25, Concert by the K.R.O. Orchestra, conducted by J. Gerritsen: Turkish Suite (Gawwin); Algerian Scene (Kotelbey). 6.40, Police Notes. 6.55 Talk. 7.15, Gramophone Music. 7.25, Concert (cont.): Overture, Die schöne Galathee (Suppé); Selection from The Gipsy Baron (Joh. Strauss); Selection from A Night in Venice (Joh. Strauss); Petersburger Schlittenfahrt (Eilenberg); Der alte Brunnhär (Fück); Hals- und Beinbruch (Morena). 8.10, News. 8.15, Gramophone Music. 8.20, Radio Sketch. 8.40, Variety Programme. 9.40, Concert by the Station Orchestra, conducted by J. Gerritsen: Overture, Prinz Carnaval (Blasius); Marmelades Lüfchen (Jensen); Selection from A Waltz Dream (Oscar Straus). 10.10, News. 10.15, A Radio Sketch. 10.30, Concert of Light Music by the K.R.O. Boys. 11.10, Gramophone Music. 11.40 (approx.), Close Down.

Horby.—See Stockholm.

HUIZEN

Announced HILVERSUM, 160 kc/s, 1,875 metres; 8.5 kW.—11.40 a.m. till Close Down, Programme of the Workers' Radio Society (V.A.R.A.). 11.40, Organ Recital by C. Steyn. 12.10 p.m., Concert by the Small Station Orchestra, conducted by H. de Groot. Overture, Jean de Paris (Boieldieu); Gipsy Serenade (Valdez); Was Blumen träumen (Translatour); Zug der Karavane (Rey); Gramophone Records; Toleaux paysannes (Monton); Waltz from Eva (Lehar); Selection from Mademoiselle Nitouche (Bervé); Lullaby (Doniderrff); Fliegender Pfeil (Holzmann); Mandoline Serenade (Desormes); Puppen-Mennett (Blon); Schlagsahne (Krotze). 1.40 to 1.55, Interval. 1.55, Gramophone Music. 2.40, Temperance Talk. 3.0, Concert by a Double Male Voice Quartet. In the interval at 3.20, Literary Talk. 3.55, Programme for Children. 4.55, Concert by the V.A.R.A. Orchestra, conducted by H. de Groot; Overture, Othello (Rossini); The Little Old Garden (Hewitt); Song (O'Hara); Song from Der Trompeter von Säckingen (Messler); Waltz, España (Waldteufel); Selection from The Maid of the Black Forest (Jesse); Vrijheidsmarsch (Carstens). 5.40, M. Timmers in his Repertoire. 5.55, Concert (cont'd.), March, King Cotton (Souss); Selection from Die Puppenfee (Bayer); Serenade (Moszkovsky); Berceuse from Jocelyn (Godard); Oriental Suite (Popy); J'y pense (Drda); March from Sigurd Jorsalfar (Grieg). 6.40, M. Timmers and Mlle. Angela Tosnerova in their Repertoire. 6.55, Concert (cont'd.), Overture, La Fille de Madame Angot (Lecocq); Melody (Westly); Grossmütterchen (Lange); Serenade (Heykens); Waltz from The Gipsy Princess (Kilmán); March (Souss). 7.25, News. 7.40, S.O.S. Messages. 7.42, Organ Recital of Popular Music, by J. Jong. 7.55, Come and Look—A Review, relayed from Amsterdam. 9.40, Concert by De Flierefluiters, conducted by J. van de Horst. In the interval at 10.10, Accordion and Pianoforte Recital. 10.55, Gramophone Records.

Innsbruck.—See Vienna.

Kalundborg.—See Copenhagen.

KATOWICE

734 kc/s, 408 metres; 16 kW.—7.20 p.m., Announcements and Gramophone Music. 7.40, See Warsaw. 9.15, Agricultural Press Review, relayed from Wilno, 533 kc/s, 563 metres. 9.30, See Warsaw.

Kiel.—See Hamburg.

Klagenfurt.—See Vienna.

Kosice.—See Prague.

LAHTI

167 kc/s, 1,796 metres; 40 kW. Relayed by Helsinki, 815 kc/s, 368.1 metres.—5.0 p.m., Gramophone Music. 6.15, Talk. 6.35, Concert by the Station Orchestra. 7.20, Talk. 7.45, Organ Recital. 8.0, Song Recital by Oiva Kapeli, relayed from Viipuri, 1,031 kc/s, 291 metres. 8.15, Cello and Harp Recital. 8.45, News in Finnish. 9.0, News in Swedish. 9.15, Light Music relayed from the Restaurant Kappeli. 10.0 (approx.), Close Down.

LANGENBERG

635 kc/s, 473 metres; 60 kW.—12 Noon, Gramophone Music. 12.50 p.m., News. 1.0,

Concert, conducted by Wolf; Soloist, Josef Poerner (Tenor); Metropole-Marsch (Lincke); Waltz, Lustige Brüder (Vollstedt); Songs: (a) Am Elmengrabb (Tymian), (b) Weisst du, Mutter, was i träumt hab' (Kutschera), (c) Müde kehrt ein Wandersmann zurück (Krome), (d) Der Rattenfänger (Neendorf); Overture, Banditenstreiche (Suppé); Melody (Dvorak); Waltz (Dvorak); Slav. Dance No. 2 (Dvorak); Selection from The Daughter of the Regiment (Donizetti); Song Potpourri, From the Rhine to the Danube (Rhode). In the interval at 2.0, News. 2.30, Concert. 3.30, Economic Notes and Time. 3.50, Talk: The War-rant Officer. 4.10, Talk: Excursions in the Rhine District and Westphalia. 4.30, Concert by the Station Orchestra, conducted by Buschköter; Soloists: Erdmüthe Fiebiger (Contralto) and Walter Kechberg (Pianoforte); Divertimento (Haydn); Cantata for Contralto and Orchestra, Amadé auf Naxos (Haydn); Talk: From the Portfolio of an Amateur Photographer; Pianoforte Concerto in E flat (Mozart); Two Songs (Handel): (a) Euch beiden vertraut from Ezio, (b) Diweil ich nicht kann sterben, from Radamisto. 5.50, Reading (Karl Schorn). 6.5, Songs by a Young People's Choir. 6.40, Topical Talk. 6.45, Time and Announcements. 7.0, Transmission for all German Stations, relayed from Berlin (Deutschlandsender). 8.0, News. 8.5, Dance Music by the Fröhliche Fünf. 9.0, Max and Moritz—Humorous Scenes and Stories about Neer-do-Wells (arranged by Alfred Erich Sisti). 10.5, News. 10.35, Dance Music, relayed from Berlin (Witzleben). 12 Midnight, Close Down.

Lausanne.—See Radio-Suisse Romande.

LEIPZIG

769.9 kc/s, 389.6 metres; 120 kW.; and Dresden, 941 kc/s, 319 metres.—12.5 p.m., German Folk Songs on Gramophone Records. 1.0, News. 1.15, Gramophone Concert. 1.45, Wireless Hints. 2.0, News. 2.10, Wireless Notes. 2.15, Oboe, Clarinet and Flute Recital. 2.45, Programme for Children. 3.30, Talk: Modern Lexicons and Dictionaries. 3.45, Market Prices. 4.0, See Hamburg. 5.0, Talk on Music. 5.10, Talk: A Tour of Munich. 5.40, Gramophone Music. 6.0, Talk: The German Language. 6.20, A Modern Dictionary. 6.30, Talk: Möbra, the Home of Luther's Parents. 6.50, To-day's News. 7.0, Transmission for all German Stations, relayed from Berlin (Deutschlandsender). 8.0, Government Announcements. 8.5, Agricultural Notes. 8.25, A Dance Potpourri by the Station Orchestra, conducted by Alfred Schröter, the Emde Orchestra, and the Station Choir; Soloists: Gertrud Wille (Soprano) and Hans Emmé-Schuehardt (Tenor). 10.30, News. 10.45, Concert Relay. 12 Midnight, Close Down.

Linz.—See Vienna.

LUXEMBOURG

252 kc/s, 1,191 metres; 200 kW.—French Programme. 7.0 p.m., Concert of Light Music on Gramophone Records. 7.40, Weather Report. 7.45, Symphony in D minor (Franck) on Gramophone Records. 8.25, Tenor Solos by Georges Thill on Gramophone Records. 8.30, Talk in French on Auguste Renoir, the Painter. 8.40, Songs (cont'd.). 8.50, News in French. 9.15, Vocal and Instrumental Concert relayed from Mondorf les Bains. In the interval 9.45, News in German. 10.30, Dance Music on Gramophone Records; Exchange and News in the intervals.

LWOW

788 kc/s, 381 metres; 16 kW.—7.20 p.m., Miscellaneous Items. 7.40, See Warsaw. 9.15, Gramophone Music. 9.30, See Warsaw. 12 Midnight (approx.), Close Down.

LYONS

LA DOUA, 644 kc/s, 465.8 metres; 1.5 kW.—7.0 p.m., Radio Gazette for Lyons and the South-East. 7.10, Racing Results. 7.20, Talk on Ex-Servicemen. 7.30, News. 7.45, Report of the Cycle Tour of France. 8.10, Talk in Esperanto. 8.30, Operetta Programme, relayed from Paris (Ecole Supérieure), 671 kc/s, 447.1 metres, followed by News.

MADRID

EAJ7; 707 kc/s, 424.3 metres; 2 kW.—8.0 p.m., Chimes, Exchange, Radio Journal, Talk by Teodoro de Pradier and Request Gramophone Records. 9.15, News. 9.30 to 11.0, Interval. 11.0, Chimes and Time. 11.5 (approx.), Song Recital with accompaniment by the Station Sextet, followed by Literary Programme. 1.15 a.m. (Sunday), News. 1.30, Chimes and Close Down.

Malmo.—See Stockholm.

Milan.—See Turin.

MORAVSKA-OSTRAVA

1,137 kc/s, 263.8 metres; 11 kW.—6.25 p.m., Concert by the Gaiety Chorus Sextet, from

New Bohumin. 7.0, See Prague. 8.40, See Bratislava. 10.0, See Prague. 10.15, See Brno. 11.30 (approx.), Close Down.

MOSCOW

TRADES UNION, 230 kc/s, 1,304 metres; 100 kW.—2.45 p.m., Weather. 3.0, Operetta Programme. 4.0, Talk. 4.30, Talk: The Achievements of the U.S.S.R. 5.30, Programme for Young People. 6.30, Orchestral Concert. 9.0, News. 9.30, Programme Announcements. 9.55, Chimes from the Red Square. 10.5, Talk in German: Antisemitism in Russia under the Czars and the Position of the Jews in the Soviet Union.

Motala.—See Stockholm.

Muhlacker.—See Stuttgart.

MUNICH

563 kc/s, 533 metres; 60 kW. Relayed by Augsburg and Kaiserlautern, 536 kc/s, 239 metres, and Nürnberg, 1,256 kc/s, 239 metres.—4.30 p.m. (from Nürnberg), Concert by the Schwarz Orchestra: March, Friedensflüge (Blankenburg); Overture, The Magic Flute (Mozart); Waltz, Morgenblätter (Strauss); Selection from Lucia di Lammermoor (Donizetti); Melody (Moret); Popular Song Potpourri (Lindsay-Thermer); March, Kreuz und Krome (Becker). 5.45 (from Nürnberg), Programme to be announced. 6.15, Pianoforte Sonata in B Minor (Liszt) by Richard Staab. 6.50, Wireless Notes. 7.0, Transmission for all German Stations, relayed from Berlin (Deutschlandsender). 8.0, From the Tyrol—Humorous-Satirical Programme. 9.5, Provincial Programme, relayed from Mainburg. 10.20, Time and News. 11.0, Serenade from Berlin (Witzleben).

Naples.—See Rome.

Notodden.—See Oslo.

OSLO

277 kc/s, 1,083 metres; 60 kW. Relayed by Fredriksstad, 815 kc/s, 368.1 metres; Hamar, 522 kc/s, 574.7 metres; Notodden, 671 kc/s, 447.1 metres; Porsgrund, 662 kc/s, 453.2 metres; and Rjukan, 671 kc/s, 447.1 metres. 5.0 p.m., Gramophone Concert. 5.45, Programme for Children. 6.15, National Music. 6.45, Talk on Economics. 7.0, Advertising Notes. 7.15, Weather and News. 7.30, Talk. 8.0, Time. 8.1, Orchestral Concert. 8.45, Recitations by Otto Monsen. 9.5, Orchestral Concert (cont'd.). 9.40, Weather and News. 10.0, Topical Talk. 10.15, Talk. 10.45, Dance Music on Gramophone Records.

Ostersund.—See Stockholm.

PALERMO

558 kc/s, 537.6 metres; 3 kW.—8.0, Doppio Anouncements, Tourist Report, Agricultural Notes and Giornale Radio. 8.20, Gramophone Music. In the interval at 8.30, Time and Announcements. 8.45, Belle di notte—Operetta in Three Acts (Cuscinà); In the intervals, Book Review and Announcements. 10.55, News.

PARIS

EIFFEL TOWER, Call FLE, 207.5 kc/s, 1,445.7 metres; 13 kW.—Time Signals (on 2,650 metres) at 10.26 a.m. and 11.25 p.m. (Preliminary and Code Signals)—6.45 p.m., Le Journal Parlé. In the interval at 7.45, Report of the Cycle Tour of France. 8.50, Two Plays: (a) A quoi rêvent les jeunes filles (de Musset), (b) Les Plaideurs (Racine). 10.0 (approx.), Close Down.

PARIS

POSTE PARISIEN, 914 kc/s, 328.2 metres; 60 kW.—5.0 p.m. (approx.), Report of the Cycle Tour of France. 7.0, Gramophone Music. 7.15, Le Journal Parlé and Press Review. 7.35, Report of the Cycle Tour of France. 7.50, Review of the Week. 8.0, Announcements. 8.5, Gramophone Music. 8.10, Interval. 8.25, Song and Harpsichord Recital of Rameau Music. 8.55, Interval. 9.10, Dance Music. 11.0, News.

PARIS

RADIO PARIS, Call CFR, 1,725 metres; 75 kW.—7.30 a.m., Weather and Physical Culture. 7.45, Gramophone Records: Fontaine (Padilla); Wine, Woman and Song (Strauss); Mandoline (May); For you (Pothier). 12.0 Noon, Operetta Music on Gramophone Records: Melodies from Hans the Flute Player (Ganne); Overture and Two Aires from Les Saltimbanques (Ganne); Four Melodies from Choulette (Hahn); Eight Aires from Brummel (Hahn); Selection from The Gipsy Princess (Kálmán); Selection from François les Bas bleus (Bernicat-Messenger); Selection from Madame l'Archiduc (Offenbach). 7.0, Market Prices, Weather, Agricultural Notes and Racing Results. 7.10, Gramophone Music. 7.50, Commercial Prices and News. 8.0, Gramophone Concert: Overture, Morning, Noon and Night (Suppé); La Serenata (Braga); Selection from The Gondoliers (Sullivan); Melody (Bohm); Mazurka from Isoline (Messenger-Auvrey); Le Tram (Mongoot); Air (Martinet); Canzone Vesuviana (Marucci); The Organ (Loreal-Cros); Johann Strauss Potpourri (Mackeben); Les Cigales (Chabrier); Le Binicu

JULY 22nd

SATURDAY

continued

(Durand); Algerian March (Bose); Melody (Little); The Cricket (Lombardo); Sospiro (Coppola); Ballet Egyptian (Luigni); La Voix des Chenes (Gouillier); French Soldiers' Marches and Songs (Lull-Pares); Berceuse (Gretchaninov); Blonde amie (Carse); Mazurka (Chopin); Primer Espada (Combel); Le reve passe (Helmer-Krieger-Foucher); Two Symphonic Dances (Coppola); Perruche et Perroquet (Corbin); Melody (Halzmann). In the intervals at 8.30, News and Weather, and at 9.15, Press Review and News.

PITTSBURGH

KDKA; 980 kc/s, 306 metres; 50 kW. Relayed by W8XK on 48.86 metres and 25.27 metres.—7.30 to 8.58 p.m., New York Relay. 7.30, Concert Echoes. 8.0, Words and Music. 8.30, Wealth of Harmony. 8.58, Baseball Scores. 9.0, Harry Sosnick's Century of Progress Orchestra from New York. 9.30, Chautauqua Opera Association, from New York. 9.55, Baseball Scores. 10.0, Rhythm Kings. 10.15, Tom Gerun and Casino Orchestra, from New York. 10.30, Behind the Law, Tales of the Pennsylvania State Police. 10.45, Little Orphan Annie, from New York. 11.0, Time Signal and Press News-Reader. 11.5, Ernie Holst and his Hotel Lexington Orchestra, from New York. 11.15, Weather Report. 11.16, Sport Review. 11.22, Press News-Reader. 11.29, Temperature Report. 11.30, A Recreer by Bill and Alex of the Downtown Y.M.C.A. 11.45, Meyer Davis and his Hotel St. Regis Orchestra, from New York. 11.59, Time Signal. 12 Midnight to 4.0 a.m. (Sunday), New York Relay. 12 Midnight, American Tax Payers' League. 12.15, Benno Rabinof, Concert Violinist. 12.30, Jack Pettis and his Orchestra. 1.0, Jack Denny and his Orchestra. 1.30, Stadium Concerts by the Philharmonic Symphony Orchestra. 3.15, Time Signal and Songs of the Heart.

PORSGRUND.—See Oslo.

POZNAN

898 kc/s, 335 metres; 1.9 kW.—6.0 p.m., Talk on Journalism. 6.15 to 7.20, See Warsaw. 7.20, Miscellaneous Announcements. 7.35, Theatre Notes and Programme Announcements. 7.40, See Warsaw. 7.58, Time Signal. 8.0 to 9.45, See Warsaw. 9.15, Agricultural Press Review, relayed from Wilno, 533 kc/s, 563 metres. 9.30, See Warsaw. 10.0, Time, Sports and Police Notes. 10.15, Dance Music from the Cafe Esplanade. 11.50 (approx.), Close Down.

PRAGUE

614 kc/s, 489.6 metres; 120 kW.—2.50 p.m., See Brno. 4.0 to 5.45, Interval. 5.45, Gramophone Music. 5.55, Talk: Open Air Theatres. 6.5, Agricultural Report. 6.10, Gramophone Music. 6.15, Talk for Workers. 6.25, News in German. 6.30, German Transmission: Talk. The Glass Industry of Northern Bohemia. 7.0, Chimes and News. 7.10, Czechoslovak Song Recital by Rudolf Zpevak. 7.30, Military Band Concert, relayed from Kralovska Obora. 8.25, Talk on Economics. 8.40, See Bratislava. 10.0, Time and News. 10.15, See Brno. 11.30 (approx.), Close Down.

RADIO-SUISSE ROMANDE

SOTTENS, 743 kc/s, 403 metres; 25 kW. and Geneva, 395 kc/s, 760 metres.—12.28 p.m., Time Signal from Neuchâtel Observatory. 12.30, News. 12.40, Gramophone Concert. In the interval at 1.0, Financial Report. 2.0, Interval. 3.28, Time Signal from Neuchâtel Observatory. 3.30, Gramophone Concert. 4.0, Gramophone Music. 4.30, Concert by the Radio-Suisse Romande Quintet. 5.30, Interval. 7.0, Scientific Talk. 7.30, Talk on the Cinema. 7.55, Results of the Cycle Tour of France. 8.0, Talk: From Zurich to Tunis. 8.25, Variety Item. 8.40, Concert by the Radio-Suisse Romande Orchestra. 8.50, News. 9.20, Dance Music by the Broadcasting Serenaders. 11.0 (approx.), Close Down.

REYKJAVIK

250 kc/s, 1,200 metres; 21 kW.—9.30 p.m., Weather Report. 9.40, Musical Programme and Announcements. 10.0, Chimes and News. 10.30, Reading. 11.0, Concert by the Station Trio, followed by Choral and Dance Music on Gramophone Records. 2.0 a.m. (Sunday), Close Down.

RIGA

572 kc/s, 525 metres; 15 kW.—6.0 p.m., History Talk. 6.30, Pianoforte Recital by A. Schillinskis. Rondo (Daquin); Sonata in C (Searlati); Sonata in E minor (Searlati); Mazurka in A minor (Chopin); Mazurka in A (Chopin); Hungarian Rhapsody (Liszt). 7.0, Weather Report. 7.3, Talk on Meteorology. 7.30, Concert of Operetta Music by the Station Orchestra, conducted by S. Parups, relayed from Bulduri. Overture, Light Cavalry (Suppe); Sirens' Waltz from The Merry Widow (Lehar). Soprano

and Tenor Songs and Duets. Selection from White Horse Inn (Stolz-Benatzky); Overture, Im Reich das Indra (Lincke); Songs and Airs; Waltz from Gipsy Love (Lehar); Selection from The Flower of Hawaii (Abraham). In the intervals at 8.20 and 9.0, Weather and News. 9.30, News and Dance Music. 11.0 (approx.), Close Down.

RJUKAN.—See Oslo.

ROME

Call 1RO; 680 kc/s, 441 metres; 50 kW. Relayed by Naples, 941 kc/s, 319 metres; and 2RO; 11,810 kc/s, 25.4 metres.—1.0 to 2.15 p.m., Orchestral Concert of Light Music. In the interval, from 1.15 to 1.20, Talk on Photography; from 1.30 to 1.45, Giornale Radio and Exchange; and at 2.0, Time and Announcements. 4.30, Children's Radio Review. 4.45, Reading. 5.5, Report of the Royal Geographical Society, and Giornale Radio. 5.15, Exchange and Weather. 5.30 to 6.15, Orchestral Concert of Light Music. 6.40 (Naples), Shipping and Sports Notes. 6.50, Agricultural and Dopolavoro Notes. 7.0, Tourist Report. 7.10, Lesson in Morse. 7.20, News in Foreign Languages. 7.40, Giornale Radio. 8.0, Time and Announcements. 8.15, Gramophone Music. 8.25, Giornale Radio and Sports Notes. 8.30, Turandot, Opera in Three Acts (Puccini). In the intervals: Book Review and Announcements; Giornale Radio after the Opera.

SALZBURG.—See Vienna.

SCHENECTADY

WGY, 790 kc/s, 379.5 metres; 50 kW. Relayed at intervals by W2XAF on 31.48 metres and by W2XAD on 19.56 metres.—12.45 a.m. (Sunday), Stock Reports. 1.0, Soloist, from New York. 1.15, Lady Fingers, Pianists. 1.30 to 4.0, New York Relay. 1.30, Musical Programme. 2.0, Ferd Grofe's Orchestra. 2.15, Musical Programme. 2.30, K-7, Secret Service Spy Story. 3.0, B. A. Rolfe and his Orchestra. 4.0, Programme Resumé.

SCHWEIZERISCHER LANDESENDER

BEROMUNSTER, 653 kc/s, 459 metres; 60 kW.; Basle, 1,229 kc/s, 244.1 metres; and Berne, 1,220 kc/s, 245.9 metres.—6.15-6.35 a.m. (from Berne), Gymnastics. 11.59, Time Signal from Neuchâtel Observatory and Weather. 12 noon (from Berne), Concert of Chamber Music on Gramophone Records. 12.30 p.m., Time, Weather and News. 12.40 (from Berne), Gramophone Music. 1.25 (from Berne), Exchange, Time and Weather. 1.30 (from Basle), The Letter Box. 1.45 (from Basle), Book Review. 2.15 (from Basle), Literary and Musical Variety Programme with Gramophone Records. 3.30 to 5.0, Interval. 5.0 (from Berne), Programme to be announced. 6.20 (from Berne), Popular Music on Gramophone Records. 6.30 (from Basle), Reading. 7.0 (from Basle), Time, Weather and Market Prices. 7.20 (from Basle), Beethoven Pianoforte Recital by Karl Weiss. 8.0 (from Basle), Dialogue: Learning to Fly. 8.30 (from Basle), Songs to the Lute. 9.0, Weather and News. 9.10 (from Basle), Variety Programme; A Swiss Sunday. 10.30 (approx.), (from Basle), Concert of Waltzes. 11.0 (approx.), Close Down.

SOTTENS.—See Radio-Suisse Romande.

STOCKHOLM

689 kc/s, 436 metres; 55 kW. Relayed by Boden, 244 kc/s, 1,229.5 metres; Göteborg, 932 kc/s, 322 metres; Hörby, 1,166 kc/s, 257 metres; Motala, 221.5 kc/s, 1,354.4 metres; Östersund, 389 kc/s, 770 metres; and Sundsvall, 554 kc/s, 542 metres.—4.0 p.m., Concert by the Herman Mårtensson String Ensemble. Overture, Tancred (Rossini); Waltz Intermezzo from Naila (Delibes); Melody (de Versey); Selection from Gasparone (Müllcker); Tango, Oh, Souja du (Mann). Flute Solo: Polish Dance (Scharwenka). I give my Heart, from The Dubarry (Müllcker-Mackben); Dance of the Derivishes (Bendix). 5.5, Programme for Children. 5.30, Provincial Programme from Hudiksvall, 1,327 kc/s, 226 metres. 6.15, Gramophone Music. 7.30 (from Sundsvall), Dialogue. 8.0, A Microphone Tour of Stockholm, Malmö and Göteborg. 9.0, (from Sundsvall), Old Time Dance Music. 10.0 (from Göteborg), Modern Dance Music. 11.0 (approx.), Close Down.

STRASBOURG

869 kc/s, 345 metres; 11.5 kW.—7.45 to 8.0 a.m., Report of the Cycle Tour of France. 11.30, Gramophone Music. 12.45 p.m., News. 1.0, Time Signal and Report of the Cycle

Tour of France. 1.15, Orchestral Concert, conducted by M. Roskam; Polonaise and Waltz from Eugen Onegin (Tchaikovsky); Minuet (Paderewsky); Spanish Dances Nos. 2 and 5 (Mozzkowsky); Caprice viennois for Violin and Pianoforte (Kreisler); Serenade in B Flat (Widor); Alt Wien (Dráha); March, The Pijonat (Souza). 2.0, Legal Talk in German. 2.15, Tyrolese Music on Gramophone Records. 2.45, Talk in French: The Operas of J. P. Rameau. 3.0 to 3.30, Interval. 3.30, Orchestral Concert, conducted by M. Bronillat, relayed from the Casino, Vichy; Overture, Fingal's Cave (Mendelssohn); Selection from The Fair Maid of Perth (Bizet); Pieces (d'Ambrosio); (a) Andantino, (b) Paysannerie, (c) Ronde des Lutinis, (d) Tarantella; Moonish Rhapsody from Le Cid (Massenet); Symphonic Suite from Tannhäuser (Wagner); Kaiserwalzer (Strauss). 5.0 (approx.), Report of the Cycle Tour of France. 5.15, Orchestral Concert, conducted by Maurice de Villers; Soloists, M. Faniard (Tenor), Mlle. Genya Marat (Mezzo-Soprano); M. Gillig (Bass), M. François Cholé (Pianoforte); Second Act of Samson and Delilah (Saint-Saëns); Concerto in C Minor, Op. 12, for Pianoforte and Orchestra (Pierne). In an interval at 6.15 to 6.30, French Elocution Lesson. 7.0, Tourist Talk. 7.15, Horticultural Talk in German. 7.30, Time and News. 7.45, Report on the Cycle Tour of France. 8.5, Press Review in French, Lottery Results and Announcements. 8.30, Alsatian Programme: S'ünfte Rad—Comedy in Three Acts (Victor Schmidt). 10.0 (approx.), Orchestral Concert, relayed from the Grand Kléber Tavern: Le Reve passe (Krier); Waltz, Gold and Silver (Lehar); Largo (Handel); Selection from White Horse Inn (Stolz-Benatzky); Selection from Madame Butterfly (Puccini); Potpourri of Hunting Melodies (Pöhler). 11.0, Dance Music relayed from the Savoy. 12 Midnight (approx.), Close Down.

STUTTGART

MUHLACKER, 832 kc/s, 360.5 metres; 60 kW. Relayed by Freiburg, 527 kc/s, 570 metres.—12.20 p.m., Month Organ and Choral Concert. 12.40, Talk with Gramophone Illustrations: Beautiful Voices. 1.30, Concert by the Station Orchestra and an Instrumental Quartet. 2.30, Time and News. 2.40, Talk on Flowers. 3.5, Accordion Concert. 3.30, Programme for Children. 4.30, Choral Concert. Part I (from Taifungen). Sanctus (Sücher) Sei getren (Weigert); Hoch empor (Curti); Auf dem Meere (Heinemann); Zieh mit (Angerer); Brückenzoll (Kireh). Part II (from Pforzheim). Die Waldquelle (Baumann); An Ammersee (Langer); Meine Muttersprache (Engelsberg); Sturmrit (Weigert); Kapitän und Leutnant (Heinrichs). 5.30, Fantasia on the Brazilian National Anthem (Burlé) on Gramophone Records. 5.55, From the Brenner Pass to Mount Etna—A Radio Report by Günther Jung. 6.35, Time and News. 7.0, Transmission for all German Stations, relayed from Berlin (Deutschlandsender). 8.0, See Munich. 9.0, Military Band Concert, relayed from Donaueschingen. Bayrischer Defiliermarsch (Seherzer); Potpourri. From Lake Constance to the River Main (Romeisch); Intermezzo, Parade der Hasler Bühnenzwerge (Kamitz); March Potpourri. Ein Spaziergang durch den Schwarzwald (Husadel); March, Willkommen in Freiburg (Gallion); March, Wer trank am klaren Donauquell (Husadel); Die Flässer auf der Donau (Vollstedt); March, Badner Land (Dörle). 10.10, Time and News. 10.30, Report of the Stuttgart Gymnastic Display. 10.45, Sports Report from Baden-Baden. 11.10, Dance Music from Berlin (Witzleben). 12 Midnight, Close Down.

SUNDSVALL.—See Stockholm.

TOULOUSE

779 kc/s, 385 metres; 8 kW.—Transmissions irregular owing to recent fire. 11.30 p.m. till Close Down. Programme in English by the I.B.C. 11.30, Organ Recital. 11.57, I.B.C. Good-night Melody. 12 Midnight (approx.), Close Down.

TRIESTE

1,211 kc/s, 247.7 metres; 10 kW.—5.40 p.m. till Close Down, See Turin.

TRONDHEIM.—See Oslo.

TURIN

1,096 kc/s, 273.7 metres; 7 kW. Relayed by Milan, 905 kc/s, 331.5 metres; Genoa, 959 kc/s, 312.8 metres; and Florence, 599 kc/s, 500.8 metres.—5.40 p.m., Operatic Concert on Gramophone Records. Overture, Sem-

ramide (Rossini); Aria from Figaro (Mozart); Bacchanale from Samson and Delilah (Saint-Saëns); Aria from Luisa Miller (Verdi); Duet from Loreley (Catalani); Aria from The Jewels of the Madonna (Wolf-Ferrari); Aria from The Force of Destiny (Verdi); Aria from Fedora (Giordano); Aria from William Ratcliff (Mascagni); Aria from Carmen (Bizet); Overture, The Mustersingers (Wagner). 6.0 to 6.5, Weather. 6.35, News. 7.0, Time, Tourist Report and Light Music on Gramophone Records. 7.20, News in Foreign Languages. 7.40, Gramophone Music. 8.0, News. 8.15, Talk: Events and Problems. 8.30, Gramophone Concert of Popular Music. 9.30, Symphony Concert by the Augusto Orchestra, relayed from the Basilica di Massenzio. In the intervals: Book Review and News. 11.0, Giornale Radio.

VATICAN CITY

15,120 kc/s, 19.84 metres (Morning), and 5,599 kc/s, 50.26 metres (Evening); 10 kW.—11.0 to 11.15 a.m., Religious Announcements in Different Languages. 8.0 to 8.15 p.m., Religions Information in Italian.

VIENNA

581 kc/s, 517 metres; 15 kW. Relayed by Graz, 852 kc/s, 352.1 metres; Innsbruck, 1,059 kc/s, 283 metres; Klagenfurt, 662 kc/s, 453.2 metres; Linz, 1,220 kc/s, 245.9 metres; and Salzburg, 1,373 kc/s, 218.5 metres.—12 noon, Concert by the Vienna Symphony Orchestra conducted by Josef Holzer. In the interval at 1.0 p.m., Time and News. 2.0, Interval. 3.0, Time, Weather and Market Prices. 3.15, Wireless Review. 3.45, Main-line Concert. 4.15, English Conversation. 4.40, Reading (Detlev von Liliencron). 5.5, Wind Instrument Concert. 6.30, Monthly Review of World Events. 6.55, The Maxim. 7.0, Topical Talk. 7.10, Time and Announcements. 7.20, Pianoforte Recital by Julius Isserlis. 8.0, Orchestral Concert relayed from Goisern. 9.0, Concert of Johann Strauss' Operetta Music: The Vienna Symphony Orchestra conducted by Josef Holzer. Soloist: Maria Reining (Soprano): Overture, Der Waldmeister; Entr'acte from Fürstin Ninetta; Two Songs from Prinz Methusalem; Overture, Simplicity; Ballet Music from Die Fledermaus; Two Songs from Eine Nacht in Venedig; Song, Kommt, ihr Leute from Carneval in Rom; Overture, Die Göttin der Vernunft; Waltz, Roses from the South; Durch Wald und Feld bin ich geirt from Der lustige Krieg; Song from The Gipsy Baron; Overture, The Gipsy Baron; March from Indigo. 10.15, News. 10.20, Talk in Italian on Austria. 10.40, Dance Music relayed from the Café Palmhof Soloists, Emil Petroff (Songs) and Willy Svoboda (Pianoforte).

WARSAW

212.5 kc/s, 1,411 metres; 120 kW.—11.5 a.m., Time Signal and Fanfare from the Tower of St. Mary's Church, Cracow. 12 p.m., Jazz Music on Gramophone Records. 2.25, Polish Press Review. 12.33, Weather. 12.35, Gramophone Music (contd.). 12.52, Radio Journal. 1.0, Interval. 2.55, Gramophone Music. 3.5, News. 3.10, Announcements. 3.15, Gramophone Music. 3.22, Economic Notes. 3.35, Gramophone Music. 4.0, Programme for Invalids, relayed from Lwow, 788 kc/s, 381 metres. 4.30, Concert of Light Music by the Station Orchestra. 5.0, Topical Talk. 5.15, Popular Concert by the Poznan Opera House Orchestra conducted by Tyllia, relayed from Cielicz cinek. 6.15, Talk. 6.35, Soprano and Baritone Song Recital by I. Dawner-Zapolski and G. Czapliski. 7.20, Miscellaneous Items. 7.35, Programme Announcement. 7.40, Reading. 8.0, Concert by the Station Orchestra, conducted by Nawrot. Soloist L. Lawinski (Songs); Overture (Suppe) Waltz (Strauss); Lotosia (Armandola) Songs; Sentimental Waltz (Nedbal); Bacarolle from The Tales of Hoffman (Offenbach); Gavotte (Lehar); Waltz, Gohle Rain (Waldteufel); Mazurka (Wronski) 9.5, Radio Journal. 9.15, Agricultural Press Review, relayed from Wilno, 533 kc/s, 563 metres. 9.30, Chopin Pianoforte Recital by L. Robowska. Sonata in C Minor, Op. 10, No. 12; Tara Tellu, Op. 43, 10.0, Dance Music. 10.2 Sports Notes. 10.35, Aviation Weather Report and Anti-Gas Drill. 10.40, Dance Music in the interval at 11.30, News for Membe of the Polish Polar Expedition.

WILNO

533 kc/s, 563 metres; 16 kW.—4.0 to 7.20 p.m. See Warsaw. 7.20, Lithuanian Weekly Review. 7.35, Programme Announcements. 7.4 See Warsaw. 8.0, Request Music on Gramophone Records. 9.5, See Warsaw. 9.15, Review of the Agricultural Press. 9.25 to Midnight, See Warsaw. 12 Midnight (approx.), Close Down.

ZURICH.—See Schweizerischer Landessender

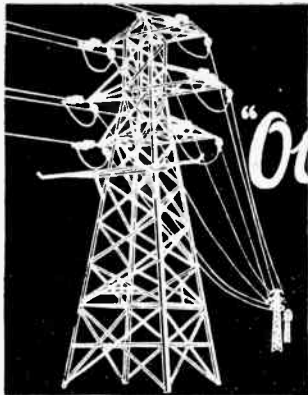

"Overheads."

How much do you spend on H.T. batteries for your radio set? Whatever it is, you will appreciate that the upkeep costs of your receiver are far too high.

But—if you have A.C. Mains available, your H.T. costs need not be more than a shilling a year. Buy, or build, an eliminator incorporating a Westinghouse Metal Rectifier—plug into the mains and then switch on to a permanent, ample and constant power supply.



METAL RECTIFIERS

Westinghouse Metal Rectifiers are standardised by all the leading manufacturers of A.C. Mains apparatus; and tests have proved that their life is equivalent to at least 25 years use with a radio set.



The WESTINGHOUSE BRAKE & SAXBY SIGNAL CO. LTD.,

82, York Rd., King's Cross, London, N.1.

Power Amplifiers and P.A. Equipment

for Fêtes, Sports Grounds, Restaurants, Public Halls, etc. Powerful output with purity of reproduction. B.S.R. Equipment is moderate in price and gives trouble-free operation.

WIRELESS WORLD Test Report states—
 "...a very high standard in reproduction...undoubtedly in a class apart"

If you want the finest possible, you must have B.S.R.

**BIRMINGHAM SOUND REPRODUCERS, LTD.,
 CLAREMONT WORKS, OLD HILL, STAFFS.**

'Phone: Cradley Heath 6370.

'Grams: Electronic, Old Hill

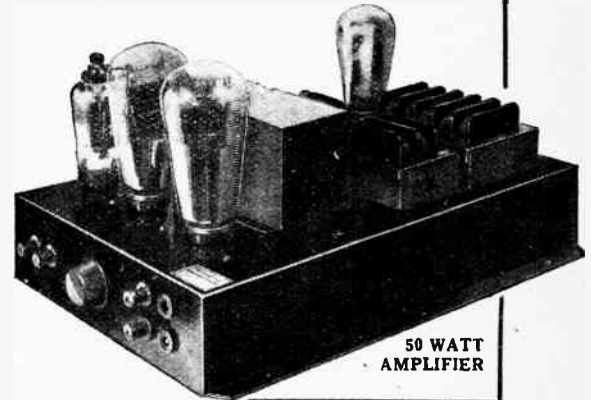

Holden.

PASSED WITH HONOURS by "Wireless World"

See Full Report, Page 371, "W.W." May 25th.

This Mains Transformer is for receivers with maximum of 4 valves. Intended for use with "C" Class full wave rectifying valve. H.T. Winding gives 350-0-350 volts at nominal load of 80 m.a. Two L.T. Windings rated at 4 v. 4a. and 4 v. 2.5a. Primary Tappings at 200, 230, 250 volts 50 cycles A.C. "WIRELESS WORLD" says:—"Coil is of generous dimensions . . . H.T. winding shows good regulation . . . both L.T. windings satisfactorily adjusted for respective loads. For example, on full load the 4 amp. winding gave 3.9 volts while the rectifier filament was operated at 3.95 volts."

PRICE POST PAID **29/6**

The Small Intervalve Transformer has a step-up ratio of 1 to 3—" and primary inductance was found by measurement to be 13.7 henrys with no D.C. flowing 10.6 henrys with 2 m.a. and 8.6 henrys with 4 m.a. passing through primary." Also available with 1 to 5 ratio.

PRICE, POST PAID **4/11**

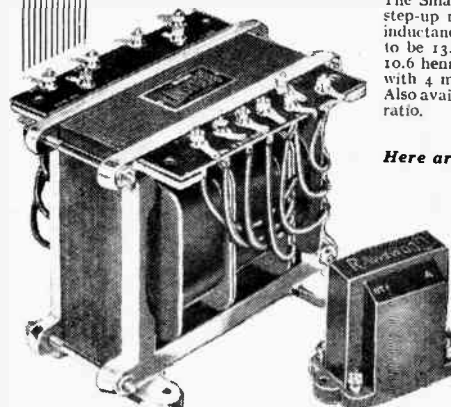

Here are a few other examples—

but our complete list contains many more:—

TRANSFORMERS FOR METAL RECTIFIERS (WESTINGHOUSE) with Combined Filament Windings.

M.F.9 210 v. 150 m.a. 4 v. 4/5a.

4 v. 1a. or 6 v. 1a. 26/-

M.F.9.240 v. 200 m.a. 4 v. 3a. 4 v. 1a. 28/6

M.F.10. 150 v. 350 m.a. 4 v. 3a. 4 v. 1a. or 6 v. 1a. 35/-

SMOOTHING AND OUTPUT FILTER CHOKES.

Hrys. Milliamps. Approx. Res. Pri.-

30 20 700 10/-

40 30 800 11/6

30 x 30 100 x 100 250 x 250 17/6

Also makers of L.F. Transformers.

SEND FOR DETAILED LIST.

RAWSWOOD

RAWSWOOD ELECTRICAL CO., Preston New Road, BLACKPOOL.

'Phone: Marton 188. 'Grams: Rawswood, Blackpool.

Player's
 please
 Everyone



NCC 178

NICORE TUNING COILS



B.P.30. Aerial or Tuned Grid with reaction 10/6

B.P.31. H.F. Intervalve Transformer with reaction 10/6

Set of 3 coils ganged on base . . . 33/-

Varley again! Leaders in the new tuning technique as in the old. . . The release of Varley NICORE Coils marks the biggest advance in radio tuning since the introduction of Square Peak Coils.

Consistency has been the great aim, and has been attained with an even greater efficiency than was thought possible. Selectivity, with these new Varley Coils, is a maximum.

The use of powdered metal cores is not new to Varley. As far back as 1925 Varley produced some Constant Inductance Chokes with iron powdered cores. Varley NICORE Coils are an outstanding result of years of research. Write to-day for FREE illustrated literature.

Varley

FOREMOST AS PIONEERS

Adot. of Oliver Pell Control Ltd., Kingsway House, 103, Kingsway, London, W.C.2. Tel.: Holborn 5303.

MAXIMUM FLUX— Across the Air-Gap

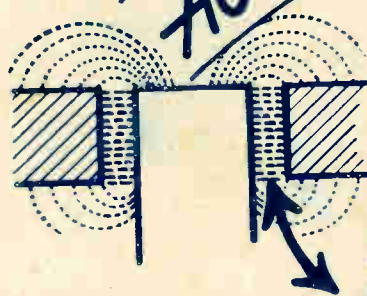

Darwin

COBALT STEEL PERMANENT MAGNETS

The sensitivity and excellence of a Loud Speaker largely depends upon the strength of the magnetic field across the air-gap. This is where Darwin Magnets excel.

Unceasing research work plus modern manufacturing methods enable Darwins to turn out magnets having a superlatively high field strength across the gap.

That is why Darwin Magnets are specified for at least one out of every two speakers on the market.

Our Technical Department will be happy to advise you on all magnet problems.

Darwins Ltd
CORRECT MAGNET DESIGN

Head Office: Fitzwilliam Works, SHEFFIELD.
London Office: 29/31, Regent St., S.W.1.

The Wireless World

4^D

THE PRACTICAL RADIO JOURNAL with

Complete Foreign Programmes

Friday, July 21st, 1933.

TELSEN SUPERHET COILS

TYPE No. S.330

Specified for the W. W. Monodial Super Battery Receiver. The ideal coils for any superhet circuit. 25/6

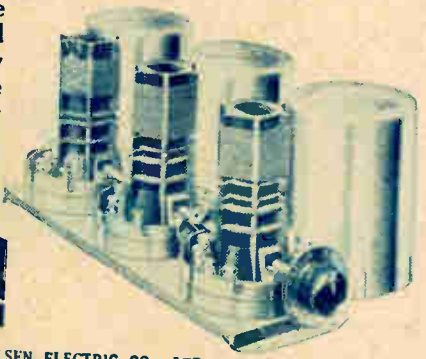

Announcement of the TELSEN ELECTRIC CO., LTD., ASTON, BIRMINGHAM

Now the SONOCHORDE BABY SPEAKER

Cone Diameter 4 1/4". Overall Diameter 5". Depth 3".

The new Sonochorde Baby units are ideal for midget, portable and automobile receivers. Available in both field excited and permanent magnet types, the performance of these new models is astoundingly lifelike whilst the reproduction possesses that realism which is typical of all Sonochorde products. Ask your dealer or write to-day for full particulars.



D.C. MODELS (2500 or 6500 ohms.) 17/6
P.M. MODEL 21/-
with Power or Pentode Transformer

Sonochorde Reproducers Ltd. 1, Willesden Lane, London, N.W.6.
Phone: Maida Vale 0000 (3 lines).
Distributors in Belgium—Von der Becke and Marsly, 40, Rempart Kiplorj, Antwerp, Belgium, under the trade name SONOVON.

25 DUBILIER RESISTANCES

exclusively specified for the

Wireless World New Monodial Super-Het

18 FOR THE RECEIVER 7 FOR THE POWER UNIT

1 Watt 1/-, 2 Watt 2/-, 3 Watt 3/-.

GET H.T. CURRENT from your L.T. BATTERY

WITH AN



ANODE CONVERTER

★ THE ORIGINAL MACHINE for this purpose; first introduced 1924.
★ Generates pure D.C.
★ Takes only modest current. ★ Built to last.
MODELS TO SUIT ALL RECEIVERS.
Write for full details!
POTAX LTD., RADIO DEPT. 1, WILLESDEN, LONDON, N.W.10.



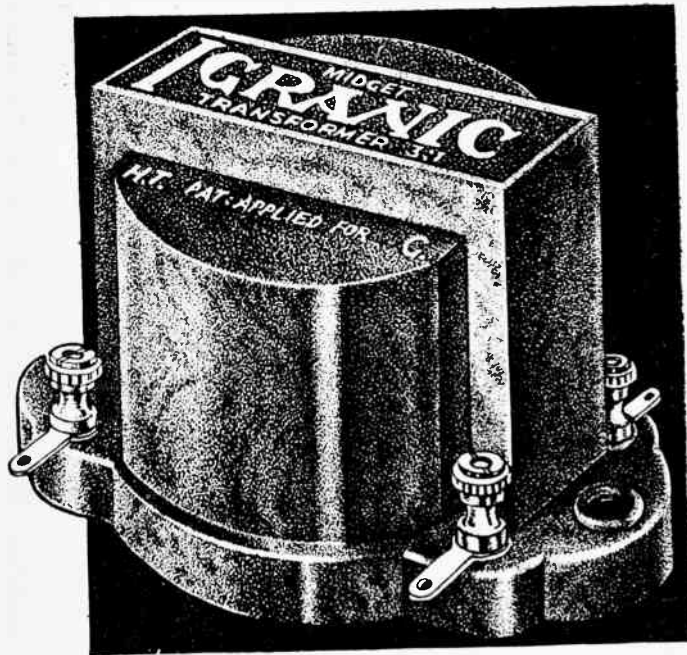

A Transformer I purchased in February 1925 is still in constant use and as good as ever . . . My slogan after all these years is "Once a user of Igranic, always a user of Igranic."
"Igranic Enthusiast," Leyland, Lancs.

IGRANIC MIDGET TRANSFORMER

Igranic have specialised in Transformer manufacture since the inception of Broadcasting, and many years of experience and costly research has led to the production of the "Midget" Transformer—unsurpassed for quality and performance. This wonderful Transformer renders the highest standard of tonal purity without a trace of "drumming." Its production reaches a standard never previously attained by a Transformer of such reasonable price. Supplied in ratios 3-1 and 5-1. Price **10/6**

Write for fully illustrated Catalogue No. U.349 of Igranic Quality Components.

Igranic Electric Co. Ltd., 149 Queen Victoria St., E.C.4.

IGRANIC COMPONENTS WILL BE THE MAKING OF YOUR SET

CVS-55

PASSED WITH HONOURS by "Wireless World"

See Full Report, Page 371, "W.W." May 26th.

This Mains Transformer is for receivers with maximum of 4 valves. Intended for use with "C" Class full wave rectifying valve. H.T. Winding gives 350-0-350 volts at nominal load of 80 m.a. Two L.T. Windings rated at 4 v. 1a. and 1 v. 2.5a. Primary Tappings at 200, 230, 250 volts 50 cycles A.C. "WIRELESS WORLD" says:—"Coil is of generous dimensions . . . H.T. winding shows good regulation . . . both L.T. windings satisfactorily adjusted for respective loads. For example, on full load the 1 amp. winding gave 3.9 volts while the rectifier filament was operated at 2.95 volts."

PRICE POST PAID **29/6**

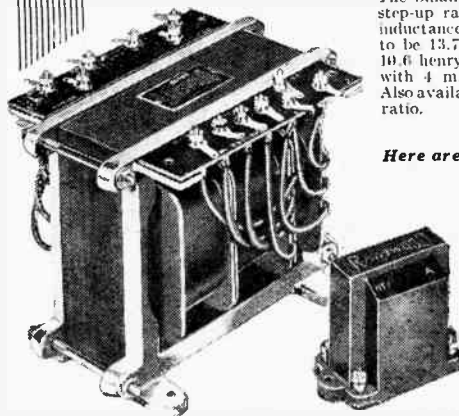

The Small Intervalve Transformer has a step-up ratio of 1 to 3—" and primary inductance was found by measurement to be 13.7 henrys with no D.C. flowing, 10.6 henrys with 2 m.a. and 8.6 henrys with 4 m.a. passing through primary." Also available with 1 to 5 ratio. PRICE POST PAID **4/11**

Here are a few other examples—

but our complete list contains many more:—
TRANSFORMERS FOR METAL RECTIFIERS (WESTINGHOUSE' with Combined Filament Winding.
M.F.8, 210 v. 150 m.a. 4 v. 4.5a. 4 v. 1 a. or 6 v. 1 a. 28/-
M.F.9, 240 v. 200 m.a. 4 v. 3a. 4 v. 1a. 28/6
M.F.10, 150 v. 350 m.a. 4 v. 3 a. 4 v. 1 a. or 6 v. 1 a. 35/-
SMOOTHING AND OUTPUT FILTER CHOSES.
Hrys. Millamps. Approx. Res. Price.
30 20 700 10/-
40 30 850 11/6
50 x 30 100 x 100 250 x 250 17/6

Also makers of L.F. Transformers. SEND FOR DETAILED LIST

RAWSWOOD

RAWSWOOD ELECTRICAL CO., Preston New Road BLACKPOOL.
Phone: Mariton 188. Grams: Rawswood, Blackpool.

WIRELESS DIRECTION FINDING

and DIRECTIONAL RECEPTION

(1927)

By R. KEEN, B.Eng. (Hons.)

Second Edition

THIS volume deals with the principles of the subject and the constructional details of direction-finding installations, and includes some information concerning aircraft equipment. It describes the principles of Direction and Position Finding in such a way that the subject may be grasped easily by engineers tackling this field of wireless work for the first time. Numerous photographs and diagrams are included.

Price 21/- net. By post 21/9

From leading booksellers or direct from the Publishers:

ILIFFE & SONS LIMITED

Dorset House, Stamford Street, London, S.E.1 w.w.68

The Wireless World

PROGRAMMES from A BROAD

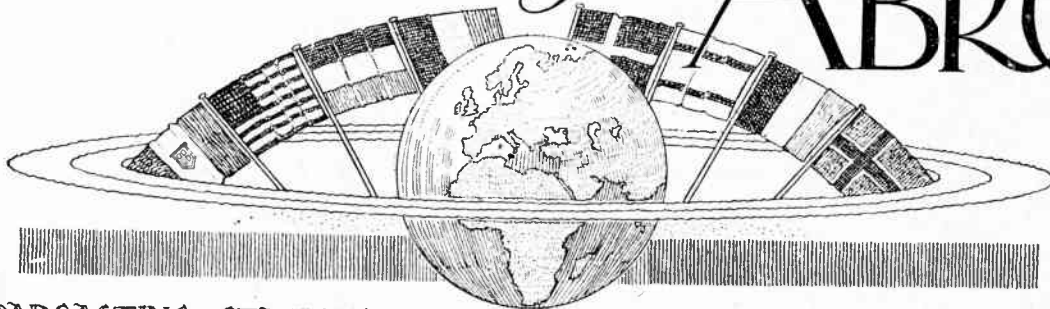

BROADCASTING STATIONS
ARRANGED IN ORDER
OF WAVELENGTH

TIMES AND DETAILS OF
FULL WEEK'S FOREIGN
TRANSMISSIONS

Metres.	kc/s.	kW.	Station.	Tuning Positions.	Metres.	kc/s.	kW.	Station.	Tuning Positions.
1935	155	7	Kaunas (Kovno) (Lithuania)	453.2	662	7	Milan (<i>Experimental Relays Rome</i>)
1875	160	8.5	Huizen (Holland)	450.3	666	20	Madona (Latvia). (<i>Relays Rigi</i>)
1796	167	40	Lahti (Finland)	447.1	671	Paris. Ecole Supérieure, PTT (7.0 kW.); Rjukan (0.15 kW.); Notodden (0.08 kW.); Alesund (0.35 kW.) (Norway) (<i>relays Oslo</i>).
1725	174	75	Radio Paris, C.F.R.	441.2	680	50	Rome, IRO. (<i>S.-W. Station, 2 RO on 25.4 m.</i>)
1635	183.5	60	Berlin (<i>Deutschlandsender</i>) (Germany). (<i>S.-W. Stn. DJA on 31.38 m., DJB on 19.73 m., DJC on 49.83 m., DJD on 25.51 m., DJE on 16.89 m.</i>)	435.4	689	55	Stockholm. S.A.S.A. (Sweden)
1554.4	193	30	Daventry National	430.4	697	2.5	Belgrade (Yugoslavia)
1538	195	7	Ankara (Angora) (Turkey)	424.3	707	2	Madrid, EAJ7 (Union Radio). (<i>After 7.0 p.m.</i>)
1481	202.5	100	Moscow, RV1 (Old Komintern) (Russia)	424.3	707	100	Moscow, Imini Stalina (Russia)
1446	207.5	13	Eiffel Tower, FL, Paris	419.5	715	1.5	Berlin, Witzleben (Germany)
1412	212.5	120	Warsaw 1 (Poland)	416.4	720.5	5	Rabat (Morocco)
1380	217.5	100	Novosibirsk, RV6 (Russia)	413	725	60	Athlone (Irish Free State)
1354.4	221.5	30	Motala (Sweden). (<i>Relays Stockholm</i>)	408.7	734	16	Katowitz (Poland)
1304	230	500	Moscow, WZSPS (Trade Union) (Russia)	403.8	743	25	Sottens (Radio Suisse Romande) (<i>Switzerland</i>)
1275	235	0.5	Tunis-Kashah (Tunisia)	398.9	752	25	Midland Regional. (Daventry)
1230	244	0.6	Boden (Sweden). (<i>Relays Stockholm</i>)	394.2	761	12	Bucharest (Roumania)
1200	250	5	Stamboul (Turkey)	389.6	770	120	Leipzig (Germany)
1200	250	21	Reykjavik (Iceland)	385.1	779	8	Toulouse (Radiophonie du Midi) (France)
1190	252	200	Luxembourg	385.1	779	10	Stalino, RV26 (Russia)
1170	256	25	Tashkent, RV11 (Russia)	381	788	16	Lwow (Lemberg) (Poland)
1154	260	7.5	Kalundborg (Denmark). (<i>Relays Copenhagen</i>)	376.4	797	50	Scottish Regional (Falkirk)
1117	268.5	40	Moscow, Popoff RV58 (Russia)	372.2	806	1.5	Hamburg (Germany)
1083	277	60	Oslo (Norway)	370.1	810.5	0.8	Radio, LL, Paris
1071	280	35	Tiflis, RV7 (Russia)	368.1	815	Seville, EAJ5 (Union Radio) (1.0 kW.); Galicia EAJ4 (0.2 kW.) (Spain); Bolzano (1.0 kW.) (Italy); Helsinki (10 kW.) (Fin- land) (<i>relays Lahti</i>); Kharkov, RV20 (10 kW.) (Russia).
1035	290	36	Kiev, RV9 (Russia)	363.1	815	0.7	Fredrikstad (Norway). (<i>Relays Oslo</i>)
1000	300	100	Moscow (Russia) (<i>S.-W. Stn. on 50 m.</i>)	364.1	824	1	Bergen (Norway)
938	320	20	Kharkov, RV4 (Russia)	363.6	825	13	Algiers (Algeria)
857	350	100	Leningrad (Russia)	360.6	832	60	Mühlacker (Stuttgart) (Germany)
840	357	18.5	Budapest (Hungary)	355.9	843	50	London Regional (Brookmans Park)
825	363.6	50	Sverdlovsk, RV5 (Russia)	352.1	852	7	Graz (Austria). (<i>Relays Vienna</i>)
760	395	1.3	Geneva (Switzerland). (<i>Relays Sottens</i>)	348.8	860	7.6	Barcelona, EAJ1 (Spain)
720	416.6	15	Monte Ceneri (Switzerland). (<i>Testing</i>)	348.8	860	10	Leningrad, RV70 (Russia)
720	416.6	20	Moscow, RV2 (Experimental) (Russia)	345.2	869	11.5	Strasbourg, PTT (France)
690	434.6	1.5	Oulu (Uleaborg) (Finland)	341.7	878	35	Brno (Brunn) (Czechoslovakia)
680	441.2	0.6	Lausanne (Switzerland). (<i>Relays Sottens</i>)	338.2	887	15	Brussels II, Velthem (Belgium). (<i>In Flemish</i>)
574.7	522	7	Ljubljana (Yugoslavia)	335	896	5	Madrid (Spain)
569	527	0.25	Freiburg-im-Breisgau (Germany). (<i>Relay Stn.</i>)	334.4	897	1.9	Poznan (Poland)
568.1	528	2	Grenoble (France)	331.5	905	50	Milan (Italy). (<i>Relays Turin</i>)
566	530	0.25	Hanover (Germany). (<i>Relays Hamburg</i>)	328.2	914	60	Poste Parisien (France)
563	533	16	Wilno (Poland). (<i>Relay Station</i>)	325	923	60	Breslau (Germany)
560	536	0.25	Augsburg (Germany). (<i>Relays Munich</i>)	321.9	932	10	Göteborg (Sweden). (<i>Relays Stockholm</i>)
560	536	1.5	Kaiserslautern (Germany). (<i>Relays Munich</i>)	318.8	941	0.25	Dresden (Germany). (<i>Relays Leipzig</i>)
550	545	18.5	Budapest No. 1 Lakihegy (Hungary)	318.8	941	1.5	Naples, INA (Italy). (<i>Relays Rome</i>)
542	554	10	Sundsvall (Sweden). (<i>Relays Stockholm</i>)	315.8	950	1.8	Marseilles, PTT (France)
537.6	558	3	Palermo (Italy)	312.8	959	0.7	Radio Vitus (Paris). (<i>S.-W. Stn. on 43.75 m.</i>)
533	563	60	Munich (Germany)	312.8	959	1.7	Cracow (Poland)
525	571	15	Riga (Latvia)	309.9	968	1	Genoa, IGE (Italy). (<i>Relays Turin</i>)
517.2	580	100	Vienna (Bismarberg) (Austria)	309.9	968	50	Cardiff
509	589	15	Brussels No. 1, Velthem (Belgium). (<i>In French</i>)	307	977	0.75	West Regional (Washford Cross)
500.8	599	20	Florence, IPI (Italy). (<i>Relays Turin</i>)	304	986	13	Zagreb (Yugoslavia)
495.8	605	1.2	Trondheim (Norway)	301.5	995	50	Bordeaux Lafayette, PTT (France)
488.6	614	120	Prague, No. 1 (Czechoslovakia)	298.8	1004	11	North National (Manchester)
480	625	50	North Regional (Manchester)	296.1	1013	20	Tallinn (Esthonia)
472.4	635	60	Langenberg (Germany)	293.5	1022	0.7	Hilversum (Holland). (<i>7 kW. before 4.40 p.m.</i>)
465.8	644	15	Lyons la Doua, PTT (France)	293.5	1022	2.6	Limoges, PTT (France)
39.4	653	60	Beromünster (Schweizerischer Landessender) (Switzerland)	291	1031	13.2	Kosice (Czechoslovakia)
33.2	662	San Sebastian, EAJS (0.6 kW.); Pori (1.0 kW.) (Finland); Danzig (0.5 kW.) (<i>relays Heilsberg</i>); Klagenfurt (0.5 kW.) (Austria) (<i>relays Vienna</i>); Forsgrund (0.7 kW.) (<i>relays Oslo</i>); Tromsø (0.1 kW.) Höls (0.5 kW.) (Norway); Uppsala (0.15 kW.) (Sweden) (<i>relays Stockholm</i>).	288.3	1040	50	Viipuri (Viiborg) (Finland). (<i>Relays Helsinki</i>)
3.2	662	0.25	Agen (France)	288.3	1040	1	Scottish National (Falkirk)
.....	286	1049	0.8	Barnmouth (Relay Station)
.....	Montpellier (France)

BROADCASTING STATIONS ABROAD

(In Order of Wavelength).

Metres.	kc/s.	P.W.	Station.	Tuning Positions.	Metres.	kc/s.	kW	Station.	Tuning Positions.
283.8	1053	0.7	Lyons (Radio-Lyon) (France)		244.1	1229	0.5	Basle (Switzerland). (Relays Beromünster)	
283.6	1058	0.5	German Relays (Berlin, Magdeburg, Stettin)		242.3	1238	1	Belfast (N. Ireland)	
283.6	1058	0.5	Innsbruck (Austria). (Relays Vienna)		240.6	1247	0.5	Stavanger (Norway)	
282.2	1063	2	Lisbon (CT 1AA (Portugal). (Short-wave Station on 31.25 m.)		238.9	1256	2	Nürnberg (Germany). (Relays Munich)	
					238	1260	1	Nimes (France)	
					237.2	1265	3	Bordeaux, Sud-Ouest (France)	
281.2	1067	0.75	Copenhagen (Denmark)		235.5	1274	0.5	Kristiansund (Norway)	
278.8	1076	13.5	Bratislava (Czechoslovakia)		235	1283	1.65	Lodz (Poland). (Relay Station)	
276.5	1085	60	Heilsberg (Germany)		232.2	1292	0.25	Kiel (Germany). (Relays Hamburg)	
273.7	1096	7	Turin (Italy)		230.6	1301	—	Swedish Relay Stations. (Malmö, Norrköping, Karlstad and Trollhättan).	
271.5	1105	1.3	Remes, PTT (France)						
269.8	1112	20	Bari (Italy)						
269.8	1112	0.25	Bremen (Germany). (Relays Hamburg)		227.4	1319	0.5	Flensburg (Germany). (Relays Hamburg)	
267.6	1121	1.5	Valencia (Spain)		225.9	1328	10	Fécamp, Radio-Normandie (France)	
265.8	1128.5	1.3	Lille, PTT (France)		224.4	1337	1	Cork (Irish Free State)	
263.8	1137	11.2	Moravska Ostrava (Czechoslovakia)		222.9	1346	0.15	Hudiksvall (Sweden)	
261.5	1147	50	London National (Brookmans Park)		219.9	1365	1.5	Béziers (France)	
259.3	1157	17	Frankfurt-a.M. (Germany)		218.5	1373	0.2	Plymouth	
259.3	1157	2.3	Trier (Germany). (Relays Frankfurt)		218.5	1373	0.5	Salzburg (Austria). (Relays Vienna)	
257.1	1167	10	Hörby (Sweden). (Relays Stockholm)		217	1382	0.5	Königsburg (East Prussia) (Germany)	
255.1	1176	0.7	Toulouse, PTT (France)		217	1382	0.25	Karlstad (Sweden)	
253.1	1185	5	Gleiwitz (Germany). (Relays Breslau)		215.6	1391	0.2	Halmstad (Sweden)	
252	1193	1	Barcelona, E.A.J.15 (Assoc. Nat.) (Spain)		214.3	1400	1	Aberdeen	
249.6	1202	0.8	Juan-les-Pins, Nice (France)		211.3	1420	1	Newcastle	
247.7	1211	10	Trieste (Italy). (Relays Turin)		209.8	1430	1.25	Magyarovar, Miskolez and Pecs (Hungary)	
245.9	1220	0.12	Swansea		207	1450	0.15	Boras (Sweden)	
245.9	1220		Berne (0.5 kW.) (Switzerland) (relays Beromünster); Eskilstuna (0.2 kW.), Sällö (0.4 kW.) (Sweden) (relays Stockholm); Cassel (0.25 kW.) (Germany) (relays Frankfurt); Linz (0.5 kW.) (Austria) (relays Vienna); Pietarsaari (0.5 kW.), Turku (Abo) (0.5 kW.) (Finland) (relays Helsinki).		206	1460	0.2	Ornsköldsвик (Sweden)	
					204.1	1470	0.2	Gävle (Sweden)	
					202.7	1480	0.25	Kristineham (Sweden)	
					201.3	1490	0.25	Hälsingborg (Sweden)	
					195	1530	0.2	Karlskrona (Sweden)	

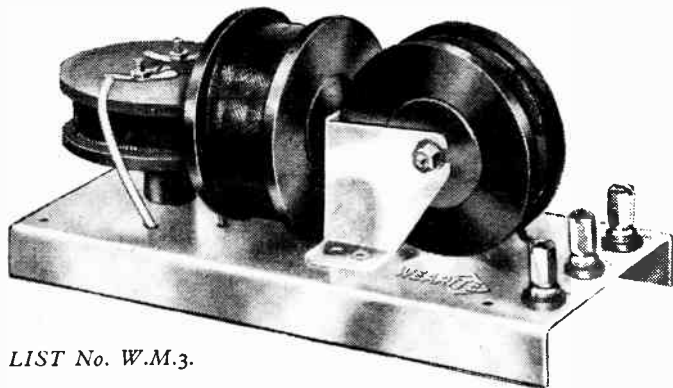

LIST No. W.M.3.

The WEARITE HETERODYNE FILTER

Of the three sectional type this unit is designed to give a sharp cut off at 3,500 cycles and is successfully employed as a Heterodyne Whistle Filter and also as a Scratch Filter following a pick-up. Impedance approx. 10,000 ohms.

PRICE 15/-

Used in the NEW MONODIAL SUPER-HET

THE original Monodial—one of the outstanding successes of W.W. circuits is brought up-to-date. The designer has again sought the Wearite list of components. Every Wearite product is the result of much experimental work and carries with it an assurance of living up to specification. That is why Wearite were selected for use in the New Monodial.

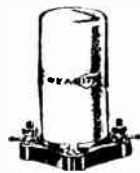

List No. H.F.P.

TWO OF THESE WEARITE H.F. CHOKES (H.F.P.) ARE ALSO USED.

A completely screened H.F. Choke suitable for operation on all wave lengths from 15 — 2,500 metres. Resistance 300 ohms. Inductance 200,000 M.H.

PRICE 3/6 each.

Registered Trade Mark.



WRIGHT & WEAIRE LTD.,

740, High Road, Tottenham, N.17.

Phone: TOT. 2847/8/9.

FOREIGN SUNDAY PROGRAMMES

JULY THE TWENTY-THIRD

PRINCIPAL EVENTS OF THE WEEK:

ALGIERS

824 kc/s, 364 metres; 13 kW.—8.0 p.m., Accordion Recital. 8.30, Monologues. 8.45, Recitation. 9.2, Orchestral Concert with Songs. 10.30, News. 10.35, Concert of Waltz Songs. 11.0 (approx.), Close Down.

ATHLONE

725 kc/s, 413 metres; 60 kW. Relayed by Cork, 1,337 kc/s, 224.4 metres.—8.30 p.m., Time Signal. 8.31, Cecilian Instrumental Quartet. 8.50, Concert by the Greenmount Industrial School Choir, Cork. 9.10, Piano-forte Recital by Fred Stone, Cork. 9.25, Original Sketches, by John MacDonagh and Company. 10.25, Tenor Solos by P. J. O'Toole. 10.40, Instrumental Quartet. 11.0, Time, News, Sports Results, Weather Report, and Close Down.

BARCELONA

EAJ1, 860 kc/s, 348.8 metres; 8 kW.—12 Noon, Chimes and Weather. 2.0 p.m., Gramophone Music. In the interval at 2.30, Theatre Notes. 3.0, Concert by the Station Sextet. 4.0, Programme for Hospitals and other Benevolent Institutions, with Gramophone Records. 5.0 to 6.30, Interval. 6.30, Agricultural Talk in Catalan and Gramophone Music. 7.0, Concert by the Station Orchestra. 7.30, Song Recital by Janette Bergmann. 8.0, Concert by the Station Orchestra and Concepcion Callao (Songs). 9.0, Dance Music, relayed from Hollywood Bar Dance Hall. 10.0, Musical Comedy Music on Gramophone Records. 11.45, Chess Lesson. 12 Midnight (approx.), Close Down.

BARI

1,112 kc/s, 269.8 metres; 20 kW.—10.45 a.m., Agricultural Notes. 11.5, Bible Reading. 11.35, Sacred Music from the Church of San Domenico. 1.0 p.m., Giornale Radio. 1.10 to 2.15, Gramophone Music. In the intervals at 1.55, Weather, and at 2.0, Time and Announcements. 5.30 to 6.30, Gramophone Music, Sports Notes in the intervals. 8.0, Sports Notes and Giornale Radio. 8.30, Time and Announcements. 8.35 (approx.), Symphony Concert on Gramophone Records. 10.30, Gramophone Music. 10.55, News.

BASEL.—See Schweizerischer Landessender.

BELGRADE

397 kc/s, 430.4 metres; 2.8 kW.—6.55 p.m., Time Signal and Programme Announcements. 7.0, Recital of Yugo-Slav Songs. 7.30, Gramophone Music. 7.50, Humorous Programme. 8.30, Concert by the Station Orchestra. 9.30, News. 10.0, Gramophone Music. 10.30, Cigany Music relayed from the Potroscaika Zadruga Restaurant.

BERLIN

DEUTSCHLANDSENDER, 193.5 kc/s, 1,635 metres; 60 kW.—6.0 a.m., Gymnastics from Terlin (Witzleben). 6.15, Review of Saturday's News. Axiom of the Day, followed by fat-hour Concert from Hamburg. 8.0, Sports report. 8.55, Chimes and Service. 9.30, Report of the Two Thousand Kilometre Race. 9.5, Weather Report from Berlin (Witzleben). 11.0, Heinrich Anacker reads from his own Poems. 11.15, Weather. 11.30, Radio report of the Hitler Cup Final. 12 Noon, See Langenberg. 12.55 p.m., Time Signal. 5, See Breslau. In the interval at 1.25, Sports Report from Stuttgart. 2.20, Gramophone Records for Children. 3.0, The German Soldier—Reminiscences by Carl Hageath. 3.25, Recital of Modern Piano-forte music: Frühliches Präludium (Walter Niemann); Old China—Suite (Walter Niemann); altz from Natalia (Delibes-Dolmányi). 4.0, Mrs. Brandenburg reads from his own works. 4.30, Concert of Light Music, conducted by Bruno Eckhardt, relayed from Wemünde. 6.0, A Discussion: One Child—Child. 6.25, Recital of Old German Love songs by Hans Stüwe and a Sinfal Choir. See Breslau. 8.0, Review of the Day's report of the Two Thousand Kilometre Race. 8.30, Stuttgart. 10.5, Dance Music from Witzleben. In the intervals at 10.25, other and News, and at 10.45, Weather report for Shipping. 12 Midnight, Close down.

BERLIN

WITZLEBEN, 715 kc/s, 419.5 metres; 1.5 kW.—11.30 a.m., Gramophone Records of Choral Music. 12 Noon, See Leipzig. 2.0 to 3.10, Talks for Garden City flowers. 3.30, Concert of Light Music. In interval from 4.30 to 5.0, The Meeting of the Directors—an Exciting Hour in a Studio. 5.55, Radio Report of the final Half of the Hitler Cup Football Final at the Grünwald Stadium. 6.40, Recital talks by Prof. Albert Fischer (Bass). Talk on Günther Greenhoff. 7.30, Ham and Cogwheel—A Radio Picture (Heinrich Becker). 7.55, Sports Notes. 8.10 p.m., Concert from Hamburg. 10.0, s, followed by Dance Music from the Garden of the Eden Hotel. In the

NATIONAL

AT HOME
Wilberforce Centenary, 1833-1933: a Civic service, conducted by Rev. Canon Seldon Morgan; address by Archbishop of York, relayed from Holy Trinity Church, Hull.
Roman Catholic service from a studio, conducted by Rev. Father M. C. d'Arcy, S.J.
String orchestral concert.

LONDON REGIONAL

MIDLAND REGIONAL

NORTH REGIONAL

Religious service from Swan Bank Methodist Church, Burslem, Stoke-on-Trent.

ABROAD

BERO-MUNSTER

BRUSSELS (No. 1)

COPENHAGEN

HAMBURG

HEILSBURG

HILVERSUM (announced Huizen)

HUIZEN (announced Hilversum)

LEIPZIG

PARIS (Radio-Paris)

STRASBOURG

6.30 p.m. Recital of English poetry, by Dorothy Müller-Bowick.
6.15 p.m. Beethoven pianoforte recital. 8.0 p.m., Chabrier concert, by the Station Symphony Orchestra.
8.5 p.m. Mozart concert.
8.0 p.m. Popular concert by the Station Orchestra.
8.0 p.m. The Königsberg Opera House Orchestra in a programme of operetta and light music.
7.50 p.m. Concert by the Groningen Orchestra, conducted by M. Kuiler.
2.40 p.m. Concert, relayed from the Kurhaus, Scheveningen.
8.20 p.m. "Die lustigen Musikanten," a romantic opera (E. T. A. Hoffman), relayed from Dresden.
3.0 p.m. (approx.). Last two matches of the Final for the Davis Cup.
8.30 p.m. "Il Trovatore," an opera (Verdi), relayed from the Casino, Vichy.

interval from 11.10 to 11.25, Topical Report. 1.0 a.m. (Monday), Close Down.

BERNE.—See Schweizerischer Landessender.

BEROMUNSTER.—See Schweizerischer Landessender.

BODEN.—See Stockholm.

BODO.—See Oslo.

BORDEAUX-LAFAYETTE

986 kc/s, 304 metres; 13 kW.—7.30 p.m., Sports Notes. 7.45, Report of the Cycle Tour of France. 8.5, Talk for Ex-service Men. 8.20, Lottery Results. 8.30, Opera relayed from the Casino, Vichy (for details see Strasbourg).

BRATISLAVA

1,076 kc/s, 279 metres; 14 kW.—12.5 p.m., Concert by the Station Orchestra, conducted by E. Dyk; Soloist: Nelly Bakosová-Baumlerová (Songs); Overture, Raymond (Thomas); Selection from Tosca (Puccini); Gilda's Aria from Rigoletto (Verdi); Meditation from Thaïs (Massenet); Smugglers' Chorus from Carmen (Bizet); Pilgrims' Chorus from Tannhäuser (Wagner); Gramophone Record, Triumphal March from Aida (Verdi); Aria from Mignon (Thomas); Intermezzo from Cavalleria rusticana (Mascagni); Prelude and Chorus of June from Weather (Massenet); Aria from Lakmé (Delibes); Selection from The Tales of Hoffmann (Offenbach). 1.30, Programme from Brno. 1.45 to 1.50, Hydrographical Report. 4.0, See Brno. 5.30, See Prague. 6.0, Gramophone Music. 6.20, Talk: A Tour through Palestine. 6.35, Cello Recital by Jos. Simandl: Minuetto pastorale (Camponi); Romance (Marfuzzo); Dance (Popper); Nocturne (Tchaikovsky); Melody (Kubát); Allegro appassionato (Saint-Saëns). 7.0, See Brno. 7.50, Talk: Touring in the Tatra Mountains, relayed from Kosice, 1,022 kc/s, 293 metres. 8.5, See Prague. 9.5, See Brno. 10.0, See Prague. 10.20, Concert of Schrammel Music. 11.30 (approx.), Close Down.

BREMEN.—See Hamburg.

BRESLAU

923 kc/s, 325 metres; 60 kW. Relayed by Gleiwitz, 1,184 kc/s, 253 metres.—12 Noon, Military Band Concert from the Berggarten. Brieg: Mussian-Marsch (Carl); Overture, Figaro (Mozart); Solveig's Song (Greig); Potpourri of March Songs, Jung-Deutschland (Weniger); Ernst August-Marsch (Blankenburg); Hymn and Triumphal March from Aida (Verdi); Selection from Tosca (Puccini); Rosenlieder (Eulenburg); Parade March (Böhr); Potpourri of Songs,

Schön ist die Jugend (Rhode); Pro patria ad artibus (Spagl). 2.0 p.m., News. 2.10, Agricultural Talk. 2.25, Talk on Photography. 2.45, Wireless Talk. 3.0, Duets for Mandoline and Guitar. 3.30, Programme for Children. 4.0, Orchestral Concert, relayed from Bad Ziegenhals. 6.0, Reading (Hermann Hesse). 6.30, Song Recital by Gertrud Gottschalk (Contralto). 7.0, Jung Mannschaft—Musical Radio Sequence dealing with the Voluntary Labour Service. 8.0, Sports Report. 8.30, Summer has come—Play (Peter Steinbach—Music by Walter Triebel). 10.15, Time and News. 10.45, Dance Music from Berlin (Witzleben). 12 Midnight, Close Down.

BRNO

878 kc/s, 342 metres; 35 kW.—4.0 p.m., Military Band Concert, relayed from a Restaurant. 5.30, See Prague. 6.0, German Transmission: Songs and Duets from Operettas. 7.0, Report from a Harvest Home in Moravia. 7.50, Talk: Touring in the Tatra Mountains, relayed from Kosice, 1,022 kc/s, 293 metres. 8.5, See Prague. 8.45, Gossip—Humorous Item (Sipek). 9.5, Concert by the Station Orchestra, conducted by Janota; Soloist: Vlasta Kubikova (Songs); Overture, A Czech Wedding Day (Bendl); Aria (Dvorák); Two Extracts from The Slovak Suite (Novak); Andante and Allegro from the String Serenade, Op. 6 (Suk); Aria from Pad Arkuna (Fibich); Two Polkas (Smetana). 10.0, See Prague. 10.20, See Bratislava. 11.0 (approx.), Close Down.

BRUSSELS (No. 1)

I.N.R., 590 kc/s, 509 metres; 15 kW.—10.0 a.m., Gramophone Music. 11.0, Concert by the Small Station Orchestra, conducted by Pierre Lecmann. 11.45, Running Commentary on the Belgian Grand Prix Motor Cycle Race at Francorchamps. 12 Noon, Concert by the Station Symphony Orchestra, conducted by Meulmans; soloist: Mme. Poushez (Songs); Overture, La princesse jaune (Saint-Saëns); Ballet Music from Sylvia (Delibes); Chasse fantastique (Guiraud); Songs; La Hussarde (Garnier); La cinquante (Gabriel Marie); Hungarian March (Berlioz). 1.0 p.m., Le Journal Parlé. 1.10, Concert by the Station Orchestra, conducted by Franz André; Soloist: Armand Crabbe (Baritone); Overture, Boccaccio (Suppé); Tales of the Vienna Woods (Strauss); Concertino for Flute (Chaminade). 1.30, Running Commentary (contd.). 1.45, Concert (contd.). Jazz 1933 (Candrix); Spanish American Songs; Selection from Sleeping Beauty (Tchaikovsky); Airs (Debussy); (a) Mazurka, (b) Minstrels; Romance for Violin (Sibelius); Polka (Dreyfus); Japanese Variations (Vidal). 2.0, Extracts from Carmen—Opera

(Bizet) on Gramophone Records. In the intervals at 2.15 and 3.15, Running Commentary on the Belgian Grand Prix Motor Cycle Race at Francorchamps. 5.0, Dance Music, relayed from the Kursaal, Ostend. 5.30, Football Results. 6.15, Beethoven Pianoforte Recital by Jean du Chastain; Andante in F; Sonata in F, Op. 57—the Appassionata. 6.45, Le Heros—Sketch (Lauville). 7.0, Gramophone Music. 7.15, Religious Address. 7.30, Wireless Notes and Music Review. 8.0, Chabrier Concert by the Station Symphony Orchestra, conducted by Meulmans; Overture, Gwendoline; Bourrée fantasque; Suite, España; Joyeuse Marche; Dances from Le roi maigre (L.). 8.45, Chez la Concierge—Sketch (Blauin). 9.0, Concert, relayed from the Kursaal, Ostend. 10.30, Le Journal Parlé. 10.40, Dance Music, relayed from the Kursaal, Ostend. 12 Midnight, Close Down.

BRUSSELS (No. 2)

N.I.R., 887 kc/s, 338.2 metres; 15 kW. Programme in Flemish. 10.0 a.m., Concert by the Little Station Orchestra, conducted by P. Lecmann. 11.0, Gramophone Concert. 12 Noon, Concert by the Radio Orchestra, conducted by Franz André; soloist: M. Crabbe (Baritone) of the Scala, Milan. 1.0, Le Journal Parlé. 1.10, Concert by the Symphony Orchestra, conducted by Arthur Meulmans. 5.0, Dance Music from the Casino, Knocke. 5.30, Sports Notes. 6.15, Gramophone Concert. 7.15, Religious Address. 7.30, Music Review by Paul Gilson. 8.0, Concert by the Radio Orchestra, conducted by Franz André. 8.45, Recitations. 9.0, Orchestral Concert, conducted by K. Candaël, relayed from the Casino, Knocke; Soloist: A. Demarey (Baritone); March from Tannhäuser (Wagner); Symphonie Entr'acte from Messidor (Bruneau); Aria from Hérodiade (Massenet); Spanish Caprice (Rimsky-Korsakov); Aria from Thaïs (Massenet); Overture, Robespierre (Litolff). 10.30, Le Journal Parlé. 10.40, Dance Music from the Casino, Knocke. 12 Midnight (approx.), Close Down.

BUCHAREST

761 kc/s, 394 metres; 12 kW.—5.0 p.m., Light Music and Romanian Music by the Budala Orchestra. In the interval at 6.0, Radio Journal. 7.0, Reading. 7.20, Dance Music on Gramophone Records. 7.40, Educational Talk. 8.0, Recital of Airs from Operetta. 8.20, Concert of Military Music. In an interval at 9.0, Talk. 9.45, Radio Journal.

BUDAPEST

545 kc/s, 550.5 metres; 18.5 kW.—9.15 a.m., News. 10.0, Reformed Church Service. 11.0, Catholic Service, followed by News and Orchestral Concert. 2.0 p.m., Gramophone Music. 3.0, Agricultural Talk. 3.45, Cigany Music. 5.5, Reading. 5.30, Concert. 6.45, Radio Report of the International Water Polo Match, Hungary v. Czechoslovakia. 7.30, Piano-forte Recital. 8.10, A Radio Play, followed by News, and Cigany Music from the Café Enke.

CASSEL.—See Frankfurt.

COPENHAGEN

1,067 kc/s, 281 metres; 0.75 kW. Relayed by Kalundborg, 260 kc/s, 1,153 metres.—2.0 p.m. (also relayed by Skamlebaek on 31.51 metres), Divine Service, relayed from Holmens Kirke. 3.30, Accordion Recital by E. Pedersen. 4.0, Concert, relayed from a Park. 5.45, Interval. 6.20, Talk: The History of the Kalundborg Palace. 6.50, Weather. 7.0, News and Sports Results. 7.15, Time. 7.30, Talk. 8.0, Chimes from the Town Hall. 8.5, Mozart Concert by the Station Orchestra, conducted by Emil Reesen; Overture, Il Seraglio; Serenade for Strings, Eine kleine Nachtmusik; Minuet and Rondo from the Divertimento, No. 17, in D; Overture, Don Giovanni. 8.50, Variety Concert. 9.50, Duet for Two Violins and Piano-forte, Op. 18 (Godard). 10.5, News. 10.15, Orchestral Concert, conducted by Emil Reesen; Overture, La petite Bohème (Hirschmann); Waltz, Siesta (Waldteufel); Selection from Cavalleria rusticana (Mascagni); Sæterjentens Song (Bull-Svendsen); Viennese Music from The Duchess of Chicago (Kálmán); March, Fairest of the Fair (Souza). 11.0, Dance Music relayed from the Wivex Restaurant. In the interval at 12 Midnight, Time and Chimes from the Town Hall. 12.30 a.m. (Monday), Close Down.

CORK.—See Athlone.

DANZIG.—See Heilsburg.

DRESDEN.—See Leipzig.

FECAMP

1,328 kc/s, 225.9 metres; 10 kW.—2.0 to 8.0 p.m., Programme in English by the I.B.C. Special Programme for South Coast Listeners. 2.0, Popular Music: Signature Tune; The Little Company (Ganglberger); Song, Hold me (Schuster); All over Italy (Butler Monroe); The Enchanted Forest (Gangl-

MORAVSKA-OSTRAVA

1,137 kc/s, 263.8 metres; 11 kW.—7.0 p.m., See Brno. 7.50, Talk: Touring in the Tatras Mountains, relayed from Kosice, 1,022 kc/s, 293 metres. 8.5, See Prague. 9.5, See Brno. 10.0, See Prague. 10.20, See Bratislava. 11.0 (approx.) Close Down.

MOSCOW

TRADES UNION, 230 kc/s, 1,304 metres; 100 kW. 3.0 p.m., Instrumental Concert. 4.0, Talk: Preserving Food. 4.30, Literary Programme. 5.30, Programme Announcements. 5.45, Talk. 6.30, Dance Music. 10.5, Talk in German: Social Democracy and the War.

MOTALA.—See Stockholm.

MUHLACKER.—See Stuttgart.

MUNICH

563 kc/s, 533 metres; 60 kW. Relayd by Augsburg and Kaiserslautern, 536 kc/s, 560 metres, and Nürnberg, 1,256 kc/s, 239 metres.—12 Noon, Military Band Concert. 1.0 p.m., Time, Weather, and Programme Announcements. 1.10, Talk: Agriculture, the Foundation of the New Germany. 1.30, Gramophone Concert. 2.30, Talk on the National Revolution. 2.50 (from Nürnberg), Concert by the Nürnberg-Fürth Society of Music Teachers. 3.25, Programme for Children. 4.0, See Stuttgart. 4.30, Concert by the Munich Concert Orchestra, conducted by Richard Planer: Overture, La Sirène (Auber); Suite (Amadei); Toscanini Serenade (Murzilli); Tyrolean Songs and Dances (Fébus); Waltz, Deutsche Grüsse (Josef Strauss); Polpourri of Russian Gipsy Songs (Lenschner); March, Telefunken (Fucik). 5.25, Talk in Memory of Delyev von Lilieneron, Soldier and Poet. 5.55, See Berlin (Witzleben). 6.50, Short Play in Dialect. 7.45, Weather and Sports Notes. 8.0, See Berlin (Deutschlandsender). 8.15, See Stuttgart. 9.45, The Good-natured Devil Play (Johann Nestroy), with Music by L. Kuschel. 10.20, Time, Weather, and News. 11.0, Serenade from Stuttgart. 12 Midnight, Close Down.

NAPLES.—See Rome.

NOTODDEN.—See Oslo.

OSLO

277 kc/s, 1,083 metres; 60 kW. Relayd by Fredrikstad, 815 kc/s, 368.1 metres; Hamar, 522 kc/s, 574.7 metres; Notodden, 671 kc/s, 447.1 metres; Porsgrund, 662 kc/s, 453.2 metres; and Rjukan, 671 kc/s, 447.1 metres.—10.15 a.m., Road Report. 10.30, Chimes. 11.0, Divine Service. Relay. 5.0 p.m., Concert by the Station Orchestra, conducted by Oivin Fjeldstad: Overture, Russian and Ludmilla (Verdi); Fantasia, The Selfish Giant (Grieg); Melody (Backer-Gronhald); Hungarian Rhapsody (Liszt); Prelude in G minor (Rachmaninov); Andante from the 'Cello Concerto (Goldtammer); Berceuse, Waltz and March (Bjarné Brustad). 6.0, Readings relayed from Stavanger, 1,247 kc/s, 240.6 metres. 6.30, Concert by a Cornet Ensemble. 7.15, Weather and News. 7.30, Song Recital by John Neergaard (Baritone). 8.0, Time Signal. 8.1, Programme of Addresses and Music in Honour of the Poet Garborg, relayed from the Museum. Glomdal. 9.30, Weather and News. 10.0, Topical Talk. 10.15, Recitations. 10.45 (approx.), Close Down.

OSTERSUND.—See Stockholm.

PALERMO

558 kc/s, 537.6 metres; 3 kW. 10.25 a.m., Bible Reading. 10.40, Sacred Music. 11.5, Agricultural Talk. 12.45 p.m., Giornale Radio. 1.0-2.0, Concert of Light Music. In the interval at 1.30, Time, Announcements and Weather. 5.30, Gramophone Music. 8.0-8.0, Interval. 8.0, Dopolavoro Announcements. Giornale Radio, and Sports Notes. 2.0 (approx.), Gramophone Music. In the interval at 8.30, Time and Announcements. 4.5, Symphony Concert, conducted by Russo. Talk in the interval. 10.55, News.

PARIS

IFFEL TOWER, Call FLE, 207.5 kc/s, 1,445.7 metres, 13 kW. Time Signals on 2,650 metres 10.26 a.m. and 11.26 p.m. Preliminary and dot signals.—4.0 p.m., News. 1.15, Weather. 1.30, Concert by the Jean Buschestra. 2.0, Running Commentary on the odds of the Davis Cup Match. 6.15, Inter-1. 6.45, Le Journal Parlé. In the interval 7.45, Report of the Cycle Tour of France. 10, Gramophone Concert. 10.0 (approx.) Close Down.

PARIS

1STE PARISIEN, 914 kc/s, 328.2 metres; 10 kW. 10.0 a.m., Fanfare of Trumpets and of Drums. 10.20, Press Review. 10.30, Concert. 11.0 Gramophone Music. Noon, Interlude. 12.15 p.m., Sponsored concert of Sound Film Songs. 12.45, Sponsored Programme. 12.50, Half an Hour of Intensity by Paul Weill. 1.20, Interlude. 1, Gramophone Music. 2.0 (approx.), part of the Cycle Tour of France. 7.0, Journal Parlé. 8.0, Gramophone Music. 5, Interlude. 8.30, Hawaiian and Spanish Music. 9.0, Interlude. 9.15, Spring-y (Maurette). 9.45, Songs and Musical Solos. 10.15, News.

PARIS

RADIO PARIS, 174 kc/s, 1,725 metres; 75 kW.—7.45 a.m., Gramophone Music. 8.0, Weather and Press Review. 8.30, Physical Culture. 12 Noon, Religious Address by the Reverend Father Lhaué. 12.20 p.m., Sacred Music Andantino (Viene); Allegro, molto and Finale from The Sixth Sonata (Mendelssohn). 12.30, Programme by Billouquet. 12.45, Gramophone Concert: Part 1: Music by Ganne; Marche lorraine; La Moussee; La père la victorie; Nocturne and Les Baigneuses from the Ballet Les Ailes; La Czarine; Air from Hans the Flute Player; Selection from Les Saltimbanques. Part 11: Light Music; Divertissement on Russian Songs (Rabaud); Fantasia (Huc); Ballet Music from Hamlet (Thomas); Harp Solo, Contemplation (René); Vivaldi (Robillard); La retraite (Huc); Clair matin (Jeanjean); Rhythmes de Rille; Clair matiu (Donogio (Hert); Two Waltzes (Chopin); Ballet Music from Marouf (Rabaud). In the intervals at 1.0, Exchange, News, and Weather, and at 1.30 and 2.0, Exchange. 3.0 (approx.), Running Commentary on the Last Two Matches of the Final for the Davis Cup. 7.0, Popular Concert. 8.0, Gramophone Concert. In the intervals at 8.30 and 9.15, News. 10.30 to 11.0, Programme in English by the L.B.C. Orchestral Concert: March, Unter der Doppel- pelader (Wagner); The Bells of St. Malo (Kummer); Musical Comedy Waltz Concerto (arr. Hall); Selection from The Tales of Hoffmann (Offenbach); Selection from The Gondoliers (Sullivan). 11.0 (approx.), Close Down.

PITTSBURGH

KDKA, 980 kc/s, 306 metres; 50 kW. Relayd by W8XK on 48.86 metres and 25.27 metres.—5.15 to 6.15 p.m., Radio City Concert from New York. 7.0, The Boys of Wyncennesster. 7.15 to 11.0, New York Relay. 7.15, World Economic Conference—William Hard from London. 7.30, Jan Garber and his Orchestra. 8.0, National Opera Concert. 9.0, Morton Gould and Bert Shaffer. 9.15, Synphonette. 9.30, Organ Recital. 10.0, Vesper Services from Shady-side Presbyterian Church. 11.0, Time Signal and Press News- Reeler. 11.5, Beethoven Chamber Music from New York. 11.15, Weather Report. 11.16, Sport Review. 11.28, Announcements. 11.29, Temperature Report. 11.30, L'Heure Exquisite from New York. 12 Midnight, Time Signal followed by Jack Pettis and his Orchestra. 12.15 a.m. (Monday) to 1 a.m., New York Relay. 12.15, World Economic Conference—William Hard from London. 12.30, Wisdom of the Ages Janet Beecher and Oliver Wyndham. 1.0, Viennese Programme. 1.30, News of the Air. 1.45 to 3.0, New York Relay. 1.45, Floyd Gibbons—World's Fair Reporter. 2.0, Gulf Headliners. 2.30, Gohdman Band. 3.5, Time Signal and Mountain Music.

PORSGRUND.—See Oslo.

PRAGUE

814 kc/s, 488.6 metres; 120 kW.—11.0 a.m., Military Band Concert relayed from Podedbrady. 12.0 noon, Chimes from St. Ludmila Church. 12.5 p.m., See Bratislava. 1.30 to 1.45, Agricultural Talk. 4.0, See Brno. 5.30, Talk by F. Bohuslav: Theatre Reminiscences. 5.45, Gramophone Music. 6.0, German Transmission: Concert followed by a Radio Report: A Day in Carlbad, and News. 7.0, See Brno. 7.50, Talk: Touring in the Tatras Mountains, relayed from Kosice, 1,022 kc/s, 293 metres. 8.5, Military Band Concert conducted by J. Labsky: March (Sctunsky); Overture, Les deux Savoyards (Offenbach); Waltz (Labsky); Selection from A Masked Ball (Verdi); Melody (Vackar); Polka (Labsky); Medley of Folk Tunes (Piskarek). 9.5, See Brno. 10.0, Time and News. 10.20, See Bratislava. 11.0 (approx.) Close Down.

RADIO-SUISSE ROMANDE

SOTTENS, 743 kc/s, 403 metres; 25 kW.; and Geneva, 395 kc/s, 760 metres.—9.55 a.m., Chimes. 10.0, Protestant Service. 11.0, Gramophone Music. 12.30 p.m., News and Weather. 12.40, Gramophone Music. 4.30, Concert by the Radio-Suisse Romande Orchestra, conducted by Robert Echevard. 5.30 to 7.0, Interval. 7.0, Protestant Address. 7.30, Sports Notes, News, and Announcements. 7.55, Report on the Cycle Tour of France. 8.30, Concert by the Radio-Suisse Romande Orchestra. Soloist: M. André Pcpin (Flute); Sonata in D (Handel); Flute Solo: Syntex (Debussy). 9.30, Madame a ses Brevets—Fare (Valabréque). 9.50, News and Weather. 10.0, Gramophone Concert. 10.30 (approx.), Close Down.

RJUKAN.—See Oslo.

ROME

Call 1RO, 650 kc/s, 441 metres; 50 kW. Relayd by Naples, 941 kc/s, 319 metres, and 2RO, 11,610 kc/s, 25.4 metres, from 5.30 p.m.—10.0, News, Sports Notes, and Amusement Guide. 10.30, Agricultural Talk. 11.0 to 12 Noon and 12.30 to 1.30 p.m., See

Turin. 1.30 to 2.30, Orchestral Concert. In the interval at 2.0, Time and Announcements. 4.45 (Naples), Programme for Children. Weather and Sports Notes. 5.0, Orchestral Concert: Sports Notes in the intervals. 6.15, Weather. 7.30, News. 8.0, Time and Announcements. 8.25, Sports Notes. 8.30, See Turin. Talk and News in the intervals. Giornale Radio after the Programme.

SALZBURG.—See Vienna.

SCHENECTADY

WGY, 790 kc/s, 379.5 metres; 50 kW. Relayd at intervals by W2XAF on 31.48 metres and by W2XAO, on 19.56 metres.—8.0 to 10.0 p.m. (approx.), New York Relay. 8.0, Wayne King's Orchestra. 8.30, Dr. Ralph Seckman in the Radio Pulpit. 9.0, Fiddlers Three. 9.15, Wildroot Institute. 9.30 to 10.0, Temple of Song. 12.45 a.m. (Monday), Horse Sense Philosophy. 1.0 to 3.45, New York Relay. 1.0, Variety Programme. 2.0, Manhattan Merry-Go-Round. 2.30, American Album of Familiar Music. 3.0, Variety Programme. 3.15, Impressions of Italy. 3.45, Sunday at Seth Parker's, from New York followed by Programme Resumé.

SCHWEIZERISCHER LANDESENDER

BEROMUNSTER, 635 kc/s, 459 metres; 60 kW.; Basle, 1,229 kc/s, 244.1 metres; and Berne, 1,220 kc/s, 245.9 metres.—10.0 a.m. (from Basle), Catholic Address. 10.45 (from Basle), Beethoven Pianoforte Recital by Professor Walter Rehberg. 11.30 (from Basle), Reading. 12 Noon (from Basle), Swiss Choral Music on Gramophone Records. 12.30 p.m., Time and News. 12.40 (from Basle), Light Music on Gramophone Records. 1.30 (from Basle), Agricultural Programme. 2.0 (from Basle), Music by the Sissach Venice Orchestra. 2.30, Interval. 5.0 (from Basle), Gramophone Dance Music. 6.0 (from Basle), Reading from the Works of Karl Spitteler. 6.30 (from Basle), Recital of English Poetry by Dorothy Miller-Bowiek. 7.0 (from Basle), Time and Sports Notes. 7.5 (from Basle), Double Concerto in A Minor for Two Violins and Pianoforte (Vivaldi) on Gramophone Records. 8.0 (from Basle), Talk: Friendship. 8.30 (from Basle), Dialect Songs by the Pratteln Women's Choir. 9.0, News. 9.10 (from Basle), Organ Recital from the Cathedral. 10.15 (from Basle), Sports Notes. 10.20 (approx.), Close Down.

SOTTENS.—See Radio-Suisse Romande.

STOCKHOLM

689 kc/s, 436 metres; 55 kW. Relayd by Boden, 244 kc/s, 1,229.5 metres; Göteborg, 932 kc/s, 322 metres; Hörby, 1,166 kc/s, 257 metres; Motala, 221.5 kc/s, 1,354.4 metres; Östersund, 389 kc/s, 770 metres, and Sundsvall, 554 kc/s, 542 metres.—9.30 a.m., Rural Programme. 10.0, Gramophone Music. 11.0, Divine Service. 12.45 p.m., Weather. 3.0, Military Band Concert, relayed from Boras, 1,450 kc/s, 207 metres. 4.0, Talk. 4.30, Pianoforte Recital by Inger Mikkelson and W. Witkowsky: Duet, Norwegian Romance with Variations (Grieg); Solos: (a) Romance (Almaes), (b) Fantasia (Hartum). 5.5, Programme for Children. 5.30, Choral Concert of Gennap Folk Music, Conductor: Felix Körling. 6.0, Evening-song. 7.35, Readings. 8.0, Orchestral Concert, conducted by Adolf Wiklund, relayed from Skansen. Soloist: Joel Berglund (Soprano). Overture, Oheron (Weber); Symphony in B minor (Schubert); Three Songs, with Orchestra; Symphony (Haydn); Overture, The Thieving Magpie (Rossini); Symphonic Dances (Grieg). In the interval at 8.45, Reading. 10.0, Gramophone Music. 11.0 (approx.), Close Down.

STRASBOURG

869 kc/s, 345 metres; 11.5 kW.—7.45 to 8.0 a.m., Report on the Cycle Tour of France. 9.30, Orchestral Concert, conducted by Maurice de Villers. 10.45, Protestant Service in French. 11.30, Catholic Service in German. 12 Noon, Gramophone Concert of Light Music. 12.45 p.m., News. 1.0, Time and Report of the Cycle Tour of France. 1.15, Gramophone Concert of Light Music. 2.0 to 3.0, Dance Music on Gramophone Records. 3.40, Concert from the Casino, Vichy. Conductor, M. Brouillac. Overture, William Tell (Rossini); Chant hindou (Rimsky-Korsakov); Spanish Dance, La vida breve (Falla); Second Suite from L'Arlesienne (Bizet) Selection from Coppélia (Delibes); Selection from Faust (Gounod); Selection from Le roi malgré lui (Chabrier). 4.30 (approx.), Radio Report of the Cycle Tour of France. 4.45, Gramophone Music. 5.15, Dance Music. 6.0, Medical Talk. 6.15, Sports Talk in French. 6.30, Chamber Music—Songs, Cello and Pianoforte Solos from the Music of Hüssoumorel. 7.30, Time and News. 7.45, Radio Report of the Cycle Tour of France. 8.5, Press Review, News in French and Lottery Results. 8.30, Il Trovatore—Opera (Verdi), relayed from the Casino, Vichy. After the Opera, Press Review in German. 11.0, Dance Music from the Savoy. 12 Midnight, Close Down.

STUTT GART

MUHLACKER, 832 kc/s, 360.5 metres; 60 kW. Relayd by Freiburg, 527 kc/s, 570 metres.—11.30 a.m. (from Mannheim), Quartet for Four Flutes op. 103 (Kuhlan). 12 noon, See Munich. 1.0 p.m., Concert of Light Music on Gramophone Records. In the interval from 1.25 to 1.40, Radio Report of the Two Thousand and Kilometres Race from Baden-Baden. 2.5, Agricultural Talk. 2.30, Guitar and Pianoforte Recital. 3.0, Programme for Children. 4.0, Radio Report of the Fifteenth German Gymnastic Festival, relayed from the Arena; Procession and opening of the Arena. 4.45, Concert from Frankfurt. 5.50 (from Freiburg), Choral Concert. 6.20, Sports Notes. 6.35, Pianoforte Recital by Siegfried Graudis; Impromptu (Schubert); Sonata in A Minor (Schubert). 7.5, Ellwangen—a Local History Sequence. 7.50, See Berlin (Witzleben). 8.0, Hullo, Hullo, Stuttgart Calling, a Popular Potpourri (arr. Gustav Götlich). 9.50 (from Freiburg), Recital of Justinius Kerner); Songs set to music by Robert Schumann. 10.25, Time and News. 10.45, Concert of Variety Music. 12 Midnight, Close Down.

SUNDSVALL.—See Stockholm.

TRIESTE

1,211 kc/s, 247.7 metres; 10 kW.—9.40 a.m., See Turin. 9.55, Mass from the Cathedral of San Giusto. 11.0, Religious Address. 11.20-11.40, Agricultural Talk. 12.30 p.m. (approx.) till Close Down, See Turin.

TRONDHEIM.—See Oslo.

TURIN

1,096 kc/s, 273.7 metres; 7 kW. Relayd by Milan, 905 kc/s, 331.5 metres; Genoa, 959 kc/s, 312.8 metres; and Florence, 699 kc/s, 500.8 metres.—9.40 a.m., Giornale Radio. 9.55-11.0, Interval. 11.0, Mass from the Church of the Annunciation, Florence. 12 Noon to 12.15, Bible Reading. 12.30 p.m., Concert of Light Orchestra Music. In the interval at 1.0, Time and Announcements. 1.30, Sponsored Musical Programme. 1.45-2.30, Gramophone Music. 4.30, Concert of Light Music, Sports Notes in the intervals. 6.15, Weather. 6.30-6.45, News. 7.0, Time and Dopolavoro Notes. 7.10, Gramophone Concert of Light Music. 8.0, Announcements and Giornale Radio. 8.25, Talk on the following transmission. 8.30, Maglietta Veneziana—Opera in Three Acts (Rito Selvaggio), conducted by the Composer. In the intervals, Talk and Theatre Notes. Giornale Radio after the Programme.

VIENNA

581 kc/s 517 metres; 100 kW. Relayd by Graz, 852 kc/s, 352.1 metres; Innsbruck, 1,058 kc/s, 283 metres; Klagenfurt, 662 kc/s, 453.2 metres; Linz, 1,220 kc/s, 245.9 metres; and Salzburg, 1,373 kc/s, 218.5 metres.—11.30 a.m., Concert of Contemporary Austrian Music: The Vienna Symphony Orchestra, conducted by Martin Spörk. Soloist: Clarisse Stukart (Soprano). Lustige Overture (Franz Jippisch); Der Erlenhügel (Casimír von Paszthory); Elegie (Egou Kornanth); Three Songs from Poems from Des Knaben Wunderhorn (Martin Spörk); Overture to a Play (Hermann Wittgenstein). 12.45 to 2.0 p.m., Concert of Light Music conducted by Josef Hölzer. 2.40, Time and Announcements. 2.45, Agricultural Talks. 3.5, Review of Books. 3.30, Chamber Music by the Mildner Quartet; String Quartet in A Minor, Op. 29 (Schubert); Slav Quartet in G (Glazunov). 4.30, Talk: Wonders of Nature in Arizona. 5.0, Concert by the Vienna Symphony Orchestra, conducted by Josef Hölzer. 6.30, Talk: A Visit to the Duchy of Luxembourg, with Illustrations. 7.0, Franz Nabl reads from his own Works. 7.30, Time, Sports Notes and Programme Announcements. 7.40, Recital of Songs by Contemporary Austrian Composers, by Anton Maria Topitz (Tenor). 8.15, Die Liebes-schaukel—Comedy in Three Acts (Lothar Ring). 9.45, News. 10.0, Concert from the Hotel Krantz-Ambassador.

WARSAW

212.5 kc/s, 1,411 metres; 120 kW.—9.55 a.m., Programme Announcements. 10.0, Divine Service from Cracow, 959 kc/s, 312.8 metres. 11.57, Time Signal and Chimes from St. Mary's Church, Cracow. 12.5 p.m., Programme Announcements. 12.10, Weather. 12.15, Concert by the Station Orchestra, conducted by S. Nawrot. Soloist: J. Paszkowska (Mezzo-Soprano). 2.0, Agricultural Talk from Cracow, 959 kc/s, 312.8 metres. 2.15, Weather. 2.20, Jazz on Gramophone Records. 2.45, Agricultural Dialogue. 3.5, Concert by the Adam Stromberg Orchestra. News in the interval. 4.0, Talks for Children. 4.30, Song Recital by Jean Popiel. 5.0, Talk: Impressions of the International Labour Conference. 5.15, Concert of Polish Music. 6.0, Popular Concert by the Poznan Opera House Orchestra, conducted by P. Tyllia, relayed from Ciechocinek. 6.35, Programme Announcements. 6.40, Miscellaneous Items. 7.0, Dramatic Programme. 7.40, Answers to Technical Correspondence. 8.0, Concert by the Radio Orchestra, conducted by St. Nawrot. 8.50, Radio Journal. 9.0, Popular Programme from Lwów, 788 kc/s, 381 metres. 10.0, Dance Music from the Café Europe, Ciechocinek. In the intervals at 10.25, Sports Notes, and at 10.40, News.

ZURICH.—See Schweizerischer Landessender.

ALGIERS

824 kc's, 364 metres; 13 kW.—7.0 p.m., Concert of Oriental Music; 8.0, Financial News; 8.10, Shipping Notes; 8.15, Agricultural Report and Weather Forecast; 8.20, Songs from Opera; 8.35, News; 9.0, Time Signal; 9.2, Lottery Results; 9.15, Concert by the Small Station Orchestra. Soloist: M. Ménélla (Accordion). Overture, King Stephen (Beethoven); Mira la Bianca Luna (Rossini); Little Grey Home in the West (Lohr); Passepied (Chaminade); Selection from A Masked Ball (Verdi); Petite Suite Russienne (Pillois); Spring Song (Mendelssohn); Selection from Le Cœur et la Main (Lecocq); Foxtrot, You're the Cream in my Coffee (De Sylva). In an interval at 9.45, Accordion Solos. 10.30, News; 10.35, Xylophone and Musical Saw Recital; 10.55, News; 11.0 (approx.), Close Down.

ATHLONE

725 kc's, 413 metres; 60 kW. Relayed by Cork, 1,337 kc's, 224.4 metres.—1.30 to 2.30 p.m., Time Signal, Stock Exchange Quotations, Weather Report, and Gramophone Music; 6.0, Programme for Children; 6.45, News; 7.0, Gaelic Talk; 7.15, Poetry Recital by Jill Noone; 7.30, Time Signal; 7.31, Tchaikovsky Concert by the Station Orchestra; Soloist: A. J. O'Farrell (Baritone); 8.0, Rimsky-Korsakov Concert by the Station Orchestra; Soloist: A. J. O'Farrell (Baritone); 8.25, Extracts from The School for Scandal—Play (Sheridan), by Mary O'Hea and Company; 8.55, Traditional Fiddle Solos by E. O'Higgins; 9.10, Irish Songs by Betty Byrne (Contralto); 9.25, Pianoforte and Violin Recital of Irish Music by V. Mackinnon and J. E. Malcolm; 9.45, Sponsored Programme; 10.30, Time Signal; 10.45, News, Weather Report, and Close Down.

BARCELONA

EJAJI, 860 kc's, 348.8 metres; 8 kW.—7.0 p.m., Trio Concert; 8.0, Request Gramophone Records; 8.20, Sports Notes; 8.30, Exchange Quotations and Talk in Catalan; 9.0, Gramophone Music and News; 10.0, Chimes from the Cathedral, Weather Forecast, Exchange Quotations, and Market Prices; 10.5, Humorous Review of the Week in Verse; 10.15, Concert of Sardanas; 11.0, Lina Concert by the Station Orchestra; Extracts from: (a) Los cadetes de la reina, (b) El niño judío, (c) Bonamor, and (d) Los calabres; 11.45, Dance Music relayed from the Casa Libre; In the interval at 12 Midnight, News; 1.0 a.m. (Tuesday), Close Down.

BARI

1,112 kc's, 269.8 metres; 20 kW.—8.0 p.m. News; 8.20, Giornale Radio and Weather; 8.30, Time and Announcements; 8.35 (approx.), Symphony Concert, conducted by Fritz Reiner (on Gramophone Records); Overture, Le baruffe chiozzotte (Sinigaglia); Three Pieces from the Tre commedie goldoniane (Malipiero): (a) La bottega del caffè, (b) Sior Todaro brontolón, (c) Le baruffe chiozzotte; Suite of Hungarian Dances (Weiner); Classical Symphony, Op. 25 (Prokofiev); Three Movements from the Suite Hary Janos (Kodaly); Overture, Tannhäuser (Wagner); After the Concert, Sly—Opera in Three Acts (Wolf-Ferrari); 10.55, News.

BASLE.—See Schweizerischer Landessender.

BELGRADE

697 kc's, 430.4 metres; 2.8 kW.—5.55 p.m., Time Signal and Programme Announcements; 6.0, Song Recital; 6.30, Talk; 7.0, Concert by the Station Orchestra; 7.50, Talk; 8.30, Programme relayed from Zagreb; 9.77 kc's, 307 metres; 10.30, News, Time Signal, and Dance Music, relayed from the Ratnicki Dom Restaurant.

BERLIN

DEUTSCHLANDSENDER, 183.5 kc/s, 1,635 metres; 60 kW.—2.0 p.m., Gramophone Records of the Berlin Philharmonic Orchestra; Overture, Egmont (Beethoven); Overture, Iphigenie in Aulis (Glück); Second Movement from the Fantastic Symphony (Berlioz); Venezia e Napoli (Liszt); Waltz from Der Rosenkavalier (R. Strauss); Hungarian March (Berlioz); 3.0, Talk for Women; Plants for the House and Balcony; 3.30, Weather and Exchange; 3.45, Review of Books; 4.0, See Breslau; 5.0, Educational Talk; 5.25, Topical Talk; 5.55, Sehnsucht an das Meer—Rhapsody (Paul Graener) by the Berlin String Quartet, Lotte Meusel (Songs) and Heinrich Steiner (Pianoforte); 6.0, A Poem; 6.5, Recital of Fritz Brandt Songs by Mia Neusitzer-Theissen; Wanderers Night; Ich bin der Welt abhanden gekommen; Der römische Brunnen; Liebesode; Der Wind klagt; Das Mädchen; 6.25, Dialoge on Spool; 6.50, Weather and Announcements; 7.0, Transmission for all German Stations relayed from Leipzig; 8.0, Epigrams; 8.5 (approx.), Concert by the Augmented Station Orchestra, conducted by Camillo Hildebrandt; Soloist: Nina Lützow (Songs); Overture, Oberon (Weber); Aria from Der Freischütz (Weber); Overture, Die Abreise (d'Albert); Two Arias, Sym-

MONDAY

JULY THE TWENTY-FOURTH

PRINCIPAL EVENTS OF THE WEEK:

AT HOME

NATIONAL An Eddie Pola revue.
LONDON REGIONAL Recital for two pianofortes; "Pastoral," a choral programme
MIDLAND REGIONAL Instrumental recital and a light orchestral programme.
WEST REGIONAL Police Band concert.

ABROAD

ATHLONE 8.25 p.m. Extracts from "The School for Scandal" (Sheridan), by Mary O'Hea and Company.
11.0 p.m. Lina concert by the Station Orchestra.
BARCELONA BUCHAREST 8.45 p.m. Recital on two pianofortes (works by Brahms and Chabrier).
BUDAPEST HUIZEN 9.5 p.m. Classical music by String Quartet.
(announced) 8.10 p.m. Concert by the V.A.R.A. Orchestra.
KONIGSWUSTERHAUSEN 8.5 p.m. (approx.). Concert by the Augmented Station Orchestra.
(Deutschland-sender)
LEIPZIG 9.0 p.m. Concert by the Symphony Orchestra.
PARIS 8.45 p.m. Pianoforte recital, by Isaac Cohen.
(Radio-Paris)
STOCKHOLM 9.0 p.m. Cello and song recital.
WARSAW 6.35 p.m. Maciejowsky pianoforte recital by the composer.

phonie Poem, Les Preludes (Liszt); 9.5, Comedy (Dario Niccodemi) with Music by Wolfgang Jacobi (arr. for Radio by Erik-Ernst Selchwach); 10.5, News; 10.30, See Stuttgart; In the interval at 10.35, Weather for Shipping; 11.0, Concert from Leipzig; 12 Midnight, Close Down.

BERLIN

WITZLEBEN, 715 kc's, 419.5 metres; 1.5 kW.—4.30 p.m., Concert, conducted by D. Knoch, from the Zoological Gardens; Triumphal March from Aida (Verdi); Overture, Mignon (Thomas); Waltz, Verschwänzte Liebe (Lincke); March, Scupper tabs (Knoch); Hungarian Dances Nos. 5 and 6 (Brahms); Potpourri of Marches, Alle mit uns (Männecke); 5.20, Dialogue on Religion; 5.40, Heinrich Zerkow reads from his own works; 6.0, Italian Ballad Opera for Soloists, Choir, and Pianoforte, Op. 20 (Kurt Boerne); 6.40, The Witzleben Station informs its listeners; 6.45, Topical Talk; 7.0, Transmission for all German Stations, relayed from Leipzig; 8.10, Recital of Swedish Songs by Marianne Möner (Soprano); 8.35, Vocal and Instrumental Concert; Scherzo from the Trio in E Flat, Op. 100 (Schubert); Trios for Two Sopranos and Contralto: (a) Sandmännchen, (b) Ich hab' die Nacht geträumt, (c) Ich fahr' dahin; Shepherd's Lament from the Pianoforte Trio in G Minor, p. 63 (Weber); Duets: (a) So wahr die Sonne scheint (Schumann), (b) Verrätene Liebe (Cornelius); Andante from the Pianoforte Trio in B Flat, Op. 99 (Schubert); Trios: (a) Ach, wie ist's möglich dann, (b) Am Brunnen vor dem Tore (Schubert); Scherzo from the Pianoforte Trio in B Flat, Op. 99 (Schubert); 9.20, Radio Report from the Orphanage at Rummelsberg; 10.0, Weather and News, followed by Dance Music from the Delphi-Palast; In the interval from 11.0 to 11.5, Talk: What they are talking about in Berlin; 12 Midnight, Close Down.

BERNE.—See Schweizerischer Landessender.

BEROMUNSTER. — See Schweizerischer Landessender.

BODEN.—See Stockholm.

BODO.—See Oslo.

BORDEAUX-LAFAYETTE

986 kc's, 304 metres; 13 kW.—7.30 p.m., News and Exchange; 7.35, Talk; Bordeaux, a Hundred Years Ago; 7.50, Charades and News; 8.0, Programme for Children; 8.15, Gramophone Concert; 8.45, Concert, relayed from the Casino, Vichy. (For Details See Strasbourg).

BRATISLAVA

1,076 kc/s, 279 metres; 14kW.—6.10 p.m., Concert of Chamber Music; Soloists: J.

Actardiell (Violin); B. Beza (Flute); L. Kratochvílová (Viola); Serenade in G Op. 141 (Reger); Partita for Flute and Viola, Op. 42 (Marteau); Serenade Op. 25 (Beethoven); 6.55, Talk for Housewives; 7.0, See Prague; 10.15 (approx.) Close Down.

BREMEN.—See Hamburg.

BRESLAU

923 kc's, 325 metres; 60kW. Relayed by Gleiwitz, 1,184 kc's, 253 metres.—2.0 p.m. Military Band Concert on Gramophone Records; 3.0, Market Prices; 3.25, Review of Books; 3.45, Talk; Wonders of the Technical World; 4.0, Concert by the Silesian Philharmonic Orchestra, conducted by Gerhard Ewald Rischka; Overture, The Merry Wives of Windsor (Nicolai); From Scandinavia (Juel-Fredriksen); Waltz (d'Ambrosio); Fantasia, From the Valleys and Mountains of Norway (Andersen); Im Hammersbach (Elgar); Waltz, Die Schöne von Valencia (Aberna); 5.0, Talk on German Culture; 5.15, Market Prices; 5.20 (approx.), Concert (cont.); Overture, Light Cavalry (Suppé); Potpourri, Lehariana (Geiger); Die kleine Kompanie (Ganglbauer); Selection from Der Opernhall (Heuberger); Pizzicato Serenade (Krome); Lagunen-Walzer (Joh. Strauss); 5.45, Topical Talk; 6.5, Talk: The Organisation of the German National Socialist Movement; 6.25, Richard Strauss Song Recital by Edith Baumert-Osadiuk (Soprano) Du meines Herzens Krönlein; All mein Gedanken; Heimkehr; Befreit; Zueignung; Ständchen; Hat' gesagt, behilf' nicht; Wiegenlied; Meinem Kinde; Mutter ständchen; 6.50, Weather and Announcements; 7.0, Transmission for all German Stations, relayed from Leipzig; 8.5 (approx.), See Berlin (Deutschlandsender); 8.30, See Hamburg; 10.0, Time and News; 10.20, Wireless, Technical Talk; 10.30, Talk: The Cinema and Photography; 10.50 (approx.), Close Down.

BRNO

878 kc's, 342 metres; 35 kW.—2.50 p.m., Concert by the Station Orchestra, conducted by Janota; Overture, Les Dragons de Villars (Maillart); Ballet Music from Faust (Gounod); Selection from Mignon (Thomas); Serenade for Strings, Pianoforte and Harmonium (Milič); Melancholy (Kostal); Moravian Dance (Konrad); 3.55, See Prague; 4.0, Interval; 5.45, Gramophone Music; 5.55, Talk for Boy Scouts; 6.5 Gramophone Music; 6.25, German Transmission; News, Readings; from Hamlet and Julius Caesar (Shakespeare) and Talk: Chemical Warfare; 7.0, See Prague; 7.10, Symphony No. 3 in D (Schubert) by the Station Orchestra, conducted by Janota; 7.40, See Prague; 8.50, Review; 9.10, See Prague; 10.30 (approx.) Close Down.

BRUSSELS (No. 1)

I.N.R., 590 kc's, 509 metres; 15 kW.—12 Noon, Extracts from Mignon—Opera (Thomas); 1.0 p.m., Journal Parlé; 1.10, Concert by the Small Station Orchestra, conducted by Leemans; Soloist: Desiré Monchet (Songs); Two Step, Angellino (Lopez); Valse des brunes (Ganne); Spanish Serenade (Laury); Three Songs; Extraete from Heather Bells (Wood); Waltz (Sykes); Selection from Gri-Gri (Lincke); 5.0, Dance Music, relayed from the Kursaal, Ostend; 6.0, Talk on Belgian Towns; Namur; 6.15, French Sonata Recital by Mm. Pitsch and Scharres; Sonata (Berlioz); Sonata (Fauré); 6.45, Le Grand Jüner—Sketch (Donnay); 7.0, Ballet Music from Marouf (Raboud), on Gramophone Records; 7.15, Talk: Professions and Callings; 7.30, Film Review; 8.0, Introductions and Variations on the Air Malbrunck s'en va-t-en-guerre—Play in Three Acts (Acharid), with Music by Aurie; 9.0, Concert, relayed from the Casino, Knocke; Soloist: Mue Flamout (Pianoforte); 10.30, Le Journal Parlé; 10.40, Dance Music, relayed from the Casino, Knocke.

BRUSSELS (No. 2)

N.I.R., 887 kc/s, 335.2 metres; 15 kW.— Programme in Flemish; 12 Noon, Concert by the Little Station Orchestra, conducted by P. Leemans; Romanian March (Volpatti); Second Little Suite (de Micheli); Serenata, A Napoli (de Cristoforo); Second Suite from L'Arlésienne (Bizet); Czardas for Violin (Monti); Song (Wood); Tango (Llossas); Foxtrot, Ein jeder hat mal Glick (Schubenberg); 1.0 p.m., Le Journal Parlé; 1.10, Lalo Concert on Gramophone Records; 5.0, Concert by the Station Symphony Orchestra, conducted by Arthur Meulemans; First Symphony (Beethoven); Overture, Hansel and Gretel (Humperdinck); Scherzo and March from A Midsummer Night's Dream (Mendelssohn); 5.45, Programme for Children; 6.30, Concert by the Little Station Orchestra, conducted by P. Leemans; Heroic Overture (Guillemin); Strauss Potpourri (Weber); Dance of the Dolls (Turina); Pianoforte Solo, Le roi des aulnes (Benad); Selection from Dalibar (Smetana); Piece (Weyst); Billy Possum (Thurban); 7.15, Talk; 7.30, Le Journal Parlé; 8.0, Concert by the Station Symphony Orchestra, conducted by Arthur Meulemans; Soloist: Octavie Belloy (Songs); Overture, The Magic Flute (Mozart); Suite No. 7 (Handel-Bayens); Fantasia appassionata (Van Boven); Songs (Van Durme); Flemish Rhapsody (Schonmaker); 8.45, Quartet in F (Haydn) on Gramophone Records; 9.0, Concert of Music by Van Durme by the Symphony Orchestra, conducted by Arthur Meulemans; Soloists: Godelieve Mahtys (Symphonic Poem, Hamlet); Sonata for Violin and Pianoforte; Extracts from the Ballet Anora; 10.0, Le Journal Parlé; 10.10, Operetta Music on Gramophone Records; Fantasia on the Tales of Hoffmann (Offelach); The Czarevitch (Lehar); The Country Girl (Moukcton); La Vie Parisienne (Offenbach); Folly to be Wise (Hupfeld); Clo-Clo (Lehar); and Trois jeunes filles nues (Moretti).

BUCHAREST

761 kc's, 394 metres; 12 kW.—5.0 p.m., Light Music and Romanian Music by the Ionescu-Gaina Orchestra; In an interval at 6.0, Radio Journal; 7.0, Reading; 7.20, Gramophone Music; 7.40, Educational Talk; 8.0, Quartet in A Flat on Gramophone Records; 8.30, Talk; 8.45, Recital on Two Pianofortes; Variations on a Theme o Haydn (Brahms); Trois valses romantique (Clabrier); 9.15, Programme relayed from the Piccadilly Restaurant; 9.45, Radio Journal.

BUDAPEST

545 kc's, 550.5 metres; 18.5 kW.—5.0 p.m. Concert of Marches by Famous Composer; 6.15, Reading; 6.45, Gypsy Music; 6.5 Reading; 8.15, Recital of Grieg Songs; 8.5 News; 9.5, Quartet Concert; Quartet in (Tchaikovsky); Quartet in A (Mozart); 10.2 News; 10.25, Gypsy Music from the Ca Ostende.

CASSEL.—See Frankfurt.

COPENHAGEN

1,067 kc's, 281 metres; 0.75 kW. Relayed I Kalmundborg, 200 kc's, 1,153 metres.— Noon, Time and Chimes from the Town Hall; 12.5 p.m., Singing Ensemble Concert relayed from the Hotel d'Angleterre; 2.0, Interv; 2.50, Talk for the Housewife; 3.0, Concert by the Station Orchestra, conducted by Walter Meyer-Radon; Soloists: Johan Grandlund (Songs); Fohner Jensen (Pianoforte); Overture, The Magic Flute (Mozart); Three Viennese Dances (Beethoven); Sel tion from The Barbered Bride (Smetana); Entry of the Guest into the Wartburg, fr Tannhäuser (Wagner); Waltz from Eug Oerghin (Tchaikovsky); Finlandia (Sibeliu); Five Danish Songs; Overture, Le Postil de Longjumeau (Adam); Oriental Su (Popy); Waltz (Lanner); Selection fr Countess Maritza (Kálmán); Gallop, Tie-T

JULY 24th

MONDAY

continued

from Die Fledermaus (Joh. Strauss), 5.0, Gramophone Music, 5.35, Exchange and Fish Market Prices, 6.10, Talk and Reading: Olaf Bull, 6.50, Weather Forecast, 7.0, News, 7.15, Time Signal, 7.50, Talk, 8.0, Chimes from the Town Hall, 8.5, Radio Report of a Visit to a Summer Holiday Camp at Jomsborg, 9.0, Concert of Scandinavian Music by the Station Orchestra, conducted by Walter Meyer-Radon; Overture, The Maid of Orleans (Söderman); Roco Variations, Bergensiana (Halvorsen); Elegy and Musette from King Christian II (Sibelius); Little Suite in A Minor for Strings (Nielsen); Norwegian Artists' Carnival (Svendsen), 9.50, Reading (Rudolf Schmidt), 10.20, News, 10.35, Mandoline Concert, conducted by Alberto Bracconi; March, Nur Fests (Fetras); Gavotte (Jesse); Barcarolle, Auf der Lagune (Lincke); Oriental March (Ritter); Melody (Albert); Russian Music, 11.15 (approx.), Close Down.

CORK.—See Athlone.

CRACOW

959 kc/s, 312.8 metres; 1.5 kW.—7.20 p.m., Miscellaneous Items and News, 7.35, Programme Announcements, 7.40 till Close Down, see Warsaw.

DANZIG.—See Heilsberg.

DRESDEN.—See Leipzig.

FECAMP

1,329 kc/s, 225.9 metres; 10 kW.—4.30 to 6.0 p.m., Programme in English by the I.B.C. 4.30, Programme for Children, 5.0, Light orchestral Concert for Chieftesther and Bogmor Listeners: Signature Tune; Spring Blossoms awaken (Lohr); Spanish Serenade (Herbert); Chinese Serenade (Herbert); Song, Forget me not (Rottler); Romance (Lohr); Salut d'Amour (Elgar); Song, Lay my head beneath a Rose (Faulkenstein); I kiss your lips (Rudolph); Selection from The Count of Luxembourg (Lehar), 5.30, Concert for Hastings and Eastbourne Listeners: Just humming along (Myers); Drifting down the Shalimar (Moll, Monaco); Song, Something came and got me in the Spring (Scholl); Weymouth Chimes (Hawgill); There's something about a Soldier (Gay); Song, Me and mine are doing fine (Woods); Hold me (Schuster); Butterflies in the Rain (Myers); Signature Tune, 6.0, Programme in French, 10.0 till Close Down, Programme in English by the I.B.C., 10.0, Dance Music by the Blue Mountainers (Electrical Transcriptions); Trumpets; Signature Tune; Lovable; Sailing on the Robert E. Lee; When we're alone; Gettin' sentimental; Babuna Mama (Gilbert); There's another empty saddle; If you were only mine (Newman); Can't we talk it over? Let's put out the lights (Hauptfeld); Was that the human thing to do? (Young); Moon (Miles); An Evening in Caroline (Donaldson); Mad about the Boy (Coward); You're my everything (Dixon); The Younger Generation (Coward); Moonlight, the Hambe and you (Mannheimer); Signature Tune, 11.0, Club Concert for Market Harborough Listeners—Part I, Orchestral Music: Signature Tune; Wine, Women and song (Strauss); A Birthday Serenade (Lincke); Song, The Doll's Song, from The Tales of Hoffmann (Offenbach); The Golden Musical Box (Krone); Song, Fairy Tales of Ireland (Coates); Air de ballet (Herbert); Wiener Praterleben (Translator), Part II—Instrumental Solos: In Vienna one night (Bordin); Song, Love me To-night (Crosby); Banjo Quartet: Snatches of Song (arr. Irmslaw); Pianoforte Solo: That futuristic lag (Bloom); The Blue Bird (Bordin); Tandoline Solo: Capriccio Mazurka (Arienza); Song, We just couldn't say goodbye (Woods); Dream Girl of Yesterday (Hauper), 12.5 a.m. (Tuesday), I.B.C. News Bulletin in English, 12.10 (approx.), Choral music: Selection of Leslie Stuart's Songs—Part I; O wasn't that a wide Ribber; Negro Love Song; Way Down South (Myddleton); Then the Dow is falling; Lady Chloe; Angle Drumis (Keteby), 12.30, Dance music: Signature Tune; Castles in the mid (Green); Forty-Second Street (Dubin Warren); Something came and got me in the Spring (Scholl); Shuffle off to Buffalo (Dubin Warren); Stormy Weather (Kocher); Hold me (Little); You've got me crying again (Newman); I can't remember (erlin); Signature Tune, 12.57, I.B.C. mid-night Melody, 1.0 (approx.), Close down.

GENSBURG.—See Hamburg.

GENOVA.—See Turin.

FRANKFURT

57 kc/s, 259.3 metres; 17 kW. Relayed Cassel, 1,220 kc/s, 245.9 metres; and ier, 1,157 kc/s, 259.3 metres.—1.30 p.m., omophone Concert of Operatic Music: erture, The Barber of Bagdad (Corme-); Aria from The Barber of Seville (Ros-); Romance from The Merry Wives of dsor (Nicolai); Selection from The- stersingers (Wagner), 2.0, News, 2.20, eal Talk, 3.0, Weather Report, 3.10, e and Exchange, 3.20, Musical Interlude, 3. Exchange, 4.30, See Langenberg, 4, Exchange, 6.0, A German Almanac, 6.10,

Programme to be announced, 6.25, Talk: The First German Emigration to America, 6.45, Review of the Day's Events, 6.50, Time and News, 7.0, Transmission for all German Stations, relayed from Leipzig, 8.5, See Berlin (Deutschlandsender), 9.0, Pianoforte Recital by Gertraud Dirrig: Three Sonatas (Searlatti); Thirty Two Variations in C Minor (Beethoven); Ecossaises (Beethoven); German Danes (Schubert), 9.50, Historical Programme (arr. Dr. Arthur Pfeiffer), 10.15, Time and News, 10.50 See Stuttgart, 12.30 a.m. (Tuesday), Close Down.

FREDRIKSSTAD.—See Oslo.

FREIBURG.—See Stuttgart.

GENEVA.—See Radio-Suisse Romande.

GENOA.—See Turin.

GLEIWITZ.—See Breslau.

GOTEBORG.—See Stockholm.

GRAZ.—See Vienna.

HAMAR.—See Oslo.

HAMBURG

Call ha (in Morse), 806 kc/s, 372 metres; 1.5 kW. Relayed by Bremen, 1,112 kc/s, 269.8 metres; Flensburg, 1,319 kc/s, 227.4 metres; Hanover, 530 kc/s, 566 metres; and Kiel, 1,292 kc/s, 232.2 metres.—6.0 p.m., Bunte Stunde, 6.45, Exchange and Weather, 7.0, Transmission for all German Stations, relayed from Leipzig, 8.0 (from Bremen), Selected Trio, Op. 58 (Hugo Kahn), 8.30, Variety Programme, 10.0, Time and News, 10.20, Radio Report of the German Gynastic Festival from Stuttgart, 10.40 (from Kiel), Serenade, conducted by Heinrich Licht; Triumphal March, Evyiva-Verdi (Zimmer); Overture, Mantred (Schumann); Intermezzo, La Chase (Gossec); Waltz, Roses from the South (Joh. Strauss); Ballet Suite, Faun and Elfeurigen (Kark); Spielfischchen (Portnov); Waltz Potpourri, Die Zeitlupe (Geister); Selection from The Mikado (Sullivan); Hungarian Triumphant March, Attila (Fueick).

HANOVER.—See Hamburg.

HEILSBERG

1,085 kc/s, 276.5 metres; 60 kW. Relayed by Danzig, 662 kc/s, 453.2 metres.—1.5 to 2.20 p.m., Gramophone Concert. In the intervals at 1.20 and 2.0, News, 3.0, Market Prices, 3.30 (from Danzig), Programme for Children, 4.0, Police Band Concert, conducted by Ernst Stiebertz, relayed from the Kurgarten, Zoppot, Prinz Arndt-Marsch (Höge), Overture, Der Königsleutnant (Til); Selection from Mignon (Thomas); Waltz, Alt-Wien (Krenser); Selection from The Mikado (Sullivan); Overture, Così fan tutte (Mozart); Hunting Chorus and Finale from the First Act of Der Wildschütz (Lortzing); Finale from Das Nachtlager von Granada (Lortzing); The Hill (Jensen); Potpourri of Marches (Waldschel), In the interval at 4.50 (approx.), Talk: Anniversaries of the Week, 5.50, Talk: Ten Years of the Treaty of Lausanne, 6.15, Market Prices, 6.25 (from Danzig), Talk: Prussian Towns and German Culture, 6.50, Weather, 7.0, Transmission for all German Stations, relayed from Leipzig, 8.5, See Berlin (Deutschlandsender), 9.0, Two Narratives (Egon von Kaphner), 9.30, Pianoforte Recital by Frieda Jürgens, Andante con variazioni in F Minor (Haydn); Fantasia in D Minor No. 1 (Mozart); Romance, Op. 118 (Brahms); Impromptu in F Sharp (Chopin), 10.0 (approx.), Weather and News, 10.20, See Stuttgart.

HILVERSUM

Announced HUIZEN, 1,013 kc/s, 296.1 metres; 20 kW. (7 kW. up to 4.40 p.m.)— Programme of the Christian Radio Society (N.C.R.V.)—11.55 a.m., Gramophone Music, 12.10 p.m., Organ Recital by Jan Zwart; Funeral March (Guilmant); Chant scraphique (Guilmant); Prelude and Fugue in B Minor (Bach); Concerto in D Minor (Handel); Selection (Rheinberger); Sonata No. 4 (Mendelssohn); Prelude, Fugue and Variations (C. Franck); Prelude and Fugue in E Minor (Bach); Finale (Zwart), 1.40, Gramophone Music, 2.15, Talk on Horticulture, 2.55, Gramophone Music, 3.10, Interval, 3.40, Bible Reading, Baritone Songs and Organ Solos, 4.40, Gramophone Music, 6.10, Answers to Correspondents, 6.40, Police Announcements, 6.55, Religious Information, 7.10, Answers to Correspondents, 7.40, Orchestral Concert, conducted by Burk, Overture, Girald (Adam); Selection from The Cid (Massenet); Equisses provinciales (Popy); Toccata and Andalone (Robinson); Minuet (Bolzoni); Overture, Le Roi d'Ys (Lalo); Selection from Il Trovatore (Verdi); Suite (Monsigny); Gavotte (Gossec); Selection from L'Amant jaloux (Grétry); Selection from Gustav et Pollux (Rameau); Minuet (Lully), In the intervals at 8.40, Talk, and at 9.30, News, 10.25, Gramophone Music, 11.10 (approx.), Close Down.

HORBY.—See Stockholm.

HUIZEN

Announced HILVERSUM, 160 kc/s, 1,875 metres; 8.5 kW.—Programme of the Workers' Radio Society (V.A.R.A.), 11.40 a.m., Concert by the Little V.A.R.A. Orchestra, conducted by Hugo de Groot. In the interval at 12.45 p.m., Gramophone Music, 1.40, Interval, 2.10, Organ Recital by t. Steyn, 2.40, Recitations, 3.10, Concert by the V.A.R.A. Orchestra, conducted by Hugo de Groot; Overture, The Gipsy Baron (Joh. Strauss); Air from Polenbut (Negbad); Indian Love Call (Friml); March from Püppen (Gilbert); Waltz from Eva (Lehar); Selection from Countess Maritza (Kalmann); Quadrille from La Belle Helene (Offenbach); Waltz from Die geschiedene Fran (Fall); March from The Merry Widow (Lehar), 4.10, Programme for Children, 4.40, Gramophone Music, 5.10, Concert by De Flicrefluiters, conducted by J. v. d. Horst, 6.10, Concert by the V.A.R.A. Orchestra, conducted by Hugo de Groot, 6.40, Organ Solos by Johan Jong; Selection from La Traviata (Verdi); Fahrt ins Blaue (Dostal), 7.10, Songs by Ria v. d. Spoel, 7.25, Violin Recital by M. N. de Klijn; suite (Feldhofer); Romanian Dance (Bartok-Szekely); Capitan Fracassa (Castellnuovo Tedesco); Tango (Albéniz-Kreisler); Scherzo brillant (Goscs); Caprice No. 20 (Paganini-Szymanowski); Gipsy Songs, Op. 11 (Espajo), In the interval at 7.40, S.O.S. Messages and News, 8.10, Concert by the V.A.R.A. Orchestra, conducted by Hugo de Groot Soloist; Ria v. d. Spoel (Songs), Selection from Lisola disabitata (Haydn); Song from Ariadne auf Naxos (Haydn); Suite from The Bartered Bride (Smetana), 8.50, Dramatic Programme, 9.10, Concert (cont'd.); Selection from Le roi d'Ys (Lalo); Illys (Ganne); Selection from Louise (Charpentier), 9.55, Gramophone Music, 10.25, Concert (cont'd.); March, Pomp and Circumstance (Elgar); English Dance (Grainger); Shepherd's Hey (Grainger); Bells across the Meadow (Keteby); Selection from The Mikado (Sullivan); March, Liberty Bell (Souza), 11.10, Gramophone Music, 11.40 (approx.), Close Down.

INNSBRUCK.—See Vienna.

KALUNDBORG.—See Copenhagen.

KIEL.—See Hamburg.

KLAGENFURT.—See Vienna.

KOSICE.—See Prague.

LAHTI

167 kc/s, 1,796 metres; 40 kW. Relayed by Helsinki, 815 kc/s, 368.1 metres.—6.15 p.m., Agricultural Report, 6.25, Pianoforte Solos by Jolli Arola, Barcarolle (Sibelius); Impromptu (Sibelius); Waltz (Sibelius); Waltz Caprice, Sarasatus (Pahungren), 6.45, Talk, 7.10, Concert by the Station Orchestra, 8.0, Dialogues, 8.20, Choral Concert, 8.45, News in Finnish, 9.0, News in Swedish, 9.15, Light Music, relayed from the Restaurant Kappeli, 10.0 (approx.), Close Down.

LANGENBERG

635 kc/s, 473 metres; 60 kW.—1.0 p.m., Concert by the Station Orchestra, conducted by Wolf, Soloist: Erich Hammacher (Pianoforte); Overture, Der Walfenschmied (Lortzing); Pianoforte Sonata in A (Schubert); Extract from the Dance Suite (Mannfred); Selection from La Bohème (Puccini); Auf stillem Waldespfad (Strauss); Invitation to the Dance (Weber); Memories (Dvorák); Dance (Dvorák); Selection from Oberon (Weber), In the interval at 2.0 (approx.), News, 2.30, Meat Market Prices, 3.0, Talk: Books to Read, 3.20, Talk: The German Language, 3.30, Market Prices and Time, 3.50, Programme for Children, 4.30, Concert by the Fröhliche Fünf, 5.50, Talk for Women, 6.10, Concert of Folk Music, 6.30, Ode to Handicrafts (Albert Korn), with Music by Gerster, 6.45, Announcements, 7.0, Transmission for all German Stations, relayed from Leipzig, 8.0, News, 8.5, Topical Talk, 8.15, Concert by the Station Orchestra, conducted by Otto Julius Kühn, Soloist: Hans Woeke (Songs), March from Die Schatzkammer des Inka (Lortzing); Aria from Der Wildschütz (Lortzing); Prelude to Act III of Tannhäuser (Wagner); O Star of Eye, from Tannhäuser (Wagner); Ballet Music from William Tell (Rossini); Figaro's Aria from The Barber of Seville (Rossini); Prelude to Ernani (Verdi); Aria from La Traviata (Verdi); Waltz, Erinnerung an Baden-Baden (Komzak); German Folk Songs for Strings (Kissmeyer); Märkische Suite (Kamm); Overture, Das Modell (Suppé); Selection from Der Bettelstudent (Millöcker); Potpourri of Johann Strauss' Waltzes (E. Strauss); Hitler March (Frühling); March, S.A. marschiert (Schedel), 10.0, News, 10.30, Opera and Dance Music on Gramophone Records, 12 Midnight, Close Down.

LAUSANNE.—See Radio-Suisse Romande.

LEIPZIG

769.9 kc/s, 389.6 metres; 120 kW, and Dresden, 941 kc/s, 319 metres.—1.15 p.m.,

Gramophone Concert, 2.0, News, 2.10, Art and Film Review, 2.20, Labour Market Review, 2.30, Dialogue for Women, 3.0, Ballet Music on Gramophone Records, 4.0, Concert from Bad Elster, by the Platen Municipal Orchestra, conducted by Hans Sach; Overture, The Merry Wives of Windsor (Nicolai); Ballet Music from Undine (Lortzing); Selection from The Valkyries (Wagner); Miniature Suite No. 1 (Rebikov); Waltz, Nachtschwärmer (Zihrer); Potpourri, Musikalische Täuschungen (Schreiner); Intermezzo, Frauenther Porzellanpüppen (Lipek); Selection from The Merry Widow (Lehar), In the interval at 5.0, Recitation, 5.50, Exchange, Weather and Time, 6.0 (from Dresden), Talk, 6.25, Talk: Women and Labour Service in the New Germany, 6.50, Events of the Day, 7.0, Transmission for all German Stations; Preussengeist-Drama (Paul Ernst), 8.0, Political Announcement, 8.5, Song Recital by Wilhelm Bauer; Songs by Schöck; (a) Frühlingsruhe, (b) Auf ein Kind, (c) Abendwolken; Songs by Schumann; (a) Lied eines Schmiedes, (b) Kommen und Scheiden, (c) Der frohe Wandersmann; Five Songs from Gesänge an Gott (Haas), 8.30, Talk: The Hungarian Defeat in 933, 8.55, Agricultural Notes, 9.0, Concert by the Symphony Orchestra, conducted by Hilmar Weber; Soloist: Fritz Wawrowsky (Cello); Overture, Scherzo and Finale, Op. 52 (Schumann); Roco Variations for Cello and Orchestra (Tchaikovsky); Symphony No. 2 (Fuchs), 10.15, News, 10.35, See Stuttgart, 12.40 (from Dresden), Orchestral Concert, conducted by Bruno Schestak; Overture, Mithridates (Mozart); Gavotte (Handel); Suite (Halvorsen); Waltz, Delirien (Strauss); Lullaby (Schestak); Consolation (Schestak); Potpourri, Strauss-Milöcker-Suppe (Zihrer), 12.30 a.m., Gramophone Concert, 1.15, O alte Burschenherrlichkeit A Summer Evening on the Radeisburg; Musical and Literary Programme, 2.45, Close Down.

LINZ.—See Vienna.

LUXEMBOURG

252 kc/s, 1,191 metres; 200 kW. Italian Programme.—7.30, Concert by the Station Orchestra, conducted by Henri Pensis, 8.10, Weather, 8.15, Italian Song Recital by M. Schoekmel (Tenor), Caro mio ben (Giordano); Arias from: (a) Lucia di Lammermoor (Donizetti), (b) I Pagliacci (Leoncavallo), (c) Rigoletto (Verdi), (d) André Chénier (Giordano), (f) Tosca (Puccini), In the interval at 8.30, Talk in Italian, 8.50, News in French, 9.15, Concert by the Station Orchestra, Overture, Peter Schmoell (Weber); Suite No. 1 from L'Arlesienne (Bizet); Murrcludes Liftehen (Jensen); Selection from The Geisha (Jones); Tango (Eysold); Réverie du soir (Saint-Saëns); Czarda No. 8 (Michele), In the interval at 9.45, News in German, 10.20, Dance Music on Gramophone Records.

LWOW

788 kc/s, 381 metres; 16 kW.—7.20 p.m., Miscellaneous Items, 7.40, See Warsaw, 8.0, Gramophone Music, 8.10, Answers to Technical Correspondence, 8.20 till Close Down, See Warsaw.

MADRID

EAJ7, 707 kc/s, 424.3 metres; 2 kW.—8.0 p.m., Chimes, Exchange and Radio Journal, 8.20 (approx.), Tenor Song Recital by Francisco Diaz Ejarque and Recitations by Antonio Fernández Caro, 9.15, News, 9.30 (approx.), Close Down.

MALMO.—See Stockholm.

MILAN

VIGENTINO, 662 kc/s, 453.2 metres; 4 kW.—8.45 p.m. till Close Down, See Rome.

MORAVSKA-OSTRAVA

1,137 kc/s, 263.8 metres; 11 kW.—6.5 p.m., Talk, 6.15, See Prague, 10.15 (approx.), Close Down.

MOSCOW

TRADES UNION, 230 kc/s, 1,304 metres; 100 kW.—2.15 p.m., Literary Programme, 2.45, Weather, 3.0, Concert, 3.45, Weather, 4.0, Talk, 4.30, Literary Programme, 5.30, Programme for Children, 6.30, Concert by the Symphony Orchestra and Soloists, conducted by Nebelkin, 9.0, News, 9.30, Programme Announcements, 9.55, Chimes, and Press Review.

MOTALA.—See Stockholm.

MUHLACKER.—See Stuttgart.

MUNICH

563 kc/s, 533 metres; 60 kW. Relayed by Augsburg and Kaiserslautern, 536 kc/s, 560 metres.—4.30 p.m., See Langenberg, 5.45, Talk for the Younger Generation, The Work of a Medical Student, 6.5, Reading (Hans Günther), 6.25, Recital of Sixteenth and Seventeenth Century Songs by Alfred Oberlindorfer (Baritone), 6.45, Time, Weather and Agricultural Notes, 7.0, Transmission for all German Stations, relayed from Leipzig, 8.0, Concert of the

JULY 24th

MONDAY

continued

Unfamiliar Mozart Music, conducted by Fritz Buehner: March in D; Soprano Aria, with Orchestral Accompaniment, from Dir, Seele des Weltalls; Two Minnets for Chamber Orchestra; Divertimento in F, Op. 13. 8.35, Summer Festivals near Munich—Musical Radio Sequence (Schroeder-Justin) by a Peasant Orchestra and Soloists. 9.35, Dance Music by the Small Station Dance Band. 10.30, See Stuttgart. 10.50, Time and News. 11.10, Concert by the Paepke Quartet; Soloists: Marya Neizel (Mezzo-Soprano) and Emil Ferstl (Double Bass); String Quartet No. 4 in C (Dittersdorf) Three Songs with String Quartet Accompaniment (Pizzetti); String Quartet in G, Op. 77 (Dvorak). 12 Midnight (approx.). Close Down.

NAPLES.—See Roma.

NOTODDEN.—See Oslo.

OSLO

277 kc/s, 1,083 metres; 60 kW.—Relayed by Fredriksstad, 815 kc/s, 368.1 metres; Hamar, 522 kc/s, 574.7 metres; Notodden, 671 kc/s, 447.1 metres; Porsgrund, 662 kc/s, 453.2 metres; and Rjukan, 671 kc/s, 447.1 metres.—5.30 p.m., Concert of Chamber Music, 6.30, Topical Talk, 7.0, Advertising Notes, 7.15, Weather and News, 7.30, Sonata for Violin and Piano (Debussy), 8.0, Time Signal and Pianoforte (Liszt), 8.1, Harp Solos by Oscar Bartlun, Fantasia, Op. 95 (Saint-Saens); Serenade (Hasschuan); Valse Caprice (Verdide), 8.20, Recitation, 8.45, Song Recital, 9.10, Political Review, 9.40, Weather and News, 10.0, Topical Talk, 10.15, Talk, 10.45 (approx.), Close Down.

OSTERSUND.—See Stockholm.

PALERMO

558 kc/s, 537.6 metres; 3 kW.—8.0 p.m., Dop-lavoro Announcements, Tourist Report, Agricultural Notes, Report of the Royal Geographical Society and Giornale Radio, 8.20, Gramophone Music, in the interval at 8.30, Time and Announcements, 8.45, Gramophone Music, 9.45, Chamber Music; C. and M. Bentivegna (Violin and Pianoforte) and Palmieri (Tenor); Sonata in A for Violin and Pianoforte (Handel); from L'elisir d'amore (Donizetti), and (b) Spring Song, from The Valkyries (Wagner); Pianoforte Sonata, Op. 110 (Beethoven); Romance and Mazurka for Violin (Wieniawski); Songs from (a) Tosca (Puccini), and (b) Rigoletto (Verdi); Pianoforte Solo: Scena infantile (Casella); Violin Solos: (a) Spanish Serenade (Hlazimov-Kreiser), (b) Waltz (Chopin-Hubermann), 10.55, News.

PARIS

207.5 kc/s, 1,445.7 metres; 13 kW.—Time Signals (on 2,650 metres), at 10.26 a.m. and 11.26 p.m. (Preliminary and End-of Signals)—6.45 p.m., Le Journal Parle, 8.45, Concert, relayed from the Casino, Vichy. (For details, see Strasbourg). 11.15 (approx.). Close Down.

PARIS

POSTE PARISIEN, 914 kc/s, 328.2 metres; 60 kW.—7.0 p.m., Gramophone Music, 7.15, Le Journal Parle, 7.30, Hot Jazz on Gramophone Records, 8.0, Gramophone Music, 8.15, Interlude, 8.30, Songs Recital by Edmeu Querey, 9.0, Interlude, 9.15, Sponsored Programme, 10.15, News.

PARIS

RADIO PARIS, Call CFR, 174 kc/s, 1,725 metres; 75 kW.—7.30 a.m., Weather and Physical Culture, 7.45, Gramophone Music, 8.0, Weather and Press Review, 12 Noon, Request Gramophone Concert: Overture, William Tell (Rossini); Songs from La Mascotte (Andran); Bach and Laverne; La Tour Eiffel S.V.P.; A la poste; A la foire; Selection from Il Trovatore (Verdi); Extracts from Manon (Massenet); Ballet Music from Coppelia (Delibes). In the intervals at 1.0, Exchange, News and Weather, and at 1.30, Exchange, 2.0, Exchange, 3.45, Exchange and Market Prices, 4.45, Pianoforte Recital by Mlle. Darre, relayed from the American Conservatoire, Fontainebleau; Sonata in G minor (Schumann); Variations on a Theme of Paganini (Brahms); Berceuse (Chopin); Mephistowalzer (Liszt); Cordoba (Albeniz); Etude (Schlozer); Fire Flies (Philip); Arabesques on the Theme of Strauss—Blue Danube (Schulz-Evler), 7.0, Market Prices, Weather, Agricultural Notes, and Racing Results, 7.10, Gramophone Concert: Rhapsody, España (Albeniz); Sizzietta (de Blou); Ballade des gros dindons (Chabrier); Les Cigales (Chabrier); Waltz, Donau-wellen (Ivanovici); Chinese Serenade (Siedle); Paysage (Hahn); Si mes vers avaient des ailes (Hahn); Melody (Monti), 7.50, Commercial Notes and News, 8.0, Extracts from Ruse d'amour—Opera (Bordese-Lecocq), followed by Waltz (Glazunov) on Gramophone Records, 8.30, News, on Weather and Sports Notes, 8.40, Review by Paul Rehoux, 8.45, Pianoforte Recital by Isaac Cohen; Fantasia in F minor (Chopin); Romance in F Sharp (Schumann); The Lark (Glilka-Balakirev); Feu d'artifice (Debussy); L'isle joyeuse (Debussy), 9.15, Press Review and News, 9.30, Chamber Music on

Gramophone Records: Concerto for Sextet (Palla); La Gitana (Kreiser); Romance without Words (Faure); Improptu No. 3 (Faure); Danse profane (Debussy); Danse sacrée (Debussy); Variations (Chabuzac); Hebrew Song (Algazi); Vergebliches Ständchen (Brahms); Le concon (Daquin); La Timide (Rameau); Le Tambourin (Rameau).

PITTSBURGH

(KDKA), 980 kc/s, 306 metres; 45 kW.—Relayed by WBXK on 48.86 metres and 25.27 metres.—7.30 p.m., KDKA Home Forum, 8.0, Betty and Bob, from New York, 8.15, Words and Music, from New York, 8.45, Human Values—A Family of Three Hundred Children, by Father F. A. Retka, Holy Family Institute, 8.58, Baseball Scores, 9.0, Radio Guild—Drama, from New York, 10.0, Rhythms Kings, 10.15, Tarzan of the Apes, 10.30, The Singing Lady, from New York, 10.45, Little Orphan Annie, 11.0, Time Signal and Press News-Reeler, 11.15, Weather Report, 11.16, Sport Review, 11.23, I Bring a Song, 11.28, Announcements, 11.29, Temperate Report, 11.30, Pittsburgh Spotlights, 11.45 to 1.30 a.m., New York Relay, 11.45, Today's News—Lowell Thomas, 12 Midnight, Amos in Andy, 12.15 a.m. (Tuesday), Rollickers, 12.30, Rudy Vallee and his Hotel Pennsylvania Orchestra, 1.0, Clitquot Club Eskimos, 1.30, Potash and Perlmutter, 1.45 to 3.0, New York Relay, 1.45, Phil Sincok and the Ingram Shavers, 2.0, Sinclair—Minstrels, 2.30, Melody Moments, 3.0, The Silver Toppers.

PORSGRUND.—See Oslo.

PRAGUE

614 kc/s, 488.6 metres; 120 kW.—2.50 p.m., See Brno, 3.55 to 4.0, Exchange, 5.45, Gramophone Music, 5.55, Talk on the History of Bread, 6.5, Agricultural Report, 6.10, Gramophone Music, 6.15, Talk: Invention, 6.25, News in German, 6.30, German Transmission: Two Talks, 7.0, Chimes and News, 7.10, Concert of Schrammell Music, 7.40, Songs by Jiri Voldán, 8.5, Talk, 8.20, Violin Recital of Czech Music, 8.50, Radio Fenitlan, 9.10, Introductory Talk to the following: Trans-mission, 9.15, Act I of The Bartered Bride (Opera (Smetana) on Gramophone Records.—10.0, Time and News, 10.15, Talk in German: Czech Watering Places, 10.30 (approx.), Close Down.

RADIO-SUISSE ROMANDE

SOTTENS, 743 kc/s, 403 metres; 25 kW.; and Geneva, 395 kc/s, 760 metres.—12.28 p.m., Time from Neuchâtel Observatory, 12.30, News and Weather, 12.40, Gramophone Concert, 1.0, Financial News, 1.10, Gramophone Music, 2.0 to 3.28, Time from Neuchâtel Observatory, 3.30, Press Review, 4.0, Concert by the Radio-Suisse Romande Quintet, 5.30 to 7.0, Interval, 7.0, Talk for Women: Women and Medical Science, 7.30, Radio Interview, 8.0, Around the World in Forty-five Minutes—Variety Programme by Max Roland (Songs), Rudy Blag and the Broadcasting Screamers, 8.45, Concert by the Radio-Suisse Romande Orchestra, conducted by Robert Ehenard, 9.50, News and Weather, 10.0, Concert (contd.), 10.30 (approx.). Close Down.

REYKJAVIK

250 kc/s, 1,200 metres; 21 kW.—9.5 p.m., Musical Programme, 9.30, Weather Report, 9.40, Musical Programme and Announcements, 10.0, Chimes and News, 10.30, Reading, 11.0, Popular Music by the Radio Quartet, with Songs.

RJUKAN.—See Oslo.

ROME

Call 1RO, 680 kc/s, 441 metres; 50 kW.—Relayed by Naples, 941 kc/s, 319 metres, and 2RO, 11,810 kc/s, 25.4 metres, from 5.30 p.m.—1.0 to 2.15 p.m., Gramophone Concert. In the intervals from 1.30 to 1.45, Giornale Radio and Exchange, and at 2.0, Time and Announcements, 4.45, Children's Radio Announcements, 5.10, Weather, 5.15, Exchange and Giornale Radio, 5.30, Vocal and Instrumental Concert: Gina Seclini (Pianoforte), mental Concert: Gina Seclini (Pianoforte), and V. Brunetti and M. Socorsini (Soprano), and Angelo Parigi (Tenor); Pianoforte Solos: (a) Prelude and Toccata (Pick-Mangia-galli), (b) Prelude in C Sharp Minor (Rachmaninov); Duets for two Sopranos: (a) Song from Le contadine bizarre (Puccini), (b) Per valli, per boschi (Blangini); Tenor Solo: (a) Sentio nel cuore (Serafini), (b) Per la gloria (Bononcini), (c) E' l'April che torna a me (Giordano); Pianoforte Solos: (a) Cordoba (Albeniz), (b) Hungarian Rhapsody No. 12 (Liszt); Duets for two Sopranos: (a) Mi balza in petto (Gabbusi), (b) Song (Rubinstein), 6.40 (Naples), Shipping and Sports Notes, 6.50, Agricultural and Popolavoro Notes, 7.10, Tourist Report, 7.20, News in Foreign Languages, 7.40, Giornale Radio, 8.0, Time and Announcements, 8.5, Gramophone Music, 8.30, Giornale Radio and Sports Notes, 8.45, Variety Programme. In the interval, Talk

on Neapolitan Folklore, 10.55, Giornale Radio.

SALZBURG.—See Vienna.

SCHENECTADY

WGY, 790 kc/s, 379.5 metres; 50 kW.—Relayed at intervals by W2XAF on 31.48 metres; and by W2XAD on 19.56 metres.—9.0 p.m., Book News by Levere Fuller, 9.15 to 10.0, New York Relay, 9.15, Winters and Weber (Organists), 9.30, Soloist, 9.45 to 10.0, Lady Next Door, 12.45 a.m. (Tuesday), Stock Reports and Baseball Scores, 1.0, Soconylund Sketch, from New York, 1.30, Dramatised Penny, 1.45 to 3.30, New York Relay, 1.45, Ferde Grofe's Orchestra, 2.0, A. and P. Gypsies, 2.30, Musical Programme, 3.0, Contented Programme, 3.30, Ship of Joy, from New York, followed by Programme Resumé.

SCHWEIZERISCHER LANDESENDER

BEROMUNSTER, 653 kc/s, 459 metres; 60 kW.—Basle, 1,229 kc/s, 244.1 metres, and Berne, 1,220 kc/s, 245.9 metres.—6.15 a.m., Gymnastics, 6.35, Interval, 11.59, Time Signal from Neuchâtel Observatory and Weather, 12 Noon (from Basle), Cigány Music on Gramophone Records, 12.30 p.m., Time and News, 12.40 (from Basle), Popular Music on Gramophone Records, 1.25 (from Basle), Time and News, 1.35 (approx.), Interval, 5.0 (from Berne), Programme for Women, 5.30 (from Berne), Popular Concert on Gramophone Records, 6.30 (from Basle), Wilhelm Kiefer reads from his Novel: Pesantilli, the Tale of a Nigger, 7.0, Time and Weather, 7.5, Gramophone Music, 7.30 (from Basle), Elementary Italian Lesson, 8.15, Overture, Fingal's Cave (Mendelssohn) on Gramophone Records, 8.30 (from Basle), Mädelchenlieder (Huber), 9.0, News, 9.10 (from Basle), Kammermusik—Comedy in Three Acts (Ilgenstein), 10.15 (approx.), Close Down.

SOTTENS.—See Radio-Suisse Romande.

STOCKHOLM

689 kc/s, 436 metres; 55 kW.—Relayed by Boden, 244 kc/s, 1,229.5 metres; Göteborg, 932 kc/s, 322 metres; Hörby, 1,160 kc/s, 257 metres; Motala, 221.5 kc/s, 1,354.4 metres; Östersund, 389 kc/s, 770 metres; and Sundsvall, 554 kc/s, 542 metres.—5.5 p.m. (from Göteborg), Folk Music, 5.45, Radio Report, 6.0, Gramophone Music, 6.55, Talk, 7.30, A Comedy (Marib), 9.0, Cello and Song Recital by Hans Bottermund and Lisa Nilsson; Cello Concerto in D (Haydn); Songs, 10.0, Concert of Light Music, conducted by Hjalde Duvander, relayed from Malmö, 1,301 kc/s, 231 metres, 11.0 (approx.), Close Down.

STRASBOURG

869 kc/s, 345 metres; 11.5 kW.—11.30 a.m., Gramophone Concert, 12.45 p.m., News, 1.0, Time, 1.1, Exchange, 1.5 to 2.0, Orchestral Concert, conducted by Maurice de Villiers, 3.30, Gala Concert, relayed from the Casino, Vichy; Conductor, Bronnlae; Overture, Die Fledermans (Joh. Strauss); Norwegian Carnival (Sveunden); Suite, Fête galante (Laocme); Extracts from Werther: (a) Prelude, (b) Clair de lune (Massenet); Selection from Romeo and Juliet (Gomrod); Concert Mazurka (Pfeiffer), 5.0, Gramophone Music, 5.15, Orchestral Concert, conducted by M. Roskam; A Hungarian Comedy Overture (Keler-Béla); Waltz, Les Fleurs (Waldteufel); Selection from Eva (Lohar); Intermezzo (Siede); March, The Entry of the Gladiators (Fucik), 6.0, Literary Review, 6.15, Talk: Across Lorraine, 6.30, Orchestral Concert, conducted by Maurice de Villiers; Symphony in A Flat (Mozart); Overture, Coriolanus (Beethoven); Invitation to the Waltz (Weber); Hungarian Rhapsody No. 2 (Liszt), 7.30, Time, 7.31, News, 7.45, Gramophone Concert, 8.15, Press Review in French, Lottery Results and Announcements, 8.45, Orchestral Concert, relayed from the Casino, Vichy; Conductor, Paul Pary; Soloist, Jacques Thibaud (Violin); The Pathetic Symphony (Tchaikovsky); Violin Concerto in E (Bach); Cydalise et le Chevrepié (Pierné); Spanish Symphony (Lalo); La Valse (Ravel); After the Concert, Press Review in German, 11.15 (approx.), Close Down.

STUTTGART

MUHLACKER, 832 kc/s, 360.5 metres; 60 kW.—Relayed by Freiburg, 527 kc/s, 570 metres.—12 Noon, Orchestral Concert, conducted by Karl Assmus, relayed from Baden-Baden, Overture, Figaro (Mozart); The German Dances (Bortkiewicz); Ballet Suite, The Arabian Nights (Bortkiewicz); Ein Immortellenkranz auf Lortzian (Mascagni); Abumblatt (Wagner); German Waltz Reminiscences of Bayreuth, on Gramophone Records, 2.0, Concert arranged by the Post Office, 2.30, Spanish Lesson, 3.0 to

3.30, Elementary English Lesson, 4.30, See Langenberg, 5.45, Operetta Music on Gramophone Records, 6.35, Time and News, 7.0, Transmission for all German Stations, relayed from Leipzig, 8.0, Comrades of the Mountains—An Alpine Programme, 9.0, Recital of Modern Italian Songs by Agnes von Spetzler (Soprano); I pastori (Pizzetti); La madre al figlio lontano (Pizzetti); E se un giorno tornasse (Respighi); Le nebbie (Respighi); Folk Song (Giannina); Il prepio (Rota); Six Folk Songs (Veretti), 9.40 (from Freiburg) Portrait Recital (Her-mann Burtel), 10.10, Time and News, 10.30, The Fifteenth German Gymnastic Festival, Report of the University Championships and the First German Police Gymnastic Championships, 10.50, Serenade by the Station Orchestra, conducted by Gustav Görllich, 12.30 a.m. (Tuesday), Close Down.

SUNDSVALL.—See Stockholm.

TRIESTE

1,211 kc/s, 247.7 metres; 10 kW.—5.10 p.m. till Close Down, See Turin.

TRONDHEIM.—See Oslo.

TURIN

1,096 kc/s, 273.7 metres; 7 kW.—Relayed by Milan, 905 kc/s, 331.5 metres; Genoa, 959 kc/s, 312.8 metres, and Florence, 699 kc/s, 500.8 metres.—5.10 p.m., Orchestral Concert, 6.0 to 6.5, Weather, 7.0, Time and Tourist Report, and Gramophone Records of Light Music, 7.20, News in Various Languages, 7.40, Gramophone Music, 8.0, News and Weather, 8.15, Sponsored Concert, 9.15, Chamber Music, 10.15, Mandoline Concert, 11.0, Giornale Radio.

VATICAN CITY

15,120 kc/s, 19.84 metres (Morning), and 5,969 kc/s, 50.26 metres (Evening); 10 kW.—11.0 to 11.15 a.m., Religious Information in Italian, 8.0 to 8.15 p.m., Religious Information in Italian.

VIENNA

581 kc/s, 517 metres; 100 kW.—Relayed by Graz, 852 kc/s, 352.1 metres; Innsbruck, 1,058 kc/s, 283 metres; Klagenfurt, 662 kc/s, 453.2 metres; Linz, 1,220 kc/s, 245.9 metres; and Salzburg, 1,373 kc/s, 218.5 metres.—12 Noon, Concert by the Vienna Symphony Orchestra, conducted by Josef Holzer. In an interval at 1.0 p.m., Time, Weather and News, 2.0 to 3.0, Interval, 3.0, Time, Weather and Exchange, 3.20, Reading (Maria Thomas), 3.30, Reading (Helene Richter), 3.55, Gramophone Concert of Classical Suites, 4.35, Programme for Young People, 5.0, Talk: Salzburg in the Last Thirty Years, 5.25, Song and Piano forte Recital by Maria Czerny-Bednarh (Soprano) and Idu Fithys, Pianoforte Solo (Liszt); (a) Extracts from Consolations, (b) Petrarca Sonata in E, (c) Rhapsody No. 12 Songs (Wagner); (a) Schmerzen, (b) Träume Songs (R. Strauss); (a) Nacht, (b) Morgen (c) Zeugnug, (d) Cécilie, 6.5, Talk: Th Belvedere in Vienna, 6.30, Talk: A Walkin Tour through Spain, 7.0, River Melodies—Baritone Song Recital by Ernst Fischer, 7.21 Time, Weather and Programme Announcements, 7.35, Concert by the Vienna Chamber Music Orchestra, conducted by Rudolf Pelm Overture, Abu Hassan (Weber); Three Pieces from Abendstimmungen (Kienzl); Waltz Intermezzo (Pelm); Klagedes Gedenke (Dvorak); Koldtanz (Dvorak); Liebesheide Walzer (Brahms); Prayer from Das heilige Gold (Bittner); Waltz, Singedichte (Je Strauss); Albulblatt (Wagner); Marie walzer (Bayer); Overture, The Vintage Bride (Nedbal); Valse triste from The La John (Nedbal); March, Auf's Korn (Je Strauss), 9.15, Topical Talk, 9.30, News, 9.45, Gramophone Concert of Variety Mus-

WARSAW

212.5 kc/s, 1,411 metres; 120 kW.—11.57 a.m. Time Signal and Fanfare from St. Mar Church, Cracow, 12.5 p.m., Beethoven Music on Gramophone Records, 12. Polish Press Review, 12.33, Weather Repo 12.55, Dance Music on Gramophone Record 12.55, Radio Journal, 1.0 to 2.55, Intery 2.55, Gramophone Music, 3.5, News, 3. Announcements, 3.15, Gramophone Music, 3.25, Economic Notes, 3.35, Gramophone Music, 3.45, Traffic Report, 3.50, Gramophone Music, 4.0, Popular Concert by Poznan Opera House Orchestra, conde by Tyllia, relayed from Ciechocinek. Talk in French, 5.15, Recital by Mme. Bialkiewicz (Songs) and B. Szulc (Hunt Horn); Songs; Sonata in F, Op. 17, for Il ing Horn and Pianoforte (Beethoven); (a) O, del mio amato ben (Luff and), (b) Sozno (Respighi), (c) Luff canzona (Tosti), (d) Les Ruines (Faure), Song (Leubert), (f) Song (Weingartn 6.15, Talk: The State and Agricul 6.35, Maciejowski Pianoforte Recital by Composer: (a) Sonata, (b) Two Mazur (c) Impresions enfantines, (d) Piel Intermezzo and Fugue, 7.20, Miscellam Items, 7.35, Programme Announcements, 7.40, Reading, 8.0, Gramophone Music, Answers to Agricultural Correspondence 8.20, Radio Journal, 8.30, No, No Nam Musical Comedy in Three Acts (Young) relayed from a Theatre. In the inter News.

ZURICH.—See Schweizerischer Landessei

TUESDAY

JULY THE TWENTY-FIFTH

PRINCIPAL EVENTS OF THE WEEK:

AT HOME

- NATIONAL** H.M. the King opening the new Graving Dock, Southampton
- LONDON REGIONAL** An Eddie Pola revue.
- NORTH REGIONAL** Orchestral concert from Buxton.
- BELFAST** Grand opera; orchestral concert.

ABROAD

- BARCELONA BERO-MUNSTER** 11.15 p.m. Band concert from the Café Español.
- BRUSSELS (No. 1)** 7.30 p.m. Concert by the Viennese Boys' Choir, the St. Thomas' Choir and the Boys' Choir of the Sistine Chapel.
- COPENHAGEN HAMBURG** 6.30 p.m. Horn and pianoforte recital by Robert Rombaux (horn) and Raoul Paulet.
- HUIZEN (announced Hilversum)** 11.0 p.m. Dance music from the Nimb Restaurant.
- PARIS (Eiffel Tower)** 8.10 p.m. Contemporary music by Hamburg composers.
- STOCKHOLM STRASBURG** 7.45 p.m. "Le Grand Mogol," an operetta, by Audran.
- WARSAW** 8.30 p.m. Mozart pianoforte recital.
- 10.0 p.m. Chamber music.
- 8.45 p.m. Symphony concert, relayed from the Orangerie.
- 8.0 p.m. Light classical concert by the Station Orchestra.

BORDEAUX-LAFAYETTE

986 kc/s, 304 metres; 13 kW.—7.30 p.m., News and Exchange. 7.40, Talk for Women. 7.55, Lottery Results. 8.0, Talk. 8.15, News. 8.30, Concert by the Station Symphony Orchestra.

BRATISLAVA

1,076 kc/s, 279 metres; 14 kW.—2.50 p.m., Concert by the Station Orchestra, conducted by E. Dyk: Overture, Maritana (Wallace); Scenes alsaciennes (Massenet); Slav Fantasia (Schreiner); Flora Waltz (Leopold); March (Pellik); 3.55 to 4.0, See Prague. 5.45, Pianoforte Recital. 6.5, See Prague. 6.25, Gramophone Music. 6.45, Talk. 6.55, Talk for Housewives. 7.0, See Prague. 7.10, See Moravská-Ostrava. 7.40, Chromatic Accordion Recital of Slav Songs. 7.55, See Brno. 8.10, See Prague. 8.30, See Brno. 10.0, See Prague. 11.0 (approx.), Close Down.

BREMEN.—See Hamburg.

BRESLAU

923 kc/s, 325 metres; 60 kW.—Relayed by Gleiwitz, 1,184 kc/s, 253 metres.—1.0 p.m., German Pianoforte Music on Gramophone Records. 1.45, Time and News. 2.0, Gramophone Concert. 3.0, Agricultural Report. 3.30, Programme for Children. 4.0, Justus Hermann Wetzel Recital by Hans Joachim Andersen (Baritone), the Composer at the Pianoforte: All mein Gedanklein; Ich schlaf, ich wach; Das zerbrochene Ringlein; Weiss ich ein schönes Röslein; Wenn ich ein Vöglein wär; Was kann schöner sein als Wandern; Canon in E flat; Fugue in E Minor; Pianoforte Piece in F Sharp; Pianoforte Piece in E; Alpenpass, Gute Stunde; Reisehecher; Morgengetel; In Danc; Weg zur Geliebten. 4.45, Review of Technical Books. 5.0 (from Gleiwitz), Octet, Op. 166 (Schubert). 5.55, Agricultural Prices. 6.0, (approx.), Reading: The Silesian Frontier District. 6.20, Topical Report. 6.50, Weather for Farmers and News. 7.0, Transmissions for all German Stations, relayed from Stuttgart. 8.0, Military Band Concert, conducted by Fritz Hänsler; Kaiser Friedrich-Marsch (Friedemann); Overture, Norma (Bellini); Potpourri of Students' Songs (Kohlmann); Waltz, Weaner Madl (Ziehrer); Overture, Banditenstreich (Suppe); Geburtstagswünschen (Léneke); Paraphrase on the Song—Waldandacht (Nehf); Potpourri, Hurra, die Musik kommt (Zimmer); Gavotte, March, Für Deutschlands Waffenherr (Blankenburg). In an interval at 9.0, Announcements. 10.15, Time and News. 10.35, Review of Political Periodicals. 10.55, Concert of Light Music

by the Maletzki Orchestra, relayed from the Café Vateländ. 12 Midnight (approx.), Close Down.

BRNO

878 kc/s, 342 metres; 35 kW.—6.25 p.m., German Transmission: News, Talk on Hygiene and Agricultural Report. 7.0, See Prague. 7.10, See Moravská-Ostrava. 7.40, See Prague. 7.55, Talk: Moravia. 8.10, Gramophone Music. 8.30, From Town to Village, from Village to Town—Musical Programme. 10.0, See Prague. 11.0 (approx.), Close Down.

BRUSSELS (No. 1)

I.N.R., 590 kc/s, 509 metres; 15 kW.—12 Noon, Request Gramophone Records. 12.20 p.m., Violin Recital by Jean Dörner; Sonata in A (Vivaldi); Variations on a Theme by Corelli (Tartini-Kriesler); Andante and Finale from the Concerto in G (Vivaldi); Caprice viennois (Kreisler). 12.50, Overture, Tannhäuser (Wagner) on Gramophone Records. 1.0, Le Journal Parlé. 1.40, Concert by the Little Station Orchestra, conducted by P. Leemans: Ma Normandie (Berat); Piece (Diaz); La charité (Faure); Panis angelicus (Franck); L'ange sur la mer (Goublier); Auprès de ma blonde (Laluc); Pensée d'automne (Massenet); La chère maison (Baleroze); Legend of the Sage Bush (Massenet). 1.40, Pianoforte Recital by Sophie Tuyns: Etude en forme de valse (Saint Saëns); Corpus Christi (Albeniz); Eroica (Liszt). 5.0, Concert by the Radio Orchestra, conducted by Charles Walpot: Rhapsody, España (Chabrier); Venise (Pierlé); Napoli (Charpentier); Provence (Fourdrain). 5.30, Programme for Children. 6.5, Religious Address. 6.30, Horn and Pianoforte Recital by Robert Rombaux (Horn) and Raoul Paulet (Pianoforte). Horn Solos: (a) Villanelle (Dukas), (b) Cantecor (Büsser); Sonata appassionata op. 57 for Pianoforte (Beethoven). 7.15, Film Review. 7.30, Art Review and Talk for Women. 8.0, Concert by the Radio Orchestra, conducted by Charles Walpot. Soloist: Simone Galin (Songs). Overture, Véronique (Messager). Song, Waltz from Monsieur Beaucaire (Messager); Waltz, Pikanterien (Lehár); Vilja's Song from the Merry Widow (Lehár); Overture, Rose Marie (Friml); Indian Love Call from Rose Marie (Friml); Waltz, Gold and Silver (Lehár); Song from The Dance of the Dragonflies (Lehár); Ballet Music from Véronique (Messager). 8.45, Talk: The Working Woman and the Home. 9.0, Concert from the Kursaal Ostend. 10.30, Le Journal Parlé. 10.40, Waltz (Ravel) on Gramophone Records. 10.55, Christus Vincit (Liszt).

BRUSSELS (No. 2)

N.I.R., 887 kc/s, 338.2 metres; 15 kW.—Programme in Flemish.—12 Noon, Concert by the Little Station Orchestra, conducted by P. Leemans: Overture, The Cunning Peasant (Dvorák); Romantic Suite (Arnandola); Bird Songs at Eventide (Cotes); Gramophone Record, Aria from Mephistopheles (Boito); Selection from The Queen of Sheba (Gounod); Gramophone Record, Aria from Mephistopheles (Boito); Serenatella (Franchesi); Slow Foxtrot, Nino, l'acht mir einmal zu (Kaper-Jurmann); March, Signorina (Kaper-Jurmann). 1.0 p.m., Le Journal Parlé. 1.10, Gramophone Concert of Sound Film Songs. 5.0, Concert by the Symphony Orchestra, conducted by Arthur Meulemans: Bourrée fantasque (Chabrier); Perpetuum mobile (Joh. Strauss); Valse triste (Sibelius); Gramophone Records: (a) Extase (Ganne), (b) Salut d'amour (Elgar); Elegy (Massenet); March No. 1 (Meyerbeer). 5.45, Programme for Children. 6.30, Abraham Concert on Gramophone Records. 7.0, Accordion Solos on Gramophone Records. 7.15, Talk: The Organisation and the Meaning of the International Anti-Fascist and Pacifist Demonstration in Antwerp on July 30th. 7.30, Le Journal Parlé. 8.0, Concert by the Symphony Orchestra, conducted by Arthur Meulemans: S.A.R.O.V. Song (Walpot); Selection from Stradella (Flotow); Joyeuse marche (Chabrier); Songs: Overture, Maximilian Robespierre (Litolfé). After the Concert, On the Lighthouse—S.A.R.O.V. Monthly Music. 9.0, Concert by the Radio Orchestra, conducted by Charles Walpot: Overture, Zampa (Hérold); Songs, Waltz, Gold and Silver (Lehár); Turkish March (Mozart). 10.0, Le Journal Parlé. 10.10, Light Music on Gramophone Records.

BUCHAREST

761 kc/s, 394 metres; 12 kW.—5.0 p.m., Light Music and Romanian Music by the Motol Orchestra. In an interval at 6.0, Radio Journal. 7.0, Reading. 7.20, Gramophone Music. 7.40, Educational Talk. 8.0, Song Recital. 8.20, Concert by the Station Orchestra: March (Fueki); Waltz (Translaten); Overture, Don Pasquale (Donizetti); Selection from André Chenier (Giordano); By the Blue Hawaiian Waters (Kotelbey); Selection from Paganini (Lehar); Venetian Gondolas (Leemans); Serenade (Grieg); Air de ballet (Gillet). In an interval at 9.0, Talk. 9.45, Radio Journal.

BUDAPEST

545 kc/s, 550.5 metres; 18.5 kW.—5.30 p.m., Pianoforte Recital. 6.0, Reading. 6.30, Gramophone Music. 7.40, Reading. 8.0, Orchestral Concert of French Operetta Music. After the Concert: News, and Cigany Music from the Café Patria. 11.15, Light Music and Dance Music from the Café Bodo.

CASSEL.—See Frankfurt.

COPENHAGEN

1,067 kc/s, 281 metres; 0.75 kW.—Relayed by Kalundborg, 260 kc/s, 1,153 metres.—12 Noon, Time and Chimes from the Town Hall. 12.5 p.m., String Ensemble Concert, relayed from the Bellevue Strandhotel. 2.0, Interval. 3.30, Concert by the Rysdals Instrumental Ensemble: Overture, The Bohemian Girl (Balfe); Waltz from Faust (Gounod); Selection from The Magic Flute (Mozart); Minuet from Berenice (Handel); Moment musical (Schubert); Dance from Volund Smed (F. Henrichsen); Reading (A. S. M. Hutchison); Selection from The Little Princess (Rygaard); Melody from Anndin (Danning); Norwegian Dance in G (Grieg); Gavotte (Michailov); Intermezzo (Edelstein); Overture, A Waltz Dream (O. Strauss). 5.35, Exchange and Fish Market Prices. 6.20, Reading (Gustav Hetsch). 6.50, Weather and News. 7.15, Time signal. 7.30, Talk: Trade Protection. 8.0, Chimes from the Town Hall. 8.5, Relay from the Tivoli. After the Programme, News. 11.0, Dance Music, relayed from the Nimb Restaurant. In the interval at 12 Midnight, Time and Chimes from the Town Hall. 12.30 a.m. (Wednesday), Close Down.

CORK.—See Athlone.

CRAKOW

959 kc/s, 312.8 metres; 1.5 kW.—7.5 p.m., Talk: Old Cracow. 7.20, Miscellaneous Items and News. 7.35, Programme Announcements. 7.40 till Close Down, See Warsaw.

DANZIG.—See Heilsberg.

DRESDEN.—See Leipzig.

FECAMP

1,328 kc/s, 225.9 metres; 10 kW.—4.30 to 6.0 p.m., Programme in English by the I.B.C. 4.30, Programme for Children. 5.0, Orchestral Concert for Torquay and Exeter Listeners: Signature Time; Suppé Potpourri (arr. Morena); Pianoforte Solo: Polon-

ALGIERS

824 kc/s, 364 metres; 13 kW.—8.0 p.m., Financial News. 8.10, Shipping Notes. 8.15, Agricultural Report and Weather Forecast. 8.20, Symphony Concert on Gramophone Records. 8.40, Lottery Results. 8.55, News. 9.0, Time Signal. 9.2, Extracts from Operetta: (a) Brummel (Hahn), (b) La Vie Parisienne (Offenbach). 9.35, News. 9.45, Algerian Review. 10.0, Concert of Oriental Music. In an interval at 10.30, News. 10.55, News. 11.0 (approx.), Close Down.

ATHLONE

725 kc/s, 413 metres; 60 kW.—Relayed by Cork, 1,337 kc/s, 224.4 metres.—1.30 to 2.30 p.m., Time Signal, Stock Exchange Quotations. Weather Report and Gramophone Music. 6.0, Programme for Children. 6.40, News. 7.0, Gaelic Reading. 7.15, Poetry Recital by Peggie Wallace. 7.30, Time Signal. 7.31, Pianoforte Recital by Carmel Turner. 7.45, Baritone Solos by R. W. Cobbe. 8.0, Musical Comedy Melodies by Tom Madden and Company and the Station Orchestra. 9.15, Violin Solos by Daphne Garratt. 9.30, Talk. 9.45, Sponsored Programme. 10.30, Time Signal. 10.45, News. Weather Report and Close Down.

BARCELONA

EAJ1, 860 kc/s, 348.8 metres; 8 kW.—7.0 p.m., Trio Concert. 8.0, Request Gramophone Music. 8.30, Exchange. 9.0, Gramophone Music and News. 10.0, Chimes from the Cathedral, Weather Report, Messages to Seamen, Exchange, Market Prices and Sponsored Programme. 10.30, Concert by the Station Orchestra: March, Fest and Iron (Fueki); Duet, Nuit d'amour (Delmas); Gavotte and Musette (d'Ambrosio); Dance of the Merry Maseots (Kotelbey); Love's Springtime (Kadman); Minuet (Meyer). 11.15, Band Concert, conducted by R. Losada, relayed from the Café Español. In an interval at 12 Midnight, News. 1.0 a.m. (Wednesday), Close Down.

BARI

1,112 kc/s, 269.8 metres; 20 kW.—8.0 p.m. News. 8.20, Giornale Radio and Weather. 8.30, Time and Announcements. 8.35 (approx.), Choral and Orchestral Concert, conducted by Biagio Gramaldi. Part I: Choral Music. La festa die fiori—Poem for Choir with pianoforte Accompaniment: Abschied—for three Voices (Mendelssohn); Two popular songs for Four Voices (Prattella); (a) Ninna-nanna, (b) La faggiolata. Part II: Quintet Music. Dance, Asturiana (Pedrollo); in from La Wally (Catalani); Suite, Impression d'Orient (Amadei); Arabesque (Handel); Melody (Fiaccone); Selection from the Girl from the Golden West (Puccini); Mademoiselle Ulra (Allegria); Literary Report in the interval. 10.30, Gramophone Music. 10.55, News.

ASLE.—See Schweizerischer Landessender.

BELGRADE

7 kc/s, 430.4 metres; 2.8 kW.—5.55 p.m., the Signal and Programme Announcements, 1, Recital of Russian Songs. 6.30, 'Cello recital by Max Nemesan. Meditation from ois (Massenet); Rondo (Bocherini); votte No. 2 (Popper); Chanson villageoise (upper); Capriccio (Schubert). 7.0, Rk. 7.30, Concert of Operetta Music. 8.0, ogramme to be announced. 10.10, Time, ws and Concert by the Station Orchestra.

BERLIN

UTSCHLANDSENDER. 183.5 kc/s, 1,635 tres; 60 kW.—2.0 p.m., Gramophone Concert of Opera Music. 3.0, Talk for Young ple. 3.30, Weather and Exchange. 3.45, iding from the Works of Richard Volk-leander. 4.0, See Leipzig. 5.0, Talks Women. 5.25, Agricultural Talk. 5.35, ler Recital by Friedrich Wilhelm Hezel. Poems. 6.5, Accordion and Pianoforte ital. 6.30, Political Press Review. 6.50, ither and Announcements. 7.0, Transmis- for all German Stations, relayed from ttgart. 8.0, Epigrams. 8.5 (approx.), ce Music. 10.0, News. 10.25, See Berlin tziehen). 10.45, Weather for Shipping. Concert from Hamburg. 12 Midnight, e Down.

BERLIN

TZLEBEN). 715 kc/s, 419.5 metres; 1.5 —6.15 p.m., Review of Books. 6.40, The eben Station informs it—Listeners. . . Topical Talk. 7.0, Transmission for all an Stations, relayed from Stuttgart. See Heilsberg. 9.20, Humorous Diaes, Scenes, and Readings (arr. Herbert leht). 10.0, News. 10.20 (approx.), rd from the Tiergarten Sports Ground. (approx.). See Hamburg. In the id from 11.0 to 11.5, Talk: What they talking about in Berlin. 12 Midnight, e Down.

NE.—See Schweizerischer Landessender.

OMUNSTER. — See Schweizerischer dssender.

EN.—See Stockholm.

J.—See Oslo.

JULY 25th

TUESDAY

continued

LWOW

788 kc/s, 381 metres; 16 kW.—6.15 p.m., See Warsaw. 7.5, Answers to Correspondence. 7.20, Miscellaneous Items. 7.40, See Warsaw. 10.40, Gramophone Music. 11.0 (approx.), Close Down.

LYONS

LA DOUA (PTT), 644 kc/s, 465.8 metres; 1.5 kW.—6.30 p.m., See Strasbourg. 7.30, Radio Gazette for Lyons and the South-East. 8.30, Programme from Paris (Ecole Supérieure), 671 kc/s, 447.7 metres, followed by News.

MADRID

EAJ7, 707 kc/s, 424.3 metres; 2 kW.—8.0 p.m., Chimes, Exchange Radio Journal and Request Gramophone Music. 8.30, Talk by Joaquin España Cantos and Gramophone Music (contd.). 9.15, News and Political Review. 9.30 to 11.0, Interval. 11.0, Chimes. Time and Political Review. 11.15 (approx.). Extracts from Carmen—Opera (Bizet) on Gramophone Records. 1.15 a.m. (Wednesday), News. 1.30, Chimes and Close Down.

MALMO.—See Stockholm.

MILAN

VIGENTINO, 662 kc/s, 453.2 metres; 1 kW.—8.45 p.m. till Close Down. See Turin.

MORAVSKA-OSTRAVA

1,137 kc/s, 263.8 metres; 11 kW.—6.25 p.m., See Brno. 7.0, See Prague. 7.10, A Radio Play. 7.40, Gramophone Music. 7.55, See Brno. 8.10, See Prague. 8.30, See Brno. 10.0, See Prague. 11.0 (approx.), Close Down.

MOSCOW

TRADES UNION, 230 kc/s, 1,304 metres; 100 kW.—2.45 p.m., Weather. 3.0, Extracts from Il Trovatore and Otello (Verdi) on Gramophone Records. 3.45, Weather. 4.0, Talk. 4.30, Reading of Russian Literature. 5.30, Programme Announcements. 5.45, Talk. 9.0, News. 9.30, Programme Announcements. 9.55, Chimes and Press Review.

MOTALA.—See Stockholm.

MUHLACKER.—See Stuttgart.

MUNICH

563 kc/s, 533 metres; 60 kW., Relayed by Augsburg and Kaiserlautern, 536 kc/s, 560 metres.—4.30 p.m., Orchestral Concert, conducted by Erich Kloss. Rakoczy Overture (Kéler-Béla); Melody (Liszt); Suite, Old Styrian Dances (Pacherneitz); Neckereien und Ständchen (Plank); Selection from Die Fledermaus (Joh. Strauss); Intermezzo (Moret). 5.45, Talk: Ten Thousand Miles on Foot Round the Equator. 6.25, Talk: The Decline and Recovery of a German Town—Eylau. 6.45, Time, Weather, and Agricultural Notes. 7.0, Transmission for all German Stations, relayed from Stuttgart. 8.0, See Braslau. 9.0, Talk on National Socialism. 9.20, Concert by the Reich Symphony Orchestra, conducted by Ludwig K. Mayer. Soloist: Erich Kloss (Piano forte). Overture, Iphigenia in Aulis d. (Gluck); Pianoforte Concerto in E Flat (Liszt); Fifth Symphony in C Minor (Beethoven). 10.20, Time and News.

NAPLES.—See Rome.

NOTODDEN.—See Oslo.

OSLO

277 kc/s, 1,083 metres; 60 kW., Relayed by Fredrikstad, 815 kc/s, 368.1 metres; Hama 522 kc/s, 574.7 metres; Notodden, 671 kc/s, 447.1 metres; Porsgrund, 662 kc/s, 453 metres; and Rjukan, 671 kc/s, 447.1 metre.—5.30 p.m., Gramophone Music. 6.0, Fa for Housewives. 6.30, Programme to be announced. 6.45, Accordion Solos. 7 Advertising Notes. 7.15, Weather and New 7.30, Soprano Solos by Hjordis Ravnas; The Songs (Brahms); (a) Wir ewiger Liebe, (b) Wir wandelten, (c) Wanderer; Song (Grieg Song (Hamikainen); Aria (Verdi); El's Dream (Wagner). 8.0, Time Signal. 8 Talk: Magazines and Child Psychology. 8. Concert by the Station Orchestra, conducted by Olvin Fielstad. Soloist: Conrad Arne (Tenor). March, Pomp and Circumstance (Elgar); Overture, Tantalusquale (Stupp Shepherdes' Dance (Halvorsen); The Se (Grieg); Melody (Alnaes); Two So (Reidarson); Opera Potpourri (Schreiner Schatzwalzer (Strauss); Waltz Song from Arabian Nights (Strauss); Russian Fanta Wolfgangster (Henscher). 9.38, Agricultural Report, Weather and News. 1 Topical Talk. 10.15, Recitation. 1 (approx.), Close Down.

NAPLES.—See Rome.

NOTODDEN.—See Oslo.

OSLO

277 kc/s, 1,083 metres; 60 kW., Relayed by Fredrikstad, 815 kc/s, 368.1 metres; Hama 522 kc/s, 574.7 metres; Notodden, 671 kc/s, 447.1 metres; Porsgrund, 662 kc/s, 453 metres; and Rjukan, 671 kc/s, 447.1 metre.—5.30 p.m., Gramophone Music. 6.0, Fa for Housewives. 6.30, Programme to be announced. 6.45, Accordion Solos. 7 Advertising Notes. 7.15, Weather and New 7.30, Soprano Solos by Hjordis Ravnas; The Songs (Brahms); (a) Wir ewiger Liebe, (b) Wir wandelten, (c) Wanderer; Song (Grieg Song (Hamikainen); Aria (Verdi); El's Dream (Wagner). 8.0, Time Signal. 8 Talk: Magazines and Child Psychology. 8. Concert by the Station Orchestra, conducted by Olvin Fielstad. Soloist: Conrad Arne (Tenor). March, Pomp and Circumstance (Elgar); Overture, Tantalusquale (Stupp Shepherdes' Dance (Halvorsen); The Se (Grieg); Melody (Alnaes); Two So (Reidarson); Opera Potpourri (Schreiner Schatzwalzer (Strauss); Waltz Song from Arabian Nights (Strauss); Russian Fanta Wolfgangster (Henscher). 9.38, Agricultural Report, Weather and News. 1 Topical Talk. 10.15, Recitation. 1 (approx.), Close Down.

OSTERSUND.—See Stockholm.

PALERMO

558 kc/s, 537.6 metres; 3 kW.—8.0 p.m. Dopplavoro Announcements, Tourist Rep Agricultural Notes and Giornale Radio. Gramophone Music. In the interval at 11.0, Time and Announcements. 8.45, 1 (social)—Opera in Three Acts (Lacetti).

nise in A (Chopin); The Gingerbread Waltz (Humperdinck); Song: The Two Grenadiers (Schumann); In the Hall of the Mountain King (Grieg); Song of the Flea (Mussorgsky); Pianoforte Solo: Minuet in G (Paderevsky); Traum (Wagner). 5.30, Gramophone Concert for Plymouth and Devonport Listeners: Dance of the Nymphs (Bíroh); War Marching Songs (arr. Somers); A Radio Roundabout (Wark); War Marching Songs (arr. Somers); The Moment I saw you (Grey and Gay); The Clatter of the Clogs (O'Flynn); Signature Tune. 6.0, Programme in French. 10.0 till Close Down, Programme in English by the I.B.C. 10.0, Dance Music; Signature Tune; Please; Look who's here; Here lies love; It's winter again; How do you do, Mr. Brown; Everyone says I love you; Leave a little for me; My Heart; Cinderella (Sabarido); Always in my Heart; Cinderella's Wedding Day; Strange Interlude; Blues; The Knave of Diamonds; Overnight; The Juggler; Waltz, Play Fiddle Play; Signature Tune. 11.0, Club Concert for Ashbury-de-la-Zouche Listeners. Part I—Military Band Music; Signature Tune; Colonel Bogey (Alford); Song: Vikings and his Dinah (Traditional); Valse des abonnées (Drigo); In a Chinese Temple Garden (Ketelbey); Glow-Worm Idyll (Lincke); Cornet Solo: Carnival of Venice (Briccahdi); Song: D'ye Ken John Peel? (Traditional); March Past of the Brigade. Part II—Extracts from Musical Comedies; Selection from He Wanted Adventure (Waller and Tunbridge); Song: I give my heart, from The Dubarry (Millöcker-Mackeben); Duet: A Paradise for Two, from The Maid of the Mountains (Fraser-Simson); Selection from The Merry Widow (Lehár); Song: Live for Today, from the Maid of the Mountains (Fraser-Simson); Pianoforte Solo; Selection from Words and Music (Coward); Song: The Night was made for Love, from The Cat and the Fiddle (Kern); Selection from He wanted Adventure (Waller and Tunbridge). 12.5 a.m. (Wednesday), I.B.C. News Bulletin in English. 12.10 (approx.), Sunshine and Showers; Selection from Sunny (Kern); Butterflies in the Rain (Myers); The Clouds will soon roll by (Woods); Rain on the Roof (Ronell); My Sunshine is you (Stolz). 12.30, Dance Music; Signature Tune; I'm sure of everything but you (Wendling); Paradise (Clifford); Just a little Home for the Old Folks (Abert); My Extraordinary Gal (Shand); Young and Healthy (Dubin); Maybe I love you too much (Berlin); I guess I'll have to change my Plans; I wake up smiling (Leslie); Signature Tune. 12.57, I.B.C. Goodnight Melody. 1.0 (approx.), Close Down.

FLENSBURG.—See Hamburg.

FLORENCE.—See Turin.

FRANKFURT

1,157 kc/s, 259.3 metres; 17 kW., Relayed by Cassel, 1,220 kc/s, 245.9 metres, and Trier, 1,157 kc/s, 259.3 metres.—4.30 p.m., See Stuttgart. 5.45, Exchange. 6.0, Habs Henning Freiherr Grote reads from his own Works. 6.25, Talk: Questions of the Time. 6.45, Review of the Day's Events. 6.50, Time and News. 7.0, Transmission for all German Stations, relayed from Stuttgart. 8.5, See Langenberg. 9.0 to 10.20, See Munich. 10.20, Time and News. 10.40 (approx.), See Hamburg. 12 Midnight, Close Down.

FREDRIKSSTAD.—See Oslo.

FREIBURG.—See Stuttgart.

GENEVA.—See Radio-Suisse Romande.

GENOA.—See Turin.

GLEIWITZ.—See Breslau.

GOTEBORG.—See Stockholm.

GRAZ.—See Vienna.

HAMAR.—See Oslo.

HAMBURG

Call ha (in Morse), 806 kc/s, 372 metres; 1.5 kW., Relayed by Bremen, 1,112 kc/s, 269.8 metres; Flensburg, 1,319 kc/s, 227.4 metres; Hanover, 530 kc/s, 566 metres; and Kiel, 1,292 kc/s, 232.2 metres.—2.10, Concert of German Folk Music on Gramophone Records; Potpourri, Wenn Gott will rechte Ginst erweisen; A Sunday on the Ahn (Koschut); Mei Grossmütterla (Gümler); Hamburger Fährjung (Rothenburg); Alpenauzug (Schmalz-Kreuger); Bayerisches Reiterlied (Sumner); Rheinlandmiedel (Ostermann); Vom Rhein zur Donau (Riodel); Mir sah die Kaiserjäger (Mühlberger); Deutscher Sang (Hannemann). 3.0, Exchange Quotations. 3.40, Shipping News and Air Report. 4.0, See Leipzig. In the interval at 4.15, Talk relayed from Langenberg. 5.0, Talk on Melanesia. 5.15, Talk: Hidden Wisdom in German Fairy Tales. 5.30, Talk: The Armies of Foreign States. 5.50 p.m. (from Hanover). Bunte Stunde. 6.45, Exchange and Weather. 7.0, Transmission for all German Stations, relayed from Stuttgart. 8.0, Topical Talk. 8.10, Contemporary Music by Hamburg Composers. The Station Orchestra, conducted by José Ebenschütz. Passacaglia and Fugue for Full Orchestra (Her-

mann Erdlen); Music for Chamber Orchestra No. 1 (Gerhard Maasz); Der Eremit, from Drei Bäcklin Fantasien (Felix Woysch); Macedonian Suite (Siegfried Scheffler); Prelude to a Comedy (Ludwig Lürmann). 9.40, Reading from the Works of Karl Pünder. 10.10, Time and News. 10.30, Topical Talk. 10.40 (from Hanover), Orchestral Concert, conducted by Richard Grille. Overture, Carnival in Rome (Joh. Strauss); Ein Melodien-traum (Urbach); Ballet Suite (Blättermann); Traumbild (Blon); Rheinländer-Potpouri (Hannemann); Dreams on the Ocean (Gungl); Schelmentanz (Schebeck); March, Der Adler von Lille (Blankenburg).

HANOVER.—See Hamburg.

HEILSBERG

1,085 kc/s, 276.5 metres; 60 kW., Relayed by Danzig, 662 kc/s, 453.2 metres.—4.0 p.m., Police Band Concert conducted by Ernst Stieberitz, relayed from the Kurgarten, Zoppot. In the interval at 5.0, Review of Books on Politics. 5.45, Talk: Bee-keeping in Old Prussia. 6.15, Market Prices. 6.25, Talk for Workers. 6.50, Weather. 7.0, Transmission for all German Stations relayed from Stuttgart. 8.0, Government Announcements, followed by Weather and News. 8.10, Police Band Concert relayed from the Kurgarten, Zoppot. Conductor: Ernst Stieberitz. Overture, Oberon (Weber); Reminiscences of Johann Brahms (Stretton); Potpourri of Johann Strauss Music (Bolme); Intermezzo (Muzilli); March, Herr Gott, der Eisen wachsen liess (Brace); Melody (Poppy); Waltz, Ball an Bord (Kuhlehn); Zwölfhundertfünfzig Jahre deutschen Lebens (Schreiner); March, Brucker Lager (Krad). In the interval at 8.50, Radio Report from the Kurgarten. 9.35, Reading (Georg Büchner). 10.5, Weather and News.

HILVERSUM

Announced HUIZEN, 1,013 kc/s, 296.1 metres; 20 kW (7 kW up to 4.40 p.m.).— Programme of the Catholic Radio Society (K.R.O.). 11.55 a.m., Concert by the K.R.O. Boys. 1.40 p.m., Programme for Women. 2.40, Gramophone Music. 3.40, Concert by the Hilversum Children's Choir. 4.10, Gramophone Music. 4.40, Police Notes. 6.55, Talk: Communism in Russia. 7.15, Gramophone Music. 7.25, Talk. 7.40, Military Band Concert. 8.40, Gramophone Music. 8.50, Pianoforte Recital, Gramophone Music in the interval at 9.10. 9.40, Orchestral Concert (continued). 10.40, Gramophone Music. 11.40 (approx.) Close Down

HORBY.—See Stockholm.

HUIZEN

Announced HILVERSUM, 160 kc/s, 1,875 metres; 8.5 kW., Programme of the Algemeene Vereeniging Radio Omroep (A.V.R.O.). 11.41 a.m., Concert by the Rotterdam Orchestra. 12.25 p.m., Gramophone Music. 1.10, Concert (continued) and 2.10, Talk on Norway. 2.40, Pianoforte and Violin Recital, by Mrs. Fie Looijnt-Kooper (Pianoforte) and Henri Tibbe (Violin); Sonata in E minor (Mozart); Sonata in D major, Op. 12, No. 1 (Beethoven). 3.10, Gramophone Music. 3.40, Pianoforte and Violin Recital (continued); Adagio (Sinding); Sonata in F major, Op. 8 (Grieg). 4.10, Concert by a Children's Choir, conducted by Jacob Hamel. 4.40, Programme for Children. 5.10, Concert by Kovacs Lajos and his Orchestra. 6.40, Talk on Aviation. 7.10, Gramophone Music. 7.40, Time Signal. 7.41, News Bulletin. 7.45, Le grand Mogol—Operetta (Audran). 9.40, Gramophone Music. 10.40, News Bulletin. 10.50, Concert by Kovacs Lajos and his Orchestra. 11.40, Close Down.

INNSBRUCK.—See Vienna.

KALUNDBORG.—See Copenhagen.

KATOWICE

734 kc/s, 408 metres; 16 kW.—5.30 p.m., Violin Recital. 6.15, Programme from Warsaw. 7.10, Talk. With the Camera on Holiday. 7.25, Announcements and Gramophone Records. 7.55, Sports Notes. 8.0 till Close Down. See Warsaw.

KIEL.—See Hamburg.

KLAGENFURT.—See Vienna.

KOSICE.—See Prague.

LAHTI

167 kc/s, 1,796 metres; 40 kW., Relayed by Helsinki, 615 kc/s, 368.1 metres.—6.15 p.m., Song Recital by Sirkuu Runne. 6.40, Recitations. 7.5, Cello Solos by Albin Olverlund; Ali (Bach); Neapolitan Song (Casella); Romance (Becker); Serenade (Pjermé); Hungarian Rhapsody (Popper). 7.30, Talk. 7.55, Concert by the Station Orchestra; Overture, The Hebrides (Mendelssohn); Lullaby (Schumann); Hofballtänze

(Lanner); Minuet (Paderevsky); Selection from Paganini (Lehár). 8.45, News in Finnish. 9.0, News in Swedish. 9.15, Light Music, relayed from the Restaurant Kappeli. 10.0 (approx.), Close Down.

LANGENBERG

635 kc/s, 473 metres; 60 kW.—1.0 p.m., Orchestral Concert, conducted by Hugo Fliedner, relayed from the Parkhaus Hohenstein, Witten. Festjubil-Marsch (Blankenberg); Overture, Undine (Lortzing); Paraphrase on the Song, Verlassen bin I (Rehndel); Selection from Martha (Flotow); Intermezzo, Wenn die Rosen blühen (Siede); Rhapsody in B minor (Hartung); Waltz, Seid unschuldig Millionen (Strauss); Potpourri, Ein Opernalbum (Schreiner). In the interval at 2.0 (approx.), News. 3.0, Programme for Children. 3.30, Economic Notes and Time. 3.50, Political Announcement. 4.0, Talk: Country Schools. 4.20, Talk: The Schedule of Work in Village Schools. 4.30, Gramophone Music. 4.50, Radio Report of the Excavation Work in an Old German Burying-ground at Söthen, near Recklinghausen. 5.15, Reading (Liess Böhle). 5.30, Orchestral Concert conducted by Kühn. 6.45, Announcements. 7.0, Transmission for all German Stations relayed from Stuttgart. 8.0, News. 8.5, Variety Programme. 9.0, Trio Concert by Egbert Grape (Pianoforte), Rudi Rhein (Violin), and Robert Grote (Cello); Trio in G, Op. 1, No. 2 (Beethoven); Passacaglia for Violin and Cello (Halvorsen); Novelletten Op. 29 (Gade). 10.0, News. 10.20, Weekly Review and Close Down.

LAUSANNE.—See Radio-Suisse Romande.

LEIPZIG

769.9 kc/s, 389.6 metres; 120 kW.; 12 Noon, Gramophone Concert; Overture, The Barber of Bagdad (Cornelius); Drinking Song from La Traviata (Verdi); Air from Il Trovatore (Verdi); Songs (Brahms): (a) Ich fahr dahin, (b) In stiller Nacht; Two Aries from Fidelio (Beethoven); Dance of the Mariouettes (Winteritz); Serenade, Polichinelle (Kreisler); Aria from The Barber of Seville (Rossini); Campanella, Op. 7 (Paganini); Arias from (a) Martha (Flotow), (b) I Pagliacci (Leoncavallo). 1.0 p.m., News. 1.15, Gramophone Concert: Divertimento No. 8 in F for Flute, Oboe, Clarinet, Bassoon, and Horn (Mozart); Two Aries from The Mastersingers (Wagner); Mazurka in G Minor, Op. 11 (Popper); Tarantella in A (Cossmann); Two Aries from The Magic Flute (Mozart); Second Movement from The Trout Quintet (Schubert); Immer leise wird mein Schlummer (Brahms); Two Tenor Arias from Tosca (Puccini). 2.0, News. 2.30, Review of Books for Young People. 3.0, Literary and Musical Programme for Invalids. 3.35, Economic Notes. 4.0, Concert by the Symphony Orchestra, conducted by Hilmar Weber; Overture, Melusine (Graumann); Suite in F for String Orchestra (Wickenhauser); Scherzo from Die Jagd nach dem Glück (Nicodé); Music to the Legend Maria von Nymwegen (d'Albert); Prelude to Die Zwillinge (Karl Weiss); Selection from Diamhild (Bizet); Waltz, Op. 38 (Brahms). In the interval at 4.15, See Langenberg. 5.50, Economic Notes. 6.0 (from Dresden), Talk: Orchard Planting. 6.25, Talk: Organised Economic Planning. 6.50, Events of the Day. 7.0, Transmission for all German Stations, relayed from Stuttgart. 8.0, Political Announcement. Stuttgart. 8.0, Building the New State. 8.30, 8.5, Talk: Organised Economic Planning. Agricultural Notes. 8.40, Variety Programme. 10.10, News. 10.30, Serenade on Gramophone Records. 12 Midnight, Close Down.

LINZ.—See Vienna.

LJUBLJANA

522 kc/s, 574.7 metres; 7 kW.—6.20 p.m., Concert. 7.30, Talk. 8.0, Programme to be announced. 10.0, Weather, News and Gramophone Music. 11.0 (approx.), Close Down.

LUXEMBOURG

252 kc/s, 1,191 metres; 200 kW.—Belgian Programme. 7.30, Concert by the Station Orchestra, conducted by Henri Bussic. 8.5, Weather. 8.10, Song and Pianoforte Recital: Songs: (a) Nocturne (César Franck), (b) Sonnet (Gustave Huberti), (c) Sur une tombe net (Leken). (d) Ronde (Leken); Pianoforte Solos: Prelude, Choral and Fugue (César Franck); Songs: (a) La fille aux cheveux de France) (Gilson), (b) Villanelle (Le passet qui elle petits ânes (Rasse), (d) Je jure (Cécile Bejdyt). 8.50, News in French. 9.15, Concert by the Station Orchestra; Overture, The Hebrides (Mendelssohn); Selection from Zaza (Leoncavallo); Invano (Amadei); Schön Ros (Kreisler); In the Steppes of Central Asia (Borodin); Aufzug der Stadtwaechse (Jessee); Spanish Dances, Nos. 1 and 5 (Moszkovsky); Selection from Mignon (Thomas); Freundschafsmarsch (Zeh). In the interval at 9.45, News in German. 10.20, Dance Music on Gramophone Records.

the intervals, Talk and Announcements. After the Programme, News.

JULY 25th

TUESDAY

continued

PARIS

7.20, News in Foreign Languages. 7.40, Gramophone Music. 8.0, News and Weather. 8.15, Sponsored Music. 8.30, A Comedy in Three Acts, followed by Programme of Variety Music. 11.0, Giornale Radio.

PARIS

POSTE PARISIEN, 914 kc s, 328.2 metres; 60 kW.—7.5 p.m., Le Journal Parlé. 7.30, Song Recital by M. Dolini. Serenade from Frasquita (Lohar). Song (Lohar). Mia Picciarella (Gomez). Neapolitan Nights (Zamcchnik). The Hills of Home (Fox). Trees (Reisbach). 8.0, Gramophone Music. 8.15, Interlude. 8.30, Concert by the Station Orchestra. Overture, Le roi d'Yvetot (Adam); Waltz from Les deux Pigeons (Messager); Talk; Selection from La Fayette du Temple (Messager); Trot de cavalerie (Rubinstein); Esquisses (Bournoisville); Par monts et par vaux (Gillet); Piano Solo, Valse légère (Vuillemin); Second Suite, Clavecinades (Beaume); Bourrée, L'Ozeral (Canteloube); Marche des esclaves (Filippucci). 10.30, News.

PARIS

RADIO PARIS, Call CFR, 174 kc s, 1,725 metres; 75 kW.—7.30 a.m., Weather and Physical Culture. 7.45, Gramophone Music. 8.0, Weather and Press Review. 12 Noon, Gramophone Concert. Marche grecque (Ganne); L'homme rouge (Borel-Clerc); Pierrot galant (Chillemont); Je voudrais lui dire (Coslov-Harding); Les lilas (Doelle); La mantille espagnole (Guereiro); The Wedding of the Painted Doll (Brown); Mandoline (May); Mon cœur est à vous (Valdieu); Siempre (Blanco); Suzon (Brown); Tom amour, c'est ma vie (Dufas); Te revoir, un soir (Sider and Mayaud); La Débutante (Tras-Dompre); Estampilla (Romero-Delino); Amorettanze (Gungl); Melody (Abraham); C'est Montparnasse (Heintz); Melody (Zevaco); A la Godille (van Hoorebeck); Pluie de roses (Avignon); Love Song (Bixio); Selection from Enlevé-moi (Gabaroché); In the intervals at 1.0, Exchange, News and Weather, and at 1.30, Exchange, 2.0, Exchange and Announcements, 3.45, Exchange and Market Prices, 7.0, Market Prices, Weather, Agricultural Report, Exchange and Racing Results, 7.10, Gramophone Music. Anbade printanière (Lacôme); Lettre à Manon (Gillet); The Skaters' Waltz (Waldteufel); Chéri (Monzey-Wilwitz); Moonlight on the Alster (Petras); La légende des flots bleus; Conchita (Pares-Van Parys); Impressions of nauticus (Kongueld). 7.50, Commercial Notes and News. 8.0, Aida—Opera (Verdi), by the Caste, Choir and Orchestra of the eala, Milan, on Gramophone Records. In the intervals at 8.30, News and Weather, 8.40, Review by M. Bonnaud, and at 11.15, Press Review and News.

PITTSBURGH

KDKA, 980 kc s, 306 metres; 50 kW. Relayed by W8XK on 48.86 metres; and 25.27 metres.—7.30 p.m., KDKA Home Forum, 8.0, etty and Bob, from New York. 8.15, Words of Music, from New York. 8.45, Congress Clubs Period. 8.58, Baseball scores, 9.0, credit Wilson's Orchestra, from New York. 9.30, Business News, and Market sports. 9.45, Sketch, from New York. 10.15, Baseball Scores, 10.0, Rhythm Kings. 11, Tarzan of the Apes. 10.30, The Sing Lady, from New York. 10.45, Little phan Annie, 11.0, Time Signal and Press wavy-Keeper. 11.5, Piano Classics, 11.15, eather Report. 11.15, Sport Review. 11.25, Bring a Song. 11.28, Announcements, 29, Temperature Report. 11.30, Pitts- burg Spotlight. 12 Midnight to 1.30 a.m. (Wednesday), New York relay. 12 Mid- night, Amos 'n' Andy. 12.15 a.m., National visory Council on Radio in Education— during the School Budget. 12.45, Ray atherphone (Baritone). 1.0, Crime Chas- o, Adventures in Health. 1.45, Floyd omans, World's Fair Reporter. 2.0, dium Concert by Philharmonic Symphony estra. 2.59, Time Signal. 3.0, House- d Musical Memories, from New York.

RSGRUND.—See Oslo.

PRAGUE

Bratislava. 3.55, Exchange. 4.0, Inter- 5.45, Gramophone Music. 5.55, Talk; International Economic Conference. 6.5, icultural Market Prices. 6.15, Talk for rkers. 6.25, News in German. 6.30, Ger- l Transmission: Radio Play (Fuchs). 7.0, nes and News. 7.10, See Moravská.

Ostrava. 7.40, Gramophone Music. 7.55, See Brno. 8.10, Nylophone Solos. 8.30, See Brno. 10.0, Time and News. 10.15, Dance Songs for Two Pianofortes. 11.0 (approx.), Close Down.

RABAT

721.1 kc s, 416 metres; 6 kW.—1.30 to 3.0 p.m., Orchestral Concert: Marelli, La Madeleine de la Victoire (Borel Clerc); Waltz (Buca- lossi); Overture, Die Fledermaus (Joh. Strauss); Song, Le temps des lilas (Chaus- son); Portrait (Chaminade-Charnettes); Selection from Hamlet (Thomas); Song, from Le Châlet (Adam); Clarinet Solo: Cantegril (Busser); Divertissement on Russian Themes (Rabaud); Song from La Basoche (Messag- ger); Clarinet Solo: Fantaisie orientale (Gd'ollone); Selection from Javotte (Saint- Saëns). 5.0 to 6.0, Gramophone Music. 8.0, Arab Transmission—News and Gramophone Music. 8.45, Journal Parlé, Weather and News. 9.0, Orchestral Concert: Waltz (Stroh); Rumeurs de la Caleta (Albeniz); Overture, Fingal's Cave (Mendelssohn); Gipsy Songs; Troika (Tchaikovsky); Selection from Les Héritières (Loyade); Aria from Tannhäuser (Wagner); Viola Solo: Romance in F (Beethoven); Song, Paysage (Hahn); Suite, Masques et Bergamasques (Faure); Song from The Huguenots (Meyer- beer); Extracts from the Ballet, The Seasons (Glazunov); Slav Dance, No. 1 (Dvorák). 11.0, Gramophone Music.

RADIO-SUISSE ROMANDE

Sottens, 743 kc/s, 403 metres; 25 kW.; and Geneva, 395 kc s, 760 metres.—12.28 p.m., Time Signal from Neuchâtel Observa- tory. 12.30, News and Weather. 12.40, Gramophone Music. 1.0, Financial News. 1.10, Gramophone Music. 2.0 to 3.28, Inter- val. 3.28, Time Signal from Neuchâtel Observa- tory. 3.30, Readings. 4.0, Dance Music by the Broadcasting Serenaders. 5.30 to 7.0, Interval. 7.0, Talk: Paris To- day. 7.30, Old Time Street Scenes—Radio Sequence of Daily Life in the Streets. 8.0, Readings. 8.15, Piano Solo Recital by Berthe Weil. Air with Variations (Händel); Aufsehung (Schumann); The Death of Isold (Wagner-Liszt); Etude (Chopin); Sérénade (Rachmaninov); Seguedillas (Albeniz). 8.45, Concert of Sacred Music. 9.10, See Schweizerischer Landessender (Beromünster). 9.55, News and Weather. 10.5, Gramophone Music. 10.30 (approx.), Close Down.

REYKJAVIK

250 kc s, 1,200 metres; 21 kW.—9.5 p.m., Musical Programme. 9.30, Weather Report. 9.40, Musical Programme and Announcements. 10.0, Chimes and News. 10.30, Reading. 11.0, Cello Solo by Thorhallur Arnason, fol- lowed by Quartet, No. 2, Op. 18 (Beethoven), on Gramophone Records.

RIGA

572 kc s, 525 metres; 15 kW.—7.3 p.m., Con- cert of Russian Opera Music. 9.0, News, 9.15, Popular Programme. 9.45, Chamber Music on Gramophone Records.

RJUKAN.—See Oslo.

ROME

Call 1R0, 680 kc s, 441 metres; 50 kW. Relayed by Naples, 941 kc s, 319 metres, and 2R0, 11,810 kc s, 25.4 metres, from 5.30 p.m.—1.0 to 2.15 p.m., Concert from Turin. In the intervals from 1.30 to 1.45, Giornale Radio and Exchange, and at 2.0, Time and Announcements. 4.45, Children's Radio Review. 5.10, Weather. 5.15, Exchange and Giornale Radio. 5.30 to 6.15, Concert of Light Music. 6.40 (Naples), Shipping and Sports Notes. 6.50, Agricultural and Dopa- lavoro Notes. 7.0, Tourist Report. 7.10, Lesson in Morse. 7.20, News in Foreign Languages. 7.40, Giornale Radio. 8.0, Time and Announcements. 8.15 till Close Down. See Turin. In the intervals, Talk and News. Giornale Radio after the Programme.

SALZBURG.—See Vienna.

SCHENECTADY

WGY, 790 kc s, 379.5 metres; 50 kW. Relayed at intervals by W2XAF on 31.48 metres; and by W2XAD on 19.56 metres.—12.45 a.m. (Wednesday), Stock Reports and Baseball Scores. 1.0 to 3.30, New York relay. 1.0, Blackstone Plantation. 1.30, Wayne King Orchestra. 2.0, Ben Bernie's Blue Ribbon Orchestra. 2.30, Ed Wynn and the Fire Chief Band. 3.0, Lives at Stake. 3.30, National Radio Forum from New York, fol- lowed by Programme Resumé.

SCHWEIZERISCHER LANDESENDER

BEROMUNSTER, 653 kc s, 459 metres; 60 kW. Basle, 1,229 kc s, 244.1 metres, and Berne, 1,220 kc s, 245.9 metres.—6.15 a.m., Gymnastics. 6.35, Interval. 11.59, Time Sig- nal from Neuchâtel Observatory and Weather. 12 Noon (from Berne), Swiss Folk

Music on Gramophone Records. 12.30 p.m., Time and News. 12.40 (from Berne), Gramo- phone Concert. 1.25 (from Berne), Time and News. 1.35, Interval. 5.0 (from Basle), Gramophone Concert. 5.40 (from Basle), Re- view of Newly-released Gramophone Records. 6.30 (from Berne), Programme for Children. 7.0, Time and Weather. 7.5 (from Berne), Programme to be announced. 7.30 (from Berne), Concert by the Viennese Boys' Choir, the St. Thomas' Choir, and the Boys' Choir of the Sixtine Chapel. 8.0 (from Berne), The Microphone's Mountain Journey. 8.30 (from Berne), Ballet Music and Dances. 9.0, News. 9.10 (from Berne), La serva padro- na—Opera (Pergolesi). 9.55 (from Berne), Dance Music. 10.15 (approx.), Close Down.

SOTTENS.—See Radio-Suisse Romande.

STOCKHOLM

689 kc s, 436 metres; 55 kW. Relayed by Boden, 244 kc s, 1,229.5 metres; Göteborg, 932 kc s, 322 metres; Hörby, 1,166 kcs, 257 metres; Motala, 221.5 kc/s, 1,354.4 metres; Östersund, 389 kc s, 770 metres; and Sunds- vall, 554 kc s, 542 metres.—5.5 p.m., Talk. 5.30, Song Recital by Gissi Welin. 5.45, Gramophone Music. 6.45, Readings. 7.30, Variety Programme. 8.15 (from Göteborg). Talk. 8.45, Military Band Concert, con- ducted by Ivar Widner. 10.0, Chamber Music. String Quartet in G, Op. 18 No. 2 (Beethoven). String Quartet No. 2 in D (Borodin). 11.0 (approx.), Close Down.

STRASBOURG

859 kc s, 345 metres; 11.5 kW.—11.30 a.m., Gramophone Concert. 12 Noon, Orchestral Concert, conducted by Maurice de Villers. Part I: Wagner Music. Overture, Rienzi. Selection from The Flying Dutchman; Ex- tracts from The Mastersingers; (a) The Prize Song, (b) Prelude to Act III, (c) Dance of the Apprentices, (d) March. 12.45, p.m., News. 1.0, Time. 1.1, Exchange. 1.5, Orchestral Concert (cont'd.). Part II. Aubert Music. Descriptive Piece, Dryade; Fantasia for Piano and Orchestra; Three Hebrew Songs; Caprice for Violin and Orchestra. 5.0, Talk: French Possessions in Cambodia. 5.15, Jazz Band Concert, con- ducted by M. Roskam. 6.0, Talk: Anti- semiticism in the Middle-Ages. 6.15, Topical Talk. 6.30, Concert of Chamber Music, Sonata for Viola and Piano (Brahms); String Quartet, No. 1 (Beethoven). 7.30, Time and News. 7.45, Gramophone Con- cert. Overture, Martha (Flotow); La Cin- quantaine (Gabriel-Marie); The Last Rose of Jeanette (Massé); Songs from Les Noces de Jeanette (Massé); Si petite (Claret); Ta promesse (Borodin). 8.15, Press Re- view, Lottery Results and Announcements. 8.45, Symphony Concert by the Municipal Orchestra, relayed from the Orangerie. Con- ductors: E. G. Munch. Symphony Poem, The Procession nocturne (Rabaud); Suite, Mother Goose (Ravel); Symphonic Fan- tasia, Aus Italien (R. Strauss). In the in- terval: Press Review in German. 10.30, (approx.), Close Down.

STUTTGART

MUHLACKER, 832 kc s, 360.5 metres; 60 kW. Relayed by Freiburg, 527 kc/s, 570 metres.—12 Noon, Promenade Concert from the Schlossplatz, Stuttgart. 1.15 p.m., Time and News. 1.30, Organ Recital from the Pfä- lalast. 2.0, Programme arranged by the Post Office, with Gramophone Records. 2.30 to 3.0, Advanced English Lesson. 3.30, Talk: Flowers. 4.0, Talk for Women: Healthy Children and Sunshine. 4.30, Concert of German Marches and Waltzes, conducted by Hermann Eschrich, relayed from Wildbad: March, Nibelungenruine (Köhler); Marien- walzer (Hilse); Army March No. 7; Waltz, Dreams on the Ocean (Gungl); King Charles March (Turath); Waltz, Hofballtänze (Lammer); March, Deutsche Matrosen (Blon); Tales of the Orient (Joh. Strauss); March, Kameradschaft hoch! (Hermann Eschrich). 5.45, Talk: Through the War Museum of Schloss Rosenstein. 6.10, Talk: German Music. 6.35, Time and News. 7.0, Trans- mission for all German Stations: Heidelberg—a Radio Picture (Curt Elwenspoek and A. Richter). 8.0, Talk: Things you should know. 8.20, Concert from Heilsberg. 9.35, Dance Music. 10.15, Time and News. 10.40, See Hamburg. 12 Midnight, Close Down.

SUNDSVALL.—See Stockholm.

TRIESTE

1,211 kc s, 247.7 metres; 10 kW.—5.0 p.m. till Close Down, See Turin.

TRONDHEIM.—See Oslo.

TURIN

1,095 kc s, 273.7 metres; 7 kW. Relayed by Milan, 905 kc s, 331.5 metres; Genoa, 959 kc s, 312.8 metres; and Florence, 599 kc/s, 500.8 metres.—5.0 p.m., Dance Music from the Savoia Dance Hall. 6.0 to 6.5, Weather. 6.35, News. 7.0, Time Report of the Royal Geographical Society and Gramophone Music.

VATICAN CITY

15,120 kc s, 19.84 metres (Morning), and 5,969 kc s, 59.26 metres (Evening); 10 kW.—11.0 to 11.15 a.m., Religious Information in English. 8.0 to 8.15 p.m., Religious Information in Italian.

VIENNA

581 kc s, 517 metres; 100 kW. Relayed by Graz, 852 kc s, 352.1 metres; Innsbruck, 1,058 kc s, 283 metres; Klagenfurt, 662 kc s, 453.2 metres; Linz, 1,220 kc s, 245.9 metres, and Salzburg, 1,373 kc s, 218.5 metres.—12 Noon, Concert by the Vienna Symphony Orchestra, conducted by Josef Holzer. In an interval at 1.0 p.m., Time and News. 2.0 to 3.0, In- terval. 3.0, Time, Weather and Exchange. 3.20, Talk: A Cycling Tour. 3.35, Gramo- phone Concert of Light Music. 4.40, Talk: Men who have given their Names to Idens. 5.5, Talk: The History of German Dwelling Houses. 5.30, Brahms Recital: Elfriede Hed- mont (Contralto), Emmy Zopf (Pianoforte), and Marcel Dick (Viola). Piano Solo: (a) Rhapsody in C Minor, Op. 79. (b) Inter- mezzo in E flat minor, Op. 118. (c) Piano- forte Solo: Intermezzo in C, Op. 119. Two Songs for Alto with Violin (Obligato, Op. 91; Songs, Op. 91; Piano-forte Solos: (a) Capriccio in B Sharp Minor, Op. 76. (b) Capriccio in B Minor, Op. 76. (c) Scherzo in E flat Minor, Op. 4. 6.10, Talk: Forest Meditations in the Neighbourhood of Vienna. 6.35, Read- ing. 7.0, Concert by the Vienna Symphony Station Orchestra, conducted by Josef Holzer. Soloist: Anton Kamper (Vio- lin) and Willy Saliger (Piccilo). Over- ture, Ein tolles Mädl (Ziehrer); Vio- lin Solo: Waltz in A (Brahms); Selection from Die schöne Kismet (Fall); Waltz, Aus der Stadt der Lieder (Fahrbach); Lampion-Marsch (Eyster); Serenade melanc- holiche from Stimmungsbilder (Fucik); Song, 'Erst wann der letzte Weana stirbt (Gruber); Ein Waldkonzert (Eilenberg); Der Zaunkönig (Eilenberg); Piccolo Solo: Die Schwalbe (Gobaert); Song, Wie ist das Leben schön (Flemming); Marien-Walzer (Lammer); Potpourri, Beim Heuriden (Kronegger). In an interval at 7.35, Time, Weather, and Programme Announcements. 8.50, The Sea. Concert by the Vienna Sym- phony Orchestra, conducted by Bernhard Paunzgartner: Overture, Meeresstille und glückliche Fahrt (Mendelssohn); Summer Night in the Fjords (Seljelidrup); Nocturne, La regata Veneziana (Liszt); Journal de bord (Cras); Une barque sur l'océan (Ravel); Overture, The Flying Dutchman (Wagner). 9.50, News. 10.5, Dance Music by the Blue Boys, from the Grabencafé. Soloist: Franz Schier (Songs).

WARSAW

212.5 kc s, 1,411 metres; 120 kW.—11.57 a.m., Time Signal and Fanfare from St. Mary's Church, Cracow. 12.5 p.m., Light Orchestral Music. 12.25, Polish Press Review. 12.33, Weather Report. 12.35, Orchestral Music (cont'd.). 12.55, Radio Journal. 1.0 to 2.55, Interval. 2.55, Gramophone Music. 3.5, Sports Notes. 3.10, Announcements. 3.15, Gramophone Music. 3.25, Economic Notes. 3.35, Gramophone Music. 3.45, Aviation Report and Anti-Gas Drill. 3.50, Gramo- phone Music. 3.55, Announcements. 4.0, Popular Concert by the Poznan Opera House Orchestra, conducted by B. Tyllia, relayed from Cieczocinek. 5.0, Talk: Polish Youth Abroad. 5.15, Gramophone Music. 6.15, Talk: The Polish Merchant Service. 6.35, Recital of Tenor Songs by Umberto Masetto: Donna vorrei morir (Costi); Stornellatrice (Respighi); Two Songs (Costi): (a) Aprile, (b) Non l'amo più; Tristesse (Chopin); Air from L'Arlesiana (Cilea). 7.5, Gramophone Music. 7.20, Miscellaneous Items. 7.35, Pro- gramme Announcements. 7.40, Topical Talk. 8.0, Concert by the Station Orches- tra, conducted by Nawrot. Soloist: Korwin-Szymanowska (Soprano). Overture, Phèdre (Massenet); Mendelssohn Fantasia (Foulds); Songs: (a) Air from L'Enfant prodigne (Debussy), (b) Pourquoi main- tenant (Szymanowski), (c) Song from Les lys (Szopski), (d) Ma chérie (Chopin); Peer Gynt Suite No. 1 (Grieg). 8.50, Radio Journal. 9.0, Agricultural Notes. 9.5, Con- cert (cont'd.): Dance from Janek (Zelenski); Ballet Music from Faust (Gounod); Songs: (a) Air from The Snow Maiden (Rimsky- Korsakov), (b) Solweig's Song (Grieg), (c) Aria from Othello (Verdi); Waltz from La belle au bois dormant (Tchaikovsky); Czardas from Der Geist des Wojewoden (Grossmann). 10.0, Dance Music from the Café Europe, Cieczocinek. In the intervals at 10.25, Sports Notes, and at 10.35, News.

WILNO

533 kc/s, 563 metres; 16 kW.—6.15 p.m., News and Gramophone Music. 7.20, Lithu- anian Talk. 7.35, Programme Announcements. 7.40, Concert of Request Gramophone Music. 8.50, See Warsaw. 11.0 (approx.), Close Down.

ZURICH.—See Schweizerischer Landessender.

See how much an Ekco Unit saves you!

50 times cheaper than batteries!

A.C. Mains.					
Class	Type of Set	Annual running cost of batteries	Ekco Unit suitable	Cost price of Ekco Unit suitable	Annual running cost of Unit *
1.	Screened-Grid 3; Straight Three, and smaller sets	50/-	A.C. 12 12 m/a Output	55/- or by Easy Payments	1/-
2.	S.G. Three with Pentode; Screened-Grid Four; Sets with "Class B" Output	75/-	A.C. 18 18 m/a Output	67/6 or by Easy Payments	1/6
3.	S.G. Four with Pentode; Super-Hets.; 5-Valve Sets; Sets with "Class B" Output	100/-	A.C. 25 25 m/a Output	77/6 or by Easy Payments	2/-
D.C. Mains.					
1.	Any set shown above	50/- to 100/- as shown above	D.C. 15/25 15 or 25 m/a Output	39/6 or by Easy Payments	Class 1 1/-
2.					Class 2 or 3
3.					1/7

L.T. Charging costs 6d. a year extra (instead of 25/- a year!).
 Combined H.T. and L.T. Charger Units from 79.6 (for A.C. Mains only).
 * Based on 3 hours' daily use.

Study the table shown above. It gives some illuminating facts about running costs of sets. It shows that whatever your set, providing you have electric light, you can reduce its running costs to a negligible amount by installing an EKCO Power Unit in place of expensive batteries! It shows that an EKCO Power Unit saves the money it costs in the first year of use! And Easy Payments are as low as 3/8 per month. All you have to do is to connect the suitable EKCO Unit in place of the battery, plug in to the electric light or power and switch on—that's all! No alterations to set, valves or wiring. Consult your dealer or post coupon below.

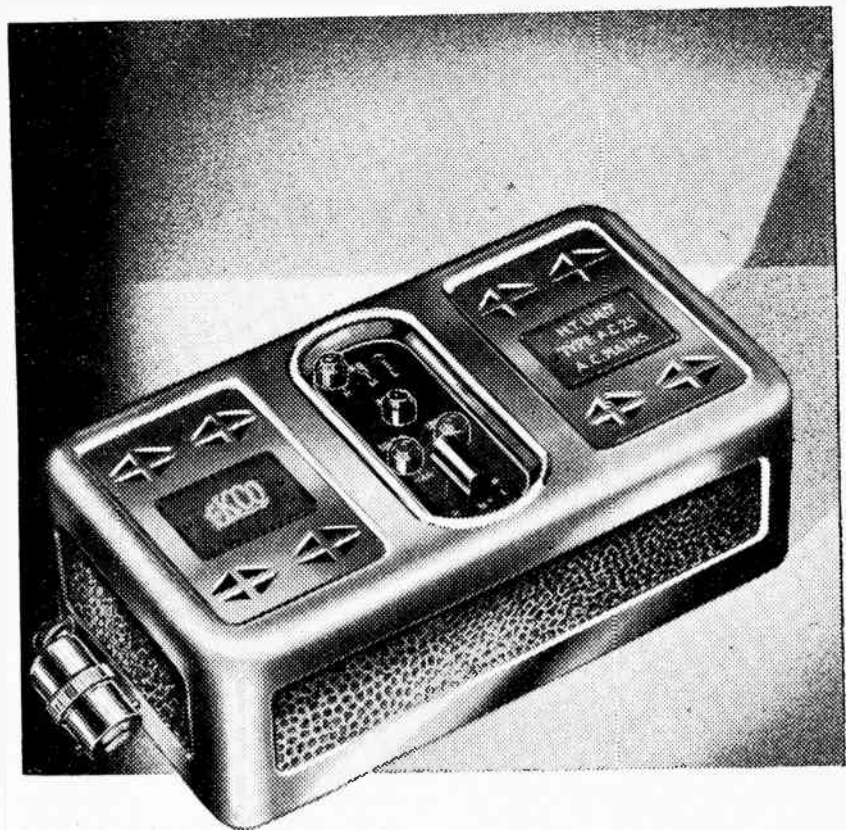

EKCO Units and "Class B"

All standard EKCO Units have adequate regulated capacity for use with receivers employing "Class B" amplification. Models A.C.18, A.C.25, K.18 and K.25 are particularly recommended.

To E. K. COLE, LTD., Dept. W.18,
 Ekco Works, Southend-on-Sea.
 Please send me FREE illustrated literature of EKCO All-Electric Radio.

Name

Address

Mention of "The Wireless World," when writing to advertisers, will ensure prompt attention.

The Wireless World

THE
PRACTICAL RADIO
JOURNAL
23rd Year of Publication

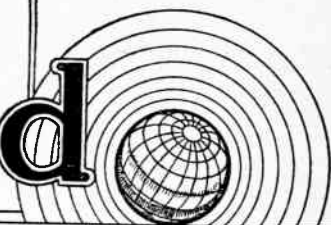
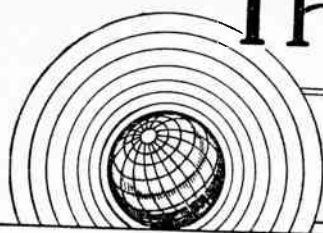

No. 725.

FRIDAY, JULY 21ST, 1933.

VOL. XXXIII. No. 3.

Proprietors: ILIFFE & SONS LTD.

Editor:
HUGH S. POCOCK.

Editorial,
Advertising and Publishing Offices:
DORSET HOUSE, STAMFORD STREET,
LONDON, S.E.1.

Telephone: Hop 3333 (50 lines).
Telegrams: "Ethaworld, Watloo, London."

COVENTRY: Hertford Street.
Telegrams: "Cyclist, Coventry." Telephone: 5210 Coventry.

BIRMINGHAM:
Guildhall Buildings, Navigation Street, 2.
Telegrams: "Autopress, Birmingham." Telephone: 2970 Midland (3 lines).

MANCHESTER: 260, Deansgate, 3.
Telegrams: "Iliffe, Manchester." Telephone: Blackfriars 4412 (4 lines).

GLASGOW: 26B, Renfield Street, C.2.
Telegrams: "Iliffe, Glasgow." Telephone: Central 4857.

PUBLISHED WEEKLY. ENTERED AS SECOND
CLASS MATTER AT NEW YORK, N.Y.

Subscription Rates:

Home, £1 1s. 8d.; Canada, £1 1s. 8d.; other
countries abroad, £1 3s. 10d. per annum.

As many of the circuits and apparatus described in these
pages are covered by patents, readers are advised, before
making use of them, to satisfy themselves that they would
not be infringing patents.

CONTENTS

	Page
PROGRAMMES FROM ABROAD, pp. I—XXIV	
Editorial Comment	33
The New Monodial Super	34
The Load Line	38
Practical Hints and Tips.. ..	41
Unbiased	42
Laboratory Tests	43
"Ultra-Shorts" from the Air	44
Burrell 3-valve A.C. Receiver	46
News of the Week	47
Broadcast Brevities	48
Correspondence	50

EDITORIAL COMMENT

Olympia 1933

Intriguing Probabilities

THE annual Radio Show is now very near at hand; the actual date of opening at Olympia is Tuesday, August 15th, and it would be well to make a special note of this date to ensure that a day is reserved for a visit. Each annual Radio Show has been of interest, largely for the reason that it provides a unique opportunity for examining and comparing the new products of the manufacturers, but Olympia 1933 promises to be of quite outstanding importance to those who are interested in something beyond the cabinet of the wireless set.

There never has been before a season when so many intriguing new ideas have cropped up for the attention of designers, and early information which we are obtaining regarding the exhibits at the Show already indicates that designers have made full use of the new ideas and valves which have become available to them.

As in previous years, *The Wireless World* will be dealing with the Show in three special numbers, to be dated August 11th, 18th and 25th. The first of these special numbers will provide a guide to the reader to ensure that he does not miss those items which are of special novelty or technical interest. The second number will deal in considerable detail with products which are definitely new and are typical examples indicating the progress which has been achieved since last season. Every section of radio progress represented at Olympia will receive attention, and in the case of new valves, components and accessories, the aim will be to show the reader how these can be utilised to the best advantage. The third Show number will describe features of the exhibits after personal

visits to every stand by the technical staff of *The Wireless World*, and this report will be fully illustrated with photographs of apparatus taken by our photographers at Olympia.

Wireless Exchanges

Attempt to Involve the Ratepayer

CONSIDERABLE discussion took place in the House of Commons recently on the question of whether or not a municipal authority should be permitted to maintain a wireless exchange and redistribute broadcast programmes.

It is well that such a proposition met with opposition, for it would indeed be unfortunate if a precedent were created and municipal authorities, backed by the ratepayers' money, were permitted to trade as distributors of broadcasting.

If there were no objections to municipal trading and ratepayers in a district were unanimous in their desire to subscribe to such a service the position might then be different, but it is manifestly unreasonable to expect ratepayers, the vast majority of whom would prefer a wireless receiver with a choice of programmes, to subsidise for a few a restricted service which they would themselves have no occasion to require.

The New Monodial

Instructions for Building

IN this and in next week's issue articles appear describing in detail the construction of the "New Monodial Super" announced last week. This receiver has already aroused much interest amongst our readers, and we confidently recommend it as an excellent introduction to *The Wireless World* for those who may start to take the paper at this time.

The New Monodial Super

An A.C. Superheterodyne
Embodying the
Latest Developments

By W. T. COCKING

THE problem of obtaining both high selectivity and realistic reproduction is by no means easy of practical solution. The use of highly selective circuits in conjunction with tone-correction enables intelligible interference to be reduced to a negligible amount without detriment to the quality of reproduction, but this cannot be said of

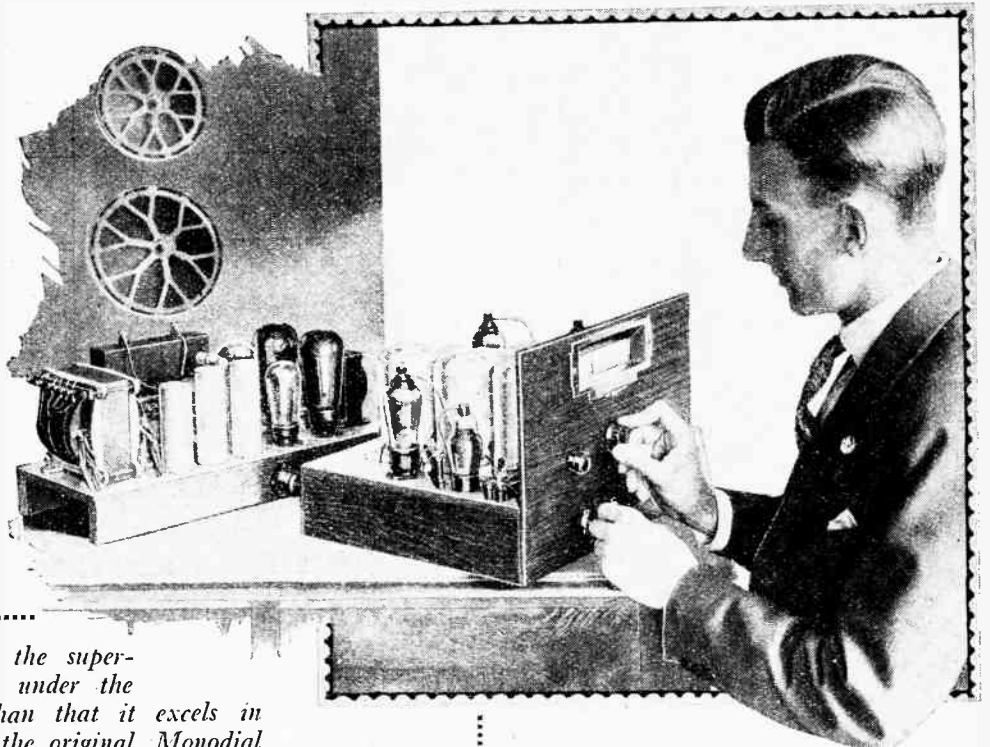

NO higher praise can be given to the superheterodyne receiver here described under the name of the New Monodial Super than that it excels in performance in almost every direction the original Monodial described in "The Wireless World." The original Monodial is still regarded by the thousands of constructors who have built it as the finest receiver which has appeared in this country, yet now "The Wireless World" beats its own record by the production of a new design which, whilst based on the original set, incorporates every new idea of practical value in superheterodyne technique.

sideband heterodyning. There is, indeed, no known way of avoiding this form of interference which does not at the same time restrict the high-frequency response of the receiver.

In the past the difficulty has been overcome by fixing a definite upper limit to the frequency response at about 5,000 cycles. With this limit really good quality can be obtained and sideband splash is reduced to modest proportions. The quality, however, is not the best obtainable and the remaining interference is all too noticeable. Fortunately, sideband splash does not occur on all stations, and on the stronger transmissions it is often absent. Obviously, therefore, the solution to the problem lies in providing alternative receiver characteristics.

The Latest Technique

Fundamentally, the receiver should be designed to provide a level frequency response up to some 7,000 or 8,000 cycles, for this is sufficient to provide the best quality with the vast majority of present-day loud speakers, and further extension of the response would result in needless expense. Means should be provided for restricting the response to about 3,500 cycles, however, when it is desired to listen

to stations suffering from sideband heterodyning.

A modern superheterodyne, therefore, must be fitted with an adjustable frequency response, but development does not stop here, and no part of the receiver is completely free from change. Automatic volume control has now become a necessity, and one of the simplest means of achieving it lies in the use of a valve of the duo-diode-pentode type for the second detector. With such a valve, not only are the initial stages controlled, but the first L.F. stage also, with the result that the system can become practically perfect.

The I.F. circuits, too, are changed, although this is not apparent from the circuit diagram. The alteration lies in the degree of coupling adopted in the transformers, for now no attempt is made to obtain a double-humped resonance curve, and tone-correction is relied upon entirely for the preservation of the upper musical frequencies. This change results in an increase in selectivity, but has been made primarily with a view to the simplification of the initial adjustments, since without elaborate apparatus it has been found difficult to adjust true band-pass circuits in such a way as to avoid obtaining an asymmetrical resonance curve.

The most striking modification, how-

ever, lies in the frequency changer, for the introduction of the special Pentagrid converter has enabled an improved performance to be obtained with one valve less than in other arrangements. The use of this valve enables interaction between the signal frequency and oscillator circuits to be avoided, with a consequent simplification of the ganging, it reduces the cost, it leads to greater efficiency, and, most important, it greatly reduces the possibility of whistle production.

Pre-Selector Circuits

The application of the latest developments to the superheterodyne have thus resulted in striking changes, and the circuit diagram of the receiver unit will be seen in Fig. 1. The H.F. valve is preceded by a single tuned circuit, and its grid bias is applied through the 2-megohm resistance R_1 , the 0.0001-mfd. condenser C_5 serving to couple the grid to the tuned circuit. The coupling between the H.F. valve and the frequency changer is by means of an H.F. transformer, and the control grid of the Pentagrid is again biased through a 2-megohm resistance R_2 , the signal being fed through the 0.0001-mfd. condenser C_6 . The two signal-frequency tuned circuits are tuned by two similar sections, C_1 , C_2 , of the three-gang condenser.

The inner grid of the Pentagrid is joined to the oscillator tuned circuit through the 0.0001-mfd. condenser C_9 , and its bias is derived by the flow of grid current through the 0.25-megohm resistance R_4 . The

The New Monodial Super—

tuned circuit is of the conventional type and is tuned by the shaped-plate section C₃ of the gang condenser. The 0.002-mfd. padding condenser C₄ is inserted on the long waveband for the maintenance of ganging. The reaction coil is shunt fed by the 0.1-mfd. condenser C₁₀ and the 20,000 ohms resistance R₅.

The primary of the first I.F. transformer is included in the Pentagrid anode circuit, and its secondary is coupled to the primary of the second transformer by a 12-mmfd. condenser C₁₁, this loose coupling being necessary in order to avoid a double-humped resonance curve. The secondary of this transformer feeds the variable-mu I.F. valve, in the anode circuit of which the third transformer is connected.

The A.V.C. System

The secondary of this transformer feeds the two diode anodes of the duo-diode-pentode which serves as the second detector, the A.V.C. valve, and as the tone-corrector. One anode is fed directly from the tuned circuit, and it provides the rectified L.F. output and the bias for the pentode portion of the valve through the I.F. filter Ch₁, C₁₃ and C₁₄, the potentiometer R₁₄ of 0.25 megohm serving as the manual volume control and also as the diode load. The other diode provides delayed A.V.C. for the H.F., frequency changer, and I.F. stages; it is fed through the 0.0001 mfd. condenser C₁₉, and its load is the 0.5 megohm resistance R₁₁, and the A.V.C. voltage developed across this resistance is applied through the filter comprising R₁₀ and C₁₅ to the grids of the controlled valves. The necessary delay voltage is provided by the voltage drop across the 100 ohms resistance R₁₂, which is shunted by a 2 mfd. condenser C₁₆.

The D.C. voltage due to the rectification of the signal is fully applied to the pentode control grid through the 2 megohm resistance R₁₅, and any desired proportion of the L.F. voltages through the 0.01 mfd. condenser C₁₈. On gramophone the connections are changed, and the pick-up is connected between the upper end of the volume control and the earth line. The fixed negative grid bias is then nearly equal to the potential across the delay resistance R₁₂.

L.F. Circuits

The tone-corrector is fitted as the intervalve coupling, and on radio it consists of the 0.25H. choke Ch₂ in series with a 2,000 ohms resistance R₁₈, the 0.002 mfd. condenser C₂₀ being joined across the combination. It is thus a tuned anode circuit resonating at 7,000 cycles, and giving a flat response curve over the lower and middle frequency ranges. Such a characteristic is quite unsuited to gramophone reproduction, and so the radio-gramophone switch changes over the connections. On gramophone the coupling consists of the 2,000 ohms resistance R₁₈,

THEORETICAL CIRCUIT DIAGRAM OF THE NEW MONODIAL SUPER

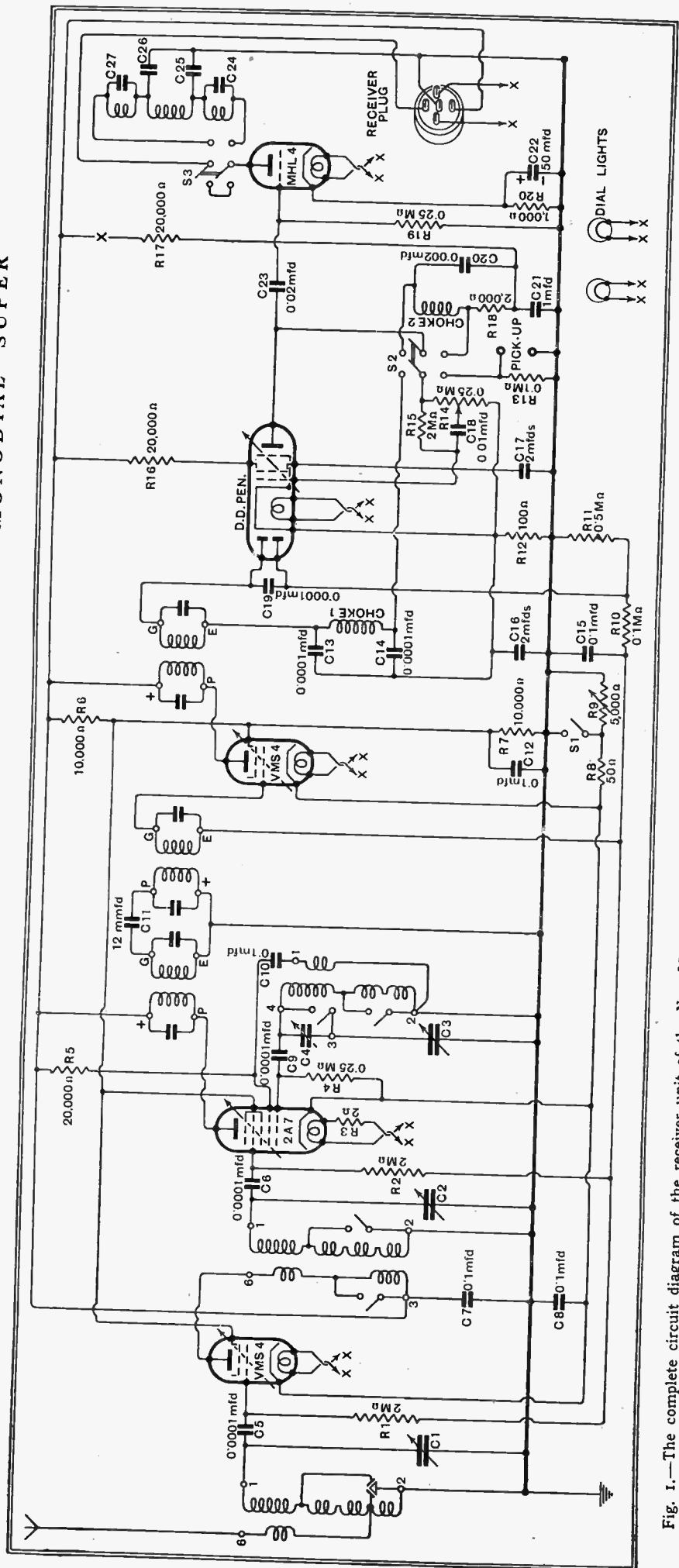

Fig. 1.—The complete circuit diagram of the receiver unit of the New Monodial Super. An American type valve is used for the frequency changer, and as its heater is rated for 2.5 volts only, a 2-ohms resistance R₃ is included in circuit. Practically perfect A.V.C. is obtained, together with signal rectification and tone-correction, from a duo-diode-pentode valve. It should be noted that the 50-ohms resistance R₈ actually consists of two 100-ohms resistances wired in parallel.

The New Monodial Super—
shunted by Ch2 and C20 in series; these components then act to some extent as a scratch filter.

The pentode screen is fed from the 200 volts line through the 20,000 ohms resistance R16, with a 2 mfd. condenser C17 connected to earth. The anode cir-

cuit is decoupled by another 20,000 ohms resistance and the 1 mfd. condenser C21; this condenser also acts to give a rising characteristic in the extreme bass to compensate for the inevitable slight loss of bass occurring in the R.C. couplings.

the anodes of the H.F., frequency changer, and I.F. valves. The screens of the variable-mu type valves, however, are fed from the tapping on the potentiometer, made up from the 10,000 ohms resistances R6 and R7, connected across the H.T. supply, and are by-passed to earth by the 0.1 mfd. condenser C12. The cathodes of these early valves are commoned and, when the switch S1 is closed, are taken to earth through a 50 ohms resistance R8 to provide the initial bias. When S1 is open a 5,000 ohms variable resistance is connected in circuit to limit the maximum sensitivity of the set; this is primarily for reducing background while searching, for the normal condition of the receiver is one of exceptional sensitivity. The secondary purpose of the resistance is to reduce the sensitivity for local reception, since, if the set be used with a good aerial very close to a powerful local, the A.V.C. system may not provide sufficient control.

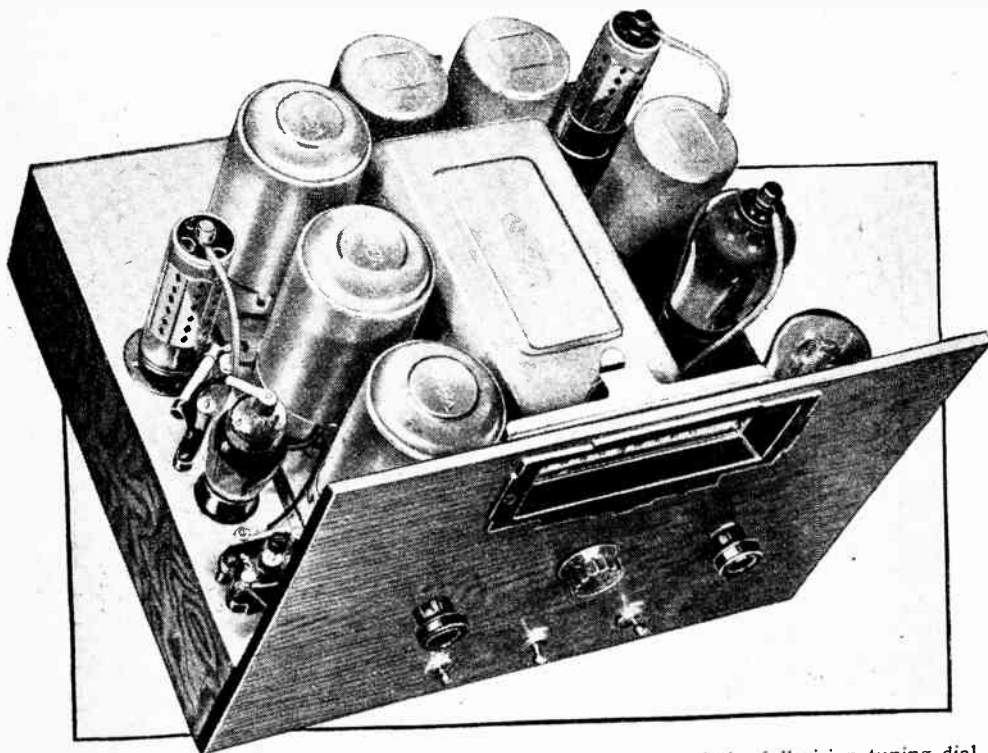

This view of the receiver unit clearly shows the clean layout and the full-vision tuning dial.

The intervalve coupling to the MHL4 L.F. valve is completed through the 0.02 mfd. condenser C23 and the 0.25 megohm resistance R19. This valve is biased by the 1,000 ohms resistance R20, shunted by a 50 mfd. electrolytic condenser C22. With the switch S3 in the upper position,

elimination of sideband heterodyning. This filter is available as a complete unit, including the three chokes and the condensers C24, C25, C26 and C27. It is designed for working between terminal impedances of 10,000 ohms; the input impedance is provided by the internal A.C. resistance of the MHL4 valve, but the output impedance must be obtained by connecting a 10,000 ohms resistance R21 across the primary of the transformer.

The L.F. valve anode is fed directly from the 200 volts line, in common with

Mains Equipment

The push-pull PX4 valves are slightly over-biased so that they take only 35 mA. apiece (nominal current); as a result, the total current of the receiver falls within the 120 mA. rating of a single rectifier valve. Owing to the push-pull connection, this over-biasing does not introduce distortion, for the harmonics are balanced out. Calculation indicates that some 4 watts output is obtainable with zero second and third harmonic distortion, and in practice some 5 to 6 watts is obtained for the usual 5 per cent. total harmonic. Decoupling of the grid circuits is likely to be ineffective in push-pull, so that the bias resistances are by-passed by 50 mfd. electrolytic condensers in order to maintain the full bass response. The load impedance required by this output stage is 10,000 ohms, so that the output transformer must be of the ratio required to give this with the particular speaker employed.

The five indirectly heated valves and the dial lights are all run from a winding

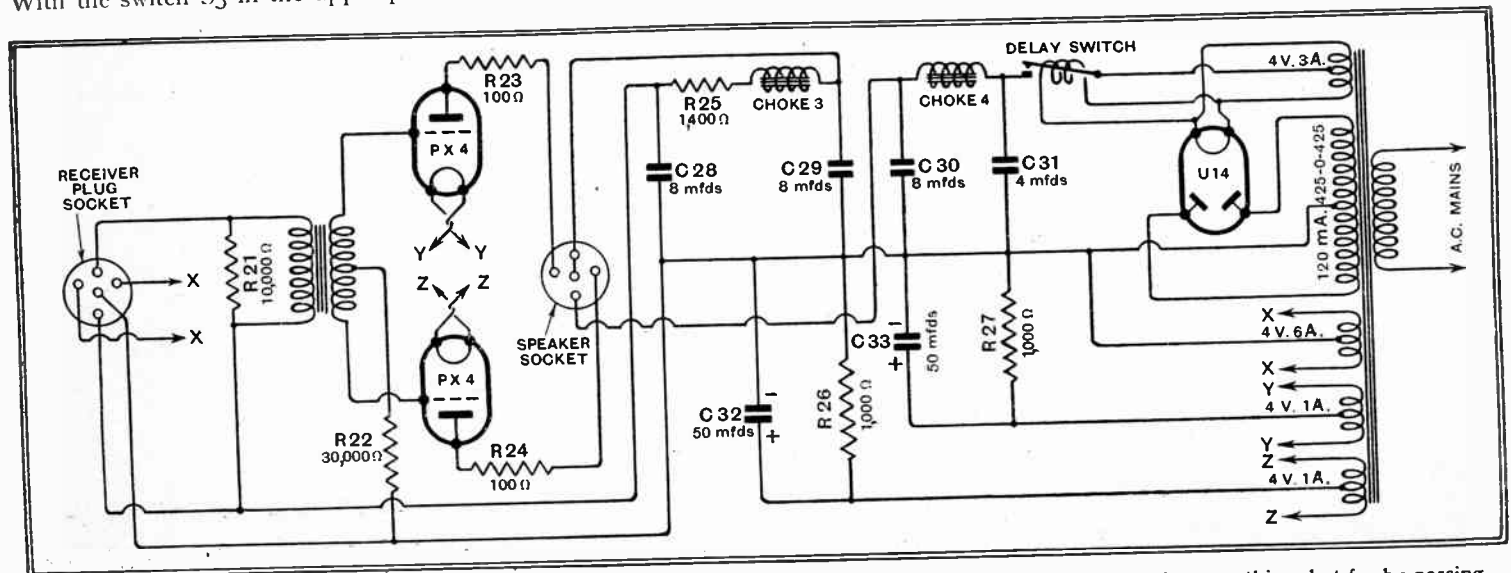

Fig. 2.—The complete circuit of the power unit is shown here; electrolytic condensers are used, not only for smoothing, but for by-passing the bias resistances and care should be taken to connect them with their negative terminals to the chassis.

WE ARE NOT NEWCOMERS TO RADIO

Advertisers in this Journal since 1919.



BUILD YOUR NEW MONODIAL

with an EXACT TO SPECIFICATION
PILOT AUTHOR KIT
and DUPLICATE THE AUTHOR'S RESULTS

FOR IMMEDIATE DELIVERY

FULL-SIZE BLUE-PRINT WITH EACH KIT.

Demonstrations of the New A.C. Monodial Super-Het Receiver are given daily at 77, CITY ROAD, LONDON, E.C.1. 62, HIGH HOLBORN, LONDON, W.C.1.

IMPORTANT NOTICE

● "THE WIRELESS WORLD" OFFICIAL LIST OF PARTS printed in this issue, shows item for item the contents of the PILOT AUTHOR KIT which comprises only those parts actually used by the Author himself. Builders of the New A.C. Monodial Super-Het with a PILOT AUTHOR KIT are assured of a square deal. Readers desiring to purchase any items separately can order with confidence from the EDITORIAL LIST OF PARTS for delivery against CASH or C.O.D. Orders over 10/- Carriage Paid, or C.O.D. Post Charges Paid. Components or Part Kits value over 50/- by EASIWAY if preferred. Quotation without obligation.

PETO-SCOTT SOLELY SPECIFIED

PLYMAX BASEBOARD assembled and drilled as specified by the Author for RECEIVER PORTION, 14" x 12" x 3". Cash or C.O.D. Carriage paid. **10/6**
Ditto in NEW METAPLEX BOARD. 6/6

PLYMAX BASEBOARD assembled and drilled as specified by the Author for POWER UNIT PORTION, 18" x 6 1/2" x 3". Cash or C.O.D. Carriage paid. **7/6**
Ditto in NEW METAPLEX BOARD. 5/-

RECEIVER KIT

Author's Kit of FIRST SPECIFIED PARTS for RECEIVER PORTION ONLY less Plymax Chassis, Panel, Cabinet and Valves
Cash or C.O.D. **£10-19-6**
Carriage Paid.

Extra for Peto-Scott Plymax Chassis as used by the Author, 14" x 12" x 3", Ready Drilled and Assembled ... 10/6
Peto-Scott Oak faced Ply Panel, Ready Drilled, 14" x 10" ... 2/6

RECEIVER KIT "A" as above but with PETO-SCOTT READY-DRILLED AND ASSEMBLED PLYMAX CHASSIS AND PANEL, less Valves and Cabinet, Cash or C.O.D., carriage paid, £11-12-0 or Deposit £1-12-0, balance in 11 monthly payments of 20/-.

Set of 5 specified Valves £4-4-8, or add 7/9 to each monthly payment.

KIT-BITS

Selected C.O.D. Items. You pay the postman—we pay post charges on orders over 10/-.

- 1 Set of Varley B.P. 19. Superhet Coils ... £1 10 0
- 1 Teisan W291, L.F. Transformers, 110 K.C. ... £1 17 6
- 1 British Radiophone type 124A Condenser with Covers and right-hand Trimmers and Slow Motion Dial, type 582A ... £1 18 6

POWER UNIT KIT

Author's Kit of FIRST SPECIFIED PARTS for POWER UNIT ONLY but less Plymax Chassis and Valves

Cash or C.O.D. **£8-13-6**
Carriage Paid.

Extra for Peto-Scott Ready-Drilled Plymax Chassis, 18" x 6 1/2" x 3" ... 7/6

POWER UNIT KIT as above but with READY-DRILLED AND ASSEMBLED PLYMAX CHASSIS, Cash or C.O.D., carriage paid, £9-0-0 or 12 monthly payments of 16/6.

Set of Valves as specified £3-0-6 (including Ediswan Delay Switch, Type DLS1.) or add 5/7 to each monthly payment.

ACCESSORIES

- 1 Sound Sales, 10 Henry Choke, type No. 10 D.C. ... 15 0
- 1 Bulgin L.F.14. 20 Henry Choke ... 10 6
- 1 Ferranti AF5C. Push-Pull Transformer ... £1 14 0
- 1 Claude Lyons, Mains Transformer with Screened Primaries as specified ... £2 10 0

COMPLETE KIT

Comprising Receiver and Power Unit Kits as Combined Kit but with Valves, less Cabinet. Cash or C.O.D. Carriage **£27-17-0**
Paid
or £5-17-0 Deposit: Balance in 11 monthl. payment of £2-4-0.

LET US BUILD YOUR NEW A.C. MONODIAL SUPER-HET

● FINISHED INSTRUMENT

READY built and Aerial tested, complete with valves, but less cabinet. Royalties included, CASH or C.O.D. Carriage Paid.

PRICES AND TERMS ON APPLICATION.

● EXQUISITE WALNUT CONSOLE

As illustrated above. Ideal for the New A.C. Monodial Super-Het, with beautiful toning walnut veneers and ready-drilled front. Ready to take single or dual speakers as required. Cash or C.O.D.

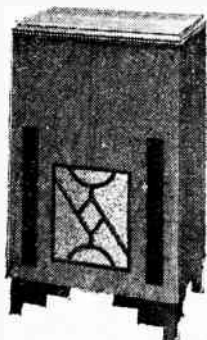

62/-

Carriage 2/6 extra England and Wales, or 8/2 Deposit and 11 monthly payments of 5/3. Carriage Paid.

COMBINED KIT

Comprising Receiver and Power Unit Kits with 2 Peto-Scott Ready-drilled Plymax Chassis and Peto-Scott Ready-drilled Oak Panel, less Valves and Cabinet. Cash or C.O.D. **£20-12-0**
Carriage Paid
or £3-12-0 Deposit and 11 monthly payments of 35/-.

CASH, C.O.D. or EASIWAY

AS FOUNDERS OF CONSTRUCTORS KITS IN 1919, we have established a world-wide reputation for the supply of Complete Kits and Part Kits for all "Wireless World" Set designs. An essential feature of this Expert Service to the Home Constructor is IMMEDIATE DELIVERY FROM STOCK—CASH or C.O.D.—of any exclusively specified or difficult to obtain components. Rely on PETO-

SCOTT, he always gives fullest satisfaction to every customer.

FOREIGN ORDERS. Send one-third value of goods with order. Balance (including forwarding charges) payable to our forwarding agents on delivery. Insurance effected if desired. All orders carefully executed and expertly packed by special export staff.

NOUS DONNONS D'ATTENTION SPECIALE AUX INSTRUCTIONS ÉTRANGÈRES

PETO-SCOTT CO. LTD., 77, CITY ROAD, LONDON, E.C.1. Telephone: Clerkenwell 9406/7, West End Showrooms: 62, High Holborn, London, W.C.1.

Dear Sirs,
Please send me C.O.D. CASH H.P. NEW MONODIAL KIT and for which I enclose £.....s.....d. CASH/H.P./DEPOSIT.
NAME
ADDRESS W.W. 21/7/33

FIRST IN 1919—FOREMOST ALWAYS

Advertisements for "The Wireless World" are only accepted from firms we believe to be thoroughly reliable.

NICORE TUNING COILS



B.P.30. Aerial or Tuned Grid with reaction 10/6
 B.P.31. H.F. Intervalve Transformer with reaction 10/6
 Set of 3 coils ganged on base . . . 33/-

Varley again! Leaders in the new tuning technique as in the old . . . Varley NICORE Coils mark the biggest advance in radio tuning since the introduction of "Square Peak."

Consistency has been the great aim—the characteristics of NICORE Coils will not change in use. In addition, these new coils give maximum efficiency and maximum selectivity.

The use of powdered metal cores is not new to Varley. As far back as 1926 Varley produced some Constant Inductance Chokes with iron powdered cores. Varley NICORE Coils are an outstanding result of years of research. Write to-day for FREE illustrated literature.

Varley

FOREMOST AS PIONEERS

RADIOLYMPIA
AUG 15-24 1/6 DAILY

STAND 85 MAIN HALL

Advt. of Oliver Pell Control Ltd., Kingsway House, 103, Kingsway, London, W.C.2. Tel.: Holborn 5303.

matched perfection



to the front again

The designers of the Wireless World New Monodial Super Het are taking no chances. No less than three components from the Radiophone "Matched Perfection" Range are specified for this splendid new set.

Discerning constructors have realised what professionals have known for years—that all selectivity troubles can be avoided completely by using British Radiophone Products. They are one and all manufactured with such scrupulous care and precision that their performance is never short of perfect. Make sure of success. Ask for British Radiophone components and accept no substitute.

Specified for the

W.W. NEW MONODIAL SUPER HET

British Radiophone 3 gang super-heterodyne condenser complete with cover Type 424A. Price 30/-.
 British Radiophone full vision disc drive Type 528A. Price 8/6.
 British Radiophone Q.M.B. Switch Type 568. Price 1/3.

FIT RECEPTU—the new low loss screened lead-in cable. It improves selectivity and increases sensitivity. 15 ft. length 10/-. Longer sizes at proportionate prices.



BRITISH RADIOPHONE LTD.
ALDWYCH HOUSE, ALDWYCH, W.C.2.

RADIOPHONE GANGED CONDENSERS

The New Monodial Super—

on the mains transformer rated at 4 volts 6 amps., and separate 4 volts 1 amp. windings are provided for each of the output valves. The U.14 rectifier and the vacuum-type delay switch are run from the 4 volts 3 amps. winding, and the H.T. secondary is rated at 425-0-425 volts at 120 mA. The primary is tapped for mains voltages of from 200 volts to 250 volts, and is electrostatically screened from the secondaries.

The rectifier provides some 460 volts unsmoothed across the 4-mfd. condenser C31, and this is dropped to 443 volts and initially smoothed by passing through the 10H. choke Ch4. This smoothing stage is completed by the 8-mfd. dry-electrolytic condenser

The Pentagrid frequency-changer valve may be seen on the right-hand side of the receiver chassis and it should be noted that its holder is mounted on the under side of the base.

C30. The current then passes through speaker fields, or their equivalent, having a total resistance of 1,250 ohms, and is still further smoothed in conjunction with the 8 mfd. condenser C29. The potential across this condenser is about 280 volts, and the supply for the output stage is tapped off; the current for the early stages passes through the choke Ch3 in series with a 1,400 ohms resistance R25, which, with the 8 mfd. condenser C28, completes the smoothing and drops the voltage to the requisite 200 volts.

In this way a very high degree of smoothing is obtained so that reception is completely hum-free, and yet the whole receiver can be operated from, and the field; of dual speakers energised by, a single class C rectifier valve. A maximum of economy is thus combined with a first-class performance.

The precise arrangement adopted in the new superheterodyne will now be apparent, and it remains to describe those details of the construction which are not readily apparent from the drawings and to give details of those adjustments which are essential for the attainment of the optimum performance. The concluding article, therefore, will appear in next week's issue.

LIST OF PARTS

After the particular make of component used in the author's model, suitable alternative products are given in some instances.

- Receiver Unit.**
 1 3-gang Superhet. condenser with right-hand trimmers British Radiophone
 (Polar.)
 1 Slow motion dial British Radiophones No. 582A
 1 Set Superhet. coils Varley BP19
 3 I.F. transformers, 110 kc. Telsn
 (Colvern.)

- 3 5-pin Valve holders Clix chassis mounting type
 1 7-pin Valve holder Clix chassis mounting type
 (Goltone, W.B.)
 1 7-pin Valve holder for 2A7 valve Claude Lyons
 1 5-pin Plug Etigin P3
 (Keystone.)
 1 5-way Battery cable with twin 70/36 leads Harbros
 1 Tapered volume control, 250,000 ohms R14 Centralab 372-097 Rothermel
 (Claude Lyons.)

- 2 Metallised resistances, 1,000 ohms 2 watts R26, R27 Dubilier
 2 Metallised resistances, 100 ohms 1 watt R23, R24 Dubilier
 1 Metallised resistance, 10,000 ohms 1 watt R21 Dubilier
 1 Metallised resistance, 30,000 ohms 1 watt R22 Dubilier
 (Eric, Claude Lyons, Seradex.)
 1 Resistance, 2,500 ohms, tapped at 1,400 ohms, 5 watts R25 Dubilier "Spirohm"
 (Electrad.)

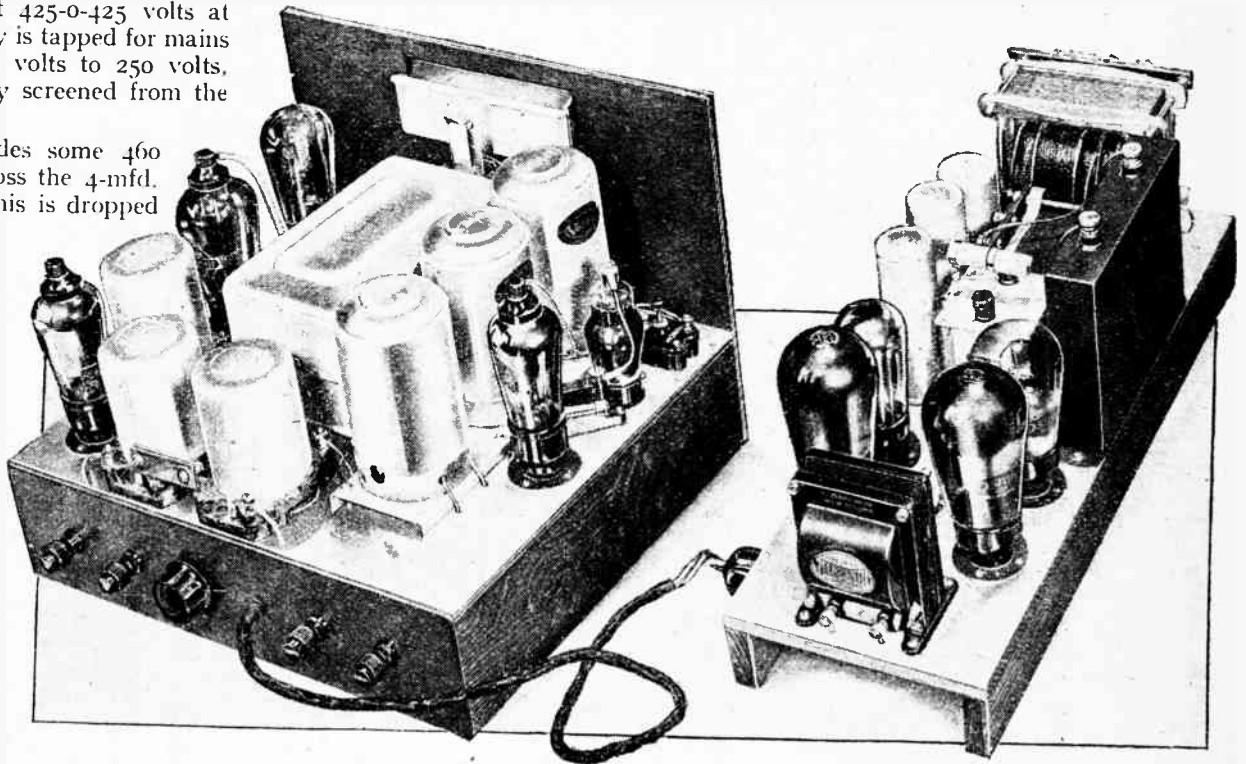

- 2 Toggle switches S2, S3 Bulglin S.96
 1 Toggle switch, make and break S1 Bulglin S.80
 (British Radiophone, Claude Lyons.)
 1 Potentiometer, 5,000 ohms, wire wound R9 Watmel No. 1
 (Haynes Radiofil, Claude Lyons.)
 1 Fixed condenser, 12 mfd. C11 Eddystone No. 929
 4 Terminals, A, E, Pickup (2) Belling-Lee Type "B" R.1
 1 Compression condenser, 0.002 mfd. C4 R.1
 1 Heterodyne filter, 3,500 cycles Wearite W.M.3
 2 Screened H.F. chokes Ch1, Ch2 Wearite Type H.F.P.
 2 Fixed condensers, 2 mfd., 400 v. D.C. test C16, C17 T.C.C. Type 50
 1 Fixed condenser, 1 mfd. 400 v. D.C. test C21 T.C.C. Type 50
 5 Fixed condensers, 0.1 mfd. 400 v. D.C. test C7, C8, C10, C12, C15 T.C.C. Type 50
 1 Fixed condenser, 0.02 mfd. mica, 500 v. D.C. test C23 T.C.C. Type 25A
 1 Fixed condenser, 0.0001 mfd. C6 T.C.C. Type 34
 1 Fixed condenser, 0.01 mfd. C18 T.C.C. Type 34
 5 Fixed condensers, 0.0001 mfd. C5, C9, C13, C14, C19 T.C.C. Type "M"
 1 Fixed condenser, 0.002 mfd. C20 T.C.C. Type "M"
 (Dubilier, Peak, Telsn.)
 1 Electrolytic condenser, 50 mfd. C22 T.C.C. Type 501
 2 Dial lamps, 6 volts Bulglin Type O.B.
 2 Metallised resistances, 10,000 ohms 2 watts R6, R7 Dubilier
 1 Metallised resistance, 1,000 ohms 1 watt R20 Dubilier
 1 Metallised resistance, 2,000 ohms 1 watt R18 Dubilier
 3 Metallised resistances, 20,000 ohms 1 watt R5, R16, R17 Dubilier
 3 Metallised resistances, 100 ohms 1 watt R8, R12 Dubilier
 3 Metallised resistances, 2 megohms R1, R2, R15 Dubilier
 2 Metallised resistances, 0.1 megohm R10, R13 Dubilier
 2 Metallised resistances, 0.25 megohm R4, R19 Dubilier
 1 Metallised resistance, 0.5 megohm R11 Dubilier
 (Eric, Claude Lyons, Seradex.)
 1 Resistance, 2 ohms R3 Claude Lyons
 1 5-way Connector Wilburn
 2 lengths Screened sleeving Harbros
 (Goltone, Leweos.)

- 1 10 henry choke Ch4 Sound Sales No. 10 D.C.
 1 20 henry choke Ch3 Bulglin L.F.14
 1 L.F. Transformer, push-pull Ferranti A.F.5c
 1 Mains transformer, Primary 200/250 volts 50 cycles, Secondaries, 425-0-425 v., 420 mA., 4V.C.T.3A., 4V.C.T.1A., 4V.C.T.1A., 4V.C.T.3A., Screened Primary Claude Lyons
 Clix Chassis Mounting Type
 6 5-pin Valve holders (Goltone, W.B.) Bulglin F3
 1 5-pin Plug (Keystone.) Bulglin F3
 Plymax Baseboard, 15in. x 6in. with 2 runners 15in. x 12in. Peto-Scott
 2 lengths Systoflex, etc.
 Screws: 36 2in. No. 4 R/hd.; 5 3/4in. No. 6 R/hd.
 Valves: 2 Osram or Marconi PX4 or Mullard AC04 or Mazda PP3250; 1 Osram or Marconi U14, or Mullard DW1, or Mazda UT120 500, or Cossor 400BC; 1 Edison DLS1 (Delay Switch).

OLYMPIA RADIO SHOW

Tuesday, Aug. 15th to Thursday, Aug. 24th

Three Special Numbers of The

Wireless World

AUG. 11th. GUIDE TO THE SHOW

What to look for at Olympia. A helpful forecast arranged conveniently under suitable headings, with a full list of exhibitors and a pictorial plan.

AUG. 18th. TREND OF DESIGN

A series of well-illustrated articles describing the year's progress in the design of sets, components and accessories.

AUG. 25th. COMPLETE SHOW REPORT

A full description, prepared by the Wireless World Technical Staff, of new apparatus shown by each exhibitor

- Power Unit.**
 1 Fixed condenser, 4 mfd., 1,500 v. D.C. test C31 T.C.C. Type 101
 (Dubilier.)
 1 Dry Electrolytic condenser, 8 mfd., 500 v. D.C. working C30 T.C.C. Type 902
 (Dubilier.)
 2 Dry Electrolytic condensers, 50 mfd., C32, C33 T.C.C. Type 521
 2 Wet Electrolytic condensers, 8 mfd., 440 v. D.C. working C28, C29 T.C.C. Type 802

The Load Line

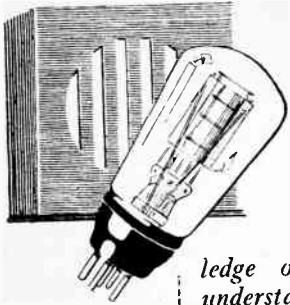

HERE is an explanation of the load line, from which so many important valve calculations can be made. Without a knowledge of its meaning it is difficult to understand how to match the output valve to the loud speaker or to determine the undistorted power which can be derived from the last stage of the receiver.

How Undistorted Output is Computed

By
A. L. M. SOWERBY,
M.Sc.

IN the bald form in which they are presented in the valve-maker's catalogue, valve curves are rather dull and unenlightening, and they seem at first sight to have but little connection with the practical behaviour of the valve as it is used in the set.

The main reason why valve-curves, considered by themselves, do not give much direct information is that they represent the response of the valve to the application of various steady voltages to grid and anode, and it is always assumed in taking them that no resistance or impedance of any kind is connected between anode, or grid, and the battery supplying it with voltage. In a set the voltages with which we are chiefly concerned are not steady, but alternating, while every valve has to have a component in its anode circuit to enable it to provide useful amplification. The official valve curves are therefore only the raw material from which the performance that the valve will give in the set can be deduced.

In practice, the voltage and current changes caused by the reception of a signal do not interest us very greatly except in the case of the output valve, from

an example of the relationship between conventional and operating curves, while at the same time we shall see how the correct loud speaker load for any valve is found, and how the volume of available sound can be estimated for each case. Incidentally, we shall derive a very clear understanding of the rather complicated voltage and current changes taking place at the anode of a valve during the process of amplifying.

Curves for Measurements

In Fig. 1 are reproduced a series of curves connecting the anode voltage E_a of an output valve with its anode current I_a . These curves are obtained from a series of measurements made with a circuit like that of Fig. 2, in which the three meters read anode and grid voltages, and anode current. For any one curve the grid bias, as indicated on the meter E_g , is held constant; the anode voltage read on the meter E_a is raised from zero in a series of small steps, the anode current shown by the meter I_a being noted for each voltage. The resulting figures, when plotted on squared paper, give one

of the curves of Fig. 1, while the whole process has to be repeated, each time with a different value of grid bias E_g , for each of the curves shown on the diagram.

The completed family of curves gives fairly full information as to the anode current resulting from any combination of grid and anode voltages that may be chosen. All values of anode current that can be obtained with a bias of -6 volts, for example, appear on the

third curve, each value being indicated by the point at which the curve crosses the vertical line representing the value of anode voltage chosen. For this grid voltage the anode current is 7 mA. at $E_a=80$, 14½ mA. at $E_a=100$, and 24½ mA. at $E_a=120$. Keeping the anode

voltage at this last value and changing the bias to -9 volts shifts us to the next curve, which shows an anode current of 15½ milliamps.

We will suppose that our high-tension battery gives 150 volts; the grid bias recommended by the makers of this particular valve at this anode voltage is -14 volts. Point A on Fig. 1, at which the curve for $E_g -14$ cuts the vertical line indicating $E_a=150$, will therefore represent the condition of the valve as it

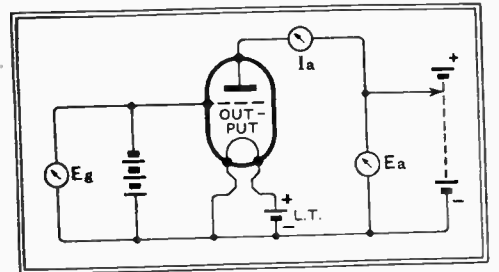

Fig. 2.—Measuring circuit for plotting curves of Fig. 1. For each value of E_g , E_a is varied over a wide range and the corresponding values of I_a are noted.

is used in the set. The anode current, as the diagram shows, will set itself at 15½ milliamps.

To begin with, we will suppose that there is no loud speaker or other component connected between the anode of the valve and the battery, so that the circuit will be that of Fig. 3. The steady state of the valve is already defined by the point A of Fig. 1, but we still have to trace the course of events when a signal is applied to the grid. The voltage of the latter will begin to swing up and down on either side of the fixed bias value, the magnitude of the swing depending upon the amplitude of the signal. What will the anode current do?

Since the anode voltage is fixed at 150 by a direct and presumably resistanceless connection to the battery, the anode cannot depart from that portion of Fig. 1 which gives its possible currents for that voltage. All these values are to be found on the vertical line BC running upwards from 150 on the anode voltage scale; as the signal swings the grid through various momentary voltages the corresponding currents will be shown by the intersection of the appropriate curves with BC. If, for example, the signal has a maximum value of 5 volts, the grid will

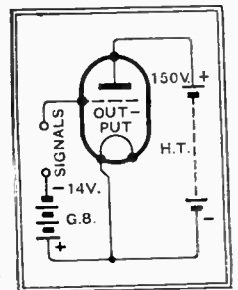

Fig. 3.—Output valve without anode-circuit load. The application of the signal swings the anode current only, along the load line AB of Fig. 1.

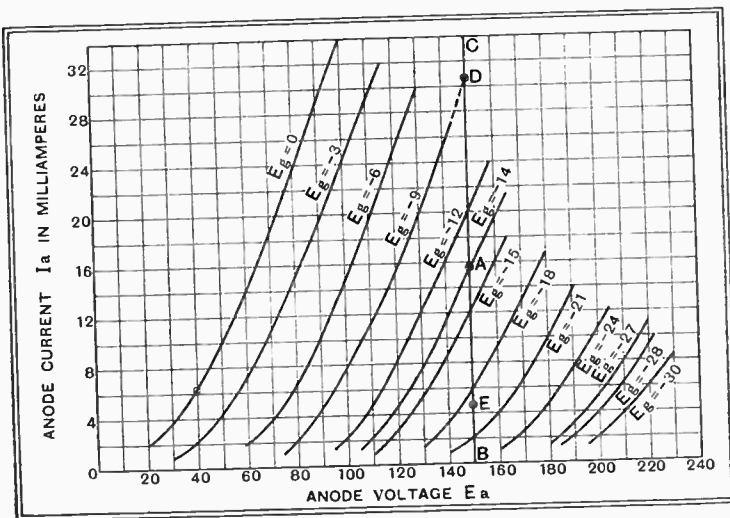

Fig. 1.—Anode volts—anode current curves of typical two-volt power valve. Each curve refers to the grid voltage indicated against it.

which we nearly always need to obtain the maximum volume that can be had before overloading and consequent distortion begin to be manifest. We will therefore restrict our scope to the examination and analysis of the curves of output valves, which will serve as well as any others as

The Load Line—

swing up and down between -9 and -19 volts; the anode current, as the curves show, will swing in sympathy between the values represented by points D and E. A weaker signal, of amplitude only three volts, will swing the grid from -11 to -17 volts, and the anode current will now vary less widely, swinging as before between the points where the curves for these two bias values, if drawn, would cut the vertical line BC.

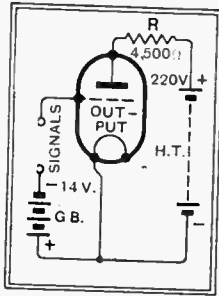

Fig. 4.—Output valve with 4,500-ohm load R, and battery voltage adjusted to correspond. The application of the signal swings both anode current and anode voltage along the load line PQ of Fig. 5.

Having seen the uses of the curves of Fig. 1 by considering this very simple case, we will progress a stage farther and imagine that a resistance is connected in the anode circuit of the valve in place of the loud speaker that would normally be used. The justification for the choice of a resistance is found in the fact that it offers the same impedance to direct as to alternating currents, and so allows us to trace out at our leisure from a D.C. diagram effects which, in reality, are taking place by virtue of the impedance of the speaker to rapidly changing voltages.

At the operating voltages taken, the correct load for the particular valve whose curves are shown will be assumed to be 4,500 ohms. This, then, must be the value of the resistance inserted as in Fig. 4 in the anode circuit. If we insert this resistance there will be a voltage drop across it, the magnitude of the drop depending, as Ohm's law describes, upon that of the steady anode current; to maintain the correct operating conditions for the valve we shall have to increase the battery voltage to compensate for this drop. At $15\frac{1}{2}$ mA. the voltage drop in R will be 4.5×15.5 , or 70 volts; adding this to the 150 volts that we require at the anode of the valve shows that the battery must now be one of 220 volts, as indicated in Fig. 4.

The main difference between this new arrangement and the last is that now any change in anode current will be accompanied by a corresponding variation in the voltage drop across R, and hence by a variation of the voltage on the anode itself. If the anode current drops the anode voltage will rise, approaching a

maximum of 220 (the battery voltage) as the current approaches zero. Zero current at 220 volts is shown by point P of Fig. 5, on which the valve curves are repeated from Fig. 1.

Starting from this point, we can find the voltage on the anode of the valve at various anode currents. At 10 mA., for example, 45 volts will be dropped in R, leaving 175 volts out of the total of 220 for the valve itself. At 20 mA. 90 volts will be lost in R, so that the anode will have a voltage of 130. Similarly, the anode voltage will drop to 85 volts at 30 mA. Plotting on Fig. 5 the points corresponding to these calculated voltages and currents, we find that they mark out the straight line PQ, and from the way in which the points were worked out we know that with the battery voltage held at 220, and the value of R fixed at 4,500 ohms, the valve can only take up voltage current combinations shown by points on this line.

The "Load Line"

The fact that PQ, which is called the "load line," passes through the operating point A is not an accident, but is an inevitable result of so choosing the battery voltage that the voltage at the anode of the valve should be 150 while passing its normal current of $15\frac{1}{2}$ milliamperes.

With the load line drawn across the valve curves, we are in a position to follow the course of events when the grid voltage of the valve in the circuit of Fig. 4 is altered. If we set it at -9 volts the voltage current condition must necessarily

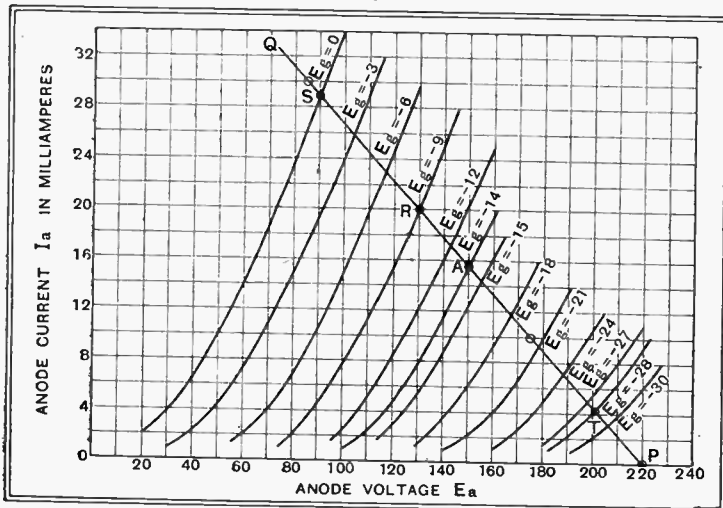

Fig. 5.—The line PQ, drawn across the valve curves repeated from Fig. 1, gives the combinations of anode-voltage and anode-current possible with a load of 4,500 ohms with A as the operating point.

lie on some point of the curve representing a 9-volt bias. But equally it must lie, as we have seen, somewhere along the load line PQ. The only possible values for which both conditions can be simultaneously fulfilled are those given by the point where the curve cuts PQ—at R, where the current is 20 milliamperes, and there are 130 volts on the anode.

We can now extend this argument to see what happens if a signal, the peak voltage of which we will take as 14, is applied to the grid. Such a signal will swing the

grid backwards and forwards over the voltage range 0 to -28 , and the anode current and anode voltage will swing in sympathy along the line PQ between the points where the curves for these limiting voltages cut the load line; that is, between S and T.

In the simpler case already discussed in connection with Fig. 3, we saw that the anode current swung through the series of values marked out by the vertical line AB of Fig. 1, the anode voltage remaining constant. In the more complex case of Fig. 4 anode voltage and

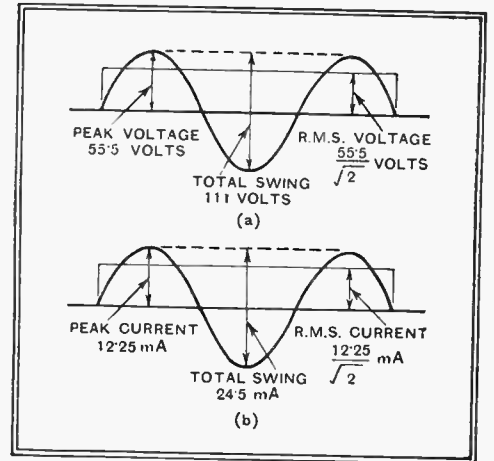

Fig. 6.—(a) Showing relationship between total voltage swing, peak voltage and R.M.S. voltage. (b) The same relationships for current. With a resistance load, power is product of R.M.S. voltage by R.M.S. current.

anode current swing together through the series of values marked out by the load line PQ. In both cases the extent of the swing is controlled by the amplitude of the signal applied to the grid, and extends along AB or PQ as far as the points where the curves for the extreme limits of the grid voltage swing cut the line in question.

Slope of the Load Line

Comparison of the two cases brings another point into prominence. A vertical load line, such as AB, indicates a zero load, while a diagonal line like PQ represents a load of a fair number of ohms. Clearly a lower load than 4,500 ohms would produce a load line more nearly vertical, and a higher load one more nearly horizontal than PQ. The slope of the load line, expressed in voltage change for each change of one milliamperes of current, gives the resistance, in thousands of ohms, of the load it represents. The choice of the correct numerical value of load for any particular output valve is necessary to enable the greatest amount of undistorted power to be extracted from the valve.

Reverting to the case of Fig. 5, we see from the diagram that the total swing of anode current is from 28.7 to 4.2 milliamperes (at S and T respectively), this making a total variation of $24\frac{1}{2}$ mA. Similarly, the voltages taken up by the anode lie between 201 and 90, a range of 111 volts.

There is therefore present at the anode

The Load Line—

an alternating signal voltage of total sweep 111 volts, and hence of peak value $55\frac{1}{2}$ volts (see Fig. 6), and this drives through the resistance an alternating current of maximum sweep $24\frac{1}{2}$ mA., and of peak value $12\frac{1}{4}$ mA. On this information the power dissipated in the resistance can be computed; it is half the product of peak current by peak voltage. In the present case this is $\frac{1}{2} (12\frac{1}{4} \times 55\frac{1}{2}) = 340$ milliwatts. This power, of course, is that due to the signals; the power used up in R by the passage of the steady current has not been taken into consideration. The 340 milliwatts are, in fact, available for operating the loud speaker for which R is standing, and causing it to deliver audible signals.

Undistorted Output

The question of distortion has not been entered into at all in this discussion, but it is not difficult to see that if each separate volt of the total swing applied to the grid evokes the same change in anode current as every other, there will be no distortion. In terms of Fig. 5, this implies that if curves were drawn for each volt of grid bias, they should divide PQ into a number of exactly equal lengths. It is evident from an inspection of the figure that this is not the case, for the curves are more closely crowded together at the bottom right-hand corner of the diagram, where the grid voltages are higher.

Since distortion cannot be eliminated altogether, it becomes necessary to fix some allowable limit on the basis of which to compare the output available from

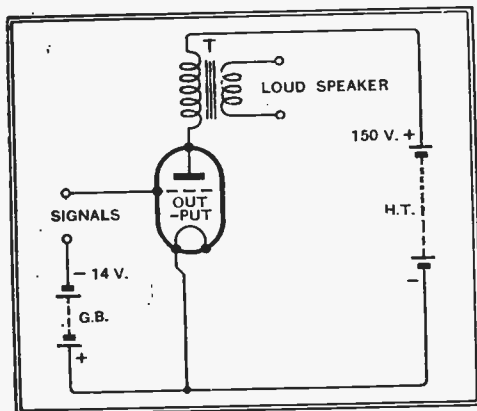
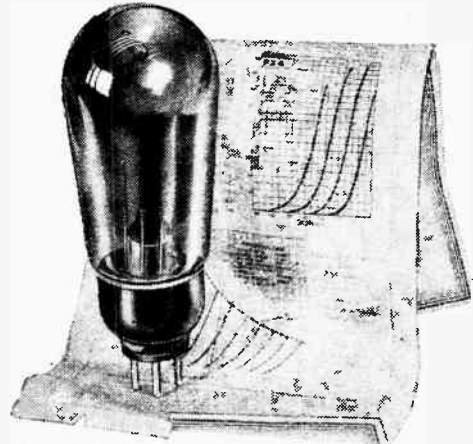

Fig. 7.—Although the output transformer T may have negligible D.C. resistance, the anode voltage will swing, at signal frequency, far above and below the 150 volts of the battery.

different valves. For the case of the triode output valve which we have been considering quite a simple convention is usually adopted. It is laid down that distortion due to the distance AS, taken as a whole, being greater than AT shall be limited, no attention being paid to the equal spacing of points lying between A and S or A and T. Experience shows that a discrepancy in these two lengths just barely begins to make itself manifest by slightly impaired quality of reproduction when AS exceeds AT in the ratio of 11 to 9. This ratio is therefore taken

as that to be satisfied when specifying the load to be connected in the output circuit, and when quoting the "undistorted output" of a valve.

When working out the correct load and



A typical output valve with the data supplied by the makers. From this sheet of details the load line is derived.

the undistorted output from any valve it is almost always assumed that the load will be a pure resistance, and that the voltage of the anode current supply will be augmented sufficiently to keep the anode of the valve at its normal working potential in spite of the introduction of this resistance. In practice, however, this is never done; the anode supply voltage is not raised above the normal value, and a loud speaker or output transformer of negligible D.C. resistance is connected in the anode circuit as in Fig. 7. It would seem at first sight that the anode voltage can now never rise above the normal working value, since there are no extra battery volts.

It is true that if in Fig. 7 the grid-bias battery is augmented from 14 to 28 volts, the anode voltage will not rise, any more than it did in the almost equivalent circuit of Fig. 3. The cases, indeed, are exactly parallel in that neither anode circuit contains any resistance to speak of to direct current. But there is a distinction, and a very big one, when rapidly alternating grid voltages, such as those due to the signal, are applied. Towards the rapidly changing anode currents called forth by the signal the transformer primary offers a very appreciable impedance; the natural result of this is that as the alternating currents flow through it a voltage is set up across it. Since the zero point round which this voltage is built up is the steady anode voltage of the valve, there are instants when the voltage at the anode is considerably in excess of that of the battery.

If we consider that to the grid of the valve of Fig. 7 there is applied an alternating voltage, at first very slow, but gradually increasing in its rate of alteration, rather a curious point comes to light. For the slowest alternations the transformer has no appreciable impedance, so that the load line corresponding to it is vertical. As the rate of alternation increases the load begins to be effective, and the load line swings over to the left and

takes up a position similar to that of PQ. There is thus the possibility that for full description of the behaviour of the output valve it might be necessary to draw a separate load line for every frequency, each line passing through the operating point of the valve, and having an angle expressing the impedance of the speaker to the particular frequency.

In practice no one ever bothers with such a family of load lines, but instead one assumes that the impedance of the speaker is roughly constant. The value that it should have, as an average over the audible scale, is found by examination of the curves of the valve it is to follow.

In finding the best load for a newly developed valve the maker of it will lay a rule on the working point A and try, by swinging the rule round about that point, to find a load line such that the 11 to 9 ratio already mentioned is exactly satisfied when the maximum permissible grid swing is applied. From this can be worked out in the manner already detailed the power available with this working point, for which the load has already been adjusted to be that giving greatest output at the predetermined level of distortion. Then a new working point is tried, taking it a little higher or lower than A on the vertical line AB of Fig. 1; keeping, that is to say, the anode voltage at its full rated value but trying different values of bias. For each of these the output available at the maximum distortion permitted is found as for the first point. Comparing the outputs for each of these tentative working points, the one for which the output is greatest can be found. The value of bias which gives it and the load that fits it best are then included in the instruction leaflet.

FIVE-METRE 'PLANE TESTS.

THE following is a list of the observers who sent in the most useful reports of 6GSM's signals on Sunday, July 9th.

On the Outward Journey (covering period 10.38 to 12.10).—E. J. Armstrong, G2RM, Burgess Hill, Sussex; Harry E. Smith, G6UH, Limsfield Common, Surrey; R. C. Richards, Seven Kings, Essex; R. E. Waters, Peckham Rye, S.E.15; R. J. Denny, G6NK, Weybridge; C. A. Reid, BRS910, Finchley; A. L. Beedle, Balham, S.W.12; E. H. Robinson, G2VW, Slough, Bucks; J. Paine, BRS1132, Slough, Bucks; E. W. Rawlings, G5RS, Guildford, Surrey; E. J. Pearce, G2JU, Harrow; R. C. Neale, G6GZ, Farnborough, Hants; W. A. Dunc-ton, Sidcup; H. L. O'Heffernan, G5BY, at Firlle Beacon, Surrey.

Liverpool, Manchester and Birmingham Districts (5.08 to 7.40 p.m.).—W. W. Kenyon, Liverpool, 15; I. D. Auchterlonie, G6OM, Heswall, Cheshire; J. Davies, G2OA-G5MT, Liverpool; W. Lucas, G2OI, Winton, Manchester; B. Webster, Eccles, Manchester; A. R. Laud, G2ASF, Bradford; J. H. Bateman, G6BX, Bradford; R. E. Summerfield, G6RK, Yarlley, Birmingham; J. S. Owner, G6XQ, Birmingham; G. A. Swinnerton, G2BJR, Smethwick, Staffs.

London District: Inward Journey (8.50 to 9.10 p.m.).—R. C. Richards, Seven Kings; A. L. Beedle, Balham, S.W.12; E. H. Robinson, G2VW, Slough, Bucks.

PRACTICAL HINTS AND TIPS

S.R.J.

EVEN though the usual precautions have been taken, it is not uncommon to find that a certain amount of H.F. energy reaches a mains-operated receiver from the power supply circuits, and is responsible for an excessively noisy background. This is particularly likely to be troublesome when the set is fed from D.C.; it is to users of this type of supply that these remarks are mainly addressed.

Mains Filters

Comparatively elaborate H.F. filters for interposition between the set and the supply mains have been suggested in these pages, and it is true that in certain cases a pair of high-inductance coils are necessary. Due to the fact that a D.C. set consumes a good deal of current, the resistance of these chokes must be kept low if an appreciable loss of voltage is to be avoided.

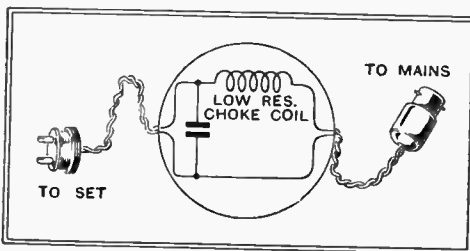

Fig. 1.—A simple anti-interference filter for inserting in the mains supply leads.

Experimental work that has been recently conducted proves conclusively that certain forms of interference may be eliminated completely by means of the simple and inexpensive filter shown diagrammatically in Fig. 1. The point about this filter is that it includes a single choking coil, by means of which the disturbing impulses are prevented from gaining access to the receiver circuits. A device of this sort is quite valueless unless the choke be connected in the right lead, and this is a matter that can be determined only by trial and error. Fortunately it only takes a moment or two to change over the choke to the other lead if, in its original position, it fails to reduce the interference.

In many cases a coil of about 100 turns of No. 22 wire on a former of roughly 2 in. or 2½ in. in diameter will meet the case. In the absence of anything better, an obsolete tuning coil may be tried, but it should be remembered that the D.C. resistance should not amount to many ohms, or the behaviour of the set may be impaired. Where a number of coils are available, it is worth while trying the effect of different inductance values.

Simplified Aids to Better Reception

The capacity of the by-pass condenser is not critical; anything from 0.1 mfd. upwards may be expected to prove satisfactory, and as low a value as 0.002 mfd. will sometimes be effective.

Although there is always an element of uncertainty with regard to the cure of interference in D.C. mains receivers, the device described is so simple and inexpensive that it is always worth a trial even if the interference is but slight. As often as not it will work, as the patent medicine advertisements used to say, "like a charm."

THERE is a tendency nowadays to "shorten the grid base" of variable-mu H.F. valves. In other words, for a given reduction in sensitivity the increased negative grid bias applied to a modern valve will be less than that necessary for its older counterpart.

The Volume Control Position

As a result of this change, the substitution of a modern valve often gives the erroneous impression that the set has become less sensitive. This is due to the fact that, to maintain the original average sensitivity, the volume control pointer must be set nearer the "maximum" end of its travel. In any case, the position of the volume control pointer is not a good indication of sensitivity, and a set should really be judged from this standpoint only when the control is at maximum.

FROM the point of view of stability, it is often possible to add a push-pull output stage to an existing receiver without making any internal alterations. The addition of a "straight" L.F. stage in this way will usually involve such a great increase of overall magnification that stray inter-circuit couplings will produce motor-boating, but push-pull tends to prevent this trouble.

But in another direction there is a possibility of introducing distortion by adding an L.F. stage—even push-pull—at random and without due consideration. Most modern detectors are arranged to give best results with a fairly large input; with considerably smaller inputs than those legislated for by the designer, rectification will no longer be linear, and serious harmonic distortion will take place.

Without making sweeping alterations the only practical way of overcoming this difficulty, and at the same time retaining full amplification for use when it is needed, is to fit a post-detector volume control at some convenient point in the L.F. amplifier. Where resistance coupling is used a grid potentiometer or an anode potentiometer may be employed without risk of impairing the amplifier characteristics; with transformer coupling it is not so easy to devise a perfect control, but usually the connection of a variable resistance across the transformer primary will prove satisfactory. For reproduction of strong signals, where the best possible quality will be required, overall L.F. amplification may, with the help of this control, be reduced to such a value that the detector is working under the best possible conditions for the avoidance of harmonic distortion.

WHERE an insulated wire is passed through a metal base-plate or screen especial care should be taken to preclude the possibility of a short-circuit. In some cases it is as well to supplement the normal insulation by a tubular sleeve, or, better still, by a rubber bush if the wire is likely to be subjected to strains.

Avoiding Short-circuits

Insulation is particularly likely to fail if a wire is bent sharply at the point where it emerges from the hole (see Fig. 2, A). When metal-covered plywood is used as a baseboard,

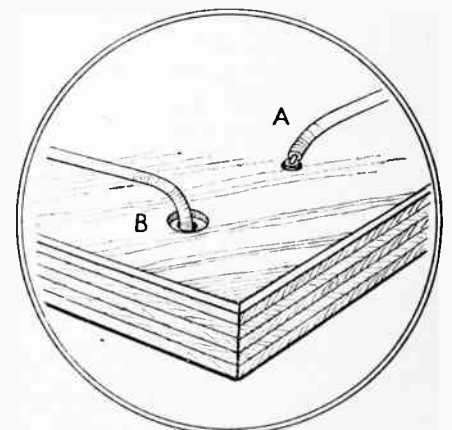

Fig. 2.—Metal-covered plywood; counter-boring wiring holes.

the possibility of this trouble is greatly reduced by drilling a small hole for the wire and then, with a larger drill, cutting away the metal surrounding the hole, as in Fig. 2, B.

UNBIASED

By FREE GRID



Divorced

To and Fro

FROM a preliminary private view which I have had of a representative collection of new receivers intended for exhibition at Olympia, I am disquieted to note that the type of receiver in which the loud speaker is incorporated will be decidedly in the ascendant.

I don't know about you, but, speaking personally, I don't like a loud speaker blaring away right by my ear, nor do I like having to keep jumping up like a jack-in-the-box every time I wish to tune in another station; yet, with this type of set, you have to choose between one of these two evils. Either you have got to have the receiver by your armchair and risk injury to the ear drums, or you have got to stick it at the other side of the room where the controls are out of reach.

There is, of course, a way out of this trouble other than my suggested one of having the loud speaker divorced from the receiver, and that is to have a remote tuning control unit fixed to the old armchair; but somehow or other these things have never taken on in this country, and, in any case, there is another reason for having a separate loud speaker, and that is you can sling it up on the wall in a position where it is found to give the most pleasing reproduction according to your own particular tastes and the acoustic properties of the room.

Tea at the N.P.L.

WHEN attending the annual "Tea Party" at the National Physical Laboratory the other week I was interested in the method adopted for producing a million volt spark; it was none other than a modification of the old method of deriving H.T. from the L.T. battery which certain of my correspondents "invent" with unfailing regularity week after week. The method of H.T. production to which I refer, of course, is to charge a large number of fat condensers in parallel across the L.T. battery and then to stick 'em all in series and so get a high voltage discharge.

The various methods brought forward by my readers for connecting up vibratory multi-contact switches so that the condensers are in parallel across the L.T. battery at one instant and in series across the H.T. terminals the next have always shown remarkable evidence of misplaced

genius. The arrangements at the N.P.L. showed definite evidence of genius, but it was not misplaced, and the results were truly impressive.

For the edification of visitors, the million-volt high-tension apparatus was hard at work disrupting wooden rods into slivers in a most spectacular fashion. The demonstrator offered to try the effect of the discharge on my precious umbrella, but I indignantly refused.

Television on the Car

AS I prophesied somewhat earlier in the year, the development of car radio is proceeding apace. Already experiments are being conducted with a view to the use of television apparatus, and it would not surprise me if a special company were formed for the development of the scheme. It is not intended, however, that the television apparatus be used for amusement purposes. On the contrary, it is hoped to develop it so that it becomes of real assistance in navigating the car during foggy weather.

The idea is that in a dense fog the front of the car should be fitted with a powerful "lamp" radiating infra-red rays. This, by itself, would not, of course, assist the motorist in the slightest degree to see what lies in front of him. It is quite different with television apparatus, which, as is well known, will quite cheerfully deal

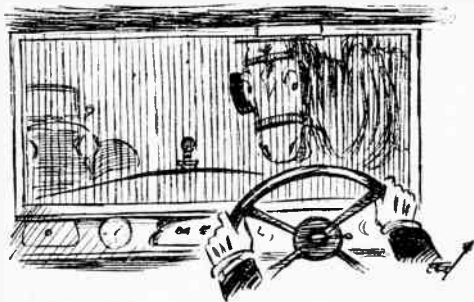

Steering by television.

with any subject "illuminated" solely by infra-red rays. The infra-red ray lamp will pierce the fog and the combined television transmitter-receiver on the car will do the rest, and pictures of approaching traffic will be flung on to the windscreen.

Tests are at present being carried out, using ordinary daylight, and some truly extraordinary results have been obtained. The windscreen and indeed all the windows of the experimental car are blocked up so that the driver has to rely solely on what he sees on the television screen.

I am sworn to secrecy regarding a privileged trial run, and can only say that the whole experience was uncanny in the extreme, and I am wondering whether the police officials will look on the scheme

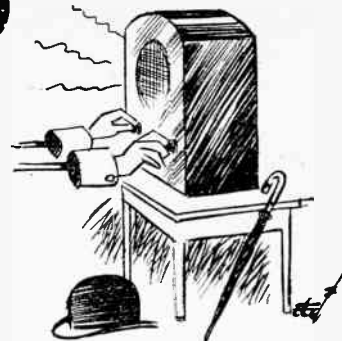

... from the receiver.

with favour or not. It is hoped to make the real trials during the usual November fogs, and I hope to arrange to secure for "W.W." the exclusive right of publishing technical details when they are "released."

Patentable ?

AS a result of my mentioning the other day that I was plagued with would-be inventors who wished me to perfect their half-baked ideas I have been bombarded by letters from more of the fraternity, who have wrongly interpreted my remarks as encouragement. Among the bunch there are some really excellent ideas which are obviously patentable, and it is, I think, strange that their originators should not perceive this fact.

The gem of the bunch is an idea for cutting out mutual interference with tuning which sometimes occurs when two aerials run parallel and very close to each other in adjacent suburban gardens. The plan is ingeniously simple; the originator of it suggests that the two neighbours should use each other's aerial poles so that their respective aerials are no longer parallel to each other. The chances are about a million to one against any two aerials being exactly the same height, and so they would not make contact at the cross-over. The only trouble is that my correspondent thinks he can patent the idea. What are your views on the subject?

Acoustics in the Courts

I AM rather surprised at the statement made by a well-known Sunday newspaper to the effect that certain police courts are being fitted with a microphone and headphone installations for the benefit of "deaf magistrates and other officials." If this be so it points to a strange state of affairs, for one must infer that, prior to this installation, magistrates have been following their cases by lip reading or some similar method. I have heard of justice being blind, or reputedly so, but never deaf.

The most charitable view that I can take is that the installation required is simply to combat the poor acoustic properties of certain courts which, as I can assure you from personal experience, are really deplorable in this respect.

LABORATORY TESTS

New Radio Products Reviewed



SATOR COMPONENTS

SEVERAL different styles of resistances, both fixed and variable, also a range of tubular fixed condensers with wire ends, are marketed by Orion Lamps, Ltd., 72, Oxford Street, London, W.1, under the name of Sator components. The small fixed resistances are available in 0.75-watt, 1.5-watt, and 4-watt types, the prices being 4d., 5d., and 6d. each respectively. The first two mentioned are of the composition type, and consist of a porcelain rod coated with the resistance compound and then lacquered. Metal end-caps are fitted, and either type can be obtained with or without wire ends.

A few specimen 1.5-watt resistances of 10,000 ohms nominal value were measured, their actual resistances being 9,900 ohms, 10,500 ohms, and 10,020 ohms. These show a good agreement with the marked values, being well within the usual tolerance of plus or minus 10 per cent. When dissipating the maximum watts the temperature of the resistor did not rise above normal, the lacquer coating showed no signs of softening, and on completion by the test the measured resistance was the same as before.

Of the several different types of wire-wound volume controls made, the linear models R.K. (1.2 watts) and R.K.G. (2.5 watts) and the graded types L.R.K., Mu L.R.K. (0.7 watt), L.R.K.G. and Mu L.R.K.G. (1.75 watts) are of greatest interest to the home constructor. The types preceded by the word "mu" are fitted with a wire element graded especially for use with variable-mu valves. Ninety per cent. of the resistance is contained in the first half and ten per cent. in the second, this division of values having been found very suitable for this style of volume control.

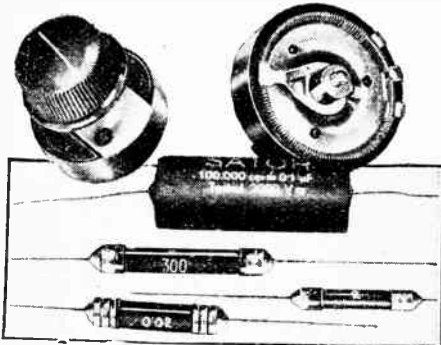

Selection of Sator components, including fixed resistances, tubular condenser, and wire-wound volume control.

They are made in all the used values, and the prices are very reasonable. A 50,000-ohm type R.K. costs 4s. 6d., a 25,000-ohm type L.R.K. or Mu L.R.K. 4s. 9d., while a 50,000-ohm Mu L.R.K.G. (1.75-watt) costs 5s. 3d. For a single H.F. valve the 0.7-watt model is suitable. Some specimens have been tested and found perfectly satis-

factory. The resistances are in close agreement with the marked values, and they are perfectly silent in operation.

Sator fixed condensers are made in values extending from 0.0001 mfd. to 0.1 mfd., and the prices range from 6d. to 1s. 4d., according to size. They are tested at 2,000 volts D.C.

MAGNUM SLOW-MOTION DIAL

MADE by Burne Jones and Co., Ltd., Magnum House, 296, Borough High Street, London, S.E.1, this slow-motion dial gives a drive reduction ratio of six to one. It will fit any make of condenser having a 1/4 in. spindle, and provision is made to at-

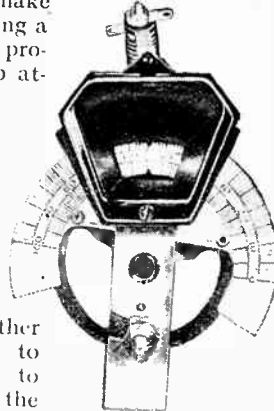

Magnum slow-motion dial.

tach the dial either to the condenser, to the baseboard, or to the front panel, the fixing being equally secure whichever form of mounting is adopted.

The scale is engraved on a translucent disc illuminated from the back, and is obtainable with a 0-100 division scale or with one marked in wavelengths, the latter being calibrated to suit the Magnum screened coils.

The dial is assembled on a cadmium-plated bent steel frame, and the price is 3s. complete.

ELECTRO DYNAMIC H.T. CONVERTER TYPE D.

THIS is a compact self-contained unit designed especially for use with battery-operated receivers, and enables the high-tension supply to be taken from the L.T. accumulator, models being available for use with two-, four-, or six-volt batteries. The type D is rated to give 150 volts at a maximum current of 30 mA., and thus the output is quite sufficient to meet the requirements of practically every type of battery-operated set. In many cases there will be a sufficient surplus to justify fitting a slightly larger power valve in the output stage.

The unit is assembled on a stout steel baseplate, and consists of a small rotary converter, H.T. smoothing equipment, and an L.T. filter, the latter being included to prevent the commutator ripple reaching the filaments of the valves.

The converter has a double-wound armature with a commutator at each end. It runs in ball bearings which are self-lubricating and require no attention, and in order to minimise vibration and mechanical noise is mounted on Sorbo rubber pads. This type of mounting is so effective that the machine is inaudible a few feet away. Carbon brushes of the box type are fitted, and these are

claimed to give 4,000 hours' working before renewal becomes necessary. They are self-adjusting.

The specimen sent to us operates on four volts, but provision is made for using it in conjunction with two-volt valves.

On test the following results were obtained:—

Input.			Output.			Efficiency, per cent.
Volts.	Current in Amps.	Watts.	Volts.	Current in mA.	Watts.	
4.0	1.04	4.16	199	1	0.199	4.8
4.0	1.21	4.97	189	5	0.945	19
4.0	1.46	5.84	175	10	1.75	30
4.0	1.72	6.88	164	15	2.46	35.8
4.0	1.96	7.84	152	20	3.04	38.8
4.0	2.24	8.96	140	25	3.5	39.1
4.0	2.47	9.88	129	30	3.87	39.2
4.0	2.68	10.73	119	35	4.01	37.7

Although we did not obtain quite so good an efficiency as the makers claim, we yet regard the performance as exceptionally good in view of its small size.

The converter was used with a sensitive superheterodyne receiver, and the results obtained were perfectly satisfactory. The almost entire absence of background noise was very marked, and, apart from a faint ripple when listening close to the loud speaker, there was nothing to indicate that the set was not working from batteries in the usual way. The only precaution that need be observed is to be sure that the L.T. accumulator is of sufficiently large capacity to stand a continuous drain of 2.5 amps. in addition to the requirements of the valves.

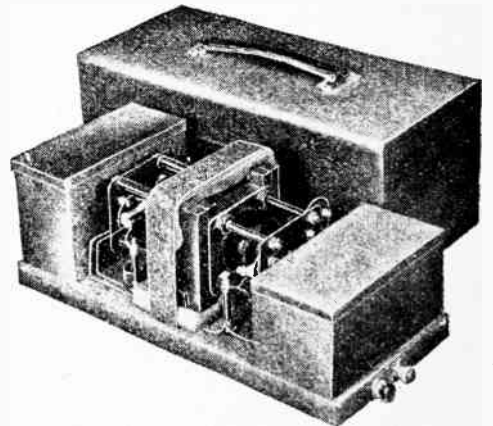

Electro Dynamic H.T. converter type D with cover removed showing the machine and filter units.

The makers are Electro Dynamic Construction Co., Ltd., Devonshire Grove, London, S.E.15, and the price is £7 10s.

TRADE NOTE

Mr. P. G. A. Voigt, for some time chief research engineer of Edison Bell, Ltd., has acquired the stocks of Edison-Bell-Voigt moving coil loud speakers and electrostatic microphones and has formed a company to carry on the manufacture of high-grade electro-acoustic devices. The address of the new concern is Voigt Patents, Ltd., The Courts, Silverdale, Sydenham, London, S.E.26, and deliveries of loud speakers and microphones can be made from stock.

"Ultra-Shorts" from the Air

G6SM's Own Story: Listeners' Reports

By S. G. MORGAN



The Gypsy Moth ready for the start. The aerial can be seen slung between the left rear strut and the tail plane.

ON Saturday evening, July the 8th, a short test flight was made around Croydon, during which signals from the 'plane were received at great strength on the ground, but with a good deal of interference from the engine and rush of air in the slipstream from the propeller.

On the previous Wednesday, H. L. O'Heffernan (G5BY) and I had taken our gear to a well-tryed spot on the South Downs, Firle Beacon, where we carried out tests with G6UH who had located himself on the North Downs at Leith Hill. Good signals were obtained at each end and we had the satisfaction of knowing that everything was ready for the big test. The morning of July the 9th was rather overcast, with bright intervals.

Signals Held by Listeners

We took off, my pilot, R. Lindsay Neale, and I, at 10.38 a.m., and straightway realised that the trip would be a bumpy one with a strong headwind. Almost from the take-off many people heard our signals. They were followed right across London and beyond until about midday by listeners in Peckham, Seven Kings, Weybridge, Finchley, Balham, Slough, Guildford, Harrow, Sidcup and Farnborough, and by G5BY at Firle Beacon and G2RM at Burgess Hill, Sussex. These two stations may be credited with the best reception of the day, as they were able to follow our signals until 11.40, when we were about 80 miles away from them. Although reports were received from these widely scattered districts, not one authentic report was received from the centre of London. This is rather a bewildering fact as it is known that there were some receivers active in Central London. The International Short Wave Club Station on the "Daily Telegraph" building reports hearing signals at 11.30 which

were believed to emanate from the 'plane "when it was near Aylesbury" and which is in agreement with the log.

We crossed London at about 3,000 feet and called in at Heston to collect a map, while I took the opportunity of changing one of the oscillator valves which showed signs of losing its emission. (Heston, 10.55 to 11.10.) After leaving Heston we climbed again to the cloud base, about 2,500 to 3,000 feet.

All the time the wind had been increasing in force and the bumps became worse, until we were finally receiving a very bad buffeting. Another of the oscillator valves then gave up owing to its filament being jarred to bits. We were just near Halton R.A.F. Aerodrome so a call was made there and the valve replaced. The weather soon became worse. The head wind seemed to have increased—the pilot estimated it at times at 50 m.p.h. From Halton we immediately shaped our course for Birmingham, where we flew around the University Tower, giving a few calls to the people who were listening. It was then realised that all was not well with the modulator. The oscillators were behaving normally, as could be seen from the anode feed, but the normal slight variations in anode feed due to modulation could not be detected in the oscillations that the needle of the milliammeter was making, due to the severe vibration. We were so much behind schedule that I decided to push on and to trust that the trouble would cure itself (1.20 p.m.).

Overcoming Engine Noise

I was, by the way, giving a running commentary on our progress during the whole of the flight. The engine and "flying" noises had been reported as obtruding so much into the transmission that the rough and ready expedient of turning down the gain control at the input

end of the modulator and shouting more loudly into the microphone had to be adopted—to the great detriment of one's vocal apparatus!

We made a landing in a field near Aldford, five miles from Chester at 2.15 p.m., in order definitely to ascertain how much fuel we had left. The bottom of the tank was only just covered. We had been using a great deal of petrol in our struggle against the headwind.

After sundry difficulties we got into the air again at 3.31 and eventually arrived at our destination, Hooton Park, Liverpool, at 3.40 p.m.

The transmitter was unslashed and the cause of the trouble was traced to a fracture, inside its insulating covering, of a 16 S.W.G. copper wire supplying the driver valve with filament current. Another lead was substituted and everything was working beautifully again. No further trouble was experienced during the rest of the day.

We took off again at 5.08 p.m. It was manifestly impossible for us to adhere to our schedule in order to be back at Croydon by sunset at 9.10, as we were without navigation lights for night flying. It was therefore much to my regret that we had to miss Leeds, Bradford and Hull on our return journey. The best possible compromise was, however, effected. We flew in a northerly direction along the South side of the Mersey, and then proceeded to Manchester, via Warrington.

The sky was overcast and the "ceiling" was still fairly low. It was while we were over the Manchester Ship Canal and while

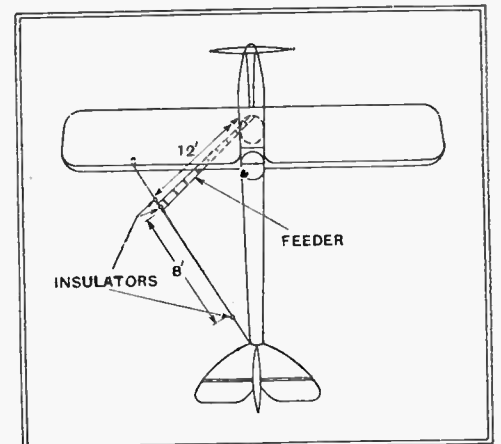

Diagram of the aerial arrangement. The 12ft. feeder wires (three-quarter wave) were separated by ebonite strips.

subsequently crossing the Pennines that we attained our greatest possible height, about 3,500 feet.

Reports on our signals have been very

"Ultra-Shorts" from the Air—

numerous from the Liverpool, Manchester, Leeds, Bradford and Birmingham districts. Our speech was picked up in Manchester and district whilst we were over Liverpool and was followed and reported from Liverpool and Bradford whilst we were over Manchester and the Pennines. A great

No signals were reported from soon after the time at which we ran into heavy weather. This suggests the possibility that thick banks of cloud or rain cast "shadows" or act as effective blankets to ultra-short waves. Several reports mention the fact that signals fluctuated wildly soon after this weather was encountered, which

consisted of a standard G.P.O. solid back microphone coupled through a suitable transformer to a Marconi LP2 valve driving, through a standard "Multitone" 1:1 Class "B" transformer, two Mazda PD220 valves in parallel. The conditions of operation for two Mazda PD220's in parallel are as follows:—

Anode volts	150
Quiescent current per pair of anodes	2.5 m.a.
Anode to Anode load	6,500 ohms.
Min. Grid Input Resistance ..	1,700 ohms.
Power Output	5.1 watts.
Power required from Driver (80% efficient transformer)	195 mW.

A larger power output may be obtained by increasing the driver power output.

The oscillators drew a current of 50 ma. at 150 volts and a special output transformer for the Class "B" stage was built by Messrs. Varley to conform with the above-mentioned characteristics. The oscillator valves were some of the old Ediswan type PV625A, which have been found to be ideal low power oscillators.

The oscillator unit is normally quite separate from the modulator and can be mounted, if desired, in the middle of the antenna system and fed with current through a three-way cable, which terminates on the small sub-panel carrying the Belling-Lee terminals and mounted on the output transformer. The antenna on G-ACCY consisted of a half-wave radiating portion fed through a three-quarter wave double feeder wire, mounted as shown in the drawing.

The receiver uses almost the same cir-

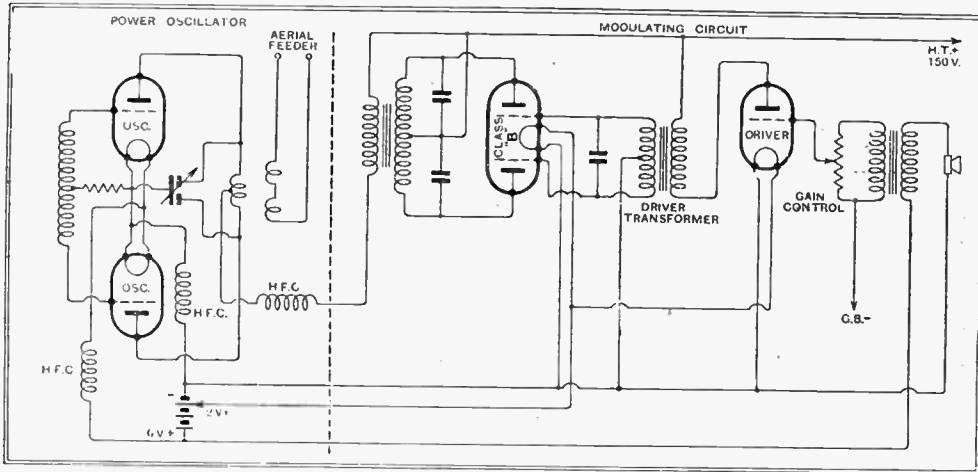

The circuit diagram of G6SM's transmitter. The push-pull oscillator unit is on the left. On the right is the Class "B" modulator.

many were able to follow us until we were 40 to 60 miles distant, but no greater ranges were, as far as we know, achieved in the north, owing to our comparatively low altitude.

From Manchester (5.42) we flew via Stockport (5.45) and Glossop (5.53) over the Pennines, thence to Chesterfield (6.13) Derby (6.29) and on to Loughborough and Ratchliffe Aerodrome (6.41), where we landed to stretch our legs.

Do Clouds Cause "Shadows" ?

While still some way from Derby we had been picked up by two or three amateurs in Birmingham, over forty miles away. G6RK, in fact, heard us when we were nearly 60 miles distant.

Our signals were held by these listeners for some time after leaving Ratchliffe, past Leicester (7.25) to Market Harborough (7.29).

Time was getting on, so we dropped down to about 1,200 feet so as to increase our speed, and we proceeded towards Northampton, and thence over Fenny Stratford, Leighton Buzzard, Tring and Berkhamsted to St. Albans, where we made a short stay of ten minutes to take on a few more gallons of petrol (8.35-8.45). We crossed the Thames again at Hammersmith at 3,000 feet, and landed at Croydon at 9.11 p.m.

Our signals had been picked up while approaching London from the North and were followed almost up to the time when we landed.

To summarise the results of the test: Many listeners were able to hold signals up to a distance of 50 miles or so, and this, taking into account our comparatively modest height owing to weather conditions and the low power input to the oscillators (about 7 watts at the start, falling to 5 watts at the conclusion of the tests) is very encouraging.

again lends force to this theory. These effects may, however, have been due to the failure of the modulator at this critical period.

It is most certainly hoped that it will be possible to use these to the full in a further flight at some future date, when, perhaps, the anticipated results will be obtained.

If it is only for the amount of enthusiasm which they have aroused, the tests have

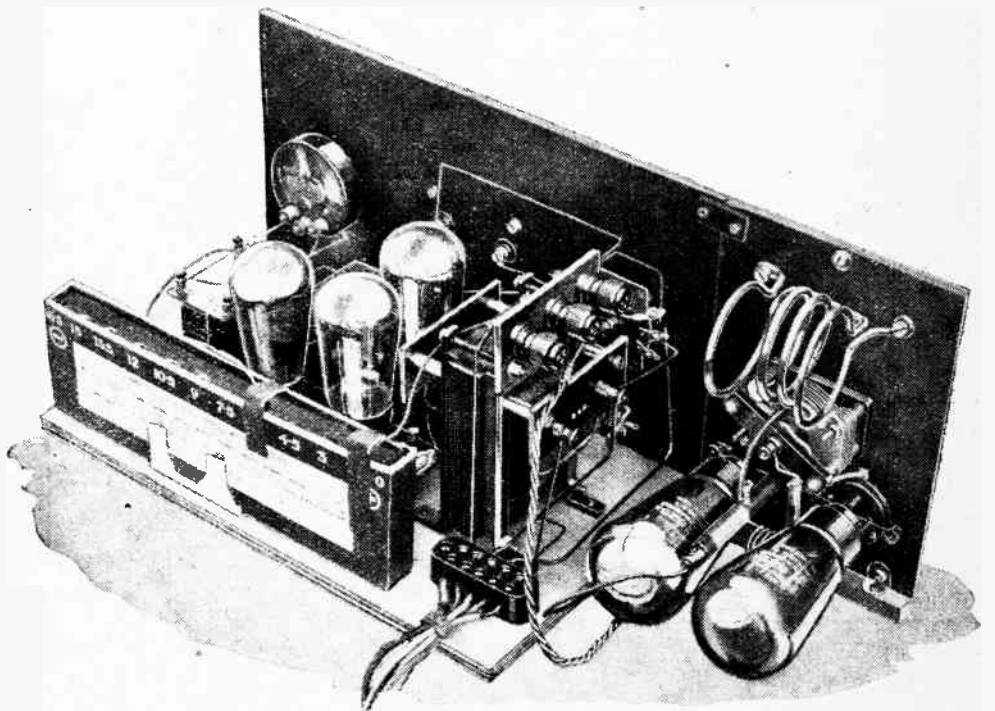

The complete transmitter showing the oscillators in push-pull on the right.

been extremely valuable. This keenness is especially apparent in the North and Midlands, and it is safe to prophesy that with so many ardent experimenters co-operating in ultra-short wave work, these "useless" frequencies will be put to great account in the near future.

The modulating unit on the 'plane set

cuit as that employed for the "Wireless World Ultra Short Wave Two." The main difference lies in the fact that the aerial is coupled to the grid of the detector through a J.B. 0.00001 trimming condenser.

A list of observers who sent in the most useful reports will be found on another page.

Burrell 3-valve A.C. Receiver

An Inexpensive Set Giving Outstanding Volume and Quality

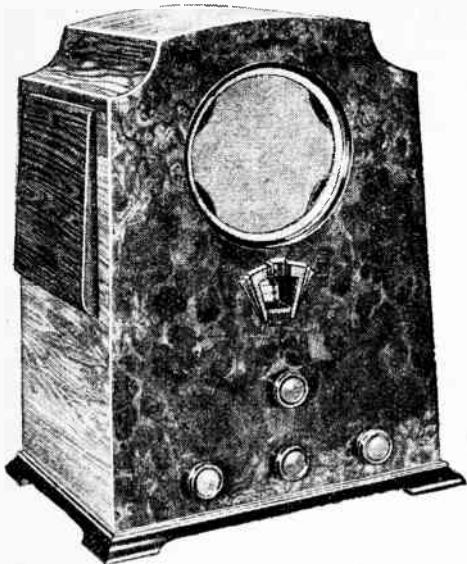

WHILE the majority of prospective purchasers of receiving sets demand a reasonably high performance in the matter of range and selectivity, there can be little doubt that the final choice rests upon the quality of reproduction of the local station. From this point of view the Burrell A.C. set is outstandingly good, the more so since the price is by no means high. It is obvious, from the moment of first switching on, that the power-handling capacity of the output valve is much above the average, and it is reasonable to conclude that a fairly high anode voltage is used. As a result there is no apparent distortion of modulation peaks when the average output is of the order of 1 watt, which is more than sufficient for a large living-room. The reproduction is exceptionally clear and has that elusive two-dimensional quality which makes the individual instruments of the orchestra stand out clear of one another. In view of the small diameter of the loud-speaker diaphragm, it is unreasonable to expect a truly proportional bass response, but the makers have wisely refrained from spoiling the good effect produced in the middle and upper registers by introducing a false resonance in the bass. It was found possible, however, to considerably improve the balance by increasing reaction and correspondingly reducing the volume control. This has the effect of appreciably increasing the bass

response provided the set is accurately tuned to the station.

High-quality reproduction of the local station does not by any means exhaust the possibilities of the set, for its range and selectivity are well up to the standard of performance we are accustomed to expect from a three-valve circuit with a single H.F. stage. On medium waves Langenberg comes in at moderate strength in Central London during daylight, and upwards of fifteen or twenty stations, depending on conditions, can be relied upon after dark. With the reaction and volume controls set for normal distant reception, the London National transmitter spreads from 245 to 270 metres, and the Regional from 320 to 325 metres. On long waves the range is all that one could wish. As regards selectivity, there is no difficulty in separating Daventry and Radio Paris, but Zeesen cannot be quite extricated from the background of Daventry. The set owes its efficiency to careful choice of valves and attention to detail in the design rather than to any novelty or elaboration in the circuit. A wave trap is included in the aerial lead on long waves to prevent break through of the medium-

wave stations. Volume is controlled in the H.F. valve, which is of the variable-mu pentode type, by varying the cathode biasing resistance. The range of this control is well distributed in relation to the movement of the control knob, and gives a good minimum. Reaction is capacity controlled

FEATURES

Type.—Straight three-valve receiver for A.C. mains. Moving coil loud speaker. Provision for pick-up and external loud speaker. **Circuit.**—Variable-mu pentode H.F. stage—power grid detector—pentode output valve. Full-wave valve rectifier. **Controls.**—(1) Tuning, with illuminated dial calibrated in wavelengths. (2) Input volume control. (3) Reaction. (4) Wave-range and on-off switch. **Price.**—12 guineas. **Makers.**—Burrell Radio Ltd., 45, High Road, Willesden, London, N.W.10.

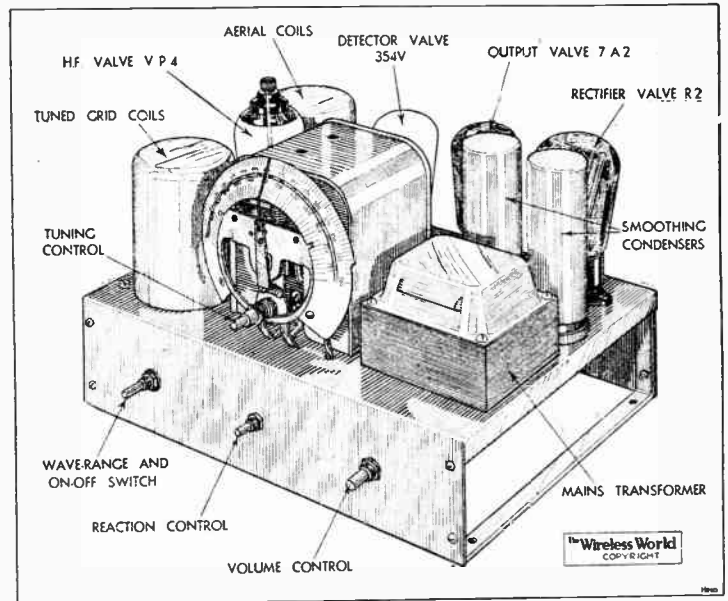

The Burrell three-valve chassis in which the gang-condenser unit is suspended on rubber.

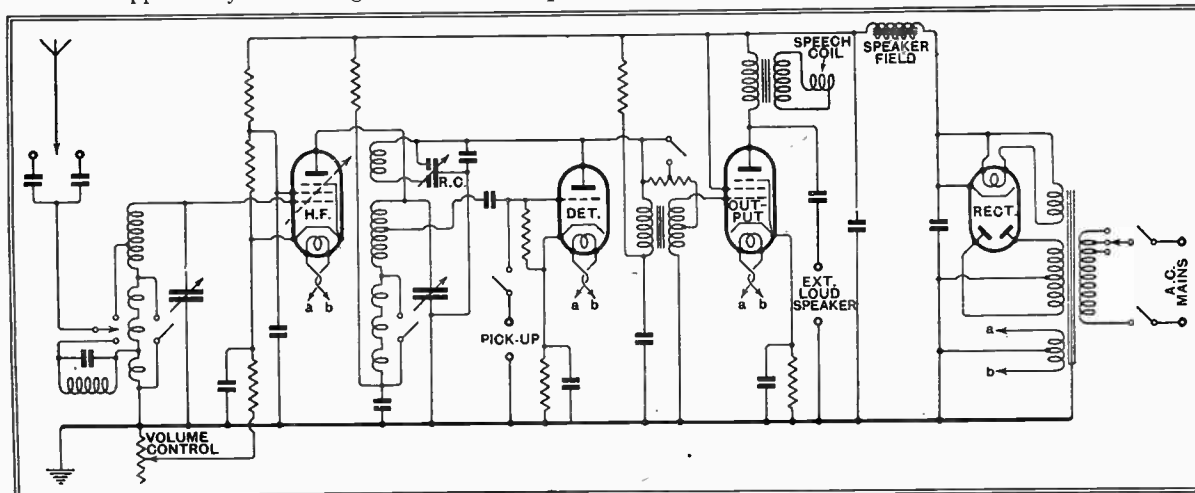

Complete circuit diagram. Note the method of balancing out the polarising current in the L.F. transformer.

and is smooth and free from backlash. The connections of the L.F. intervalve transformer are interesting and have been designed to improve bass response. To neutralise the polarisation of the core by the D.C. current in the primary, a reverse current is passed through a section of the secondary in the opposite sense, with the result that the primary inductance is raised. The increase in the primary D.C. current when the detector is biased to zero for radio reception is met by short-circuiting a part of the resistance feeding the secondary winding.

The set is housed in an attractive walnut cabinet. It is in every way a sound and workmanlike job, and the performance offered—particularly as regards quality of reproduction—is remarkably good value for money.

News of the Week

Current Events in Brief Review

Will Olympia Go Feminine ?

MORE than half the visitors at last year's Olympia Radio Show were women. Yet in 1929 it could not truthfully be said that women visitors numbered more than about 15 per cent.

"Broadcasting House" for Brussels

NO fewer than thirty architects have submitted plans for the new building for the National Institute of Broadcasting to be erected in Brussels. The winning design will be announced within the next few days.

Eight Simultaneous Programmes

BY November next "Broadcasting House" in Berlin will have one of the most imposing control rooms in Europe, capable of handling eight programmes simultaneously in addition to rehearsals. It will also be possible to record as many as six programmes at one time.

Mr. W. I. G. Page

AFTER a number of years' association with *The Wireless World*, Mr. W. I. G. Page, B.Sc., designer of many well-known receivers, is now leaving the staff to take up general wireless consultancy, and also the commercial development of car radio. His many friends in the radio world will wish him continued success in his new sphere of activity.

Ban on Loud-speaker Parts

CONCERN is felt among German amateurs over the announcement that, from September 1st, next, no loud speaker parts will be available. This measure is designed to help the loud speaker trade, which has made special sacrifices in connection with the new "popular" receiver (described in *The Wireless World* of July 7th). German home constructors must henceforth buy their loud speakers ready made.

Eight Super Stations for Germany

THE German Post Office announces that, in accordance with the provisions of the Lucerne Plan, the stations at Mühlacker, Langenberg, Munich, Breslau, and Hamburg will increase their unmodulated carrier wave power to the maximum of 100 kW. In most cases the increase will take effect in December next.

Königswusterhausen is to be rebuilt and the power increased to 150 kW., thus overshadowing the B.B.C. Droitwich transmitter by 50 kW. Should it be necessary, the power of Heilsburg and Breslau will also be increased to 100 kW. next year, so that, by the end of 1934, Germany may have seven 100-kW. stations and one of 150 kW., all equipped with the new anti-fading aerials of the type now used at Breslau.

Toulouse Returns, but . . .

ALTHOUGH it is cheering to learn that Radio Toulouse is about to "come on the air" again, listeners who have hoped for an increased power output will be disappointed. According to our Paris correspondent, the official permit lays down that the power must not exceed that employed by the original transmitter at the Villa Schmidt, which, as all the world knows, was 8 kW.

French Women to Forgo Radio

A NEW grievance is being aired by the multitudes of French listeners who are now called upon for the first time to take out a wireless licence. In the form of application the prospective licensee

must give the place and date of birth—a piece of information which most Frenchwomen resolutely decline to vouchsafe. It would seem, therefore, that the majority of France's feminine population must forgo the delights of wireless.

The Propaganda War

THE plot to blow up Radio Strasbourg last week seems to have been anticipated by the French Secret Service. Recent broadcasts by the German stations under the direction of Dr. Goebbels, Minister of Propaganda, have referred in no uncertain terms to foreign propaganda. Dr. Goebbels has officially announced that the German stations will in future effectively counteract "poisonous news broadcasts"

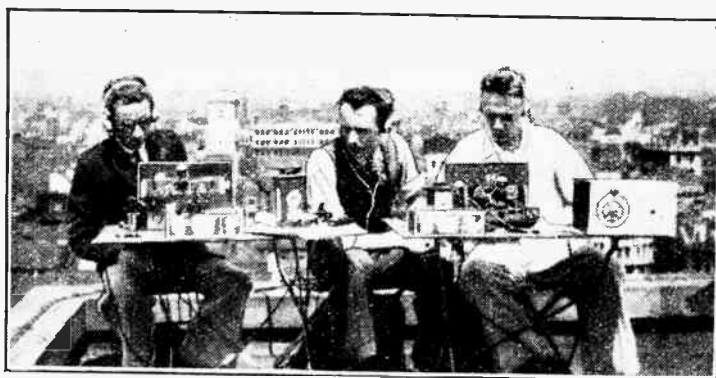

THE FIVE-METRE VIGIL. Members of the International Short-wave Club, London Chapter, photographed on the roof of the *Daily Telegraph* building in Fleet Street, on July 9th, while listening for signals from G6SM. Morse was picked up when the 'plane was at Aylesbury.

and "provocative propaganda" of certain foreign stations.

On July 8th all German stations broadcast an item referring to a certain statement broadcast by "a well-known station in Eastern France," which, it is felt, can have been none other than Strasbourg.

Does Radio Pep Up Brain Cells ?

THE remarkable discovery has been made by Dr. Frank N. Freeman, Professor of Educational Psychology to the University of Chicago, that the general intelligence of the radio audience is well above that of the average adult.

Answers to three questionnaires were submitted by more than 2,500 listeners, and Dr. Freeman found that the average score of listeners responding to the test was thirty-two, as compared with the average adult intelligence designated by the numeral twenty-four.

Obviously, contact with the ether stimulates the mental faculties, and "the man on the air" is mentally superior to "the man in the street."

Not Enough Listeners

THE Cracow station, in Poland, has ceased its educational transmissions because it has been found that "very few schools are equipped with receivers."

Papal Set is Silent

THE Vatican City station apparently cannot make itself heard in Washington, according to the sad tale of an apostolic delegate there, who recently received one of the short-wave sets distributed by His Holiness the Pope, for the benefit of Vatican embassies abroad. The delegate at Washington states that he has never been able to get the set in working order, possibly because the American capital is a "dead spot."

Britain's Youngest ?

ALTHOUGH this country cannot boast of any infant prodigy amateur transmitters such as those eight- and nine-year-old operators recently mentioned in *The Wireless World*, many British "hams" have several years to live before they attain their majority.

Until recently it was believed that Mr. R. Miller (G6ND), the Stirlingshire transmitter, held the record, being eighteen years of age, but a subsequent claim comes from Mr. R. D. L. Dutton, whose call-sign, G6QQ, emanates from Oxford. Mr. Dutton is sixteen. Both these amateurs are exceptionally efficient operators, and are widely respected among the "hams." They have both figured prominently in recent R.S.G.B. transmitting tests.

What Man-made Static Costs

DURING the twelve months ended March 31st, 1933, the Postmaster-General received 20,624 complaints of electrical interference with broadcast reception, according to a statement by Sir Kingsley Wood, Postmaster-General, in the House of Commons last week.

The Postmaster-General was also asked how much had been spent during the past five years by his Department upon research into remedial measures against interference with broadcast reception. Sir Kingsley Wood replied that the total cost to the Post Office of engineering work in connection with broadcasting during the last five financial years was as follows:—

	£
1928-29	12,245
1929-30	16,498
1930-31	23,103
1931-32	33,441
1932-33	51,000 (approx.)

It was not practicable to subdivide this amount but the expenditure was mainly incurred in the treatment of complaints of electrical interference with broadcast reception, including the research work which had been necessary to find remedies.

Contributions in the first number touch upon carrier telephony in military signals, the training of territorial (Royal Signals) recruits, the Signal Service in the Palestine Campaign, and other pertinent topics. The journal is obtainable, price 2s. 6d., at 95, Belgrave Road, London, S.W.1.

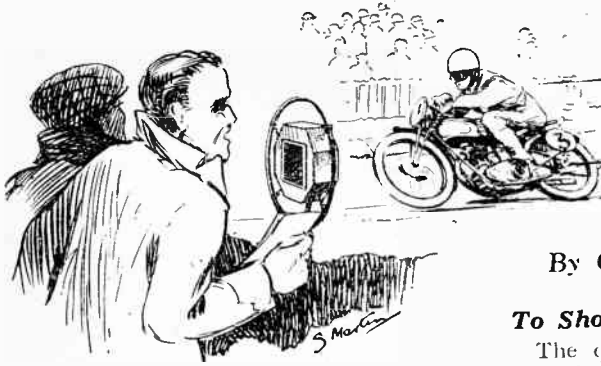

Broadcast Brevities

By Our Special Correspondent

Synchronisation Freaks

NOW that West National is actually working in synchronisation with London National during programme hours—the transmitter is now functioning daily between 8 and 10.50 p.m.—listeners are probably noticing some unexpected variations in signal strength.

During the early morning tests the B.B.C. engineers discovered that while the two transmitters were in synchrony there was a noticeable diminution of signal strength in London's western suburbs and even towards the east.

Phase Differences

This is not the page for a discussion of the mathematical aspect of the question, but the plain truth seems to be that phase differences are at work. Far from giving increased strength with a double transmission, the two waves actually tend in some districts to cancel each other.

Western National will enter into full service or on about Saturday, August 12th.

Problem for Balance and Control

LAST week the Balance and Control Section were eagerly discussing whether they would be required to make a public appearance at the Olympia Wireless Show in connection with the broadcasts from the great B.B.C. Concert Studio in the National Hall.

There is no doubt that a large percentage of visitors will know little and care less about Balance and Control, and are likely to think that the polished panels and gleaming knobs form a sort of soda fountain for hot artistes.

To Show or Not to Show?

The question is whether the discerning few should be initiated into the rites of Balance and Control. If so, the engineers must, they feel, be spick and span, as likewise their apparatus. On the other hand, the Balance and Control can hide itself as in an ordinary O.B., the usual impromptu lash-up being used.

For my part I would prefer to see the engineers doing the job in the ordinary way. It is the curse of most exhibitions that everything is too sacredly clean and polished "for human nature's daily food."

R.M.A. Theatre

Apart from the theatre, which, incidentally, is being constructed by the R.M.A., the B.B.C. will not feature very much on their own account at Olympia, though there will be a small stand to represent the multifarious activities of the Corporation, ranging from the sale of portraiture to home cookery hints.

A Special Revue

Eric Maschwitz is arranging for an Olympic Revue, which will be given each night and broadcast twice during the period of the Show.

There will also be a vaudeville, which will be broadcast four times in all. The theatre will hold 1,500 people.

Dramatising the News

NEXT winter the News Studios at Broadcasting House may, it seems, be fitted up with an "effects" panel to enable the announcers to "hot-up" the bulletins.

The other day the method was tried very effectively; to each of the more important news items was appended a talk or gramophone record in keeping with the topic under review. So successful was the ven-

ture that H.R.H. the Prince of Wales, who happened to be listening, 'phoned the B.B.C. to express his appreciation of the new system.

A New Appointment?

Now the B.B.C. is looking round for a news editor—a man combining the eagle eye and discrimination of a Fleet Street sleuth with the dramatic perceptions of a West End play producer.

Among the names which I have heard mentioned in connection with the new post is that of Cecil Lewis, who, despite his allegiance to the films, is still burning with enthusiasm for broadcasting, and teems with ideas for new methods of presentation.

When Good News is Bad

Bad news, of course, will always offer better opportunities to the Effects Department, who will only be able to express themselves adequately when the bulletins tell of war, revolutions, accidents and sudden death. However, a new technique will probably be devised to give flavour to the more hum-drum events. Here music would be of inestimable help in tiding over the dull days of peace and plenty—when pastoral symphonies would form a background to the announcer's voice—until the next outbreak of human passions would set the big drum banging.

A New Music Committee?

THE rumour that Mr. Arthur Bliss, the composer of "Rout" and "Morning Heroes," has been appointed to a position in the B.B.C. is untrue.

Nevertheless, the idea is being explored of appointing a small committee of first-class musicians to assist Dr. Adrian Boult.

A Big Job

The B.B.C.'s Director of Music has a tremendous responsibility, for he caters for one of the biggest audiences in the world, and, as anyone knows who has ever prepared a concert programme, the difficulty of entirely pleasing even a fraction of an audience is formidable. The wonder is that Dr. Boult has interpreted public opinion so cleverly in the past. Even a small committee should be of immense help.

Promenade Concerts, 1933

NO one looks for any outstanding change in the general arrangement of the Promenade Concerts, and it is satisfactory to note that the 1933 season, which opens on August 12th next, will follow the old and tried tradition.

New Artistes

Saturday nights will, as usual, be "popular." Bach and Brahms evenings will be given on alternate Wednesdays, while, as of old, Mondays will be devoted to Wagner and Fridays to Beethoven. Tuesdays and Thursdays are left open for miscellaneous programmes, and it will be on these nights that British music will be included. There will be no exclusively "British nights."

No fewer than fourteen artistes, new to these concerts, will appear in the course of the season. They will include Elsie Board-



A FLOURISH FROM RABAT. Even the mace-bearer made his appearance before the Radio-Moroc microphone when the Sultan's Black Guard (Garde Noire) turned out to give listeners an evening of military music.

Correspondence

The Editor does not hold himself responsible for the opinions of his correspondents.

Correspondence should be addressed to the Editor, "The Wireless World," Dorset House, Stamford Street, S.E.1, and must be accompanied by the writer's name and address.

A New Symbol ?

THE standardisation of all symbols used for circuit representation is undoubtedly highly desirable, and I would express myself in complete agreement with Mr. Tyers in his letter published in your June 30th issue, for the adoption of a broken line "core" figure to distinguish iron dust transformers.

I would also suggest the adoption of a standard symbol for the indication of an intermediate-frequency transformer. It will be found that the distinctive symbol most generally used both in American and European laboratories is a "core" consisting of three large dots. This figure particularly simplifies the identification of the first I.F. transformer in a superheterodyne circuit, a factor which is not always immediately apparent in modern mixer circuits.

Finally, might I commend to your notice a symbol for a trimming condenser in almost universal use outside this country which, I

Television

PROPOS your editorial on television. What is this television?

Has it anything to do with those very queer noises we hear on the wavelength of London National when it should be shut down, and the other sounds of people enjoying themselves to alleged comic songs and piano music in the region of Midland Regional?

I have had a wide experience in wireless circles, and know many of the leaders in this part of the world, but I have never yet seen a television set, never seen anyone who has one, or, what is more strange, never seen or spoken to anyone who has seen or spoken to anyone who knows anyone who has a television set or knows anyone who knows anyone who has, or has had, or intends to get, a chance to look at a television set!

Possibly, if the transmissions were done in the North (where the intelligent people

can City (50.26) can be tuned in equally as easily at full loud speaker strength.

I make a point of listening to the Empire News at 11.10 p.m. each night, and often also at 1.40 a.m. What is specially remarkable—my set is installed in a basement.

The set is a superheterodyne, and I convert it for short-wave reception merely by connecting the aerial leads to a 5-turn plug-in coil, with centre tapping on the first turn. A 20ft. length of insulated aerial wire stretched across the room serves as an aerial.

S. J. NOEL-BROWN.
Portman Square, W.1.

Synchronised Transmitters

NOTICE in "Broadcast Brevities" that the B.B.C. are congratulated on synchronising two of their transmitters.

It seems to me that after sunset listeners within the service area of one transmitter and outside the other will have a fine time with their volume-controlling devices. Stations broadcasting on 260 metres or less receive a hefty push from the Heavyside Layer after dark, and this will result in the steady voltage in the receiving aerial from the "local" being supplemented with sudden reinforcements of power arriving from the "distant" synchronised station. Of course, fading cannot occur, but overloading may; this may be bad enough to force one to turn for relief to Daventry 5XX, in spite of its inferior quality. Anyway, we shall see!

CLEMENT R. MOSCROP.
Aylesbury, Bucks.

The A.V.C. Unit

MAY I point out an application of *The Wireless World* A.V.C. unit described in the issue for March 31st which may be of interest to some of your readers?

When trying to gang my set accurately, I found that the deflection of the milliammeter in the anode circuit to indicate resonance was so small that greater accuracy could be obtained by ear. I constructed the A.V.C. unit, and connected it up, omitting the connection to the grid return lead of the controlled valve, and substituted a milliammeter for the biasing resistance R₄.

The set and the unit were switched on, and the meter adjusted to read zero by means of the potentiometer R₃. When the set was tuned through resonance, the meter showed quite a large current reading. By choosing a suitable valve for the A.V.C. unit, an indication of resonance can be obtained from quite a small signal, even if the meter is not very accurate.

Actually, my meter reads up to 10 milliamps., and as the total anode current of the detector valve is only about 1.5 mA, only a very strong signal would cause an appreciable deflection if the meter were connected in the detector anode circuit. By the above method I have succeeded in ganging my set accurately, and the arrangement is also useful for calibrating the set. It can be quickly converted back to an A.V.C. unit.

D. P. C. HEPBURN.
Loscoe, Nr. Derby.

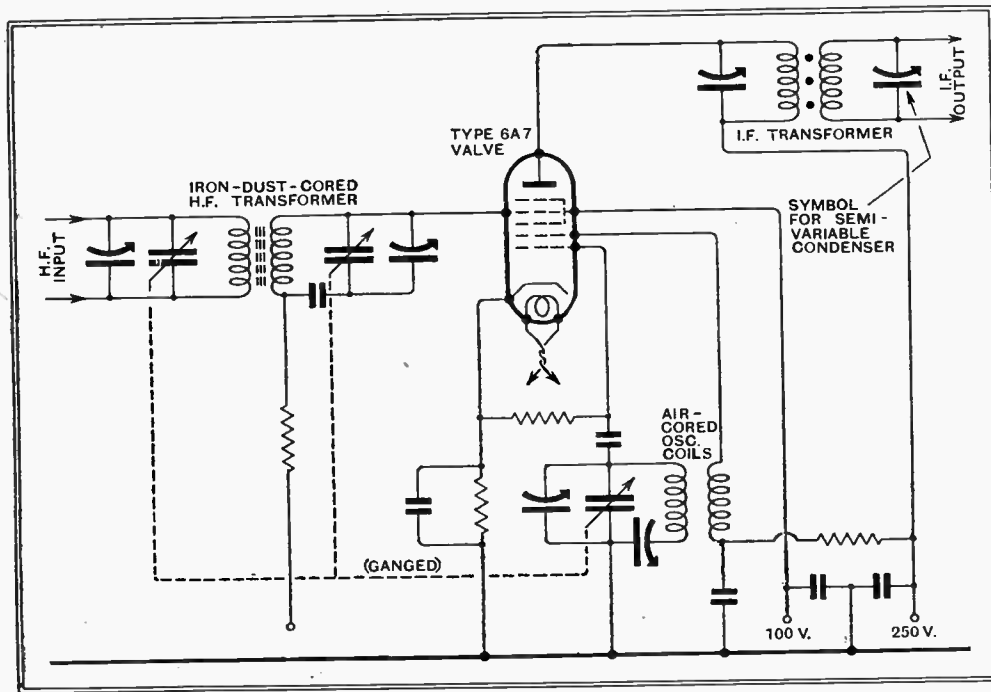

Suggested new symbols are illustrated in this representative circuit.

am sure, could be adopted with advantage. This takes the form of single short heavy lines which indicate either the fixed earthed plate(s) or the plates which are at the lower H.F. potential, while the moving plate(s) are shown as a curved line of similar length, terminating in an arrow head.

The symbol at present used to illustrate this component in circuits appearing in *The Wireless World* admirably fulfils most requirements, but it can quite easily lead to confusion in a less excellently printed paper, either through line-block defects or the use of poor paper.

A portion of a modern mixer circuit using these symbols is given in the accompanying diagram.

G. S. HOLIDAY.
Mill Hill, N.W.7.

are), the television folks may make some progress. What do you think?

LEWIS J. WOOD,
Hon. Sec., Halifax Wireless Club.

London Reception of Daventry Short Waves

AS I understand that the reception of the B.B.C. Empire short-wave programmes in London is unusual, you may be interested to know that I tune in to the African and West African and Canadian Zone programmes nightly—GSA, 49.59 metres, and GSB.

I receive these stations at full loud speaker strength. Tuning is by no means difficult, and Moscow (50 metres) and Vati-

A Boon to the Home Constructor

We are now in a position to supply

ALUMINIUM CHASSIS FOR ANY CIRCUIT

drilled or undrilled, and beautifully finished in French-Grey Cellulose.

When building your

NEW MONODIAL SUPER

be sure to give it that perfect professional finish which so enhances the appearance of the instrument, by using one of these new aluminium chassis.

Constructors of this excellent Receiver should await next week's issue, when we shall announce particulars of an ideal Cabinet which we have designed and produced specially for this set.

"THE WIRELESS WORLD"

CLASS "B" FERROCART RECEIVER

The most outstanding Battery Set of the Year. Designed by Mr. W. I. G. Page, B.Sc., late of "The Wireless World" and now our Chief Technical Consultant.

KIT 'A'
Complete (less Valves, Batteries, Cabinet and Loud Speaker) **£7-11-0**

KIT 'B'
Complete with Valves (less Batteries, Cabinet and Loud Speaker) **£9-17-3**

KIT 'C'
Complete with Valves, Cabinet and Loud Speaker (less Batteries) **£13-9-3**

Cabinet, as illustrated, £1 . 12 . 6

WE EXTEND

A CORDIAL INVITATION

to all "W.W." Readers to pay a visit to our new factory premises and showrooms, where advance models of our next season's lines can be inspected.

THE CITY ACCUMULATOR CO., LTD.

18-20, NORMAN'S BUILDINGS,

off CENTRAL STREET, E.C.1.

(Nearest station, Old Street.)

'Phones:

Clerkenwell 1038 and 6206.

STAND No. 94
RADIOLYMPIA

WEST END SHOWROOMS:

4, Surrey St., STRAND, W.C.2.

'Phone: Temple Bar 8620.



FREE. In view of the phenomenal interest taken in this wonderful circuit, we have reprinted 10,000 copies of the original article which appeared in "The Wireless World" of April 7th last and readers are invited to send for a copy, which will be forwarded gratis and post free on application.

NOTE THE NEW ADDRESS AND TELEPHONE NUMBERS

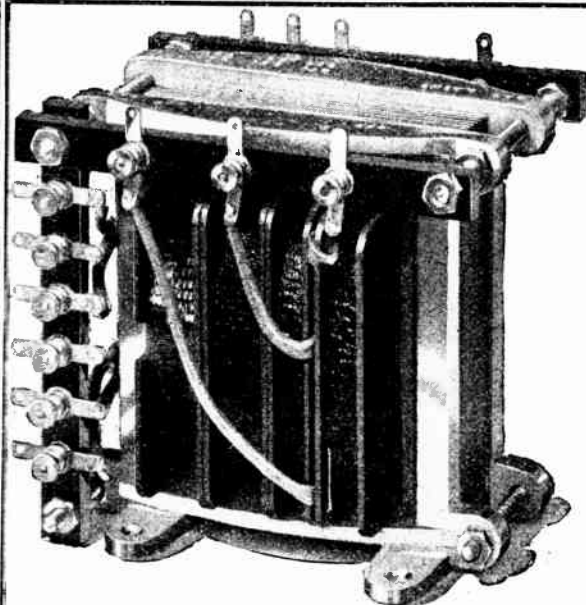

LYONS' "B.A.T."
(Best-After-Test)
MAINS TRANSFORMER
No. 262 . . . 50/-
GOOD STOCKS. NO WAITING.
ORDER YOURS NOW!

SPECIFIED for the "WIRELESS WORLD" NEW MONODIAL SUPERHET, DESCRIBED IN THIS ISSUE!

We feel very gratified that within a few weeks of the introduction of our revolutionary Type 2A7 "Pentagrid-Converter" Valve, same has been selected for incorporation in the remarkable new "Monodial" Set, described in this issue. Numerous British-Made Lyons-"B.A.T." (Best-After-Test) Products have also been specified, proof positive of their sterling merits. The complete selection is:-

FOR THE RECEIVER UNIT:

- 1 "B.A.T." Type 728 Toggle Switch 16
- 1 Type P-58, 5,000 Ohms W.W. Volume Control 5 6
- 1 Tapered Volume Control, 250,000 Ohms 6 6
- 1 Special 2-Ohm W.W. Power Resistance 16
- 1 Complete Kit of 18 "B.A.T." Precision Resistors, as specified, at 10½d. per Watt 17 6
- 1 LYONS-SYLVANIA Type 2A7 PENTAGRID-CONVERTER VALVE, with Grid-Clip 17 6
- 1 USA-Pattern 7-Pin (Medium) Valveholder 2/-

FOR THE POWER UNIT:

- 1 Complete Kit of 6 "B.A.T." Precision Resistors, at 10½d. per Watt 7/-
- 1 "B.A.T." (BEST-AFTER-TEST) MAINS TRANSFORMER, with correct length colour-coded leads, exactly to specification, Catalogue No. 262 50/-

SHOULD YOU EXPERIENCE DELIVERY DELAYS, WRITE TO US, AND WE WILL IMMEDIATELY ASSIST YOU.

CLAUDE LYONS LTD.
76, OLDHALL STREET, LIVERPOOL, 3
40, BUCKINGHAM GATE, WESTMINSTER, S.W.1.



LYONS-
"SYLVANIA"
TYPE 2A7
"PENTAGRID-
CONVERTER"
VALVE (See
"WIRELESS
WORLD" ISSUE
JUNE 9, PAGES
407-9) **17/6**

MISCELLANEOUS ADVERTISEMENTS

NOTICES.

THE CHARGE FOR ADVERTISEMENTS in these columns is 12 words or less, 3/- and 3d. for every additional word.

Each paragraph is charged separately and name and address must be counted.

ADVERTISEMENTS for these columns are accepted up to FIRST POST on MONDAY MORNING (previous to date of issue) at the Head Offices of "The Wireless World," Dorset House, Stamford Street, London, S.E.1. or on SATURDAY MORNING at the Branch Offices, 19, Hertford Street, Coventry; Guildhall Buildings, Navigation Street, Birmingham, 2; 260, Deansgate, Manchester, 3; 26, Renfield Street, Glasgow, C.2.

The proprietors retain the right to refuse or withdraw advertisements at their discretion.

Postal Orders and Cheques sent in payment for advertisements should be made payable to ILLIFFE & SONS Ltd., and crossed

& Co. Notes being untraceable if lost in transit should not be sent as remittances.

The proprietors are not responsible for clerical or printers' errors, although every care is taken to avoid mistakes.

For particulars of Box Number Advertisements and Deposit System see previous issues.

IMPORTANT NOTICE.

Owing to the August Bank Holiday, the issue of "THE WIRELESS WORLD" for August 11th must be closed for press earlier than usual.

MISCELLANEOUS ADVERTISEMENTS for insertion in that issue can be accepted up to

FIRST POST FRIDAY, August 4th.

RECEIVERS FOR SALE.

MONODIAL Super, with A.V.C., may be heard by appointment; £18.-7, Gravelly Hill North, Birmingham. [3099]

SUNDAY EXPRESS" Empire Five Chassis and mains, without valves; £5.-Collins, 304, Thimblemill Rd., Methwick. [3115]

SHRAM Music Magnet Four, 1932, 2 S.C., with large P.M. Ormond M.C. speaker; £6.-Ryan, 38, Laver's Rd., N.16. [3096]

SIX-SIXTY" 3-valve Screen Grid, hardly used, guaranteed condition; cost £6 17/6, what offer?—56, Sydenham Rd., Croydon. [3119]

UNIVERSAL A.C. D.C. Chassis, complete with valves and Magnavox speaker; enquires invited.—Burlerick, 19-21, Hamilton Rd., N.5. [3136]

MORE Part Exchange Receiver Bargains for Disposal; state approximate requirements for quotation.—Conlts. Wireless Engineers, Horley. [2613]

PYRE M.M. A.C. Mains Transportables, listed £17/17. brand new, unopened, manufacturers' full guarantee; £9, c.o.d.—Dunlop, Blakeney, Gloucestershire. [3124]

4-VALVE Class B Receiver, M.C. speaker, Mazda valves; £9; 6-valve G.E.C. battery superhet, with new valves; £10, or offer.—Wright, Jesty's Av., Broadway, Weymouth, Dorset. [3102]

CLIMAX All-electric 200-250 A.C. Band Pass Three, in walnut cabinet, complete with valves and moving coil speaker; listed £16/16, unopened, £8/8, c.o.d., carriage paid. [3102]

OSTEEL-GANZ Combined A.C./D.C. All-electric Set, 3 valves and Magnavox moving coil speaker, in walnut cabinet; listed £11/11, our price £4/19/6, c.o.d., carriage paid.—Kay, 167, City Rd., Finsbury, E.C.1. [2835]

RADIOHOLAB Set Tester, as reviewed by "Wireless World," listed 12 guineas, 8 guineas new; Sound Sales Class B unit, 19/6; Radiopak unit, sealed, 39/6.—White House, Rosehill, Parkwest, Sutton. [3120]

AMERICAN 6-valve Superheterodyne Table Model, 200-230 volts A.C., six months old; cost £25, sell £15, or nearest offer.—Maurice, 32, Goodenough Rd., Wimbledon, S.W.19. [3091]

CHARGERS AND ELIMINATORS.

P. Battery Chargers for A.C. Mains, from 62/6.

P. Send New Trade List and Photographs, showing Range of Chargers up to £40.

P. Have a Few Slightly Soiled Instruments from 57/6 to £12; Westinghouse or valve rectification up to 3 circuits; bargains cannot be repeated.

P. Senior Two, £3 5/-; will do I.T. batteries up to 36, H.T. up to 120 volts 1/2 amp.; highest value ever offered.

P. Exchange Charger as Business Grows; new trade lists now ready.—Nash Products, Ltd., Stechford, Birmingham, 9. [3112]

VORTEXION, Wimbledon, for 99.9% reliable transformers.

If You Haven't Tried Them Yet Ask Someone who has, or call and inspect complimentary letters.

L. Standard Models Delivery by Return; all secondaries are tested.

G. UNRATED 12 Months, and within 5% normal and 2 1/2% super models, neat shrouding, with detachable feet, as used by Government Departments, etc., etc.

VORTEXION.—New monodial transformer, 200-250, 50 cycles, 425-0-425, 120 m.a., 4v. C.T. 3a., 4v. C.T. 1a., 4v. C.T. 1a., 4v. C.T. 6a., screened primary, open type, 20/-; shrouded, 22/-; super shrouded, 26/-; 10 henry choke, 5/6; 20 henry choke, 8/6.

VORTEXION.—Specified for A.C., quality amplifier, 400 watts 110 m.a., 4v. 3, C.T., 4v. 2, 4v. 1, C.T., terminals, 24/-; tagged leads, 20/-; shrouded, 24/-.

VORTEXION.—Ferrocart III, 350-0-350, 60 m.a., 4v. 2.5, C.T., 4v. 3.5, C.T.; open type 13/6, shrouded 16/-; post 9d.

(This advertisement continued in third column.)

ALL PARTS AND KITS IN STOCK FOR THE NEW A.C. MONODIAL

PILOT AUTHOR KITS—

DELIVERY BY RETURN

RECEIVER KIT

Author's Kit of FIRST SPECIFIED PARTS for Receiver Portion only, less Plymax Chassis, Panel, Valves and Cabinet. **£10-19-6** Subject.

Peto-Scott Plymax Chassis, as specified, assembled and drilled, 14" x 12" x 3/4" - - - - - **10/6**

Peto-Scott Oak-faced Ply Panel, ready drilled, 14" x 10" - - - - - **2/6**

POWER UNIT KIT

Author's Kit of FIRST SPECIFIED PARTS for Power Unit only, but less Plymax Chassis and Valves. **£8-13-9** Subject.

Peto-Scott Ready-drilled assembled, Plymax Chassis, as specified, 18" x 6 1/2" x 3/4" - - - - - **7/6**

COMBINED KIT

Comprising Receiver and Power Unit Kits including specified Chassis, but less Valves and Cabinet. **£20-12-0** Subject.

COMPLETE KIT

Combined Receiver and Power Unit Kits as above, with Valves, but less Cabinet. **£27-17-0** Subject.

SOLE DISTRIBUTORS FOR PETO-SCOTT PLYMAX CHASSIS AS USED AND SPECIFIED BY THE AUTHOR

PLYMAX Baseboard assembled and drilled as specified by the Author for RECEIVER PORTION, 14" x 12" x 3/4". **10/6** Subject.

PLYMAX Baseboard assembled and drilled as specified by the Author for POWER UNIT PORTION, 18" x 6 1/2" x 3/4". **7/6** Subject.

SOLE TRADE DISTRIBUTORS:

PILOT AUTHOR KITS

(BRITISH)

RADIOGRAM

RADIO WHOLESALE

Full recognised Discounts. (Bona fide Dealers only.) Enclose Trade Card when ordering, or send immediately for fuller details of our Rapid Service. Best Discounts. Daily van deliveries in London area.

BRITISH RADIO GRAMPHONE Co. Ltd.

PILOT HOUSE, CHURCH STREET, STOKE NEWINGTON, LONDON, N.16

Telephone: Clissold 6287-8.

Chargers and Eliminators.—Contd.

(This advertisement continued from first column.)

VORTEXION.—250-0-250, 4v. 1 to 2a., 4v. 2 to 4a.; open type 10/6, shrouded 12/6; post 9d.

VORTEXION.—Super model for H.T.8 or 9 or 10, 4v. 1 to 2, 4v. 2 to 4; open type 14/6, shrouded 16/6; post 1/-.

VORTEXION.—21-watt Monodial A.V.C. model; open type 14/6, shrouded 16/6; post 1/-.

VORTEXION.—5-watt Monodial A.V.C. model, 400-0-400, 120 m.a., 4v. 6a., 4v. 3 1/2a., 4v. 2, 4v. 1a., super screened; 20/-, shrouded 24/-.

VORTEXION.—350-0-350, 120 m.a., 4v. 2 to 5a., 4v. 2 to 4a., 4v. 2.5a.; open type 14/6, shrouded 16/6.

VORTEXION.—400 or 450 or 500v., 120 m.a., 4v. 2 to 5, 4v. 2 to 5, 4v. 2 to 5; open type 19/-, shrouded 23/-.

VORTEXION.—400 or 450 or 500, 150 m.a., 4v. 4a., 4v. 2.5, 4v. 2, 4v. 2, 4v. 2, core size 2 1/2 in. x 1 1/2 in., a super job, 2% regulation; 35/- shrouded, with terminals, less terminals, 30/-, open type 26/-; post 1/3.

VORTEXION Auto Transformers to B.E.S.A. Specification, 100, 110, or 120v. to 200, 220 or 240 volts, 60 watts, 7/5, post 9d.; 120 watts, shrouded 12/6, open type 10/6, post 1/-; 200 watts, open 14/6, shrouded 16/6, post 1/-; 500 watts, 30/-, 2,000 watts £4/10.

VORTEXION 600-watt Transformers; £4/10, carriage free.

VORTEXION 30h. at 60 m.a. Chokes, 5/6; 40h. at 60 m.a., 8/6; 30h. at 150 m.a., 200 ohms, 10/6 open type, 12/6 shrouded.

VORTEXION 200v. 30 m.a. Eliminators, 110 or 220 V input with 4v. 4a. winding; 37/6.

VORTEXION.—Transformers made to your specification. All standards in stock. Phone all hours.

VORTEXION (S. A. Brown), 182, The Broadway, Wimbledon, Rd., Liberty 2814. [3117]

TANTALUM for A.C. Chargers, H.T. and L.T.—Blackwell's Metallurgical Works, Ltd., Garston, Liverpool. [2139]

180 Accumulator Chargers, 1/2 amp., 2-6v., in ventilated metal case, with mains flex (Westinghouse rectifiers), 10/8; 1 1/2 amp., 2 1/2v.; 7 days' trial.—Arden Agency, Wollaton, Wellington. [2964]

HOYNES Transformers and Chokes the Best Obtainable, perfect insulation, regulation and reliability, used exclusively by discriminating set manufacturers, all fitted with tapped and screened primaries, filaments all centre tapped, stout cast aluminium clamps fitted to all models, also clearly marked terminal strips.

HOYNES Components are Guaranteed for One Year.

HOYNES Transformers Built to Your Specifications, at very competitive prices.

HOYNES New Monodial Super Model, 425-0-425v. 120 m.a., 4v. 3a., 4v. 1a., 4v. 1a., 4v. 6a., 17/6, post 1/3; super model, 24/-, post 1/3; chokes for same, 10h., 20h., 16/6 the pair, post 1/-.

HOYNES.—250-0-250v. 60 m.a., 4v. 1-2a., 4v. 2-4a.; 10/-, post 9d.

HOYNES.—250-0-250v. 60 m.a., 4v. 1-2a., 4v. 2-4a.; 4v. 1a.; 12/6, post 1/-.

HOYNES.—350-0-350v. 60-70 m.a., 4v. 2-3a., 4v. 3-4a., 12/6, post 1/-, Ferrocart III model.

HOYNES.—350-0-350v. 70-20 m.a., 4v. 2-3a., 4v. 3-4a., 4v. 1-2a.; 13/6, post 1/-.

HOYNES.—350-0-350v. 120 m.a., 4v. 2-3a., 4v. 4-6a., 4v. 1-2a.; 16/-, post 1/3.

HOYNES.—500-0-500v. 140 m.a., 4v. 2-4a., 4v. 4-6a., 4v. 2a., 4v. 2a., 27/6, carriage 1/6, weight 12lb.

HOYNES.—0-110-135v. 90 m.a., 4v. 2-4a., suitable for H.T.6 or 7; 10/-, post 9d.

HOYNES.—200v. 200 m.a., 4v. 2-4a., 4v. 1-2a., suitable for H.T.8; 13/6, post 1/-.

HOYNES.—0-200-240v. 200 m.a., 4v. 2-4a., 4v. 1-2a., suitable for H.T.8 or 9; 14/6, post 1/3.

HOYNES.—Line transformers and chokes always in stock; we can also supply all components.

M. J. HOYNE, Offices and Works, 8a, Gladstone Rd., Wimbledon, S.W.19, H.L. Liberty 3305. [3107]

BRIMMAM Mains Equipment for the "Wireless World" Super Monodial; enquiries invited for mains transformers, chokes, all parts and components for this very fine set; A.C. eliminators, power packs and parts designed and made to special requirements for valve or metal rectification; all parts supplied; overhauls, repairs, alterations, and test reports; mains transformers rewound; trade inquiries invited.—J. W. Bridgland, Instrument Maker, 61, Dartmouth Rd., Forest Hill, S.E.25, Syd. 6741. [3127]

CABINETS.

RADIOGRAM Cabinets; fully illustrated list free; remarkable values.—Gilbert, Cabinet Maker, Swindon. [1686]

DYNAMOS, ETC.

M.-I. Converter, 12 volt input, 300 volt output, perfect condition; 67/6.—Webb, New St., Dunmow. [3125]

ROTARY Converters, 220 volts D.C. to 200 volts A.C., capacities up to 0.44 K.V.A., cheap—Milo Engineering Works, Milo Rd., East Dulwich, S.E.22. Sydenham 4422. [2907]

CONVERTOR (Bayless), input 270 volts D.C. output up to 500 watts, 230 volts A.C., heavy duty transformer, variable voltages, 210 to 260 in 10-volt stages, adequate filter circuit, rheostat; cost £35, offers wanted.—Squire, 51, Coney Green Drive, Northfield, Birmingham. [3105]

GRAMOPHONES, PICK-UPS, ETC.

GARRARD Record-changer, sealed, £7; Collaro pick-up, with control, 16/6.—White House, Rosehill, Parkwest, Sutton. [3119]

LOUD-SPEAKERS.

30/-—11—B.T.H. R.K. moving coil speakers, 6in. cone, new and unused, guaranteed; these speakers are type as used in cinema sound equipments; suitable for public address work; weight 3 lb., and are vastly superior to cheap speakers now on the market, 100 volts, 150 volts, and 200 volts D.C.

27/6—11—5v. D.C. speaker, as above; £27/6, speaker as above for 100-250 A.C.; carriage paid; cash with order, or c.o.d.

B.T.H. Brand New Public Address Amplifiers, 4-stage, including microphone stage, 2 types, 12 watts and 6 watts outputs, 12-watt type has 2 P.P.5/400s in output, 6-watt type has 2 P.P.3/425s in output, 12-watt type price £15, 6-watt type £12/10; B.T.H. cinema type pick-ups, brand new, 17/6.—Ward, 12, Tredgar Rd., Bow, E.3. Advance 3668. [3032]

Loud-Speakers.—Contd.

B.T.H. R.K. Moving Coil Speakers, guaranteed new, unused, manufacturers' surplus, original price. 6 Guineas, highly sensitive and wonderful tone response, will handle up to 10 watts output, available for 6v., 100v., 200v. D.C., 30/-; also A.C. models. £2/10; carriage paid, c.o.d., or cash with order; the best value in speakers obtainable to-day.—Seakamp, 46, Farringdon St., London, E.C.4. Telephone: Holborn 0129. [1425

PICTURE RECEIVER APPARATUS.

TELEVISION.—All components supplied direct from the actual manufacturer.—Send your enquiries to John Salter, Member Television Society, Featherstone Buildings, High Holborn, W.C. [3003

TRANSMITTERS.

TRANSMITTING Gear for Sale; list free.—G2AW, 5, Benson St., Norton, Stockton-on-Tees. [3097

VALVES.

THE Following Valves are Guaranteed as New, and any valve differing from the makers' characteristics will be exchanged, all latest types. A.C. Pens., P.T.4s, G.U.1s, A.C.S.G./V.M.s, Pen. 4V.s, M.V.S.G.s, P.T.625s, V.M.S.4s, D.C.2 Pens., D.P.T.s, M.P.T.4s, V.M.4V.s, A.C.S.1/V.M.s, P.M.24B.s, D.C.2S.G./V.M.s, 11/-; M.S.4s, M.S.4B.s, A.C.S.G.s, S.4V.A.s, S.4V.B.s, M.S.G./L.A.s, D.S.B.s, A.C.S.2s, P.X.4s, D.C.28G.s, 9/6; U.14s, 10/-.

M.L.4s, A.C./P.s, 41M.P.s, P.M.24s, 8/-; A.C./H.L.s, 164V.s, 354 V.s, A.C.2 H.L.S., 41M.H.L.s, U.C.s, P.U.60 250s, M.H.4s, M.H.L.4s, 7/6; V.S.2s, 215S.G.s, 220S.G.s, P.M.12s, P.M.12A.s, 9/-; 442B.U.s, D.W.3s, 8/6; 215P.s, 220 P.s, L.P.2s, 4/9; P.2s, 6/6; P.T.2s, P.M.22A.s, 9/-; H.L. 210s, H.210s, L.210s, 3/9.

A list Types of Brand New American Valves in Stock, all first class makes; 247s, 235s, 24s, 236s, 237s, 233s, 245s, 244s, 12/-; 227s, 226s, 280 245s, 9/6; 242s, 232s, 11/-; U.N.210s, 15/-.

U.X.250s, 7 watts output, 16/-; 281s 14/6; for quickest delivery send telegraph money order.

OVER 5,000 Valves Always in Stock for Immediate Delivery; carriage paid; cash with order or c.o.d.—Ward, 12, Tredgar Rd., Bow, E.3. Advance 3668. [3081

CATKIN V.M.S.4, M.S.4B, 11/6; Class B, 240B, 220B, P.M.2B, 8/11; P.P.5 400, 17/6; slightly used.—White House, Rosehill, Parkwest, Sutton. [3121

AND Another Large Purchase of Set Manufacturers' Stock, guaranteed as new, and any valve differing from the makers' characteristics will be exchanged free; all latest types.

H.L.210s, H.210s, L.210s, 210H.L.s, 210H.P.s, P.M.H.L.s, 3/9; P.M.2s, P.M.2A.s, L.P.2s, 220P.s, 215P.s, 4/9; D.H.s, 41M.H.L.s, M.H.4s, A.C. H.L.s, A.C.2H.L.s, 354V.s, D.C./3H.L.s, 1821s, 7/-; M.L.4s, A.C. P.s, 164V.s, 104V.s, P.M. 24s, 442B.U.s, 1807s, 7/6; S.4V.B.s, S.4V.s, M.S.4B.s, M.S.G./H.A.s, A.C. S.G.s, A.C. S.2, 41M.S.G.s, D.S.B.s, 215 S.G.s, P.M.12s, P.M.12A.s, 9/-; Pen.4s, V.M.S.4s, M.M.4V.s, P.T.41s, P.T.41B.s, D.P.T.s, A.C./Pens., 11/-; 420P.s, 680P.s, 10/-.

OVER 4,500 Valves Always in Stock for Immediate Delivery; carriage paid for cash or c.o.d.; prompt delivery.

NEWMAN 303, Roman Rd., E.3 [2892

OSRAM and Mullard Valves, guaranteed as new, any found faulty exchanged free; H.L.210, L.210, P.M.H.L., P.M.H.F., 3/3; L.P.2, 4/-; P.2, P.M.20, 5/-; P.T.2, 8/6.—H. Smith, 20a, Grange Rd., N.W.1. [3101

COMPONENTS, ETC., FOR SALE.

PREMIER Summer Sale. 10% Discount on All Orders of £1 or Over.

MANY Prices Reduced Apart from Discount.

PREMIER SUPPLY STORES Offer the Following Set Manufacturers' Surplus Brand New Goods at a Fraction of the Original Cost; all goods guaranteed perfect; carriage paid over 5/- under 5/-, postage 6d. extra. (Ireland carriage forward.)

ELIMINATOR KITS, including Transformer, Westinghouse metal rectifier, Pye choke, T.C.C. condensers, resistances, and diagram; 250 volts at 60 m.a., 30/-; 150 volts at 30 m.a., 25/-; 120 volts at 20 m.a., 20/-.

PHONE SHEETS for Charging Boards, 24in. x 24in. x 3/16in., 3/- each.

T.C.C. Condensers.—2 mfd., 750v. working, 4/-; 4 mfd., 6/-; 4 mfd., 400v. D.C. working (300v. A.C.), 4/-.

I.M.F., 500v. working, 1/6; 4 mfd., 200v. working, 2/6; 0.5 mfd., 1,500v. working, 2/-; 0.25 mfd. mica, 2/6.

4 mfd. Electrolytic (aqueous type), 440v. working, 3/-; 8 mfd., 3/6.

DUBILIER Condensers, 0.01 mica, 6d.; 0.01 mica, 1,000v. working, 1/6.

POLAR 3-gang 0.0005 Condensers, split end vanes, totally screened, disc drive; 6/11.

MSCO Triple-gang 0.0005 Condensers, with trimmers; 4/11.

ORMOND 0.0005 Condensers, 1/3; 2 gang semi shielded, 2/6.

WESTERN ELECTRIC Mains Transformers, input 200-250 volt, output 500-0-500 volt, at 150 milliamps., 4v. 4a., 4v. 2.5a., 4v. 2a., 4v. 1a., 4v. 1a., massive job, 19/6.

T.C.C. Electrolytic Condensers, 10 mfd., 100 volts working 1/-; 15 mfd., 1/3.

SPECIAL Offer of Mains Transformers, manufactured by Philips, input 100-115v. or 200-250v., output 180-0-180 volts, 4) m.a., 4v. 1a. and 4v. 3a., 4/6; 200-0-200v., 4v. 1a., 4v. 3a., 4/6.

ALL Premier Guaranteed Mains Transformers have engraved terminal strips with terminal connections, input 200-250 volts, 40-100 cycles, all windings paper insulated.

PREMIER H.T.8 Transformer, 250v. 60 m.a., rectified, with 4v. 3.5a. c.t. L.T. and screened primary, 15/-; with Westinghouse rectifier, 25/-.

PREMIER H.T.9 Transformer, 300v. 60 m.a., rectified, with 4v. 3.5a. c.t. L.T., and screened primary, 15/-; with Westinghouse rectifier, 26/-.

PREMIER H.T.10 Transformer, 200v. 100 m.a., rectified, with 4v. 3.5a. c.t. L.T., and screened primary, 15/-; with Westinghouse rectifier, 26/-.

PREMIER Mains Transformer, output 135v. 80 m.a., for voltage doubling, 8/6; 4v. 3.5a. c.t. L.T., 2/- extra; Westinghouse rectifier for above, giving 180v. 30 m.a., 8/6.

(This advertisement continued in third column.)

EVERY TEST WITH ONE INSTRUMENT ONLY. D.C. AND A.C. The AVOMETER. REGD. TRADE MARK. THE AUTOMATIC COIL WINDER AND ELECTRICAL EQUIPMENT CO., LTD. Winder House, Douglas Street, London, S.W.1. Phone: Victoria 3405-7. BRITISH MADE.

ELECTRADIX BARGAINS

W.W. "Measurements with a Photocell" We have some £5 Photo Cells for Talks, Light Tests, Timing Controls, etc., at bargain prices. Response to light 50 micromicros. per lumen, 40 watt lamp, 75 c.m. King B.T.P., 15/-; R.C.A., 25/-; Holders: 1.-; Beck Prisms, 5/6; Focus Lens, 3/6. SELENIUM CELLS. Light sensitive resistance, gold grids, moisture-proof. L to D ratio 5 to 1. 5/- each. Mounted in Bakelite. 7/6. Super Model in Oxycopper body with window, 10/-.

MICROPHONES 1-

Microphone Buttons for all purposes, 1.-. Bocket free. Announcers No. 11 Mikes, 5/6; Pedestal type, 18/6. Microphone Carbon Granules, in glass capsule, enough for four buttons, Grade No. 1, 8d.; No. 2, Medium, 1/-; No. 3, Fine, 1/6; Carbon solid back blocks, 3d.; Mouthpieces, curved or straight, 10d. Carbon diaphragm, 55 mm., 4d. Panel brackets, pivoted, 5/-.

TELESCOPES. Cooke monocular prism R.F., with 9-mile distance scale, 7in. long weight 3 1/2 lb., sale 17/6. Naval Gun Sighting Telescopes, internal focus ring, 24in. long, 2in. dia. weight 6 lb., magnification 6, for short and long range. Cost £25. Sale, 17/6. Spotting Telescopes, 17in. x 1 1/2in., by Watson, 25/-.

THE GENEROMETER BATTERY SUPER-SEDER makes H.T. from your L.T. 2-vol. bat. rev. rectified and smoothed. 3 tappings. A boon to those who are not on the mains. Reduced from £3 15/- New and Guaranteed, 37/6.

Double Current DYNAMOS, cos. Govt. £15. Two comms. D.C., 6-8-volt, 3-5 amps. and H.T., 400-600-volt, 100 ma., 17 lb., 4,000 revs., ball bearings. Sacrificed at 22/6. Carriage 2/6.

MOTOR GENERATORS. For Battery Charging and Amplifiers. R.C.A. 220 volt to 500 volt 200 m.a., £5; 3-phase 380 volts to 12 volts 10 amps. and 320 volts 300 m.a., £6. S.M.D. Co. 12 volts to 800 volts m.a., £4. D.C. 7 1/2 H.P., 400 volts 12 amps. to 100 volts 66 amps., 1,700 revs., by E.C.C., £15. D.C. 115 volts 3 H.P., 23 amps. Motor coupled to 110 volts 14 amp. 50 cycle 1 1/2 K.W. A.C. Gen., £12. 220 D.C. to 310 volt 300 m.a. and 12 volts 10 amps., £6. Ditto to 480 volts 200 m.a. and 18 volts 20 amps., £6 10/-.

The best bargains ever offered in A.C./D.C. sets. A quarter original cost. Write for List "W." ELECTRADIX RADIOS 218, UPPER THAMES STREET, LONDON, E.C.4.

Components, etc., for Sale.—Contd.

(This advertisement continued from first column.)

PREMIER Mains Transformers, output 250-0-250 volts, 60 m.a., 4v. 1-2a., 4v. 2-3a., 4v. 3-4a. (all c.t.), with screened primary, 15/-.

PREMIER Mains Transformers, output 350-0-350 volts, 90 m.a., 4v. 3-5a., 4v. 2-3a. (both c.t.), with screened primary, 15/-.

PREMIER Mains Transformers, output 400-0-400 volts, 100 m.a., 4v. 4-5a., 4v. 2-3a. (both c.t.), with screened primary, 15/-.

PREMIER Auto Transformers, 100-110/200-250 volts or vice versa, 60-watt, 7/9; 100-watt, 10/-.

SPECIAL Offer of Manufacturers' Type Transformers, any input, output 250-0-250 volts, 60 m.a., 4v. 1a., 4v. 3a. (both c.t.), 8/6; H.T.8 transformer, with 4v. 3-4a. (c.t.), 8/6; with rectifier, 18/6.

AMPLION Mains Transformers, input 100-250 volts, output 350-0-350 volts, 120 m.a., 4v. 5a., 4v. 2a., 6v. 1a. (all c.t.), 17/6.

FILAMENT Transformers, polished and engraved terminal boards, N.P. terminals, 4v. 3.4a., 5/-; 10v. 3a., 6/6; 12v. 1a., 5/-; 4v. 4-6a., 6/6; 14v. 4a., 6/6; 22v. 1a., 6/-; 2v. 5a., 5/-; 9v. 2.5a., 5/-.

PREMIER Chokes, 40 m.a., 25 hys., 4/-; 65 m.a., 30 hys., 6/-; 150 m.a., 30 hys., 10/6.

PYE Chokes, 20 or 32 hys., 4/-; Premier multi-ratio output transformers, giving 15 different ratios, 7/6.

PREMIER Eliminators, output 200-250 volts, 40-100 cycles, A.C., incorporating Westinghouse metal rectifiers, output 250v. 60 m.a., S.G. and 120v. taps, 42/6; with 4v. 4a. c.t. L.T., 7/6 extra.

PREMIER Eliminators, output 150v. at 30 m.a., S.G., and 100v. taps, with 4v. 3-4a. c.t. L.T., 37/6; or with trickle charger, 42/6.

PREMIER Eliminators, output 120v. at 20 m.a., S.G., and 100v. taps, 27/6; with L.T. trickle charger incorporated, 35/-.

PREMIER D.C. Eliminators, output 120v. at 20 m.a., S.G., and 100v. taps, 15/-.

ACCUMULATOR Chargers, 200-250 volts A.C., all incorporating Westinghouse metal rectifiers, 2, 4, and 6v. at 1/2 amp., 12/6; 2, 4, and 6v. at 1 amp., 17/6; 12v. 1a., 27/6; 6v. 2a., 35/-; 12v. 2a., 35/-; 12v. 1.5a., 30/-; 6v. 3a., 39/6; 12v. 3a., 42/6.

AMPLION Moving Coil Speakers, type E.M.644, dual fields, 2,500 and 5,000 ohms (100 and 200v.), with output transformer, 12/6; A.C. conversion kit for this speaker, 10/- extra.

WESTINGHOUSE Metal Rectifiers: 120v. at 20 m.a., 6/6; 180v. at 30 m.a., 8/6; 8v. at 1/2 amp., 6/6; 6v. at 1 amp., 9/6.

KOLSTER BRANDES Electric Gramophone Motors, K complete with turntable and automatic stop, 100-250v. A.C. and D.C.; list price £5, to clear £2.

B.T.H. Induction Type (A.C. only) Electric Gramophone Motors, 100-250v.; 30/- complete.

O.L.A. Type Moving Coil Speakers, 2,000 or 6,500 Ohms, with power or pentode output transformers, 17/6; A.C. conversion kit for this speaker, 10/- extra.

AMPLION Moving Coil Speakers, type E.M.644, dual fields, 2,500 and 5,000 ohms (100 and 200v.), with output transformer, 12/6; A.C. conversion kit for this speaker, 10/- extra.

WESTERN ELECTRIC Condensers, 250v. working, 1 mfd. 6d., 2 mfd. 1/-; 500v. working, 1 mfd., 1/-; 400v. working, 3 separate 4 mfd. condensers, 8/6.

T.C.C. Condensers, 250v. working, 4x4x1 mfd., 3/6; 300v. working, 4x4x2x2 mfd., 6/-; 300v. working, 4x4x2x1 mfd., 6/-; 6x4x2x2x2 mfd., 375v. working, 6/11.

SPECIAL Offer of Wire Wound Resistances.—4 watts, up to 15,000 ohms, 1/-; 8 watts, any value up to 50,000 ohms, 1/6; 15 watts, any value up to 50,000 ohms, 2/-; 25 watts, any value up to 50,000 ohms, 2/6; 50 watt, any value up to 50,000 ohms, 3/6.

WIRE Wound Potentiometers, 15,000 ohms, 1/6; Central Potentiometer volume controls, 50,000 ohms, 2/-; wire wound Clarostat Potentiometer, 50,000 ohms, 2/6; Colverstats, logarithmically wound Potentiometers, 6,000 ohms, 1/9.

HEAVY Duty Variable Resistances, slider type, wound on porcelain, 2,000 ohms quarter-amp. and 500 ohms half-amp.; 5/- each.

FOR Callers Only.—The following valves, guaranteed as new: P.T.625, M.P./P.E.N., D.C.S.G., V.D.S., V.M.S., S.4V.A., A.C.S.G., A.C.S.G./V.M., V.M.S.G., 41M.S.G., V.M.S.4, M.S.4B., U.S., 904V., M.S.G.L.A., M.S.G.H.A., M.H.L.4, M.L.4, M.H.4, U.14, S.4V.B., D.W.3, P.T.4, D.S., D.S.B., M.M.4, 41M.L.E., P.E.N.4V., M.V.S.G., A.C.H.L.; at half price.

THE Last Few Western Electric 4211-D Valves, 10v. 3a. filament, 750-1,000v. plate, 50-65 m.a., impedance 3,500 ohms, amplification factor 12; cost £5, to clear at 15/-.

500-VOLT 125-milliamp. Full Wave Rectifying Valves, v. 2a. filament; 7/6.

PHILIPS 328 Valves for L.T. Charging, 5/6; 329 Barretts lamps, 2/-.

ALL the Following Lines 6d. each, or 5/- doz. assorted: shielded 8-6, or Pentode leads; 2in. lengths of screened wire; 5-pin valve holders; Grabtree 5-amp. sunk switches; T.C.C. 0.1 mfd. condensers.

THE "MIRROR" REFLECTS TANNOY QUALITY

by again choosing Tannoy Power Amplifiers for the annual tour of the "Daily Mirror" Eight."

There are Tannoy Amplifiers for all purposes. Individually built—not mass produced.

TANNOY PRODUCTS
(Guy R. Fountain Ltd.)
Canterbury Grove, West Norwood, London, S.E.27.
Manchester, Birmingham, Scotland, Ireland.

YOUR NEW A.C. MONODIAL SUPER-HET

LET us take your old Set or components in **PART EXCHANGE** for this New "Wireless World" Super-Het. Best quotations and fullest allowance given. Balance payable by Cash or H.P. Send us your enquiry for quotation by return. Fill in the coupon—no obligation.

PARTEX RADIO, VULCAN HOUSE,
56, Ludgate Hill, LONDON, E.C.4.

NAME
ADDRESS

EPOCH

MOVING COIL SPEAKERS

The Finest in The World in Each of Their Price-classes.

Ask your dealer or call for a demonstration at Exmouth House.

Send for New Booklet W.S.5a. It is free.
EPOCH RADIO MANUFACTURING Co. Ltd.
Exmouth House, Exmouth St., London, E.C.1
At the junction of Rosebery Avenue and Farringdon Road.
Phone: Clerkenwell 6666 (4 lines).

SAVAGE for AMPLIFIERS

Write for leaflet to W. Bryan Savage, 56/8, Clerkenwell Road, London, E.C.1.

Components, etc., for Sale.—Contd.

R. SELECTED Parts for Sale, as new; any c.o.d. or "Wireless World" deposit system, which we recommend if in doubt as to the splendid value offered; we take risk of damage in transit to our customers; goods tested for callers and guaranteed.

WE Hold a Large Stock of First Class Radio Apparatus, meters, resistances, condensers, heavy chokes, etc., in addition to goods advertised.

ANNUAL Summer Sale, all goods guaranteed.—Set cabinet, 18x7, 5/6 to caller; light oak table cabinets, new, for 3v. set and speaker, 15/-; slightly used, 12/6.

VARLEY Q.P.P. Input Transformer, 9/-; Varley Q.P.P. output choke, 10/-; Ampion P.M. Q.P.P. speaker, 27/6; Atlas Q.P.P. H.T. eliminator, 37/6; Cosmor P220 valves, 4/6; Radiophone 2-gangs, less drive and cover, 6/-; to clear; Ekco A.C. 18 eliminator, 37/6; Ekco A.C. 25 eliminator, 47/6; Weston projecting 0.2 m.a. meters, 20/-; Elliott 0-240v. A.C. meters, projecting 2 1/2 in., face radio type, 25/-.

T.C.C. Condensers, 250v., working, 4x4, 3/-; ditto, 4x4x1x1x0.5, 3/-, post 9d.; Lamplugh D.C. speakers, 2,200 ohm, new, 9/6; Polar 3-gangs tub, 10/-; Polar Star 3-gang, 15/-; Climax D.C. eliminator, 14/6; Lissen D.C. eliminator, 12/6.

K.B. 6v. I.R. m.c. speaker, new, 7/6; Lotus new 4-gangs, fully screened, 15/-; Mazda A.C./S.G. metal caps, 5/-; Igranic mains transformers, 460v. full wave, 7.5v. 4v., 8v., 15v., to clear, 11/- each, brand new, 120 m.a. output; Igranic half wave 550v. 60 m.a., 7.5, 7.5, 6/-, new.

TELSEN Mains Transformer, 350v., etc., 9/-; ditto new, 10/-; manufacturers' type P.M. 4v. valves, 1/- each; P.M.14, 4/-; Igranic L.F. transformers, 2/- each.

VALVES.—M.S.4B., 9/-; M.S.V.G., new, 9/-; A.C.S.G.V.M., new, 9/-; M.S.4, 7/6; A.C./pen., 10/-; Pen. 4v., new, 10/-; 904v., new, 7/6; U.10, new, 8/6; D.P.T., 10/-; D.S.B., 10/-.

RYALES RADIO, 35, Chancery Lane, London, W.C.2 (nearest Tube Chancery Lane; bus 67 passes door, or tram to Savoy St.), Highbury 3529. Open Saturday afternoon. Close 7 p.m., Thursdays 1 o'clock, Saturday 6 p.m.

R. GILBERT INDUSTRIES Latest Offer:—

"D" Parcels, containing all the following high grade components:—One transformer, 350-0.350 at 80 m.a., 4v. 4 to 6a., C.T., 4v. 2a., one chassis and 3-valve holders, one H.M.V. 2-gang with trimmers, one 15 mid. T.C.C. electrolytic, one 4+4 mid. T.C.C. block, one volume control, 4 assorted resistances, 6 small assorted condensers, one Paxolin strip (10in.x4in.), one packet of "Varcos" insulating sleeving, 6 3ds. heavy flex.

"C" one A.C. Paillard motor, type 1504, universal input, complete with turntable, £2, post paid; also a few "A," "B" and "C" parcels still available. (See previous issues.)

TRADERS.—Do you realise that these parcels, when split up, will realise £3 to £4 in the shop?—Gilbert Industries, 519, London Rd., Westcliff-on-Sea. [3002]

M.R.D. Co.'s Set Manufacturers Surplus Goods, as new; carriage paid or call.

2-VALVE Battery Sets, oak cabinets, room for batteries, with Cosmor and Marconi valves, new, £1; also other sets as advertised last week.

FORMO 0.0003 Reaction Condensers, 9d.; Polymet condensers—new, 0.005, 0.002, 0.001, 0.0005, 0.00025, 0.0002, 0.0001, 1/6 per any halftone; Utility 2-gang, 0.0005, trimmers, 4/6; 3-gang, 5/9; Varley 250,000 ohm Potentiometers, 2/-; assorted American canned coils, 1/- each.—Mains Radio Development Co., 4-6, Muswell Hill Rd., N.6. [3131]

SOUTHERN RADIO'S Wireless Bargains.—Set manufacturer's guaranteed surplus:—

VARIABLE Condensers.—British Radiophone 4-gang superhet type, fully screened and trimmers, 0.0005, 8/9 each (list 45/-); Cydon 3-gang fully screened and trimmers, 0.0005, 7/- each (list 32/-); Utility 2-gang 0.0005, fully screened with trimmers, dial eucytechon and knob, 8/- each (list 39/6); Hydra block condensers, brand new, 16 mid., 2+2+3+2+1+1, 1,000 volt test (made for Canadian Marconiophone Co.), 8/9 each; 4 mid., 2/6 each; 2 mid., 1/9 each; 1 mid., 1/- each; all 750 volt.

GRAMOPHONE Motors.—Electric A.C., 110 volt to 250 V. volt, guaranteed dead silent; made Dr. Max Levy, of Berlin, and listed at £9/9/0; 12 only at 27/6 each, complete with turntable.

SPEAKERS.—Celestion Soundex permanent magnet, 16/6 (list 27/6); Rola F6 permanent magnet, 28/- (listed 49/6); D.C. mains energised, 2,500 to 6,500 ohms, complete with humbucking coils and transformers, 16/6 (list 39/6); Peter Grassman dynamic speakers and chassis, 10/6 each (list 35/-).

CONSTRUCTORS' Kits.—Ready Radio "303" battery 3 valve kits, less valves, 15/- each; complete with 3 Mullard valves (P.M.11.F., P.M.2, 21.X.), 33/- each (list 70/-); Ready Radio Meteor screen grid 3 valve kit, less valves, 26/-, with 3 Mullard valves (P.M.12a, P.M.2D.X., P.M.2a), 49/- (list £3.10).

READY RADIO S.T.400 Kits, as specified by Scott Taggart, £3 5 each (list £4 17/6).

READY RADIO Meteor Screen Grid 3-valve "A" Kit, complete with cabinet, permanent magnet speaker (less valves), £5/7/6 with Mullard valves, £4/10 (list £8 17/6); Mullard Radio for Million 3-valve A.C. kit, complete with 3 Mullard A.C. valves (Pen.4V., 354 V., 8.4V.), £3 10 (list £6/10); all kits brand new, in original sealed cartons.

All Goods Guaranteed Brand New and Perfect and A Sent Carriage Paid.

PLEASE Note.—We have opened a branch shop at 271-275, High Rd., Willesden Green, N.W.10, where callers are cordially invited to inspect our large stocks of wireless bargains. Please send all post orders to 323, Euston Rd., N.W.1.

SOUTHERN RADIO, 323, Euston Rd. (near Warren St. Tube), London, N.W.1. Phone: Museum 6324. [3129]

SERVICE RADIO, 46, Lisle St., London, W.C.2, offer set Manufacturers guaranteed surplus:—

SMOOTHING Chokes, 20 Henries 120 m.a., 9/- each; 50 Henries 60 m.a., 7/3 each; 40 Henries 40 m.a., 5/9 each; Weston potentiometers, flush type, model 354, 30-0-30, 4/9 each (listed 25/-), brand new and boxed; H.M.V. tone controls, 1/3 each (listed 12/6); Rola P.M. speakers, P.6, 28/- each (listed 49/6); Mains energised D.C. speakers, 2,500 ohms to 6,500 ohms, complete with Universal transformers and humbucking coil, 16/6 each (listed 39/6); F.7 mains energised D.C. speakers, with Universal transformers and humbucking coils, 23/6 each (listed 42/-); Pifco All-in-one Radiometer, latest type with bakelite case, 6 only at 9/6 each (listed 12/6).

(This advertisement continued on next page.)

ALL P.A. EQUIPMENT SHOULD INCORPORATE "SCIENTIFIC" EXPONENTIAL BAFFLES



Avoid waste! energy. Focus power over required area and save watts. Non-metallic in ferral. Circular cross-section gives better forward tone.

Approx. 2' 6" long
MODELS FOR ALL TYPES OF EQUIPMENT.
KEENEST PRICES. WE SOLICIT YOUR ENQUIRY.
LISTS ON APPLICATION.
SCIENTIFIC SUPPLY STORES (Wireless) Ltd.
126, Newington Causeway, London, S.E. 1
Tel.: Hop 4177.

SILVER-GHOST



SIZE DIAM. 12" DEPTH 6 1/2"
FARRAND INDUCTOR 50% DYNAMIC

PREFERRED BY MUSICIANS

WIRELESS WORLD SAID "WILL SUIT THE MOST HYPERCRITICAL EAR"

LAMPLUGH RADIO
Silver Ghost Works, COVENTRY, ENGLAND.
SEND FOR LITERATURE.

COMING; THE NEW IRON-DUST-CORE SCREENED H.F. CHOKES, for S.G. ANODES; THE NEW "STEEPSLOPE"—SCREENED WHISTLE FILTERS; NEW TYPE I.F. TRANSFORMER; A SERIES OF FIRST CLASS MAINS TRANSFORMERS & SMOOTHING CHOKES; (lists ready in a few days).



POSTLETHWAITE Bros. KINVER, STOURBRIDGE.

FIRST CLASS REPRODUCTION

AN UNREPEATABLE OPPORTUNITY TO SECURE A REAL B.T.H. **R. K. LOUDSPEAKER**

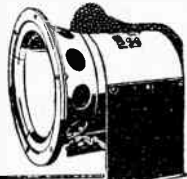

GUARANTEED NEW AT BARGAIN PRICES

Specification:—6 in. diameter cone Moving Coil Loudspeaker giving full bass response and handling the output from the heaviest power valve. Far superior to many small modern moving coil speakers. Weight 30 lbs. Field winding to suit 6, 100, or 230 volts D.C. Send cash with order or C.O.D.

R. K. SPEAKER
Originally listed at £6. 6. 0
Now offered for **30/-**
A.C. MODELS £2. 10. 0

Telephone: Highbury 0129
O H SEEKAMP 46, FARRINGTON ST. E.C.4

FIT THIS ELECTRIC CLOCK TO YOUR SET!



NO MAINS NEEDED! KEEPS CORRECT TIME! NO WINDING!

Works off small battery lasting 12 months, or can be plugged into G.B. Battery without affecting reception. Uses practically no current. Fits into hole 3 1/2" dia. in any panel up to 1 1/2" thick. Easy to fix—no screws required. Only 1" from front of panel to back of case. Swiss movement. Hands set from front. Nickel plated bezel. Useful addition to any set.

RIVERSIDE MFG. CO., LTD.
Dpt. 20, Crisp Rd., Hammersmith, W.8
Telephone: Riverside 6392.

COMPLETE WITH BATTERY POSTAGE 6D

Components, etc., for Sale.—Contd.

EPOCH "Domino" Speaker. 200-250v. D.C., £3; B.T.H. Universal gram. motor, 25; Edison Bell pick-up and tone arm, 12 6; Varley 120v. transformer, 509-0-503, etc., 20; Healybert ditto, 200-0-200v. 50 m.a., 2-5-0-2.5v. 2a., ditto 4v. 5a. fl. trans., 12 6; Ferranti trans., 0.1 P. 1 9/6, O.P.2 9 6, A.F.5 12 6, A.F.7 11/6, O.P.M.10 9/6; B2 choke, 7 6; Healybert chokes, 4 6; condensers, C2 1/6, C10 1 5, C6 2; T.C.C. 2 mfd. 1/-, 0.5 mfd. 1/-; coils, with screens, T.G.S.C. 4 6, R.M.38 4 6; Utility 3-gang, 10 6; Utility 4-gang, 12 6; valves, guaranteed as new, P.625A, 5; L.610, 3; P.M.24, 6; P.M.24A, 7 6; P.M.24B, 9 6; S.G.610, 5; D.W.4, 9 6; 506K (unused), 11 6; U.5, 7 6; L.410, 3; S.4V, 7 6; 354V, 6/-; 230V.T., 6;—Wright, Jesty's Av., Broadway, Weymouth. [3103]

CLASS "B" COMPONENTS.

CLASS "B."—The new "UB" driver transformer suits all the new class "B" valves and gives optimum results with all types of driver valves. A boon to experimenters and a necessity for anybody seriously interested in class "B"; price 10/-.—Below.

CLASS "B."—The "Sound Unit" converts any battery set to class "B" by means of a new adaptor system of connection (Patents Pending). In a few moments gives your old battery set a 1933 mains set performance. Suits all the class "B" valves.—Below.

THE Sound Unit.—Send for amazing test reports; better still, send for the "Sound Unit." It substantiates the experts approval shown in the reports. The "Sound Unit" costs only 35/- (less valve), suits practically any speaker, moving coil or cone type. You cannot do without the "Sound Unit" now reception is getting weaker and greater amplification is needed. The "Wireless World" stated that 6-7 times the amplification is added to your set by simply plugging in the "Sound Unit." All the other technical papers substantiate their claim.—Below.

ATTACHED Perfection.—The "Sound Speaker Unit" has a balanced permanent magnet moving coil speaker with "Sound Unit" attached, complete with tone and volume control, incorporating specially designed output transformer and point for extra speaker. You can now run your remote speaker on class "B." Price £3/15 (less valve).—Below.

SOUND SALES are Releasing a New Catalogue, containing an even greater range of their famous Mains Transformers and Chokes; let us register your name for circulation.—Write Dept. "B.B." Sound Sales, Ltd., Trenchett Grove Works, Junction Road, Highgate, London, N.19. [0400]

MISCELLANEOUS.

EASY Payments.—We supply, by easy payments, components, accessories, and sets, any make; 10% down, balance spread over 11 months.—Send list of requirements to London Radio Supply Co., 11, Oat Lane, London, E.C.2. [0337]

ENGINEERS and Technical Workers of All Kinds.—A proper training by post in your spare time will take you through your right examination, then employment is waiting. Our advice on all careers free.—Dept. 92, The Bennett College, Ltd., Sheffield. [0395]

AMBITIOUS Engineers Wanted to Apply for Our Free 250-page Handbook gives details of A.M.I.Mech.E., I.E.E., A.M.I.A.E., G.P.O., etc., exams., outlines latest courses in mech., elec., motor, radio and aero. engineering, and shows clearly where first class vacancies occur each year.—Send P.C. for free handbook immediately to British Institute of Engineering Technology, 87, Shakespeare House, 29, Oxford St., W.1. [3012]

AMBITIOUS MEN.—Qualify for a well-paid post by studying at home with the T.I.G.B. Write to-day for "The Engineer's Guide to Success," 144 pages, free, which contains the widest selection of engineering and wireless courses in the world, and shows you how to become A.M.I.E.E., A.M.I.Mech.E., A.Rad.A., etc. State Branch, post or qualification that interests you.—The Technological Institute of Great Britain, 82, Temple Bar House, London, E.C.4. (Founded 1917, 19,000 Successors.) [3008]

PATENT AGENTS.

KING'S PATENT AGENCY, Ltd., 146a, Queen Victoria St., London, E.C.4. Phone: Central 0682. 47 years' experience. Advice Handbook free. [0381]

PATENTS and Trade Marks. British and foreign.—Gee and Co. (H. T. P. Gee, Member R.S.G.B. and A.M.I.R.E.), 51-52, Chancery Lane, London, W.C.2. Phone: Holborn 1525. [0001]



There is a model to suit every output.
Prices from 15 - to 70 - . Your dealer will demonstrate.
REPRODUCERS & AMPLIFIERS, LTD., WOLVERHAMPTON.

Grippleshell
Aerial Brackets

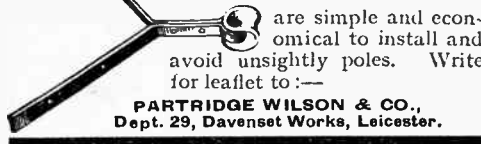

are simple and economical to install and avoid unsightly poles. Write for leaflet to:—
PARTRIDGE WILSON & CO.,
Dept. 29, Davenset Works, Leicester.

BAKER WRITE NOW FOR OUR NEW BOOKLET GLEAFLETS

75-77 SUSSEX ROAD, CROYDON, SURREY.
Phone: Croydon 3141-2
FOR QUALITY MOVING-COIL SPEAKERS.

PARIMA SELENIUM CELLS

FOR ALL PURPOSES.

Parima Light-Sensitive Resistances are constant, mechanically strong, moisture proof and exceedingly sensitive. Fully guaranteed for 12 months. 5/- Prices from

PARIMA MANUFACTURING CO.
21, BROMLEY ROAD, S.E.6. *Hither Green 3629*

REPAIRS.

REPAIRS to L.F. Transformers, phones, loud-speakers (except Blue Spots), 4/-, post free; quotations for mains transformers and all coil winding jobs; "Wireless World" transformers supplied; terms to trade.—Electrical Depot, 70a, Exmouth Rd., Walthamstow, E.17. [3122]

REPAIRS to Loud-speakers, transformers and headphones, 4/- each; Blue Spots or Wufa's, 5/-; mains eliminators, etc., quoted for; prompt service; satisfaction guaranteed; terms to trade.—Loud-speaker Repair Works, 2, Shipka Rd., Balham, London. Streatham 6618. [0394]

REPAIRS.—Rebuilding to any set; highest quality work only; lowest charges; estimates given free; distance no object.—L. Eastwood, Radio Manufacturers' Consultant, Late of His Master's Voice and Marconi Wireless Telegraph Co. Telephone: Clerkenwell 4520. Address: 60, Horder Rd., Fulham, S.W.6. [3085]

GUARANTEED Repairs by Experts; specialists for repairs to S. G. Brown and Amphion radio apparatus, also loud-speakers, headphones, pick-ups, Blue Spots, any type re-wound, remagnetised and adjusted; 4/-; post free; mains transformer repairs; terms to trade.—Howell, 91, Morley Hill, Enfield, Middlesex. [9716]

TUITION.

RADIO Engineering.—Day, evening, and postal courses. This school is fitted with most modern apparatus. Prospectus free. Valuable recommendations given to qualified students.—Northern Counties Wireless School, Preston. [0399]

R.T.I. Training Methods are Recognised; write for particulars of home study for radio appointments; secure "Certificate of Proficiency" and become "A.M.R.T.I."—Radio Training Institute, 85, New Oxford St., London, W.C.1. [2947]

EXCHANGE.

EXCHANGE Your Present Set or Components for the New Mondial Super; best allowance.—Radio Exchanges, 114, Ramuz Drive, Westcliff-on-Sea. [3124]

HIGH Allowances Made on Second-hand Goods in Part Payment for New Sets or Components; easy payments available; we have tremendous stocks tested second-hand goods; send list of your requirements for quotation.—Bostock and Stonhill, 1, Westbourne Terrace, S.E.23. [3123]

WANTED.

SPOT Cash for Components, etc.—Economic Radio Co., 96-98, South Lambeth Rd., S.W.8. [2923]

WANTED, new and second-hand valves.—Send particulars and prices to Box 7561, c/o The Wireless World. [3128]

SURPLUS Components and Electrical Goods Bought for Cash.—24a, Newport Court, Charing Cross Rd., W.C.2. [3113]

ROTARY Converter, 100v. D.C. to 230v. A.C. (160 W. watt.)—Brownson, 10, Dalmeny Mansions, Drake St., W.C.1. [3102]

HIGH Class Radio Sets and Parts Wanted for Cash. Midday Radio Exchange, 24, Midday Grove, London, N.1. [2972]

WANTED, all types of A.C., D.C. and battery valves, receivers and any other new components in quantities.—Ward, 12, Tredegar Rd., Bow, E.3. Advance 3668. [3030]

SITUATIONS VACANT.

IF You Wish to Enter the Wireless Profession with a Thorough Training, or if you wish to improve your present position, you will need the certificate issued by Britain's leading wireless college. This is not a correspondence college. Apparatus of all leading makes installed for instructional purposes. Boarders accepted. Training fees can be paid after appointment. Prospectus free.—Wireless College, Colwyn Bay. [0383]

SITUATIONS WANTED.

YOUTH, 22, desires any position in radio industry.—R.O.N., Fairfield, Penmaenmawr. [3094]

RADIO, electrical engineer, 10 years' designs, mains and battery models service all types, power and h.k.k.e., previous manufacturing experience electrical, mechanical, age 33, smart appearance, responsible progressive position, any branch.—Box 7529, c/o The Wireless World. [3093]

TRANSFORMER AND CHOKE STAMPINGS, INSTRUMENT AND RESISTANCE WIRES.

Lists Free

LUMEN ELECTRIC CO.
9, SCARISBRICK AVE., LITTLERLAND, LIVERPOOL, 21

FOR HIRE RADIO, MICROPHONE & GRAMOPHONE AMPLIFIERS

giving exceptional quality and volume, suitable for Dances, Sports Meetings, Fêtes, etc., from 15/- per day. McMichael Portable Sets 15/- a week; £2-12-6 a month.

ALEXANDER BLACK, LTD

WIRELESS CONSULTANTS
55, EBURY STREET, LONDON, S.W.1.
ESTABLISHED IN 1925. SLOANE 1653.

Trade Inquiries Invited.

SERVICE

SETS OF ALL TYPES

Supplied, Serviced and Visited in any district, or may be sent for Full Test and Report, at 2/- per valve-holder; portables, 1/6 per valve-holder.

No cheap materials—no cheap workmanship

OSBORN CABINETS

are recommended everywhere

Model No. 225 Radio-Gram. Cabinet 3' 6" high x 2' 2" wide x 1' 6" deep. Baffle behind fret, 24" x 17". Silk fabric for fret front included. Opening at top and back. Takes panel 24" x 13" or smaller. Accommodates any type of gramophone motor. **PRICES:—Machined Ready to Assemble, Kit of Parts, Oak £3-5-0, Mahogany £3-10-0, Walnut £4-0-0. Assembled Ready to Polish, Oak £4-5-0, Mahogany £4-10-0, Walnut £5-0-0. Assembled and Polished, Oak £5-5-0, Mahogany £6-0-0, Walnut £6-15-0.**

OSBORN SUPER ACOUSTIC BAFFLE BOARD. Prevents 90% speaker worry. Guaranteed no vibration. Any size hole cut **FREE.** 18" x 18" 3/4, 24" x 24" 5/8, 30" x 30" 8/8, 36" x 36" 11/8. **SEND FOR FREE SAMPLE.**

SPECIAL QUOTATIONS FOR YOUR OWN DESIGN

CHAS. A. OSBORN, Regent Works, Arlington Street New North Road, London, N.1 Tel.: Clerkenwell 5095. Showrooms: 21, Essex Road, Islington, N.1. Tel.: Clerkenwell 5834.

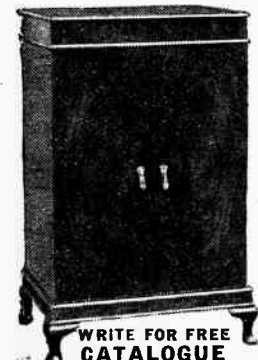

WRITE FOR FREE CATALOGUE

THE WIRELESS ENGINEER

AND EXPERIMENTAL WIRELESS

The Journal for Professional Engineers and Advanced Wireless Experimenters

Monthly 2/6 net

Annual Subscription 32/- post free

LIFFE & SONS LTD., Dorset House, Stamford Street, London, S.E.1

Mention of "The Wireless World," when writing to advertisers, will ensure prompt attention.

PEAK CONDENSERS

Specified for
"THE NEW MONODIAL SUPERHET."

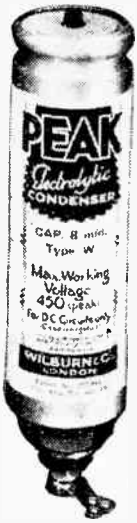

Extract from report on PEAK ELECTROLYTIC Condensers published in The "WIRELESS TRADER," May 13th, 1933.

Specimen No.	Capacity μ F.	D.C. Leakage (mA) with Various Applied Voltages.					
		300 V.	350 V.	400 V.	450 V.	500 V.	550 V.
1	7.6	0.05	0.075	0.1	0.15	0.225	1.3
2	7.7	0.075	0.125	0.175	0.225	0.75	3.5

The voltage rating appears to be very conservative, since even at 100 V over the rated value the leakages were only 1.3 and 3.5 mA. With some similar condensers we have handled, it has been found that almost immediately after the rated voltage is exceeded, more or less violent gassing takes place and the leakage current rises considerably.

In view of the above figures the significance of which will be at once apparent, it is not surprising to find these Electrolytic Condensers together with certain other PEAK Condensers specified for the NEW MONODIAL SUPERHET. The complete list is as follows:

- 750 Volt D.C. Test. TYPE A4.
- 2 .. 2 mfd. at 2/9 each
 - 1 .. 1 ,, at 2/2 ,,
 - 5 .. 0.1 ,, at 1/10 ,,
- 1500 Volt D.C. Test. TYPE CB7.
- 1 .. 4 mfd. at 6/- each
- ELECTROLYTIC TYPE W.
- 3 .. 8 mfd. at 4/9 each

CAPACITY
8 mfd.
PRICE
4/9 ea.

Delivery from Stock.

A new illustrated list containing full particulars of the complete PEAK range is ready and will be sent on application.

Wheatstear House
Carmelite Street,
Northern Distributors :

WILBURN & COMPANY

London, E.C.4
Phone: CENTRAL 6810

W. Andrew Bryces & Co., Bury, Lancs

FOR YOUR
W.W. NEW MONODIAL SUPERHET

"GOLTONE" SCREENED H. F. CHOKE

Type S.H.F.

Highly efficient. Robust Mechanical Construction.

The Best in its Class.

Inductance 250,000 mics. approx. ; D.C. resistance 550 ohms. Current (max.) 50 m a approx. Grey enamelled metal screening cover.

No. RS.S.H.F. Price **4/-** Each.

USE "GOLTONE" COMPONENTS FOR THE "W.W. NEW MONODIAL SUPERHET" FOR BEST RESULTS.

Obtainable from all First Class Radio Stores. Refuse substitutes. If any difficulty write direct.

JUST RELEASED.
"GOLTONE" 1933 34 RADIO CATALOGUE.
Send for this 56-page profusely illustrated list.
FREE on request.



GENUINE REISZ P.A. MICROPHONES

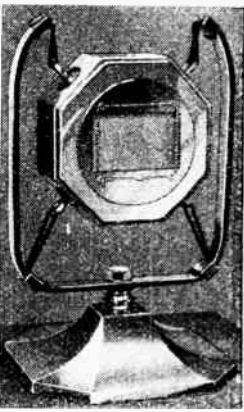

Brand New and Guaranteed.
Continuation of our Magnificent Bargain Offer.

55/- POST 1RLE

Since our last announcement we have supplied many important P.A. Contractors and Taxis Engineers (including Broadcast House, Singapore) with these Mikes and have received most enthusiastic testimonials. (Copies on request.) Full approval or return or cash. Great opportunity for immediate or future requirements.

In heavy octagonal polished solid aluminium case, 3 1/2" dia., with 4 suspension rings. Perfect even response no peaks, no cut-off, no background noise. Hand-some plated stand with heavy oxidized base and turner suspension (as illustrated) 15/- extra. Reisz type transformer, perfectly matched, 7/6 extra. Adjustable floor stand, well-made and hand-some, standard 25/6.

We also have the finest Moving Coil Speaker bargains. Just in. The new R.C. (ROTHEMUND) suggested, 7,500 ohm with Levator transformer, 35/- model or 13/6 (incl. L.S.). EPOCH P.M. Sennor 3 column model with 2500 ohm transformer, 25/- (incl. 1/3). EPOCH 12,500 or 4,000 ohm, with 2500 ohm transformer, 14/6 (incl. 1/3). A.C. ELIMINATOR, Westinghouse rectifier, output 150, 150 volts, 35 ma. (3 pos., 1 neg.). Very spec. order, 20/6 (post 1/3).

All above goods are brand new. Head Office and Mail Order Dept. SHARPESSBURY SUPPLIES, 224, Shaftesbury Av., London, W.C.2. (Phone: Tem. Bar 4173).

Branches: Southampton: 17, St. Mary St. Bristol: 13, Cumberland Street, St. Nicholas Croft.

The CAMCO 'NUTONE' Speaker Cabinets

Scientifically designed for the Expert



You will notice a definite improvement in the tone of your loud speaker, housed in the Camco 'Nutone' Cabinet. There is an entire absence of box resonance and the results are equal to those obtained with a large baffleboard. Supplied in Oak, Mahogany and Walnut finish. Price 32/6.

See it at our Showrooms open 9-15 to 5-45 (Sat. 12-30) and send for a copy of the Camco Cabinet Catalogue.



Carrington Manufacturing Co., Ltd., Holborn 8202.

Showrooms: 24, Hatton Garden, London, E.C.1.
Works: S. Croydon

INDEX TO ADVERTISEMENTS.

PAGE	PAGE	PAGE
Automatic Coil Winder & Elec. Equipment Co., Ltd. 5	Electrical Trading Association, Ltd. 6	Radio-Gramophone Development Co. Back Cover
Baker's "Selhurst" Radio 8	Epoch Manf. Co., Ltd. 6	Raw-wood Electrical Co. Inside Front Cover
Belling & Lee, Ltd. 8	Gambrell Bros., Ltd. 6	Reproducers & Amplifiers, Ltd. 8
Benjamin Electric, Ltd. 8	General Electric Co., Ltd. 6	Riverside Manf. Co., Ltd. 6
Birmingham Sound Reproducers, Ltd. Inside Back Cover	Heyberd, F. C. & Co. 6	Rotax, Ltd. (M.L. Equipment) Front Cover
Black, Alexander, Ltd. 8	Igranic Electric Co., Ltd. Inside Front Cover	Savage, W. Bryan 6
Britannia Batteries, Ltd. 8	Jackson Bros 6	Scientific Supply Stores (Wireless), Ltd. 6
British Blue Spot Co., Ltd. 4	Lampugh Radio, Ltd. 8	Scott Sessions & Co. 6
British Radio Gramophone Co., Ltd. 4	Lectro Lux, Ltd. 8	Seekamp, O. 6
British Radiophone Co., Ltd. 2	London Electric Wire & Smiths, Ltd. 8	Shaftesbury Supplies 9
British Rola Co., Ltd. 9	Lumen Elec. Co. 8	Shoeburde Reproducers, Ltd. Front Cover
Bryce, W. Andrew, & Co. 9	Lysens, Claude, Ltd. 3	Tannoy Products 6
Bulgin, A. F., & Co., Ltd. 7	Osborn, Chas. A. 8	Telsen Electric Co., Ltd. Front Cover
Carrington Manf. Co., Ltd. 9	Parina Manf. Co. 8	Varley (Oliver Pell Control, Ltd.) 2
City Accumulator Co., Ltd. 3	Parlex Radio 6	Ward & Goldstone, Ltd. 9
Cole, E. K., Ltd. 11	Partridge & Mee, Ltd. Inside Back Cover	Watmel Wireless Co., Ltd. 7
Columbia Gramophone Co., Ltd. 11	Partridge, Wilson & Co. 8	Westinghouse Brake & Saxby Signal Co., Ltd. Inside Back Cover
Colvern, Ltd. 10	Paper, Trevor (Seradex) 1	Wilburn & Co. 9
Concordia Electric Wire Co., Ltd. 10	Peto-Scott Co., Ltd. 1	Wright & Weaire, Ltd. 11
Cosson, A. C., Ltd. 10	Picketts 6	
Dubilier Condenser Co. (1925), Ltd. Front cover	Postlethwaite Bros. 6	
Eastick, J. J., & Sons 5		
Electradix Radios 5		



Give your Set the power to bring in **MORE STATIONS**

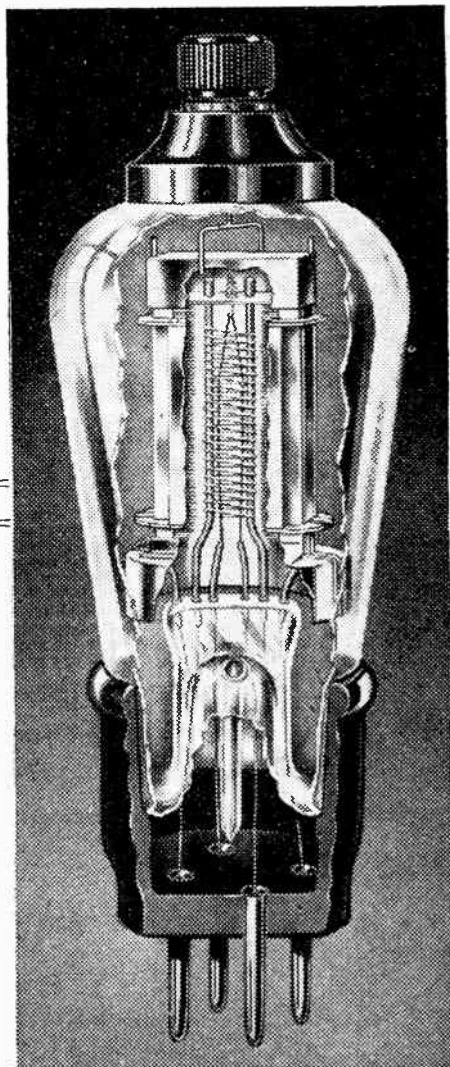

If you use a Screened Grid Receiver you can easily widen your choice of programmes by fitting a Cossor S.G. Valve.

Due to their unique construction (including the famous Mica Bridge) Cossor S.G. Valves are exceptionally efficient. They will definitely improve the performance of any well-designed Screened Grid Receiver (A.C. Mains or Battery operated)—increase its range and maintain a high degree of selectivity.

Your dealer will tell you the type you need.

COSSOR SCREENED GRID VALVES

NEW REDUCED PRICES

Cossor 2-volt Screened Grid Valves

Type	Fila-ment Amps.	Anode Volts	Imped.	Amp. Factor	Mutual Conduc-tance m.a./v.	Price
*215 S.G.	-15	120-150	300,000	330	1-10	15/6
*220 S.G.	-2	120-150	200,000	320	1-60	15/6
*220 V.S.G.	-2	120-150	110,000	—	1-60	15/6
220 V.S.	-2	120-150	400,000	—	1-60	15/6

Cossor A.C. Mains Screened Grid Valves

Type	Purpose	Imped.	Amp. Factor	Mutual Conduc-tance m.a./v.	Price
*†MSG-HA	Super H.F. Amp'n.	500,000	1,000	2-0	17/6
*41 MSG	Super H.F. Amp'n.	400,000	1,000	2-5	17/6
**MSG-LA	Super H.F. Amp'n.	200,000	750	3-75	17/6
*†MMSG	Variable-Mu	200,000	—	2-5	17/6
**MS PEN-A	H.F. Pentode	—	—	4-0	17/6
*†MS PEN	H.F. Pentode	—	—	2-8	17/6
*†MVS PEN	Variable-Mu H.F. Pentode	—	—	2-2	17/6

These Mains Valves have Indirectly Heated Cathode, 4 Volts, 1 Amp.

*These Valves available with or without Metallised Bulbs.

† Characteristics measured at 1.5 grid volts.

** Stocked with Metallised Bulb only.

To A. C. COSSOR LTD., Melody Dept., Highbury Grove, London, N.5.

Please send me free of charge, a copy of the 40-page Cossor Valve and Wireless Book B.17.

Name.....

Address.....

W.W. 21/7.33.....

Mention of "The Wireless World," when writing to advertisers, will ensure prompt attention.

WEDNESDAY

JULY THE TWENTY-SIXTH

PRINCIPAL EVENTS OF THE WEEK:

AT HOME

- NATIONAL** "The Road to Ireland," a feature programme, by Filson Young.
- LONDON REGIONAL** Instrumental concert.
- MIDLAND REGIONAL** "Etc., Etc.," one inconsequential thing after another.
- WEST REGIONAL** Prince George, the Earl of Lisburne and Lord Davies of Llandinaw speaking at the Annual Luncheon of the Royal Welsh Agricultural Show, Aberystwyth.

ABROAD

- BRUSSELS (No. 1)** 9.0 p.m. Concert from the Ostend Kursaal.
- BUDAPEST** 7.40 p.m. Operetta music by Lehar, Kálmán and Szabados.
- HAMBURG** 9.10 p.m. Old Hanoverian military music, relayed from Hanover, with commentary.
- 7.40 p.m. Bach organ recital, by Jan Zwart.
- 9.35 p.m. Concert of Schrammel music.
- HILVERSUM KONIGSWUSTERHAUSEN LANGENBERG PARIS (Eiffel Tower)** 9.35 p.m. Pianoforte recital, by Hans Haass.
- PARIS (Radio-Paris)** 8.0 p.m. "The Valkyries," opera (Wagner), relayed from l'Opéra.
- 9.30 p.m. Russian operatic music.
- ROME** 8.45 p.m. Pianoforte, orchestral and vocal concert.
- TURIN** 8.40 p.m. "Maggiolata Veneziana," opera (Selvaggi), conducted by the composer.
- 9.10 p.m. Pianoforte and song recital.
- WARSAW**

ALGIERS
824 kc/s, 364 metres; 13 kW.—8.0 p.m., Financial News. 8.10, Shipping Notes. 8.15, Agricultural Report and Weather Forecast. 8.30, Songs from Sound Films. 8.55, News. 9.0, Time Signal. 9.2, Lottery Results. 9.15, Le Permis de Pétion—Comedy in One Act (Charles Val). 9.45, Concert relayed from the Gardens of the Aristide-Briand Square.

ATHLONE
725 kc/s, 413 metres; 60 kW. Relayed by Cork, 1,337 kc/s, 224.4 metres.—1.30 to 2.30 p.m., Time Signal, Stock Exchange Quotations, Weather Report and Gramophone Music. 6.0, Programme for Children. 6.45, News. 7.0, Gaelic Talk. 7.15, German Lesson. 7.30, Time Signal. 7.31, Variety Programme by Mary and Agnes Wickham. 7.50, Songs and Readings by Fay Sargent. 8.5, The Station String Orchestra. 8.20, Future Arrangements—a Sketch, by H. Fraser and Company. 8.50, The Station Orchestra. 9.15, Contralto Solos by Joan Burke. 9.30, Talk by T. Shaw: The Underdeveloped Natural Resources of Ireland. 9.45, Sponsored Programme. 10.30, Time Signal. 10.45, News, Weather Report and Close Down.

BARCELONA
EAJJ, 860 kc/s, 348.8 metres; 8 kW.—7.0 p.m., Trio Concert. 8.0, Request Gramophone Records. 8.30, Exchange, followed by Relay from the Ayuntamiento. 9.0, Gramophone Music and News. 10.0, Chimes from the Cathedral, Weather, Exchange and Market Prices. 10.5, Concert by the Station Orchestra: Pasodoble, solera fina (Marquina); Selection from La Mascotte (Audran); Waltz, Dobres (Walldteufel); Durmiendo al nene (Fernández); Humoresque (Demaret); Overture, Pique Dame (Suppé). 1.0, Recitation of Poems. 11.15, Light Orchestral Concert, relayed from the San Sebastian Casino. In the interval at 12 Midnight, News. 1.0 a.m. (Thursday), Close Down.

BARI
1,112 kc/s, 269.8 metres; 20 kW.—8.0 p.m., News. 8.20, Giornale Radio and Weather. 8.30, Time and Announcements. 8.35 (approx.), Violin Recital by Gioconda De Vito. Concerto, No. 4 (Vieuxtemps); Air on the G String (Bach); Prelude and Allegro (Paganini-Kreisler); Caprice, No. 13, La risata (Paganini-Kreisler); Caprice, No. 20—Pastorale (Paganini-Kreisler); Introduction and Tarantella (Sarastri). 9.30, Concert of Light Music. Waltz, Wiener Praterleben (Gronzler); Selection from Lo schiavo (Giacca); Intermezzo from the Third Act of William Ratelli (Mascagni); Selection from Il re della rosmine (Bettinelli); Idillio (Caldota); Fantasia, Excelesior (Marenco); Talk in the interval. 10.30, Dance Music from the Café del Levante. 10.55, News.

BASLE—See Schweizerischer Landessender.

BELGRADE
697 kc/s, 430.4 metres; 2.8 kW.—6.0 p.m., Orchestral Concert. 7.0, Talk. 7.30, Concert. 8.0, Talk. 8.30, Faust Opera (Gomrod), on Gramophone Records. In an interval at 9.30, Time and News.

BERLIN
DEUTSCHLANDSENDER; 183.5 kc/s, 1,635 metres; 60 kW.—2.0 p.m., Gramophone Concert: Overture, Zampa (Hérold); To Music (Sjöberg); Berceuse (Godard); Cavatina (Raff); Potpourri of Lehar Music; Minuet (Bocherini); Sizzietta (Blon); Das Zauberlied (Meyer-Heilmund); Grossmutterchen (Langer); Altddeutscher Liebesstein (Bohn). 3.0, Reading. 3.30, Weather and Exchange. 3.45, Reading from Tales of Transylvania (Hans Liebert). 4.0, See Hamburg. 5.0, Hitler Youth on the March—a Radio Play (Karl Cerff). 5.30, Mozart Pianoforte Recital by Eberhard Rebling; Fantasia in C Minor; Sonata in F. 6.0, Poems. 6.5, Address. 6.35, Wireless Technical Talk. 6.50, Weather and Announcements. 7.0, Transmission for all German Stations. Symphony Concert by the Augmented Station Orchestra, conducted by Dr. Wilhelm Buschköter: The Fourth Symphony, Op. 41 (Ewald Straesser); Variations and Fugue on a Theme by Mozart, Op. 132 (Reger). 8.0, An Appeal for Funds for the National Labour Scheme. 8.5 (approx.), Talk for Women: The German Mother and the German Nation. 8.15, See Munich. 9.35, Concert of Schrammel Music: March, Rastlos vorwärts (Edmund Kellner); Waltz, Liebessträume (Ertel); Overture, Frau Luna (Lincke); Sailor Songs for Accordion and Guitar: (a) Seemannswalzer (Dietrich-Radtke). (b) Schilbertanz (Dietrich); Mazurka, Francherherz (Joh. Strauss). 10.15, See Stuttgart. 10.25, News. 10.45, Weather. 11.0, Dance Music. 12 Midnight, Close Down.

BERLIN
WITZLEBEN, 715 kc/s, 410.5 metres; 1.5 kW.—4.30 p.m., Concert from the Sprengarten, Treptow; Conductor: Paul Müller; Mosele-Marsch (Hörsler); Overture, The Caliph of Bagdad (Baldelloni); Waltz on Melodies from Zeller's Operettas (Thiele); Potpourri, Rheinischer Sang (Hannemann);

Caprice (Kling); Two Slav Dances (Dvorák); March, Erinnerung an Dänemark (Jansson); March, Fürs Vaterland (Christ); March Potpourri (Kornzaki). 5.20, Dialogue on Psychology. 5.45, Women at Work—a Recital of Folk Songs by Lotte Theile (Soprano). 6.5, See Berlin (Deutschlandsender). 6.40, The Witzleben Station informs its Listeners. . . . 6.45, Topical Talk. 7.0, Transmission for all German Stations, relayed from Berlin (Deutschlandsender). 8.0, See Berlin (Deutschlandsender). 8.15, See Munich. 9.35, Government Announcements. 9.45, Report on the Sakrower See Camp. 10.0, Weather and News. 10.15, See Stuttgart. 11.0, Dance Music from the Sprengarten, Treptow. 12 Midnight, Close Down.

BERNE—See Schweizerischer Landessender.

BEROMUNSTER. — See Schweizerischer Landessender.

BODEN.—See Stockholm.

BODO.—See Oslo.

BORDEAUX-LAFAYETTE
986 kc/s, 304 metres; 13 kW.—7.50 p.m., News. 7.25, Agricultural Prices. 7.40, News. 8.0 (approx.), See Paris (Eiffel Tower).

BRATISLAVA
1,076 kc/s, 279 metres; 14 kW.—5.55 p.m., Hungarian Programme. Talk and Song Recital. 6.55, Talk for Housewives. 7.0, See Prague. 10.15 (approx.), Close Down.

BREMEN.—See Hamburg.

BRESLAU
923 kc/s, 325 metres; 60 kW. Relayed by Gliwicz, 1,184 kc/s, 253 metres.—1.45 p.m., Time and News. 2.0, Gramophone Concert of Marches. 3.0, Agricultural Prices. 3.20, Talk for Parents. 3.50, Reading. 4.15, Pianoforte Recital by Johanna Sauerland: La Cathédrale enrubinée (Debussy); Le jet d'eau (Debussy); Little Suite (Korngold). 4.45, Book Review. 5.0, Ernst Licht Song Recital by Hanns Laqua (Tenor); Schäferlied; Der Rongarten; Liebesweh; Der sonderbare Vogel; Verlöbendes Feuer; Abendlied; Der ferne Stern. 5.30, Agricultural Prices. 5.35, Talk: The German Element in Poland. 5.55, Violin Recital by Günther Hiller; Air on the G String (Matthieson); Largo from the Suite (Reger); Sonata in A (Handel); Andante cantabile (Mozart); Waltz in A (Brahms). 6.25, Talk. 6.50, News. 7.0, Transmission for all German Stations, relayed from Berlin (Deutschlandsender). 8.0, See Berlin (Deutschlandsender). 8.10, Topical Report. 8.40, See Heilsberg. 9.0, See Stuttgart. 10.0, Time and News. 10.15, See Stuttgart. 11.0, News. 11.15, Dance Music, relayed from Berlin (Witzleben). 12 Midnight, Close Down.

BRNO
878 kc/s, 342 metres; 35 kW.—6.25 p.m., German Transmission: News, Educational Talk, Programme for Workers and Gramophone Music. 7.0, See Prague. 7.10, Concert of Folk Music by a Village Orchestra. 7.15, See Prague. 10.30 (approx.), Close Down.

BRUSSELS (No. 1)
I.N.R., 590 kc/s, 509 metres; 15 kW.—12 Noon, Concert by the Station Symphony Orchestra, conducted by Arthur Meulemans. Soloist, E. De Decker (Bass). Overture, A May Day (Haydn Wood); Petite suite de concert (Goldrige Taylor); Ballet Music from Hérodiade (Massenet); Bass Solos: (a) Le cor (Flügel), (b) Song from La Juive (Halévy); Gopak (Musorgsky); Tango (Albeniz); Waltz, Wienerlied (Joh. Strauss); Marche héroïque (Saint-Saëns). 1.0 p.m., Le Journal Parlé. 1.10, Concert by the Sykes Orchestra, relayed from the Scala, Ostend. 5.0, Dance Music, relayed from the Continental Palace Hotel, Blankenberghe. 6.0, Talk. 6.15, Saxophone Solos by Paul Gason. 6.30, Cello Recital by Maurice Dambosi. 7.0, Gramophone Music; Selection from White Horse Inn (Bona-Zky); Tango, Je yeux rêver (Goeyens); The Wedding of the Rose (Gossel). 7.15, Talk: The Results of the International Labour Conference. 7.30, Medical Talk. 8.0, Pianoforte Recital by J. Constant: Le retour des muletiers (de Séverac); Three Waltzes (Brahms); Three Ecossaises (Chopin); Polchienne (Villa Lobos). 8.15, Eine kleine Nachtmusik (Mozart) on Gramophone Records. 8.30, Song Recital by Mme. Marie Prévère: Le colibri (Chausson); Pendant l'attente (de Bourguignon); Fédie (Erlanger); Sérénade (Strauss). 8.45, Lucien Christophe reads from his own Poems. 9.0, Concert, relayed from the Kursaal, Ostend. 10.30, Le Journal Parlé. 10.40, Dance Music, relayed from the Kursaal, Ostend.

BRUSSELS (No. 2)
N.I.R., 887 kc/s, 338.2 metres; 15 kW.—Programme in Flemish.—12.0 noon, Orchestral Concert relayed from the Scala, Ostend. 1.0 p.m., Le Journal Parlé. 1.10, Concert by the Station Symphony Orchestra conducted by Arthur Meulemans: Soloist: M. de Decker (Bass); Overture, The Thieving Magpie (Rossini); Spanish Sérénade (Glazunov); Pavane (Ravel); Dance (Debussy); Bass Solos: (a) Aria from The Seasons (Haydn); (b) De Vlaamsche taal (Mortelmans); Ballet Music from Henry VIII (Saint-Saëns). 5.0, Concert by the Radio Orchestra, conducted by Franz André: Overture; The Thieving Magpie; Selection from Madame Butterfly (Puccini); Finale from Violin Concerto No. 3 (Saint-Saëns); Esquisses flamandes (Brusselsmaus); Le roman d'Arlequin (Massenet);

Ballet Suite (Lachaume). 6.0, Pianoforte Recital by Mlle. Jeanne Kennes: Pastorale (Mozart); Ecossaises (Beethoven); Impromptu Waltz (de Boeck); Staccato étude (Rubinstein). 6.15, Talk: Free Thought. 6.30, Gramophone Music; Extracts from the Surprise Symphony (Haydn); Du bist die Ruh' (Schubert-Tortis); Ballet, The Seasons (Glazunov). 7.15, Recitations. 7.30, Horticultural Talk. 8.0, Concert by the Radio Orchestra, conducted by Franz André: Calet March (Souza); L'eau à la bouche (Paris Van Parys); Minuet (Valencin); Cossack Dance (Tchaikovsky); Trumpet Solo; Melody (Haydn-Wood); Clair de lune (Lacôme); Selection from Carmen (Bizet). 8.45, A Face in Two Scenes. 9.15, Humorous Song Recital by M. Remes. 9.30, Concert relayed from the Continental Palace Hotel, Blankenberghe. 10.30, Le Journal Parlé. 10.40, Dance Music relayed from the Continental Palace Hotel, Blankenberghe.

BUCHAREST
761 kc/s, 394 metres; 12 kW.—5.0 p.m., Dance Music by the Corobagos Jazz Band. In an interval at 6.0, Radio Journal. 7.0, Reading. 7.20, Romanian Songs and Music on Gramophone Records. 7.40, Educational Talk. 8.0, Pianoforte Recital. 8.20, Violin Recital by Nina Alexandresco; Concerto in E Minor (Nardini); Andantino (Martini-Kreisler); Berceuse (Cui); Variations on a Theme of Corelli (Tartini-Kreisler). 8.50, Talk. 9.5, Horn Solos. 9.55, Dance Music by the Syncop Accorders Jazz Band, relayed from the Lido. 10.0, Radio Journal.

BUDAPEST
545 kc/s, 550.5 metres; 18.5 kW.—5.0 p.m., Concert of Gypsy Music. 6.0, Reading. 6.30, Violin Recital. 7.0, Programme of Finnish Poetry and Songs. 7.40, Orchestral Concert of Operetta Music by Lehar, Kálmán, and Szabados. 9.0, News. 9.15, Programme of Dance Music.

CASSEL.—See Frankfurt.

COPENHAGEN
1,067 kc/s, 281 metres; 0.75 kW. Relayed by Kalundborg, 260 kc/s, 1,153 metres.—12 Noon, Time and Chimes from the Town Hall. 12.5 p.m., String Ensemble Concert, relayed from the Wivex Restaurant. 2.0, Interval. 3.0, Gramophone Music. 3.30, Concert by the Station Orchestra, conducted by Walter Meyer-Radon: Overture, Djamilah (Bizet); Dance from Les Indes galantes (Rameau); Selection from Samson and Delilah (Saint-Saëns); Introduction to Act Two of Et Folkesagn (Hartmann); Brudevals (Gade); Overture, Tannhäuser (Wagner); Overture, Norma (Bellini); Ballet Music from William Tell (Rossini); Selection from The Geisha (Jones); Reitermarsch (Schubert); Kaiserwalzer (Joh. Strauss); One-step from No. No, Nanette (Voumann). In the interval at 4.15 (approx.), Programme for Children. 5.30, Interval. 5.50, Agricultural Talk. 6.20, Interval. 6.50, Weather and News. 7.15, Time Signal. 7.30, Talk: The Boarding School. 8.0, Chimes from the Town Hall. 8.5, Concert of Viennese Operetta Music by the Station Orchestra, conducted by Walter Meyer-Radon: Overture, A Night in Venice (Joh. Strauss); Selection from The Gipsy Baron (Joh. Strauss); Overture, Die schöne Galathee (Suppé); Waltz from Der arme Jonathan (Müllbacher); Selection from Der liebe Augustin (Fald); March from The Chocolate Soldier (O. Strauss). 9.0, Topical Talk. 9.30, Overture in A for Harschord (Felsenmann), played by Folmer Jensen. 9.45, Jazz Songs by the Wiggers Quartet. 10.15, News. 10.30, The Dumky Trio, Op. 90, for Pianoforte, Violin and Cello (Dvorak). 11.10, Dance Music, relayed from the Arena. In the interval at 12 Midnight, Time and Chimes from the Town Hall. 12.30 a.m. (Thursday), Close Down.

CORK.—See Athlone.

CRACOW
959 kc/s, 312.8 metres; 1.5 kW.—7.5 p.m., Talk: Foreigners in Poland. 7.20, Miscellaneous Items and News. 7.35, Programme Announcements. 7.40, See Warsaw. 10.0, Talk in Esperanto. 10.20, Sports Notes. 10.35 till Close Down. See Warsaw.

DANZIG.—See Heilsberg.

DRESDEN.—See Leipzig.

FECAMP
1,228 kc/s, 225.9 metres; 10 kW.—4.30 to 6.0 p.m., Programme in English by the I.B.C. 4.30, Programme for Children. 5.0, Tango Band Concert for Portsmouth and Southsea Listeners: Signature Tune; Corazon (Ghirland); Plegaria (Bianco); Song, That's my Song (Colville); Todavía (Pizarro); Maman, so quiero un novio (Collazo); Song, In Old Madrid (arr. Cardew); Madrid (Rotter); Adios Juventud. 5.30, Gramophone Concert for Isle of Wight Listeners; Rhinoceros-fluster (Von Blon); Sicilienne et Rigaudon (Francoeur-Kreisler); Song, All over Italy (Butler-Munroe); Shepherd's Dance (German); Song, The Moment I saw you (Grey and Gay); Rose Mousse (Bose); Song, Don't be late in the Morning (Le Clerq); Minstrel Memories; Signature Tune. 6.0, Programme in French. 10.0 till Close Down, Programme in English by the I.B.C. 10.0, Dance Music by Jack Hylton and his

JULY 26th

WEDNESDAY

continued

Orchestra (Electrical Transcriptions): Signature Tune; Selection from Tell me Tonight (Spoliansky); Same Old Moon (Basketette); Where is this lady? (Lehár) Goodbye Blues (McHugh); Marry me (Krausz); Rock your cares away (Towers); After Tonight we say Goodbye (Towers); A Bedtime Story (Towers); Silver Hair and Heart of Gold (Gilbert); Love is the sweetest thing (Noble); Song of the Bells (Polak); Round the Bend of the Road (Klemmer); Selection from Yes Mr. Brown (Abraham); Farewell to Arns (Wrubel); Take a Spot of Happiness (Reisfeld); Her Name is Mary (Sievier); Signature Tune. 11.0, Choral and Orchestral Music: Moonlight on the Aster (Fetras); Believe me if all those endearing young Charms; Selection from Cavalcade (Coward); Down in the Forest (Landon Ronald); Selection from The Quaker Girl (Monckton); Ich liebe dich (Grieg). 11.30, Concert of Light Music by the I.B.C. (Brand), Ltd.: Signature Tune; The capricious Music Box (Pescio); In Tulip Time beside the Water Mill (Ailbott-Niel); Mullingar Races; Wexford Lassies; Homing (del Riego); Stephanie Gavotte (Czibulka); The Wedding of the Painted Doll (Brown); Song: To you it's only Ireland (Stroud); Beautiful (Gillespie-Slay). 12.5 a.m. (Thursday), News Bulletin in English. 12.10 (approx.), Club Concert for Melton Mowbray Listeners: Signature Tune; Me and the Man in the Moon (Mouaco); Song: Thompson's Old Grey Mule (Pickard); Pianoforte: Everyone says I love you (Kálmán); Song, Horses carry Tails (Redmond); Last Night I dreamed of you (Kálmán). Part II—Dance Music: Under my Umbrella (O'Flynn); Sylvia (Sealard); And so I married the girl (Wending); I wake up smiling (Ahlert); Chansonette (Fritli); Someone to care for (Warren); Body and Soul (Green); Won't you stay to Tea? (Revel). 12.57, I.B.C. Goodnight Melody. 1.0 (approx.), Close Down.

FLENSBURG.—See Hamburg.

FLORENCE.—See Turin.

FRANKFURT

1,157 kc/s, 259.3 metres; 17 kW. Relayed by Cassel, 1,220 kc/s, 245.9 metres; and Trier, 1,157 kc/s, 259.3 metres.—12 Noon, Gramophone Concert. Part I: Finale Music from Famous Operas: Siegfried (Wagner), Carmen (Bizet), Aida (Verdi), and The Mastersingers (Wagner). Part II: Overtures: Egmont (Beethoven), Benevento Cellini (Berlioz), Rienzi (Wagner). 1.15 p.m., Time and News. 1.30, Concert from Langenberg. 2.0, News. 2.20, Topical Talk. 3.0, Weather Report. 3.10, Time and Exchange. 3.20, Programme for Young People. 4.25, Exchange. 4.30, Orchestral Concert, conducted by Otto Niesch, relayed from the Kurhaus, Wiesbaden. Overture, Abu Hassan (Weber); Cradle Song and Prelude (Järnefeldt); Selection from The Magic Flute (Mozart); Ochsennett (Haydn); Hungarian Rondo (Haydn); Waltz, Golden Rain (Waldteufel); Selection from The Gipsy Baron (Joh. Strauss). 5.45, Exchange. 6.0, Talk: Behind the Scenes of a Large News Agency. 6.25, Topical Talk. 6.45, Review of the Day's Events. 6.50, Time and News. 7.0, Transmission for all German Stations, relayed from Berlin (Deutschlandsender). 8.0, See Berlin (Deutschlandsender). 8.5 (approx.), Programme to be announced. 8.15, See Munich. 9.35, Paul Graener Song Recital by Richard Hellriegel (Baritone). 10.10, Time and News. 10.15, See Stuttgart. 11.0, See Munich. 12 Midnight, Close Down.

FREDRIKSSTAD.—See Oslo.

FREIBURG.—See Stuttgart.

GENEVA.—See Radio-Suisse Romande.

GENOA.—See Turin.

GLEIWITZ.—See Breslau.

GOTEBORG.—See Stockholm.

GRAZ.—See Vienna.

HAMAR.—See Oslo.

HAMBURG

Call ha (in Morse), 806 kc/s, 372 metres; 1.5 kW. Relayed by Bremen, 1,112 kc/s, 269.8 metres; Flensburg, 1,319 kc/s, 227.4 metres; Hanover, 530 kc/s, 566 metres, and Kiel, 1,292 kc/s, 232.2 metres.—4.0 p.m. (from Bremen), Military Band Concert, conducted by Niemann. Soloist: Paul Koller (Cornet). March (Blankenburg); Overture, Light Cavalry (Suppe); Kiss Waltz (Strauss); Selection from Il Trovatore (Verdi); Cornet Solo: Two Brown Eyes (Gumbert); Waltz Potpourri (Robrecht); Intermezzo (Noack); March Potpourri, Deutschlands Erwachen (Kochmann). 5.0, Talk and Reading by two North German Authors. 5.30, Hamburg, Bremen and Lübeck—Report on Events in the Senates and Houses of Burgesses of the Hanseatic Free Cities. 6.0, Variety Programme. 6.45, Frankfurt Exchange and Hamburg Market Prices. 6.50, Weather. 7.0, Transmission for all German Stations, relayed from Berlin (Deutschlandsender). 8.0, See Berlin (Deutschlandsender). 8.5 (from Hanover), Talk on Hanover. 9.0, News. 9.10 (from Hanover), Concert of Old Hanoverian Military Music: A Nazi Band, conducted by Schilling; Commentary by Otto Ebel von Sosen; March, Henry the Lion (Crown Prince

George); Polonaise (Gerold); March of the Hanoverian Guard (Gerold); Dance (Wierprecht); March; Torch Dance (Wenzel); Hanoverian Revellie (Gerold); Hanoverian Retreat. 10.0, Time and News. 10.15, See Stuttgart. 10.45, Programme to be announced.

HANOVER.—See Hamburg.

HEILSBURG

1,085 kc/s, 276.5 metres; 60 kW. Relayed by Danzig, 662 kc/s, 453.2 metres.—1.5 p.m., Gramophone Concert. In the intervals at 1.20 and 2.0, News. 2.30, Programme arranged by the Post Office, with Gramophone Records. 3.0, Market Prices. 3.20, Talk for the Housewife. 3.30, Programme for Children. 4.0, Talk for Women: Woman's Role in the Regime of the National Socialists. 4.30, Orchestral Concert from the Kurgarten, Zoppot; Conductor: Karl Tutein; Overture, Larghetto from the Clarinet Quintet (Mozart); Selection from The Flying Dutchman (Wagner); Nocturne (Chopin-Sarasate); Canzonetta (d'Ambrosio); Festival Music in March-Form (Brandt-Buys); Cello Solos: (a) Adagio (Haydn), (b) Tarantella (Popper); Selection from Romeo and Juliet (Gounod). In the interval at 5.0, Review of Books. 6.0, Reading (Ruth Kristekat). 6.15, Market Prices. 6.25, Recital of Songs from Tietz's Magdalone (Brahms) by Georg Höfger. 6.50, Weather. 7.0, Transmission for all German Stations, relayed from Berlin (Deutschlandsender). 8.0, See Berlin (Deutschlandsender). 8.5, Weather and News. 8.10, Talk: The Preponderance of the Nordic Element in the Slay Countries. 8.40, Zither Trio Recital: Kinder der Puszta (Koltmaneck); Trio in G (Svoboda); Rocooco Minuet (Hans Ludwig); Soirée-Walzer (Seifert); March, Gruss an das schöne Elbflorenz (H. Wagner). 9.10, Radio Report of the Meeting of the Fishing Fleet, from Granz. 9.50, Weather and News. 10.15, See Stuttgart. 10.45, Dance Music. 12 Midnight, Close Down.

HILVERSUM

Announced Huizen, 1,013 kc/s, 296.1 metres, 20 kW. (7kW, up to 4.40 p.m.).—11.40 a.m. to 1.40 p.m., Programme of the Catholic Radio Society (K.R.O.). 11.40, Police Announcements. 11.55, Concert by the K.R.O. Boys. 1.40 till Close Down, Programme of the Christian Radio Society (N.C.R.V.). 1.40, Quartet Concert: Overture, The Caliph of Bagdad (Boieldieu); Pianoforte Solos: Albulblätter (Schumann); Minuet (Mozart); Gramophone Music: Organ Solos, Arlequina (Popper); Potpourri, Ein Melodien-trium (Urbach). 2.40, Reading. 3.10, Choral Concert. 4.25, Interval. 4.40, Programme for Children. 5.40, Frisian Programme. 6.10, Talk. 6.40, Police Announcements. 6.55, Religious Information. 7.10, Talk. 7.25, Talk by M. A. Stapelkaup. 7.40, Bach Organ Recital by Jan Zwart; Preludes: (a) Alle Menschen müssen sterben, (b) Valet will ich dir geben, (c) Herzlich dich mich verlaugnet; Fantasia am Fugue in G Minor; Adagio e doler; Fugue gigue; Andante; Toccata in F; Preludes: (a) Vater unser im Himmelreich, (b) Nun danket alle Gott, (c) Ich rufe dir Herr Jesu an; Toccata and Fugue in D Minor. 8.40, Talk. 9.10, Choral Concert, relayed from Weesp; Soloist: M. J. Boom (Baritone). 10.10, News. 10.20, Gramophone Music. 11.10 (approx.), Close Down.

HORBY.—See Stockholm.

HUIZEN

Announced Hilversum, 160 kc/s, 1,875 metres; 8.5 kW.—11.40 a.m. till Close Down, Programme of the Workers' Radio Society (V.A.R.A.). 11.40, Concert of Light Music. 12.25 p.m., Organ Recital. 12.55, Concert (cont'd.). 1.25 to 1.40, Interval. 1.40, Programme for Women. 2.40, Programme for Children. 4.10, Organ Recital. 4.30, Gramophone Music. 4.40, Concert of Light Music by De Flierefluiters. 6.10, R.V.U. Talk. 6.40, Talk by M. Oudegeest. 6.55, Gramophone Music. 7.0, Talk. 7.20, Concert by the Bel Canto Male Voice Double Quartet: Die Nacht (Schubert); Vieux arbre (Honegger); Wiegenlied (Brahms); De kuiper (Kools). 7.40, S.O.S. Announcements. 7.42, Press Review. 7.55, Concert by the V.A.R.A. Orchestra, conducted by Hugo de Groot; Overture, Poet and Peasant (Suppe); Kaiserwalzer (Joh. Strauss); Banditen-galopp (Joh. Strauss); Tiroler Holzhaecker (Wagner); Song from The Bird Fancier (Zeller); The Gay Postillion (Pesse); Picador (Oscheit). 8.25, Quartet Concert (cont'd.). 8.40, Orchestral Concert (cont'd.): Soloist: Maria Vos (Soprano); Overture, The Barber of Seville (Rossini); Aria from The Barber of Seville (Rossini); Selection from Benvenuto Cellini (Diaz); Second Hungarian Rhapsody (Liszt). 9.20, Dramatic Programme. 9.40, Concert (cont'd.): Rakoczy Overture (Keler-Bela). Frühlingstimmen (Joh. Strauss); Fourteenth Hungarian Rhapsody (Liszt). 10.10, Song

Recital by Mlle. Vos (Soprano). 10.25, Concert (cont'd.): Allemandes (Schubert-Pagel); Waltz, Hydraphon (Gungl); Frühling in Wien (Stolz); Im Prater blüh'n wieder die Bäume (Stolz); Pizzicato (Strauss). 10.55, Gramophone Music. 11.40 (approx.), Close Down.

INNSBRUCK.—See Vienna.

KALUNDBORG.—See Copenhagen.

KATOWICE

734 kc/s, 408 metres; 16 kW.—6.0 p.m., Light Music. 6.15, See Warsaw. 7.5, Talk. 7.25, Announcements and Gramophone Music. 7.40, See Warsaw. 10.0, See Cracow. 10.20, See Warsaw. 11.0, The Letter Box in French.

KIEL.—See Hamburg.

KLAGENFURT.—See Vienna.

KOSICE.—See Prague.

LAHTI

167 kc/s, 1,796 metres; 40 kW. Relayed by Helsinki, 815 kc/s, 368.1 metres.—6.15 p.m., Programme for Children. 6.50, Programme for Boys. 7.0, Flute Solos by Ilmari Gruska. 7.20, A Play (Olavi Kiveli). 7.50, Dance Music by the Amarillo Band. 8.10, Humorous Items by Walter Tuomi. 8.20, Dance Music (cont'd.). 8.45, News in Finnish. 9.0, News in Swedish. 9.15, Light Music, relayed from the Kappeli Restaurant. 10.0 (approx.), Close Down.

LANGENBERG

635 kc/s, 473 metres; 60 kW.—12 Noon, Orchestral Concert, conducted by Wolf, Suite der Freude (Schoppling); Waltz, Blumen aus Spanien (Ailbott); Potpourri, Alte deutsche Treue (Frantzen); Stolzenfels am Rhein (Meissler); Selection from The Three Wishes (Zieherer). 12.50 p.m., News. 1.0, Concert by the Station Chamber Orchestra, conducted by Breuer. Soloists: Kläre Hansen (Soprano), Erdmuth Fielder-Guermanova (Contralto) and Wilhelm Strienz (Bass). Overture, The Merry Vices of Windsor (Niola); Suite, Liebeslieder-Walzer (Brahms); Soprano and Contralto Duets: (a) Wechsengesang (Zieherer), (b) Botenschaft (Schumann), (c) Die Schwestern (Brahms); Norwegian Rhapsody (Svendson); Bass Solo from Das Fürstentum (Lehár); Waltz, Sonnenkinder (Kroth); Bass Solos: Two Arias from Gasparone (Müllerkat); Selection from Schön ist die Welt (Lehár). In the interval at 2.0, News. 3.0, Handwork for Children. 3.30, Market Prices and Time. 3.50, Programme for Children. 4.30, A Fête Day in Münster. 5.10, German Elocution Lesson. 5.30, Concert by the Fröhliche Fünf. Soloist: Karl Delseit (Pianoforte). 6.45, Announcements. 7.0, Transmission for all German Stations relayed from Berlin (Deutschlandsender). 8.0, See Berlin (Deutschlandsender). 8.5, News. 8.15, See Munich. 9.35, Pianoforte Recital by Hans Haas. 10.0, News. 10.15, See Stuttgart. 11.0, Dance Music.

LAUSANNE.—See Radio-Suisse Romande.

LEIPZIG

769.9 kc/s, 389.6 metres; 120 kW; and Dresden, 941 kc/s, 319 metres.—12 Noon, News and Weather. 12.5 p.m., Concert by a Chemnitz Orchestra, conducted by Paul Steinbach. In the interval at 1.0, News. 2.0, Second News. 3.35, Economic Notes. 4.0, Programme for Young People. 5.50, News, Time and Weather. 6.0, Book Review. 6.20, Talk on Agricultural Policy. 6.50, Events of the Day. 7.0, Transmission for all German Stations, relayed from Berlin (Deutschlandsender). 8.0, See Berlin (Deutschlandsender). 8.5, After Work Programme. 8.35, Gramophone Concert. 9.20, Economic Notes. 9.30 (from Dresden), The Honest Merchant—Literary Sequence (Fritz Müller-Birtokirchen). 10.5, News. 10.15, See Stuttgart. 11.0, News.

LINZ.—See Vienna.

LJUBLJANA

522 kc/s, 574.7 metres; 7 kW.—6.0 p.m., Programme for Children. 6.30, Gramophone Music. 7.0, Nature Talk. 7.50, Literary Programme. 8.0, Song Recital. 9.0, Gramophone Music. 9.30, Weather and News. 9.45, Concert. 10.30, English Gramophone Music. 11.0 (approx.), Close Down.

LUXEMBOURG

252 kc/s, 1,191 metres; 200 kW. Luxembourg Programme.—7.30, Concert by the Station Orchestra, conducted by Henri Pénis: Overture, Ruy Blas (Mendelssohn); Ninna nanna (Micheli); The Nutcracker Suite (Tchaikovsky); Czardas from Coppélia (Delibes). 8.5, Weather. 8.10, Songs from Sound Films by René Carcei (Tenor). 8.25, Talk in Luxembourg Dialect: What many people do not know. 8.35, Songs from Sound Films (cont'd.). 8.50, News in French. 9.15, Concert by the Station Orchestra; Wedding March from A Midsummer Night's Dream

(Mendelssohn); Selection from Loreley (Catalani); Geburtstagsständchen (Lincke); Wedgwood Blue (Kettelbey); Waltz from The Rose of Stamboul (Fall); Suite (Amadei); Chanson d'automne (Tchaikovsky); Titan-narrsch (Storch). In the interval at 9.45, News in German. 10.20, Dance Music on Gramophone Records.

LWOW

788 kc/s, 381 metres; 16 kW.—5.0 p.m., Gramophone Music. 6.15, See Warsaw. 7.5, Gramophone Music. 7.20, Miscellaneous Items. 7.40, See Warsaw. 9.0, News. 9.10, See Warsaw. 10.0, Talk from Cracow. 10.25, See Warsaw. 10.45, Gramophone Music. 11.0 (approx.), Close Down.

LYONS

LA DOUA (PTT), 644 kc/s, 465.8 metres; 1.5 kW.—7.30 p.m., Radio Gazette for Lyons and the South-East. 7.50, The Valkyries—Opera (Wagner), relayed from the Opera House. After the Opera, News.

MADRID

EAJ7; 707 kc/s, 424.3 metres; 2 kW.—8.0 p.m., Chimes, Exchange, Radio Journal, Programme for Women, and Dance Music. 9.25, News and Political Review. 9.30 to 11.0, Interval. 11.0, Chimes, Time, and Political Review. 11.15 (approx.), Macbeth—Tragedy (Shakespeare), arranged for Radio by Martin Becerra, with Music. 1.15 a.m. (Thursday), News. 1.30, Chimes and Close Down.

MALMO.—See Stockholm.

MILAN

VIGENTINO; 662 kc/s, 453.2 metres; 4 kW.—8.45 p.m. till Close Down, See Rome.

MORAVSKA-OSTRAVA

1,137 kc/s, 263.8 metres; 11 kW.—6.25 p.m., Concert by a Country Band. 7.0, See Prague. 10.15 (approx.), Close Down.

MOSCOW

TRADES UNION, 230 kc/s, 1,304 metres; 100 kW.—4.0 p.m., Talk on Cattle Breeding. 4.30, Literary Programme. 5.30, Concert for Young People. 6.30, Scriabin and Liszt Concert by the Symphony Orchestra, conducted by Bron; Soloist: Jucheles (Pianoforte). 9.0, News. 9.30, Programme Announcements. 9.55, Chimes and Press Review.

MOTALA.—See Stockholm.

MULLACKER.—See Stuttgart rt.

MUNICH

563 kc/s, 533 metres; 60 kW. Relayed by Augsburg and Kaiserslautern, 536 kc/s, 560 metres; and Nürnberg, 1,256 kc/s, 239 metres.—12 Noon, Orchestral Concert, conducted by Erich Kloss: Overture, The Maid of Artois (Balfe); Die Tageszeiten (R. Strauss); Spanish Dance (Falla); Selection from André Chénier (Giordano); Two Waltzes (Brahms); German Dances (Reger); Rondo (Weber); Reitermarsch (Schubert). 1.15 p.m., Time and News. 1.30, Gramophone Concert: Die böse Farbe (Schubert); Die liebe Farbe (Schubert); Traun durch die Dämmerung (R. Strauss); Choir: Ach du klarblauer Himmel (Silcher); Die Heide ist grün (Blumer-Löns); Waltz, The Blue Danube (Joh. Strauss); Choir: Schwärzbraun ist die Haseluss; Folk Song: Green Window, blue Gatter; Bei der Wirtin zum weissenblauen Kranzler (Richardz). 2.0, Time and News. 2.20, Programme arranged by the Post Office, with Gramophone Records. 2.50, Pianoforte Sonata in A Minor (Schubert), played by Laie Winter. 3.10, Talk for Young People. 3.30, Talk: Traces of Gothic in Bavaria. 3.55, Weather and Market Prices. 4.0 (from Nürnberg), Programme for Children. 4.30 (from Nürnberg), Orchestral Concert, conducted by Johann Schwarz; March from Rienzi (Wagner); Overture, The Hermit's Bell (Maillart); Waltz, Soirée d'été (Waldteufel); Romanesca (Zikov); Potpourri of Favorite German Music (Schwarz); March (Souza). 5.45, Talk: Cromwell, Soldier and Leader. 6.5, Recitations with Pianoforte accompaniment. 6.25, Talk: Münster Cathedral. 6.45, Time and Weather. 7.0, Transmission for all German Stations, relayed from Berlin (Deutschlandsender). 8.0, See Berlin (Deutschlandsender). 8.15, The State saves Vienna—Radio Play in Three Acts and a Prelude (Alfons von Czibulka), with Music by Alfred Beckerath. 9.45, Time and News. 10.15, See Stuttgart. 11.0, Serenade conducted by Erich Kloss. 12 Midnight, Close Down.

NAPLES.—See Rome.

NOTODDEN.—See Oslo.

OSLO

277 kc/s, 1,083 metres; 60 kW. Relayed by Fredrikstad, 815 kc/s, 368.1 metres; Hamar, 522 kc/s, 574.7 metres; Notodden, 671 kc/s, 447.7 metres; Porsgrind, 662 kc/s, 453.2 metres; and Rjukan, 671 kc/s, 447.1 metres.—5.30 p.m., Orchestral Concert, conducted by Hans Bache, relayed from the Grand Café; Overture, Maritana (Wallace); Waltz (Lanner); Selection from The Gipsy Baron (Strauss); One Larine (Mussorgsky); Czardas (Svendson). 6.30, Talk for Girls: A Sunday in Bergen. 7.0, Advertising Notes. 7.15, Weather and News. 7.30, Topical Talk.

JULY 26th

WEDNESDAY

continued

8.0, Time Signal. 8.4, Concert by the Station Orchestra, conducted by Oivin Fjeldstad; Overture, Phedre (Massenet); Selection from Boris Godunov (Musorgsky); Zorahayde (Svendsen); Cello Solo, Serenade (Volkmann); Overture, Euryanthe (Weber). 9.0, Reading. 9.30, Agricultural Report. 9.40, Weather and News. 10.0, Topical Talk. 10.15, Light Music and Dance Music by the Henschien Trio. 10.45 (approx.), Close Down.

OSTERSUND.—See Stockholm.

PALERMO

558 kc/s, 537.6 metres; 3 kW.—8.0 p.m., Dopulavoro Announcements, Tourist Report, Agricultural Notes and Giornale Radio. 8.20, Gramophone Music. In the interval at 8.30, Time and News. 8.45, Concert. Soloists: Iole Manno Rondini (Violin), and Maziotti (Cello). Wedding March (Mendelssohn); Adagio and Allegro from the Spanish Symphony for Violin (Lalo); Tenor Solos: (a) Gli occhi tuoi (Camano), (b) Air from The Girl of the Golden West (Puccini); Mozartiana (Tchaikovsky); Talk; Violin Solos: (a) Adagio from the Concerto (d'Ambrósio), (b) Melody (Grieg); In the Steppes of Central Asia (Borodin); Tenor Solos: (a) Air from Mignon (Thomas), (b) Te quiero (Serrano); Overture, Prometheus (Beethoven). 10.0 (approx.), Popular Songs. 10.55, News.

PARIS

EIFFEL TOWER, Call FLE, 207.5 kc/s, 1,445.7 metres; 13 kW. Time Signals (on 2,650 metres) at 10.26 a.m. and 11.26 p.m. (Preliminary and 6-dot signals).—6.45 p.m., Le Journal Parle. 8.0, The Valkyries—Opera in Three Acts (Wagner), relayed from the Opera House.

PARIS

POSTE PARISIEN, 914 kc/s, 328.2 metres; 60 kW.—7.0 p.m., Gramophone Music. 7.15, Le Journal Parle. 7.30, Gramophone Music. 7.50, Talk on Economics. 8.0, Report on the Walking Race from Paris to Strasbourg. 8.15, Interlude. 8.30, Si je voulais—Play (Géraldy and Spitzer). 10.30, Dance Music from the Lido. 11.0, News.

PARIS

RADIO PARIS, Call CFR, 174 kc/s, 1,725 metres; 75 kW.—7.30 a.m., Weather and Physical Culture. 7.45, Gramophone Music. 8.0, Weather and Press Review. 12 Noon, Educational Talk. 12.15 p.m., Clair Clair Gramophone Music: Bourrée Fantastique; España. 12.30, Organ Recital, relayed from Gaumont Palace. 1.0, Exchange, News and Weather. 1.5, Gramophone Music (cont'd): Extract from Opera: (a) Don Pasquale (Donizetti); (b) L'Elisir d'Amour (Lucez); (c) La Favorita (Donizetti); (d) Lucia di Lammermoor (Donizetti); (e) Lucrezia Borgia (Donizetti); (f) La Juive (Halévy). 2.0, Exchange. 3.45, Exchange and Market Prices. 7.0, Market Prices, Weather, Agricultural Report and Racing Results. 7.10, Gramophone Music: Old Comrades (Teike); Suite carnavalesque (Thomé); Concerto Polonaise (Vidal); La noce bretonne (Willame); Moments antiques (Winter); Estudiantina (Waldteufel); Melody (Tullip). 8.0, Gramophone Concert: Quintet for Wind Instruments and Piano-forte (Mozart); Song: Amoureux séparés (Roussel); Song, Marine (Delannoy); Cello Solo: Gopak (Musorgsky). 8.30, News and Weather. 8.45, Gramophone Concert (cont'd): Songs: (a) Aria from Rigoletto (Verdi); (b) Song (Eslavay); (c) Song (Bohnn); Quintet (Rameau). 9.15, Press Review and News. 9.30, Concert of Russian Operatic Music: Selection from A Life for the Czar (Glinka); Aria from Eugene Onegin (Tchaikovsky); Melodies from the Queen of Spades (Tchaikovsky); Arias and Dance from Prince Igor (Borodin); Wedding Procession from The Golden Cockerel (Rimsky-Korsakov); Hindi Song (Rimsky-Korsakov); Arias from Sadko (Rimsky-Korsakov); Prelude to Koyunbashi (Musorgsky); Prelude to The Fair at Sorochinsk (Musorgsky); Melodies from The Firebird (Stravinsky); in the intervals at 8.30, News and Weather, at 8.40, Fashion Talk and at 9.15, Press Review and News.

PITTSBURGH

(KDKA), 980 kc/s, 306 metres; 50 kW. Relayed by W8XK on 48.86 metres and 25.27 metres.—7.30 p.m., KDKA Home Forum. 8.0-8.58, New York Relay. 8.0, Betty and Bob. 8.15, Words and Music. 8.30, Happy Days in Dixie. 8.58, Baseball Scores. 9.0, Southern Symphonies, from New York. 9.30, Business News and Market Reports. 9.45, Dance Masters: Harold Stokes' Orchestra, from New York. 9.58, Baseball Scores. 10.0, Rhythm Kings. 10.15, Tarzan of the Apes. 10.30, The Singing Lady. 10.45, Little Orphan Annie, from New York. 11.0, Time and Press News Reeler. 11.5, Piano Classic. 11.15, Weather Report. 11.16, Sport Review. 11.23, I Sing a Song. 11.28, Announcements. 11.29, Temperature Report. 11.30, Pittsburgh Spotlight. 11.45 to 1.30 a.m. (Thursday), New York Relay. 11.45, To-day's News by Lowell Thomas. 12.0 midnight, Amos 'n' Andy. 12.15 a.m., Annie, Judy and Zeke. 12.30, Moods. 1.0, Crime Clues. 1.30, Potash and Perlmutter. 1.45, Popular Programme from New York. 2.0, Programme to be an-

nounced. 2.15, Rocking Chair Memories, from New York. 2.30, Century of Progress Festival Orchestra, from New York. 3.30, Around the Cracker Barrel.

PORSGRUND.—See Oslo.

PRAGUE

614 kc/s, 488.6 metres; 120 kW.—2.50 p.m., Orchestral Concert of the Music of Frantisek Kovarik for his Seventy-fifth Birthday. 3.55, Exchange. 4.0, Interval. 5.45, Gramophone Records. 5.55, Talk. 6.5, Agricultural Market Prices. 6.10, Gramophone Music. 6.25, News in German. 6.30, German Transmission, Talk on the Labour Market. 7.0, Chimes and News. 7.10, Flute Recital by Albert Burzik; Symphonic Canzona (Karg-Elert); Concertino op. 107 (Chaminade); Oriental Serenade op. 70 (Köhler). 7.30, Talk on Economics. 7.45, Spring Showers (Strejcek). In the intervals, Songs and Poems. 9.20, Act II of The Bartered Bride—Opera (Smetana) on Gramophone Records. 10.0 Time and News. 10.15, News in French for Foreign Countries. 10.30 (approx.). Close Down.

RADIO-SUISSE ROMANDE

SOTTENS, 743 kc/s, 403 metres; 25 kW.; and Geneva, 395 kc/s, 760 metres.—12.28 p.m., Time Signal from Neuchâtel Observatory. 12.30, News and Weather. 12.40, Gramophone Music. 1.0, Financial Notes. 1.10, Gramophone Music. 2.0 to 3.30, Interval. 3.30, Talk by a Journalist. 4.0, Concert by the Radio-Suisse Romande Quintet. 5.30 to 7.0, Interval. 7.0, Travel Talk. 7.30, A Radio Interview. 8.0, Cabaret Programme. 8.50, Concert by the Radio-Suisse Romande Orchestra, conducted by Robert Eichenard. 9.50, News and Weather. 10.0, Dance Music on Gramophone Records. 11.0 (approx.). Close Down.

REYKJAVIK

250 kc/s, 1,200 metres; 21 kW.—9.5 p.m., Musical Programme. 9.30, Weather Report. 9.40, Musical Programme and Announcements. 10.0, Chimes and News. 10.30, Reading. 11.0, Violin Solo by Thorarinn Gudmundsson, followed by Ballad in G Minor (Grieg) on Gramophone Records.

RIGA

572 kc/s, 525 metres; 15 kW.—7.30 p.m., Concert by the Radio Orchestra, conducted by Vladimir Savitich: Prelude and Fugue No. 22 (Bach); Le fontaine di Roma (Respighi); Italian Concerto (Bach); Rondo (Mozart); Etude (Chopin); Scherzo in B Minor (Chopin); Easter Overture (Rimsky-Korsakov). In the interval at 8.10, News. 9.0, News and Weather. 9.20 (approx.). Dance Music. 10.30 (approx.). Close Down.

RJUKAN.—See Oslo.

ROME

Call IRO, 680 kc/s, 441 metres; 50 kW. Relayed by Naples, 941 kc/s, 319 metres, and 2R2, 11,810 kc/s, 25.4 metres, from 5.40 p.m.—1.0 (approx.). 2.15 p.m., Orchestral Concert of Light Music. In the intervals from 1.30 to 1.45, Giornale Radio and Exchange, and at 2.0, Time and Announcements. 4.45, Children's Radio Review. 5.10, Weather. 5.15, Exchange. Report of the Royal Geographical Society and Giornale Radio. 5.30 to 6.15, Orchestral Concert of Italian Music. 6.40 (Naples), Shipping and Sports Notes. 6.50, Agricultural and Dopulavoro Notes. 6.57, Report of the International Institute of Agriculture (in Italian and English). 7.10, Tourist Report. 7.20, News in Foreign Languages. 7.40, Giornale Radio. 8.0, Time, Announcements and Gramophone Music. 8.15, Medical Talk. 8.30, Giornale Radio and Sports Notes. 8.45, Variety Concert: Ornella Puliatti Santoliquido (Pianoforte) and Emilio Livi (Tenor); Overture, La Princesse Jeanne (Saint-Saëns); Nights in the Gardens of Spain (Fallas); Songs for Tenor; Concertino for Pianoforte and Orchestra, Op. 15 (Weiner). 10.0 (approx.), Bianca e Maria—Play in One Act (Washington Borg), followed by Dance Music. 10.55, Giornale Radio.

SALZBURG.—See Vienna.

SCHENECTADY

WGY, 790 kc/s, 379.5 metres; 50 kW. Relayed at intervals by W2XAF on 31.48 metres and by W2XAD on 19.50 metres.—9 to 10 p.m., (approx.), New York Relay. 9.0, Pop Concert. 9.30 Texas Cowgirl. 9.45, Lady Next Door. 12.45 a.m. (Thursday), Stock Reports and Baseball Scores. 1.0 to 2.15, New York Relay. 1.0, Variety Programme. 1.30, Life and Songs of Stephen Foster. 2.0, Ferde Grofé's Orchestra. 2.15, Outdoor Girl. 2.30, Popular Programme. 3.0, Variety Programme, from New York. 3.30, Musical Programme from New York, followed by Programme Resumé.

SCHWEIZERISCHER LANDESENDER

BEROMUNSTER, 653 kc/s, 459 metres; 60 kW. Basle, 1,229 kc/s, 244.1 metres; and Berne, 1,220 kc/s, 245.9 metres.—6.15 a.m. (from Berne), Gymnastics. 6.35, Interval. 11.59, Time Signal from Neuchâtel Observatory and Weather. 12 Noon (from Berne), Bizet Concert on Gramophone Records. 12.30 p.m., Time and News. 12.40 (from Berne), Wagner and Beethoven Music on Gramophone Records. 1.25 (from Berns), Time, Weather and Exchange. 1.35, Interval. 5.0 (from Basle), Programme for Children. 5.30 (from Basle), Wind Instrument Music on Gramophone Records. 6.30, Talk: Vitamins and Vitamin Mania. 7.0 (from Berne), Time and News. 7.5 (from Berne), Wand an Wand—Radio Play (Wohlwend). 7.45 (from Berne), Talk: The Early Days of the Film Industry. 9.0, News. 9.10 (from Berne), Programme to be announced. 10.15 (approx.). Close Down.

SOTTENS.—See Radio-Suisse Romande.

STOCKHOLM

689 kc/s, 436 metres; 55 kW. Relayed by Boden, 244 kc/s, 1,229.5 metres; Göteborg, 932 kc/s, 322 metres; Hörby, 1,166 kc/s, 257 metres; Motala, 221.5 kc/s, 1,354.4 metres; Östersund, 389 kc/s, 770 metres; and Sundsvall, 554 kc/s, 542 metres.—5.5 p.m. (from Göteborg), Concert of Accordion Music and Songs. 5.40, Readings. 6.0, Gramophone Music. 7.0, Talk, relayed from Uppsala, 662 kc/s, 453.2 metres. 7.30, Orchestral Concert, conducted by Adolf Miklund; Symphony No. 4 in F Minor (Tchaikovsky); Bellman Melodies (Södermann); Suite (Seymer); Suite from A Midsummer Night's Dream (Mendelssohn). In the interval at 8.10, Reading. 9.15, Radio Report from Pösa. 10.0, Modern Dance Music. 11.0 (approx.). Close Down.

STRASBOURG

869 kc/s, 345 metres; 11.5 kW.—11.30 a.m., Gramophone Concert. 12.45 p.m., News. 1.0, Time Signal. 1.1, Exchange. 1.5, Gramophone Concert. 2.6-3.30, Interval. 3.30, Orchestral Concert, conducted by M. Brouillette relayed from the Casino, Viévy; Overture, Masaniello (Auber); Polonaise from Stravensce (Meyerbeer); Ballet, The Heretics (Lévaé); Serenade (Rachmaninov); Prelude (Rachmaninov); Selection from Aida (Verdi). 5.0, Talk in German on Electricity. 5.15, Dance Music. 6.0, Concert relayed from Lille, 1,130 kc/s 265.4 metres. 7.0, Talk: The Education of Backward Children in France. 7.15, Talk in German. 7.30, Time. 7.31, News. 7.45, Gramophone Music. 8.0, News in French. 8.30, Brenier—Tragedy in Five Acts (Racine), with Music by Rousseau. In the interval, News. 11.0, Dance Music from the Savoy. 12.0 Midnight (approx.). Close Down.

STUTTART

MUHLACKER, 832 kc/s, 360 metres; 60 kW. Relayed by Freiburg, 527 kc/s, 570 metres.—2.0 p.m., Concert arranged by the Post Office. 2.15, Interval. 3.30, Programme for Children. 4.30, See Frankfurt. 5.45, Talk: The German Saar. 6.10, Talk: The State Forces and the Old Army—a Comparison. 6.35, Time and News. 7.0, Transmission for all German Stations, relayed from Berlin (Deutschlandsender). 8.0, See Berlin (Deutschlandsender). 8.5, See Leipzig. 8.35, The Dead Village—Talk for Ex-Service Men. 9.0, Hans Ailbott Concert from Cannstatt; The Station Orchestra, conducted by the Composer; Army March No. 193; Rocco suite; Catalan Rhapsody; Waltz; Blumen aus Spanien; Chinese Fantasy; Fantasia on Ich hatte einst ein schönes Vaterland; Humoresque; Five o'clock Tea in the Frog Pond; Idyll; Im dunklen Milieental schlägt eine Nachtigall; March; Die Potsdamer Linde. 10.0, Time and News. 10.15, Opening Ceremony of the Fifteenth German Gymnastic Festival, 1933, from the Courtyard of the New Palace. 11.0, Serenade, from Munich. 12 Midnight, Dance Music on Gramophone Records. 1.0 a.m. (Thursday), Close Down.

SUNDSVALL.—See Stockholm.

TRIESTE

1,211 kc/s, 247.7 metres; 10 kW.—5.10 p.m., Vocal and Instrumental Concert. Enrico Martucci (Pianoforte); Lydia Bulajich Zeller (Violin); and Augusta Rapetti Bassi (Soprano); Sonata for Violin and Pianoforte (Debussy); Songs: (a) Canto d'amore (Luzzi), (b) Song (Grieg); Pianoforte Solos: (a) Rondo in A Minor (Mozart), (b) Prelude and Toccata, Op. 27 (Dick-Mangiagalli), (c) Murmur of the Wind (Sauer); Soprano Solos, with Violin obbligato: (a) Verdi trionchi, annessa piante (Bernardo Pasquini), (b) Piti non ti voglio credere (Biononcini). 6.0 p.m. till Close Down, See Turin.

TRONDHEIM.—See Oslo.

TURIN

1,096 kc/s, 273.3 metres; 7 kW. Relayed by Milan, 905 kc/s, 331.5 metres; Genoa, 959 kc/s, 312.8 metres; and Florence, 599 kc/s, 500.8 metres.—5.10 p.m. Song Recital. 6.0 to 6.5, Weather. 6.35, News. 7.0, Time, Tourist Report and Light Music on Gramophone Records. 7.20, News in Foreign Languages. 7.40, Gramophone Music. 8.0, News and Weather. 8.15, Medical Talk. 8.30, Talk on the following Transmission. 8.40, Magliolatta veneziana—Opera in Three Acts (Rito Selvaggi), conducted by the Composer. In the intervals: Talk and Literary Review. Giornale Radio after the Opera.

VATICAN CITY

15,120 kc/s, 19.84 metres (Morning), and 5,969 kc/s, 50.26 metres (Evening); 10 kW.—11.0 to 11.15 a.m., Religious Information in Spanish. 8.0 to 8.15 p.m., Religious Information in Italian.

VIENNA

581 kc/s, 517 metres; 100 kW. Relayed by Graz, 852 kc/s, 352.1 metres; Innsbruck, 1,058 kc/s, 283 metres; Klagenfurt, 662 kc/s, 453.2 metres; Linz, 1,220 kc/s, 245.9 metres; and Salzburg, 1,373 kc/s, 218.5 metres.—12 Noon, Concert by the Vienna Symphony Station Orchestra, conducted by Josef Holzer: Overture, Lysistrata (Lincke); Invitation to the Dance (Weber); Air from Frederica (Lelhar); Old Vienna (Drdla); Die Post kommt (Eilenberg); Zeppler-Polka (Joh. Strauss); Selection from Bruder Straubinger (Eysler); Waltz, Grubenlichter (Zeller); March, Linzer Bäum (Drescher); Die goldene Spieluhr (Kroner); Hungarian Serenade (Burgmeier); Sei mir gut, schöne Marietta (Arnold); American Intermezzo (Reektenwald); Waltz, Die Schönbirner (Lauer); Lied (O. Straus); Bolero (O. Straus); Two Hearts and a Waltz Refrain (Stolz); Song (Stolz); Potpourri, Was euch gefällt (Borchert). In the interval at 1.0 p.m., Time and News. 2.0, Interval. 3.0, Time and Announcements. 3.20, Talk: The North European Town. 3.45, Four Ballads for Pianoforte (Chopin) on Gramophone Records. 4.20, Talk: Romanesque Country Houses in Austria. 4.45, Talk on Josef von Hammer-Burgstall. 5.10, Violin and Pianoforte Recital by Magda Hajos and Hertha Offner; Violin Sonata in A Op. 30 No. 1 (Beethoven). Pianoforte Solos: Davidsbüdertänze Op. 6 (Schumann). 5.55, Talk. 6.20, Talk: Touring in the Kaisergerberg District. 6.45, Talk. 7.0, Concert of Old and New Viennese Folk Music. The Vienna Symphony Station Orchestra, conducted by Josef Holzer, the Mandl Quartet and Adalbert Vesely (Zither). In the interval at 7.35, Time and Announcements. 8.30, Topical Talk. 8.45, Josef August Lux reads from his own Works, with Introductory Talk by Erwin Weill. 9.20, News. 9.35, Gramophone Concert.

WARSAW

212.5 kc/s, 1,411 metres; 120 kW.—11.57 a.m., Time and Fanfare from St. Mary's Church, Cracow. 12.5 p.m., Gramophone Music. 12.25, Polish Press Review. 12.35, Weather. 12.35, Gramophone Music. 12.55, Radio Journal. 1.0-2.55, Interval. 2.55, Gramophone Music. 3.5, News. 3.10, Announcements. 3.15, Gramophone Music. 3.25, Talk on Economics. 3.35, Gramophone Music. 3.45, Announcements. 4.0, Symphony Concert by the Poznan Opera House Orchestra, relayed from Cichocinek. 5.0, Topical Talk. 5.15, Concert by M. Mossozy (Bass), and Jean Glowdewsky (Flute). 6.0, Gramophone Music. 6.15, Talk: Sport and Physical Education. 6.35, Song Recital by Mme. Szabranska (Mezzo-Soprano); A Swan (Grieg); The Rosary (Seyvin); Song (Ribecky); Spring (Hildich); Reverie from Le Château Hauté (Moniuszko); Aria from La Gioconda (Ponchielli); Aria from Werther (Massenet); Aria from Il Trovatore (Verdi). 7.5, Gramophone Music. 7.20, Miscellaneous Items. 7.35, Programme Announcements. 7.40, Talk: Famous Modern Poets. 8.0, Song Recital. 8.50, Radio Journal. 9.0, Agricultural Report. 9.10, Pianoforte and Song Recital by Mme. Familier-Hepner (Pianoforte) and W. Kaczmar (Bass); Pianoforte Solos: (a) Rhapsody in G minor (Brahms), (b) Two Romances (Schumann); Bass Solos: (a) Song, Plaisir d'amour (Martini), (b) Silence (Walter), (c) The Clouds (Brugnoli), (d) Song (Rachmaninov), (e) The Bagpiper (Paderevsky); Pianoforte Solos: (Liszt); (a) Impromptu Waltz, (b) Waldesrauschen (Liszt); Bass Solos: (a) Si vous l'avez compris (Denza), (b) You are my Heart's Delight (Lehar). 10.0, Talk in Esperanto relayed from Cracow, 959 kc/s, 312.8 metres. In the intervals at 10.25, Sports Notes, and at 10.35, News.

WILNO

533 kc/s, 563 metres; 16 kW.—7.5 p.m., News and Gramophone Music. 7.20, Lithuanian Review. 7.35, Programme Announcements. 7.40, See Warsaw. 9.0, Humorous Monologue. 9.10, See Warsaw. 11.0 (approx.). Close Down.

ZURICH.—See Schweizerischer Landessender.

ALGIERS

824 kc/s, 364 metres; 13 kW.—7.30 p.m., Programme for Children. 8.0, Financial News. 8.10, Shipping Notes. 8.15, Agricultural Report and Weather Forecast. 8.20, Song Recital. 8.45, Lottery Results. 8.55, News. 9.0, Time Signal. 9.2, Instrumental Concert. 9.45, Gramophone Records. 10.40, News. 10.45, Two Sicilian Songs. 10.55, News. 11.0, Concert of Oriental Music.

ATHLONE

725 kc/s, 413 metres; 60 kW. Relayed by Cork, 1,337 kc/s, 224.4 metres.—1.30-2.30 p.m., Time Signal, Stock Exchange Quotations. Weather Report and Gramophone Music. 6.0, Programme for Children. 6.40, News. 7.0, French Lesson. 7.15, Talk: The Poetry of J. Clarence Mangan, by Gabriel Fallon. 7.30, Time Signal. 7.31, Illustrated Lecture Recital by C. M. Ni Dhuibhghaill. 8.6, Irish Music by the Station Orchestra. 8.20, Irish Programme by Mr. and Mrs. P. J. Dully. 8.40, Traditional Fiddle Solos by P. O'Rogallaig. 8.50, Foiled—A Sketch, by C. Keogh and Company. 9.20, The Station Orchestra. 9.30, Contralto Solos by Florence Howley. 9.45, Sponsored Programme. 10.30, Time Signal. 10.45, News, Weather Report and Close Down.

BARCELONA

EAJ1, 860 kc/s, 248.8 metres; 8 kW.—7.0 p.m., Trio Concert. 8.0, Request Gramophone Records. 8.30, Exchange. 9.0, Gramophone Music and News. 10.0, Chimes from the Cathedral, Weather, Exchange and Market Prices. 10.5, Concert by the Station Orchestra. 11.0, Don Meudo's Revenge—Play (Pedro Muñoz Seca). In the interval at 12 Midnight, News. 1.0 a.m. (Friday), Close Down.

BARI

1,112 kc/s, 269.8 metres; 20 kW.—8.0 p.m., News. 8.20, Giornale Radio and Weather. 8.30, Time and Announcements. 8.35 (approx.), Concert of Mandoline and Guitar Music. Overture, Il Signor Bruschino (Rossini); Sognando (Sartori); Romance, Primi fiori (Salvetti); Selection from Adriana Lecouvreur (Gilea); Overture, La Caravane du Caire (Grétry); Ad un angelo (Mascheroni); Fantasia africana (Donati); Scherzo from the Symphony, Città di Genova (Bottacchini); Rimebranze Latine (Pizzoli); Talk in the interval. 10.30, Gramophone Music. 10.55, News.

BASLE.—See Schweizerischer Landessender.

BELGRADE

697 kc/s, 430.4 metres; 2.8 kW.—5.55 p.m., Time and Programme Announcements. 6.0, Physical Culture. 6.30, Talk. 7.10, See Prague. 8.10, Gramophone Music. 8.30, Programme from Ljubljana, 522 kc/s, 574.7 metres. 10.30, Time, News and Cigány Restaurant, relayed from the Rudinean.

BERLIN

DEUTSCHLANDSENDER, 183.5 kc/s, 1,635 metres; 60 kW.—1.45 p.m., News. 2.0, Gramophone Music. 3.0, Programme for Children. 3.30, Weather and Exchange. 3.45, Reading (Schauwecker). 4.0, See Heilsberg. 5.0, Talk for Women. 5.35, Sonata, Op. 47, for Violin and Pianoforte (Koch), by Hermann Diener and Prof. Julius Dahlke. 6.0, A Poem. 6.5, Brahms Folk Song Recital by Hermine Behn. Wach auf, meine Herzensschöne; In stiller Nacht; Dort in den Weiden steht ein Hans; Der tote Gass; Es steht ein Lind; Mein Mädel hat einen Rosenmund. 6.30, A Radio Report on Horse-breeding in Germany. 6.50, Weather and Announcements. 7.0, Transmission for all German Stations, relayed from Breslau. 8.0, Epigrams. 8.10, See Hamburg. 10.25, News. 10.45, Weather for Shipping. 11.0, Concert by a Nazi Band, relayed from the Nationale Gaststätten. 12 Midnight, Close Down.

BERLIN

WITZLEBEN, 715 kc/s, 419.5 metres; 1.5 kW.—4.30 p.m., Recital of Transylvanian Songs by Helene Eslinger (Soprano); Transylvanian National Anthem; Es sass ein klein wild Vögelin; Song of the Swabian Banat; Folk Song, Ich darf und mag nicht fröhlich sein; Der Holderstrauen (Hermann Kirchner); Sachs, halte Wacht (Paul Geisdorf). 4.50, Ferruccio Busoni Pianoforte Recital: Polonaise in A Flat (Chopin); Prelude in D Flat (Chopin); Rigoletto—Paraphrase (Liszt); La campanella (Liszt); Norma—Fantasia (Liszt). 5.30, Filippo Boljono reads from his own works. 5.50, Recital of Bulgarian Folk Songs by Mara Fratwa (Soprano). 6.10, Talk: The Woman Companion. 6.30, Talk on Pomerania. 6.40, The Witzleben Station Infornus its Listeners. . . 6.45, Topical Talk. 7.0, Transmission for all German Stations, relayed from Breslau. 8.10, Folk Songs. 8.40, Government Announcement. 8.50, Topical Talk. 9.0, Dance Music. In the intervals, Songs of the Streets. In the interval at 10.0, Weather and News, and from 11.0 to 11.5, Talk:

THURSDAY

JULY THE TWENTY-SEVENTH

PRINCIPAL EVENTS OF THE WEEK:

AT HOME

NATIONAL Tango orchestral programme.
LONDON REGIONAL A relay from the Argyle Theatre, Birkenhead.
NORTH REGIONAL "Wilberforce," a play.
SCOTTISH REGIONAL Eye-witness account of the National Sheep Dog Trials (Scotland) at Aberlady.

ABROAD

BRUSSELS (No. 2) 5.0 p.m. Italian music, by the Radio Orchestra.
COPENHAGEN HAMBURG 9.30 p.m. 'Cello recital.
8.10 p.m. "Die beiden Schützen," comic opera (Lortzing), in three acts.
9.0 p.m. Concert by the Wireless Orchestra.
HUIZEN (announced Hilversum) 8.30 p.m. Violin recital.
OSLO 4.45 p.m. Widor Festival concert from the American Conservatoire, Fontainebleau; the composer at the pianoforte.
PARIS (Radio-Paris) 6.50 p.m. Dialogue in English: "The Daily Round of a Londoner's Life."
STOCKHOLM 8.30 p.m. The Metz Municipal Orchestra in a concert from the Esplanade.
STRASBOURG 8.35 p.m. Italian operatic evening.
TURIN 8.0 p.m. Kálmán concert.

What they are talking about in Berlin. 12 Midnight, Close Down.

BERNE.—See Schweizerischer Landessender.

BEROMUNSTER. — See Schweizerischer Landessender.

BODEN.—See Stockholm.

BODO.—See Oslo.

BORDEAUX-LAFAYETTE

986 kc/s, 304 metres; 13 kW.—7.40 p.m., Talk, arranged by the International Labour Bureau. 7.55, Lottery Results. 8.0, Talk on Wine. 8.15, News. 8.30, Gramophone Music. 9.0, Prête moi ta femme—Comedy in Two Acts (Desvallières).

BRATISLAVA

1,076 kc/s, 279 metres; 14 kW.—5.55 p.m., Talk: Water Sports. 6.5, Gramophone Music. 6.40, Talk: A Legionary's Reminiscences. 6.55, Talk for Housewives. 7.0, See Prague. 9.30, Violin Concerto in F sharp minor, Op. 14 (Wieniawski). 10.0, See Prague. 11.0 (approx.), Close Down.

BREMEN.—See Hamburg.

BRESLAU

923 kc/s, 325 metres; 60 kW. Relayed by Gleiwitz, 1,184 kc/s, 253 metres.—12 Noon, Concert by the Silesian Symphony Orchestra, conducted by Gerhard Ewald Rischka; Overture, The Thieving Magpie (Rossini); Aus Deutschlands schweren Tagen 1918 (Herzig); Selection from Carmen (Bizet); The Emperor Waltz (Joh. Strauss); Indigo March (Joh. Strauss); Overture, Der lustige Krieg (Joh. Strauss); Potpourri of Classical and Viennese Music (Kozak); Hochzeit der Teddybären (Meisel); Peasant Dances from Austria (Pachernegg); March, Der alte Fritz (Blon). 1.45 p.m., Time and News. 2.0, Operetta Music on Gramophone Records. 3.0, Agricultural Prices. 3.30, Talk: Holiday Excursions. 3.40, Book Review. 4.0, Concert of Chamber Music: Käte Mann (Soprano) and Käte Schmitz (Lute); Prelude and Allemande from a Suite for the Lute (Bach); Wecke den Amor nicht auf (Reichardt); Song (Dowland); Dance (Newidler); Spagnolella, for Lute; Jo non compro (Bosinensis); Con lagrime e sospiro (Willhaert); Melody (Besardo); Passamezzo, for Lute. 4.30, Programme for Children. 5.0 (from Gleiwitz), Concert of Light Music by the Fred Kuhnert Orchestra. In an interval at 5.30, Agricultural Prices. 6.0, Talk for Workers. 6.30, Programme to be announced. 6.50, Weather for Farmers and News. 7.0, Transmission for all German Stations: Das Grosse Wandern—Radio Play of the Youth Movement (Kurt Eggers). 8.0, A Discussion: Nations and their Neighbours. 8.40, News. 8.50, Concert

by the Augmented Waldenburg and Bad Salzbrunn Orchestra, conducted by Franz Marszalek. Soloist: Celeste Chop-Groenevelt (Pianoforte). Overture, The Gid (Cornelius); Pianoforte Concerto in A (Liszt); Dance Suite (Franckenstein); Symphonic Dances (Grieg). 10.20, Time and News. 10.35, Report of the Fifteenth German Gymnastic Festival, 1933, in Stuttgart. 10.45, Reading. 11.0, Dance Music from Berlin (Witzleben). 1.0 a.m. (Friday), Close Down.

BRNO

878 kc/s, 342 metres; 35 kW.—2.50 p.m., Concert by the Station Orchestra, conducted by Bakala. 3.55, See Prague. 4.0, Interval. 5.25, See Moravská-Ostrava. 5.45, Gramophone Music. 5.55, See Bratislava. 6.5, Gramophone Music. 6.25, German Trans-mission, News and Two One-act Plays: (a) mission, News and Two One-act Plays: (a) Max ist ein Berserker (Löwitz). (b) Snieide (Cornelius). 7.0, See Prague. 9.30, Sketch (Konecny). 10.0, See Prague. 11.0 (approx.), Close Down.

BRUSSELS (No. 1)

I.N.R., 590 kc/s, 509 metres; 15 kW.—12 (Noon), Concert by the Small Station Orchestra, conducted by M. Leemans; Overture, Pique Dame (Suppé); Waltz (Smetana); Potpourri, Romantical Melodies (Daubert); Violin Solo, Serenade (Voss); Song from The Land of Smiles (Lehar); Flute Solo, L'Oiseau tapageur (Ballero); Selection from Il est charmant (Moretti); Intermzzo, Caresse de fleurs (Demaret); Le Paso doble (Hollaender). 1.0 p.m., Le Journal parlé. 1.10, Gramophone Concert of Popular Music. 5.0, Concert by the Station Symphony Orchestra, conducted by Arthur Meulemans; Overture, Les Saltimbanques (Ganne); Selection from La Bohème (Puccini); Overture, The Gipsy Baron (Joh. Strauss); Waltz, Wine, Women and Song (Joh. Strauss). 5.30, Programme for Children. 6.0, Talk for Girls. 6.15, La nuit ensorcelée (Chopin-Aubert), on Gramophone Records. 6.30, Concert by the Small Station Orchestra, conducted by M. Leemans; Overture, Così fan tutte (Mozart); La Melody (Rachmaninov); Jota (Lainc); La danse de Djolité (Marsac); Selection from Le Pré aux Clercs (Herold); Two Pieces (Weyts): (a) Colombine, (b) Aimable carillon; Valse oubliée (Guillemin); Rag-time (Satie). 7.15, Review for Workers. 7.30, Sports Report. 8.0, Concert by the Station Symphony Orchestra, conducted by M. A. Meulemans; Carnaval à Paris (Svend-M. A. Meulemans); Carnival (Svend-M. A. Meulemans); Norwegian Dances (Grieg); Music (Jensen); Norwegian Dances (Grieg). 8.45, Talk by M. Emile van der Velde, Minister of State: The Next International Congress. 9.0, Concert relayed from the Kursaal, Ostend. 10.30, Le Journal parlé. 10.40, Gramophone Concert of Light Music.

BRUSSELS (No. 2)

N.I.R., 887 kc/s, 338.2 metres; 15 kW.—Programme in Flemish.—12 Noon, Gramophone Concert. 1.0 p.m., Le Journal parlé. 1.10, Concert of Scandinavian Music by the Small Station Orchestra, conducted by Pierre Leemans. Finlandia (Sibelius); Symphonic Dances (Grieg); Rustle of Spring (Sinding); Fantasia on Popular Swedish Songs (Sjölermann); Romance for Violin (Svendsen); Elfin Dance (Nielsen); Valse triste (Sibelius); Pianoforte Solos: Two Pieces (Grieg); Overture, Nordische Seinfahrt (Gade); Popular Swedish Dances (Malm). 5.0, Concert of Italian Music by the Radio Orchestra, conducted by Charles Walpot. Overture, The Secret Marriage (Cimarosa); Selection from La Favorita (Donizetti); Serenade (Leoncavallo); Madrigal (Simonetti); Ballet Music from William Tell (Rossini); Overture, Il Trovatore (Verdi). 5.45, Programme for Children. 6.30, Programme for Young People. 7.15, Film and Book Review. 7.30, Talk for Women. 8.0, Humorous Programme by the Radio Orchestra, conducted by Charles Walpot and the Cercle artistique Pogen, under the direction of Jan Stalmans. 9.0, Humorous Readings. 9.15, Concert by the Station Symphony Orchestra, conducted by Meulemans. Easter Overture (Rimsky-Korsakov); Concert Waltz (Glazunov); Les Preludes (Liszt); Overture, Don Giovanni (Mozart). 9.55, Evening Prayer. 10.0, Le Journal parlé. 10.10, Gramophone Music.

BUCHAREST

761 kc/s, 394 metres; 12 kW.—5.0 p.m., Light Music and Romantical Music by the Dinico Orchestra. In an interval at 6.0, Radio Journal. 7.0, Reading. 7.20, Gramophone Music. 7.40, Educational Talk. 8.0, Song Recital. 8.20, Symphony Concert on Gramophone Records: Prelude to Lohengrin (Wagner); Prelude, L'Après midi d'un Faune (Debussy); G. Enesco and Veludii Memlin: Double Concerto for Two Violins (Bach); Seventh Symphony (Beethoven). In an interval at 8.45, Talk. 10.0, Radio Journal.

BUDAPEST

545 kc/s, 550.5 metres; 18.5 kW.—5.30 p.m., Hungarian Folk Melodies with Gymbal Accompaniment. 6.0, Reading. 7.40, Concert of Music by Doppler. 8.40, Concert by the Opera House Orchestra, conducted by Ernst Dohnányi; Overture, Ilka (Doppler); Symphonic Poem, Tasso (Liszt); Rrualia Hungarica (Dohnányi). 9.40, News, followed by Danc Music. 11.15, Cigány Music from the Hotel Dumapata.

CASSEL.—See Frankfurt.

COPENHAGEN

1,067 kc/s, 281 metres; 0.75 kW. Relayed by Kalundborg, 260 kc/s, 1,153 metres.—12 Noon, Time and Chimes from the Town Hall. 12.5 p.m., String Ensemble Concert, relayed from the Hotel d'Angleterre. 2.0, Interval. 3.30, Concert by the Louis Preil Instrumental Ensemble. Soloist: Magna Andersen (Songs). Spanish March, Cartagena (Grieg); Poème d'extase (Bullerian); Waltz from Show Boat (Kern); Melody (Johnson); Neapolitan Serenade (Bece); To man naa vaere (Henriques); Two-step, Torero fino (Luchessi); English Songs: (a) Play Fiddle, Play, (b) Have you ever been lonely, (c) No more love, (d) There's something about a Soldier; Shanson (Prinl); Waltz-Serenade, A Venetian Night (Padilla); Fantasia on La Paloma (Weninger); Serenade, A te sola (Guiliani); Venetian Serenade (Svendsen); Marimba Solo; Melody (Mathiesen); Waltz (Aloe); Hylton Stomp (Tortent). 5.35, Exchange and Fish Market Prices. 6.20, Talk on Amber. 6.50, Weather and News. 7.15, Time Signal. 7.30, Reading. 8.0, Chimes from the Town Hall. 8.5, Italian Opera and Ballet Music by the Station Orchestra, conducted by Walter Meyer-Radon; Overture, Norma (Bellini); Selection from La Boutique, fantaisie (Rossini-Respighi); Ballet Music from Aida (Verdi); Intermezzo from Suor Angelica (Puccini); Selection from Il carillon magico (Castelnuovo-Tedesco); Overture, William Tell (Rossini). 9.30, Radio Report of a Visit to an Hotel. 9.30, 'Cello Recital by Hans Bottemund; Arioso (Bach); Toccata (Frescobaldi); Sonata (Lo-atelli). 10.0, News. 10.15, Mendelssohn Concert by the Station Symphony Orchestra, conducted by Walter Meyer-Radon; Concert Overture, The Hebrides; Symphony No. 3 in A Minor, Op. 56. 11.0 (approx.), Close Down.

CORK.—See Athlone.

CRACOW

959 kc/s, 312.8 metres; 1.5 kW.—6.35 p.m., Gramophone Music. 6.45, The Letter Box. 7.0, See Warsaw. 7.20, Miscellaneous Items and News. 7.35, Programme Announcements. 7.40, See Warsaw. 10.0, Light Music, relayed from the Pavillon Restaurant. In an interval at 10.25, Sports Notes and Weather Report. 11.0, Fantare from St. Mary's Church.

DANZIG.—See Heilsberg.

DRESDEN.—See Leipzig.

FECAMP

1,328 kc/s, 225.9 metres; 10 kW.—4.30 to 6.0 p.m., Programme in English by the I.B.C. 4.30, Programme for Children. 5.0, Concert for Worthing and Littlehampton Listeners: Signature Tune; Quartet, Dream of the Ocean (Gungl); Violin Solo: Minuet in D (Mozart); Song: In Cellar Cool (Traditional); Quartets: (a) Cherry Ripe (Traditional), (b) When the Convent Bell is ringing (Clifford); Song: The Storm Fiend (Weatherley); Violin Solo: Moment musicale (Schubert); Quartet: I do like to be beside the Seaside (Glover). 5.30 to 6.0, Concert for Brighton and Hove Listeners: All over Italy (Butler-Munro); Song: Me and Mine are doing fine (Woods); Now I'm in Love (Shapiro); Song: Castles in the Sand (Sandford); Some of these days (Brooks); Song: Something came and got me in the Spring (Scholl); It seems to be Spring; The Japanese Sandman; Signature Tune. 6.0, Programme in French. 10.0 till Close Down. Programme in English by the I.B.C. 10.0, Dance Music; Signature Tune; Sweetheart (Miller); Hold up your Hands (Robinson); Can't we meet again? (Connelly); What did I get in return? (Young); The Girl in the Little Green Hat (Rich); Moon Song (Casslow); If I ever get a Job again (Lewis); Twenty Million People (Johnson); What have I got to Lose? (Kahn); Oh, you sweet thing (Wallier); Hyde Park Corner (Hargreaves); Deep Forest (Hines); Rosa Mia (Potter); Hot 'n' Anxious (Henderson); Let me explain (Towers); Mad Moments (Hopkins); Signature Tune. 11.0, Club Concert for Harrow Listeners. Part I: Orchestral Music; Signature Tune; Selection from Naxos (Delibes); Song: The Song of Songs (Moya); The Fortune Teller (Herbert); Pianoforte Selection from The Desert Song (Romberg); Song: Serenade (Toselli); Selection (Kálmán); Selection from Princess Pat (Herbert). Part II: Concert of Gramophone Records; Selection from Wild Violets. Part I (Stolz); The Chatter of the Clogs (Flynn); Veterans of Variety. Part II: Clapham and Dwyer on Photography. Part I and II: Pianoforte Solo: Sweetheart I'm dreaming of you (Desmond); There's something about a Soldier (Gay); Selection from Wild Violets. Part II (Stolz). 12.5 a.m. (Friday), News Bulletin in English. 12.10 (approx.), Moonlight Music: Pale Volga Moon (Hagan); I love the Moon (Rubens); Selection from The New Moon. Part II (Romberg); Moonlight at Sans-Souci (Rottler); Gipsy Moon (Borganov); Dance Music; Signature Tune; Drifting down the Shalimar (Moll); Rum Tum Tiddlely (Aitch); I'll see you in the Morning (Fields); Drifting under a summer moon (Harding); Castles in the Sand (Green); Just for a Sight, just for a Kiss (Rienardson); Something came and got me in the Spring (Scholl); Especially yours (Marks); Signature Tune. 12.57, I.B.C. Goodnight Melody. 1.0, Close Down.

FLENSBURG.—See Hamburg. FLORENCE.—See Turin.

FRANKFURT

1,157 kc/s, 259.3 metres; 17 kW. Relayed by Cassel, 1,220 kc/s, 245.9 metres; and Trier, 1,157 kc/s, 259.3 metres.—4.30 p.m., See Stuttgart. 5.45, Economic Notes. 6.0, Reading from the Works of Women Poets. 6.15, Reading: Nicolaus. 6.25, Dialogue: The German Employee and the Establishment of Health Insurance. 6.45, Review of the Day's Events. 6.50, Time and News. 7.0, Transmission for all German Stations, relayed from Breslau. 8.10, See Hamburg. 10.25, Time and News.

FREDRIKSSTAD.—See Oslo. FREIBURG.—See Stuttgart.

GENEVA.—See Radio-Suisse Romande. GENOA.—See Turin.

GLEIWITZ.—See Breslau. GÖTEBORG.—See Stockholm.

GRAZ.—See Vienna. HAMAR.—See Oslo.

HAMBURG

Call ha (in Morse), 806 kc/s, 372 metres; 1.5 kW. Relayed by Bremen, 1,112 kc/s, 269.8 metres; Flensburg, 1,319 kc/s, 227.4 metres; Hanover, 530 kc/s, 566 metres; and Kiel, 1,292 kc/s, 232.2 metres.—5.50 p.m., Variety Programme. 6.45, Exchange and Weather. 7.0, Transmission for all German Stations, relayed from Breslau. 8.0, Political Talk. 8.10, Die beiden Schützen—Comic Opera in Three Acts (Lortzing). In the interval, News. 10.25, Time and News. 10.35, Topical Talk. 10.45 (from Hanover), Light Music and Dance Music by the Station Orchestra.

HANOVER.—See Hamburg.

HEILSBURG

1,085 kc/s, 276.5 metres; 10 kW. Relayed by Danzig, 662 kc/s, 453.2 metres.—1.5 to 2.30 p.m., Gramophone Concert. In the intervals at 1.20 and 2.0, News. 3.0, Market Prices. 3.30, Programme for Young People. 4.0, Concert by the Königsberg Opera House Orchestra, conducted by Karl Hrubetz; Deutschermeister Regiments-Marsch (Bayer); Over-

JULY 27th

THURSDAY

continued

ture, Das süsse Mädel (Reinhardt); Elfenreigen-Walzer (R. Stier); Selection from Das Fürschenkind (Lehar); Overture, Erlkönig (Lücke); Ziehler Potpourri (Dauber); Intermezzo, Ein bla Fiecher (Siede); Potpourri of Marches and Dances, Bei Lied und Wein (Armandola); Polka-Mazurka, Wenn die Rosen blüh'n (Fahrbach); March, Es lebe die Freundschaft (Hrubetz). In the interval at 5.0, Review of Books. 5.50, Talk: The German Element in Riga, Past and Present. 6.15, Market Prices. 6.25, Agricultural Talk. 6.50, Weather Report. 7.0, Transmission for all German Stations, relayed from Breslau. 8.0, Weather and News. 8.5, Talk: Espionage against Germany. 8.35, Orchestral Concert, conducted by Ludwig Leschetizky, relayed from the Tergarten, Königsberg; Soloist, Fritz Schmidtko (Tenor); Overture, Don Giovanni (Mozart); Aria from Così fan tutte (Mozart); Serenade from Don Juans letztes Abenteuer (Paul Graener); Aria from Der Vampyr (Marschner); Two Songs (Paul Fleischmann); (a) Verklungen, (b) Abendsegen; Eight Russian Folk Melodies (Lidov); Carnaval à Paris (Svendsen); Quadrille from The Gipsy Baron (Joh. Strauss). 10.0, Weather and News.

HILVERSUM

Announced HUIZEN, 1,013 kc/s, 296.1 metres, 20 kW. (7 kW. up to 4.40 p.m.).—10.40 till Close Down, Programme of the Christian Radio Society (N.C.R.V.). 10.40, Programme of Orchestral and Choral Music, with Addresses. In the intervals at 12.10 p.m., Police Notes, and at 1.40, News. 3.40, Concert by the N.C.R.V. Orchestra, conducted by P. van de Hurk and the Amsterdam Orchestra, conducted by Frans van Diepenbeek. 4.40, Radio Report. 5.40, Gramophone Music. 6.40, Concert of Military Music, conducted by L. Leistikow. 7.40, Police Messages. 7.45 (approx.), Concert by the N.C.R.V. Orchestra. 8.55, News. 9.10, Concert by the Amsterdam Orchestra. In the interval at 9.55, Report on the Firework Display. 10.25, Gramophone Music. 11.10 (approx.), Close Down.

HORBY.—See Stockholm.

HUIZEN

Announced HILVERSUM, 160 kc/s, 1,875 metres; 8.5 kW.—Programme of the Allgemeine Vereeniging Radio Omroep (A.V.R.O.). 12.10 p.m., Concert by the Wireless Orchestra, conducted by Nio Treep. 2.10, Concert of English Music by the Wireless Orchestra, conducted by Nio Treep; Cinderella (Coates); In Hammersbach (Elgar); Three Dances from Nell Gwynn (German). 2.40, Recitations. 3.10, Gramophone Music. 3.40, Programme for Hospitals. 4.10, Gramophone Music. 4.40, Play for Children. 5.20, Gramophone Music. 6.10, Talk on Sports. 6.40, Gramophone Music. 7.10, Concert of Light Music by Kovacs Lajos and his Orchestra. 7.40, Time Signal. 7.41, News Bulletin. 7.45, Concert of Light Music by Kovacs Lajos and his Orchestra. 8.40, Concert by a Male Voice Choir. 9.0, Concert by the Wireless Orchestra, conducted by Nio Treep; Soloist: Fernando Zepparoni (Violin); Overture, Figaro (Mozart); Violin Solos: (a) Aria (Bach), (b) Romance (Svendsen); Ballet Suite from Céphale et Procris (Grétry-Moth); Violin Solos (d'Ambrósio); (a) Romance, (b) Canzonetta; Piece (Fischer). 9.40, Gramophone Music. 9.55, Concert by the Wireless Orchestra, conducted by Nio Treep; Piece (Sambelini); Dreamwaltz (Millöcker); Loin du bal (Gillet); Parade des enfants (Gillet); Selection from Wie einst im Mai (Kollo); March (V. Mecklen). 10.40, News Bulletin. 10.50, Concert of Light Music by John Bruck and his Orchestra. 11.40, Close Down.

INNSBRUCK.—See Vienna. KALUNDBORG.—See Copenhagen.

KATOWICE

734 kc/s, 408 metres; 16 kW. 6.35 p.m., Dance Music. 6.45, Sports Talk. 7.0, See Warsaw. 7.20, Announcements and Gramophone Music. 7.40 till Close Down. See Warsaw.

KIEL.—See Hamburg. KLAGENFURT.—See Vienna.

KOSICE.—See Prague.

LAHTI

167 kc/s, 1,796 metres; 10 kW. Relayed by Helsinki, 815 kc/s, 368.1 metres.—6.15 p.m., Concert by the Station Orchestra. 7.0, Agricultural Talk. 7.25, Pianoforte Recital by Tanelli Kuusisto; Prelude in E (Bach-Melartin); Prelude, Choral and Fugue (César Franck). 7.50, Recitations by Anni Kaste. 8.10, Concert by the Station Orchestra; Melody from Il Trovatore (Verdi); Träume (Wagner); Czardas (Grossmann). 8.45, News in Finnish. 9.0, News in Swedish. 9.15, Light Music relayed from the Restaurant Kappeli. 10.0 (approx.) Close Down.

LANGENBERG

635 kc/s, 473 metres; 60 kW.—1.0 p.m., Orchestral Concert, conducted by Wolf. In the interval at 2.0, News. 3.0, Programme for Children. 3.30, Exchange and Time. 3.50, Talk: The Prospects for German Export Trade. 4.10, Talk: Making the best use of Holidays. 4.30, Talk: Army Training in Foreign Universities. 4.55, Talk on Everyday Legal Affairs. 5.15, German Lesson for Germans. 5.30, Concert by the Fröhliche Fünf and the Station Chamber Choir, conducted by Breuer; Ballet des Parfume (Poppy); Flirtation (Steck); Choir: (a) Mein eigen soll sie sein, (b) Wohin mit der Freud' (Sileher), (c) Aeneas von Tharau (Sileher); Murnehdes Lüftchen (Jensen); Bereuse (Godard); Choir: (a) Das stille Tal (Folk Song), (b) Hans und Liesel (Folk Song), (c) Wanderschaft (Zöllner); Serenata (Tosti); Slav Dance No. 6 (Dvorák). 6.45, Weather, Time, Exchange and Sports Notes. 7.0, Transmission for all German Stations, relayed from Breslau. 8.0, First General News. 8.5, Bunte Stunde. 9.15, Radio Report of the International Horse Show at Aachen, with Programme of Army Marches. 10.0, News. 10.30, Gramophone Records of the Berlin State Opera House Productions. 11.0, Dance Music by the Station Orchestra. 12 Midnight, Close Down.

LAUSANNE.—See Radio-Suisse Romande.

LEIPZIG

769.9 kc/s, 389.6 metres; 120 kW; and Dresden, 941 kc/s, 319 metres.—12 Noon, Weather and Time. 12.5, Gramophone Concert. 1.0, News. 1.15, Soloist Concert, Johannes Schneider-Marfels (Pianoforte), Walter Döll (Violin), and Richard Krenziger (Baritone). Scherzo, Op. 4 (Brahms); Three Songs (Graener): (a) Der Page sprach, (b) Der alte Herr, (c) Im Himmelreich; Hungarian Dances (Brahms-Joachim); Two Songs (Trunk); (a) Die Stadt, (b) Tanzlied; Nocturne (Chopin); Three Pieces from the Diary (Roger). 2.0, News. 2.10, Film Review. 2.30 (from Dresden), Zither Recital of Folk Music by Fred Riffer. 3.0, Educational Talk. 3.35, Economic Notes. 4.0, See Breslau. Talk: Geneo-logical Investigations. 5.50, Economic Notes, Weather and Time. 6.0, Talk on Taxation. 6.25, Talk. 6.50, Events of the Day. 7.0, Transmission for all German Stations, relayed from Breslau. 8.0, Old and New Dances by the Ende Orchestra. 9.15, All through the Summer, Radio Sequence with Music by Wilhelm Gade and Louis Glass. 10.15, News. 10.30 (approx.), Concert by the Station Orchestra, conducted by Hilmar Weber, Comedy Overture (Kleemann); Selection from Lucia di Lammermoor (Donizetti); German Dances (Schubert); Selection from the Suite, The Merchant of Venice (Sullivan); Waltz, Frühlingkinder (Waldteufel); Waltz, Natur-Singer (Ziehler); Selection from The Gipsy Baron (Strauss). 12 Midnight, Close Down.

LINZ.—See Vienna.

LJUBLJANA

522 kc/s, 574.7 metres; 7 kW.—6.30 p.m., Gramophone Music. 7.10, Choral Concert, relayed from Prague. 8.10, Gramophone Music. 8.30, Song Recital. 9.15, Concert by a Slovene Vocal Quintet. 10.0, Programme relayed from Bled. 11.0 (approx.), Close Down.

LUXEMBOURG

252 kc/s, 1,191 metres; 200 kW.—German Programme. 7.30 p.m., The Krentzer Sonata (Beethoven) on Gramophone Records. 8.5, Weather. 8.10, Talk in German. 8.20, Concert by the Station Orchestra, conducted by Henri Pensis; Overture, Don Giovanni (Mozart); Suite, Prometheus (Beethoven); Träumerei (Schumann); Overture, Manfred (Schumann). 8.50, News in French. 9.15, Song and Pianoforte Recital by Mme. Germaine Türk and M. Jean Dax. Songs: (a) Gottes Zeit (Bach), (b) Der Lindenbaum (Schubert); Pianoforte Solos: Paganini and Brahms Variations, Songs: (a) Sapphische Ode (Brahms), (b) Das Mädchen spricht (Brahms), (c) Wenn ich in deine Augen seh (Schumann), (d) Und wüsstest die Blumen, (e) Ich grille nicht (Schumann); Pianoforte Solos: (a) Etude in C minor (Chopin), Etude in F (Chopin), (b) Etude in C (Rubinstein). 9.50, News in German. 10.0, Concert by the Station Orchestra; Overture, The Caliph of Bagdad (Boieldieu); Melody (Korngold); S'kommt ein Vogel geflogen (Oehls). 10.20, Dance Music on Gramophone Records.

LWOW

788 kc/s, 381 metres; 16 kW.—6.35 p.m., Song Recital. 7.0, See Warsaw. 7.20, Miscellaneous Items. 7.40, See Warsaw. 9.0, Literary Programme. 9.10, Programme from Warsaw. 10.40, Gramophone Music. 11.0 (approx.), Close Down.

LYONS

LA DOUA (PTT), 644 kc/s, 465.8 metres; 1.5 kW.—7.30 p.m., Radio Gazette for Lyons and the South-East. 8.30, Vocal and Orchestral Concert. After the Concert, News.

MADRID

EAJ7; 707 kc/s, 424.3 metres; 2 kW.—8.0 p.m., Chimes, Exchange, Radio Journal, and Programme for Children. 9.15, News and Political Review. 9.30 to 11.0, Interval. 11.0, Chimes, Time, and Political Review. 11.15, Juan Almela Soler reads from his Poems. Incidental Pianoforte Music by Rafael Espinosa. 11.30, Municipal Band Concert, relayed from the Rosales. 1.15 a.m. (Friday), Time and News. 1.30, Close Down.

MALMO.—See Stockholm. MILAN

VIGENTINO; 662 kc/s, 453.2 metres; 4 kW.—8.45 p.m. till Close Down, See Rome.

MORAVSKA-OSTRAVA

1,137 kc/s, 263.8 metres; 11 kW.—5.25 p.m., Talk on Holiday Homes for Children. 5.45, Gramophone Music. 5.55, See Bratislava. 6.5, Gramophone Music. 6.15, See Prague. 11.0 (approx.), Close Down.

MOSCOW

TRADES UNION, 230 kc/s, 1,304 metres; 160 kW.—2.45 p.m., Weather. 3.0, Wagner and Liszt Song Recital by Stadkovtsev (Tenor). 3.45, Weather. 4.0, Talk on Harvesting. 4.30, Literary Programme. 5.30, Programme Announcements. 5.45, Talk: The Fire Brigade. 6.30, Dance Music. 9.0, News. 9.30, Programme Announcements. 9.55, Chimes and Press Review.

MOTALA.—See Stockholm.

MUHLACKER.—See Stuttgart.

MUNICH

563 kc/s, 533 metres; 60 kW. Relayed by Augsburg and Kaiserslautern, 536 kc/s, 560 metres, and Nürnberg, 1,256 kc/s, 239 metres.—6.5, Carl Herle Memorial Programme. Maria Jerabeck (Soprano), Helma Panke (Soprano), Alons Kiechle-Vogler (Bass), and Dr. Max Neuhaus (Pianoforte). Introductory Talk and Commentary by Dr. Max Neuhaus; Laerymoso from Requiem (Mozart); Vergebliches Ständchen (Mozart); Trio: Mädchen ich komme mit der Zither (Mozart). 6.25, Talk. 6.45, Time, Weather, and Agricultural Report. 7.0, Transmission for all German Stations, relayed from Breslau. 8.0, Friedrich Georg Jünger reads from his own Works. 8.15, The Story of the Lovely Lilofee—an Arrangement of an Old Ballad for Soloists, Choir, and Orchestra (Tauts). 9.0, Dance Music relayed from Berlin (Witzleben). 10.0, Gramophone Records. 10.20, Time and News.

NAPLES.—See Rome.

NOTODDEN.—See Oslo.

OSLO

277 kc/s, 1,093 metres; 60 kW. Relayed by Fredrikstad, 815 kc/s, 368.1 metres; Hamar, 522 kc/s, 574.7 metres; Notodden, 671 kc/s, 447.1 metres; Porsgrund, 662 kc/s, 453.2 metres; and Rjukan, 671 kc/s, 447.1 metres.—5.30 p.m., Gramophone Concert. 6.30, Divine Service and Songs from the Studio. 7.0, Advertising Notes. 7.15, Weather and News. 7.30, Topical Talk. 8.0, Time Signal. 8.1, Agricultural Talk. 8.30, Violin Recital; Sonata No. 9 for Violin and Pianoforte (Mozart); Hungarian Dance No. 7 (Joachim); Air from the Violin-Blaker of Cremona (Hubay); Norwegian Dance (Halvorsen). 9.10, Recitation. 9.40, Weather and News. 10.0, Topical Talk. 10.15, Choral Concert. 10.45 (approx.), Close Down.

OSTERSUND.—See Stockholm.

PALERMO

558 kc/s, 537.6 metres; 3 kW.—8.0 p.m., Dopolaro Announcements, Agricultural Report and Giornale radio. 8.20, Gramophone Music. In the interval at 8.30, Time and Announcements. 8.45, Popular Song Recital. In the interval at 9.30, Luntie di Sicilia—Comedy in One Act (Pirandello). 10.55, News.

PARIS

EIFFEL TOWER, CALL FLE, 207.5 kc/s, 1,445.7 metres; 13 kW. Time Signals (on 2,650 metres) at 10.26 a.m. and 11.26 p.m. (Preliminary and 6-dot signals).—6.45 p.m., Le Journal Parle. 8.30, Gramophone Concert; Overture and Ballet Music from The Battered Bride (Smetana); Habanera (Chabrier); Dance from El amor brujo (Fallá); Petite Suite (Debussy); L'apprenti sorcier (Dukas); Overture, La princesse janne (Saint-Saëns); Nocturne from Cocorico (Ganne); Pourtant (Bayle); C'est toi nous devons aimer (Tranchesi); Ça va et poule (Paradis); Finale from Act II of Frederick (Lehar); In the Temple of the Bulls (Vostokov); Au pays du soleil (Scotti); Amoretzünze (Gungl); Over the Waves (Kosas); Piece (Richter); The Blue Sea (Benedict); Melody (Sentengini). 10.0 (approx.), Close Down.

PARIS

POSTE PARISIEN, 914 kc/s, 328.2 metres; 60 kW.—7.0 p.m., Gramophone Music. 7.15, Le Journal Parle. 7.30, Gramophone Music. 8.0, Folies Bergères Programme arranged by Derval. 8.30, Interlude. 8.45, Concert by the Station Orchestra: Overture, Tutti in maschera (Pedrotti); Waltz, The Roses (Metra); Nivernaise (Taffanel); Ballet Music from Les Fantoines (Lecocq); Piece-Messenger; Madrigal (Gaubert); Song for Cello and Orchestra (d'Indy); Habanera (Turina); Selection from Marietta (Strauss); Neapolitan Dance (Desormes); Youth March (Kricka). 10.30, Report of the Walking Race from Paris to Strasbourg. 10.45, News.

PARIS

RADIO PARIS, Call CFR, 174 kc/s, 1,725 metres; 75 kW.—7.30 a.m., Weather and Physical Culture. 7.45, Ballet Music from Herodiade (Massenet), on Gramophone Records. 8.0, Weather and News. 12 Noon, Protestant Address. 12.30 p.m., Gramophone Concert. Part I—Music for Young People: Fairy on the Clock (Myers); Le beau bébé (Dalcroze); Nocturne (Keramy); Marche nuptiale d'une poupée (Lecocq); Recitative from Le Cid (Cornelle); Le carnaval des animaux (Saint-Saëns). Part II—Operetta and Sound Film Music: Song (Hollaender); Beaucoup d'amour from Ma femme homme d'affaires (Moretti); Song from Tell me Tonight (Spoliansky); Song (Messenger); Songs from Il est charmant (Moretti); (a) Histoire de voir, (b) En parlant un peu de Paris; Qui peut savoir from La Comtesse de Monte-Christo (Gray); Avec un bruit sec from Oh! Papa (Yvain); Songs from Au pays du soleil (Scottot); (a) J'ai rêvé d'une fleur, (b) Le pays du soleil. In the intervals at 1.0, Exchange, News and Weather, and at 1.30, Exchange. 2.0, Exchange. 3.45, Exchange and Market Prices. 4.45, Widor Festival Concert, relayed from the American Conservatoire, Fontainebleau. The Composer at the Piano. Soloists: Mme. Hilda Roosevelt (Songs), M. Maillard Verger (Piano), André Pascal (Violin), Jacques Desestre (Viola), and Paul Bazelaire (Cello). Piano-forte Quartet; Songs accompanied by the Composer: (a) Contemplation, (b) Enfant de Catinne, (c) Les étoiles, (d) Non credo, (e) Rosa la rose; Piano-forte Quintet; Priere de Saint Jean, by Mme. Roosevelt. The Composer at the Organ, and a String Quartet. 7.0, Market Prices, Weather, Agricultural Notes and Racing Results. 7.10, Gramophone Concert: Selection from La vie parisienne (Offenbach); Polka for Cornet Solo, Myrto (Petit); Sérénade printanière (Holmer); Air from Les aventures du Roi Pausole (Honegger); Algerian Nights (Grieg); Auf wiederhören (Meninger). 7.50, Commercial Notes and News. 8.0, Variety Music on Gramophone Records. 8.30, News, Weather and Sports Notes. 8.40, Review by M. Christophe. 8.45, Operetta Music on Gramophone Records. Overture, The Italian Girl in Algiers (Rossini); Melodies from The Tales of Hoffmann (Offenbach); Selection from Fortunio (Messenger); Songs from Marouf (Rabaud); Dance from The Three-Crowned Hat (Falla). 9.15, Press Review and News. 9.30, Dance Music on Gramophone Records.

PITTSBURGH

KDKA, 980 kc/s, 306 metres; 50 kW. Relay by W8XK on 48.86 metres and 25.27 metres.—7.30 p.m., The Pioneers, from New York. 7.45, KDKA Home Forum. 8.0, Betty and Bob, from New York. 8.15, Words and Music, from New York. 8.45, State Federation of Pennsylvania Women. 8.58, Baseball Scores. 9.0, Thursday Special from New York. 9.30, Business News and Market Reports. 9.45, Thursday Special (cont'd.), from New York. 9.58, Baseball Scores. 10.15, Tarzan of the Apes. 10.30, Singing Lady, from New York. 10.45, Little Orphan Annie. 11.0, Time Signal and Press News-Reciter. 11.15, Piano Classique. 11.25, I Bring a Song. 11.36, Sport Review. 11.23, I Bring a Song. 11.28, Announcement. 11.29, Temperature Report. 11.30, Pittsburgh Spotlight—The Pittsburghers. 11.45, Today's News by Lowell Thomas, from New York. 12 Midnight, Anous' Andy, from New York. 12.15 a.m. (Friday), Concert Footlights. 12.45, Pathic News of the Air. 1.0 to 4.0, New York Relay. 1.0, Captain Diamond's Adventures. 1.30, Aldo Ricci and his Phantom Strings. 1.45, Floyd Gibbons, World's Fair Reporter. 2.0, Death Valley Days. 2.30, Wayne King's Orchestra with Lady Esther. 3.0, Century of Progress Festival Orchestra.

PORSGRUND.—See Oslo.

PRAGUE

614 kc/s, 488.6 metres; 120 kW.—2.50 p.m., See Berne. 3.55, Exchange. 4.0, Interval. 5.25, See Moravská-Ostrava. 5.45, Gramophone Music. 5.55, See Bratislava. 6.5, Talk on Bee-keeping. 6.15, Talk for Workers. 6.25, News in German. 6.30, German Transmission. Book Review and Agricultural Report. 7.0, Chimes and News. 7.10, Concert by the Police Choral Society, conducted by E. Karasek. 7.45, Talk: Conversational Difficulties. 8.0, Trio Concert. 8.25, Military Band Concert: Overture, Orpheus in

JULY 27th

THURSDAY

continued

the Underworld (Offenbach); Selection from Rousalka (Dvorák); Intermezzo from Cavalleria rusticana (Mascagni); Czeli Polka (Schwarz); Selection from The Bonbon King (Provasnik); Piece (Kasperek). 9.30, Chopin Piano-forte Recital by Erhard Michel: Scherzo in B Minor; Waltz in C sharp minor; Waltz in E minor; Mazurka in B minor; Etude in A flat; Polonaise in A flat minor. 10.0, Time and News. 10.15, Concert of Light Music. 11.0 (approx.) Close Down.

RADIO-SUISSE ROMANDE

SOTTENS, 743 kc/s, 403 metres; 25 kW.; and Geneva, 395 kc/s, 760 metres.—12.28 p.m., Time Signal from Neuchâtel Observatory. 12.30, News and Weather. 12.40, Gramophone Music. 1.0, Financial News. 1.10, Gramophone Music. 2.0 to 3.28, Interval. 3.28, Time Signal from Neuchâtel Observatory. 3.30, Concert by the Radio-Suisse Romande Quintet. 5.0, Programme for Children. 5.30 to 7.0, Interval. 7.0, Talk on Mountaineering. 7.30, Announcements. 7.35, The Optimists Programme. 8.0, Harpsichord Solos by Charles Koller. 8.20, Readings from the Works of Russian Authors. 8.35, Concert of Russian Music by the Radio-Suisse Romande Orchestra. Soloist: Mlle. Tatianov (Songs); Arias from Prince Igor (Borodin); Mushrooming (Mussorgsky); Gopak (Mussorgsky). 9.50, News and Weather. 10.0, L'aimable Daïda—Play (Tristan Bernard), with Music by Iahn. 10.30 (approx.), Close Down.

REYKJAVIK

250 kc/s, 1,200 metres; 21 kW.—9.5 p.m., Musical Programme. 9.30, Weather Report. 9.40, Musical Programme and Announcements. 10.0, Chimes and News. 10.30, Reading. 11.0, The Radio Trio, followed by Icelandic Songs on Gramophone Records.

RIGA

572 kc/s, 525 metres; 15 kW.—7.30 p.m., Concert by the Radio Symphony Orchestra, conducted by Vladimir Savitch. Soloist: Herta Lusis (Songs). Seventh Symphony (Brahms); Aria from Samson and Delilah (Saint-Saëns); Two Songs (Medins); Suite, Precious Stones (Vitols). 9.0, News. 9.40 (approx.), The Barber of Seville—Opera (Rossini).

RJUKAN.—See Oslo.

ROME

Call 1R0, 680 kc/s, 441 metres; 50 kW. Relay by Naples, 941 kc/s, 319 metres, and 2R0, 1,810 kc/s, 25.4 metres, from 5.30 p.m.—1.5 to 2.15 p.m., Concert from Turin. In the intervals from 1.30 to 1.45, Giornale Radio and Exchange, and at 2.0, Time and Announcements. 4.45, Children's Radio Review. 5.10, Weather. 5.15, Exchange and Giornale Radio. 5.30 to 6.30, Vocal and Instrumental Concert: Maria Flori (Violin), Augusta Berta (Mezzo-Soprano) and Guglielmo Bandini (Bass); Suite in E (Corelli); Mezzo-Soprano Solos: (a) Aria from Don Sebastian (Donizetti); (b) Chant hindou (Bemberg); (c) Rondo (Cimarosa); Bass Solo from Don Carlos (Verdi); Violin Solos: (a) Andante religioso from the Fourth Concerto (Vieuxtemps); (b) Hejre Kati (Habay); Duets for Soprano and Bass: (a) Duet from La scala di seta (Rossini); (b) Il campanello (Donizetti). 6.40 (Naples), Shipping and Sports Notes. 6.50, Agricultural and Dopolavoro Notes. 7.10, Tourist Report. 7.20, News in Foreign Languages. 7.40, Giornale Radio. 8.0, Time and Announcements. 8.15, Gramophone Music. 8.30, Giornale Radio and Sports Notes. 8.45, Concert by a Military Band, conducted by Andrea Marchesini. 9.45, La voce dell'illusione—Comedy in One Act (Enrico Ragusa). 10.40, Concert (cont'd.). 10.55, Giornale Radio.

SALZBURG.—See Vienna.

SCHENECTADY

WGY, 790 kc/s, 379.5 metres; 90 kW. Relay at intervals by W2XAF on 31.48 metres and by W2XAD on 19.56 metres. 12.45 a.m. (Friday), Stock Reports and Baseball Scores. 1.0 to 3.0, New York Relay. 1.0, Variety Programme. 2.0, Captain Henry's Show Boat. 3.0, Musical Programme from New York, followed by Programme Résumé.

SCHWEIZERISCHER LANDESSENDER

BEROMUNSTER, 653 kc/s, 459 metres; 60 kW. Basle, 1,229 kc/s, 244.1 metres, and Berne, 1,220 kc/s, 245.9 metres.—6.15 a.m. (from Berne), Gymnastics. 6.35, Interval. 11.59, Time Signal from Neuchâtel Observatory; and Weather. 12 Noon (from Basle), Balalaika Music on Gramophone Records. 12.30 p.m., Time and News. 12.40, concert by the Swiss Radio Orchestra. 1.25 (from Basle), Time, Weather and Exchange. 1.35, Interval. 5.0 (from Berne), Songs in

TRIESTE

1,211 kc/s, 247.7 metres; 10 kW.—5.10 p.m. till Close Down, See Turin.

TRONDHEIM.—See Oslo.

TURIN

1,096 kc/s, 273.3 metres; 7 kW. Relay by Milan, 905 kc/s, 331.5 metres; Genoa, 959 kc/s, 312.8 metres; and Florence, 599 kc/s, 500.8 metres.—5.10 p.m., Orchestral Concert. 6.0 to 6.5, Weather. 6.35, News. 7.0, Time Signal. 8.15, News in Foreign Languages. 7.40, Gramophone Music. 8.0, News and Weather. 8.15, Sponsored Music. 8.30, Talk on the following Transmission. 8.35, Italian Operatic Evening: (a) Entral—Operetta in One Act (Bruno Barilli). (b) Il gobbo del Califfo—Opera in One Act (F. Casavola). (c) Il diavolo nel campanile—Opera in One Act (Adriano Luabbi). Giornale Radio after the Programme.

VATICAN CITY

15,120 kc/s, 19.54 metres (Morning), and 5,969 kc/s, 50.25 metres (Evening); 10 kW.—11.0 to 11.15 a.m., Religious Information in French. 8.0 to 8.15 p.m., Religious Information in Italian.

VIENNA

581 kc/s, 517 metres; 15 kW. Relay by Graz, 852 kc/s, 352.1 metres; Innsbruck, 1,058 kc/s, 283 metres; Klagenfurt, 662 kc/s, 453.2 metres; Linz, 1,220 kc/s, 245.9 metres; and Salzburg, 1,373 kc/s, 218.5 metres.—12 Noon, Concert by the Vienna Symphony Orchestra, conducted by Josef Holzer. In the interval at 1.0 p.m., Time and News. 3.0, Time and News. 3.20, Talk on Marie Geisinger, of the Century of her Birth. 3.30, Programme for Children. 3.55, Gramophone Records of Sound Film Music. 4.40, Talk: Wai-ho-n-an der Thaya. 5.0, Talk for Women: German Women in the Sixteenth Century. 5.30, Song Recital by Alice Burger (Soprano) and Willy Harand (Bartitone). 6.5, Talk: Three Times round the World in a Glider. 6.30, Talk: Radicalism of Young People. 7.0, Symphony Concert by the Vienna Symphony Orchestra, conducted by Rudolf Nims. Soloist: Wilhelm Winkler (Cello). Overture, Oberon (Weber); Cello Concerto in D Minor (Lalo); Symphonie Suite (Debussy); Scherzo in A (Goldmark). In the interval at 7.35, Time and News. 8.15, Reading: Die Abfahrt (Wittner). 8.45, Military Band Concert: Kaiserschützen-Marsch (Kummerer); Festival Overture (Suppe); General-Tabakreisen (Neidhardt); Waltz, Gute Kameraden (Tham); March, Hoch Heideckburg (Herzer); Potpourri, Wiener Melodienstrauss (Kliment); March (Frank); Waltz, Alt-Wien (Lamber-Kremer); Starhemberg-Marsch (Schneider). 10.0, Talk in Italian: The Latin Element in Vienna. 10.15, Time and News. 10.30, Concert from the Hotel Krantz-Ambassador.

WARSAW

212.5 kc/s, 1,411 metres; 120 kW.—11.57 a.m., Time Signal and Fanfare from St. Mary's Church, Cracow. 12.5 p.m., Popular Orchestral Concert from the Café Dakowski. 12.25, Review of the Polish Press. 12.33, Weather. 12.35, Concert from the Café Dakowski (cont'd.). 12.55, Radio Journal. 1.0 to 2.55, Interval. 2.55, Gramophone Music. 3.5, News. 3.10, Announcements. 3.15, Gramophone Music. 3.25, Announcements. 3.35, Gramophone Music. 3.45, Review for Boy Scouts. 3.50, Gramophone Music. 4.0, Programme for Children, relayed from Lwów, 798 kc/s, 381 metres. 4.30, Song Recital by J. Korolkiewicz: Aria from Eugene Onegin (Tchaikovsky); Two Songs (Tchaikovsky); (a) Chant sans paroles, (b) Chanson triste; Two Songs (Sym); (a) Le Cyprien, (b) Les feuilles; Sei morta ne la vita mia (Costa); Sérénade (Beere). 5.0, Programme for Women. 5.15, Concert by the Poznan Opera House Orchestra, conducted by B. Tyllia, relayed from Ciechocinek. 6.15, Talk: Poland in the Time of Boleslaus the Brave. 6.35, Gramophone Records. 7.0, Song Recital. 7.20, Miscellaneous Announcements. 7.35, Programme Announcements. 7.40, Reading. 8.0, Kálmán Concert by the Station Orchestra, conducted by Z. Gorzanski; Soloist: M. Wawrzakowicz (Tenor); March Fox-trot; Selection from Countess Maritza. 8.50, Radio Journal. 9.0, Agricultural Report. 9.5, Concert (cont'd.). Selection from The Bayadere; Songs; Selection from Die Fäselinger. 10.0, Dance Music from the Café Europe, Ciechocinek. In the intervals at 10.25, Sports Notes, and at 10.33, News.

WILNO

533 kc/s, 553 metres; 16 kW.—6.35 p.m., Dance Music on Gramophone Records. 7.5, Programme from Warsaw. 7.20, The Letter Box. 7.40, See Warsaw. 9.0, Recitation. 9.10, Programme from Warsaw. 11.0 (approx.), Close Down.

Eight Languages on Gramophone Records. 5.30 (from Berne), Popular Gramophone Music. 6.0 (from Berne), Light Music by the Tegetmuse Concert Trio. 6.30 (from Basle), Reading. 7.0 (from Basle), Time and News. 7.10 (from Basle), Italian Folk Music on Gramophone Records. 7.45 (from Basle), Elementary English Lesson. 8.30 (from Basle), Concert by the Basle Mandoline Society, conducted by E. Krähnbühl. 9.0, News. 9.10 (from Basle), Der Herr Doktor—Comedy (Helene and Dr. A. Wiesendanger), Music by Franz Gelpke. 9.55 (from Basle), Trio in E (Mozart) on Gramophone Records. 10.15 (approx.), Close Down.

SOTTENS.—See Radio-Suisse Romande.

STOCKHOLM

689 kc/s, 436 metres; 55 kW. Relay by Boden, 244 kc/s, 1,229.5 metres; Göteborg, 932 kc/s, 322 metres; Hörby, 1,166 kc/s, 257 metres; Motala, 221.5 kc/s, 1,354.4 metres; Östersund, 389 kc/s, 770 metres; and Sundsvall, 545 kc/s, 542 metres.—5.5 p.m., Divine Service, relayed from Helsingborg, 1,301 kc/s, 231 metres. 5.30 (from Göteborg), Talk. 6.0, Gramophone Music. 6.50, Dialogue in English: The Daily Round of a Londoner's Life, relayed from Jönköping, 1,490 kc/s, 201.3 metres. 7.30, Talk. 8.0 (from Göteborg), Concert of Light Music, conducted by Karl Borjfors. 8.45, Talk. 9.15, Zither Recital by Max Funk, relayed from Malmö, 1,301 kc/s, 231 metres. 10.0, Organ Recital: Air with Variations (Martini-Bossi); O, del mio dolce ardor (Ghuck); Alleluiah, from Exultate jubilate (Mozart); Variations on a Theme of Corelli (Tartini-Kreiser); Elegy (Mclartini); Legend (Appelton); Agnus Dei (Bizet); Die Altmacht (Schubert); Romance (Kryianowsky); Berceuse (Arnesky); Marche solennelle (Ohsson). 11.0 (approx.), Close Down.

STRASBOURG

869 kc/s, 345 metres; 11.5 kW.—11.30 a.m., Wagner Concert on Gramophone Records. 12.45 p.m., News. 1.0, Time Signal. 1.1, Exchange. 1.5, Concert by the Station Orchestra, conducted by Maurice de Villers. 2.0, Programme for Children. 3.0, Interval. 4.15, Elocution Lesson in French. 4.30, Programme for Children, relayed from Bordeaux-Lafayette. 6.0, Recital of Old and New Songs, relayed from Paris (Radio-Coloniale), 11,905 kc/s, 25.2 metres. 6.30, Talk in German: French Civilisation. 6.45, Talk for Women. 7.0, Gramophone Music. 7.30, Time. 7.31, News. 7.45, Gramophone Music. 8.0, News in French. 8.30, Concert by the Metz Municipal Orchestra, conducted by Louis Narbonne, relayed from the Esplanade, En Liesse (Turine); Overture, Mirella (Gounod); Minuet from the Quintet (Bocherini); Song without Words, No. 4 (Mendelssohn); Tambourin (Rameau); Minuet from the Sextet (Bethoven); Waltz, The Blue Danube (Joh. Strauss); Gavotte, Confidences (Wesly); Selection from Les Saltimbanques (Ganne); Selection from The Merry Widow (Lehar); Scènes pittoresques (Massenet); Waltz, Hymne à l'Amour (Popy); Spanish Bolero, Chiquita (Leroux). In the interval, News in German. 10.30 (approx.), Close Down.

STUTTGART

MUHLACKER, 832 kc/s, 360.5 metres; 60 kW. Relay by Freiburg, 527 kc/s, 570 metres.—12 Noon, Orchestral Concert, conducted by Gustav Gricch. Soloist: Edward Oswald (Violin). 1.0 p.m., Report of the Fifteenth German Gymnastic Festival, 1933. 1.30, Time and News. 1.45, Songs on Gramophone Records. 2.0, Concert arranged by the Post Office. 2.30, Spanish Lesson. 3.0, English Lesson for Beginners. 3.30, Programme for Children. 4.30 (from Badenweiler), Orchestral Concert, conducted by Albert Hitzig: Kaisermarsch (Wagner); Overture, William Tell (Rossini); Aquatella-Walzer (Jos. Strauss); Selection from Faust (Gounod); Sarasate Potpourri (Friedmann); Intermezzo, Gnomenselchle (Rhode); Selection from Pagauini (Lehar); Ernst-August-Marsch (Blankenburg). 5.45, The Work of the Sculptor—a Dialogue between Carl Besier and Dr. Curt Elwenspeck. 6.10, Talk. 6.35, Time and News. 7.0, Transmission for all German Stations, relayed from Breslau. 8.0, Variety Programme with Willi Reichert. 9.15 (from Mannheim), Concert by the Mannheim Chamber Orchestra, conducted by Helmuth Schlawing. Soloist: Sofie Kerst (Soprano). Sonata da Chiesa in B minor (Corelli); Il mio ben quando verra (Paisiello); Selection from Intermezzi Goldoniiani, Part I (Bassi); Aria from Demofonte (Cherubini); Selection from Intermezzi Goldoniiani, Part II (Bassi); Einsam ging ich jüngst im Hain (Mozart); Minuet in A (Bocherini). 10.0, Time and News. 10.30, Report of the Fifteenth German Gymnastic Festival, 1933. 11.0, Dance Music on Gramophone Records. 1.0 a.m. (Friday), Close Down.

SUNDSVALL.—See Stockholm.

ZURICH.—See Schweizerischer Landessender.

FRIDAY

JULY THE TWENTY-EIGHTH

PRINCIPAL EVENTS OF THE WEEK:

AT HOME

- NATIONAL** Orchestral concert and pianoforte recital.
- LONDON REGIONAL** "The Road to Ireland," a feature programme, by Filson Young.
- MIDLAND REGIONAL** "From the Musical Comedies," an orchestral concert.
- WEST REGIONAL** "Gaffer and Gavotte," No. 4; a West Country programme.

ABROAD

- BUDAPEST** 9.0 p.m. Cigany music.
10.10 p.m. Talk in English.
- COPENHAGEN** 9.0 p.m. Debussy pianoforte recital.
- HEILSBURG** 8.20 p.m. Recital of New German Lieder.
- HILVERSUM (announced Huizen)** 7.40 p.m. Concert by the Maastricht Municipal Orchestra.
- HUIZEN (announced Hilversum)** 8.10 p.m. Concert from the Kurhaus, Scheveningen.
- PARIS (Eiffel Tower)** 8.30 p.m. Italian concert by the Symphony Orchestra.
- STRASBOURG** 8.30 p.m. Festival programme for the inauguration of the new station at Lille; relayed from Lille.
- TURIN** 8.30 p.m. "La Fille de Madame Angot," an operetta, by Lecocq.
- WARSAW** 8.0 p.m. Symphony concert.

Polichinelle; Pièce en forme de habanera (Ravel); Flute Solo: Rossignolet (Bades); Violin Solo: Chanson à Lorette (Callin); Extracts from Carmen (Bizet); Marche Française (Saint-Saëns). 6.0, Talk on Painting. 6.15, Gramophone Music: Phaëton (Saint-Saëns); Allegro appassionato (Saint-Saëns); Caprice italien (Tchaikovsky); Mélodies corces, Nos. 3 and 4 (Tomasis). 6.30, Humorous Soldier Songs by M. Delstanches (Baritone) and M. Claret (Singer); Sous l'Uniforme (Boland); Un castar Belgique (Boland); Jannais congé (Boland); Le service de santé (Boland); Ah! le beau séjour! (Hendrick). 7.15, Talk: Physical Training in Belgium. 7.30, Legal Talk and Literary Review. 8.0, Programme for Ex-Servicemen. 9.0, Concert, relayed from the Kursaal, Ostend. 10.30, Le Journal Parlé. 10.40, Dance Music relayed from the Kursaal, Ostend. 11.0, Le Brabantonne.

BRUSSELS (No. 2)

N.I.R., 887 kc/s, 338.2 metres; 15 kW. Programme in Flemish.—12 Noon, Concert by the Small Station Orchestra, conducted by Pierre Leemans: Overture, Die Frau Meisterin (Suppé); Waltz, Die Koseniden (Lanner) Garden happiness (Wood); Slav Rhapsody, No. 2 (Friedemann); Violin Solo: Liebeslied (Kreisler); Selection from Mignon (Thomas); Anbade à Elly (Demare); Tango, Auch ich träum, so gern von der Liebe (Grothe); Foxtrot (Landschulz-Schoppe). 1.0 p.m., Le Journal Parlé. 1.10, Gramophone Concert. 5.0, Dance Music, relayed from the Casino, Knocke. 6.15, Talk: The Art of Speaking. 6.30, Concert by the Small Station Orchestra, conducted by Pierre Leemans: Cortège antique (Hermite); Evocation (Sykes); Selection from Miss Decima (Audran); Galop, He! la! hop! (Laurens); Selection from La Navarraise (Massenet); Gramignon (Gillon); Torero Ramon (Kostal). 7.15, Talk: The History of Belgian Navigation. 7.30, Wireless Talk. 8.0, Extracts from Rigoletto; Opera (Verdi) on Gramophone Records. 8.45, Recitations. 9.0, Orchestral Concert, relayed from the Casino, Knocke; Conductor, K. Candaël; Soloist, Mlle. Marie-Louise Marichal (Pianist, Age 11); Jeux d'enfants (Bizet); Pianoforte Concerto in G Minor (Mendelssohn); Extract from Sea Pictures (Chopin); Petite Suite (Debussy); Caprice italien (Tchaikovsky). 10.0, Le Journal Parlé. 10.10, Dance Music, relayed from the Casino, Knocke.

BUCHAREST

761 kc/s, 394 metres; 12 kw.—5.0 p.m., Concert by the Sincop Accordion Jazz Band, relayed from the Lido. In an interval at 6.0, Radio Journal. 7.0, Reading. 7.20, Educational Talk. 7.40, Opera (to be announced). In the intervals, Radio Journal.

BUDAPEST

545 kc/s, 550.5 metres; 18.5 kw.—5.30 p.m., Trio in A Minor (Tchaikovsky). 6.30, Variety Programme. 7.35, Gramophone Music. 8.45, Review of Foreign Affairs. 9.0, Concert of Cigany Music. 10.10, Talk in English. 10.30, Concert of Light Music.

CASSEL.—See Frankfurt.

COPENHAGEN

1,067 kc/s, 281 metres; 0.75 kw. Relayed by Kalundborg, 260 kc/s, 1,153 metres.—12 Noon, Time and Chimes from the Town Hall. 12.5 p.m., String Ensemble Concert, relayed from the Bellevue Strand-hotel. 2.0, Interval. 3.10, Reading (Hilditch). 3.30, Orchestral Concert, relayed from the Wivex Restaurant. 5.0, Reading. 5.35, Exchange and Fish Market Prices. 6.20, Talk: The Motor Car Industry. 6.50, Weather and News. 7.15, Time Signal. 7.30, Talk on Fede Boisen. 8.0, Chimes from the Town Hall. 8.5, A Vandeville in One Act (Erik Bogh). 9.0, Debussy Pianoforte Recital by Esther Vazuing; Prelude, Sarabande and Toccata; Reflets dans l'eau; Jardins sous la pluie. 9.20, Reading (Rasmussen). 9.40, Song Recital by Frida Budtz-Müller. 10.0, News. 10.15, Orchestral Concert, conducted by Emil Reesen: Overture, The Mandarin's Son (Cui); Selection from the Egyptian Suite (Hady Wood); Ballet Suite from Lakmé (Delibes); Selection from Tarandot (Puccini); Procession orientale (Ganne). 11.0, Dance Music, relayed from the National Scala. In the interval at 12 Midnight, Time and Chimes from the Town Hall. 12.30 a.m. (Saturday), Close Down.

CORK.—See Athlone.

CRACOV

959 kc/s, 312.8 metres; 1.5 kw.—7.20 p.m., Miscellaneous Items and News. 7.35, Programme Announcements. 7.40 till Close Down, See Warsaw.

DANZIG.—See Heilsberg.

DRESDEN.—See Leipzig.

FECAMP

1,328 kc/s, 225.9 metres; 10 kw.—4.30 to 6.0 Programme in English by the I.B.C. 4.30, Programme for Children. 5.0, Concert for Southampton and Winchester Listeners. Light Music; Signature Tune; Waltz, Künstlerleben (Joh. Strauss); Monastery Bells

ALGIERS

824 kc/s, 364 metres; 13 kw.—8.0 p.m., Financial News. 8.10, Shipping Notes. 8.15, Agricultural Report and Weather Forecast. 8.20, Agricultural Talk. 8.35, News Recital. 8.40, Lottery Results. 8.55, News. 9.0, Time Signal. 9.2, Concert by the Small Station Orchestra. Soloist: M. Lloret (Songs). Peer Gynt Suite (Grieg); Selection from Tannhäuser (Wagner); Songs: (a) The Two Grenadiers (Schumann). (b) Aria from Robert le Diable (Meyerbeer); Nocturne (Debussy); Slav Dance (Dvorák); Prologue to I Pagliacci (Leoncavallo); Le Rouet d'Omphale (Saint-Saëns). 10.30, News. 10.35, Recitations. 10.55, News.

ATHLONE

725 kc/s, 413 metres; 60 kw. Relayed by Cork, 1,337 kc/s, 224.4 metres.—1.30 to 2.30 p.m., Time Signal, Stock Exchange Quotations, Weather Report and Gramophone Music. 6.0, Programme for Children. 6.45, News. 7.0, Gardening Talk by G. O. Sherrard. 7.15, Literary and Dramatic Talk by Aodh de Blarain. 7.30, Time Signal. 7.31, Pipe Duets by Leo and Thomas Kowsome. 7.50, The Station Orchestra. 8.15, Pianoforte Recital by Cathleen Wright. 8.35, Baritone Solos by Myles Kelly. 8.50, Banjo Solos by R. W. Hope. 9.0, The Station Orchestra. 9.15, Contralto Solos by Ella Clarke. 9.30, Talk by P. J. O'Brien: Tours in Ireland. 9.45, Sponsored Programme. 10.30, Time Signal. 10.45, News, Weather Report and Close Down.

BARCELONA

EAJ1, 860 kc/s, 348.8 metres; 8 kw.—7.0 p.m., Trio Concert. 8.0, Request Gramophone Concert. 8.30, Exchange. 9.0, Gramophone Music and News. 10.0, Chimes from the Cathedral, Weather, Messages to Seamen, Exchange and Market Prices. 10.10, Concert by the Station Orchestra: March (Lincke); Selection from El padrino del nene (Caballero and Hermoso); Waltz (Sancho); In a Monastery Garden (Kettelbey); Carnaval japonais (de Basque); Overture, Poet and Peasant (Suppé). 11.0, Song Recital by Maria Teresa González (Soprano). 11.30, Dance Music, relayed from the Casa Libre. In the interval at 12 Midnight, News. 1.0 a.m. (Saturday), Close Down.

BARI

1,112 kc/s, 269.8 metres; 20 kw.—8.0 p.m., News. 8.20, Giornale Radio and Weather. 8.30, Time and Announcements. 8.35 (approx.), Concert of Music from Operas, Soloists: Maria De Santis Bruno (Soprano); Franco Signorile (Tenor). Overture, Le caid (Thomas); Musetta's Waltz from La Bohème (Puccini); Song from Memphis-tophiles (Boito); Selection from the Third Act of André Chénier (Giordano); Air from L'Amico Fritz (Mascagni); Aria from Lucia di Lammermoor (Donizetti); Intermezzo from Suor Angelica (Puccini); Overture, Masaniello (Amber); Soprano Solo from The Pearl Fishers (Bizet); Tenor Solo from La Traviata (Verdi); Selection from Lohengrin (Mascagni); Duet from Rigoletto (Verdi); Selection from La Gioconda (Ponchielli); Talk for Women in the interval. 10.30, Dance Music from the Café del Levante. 10.55, News.

BASLE.—See Schweizerischer Landessender.

BELGRADE

697 kc/s, 430.4 metres; 2.8 kw.—5.55 p.m., Time Signal and Programme Announcements. 6.0, Yugoslav Songs. 6.30, Talk. 7.0, Orchestral Concert. 7.50, Talk. 8.30, Concert by a Russian Choir. 10.0, Recital on Two Pianofortes: Toccata and Fugue (Bach); Fantasia, Op. 101 (Glazunov). 10.30, Time, News and Dance Music from the Ratnicki Dom Restaurant.

BERLIN

DEUTSCHLANDSENDER, 183.5 kc/s, 1,635 metres; 60 kw. 1.45 p.m., News. 2.0, Gramophone Music. 3.0, Talk for Girls. 3.30, Weather and Exchange. 3.45, Reading. 4.0, Concert from Leipzig. 5.0, Educational Talk. 5.30, String Quartet in C minor (Brahms) by the Borber Quartet. 6.0, A Poem. 6.5, Talk. 6.30, Talk on Enginies. 6.50, Weather and Announcements. 7.0, Transmission for all German Stations, relayed from Munich. 8.0, Epigrams. 8.5, See Stuttgart. 8.20, Talk. 8.50, New German Dance Music. 10.0, News. 10.45, Weather for Shipping. 11.0, See Frankfurt. 11.50, New German Dance Music (contd.). 12.30 a.m. (Saturday), Close Down.

BERLIN

(WITZLEBEN), 715 kc/s, 419.5 metres; 1.5 kw.—11.30 a.m., Concert of Light Music, relayed from the Town Hall, Bremen. In an interval at 12.20, Weather for Farmers. 1.0 p.m., History of the Dance—Concert on Gramophone Records: (a) Tador Dances, (b) Gavotte (Lolly), (c) Contraite (Baeb), (d) Gavotte, Sarabande, Minuet, Gavotte, and Tamburino, from Alcina (Handel), (e) Musette from Armida (Gluck), (f) Minuet from The Third Quintet (Bocherini), (g) Three German Dances (Haydn), (h) Three Contra-Dances (Alzart), (i) Dance No. 12 (Beethoven), (j) Three Minuets (Schubert), (k) Waltz, Die Schöbrauner (Lanner), (l) Annen-Polka (Joh. Strauss), (m) Waltz, The

Blue Danube (Joh. Strauss). In an interval at 2.15, News. 3.0, Exchange. 3.20, Fashion Talk. 3.35, Soldier Songs with Lite Accompaniment. 4.0, Talk on Hygiene. 4.15, Report on a Gymnastic Festival. 4.30 p.m., Orchestral Concert from the Cate Corso: Waltz from Der Rosenkavalier (R. Strauss); Romanze (Svendson); Serenata (Camiziti); Es rauscht das Meer ein Liebeslied (Kauler); Serenata amorosa (Beer); Rose mousse (Beer); Leichter-Walzer (Bort). 5.10, Talk: Trips by Water. 5.30, Tea-Time Gossip. 6.0, Talk: Holiday Hints—A Journey to Berlin. 6.15, A Radio Report from a Machinery Factory in Niederlinow. 6.40, The Witzleben Station informs its Listeners. 6.45, Topical Talk. 7.0, Transmission for all German Stations, relayed from Munich. 8.10, Topical Programme. 8.20, A Radio Picture—On the Monte Rose in the Norwegian Fjords. 9.0, Symphony Concert, conducted by Dr. Helmuth Thierfelder: Symphony No. 2 in F. Op. 25 (Brahms); Sinfonie breve, Op. 96 (Grieg). 10.0, News. 10.15 (approx.), Dance Music, relayed from the Wilhelmshalle in the Zoological Gardens. In the interval at 11.0 (approx.), Programme from Frankfurt. 12.30 a.m. (Saturday), Close Down.

BERNE.—See Schweizerischer Landessender.

BEROMÜNSTER. — See Schweizerischer Landessender.

BODEN.—See Stockholm.

BODO.—See Oslo.

BORDEAUX-LAFAYETTE

986 kc/s, 304 metres; 13 kw.—7.30 p.m., News. 7.40, Gramophone Music. 7.55, Lottery Results. 8.0, Spanish Lesson. 8.15, News. 8.30, Programme for the inauguration of the New Station at Lille, relayed from Lille, 1,130 kc/s, 265.4 metres.

BRATISLAVA

1,076 kc/s, 279 metres; 14 kw.—2.50 p.m., Concert by the Station Orchestra, conducted by F. Dyk: Die Felsenmühle (Reissiger); Fantasia, Jenifa (Janacek); Ballet, egyptien (Ligutti); Romance (Figu-Bystry); Melody (Kostal); Serenade (Moer); Irish Dance, Molly on the Shore (P. Granger); Florentine March (Fueik). 3.55 to 4.0, See Prague. 5.45, See Prague. 6.5, Sports Report. 6.20, Gramophone Music. 6.45, Talk for Women. 6.55, Talk for Housewives. 7.0, See Prague. 7.30, Talk on Czechoslovakia. 7.45, See Brno. 9.20, See Prague. 10.30 (approx.), Close Down.

BREMEN.—See Hamburg.

BRESLAU

923 kc/s, 325 metres; 60 kw. Relayed by Gleiwitz, 1,184 kc/s, 253 metres.—1.0 p.m., Gramophone Concert. In the interval at 1.45, Time and News. 3.0, Agricultural

Prices. 3.30, Programme for Children. 4.0 (from Gleiwitz), Orchestral Concert, conducted by Richard Pöschke: March, Kopf hoch (Münch); Waltz, A toi (Wald-tenfel); Three String Quartets (Kontzak); (a) Volkshiedchen, (b) Tannverloren, (c) Bosnische Legende; Overture, Maritima (Wallace); Intermezzo, Charlie (Leopold); Fantasia on Themes from Verdi's Opera, Rigoletto (Tavan); Waltz-Intermezzo, Ein schöner Traum (Kochman); Tonwellen-Potpouri (Mannfred); March, Das Tarnowitz (Glöcklein (Meisner). In the interval at 4.45, Recitations. 6.5, Agricultural Prices. 6.10, Talk. 6.40, See Berlin (Witzleben). 6.50, News. 7.0, Transmission for all German Stations, relayed from Munich. 8.0, Radio Report from a Silesian Castle. 8.30, Recital of Workers', Peasants' and Soldiers' Songs. 9.30, Organ Recital, relayed from the Jugendhof, Hassitz. Organist: Max Drischner. Prelude and Fugue in E minor (Bach); Einige kleine Orgelstücke (Pachelbel); Nordische Canzona in a minor (Drischner); Variations on the German National Anthem (Drischner). 10.10, Time and News. 10.30, Report of the Fifteenth German Gymnastic Festival, 1933. 10.40, Talk: Russian Collectivism and German Co-operation. 11.0, See Frankfurt. 11.50, Close Down.

BRNO

878 kc/s, 342 metres; 35 kw.—6.25 p.m., German Transmission: News, Sports Notes and Talk on Mussolini. 7.0, See Prague. 7.10, Recital of Wolf and Schumann Songs by Bozena Stogrova. 7.30, See Bratislava. 7.45, Literary and Musical Programme. 8.45, Concert of Schrammel Music. 9.20, See Prague. 10.30 (approx.), Close Down.

BRUSSELS (No. 1)

N.I.R., 590 kc/s, 509 metres; 15 kw.—12 Noon, Concert of Music on Gramophone Records: Holidays by the sea and on the beach, Overture, The Flying Dutchman (Wagner); Sunbathers (de Sévère); Les goélands (Boyer); En bateau (Debussy); La berceuse de la vague (Gey); Jeux d'eau (Ravel); La chanson du vieux marin (Daniderff); The Sea and Sindbad's ship, from Scheherazade (Rimsky-Korsakov); Easter Day at sea (Dupont); Les berceaux (Faure); Danse des vagues (Catalani). 1.0 p.m., Le Journal Parlé. 1.10, Concert by the Small Station Orchestra, conducted by Pierre Leemans: Overture, The Merry Wives of Windsor (Nicolaï); Chanson italienne (de Taey); Selection from Samson and Delilah (Saint-Saëns); Sérénade royale (van Herck); Foxtrot, Sneakyasy (Gensler); Selection from Les Géorgiennes (Offenbach); Melody (Rotter-Yurman); Tarantella, Capodimonte (Solazzi). 5.0, Concert by the Radio Orchestra, conducted by Franz André: Marche baroque (Goeyens); Violin Solo: Pièce (Guillaume); Volupté (Guillaume); Railway (Brusselmans); Old Czech Polka (Hilmar);

JULY 28th

FRIDAY

continued

(Wely); Song, Take a Pair of Sparking Eyes (Sullivan); Goodbye (Tosti); Babes in Toy-land (Herbert); Song, O Sole Mio (di Capua); Demande et Reponse (Coloridge-Taylor); Once on the Rhine (Ostermann). 5.30, Vocal and Orchestral Concert for Bonnemouth and Weymouth Listeners. The Valley of the Poppies (Ancliffe); Nirvana (Adams); Selection from Amina (Lincke); Kashmiri Song (Woodforde-Finden); Temple Bells (Woodforde-Finden); The Valley where the Bluebirds Sing (Salman); Mountain Lovers (Squire); The Old Spinning Wheel (Hill); Signature Tune. 6.0 to 10.0 (approx.), Programme in French. 10.0 till Close Down, Programme in English by the I.B.C. 10.0, Dance Music, Signature Tune; A Big Bouquet for You; Fooling Me; Get Happy (Ochita); Just an Echo in the Valley; Wild Man Blues; Ich liebe dich, my dear; Melancholy; Harlem Holiday; Room 1411; I've got the World on a String; Jungle Blues; I don't mean a Thing; The Voodoo; Rose Room; As long as you're there; Signature Tune. 11.0, Club Concert for Hinecky Listeners. Part 1: Operetta Music, Signature Tune; Overture, Die Fledermaus (Joh. Strauss); Duet, Give me thy Hand, from Monsieur Beaucaire (Massenet); Waltz from Der Rosenkavalier (R. Strauss); Song, O Maiden, my Maiden, from Frederica (Lehar); Selection from The Beggar's Opera, Parts I and II (Gay); Duet, Lightly, lightly, from Monsieur Beaucaire (Massenet); Selection from The Mikado (Sullivan). Part II: Orchestral Concert with Songs, Spring Song (Mendelssohn); Song, The Sweetest Flower that Blows (Hawley); Ave Maria (Schubert); Song, Beauce (d'Harleot); Torador and Andalousse (Rubinstein); Song, The Second Minuet (Besly); Hungarian Dance in A Minor (Brahms); Romance (Rubinstein). 12.5 a.m., The I.B.C. Late News Bulletin. 12.10 (approx.), Gramophone Records. Git along (Astin); The Whip (Harbach); I'm the Landlord of the Inn in Aberfoyle (Bell and Fyfe); Sweetheart I'm dreaming of You (Desmond); Dirt Dishin' (Klein). 12.30, Dance Music, Signature Tune. Moon Song; Maybe I love you too much; Picaninies; Heaven; It's within your Power; All over Italy; Maria my own; Something came and got me in the Spring; Castles in the Sand; signature Tune. 12.57, I.B.C. Goodnight Melody. 1.0 (approx.), Close Down.

FLENSBURG.—See Hamburg.

FLORENCE.—See Turin.

FRANKFURT

1,157 kc/s, 259.3 metres; 17 kW. Relayed by Cassel, 1,220 kc/s, 245.9 metres; and Trier, 1,157 kc/s, 259.3 metres.—4.30 p.m., See Munich. 5.45, Economic Notes. 6.0, Talk: Peasant Families in the New German State. 6.15, Wireless Talk. 6.25, Talk: Present Day Problems. 6.45, Review of the Day's Events. 6.50, Time and News. 7.0, Transmission for all German Stations, relayed from Munich. 8.0, See Stuttgart. 8.20, See Berlin (Witzleben). 9.0, See Stuttgart. 10.0, Programme to be announced. 10.15, Time and News. 11.0, The Youth of Germany greets Italy. 11.50 (approx.), Close Down.

FREDRIKSSTAD.—See Oslo.

FREIBURG.—See Stuttgart.

GENEVA.—See Radio-Suisse Romanda.

GENOA.—See Turin.

GLEIWITZ.—See Breslau.

GOTEBORG.—See Stockholm.

GRAZ.—See Vienna.

HAMAR.—See Oslo.

HAMBURG

Call ha (in Morse). 806 kc/s, 372 metres; 1.5 kW. Relayed by Bremen, 1,112 kc/s, 269.8 metres; Flensburg, 1,319 kc/s, 227.4 metres; Hanover, 530 kc/s, 566 metres; and Kiel, 1,292 kc/s, 232.2 metres.—4.0 p.m., See Leipzig. 5.0, Dialect Programme for Young People. 5.30, Hamburg, Lübeck and Bremen, Report on Events in the Senates and Houses of Burgesses of the Hanseatic Free Cities. 6.0, Book Review. 6.25, Talk: Amusing Stories from Legal Records. 6.45, Frankfurt Exchange and Hamburg Market Prices. 6.50, Weather. 7.0, Transmission for all German Stations, relayed from Munich. 8.0 (from Bremen), Programme of Lower Saxon Dance Music. 9.30, Pianoforte Recital by Karl-Heinz Ahrens: From my Diary, Op. 82, 5 and 8 (Reger); Negro Dance (C. Scott); Variations on Kuckuck, Kuckuck rufts aus dem Wald (Reutter); Extracts from Preludes: (a) Minstrels, (b) Les tierces alternees, The Little Li-h-tse, from Old China, Op. 62 (Niemann); Garden Music, Op. 117 (Niemann). 10.0, Time and News. 10.20, Topical Talk. 10.30, Concert from the Banerhaus-Café in the Municipal Park.

HANOVER.—See Hamburg.

HEILSBURG

1,035 kc/s, 276.5 metres; 60 kW. Relayed by Danzig, 662 kc/s, 453.2 metres.—1.5 p.m., Concert by the Königsberg Opera House Orchestra, conducted by Georg Wöllner. March, Treue um Treue (Blankenburg); Overture, Der Göttergatte (Lehar); Ein Opernalbum (Schreiner); Two Pieces (Aleyer-Helmund): (a) Pavlova-Waltz, (b) Weltentrückt: The Sacred Hour (Kotelby); Im Zeichen des Rokoko (Albion); Luna-Wal-

zer (Lincke); Schlager-Echo Lindsay-Theimer; Potpourri of Marches. Hurrah, die Musik kommt (Zimmer). In the intervals at 1.20 and 2.0, News. 2.30, Programme arranged by the Post Office, with Gramophone Records. 3.0, Market Prices. 3.30, Programme for Children. 4.0, Talk for Women: Aids to Beauty. 4.30 Police Band Concert, conducted by Ernst Stieberitz, relayed from the Kurgarten, Zoppot. March from the Suite in D Minor (Lachner); Overture, Zampa (Hérold); Minuet from the Sonata, Op. 19 (Beethoven); Overture, II Guarany (Gomez); Waltz (Waldteufel); Die Heinzelmännchen (Eilenberg); March, Hohenzollernhymn (Unrath). In the interval: Talk: Where shall we go for our next excursion? 5.25, Review of Books. 6.15, Market Prices. 6.25, See Berlin (Deutschlandsender). 6.50, Weather. 7.0, Transmission for all German stations, relayed from Munich. 8.20 (from Danzig), Recital of New German Lieder by Claire Winder (Contralto), Erste-Lieder, Op. 16 (Max von Schillings): (a) Ederle soll in dem Werken sein, (b) Nach getaner Arbeit ist gut ruhn, (c) Und wieder ein Gang durch die Heide, (d) Von den Hügeln hallen lachende Lieder. Songs (Hans Pfitzner): (a) Abbitte, (b) Es fällt ein Stern, (c) Herbstlied, (d) Warum sind deine Augen denn so nass, (e) Mein Herz ist wie die dunkle Nacht. 8.50, Herr Peter Sequenz-Comedy (Andreas Gryllbus). 10.5, Weather and News. 10.20, Programme from Berlin (Deutschlandsender). 11.0 (approx.), Close Down.

HILVERSUM

(Announced HUIZEN). 1,013 kc/s, 296.1 metres; 20 kW. (7 kW up to 4.40 p.m.). Programme of the Catholic Radio Society (K.R.O.). 11.55 a.m., Concert by the K.R.O. Sextet. March, Sambre et Meuse (Turlet); Valse mazurka (Thomas); Ballet Music from Czar and Carpenter (Lortzing); Sotto al Verone (De Michel); Potpourri of Dutch Songs (Lustenhouwer); Le soir (Thomas); Gramophone Music, Selection from Les cloches de Corneville (Planquette); Ball-zauber (Lincke); Fantasia, Hungaria (Leopold); Waltz, Schwert und Leier (Strauss); Venetian Bazaar (Mendelssohn); Finale, 1.40 p.m., Organ Recital with Mlle. T. ter Stooge (Contralto). In the interval, Gramophone Music. 2.55, Gramophone Music. 3.25, Recitations. 3.40, Gramophone Music. 4.10, Recitations. 4.25, Gramophone Music. 4.40, Concert by the K.R.O. Boys. 6.25, Gramophone Music. 6.40, Police Notes. 6.55, Talk on Hunting. 7.15, Gramophone Music. 7.40, Concert by the Maastriicht Municipal Orchestra, conducted by M. H. Hermans. Overture, Rosamund (Schubert); Suite, Heideschloosen (Menckens); Symphonie Poem, Les Préludes (Liszt); Suite No. 2 from L'Arlesienne (Bizet); Waltz (Wagner); Berceuse (Faure); Melody (Schmitt); Ballet Music from Nanamoa (Lalo); Overture, Stradella (Flotow); Selection from Werther (Massenet); Waltz from Der Rosenkavalier (R. Strauss); Gramophone Records, Spanish caprice (Rimsky-Korsakov). In the intervals: News and Talk. 10.10, News. 10.15, Concert by Ivan Schustow and his Balalaika Orchestra. 11.40 (approx.), Close Down.

HORBY.—See Stockholm.

HUIZEN

Announced HILVERSUM, 160 kc/s, 1,875 metres; 8.5 kW.—7.40 a.m., Programme of the Workers' Radio Society (V.A.R.A.); Gramophone Music. 9.40, Programme of the Liberal Protestant Radio Society (V.P.R.O.); Religious Address. 9.55 to 11.40, Programme of the V.A.R.A. 9.55, Recitations. 10.10, Concert. 10.40, Gastronomie Talk. 11.10, Concert (cont'd). 11.40 to 3.40 p.m., Programme of the Algemeene Vereeniging Radio Onroep (A.V.R.O.). 11.40, Time, and Gramophone Music. 12.10 p.m., Concert of Light Music by Kovacs Lajos and his Orchestra. 1.55, Recital of Songs by Alice Frank; Adieu, toujours (Faure); Chanson triste (Duparc); Melody (Messenger); L'air qui court (Georges); Quand on est jolie (Coudin). 2.15, Gramophone Music. 2.40, Recitations. 3.16, Gramophone Music. 3.40 to 7.40, Programme of the V.A.R.A. 3.40, Organ Recital. 4.10, Programme for Children. 4.40, Orchestral Concert, conducted by M. Duchant; Overture, The Thieving Magpie (Rossini); Wenn Blumen träumen (Lederer); Three Dances from Nell Gwynn (German); Melody (Fueki); Im Zigeunerlager (Oscheit); Gramophone Music; Overture, L'Élysée chez le moulin (Popy); Sérénade (Drigo); Im Puppenhaus (Engelmann); Melody (Morena); March of Freedom (Carstens). 6.5, Talk. 6.25, Gramophone Music. 7.40 to 8.10, Programme of the V.P.R.O.; Talk. 8.10 to 9.55 (approx.), Programme of the A.V.R.O. Concert, relayed from the Kurhaus, Scheveningen; The Orchestra of the Hague, conducted by Carl Schuricht. 9.55 (approx.) to 10.40, Programme of the V.P.R.O. 9.55 (approx.), News and Recitations. 10.25, Gramophone Music. 10.40 till Close Down, Programme of the V.A.R.A. Gramophone Music. 11.40 (approx.), Close Down.

INNSBRUCK.—See Vienna.

KALUNDBORG.—See Copenhagen.

KATOWICE

734 kc/s, 408 metres; 16 kW.—7.20 p.m., Announcements and Gramophone Music. 7.35, Sports Notes. 7.40, See Warsaw. 11.0, The Letter Box in French.

KIEL.—See Hamburg.

KLAGENFURT.—See Vienna.

KOSICE.—See Prague.

LAHTI

167 kc/s, 1,796 metres; 10 kW. Relayed by Helsinki, 816 kc/s, 368.1 metres.—6.15 p.m., Programme for Children. 6.40, Talk. 7.5 (from Helsinki), Concert by the Station Orchestra: March from The Sleeping Beauty (Mehartin); Berceuse (Klaim); Valse chevaleresque (Sibelius); March (Kajanus). 8.0, Recitations by Helmi Krohn. 8.20 (from Helsinki), Gramophone Music. 8.45, News in Finnish. 9.0, News in Swedish. 9.15, Light Music relayed from the Restaurant Kappeli. 10.0 (approx.), Close Down.

LANGENBERG

635 kc/s, 473 metres; 60 kW.—1.15 to 2.30 p.m., Concert by the Station Orchestra, conducted by Wolf. Overture, Der Opernball (Heuberger); Sérénade (Albeniz); Dance (Debussy); Potpourri of Romanian Music (Dabner); Rhapsody in B Flat Minor (Hartung); Waltz, Sied umschlingende Millionen (Strauss); Wedding Day on Trobhaugen (Grieg); Selection from Czar and Carpenter (Lortzing). In the interval at 2.0, News. 3.0, Reading. 3.15, Poems by Fritz Wolke. 3.30, Exchange and Time. 3.50, Programme for Young People. Topical Talk in the interval. 4.30, Talk: The National Socialist Revolution and the Theatre. 4.50, Talk: German Gramophone Records. 5.10, Reading from the Diary of a Carinthian. 5.30, Concert. 6.30, See Berlin (Deutschlandsender). 6.50, Weather, Time, Exchange and Sports Notes. 7.0, Transmission for all German Stations, relayed from Munich. 8.0, See Stuttgart. 8.20, First General News. 8.30, Datterich—Fare in Six Scenes (Ernst Elias Niebergall). 10.0, News. 10.0, Sérénade by the Fröhliche Fünf. 11.30 (approx.), Close Down.

LAUSANNE.—See Radio-Suisse Romande.

LEIPZIG

769.9 kc/s, 389.6 metres; 120 kW.; and Dresden, 911 kc/s, 319 metres.—12 Noon, Weather and Time. 12.5 p.m., Concert by a Nazi Band from Plauen. In the interval at 1.0, News. 2.0, News. 2.10, Talk. 2.20, Art Review. 2.40 (from Dresden), Pianoforte Recital by Karl Weiss: Three Pieces, Op. 3 (Chailly); Extracts from the Suite in Old Style, Op. 8 (Müller). 3.15 (from Dresden), Talk for the Country Woman. 3.35, Economic Notes. 4.0, Concert by the Station Orchestra, conducted by Rudolf Crienitz; Overture, Der Erlenhügel (Kullau); Pesther-Walzer (Lanner); Selection from The Girl from the Golden Veil (Puccini); Intermezzo, Rendezvous (Aelter); Potpourri, Dur und Moll (Schreiner); March, Heil Europa (Blow); Hungarian Dances Nos. 2 and 7 (Brahms); Humoresque (Reger); Intermezzo (Gfaller). In the interval at 5.0, Book Review. 5.50, Economic Notes, Weather and Time. 6.0, Elocution Lesson. 6.40, Agricultural Notes. 6.50, Events of the Day. 7.0, Transmission for all German Stations, relayed from Munich. 8.0, See Stuttgart. 8.20, Recital of Folk Music for Accordion and Zither. 9.0, See Stuttgart. 10.0, News. 10.20, Concert by the Chamber Music Orchestra. Soloists: Fritz Römisch (Viola da Gamba) and Lotte Daeger-Meyer (Harpisichord). Harpsichord Concerto, Op. 3, No. 1 (Avison); Extracts from the Don Quixote Suite for Harpsichord and String Orchestra (Telemann); Sonata No. 7 for Viola da Gamba and Harpsichord (Kühnel); Symphony for String Orchestra and Harpsichord, No. 2, Op. in G (Frederick the Great); Two Minuets for String Orchestra (Haydn). 11.0, See Frankfurt.

LINZ.—See Vienna.

LJUBLJANA

522 kc/s, 574.7 metres; 7 kW.—6.30 p.m., Accordion Recital. 7.30, Talk on Pizcon Breeding. 8.0, Humorous Talk. 8.30, See Belgrade. 10.30, Gramophone Music. 11.0 (approx.), Close Down.

LUXEMBOURG

252 kc/s, 1,191 metres; 200 kW.—Dutch Programme. 8.10, Weather. 8.15, Violin Recital by Ernest Eichel. 8.30, Talk in Dutch. 8.40, Violin Recital (cont'd). 8.50, News in French. 9.15, Concert by the Station Orchestra: Waltz, Longchamps fleuris (Waldteufel); Rhapsody, No. 14 (Liszt); Sérénade (de Michel); Märchen und Liedchen (Konczak). 9.45, News in German. 9.55, Concert (cont'd). Finlandia (Sibelius); Madrigal (Simonetti); Selection from Rose Marie (Früh); March, Sambre et Meuse (Planquette). 10.20, Dance Music on Gramophone Records.

LWOW

788 kc/s, 381 metres; 16 kW.—5.15 p.m., See Warsaw. 7.20, Miscellaneous Items. 7.40, See Warsaw. 10.40, Gramophone Music. 11.0 (approx.), Close Down.

LYONS

LA DOUA (PTT), 644 kc/s, 465.8 metres; 1.5 kW.—7.30 p.m., Radio Gazette for Lyons and the South-East. 8.30, Vocal and Orchestral Concert. After the Concert, News.

MADRID

EAJ7, 707 kc/s, 424.3 metres; 2 kW.—8.0 p.m., Chimes, Exchange, Radio Journal and Request Gramophone Records. 9.15, News and Political Review. 9.30 to 11.0, Interval. 11.0, Chimes, Time and Political Review. 11.15 (approx.), Symphony Music on Gramophone Records: The Brandenburg Concerto, No. 1 in F (Bach); Extracts from Puleinella (Stravinsky); The Pathetic Symphony (Tchaikovsky); Symphonic Variations for Pianoforte and Orchestra (César Franck); Selection from The Valkyries (Wagner). 1.15 a.m. (Saturday), News and Programme Announcements for Listeners Abroad. 1.30, Chimes and Close Down.

MALMO.—See Stockholm.

MILAN

VIGENTINO, 662 kc/s, 453.2 metres; 1 kW.—8.45 p.m. till Close Down, See Rome.

MORAVSKA-OSTRAVA

1,137 kc/s, 263.8 metres; 11 kW.—7.10 p.m., Song Recital. 7.30, See Bratislava. 7.45, See Brno. 9.20, See Prague. 10.30 (approx.), Close Down.

MOSCOW

TRADES UNION, 230 kc/s, 1,304 metres; 100 kW.—2.45 p.m., Weather. 3.0, Extracts from The Czar's Bride—Opera (Rimsky-Korsakov). 3.45, Weather. 4.0, Talk. 4.30, Radio Film. 5.30, Programme for Children. 6.30, Concert conducted by Ancevov: Soloists: Oksjemev (Bass), and Aptekarev (Pianoforte). 9.0, News. 9.30, Programme Announcements. 9.55, Chimes and Press Review.

MOTALA.—See Stockholm.

MUHLACKER.—See Stuttgart.

MUNICH

563 kc/s, 533 metres; 60 kW. Relayed by Augsburg and Kaiserslautern, 536 kc/s, 560 metres; and Nürnberg, 1,256 kc/s, 239 metres.—4.30 p.m., Orchestral Concert, conducted by Erich Kloss; Prelude to the Third Act of Lohengrin (Wagner); Minuet and Scherzo from the Sérénade, Op. 11 (Brahms); Suite from The Queen of Spades (Tchaikovsky); Cavatine (Donizetti); Selection from The Mikado (Sullivan-Weninger); Sérénade for Cello (Squire); Waltz (Schubert); Cigány Music (Pataky). 5.45, Talk: Germany and the Modern Generation. 6.5, Songs on Gramophone Records. 6.25, Talk: Development of the Home Market. 6.45, Time, Weather and Agricultural Report. 7.0, Transmission for all German Stations; The Nibelungenstrasse—a Radio Picture of the German Danube (Alfons von Zibulka). 8.0, Concert by the Munich Symphony Orchestra, conducted by Helmut Fritz. 8.40, Topical Report. 9.0, Swedish Programme. 9.50, Song Recital by Mia Neusitzer-Thönnissen (Soprano); Part I—Schlageter; Choral from the Cantata, Aus der Tiefe rufe ich, Herr, zu dir; Graue Tage; Wir sind ganz Angsterfüllt allein; Lass mich in deinem stillen Auge ruhen; Schallid für Torberg; Widmung; Im Volkston; Part II—Brahms; Du mein einzig Licht; Jungfräulein, soll ich mit Euch gehen?; Da unten im Tale; Wie Sonne scheint nicht mehr. 10.20, Time and News. 11.0, See Frankfurt.

NAPLES.—See Rome.

NOTODDEN.—See Oslo.

OSLO

277 kc/s, 1,063 metres; 60 kW. Relayed by Fredriksstad, 815 kc/s, 368.1 metres; Hamar, 522 kc/s, 574.7 metres; Notodden, 671 kc/s, 447.1 metres; Porsgrund, 662 kc/s, 453.2 metres; and Rjukan, 671 kc/s, 447.1 metres.—6.30 p.m., Talk. 7.0, Advertising Notes. 7.15, Weather and News. 7.30, Soloist Concert. 8.0, Time Signal. 8.1, Divine Service relayed from Trondheim. 9.20, Foreign Agricultural Report. 9.40, Weather and News. 10.0, Topical Talk. 10.15, Concert of Light Music. 11.0 (approx.), Close Down.

OSTERSUND.—See Stockholm.

PALERMO

558 kc/s, 537.6 metres; 3 kW.—8.0 p.m., Dopolavoro Announcements, Tourist Report, Agricultural Notes, Giornale radio and Report of the Royal Geographical Society. 8.20, Gramophone Music. In the interval at 8.30, Time and Announcements. 8.45, I dispettosi amanti; Comic Opera in One Act (Parelli); Talk: Third Act of Chopin; Opera (Offredo); Announcements; Extracts from L'amore Medico; Opera (Wolf-Ferrari). 10.55, News.

PARIS

EIFFEL TOWER, Call Flo, 207.5 kc/s, 1,445.7 metres; 13 kW.—Time Signals (on 2,650 metres) at 10.26 a.m. and 11.26 p.m. (Preliminary and 6-dot Signals).—6.45 p.m., Le Journal Parlé. 8.30, Concert of Italian Music by the Symphony Orchestra, conducted by Edouard Blumenthal. Soloist: M. Zennaro (Soprano); Selection from an Opera (Sacchini); Pavane from Le Maschere (Scappilli); Prologue to I Pagliacci (Leoncavallo); Selection from The Secret Marriage (Cimarosa); Fagottino, giullare di Corte (Camuzzi); Monologue from André Chénier (Giordano); Overture and Selection from Le Baruffe Trasteverine (Cordoni); Piccola mia (Dardany); Autunno (Stajano); Dance of the Hours, from La Gioconda (Ponchielli). 10.0 (approx.). Close Down.

PARIS

POSTE PARISIEN, 914 kc s, 328.2 metres; 60 kW.—7.5 p.m., Talk. 7.15, Le Journal Parlé. 7.30, Gramophone Music. 8.15, Interlude. 8.30, Concert by the Station Orchestra: Overture, Le Pré aux Cleres (Hérold); Valse des brunes (Ganne); Pièce romantique (Chaminade); Piano-forte Solos: L'Esch joyeuse (Debussy); Selection from Le jongleur de Notre Dame (Massenet); Histoire, Suite No. 2 (Ibert); Foxtrot, Five O'Clock (Ray); Joueurs de Flûte for Flute and Piano-forte (Roussel); Esquisse No. 1 (Aubert); Petites musiques, Suite No. 1 (Schmitt); Gothic Minuet (Bohlmann); Ronde de nuit from Etienne Marcel (Saint-Saëns). 10.30, Report of the Walking Race from Paris to Strasbourg. 10.45, News.

PARIS

RADIO PARIS, Call CFR, 174 kc s, 1,725 metres; 75 kW.—7.30 a.m., Weather and Physical Culture. 7.45, Gramophone Music. 8.0, Weather and Press Review. 12 Noon, Jewish Programme. Illustrated Talk on Music. 12.30 p.m., Gramophone Concert: Mascarade (Lacôme); Chante Pierrot (Bixio); Polichinelle (Rachmaninov); Harlequin (Popper); Colombine (Delarbe-Dumestre); Puleinella (Stravinsky); Selection from Les millions d'Arlequin (Drigo); Extracts from I Pagliacci (Leoncavallo); Melody (Zimmermann); Suite carnavalesque (Thomé). In the intervals at 1.0, Exchange, News and Weather, and at 1.30, Exchange. 2.0, Exchange and Announcements. 2.15, Running Commentary on the first two singles matches of the Final of the Davis Cup. 3.45, Exchange and Market Prices. 7.0, Market Prices, Weather, Agricultural Notes and Racing Results. 7.10, Report of Social Assurance Societies. 7.20, Gramophone Music: Melody (Forrester); My blue Heaven (Donaldson); Song from Good News (Sylvia-Brown-Henderson); That's your Baby (Mittelhep); Suzanne (Mirsky); Selection from Si (Yvain); Chanson (Friml); Joyeux retour (Avignon). 7.50, News and Weather. 8.0, Symphony Concert on Gramophone Records: Symphony No. 7 (Beethoven); Third Movement from the Piano-forte Concerto in A Minor (Grieg); La nuit ensorcelée (Chopin-Aubert); Le romant d'Omphale (Saint-Saëns); Absence (Berlioz); Selection from The Damnation of Faust (Berlioz); Eclogue (Rabaud); La Procession (César Franck); La vie antérieure (Duparc); Melodies from Le martyre de St. Sébastien (Debussy); Bolero (Ravel). In the intervals at 8.30, News and Weather. At 8.40, Gastronomic Talk, and at 9.15, Press Review and News.

PITTSBURGH

KDKA, 980 kc s, 306 metres; 50 kW. Relayed by W8XK on 48.86 metres and 25.27 metres.—4.0 to 4.59 p.m., U.S. Marine Band from New York. 7.30 p.m., K.D.K.A. Home Forum. 8.0 to 8.58, New York Relay. 8.0, Betty and Bob. 8.15, Words and Music. 8.45, Happy Jack Turner. 8.58, Baseball Scores. 9.0, Gene Quaw and his Hotel Cosmopolitan Orchestra, from New York. 9.30, Business News and Market Reports. 9.45, Arcadians, from New York. 9.58, Baseball Scores. 10.0, Rhythm Kings. 10.15, Tarzan of the Apes. 10.30, The Singing Lady, from New York. 10.45, Little Orphan Annie. 11.0, Time Signal and Press News-Recap. 11.15, Weather Report. 11.16, Sport Review. 11.23, I bring a Song. 11.28, Announcement. 11.29, Temperature Report. 11.30, Pittsburgh Spotlight. 11.45, To-day's News by Lowell Thomas, from New York. 12 Midnight, Amos 'n' Andy, from New York. 12.15 a.m. (Saturday), Rondoliers. 12.30, Pastoral, from New York. 1.0, Manchester Arms KDKA Players. 1.15, The Silver Toppers. 1.30, Potash and Perimeter. 1.45 to 4.45, New York Relay. 1.45, Phil Cook and his Ingram Shavers. 2.0, Let's Listen to Harris. 2.30, Variety Programme. 3.0, First Nighter.

PORSGRUND.—See Oslo.

PRAGUE

614 kc s, 488.6 metres; 120 kW.—2.50 p.m., See Bratislava. 3.55, Exchange. 4.0, Interval. 5.45, Gramophone Music. 5.55, Talk: Carpathian Ris-ée. 6.5, Agricultural Market Prices. 6.15, Gramophone Music. 6.25, News in German. 6.30, German Transmission: Talk and Recitations. 7.0, Chimes and News. 7.10,

JULY 28th

FRIDAY

continued

Song Recital by Hilda Raave. 7.30, See Bratislava. 7.45, See Brno. 9.20, Act III of The Bartered Bride—Opera (Smetana), on Gramophone Records. 10.0, Time and News. 10.15, News in Russian. 10.30 (approx.). Close Down.

RADIO-SUISSE ROMANDE

SOTTENS, 743 kc s, 403 metres; 25 kW.; and Geneva, 395 kc s, 760 metres.—12.28 p.m., Time Signal from Neuchâtel Observatory. 12.30, News and Weather. 12.40, Gramophone Music. 1.0, Financial News. 1.10, Gramophone Music. 2.0 to 3.28, Time Signal from Neuchâtel Observatory. 3.30, Dance Music by the Broadcasting Service. 4.30, Programme for Women. 5.30 to 7.0, Interval. 7.0, Sports Talk. 7.20, Announcements. 7.30, Weekly Review of Foreign Politics. 8.0, Chamber Music: Quartet (Haydn); Quartet (Kaminsky). 8.50, Music for Two Piano-fortes. 9.20, Military Band Concert, conducted by M. Hoogstuel; Overture, Ramuntcho (Pierné); Ballet Music from Isolde (Messager); Tyrolienne (Schubert); Military March No. 2 (Schubert). 9.50, News and Weather. 10.0, Gramophone Music. 10.30 (approx.). Close Down.

REYKJAVIK

250 kc s, 1,200 metres; 21 kW.—9.5 p.m., Musical Programme. 9.30, Weather Report. 9.40, Musical Programme and Announcements. 10.0, Chimes and News. 10.30, Reading. 11.0, Quartet in D Minor (Mozart), on Gramophone Records.

RIGA

572 kc s, 525 metres; 15 kW.—7.3 p.m., Concert of Viennese Music, conducted by Parups; Overture, Die Fledermaus (Joh. Strauss); Waltz, Tales from the Vienna Woods (Joh. Strauss); Waltz, from Wiener Luft (Jos. Strauss); Waltz, Songs for Soprano; Military March (Schubert); Overture, The Gipsy Baron (Joh. Strauss); Waltz, Songs and Arias for Soprano; Dorfswalben aus Oesterreich (Jos. Strauss); Waltz: Wine, Woman, and Song (Joh. Strauss); Waltz, The Blue Danube (Joh. Strauss). In the interval at 8.0, News. 9.0, Weather and News. 9.15, Trio in B flat (Schubert), followed by Dance Music.

RJKAN.—See Oslo.

ROME

Call 1R0, 680 kc s, 441 metres; 50 kW. Relayed by Naples, 941 kc s, 319 metres, and 2R0, 11,810 kc s, 25.4 metres, from 5.30 p.m.—1.0 to 2.15 p.m., Orchestral Concert of Italian Music. In the intervals from 1.30 to 1.45, Giornale Radio and Exchange, and at 2.0, Time and Announcements. 4.45, Children's Radio Review. 5.10, Weather. 5.15, Exchange and Giornale Radio. 5.30, Vocal and Instrumental Concert: The Rome Quartet, Maria Senes (Soprano) and Giovanni Ugolotti (Tenor); Second Quartet for two Violins, Viola and Cello (Bustini); Songs for Soprano (Esperanza Oteo, Yradier and Albéniz); Tenor Solos: (a) Barcarolle (Rossini), (b) Le mubi folli (Zanelli), (c) Aria from L'Africaine (Meyerbeer); Quartet (a) Alla spagnuola, (b) Tempo di mazurca. 6.40 (Naples), Shipping and Sports Notes. 6.50, Agricultural and Dopolavoro Notes. 6.57, Report of the International Institute of Agriculture (in Spanish, German, French). 7.10, Tourist Report. 7.20, News in Foreign Languages. 7.30, News. 7.40, Giornale Radio. 8.0, Time Signal. 8.2, Sponsored Concert. 9.0, The Tales of Hoffmann, Opera in Four Acts (Offenbach). In the intervals: Talk on Literature and Art, Theatre Notes, and Giornale Radio.

SALZBURG.—See Vienna.

SCHENECTADY

WGY, 790 kc s, 379.5 metres; 50 kW. Relayed at intervals by W2XAF on 31.48 metres, and by W2XAD on 19.56 metres.—9.0 p.m., May We Present, from New York. 9.15, Variety Programme from New York. 9.30, Talk: The Mind Age. 9.35, South Sea Islanders. 12.45 a.m. (Saturday), Stork Reports and Baseball Scores. 1.0, Cities Service Concert. 1.30, WGY Farm Forum. 2.0, Variety Programme, from New York. 2.30, Popular Programme, from New York. 3.0, WGY Players: Red Adams. 3.30, Musical Programme from New York, followed by Programme Résumé.

SCHWEIZERISCHER LANDESENDER

BEROMUNSTER, 653 kc s, 459 metres, 60 kW.; Basle, 1,229 kc s, 244.1 metres; and Berne, 1,220 kc s, 245.9 metres.—6.15 a.m., Gymnastics. 6.35, Interval. 11.59, Time Signal from Neuchâtel Observatory and Weather. 12 Noon (from Basle), Famous Overtures on Gramophone Records. 12.30 p.m., Time and News. 12.40 (from Basle), Celebrity Gramophone Records. 1.25 (from Basle), Time, Weather and Exchange. 1.35, Interval. 5.0 (from Basle), Programme for Children. 5.30 (from Basle), Gramophone Records for Children. 6.30, Talk: Frida

Hanswirth-Das and her Books on China. 7.0 (from Berne), Time and Weather. 7.20 (from Berne), Concert by the Russland Echo Balalaika Orchestra. 7.45 (from Berne), Paderevsky on Gramophone Records. 8.0 (from Berne), Hokuspokus—a Chapter of Medieval Superstitions (Fankhauser). 8.30 (from Berne), Concert of Trios by Bach, Mendelssohn and Haydn, sung by the Wyss Sisters. 9.0, News. 9.10 (from Geneva), Programme to be announced. 9.50 (from Berne), Dance Music by the Maxim Band. 10.15 (approx.). Close Down.

SOTTENS.—See Radio-Suisse Romande.

STOCKHOLM

689 kc/s, 436 metres; 55 kW. Relayed by Boden, 244 kc/s, 1,229.4 metres; Göteborg, 932 kc/s, 322 metres; Hörby, 1,166 kc/s, 257 metres; Motala, 221.5 kc/s, 1,354.4 metres; Östersund, 389 kc/s, 770 metres; and Sundsvall, 554 kc/s, 542 metres.—5.5 p.m., Programme for Children. 5.25, Light Music. 5.45, Gramophone Concert. 6.45, Talk, relayed from Säfte, 1,220 kc/s, 245.9 metres. 7.30, Piano-forte Recital by Greta Beren; Le concert (Daquin); Pièces (Schumann): (a) Einsame Blüthen, (b) Jäger auf der Lauer, (c) Vogel als Prophet; Springbrunnen (Liszt); Pièces (Grieg): (a) Nachtstück, (b) Der Wanderer, (c) Morning. In the intervals and after the Recital, Readings by Margit Andelius. 8.15, Hansen—A Comedy (Ove Ansténsson). 10.0, Light Music, relayed from Malmö, 1,301 kc/s, 231 metres. 11.0 (approx.). Close Down.

STRASBOURG

869 kc s, 345 metres; 11.5 kW.—11.30 a.m., Bach Concert on Gramophone Records. 12.45 p.m., News. 1.0, Time Signal. 1.1, Exchange. 1.5, Light Music on Gramophone Records. 2.0, Interval. 3.30, Orchestral Concert, conducted by M. Broullier, relayed from the Casino, Vichy; Overture, Semiramis (Rossini); Persian Dance (Günrad); Overture and Ballet Music from Rosamund (Schubert); Waltz from Rosenkavalier (Strauss); Selection from William Tell (Rossini); Military March (Schubert). 5.0, Literary Talk: The Polish Novelist, Stanislas Reymont. 5.15, Orchestral Concert, conducted by Roskam: The Arrival of the Circus (Rust); Waltz, Blue Diamonds (Waltz); Premier song (Pelloni); Romantic Overture (Keler-Béla); Selection from Le Comte oligodago (Moretti); Waltz: Song. 6.0, Trio Concert, relayed from Lille, 1,130 kc/s, 265.4 metres. 7.0, Talk in German. 7.15, Tourist Talk. 7.30, Time Signal. 7.31, News. 7.45, Gramophone Music. 8.0, News. 8.30, Festival Programme for the Inauguration of the New Station at Lille, relayed from Lille. After the Programme, News in German. 10.30, Dance Music from the Savoy. 12 Midnight, Close Down.

STUTTGART

MUHLACKER, 832 kc/s, 360.5 metres; 60 kW. Relayed by Freiburg, 527 kc/s, 570 metres.—12.45 p.m., Report of the Fifteenth German Gymnastic Festival, 1933. 1.15, Time and News. 1.30, Extracts from Der Rosenkavalier Opera (E. Strauss), on Gramophone Records. 2.0, Concert arranged by the Post Office. 2.30, Advanced English Lesson. 3.0, Interval. 3.5 (from Mannheim), Talk: My Sunday Excursion. 4.30, See Munich. 5.45 (from Freiburg), Talk: Local History and the German Race. 6.10, Agricultural Notes and Weather. 6.30, Talk on Eugenics. 6.35, Time and News. 7.0, Transmission for all German Stations relayed from Munich. 8.0, The Fifteenth German Gymnastic Festival, 1933, relayed from the Market Place: The German Saar. 8.20, The Pastoral Symphony No. 6 in F (Beethoven), by the Station Orchestra. 9.0, National Demonstration of the German Gymnastic Society, and the Presentation of the Banner of the Foreign Gymnastic Club, relayed from the Town Hall. 10.0, Time and News. 10.30, Report of the Display by the 18 Gymnastic Clubs, from the Fifteenth German Gymnastic Festival. 11.0, Dance Music on Gramophone Records. 1.45 a.m. (Saturday), Report of the National Demonstration of the Gymnastic Society, and the Presentation of the Banner of the Foreign Gymnastic Club (on Gramophone Records). 2.45, Close Down.

SUNDSVALL.—See Stockholm.

TRIESTE

1,211 kc s, 247.7 metres; 10 kW.—5.0 p.m. till Close Down, See Turin.

TRONHEIM.—See Oslo.

TURIN

1,096 kc/s, 273.7 metres; 7 kW. Relayed by Milan, 995 kc/s, 331.5 metres; Genoa, 959 kc/s, 312.8 metres; and Florence, 599 kc/s, 508.8 metres.—5.0 p.m., Concert of Chamber Music. 6.0 to 6.5, Weather. 6.35, News. 7.0, Time, Report of the Royal Geographical Society and Italian Music on Gramo-

phone Records. 7.20, News in Foreign Languages. 7.40, Gramophone Music. 8.0, News and Weather. 8.15, Sponsored Music. 8.30, La Fille de Madame Angot—Opérette in Three Acts (Lecocq). 11.0, Giornale Radio.

VATICAN CITY

15,120 kc/s, 19.84 metres (Morning), and 5,969 kc/s, 50.26 metres (Evening); 10 kW.—11.0 to 11.15 a.m., Religious Information in German. 8.0 to 8.15 p.m., Religious Information in Italian.

VIENNA

581 kc s, 517 metres; 100 kW. Relayed by Graz, 852 kc/s, 352.1 metres; Innsbruck, 1,058 kc/s, 283 metres; Klagenfurt, 662 kc/s, 453.2 metres; Linz, 1,220 kc/s, 245.9 metres; and Salzburg, 1,373 kc/s, 218.5 metres.—12 Noon, Concert by the Vienna Symphony Orchestra, conducted by Theodor Christoph. In the interval at 1.0 p.m., Time and News. 2.0, Interval. 3.0, Time and News. 3.20, Hints for the Housewife. 3.30, Talk: The Life of Charlotte Grainer. 3.55, Opera Music on Gramophone Records. 4.35, Talk: The Source of the River Enns. 5.0, Song and Piano-forte Recital by Ernst Urbach (Baritone) and Rita Schmitz. Part I: Modern Austrian Piano-forte Music. Part II: Italian Songs. 5.45, Tourist Report. 6.0, Talk: Games, Sports and Recreation in Large Towns. 6.15, Sports Report. 6.25, Dr. Hugo Adolf Bernatzik reports on his South-Sea Expedition. 6.50, Talk: The Naval Battle near Lissa. 7.15, Time and Announcements. 7.25, Concert by the Vienna Symphony Orchestra, conducted by Josef Holzer: Overture, Der Verschwendter (Kreutzer); Märchen aus Alt-Wien (Ziehrer); Es war einmal from Jabuka (Joh. Strauss); German Dances (Schubert); Potpourri, Anno dazumal (Morena); Beim Burgtor am Michaelerplatz (Arnold); Klänge aus der Raumdzeit (Joh. Strauss); Waltz, Die guten alten Zeiten (Jos. Strauss); Ja, so war's amal im alten Wien (Strecker); Radetzky March (Joh. Strauss); Waltz, Die Schönbrunner (Lanner); Potpourri, Selbige Wiener Zeiten (Morena). 8.40, Adventures in Africa. Part I: Talk: The Call of the Primeval Forest. Part II: War against the Mosquito—Radio Play about Albert Schweitzer (Schmidlbönn). 10.10, News. 10.25, Dance Music on Gramophone Records.

WARSAW

212.5 kc s, 1,411 metres; 120 kW.—11.57 a.m., Time and Fanfare from the Tower of St. Mary's Church, Cracow. 12.5 p.m., Gramophone Music. 12.25, Review of the Polish Press. 12.33, Weather. 12.35, Dance Music on Gramophone Records. 12.55, Radio Journal. 1.0 to 2.55, Interval. 2.55, Gramophone Music. 3.5, News. 3.10, Announcements. 3.15, Gramophone Music. 3.25, Announcements. 3.35, Gramophone Music. 3.45, Aviation Report and Anti-Gas Drill. 3.50, Gramophone Music. 3.55, Report on Maritime and Colonial Affairs. 4.0, Concert by the Poznan Opera House Orchestra, conducted by B. Tyllia, relayed from Ciechocinek. 5.0, Talk from Cracow, 959 kc/s, 312.8 metres. 5.15, Vocal and Instrumental Concert. M. Mokrzycka (Soprano) and E. Sznajderman (Violin). Violin Solos; Songs: (a) Cradle Song from Maurin (Paderewski), (b) Air from Thaïs (Massenet), (c) Aria from Aida (Verdi); Violin Solos; Songs: (a) Cradle Song (Mlynarski), (b) Cradle Song (Tchaikovsky), (c) Triste avril (de Léva), (d) Strimpellata al tramonto (Bettinelli). 6.15, Talk: The Polish Police. 6.35, Piano-forte Recital: Toccata in D (Bach); Sonata in D Minor, Op. 31, No. 2 (Beethoven); Sonata di Petrarca (Liszt); Spanish Dance (Albéniz); Puerte de Tierra (Granados); Le petit âne blanc (Ibert); Toccata (Isserlis). 7.20, Miscellaneous Items. 7.35, Programme Announcements. 7.40, Topical Talk. 8.0, Symphony Concert by the Station Symphony Orchestra, conducted by A. Dolzycki. Soloist: R. Lanes (Cello). Suite in B Minor (Bach); Siegfried Idyll (Wagner); Variations for Cello and Orchestra (Mengeberg). 8.50, Radio Journal. 9.0, Talk. 9.5, Concert (cont'd): Toccata (Frescobaldi); Largo (Chopin); Song (Szymanowski); Three Spanish Dances (Granados-Nin-Popper); Symphony No. 7 (Beethoven). 10.0, Dance Music. 10.25, Sports Notes. 10.35, News. 10.40, Dance Music.

WILNO

533 kc/s, 563 metres; 16 kW.—7.20 p.m., Lithuanian Announcements. 7.30, Programme Announcements. 7.40, See Warsaw. 11.0 (approx.), Close Down.

ZAGREB

307 metres; 0.8 kW.—12.20, Talk on Cookery. 12.30, Extracts from L'Arlesienne—Opera (Bizet), on Gramophone Records. 1.0, Programme Announcements. 1.5, Gramophone Concert of Opérette Music. 1.30, News. 7.55, Talk on Sport. 8.10, Announcements. 8.30, Concert relayed from Belgrade. 10.30, News and Weather Report. 10.40, Dance Music.

ZURICH.—See Schweizerischer Landessender.

ALGIERS

824 kc/s, 364 metres; 13 kW.—8.0 p.m., Dance Music. 8.10, Shipping Notes. 8.15, Agricultural Report and Weather Forecast. 8.20, Concert of Military Band Music. Marche de Chantecler (Allier); Le Régiment de Sambre et Meuse (Planquette); Unter den Doppelädeln (Wagner); Soldier's Chorus from Faust (Gounod); Per aspera ad astra (Urbach); Heil Europa (von Blon); Dukerque (Harziaux). 8.55, News. 9.0, Time Signal. 9.2, Request Gramophone Concert. 9.40, News. 9.45, Concert relayed from the Gardens of the Aristide-Briand Square.

ATHLONE

725 kc/s, 413 metres; 60 kW. Relayed by Cork, 1,337 kc/s, 224.4 metres.—1.30 to 2.30 p.m., Time Signal. Weather Report. Stock Report and Gramophone Music. 6.0, Gramophone Concert. 6.45, News. 7.0, Humorous Programme by Desmond Cream. 7.15, Gaelic Talk. 7.30, Time Signal. 7.31, The Station Orchestra. 7.45, Contralto Solos by Elizabeth Downey. 8.0, Pianoforte Recital by Claud Biggs. 8.30, Baritone Solos by Sam Joy. 8.45, Brannigan Listens in Sketch, by A. Taaffe and Company. 9.15, Orchestral Music. 9.30, Uilleann Pipe Solos by P. Martin. 9.45, Sponsored Programme. 10.30, Time Signal. 10.45, News, Weather Report, and Close Down.

BARCELONA

EAJ1, 860 kc/s, 348.8 metres; 8 kW.—7.0 p.m., Trio Concert. 8.0, Request Gramophone Concert. 8.30, Exchange. 9.0, Gramophone Music. 9.15, Talk on Disarmament, Gramophone Music, and News. 10.0, Chimes. Weather, Exchange, and Market Prices. 10.5, Concert by the Station Orchestra: Pasodoble, Granada la arabeza (de Lesmo); Selection from Los desamados (Chueca); Cáradas, Royale (Michele); Habanera, A orillas del Nilo (Cotó); Allegretto from Danzas montañas (Gorostiza); Overture, The Caliph of Bagdad (Hoelien). 11.0, Guitar Solos by Francisco Alfonso. 11.30, An Opera on Gramophone Records. In the interval at 12 Midnight, News. 1.0 a.m. (Sunday), Close Down.

BARI

1,112 kc/s, 269.8 metres; 20 kW.—8.0 p.m., News. 8.20, Giornale Radio and Weather. 8.30, Time and Announcements. 8.35 (approx.), Rigoletto—Opera (Verdi), on Gramophone Records. In the intervals: Literary Talk and Announcements. News after the Opera.

BASLE.—See Schweizerischer Landessender.

BELGRADE

697 kc/s, 430.4 metres; 2.8 kW.—5.55 p.m., Time and Programme Announcements. 6.0, Gramophone Music. 7.0, See Vienna. 9.30, Talk. 10.10, News, Time, and Cigány Music from the Potrosacka Zadruga Restaurant. 10.50, Dance Music on Gramophone Records.

BERLIN

DEUTSCHLANDSENDER, 183.5 kc/s, 1,635 metres; 60 kW.—1.45 p.m., News. 2.0, Operetta Music on Gramophone Records. 3.0, Handwork for Children. 3.30, Weather. 3.45, Readings (Kayaser). 4.0, Radio Report from a Children's Holiday Camp in Fürstenwalde, followed by Folk Songs from the Market Square, in Fürstenwalde. 4.40, Concert from Hamburg. 5.15, See Stuttgart. 5.30, Song and Pianoforte Recital by Franz Baumann and Paul Dietrich. 6.0, A Poem. 6.5, Talk with Gramophone Records. 6.30, Programme for Girls. 6.50, Weather and Announcements. 7.0, Transmission for all German Stations, relayed from Berlin (Witzleben). 8.0, Song Recital by Herbert Ernst Groh; Week-end Programme. 9.30, See Stuttgart. 10.0, News. 10.45, Weather for Shipping. 11.10, See Munich. 12 Midnight, Close Down.

BERLIN

(WITZLEBEN), 715 kc/s, 419.5 metres; 1.5 kW.—4.40 p.m., Concert, relayed from the Krollgarten, in the interval at 5.0 (approx.), Talk on Sports Clubs. 5.30, A Radio Report from a Film Studio in Neubabelsberg. 6.0, Song Recital by Maria Peschken (Contralto); Songs (Dettinger): (a) Gebet, (b) Dorfnacht, (c) Verträumte Jugend, (d) Abendlicht; Songs (Trunk): (a) In der Nacht, (b) Die Stadt, (c) Meine Mutter hat's gewollt, (d) Frühlingssonne. 6.20, Practical and Theoretical Weather Forecasts—a Countryman and a Meteorologist Microphone. 6.40, The Witzleben Station informs its Listeners. . . . 6.45, Topical Talk. 7.0, Transmission for all German Stations; Volk aus Gewehr—a Nazi Song Sequence. 8.10, Topical Programme. 8.20, Concert by a Nazi Band. 9.30, See Stuttgart. 10.30 (approx.), Dance Music, relayed from the Moka Effi. In the intervals at 10.45, News, and

SATURDAY

JULY THE TWENTY-NINTH

PRINCIPAL EVENTS OF THE WEEK:

AT HOME

NATIONAL Variety programme.

LONDON Symphony concert.

REGIONAL

NORTH The Arcadian Follies, relayed from the South Pier, Blackpool.

REGIONAL

SCOTTISH Excerpt from Poppewell's Fourth Annual Original Production, "Gaiety Whirl" of 1933, from the Gaiety Theatre, Ayr.

REGIONAL

ABROAD

ALGIERS 9.45 p.m. Open-air concert.

ATHLONE 9.30 p.m. Uilleann pipe solos, by P. Martin.

BERO- 8.30 p.m. Music for two pianofortes.

MUNSTER

BRUSSELS 8.0 p.m. Pianoforte recital of dance music through the ages.

(No. 1)

HEILSBURG 8.5 p.m. Festival concert in aid of the Winter Relief Fund, relayed from the Kurgarten, Zoppot.

8.25 p.m. Concert of Piémé chamber music.

8.40 p.m. "The White Horse Inn," musical play, relayed from the Théâtre Mogador.

9.30 p.m. Concert by the Augusteo Orchestra, relayed from the Basilica di Massenzio.

7.15 p.m. "Fidelio," an opera (Beethoven), relayed from Salzburg. Conductor: Richard Strauss.

9.30 p.m. Pianoforte recital of Polish music.

at 11.0, Talk: What they are saying in Berlin. 1.0 a.m. (Sunday), Close Down.

BERNE.—See Schweizerischer Landessender.

BEROMUNSTER.—See Schweizerischer Landessender.

BODEN.—See Stockholm.

BODO.—See Oslo.

BORDEAUX-LAFAYETTE

986 kc/s, 304 metres; 13 kW.—7.0 p.m., See Vienna. 9.0, Gramophone Music. 9.30, Monsieur Tranquille—One Act Comedy (Vely).

BRATISLAVA

1,076 kc/s, 279 metres; 14 kW.—6.25 p.m., Folk Music by a Village Band. 6.55, Talk for Housewives. 7.0, See Prague. 8.0, An Operetta in Three Acts (Kinec). 10.0, See Prague. 11.30 (approx.), Close Down.

BREMEN.—See Hamburg.

BRESLAU

923 kc/s, 325 metres; 60 kW. Relayed by Gleiwitz, 1,184 kc/s, 253 metres.—1.0 p.m., Gramophone Music. In the interval at 1.45, Time and News. 3.0, Agricultural Prices. 3.15, Book Review. 3.35, Talk: Youth and Christianity. 3.55, Dialogue: The Films of the Week. 4.10, Concert, relayed from the Café Vaterland. 5.0, Concert relayed from the Restaurant Wilhelmshafen. 5.50, Programme Announcements. 6.0, Programme to be announced. 6.25, Talk: A Theory of Education. 6.50, Weather and News. 7.0, Transmission for all German Stations, relayed from Berlin (Witzleben). 8.0, See Stuttgart. 10.45, Time and News. 11.5, Radio Report of the Eighth Upper Silesian Fête Day from Bad Altheide. 11.35, Orchestral Concert from the Café Vaterland. 1.0 a.m. (Sunday), Close Down.

BRNO

878 kc/s, 342 metres; 35 kW.—6.25 p.m., German Transmission: News and Song Recital by R. Ondruschka. 7.0, See Prague. 8.0, See Bratislava. 10.0, See Prague. 11.30 (approx.), Close Down.

BRUSSELS (No. 1)

N.I.R., 590 kc/s, 509 metres; 15 kW.—12 Noon, Concert by the Radio Orchestra, conducted by Charles Walpot; Soloists: Mme. Lambert (Soprano) and M. Locuifer (Tenor); Overture, Masaniello (Auber); Waltz (Ströbl); Songs by Mme. Lambert: Selection

from The Pearl Fishers (Bizet); Tenor Solos; Suite, Masquerade (Lacôme). 1.0 p.m., Le Journal Parlé. 1.10, Concert by the Symphony Orchestra, conducted by Memlemans; Soloist, Mme. Adriani (Songs): Overture, Der Freischütz (Weber); Symphonie Poem, Phäeton (Saint-Saëns); Flemish Lullaby (Crabbé); Dance of the Tumblers (Rimsky-Korsakov); Songs; Divertissement on Russian Airs (Rabaud). 4.45, Talk: Belgium and the London Conference. 5.0, Concert by the Radio Orchestra, conducted by Charles Walpot; Soloist, Walter Féron (Violin); Marche Lorraine (Ganne); Overture, Les hirondelles (Hirschmann); Selection from Mirella (Gounod); Violin Solo, Three Faithful Etchings (Ketelbey); Potpourri (Morena). 6.0, Talk: The Municipal Museum at Brussels. 6.15, Gramophone Concert. 6.30, Concert by the Small Station Orchestra, conducted by Lecmans; Overture (Adam); Les feuilles tombent (Bramagne); Two Pieces (Guillemin): (a) Algerian Song, (b) Oriental Song; Knave of Diamonds (Steelle); Dance of the Elves (Henriques); Fortissimo (Kahman); Waltz, Alt Wien (Ziehrer). 7.15, Talk: Public Libraries. 7.30, Le Journal Parlé. 8.0, Pianoforte Recital by Francis de Bourguignon; Dance Music through the Centuries; Bourrée (Bach); Waltz in A Flat (Chopin); Polonaise in A (Chopin); Danse de la St. Jean (Baton); Tango (Bourguignon); Selvilana (Albéniz); Segundillas (Albéniz). 8.30, Gramophone Concert. 8.40, La voix humaine—Sketch in one Act (Cocteau), on Gramophone Records. 9.0, Concert from the Kursaal, Ostend. 10.30, Le Journal Parlé. 10.40, Dance Music from the Kursaal, Ostend.

BRUSSELS (No. 2)

N.I.R., 887 kc/s, 338.2 metres; 15 kW.—Programme in Flemish. 12 Noon, Concert by the Station Symphony Orchestra, conducted by Memlemans; Soloist, Mme. Adriani (Songs): Overture, Oberon (Weber); Persian Dance from Kovanstchina (Mussorgsky); Piedmontese Dances (Sinigaglia); Cossack Dance (Tchaikovsky); Songs; Waltz, Tales from the Vienna Woods (Joh. Strauss); Ballet égyptien (Luigini). 1.0 p.m., Le Journal Parlé. 1.10, Concert by the Radio Orchestra, conducted by Charles Walpot; Soloists: Mme. Lambert (Songs) and M. Locuifer (Tenor); Overture, Der Bettelstudent (Milbeck); Waltz, Je t'aime (Waldteufel); Songs; Ballet Music from Coppélia (Delibes); Tenor Solos; Waltz from The Sleeping Beauty (Tchaikovsky). 5.0, Dance Music, relayed from the Continental Palace Hotel, Blankenberghe. 5.0, Illustrated Talk on Fidelio—Opera (Beethoven). 6.30, Agricultural Report. 7.0, See Vienna. In the interval, Recitals. After the Opera, Le Journal Parlé, followed by Dance Music, relayed from the Continental Palace Hotel, Blankenberghe.

BUCHAREST

731 kc/s, 394 metres; 12 kW.—5.0 p.m., Light Music and Romanian Music by the Sibiceano Orchestra. In an interval at 6.0, Radio Journal. 7.0, Reading. 7.20, Gramophone Music. 7.40, Educational Talk. 8.0, Song Recital. 8.20, Concert by the Station Orchestra: March (Blankenburg); Waltz (Mayer-Helmund); Suite, Arabian Nights (Bortkiewicz); Potpourri of Russian Songs (Selin-sky); Cracoviak (Leopold); Aubade (D'Ambrósio); Selection from J'adore ça (Christine). In an interval at 9.0, Talk. 9.45, Radio Journal.

BUDAPEST

545 kc/s, 550.5 metres; 18.5 kW.—6.0 p.m., Choral Concert. 5.40, Talk for Workers. 6.10, Flute Recital of Hungarian Music. 6.40, The Letter Box. 7.10, Gramophone Music. 8.0, Programme to be announced, followed by Cigány Music from the Café Bodo. 10.0, Dance Music.

CASSEL.—See Frankfurt.

COPENHAGEN

1,067 kc/s, 281 metres; 0.75 kW. Relayed by Kalundborg, 260 kc/s, 1,153 metres.—12 Noon, Time and Chimes from the Town Hall. 12.2, Concert by the A. Bendix String Ensemble, relayed from the Restaurant Wivex. 2.0 to 3.0, Interval. 3.0, Concert by the Radio Orchestra, conducted by Emil Reesen; Soloist: Einar Johansen (Pianoforte); Overture, Mignon (Thomas); Waltz from Polendhut (Nedbal); Humoresque (Dvorak); Spring Song (Mendelssohn); Selection from Carmen (Bizet) Gavotte (Ganne); Persian March (Joh. Strauss); Prelude (Bach); Intermezzo (Brahms); Two Etudes (Chopin); March, The Liberty Bell (Sousa); Overture, The Black Domino (Auber); Waltz, Dolores (Waldteufel); Selection from Rigoletto (Verdi); Invocation (Gounod); Aragonese (Falla); Marche lorraine (Ganne). 5.0, Gramophone Music. 5.35, Exchange and Fish Market Prices. 6.20, Talk: Church Bells. 6.50, Weather. 7.0, News. 7.15, Time Signal. 7.30, Talk. 8.0, Time Signal from the Town Hall. 8.1, Lumbye Concert by the Station Orchestra, conducted by Emil Reesen; March, King Christian IX; Waltz, Krolls Balklänke; Indian War Dance; Mazurka, Helga; Polka, Camelia; Waltz, Amelia; Gallop. 8.40, Lange-Müller Song Recital by Ellen Münter-Jessen. 9.0, Reading. 9.25, Saxophone Solos. 9.40, News. 9.55, Concert by the Radio Orchestra, conducted by Emil Reesen; Hungarian Festival Overture (Keler-Bela); Song Without Words (Tchaikovsky); Selection from Les Brigands (Offenbach); Waltz and Polka from Les millions d'Arlequin (Drigo); Spanish Dances (Moszkowsky); Overture, Der Göttergatte (Lehár). 10.45, Dance Music relayed from the Lodberg Restaurant. 12 Midnight, Time and Chimes from the Town Hall.

CORK.—See Athlone.

CRACOW

959 kc/s, 312.8 metres; 1.5 kW.—7.5 p.m., Talk. 7.20, Miscellaneous Items and News. 7.35, Programme Announcements. 7.40, See Warsaw. 10.25, Sports Notes. 10.40, Light Music from the Pavillon Restaurant. 11.30, See Warsaw. 11.35, Gramophone Music. 12 Midnight, Fanfare from St. Mary's Church.

DANZIG.—See Heilsberg.

DRESDEN.—See Leipzig.

FECAMP

1,328 kc/s, 225.9 metres; 10 kW.—4.30 till 6.30 p.m., Programme in English by the I.B.C. 4.30, Programme for Children. 5.0, Military Band Concert for Tunbridge Wells and Isle of Thanet Listeners. Signature Time, Hands across the Sea. Song, The Gay Highway (Drummond). Bells across the Meadow (Ketelbey); Festival March, Holomoko (Reeves); Song, The Yeoman's Wedding (Poniatowsky); The Three Musketeers (Elliott); Amorettenanz (Gungl). 5.30, Concert of Request Music for Dover and Folkestone Listeners. Viscount Nelson (Zehle); Twilight Reveries (Roberts); Suite Americana, Part I (Thurban); Bella, the Belle o' Dunoon (Lauder); Wedgewood Blue (Ketelbey); Suite Americana, Part II (Thurban); Till the Sands of the Desert grow cold (Ball); March, El Abanico (Javaloyes); Signature Time. 6.0, Programme in French. 11.0, Dance Music. Signature Time; We belong together (Hammerstein); A Ghost of a Chance (Young); In Eger on the Tegera Sea (Hammerstein); My Darling (Heyman); I've told every little Star (Kern); No more Love (Friend); The Song is you (Kern); Waltzing in a Dream (Young); Signature Time. 11.30, Concert of Light Music by the I.B.C. (Ireland) Ltd. Signature Time; Poor Butterfly (de Phillips); Violin Solo, Souvenir (Drdla); Song, Teenee's Farewell to Kathleen (Duffin); Violin Solo, Bohemian Song (Baldi); Waltzes, from A Waltz Dream (Strauss); Song, Eileen Alanna (Thomas); Charming Episode (Ormandy); Selection (Kalman). 12.5 a.m., (Sunday), News Bulletin in English.

JULY 29th

SATURDAY

continued

MOSCOW

TRADES UNION, 230 kc s, 1,304 metres; 100 kW.—2.45 p.m., Weather. 3.0, Request. Concert. 3.45, Weather. 4.0, Talk: Agricultural Machinery. 4.30, Literary and Musical Programme. 5.30, Programme Announcements. 5.45, Running Commentary on a Motor Car Race. 6.30, Dance Music. 9.0, News. 9.30, Programme Announcements. 9.55, Chimes. 10.5, Talk in German: Menskeviki and the Power of the Soviet.

MOTALA.—See Stockholm.

MUHLACKER.—See Stuttgart.

MUNICH

563 kc s, 533 metres; 60 kW. Relayed by Augsburg and Kaiserlautern, 536 kc/s, 560 metres, and Nürnberg, 1,256 kc/s, 239 metres.—5.45 p.m., Programme for Children. 6.30, Recital of Old German Songs to the Lute by Gretel Reinicke. 6.45, Wireless Notes. 7.0, Transmission for all German Stations, relayed from Berlin (Witzleben). 8.0, Concert by the Small Station Orchestra, conducted by Erich Kloss. Soloists: Ilugo Reker and George Troibner, with Recitations by Adolf Gondrell. 9.0, Concert by the Bad Folz Zither Club: March, Auf golden Höhen (Kreihner); Melody; Altbayerische spielmusk (Hauser); Intermezzo, Dornröschen (Rhode); Tölzer Schützenmarsch (Kretzner). 9.30, See Stuttgart. 10.45, Time and News. 11.10, Serenade by the Bavarian Schrammel Ensemble. In the interval, Songs by Eichhorn, sung by Walter Hilbring with the Composer at the Piano-forte. 12 Midnight, Close Down.

NAPLES.—See Rome.

NOTODDEN.—See Oslo.

OSLO

277 kc s, 1,083 metres; 60 kW. Relayed by Fredrikstad, 815 kc s, 368.1 metres; Hamar, 522 kc s, 574.7 metres; Notodden, 671 kc/s, 447.1 metres; Porsgrund, 662 kc/s, 453.2 metres, and Rjukan, 671 kc s, 447.1 metres.—5.0 p.m., Divine Service Relay. 6.0, Programme for Children. 6.30, Hardanger Fiddle Recital of National Music. 6.45, Talk on Economics. 7.0, Advertising Notes. 7.15, Weather and News. 7.30, Talk on Henry Ford. 8.0, Time Signal. 8.1, Festival Programme, relayed from Lom. 9.0, Concert by the Station Orchestra, conducted by Oivin Ejelstad. Soloist: Ernst Glaser (Violin). Norwegian Bridal Procession (Grieg); Ruskle of Spring (Sinding); Melody (Svendsen); Waltz (Baeker Gründahl); Piece (Jordan); Melody (Johansen); Romance for Violin (Svendsen); Bergensiana (Halvorsen). 9.40, Weather and News. 10.0, Topical Talk. 10.15, Concert (cont'd): March, Manhattan Beach (Souza); Geschichten aus dem Erimotal (Pacherregg); Czardas (Monti); Rhapsody (Beck); Midnight Polka (Waldteufel); Finnish Mazurka (Franko); March Polpourri (Winter). 11.15 (approx.), Close Down.

OSTERSUND.—See Stockholm.

PALERMO

558 kc/s, 537.6 metres; 3 kW.—8.0 p.m., Dopolavoro Announcements. Tourist Report, Agricultural Notes, and Giornale Radio. 8.20, Gramophone Music. In the interval at 8.30, Time and Announcements. 8.45, Quartetto vagabondo—Operetta in Three Acts (Pietri). In the intervals, Book Review and Announcements. 10.55, News.

PARIS

EIFFEL TOWER, Call FLE, 207.5 kc/s, 1,445.7 metres; 13 kW.—Time Signals (on 2,650 metres) at 10.26 a.m. and 11.26 p.m. (Preliminary and 6-dot Signals).—6.45 p.m., Le Journal Parlé. 8.30, Three Plays: (a) L'Express 175 (Christaeflour), (b) La voix (Revel), (c) A Story (Renard), adapted by Paul Castan. 10.0 (approx.), Close Down.

PARIS

POSTE PARISIEN, 914 kc/s, 328.2 metres; 60 kW.—7.0 p.m., Gramophone Music. 7.15, Le Journal Parlé. 7.30, Gramophone Music. 7.55, Report of the Walking Race from Paris to Strasbourg. 8.10, Interlude. 8.25, Concert of Pierné Chamber Music. 8.55, Interlude. 9.10, Dance Music. 11.0, News.

PARIS

RADIO PARIS, Call CFR, 174 kc/s, 1,725 metres; 75 kW.—7.30 a.m., Weather and Physical Culture. 7.45, Gramophone Music. 8.0, Weather and News. 12 Noon, Gramophone Music. 8.0, Weather and News. 12 Noon, Gramophone Concert. Bulgarian Suite (Wladigerov): La violle heresuse (Botrel); Dors mon gars (Botrel); Clarinet Concertino (Weber); Two Melodies (Busser); Melody (Wachs); La Forêt (Caplet); L'anneau d'argent (Chaminade); Si j'étais jardinier (Chaminade); Flower Waltz

of the Metropolitan Opera House, New York, and Karl Hartmann of the Municipal Opera House, Berlin. Part I—Overture, Rienzi (Wagner); Karl Hartmann: (a) Prayer from Rienzi (Wagner); (b) Prize Song from The Mastersingers (Wagner); Götha Ljungberg: Finale from The Twilight of the Gods (Wagner). Part II—Symphonic Poem, Tasso (Liszt); Symphonic Poem, Don Juan (R. Strauss); Autumn Festival from Mohoch (Max von Schillings). 10.0, News, followed by Dance Music from Berlin (Witzleben).

HILVERSUM

Announced **HUIZEN, 1,013 kc s, 296.1 metres; 20 kW.** (7 kW. up to 4.40 p.m.).—Programme of the Catholic Radio Society (K.R.O.). 11.55 a.m., Concert by the K.R.O. Sextet: Two-Step (Alfonso); In der Erinnerung (Lincke); Selection from Wonder Bar (Katcher); Waltz Profient (de Jong); Erica (Lincke); Potpourri (Dostal); Finale. In the interval, Gramophone Records and Announcements. 1.25, Gramophone Music. 1.40, Programme for Young People. 2.10, Programme for Children. 3.40, Gramophone Music. 4.40, Military Band Concert, conducted by L. de Morée: March, Vers la paix (de Morée); Overture, Mignon (Thomas); Selection from Lakmé (Delibes-Maun); March solennelle (Dorboonde-Morée); Waltz, Honrida (Gillet); Offenbach Potpourri (arr. Pétras); A Musical Parade (Asten). In the intervals, Esperanto Notes and Press Review. 6.40, Police Messages. 6.55, Talk. 7.25, Gramophone Music. 7.40, Variety Programme by the K.R.O. Boys, conducted by P. Lustenhouwer, and Soloists. In the intervals at 8.10 and at 10.10, News. 10.40, Gramophone Music. 11.40 (approx.), Close Down.

HORBY.—See Stockholm.

HUIZEN

Announced **HILVERSUM, 160 kc/s, 1,875 metres; 8.5 kW.** Programme of the Workers' Radio Society (V.A.R.A.).—11.40 a.m., Gramophone Music. 12.40, Concert by the Little V.A.R.A. Orchestra, conducted by P. Duchant: Wo die Zitronen blühen (Joh. Strauss); Piece (Kark); Le Cygne (Saint-Saëns); The Wedding of the Winds (Hall); Ballet Music from Rosamunde (Schubert); Gramophone Music; Only a Smile (Zamecnik); I love a little Cottage (O'Hara); Parisiana (Leopoldi). 1.55, Gramophone Music. 2.30, Talk: The Principle of National Disarmament. 2.50, Gramophone Music. 3.20, Literary Talk. 3.40, Concert by De Notenkrakers, conducted by D. Wins: March Potpourri (Cierra); Dolores (Waldteufel); Only a Smile (Zamecnik); Selection from The Gipsy Princess (Kálmán); Gramophone Records; Dance of the Butterflies (Kockert); Why (v.d. Linden); Russian Dance (Berger); Spanish Dances (Moszkowsky); Schwert and Leier (Joh. Strauss); Spieluhr and Puppentanz (Schebek); In the Twilight (Bianco); Whistling Waltz (Webster); Das Märchen vom Glück (Stolz); Selection from The Desert Song (Romberg); Sevilla (Abraham). 5.40, Programme for Children. 6.40, Song Recital. Gramophone Music in the interval. 7.10, Concert by the Small V.A.R.A. Orchestra, conducted by M. Duchant: La Marseillaise (Lilke); Gavotte from Der Gaisogner (Suppe); Polka from Banditenstreiche (Suppe); Ballet Potpourri (Barière); Danish Socialist March; Melody (Gaveaux). 7.40, S.O.S. Announcements. 7.42, Revue on the Twenty-Fifth Anniversary of the Freeword Football Association. 9.10, News. 9.25, Revue (cont'd.). 10.55, Gramophone Music. 11.40 (approx.), Close Down.

INNSBRUCK.—See Vienna.

KALUNDBORG.—See Copenhagen.

KATOWICE

734 kc s, 408 metres; 16 kW.—7.5 p.m., Recitations. 7.25, Announcements and Gramophone Music. 7.35 till Close Down, See Warsaw.

KIEL.—See Hamburg.

KLAGENFURT.—See Vienna.

KOSICE.—See Prague.

LAHTI

167 kc s, 1,796 metres; 40 kW. Relayed by Helsinki, 815 kc s, 368.1 metres.—5.0 p.m., Gramophone Music. 6.15, Talk. 6.35, Song Recital by Erkki Eklund. 7.0, Talk. 7.20, Accordion Quartet Concert. 7.40, Recitations by Kauppi-Hoiki. 7.55, Dance Music by the Station Orchestra. 8.45, News in Finnish. 9.0, News on Swedish. 9.15, Light Music, relayed from the Restaurant Kappeli. 10.0 (approx.), Close Down.

LANGENBERG

635 kc s, 473 metres; 60 kW. 12 Noon, Concert of Light Music by the Münster Orchestra, conducted by Wolf. 12.50 p.m., Time, Weather and News. 1.15, Concert by the Station Orchestra, conducted by Kühn. Soloists: Tans Roof (Tenor). Overture, Si j'étais Roi (Adam); Aria from Aida (Verdi); Intermezzo from The Jewels of the Madonna (Wolf-Ferrari); Little Romantic Suite (Rieth); Aria: The Stars were shining, from Tosca (Puccini); Ballet Music from Die Fledermans (Joh. Strauss); Waltz from The Sleeping Beauty (Tchaikovsky). In the interval at 2.0, News. 2.30, Concert. 3.30, Exchange and Time Signal. 3.50, Reading (Käthe Bent). 4.10, Talk: Through the Rhineland and Westphalia—Through the Valley of the Ahr. 4.30, Concert by the Fröhliche Fünf. Liebesmagnet (Eysoldt); Czardas (Monti); Red Roses (Gemünd); Ballet Suite (Popy); Bohemoko (Reeves); Leggenda d'amore (Brece); Dance of the Dervishes (Bendix); Waltz, Mein Juwel (Lincke); 5.50, Poems (Dr. Theo Goerlitz). 6.0, An Old Rhinish Legend. 6.15, Talk on Benito Mussolini, on his Fiftieth Birthday. 6.45, Weather and News. 7.0, Transmission for all German Stations, relayed from Berlin (Witzleben). 8.0, First General News. 8.5, Orchestral Variety, relayed from Horst Castle. 9.40, See Stuttgart. 10.45, News. 11.0, Concert with Commentary, from Orsoy. 12 Midnight, Close Down.

LAUSANNE.—See Radio-Suisse Romande.

LEIPZIG

769.9 kc s, 389.6 metres; 120 kW.; and Dresden, 941 kc s, 319 metres.—12 Noon, Weather and Time. 12.5 p.m., Gramophone Concert. 1.0, News. 1.15, Gramophone Concert. In the interval at 1.45, Wireless Notes. 2.0, News. 2.10, Wireless Notes. 2.45, Programme for Children. 3.25, Book Review. 3.45, Economic Notes and News. 4.0, See Hamburg. 5.30, Music Notes. 5.40, German for Germans. 6.0 A Modern Dictionary. 6.10, Talk on Eugénie. 6.30, Trauer und Trost—Song Cycle for Soprano (Cornelius), by Lily Goerger. 6.50, Events of the Day. 7.0, Transmission for all German Stations, relayed from Berlin (Witzleben). 8.0, Political Announcement. 8.5, Talk: Mussolini and Nietzsche. 8.30, See Berlin (Deutschlandsender). 9.30, See Stuttgart. 10.30, News. 10.45 (approx.), Dance Music and Light Music from Dessau. 12 Midnight, Close Down.

LINZ.—See Vienna.

LUXEMBOURG

252 kc s, 1,191 metres; 200 kW. French Programme.—8.10, Weather. 8.15, Song Recital by Annette Cornavin. 8.30, Talk in French. 8.40, Song Recital (cont'd.). 8.50, News in French. 9.15, Concert by the Station Orchestra. Overture, Carnival roman (Berlioz); Petite Suite (Debussy); Military March (Saint-Saëns); March-solennelle (Bossi); Melody (Caludi); Ballet égyptien (Luigini); Ballet Music from Coppélia (Delibes); March, Ben Hur (Argandola). In the interval at 9.50, News in German. 10.30, Dance Music on Gramophone Records. 11.30 (approx.), Close Down.

LWOW

788 kc s, 381 metres; 16 kW.—7.5 p.m., Gramophone Music. 7.20, Miscellaneous Items. 7.40, See Warsaw. 9.15, Literary Review. 9.30, See Warsaw. 12 Midnight (approx.), Close Down.

MADRID

EAJ7, 707 kc s, 424.3 metres; 2 kW.—8.0 p.m., Chimes, Exchange, Radio Journal and Request Gramophone Records. 9.15, News. 9.30 to 11.0, Interval. 11.0, Chimes and Time. 11.5 (approx.), Song Recital, with accompaniment by the Station Sextet, followed by Literary Programme. 1.15 a.m. (Sunday), Time and News. 1.30, Chimes and Close Down.

MALMO.—See Stockholm.

MILAN

VIGENTINO, 662 kc/s, 453.2 metres; 4 kW.—8.45 p.m. till Close Down, See Rome.

MORAVSKA-OSTRAVA

1,137 kc s, 263.8 metres; 11 kW.—6.25 p.m., Concert by a Russian Balalaika Orchestra. 7.0, See Prague. 8.0, See Bratislava. 10.0, See Prague. 11.30 (approx.), Close Down.

12.10 (approx.), Club Concert for Loughborough Listeners. Part I. Organ Recital with Songs. Signature Tune: Selection from Illegal; Song, I'm Playing with Fire (Berlia); Paradise (Brown); Song, A Ghost of a Chance (Washington); The Wooden Soldier and the China Doll (Jones). Part II. Dance Music: The Wise Old Owl said Hoo (White); It pays to advertise (O'Hogan); Love Tales (Ager); London Bridge is falling down (arr. Bleyer); What more can I ask? (Noble); Contented (Turk-Bostor); Brighter than the Sun (Noble); That's my Home (Rene). 12.57, I.B.C. Good-night Melody. 1.0 (approx.), Close Down.

FLENSBURG.—See Hamburg.

FLORENCE.—See Turin.

FRANKFURT

1,157 kc s, 259.3 metres; 17 kW. Relayed by Cassel, 1,220 kc s, 245.9 metres; and Trier, 1,157 kc s, 259.3 metres.—3.30 p.m., Programme for Children. Italian Folk Song Recital by Renato Guerrini, with Guitar Accompaniment. 4.25, Talk on Economics. 4.30, See Stuttgart. 5.45, Economic Notes. 6.0, Report: The March on Rome. 6.25, Time and News. 6.30, Review of the Week. 6.50, Review of the Day's Events. 7.0, Transmission for all German Stations, relayed from Berlin (Witzleben). 8.5, See Heilsberg. 9.30, See Stuttgart. 10.45, Time and News. 11.10, Dance Music from Berlin (Witzleben).

FREDRIKSSTAD.—See Oslo.

FREIBURG.—See Stuttgart.

GENEVA.—See Radio-Suisse Romande.

GENOA.—See Turin.

GLEIWITZ.—See Breslau.

GOTEBORG.—See Stockholm.

GRAZ.—See Vienna.

HAMAR.—See Oslo.

HAMBURG

Call ha (in Morse), 806 kc/s, 372 metres; 1.5 kW. Relayed by Bremen, 1,712 kc/s, 269.8 metres; Flensburg, 1,319 kc/s, 227.4 metres; Hanover, 530 kc/s, 566 metres; and Kiel, 1,292 kc/s, 232.2 metres.—4.0 p.m., Concert by the Philharmonic Orchestra, conducted by Eibenschütz: Suite from Domènec (Mozart-Bonini); Prelude to Act III of Kunihild (Kistler); Italian Caprice (Tchaikovsky); Prelude to Act II of Die Königskinder (Humpfenick); Dream Waltz from Der Feldprediger (Müllacker). 5.0, Talk in Dialect. 5.30, Dialogue in Commemoration of the Death of Bismarck. 5.50, Variety Programme. 6.30 (from Kiel), Talk. 6.50, Weather Report. 7.0, Transmission for all German Stations, relayed from Berlin (Witzleben). 8.0, Political Talk. 8.10, See Berlin (Deutschlandsender). 9.30, See Stuttgart. 10.30, Time and News. 10.50, Topical Talk. 11.0, Light Music and Dance Music from Berlin (Witzleben).

HANOVER.—See Hamburg.

HEILSBURG

1,085 kc s, 276.5 metres; 60 kW. Relayed by Danzig, 662 kc s, 453.2 metres. 11.30 a.m., Concert by the Königsberg Opera House Orchestra, conducted by Georg Wöhler; Overture, The Golden Cross (Brüll); Suite pastorale (Scassola); Catalan Rhapsody (Ailbont); Selection from Carmen (Bizet); Waltz, Wiener Fäsehung (Kochmann); Clair de Lune (Kételby); Selection from Boccaccio (Suppe); Im Walzertrausch (Lincke); L'étudiant passe (Ibanez); Heckenrosenmarsch (Zimmer). In the interval at 12 Noon, Weather. 1.5 p.m., Gramophone Concert of Light Music. In the interval at 2.0, News. 2.30, Programme arranged by the Post Office, with Gramophone Records. 3.0, Market Prices. 3.30, Schumann Song Recital by Gertrud von Borzestowski (Contract); Sehnsucht; Frage; Die Nonne; Liebeslied; Metanohie (Zigemeitelen); (a) Unter die Soldaten, (b) Jeden Morgen in der Frühe; Lieder der Braut; Der arme Peter; (a) Mutter glaube nicht, (b) Lass mich; ihm am Busen hangen. 4.0, Concert by the Königsberg Opera House Orchestra, conducted by Ludwig Leschetizky, relayed from the Tiergarten, Königsberg; Overture, Pique Dame (Suppe); Selection from Der arme Jonathan (Müllacker); Selection from Eva (Lehar); Zigeunerleben (Machts); Suite, Caucasian Sketches (Ippolitov-Ivanov); Galop, Im Sturmschritt (Joh. Strauss). In the interval at 5.0, Talk: The Supervision of Roads in East Prussia. 5.25, Talk: The Dopolavoro Society. 6.5, Programme Announcements for the Coming Week. 6.15, Market Prices. 6.25, Political Press Review for the Month. 6.50, Weather. 7.0, Transmission for all German Stations, relayed from Berlin (Witzleben). 8.0, Weather and News. 8.5, Festival Concert for the Benefit of the Winter Relief Fund, relayed from the Kurgarten, Zoppot. Conductor: Prof. Max von Schillings. Soloists: Götha Ljungberg,

JULY 29th

SATURDAY

continued

TURIN

1,096 kc/s, 273.7 metres; 7 kW. Relayed by Milan, 905 kc/s, 331.5 metres; Genoa, 959 kc/s, 312.8 metres; and Florence, 599 kc/s, 500.8 metres.—5.40 p.m., Gramophone Music. 6.0 to 6.5, Weather. 6.35, News. 7.0, Time. Tourist Report and Songs on Gramophone Records. 7.20, News in Foreign Languages. 7.40, Gramophone Music. 8.0, News, Weather and Gramophone Music. 8.45, Variety Programme on Gramophone Records. 9.30, See Rome. 11.0, Giornale Radio.

VATICAN CITY

15,120 kc/s, 19.84 metres (Morning), and 5,969 kc/s, 50.26 metres (Evening); 10 kW.—11.0 to 11.15 a.m., Religions Announcements in Various Languages. 8.0 to 8.15 p.m., Religions Information in Italian.

VIENNA

581 kc/s, 517 metres; 100 kW. Relayed by Graz, 852 kc/s, 352.1 metres; Innsbruck, 1,058 kc/s, 283 metres; Klagenfurt, 662 kc/s, 453.2 metres; Linz, 1,220 kc/s, 245.9 metres; and Salzburg, 1,373 kc/s, 218.5 metres.—11.30 a.m., Famous Artists on Gramophone Records. 11.55, Weather and News. 12 Noon, Orchestral Concert, conducted by Josef Holzer. In the interval at 1.0 p.m., Time and News. 3.0, Time and Weather. 3.15, Choral Concert, conducted by Hans Bressing. Three Styrian Songs for Male Voice Choir: (a) Dirf i' diandl habn? (b) Dirndl, mach' auf. (c) In der Oberwitzer Pfarr; Three Carinthian Folk Songs for Male Voice Choir: (a) An Sprung übers Wasser. (b) Af der Pfadnitzer Alm. (c) Liesertal is ka Tal; Two Folk Songs for Women's Choir: (a) Heunt is Samstnacht. (b) Hinter mein Vodan sein Stadl; Four Folk Songs for Mixed Choir: (a) Phat di God, mei liaba Täuberl. (b) Drei Berg und drei Tal. (c) Der Ladnastatler Holznecht. (d) Ausseer Schmadhäupte n. 4.0, Recitation. 4.30, French Lesson. 5.0, Orchestral Concert from Bad Tatzmannsdorf. 6.25, The Moon in Song—Talk, with Gramophone Records. 6.50, Today's Motto. 6.55, Topical Talk. 7.5, Time and News. 7.15, Programme in Connection with the Salzburg Festival, 1933. Fidele—Opera in Two Acts (Beethoven), conducted by Richard Strauss, relayed from the Festspielhaus. In the interval at 8.30, Diablogue; Salzburg in Festival Time. 9.55, News. 10.10, Dance Music from the Café Palmhof.

WARSAW

212.5 kc/s, 1,411 metres; 120 kW.—11.57 a.m., Time and Fanfare from St. Mary's Church, Cracow. 12.5 p.m., Gramophone Music. 12.25, Polish Press Review. 12.33, Weather. 12.35, Dance Music on Gramophone Records. 12.55, Radio Journal. 1.0 to 2.55, Interval. 2.55 Gramophone Music. 3.5, News. 3.10, Announcements. 3.15, Economic Notes. 3.35, Gramophone Music. 4.0, Programme for Invalids, relayed from Lwow, 788 kc/s, 381 metres. 4.30, Gramophone Music. 5.0, Topical Talk. 5.15, Song Recital by J. Filinger-Kulikowska (Soprano) and J. Gaczynsky (Tenor); Tenor Solos: (a) Song from Act III of Dinorah (Meyerbeer); (b) Aria from Don Carlos (Verdi); (c) Aria from Chatterton (Leoncavallo); (d) Lellita (Bucci-Peccia); Soprano Solos: (a) Aria from Manon (Massenet); (b) Two Songs (Zelenka); (c) Song from La Bohème (Puccini); (d) Two Songs (Niewiadomsky); Tenor Solos: (a) Song (Gretchaninov); (b) Song (Tchaikovsky); (c) Aria from Tannhäuser (Wagner); Soprano Solos: (a) Viennese Waltz (Strauss); (b) Song (Gall); (c) Air (Berger). 6.15, Talk. 6.35, Song Recital by Mme. Dudicz (Soprano). 7.5, Light Music on Gramophone Records. 7.20, Miscellaneous Items. 7.35, Programme Announcements. 7.40, Reading from Rudyard Kipling. 8.0, Concert by the Station Orchestra, conducted by St. Xawrot; Soloist: Dubrowin (Balalaika); March (Konczak); Selection from The Merry Widow (Lehar); Ilanona (Oskarita); Humoresque (Dvorak); Balalaika Gipsy Melodies, Two Pieces (Helmberger); Polka (Wronsky); Musical Sketch (Tchaikovsky); Moment musical (Schubert); Mazurka (Andrzejew); Balalaika Solo; Tango (Dubrowin); Waltz, Plnie d'Or (Walzenfestel); Intermezzo, Gallantry (Kotzebey); Mazurka (Nanyshowsky). 9.5, Radio Journal. 9.15, Agricultural Report. 9.30, Pianoforte Recital of Polish Music: Two Polonaises (Moniuszko); (a) in G, (b) in E Flat; Spring (Aloniuszko-Meleer); Pieces (Paderewsky); (a) Sarabande in B minor; (b) Legend in A flat; Pieces (Szymanowski); (a) Two Preludes Op. Nos. 1 and 7; (b) Etude n. B flat, Op. 4 No. 3; Two Mazurkas, Op. 50, Nos. 1 and 2. 10.0, Dance Music relayed from the Café Europe, Cichocinek. In the intervals at 10.25, News, and at 11.30, News for Members of the Polish Polar Expedition.

ZÜRICH.—See Schweizerischer Landessender.

and Hunkeler). 10.15 (from Basle). Dance Music from the Summer Casino. 11.0 (approx.), Close Down.

SEVILLE

EAJ5, 815 kc/s, 368.1 metres; 1.5 kW.—9.30 to 10.0 a.m., News. 3.0 to 4.0 p.m., Music by the Station Orchestra and Flamenco Songs. 10.0, Musical Comedy Programme. Selection from: (a) La Viejeita (Caballero). (b) La rosa del azafran (Guerrero). In the interval, News, Exchange, and Weather Forecast. After the Programme, Flamenco Songs. 12 Midnight (approx.), Close Down.

SOTTENS.—See Radio-Suisse Romande.

STOCKHOLM

689 kc/s, 436 metres; 55 kW. Relayed by Boden, 244 kc/s, 1,229.5 metres; Göteborg, 932 kc/s, 322 metres; Hörby, 1,166 kc/s, 237 metres; Motala, 221.5 kc/s, 1,354.4 metres; Östersund, 389 kc/s, 770 metres, and Sundsvall, 554 kc/s, 542 metres.—4.0 p.m., Concert of Light Music by Per Carlsten (Violin), and Pelle Nordström (Songs to the Late), with Readings by Axel Högel. 5.5, Programme for Children. 5.35, Gramophone Music. 6.30, The Practical Corner. 7.30, Talk. 8.0, Old Dance Music. 10.0, Modern Dance Music. 12 Midnight (approx.), Close Down.

STRASBOURG

869 kc/s, 345 metres; 11.5 kW.—11.30 a.m., Gramophone Music. 12.45 p.m., News. 1.0, Time Signal. 1.1, Dance Music. 2.0, Legal Talk in German. 2.15, Gramophone Music. 2.30, Talk on Music; Rameau and Lully. 2.45, Interval. 3.15, Talk on Algeria. 3.30, Orchestral Concert conducted by M. Brouillie relayed from the Casino, Vichy; Overture, Egmont (Beethoven); Prelude (Hirschmann); Prelude, Ritzbezahl (Hüe); Orchestral Suite, Gitaueries (Razigade); Selection from The Rhinegold (Wagner); Selection from Sigurd (Reyer); Waltz, Les Rêves (Petras). 5.0, Orchestral Concert, conducted by M. Leggart, relayed from Colmar; Torch March No. 1 (Meyerbeer); Overture, Phèdre (Massenet); Ballet Music from Isoline (Messager); First Movement from the Unfinished Symphony (Schubert); Selection from The Valkyries (Wagner). 6.15, French Lesson. 6.30, News. 6.45, Lottery Results. 7.0, Salzburg Festival Programme, relayed from Paris (Ecole Supérieure) 671 kc/s, 447.1 metres; Fidele, Opera (Beethoven), conducted by Richard Strauss. Soloists: Lotte Lehmann, Richard Mayer and Franz Volker. 10.0 (approx.), News in French and German.

STUTT GART

MUHLACKER, 832 kc/s, 360.5 metres; 60 kW. Relayed by Freiburg, 527 kc/s, 570 metres.—12.20 p.m., New German Music on Gramophone Records. 12.45, Report of the Fifteenth German Gymnastic Festival, 1933. 1.30 (from Freiburg). Orchestral Concert, conducted by Willi Böhrmann. 2.30, Time and News. 2.50, Reading of Swabian Anecdotes by Anna Förtseh. 3.10 (from Pforzheim). Zither Concert. 3.30, See Frankfurt. 4.30 (from Karlsruhe). Orchestral Concert of German Operetta Music, conducted by Erwin Kossakovsky; Overture, Die schöne Galathee (Suppé); Mazurka from Frauenther (Joh. Strauss); Selection from Gasparone (Müllbacher); Overture, Light Cavalry (Suppé); Waltz, Wiener Blut (Joh. Strauss); Treasure Waltz from The Gipsy Baron (Joh. Strauss). 5.15, The Fifteenth German Gymnastic Festival, 1933—A Report of the Handball Final. 5.45, Talk. 6.10, Talk: The Return of the Air Ship, Westfalen. 6.35, Time and News. 7.0, Transmission for all German Stations, relayed from Berlin (Witzleben). 8.0, Variety Programme. 8.45, Concert of German Overtures by the Station Orchestra, conducted by Ferdinand Drost; Iphigenie in Aulis (Glück); The Magic Flute (Mozart); Coriolanus (Beethoven); Euryantle (Weber); Tannhäuser (Wagner); Riazzi (Wagner). 9.30, Programme for the Fifteenth German Gymnastic Festival, 1933. Community Singing and Addresses by Dr. Neuenendorff and Dr. Gübbels. 10.45, Time and News. 11.0, Report on Gramophone Records of the Fifteenth German Gymnastic Festival, 1933. 11.30, Dance Music relayed from Berlin (Witzleben). 1.0 a.m. (Sunday), Close Down.

SUNDSVALL.—See Stockholm.

TRIESTE

1,211 kc/s, 247.7 metres; 10 kW.—5.40 p.m. till Close Down, See Turin.

TRONDHEIM.—See Oslo.

tory. 3.30, Gramophone Music. 4.0, Gramophone Concert. 4.30, Concert by the Radio Suisse Romande Quintet. 5.30 to 7.0, Interval. 7.0, Science Talk. 7.30, Talk on Films. 8.0, Cello Recital by Franz Walter; Sonata in D minor (Debussy); Popular Spanish Suite (Fallas). 8.30, Variety Items by Ruy Blag. 8.45, Concert by the Radio Suisse Romande Orchestra, conducted by Robert Echenard. 9.50, News and Weather. 10.0, Dance Music by the Broadcasting Semblers. 11.0 (approx.), Close Down.

REYKJAVIK

250 kc/s, 1,200 metres; 21 kW.—9.5 p.m., Musical Programme. 9.30, Weather Report. 9.40, Musical Programme and Announcements. 10.0, Chimes and News. 10.30, Reading. 11.0, The Radio Trio, followed by Dance Music. 2.0 a.m. (Sunday), Close Down.

RIGA

572 kc/s, 525 metres; 15 kW.—7.30 p.m., Concert by the Radio Orchestra, conducted by Werner Jansen. Overture, Fingal's Cave (Mendelssohn); Les Préludes (Liszt); The Ride of the Valkyries (Wagner); March and Nocturne (Griffes); Virginius Dance (Powell); Adagio (Hansen); An American in Paris (Gershwin). In the interval at 8.10, News, and at 9.0, Weather. After the Concert, News and Dance Music. 11.0 (approx.), Close Down.

RJUKAN.—See Oslo.

ROME

Call 1R0, 680 kc/s, 441 metres; 50 kW. Relayed by Naples, 941 kc/s, 319 metres, and 2R0, 11,810 kc/s, 25.4 metres, from 5.30 p.m.—1.0 to 2.15 p.m., Orchestral Concert. In the intervals from 1.15 to 1.20, Talk on Photography. 1.30 to 1.45, Giornale Radio and Exchange, and at 2.0, Time and Announcements. 4.30, Children's Radio Review. 4.45, Report of the Royal Geographical Society and Giornale Radio. 5.5, Reading. 5.15, Exchange and Weather. 5.30 to 6.15, Orchestral Concert; Dance (Shaw); Vagabonda (Rampoldi); Second Slay Rhapsody (Friedmann); Danza di Colombina (Manno); Giocando Zappatorra (Pietro); Waltz, Alba d'amore (Figarola); Che importa a me (Lao Schor); Baby (Abel). 6.40 (Naples). Shipping and Sports Notes. 6.50, Agricultural and Dopolavor Notes. 7.0, Tourist Report. 7.10, Lesson in Morse. 7.20, News in Foreign Languages. 7.40, Giornale Radio. 8.0, Time and Announcements. 8.15, Gramophone Music. 8.25, Giornale Radio and Sports Notes. 8.30, Sponsored Concert. 9.30, Concert by the Augusto Orchestra, relayed from the Basilica di Massenzio; Review of New Books in the interval. 10.55, Giornale Radio.

SALZBURG.—See Vienna.

SCHENECTADY

WGY, 790 kc/s, 379.5 metres; 50 kW. Relayed at intervals by WZXF on 31.48 metres; and by W2XAD, Stock Reports and Baseball Scores, 1.0, Lady Fingers (Pianists). 1.30 to 4.0, New York relay. 1.30, Pedro Via Orchestra, 2.0, Forde Grote's Orchestra. 2.15, Four Horsemen. 2.30, K-7, Secret Service Spy Story. 3.0, B. A. Rolfe and his Orchestra. 4.0, Programme Résumé.

SCHWEIZERISCHER LANDESENDER

BEROMUNSTER, 653 kc/s, 459 metres; 60 kW.; Basle, 1,229 kc/s, 244.1 metres; and Berne, 1,220 kc/s, 245.9 metres.—11.59 a.m., Time Signal from Neuchâtel Observatory and Weather. 12 Noon (from Zürich). Gramophone Music. 12.30 p.m., Time and News. 12.40 (from Zürich). Concert by a Peasant Orchestra. 1.25 (from Zürich). Time, Weather, and Exchange. 1.30 (from Zürich). Answers to Correspondence. 1.45 (from Zürich). Book Review. 2.15 (from Zürich). Gramophone Concert. 2.45 (from Zürich). Talk for Gardeners. 3.30, Interval. 5.0 (from Zürich). Musical Programme by the Kollbrunn School. 6.0 (from Zürich). Technical Talk. 6.30 (from Basle). Programme for Children. 7.0, Chimes. 7.15 (from Basle). Time and News. 7.20 (from Basle). Gramophone Dance Music. 8.0 (from Basle). Topical Programme. 8.30 (from Basle). Music for Two Pianofortes. 9.0, News. 9.10 (from Basle). Leutlin seid's lustig!—Play (Anders

(Tchaikovsky); Chant d'après-midi (Cuvillier). La chère maison (Dalcroze); Idéale (Tosid); Mélancoie (Delmet); Les uanans (Delmet). In the intervals at 1.0, Exchange, News and Weather, and at 1.30, Exchange. 2.0, Exchange and Market Prices. 2.45 (approx.). Running Commentary on the last Doubles. Match of the Final for the Davis Cup. Matches. 3.45, Market Prices. 7.0, Market Prices, Weather, Agricultural Notes and Racing Results. 7.10, Dance Music on Gramophone Records. 7.50, Commercial Notes and News. 8.0, Gramophone Music. In the intervals: News. 10.30, Popular Concert.

PITTSBURGH

KDKA, 980 kc/s, 306 metres; 59 kW. Relayed by W8XK on 48.85 metres; and 25.27 metres.—7.30 to 8.53 p.m., New York relay. 7.30, Concert Echoes. 8.0, Words and Music. 8.30, Wealth of Harmony. 8.58, Baseball Scores. 9.0, Harry Sosnick's Century of Progress Orchestra, from New York. 9.30, Chautauqua Opera Association, from New York. 9.55, Baseball Scores. 10.0, Rhythm Kings. 10.15 to 11.0, New York relay. 10.15, Tom Gerun and Casino Orchestra. 10.30, Neil Sisters. 10.45, Little Orphan Annie. 11.0, Time Signal and Press News-Reeler. 11.5, Piano Classique. 11.15, Weather Report. 11.16, Sport Review. 11.22, Press News-Reeler. 11.25, Temperature Report. 11.30, A Récro by Bill and Alex of the Downtown Y.M.C.A. 11.45, Meyer Davis and his Hotel St. Regis Orchestra, from New York. 11.59, Time Signal. 12 Midnight, American Tax Payers' League, from New York. 12.15 a.m. (Sunday), Annie, Judy and Zuke. 12.30 to 3.15, New York relay. 12.30, Jack Pettis and his Orchestra. 1.0, Jack Denny and his Orchestra. 1.30, Stadium Concert by the Philharmonic Symphony Orchestra. 3.15, Time Signal and Behind the Law—Tales of the Pennsylvania State Police.

PORSGRUND.—See Oslo.

POZNAN

896 kc/s, 335 metres; 1.9 kW.—6.15 p.m., See Warsaw. 7.20, Miscellaneous Announcements and News. 7.35, Amusement Guide and Programme Announcements. 7.40, See Warsaw. 7.58, Time Signal. 8.0, See Warsaw. 10.0, Sports and Police Notes. 10.15, Dance Music from the Café Esplanade. 11.0 (approx.), Close Down.

PRAGUE

614 kc/s, 488.6 metres; 120 kW.—2.50 p.m., Concert of Light Music. 4.0, Interval. 5.45, Gramophone Music. 5.55, Talk. 6.5, Agricultural Report. 6.10, Gramophone Music. 6.15, Talk for Workers. 6.25, News in German. 6.30, German Transmission; Talk on the Opening of the Salzburg Festival and Reading. 7.0, Chimes. 7.10, Talk; Women and the Constitution. 7.25, Brass Band Concert on Gramophone Records. 8.0, See Bratislava. 10.0, Time and News. 10.15, Variety Programme. Is Sir Conan Doyle guilty?—Sketeh (Stendy); Songs from Sound Films; Pianoforte Improvisation (Lefius); Sound Film Music on Gramophone Records. 11.30 (approx.), Close Down.

RABAT

721.1 kc/s, 416 metres; 6 kW.—1.30 p.m., Concert by the Symphony Orchestra, conducted by Marcel Sallin. Persian Dance (Guiraud-Mouton); Plaisir d'amour (Martini). Napoli (Charpentier-Mouton); Song, Poème for Viola and Pianoforte (Cool); Selection from Madame Butterfly (Puccini-Ravan); Arabesque for Pianoforte (Schumann); Song; Selection from Il est charmant (Moretti-Salabert); Guitare (Bizet-Mouton); Tango, Campañas (Ventura). 3.0, Interval. 5.0, Gramophone Concert. 6.0, Interval. 8.0, Arab Programme—Concert of Andalusian Music. 8.45, Le Journal Parlé, Weather, and News. 9.0, Orchestral Concert. Selection from Marietta (O. Strauss-Salabert); Song, Vous menacez from Le petit duc (Lecocq); Selection from Bouche à bouche (Yvain-Salabert); Song, Que ne puis je? from Miss Decima (Andran); Selection from La jolie persane (Lecocq-Gauwin); Song, Les soldats d'Angereau from La fille de Madame Angot (Lecocq); Selection from Le Comte obligado (Moretti-Salabert). 10.0, Sponsored Gramophone Concert.

RADIO-SUISSE ROMANDE

SOTTENS, 743 kc/s, 403 metres; 25 kW.; and Geneva, 395 kc/s, 760 metres.—12.28 p.m., Time Signal from Neuchâtel Observatory. 12.30, News and Weather. 12.40, Gramophone Music. 1.0, Financial News. 1.10, Gramophone Music. 2.0 to 3.28, Interval. 3.28, Time Signal from Neuchâtel Observa-

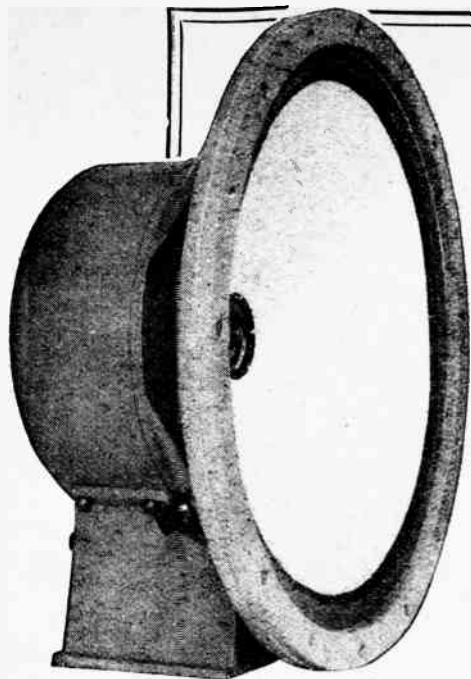

PARMEKO

NEW "SENIOR" MODEL LOUD SPEAKER

In order to meet the demand of those who prefer a Loud Speaker of the large cone type, we have recently introduced our "SENIOR" MODEL. This speaker will be found similar in all respects to our "STANDARD" MODEL, with the exception that it has a 12" diameter diaphragm with a cone angle of 120°.

It is capable of handling a large input without distortion. Supplied complete with Unit, Base and Transformer, giving Ratios of 11:1 and 22:1.

PRICE £7

CATALOGUE AND FULL PARTICULARS FREE ON REQUEST

PARTRIDGE & MEE LTD.,

"Parmeko" Works,
Aylestone Park, LEICESTER

74, New Oxford Street,
LONDON, W.C.1.
Mus. 5070.

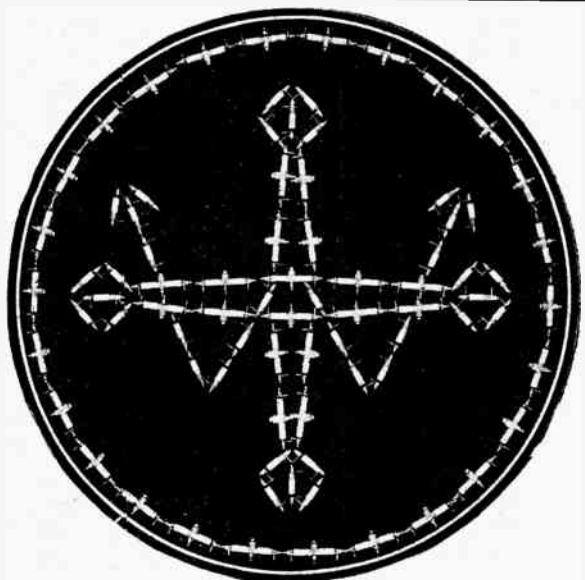

FIT THE WESTECTOR IN YOUR SET

and get pure detection with no distortion and consequently better quality. Its use also means a saving in current, as the Westector contains neither anode nor filament. Write to-day for particulars of the new metal detector.

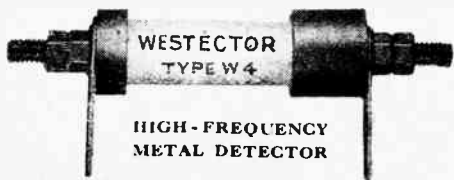

IT'S A WESTINGHOUSE PRODUCT!

THE WESTINGHOUSE BRAKE & SAXBY SIGNAL CO., LTD.
82, YORK ROAD, KING'S CROSS, LONDON.

Power Amplifiers and P.A. Equipment

for Fêtes, Sports Grounds, Restaurants, Public Halls, etc. Powerful output with purity of reproduction. B.S.R. Equipment is moderate in price and gives trouble-free operation.

WIRELESS WORLD Test Report states—

"...a very high standard in reproduction...undoubtedly in a class apart"

If you want the finest possible, you must have B.S.R.

**BIRMINGHAM SOUND REPRODUCERS, LTD.,
CLAREMONT WORKS, OLD HILL, STAFFS.**

Phone: Cradley Heath 6370.

Grams · Electronic · Old Hill

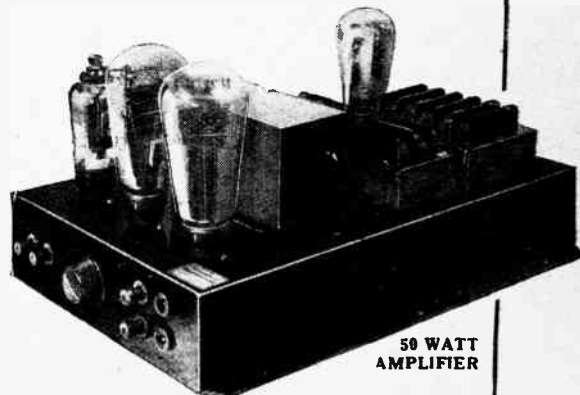

**50 WATT
AMPLIFIER**

Holder:

Advertisements for "The Wireless World" are only accepted from firms we believe to be thoroughly reliable.

The instrument for to-day and to-morrow



If you are considering the purchase of a radio gramophone ask yourself these important points.

1. Will the design and appearance harmonise with my scheme of furnishing?
2. Is the instrument sufficiently selective, not only for to-day, but also for the future, when the ether will be even more crowded than it is to-day?
3. Is the power output sufficient to give a maximum volume without distortion, adequate for all my requirements?
4. Is the reproduction of the highest quality it is possible to obtain, regardless of price considerations.
5. Is operation so simple that my child can switch on and tune in?

A satisfactory answer to *all* these questions is found in the R.G.D. Radio gramophone. Your choice then?—It *must* be R.G.D.

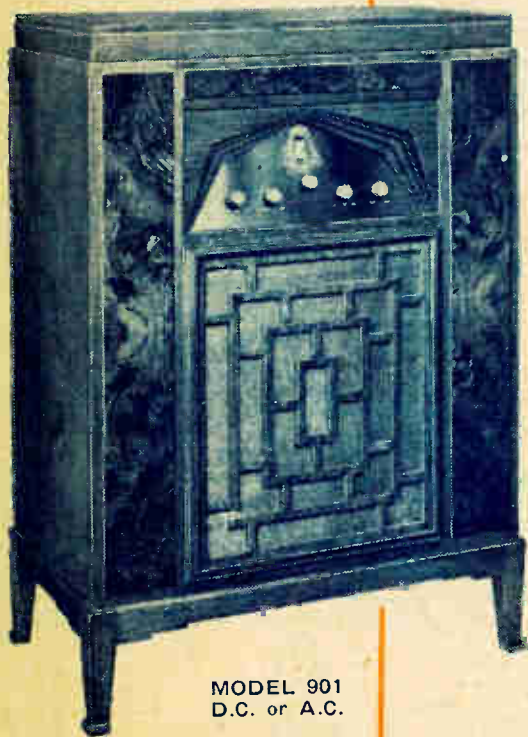

MODEL 901
D.C. or A.C.

The 9-valve superheterodyne circuit has 9 tuned circuits, and tuning is by a single illuminated dial. Two balanced loud speakers are incorporated, thus ensuring amazing fidelity of reproduction. The volume control is effective on both radio and gramophone, and a tone control and delayed A.V.C. are also fitted. Equipment includes a Garrard Electric Motor and R.G.D. Pick-up.

Price. In Oak **80 Gns.**

Model 701 is a 7-valve superheterodyne instrument having 7 tuned circuits. Tuning is by a single illuminated dial. This model is "little brother" to the famous Model 901, and its performance is similar. It is however, produced at a lower price.

Price. In Walnut **48 Gns.**

Automatic Record Changer available on both models.

R·G·D

The Ultra Modern Radio Gramophone

RADIO GRAMOPHONE DEVELOPMENT CO., LTD.
17-20, FREDERICK ST., BIRMINGHAM.

Manchester : 17, Bridge Street. London : 40, Doughty Street, W.C.1

Holens

OLYMPIA'S PRIZE-WINNER FOR TWO CONSECUTIVE YEARS

4^D

The Wireless World

THE PRACTICAL RADIO JOURNAL

with

Complete Foreign Programmes

Friday, July 28th, 1933.

H.T. for ever for 1/- a year

EKCO POWER UNITS

Write to: E. K. Cole, Ltd., Dept. W.19, Ekco Works, Southend-on-Sea.

AN INTERESTING GIFT

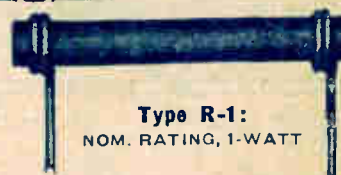

Type R-1:
NOM. RATING, 1-WATT

RESISTORS

To prove the superiority of our "B.A.T." (Best-After-Test) BRITISH-MADE FIXED RESISTANCES (1, 1/2, 1, 2, 3, and 5-WATTS) we will send Free and Post-Free to applicants mentioning this Journal, our 2-Colour Art Booklet, 2nd, ENLARGED EDITION 16pp., entitled:

"OHMS LAW WITHOUT TEARS"

A Complete Treatise, with Circuits, Simple Formulae, Voltage-Dropping and Current-Carrying Charts, "ABAC," worked examples, etc. It tells you all you ought to know about the "mysteries" of Volts, Amps, Resistance Values and Watts-Dissipation as applied to the use of Resistors for Radio purposes. The edition is limited.

CLAUDE LYONS, LIMITED,

76, OLDHALL STREET, LIVERPOOL.
40, BUCKINGHAM GATE, LONDON, S.W.1.

The "CHALLENGER"

Standard Model for use with Super Power and Pentode Outputs. Includes 3 ratio Transformer.

OTHER "CHALLENGER" MODELS—

TYPE "B" for Class B Amplification. (B8 for Cossor, and B15 for Mullard and Mazda Class B Valves.)

"P" An Extension Instrument for Commercial Receivers.

"Q" for Quiescent Push-Pull, (15,000 ohms Plate-to-Plate Load.)



RA & REPRODUCERS
REPRODUCERS & AMPLIFIERS LTD.
WOLVERHAMPTON

35/-

TELSEN SUPERHET COILS

TYPE No. S.330

Specified for the W.W. Monodial Super Battery Receiver. The ideal coils for any superhet circuit. **25/6**

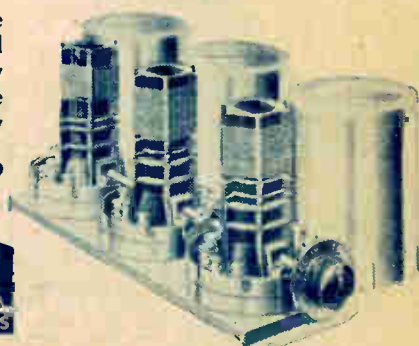

TELSEN
RADIO COMPONENTS

Announcement of the TELSEN ELECTRIC CO., LTD., ASTON, BIRMINGHAM

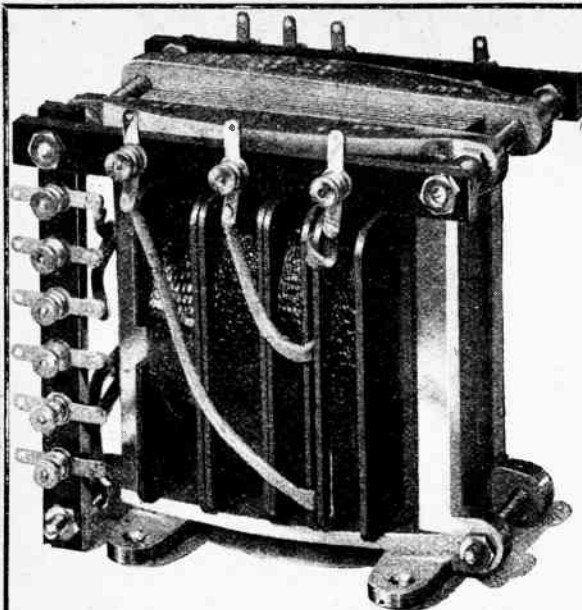

LYONS' "B.A.T."
 (Best-After-Test)
MAINS
TRANSFORMER
 No. 262 . . . 50/-
 GOOD STOCKS. NO WAITING.
ORDER YOURS NOW!

**SPECIFIED for the "WIRELESS WORLD"
 NEW MONODIAL SUPERHET,
 DESCRIBED IN THIS ISSUE!**

We feel very gratified that within a few weeks of the introduction of our revolutionary Type 2A7 "Pentagrid-Converter" Valve, same has been selected for incorporation in the remarkable new "Monodial" Set, described in this issue. Numerous British-Made Lyons-"B.A.T." (Best-After-Test) Products have also been specified, proof positive of their sterling merits. The complete selection is:—

FOR THE RECEIVER UNIT:

- 1 "B.A.T." Type 728 Toggle Switch, 3 amps. 250 v. 16
- 2 "B.A.T." Type 6728 D.P.D.T., Q.M.B. Switches @ 3/9 7 6
- 1 Type P-58, 5,000 Ohms W.W. Volume Control 5 6
- 1 Tapered Volume Control, 250,000 Ohms 6 6
- 1 Special 2-Ohm W.W. Power Resistance 1 6
- 1 Complete Kit of 18 "B.A.T." Precision Resistors, as specified, at 10½d. per Watt 17 6
- 1 LYONS-SYLVANIA Type 2A7 PENTAGRID-CONVERTER VALVE, with Grid-Clip 17 6
- 1 USA-Pattern 7-Pin (Medium) Valveholder 2/-

FOR THE POWER UNIT:

- 1 Complete Kit of 6 "B.A.T." Precision Resistors, at 10½d. per Watt 7/-
- 1 "B.A.T." (BEST-AFTER-TEST) MAINS TRANSFORMER, with correct length colour-coded leads, exactly to specification, Catalogue No. 262 50/-



LYONS-SYLVANIA "TYPE 2A7 PENTAGRID-CONVERTER" VALVE (See "WIRELESS WORLD" ISSUE JUNE 9, PAGES 407-9) **17'6**

SHOULD YOU EXPERIENCE DELIVERY DELAYS, WRITE TO US, AND WE WILL IMMEDIATELY ASSIST YOU

CLAUDE LYONS LTD.
 76, OLDHALL STREET, LIVERPOOL, 3
 40, BUCKINGHAM GATE, WESTMINSTER, S.W.1.

RADIO DATA CHARTS

A SERIES OF ABACS

providing most of the essential Data required in Receiver Design

By **R. T. BEATTY, M.A., B.E., D.Sc.**

(1930)

Reprinted from "The Wireless World"

"Radio Data Charts" provide designers of wireless apparatus with a ready and convenient means of solving problems without having recourse to complicated formulæ and mathematics.

By the use of the charts it is possible to tackle all the more familiar problems in radio receiver design; such as, for example, finding the relationship between inductance capacity and frequency, and working out the design of high frequency transformers. All keen amateurs will appreciate this helpful book.

Price 4'6 net By post 4'10

(39 CHARTS and more than 50 Diagrams)

From all leading booksellers or direct from the Publishers
 Published from the Offices of "THE WIRELESS WORLD"

ILIFFE & SONS LTD., Dorset House, Stamford St., London, S.E.1

The Wireless World

PROGRAMMES from A BROAD

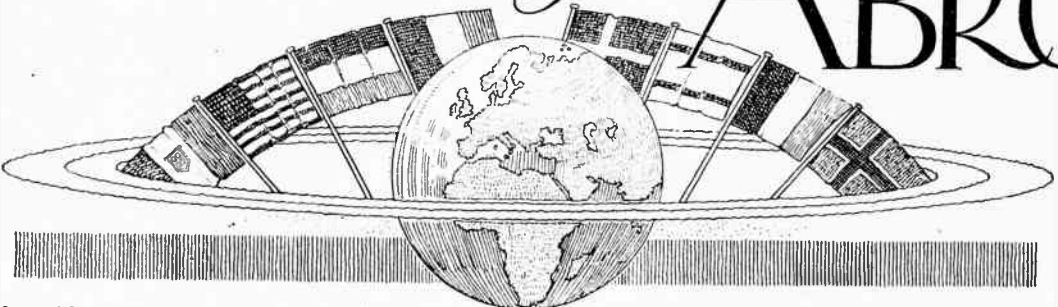

**BROADCASTING STATIONS
ARRANGED IN ORDER
OF WAVELENGTH**

**TIMES AND DETAILS OF
FULL WEEK'S FOREIGN
TRANSMISSIONS**

Metres.	kc s.	kW.	Station.	Tuning Positions.	Metres.	kc s.	kW.	Station.	Tuning Positions.
1935	155	7	Kaunas (Kovno) (Lithuania)		453.2	662	7	Milan (<i>Experimental Relays Rome</i>)	
1875	160	50	Huizen (Holland) (8.5 kW. before 4 p.m.)		450.3	666	20	Madona (Latvia). (<i>Relays Riga</i>)	
1796	167	40	Lahti (Finland)		447.1	671		Paris, Ecole Supérieure, PTT (7.0 kW.); Rjukan (0.15 kW.), Notodden (0.08 kW.); Aalsund (0.35 kW.) (Norway) (<i>relays Oslo</i>).	
1725	174	75	Radio Paris, C.F.R.						
1635	183.5	60	Berlin (Deutschlandsender) (Germany). (S.-W. <i>Stn. DJA</i> on 31.38 m., <i>DJB</i> on 19.73 m., <i>DJC</i> on 49.83 m., <i>DJD</i> on 25.51 m., <i>DJE</i> on 16.89 m.)		441.2	680	50	Rome, IRO. (S.-W. <i>Station</i> , 2 RO on 25.4 m.)	
1554.4	193	30	Daventry National		435.4	689	55	Stockholm, S.A.S.A. (Sweden)	
1538	195	7	Ankara (Angora) (Turkey)		430.4	697	2.5	Belgrade (Yugoslavia)	
1481	202.5	100	Moscow, RV1 (Old Komintern) (Russia)		424.3	707	2	Madrid, EAJ7 (Union Radio). (After 7.0 p.m.)	
1446	207.5	13	Eiffel Tower, P.L., Paris		424.3	707	100	Moscow, Imini Stalina (Russia)	
1412	212.5	120	Warsaw 1 (Poland)		419.5	715	1.5	Berlin, Witzleben (Germany)	
1380	217.5	100	Novosibirsk, RV6 (Russia)		416.4	720.5	5	Rabat (Morocco)	
1354.4	221.5	30	Motala (Sweden). (<i>Relays Stockholm</i>)		413	725	60	Athlone (Irish Free State)	
1304	230	500	Moscow, WZSPS (Trade Union) (Russia)		408.7	734	16	Katowitz (Poland)	
1275	235	0.5	Tunis-Kasbah (Tunisia)		403.8	743	25	Sottens (Radio Suisse Romande) (<i>Switzerland</i>)	
1230	244	0.6	Boden (Sweden). (<i>Relays Stockholm</i>)		398.9	752	25	Midland Regional. (Daventry)	
1200	250	5	Stamboul (Turkey)		394.2	761	12	Bucharest (Roumania)	
1200	250	21	Reykjavik (Iceland)		389.6	770	120	Leipzig (Germany)	
1190	252	200	Luxembourg		385.1	779	8	Toulouse (Radiophonie du Midi) (France)	
1170	256	25	Tashkent, RV11 (Russia)		385.1	779	10	Stalino, RV26 (Russia)	
1154	260	7.5	Kalundborg (Denmark). (<i>Relays Copenhagen</i>)		381	788	16	Lwow (Lemberg) (Poland)	
1117	268.5	40	Moscow, Popoff RV58 (Russia)		376.4	797	50	Scottish Regional (Falkirk)	
1083	277	60	Oslo (Norway)		372.2	806	1.5	Hamburg (Germany)	
1071	280	35	Tillis, RV7 (Russia)		370.1	810.5	0.8	Radio, L.L., Paris	
1035	290	36	Kiev, RV9 (Russia)		368.1	815		Seville, EAJ5 (Union Radio) (1.0 kW.); Cadix, EAJ1 (0.2 kW.); Bolzano (1.0 kW.) (Italy); Helsinki (10 kW.) (Fin- land) (<i>relays Lahti</i>); Kharkov, RV20 (10 kW.) (Russia).	
1000	300	100	Moscow (Russia) (S.-W. <i>Stn.</i> on 50 m.)		368.1	815	0.7	Fredriksstad (Norway). (<i>Relays Oslo</i>)	
938	320	20	Kharkov, RV4 (Russia)		364.1	824	1	Bergen (Norway)	
857	350	100	Leningrad (Russia)		363.6	825	13	Algiers (Algeria)	
840	357	18.5	Budapest (Hungary)		360.6	832	60	Mühlacker (Stuttgart) (Germany)	
825	363.6	50	Sverdlovsk, RV5 (Russia)		355.9	843	50	London Regional (Brookmans Park)	
760	395	1.3	Geneva (Switzerland). (<i>Relays Sottens</i>)		352.1	852	7	Graz (Austria). (<i>Relays Vienna</i>)	
720	416.6	15	Monte Ceneri (Switzerland). (<i>Testing</i>)		348.8	860	7.6	Barcelona, EAJ1 (Spain)	
720	416.6	20	Moscow, RV2 (Experimental) (Russia)		348.8	860	10	Leningrad, RV70 (Russia)	
690	434.6	1.5	Oulu (Uleaborg) (Finland)		345.2	869	11.5	Strasbourg, PTT (France)	
680	441.2	0.6	Lausanne (Switzerland). (<i>Relays Sottens</i>)		341.7	878	35	Brno (Brunn) (Czechoslovakia)	
574.7	522	7	Ljubljana (Yugoslavia)		238.2	887	15	Brussels II, Velthem (Belgium). (<i>In Flemish</i>)	
569	527	0.25	Freiburg-im-Breisgau (Germany). (<i>Relay Stn.</i>)		335	896	5	Cadiz (Spain)	
568.1	528	2	Grenoble (France)		334.4	897	1.9	Poznan (Poland)	
566	530	0.25	Hanover (Germany). (<i>Relays Hamburg</i>)		331.5	905	50	Milan (Italy). (<i>Relays Turin</i>)	
563	533	16	Wilno (Poland). (<i>Relay Station</i>)		328.2	914	60	Poste Parisien (France)	
560	536	0.25	Augsburg (Germany). (<i>Relays Munich</i>)		325	923	60	Breslau (Germany)	
560	536	1.5	Kaiserslautern (Germany). (<i>Relays Munich</i>)		321.9	932	10	Göteborg (Sweden). (<i>Relays Stockholm</i>)	
550	545	18.5	Budapest No. 1 Lakihegy (Hungary)		318.8	941	0.25	Dresden (Germany). (<i>Relays Leipzig</i>)	
542	554	10	Sundsvall (Sweden). (<i>Relays Stockholm</i>)		318.8	941	1.5	Naples, INA (Italy). (<i>Relays Rome</i>)	
537.6	558	3	Palermo (Italy)		315.8	950	1.6	Marseilles, PTT (France)	
533	563	60	Munich (Germany)		312.8	959	0.7	Radio Vitus (Paris). (S.-W. <i>Stn.</i> on 43.75 m.)	
525	571	15	Riga (Latvia)		312.8	959	1.7	Cracow (Poland)	
517.2	580	100	Vienna (Bisamberg) (Austria).		312.8	959	-10	Genoa, IGE (Italy). (<i>Relays Turin</i>)	
509	589	15	Brussels No. 1, Velthem (Belgium). (<i>In French</i>)		309.9	968	1	Cardiff	
500.8	599	20	Florence, IF1 (Italy). (<i>Relays Turin</i>)		307	977	0.75	West Regional (Washford Cross)	
495.8	605	1.2	Fronthheim (Norway)		304	986	13	Zagreb (Yugoslavia)	
488.6	614	120	Prague, No. 1 (Czechoslovakia)		301.5	995	50	Bordeaux Lafayette, PTT (France)	
480	625	50	North Regional (Manchester)		298.3	1001	11	North National (Manchester)	
472.4	635	60	Langenberg (Germany)		296.1	1013	20	Tallinn (Esthonia)	
465.8	644	15	Lyons la Doua, PTT (France)		293.5	1022	0.7	Hilversum (Holland). (7 kW. before 4.40 p.m.)	
459.4	653	60	Beromünster (Schweizerischer Landessender) (Switzerland).		293.5	1022	2.6	Limoges, PTT (France)	
453.2	662		San Sebastian, EAJ8 (0.6 kW.); Pori (1.0 kW.) (Finland); Danzig (0.5 kW.) (<i>relays Helsinki</i>); Klagenfurt (0.5 kW.) (Austria) (<i>relays Vienna</i>); Porsgrund (0.7 kW.) (<i>relays Oslo</i>), Tronsö (0.1 kW.) Bodö (0.5 kW.) (Norway); Uppsala (0.15 kW.) (Sweden) (<i>relays Stockholm</i>).		291	1031	13.2	Kosice (Czechoslovakia)	
453.2	662	0.25	Agen (France)		288.3	1040	50	Viipuri (Viborg) (Finland). (<i>Relays Helsinki</i>)	
					288.3	1040	1	Scottish National (Falkirk)	
					286	1049	0.8	Bournemouth (<i>Relay Station</i>)	
								Montpellier (France)	

BROADCASTING STATIONS ABROAD (In Order of Wavelength).

Metres.	kc/s.	kW.	Station.	Tuning Positions.	Metres.	kc/s.	kW.	Station.	Tuning Positions.
284.8	1053	0.7	Lyons (Radio-Lyon) (France)		244.1	1229	0.5	Basle (Switzerland). (Relays Beromünster)	
283.6	1058	0.5	German Relays (Berlin, Magdeburg, Stettin)		242.3	1238	1	Belfast (N. Ireland)	
283.6	1058	0.5	Innsbruck (Austria). (Relays Vienna)		240.6	1247	0.5	Stavanger (Norway)	
282.2	1063	2	Lisbon CT 1AA (Portugal). (Short-wave Station on 31.25 m.)		238.9	1256	2	Nürnberg (Germany). (Relays Munich)	
281.2	1067	0.75	Copenhagen (Denmark)		238	1260	1	Nimes (France)	
278.8	1076	13.5	Bratislava (Czechoslovakia)		237.2	1265	3	Bordeaux, Sud-Ouest (France)	
276.5	1085	60	Heilsberg (Germany)		235.5	1274	0.5	Kristiansand (Norway)	
273.7	1096	7	Turin (Italy)		235	1283	1.65	Lodz (Poland). (Relay Station)	
271.5	1105	1.3	Rennes, PTT (France)		232.2	1292	0.25	Kiel (Germany). (Relays Hamburg)	
269.8	1112	20	Bari (Italy)		230.6	1301	—	Swedish Relay Stations. (Malmö, Norrköping, Karlstad and Trollhättan).	
269.8	1112	0.25	Bremen (Germany). (Relays Hamburg)		227.4	1319	0.5	Flensburg (Germany). (Relays Hamburg)	
267.6	1121	1.5	Valencia (Spain)		225.9	1328	10	Fécamp, Radio-Normandie (France)	
265.8	1128.5	1.3	Lille, PTT (France)		224.4	1337	1	Cork (Irish Free State)	
263.8	1137	11.2	Moravska Ostrava (Czechoslovakia)		222.9	1346	0.15	Hüdkösvall (Sweden)	
261.5	1147	50	London National (Brookmans Park)		219.9	1365	1.5	Béziers (France)	
259.3	1157	17	Frankfurt-a.M. (Germany)		218.5	1373	0.2	Plymouth	
259.3	1157	2.3	Trier (Germany). (Relays Frankfurt)		218.5	1373	0.5	Salzburg (Austria). (Relays Vienna)	
257.1	1167	10	Hörby (Sweden). (Relays Stockholm)		217	1382	0.5	Königsburg (East Prussia) (Germany)	
255.1	1176	0.7	Toulouse, PTT (France)		217	1382	0.25	Karlstad (Sweden)	
253.1	1185	5	Gleiwitz (Germany). (Relays Breslau)		215.6	1391	0.2	Halmstad (Sweden)	
252	1193	1	Barcelona, EAJ15 (Assoc. Nat.) (Spain)		214.3	1400	1	Aberdeen	
249.6	1202	0.8	Juan-les-Pins, Nice (France)		211.3	1420	1	Newcastle	
247.7	1211	10	Trieste (Italy). (Relays Turin)		209.8	1430	1.25	Magyarovar, Miskolcz and Pecs (Hungary)	
245.9	1220	0.12	Swansea		207	1450	0.15	Boras (Sweden)	
245.9	1220		Berne (0.5kW.) (Switzerland) (relays Beromünster); Eskilstuna (0.2 kW.), Säffle (0.4 kW.) (Sweden) (relays Stockholm); Cussel (0.25 kW.) (Germany) (relays Frankfurt); Linz (0.5 kW.) (Austria) (relays Vienna); Pietarsaari (0.5 kW.), Turku (Abo) (0.5 kW.) (Finland) (relays Helsinki).		206	1460	0.2	Ornsköldsвик (Sweden)	
					204.1	1470	0.2	Gävle (Sweden)	
					202.7	1480	0.25	Kristinehamn (Sweden)	
					201.3	1490	0.25	Hälsingborg (Sweden)	
					195	1530	0.2	Karlskrona (Sweden)	

PRINCIPAL SHORT-WAVE STATIONS.

(N.B.—Times of Transmission, given in parentheses, are approximate only and represent B.S.T.)

Metres.	kc/s.	Call Sign.	Station.	Tuning Positions.	Metres.	kc/s.	Call Sign.	Station.	Tuning Positions.
80.0	3,750	2RO	Rome (Ecuador). (Daily 13.30)		40.3	7,413	HBBQ	Radio Nations, Prangins (Switzerland). (Sun. 23.00-23.15)	
73.0	4,110	IICJB	Quito (Ecuador). (Daily 13.30)		39.7	7,556	HKF	Bogota (Colombia). (Westinghouse Labs.)	
70.2	4,273	RW15	Khabarovsk (Russia). (Daily 10.00-13.00)		39.4	7,612	X26A	Nuevo Laredo (Mexico). (Thurs. 17.00)	
62.56	4,795	VE9BY	London, Ont. (Canada). (Sun. 07.00)		38.7	7,797	HBL	Radio Nations, Prangins (Switzerland). (Sun. 23.00-23.45)	
62.5	4,800	W2XY	Long Island, N.Y. (U.S.A.). (Fri. 01.00)		34.68	8,650	W2XV	Long Island, N.Y. (U.S.A.). (Fri. 21.00)	
58.31	5,115	OK1MPT	Prague (Czechoslovakia). (Tues. and Fri. 20.30)		34.68	8,650	VE9BY	London, Ont. (Canada). (Mon. 22.00)	
58.3	5,146	PMY	Bandoeng (Java). (Daily 13.20 and 08.00)		33.50	8,928	TGX	Guatemala City (S. America)	
54.52	5,502	W2XBH	Brooklyn, N.Y. (U.S.A.). (Relays WCGU)		32.26	9,300	—	Rabat (Morocco). (Sun. 22.00)	
52.7	5,690	F1QA	Tananarive, P.T.T. (Madagascar)		31.6	9,490	SR1	Posen (Poland). (Tues. and Thurs. 18.30)	
51.22	5,714	XDA	Chapultepec (Mexico)		31.58	9,500	PRBA	Rio de Janeiro (Brazil). (Daily 22.30)	
50.6	5,930	HKO	Medellin (Colombia)		31.55	9,510	VK3ME	Melbourne (Australia). (Wed. and Sat. 11.00)	
50.26	5,970	HVJ	Vatican State, Rome. (Daily 20.00)		31.54	9,510	GSB	Empire Broadcasting, Zones 2, 4, 5	
50.0	6,000	ZL3ZC	Christchurch (New Zealand). (Wed. 01.00, Sat. 08.30)		31.48	9,530	W2XAF	Schenectady, N.Y. (U.S.A.) (Relays WGI)	
50.0	6,000	—	Bucharest (Roumania)		31.38	9,560	DJA	Zeesen (Germany). (Daily 23.00)	
50.0	6,000	EAR25	Moscow (Relays Trade Union Stn.)		31.35	9,570	W1XAZ	East Springfield, Mass. (U.S.A.). (Relays WBZ)	
49.96	6,005	IIRB	Tegucigalpa (Honduras). (Daily ex. Sun. 01.00-06.00)		31.3	9,582	W3XAU	Philadelphia, Pa. (U.S.A.). (Daily ex. Thurs. and Fri. 22.00)	
49.83	6,020	DJC	Zeesen (Germany)		31.3	9,580	HBL	Radio Nations, Prangins (Switzerland). (Sun. 23.00-23.45)	
49.8	6,023	XEW	Mexico City (Mexico). (Daily 02.00)		31.29	9,585	GSC	Empire Broadcasting, Zone 3	
49.67	6,042	W2XAL	Coytesville, N.J. (U.S.A.). (Relays WRFY)		31.28	9,590	VK2ME	Sydney (Australia). (Sun. 11.00)	
49.67	6,042	W1XB	Miami Beach, Florida (U.S.A.)		31.25	9,598	CT1AA	Lisbon (Portugal). (Tues. and Fri. 23.00-01.00)	
49.6	6,018	W3XAU	Philadelphia, Pa. (U.S.A.). (Relays WCAU)		31.10	9,640	HS2PJ	Bangkok (Siam). (Mon. 03.00-06.00)	
49.58	6,050	GSA	Empire Broadcasting, Zones 4-5		31.0	9,675	T14NRII	Heredia (Costa Rica). (Daily 23.00 and 03.00)	
49.5	6,060	VQ7LO	Nairobi (Kenya Colony). (Daily 17.30)		30.0	10,000	EAQ	Aranjuez (Spain). (Daily 22.30, Sat. 18.00)	
49.5	6,060	W8XAL	Nairon, Ohio (U.S.A.). (Relays WLB)		29.98	10,350	LSX	Belgrade (Yugoslavia). (Mon. 20.00)	
49.43	6,069	VE9CS	Vancouver, B.C. (Canada)		28.98	11,180	CT3AQ	Buenos Aires (Argentina). (Daily 21.30)	
49.4	6,072	OXY	Skamlebaek (Denmark). (Relays Copenhagen)		26.83	11,800	—	Funchal (Madeira). (Tues. and Thurs. 11.30-13.30)	
49.4	6,072	UOR2	Vienna. (Tues. 14.00, Thurs. 16.00, Sat. 21.00)		25.63	11,705	FYA	Pontoise (France). (Colonial Stn. E-W, daily 20.30)	
49.34	6,080	W2XCX	Kearny, N.J. (U.S.A.). (Relays WOB)		25.6	11,720	VE9JR	Winnipeg (Canada). (Daily ex. Sat. and Sun. 18.45)	
49.34	6,080	W9XAA	Chicago, Ill. (U.S.A.). (Relays WCFB)		25.53	11,750	GSD	Empire Broadcasting, Zones 1 & 4	
49.22	6,095	VE9GW	Bowmanville, Ont. (Canada). (Daily 21.00)		25.5	11,760	XDA	Chapultepec (Mexico). (Daily 21.00)	
49.2	6,098	ZTJ	Johannesburg (S. Africa). (Weekdays 10.00, 15.00 [Sat. 15.30] and 18.00, Sun. 14.00 and 17.30)		25.5	11,760	DJD	Zeesen (Germany)	
49.18	6,100	W3XAL	Bound Brook, N.Y. (Relays WJZ)		25.45	11,790	W1XAL	Boston, Mass. (U.S.A.)	
49.1	6,110	VUC	Calcutta, India. (Daily 14.00)		25.4	11,810	2RO	Prato Smeraldo, Rome. (17.00 and 20.30)	
49.02	6,120	PK1WVK	Bandoeng (Java). (Daily 23.15)		25.34	11,840	W9XAA	Chicago, Ill. (U.S.A.). (Relays WCFB)	
49.02	6,120	W2XE	Long Island, N.Y. (U.S.A.). (Relays W1BC)		25.28	11,865	GSE	Empire Broadcasting, Zone 2	
48.86	6,140	W8XK	East Pittsburg, Pa. (U.S.A.). (Relays KDKA)		25.27	11,870	W8XK	East Pittsburg, Pa. (U.S.A.). (Relays KDKA)	
48.8	6,147	VE9CL	Winnipeg (Canada). (Daily ex. Sun. 01.30)		25.14	11,933	FYA	Pontoise (France). (Colonial Stn. N-S)	
48.65	6,167	XIF	Mexico City (Mexico)		23.38	12,830	—	Rabat (Morocco). (Sun. 12.30)	
48.35	6,205	HKO	Bogota (Colombia). (Daily 16.00)		20.5	14,630	XDA	Chapultepec (Mexico). (Daily 20.30)	
48.2	6,220	2RO	Rome (Italy)		19.9	15,075	T14NRII	Heredia (Costa Rica). (Sat., Sun., Mon. 17.00 and 22.00)	
48.05	6,243	HKO	Barranquilla (Colombia). (Weekdays 21.45)		19.84	15,120	HVJ	Vatican State, Rome. (Daily 11.00)	
48.0	6,250	CN8MC	Casablanca (Morocco). (Relays Rabat)		19.81	15,140	GSF	Empire Broadcasting, Zone 5	
47.0	6,382	HQ1DR	Quito, Ecuador. (Daily 02.00)		19.73	15,200	DJB	Zeesen (Germany). (Daily 16.00-24.00)	
46.69	6,425	W3XL	Bound Brook, N.J. (U.S.A.). (Relays WJZ irregular)		19.72	15,210	W8XK	East Pittsburg, Pa. (U.S.A.). (Relays KDKA)	
46.67	6,426	VE9BY	London, Ont. (Canada). (Sat. 02.00 Sun. 03.00)		19.68	15,244	FYA	Pontoise (France). (Colonial Stn. E-W)	
45.38	6,611	RW72	Moscow (Relays Trade Union Stn.)		19.56	15,340	W2XAD	South Schenectady, N.Y. (U.S.A.) (Daily 19.00)	
45.0	6,667	FM8KR	Constantine (Algeria). (Mon. and Fri. 23.00)		16.9	17,750	HSP	Bangkok (Siam). (Sun. and Tues. 22.00)	
45.0	6,667	TGW	Guatemala City (Central America). (Daily 04.00)		16.89	17,760	DJE	Zeesen (Germany)	
43.75	6,860	—	Radio Vitus, Paris. (Daily 20.30)		16.88	17,770	GSG	Empire Broadcasting, Zone 2	
43.0	6,970	EAR110	Madrid. (Tues. and Sat. 23.30)		16.87	17,780	W3XAL	Bound Brook, N.J. (Weekdays 11.00)	
41.7	7,195	VS1AB	Singapore (Malay States). (Sun. and M-F, 16.30)		16.57	18,105	W9XAA	Chicago, Ill. (U.S.A.). (Relays WCFB)	
41.6	7,211	EAR58	Tenerife (Radio Club) (Canary Islands)		14.47	20,730	LSY	Buenos Aires (Argentina). (Sun. 22.00)	
41.5	7,230	HB9D	Zurich (Radio Club) (Switzerland). (1st and 3rd Sun.)		13.97	21,470	GSH	Empire Broadcasting, Zone 3 (Daylight working)	
41.0	7,320	HSP2	Bangkok (Siam). (Mon. 15.00)		13.92	21,540	W8XK	East Pittsburg (Relays KDKA)	

FOREIGN SUNDAY PROGRAMMES

JULY THE THIRTIETH

PRINCIPAL EVENTS OF THE DAY:

AT HOME

- NATIONAL** Service and address by the Bishop of Durham, from Newcastle.
- LONDON REGIONAL** "Acis and Galatea," by Handel.
- MIDLAND REGIONAL** Service, relayed from Peterborough Cathedral, with an address by the Dean.
- NORTH REGIONAL** Roman Catholic service, relayed from St. Winifrede's Church, Holywell, with an address by Rev. F. J. Vaughan.
- SCOTTISH REGIONAL** Service for the Unemployed, conducted by Rev. A. Gordon James, relayed from Edinburgh.
- BELFAST** Studio service with address by W. E. Coulthart.

ABROAD

- BRUSSELS (No. 1)** 9.0 p.m. The Knocke Casino Orchestra, conducted by K. Candael.
- BRUSSELS (No. 2)** 9.0 p.m. Concert from the Kursaal, Ostend.
- COPENHAGEN HAMBURG HEILSBURG** 8.5 p.m. Orchestral concert.
- HAMBURG** 12.0 noon. Concert by the Philharmonic Orchestra.
- HEILSBURG** 4.0 p.m. Act I of "The Mastersingers," relayed from Bayreuth. 6.30 p.m., Act II. 8.30 p.m., Act III.
- HUIZEN** 2.40 p.m. The Residence Orchestra from the Kurhaus, Schevvingen. 9.30 p.m., The Wireless Orchestra.
- ROME** 8.45 p.m. Operetta: "Clo-Clo," by Lehár.
- TURIN** 8.35 p.m. Italian opera.
- VIENNA** 11.0 a.m. The Philharmonic Orchestra, conducted by Richard Strauss. 8.0 p.m., Operetta: "Ein Märchen aus Florenz," by Benatsky.

BARCELONA
E.A.U.I., 860 kc/s, 348.8 metres; 8 kW.—2.9 p.m., Gramophone Music. In the interval at 2.30, Theatre Notes. 3.0, Film Review. 3.10 (approx.), Concert by the Station Sextet. 4.0, Programme for Hospitals and Benevolent Institutions, with Gramophone Records. 5.0, Interval. 6.30, Agricultural Report and Gramophone Music. 7.0, Concert by the Station Orchestra. 7.30, Tenor Song Recital. 8.0, Orchestral Concert. Soloist: Pascal Duarte (Baritone). 9.0, Dance Music from the Hollywood Bar. 10.0, Musical Comedy Music on Gramophone Records. 11.45, Chess Lesson. 12 Midnight, (approx.), Close Down.

BARI
1,112 kc/s, 268.8 metres; 20 kW.—10.45 a.m., Agricultural Notes. 11.5, Bible Reading. 11.35, Sacred Music from the Church of San Domenico. 1.0 p.m., Giornale Radio. 1.30 to 2.15, Gramophone Music. In the intervals at 1.55, Weather, and at 2.0, Time and Announcements. 3.0, See Turin. 5.30 to 6.30, Gramophone Music and Sports Notes. 8.0, Sports Notes and Giornale Radio. 8.30, Time and Announcements. 8.35 (approx.), Concert of Songs and Operetta Music. In the interval, Art Notes. 10.30, Gramophone Music. 10.55, News.

BASLE—See Schweizerischer Landessender.

BELGRADE
BEOGRAD, 697 kc/s, 430.4 metres; 2.8 kW.—6.55 p.m., Time Signal and Programme Announcements. 7.0, Recital of Yugoslav Songs. 7.30, A Radio Plays 8.30, Orchestral Concert. 10.0, Sports Notes, News, and Time Signal. 10.15 (approx.), Cigány Music, relayed from the Potrosacka Zadruga Restaurant.

BERLIN
DEUTSCHLANDESENDER, 183.5 kc/s, 1,633 metres; 60 kW.—6.0 a.m., Gymnastics from Berlin (Witzleben). 6.15, Review of Saturday's News. 6.30 (approx.), The Day's Motto, followed by Harbour Concert from Hamburg. 8.0, Agricultural Programme. 8.55, Chimes and Service from the Erlaser Kirche. 9.30, Interval. 10.5, Weather Report from Berlin (Witzleben). 11.0, Reading (Joseph Goebbels). 11.15, Weather. 11.30, A Village Inn Entertainment. 12 Noon, Nazi Band Concert, conducted by Hans Krüger-Burghardt. 12.55 p.m., Time Signal. 1.0, Concert from Leipzig. 2.0, See Hamburg. 3.0, Programme for Children. 3.30, Talk: Bayreuth. 4.0, Programme to be announced. 5.25, Das Waldhäuschen—Radio Sequence adapted from Peter Rossegger (Fortner), with Music by a Schrammel Trio. 6.25, See Stuttgart. 8.0, Dance Music and Light Music by Hansheim-Drausmann and his Band. 10.0, Weather and News. 10.45, Weather Report for Shipping. 11.0, Dance Music relayed from Berlin (Witzleben). 12.30 a.m. (Monday), Close Down.

BERLIN
WITZLEBEN, 715 kc/s, 419.5 metres; 1.5 kW.—11.30 a.m., Choral and Organ Recital. 12 Noon, See Leipzig. 2.0 to 3.0 p.m., Talks for Garden City Dwellers. 3.30, Relay of a Nazi Festival from Treptow. In the interval at 4.30 (approx.), Radio Report of the Fifteenth Germany Festival in Stuttgart. 6.0, Places Made Memorable by Famous Germans—Radio Sequence (Herbert Günther). 6.30, See Stuttgart. 8.0, Sports Notes. 8.10, Song and Pianoforte Recital by Herbert Ernst Groh and Ferd. Kautmann; Selection from Cavalleria rusticana (Mascagni); Siciliana from Cavalleria rusticana (Mascagni); Selection from Madame Butterfly (Puccini); Aria from Carmen (Bizet); Festival March from Aida (Verdi); Aria from Rigoletto (Verdi); Selection from Der Obersteiger (Zeller); Lagunenwälder (Joh. Strauss); Strig' in die Gondel from Eine Nacht in Venedig (Joh. Strauss); Overture, The Mikado (Sullivan); Liebeslied (Moya); Overture, The Queen's Knecht (Joh. Strauss). 10.0, News. 10.15 (approx.), Dance Music relayed from the Roof Garden of the Eden Hotel. In the interval at 11.0 (approx.), Topical Talk. 1.0 a.m. (Monday), Close Down.

BERNE—See Schweizerischer Landessender.

BEROMÜNSTER—See Schweizerischer Landessender.

BODEN—See Stockholm.

BODO—See Oslo.

BORDEAUX-LAFAYETTE
986 kc/s, 304 metres; 13 kW.—6.0 p.m., Les Noces de Jeannette—Lyric Comedy in One Act (Masset), relayed from the Théâtre de la Verdure. 7.30, L'Arlesienne (Bizet), relayed from the Théâtre de la Verdure. 10.30, Fête de Nuit, relayed from Le Lac de Born.

BRATISLAVA
1,076 kc/s, 279 metres; 11 kW.—11.0 a.m., Concert by the Municipal Orchestra, conducted by Motal, relayed from Trencanske Teplice. 12 Noon, See Prague. 1.45 p.m., Hydrographical Report. 4.0, Concert from

Trencanske Teplice (cont'd.). 5.30, See Prague. 5.50, Reading. 6.5, Gramophone Records. 6.55, Report for Housewives. 7.0, See Prague. 9.0, See Brno. 10.0, See Prague. 11.0 (approx.), Close Down.

BREMEN—See Hamburg.

BRESLAU
923 kc/s, 325 metres; 60 kW.; and GLEIWITZ, 1,184 kc/s, 253 metres.—12 Noon (from Gleiwitz), Concert by a Nazi Band, conducted by Peter Cyganek. 2.0, Topical Report. 2.10, Talk: The German Bakers' Exhibition. 2.25, Talk: Air Sports and Air Defence in England. 3.0, Pianoforte Recital by Lily Schmidt; Variations in F (Haydn); Fantasia in D (Mozart); Rondo in C (Beethoven). 3.30, Programme for Children. 4.0, Act I of The Mastersingers—Opera in Three Acts (Wagner), relayed from Bayreuth. 5.20, Concert by the Upper Silesian Landestheater Orchestra, conducted by Albin Eschrich, relayed from Bad Altheide. In an interval, Radio Report from the Eighth German Upper-Silesian Festival at Bad Altheide. 6.5, Tales about Smugglers and Rogues. 6.30, Act II of The Mastersingers (Wagner). 7.30, Song Recital by Walter Linke. Aufbruch (v. Heisterlin); Die Musik kommt (Münch); Rosterliedchen (Teohritz); Der Schatzgräber (Loewe); Der Sängers Fluch (Esser). 8.0, Radio Report of the Motor Endurance Tests at Ober Schrieberhau. 8.30, Act III of The Mastersingers (Wagner). 10.20, Time and News. 10.50, Dance Music from Berlin (Witzleben). 12 Midnight (approx.), Close Down.

BRNO
878 kc/s, 342 metres; 35 kW.—6.0 p.m., German Transmission: Concert by a Village Band. 7.0, See Prague. 9.0, Concert of Czech Serenades by the Station Orchestra, conducted by Bakala; Serenade of the Seventeenth Century (Veivanyovsky); Cassation for Wind Instruments (Hrovec); Serenade, Op. 22, for Strings (Dvorak). 10.0, See Prague. 11.0 (approx.), Close Down.

BRUSSELS (No. 1)
I.N.R., 590 kc/s, 509 metres; 15 kW.—9.45 a.m., Cookery Hints and Pigeon Breeding Notes. 10.0, Concert by the Small Station Orchestra, conducted by Pierre Leemans. Soloist: Marcel Quenon (Tenor). 11.0, Gramophone Concert. 12 Noon, Concert by the Radio Orchestra and a Vocal Quartet. Conductor: Charles Walpot. Soloist: J. Veldya (Songs). 1.0 p.m., Journal Parlé. 1.10, Concert by the Symphony Station Orchestra, conducted by Arthur Meulemans.

Soloist: Betty Dasnoy (Songs). 1.30, Recitations. 1.40, Orchestral Concert (cont'd.). 2.0, Symphony No. 3—Eroica (Beethoven), on Gramophone Records. 2.45, Report of the Unveiling of a Monument to Lieutenant General Michel du Faing d'Aigremont, at Namur. 4.0, Gramophone Music. 5.0, Dance Music by Mickey's Club Band, relayed from the Casino, Knocke. Conductor: Ludo Langlois. 5.30, Football Match Results. 6.0, Pianoforte Recital by Gabrielle Tamboyser. 6.30, Programme for Children. 7.0, Gramophone Music. 7.15, Religious Address. 7.30, Talk on Music. 8.0, Concert by the Radio Orchestra, conducted by Charles Walpot. 8.45, Walloon Music on Gramophone Records. 9.0, Concert by the Knocke Casino Orchestra conducted by K. Candael. Soloist: Mme. Ritter-Giampi (Songs). Overture, Taurer (Rossini); Intermezzo from Cavalleria rusticana (Mascagni); Aria from I Puritani (Bellini); Constance's Aria from Act II of Il Scraffio (Mozart); Scène de bal after an Etude by Mayseder (Hellmesberger); Selection from the Carnaval de Venise (Masset); Fête polonoise from Le roi malgré lui (Chabrier). After the Concert, Journal Parlé, and Dance Music by Mickey's Club Band, conducted by Ludo Langlois, relayed from the Casino, Knocke. 12 Midnight (approx.), Close Down.

BRUSSELS (No. 2)
N.I.R., 687 kc/s, 338.2 metres; 15 kW. Programme in Flemish.—10.0 a.m., Gramophone Concert. 11.0, Concert by the Small Station Orchestra, conducted by P. Leemans. 12 Noon, Concert by the Station Symphony Orchestra, conducted by Meulemans. Soloist: Betty Dasnoy (Songs). 1.0 p.m., Le Journal Parlé. 1.10, Concert by the Station Orchestra, conducted by Charles Walpot. Mme. Veldya (Songs) and a Vocal Quartet. March. Semper fidelis (Souza); Waltz, Frühlingsstimmen (Joh. Strauss); Overture, Girollo Girollo (Lecoq); Songs from Operettas; Selection from The Three Musketeers (Friml); Quartets; Parade of the Tin Soldiers (Jes-Cl). 2.30 to 5.0, Report of the International Peace Manifestation. 5.0, Dance Music relayed from the Kursaal, Ostend. 5.30, Sports Results. 6.30, Concert of Light Music by the Small Station Orchestra, conducted by P. Leemans. 7.15, Religious Address. 7.30, Music Review. 8.0, Concert by the Station Symphony Orchestra, conducted by Meulemans; Overture, Carnival remain (Berlioz); Potpourri of Flemish Melodies (arr. De Boeck); Petite suite (Debussy); Slav Dances (Dvorak). 8.45, Recitations. 9.0, Concert relayed from the Kursaal, Ostend. After the Concert, Le Journal Parlé, followed by Dance Music relayed from the Kursaal, Ostend.

BUCHAREST
761 kc/s, 394 metres; 12 kW.—5.0 p.m., Concert by the Jean Marco Orchestra. In an interval at 6.0, Radio Journal. 7.0, Reading. 7.20, Dance Music on Gramophone Records. 7.40, Educational Talk. 8.0, Saxophone Solos. 8.20, Baritone Solos. 8.40, Talk. 9.5, Romanian Music by the Fanica Luca Orchestra. 9.45, Radio Journal.

BUDAPEST
545 kc/s, 550.5 metres; 18.5 kW.—9.15 a.m., News. 10.0, Catholic Service. 11.15, Unitarian Service, followed by News and Cigány Music by the Bura Károly Band. 1.45 p.m., Gramophone Music. 3.0, Agricultural Talk. 3.45, Chamber Music. 5.0, Talk for Scouts. 5.30, Concert. 6.20, Variety Programme. 7.0, Clarinet Recital. 7.30, Talk with Gramophone Illustrations: The Cherry Blossom Festival in Japan. 8.10, Letár Concert by the Station Orchestra, followed by Jazz Music from the Domnapalais Hotel. 10.45, Cigány Music by the Bura Sándor Band from the Hotel Domnapalais.

CASSEL—See Frankfurt.

COPENHAGEN
1,067 kc/s, 281 metres; 0.75 kW. Relayed by Kalundborg, 260 kc/s, 1,153.8 metres.—8.30 a.m., Morning Gymnastics. 9.0 to 9.30, Talk. 10.0, Divine Service from the Cathedral. 11.30, Weather Forecast. 11.40, News. 12 Noon, Time and Chimes from the Town Hall. 12.5 p.m., Concert by Carl Rydahls' Instrumental Ensemble: Overture, Jean de Paris (Boieldieu); Waltz, Immortellen (Gungl); Selection from I Pagliacci (Leoncavallo); Amlaute cantabile (Tchaikovsky); Punchello (Herbert); Two Hungarian Dances (Brahms); (a) No. 5 in G minor, (b) No. 6 in D; Minuet in A (Boccherini); Vienna, City of my Dreams (Sieczynski); Waltz, Mon réve (Waldteufel); Spring Song (Gounod); Radetzky March (Joh. Strauss). 1.30, Mandoline Concert. 2.0, Divine Service relayed from the Holmens Kirke. 3.30, Relay of the Danish and Norwegian Scouts' Jamboree, from Larsens Plads. 4.15, Concert, relayed from a Park. 6.20, Talk. 6.50, Weather and News. 7.15, Time Signal. 7.30, Talk. 8.0, Chimes from the Town Hall. 8.5, Orchestral Concert: Overture, The Merry Wives of Windsor (Nicolaï); Selection from The Barber of Seville (Rossini); Overture, Czar and Carpenter (Lortzing); Waltz from Hansel and Gretel (Humperdinck); Blues from Johnny spielt auf (Krenek); Overture, Donna Diana (von Reznicek). 8.50, Recital of Student Songs, with Talk. 9.40, 'Cello Recital by Edmund Fabricius; Suite in D (Caix d'Hervé); Les tendres plaintes (Rameau); Allegro spiritoso (Senaillé). 10.0, News. 10.10, Gramophone Music. 10.20, Kaban Concert by the Station Orchestra, conducted by Walter Meyer-Radon; Selection from (a) Zizekoprinnas, (b) The Gipsy Princess, (c) Countess Maritza, and (d) Die Bayadere. 11.0, Dance Music, relayed from the Arena. In the interval at 12 Midnight, Time and Chimes from the Town Hall. 12.30 a.m. (Monday), Close Down.

CORK—See Athlone.

DANZIG—See Heilsberg.

DRESDEN—See Leipzig.

FECAMP
1,328 kc/s, 225.9 metres; 10 kW.—2.0 to 8.0 p.m., Programme in English by the I.B.C. 2.0, Special Programme for South Coast Listeners. Orchestral Concert: Signature Tune, The Night by the Sea; Selection from Music in the Air; Part I, Pianoforte Solo, Hot Scotch (Peterson); Overture, Amina (Lincke); Violin Solo, The Indian Love Call, from Rose Marie (Friml); The Match Parade (Wohle); A Birthday Serenade (Lincke); Pianoforte Solo, Just wonderful you (Maurie); Animal Antics (Wark). 2.30, Light Music: The Little Company (Gangberger); The Old Spinning Wheel (Hill); Hold Me (Seluster); Beautiful (Shay); All over Italy (Mouroe); You've got me crying again (Jones); Don't be late in the Morning (Mendoza); The Enchanted Forest (Gangberger). 3.0, Gramophone Concert: Selection from The Merry Widow, Part II (Lehár); Folks I used to know; After the Ball; Sans Souci (v. Blon); I want to cling to Ivy; Cello Solo, The Nightingale and the Rose (Rimsky-Korsakov); Come Gipsy, from The Countess Maritza (Kálmán); Git along (Austin). 3.30, Military Band Music: The Thunderer (Souza); Xylophone Solo, Light Cavalry Overture (Suppé); Light of Foot (Latann); Song, The Meynell Hunt (Cotton); L'entente cordiale (Allier); Selection from The Geisha (Jones); Xylophone Solo; First Waltz (Durand); The Battle of Waterloo (Eckersberg); Signature Tune. 4.0, Judge Rutherford's Address.

JULY 30th

SUNDAY

continued

followed by Programme for Children. 4.50, Descriptive Adventure Story. 5.0, I.B.C. Members' Request Half-hour; March, Pomp and Circumstance (Elgar); Waltz, Tres Jolie (Waldteufel); Selection from The Pirates of Penzance (Sullivan); The Grass-hoppers' Dance (Bucalossi); Blaydon Races; Narcissus (Nevin); The Midnight Waltz (Amadio); Selection from The Maid of the Mountains, Part II (Fraser-Simson). 5.30, Octet Concert: The Golliwog's Cake Walk (Debussy); Valse caprice; Song, Wayside Rose (Lohr); Slav Dance (Dvorak); Waltz from Der Rosenkavalier (R. Strauss); Song, O Maiden, my Maiden from Frederica (Lohr); Narcissus (Nevin); Mock Morris (Grainger). 6.0, Club Concert for Carnation Listeners; Part I, Orchestral Concert: Signature Tune, The Chum Song; Selection from The Flower of Hawaii (Abraham); Song, Y Bore Glas; Xylophone Solo, The First Waltz (Durand); Vienna, Vienna (Foss); When the Lilac blooms again (Rottler); Song, Y Bwtyn Bach to Gwellt; Glockenspiel Solo; The Black Forest Chiming Clock (Doppler); The Phantom Brigade (Myddleton). Part II, Gramophone Records: Selection from The Belle of New York (Kerker); The Moment I saw you (Gay); Mazurka (Wieniawsky); Pianoforte Solo, When Day is done (de Sylva); Song, Droop not, young love (Handel); What Aloha means, Part I (Alphin); Play Fiddle play (Lawrence); Minuet No. 1 (Paderewsky); Signature Tune. 7.0, Organ Recital: Drifting down to Shalimar (Monaco); Song, Deep Water (Brian); Paradise (Brown); Song, My Darling (Henderson); My Wishing Song (Burke); Sing Brothers (Tunbridge); Song, It's Winter again (Hoffmann); Friends once more united (Spoliansky). 7.30, Orchestral Concert: Selection from Wild Violets, Part II (Stolz); Song, Nirvana (Adams); Valse Septembre (Godin); Spanish Gipsy Dance (Marquina); Song, Mountain Lovers (Squire); Woodland Peace (Favilla); Ke-Sa-Ko (Chapman); Selection of War Marches (Gossett); Part I, 8.0, Programme in French. 9.0 till Close Down, Programme in English by the I.B.C. 9.0, Military Band Concert: Ca c'est Paris (Padilla); Song: Drake's Drum (Stanford); Wood Nymphs (Coates); Lion du Bal (Gillet); Festival March; Valse triste (Sibelius); Song: The Old Superb (Stanford); Parade of the Tin Soldiers (Jessel). 9.30, Vocal Concert: The Blue Danube (Strauss); The Rakefather's Daughter (Trad.); The Fly on the Turnouts (arr. Weatherley); Columbine (Garland); At the Convent Gate (Sherwood); Villkins and his Dinah (Trad.); A fine old English Gentleman (Trad.); Fleurette (Fletcher). 10.0, Gramophone Concert: Ballet from Petite Suite (Debussy); The Clatter of the Clogs (Flynn); A Spot of Bother, Part I; In the Valley where the Bluebirds sing (Rosenfeld); Milking Time in Switzerland; A Radio Roundabout, Part I; The Girl in the Little green Hat (Rich); Selection from The Wanted Adventure, Part I (Tunbridge). 10.30, Helen's Concert of Dance Music: Look what you've done (Kalmár); Love is the Sweetest Thing (Noble); In the Valley of the Moon (Burke); Something came and sang me in the Spring (Rich); The old spinning Wheel (Hill); Spanish Eyes; That's what life is made of; Falling Star; Somebody stole my Gal. 11.0, Concert by a Balalaika Orchestra: Wear a great big smile (Gilbert); Chorus: The Twelve Robbers; Ballet Air (Andraiev); In a Pine Forest (Riad); Violin Solo: Hymn to the Sun (Rimsky-Korsakov); Lovely Night (arr. Leontiev); Chorus: The Imprisoned Cossacks; The Red Sarafan (Traditional). 11.30, Concert by the I.B.C. Ireland, Ltd.: Signature Tune, Come back to Erin; Jolly Fellow (Vollstedt); Pianoforte Solo: Butterflies in the Rain (Myers); Song of my Heart (McCarthy); Amoreuse (Berger); Hawaiian Memories (Armandola); Song: My Little Irish Cottage (Summers); Pianoforte Solo: Everyone says, I love you (Kalmár); Selection from The Student Prince, Part II (Roinberg). 12.5 a.m. (Monday), I.B.C. Late News Bulletin. 12.10 (approx.), Concert by a Tango Band: Se tu me bací (Mascheroni); Song: En la Estancia Sombria (Alvarez); Se nunció la prima (Jurmán); Song: O Sole mio (di Capua); Two-step, Cualquier cosa. 12.30, Dance Music by Jack Payne and his Band (Electrical Transcriptions); Try a little Tenderness (Woods); All over Italy (Munroe); Sergeant Flagg and Sergeant Quirt (Moll); Something came and got me in the Spring (Rich); How'n I doin' (Fowler); Love me to-night (Young); Say it isn't so (Berlin); While we danced at the Mardi Gras (Merzer). 1.0, Instrumental Solos: The Old Rustic Bridge by the Mill (arr. Wood); Song: I wish I knew a bigger Word than Love (Polay); Selection from Congress Dances, Part II (Heymann); Song: Have you ever been lonely (Brown); Sweet Adeline (Armstrong); Mona Lisa (Garter); Song: Just because I lost my Heart (Gilbert); A good old Irish Stew, Part I. 1.30, Dance Music: Signature Tune, Bells of Normandy; Night shall be filled with Music (Collins); Sing a New Song (Wever); We've got the Moon and Sixpence (Grey); The Clouds will soon roll by (Woods); Nightfall (Lewis); I can't believe it's true (Newmann); A Bedtime Story (Nicholas); Moon (Miles); Signature Tune. 1.57, I.B.C. Good-night Melody. 2.0 (approx.), Close Down.

FLENSBURG.—See Hamburg.

FLORENCE.—See Turin.

FRANKFURT

1,157 kc/s, 259.3 metres; 17 kW. Relayed by Cassel, 1,220 kc/s, 245.9 metres; and Trier, 1,157 kc/s, 259.3 metres.—11.20 a.m., A Radio Report of a Pilgrimage to Trier. 11.40, Talk on Bismarck. 12 Noon, See Stuttgart. 1.0 p.m., Concert by the Peter Quartet. 2.0, Radio Report from the 1933 Machinery Exhibition at Giessen, arranged by the Wiesbaden Board of Agriculture. 2.10, Rural Programme—Two Talks. 3.0, Programme for Children. 4.0, Concert, relayed from the Kurhaus, Wiesbaden. 6.0, Sports Report. 6.30, See Stuttgart. 8.0, See Berlin (Deutschlandsender). 10.20, Time and News. 10.45, Dance Music, relayed from Berlin (Witzleben). 12 Midnight, Close Down.

FREDRIKSSTAD.—See Oslo.

FREIBURG.—See Stuttgart.

GENEVA.—See Radio-Suisse Romande.

GENOA.—See Turin.

GLEIWITZ.—See Breslau.

GOTEBORG.—See Stockholm.

GRAZ.—See Vienna.

HAMAR.—See Oslo.

HAMBURG

Call ha (in Morse), 806 kc/s, 372 metres; 1.5 kW. Relayed by Bremen, 1,112 kc/s, 259.8 metres; Flensburg, 1,319 kc/s, 227.4 metres; Hanover, 530 kc/s, 566 metres; and Kiel, 1,252 kc/s, 232.2 metres.—11.0 a.m., Orchestral Concert, relayed from the Café Wallhof. 11.30 (from Kiel), German Songs by the Euphonie Double Quartet. 12 Noon, Concert by the Hamburg Philharmonic Orchestra, conducted by Secker; Overture, Aho Hassan (Weber); Ballet Suite from Die Liebesprobe (Mozart); Military March No. 2 (Schubert); Melody (Blumer); Idyll (Kaun); Wedding March from The Pied Piper of Hamelin (Nesslin); Selection from Lis-clott (Künneke); Delirium-Walzer (Jos. Strauss); Overture, Indigo und die vierzig Räuber (Joh. Strauss); Scandinavian Folk Music, Suite No. 1 (Hartmann); Selection from The Mikado (Sullivan); Festival March (Kempfer). In an interval at 12.55 p.m., Time and Weather. 2.0, Programme for Young Hitlerites—A Meeting of Young Peasants at Jever. 3.0, Recital of the Ballads of the Poetess Agnes Miegel. 3.30 (from Kiel), Band Concert by a Wind Band, conducted by Licht. Festival March from the Concerto in E Flat (Beethoven); Hungarian Rhapsody No. 2 (Liszt); Fröhliche Jagd (Blon); Overture, Dem deutschen Volke (Zimmer); Waltz, Mein Lebenslauf ist Lieb und Lust (Jos. Strauss); Selection from Der Obersteiger (Zeller); Waltz, Hofballtänze (Lammer); Am Lagerfeuer (Siede); March, Wir präsentieren! (Albion). 4.45 (from Kiel), Tea Time Programme. 6.15, Sports Notes. 6.25, Weather. 6.30, See Stuttgart. 8.0, See Berlin (Deutschlandsender). 10.0, Time and News. 10.20, Hamburg, Bremen and Lübeck—Review of Political, Educational and Artistic Events in the Three Hanseatic Free Cities. 10.35, Musical Programme from Berlin (Witzleben).

HANOVER.—See Hamburg.

HEILSBURG

1,085 kc/s, 276.5 metres; 60 kW. Relayed by Danzig, 662 kc/s, 453.2 metres.—11.30 a.m., Recital of Friedrich Welter Songs, by Charlotte Bousa-Pirashy (Soprano), with the Composer at the Pianoforte. 12 Noon, Police Band Concert, conducted by Ernst Stieberitz, relayed from the Kurgarten, Zoppot. 2.0, Talk on Chess. 2.30, Talk: German Girls, what do you read? 3.0, Pianoforte Recital of Music by Bach, Haydn and Schumann. 3.30, Reading (Hanna Maria Ottinger). 3.50, Sports Notes. 4.0, Programme in Connection with the Wagner Festival at Bayreuth: First Act of The Mastersingers (Wagner), relayed from Bayreuth. In the interval at 4.50 (approx.), Sports Talk. 5.20, Poems (Herbert Schwarz). 5.30 (from Danzig), Violin Recital. 6.0, Talk: Bismarck and the New Germany, on the Thirty-Fifth Anniversary of the Chancellor's Death. 6.30, Second Act of The Mastersingers (Wagner), relayed from Bayreuth. 7.30, See Breslau. 8.0, Sports Notes. 8.5, Von Scheiden und Meiden—Sequence of Songs to the Lute from Des Knaben Wunderhorn. 8.30, Third Act of The Mastersingers (Wagner), relayed from Bayreuth. 10.20, News, followed by Dance Music from Berlin (Witzleben).

HILVERSUM

Announced HUIZEN, 1,013 kc/s, 296.1 metres; 20 kW. (7 kW. up to 4.40 p.m.).—8.10 a.m., Religious Programme of the Catholic Radio Society (K.R.O.). 9.10 to 1.55 p.m., Programme of the Christian Radio Society (N.C.R.V.). 9.10, Organ Recital by Chr. Kloppenburg, relayed from Amster-

dam: Fantasia on Psalm No. 24 (Kee); Prayer (Boßlmann); Vrees niet, o myn ziele (Zwart). 9.30, Divine Service, relayed from Amsterdam. 11.55 (approx.), Organ Recital (contd.): Fantasia in G Minor (Bach); Three Songs by Mme. Ravenzwaay; Nöllenkamp (Contralto); (a) Bringt her dem Herren (Schütz); (b) Dettungen (To dem Haudel); (c) Sei stille dem Herrn (Mendelssohn); Grave and Adagio from the Second Sonata (Mendelssohn); Two Songs (Möblich); Prelude from the Third Sonata (Güldenast); Carillon (Bonset); Psalm No. 75 (Kloppenburg). 11.55 to 4.40, K.R.O. Programme. 11.55, Sextet Concert: Parade of Jack and Jill (Lake); Moment musical (Schubert); Waltz, Märchenzauber (Naeff); Suite, Straussfedern (Morena); Marmelades Lüftchen (Jensen); Music and Roses (Lindern). 12.40 p.m., Talk. 1.0, Concert (contd.): Waltz, Klänge aus Oesterreich (Döring); Geburtstagsständchen (Linke); Selection from William Tell (Rossini); Waltz from Eva (Lohr); Potpourri, Für Alle (Dostal); March, Au revoir (Schootenmeyer). 1.50, Talk on the Blind. 2.10, Orchestral Concert. 4.10, Programme for Invalids. 4.40 to 7.25, N.C.R.V. Programme. 4.40, Religious Programme. 5.30, Divine Service, relayed from Wageningen. After the Programme, Religious Music on Gramophone Records. 7.25 till Close Down, K.R.O. Programme. 7.25, Football Results. 7.30, Talk. 7.55, Gramophone Music. 8.10, Concert by the K.R.O. Boys: Schöne Isabella von Kastilien (Boottz); Souvenir de Mona Lisa (Schebek); Symphonie Foxrot (Barney); Ritorna (Carioso); Du bist mein bester Kamerad (Doelle); Ein Walzerabend bei Suppe (Dostal). 8.40, News. 8.45, Address. 9.0, Gramophone Music. 9.30, Concert (contd.): Potpourri, Wir kurbeln ein (Dostal); Celesta; Man trägt wieder treue Augen (Grosz); Finale. 9.55, News. 10.40, Address. 10.15, Gramophone Music. 10.20, Epilogue by the Small Choir. 10.40 (approx.), Close Down.

HORBY.—See Stockholm.

HUIZEN

Announced HILVERSUM, 160 kc/s, 1.875 metres; 8.5 kW.—9.10 to 11.40 a.m., Programme of the Workers' Radio Society (V.A.R.A.). 9.10, Concert by the Small V.A.R.A. Orchestra, conducted by P. Duchant. 9.40, Concert by De Notenkrakers Band, conducted by D. Wins. 10.25, Talk. 10.40, Organ Recital by C. Steyn. 11.10, Address. 11.40 to 4.40 p.m., Programme of the Algemeene Vereeniging Radio Orceop (A.V.R.O.). 11.40, Time. 11.41, Concert by the Wireless Orchestra, conducted by Neo Gerharz; March, Blaze away (Holzmann); Overture (Offenbach); Chant d'amour (Stovisky); Marche grotesque (Sinding); Waltz, Wiener Mad'n (Ziehrer); Gramophone Records; Selection of Viennese Songs (Dostal); Jangle Drums (Ketelbey); Czardas from Der Geist des Woiewoda (Grossmann); Gramophone Records; Overture, the Black Domino (Auber); Baccalante from Samson and Delilah (Saint-Saëns); Selection from Carmen (Bizet). 1.40 p.m., Book Review. 2.10, Concert by a Male Voice Choir. 2.40, Concert by the Residence Orchestra, relayed from the Kurhaus, Scheveningen. Conductor: Ignaz Neumark. Soloist: Siegmund Bleier (Violin). Overture, Titus (Mozart); Violin Concerto in E minor, Op. 64 (Mendelssohn); Gramophone Records; Overture, Im Frühling (Goldmark); A Musical Smell Box (Liadov); Invitation to the Waltz (Weber-Weingartner). 4.10, Gramophone Music. 4.40 to 5.40, V.A.R.A. Programme. 4.40, Concert by a Children's Choir. 5.40, Programme of the Liberal Protestant Radio Society (V.P.R.O.). 7.40 till Close Down, A.V.R.O. Programme. 7.40, Time and News. 7.55, Concert by Kovacs Lajos and his Band. Soloist: Renate Müller (Songs). In the interval at 8.25, Gramophone Music. 9.10, Reading. 9.30, Concert by the Wireless Orchestra, conducted by Neo Gerharz; Overture, Masaniello (Auber); Hymn to Saint Cecilia (Gounod); Ballet Music from La Juive (Halévy); Gramophone Records; Waltz, Mon rêve (Waldteufel); Liebestraum (Liszt); Selection from Lohengrin (Wagner-Lugini). 10.40, Gramophone Concert. 11.40 (approx.), Close Down.

INNSBRUCK.—See Vienna.

JUAN LES PINS

1,205 kc/s, 249 metres; 0.8 kW.—8.0 p.m., Amusements Guide and Sports Notes. 8.15, Radio Concert. 9.0, News. 9.15, Radio Concert. 10.0, The Listeners' Half-Hour. 10.30 till Close Down, Programme in English by the I.B.C. 10.30, Orchestral and Vocal Concert: Selection from The Maid of the Mountains (Fraser-Simson); Song: If I am dreaming, from The Dubarry (Müllbacher); Serenade (Toselli); Song: I think of you (Oakley); Waltz, Wedding Dance (Linke); Augero March (Franco); Song: The Lavender Seller (Breville Smith); Selection from The Maid of the Mountains (Fraser-Simson). 11.0, Light Music: Trio: Play Fiddle, play (Lawrence); Songs: (a) That's my Home (Ellison); (b) Me and Mine are doing fine (Connolly); Trio: Adios, Good-bye (Fernandez); Songs: (a) Something came and got me in the Spring (Rich); (b) You've got me

crying again (Jones); (c) The Old Spinning Wheel (Hill); Trio: Old Vienna Moon (Lehbert). 11.30, Organ Recital with Songs: My Wishing Song (Burke); Friends once more united (Spoliansky); Song: When it's sleepy time down South (Muse); The Old Spinning Wheel (Hill); Hold me (Sehnster); Song: Trees (Rasbach); In the Valley of the Moon (Burke); Drifting Down the Shalimar (Monaco). 12.0 Midnight, Gramophone Concert: Fantasy, Rumanesco (Stefanescu); Song: Devil may care (May); The Skaters' Waltz (Waldteufel); Uncle Ned (Foster); Pianoforte Solo: Selection from Follow a Star, Part II (Ellis); Fiddler Joe (London and More); To my First Love (Lohr); You'd better ask me (Lohr); Selection from Countess Maritza (Kálmán). 12.30 a.m. (Monday), Dance Music: It's within your power; Don't be late in the morning; Maybe I love you too much; When my little Pomeranian met your little Pekinese; I can't remember; Picaninies' Heaven; Waltzing in a Dream; Moon Song. 12.57, I.B.C. Good-night Melody. 1.0 (approx.), Close Down.

KALUNDBORG.—See Copenhagen.

KIEL.—See Hamburg.

KLAGENFURT.—See Vienna.

KOSICE.—See Prague.

LANGENBERG

635 kc/s, 473 metres; 60 kW.—12 Noon, See Munich. 1.0 p.m., Pianoforte Recital by Hans Haass. 1.30, Concert by the Station Orchestra, conducted by Kühn. 2.30, Choral Music from Brühl Castle. In the interval, Talk: Town-planning. 3.15, Gramophone Music. 3.45, Talk: A Walk through Bayreuth. 4.0, First Act of The Mastersingers—Opera (Wagner), relayed from Bayreuth. 5.20, Report of the International Riding and Driving Tournament at Aachen. 6.0, See Stuttgart. 6.30, Second Act of The Mastersingers—Opera (Wagner), relayed from Bayreuth. 7.30, See Stuttgart. 8.30, Third Act of The Mastersingers—Opera (Wagner), relayed from Bayreuth. 10.20, News. 10.45, Serenade by the Station Chamber Orchestra, conducted by Breuer. 12 Midnight, Close Down.

LAUSANNE.—See Radio-Suisse Romande.

LEIPZIG

769.9 kc/s, 389.6 metres; 120 kW.; and Dresden, 941 kc/s, 319 metres.—12 Noon, Concert by the Symphony Orchestra, conducted by Hilmar Weber; Heitere Ouvertüre (Scharer); German Folk Song Fantasia (Blumer); Serenade in E (Braunfels); Hungarian Rhapsody No. 9 (Liszt); The Song of the Rhine Maidens from The Dusk of the Gods (Wagner); Selection from La Traviata (Verdi); Moresque (Humperdinck); Peer Gynt Suite (Grieg). In the interval at 1.0 p.m., Talk: Germans Abroad. 2.0, Weather, Time and Programme Announcements. 2.25, Review of Economics. 2.40, Agricultural Report. 2.50, Franzl wird Zimmermann (Franz turns Carpenter)—Radio Play (Sorenby). 3.30, Concert by the Zwickau Double Quartet. 4.10, A Summer Day—Radio Sequence (Fritz Gay). 4.45, Concert of Light Music. 6.30, See Stuttgart. 8.0, Gipsy Love—Operetta in Two Acts (Lehár). 10.10, News. 10.20 (approx.), Johann Strauss Waltz Concert by the Radio Orchestra, conducted by Hilmar Weber; Seid umhengen Millionen; Wo die Zitronen blühen; Seltsam-walzer; Künstlerleben; Kaiser-Walzer; Du und Du; Wiener Blut. 12 Midnight (approx.), Close Down.

LINZ.—See Vienna.

LUXEMBOURG

252 kc/s, 1,191 metres; 200 kW.—English Programme.—7.30 p.m., Orchestral Concert on Gramophone Records. 8.0, Weather Report. 8.5, Gramophone Concert. 8.50, News in French. 9.0, Orchestral Concert on Gramophone Records. 9.45, News in German. 9.55, Variety Concert on Gramophone Records. 10.30, Dance Music on Gramophone Records.

MADRID

EAJ7, 707 kc/s, 424.3 metres; 2 kW.—9.0 to 10.0 a.m., Topical Review. 3.0 p.m., Chimes, Time, Theatre Notes and Concert of Popular Music. 5.0 to 8.0, Interval. 8.0, Chimes, Radio Journal and Dance Music. 9.30 to 11.0, Interval. 11.0, Chimes and Time. 11.5 (approx.), Song Recital by Isabel Ferras. 11.30, Municipal Band Concert, relayed from the Rosales. 1.30 a.m. (Monday), Close Down.

MALMO.—See Stockholm.

MILAN

VIGENTINO, 662 kc/s, 453.2 metres; 4 kW.—8.45 p.m. till Close Down, See Rome.

MORAVSKA-OSTRAVA

1,137 kc/s, 263.8 metres; 11 kW.—5.30 p.m., See Prague. 9.0 p.m., See Brno. 10.0, See Prague. 11.0 (approx.), Close Down.

MOSCOW

TRADES UNION, 230 kc/s, 1,304 metres; 100 kW.—2.15 p.m., Literary Programme. 4.0, Talk for Workers. 4.30, A Sound Film. 5.30, Programme for Children. 6.30, Concert of Russian Music by the Symphony Orchestra, conducted by M. Noblein, and Soloists.

JULY 30th

SUNDAY

continued

10.5, Talk in German: The Soviet. 10.30, Press Review.
MOTALA.—See Stockholm.
MUHLACKER.—See Stuttgart.

MUNICH

563 kc/s, 533 metres; 60 kW. Relayed by Augsburg and Kaiserslautern, 536 kc/s, 560 metres; and Nürnberg, 1,256 kc/s, 239 metres.—12 Noon, Military Band Concert. 1.0 p.m., Time, Weather, and Programme Announcements. 1.10, Agricultural Talk. 1.30, Variety Concert on Gramophone Records. 2.30, Talk on the National Revolution. 2.50, Programme for Children. 3.15, Report on the Bavarian Grand Prix from the Munich-Daglfing Race Course. 3.25, Concert by the Haidhausen Zither Club. 3.45, Reading. 4.0, Concert by the Lorenz Jais Orchestra: Overture, Der Erlenhögel (Kuhlan); Ballet des parfums (Popy); Waltz, Rote Rosen (Lehar); Potpourri, Ein Abend in Grinzling (Dauber); Waltz Intermezzo, Träume der Nacht (Schmalstieg); March, Unsere Reichswehr (Blankenburg). In the interval of the Bavarian Grand Prix, at 5.30, Reading (Paul Rohrbach). 5.40, Song and Harp Recital: Folk Songs for Soprano (Porter): (a) Rosenrith, (b) Ich hört' ein Sichelrauschen, (c) Blumenhaus, Harp Solo; Baritone Solos: Recitative and Aria from Eurynthe (Weber); Pianoforte Duet: Allegro from Lebensstürme in A minor, Op. 141 (Schubert); Soprano Songs (Brahms): (a) Immer leiser wird mein Schlummer, (b) Ständchen, (c) Meine Liebe ist grün; Baritone Songs: (a) Mimmeli (Brahms), (b) Der Rattenfänger (H. Wolf). 6.15, Weather and Sports Notes. 6.30, See Stuttgart. 8.0, Programme by the Three Fratellini. 8.20, Austria—Literary and Musical Programme. 9.5, Puccini Concert: The Small Station Orchestra, conducted by Erich Kloss; Soloists: Maria Agathe Maechler (Soprano), Josef Janko (Tenor), and Max Hartmann (Baritone). 10.0, Talk. 10.20, Time and News. 11.0, Dance Music from Berlin (Witzleben). 12 Midnight (approx.), Close Down.

NAPLES.—See Rome.

NOTODDEN.—See Oslo.

OSLO

277 kc/s, 1,083 metres; 60 kW. Relayed by Fredriksstad, 815 kc/s, 368.1 metres; Hamar, 522 kc/s, 574.7 metres; Notodden, 671 kc/s, 447.1 metres; Porsgrund, 662 kc/s, 453.2 metres; and Rjukan, 671 kc/s, 447.1 metres.—10.15 a.m., Road Report. 10.30, Religious Address, relayed from a Church in Tingelstad. 11.0, Divine Service, relayed from Tingelstad, followed by Choral Concert. 5.0 p.m., Programme relayed from the Hadeland Museum: Talk, Around the Museum. Agricultural Report and Choral Music. 6.45, Recital of National Songs by Mme. Monrad. 7.15, Weather and News. 7.30, Talk on Caruso. 8.0, Time. 8.1, Concert by the Station Orchestra, conducted by Olvin Fjelstad: Carnival Overture (Dvorak); Selection from The Pearl Fishers (Bizet); Five Contredanses (Mozart); Mazurka (Wieniawsky); Valse triste (Sibelius); Rondo (Brahms); Syncope (Kreisler). 9.10, Recitations by Mme. Sesö, relayed from Trondheim, 605 kc/s, 495.8 metres. 9.38, Agricultural Notes, Weather and News. 10.0, Topical Talk. 10.15, Old Dance Music relayed from Hadeland.

OSTERSUND.—See Stockholm.

PALERMO

558 kc/s, 537.6 metres; 3 kW.—10.25 a.m., Bible Reading. 10.40, Sacred Music. 11.5, Agricultural Talk. 12.45 p.m., Giornale Radio. 1.0 to 2.0, Concert of Light Music. In the interval at 1.30, Time, Announcements and Weather. 3.0, See Turin. 5.30, to 6.30, Gramophone Music. 8.0, Popolavoro Notes, Giornale Radio and Sports Notes. 8.20, Gramophone Music. In the interval at 8.30, Time and Announcements. 8.45, Symphony Concert conducted by A. La Rosa Parodi. In the interval, Talk. 10.0, Light Music on Gramophone Records. 10.55, News.

PARIS

EIFFEL TOWER; 207.5 kc/s, 1,445.7 metres; 13 kW.—Time Signals (on 2,650 metres) at 10.26 a.m. and 11.26 p.m. (Preliminary and 6-dot signals). 1.0 p.m., News. 1.15, Weather. 1.30, Concert by Jean Bos and his Orchestra: Czardas (Leon); Selection from Die geschiedene Frau (Fall); Peles Czardas (Barelli); Overture, Light Cavalry (Suppe); Torna a Sorrento (de Curtis); Si vous l'aviez compris (Dezza); Ballet Music from Faust (Gounod). 2.0, Running Commentary on the Davis Cup Match. 6.45, Le Journal Parlé. 8.30, Gramophone Concert. 10.0, (approx.), Close Down.

PARIS

POSTE PARISIEN; 914 kc/s, 328.2 metres; 10 kW.—10.0 a.m., Fanfare of Trumpets and Roll of Drums. 10.20, Press Review. 10.30, Sponsored Concert. 11.0, Gramophone Music. 12.15 p.m., Sponsored Concert of Sound Film Music. 12.45, Sponsored Programme. 12.50, Half an Hour of Fantasy by Paul Weill. 1.30, Sponsored Programme. 2.0 to 7.0; Interval. 7.0, Le Journal Parlé. 7.5, Sports Notes. 7.15, Gramophone Music. 7.30, Catholic Review. 8.0, Gramophone Music. 8.30, Variety Concert. 9.15, Paul Fort—Play in Verse. 9.45, Jucert. 10.30, News.

PARIS

RADIO PARIS; 174 kc/s, 1,725 metres; 75 kW.—7.45 a.m., Gramophone Music. 8.0, News. 8.30, Physical Culture. 12 Noon, Religious Address. 12.20 p.m., Sacred Music: Cantate Domino (Alain); Toccata and Fugue in D minor (Bach). 12.30 Bilboquet as a Reporter. 12.45, Gramophone Concert. 2.0 (approx.), Running Commentary on the Last Two Singles Matches of the Davis Cup Final. 7.0, Popular Concert. 8.0, Gramophone Concert, with Songs and Pianoforte Duets. In the intervals at 8.30 and 9.15, News. 10.30 to 11.0, Programme in English by the I.B.C. Orchestral Concert: Overtures (arr. Englemann); Bird Songs at Eventide (Coates); Selection from The Arcadians (Monckton Talbot); Waltz, Siziiletta (V. Bon); Selection from Linca Time (Schubert). 11.0 (approx.), Close Down.

PITTSBURGH

KDKA; 980 kc/s, 306 metres; 50 kW. Relayed by W8XK, on 48.86 metres and 25.27 metres.—5.15 to 6.15 p.m., Radio City Concert, from New York. 7.0, The Boys of Wynnecastle. 7.15 to 11.0, New York Relay. 7.15, World Economic Conference—William Hard from London. 7.30, Jan Garber and his Orchestra. 8.0, National Opera Concert. 9.0, Morton Gould and Bert Shefter. 9.15, Symphonette. 9.30, Organ Recital. 10.0, Vesper Services from Shadyside Presbyterian Church. 11.0, Time Signal and Press Newsletter. 11.5, Beethoven Chamber Music, from New York. 11.15, Weather Report. 11.16, Sport Review. 11.28, Announcement. 11.29, Temperature Report. 11.30, L'Heure Exquise, from New York. 12 Midnight, Time Signal and Jack Pettis and his Orchestra. 12.15 to 1.30 a.m. (Monday), New York Relay. 12.15, World Economic Conference—William Hard from London. 12.30, Wisdom of the Ages. 1.9, Riesenfeld's Viennese Programme. 1.30, Pathic News of the Air. 1.45 to 4.0, New York Relay. 1.45, Floyd Gibbons, World's Fair Reporter. 2.0, Gulf Headliners, Arthur Brisbane and Walter C. Kelly. 2.30, Goldman Band. 3.0, Time Signal and Mountain Music.

PORSGRUND.—See Oslo.

PRAGUE

614 kc/s, 488.6 metres; 120 kW.—12 Noon, Chimes. 12.5 p.m., Municipal Band Concert. 1.30, Agricultural Report. 1.45, Interval. 4.0, See Bratislava. 5.30, Topical Talk. 5.50, Gramophone Music. 6.0, German Transmission: Review of the Czechoslovak Stations Musical Programmes, followed by Lore—Comedy (Hartleben). After the Comedy, News. 7.0, Brass Band Concert. 8.0, Radio Play. 9.0, See Brno. 10.0, Time and News. 10.20, Dance Music on Two Pianofortes. 11.0 (approx.), Close Down.

RADIO-SUISSE ROMANDE

SOTTENS; 743 kc/s, 403 metres; 25 kW.; and **GENEVA;** 395 kc/s, 760 metres.—9.55 a.m., Chimes. 10.0, Protestant Service, relayed from the St. Laurent Church. 11.0, Gramophone Music. 12.30 p.m., News and Weather. 12.40, Gramophone Music. 2.0 to 3.30, Interval. 3.30, Concert by the Radio Lausanne Orchestra, conducted by M. Moser. 5.0, Dance Music on Gramophone Records. 7.0, Religious Talk. 7.30, Sports Talk: Results of the Swiss Light Athletics Championship. 7.40, Talk: Sunday Sports. 8.0, Concert by the Radio Lausanne Orchestra. 8.50, Recitation of Poems. 9.15, Violin Recital by F. Rothpletz. 9.50, News and Weather. 10.0, Recitations by Sacha Guitry, on Gramophone Records. 10.30 (approx.), Close Down.

RJUKAN.—See Oslo.

ROME

Call 1RO; 680 kc/s, 441 metres; 50 kW. Relayed by Naples, 941 kc/s, 319 metres; and **2RO;** 11,810 kc/s, 25.4 metres, from 5.30 p.m.—10.0 a.m., News, Sports Notes and Amusement Guide. 10.30, Agricultural Notes. 10.40, Bible Reading. 11.0, See Turin. 12 Noon, Interval. 12.30 p.m., See Turin. 1.45 to 2.30, Gramophone Music. In the interval at 2.0, Time and Announcements. 3.0, See Turin. 4.45 (Naples), Programme for Children, Shipping and Sports Notes. 5.0, Orchestral Concert. In the interval at 5.30, Sports Notes. 6.15, Weather Forecast. 7.30, News. 8.0, Time and Announcements. 8.30, Sports Notes. 8.45, Clo-Clo—Opera in Three Acts (Lehar). In the intervals: Talk and Monologue. Giornale Radio after the Operetta.

SALZBURG.—See Vienna.

SCHENECTADY

WGY; 790 kc/s, 379.5 metres; 50 kW. Relayed at intervals by W2XAF on 21.48 metres; and by W2XAD on 19.56 metres.—8.0 to 10.0 p.m. (approx.), New York Relay. 8.0, Wayne King's Orchestra. 8.30, Dr. Ralph Sockman in the Radio Pulpit. 9.0, Fiddlers Three. 9.15, Wildroot Institute. 9.30 to 10.0, Temple of Songs. 12.45 a.m. (Monday), Horse Sense Philosophy. 1.0 to 3.45, New York Relay. 1.0, Variety Programme 2.0, Manhat-

tan Merry-Go-Round. 2.30, American Album of Familiar Music. 3.0, Variety Programme. 3.15, Impressions of Italy. 3.45, Sunday at Seth Parker's, from New York, followed by Programme Resume.

SCHWEIZERISCHER LANDESSENDER

BEROMUNSTER; 653 kc/s, 459 metres, 60 kW.; **Basle;** 1,229 kc/s, 244.1 metres; and **Berne;** 1,220 kc/s, 245.9 metres.—10.0 a.m. (from Basle), Protestant Service. 10.45 (from Basle), Concert of Chamber Music. 11.30 (from Basle), Bernhard Moser reads from his own Poems. 12 Noon (from Basle), Swiss Songs on Gramophone Records. 12.30 p.m., Time and News. 12.40 (from Zürich), Concert by the Swiss Radio Orchestra, conducted by H. Neppach. 1.30 (from Basle), Agricultural Programme. 2.0 (from Basle), Concert by a Peasant Orchestra. 2.30, Interval. 5.0 (from Zürich), Concert by the Swiss Radio Orchestra, conducted by Erwin Gilbert. 6.0 (from Basle), Talk: Gipsy Music. 6.30 (from Basle), Talk: Walking in the Vosges Mountains. 7.0 (from Basle), Time and Sports Notes. 7.5 (from Basle), Gramophone Concert. 8.0 (from Basle), Talk: Painting and Tattooing. 8.30 (from Basle), Violin Music by Contemporary Basle Composers. 9.0, News. 9.10 (from Basle), Folk Song Recital by Fran Lovskaya. 10.15 (from Basle), Sports Notes. 10.20 (approx.), Close Down.

SOTTENS.—See Radio-Suisse Romande.

STOCKHOLM

689 kc/s, 436 metres; 55 kW. Relayed by **BoTen;** 244 kc/s, 1,229.5 metres; **Göteborg;** 932 kc/s, 322 metres; **Hörby;** 1,166 kc/s, 257 metres; **Motala;** 221.5 kc/s, 1,354.4 metres; **Ostersund;** 389 kc/s, 770 metres; and **Sundsvall;** 554 kc/s, 542 metres.—9.30 a.m., Rural Programme. Part I, relayed from Karlstad, 1,382 kc/s, 217 metres. Part II, relayed from Örebro, 1,265 kc/s, 237.2 metres. 10.0, Gramophone Music. 11.0, Divine Service. 12.45 p.m., Weather. 3.0, Concert of Light Music by Erich Ernst's String Ensemble. 4.0 (from Sundsvall), Programme for Children. 4.25, Trio (concert). 5.5, Reading. 5.30, Recital by Gösta Lindberg (Songs) and Vivian Wenberg (Pianoforte). 6.0 (from Göteborg), Evensong. 7.15, Weather and News. 7.35, Talk: The Galapagos Islands. 8.0, Orchestral Concert, conducted by Adolf Wiklund, relayed from Skansen. Part I: Wagner Music: Overture, Tannhäuser; Selection from Lohengrin; Forest Murmurs from Siegfried; Siegfried's Rhine Journey, from The Twilight of the Gods (Wagner). Part II: Symphony No. 6 in F—The Pastoral (Beethoven). In the interval at 8.50 (approx.), Reading. 9.45, Weather and News. 10.0 (from Göteborg), Light Orchestral Concert. 11.0 (approx.), Close Down.

STRASBOURG

569 kc/s, 345 metres; 11.15 kW.—9.30 a.m., Orchestral Concert, conducted by de Villers. 10.45, Protestant Service in German. 11.30, Programme by the Blind of Still: Part I—Religious Address in German; Part II—Songs and Recitations. 12.30 p.m., Gramophone Music. 12.45, News. 1.0, Time. 1.10, Gramophone Music. 2.0, Agricultural Talk. 2.15, Gramophone Music. 3.30, Orchestral Concert, relayed from the Casino Park, Vichy. Conductor: Brouillat: Overture, Le Roi d'Ys (Lalo); Two Hungarian Dances (Brahms); Scènes napolitaines (Masenet); Violin Solo: Czardas (Monti); Serenade for Flute and Horn (Titl); Selection from Mirella (Gounod); Waltz, The Blue Danube (Strauss). 5.0, Talk: Across Algeria. 5.15, Berenice—Play in Five Acts (Racine), with Music by Marcel Samuel Rousseau. 7.0, Medical Talk in German: The Effect of Sport on the Heart. 7.15, Sports Talk. 7.30, Time and News. 7.45, New Gramophone Records. 8.15, News in French, Lottery Results, and Announcements. 8.45, Wind Instrument Concert, relayed from Nancy: Les Gars du Ving-sixième (Taellmann); Overture, L'Enfant Roi (Bruneau); Extracts from Act III of The Mastersingers (Wagner); Recitative and Polonaise (Weber); Valse lente (Chopin); Overture, Rienzi (Wagner); Marche lorraine (Ganne). 10.30 (approx.), News in German. 10.45, Dance Music from the Savoy. 12 Midnight, Close Down.

STUTTGART

MUHLACKER; 832 kc/s, 360.5 metres; 60 kW.; and **Freiburg;** 527 kc/s, 570 metres.—9.20 a.m., Programme in connection with the Fifteenth German Gymnastic Festival, 1933: The Procession of 150,000 before Adolf Hitler. 10.0, Evangelical Morning Recital. 10.50, Interval. 11.30, Hugo Wolf Song Recital, by G. Walter (Tenor). 12 Noon, Orchestral Concert, conducted by Ferdinand Diest: Overture, Fra Diavolo (Auber); Rhapsody No. 13 (Liszt); Dance of the Hours, from La Gioconda (Ponchielli); Overture, William Tell (Rossini); Polka, Elyen Magyar (Joh.

Strauss). 1.0 p.m., Topical Talk. 1.15, La Bohème—Opera in Four Acts (Puccini), by the Choir and Orchestra of the Scala, Milan (on Gramophone Records). 3.30, See Frankfurt. 3.55, Military Band Concert, relayed from London. 5.0, Accordion Concert. 5.40, Ilse Ringer-Kellner reads from her own Works. 6.0, Talk: The Black Forest. 6.30, The Fifteenth German Gymnastic Festival, 1933—Final Relay from the Festwiese: Fanfare, March, Addresses, and the German National Anthem. 8.0, Songs by the Albatros Quartet. 8.20, Dance Music from Berlin (Deutschlandssender). 10.0, Time and News. 10.45, Dance Music, relayed from Berlin (Witzleben). 1.0 a.m. (Monday), Close Down.

SUNDSVALL.—See Stockholm.

TRIESTE

1,211 kc/s, 247.7 metres; 10 kW.—9.40 a.m., See Turin. 9.55, Mass from the Cathedral of San Giusto. 11.0, Religious Address. 11.20 to 11.40, Agricultural Talk. 12.30 p.m. (approx.) till Close Down, See Turin.

TRONDHEIM.—See Oslo.

TURIN

1,096 kc/s, 273.7 metres; 7 kW. Relayed by Milan, 905 kc/s, 331.5 metres; Genoa, 959 kc/s, 312.8 metres; and Florence 599 kc/s, 500.8 metres.—9.40 to 9.55 a.m., Giornale Radio. 10.40, Agricultural Talk. 11.0, Mass from the Church of the Annunciation, Florence. 12 Noon to 12.15 p.m., Bible Reading. 12.30 p.m., Orchestral Concert. In the interval at 1.0, Time and Announcements. 1.30, Sponsored Musical Programme. 1.45 to 2.30, Gramophone Music. 3.0, Report on the Contest for the Ciano Cup. 4.30, Orchestral Concert. Sports Notes in the intervals. 6.15, Weather. 6.30 to 6.45, Giornale Radio and Sports Notes. 7.0, Time Signal and Popolavoro Notes. 7.10, Gramophone Music. 8.0, News. 8.45, L'Antenato—Comedy in Three Acts (Veneziani). After the comedy, Dance Music. 11.0, Giornale Radio.

VIENNA

581 kc/s, 517 metres; 100 kW. Relayed by Graz, 852 kc/s, 352.1 metres; Innsbruck, 1,058 kc/s, 283 metres; Klagenfurt, 662 kc/s, 453.2 metres; Linz, 1,220 kc/s, 245.9 metres; and Salzburg, 1,373 kc/s, 218.5 metres.—8.25 a.m., Festival Programme of the Laying of the Foundation Stone of the Dr. Seipel Monument. 10.15, Recital of Songs and Arias. 10.40, Dialogue: The Art of enjoying oneself. 11.0, Concert by the Vienna Philharmonic Orchestra, conducted by Dr. Richard Strauss, relayed from the Mozartium; Soloist: Ralph Lawton (Pianoforte); Symphony in D (Mozart); Serenade in B flat for Thirteen Wind Instruments (Mozart); Concerto for Pianoforte and Orchestra in A (Mozart). 1.0 to 2.0 p.m., Gramophone Concert of Light Music. 2.40, Time and Weekly Press Review. 2.45, Agricultural Talk. 3.5, Review of Books. 3.30, Haydn's String Quartets: String Quartet in F Sharp Minor, Op. 50, No. 4; String Quartet in G, Op. 76, No. 1. 4.25, Talk: The Tyrol. 4.55, Orchestral Concert, conducted by Joseph Holzer. 6.40, Modern Austrian Literature. 7.10, Time, Sports Notes, and Programme Announcements. 7.20, Recital of Songs and Arias by Robert Shilton (Baritone): Aria from Don Carlos (Verdi); Valentine's Prayer from Faust (Gounod); The Dreary Steppe (Gretcheninov); Le cor (Félicier); Romanian Folk Songs (Brediceanu); Star of Eve from Tannhäuser (Wagner); Aria from Hamlet (Thomas); Two Songs (Tagliaferrri); (a) Nun me seeta, (b) Amore canta. 8.0, Ein Märchen aus Florenz—Operetta in Three Acts (Benatzky). In an interval at 9.30, News. 10.15, Dance Music on Gramophone Records.

WARSAW

212.5 kc/s, 1,411 metres; 120 kW.—9.55 a.m., Programme Announcements. 10.0, Divine Service, relayed from Wilno, 533 kc/s, 663 metres. 10.45, Sacred Music on Gramophone Records. 11.0, See Vienna. 1.0 p.m., Programme Announcements. 1.5, Weather. 1.10, Gramophone Concert. 2.0, Agricultural Talk. 2.15, Weather for Farmers. 2.20, Songs on Gramophone Records. 2.45, Legal Talk. 3.5, Gramophone Music. In the intervals, News and Announcements. 4.0, Programme for Children. 4.30, Popular Concert by the Poznan Opera House Orchestra, conducted by Tyllia, relayed from Cichocinck. 5.0, Talk: The Importance of Light and Sun to Health. 5.15, Popular Programme, relayed from Lwow, 788 kc/s, 381 metres. 6.0, Choral Concert. 6.35, Programme Announcements. 6.40, Miscellaneous Items. 7.0, Dramatic Programme, relayed from Wilno. 7.40, Answers to Technical Correspondents. 8.0, Concert by the Station Orchestra, conducted by Nawrot. Soloist: Henri Domanski (Mouth Organ). Suite, Impressions exotiques (Monton); Mouth Organ Solos: Waltz from The Dollar Princess (Fall); Mouth Organ Solos, Madrigalesca (Albergoni); Ballet Scene (Tzibulka); March (Namy-slawski). 8.50, Radio Journal. 9.0, Variety Programme relayed from Lwow. 10.0, Dance Music. 10.25, Sports Notes. 10.40, Aviation Weather Report and Police Notes. 10.45, Dance Music.

ZURICH.—See Schweizerischer Landesender.

MONDAY

JULY THE THIRTY-FIRST

PRINCIPAL EVENTS OF THE DAY:

AT HOME

- NATIONAL "Depression over Fairyland," a musical fantasy, by Henrik Ege. Organ recital from Broadcasting House. LONDON REGIONAL Military Band programme. MIDLAND REGIONAL "Both Sides of the Picture: Sailing in Northern Waters." by Lord Stanley of Alderley. WEST REGIONAL Two plays: "Let it go at that," by Essex Dane, and "The Greater Law," by Leonard C. White, relayed from Bath. SCOTTISH REGIONAL Band concert. BELFAST Instrumental concert.

ABROAD

- BRUSSELS 9.0 p.m. Concert, relayed from the Casino, Knoeke. COPENHAGEN 8.5 p.m. Danish music by the Station Orchestra. 10.15 p.m. Schubert concert. HAMBURG 10.30 p.m. The Kiel Orchestra of Unemployed Musicians. HILVERSUM 7.40 p.m. Chamber music. HUIZEN 7.45 p.m. Concert by the Station Orchestra. MUNICH 8.0 p.m. Acts II, III and IV of "Figaro" (Mozart). RADIO PARIS 8.45 p.m. Chamber music. ROME 5.30 p.m. Vocal and instrumental concert. STRASBOURG 8.45 p.m. "Samson and Delilah," opera by Saint-Saens, from the Casino, Vichy. TURIN 9.15 p.m. Operetta: "La fille de Madame Angot," by Lecocq. WARSAW 8.0 p.m. Operetta: "Hotel Stadt Lemberg," by Gilbert.

BRESLAU

923 kc/s, 325 metres; 60 kW.; and Gleiwitz, 1,184 kc/s, 253 metres.—1.0 p.m., Gramophone Concert. In the interval at 1.45, Time and News. 2.0, Request Gramophone Concert. 3.0, Agricultural Prices. 3.25, Talk: The Milky Way. 3.40, Book Review. 4.0, Concert by the Silesian Philharmonic Orchestra, relayed from Bad Reinerz. Conductor: Wolfgang Friebe. Soloist: Kurt Becker (Songs). Overture, Friedensfeier (Reinecke); Fredericus Rex (Loewe); Aria from Der Waffenschmidt (Litzing); Violin Solo: Faust-Fantasia (Sarasate); Slav March (Tchaikovsky); Overture, Die schöne Galanthe (Suppé); Hungarian Rhapsody (Reinde); Waltz, Bei uns z'haus (Strauss); March (Friebe). 5.30, Agricultural Prices. 5.35, Talk: German Culture. 5.50, Topical Talk. 6.10, Talk: The Organisation of the German Movement for Freedom. 6.30, Sonata in C Sharp Minor, Op. 27 (Beethoven). 6.50, Weather for Farmers and News. 7.0, Transmission for all German Stations, relayed from Friedrichshafen. 8.10, Radio Report from Friedrichshafen. 8.30, Concert by Margarete Rölls (Soprano), Rudolf Schulz (Violin), Theo Schwoon (Viola), Peter Herbert Lehmann (Cello), Kurt Borack and Helmut Hildeguth (Pianofortes). 10.0, News. 10.15 (approx.). Dance Music, relayed from the Delphi-Palast. In the interval at 11.0 (approx.). Talk: What they are saying in Berlin. 12 Midnight, Close Down.

BRNO

878 kc/s, 342 metres; 35 kW.—6.25 p.m., German Transmission, News, Literary Talk. 7.0, See Prague. 7.10, Report from the Studio. 8.10, Village Band, relayed from Svatorborice. 8.45, See Prague. 9.5, See Bratislava. 10.0, See Prague. 10.15 (approx.), Close Down.

BRUSSELS (No. 1)

I.N.R., 590 kc/s, 509 metres; 15 kW.—12 Noon, Gramophone Music. 1.0 p.m., Journal Parlé. 1.10, Concert by the Small Station Orchestra, conducted by Pierre Leemans. Overture, Martha (Flotow); Symphonie Entr'acte (Desprez); Berceuse (Brammante); Selection from Coppélia (Delibes); Mitologine (Marsick); Chanson d'amour (Candil); Overture, La belle Hélène (Offenbach); Violin Solo: Bécsir (Kálmán); Akita (Bourmerek); American Patrol (Haugregard). 5.0, Concert by the Station Symphony Orchestra, conducted by Arthur Meulemans. Overture to a Drama (Dupuis); Petite Suite (Jongen); Romance in F (Rubinstein—d'Indy); Nocturne and Scherzo (Mendelssohn); Song

d'amour (Marsick); Marche joyeuse (Chabrier). 6.0, Talk The Walloon Movement and the Reform of the Constitution. 6.15, Song Recital by M. Eyraud. 6.30, Gramophone Concert. Selection from Mignon (Thomas); Selection from Samson and Delilah (Saint-Saens); Selection from Le jongleur de Notre Dame (Massenet); Ballad and Polish (Vicentemps); Selection from Lakmé (Delibes-Tavan); Selection from Louise (Charpentier). 7.15, Review of the Walloon Movement. 7.30, Film Notes. 8.0, Concert by the station Symphony Orchestra, conducted by Arthur Meulemans. Overture, Zampa (Hérold); Symphonic Poem, Paysage (Rogister); Pianoforte Solos: (a) Hebrew Dance (Sally), (b) Exuberance (Russe), (c) Scherzo (Basse); First Suite from L'Arlesienne (Bizet); Finale from Les tableaux grecs (Marsick). 8.45, Gramophone Concert. Les temps des cerises (Renard); Air from Romeo and Juliet (Gomodo); Selection from Mlle. Nitouche (Tavan). 9.0, Concert, relayed from the Kursaal, Ostend. After the Concert, Le Journal Parlé and Dance Music by Robert de Kers and his Cabaret Kings, relayed from the Kursaal, Ostend.

BRUSSELS (No. 2)

I.N.R., 887 kc/s, 338.2 metres; 15 kW. (Programme in Flemish).—12 Noon, Concert by the Small Station Orchestra, conducted by P. Leemans. Comedy, Overture (Kéfer Béla); Old Spanish Songs (Albert); Symphonic Dances (Grieg); Selection from Le petit Duc (Lecocq); Violin Solo: Habanera (Sarasate); A Musical Box (Nicolaiewsky); Waltz, Es führt kein anderer Weg zur Seligkeit (Heymann); Ballet Music from Hamlet (Thomas). 1.0 p.m., Le Journal Parlé. 1.10, Extracts from Cavalleria rusticana (Mascagni), on Gramophone Records. 5.0, Concert by the Station Orchestra, conducted by Franz André. Hubens March (Benoit); English Scenes (Hantock); Selection from New Moon (Romberg); Melodies (Albeniz); (a) España, (b) Granada, (c) Cadiz; Humorous Scenes (Leonard); Ballet Music from Lakmé (Delibes). 5.45, Programme for Children. 6.30, Concert by the Small Station Orchestra. 7.15, Wireless Talk: The Valde. 7.30, Le Journal Parlé. 8.0, Concert by the Station Orchestra, conducted by Franz André. Slav March (Tchaikovsky); Paysages flamands (de Taveye); Finale from the Third Violin Concerto (Saint-Saens); Overture, The Bartered Bride (Smetana); Military March (Schubert). 8.45, Talk for Stamp Collectors. 9.0, Concert, relayed from the Casino, Knoeke, conducted by K. Candael. Soloist: Theo Van Hamberg (Cello); Suite, No. 7 (Handel); Cello Concerto in D (Haydn); Allegro con grazia from The Pathetic Symphony (Tchaikovsky); Cello Sonata in A Minor (Beethoven); Les Préludes (Liszt). After the Concert, Le Journal

Parlé, followed by Dance Music, relayed from the Casino, Knoeke.

BUCHAREST

761 kc/s, 394 metres; 12 kW.—5.0 p.m., Light Music and Romanian Music by the Ionescoga Orchestra. In an interval at 6.0, Radio Journal. 7.0, Reading. 7.20, Gramophone Music. 7.40, Educational Talk. 8.0, Octet (Schubert) on Gramophone Records. 8.40, Talk. 8.55, Recital of Modern Music on Two Pianofortes. 9.25, Programme relayed from the Piccadilly Restaurant. 10.0, Radio Journal.

BUDAPEST

545 kc/s, 550.5 metres; 18.5 kW.—5.0 p.m., Pianoforte Recital. 5.30, Talk. 6.0, Chamber Music. 7.0, Reading. 7.30, Brahms Concert by the Station Orchestra. 9.15, Cigány Music by the Veres Band, from the Café Ostende. 10.15, Weather Report. 10.20, Gramophone Music. 11.20, Jazz Music.

CASSEL.—See Frankfurt.

COPENHAGEN

1,067 kc/s, 281 metres; 0.75 kW. Relayed by Kalundborg, 260 kc/s, 1,153.8 metres.—2 Noon, Time and Chimes from the Town Hall. 12.5 p.m., String Ensemble Concert, relayed from the Hotel d'Angleterre. 2.0, Interval. 2.50, Hints for the Housewife. 3.0, Concert by Louise Preis's Instrumental Ensemble. Soloist: Rigmor Heyde (Songs). 5.0, Gramophone Music. 5.35, Exchange and Fish Market Prices. 6.20, Talk. 6.50, Weather and News. 7.15, Time Signal. 7.30, Talk. 8.0, Chimes from the Town Hall. 8.5, Concert of Danish Music by the Station Orchestra, conducted by Emil Reesen. Overture, Røverborger (Kuhlau); Andante con moto from the Fourth Symphony, No. 4 in B Flat (Gade); Overture, Youth and Madness (Dupuy); Drommedeller (Lumbye); Selection from Gurte (Hornemann); March from Modern (Nielsen). 8.45, Folk Dances for Violin, Viola, Clarinet and Double Bass (arr. Grøndahl), followed by Reading. 9.15 Concert by the Ydm Male Voice Choir. 9.50 Humorous Reading. 10.0, News. 10.15, Schubert Concert by the Station Symphony Orchestra, conducted by Emil Reesen. Soloist: Folner Jensen (Pianoforte). Overture, Rosamunde; Allegro moderato and Andante con moto from Symphony No. 8 in B Minor the Unfinished Fantasia, Der Wanderer, for Pianoforte and Orchestra (arr. Liszt). 11.3 (approx.), Close Down.

CORK.—See Athlone.

CRACOW

959 kc/s, 312.8 metres; 1.5 kW.—7.5 p.m. Gramophone Music. 7.20, Miscellaneous Items and News. 7.35, Programme Announcements. 7.40, See Warsaw. In an interval at 10.30, Sports Notes. 10.45, Dance Music on Gramophone Records. 11.0, Fare fare from St. Mary's Church.

DANZIG.—See Heilsberg.

DRESDEN.—See Leipzig.

FECAMP

1,328 kc/s, 225.9 metres; 10 kW.—4.30 to 6. p.m., Programme in English by the I.B.C. 4.30, Programme for Children. 5.0, Concert for Chieftester and Bognot Listeners: Signature Tune: The Night by the Sea; A Cottage for Sale; Song, You're still in my Heart (Dougherty); Until we meet again Sweetheart; Song, Paradise (Brown); I seem to me; Song, Brother, can you span a dime? (Harburg); Some of these days (Brooks); In a Monastery Garden (Kete bey). 5.30, Concert for Hastings and Esbourne Listeners: Ginger Snaps (Bourdon); Letting in the Sunshine (Gay); The Ghou Walk; The Girl in the Little Green Hat (Rich); I raised my Hat (Pola); Rhapsody in Blue; That's my Home (Ellison); Dans Bagatelle (Bourdon); Signature Tune. 6. Programme in French. 10.0 (approx.) to 11.0 p.m., Programme in English by the I.B.C. 10.0, Dance Music: Signature Tun-Bells of Normandy (Evans); Kalna (Kern) Harlem Madness (Ager); Dancing Tin (Kern); Blue turning grey over you (Waller); I like to do things for you (Ager); I can't write the words (Fields); Happy Feet (Ager); Let's put out the Light (Hupfeld); When work is through (Sheehan); How'm I doin' (Fowler); Gosh Dan (Young); Say it isn't so (Berlin); Whi we danced at the Mardi Gras (Mercer) What makes you so adorable? (de Rose) Love me to-night (Young); Don't tell a so (Pepper); Signature Tune. 11.0, Club Concert for Colwyn Bay Listeners: Part I: Orchestral Programme: Signature Tune, Ti Chini Song; Waltz Impromptu (Andraier) Song: Eleanor (Coleridge-Taylor); In introduction and Valse Lente from Coppélia (Delibes); Violin Solo: Meditative from Thais (Massenet); Waltz Song from La Bohème (Puccini); Song: The Ty Grenadiers (Schumann); Rakoczy Mar (Berlioz). Part II—Concert of Gramophone Records: Selection from La Belle Hélène (Offenbach); Looking on the Bright Side (Therby); There's something about a Soldier (Gay) The Buffoon (Curzon); He's been on t' bottle since a baby (Bell-Fyffe); Clapha and Dwyer on Photography; The Porter Love Song (Razaf); Selection from La Belle Hélène (Offenbach); Signature Tune. 12

BARCELONA EAJ1, 860 kc/s, 348.8 metres; 8 kW.—7.0 p.m., Trio Concert: Selection from The Flying Dutchman (Wagner); Arioso (Delibes); Romance, Krottschak (Reckenwald); Mimmet from Samson (Handel); Canto appassionado (Malvezzi); Waltz—Scherzo (O. Strauss); Selection from La Traviata (Verdi). 8.0, Request Gramophone Records. 8.20, Sports Notes. 8.30, Exchange and Talk in Catalan. 9.0, Gramophone Music and News. 10.0, Chimes, News and Exchange. 10.5, Humorous Review of the Week's Events in Verse. 10.15, Dance Music. 11.0, Concert by the Station Orchestra. 11.30, Vicente Díez de Tejada reads from his Novel, La rubia del Far West. 11.45, Concert from the Casino San Sebastian. In the interval at 12 Midnight, News. 1.0 a.m. (Tuesday), Close Down.

BARI 1,112 kc/s, 269.8 metres; 20 kW.—8.0 p.m., Agricultural Notes, Tourist Report and Dopolavoro Announcements. 8.20, Giornale Radio, Weather, Time and Announcements. 8.30, Sly—Opera in Three Acts (Walf-Ferrari). In the intervals, Announcements and Literary Notes. After the Opera, News. BASLE.—See Schweizerischer Landessender.

BELGRADE BEOGRAD, 697 kc/s, 430.4 metres; 2.8 kW.—6.0 p.m., Gramophone Music. 6.30, Talk. 7.0, Quartet in B Flat (Goldmark). 7.40, Concert by the Station Orchestra. 8.30, Programme from Zagreb, 977 kc/s, 307 metres. 10.30, Time Signal, News and Cigany Music from the Rudnician Restaurant.

BERLIN DEUTSCHLANDSENDER, 183.5 kc/s, 1,653 metres; 60 kW.—2.0 p.m., Gramophone Concert of Variety Music. 3.0, Talk for Mothers. 3.30, Weather and Exchange. 3.45, Book Review. 4.0, See Breslau. 5.0, Talk by Dr. Johann Friedrich Dietz. 5.25, Talk: Our Duty to Coming Generations. 5.35, Liszt Memorial Recital. Erinnerung. Eroica; Rhapsody No. 13. 6.0, A Poem. 6.5, Song Recital of Modern Music, by Waldemar Weddland, with the Composer at the Pianoforte. Hans Joachim Andresen (Baritone) and Else Hinkel (Soprano); Baritone Solos (a) Sehnsucht, (b) Welgetan? Soprano Solos: (a) Mädchenlieder, (b) Legendr. Baritone Solos: (a) Liebe, (b) Die alte Geige. 6.25, Peter Rosegger Memorial Programme for the Fifteenth Anniversary of his death. 6.50, Weather for Farmers and News. 7.0, Transmission for all German Stations, relayed from Breslau. 8.0, Today's Motto. 8.5 (approx.), Concert from Hamburg. 9.0, Variety Programme. 10.0, Weather and News. 10.45, Weather for Shipping. 11.0, See Munich. 12 Midnight (approx.), Close Down.

BERLIN WITZLEBEN, 715 kc/s, 419.5 metres; 1.5 kW.—4.30 p.m., Concert by the Stamitz Chamber Orchestra. Six Sketches for Strings (Götz); Kleine Serenade Op. 55 (Trink); Serenade Op. 242 (Reinecke). 5.30, Talk: Small Pleasures. 5.50, Reading. 6.10, Orchestral Concert relayed from the Krumme Lanke Restaurant, Zehlendorf; Wanderer Suite (Kuimann); Waltz, Leuchtende Sterne (Robrecht); Selection from Madame Butterfly (Puccini-Wenzel); March, Um den Lorbeer (Christ). 6.40, The Witzleben Station informs its Listeners. . . . 6.45, Topical Talk. 7.0, Transmission for all German Stations, relayed from Breslau. 8.10, Radio Report from Friedrichshafen. 8.30, Concert by Margarete Rölls (Soprano), Rudolf Schulz (Violin), Theo Schwoon (Viola), Peter Herbert Lehmann (Cello), Kurt Borack and Helmut Hildeguth (Pianofortes). 10.0, News. 10.15 (approx.). Dance Music, relayed from the Delphi-Palast. In the interval at 11.0 (approx.). Talk: What they are saying in Berlin. 12 Midnight, Close Down.

BERNE.—See Schweizerischer Landessender.

BEROMUNSTER.—See Schweizerischer Landessender.

BODEN.—See Stockholm.

BODO.—See Oslo.

BORDEAUX-LAFAYETTE

985 kc/s, 304 metres; 13 kW.—6.15 p.m., Radio Journal. 7.30, News. 7.35, Talk: Bordeaux a Century Ago. 7.50, News. 8.0, Talk on Social Hygiene. 8.15, Gramophone Music. 8.45, Samson and Delilah—Opera (Saint-Saens), relayed from the Casino, Vichy.

BRATISLAVA

1,076 kc/s, 279 metres; 14 kW.—2.50 p.m., Concert by the Station Orchestra, conducted by Fr. Dyk. 3.55 to 4.0, See Prague. 5.45, See Prague. 6.25, Gramophone Music. 6.45, Talk. 6.55, Talk for Housewives. 7.0, See Prague. 7.10, See Brno. 8.10, See Prague. 9.5, Concert of Light Music by the Station Orchestra, conducted by Fr. Dyk. 10.0, See Prague. 10.15, Close Down.

BREMEN.—See Hamburg.

JULY 31st

MONDAY

continued

a.m. (Tuesday), The I.B.C. Late News Bulletin. 12.10 (approx.). Tango Band Cara Mucha; Luz de Granda; Accordion Solo; Tango de Paques; Cuvetier; Tierra Hispana; Adios Muchachos. 12.30, Dance Music; Signature Tune, Bells of Normandy; Under my Umbrella (Meyer); Sylvia (Scollard); And so I married the Girl (Wending); I wake up smiling (Leslie); Chansonette (Friml); That's my home (Rene); Body and Soul (Heyman); Contented; Signature Tune. 1.0, Light Songs: Lawd, you made the night too long (Lewis); Love me to-night (Crosby); Guitar Solo: Picking my way (Lang-Kress); We just couldn't say Good-bye (Woods); Washboard Blues (Callahan); You're still in my heart (Dougherty); Brother, can you spare a dime? (Harburg); Out of Breath. 1.30, Dance Music; Signature Tune, Bells of Normandy; Let's all dance the polka (Benison); There's a Crowd (Warren); Marching along together (Pola); Sweethearts forever (Cresar); You're my everything (Warren); I guess I'll have to change my plan (Schwarz); Oh! that Kiss (Warren); I'm forgetting myself (Meyer); Signature Tune. 1.57, I.B.C. Good-night Melody (Woods). 2.0, Close Down.

FLensburg.—See Hamburg.

FLORENCE.—See Turin.

FRANKFURT

1,157 kc/s, 259.3 metres; 17 kW. Relayed by Cassel, 1,220 kc/s, 245.9 metres; and Trier, 1,157 kc/s, 259.3 metres.—6.25 p.m., Talk: Fourteen Years of German Gliding. 6.45, Review of the Day's Events. 6.50, Time and News. 7.0, Transmission for all German Stations, relayed from Breslau. 8.0, See Hamburg. 9.0, Reading: Der Waldhaenerberg—Peter Rosegger (Richard Plattensteiner). 1.30, News Programme. 10.20, Time and News. 10.45, See Stuttgart.

FREDRIKSSTAD.—See Oslo.

FREIBURG.—See Stuttgart.

GENEVA.—See Radio-Suisse Romande.

GENOA.—See Turin.

GLEIWITZ.—See Breslau.

GOTEBORG.—See Stockholm.

GRAZ.—See Vienna.

HAMAR.—See Oslo.

HAMBURG

Jail ha (in Morse). 806 kc/s, 372 metres, 26 kW. Relayed by Bremen, 1,112 kc/s, 269.8 metres; Flensburg, 1,319 kc/s, 227.4 metres, 530 kc/s, 566 metres; and Kiel, 292 kc/s, 232.2 metres.—6.0 p.m., Peter Rosegger Memorial Programme for the fiftieth Anniversary of his Death—Address and Reading. 6.30, Talk: The Western Coast line of Schleswig. 6.46, Frankfurt Exchange. 7.0, Weather. 7.0, Transmission for all German Stations, relayed from Breslau. 8.0 (from Hanover), Concert by the Hanover Orchestra: Little Overture (Beccor); Flute solo: Le Tremolo (Pony); Cello Solo: Hungarian Fantasia (Grützmecher); Styrian Impromptu, for Two Violins (Spary); Giocondita (Ebbe); Tango, Der vertriebtetrididit (Heykens); Clarinet Solo: Variations on the Folk Song, Laht' lang' ist's her Ritter. Piano Solo: (a) Kleiner Valtzer (Schüll), (b) Polichinella-Burlesque Schüll); Vibraphone Solo: Waltz Intermezzo, Feenbogen (Schmitt); Gallop, Insaremit (Spindler). 9.0, Announcements. 9.10 (from Hanover), Lower Saxony Programme by the Hanover Radio Orchestra and George Friedrich Konrich. 10.10, Time and News. 10.20, Topical Talk. 10.30 (from Kiel), Concert by the Kiel Orchestra of employed Musicians. Conductor: Heinrich Licht. Festival March (R. Strauss); Overture, Beherrscher der Geister (Weber); eberzo in B flat (Schubert); Four Movements from Beischarazz's Feast (Sibelius); hernen-Waltzer (Strauss); Grosser Bravour-larsch (Prekker); Old German Gavotte (Jüling); Intermezzo, Love's Dream after the Ball (Czibulka); Indian War Dance (Imbye); Gallop, Bahn frei! (Siede); Waltz otpourri, Alt-Berlin (Leuschner); Bruckerger-Marsch (Krad).

HANOVER.—See Hamburg.

HEILSBURG

085 kc/s, 276.5 metres; 60 kW. Relayed by anzig, 662 kc/s, 453.2 metres.—1.5 to 2.30 m., Gramophone Concert. In the intervals 1.20 and 2.0, News. 3.0, Market Prices. 3.0, Programme for Children. 4.0, Police and Concert, conducted by Ernst Stieberich, layed from the Kurgarten, Zoppot; olisim-Marsch (Hauschild); Overture, vat Akademia (Zimmer); Waltz Melodies (obrecht); Spanish Rhapsody (Richardy); t'pourri of Music by Adam (Kling); ornrochens Brautfahrt (Rhode); Aus der ermerizeit (Kockert); Reminiscences of itary Life (Reckling); March, Wir äsentieren (Allhout) In the interval at 5.0, Talk: Anniversaries of the Week. 5.30, view of Books on The Place of Women

in the New Germany. 5.45, Song Recital by Henry Wolff (Soprano); Mädchenlieder (Armin Kuhl); Löns-Lieder (Karl August Fischer). 6.15, Market Prices. 6.25 (from Danzig), Talk: Systems of Defense in the Old Danzig. 6.50, Weather and News. 8.10, Transmission for all German Stations, relayed from Breslau. 8.0, Weather and News. 8.10, Extracts from L'elisir d'amore—Opera (Donizetti), by the Orchestra and Choir of the Scala, Milan, on Gramophone Records. 9.20, Ay Styrian Peasant Wedding—Programme for the Ninetieth Anniversary of the Birth of Peter Rosegger. 10.0, News.

HILVERSUM

Announced HUIZEN, 296.1 metres; 20 kW (7 kW up to 4.40 p.m.). Programme of the Christian Radio Society (N.C.R.V.).—11.40 a.m., Police Notes. 11.55, Gramophone Music. 12.10 p.m., Organ Recital by Jan Zwart. Moderato-allegro (Kühmstedt); Three Preludes and Psalms (Zwart); Concert Fantasia (Luz); Preludes (Bach): (a) Von Himmel hoch, (b) In Dir ist Freude, (c) In dilei Juhilo; Symphony No. 1 (Guilmant); Three Hymns (Zwart); Concert Fantasia, Ein feste Burg (Luz). 1.40, Beethoven Concert of Gramophone Records. 3.10, Interval. 3.40, Bible Reading and Organ and Baritone Song Recital. 4.40, Concert by the Van der Horst Ensemble. Song Cycle, Groot Nedeland; Adagio (Beethoven); Gavotte (Hanser); Selection from Rigoletto (Verdi), on Gramophone Records; Melodies from The Prophet (Meyerbeer); Paraphrase on Loyalty (Nesvadba); Selection from Faust (Gottsch); Selection from The Drum-Major's Daughter (Offenbach); Overture, The Black Domino (Anber). 6.10, Answers to Correspondence. 6.40, Police Notes. 6.55, Religious News. 7.10, Answers to Correspondence. 7.40, Chamber Music Concert. Conductor: Otto Glaszre van Loon. Soloists: Mlle. E. Glastra van Loon (Soprano), and M. H. Schoonman (Harpisichord); Triple Concerto in A (Bach); Symphony in E flat (Stanitz); Aria: Mia Speranza adorata (Mozart); Symphony in A (Mozart); Aria in C (Erlsbach); Aria in G. Miserere (Sarti); Symphony in C (Bocherini); Suite for Strings (Janacek). In the intervals at 8.40, Talk, and at 9.40, News. 10.10, Gramophone Music. 11.10 (approx.), Close Down.

HORBY.—See Stockholm.

HUIZEN

Announced HILVERSUM, 160 kc/s, 1,875 metres; 8.5 kW.—11.40 a.m. till Close Down, Programme of the Algemeene Vereeniging Radio Omroep (A.V.R.O.). 11.40, Time Signal and Gramophone Music. 12.10 p.m., Concert of Popular Music by Kovacs Lajos and his Dance Orchestra. In the interval, Choral Songs. 1.55, Gramophone Music. 2.10, Recital by Gustave Ferrari. 2.40, Gramophone Music. 3.25, Interval. 3.40, Violin Recital by Leon Ridelheim: Concerto in D Minor (Tartini); Andante cantabile (Nardini); Romanza andaluzza (de sarasate). 4.10, Talk by Max Tak with Gramophone Illustrations: Schubert's Songs. 5.10, Song, Violin and Organ Recital. 6.40, Book Review. 7.10, Gramophone Music. 7.40, Time, Weather and News. 7.45, Concert by the Station Orchestra, conducted by Ignaz Neumark. Soloist: Maurits van den Berg (Violin). Overture, Il Seraglio (Mozart); Ballad and Polonaise for Violin (Vieuxtemps); Valse des Fleurs (Tchaikovsky); Hungarian Dances, Nos. 1 and 2 (Brahms); Variations on a Hungarian Theme for Violin (Hubay); Military March (Schubert). 8.40, The Moonlight Sonata (Beethoven) by Egbert Veen. 8.55, Concert (cont'd.): Overture, The Thieving Magpie (Rossini); Morgenstimmung and Andra's Dance from Peer Gynt (Grieg); Torador et Andalouse (Rubinstein); Waltz, Roses from the South (Joh. Strauss); Cello Solo, Le Cygne (Saint-Saens); Hungarian Rhapsody, No. 2 (Liszt). 9.55, Gramophone Music. 10.10, Dance Music by Lismonde and his Ensemble, relayed from the Café Haek, The Hague. In an interval at 10.40, News. 11.10, Gramophone Music. 11.40 (approx.), Close Down.

INNSBRUCK.—See Vienna

KALUNDBORG.—See Copenhagen.

KATOWICE

734 kc/s, 408 metres; 16 kW.—5.15 p.m., Concert by the Moniuszko Mandoline Orchestra, conducted by Casimir Bonczak-Tomaszewski; Polonaise (Bonczak-Tomaszewski); Waltz, Espana (Waldteufel); Overture, Die Fledermaus (Joh. Strauss); In a Persian Market (Ketyberg); Aria from Halka (Moniuszko); Serenade (Moszkovsky); Selection from Viktoria and her Hussar (Abraham); Hungarian Dances Nos. 5 and 6 (Brahms); March, Boukala (Bonczak-Tomaszewski). 6.15, Tourist Talk relayed from Lwow, 788 kc/s, 381 metres. 6.35, Programme from Warsaw. 7.10, Talk. 7.25, Announcements and Gramophone Music.

7.40, See Warsaw. 10.45 till Close Down, Dance Music.

KIEL.—See Hamburg.

KLAGENFURT.—See Vienna.

LAHTI

167 kc/s, 1,796 metres; 40 kW. Relayed by Helsinki, 815 kc/s, 369.1 metres.—6.15 p.m., Talk. 6.25, Cello Recital. 6.45, Talk. 7.10, Song Recital. 7.35, Humorous Items. 8.0, Popular Music by the Station Orchestra. 8.45, News in Finnish and Swedish. 9.15, Light Music relayed from the Kappeli Restaurant. 10.0 (approx.), Close Down.

LANGENBERG

635 kc/s, 473 metres; 60 kW.—1.0 p.m., Concert by the Station Orchestra, conducted by Kühn and the Fünf frohe Sänger. In the interval at 2.0 (approx.), News. 2.30, Meat Market Prices. 3.30, Market Prices. 3.50, Programme for Children. 4.30, Talk for Women. 4.50, Recitation: Der Strassenbauer (Jungmann). 5.0, Cello, Piano forte, and Violin Recital. 5.30, Talk for Parents. 5.50, Talk: The Village Community. 6.0, Concert by the Essen Symphony Orchestra, conducted by Nowakowski. 6.45, Announcements. 7.0, Transmission for all German Stations, relayed from Breslau. 8.0, News. 8.5, Concert from Hamburg. 9.0, Westphalian Legends—A Radio Sequence (Friedrich Gastelle). 10.0, News. 10.45, Serenade, relayed from Stuttgart.

LAUSANNE.—See Radio-Suisse Romande.

LEIPZIG

769.9 kc/s, 389.6 metres; 120 kW. and Dresden, 941 kc/s, 319 metres.—12 Noon, Gramophone Concert. In the interval, Weather and News. 1.15 p.m., Opera and Operetta Music on Gramophone Records. 2.0, News. 2.10, Art and Film Review. 2.40, Soprano Song Recital by Gertrud Naumann. 3.0, Programme for Women. 3.35, Market Prices. 4.0, Concert Relay. 5.30, Talk: The Legend of Siegfried. 5.50, Economic Notes and News. 6.0, Reading: Petri Rosegger (Josef Plattensteiner). 6.25, Talk: Richard Barthold. 6.50, To-day's News. 7.0, Transmission for all German Stations, relayed from Breslau. 8.0, Wind Instrument Concert, conducted by Hans Teichmann: March, Grosse Zeit, neue Zeit (Brasse); Overture, The Golden Cross (Brüll); Intermezzo, Ein Vöglein sang im Lindenbaum (Eberle); Suite No. 2 from L'Arlesienne (Bizet); Selection from Carmen (Bizet); Waltz, Wine, Woman and Song (Joh. Strauss); Potpourri, Jugendklänge aus Alt-Haidelberg (Rhode); Mondnacht am Rhein (Brandt); March, Unter dem Haakenkreuz (Berndt); March, Zweierlei Tuch (Rust). 9.25, Agricultural Talk. 9.35, Recital of Songs to the Late by Oskar Besenfelder. Part I: Old German Folk Songs: Innsbruck, ich muss dich lassen; Herzlich tut mich erfreuen; Es sass ein Käterlein auf dem Dach Unser lieben Frauen; Hört, ihr Herrn. Part II: New Folk Songs: O Strassburg, du wunderschöne Stadt; Es reiten itz die ungrischen Husaren; Wenn ich ein Vöglein wär, Dna net a so. 10.5, News. 10.20 (approx.), Dance Music by the Arno Kaufmann Orchestra. 12 Midnight (approx.), Close Down.

LINZ.—See Vienna.

LJUBLJANA

522 kc/s, 574.7 metres; 7 kW.—6.30 p.m., Concert by the Station Orchestra. 7.30, Recitations in Esperanto. 8.0, Gramophone Music. 8.30, Programme relayed from Zagreb, 977 kc/s, 307 metres. After the relay, Time and News. 10.30, Gramophone Music. 11.0 (approx.), Close Down.

LUXEMBOURG

252 kc/s, 1,191 metres; 200 kW. Polish Programme.—7.30, Piano forte Recital of Polish Music. 8.0, Weather Report. 8.5, Concert of Polish Music by the Station Orchestra, conducted by Henri Pensis. Overture, Ilka (Doppler); Selection from Halka (Moniuszko); Melody (Paderewski); Minuet (Paderewski); Polonaise in A (Chopin). In an interval at 8.30, Talk in Polish. 8.50, News in French. 9.0, Song Recital by Jean Webster. 9.30, Orchestral Concert. In an interval at 9.50, News in German. 10.25, Dance Music on Gramophone Records.

LWOW

788 kc/s, 381 metres; 16 kW.—7.5 p.m., Gramophone Music. 7.20, Miscellaneous Items. 7.40, See Warsaw. In an interval, Answers to Technical Correspondence. 10.45, Gramophone Music. 11.0 (approx.), Close Down.

LYONS

LA DOUA (PTT), 644 kc/s, 465.8 metres; 1.5 kW.—7.30 p.m., Radio Gazette for Lyons and the South East. 8.45, See Strasbourg. After the Relay, News

MADRID

EAJ7, 707 kc/s, 424.3 metres; 2 kW.—8.0 p.m., Chimes, Exchange, Radio Journal, and Talk. 8.30 (approx.), Baritone Song Recital by Francisco Gines, followed by Recitation of Poems. 9.15, News. 9.30 (approx.), Close Down.

MALMO.—See Stockholm.

MILAN

VIGENTINO, 662 kc/s, 453.2 metres; 4 kW.—8.45 p.m. till Close Down, See Rome.

MORAVSKA-OSTRAVA

1,137 kc/s, 263.8 metres; 11 kW.—7.10 p.m., See Brno. 8.10, See Prague. 9.5, See Bratislava. 10.0, See Prague. 10.15 (approx.), Close Down.

MOSCOW

TRADES UNION, 230 kc/s, 1,304 metres; 100 kW.—2.45 p.m., Weather. 3.0, Folk Songs and Dance Music on Gramophone Records. 3.45, Weather. 4.0, Talk on Harvesting. 4.30, A Sound Film. 5.30, Talk on Finance. 9.0, News. 9.30, Programme Announcements. 9.55, Chimes from the Red Square.

MOTALA.—See Stockholm.

MUHLACKER.—See Stuttgart.

MUNICH

563 kc/s, 533 metres; 60 kW. Relayed by Augsburg and Kaiserslautern, 536 kc/s, 560 metres; and Nürnberg, 1,256 kc/s, 233 metres.—12 Noon, Gramophone Concert. Overture, Christellera (Piltzner); Recitative and Aria from Don Giovanni (Mozart); Quintet from The Mastersingers (Wagner); Overture, Le Bourgeois gentilhomme (R. Strauss); Allegro from The Piano forte Concerto in D (Liszt); Air from The Flying Dutchman (Wagner); Song, Warning (Hermann); Potpourri of German Folk Songs; Song, Frühling am Rhein (Höser); Song, An der Weser (Pressel); March, Grenzmarkgruss (Schurde). 1.0 p.m., Orchestral Concert. 1.15, Time, News, and Weather. 1.30 Orchestral Concert (cont'd.). 2.0, Time, News, and Weather. 2.20, Sponsored Concert of Light Music. 2.60, Concert of Variety Music. 3.15, Talk on the Anniversary of Peter Rosegger's Death. 3.35, Programme for Children. 3.55, Weather. 4.5, Reading. 4.30 p.m., See Langenberg. 5.45, Programme for the Younger Generation: Reading. 6.5, Piano forte Recital by Richard Staab: Polonaise in A flat (Chopin); Etude in G flat (Chopin); Witches' Dance (Macdowell); Polonaise in E (Liszt). 6.25, Reading (F. A. Kramer). 6.45, Time, Weather, and Agricultural Notes. 7.0, Transmission for all German Stations, relayed from Breslau. 8.0, Act II, III, and IV of Figaro—Opera (Mozart), relayed from the Residenztheater. 10.20, Time and News. 11.0 (from Nürnberg), Serenade by the Franken Orchestra, conducted by Willy Böhm. 12 Midnight (approx.), Close Down.

NAPLES.—See Rome.

NOTODDEN.—See Oslo.

OSLO

277 kc/s, 1,083 metres; 60 kW. Relayed by Fredrikstad, 815 kc/s, 368.1 metres; Hamar, 522 kc/s, 574.7 metres; Notodden, 671 kc/s, 447.1 metres; Porsgrund, 662 kc/s, 453.2 metres; and Rjukan, 671 kc/s, 447.1 metres.—5.30 p.m., Chamber Music by the Radio Ensemble. 6.30, Talk. 7.0, Announcements, Weather, and News. 7.30, Agricultural Report. 8.0, Time. 8.1, Extracts from: (a) Don Giovanni (Mozart), and (b) Figaro (Mozart) on Gramophone Records. 8.30, Piano forte Recital by Elisabeth Onarheim Ringdal: Sonata in A (Mozart); Nocturne, Op. 15, No. 2 (Chopin); Suite, The Children's Corner (Debussy). 9.10, Political Review. 9.40, Weather and News. 10.0, Topical Talk. 10.15, Recitations. 10.45 (approx.), Close Down.

OSTERSUND.—See Stockholm.

PALERMO

588 kc/s, 537.6 metres; 3 kW.—8.0 p.m., Dopplavoro Notes, Tourist Report, Agricultural Notes, Report of the Royal Geographical Society and Giornale Radio. 8.20, Gramophone Music. In an interval at 8.30, Time and Announcements. 8.45, Concert of Chamber Music. V. Mammino (Piano forte), G. Gagliano (Cello), and Esmeralda Corti (Soprano); Sonata in A Minor for Piano forte and Cello (Grieg); Soprano Solos: (a) Serenata amara (Colotta), (b) Melody (Quaranta); Piano forte Solos: Selection from (a) Triana (Albeniz), (b) Petronelka (Stravinsky); Soprano Solos: (a) Il Sogno (Tosti), (b) Visione veneziana (Broggi); Cello Solos: (a) Medieval Serenade (Zandoni), (b) Nocturne and Tarantella (Casella). After the Concert, Light Music on Gramophone Records. 10.55, News.

PARIS

EIFFEL TOWER, 207.5 kc/s, 1,445.7 metres; 13 kW. Time Signals (on 2,650 metres) at 10.26 a.m. and 11.26 p.m. (Preliminary and 6-dot Signals).—6.45 p.m., Le Journal Parle. 8.45, Sanson and Pellah—Opera (Saint-Saens), relayed from the Casino, Viehy. 11.15 (approx.), Close Down.

PARIS

POSTE PARISIEN; 914 kc/s, 328.2 metres; 60 kW.—7.0 p.m., Gramophone Music, 7.15, Journal Parlé, 7.30, Hot Jazz on Gramophone Records, 8.0, Gramophone Music, 8.30, Literary and Musical Programme, 9.15, Sponsored Programme, 10.15, News.

PARIS

RADIO PARIS; Call CFR, 174 kc/s, 1,725 metres; 75 kW.—7.30 a.m., Weather and Physical Culture, 7.45, Suite inambule (Messenger) on Gramophone Records, 8.0, News, 12 Noon, Gramophone Concert; Symphonie No. 4 in C Minor (Schumann); Dichterliche (Schumann); Kinder-scenen for Piano-forte (Schumann); Song from Der Freischütz (Weber); Aria from Don Pasquale (Donizetti); Chorus from William Tell (Rossini); Aria from The Barber of Seville (Rossini); Quartet from Rigoletto (Verdi); Duet from Il Trovatore (Verdi); Seguedilla, Duet and Finale from Carmen (Bizet); Scene from Faust (Gounod). In the intervals at 1.0 p.m., Exchange and News; and at 1.30 and 2.0, Exchange, 3.45, Exchange and Market Prices, 4.45, Song and Flute Recital by Ninon Vallin and René Leroy relayed from the American Conservatoire, Fontainebleau; Songs (Poulenc): (a) Air romantique (b) Air champêtre, (c) Air grave, (d) Air VII: Le Promenoir des deux amants (Debussy); (a) La grotte, (b) Crois mon conseil, (c) Je tremble en voyant ton visage; Jours de Flûte (Roussel): (a) Pau, (b) Tityre, (c) Krishna, (d) Monsieur de la Pejaudie; Fantasia for Flute (Faure); Gigue (Kelly); Four Spanish Songs; Two Poems by Ronsard (Roussel): (a) Rossignol, mon mignon, (b) Ciel! La flûte enchante, from Scheherazade (Ravel); Indian Songs, with Flute and Piano-forte Accompaniment (arr. d'Harcourt): (a) Wasi wasita, (b) Saucedito, (c) Tapicito, (d) Teapampa, 6.15, Interval, 7.0, Exchange and Racing Results, 7.10, Gramophone Concert; Selection from Le Grand Mogol (Andran-Tavan); La Serenata (Braga); Melody (Codini); La Mousmé (Ganne); Norwegian Dances (Grieg), 7.50, Commercial Prices and News, 8.0, Variety Programme on Gramophone Records, Au fond du square (Bonincontro-Bousquet); Folie musicale (Bétove); T.S.E. appareils en tous genres (Bétove); Bécausse dit des bêtises (Dandelin); On revient (Hermitte-Bousquet); Le super siffleur (Bergeret), 8.30, News, 8.40, Review by Paul Reboux, 8.45, Chamber Music Concert: Trio in G (Haydn) on Gramophone Records; Songs by Marguerite Lavier; (a) Butterfly Song (Campana), (b) Die Stadt (Schubert), (c) Elegy (Duparc), (d) Harmonies intimes (Lesur), (e) The Rose and the Nightingale (Rimsky-Korsakov), 9.15, News, 9.30, Concert (cont'd); Ballad No. 4 in F Minor (Chopin), by Robert Casadesu; Songs (Debussy), by Ninon Vallin; (a) Pêches galantes, (b) Mandoline; Five Mazurkas (Tausman), the Composer at the Piano; Six French Songs (Falleferre), by Jane Bathori; Quartet No. 2 for Strings (Milhand) by the Kretzky Quartet.

PITTSBURGH

KDKA; 980 kc/s, 306 metres; 50 kW. Relay by W8XK on 48.86 metres and 25.27 metres.—7.30 p.m., KDKA Home Forum, 8.0, Betty and Bob, from New York, 8.15, Words and Music, from New York, 8.45, Human Values (Subject to be announced), 8.58, Baseball Scores, 9.0, Radio Guild—Drama, from New York, 10.0, Rhythm Kings, 10.15, Tarzan of the Apes, 10.30, The Singing Lady, from New York, 10.45, Little Orphan Annie, 11.0, Time Signal and Press News-Review, 11.15, Weather Report, 11.16, Sport Review, 11.23, I Bring a Song, 11.28, Announcement, 11.29, Temperature Report, 11.30, Pittsburg Spotlights, 11.45, Today's News, by Lowell Thomas, from New York, 12 Midnight, Amos 'n' Andy, from New York, 12.15 a.m. (Tuesday), Mezzo-Soprano Solos, by Frances Papert, 12.30, Meyer Davis and his St. Regis Hotel Orchestra, from New York, 1.0, Programme to be announced, 1.30, Potash and Perlmutter, 1.45 to 3.0, New York Relay, 1.45, Phil Cook and the Ingram Shavers, 2.0, Sinclair Minstrels, 2.30, Jack Frost Melody Mounts, 3.0, The Silver Toppers.

PORSGRUND.—See Oslo.

POZNAN

896 kc/s, 335 metres; 1.9 kW.—6.10 p.m., Topical Talk, 6.15, Tourist Talk, relayed from Lwów, 7.88 kc/s, 381 metres, 6.35, See Warsaw, 7.20, Miscellaneous Items and News, 7.35, Theatre Notes and Programme Announcements, 7.40, See Warsaw, 10.30, Time Signal, Sports and Police Notes, 10.45 (approx.), Close Down.

PRAGUE

614 kc/s, 488.6 metres; 120 kW.—2.50 p.m., See Bratislava, 3.55, Exchange, 4.0, Interval, 5.45, Gramophone Music, 5.55, Talk, 6.5, Agricultural Report, 6.25, News in German, 6.30, German Transmission; Talk: Your Character by your Walk, 7.0, Chimes and News, 7.10, See Brno, 8.10, Talk: Textiles in the Modern Household, 8.25, Concert by the Prague Mandoline Quartet, 8.45, Tenor Song Recital by Otakar Marak, 9.5, See Bratislava, 10.0, Time and News, 10.15, Talk in German; German Music in Prague during the past Year, 10.30 (approx.), Close Down.

JULY 31st

MONDAY

continued

RADIO-SUISSE ROMANDE

SOTTENS, 743 kc/s, 403 metres; 25 kW.; and **Geneva**, 395 kc/s, 760 metres.—6.15 to 6.30 a.m., Gymnastics, 12.28 p.m., Time Signal from Neuchâtel Observatory, 12.30, News and Weather, 12.40, Gramophone Music, 1.0, Financial News, 1.10, Gramophone Music, 2.0 to 3.28, Interval, 3.28, Time Signal from Neuchâtel Observatory, 3.30, Concert of Chamber Music and Light Music by the Radio Lausanne Orchestra, 5.0, Programme for Children, 5.30 to 7.0, Interval, 7.0, Talk: Summer Hygiene, 7.25, News, 7.30, Talk: The Broadcast Gymnastics Lessons, 8.0, Lucia di Lammermoor—Opera in Three Acts (Donizetti) on Gramophone Records, 9.50, News and Weather, 10.0, De Musset Plays on Gramophone Records; Extracts from: (a) A quoi rêvent les jeunes filles, (b) Il ne faut jurer de rien, (c) Fantasio, (d) Le Chandelier, 10.30 (approx.), Close Down.

REYKJAVIK

250 kc/s, 1,200 metres; 21 kW.—9.5 p.m., Musical Programme, 9.30, Weather Report, 9.40, Musical Programme and Announcements, 10.0, Chimes and News, 10.30, Reading, 11.0, Popular Music by the Radio Quartet and Songs.

RIGA

572 kc/s, 525 metres; 15 kW.—6.0 p.m., Talk, 6.30, Talk on Fishing, 7.0, Weather Report, 7.3, Piano-forte Recital by Hugo Strauss; Sonata No. 3 (Beethoven); Daina (Medins); Waltz (Paul Schubert); Mazurka and Waltz (Chopin), 7.30, Humorous Programme, 8.0, News, 8.15, Concert of Bird Songs on Gramophone Records, 9.0, Weather and News, 9.15, Humorous Programme, 9.50, Dance Music, 10.30 (approx.), Close Down.

RJUKAN.—See Oslo.

ROME

Call **190**, 680 kc/s, 441 metres; 50 kW. Relay by **Naples**, 941 kc/s, 319 metres; and **290**, 11,810 kc/s, 25.4 metres, from 5.30 p.m.—1.0 to 2.15 p.m., Gramophone Concert. In the intervals from 1.30 to 1.45, Giornale Radio and Exchange, and at 2.0, Time and Announcements, 4.45, Children's Radio Review, 5.10, Weather, 5.15, Exchange and Giornale Radio, 5.30, Vocal and Instrumental Concert: Paolo Leonori (Cello), Gregorio Pasetti (Bass) and Berenice Sberri (Mezzo-Soprano); (a) Cello Solos, (a) Slay Song (Friedman), (b) Ballet of the Gnomes (Popper); Bass Solos from: (a) Ernani (Verdi), (b) Lucia di Lammermoor (Donizetti); Three Mezzo-Soprano Arias from Samson and Delilah (Saint-Saëns); Cello Solos: (a) Humorous Gavotte (Squire), (b) Dance (Scharwenka), (c) Bourrée (Nok); Bass Aria from The Barber of Seville (Rossini); Mezzo-Soprano Solo: Cécilie (R. Strauss), 6.40 (Naples), Shipping and Sports Notes, 6.50, Agricultural Notes and Dopolavoro Announcements, 7.10, Tourist Talk, 7.20, News in Foreign Languages, 7.40, Giornale Radio, 8.0, Time and Announcements, 8.5, Gramophone Music, 8.30, Giornale Radio and Sports Notes, 8.45, Concert of Light Music, conducted by Illuminato Calotta. In the interval: Humorous Talk, 10.0 (approx.), Dance Music from the Giardino degli aranci, 10.55, Giornale Radio.

SALZBURG.—See Vienna.

SCHENECTADY

WGY, 790 kc/s, 379.5 metres; 50 kW. Relay at intervals by **W2XAF**, on 31.48 metres; and by **W2XAT**, on 19.56 metres.—9.0 p.m., Book News by Levere Fuller, 9.15, Winters and Weber, Organists, 9.30, Soloist, from New York, 9.45 to 10.0, Lady Next Door, from New York, 12.45 a.m. (Tuesday), Stock Reports and Baseball Scores, 1.0 to 3.30, New York Relay, 1.0, Socio-land Sketch, 1.50, World Economic Conference, 1.45, Ferde Grofé's Orchestra, 2.0, A. and P. Gypsies, 2.30, Musical Programme, 3.0, Contented Programme, 3.30, Paul Whiteman's Orchestra, from New York.

SCHWEIZERISCHER

LANDESSENDER

BEROMUNSTER, 653 kc/s, 459 metres, 60 kW.; **Basle**, 1,229 kc/s, 244.1 metres; and **Berne**, 1,220 kc/s, 245.9 metres.—11.59 a.m., Time Signal from Neuchâtel Observatory, 12 Noon (from Basle), Songs by the Bon Cosacks on Gramophone Records, 12.30 p.m., Time and News, 12.40 (from Basle), Gramophone Concert, 1.25 (from Basle), Time, Weather, and Exchange, 1.45 (approx.), Interval, 5.0 (from Basle), Programme for Women, 5.30 (from Basle), Gramophone Music, 6.30 (from Zürich), Talk: Romanesque Architecture, 7.0, Time and Weather, 7.5 (from Zürich), Concert by the Swiss Radio Orchestra, conducted by H. Neppach, 7.50 (from Zürich), Talk in English: The Swiss through English Eyes, 8.0 (from Zürich), Concert (cont'd.), 8.30, Talk: The Foundation of the Swiss Confederacy, 9.0, Weather and News, 9.10 (from Zürich), Ländler Music and Songs to the Lute, 10.15 (approx.), Close Down.

SOTTENS.—See Radio-Suisse Romande.

STOCKHOLM

689 kc/s, 436 metres; 55 kW. Relay by **Boden**, 244 kc/s, 1,229.5 metres; **Göteborg**, 932 kc/s, 322 metres; **Hörby**, 1,166 kc/s, 257 metres; **Motala**, 221.5 kc/s, 1,354.4 metres; **Ostersund**, 389 kc/s, 770 metres; and **Sundsvall**, 554 kc/s, 542 metres.—5.5 p.m., Programme for Children, 5.30 (from Sundsvall), Cabaret Programme, 6.0, Gramophone Music, 7.0, Reading, 7.15, Weather and News, 7.30, Weather Report, 7.45, Concert of Old and New American Songs, 8.15, Talk, 8.45, Concert by Elsa Larcén (Songs), Carl Garaguy (Violin), and Gertrud Lindström (Piano-forte): Sonata No. 3 in E, for Violin and Piano-forte (Bach); Three Songs (Kilpinen); Violin Solos: (a) Scherzo in E Minor (Mendelssohn), (b) Melody (Tchaikovsky), (c) Bulgarian Rhapsody (Wladizerov); Three Songs, 9.45, Weather and News, 10.0 (from Göteborg), Light Orchestral Concert, conducted by Karl Bornfors, 11.0 (approx.), Close Down.

STRASBOURG

869 kc/s, 345 metres; 11.5 kW.—11.30 a.m., Classical Music on Gramophone Records, 12.45 p.m., News, 1.0, Time and Exchange, 1.5, Jazz Music by the Station Orchestra, conducted by Roskam, 2.0 to 3.30, Interval, 3.30, Orchestral Concert conducted by Brüllaire relayed from the Casino, Vichy; Overture, Chérubin (Massenet); Adagio from The Pathetic Sonata (Beethoven); Turkish March from The Ruins of Athens (Beethoven); Ballet Music from Isolde (Messager); Träume (Wagner); Spinning Chorus (Wagner); Selection from the Tales of Hoffman (Offenbach); Moonlight on the Alster (Ferlas), 5.0, Gramophone Music, 5.15, Orchestral Concert conducted by Roskam; March (Zieher); Waltz, Eternal Printemps (Popy); Overture, Masaniello (Auber); Cavatine (Raaf); Down South (Myddleton), 6.0, Film Review, 6.15, Talk, 6.30, Orchestral Concert conducted by de Villers, Soloist: M. Gillig (Bass); Scene and Waltz (Guiraud); Aria for Bass, Petite Suite (Pierné); Song, La Vieille Mère (Delmas); Caprice Chanson (Erb); Epitaphie (Poulenc); Selection from Aphrodite (Février), 7.30, Time and News, 7.45, Gramophone Music, 8.15, News, Lottery Results and Announcements, 8.45, Samson and Delilah—Opera (Saint-Saëns) relayed from the Casino, Vichy, 11.15, Press Review in German.

STUTTGART

MUHLACKER, 832 kc/s, 360.5 metres, 60 kW.; and **Freiburg**, 527 kc/s, 570 metres.—12 Noon, Orchestral Concert, relayed from Baden-Baden: March, Einig und frei (Schweichert); Overture, Bocaccio (Suppé); Nordische Volkstänze (Bartman); Spitzweg-Ständchen (Gambke); Ballet Suite (Armandola); Amante and Mimet from the Clock Symphony (Haydn); Waltz, Tales from the Vienna Woods (Joh. Strauss), 1.15 p.m., Time and News, 1.30, Gramophone Concert. In the interval, from 2.0 to 2.15, Concert arranged by the Post Office, 2.30, Spanish Lesson, 3.0, English Lesson for Beginners, 3.50, Interval, 4.20, Concert by the Esser Symphony Orchestra, relayed from Cologne, 5.45, Wolf Hirth reads from his own works, 6.10, Talk: Stefan George, 6.35, Time and News, 7.0, Transmission for all German Stations, relayed from Breslau, 8.0, See Hamburg, 9.0, Talk for Ex-Servicemen, 9.15 (from Freiburg), A Folk Play with Songs (Brachvogel-Lutz), 9.50, Schumann Programme: Extracts from Schumann's Letters and Piano-forte Pieces, 10.25, Time and News, 10.45 (from Mannheim), Concert by the Mannheim Philharmonic Orchestra, conducted by Hans Reger; Soloist, Alfred Färbach (Tenor); Overture, Euryantke (Weber); Prelude and Selection from Der Evangelist (Kienzl); Aria from Der Freischütz (Weber); Second Suite from Peer Gynt (Grieg); Waltz on Themes from Zeller's Operas (Thiele); Songs: (a) Air from Der Bettelstudent (Möbber), (b) Air from The Gipsy Baron (Joh. Strauss); Circus Suite (Armandola); Wiener Heurigen-Marsch (Rönnischel), 12 Midnight, Close Down.

SUNDSVALL.—See Stockholm.

TRIESTE

1,211 kc/s, 247.7 metres; 10 kW.—5.10 p.m. till Close Down, see Turin.

TRONDHEIM.—See Oslo.

TURIN

1,096 kc/s, 273.7 metres; 7 kW. Relay by **Milan**, 905 kc/s, 331.5 metres; **Genoa**, 959 kc/s, 312.8 metres; and **Florence**, 599 kc/s, 500.8 metres.—5.10 p.m., Concert by the Station Orchestra, 6.0 to 6.5, Weather, 6.35, Giornale Radio, Agricultural Notes and Dopolavoro Announcements, 7.0, Time and Tourist Talk, followed by Gramophone Music, 7.20, News

in Foreign Languages, 7.40, Gramophone Music, 8.0, Announcements, Giornale Radio Sports Notes and Weather, 8.15, Sponsors' Concert, 9.15, La fille de Madame Angot—Opera in Three Acts (Lecocq), After the Opera: Giornale Radio.

VATICAN CITY

15,120 kc/s, 19.84 metres (Morning), and 5,969 kc/s, 50.26 metres (Evening); 10 kW.—11.0 to 11.15 a.m., Religious Information in Italian, 8.0 to 8.15 p.m., Religious Information in Italian.

VIENNA

581 kc/s, 517 metres; 100 kW. Relay by **Graz**, 852 kc/s, 352.1 metres; **Innsbruck**, 1,05 kc/s, 283 metres; **Klagenfurt**, 662 kc/s, 453 metres; **Linz**, 1,220 kc/s, 245.9 metres; and **Salzburg**, 1,373 kc/s, 218.5 metres.—12 Noon, Concert by the Vienna Symphoniker, conducted by Josef Holzer. In the interval, 1.0 p.m., Time and News, 2.0, Interval, 2.4 Time and News, 3.20, Talk: The Chess Tournament in Klosterneuburg, 3.30, Concert by Bajos Béla's Orchestra on Gramophone Records, 4.35, Talk for Young People: Trifalgar and Nelson, 5.0, Talk: The Waltz King, Johann Strauss, 5.25, Song and Piano-forte Recital by Gusti Fogarasscher (Soprano) and Dr. Felix Rosenthal, Song: (a) Gebet (Hiller), (b) Hölre, Israel, (c) Elias Elijah (Mendelssohn), (c) Die Allmäh (Schubert); Piano-forte Sonata in C minor Op. 111 (Beethoven), 6.5, Talk: The Summer Show of the Secessionists' Exhibition, 6.2 Talk: Books of Reference in Connection with the Week's Talks, 6.30, Talk: Aviation Caricature, 7.0, Concert by the Vienna Symphony, conducted by Josef Holzer: Ostreicherischer Postmarsch (Wagner); Selection from Gipsy Love (Lehar); Du lieber Alt Stephansturm (Jurek); Intermezzo, Arabi (Neumann); Waltz, Ohne Tanz kein Leben (Zieher); Selection from Der Generalkonz (Reinhardt); Traumlied from Der blaue Kl (Kapeller); Variations on a Theme of Schubert (Heuberger); Gnomentanz (Meyer-Hmund); Waltz, Ernst und Humor (J. Strauss); Potpourri, Für's Herz und Gem (Konizak); Galop (Zieher). In the interval, 7.35, Time and Announcements, 8. Topical Talk, 8.45, A Summer Night's Dream—Concert by the Vienna Symphoniker conducted by Max Schönherr, w Fritz Merley (Soprano); Overture, Ein Sommertraum (Suppé); Songs: (a) B carolle from The Tales of Hoffman (Offenbach), (b) Venetian Barcarolle (Mendelssohn), (c) Ständchen (R. Strauss); Waf Sommernachtssträume (Joh. Strauss); B carolle and Nocturne (Tchaikovsky); A Summer Night in Madrid (Glinka); Songs: (a) Lichte Nacht, and (b) Am schönsten (Grieg) (c) O komme, holde Sommernacht (Brahm) Waltz, A Summer Night on the Rhine (Fras); Romance, Die Nacht (Rubinstein) Overture, Scherzo, Dance, and March for A Midsummer Night's Dream (Mendelssohn) 10.15, News, 10.30, Talk in Dialect, 10. Dance Music on Gramophone Records.

WARSAW

212.5 kc/s, 1,411 metres; 120 kW.—11.57 a.m. Time Signal and Fanfare from the To of St. Mary's Church, Cracow, 12.5 p.m. Popular Concert relayed from the Bagat Café, 12.25, Polish Press Review, 12 Weather, 12.35, Concert Relay (cont 12.55, Radio Journal, 1.0, Interval, 2 Gramophone Music, 3.5, News, 3.10, nouncements, 3.15, Gramophone Music, 2 Economic Notes, 3.35, Gramophone M. 3.45, Traffic Report, 3.50, Gramoph Music, 4.0, Concert by the Poznan S phony Orchestra, conducted by Tyllia, layed from Cichocinek, 5.0, Talk in Fro 5.15, Soloist Concert on Gramophone cords, 6.15, Tourist Talk relayed from Lw 7.88 kc/s, 381 metres, 6.35, Piano-forte cital by Aline Teitelbaum; Papillons (S man); 'L'isle joyeuse (Debussy); Jarsous la pluie (Debussy); Bourrée fanta (Chabrier); Berceuse (Tausman); Ob (Tausman); Hungarian Rhapsody No. (Liszt), 7.20, Miscellaneous Items, Programme Announcements, 7.40, Lite Talk, 8.0, Hotel Stadt Lemberg—Oper in Three Acts (Gilbert). In the interval, Answers to Agricultural Correspondence Radio Journal, 10.30, Sports Notes, 1 Aviation Weather Report and Police N, 10.45, Dance Music on Gramophone Rec

WILNO

533 kc/s, 563 metres; 16 kW.—7.5 p.m., 2 and Gramophone Music, 7.20, Lithua Talk, 7.35, Programme Announcement, 7.40, See Warsaw, In an interval at Sports Notes, 11.0 (approx.), Close Down

ZAGREB

977 kc/s, 307 metres; 0.75 kW.—7.55 p.m. Book Review, 8.10, Announcements, Concert by the Radio Orchestra, Sol Irma Pater (Soprano), 10.30, News, 1 Dance Music, 11.30 (approx.), Close Down

ZÜRICH.—See Schweizerischer Landesse

TUESDAY AUGUST THE FIRST

PRINCIPAL EVENTS OF THE DAY:

AT HOME

- NATIONAL Military Band concert. Chamber music.
LONDON "Depression over Fairyland," a musical fantasy, by Henrik Ege.
MIDLAND REGIONAL Choral programme.
NORTH REGIONAL "Art and Artifice," a comedy, by Norman Hillas.
WEST REGIONAL Ladies' orchestral programme, from Minehead.
SCOTTISH REGIONAL Excerpt, relayed from the Theatre Royal, Edinburgh.
BELFAST Orchestral concert. Chamber music.

ABROAD

- BERLIN 8.5 p.m. Symphony concert, from the K rhaus, Swinem nde.
BRUSSELS 9.0 p.m. Concert, from the Kursaal, Ostend.
BUCHAREST 8.20 p.m. The Station Orchestra. 8.30 p.m. Symphony concert.
HAMBURG 10.30 p.m. The Philharmonic Orchestra.
HEILSBERG 8.5 p.m. The K nigsberg Opera House Orchestra.
HILVERSUM 7.40 p.m. The Arnhem Orchestra.
PALERMO 8.45 p.m. Opera: "Turandot," by Puccini.
ROME 8.45 p.m. Concert of opera music.
STRASBOURG 8.0 p.m. Concert by the Station Orchestra.
WARSAW 9.10 p.m. Violin recital, by Mme. Dubiska.

BARCELONA
AJ1, 860 kc/s, 348.8 metres; 3 kW.—7.0 p.m., Trio Concert: Czardas, Iza (Michiels); Astoral (Wenisch); Salut d'amour (Eigar); Selection from Don Quichotte (Massenet); The Butterfly Chase (Leopold); Prelude No. 23 in F (Chopin); Selection from Lakme (Delibes). 8.0, Request Gramophone Music. 8.30, Exchange and Talk on the history of Art. 9.0, Gramophone Music. In the interval at 9.15, Football Report. 10.0, Times, Weather, Messages to Seamen, and Exchange. 10.5, Sponsored Programme. 10.30, Concert by the Station Orchestra. 11.15, Astronomical Talk. 11.30, Concert from the Of  Espafiol. In the interval at 12 Midnight, News. 1.0 a.m. (Wednesday), Close Down.

BARI
112 kc/s, 269.8 metres. 20 kW.—8.0 p.m., Agricultural Notes. Tourist Report and Spolavoro Announcements. 8.20, Giornale dio and Weather. 8.30, Time and Announcements. 8.35, Concert by a Mandoline and Gitar Quartet; Selection from Nabucco (Verdi); Arab Procession (Barvas); Melody (Imier); Canestro di fiori (Sartori); Selection from The Puritans (Bellini); Overture, more et arte (Bitelli); Serenade (Schubert); Nuvio di primavera (Sartori); Notturmo operini; Overture, Figaro (Mozart). In the interval, Art Notes. 10.30, Gramophone Music. 10.55, News.
1.0 a.m.—See Schweizerischer Landessender.

BELGRADE
100GRAD, 697 kc/s, 430.4 metres; 2.8 kW. 5.55 p.m., Time Signal and Programme Announcements. 6.0, Cigany Music from the Maraca Restaurant. 6.30, Gramophone Music. 7.0, Talk. 7.30, Song Recital. 8.10, Concert by the Station Orchestra. 9.0, valeria rusticana—Opera (Mascagni) on amophone Records. 10.15, Time Signal, ws and Dance Music from the Ratnicki an Restaurant.

BERLIN
UTSCHLANDSENDER, 183.5 kc/s, 1,635 metres; 60 kW.—2.0 p.m., Gramophone Concert of Light Music. 3.0, Talk for Women. 4.0, Weather and Exchange. 4.45, Reading (einrich Friedrichs). 4.0, See Leipzig. 5.0, gramme for Young People. 5.20, Talk by M ller-Gordon. 5.35, Violin Recital of Classical Music by Helmut Lingershausen, Chaconne in G Minor (Vivaldi); rita in C Minor (Riber). 6.0, A Poem. 6.5, rital of Finnish and Swedish Songs by ianne M rner. Part I: Finnish Songs (a) der the Black Alder, (Melartin). (b) adows in the Sunshine (Melartin). (c) The Church (Kilpinen). (d) Song (Kilpinen). Carmen (J rnefeldt). Part II: Swedish igs: (a) Goldilock's Lullabies (Petersonger), (b) Girls under the New Moon (ngstr m), (c) Wings of Night (Rangstr m), (d) Melody (Rangstr m), (e) The stericus Flute (Sj gren), (f) Song (Aif-). 6.30, Political Press Review. 6.50, atter for Farmers and News. 7.0, Transiion for all German Stations, relayed from nktfurt. 8.0, Today's Motto. 8.5 (app.), Symphony Concert, relayed from the aus, Swinem nde. Conductor: Paul einpflug. Soloist: G nther Baum (Bari-). Prelude to Lohengrin (Wagner); Tone Solos (Hugo Wolf): (a) Der Rattenger, (b) Gesang Weylas; Extracts from iphony No. 5 in E Minor—From the New rld (Dvorak). 9.10, See Munich. 9.35, ee Music. 10.20, Weather and News. 5, Weather Report for Shipping. 11.0, cert from Stuttgart. 12 Midnight (app.), Close Down.

BRATISLAVA
1,076 kc/s, 279 metres; 11 kW.—6.25 p.m., Gramophone Music. 6.45, Reading from a Novel. 6.55, Talk for Housewives. 7.0, See Prague. 7.35, See Moravska-Ostrava. 7.50, See Prague. 11.0, Close Down.
BREMEN.—See Hamburg.

BRELAU
923 kc/s, 325 metres; 60 kW.; and Gleiwitz, 1,184 kc/s, 253 metres.—1.0 p.m., Gramophone Concert. 1.45, Time and News. 2.0, Lincke Concert on Gramophone Records. 3.0, Agricultural Prices. 3.15, Book Review. 3.30, Programme for Children. 4.0, Song and Violin Recital by Elfride Boehm (Soprano) and Eva Olbrich-Talksdorff: Violin Concerto in D (Paganini); Songs: (a) Morir voglio (d'Astorga), (b) Anarilli (Caccini), (c) Es hat die Rose sich beklagt (Franz), (d) Aus meinen grossen Schmerzen (Franz), (e) Fur Musik (Franz); Violin Solo: Souvenir of Moscow (Wieniawsky); songs (Grieg): (a) Im K hne, (b) Vom Monte Pincio. In the interval at 4.30, Fritz Woike, the Silesian Poet, reads from his own Works. 5.15, Agricultural Prices. 5.20 (approx.), Talk. 5.45, Topical Report. 6.10, Concert of Light Music relayed from the Caf  Vaterland. 6.50, Agricultural Prices and News. 7.0, Transmission for all German stations relayed from Frankfurt. 8.0, See Stuttgart. 9.0, News. 9.10, Four Walls, a Journey and a Maiden—Radio Play in Verse (Thiemer), with Music by Klausenck and Zanke. 10.0, Time and News. 10.20, Political Press Review. 10.45, Talk: Russian Collectivism and German Communal Ownership. 11.0, Light Music and Dance Music, relayed from the Haus Oberschlesien. Gleiwitz. 12 Midnight (approx.), Close Down.

BRNO
878 kc/s, 342 metres; 35 kW.—6.15 p.m., Talk for Workers; Social Insurance. 6.25, German Transmission; News. Talk: The Architectural Exhibition and Agricultural Talk. 7.0, See Prague. 7.10, Song Recital, by Nina Bobby. 7.35, See Moravska-Ostrava. 7.50, See Prague. 8.15, Recitations. 8.40, See Prague. 11.0 (approx.), Close Down.

BRUSSELS (No. 1)
I.N.R., 590 kc/s, 509 metres; 15 kW.—12 Noon, Selection from Gwendoline (Chabrier), on Gramophone Records. 12.20 p.m., Violin Recital by Abel Bourdanduc. Melody (Pardini—Kreiser); Variations on a Theme of Corelli (Kreiser). 12.35, Request Gramophone Music. Voici l'adonette (Bishop); American Dentist (Bach-Laverne); La

phone Music. 8.15, News. 8.30, Les Vivacit s du Capitaine Tie—Comedy in Three Acts (E. Labiche and E. Martiny).

partenaire (Weckerlin); La belle est au jardin d'amour (Weckerlin). 1.0, Journal Parl . 1.10, Ravel Concert on Gramophone Records. Pavane pour une Infante dante; Piece in the Form of a Habanera; Bolero. 1.40, Pianoforte Recital by Felix Annie. Tocata (Debussy); Nocturne in B Flat (Faure); Finale from the Moonlight Sonata (Beethoven). 5.0, Pianoforte and Violin Sonata (Lekeu), played by M. Borremans and Mlle. Nalio. 5.30, Programme for Children. 6.5, Literary Review. 6.15, Organ Recital by Eraly, relayed from St. Servais Church. Tocata in F (Bach); Recitative and Aria from The Christmas Oratorio (Bach); Finale from the Second Symphony (Widor). 6.30, Chamber Music Concert by Mlle. Debacher (Cello), M. Bourdanduc (Violin), and M. Annis (Pianoforte); Cello Solos, Pianoforte, Violin and Cello Trio (Franck). 7.15, Catholic Review and Film Notes. 7.30, Talk for Women and Art Notes. 8.0, The Sea, Literary and Musical Programme on Gramophone Records. La mer (Debussy); Oceano Nox (Victor Hugo); L' pave (Copp ); Les chants de la mer (Gaubert). 8.45, Talk by an Ex-Serviceman; Nineteen Years after. 9.0, Concert, relayed from the Kursaal, Ostend. After the Concert, Journal Parl , followed by Trio for (Oboe, Bassoon and Pianoforte (Poulenc). 10.55, Christus Vine  (Liszt).

phone Music. 8.15, News. 8.30, Les Vivacit s du Capitaine Tie—Comedy in Three Acts (E. Labiche and E. Martiny).

partenaire (Weckerlin); La belle est au jardin d'amour (Weckerlin). 1.0, Journal Parl . 1.10, Ravel Concert on Gramophone Records. Pavane pour une Infante dante; Piece in the Form of a Habanera; Bolero. 1.40, Pianoforte Recital by Felix Annie. Tocata (Debussy); Nocturne in B Flat (Faure); Finale from the Moonlight Sonata (Beethoven). 5.0, Pianoforte and Violin Sonata (Lekeu), played by M. Borremans and Mlle. Nalio. 5.30, Programme for Children. 6.5, Literary Review. 6.15, Organ Recital by Eraly, relayed from St. Servais Church. Tocata in F (Bach); Recitative and Aria from The Christmas Oratorio (Bach); Finale from the Second Symphony (Widor). 6.30, Chamber Music Concert by Mlle. Debacher (Cello), M. Bourdanduc (Violin), and M. Annis (Pianoforte); Cello Solos, Pianoforte, Violin and Cello Trio (Franck). 7.15, Catholic Review and Film Notes. 7.30, Talk for Women and Art Notes. 8.0, The Sea, Literary and Musical Programme on Gramophone Records. La mer (Debussy); Oceano Nox (Victor Hugo); L' pave (Copp ); Les chants de la mer (Gaubert). 8.45, Talk by an Ex-Serviceman; Nineteen Years after. 9.0, Concert, relayed from the Kursaal, Ostend. After the Concert, Journal Parl , followed by Trio for (Oboe, Bassoon and Pianoforte (Poulenc). 10.55, Christus Vine  (Liszt).

BRUSSELS (No. 2)
N.I.R. 887 kc/s, 338.2 metres; 15 kW.—Programme in Flemish. 12.0 Noon, Extracts from Les Cloches de Corneville (Phanquette) on Gramophone Records. 1.0 p.m., Le Journal Parl . 1.10, Concert by the Small Station Orchestra, conducted by E. Lauwers; March, The Phantom Brigade (Myddleton); French Comedy Overture (K ler B la); Waltz from The Gipsy Baron (Joh. Strauss); Song, D'une prison (Hahn); Selection from Lakme (Delibes); Ronde des lutins (Razigade); Au den Fr hling (Grieg); Selection from White Horse Inn (Stoltz-Benatzky); March (Filipucci). 5.0 p.m., Italian Music on Gramophone Records: Selection from The Italian Girl in Algiers (Rossini); Selection from La Favorita (Donizetti); La Gironda, Selection from La Boh me (Puccini); Overture, The Barber of Seville (Rossini); Ninnu Nanna (Benelli); Selection from Cavalleria rusticana (Mascagni); Mattinata (Leoncavallo); Selection from Mephistopheles (Boito). 5.45, Programme for Children. 6.30, Gramophone Concert. 7.0, Gramophone Concert. 7.15, Talk: An Excursion in the Vegetable World. 7.30, Tourist Talk. 8.0, Gramophone Concert: The Marine Guards (Heymann); Selection from Bal im Savoy (Abraham); Foxtrot, Ein Lied, ein Kuss, ein M del (Stolz); Song from Viktoria and her Hussar (Abraham); Selection from Rose Marie (Fr m); Song from Das Lied der Liebe (Strass-Korngold); Potpourri, Fortissimo (K lm n); Duet from The Land of Smiles (Lehar); Selection from La

vie Parisienne (Offenbach); Selection from The Gipsy Baron (Strauss); Song from White Horse Inn (Stolz-Benatzky); Selection from The Merry Widow (Lehar); So k sst man nur in Wien (Abraham); Es war einmal ein Walzer; Selection from The Desert Song (Romberg); March (Gilbert); Duet from The Land of Smiles (Lehar); March of the Grenadiers (Schertzingler). 10.0, Le Journal Parl . 10.10, Gramophone Concert.

BUCHAREST
761 kc/s, 394 metres; 12 kW.—5.0 p.m., Light Music and Romanian Music by the Motos Orchestra. In an interval at 6.0, Radio Journal. 7.0, Reading. 7.20, Gramophone Music. 7.40, Educational Talk. 8.0, Song Recital. 8.20, Concert by the Station Orchestra: Ballet Overture (Lincke); Waltz, Ballnacht (O. Strauss); Suite from La Source (Delibes); Song Potpourri (Dostal); R ve angli e (Rubinstein); Aubade (d'Ambrosio); Monastery (Borodin); Selection from Fr hling im Wienerwald (Ascher). In an interval at 9.0, Talk. 9.45, Radio Journal.

BUDAPEST
545 kc/s, 550.5 metres; 18.5 kW.—5.30 p.m., Reading. 6.0, Light Music. 7.0, Reading. 7.30, Violin Recital. 8.10, One Act Play. 10.0, News, followed by Cigany Music and Talk in English: The World Jamboree.
CASSEL.—See Frankfurt.

COPENHAGEN
1,067 kc/s, 281 metres; 0.75 kW.—Relayed by Kalundborg, 260 kc/s, 1,153.8 metres. 12 Noon, Time and Chimes from the Town Hall. 12.5 p.m., String Ensemble Concert relayed from the Bellevue Strand-Hotel. 2.0, Interval. 3.0, Orchestral Concert from the Wivex Restaurant. 5.0, Reading. 5.20, Interval. 5.35, Exchange and Fish Market Prices. 6.20, Talk. 6.50, Weather and News. 7.15, Time Signal. 7.30, Talk on Industrial Accidents. 8.0, Chimes from the Town Hall. 8.5, A Revue relayed from the Tivoli. After the Programme, News. 11.0, Dance Music from the Nimb Restaurant. In the interval at 12 Midnight, Time and Chimes from the Town Hall. 12.30 a.m. (Thursday), Close Down.
CORK.—See Athlone.

CRACOW
959 kc/s, 312.8 metres; 1.5 kW.—7.20 p.m., Talk: Old Cracow. 7.35, Miscellaneous Items and News. 7.40, See Warsaw. 7.55, Programme Announcements. 8.0, See Warsaw. 10.0, Pianoforte Recital. 10.30, Sports Notes. 10.35, See Warsaw. 11.0 (approx.), Close Down.

DANZIG.—See Heilsberg.
DRESDEN.—See Leipzig.

FECAMP
1,328 kc/s, 225.9 metres; 10 kW.—4.30 to 6.0 p.m., Programme in English by the I.B.C. 4.30, Programme for Children. 5.0, Concert for Torquay and Exeter Listeners: Signature Tune, The Night by the Sea; Pale Volga Moon (O'Hagan); I wish I knew a bigger Word than Love (Pola); Song: In the Valley of the Moon (Tobias); Pianoforte Solo: The Futuristic Rag (Bloom); Gipsy Moon (Boragnov); Song: Having a good time, wish you were here (Fain); Have you ever been lonely? (Brown); Pianoforte Solo: He wanted adventure (Waller-Tunbridge). 5.30, Concert for Plymouth and Devonport Listeners: Troika and a Lady (Andreeff); Shining Moon; Chorus: The Twelve Robbers; Waltz, Faun (Andreeff); The Red Sarafan (arr. Leontie); Mazurka (Wieniawsky); Chorus: The Cossack Prisoners; Song of the Volga Boatmen (arr. Leontieff); Signature Tune. 6.0, Programme in French. 10.0 (approx.) till Close Down. Programme in English by the I.B.C. 10.0, Dance Music: Signature Tune, Belis of Normandy; How are you (Steinger); If you were only mine (Newman); Let's all dance the Polka (Lowton); My silent Love (Suesse); In sunny Monterey (Nicholl); Bahama Mama (Gilbert); When Yuba plays the Rumba (Upfeld); Cabin in the Cotton (Parish); For you, just you, my baby (Connelly); Love me to-night (Rodgers); Night shall be filled with Music (Collins); Isn't it romantic (Rodgers); Just another dream of you (Burke); This is my love song (Burke); You know what I'll do (Buechel); Give me a tune (Koger); Signature Tune. 11.0, Club Concert for Rhy! Listeners: Part I—Orchestral Concert: Signature Tune, The Chum Song; The Phantom Brigade (Myddleton); Overture, The Marriage of Figaro (Mozart); Love in Cloverland (Peter); The Clock and the Dresden Figures (K telbey); Song: Maire my Girl (Aitken); Waltz, Acclamations (Waldteufel); The Grasshopper's Dance (Bucalossi). Part II—I.B.C. Listeners' Request: Half-Hour: The Midnight Waltz (Spoliansky); On Ilka Moor bait 'at; Bless this House (Taylor); The Old Rustic Bridge by the Mill (arr. Wood); Love will find a way (Graham); Stormy Weather (Koehler); The Battle Eve; Butterflies in the Rain (Myers); Signature Tune. 12.5 a.m. (Wednesday), The I.B.C. Late News Bulletin. 12.10 (approx.), Light Music: Wedding of the Birds; Night aboard the Sancy Sue; A Fo'c'sle; You were meant for me (Brown); Some of these days

AUGUST 1st

TUESDAY

continued

(Brooks); Selection from No. No. Nanette (Youmans). 12.30, Dance Music; Signature Tune, Bells of Normandy; You're getting to be a habit with me (Dubin); Someone to care for (Warren); You're beautiful to-night, my dear (Lombardo); Won't you stay to tea (Revel); It pays to advertise (O'Hagan); I sigh for you, Rio Rita (Santouguini); London Bridge is falling down (arr. Bleyer); They all do the Rumba (Pola); Signature Tune, 1.0, Light Orchestral Music; In Pierrette's Garden (Clifton-Brookes); Song: The Blackbird in the Apple Tree (Lubbock); Cello Solo: The Broken Melody (van Biene); Black Eyes (Ferraris); Song: Fairy Tales of Ireland (Cotes); Violin Solo: Caprice Basque (Sarasate); Poor Butterfly (de Phillipi); Serenade (Pierri). 1.30, Dance Music; Signature Tune, Bells of Normandy; How deep is the Ocean (Hupfeld); Pulceze, Mr. Hemmingway; What would happen to me (Woods); Everyone says I love you (Kalmar); How do you do, Mr. Brown? (Abraham); Please (Robin); Leave a little for me (Abraham); Here lies love (Robin); Signature Tune, 1.57, I.B.C. Good-night Melody, 2.0, Close Down.

FLENSBURG.—See Hamburg.
FLORENCE.—See Turin.

FRANKFURT

1,157 kc/s, 259.3 metres; 17 kW. Relayed by Cassel, 1,220 kc/s, 245.9 metres; and Trier, 1,157 kc/s, 259.3 metres.—4.30 p.m., Concert by the Small Chamber Orchestra, conducted by Gustav Schumacher: Overture in E Minor (Schubert); Scenes from Der Waffenschmidt (Lortzing); Nüßchen-Walzer (Joh. Strauss); Hungarian Rhapsody No. 2 (Liszt); Manchurian Sketches, Nos. 1 and 11 (Glan); Song, Heimat (Glan); Puppe und Kohle (Lautenschläger); Wochenend im Schlaraffenland (Lautenschläger); Abendlied (Lautenschläger); Marionetten an der Spinnrad (Lautenschläger); Potpourri, Musical Jokes (Aston). 5.45, Economic Notes, 6.0, Reading (Albert Schweitzer). 6.25, Astronomical Talk: The Skies in August. 6.45, To-day's News. 6.50, Time and News. 7.0, Transmission for all German Stations; The Eternal Flame—A Young Germany Festival Programme. 8.10, See Hamburg. 9.30, Discussion by Dr. C. G. Jung and Dr. Adolf Weizsäcker on Psychology (Gramophone Records). 9.50, Recital of Old German Songs by Rose Koppe (Contract); Willst du dein Herz mir schenken (Giovanni-Bach); Lindenlaub; Der Schwere Traum (Nicolaï); Im Wald bei der Amsel; Männelied from Das Lochheimer Liederbuch; Phyllis und die Mutter. 10.20, Time and News. 10.45, See Stuttgart. 12 Midnight (approx.), Close Down.

FREDRIKSSTAD.—See Oslo.
FREIBURG.—See Stuttgart.
GENEVA.—See Radio-Suisse Romande.
GENOA.—See Turin.
GLEIWITZ.—See Breslau.
GOFEBORG.—See Stockholm.
GRAZ.—See Vienna.
HAMAR.—See Oslo.

HAMBURG

Call ha (in Morse), 806 kc/s, 372 metres; 15 kW. Relayed by Bremen, 1,112 kc/s, 265.8 metres; Flensburg, 1,319 kc/s, 227.4 metres; Hanover, 530 kc/s, 566 metres; Kiel, 1,292 kc/s, 232.2 metres.—6.15 p.m., Zither Recital by Johann Konz. 6.45, Frankfurt Exchange and Hamburg Market Prices. 6.50, Weather. 7.0, Transmission for all German Stations, relayed from Frankfurt. 8.0, Topical Talk. 8.10, Concert by the Hamburg Philharmonic Orchestra, conducted by José Eibenschütz: Overture, King Stephan (Beethoven); Lyric Suite (Grieg); Symphonic Poem, En Saga (Sibelius); Intermezzo from Eibenschütz; Overture, King Stephan (Beethoven); Overture, King Stephan L'ancio Fritz (Mascanig); Berceuse (Jännefeld); Spring Serenade (Lacombe); Flirtation (Steck); Waltz, Illusionen (Eibenschütz). 9.30, Reading (F. A. Schmid-Noerr). 10.0, Time and News. 10.20, Topical Talk. 10.30, Concert by the Hamburg Philharmonic Orchestra, conducted by José Eibenschütz: Overture, The Merry Wives of Windsor (Nicolaï); Eine kleine Nachtmusik (Mozart); Hausente Suite (Schöffer); The Flute of Sans-Souci (Graener); Polovtsian Dances from Prince Igor (Borodin); Selection from Aida (Verdi); Blumengelüster (Blon); Waltz, Du-mid-Du from Die Fledermans (Joh. Strauss).

HANOVER.—See Hamburg.

HEILSBURG

1,085 kc/s, 276.5 metres; 60 kW. Relayed by Danzig, 662 kc/s, 453.2 metres.—11.30 a.m., Police Band Concert, conducted by Ernst Stieberitz; March, Wir von der Infanterie (Pischel); Overture, King Midas (Eilenberg); Selection from Der Kuhreigen (Kienzl); Tscherkessenzug (Steinbeck); Selection from William Tell (Rossini); Two Marches: (a) Dies Land bleibt Deutsch, (b) Am Tannenberg-Denkmal (Stieberitz); Selection from Der Freischütz (Weber); Wedding Day on Trilchangen (Grieg); March, Im Felde unbesiegt (Stieberitz). 1.0, Time and News. 1.5, Gramophone Concert. In the interval at 1.20 and 2.0, News. 2.30, Pro-

gramme arranged by the Post Office with Gramophone Records. 3.0, Market Prices. 3.30, Programme for Children. 4.0, Concert by the Small Station Orchestra, conducted by Eugen Wilcke; Uncle Teddy March (Fueck); Overture, The Caliph of Bagdad (Boieldien); Malicid (Blume); Schmetterlinge (Rathke); Selection from Gasparone (Müllcker); Waltz, Donauwellen (Ivanovici); Traun-Suite (Richter); O schöne Zeit, o selige Zeit; Bolero brillant (Götze); Overture, Semiramis (Rossini). In the interval at 4.50 (approx.), Book Review. 5.45, Talk on Music with Gramophone Illustrations; Songs that have become Classics. 6.15, Agricultural Prices. 6.25, Talk: Documents, in connection with the Declaration of War on August 1st, 1914. 6.50, Weather. 7.0, Transmission for all German Stations, relayed from Frankfurt. 8.0, Political Address and News. 8.5, Concert by the Königsberg Opera House Orchestra, conducted by Heinz Hoeglauer. 9.40, (from Danzig), Kadans (Reinhold Conrad Muschler). 10.10, News.

HILVERSUM

Announced **HUIZEN**, 1,013 kc/s, 296.1 metres; 20 kW. (7 kW up to 4.40 p.m.). Programme of the Catholic Radio Society (K.R.O.).—11.55 a.m., Gramophone Music (K.R.O.).—1.25 to 1.40 p.m., Interval. 1.40, Programme for Women. 2.40, Gramophone Music. 3.10, Pianoforte Recital by Thea Schwarz. Sixteen Waltzes (Brahms); Two Preludes (Chopin); Etude (Chopin); Polonaise (Chopin); Valse impromptu (Liszt). In the interval at 3.25, Gramophone Records. 4.5, Concert by the K.R.O. Boys. 4.40, Organ Recital from the Rembrandt Theatre, Amsterdam. 6.40, Police Notes. 6.55, Talk. 7.15, Gramophone Music. 7.25, Talk. 7.40, Concert by the Arnhem Orchestra, conducted by M. Hanks. March from Tannhäuser (Wagner); Overture, Meeresstille und Glückliche Fahrt (Mendelssohn); Selection from Rosamund (Schubert); The Oxford Symphony (Haydn). In the interval at 8.10, News. 8.40, Gramophone Music. 9.10, Concert (cont.). Overture, Phédre (Massenet); Ballet Music from Coppelia (Delibes); Selection from Les Dragons de Villars (Maillart); Rhapsody No. 1 (Liszt). 10.10, News. 10.15, Concert by the K.R.O. Boys. 11.40 (approx.), Close Down.

HORBY.—See Stockholm.

HUIZEN

Announced **HILVERSUM**, 160 kc/s, 1,875 metres; 8.5 kW.—11.40 a.m. till Close Down. Programme of the Workers' Radio Society (V.A.R.A.).—11.40, Concert by the Small V.A.R.A. Orchestra, conducted by P. Ducliant. 1.10 p.m., Gramophone Music. 3.40 to 3.55, Interval. 3.55, Organ Recital by J. Jong. 4.25, Concert by de Notenkrakers, conducted by D. Wijn. Der Torero, Roses from the South (Strauss); St. von, Faviez compris (Denza); Piazza del popolo (Fredriksen); Spiel Zigeuner (Huber); Gipsy Melody (Borzanov); Gramophone Records; Serenade d'amour (Waldan); The Rainbow (Wenrich); Extase (Rubinstein); Melody (Kockert); Waltz, Mon reve (Wahlteufel); Gramophone Records: Ein schöner Tag (Bond); Barcelona and Catalonia (Michiels); Czardas (Michiels); Socialist March (Gramm). 6.10, Talk by the R.V.U. 6.40, Dialogue. 7.20, Concert by J. Lammen (Songs), and C. Steyn (Organ). 7.25, Gramophone Report. 7.55, S.O.S. Messages. 7.57, Concert by the Small V.A.R.A. Orchestra. Soloist: J. Lammen (Songs); Marschaise; Vaandellied (de Nobel-Renes); Overture, Othello (Rossini); By day, by Night (Knorr-Renes); Volk outwork (Gaveaux); En Hollande (Kriens). 8.25, Gramophone Report. 8.55, Concert (cont.). Carmagnole; Internationale (de Geyer-Renes); Italian Suite (Kostald). Le Torero (Metallo). 9.25, Song and Pianoforte Recital by Mlle. F. de la Mar, and H. Benker. In the interval at 9.40, Press Review and Announcements. 10.10, Accordion Trio Concert. In the interval at 10.25, Gramophone Music. 10.40, Gramophone Concert. 11.40 (approx.), Close Down.

INNSBRUCK.—See Vienna.

KALUNDBORG.—See Copenhagen.

KATOWICE

734 kc/s, 405 metres; 16 kW.—7.20 p.m., Announcements and Gramophone Music. 7.35, Sports Notes. 7.40 till Close Down. See Warsaw.

KIEL.—See Hamburg.

KLAGENFURT.—See Vienna.

LAHTI

167 kc/s, 1,795 metres; 40 kW. Relayed by Helsinki, 815 kc/s, 369 metres.—6.15 p.m., Concert by the Station Orchestra. 7.0, Talk. 7.20, Suite for Pianoforte, Pictures from an Exhibition (Mussorgsky). 7.50, Dramatic Programme. 7.45, News in Finnish and Swedish. 8.15, Light Music, relayed from the Kappeli Restaurant. 10.0 (approx.), Close Down.

LANGENBERG

635 kc/s, 473 metres; 60 kW.—12 Noon, Concert from Munich. 12.50 p.m., Announcements. 1.0-2.30, Concert conducted by Ey-soldt. In an interval at 2.0 (approx.), Announcements. 3.0, Programme for Children. 3.30, Economic Notes and Time. 3.50, Talk; Summer Holidays and the Problem of Expenses. 4.10, Talk: Provincial School Administration. 4.30, Talk: Nature in August. 4.50, Political Address. 5.0, Song Recital on Gramophone Records. 5.15, Talk, with Gramophone Illustrations: Chile. 6.35, Italian Lesson. 5.50, Humorous Items. 6.0, Concert by the Fröhliche Fünf. 6.45, Weather, Economic and Sports Notes. 7.0, Transmission for all German Stations, relayed from Frankfurt. 8.0, Announcements. 8.5, Songs of the Fatherland, Children's Choir Concert by the Cologne Singakademie Male Voice Choir, a Children's Choir and the Station Orchestra conducted by Max Meier. 8.55, A Flying Visit. 9.10, Heimkehr der Helden (The Return of the Heroes)—Radio Play (Walter Heuer), with incidental Music by Clausius. 10.10, Announcements. 10.30, Review of the Week.

LAUSANNE.—See Radio-Suisse Romande.

LEIPZIG

769.9 kc/s, 389.6 metres; 120 kW.; and Dresden, 941 kc/s, 319 metres.—1.15 p.m., Great German Composers on Gramophone Records. 2.0, News. 2.10 (from Dresden), Talk: The Internationalisation of Civil Aviation. 2.45, German for Germans. 3.0, Programme for Invalids. 3.35, Market Prices. 4.0, Orchestral Concert, relayed from Chemnitz: Overture, Alceste (Glück); Viennese Dances (Beethoven); Extracts from Rosamunde (Schubert); Selection from Das Nachtlager von Granada (Kreutzer); Waltz, Morgenblütter (Joh. Strauss); Selection from The Bird Fancyer (Zeller); Rheinische Nachtmusik Op. 35 (Niemann); Florentine March (Fueck). 5.50, Market Prices, Weather and Time. 6.0, Agricultural Talk. 6.25, Talk for Parents. 6.50, To-day's News. 7.0, Transmission for all German Stations, relayed from Frankfurt. 8.0, Concert by the Station Orchestra, conducted by Hilmar Weber: Overture, William Tell (Rossini); Tarantella, Minuet and Waltz from A Tale of the Champagne (Brüll); Slav Dances Nos. 1 and 3 (Dvorak); Selection from The Merry Wives of Windsor (Nicolaï); Overture, Pique Dame (Suppe). 9.10, See Munich. 9.20, Talk on Economics. 9.30 (from Dresden), Quartetto Dorico in E Minor (Respighi) by the Dresden String Quartet. 10.5, News. 10.15 (approx.), Gramophone Concert. 12 Midnight, Close Down.

LINZ.—See Vienna.

LJUBLJANA

522 kc/s, 574.7 metres; 7 kW.—6.30 p.m., Concert by the Station Orchestra. 7.30, Talk. 8.0, Song Recital by Marian Rus. 8.45, Concert by the Station Orchestra. 9.30, Time and News. 10.0, Jazz Music. 11.0 (approx.), Close Down.

LUXEMBOURG

252 kc/s, 1,191 metres; 200 kW.—Belgian Programme. 7.30 p.m., Tenor Solos by Scho-Kmel: Aria from Amadis de Gaule (Lully); Romance (Debussy); Aria from L'Enfant prodigue (Debussy); L'Absence (Berlioz); Aria from Lakmé (Delibes); Song from Carmen (Bizet). 8.0, Weather Report. 8.5, Concert of Belgian Music by the Station Orchestra, conducted by Henri Pénis. In an interval at 8.25, Talk in French: The Tourist Traffic and Aviation. 8.50, News in French. 9.0, Sonata in E minor (Brahms). 9.20, Concert by the Station Orchestra: Overture, Il Seraglio (Mozart); Verdi Potpourri (Weber); Egyptian Serenade, Amira (Lincek); Intermezzo, Nix et Nac (Dvorak); Slav Dance No. 6 (Dvorak); Xantippchen (Königberger); Blues (D'Albert); Selection from The Geisha (Jones). In an interval at 9.50, News in German. 10.25, Dance Music on Gramophone Records.

LWOW

788 kc/s, 381 metres; 16 kW.—7.20 p.m., Miscellaneous Items. 7.40, See Warsaw. 9.0, Answers to Correspondents. 9.10, See Warsaw. 10.40, Gramophone Music. 11.0 (approx.), Close Down.

LYONS

LA DOUA (PTT), 644 kc/s, 465.8 metres; 1.5 kW.—7.30 p.m., Radio Gazette for Lyons and the South East. 8.30, Programme to be announced. After the Programme, News.

MADRID

EAJ7, 707 kc/s, 424.3 metres; 2 kW.—8.0 p.m., Chimes, Exchange, Radio Journal and Request Gramophone Records. 8.30, Talk by Joaquin España Cantos and Request Gramophone Records (cont.). 9.15, News and Political Review. 9.30 to 11.0, Interval.

11.0, Chimes, Time and Political Review. 11.15 (approx.), Manon—Opera (Massene on Gramophone Records. 1.15 a.m. (Wednesday), News. 1.30, Chimes and Close Down.

MALMO.—See Stockholm.

MILAN

VIGENTINO, 662 kc/s, 453.2 metres; 4 kW. 8.45 p.m. till Close Down. See Rome.

MORAVSKA-OSTRAVA

1,137 kc/s, 263.8 metres; 11 kW.—2.50 p.m. Concert by the Station Orchestra, conducted by V. Musil: Overture, Si j'étais roi (Adam Waltz from Faust (Gounod); Sui (Jalowiec). 3.55-4.0, See Prague. 5.45, See Prague. 6.5, Gramophone Music. 6.15, S. Brno. 7.0, See Prague. 7.35, Talk on the Jeseniky Mountains. 7.50, See Prague. 8.1 Violin Recital by Emil Myslivec. 8.40, S. Prague. 11.0 (approx.), Close Down.

MOSCOW

TRADES UNION, 230 kc/s, 1,304 metres; 100 kW.—2.45 p.m., Weather. 3.0, Popul Orchestral Concert. 3.45, Weather. 4. Agricultural Talk. 4.30, Literary Talk. 5.30, Programme Announcements. 5.5, Educational Programme. 9.0, News. 9.5, Programme Announcements. 9.55, Chirm from the Red Square. 10.5, Talk: The International Anti-War Day. 10.30, Press Review.

MOTALA.—See Stockholm.

MUHLACKER.—See Stuttgart.

MUNICH

563 kc/s, 533 metres; 60 kW. Relayed Augsburg and Kaiserslautern, 536 kc/s, metres; and Nürnberg, 1,256 kc/s, metres.—4.30 p.m., Concert by the Qui Huber Orchestra: Overture, Der Göttliche (Lehar); Waltz Rhapsody, Pusz Legenden (Lindsay-Thiemer); Bavarian Tut mezzo, Violetta (Rust); Potpourri, Mos (Zimmer); Serenade, Fascinata (Murzil); Waltz, España (Waldteufel); Ballet S. Fann und Elfreunde (Kark); Mar Hurra, die Musik kommt (Zimmer). 5 Talk: The Outbreak of the World War 6.5, Song Recital by Anton Maria Tq (Tenor); Verspruch (Graener); Mädel a (Repick); "Nachtwanderer (Pfitzner); Schlagen die Herzen (Schattmann); sänmige Landknecht (Reiter); Heim land (Kistenmacher); Die Stimme (Kien 6.25, Günther Grochhoff Memorial I gramme. 6.45, Time, Weather and Agricul tural Notes. 7.0, Transmission for all e man Stations, relayed from Frankfurt. Provincial Programme from Kumback. 7. The First of August—One Act Play (J wig Thoma). 9.35, Concert by the P. Quartet; Quartet No. 2 (Schiffmann); Q uet in E Minor Op. 59 No. 2 (Beethov 10.20, Time and News.

NAPLES.—See Rome.

NOTODDEN.—See Oslo.

OSLO

277 kc/s, 1,083 metres; 60 kW. Relayed Fredriksstad, 815 kc/s, 368.1 metres; Har 522 kc/s, 574.7 metres; Notodden, 671 k 447.1 metres; Porsgrunn, 662 kc/s, 4 metres; and Rjukan, 671 kc/s, 447.1 met —5.0 p.m., Light Orchestral Concert rela —from the Theatre Cafe. 6.0, Talks for Ho wives: (a) Jam Making, (b) Topical T 6.45, Recital of Popular Melodies and Da Music by Alfred Eriksen (Accordion). Announcements, Weather, and News. 7 Talk on Child Psychology. 8.0, Time. Concert by the Station Orchestra, condu by Hugo Kramm: Overture, In He (Grieg); Suite, Mozartiana (Tchaikovsk The "Front" Quartet (Schubert); Mon musical (Schubert); Melody (Eggen); e wagian Rhapsody No. 4 (Svendsen); Lie (Fred Krieger); Ballet Suite (Helb Eotie Dances (Mascanig); Johann Str Potpourri (Weber). 9.38, Agricultural N Weather, and News. 10.0, Topical T 10.15, Recitations. 10.45 (approx.), C Down.

ÖSTERSUND.—See Stockholm.

PALERMO

558 kc/s, 537.6 metres; 3 kW.—8.0 p.m., D lavoro Notes, Tourist Report, Agricul Notes and Giornale Radio. 8.20, Gramop Music. In an interval at 9.20, Time Announcements. 8.45, Turandot—Oper Three Acts (Puccini). In the intervals, A and Announcements. After the Opera, X

PARIS

EIFFEL TOWER, 207.5 kc/s, 1,445.7 met 13 kW. Time Signals (on 2,650 metres 10.26 a.m. and 11.26 p.m.). (Preliminary 6-dot signals).—6.45 p.m., Theatre N 7.0, Le Journal Parlé. 8.30, Orchestral cert, conducted by Edouard Flament: s. bois (Fourdrain); La camp s'éveille (Flament); Promenade en (Christiné); Paysage (Gittet); Ronde nu champ de coquelicots (Akimenko); moulin (Gillet); sous bois (Staub); At lage (Mouquet); Paysanne (d'Ambro Coq et poules, Au fond des bois and 1

AUGUST 1st

TUESDAY

continued

VATICAN CITY

15,120 kc/s, 19.84 metres (Morning), and 5,969 kc/s, 50.26 metres (Evening); 10 kW.—11.0 to 11.15 a.m., Religious Information in English. 8.0 to 8.15 p.m., Religious Information in Italian.

VIENNA

581 kc/s, 517 metres; 100 kW. Relayed by Graz, 852 kc/s, 352.1 metres; Innsbruck, 1,055 kc/s, 283 metres; Klagenfurt, 662 kc/s, 453.2 metres; Linz, 1,220 kc/s, 245.9 metres; and Salzburg, 1,373 kc/s, 218.5 metres.—12 Noon, Concert by the Vienna Symphoniker Orchestra, conducted by Josef Holzer. In the interval at 1.0 p.m., Time and News. 2.0, Interval. 3.0, Time and Announcements. 3.20, Practical Hints for the Housewife. 3.35, Gramophone Concert. 4.25, Talk: The History of the Dwelling House. 4.50, Talk: From the Letters of a Mountain Climber. 5.5, Song and Pianoforte Recital by Erika Heller and Rosalinde Kaplan. 5.45, Airs from Oratorios by Dr. Paul Lorenzi (Baritone). 6.5, Talk: Baumgartenberg, a Forgotten Cistercian Monastery in Upper Austria. 6.30, Talk. 7.0, Concert of German Opera Music by the Vienna Symphoniker Orchestra, conducted by Karl Auerlath, and soloists: Maria Reining (Soprano) and Ernst Tauber (Baritone). Overture and Aria from Der Freischütz (Weber); Prelude to Der Muskat (Bittner); Arias (Lortzing) from (a) Czar and Carpenter and (b) Der Wildschütz; Overture, The Merry Wives of Windsor (Nicolaï); Prelude and Melody from Der Vogelmann (Kienzl); Aria from The Golden Cross (Brüll); Overture, Der Bärenhäuter (S. Wagner); Melody from Hansel and Gretel (Humperdinck); Arias from The Magic Flute (Mozart); Dance of the Apprentices, and Procession of the Guilds from The Mastersingers (Wagner); Overture, Hans Sachs (Lortzing). In the interval at 7.35, Time and Announcements. 8.30, Reading from the Works of Dr. Ignaz Seipel, with Commentary. 9.0, Eysler Concert by the Vienna Symphoniker Orchestra, conducted by Josef Holzer. March, Servus Wien from Ein Tag im Paradies; Overture, Hezenpigel; Waltz from Vera Violetta; Melody from Ein Tag in Paradies; Selection from Künstlerblut; Overture, Schützenlied; Waltz-Intermezzo from Die gold'ne Meist'erin; Viennese Song, Cind Ischeln beim Heimgen O'Lichterl aus; Polka, Kommen Sie Polka tanzen from Der Draufesser; Selection from Bruder Straubinger; Lumpen-Marsch. 10.15, News. 10.30, Gramophone Concert.

WARSAW

212.5 kc/s, 1,411 metres; 120 kW.—11.57 a.m., Time Signal and Fanfare from the Tower of St. Mary's Church, Cracow. 12.5 p.m., Jazz Music on Gramophone Records. 12.25, Polish Press Review. 12.33, Weather. 12.35, Gramophone Music. 12.55, Radio Journal. 1.0, Interval. 2.55, Gramophone Music. 3.5, News. 3.10, Announcements. 3.15, Gramophone Music. 3.25, Economic Notes. 3.35, Gramophone Music. 3.45, Aviation Report and Anti-Gas Drill. 3.50, Gramophone Music. 3.55, Announcements. 4.0, Popular Concert by the Poznan Opera House Orchestra, conducted by Tyllia, relayed from Cichocinek. 5.0, Talk: A Visit to Fez. 5.15, Song Recital by Christina Dely (Soprano) and Eugene Maj (Baritone). Baritone Solos: (a) Wiegenlied (Brahms). (b) Schlagende Herzen (R. Strauss). (c) Le Cœur desé (Rubinstein). (d) Song (Tosti); Soprano Solos: Arias from (a) Figaro (Mozart). (b) Ariane (Massenet). (c) Figaro (Mozart); Baritone Solos: (a) Aria from Hérodiade (Massenet). (b) Aria from Otello (Verdi). (c) Prologue to I Pagliacci (Leoncavallo). (d) Aria from Zaza (Leoncavallo); Soprano Solos: (a) Three Vocal Preludes (Opinski). (b) Two Songs (Noskowski). (c) Autumn (Lipski). (d) Cradle Song and Love Song (Matsujama). 6.15, Talk: Our Agricultural Exports. 6.35, Concert of Light Music by the Station Orchestra, conducted by Nawrot. Soloist: B. Mierzejewski (Tenor). 7.20, Miscellaneous Items. 7.35, Programme Announcements. 7.40, Topical Talk. 8.0, concert by the Station Orchestra, conducted by Nawrot; Suite: Goliardie (Amadei); Serenade (Margutti); Song (Kreiser); The Phantom Melody (Kretelbey); Wedgwood Blue (Kretelbey); March (Fucik). 8.50, Radio Journal. 9.0, Medical Talk. 9.10, Vidin Recital by Mme. Dubiska: Sonata in A (Benda-Moffat); Caprice (Pagani-Auer); Havanaise (Saint-Saëns); Spanish Serenade (Chaminade-Kriesler); Krakowiak (Gustakowski); Cradle Song (Mlynarski); Mazurka (Mlynarski). 10.0, Dance Music. 10.25, Sports Notes. 10.35, Aviation Weather Report and Police Notes. 10.40, Dance Music.

WILNO

533 kc/s, 563 metres; 16 kW.—7.10 p.m., News. 7.20, Talk in Lithuanian. 7.35, Programme Announcements. 7.40, See Warsaw. 8.0, Concert of Request Gramophone Music. 8.50, See Warsaw. 11.0 (approx.), Close Down.

ZAGREB

977 kc/s, 307 metres; 0.75 kW.—8.10 p.m., Announcements. 8.30, One-Act Play. 9.30, Concert by the Radio Orchestra. 10.30, News. 10.40, Dance Music. 11.30 (approx.), Close Down.

ZURICH.—See Schweizerischer Landessender.

from William Tell (Schiller). 15.0, Time and News. 10.15, Gramophone Music. 11.0 (approx.), Close Down.

RADIO-SUISSE ROMANDE

SOTTENS, 743 kc/s, 403 metres; 25 kW.; and Geneva, 905 kc/s, 760 metres.—6.15 to 6.30 a.m., Gymnastics. 12.28 p.m., Time Signal from Neuchâtel Observatory. 12.30, News. 12.40, Gramophone Concert. 1.0, News. 1.10, Gramophone Music. 2.0 to 3.28, Interval. 3.28, Time Signal from Neuchâtel Observatory. 3.30, Concert by the Radio Lamsane Orchestra, conducted by M. Moser: Three Dances (German); Selection from A Waltz Dream (O. Strauss); Serenata galante (Ranzani); Il tamburino arabo (Ranzani); Overture, Tamerlan (Rossini); Spanish Dance (Malvezzi). 4.10, Pianoforte Recital by Mlle. Gaseard. 4.30, Concert (cont'd.). 5.30 to 7.0, Interval. 7.0 to 10.30, Swiss Gala Evening. 7.0, Talk, with Illustrations: The History of Swiss Popular Songs, Musical Plays, and Choral Music. 7.31, The Foundation of the Swiss Confederation—History Talks. 8.0, August 1st Festival Programme: Address by C. Gerzat, Relay of a Patriotic Ceremony and Recital by Mlle. Rochat (Songs) and Paul Sandoz (Baritone). 10.0, Old Swiss Dance Music on Gramophone Records. In the interval at 7.30, Weather and Announcements, and at 9.50, News and Weather. 10.30 (approx.), Close Down.

(from Basle). Light Music on Gramophone Records. 6.30 (from Basle). Reading. 7.0, Time and Weather. 7.5 (from Basle), Swiss Music on Gramophone Records. 7.30 (from Basle), August 1st Programme. 9.0 (from Basle), News. 9.10 (from Basle), William Tell—Play (Schiller). 10.25 (approx.), Close Down.

SOTTENS.—See Radio-Suisse Romande.

STOCKHOLM

689 kc/s, 436 metres; 55 kW. Relayed by Eöden, 244 kc/s, 1,229.5 metres; Göteborg, 932 kc/s, 322 metres; Hörby, 1,166 kc/s, 257 metres; Motala, 221.5 kc/s, 1,354.4 metres; Östersund, 389 kc/s, 770 metres; and Sundsvall, 554 kc/s, 542 metres.—5.5 p.m., Sextet Concert of Light Music. 5.45, Reading. 6.15, Gramophone Music. 7.15, Weather and News. 7.30 (from Göteborg), Talk: Swedish Literature. 8.0, A Comedy (Ella Byström). 9.0, Concert by the Station Orchestra; Soloist, Gunnar Norrby (Cello); Overture, The Maid of Orleans (Süßmann); Cello Concerto in A Minor (Benjaminson); Swedish Dance (Lind). 9.45, Weather and News. 10.0, Concert (cont'd.); Extracts from Die Follkunger (Kretzschmar); Overture, Libuse (Smetana); Selection from The Dollar Princess (Fall); Canzonetta (Friml); Butterfly Waltz (Friml); Melody (Niemann); Valse caprice (Rubinstein); Espana (Chabrier). 11.0 (approx.), Close Down.

STRASBOURG

869 kc/s, 345 metres; 11.15 kW.—11.30 a.m., Gramophone Music. 12 Noon, Orchestral Concert, conducted by de Villers. 12.45 p.m., News. 1.0, Time and Exchange. 1.5, Concert (cont'd.). 2.0 to 5.0, Interval. 5.0, Talk on Colonies: Guadeloupe. 5.15, Orchestral Concert, conducted by Roskam; Overture, Czar and Carpenter (Lortzing); Waltz from Die Puppe (Bayer); Potpourri, Offenbachiana (Conradi); Loutanetta (Razigade); Mylle passionnelle (Razigade); Czardas (Michiels); March, King Cotton (Souza). 6.0, Talk: Anti-Semitism in the Modern World. 6.15, Topical Talk. 6.30, Gramophone Concert. 7.30, Time and News. 7.45, Gramophone Music. 8.0, Press Review in French, Lottery Results, and Announcements. 8.0, Concert by the Station Orchestra, conducted by de Villers; Overture, Così fan tutte (Mozart); Two Duets from Così fan tutte (Mozart); Pianoforte Concerto in G minor (Mendelssohn); Greek Suite (Bazelaire); Two Sketches for Voice and Orchestra (Moreau); Duet; Valse nobles et sentimentales (Ravel); Corsican Folk Songs (Tomasi); Musiques foraines (Schmidt). In the interval at 9.30 (approx.), Press Review in German.

STUTTGART

MUHLACKER, 822 kc/s, 360.5 metres, 60 kW.; and Freiburg, 527 kc/s, 570 metres.—1.30 p.m. (from Mannheim), Old German Love Songs and Folk Songs—Recital by Gustav Adolf Knörzer (Bass); Jungbrunnen; Zwei Wasser; Der Gützchen; Lindenlaub; Jägers Morgenbesuch; Heiderösch; Brauns Mägdlein; Abschied vom Liebelien; Das Muskatellerbad. 2.0, Concert arranged by the Post Office. 2.30, Advanced English Lesson. 3.0, Interval. 3.30, Talk on Flowers. 4.0, Talk for Housewives. 4.30, See Frankfurt. 5.45, Hermann Bahr Programme for his Seventieth Birthday. 6.35, Time and News. 7.0, Transmission for all German Stations, relayed from Frankfurt. 8.0, Field Grey and Brown—Musical Radio Sequence by a Male Voice Choir, the Radio Orchestra, and Soloists. 9.10, See Munich. 9.20 (from Karlsruhe), Oboe Recital by Fried Grabert; Grave and Sarabande from the Oboe Concerto (Handel); Larghetto and Allegro from Sonata da Camera, No. 7 (Handel); Andante (Mozart). 9.50, Wir lassen von der Fahne nicht...—Radio Sequence (Eyb). 10.30, Time and News. 10.45, Concert of Operetta and Dance Music by the Station Orchestra, conducted by Gustav Gorlich; Soloist, Manfred Kömpel (Tenor). 12 Midnight (approx.), Close Down.

SUNDSVALL.—See Stockholm.

TRIESTE

1,211 kc/s, 247.7 metres; 10 kW.—5.0 p.m. till Close Down. See Turin.

TRONDHEIM.—See Oslo.

TURIN

1,096 kc/s, 273.7 metres; 7 kW. Relayed by Milan, 905 kc/s, 331.5 metres; Genoa, 959 kc/s, 312.8 metres; and Florence, 599 kc/s, 500.8 metres.—5.0 p.m., Dance Music from the Savoia Dance Hall. 6.0 to 6.5, Weather. 6.35, Giornale Radio, Agricultural Notes and Dopolavoro Announcements. 7.0, Time, Report of the Royal Geographical Society and Gramophone Music. 7.20, News in Foreign Languages. 7.40, Gramophone Music. 8.0, Announcements, Giornale Radio, Sports Notes, Weather and Gramophone Music. 8.30, A Comedy in Three Acts. After the Comedy—Variety Music. 11.0, Giornale Radio.

et l'aüter (Léonard); Les accordailles (Gillet); Sous les tilleuls (Massenet); Mariage villageois (Flament); Village Dance (Wesly); La fête du village voisin (Boieldieu); L'Angelus and Cloches du soir (Ropartz); Clair de lune (Debussy); L'été dans la plaine (Brusselmans). 10.0 (approx.), Close Down.

PARIS

POSTE PARISIEN, 914 kc/s, 328.2 metres; 60 kW.—7.0 p.m., Gramophone Music. 7.15, Journal Parlé. 7.30, Gramophone Music. 8.30, Concert by the Station Orchestra; Prelude from Chants d'Espagne (Albeniz); Valse viennoise (Debussy); Piesnia (Cools); Sketches (Gaubert); Selection from François les basbleus (Messager); Scherzo Waltz (Brun); Suite albanaise (Pouget); Ballet Music (ou Callirhoé (Chaminade); Pastorale for Clarinet and Strings (Pierné); Summer Evening on the Terrace (Turina); Promenade militaire (Billet). 10.30, News.

PARIS

RADIO PARIS, Call CFR, 174 kc/s, 1,725 metres; 75 kW.—7.30 a.m., Weather and Physical Culture. 7.45, Gramophone Music; Deauville (Corbin); Jota aragonesa (Sarastate); Piece (Suk). 8.0, News. 12 Noon, Gramophone Concert: J'adore les espagnoles (Scott-Raiter); De tout mon cœur (Claret); Aurai-je le bonheur (Hugnet); Melody (Erwin); Quand on est vraiment amoureux (Moretti); Tell me to-night (Spoliansky); La petite maison (Beydts); Java d'un soir (Ferrari); The Midnight Review (Glinka); Two Steps; Granadino (Carreri); Waltz from The Girl in the Taxi (Gilbert); Ol' man river from Show Boat (Kern); Sautex Bébés (Paradis); Tango, Jealousy (Gade); La Pampolaise (Botrel); Cockney Suite (Kotelbey); C'est Jean de la lune (Augé); Overture, Amnia (Lincke); Valse Caprice No. 2 (Philipp); Sous la feuille (Thomé); Song of Love (Holmann); Valse caprice (Rubinstein); Ideale (Tosti); Moss Rose (Bose); Chant du berger (Serren-Bergeret); Piece (Komzak). In the intervals at 1.0, Exchange and News, and at 1.30, Exchange. 2.0, Exchange. 3.45, Exchange and Racing Results. 7.10, Gramophone Concert: Concert Polonoise (Vidal); Estudiantina (Waldteufel); Songs from La Poupée (Audran); Italian Serenade (Wolf); Invitation to the Waltz (Weber). 7.50, Commercial Prices and News. 8.0, Rigoletto—Opera (Verdi), on Gramophone Records, by the Cast of the Scala, Milan. In the intervals at 8.30 and 9.15, News.

PITTSBURGH

KDKA, 980 kc/s, 306 metres; 50 kW. Relayed by W8XK on 48.86 metres and 25.27 metres.—7.30 p.m., KDKA Home Forum. 8.0, Betty and Bob, from New York. 8.15, The Smiths Play Bridge. 8.30, Words and Music. 8.45, Congress of Clubs Period. 8.58, Baseball Scores. 9.0, Meredith Wilson's Orchestra, from New York. 9.30, Business News and Market Reports. 9.45, Programme to be announced. 9.58, Baseball Scores. 10.0, Rhythm Kings. 10.15, Tarzan of the Apes. 10.30, The Singing Lady, from New York. 10.45, Little Orphan Annie. 11.0, Time Signal and Press News-Reeler. 11.5, Pianoforte Classique. 11.15, Weather Report. 11.16, Sport Review. 11.23, I Bring a Song. 11.28, Announcement. 11.29, Temperature Report. 11.30, Pittsburgh Spotlight. 12 Midnight, Amos 'n' Andy, from New York. 12.15 a.m. (Wednesday), National Advisory Council on Radio Education, Reducing the Library Budget, from New York. 12.45, Aldo Ricci and his Phantom Strings, with Ray Heatherstone, Baritone. 1.0, Crime Clues, from New York. 1.30, Adventures in Health, from New York. 1.45, Floyd Gibbons, World's Fair Reporter. 2.0, Stadium Concert by Philharmonic Symphony Orchestra. 2.59, Time Signal. 3.0, Household Musical Memories, from New York.

PORSGRUND.—See Oslo.

POZNAN

96 kc/s, 335 metres; 1.9 kW.—6.35 p.m., See Warsaw. 7.20, Miscellaneous Items and News. 7.35, Theatre Notes and Programme Announcements. 7.40, See Warsaw. 10.0, Time Signal, Sports and Police Notes. 0.15, Dance Music from the Esplanade Café. 1.0 (approx.), Close Down.

PRAGUE

14 kc/s, 488.6 metres; 120 kW.—2.50 p.m., See Moravská-Ostrava. 3.55, Exchange. 4.0, Interval. 5.45, Gramophone Music. 5.56, Talk: Prague Castle. 6.5, Market Prices. 7.15, Talk for Workers. 6.25, News in German. 6.30, German Transmission: Song recital by R. Popovitch. 7.0, Chimes and News. 7.10, Cello Recital by J. Simandl; Javotte, Op. 7 (Jérat); Pathetic Adagio, p. 128 (Godard); Romance (Vaček); Melody nd Minuet (Kubati); Meditation (Popper); Lazarika, Op. 64 (Neruda). 7.35, See Moravská-Ostrava. 7.50, A Gramophone our Round the World. 8.15, Song Recital y Louisa Gličekseligova-Pavova. 8.40, Programme on the Occasion of the Swiss national Festival. 8.45, Talk on Switzerland. 9.0, Concert of Swiss Music by the Station Orchestra, conducted by Jeremias. In the interval, Recitations; Monologue

REYKJAVIK

250 kc/s, 1,200 metres; 21 kW. 9.5 p.m., Musical Programme. 9.30, Weather Report. 9.40, Musical Programme and Announcements. 10.0, Chimes and News. 10.30, Reading. 11.0, Pianoforte Recital by Emil Thordarson, followed by Overture, A Midsummer Night's Dream (Mendelssohn) on Gramophone Records.

RIGA

572 kc/s, 525 metres; 15 kW.—6.0 p.m., Talk on the New Penal Code. 6.30, Soprano Song Recital on Gramophone Records. 7.0, Weather Report. 7.3, Educational Talk. 7.30, Concert by the Station Orchestra, conducted by Werner Jansen, relayed from Bulduri: Second Indian Suite (Machdowell); Suite, Gli Uccelli (Respighi); Latvian Rhapsody (Vitols); Virginia (Tate); The American in Paris (Gershwin). In the intervals at 8.15, News, and at 9.0, Weather. 9.30, News, followed by Popular Music.

RJUKAN.—See Oslo.

ROME

Call 1R0, 660 kc/s, 441 metres; 50 kW. Relayed by Naples, 941 kc/s, 319 metres; and 2R0, 11810 kc/s, 25.4 metres, from 5.30 p.m.—1.0 to 2.15 p.m., Concert by the Station Orchestra. In the intervals from 1.30 to 1.45, Giornale Radio and Exchange, and at 2.0, Time and Announcements. 4.45, Children's Radio Review. 5.10, Weather. 5.15, Exchange and Giornale Radio. 5.30, Concert by the Station Orchestra. 6.40 (Naples), Shipping and Sports Notes. 6.50, Agricultural Notes and Dopolavoro Announcements. 7.0, Tourist Talk. 7.10, Lesson in Morse. 7.20, News in Foreign Languages. 7.40, Giornale Radio. 8.0, Time and Announcements. 8.15, Sponsored Musical Programme. 8.30, Sports Notes. 8.45, Concert of Opera Music; Soloists: Virginia Brunetti (Soprano) and Mario Cavagnini (Tenor); Overture and March from Tannhäuser (Wagner); Duet from La Sonnambula (Bellini); Duet from Act 1 of Lucia di Lammermoor (Donizetti). 9.30 (approx.), Agenzia commerciale—Comedy in one Act (Forté). 10.0, Pianoforte Recital by Mario Ceccarelli. 10.15, Gramophone Concert. 10.55, Giornale Radio.

SALZBURG.—See Vienna.

SCHENECTADY

(WGY), 790 kc/s, 379.5 metres, 50 kW.—Relayed at intervals by W2XAF on 31.48 metres and by W2XAD on 19.56 metres.—12.45 a.m. (Wednesday), Stock Reports and Baseball Scores. 1.0 to 3.30, New York Relay. 1.0, Blackstone Plantation. 1.30, Wayne King's Orchestra. 2.0, Ben Bernie's Blue Ribbon Orchestra. 2.30, Ed Wynn and the Fire Chief Band. 3.0, Lives at Stake. 3.30, National Radio Forum, from New York, followed by Programme Resumé.

SCHWEIZERISCHER LANDESENDER

BEROMUNSTER, 653 kc/s, 459 metres; 60 kW.; Basle, 1,229 kc/s, 244.1 metres; and Berne, 1,220 kc/s, 245.9 metres.—6.15 a.m. (from Basle), Gymnastics. 6.35, Interval. 11.59, Time Signal from Neuchâtel Observatory. 12 Noon (from Zürich), Concert of Light Music. 12.30 p.m., Time and News. 12.40 (from Zürich), Concert (cont'd.). 1.25 (from Zürich), Exchange, Time and Weather. 1.45 (approx.), Interval. 5.0 (from Zürich), Concert by the Little Swiss Radio Orchestra. 5.30

BUILD YOUR NEW MONODIAL WITH A PILOT AUTHOR KIT EXACT TO SPECIFICATION

● SEE OUR FULL-PAGE ANNOUNCEMENT IN LAST WEEK'S ISSUE Page One of Advertisements

Demonstrations of the New A.C. Monodial Super-Het Receiver are given daily at 77, CITY ROAD, LONDON, E.C.1. 62, HIGH HOLBORN, LONDON, W.C.1.

● FULL-SIZE BLUE-PRINT WITH EACH KIT.

PETO-SCOTT CHASSIS SOLELY SPECIFIED

PLYMAX BASEBOARD assembled with Runners and drilled as specified by the Author for RECEIVER PORTION, 14" x 12" x 3". Cash or C.O.D. Carriage paid. **10/6**

Ditto in NEW METAPLEX BOARD. 6/6

PLYMAX BASEBOARD assembled with Runners and drilled as specified by the Author for POWER UNIT PORTION, 18" x 6 1/2" x 3". Cash or C.O.D. **7/6**

Ditto in NEW METAPLEX BOARD, 5/-

KIT-BITS *Any item supplied separately. You pay the postman—we pay post charges on orders over 10/-. Send for detailed list.*

● RECEIVER PORTION

- 1 Set of Varley B.P. 19. Superhet Coils £1 10 0
- 3 Telsen W294, L.F. Transformers, 110 K.C. £1 17 6
- 1 British Radiophons type 424A Condenser with Covers and right-hand Tunners and Slow Motion Dial, type 582A £1 18 6

● POWER UNIT PORTION

- 1 Sound Sales, 10 Henry Choke, type No. 10 D.C. ... 15 0
- 1 Bulgln L.F.14. 20 Henry Choke 10 6
- 1 Ferranti AF5C. Push-Pull Transformer £1 14 0
- 1 Claude Lyons, Mains Transformer with Screened Primaries as specified £2 10 0

RECEIVER KIT

Author's Kit of FIRST SPECIFIED PARTS for RECEIVER PORTION ONLY less Plymax Chassis, Panel, Cabinet and Valves
Cash or C.O.D. **£10-19-6**

Carriage Paid.

Extra for Peto-Scott Plymax Chassis as used by the Author, 14" x 12" x 3". Ready Drilled and Assembled with Runners 10 6
Peto-Scott Oak faced Ply Panel, Ready Drilled, 14" x 10" 2 6

RECEIVER KIT "A" as above but with PETO-SCOTT READY-DRILLED AND ASSEMBLED PLYMAX CHASSIS WITH RUNNERS AND PANEL, less Valves and Cabinet, Cash or C.O.D., carriage paid, £11-12-0 or Deposit £1-12-0, balance in 11 monthly payments of 20/-
Set of 5 specified Valves £4-4-6, or add 7/9 to each monthly payment.

POWER UNIT KIT

Author's Kit of FIRST SPECIFIED PARTS for POWER UNIT ONLY but less Plymax Chassis and Valves

Cash or C.O.D. **£8-13-6**
Carriage Paid.

Extra for Peto-Scott Ready-Drilled Plymax Chassis with Runners, 18" x 6 1/2" x 3" ... 7 6

POWER UNIT KIT as above but with READY-DRILLED AND ASSEMBLED PLYMAX CHASSIS, WITH RUNNERS, Cash or C.O.D., carriage paid, £9-0-0 or 12 monthly payments of 16/6.

Set of Valves as specified £3-0-6 (including Ediswan Delay Switch, Type DLS1.) or add 5/7 to each monthly payment.

COMBINED KIT

Comprising Receiver and Power Unit Kits with 2 Peto-Scott Ready-drilled Plymax Chassis with Runners and Peto-Scott Ready-drilled Oak Panel, less Valves and Cabinet. Cash or C.O.D. **£20 - 12 - 0**
Carriage Paid

or £3-12-0 Deposit and 11 monthly payments of 35/-

COMPLETE KIT

Comprising Receiver and Power Unit Kits as Combined Kit but with Valves, less Cabinet. Cash or C.O.D. Carriage **£27 - 17 - 0**
Paid

or £5-17-0 Deposit ; Balance in 11 monthly payments of £2-4-0.

IMMEDIATE DELIVERY — CASH — C.O.D. — H.P.

AS FOUNDERS OF CONSTRUCTORS SETS IN 1919, we have established a world-wide reputation for the supply of Complete Kits and Parts for all "Wireless World" Set designs. An essential feature of this Expert Service to the Home Constructor is IMMEDIATE DELIVERY FROM STOCK—CASH or C.O.D.—of any exclusively specified or difficult to obtain components. Rely on PETO-SCOTT, he always gives fullest satisfaction to every customer.

FOREIGN ORDERS. Send one-third value of goods with order. Balance (including forwarding charges) payable to our forwarding agents on delivery. Insurance effected if desired. All orders carefully executed and expertly packed by special export staff.

NOUS DONNONS D'ATTENTION SPECIALE AUX INSTRUCTIONS ETRANGERES.

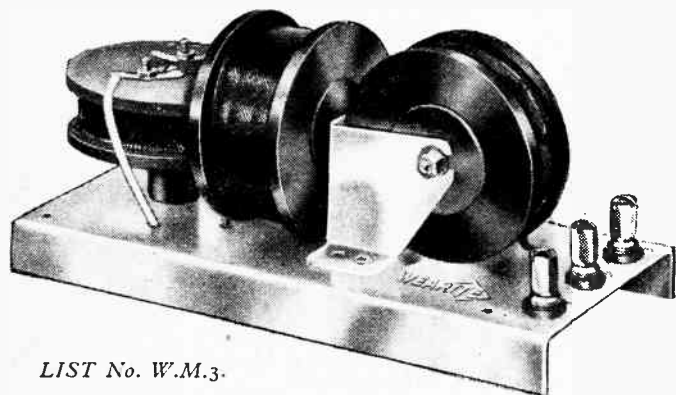

LIST No. W.M.3.

The WEARITE HETERODYNE FILTER

Of the three sectional type this unit is designed to give a sharp cut off at 3,500 cycles and is successfully employed as a Heterodyne Whistle Filter and also as a Scratch Filter
PRICE following a pick-up. Impedance approx. 10,000 ohms. **15/-**

Used in the NEW MONODIAL SUPER-HET

THE original Monodial—one of the outstanding successes of W.W. circuits is brought up-to-date. The designer has again sought the Wearite list of components. Every Wearite product is the result of much experimental work and carries with it an assurance of living up to specification. That is why Wearite were selected for use in the New Monodial.

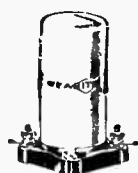

List No. H.F.P.

TWO OF THESE WEARITE H.F. CHOKES (H.F.P.) ARE ALSO USED.

A completely screened H.F. Choke suitable for operation on all wave lengths from 15—2,500 metres. Resistance 300 ohms. Inductance 200,000 M.H. PRICE **3/6** each

Registered Trade Mark.



WRIGHT & WEAIRE LTD.,

740, High Road, Tottenham, N.17.

Phone: TOT 2847/8,9.

Mention of "The Wireless World," when writing to advertisers, will ensure prompt attention;

The Wireless World

THE
PRACTICAL RADIO
JOURNAL
23rd Year of Publication

No. 726.

FRIDAY, JULY 28TH, 1933.

VOL. XXXIII. No. 4.

Proprietors: ILIFFE & SONS LTD.

Editor:
HUGH S. POCOCK.

Editorial,
Advertising and Publishing Offices:
DORSET HOUSE, STAMFORD STREET,
LONDON, S.E.1.

Telephone: Hop 3333 (50 lines).
Telegrams: "Ethaworld, Watloo, London."

COVENTRY: Hertford Street.
Telegrams: "Cyclist, Coventry." Telephone: 5210 Coventry.

BIRMINGHAM:
Guildhall Buildings, Navigation Street, 2.
Telegrams: "Autopress, Birmingham." Telephone: 2970 Midland (3 lines).

MANCHESTER: 260, Deansgate, 3.
Telegrams: "Hife, Manchester." Telephone: Blackfriars 4412 (4 lines).

GLASGOW: 26B, Renfield Street, C.2.
Telegrams: "Hife, Glasgow." Telephone: Central 4857.

PUBLISHED WEEKLY. ENTERED AS SECOND
CLASS MATTER AT NEW YORK, N.Y.

Subscription Rates:

Home, £1 1s. 8d.; Canada, £1 1s. 8d.; other
countries abroad, £1 3s. 10d. per annum.

*As many of the circuits and apparatus described in these
pages are covered by patents, readers are advised, before
making use of them, to satisfy themselves that they would
not be infringing patents.*

CONTENTS

	Page
PROGRAMMES FROM ABROAD, pp. I—XXIV	
Editorial Comment	51
The New Monodial Super ..	52
Practical Hints and Tips ..	57
Phase Difference	58
Unbiased	60
News of the Week	61
Higgs "Super B" Receiver ..	62
Broadcast Brevities	63
Letters to the Editor	64
Laboratory Tests	65
Readers' Problems	66

EDITORIAL COMMENT

Wireless Propaganda *The Risk of International Friction*

MANY times in the past we have referred to the risk which is always present that broadcasting may be used for purposes of propaganda unfriendly to a neighbouring State and completely out of harmony with the B.B.C. motto, "Nation Shall Speak Peace Unto Nation."

Just recently unfortunate incidents have occurred in connection with the Strasbourg station, which has been accused of an unfriendly action of this kind.

Under existing conditions it seems certain that broadcasting stations would be put to use as distributors of propaganda matter immediately if any serious incident occurred to upset the comparatively good relations at present existing between the nations of the world. It is hardly to be hoped that broadcasting could fail to be drawn into the general scheme and utilised as a propaganda instrument in the unhappy event of actual hostilities.

But surely some steps might be taken internationally to guarantee that in times of peace broadcasting stations should avoid issuing any matter calculated to be regarded as deliberately offensive to neighbouring countries. It would indeed be a tragedy if broadcasting, which we regard as a magnificent vehicle for friendly intercourse between nations, should itself come to be the cause of international strife. Broadcasting differs from the Press in that in the majority of countries broadcasting stations are directly under the control of the State and, therefore, the State is liable to be regarded as responsible for the nature of the transmissions where these are concerned with political issues. News-

papers, on the other hand, are generally independent of Government control, and the expressions of opinion which they print are not, therefore, regarded as having the endorsement of the Government of the country.

It would be well for an early attempt to be made to obtain some form of international agreement on this question.

Relay Services

Should They Pick and Choose ?

WHILST touching upon the subject of propaganda and the distribution of broadcast matter, we cannot refrain from drawing attention to the peculiar position of the relay services which have been developed in various parts of the country.

Relay services are apparently left free to pick and choose what items they will from the B.B.C. programmes and programmes from abroad. True, they are not permitted to originate matter of their own, but with so wide a choice as is available to them it is almost equivalent to giving them permission to do so. Again, whilst we have recently had an assurance in the House from the Postmaster-General that relay services are not entitled to receive remuneration for relaying particular programmes, yet, nevertheless, it is a fact that they are in the habit of relaying programmes from stations outside the B.B.C. control and sponsored by advertisers.

It is difficult to understand why a policy laid down by the Postmaster-General to be observed by the B.B.C. should not be equally applicable to relay services, and the question of whether or not the relay services receive payment for the retransmission of sponsored programmes seems to us to be only a minor point in a question of general principle.

The New Monodial Super

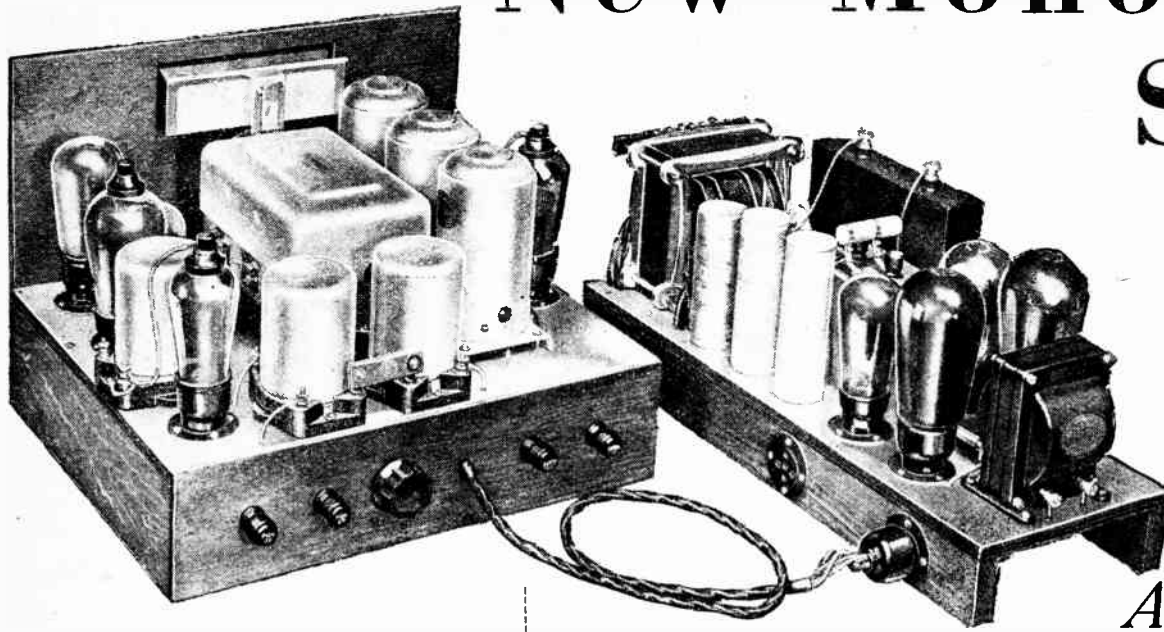

Constructing
and Operating
the New
Superheterodyne

THE receiver is constructed on a chassis built of aluminium covered plywood, which may be obtained ready built with the large holes drilled. With the exception of the valveholder for the Pentagrid, the valveholders are all mounted with their main bodies on the upper side of the base, and their legs projecting through large diameter holes. No British Pentagrid valve is as yet available, and the valve specified is of American origin, and is fitted with an American type 7-pin base. Consequently, an American valveholder is necessary, and this cannot readily be mounted in the same manner as the others. This valveholder, therefore, is mounted on the underside of the chassis, and the hole in the base is large enough to accommodate the base of the valve.

When wiring up the circuits of this valve it should be remembered that the control grid is mounted on the top of the bulb, not the anode, as in British valves. There is no terminal on the valve, merely a metal boss, and for the connection it is necessary to use the special clip provided. The valve is rated for a heater potential of 2.5 volts at 0.8 ampere, so that it is necessary for a resistance to be included in its heater circuit. This resistance R3 has a value of 2 ohms, and the actual heater potential is slightly under 2.5 volts.

Checking the Operation

Apart from these points, the construction is entirely straightforward, but it should be noted that it is necessary for the base to be cut away slightly to accommodate the volume control. In most places the wiring is carried out with No. 22 tinned copper wire run in small diameter sleeving, and in certain cases screened leads are used. It is important that the screened sleeving be of the type specified or of similar characteristics, and that the internal wire be no heavier than

A FULL account of the theoretical side of the new superheterodyne appeared in last week's issue of "The Wireless World," while constructional details and initial adjustments are dealt with in the present article. In spite of the exceptionally high performance of which the receiver is capable, these operations are essentially simple and need occasion no difficulty even to the inexperienced.

By W. T. COCKING

No. 22 gauge. Thick rubber-covered metal braided wire or motor car type armoured cable must not be used.

The inter-unit cable must have two heavy members for the heater current, and if an excessive voltage drop is to be avoided these must be of at least 70/36 gauge and no longer than 30in. The speaker connections will depend upon the type of loud speaker used, and six alternative arrangements are shown in Fig. 1. The output transformer employed is of importance if the best results are to be obtained; it should have a primary inductance with no D.C. of not less than 60H, and be of such ratio that the average

primary impedance is about 10,000 ohms. With Magnavox dual speakers this calls for a ratio of 112-1, and with Rola dual speakers a ratio of 100-1. A single Magnavox speaker, however, would call for a ratio of 79-1, and a single Rola a ratio of 70-1; the B.T.H. R.K. Senior speaker needs a ratio of 25.8-1, and the Ferranti M.1 a ratio of 25-1.

When the set has been switched on for a quarter of an hour or so the various voltages and currents should be checked over to make sure that they are reasonably in accordance with the figures of the Table given herewith. Any wide discrepancy would indicate a defect in the receiver or a valve,

TABLE.

Valve.	Meter Reading.			True Voltage.			Current.	
	Anode Volts.	Screen Volts.	Grid Volts.	Anode Volts.	Screen Volts.	Grid Volts.	Anode Current. mA.	Screen Current. mA.
H.F. VMS4.....	200	58.5	- 1	200	68	- 1.03	7.3	1.7
Freq. Chan. 2A7:								
Tetrode.....	200	58.5	- 1	200	68	- 1.03	2.25	1.45
Osc.....	87	—	—	168	—	—	1.6	—
L.F. VMS4.....	200	58.5	- 1	200	68	- 1.03	5.2	1.1
2nd Det. DD Pen.	23.5	83	- 1.9	24	116	- 1.3	8.95	4.2
L.F. MHL4.....	184	—	- 5.5	184	—	- 5.85	5.85	—
Output PX4:								
1.....	270	—	- 35	270	—	- 38	38	—
2.....	270	—	- 36	270	—	- 40	40	—

Volts across C31 .. 460 volts.
C30 .. 443 volts.
C29 .. 280 volts.
C28 .. 200 volts.

Total measured current through Ch4 = 118 mA.

All readings taken with Avometer, mains voltage 240 volts connected to 240 volts tapping on transformer, set tuned to no signal. The columns headed True Voltage are corrected for the load imposed by the meter in the measured voltage columns.

The New Monodial Super—

but no notice need be taken of a general rise or drop in voltages by some 10 per cent., since this may be due merely to the mains voltage being different from its rated value. Such a change in voltage, of course, would be accompanied by a similar, although usually smaller, change in current; low voltages accompanied by abnormally high currents or high voltages with low currents would show a defect in the receiver.

Preliminary Adjustments

Having made certain that the operating conditions are in order, it remains to carry out the initial adjustments of trimming and ganging, and here a milliammeter connected in the anode circuit of the DD/Pen. at the point "X" is of great service. The meter should give a full scale deflection for 10 mA. or 12 mA. At first, the I.F. coil couplings should be set fairly close together, and in any location it should be found possible to obtain some signal; this should be tuned in as accurately as possible, and the I.F. adjustments proceeded with.

The I.F. couplings should next be loosened as much as possible without completely losing the signal, retuning if necessary, and the coil cans replaced. Each I.F. trimmer must then be adjusted for maximum response. Some trimmers will be more critical than others, but a definite optimum setting on each should be obtained. If the signal is weak this adjustment must be carried out by ear, for the meter deflection will be too small

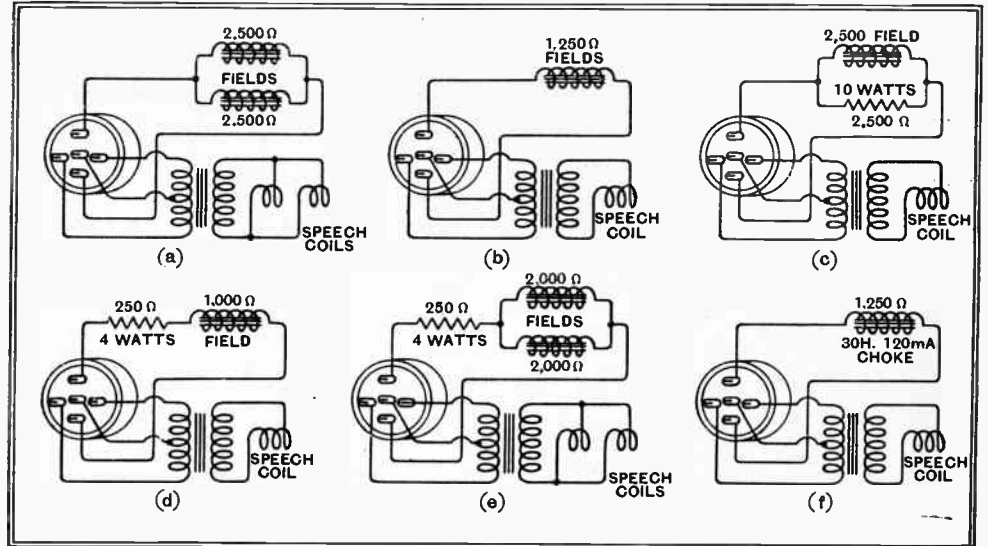

Fig. 1.—The various speaker connections for different cases are illustrated, at (a) for dual speakers with 2,500-ohms fields, at (b) for a single 1,250-ohms speaker, at (c) for a single 2,500-ohms field, at (d) for a single 1,000-ohms field, at (e) for dual 2,000-ohms speakers, and at (f) for a non-energised speaker.

to be observed. With a strong signal, however, the meter is essential, for, owing to the action of A.V.C., the ear is not sufficiently critical. A really accurate adjustment can only be obtained with the aid of the meter and with a strong signal.

When a rough preliminary adjustment of the I.F. trimmers has been obtained in this way the coil couplings should receive attention. Each coil coupling must be set for maximum signal strength, whether judged audible or by the change of current indicated by the meter. The I.F. cir-

cuits are now roughly adjusted, but, before paying great attention to their precise adjustment, it is as well to make sure that their frequency is correct.

The Final Ganging

The input circuits should, therefore, next be roughly ganged. The oscillator trimmer should be set to about one-half of its capacity and a very low wavelength station tuned in. The two pre-selector trimmers should then be adjusted for maximum response; in general, that on C₂ will have to be nearly fully screwed home, and that on C₁ nearly fully unscrewed. A station on some 500 metres should next be found, and the oscillator trimmer adjusted while rocking the tuning dial backwards and forwards over a few degrees until the optimum combination of settings be found. A return should then be made to the low wavelength station, and the two pre-selector trimmers readjusted. The I.F. frequency can now be checked. If all is in order, a whistle should be heard when receiving a station on a frequency 220 kc/s lower than that of the local station. Thus, in the London area, a whistle will be found on North Regional due to second channel interference from the London Regional. The frequency of the latter station is 843 kc/s and that of the North Regional is 625 kc/s; the difference is 218 kc/s; consequently, when tuned accurately to North Regional with a 110 kc/s intermediate frequency, the whistle would have a frequency of 2,000 cycles. Its note, however, will vary with the setting of the tuning dial. Another similar whistle will be found between Breslau and Goteborg, due to second channel interference from the London National. Even if other whistles are present at this stage, the particular ones due to second channel interference can readily be picked out owing to their strength.

If the second channel whistle is from 215 to 225 kc/s lower than the frequency of the local station, the I.F. adjustment can be taken as correct, but if it be found

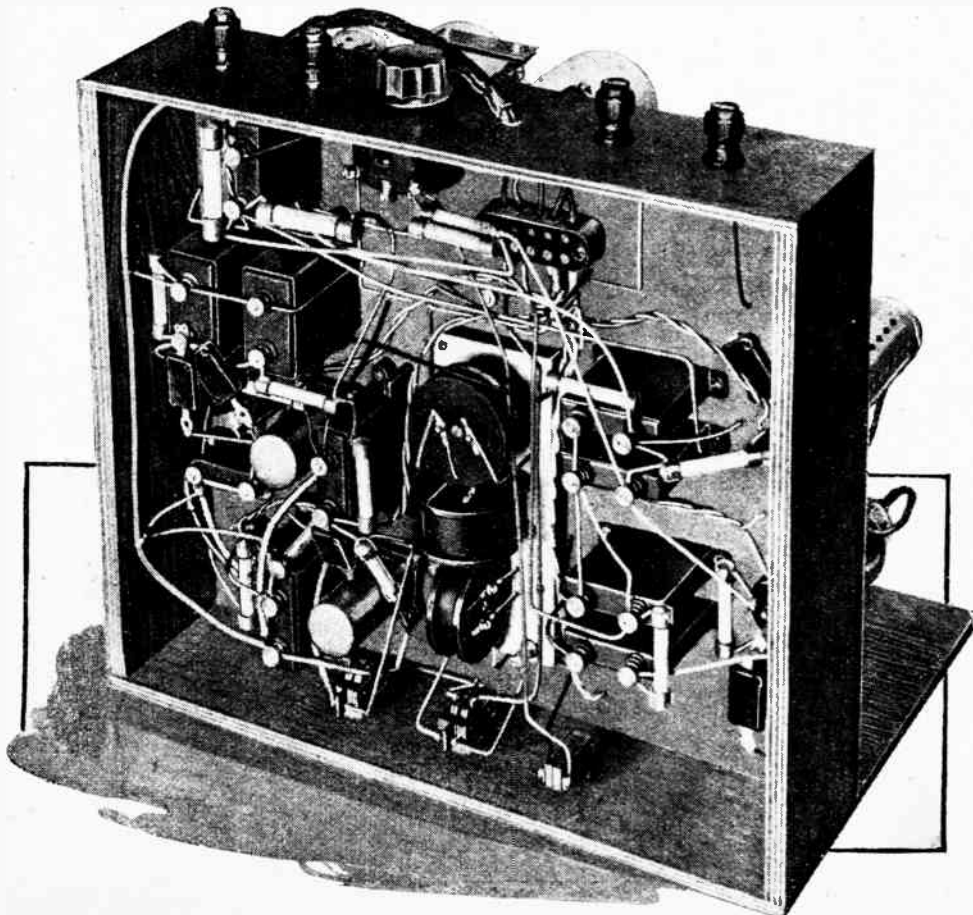

The low-pass filter can be seen in the centre of the chassis, above its controlling switch.

The New Monodial Super—

to occur at some other frequency, all the I.F. trimmers must be appropriately altered. Thus, it is not uncommon to find that the whistle occurs on Brussels No. 1 in the London area. This means that the intermediate frequency is 127 kc/s, and is too high for accurate ganging to be maintained. The frequency must be lowered by increasing the capacity of all I.F. trimmers, and this is accomplished by rotating the adjusting wheels all in an anti-clockwise direction when viewed from above.

Full-size blue print of this receiver, including the power unit, is available from the publishers at 1s. 6d., post free.

When the correct frequency has been obtained, a strong signal should be tuned in so that the meter needle is deflected by several milliamperes and a change in current is easy to detect. Each trimmer can then be accurately adjusted for maximum change in current, and the couplings readjusted for the same condition. The ganging can then be similarly readjusted, using the meter as an indicator, and no difficulty should be experienced with a good aerial in obtaining a large deflection even in daylight from such stations as Fécamp and Brussels No. 1. As before, the adjustment on the low wavelength station is to the pre-selector trimmers, and is for maximum response, as indicated by maximum change of current on the indicating meter. On the high wavelength station the oscillator trimmer is adjusted while rocking the tuning dial for the best combination of settings. After this adjustment it is always necessary to return to the lower wavelength, and retrim the two pre-selector circuits.

Long-wave Ganging

When the medium waveband ganging has been completed, attention can be paid to the long-wave adjustment. This is only to the padding condenser C4; the tuning dial should be set to about 60° and C4 adjusted until Daventry National is heard. Huizen should then be receivable at a higher dial setting, and C4 can be adjusted while rocking the tuning dial backwards and forwards until the optimum combination of settings is found.

The adjustments are now completed, and the receiver can be tested. The manual volume control will be found to give a smooth and gradual change of volume from maximum to minimum; the latter is very low, but does not represent complete extinction of the signal. The A.V.C. system should hold all stations at the same volume as set by the manual control, except those which are too weak to bring the control into action and those which employ a different level of modulation from the usual. These include many French stations, and it will usually be found that Radio Paris in particular is received at greater strength than other

stations, because its average modulation depth is greater. The volume variations of fading should be entirely absent, except when it is so severe as to amount virtually to complete extinction of the signal.

The Switches

Background hiss should prove negligible on all but the weakest of signals with any reasonably good aerial, and the sensitivity is normally sufficient to provide full loud speaker volume from any station stronger than the generally prevailing mush level. With the switch S3 in the upper position, the quality of reproduction should be really first class, and the lowest and highest frequencies fully represented. With the switch in the lower position, the high-frequency response will be restricted to 3,500 cycles, and the quality will deteriorate, although not as much as one might expect. Indeed, on certain transmissions in which there is only a small amount of the upper register, it is difficult to detect any change in quality. True sideband heterodyning will normally be completely absent with the switch in this position.

The maximum volume obtainable on both radio and gramophone is sufficient for all normal requirements, and for ordi-

nary domestic use, where the volume control will be somewhat retarded, there should be a complete absence of overloading effects on even the loudest passages. On gramophone, it should be noted, the low-pass filter can still be used if desired, and here it will serve to remove all traces of needle scratch.

The purpose of the switch S1 and the resistance R9 have yet to be explained. The normal condition of the receiver is with this switch closed, and the sensitivity is then at its maximum. As a result, the process of tuning is apt to be rather noisy; the maximum sensitivity of the set is exceptionally high, and with the switch closed is always present when the set is not tuned to a station. Atmospherics and local interference, therefore, present an annoyingly strong background. As the set is tuned into a station the sensitivity decreases, but it is still abnormally high until exact resonance is obtained. While tuned to the sidebands, therefore, distorted reproduction is found. For correct results it is essential that the tuning be really accurate, and it is a help, therefore, if the meter at "X" be left permanently in circuit to serve as a tuning indicator; it is by no means essential, however, for

PRACTICAL WIRING DIAGRAM

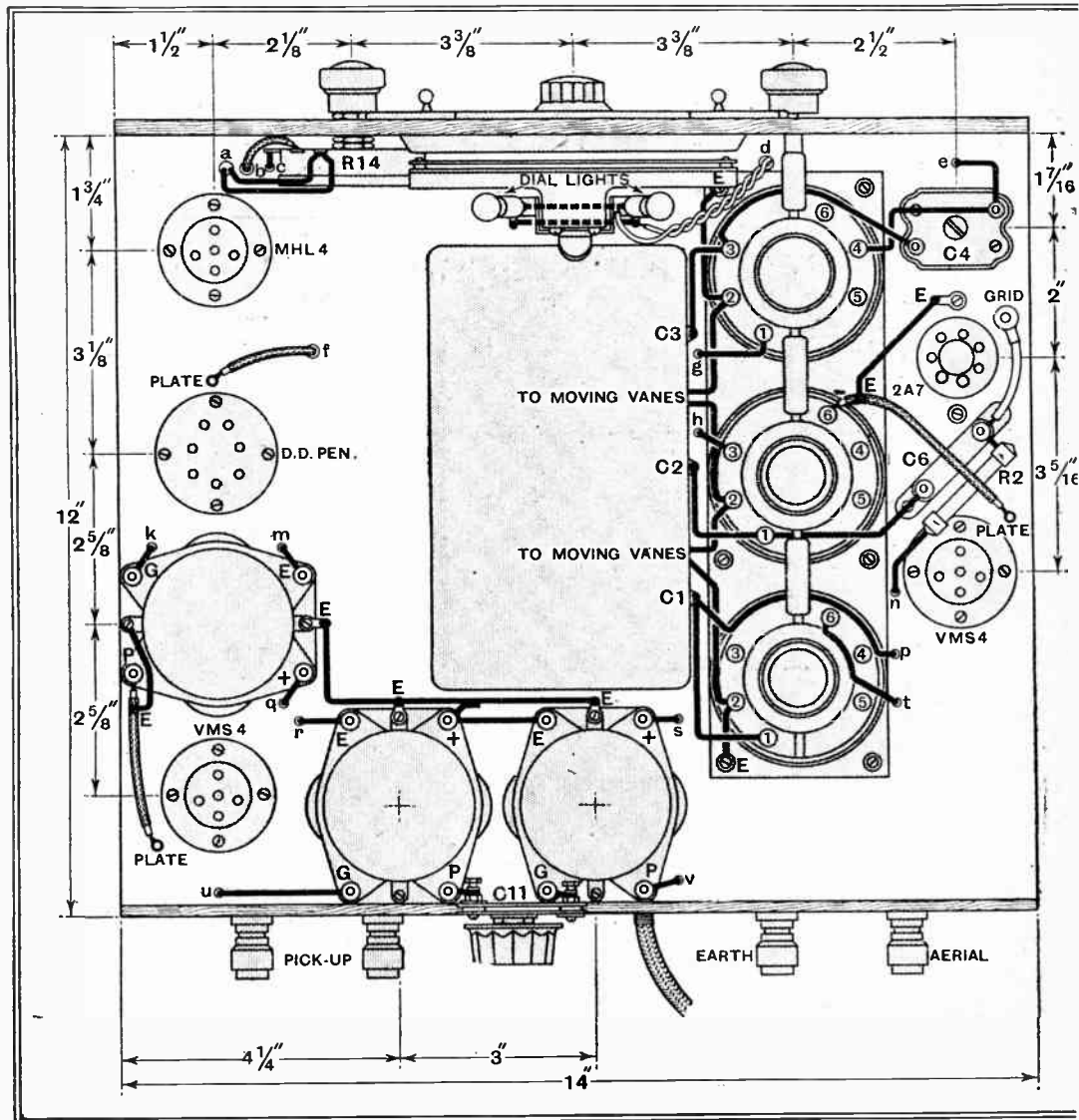

The layout of components and wiring in the receiver unit is readily appar

The New Monodial Super—

it is quite easy to arrive at the correct condition by ear.

It will be evident, therefore, that during the process of tuning a reduction in the maximum sensitivity is desirable. This is achieved through the use of R₉. With the switch S₁ open, R₉ should be adjusted so that the background found with the set not tuned to a station is as loud as can be comfortably tolerated. During tuning, therefore, the switch is kept open, and nothing louder than the predetermined level will be found. When a station is tuned in, the switch can be closed; if the station is strong there will be no change in apparent volume owing to the A.V.C. system, but there will be a change in the meter reading. If the station is weak, of course, volume will increase. Although there will be no change of volume on closing the switch with a strong signal, it is advisable to do so in case the station starts fading, for if the switch be left open A.V.C. may fail to compensate fully for fading.

The second use of the switch is for local reception. The A.V.C. system will hold the output constant provided the input to the H.F. valve does not exceed about 1 volt; when the set is used with a good

aerial close to a local station, however, some 5 volts or more may be found on the first valve, and the valves may be-

come overloaded. It is usually the I.F. stage which overloads and makes it

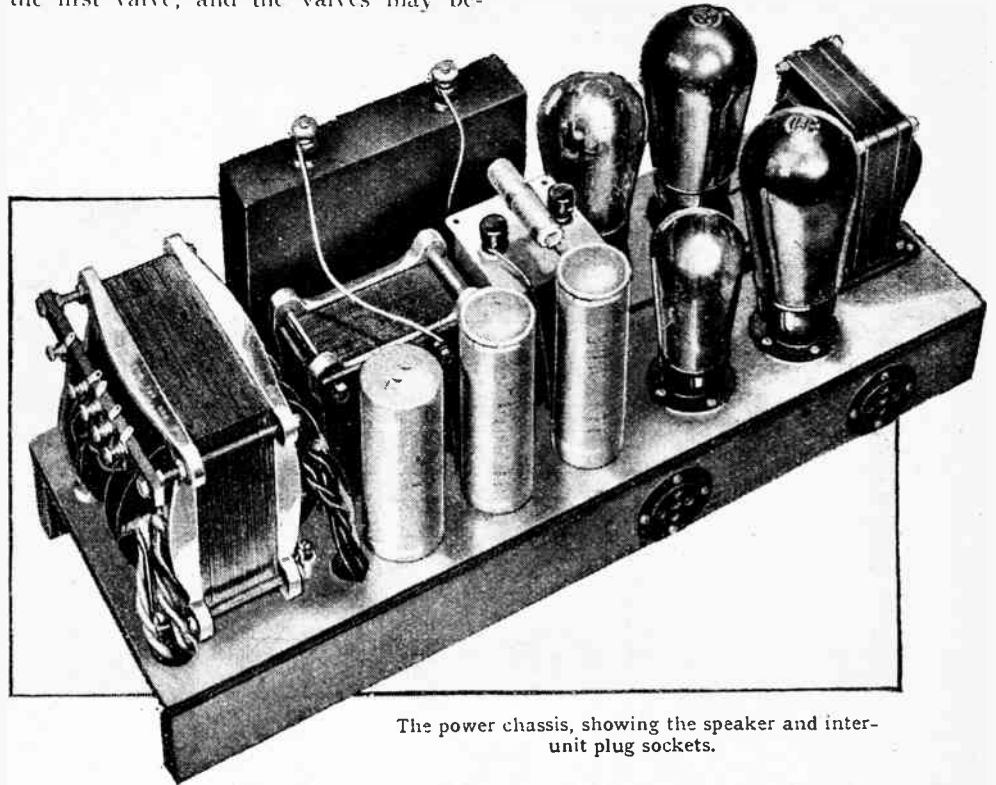

The power chassis, showing the speaker and inter-unit plug sockets.

THE NEW MONODIAL SUPER

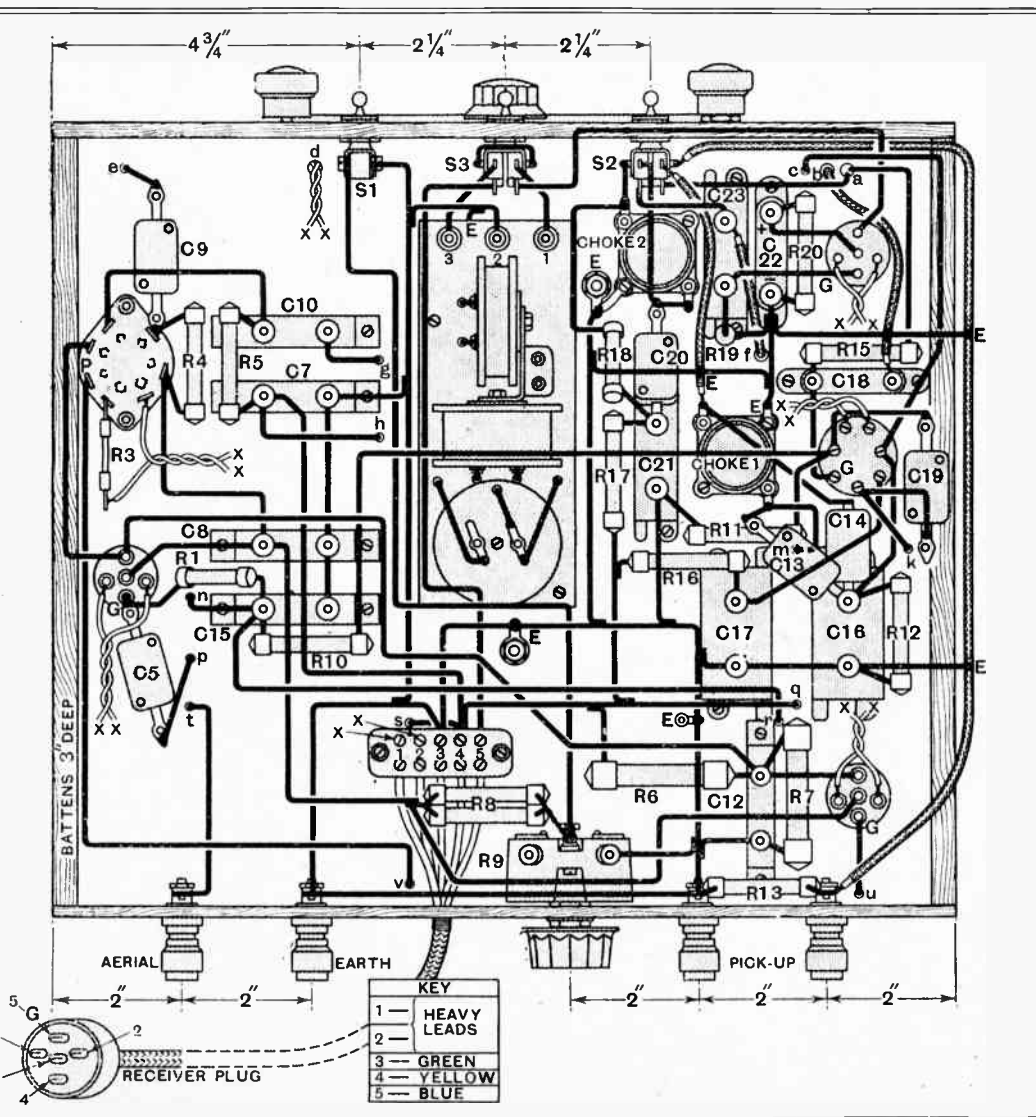

it will be noted that a minimum of leads passes through the base.

impossible for the A.V.C. system to provide sufficient bias voltage. Should it be found, therefore, that reproduction from the local station is distorted with the switch S₁ closed, it should be opened and R₉ should be adjusted to such a value that good quality is secured. This point will usually be just short of that at which it begins to have an effect upon the volume.

Every station which is separated from its neighbours by 9 kc/s or more should be receivable without interference, and if use be made of the switch S₃ even stations separated by 5 kc/s can be made to give enjoyable results. The dial settings are bound to vary somewhat with different sets owing to variations in the components, so that little purpose would be served by giving a list of dial settings. In general, however, they will be similar to those of the original Monodial A.C. Super,¹ and the list given for this may be taken as a rough guide. The tuning range has been measured, and was found to be 1,500-525 kc/s and 395-145 kc/s, corresponding to 200-570 metres and 760-2,060 metres.

Mounting the Receiver

The question of cabinets for this receiver has been left to the choice of the constructor, since this is a matter in which personal preference counts for more than technical merit. It may be mentioned, however, that suitable types are obtainable from a number of firms, including Peto-Scott Co., Ltd., and The City Accumulator Co., Ltd.

If the cabinet selected be arranged to include both set and speaker it is wise to mount the receiver chassis upon rubber

¹ *The Wireless World*, April 13th, 20th, and 27th, 1932.

The New Monodial

Super-

cushions, otherwise acoustic reaction from the speaker may cause a low-frequency resonance, or even a sustained howl. An absorbent mounting is easy to arrange by resting the receiver chassis on blocks of sponge rubber so that it can float freely. A gap must, of course, be left between the panel and the cabinet, and this may well be filled with rubber to exclude dust. The precise method of mounting must obviously vary in different cases, but it is usually easy to arrange an absorbent support which is fully effective in eliminating the effects of feed-back.

The choice of a loud speaker is a matter of some importance, but one which is too lengthy to enter into here. It is hoped to deal with this matter in a further article, therefore, and in the meantime it is sufficient to stress the importance of securing a type capable of giving a uniform and wide frequency response, and also able to handle an input of some 6 watts without causing harmonic distortion. A point often overlooked, but not without importance, is the power rating of the output transformer, and here again this must be for 6 watts.

In connection with the table of voltages, it should be mentioned that the columns headed Anode Volts refer to the voltage measured between the chassis and the anode terminal of the valve in question. The bias voltage is measured between chassis and cathode, so that the reading obtained for anode voltage is really the sum of the true anode and the bias voltages. This accounts for the figure of 270 volts for the P.X.4 valve. The actual anode voltage, of course, is $270 - 38 = 232$ volts, which is well within the maker's rating.

It should be noted that the control knobs supplied with the various components do not all match. For the sake of a neat finish, therefore, it may be considered advisable to obtain uniform knobs for the volume and range change controls.

A receiver built to this design is available for inspection at 116/117, Fleet Street, London, E.C.4, and will later be on view at "The Wireless World" Stand at the Olympia Radio Show, August 15th to 24th.

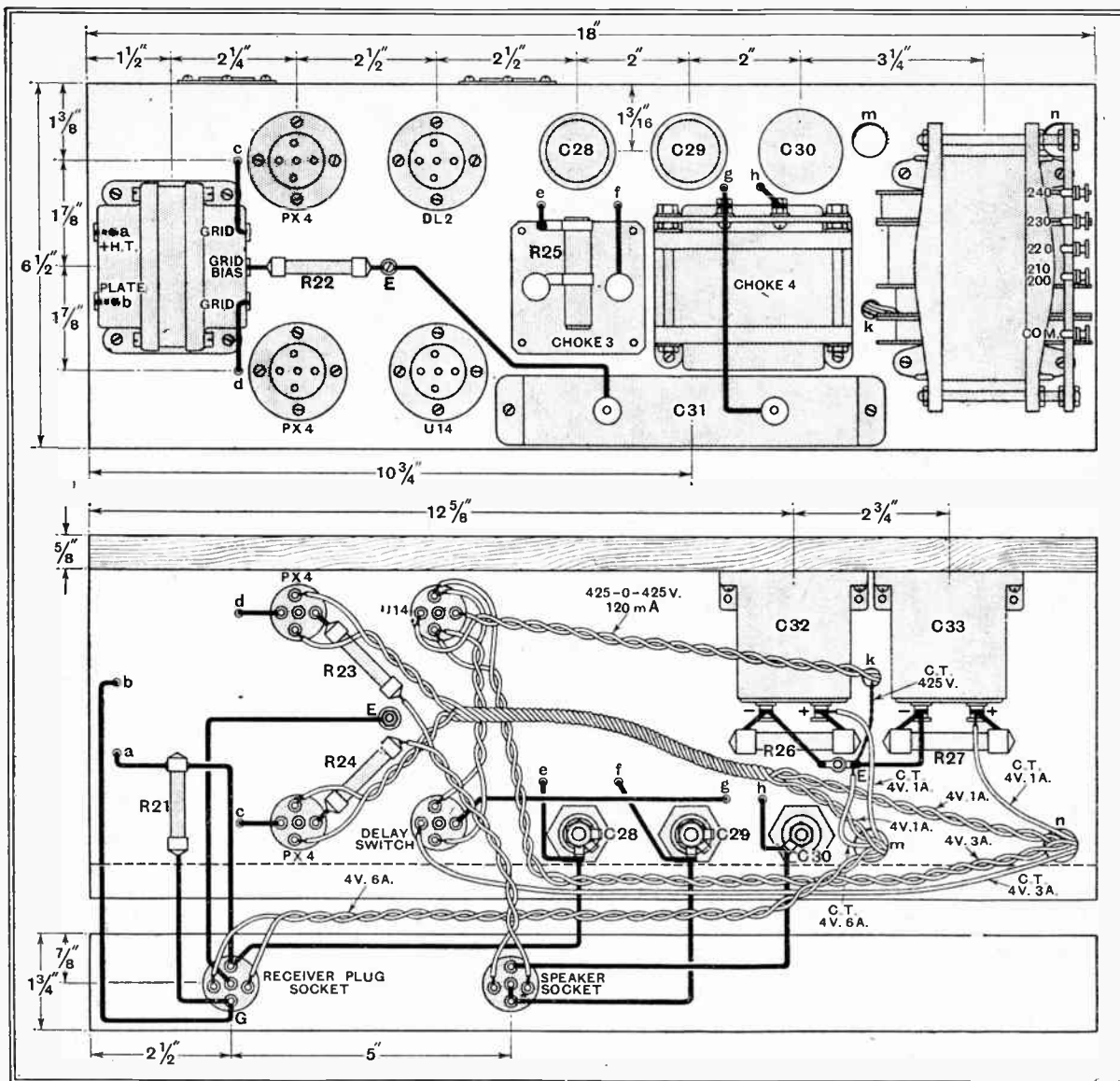

The wiring of the power unit is straightforward, but care should be taken to connect C32 and C33 with the correct polarity.

Those used in the original receiver were the Bulgin types K13 and K14.

BOOK REVIEW

TELEVISION TO-DAY AND TO-MORROW.
By Sydney A. Moseley and H. J. Barton
Chapple. Sir Isaac Pitman and Sons, Ltd.,
London, 1933. Price 7s. 6d. net.

The third edition of this book, which deals in a popular way with the subject of television, mainly from the standpoint of the Baird system, may be said to represent a retrospect of the subject and a record of the achievements of Mr. Baird rather than a forecasting, in any great measure, of the lines on which future developments are likely to occur.

The emphasis, in fact, is throughout upon "yesterday" rather than "to-morrow," and, though it is natural to suppose that Mr. Baird and his collaborators have a great deal more up their sleeves than it would be politic for them to divulge, it is a matter for some regret that, in a book which purports to deal with the subject as a whole, so little is said with regard to the broad issues involved in any attempt to improve the quality of the picture.

Television has now become an accepted fact, and there is no doubt that on this account we are mainly indebted to the genius of Mr. Baird and the energetic way he has

pursued his object. By the results he has achieved he has, to a large extent, confounded those of his critics who denied that anything of practical interest could be transmitted within the restricted band of frequencies dictated by present practical considerations. The eye has, in fact, been proved to have the same tolerant characteristics as the ear, and this circumstance, combined with the ingenuity displayed by those responsible for the transmissions in selecting suitable subject matter, has made possible the broadcasting of combined sound and vision of genuine entertainment value.

At the same time, it is abundantly clear that matters cannot stay as they are, and the whole difficulty of television lies in the fact that any material improvement of the results at present obtainable calls for an increase in the number of "picture lines," and, in consequence, a complete re-vision of the transmitting conditions. Any consideration of the "to-morrow" of television which passes over the necessity for more "lines" and the difficulties involved in providing them must, of necessity, be partial, and for this reason, if for no other, we would have welcomed any revision of this interesting and well-written book, which, while not necessarily ignoring the glories of the past, gave greater emphasis to the problems of the future and the manner in which these were to be solved.

P. W.

Practical HINTS and TIPS

AIDS TO BETTER RECEPTION



SPEED WITH CERTAINTY. A new Columbia Q.P.P. receiver undergoing tests. All circuits are checked in one operation with the help of an array of meters.

It should also be remembered that, when the converter is operated with a set having ganged tuning, the removal

of the aerial from its normal position and the substitution of a converter may bring about a change in the stray capacities of the circuit to which the aerial was originally connected. A slight readjustment of the trimming condenser associated with this condenser should therefore be tried.

ALMOST everyone knows by now that, when modifying a receiver design, instability may be introduced by taking liberties in the rearrangement of the purely H.F. components. But, so far as the L.F. amplifier is concerned, almost the only possible ill-effect of making a change is to introduce hum, which is likely to be brought about by an unsuitable position of the L.F. transformer in relation to the power supply equipment of a mains set.

In a superheterodyne, the intermediate frequency amplifier may be regarded in very much the same way as the L.F. part of the set, and, as a rule, it may be altered quite freely without untoward effects. This is due, of course, to the relatively low frequency, and to the fact that most modern I.F. amplifiers have but a single stage.

MOST constructors of highly sensitive sets, and particularly of superheterodynes, have encountered a form of L.F. howling which is due to acoustic reaction between the loud speaker and the vanes of a section (generally the oscillator section) of the tuning condenser. It is not generally recognised that this form of

undesirable reaction may produce a bass resonance without being strong enough to cause audible howling. Distortion introduced in this way is particularly disturbing, and is none too easy to trace.

The usual remedy is to insulate mechanically the whole tuning condenser assembly, including the drive mechanism from both the chassis and the control panel. Most modern condensers are constructed in such a way that it requires little ingenuity to devise an insulating system which will be quite as effective; usually an arrangement of rubber bushes or rubber packing pieces can be employed successfully.

Finally, it may be pointed out that the addition of a short-wave converter to a superheterodyne receiver seems to provoke this trouble. The probable cause is additional acoustic feedback to the condenser of the short-wave unit, which accordingly should be shielded or mechanically insulated if the trouble is suspected.

IN the "Hints and Tips" page of last week's issue there was described an extremely simple, but often very effective, type of H. F. stopping filter, which is intended to keep stray H.F. currents in the mains out of the receiver circuits.

The arrangement discussed is especially applicable to D.C. mains, but may sometimes be used with advantage with A.C. supplies.

It will sometimes be found that, instead of connecting the by-pass condenser directly across the mains, as originally shown, it is distinctly better to earth one side of it, as indicated in Fig. 1. Generally speaking, it will be sufficient to make the connection to the normal receiver "earth," but occasionally the use of a separate local earth is beneficial.

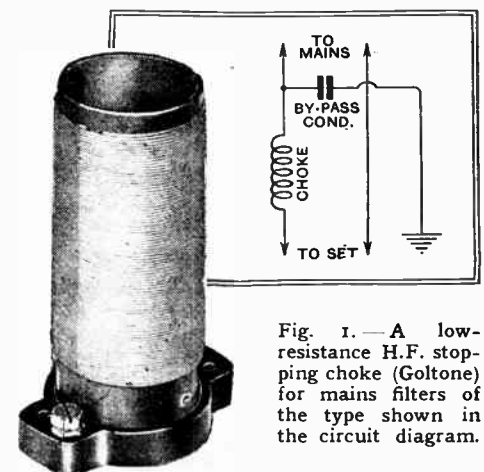

Fig. 1.—A low-resistance H.F. stopping choke (Goltone) for mains filters of the type shown in the circuit diagram.

The benefits of the alternative system of connection now under discussion are especially likely to be felt when the receiver earth is none too efficient; the great advantage is that interfering H.F. energy is by-passed quite clear of the receiver.

UNTIL recently, ganged condensers were not matched to a common standard. The various sections of each specimen were adjusted to have the same capacity at various angular settings, but there was no guarantee that these capacities

Linking Ganged Condensers

would be the same as those of another condenser of the same make.

As a result, it was most unlikely that, for example, two 2-gang condensers could be linked together mechanically and be used successfully for controlling a four-circuit single-control receiver.

Improved manufacturing methods have brought about a change, and at least one manufacturer now makes a practice of matching all condensers to the same standard. As a result, it becomes possible to link condensers in this way, but this practice should never be followed without the maker's assurance that his condensers are suitable.

THOSE readers who are using short-wave converters of the superheterodyne type in conjunction with a normal "straight" broadcast set will generally find that it pays to take a little trouble to ascertain the best operating conditions

Operating Short-wave Converters

for the set itself when its H.F. amplifier is converted temporarily into an I.F. amplifier for this special purpose.

Generally speaking, it will be best to work on the long waves, for the reason that a lower percentage detuning of the frequency changer will be necessary in order to get the right beat frequency.

The longer the wavelength, indeed, the greater the efficiency of the arrangement. This is fortunate, because it happens that many "straight" sets give maximum amplification at a wavelength of about 2,000 metres.

PHASE DIFFERENCE

When Alternating Quantities are Out of Step

By S. O. PEARSON, B.Sc., A.M.I.E.E.

WHEN dealing with two alternating quantities of the same frequency, such as the voltage and current in a circuit, it is necessary to know not only their R.M.S. values or their peak values, but also the extent to which the two waves representing them are out of step. For instance, if a sine-shaped E.M.F. wave is applied to a pure resistance it is readily appreciated that the current is at every instant proportional to the value of the E.M.F., according to Ohm's law. Consequently the current wave will be one of exactly the same shape, and it will pass through its maximum positive values simultaneously with the E.M.F. wave, and the two waves will pass through their zero values at the same instants, as shown in Fig. 1. Two waves which are exactly in step like this are said to be *in phase*, there being no relative displacement, or *phase difference*, between them.

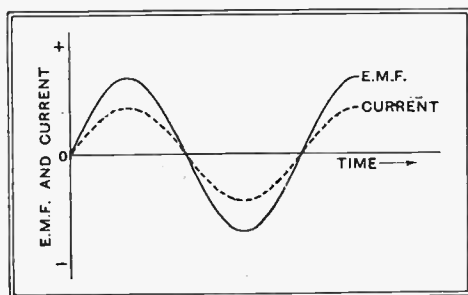

Fig. 1.—Sine waves which are in phase with each other plotted to a time base.

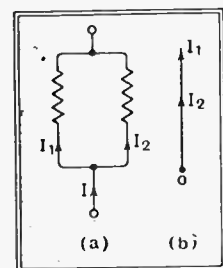

Fig. 2 (a).—A circuit with two pure resistance branches taking currents I_1 and I_2 in phase with each other. The corresponding vectors are shown at (b).

An alternating current is one which is changing in value from instant to instant, and therefore has no fixed values, but it fluctuates between two definite equal values in opposite directions round the circuit, the maximum, or peak, value in each direction being known as the amplitude of the wave. Now an A.C. ammeter gives a steady reading in one direction, this reading being the effective or R.M.S. value of the current. The effective value is equal to the value of the direct current which would have the same average heating effect in a given fixed resistance. It is called the Root Mean Square value because it is equal to the square root of the mean of the squares of all the instantaneous values. For a sine wave of current the R.M.S. value is 0.707 of the maximum value, and this relationship applies to a sine wave of any other quantity, such as voltage.

Because the R.M.S. value of an alter-

nating quantity is equivalent to a constant number, such a quantity, for example, current or voltage, can conveniently be represented by a straight line, called a vector, whose length is made to represent the R.M.S. value to some suitable scale; for instance, a current whose R.M.S. value is 2 amperes can be represented by a straight line two inches long, one inch representing one ampere.

It would appear that, by the adoption of the R.M.S. value (or value of the equivalent direct current) to represent the useful magnitude of an alternating current, all question of time and direction had been eliminated. But this is only true when applied to a single current without reference to any other currents and voltages in the circuit. For instance, the sine waves representing two alternating quantities may be in step as in Fig. 1, or out of step as in Fig. 4 (a), and the question arises as to how the two vectors representing the individual quantities can be made to indicate clearly whether they are in step or not, and if not, the extent to which they are out of step, or *out of phase*. To do this it is necessary for each vector to indicate not only the R.M.S. value of the corresponding alternating quantity but also the passage of time.

What the Vector Shows

This is accomplished by assuming that each vector is rotating about one end, like the spoke of a wheel or the hand of a clock, with constant speed. And the speed is such that the vector makes one complete revolution in the counter-clockwise direction during each cycle of the alternating quantity it represents. For this reason one cycle of a sine wave corresponds to 360 degrees, and sine waves are conveniently plotted to an angle base rather than a time base. A quarter of a cycle then corresponds to 90 deg., and so on. The speed of the vector in revolutions per second is equal to the frequency in cycles per second.

Now when there are two alternating quantities of equal frequency they will be represented by two respective vectors, each rotating at the same speed, and so the angle between these two vectors will be a fixed one, just as the angle between two

WHEN calculation has to be made with alternating currents and voltages, it is not enough to know just the amplitude of the waves. There is the question of the extent to which the waves are out of step. In the case of sine waves this can conveniently be expressed in terms of an angle as explained in the accompanying article.

spokes of a wheel is constant. It is this fixed angle between two rotating vectors which represents the phase difference between the two corresponding alternating quantities.

Application to Circuits

When two non-inductive or pure resistances are connected in parallel to a source of A.C. supply, as in Fig. 2 (a), each will take a current in phase with the voltage, and the currents will therefore be in phase with each other. If I_1 and I_2 are their R.M.S. values, the vectors representing them will be as shown in Fig. 2 (b) by OI_1 and OI_2 respectively. Since there is no phase difference between the currents there is no angle of inclination between the vectors—that is to say, the two vectors are parallel to each other, and so coincide. The total current is in this case simply equal to the sum of the individual R.M.S. currents, being in phase with them. Simple addition in this manner is only permissible where the two alternating quantities are in phase with each other.

Now let us consider a branched circuit such as that of Fig. 3 (a), where the branch currents I_1 and I_2 are out of phase by a quarter of a cycle. The same voltage E is applied to each branch. The current I_1 , taken by the pure resistance branch, is exactly in phase with the voltage, and therefore the corresponding current vector OI_1 , in Fig. 3 (b), coincides with the voltage vector OE , as shown. Now a condenser takes a current which *leads* the voltage by exactly a quarter of a cycle, and so the corresponding vector OI_2 will

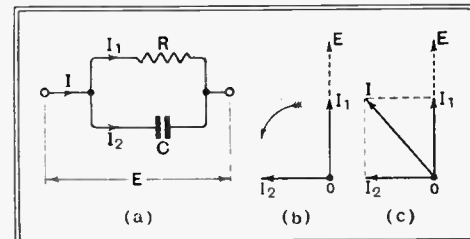

Fig. 3.—A branched circuit taking two currents a quarter of a cycle, or 90°, out of phase. The corresponding vectors are shown at (b) and the method of finding the total current is indicated at (c).

be a quarter of a revolution *ahead* of the voltage vector. The current is said to lead the voltage if it reaches its maximum positive value before the voltage. Since the vectors are assumed to be rotating in the

Phase Difference—

counter-clockwise direction, it follows, in this case, that the condenser current vector OI_2 will be drawn at right angles to the voltage vector *to the left*, so that as they rotate OI_2 is 90° in advance of OE and OI_1 .

Maximum Current Values.

When two sine waves are out of phase by a quarter of a cycle, or 90 degrees, one is always passing through a zero value when the other is passing through a maximum value, and from this it follows that the maximum values never occur simultaneously. Consequently, the maximum value of the total current is bound to be less than the sum of the maximum values of the individual currents, and similarly for R.M.S. values. Actually, the total current is found by completing the

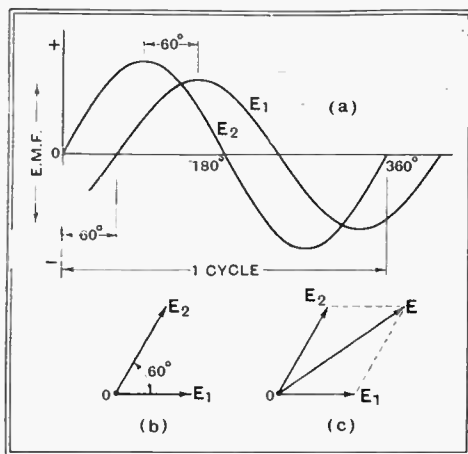

Fig. 4.— Showing how two waves out of phase by $\frac{1}{6}$ of a cycle, or 60° , are represented by two vectors mutually inclined at 60° . The sum is found by the parallelogram method as at (c).

rectangle $O I_1 I_2$, as in Fig. 3 (c). The diagonal OI then gives the total current I to the same scale as the other current vectors. OI may be found by measurement, or may be calculated. (In this case the total current is $I = \sqrt{I_1^2 + I_2^2}$.)

In a more general case the two alternating quantities may be out of phase by some odd fraction of a cycle. For instance, suppose that two alternating voltages E_1 and E_2 in series are out of step by one-sixth of a cycle, as shown by the curves of Fig. 4 (a), then the angular displacement between the two vectors OE_1 and OE_2 representing them would be one-sixth of a revolution, namely, one-sixth of 360 degrees, or 60 degrees, as shown in Fig. 4 (b). The sum of these two voltages is then found by completing the parallelogram $O E_1 E_2$, as in Fig. 4 (c), and measuring or calculating the length OE of the diagonal.

ON THE SPOT Visits to Foreign Broadcast Stations

IX. Cologne-Langenberg

635 kc. 472.4 m. 60 kW.

MENTION of Cologne-Langenberg always recalls to me the afternoon on which I was privileged to broadcast from that station, and I am still thrilled at the thought of that imposing array of clean tumblers and the big jug of fresh water all carefully aligned for me at the microphone desk.

The Cologne Broadcasting House, which serves the Langenberg transmitter, was the first of its kind in Germany. It stands at the corner of the Dagobertstrasse, and, although it was not actually built for broadcasting purposes, Westdeutscher Rundfunk were the first tenants, and were, indeed, fortunate to have their own premises at a time when other German stations were housed in all kinds of out-of-the-way places.

In addition to the main studios in Cologne there are smaller studios at Münster, in Westphalia, and several other towns in the same region, though the original relay stations in those areas have been silent ever since high-powered Langenberg took the place of the old 20 kW. transmitter at Cologne some years ago.

Cologne has become famous throughout Germany for its "Bunte-Abende," or "variety evenings." When the Cologne identification signal is relayed throughout

Germany listeners know that it precedes something unusually good.

WANDERING WAVE.

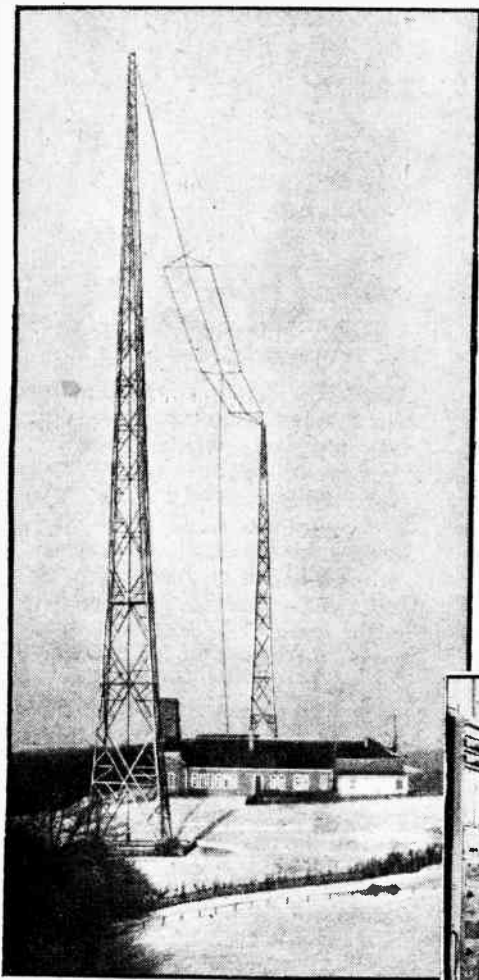

LANGENBERG, the mouthpiece of the Westdeutscher Rundfunk. The studios are located in an unpretentious building in Cologne (seen inset on the right).

The corner of the main transmitter hall at Langenberg, showing the control engineer superintending transmissions.

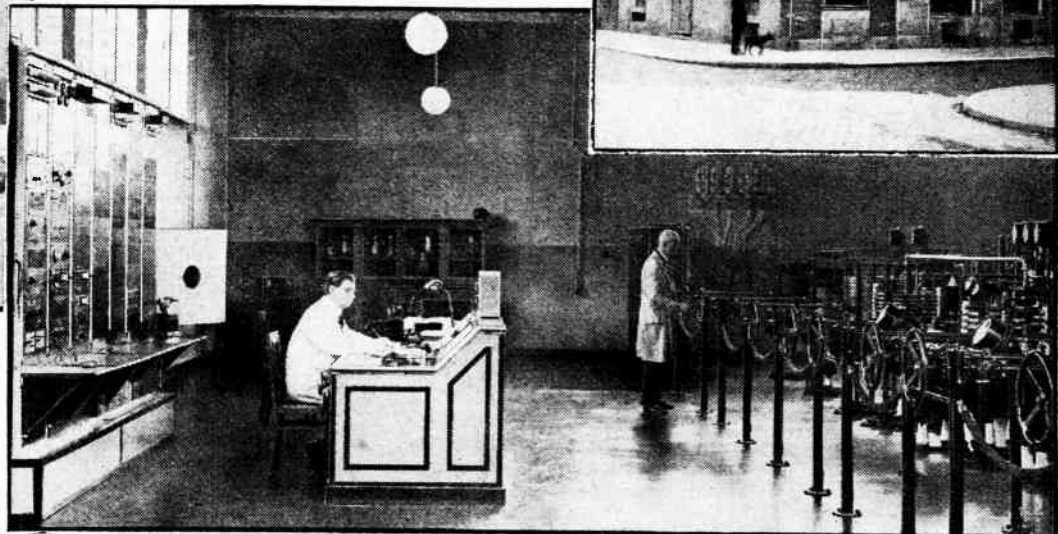



Girt on my armour to give battle.

Just Units

AS my readers know, truth and accuracy are the twin standards by which I order my life. Consequently I was considerably pained when a kind-hearted reader recently drew my attention to yet another instance of the deplorable looseness of expression so prevalent in the "literature" issued by wireless manufacturers.

Among the items listed in this literature were several models of the ubiquitous electric gramophone motor. Quite properly the makers gave—or perhaps I should say attempted to give—the power rating, so that the intending purchaser could calculate whether his wife's house-keeping allowance would stand the strain of the running costs as well as that of the weekly instalments. As, however, they merely stated that its consumption was *two units*, and omitted to say whether the consumption of these units took a woman's half-minute or merely a couple of hours I quite naturally girt on my armour and, like Don Quixote of old, sallied forth to give battle.

Their first line of defence was a beardless youth who evidently combined the functions of office boy and chief of the "Q. and A." department. I propounded to him the conundrum as to what sort of units these might be and, after being torn betwixt the rival attractions of volts-per-minute and ohms-per-mile, he finally decided that after all they were just plain units and needed no qualification.

Penetrating to the second line of defence, which consisted of the combined forces of all the salesmen in the shop, I was speedily unhorsed, the scurvy knaves taking refuge behind the ever-ready skirts of their printers, and I had to retire discomforted.

It was notable, however, that although they alleged it to be a printer's error I was quite unable to find out what these units did stand for, as, although the day was yet young, the firm's technical man had emulated the masterly example set by his confrères at Olympia, and had "just gone to lunch."

UNBIASED

BY FREE GRID

"Permanent" Magnets

IT is a strange thing that, although most wireless enthusiasts are nowadays quite familiar with the elementary principles of electricity, very few of them are equally acquainted with the fundamental laws of magnetism. For instance, no one would dream of expecting a valve filament to do anything else but wilt if it were accidentally stuck across the H.T. battery, and yet if something analogous is allowed to happen to the magnets of a P.M. loud speaker people are surprised if it peters out.

An example of this sort of thing has recently reached me in the shape of a bitter moan from a reader who wrote to me some months ago, asking me if the magnets of a P.M. loud speaker were really permanent. I told him that, although nothing was permanent in this transitory life, he could safely invest in one and be assured that it would last for a goodly number of years.

He has now written to say that after taking my advice he finds that the magnets are about as permanent as a permanent wave. I felt slightly distressed until he added that even the paper cone was more permanent than the magnets, for the cone was still undamaged, although the loud speaker had fallen off the nail in the wall about half a dozen times!

I Stand Accused

READERS often write to me about their troubles, and I am proud to say that in quite a large number of cases I have been instrumental in bringing recalcitrant manufacturers to heel when a case of obvious injustice to one of their customers has been brought to my notice.



Frivolous and groundless complaints.

I am sorry to say, however, that certain readers have attempted to impose on my good nature by getting me to take up frivolous and groundless complaints with manufacturers; worse still, when their nefarious schemes have been brought to light by the manufacturers concerned they

have rounded on me and bitten the hand that fed them.

Some of them have even gone so far as to accuse me of being a friend of the manufacturers, although in their hearts they must know that I have never sunk so low as that.

Olympia Yarns, 1933

NOWADAYS we almost take for granted the hoary old story of the "secret circuit" which certain loose-moralled manufacturers are so fond of dishing up in the few weeks preceding the



In the small hours.

annual Radio Exhibition. I think, however, that this year matters have gone just a little too far, judging by a yarn which has been dished up to the lay Press—for I can hardly believe that the story could have appeared word for word in over a dozen newspapers in which I have seen it unless it had been deliberately circulated. I feel that only a verbatim quotation of the report will properly bring home to you the absurdity of the whole affair, and so I give it herewith:—

"Engineers and research workers have been sworn to secrecy under guarantee bonds, while one well-known firm has gone to the extent of supplying living rooms attached to the laboratory so that the chief engineer shall not leave the premises during the vital weeks preceding the show."

No provision seems to have been made for the wretched man to take exercise, but I suppose this is too secret even to be mentioned, and that he is led round the back streets by an armed guard in the small hours of the morning. In any case it does not seem that the company concerned have any great opinion of the chief engineer's trustworthiness.

Isn't it about time that this sort of stunt was debunked?

News of the Week

Current Events in Brief Review

Sundays at Athlone

THE Editor of the *Irish Radio News*, 179, Pearse Street, Dublin, is anxious to receive reports from listeners in the South of England regarding the transmissions from Athlone on Sunday afternoons between 1.30 and 2.30 p.m.

Swiss Broadcasting Palace

A "BROADCASTING Palace" is to be opened in a suburb of Lausanne next year. There will be three large studios for concerts and dramas with two smaller ones for talks and gramophone recitals.

August Bank Holiday

THE approach of the August Bank Holiday necessitates slight alterations in our printing arrangements. Miscellaneous advertisements intended for our issue of August 11th should reach this office not later than first post on Friday, August 4th.

Sponsored Programmes Ban

ON account of alleged "breaches of regulations" concerning sponsored programmes, 1ZR, Auckland, one of the most popular B class broadcasting stations in New Zealand, has had its licence withdrawn by the Post Office. It is believed that the Post Office took action after an appeal by the New Zealand Newspaper Proprietors' Association.

Try a 5-Metre Holiday

AN ultra-short-wave test of exceptional interest and importance to listeners in Ireland, Southern Scotland, Wales, North-west England and the Midlands is to be carried out on Saturday, August 12th. The organisers, who desire to remain anonymous until next week, state that all listeners who will be on holiday in the West of England on that date should take their 5-metre receivers with them as opportunities may occur to set up world records.

In our next issue we hope to give full particulars of the test and details regarding special awards to successful listeners.

Radio-equipped 'Planes in Thunderstorms

THE possibility that trailing wireless aerials are a danger to aircraft in thunderstorms is suggested in the Air Ministry Orders, just issued. Only ten cases of British aircraft being struck by lightning have been reported since 1925, and in nearly all instances the aircraft had the wireless aerial trailing. The Ministry states that when wireless is in use an increase in the number or strength of atmospherics would generally indicate that a danger area is being approached; if it is not possible to avoid danger areas, the trailing aerial should be earthed and wound in.

Acid Test

APPLICANTS for an announcer's post in Japan must not only pass an examination in diction, but must also exhibit "common sense."

"Ceylon Regional"

THE site has now been chosen for Ceylon's short-wave relay station to be designed specially for picking-up and distributing the Empire programmes of the B.B.C. It is believed that there will be

Anti-Static Film

HOW to recognise and overcome various forms of electrical interference with radio reception is the theme of a new Pathé film which will shortly be shown at cinemas throughout the country.

Various offenders, such as trolley buses and electrical machinery, will be seen in operation; the sound record will then provide a faithful rendering of the noise produced in the loud speaker.

THE RADIO SHOWS

The National Radio Shows of 1933 are to be held on the following dates:

LONDON (Olympia) - - -	AUGUST 15th - 24th.
GLASGOW - - - - -	SEPT. 1st - 9th.
MANCHESTER - - - - -	SEPT. 27th - OCT. 7th.

no difficulty in covering the entire island, and, judging by quality experienced in the Indian zone, reception will be so reliable that Ceylon could almost be counted as a B.B.C. "Region."

"Broadcasting" at "No. 10"

THE secluded garden of the Prime Minister's house at No. 10, Downing Street, was enlivened with a public address system supplied by Tannoy Products on Wednesday, July 10th, on the occasion of the Hospital Fête. A standard "Tannoy" 61 amplifier was used with three or four giant speakers placed at strategic points. The microphone on the terrace was used by Mrs. Baldwin to declare the fête open.

Herr Giesecke

MINISTERIAL - DIREKTOR Heinrich Giesecke, the Vice-President of the International Broadcasting Union and special commissioner in connection with foreign programmes, has suddenly been placed on the retired list.

Herr Giesecke, who took a prominent part at the Lucerne Conference a month ago, was formerly Director of the Reichs Rundfunk Gesellschaft. Although Herr Giesecke is unable to explain the reasons for his compulsory retirement, it is understood in informed circles that the work of the Foreign Relations Commissioner is to be taken over by the Ministry of Propaganda, which commands all forms of publicity.

400 Announcers Waiting

THE belief that the announcer's lot is a happy one is widespread in New Zealand. The Broadcasting Board in the Dominion reports a waiting list of 400—enough to supply announcers to all the stations of Europe.

Amateur Morse Contest

AT Chicago on Thursday, Friday and Saturday next (August 3rd, 4th and 5th) the battle will be fought for the title of "World's Champion Radio Operator." The contest, organised by the American Radio Relay League, consists of eight classes, ranging from a minimum of eight words per minute to one of forty words per minute. The present holder of the title, Theodore R. McElroy, won in 1922 with a speed of 56.3 words per minute.

Amateurs from all parts of the world will compete.

50 kW from Huizen

THE remarkable strength of the Huizen transmissions is explained by the news that the A.V.R.O. programmes are now relayed from the Kootwijk station after 4 p.m. on 50 kW.—an increase of over 30 kW. over the normal power. This step, writes a correspondent, is attributed to a desire on the part of Holland to improve its position at the next conference of the International Broadcasting Union at Amsterdam in October. Holland, it appears, is seeking to justify the 1,875-metre wave, which it is unwilling to sacrifice, by using really high power before the signing of the Convention. This means that Kharkoff, which is to share a wave with Huizen, will be under an obligation not to increase its power.

Televisor with Cinema Film Quality

A 180-LINE television receiver giving quality and detail said to be equal to that of the 16 mm. home cinema film is to be demonstrated at the forthcoming German Radio Exhibition. According to our Berlin correspondent, the set is the work of Dr. Loewe and his colleague, Dr. Schlesinger. Ultra-short-waves are used, and it is understood that the 7-metre transmitter in Berlin may shortly be used for experiments.

The German Ministry of Propaganda has expressed its surprise at the improvements achieved since last year, and it is generally assumed that some twenty German towns will soon be equipped with ultra-short-wave television transmitters.

Radio Loewe will be able to manufacture the complete television receiver, comprising cathode ray tube with a half-plate size projector, ultra-short-wave receiver for television, receiver for sound, loud speaker and synchronising unit for under £20. Synchronisation in the Loewe system is secured by a special synchronising signal transmitted with the television image.

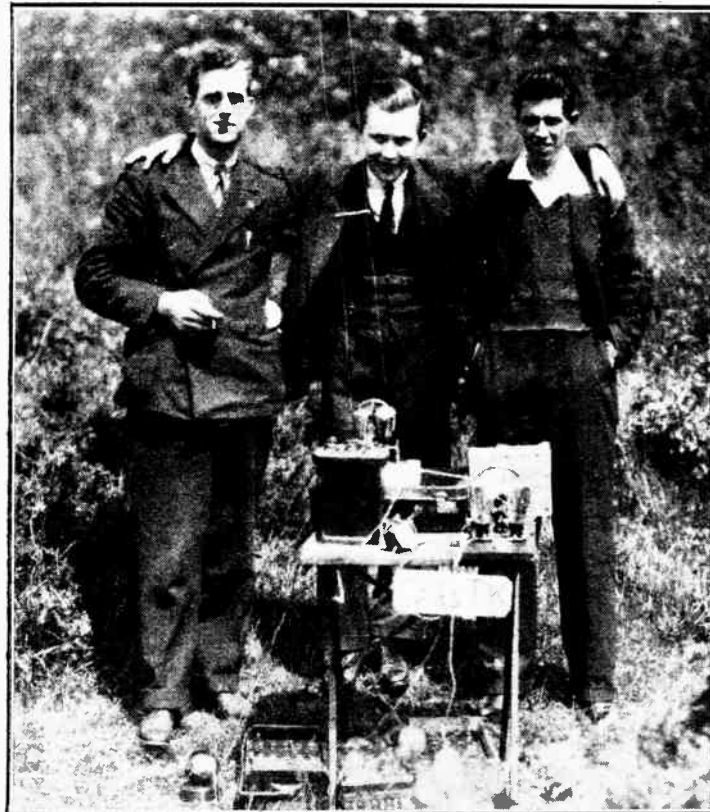

"ULTRA SHORTS" IN NORTHERN IRELAND. Mr. F. A. Robb (G16TK) is the central figure in this group of amateurs who recently spent a 5-metre field day near Belfast.

Higgs "Super B" Receiver

A Battery Superheterodyne with Automatic Volume Control

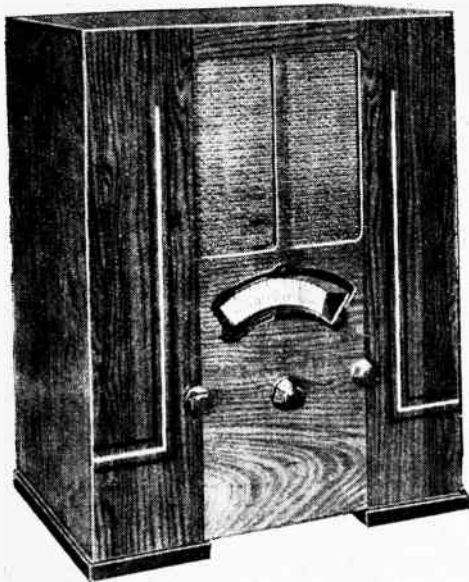

FEATURES

Type.—Six-valve battery superheterodyne with automatic volume control and Class "B" output stage. Moving-coil loud speaker and provision for gramophone pick-up. **Circuit.**—First detector with band-pass input filter—oscillator—I.F. amplifier—anode bend second detector—driver valve—Class "B" output valve. **Controls.**—(1) Tuning with illuminated dial calibrated in wavelengths. (2) Manual volume control. (3) Wavrange and on-off switch. **Price.**—18 gns. **Makers.**—Higgs (Great Britain) Ltd., Westbourne Place, Hove, Sussex.

ated in the receiver itself are few. Those due to second channel interference from the local stations on medium waves were quite negligible and would probably be overlooked unless one knew where to look for them.

In estimating the overall sensitivity of the set it is, of course, necessary to take into account effects due to the automatic volume control. In London, for instance, it is possible to receive North Regional at greater volume than London Regional when both are sending out the same programme. This anomaly is probably due to overload-

THE country listener, who is compelled to rely on batteries as a source of power, has in the past complained bitterly of the apparent indifference of the manufacturer to his requirements. That state of affairs is now rapidly being mended, for the introduction of Class "B" amplification has given to battery receivers the same kind of stimulus that the indirectly heated valve gave to mains sets.

The Higgs "Super B" is typical of the new range of receivers from which the battery user will be able to choose during the coming season. Its circuit is of up-to-date design and there are no less than six stages, yet the consumption of H.T. current is well within the capacity of what used to be known as the "intermediate" size of battery.

An inductively coupled band-pass filter in the aerial circuit provides an adequate degree of selectivity for the incoming signals before they are passed to the first detector valve. A separate oscillator is employed and is coupled to the plate of the first detector through the primary of the first I.F. transformer. There is a single stage of I.F. amplification, and it is in this stage that the circuit has been arranged to give automatic control. The component by which this is effected is known as the "Plew Anti-fading Unit." It consists of a resistance capacity filter included in the plate circuit of the anode bend second detector, the fluctuations in the mean anode current of which are utilised to vary the screened potential of the I.F. valve.

The second detector is coupled to the driver valve by an auto-transformer across

which is connected a high resistance potentiometer for manual volume control. A Class "B" valve is used in the output stage and feeds a permanent magnet moving coil loud speaker unit. Pick-up sockets are provided, and the input from the pick-up is injected into the grid circuit of the second detector valve. When the pick-up is not in use the sockets must be short-circuited and a tumbler switch is fitted at the back of the cabinet for this purpose.

The set is a pleasant one to handle, and the degree of automatic volume control provided effectively prevents bursts of noise from powerful stations when searching round the dial at maximum sensitivity. The maximum volume available, while it does not perhaps represent the full loading capacity of the output stage is nevertheless quite sufficient for average domestic requirements, and the reproduction is of soft and pleasing quality with no trace of harshness or irritating resonance.

There is a commendable absence of background noise, and on the long waves in particular the stations stand out with exceptional clarity. Heterodyne whistles gener-

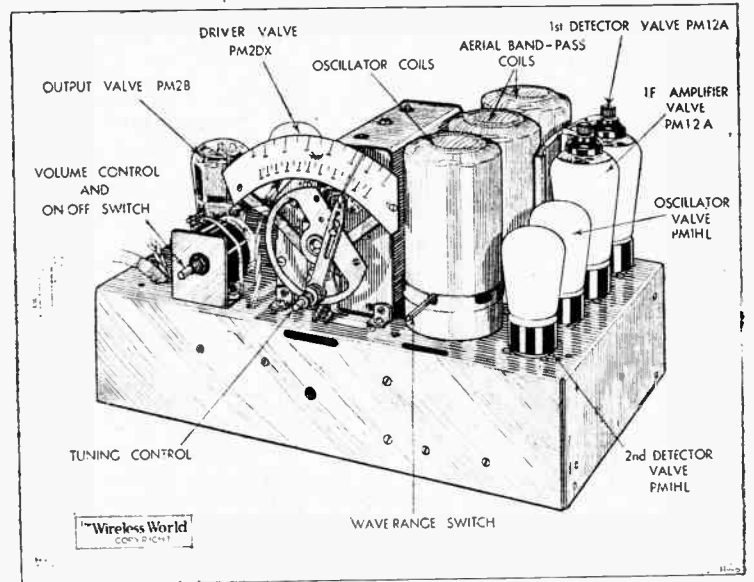

In addition to the controls shown in this view there is a radio-gram switch mounted at the back of the chassis.

ing of the first detector, as the A.V.C. effectively shields the second detector stage. Shortening the aerial or breaking and twisting up the insulated lead-in to form a small series capacity actually increases the volume from the local station so that it would appear that some form of input volume control might be added to the circuit with advantage. On distant stations, however, the sensitivity is excellent, and five Continental medium-wave stations were received during the middle of the day. As regards selectivity, not more than three channels were lost on either side of the two local transmitters, and on long waves Zeesen was received absolutely clear of both Daventry and Radio Paris at good strength and without sideband "splashing."

In addition to the "Super B" there are models for A.C. and D.C. mains at the same price of 18 guineas and a universal model at 20 guineas. The mains-operated sets are also supplied in radio-gram form at 29 guineas for A.C. or D.C. mains, and 31 guineas for the universal A.C.-D.C. model.

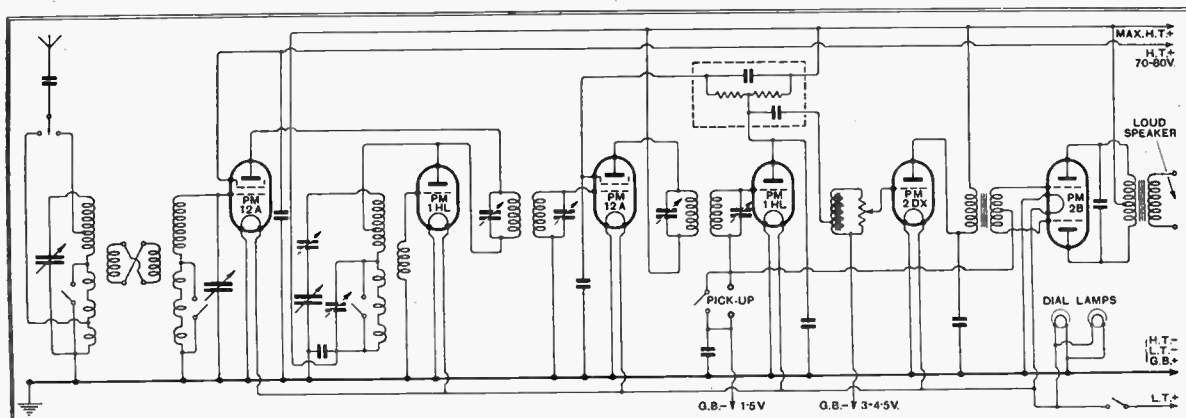

Automatic volume control is obtained in the I.F. stage by a varying screen voltage derived from the second detector.

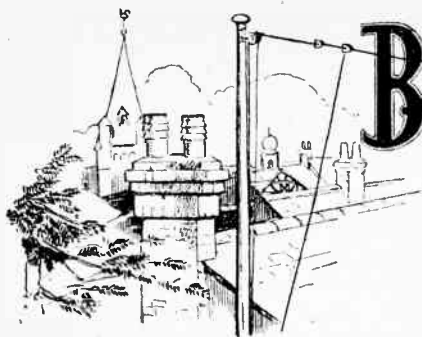

Broadcast Brevities

By Our Special
Correspondent



Those Sunday Evenings

WHEN the B.B.C.'s greatest admirers begin to frown at the Corporation's decisions it is time to ask who, if anybody, is really pleased.

I hear that many of the B.B.C.'s most friendly listeners—those who look to their receivers for regular entertainment—are protesting at the inconsiderateness of the powers-that-be in ordaining that transmissions shall be made during the 6.30 to 8 o'clock period on Sunday evenings.

Is the B.B.C. a Bore ?

Even their beloved B.B.C., it seems, can become a bit of a bore when it chatters and sings unceasingly. After all, there are stations on the Continent which cannot well be heard while the B.B.C. is transmitting. Now, under the new rule which takes effect on September 17th, they will be silent until the reshuffling of wavelengths under the Lucerne Plan brings a merciful variation. The B.B.C. will then eclipse a new bunch of Continental stations.

Sober Programmes

Henceforth, Sundays will be packed with B.B.C. programmes from 12.30 until after 10.30 at night with the addition of a Welsh service at 11 a.m. from Daventry (5XX) once a month.

The lighter evening programmes will be on the Regional wavelengths, and will consist of ballads and light orchestral music interlarded with gramophone recitals. On the National wavelength the programmes will be grouped under such headings as "For the Children," "Missionary Talk," "Chamber Music," "Classical Reading," "Bible Reading," and "Recital."

Challenge to Sponsored Programmes

Whatever else may be said for the new scheme, it is a serious challenge to the Sunday sponsored concerts from the stations on the Continent, but a study of the material which the B.B.C. proposes to offer does not convince me that Radio Paris and Fécamp will confront a very serious rival in the matter of programmes.

No New Music Left

One wonders how the B.B.C. will succeed in filling so much extra programme time when, as at present, they have even abandoned the attempt to put out alternative programmes during the 6.30 to 8 p.m. period on weekdays. Despite the so-called unlimited repertoire of music available, there can be no doubt that the field of music, like any other field, has length and breadth; sooner or later the much ploughed ground will become exhausted.

Encouraging Young Composers

Even to-day how many listeners with any musical ear fail to recognise at least 50 per cent. of the compositions broadcast? There is an irritatingly large number of pieces

which are dead but "they won't lie down."

It is time that the Corporation gave greater encouragement to the young composer instead of restricting him by ordaining that new works shall be judged only once a year.

Hands Across the Sea

MR. MERLIN AYLESWORTH, President of the American National Broadcasting Company, has paid a graceful tribute to Britain by inviting Sir John Reith to give an inaugural address at the opening of the great Radio City in Sixth Avenue, New York, in October next.

"Affectionately yours," concludes Mr. Aylesworth in his letter of invitation, for he and Sir John have met on more than one occasion, and if opportunity permitted, there is no doubt that Sir John would hasten across the Atlantic to please his friend and attend this really important ceremony.

Too Busy ?

It would not surprise me, however, if Sir John stayed at home. Reorganisation difficulties at Broadcasting House and the commencement of the winter season throw a tremendous load on the shoulders of the "D.G." The impressive rearrangement of the staff under the headings of "Output" and "Administrative" is not yet completed and, in justice to Colonel Dawnay, the new "Output" chief, it is likely that Sir John will consider it his duty to super-

When the intervening houses fall vacant the B.B.C. may take over the entire block and thus double the size of Broadcasting House

As Far as the Zoo

Who knows but what the B.B.C. may eventually extend the half-mile up to Regent's Park itself. This would certainly be appreciated by the animals in the Zoo, who would be spared the indignity, which I witnessed last week, of being transported to Broadcasting House in a common or Zoological garden van. I followed them into the television studio where the rehearsal for last Wednesday's programme took place, and their attitude of offended *amour propre* could not be disguised. Charlie, the Capuchin monkey, suffered also from hiccoughs.

The Man in Disguise

THE "O.B." engineers do not lack imagination. There is something thrilling in the tale of how the microphone will be made to keep in touch with the parading troops during the Tidworth Tattoo on August 5th. It is considered inadvisable to locate the microphones in settled positions. An engineer, therefore, will carry a mike around the arena, but as, in the words of the



HALF-PAST SEVEN AT LUGANO. Here is Signorina Nini, the English-speaking announcer at Lugano, broadcasting the time signal with the aid of a ship's chronometer. The new Monte Ceneri station which broadcasts the Lugano programme, is surrounded by mountains, and considerable secrecy is observed regarding the transmitting plant.

intend the final arrangements for turning the Corporation into a machine.

"No. 16"

A SOMBRE, shuttered and dirty-windowed building in Portland Place—"No. 16" to be precise—will shortly blossom forth as a new office for the B.B.C. There are actually three houses between this and the northern end of Broadcasting House, but as No. 16 has only been taken on lease, there will, I am told, be no underground passages constructed between the two buildings.

official notice, the sight of a civilian amidst the massed bands might create anxiety in the minds of the audience, he will be hooded and dressed entirely in green. This sinister figure, like Robin Hood chasing King John's troops with a hand-mirror, will move inconspicuously against the verdant background.

Queer Thought

This idea might be developed; in fact, I am not at all sure that some of the engineers at the opening of the Southampton Graving Dock were not disguised as ducks.

Correspondence

The Editor does not hold himself responsible for the opinions of his correspondents
Correspondence should be addressed to the Editor, "The Wireless World," Dorset House, Stamford
Street, London, S.E.1, and must be accompanied by the writer's name and address

Automatic Volume Control

ALLOW me to comment on recent correspondence under the above heading which has appeared in your paper during the last few months.

In the issue of May 5th Mr. Haynes adopts the pessimistic view, and amplifies the defects which are, after all, only natural in a system which, although conceived in the dim past, has only recently become a manageable child; if perfection were essential, then would nothing escape condemnation. Taking the broader view, we find that the advantages of A.V.C. far outweigh the drawbacks, and, in fact, fully justify the additional cost involved.

Considering the various methods separately, the original and basic form, simple A.V.C., operates primarily to prevent overloading and consequent distortion when a local station is received on a sensitive set. This overloading may be only momentary, as in the inadvertent reception of the local station during "searching," or it may be continuous, due to the inexpert adjustment of the controls, but in either case the result is undesirable. Thus, from this point of view, a set incorporating simple A.V.C. forms a good commercial proposition, but does not go far enough in the equalisation of signals, due to the operation of the gain-reducing control, even on small signals.

The delayed and/or amplified version of A.V.C. introduces an effect considerably more distressing than the amplitude distortion it is desired to eliminate; when the receiver is distuned by 3 or 4 kH. from the local station, the carrier, which is the controlling factor in the A.V.C., is reduced to a very small value, the gain is enormously increased, and the combination of carrier and top sidebands produces a loud, high-pitched mush, the continued reappearance of which during tuning soon becomes intolerable.

The elimination of the above defect is accomplished in the Quiet A.V.C., this giving very satisfactory results.

There is nothing to be gained by a discussion of propagation distortion in connection with A.V.C., as the two are connected only in so far as the A.V.C., by elimination of the major faults in present-day wireless reception, focuses attention on the remaining minor imperfections.

Background Noise

The accusation against A.V.C. of enhanced mush, which is countered by Mr. Redfern in his excellent letter in the issue dated June 2nd, is to some extent justified, in that to obtain good control a high degree of HF (or IF) amplification is required, so that in two receivers of equal sensitivity the one with the greater HF amplification (and less LF amplification) will give more background noise. In practice this defect is not so serious as may be thought, and it is not difficult to arrive at a satisfactory compromise with small background coupled with the advantages of A.V.C. It should here be noted that the rectified current for audio reproduction may be taken from an intermediate point in the HF amplifier, thus removing all ground for

the above objection, the remainder of the amplifier being merely to provide the biasing potential for control purposes.

Mr. Redfern's remarks about cold rectifiers may be construed to mean that these have no application at all in A.V.C., but a little thought will show that this cannot be so; the Westinghouse HF rectifier is the purest example of the genus rectifier, and can in no way be inferior to any thermionic arrangement. The diode, with its inconveniently earthy cathode, demands electrical sustenance during its modest life, while its strangely preconceived offspring, the AB and LG triode rectifiers, aspire to a dual function which they succeed in doing only moderately well, owing to conflicting demands of polarising voltages for the best performance of each function. The argument against the "Westector" is that it insists on doing its own job well; in practice its small physical dimensions and independence of power supplies render it of much greater use in A.V.C. circuits than the multi-function thermionic devices.

I cannot agree with Mr. Haynes' sugges-

tion that A.V.C. "limits the tuning spread due to detector overloading," and, in fact, the reverse is the case, for an A.V.C. receiver will bring in the sidebands when detuned from the carrier, these being normally inaudible on an uncontrolled set. It is doubtful, also, whether A.V.C. can give any freedom from atmospheric disturbances, as the time constant of the control circuits must be large compared with the purely transient static discharge. In the case of continuous "man-made" static, the relative volume levels of the station and static will be the same for an A.V.C. set as for one not so equipped.

In conclusion, some of the phenomena associated with Q.A.V.C. may be of general interest. It can be adjusted to eliminate all signals below a given level; thus, in a situation where electrical interference is bad, it may be set to receive only those stations which give a signal well above the background level. A station which is only just qualified by signal strength to be passed on to the loud speaker will be subject to enhanced fading, so much so that, in extreme cases, the signal will be alternately cut in and out as the incoming signal varies above and below the critical cut-off voltage. A sense of extreme selectivity will be experienced during tuning by the sudden appearance and disappearance of powerful signals in a perfectly blank background.

Per pro. Precision Electric, Ltd.
G. FARREN CLARKE,

DISTANT RECEPTION NOTES

High Power Problems : Outstanding Stations.

AS stated in the "News of the Week" page in July 21st issue, it is the St. Agnan station of Toulouse which is now heard and which I reported upon recently. Permission has been given by the Government, it appears, for the station to be used, though the power is not to exceed 8 kilowatts, which was the amount used by the old station.

Some interesting information is given in the French wireless paper *Le Haut Parleur* in an article dealing with the Lucerne Plan. The writer discloses that Radio Vitus, like Toulouse, has already built a high-powered station and had been hoping for permission to use it, but is not assigned any channel under the new scheme. He also discloses that Radio Lyons has just completed a new transmitter capable of an output of 50 kilowatts. If Radio Vitus and Radio Lyons continue to work at all they will have to do so on one or other of the French common-wave channels and their maximum power will be 5 kilowatts.

I can again record very strong reception from Moravska-Ostrava on Saturday evening. Either a new transmitter is being put into operation at the week-ends or the power of the existing one is considerably increased at these times. Lyons Doua, which has been received so splendidly for weeks and weeks, suddenly disappeared and remained silent for six consecutive nights. I was unable to hear so much as a whisper from this station and began to fear that Lyons Doua might have been a victim of one of these anti-wireless plots of which so many accounts have appeared in the papers recently. Strasbourg, Luxembourg and Vienna have all been threatened, but luckily the plots have been foiled in time to prevent

serious damage from being done. On the last two evenings, however, the station has been received with all its old strength.

It is announced that Monte Ceneri is to continue using a wavelength of 1153.8 metres, which is exactly that of Kalundborg. Since the Swiss station is rated at 15 kilowatts and Kalundborg at 7.5 this means that in all probability we must say good-bye to the Danish station until the Lucerne Plan comes into force next January.

Old Friends Return

The past few days have been marked by the welcome return of several old friends which have not been well received for some weeks. Amongst these are Budapest, which now frequently gives good reception after dark, and Munich, which has been very well received during the entire week preceding the writing of these notes.

Though Kaiserslautern shares a wavelength with both Augsburg and Tampere, its transmissions are frequently to be heard wonderfully well rather late in the evening. This station relays the Munich programmes and is probably synchronised with Augsburg, which also transmits them. It seems likely that Tampere closes down rather early and therefore ceases to interfere.

Last week I mentioned Huizen as an outstanding transmission. Since then it has become even better and readers should make a point of tuning it in. Warsaw and Motala are both in fine form on the long waves.

On the medium waveband I can particularly recommend Langenberg, Rome, Leipzig, Strasbourg, Brussels No. 2, Milan, Breslau, Heilsberg, Turin and Nürnberg.

D. EXER.

LABORATORY TESTS

NEW RADIO PRODUCTS REVIEWED

NEW EELEX CONNECTORS

A NEW wander plug just added to the Eelex range of specialities has been designed to ensure a good electrical contact when inserted into battery sockets of different size. It is fitted with a split prong,

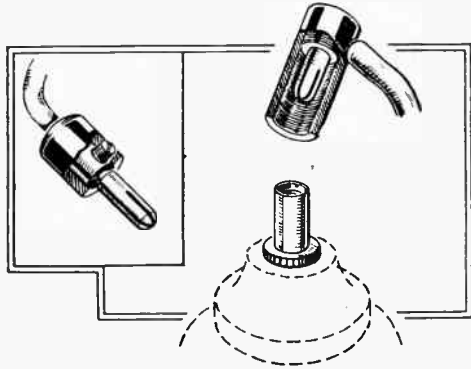

Eelex shrouded anode connector and new style wander plug with adjustable prongs.

the diameter of which can be varied within small limits. This is effected by turning the wire-retaining grub screw beyond the point necessary to grip the conductor. It is available in a wide range of markings, and the price is 2d. each.

The other new item is an anode connector for use with S.G. valves. Described as the type A, it takes the form of an insulated sleeve completely enclosing a four-prong plug, and into this fits a small metal socket, one end of which is threaded, and replaces the top anode terminal cap on screen-grid valves. As the metal part of the connector which is "live" to H.T. is completely insulated, absolute immunity to short circuits is ensured, even though the lead may become entangled in the wiring when removed from its valve. The price of this new anode connector is 3d., and the makers are J. J. Eastick and Sons, Eelex House, 118, Bunhill Row, London, E.C.1.

GODFREY SHORT-WAVE CONDENSER

SEVERAL interesting and novel features are embodied in the new short-wave condenser developed by F. E. Godfrey (Radio), Ltd., 63-67, Chancery Mews, Francis Street, London, W.C.1.

The plates are shaped to give a S.L.F. law and the moving vanes rotate through 270 degrees as compared with the customary 180-degree movement. This comparatively wide sweep of the rotor provides considerably more space on the dial for logging stations. Obviously a dial

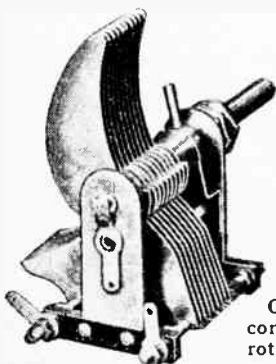

Godfrey short-wave condenser having a rotor movement of 270 degrees.

designed especially for use with this condenser is required, and one fitted with a suitable scale is obtainable from the makers.

Although the condenser is fitted with back and front supports for the moving vanes, the latter alone serves as the main bearing, the rear support acting as a steady bearing only and as an anchorage point for the concealed pigtail. The fixed vanes are bonded together at two points and soldered to their supporting rods; this method of construction not only ensures good electrical contact throughout, but results in a very rigid assembly.

The condenser is made entirely of brass, and Keramot is employed for the insulating strips carrying the stator, this material having been found most suitable for use in the tropics.

On test the condenser was found to be perfectly silent in operation, and the wide sweep of the moving vanes rendered tuning far easier than is the case with the normal 0-180-degree movement.

The minimum capacity of our specimen was 9 m-mfds., and its maximum value 0.000183 mfd., its nominal rating being 0.00016 mfd. A single hole fixing bush is fitted, also a long $\frac{1}{4}$ in. spindle, and the price is 7s. 6d.

BULGIN NEW TRANSCOULER, MODEL L.F.10

IN its original form the Bulgin Transcoupler afforded a voltage step-up of one to three, but a slight modification has now been made and the turns ratio of the small parallel-fed transformer has been raised to one to four. This has not led to any appreciable reduction in its primary inductance, which is still maintained at a level quite

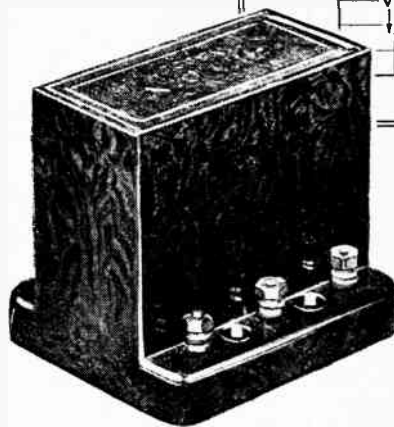

adequate to ensure a good low-frequency response.

The overall characteristic curve of the new model, here reproduced, shows that at 50 c/s the amplification is sensibly the same as at 5,000 c/s, furthermore, the amplification is well maintained up to 10,000 c/s.

When following a medium impedance amplifying valve, such as one having an A.C. resistance of 18,000 ohms and an amplification factor of 27, an overall stage gain of 65 is attained, a most creditable performance for a component of this type.

Physically the new model is the same as

its prototype, being housed in the familiar green mottled bakelite case, and the price is unchanged, namely, 11s. 6d. The anode resistance is tapped and allows 30,000 ohms for the anode load and 20,000 ohms for decoupling requirements. The makers are A. F. Bulgin, Ltd., Abbey Road, Barking, Essex.

LOEWE GRID-LEAK-TYPE RESISTANCE

THE Loewe Radio Co., Ltd., Fountayne Road, Tottenham, London, N.15, have now introduced a range of inexpensive resistances of one-watt rating. Known as High Ohmic Grid-Leak-Type Resistance, they are

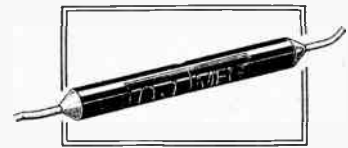

New Loewe grid-leak-type one-watt resistance with wire ends.

made in all the usual sizes from 500 ohms to 10 megohms. The component consists of a small porcelain tube $1\frac{3}{8}$ in. long and $\frac{1}{4}$ in. in diameter carrying the resistance material. Wire ends, securely fixed and about $1\frac{1}{2}$ in. long, are allowed for connecting, and the price is 9d. for all values.

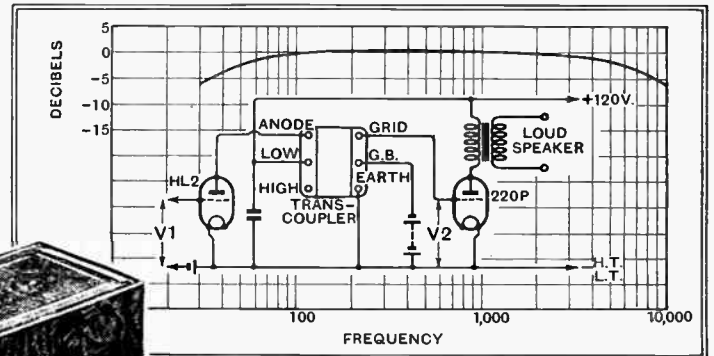

Overall characteristic curve of Bulgin L.F.10 Transcoupler which is fitted with a 1 to 4 ratio transformer.

The specimen sent in for test had a nominal value of 100,000 ohms, which, measured, was found to be 104,200 ohms, this being well within the makers' tolerance of plus or minus 10 per cent. This size will pass three milliamps. at one-watt rating, and when doing so shows a small decrease in the value of the order of 3 per cent. The temperature rise is not above normal for a small resistance of this type, and on the whole it represents very good value for money.

TRADE NOTE

A new distributing depot has now been opened at Newcastle by the Ever Ready Co. (Great Britain), Ltd., Hercules Place, Holloway, London, N.7. The address of the new depot is 23, Gallowgate, Newcastle-on-Tyne; the telegraphic address is Eveready, Newcastle-on-Tyne, and the telephone number, Newcastle 26553.

READERS' PROBLEMS

Cost of "Free" Bias

WHEN adapting an existing battery-fed receiver for Class "B" amplification, it is, practically speaking, almost always necessary to abandon any "free" grid bias scheme that may be included in the original set. Bias voltages are always developed across a resistance in the H.T. negative lead, and if the current flowing through this resistance is constantly varying, perhaps between 10 and 40 milliamperes (depending on modulation), it is obvious that a steady grid voltage cannot be obtained in the usual way.

At first sight it might appear possible to overcome this difficulty by inserting the bias resistance in such a position that it is not traversed by the anode current of the output valve in which fluctuations take place. But a little consideration will show that, with ordinary battery valves fed from a common source of L.T. current, this is impossible.

If automatic bias is to be retained when Class "B" amplification is added, it will be essential to feed the output valve from

THESE columns are reserved for the publication of matter of general interest arising out of problems submitted by our readers. Readers requiring an individual reply to their technical questions by post are referred to "The Wireless World" Information Bureau, of which brief particulars, with the fee charged, are to be found at the foot of this page.

heterodyne it is normal that there should be relatively more high-note loss on the long waveband. This loss takes place in the signal-frequency tuned circuits, but as a matter of fact is very small indeed. Most of the lack of brilliancy that our correspondent has noticed is probably due to the fact that the long-wave transmitters are, in general, less perfectly modulated.

The Padding Condenser

FROM the symptoms described by a constructor of an A.C. Monodial receiver, we are inclined to think that the stray capacity associated with the oscillator circuit is excessively high. This may well be

We consider it much more likely that a fault has developed in the long-wave section of one of the signal-frequency coils, or even in the corresponding section of the oscillator coil assembly. It is not altogether impossible that the oscillator valve has lost some of its emission, but if it has, the fault might be expected to manifest itself by a complete cessation of signals over a part of the band, rather than by a falling-off in strength.

Extra Screening Needed

COMMENTING on the relatively small amount of screening included in the Two-Unit Portable (*Wireless World*, June 23rd), a reader asks whether it would be as easy to make a set on the same lines, but with the substitution of a frame for the "open" aerial specified.

The use of a frame aerial, in the field of which all the H.F. components will be mounted, always calls for more extensive screening, and the design in question would certainly need modification if this alteration were made. It might, however, be possible to retain simplicity of construction by mounting the frame aerial as part of the loud-speaker unit, but this plan would necessitate the use of low-capacity inter-connecting leads. Further, as the capacity of these leads would probably be subject to variation, a completely ganged tuning system would hardly be practicable.

High- and Low-Resistance Loud Speakers

A CORRESPONDENT, referring to our review of the Multitone Class "B" Converter in the issue of *The Wireless World* for July 7th, asks whether the statement that the auto-transformer fitted will match any high-resistance speaker may be taken to imply that the converter is intended only for operation with loud speakers of the moving-iron type.

This instrument is usable with both moving-iron and moving-coil speakers. Although the speech coil of a moving-coil instrument is almost invariably of low resistance, a step-down transformer is fitted to all standard loud speakers, and with the addition of this transformer the instrument may be treated exactly as if it were of the high-resistance type.

This is true of all moving-coil loud speakers with built-in transformers, provided that the external connections be made to the primary winding of the transformer.

The Wireless World INFORMATION BUREAU

THE service is intended primarily for readers meeting with difficulties in the construction, adjustment, operation, or maintenance of wireless receivers described in *The Wireless World*, or those of commercial design which from time to time are reviewed in the pages of *The Wireless World*. Every endeavour will be made to deal with queries on all wireless matters, provided that they are of such a nature that they can be dealt with satisfactorily in a letter.

Communications should be addressed to *The Wireless World* Information Bureau, Dorsét House, Stamford Street, London, S.E.1, and must be accompanied by a remittance of 5s. to cover the cost of the service. The enquirer's name and address should be written in block letters at the top of all communications.

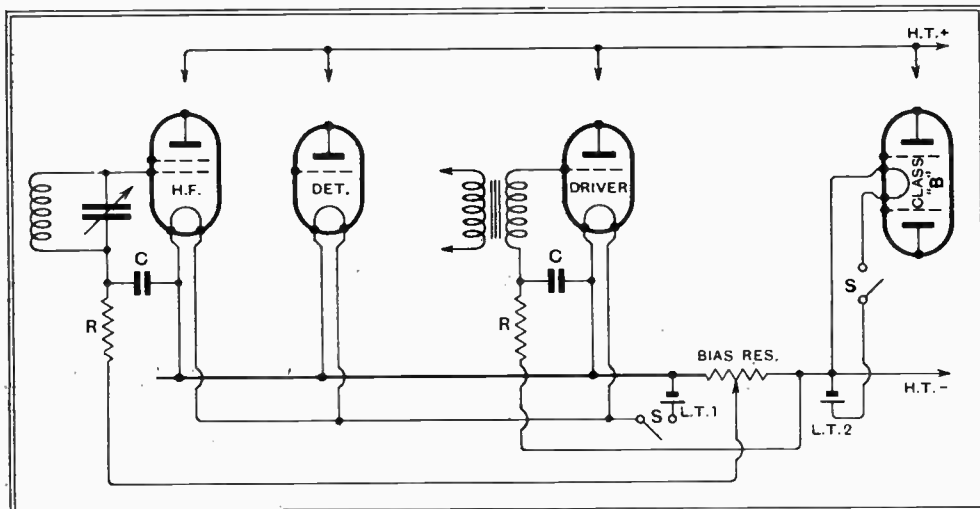

Fig. 1.—To make automatic bias possible in a Class "B" set, anode current variations must be "short-circuited." An extra L.T. cell is needed.

a separate L.T. battery. This is the conclusion reached by a querist, who asks us to confirm its truth, and if so, to publish a circuit diagram showing how the filament and grid bias circuits should be arranged when converting an existing H.F.-det.-L.F. set for Class "B" amplification.

An appropriate system of connections is shown in Fig. 1, from which it will be seen that a separate L.T. cell is employed for the Class "B" valve, and that the anode current of this valve does not pass through the bias resistor.

The Long-wave Handicap

IT is almost impossible to design an ambitious receiver—particularly a superheterodyne—which will have the same performance on both medium and long wavebands. For instance, an observant correspondent, who has recently built a superheterodyne in which *Wireless World* practice has been followed, has noticed that reproduction in general is distinctly "brighter" on the medium band. We are asked to explain why this should be.

In almost every modern type of super-

due to the use of a padding condenser (C_4) which is not of the make specified.

When using other types of condenser, between which and the metal base-plate an excessive capacity may exist, it is recommended that the component should be mounted about a quarter-inch above the base by means of distance-pieces.

Long-wave Failure

AFTER working well for many months, a Monodial receiver built by a reader now shows a serious falling-off in performance on the long-wave band only; medium-wave signals are received as well as ever. The owner of the set asks whether this falling-off should be attributed to decline in emission of one of the valves, and, if this is probable, asks us to say which valve is likely to be at fault.

The tracing of faults in a superheterodyne is generally susceptible to a logical line of reasoning. As all the valves are in operation equally on the long and medium bands it is hardly likely that failing emission is responsible for an impaired performance manifesting itself only on one band.

BUILD YOUR NEW MONODIAL SUPER FROM A "C.A.C." KIT OF PARTS

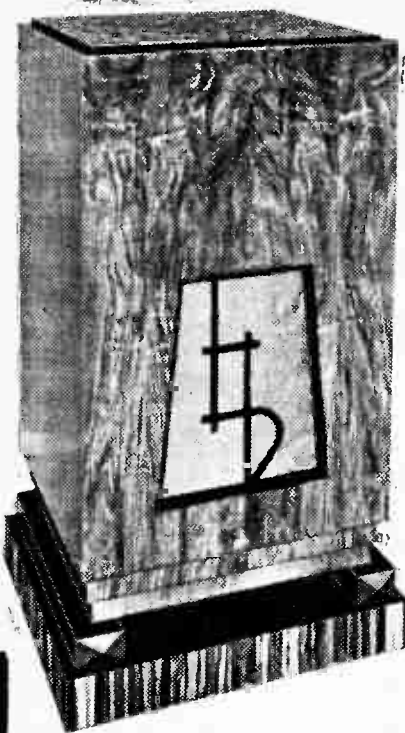

KIT "A" RECEIVER UNIT: Comprising the Designer's first specified components, (less Chassis, Panel, Valves and Cabinet) **£10-19-6**
KIT "B" POWER UNIT: Comprising the Designer's first specified components, (less Chassis and Valves) **£8-13-6**

Detailed Price List Free on Application.

EXTRAS: "C.A.C." Aluminium Chassis, correctly drilled, with side members, and beautifully finished in French-grey cellulose. Receiver Chassis, 19/-; Power Unit Chassis, 7/6.
 "C.A.C." Panel, 14" x 10" in Polished Oak Walnut or Mahogany, 2/-.
 Valves: Receiver (5), £4-4-6. Power Unit (4), £3-0-6.
 Cabinet, as illustrated, in beautifully finished selected Burr Walnut and Macassar Ebony, £5-10-0.

TRADE ENQUIRIES SOLICITED

THIS MAGNIFICENT BURR-WALNUT CABINET

One of the prize-winning designs in our recent competition, has been
SPECIALLY CONSTRUCTED FOR THE NEW MONODIAL SUPER

It represents the finest example of Cabinet-making Craftsmanship, and is manufactured throughout in our own Factory. As regards appearance, quality of construction and finish it is in a class entirely of its own. It is manufactured in specially selected Burr-Walnut, with an ebonised platform and Macassar Ebony base. The Cabinet can also be supplied as a Radio-gram, with raised hinged lid, at an additional cost of 20/-.

EXTERNAL DIMENSIONS: Height 3' 4", Width 20", Depth 17".

INTERNAL DIMENSIONS: Height 2' 5", Width 19" Depth 16".

PRICE - - - £5-10-0

A VERY CORDIAL INVITATION IS EXTENDED TO ALL "W.W." READERS TO PAY A VISIT TO OUR NEW FACTORY AND SHOWROOMS, WHERE CONTINUOUS DEMONSTRATION OF THIS EXCELLENT RECEIVER ARE BEING GIVEN DAILY.
BUSINESS HOURS: 9.30 a.m. to 6 p.m. (or later by appointment).

SEE OUR EXHIBITS ON STAND 94, RADIOLYMPIA

The general public, and readers of "The Wireless World" in particular, will remember the success which attended the publication of Major Page's Ferrocart Class "B" Receiver circuit in April of this year. This type of Receiver came as a boon to the listener whose source of H.T. supply was confined to batteries, for it enabled him to enjoy all the advantages of a mains operated Receiver as regards quality and output, with a maximum drain on his battery of only 12 milliamperes.

The combination of this class of output with the new Ferrocart tuning coils was a happy combination, and it is not surprising that this particular circuit has easily proved the most popular of all battery Receiver designs for many years. Since Major Page was appointed to our technical staff he has devoted considerable time to the perfection of several Receivers of the most advanced radio technique, and the public should not fail to inspect his latest achievements. Those interested in Class "B" amplification will find Receivers which, after considerable research, incorporate advanced driver and output stage technique, giving quality and volume of reproduction from a Permanent Magnet Moving Coil Speaker beyond reproach and hitherto unobtainable.

"THE WIRELESS WORLD" CLASS "B" FERROCART RECEIVER

The most outstanding battery set of the year designed by Mr. W. I. G. Page, B.Sc., late of "The Wireless World" and now our Chief Technical Consultant.

We are still experiencing an enormous demand for Kits of parts for this excellent Receiver. All orders are despatched to nearest Railway Station within two hours of receipt.

KIT "A." Complete (less Valves, Batteries, Cabinet and Loud **£7-11-0**
 Speaker)

KIT "B." Complete with Valves (less Batteries, Cabinet and Loud Speaker) **£9-17-3**

KIT "C." Complete with Valves, Cabinet and Loud Speaker (less Batteries) **£13-9-3**

Cabinet, beautifully finished in Figured Walnut, exclusively specified by the designer and manufactured in our own factory **£1-12-6**

(Front drilled, if desired, without extra charge.)

FREE. In view of the phenomenal interest taken in this wonderful circuit, we have reprinted 10,000 copies of the original article which appeared in "The Wireless World" of April 7 last, and readers are invited to send for a copy, which will be forwarded gratis and post free on application.



COME AND SEE AND HEAR IT!

The CITY ACCUMULATOR COMPANY, Ltd.,

HEAD OFFICE, SHOWROOMS & WORKS:—

18-20, NORMAN'S BUILDINGS,

Off CENTRAL STREET, LONDON, E.C.1.

Telephones:
 Radio Dept.: Clerkenwell 6206
 Cabinet Dept.: ... 1038
 Telegrams:
 "Cityacco, Barb, London."

The First of our 1933-4 Achievements.

The "NORMAN" Class "B" Three

Designed by Mr. W. I. G. PAGE, B.Sc., the designer of the "Wireless World" Ferrocart Receiver.

A remarkable three valve battery set, incorporating a Detector valve, a Driver and a Class "B" output valve, embodying the latest technique and constituting a distinct advance over all other Detector sets.

The introduction of a new type of Iron-cored (Ferrocart) tuning coil, which has been specially designed for us, renders possible a hitherto undreamt of degree of selectivity for a single tune circuit. As a ganged condenser is thus avoided, there is a considerable saving of cost without sacrifice of performance and the power to select stations free from interference is remarkable.

A continuously variable tone control is embodied, which allows the character of the reproduction to be altered to suit the changing moods of the listener. Furthermore, the annoyance of sideband "splash," heterodyne whistles and needle scratch (with records) can be almost completely removed.

The set is self-contained with speaker, also H.T.-cum-bias and L.T. batteries. The Cabinet sets a new standard in modern design and is finished in beautiful selected Burr Walnut and Macassar Ebony.

PRICE, complete in cabinet, as illustrated, including batteries.

£6-17-6

Stand, to match Cabinet, 37/6 extra.

Electric Clock, working from a 2-volt battery, giving 800 days service without attention, fitted to stand at an extra cost of 45/-.

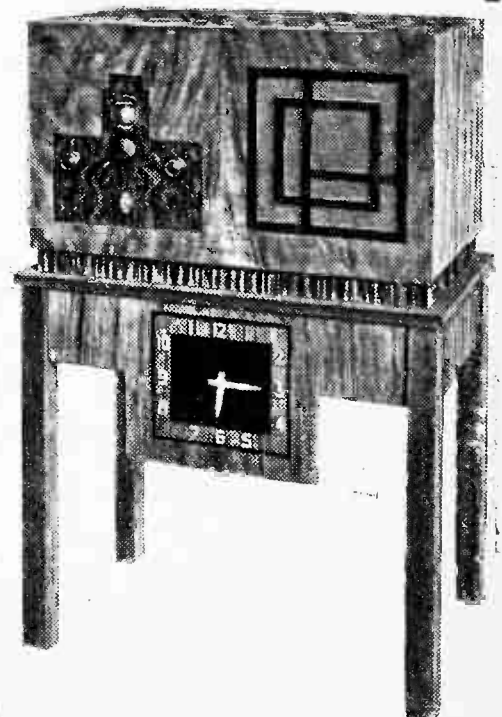

MISCELLANEOUS ADVERTISEMENTS

NOTICES.

THE CHARGE FOR ADVERTISEMENTS in these columns is 12 words or less, 3/- and 3d. for every additional word.

Each paragraph is charged separately and name and address must be counted.

ADVERTISEMENTS for these columns are accepted up to **FIRST POST ON MONDAY MORNING** (previous to date of issue) at the Head Offices of "The Wireless World," Dorset House, Stamford Street, London, S.E.1, or on **SATURDAY MORNING** at the Branch Offices, 19, Hertford Street, Coventry; Guildhall Buildings, Navigation Street, Birmingham, 2; 280, Deansgate, Manchester, 3; 26a, Renfield Street, Glasgow, C.2.

The proprietors retain the right to refuse or withdraw advertisements at their discretion.

Postal Orders and Cheques sent in payment for advertisements should be made payable to **ILIFFE & SONS Ltd.**, and crossed

& Co. Notes being untraceable if lost in transit should not be sent as remittances.

The proprietors are not responsible for clerical or printers' errors, although every care is taken to avoid mistakes.

For particulars of **Box Number Advertisements and Deposit System** see previous issues.

IMPORTANT NOTICE.

Owing to the August Bank Holiday, the issue of "THE WIRELESS WORLD" for August 11th must be closed for press earlier than usual.

MISCELLANEOUS ADVERTISEMENTS for insertion in that issue can be accepted up to

FIRST POST FRIDAY, August 4th.

RECEIVERS FOR SALE.

POWER Amplifier, 8-valve, 2 stages, push-pull (maker Celebretone); £5-9, Holborn Place, Plymouth. [3144

UNUSED ZETAVOX All A.C. 5-valve Chassis, complete with valves; £3/10.—Franklin, 103, Torrione Av., Kentish Town. [3145

UNIVERSAL A.C. D.C. Chassis, complete with valves and Magnavox speaker; trade enquiries invited.—Burler, 19-21, Hamilton Rd., N.5. [3136

R.G.D. 701 A.C. Radiogram, only few months old; bargain at £30.—Murgatroyd, "Riddle-deu," Elm Av., Great Crosby, Liverpool. [3177

MILDMAY RADIO EXCHANGE Offers the Following A.C. Mains Receivers, complete with English valves, and guaranteed sound and perfect.

MICHAEL Dimple Mains 3-valve Receiver, complete with built-in moving coil speaker; listed at £25/4, 1933 model. £9 10.

AMPLION Six, complete with built-in moving coil speaker; £9.

G.E.C. Compact 3-valve, complete with speaker; listed £18/8, £8.

ROSSOR Model 533, 4-valve, with 2 stages of Var. Mu built-in moving coil speaker; £9 net.

ALL Carriage Paid.

PHONE: Clissold 5001.

24, Mildmay Grove, London, N.1. [3156

MORE Part Exchange Receiver Bargains for Disposal; state approximate requirements for quotation.—Contts, Wireless Engineers, Horley. [2613

5-VALVE Portable Sets, 1933 Burgoyne, British valves and batteries, complete; £3/19/6, post paid.—Radio Supply, 13, Aston St., Birmingham. [3150

CLIMAX All-electric 200-250 A.C. Band Pass Three, in walnut cabinet, complete with valves and moving coil speaker; listed £16/16, unopened, £8/8, c.o.d., carriage paid.

OSTER-GANZ Combined A.C./D.C. All-electric Set, 3 valves and Magnavox moving coil speaker, in walnut cabinet; listed £11/11, our price £4/19/6, c.o.d., carriage paid.—Kay, 167, City Rd., Finsbury, E.C.1. [2835

"**WIRELESS** World" Receivers Built to Specification, fully guaranteed; also supplied as kits; trade supplied; write for quotations.—London Radio Development Services, 56, Hazel Rd., Kensal Rise, N.W.10. [2987

CONTINUOUS Gramophone Walnut Console Cabinet, A.C. all mains model, moving coil speaker, B.T.H. pick-up, changes own needle, plays 36 records, full working order.—Apply Advertiser, 385, City Rd., E.C.1. [3151

WALNUT Transportable American 1933 Victor (H.M.V. America) 6-valve superhet, incorporating latest H.F. pentodes, output 3 watts undistorted, 200-500, and 1-000-2,000 metres; listed £24, at £12.—Mayfair Radio, 31, George St., Hanover Sq., W.1. [3186

MAINS EQUIPMENT

N.P. Battery Chargers for A.C. Mains, from 62/6.

N.P. Send New Trade List and Photographs, showing Range of Chargers up to £40.

N.P. Have a Few Slightly Soiled Instruments from 5/7.6 to £12; Westinghouse or valve rectification up to 3 circuits; bargains cannot be repeated.

N.P. Senior Two, £5/5; will do L.T. batteries up to 36, H.T. up to 120 volts 1/2 amp; highest value ever offered.

N.P. Exchange Charger as Business Grows; new trade lists now ready.—Nash Products, Ltd., Stechford, Birmingham, 9. [3112

"Outstanding Volume and Quality"

says "The Wireless World."

"The Burrell A.C. Set is outstandingly good... the power-handling capacity of the output valve is much above the average... there is no apparent distortion of modulation peaks... the reproduction is exceptionally clear and has that elusive two-dimensional quality which makes the individual instruments of the orchestra stand out clear of one another... high-quality reproduction... its range and selectivity are well up to the standard of performance we are accustomed to expect from a three-valve circuit with a single H.F. stage... the set owes its efficiency to careful choice of valves and attention to detail in the design... it is in every way a sound and workmanlike job, and the performance offered—particularly as regards quality of reproduction—is remarkably good value for money."

vide "The Wireless World," July 21st.



That "The Wireless World" should speak so highly of our Receiver is very gratifying to us.

It is also a guarantee to you of the excellent quality of our productions.

A reprint of "The Wireless World" Test Report, together with full particulars, will be sent to any reader on receipt of a postcard.

Price 12 GNS.

Deferred terms arranged if desired.

Trade Enquiries Invited.

BURRELL

RADIO, LTD.,

45, High Road, Willesden Green, London, N.W.10

Phone: Willesden 4203.

ESTABLISHED SUPERIORITY

Specified by the Experts

SOUND SALES

10 HENRY CHOKE

Again exclusively specified by the designer of the NEW MONODIAL SUPERHET

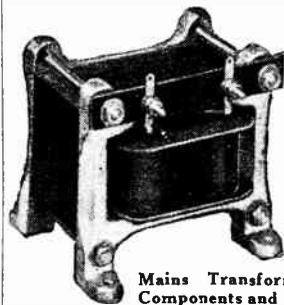

Type 10 D.C.

15/-

You must have SOUND SALES NEW LIST "T"

covering an enormous range of New

Mains Transformers—Class "B" Components and Class "B" Adaptors to convert existing sets to Class "B."

SOUND SALES LTD.,

Tremlett Grove Works, Junction Rd., Highgate, N.19.

CAGE BIRDS

The weekly journal for all who keep Canaries, British Hybrids or Foreign Pet Birds.

EVERY FRIDAY ad.

W.W. 98

Specimen copy of recent issue free on request from The Publisher (W.W.), Dorset House, Stamford St., London, S.E.1

Mains Equipment.—Contd.

SERADEX Products specified for New Monodial Super.

SERADEX Resistors.—Kit A for receiver (19 resistors), 12 9; Kit B for power unit (including tapped power type), 6/10.

SERADEX Monodial Mains Transformer, with colour coded heads, as specified; 37 6.

SERADEX Condensers, 400v. working, 5 0.1 mfd., 8d. each; 2 at 2 mfd., 2/3 each; 1 at 1 mfd., 1/6; one type D, 750v., working 4 mfd., 6 6.

SERADEX Monodial Chokes, weight 3 lb., 10H 200 m.a., 13 6; 20H 100 m.a., 13 6.

TREVOR PEPPER, Wake Green Rd., Birmingham. [3166

SOUND Sales Surplus (Guaranteed Transformers and Chokes).

ANNUAL Audit.—During the past financial year we have produced many thousand transformers and chokes for reputable set manufacturers, experimenters and others; to simplify our annual audit, we are offering a number of surplus transformers and chokes which will be disposed of at clearing prices and are guaranteed; here is an example: mains transformer, primary 210, 230, 250, output 300-0-300 at 60 m.a., 4v, 2 amp. I.T. and 4v, 3 amp. I.T.; price 7 6; many other types offered, subject to being unsold; send for list, these lines will not be repeated; chokes: 20 Henry 200 m.a., price 2 9.—Sound Sales, Ltd., Tremlett Grove Works, Junction Rd., Highgate, N.19. [3185

VORTEXION, Wimbledon, for 99.9% reliable transformers.

If You Haven't Tried Them Yet Ask Someone who has, or call and inspect complimentary letters.

All Standard Models Delivery by Return; all secondaries centre tapped.

GUARANTEED 12 Months, and within 5% normal and 2 1/2% super models, neat shrouding, with detachable feet, as used by Government Departments, etc., etc.

VORTEXION—New monodial transformer, 200-250, 50 cycles, 425-0-425, 120 m.a., 4v. C.T. 3a., 4v. C.T. 1a., 4v. C.T. 1a., 4v. C.T. 6a., screened primary, open type, 20/-; shrouded, 22/-; super shrouded, 26/-; 10 Henry choke, 5 6; 20 Henry choke, 8 6.

VORTEXION—Ferrocort III, 350-0-350, 60 m.a., 4v. 2.5, C.T., 4v. 3.5, C.T.; open type 13/6, shrouded 16/-; post 9d.

VORTEXION—250-0-250, 4v. 1 to 2a., 4v. 2 to 4a.; open type 10 6, shrouded 12 6; post 8d.

VORTEXION—Super model for H.T.8 or 9 or 10, 4v. 1 to 2, 4v. 2 to 4; open type 14/6, shrouded 16/6; post 1/-.

VORTEXION—2 1/2-watt Monodial A.V.C. model; open type 14/6, shrouded 16 6; post 1/-.

VORTEXION—5-watt Monodial A.V.C. model, 400-0-400, 120 m.a., 4v. 6a., 4v. 3 1/2a., 4v. 2, 4v. 1a., super screened; 20/-, shrouded 24/-.

VORTEXION—350-0-350, 120 m.a., 4v. 2 to 5a., 4v. 2 to 4a., 4v. 2.5a.; open type 14/6, shrouded 16/6.

VORTEXION—400 or 450 or 500v., 120 m.a., 4v. 2 to 5, 4v. 2 to 5, 4v. 2 to 5; open type 19/-, shrouded 23/-.

VORTEXION—400 or 450 or 500, 150 m.a., 4v. 4a., 4v. 2.5, 4v. 2, 4v. 2, 4v. 2, core size 2 1/2 in. x 1 1/2 in., a super job, 2% regulation; 35/- shrouded, with terminals, less terminals, 30/-, open type 26/-; post 1/3.

VORTEXION Auto Transformers to B.E.S.A. Specification, 100, 110, or 120v. to 200, 220 or 240 volts, 60 watts, 7/3, post 9d.; 120 watts, shrouded 12 6, open type 10 6, post 1/-; 200 watts, open 14/6, shrouded 16/6, post 1/-; 500 watts, 30/-, 2,000 watts, £4/10.

VORTEXION 600-watt Transformers; £4/10, carriage free.

VORTEXION 30h. at 60 m.a. Chokes, 5/6; 40h. at 60 m.a., 8/6; 30h. at 150 m.a., 200 ohms, 10/6 open type, 12 6 shrouded.

VORTEXION 200v. 30 m.a. Eliminators, 110 or 220 input with 4v. 4a. winding; 37/6.

VORTEXION—Transformers made to your specification. All standards in stock. Phone all hours.

VORTEXION (S. A. Brown), 182, The Broadway, Wimbledon, Tel.: Liberty 2814. [3117

TANTALUM for A.C. Chargers, H.T. and L.T.—Blackwell's Metallurgical Works, Ltd., Garston, Liverpool. [2139

PUBLIC Address!—Eliminator, input 200-250 volts 40-100 cycle, output 500 volts 25c millamps (two new rectifying valves included); £7-9, Holborn Place, Plymouth. [3140

180 Accumulator Chargers, 1/2 amp., 2-6v., in ventilated metal case, with mains flex (Westinghouse rectifiers), 10/8; 1 1/2 amp., 21/-; 7 days' trial.—Arden Agency, Wollaston, Wellingborough. [2964

HOYNE'S Transformers and Chokes the Best Obtainable, perfect insulation, regulation and reliability, used exclusively by discriminating set manufacturers, all fitted with tapped and screened primaries, filaments all centre tapped, stout cast aluminium clamps fitted to all models, also clearly marked terminal strips.

HOYNE'S Components are Guaranteed for One Year.

HOYNE'S Transformers Built to Your Specifications, at very competitive prices.

HOYNE'S New Monodial Super Model, 425-0-425v. 120 m.a., 4v. 3a., 4v. 1a., 4v. 1a., 4v. 6a., 17/6, post 1/3; super model, 24/-, post 1/3; chokes for same, 10h., 20h., 16/6 the pair, post 1/-.

HOYNE'S—200-250v. 60 m.a., 4v. 1-2a., 4v. 2-4a.; 10/-, post 9d.

HOYNE'S—250-0-250v. 60 m.a., 4v. 1-2a., 4v. 2-4a.; 4v. 1a.; 12/6, post 1/-.

HOYNE'S—350-0-350v. 60-70 m.a., 4v. 2-3a., 4v. 3-4a., 12/6, post 1/-, Ferrocort III model.

HOYNE'S—350-0-350v. 70-80 m.a., 4v. 2-3a., 4v. 3-4a., 4v. 1-2a.; 13/6, post 1/-.

HOYNE'S—350-0-350v. 120 m.a., 4v. 2-3a., 4v. 4-6a., 4v. 1-2a., 16/-, post 1/3.

HOYNE'S—500-0-500v. 140 m.a., 4v. 2-4a., 4v. 4-6a., 4v. 2a., 4v. 2a., 27/6, carriage 1/6, weight 12lb.

HOYNE'S—0-110-135v. 90 m.a., 4v. 2-4a., suitable for H.T.6 or 7; 10/-, post 9d.

HOYNE'S—200v. 200 m.a., 4v. 2-4a., 4v. 1-2a., suitable for H.T.8; 13/6, post 1/-.

HOYNE'S—0-200-240v. 200 m.a., 4v. 2-4a., 4v. 1-2a., suitable for H.T.8 or 9; 14/6, post 1/3.

HOYNE'S—Line transformers and chokes always in stock; we can also supply all components.

J. HOYNE, Offices and Works, 8a, Gladstone Rd., M. Wimbledon, S.W.19. Tel.: Liberty 3303. [3107

Mains Equipment.—Contd.

A.C. or D.C. Chargers for 2 to 200 Cells at Low Prices; state requirements; dynamos and rotaries in stock, all sizes; Brown's Generator, battery superchargers for H.T. for 2v. or 6v. input, 37/6 and 52/6; television and sewing machine universal motors, 25/-; lists.—Electradix Radios, 218, Upper Thames St., E.C.4. [10398]

CABINETS.

RADIOGRAM Cabinets; fully illustrated list free; remarkable values.—Gilbert, Cabinet Maker, Swindon. [1686]

CHEAP Cabinets for Radio Sets, loud-speakers and radiograms, hundreds to select from; no catalogues.—H. J. Smith and Co., Ltd., 289, Edgware Rd., London, W.2. [2958]

DYNAMOS, ETC.

ROTARY Converters, 220 volts D.C. to 200 volts A.C., capacities up to 0.44 K.V.A., cheap.—Milo Engineering Works, Milo Rd., East Dulwich, S.E.22. Sydenham 4422. [2907]

OFFERS Wanted.—Motor generator, input 210 volts D.C., output 360 volts and 6 volts, 6 amps., both circuits smoothed; motor generator, 210 volts input D.C., 400 volts 100 milliamperes output smoothed; also 110 volts and 200 volts moving coil Rice Kellogg speakers.—Walker, Park Motor Co., Ltd., Wells St., Jermyn St., S.W.1. [3183]

GRAMOPHONES, PICK-UPS, ETC.

AUTOMATIC Record Changer, with tone arm and pick-up, 220-240 volts, A.C., 50 cycles; bargain, £5.—Lipton, 614, Old Ford Rd., London, E.3. Advance 3345. [3148]

LOUD-SPEAKERS.

B.T.H. RK Moving Coil Speakers, guaranteed new, unused, manufacturers' surplus, original price.

6 Guitars, highly sensitive and wonderful tone response, will handle up to 10 watts output, available for 6v., 100v., 200v. D.C., 30/-, also A.C. models.

£2.10; carriage paid, c.o.d., or cash with order; the best value in speakers obtainable today. Seakamp, 46, Farringdon St., London, E.C.4. Telephone: Holborn 0129. [1425]

CINEMA Moving Coil Speakers on 4-foot Baffles, 110 volt net; 50/- each.—9, Holborn Place, Plymouth. [3141]

2,000 Blue Spot 100.H. Indicator Units, guaranteed brand new, unpacked; usual price 39/6, our price 15/-, post paid.—Radio Supply, 13, Aston St., Birmingham. [3149]

PETER GRASSMANN Moving Coil Speakers, 6in. cone, 7 Watt dissipation, 220 volt D.C. type, 20/- each; discontinuing line.—Rotor Electric, Ltd., 4, Robert St., N.W.1. [3154]

30/-!—B.T.H. RK moving coil speakers, 6in. cone, new and unused, guaranteed; these speakers are type as used in cinema sound equipments; suitable for public address work; weight 35lb., and are vastly superior to cheap speakers now on the market, 100 volts, 150 volts, and 200 volts D.C.

27/6!—6v. D.C. speaker, as above; £2 7/6, speaker as above for 100-250 A.C.; carriage paid; cash with order, or c.o.d.

B.T.H. Brand New Public Address Amplifiers, 4-stage, including microphone stage, 2 types, 12 watts and 6 watts outputs, 12-watt type has 2 P.P.5 400s in output, 6-watt type has 2 P.P.3/425s in output, 12-watt type price £15, 6-watt type £12/10; B.T.H. cinema type pick-ups, brand new, 17/6—Ward, 12, Tredegar Rd., Bow, E.3. Advance 3668 [3082]

VALVES.

THE Following Valves are Guaranteed as New, and any valve differing from the makers' characteristics will be exchanged, all latest types.

A.C./Pens., P.T.4s, G.U.1s, A.C.S.G./V.M.s, Pen. 4V.s, M.V.8.G.s, P.T.625s, V.M.8.4s, D.C.2 Pens., D.P.T.4s, M.P.T.4s, V.M.4V.s, A.C.S.1/V.M.s, P.M.24B.s, D.C.28.G./V.M.s, 11/7, M.S.4s, M.S.4B.s, A.C.S.G.s, S.4V.A.s, S.4V.B.s, M.S.G./H.A.s, D.S.B.s, A.C.S./2s, P.X.4s, D.C.28.G.s, 9/6; U.14, 10/7.

M.L.4s, A.C./P.s, 41M.P.s, P.M.24s, 8/7; A.C./H.L.s, 164V.s, 354 V.s, A.C.2/H.L.s, 41M.H.L.s, U.10s, U.U.60/250s, M.H.4s, M.H.L.4s, 7/6; V.S.2s, 215H.G.s, 220S.G.s, P.M.12s, P.M.12A.s, 9/7; 442H.U.s, D.W.3s, 8/6; 215P.s, 220 P.s, I.P.2s, 4/9; P.2s, 6/6; P.T.2s, P.M.22A.s, 9/7; H.L.210s, H.210s, 4/210s, 3/9.

ALL Types of Brand New American Valves in Stock. A first class makes: 247s, 235s, 224, 236s, 237s, 245s, 248s, 12/7, 227s, 226s, 280 245s, 9/6; 242s, 232s, 11/7; U.X.210s, 15/7.

U.X.250s, 7 watts output, 16/7; 231s, 14/6; for quickest delivery send telegraph money order.

OVER 5,000 Valves Always in Stock for Immediate Delivery; carriage paid; cash with order or c.o.d.—Ward, 12, Tredegar Rd., Bow, E.3. Advance 3668 [3081]

0111—Slightly used valves, boxed, A.C./Pens., D.C./Pens., V.M.S.4s, M.S.4B.s, A.C./S.G.s, P.T.41s, 41M.D.G.s, S.4V.B.s, A.C.S.1/V.M.s, 9/11 each.

0111—Calkin V.M.S.4s, M.S.4B.s, 11/6; Calkin M.H.4s, 8/11; Class B, 240B, 220B, P.M.2B, 7/11; P.X.4s, 10/6 each.

0111—S.G.215s, S.215A.s, S.215B.s, 220V.S.G.s, P.M.12s, P.M.12A.s, Pen. 220s, Pen. 220A.s, P.M.22s, P.M.22A.s, 8/11 each.

0111—M.H.4s, M.H.L.4s, A.C./H.L.s, A.C.2/H.L.s, 354V.s, 904V.s, U.U.60/250s, 6/11; H.L.210s, P.M.11L.s, P.M.11F.s, P.M.11D.s, P.M.2D.X.s, 3/9; P.220s, P.M.2s, 4/9.

0111—P.P.5/400s, 17/6; A.C./P.s, A.C./P.1s, P.220A.s, A.C.O.64, 7/6 each; enquiries invited others.

0111—Cash or c.o.d. orders to White House, Rosehill Parkway, Sutton, Surrey, Sutton 4591. [3155]

AND Another Large Purchase of Set Manufacturers' Stock, guaranteed as new, and any valve differing from the makers' characteristics will be exchanged free; all latest types.

H.L.210, H.210s, 1.210s, 210H.L.s, 210H.F.s, P.M.11F.s, H.L.3 9/7; P.M.2s, P.M.2A.s, L.P.s, 220P.s, 215P.s, 4/9; H.L.s, 41M.H.L.s, M.H.L.s, A.C./H.L.s, A.C.2H.L.s, 354V.s, D.C./3H.L.s, 1821s, 7/7; M.L.4s, A.C./P.s, 164V.s, 104V.s, P.M.24s, 442H.U.s, 1807s, 7/6; S.4V.B.s, S.4V.s, M.S.4B.s, M.S.G./H.A.s, A.C./S.G.s, A.C.2, 41M.S.G.s, D.S.B.s, 215/S.G.s, P.M.12s, P.M.12A.s, 9/-; Pen.4V.s, V.M.S.4s, M.M.A.V.s, P.T.41s, P.T.41B.s, D.P.T.s, A.C./Pens., 11/7; 620P.s, 680P.s, 10/7.

OVER 4,500 Valves Always in Stock for Immediate Despatch; carriage paid for cash or c.o.d.; prompt delivery.

NEWMAN, 303, Roman Rd., E.3. [2892]

The OSTAR GANZ HIGH VOLTAGE MAINS VALVES

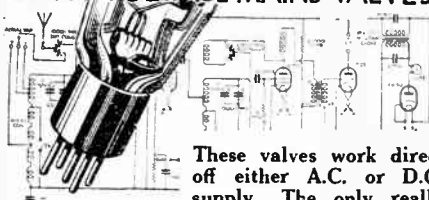

These valves work direct off either A.C. or D.C. supply. The only really UNIVERSAL high voltage mains valves. No transformers or resistances required. Remarkably free from mains hum.

YOU CAN BUILD THIS "UNIVERSAL THREE"

A proved circuit that gives perfect results. Economical to build. These are the valves you need.

A.520. Detector - 17/6 | L.1525. Super Power 18 - W.310. Res. Cap. - 17/6 | E.G.50. Rectifier - 14/6 FREE CIRCUIT WITH VALVES.

CONVERT YOUR BATTERY SET TO ALL - MAINS

It's easy and economical with Ostar Ganz.

BUY A "UNIVERSAL" KIT.

2 Valve Set - - £5 . 15 . 0. 3 Valve £8 . 15 . 0.

2 Valve Amplifier £4 . 4 . 0. 3 Valve £5 . 5 . 0.

All-electric Radiogram Kit complete £12 - 18 - 0

All Price include Valves and Rectifier.

Blue prints Free with kit.

For full range of Values, write for Leaflet.

CALL AND HEAR A DEMONSTRATION.

EUGEN FORBAT

Sole Agent for Great Britain. 28-9, Southampton Street, Strand, W.C.2. Telephone: Temple Bar 8608.

THE RECOMMENDED RESISTANCES

FOR THE NEW MONODIAL SUPERHET

you'll need

ERIE

IMPREGNATED

RESISTORS

of course



Note that 18 Eries are recommended for the New Monodial Super and 6 for the Power Unit... recommended because Eries don't let you down. Just ask for the "New Monodial Super" Kit—"A" (18) or "B" (24).

1/- per watt in all values. Color coded and labelled.

Ask definitely for Erie. Write for Color code chart.

THE RADIO RESISTOR CO. 1, Golden Sq., Piccadilly Circus, London, W.1

COMPONENTS, ETC., FOR SALE.

R. SELECTED Parts for Sale, as new, any c.o.d. or "Wireless World" deposit system, which we recommend if in doubt as to the splendid value offered; we take risk of damage in transit to customers; goods tested for callers and returned.

THE New Monodial Super, Ryalls 1-watt resistances, all values, 6d. each; 4 mfd. 900v. working condenser, with terminals, 6/6; V.M.8.4, new, 10/-; T.C.C. type 50 2 mfd., 2/-; 1 mfd. ditto, 1/6; radiophone 5,000 ohm volume control, with switch, 2/6; A.F.5e Ferranti, as new, 21/6; Ryalls 20H choke, 8/9; 10H, 8/9. (to specification); Ryalls 8 mfd. wet electrolytic 450v. working, 3/6; T.C.C. 8 mfd. dry, 3/6.

B.T.H. Senior P.M. Speaker, with transformer, 50/-; B.T.H. Junior nickel pick-up, 8/6; Amplion microphone, £3.

WE hold a large stock of First Class Radio Apparatus, meters, resistances, condensers, heavy chokes, etc., in addition to goods advertised.

VARIABLE heavy duty inductive transformer, 10/6; pair Variable P.P. transformers, separate G.B., 22/6.

POLAR Star 3-gang Condensers, 16/6; with drive, 18/6;

Radiophone 3-gang condensers, fully screened, with trimmers, Radiopak type, 9/-; post 9d.; Polar Uniknob 2 gangs, with drive, 7/6; Radiophone 4 gangs, 12/6;

with cover and drive, 16/-; Radiophone 4-gang superhet, type, screened, with trimmers, Radiopak type, 9/-, post 9d.

T.C.C. Block Condensers, 2.4 mfd., 250v., working, 3/6;

ditto, 2.4 mfd., 2.2 mfd., 4/-; Ryalls condenser block, 2.4 mfd., 2.2 mfd., 400v. working, 3/-; Lotus new 4 gangs, 17/6.

VALVES, all guaranteed as new, full emission.—A.C./P.1, 8/6; A.C./H.L., 7/6; A.H.F., 7/-; A.C./S.2, 9/-; S.4V.A., 12/-; Mazda S.G.V.M., 9/6; A.C./P. 8/-; A.C./P.E.N., 10/6; 904v., 7/6; U.10, 7/6; 164v., 7/6. Following callers only: P.625, 5/-.

RYALLS RADIO, 35, Chancery Lane, London, W.C.2. (nearest Tube, Chancery Lane; bus 67 passes door, or tram to Savoy St.). Holborn 3529. Open Saturday afternoon. Close 7 p.m., Saturday 6 p.m., Thursday closed all day. [3169]

PREMIER Summer Sale.

10% Discount on All Orders of £1 or Over.

MANY Prices Reduced Apart from Discount.

PREMIER SUPPLY STORES offer the Following Set Manufacturers' Surplus Brand New Goods at a Fraction of the Original Cost; all goods guaranteed perfect; carriage paid over 5/-, under 5/-, postage 6d. extra. (Ireland carriage forward.)

RE-IGNITOR Kits, including Transformer, Westinghouse metal rectifier, Pye choke, T.C.C. condensers, resistances, and diagram; 250 volts at 60 m.a., 30/-; 150 volts at 30 m.a., 25/-; 120 volts at 20 m.a., 20/-.

MONTE Sheets for Charging Boards, 24in. x 24in. x 3/16in., 3/- each.

T.C.C. Condensers.—2 mfd., 750v. working, 3/6; 4 mfd., 6/-; 4 mfd., 400v. D.C. working (300v. A.C.), 4/-.

M.F., 500v. working, 1/6; 4 mfd., 200v. working, 2/6; 0.5 mfd., 1,500v. working, 1/6; 4 mfd. Electrolytic (aqueous type), 440v. working, 3/-; 8 mfd., 3/6.

RE-IGNITOR Condensers, 0.01 mica, 6d.; 0.01 mica, 1,000v. working, 1/-, mica.

POLAR 3-gang 0.0005 Condensers, split end vanes, totally screened, disc drive, 6/11.

AMSCO Triple-gang 0.0005 Condensers, with trimmers; 4/11.

ORMOND 0.0005 Condensers, 1, 3; 2-gang semi shielded, 2/6.

WESTERN ELECTRIC Mains Transformers, input 200-250 volt, output 500-500 volt, at 150 milliamperes, 4v. 4a., 4v. 2.5a., 4v. 2a., 4v. 1a., 4v. 1a., massive job; 19/6.

T.C.C. Electrolytic Condensers, 10 mfd., 100 volts working, 1/-; 15 mfd., 1/3.

SPECIAL Offer of Mains Transformers, manufactured by Philips, input 100-115v. or 200-250v., output 180-0-180 volts, 40 m.a., 4v. 1a., and 4v. 3a., 4/6; 200-0-200v., 4v. 1a., 4v. 3a., 4/6.

ALL Premier Guaranteed Mains Transformers have engraved terminal strips with terminal connections, input 200-250 volts, 40-100 cycles, all windings paper interleaved.

PREMIER H.T.8 Transformer, 250v. 60 m.a., rectified, with 4v. 3.5a. c.t. L.T., and screened primary, 15/-; with Westinghouse rectifier, 25/-.

PREMIER H.T.9 Transformer, 300v. 60 m.a., rectified, with 4v. 3.5a. c.t. L.T., and screened primary, 15/-; with Westinghouse rectifier, 26/-.

PREMIER H.T.10 Transformer, 200v. 100 m.a., rectified, with 4v. 3.5a. c.t. L.T., and screened primary, 15/-; with Westinghouse rectifier, 25/-.

PREMIER Mains Transformer, output 135v. 80 m.a., for voltage doubling, 8/6; 4v. 3.4a. c.t. L.T., 2/- extra; Westinghouse rectifier for above, giving 180v. 30 m.a., 8/6.

PREMIER Mains Transformers, output 250-0-250 volts, 60 m.a., 4v. 1.2a., 4v. 2.3a., 4v. 3.4a. (all c.t.), with screened primary; 15/-.

PREMIER Main Transformers, output 350-0-350 volts, 50 m.a., 4v. 3.5a., 4v. 2.3a. (both c.t.), with screened primary; 15/-.

PREMIER Mains Transformers, output 400-0-400 volts, 100 m.a., 4v. 4.5a., 4v. 2.3a. (both c.t.), with screened primary; 15/-.

PREMIER Auto Transformers, 100-110/200-250 volts or vice versa, 60-watt, 7/9; 100-watt, 10/-.

SPECIAL Offer of Manufacturers' Type Transformers, any input, output 250-0-250 volts, 60 m.a., 4v. 1a., 4v. 3a. (both c.t.), 8/6; H.T.8 transformer, with 4v. 3.4a. (c.t.), 8/6; with rectifier, 18/6.

AMPLION Mains Transformers, input 100-250 volts, output 350-0-350 volts, 120 m.a., 4v. 5a., 4v. 2a., 6v. 1a. (all c.t.); 17/6.

FILAMENT Transformers, polished and engraved terminal boards, X.P. terminals, 4v. 3.4a., 5/-; 10v. 3a., 6/6; 12v. 1a., 5/-; 4v. 4.6a., 6/6; 14v. 4a., 6/6; 22v. 1a., 6/-; 6v. 2a., 5/-; 9v. 1a., 5/-.

PREMIER Chokes, 40 m.a., 25 hys., 4/-; 65 m.a., 30 hys., 6/-; 150 m.a., 30 hys., 10/6.

PREMIER Chokes, 20 or 32 hys., 4/-; Premier multi-ratio output transformers, giving 15 different ratios, 7/6.

PREMIER Eliminators, input 200-250 volts, 40-100 cycles, A.C., incorporating Westinghouse metal rectifiers, output 250v. 60 m.a., S.4V. and 120v. taps, 42/6; with 4v. 4a. c.t. L.T., 7/6 extra.

(This advertisement continued on next page.)

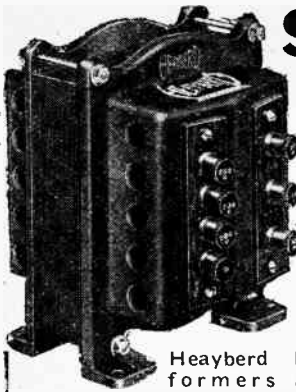

SAFE POWER from the MAINS

Heyberd Mains Transformers are safe in operation and absolutely foolproof. The windings are totally enclosed in special metal end-plates, which provide ample protection against mechanical damage, and insulated terminals are fitted. All Transformers are submitted to a series of very severe tests before leaving the works. Made by British workmen from the finest British materials—Heyberd Transformers ensure a really safe power unit. Whether you prefer valve or metal rectification, there is a Heyberd Transformer to meet your requirements. Here is a popular model for use with Westinghouse HT.8 Rectifier: **HEYBERD W.31 TRANSFORMER Rectified Outputs: 200 or 250v at 60 ma. L.T., A.C.4v. 1 amp. and 4v. 5 amps. C.T. Price 30/-**

Send 3d. stamps TO-DAY for 36pp. Handbook—packed with hints and circuit diagrams on Mains Workings.

F. C. HEYBERD & Co.
10, Finsbury St., LONDON, E.C.2
Minutes from Moorgate Station.



IF YOUR RECEPTION IS ONLY "LOCAL"



WILL MAKE IT CONTINENTAL



because it is the most selective aerial. The extra heavy rubber insulation not only cuts out interference, but abolishes masts, insulators and separate leads-in. Don't buy inferior imitations, but insist on SUPERIAL, the only efficient invisible or indoor aerial. Get your £100 Free Lightning Insurance today from your wireless shop.

100ft 3/6: 75ft 2/6: 50ft 1/9: 25ft 1/4
THE NEW LONDON ELECTRON WORKS LTD EAST HAM LONDON E.6

FIRST CLASS REPRODUCTION

AN UNREPEATABLE OPPORTUNITY TO SECURE A REAL B.T.H. R. K. LOUDSPEAKER GUARANTEED NEW AT BARGAIN PRICES

Specification:—6in. diameter cone Moving Coil Loudspeaker giving full bass response and handling the output from the heaviest power valve. Far superior to many small modern moving coil speakers. Weight 30 lbs. Field winding to suit 6, 100, or 200 volts D.C. Send cash with order or C.O.D.

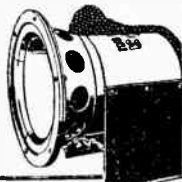

R. K. SPEAKER Originally listed at £6.6.0 Now offered for **30/-** A.C. MODELS £2. 10. 0

Telephone: HARBORN 0129
O. H. SEEKAMP, 46, FARRINGTON ST., E.C.4

Components, etc., for Sale.—Contd.

(This advertisement continued from previous page.)
PREMIER Eliminators, output 150v. at 30 m.a., S.G., and 100v. taps, with 4v. 3-4a. c.t. L.T., 37/6; or with trickle charger, 42/6.
PREMIER Eliminators, output 120v. at 20 m.a., S.G., and 100v. taps, 27/6; with L.T. trickle charger incorporated, 35/-.
PREMIER D.C. Eliminators, output 120v. at 20 m.a., S.G., and 100v. taps; 15/-.
ACCUMULATOR Chargers, 200-250 volts A.C., all incorporating Westinghouse metal rectifiers; 2, 4, and 6v. at 1/2 amp., 12/6; 2, 4, and 6v. at 1 amp., 17/6; 12v. at 1/2 amp., 27/6; 6v. 2a., 35/-. 12v. 2a., 35/-. 12v. 1.5a., 30/-. 6v. 3a., 39/6; 12v. 3a., 42/6.
AMPLION High Inductance Chokes, resistance 2,500 ohms, 80 hys., 60 m.a.; 5/6.
WESTINGHOUSE Metal Rectifiers: 120v. at 20 m.a., 6/6; 180v. at 30 m.a., 8/6; 8v. at 1/2 amp., 6/6; 6v. at 1 amp., 9/6.
KOLSTER BRANDES Electric Gramophone Motors, complete with turntables and automatic stop, 100-250v. A.C. and D.C.; list price £5, to clear £2.
BT.H. Induction Type (A.C. only) Electric Gramophone Motors, 100-250v.; 30/- complete.
ROLA Type F6 Moving Coil Speakers, 2,000 or 6,500 ohms, with power or pentode output transformers, 17/6; A.C. conversion kit for this speaker, 10/- extra.
AMPLION Moving Coil Speakers, type E.M.644, dual fields, 2,500 and 5,000 ohms (100 and 200v.), with output transformer, 12/6; A.C. conversion kit for this speaker, 10/- extra.
WESTERN ELECTRIC Condensers, 250v. working, 1 mfd. 6d., 2 mfd. 1/-; 500v. working, 1 mfd. 1/-; 400v. working, 3 separate 4 mfd. condensers, 8/6.
TC.C. Condensers, 250v. working, 4 4-1 mfd., 3/6; 300v. working, 4x4x2-2x2 mfd., 6/-; 300v. working, 4x4-2x1 mfd., 6/-; 6x4x2-2x2 mfd., 375v. working, 6/11.
SPECIAL Offer of Wire Wound Resistances—4 watts, any value up to 10,000 ohms, 1/-; 8 watts, any value up to 15,000 ohms, 1/6; 15 watts, any value up to 50,000 ohms, 2/-; 25 watts, any value up to 50,000 ohms, 2/6; 50 watts, any value up to 50,000 ohms, 3/6.
WIRE Wound Potentiometers, 15,000 ohms, 1/6; Centralab Potentiometer volume controls, 50,000 ohms, 2/-; wire wound Clarostat Potentiometer, 50,000 ohms, 2/6; Colverstat, logarithmically wound Potentiometers, 6,000 ohms, 1/9.
HEAVY Duty Variable Resistances, slider type, wound on porcelain, 2,000 ohms quarter-amp, and 500 ohms half-amp.; 5/- each.
FOR Callers Only.—The following valves, guaranteed as new: P.T.625, M.P., P.E.N., D.C.S.G., V.D.S., V.M.S., S.V.A., A.C.S.G., A.C.S.G.V.M., V.M.S.G., 41M.S.G., V.M.S.4, M.S.4B., T.5, 904V., M.S.G.L.V., M.S.G.H.A., M.H.L.4, M.L.4, M.H.4, T.14, S.V.B., D.W.3, P.T.4, D.S., D.S.B., M.S.4, 41M.L.F., P.E.N.4V., M.V.S.G., A.C.H.L.; at half list price.
THE Last Few Western Electric 4211-D Valves, 10v. 3t. filament, 750 1,000v. plate, 50-65 m.a., impedance 3,500 ohms, amplification factor 12; cost £5, to clear at 15/-.
500-VOLT 125-millamp. Full Wave Rectifying Valves, 4v. 2a. filament; 7/6.
PHILIPS 328 Valves for L.T. Charging, 5/6; 329 Barrier lamps, 2/-.
ALL the Following Lines 6d. each, or 5/- doz. assorted: Shielded S.G. or Pentode leads, 2ft. lengths of screened wire; 5-pin valve holders; Crabtree 5-amp. sunk switches; T.C.C. 0.1 mfd. condensers.
AMPLION 6 (second-hand) A.C. 200-240v., complete with valves and enclosed moving coil loud-speaker; £7 19/6.
HANLEY Pick-ups with arm and volume control; 12/6.
PREMIER SUPPLY STORES, 20-22, High St., Clapham, S.W.4. Macaulay, 218B, closed 1 o'clock Wednesdays, open to 9 o'clock Saturdays. Nearest Station, Clapham North Underground.
PREMIER. [3139]

GILBERT INDUSTRIES Latest Parcel Offer:—
COMPLETE Kit for 30 m.a. 150-180 volt A.C. Eliminator, comprising one "B" parcel as under, together with handsome cellulose finished steel case, engraved panel, plugs, wiring wire, solder, nuts, bolts, flex, plug, etc., and blue print; a complete £5/5 eliminator ready for assembly, at 30/- post paid.
A "PARCELS, containing one each of the following high grade components: 1 cadmium plated chassis, 1 heavy mains transformer, 350-0-350 at 60 m.a., 4v. 4a., C.T., 4v. 2a. rect., one H.M.V. 2-gang, with trimmers, and 2 coils, one electrolytic 8 mfd., 435 working, one H.M.V. screened H.F. choke, one volume control, one smoothing choke, 50 h., 50 m.a.; complete parcel, post paid, £1.
B "PARCELS, containing one each of the following high grade components, suitable for building Class B or straight 30 m.a. 150-180v. A.C. eliminators: One Westinghouse rect., voltage doubler, one transformer, one condenser pack, 4-4+2+1+1+0.25, one choke, 50 h., 50 m.a., 4 resistances (please state mains voltage), complete parcel, post paid, £1.
D "PARCELS, containing all the following high grade components: One transformer, 350-0-350 at 60 m.a., 4v. 4 to 6a., C.T., 4v. 2a., one chassis and 3-valve holder, one H.M.V. 2-gang, with trimmers, one 15 mfd. T.C.C. electrolytic, one 4-4 mfd. T.C.C. block, one volume control, 4 assorted resistances, 6 small assorted condensers, one Paxolin strip (10in. 4in.), one packet of "Varic" insulating sleeving, 6yds. heavy flex, complete parcel, post paid, £1.
ONE "A," "B," or "D" Parcel, and one Paillard type 1504 gramophone motor, 100-250 volts a.c. input, complete with turn table, post paid; £2.
CONDENSER Parcels.—One 8 mfd. (tapped 4+4), one 4 mfd. T.C.C., one 15 mfd. electrolytic T.C.C., one decoupling pack, 2-0.5+0.5+0.5+0.1, 6 small useful condensers; all new and unused, post paid, 10/-.
TRADERS.—Do you realise that these parcels, when split up, will realise £3 to £4 in the shop?
GILBERT INDUSTRIES, Ltd., 519, London Rd., West-cliff-on-Sea. [3184]

SHORT-WAVES!

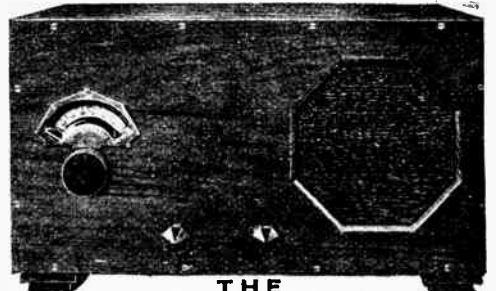

THE "EQUATOR-SUPER" (Battery Model)

FOR TROPICAL USE and Empire Station Reception

PRICE £33 plus £1. 1. 0 Royalty (Overseas) Incorporating Westinghouse Metal Oxide Detector and Automatic Volume Control. Write for full details

SCOTT SESSIONS & CO. Radio Engineers

MUSWELL HILL, LONDON, N.10
Cables: "Tropiset, London."
Contractors to H.M. Government depts., &c.

"DO NOT SPOIL THE SHIP"

Build into your "WIRELESS WORLD" NEW MONODIAL SUPERHET

MODEL "240" RICH & BUNDY MAINS TRANSFORMER

Secondaries: 425-0-425v V. 120 m.a.
4v.c.t. 3 amps. 4v.c.t. 6 amps.
4v.c.t. 1 amp. 4v.c.t. 1 amp.
Screened Primary: 200 250v. 40 100 cycles.

PRICE £3-5-0

First in the field:—"RICH & BUNDY FOR RELIABILITY."

Write to-day for descriptive Art Catalogue. RICH & BUNDY LTD., Transformer Manufacturers, New Road, Ponders End, Middx.

Phone: Enfield 0777. Sole Distributors I.F.S.: KELLY & SHEEL Ltd., 47, Fleet St., Dublin, U.I.



"MASTER" WALL PLUGS

PERFECT CONTACT IN ANY SOCKET. NO ANNOYING CRACKLES. SELF-CENTERING. SELF-ADJUSTING. NON-COLLAPSIBLE PINS. WIRED IN A MINUTE. NO TOOLS REQUIRED.

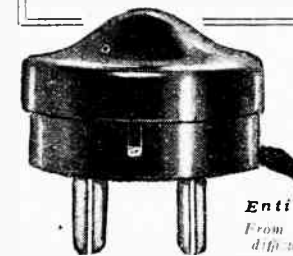

5 AMP. TWIN PLUG Supplied Black or Brown 9d.

Entirely British Made From most dealers. If any difficulty, send us 3/- P.O.

LECTRO LINX, Ltd., 79a, Rochester Row, London, S.W.1.



Every Thursday 3d. W.M.15

WATMEL POTENTIOMETERS GIVE THE BEST CONTROL

It is obvious that if a firm concentrates on one type of component it is going to turn out a better job than a firm that dabbles in many. This year we are concentrating on potentiometers, and you may rest assured that when you purchase a Watmel potentiometer you are obtaining the very best from a firm that specialises in this type of component.

Here is illustrated the Watmel Type 1 Potentiometer.

Any resistance up to 50,000 ohms (Standard Wiring).

Price **5/6**

With quick break Switch

Price **7/6**

Please write for free fully illustrated catalogue that will give you interesting information on Volume Control.

Special models made for manufacturers and for the Export Market. Please write for further particulars.

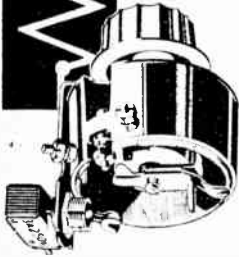

Watmel POTENTIOMETERS GIVE THE BEST CONTROL

WATMEL WIRELESS CO. LTD.,
Imperial Works, High Street, Edgware.

Telephone: Edgware 0223. (M.U. 91)

Components, etc., for Sale.—Contd.

GENUINE Manufacturers' Surplus by Leading Makers.

DDOUBLE Smoothing Chokes Mounted, sound robust job, 120 m.a., 14-28 Henrys each; usual price 35/-, our price 6 6 each, 9d. postage; single ditto, 4 6 each.—Below.

CHOKES, small iron core, 2,000 ohms, for output or choke coupling; 1 6 each, 3d. postage.—Below.

65 Only, massive twin gang condensers, 0.0005, with drum drive, change over switch and trimmers; original cost 45/-, our price 7/6 each, postage 9d. Below.

14 mid. Block Condensers, 250v. A.C. working, 6 4 2-1 1; 2 6 each, postage 6d. Below.

RESISTANCES, wire wound, finest quality at ridiculous prices: 3,000, 5,000, 8,000 ohms, 13,000, 15,000, 65,000 ohms, all 5 watt, worth 3 6 each; 6d. each; postage 3d.; wire wound potential dividers, 60 Watt wound 3 sections, 4,500 ohms, 3,000 ohms, 2,000 ohms, 1 6 each, postage 4d.; 5 Watt ditto, 20,000 ohms, 20,000 ohms, 20,000 ohms, 1 6 each, postage 3d. Below.

2 SEPARATE 60 Watt Resistances on One Tube, 2,500 ohms and 500 ohms, 1/6 each; L.F. transformers, in Bakelite case, ratios 3-1 and 5-1, 2 6 each. Below.

3 SEPARATE 5 Watt Resistances on One Tube, 2,500 ohms, 1,000 ohms, 80 ohms; 1/- each, postage 3d.—Below.

1 00,000 ohms 1 Watt Resistances; 4/6d. each, postage 1/2d.—Below.

RC. Coupling Units, 1/- each, postage 3d. Below.

1 mid. Condensers, 250 volt D.C. working; 6d. each, postage 2d.

4 mid. Condensers, 250 volt D.C. working; 1/6 each, postage 4d. Below.

METAL Screws (first sprayed), with valve holders complete, suitable for adding S.G. valve; 1/6 each, postage 4d.

GOODS Order Value 20/- Carriage Free.

EACH Article is Tested Before Despatch and Guaranteed First Class Manufacture.

CASH With Order, all goods despatched same day.

SURPLUS RADIO, 32, Queensway, Ponders End, Middlesex. [3147]

PEPPEY Offers the Following Under Usual Money-back Guarantee; cash or c.o.d.

VALVES, as new, all tested before despatch, P.M.14, P.M.16, P.M.26, P.T.625, 7 6; P.625a, 5 3; P.M.14g., V.M.S.220, etc., 8 3; P.M.24a, 8 11; P.M.24l, 9 6; 354v., 904v., A.C. p. 104v., U.C.60/250, 7 6; P.M.5x, P.M.5b, H.L.610, D.E.L.610, many other types, 2 3 each.

COHLS, Telsen Ariel, 3 9; Telsen S.T.500, 4 3 pair; Larsen Ganged Oscillator, handpass set (3), 16 6; G.T.2, 4 6; B.P.P., Varley Sinter-peaks, 6 6; A.T.G., T.O.S., Varley, B.P.22, 4 3; bin-waves, type C, 4 6.

LISTS of Slightly Used Battery Chargers, etc., for stamp, Trevor Pepper, Wakegreen Rd., Birmingham. [3157]

SOUTHERN RADIO'S Wireless Bargains. Set manufacturer's guaranteed surplus:—

VARIABLE Condensers, British Radiophine 4-gang superhet type, fully screened and trimmers, 0.0005, 8 9 each (list 45/-); Cydon 3-gang fully screened and trimmers, 0.0005, 7 6 each (list 32/-); Utility 2-gang 0.0005, fully screened with trimmers, dial escutcheon and knob, 8 6 each (list 39 6); Hydra block condensers, brand new, 16 mfd., 2-2 8; 2 1/2, 1, 1,000 volt test (made for Canadian Gramophone Co.), 8 9 each; 4 mfd., 2 6 each; 2 mfd., 1 9 each; 1 mfd., 1/- each; all 750 volt.

GRAMOPHONE Motors, Electric gramophone motors, working on all voltages and cycles, D.C. or A.C., non-interference type, absolutely dead silent, £2 2 each (list at £9 15); A.C. only, 27 6 each (list at £7 10).

SPEAKERS, Celestion Soundex permanent magnet, 16/- (list 27 6); Rola F6 permanent magnet, 25/- (list 49 6); D.C. mains energised, 2,500 to 6,500 ohms, complete with humbucking coils and transformers, 16 6 (list 39 6); Peter Grassman dynamic speakers and chassis, 10 6 each (list 35/-).

CONSTRUCTORS' Kits, Ready Radio "303" battery 3-valve kits, less valves, 18/- each; complete with 3 Mullard valves (P.M.11, F., P.M.2, 21X.), 33/- each (list 70/-); Ready Radio Meteor screen grid 3-valve kit, less valves, 26/-, with 3 Mullard valves (P.M.12a, P.M.21X., P.M.2a), 49/- (list £3 10).

READY RADIO S.T.400 Kits, as specified by Scott Taggart, £3 5 each (list £4 17 6).

READY RADIO Meteor Screen Grid 3-valve "A" Kit, complete with cabinet, permanent magnet speaker, less valves, £3 7 6, with 3 Mullard valves, £4 10 (list £7 10); Mullard Radio for Million 3-valve A.C. kit, complete with 3 Mullard A.C. valves (Pen.4V., 354 V., S.4V.), £3 10 (list £6 10); all kits brand new, in original sealed cartons.

All Goods Guaranteed Brand New and Perfect and Sent Carriage Paid.

PLEASE Note.—We have opened a branch shop at 271-275, High Rd., Willesden Green, N.W.10, where callers are cordially invited to inspect our large stocks of wireless bargains. Please send all post orders to 323, Euston Rd., N.W.1.

SOUTHERN RADIO, 323, Euston Rd. (near Warren St. Tube), London, N.W.1. Phone: Museum 6324. [3175]

SERVICE RADIO, 46, Lisle St., London, W.C.2, offer set Manufacturers' guaranteed surplus:—

SMOOTHING Chokes, 20 Henrys 120 m.a., 9/- each; 50 Henrys 60 m.a., 7/3 each; 40 Henrys 40 m.a., 5 9 each; Weston trimmers, flush type, model 354, 30-50, 4 9 each (list 25 4), brand new and boxed; H.M.V. tone controls, 1 5 each (list 12 6); Rola P.M. speakers, P.6, 28/- each (list 42 6); Mains energised D.C. speakers, 2,500 ohms to 6,500 ohms, complete with Universal transformers and humbucking coil, 16 6 each (list 39 6); P.7 mains energised D.C. speakers, with Universal transformers and humbucking coils, 23 6 each (list 42 4); Pileo All-in-one Radiometer, latest type with bakelite case, 6 only at 9/6 each (list 12 6).

WE Have Purchased a Large Stock of Marconiphono High Power Amplifiers, generators and converters, etc., etc.; this stock is too large and varied to be enumerated in this advertisement; we cordially invite readers of *The Wireless World* to call and inspect our stock, and can guarantee a saving of pounds on any goods purchased; all goods are brand new and guaranteed, and sent carriage paid.—Service Radio, 46, Lisle St., London, W.C.2. Phone: Gerrard 6653. [3130]

CLIX CHEAPEST PERFECT CONTACT

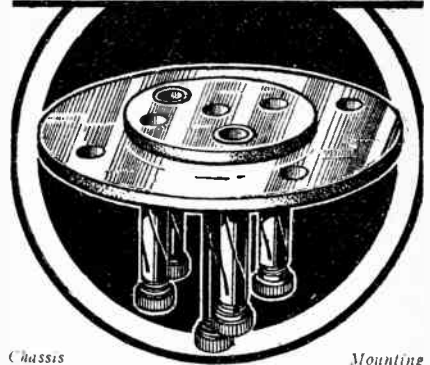

VALVEHOLDERS Specified for the NEW MONODIAL SUPER and POWER UNIT

Contact is all-important in any receiver, therefore Clix is again specified for the improved version of this famous receiver. To ensure perfect, reliable contact and freedom from annoying crackles, always use CLIX. As chosen by experienced designers.

STANDARD TYPE	
4-pin	8d.
5-pin	9d.
FLOATING TYPE	
7-pin	1/-
ANTI-MICROPHONIC	
4-pin	1 2
5-pin	1 3

For details of over 30 Perfect Contact Components, write for the Clix New Folder 'W'

Lectro Linx, Ltd., 79a, Rochester Row, S.W.1

50 RANGES WITH THE DIX-ONEMETER

Micro-amps to 20 amps. Millivolts to 2,000 volts, 50 Ohms to 50 megohms

MULTIPLIERS EACH, 6/6

6 TERMINALS
Ranges by multipliers at extra cost. Latest Model. To Is: Grade Brit. Eng. Standard. Mirror Double Scale. Moulded Base. The finest precision Multi-measuring instrument obtainable. The High-grade Radio Tester. Low P.c.e. High **60/-** Value

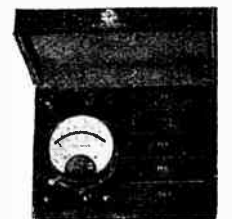

An Ideal COMPLETE RADIO OUTFIT £4 : 19 : 6

If you want a small A.C. Test Meter that is really a VEST POCKET TESTER, a wonderfully versatile moving-iron, multi-range meter for service on A.C. jobs.

No projecting terminals. THREE ranges of volts: 0-7.5, 0-150, 0-300. Used for MILLIAMPS reads 0-123 m.a., and 0.75 m.a. THE DIX-MIPANTA. In black bakelite case. Measures only 2 1/2 in. x 2 1/2 in.

Complete in case with pair of test leads and plugs. Lcaflet "M" gives full information. **19/6** THE DIX-MIPANTA



METERS. Testers No. 108, with moving-coil meter and graded Rheo., 12 6. Silvertown astatic horizontal galvos, jewel pivots, 7/- Sifam polarised Central Zero Ammeters, 303 amps., 7/- Recording Graph. Voltmeters, £4-10s. Cambridge meters for Pyrometers to 1,200 cent., 35/- 3-in. dial, 1,500 volts, D.C. Moving Coil panel, 35/- Testing Sets, Elliott, etc. E. 108, 4 ranges amps and volts, 45/- A. C. Hot Wire, 1/2 amp., 5 6 and 110 volts, 5 9. Cell testers, pocket, 15/-; with spikes 30/- Bridges, 10,000 ohm 4-dial Wheatstone, with Galvo, £10. G.P.O. type, £7 10s. Mirror Galvos Reflecting Beam, by Paul Gambrell, Sullivan and Tinsley, £3 to £10. Standard Res. Boxes and Univer. Shunts, 35/- Electrostatic Voltmeters to 2,800 volts, £2. 1st grade Moving Coil Meter movements for 5-. In portable wood case, 7 6, or complete Portable Meters, 12/-, for home test sets. Record Circule, 25/- Weston Moving Coil Panel Meters, 30 m.a., 17 6.

ELECTRADIX RADIOS,
218, UPPER THAMES STREET, E.C.4.

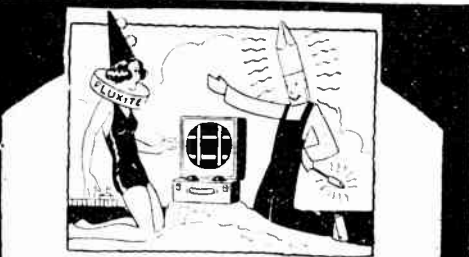

"We're Fluxite and Solder — the reliable pair; Famous for Soldering — known everywhere!"
Take your RADIO with you without any quibbles; For if WE are near you — Music still hath her charms!"

See that Fluxite and Solder are always by you — in the house — garage — workshop — anywhere where simple, speedy soldering is needed.

ALL MECHANICS WILL HAVE FLUXITE IT SIMPLIFIES ALL SOLDERING

All Ironmongers sell Fluxite in tins: 4d., 8d., 1s. 4d., and 2s. 8d. Ask to see the FLUXITE POCKET SOLDERING SET—complete with full instructions—7s. 6d. Ask also for our leaflet on HARDENING STEEL with Fluxite.

FLUXITE LTD.,
(Dept. W.W.), ROTHERHITHE, S.E.16

FOR ALL REPAIRS!



Components, etc., for Sale.—Contd.

EBURY BRIDGE RADIO Offer You the Following Stupendous, bankrupt and surplus bargains.

WESTINGHOUSE Metal Rectifiers, 120v. 12 m.a., 2/6; 120v. 15 m.a., 3/6; 120v. 20 m.a., 3/3, guaranteed; post 6d.

PHILLIPS Mains Transformers, 200/250v. input, output 200-0-200v. 40 m.a., 4v. 1a, 4v. 3a.; 4/6; post 9d.

PHILLIPS Heavy Duty Smoothing Chokes, 50 Henry 75 milliamps; 5/6; post 9d.

PARALLEL FEED Manufacturers J.P. Transformers, 2/6, post 3d.; toggle switches, 2-pole, 6d., post 1d.

E.K. Ekco Mains Transformers, 200-250 input, outputs, 350-0-350v., m.a. 4v. 4a., C.T. 4v. 2a.; 9/6.

SPECIAL OFFER—T.C.C. pack condensers, 9 M.F. (4+4+1) 250v. working, 5/-, post 6d.; 4 M.F., 250v., 2/3, post 4d.

NON-INDUCTIVE Electrolytic, 100v. working, 15 M.F. for Auto G.B., 1/6 each, post 2d.; Hydra 2 M.F., 500v. test, 1/3, post 3d.

PYE Chokes, 20 or 32 Henry, listed 12/6, 4/6, post 9d.; Multi Ratio output transformer, for power or Pentode, 6/6, post 9d.

AMAZING Low Price Offer of A.C. Eliminators, 200-250v. input, output 150v. 30 m.a., one fixed, one variable positive taps, Westinghouse rectified, guaranteed, also 100v. input; 25/-, post 1/3.

REISZ, P.A. Mikes (genuine) for Amplifiers up to 60 Watts, straight line response, none better, 55/-; oxidised stand, 15/-, post free.

D.C. Motors, by G.E.C. (U.S.A.), 1/4 h.p., 230v., 1/40 D.C. m.m., shunt and compound wound, double ended shaft, suitable grinder or make good dynamo, 1 1/2 amp., new condition, guaranteed, 22/6, real bargain.

QUAIN D.C. Slot Meters (6d.), ideal check meter, fitted motor and tons of gears, perfect; 9/-, post 1/3.

KOLSTER BRANDES Cobra 3-valve A.C. Mains Sets, 100-250 volts, Mazda valves moving coil speaker; listed 11 guineas, £5 19/6.

J.B. Condensers, with disc drive and escutcheon plate, Nugag 2-gang 0.0005, fully screened with trimmers and dial, list 18/6, 9/11; 3-gang, list 28/6, 11/6; 4-gang, list 36/-, 13/6; 0.0005 single, list 12/6, 5/11.

BURGOYNE—Selective portables, suitcase, 5 Mullard valves, Exide unspillable accumulator, Drylex H.T.; listed £5 19/6, bargain, few only £3 19/6.

ALL ABOVE Goods 3 Days' Approval Against Cash or c.o.d. Hours 9 a.m. to 8 p.m., Thursday 1 o'clock, Saturday 9 p.m.—Ebury Bridge Radio Co., 33, Ebury Bridge Rd., S.W.1 (near Victoria Station, No. 11 bus to Ebury Bridge). 'Phone: Shaone 8407. [3172]

MAYFAIR RADIO Offers Brand New Surplus Stock, all guaranteed, carriage paid, cash with order or c.o.d.

AUTOMATIC Record Changers, complete with pick-up, A.C. 200-250, A.C. Carrard; listed at £10/10, at £7/10/6 (6 only).

RADIO-GRAMOPHONE Cabinets, solid walnut, Marconi complete type 535, overall 40 1/2 x 19 1/2 x 16 1/2, take chassis up to 19 x 16, cost to make £28 10, at 45/-, carriage and packing 7/6 extra; H.M.V. faired walnut, type 531, as used in H.M.V. 70 guineas job, overall 40 x 27 x 20, take chassis up to 26 1/2 x 19 1/2, cost to make £12, at £4/15, carriage and packing 7/6 extra.

VARIABLE Condensers, British Radiophone, 4-gang Superhet, fully screened, with trimmers, listed 35/-, at 10/-; H.M.V. 3-gang, semi screened, fitted trimmers and drum drive, listed 32/-, at 10/-; Utility, 2-gang, complete with covers, trimmers, disc drive, etc., at 8/-.

MOVING COIL Speakers, Roia's R.6 (2,000 and 2,500 ohms), listed 35/-, at 18/- each; F.6, P.M., listed 49/6, at 28/- each. All incorporate humbucking coils.

PICK-UPS: B.T.H. Senior, 1933, complete with volume control, listed £2/2, at 28/- each; Harlie, with volume control, listed 27/6, at 15/- each.

SMOOTHING Condensers, G.E.C. and Murphy, 800 test, 1 mfd. 1/1, 1 mfd. 1/9, 4 mfd. 2/6; the following 1,500 test, 500 A.C. working, 800 peak, 1 mfd. 1/9, 2 mfd. 2/4, 4 mfd. 4/-; multiple blocks (separate tappings), 20 mfd., 2+2+2+2+2+2+2+2+2+2+1+1, at 11/-; 11 mfd., 4+2+2+2+1, at 6/9; 14 mfd. block, 4+4+4+1+1, at 7/6; 9 mfd. block, 4+4+1, at 5/3.

ASK for special quotations for all your requirements.

MAYFAIR RADIO, 31, George St., Hanover Sq., W.1 [3066]

CENTRE Tapped Frame Aerials.—Lewros, 7/6; Wearite, 17/6; Petoscott and Ready Radio, 5/6.

VARIABLE Push-pull Transformers, 19/6 pair; second-hand R.L. Hypercork chokes (centre tapped), 7/9; Formo L.E. transformers, 1/7.

FILAMENT Transformers, 2-0-2 volts, 4 amps., Hayberd, 5/9; second-hand R.L. 7/9; Phillips, 5/6.

OUTPUT Transformers.—Ratio, 1/1; Lissen, 2/6; Telsen, 2/6; Lissen output and smoothing chokes, 3/9.

BALANCED Amplitude Units.—Blue Spot 66H, 7/9; Ideal, 3/3. Major chassis, 2/6.

SOME of the Second-hand Bargains from the North London Wireless Mart, 54, Malden Rd., N.W.5. Write for complete lists of speakers, pick-ups, sets, mains units, etc. [3173]

CHAL-ELECTRIC offers Brand New Set Manufacturers Boxed Surplus, all carriage paid, cash with order or c.o.d.

VARIABLE Condensers, Polar Star 3-gang, 1933, complete with disc drive trimmers, covers, light, escutcheon, knob, etc., listed 30/6, at 17/-; Polar 2-gang Uniknob, complete as above, 10/-; J. B. Nugag 3-gang, complete as above, 15/-; 2-gang Nugag, 9/6; J. B. Utility 2-gang, complete as above, 8/6; British Radiophone superhet (4 only), 3-gang type, 422a, with full vision disc drive, at 31/-, complete coils; Colvern Ferrocart V.L. P2, and P3 gauged, at 28/-; Varley B.P.19 (3-gang, 8 sets only), at 26/- set.

MOVING COIL Speakers, last batch only.—Rogas F.6., 90/130 volts (2,500 ohms), 200/250 volts (6,500 ohms) listed 35/-, at 18/- each; F.7 voltages as above, listed 47/6, at 25/-; state if power or pentode transformer. All incorporate humbuckers.

PERMANENT Magnets.—F.6 P.M., listed 49/6, at 23/-; F.7 P.M., listed 60/-, at 33/-.

A REAL Betty Job.—Ultra 95 P.M., with Multi Ratio A Transformer, listed £4 15, at 47/6. Chal-Electric, 6, Condit St., London, W.1. [3064]

WESTON Radio Set and Valve Tester, model 547; tested, sealed, insured; £18.—Box 7613, c/o The Wireless World. [3152]

ALMOST New D.O.24's 12/6; Colverdynes, 5/-; O.P.M.6c, 15/-.—Tooley, 50, Sturdee Av., Great Yarmouth. [3159]

TESTING Set, valve and set, Six Sixty, guaranteed perfect; £3 15, cost £3 16 3.—9, Holborn Place, Plymouth. [3142]

EPOCH

MOVING COIL SPEAKERS

The Finest in The World in Each of Their Price-classes.

Ask your dealer or call for a demonstration at Exmouth House.

Send for New Booklet W.S.5a. It is free.

EPOCH RADIO MANUFACTURING Co. Ltd.
Exmouth House, Exmouth St., London, E.C.1
At the junction of Rosebery Avenue and Farringdon Road.
'Phone: Clerkenwell 6066 (4 lines).

FIT THIS ELECTRIC CLOCK TO YOUR SET!

NO MAINS NEEDED!
KEEPS CORRECT TIME!
NO WINDING!

Works off small battery lasting 12 months, or can be plugged into G.B. Battery without affecting reception. Uses practically no current. Fits into hole 3 1/2" dia. in any panel up to 1/2" thick. Easy to fix—no screws required. Only 1/4" from front of panel to back of case. Swiss movement. Hands set from front. Nickel plated bezel. Useful addition to any set.

RIVERSIDE MFG. CO. LTD.
Dpt. 20, Crisp Rd., Hammermith, W.6
Telephone: RIVERSIDE 6382.

COMPLETE WITH BATTERY
POSTAGE 6D

Lamplugh

RADIO LTD COVENTRY

Silver Ghost Inductor Moving Coil Dynamic

SAVAGE

FOR AMPLIFIERS

56 58, CLERKENWELL ROAD, LONDON, E.C.1
'Phone: Clerkenwell 3068.9.

BAKER

WRITE NOW FOR OUR NEW BOOKLET BLEAFLETS

75-77 SUSSEX ROAD, CROYDON, SURREY.
'Phone: Croydon 3441-2.
FOR QUALITY MOVING-COIL SPEAKERS

PARIMA SELENIUM CELLS

FOR ALL PURPOSES.

Parima Light-Sensitive Resistances are constant mechanically strong, moisture proof and exceedingly sensitive. Fully guaranteed for 12 months.

Prices from **5/-**

PARIMA MANUFACTURING CO.
21, BROMLEY ROAD, S.E.6. *Hither Green 3629*

HAVE YOU HAD?

particulars of the famous "Magnum" Short Wave Adaptor, which is now available for every type of receiver?

Full particulars, with a list of short wave stations and free trial offer, on request.

BURNE-JONES & CO. LTD.
296, Borough High St., London, S.E.1

Components, etc., for Sale.—Contd.

BARRGAIN Bulletin Offering Readers Extraordinary Radio Component Values Sent Post Free.—Taylor, Macaulay St., Huddersfield. [3103]

K.B. Pup. valves, less batteries, 25/-; eliminators, Ekco A.C.18, unused, 45/-; Atlas A2, 25/-; "St. Clare," Allwood Bailey, Maidenhead. [3158]

FERRANTI A.F.5, 14/-, pair Sonochordic matched speakers, 24/-; P.M.10.G. (new), 8/-; B. Frame, 332, Cleethorpe Rd., Grimsby. [3146]

FERRANTI Multi Range Test Set, resistance box 500 volts, valve plugs, heads, case; cost £11/15, accept £5.-9, Holborn Place, Plymouth. [3143]

SPECIAL Clearance Bargains.—Projectors (9, 16 and 35 mm.), 30/-; Gramos from 20/-; everything for Moving, Walkies and Talkies; inspection invited.

ILLUSTRATED ENTERPRISES, 159, Wardour St. (facing I. Film House), London, W.1. 'Phone: Gerrard 6889. [3004]

NEW! Coils, K.21-2-3, 12/-; tunnel grid, 2/-; I.P., 7/6; J.13, 3-gang, 2-gang, 15/-; 0.00025, 0.0001, 4/-; Lissen transformer, P.T.240, 9/6.—Allen, Greatwood, Chislehurst. [3187]

EPSON First Again!—Radiophone volume controls, wire wound (listed 4/6), 3,500, 4,000, 5,000, 6,000, 10,000, 15,000 ohms, 2/6 (21/- dozen); 20,000, 50,000, 100,000 ohms, 2/9 (24/- dozen).

VALVES (as new); reduced prices—8.4V., 41M.P., 624B.U., 7/2; A.C.S.G. V.M., 220V.S.C., M.S.G./I.A., 9/6; A.C. Pen., 11/-; 1821, A.C.H.L., A.C.2H.L., 6/9; M.S.4B., D.W.3, P.M.26, P.M.24, P.T.425, P.650, 8/9; A.C.S.G. (metal top), 5/-; P.M.3, P.M.4, P.M.256A., P.625, 5/9.

EPSON, 93, New Rd., Chingford, E.4. Cash with order or c.o.d. [3182]

MOVING COIL Milli-Ammeters, 0-50, 10/6 each; 2 milliamms and 120v., 17/6 each; other ranges in stock; alterations, repairs of every description.—The Victoria Electrical Co., 47, High St., Battersea, S.W.11. [3055]

EPSON Superhet Kit (list 46/-), 30/-; Band Pass, 7/6; Colvern Ferrocart, 30/- set; Garrard record changer, complete, £7 10; Garrard induction motor, new, £2; cash with order, or c.o.d.—F. Gill, Vicarage Rd., Hinxley. [3170]

BARGAINS—Magnavox Magna m.c. speaker, 2.500 ohms field, universal transformer, 37/6; Radiophone Radiopak, 28/-; both items as brand new, unused; Quality 6-watt amplifier, £5.—169, Mar-kintosh Place, Cardiff. [3179]

M.R.D. Co's Set Manufacturers' Surplus, as new, carriage paid, Astra drum drives, 3/-; Heurt M.M. diabs, 1/8; most Bakelite condensers, 0.005, 0.002, 0.001, 0.0005, 0.00025, 0.0002, 0.0001, 1/3, any half dozen; modern aerial coils, 1/6; Utility 2-gang, 0.0005 trimmers, 4/3; 3-gang, 5/3; 5-pin valve holders (chassis), 1/3 half dozen. Mains Radio Development Co., 4-6, Muswell Hill Rd., London, N.6. [3130]

CLASS "B" COMPONENTS.

SOUND SALES, Ltd., for Class "B" Components, List "B.B." on request, Tremlett Grove, Highgate, N.19. [3041]

MISCELLANEOUS.

RADIO Problems Solved, 2/6 query, including diagrams.—Leary, 66, Windmill Lane, E.15. [3173]

EASY Payments.—We supply, by easy payments, components, accessories, and sets, any make; 10% down, balance spread over 11 months. Send list of requirements to London Radio Supply Co., 11, Oat Lane, London, E.C.2. [3037]

ENGINEERS and Technical Workers of All Kinds.—A proper training by post in your spare time will take you through your right examination, then employment is waiting. Our advice on all careers free.—Dept. 92, The Bennett College, Ltd., Sheffield. [3095]

AMBITIOUS Engineers Wanted to Apply for Our Free A 250-page Handbook gives details of A.M.I., Mech.E., I.E.E., A.M.I.A.E., G.P.O., etc., exams, outlines latest courses in mech., elec., motor, radio and aero, engineering, and shows clearly where first class vacancies occur each year.—Send P.C. for free handbook immediately to British Institute of Engineering Technology, 87, Shakespeare House, 29, Oxford St., W.1. [3012]

AMBITIOUS Men. Quality for a well-paid post by studying at home with the T.L.G.B. Write to-day for "The Engineer's Guide to Success," 144 pages, free which contains the widest selection of engineering and wireless courses in the world, and shows you how to become A.M.I.E.E., A.M.I.Mech.E., A.R.A., etc. State Branch, post or qualification that interests you.—The Technological Institute of Great Britain, 82, Temple Bar House, London, E.C.4. (Founded 1917, 19,000 Successes.) [3001]

PATENT AGENTS.

KING'S PATENT AGENCY, Ltd., 146a, Queen Victoria St., London, E.C.4. 'Phone: Central 0682. 47 years' experience. Advice Handbook free. [3038]

PATENTS and Trade Marks, British and foreign.—Geo and Co. (H. T. P. Gee, Member R.S.G.B. and A.M.I.E.E.), 51-52, (Chancery Lane, London, W.C.2. 'Phone: Holborn 1525. [0001]

REPAIRS.

GUARANTEED Repairs by Experts; specialists for re-pairs to S. G. Brown and Ampton radio apparatus, also loud-speakers, headphones, pick-ups, Blue spots, any type rewound, remagnetised and adjusted. 4/-; post free; mains transformer repairs; terms to trade.—Howell, 91, Morley Hill, Enfield, Middlesex. [971F]

REPAIRS to Loud-speakers, transformers and head phones, 4/- each; Blue Spots or Wind's, 5/-; main eliminators (etc.) quoted for; prompt service; satisfaction guaranteed; terms to trade. Loud-speaker Repair Works, 2, Shipka Rd., Balham, London, Stratham 6618. [0394]

REPAIRS, Rebuilding to any set; highest quality work only; lowest charges; estimates given free; distance no object. L. Eastwood, Radio Manufacturers' Consultant, Late of His Master's Voice and Marconi Wireless Telegraph Co. Telephone: Clerkenwell 4520. Address: 60, Horder Rd., Fulham, S.W.6. [3085]

EXCHANGE.

EXCHANGE, Rotary, converter, 230 D.C., for £10, or E.B. D.C. receiver.—Roydhouse, 28, Brownlow Rd., London, E.8. [3163]

EXCHANGE Your Present Set or Components for the New Mondial Super; best allowance.—Radio Exchanges, 114, Ramuz Drive, Westcliff-on-Sea. [3124]

Exchange.—Contd.

HIGH Allowances Made on Second-hand Goods in Part Payment for New Sets or Components; easy payments available; we have tremendous stocks tested second-hand goods; send list of your requirements for quotation.—Bostock and Stonhill, 1, Westbourne Terrace, S.E.23. [3176]

HELSON ELECTRIC Offer You Finest Value in the Trade for Your Old Set; Marconiophone and Philco dealers; all makes supplied; components on easy terms, send us your requirements, we give service after sales; if in trouble with your radio, consult us, advice gratis; any distance, any time. 641a, Fulham Rd., S.W.6. Fulham 7217. [3167]

TUITION.

RADIO Engineering, Day, evening, and postal courses. This school is fitted with most modern apparatus. Prospectus free. Valuable recommendations given to qualified students.—Northern Counties Wireless School, Preston. [0399]

R.T.I. Training Methods are Recognised; write for particulars of home study for radio appointments; secure "Certificate of Proficiency" and become "A.M.R.T.I."—Radio Training Institute, 85, New Oxford St., London, W.C.1. [2947]

If You Wish to Enter the Wireless Profession with a present position, or if you wish to improve your position, you will need the certificate issued by Britain's leading wireless college. This is not a correspondence college. Apparatus of all leading makes installed for instructional purposes. Boarders accepted. Training fees can be paid after appointment. Prospectus free.—Wireless College, Colwyn Bay. [0388]

WANTED.

SPOT Cash for Components, etc. Economic Radio Co., 96/98, South Lambeth Rd., S.W.8. [2923]

WANTED, second-hand Avometer, Kennedy, 38, Whitworth Rd., South Norwood, S.E.25. [3164]

CASH Paid by Return for Modern Components, North London Wireless Mart, 54, Malden Rd., N.W.5. [3174]

HIGH Class Radio Sets and Parts Wanted for Cash, Midway Radio Exchange, 24, Midway Grove, London, N.1. [2972]

WANTED, second-hand Avometer (D.C.); must be cheap and accurate; approval against cash. Box 7635, c/o The Wireless World. [3168]

WIRELESS Goods, new or second-hand, bought and sold; best allowances in part exchange. R. Wigfield, Furlong Rd., Goldthorpe, Yorks. [3171]

"STERLING" Variable Condensers, 0.0005, Bakelite end plates, vernier vane. State quantity and price to Box 7635, c/o The Wireless World. [3161]

REQUIRED for Overseas. Quotations and full particulars of British all-wave wireless sets for use on A.C. mains; suitable for flats.—Box 7632, c/o The Wireless World. [3160]

WANTED, all types of A.C., D.C. and battery valves, receivers and any other new components in quantities.—Ward, 12, Tredegar Rd., Bow, E.3. Advance 3668. [3080]

SITUATIONS VACANT.

TESTER for Radio Receivers, N.W.3 district. State experience and wage required, Box 7611, c/o The Wireless World. [3153]

RADIO Set Testers Required by Large Manufacturers, North West London, must be accustomed superhet testing and sensitivity measurement. Write, stating experience, age and salary required, Box 7634, c/o The Wireless World. [3162]

SITUATIONS WANTED.

EX-NAVAL Operator, time expired, P.M.G. certificate, 32, married; wireless or electrical with prospect, if possible, or any capacity.—Box 7593, c/o The Wireless World. [3159]

TELEPHONE Engineer, magnet, C.B. and auto, switchboard fitting and testing, auto and similar circuits; wide and varied experience with leading firms. Box 7592, c/o The Wireless World. [3158]

RADIO Engineer, 12 years' experience, public address, talkie, showroom, exhibition, interphone personality, keen salesman, desires progressive situation, age 32. Box 7639, c/o The Wireless World. [3165]

BUSINESSES AND PROPERTY FOR SALE, TO BE LET, OR WANTED.

ESTABLISHED Radio Business, 18 miles from London; £350 all in for quick sale; living accommodation; good proposition. Box 7591, c/o The Wireless World. [3137]

COLLARO

COMBINED PICK-UP AND MOTOR UNIT

A complete self-contained unit comprising "32" model Induction Motor, suitable for 100-130 Volts and 200-200 Volts, 40-60 Cycles. (Can also be supplied for 25-40 and 60-100 Cycles.)

Automatic start and stop, combined with "Collaro" Pick-up; all that is required for the Gramophone side of a Radio-gram. The "Collaro" Pick-up can be used in conjunction with all receiving sets and amplifiers. The built-in wire wound Volume Control will show no signs of deterioration or crackling in use.

The Pick-up base head and arm are Bakelite mouldings and the general outline is designed to harmonise with the clean lines of the modern Radio-Gramophone.

Obtainable from all Radio Factors and Dealers.

COLLARO LIMITED, Calmore Works, Calmore Rd., Peckham, London, S.E.15.



PRICE 76/- WITH BUILT-IN VOLUME CONTROL 80/-

Starts automatically Stops automatically

BELLING-LEE PICK-UP



MODEL A. Adjustable arm allows distance between needle point and centre of base to be varied from 7 1/2" to 9 1/2". The arm should be as long as cabinet space permits. Head angle is also adjustable to obtain minimum tracking error for different arm lengths.

Special Features.—Perfectly natural frequency response . . . minimises needle scratch while retaining high notes and brilliancy of reproduction . . . Minimum record wear . . . Copper screened flex.

BELLING-LEE FOR EVERY RADIO CONNECTION

Cambridge Arterial Rd., Enfield, Middx.

FOR HIRE RADIO, MICROPHONE & GRAMPHONE AMPLIFIERS

giving exceptional quality and volume, suitable for Dances, Sports Meetings, Fêtes, etc., from 15/- per day, McMichael Portable Sets 15/- a week; £2-12-6 a month,

ALEXANDER BLACK, LTD

WIRELESS CONSULTANTS

55, EBURY STREET, LONDON, S.W.1.

ESTABLISHED IN 1925.

SLOANE 165.

Trade Inquiries Invited.

SERVICE

SETS OF ALL TYPES

Supplied, Serviced and Visited in any district, or may be sent for Full Test and Report, at 2/- per valve-holder; portables 1/6 per valve-holder.

TENDERS.

TOTTENHAM URBAN DISTRICT COUNCIL

"RADIO-GRAM" AND PUBLIC ADDRESS EQUIPMENT.

The Council invites Tenders for the supply of a PORTABLE "RADIO-GRAM" and PUBLIC ADDRESS APPARATUS of the "all-electric type," suitable for both indoor and outdoor use.

Tenders should be accompanied by a Specification setting forth the Range, and general capacity, and full particulars concerning the "set." Persons tendering will be required to submit their apparatus to a comparative examination, also to a competitive demonstration. Further information can be obtained from the Baths Superintendent, Central Baths, The Green, Tottenham, N.15.

Tenders, endorsed "Radio-Gram and Public Address Equipment," must be sent to the Clerk and Solicitor of the Council not later than 12 noon on Saturday, the 5th of August next.

Only those tenders delivered within the advertised time will be considered. E. TOWNSEND, Clerk and Solicitor of the Council.

Town Hall, Tottenham, 19th July, 1933.



GOOD RECEPTION MEANS

RECEPTICON

INSULATED AERIAL CABLE

in the ORANGE & BLUE CARTON

"Recepticon" can be used either as an indoor or outdoor aerial or as an earth. It is a seven-strand insulated aerial cable drawn from pure electrolytic copper and protected with a weatherproof covering, and is definitely non-corrosive. The conductivity of the aerial is, of course, extremely high, so that when "Recepticon" is fitted perfect satisfaction is assured. Obtainable from all Wireless dealers, or if in difficulty apply direct to the manufacturers.

THE CONCORDIA ELECTRIC WIRE CO. LTD. New Sawley Nr. Nottingham

BOOKS on WIRELESS

Write for complete list to ILIFFE & SONS LTD. Dorset House, Stamford St., London, S.E.1. w.w.r

INDEX TO ADVERTISEMENTS.

Table listing advertisements and their page numbers: Apollo Gramophone Co., Ltd. (Page 6), Automatic Coil Winder & Elect. Equipment Co., Ltd. (Page 6), Baker's Silbust Radio (Page 6), Barber & Colman, Ltd. (Page 7), Belling & Lee, Ltd. (Page 7), Benjamin Electric, Ltd. (Page 7), Birmingham Sound Reproducers, Ltd. (Page 7), British Blue Spot Co., Ltd. (Page 7), British Pix Co., Ltd. (Page 8), British Radiophone, Ltd. (Page 8), British Rola Co., Ltd. (Page 8), Bryce, W. Andrew & Co. (Page 6), Burne-Jones & Co., Ltd. (Page 6), Burrell Radio, Ltd. (Page 2), Celebration, Ltd. (Page 1), City & General Equipment Co. (Page 1), City & General Equipment Co. (Page 1), Cobb, E. K., Ltd. (Page 7), Collare, Ltd. (Page 7), Colvern, Ltd. (Page 7), Concordia Electric Wire Co., Ltd. (Page 7), Corsor, A. C., Ltd. (Page 7), Dubilier Condenser Co. (1925), Ltd. (Page 7)

Table listing advertisements and their page numbers: Electradix Radios (Page 5), Epoch Radio Mfg. Co., Ltd. (Page 6), Ferranti, Ltd. (Page 5), Fluxite, Ltd. (Page 5), Gammell Bros. Ltd. (Page 6), Garrard Engineering and Manufacturing Co., Ltd. (Page 6), General Electric Co., Ltd. (Page 6), Gilbert, J. C. (Page 6), Gramophone Co., Ltd. (Page 6), Haynes Radio (Page 4), Hayward, F. C. & Co. (Page 4), Jackson Bros. (Page 6), Junat Mfg. Co., Ltd. (Page 6), Lamplugh Radio, Ltd. (Page 6), Letco Lux, Ltd. (Page 4 & 5), Lever, Eric J. (Trixi), Ltd. (Page 8), London Electric Wire Co. & Smiths, Ltd. (Page 8), Lyons, Claude, Ltd. (Page 6), Marconiophone Co., Ltd. (Page 4), New London Electron Works, Ltd. (Page 4)

Table listing advertisements and their page numbers: Ostar-Ganz (Engen Forbat) (Page 3), Parina Mangle Co. (Page 6), Partridge Wilson & Co. (Page 8), Peiper, Trevor (Page 8), Pto-Scott Co., Ltd. (Page xii), Radio Resistor Co. (Page 3), Reproducers & Amplifiers, Ltd. (Page 4), Rich & Bundy, Ltd. (Page 4), Riverside Manufacturing Co., Ltd. (Page 6), Savage, W. Bryan (Page 6), Scott Sessions & Co. (Page 4), Seekamp, O. H. (Page 4), Signal Sales, Ltd. (Page 2), Tannoy Products (Page 4), Telegraph Condenser Co., Ltd. (Page 4), Telsen Electric Co., Ltd. (Page 4), V.G. Manufacturing Co., Ltd. (Page 5), Watmel Wireless Co., Ltd. (Page 5), Westinghouse Blake & Saxby Signal Co., Ltd. (Page 4), Wilburn & Co. (Page 4), Wingrove & Rogers, Ltd. (Page 4), Wright & Weare, Ltd. (Page xii)

matched perfection

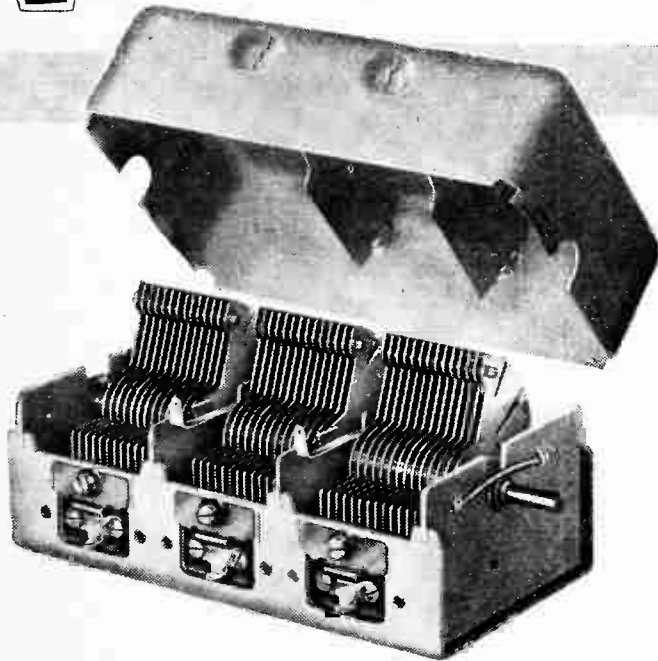

guarantees BETTER RADIO

To ensure perfect selectivity you *must* have British Radiophone components. Whether you want them for the New Monodial Super Het or any other receiver you will never get really perfect results unless you use British Radiophone.

As you can see for yourself the designers of the New Monodial were careful to choose a British Radiophone Ganged Condenser. This fact tells its own story, for in a set of this quality only the best is good enough.

Specified for the

W.W. New Monodial Super Het

British Radiophone 3 gang super-heterodyne condenser complete with cover and special stator tracking vanes. Type 32-1A. Price 30/-.
British Radiophone full vision disc drive Type 528A. Price 8/6.

British Radiophone Q.M.B. Switch Type 568. Price 1/3.

FIT RECEPTRU—the new low loss screened lead-in cable. It improves selectivity, and increases sensitivity. 15 ft. length 10/-. Longer sizes at proportionate prices.



BRITISH RADIOPHONE LTD.

ALDWYCH HOUSE, ALDWYCH, W.C.2.

Telephone: Holborn 5744.

RADIOPHONE GANGED CONDENSERS

Use **GLAZITE** BRITISH MADE REGD.
Circuit Wiring

The popularity of Glazite Connecting Wire is attributable to the superior craftsmanship and superb raw materials used in its manufacture and it is damp proof.
Glazite Connecting Wire is made in six colours at sixpence per ten foot coil by a firm with over 50 years' manufacturing experience.

BEWARE OF IMITATIONS!

THE LONDON ELECTRIC WIRE COMPANY AND SMITHS, LIMITED
CHURCH ROAD LEYTON LONDON E.10

Illustration shows the Davenset List No. 101 smoothing choke Inductance 30 Henrys at 50 Ma. List Price 18/6 complete with instrument screwdriver as illustrated.

Ensure the success of your set with

DAVENSET TRANSFORMERS

THE "Wireless World" Laboratory has tested DAVENSET Transformers and finds them "well above the average in performance and exceptionally well made." Such unbiased judgment is the best guarantee to home set constructors, and others, that DAVENSET Transformers will make a material contribution to the success of their sets.

WRITE FOR a copy of "Mains Transformers and Power Smoothing Chokes for Radio and Industrial Purposes."

Davenset Transformers are manufactured to your own individual requirements, whilst our Technical Department is at your service to advise and suggest the simplest and yet most practical schemes for overcoming your Transformer or Rectification problem.

PARTRIDGE, WILSON & CO.
Dept. 29, Davenset Works, Leicester.
Scottish Branch: 200, St. Vincent Street, Glasgow, G.2.

WEDNESDAY

AUGUST THE SECOND

PRINCIPAL EVENTS OF THE DAY:

AT HOME

- NATIONAL LONDON REGIONAL MIDLAND REGIONAL NORTH REGIONAL WEST REGIONAL SCOTTISH REGIONAL BELFAST** "Quinneys," a comedy, by Horace Annesley Vachell. "This Radio Racket," a burlesque, by G. M. Hayes and F. K. Clark. Orchestral concert.
- NORTH REGIONAL** Brass Band concert.
- WEST REGIONAL** Choral and instrumental programme.
- SCOTTISH REGIONAL** Orchestral programme.
- BELFAST** Variety programme.

ABROAD

- BRUSSELS (No. 1)** 9.0 p.m. Orchestral concert, from the Casino, Knoccke.
- BRUSSELS (No. 2)** 8.30 p.m. Hugo Wolf song recital.
- BUCHAREST COPENHAGEN** 8.20 p.m. Chopin recital, by Nadia Chebap.
- HEILSBERG** 8.5 p.m. Orchestral concert, conducted by E. Reesen.
- HILVERSUM POSTE PARISIEN** 8.10 p.m. Georg Vollerthun song recital, with the composer at the pianoforte. 10.10 p.m., The Small Station Orchestra.
- ROME STRASBOURG** 7.40 p.m. Carillon recital, by J. de Zwaan.
- WARSAW** 8.30 p.m. Orchestral concert.
- 8.45 p.m. Operetta: "Stenterello," by Cuscina.
- 8.45 p.m. Mozart concert by the Municipal Orchestra.
- 8.0 p.m. Pianoforte recital, by J. Turczynski.

BARCELONA
EAJ1, 860 kc/s, 348.8 metres; 8 kW.—7.0 p.m., Trio Concert: Overture, Der Freischütz (Weber); Gavotte (Massenet); Serenata (Boland); Träume (Wagner); Entr'acte (Chillemont); Canzonetta (Toselli); Selection from Hamlet (Thomas). 8.0, Request (Gramophone Records, 8.20, Exchange, 9.0, Gramophone Music and News, 10.0, Chimes, Weather and Exchange, 10.5, Concert by the Station Orchestra, 11.0, Song Recital by Anita Reuhl, 11.30, Dance Music from the Casa Libre. In the interval at 12 Midnight, News, 1.0 a.m. (Thursday), Close Down.

BARI
1,112 kc/s, 269.8 metres; 29 kW.—9.0 p.m., Agricultural Notes, Tourist Report, and Popolavoro Announcements. 8.20, Giornale Radio and Weather. 8.30, Time and Announcements. 8.35, Concert of Chamber Music. M. De Santis Bruno (Soprano), Ita Lombardo d'Angelo (Pianoforte), and Nicola delle Foglie (Cello). Overture, Oberon (Weber); Songs: (a) Malinconia (Alfano), (b) A Madrigal of Tasso (Staffelli); Pianoforte Sonata in A (Mozart); Cello Solo: Kol Nidrei (Bruch); Song: Addio alla luna (Casavola); Pianoforte Solos: (a) Song without Words (Tcherépine), (b) Dance (Pik-Mangiagalli); Selection from Otello (Rossini); Pianoforte Solo: Pavane pour une Infante défunte (Ravel); Song: Nina nanna (Pesce); Cello Concerto No. 2 (Saint-Saëns); Song: Air from La serva padrona (Pergolesi); Pianoforte Solo: Campanella (Paganini-Liszt); Talk in the interval. 10.30, Dance Music, relayed from the Caffè del Levante. 10.55, News.

BASLE—See Schweizerischer Landessender.

BELGRADE
BEOGRAD, 697 kc/s, 430.4 metres; 2.8 kW.—5.55 p.m., Time Signal and Programme Announcements. 6.0, National Music. 7.0, Recital of National Songs. 7.30, Recitations. 8.0, Gramophone Music. 8.40, Relay of an Opera. 10.30, Time Signal, News, and Cigany Music from the Potrosacka Zadruga Restaurant.

BERLIN
DEUTSCHLANDSENDER; 183.5 kc/s, 1,635 metres; 60 kW.—2.0 p.m., Gramophone Concert of Variety Music. 2.45, Programme for Children. 3.10, Programme for Young People. 3.30, Weather and Exchange. 3.45, Reading (Paul Alverdes). 4.0, See Hamburg. 5.0, Radio Report on the Training of the German International Football Team. 5.30, Schubert Recital by Richard Kerschbaumer (Violin); Extracts from Sonata No. 1 in D, Op. 137; Extracts from Sonata No. 3 in G Minor, Op. 137. 6.0, A Poem. 6.5, Religious Address and Organ Music. 6.35, Wireless Technical Talk. 6.50, Weather for Farmers. 7.0, Transmission for all German Stations, relayed from Hamburg. 8.0, An Appeal in connection with the National Labour Scheme, followed by Soldiers' Songs. 9.0, Wo ist Deutschland?—Radio Play (Dwinger). 10.15, Weather and News. 10.45, Weather Report for Shipping. 11.0, Concert from Hamburg. 12 Midnight (approx.), Close Down.

BERLIN
WITZLEBEN; 715 kc/s, 419.5 metres; 1.5 kW.—4.30 p.m., Military Band Concert, relayed from the Sprengarten, Treptow; Titanen-Marsch (Storck); Overture, Das Nachtlager von Gramada (Kreutzer); Waltz, Verschmühte Liebe (Lincke); March Potpourri (Kaiser-Haekelberger); March, Unsere Zeit ist endlich gekommen (Becke). 5.20, Talk on Hobbies—Collecting. 5.40, Schumann Song Recital by Elisabeth Hönges (Contralto); Frauenthe und Leben; Seit ich ihn gesehen; Er, der Herrliche von allen; Ich kann's nicht fassen; Du Ring an Meinem Finger; Hoff mir, ihr Schwestern; Süßer Freund; Nun hast du mir den ersten Schmerz getan. 6.5, See Berlin (Deutschlandsender). 6.40, The Witzleben Station informs its Listeners. . . . 6.45, Topical Talk. 7.0, Transmission for all German Stations, relayed from Hamburg. 8.0, See Berlin (Deutschlandsender). 8.20, See Langenberg. 9.10, The Green Canopy—a Sketch (Heinz Pauek). 10.0, News. 10.15 (approx.), Dance Music, relayed from the Moka Erdi. In the interval at 11.0 (approx.), Talk: What they are saying in Berlin. 12 Midnight, Close Down.

BERNE—See Schweizerischer Landessender.

BEROMUNSTER — See Schweizerischer Landessender.

BODEN—See Stockholm.

BODO—See Oslo.

BORDEAUX-LAFAYETTE
986 kc/s, 304 metres; 13 kW.—6.15 p.m., Radio Journal. 7.30, News. 7.40, Tourist Talk. 7.55, Lottery Results. 8.0, Agricultural Report. 8.15, News. 8.30, Concert of Gramophone Music. 9.0, Concert of Operetta Music by Varney, Massé, Bazin, and Mauprey.

BRATISLAVA
1,076 kc/s, 279 metres; 11 kW.—5.55 p.m., Hungarian Programme. 6.55, Talk for Housewives. 7.0, See Prague. 10.15, Close Down.

BREMEN—See Hamburg.

BRESLAU
923 kc/s, 325 metres; 60 kW; and Gleiwitz, 1,184 kc/s, 253 metres.—1.45 p.m., Time and News. 2.0, Gramophone Concert of Variety Music. 3.0, Agricultural Prices. 3.30, Talk: The First Victims of the World War. 3.50, Pianoforte Recital by Helmut Korbella; Papillons (Schumann); Ballad in A flat (Chopin); Paraphrase on Rigoletto (Liszt). 4.20, Reading. 4.40, Song Recital by Lisa Rosbach-Seebach. 5.10, Talk: German Architecture. 5.30, Agricultural Prices. 5.35 (approx.), Concert by the Benthen Hunting-Horn Quartet: March from The Magic Flute (Mozart); Hymn to Night (Bethoven); Die Kapelle (Kreutzer); Tyrolean Songs (Kästner); Chorus from Das Nachtlager von Gramada (Kreutzer). 6.5, Talk: The Frontiers of Upper Silesia. 6.50, Weather for Farmers and News. 7.0, Transmission for all German Stations, relayed from Hamburg. 8.0, See Berlin (Deutschlandsender). 8.10, Concert by Massed Orchestras, relayed from the Jahrhunderthalle: Nibelungen Marsch (Sontag); Slav Rhapsody (Friedemann); Waltz (Petras); March; Czardas from Der Geist des Wajwoden (Grossmann); Overture, Der Freischütz (Weber); Hungarian Rhapsody (Reinold); March from Parsifal (Wagner); Gipsy Serenade (Nehli); Jubel-Ouverture (C. Bach); Waltz, Wine, Woman and Song (Strauss); Military Marches (Franzen). 10.0, Time and News. 10.20, Talk. 10.40, Radio Report from the Life-Saving Station at Pillau. 11.5, Dance Music relayed from Berlin (Witzleben). 12.0 Midnight (approx.), Close Down.

BRNO
878 kc/s, 342 metres; 35 kW.—6.25 p.m., German Transmission: News, Talk and Broadcast for Workmen. 7.0, See Prague. 10.30 (approx.), Close Down.

BRUSSELS (No. 1)
I.N.R., 590 kc/s, 509 metres; 15 kW. 12 Noon, Concert by Sykes and his Orchestra, relayed from the Scala, Ostend. 1.0 p.m., Journal Parlé. 1.10, Concert by the Small Station Orchestra. Conductor and Soloists: Emile Lanwers (Violin), Suite—Children's Corner (Debussy); Overture, Il Seraglio (Mozart); Violin Solo: souvenir (Drdla); Melody from Sunny Boy; Waltz from Die geschiedene Frau (Fall); Selection from The Student Prince (Romberg); Extase (Ganne); Tango, Como tu (Gosse). 5.0, Dance Music by Mickey's Club Band, conducted by Ludo

Langlois, relayed from the Casino, Knoccke. 6.0, Talk: Excursions in Belgium. 6.15, Gramophone Music. 6.30, Sonata for Cello and Pianoforte (Strens). 7.15, Protestant Address. 7.30, Medical Talk. 8.0, Extracts from Faust (Gounod), on Gramophone Records. 8.45, Talk with Readings on Marie Gervers. 9.0, Orchestral Concert, relayed from the Casino, Knoccke. Conductor: M. Candaul. Soloist: M. Perlemuter (Pianoforte). Prelude to Ingwilde (Schillings); Symphonic Variations for Pianoforte and Orchestra (Franck); First Peer Gunt Suite (Grieg); Hungarian Fantasy for Pianoforte and Orchestra (Liszt); Hungarian Rhapsody No. 2 (Liszt). After the Concert, Le Journal Parlé, followed by Dance Music by Mickey's Club Band, relayed from the Casino, Knoccke. Conductor: Ludo Langlois.

BRUSSELS (No. 2)
N.I.R.; 897 kc/s, 335.2 metres; 15 kW.—Programme in Flemish. 12 Noon, Concert by the Small station Orchestra, conducted by E. Lanwers. Overture, The Merry-makers (Coste); Paganini (Fibich); Suite No. 2 from L'Arlesienne (Bizet); Cello Solo: Romye (Gollin); Gipsy Caprice (Pjorini); Waltz, Tout Paris (Waldteufel); Ein nettes kleines Fräulein (Schwarz); Intermezzo (Bridge-water); Melody (Montoni). 1.0 p.m., Le Journal Parlé. 1.10, Orchestral Concert, relayed from the Scala, Ostend. 5.0, Concert by the Jacky Ganzo Orchestra, relayed from the Continental Palace Hotel, Blankenberghe. 6.15, Gramophone Music: Selection from L'Elisir d'Amour (Donizetti); Concert Waltz, Op. 17 (Glazunov); Overture, Così fan tutte (Mozart). 7.15, Talk: The Life of Chafinches. 7.30, Le Journal Parlé. 8.0, Pianoforte Recital by M. van Durme; Fantastische Stücke (Schumann); (a) Aufschwung, (b) Das Ende vom Lied; Waltz (Chopin). 8.15, Extracts from: (a) Lohengrin (Wagner), (b) The Flying Dutchman (Wagner), on Gramophone Records. 8.30, Hugo Wolf Song Recital by Maria Mussafia; Auch kleine Dinge können uns entzücken; Mir ward gesagt, du reitest in die Ferne; Geseget sei, durch den die Welt entstand; Der Mond hat eine schwere Klag' erhoben; Nun lass uns Frieden schliessen; Auf ein altes Bild; In der Frühe. 8.45, Recitations. 9.0, Concert, relayed from the Continental Palace Hotel, Blankenberghe. After the Concert, Le Journal Parlé, followed by Dance Music relayed from the Continental Palace Hotel, Blankenberghe.

BUCHAREST
761 kc/s, 394 metres; 12 kW.—8.0 p.m., Light Music and Romanian Music by the Iordachescu Orchestra. In an interval at 6.0, Radio Journal. 7.0, Reading. 7.20, Romanian Music. 7.40, Educational Talk. 8.0, Flute Solos. 8.20, Chopin Pianoforte Recital by Nadia Chebap: (a) Nocturne in D Flat, (b) Mazurka in C Sharp Minor, (c)

Waltz in F, (d) Scherzo in C Sharp Minor. 8.50, Talk. 9.5, Cello Recital. 9.35, Programme, relayed from the Iordachescu Restaurant. 10.0, Radio Journal.

BUDAPEST
545 kc/s, 550.5 metres; 18.5 kW.—5.30 p.m., News. 5.45, Cigany Music. 6.30, Talk. 7.0, Pianoforte and Violin Recital. 7.45, Talk on World Politics. 8.0, Song Recital. 9.15, News. 9.30, Light Orchestral Music. 10.15, News and Cigany Music by the Dénes József Band, from the Baross Café.

CASSEL—See Frankfurt.

COPENHAGEN
1,067 kc/s, 281 metres; 0.75 kW. Relayed by Kahunborg, 260 kc/s, 1,153.8 metres.—12 Noon, Time and Chimes from the Town Hall. 12.5 p.m., String Ensemble Concert, relayed from the Wivex Restaurant. 2.0, Interval. 3.0, Gramophone Music. 3.30, Concert by the Station Orchestra, conducted by Emil Reesen. Overture, Sicilian Vespers (Verdi); Ballet Music from Le Cid (Massenet); From the Fields and Groves of Bohemia (Smetana); Ballet Egyptian (Luigini); Overture, Russian and Ludmilla (Glinka); Waltz, A toi (Waldteufel); Selection from Mignon (Thomas). In a Persian Market (Kettelbey); March (Latan). In the interval at 4.15 (approx.), Programme for Children. 5.35, Exchange and Fish Market Prices. 6.20, Talk. 6.50, Weather and News. 7.15, Time Signal. 7.30, Agricultural Talk. 8.0, Chimes from the Town Hall. 8.5, Orchestral Concert, conducted by Emil Reesen. Overture, La Jolie Parfumeuse (Offenbach); Selection from La Vie parisienne (Offenbach); Waltz, Tout Paris (Waldteufel); Marche parisienne (Ganne); Waltz, Soirée d'été (Waldteufel); Overture, Giroflé-Girofla (Leocq); March, Le père la victoire (Ganne). 8.50, Talk. 9.20, Extracts from Il Trovatore—Opera (Verdi) on Gramophone Records. 9.35, Radio Play (Ewald Longfors). 9.50, News. 10.5, Mozart Sonatas for Violin and Pianoforte, by Chr. Kjellerup and Aksel Aerby. Sonata No. 4 in E Minor; Sonata No. 11 in A. 10.35, Reading. 10.45, Pianoforte Duets by Felmer Jensen and Ove Petras; Nordischer Carneval (Schytte). 11.5 (approx.), Close Down.

GORK—See Athlone.

CRACOW
959 kc/s, 312.8 metres; 1.5 kW.—7.5 p.m., Talk: The Egyptians and Plastic Art. 7.20, Miscellaneous Items and News. 7.35, Programme Announcements. 7.40, See Warsaw. In an interval at 10.25, Sports Notes. 11.0 (approx.), Close Down.

DANZIG—See Heilsberg.

DRESDEN—See Leipzig.

FECAMP
1,328 kc/s, 225.9 metres; 10 kW.—4.30 to 6.0 p.m., Programme in English by the I.B.C. 4.30, Programme for Children. 5.0, Gramophone Concert for Port-mouth and Southsea Listeners: Signature Tune, The Night by the Sea; Sweethearts of Yesterday; Part I—My Old Kentucky Home (Foster); Some of these Days (Brooks); Siboney (Lecuna); She didn't say "Yes" (Ker); Llandaw Solo: In a Monastery Garden (Kettelbey); Back to the Shore where the Heather grows (Lauder); The Old Man of the Mountain. 5.30, Concert for Isle of Wight Listeners: Overture, Zampa (Hérold); Squirrel Dance (Elliott Smith); Cornet Solo: Carnival of Venice (Briccialdi); Tally Ho! (Barrot); Wiegand (Brahms); Cornet Solo: Il Bacio (Ardi); The Three Musketeers (Elliott); King's Guard March (Keith); Signature Tune. 6.0, Programme in French. 10.0 (approx.) till Close Down, Programme in English by the I.B.C. 10.0, Dance Music: Signature Tune, Bel's of Normandy; Sharing (Lombardo); I'll never be the Same (Kahn); With Summer coming on (Ahlert); We just couldn't say "Good-bye" (Woods); You Rascal, you (Theard); Clarinet Marmalade (Shields); Get Canibal (Weems); Sweet Sue, just you (Harris); The Sheik of Araby (Wheeler); Is I in Love? I is (Robinson); Blue Rumble (Ellington); Hummity to Myself (Magidson); Cotton Club Stomp (Ellington); Same Old Moon (Basket); Wall Street Wall (Ellington); Moon (Caleo); Signature Tune. 11.0, Organ Recital: Friends once more (Spoliangy); My Wishing Song (Burke); Song, Letting in the Sunshine (Gay); Song, For you alone (O'Reilly); Hold me (Selmer); Song, I raised my Hat (Pola); The old Spinning Wheel (Hill); Drifting down the Shalimar (Monaco). 11.30, Concert by the I.B.C. (Ireland), Ltd.: Signature Tune, Como back to Erin; Waltz, Wiener Blut (Joh. Strauss); Selection from The Dubarry (Müllcker-Mackeben); Song, Innis Farrel (Aitken); Barcarolle (Waldteufel); Under Heaven's Blue (Payan); I give my Heart (Müllcker-Mackeben); Quartet: The Irish Washerwoman; By the Sleepy Lagoon (Coste). 12.5 a.m. (Thursday), The I.B.C. Late News Bulletin. 12.10 (approx.), Club Concert for Llandudno Listeners: Part I—Variety Music; Signature Tune, The Chum

AUGUST 2nd

WEDNESDAY

continued

Song; That's my Home (Ellison); Piano-forte Solo: He wanted Adventure (Waller and Tunbridge); The Old Spinning Wheel (Hill); Piano-forte Solo: Just humming along (Ewing); Hold me (Schuster); Part II—Dance Music: I've told every Little Star (Kern); No more Love (Lombardo); The Song is you (Kern); Waltzing in a Dream (Young); My Darling (Myers); You've got me crying again (Jones); A Ghost of a Chance (Young); Stormy Weather (Arlen); Signature Tune. 1.0, Concert of Light Music: Selection from Die Fledermans (Joh. Strauss); The Wraggle Taggle Gipsies O (Traditional); Hares on the Mountain (Traditional); Orchestra: In the Valley of the Poppies (Anchiff); Cello Solo: Harlequinade (Squire); Song: A Brown Bird singing (Haydn Wood); Violin Solo: Valse Bluette (Drigo); A Birthday Serenade (Lincke); A Selection of Good Old Songs. 1.30, Dance Music: Signature Tune, Bells of Normandy; Cinderella's Wedding Day (Traumbauer); Overnight (Alter); Business in Q (Bleyer); Cheerful little Earful (Kosc); The Japanese Sandman (Whiting); Well! Well! Well! (Donaldson); Pal of my Dreams (Gilbert); Jack in the Box (Shand); Signature Tune. 1.57, I.B.C. Good-night Melody. 2.0, Close Down.

FLENSBURG.—See Hamburg.

FLORENCE.—See Turin.

FRANKFURT

1,157 kc/s, 259.3 metres; 17 kW. Relayed by Cassel, 1,220 kc/s, 245.9 metres; and Trier, 1,157 kc/s, 259.3 metres.—4.30 p.m., See Stuttgart. 5.45, Economic Notes. 6.0, Talk on Sport. 6.25, See Heilsberg. 6.45, To-day's News. 6.50, Time and News. 7.0, Transmission for all German Stations, relayed from Hamburg. 8.0, See Berlin (Deutschlandsender). 8.10, Concert. 9.15, Variety Items. 9.30, Talk: Hans Michael Obertraut, the Typical German. 10.15, Time and News. 10.45, See Langenberg.

FREDRIKSSTAD.—See Oslo.

FREIBURG.—See Stuttgart.

GENEVA.—See Radio-Suisse Romande.

GENOA.—See Turin.

GLEIWITZ.—See Breslau.

GOTEBORG.—See Stockholm.

GRAZ.—See Vienna.

HAMAR.—See Oslo.

HAMBURG

Call ha (in Morse). 806 kc/s, 372 metres; 1.5 kW. Relayed by Bremen, 1,112 kc/s, 269.8 metres; Flensburg, 1,319 kc/s, 227.4 metres; Hanover, 530 kc/s, 566 metres; and Kiel, 1,292 kc/s, 232.2 metres.—4.0 p.m., Concert by the Hamburg Philharmonic Orchestra, conducted by José Eibenschütz. Soloist: Hubert Barwasser (Flute). Overture, The Water-Carrier (Cherubini); Flute Concerto in D (Mozart); Siegfried Idyll (Wagner); Finlandia (Sibelius). 5.0, Talk: The Towns of Mecklenburg. 5.30, Hamburg, Bremen and Lübeck—Report on Events in the Senates and Houses of Burgesses of the Hanseatic Free Cities. 6.0, Talk: The Armies of Foreign States. 6.20 (from Kiel), Songs to the Lute by Erika Beckert: Two Folk Songs (arr. E. Beckert): (a) Alle Tage ist kein Sonntag, (b) Es stellt in Deutschland eine Lind; Folk Song (arr. Rueff); Der Spielmann vor der Himmelstür; Russian Folk Song (arr. E. Beckert); Prinzessin Arm (Lemke-Hornstein); Der Eine allein (Löss-Licht); Mädchenlied (Baumbach-Albert); Guter Rat (Schätz-Ruch). 6.45, Frankfurt Exchange and Market Prices. 6.50, Weather. 7.0, Transmission for all German Stations. The German Navy—Radio Sequence (Fritz Otto Bueh). 8.0, See Berlin (Deutschlandsender). 8.5, Folk Songs: Op. 53 (Alfred Huth) for Women's Choir and Piano-forte, with the Composer conducting, relayed from Deutsches Haus, Flensburg. 8.40, Concert of Mecklenburg Dance Music. 10.0, Time and News. 10.20, Topical Talk. 10.30 (from Bremen), Orchestral Concert, conducted by Fredo Niemann: Hindenburg March (Gerloff); Overture, Die schöne Galathée (Suppé); Waltz, Wiener Blut (Joh. Strauss); Erzherzog-Albrecht-Marsch (Komzak); Selection from The Flying Dutchman (Wagner); Potpourri, Mit vereinten Kräften (Recktenwald); Waltz, Hereinspaziert (Ziehrer); An Indian Wedding (Perex); Bugle Horn Solo: Oh du mich liebste (Lincke); Overture, Venus auf Erden (Lincke); Waltz, Wir sind ja heute so vernünftig (Meisel); March, Hoch die Friedensflagge (Blankenburg).

HANOVER.—See Hamburg.

HEILSBURG

1,085 kc/s, 276.5 metres; 60 kW. Relayed by Danzig, 662 kc/s, 453.2 metres.—1.5 p.m., German Songs on Gramophone Records. In

the intervals at 1.20 and 2.0, News. 2.30, Programme arranged by the Post Office with Gramophone Records. 3.0, Agricultural Prices and Exchange. 3.20, Talk for Housewives. 3.30, Programme for Children. 4.0, Talk: Educating Young People in Citizenship. 4.30, Concert by the Königsberg Opera House Orchestra conducted by Ludwig Leschetizky, relayed from the Königsberg Zoological Gardens. Soloist, Georg Höllger (Baritone); Comedy Overture (Paul Scheinpflug); Selection from Hansel and Gretel (Humperdinck); Introduction to Act III of Tannhäuser (Wagner); Aria, Oh! Star of Eye from Tannhäuser (Wagner); Hungarian March from the Damnation of Faust (Berlioz); Aria from A Masked Ball (Verdi); Overture, William Tell (Rossini). 6.0, Talk in Dialect. 6.15, Agricultural Prices. 6.25, Seamen in Distress—Radio Report relayed from the Rescue Station, Pillau. 6.50, Weather. 7.0, Transmission for all German Stations, relayed from Hamburg. 8.0, See Berlin (Deutschlandsender). 8.5, Weather and News. 8.10, Georg Vollerthun Song Recital by Mia Neusitzer-Thoenissen (Soprano), with the Composer at the Piano-forte; Six Songs from the First Song Cycle, Op. 16; Four Songs from the Song Cycle, Ein Sommer. 8.40, Talk: German Colonization in the East under the New Government. 9.10, Dance Music by the Eugen Wilken Band. 10.0, Weather and News. 10.10 (approx), Concert by the Small Station Orchestra conducted by Eugen Wilken: Overture, Prometheus (Beethoven); The Nutcracker Suite (Tchaikovsky); Dance Waltz (Busoni); Ballet Music from The Merry Wives of Windsor (Nicola); Ballet Music from Otello (Verdi); Bolero from Don Quixote (Kienzl); Ballet Music from Undine (Lortzing); Overture, Die Fledermans (Johann Strauss). 12 midnight (approx.), Close Down.

HILVERSUM

Announced HUIZEN, 1,013 kc/s, 296.1 metres; 20 kW. (7 kW. up to 4.40 p.m.). Programme of the Christian Radio Society (N.C.R.V.).—12.10 p.m., Concert by Mmc. de Kragt-ter Haar (Songs), Mlle. Beute (Piano-forte) and H. Berghout (Cello): Arias from: (a) The Messiah (Handel), (b) Joshua (Handel); Old Dutch Peasant Songs (Röntgen); Cello Solos (J. C. Berghout): (a) Romance, Op. 9, (b) Song, Op. 54, No. 11; Oogstlied (J. C. Berghout); Herbstgedachten (J. C. Berghout). 12.55, Organ Recital by F. Klock. 1.40 to 2.10, Interval. 2.10, Concert (contd.): Adagio (Bocherini); Minuet (Bocherini); Dutch Songs; Les Jeux d'eau à la ville d'Este (Liszt); Te Deum (Hüré); Tomadilla (de Laserna); Anduitza (Granados); Five Songs (van Rennes); Zonne-Heid (van Rennes). 3.10, Marine Band Concert, conducted by L. Leistikov. 4.40, Programme for Children. 5.40, Choral Music on Gramophone Records. 6.10, Talk. 6.40, Police Notes. 6.55, Religious News. 7.10, Talk. 7.40, Carillon Recital by J. de Zwaan. 8.40, Gramophone Music. 9.10, Concert by the Amsterdam Orchestra, conducted by F. van Diepenbeek. In the interval at 9.40, News. 10.40, Gramophone Music. 11.10 (approx.), Close Down.

HORBY.—See Stockholm.

HUIZEN

Announced HILVERSUM, 160 kc/s, 1,875 metres; 8.5 kW. Programme of the Algemeene Vereeniging Radio Omroep (A.V.R.O.).—11.40 a.m., Time Signal. 11.41, Concert by the Wireless Orchestra, conducted by Nico Gerharz, with Barrel Organ Interludes. 1.40 p.m., Reading. 2.40, Concert by the Wireless Orchestra, conducted by Nico Gerharz: Festival Overture (Leutner); Heinzelmännchen Wachtparade (Noack); Selection from Le petit Duc (Lecocq-Tavan); March, Old Comrades (Teike). 2.40, Programme for Children, relayed from the Kurhaus, Scheveningen. 3.25 to 3.40, Interval. 3.40, Piano-forte Recital by Mrs. Stein. 4.10, Children's Choir, conducted by Jacob Hanel. 4.40, Programme for Children. 5.10, Military Band Concert. 6.40, Gramophone Music. 7.10, Talk by Mrs. Rika Hopper: America. 7.40, Time. Weather and News. 7.45, Gramophone Music. 7.55, Orchestral Concert, conducted by Carl Schuricht, relayed from the Kurhaus, Scheveningen; Soloist: Jacques Thibaud (Violin). 8.50, Gramophone Music. 9.10, Concert of Popular Music by Kovacs Lajos and his Dance Orchestra; Soloist: Liesje v.d. Poll-Coster (Songs). 10.40, News. 10.50, Gramophone Music. 11.40 (approx.), Close Down.

INNSBRUCK.—See Vienna.

KALUNDBORG.—See Copenhagen.

KIEL.—See Hamburg.

KLAGENFURT.—See Vienna.

LAHTI

167 kc/s, 1,796 metres; 40 kW. Relayed by Helsinki, 815 kc/s, 368.1 metres.—6.15 p.m., Programme for Children. 6.50, Talk for Girls. 7.0, Talk. 7.20, Song Recital. 7.45, Humorous Items. 8.0, Orchestral Concert, relayed from Viipuri, 1,031 kc/s, 291 metres: Selection from The Barber of Seville (Rossini); Gipsy Dance (Saint-Saëns); Childhood Friends (Faltin, arr. Toivonen); Two Guitars (Horliek); Waltz, España (Waldteufel); Cardas (Grossmann). 8.45, News in Finnish and Swedish. 9.15, Light Music, relayed from the Kappeli Restaurant. 10.0, Close Down.

LANGENBERG

635 kc/s, 473 metres; 60 kW.—12 noon, Orchestral Concert conducted by Breuer. 12.50 p.m., Announcements. 1.0, Piano-forte Recital by Hans Haass. 1.30, Concert (continued). In the interval at 2.0, (approx.), News. 2.30, Interval. 3.0, Handwork for Children. 3.0, Market Prices. 3.50, Programme for Children. 4.30, Reading. 4.50, A German Catechism. 5.0, Concert by the Fröhliche Fünf. 5.30, Talk: The Discipline of Thought. 5.50, Reading. 6.0, Concert. 6.45, Announcements. 7.0, Transmission for all German Stations, relayed from Hamburg. 8.0, An Appeal in connection with the National Labour Scheme. 8.5, News. 8.10, Political Address. 8.20, The Girls of the Rhineland—Programme arranged by Curt Baumgarten. 9.30, Cabaret Programme arranged by Kurt Georg Treumer. 10.0, News. 10.30, Serenade by the Fröhliche Fünf. 12 midnight, Close Down.

LAUSANNE.—See Radio-Suisse Romands.

LEIPZIG

769.9 kc/s, 389.6 metres; 120 kW.; and Dresden, 941 kc/s, 319 metres.—12 Noon (from Dresden), Concert by a Nazi Band, conducted by Bruno Schestak. In an interval at 1.0 p.m., News. 2.0, News. 2.30, Talk: Driving Licences. 3.0, Baritone and Piano-forte Recital by Theo Straub and Alf Nestmann: Songs (Mozart): (a) Abendempfindung, (b) An Chloë, (c) Warning; Extracts from the Sonata in D (Friedrich Bach); Songs (Beethoven): (a) Mit Mädchen sich vertragen, (b) Neue Liebe, neues Leben, (c) Sehnsucht. 3.35, Economic Notes. 4.0, Programme for Young People. 5.50, Market Prices. Weather, and Time. 6.0, A Dresden Court Concert. Commentator: Tadzio Koidziella. 6.50, News. 7.0, Transmission for all German Stations, relayed from Hamburg. 8.0, Concert of Opera Music by the Leipzig Symphony Orchestra, conducted by Hilmar Weber. Soloist: Liesel Sturmfels (Soprano); Overture, L'isola disabitata (Haydn); Selection from The Magic Flute (Mozart); Entr'acte from Die drei Pintos (Weber); Overture, The Daughter of the Regiment (Donizetti); Recitative and Aria from La Traviata (Verdi); Ballet Music from William Tell (Rossini); Air from Die Vögel (Braunfels); Recitative and Aria from Ariadne auf Naxos (R. Strauss); Prelude to Die Abreise (d'Albert). 9.30, Mobilisation for War—Reading of War Documents. 10.10, News. 10.15 (approx.), Serenade. 12 Midnight (approx.), Close Down.

LINZ.—See Vienna.

LJUBLJANA

522 kc/s, 574.7 metres; 7 kW.—6.30 p.m., Concert by the Station Orchestra. 7.30, Literary Programme. 8.0, Vocal Duets by M. Sok and M. Jelacin. 9.0, Programme relayed from Bled. 9.30 to 10.0, Programme in English by the I.B.C. 9.30, Light Music: Why waste your Tears?; Night shall be filled with Music; Three's a Crowd; Sweet hearts forever; Let's all sing like the Birds; sing; Venetian Lady; I do like to see a game of Football; Slow Foxtrot, Underneath the Arches. 10.0, Gramophone Music. 11.0 (approx.), Close Down.

LUXEMBOURG

252 kc/s, 1,191 metres; 200 kW.—Luxembourg Programme. 7.30 p.m., Concert by the Station Orchestra, conducted by Henri Pénis: Les Préludes (Liszt); Valse caprice (Rubinstein); Suite from Swan Lake (Tchaikovsky). 8.10, Weather Report. 8.15, Recital of Luxembourg Songs. 8.50, News in French. 9.0, Cello Solo by Mlle. Braum: Elégie (Faure); Ballad (Schubert). 9.15, Concert by the Station Orchestra. In an interval at 9.50, News in German. 10.25, Dance Music on Gramophone Records.

LYONS

LA DOUA (PTT), 644 kc/s, 465.8 metres; 1.5 kW.—7.30 p.m., Radio Gazette for Lyons and the South East. 8.30, Opéra Comique Programme relayed from Paris (Ecole Supérieure) 671 kc/s, 447.1 metres. After the Relay, News.

MADRID

EAJ7, 707 kc/s, 424.3 metres; 2 kW.—8.0 p.m., Chimes, Exchange, Radio Journal, Programme for Women and Dance Music. 9.25, News and Political Review. 9.30 to 11.0, Interval. 11.0, Chimes, Time and Political Review. 11.15 (approx.), L'Avare — Play (Molière). 1.15 a.m. (Thursday), News. 1.30, Chimes and Close Down.

MALMO.—See Stockholm.

MILAN

VIGENTINO, 662 kc/s, 453.2 metres; 4 kW.—8.45 p.m. till Close Down, See Rome.

MORAVSKA-OSTRAVA

1,137 kc/s, 263.8 metres; 11 kW.—6.25 p.m., Concert of Schrammel Music. 7.0, till Close Down, See Prague. 10.15 (approx.), Close Down.

MOSCOW

TRADES UNION, 230 kc/s, 1,304 metres; 100 kW.—2.45 p.m., Weather. 3.0, Extracts from The Fair at Sorochinsk—Opera (Musorgsky). 5.30, Programme for Children. 6.30, Open Air Concert. 9.0, News. 9.30, Programme Announcements. 9.55, Chimes from the Red Square. 10.5, Talk in Dutch. 10.30, Press Review.

MOTALA.—See Stockholm.

MUHLACKER.—See Stuttgart.

MUNICH

563 kc/s, 533 metres; 60 kW. Relayed by Augsburg and Kaiserslautern, 536 kc/s, 560 metres; and Nürnberg, 1,256 kc/s, 239 metres.—4.30 p.m., Orchestral Concert, conducted by Erich Kloss: Overture, Idomeneo (Mozart); Lyric Suite (d'Albert); Selection from Le Bourgeois Gentilhomme (R. Strauss); Steirische Ländler (Lanner); Suite, As You Like It (Zichler); Faust Fantasia (Sarasate); Alhambra (Wagner); Hungarian Dance No. 8 (Brahms). 5.45, Talk: Ferner von Siemens, the Founder of Modern Electro-Technics. 6.5, Folk Song Recital. 6.25, Talk: Constructive and Descriptive Revolutionary Movements—The French Revolution. 6.45, Time, Weather, and Agricultural Report. 7.0, Transmission for all German Stations, relayed from Hamburg. 8.0, See Berlin (Deutschlandsender). 8.10, Concert by the Reich Symphony Orchestra, conducted by L. It. Mayer. Soloists: Irmgard Fröhlich (Soprano) and Hans Scherer (Bass). Overture, The Merry Wives of Windsor (Nicola); Aria from The Merry Wives of Windsor (Nicola); German Dances (Beethoven); Aria from Tzar and Carpenter (Lortzing); Rhapsody No. 1 (Liszt); Homage March (Wagner). 9.15, Mobilisation in 1914—Historical Report by Josef Wanninger. 9.35, Soldier Songs and Marches, on Gramophone Records. 9.55, Talk: General Mobilisation. 10.20, Time and News. 11.0, Serenade, from Langenberg. 12 Midnight, Close Down.

NAPLES.—See Rome.

NOTODDEN.—See Oslo.

OSLO

277 kc/s, 1,083 metres; 60 kW. Relayed by Fredrikstad, 815 kc/s, 368.1 metres; Hamar, 522 kc/s, 574.7 metres; Notodden, 671 kc/s, 447.1 metres; Porsgrund, 662 kc/s, 453.2 metres; and Rjukan, 671 kc/s, 447.1 metres.—5.30 p.m., Gramophone Concert. 6.15, Programme for Boys: Arabian Boy Scouts welcome Norwegian Boy Scouts—a Report by Georg Seyfersted, followed by Reading. 7.0, Announcements. Weather and News. 7.30, Talk: Theatrical Life in Germany To-day. 8.0, Time. 8.1, Concert by the Station Orchestra, conducted by Hugo Kram: Overture, Orpheus in the Underworld (Offenbach); Musical Memories (Finck); Wedgwood Blue (Ketelbey); Norwegian Wedding March (Sandy); Persian Dance (Musorgsky); Suite, Summer in Norway (Torjussen); Toréador et Andalouse (Rubinstein); Waltz, Pluie d'or (Waldteufel); Selection from The Maid of the Black Forest (Jessel). 9.25, Agricultural Notes, Weather, and News. 10.0, Topical Talk. 10.15, Songs and Review of the Week. 10.45 (approx.), Close Down.

OSTERSUND.—See Stockholm.

PALERMO

558 kc/s, 537.6 metres; 3 kW.—8.0 p.m., Dopolaro Notes, Tourist Report, Agricultural Talk, and Giornale Radio. 8.20, Gramophone Music. In the interval at 8.30, Time and Announcements. 8.45, Variety Concert: Soloists: Gilda Adelfo (Soprano) and A. Micozzi (Clarinet); Il cavaliere romantico (Tonio); Soprano Solos: (a) Ti vorrei rapire (Gastaldon), (b) Serenade (Mascagni); Carovane notturne (Bettinelli); Clarinet Concerto (Mozart); Largo (Zuelli); Soprano Songs: (a) Portami via (Tirino).

delli), (b) Luigi (Fosti), Scènes napolitaines (Massenet). In the interval, Talk, 10.0, Popular Songs, 10.55, News.

PARIS

EIFFEL TOWER; 207.5 kc/s, 1,445.7 metres; 13 kW.—Time Signals (on 2,650 metres) at 10.26 a.m. and 11.26 p.m. (Preliminary and 6-dot Signals). 6.45 p.m., Theatre Notes, 7.0, Le Journal Parlé, 8.30, Concert by the Symphony Orchestra, conducted by Edouard Flament. Soloists: Edouard Flament (Pianoforte) and M. Cantrelle (Violin). Concerto in D, Op. 21, for Pianoforte, Violin, and String Quartet (Chausson); Peer Gynt Suite (Grieg). 10.0 (approx.), Close Down.

PARIS

POSTE PARISIEN, 914 kc/s, 328.2 metres; 60 kW.—7.0 p.m., Gramophone Music, 7.15, Journal Parlé, 7.30, Gramophone Music, 8.0, Assurance Societies' Report, 8.5, Talk on Parasites, 8.30, Orchestral Concert: Overture, Mirella (Gounod); Valse militaire (Waldteufel); Canzonetta (Filipponi); Idylle rhénane (Lutj); Selection from Amour de province (Delibes); Ballet Music from Coppélia (Delibes); Melody (Staub); Interlude from Pepita Jimenez (Albeniz); Selection from L'amour masqué (Messager); Castilian Dance (Turina). 10.30, Orchestral Concert of Dance Music, relayed from the Lido.

PARIS

RADIO PARIS, Call CFR, 174 kc/s, 1,725 metres; 75 kW.—7.30 a.m., Weather and Physical Culture, 7.45, Light Music on Gramophone Records, 8.0, News, 12 Noon, Educational Talk, 12.15 p.m., Spanish Rhapsody (Ravel), Gramophone Concert, Part I—Le carnaval des animaux (Saint-Saëns); Part II—Offenbach Programme, Overture, Orpheus in the Underworld; Selection from La Boulangère a des écus; La Lettre from La Périole; Dites-lui qu'on l'a remarqué from La Grande Duchesse de Gérolstein; Selection from Blue Beard; Amour divin and Invocation a Venus from La belle Hélène; Duet, Le plus gentil des trois from Madame l'Archiduc; Songs from The Tales of Hoffmann. In the interval at 1.0 and 1.30, Exchange, 2.0, Exchange, 3.45, Exchange and Market Prices, 7.0, News, 7.10, Gramophone Concert; Spanish Dance No. 6 (Granados); Selection from La Folia (Lacôme); Prelude, Sacred Scene, Entr'acte and Divertissement from Les Erynnies (Chabrier); Ballade des gros dindons (Chabrier); Ronde d'amour (Chaminade); Impressions de Danus (Kœnig); 7.50, Commercial Prices and News, 8.0, Gramophone Records, with Songs by Mlle. Vothy; Selection from Le petit duc (Lecocq); Souvenir (Drda); Rigaudon (Lacôme); Bonsoir Madame la Lune (Marnier); Joyeux retour (Aignou); French Rondos (Morawek); 8.30, News, 8.40, Fashion Review by Mlle. José, 8.45, Concert (cont'd.); Paris qui brille (Maliheu-Grigaut); Songs from Operettas by Mlle. Vothy; Perle et perle (Corbin); Pastel (Paradis); Glad Rag Doll (Herb-Brown), 9.15, News, 9.30, Concert (cont'd.); Pour danser le Charleston (Yvain); Blonde amie (Carcel); Melody (Bud-Green); Madrigal (Simonetti); Madrid (Alex); Melody (May); Melody (Lohr); In a Circassian Village (Yvain); Souvenir de Rouen (Sombrun); Quadrille from La Vie Parisienne (Offenbach); The Whistler and his Dog (Pryor); Waltz Potpourri (Berlin); Ballet Music from Le Cid (Massenet). 10.30 (approx.), Close Down.

PITTSBURGH

(KDKA), 980 kc/s, 306 metres; 50 kW. Relayd by W8XK on 48.86 metres and 25.27 metres.—7.30 p.m., KDKA Home Forum, 9.0 to 8.59, New York Relay, 8.0, Betty and Bob, 8.15, Words and Music, 8.30, Happy Days in Dixie, 8.58, Baseball Scores, 9.0, Southern Symphonies, from New York, 9.30, Business News and Market Reports, 9.45, Dance Masters, Harold Stokes' Orchestra, from New York, 9.58, Baseball Scores, 10.0, Rhythmic Kings, 10.15, Tarzan of the Apes, 10.30, The Singing Lady, 10.45, Little Orphan Annie, from New York, 11.0, Time Signal and Press News-Reeler, 11.5, Piano Classique, 11.15, Weather Report, 11.16, Sport Review, 11.23, I Bring a Song, 11.28, Announcement, 11.29, Temperature Report, 11.30, Pittsburgh Spotlight, 11.45 to 1.30 a.m. (Thursday), New York Relay, 11.45, To-day's News, by Lowell Thomas, 12 Midnight, Amos 'n' Andy, 12.15, Annie, Judy and Zeke, 12.30, Moods, 1.0, Crime Lines, 1.30, Potash and Perlmutter, 1.45, Phil Cook and the Ingram Shavers, from New York, 2.0, Goldman Band, from New York, 3.0, Programme to be announced.

PORSGRUND.—See Oslo.

POZNAN

896 kc/s, 335 metres; 1.9 kW.—6.35 p.m., See Warsaw, 7.20, Miscellaneous Items and News, 7.35, Theatre Notes and Programme Announcements, 7.40, See Warsaw, 10.0, Time Signal, Sports, and Police Notes, 10.15, Dance Music on Gramophone Records, 11.0 (approx.), Close Down.

AUGUST 2nd

WEDNESDAY

continued

PRAGUE

614 kc/s, 488.6 metres; 120 kW.—2.50 p.m., Concert by the Station Orchestra conducted by Parik, 3.55, Exchange, 4.0, Interval, 5.45, Gramophone Music, 5.55, Talk, 6.5, Agricultural Report, 6.10, Gramophone Music, 6.25, News in German, 6.30, German Transmission, Talk: Touring in Eastern Slovakia, and Broadcast for Workers, 7.0, Chimes and News, 7.10, Concert of Music by Knoch, relayed from Kolín, 8.15, Talk, 8.30, I Pagliacci—Opera (Leoncavallo) on Gramophone Records, 10.0, Time and News, 10.15, News in French, 10.30 (approx.), Close Down.

RADIO-SUISSE ROMANDE

SOTTENS; 743 kc/s, 403 metres; 25 kW.; and Geneva, 395 kc/s, 760 metres.—6.15 to 6.30 a.m., Gymnastics, 12.28 p.m., Time Signal from Neuchâtel Observatory, 12.30, News and Weather, 12.40, Gramophone Concert, 1.0, Financial News, 1.10, Gramophone Music, 2.0 to 3.28, Interval, 3.28, Time Signal from Neuchâtel Observatory, 3.30, Gramophone Music, 5.0, Talk: Upton Sinclair, 7.0, Talk on Football, 7.25, Agricultural Report and Weather Forecast, 7.30, Radio Interview, 8.0, Concert by the Vienna Chamber Trio; M. Albert Meitner (Violin), Leopold Bracharz (Viola) and Otto Schindler (Guitar); Trio (Svoboda); Viennese Melody No. 1 (Hassenhülrl); Variations on a Waltz of Beethoven (Pisk); Oriental Fantasia (Skocic); Dance Suite (Sainhofer), 8.55, Let us drink, dance and sing—Italian-Swiss Programme, 9.50, News and Weather, 10.0, Dance Band on Gramophone Records, 11.0 (approx.), Close Down.

REYKJAVIK

250 kc/s, 1,200 metres; 21 kW.—9.5 p.m., Musical Programme, 9.30, Weather Report, 9.40, Musical Programme and Announcements, 10.0, Chimes and News, 10.30, Reading, 11.0, Cello Concerto in A Minor (Grieg) on Gramophone Records.

RJUKAN.—See Oslo.

ROME

Call 1RO, 680 kc/s, 441 metres; 50 kW. Relayd by Naples, 941 kc/s, 319 metres; and 2RO, 11,810 kc/s, 25.4 metres, from 5.30 p.m.—1.0 to 2.15 p.m., Orchestral Concert of Light Music. In the intervals from 1.30 to 1.45, Giornale Radio and Exchange, and at 2.0, Time and Announcements, 4.45, Children's Radio Review, 5.10, Weather, 5.15, Exchange, Report of the Royal Geographical Society, and Giornale Radio, 5.30 to 6.15, Orchestral Concert of Light Italian Music, 6.40 (Naples), Shipping and Sports Notes, 6.50, Agricultural Notes and Dopolavoro Announcements, 6.57, Report on the International Institute of Agriculture (in Italian and English), 7.10, Tourist Talk, 7.20, News in Foreign Languages, 8.0 Time, Announcements and Gramophone Music, 8.15, See Turin, 8.35, Giornale Radio and Sports Notes, 8.45, Stenterello—Operetta in Three Acts (Cusina). In the intervals: Talk and Science Review, After the Operetta, Giornale Radio.

SALZBURG.—See Vienna.

SCHENECTADY

(WGY), 790 kc/s, 379.5 metres; 50 kW. Relayd at intervals by W2XAF on 31.48 metres, and by W2XAD on 19.56 metres.—9.0 p.m., Business and Professional Women, 9.10 to 10.0 (approx.), New York Relay, 9.10, Pop Concert, 9.30, Texas Cowgirl, 9.45 to 10.0, Lady Next Door, 12.45 a.m. (Thursday), Stock Reports and Baseball Scores, 1.0 to 2.15, New York Relay, 1.0, Variety Programme, 1.30, Ferde Grofe's Orchestra, 2.15, Popular Programme, 2.30, Variety Programme, 3.0, Popular Programme, from New York, 3.30, Musical Programme, from New York, followed by Programme Resumé.

SCHWEIZERISCHER LANDESENDER

BEROMUNSTER; 653 kc/s, 459 metres; 60 kW.; Basle, 1,229 kc/s, 244.1 metres; and Berne, 1,220 kc/s, 245.9 metres.—6.15 to 6.35 a.m., Gymnastics, 11.59, Time Signal from Neuchâtel Observatory, 12 Noon (from Zürich), Concert of Opera Music on Gramophone Records, 12.30 p.m., Time and News, 12.40 (from Zürich), Concert (cont'd.), 1.25 (from Zürich), Exchange, Time and Weather, 1.45, Interval, 5.0 (from Zürich), Gramophone Dance Music, 5.30 (from Zürich), Programme for Children, 6.0 (from Zürich), Light Music on Gramophone Records, 6.30 (from Zürich), St. Gall—Literary and Musical Programme, 7.0 (from Zürich), Time, News, and Market Prices, 7.10 (from Zürich), Extracts from Old Operettas and Comic Operas, 8.0, Concert by the Swiss Radio Orchestra, conducted by

Neppach, 9.0, News, 9.10 (from Zürich), Billeberger and Company—Face in One Act (K. Freuler and H. Jenny-Fehr), 10.15 (approx.), Close Down.

SOTTENS.—See Radio-Suisse Romande.

STOCKHOLM

689 kc/s, 436 metres; 55 kW. Relayd by Boden, 244 kc/s, 1,229.5 metres; Göteborg, 932 kc/s, 322 metres; Hörby, 1,166 kc/s, 257 metres; Motala, 221.5 kc/s, 1,354.4 metres; Östersund, 389 kc/s, 770 metres; and Sundsvall, 554 kc/s, 542 metres.—5.5 p.m., Programme for Children, 5.30, Song Recital by Ingborg Wiberg, 5.45 (from Göteborg) A Visit with the Microphone, 6.15, Gramophone Music, 7.15, Weather and News, 7.30, Talk: The Results of the World Economic Conference, 8.0, Military Band Concert, conducted by Herman Nordström; March (Fürst); Waltz, Lotus Flowers (Ohlsen); Overture, Die schöne Galathée (Suppé); Dance (Peterson-Berger); Extracts from Aida (Verdi). Foxtrot, Selection from Hollandvibeihen (Kälmin); March (Korsgren), 9.0, Talk, 9.25, Cello Recital by Carl Christensen; Cello Sonata (Grazioli); Spanish Serenade (Cassado); Ständchen (Schubert), 5.45, Weather and News, 10.0, Dance Music from Berns Dance Hall, 11.0 (approx.), Close Down.

STRASBOURG

869 kc/s, 345 metres; 11.5 kW.—11.30 a.m., Gramophone Concert, 12.45 p.m., News, 1.0, Time and Exchange, 1.5, Orchestral Concert, conducted by Roskam, 2.0 to 3.30, Interval, 3.30, Orchestral Concert, conducted by Broullac, relayed from the Casino Park, Vichy; Overture, Don Giovanni (Mozart); Serenade and Spring Song (Mendelssohn); Two Scenes from Les Erynnies (Massenet); Rhapsody on Airs of the Pays d'Océ (Lacombe); Selection from Grisélidis (Massenet); Marche héroïque (Saint-Saëns), 5.0, Talk on Electricity, 5.15, Jazz Music by the Station Orchestra, conducted by Roskam, 6.0, Trio Concert, relayed from Lille, 1.130 kc/s, 265.4 metres, 7.0, Talk: The Population of France since 1913, 7.15, Talk on Technology, 7.30, Time and News, 7.45, Gramophone Music, 8.15, Press Review in French, Lottery Results and Announcements, 8.45, Mozart Concert by the Municipal Orchestra, conducted by Münch, relayed from the Orangerie Restaurant, Soloist: Mme. Pelletier-Sattler (Pianoforte), Overture, Don Giovanni; Pianoforte Concerto in E Flat; Symphony in C. In the interval, Press Review in German, 10.30, Orchestral Concert, relayed from the Grand Kleeber Mu; March, On the Banks of the Rhine (Blankenburg); Waltz from The Count of Luxembourg (Lehar); Down South (Myddleton); Overture, Orpheus in the Underworld (Offenbach); Selection from Rigoletto (Verdi); Potpourri (Rhode); Selection from The Bird Faucier (Zeller).

STUTTGART

MUHLACKER 832 kc/s, 360.5 metres; 60 kW.; and Freiburg, 527 kc/s, 570 metres.—12.30 p.m., Symphony No. 4 in F minor (Tchaikovsky), on Gramophone Records, 1.30, Organ Recital of Russian Music by Wilhelm Locks, relayed from the Ufa-Palast; Impromptu in B Op. 25 No. 1 (Arensky); In a Monastery (Borodin); Nocturne (Borodin); Intermezzo (Mussorgsky); Two Airs (Mussorgsky), 2.0, Programme arranged by the Post Office, 2.30 to 3.30, Interval, 3.30, Programme for Children, 4.30, Concert by the Korochostra, relayed from Badenweiler, Conductor: Albert Hitzig; Triumphal March from Aida (Verdi); Overture, The Merry Wives of Windsor (Nicolaï); Emperor Waltz (Joh. Strauss); Selection from Il Trovatore (Verdi); Rhapsody No. 2 (Kämpfert); Serenade (Drigo); Hungarian Songs and Dances, Hungaria (Leopold); March, The Gladiator's Farewell (Blankenburg), 5.45, Review of Post War Books, 6.10, Agricultural Notes, 6.25, See Heilsberg, 6.50, Time and News, 7.0, Transmission for all German stations, relayed from Hamburg, 8.0, See Berlin (Deutschlandsender), 8.5, Caruso Memorial Programme (Died August 2nd, 1921) Talk, with Gramophone Illustrations, 9.15, Reading of Swabian Poems (Wilhelm Schussen), 9.35 (from Freiburg); Concert of Viennese Schrammel Music, conducted by Ewald Knoch, 10.10, Time and News, 10.45, Serenade from Langenberg, 12 Midnight, (approx.), Close Down.

SUNDSVALL.—See Stockholm.

TRIESTE

1,211 kc/s, 247.7 metres; 10 kW.—5.10 p.m., Concert of Chamber Music, Lillian Caravan (Pianoforte) and Mira Chitter-Martorana (Soprano), Pianoforte Solos: (a) Gavotte with Variations (Handel), (b) Tocatta (Paradis), (c) Improvisation in E flat (Schubert); Soprano Solos: (a) Aria from Don Giovanni (Mozart), (b) Abschied (Schubert),

(c) Die Forelle (Schubert), (d) Im Herbst (Grieg), (e) Zwei braune Augen (Grieg); Pianoforte Solos: (a) Rondo (Field), (b) Three Preludes (Scriabin), (c) La ronde d'Ariel (Piek-Mangiagalli); Soprano Solos: (a) Mainacht (Brahms), (b) Regenlied (Brahms), (c) Serenade (Zandonai), (d) Guarda che bianca luna (Vitt. Levi), (e) La storiella di Piccini (Mortari), 6.0 till Close Down. See Turin.

TRONOHEIM.—See Oslo.

TURIN

1,096 kc/s, 273.7 metres. Relayd by Milan, 905 kc/s, 331.5 metres; Genoa, 959 kc/s, 312.8 metres; and Florence, 599 kc/s, 500.8 metres.—5.10 p.m., Song Recital, 6.0 to 6.5, Weather, 6.35, Giornale Radio, Agricultural Notes and Dopolavoro Announcements, 7.0, Time, Tourist Talk and Gramophone Music, 7.20, News in Foreign Languages, 7.40, Gramophone Music, 8.0, Announcements, Giornale Radio, Sports Notes and Weather, 8.15, Medical Talk, 8.30, Military Band Concert, 11.0, Giornale Radio.

VATICAN CITY

15,120 kc/s, 19.84 metres (Morning) and 5,969 kc/s, 50.25 metres (Evening); 10 kW.—11.0 to 11.15 a.m., Religious Information in Spanish, 8.0 to 8.15 p.m., Religious Information in Italian.

VIENNA

581 kc/s, 517 metres; 100 kW. Relayd by Graz, 852 kc/s, 352.1 metres; Innsbruck, 1,058 kc/s, 283 metres; Klagenfurt, 662 kc/s, 453.2 metres; Linz, 1,220 kc/s, 245.9 metres; and Salzburg, 1,373 kc/s, 218.5 metres.—12 Noon, Concert by the Vienna Symphoniker Orchestra, conducted by Josef Holzer; Soloist: Anton Kamper (Violin). In an interval at 1.0 p.m., Time and News, 2.0 to 3.0, Interval, 3.0, Time, Weather, and Exchange, 3.20, Talk on Anton Bleichschmidt, 3.30, Talk: The Taferberg, 4.0, Report of the International Jamboree in Gdödlö, relayed from Gdödlö—The Opening Ceremony, 5.30, Song and Pianoforte Recital by Vera Borska and Heinz Sandauer; Songs: (a) Ich atmet' einen linden Duft (Mahler), (b) Die weisse Rose (Heger), (c) Geübtes Jers (Schubert), (d) Mond, so gehst du wieder (Korngold), (e) Sommerstage (Berg); Cello Solo, Jazz Paraphrase on Themes by Johnson, Hupfield, Niederberger, Warren, and Stolz, 6.5, Talk: From the History of an Old Castle, 6.30, Talk: The Ottoman Empire in the Seventeenth Century, 7.0, Reminiscences of a Diplomat (Gies-Gieslingen), 7.25, Time and News, 7.35, Military Band Concert, conducted by Moritz Thann; Dr. Doffuss-Marsch (Thann); Waltz, Dorkinder (Kälmin); March, One, Two, Three (Dostal); Overture, Titus (Mozart); Selection from The Gipsy Baron (Joh. Strauss); March, Freiherr von Gieslingen (Dobes); Waltz, Fürstentkünd (Lehár); March, Schwert Österreich (Wagner); Potpourri, Ein Abend in Grinzing (Fueik); Egerländer-Marsch (Kopetzky); March, Mein Österreich (Preiss), 8.40, Petri Roseger Memorial Programme: His Work and his World, 9.40, Topical Talk, 9.55, News, 10.10, Concert from the Hotel Kranz-Ambassador, by a Schramm Trio and Soloists.

WARSAW

212.5 kc/s, 1,411 metres; 120 kW.—11.57 a.m., Time Signal and Fanfare from the Tower of St. Mary's Church, Cracow, 12.5 p.m., Gramophone Music: The Quartets of Beethoven, 12.25, Polish Press Review, 12.33, Weather, 12.35, Gramophone Music (cont'd.), 12.55, Radio Journal, 1.0, Interval, 2.55, Gramophone Music, 3.5, News, 3.10, Announcements, 3.15, Gramophone Music, 3.25, Economic Notes, 3.35, Gramophone Music, 3.45, Announcements, 4.0, Light Music and Dance Music on Gramophone Records, 5.0, Talk: The Importance of Flax-growing, relayed from Wilno, 533 kc/s, 563 metres, 5.15, Orchestral Concert of Polish Music, 6.15, Talk: Cross-Country Running, 6.35, Song Recital by Mme Hedwig Hennert; Zuleika's Song (Rimsky-Korsakov); Arietta from The Snow Maiden (Rimsky-Korsakov); Berceuse (Tchaikovsky); Two Songs (Lubanski); Popular Song (Perkowski); Four Spanish Songs (Falba), 7.5, Instrumental Music on Gramophone Records, 7.20, Miscellaneous Items, 7.35, Programme Announcements, 7.40, Reading, 8.0, Pianoforte Recital by Joseph Turczynski; Air and Gavotte (Hinek); Sonata Op. 27, No. 2 (Beethoven); Pieces from the Cycle, Switzerland (Liszt); Scherzo in B flat Minor, Op. 31 ('Chopin), 8.50, Radio Journal, 9.0, Answers to Agricultural Correspondence, 9.10, Concert of Songs, 10.0, Dance Music, relayed from the Europa Café, Cichocinek, 10.25, Sports Notes, 10.35 Aviation Weather Report and Police Notes, 10.40, Dance Music Relay (cont'd.).

WILNO

533 kc/s, 563 metres; 16 kW.—7.5 p.m., News and Gramophone Music, 7.20, Lithuanian Review, 7.35, Programme Announcements, 7.40, See Warsaw, 9.0, Talk, 9.10, See Warsaw, 11.0 (approx.), Close Down.

ZURICH.—See Schweizerischer Landessender.

BARCELONA

EAJ1, 860 kc/s, 348.8 metres; 8 kW.—7.0 p.m., Trio Concert: Selection from Don Gil de Alcalá (Penella); Canción andaluza (Tena Perales); Barcarolle, Del Puente de los Suspiros (Pla); Oriental Dance (Bréton); Bolero (Bréton); Serenata (Ceballos Farpón); Selection from La Balada de la luz (Vives). In the interval, Talk. 8.0, Request Gramophone Records. 8.30, Exchange. 9.0, Gramophone Music and News. 10.0, Chimes, Weather, and Exchange. 10.5, Concert by the Station Orchestra. 10.45, Luisa Fernanda—Musical Comedy in Three Acts (Torroba). In the interval at 12 Midnight, News. 1.0 a.m. (Friday), Close Down.

BARI

1,112 kc/s, 269.8 metres; 20 kW.—8.0 p.m., Agricultural Notes, Tourist Report and Dopplavoro Announcements. 8.20, Giornale Radio and Weather. 8.30, Time and Announcements. 8.35, Orchestral Concert. Soloists: Milena Barberio (Soprano) and Franco Sighorile (Tenor). Carnival Overture (Ragni); Soprano Solo: Air from Dolores (Auteri-Manzocchi); Tenor Solo: Air from Tosca (Puccini); Selection from Loreley (Catalani); Soprano Solo: Air from Fedora (Giordano); Tenor Solo: Ballad from Rigoletto (Verdi); Overture, Le femmine litigiose (Cardoni); Soprano Solo: Air from Iris (Mascagni); Tenor Solo: Air from André Chénier (Giordano); Intermezzo from the Second Act of Cavalleria rusticana (Mascagni); Tenor Solo: Air from Lodoletta (Mascagni); Selection from La Gioconda (Ponchielli). In the interval, Theatre Notes. 10.30, Gramophone Music. 10.55, News.

BASLE.—See Schweizerischer Landessender.

BELGRADE

BEOGRAD, 697 kc/s, 430.4 metres; 2.8 kW.—5.55 p.m., Time Signal and Programme Announcements. 6.0, Talk on Physical Culture. 6.30, Talk. 7.0, Orchestral Concert. 7.50, Talk. 8.30, Programme from Ljubljana, 522 kc/s, 574.7 metres. 10.30, Time Signal, News and Cigány. Music from the Rudinacian Restaurant.

BERLIN

DEUTSCHLANDSENDER, 183.5 kc/s, 1,635 metres; 60 kW.—2.0 p.m., Request Gramophone Concert. 2.45, Programme for Children. 3.10, Programme for Young People. 3.30, Weather and Exchange. 3.45, Reading (Paul Schulze-Bergthof). 4.0, See Heilsberg. 5.0, Talk for Women. 5.15, Talk for Housewives. 5.25, Duets from Lortzing's Operas by George Boye and Hans Broermann. 6.0, A Poem. 6.5, String Quartet in E minor Op. 20 (Ehrensberg), by the Dresden String Quartet. 6.30, Agricultural Programme: Radio Report of Horse-breeding, from Neustadt. 6.50, Weather for Farmers and News. 7.0, Transmission for all German Stations, relayed from Heilsberg. 8.0, To-day's Motto. 9.0, See Berlin (Witzleben). 10.0, Weather and News. 10.45, Weather Report for Shipping. 11.0, Concert of Light Music by a Nazi Band, relayed from the Nationale Gaststätte, Braundenburg. 12 Midnight (approx.), Close Down.

BERLIN

WITZLEBEN, 715 kc/s, 419.5 metres; 1.5 kW.—4.20 p.m., Orchestral Concert, relayed from Swinemünde: Overture, Der Opernball (Heuberger); Selection from Tiedland (d'Albert); Am Meer (Schubert); Tarantella for 'Cello (Popper); Ballet Music from La Gioconda (Ponchielli); Waltz, Ueber den Wellen (Rosas-Pacherer); March, Heil Deutschland (Thiele). 5.30, Reading. 5.50, Max Reger Pianoforte Recital, by Hans Martin Theopold: Humoresque from the Characteristic Pieces Op. 32; Andantino from Aus meinem Tagebuch Op. 82; Burlesque and Intermezzo from the Characteristic Pieces Op. 32. 6.10, Talk: Youth and the State. 6.30, Talk on Magdeburg. 6.40, The Witzleben Station informs its listeners. . . . 6.45, Topical Talk. 7.0, Transmission for all German Stations, relayed from Heilsberg. 8.10, Topical Talk. 8.30, Recital of Folk Songs. 9.0 to 1.0 a.m. (Friday), The Joys of Life—Programme of Dance Music, Part I—Waltzes by Lanner, Strauss and Ziehrer, played by The German Symphony Orchestra, conducted by Siegfried Schulz. Part II—German Folk Songs and Dance Songs by Rosl Seegers (Soprano) and Franz Baumann (Tenor). Part III—Old and New Dance Music by the Waldemar Brass Band. Part IV—Instrumental Solos. In the intervals at 10.0 (approx.), News, and at 11.0 (approx.), Talk: What they are saying in Berlin. 1.0 a.m. (Friday), Close Down.

BERNE.—See Schweizerischer Landessender.

BEROMUNSTER. — See Schweizerischer Landessender.

BODEN.—See Stockholm.

BODO.—See Oslo.

THURSDAY

AUGUST THE THIRD

PRINCIPAL EVENTS OF THE DAY:

AT HOME

NATIONAL Vocal and instrumental recital.
LONDON "Quinneys," a comedy, by H. A. Vachell.
REGIONAL
MIDLAND Rhythm, a gramophone recital.
REGIONAL
NORTH "The Super-Optimists," relayed from New Brighton.
REGIONAL
WEST Camp-fire songs, from the Urd Girls' Camp, at Llangrannog.
REGIONAL
SCOTTISH Band concert.
REGIONAL
BELFAST Orchestral concert. Chamber music.

ABROAD

BARI 8.0 p.m. Vocal and Orchestral concert.
BRUSSELS 9.0 p.m. Concert from the Kursaal, Ostend.
(No. 1)
BRUSSELS 9.0 p.m. Orchestral concert, from the Casino.
(No. 2)
COPENHAGEN 9.0 p.m. Concert of Russian music, by the Station Orchestra.
HEILSBURG 9.30 p.m. Georg Vollerthun song recital, with the composer at the pianoforte.
HUIZEN 7.45 p.m. Concert by the Wireless Orchestra.
RADIO PARIS 9.0 p.m. Operetta: "S. M. Rokoko," by Lelong and Jefferson, from the Scala Theatre.
ROME 8.45 p.m. Opera: "The Tales of Hoffmann," by Offenbach.
VIENNA 9.0 p.m. Concert by the Vienna Symphoniker.
WARSAW 8.0 p.m. Popular concert by the Station Orchestra.

BORDEAUX-LAFAYETTE

986 kc/s, 304 metres; 15 kW.—6.15 p.m., Radio Journal. 7.40, Talk, arranged by the International Labour Bureau. 7.55, Lottery Results. 8.0, Talk on Wine. 8.15, News. 8.30, Le Beau Métier—Comedy in Three Acts (H. Clerc).

BRATISLAVA

1,076 kc/s, 279 metres; 14 kW.—6.25 p.m., Gramophone Music. 6.40, Talk: Alexander Pushkin. 6.55, Talk for Housewives. 7.0, See Prague. 7.10, See Moravská-Ostrava. 7.40, Nature Talk from Kosice, 1,022 kc/s, 293 metres. 7.55, See Brno. 8.20, See Prague. 9.0, See Moravská-Ostrava. 10.0, See Prague. 11.0, Close Down.

BREMEN.—See Hamburg.

BRESLAU

923 kc/s, 325 metres; 60 kW; and Gienwitz, 1,184 kc/s, 253 metres.—12.0 Noon, Concert by the Silesian Symphony Orchestra, conducted by Hermann Behr: Overture, Semiramis (Rossini); Ballet Suite (Gluck-Mottl); Allegretto and Minuet from the Military Symphony (Haydn); Waltz (Volkmann); Serenade in F (Volkmann); Suite, Aus dem Morgenlande (Heuberger); Overture, Baccaccio (Suppé). 1.45 p.m., Time and News. 2.0, Russian Music on Gramophone Records. 3.0, Agricultural Market Prices. 3.30, Talk: Touring in Silesia. 4.0, See Heilsberg. 5.25, Agricultural Prices, followed by Programme for Children. 6.0, Topical Talk. 6.20, Dialogue between a Worker and a Workers' Leader. 6.50, Weather for Farmers, followed by News. 7.0, Transmission for all German Stations, relayed from Heilsberg. 8.0, The Corn is Ripe—Seven Centuries of German Peasant Poetry. 9.0, News. 9.10, Musical Programme for Workers. 10.10, Time and News. 10.30, Dance Evening, relayed from Berlin (Witzleben). 12.0 Midnight (approx.), Close Down.

BRNO

878 kc/s, 342 metres; 35 kW.—6.25 p.m., German Transmission: News, Talk for Women, Talk on Selecting a Profession, and Agricultural Talk. 7.0, See Prague. 7.10, See Moravská-Ostrava. 7.45, Nature Talk, relayed from Kosice, 1,022 kc/s, 293 metres. 7.55, Report from a Scouts' Camp. 8.20, Pianoforte Recital by Emma Salova. 8.50, See Prague. 9.0, See Moravská-Ostrava. 10.0, See Prague. 11.0 (approx.), Close Down.

BRUSSELS (No. 1)

1.1 N.R., 590 kc/s, 509 metres; 15 kW.—12 Noon, Concert by the Small Station Orchestra, conducted by Emile Lauwers. Soloist:

M. Michot (Violin). March, The Student passes by (Ibanez); Overture, Morning, Noon and Night (Suppé); Waltz (Ziehrer); Diver-tissement (Capri); Selection from Lilac Time (Schubert-Berthé); Violin Solo: Minuet (Porpora-Kreisler); Spanish Caprice (Malvezzi); Serenade (Frank Bridge). 1.0 p.m., Le Journal Parlé. 1.10, Gramophone Concert. 5.0, Gramophone Concert: March from The Ruins of Athens (Beethoven); March from Prince Igor (Borodin); Irish National March (Brace); Coronation March (Saint-Saëns); Egyptian March (Joh. Strauss); Spearmint March (Turine); Radetzky March (Joh. Strauss); Cadettenmarsch (Sousa). 5.30, Programme for Children. 6.0, Talk: The Children's Republic. 6.15, Musical and Dramatic Programme on Gramophone Records: Aux étoiles (Duparc); Lento and allegro ma non troppo from the Symphony in D (César Franck); Popular Hungarian Melodies (Bartok-Szigeti); Impromptu, Op. 142, No. 2 (Schubert); Extracts from Lakmé (Delibes); Tarentelle (Cui); Sketches: (a) Le cestist (Bach-Laverne); (b) Les marins bretons (Scott); (c) Heu ben mon vieux! (Bonquet); (d) Le quatuor de clarinettes (Grove); (e) Le hoquet chinois (Bach-Laverne). 7.15, Talk for Workers. 7.30, Sports Review. 8.0, Ballet Music on Gramophone Records: Harlequin Doll (Burey); Extracts from La vida breve (Fallá); Ballet Music from Herodiade (Massenet); Ballet Music from Marouf (Rabaud). 8.45, Talk for Peasants. 9.0, Concert, relayed from the Kursaal, Ostend. After the concert, Le Journal Parlé, followed by Dance Music by Robert de Kers and his Cabaret Kings, relayed from the Kursaal, Ostend.

BRUSSELS (No. 2)

1.1 N.R., 887 kc/s, 338.2 metres; 15 kW. Programme in Flemish.—12 Noon, Gramophone Concert: Overture, Les Saltimbanques (Ganne); Waltz, The Blue Danube (Strauss); Selection from The Merry Widow (Lehár); Richard Tauber: (a) Two Songs from The Csarevitch (Lehár); (b) Song from Martha (Flotow); Song from The Land of Smiles (Lehár); Music by Ketylbey: (a) In a Monastery Garden; (b) Bells across the Meadows; (c) In a Chinese Temple Garden; Song from Lakmé (Delibes); Song from Manon (Massenet); Variations on a Theme (Proch). 1.0 p.m., Le Journal Parlé. 1.10, Gramophone Concert. 5.0, Mendelssohn Music on Gramophone Records: Overture and Wedding March from A Midsummer Night's Dream; Song without Words; Overture, Fingal's Cave. 5.45, Programme for Children. 6.30, Gramophone Concert. 7.15, Talk for Young People. 7.30, Talk for Women. 8.0, Heer bind mij vast—Radio Play (Weyts). 8.55, Talk: A Pilgrimage to Rome. 9.0, Orchestral Concert relayed from the Casino, Knocke. Conductor: M. Caudael. Soloist:

Mme. Van Dyck (Songs). Overture, Oberon (Weber); Symphony No. 7 (Beethoven); Azatha's Song from Der Freischütz (Weber); Extracts from A Midsummer Night's Dream (Mendelssohn): (a) Horn Solo; Nocturne; (b) Flute Solo; Scherzo; Elsa's Song from Lohengrin (Wagner); Overture, The Bartered Bride (Smetana). 10.30, Evening Prayer. 10.35, Le Journal Parlé. 10.45, Concert of Marches on Gramophone Records.

BUCHAREST

761 kc/s, 394 metres; 12 kW.—5.0 p.m., Concert by the Motoi Orchestra, relayed from the Monte-Carlo Restaurant. In an interval at 6.0, Radio Journal. 7.0, Reading. 7.20, Gramophone Music. 7.40, Educational Talk. 8.0, Baritone Solos. 8.20, Symphony Concert on Gramophone Records: Symphony in D Minor (Franck); Pianoforte Concerto No. 17 in G (Mozart); Overture, Coriolan (Beethoven). In an interval at 9.0, Talk. 9.45, Radio Journal.

BUDAPEST

545 kc/s, 550.5 metres; 18.5 kW.—5.30 p.m., 'Cello Recital. 6.0, Radio Report from the World Jamboree at Gödöllő. 6.30, Light Music. 7.40, Ballads. 8.15, Two Comic Operas: (a) Der wiespenstige Prinz (Gagány); (b) Die schöne Galathée (Suppé). 9.0, News and Jazz Music from the Hotel Bellevue. 11.0, Gypsy Music by the Arpad Károlyi Band from the Emke Café. 11.30, Greetings of Scouts from Distant Lands to their Parents.

CASSEL.—See Frankfurt.

COPENHAGEN

1,067 kc/s, 281 metres; 0.75 kW. Relayed by Kalundborg, 260 kc/s, 1,153.8 metres.—12 Noon, Time and Chimes from The Town Hall. 12.5 p.m., String Ensemble Concert, relayed from the Hotel d'Angleterre. 2.0, Interval. 3.30, Orchestral Concert, conducted by Walter Meyer-Radon. Soloist: Inger Pedersen (Pianoforte); Overture, Alfonso and Estrella (Schubert); Waltz in A (Dvorák); Selection from The Force of Destiny (Verdi); Hindu Dance and Oriental March from Aladdin (Nielsen); Slav Dance (Chabrier); Rakoczy March (Berlioz); Pianoforte Solos: (a) Fantasia in C Minor (Bach); (b) Preludes Nos. 1, 2, 3, 9 and 23 (Chopin); (c) Etude in E Flat Minor (Chopin); (d) Allemande, Gavotte and Minuette from the Suite Op. 1 (d'Albert); Overture, Poet and Peasant (Suppé); Hindu Song from Sadko (Rimsky-Korsakov); Selection from The Grand Duchess of Gerstein (Offenbach); Ballet Music from The Demon (Rubinstein); Waltz, La Hussarde (Ganne); MacMahon March (Lumbye). 5.35, Exchange and Fish Market Prices. 6.20, Talk: The Treatment of Young Criminals. 6.50, Weather and News. 7.15, Time Signal. 7.30, Religious Address. 8.0, Chimes from the Town Hall. 8.5, Organ and Song Recital of Danish Music, relayed from the Cathedral, Odense. 8.30, Microphone Report: A Visit to a Knife Factory. 9.0, Concert of Russian Music by the Station Orchestra, conducted by Walter Meyer-Radon: Selection from The Nutcracker Ballet (Tchaikovsky); Variations for Strings on a Theme of Tchaikovsky (Arensky); Overture, A Life for the Czar (Glinka); Polovtsian Dances from Prince Igor (Glazunov). 10.0, Reading. 10.20, News. 10.35, Chamber Music by Erling Bloch (Violin), Hans Kussow (Viola) and Otto Lützhof ('Cello): Duet in E Flat for Viola and 'Cello (Beethoven); Trio in G, Op. 53 (Haydn). 11.0 (approx.), Close Down.

CORK.—See Athlone.

CRACOW

959 kc/s, 312.8 metres; 1.5 kW.—6.35 p.m., Gramophone Music. 7.5, The Letter Box. 7.20, Miscellaneous Items and News. 7.35, Programme Announcements. 7.40, See Warsaw. In an interval at 10.25, Sports Notes. 11.0 (approx.), Close Down.

DANZIG.—See Heilsberg.

DRESDEN.—See Leipzig.

FECAMP

1,328 kc/s, 225.9 metres; 10 kW.—4.30 to 6.0 p.m., Programme in English by the I.R.C. 4.30, Programme for Children. 5.0, Concert for Worthing and Littlehampton Listeners: Signature Tune, The Night by the Sea; Toréador et Andalousse (Rubinstein); Song, Love is King to-day; Pizzicato from Sylvia (Delibes); Viola Solo: Oh could I but express in Song (Malashkin); Evenson (Easthope Martin); Pearl of Mine (Fletcher); Song, I shall remember you; Selection from The Gipsy Princess, Part II (Kalmán). 5.30, Concert for Brighton and Hove Listeners: On the Quarter Deck (Alford); Blow the Man down; The Merchant Ship; A Rovin' (Terry); A Life on the Ocean (Binding); One more Day; On the Banks of Sacramento; Rio Grande (Harris); One Dollar Fifty a Day; Naval Patrol (Williams); Signature Tune. 6.0,

AUGUST 3rd

THURSDAY

continued

Programme in French. 10.0 (approx.), Concert; Signature Tune, Bells of Normandy; You've got me in the Palm of your Hand (Friend); If you were only mine (Newman); Sing a New Song (Ager); Pagan Moon (Dubin); Trees (Kilmer); Eagle Call Rag; Stardust (Carmichael); Almie the Mocher (Galloway); Hot and anxious (Redman); How'm I doin' (Fowler); I got Rhythm (Gershwinn); Try getting a Good Night's Sleep (Pinkard); Farewell Blues (Schoebel); Now that you're gone (Kahn); Twelfth Street Rag (Summer); Can't we talk it over? (Washington); Signature Tune. 11.0, Club Concert for Wrexham Listeners; Signature Tune, The Chum Song; Beautiful (Gillespie); Song, Castles in the Sand (Sandford); Guitar Solo: Feeling my Way (Lang-Kress); In the valley of the moon (Burke); Song, Don't be late in the Morning (Mendoza); Guitar Duet: Hawaiian Sweetheart of Mine (Bangney); Song, Jolly old Ma, Jolly old Pa (Wallace); The Blue Bird (Bordin); Selection from Lilac Time (Schubert-Berthold); Violin Solo: Waltz, Op. 39 (Brahms); Walther's Prize Song, from The Mastersingers (Wagner); Dance of the Clowns (Smetana); Barcarolle, from The Tales of Hoffman (Offenbach); Violin Solo: Larghetto (Weber); Room for the Factotum, from The Barber of Seville (Rossini); Musical Gems, Part II (arr. Shalimar); Signature Tune. 12.5 a.m. (Friday), I.B.C. Late News Bulletin. 12.10 (approx.), The Studio Pets and Pests; Selection from The Cat and the Fiddle (Kern); Wasps (Holbrook); The Golden Bird, Part I; The Flies crawled up the Window (Ellis); Ali Baba's Camel (Gay). 12.30, Dance Music; Signature Tune, Bells of Normandy; When my Little Pomeranian; Maybe I love you too much (Berlin); Piccadilly (Goldberg); I wake up smiling (Albert); Shuffle off to Buffalo (Warren); I shall still keep smiling along; Forty Second Street; Hiawatha's Lullaby; Signature Tune. 1.0, Organ and Song Recital: Ca c'est Madrid (O'Hare); Butterflies in the Rain (Myers); Song, For Good or for Bad (Pearson); Song, It's Winter again (Hoffmann); There's something about a Soldier (Gay); Paradise (Brown); I'll stay with you (Woods); The Wooden Soldier and the China Doll. 1.30, Dance Music; Signature Tune, Bells of Normandy; To-night; The King's Nave; Play, Fiddle, Play; Toasts; I may never pass your Way again; Leave a Little for me; A Boy and Girl were dancing; How do you do, Mr. Brown?; Signature Tune. 12.57, I.B.C. Good-night Melody. 2.0, Close Down.

FLensburg.—See Hamburg.

FLOrence.—See Turin.

FRANKFURT

1,157 kc/s, 259.3 metres; 17 kW. Relayed by Cassel, 1,220 kc/s, 245.9 metres; and Trier, 1,157 kc/s, 259.3 metres.—6.0 p.m., Review of War Books. 6.25, Talk. 6.45, To-day's News. 6.50, Time and News. 7.0, Transmission for all German Stations, relayed from Heilsberg. 8.0, Gramophone Concert. 8.15, Literary Programme; Three Sketches: (a) The Speaker, from Reykjavik, (b) Lunch Hour in the Park, (c) When the Prussians marched into Frankfurt—a Memory of July, 1906. 9.0, See Berlin (Witzleben). In an interval at 10.0, Time and News. 1.0, a.m. (Friday), Close Down.

FREDRIKSSTAD.—See Oslo.

FREIBURG.—See Stuttgart.

GENEVA.—See Radio-Suisse Romande.

GENOA.—See Turin.

GLEIWITZ.—See Breslau.

GOTEBOURG.—See Stockholm.

GRAZ.—See Vienna.

HAMAR.—See Oslo.

HAMBURG

Call ha (in Morse), 806 kc/s, 372 metres; 1.5 kW. Relayed by Bremen, 1,112 kc/s, 269.8 metres; Flensburg, 1,319 kc/s, 227.4 metres; Hanover, 530 kc/s, 560 metres; and Kiel, 1,292 kc/s, 232.2 metres.—6.20 p.m., Review of Books on the Life and Work of Richard Wagner. 6.45, Frankfurt Exchange. 6.50, Weather. 7.0, Transmission for all German Stations, relayed from Heilsberg. 8.0, Barrack-Room Humour—a Radio Sequence (Herbert Wilk). 9.0, Military Band Concert of Marches and Soldier Songs. 10.0, Time and News. 10.50, Topical Talk. 10.50, Dance Music, relayed from Berlin (Witzleben). 1.0 a.m. (Friday), Close Down.

HANOVER.—See Hamburg.

HEILSBURG

1,085 kc/s, 276.5 metres; 60 kW. Relayed by Danzig 662 kc/s, 453.2 metres.—1.5 p.m., Variety Music on Gramophone Records. In

the intervals at 1.20 and 2.0, News. 2.30 (from Danzig), Danzig Exchange and Market Prices. 3.0, Agricultural Prices and Exchange. 3.30, Programme for Young People. 4.0, Concert by the Small Station Orchestra, conducted by Eugen Wilken. Overture, La hancée (Anber); Hungarian Rhapsody (Reindl); Prelude and Serenade (Rachmaninov); Selection from Don Carlos (Verdi); Romantic Suite (Lilling); Waltz, Diesen Kuss der ganzen Welt (Ziehrer); Romaneska-Fantasia (Zikoff); Overture, La Cenerentola (Rossini). 5.15, Review of Periodicals. 5.45, Talk on German Art. 6.15, Agricultural Prices. 6.25 (from Danzig), Agricultural Talk. 6.50, Weather. 7.0, Transmissions for all German Stations; The East Prussian Countryside—Radio Picture (Martin Borman), with Music by Otto Bensch. The Königsberg Opera House Orchestra, conducted by Erich Seidler. 8.0, Weather and News. 8.5, Variety Concert by the Small Station Orchestra, conducted by Eugen Wilken. 9.5, Elementary English Lesson. 9.30, Georg Vollerthum Song Recital by Mia Neasitzer-Thermissen (Soprano), with the Composer at the Piano/forte. Slav Song: Die Liebende schreibt; Schmunneliederchen; Nachsprung zum Hochzeitstanz; Ein Mädchen singt; Die Wünsche; Der Esel. Heimliches Ständchen; Zweifel. 10.0, Weather and News.

HILVERSUM

Announced HUIZEN, 1,013 kc/s, 296.1 metres; 20 kW. (7 kW. up to 4.40 p.m.).—11.55 a.m., Programme of the Catholic Radio Society (K.R.O.). Concert by Iwan Schustow and his Balalaika Orchestra. In the interval, Gramophone Music. 1.40 p.m. till Close Down, Programme of the Christian Radio Society (N.C.R.V.). 1.40, Elijah—Oratorio (Mendelssohn) on Gramophone Records. 3.40, Bible Reading and Sacred Music. 4.40, Contralto Song Recital by R. Dijs-Oebel. Sacred Songs. Gramophone Music: Air from the Dettinger; Te Deum (Händel); Aria from Xerxes (Händel); Se Florindo è fidele (Scarlatti); Vittoria, Vittoria (Carissimi); Song (Caldara); Der Wanderer an den Mond (Schubert); Liebesfeier (Weingartner); Die Mainacht (Brahms) Sonntag (Brahms); Wiegenlied (Brahms); Gramophone Music: All mein Gedanken (R. Strauss); Traum durch die Dämmerung (R. Strauss); Füsse-reise (Wolf); Gehet (Wolf); Ach im Maien war's (Wolf); Gramophone Music: Romance (Debussy); Mandoline (Debussy); Old Spanish Song (Anbert); Berceuse (Andriessen); Een Iordje van de linden (Wagneaar). 6.25, Dressmaking Lesson. 6.40, Police Notes. 6.55, Gramophone Music. 7.10, Press Review. 7.40, Concert by the Dutch Harp Quartet: Prelude on Two Dutch Songs (Berghout); Bourrée from Suite ancienne (Halvorsen); Hungarian Rhapsody (Chernmann); Poème (Drda-Berghout); Impression (MacDowell); Romance (Lalo); Epithalame (Roussseau); Réve (Rubinstein); Adoration (Philippucci). 8.40, Talk. 9.10, Organ Recital by E. Bonwester. 10.10, News, followed by Gramophone Music. 11.10 (approx.), Close Down.

HORBY.—See Stockholm.

HUIZEN

Announced HILVERSUM, 160 kc/s, 1,875 metres; 8.5 kW. Programme of the Algenecne Vereeniging Radio Omroep (A.V.R.O.).—11.40 a.m., Time. 11.41, Concert of Light Music by the Rentmeester Ensemble. In the interval: Gramophone Records. 1.40 p.m., Gramophone Music. 2.10, String Quartet Concert. 3.25 to 3.40, Interval. 3.40, Programme for Hospitals. 4.10, Gramophone Music. 4.40, A Play for Children. 5.20, Concert of Light Music by Kovacs Lajos and his Orchestra. 6.10, Sports Talk. 6.40, Concert of Light Music (cont'd.). 7.10, Talk. 7.40, Time and News. 7.45, Concert by the Wireless Orchestra, conducted by Neo Gerharz; Soloist: Paul Marion (Tenor): Overture, Tancered (Rossini); Tenor Arias from: (a) L'elisir d'amore (Donizetti), (b) Mephistopheles (Boito); Selection from La Gioconda (Ponchielli); Melody from André Chénier (Giordano). 8.20, Radio Play. 8.55, Concert (cont'd.): Overture, Norma (Bellini); Aria from the Requiem (Verdi); Albumblatt (Wagner); Selection from Lohengrin (Wagner); Les Préludes (Liszt). 9.40, Gramophone Music. 10.0, Concert (cont'd.): Deutschmeister Regiment's Marsch (Jurek); Hungarian Comedy Overture (Keler-Béla); By the Blue Hawaiian Waters (Kettelby); Waltz, España (Waldtenfel); March Pot-pourri (Blankenburg). 10.40, News. 10.50, Gramophone Music. 11.0 (approx.), Close Down.

INNSBRUCK.—See Vienna.

KALUNDBORG.—See Copenhagen.

KATOWICE

734 kc/s, 408 metres; 16 kW.—6.35 p.m., Violin and Pianoforte Recital. 7.10, Sports Talk.

7.25, Announcements and Gramophone Music. 7.40 till Close Down, See Warsaw.

KIEL.—See Hamburg.

KLACENFURT.—See Vienna.

KOSICE.—See Prague.

LAHTI

167 kc/s, 1,796 metres; 10 kW. Relayed by Helsinki, 815 kc/s, 368.1 metres.—6.15 p.m., Song Recital. 6.40, Recitation. 7.5, Violin Recital by Elne Grönroos; Chaconne (Vitali); Mazurka (Dvorak); Hymn to the Sun (Rimsky-Korsakov). 7.30, Talk. 7.56, Concert by the Station Orchestra: Overture, Figaro (Mozart); Selection from Der Freischütz (Weber); Extracts from the Ballet Gretina Green (Guiraud); Toreador's Song from Carmen (Bizet); Waltz from Countess Maritza (Kálmán); Selection from The Merry Widow (Lehár). 8.45, News in Finnish. 9.0, News in Swedish. 9.15, Light Music relayed from the Kappeli Restaurant. 10.0 (approx.), Close Down.

LANGENBERG

635 kc/s, 473 metres; 60 kW.—1.0 p.m., Concert conducted by Eysoldt. In the interval at 2.0 (approx.), News. 2.30, Interval. 3.0, Programme for Children. 3.30, Market Prices and Time. 3.50, Talk: Two Thousand Town Boys help German Peasants. 4.10, Talk. 4.30, A Radio Report from the Pre-historic Museum in Cologne. 5.0, The Siebengebirge—a Radio Sequence (Aenne von Werden). 5.40, Talk: Sulplie Bois-serée, on the 150th Anniversary of his Birth. 6.0, Choral and Orchestral Concert. Soloists: Liselotte Mann (Mezzo-Soprano) and Heinz Hoersch (Tenor). In the intervals, Readings. 6.45, Time and Announcements. 7.0, Transmission for all German Stations, relayed from Heilsberg. 8.0, News. 8.5, Rheinisch Wine—Programme arranged by Kaudner. 9.30, The Hunsrück—a Provincial Programme. 10.15, News. 10.35, Topical Talk. 10.45, Serenade and Dance Music, conducted by Eysoldt. 12 Midnight, Close Down.

LAUSANNE.—See Radio-Suisse Romande.

LEIPZIG

769.9 kc/s, 389.6 metres; 120 kW.; and Dresden, 941 kc/s, 319 metres.—12 Noon, Recital by Charlotte Wolf-Matthäus (Contralto) and Gisela Tiedke (Harpichord). 1.0 p.m., News. 1.15, Waltz Music on Gramophone Records. 2.0, News. 2.10, Seventieth Anniversary Programme of the Halle Hungarian Society. 3.0, Programme for Young People. 3.35, Market Prices. 4.0, Concert. 4.40, Talk on Taxation. 5.50, Economic Notes, Weather and Time. 6.0, Dialogue: The Einhart Basilica at Michelstadt, in the Odenwald. 6.25, Talk for Nazis. 6.50, News. 7.0, Transmission for all German Stations, relayed from Heilsberg. 8.0 (from Dresden), Zither Music by Adolf and Elise Arnold; Sonata No. 1 in B Flat for Two Zithers (Adolf Arnold). 8.30, Cabaret Programme. 9.0, Agricultural Notes. 9.25, Concert by the Leipzig Symphony Orchestra, conducted by Richard Richter; Extracts from the Symphony in B Flat (Bach); Gavotte from Idomenio (Mozart); Hungarian Rondo (Haydn); Three Movements from Prometheus (Beethoven); Overture, Claudine von Villa Bella (Schubert). 10.25, News.

LINZ.—See Vienna.

LUXEMBOURG

252 kc/s, 1,191 metres; 200 kW.—German Programme. 7.30 p.m., Symphony No. 6 (Beethoven) on Gramophone Records. 8.10, Weather Report. 8.15, Concert of German Music by the Station Orchestra, conducted by Henri Pensis; Suite, Wie es euch gefällt (Wetzler); German Dances (Unger); Overture, Tannhäuser (Wagner). 8.50, News in French. 9.0, Song Recital. 9.30, Concert by the Station Orchestra; March, Vater Rhein (Lincke); Faun and Nymph (Königsberger); Scheuknaut sich Rosen (Brankner); Selection from Viktoria and her Hussar (Abraham); Serenade (Moszkow-ki) Legenda d'amore (Becco); Selection from The Maid from the Black Forest (Jessen). In an interval at 9.50, News in German. 10.20, Dance Music on Gramophone Records.

LWOW

788 kc/s, 381 metres; 16 kW.—6.35 p.m., Talk and Choral Concert. 7.0, Song Recital. 7.20, Miscellaneous Items. 7.40, See Warsaw. 10.40, Gramophone Music. 11.0 (approx.), Close Down.

LYONS

LA DOUA (PTT), 644 kc/s, 465.8 metres; 1.5 kW.—7.30 p.m., Radio Gazette for Lyons and the South East. 8.35, Bérénice—Play (Racine). After the Play, News.

MADRID

EAJ7, 707 kc/s, 424.3 metres; 2 kW.—8.0 p.m., Chimes, Exchange, Radio Journal and Programmes for Children. 9.15, News and Political Review. 9.30 to 11.0, Interval. 11.0, Chimes, Time and Political Review. 11.30, Municipal Band Concert, conducted by M. Villa, relayed from the Rosales. 1.15 a.m. (Friday), News. 1.30, Chimes and Close Down.

MALMO.—See Stockholm.

MILAN

VIGENTINO, 662 kc/s, 453.2 metres; 4 kW.—8.45 p.m. till Close Down, See Rome.

MORAVSKA-OSTRAVA

1,137 kc/s, 263.8 metres; 11 kW.—2.50 p.m., Concert by the Station Orchestra, conducted by V. Musil. Overture, Sicilian Vespers (Verdi); Selection from La Bohème (Puccini); Melody (Weinberger); Capriccio (Dvorak); Selection from Gipsy Love (Lehár); Waltz (Leopold); Humoresque (Bayer); Moravian Dance (Ballig); March (Kovarig). 3.55 to 4.0, See Prague. 5.25, See Prague. 6.5, Gramophone Music. 6.15, See Prague. 7.10, Humorous Choral Music. 7.40, Nature Talk from Kosice, 1,022 kc/s, 293 metres. 7.55, See Brno. 8.20, See Prague. 9.0, Dance Music by the Station Orchestra. 10.0, See Prague. 11.0, (approx.), Close Down.

MOSCOW

TRADES UNION, 230 kc/s, 1,304 metres; 100 kW.—2.45 p.m., Weather. 3.0, Liszt, Tchaikovsky, and Rachmaninov. Concert on Gramophone Records. 5.30, Programme Announcements. 5.45, Educational Talk. 6.30, Dance Music. 9.0, News. 9.30, Programme Announcements. 9.55, Chimes from the Red Square. 10.5, Review of the English Press. 10.30, Press Review.

MOTALA.—See Stockholm.

MUHLACKER.—See Stuttgart.

MUNICH

563 kc/s, 533 metres; 60 kW. Relayed by Augsburg, and Kaiserslautern, 536 kc/s, 560 metres; and Nürnberg, 1,256 kc/s, 239 metres.—4.30 p.m., Concert conducted by Erich Kloss: Overture, The Mikado (Sullivan); Romance (Svendson); Scene from Carmen (Bizet); Tango, Expression (Brade); Ungaria (Leopold); Dance leute (Franck); Peterchen's Mondfahrt (Schamstich); March, Lachendes Leben (Blankenburg). 5.45, Agricultural Talk. 6.5, Song Recital by Elise von Catapal: Two Songs (Schumann); (a) Der arme Peter, (b) Widmung; Three Songs (H. Wolf); (a) Auch kleine Dinge können uns entzücken, (b) Er ist's, (c) Song; Two Songs (R. Strauss); (a) Wiegenlied, (b) Cécile. 6.25, Talk: French Educational Propaganda and the Rhineland. 6.45, Time, Weather and Agricultural Notes. 7.0, Transmission for all German Stations relayed from Heilsberg. 8.0, See Langenberg. 9.30, Talk: Austria. 9.50 (from Nürnberg), Concert by the Frankish Chamber Music Orchestra, conducted by Markus Rümmelein; Overture, Le roi Pa dit (Delibes); Allegro from the Symphony in B flat (Mozart); Andante cantabile (Tschai-kovsky); Minuet in E flat (Bocherini); Waltz, Künstlerleben (Joh. Strauss); Selection from The Cunning Peasant (Dvorak). 10.20, Time and News.

NAPLES.—See Rome.

NOTODDEN.—See Oslo.

OSLO

277 kc/s, 1,083 metres; 60 kW. Relayed by Fredrikstad, 815 kc/s, 368.1 metres; Hamar, 522 kc/s, 574.7 metres; Notodden, 671 kc/s, 447.1 metres; Porsgrund, 662 kc/s, 453.2 metres; and Rjukan, 671 kc/s, 447.1 metres.—2.0 to 3.0 p.m., Military Band Concert, conducted by J. Hansen. 5.0, Concert of Light Music, relayed from the Theatre Café. 6.0, Genealogical Talk in German. 6.30, Divine Service. 7.0, Announcements and News. 7.30, Trio Concert by Oscar Halvorsen (Accordion), Leif Myhr (Violin), and Alf Myhr (Pianoforte). 8.0, Time Signal. 8.1, Agricultural Talk. 8.30, Liszt Gramophone Concert. 9.15, Humorous Recitations by Signe Eldegard. 9.40, Weather and News. 10.0, Topical Talk. 10.15, Song Recital by Jens Book Jensen. 10.45 (approx.), Close Down.

OSTERSUND.—See Stockholm.

PALERMO

558 kc/s, 537.6 metres; 3 kW.—8.0 p.m., Dopplavoro. Notes, Agricultural Talk and Giornale Radio. 8.20, Gramophone Music. In the interval at 8.30, Time and Announcements. 8.45, Concert of Operetta Music; Selection from (a) Les saltinbanques (Ganne), (b) La casa inamorata (Lombardo), (c) Der Tanz ins Glück (Stolz), Eva (Lehár). In an interval at 9.30, Festa di beneficenza—One-Act Comedy (Niccodem). 10.55, News.

PARIS

EIFFEL TOWER, 207.5 kc/s, 1,445.7 metres; 13 kW. Time Signals (on 2,650 metres) at 10.26 a.m. and 11.26 p.m. (Preliminary and 6-dot Signals). 6.45 p.m., Theatre Notes. 7.0, Le Journal Parlé. 8.30, Gramo-

phone Concert: Part I, Symphonie fantas-tique (Berlioz); Part II, Light Music. 10.0 (approx.), Close Down.

PARIS

POSTE PARISIEN, 914 kc/s, 328.2 metres; 60 kW.—7.0 p.m., Gramophone Music. 7.15, Journal Parle. 7.30, Gramophone Music. 7.45, Talk for Workers. 7.50, Talk. 8.0, Folies-Bergere Programme. 8.45, Concert by the Station Orchestra: Overture, The Crown Diamonds (Anber); Waltz (Strauss); Romance sans paroles (Urgel); Entr'acte Gavotte from Mignon (Thomas); Selection from Madame Favart (Offenbach); Dance Suite (Godard); Page d'amour (Laty); Tableau villageois (Fevrier); Frissons d'ames (Lauderoin); Ballet Music from Herodiade (Massenet); Ronde de nuit (Witkowski). 10.30, News.

PARIS

RADIO PARIS, Call CFR, 174 kc/s, 1,725 metres; 75 kW.—7.30 a.m., Weather and Physical Culture. 7.45, Gramophone Music. 8.0, Weather and News. 12 Noon, Protestant Address. 12.30 p.m., Request Gramophone Concert: Overture, The Magic Flute (Mozart); Selection from Werther (Massenet); Fantastic Symphony (Berlioz). In the intervals at 1.0, Exchange, News and Weather, and at 1.30, Exchange. 2.0, Price change. 3.45, Exchange and Market Prices. 4.45, Saint-Saens Concert, relayed from the American Conservatoire, Fontainebleau, M. Isidore Philipp (Pianoforte), Andre Pascal (Violin), Jacques Desestre (Viola) and Paul Bazelara (Cello). Quartet; Pianoforte and Cello Sonata, No. 1; Pianoforte and Violin Sonata No. 1. 7.0, Market Prices, Weather, Agricultural Report and Racing Results. 7.10, Gramophone Concert: Turkish Patrol (Michaels); Hawaiian Guitar (Scott); Negro Air and Dance (Cyril Scott); Melody (Berlin); Les papillons de nuit (Gabaroche); On pardonne tout (Gael); Serenade (Chapi); An American in Paris (Gershwin). 7.50, Commercial Notes and News. 8.0, Light Music. 8.30, News, Weather and Sports Notes. 8.45, Cello Recital by Genevieve Mardnet. 9.15, Press Review and News. 9.30, Pellets et Melisande—Opera (Debussy) on Gramophone Records.

PITTSBURGH

KDKA, 980 kc/s, 306 metres; 50 kW. Relayed by W8XK on 48.86 metres and 25.27 metres.—7.30 p.m., The Pioneers, from New York. 7.45, KDKA Home Forum. 8.0, Betty and Bob, from New York. 8.15, The Smiths Play Bridge. 8.30, Words and Music, from New York. 8.45, State Federation of Pennsylvania Women. (Subject to be announced). 8.58, Baseball Scores. 9.0, Thursday Special, from New York. 9.30, Business News and Market Reports. 9.45, Thursday Special (contd.), from New York. 9.58, Baseball Scores. 10.15, Tarzan of the Apes. 10.30, Singing Lady, from New York. 10.45, Little Orphan Annie. 11.0, Time Signal and Press News Reeler. 11.5, Piano Classique. 11.15, Weather Report. 11.16, Sport Review. 11.23, I Bring a Song. 11.28, Announcement. 11.29, Temperature Report. 11.30, Pittsburgh Spotlight. 11.45, To-day's News, by Lowell Thomas, from New York. 12 Midnight, Amos 'n' Andy, from New York. 12.15 a.m. (Friday), Concert Footlights. 12.45, News of the Air. 1.0 to 4.0, New York Relay. 1.0, Captain Diamond's Adventures. 1.30, Aldo Ricci and his Phantom Strings. 1.45, Floyd Gibbons, World's Fair Reporter. 2.0, Death Valley Days. 2.30, Wayne King's Orchestra with Lady Esther. 3.0, Goldman Band.

PORSGRUND.—See Oslo.

POZNAN

896 kc/s, 335 metres; 1.9 kW.—6.15 p.m., See Warsaw. 7.20, Miscellaneous Items and News. 7.35, Theatre Notes and Programme Announcements. 7.40, See Warsaw. 10.0, Talk. 10.15, Time Signal, Sports and Police Notes. 10.30 (approx.), Close Down.

PRAGUE

614 kc/s, 488.6 metres; 120 kW.—2.50 p.m., See Moravská-Ostrava. 3.55, Exchange. 4.0, Interval. 5.25, Musical Programme for Children. 5.45, Gramophone Music. 5.55, Reading of French Stories. 6.5, Talk for Gardeners. 6.15, Talk for Workers. 6.25, News in German. 6.30, German Transmission: Agricultural Report. 7.0, (Chimes and News. 7.10, See Moravská-Ostrava. 7.40, Nature Talk from Kosice, 1,022 kc/s, 293 metres. 7.55, See Brno. 8.20, Hebrew Songs by S. Sudd and a Synagogue Choir. 8.50, Microphone Report from a Cafe. 9.0, See Moravská-Ostrava. 10.0, Time and News. 10.15, Concert of Light Music. 11.0 (approx.), Close Down.

RABAT

721.1 kc/s, 416 metres; 6 kW.—1.30 to 3.0 p.m., Vocal and Orchestral Concert. 5.0 to 6.0, Gramophone Music. 8.0, Arab Programme: News and Arab Music on Gramophone Records. 8.45, Le Journal Parle, Weather and News. 9.0, Orchestral Concert: Waltz, Je l'aime (Waldteufel); Intermezzo, Agnes, Dame galante (Fevrier); Overture miniature (Tchaikovsky); Aria from The

AUGUST 3rd THURSDAY continued

Barber of Seville (Rossini); Intermezzo (Bathou); Selection from I Pagliacci (Leoncavallo); Hans Sachs' Monologue from The Mastersingers (Wagner); Last Movement from the Violin Concerto (Beethoven); Aria from I Pagliacci (Leoncavallo); Suite, Kinderszenen (Schumann-Fauré); Trio from Faust (Gounod); Estudiantina (Turina-Chapelier); Kusle of Spring (Sinding). In an interval, Polypheme—Play in Two Acts (Albert Samain). 11.0, Gramophone Music.

RADIO-SUISSE ROMANDE

SOTTENS, 743 kc/s, 403 metres; 25 kW.; and Geneva, 395 kc/s, 760 metres.—6.15 to 6.30 a.m., Gymnastics. 12.28 p.m., Time Signal from Neuchâtel Observatory. 12.30, News and Weather. 12.40, Concert by the Radio Lausanne Orchestra, conducted by M. Moser. 1.0, Financial News. 1.10, Concert (contd.). 2.0 to 3.28, Interval. 3.28, Time Signal from Neuchâtel Observatory. 3.30, Concert by the Radio Lausanne Orchestra: Overture, The Italian Girl in Algiers (Rossini); Waltz, Blonde or Brunette (Waldteufel); Scottish Scenes (Godard); Selection from The Dollar Princess (Fall); Overture, The Gipsy Baron (Strauss); Waltz (Naef); Selection from The Drum-Major's Daughter (Offenbach). 5.0, Song Recital by Mme. Meylan-Schnittel. 5.30 to 7.0, Interval. 7.0, Two Contemporary Belgian Poets; Talk with Illustrations. 7.30, Weather and Announcements. 7.31, New Gramophone Records. 8.0, Tourist Report. 8.5, Pianoforte Recital by Mlle. Zopf: Three Pieces (Chopin); (a) Prelude in B, (b) Nocturne in F, Op. 15. (c) Scherzo in C minor, Op. 39; La soiree dans Grenade (Debussy); Jardins sous la pluie (Debussy); Prelude in G minor, Op. 23 (Rachmaninov). 8.35, Cabaret Programme. 9.50, News and Weather. 10.0, Popular Programme. 10.30 (approx.), Close Down.

REYKJAVIK

250 kc/s, 1,200 metres; 21 kW.—9.5 p.m., Musical Programme. 9.50, Weather Report. 9.40, Musical Programme and Announcements. 10.0, Chimes and News. 10.30, Reading. 11.0, Concert by the Radio Trio, followed by Icelandic Songs on Gramophone Records.

RIGA

572 kc/s, 525 metres; 15 kW.—6.30 p.m., Recital of National Songs. 7.0, Weather Report. 7.3, Legal Talk. 7.30, Symphony Concert by the Station Orchestra, conducted by Vladimir Shavitch, relayed from Bulduri. Soloist: Tina Leimer-Shavitch (Pianoforte). Fifth Symphony (Tchaikovsky); Pianoforte Concerto in A (Liszt). In the intervals at 8.20, News, and at 9.0, Weather. After the Concert, News and Dance Music. 10.30 (approx.), Close Down.

RJUKAN.—See Oslo.

ROME

Call IRO, 680 kc/s, 441 metres; 50 kW. Relayed by Naples, 941 kc/s, 319 metres; and 2R0, 11,810 kc/s, 25.4 metres, from 5.30 p.m.—1.5 to 2.15 p.m., Orchestral Concert. In the intervals from 1.30 to 1.45, Giornale Radio and Exchange, and at 2.0, Time and Announcements. 4.45, Children's Radio Review. 5.10, Weather. 5.15, Exchange and Giornale Radio. 5.30, Instrumental and Vocal Concert. Bianca Metall (Pianoforte), Luigi Nommis (Tenor), and Vella Capuano (Soprano). Pianoforte Solos: (a) Festa campestre (Zanella), (b) Concert Study (Martucci); Tenor Solos: (a) Perduto ho la speranza (Donandy), (b) Treue liebe (Brahms), (c) Aria from Cavalleria rusticana (Mascagni); Pianoforte Solos: (a) Poissons d'or (Debussy), (b) Gouttes d'eau (Ravel); Soprano Solos: (a) Ecco la zingarella (Cimarosa), (b) Ophelia's Aria (Thomas), (c) Habanera Pepita (Puentes). 6.40 (Naples), Shipping and Sports Notes. 6.50, Agricultural Notes and Dopolavoro Announcements. 7.10, Tourist Talk. 7.20, News in Foreign Languages. 7.40, Giornale Radio. 8.0, Time and Announcements. 8.15, Gramophone Music. 8.30, Giornale Radio and Sports Notes. 8.45, The Tales of Hoffmann—Opera in Three Acts (Offenbach). In the intervals: Literary Talk and Giornale Radio.

SALZBURG.—See Vienna.

SCHENECTADY

WGY, 790 kc/s, 379.5 metres; 50 kW. Relayed at intervals by W2FAK on 31.48 metres and by W2XAD on 19.56 metres.—12.45 a.m. (Friday), Stock Reports and Baseball Scores. 1.0 to 3.0, New York Relay. 1.0, Variety Programme. 2.0, Captain Henry's Show Boat. 3.0, Musical Programme, from New York, followed by Programme Resume.

SCHWEIZERISCHER LANDESENDER

BEROMUNSTER, 653 kc/s, 459 metres; 60 kW.; Basle, 1,229 kc/s, 244.1 metres; and Berne, 1,220 kc/s, 245.9 metres.—6.15 a.m. (from Basle), Gymnastics. 6.35, Interval. 11.59, Time Signal from Neuchâtel Observatory. 12 Noon (from Basle), Music in Waltz

Time on Gramophone Records. 12.30 p.m., Time and News. 12.40 (from Basle), Sous les toits de Paris—Concert of French Music on Gramophone Records. 1.25 (from Basle), Time, Weather, and Exchange. 1.45 (approx.), Interval. 5.0 (from Zurich), Concert by the Little Swiss Radio Orchestra, conducted by Max Scherbaum. 6.0 (from Zurich), Gramophone Music. 6.30 (from Basle), Talk, Actors and their Fortunes. 7.0 (from Basle), Time, Weather, and Traffic Report. 7.10 (from Basle), Italian Music on Gramophone Records. 7.30 (from Basle), Italian Lesson. 8.15 (from Basle), Viennese Popular Songs. 9.0, Weather and News. 9.10, Concert by the Viennese Guitar Chamber Trio. 10.0 (from Basle), Dialect Programme. 11.0 (approx.), Close Down.

SEVILLE

EAJ5 815 kc/s, 368.1 metres; 1.5 kW.—9.30 to 10.0 a.m., News. 3.0 to 4.0 p.m., Concert by the Station Orchestra: Foxtrot, Mickey (Palau); Overture, Così fan tutte (Mozart); Selection from Eudlich allein (Lehár); Selection from La Moreria (Millat); Dance Music. 10.0, Variety Programme. 11.0, See Madrid. EAJ7. 1.30 a.m. (Friday), Close Down.

SOTTENS.—See Radio-Suisse Romande.

STOCKHOLM

689 kc/s, 436 metres; 55 kW. Relayed by Boden, 244 kc/s, 1,229.5 metres; Göteborg, 932 kc/s, 322 metres; Hörby, 1,166 kc/s, 257 metres; Motala, 221.5 kc/s, 1,354.4 metres; Östersund, 389 kc/s, 770 metres; and Sundsvall, 554 kc/s, 542 metres.—5.5 p.m., Religious Address, relayed from Malmö, 1,301 kc/s, 231 metres. 5.30, Provincial Programme, relayed from Örebro, 1,256 kc/s, 237.2 metres. 6.15, Gramophone Music. 7.15, Weather and News. 7.30, Talk. 8.0, Concert by the Station Orchestra. Soloist: W. Witkowski (Pianoforte). Concert Overture in A minor (Atterberg); Suite, Meister Olf (Aulin); Elegy (Alfvén); Dance from Bergtagna (Alfvén); Pianoforte Concerto in C Sharp minor (Asplöf). 9.15, Talk. 9.45, Weather and News. 10.0, Gramophone Concert: String Quartet in C minor, Op. 59 No. 3 (Beethoven); Trio in D minor, Op. 63 No. 1 (Schumann). 11.0 (approx.), Close Down.

STRASBOURG

869 kc/s, 345 metres; 11.5 kW.—11.30 a.m., Gramophone Records. 12.45 p.m., News. 1.0, Time and Exchange. 1.5, Gramophone Music. 2.0, Programme for Children. 3.0 to 3.30, Interval. 3.30 p.m., Orchestral Concert, conducted by M. Brouillac, relayed from the Casino Park, Vichy; Overture, Le Roi Fa dit (Debussy); Prelude to Messidor (Bruneau); Prelude to La Habanera (Laparra); Ballet Music from Henry VIII (Saint-Saens); Slav Dance (Chabrier); Selection from Les Huguenots (Meyerbeer); Carnival (Guiraud). 5.0, Elocution Lesson. 5.15, Liszt Concert on Gramophone Records; Les Fumerailles; Hungarian Rhapsody No. 2; Pianoforte Concerto in E Flat; Liebestraum; Mazurka. 6.0, Talk in German: Chateaubriand. 6.15, Talk: The Women of Alsace. 6.30, Gramophone Music. 7.30, Time and News. 7.45, Gramophone Music. 8.0, Press Review in French, Lottery Results, and Announcements. 8.30, Orchestral Concert, relayed from Plombières-les-bains; Conductor: Wolfert; Overture, The Flying Dutchman (Wagner); Impressions d'Italie (Charpentier); Suite bergamasque (Debussy); Violin Solo: Zigeunerweisen (Sarasate); Selection from La Navarraise (Massenet). In the interval, Talk. After the Concert, News in German.

STUTTGART

MUHLACKER, 832 kc/s, 360.5 metres, 60 kW.; and Freiburg, 527 kc/s, 570 metres.—1.30 p.m., Bass Solos on Gramophone Records. 2.0, Concert arranged by the Post Office. 2.30, Spanish Lesson. 3.0, Elementary English Lesson. 3.30, Programme for Young People. 4.30, See Munich. 5.45 (from Karlsruhe), Concert by a Police Band, conducted by Johannes Heisig; March, Der Brautwerber (Becker); Overture, Eine Nacht in Venedig (Joh. Strauss); Selection from Carmen (Bizet); Invitation to the Dance (Weber); Polonaise from Eugene Onegin (Tchaikovsky); Valse cronatique (Koekert). 6.35, Time and News. 7.0, Transmission for all German Stations, relayed from Heilsberg. 8.0, See Breslau. 9.0, Concert by Ferdinand Drost; Overture, Le carnaval romain (Berlioz); Symphonic Poem, Tasso (Liszt); Selection from The Damnation of Faust (Berlioz). 10.0, Time and News. 10.30, Richard Strauss Song Recital, by Anton Knoll: Ich selbste, Op. 48; Waldselige it; Eimerlei Op. 69; An die Nacht Op. 68; Four Songs from Mädchenblumen Op. 22. 11.0 See Berlin (Deutschlandsender). 12 Midnight (approx.). Close Down.

SUNDSVALL.—See Stockholm.

TRIESTE

1,211 kc/s, 247.7 metres; 10 kW.—5.10 p.m. till Close Down, See Turin.

TRONDHEIM.—See Oslo.

TURIN

1,096 kc/s, 273.7 metres; 7 kW. Relayed by Milan, 905 kc/s, 331.5 metres; Genoa, 959 kc/s, 312.8 metres; and Florence, 599 kc/s, 500.8 metres.—5.10 p.m., Orchestral Concert. 6.0 to 6.5, Weather. 6.35, News. 7.0, Time, and Tourist Report. 7.20, News in Foreign Languages. 7.40, Gramophone Music. 8.0, News, Weather and Sports Notes. Introductory Talk to the following transmission. 8.45 (approx.). See Rome. In the intervals, Talk, Literary Notes and Giornale Radio.

VATICAN CITY

15,120 kc/s, 19.84 metres (Morning), and 5,969 kc/s, 50.26 metres (Evening); 10 kW.—11.0 to 11.15 a.m., Religious information in French. 8.0 to 8.15 p.m., Religious Information in Italian.

VIENNA

581 kc/s, 517 metres; 100 kW. Relayed by Graz, 852 kc/s, 352.1 metres; Innsbruck, 1,058 kc/s, 283 metres; Klagenfurt, 662 kc/s, 453.2 metres; Linz, 1,220 kc/s, 245.9 metres; and Salzburg, 1,373 kc/s, 218.5 metres.—12 Noon, Concert by the Vienna Symphony Orchestra, conducted by Josef Holzer. In an interval at 1.0 p.m., Time, Weather, and Exchange. 2.0 to 3.0, Interval. 3.0, Time, Weather, and Exchange. 3.20, Talk: Practical Hints for the Housewife. 3.30, Programme for Children. 3.55, Quartet in A minor, Op. 51, No. 2 (Brahms), on Gramophone Records. 4.35, Talk: Old-Time Knowledge of Chemistry. 5.0, Programme for Young People. 5.25, Song and Violin Recital by Karl Köstler (Tenor) and Jaro Schmied; Violin Solos: (a) Valse triste (Prozavnik), (b) Slav Dance in G minor (Dvorák-Kreisl), (c) Waltz in A (Brahms), (d) Ronanza andalousa (Sarasate), (e) Capriccio Valse (Wieniawski); Operetta Songs (Joh. Strauss); Songs from (a) The Queen's Kerechief (Joh. Strauss), (b) Eine Nacht in Venedig, (c) The Gipsy Baron, (d) Die Fledermas, (e) Der lustige Krieg. 6.5, Talk: Famous Viennese Women. 6.30, Talk by Dr. Hugo Adolf Bernatzik: Report of my Expedition to the South Seas—A Letter from the Solomon Islands. 7.0, Concert by the Vienna Symphony Orchestra, conducted by Josef Holzer; Soloist: Anton Kamper (Violin); Overture, Die Göttin der Vernunft (Joh. Strauss); Romance for Violin (Svensen); Short Fantasy on the Folk Song, Fuchs, du hast die Gans gestohlen (Nennmann); Idyll in Ländler Form, Grosstanchen (Ochs); Waltz, In die weite Welt (Konzak); March, Festjubil (Blankenburg); Gavotte, Entr'acte (Gillet); Original Tauganilla (Bazant); Song, Du guater Himmelvater (Kraukauer); I n t e r m e z z o (Schüek); Overture, The Grand Duchess of Gerolstein (Offenbach); Waltz, Liebesträume (Ertl); Viennese Folk Music (Scherhammer). In an interval at 7.35, Time and News. 8.30, Reading (Franz Dattner). 9.0, Concert by the Vienna Symphony Orchestra, conducted by Anton Konrath; Overture, The Water Carrier (Cherubini); Extracts from Symphony No. 88 in G (Haydn); Suite in F sharp minor, Op. 19 (Dohnányi); Symphonic Tone Poem, Macbeth, Op. 23 (R. Strauss). 10.30, News. 10.45, Dance Music on Gramophone Records.

WARSAW

212.5 kc/s, 1,411 metres; 120 kW.—11.51 a.m., Time Signal and Fanfare from the Tower of St. Mary's Church, Cracow. 12.5 p.m., Popular Concert, relayed from the Bagatela Cafe. 12.25, Polish Press Review. 12.33, Weather. 12.35, Concert Relay (contd.). 1.0, Interval. 2.55, Gramophone Music. 3.5, News. 3.10, Announcements. 3.15, Gramophone Music. 3.25, Economic Notes. 3.35, Gramophone Music. 3.45, Boy Scouts Report. 3.50, Gramophone Music. 4.0, Programme for Children. 4.30, Light Music on Gramophone Records. 5.0, Talk for Housewives. 5.15, Song and Violin Recital by Marie Olena (Soprano) and Henri Chumek; Violin Solos: (a) Elegy (Rachmaninov-Hubay); (b) Mazurka (Hubay); (c), Hebrew Song (Bloch); Songs. Violin Solos: (a) La Valse ondulée (Franck-Liszt); (b) Largo (Veracini); (c) Mazurka (Zarzycki); Songs. 6.15, Talk. 6.35, Vocal Duets on Gramophone Records. 7.20, Miscellaneous Items. 7.35, Programme Announcements. 7.40, Talk: From Stambul to the Oriental Market Towns. 8.0, Popular Concert by the Station Orchestra, conducted by Nawrot; Soloist: Lucie Szezepanska (Soprano). In the intervals at 8.50, Radio Journal and at 9.0, Agricultural Notes. 10.0, Dance Music. 10.25, Sports Notes. 10.35, Aviation Weather Report and Police Notes. 10.40, Dance Music.

WILNO

533 kc/s, 563 metres; 16 kW.—6.35 p.m., Dance Music on Gramophone Records. 7.5, Programme Announcements. 7.10, News and Gramophone Music. 7.20, The Letter Box. 7.40, Programme from Warsaw. 9.0, Reading. 9.10, Programme from Warsaw. 11.0 (approx.), Close Down.

ZAGREB

977 kc/s, 307 metres; 0.75 kW.—8.10 p.m., Announcements. 8.30, Programme from Ljubljana, 522 kc/s, 574.7 metres. 10.30, News. 10.40, Dance Music. 11.30 (approx.), Close Down.

ZURICH.—See Schweizerischer Landessender.

FRIDAY

AUGUST THE FOURTH

PRINCIPAL EVENTS OF THE DAY:

AT HOME

- NATIONAL** Symphony concert.
- LONDON REGIONAL** Harry Gordon and his Company, feature programme, relayed from Aberdeen.
- MIDLAND REGIONAL** From the light operas and musical comedies: orchestral concert.
- NORTH REGIONAL** Orchestral concert from the Pier Pavilion, Llandudno.
- WEST REGIONAL** Orchestral concert.
- SCOTTISH REGIONAL** Harry Gordon and his Company.
- BELFAST** The Second Holiday Parade, from Portrush.

ABROAD

- HEILSBERG** 9.30 p.m. The Königsberg Opera House Orchestra.
- HILVERSUM** 7.40 p.m. The Tiel Orchestra, conducted by F. Hendriehs.
- PALERMO** 8.45 p.m. Concert of opera music.
- PRAGUE** 8.30 p.m. Czech opera music by the Station Orchestra.
- RADIO PARIS** 8.0 p.m. Symphony concert on gramophone records.
- ROME** 9.15 p.m. Verdi concert.
- STRASBOURG** 10.30 p.m. Orchestral concert, conducted by M. Paray, relayed from the Casino, Vichy.
- WARSAW** 5.15 p.m. Song and cello recital. 8.0 p.m., The Station Symphony Orchestra.

BRESLAU

1,923 kc/s, 325 metres; 60 kW; and Gleiwitz, 1,184 kc/s, 253 metres.—1.0 p.m., Gramophone Concert, relayed from Berlin (Witzleben). 1.45, Time and News. 2.0, Gramophone Concert. 3.0, Agricultural Prices. 3.15, Programme for Children. 3.45, Peter Cornelius Song Recital by Magda Pfeiffer (Contralto). 4.15, Reading. 4.30, Talk: The German National Theatre. 5.0, Military Band Concert, relayed from the Jahrhunderthal. 6.0, Agricultural Prices and Talk. 6.25, Cello Recital by Fritz Binnowicz: Sonata in E minor (Birkenstock); Sonata (Ario-sti). 6.50, Weather for Farmers, followed by News and Market Prices. 7.0, Transmission for all German Stations, relayed from Leipzig. 8.20, Folk Song Recital by Gerhard Jekelius. 9.0, News. 9.10, Concert by the Silesian Symphony Orchestra, conducted by Franz Marszalek. In the interval at 10.10, Time and News. 11.0, Talk. 11.20 (approx.), Close Down.

BRNO

878 kc/s, 348 metres; 35 kW.—6.25 p.m., German Transmission: News, Sports Notes and Topical Talk, followed by Talk: The History of Czech Literature. 7.0, See Prague. 7.10, Flute Recital. 7.30, See Prague. 7.45, See Moravska-Ostrava. 8.15, Recitations. 8.30, See Prague. 10.15, Talk in Esperanto: Czechoslovakia and Europe of To-day. 10.30 (approx.), Close Down.

BRUSSELS (No. 1)

1.1 N.R., 590 kc/s, 509 metres; 15 kW.—12 Noon, Gramophone Concert. 1.0 p.m., Le Journal Parlé. 1.10, Concert by the Small Station Orchestra, conducted by Emile Lauwers: Kleiner Wienermarsch (Kreisler); Overture, The Caliph of Bagdad (Boieldieu); Waltz, Snow Balls (Zielner); Selection from Il Trovatore (Verdi); Seguidillas (Albeniz); Gramophone Records: (a) Habanera (Craibek); (b) Jota (Fallas); Meditation (Sporeck); Lehár Potpourri (Hrubý). 5.0, Dance Music by Mickey's Club Band, relayed from the Casino, Knocke. 6.0, Literary Talk. 6.15, Violin Concerto No. 3 (Saint-Saëns), on Gramophone Records. 6.45, Weber Piano-forte Recital by Oscar Delvigne: Grand Sonata in C, Op. 24, Invitation to the Waltz. 7.15, Talk: Military Service in Belgium. 7.30, Local Talk and Literary Review. 8.0, Operetta Music on Gramophone Records: Selection from Maritana (Wallace); Song from Le Grand Mogol (Andraud); Songs: (a) Aria from Alceste (Gluck); (b) Arioso (Debussy); Selection from Virginia (Waller); Extracts from La Mascotte (Andraud). 8.45, Talk: Franco-Belgian Relations. 9.0, Orchestral Concert, conducted by K. Caudal, relayed from the Casino, Knocke. After the

Concert, Le Journal Parlé, followed by Dance Music relayed from the Casino, Knocke. 11.0, La Brabançonne.

BRUSSELS (No. 2)

N.I.R., 887 kc/s, 338.2 metres; 15 kW. Programme in Flemish.—12 Noon, Concert by the Small Station Orchestra, conducted by Emile Lauwers: Ballet Music from Rosamunde (Schubert); Melody (Hollmann); Slow Waltz (Grelinger); Czardas from Der Geist des Wajwoden (Grossmann); Granada (Albeniz); Malaguena (Albeniz); Selection from Surcouf (Planquette); Fox-trot, Speak Easy (Giesler); Fox-trot, Castilian Night (Druoman). 1.0 p.m., Le Journal Parlé. 1.10, Gramophone Concert. 5.0, Dance Music, relayed from the Kursaal, Ostend. 6.15, Talk: Francis Ferdinand of Austria. 6.30, Gramophone Concert: Overture, The Magic Flute (Mozart); Tambourin (Leclair); The Jupiter Symphony (Mozart). 7.15, Talk: The Art of Speaking. 7.30, Wireless Notes. 8.0, Quartet in G minor (Grieg), played by Andelhof and De Rudder (Violin), Piel (Viola), and Lataster (Cello). 8.30, Gramophone Music. 8.45, Recitations. 9.0, Concert, relayed from the Kursaal, Ostend. After the Concert, Le Journal Parlé, followed by Dance Music by Robert de Kers and his Cabaret Kings, relayed from the Kursaal, Ostend.

BUCHAREST

761 kc/s, 394 metres; 12 kW.—5.0 p.m., Concert by the Synop Accorders Jazz Band, relayed from the Lido. In the interval at 6.0, Radio Journal. 7.0, Reading. 7.20, Educational Talk. 7.40, Two Operas on Gramophone Records: (a) I Pagliacci (Leoncavallo); (b) Cavalleria rusticana (Mascagni). In the intervals, Radio Journal.

BUDAPEST

545 kc/s, 550.5 metres; 18.5 kW.—5.0 p.m., Chamber Music. 6.10, Variety Concert. 7.0, Concert of Military Music. 8.15, News. 8.30, Gramophone Music. 9.45, Cigány Music by the Kiss Lajos Band from the Hotel Gellert. 10.45, Songs.

CASSEL.—See Frankfurt.

COPENHAGEN

1,067 kc/s, 281 metres; 0.75 kW. Relayed by Kalundborg, 260 kc/s, 1,153.8 metres. 12 Noon, Time and Chimes from the Town Hall. 12.2 p.m., String Ensemble Concert, relayed from the Bellevue Strandhotel. 2.0 to 3.0, Interval. 3.0, Concert by the Rydals Instrumental Ensemble; Soloist: Henry Christoffersen (Songs); Turkish March (Mozart); Overture, The Daughter of the

Regiment (Donizetti); Waltz from The Gipsy Baron (Joh. Strauss); Selection from The Girl of the Golden West (Puccini); Minuet from Samson (Handel); Polonaise from Eugene Onegin (Tchaikovsky); Arias from Danish Operas: Czardas (Alouid); Waltz, Gold and Silver (Lehár); Melody (Danning); Polka, Pepita (Lumbye); Tango, carree (Dichfeldt); March, Per aspera ad adstra (Urbach). 5.0, Reading. 5.35, Exchange and Fish Market Report. 6.20, Talk: Summer Flowers. 6.50, Weather. 7.0, News. 7.15, Time Signal. 7.30, Talk: Surmounting the Crisis. 8.0, Time Signal from the Town Hall. 8.2, Recitations. 8.10, A Humorous Radio Play (Heiberg), with Music. 9.35, Saxophone Solos by Otto Banner Jansen and Gramophone Music: Gramophone Record: Richard Tauber: Ich wollt' meine Liebe ergosse sieh (Mendelssohn); Saxophone Solos (Rosenberg); Gramophone Record: Alexander Flessburg and Choir: Waltz Potpourri (Flessburg and Kernbach). 10.0, News. 10.15, Concert by the Station Orchestra, conducted by Emil Reesen: The Merry-makers (Coates); Four Characteristic Waltzes (Coleridge-Taylor); Selection from Funny Face (Gershwin); Melody (Delmas). 10.50, Dance Music, relayed from the Restaurant Lodberg. 12 Midnight, Time and Chimes from the Town Hall.

CORK.—See Athlone.

CRACOW

959 kc/s, 312.8 metres; 1.5 kW.—7.5 p.m., Talk. 7.20, Miscellaneous Items and News. 7.35, Programme Announcements. 7.40, See Warsaw. In the interval at 10.25, Sports Notes. 11.0 (approx.), Close Down.

DANZIG.—See Heilsberg.

DRESDEN.—See Leipzig.

FECAMP

1,328 kc/s, 225.9 metres; 10 kW.—4.30 to 6.0 p.m., Programme in English by the I.B.C. 4.30, Programme for Children. 5.0, Light Orchestral Concert for Southampton and Winchester Listeners. Signature Tune, The Night by the Sea; The Japanese Sandman; Song: No more love (Friend); Oh, I wish I could sing a love song; Song: The Porter's Love Song (Johnson); Hittin' the Bottle; The Moon is low; Song: The Moment I saw you (Gay); Old Medley. 5.30, Concert for Bonmouth and Weymouth Listeners: I do like to be beside the Seaside (Glover); Selection from Les millions d'Arlequin (Drigo); Song: Mountain Lovers (Squire); Accordion Nights; Veterans of Variety, Part II; Doggone, I've done it (Franklin); Pianoforte Selection from He wanted Adventure (Waller and Tunbridge); Rose Mousse (Bose); Signature Tune. 6.0, Programme in French. 10.0 (approx.) till Close Down, Programme in English by the I.B.C. 10.0, Dance Music; Signature Tune, Bells of Normandy; Say (Brown); Holding my Honey's Hand (Goering); You can make my Life a bunch of Roses (Brown); Sing a New Song (Wever); When the Band goes marching by (Sarony); Actions speak louder than words (Vallee); Watch the Navy (Howell); You Rascal, you (Theard); Happy Darkies (Godfrey); Tell me To-night (Spoliensky); The Brooklyn Cake Walk (Timbran); Where is this Lady? (Lehár); Yes, Mr. Brown (Abraham); Love is the Sweetest Thing (Noble); Take a Spot of Happiness (Reisfeld); Round the Bend of the Road (Kiemer); Signature Tune. 11.0, Club Concert for Prestatyn Listeners. Part I: Request Half Hour; Signature Tune, The Chum Song; Parade of the Tin Soldiers (Jesse!); They cut down the Old Pine Tree; Tell me to-night (Spoliensky); There's something about a Soldier (Gay); All over Italy (Butler-Monroe); Hallehujah, I'm a Bum (McClintock); Goodnight Vienna (Postford); My Sweet Virginia; The Voice in the Old Village Choir. Part II: Light Orchestral Music: Selection from Amina (Lincke); The Way to the Heart (Lincke); Pianoforte solo: Still I love her (Gaskill); Song: Drifting under a Summer Moon (Harding); Serenade d'amour (von Blon); Animal Antics (Wank); Song: Ich liebe dich, my dear (Bright); The Valley of the Poppies (Ancliffe); Signature Tune. 12.5 a.m. (Saturday), I.B.C. News Bulletin in English. 12.10 (approx.), Organ Recital; Chanson (Friml); Song: Only a Rose (Friml); Selén Rosmarin (Kreisler); Song of the Vagabonds (Friml); Love's Garden of Roses (Haydn Wood). 12.30, Dance Music: Signature Tune, Bells of Normandy; Hold me (Schuster); Something came and got me in the Spring (Rich); I can't remember (Berlin); All over Italy (Monroe); Maria, my own (Lucuona); Moon Song (Coslow); Castles in the Sand (Sandford); Piekannies' Heaven (Coslow); Signature Tune. 1.0, Gramophone Concert; Selection from Music in the Air. Part I: Noah Beery: The Whip; Clapham and Dwyer; Photography; Gaicie Fields; Song of the Highway; Raie da Costa; When day is done (de Sylva); Flannagan and Allen; Oh, Selection from Music in the Air. Part II. 1.30, Dance Music: Signature Tune, Bells of Normandy; Her name is Mary (Ramsay); Willow weep for me (Ronell); Roll along Kentucky Moon (Halley); Look what you've don (Kalmar); When you've fallen in love

BARCELONA
E.A.J.I., 863 kc/s, 348.8 metres; 8 kW.—7.0 p.m., Concert of Russian Music by the Station Trio, Prelude in C Minor (Rachmaninov); Melody (Rachmaninov); Selection from The Snow Maiden (Rimsky-Korsakov); Beregnus (Rimsky-Korsakov); Bolero (Mozzkowsky); The Musical Smulbox (Ladov); Romance (Rubinstein); Duet and Polonaise from Boris Godunov (Mussorgsky). 8.0, Request Gramophone Records. 8.30, Exchange. 9.0, Gramophone Music and News. 10.0, Chimes, Weather, Messages for Seamen and Exchange. 10.10, Concert by the Station Orchestra. 11.15, Poetry Recitation. 11.30, Dance Music from the Casa Ebre. In the interval at 12 Midnight, News. 1.0, a.m. (Saturday), Close Down.

BARI

1,112 kc/s, 269.8 metres; 20 kW.—8.0 p.m., Agricultural Notes, Tourist Report, and Popolavero Announcements. 8.20, Giornale Radio and Weather. 8.30, Time and Announcements. 8.35, Orchestral Concert: Selection from Les Erynie (Massenet); Moto perpetuo (Paganini); La chasse fantastique (Guiraud); Selection from Werther (Massenet); Dances (Tullilli); Lamento and Scherzo from the Suite (Re-spighi); Finale from the Second Act of Ero e Leandro (Mancinelli). In the interval, Talk. 10.30, Concert relayed from the Gran Caffè del Levante. 10.55, News.

BASLE.—See Schweizerischer Landessender.

BELGRADE

BEograd, 697 kc/s, 430.4 metres; 2.8 kW.—5.55 p.m., Time Signal and Programme Announcements. 6.0, Gramophone Music. 6.30, Talk. 7.0, National Songs. 7.30, Gramophone Music. 8.0, Talk. 8.30, Recital of Yugoslav Songs. 9.0, Concert. 9.30, Orchestral Concert. 10.30, Time Signal, News and Dance Music from the Ratnicki Dom Restaurant.

BERLIN

(Deutschlandsender) 183.5 kc/s, 1,635 metres; 60 kW.—2.0 p.m., Gramophone Concert. 3.0, Talk for Girls: Books to read. 3.30, Weather and Exchange. 3.45, Reading (Elgar von Hermann). 4.0, Concert from Leipzig. 5.0, Talk. 5.25, Orchestral Concert. 6.0, A Poem. 6.5, Topical Talk. 6.15, Talk. 6.35, Talk: Siegfried Wagner. 6.50, Weather and Announcements. 7.0, The Ninth Symphony (Beethoven) by the Festspiel Choir and Orchestra, conducted by R. Strauss, relayed from the Festspielhaus, Bayreuth. Soloists: Kirsten-Flagstad, Lilly Heitzer, Fritz Wolf and Rudolf Bockelmann. 8.20, My Native Heath: A Radio Sequence (Helmut Hansen). 9.15, Siegfried Wagner Concert. 10.15, News. 10.45, Weather for Shipping. 11.0, Concert from Leipzig. 12 Midnight, Close Down.

BERLIN

(Witzleben) 715 kc/s, 419.5 metres; 1.5 kW.—4.10 p.m., Orchestral Concert relayed from the Cate Corso, Waltz, Lordey-Rhein-klinge (Joh. Strauss); Serenata amorosa (Becc); Tango, Du bist die Frau für mich (Sorek); Tango, In deine Hände (Kollo); Folk Song (Komzak); Volkslied und Märchen (Komzak); Canzonetta (Brusso); Persian March (Joh. Strauss). 4.55, July Sports Review with Gramophone Records. 5.30, Programme of Modern Lyrics. 6.0, Technical Talk. 6.15, See Berlin (Deutschlandsender). 6.35, The Witzleben Station informs its Listeners. . . . 6.40, Topical Talk. 7.0, Transmission for all German Stations relayed from Leipzig. 8.25, Programme from Hamburg. 9.10, Violin and Pianoforte Recital by Prof. Gustav Havemann and Prof. Wilhelm Kempff: Sonata in B flat (Mozart); Sonata in G, Op. 78 (Brahms). 10.0, News. 10.15 (approx.), Dance Music relayed from the Wilhelmshallen in the Zoo. In the interval at 11.0 (approx.), Talk: What they are saying in Berlin. 12 Midnight, Close Down.

BERNE.—See Schweizerischer Landessender.

BEROMUNSTER. — See Schweizerischer Landessender.

BODEN.—See Stockholm.

BODO.—See Oslo.

BORDEAUX-LAFAYETTE

986 kc/s, 304 metres; 13 kW.—6.15 p.m., Radio Journal. 7.30, News. 7.40, Film Review. 7.55, Lottery Results. 8.0, Gramophone Music. 8.15, News. 8.30, Concert by the Symphony Orchestra; Soloists: Mlle. de Ligny and M. Lopeyre (Songs).

BRATISLAVA

1,076 kc/s, 279 metres; 14 kW.—6.35 p.m., Gramophone Music. 6.40, Sports Report. 6.55, Talk for Home-sitters. 7.0, See Prague. 7.45, See Moravska-Ostrava. 8.15, See Brno. 8.30, See Prague. 10.15, See Brno. 10.30, Close Down.

BREMEN.—See Hamburg.

AUGUST 4th

FRIDAY

continued

(Grey); On a Dreamy Afternoon (Ewing); My Heart's to let (Waller); Moonlight on the River (Green); Signature Tune. 1.57, I.B.C. Goodnight Melody. 2.0 (approx.). Close Down.

FLENSBURG.—See Hamburg.

FLORENCE.—See Turin.

FRANKFURT

1,157 kc/s, 259.3 metres; 17 kW. Relayed by Cassel, 1,220 kc/s, 245.9 metres; and Trier, 1,157 kc/s, 259.3 metres.—6.0 p.m., Medical Talk. 6.25, Talk: Modern Italian Painting. 6.45, Today's News. 6.50, Time and News. 7.0, Transmission for all German Stations, relayed from Leipzig. 8.30, See Langenberg. 10.15, Time and News. 10.45, Serenade. Part I: Recital of Folk Songs by Oskar Jellli (Tenor). Part II: Recital of the Oldest Organ in Frankfurt, by W. H. Simmermacher; Choral Prelude, Da Jesus an dem Kreuze stand (Scheidt); Choral Prelude, Jesu Leiden, Pein und Tod (Vogler); Chaconne in E minor (Buxtehude); Partita, Jesu meine Freude (Walter); Grave from the Fantasia in G (Bach).

FREDRIKSSTAD.—See Oslo.

FREIBURG.—See Stuttgart.

GENEVA.—See Radio-Suisse Romande.

GENOA.—See Turin.

GLEIWITZ.—See Breslau.

GOTEBORG.—See Stockholm.

GRAZ.—See Vienna.

HAMAR.—See Oslo.

HAMBURG

Call ha (in Morse), 806 kc/s, 372 metres; 1.5 kW. Relayed by Bremen, 1,112 kc/s, 269.8 metres; Flensburg, 1,319 kc/s, 227.4 metres; Hanover, 530 kc/s, 566 metres; and Kiel, 1,292 kc/s, 232.2 metres.—11.30 a.m., Concert conducted by Karl Becker: March from Rienzi (Wagner); Jubelouvertüre (Bach); Hofballtanz (Lanner); Two Marches (Quiter); Selection from Die Fledermaus (Strauss); Scottish Caprice (Kling); Waltz (Fueik); Czardas (Grossmann); Potpourri of German Marches (Blankenburg). In the interval, at 12.10 p.m., Time and Weather. 1.0, Exchange. 1.10, Weather. 1.15, Gramophone Concert. 2.0, News. 2.10, Gramophone Concert. 3.0, Exchange. 3.40, Aviation Notes. 4.0, See Leipzig. 5.0, Readings. 5.30, Hamburg, Bremen and Lübeck—Report on Events in the Senates and Houses of Burgesses of the Hansatic Free Cities. 6.0, Variety Programme. 6.35, A Dialogue. 6.45, Frankfurt Exchange and Hamburg Market Prices. 6.50, Weather. 7.0, Transmission for all German Stations, relayed from Leipzig. 8.0, Topical Talk. 8.10, Variety Programme. 9.10, See Berlin (Witzleben). 10.0, Time and News. 10.20, Concert from Leipzig.

HANOVER.—See Hamburg.

HEILSBURG

1,085 kc/s, 275.5 metres; 60 kW. Relayed by Danzig, 662 kc/s, 453.2 metres.—1.5 p.m., Concert by the Small Station Orchestra, conducted by Eugen Wilken. March, Unter Hindenburg's Fahnen (Witteborn); Wiener Jubel-Ouvertüre (Stappé); Erwachen der Frühlingsblumen (Lohr); Stryan Humoresque (Spar); Selection from Eine Nacht in Venedig (Joh. Strauss); Marien-Walzer (Lanner); Hungarian Songs (Lehar); Bei den Wiener Schrammeln (Reckenwald); Rusticanelia (Cortopassi); Ein Lila-Fächer (Siede); Overture, Ilka (Doppler). In the intervals at 1.20 and 2.0, News. 2.30, Programme arranged by the Post Office with Gramophone Records. 3.0, Market Prices. 3.30, Programme for Children. 4.0, Talk for Women. 4.30, Concert by the Small Station Orchestra, conducted by Eugen Wilken. Overture, Giovinetta allegra (Cortopassi); Spanish Suite (Börschell); Valse caprice (Rubinstein); Selection from The Land of Smiles (Lehar); Daff il dir Märchen erzählen? (Witteborn); Juanita (Schridder); Symphonic Prelude (Trevisiol). In the interval at 5.0 (approx.), Where shall we go for our next Excursion? 5.45, Talk: The Art of Pianoforte Playing, with Illustration; Sonata in F Minor, Op. 57—the Appassionata (Beethoven). 6.15, Agricultural Prices. 6.25, Monthly Review of World Economics. 6.50, Weather. 7.0, Transmission for all German Stations, relayed from Leipzig. 8.20, Political Address and News. 8.30, Reading from the Works of Johanna Ambrosius on the Seventy-Ninth Anniversary of her Birth. 8.50, Trio Concert: Trio in E, Op. 61 (Fueik); Trio in C, Op. 74 (Dvorak). 9.30, Concert by the Königsberg Opera House Orchestra, conducted by Peter Schmitz. In the interval at 10.0 (approx.), News. 11.0 (approx.), Close Down.

HILVERSUM

Announced HUIZEN, 1,013 kc/s, 296.1 metres; 20 kW. (7 kW. up to 4.40 p.m.).—Programme of the Christian Radio Society (N.C.R.V.). 11.40 a.m., Police Notes. 11.55, Gramophone Music. 12.10 p.m., Concert by the van der Horst Ensemble: Overture, Queen for a Day (Adam); Bei uns z'haus (Strauss); Marcietta (Sudes); Rapsodie Lombarda (Cerrri); Selection from The Daughter of the Regiment (Donizetti); Gramophone Records; Torch Dance from Dinarah (Meyerbeer); Spanish Rhapsody (Richard); Babillage (Gillet); Ein Melodientraum (Urbach). 1.40, Interval. 2.10, Religious Concert: Concerto in A minor (Vivaldi); Sonata in D (Handel); Andantino (Martini-Kreisler); Tempo di minuetto (Pugnani-Kreisler); Gramophone Music; Fantasiestücke (Schumann); Romance (Svendsen); Le Printemps (Milhaud). 3.40, Gramophone Music. 4.40, Talk. 5.10, Quartet Concert. 6.10, Horticultural Talk. 6.40, Police Notes. 6.55, Religious News. 7.10, Literary Talk. 7.40, Concert by the Tiel Orchestra, conducted by F. Heindrichs: Per aspera ad astra (Urbach); Overture, The Barber of Seville (Rossini); Organ Solo: Streichholz-Wachtparade (Wellsch-Schroder); Fremersberg (Koenemann); Loreley-Paraphrase (Nesvadba); Aria from Stabat Mater (Rossini); Peer Gynt Suite (Grieg); Overture, The Crown Diamonds (Auber); La Hussare (Ganne); March of the Gladiators (Sonsa); Organ Solos. In the intervals, Talk and Press Review. 10.40, Gramophone Music. 11.10 (approx.), Close Down.

HORBY.—See Stockholm.

HUIZEN

Announced HILVERSUM, 160 kc/s, 1,875 metres; 8.5 kW.—11.40 a.m. to 3.40 p.m., Programme of the Algemeene Vereeniging Radio Onroep (A.V.R.O.). 11.40, Time and Gramophone Music. 12.10 p.m., Concert of Light Music by Kovacs Lajos and his Orchestra, with Gramophone Music in the intervals. 1.55, Gramophone Music. 2.10, Recitations. 2.40, Gramophone Music. 3.40 to 7.40, Programme of the Workers' Radio Society (V.A.R.A.). 3.40, Organ Recital: Einzug auf Mars (Diecker); In einem alten Rosengarten (Huerter); Only a Memory (Henderson); Selection from Turandot (Puccini); Selection from Countess Maritza (Kalman). 4.10, Programme for Children. 4.50, Extracts from Faust—Opera (Gounod), on Gramophone Records. 5.40, Concert of Light Music. 6.20, Talk. 6.40, Concert (cont'd.). 7.40, Programme of the Liberal Protestant Radio Society (V.P.R.O.). 8.10 to 10.10, A.V.R.O. Programme. Concert relayed from the Kurlans, Scheveningen, The Orchestra of the Hague, conducted by Carl Schuricht. 10.10 to 10.40, Programme to be announced. 10.40 to 11.40, V.A.R.A. Programme: Gramophone Music. 11.40 (approx.), Close Down.

INNSBRUCK.—See Vienna.

KALUNDBORG.—See Copenhagen.

KATOWICE

734 kc/s, 408 metres; 16 kW.—7.5 p.m., Talk. 7.20, Announcements and Gramophone Music. 7.35, Sports Notes. 7.40, See Warsaw. 11.0, The Letter Box in French.

KIEL.—See Hamburg.

KLAGENFURT.—See Vienna.

KOSICE.—See Prague.

LAHTI

167 kc/s, 1,796 metres; 40 kW. Relayed by Helsinki, 815 kc/s, 368.1 metres.—6.15 p.m., Programme for Children. 6.40, Talk. 7.10 (from Helsinki), Cello Solos. 7.40, Talk. 8.0 (from Helsinki), Orchestral Concert. 8.45, News in Finnish. 9.0, News in Swedish. 9.15, Light Music relayed from the Kappeli Restaurant. 10.0 (approx.), Close Down.

LANGENBERG

635 kc/s, 473 metres; 60 kW.—12 Noon, Concert of Light Music by the Fröhliche Fünf, 12.50 p.m., Announcements. 1.30, See Stuttgart. In an interval at 2.0 (approx.), Announcements. 3.0, Talk: Health Insurance and Unemployment. 3.15, Dialogue: Legal Problems of Every Day. 3.50, Economic Notes. 3.50, Programme for Young People. 4.30, Talk on Genealogy. 4.50, Political Address. 5.0, Musical Programme. 5.30, Programme to be announced. 6.0, Variety Concert conducted by Kniep. North German Folk Dance, Achttertanz; Hessian Folk Dance, Et gahlt nix über die Gemütlichkeit; Ländler aus Österreich; North German Folk Dance, Willst du, schönes Kind; Faschingsmarsch aus Aussen; Ach, Bursche sein; Westphalian Folk Dance, Artländer Kontz; North German Folk Dance, Das Mädle ich sah; Folk Dance, Schwingkontra; Ich sehe hier im

Kreise; North German Folk Dance, Vierton; Sieh, wie heiter wir uns drehn; Ländler aus Österreich; Danish Folk Dance, Der lustige Kupferschmied. 6.45, Time, Economic Notes and Sports Notes. 7.0, Programme in connection with the Bayreuth Festival. Symphony, No. 9 (Beethoven). Conductor: Richard Strauss. 8.25, Announcements. 8.30, The Mountaineer—Play (Friedrich Dorn), with Incidental Music by Gustav Kneip. 9.30, Travellers' Tales. Humorous Musical Programme with Recitations (Gorlitz); The Small Station Orchestra, conducted by Eysoldt, and an Accordion Soloist. 10.15, Announcements. 10.35, Talk: Coming Events in West Germany. 10.45, See Frankfurt. 11.30 (approx.), Close Down.

LAUSANNE.—See Radio-Suisse Romande.

LEIPZIG

769.9 kc/s, 389.6 metres; 120 kW. Relayed by Dresden, 941 kc/s, 319 metres.—12 Noon, Gramophone Concert of Variety Music. 1.0 p.m., News. 1.15, Concert of Old and Modern Folk Music by the Leipzig Concertina Orchestra, conducted by Paul Frey. 2.0, News. 2.10, Art Notes. 2.20, Reading of Lyrics. 3.15, Talk for Country Women. 3.35, Economic Notes. 4.0, Concert by the Leipzig Symphony Orchestra, conducted by Hilmar Weber. Overture, Der Bärenhäuter (Siegfried Wagner); Prelude to Die heilige Linde (Siegfried Wagner); Symphonic Tone Poem, Waldstein (Rheinberger); Les préludes (Liszt); Minuet and Rondo from the Serenade in D (Brahms); Selection from A Winter's Tale (Humperdinck); Overture, Semiramide (Rossini). In an interval at 5.0, Talk on Schütz and Neustadt. 5.50, Economic Notes. Weather and Time. 6.0, Talk: The World in which Martin Luther Moved. 6.25, Reading. 6.50, Today's News. 7.0, Transmission for all German Stations: The Ninth Symphony (Beethoven), by the Festspiel Choir and Orchestra, conducted by Richard Strauss, relayed from the Festspielhaus, Bayreuth. Soloists: Kirsten-Flagstad, Lilly Neitzler, Fritz Wolf and Rudolf Bockelmann. 8.20, Radio Play (Pade). 9.0, Agricultural Notes. 9.10, Concert by the Halle Concert Orchestra, conducted by Fritz Zschiesing. 10.20, News. 10.25 (approx.), Orchestral Concert. Conductor: Bruno Schestak. Soloist: Kurt Wolf (Tenor). 12 Midnight (approx.), Close Down.

LINZ.—See Vienna.

LJUBLJANA

522 kc/s, 574.7 metres; 7 kW.—6.30 p.m., Concert by the Station Orchestra. 7.30, Talk: Dog and Cat Breeding. 8.0, Talk: Nature Painting. 8.30, Concert Relay from Belgrade, 697 kc/s, 430.4 metres. After the Concert, Time and News. 10.30, Gramophone Music. 11.0 (approx.), Close Down.

LUXEMBOURG

252 kc/s, 1,191 metres; 200 kW.—Dutch Programme.—7.30 p.m., Orchestral Concert on Gramophone Records: Les Préludes (Liszt); Bolero (Ravel). 8.5, Weather Report. 8.10, Fritz Fischer Song Recital by Elisabeth Corty. In an interval at 8.30, Talk in Dutch: The Underworld of Luxembourg. 8.50, News in French. 9.0, Concert by the Station Orchestra, conducted by Henri Pensis. 9.50, News in German. 10.0, Concert, relayed from the Hotel International.

LWOW

788 kc/s, 381 metres; 16 kW.—7.5 p.m., Gramophone Music. 7.20, Miscellaneous Items. 7.40, See Warsaw. 10.40, Gramophone Music. 11.0 (approx.), Close Down.

LYONS

LA DOUA (PTT), 644 kc/s, 465.8 metres; 1.5 kW.—7.30 p.m., Radio Gazette for Lyons and the South East. 8.30, Concert of Classical Music, conducted by Jean Witkowski. After the Concert, News.

MADRID

EAJ7, 707 kc/s, 424.3 metres; 2 kW.—8.0 p.m., Chimes, Exchange, Radio Journal and Request Gramophone Records. 9.15, News and Political Review. 9.30 to 11.0, Interval. 11.0, Chimes, Time, and Political Review. 11.15 (approx.), Symphony Music on Gramophone Records. Ballet Suite (Gluck-Mottl); Valse triste (Sibelius); Nocturne No. 2 (Debussy); Violin Concerto (Beethoven); Songs and Dances of Majorca (Samper). 1.15 a.m. (Saturday), News and Programme Announcements for Listeners Abroad. 1.50, Chimes and Close Down.

MALMO.—See Stockholm.

MILAN

VIGENTINO, 662 kc/s, 453.2 metres; 4 kW.—8.15 p.m. (approx.) till Close Down, See Rome.

MORAVSKA-OSTRAVA

1,137 kc/s, 263.8 metres; 11 kW.—6.15 p.m., Gramophone Music. 6.25, See Prague. 7.10, Pianoforte Recital by Mitzi Markowitzová: Ballad in G Minor, Op. 118 (Brahms); Jardins sous la pluie (Debussy); Moment musical, Op. 44, No. 5 (Reger); Schmetterling (Grieg). 7.30, See Prague. 7.45, Popular Concert by the Station Orchestra and Soloists. 8.15, See Brno. 8.30, See Prague. 10.15, See Brno. 10.30 (approx.), Close Down.

MOSCOW

TRADES UNION, 230 kc/s, 1,304 metres; 100 kW.—2.45 p.m., Weather. 3.0, Popular Concert of Music by Brahms, Delibes, Sarasate, Rossini and Ravel. 5.30, Programme for Children. 9.0, News. 9.30, Programme Announcements. 9.55, Chimes from the Red Square. 10.5, Press Review.

MOTALA.—See Stockholm.

MUHLACKER.—See Stuttgart.

MUNICH

563 kc/s, 533 metres; 60 kW. Relayed by Augsburg and Kaiserslautern, 536 kc/s, 560 metres; and Nürnberg, 1,256 kc/s, 239 metres.—12 Noon, Gramophone Concert. 1.0 p.m., Orchestral Concert, conducted by Erich Kloss: Overture, Marinella (Fueik); Suite (Sibelius); Selection from La Favorita (Donizetti); Liebesfeier (Weingartner); Serenade (Kart); Polish Dance (Scharwenka). In the interval at 1.15, Time, Weather and News. 2.0, Time and News. 2.20 (from Nürnberg), Gramophone Concert, with Commentary. 3.0, Programme for Women. 3.55, Weather and Agricultural Notes. 4.10, Programme for Young People. 4.30 p.m., See Langenberg. 5.45, Talk: The Younger Generation. 6.5, Siegfried Wagner Concert. 6.45, Time, Weather and Agricultural Report. 7.0, Transmission for all German Stations, relayed from Leipzig. 8.10, Die Heimat in Blut—a Radio Play of Bavaria in 1805 (Loever). 9.20, Topical Talk. 9.45, Orchestral Concert conducted by Erich Kloss. 10.20, Time and News.

NAPLES.—See Rome.

NOTODDEN.—See Oslo.

OSLO

277 kc/s, 1,083 metres; 60 kW. Relayed by Fredrikstad, 815 kc/s, 368.1 metres; Hamar, 522 kc/s, 574.7 metres; Notodden, 671 kc/s, 447.1 metres; Porsgrund, 662 kc/s, 453.2 metres; and Rjukan, 671 kc/s, 447.1 metres.—6.30 p.m., Recital of Old and New Dance Music on Two Pianofortes. 7.0, Announcements, Weather and News. 7.30, Talk. 8.0, Time. 8.1, Opera Arias by Mme. Erica Darbor (Soprano). 8.30, Violin Recital of Dutch Music by Julius Röntgen. 9.0, Agricultural Report, relayed from the Fair at Hamar. 9.40, Weather and News. 10.0, Topical Talk. 10.15 (approx.), Close Down.

OSTERSUND.—See Stockholm.

PALERMO

558 kc/s, 537.6 metres; 3 kW.—8.0 p.m., Dopplavoro Notes, Tourist Talk, Agricultural Notes, Giornale Radio and Report of the Royal Geographical Society. 8.20, Gramophone Music. In an interval at 8.30, Time and Announcements. 8.45, Concert of Opera Music, conducted by Russo. Soloists: Mazzeotti (Tenor), Tita (Baritone), and Ciccoppo (Soprano). Overture, Bruschiino (Rossini); Tenor Aria from L'Africaine (Meyerbeer); Baritone Aria from Rigoletto (Verdi); Soprano Aria from Tosca (Puccini); Tenor and Soprano Duet from Act I of Carmen (Bizet); Baritone Solo: Creolo from Otello (Verdi); Duet from Act IV of The Force of Destiny (Verdi); Overture, Gli Orzelli e Curiazii (Cimarosa); Prelude to Loreley (Catalani); Overture, The Bartered Bride (Smetana). In the interval, Fashion Talk. 10.55, News.

PARIS

EIFFEL TOWER, 207.5 kc/s, 1,445.7 metres; 13 kW. Time Signals (on 2,650 metres) at 10.26 a.m. and 11.26 p.m. (Preliminary and 6-dot Signals).—6.45 p.m., Theatre Notes. 7.0, Le Journal Parlé. 8.30, Concert by the Station Symphony Orchestra, conducted by Edouard Flament: Prelude in G (de Massi-Hardman); Passéed du jardinier (Lortie); Soirs somptueux (Sauvrezis); Evening in the Odenwald (Foulds); By the Swanee River (Maddleton); Selection from Paganini (Lehar). 10.0 (approx.), Close Down.

PARIS

POSTE PARISIEN, 914 kc/s, 328.2 metres; 60 kW.—7.0 p.m., Gramophone Music. 7.5, Sponsored Talk. 7.15, Journal Parlé. 7.30, Gramophone Music. 8.0, Agricultural Talk. 8.10, Gramophone Music. 8.30, Concert by the Station Orchestra. Overture, Jeanne, Jeannette et Jeanneton (Lacôme); Suite of Viennese Waltzes (Gilsou); Russian Rhapsody, Svetlana (Weksler); Pieces for

AUGUST 4th

FRIDAY

continued

RADIO-SUISSE ROMANDE

SOTTENS, 743 kc/s, 403 metres; 25 kW.; and Geneva, 395 kc/s, 760 metres.—6.15 to 6.30 a.m., Gymnastics. 12.28 p.m., Time Signal from Neuchâtel Observatory. 12.30, News and Weather. 12.40, Gramophone Music. 1.0, Financial News. 1.10, Gramophone Music. 2.0 to 3.28, Interval. 3.28, Time Signal from Neuchâtel Observatory. 3.30, Gramophone Concert. 5.0, Talk. 5.30 to 7.0, Interval. 7.0, The Smiling Pacific—Travel Talk by a Journalist. 7.30, Weather and Announcements. 7.40, Talk: Darius Milhaud. 8.0 (from Zürich), Concert of German Music by the Radio-Suisse Alemannic Orchestra, conducted by M. Nepach; Soloist, Maria Fiechtl (Soprano). 9.0, Variety Items. 9.15, Cello and Piano Recital: Sonata in G Minor (Bach); Sonata in C Minor (Saint-Saëns). 9.50, News and Weather. 10.0, Out dine à sept heures—Comedy (Moreaux). 10.30 (approx.), Close Down.

REYKJAVIK

250 kc/s, 1,200 metres; 21 kW.—9.5 p.m., Musical Programme. 9.30, Weather Report. 9.40, Musical Programme and Announcements. 10.0, Chimes and News. 10.30, Reading. 11.0, Piano Recital in A Minor (Grieg), on Gramophone Records.

RIGA

572 kc/s, 525 metres; 15 kW.—6.0 p.m., Concert of Old Dance Music by the Y.M.C.A. Orchestra. 6.30, Talk on Tuberculosis. 7.0, Weather Report. 7.5, Concert of Operetta Music. In an interval at 8.0, News. 9.0, Weather and News. 9.15 (approx.), Gramophone Concert.

RUUKAN.—See Oslo.

ROME

Call 1R0, 680 kc/s, 441 metres; 50 kW. Relayed by Naples, 941 kc/s, 319 metres; and 2R0, 11,810 kc/s, 25.4 metres, from 5.30 p.m.—1.0 to 2.15 p.m., Orchestral Concert. In the intervals from 1.30 to 1.45, Giornale Radio and Exchange, and at 2.0, Time and Announcements. 4.45, Children's Radio Review. 5.10, Weather. 5.15, Exchange and Giornale Radio. 5.30, Vocal and Instrumental Concert. Giacomina Protto (Violino), Nelly Africano (Pianoforte), Giuseppina Marciano (Soprano), and Clara Fioravanti (Mezzo-Soprano). Sonata for Violin and Piano and Piano Solos: (a) Adagio (Tartini-Corti), (b) Rondo (Schubert-Friedberg); Three Duets: (a) Wanderers Naethlich (Rubinstein), (b) Vorrei farti una corona (Blaehni), (c) Sonetto (Calosso). 6.40 (Naples), Shipping and Sports Notes. 6.50, Agricultural and Dopolavoro Notes. 6.57, Report of the International Institute of Agriculture (in Spanish, German, and French). 7.10, Tourist Report. 7.20, Announcements in Foreign Languages. 7.40, Giornale Radio. 8.0, Time and Announcements. 8.15, Sponsored Musical Programme. 9.15, Verdi Concert. Soloist: Carlo Mangeri (Baritone). Overture, The Force of Destiny; Selection from the Second Act of Rigoletto; Selection from Otello. 10.50, All Roads lead to Rome—Comedy in One Act (Maria Ferraris and Ignia Vaccaromunatori). After the Comedy, Dance Music from the Giardino degli Aranci. In the interval at 10.55, Giornale Radio. 11.30, Close Down.

SALZBURG.—See Vienna.

SCHENECTADY

WG Y, 790 kc/s, 379.5 metres; 50 kW. Relayed at intervals by W2XAF on 31.48 metres and by W2XAD on 19.56 metres.—9.0 p.m., May We Present, from New York. 9.15, Musical Programme from New York. 9.30, Talk: The Mind Age. 9.35 to 10.0 (approx.), South Sea Islanders, from New York. 12.45 a.m. (Saturday), Stock Reports and Baseball Scores. 1.0, Cities Service Concert, from New York. 1.30, WGY Farm Forum. 2.0, Variety Programme, from New York. 2.30, Popular Programme, from New York. 3.0, WGY Players, Dramatic Programme. 3.30, Musical Programme, from New York, followed by Programme Resumé.

SCHWEIZERISCHER LANDESENDER

BEROMUNSTER, 653 kc/s, 459 metres; 60 kW. Basle, 1,229 kc/s, 244.1 metres; and Berne, 1,220 kc/s, 245.9 metres.—6.15 a.m. (from Basle), Gymnastics. 6.35, Interval. 11.59, Time Signal from Neuchâtel Observatory. 12 Noon (from Zürich), Concert of Light Music. 12.30 p.m., Time, Weather and News. 12.40 (from Zürich), Concert (cont'd.). 1.25 (from Zürich), Time, Weather and Exchange. 1.45 (approx.), Interval. 5.0 (from

Basle), Programme for Children. 6.30 (from Zürich), Talk: German Novels at the Present Time. 7.0 (from Zürich), Time, Weather, Market Prices and Traffic Report. 7.15 (from Zürich), Concert by the Swiss Radio Orchestra. 7.30, Talk: The Serious and the Humorous Side of Traveling. 8.0 (from Zürich), Folk Song Recital by Maria Fiechtl. 9.0, News. 9.10 (from Zürich), Concert by the Municipal Orchestra. 10.15 (approx.), Close Down.

SOTTENS.—See Radio-Suisse Romande.

STOCKHOLM

689 kc/s, 436 metres; 55 kW. Relayed by Boden, 244 kc/s, 1,229.5 metres; Göteborg, 932 kc/s, 322 metres; Hörby, 1,166 kc/s, 257 metres; Motala, 221.5 kc/s, 1,354.4 metres; Östersund, 389 kc/s, 770 metres; and Sundsvall, 554 kc/s, 542 metres.—5.5 p.m., Folk Music. 5.25, Reading. 5.45, Gramophone Music. 6.45, The Practical Corner. 7.0, Yugoslav Song Recital by Mladen Karanovic, with guitar accompaniment. 7.15, Weather and News. 7.30, Cabaret Programme. 8.15, A Play (Ibsen). 9.45, Weather and News. 10.0, Light Orchestral Concert: March (von Blon); Melody (Merikanto); Waltz from Cinderella (Palmgren); Slav Rhapsody, No. 2 (Friedemann); Bizet Potpourri (Urbach); Waltz Intermezzo (Ruseh); Selection from Gipsy Love (Lehar). 11.0 (approx.), Close Down.

STRASBOURG

869 kc/s, 335 metres; 11.5 kW.—11.30 a.m., Gramophone Music. 12.45 p.m., News. 1.0, Time and Exchange. 1.5, Light Music on Gramophone Records. 2.0 to 3.30, Interval. 3.30, Orchestral Concert, conducted by Broullac, relayed from the Casino Park. Vichy, Overture, The Magic Flute (Mozart); Symphonic Suite, Dolly (Fauré); Suite, from Eschermunde (Massenet); Funeral March of a Marionette (Gounod); Selection from Louise (Charpentier); Waltz, Amour et Printemps (Watteufel). 5.0, Literary Talk. 5.15, Rossini Concert on Gramophone Records. Overture, The Barber of Seville; Duet and Arias from The Barber of Seville; Overture, William Tell. 6.0, Trio Concert, relayed from Lille, 1,130 kc/s, 265.4 metres. 7.0, Topical Talk in German. 7.15, Gramophone Music. 7.30, Time and News. 7.45, Gramophone Music. 8.0, Press Review in French, Lottery Results and Announcements. 10.30, Orchestral Concert, conducted by M. Paray, relayed from the Casino, Vichy. Overture, Benvenuto Cellini (Berlioz); Overture, L'Enfant Roi (Brumant); A Night on the Bare Mountain (Mussorgsky); Suite, Scheherazade (Rimsky-Korsakov). 10.0 (approx.), Press Review in German.

STUTTGART

MUHLACKER, 832 kc/s, 360.5 metres; 60 kW.; and Freiburg, 527 kc/s, 570 metres.—12 Noon, Gramophone Concert. 1.15 p.m., Time and News. 1.30 from Freiburg, Concert by the Freiburg Kampfbund Orchestra, conducted by Karl Körner; Prinz-Eitel-Friedrich-Marsch (Blankenburg); Overture, Pique Dame (Suppé); Hochzeitszug in Liliput (Translator); Ein Tag in Potsdam (Schmalstieg); Military Fanfare (Ascher); March, Unter Flage und Wimpel (Schmidt). 2.30, Advanced English Lesson. 3.45, Talk: Suggestions for Sunday Rambles. 4.30, Concert by a Nazi Band, conducted by Hans Ullmann; Rudolfsklänge-Marsch (Herzer); Prelude to Banditenstreiche (Suppé); Waltz, Accelerationen (Joh. Strauss); Schubert Fantasia (Urbach); Serenade (Heykens); Selection from Gasparone (Müllacker); March, In Treue (Teike); Prinz-Eitel-Friedrich-Marsch (Blankenburg). 5.45 (from Freiburg), Legal Talk. 6.10, Medical Talk. 6.35, Time and News. 7.0, Transmission for all German Stations, relayed from Leipzig. 8.20, Concert of Light Music by the Station Orchestra, conducted by Gustav Görlich. In an interval, Report from Lake Constance. 10.0, Time and News. 10.25, Mozart Piano-forte Recital by Otto Sonnen; Fantasia in D minor; Sonata in F. 11.0, Dance Music on Gramophone Records. 12 Midnight (approx.), Close Down.

SUNDSVALL.—See Stockholm.

TRIESTE

1,211 kc/s, 247.7 metres; 10 kW.—5.0 p.m. till Close Down. See Turin.

TRONDHEIM.—See Oslo.

TURIN

1,096 kc/s, 273.7 metres; 7 kW. Relayed by Milan, 905 kc/s, 331.5 metres; Genoa, 959 kc/s, 312.8 metres; and Florence, 599 kc/s, 500.8 metres.—5.0 p.m., Concert of Chamber Music.

6.0 to 6.5, Weather. 6.35, News. 7.0, Time, Report of the Royal Geographical Society and Gramophone Records of Italian Music. 7.20, News in Foreign Languages. 7.40, Gramophone Music. 8.0, News, Sports Notes and Weather. 8.15, Sponsored Musical Programme. 8.30 (approx.), Symphony Concert. 11.0, Giornale Radio.

VATICAN CITY

15,120 kc/s, 19.84 metres (Morning), and 5,969 kc/s, 50.26 metres (Evening); 10 kW.—11.0 to 11.15 a.m., Religious Information in German. 7.0 to 8.15 p.m., Religious Information in Italian.

VIENNA

581 kc/s, 517 metres; 100 kW. Relayed by Graz, 852 kc/s, 352.1 metres; Innsbruck, 1,058 kc/s, 283 metres; Klagenfurt, 662 kc/s, 453.2 metres; Linz, 1,220 kc/s, 245.9 metres; and Salzburg, 1,373 kc/s, 218.5 metres.—12 Noon, Concert by the Vienna Symphoniker Orchestra. In an interval at 1.0 p.m., Time and News. 2.0, Interval. 3.0, Time, Weather and Exchange. 3.20, Talk: Practical Hints for the Housewife. 3.30, Programme for Children. 3.35, Gramophone Concert of Cigány Music. 4.30, Programme for Women. 4.55, Talk: Insects as Builders. 5.30, Viola Recital by Gustav Gruber. 6.5, Tourist Report. 6.20, Sports Talk. 6.35, Sports Review. 7.10, Concert by the Vienna Symphoniker Orchestra, conducted by Anton Konrath; Soloist: Rafael Lemes (Cello). In an interval at 7.45, Time and News. 8.15, Concert by the Vienna Symphoniker Orchestra, conducted by Josef Holzer; Soloists: Dina Grohmann (Soprano) and Karl Ziegler (Tenor); Overture, Kund um die Liebe (O. Strauss); Song from Der Göttergatte (Lehar); Tenor Solo from The Bayadere (Kálmán); Gavotte, Liebesheimlich (Komzak); Song from Eine einzige Nacht (Stolz); Soprano Solo from Friederica (Lehar); Waltz from A Waltz Dream (O. Straus); Song from Gipsy Love (Lehar); Duet from Apajme, der Wassermann (Müllacker-Riedinger); Overture, Gipsy Love (Lehar); Tenor Solo from Das Veilchenmädchen (Hellmesberger); Tenor Solo from Wiener Blut (Joh. Strauss-Müller); Selection from The Arabian Nights (Joh. Strauss); Soprano Solo from Paganini (Lehar); Barcarolle (Offenbach-Pausperl); Kiss Waltz from Der lustige Krieg (Joh. Straus); Duet from The Bayadere (Kálmán); Duet from Gipsy Love (Lehar); March from Polen Blut (Nedbal). 9.45, News. 10.0, Talk on Austria. 10.15, Gramophone Concert of Variety Music.

WARSAW

212.5 kc/s, 1,411 metres; 120 kW.—11.57 a.m., Time Signal and Fanfare from the Tower of St. Mary's Church, Cracow. 12.5 p.m., Light Music and Jazz Music on Gramophone Records. 12.25, Polish Press Review. 12.33, Weather. 12.35, Gramophone Music. 12.55, Radio Journal. 1.0, Interval. 2.55, Gramophone Music. 3.5, News. 3.10, Announcements. 3.15, Gramophone Music. 3.25, Economic Notes. 3.35, Gramophone Music. 3.45, Aviation Report and Anti-Gas Drill. 3.50, Gramophone Music. 3.55, Naval and Colonial Report. 4.0, Popular Concert by the Poznan Opera House Orchestra, conducted by Tyllia, relayed from Ciechocinek. 5.0, Review of Publications. 5.15, Song and Cello Recital by Berta Fryman-Kiszyczer (Mezzo-Soprano), and B. Ginsburg Cello Solos: (a) Variations (Tartini-Skutschewski), (b) Elegy (Fauré); Songs: (a) Aria from The haunted Castle (Moniusko), (b) Aria from The Queen of Sheba (Gounod). (c) Les Cloches (Niewiadomski); Symphonic Variations for Cello (Boellmann); Two Songs (Schubert); Two Songs (Moniusko); Cello Solos: (a) Intermezzo (Granados-Cassado), (b) Second Arabesque (Debussy), (c) Andalusia (Casella). 6.15, Talk: Fruit Trees in Poland. 6.35, Baritone Song Recital by Eugene Moskowsky. 7.5, Gramophone Music. 7.20, Miscellaneous Items. 7.35, Programme Announcements. 7.40, Topical Talk. 8.0, Concert by the Station Symphony Orchestra, conducted by Wilkomirski. Soloist: A. Koltun (Violin); Brandenburg Concerto in G (Bach); Violin Concerto in D (Beethoven). 8.50, Radio Journal. 9.0, Hints for the Week-end. 9.10, Concert (cont'd.), Symphony in G Minor (Mozart); Symphonic Poem, Tasso (Liszt). 10.0, Dance Music from the Café Europe, Ciechocinek. 10.25, Sports Notes. 10.35, Aviation Weather Report and Police Notes. 10.40, Dance Music Relay (cont'd.).

WILNO

533 kc/s, 563 metres; 16 kW.—7.5 p.m., News and Gramophone Music. 7.20, Lithuanian Review. 7.35, Programme Announcements. 7.40, See Warsaw. 9.0, Hints for the Week-End. 9.10, See Warsaw. 11.0 (approx.), Close Down.

ZAGREB

977 kc/s, 307 metres; 0.75 kW.—7.55 p.m., Sports Notes. 8.10, Announcements. 8.30, See Belgrade. 10.30, News. 10.40, Dance Music. 11.30 (approx.), Close Down.

ZURICH.—See Schweizerischer Landessender.

Clarinet, Viola and Pianoforte (Bruch); Selection from La mascotte (Audran); Orchestral Suite, Clair de Lune (Lacôme); Un soir dans l'Odenwald (Foulds); Blottie dans mes bras (Bery); Spanish Dance and Italian Dance from Le tribut de Zamora (Gounod); Poèmes galants (Lafy); Ségoviaine (Lacôme). 10.30, News.

PARIS

RADIO PARIS, Call CFR, 174 kc/s, 1,725 metres; 75 kW.—7.30 a.m., Weather and Physical Culture. 7.45, Gramophone Music. 8.0, Weather and News. 12 Noon, Jewish Programme. 12.30 p.m., Gramophone Concert of French Music. Old Limousine Melodies (Rouchaud); Maman, dites-moi (Weckerlin); O ma tendre musette (Weckerlin); Tous les bourgeois de Châtre (Tiersot); Chantons, je vous en prie; La Franc-Comtoise; Le comtesseux de Marninod; La Noce; Le roi a fait battre tambour; A Parthenay; Le Général Finfin; Gigue and Polka; Les P'tit Quinquin (Desrousseaux); Triseldes; Les cloches de Nantes; en venant le Lyon; La boucree populaire d'Avnergne; au bouyé (Fontbernat); Magadi. (Loré); Montanyas regalados; Le retour du marin Tiersot; Bro goz ma zadou; Chansons de oze (Hayet). 7.0, Market Prices, Weather, Agricultural Report and Racing Results. 7.10, Social Assurance Societies' Reports. 7.20, Gramophone Concert. Overture, The Merry Wives of Windsor (Nicolaï); By the Waters of Minnetonka (Lienance); Selection from El nino indio (Luna); J'ai peur de (Cazes); Serenade (Malats); Melody (Wayne); Selection from Show Boat (Kerul). 8.0, Commercial Notes and News. 8.0, symphony Concert on Gramophone Records: The Unfinished Symphony (Schubert); Aria from Figaro (Mozart); Aria from Don Giovanni (Mozart); Iberia (Albeniz); Two songs from Turandot (Puccini); Prelude and waltz from La tragédie de Salomé (Schmitt); Jeilie (R. Strauss); To Music (Spiegel); by March (Tchaikovsky). In the intervals 8.30, News and Weather; at 8.40, Review y Pierre Seize, and at 9.15, Press Review and News. 10.0, Light Music on Gramophone records.

PITTSBURGH

DKA, 980 kc/s, 306 metres; 50 kW. Relayed by W8XK on 48.86 metres; and 25.27 metres.—4.0 to 4.59 p.m., U.S. Marine Band, from New York. 7.30, DKA Home Forum. 8.0 to 8.58, New York Relay. 8.0, Betty and 8.15, Words and Music. 8.45, Happy ack Turner. 8.58, Baseball Scores. 9.0, ene Qwaw and His Hotel Cosmopolitan rehearsal, from New York. 9.30, Business ews and Market Reports. 9.45, Areadians, from New York. 9.58, Baseball Scores. 10.0, hlythm Kings. 10.15, Barzan of the Apes. 1.30, The Singing Lady, from New York. 1.45, Little Orphan Annie. 11.0, Time Signal and Press News-Review. 11.15, Weather report. 11.16, Sport Review. 11.23, I ring a Song. 11.28, Announcement. 11.29, emperature Report. 11.30, Pittsburgh Sport ght. 11.45, Today's News by Lowell omas, from New York. 12 Midnight, Amos Andy from New York. 12.15 a.m. (Saturday), Rontollers. 12.30, Pastoral, from New ork. 1.0, Manchester Arms—DKA layers. 1.15, The Silver Toppers. 1.30, ash and Permittor. 1.45 to 3.45, New ork Relay. 1.45, Phil Cook and his In- 30, Shavers. 2.0, Let's Listen to Harris. 3.0, Variety Programme. 3.0, First Nighter.

ORSGRUND.—See Oslo.

POZNAN

6 kc/s, 335 metres; 1.0 kW.—6.15 p.m., Warsaw. 7.5, Light Music on Gramophone Records. 7.20, Miscellaneous Items and News. 7.35, Theatre Notes and Programme Announcements. 7.40, See Warsaw. 8.0, Time Signal, Sports and Police Notes. 8.15, Dance Music on Gramophone Records. 8.0 (approx.), Close Down.

PRAGUE

4 kc/s, 488.6 metres; 120 kW.—2.50 p.m., Concert of Light Music. 3.55, Exchange. 4.0, Interval. 5.45, Gramophone Music. 5.55, dk: The Centenary of the Oxford Movement in England. 6.5, Market Prices. 6.15, amophone Music. 6.25, News in German. 7.0, German Transmission; Talk: The History of Music. 7.0, Chimes and News. 7.10, ighlish Popular Song Recital by Lisa Frankoboda; Clouds (Charles); Somebody's ong (Marshall-Whiting); There's Happiness ead (Flynn-Burns); Somebody loves you ose); June Time is Love Time (Sher- ington); Song (Campbell-Tipton). 7.30, Talk: hemia. 7.45, See Moravská-Ostrava. 8.15, e Brno. 8.30, Concert of Czech Opera sic by the Station Orchestra, conducted O. Parik; Overture, The Tinker (Skroup); ntasia (Smetana); Polka from The Two idows (Smetana); Introduction to Act III The Devil and Kate (Dvorák); Ballet sic from Hody (Fibich); Polka and Melody m Deborah (Foerster). 9.30, Dinner for 10—One Act Comedy (Ditcovka). 10.0, ne and News. 10.15, See Brno. 10.30 pprox.), Close Down.

BARCELONA

EAJ1, 860 kc/s, 348.8 metres; 8 kW.—7.0 p.m., Trio Concert: Selection from Lohengrin (Wagner); Meeres stille und glückliche Fahrt (Mendelssohn); Cello Solo, Réverie (Vallaury); Minuet No. 2 in G (Beethoven); Idyll (Février); Ballet (Pesse); Selection from Mirella (Gounod). 8.0, Request Gramophone Records. 8.30, Exchange. 9.0, Gramophone Concert. In the interval at 9.15, Talk on Disarmament. After the Concert, News. 10.0, Chimes, Weather and Exchange. 10.5, Concert by the Station Orchestra. 11.15, Poetry Recitation. 11.30, An Opera on Gramophone Records. In the interval at 12 Midnight, News. 1.0 a.m. (Sunday), Close Down.

BARI

1,112 kc/s, 269.8 metres; 20 kW.—8.0 p.m., Agricultural Notes, Tourist Report and Popolavoro Announcements. 8.20, Giornale Radio and Weather. 8.30, Time and Announcements. 8.35, Symphony Concert conducted by Fritz Reiner: Selection from Le Caruffle Chiozzate (Sinigaglia); Three Pieces (Mallipiero); Hungarian Dance Suite (Weiner); Symphony Classique Op. 25 (Prokofiev); Three Pieces from Hary Janos (Kadoly); Overture, Taubhäuser (Wagner). In the interval, Talk. After the Concert, News.

BASLE.—See Schweizerischer Landessender.

BELGRADE

BEOGRAD, 697 kc/s, 430.4 metres; 2.8 kW.—5.55 p.m., Time Signal and Programme Announcements. 6.0, Gramophone Music. 7.0, Orchestral Concert. 8.0, A Radio Play. 9.0, Gramophone Music. 9.45, Time Signal, News and Relay of Foreign Stations. 10.45, Dance Music on Gramophone Records.

BERLIN

DEUTSCHLANDSENDER 183.5 kc/s, 1,635 metres; 60 kW.—2.0 p.m., Gramophone Concert. 3.0, Handwork for Children. 3.30, Weather. 3.45, Reading (Frauz Hermann). 4.0, See Hamburg. 5.0, Sports Notes. 5.15, Weekly Review. 5.30, Concert by the Berlin Mandoline Orchestra, conducted by Bruno Heitz: Military March, No. 1 (Schubert); Waltz in A (Brahms); Harlequin's Serenade from the Carnival Suite (Schmalstich); Russian Dance No. 6 Gopak (Butlerian); Intermezzo, Schmsucht (Henzel); March Potpourri, Mit Lante und Fiedel (Lautenschläger). 6.0, A Poem. 6.5, Animal Interpretations by Friedrich Herzfeld. 6.30, Programme to be announced. 6.50, Weather and Announcements. 7.0, Transmission for all German Stations. A Street under Construction Radio Play (Nierentz and Hagen), with incidental Music by Windt. 8.0, Today's Motto. 8.5, Dance Music by the Kaufmann and Treuss Dance Bands. 9.30, The Spell of Havel—A Comedy (Werner E. Hintz). 10.10, News. 10.45, Weather for Shipping. 11.0, Dance Music from Langenberg. 12 Midnight, Close Down.

BERLIN

WITZLEBEN, 715 kc/s, 419.5 metres; 1.5 kW.—4.0 p.m., Orchestral Concert, conducted by Josef Balay, Overture, The Thieving Magpie (Rossini); Selection from La Foyola di Helga (Santoliquido); Waltz, Spätklänge (Joh. Strauss); Serenade in F (Volkman); Waltz, Gruss aus Wien (Bausnern); Frühliches Wandern (Kamm); Waltz-Caprice (Bortkiewicz); Two Russian Dances (Butlerian). In the interval at 4.55 (approx.), Radio Report of the Berlin-Brandenburg Nazi Sports Festival, relayed from the Stadium, Grunewald. 5.30, Topical Programme. 6.0, Reutter Song Recital by Henny Wolf (Soprano). In der kleinen blauen Stube; Gebet; Der Weg; Abendgefühl; Litanei; Liebeslied; Strom der Tränen. 6.20, Talk with Gramophone Illustrations: The Song as an Expression of National Character. 6.40, The Witzleben Station informs its Listeners. . . 6.45, Topical Talk. 7.0, Transmission for all German Stations, relayed from Berlin (Deutschlandsender). 8.10 to 1.0 a.m. (Sunday), Variety Programme. In the intervals at 10.0, News, and at 11.0 (approx.), Police Announcements. 1.0 a.m. (Sunday), Close Down.

BERNE.—See Schweizerischer Landessender.

BEROMUNSTER.—See Schweizerischer Landessender.

BODEN.—See Stockholm.

BODO.—See Oslo.

BORDEAUX-LAFAYETTE

986 kc/s, 304 metres; 13 kW.—6.15 p.m., Radio Journal. 7.40, Sports Talk. 7.45, News. 7.55, Gramophone Music. 8.20, News. 8.30, Gramophone Concert. 9.0, Concert.

BRATISLAVA

1,076 kc/s, 279 metres; 14 kW.—6.25 p.m., Gramophone Music. 6.40, Talk: Touring

SATURDAY

AUGUST THE FIFTH

PRINCIPAL EVENTS OF THE DAY:

AT HOME

NATIONAL The Tidworth Tattoo. Community singing led by Joseph Lewis.
LONDON REGIONAL Orchestral concert.
MIDLAND REGIONAL "The Regional Revellers," feature programme.
NORTH REGIONAL Gilbert and Sullivan selection: orchestral programme.
SCOTTISH REGIONAL Variety programme.
BELFAST Eye-witness account of the Grass-track Motor Cycle Racing at Maze Racecourse.

ABROAD

BARI 8.35 p.m. Symphony concert.
BERLIN (Deutschlandsender) 5.30 p.m. The Berlin Mandoline Orchestra.
BRUSSELS (No. 1) 9.0 p.m. Concert from the Kursaal, Ostend.
EIFFEL TOWER 9.30 p.m. "Le Médecin Malgré Lui," a comedy, by Molière.
HUIZEN 5.0 p.m. String Orchestra. 7.42 p.m., The Amsterdam Salon Orchestra.
LANGENBERG 5.50 p.m. The Cologne Young People's Choir and the Radio Orchestra.
LYON LA DOUA 8.30 p.m. Opera: "Dinorah," by Meyerbeer, relayed from Vichy.
RADIO PARIS 8.30 p.m. "White Horse Inn," a musical play, by Stolz-Benatzky, from the Théâtre Mogador.
WARSAW 9.30 p.m. Chopin pianoforte recital, by Flota Czarnocka.

through Eastern Slovakia. 6.55, Talk for Housewives. 7.0, See Prague. 10.15, See Moravska-Ostrava. 11.30, Close Down.

BREMEN.—See Hamburg.

BRESLAU

923 kc/s, 325 metres; 60 kW.; and Gleiwitz, 1,184 kc/s, 253 metres.—1.0 p.m., Gramophone Concert. 1.45, Time, Weather, and News. 2.0, Gramophone Concert. 3.0, Agricultural Notes. 3.20, Programme to be Announced. 3.40, Book Review. 4.0, Concert, conducted by Max Kaden, relayed from Bad Salzbrunn. 5.30, Dialogue: Films of the Week. 5.50, Programme Announcements. 6.0, Topical Talk. 6.20, Variety Programme on Gramophone Records. 6.50, Weather for Farmers, followed by News. 7.0, Transmission for all German Stations, relayed from Berlin (Deutschlandsender). 8.0, Variety Programme. In the interval at 9.0, News. 10.0, Time and News. 10.30, Programme from Berlin (Witzleben). 12 Midnight (approx.), Close Down.

BRNO

873 kc/s, 342 metres; 35 kW.—6.5 p.m., Gramophone Music. 6.25, German Transmission: News and Recital of Waltzes by Emmy Seveik and Kurt Gas; Dorfschwalben aus Oestereich (Strauss); Wo die Citronen wachsen (Strauss); Waltz Paraphrase (Glas); Parla (Arditi). 7.0, See Prague. 10.15, See Moravska-Ostrava. 11.30 (approx.), Close Down.

BRUSSELS (No. 1)

I.N.R., 590 kc/s, 509 metres; 15 kW.—12 Noon, Concert by the Small Station Orchestra, conducted by Emile Lauwers: Spring Song (Mendelssohn); Overture, A Life for the Czar (Glinka); Waltz, Barcarolle (Waldteufel); Nocturne (Faure); Selection from Rigoletto (Verdi); Meditation (Rogister); Spanish Dances (Moszkowsky); Elan (Douliez). 1.0 p.m., Le Journal Parlé. 1.10, Gramophone Concert. 4.45 p.m., Talk on Commerce. 5.0, Dance Music relayed from the Continental Palace Hotel, Blankenberghe. 6.0, Talk. 6.15, Gramophone Music: Quintet for Pianoforte and Strings, Op. 34 (Brahms); Melody (Nistschensky); Les Preludes (Liszt). 7.15, Talk: The Prevention of Industrial Accidents and Illnesses. 7.30, Le Journal Parlé. 8.0, Accordion Solos by Eugène Hansen. 8.20, Strauss Potpourri on Gramophone Records. 8.30, Extracts from the Repertoire of the Comédie Française on Gramophone Records. 9.0, Concert relayed from the Kursaal, Ostend. After the Concert, Le Journal Parlé, followed by Dance Music by Robert de Kers and his Cabaret Kings, relayed from the Kursaal, Ostend. 12 Midnight (approx.), Close Down.

BRUSSELS (No. 2)

N.I.R.; 887 kc/s, 338.2 metres; 15 kW.— Programme in Flemish. 12 Noon, Selection from Lucia di Lammermoor (Donizetti), on Gramophone Records. 1.0 p.m., Le Journal Parlé. 1.10, Concert by the Small Station Orchestra, Conductor and Soloist: Lauwers (Violin): Military March (Schubert); Suite, Sylvan Scenes (Fletcher); Melody (Marchetti); Violin Solos: (a) Idyll (Meadowell-Auer), (b) The Bee (Schubert); Waltz, Roses from the South (Strauss); Selection from Viktoria and Her Hussar (Abraham); Fox-trot (Kalmán); Tango, Two Blue Eyes (Stravinsky). 4.45, Reading. 5.0, Dance Music relayed from the Kursaal, Ostend. 6.0, Talk with Gramophone Illustrations. 6.45, Gramophone Music: Overture, Euryanthe (Weber); Kamarinskaya (Glinka); Spanish Suite (Falla-Kochansky); Concerto (Gershwin). 7.15, Talk: A Review of Europe 1933. 7.30, Film Notes. 8.0, Gramophone Concert: Air with Variations on a Swiss Theme (Moltr); Suite, Les Erynnies (Massenet). 8.40, Recitation. 9.0, Concert Relayed from the Continental Palace Hotel, Blankenberghe. After the Concert, Le Journal Parlé, followed by Dance Music by the Jacky Ganzo Band from the Continental Palace Hotel at Blankenberghe.

BUCHAREST

761 kc/s, 394 metres; 12 kW.—5.0 p.m., Light Music and Romanian Music by the Sibiceano Orchestra. In an interval at 6.0, Radio Journal. 7.0, Reading. 7.20, Instrumental Music. 7.40, Educational Talk. 8.0, Concert by the Station Orchestra: Overture, The Nuremberg Doll (Adam); Waltz (Fueick); Selection from Faust (Gounod); Erotika (Grieg); Serenade (Grieg); Danse lente (Franck); Selection from The Flower of Hawaii (Abraham); Serenata della Laguna (Beccel); Marche militaire (Saint-Saëns). In an interval at 8.40, Dramatic Programme. 9.45, Radio Journal.

BUDAPEST

541 kc/s, 550.5 metres; 18.5 kW.—5.30 p.m., Choral Concert. 6.10, Reading. 6.30, Gramophone Music. 7.30, Humorous Talk. 8.0, Radio Report from the Camp of the International Jamboree at Gödöllő. 8.45, News. 9.0, Cigány Music from the Café Boda. 10.0, Concert by the Opera House Orchestra. 11.30, Greetings of Scouts from Distant Lands to their Parents.

CASSEL.—See Frankfurt.

COPENHAGEN

1,067 kc/s, 281 metres; 0.75 kW. Relayed by Kalundborg, 260 kc/s, 1,153.8 metres.—12 Noon, Time and Chimes from the Town Hall.

12.5 p.m., String Ensemble Concert relayed from the Vivex Restaurant. 2.0, Interval. 3.0, Orchestral Concert conducted by Walter Meyer-Radon: Overture, The Mikado (Sullivan); Waltz, Dichterliebe (Johann Strauss); Melody (von Dittersdorf); Selection from Der Freischütz (Weber); Abendlied for Strings (Schumann-Sydnelsen); Trüneri for Strings (Schumann); Homage March from Sigurd Jorsalfar (Grieg); Danish Recitations by Tavs, Neilemand; Polonaise (Schubert); Arabesque No. 2 in G (Debussy); Two Spanish Dances (Moszkowsky); Selection from Blue Beard (Offenbach); Overture, La belle Héloïse (Offenbach); Military Gallop (Lumbye). 5.0, Gramophone Music. 5.35, Exchange and Fish Market Prices. 6.20, Talk. 6.50, Weather and News. 7.15, Time Signal. 7.30, Talk: The Copenhagen Water Supply. 8.0, Chimes from the Town Hall. 8.5, Concert by the Station Orchestra conducted by Walter Meyer-Radon: Selection from the Haydn Serenade (Mozart); Andante and Finale from the Surprise Symphony (Haydn); Overture, Die Fledermäus (Johann Strauss). 8.40, Reading. 9.10, Danish and Swedish Songs to the Guitar by Ellen Malberg. 9.30, Pianoforte Recital by Svend Hansen: Prelude in G minor (Rachmaninov); Valse nonchalante (Saint-Saëns); Three Rag Caprices (Milhaud); Negro Air and Dance (C. Scott). 9.50, News. 10.5, Orchestral Concert conducted by Walter Meyer-Radon: Overture, La Princesse de Trébizonde (Offenbach); Waltz, Die Schönbrenner (Lanner); Selection (Nedbal); Waltz Intermezzo from The Count of Luxembourg (Lehár); Dance (Coates); March from Sunny (Kern). 10.55, News.

CORK.—See Athlone.

CRACOW

959 kc/s, 312.8 metres; 1.5 kW.—7.20 p.m. Miscellaneous Items and News. 7.35, Programme Announcements. 7.40, See Warsaw. 9.15, Agricultural Press Review, relayed from Wilno. 9.30, See Warsaw. 12.0 Midnight (approx.), Close Down.

DANZIG.—See Heilsberg.

DRESDEN.—See Leipzig.

FECAMP

1,328 kc/s, 225.9 metres; 10 kW.—4.30 to 6.0 p.m., Programme in English by the I.B.C. 4.30, Programme for Children. 5.0 Concert for Tunbridge Wells and Isle of Thanet Listeners: Signature Tune, The Night by the Sea; In Tulip Time beside the Water Mill (Aibout); Song, The Last Rose of Summer (Moore); When the Convent Bell is ringing (Trevor); Stephanie Gavotti (Czibulka); Song, Down in the Forest (London Ronald); There's something in your eyes (Grotlie); Song, The Pipes of Pan (Monckton); Heartaches (Hoffmann). 5.30 Military Band Concert for Dover and Folkestone Listeners: Selection from Mariama (Wallace); Old Panama (Alford); Song The Song of Hylbia the Cretan (Elliott); Selection from The Pirates of Penzance (Sullivan); Song, Ho Jolly Jenkin (Sullivan); The Bullfighters' March (Kottmann); Song Sinners and Saints (Geehl); The Wedding of the Rose (Jessel); Signature Tune. 6.0 Programme in French. 11.0 till Close Down Programme in English by the I.B.C. 11.0 Dance Music: Signature Tune, Bells o' Normandy; Come out Vienna; Rock-a-bye My heart was made for love; Butterflies in the rain (Myers); Don't be late in the Morning; Hold me; When my little Pomerania met your little Pekinese; I can't remember Signature Tune. 11.30, Concert given by the I.B.C. (Ireland), Ltd.: Signature Tune, Come back to Erin; Overture Medley (arr. Carl Peters); Song, As the King went forth to War (Koenemann); Selection from The Yeoman of the Guard (Sullivan); Cymr Silent O'Myle (Hughes); Waltz from Sleeping Beauty (Tchaikovsky); Violin Solo, L'Cygne (Saint-Saëns); Song, Molly Baw (Lover); March from Aida (Verdi). 12.5 a.m. The I.B.C. Late News Bulletin. 12.10 (approx.), Club Concert for Bangor Listeners Part I: Choral and Orchestral Selections Land of my Fathers; orchestra: The Moo and I, from The Mikado (Sullivan); Cymr Fess (Perry); Orchestra: Merry-maker Dance (German); March of the Men o' Harlech; Part II: Dance Music: The Ol' Spinning Wheel; You are too beautiful Waltzing in a dream; I got a right to sin the blues; Old Man Harlem; In the Valley of the Moon; Here is my heart; Something came and got me in the Spring; Signature Tune. 1.0, Light Music: Evolution of Dixy (Lafke); Song, Shetland Lullaby (arr. Grehl); Pianoforte Solo, Everyone says I love you (Kalmár); Pulcinello (Aletter); Street o' Dreams (Lewis); Xylophone Solo, The Dripping Well (Abbey); Veterans of Variety; Part I: Southern Rhapsody (Hosmer). 1.30 Dance Music: Signature Tune, Bells o' Normandy; "editermannu" Madneses Twentieth Century Blues; The World is a small; Lover of my dreams; I'm one of the Lads of Valencia; Just an echo in the Valley; Put a little springtime in the wint of their lives; A little street where of friends meet; Signature Tune. 1.57, I.B.C. Goodnight Melody. 2.0, Close Down.

FLensburg.—See Hamburg.

FLORENCE.—See Turin.

AUGUST 5th **SATURDAY** continued

FRANKFURT

1,157 kc/s, 259.3 metres; 17 kW. Relayed by Cassel, 1,220 kc/s, 245.9 metres; and Trier, 1,157 kc/s, 259.3 metres.—3.30 p.m., Programme for Young People. 4.25, Economic Notes. 4.30, See Munich. 5.45, Economic Notes. 6.0, Readings from the Unpublished Works of Heinrich Heine. 6.25, Time and News. 6.30, Review of the Week. 6.50, Today's News. 7.0, Transmission for all German Stations, relayed from Berlin (Deutschlandsender). 8.5, See Langenberg. 10.15, Time and News. 10.45, Programme from Berlin (Witzleben).

FREDRIKSSTAD.—See Oslo.

FREIBURG.—See Stuttgart.

GENEVA.—See Radio-Suisse Romande.

GENOA.—See Turin.

GLEIWITZ.—See Breslau.

GOTEBORG.—See Stockholm.

GRAZ.—See Vienna.

HAMAR.—See Oslo.

HAMBURG

Call ha (in Morse), 806 kc/s, 372 metres; 1.5 kW. Relayed by Bremen, 1,112 kc/s, 269.8 metres; Flensburg, 1,319 kc/s, 227.4 metres; Hannover, 530 kc/s, 566 metres; and Kiel, 1,292 kc/s, 232.2 metres.—4.0 p.m., Orchestral Concert, conducted by Josef Eibenschütz. Prelude to Hansel and Gretel (Humperdinck); Symphonic Poem, Les Preludes (Liszt); Selection from A Masked Ball (Verdi); Selection from Mignon (Thomas); Ballet Suite No. 2 (Gluck-Mottl); Radetzky March (Jos. Strauss). 5.15, Talk: In Styria, 5.45 (from Bremen), Concert by a Male Voice Choir. 6.30 (from Kiel), Religious Address. 6.50, Weather. 7.0, Transmission for all German Stations, relayed from Berlin (Deutschlandsender). 8.10, See Berlin (Witzleben). 10.0, News. 10.20, Topical Talk. 10.30, Programme from Berlin (Witzleben).

HANOVER.—See Hamburg.

HEILSBURG

1,085 kc/s, 276.5 metres; 60 kW. Relayed by Danzig, 662 kc/s, 453.2 metres.—11.30 a.m., Concert by the Small Station Orchestra, conducted by Eugen Wilken; Overture, and Selection from Alee-to (Gliick); Adagio and Minuet (Beethoven); Ballet Music from Rosamunde (Schubert); Selection from Oberon (Weber); Overture, The Barber of Bagdad (Cornelius); Hungarian Dances No. 1, 2, 3 and 6 (Brahms); Gruss an Wien (Baussons); Einsame Fichtwacht (Graener); Selection from Der Evangelist (Kienzl). 1.5 p.m., Gramophone Concert. In the intervals at 1.20 and 2.0, News. 2.30, Programme arranged by the Post Office with Gramophone Records. 3.0, Market Prices. 3.30, Talk: The Deaf and Dumb. 3.50, Review of New Publications. 4.0, Concert by the Small Station Orchestra, conducted by Eugen Wilken; Waltz, G'schichten aus dem Emstal (Pacherweg); Traumlieder-Fantasia (Lumby); Flotte Postillon (Radtke); Puppe und Kobold (Armandola); Overture, Der Wolkegänger (Spialek); Selection from Der Obersteiger (Zeller); Waltz, Mon rêve (Waldteufel); Potpourri, Lieder, die meine Mutter sang (Batzem); Overture, Bantienstrieche (Suppé). In the interval at 5.0 (approx.), Talk: The Supervision of Roads in East Prussia. 5.30, Humorous Talk by Frank Günther. 6.5, Programme Announcements. 6.15, Agricultural Prices. 6.25, Talk: The Modern State. 6.50, Weather. 7.0, Transmission for all German Stations, relayed from Berlin (Deutschlandsender). 8.0, Concert by the Königsberg Opera House Orchestra, conducted by Wolfgang Brückner. 9.0, East German Military Programme. 10.0, News, followed by Dance Music from Berlin (Witzleben). 12.30 a.m. (Sunday), Close Down.

HILVERSUM

Announced HUIZEN; 296.1 metres; 20 kW. (7 kW. up to 4.40 p.m.).—Programme of the Catholic Radio Society (K.R.O.). 11.55 a.m., Gramophone Music. 1.25 to 1.40, Interval. 1.40, Programme for Young People. 2.10, Programme for Children. 3.40, Programme arranged by the H.I.R.O. 4.40, Concert; Overture, Orpheus in the Underworld (Offenbach); Selection from Les Saltimbanques (Ganne); Gramophone Music; Kleiner Wiener Marsch (Kreisler); Rakoczy Overture (Keler-Bela); Kaiserwalzer (Strauss); Selection from Lilac Time (Schubert-Berté); An Old Violin (Fischer); Selection from Nell Gwynn (German); Gipsy Moon (Borganow); Florentine March (Fueik). 6.0, Press-Review. 6.25, Concert (cont'd.); Selection from Countess Maritza (Káhnán). 6.40, Police Notes. 6.55, Talk. 7.15, Gramophone Music. 7.40, Concert from Bois-le-Duc; March, Barnum and Bailey (Chadwick); Automobile (Hall); Overture, Pique Dame (Suppé); Overture, Le Voyage dans la lune (Offenbach); La Hussarde (Ganne); Divertissement espagnol (Desormes). 8.15, News. 8.20, Concert (cont'd.); Air varié (Suppé-Goussens); Melody (Leuwen); March (Schootenewer). 8.40, A Radio Sketch in Four Acts. 9.25, Gramophone Music. 9.40, Concert (cont'd.); Overture, Orpheus in the Underworld (Offenbach); Mon Rêve (Waldteufel); Quartet for Saxophones (Akker); Reminiscences of Prague (Hoch). 10.10, News. 10.15, Concert (cont'd.); Melody (Maa); Melody (Akker); Selection from Le

Tribut de Zamora (Goumod); Bon Voyage. 10.40, Gramophone Music. 11.40 (approx.), Close Down.

HORBY.—See Stockholm.

HUIZEN

Announced HILVERSUM; 160 kc/s, 1,875 metres; 8.5 kW.—Programme of the Workers' Radio Society (V.A.R.A.). 11.40 a.m., Concert by the Haarlem Salon Orchestra, conducted by J. Steffer, with Gramophone Interludes. 1.40, Rigoletto—Opera (Verdi) on Gramophone Records. 3.55, Gramophone Music. 4.40, Literary Talk. 5.0, Concert by a String Orchestra, conducted by L. Coehn. Soloist: J. Vogel (Organ). Overture, Edelweiss (Komzák); Two Elegiac Melodies (Grieg); Petite Suite de Concert (Coleridge-Taylor); Extase (Ganne); Perlen der Donau-Ufer (Uhl). 5.40, Albert Hahn Commemoration Programme. 6.0, Concert (cont'd.); Selection from La Bohème (Puccini); La Lettre de Manon (Gillet); Zigeuner-elusuecht (Kempner); Chant hindou (Rinsky-Korsakov); Diamanten und Perlen (Dostal). 6.40, V.R.O. Programme. 7.40, S.O.S. Messages. 7.42, Concert by the Amsterdam Salon Orchestra, conducted by D. Kiekens, with the Four Serenaders (Accordion). J. Vogel (Organ and Accordion), J. Müller (Saxophone), E. Busch (Songs), W. V. Cappellen (Recitations), and the V.A.R.A. Dramatic Society. Overture, Raymond (Thomas); Selection from Mignon (Thomas); Organ Solos: (a) Tell me I'm forgiven, from Wonder Bar (Katscher), (b) Ballgeföhler (Meyer-Helmund), (c) Viennese Folk Song (Brandl), (d) Fantasia (Niek); Songs: (a) The Song of the Flea (Mussorgsky), (b) Edward (Harder-Lowe); Andalusian Romance (Sarastie); Selection from Tiefland (d'Albert); Recitations; Saxophone and Piano-forte Duets: (a) Hot-Sax (Philips), (b) Valse mélodieuse (Vogel), (c) Melody (King), (d) Melody (Doerr), (e) Narcissus (Doerr); Songs: (a) Ballade des chinois (Weber-Lauberg), (b) De mangoboum (Wolff-Graf), (c) Keunst du das Land (Kästner-Krieg), (d) Es wird wohl gehen (Klabund-Reinitz), (e) Adieu (Reinitz); Dramatic Programme; Hofballtänze (Lanner); Hungarian Dances Nos. 5 and 6 (Brahms); Accordion Solos: (a) Russian Foxrot (Weiss), (b) Please (Rainer), (c) Du, schwarzer Zigeuner (Vacek), (d) Dinah (Noordijk), (e) Wie hab' ich leben können ohne dich (Hölander), (f) Some of these Days (Brooks), (g) Hyde Park Corner (Evans). 10.40, Gramophone Music. 11.40 (approx.), Close Down.

INNSBRUCK.—See Vienna.

KALUNDBORG.—See Copenhagen.

KATOWICE

734 kc/s, 408 metres; 16 kW.—5.45 p.m., Programme for Invalids relayed from Lwow. 788 kc/s, 381 metres. 6.0, Divine Service relayed from the Ostra Brama, Wilno, 533 kc/s, 563 metres. 7.0, See Warsaw. 7.20, Announcements and Gramophone Music.

KIEL.—See Hamburg.

KLAGENFURT.—See Vienna.

LAHTI

167 kc/s, 1,796 metres; 40 kW. Relayed by Helsinki, 815 kc/s, 368.1 metres.—6.15 p.m., Talk. 6.40, Concert by the Station Orchestra; Intermezzo from L'Amico Fritz (Mascagni); Brise de mer (Leoncavallo); Selection from La Traviata (Verdi); Dauer of the Hours from La Gioconda (Ponchielli); Overture, Norma (Bellini). 7.25, Talk. 7.50, Song Recital. 8.15, Dramatic Programme. 8.45, News in Finnish. 9.0, News in Swedish. 9.15, Light Music, relayed from the Kappeli-Restaurant. 10.0 (approx.), Close Down.

LANGENBERG

635 kc/s, 473 metres; 60 kW.—12 Noon, Concert by the Fröhliche Fünf. 12.50 p.m., Announcements. 1.0, Concert, conducted by Ey-sold. In an interval at 2.0 (approx.), Announcements. 2.30, Gramophone Concert. 3.30, Economic Notes. 3.50, Time, Early Days of the Rhine Steamers. 4.10, Talk: Excursions in the Rhine-land and Westphalia. 4.25, Talk: Bathing Accidents and Life Saving Methods. 4.35, Talk in Westphalian Dialect. 5.0, Programme of Famous Serenades and Minuets. 5.30, Talk on Economics. 5.50, Literary and Musical Programme by the Cologne Young People's Choir, conducted by Käthe Schmitz and Members of the Radio Orchestra; Soloist, Amy Gerzsen (Soprano); Serenade for Flute, Violin and Viola (Hoeftoven); Song, Klein' Marianne; Schmelztranz; Choir; Wiegenlied, Susala; Soprano Song, Meine Mutter (Pestalozzi); Two Poems; Recitation, Man and Women, or The Birdlay; Soprano Solo, Das Echo (Schubert); Choir; Transylvanian Hunting Song; Folk Dance, Silesian Dance; Song, In meinem Garten die Nelken; Short Story; Folk Dance, Kriz-Fönig; Soprano Solo; Die Männer sind mechant (Schubert); Music by Frederick the Great for Flute and Piano-forte; Choir; Reiters Morgenlied; Reiter-

marsch; Song, Hildetrant; Music by Frederick the Great for Flute and Piano-forte; Soprano Solo, Die Unterscheidung (Schubert); Two Poems; Soprano Solo, Petersilie, Suppenkrant; Choir and Soprano, Das Nachtgebet; Old Polka. 6.45, Time, Economic and Sports Notes. 7.0, In the interval, Topical Talk. Transmission for all German Stations, relayed from Berlin (Deutschlandsender). 8.0, Announcements. 8.5, Langenberg, Stuttgart, and Frankfurt Exchange Programme; Down the Rhine; Variety Programme. 10.15, Announcements. 10.45, Dance Music. 12 Midnight (approx.), Close Down.

LAUSANNE.—See Radio-Suisse Romande.

LEIPZIG

709.9 kc/s, 389.6 metres; 120 kW.; and Dresden, 941 kc/s, 319 metres.—12 Noon, Concert by a Nazi Band, conducted by Arno Kühn; Hymn (Blon); Des grossen Kürfürsten Reiter-marsch (von Molke); March from Grosser Kürfürst (von Simon); Prelude to Act I of Hermanns Conrtractus (Hobue); Selection from Cavalleria rusticana (Mascagni); Bittgesang für's Vaterland (Richter); March, Der alte Berner (Schmelting); Overture, Das dritte Reich (Theil); Baalat (Rüdiger); Waltz, Wiener Blut (Joh. Strauss); March, Der Admiral der Luft (Blankenburg); March, Unter deutscher Flagge (Kretschmar); Overture, Die Musikanten (Flotow); Nationaler Weckruf (Kunoth). In an interval at 1.0 p.m., News. 2.0, News. 2.10, Gramophone Records of Songs by Lotte Scheone and Franz Völker. 2.45, Programme for Children. 3.30, Talk on Music. 3.45, Economic Notes. 4.0, Programme to be announced. 4.30, Concert from Hamburg. 5.20, German for Germans. 5.40, A Modern Dictionary. 5.50, Talk: Echterdingen, a Starting Point for the German Zeppelin Flight. 7.0, Transmission for all German Stations, relayed from Berlin (Deutschlandsender). 8.5, See Langenberg. 10.5, News. 10.10 (approx.), Dance Music by the Eudé Band. 12 Midnight (approx.), Close Down.

LINZ.—See Vienna.

LJUBLJANA

522 kc/s, 574.7 metres; 7 kW.—6.30 p.m., Concert by the Station Orchestra. 7.30, Review of Foreign Affairs. 8.0, Concert by the Station Orchestra. 9.0, Programme relayed from Bled. 9.45, Time and News. 10.0, Jazz Music. 11.0 (approx.), Close Down.

LUXEMBOURG

252 kc/s, 1,191 metres; 200 kW. French Programme.—7.30 p.m., Gramophone Concert. 8.10, Weather Report. 8.15, Song Recital by Mme. Gossifis de Guyper. Pentecost Cantata (Bach); Cherubino's Aria from Figaro (Mozart); Elsa's Aria from Lohengrin (Wagner); Der Nussbaum (Schumann); Der Traum (Grieg). 8.50, News in French. 9.0, Concert by the Station Orchestra, conducted by Henri Pensis. Ballet Music from Faust (Goumod); Habanera (Turina); Sur le lac sacré (Février); Overture, Le Roi d'Ys (Lalo). In an interval at 9.20, Talk in French: Anguste Renoir. 9.45, News in German. 9.55, Concert by the Station Orchestra. Marmelades Löffchen (Jensen); Wedgwood Blue (Ketybey); Selection from Rose Marie (Frini); Florentine March (Fueik). 10.25, Dance Music on Gramophone Records.

LWOW

785 kc/s, 381 metres; 16 kW.—6.0 p.m., Divine Service, relayed from the Ostra Brama, Wilno. 7.0, See Warsaw. 7.20, Miscellaneous Items. 7.40, See Warsaw. 9.15, Agricultural Press Review, relayed from Wilno, 533 kc/s, 563 metres. 9.30, See Warsaw. 12 Midnight (approx.), Close Down.

LYONS

LA DOUA (PTT), 644 kc/s, 465.8 metres; 1.5 kW.—7.30 p.m., Radio Gazette for Lyons and the South East. 8.30, Dinorah—Opera (Meyerbeer), relayed from Vichy. After the Opera, News.

MADRID

EAJ7, 707 kc/s, 424.3 metres; 2 kW.—8.0 p.m., Chimes, Exchange, Radio Journal and Request Gramophone Records. 9.15, News. 9.30 to 11.0, Interval. 11.0, Chimes and Time. 11.5 (approx.), Song Recital with accompaniment by the Station Sextet, followed by Readings. 1.15 a.m. (Sunday), News. 1.30, Chimes and Close Down.

MALMO.—See Stockholm.

MILAN

VICENTINO, 662 kc/s, 453.2 metres; 4 kW.—8.45 p.m. till Close Down, See Rome.

MORAVSKA-OSTRAVA

1,137 kc/s, 263.8 metres; 11 kW.—6.25 p.m., Concert by a Mandoline Orchestra, conducted by R. Percival, relayed from Koprivnice. 7.0, See Prague. 10.15, Radio Film—Programme of Songs, Instrumental Solos, a One-Act Comedy, and Music by the Station Orchestra. 11.30 (approx.), Close Down.

MOSCOW

TRADES UNION, 230 kc/s, 1,304 metres; 100 kW.—2.45 p.m., Weather. 3.0, Gramophone Concert. 4.30, Literary Programme. 5.30, Programme Announcements. 5.45, Educational and Technical Wireless Propaganda. 6.30, Dance Music. 9.0, News. 9.30, Programme Announcements. 9.55, Chimes from the Red Square. 10.5, Talk in German: Karl Marx. 10.30, Press Review.

MOTALA.—See Stockholm.

MUHLACKER.—See Stuttgart.

MUNICH

563 kc/s, 533 metres; 60 kW. Relayed by Augsburg and Kaiserslautern, 536 kc/s, 560 metres; and Nürnberg, 1,256 kc/s, 239 metres.—4.30 (from Nürnberg), Concert by the Josef Schwarz Orchestra; Im Fluge der Zeit (Brückner); Waltz, Stunden die wir nie vergessen (Grüschel); Serenade and Scherzo (Wagner); Overture, Die Windsbraut (Günther); Minuet in A (Zorn); Song (Ponzioli); Fantastic Dance (Bauer); Die Wachtelmannen kommen (Weise); March, Heil Franken (Feist). 5.45, Programme for Girls; Rosin im Tal—Play (Kuhmert). 6.15, Extracts from the Trio in D (Haydn) for Violin, Cello, and Piano-forte. 6.45, Wireless Notes. 7.0, Transmission for all German Stations, relayed from Berlin (Deutschlandsender). 8.0, Talk: Austria. 8.20, Variety Programme by the Small Station Orchestra and Soloists. After the Programme, Dance Music. 10.20, Time and News. 11.0, Serenade. In the interval, Viennese Songs by Emilie Berneck. 12 Midnight (approx.), Close Down.

NAPLES.—See Rome.

NOTODDEN.—See Oslo.

OSLO

277 kc/s, 1,083 metres; 60 kW. Relayed by Fredriksstad, 815 kc/s, 368.1 metres; Hamar, 522 kc/s, 574.7 metres; Notodden, 671 kc/s, 447.1 metres; Porsgrund, 662 kc/s, 453.2 metres; and Rjukan, 671 kc/s, 447.1 metres.—5.0 p.m., Gramophone Concert. 5.45, Programme for Children. 6.15, Concert of National Music. 6.45, Talk on Economics. 7.0, Announcements, Weather, and News. 7.30, The Roros Copper Mines—an Interview with the Miners. 8.0, Time. 8.1, Concert by the Station Orchestra, conducted by Hugo Kraam; Regimental March (Lundvall); Selection from Flotte Bursche (Suppé); The Forge in the Forest (Michaelis); Melody (Neupert); Syncopeation (Kreisler); The Lost Chord (Sullivan); Dance of the Merry Masquers (Ketybey); Melody (Svensen); Piece (Wingar); Sweet Ann Page (Lemon); Aria (Sammartini); Minuet (Padrevsky); French Serenade (Grieg); Dance of the Nations (Manfred). 9.38, Agricultural Notes. 9.40, Weather and News. 10.0, Topical Talk. 10.45, Dance Music. 12 Midnight (approx.), Close Down.

OSTERSUND.—See Stockholm.

PALERMO

558 kc/s, 537.6 metres; 3 kW.—8.0 p.m., Dopolavoro Notes, Tourist Talk, Agricultural Notes and Giornale Radio. 8.20, Gramophone Music. In an interval at 8.30, Time and Announcements. 8.45, Relay of an Operetta. In the intervals, Book Review and Announcements. 10.55, News.

PARIS

EIFFEL TOWER, 207.5 kc/s, 1,445.7 metres; 13 kW.—Time Signals (on 2,650 metres) at 10.26 a.m. and 11.26 p.m. (Preliminary and Call Signals). 6.45 p.m., Theatre Notes. 7.0, Le Journal Parle. 8.30, Le médecin malgré lui—Comedy (Molière). 10.0 (approx.), Close Down.

PARIS

POSTE PARISIEN, 914 kc/s, 328.2 metres; 60 kW.—7.0 p.m., Gramophone Music. 7.15, Journal Parle and Review of Foreign Affairs. 7.50, Talk: The Event of the Week. 8.0, Gramophone Music. 8.25, Weher Concert: Sonata for Piano-forte and Violin; Agatha's Aria and Cavatina from Der Freischütz. 9.10, Dance Music by the Sonora Radio Band, conducted by Fred Hoffmann. 11.0, News.

PARIS

RADIO PARIS. Call CFR, 174 kc/s, 1,725 metres; 75 kW.—7.30 a.m., Weather and Physical Culture. 7.45, Gramophone Music. 8.0, Weather and News. 12 Noon, Gramophone Concert; Suzanne; C'est ma compagne; Selection from Il Trovatore (Verdi); L'ange; Selection from No. No. Nanette (Vaumans); Belial (Nielhoff); Melody (Navarina); Napoléon (Cazes); Giordina (Bracale); Le mélodie du coeur (Gertler); Elisabeth from Wondet Bar (Katscher); Vienna, City of my Dreams (Sieczynsky); Borracho (Tanca); It's you Baby (Mitchell);

AUGUST 5th SATURDAY continued

Les lilas (Doelle); Milongo (Rio); Chérie, tous les deux (Calabrese-Simonot); Souvenance (Borel-Clerc); Mariage d'amour (Verdun); Letango du rêve (Madren); O dona Clara (Petersbursky); Ecoutez-ca (Blangy); Selection from Eulevez moi (Baroque). In the interval, at 1.0 p.m., Exchange, News and Weather, and at 1.30, Exchange, 2.0, Exchange, 3.45, Exchange and Market Prices, 7.0, Market Prices, Weather, Agricultural Notes and Racing Results, 7.10, Gramophone Concert: Overture, Rienzi (Wagner); Aria from Louise (Charpentier); Habanera (Aubert); Selection from The Magic Flute (Mozart); Dionysiaques (Florent Schmitt), 7.50, Commercial Notes and News, 8.0, Gramophone Music, 8.15, News, 8.30, White Horse Inn—Musical Play (Stolz-Reunatzy), relayed from the Théâtre Mogador. In the interval, News.

PITTSBURGH

KDKA, 980 kc/s, 306 metres; 15 kW. Relayed by W8XK on 48.86 metres and 25.27 metres.—7.30 to 8.58 p.m., New York Relay, 7.30, Concert Echoes, 8.0, Words and Music, 8.30, Wealth of Harmony, 8.58, Baseball Scores, 9.0, Dance Masters, from New York, 9.30, Concert Favorites—Joseph Galliccio's Orchestra, from New York, 9.55, Baseball Scores, 10.0, Rhythm Kings, 10.15 to 11.0, New York Relay, 10.15, Tom Gerum and Casino Orchestra, 10.30, Neil Sisters, 10.45, Little Orphan Annie, 11.0, Time Signal and Press News-Reeler, 11.5, Piano Classique, 11.15, Weather Report, 11.16, Sport Review, 11.22, Press News-Reeler, 11.29, Temperature Report, 11.30, A Recreo by Bill and Alex, of the Downtown Y.M.C.A., 11.45, Izaak Walton League, 11.59, Time Signal, 12 Midnight, American Tax Payers' League, from New York, 12.15 a.m. (Sunday), Annie, Judy and Zeke, 12.30 to 3.15, New York Relay, 12.30, Jack Pettis and his Orchestra, 1.0, Jack Denny and his Orchestra, 1.30, Stadium Concerts by the Philharmonic Symphony Orchestra, 3.15, Time Signal and Behind the Law—Tales of the Pennsylvania State Police.

PORSGRUND.—See Oslo.

POZNAN

896 kc/s, 335 metres; 1.9 kW.—6.0 p.m., Divine Service, relayed from the Ostra Brama, Wilno, 7.0, See Warsaw, 7.20, Miscellaneous Items and News, 7.35, Theatre Notes and Programme Announcements, 7.40, See Warsaw, 9.15, Agricultural Press Review, relayed from Wilno, 9.30, See Warsaw, 10.0, Time Signal, Sports and Police Notes, 10.15, Dance Music, relayed from the Esplanade Café, 11.0 (approx.), Close Down.

PRAGUE

614 kc/s, 488.6 metres; 120 kW.—2.50 to 4.0 p.m., Concert by Jaroslav Cech's Chamber Orchestra; March of the Cadets (Bayer); Selection from an Opera (Nedbat); Waltz, Mon rêve (Waldteufel); Czech Polka (Hilmar); Suite, Nel Gwynn (German); Tango (Anst); Waltz (Coots); Polka (Tichy); Florentine March (Fueck), 5.45, Gramophone Music, 5.55, Talk on Mineral Waters, 6.5, Agricultural Talk, 6.10, Gramophone Music, 6.15, Talk for Workers, 6.25, News in German, 6.30, German Transmission: Humorous Programme with Gramophone Records, 7.0, Chimes from St. Ludmila Church and News, 7.10, Brass Band Concert, 8.10, Theatre Reminiscences by R. Naskova, 8.25, Three Travel Sketches, 10.0, Time, News Press Review and Sports Notes, 10.15, See Moravská-Ostrava, 11.30 (approx.), Close Down.

RADIO-SUISSE ROMANDE

SOTTENS, 743 kc/s, 403 metres; 25 kW.; and Geneva, 395 kc/s, 760 metres.—6.15 to 6.30 a.m., Gymnasium Lesson, 12.28 p.m., Time signal, relayed from Neuchâtel Observatory, 12.30, News and Weather, 12.40, Gramophone Concert, 1.0, Financial News, 1.10, Gramophone Concert, 2.0 to 3.28, Interval, 3.28, Time Signal from Neuchâtel Observatory, 3.30, Concert by the Radio Lausanne Orchestra, conducted by M. Moser, 5.0, Dance Music on Gramophone Records, 5.30 to 7.0, Interval, 7.0, Talk: The Hands, 7.30, Weather and Announcements, 7.31, Talk, The Literary Movement in England, 8.0, Concert of Popular Music by the Radio Lausanne Orchestra, conducted by M. Moser; Soloist: Edouard Glussen (Accordion), 9.0, Humorous Monologues, 9.10, Recital of Viennese Songs by Mlle. Winckler and M. Kramer, 9.50, News and Weather, 10.0, Dance Music, relayed from the Perrotet Dance Hall, Montreux, 10.30 (approx.), Close Down.

REYKJAVIK

250 kc/s, 1,200 metres; 21 kW.—9.5 p.m., Musical Programme, 9.30, Weather Report, 9.40, Musical Programme and Announcements, 10.0, Chimes and News, 10.30, Reading, 11.0, Concert by the Radio Trio, followed by Dance Music, 2.0 a.m. (Sunday), Close Down.

RIGA

572 kc/s, 525 metres; 15 kW.—7.0 p.m., Weather Report, 7.3, Talk, 7.30, Concert by the Station Orchestra, conducted by Vladimir Shavitch, relayed from Bulduri, Overture, Oberon (Weber); Symphony in G minor (Mozart); Preludes to the Second and Third Acts of Lohengrin (Wagner); Songs; Spanish Caprice (Rimsky-Korsakov). In the interval, at 8.10, News and at 9.0, Weather, 9.30, News and Dance Music.

RJKUKAN.—See Oslo.

ROME

Call 1RO, 680 kc/s, 441 metres; 50 kW. Relayed by Naples, 941 kc/s, 319 metres; and 2RO, 11,810 kc/s, 25.4 metres, from 5.30 p.m.—1.0 to 2.15 p.m., Concert of Light Orchestra Music, In the interval from 1.15 to 1.20, Talk on Photography, 1.30 to 1.45, Giornale Radio and Exchange, and at 2.0, Time and Announcements, 4.30, Children's Radio Review, 4.45, Reading, 5.5, Report of the Royal Geographical Society, and Giornale Radio, 5.15, Exchange and Weather, 5.30 to 6.15, Orchestral Concert, Soloist: Colonnese (Violin), Amore e champagne (Tagliaventi); Largo (Vescey); Goece di rugiada (Giachino); Melody (Profes); Selection from Siberia (Giordano); Violin Solo, Chant hindou (Rimsky-Korsakov); Serenata (Escobar); Fiore andalusio (Borghesano), 6.40 (Naples), Shipping and Sports Notes, 6.50, Agricultural and Popolavoro Notes, 7.0, Tourist Report, 7.10, Lesson in Morse, 7.20, News in Foreign Languages, 7.40, Giornale Radio, 8.0, Time and Announcements, 8.15, Gramophone Music, 8.25, Giornale Radio and Sports Notes, 8.30, Song Recital by Vera Nadia Poggioli (Soprano), 8.45, Concert by the Metropolitan Police Band, conducted by Andrea Marchesini: Overture, Norma (Bellini); Selection from La Bohème (Puccini); Scherzo from L'Apprenti sorcier (Dukas); Symphonic Poem, Feste romane (Respighi); Selection from William Ratcliff (Mascagni). In the interval, Review of New Books, 9.30 (approx.), Il viale dei pioppi—Comedy in One Act (Alessandro de Stefani), 10.0, Concert (cont.): Prelude to the Second Part and Finale from The Resurrection of Christ (Perosi); L'Italiana in Oriente (Marchesini); Trumpet Solo, Der Liebespostillon (Neumann), 10.55, Giornale Radio.

SALZBURG.—See Vienna.

SCHENECTADY

WGY, 790 kc/s, 379.5 metres; 50 kW. Relayed at intervals by W2XAF on 31.48 metres and by W2XAD on 19.56 metres.—12.45 a.m. (Sunday), Stock Reports and Baseball Scores, 1.0-4.0, New York Relay, 1.0, Musical Programme, 1.30, Pedro Via Orchestra, 2.0, Musical Programme, 2.15, Four Horsemen, 2.30, K-7, Secret Service Spy Story, 3.0, B.A. Rolfe and his Terraplane Orchestra, 4.0, Programme Résumé.

SCHWEIZERISCHER LANDESENDER

BEROMUNSTER, 653 kc/s, 459 metres; 60 kW.; Basle, 1,229 kc/s, 244.1 metres; and Berno, 1,220 kc/s, 245.9 metres.—6.15 a.m. (from Basle), Gymnastics, 6.35, Interval, 11.59, Time Signal from Neuchâtel Observatory, 12 Noon (from Zürich), Gramophone Concert, 12.30 p.m., Time and News, 12.40 (from Zürich), Concert (cont.), 1.25 (from Zürich), Time, Weather, and Exchange, 1.30 (from Zürich), Answers to Correspondence, 1.45 (from Zürich), Book Review, 2.15 (from Zürich), Gramophone Music, 2.45 (from Zürich), Sports Talk, 3.30, Interval, 5.0 (from Zürich), Accordion Concert, 5.30 (from Zürich), Light Music on Gramophone Records, 6.0 (from Zürich), Talk on Hygiene, 6.50 (from Basle), Austrian Humour, 7.0, Chimes from the Zürich Churches, 7.15 (from Basle), Time, Weather, and Market Prices, 7.20 (from Basle), The Strauss Family — Gramophone Concert, 8.0 (from Basle), Talk, 8.30 (from Basle), Fute Recital, 9.0, News, 9.10 (from Basle), Mozart's Journey to Prague—Radio Sequence, 10.15 (from Basle), Dance Music by the Leo Sar Viennese Orchestra from the Summer Casino, 11.0 (approx.), Close Down.

SEVILLE

SPAIN, EAJS, 815 kc/s, 368.1 metres; 1.5 kW.—9.30 to 10.0 a.m., News, 3.0 to 4.0 p.m., Concert by the Station Orchestra, followed by Dance Music, 10.0, Extracts from Musical Comedies (Alonso and Chueca), followed by Dance Music. In the interval, News, Exchange, and Weather, 12.0 Midnight (approx.), Close Down.

SOTTENS.—See Radio-Suisse Romande.

STOCKHOLM

689 kc/s, 436 metres; 55 kW. Relayed by Boden, 244 kc/s, 1,229.5 metres; Göteborg, 932 kc/s, 322 metres; Hörby, 1,166 kc/s, 257 metres; Motala, 221.5 kc/s, 1,354.4 metres; Östersund, 389 kc/s, 770 metres; and Sundsvall, 554 kc/s, 542 metres.—4.0 p.m., Technical Talk, 4.20, Orchestral Concert, relayed from Malmö, 1,301 kc/s, 231 metres. Overture, Don Giovanni (Mozart); Waltz, Tres jolies (Waldteufel); Oriental Suite (von Platea); Moorish Serenade (Nicodé); Song of Provence (Nicodé); Waltz (Heuberger); Suppé Potpourri (Morena). In the interval at 5.0, Weather, 5.20 (from Sundsvall), Programme for Children, 5.50, Gramophone Music, 6.50, Radio Report, 7.15, Weather and News, 7.30, Talk, 8.0, Concert of Old Dance Music, relayed from Malmö, 8.45, A Dialogue, 9.15, Recital by Brita Westerberg (Songs) and Charles Barkel (Violin); Four Gipsy Songs; Violin Solos: (a) La gitana (Kreisler); Spanish Dance (Granados); Spanish Serenade (Chaminade); Jota (Falla), 9.45, Weather and News, 10.0, Modern Dance Music, relayed from the Savoy, 11.0 (approx.), Close Down.

STRASBOURG

869 kc/s, 345 metres; 11.5 kW.—11.30 a.m., Gramophone Music, 12.45 p.m., News, 1.0, Time and Exchange, 1.5, Dance Music on Gramophone Records, 2.0, Legal Talk in German, 2.15, Gramophone Music, 2.45, Talk on Music, 3.0 to 3.30, Interval, 3.30, Orchestral Concert, conducted by Brouillard, relayed from the Casino Park, Vichy, Overture, La Princesse jaune (Saint-Saëns); Aubade printanière (Lacombe); Suite algérienne (Saint-Saëns); Siegfried's Rhine Journey, from The Dusk of the Gods (Wagner); Selection from Don Giovanni (Mozart); Waltz, Roses from the South (Strauss), 5.0, Gramophone Music, 5.15, Pianoforte and Song Recital by Ferdinand Riel and Genya Marat (Mezzo-Soprano), Pianoforte Solos: Etudes (Chopin); (a) in F Minor, Op. 10, (b) in C Minor, Op. 25; Songs: (a) Song from The Queen of Spades (Tchikovsky), (b) Melody (Weingartner); Pianoforte Solos: (a) Nocturne (Ropartz), (b) Impromptu (Faure), (c) Waltz, Impromptu (Erb); Songs: (a) Soixans unis (Baton), (b) Berceuse amoureuse (Jaquell), (c) Beau Soir (Rich), (d) Italian Serenade (Rich); Pianoforte Solos: (a) Prélude élégiaque (Rich), (b) Minuet (Rich); Songs: Four Indian Love Lyrics (Woodford Finden), 6.15, Gramophone Concert, 7.0, Tourist Talk, 7.15, Talk in German on Horticulture, 7.30, Time and News, 7.45, Gramophone Music, 8.0, Press Review in French, Lottery Results and Announcements, 8.30, Alsatian Programme, D'r Millionengärtner—Folk Play in Three Acts (Bastien), 10.30 (approx.), Press Review in French, 10.30, Dance Music, relayed from the Savoy, 12 Midnight (approx.), Close Down.

STUTTGART

MUHLACKER; 832 kc/s, 360.5 metres; 60 kW.; and Freiburg, 527 kc/s, 570 metres.—12.20 p.m., Gramophone Concert of Variety Music, 1.30, Concert by the Station Orchestra, conducted by Gustav Görlich: Bruker Lager-Marsch (Kral); Overture, The Nürnberg Doll (Adam); Waltz, Sommerfreuden (Lincke); Ballet Suite (Lautenschläger); Selection from The Mikado (Sullivan), 2.30, Time and News, 2.50, Mouth Organ Recital by the Camstatt Mouth Organ Club; March, Farewell of the Gladiators (Blauenburg); Overture, The Caliph of Bagdad (Boieldieu); Sanctus (Schubert); Das Elternhaus (Bühls); Japanese Lantern Dance (Yoshitomo); March, Durch Nacht zum Licht (Lauken), 3.10, Talk on Flowers, 3.30, Programme from Frankfurt, 4.30, See Munich, 5.45, Talk on Aerial Defence, 6.10, Talk, 6.35, Time and News, 7.0, Transmission for all German Stations, relayed from Berlin (Deutschlandsender), 8.5, See Langenberg, 10.0, Time and News, 10.25, Programme to be announced, 10.45, Dance Music from Berlin (Witzleben), 12 Midnight (approx.), Close Down.

SUNDSVALL.—See Stockholm.

TRIESTE

1,211 kc/s, 247.7 metres; 10 kW.—5.40 p.m. till Close Down, See Turin.

TRONDHEIM.—See Oslo.

TURIN

1,096 kc/s, 273.7 metres; 7 kW. Relayed by Milan, 905 kc/s, 331.5 metres; Genoa, 959 kc/s, 312.8 metres; and Florence, 599 kc/s, 500.8 metres.—5.40 p.m., Gramophone Music, 6.0 to 6.5, Weather, 6.35, News, 7.0, Time, Tourist Report and Italian Music on Gramophone Records, 7.20, News in Foreign Languages, 7.40, Gramophone Music, 8.0, News, Sports Notes, Weather and Gramophone

Music, 8.30, Talk: Events and Problems, 8.45, Variety Programme. In the interval: Review of New Books, 11.0, Giornale Radio.

VATICAN CITY

15,120 kc/s, 19.84 metres (Morning), and 5,969 kc/s, 50.26 metres (Evening); 10 kW.—11.0 to 11.15 a.m., Religious Announcements in Various Languages, 8.0 to 8.15 p.m., Religious Information in Italian.

VIENNA

581 kc/s, 517 metres, 100 kW. Relayed by Graz, 852 kc/s, 352.1 metres; Innsbruck, 1,058 kc/s, 283 metres; Klagenfurt, 662 kc/s, 453.2 metres; Linz, 1,220 kc/s, 245.9 metres; and Salzburg, 1,373 kc/s, 218.5 metres.—12 Noon, Concert by the Vienna Symphony Orchestra, Conductor: Josef Holzer. In an interval at 1.0 p.m., Time and News, 2.0 (from Graz), Report of the Austrian Swimming Championship, 2.10 to 3.0, Interval, 3.0, Time, Weather, and Exchange, 3.15, Variety Programme, 3.35, English Talk: English Humour, 4.0, Short Stories, 4.30, Concert by the Vienna Mandoline Society: Overture, Joseph (Méhul); Moment musical (Schubert); Die Spinner (Leiss); Volksliedchen (Komzak); Märchen (Komzak); The Turkish Patrol (Michels); Waltz, El Turia (Granados), 5.0, Concert by the Alois Dostal Orchestra, relayed from Bad Hall: Overture, Prince Methusalem (Joh. Strauss); Waltz, Bad Haller Promenade (Dostal); Selection from I Pagliacci (Leoncavallo); Polka, Herzklopfen (Riedel); Xylophone Solo: Gallop, Geschwindigkeit ist keine Hexerei (Opel); Potpourri, Wiener Spaziergänger (Komzak); March, Linzer Buam (Drescher), 6.0, Talk, Illustrated with Gramophone Records, The Oases of Tripolis, 6.30, Topical Talk, 6.55, Today's Motto, 7.0, Topical Talk, 7.10, Time and News, 7.20 (from Graz), Report of the Austrian Swimming Championship, 7.55, Recital of Jazz Music on Two Pianos: Selections by Alois Höglberger and Alfred Schneider, 8.25, Der Ruf der Sterne—Radio Play (Fred Herffeld), after the Novel by Erich Dolezal, 10.0, News, 10.15, Report of the Austrian Swimming Championship, 10.20, Concert by the Vienna Symphony Orchestra, Conductor: Josef Holzer: March, Ta-ra-rum-dara (Komzak); Overture (Berté); Viennese Song, Beim Agnesbrunnen in Sierling (Mühlbacher); Waltz, Du meine Wonne, du mein Glück (Fehrbach); Russian Intermezzo, Tatjana (Jessel); Gavotte, Goldene Myrthe from Die Landstreicher (Ziehrer); Song from A Waltz Dream (O. Strauss); Song from Der Soldat der Marie (Acher); Short Lyric Rhapsody (Mann); Potpourri, Liebe, Lust und Leben (Ischepold); Quick Polka, Leichtes Blut (Joh. Strauss).

WARSAW

212.5 kc/s, 1,411 metres; 120 kW.—11.57 a.m., Time and Fanfare from the Tower of St. Mary's Church, Cracow, 12.5 p.m., Concert relayed from the Bagatela Café, 12.25, Polish Press Review, 12.33, Weather, 12.35, Concert (cont.), 12.55, Radio Journal, 1.0, Interval, 2.55, Gramophone Music, 3.5, News, 3.10, Announcements, 3.15, Gramophone Music, 3.25, Economic Notes, 3.35, Gramophone Music, 3.50, Military Notes, 4.0, Popular Concert by the Poznan Opera House Orchestra, conducted by Tyllia, relayed from Cielochocinek, 5.0, Topical Talk, 5.15, Recital on Two Pianos: Selections by Bukin and Walenty Nowicz; Silhouettes (Arenski); Valse triste and Popular Dance (Glière); Romance (Rubinstein-Wolkonski); Capriccio (Blumenfeld), 5.45, Programme for Invalids, relayed from Lwow, 788 kc/s, 381 metres, 6.0, Divine Service, relayed from the Ostra Brama, Wilno, 533 kc/s, 563 metres, 7.0, Talk, 7.20, Miscellaneous Items, 7.35, Programme Announcements, 7.40, Literary Talk, 8.0, Programme in Honour of the Anniversary of the Departure of Pilsudski's Polish Legion, 8.40, Choral Concert, 9.5, Radio Journal, 9.15, Agricultural Press Review, relayed from Wilno, 9.30, Chopin Pianoforte Recital by Flora Czarnocka: Sonata in B minor; Etudes in F minor, Op. 10, No. 9, and in G sharp minor, Op. 26, No. 6; Tarantella, 10.0, Dance Music, 10.25, Sports Notes, 10.35, Aviation Weather Report and Police Notes, 10.40, Dance Music. In the interval at 11.30, News for Members of the Polish Polar Expedition.

WILNO

533 kc/s, 563 metres; 16 kW.—6.0 p.m., Divine Service relayed from the Ostra Brama, 7.0, See Warsaw, 7.20, Weekly Review in Lithuanian, 7.35, Programme Announcements, 7.40, See Warsaw, 9.15, Agricultural Press Review, 9.25, See Warsaw, 12 Midnight (approx.), Close Down.

ZAGREB

977 kc/s, 307 metres; 0.75 kW.—8.10 p.m., Announcements, 8.30, Concert by the Radio Orchestra, Soloist: Wanda Zitherl (Mezzo Soprano), 10.30, News, 10.40, Dance Music, 11.30 (approx.), Close Down.

ZURICH.—See Schweizerischer Landessender.



SIT BACK COMFORTABLY!

You can arrange your own gramophone programme of any number of records up to eight and the Garrard Record-Changing Unit will play them through, automatically stopping as the last one is reached! Simply turn a knob and it will repeat or reject any record desired. It is supplied complete with Pick-up and Arm and affords the ideal opportunity of converting your set into a modern radiogram unit.

Price with Pick-up and Arm £10

THE

GARRARD

AUTOMATIC RECORD CHANGER

"Perfection in every type of Gramophone Motor."

GARRARD ENGINEERING AND MANUFACTURING CO. LTD.,
Swindon, Wilts. or 17, Grafton St., London, W.1.
Swindon 534 and 555 Royal 7956
12 Lines

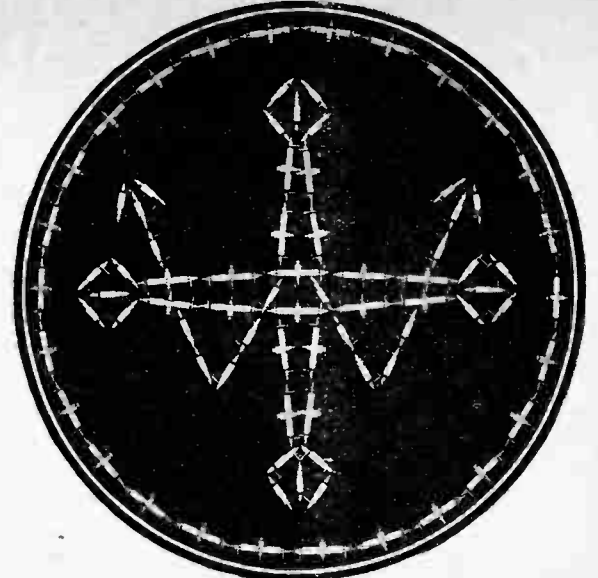

FIT THE WESTECTOR IN YOUR SET

and get pure detection with no distortion and consequently better quality. Its use also means a saving in current as the Westector contains neither anode nor filament. Write to-day for particulars of the new metal detector.

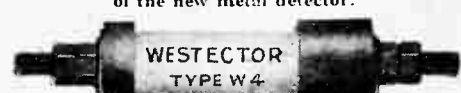

WESTECTOR
TYPE W4

HIGH-FREQUENCY
METAL DETECTOR

IT'S A WESTINGHOUSE PRODUCT!

THE WESTINGHOUSE BRAKE & SAXBY SIGNAL CO., LTD.,
82, YORK ROAD, KING'S CROSS, LONDON.

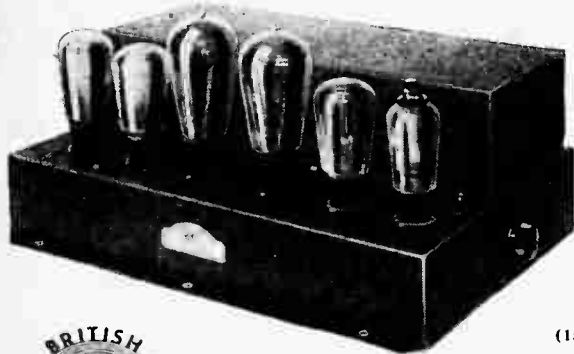

NEW
60 WATT
AMPLIFIER
(15 Watts U.D.O.)

BRITISH BSR THROUGHOUT

Power Amplifiers and P.A. Equipment

always give satisfaction. The following is an entirely unsolicited letter of appreciation—

"A Perfect and Unqualified Success"—

Dear Sirs,—

We have been approached by Wholesale Electric Supplies (Bolton), Ltd. to furnish you with a testimonial for the performance put up by your B.S.R. 1200 Amplifier used in connection with the Public Address and Music Reproducer now installed at the Blackburn Greyhound Racing Stadium by us. The equipment is driving 3 R.K.M.C. Speakers in the Members' Clubs and 8 on the ground itself, and last Saturday, the opening day, many experts were astounded at the perfect reproduction of speech and music, and the Company Directors expressed their entire satisfaction at what they described as a perfect and unqualified success.

Yours faithfully,
T. FRANCIS & SONS.

You need the best—you must have B.S.R.
BIRMINGHAM SOUND REPRODUCERS, LTD.,
CLAREMONT WORKS, OLD HILL, STAFFS.
 Phone: Cradley Heath 6370. Grams: Electronic Old Hill.

SCRUIT

MIDGET AND NORMAL CONNECTORS



The Mark of the finest made Electrical Wire Connector.

USE THEM TO-DAY to save Time, Temper and Money. Designed for Speed, Simplicity and Absolute Perfect Insulation.

Stocked by the Principal Wholesalers and Factors throughout the Country.

Made by:
V.G. MFG. CO., LTD.,
 Gorst Road, Park Royal
 LONDON, N.W.10.
 Willesden 1632.

FITTED WITH

'A TWIST OF THE WRIST'

SIMPLE • SAFE • SPEEDY

25 DUBILIER RESISTANCES

exclusively
specified
for the

Wireless World



New
Monodial
Super-Het



Chosen for dependability
Follow the designer's lead!

- 1 WATT TYPE 1/-
- 2 WATT TYPE 2/-
- 3 WATT TYPE 3/-

DUBILIER CONDENSER CO. (1925) LTD. VICTORIA RD. NORTH ACTON LONDON W3

The Journal
for the Owner-Driver

The Autocar

LEADER OF THE WORLD'S MOTORING PRESS
EVERY FRIDAY 4d.

●
"The Autocar" makes motoring
more enjoyable—and more
economical. It helps the motorist
in countless ways.

●
Regular features of outstanding value are

"The Autocar" Road Tests of New
and Used Cars—which give an unprejudiced
account of performance.

"The Autocar" Articles on Care
and Maintenance—which enable owners to
keep their cars in first-class condition, and so save money.

Articles on Touring at Home and
Abroad—which open up new aspects of pleasurable
travel and exploration.

In addition, "The Autocar" gives graphic accounts of
all sporting events; and news, comment, and corres-
pondence concerning important motoring affairs of
the moment.

A larger number of new and second-hand
cars are advertised for sale in "The Autocar"
than in any other medium

Subscriptions: Home
£1.6.10, Canada £1.3.10
other countries abroad
£1.15.6 per annum
post free.

ILIFFE & SONS LTD
London, S.E.1

