

The Wireless World

AND
RADIO REVIEW
(19th Year of Publication)

No. 640.

WEDNESDAY, DECEMBER 2ND, 1931.

VOL. XXIX. No. 23.

Editor: HUGH S. POCKOCK.

Assistant Editor: F. H. HAYNES.

Editorial Offices: 116-117, FLEET STREET, LONDON, E.C.4.

Editorial Telephone: City 9472 (5 lines).

Advertising and Publishing Offices: DORSET HOUSE, TUDOR STREET, LONDON, E.C.4.

Telephone: City 2816 (15 lines).

Telegrams: "Ethaworld, Fleet, London."

COVENTRY: Hertford St. BIRMINGHAM: Guildhall Bldgs., Navigation St.

MANCHESTER: 260, Deansgate.

GLASGOW: 101, St. Vincent St., C.2.

Telegrams: "Cyclist, Coventry."
Telephone: 8210 Coventry.

Telegrams: "Autopress, Birmingham."
Telephone: 2070 Midland (8 lines).

Telegrams: "Diffe, Manchester."
Telephone: 8970 City (4 lines).

Telegrams: "Diffe, Glasgow."
Telephone: Central 4857.

PUBLISHED WEEKLY.

ENTERED AS SECOND CLASS MATTER AT NEW YORK, N.Y.

Subscription Rates: Home, £1 1s. 8d.; Canada, £1 1s. 8d.; other countries abroad, £1 3s. 10d. per annum.

As many of the circuits and apparatus described in these pages are covered by patents, readers are advised, before making use of them, to satisfy themselves that they would not be infringing patents.

EDITORIAL COMMENT.

British Radio Christmas Gifts.

EACH year, as Christmas comes round, we are confronted to a greater or less extent, according to our obligations or means, with the problem of choosing gifts for presentation amongst our family and our friends. Circumstances this year have combined almost to decide for us that our Christmas gifts must be British, and we would like to feel that, so far as readers of *The Wireless World* are concerned, this restriction on the choice of gifts is narrowed still farther by a decision that, wherever wireless can fit in as a gift, it should be chosen in preference to other alternatives. Wireless has a universal appeal, and there seems to be no limit to the choice of wireless articles from which a selection can be made to provide gifts from the most expensive down to those which require the outlay only of a very modest sum. Wireless, too, as a gift has the added attraction that the pleasure which it gives is more or less permanent; a receiver assists in providing enjoyment all the year round, and we doubt whether any other present can be regarded as providing such a perpetual reminder of the giver.

Another feature of a wireless gift, especially if it is in the form of a complete set, a mains unit, or some other valuable accessory, is that a present of this kind can be unhesitatingly given as a joint present to a family, and will give far more pleasure to every member of the household than would result from splitting up the funds available amongst a number of smaller and unimportant gifts.

Elsewhere in this issue suggestions are given on the choice of Christmas gifts, which we hope may assist our readers in making their selections, and will also be a reminder of the variety of choice which exists at prices to suit every pocket.

The Valve Supplement.

THE special Valve Supplement presented with this issue is an annual feature of *The Wireless World* which has been widely appreciated for many years. It is the only reference sheet of its kind which gives information on all types of valves and provides the fullest available data to guide the user, both in his selection of valves for any particular purpose, and in ensuring that they are used under the best operating conditions.

The sheet contains some 450 valves, classified under headings, with some 200 output and pentode valves with which a column is provided giving the A.C. undistorted output of the valve, as has been done in the past two years. The process of calculating these figures is laborious, but we believe it is essential to the designer of a receiver to have this information. Unfortunately, agreement has not yet been reached between the various valve manufacturers on a standardised method of measurement to obtain the figure for undistorted output. Now that the importance of this information has been established, and *The Wireless World Data Sheet* has included these figures for three successive years, we hope that manufacturers will no longer delay in reaching agreement.

Readers are no doubt aware that manufacturers of screen-grid valves invariably indicate to-day in their literature what is the inter-electrode capacity; and, in fact, this figure is to-day recognised as a criterion of the goodness of a screen-grid valve. These figures giving inter-electrode capacities of screen-grid valves were also included in *The Wireless World Valve Data Sheet* a long while prior to agreement being reached between valve manufacturers as to the importance of supplying such information themselves.

Give Radio

This Year

Accessories for the Broadcast Listener.

THE time-honoured custom of giving presents at Christmas is one which few of us would like to see abolished. It affords an excellent opportunity of giving expression to sentiments of goodwill which it would be difficult to convey in any other way.

Yet in the period immediately preceding Christmas the average Englishman generally permits himself a minor grouse on the subject of Christmas presents in general. This does not arise from any Scrooge-like attitude towards what is admittedly a most happy convention, but is prompted by the difficulty of deciding just what to give in each individual case.

Then why not give a "wireless" present this year? In these days everyone is interested, directly or indirectly, in the reception of broadcasting, and the products of the radio industry afford an unusually wide range of choice both as regards variety and price. From a grid leak holder at 6d. to a radio-gramophone at 80 guineas or more there is an unbroken sequence of useful and attractive articles to suit every pocket. Price is, of course, an important factor, and to assist readers who already have in mind a definite figure, a classified list of

Components for the Home Constructor.

suggestions between various price limits is given on the next page.

Taking first the case of complete sets, there is now no reason why these should be ruled out on account of cost. The majority of people to whom the gift of a receiver would be acceptable would be quite content to receive the alternative B.B.C. programmes, with an occasional foreigner under favourable conditions, and there are plenty of two-valve receiving sets, complete with valves, batteries, and loud speakers, which can be bought for £5 or less. The "1932 Super Two" at 4 guineas, made by Hustler Simpson and Webb, Ltd., the Brownie "Baby Grand" at £3 15s. (less batteries), and the K.B. "Pup" at £5 3s. 9d. complete, are representative of this class, which is specially suitable for friends living in the country. If slightly more power is required the Burton "Empire Speaker Three" at £7 15s., including valves, will fill the bill, while if electric supply mains are available sets such as the Regentone 2-valve A.C. receiver at £6 15s., or the Climax "Three," with moving-coil loud-speaker at 9 guineas, will naturally have preference on account of low maintenance costs. There is always the possibility, of course, of making the presentation of

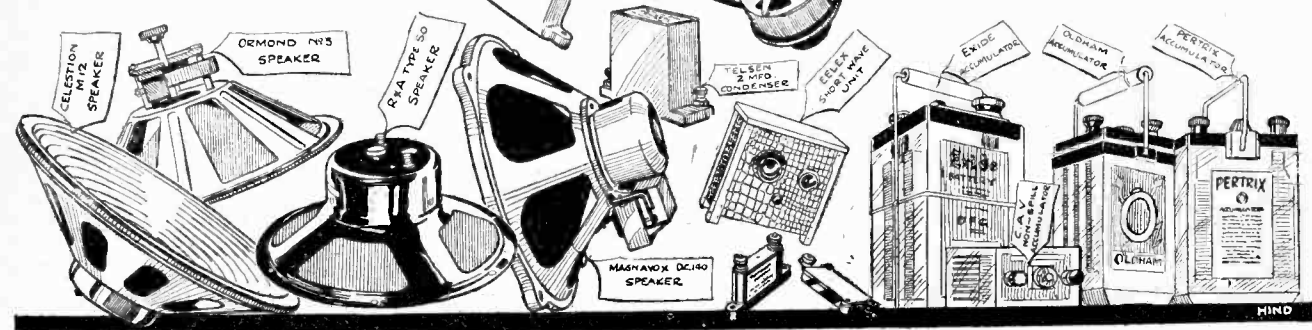

Give Radio This Year.—

a receiver a joint family affair, and in this case it may be well to consider one of the many long-range three-valve mains sets, costing about £20, or even a pedestal radio-gramophone, of which several examples are to be found in the region of £30 to £40.

For those already in possession of a receiving set there is ample scope among components which may be regarded as accessories to the receiver proper. The owner of a battery set will appreciate a spare accumulator for use while the other is being charged, while if his house has been connected recently to the supply mains the gift of an eliminator will considerably reduce his maintenance costs. It will be necessary to find out the number and voltage of the existing H.T.appings, but there will be no difficulty in finding an instrument to fit any given set of conditions from the wide range of models made by such firms as E. K. Cole, Ltd., Tannoy Products, H. Clarke and Co. (M/c), Ltd., Regentone, Ltd., Radio Instruments, Ltd., and the Formo Company. The price of an eliminator of this type would be from £2 to £5. For those with a flair for home construction there are also complete kits of parts made by firms such as Ferranti, Ltd., and F. C. Healyberd and Co.

We know that many of our friends are not getting the best enjoyment from their sets because their loud speaker is of obsolete design. Provided the set has a power output of, say, 400 milliwatts or more, a small permanent-magnet moving-coil unit costing between £2 and £3 will reveal qualities of tone which have hitherto passed unnoticed. In recent months the sensitivity of permanent-magnet moving coils of this type has been enormously improved, and units such as the Epoch A2, R. and A. type 100, Whiteley W.B.3, Ediswan Minor R.K., Magnavox, and Rola can be

recommended with confidence. Even in the case of low-powered battery sets a marked improvement in performance both from the point of view of volume and quality is certain to result from the substitution of a thoroughly up-to-date moving-iron unit such as the Celestion M.12 for a loud speaker of earlier design. That the cost of replacement need not necessarily be high is proved by the existence of such modern units as the R. and A. types 40 and 50 at 16s. 6d. and the Ormond No. 3 unit and chassis at 15s.

If it is desired to give something out of the ordinary, the Baker Selhurst "Klock" is well worth consideration. The cabinet of this loud speaker incorporates a synchronous electric clock, and the complete unit sells for £12.

While on the subject of loud speakers, two useful accessories, the Harlie Tone Selector and the Ready Radio "Instamat" transformer are worth noting. Both these units are easily connected between the loud speaker and the set. The tone selector gives a wide range of control of quality, particularly in the upper register, while the "Instamat" transformer, with its instantaneously variable ratio, ensures not only that maximum power is transferred to the loud speaker, but also provides some measure of control over quality of reproduction.

The recent announcement of the proposed new Empire broadcasting station has redirected attention to short-wave converter units suitable for connection to any existing receiver. To the short-wave enthusiast, either in the home country or abroad, a unit of this type would make a most acceptable present. The Magnum (Burne-Jones) at £3 15s. is a good example of this class of instrument and is suitable for battery-operated sets. It has a tuning range of 20 to 80 metres, and is connected to the detector stage of the existing

A Few Suggestions

Less than 5/-

Valve holders. Fixed resistances. By-pass and fixed mica condensers. Set of terminals. H.F. chokes. Grid leaks. L.T. "on-off" switch. Dial or turntable lamp. Set of crocodile clips. Polarity tester. Set of wander plugs. Acid hydrometer.

5/- to 10/-

Spare two-volt accumulator. L.S. tone selector. Pocket voltmeter. Thermal delay switch. Intervalve transformer. L.F. choke. Volume control rheostat. Slow-motion condenser dial. Midget variable condenser.

10/- to £1

Moving-iron loud speaker unit. Metal rectifier unit. Intervalve transformer. Spare valve. Screened band-pass coils. L.S. cabinet.

£1 to £5

Battery eliminator. Two-valve battery set. P.M. moving-coil unit. Short-wave converter. Gramophone pick-up. Electric gramophone motor. Home recorder. High-grade milliammeter. Raycraft kit. Gang condenser. Console cabinet.

£5 to £10

Two-valve mains set. Universal test meter. Constructor's kit of parts.

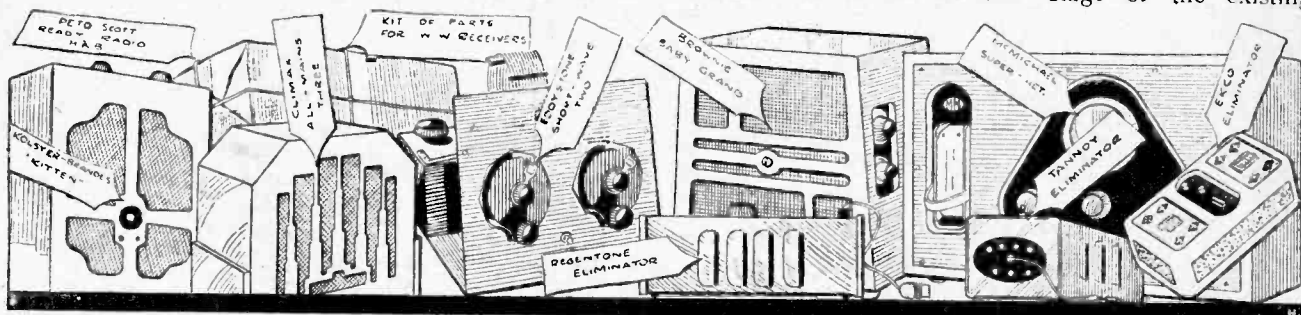

Give Radio This Year.—

receiver. Another notable example is the Ealex converter, which is made also for all-mains operation.

If it is desired to construct a complete short-wave receiver, kits of parts are available from Stratton and Co. of Birmingham. A complete receiver of robust construction specially designed for use in the tropics is to be found in the McMichael "Supersonic Four," which is housed in a teak cabinet and costs £15.

Gramophone reproduction is a side-line to broadcast reception which gives ample scope in the choice of useful presents. A gramophone pick-up and tone arm such as the Limit, Harlie, or B.T.H. Minor can be bought for 30s. or £2. If it is known that an acoustic gramophone is already in existence, a pick-up attachment such as the Igranic Phonovox or the H.M.V. No. 11 will be more suitable.

Another suggestion is an electric motor such as the B.T.H. or Macom for converting an existing clock-work-driven turntable, or, better still, a complete playing desk, such as the H.M.V., which includes a pick-up and volume control.

Materials for Home Construction.

So much for complete receivers and accessories. When we turn to the requirements of the home constructor an even wider scope is available. What could be more acceptable than a complete kit of parts for a *Wireless World* receiver as retailed by the Peto Scott, Ready Radio and the H. and B. Radio companies? When it comes to the choice of individual components, however, it is necessary to proceed with caution. The knowledgeable experimenter generally has very strong preferences where such components as gang condensers, interval transformers, and valves are concerned, and if it is desirable to give components of this type, his requirements should be consulted beforehand.

There are many parts, however, which find a place in almost every type of set. Decoupling resistances of 20,000 ohms, for instance, are continually in demand, while 2-mfd. by-pass condensers are equally useful. Another suggestion is a small selection of fixed mica condensers of the postage-stamp variety as made by T.C.C., Dubilier, and Graham Farish. It will be fairly safe to include the following values: 0.0001, 0.0003, 0.0005, and 0.001 mfd. Valve holders, again, are in constant demand, and 4- and 5-pin types are available from firms such as Benjamin, Clix, Telsen, and Wearite at 1s. 6d. and 1s. 9d. respectively. A set of terminals such as the Clix Constructor's Kit at 3s. or a box of crocodile clips would also soon

find themselves put to good use.

These are but a few of the more obvious suggestions. The reader will find inspiration for innumerable presents of reasonable cost in the very comprehensive catalogue of A. F. Bulgin and Co., Ltd. It is difficult to choose examples from so varied a list, but mention might be made of the thermal delay switch, at 7s. 6d., which affords protection to the smoothing condensers in A.C. sets using indirectly heated valves.

Meters for the Experimenter.

The serious experimenter is constantly in need of measuring instruments, and a universal testing meter such as the Avometer would probably please him more than any other gift. This instrument, which is capable of measuring not only voltage and current but also resistance, has no less than thirteen ranges, and is certain to be put to almost continuous use.

In these days of band-pass circuits a meter in the anode circuit of the detector is extremely useful in securing accurate alignment of the circuits. Panel-mounting meters such as those made by the Ferranti, Weston, and Park Royal companies are well adapted for this purpose. For ordinary leaky-grid detection a range of 0/5 mA. will be suitable, and, in the case of power-grid detection, 0/10 mA. For the owner of a battery-operated set the pocket-type meter such as the Wates or Pifco "All-in-One" meter will provide definite proof of the condition of both the H.T. and L.T. batteries.

Your true experimenter is an untidy fellow, but the gift of a cabinet may tempt him to make his base-board layout a little more compact and presentable. The cabinet should, if possible, be of the console type with plenty of room inside for modifications and extensions.

Christmas Entertainments.

So far we have dealt with accessories and components of exclusive interest to the wireless enthusiast, but it should not be forgotten that there are many devices which have a wider appeal and are of special interest during the festive season. The Raycraft, for instance, gives ample scope for experiments in which everyone can participate, while microphones such as the Harlie and Adolf can be used to convert the wireless set into a miniature public-address system. Finally, the many excellent home-recording outfits, such as the Ekco, Kingstophone, and Cairmor, are a never-ending source of enjoyment, as well as a means of providing a permanent record of Christmas gatherings.

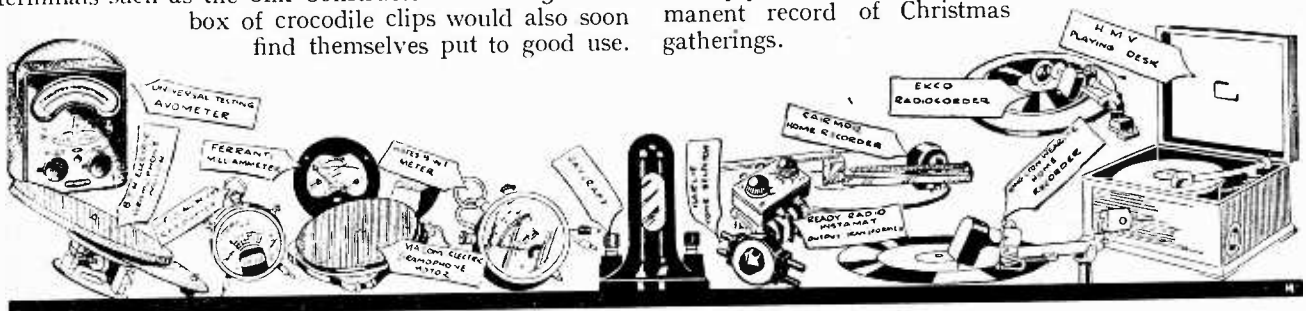

POWER GRID and LEAKY GRID

- A Comparison

How the Two Methods of Detection Differ in Principle.

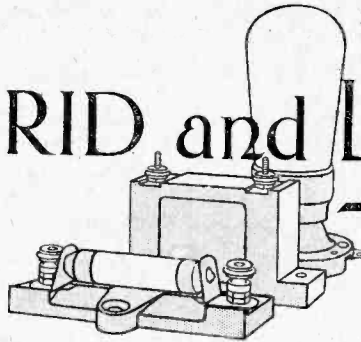

By W. I. G. PAGE, B.Sc.

EARLY last year considerable attention was focused on a new and distortionless type of detection which came to be known as "Power Grid Detection." Since then a large number of mains receivers have been described with this new circuit which has undoubtedly helped in the attainment of a general improvement of the quality of reproduction. There are, however, instances where power grid detection is claimed just because a 0.0001 mfd. grid condenser and a 0.25 or 0.5 megohm grid leak is used before the detector valve without any attention being paid to the value of voltage actually applied to the anode terminal of the valve and perhaps, which is more important, to the strength of the signal at the detector grid.

denser and leak as in Fig. 1 (b) so that the grid current is diverted by the condenser through the one-megohm resistance. The opposition of one million ohms will reduce the fifty microamperes very considerably, but if only one microampere can pass, it will set up according to Ohms Law a difference of potential of one volt across the leak, which will bias the grid *negatively* to that amount. Although the tuned circuit is still returned direct to the cathode, there is now a steady negative bias on the grid.

Finding the Bias Point

Quite a simple method exists of finding the exact bias produced by any value of leak with any grid detector

A circuit can be designed to conform to the principles of power grid detection and meticulous care both as to the value of grid and anode components can be taken, but if the signal voltage is very low, due either to lack of H.F. amplification or to poor pick-up in the aerial, leaky grid rectification with all its disadvantages will result. To make the matter clearer, let us examine some simple diagrams. In Fig. 1 (a) a tuned circuit is joined across grid and cathode of an indirectly heated valve of the AC/HL type. The cathode is said to be a point of zero potential, and as the grid is returned to it, the grid potential or grid bias will also be zero.

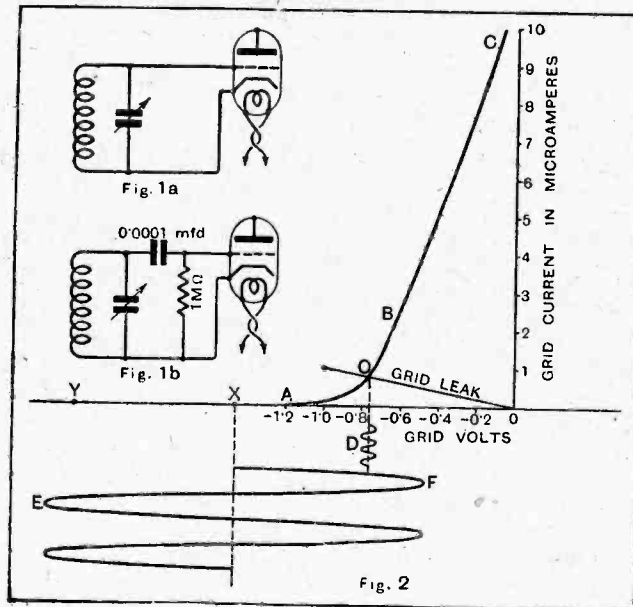

Fig. 1.—(a) Simple tuned circuit connected to the input of an indirectly heated valve: although grid current will flow through the coil, the grid bias will be zero. Fig. 1.—(b) Interposing a grid leak and condenser causes the valve to be biased negatively before any signal is applied. Fig. 2.—The operating point is given by finding where the grid leak load line cuts the grid current curve. The application of large and small signals is illustrated.

valve, provided that the grid current curve can be obtained from the manufacturers; happily most makers can be relied on to help us in this respect. A typical grid current curve for an A.C. valve is given as ABC in Fig. 2. There is a sharp bend at the lower extremity, and the upper portion BC is almost straight. Now a megohm resistance allows one microampere to flow if one volt is applied across its ends (or two microamperes to flow if two volts are applied), and to represent a grid leak of this value on our diagram we must join the point of zero potential (the cathode connection of the leak) with a point giving one microampere of grid current at one volt of grid potential.

It so happens that with practically all indirectly heated valves grid current flows round the grid circuit at zero grid potential, and in this case about fifty microamperes will pass through the tuning coil, the D.C. resistance of which is so low that no appreciable voltage will be developed across it. Now interpose a grid con-

This has been done in the illustration, and where the line, or load-line, as it is called, cuts the grid current curve at O is the operating point before the signal arrives or under "pre-signal" condition. It will be seen that the valve is now biased negatively at about 0.8 volt. Had the grid leak a

Power Grid and Leaky Grid.

resistance of half a megohm the load line would have started as before at zero potential, but have been joined to a point representing two microamperes and one grid volt intersecting the grid current curve nearer to B, where the curvature is less and the bias slightly reduced.

Suppose, now, that a very small signal D of a fraction of a volt is applied to the detector. Since the operating point happens to fall at the sharpest part of the bend in the curve, the action is just the same as that of an anode bend rectifier. The increase of grid current due to the positive (right-hand) half cycles of the wave will be greater than the decrease due to the negative half cycles, and the net result is a rise in grid current which will flow through the grid leak. This will still further increase the negative bias, and the operating point will be shifted a little to the left of O to, say, about 0.85 grid volts. If the fringe of the H.F. wave had been modulated, then the sympathetic changes in grid current would affect the mean grid potential just in the same way as an alteration in amplitude of the H.F. input.

The foregoing briefly describes the process of leaky grid detection of weak signals so popular in battery sets. It will now be appreciated that the shape of the grid current curve and the choice of the pre-signal operating point by employing the correct value of leak are all-important. To emphasise this point, the grid current curve of a typical two-volt battery valve is given in Fig. 3; grid current in this case flows almost entirely on the positive side of zero grid volts, and if we assume the use of a one-megohm leak as before, but with its low-potential end connected to the slider of a potentiometer shunted across the two-volt L.T. battery, we can draw a number of load lines. Each of them, of course, will be parallel, as the value of the leak does not change. They represent the different position of the slider, or, which is the same thing, the low-potential end of the leak.

Those who have used such an arrangement will know that as the slider is moved to zero grid volts (the negative terminal of the L.T. battery), signals get weaker, for the curve here is almost horizontal, and both positive and negative half cycles hardly cause any change in grid current, and rectification is negligible. If, however, the potentiometer control is moved in the other direction up to the extreme of plus two volts, the load line will cut the grid current curve and give a pre-signal operating point first at Y and then at Z, and somewhere about this region the curvature will be

greatest, and the rectification (and therefore the signal strength) at a maximum. The same effect could be got by varying the angle of the load line from a fixed point, say, at plus one volt, and in theory this might be a somewhat better plan, but variable grid leaks of high value are none too satisfactory in practice.

Distortion with Leaky Grid Detection.

When the rectification takes place wholly on the curved portion of a grid current characteristic, as must perforce occur with weak signals, the effect is to exaggerate badly the more deeply modulated passages, to introduce harmonics which were not present in the original music and to cause distortion which can be quite audible. Such rectification is called "square law," and the figure for second harmonic distortion is given by dividing the percentage modulation by four; thus, for 80 per cent. modulation the distortion will be 20 per cent.—rather a high figure. Further details and practical measurements of detector distortion can be obtained from a book recently published by Messrs. Ferranti.¹

Up to the present we have considered the process of pure rectification only. The signal is applied to the grid circuit, where it is rectified on the grid current characteristic, and the L.F. pulses representing the modulation are then free to be amplified in the ordinary way between grid and anode of the valve. The H.F. component, however, does not disappear in the detection process, and the fact that we can feed back H.F. energy from the anode to give reaction effects is evidence that its suppression is not complete at the grid.

Although the leaky grid detector designed to accept small signals is by no means distortionless, its use will probably continue in battery sets where anode current is restricted. It is sensitive to weak signals and provides a simple and effective means of introducing reaction, whereas the anode bend detector cannot claim either of these advantages. In the next instalment the principles of the power grid rectifier will be discussed and data given for the design of a linear detector stage. (To be concluded.)

¹ See "The True Road to Radio," by A. Hall.

THERE appears to be some confusion regarding the difference between power grid and leaky grid detection. With strong signals the action of the grid detector differs considerably from that with weak signals, and a simple explanation of the underlying principles of each type of rectification is given. The category to which the grid detection in any receiver belongs is governed as much by the strength of the signal as by the circuit arrangement used. In a subsequent instalment practical data will be given which should assist in the choice of suitable components and voltage values to obtain distortionless detection.

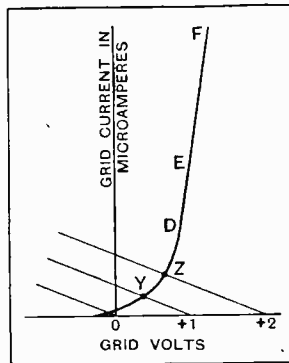

Fig. 3.—When the grid leak is attached to the slider of a potentiometer the operating point can be changed until the greatest curvature is met. The case of a 2-volt battery valve is given.

YOU CAN INSURE YOURSELF against wireless trouble by securing a "Wireless World" Diary. It includes a Technical Section full of useful hints and formulae which you may need at a moment's notice. The price is 1s. 6d., or 1s. 7d. post free, from the publishers, Iliffe and Sons Ltd., Dorset House, Tudor Street, E.C.4.

How to Use the

Notes on the Choice of New Valves.

THE *Wireless World* annual valve data sheet that is now well known to readers needs but little introduction. The valves are classified into five main headings as before, and it only remains to give consideration to them *seriatim*.

Screen-grid Valves.—In choosing an S.G. valve it should be remembered that the modern screened coupling coil with a diameter of perhaps $1\frac{1}{4}$ inches has such a low dynamic resistance that stage gain calculations, hitherto somewhat involved, are now susceptible to the very simplest of treatment. When the load in the anode circuit is considerably less than the A.C. resistance of the valve, the stage gain is given by $R \times g$ where R is the effective dynamic resistance of the anode coil, and g the mutual conductance of the valve in amperes per volt. The stage gain, for instance, with a typical untapped and screened tuned anode coil of 60,000 ohms dynamic resistance using a Marconi or Osram S.22 valve would be $60,000 \times 1.75 \times 1/1,000 = 105$. For a given coil the greatest signal strength will therefore be obtained where the figure in the mutual conductance column is highest, always remembering in a well-screened receiver that the stability will depend upon a low interelectrode capacity, figures for which are shown alongside mutual conductance. Cross-modulation accounting for apparent lack of selectivity is generally more serious the higher the A.C. resistance and mutual conductance of the valve; it may therefore be expedient to choose a screened valve of medium conductance to ensure a satisfactory compromise between selectivity and stage gain. For two H.F. sets the new variable-mu valves described at length in recent issues should be carefully considered.

Miscellaneous Valves.—From this section, comprising triodes with A.C. resistances greater than 7,000 ohms will be chosen leaky grid and power grid detectors, also early L.F. amplifiers where more than one valve is used after the detector. For power grid detection in A.C. sets, indirectly heated valves having A.C. resistances

between about 8,000 and 17,000 ohms should be selected. The higher the amplification factor in association with a high mutual conductance, the greater the L.F. output of the detector for signals of medium strength. For large H.F. inputs the A.C. resistance must be low—of the order of 7,000 to 11,000 ohms. The average anode current column will be found useful for calculating voltage-dropping and self-bias resistances when deriving current from the mains. It should be noted that grid bias values are quoted for L.F. amplifying conditions, and do not refer to detection.

Output Valves.—A new column, giving sensitivity in undistorted milliwatts output per volt (R.M.S.), squared input is included this year and provides a useful comparison of performance between valves of about the same power output. When two valves have the same undistorted output, that with the highest sensitivity will be the most efficient and will require the least prior amplification and grid swing. The reason that the input voltage is squared is due to the fact that output power is proportional to the square of the input voltage; thus, if the input is doubled, the power output is increased four times. That tremendous strides have been made in the efficiency of output valves will be appreciated when it is realised that about two years ago a typical sensitivity figure was 1.0 or 1.5, while we now see no less than 51 against one of the indirectly heated valves. The load figures represent the impedance in ohms that should be offered at about 256

cycles by the loud speaker, which should be matched, if necessary, by a transformer having the following ratio:

$$\sqrt{\frac{\text{Required load.}}{\text{Speaker impedance.}}}$$

In selecting an output valve, first decide from column D the undistorted power required for the size of the room concerned, choose a high sensitivity figure, artificially adjust the speaker load, if it does not happen to be

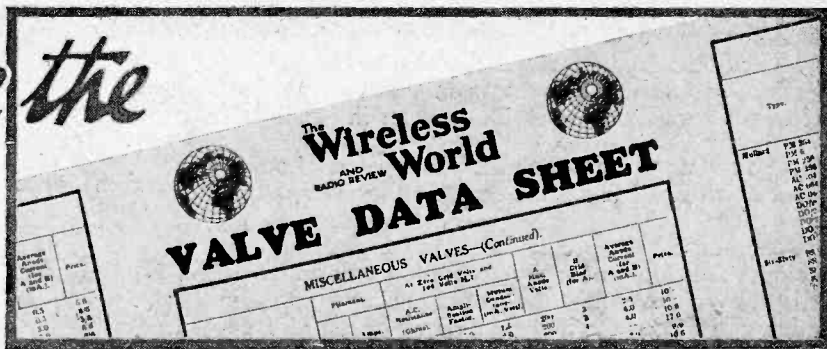

NOWHERE is a guide more necessary than in the radio valve market, which now offers nearly 450 specimens from which the amateur can make a good, bad or indifferent choice, depending upon the particular purpose for which his valves are required. The supplementary valve data sheet accompanying this issue simplifies the problem by classifying practically all available receiving valves so as to facilitate quick reference and by supplying the comprehensive data necessary if the right choice is to be made. The chart includes more than 100 new valves which have made their appearance this season. A valuable new feature in the output and pentode valves section is the column giving the sensitivity in terms of milliwatts per volt² (R.M.S.) input. There is also additional data in the rectifying valve class which should assist in designing accurately the mains equipment in an A.C. receiver.

How to Use the "Wireless World" Valve Data Sheet.—

correct, to approximately the figure in column G, and, if deriving current from the mains, divide the bias volts in column B by the anode current (in amperes) in column C to obtain the value of the self-bias resistor in ohms.

Pentode Valves.—The considerations when choosing a pentode are very much the same as those for output valves. The matching of the speaker is more critical, however, and steps must be taken to see that the load of column G is imposed fairly accurately. Fortunately, this is not very difficult if the output choke is tapped in a number of places and a compensating circuit of capacity and resistance, so often advocated in this journal, is arranged across the output. The increase in the number of pentodes this year reflects their well-earned popularity, and the sensitivity figures, which, on the average, are considerably above those of all other output valves, explain their superiority. In calculating self-bias resistances, it is important to divide the bias required (column B) by the combined anode and screen currents (columns C and F). With pentodes the distortion due to the third harmonic is generally greater than the second, and undistorted output figures have been worked out for a maximum of 5 per cent. of the former. Amplification factors and A.C. resistances have been omitted, as they provide no useful meaning under working conditions. The extraordinarily high efficiency of some of the new pentodes will be appreciated when the sensitivity column is examined. Reference is made to the Marconi and Osram PT2, the Mazda Pen.220, and all the indirectly heated types.

Rectifying Valves.—It is hoped that the new column added to this section will assist in choosing the most suitable rectifier for an A.C. mains set. Data is given for the unsmoothed D.C. volts developed across a 4-mfd. condenser with both maximum and half-maximum D.C. load in milliamperes. From these two figures a rough regulation curve can be drawn, which is sufficiently accurate to give intermediate values corresponding to the load of almost any receiver. Suppose that a set is built requiring a total of 60 mA., and that the initial D.C. volts required before the first smoothing choke is 380; which valve should be selected? As the voltage is high and the current low, the half-current column should be examined, when it will be seen that type B valve will give the required output if the R.M.S. input is 350.v.-0-350.v. Attention should be drawn to types A, B, and C now available with standardised ratings. The indirectly heated type of rectifier, the emission of which is delayed until after that of the A.C. valves in the receiver, merit consideration, as by their use the various smoothing and by-pass condensers are safeguarded from a high voltage when switching on. For very large rectified outputs a hot cathode mercury-vapour valve is available

Next Week's Set Review :

**KOLSTER BRANDES
THREE VALVE A.C. RECEIVER**

HALF-METRE TELEPHONY.

IN an official demonstration before representatives of the Italian Government, Marchese Marconi has now shown that his new quasi-optical fifty centimetre-wave radio telephone system can easily exceed the range of eleven miles covered in an earlier test carried out between Santa Margherita Ligure and Sestri Levante.

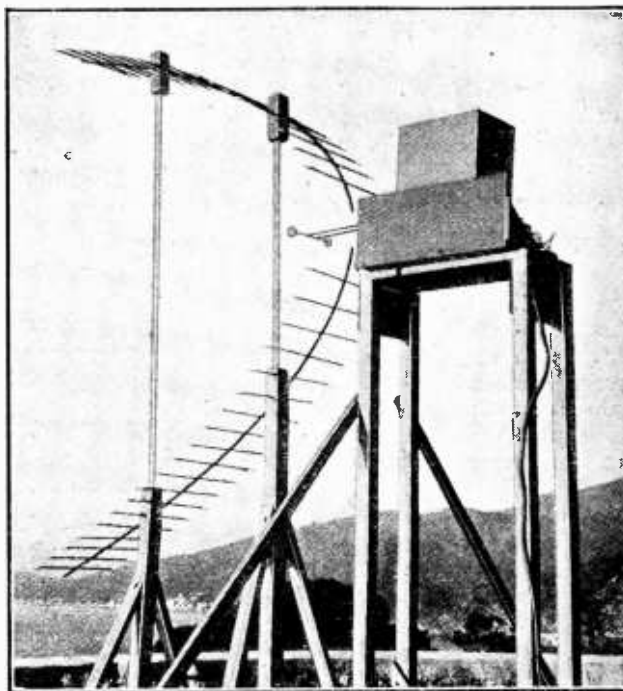

MARCONI'S HALF-METRE AERIAL. Marchese Marconi and his assistants are participating in the new trend towards the development of ultra-short wave telephony by direct ray over short distances. The photograph shows a short rod aerial and semi-circular reflector used for reception in the latest demonstration of 50-centimetre telephony in Italy.

On November 20th telephony from the former point was successfully received at Levanti—twenty-five miles distant—with an ample margin of strength. It is stated that the power used was only a few watts.

Special interest attaches to these tests on account of the somewhat similar experiments conducted by the International Telephone and Telegraph Laboratories in March last, when telephony on an 18-centimetre wavelength was exchanged over the twenty-one miles between Dover and Calais, using paraboloidal reflectors.

In an interview after his latest demonstration, Marchese Marconi said that, far from being a mere scientific experiment, the new invention must be regarded as a practical and commercial system which will shortly be used for public services in Italy, particularly for communication between the scattered Mediterranean islands which do not enjoy a reliable telephone service owing to the high cost of submarine cables. Marchese Marconi added: "At the present stage of our knowledge I do not anticipate a reliable range of more than about 100 miles; but this is a very useful range and could, of course, be greatly increased by making use of relays and repeaters."

Current Topics.

NON-STOP FLIGHT POSTPONED.

Squadron-Leader Gayford's projected non-stop flight from England to Capetown, referred to in our issue of November 11th, has been postponed. The original intention was to start on November 22nd, but the Air Ministry informs us that special tests with the long-range monoplane have necessitated the delay. The start will probably be made on or about December 22nd. The plane carries a short-wave transmitter operating on 33.71 metres (8,900 kc.), with the call-sign GEZAA.

o o o o

THE RADIO PARIS "MYSTERY."

Very conflicting reports are being given concerning the reception of the new Radio Paris, both in France and in this country. In some districts, notably on the south coast of England, the signals are formidable enough, while in areas quite close to the transmitter listeners are expressing strong dissatisfaction with the alleged "weakness" of the transmission.

Some of the mystery is cleared up by an announcement by the management that the station is still "working up" to its normal power of 120 kilowatts. Day by day the power is being gradually increased, but the engineers decline to name the date on which the maximum power will be reached. The truth seems to be that the station is still testing.

o o o o

REGIONAL SCHEME FOR HOLLAND?

A plan to provide Holland with two powerful regional stations has been suggested by the Dutch Finance Minister, representing the Government's attitude in face of the growing discontent among listeners in Holland over the chaotic conditions of broadcasting in that country.

The existing stations are run by political and religious associations.

o o o o

BATTLE FOR SPONSORED PROGRAMMES.

A big struggle is developing in Belgium over the Government decree forbidding the broadcasting of advertisements by private stations. Over 30,000 signatures have been obtained for a pro-advertisement petition organised by Radio Chatilineau, and signatures are being collected by Radio Schaerbeek, Radio Conference, and Radio Cointes (Liège). A mass meeting of protest is to be held in Brussels on December 13th.

o o o o

TRUTH ABOUT RADIO LUXEMBOURG?

The 200 kW. "publicity" broadcasting station now under construction at Luxembourg is already creating considerable distrust, not to say alarm, in the surrounding districts. The French Press has been particularly aggressive in the last few weeks, contending that the new transmitter will create a wipe-out area in which listeners will hear nothing but advertisements.

It has been left to a local radio club, however, to wrest from the owners a declaration that advertisements will not absorb more than "five minutes per broadcasting hour."

The station is expected to begin its tests on the short waveband on or about July 15th, 1932

B 33

VATICAN OPENS PUBLIC RADIO SERVICE.

"The man in the street" may now use the Vatican short-wave station for his private messages. The station was originally intended solely for communication with priests and Catholic missionaries in various parts of the world.

o o o o

A FRANK ADMISSION.

Commenting on the effect of sunspots on radio reception, the "Indian Radio Times" says:—

"We are afraid we shall be unable to prevent the formation of sunspots, so that for the time being we shall probably have to put up with fading."

o o o o

INVALIDS' HOUR AT TURIN.

The newest arrival on the staff of the Turin broadcasting station is a physician whose task it is to collect listeners' symptoms, make a correct diagnosis, and prescribe treatment over the microphone. We understand that the service is highly popular, not only with the patients themselves, but with listeners who grow bored with the ordinary programmes.



A CZECHO-SLOVAKIAN "W. A. C." OK IAW, which has "worked all continents," is owned and operated by Mr. Weirauch, at Mestec Kralove. Two transmitters are used, a C.O.F.D. and a push-pull T-P-T-G. using 30 watts input on 3.5, 7, 14, 28 and 56 MC. Mr. Weirauch has been in communication with 53 different countries, and therefore has thoroughly justified his country's prefix!

PORTUGAL'S BROADCASTING COMPETITION.

Prizes are to be offered by the Portuguese Post Office, for designs for a new broadcasting station operating on a wavelength of 456 metres. The studio will be situated in Lisbon, and the transmitter at Barcarena.

o o o o

AMERICA AND THE ULTRA-SHORTS.

That harassed body, the American Federal Radio Commission, is rubbing its eyes over a request from the International Communications Laboratory, Hillsborough, N.J., for permission to erect two transmitters operating on wavelengths between 1 and 3 cms. The company is a branch of the International Telegraph and Telephones Company, which early this year conducted telephony tests on 18 cms. across the English Channel. Such wavelengths have, apparently, never been heard of by the F.R.C.

o o o o

"SMALL ADS." AT CHRISTMAS.

With the approach of the Christmas holidays certain alterations become necessary in our printing programme. Miscellaneous advertisements intended for *The Wireless World* of December 23rd can be accepted up to the first post on Wednesday, December 16th.

o o o o

TAKING PORTABLES TO FRANCE.

Ambiguity in a French official notice has given a widespread impression that tourists' portable wireless sets are now to be admitted to the country without the payment of a deposit. The correct interpretation of the new order is that, while a small fee is chargeable at the Customs Offices when the tourist arrives, it is returnable on his departure; in addition, however, he must now immediately register the set at the post office nearest to the locality in which it is to be used. Thus the tourist, far from obtaining any concession, is saddled with a new responsibility!

o o o o

DISPATCH RIDERS' REUNION.

A reunion of R.E. Dispatch Riders is to be held on January 9th next at the Wharnecliffe Rooms, Hotel Great Central, London. Applications for further information and tickets should be made to Mr. Ernest R. Gilbert, 14, Holborn, London, E.C.1.

o o o o

EMPIRE BROADCASTING. FROM AUSTRALIA.

The times of transmission from the Sydney (2ME) station of Amalgamated Wireless (Australasia), Ltd., the Australian National Empire Broadcasting Station, which takes place every Sunday on a wavelength of 31.28 metres, were rearranged on November 29th to compensate for the change in reception conditions as the season advances. Programmes are now sent every Sunday between 14.30 and 16.30 for the benefit of Great Britain, Western Europe, British East African possessions, South Africa, Egypt, and other African countries.

The A.W.A. Melbourne (3ME) Centre continues to radiate Australian programmes for listeners abroad every Wednesday and Saturday on Sydney's wavelength between 10.00 and 11.30 G.M.T.

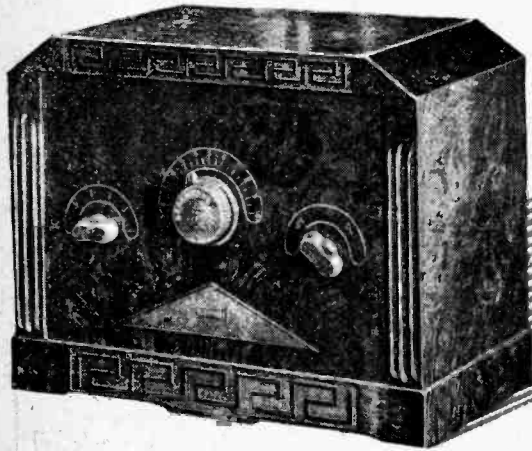

REGENTONE

TWO VALVE ALL ELECTRIC

A Compact and Inexpensive A.C. Mains Set.

FOR simplicity and freedom from trouble it is still hard to beat a detector-L.F. set, which has been popular since the earliest days of broadcasting, and bids fair to remain so. Such sets, provided they are carefully designed and well constructed, only fail to give satisfaction when their owners expect too much from them. A receiver without H.F. amplification is, properly speaking, only for local-station work, or the occasional reception of foreign programmes when conditions are exceptionally good; when attempts are made to use it for receiving weak signals, quality will inevitably be marred by the excessive reaction that is necessary in order to put it into a highly sensitive condition, and even more serious, the reception of other listeners is almost certain to be interfered with by re-radiation.

The circuit arrangement of the Regentone set, illustrated on the following page, is conventional enough, but there are several points of interest. To make a start at the aerial end, it will be seen that the tuning coils are arranged in parallel for medium-wave reception, while the long-wave winding only is in circuit for the other band. Three optional sockets for the aerial plug are provided. Connection to A₁ gives maximum selectivity, due to the interposition of a very small condenser, while A₂ is joined directly to a tapping on the coil. The third socket, connected internally to the high-potential end of the tuned circuit through another condenser, is mainly intended for use with short indoor aeri-als.

The values of grid condenser and leak associated with the detector are those that are generally considered as being the most satisfactory; reaction is controlled by a comparatively large condenser, and a fixed anode by-pass condenser is fitted to prevent anti-regenerative feedback. Transformer coupling and direct output are used in the single L.F. stage.

Anode current is supplied through a Westinghouse half-wave rectifier, and is smoothed by a pair of electrolytic condensers of large capacity. This arrangement is unusual, but it should be said at once that it seems to be entirely satisfactory, as there is a good—indeed, an exceptionally good—background, with practically no hum that can be detected even with a moving-coil loud speaker having a good response at 50 cycles.

There is much to be said in favour of a three-electrode output valve, as used in the present case. Practically any good loud speaker of conventional design may be used, without the need for taking special precautions in matching. Reproduction of good quality is, in fact, readily obtainable, and the maximum volume, though not great, is adequate for most needs; about 9 milliamperes at some 130 volts is passed in the output anode circuit.

Constructionally, the receiver is beyond criticism, and there is little need to make any allowances for its exceptionally low price. Everything is solid and robust, and the heavy metal chassis, to which all components are attached, may be withdrawn very easily for examination, though as a matter of fact, there are few sets likely to need less "service." The obvious reliability of this set is indeed one of its most attractive

features. Most of the parts are of Regentone manufacture, but where the products of other firms are used we find reliable components, such as T.C.C. condensers and a Wearite switch. The cheap parts that one might fairly expect to see in such an inexpensive set are conspicuous by their absence. True, an air-dielectric tuning condenser might have been used, but this is a matter of next to no importance in any detector-L.F. set.

General performance is fully up to the usual detector-L.F. standard, and, by making proper use of the aerial coupling adjustment, enough selectivity for all reasonable needs is ensured.

SPECIFICATION.

CIRCUIT: Regenerative detector and one L.F. stage, with directly and indirectly heated three-electrode valves. Half-wave metal rectifier.

CONTROLS: (1) Tuning condenser. (2) Capacity-controlled reaction. (3) Wave-range switch.

GENERAL: Gramophone pick-up terminals. Moulded bakelite cabinet.

PRICE: £6 15s., complete with valves.

MAKERS: Regentone, Ltd., Regentone House, 21, Barlett's Buildings, Holborn Circus, London, E.C.4.

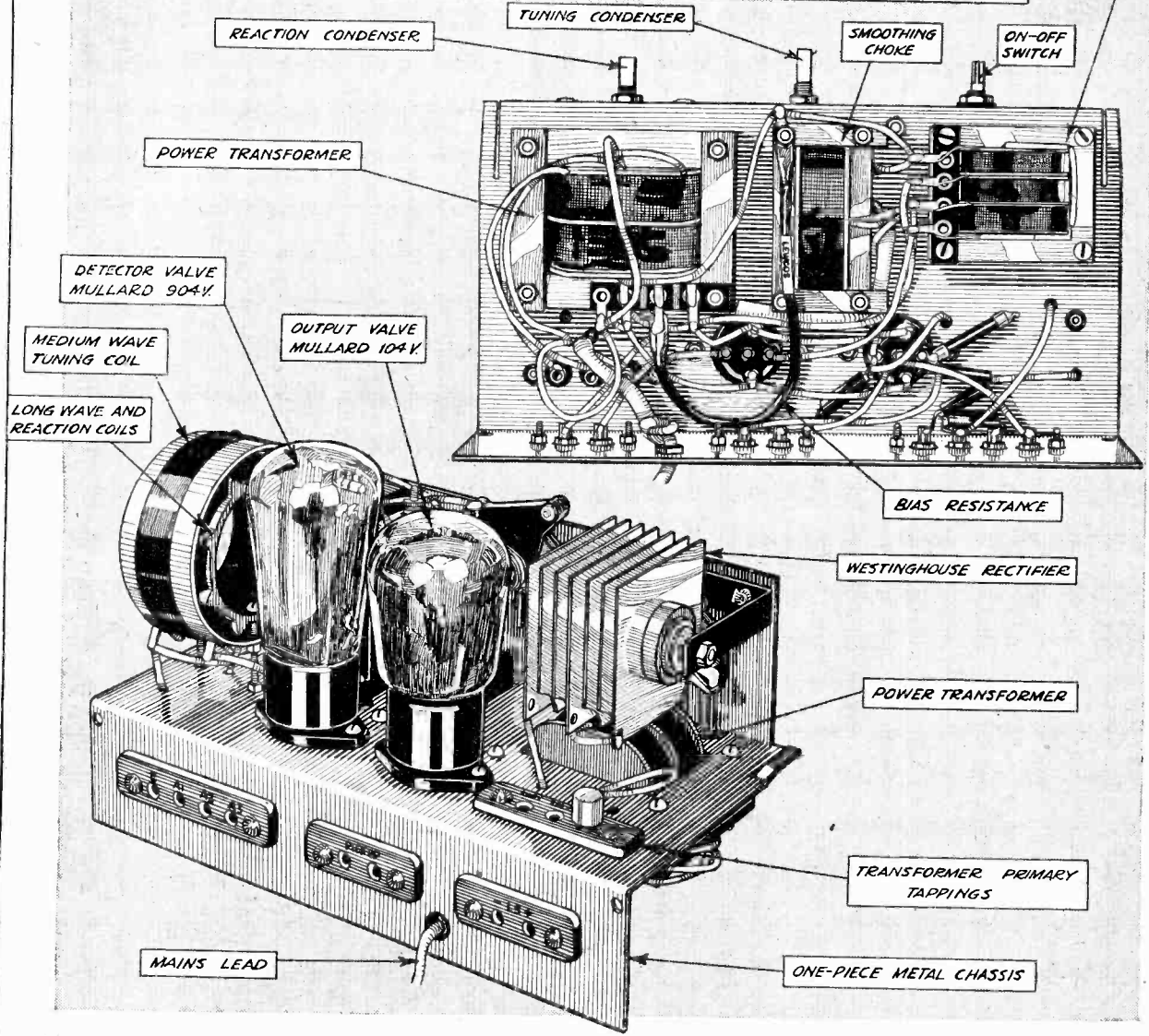
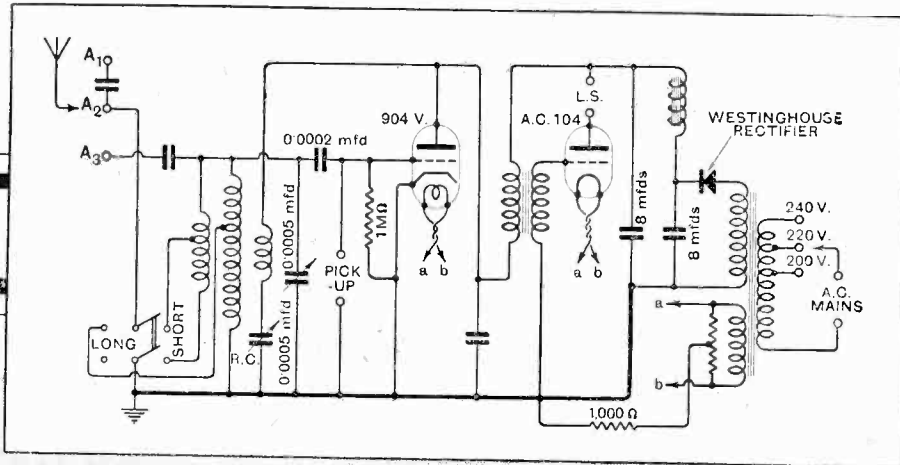

The chassis of the Regentone two-valve receiver is pressed from a single sheet of metal. Inset: complete circuit diagram.



NEW REMOTE VOLUME CONTROL

An Extended Grid-bias Potentiometer.

By W. T. COCKING.

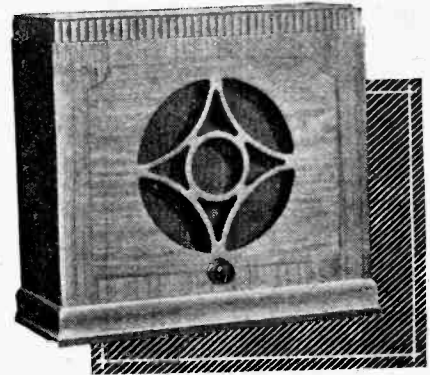

IT is now quite common practice to have the loud speaker and receiver in different rooms with extension leads connecting the two. As the same programme is often listened to for the greater part of the evening the necessity for going to the receiver when a change of station is desired causes little inconvenience. This is not the case with the volume control, however, for one often wishes to change the volume in the course of an evening's entertainment, and it is quite difficult to adjust the volume accurately to the desired level at some distance from the speaker.

Hitherto, the only form of remote volume control which has been available has been the somewhat unsatisfactory method of connecting a resistance or potentiometer in the speaker circuit. The great objections to this form of control are, first, that no protection whatever is offered against valve overloading, and secondly, that a considerable amount of frequency distortion is usually introduced.

The new variable- μ tetrode, however, which has recently been described in these pages, would seem to be ideal for the purpose. Volume control is carried out by varying the grid-bias voltage of the H.F. valves,

and so there can be no objection to fitting extension leads to the volume control potentiometer so that it can be mounted with the loud speaker and used in a room remote from the receiver.

A Simplified Circuit.

Although there are three connections required for the potentiometer, in most cases only two additional extension leads will be needed, for one of the speaker leads can be used for the third connection. A scheme of this nature is outlined in the illustration, which shows the skeleton circuit of a receiver with a variable- μ H.F. stage. The potentiometer R_1 is the normal volume control mounted in the receiver; the jack J , however, is connected in circuit in such a way that the insertion of the plug P causes the receiver control R_1 to be cut out of circuit, and the speaker control R_2 inserted in its stead.

When the plug P is not in the jack the receiver is tuned in the normal way, and the volume adjusted to the desired level by means of the usual receiver control R_1 . Inserting the plug P renders this control inoperative, and the volume level is then entirely dependent upon the setting of the control R_2 , which is most conveniently mounted on the speaker cabinet.

The connections shown are for a transformer output circuit from the power valve, but the arrangement may be used equally well with a choke filter output circuit, provided that the speaker return lead is taken to negative H.T., not to the output valve cathode, as is commonly the case. Where these conditions cannot be complied with the remote volume control will necessitate three extension leads, in addition to the speaker connections. It may be remarked that in cases where the extension leads are very long, or where they have appreciable resistance, it is

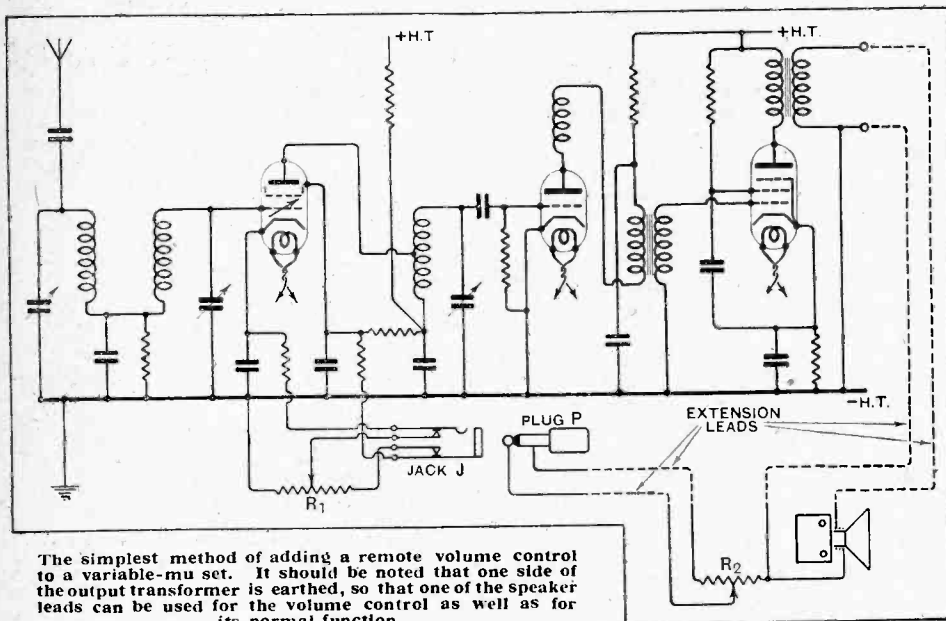

The simplest method of adding a remote volume control to a variable- μ set. It should be noted that one side of the output transformer is earthed, so that one of the speaker leads can be used for the volume control as well as for its normal function.

New Remote Volume Control.—

advisable to use entirely separate wires for the volume control and the speaker, in order to avoid any risk of trouble through feed-back.

It will, of course, be realised that this remote control arrangement is not confined to the grid bias variation method of volume control with variable- μ tetrodes, for it can be used with any type of control operating by varying the steady voltages applied to the valves.

Except with variable- μ valves, however, these controls introduce considerable distortion, and so they are commonly employed in conjunction with another control acting upon the signal input. In this latter case no simple remote volume control is possible.

It will be seen, therefore, that not the least of the striking advantages offered by the variable- μ tetrode is the extremely simple and convenient remote volume control which can be used.

NEXT WEEK—

“The Wireless
World”

SINGLE-DIAL SUPER Battery Model.

An easily constructed five-valve set possessing many outstanding features.

By F. H. HAYNES AND
W. T. COCKING.

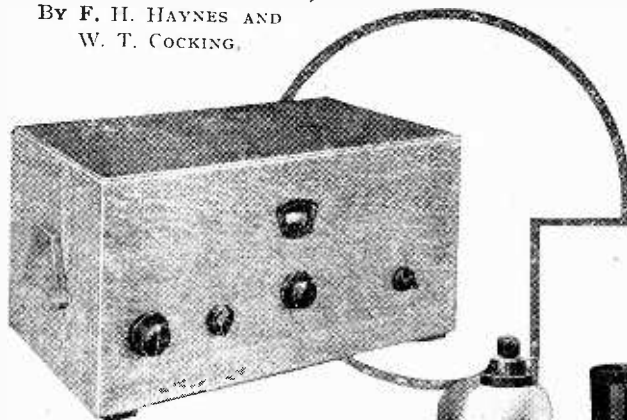

POINTS FROM SPECIFICATION.

First single-dial two-range superheterodyne with correct tracking of input and oscillator circuits while avoiding the use of auxiliary tuning equipment.

Simple construction on prepared aluminium baseplate. Can be assembled in an evening.

Selective band-pass input circuits and band-pass intermediate couplings.

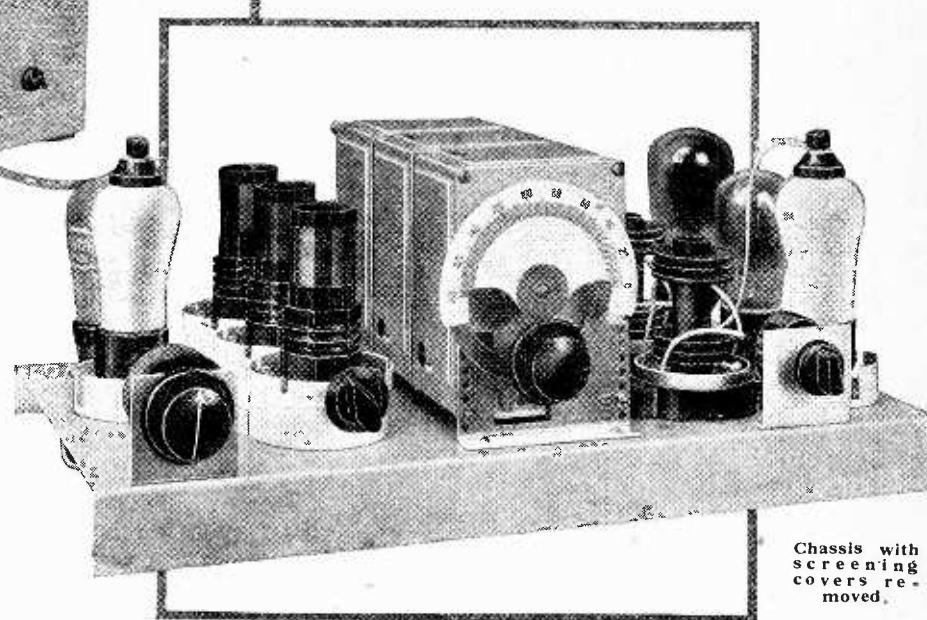

Chassis with screening covers removed.

- Compensated pentode output.
- Input volume control.
- Low H.T. current consumption.
- Unrivalled in appearance.
- Inexpensive—the components costing a little over £7.
- Highly selective.
- Gives daylight reception of most foreign stations when used with small aerial.

LIST OF MATERIALS REQUIRED.

- 1 Three-section gang controlled tuning condenser with trimmers knob and dial 0.0005 mfd. . . (R3W Type Jackson Bros.)
- 1 Tuning coil with long wave band-pass capacity coupling.
- 1 Tuning coil with short-wave band-pass capacity coupling.
- 1 Tuning coil with modified windings and special long wave compensating condenser (Colvern, Types K.21, K.22 and K.23)
- 2 Adjustable intermediate couplings, 110 k.c. (Colvern "Colverdynes")
- 5 Valve holders for under baseboard mounting (W.B. 5-pin type with reversed and recessed screws)
- 1 On-and-off switch (Ready Radio)
- 1 L.F. intervalve transformer . . . (R.I. "Dux")
- 1 Potentiometer, 50,000 ohms (Colvern)
- 1 Condenser, 2 mfd. non-inductive, 400 volts D.C. test (T.C.C. Type 50)

- 1 Condenser, 0.01 mfd. tag type (T.C.C. Type 50)
- 1 Condenser, 0.005 mfd. tag type (T.C.C. Type 50)
- 2 Condensers, 0.002 mfd. tag type (T.C.C. Type 50)
- 1 Condenser, 0.0002 mfd. tag type (T.C.C. Type 50)
- 1 Condenser, 0.0001 mfd. tag type (T.C.C. Type 50)
- 1 Grid leak resistance with end caps and wire extensions, 1 megohm (Loewe)
- 1 Resistance with end caps and wire extensions, 10,000 ohms (Loewe)
- 1 Cable battery connector, 5-wire, H.T. + 1, H.T. + 2, H.T. + 3, L.T. +, common H.T. — and L.T. — (Ready Radio)
- 1 Grid bias battery, 3½ volts (Siemens Type G.1)

- 1 Metal baseplate in 16 gauge aluminium, punched with all necessary holes for securing components complete with clips for securing battery cable and grid bias battery . . (White Bros. & Jacobs)
- 1 Resistance, 50,000 ohms ("Lewcos" Spaghetti type)
- Small quantity of No. 24 S.W.G. tinned copper wire and 6 lengths of ½ min. silk sleeving, screws and nuts.
- 2 Valve screens should H.F. valves not be metallised.
- 4 Wander plugs (Belling-Lee side lead type)
- 4 Terminals, Aerial, Earth, L.S. +, L.S.— with insulating spacers . . (Belling-Lee type)
- Valves, S.22, S.22, H.L.2, H.L.2, and P.T.2 (Osram)
- 1 Cabinet with sliding baseboard and pierced front wooden panel (Longley Radio Manufacturing Co.), 63, Longley Road, Harrow, Middlesex.

WIRELESS ENCYCLOPEDIA

No. 7

Brief Definitions
with Expanded
Explanations.

CROSS-MODULATION. A particular form of interference between two transmissions on adjacent wavelengths caused by a high-frequency amplifying valve in circumstances where partial rectification occurs. Screen-grid valves giving a high degree of amplification are particularly prone to cross-modulation owing to the sharp curvature of the grid-voltage/anode-current characteristic.

FOR a valve to act as a distortionless high-frequency amplifier of modulated waves, the part of the grid voltage/anode current curve involved between the upper and lower limits of voltage reached by the grid, under conditions of maximum depth of modulation, must be straight. When the straight part of the curve is long, as in Fig. 1, the amplitude of the grid voltage oscillation may be varied over a considerable range without any change in effective amplification, the proportionality between grid voltage oscillation and anode current oscillation being maintained.

In the case of a screen-grid valve with high amplification factor, the grid voltage/anode current characteristic is sharply curved in comparison with a three-electrode valve, and there is practically no straight portion. The form of curve for this class of valve is indicated in Fig. 2, from which it is clear that the ideal conditions of Fig. 1 are not even approached unless the grid voltage variation is exceedingly small.

Fig. 2 shows that with a signal voltage of moderate amplitude the

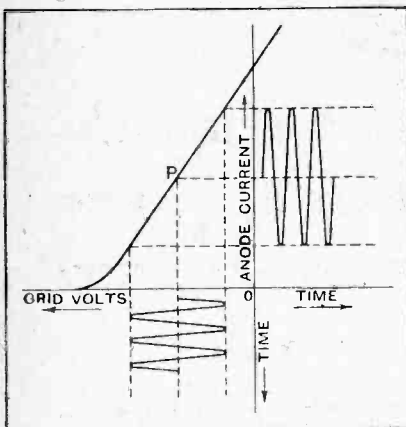

Fig. 1.—Illustrating an ideal grid voltage/anode current curve in the upper left-hand portion. The signal oscillation produces no change of mean anode current.

positive half-waves of an unmodulated oscillation will be amplified to a greater extent than the negative ones. This means, of course, that the valve is acting to some extent as a rectifier; when the signal voltage is applied the mean anode current rise is from OA to OB (Fig. 2), so AB is the change in anode current due to the presence of the high-frequency voltage at the grid. In these circumstances the valve is acting, so far as amplification is concerned, about the point Q on the curve instead of about P, as would be the case if the curve were straight. The increased slope at Q means a higher degree of amplification, and so the latter increases with signal strength.

Now, consider what happens when two signal voltages are impressed on the grid simultaneously. If the difference between their frequencies is sufficiently great the resulting beat frequency will be above the audible range, and no interference would be noticed between two unmodulated carrier waves, whether the valve characteristic curve were straight or not. However, when one of the received waves is modulated, it actually causes the other carrier wave to be modulated in unison with it.

To simplify the explanation of this effect, let it be supposed that the desired transmission is silent during an interval in the programme, whilst an unwanted station is operating with full modulation on an adjacent wavelength just far enough removed to prevent a heterodyne whistle. Now, if the tuned circuit preceding the first valve is not very selective, both stations will set up voltage variations at the grid and those two voltages are added together. Thus the total grid swing is increased; and the voltage excursions of the grid extend over a wider range than that represented by the desired carrier alone.

Now, it has already been explained that the effective amplification increases as the range of the grid swing is raised. Consequently, the varying amplitude of the unwanted transmission, with the resulting variation in total grid swing, will cause the desired carrier wave to be amplified to varying degrees in accordance with the modulations of the unwanted signal. The desired carrier wave becomes itself modulated and the unwanted signal becomes inseparably mixed up with the wanted.

Once the carrier frequency is cross modulated in this way it is quite impossible to eliminate the interference; highly selective circuits succeeding the first amplifying valve are totally ineffective. The only solution is to provide adequate selectivity before the first stage to prevent unwanted signal voltages from reaching the grid of the valve at any strength. With a single tuned circuit it is not possible to obtain adequate selectivity without seriously attenuating the higher note frequencies, and it is in this connection that band-pass tuning has been successfully developed and applied.

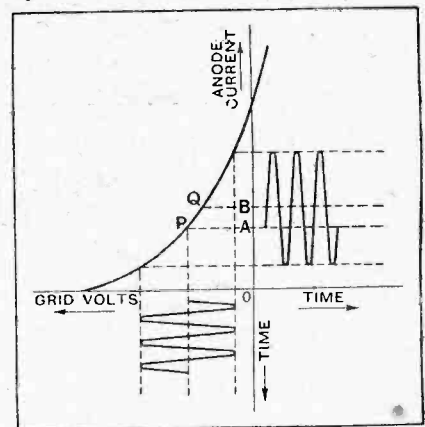
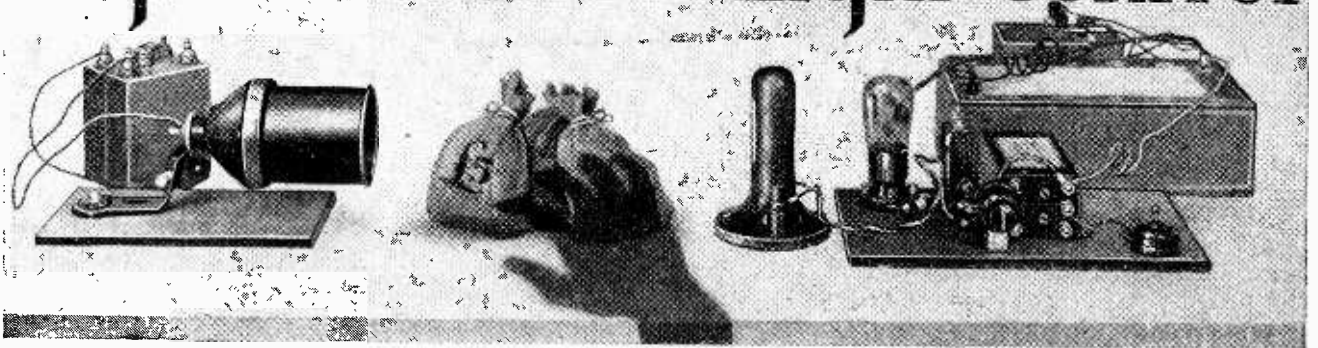

Fig. 2.—Illustrating how a curved grid voltage/anode characteristic produces partial rectification and a degree of amplification dependent on the signal strength.

Experiments with Light Control



Raycraft Constructor's Kit for Building a Relay Operated by an Invisible Ray.

JUST over a century ago the Swedish scientist Berzelius discovered an element, which, when prepared in a certain manner, became a fair conductor of electricity but possessing the peculiar property that its conductivity improved under the influence of light. Thus was born the selenium cell, which for long has been used in laboratories, and to some extent elsewhere, to control electrical apparatus through the medium of relays, by the brilliancy of the light to which the cell is exposed.

The commercial types of selenium cells used hitherto were rather costly, but recently a new development has been made which, in the form of the Raycraft bridge, brings this useful device within the reach of the average experimenter.

It is a selenium cell of compact size and, withal, comparatively cheap, so that in the near future light control of electrical and other apparatus will undoubtedly play an important part in everyday life. The sensitivity of the bridge to artificial light is its greatest asset, for it can be used on numerous occasions indoors both for amusement and for serious purposes.

At this season we are particularly interested in devices which afford entertainment, and those which possess an element of mystery always have the greatest appeal.

The Raycraft kit contains all the necessary components for the construction of a sensitive light-controlled bridge. It consists of two main parts, the Raycraft bridge and a single valve amplifier incorporating a special relay, by means of which the current changes in the sensitive cell are, after amplification, made to light lamps, ring bells, and switch on and off a wireless receiver, to mention a few of its many applications.

Small Current Consumption.

The valve specified is a Mullard PM2DX, or one of similar characteristics, which can be operated at between 100 and 150 volts H.T. The same battery supplies the selenium cell, and as a resistance of about seven megohms is connected in series with it, the drain on the battery from this source is negligible. The normal current taken by the valve is of the order of only four to five milliamperes.

The sensitivity of the apparatus can be enhanced by enclosing the bridge and its amplifier in a cabinet, thus shading the sensitive cell from as much stray light as possible, and employing a special projector lamp giving a strong concentrated beam. When used in the dark the presence of the apparatus will be undetectable if an invisible ray is employed; this can be arranged by fitting a light filter to the projector which kills the visible light, allowing the infra-red rays

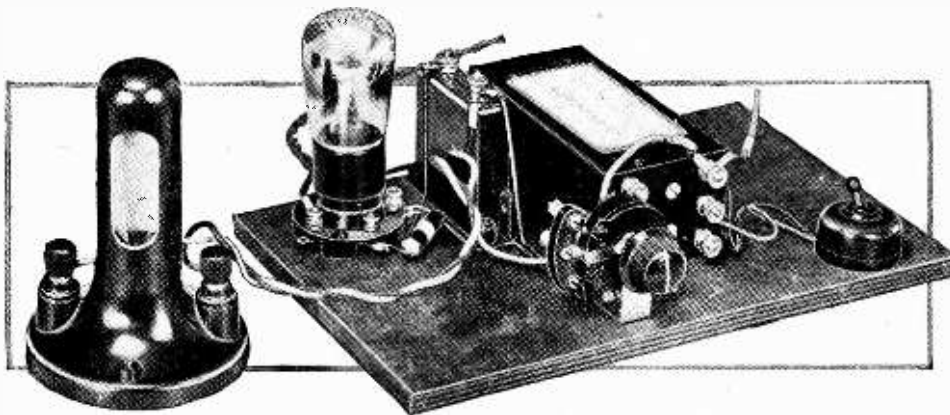

The Raycraft kit assembled showing the special selenium cell on the left. Note the addition of a switch on the baseboard to short circuit terminals 4 and 5 when required.

Experiments with Light Control.—

only to pass through. These will act on the selenium in the same way as visible rays.

The theoretical arrangement is given in the circuit diagram, which shows the relay contacts in the position taken up when the magnet is energised by the anode current passed by the valve. To do this, terminals 4 and 5 are short-circuited. If the apparatus is required to set some external electrical device in action, which continues to operate until switched off, then terminals 1 and 2 are used, and after setting the relay, the connecting strap between terminals 4 and 5 is removed. As this strap must be removed without disturbing the H.T. lead, it would be advisable to fit a small on-off switch to short-circuit these terminals when necessary. By connecting the external circuit to terminals 2 and 3, the lamp, bell, or radio-gramophone will cease to operate when the light beam is intercepted. Now, if terminals 4 and 5 are permanently connected and terminals 1 and 2 joined to the external circuit, the contacts will close when the light beam is interrupted as before, but they will remain closed for about four seconds only, and then they open automatically resetting the relay for the next interruption of the light beam. Some very amusing effects can be produced by this means, for example, by mounting the bridge and amplifier on one side of a door and the projector on the other side; each time the door is opened and the incoming person intercepts the light ray, a bell can be made to ring, a light go on or go out, or a wireless receiver brought in, or put out, of action. A variation of this would be to locate the apparatus so that by merely walking across the room similar effects are produced.

A Useful Burglar Alarm.

Arrangements could be made so that anyone extending an arm to remove an article placed on a table causes bells to ring, lamps to light or, by suitable wiring, for the light to change from white to red, or any other colour. There are endless possibilities in this

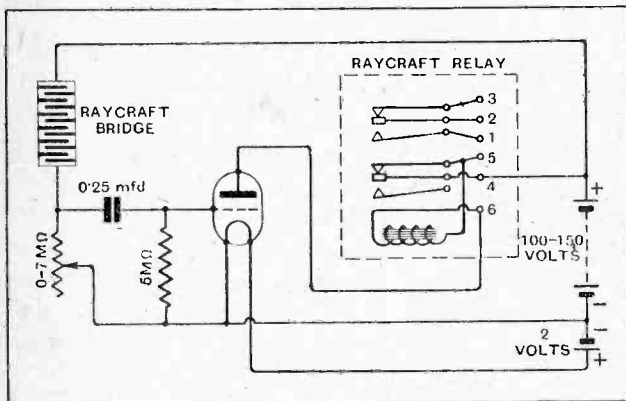

Theoretical circuit diagram.

direction, all of which possess that desired element of mystery so welcome at Christmas.

For the benefit of the younger members of the household mechanical toys, such as model electric railways,

can be stopped, or signals operated, when the train passes through the ray and, without human intervention, continue their course after a short interval.

There is a serious side to the usefulness of the Raycraft bridge, for it is far from being a toy. Its potentialities as a burglar alarm are enormous, especially as with a light filter fitted to the projector lamp the ray is invisible in the dark. To take another case; suitably arranged, a hall light will come on when the front door is opened, thereby obviating the necessity for groping in the dark for the switch.

An Electrical Counting Device.

It can be turned to good account in industry, as the bridge can be utilised to count articles carried along a conveyor by attaching an electrical counter to the relay terminals. If a four-second relay is too long for this purpose, the relay action can be speeded up by fitting a smaller grid condenser or using a lower value grid leak.

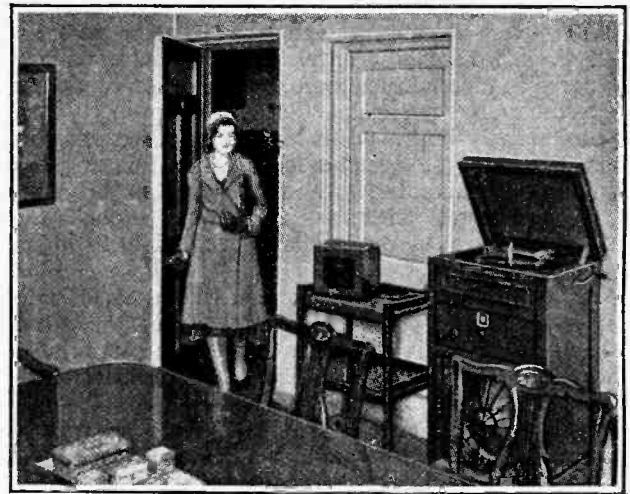

The possibilities of the Raycraft apparatus are innumerable. Here is shown a radio-gramophone switched on by the opening of a door which intercepts a light ray.

Space forbids more than a brief reference to a few of the possible applications of the Raycraft kit, but enough has been said to show that it has endless possibilities even at this comparatively early stage in its history, when its potentialities have not, by any means, been fully explored.

The Raycraft kit is made by Audiovisor, Ltd., 28, Little Russell Street, London, W.C., and the price, complete with wiring diagram and instructional booklet, which incidentally contains many suggestions for its application, costs £3 17s. 6d., without valve or batteries.

The special projector lamp is available for battery use at £1 2s. 6d., while an A.C. mains model costs £1 15s. The lamp is made especially for this purpose by Joseph Lucas, Ltd., and is fitted with a 4-volt bulb consuming two watts, and a light filter to produce the invisible ray is included.



Our Distinguished Contributor in His Most Homely Vein.

THE season of highway robbery, acute dyspepsia, and gout is once more approaching, and again the food vendors and wine merchants are assembled behind locked doors in solemn conclave with representatives of the medical associations, all "seeking a formula" whereby they can best turn this great occasion to their mutual advantage. And we, too, must be up and doing, for but little time is left, and we must hie to the lumber room and bring out the unwanted presents received last year and give them a good dusting before we send them off once more on their mission of peace and good will.

If we are wise we shall naturally have labelled each one clearly before storing it away, after last Yuletide, in order to avoid all risk of increasing the acid content of our relatives by returning the presents to their original donors.

Nor must we forget those Christmas cards upon which some embittered relations, before despatching them to us last year, deliberately wrote their names in ink. To attempt to erase the name with any form of so-called ink-eraser is to invite detection, even without the aid of the magnifying glass with which their recipients will inevitably give the cards the once-over as you and I did, dear reader, when we received them in previous years. To moisten a silk handkerchief in the accumulator acid and to pass it lightly over the inked writing is a far, far better way.

And now a word about "Forth-

coming Events." This year I have received an invitation to act as Father Christmas at a children's party. Having accepted with the proviso that I make my own arrangements, I am preparing a stunt whereby the tree itself will speak. This, of course, will be managed with the aid of a miniature loud speaker skilfully hidden in the foliage and operated via a microphone connected to the gramophone pick-up terminals of a receiver placed in another room. I intend, also, to use a moving-coil loud speaker as a microphone. It was while experimenting with one of these in a rehearsal at home the other day that I overheard the discussion of a ghastly plot by two of the little Grid Leaks, and was reminded of a bitter experience which befell me in the early hours of last Christmas Dav.

approaches it, with nefarious intent or otherwise, unwittingly cuts through the ray, thereby setting off an alarm. Such devices are available this year from radio manufacturers. Although the ray is not absolutely invisible in a dark room if looked at direct, it cannot be seen if approached at an angle. Last year I had some home-made apparatus of this kind of my own, and the little Grid Leaks, curious to probe the great mystery of the identity of Santa Claus, had stolen the apparatus from my den on Christmas Eve. They had also the foresight to borrow the electric horn and its battery from my car, rigging up the gear in such a way that anyone approaching their stockings would cut the ray and sound the alarm.

I cut the ray and my foot simultaneously at 2.30 o'clock on Christmas morning, and, startled by the sudden sounding of the electric motor horn in the bedroom, I put my foot heavily on the cooling-fins of a metal-rectifier chassis. The noise of the horn, my loud imprecations, and the wails of the little Grid Leaks, who received the just reward of eating of the forbidden fruit of the tree of knowledge, rang out almost simultaneously.

But I digress, as the charwoman said. I was telling you, or at least was

meaning to tell you, of my discovery of a dastardly plot. As a means of testing sensitivity, I was using the tick of a clock in the room where my moving-coil "microphone" was placed, and was listening in a remote part of the house when the two little



Simultaneously cutting ray and toe.

Cutting the Ray.

ALL readers of *The Wireless World* are familiar with the invisible-ray method of protecting a safe or cash-box, whereby any person who

Unbiased.

Grid Leaks entered the room and were evidently unaware of the espionage work unwittingly undertaken by the innocent-looking loud speaker. I heard them propose once more to use the light ray, but this time not so much for the purpose of adding to their store of knowledge as of adding to their pocket money.

Spotting the "Enemy."

KNOWING of Mrs. Free Grid's impending Christmas party and dance, with its customary decorations of holly and mistletoe, and knowing as much as did Solomon of "the way of a man with a maid," they proposed to "pro-tect," by invisible rays, all parts of the house where mistletoe was hung. By a simple wiring system run behind picture rails and decorations to their room, wherein was an ordinary electric bell indicator and a buzzer, they would be able to speed off at once to any area in which the "enemy," in the shape of one of their sisters and her dancing partner, unconsciously indicated their presence, and demand hush-money.

I was highly incensed on hearing of this most disreputable plot, and could scarcely restrain myself from meting out justice to them there and then; however, on second thoughts, I am inclined to reward them for their ingenuity by presenting them with one or two small but sensitive microphones placed at strategic points. By using a pair of headphones in their room my little ones will be able to gain further evidence worth, in certain cases, far more hush-money. In fact, I am seriously considering the question of "tapping-in" a pair of headphones into the line myself in order to obtain first-hand knowledge of

the truth, or otherwise, of certain scandalous rumours which have reached my ears concerning the deportment of one of my female offspring.

If such rumours prove to be true, retribution can be made swift and effective, while if untrue it will be interesting for me to see if this mistletoe business thrives as much as it did nearly a quarter of a century ago.



—moment.

'Phones at the Pantomime.

THE approach of Christmas always reminds me that the Pantomime Season is at hand, and I shall soon be compelled to pay my annual visit to the theatre and sit for three solid hours on the hard stool of repentance from which the good old theatre manager, scornful of the comforts of the modern cinema, compels us to view his productions. I well remember the physical discomfort which I experienced last Boxing Day, to which was added the mental annoyance caused by the wriggings of the little "Grid Leaks," who were in a truly parlous plight from the effects of the retribution meted out on the previous morning.

To my mind the word "pantomime" is exceedingly apt, and I cannot understand why it is confined to Christmas productions only, for, although I possess normal hearing, the acoustic properties of many theatres are so bad that, to me, the play is literally a dumb show. Now that microphones and valve amplifiers have reached such a pitch of perfection, surely it is time that a few microphones were suspended in the "flies" and a pair of headphones hung on the back of each seat for the use of those who need them. I saw this arrangement in an American theatre some time ago, and it was indeed a boon and a blessing, as at that time I had not become word perfect in that language, and it was vital to my understanding of the plot that I should at least hear the few words which I *could* comprehend. In this particular theatre

the insertion of a small coin in a box made available both headphones and opera glasses.

Why Not a Pirate Hunt?

AND now a kindly thought for our neighbours. If, as in my own case, you suspect that your neighbours are "pirates," why not decide the point by hiring a motor van and affixing a pretentious-looking frame aerial to its roof? What, then, is to prevent you from driving slowly round the district and watch them scuttle to the Post Office? Better still, if you have a saloon car, you can extend the "shaft" of the frame aerial through the roof ventilator. All that is then necessary is to pull up just outside a neighbour's house and, having got into the car (the blinds must, of course, be drawn), proceed to rotate the frame, at first wildly, and then more slowly, until you finally let it come to rest pointing at the desired residence.

This should once and for all settle your doubts; if you keep a sharp look out through a peep-hole you could probably observe the neighbour's small son scrambling over the back-garden wall with a ten-shilling note gripped between his teeth. It might be necessary, of course, for you to have some suitable disguise, and this should be easily arranged, as any public-spirited railway porter or bus conductor would be only too glad to lend you his peaked cap and tunic in his "off-duty" hours.

But perhaps this ghost-car business would be a shabby trick to play at the season of good will; a more generous act would be to go to the Post Office yourself and take out a licence in your neighbour's name and post it to him. In subsequent years he will never be able to use his set without renewing the licence. And, while you are at the Post Office, why not buy a licence for yourself?

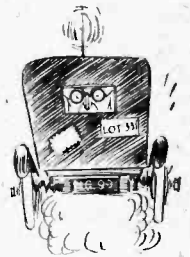

Still watching.

PRACTICAL HINTS AND TIPS.

SIMPLIFIED AIDS TO BETTER RECEPTION.

IT is a relatively simple matter to match a set of coils of the type used in a modern receiver, because

**MATCHING
FRAME
AERIALS.**

each one is wound in a similar way, and so all are bound to have

essentially the same self-capacity. Consequently, this factor can safely be ignored, and if all the coils resonate to the same frequency when shunted by the same value of capacity it may almost invariably be assumed that their inductance values are properly matched.

If it is not obvious at the outset, it will soon become apparent, after making a test, that the same simple procedure is inapplicable when an attempt is made to match one or more coils and a frame aerial, in order that they may all be tuned by a ganged condenser. The frame, wound with a small number of turns of wire, and as a rule with a certain amount of spacing between turns, is bound to have a lower self-capacity than any compact coil; if they are matched together by the method referred to it will be found that the adjustment will hold good only over a limited band of frequencies.

What is needed is a method of true inductance matching, whereby the qualities of inductance and self-capacity may be separated. This is rather beyond the scope of the average amateur, but with a little patience it is possible to strike a balance by trial and error, provided the difficulties that will be encountered are appreciated and guarded against. Before going any farther, it should be made clear that differences in self-capacity can be balanced out by means of trimming condensers, which do not, however, help to compensate for variations in inductance between one circuit and another.

The circuit diagram given in Fig. 1 represents a practical case, and it is assumed that the frame and the coupling coil L are both to be tuned by a two-member ganged condenser (C and C₁), both of which are shunted

by trimmers. As a critical adjustment of inductance cannot be made to an ordinary frame merely by removing turns or fractions of a turn, it is a good plan to connect in series with the winding a small matching coil, with a dozen turns or less, tapped at frequent intervals, so that experimental connections can be made with a spring clip.

Assuming that frame inductance is roughly right, operations can be started by tuning in a transmission at a short wavelength—about 250 metres—and adjusting both circuits for maximum response by means of the trimmers. When it is certain that the set is accurately “ganged,” change over to a considerably longer wavelength—400 metres or so—and notice whether it is necessary, in order again to attain maximum signal strength, to reduce or to increase the trimming capacity across the frame. If more capacity is needed one knows that the frame inductance is too low, and vice versa.

After having added to or subtracted from the number of turns in

adjustments are done, of course, on the series-connected coil.



IT is not generally appreciated that every voltmeter is a potential milliammeter—admittedly of high internal resistance. But this property is not of necessity a complete bar to

**AN
IMPROVED
MILLIAMMETER.**

the usefulness of the instruments for measuring currents. Many H.F. amplifying valves, detectors, and resistance-coupled L.F. amplifiers pass no more than two or three milliamperes in their anode circuits; this means that quite a number of thousands of ohms can be included in series without seriously upsetting the circuit conditions.

Again, circumstances sometimes arise—as, for instance, when setting up a number of ganged circuits—when it is highly desirable to have some visual indication of what is happening. This is provided by a

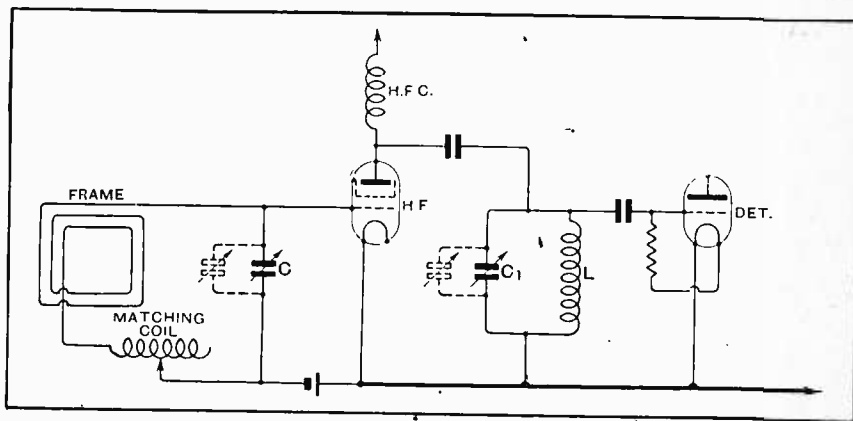

Fig. 1.—Ganged tuning control of a frame and H.F. coupling circuit. A small tapped coil in series with the frame is a useful adjunct.

the frame, as indicated by the preceding test, the whole procedure should be repeated again, and as a rule it is found necessary to make several approximations before inductance values are perfectly matched. When the stage of almost perfect matching is reached, all ad-

measuring instrument in the detector anode circuit, but it is by no means vital to our purpose to know the actual value of current passing; what we need is merely an indication of changes in current value.

Without suggesting for a moment that the voltmeter is an entirely satis-

factory substitute for a proper milliammeter, it is thought that a description of the simple procedure necessary to translate a "volts" scale into milliamperes may be useful.

The first step is to find the total resistance of the instrument by multiplying "ohms per volt" (which will be engraved on the scale, or will be given in the manufacturers' literature) by the "maximum voltage reading."

Next, the current consumed for a full-scale deflection is ascertained by dividing "maximum voltage reading" by "total resistance" (as ascertained from the preceding calculation).

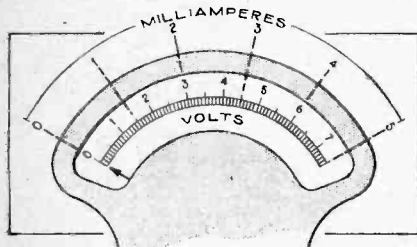

Fig. 2.—Equivalent milliamperes readings of a typical L.T. voltmeter.

Lastly, the current represented by each 1-volt division is ascertained by simple proportion.

A 0-7.5-volt L.T. meter with a resistance of 200 ohms per volt will serve as a good example, as meters of this type are quite common. Its resistance is 200 multiplied by 7.5, or 1,500 ohms. Thus, current consumed for a full-scale deflection is 7.5, divided by 1,500, or 0.005 amp., equivalent to 5 milliamps. Therefore, as 5 milliamps is represented by 7.5 volts, it follows that 1 milliamp will be represented by 7.5 divided by 5, or 1.5 volts.

It is sometimes convenient to paste a paper scale, giving roughly the current equivalents, on to the dial, rather in the manner suggested in Fig. 2.

Internal resistance becomes rather more serious when we come to deal with H.T. meters, but a little trick can often be used to offset, to a large extent, the inaccuracy introduced by interposing this resistance in circuit. It is a coincidence that the type of H.T. meter that is, or was—in the days of lower voltages—most generally in use, reads up to about 120 or 150 volts, and has a resistance of

roughly 200 ohms per volt. It thus has a resistance of between 20,000 and 30,000 ohms, and, if connected in place of a decoupling resistance of similar value, will not introduce any error.



THE trimming condenser of a receiver with ganged tuning should always be set at the lowest possible capacity value; otherwise, the tuning range of the receiver will be restricted to an unnecessary extent.

TRIMMING CONDENSER ADJUSTMENT.

It is often convenient to make the initial adjustment more or less at random, and, when everything else is working properly, to return to the trimmers, reducing the capacity of each of them slightly in steps, and "reganging" at each position. The reason for this progressive method is that it is possible to reduce capacity to too great an extent, with the result that one, or perhaps even more, of the circuits is not correctly tuned.

As a rule, it is hardly safe to assume that matching of the circuits is perfect if any one of the trimmers is at its maximum or minimum setting.



ALTHOUGH the two-circuit aerial tuner has been to a great extent superseded by the band-pass input filter, it still has a definite field of usefulness, particularly when the

TWO-CIRCUIT TUNERS: Automatically Variable Coupling.

modification of an existing set is in question. As separate tuning controls are practically always used, it is obviously much cheaper than a ganged filter in such cases, as the existing aerial tuning condenser, and probably the existing coils as well, can still be used.

The objection—and it is quite a valid one—commonly urged against the two-circuit tuner is that it needs three separate controls. There are two variable condensers to be adjusted, as well as some form of inter-circuit coupling; the latter admittedly does not require continuous adjustment, but if coupling between the

component circuits is to be maintained at the value giving best signal strength, a number of different settings will be needed when passing from one end to the other of the wave range.

Tests have recently been made with a slightly modified type of tuner, in which coupling is automatically maintained at, as near as no matter, the optimum value over the whole wave-band, in a very simple way. The circuit arrangement actually used is given in Fig. 3; primary and secondary circuits are linked by means of a small variable condenser, which is "ganged" to the primary tuning condenser by means of a flexible insulating joint. It will be obvious that, as the two condensers rotate together, matters can be so arranged that the coupling condenser (C.C. in the diagram) is increased in capacity as wavelength is increased, thus providing the essential conditions for optimum coupling. A certain amount of finesse is necessary in order to obtain results approaching perfection, but it is not difficult to set

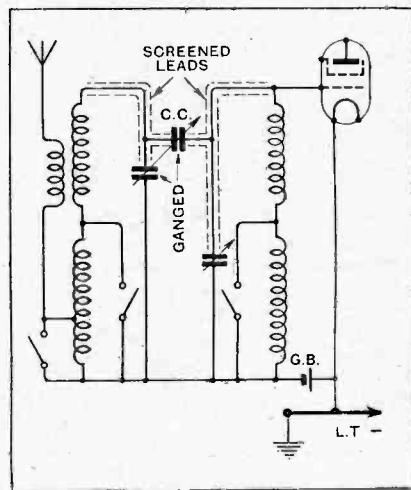

Fig. 3.—A two-circuit input tuner with separate tuning controls, but with automatic regulation of inter-circuit coupling.

up a very satisfactory tuner on these lines. Stray capacity couplings between the circuits must be guarded against if tuning is to be satisfactorily sharp at low wavelengths, and it will generally be necessary to screen some of the leads. This point is also illustrated in the diagram. Needless to say, the tuning coils and condensers must also be thoroughly screened.

Broadcast Brevities

By Our Special Correspondent.

The Christmas Programmes.—“Good Night!”—A Perfect “Studio.”—Broadcasting Parliament.—Cramping the Orchestra.—Surprise about Surprise Items.—Radio Brain-waves.

Christmas Broadcasting.

“If you wish for ‘Christmassy’ programmes, stick to the National.” This is the conclusion I have drawn from a privileged glance through the programme sheets for December 24th, 25th and 26th. The programmes of the Regional transmitters seem to be mostly of the “sustaining” kind, to use the American term applied to those programmes which keep the transmitter alive in the absence of a sponsoring advertiser.

Carols.

On Christmas Eve afternoon, the National transmitters will relay carols from King’s College, Cambridge, and the now-familiar Carol Service from St. Mary’s, Whitechapel, in the evening.

An Hour with the Gramophone.

The Christmas morning service in Canterbury Cathedral will be relayed Nationally. Then Christopher Stone will help us to endure life until dinnertime with an hour’s recital of specially chosen gramophone records. Reginald Foort will accompany the feast with an hour at the Regal Cinema organ.

A Christmas Day Pantomime.

The feature on the evening of Christmas Day will be Ernest Longstaffe’s pantomime, “Aladdin.” Later, after an appeal for the “Wireless for the Blind Fund,” there will be a recital of Yuletide songs by John Coates, the famous tenor.

The “Grand Good-night.”

New Year’s Eve without Mr. J. C. Stobart’s “Grand Good-night” would be incomplete, and I am glad to hear that the Director of Educational Talks is to repeat his annual benediction for all the world to listen.

Mr. Stobart has no fixed formula for these happy effusions, but each year it becomes more difficult to introduce those neat little variations which make for true spontaneity.

He Won’t Go Home Till Morning.

By the way, the world will have to sit up late to hear Mr. Stobart this year, or, rather, next year, for his “turn” comes on at 12.45 a.m. on January 1st, following a programme of dance music.

There will be a few “heads,” I fear,

on the morning after such a grand good-night.

A Happy Annual.

The Nativity play by the St. Hilary Players at Marazion will be broadcast on the National wavelengths on December 21st.

Have You Had One?

If you “have a friend at the B.B.C.” don’t be excited when he (or she) sends you one of the Christmas cards, official, Corporation Staff, for the use of, etc. The picture of “Broadcasting House,”

Yes, Why?

Apparently it is perfectly legitimate to announce that Professor Brazenchops will give his Haughty Culture Talk on Saturday, but altogether wicked to suggest that his preliminary cough will be heard at 7.15. Why?

Truth About the Commodore Orchestra.

People were marvelling last week at the good behaviour of the audience at the Commodore Theatre, Hammersmith, when Joseph Muscant’s Grand Orchestra gave its first evening broadcast. Actually, of course, the perfect silence between items was due to the fact that there was no audience. While the film programme is running in the theatre, the orchestra performs in the café, which, I am inclined to believe, is one of the best broadcasting “studios” in London. The reproduction is irreproachable.

Cutting Down Costs.

The unfortunate people charged with the task of reducing costs at Savoy Hill are rejoicing at the fact that this is the off-season at so many watering places from which expensive relays have been given in the past. Those “bare, ruined choirs, where late the sweet birds sang”—Scarborough, Whitby, Leamington, Blackpool, Brighton, Weston-super-Mare, and Hastings—are now out of sight and out of mind, so far as most of us are concerned.

A Promise.

Still, I am assured that even the “O.B.” Department, pestered as they are with economy demands, are determined to spare no expense when really important events occur, whatever the distance. They are not going to spoil the ship for a ha’porth of tar.

Broadcasting Parliamentary Debates.

Those who write so glibly about the broadcasting of Parliamentary debates in the near future—and the canard burst out afresh a few days ago—can hardly have paused to reflect that such a step would upset the jealously guarded “privilege” of the House of Commons.

Slander by Wireless?

It is common knowledge that slander cannot be committed within the walls of the House. Everything said, whether



“STUDIO 10a” is the unofficial name for the much-criticised interval signal which is here seen in the loft above the Savoy Hill control room. The microphone picks up the ticks from an electric clock fitted with a second hand.

with its remnants of scaffolding, is quite nice, and the lion rampant on the cover, spitting out electric sparks, makes up in obvious warmth what he lacks in Yuletide amiability.

B.B.C. and the Relays.

I don’t know why the B.B.C. should wish to quarrel with the wireless relay folk, but a tale reaches me from the Southern Midlands to the effect that the Corporation is coming down heavily on one or two relay firms who have had the temerity to liven up their programme circulars by including the probable times of performance.

personal or otherwise, is *cum privilegio*; hence, complete freedom of debate is possible. If, however, the proceedings were broadcast it is doubtful whether this condition would apply and candid discussion would therefore be out of the question.

But, apart from this, who really *wants* to hear dreary, unedited debates at Westminster?

Trouble at "Broadcasting House."

Although the acoustics of the big concert studio at Broadcasting House are not so bad as has been suggested, the engineers did not have an easy time in smoothing out the unwanted resonances and securing the right amount of echo.

And just when everything seemed "O.K.," it was found that the platform was not large enough to accommodate the National Orchestra of 117 players; an extension of three feet has been found necessary.

Crab Fashion.

At a rehearsal held before the alterations were made the orchestra had to be arranged sideways.

There was so little space, according to rumour, that the bass trombones (or slip-horns) had to miss the low notes.

Vocal Railway "Effects."

Haver and Lee, who hit upon the unusual expedient of a smash-and-grab raid for their recent broadcast, to the delight of a host of listeners, are in a vaudeville programme again on December 10th.

Another "star" turn will be Reginald Gardiner, broadcasting a vocal imitation of a railway journey. Jeanne de Casalis is also to present her motor car sketch in this programme.

Broadcast Operetta.

"Good-Night, Vienna," the first operetta of its kind to be specially written for broadcasting, will be given from Savoy Hill in the first week of the New Year. It is the work of Holt Marvell and George Posford.

The producers will be Val Gielgud and John Watt. A quintet, as well as the theatre orchestra, will be employed on the musical side, and some novel ventures in sound and speech will be made.

The talkie version of "Good-Night, Vienna," goes into rehearsal at Elstree immediately, with Jack Buchanan and Anna Neagle in the chief rôles.

The Surprise Items.

M. Jourdain, in the old French comedy, was astonished to hear that he had been talking prose all his life. Apparently we, too, are in much the same case, for, according to the B.B.C., we have been listening to "Surprise Items" ever since they were stopped two years ago.

Joys of Anticipation.

Savoy Hill considers that a "Surprise Item" announced in advance is no surprise. I disagree. The delights of antici-

pation gave the "Surprise Item" half its value. To be frank, very often the item, when it did come, was a poor thing; but

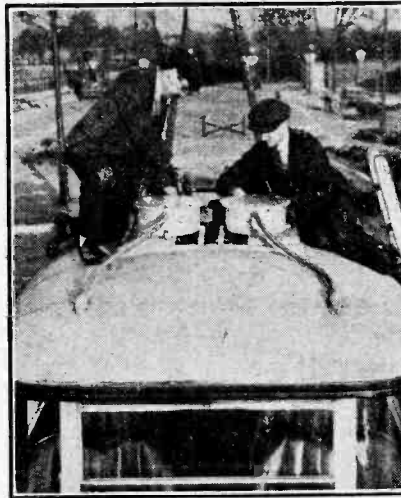

CUTTING OUT THE CRACKLE. Many listeners in the Kingston area have complained of interference to reception caused by the trolley 'buses' of the London United Tramways. The authorities are now fitting "stopper coils" at their own expense. The photograph was taken at the Fulwell bus depot last week.

there was surprise even in that discovery, and in such cases we could always look forward with renewed hope to the following Friday.

FUTURE FEATURES

National (261, 301 and 1,554 metres).

DECEMBER 7TH.—"Weather or No," a revue.
DECEMBER 9TH.—B.B.C. Symphony Concert, from Queen's Hall.
DECEMBER 10TH.—Vaudeville programme.
DECEMBER 11TH.—Shakespeare's "Julius Caesar."
DECEMBER 12TH.—"Nuts and Wine," a programme of songs.

London Regional.

DECEMBER 6TH.—Sunday Orchestral Concert—S.
DECEMBER 7TH.—"Der Rosenkavalier" (Strauss), Act I, from the Prince of Wales' Theatre, Birmingham.
DECEMBER 8TH.—Oxford v. Cambridge, a running commentary on the Rugby Football Match, from Twickenham.
DECEMBER 9TH.—Songs from the Shows—3.
DECEMBER 12TH.—Vaudeville programme.

Midland Regional.

DECEMBER 6TH.—Service from St. Chad's Cathedral, Birmingham.
DECEMBER 10TH.—"Façade," by William Walton, arranged for voice and piano.

North Regional.

DECEMBER 8TH.—"Master Wayfayer," a Happening of Long Ago, by J. E. Harold Terry.
DECEMBER 9TH.—Vaudeville programme.
DECEMBER 10TH.—Hallé Concert, from the Free Trade Hall, Manchester.

West Regional (Cardiff).

DECEMBER 12TH.—"Vigil," a play, by Emlly Williams.

Glasgow.

DECEMBER 8TH.—A Gaelic Concert
DECEMBER 12TH.—Choral and Orchestral Union of Glasgow's Orchestral Concert, relayed from St. Andrew's Hall, Glasgow.

Belfast.

DECEMBER 10TH.—An Irish orchestral programme.
DECEMBER 12TH.—"The House in the Quiet Glen," an idyll of Rural Ulster, by John W. Coulter.

We Are Surprised!

However, according to Savoy Hill, the Surprise Items continue. When a star of the film, stage, or politics suddenly looms up from nowhere, or has something important to say, the B.B.C. gets him to broadcast "on the spot." "Thus," says the B.B.C., "the listener is surprised!"

No Ideas.

I am afraid the real truth is that the B.B.C. shrink from putting surprises on a time-table basis, and the cause of this timidity is lack of ideas. Many listeners were sorry when the Ideas Research Department broke up three years ago. The genuine "idea merchants" now at Savoy Hill can be numbered on the fingers of one hand.

Laying the Golden Eggs.

Lance Sieveking and John Watt furnish most of the original ideas on the dramatic side, but they are staunchly supported by Gordon McConnel and T. J. King Bull; all of these young gentlemen are subject to sudden brainwaves, and on this account they are treated with the respect usually meted out to hens that lay golden eggs.

Why can't they lay a little egg for us each Friday?

Dramatic Optimism in Italy.

I wonder whether the same sort of shock awaits the famous Italian dramatists—Pirandello, Marinetti, Bontempelli, and others—as was experienced by some of our famous British playwrights when asked to write for the microphone. They found that the job was beyond them.

But at all events the Italians are going to make the attempt. A friend in Turin tells me that the broadcasting authorities there are determined to create a school of Italian Radio Drama, and, with this end in view, have approached the giants whose names I have already mentioned. The response has been surprising. In fact, the dramatists have promised works that shall be interesting and original.

Our own dramatists never made such rash promises; which, for them, was fortunate.

Strauss Opera Broadcast.

The Covent Garden Opera Company will broadcast the second act of Richard Strauss's opera, "Der Rosenkavalier," from the Prince of Wales' Theatre, Birmingham, on December 15th. This will be the fifth broadcast from the theatre.

Music from Park Lane.

The Grosvenor House Band is justly popular among listeners. During December the band is broadcasting every Thursday afternoon, beginning to-morrow, from 4.30 to 5.15.

A Courteous Correspondent.

In a letter to the B.B.C.: "Thank you for all the trouble I am giving you."

CORRESPONDENCE

The Editor does not hold himself responsible for the opinions of his correspondents.

Correspondence should be addressed to the Editor, "The Wireless World," Dorset House, Tudor Street, E.C.4, and must be accompanied by the writer's name and address.

DECOUPLING AND GRID BIAS.

Sir,—With reference to an article in *The Wireless World* of September 23rd on decoupling and automatic grid bias circuits it may interest some of your readers to know what the actual comparative readings of bass cut-off are for battery bias (a), plain automatic bias (b), and decoupled automatic bias (c).

The figures quoted below are those for a Mullard 164V with 120 volts H.T. and an equivalent grid bias of 4.5 volts, and are representative of all types of amplifier valves.

	Frequency.			
	1000~	100~	62~	39~
(1) Battery, bias, circuit (A)	0 db.	0 db.	0 db.	0 db.
(2) Auto bias, with 1,000 ohms and 2 M.F., circuit (B)	0 "	3.5 "	5.0 "	7.5 "
(3) Auto bias with 1,000 ohms and 10 M.F., circuit (D)	0 "	1.5 "	2.5 "	4.5 "
(4) Auto bias decoupled with 0.1 megohm and 2 M.F., circuit (C)	0 "	1.5 "	2.5 "	3.5 "
(5) Auto bias decoupled with 0.1 megohm and 10 M.F., circuit (C)	0 "	1.5 "	2.5 "	3.5 "

The figures were taken with the valve arranged as a single-stage amplifier with choke output, and the apparatus was set up with the utmost care in order to obviate any errors. The figures represent the loss in decibels compared with the gain or amplification at 1,000 cycles.

It is clear from the above figures that a considerable improvement results from decoupling the grid circuit, and when decoupled the size of the condenser is not very material. But, nevertheless, the bass response is not as good with automatic bias as with a grid battery to the extent of 3.5 db. at 39 cycles. Whilst a 3.5 db. loss would scarcely be perceptible to the ear, this figure only applies to one stage and with, say, three stages of amplification a loss of 10.5 db. would result, the cut-off being marked and detrimental to quality in a high-grade amplifier, representing as it does a reduction in output of nearly a quarter.

It would not be advisable to try to improve this cut-off by increasing the decoupling resistance above 0.1 megohm, because the time constant of the grid circuit would become high, giving a bad response to any transient overloads.

Trusting this information may be of value to those interested in high-grade amplifiers.
D. N. CORFIELD.
Hendon, N.W.4.

INTERFERENCE TROUBLES.

Sir,—I am operating an all-mains screen-grid three receiver, self built, and I am experiencing severe trouble with traffic signals situated a matter of 30 to 40 yards from my house. Everything has been done, as far as I know, to eliminate this interference, which takes place every 40 seconds when the traffic signals change.

The postal authorities have tried placing condensers across the various switches in the traffic signals, to no purpose; the interference was just as bad with the condensers as without them. I personally have tried a different aerial facing in

another direction, several different earths, including a counter-poise earth, to no purpose. This severe interference still persists. It would appear to me that the interference is transmitted through the mains themselves and not by means of static spark. My reason for thinking this is due to the fact that at the house next door, where another wireless receiver is operated, no interference is noticeable. I have been given to understand that this particular house next door is on an entirely different circuit from my own house. That is to say, my house is on the same circuit as the traffic signals.

I shall be very grateful if any reader can inform me whether there is anything that I can do from my end to eliminate this interference, which completely spoils reception at all times, and is infinitely worse when it is a wet day.

Gravesend, Kent. WALTER C. ROWE.

EMPIRE SHORT-WAVE BROADCASTING.

Sir,—It is gratifying to learn that at long last your untiring endeavours to promote Empire Broadcasting will soon bear fruit.

The very title "Empire Broadcasting," coined by yourselves, should have been sufficient to awaken practical interest at a much earlier date. Now that it will shortly be an accomplished fact, no reasonable expense should be grudged in order to make it a complete success, both from a technical and

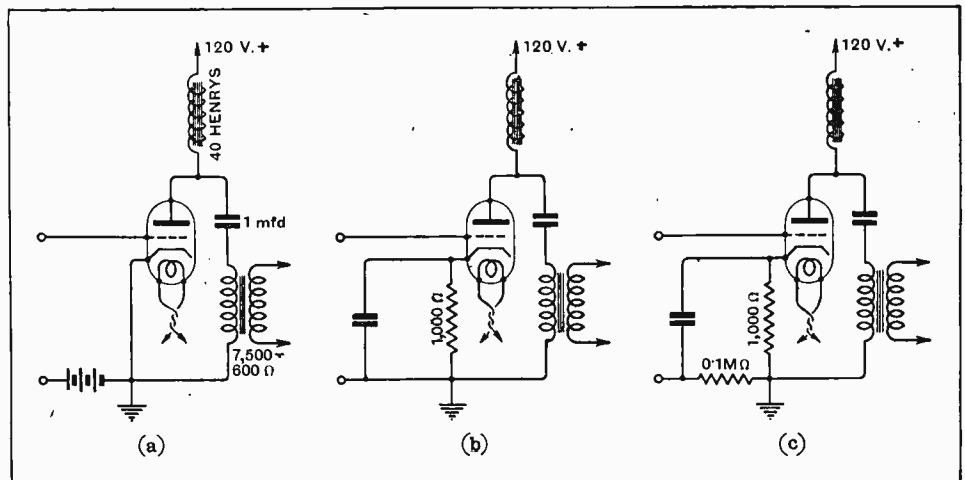

organising aspect. Your suggestion that an additional Governor might very well be appointed by the B.B.C. to further the interests of Empire Broadcasting is an excellent one. Indeed, when one considers the vast amount of work entailed in keeping our "local" house in order, it would seem that such an official is essential.

Perhaps the delay in the materialisation of Empire Broadcasting is not altogether to be regretted, because with the recent crisis in world conditions and the imperative need for Empire unity, the present time is ideal for the consolidation of the scheme.

It will be remembered that a good deal of the pioneer work was done by Mr. H. Anthony Hankey on behalf of this League. Four years ago, Mr. Hankey, sponsored by Sir Arthur Stanley, chairman, and Lord Drogheda, vice-chairman, of the Wireless League, made a world tour in order to stimulate interest in Empire Broadcasting. Incidentally, he was the author of the original article "England in the Colonies," published in your

journal. Valuable experiments were also carried out by Mr. Gerald Marcuse, who did much practical transmission work at his own expense.

You will, no doubt, wish to place on record this consolidation of effort together with that of *The Wireless World*, to link up the Homeland with the various outposts of Empire.

I. JOSS,
Secretary, Wireless League.

12, Grosvenor Crescent, S.W.1.

Sir,—In the issue of *The Wireless World* of June 10th last (page 634) you state that the B.B.C., after the Colonial Conference in 1930, prepared and despatched towards the end of that year circulars to the Colonies and Minor Dependencies indicating the nature of the Empire Broadcasting service which could be provided, and enquiring to what extent each colony would be prepared to co-operate. Ceylon is specially mentioned as one of the Colonies to which a circular was sent. You further state that since then not one reply has been received.

This club has for so long keenly supported the proposal for Empire Broadcasting that it at once took up the matter with the Telegraph Department in Ceylon, which controls the local Broadcasting Service. We wrote to the department on July 3rd:—

"We have the honour to draw your attention to the enclosed cutting taken from *The Wireless World* of 10th June (page 634) in which it is asserted that Ceylon, among other British Colonies and Dependencies, has neglected to reply to a circular issued six months ago by the British Broadcasting Corporation as a result of the Colonial Governors' Conference. We can hardly believe that the statement is correct as regards Ceylon, but we should be greatly obliged if you would advise us of the true position.

"The matter of Empire Broadcasting is one of the utmost interest and importance to short-wave listeners, and, indeed, to listeners generally, who would naturally all benefit from relays from the Empire transmitter by local broadcasting stations."

On 28th July the following letter was received in reply:—

"With reference to your letter of July 3rd, I have the honour to state that no such circular as that mentioned or any further communication on this subject has been received. It may be pointed out that the paragraph in *The Wireless World* is obviously incorrect, as the British Broadcasting Corporation would in normal circumstances not circularise the Government of the Colony direct, but through the Secretary of State."

We shall be very much obliged if you will put the matter right as far as Ceylon is concerned in an early number of *The Wireless World*. We flatter ourselves that as a Colony Ceylon has always been in the forefront of the demand for Empire short-wave broadcasting, and the paragraph in *The Wireless World* of June 10th conveys, you will appreciate, to your large

circle of readers all over the world a wrong and misleading impression of our interest in the subject.

We have forwarded a copy of this letter to the Foreign Director, B.B.C., for his information.

G. H. JOLLIFFE,
President,
Colombo.
Radio Club of Ceylon and South India.

AUTOMATIC GRAMOPHONES.

Sir,—With reference to the remarks made by "Free Grid" in your issue of November 18th, concerning automatic record-changing gramophones, there are a few points which we should like to bring to your notice:—

We have designed an automatic gramophone which plays both sides of a record. It is obvious that the instrument is large, as there must be at least space of over a foot above the turntable in order that a twelve-inch record may be turned over.

The whole tendency in the design of radio-instruments at the present time is to make them as simple as possible. Sets are now smaller in size and more compact than they were a few years ago, and the same tendencies are revealed in our production of an automatic record-changing mechanism. The first automatic gramophone was the "His Master's Voice" Model 1A, which changed up to twenty records, but was, unfortunately, large in size. The latest "His Master's Voice" record-changing mechanism, introduced this season, operates on up to eight records, and is approximately the same size as the ordinary table-type gramophone.

"Free Grid" states that gramophone record makers are meeting a situation of playing consecutively both sides of records in a complete work by supplying two one-sided records at about the price of one. We believe that he has been misinformed regarding this point, certainly as far as this company is concerned.

Since the introduction of their first automatic gramophone "His Master's Voice" have arranged to supply album works such as symphonies, operas, etc., specially coupled for use on automatic instruments. By this, we mean that the records are so arranged that consecutive parts appear on separate records; for example, the "Gondoliers" is supplied on twelve double-sided twelve-inch records, for the automatic edition parts 1 to 12 are on separate records, with parts 3 to 24 on the opposite sides; it is, therefore, possible to play a complete work on one of our large instruments without touching the machine more than once.

In conclusion, it must be remembered that by making automatic record-changing mechanism as simple as possible, the number of working parts are reduced to a minimum, thus keeping the cost as low as possible.

R. ARBIB,
The Gramophone Co., Ltd.
Technical Press Department (English Branch).

A Popular Subject.

A record audience assembled to hear a lecture on "Good Amplification in L.F. Amplifiers" given by Mr. T. M. Wood of the Mullard Company at a recent meeting of Slade Radio (Birmingham). By the use of two identical amplifiers which could be switched in alternately, comparisons were made between pentodes and triodes and various other combinations of valves and different types of couplings. At the conclusion Messrs. British Acoustics, Ltd., demonstrated their new portable talkie apparatus.

Hon. Secretary: 110, Hillaries Road, Gravelly Hill, Birmingham.

o o o o

Below 24 Metres.

A demonstration of a short-wave adapter was given by Mr. Hall of Messrs. Philips Lamps, Ltd., at the last meeting of the Woodford, Waustead and District Radio Society. Mr. Hall, after explaining that it was difficult to receive stations on wavelengths below 24 metres after dark immediately proceeded to do so! The adapter consisted of an S.G. Separator valve and a Triode Autodyne valve connected to a Philips 5-valve receiver.

Joint Hon. Secretaries: Mr. H. O. Crisp, 2, Ramsay Road, E.7, and Mr. W. H. Crown, 1, Thornton Road, E.11.

CLUB NEWS.

Metal Rectifiers.

Mr. D. Ashby, B.Sc., of the Westinghouse Brake and Saxby Signal Co., Ltd., dealt with the subject of rectifiers in an interesting lecture before the Bec Radio Society on November 19th. A series of lantern slides of oscillographs of the wave forms of various types of rectifiers was shown, together with details of the complete circuits of eliminators.

Asst. Hon. Secretary: Mr. J. C. Gilbert, 54, Hazelbourne Road, Balham Hill, S.W.12.

o o o o

Short Waves.

The Radio and Television Society, with headquarters at 195, Hammersmith Road, is beginning a series of lectures on short-wave receivers to cater for the big demand from amateurs interested in short-wave work generally. New members and friends will be cordially welcomed at the next meeting which will be held on Thursday, December 3rd, at 8 p.m.

Hon. Secretary: Mr. E. G. Nurse, London Lazonda Service Depot, 195, Hammersmith Road, London, W.6.

"Wireless World" Quality Amplifier on Test.

Mr. H. T. Stott of Messrs. Bulgin did justice to the title of his recent lecture—"Gadgets"—before the Ilford and District Radio Society by handing round for detailed inspection about 200 components and switches, each of which he described with its various uses. A new pick-up was tested on the Society's "Wireless World" Quality Amplifier with excellent results. On November 21st a large party of members in company with representatives of the Woodford Society visited the Research Laboratories of the General Electric Co. at Wembley.

Hon. Secretary: Mr. C. E. Larget, 16, Clements Road, Ilford.

o o o o

Variable-mu, Short Waves, and Other Topics.

The merits and demerits of the variable-mu S.G. valve were freely discussed at a recent meeting of the Liverpool Wireless Society at which a discussion on a wide range of topics took place. Short-wave super-hets. were discussed and the opinion was expressed that all frequency changers should be of the non-radiating type as advocated by *The Wireless World*.

New members will be welcomed and full particulars can be obtained from the Asst. Hon. Secretary, Mr. R. Reid Jones, 24, Oak Leigh, Tue Brook, Liverpool.

READERS' PROBLEMS.

Readers' technical enquiries are not replied to through the post, but in these pages replies to questions of general interest are dealt with week by week.

Substituting a Triode.

EXCEPT for the fact that a general falling-off in efficiency would result, a three-electrode output valve could be substituted for the new type of pentode for which the "Wireless World Two" (October 28th) was specifically designed. The majority of readers who are considering this modification will hardly need to be told that the necessary alterations are of the simplest nature. Obviously, the special tone-correcting resistance and condenser will be omitted, and the only other change that may be necessary is in the value of the 750-ohm bias resistance.

Pick-up Voltage Output.

A READER who has been studying the comparative tests of commercial pick-ups which were published in this journal some time ago, asks whether the voltage output of a pick-up can be taken as a measure of the volume that will be given by the receiver to which it is connected. He goes on to enquire as to the reason for the great discrepancy between the outputs of various makes of pick-up.

It is a fact that the pick-up with the greatest output will give the greatest volume under given operating conditions; in fact, provided the set is working within its capacity, the output from the last valve will be directly proportional to the output of the pick-up.

The difference between various makes in the matter of output is entirely a matter of design, and is accounted for by the fact that various manufacturers attack the problem from a different angle. It is not right to assume, as our correspondent rather seems to do, that the instrument with the greatest output is necessarily the best—or vice versa.

Impracticable for D.C.

QUESTIONS have been asked as to whether the "free field current" scheme exemplified in the "Wireless World Three" could be employed in a D.C. mains set. A careful consideration of the subject should, we think, show that the advantages of this plan are confined almost entirely to A.C. receivers: in the first place, the D.C. user has, of course, little, if any, H.T. voltage to spare, and the performance of his receiver would be impaired seriously if the loud speaker field magnet winding were inserted in series with the anode supply.

Again, when a D.C. supply is available, there is no need to economise unduly in current, and the usual plan is to obtain a loud speaker with a field winding suitable

for direct connection across the mains: it will thus be quite independent of the receiver, and its consumption will probably be no more than about one-tenth of that of an ordinary electric lamp.

The only practicable way of getting entirely "free" field current is to insert a specially designed winding in the cathode circuit, using it in place of—or as a part of—the usual voltage-reducing resistance.

An Undesirable Form of Aerial.

IT has been asked whether a loud speaker extension lead could be used as an extemporised indoor aerial, very much in the same way as the electric light wiring is employed for the same purpose. Although it is possible to make the extension wires perform this function, the plan is distinctly not one that can be recommended for wide adoption. Unless H.F. filtering is unusually thorough there will be a residue of H.F. energy in the anode circuit of the output valve, and this, if allowed to interact with the input circuit of the first valve, is bound to produce instability, either actual or incipient.

Band-pass Frequency Response.

IN a recent article it was suggested that heterodyne interference from stations operating on adjacent frequency channels may sometimes be reduced in strength, if

concerned is prevalent, it is obviously much better to sacrifice some of the higher tones rather than to put up with a continuous background whistle.

There seems to be a good deal of confusion as to how to set about making the necessary alterations to filter circuits of the simpler type: this confusion doubtless arises through the fact that in one case the effect of increasing coupling capacity is to decrease band width, while with another type the opposite effect takes place.

The accompanying diagram (Fig. 1) should make the position clear at a glance. To increase the selectivity of the most popular type of filter, with a large common capacity as coupling, a larger condenser must be used, or, of course, the existing condenser may be shunted by extra capacity.

The band width of a filter coupled by a common inductance is narrowed down by reducing coupling inductance—by taking off turns, by substituting a smaller coil, or even by connecting another coil in parallel. The same alteration to the characteristics of a filter coupled by a small condenser joined between the high-potential ends of the circuits is made by decreasing coupling capacity.

It is not a bad plan to provide means for making temporary alterations to a receiver so that selectivity may be improved—but inevitably at the expense of high-note reproduction—when interference is prevalent; normal conditions can be

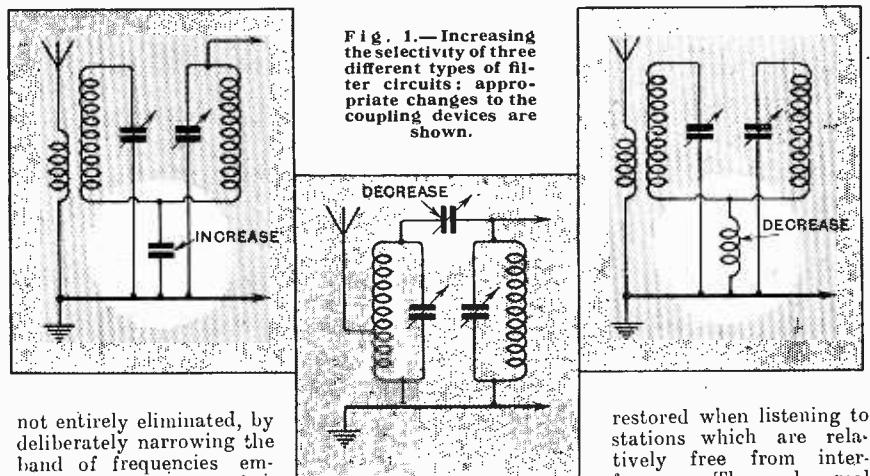

Fig. 1.—Increasing the selectivity of three different types of filter circuits: appropriate changes to the coupling devices are shown.

not entirely eliminated, by deliberately narrowing the band of frequencies embraced by a band-pass filter circuit. Normally the constants of these circuits are chosen so that this band will have a width of about ten kilocycles, which is generally considered to be adequate for good musical reproduction. Where interference of the type with which we are

restored when listening to stations which are relatively free from interference. The only real drawback to the adoption of this scheme is the possibility that by interfering with the constants of the filter circuits the "ganging" of subsequent circuits in a single-knob receiver will be upset unless suitable precautions are taken.

Worth While Trying.

AFTER reading the article in which the "Variable-mu Three" was described, several readers who are using A.C. mains sets of entirely different type have asked whether the special method of connecting the loud speaker, which was one of the features of the new set, could be used in their own apparatus. The reason for making a change, of course, is to get rid of a residue of mains hum.

It should be borne in mind that the "Variable-mu Three" is a specialised receiver embodying principles that are not

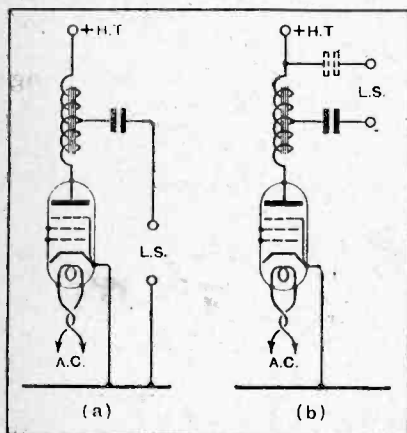

Fig. 2.—Alternative methods of connecting a loud speaker across a tapped output choke.

found in more conventional sets. One of the great advantages of combining the functions of detection and output in a single pentode valve is that the set will be inherently stable, and will not normally show any tendency towards motor-boating. By connecting the loud speaker of an ordinary set directly between a tapping point on the output choke and the H.T. positive side of this choke, a greater proportion of the signal frequency energy in the anode circuit will be passed through the common resistance or impedance of the eliminator, and so there will be more chance of provoking L.F. instability.

In spite of this, the plan is well worth while trying; if it is unsuccessful no harm will have been done, and no extra apparatus is necessary for making the test.

The alternative methods of connection with which we are concerned are shown diagrammatically in Fig. 2 (a) and (b). The second (b) is the method that will often prove effective in reducing hum. If the loud speaker leads are unusually long, it will be as well to interpose a second condenser (shown in dotted lines) in order that the extension leads may not be at high D.C. potential with respect to earth.

Niceties of Filter Adjustment.

IT seems to be generally assumed that the sensitivity of a band-pass filter will be reduced by narrowing down the frequency band embraced by the circuits. This opinion is diametrically opposed to the true facts. As coupling between the circuits is progressively reduced from the

value which gives the normal 10-kilocycle separation, signal strength will increase up to a point where the circuits are coupled to the extent necessary to give single-peak tuning. Admittedly this increase will not be great, but it is easily measurable.

In this condition, it is obviously incorrect to describe the filter as a "band-pass" device, as it will give maximum response at a single definite frequency only. It will no longer be superior to a single-tuned circuit in preventing high-note loss, but will be more selective.

Of course, if we go further and again reduce coupling below the optimum value, a decrease in signal strength will become evident, but selectivity will be still further increased.

Three-control Superheterodyne.

IT has been asked whether the "Super-Selective Six" receiver could be expected to work satisfactorily if separate tuning were provided for each element of the input filter circuit, instead of a ganged condenser. Naturally, questions of this nature are received generally from those who wish to use existing components as far as possible.

At first sight one is inclined strongly to deprecate the introduction of this modification, because, as is well known, a true filter circuit can hardly be properly tuned except by mechanically linked condensers. But it is an undoubted fact that, in spite of added complexity in operation, the set works extremely well when modified in this way, although it should be made quite clear that, with separate tuning of each element of the filter, this part of the receiver cannot be expected to function in the way intended by the designer.

Absorbing Surplus Voltage.

WHEN it is desired to operate a power transformer on a greater voltage than that for which it is designed, it is permissible—at any rate, if the difference is not too great—to insert in series with the primary winding a limiting resistance of suitable value.

Questions have often been received as to the correct value of resistance to be used in specific cases, but it should be made quite clear that it is never possible to give a definite answer unless the current passed through the primary winding under normal conditions is known. True, an approximation can often be made by guessing at the efficiency of the transformer, provided full details of its secondary output are known, but in most cases one can do no more than make a rough approximation.

It is useful to remember that the average small transformer as used in a wireless receiver consumes something between 0.15 and 0.25 amp., and thus, for example, to absorb 50 volts resistances of between 200 ohms and rather more than 300 ohms will be needed. Very often a wire-wound potentiometer of the type capable of carrying about $\frac{1}{4}$ ampere is suitable for this purpose. It will be connected as a simple rheostat, and start-

ing from maximum, its value will be progressively reduced until operating conditions are right. The difficulty, of course, is to know when they are right, unless an A.C. meter is available. Failing this, a fairly good approximation may be made by inserting a D.C. milliammeter in the various anode circuits of the receivers; when the average anode current is about right, it is probable that the A.C. secondary voltages also are correct.

Transformer Heater Windings.

IT is well known that the output of a power transformer secondary is dependent to a certain extent on load. For instance, the voltage delivered by an L.T. secondary rated to give 4 amps. at 4 volts will rise if the instrument be used for a two-valve set consuming only 2 amps.

The extent of this voltage rise depends entirely on the design of the transformer, and in the case in question might possibly be serious enough to reduce the life of the valves. Correspondents who have asked questions regarding this matter will be safe enough in employing an artificial load to absorb the surplus; resistors of 4 ohms capable of carrying 1 amp. are obtainable, and one of these, if connected across a 4-volt 4-amp. secondary which is actually feeding two 1-amp. valves, will in most cases impose a sufficient load for complete safety.

To be entirely logical, two of these loading resistances (or a single 2-ohm resistance) should be connected in parallel, but such a transformer as that under consideration will generally be designed with a view to its being used in three- or four-valve sets, and on a load of 3 amperes will maintain almost exactly its rated voltage.

FOREIGN BROADCAST GUIDE.

CORK

(Irish Free State).

Geographical position: 51° 53' 57" N., 8° 29' 55" W.

Approximate air line from London: 353 miles.

Wavelength: 224.4 m. Frequency: 1,337 kc. Power: 1.5 kW.

Time: Greenwich Mean Time.

Standard Daily Transmissions.

G.M.T. 13.30, Time, weather, news, gramophone records; 18.00, gramophone records; children's hour; 19.20, news, etc.; 20.30 (Sun.), time signal and concert (21.30 week-days); 22.30, time, news and weather.

Man and woman announcer.

Call (in Erse): *Gladhach radio Corcaigh é seo* (Cork calling).

Opening signal: tuning note.

Closes down with good-night greetings in both Erse and English, followed by Irish Free State National Anthem.

The Wireless World

AND
RADIO REVIEW
(19th Year of Publication)

No. 641.

WEDNESDAY, DECEMBER 9TH, 1931.

VOL. XXIX. No. 24.

Editor : HUGH S. POCOCK.

Editorial Offices : 116-117, FLEET STREET, LONDON, E.C.4. Editorial Telephone : City 9472 (5 lines).
 Advertising and Publishing Offices : DORSET HOUSE, TUDOR STREET, LONDON, E.C.4.
 Telephone: City 2846 (15 lines). Telegrams: "Ethaworld, Fleet, London."

COVENTRY : Hertford St. BIRMINGHAM : Guildhall Bldgs., Navigation St. MANCHESTER : 260, Deansgate. GLASGOW : 26B, Renfield Street, C.2.
 Telegrams: "Cyclist, Coventry." Telegrams: "Autopress, Birmingham." Telegrams: "Iliffe, Manchester." Telegrams: "Iliffe, Glasgow."
 Telephone: 5210 Coventry. Telephone: 2970 Midland (3 lines). Telephone: 8970 City (4 lines). Telephone: Central 4857.

PUBLISHED WEEKLY. ENTERED AS SECOND CLASS MATTER AT NEW YORK, N.Y.

Subscription Rates : Home, £1 1s. 8d. ; Canada, £1 1s. 8d. ; other countries abroad, £1 3s. 10d. per annum.

As many of the circuits and apparatus described in these pages are covered by patents, readers are advised, before making use of them, to satisfy themselves that they would not be infringing patents.

Electricity for Radio Receivers.

AT a meeting of the Faversham Town Council held on October 21st, it was decided that all electricity used for radio apparatus must be paid for at the lighting rate."—*Electrical Review*.

From time to time we come across reports of pious decisions of this nature made by authorities responsible for the supply of electricity in various districts. It is easy to understand that those whose job in life it is to sell electricity, especially where they enjoy a monopoly, may endeavour to sell it at the highest price.

The difference in charge between a lighting and a power rate was, we venture to believe, introduced for the very simple reason that electricity would never have been used for power if it had to be paid for at the same rate as electricity for purposes of illumination.

An "Electricity Era."

We freely talk of the times in which we live as an "electricity era," and great efforts are being made in many directions to extend the use of electricity for almost every conceivable purpose. We are constantly urged to use electricity to a greater extent in our homes, in our offices, and in our factories, yet we believe that if an independent investigation were made to-day it would be found that the responsibility for delay in popularising electricity would rest very largely with those whose business it is to sell electricity. The pettifogging attitude of some of these bodies in regard to minor regulations, and the lack of any uniform policy amongst them, prevent the public from forming any opinion in advance of what precisely their commitments are likely to be if they use electricity more freely.

The public should be given every encouragement to extend the uses which they make of electricity, and any unreasonable, not to mention unwarranted, restrictions, can only have the effect of retarding that expansion

which it should be the aim of the supply companies to encourage. If one wants to know what it will cost to use electricity for water heating, for radiators, or for cooking in the home, or for factory installations, it should be possible for the supply companies to give a very close estimate of the probable running costs for the benefit of the consumer, yet to-day we believe that thousands of potential users of electricity are discouraged from employing it for additional purposes because they have failed to obtain a proper idea of what the running cost would be.

Inconsistency.

But this is all by the way; the purpose of the present comment is to question the decision which we quote above, and to ask by what authority such a regulation is made. The lighting rate is chargeable, we believe, for illumination only, and any consumer who accepts such a decision as that quoted above is, we consider, doing a disservice to the cause of electricity. We would like to ask those responsible for this decision what degree of illumination they think the user of a wireless set derives, particularly if the electricity is used for indirectly heating the filaments of modern valves. Again, in the case of many modern electric radiators approved by electricity authorities, why is it that those which have lamps incorporated, to provide illumination even when the heating elements are not energised, are not wired so that the lamps are connected to a lighting circuit and the heaters to a power circuit? Surely, to be consistent, this should be insisted upon to add another inconvenience and discomfort for the benefit of the consumer! Cannot supply companies be induced to get together and agree as to *conditions of supply*, even though for the time being it may be difficult to standardise the charges?

Wireless World

SINGLE DIAL



SUPERHETERODYNE

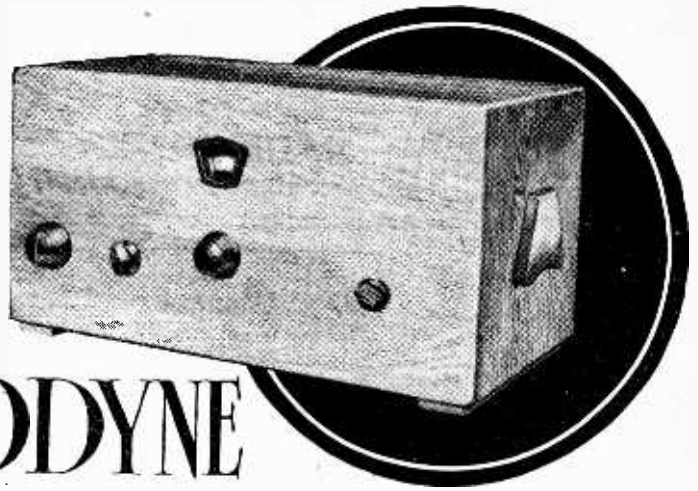

An Easily Constructed and Inexpensive Five-valve Set Possessing many Outstanding Features.

By F. H. HAYNES and W. T. COCKING.

RANGE of reception is the usual attribute of the superheterodyne, but the beginner in the hobby of home construction not yet, perhaps, conversant with its principles is apt to regard it as the most complicated type of set to pursue. Actually it is one of the simplest forms of receiver to construct where long range reception is the aim, and compared with the straight H.F. amplifier possesses none of the pitfalls. Its amplifying properties are certain, not being marred by the intricate condition incurred by self-oscillation against which the designer has difficulty in providing safeguards. Every valve circuit operates at a different frequency, and the need for decoupling practically disappears. The possibility of difficulties with a reaction adjustment are not present, and the volume control does not become unintentionally interlocked with a condition of regeneration. In the hands of the constructor the superheterodyne proves itself to be free from drawbacks, and the design given here reduces the amount of work involved to no more than the bolting together of components.

In addition to giving an attractive appearance to the complete chassis, metal baseplate assembly removes all that trouble of working with square, rule and dividers for positioning the components and gives precision to their location. In this design also the need for drilling and soldering has been avoided.

From the circuit it will be seen that the non-radiating frequency changer employed in other *Wireless World* superheterodynes is used, and that it is preceded by a two-stage band-pass filter, which is tuned by two sec-

tions of the three gang condenser. The coupling between the two band-pass filter sections is by means of very small condensers connected across their high potential ends; these condensers are mounted inside the coil bases, and require no adjustment by the user. A high degree of pre-selection is thus obtained, and second channel interference is reduced to a minimum.

THE superheterodyne principle provides the most selective type of receiver, and as it can also combine a maximum of sensitivity with first-class quality of reproduction, it is pre-eminently suited to modern broadcasting conditions. A superheterodyne is also easier to build and adjust than a tuned H.F. set of equal sensitivity, for the usual instability problems of the latter are not encountered. Until recently superheterodynes have suffered from the disadvantage of utilising two tuning controls requiring critical adjustment. The receiver described here employs single-dial tuning correctly adjusted for operation both on medium- and long-wave ranges.

The disadvantage of the superheterodyne in that two tuning dials are normally required, each necessitating a critical setting, has here been removed. Single dial superheterodynes are, of course, already well known, but those of American origin operate only on one waveband, and this receiver probably represents the first solution of the difficulty of correct ganging of oscillator and input circuits operative over both the medium and long-wave ranges. The commercial production of a new type of coil solves once and for all the single dial problem, and the considerations behind its development may be briefly considered.

The variable condenser, used to tune the oscillator, is, of course, identical with those used for the pre-selector; this circuit, however, is not tuned to the frequency of the incoming signal, but to a frequency 110 kc. higher. At first this may seem impossible, but by the careful adjustment of the relative values of the coil inductances and the condenser values, it can be achieved within close limits. When the condensers are all set at minimum the tuning capacity is chiefly the stray capacity, and this is about the same in all three circuits. For the oscillator to tune to a higher frequency than the others, therefore, a smaller value of

Single Dial Superheterodyne.—

inductance must be used for its coil. When we consider the state of affairs with the condenser vanes all fully enmeshed, however, we find that if all the condensers have the same capacity the oscillator is resonant at too low a frequency, in spite of the reduction in the inductance of its coil.

The difficulty is got over by inserting a fixed condenser in series with the oscillator tuning condenser, and so reducing the total effective capacity in this circuit. It has been found that this condenser should have a capacity of about 0.002 mfd.; its exact value is, of course, critical, but this need not concern us, since it requires no adjustment by the user. It is readily possible by this means to obtain perfect ganging at the two extreme ends of the tuning scale, and simultaneous resonance is only very slightly imperfect at any point. This imperfection, of course, is theoretical, for in practice the ganging is as accurate as anyone could desire.

So far, the ganging follows normal commercial prac-

employ the same method as on the medium waveband. The objection to this is the circuit and switching complications which it involves. When we consider that the long waveband covers a narrower frequency range than the medium waveband, we see that it is possible to employ a somewhat simpler arrangement. By adjusting the inductance of the long-wave oscillator winding and the minimum value of the circuit capacity, it is possible to obtain accurate ganging with the same value of series capacity as on the medium waveband. As a result, there need be no increase in the switching, for the long-wave trimmer shown in the circuit across the long-wave section is effective with this coil only, and is controlled by the normal shorting switch. The capacity of this long-wave compensating

condenser has been determined by the makers of the coil and fitted into the base, while the long-wave coil has been suitably modified so that the frequency difference followed between the minimum and maximum condenser settings is equal to that of the input filter, but displaced by the required 110 kc.

SPECIFICATION.
 First single-dial two-range superheterodyne with correct tracking of input and oscillator circuits while avoiding the use of auxiliary tuning equipment.
 Simple construction on prepared aluminium baseplate.
 Selective band-pass input circuits and band-pass intermediate couplings.
 Compensated pentode output.
 H.T. current 12 mA.
 Power output about 350 milliwatts.
 Input volume control.
 Highly selective.
 Gives daylight reception of most foreign stations when used with a small aerial.

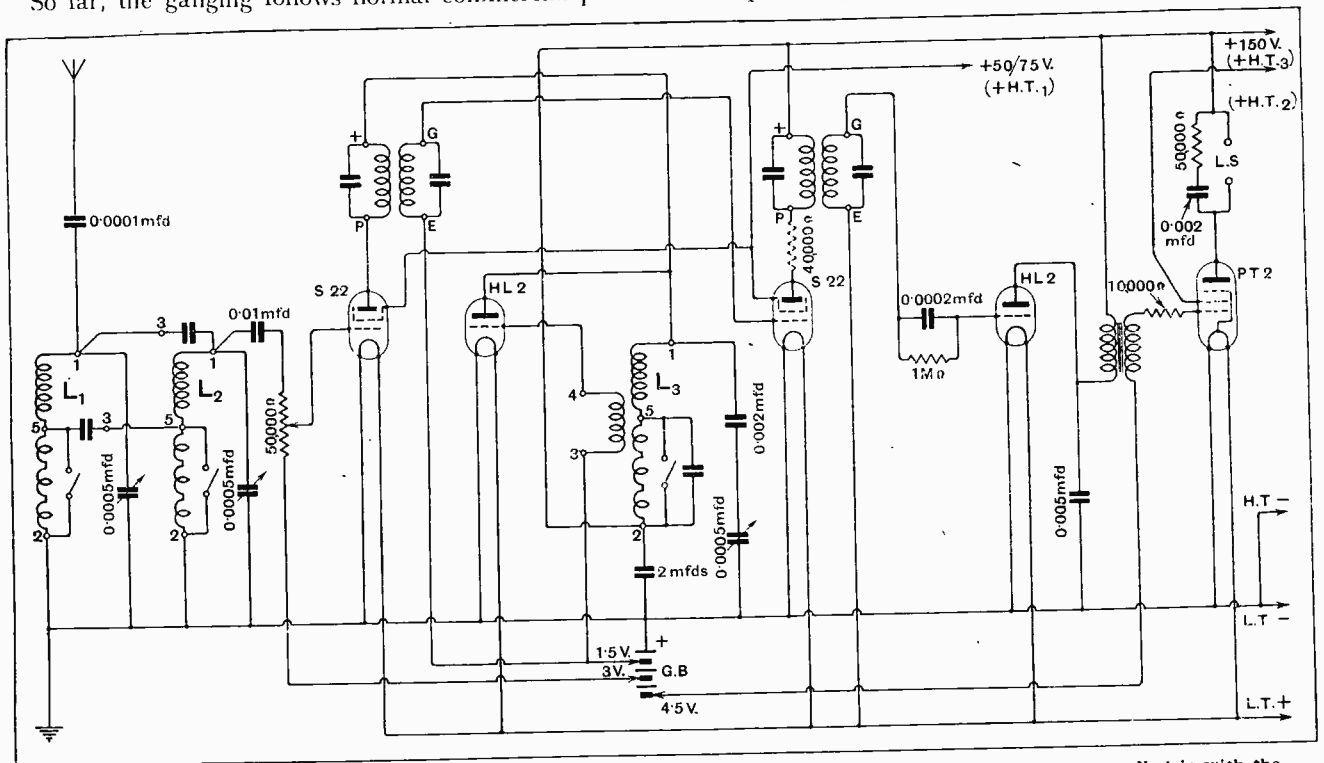

The long-wave band-pass coupling condenser is associated with the first coil and the medium band capacity coupling is with the second. The medium band tracking condenser removes the H.T. potential from across the plates of the oscillator tuning condenser.

tice for single-control superheterodynes, and no particular difficulties have arisen. The case is entirely different when we come to the long waveband, however; the obvious solution to the problem is to switch the compensating condenser as well as the coils, and to

It would appear that these numerous trimmers would make the adjustment of the ganging extremely difficult, and this would be the case had they all to be adjusted when setting up the receiver. The oscillator coil unit, with its factory-set condenser, renders the entire process

Single Dial Superheterodyne.—

as straightforward as if the oscillator tuning corresponded with the other tuned circuits. The adjustment of the ganging consists merely of setting the three parallel trimmers mounted on the gang condenser, and is but little different from that encountered in ganging an ordinary tuned-H.F. set.

Coming now to the rest of the receiver, a single screen-grid valve, an S.22, is employed as the I.F. amplifier, with the band-pass filter coupling tuned to 110 kc. The adjacent channel selectivity of the set is controlled almost entirely by these transformers, and so their correct adjustment is of considerable importance. Small trimmers, actuated by levers projecting from their bases, are provided so that each circuit may be accurately tuned to the correct wavelength and amplification brought up to a maximum. The coupling between the coils in each transformer is also adjustable in order that a desirable compromise between selectivity and quality may readily be reached in any circumstances.

The second detector is of the leaky-grid type employing an H.L.2 valve, and it is coupled to the output stage by means of a 3.5-1-ratio L.F. transformer. No low-pass filter comprising H.F. choke and condensers is fitted in the detector anode circuit, since it was found unnecessary with the layout and components employed; a 0.005 mfd. by-pass condenser is connected between the detector anode and filament. The output valve is one of the new high-efficiency pentodes, the P.T.2, and with 150 volts anode potential and 125 volts on the screen grid it gives an output of about 370 milliwatts requiring a grid bias of only 4.5 volts, while the anode and screen currents total only 5 mA. No output filter is fitted, since it is intended that the receiver be used with a speaker designed to work with this particular valve, such as the Ormond or Celestion units. A resistance-condenser impedance-limiting circuit, with values of 50,000 ohms and 0.002 mfd. respectively, is connected across the speaker terminals, giving the required tone connection.

The volume control consists of a 50,000-ohms potentiometer connected across the secondary of the input band-pass filter, with the slider taken to the grid of the S.22 first detector. That this gives no control over the receiver amplification is unimportant with battery

valves, since, compared with mains types, they are quiet in operation and background noise is unlikely to be noticeable. The single control is, of course, cheaper than one of the ganged type, and it is quite distortionless. The range of control which it affords is amply sufficient for all but the very strongest stations. It may not be sufficient to reduce the local station to a low enough level when an outdoor aerial is employed, however, and so it may sometimes be necessary to disconnect the aerial when receiving the local station.

Construction has been rendered particularly straightforward. The first components to attach are the valve holders, and in doing so care should be taken to ensure that there is no possibility of the screw heads making contact with the under face of the plate, or a fault will

be created of a type difficult to trace. Next attach the 2-mfd. condenser, as the heads of the fixing screws will not be accessible when the tuning condenser is placed in position. The grid battery goes on next. With the extension terminals screwed in tightly to the under part, the tuning condenser is attached, taking note that the adjusting screws pass through the second hole in the end brackets. Swing the terminal stems so that they fall central in the holes in the plate as viewed from the underside.

The tuning coils are identified by their reference labels and, if accidentally interchanged, the set may work, but the results will be poor. The K.21 is at the front of the set, and the special K.23 compensated oscillator at the back. Keep the operating rod through the coils while attaching them, taking care to adjust the position of the base lids, as well as the coils themselves, so that the

underside extension terminals are well away from the edges of the metal. It is unwise to tamper with the setting of the screws on the condensers in the coil bases, these having been correctly adjusted at the factory.

New Band-pass Filter Coupling.

The actual value of coupling capacity in the band-pass filter on medium waves is about 1 micromicrofarad.

With the coils in position it will be noted that the switch rod can be withdrawn, being forced through again with all cams in the same position. Earthing of the switch rod in this instance is not essential.

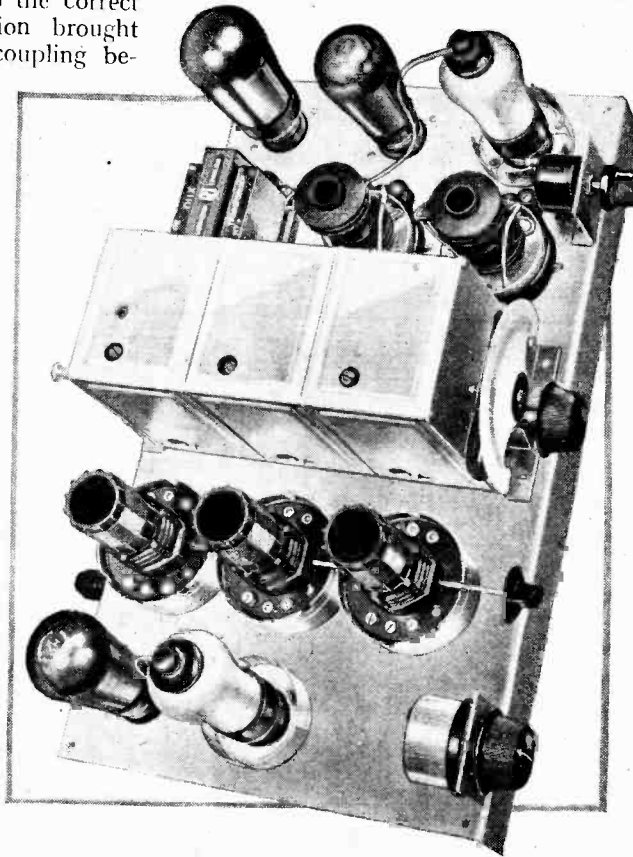

This plan view of the complete chassis, with screening covers removed, reveals the merits of under baseboard wiring

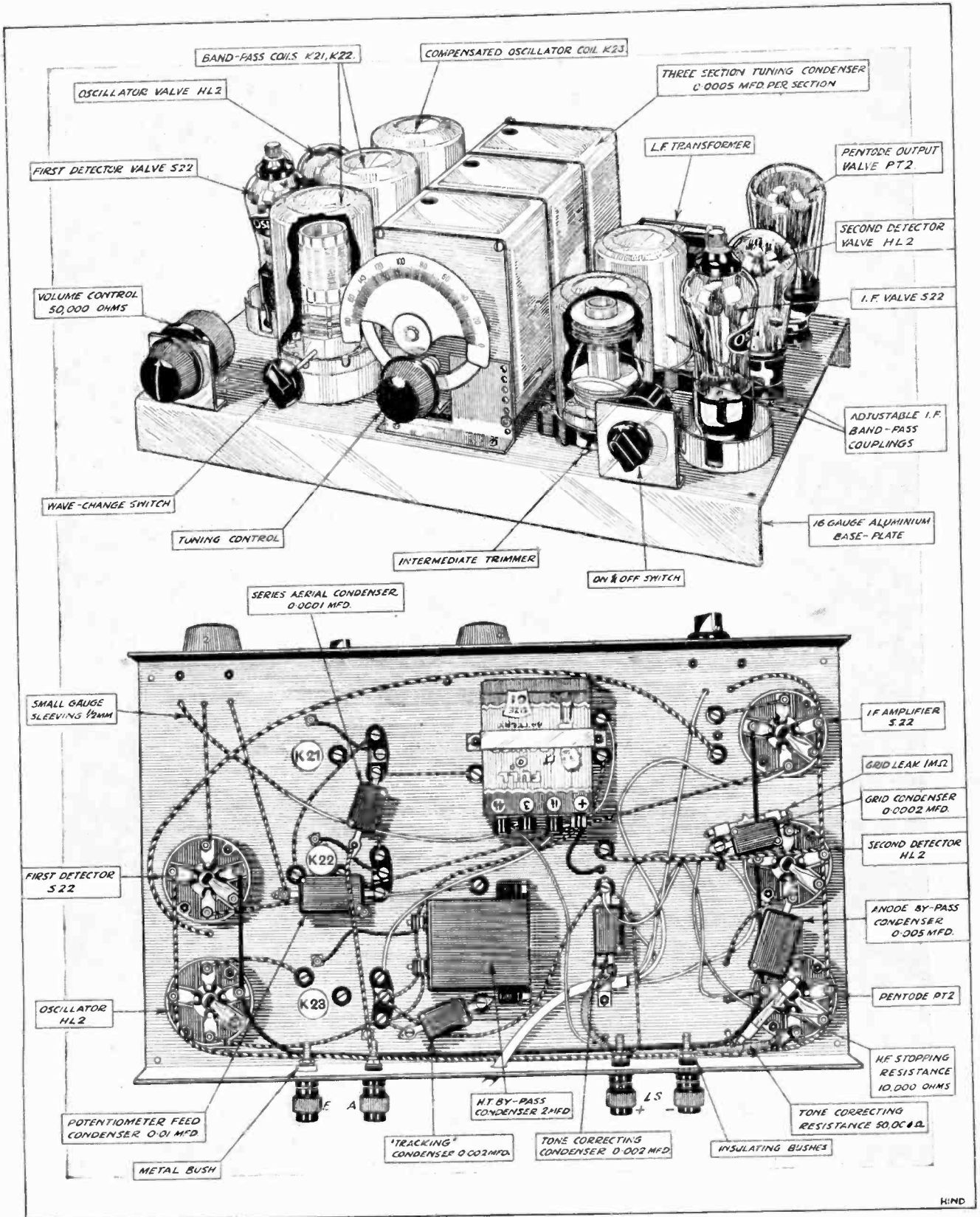

ASSEMBLY GUIDE, showing the identity and location of all components.

- 1 Three-section gang controlled tuning condenser with trimmers knob and dial 0.0005 mfd., with underside terminals. (Jackson Bros. Type R3W)
- 1 Tuning coil with long-wave band-pass capacity coupling (front coil).
- 1 Tuning coil with short-wave band-pass capacity coupling (centre coil).
- 1 Oscillator coil with modified windings and special long-wave compensating condenser (back coil)
- (Colvern, Types K.21, K.22 and K.23)
- 2 Adjustable intermediate couplings, 110 kc., with under baseplate terminal extensions (Colvern "Colverdynes")
- 5 Valve Holders for under baseboard mounting (W.B. 5-pin type with reversed and recessed screws)
- 1 On-and-off switch (Ready Radio)
- 1 L.F. intervalve transformer . . . (R.I. "Dux")

LIST OF COMPONENTS REQUIRED.

- 1 Potentiometer, 50,000 ohms. (Colvern)
- 1 Condenser, 2 mfd. non-inductive, 400 volts D.C. test (T.C.C. Type 50)
- 1 Condenser, 0.01 mfd. tag type (T.C.C. Type M)
- 1 Condenser, 0.005 mfd. tag type (T.C.C. Type M)
- 2 Condensers, 0.002 mfd. tag type (T.C.C. Type M)
- 1 Condenser, 0.0002 mfd. tag type (T.C.C. Type M)
- 1 Condenser, 0.0001 mfd. tag type (T.C.C. Type M)
- 1 Grid leak resistance with wire extensions, 1 megohm (Loewe)
- 1 Resistance with wire extensions, 10,000 ohms. (Loewe)
- 1 Cable battery connector, 5-wire, H.T. +1, H.T. +2, H.T. +3, L.T. +, common H.T. - and L.T. - (Ready Radio)
- 1 Grid bias battery, 4½ volts (Siemens Type G.1)

- 1 Metal baseplate in 16 gauge aluminium, punched with all necessary holes for securing components complete with clips for holding battery cable and grid bias battery . . . (White Bros. & Jacobs)
- 1 Resistance, 50,000 ohms
- (“Lewcos” Spaghetti type)
- 6 yards of No. 24 S.W.G. tinned copper wire and 6 lengths of ½ in. silk sleeving, screws and nuts.
- 4 Wander plugs . . . (Belling-Lee side lead type)
- 4 Terminals, Aerial, Earth, L.S. +, I.S. - with insulating spacers . . (Belling-Lee type)
- Valves, S.22, S.23, H.L.2, H.L.2, and P.T.2 (Osram)
- 1 Cabinet with sliding baseboard and pierced front wooden panel (Longley Radio Manufacturing Co.), 63, Longley Road, Harrow, Middlesex.

Approximate cost of parts including valves, but excluding cabinet, £11 3s. 6d.

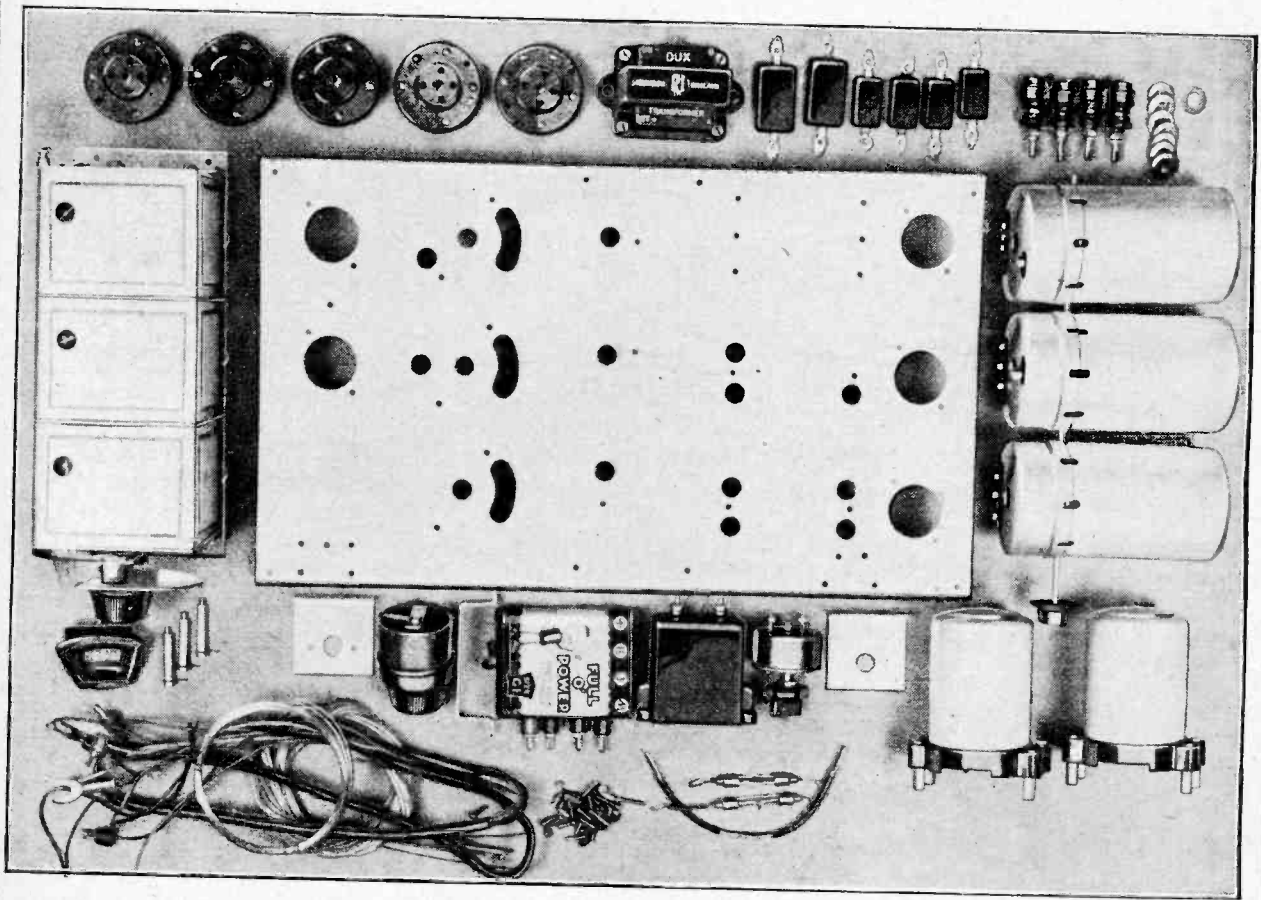

In fitting up the intermediates with their stem terminals it should be observed that the "P" terminal on the second intermediate requires no underside extension. The "+" and "E" terminals face towards the tuning condenser position. Mount the L.F. transformer the correct way round for its outgoing connections. Handle the potentiometer with care so as to avoid damaging its fine winding and, when finally fitting, take care that the terminals do not make contact with the top side of the plate. If there is any possibility of contact, mount the potentiometer with its terminals to the top, remembering to cross over the outside leads when wiring. Caution is needed when

fitting the "on" and "off" switch, not only to ensure that its action is reliable, but also to avoid contact between its spindle and the metal bracket in cases where the spindle is "live." Before the wiring is proceeded with the six small condensers are placed in position, being careful not to confuse the values, as a mistake will impair performance while not causing complete failure. The first wires to be run are the short connections going to earth.

(To be concluded.)

A specimen receiver is on view at the Editorial Offices, 116, Fleet Street, London, E.C.4.



Factors which Affect the Output.

By W. T. COCKING.

THOSE in search of high-quality reproduction must pursue a path strewn with many difficulties. At the outset they usually decide to tolerate no distortion whatever, a most laudable ambition, but one which is almost impossible of achievement. Distortion is invariably present in every receiver, and the most that can be done is to reduce it to such a small degree that the ear is deceived into believing that none exists.

There are two main kinds of distortion, frequency distortion and amplitude distortion, and one is much more noticeable than the other. The former is often considered the greater evil, and extraordinary precautions are taken to prevent it from creeping in. In actual fact, however, frequency distortion is not very readily detectable by ear, and large amounts, such as a 50 per cent. loss of high notes, are often present when the owner of the set believes it to be perfect in this respect.

It is quite different with amplitude distortion, however, for the smallest amounts force themselves upon one's notice; in spite of this, it is responsible for 99 per cent. of the distortion given by the average receiver. That amplitude distortion is more readily detectable can be shown by a few simple experiments. If we double the capacity of the by-pass condenser C in a receiver similar to that of Fig. 1, we are introducing frequency distortion, but it will usually be found that this alteration makes very little difference to the tone. On the other hand, if we increase the value of the grid bias on the output valve at a time when the

signal is fully loading this valve, the resulting amplitude distortion becomes intolerable.

It is, of course, important that the frequency distortion should not be too great, for it is upon the upper harmonics of musical notes that we rely to distinguish different instruments from one another. An excessive loss of high notes, therefore, causes some of these harmonics to be lost, and makes a violin sound rather like a flute. Frequency distortion, it will be seen, merely removes certain frequencies which were originally present; amplitude distortion, on the other hand, adds frequencies which were not originally present. The addition of such unwanted harmonics, which are again harmonics of the original frequency, changes the character of the note, making it harsh and unpleasant.

It will be seen, therefore, that amplitude distortion is considerably more important than frequency distortion, and that its elimination must receive the greater care in the receiver design. Apart from the detector, it is usually introduced in the output stage of the receiver, and so it is essential to

employ a valve large enough to handle the necessary power. Let us consider, therefore, those factors which influence the power

output that is developed in the speaker.

The Volume Level.

First, of course, there is the required volume level, for it is obvious that large volume necessitates a greater power output than small volume. The dependence of the one upon the other, however, is greater than is often

/ F, with a certain power output, some distortion is inevitable, shall it be frequency or amplitude distortion? How these differ and how they should be treated is explained in this article.

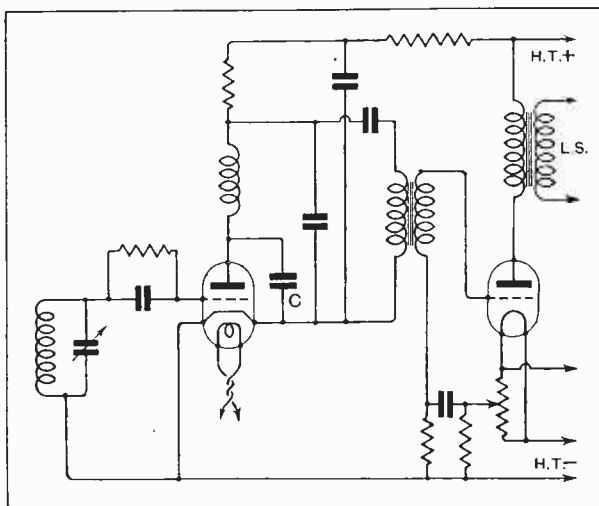

Fig. 1.—A commonly employed detector and output stage capable of giving first-class quality.

How Much Power?

realised, for the ear acts logarithmically, and it is necessary to increase the sound power four times in order to double the apparent volume. It is chiefly this factor which makes large volume so expensive, for if we are using a P.625 valve with an output of about 1,000 milliwatts in a circuit such as that of Fig. 1, and we wish to double the apparent volume, it will be necessary to change to an L.S.6a output valve to obtain the full 4,000 milliwatts which will be needed.

Not only the volume level required, but the range of frequencies with which the amplifier will deal, affects the power output necessary, for the power in sound increases inversely as the square of the frequency. This means that for equal apparent intensities at 100 cycles and at 50 cycles, four times the power is required at the lower frequency. A set, therefore, which will pass freely all frequencies down to 30 cycles will need a much larger output stage than one which cuts off at 80 cycles for the same apparent volume level at medium frequencies.

Where the cost of the apparatus must be taken into consideration, therefore, we have to choose either amplitude distortion on frequencies below about 80 cycles or reduced volume from these same frequencies. On many broadcast transmissions and with most gramophone records, it makes little difference which of the two alternatives is chosen, for these low frequencies occur comparatively rarely. When these very low notes are present in music, however, there is not the slightest doubt which is preferable. After a short time, amplitude distortion becomes intolerable, whereas one can get accustomed to a small amount of frequency distortion.

It is the writer's opinion, therefore, that in any case where the power output is limited, it is good practice to reduce the amplification of the very low notes in order to avoid valve overloading. In this connection, it must be remembered that few speakers give much response to these very low frequencies, since the usual small speaker cabinet cannot provide sufficient baffle area for their efficient radiation. This argument for reducing the bass is, of course, only applicable to cases where the power output is small, for there is no

doubt that the best quality cannot be obtained unless the lowest frequencies are fully reproduced, but this often calls for an unjustifiably large output stage.

Speaker Efficiency.

The next point to be taken into consideration is one which is usually ignored, in spite of the fact that it is of the greatest importance. It is the question of the speaker efficiency. The efficiency of the average speaker is extraordinarily low, and is probably in the neighbourhood of 2 per cent. In the case of a valve with an output of 5,000 milliwatts, therefore, only 100 milliwatts is actually used to produce sound, and the remaining 4,900 milliwatts is wasted. If a speaker of 100 per cent. efficiency could be produced, a valve such as the P.215 would produce a greater volume of sound than a P.P.5/400 with the present speakers!

If the power output is to be kept at a minimum, therefore, it is of the utmost importance to choose as efficient a speaker as possible. There is, unfortunately, little data available on the subject, and we must have recourse to the unscientific test of listening. So far as the writer can judge, the most sensitive speakers are usually of the moving-coil type with a mains-energised field, a high flux density, a small diameter moving coil, a narrow air gap, and a cone between 7in. and 10in. in diameter, and the efficiency appears to be about 4 per cent. Permanent magnet moving-coil speakers, many mains-energised types, and the best reed-drive speakers come next with an efficiency of about 2 per cent. The least efficient class includes a few moving-coil types, but

is composed chiefly of reed-drive speakers with an efficiency of about 1 per cent. It will, of course, be understood that these figures are only approximate, and, in practice, the various classes merge into one another.

The output power required from the receiver is inversely proportional to the speaker efficiency, and so we find that if 1,000 milliwatts is sufficient with a 4 per cent. efficient speaker, we shall need 2,000 milliwatts with a 2 per cent., and 4,000 milliwatts with a 1 per cent. efficient speaker. In practice, the difference between a 1,000 milliwatts output and a 4,000 milliwatts output

Fig. 2.—A push-pull output stage is often used where considerable volume is necessary.

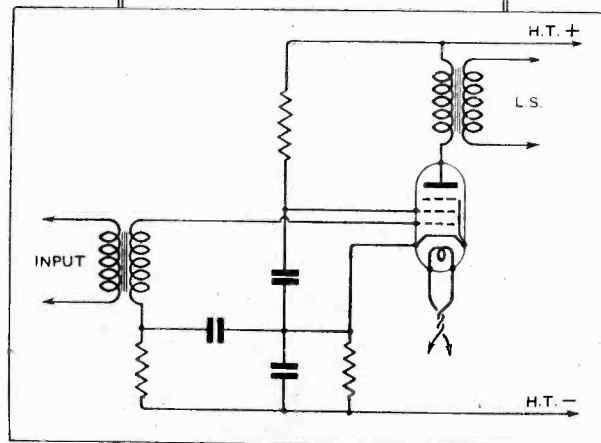
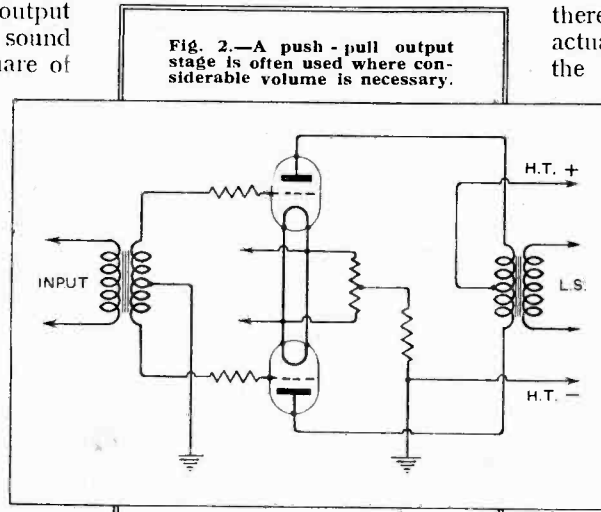

Fig. 3.—Probably the most efficient output stage yet devised is obtained when a mains pentode is used.

How Much Power?

is the difference between a P.625 and an L.S.6a valve in the circuit of Fig. 1; a 2,000 milliwatts output is perhaps most economically obtained with two P.625 valves in the push-pull circuit of Fig. 2, although a single pentode can often be employed as in Fig. 3.

In the interests of economy, therefore, it is extremely important to use as efficient a speaker as possible. Care must be taken in choosing a speaker, however, for if the high efficiency is obtained by means of resonances, the general reproduction will be unsatisfactory. Where the high efficiency is obtained by sound design, it will usually be found that the speaker is capable of giving as good, if not better, quality than one of lower efficiency.

These, then, are the chief considerations in the attainment of good quality. The speaker must be as efficient as possible, and yet have a good frequency response. The output valve must be capable of giving sufficient output for the desired volume level with the particular speaker used, and with the amount of bass which is

retained in the amplifier. In general, this will lead to an output of about 1,000 milliwatts for normal volume in a medium-sized room when frequencies down to 50 cycles are fully retained. If fairly loud volume is desired, however, at least 2,000 milliwatts are necessary. Where the output is limited to 350 milliwatts, as with many battery sets, we must be content with less volume, or a reduced bass response, or we can effect a compromise between the two. We can reduce both bass and volume to some extent, and this is probably the most satisfactory way out of the difficulty.

The above figures are based upon a speaker of about 4 per cent. efficiency; with the average speaker, about double the power output is necessary, and 2,000 milliwatts—that is, a valve such as the AC/Pen—is required for normal output. With a really inefficient speaker, a larger power valve would be needed, and so it will be seen that in cases where increased volume is needed it may sometimes be cheaper to obtain this by changing to an efficient speaker, instead of increasing the size of the receiver output stage.

A New Transmitting Society.

A society intended to bring together the local amateur transmitters has been formed at Gillingham, Kent, under the name of the Medway Experimental Society. Meetings are held on Tuesdays at 33, Seaview Road, Gillingham, and visitors, especially licence-holders, are welcomed. The hon. secretary is Mr. J. Nixon (G6XO).

o o o o

On the Ether Again.

Mr. W. P. Dolphin (G6DP), whose station was some years ago located at Tottenham, asks us to state that he is now transmitting on 21 and 42 metres, crystal controlled, from 127, King's Road, Old Trafford, Manchester, and will be glad to receive reports on tests on these wavelengths and on telephony, choke controlled, on a frequency of 7,143 kc.

o o o o

Notes from India.

Mr. J. W. J. Tyrell, formerly 2BLX, writes from Kohat, N.W.F.P., India, where he is now stationed with the Kohat District Signals and transmitting under the call-sign VUIKDS on either 20 or 40 metres. He apologises to any of our readers who may have communicated with him in regard to the appeal which appeared in our issue of March 4th, 1931, but says that a considerable portion of his mail has been lost through his being away from Jubbulpore and travelling over India, but he will always be pleased to communicate with anyone on either of the wavelengths mentioned.

o o o o

Under Difficult Conditions.

The station is about 2,000ft. above sea level, but is completely surrounded by hills rising to twice that height, so that it is badly screened. Electrical storms are frequent, and it is not unusual when manipulating the aerial switch to get sparks $\frac{1}{2}$ in. in length. Two transmitters are used, one being of the T-P. T-G. type with 1,200 volts on an AT50 valve, the other a balanced Colpette's circuit with

TRANSMITTERS' NOTES.

30 volts to an LS5. Both use the half-wave Hertz aerial.

o o o o

Fading Observations.

From 10 p.m. until about 6 to 7 a.m. Indian time (4.30 p.m. to 1.30 a.m. G.M.T.) the 40-metre wavelength is undoubtedly best, bad fading being experienced on 20 metres, but from 6 a.m. till about 10 a.m., Indian time, 20 metres is better, the signal strength improving from R3.4 to R8.9. From 10 a.m. until early evening both wavelengths practically fade out. The amateur stations which are best heard are those in Russia, Siberia, and Finland, while South Africa is occasionally picked up.

Broadcast Reception.

As regards broadcast reception, Mr. Tyrell says that PCJ, Saigon, and Moscow are far the loudest, while G5SW is never more than a whisper.

o o o o

Expedition to the West Indies.

Mr. Stratford D. Jolly has recently purchased the Brixham trawler *Vigilant*, and is fitting her out for an extended trip to the West Indies, where it is his intention to explore many of the islands.

He wishes to install a short-wave set on the vessel, and will be glad of the advice and assistance of any amateur transmitters willing to help him in the design and construction of a suitable set to work off a lighting supply at 25 volts, and those who are willing to arrange a regular schedule with his operator during the voyage.

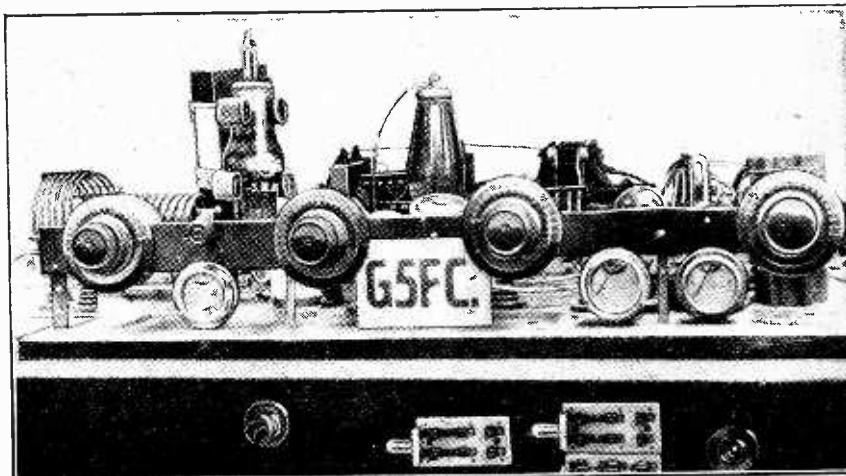

G5FC, owned by Mr. F. Donald Cawley, at Hale, Cheshire, employs a 3.5 megacycle crystal as drive; this actuates, through various frequency-doubling stages, a final amplifier which uses a S.W.50 valve with an input of 50 watts. The station has worked all continents and is in regular operation on the 7 and 14 mc. wavebands. Reports are always appreciated.

Unbiased — "FREE GRID" —

Loose Thinking.

IF there is anything that is calculated to make me go off the deep end it is the terrible looseness of expression which is gaining ground among amateurs nowadays. I refer to such things as "volts on the plate," which, to me, is perfectly revolting (pardon the pun) and indicative of very slack thinking. Nobody talks of "volts on the filament"; the expression is "filament voltage," although some notorious pedants go to the other extreme and try to emphasise the obvious by talking of "volts across the filament." Personally, I think that the reason is that, while people are perfectly clear in their minds that the filament is merely a resistance shunted across the L.T. battery, it is not fully realised that the valve itself is merely a resistance shunted across the H.T. battery (I am, of course, ignoring decouplers and other impedimenta that may be in series with the valve).

It is no use shutting our eyes to the fact that, considered from the D.C. point of view, the valve-space between the plate and filament is



Volts on the plate.

merely a resistance, and although it is true that it is one which can be varied from within by such things as altering the voltage of the third electrode, yet its relationship to the H.T. battery is pretty much the same as that of the filament to the L.T. battery. So let us have plain

"plate voltage" in future, and be clear in our own minds that we mean the potential difference existing across the plate-filament path of the valve; and let us use "H.T. voltage" when we wish to indicate the difference of potential across the output terminals of our H.T. battery or eliminator.

Even highbrows are guilty of these misdemeanours of expression, but in their case I think the cause is sheer mental laziness.

Wrong Number.

WHEN I was very young I remember that I got the impression firmly fixed in my mind that all foreign languages were pronounced alike, and it occurs to me that the bright young people at Savoy Hill who try so hard to educate us have fallen into the same error.

It so happened that Brazil figured quite largely in the news again not so very long ago, and we were treated to a whole list of names of towns pronounced with the most delicate Castilian lisp one could wish to hear. I am all for giving a place its anglicised name, or, if there is not one, giving it its native pronunciation: I can see no reason for dragging in a third language. A particularly glaring example was made in all the news bulletins over the name "Julio Prestes" some while back. In the name of all that is wonderful, where did they get the pronunciation "Hoolio" from?

Can it be that the B.B.C. staff, with all their vaunted "education," do not know that Brazil is the one South American republic where Spanish is *not* the language of the country? With all their vast organisation they could at least ring up the charwoman at the Portuguese or Brazilian Consulates; she would, I feel sure, be willing to "oblige" once more. Apparently they did this in the case of the visit of Prince and Princess Takamatsu, but, according to a letter of protest from a Japanese medical man which appeared in one of our leading morning papers, they apparently got the wrong number

and spoke to the lady who "obliges" at the Chinese Embassy.

Ten Years Hence.

I HAVE just returned from a visit to the Fatherland in order to witness what was claimed to be an entirely novel stunt in television. I was directed into a small room cluttered up with all the usual paraphernalia of television.

On the small screen appeared in due course the figure of a soldier standing rigidly to attention. I was wondering what it was all about when a reverberating roar just

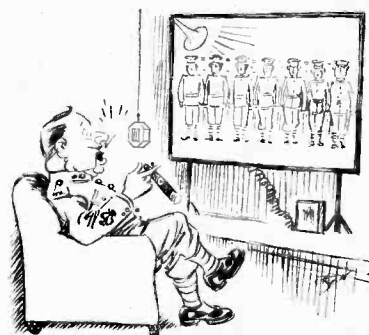

A withering blast.

behind me nearly tumbled me off my *sitzplatz*. Looking round I beheld the magnificent figure of a full-blown *sauerkraut*—or whatever the German word for sergeant-major is—blasting in more senses than one into a microphone. Obedient to the commanding voice the wretched soldier—who was in a room at the other side of Berlin—kept on sloping arms and performing all the other amusing parlour tricks in which we indulged during the War.

Of the unhappy man little was visible, but quite enough, apparently, for our friend at the microphone to find fault with. The whole arrangement was naturally rather crude, but I have only to think of the state of wireless telephony a bare dozen years ago to realise with a shudder the terrible sufferings which the troops of a decade or so hence will have to endure when the eye of the television transmitter will embrace the whole parade ground, and the unfortunate men will be exposed to the withering blast of a whole battery of sergeant-majors comfortably seated in front of a full-size screen in the sergeants' mess.

Current Topics.

News of the Week in Brief Review.

MILAN'S 75 KILOWATTS.

The new broadcasting station at Milan is to have a power of 75 kW., and will thus be as powerful as Rome.

A new wavelength distribution has been decided upon by the Italian authorities. The five exclusive waves granted to Italy under the Prague Plan are to be allotted to the most important stations, viz., Rome, Milan, Florence, Trieste and Bari. Florence is taking the longest wavelength (500.8 metres) on account of the mountainous district which it has to serve.

o o o o

HIDDEN MICROPHONES.

The invisible microphone has arrived in Germany. According to a correspondent, radio reporters, who are remarkably active in the Fatherland, can now approach their "victims" without evoking symptoms of "mike fright," a complaint which always threatens to ruin a good broadcast. The new microphones can be concealed in the pocket.

A malicious newspaper suggests that the reporters ought also to be invisible.

o o o o

A REAL TRIBUTE.

Can wireless transmission do justice to Grand Opera? The famous Metropolitan Opera of New York has had grave doubts on this point for ten years past, but now, according to a correspondent, the authorities have been converted. For the first time permission is to be given for the broadcasting of the performances this winter, and the reputation of the "Metropolitan" being what it is, American radio engineers are hailing the new decision as a definite recognition of the progress accomplished in radio.

o o o o

HEAR AMERICA VIA GERMANY.

Breslau, Gleiwitz, Heilsberg and Langenberg have begun regular relays of the American short-wave transmissions. We understand that a different day is chosen each week, but the time chosen is usually between 8 and 9 p.m.

o o o o

MISCELLANEOUS ADVERTISEMENTS.

As a result of Christmastide alterations in our printing schedule it is necessary that "Small Ads." intended for *The Wireless World* of December 23rd and



A LEADER OF AMATEURS. Mr. Hiram Percy Maxim, president of the International Radio Relay League, whose membership includes short-wave enthusiasts all over the world, is here seen delivering a message to the 22,000 amateurs of America through WIMK, Hartford, Conn.

30th should reach us not later than first post on December 16th and 23rd respectively.

o o o o

IS THIS YOUR TROUBLE?

"Readers' Problems" in Algeria are even more complex than those encountered in this country. The *Echo d'Alger* reports the case of one of its readers who, experiencing poor reception, dismantled his set before discovering that the feed terminals were being short circuited by the carbonised bodies of several cockroaches.

o o o o

PHYSICAL AND OPTICAL SOCIETIES' EXHIBITION.

Radio is always well represented at the annual exhibition of the Physical and Optical Societies at the Imperial College of Science and Technology, South Kensington. The twenty-second of the series is to be held on January 5th, 6th and 7th, and will include a research and experimental section.

o o o o

BROADCASTING FROM CARDIFF INDUSTRIES SHOW.

The B.B.C. are providing a special studio for broadcasting from the Cardiff Industries Exhibition to be held in the Greyfriars Hall from February 11th to 24th next. An interesting feature of the Show, which will be held in aid of the Cardiff Y.M.C.A., will be a wireless section. Wholesale and retail radio firms are being invited to exhibit.

o o o o

TWENTY-TWO THOUSAND TRANSMITTERS.

With an increase of 4,000 during the past year, American amateur transmitters have now reached the enormous number of 22,739, according to the annual report of the Radio Division of the U.S. Depart-

ment of Commerce. A specially significant feature, in view of the increased number of transmitters, is the comparative rarity of "wavelength wobbling." Amateurs appear to have realised that their future success and popularity depend upon their strict adherence to the regulations.

Because of their recognition of this fact, American amateurs are permitted to operate their own wavelength-checking service, and, to a certain extent, are allowed freedom from official supervision.

o o o o

SETS FOR EX-CONVICTS.

A proposal by the "Armée du Salut" (the Salvation Army in France) that the Government should make a grant of 100,000 francs for providing ex-convicts in Guiana with radio sets is being viewed with mixed feelings by the French public. Such charity, it is contended, should not be bestowed at the expense of the taxpayer, and an urgent plea is made in Paris journals that the virtuous, if unfortunate, unemployed should be the first recipients of any bounty, whether radio or otherwise.

o o o o

CHOOSING A GIFT.

A small Christmas present often offers greater difficulty in the matter of choice than a large one. An ideal selection where a little gift is required is *The Wireless World* Diary for 1932, which provides the amateur with a whole compendium of radio information in handy form. The sections include Broadcasting Stations of Europe, with quick-tuning chart, short-wave stations of the world, useful formulae, valuable abacs, and a series of circuit diagrams. The price of the Diary is 1s. 6d., or 1s. 7d. post free from the Publishers, Dorset House, Tudor Street, London, E.C.4.



**WIRELESS IN
HERALDRY.** The inevitable wave and thunderbolt appear in the new coat of arms which has just been registered by the Radio Manufacturers' Association.



KOLSTER BRANDES

THREE VALVE AC. MAINS RECEIVER

A Compact Cabinet Set with Built-in Moving-coil Loud Speaker.

IN a surprisingly short space of time the self-contained three-valve receiver, mains-operated and almost invariably fitted with a moving-coil loud speaker, has firmly established itself, and it is hardly an exaggeration to say that for this season it is almost the mainstay of the British radio industry.

The attractiveness of this type of set lies mainly in its compactness, and in the fact that, except for an aerial and earth connection—the former is often optional, so far as short-wave work is concerned—no external accessories whatsoever are needed.

In many ways the Kolster-Brandes Model K.B.279 is a typical example of the better type of set in this category. It is a well-finished job throughout, and, moreover, this finish is not confined merely to externals; the circuit design embodies practically every refinement that has been proved to be really worth while; and, indeed, it is difficult to suggest any elaboration that might with advantage be added, even if cost were no object. Admittedly, a single-tuned input circuit is employed in place of the popular band-pass filter, but details have been so well arranged that there is no apparent lack of selectivity, and in this respect the set is quite capable of putting up as good a performance as might reasonably be required, even under the more exacting kind of conditions.

The circuit arrangement is mainly conventional, and does not include any untried features that might possibly give rise to trouble. In essentials, it embodies an H.F. stage, followed by a grid detector, which in turn is coupled by a transformer to a pentode in the output position. The first two valves are indirectly heated, while the pentode, of the directly heated type, is supplied with current from a separate winding on the power transformer.

A simple auto-transformer is embodied in the aerial input circuit, but interference from a near-by medium-wave station, when receiving at the lower end of the long-wave band, is prevented by inserting a special form of choke coil in the long-wave aerial circuit. Incidentally, this choke coil is wound on a flat strip former in such a way that its inductance must be low in proportion to its resistance: the device seems to work almost perfectly.

For the H.F. coupling a tuned anode circuit is used, and it has been so arranged that the coil acts as an auto-transformer, suitable provision being made for changing over the anode connection for either wave-band. In order to avoid all risk of damage in the unlikely event of a short-circuit developing between the variable condenser vanes, a fixed condenser is inserted at the high-potential end of the tuned anode circuit, which is "earthed" through a second condenser.

Mechanically linked tuning is provided for the two circuits, but an external trimmer is fitted; this control is operated by a knob mounted concentrically with the main tuning adjustment—a satisfactory and very convenient plan. Whatever may be the advantages of a fully ganged tuning system—without external trimming adjustment—it is extremely reassuring to know that both circuits may be maintained in perfect resonance over the whole of the two wave ranges.

The grid detector is planned on modern lines, and operates with an ample anode voltage; reaction between the plate and grid circuits is controlled

by a differential condenser operating with an earthed rotor. H.F. energy is kept out of the L.F. amplifier by a filter in the detector anode circuit.

There is nothing calling for special comment in the output stage. Automatic bias for the directly heated pentode is developed across a resistance joined between an artificially located centre point of the cathode of this valve and the H.T. negative terminal. A double-wound transformer is used as a coupling for the moving-coil loud speaker, and a corrector consisting of the usual condenser-resistance combination is shunted across the primary winding. It should be noted that the field winding of the instrument serves as a smoothing choke, and is connected in series with the feed circuits. The H.T. supply is rectified by a full-wave valve with a high-capacity electrolytic condenser across the output circuit. All possible precautions are taken

SPECIFICATION.

GENERAL: Self-contained A.C. mains receiver for operation with external or "mains" aerial and earth. Gramophone pick-up jack; moving-coil loud speaker.

CIRCUIT: One H.F. stage, coupled by tuned anode system to grid detector. Transformer-coupled pentode output valve. Full-wave power rectifying valve.

CONTROLS: (1) Single-knob tuning with external trimmer. (2) Differential reaction. (3) Input volume control. (4) Wave-range switch. (5) On-off switch.

PRICE: £18 18 0 complete with valves (for 25-cycle mains, 12/- extra).

MAKERS: Kolster-Brandes, Ltd., Cray Works, Sidcup, Kent.

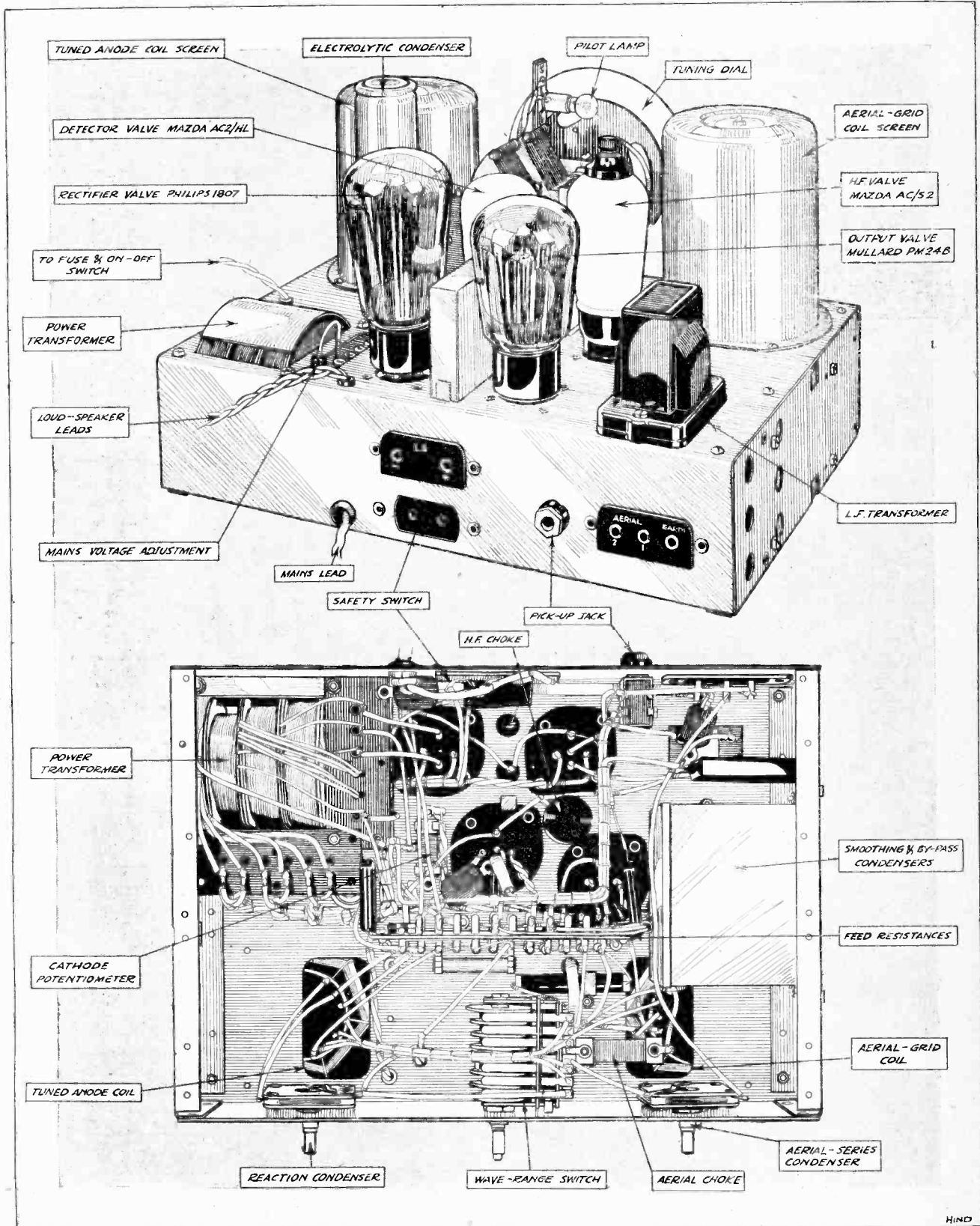

HIND

Chassis of the Kolster-Brandes Model K.-B.279 receiver, and (below) arrangement of wiring and components in the base compartment.

Kolster-Brandes Three-valve A.C. Mains Receiver.—

to avoid hum, including the connection of a condenser between the mains input and earth and a semi-fixed cathode potentiometer.

It is hardly necessary to say that complete decoupling is included both in anode and grid circuits. Among what may be called the refinements of the receiver are a pick-up jack, mounted at the back of the cabinet, and provision for an external loud speaker, for which the primary of the output transformer acts as a feed choke. There is also a safety device, which takes the form of "breaks" in each of the mains leads, which are automatically closed when the back cover of the cabinet is placed in position; the set is entirely "dead" when this cover is removed, and so there is

selectivity; where the fullest possible immunity from interference is needed it is a good plan to reduce aerial input by decreasing the series capacity, and then to restore sensitivity by reaction. That reaction control is not quite so good on the long-wave side is compensated for by the fact that the circuits, without adventitious aid, give exceptionally good results on this band.

Reproduction is marked by a good, but not overpowering, bass, free of the lower-register resonance that is usually found in sets of this type. Output is well maintained up to about 4,500 cycles, with the result that reproduction is bright, but without hiss or scratch. Frequencies in the neighbourhood of 2,500 cycles are rather over-emphasised, and on some heavily modulated musical passages there is an effect akin to

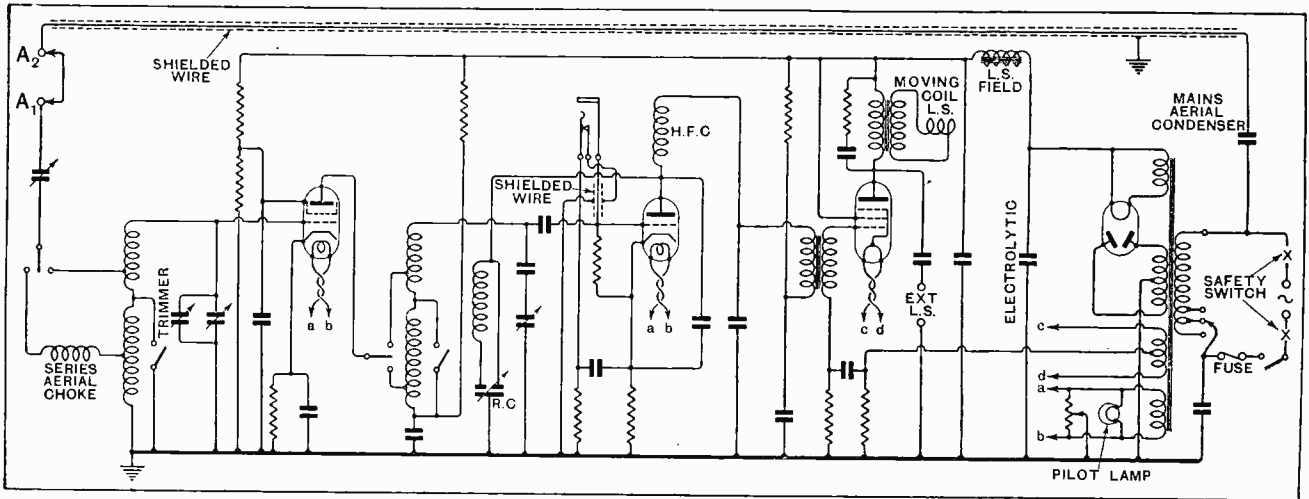

Complete circuit diagram. The tuning condensers are ganged, and all wave-range switches are mechanically linked.

no risk of shock. A glass cartridge fuse is mounted in an accessible position.

Cadmium-plated steel is the material used for the chassis, which may be removed for test after disconnecting the leads to the fuse and loud speaker and taking out a few screws. It is reassuring to see that proper precautions are taken against accidental short circuits; for instance, the leads passing through the metal work are protected by soft rubber bushes.

In order to ensure sufficient selectivity in a set of this type, it is necessary to effect a compromise by working with fairly loose coupling in the aerial-grid and H.F. intervalve circuits. As a result of making a careful comparative test, it can be stated definitely that this compromise has been effected in an extremely satisfactory manner; there has been no undue sacrifice of sensitivity, as witness the fact that a good selection of foreign programmes can be received under fair conditions, even in daylight. Selectivity with the aerial series condenser set at maximum is quite good, and can be increased by suitable operation of this control to almost any desired extent. Well-proportioned screened tuning coils, with an H.F. resistance apparently well below the usual value, undoubtedly contribute something towards these results.

Reaction works smoothly and well; apart from increasing sensitivity, it also has a slight effect on

that produced by overloading, although the output valve is actually working within its capacity; this effect is not so marked as to be really objectionable.

MR. F. H. HAYNES.

AFTER an association with *The Wireless World* lasting over a number of years in the capacity of Assistant Editor, Mr. F. H. Haynes, whose contributions are well known to our readers, relinquishes his appointment on the staff to enter another sphere of wireless activity. Mr. Haynes, in leaving his former association, does so in order to set up in the wireless industry on his own account, and in his new enterprise we feel sure that our readers will, with us, wish him every success.

In previous issues of this journal we have announced a Single-dial Superheterodyne receiver, designed jointly by Mr. Haynes and Mr. W. T. Cocking, the description of which appears elsewhere in this issue, and will be continued next week.

Further information regarding this receiver will in future issues be given by Mr. Cocking, or by other members of the staff of *The Wireless World*.

We are pleased to be able to announce that *The Wireless World* will have the advantage of publishing exclusive contributions from Mr. Haynes from time to time.



By Our Special Correspondent.

**7-metre Transmissions.—The Receivers.—Measuring Field Strength.—
Schoolboy Wireless.—A Danish Plebiscite.**

Those Ultra Shorts.

What an age it seems since the B.B.C. issued that interesting little announcement concerning its intentions in regard to the ultra-short waves! So much national history has been made since the beginning of September that the public can be forgiven if the notion of a seven-metre transmitter on the roof of "Broadcasting House" is not causing any profound agitation.

Not even the knowledge, common to everybody, that the B.B.C. is economising, has prompted any question as to whether the axe is to fall on the ultra-short-wave project.

The Transmitter.

For the benefit of the few who may be really interested in these experiments and their possible influence on future receiver design, I am glad to state that the B.B.C. is going ahead with the scheme, and that the 1-kilowatt transmitter now under construction at the Marconi Company's Chelmsford works is nearing completion.

It is expected that the whole "box of tricks" will be ready for delivery at Portland Place soon after Christmas.

Radiation in March?

The only man who ever accused the B.B.C. engineers of lack of reticence was a friend of mine who once accidentally bumped into an "O.B." man carrying a 120-amp. accumulator. The subject of ultra-short waves is mentioned only with bated breath at Savoy Hill, and the most that I can elicit is that "we shall not be disappointed if the seven-metre transmitter begins radiating by March 1st."

Constructing Receivers.

The real truth, however, is that the engineers hope to have a good deal of fun with the new toy before then. Ultra-short-wave receivers will have to be constructed, and, as these can be fairly tested only by the reception of signals, it is likely that the transmitter will be radiating at unscheduled intervals early in February.

Field Strength Measurements.

When the preparations are complete the test receivers will be taken to various scattered points for the purpose of carrying out field strength measurements.

The choice of Broadcasting House as the transmitter base—first suggested in *The Wireless World* (September 9th,

1931)—means that the system will be tested under the most exacting, and, therefore, the most ideal, conditions.

"Finding" the Transmissions.

It is worth warning ambitious listeners who attempt to receive the signals that these extraordinarily high frequencies are very difficult to tune. One amateur of international repute tried recently to pick up a German seven-metre wave; he took an hour to "find" it!

Dormitory Concerts.

Prisoners, hotel residents, and subscribers to the wireless relay systems are usually condemned to listen to the same programmes. At all events, they are denied the joys of knob-twiddling. Not so the average public-school boy.

A young friend of mine who comes under this category has been entertaining me with an account of radio exploits in his school dormitory.

The Bed Set.

Every occupant has his own set—generally a one-valver—ensconced under the bed with an earth lead to the steam radiator and a pair of 'phones ready for instant use. Unfortunately, perhaps, there is only one aerial. There is much competition for the bed nearest the window

through which the lead-in comes, everybody being fully aware of the advantages of a short aerial lead.

Choosing a Present.

I gather that no undue secrecy is observed in the operation of these sets, but whether they are all religiously switched off when curfew sounds is not a question for public debate.

One thing is certain: when I choose a Christmas present for the boy it will be radio, but it will not be a loud speaker.

What They Want.

The paramount popularity of the military band is one of the surprising revelations of a listeners' ballot which has just been conducted by the Danish broadcasting authorities. Of the 27,353 votes for the most popular form of broadcast entertainment, military bands received 3,915, closely followed by "old dance music" with 2,197. Gramophone recitals were given 2,559 votes, accordion concerts 2,193, and light orchestral selections 2,059. The other results were: Radiocabarets, 1,860; variety programmes, 1,647; modern dance music, 1,559; choirs, 1,472; talks, 1,441; light operas, 1,371; classical orchestral selections, 1,267; vocal solos, 1,106; "outside" concerts, 975; chamber music, 767; symphony concerts, 720; and operas, 488.

A Relay from Brussels.

Listeners who expressed their appreciation of the first of the season's international relays from Vienna early last month will, I hope, find the next European programme on December 17th—a symphony concert from the Palais des Beaux Arts, Brussels—equally enjoyable.

A Bumper Programme.

On Boxing Day, those of us who are not *hors de combat* after the Christmas festivities will be able to enjoy what promises to be one of the best vaudeville concerts ever put out by the B.B.C. The programme will go out from the National transmitters between 7.30 and 9 p.m.

No details are yet available, but I can say that the bill includes Clapham and Dwyer, Flotsam and Jetsam, Cicely Courtneidge, Ernest Butcher, Tommy Handley, Elsie and Doris Waters, the Buggiss family, and a musical background by Jack Payne and his band.

If this programme "flops" the B.B.C. should take up stamp-collecting or silk-worm culture.



THE NERVE CENTRE. A glimpse of the main control desk at Broadcasting House. The B.B.C. engineers hope to leave the Savoy Hill control room in February or March.

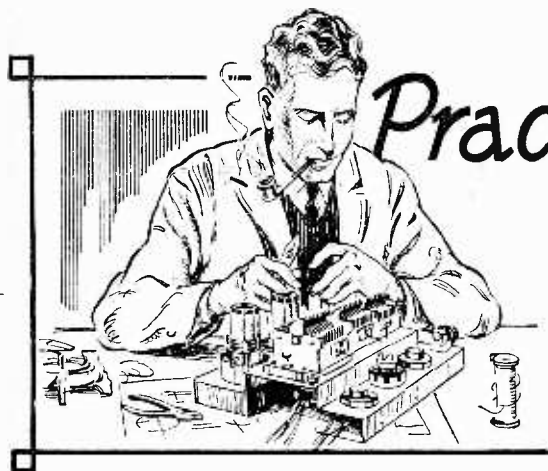

Practical Hints and Tips

Simplified Aids to Better Reception.

IT is not always easy, at any rate when dealing with a compact receiver constructed on modern lines, to trace out the connections of the tuning coils by following the

A QUICK TEST.

wiring from point to point. In making alterations to a receiver, or when searching for a fault, this information is sometimes necessary; it can very easily be obtained by touching either end of the winding with the finger while a signal is actually being received. A very considerable reduction in signal strength will be brought about by touching the high-potential (grid) end, but no appreciable change will be observed as a result of making contact with the earthed end. It is often quite unnecessary actually to touch the coil, as sufficient indication will be given if the finger is brought into proximity to it.



WHEN recently testing a mains-operated "quality" receiver embodying two resistance-coupled L.F. stages, an unexpected tendency towards L.F. instability was

DECOUPLING CONDENSER CONNECTIONS.

all too apparent, in spite of the fact that all danger points were thoroughly decoupled. The decoupling condensers were in each case "returned," according to usual practice, directly to the cathode terminal of the indirectly heated valve

concerned, in the manner shown in Fig. 1 (a).

Experimentally, these by-pass condensers were joined directly to the H.T. "earth line" (H.T. negative), with the result that all signs of instability disappeared entirely, and the L.F. amplifier behaved in an unexceptionable manner.

This may appear, at first sight, to be a negation of the principle of scientific wiring; but subsequent experimental work fully confirms the theory that undesirable L.F. reaction can often be prevented in this way, particularly when valves are biased by means of resistors in their cathode leads. The alteration is one that is

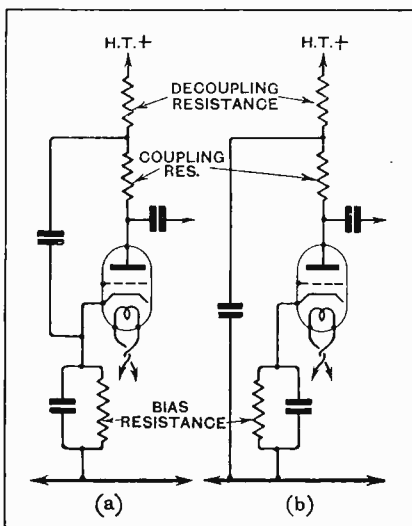

Fig. 1.—The principle of joining grid and anode "return" leads directly to cathode need not always be followed slavishly. Alternative methods of connecting a decoupling condenser.

worth while trying when an amplifier does not seem to behave "according to plan."

A QUITE unnecessary amount of thought and care is often devoted to the question of supplying exactly the maximum rated voltage for the anode of a screen-grid valve or

WHERE VOLTS DON'T MATTER.

a pentode in a mains-operated receiver. It may be worth while to remember that, in this type of valve, current is controlled almost entirely by the screening grid (or priming grid) voltage, and that, within reasonable limits, not the slightest harm will be done by applying a considerably greater pressure to the anode than that at which the valve is rated.



MANY screen-grid H.F. valves are particularly susceptible to the good effects of negative grid bias; a receiver that is normally quite selective may appear to be deplorably lacking

H.F. BIAS CIRCUITS.

in this quality if for any reason the H.F. grid is operating at zero.

It is always worth while to give periodical attention to the bias arrangements; in a battery set the grid cell should be changed fairly frequently, and in a mains-operated set, where the ill effects of lack of bias are likely to be much more pronounced, one should guard against the possibility of an accidental short-circuit across the automatic bias resistor. In a modern screened set it is all too easy for such an accident to occur; we are all inclined to regard grid return leads as unimportant, and consequently they are often carelessly arranged in such a way that a short-circuit to the metalwork can take place. A common source of trouble is the screening can; it is quite possible that the connecting lead may be chafed where it is passed out through the wiring channel.

THE usefulness of *The Wireless World Valve Data Sheet*, which has just made its annual appearance,

**ESTIMATING
RECTIFIED
VOLTAGE.**

is now increased to a still greater extent by the addition of a column giving

the voltage outputs of power-rectifying valves on "half load." With the help of this information, plus the normal figure for full output, it becomes an extremely simple matter to

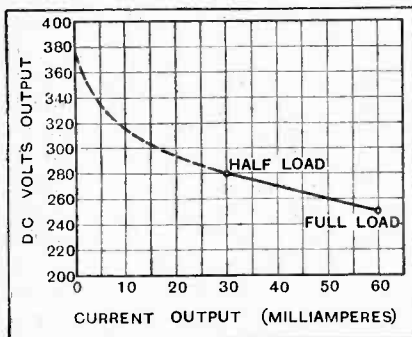

Fig. 2.—Output curve of a typical rectifying valve, prepared with the help of *The Wireless World Valve Data Sheet*.

prepare a graph showing the D.C. voltage that will exist across the rectifier for intermediate loads.

A suggested method of preparing the graph is shown in Fig. 2; this does not represent any particular valve, but may be taken as illustrating roughly the properties of a standardised A-type rectifier, suitable for the great majority of sets, and giving a maximum of 60 milliamperes at 250 volts. We will assume that the half-load figures are 30 milliamperes at 280 volts.

These points, plotted on squared paper with voltage and current scales suitably marked, are joined together by a straight line, when almost all the information we are likely to need is revealed at a glance. For instance, if the estimated total consumption of the set amounts to 40 milliamperes, it will be seen that, on this load, voltage will rise to 270 volts; thus, at once we have a basis on which to estimate the values of any feed resistances that may be necessary to avoid over-running the valves.

When considerably less than half the full load is drawn from the rectifier, the curve is no longer a straight line, but will always have roughly

the form shown in dotted lines. By drawing his own curve in this manner the amateur will be able to form a useful idea as to the extent of the voltage rise across his own particular valve when it is working "light."



WHEN a band-pass filter fails to function properly, and particularly when the tuning of the circuit is too broad, it is

**FILTER-CIRCUIT
ISOLATION.**

logical to suspect that excessive interaction between circuits is taking place. Perfect isolation is hardly ever obtained in practice, but good results cannot be expected if, for example, there is excessive magnetic interaction between the two coils, brought about by insufficient or ineffective screening.

The best test as to the extent and nature of this trouble is made in a very simple way by removing all intentional sources of inter-circuit coupling when listening to a powerful local transmission; under ideal conditions, nothing whatever should be heard; but one hardly expects that such complete absence of interaction and stray pick-up should be present. At best, very weak signals only should be audible, and the great advantage of this test is that while listening to these signals it is easy to find out if an improvement can be made by—for example—closing up the joints of screens or rearranging external wiring. Excessive interaction has in more than one case been traced to the use of a high-resistance condenser in the grid return circuit of certain types of filter.

With a plain capacity filter, the coupling device is easily eliminated for purposes of test by short-circuiting the coupling condenser; the same procedure applies to a filter coupled by means of a common inductance. When dealing with a mixed filter the coupling condenser should be short-circuited, and the negative inductance winding should be disconnected entirely. Filters coupled by means of a small condenser joined between the high-potential ends of the circuits should be tested with the condenser disconnected and its leads entirely removed.

THOSE who use a superheterodyne receiver in which there is no fundamental high-frequency stage

**SUPER-HETERODYNES—
where efficiency
is vital.**

before the frequency-changer, and who, by virtue of having the

oscillator so connected that there is a possibility of radiation from it, are limited to the use of a frame aerial, need to be very careful indeed in the choice of their frame.

Experience with the superheterodyne leads to the impression that it is necessary for the received signal to have a certain minimum strength at the frequency-changer, and that if it falls below this minimum no amount of intermediate-frequency amplification will bring it up to satisfactory strength in the loud speaker. Save by careful attention to the efficiency of the frame, there is no means of bringing the strength up to the required minimum.

The effect described is very noticeable in practice; with a poor frame a superheterodyne may fail to

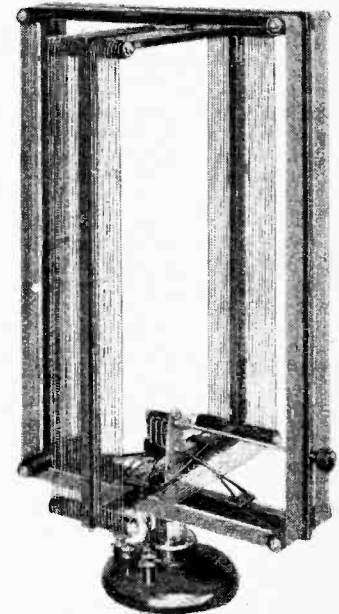

A frame aerial (Wearite) in which absorption losses on the medium waveband are reduced to the maximum practicable extent by mounting the two windings at right angles.

bring in more than five or six stations, while the substitution of a better frame results in a prodigious log of distant transmitters, all apparently received with a tremendous reserve of amplification.

Wireless
World

LABORATORY TESTS



Review
of New
Radio
Products.

RED DIAMOND SWITCH. Type R.D. 35.

This is a four-point switch which can be used to make and break two circuits not connected electrically, as the two pairs of contacts are entirely separate. It functions on the push-pull principle, and has an insulated spindle, so that it can be mounted on metal panels without first

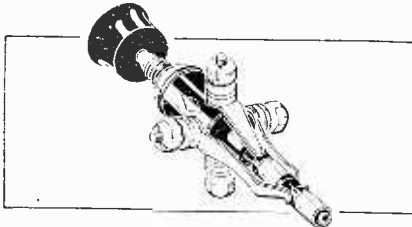

Red Diamond two-circuit switch with insulated spindle.

bushing the hole. A point of interest is that the back contacts, connected to the longer springs, make connection a fraction earlier than the other pair, and, of course, break slightly later.

The switch exhibits the high standard of workmanship which is a feature of all Red Diamond products, and at the reasonable price of 2s. is excellent value.

The makers are the Jewel Pen Co., Ltd., 21-22, Great Sutton Street, London, E.C.1.

WATMEL "LOG" VOLUME CONTROL.

This is a wire-wound potentiometer and is fitted with a special tapered resistance element. It has been designed to follow

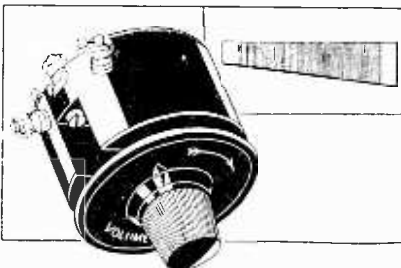

Watmel "Log" potentiometer volume control fitted with a tapered resistance.

a logarithmic law so that the control of volume should be fairly evenly distributed

over the range of movement of the slider. The resistance is protected by a bakelite shell, only the small portion constituting the track over which the slider travels being exposed. A back contact is fitted to the moving member, and this rides over a circular metal disc, thus assuring a good electrical contact. It has a wiping action, and is self-cleaning.

Measurements show that the change in resistance follows approximately a logarithmic law, and, as a consequence, when used as a post-detector volume control, the change in output from the last valve will be proportionate to the angular movement of the slider. That is to say, the control will be evenly distributed over the scale.

These resistances are made in various standard values ranging from 1,000 ohms to 50,000 ohms, and the price is 6s. 6d. The makers are the Watmel Wireless Co., Ltd., High Street, Edgware, Middlesex.

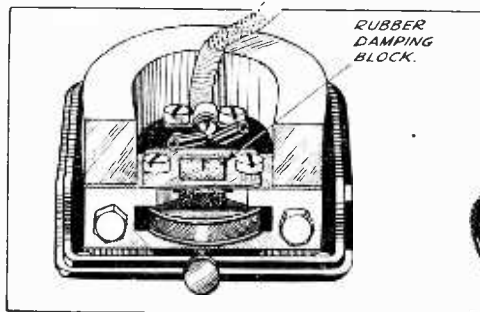

H.M.V. MODEL NO. 11 PICK-UP UNIT.

This unit is designed to replace the soundbox on the tone arm of existing acoustic gramophones, and is provided with interchangeable sleeves to fit both H.M.V. and Columbia instruments.

The movement, which is housed in a neat moulded case, is similar in design to that used in the Model No. 15 pick-up and tone arm fitted to current models of H.M.V. electric gramophones and radio-gramophones. It is different in principle from that of last year's model, and is of the conventional half-rocker type. The damping, which is very light, is provided by a comparatively large block of special rubber treated to resist oxidation. A 36 per cent. cobalt steel permanent magnet is employed, and the armature is of best Swedish iron.

The characteristic curve shows that an average output of 1 volt R.M.S. is obtained between 450 and 4,000 cycles. Below 450 cycles the curve rises steeply, and gives more than adequate compensation for the restricted amplitude of the bass in ordinary gramophone records. A slight double resonance is noticeable in the region of 3,000-3,500 cycles, though this is

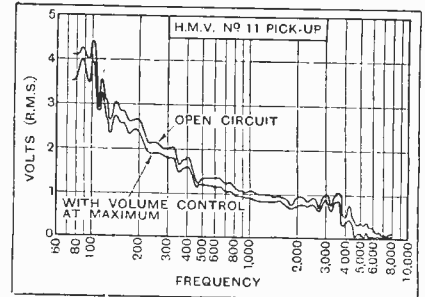

Voltage output characteristic of H.M.V. No. 11 pick-up with "Loud Tungstyle" needle.

not quite so marked as in last year's model. Between 4,000-5,000 cycles there is a distinct cut-off, which should be helpful in reducing needle scratch.

A volume control of 250,000 ohms incorporating the new H.M.V. carbon track logarithmic resistor unit is included in the equipment, while other accessories include

(Left) Interior view of H.M.V. No. 11 pick-up head.

(Below) H.M.V. No. 11 pick-up unit and volume control for attachment to existing acoustic gramophones.

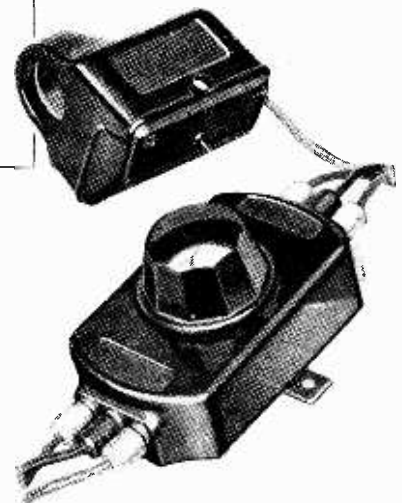

metal clips for guiding the cable along the tone arm.

The makers are The Gramophone Co., Ltd., Hayes, Middlesex, and the price, complete with volume control and leads, is £2 2s.

BELLING-LEE MAINS FUSE.

The ordinary domestic lighting fuses are usually arranged to blow at about 5 amps., and, as a consequence, are hardly a satisfactory safeguard for a mains-operated receiver, although they do afford a measure of protection. Thus it is often advisable to fit special "light" fuses in the set, for which purpose Belling and Lee, Ltd., have developed a special model, described as a Twin Baseboard Fuse-holder. It is very compact, and can be accommodated in a space measuring $2\frac{1}{2} \times 1\frac{1}{2}$ in. It consists of a moulded case divided into two compartments, and fitted with an easily-removable lid. This carries the two fuses and two "U"-shaped contacts, so that when the lid is removed the fuses can be handled with perfect safety, as the mains are disconnected.

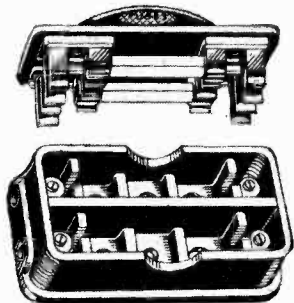

Belling-Lee mains twin baseboard fuse-holder.

The two sets of leads can be led into the fixed portion of the fuse-holder, either from underneath or through holes in the ends, whichever happens to be the more convenient. Whichever method is adopted complete immunity from accidental shocks is assured, as all metal parts are insulated.

The holder is fitted normally with a pair of one-amp. fuses, but it can be obtained fitted with 2- or 3 amp. fuses for use with radio-gramophones, since the lighter fuse would not be suitable for sets of this type.

The makers are Belling and Lee, Ltd., Queensway Works, Ponders End, Middlesex, and the price is 3s. 6d. complete.

DUBILIER CONDENSERS.
Types 665 and 670.

These condensers have been introduced to meet the demand for a high-class component at a reasonable price. They are tested at 500 volts A.C., and the normal working potential is 250 volts D.C. The type 665 are fitted with long soldering tags, while the companion model, type 670, are provided with small terminals. The first-mentioned are exceedingly compact and light, and can be connected between the wiring, but the type 670 are somewhat larger in size, and will normally be screwed to the baseboard, holes being provided in the moulding for this purpose.

There are eight different capacities available in the 670 type, ranging from 0.0001 mfd. to 0.006 mfd., the prices being 1s. up to 0.0003 mfd., 1s. 3d. for 0.0005 mfd. to 0.002, and 1s. 6d. for the larger sizes. In the case of the 665 style, four capacities only are made, these being 0.0001 mfd., 0.0002 mfd., 0.0003 mfd., and 0.0005 mfd., the prices being 6d. for the

first three and 9d. for the last-mentioned. Measurements show that the actual capacities agree reasonably well with the marked values, the average deviation being of the order of 10 per cent.

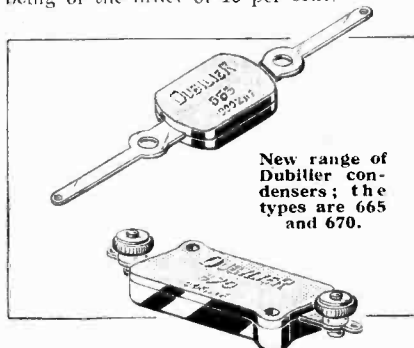

New range of Dubilier condensers; the types are 665 and 670.

The makers are the Dubilier Condenser Co. (1925), Ltd., Ducon Works, Victoria Road, North Acton, London, W.3.

ETA COIL WINDER.

This machine will wind coils up to 5in. in length and 5in. in diameter, and is suitable for manufacturing on a moderate scale most of the coils used in wireless receivers and accessories. Any shape of coil can be constructed, so that the machine would make a useful addition to the workshop equipment of those engaged in serious experimental work. It is hand-driven, and for winding coils with fine-gauge wire a speed of 500 turns per

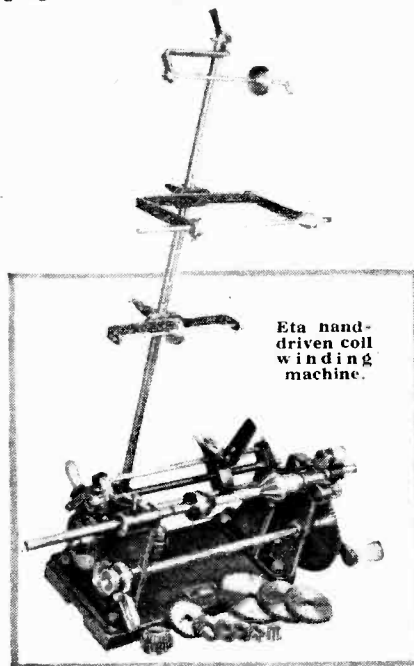

Eta hand-driven coil winding machine.

minute can be attained. A direct drive is available when using heavier gauge wires.

The wire is guided by two fibre fingers attached to a traversing carriage driven through a train of gear wheels. Ten gears are supplied, giving a pitch, or turns per inch, of 86, 100, 119, 150, 185, 227, 277, 310, 357, and 450 respectively. By

changing the jockey pinion for one of half the size the gears supplied will give feeds equal to half their marked values. These ranges provide traversing speeds suitable for most gauges of wire with any style of covering between 24 s.w.g. and 47 s.w.g. A revolution counter is fitted, reading up to 10,000, and the price, complete with counter, is £6 5s.

The makers are the Eta Tool Co., 70a-70c, Asylum Street, Leicester.

CLIX CONSTRUCTOR'S KIT AND "VICEGRIP" WANDER PLUG.

The Clix Constructor's Kit, comprising an assortment of Clix fittings, should prove especially useful to the experimenter and set builder, as it contains such items as engraved terminals, spade-end connec-



Clix Constructor's Kit containing five different styles of connectors.

tors, plugs, and sockets, and six of the new "Vicegrip" wander plugs. Purchased separately the contents would cost 3s. 5d., but in kit form the five different varieties and nineteen parts are available at 3s. only.

The latest addition to their range of Clix specialities is the "Vicegrip" wander plug fitted with a special spring prong somewhat resembling a cotter pin in shape but possessing exceptional springiness. It will fit any standard-type battery socket, and makes a good contact. Unlike the split pin variety, it does not lose its resilience after a very short period of use.



New Clix "Vicegrip" wander plug.

These are made in the horizontal and vertical pattern, and in various colours with a wide range of markings. They cost 1½d. each engraved.

The makers are Lextro Linx, Ltd., 254, Vauxhall Bridge Road, London, S.W.1.

General Electric Co., Ltd.

The General Electric Co., Ltd., has brought out a useful price list of their Osram valves, which also comprises two rotatable dials, on one of which, by bringing one pointer opposite the name of any station, the wavelength and dial-reading are indicated by two opposite pointers. On the other dial a pointer can be brought opposite the mark indicating the purpose for which a valve is required when the type of valve suitable appears in a window cut in the dial.

Power Grid and

~ A COMPARISON

Leaky Grid

By W.I.G. PAGE, B.Sc.

(Concluded from page 632
of previous issue.)

The
Distortionless
Grid Detector:
Some
Practical Data.

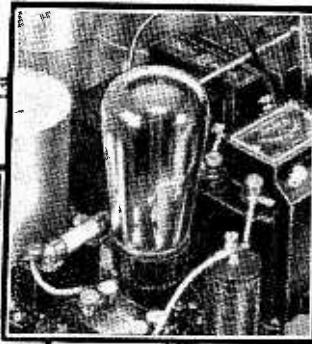

HAVING discussed in the last instalment the process of leaky grid detection with small signals, it now remains to consider the behaviour of the grid rectifier with large signals of a substantial fraction of a volt or even a number of volts having an amplitude such as EF in Fig. 4. So much greater is the input than that of the case cited for leaky grid detection that naturally the increase of grid current due to rectification is much larger, which in its turn means that the drop in potential in the leak is greater. The mean grid potential or bias moves to the left from the operating point O to a more negative point at X, where grid current has entirely ceased to flow for some distance along the horizontal scale. Only the tips of the positive half-cycles get through, the whole of the negative half-cycles and part of the positive being suppressed.

While the wave is unmodulated the mean negative bias remains at X, for each half-wave is of the same amplitude, but as soon as modulation occurs the edge or envelope of the high-frequency carrier becomes irregular. In Fig. 5 the wave EF is shown again to a smaller scale and the effect of 100 per cent. modulation illustrated. The amplitude momentarily grows to double the normal at H and subsides to zero at G. For 90 per cent. modulation the expansion is a little less than that at H, and the contraction does not bring the voltage quite to zero as at G. The question now arises as to what will happen to the point X in these circumstances. Obviously with G (zero signal volts) the detector operating point will be O—the pre-signal bias—while for the expanded part H the bias will shift to, say, Y—quite an appreciable negative value. For 90 per cent. modulation there will be a small signal causing leaky grid action, followed by a large signal bringing the bias nearly to Y.

By considering successively smaller percentage modulations of large H.F. carrier waves it can be shown that harmonic distortion due to leaky grid detection of the momentarily contracted wave is exceptional, as 80 per cent. modulation, at which the power grid detection is linear, is rarely exceeded in practice. In other words, with 80 per cent. modulation of a comparatively large H.F. input the wave will not be reduced to a voltage low enough for the disabilities of leaky grid detection to occur.

From the foregoing, which explains in part the principles of power grid detection, it will be clear that the valve is automatically self-biased to a potential which varies in accordance with the changing voltage of the modulated carrier wave and the mean operating point (or negative bias) adjusts itself so that the modulated fringe of the positive half-cycle is always applied to the straight part of the grid current curve.

The spurts of grid current produced by the positive half-cycles charge up the grid condenser, which discharges through the leak during the negative half-cycles, at which period the grid-cathode path inside the valve is non-conducting. In order that the rate of discharge of the condenser shall be fast enough to follow faithfully the change in shape of the modulation envelope, the time constant of the leak condenser combination is critical, and mathematicians show us that for equal reproduction of high and low notes the condenser must not exceed 0.0001 or 0.00015 mfd. and the leak should be about

0.25 megohm, otherwise high notes will be lost.

With leaky grid detection, grid current is flowing during both positive and negative half-cycles of the

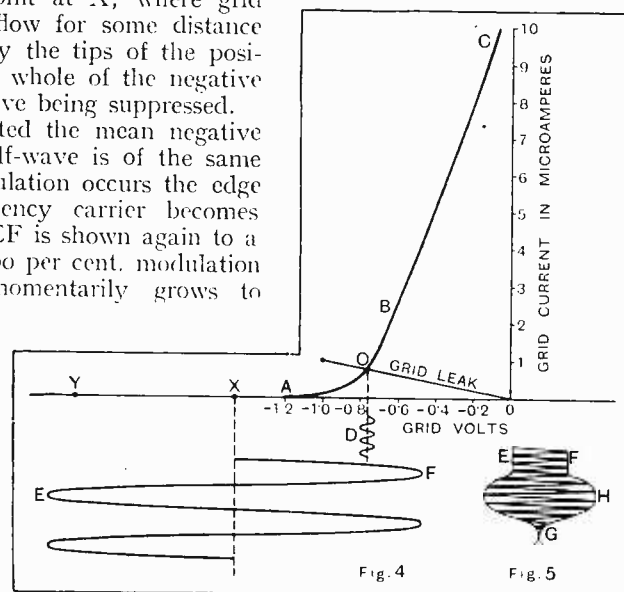

Fig. 4.—The grid detector with large signals such as EF is practically distortionless. Grid current only flows during part of the positive half-cycles of the signal. Fig. 5.—With 100 per cent. modulation the wave EF expands momentarily to double its normal amplitude as at H and then contracts to zero (G).

Power Grid and Leaky Grid.—

signal and the grid-cathode path inside the valve is always conductive, therefore the condenser tends to discharge through it. This calls for different values of condenser and leak; in fact, no great departure from the conventional 0.0003 mfd. and 2 megohms need be made. As a compromise between quality and sensitivity the grid condenser might be reduced to 0.0002 mfd.

We are now in a position to define the difference between the two types of grid detection. Leaky grid detection takes place when the input is sufficiently small to give grid current with both positive and negative half-cycles. As the action takes

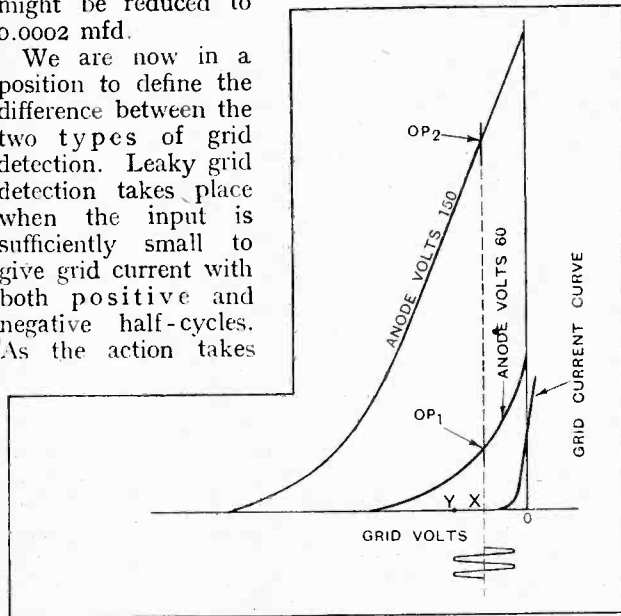

Fig. 6.—The essential details of Fig. 4 repeated on a smaller scale so that a study of the application of the rectified signals to anode characteristics of low and high H.T. voltage can be made.

place only on the curved part of the grid current characteristic there is a square law effect and second harmonic distortion, especially when deep modulation is high, but conventional leak and condenser values can be used. Clearly the shape of the grid current curve is important. Power grid detection, on the other hand, takes place when the signal is large enough to move the operating point so far to the left that grid current only flows during part of the positive half-cycle. A critical time constant (owing to a difference of discharge path) must be given to the condenser leak combination calling for low values of capacity and resistance. The grid-filament path through the valve is not conductive during negative half-cycles, and as the rectifying action takes place on the straight portion of the characteristic no distortion occurs except at very deep modulation, namely, 90 per cent. to 100 per cent., which is not often encountered. With power grid detection of large inputs rectification is independent of the shape of the grid current curve.

Anode Distortion in Grid Rectifier.

Investigations have shown that there is practically no upper limit to the value of H.F. voltage which can be accepted for linear rectification by the power grid detector as far as the grid circuit is concerned. Even signals of 40 volts will be handled satisfactorily, but

in practice the same valve which rectifies also performs the function of L.F. amplification in the anode circuit. It is here that overloading and distortion will take place with quite small inputs unless the same rules which govern H.T. and bias values in an ordinary separate L.F. amplifier are applied. In explanation of this Fig. 6 has been compiled showing on a smaller scale the essential features of Fig. 4, such as the wave EF, the grid current curve, and the mean bias points X and Y. The changing grid potentials produced by rectification and the H.F. wave must be accommodated by the anode characteristic. Two of the latter are given in the diagram for 60 and 150 volts H.T. actually applied to the anode terminal of the valve. It will at once be apparent that around OP₁ only very small changes of grid potential without curvature distortion are possible, whilst OP₂ should accept large rectified signals without adding unwanted harmonics. Thus we find an explanation for the conventional 60 volts H.T. for leaky grid and an applied voltage of more than double this figure for power grid detection.

Some Practical Data.

A great deal of information can be gleaned from the movement of the needle of a millimeter interposed in the anode lead of a power grid detector. The standing pre-signal anode current may generally be allowed to drop one-eighth of its value when the maximum signal is applied. Typical figures for a modern A.C. detector valve would be a decrease from 8 to 7 mA. If an upward kick from the depressed reading of the meter needle is observed on loud passages, anode bend rectification in opposite phase to the grid detection is indicated and either a reduction in input or an increase

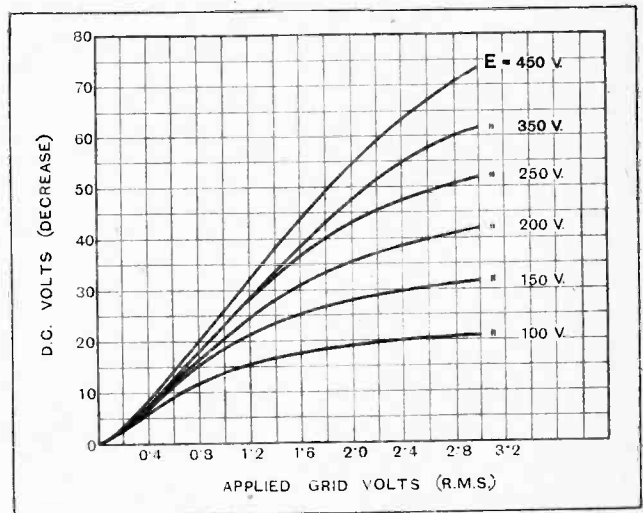

Fig. 7.—Rectification characteristics of the Mazda AC.HL valve. The relation between signal volts input and total D.C. volts developed across a 30,000-ohm resistance for various H.T. supply volts (E) is given. The grid leak used was 0.25 megohm.

of H.T. potential is necessary. In designing a receiver it is essential, in order to maintain distortionless detection, so to proportion the L.F. stage gain that for worthwhile transmissions the detector is receiving a large

Power Grid and Leaky Grid.—

enough input to avoid leaky grid detection—say, 0.5 volt upwards—before the output valve overloads. Often enough one finds A.C. receivers in which the L.F. amplification is so high that power grid detection can never be realised because the power valve overloads long before the detector input is large enough for linear results. For sensitivity with distant transmissions considerable L.F. gain is permissible; when, however, local reception is desired, it would seem that a post-detector volume control is essential.

To obtain some practical design data Figs. 7 and 8 are given, for which the writer is indebted to Mr. E. Y. Robinson, of the Mazda valve engineering department. They refer to the Mazda AC/HL valve, which has been specially designed for power grid detection.

Fig. 7 shows the change of D.C. volts across a 30,000-ohm anode resistance for various inputs using different H.T. potentials (E). The characteristics are curved, due to leaky grid detection, up to about 0.2 volt R.M.S. input (peak volts=about 0.3), after which there are increasingly greater straight portions as the H.T. voltage is increased until curvature takes place again in the opposite direction due to anode bend rectification. With 100 volts H.T., for example, applied to the 30,000-ohm resistance, there is curvature at all points except, perhaps, around 0.4 grid volts. Suppose that a receiver is built with an AC/HL power grid detector which must accept and rectify without appreciable distortion an input of 1 volt (R.M.S.) modulated to a maximum of 80 per cent. The signal voltage will swing from 0.2 to 1.8 volts (R.M.S.), and a brief examination of the curves shows that between these limits reasonable linearity is only obtained with the 250, 350 and 450

H.T. volts characteristics. How much anode curvature is allowable for unobjectionable distortion? On the assumption that 5 per cent. second harmonic is permissible as with power output valves, measurement shows that 250 to 300 volts H.T. will suffice for the above case. The total D.C. voltage change across the 30,000-ohm resistance read on the vertical scale will be

from 3 to about 43 volts, giving a peak value of $43 - 3 \div 2 = 20$ volts. Using resistance coupling, therefore, the last valve in the receiver must be capable of handling 20 volts (peak) input and must be biased negatively to at least that amount.

A more valuable curve is given in Fig. 8 for an AC/HL valve resistance-coupled to the power stage. For 80 per cent. modulation and a maximum of 5 per cent. distortion the total H.T. voltage required for various peak

outputs is at once obtained. A set designed with a PP5/400 valve in the output stage, for instance, would require 32 peak volts¹ from the power grid detector, and to ensure negligible distortion using resistance coupling with values as quoted, it will be seen that 375 volts H.T. is required for the detector. This assumes, of course, that the H.F. amplifier in the receiver is capable of delivering, as it almost certainly would be, sufficient signal volts.

In all-mains equipment the power grid detector is finding wide application, chiefly because of the obvious advantage of distortionless rectification. There is another advantage of the straight-line characteristic not so well known: selectivity is considerably improved by the process of demodulation.²

¹ Optimum bias for this valve is 32 volts; see Valve Data Sheet accompanying last week's issue.

² See "The Variable-mu Three." November 18th and 25th, 1931.

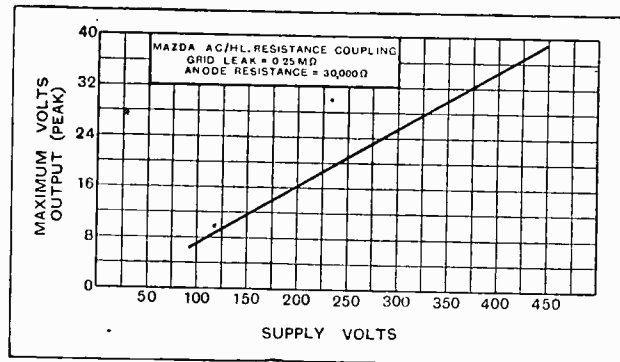
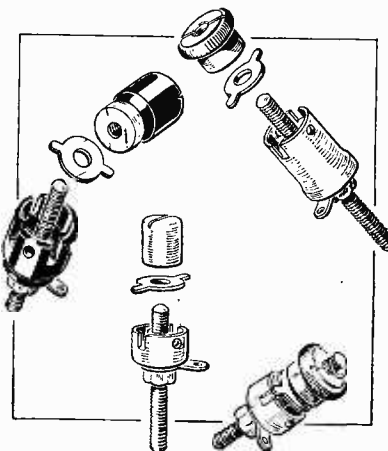

Fig. 8.—The total H.T. voltage required for various D.C. peak volts output using an AC/HL valve. The figures refer to an undistorted detector output with a maximum of 5 per cent. second harmonic distortion and 80 per cent. modulation. Circuit data are given at the top of the diagram.

A NEW TERMINAL.

Dust-protected Clamping Surfaces and Prevention of Galvanic Action.

ALTHOUGH terminals may occupy a rather insignificant place in the make-up of a wireless receiver, considerable thought and time is devoted to the question of design by those especially interested in their manufacture. A new design, so far not put into production, has made its appearance recently. Its principal features are: dust-protected clamping surfaces, security of clamping without cutting even the finest gauge of wire, a large contact area, and the ability to accommodate various wires of different size at the same time without any of the leads being displaced when



the terminal head is screwed home. Galvanic action, due to contact between dissimilar metals, is avoided by using an acid-resisting alloy.

The body of the terminal is cylindrical in shape, with a deep recess into which the knurled nut screws. It carries with it a non-rotatable washer provided with two small lugs, which engage in slots cut in the side of the terminal. The wires are inserted, from either side, through holes drilled in the cylindrical body.

Various modifications are suggested by the designers, a few of which are shown in the illustration.

Information relating to manufacturing concessions can be obtained from the International Exhibition of Inventions c/o Institute of Patentees (Inc.), 39, Victoria Street, London, S.W.1.

Readers' Problems.

Readers' technical enquiries are not replied to through the post, but in these pages replies to questions of general interest are dealt with week by week.

"The Wireless World Two" with an Eliminator.

AS "The Wireless World Two" (October 28th) is an exceptionally economical set in the matter of anode current, it follows that there would be a slight risk of an undue voltage rise if it were connected to an H.T. eliminator. Those readers who have asked for information on this subject may be referred to page 565 of our issue of November 11th, where specific instructions were given as to how one of these instruments could be used. It was recommended that a 10,000-ohm limiting resistance should be connected between the eliminator and the receiver; this value of resistor will be about right for any eliminator of the popular type, giving between 120 and 150 volts on normal loads, but a higher or lower value may sometimes be necessary.



Matching Moving-coil Loud Speakers.

THE high-efficiency pentode valves used in "The Wireless World Two" and the "Band-Pass Pentode Three" will provide just enough output when operated with maximum anode voltage to work many types of moving-coil loud speaker. Questions are asked as to the best method of matching loud speakers of this type, which include a built-in output transformer, to the pentode valve.

As a rule it is best to adopt the special type of tapped output choke which was specified for the "Band-pass Pentode Three," and to treat the loud speaker transformer combination exactly like an ordinary loud speaker. This means that the built-in transformer will be filter-fed by means of the output choke, matching being carried out by varying the tapped choke connection in the usual way.



D.C. to A.C.

A CORRESPONDENT whose supply system is shortly to be changed over from direct to alternating current asks whether it would be satisfactory to construct, for use during the interim, a three-valve receiver with A.C. valves wired in series, and, in fact, all the circuits arranged exactly as if modern indirectly heated D.C. valves were fitted. It is fully realised that this plan would be somewhat uneconomical, but it is expected that the change will be made so soon that this is not a matter of great moment.

Actually, there are no insuperable technical barriers against the adoption of this scheme, but it should be realised that one of the main differences (apart from the question of voltage rating) between

A.C. and D.C. valves is that the heaters of the former are intended to operate under conditions of constant voltage, while the latter are made to work with a constant current. This is a subtle difference, and by doing as our reader proposes, he may actually overrun, or under-run, a valve, in spite of the fact that the current passing through it is exactly one ampere.

However, the matter is not a very serious one, and we think it is worth while taking the small risk entailed.



The Simplest Radio-Gramophone Conversion.

SEVERAL popular commercial sets are not provided with means for connecting a gramophone pick-up, and requests are often received for information as to how this addition may be made. The sets in question are generally of the H.F.-det.-L.F. mains-operated type, and include grid detection. Almost without

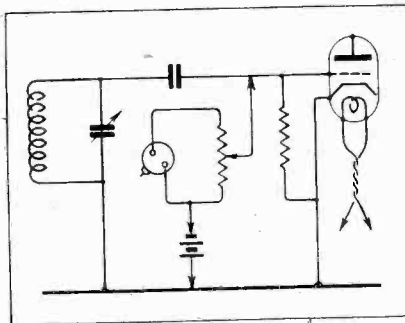

Fig. 1.—Improving a gramophone pick-up connection: an arrangement applicable to the majority of modern sets.

exception, these receivers may be converted quite satisfactorily for gramophone reproduction in the simple manner shown in Fig. 1.

All that is necessary is to connect the pick-up, with a volume-control potentiometer (of 50,000 ohms or more) and a small bias battery, between grid and cathode of the detector valve. The grid terminal of the valve-holder is generally get-at-able, and the cathode will probably be in electrical connection with the metal chassis on which most modern sets are assembled.

Several of these queries come from new readers, who say that they have not yet mastered the art of reading circuit diagrams; for their benefit, the connections are given diagrammatically in such

a way as to suggest a method of disposing the various components. Spring clips afford quite a good means of making connection in cases where it is not desired to make structural alterations to the set.

At the worst, if this method of connection does not happen to suit any particular set, no serious harm can be done by trying it.



A Hardy Annual.

REQUESTS are always being received for suggestions as to how interference at the lower end of the long wave-band may be eliminated. In every case the interference comes from a nearby station operating on the medium band, and is often troublesome in receivers of which the general selectivity is quite good.

This trouble is confined almost entirely to sets with single-tuned aerial circuits, and is hardly ever met with when band-pass or two-circuit aerial tuning is employed. Short of installing an up-to-date tuning system, the best cure is the insertion in the aerial circuit of a compact choke coil having about 300 turns of fine wire; it is as well to make provision for short-circuiting this coil when receiving on the medium wave-band.

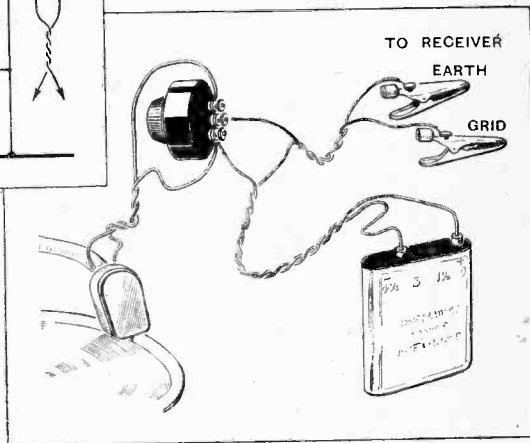

Pentode Output Transformer.

IT has been asked whether an existing pentode output transformer could be used in place of the special tapped choke in the "Band-Pass Pentode Three."

It must be remembered that the ordinary type of transformer is designed for a pentode having characteristics differing considerably from those of the new-type battery valves, and in general alterations of this nature cannot be contemplated. The high-efficiency pentode can only give good results if great care is taken in matching the loud speaker.

"Local-distance" H.F. Potentiometer.

A READER who finds that the volume control fitted to his receiver is inadequate for reducing volume from his local station to a sufficient extent, asks whether it would be possible to employ a fixed input potentiometer across the tuned aerial circuit, matters being so arranged that, by the connection of a switch, a small proportion of the total available signal voltage might be applied

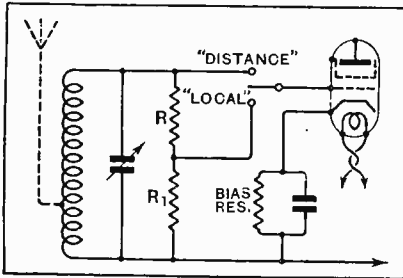

Fig. 2.—Optional signal inputs: a simple method of reducing sensitivity for short-range reception.

to the grid of the first valve. It is proposed that the potentiometer should consist of two fixed resistances of the grid-leak type, and information is sought as to values.

An arrangement of this sort (Fig. 2) should work quite satisfactorily, but we fear it is inevitable that some alteration in tuning will take place on switching over from "local" to "distance," or vice versa.

Without complete data as to the receiver, and the amount of signal energy picked up from the local station, it is not possible for us to do more than guess at the values of the potentiometer resistances. Their total value may be something between a quarter- and a half-megohm; the difficulty is to know the right ratio between R and R_1 (see diagram). This is a matter that can only be determined by trial and error, and we suggest that, as a start, R should be made 250,000 ohms, and R_1 20,000 ohms. Signal strength may then be increased or decreased by respectively increasing or decreasing the value of R_1 .

Some care should be taken to avoid the introduction of losses by fitting the change-over switch; on this score, a plug-and-socket arrangement might be preferable.

Battery Bias.

READERS who have eliminators—on D.C. mains supplies—giving a rather lower voltage than is desirable for their special purposes sometimes ask whether, in the design of mains-operated receivers, it is safe to assume that good results could be obtained by abandoning automatic bias in favour of battery bias. By doing this, of course, a greater voltage becomes available for application to the anodes of the valves.

In almost every case alterations of this sort are permissible. At first sight it would appear that there should be no

exceptions to this rule, but experience shows that, contrary to expectations, the substitution of battery bias for automatic bias will produce instability in at least one special case.

This effect has been noticed when using a combined eliminator (H.T. and bias) with a set designed for batteries. Inter-stage coupling is introduced in the anode circuit, and tends to promote self-oscillation, but this appears to be cancelled out by a feedback in the reverse sense, which takes place in the grid bias eliminator section of the instrument.

A.A. Telephone: Radio Version.

IT is a fact that the average broadcast receiver will not tune, on the long-wave side, to wavelengths as low as 833 metres, on which the Automobile Association weather reports are transmitted from the Heston Aerodrome. Readers having various types of receivers have asked for information as to how their wavelength range may be increased to the necessary extent, usually prefacing requests for information by saying that it is desired to avoid all structural alterations.

Except so far as the simplest detector-L.F. sets with plug-in or tapped coils are concerned, it is in practice almost impossible to extend wave range without making internal alterations. Very rarely can an appreciable addition be made by reducing the stray capacity, and even to do this it would almost always be necessary to alter some of the components. Broadly speaking, the only satisfactory way of doing it is to remove turns from the tuning coils; this reduction should be made gradually—five turns or so at a time—until the Croydon transmissions on 900 metres, which act as a good guide, are receivable. It would then be known that only a further small reduction is necessary in order that the set may be tuned to 833 metres.

As a rule there need be no fear that by adopting this course the range at the other end of the long-wave band will be unduly restricted; everything depends on the amount of stray capacity in the tuned circuits.

Finally, a word of warning. It is hardly advisable to alter the coils of receivers having ganged tuning; rematching will be necessary, and the incidental capacities are usually so high that the upper wave-range limit may become too low.

Outside Causes.

READERS whose reproduction is impaired by occasional buzzings and other forms of interference seem to be rather too ready to assume that the trouble lies in the set. It is not always easy to determine aurally what is responsible for the interference, but in practically every case a conclusive test may be made by disconnecting the aerial. If the offending noise ceases, it can be almost definitely assumed that the set is not to blame. Assurance can be made doubly sure by trying another set under

the same conditions, and noticing whether or not the same form of interference is present.

The simple test of removing the aerial is not easily applied to sets with built-in frame aerials; here the best plan is usually to short-circuit the frame rather than to disconnect it.

Short-wave Reception.

IT is generally admitted that the super-heterodyne type of receiver is definitely superior to a regenerative detector-L.F. set for the reception of short-wave telephony. A reader who is interested in short-wave telegraphic reception asks whether the superiority of the super-heterodyne for this special purpose is equally well marked. He goes on to ask whether continuous wave signals can be received with an ordinary superheterodyne, or if any modifications are necessary.

It is quite safe to express the opinion that, although a superheterodyne is highly satisfactory for the reception of short-wave telegraphic signals, its performance is not so noticeably better—when compared with a det.-L.F. set—as when dealing with telephony. A regenerative detector, working at its best, is extraordinarily sensitive when in the "just oscillating" condition.

An ordinary short-wave superheterodyne, with "autodyne" detector-oscillator, will not normally receive continuous wave signals. For this purpose it is necessary either to provide a separate oscillator or, more usually, to provide means for making the second detector oscillate by employing reaction between its plate and grid circuits.

FOREIGN BROADCAST GUIDE.

FÉCAMP

(France).

Geographical position: 49° 45' N.; 0° 23' E.
Approximate air line from London: 114 miles.

Wavelength: 222.9 m.*

Frequency: 1,346 kc. Power: 5 kW.

Time: Greenwich Mean Time (France adopts B.S.T.).

Standard Daily Transmissions.

G.M.T. 12.00, gramophone records (week-days); 20.00, commercial reports and news bulletin; 20.30, main evening programme. Relays outside broadcasts from Hotel Frascati, The Havre.

Opening signal: gramophone record (*Nos Vieux Pommiers*).

Interval signal: Bell (irregular).

Call: *Ici le poste de Radio Normandie a Fécamp.*

Time signal: G.M.T. 21.00, Chimes from the old Benedictine Monastery at Fécamp. Closes down with usual French *Bon Soir* greetings, followed by local folk song: *Ma Normandie* and *La Marseillaise*.

(*Special sponsored concerts intended for British listeners are broadcast on 245.9m. (1,220 kc.).)

The Wireless World

AND
RADIO REVIEW
(19th Year of Publication)

No. 642.

WEDNESDAY, DECEMBER 16TH, 1931.

VOL. XXIX. No. 25.

Editor: HUGH S. POCOCK.

Editorial Offices: 116-117, FLEET STREET, LONDON, E.C.4.

Editorial Telephone: City 9472 (5 lines).

Advertising and Publishing Offices: DORSET HOUSE, TUDOR STREET, LONDON, E.C.4.

Telephone: City 2846 (15 lines).

Telegrams: "Ethaworld, Fleet, London."

COVENTRY: Hertford St. BIRMINGHAM: Guildhall Bldgs., Navigation St. MANCHESTER: 260, Deansgate. GLASGOW: 26B, Renfield Street, C.2.

Telegrams: "Cyclist, Coventry."
Telephone: 3210 Coventry.

Telegrams: "Autopress, Birmingham."
Telephone: 2970 Midland (3 lines).

Telegrams: "Hiffe, Manchester."
Telephone: 8570 City (4 lines).

Telegrams: "H.F.S., Glasgow."
Telephone: Central 4857.

PUBLISHED WEEKLY.

ENTERED AS SECOND CLASS MATTER AT NEW YORK, N.Y.

Subscription Rates: Home, £1 rs. 8d.; Canada, £1 rs. 8d.; other countries abroad, £1 3s. 10d. per annum.

As many of the circuits and apparatus described in these pages are covered by patents, readers are advised, before making use of them, to satisfy themselves that they would not be infringing patents.

Europe's Wavelength Difficulties.

NOTHING has occurred during recent weeks which holds out any hope of a solution of Europe's broadcasting difficulties arising out of the increase in the number of stations and their power, and opinions held by various broadcasting authorities on the Continent seem to indicate that the divergencies of opinion as to how a solution might be arrived at have been increased rather than lessened as the result of the conferences recently held.

In this issue we include an article which puts forward certain points of view held in Germany and elsewhere on the Continent regarding the attitude of the British broadcasting representatives towards this European problem, and it seems to us that no solution is likely to be forthcoming so long as disagreement exists as to the relationship between the band of frequencies to be covered in transmission, and reception quality.

The Question of Kilocycle Separation.

The German point of view is that a separation of 9 kilocycles between stations is sufficient to provide adequate quality. The B.B.C. take the view that 11 to 12 kilocycles is the minimum frequency band required if the present standard of quality of their transmissions is to be maintained. Now, it would seem to us that very sound arguments exist which can be put forward to support either point of view. Our B.B.C. is striving at an ideal; one cannot get out of a receiver, however perfect in design, a range of frequencies in excess of those which are transmitted from the broadcasting station, and, therefore, it would seem desirable, if at all possible, that all the frequencies necessary for ideal quality should be transmitted. This would result in the necessity for a wide separation of broadcasting stations in terms of kilocycles, for it is obvious that if overlapping is to be avoided fewer stations can be

accommodated in the band of wavelengths available for broadcasting under international agreement.

If overlapping of stations is allowed to continue, then with sets of simple type reception will become more and more unsatisfactory, for the modulation of more than one station will be included in whatever programme we try to listen to, and consequently the vast majority of sets owned by European listeners to-day will be rendered obsolete and unsatisfactory.

B.B.C. Ideal May Fail in Practice.

If sets are designed where the tuning of the high-frequency side is sufficiently sharp to pick out from any one transmission a band of frequencies narrow enough to avoid interference from adjacent stations, then it is probable that the frequencies sacrificed will mean that the idealistic transmissions of the B.B.C. are being wasted, since the full range broadcast cannot be utilised by listeners, and quality suffers in consequence.

Recent investigations seem to offer a line of research which may eventually provide some solution to this difficulty, whilst at the same time enabling us to make full use of the frequency range broadcast, even though overlapping with adjacent stations may take place. The proposals of Dr. Robinson put forward in connection with the Stenode receiver have revived interest in the investigation of certain aspects of the problem, and it would seem that far more use is likely to be made of the principle of correction in the amplifier for loss of frequencies in the selective high-frequency circuits than has been done in the past. Investigation seems to indicate that introducing a correction of this nature after H.F. circuits of extreme selectivity does not result in a reinstatement of that part of the interfering overlapping frequencies of adjacent stations which is modulated, although actual heterodyne whistles remain.

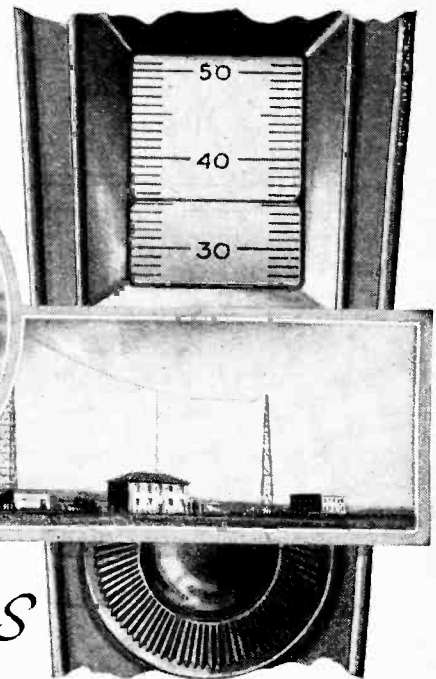
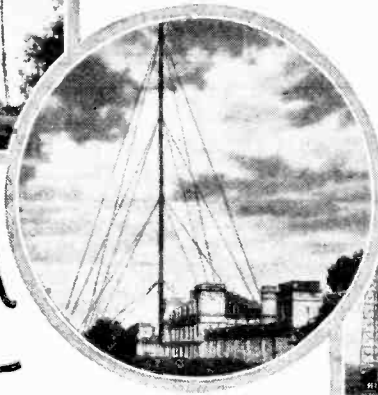
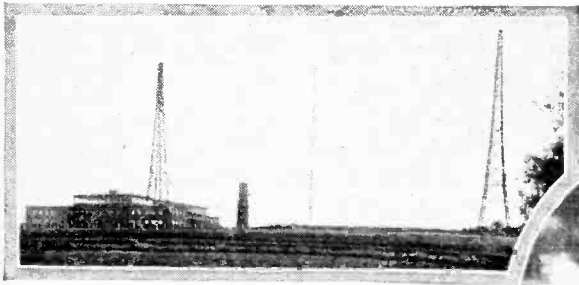

The Wavelength Squabble —

Through Continental Eyes

A CERTAIN army major, celebrated for his powers of endless argumentation, once defined his position as follows: "I'm perfectly open to conviction," he said frankly, "but I'd like to see the fellow who'll convince me." Such a spirit, possessed of an enviable impermeability to unwelcome notions, is, however, rare. The average man sticks to his opinions for the reason that, as a rule, he has come across only one side of the question—very often owing to the fact that he obtains his information entirely from one family of newspapers. If by any chance he comes into contact with the other side of the question in some other family of newspapers, or in an argument, the fare is so strange to his mental digestion that it is automatically rejected; but there is quite a good chance that a train of thought will have been set going which may lead to further investigation and a final outlook better balanced than the first.

Two Sides to Most Questions.

SO it would seem quite desirable that we who have heard so much about the efforts of our British representatives at the U.I.R. confer-

ences, we who know what we want "put right"—from our point of view—and who are inclined to feel that any opposition must be due simply to unreasonable foreign obstinacy, should once in a while be induced to look at the European Wavelength Squabble from the viewpoint of, say, a Frenchman or a German.

ARE we, as Britons, quite sure that ours is the only valid argument in the international wavelength debate? Both Germany and France are submitting points of view which, to say the least, deserve more attention than they have received from listeners in this country.

Here, for instance, is an expression of the point of view of the German representatives which we might do well to examine. It comes from a high official of the German Post Office. "It was," he says, "the English representatives, in particular, at the U.I.R. Conference who strove to obtain a larger separation (11 to 12 kc.) between the high-power stations, while Germany took up the standpoint that the relinquishing of wavelengths, without which increase of separation would be impossible, would be harder to bear under

present conditions than any sacrifice resulting from the 9 kc. separation—particularly if selective receivers are employed. . . . So far as Germany is concerned, the high-power foreign stations in general only cause trouble with distant reception in those cases where receivers with insufficient selectivity are used."

Now here is a perfectly clear-cut statement which deserves careful consideration. If this is the German opinion, then it must seem to German listeners that England is calmly asking them to abandon two of their precious national wavelengths in order to allow Englishmen to stick to their unnecessarily unselective receivers.

Are Germans Easily Pleased?

WE reply, of course, that our sets are as selective as is consistent with a fidelity worthy of our admirable B.B.C. transmissions; that if our German neighbours get over their 9 kc. troubles by using more selective receivers, they must be degrading the quality of the broadcast service—a shocking thing to do. This seems to be quite a good answer; at the same time, the inference as to the habits of the music-

The Wavelength Squabble.—

loving German race is sufficiently curious to suggest that it would be worth our while to look into the question and see whether our receivers are really without reproach in this matter of selectivity and consider if the German public really has to put up with indifferent quality.

Two other points from this official German communication may be mentioned. While hoping that the Madrid Radio Conference of 1932 will be persuaded to concede more wavelengths to broadcasting, little hope is held out that even this will make the 11-12 kc. interval practicable, since the bands hoped for are already earmarked, for existing or projected stations. The other point is that it is stressed that Germany, at one conference after another, has striven hard to keep down the maximum allowable power, in anticipation of the very troubles which are now complained of.

Wasted Wavelengths.

NOW we may well consider a second Continental point of view, put into words by a well-known *Wireless World* contributor, Major R. Raven-Hart. Writing from Paris under the above title, he puts in no half-hearted way an extremely interesting point. "It is probably not generally realised in Great Britain," he writes, "that there is considerable feeling on the Continent as regards the 'wasteful' use made by the B.B.C. of the wavelengths allotted to this country. It is felt abroad that to put out the same programme on several wavelengths simultaneously, from high-power stations, is not a proper use of these; and that, if the B.B.C. does not require them for the broadcasting of separate and distinct programmes, they should be allotted elsewhere. Relaying of programmes, it is considered, should be done exclusively by low-power 'local' stations, working on the less valuable wavelengths set aside for this service.

"Certainly it is a fact that any ordinary receiving set on the Con-

inent will at almost any moment find the same British programme on at least two points of its tuning scale, and not infrequently on three or four. Figures, however, will be more conclusive: taking a Sunday and a week-day at random, the 'station-hours' of the six high-power British stations totalled 37 and 62.5 respectively. For the same two days the hours during which the programme of a station was also to be heard from another transmitter totalled 26.5 and 31 respectively.

"A comparison," he continues, "may fairly be made with Germany, where the broadcast system is also State controlled: here a Sunday taken at random gave totals of 85 hours, with 17.5 hours of duplication (taking the five high-power stations), and a week-day 67.5 hours of total transmissions with only 2 hours of duplication. If the four French high-power stations were to be taken, the comparison would be even more unfavourable to Great Britain, since it may be said that these never duplicate each other's programmes, except in the case of matters of national importance (such as M. Laval's speech before leaving for America); but the comparison is perhaps somewhat unfair here, because these four stations are controlled by three

These points of view by no means exhaust the Continental comments on the attitude of the British broadcasting authorities, but they are sufficiently representative to make us feel that there is need to subject our own attitude and demands to the closest scrutiny.

**Where Compromise
Might Help.**

THE British attitude should be that no favouritism amongst nations of Europe in regard to the use of the ether for broadcasting purposes should exist. It would be a distressing state of affairs if eventually co-operation between the nations of Europe, in an attempt to solve the wavelength problem, broke down as the result of any obstinate attitude adopted by our own representatives, more especially if an obstinate attitude were maintained at the expense of fairness and consideration for others. At the same time, we do not want to see any unnecessary sacrifices made by this country, especially if quality of reproduction has to suffer, but compromise in this case is probably necessary and should not be ruled out if it is to provide a solution to the present difficulties.

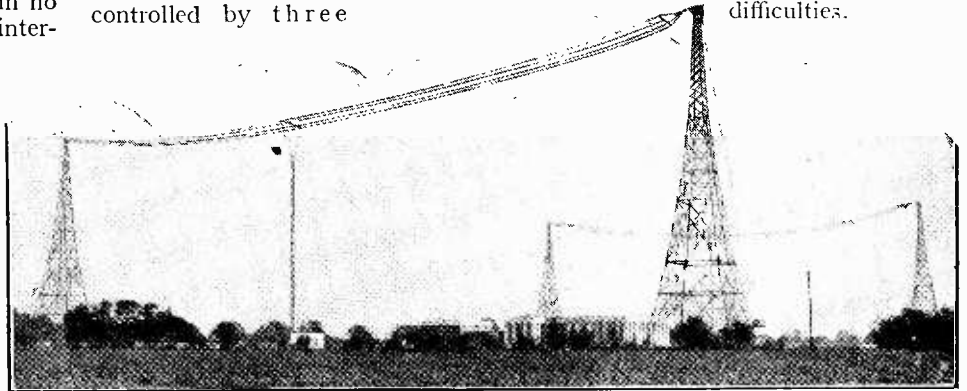

The two London transmitters have a frequency separation of 306 kc. and work on powers of 68 and 70 kw.

entirely independent organisations.

"However, to return to Germany: for a Sunday 20 per cent. of duplication as against the British 72 per cent.; for a week-day, 3 per cent. as against the British 50 per cent.; for a week, 6 per cent. as against the British 60 per cent. The complaints therefore seem to have a solid foundation in fact."

It is difficult to imagine that such positive statements as we come across in the Press of Continental countries should be made against the attitude adopted by this country, unless there is at least some foundation for the accusations made. It is important that we should be quite sure of our own position before making any accusations abroad.

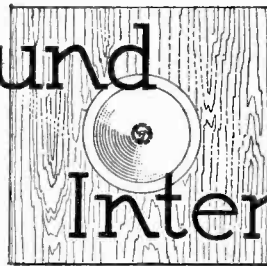

Sound Intensities

THE OUTPUT OF THE LOUD SPEAKER

The Many Causes of Variation in Acoustic Output.

IT is disconcerting that our knowledge of the power delivered by a loud speaker in the form of sound is meagre, and still lags far behind the exact information which is available as regards the behaviour of all other components of a receiving set. The reason is that the measurement of the small powers involved requires a very considerable outfit, the cost of which is prohibitive not only to the amateur but to most manufacturers.

The power which is conveyed to the ear from a normal receiving set is surprisingly small. Though the pentode valve may consume 5 watts, the power which enters the ear is of the order of a micro-watt, and the air particles vibrate through a distance of only a thousandth of a millimetre for frequencies of 1,000 cycles per second.

But even though it may be difficult to measure the output of sound directly, the comparison of one loud speaker with another is fortunately a simple matter. Experimental investigations have shown that it is possible to judge when the loudness of a complex sound is equal to that of a pure musical tone of a single frequency, and accordingly, if we have a source which emits a pure tone with an intensity which can be adjusted at will, comparisons of intensity can be made.

A tuning-fork supplies such a source. The power emitted by a vibrating fork dies down in such a way that the power falls off in any one second by a constant fraction of the power at the beginning of that second. Thus, if the power falls in five seconds to one-tenth of its initial value, it will fall in another five seconds to one-hundredth, in another to one-thousandth, and so on. If the scale of power in Fig. 1 is drawn so that there is a tenfold decrease of power in descending from one horizontal line to the next, then the power curve of the fork, when plotted against time, becomes a straight line.

This leads to a simpler way of regarding power changes. Let us regard the horizontal lines in Fig. 1 as the rungs of a ladder which indicate ten-fold changes in power from rung to rung. Then we may say that each rung marks a rise of *power level* over the rung just below. Such a rise in level is called a *bel*; when power increases to a ten-fold value the rise in level is one bel, and we have the following scheme:—

Relative Power	Change in power level
100	2 bels up
10	1 bel up
1	
0.1	1 bel down
0.01	2 bels down

WHAT our loud speakers are actually giving in terms of sound output is a pertinent question in these days of small rooms and semi-detached houses. Interesting parallels between other sounds and the output intensity of loud speakers in a moderate-sized room are shown in a pictorial "ladder of sound."

Now suppose we have a tuning-fork of suitable frequency, say, 500 cycles, and that we know (1) the rate at which its level falls per second, (2) the time required for the fork to become inaudible in a quiet room (the fork being held close to the ear), then we can draw a calibration curve as in Fig. 2.

The power level at any point in a room due to a loud speaker can now be immediately found. Strike the fork on the heel of the boot (it is found that the energy given in this way does not vary by more than 5 per cent. from one trial to another) and count seconds till the music sounds just as loud as the fork held close to the ear. If this time is, say, 10 seconds, then Fig. 2 shows

that the music is 7 bels above the limit of audibility. Tests of this kind have been carried out by Dr. Davis, with the results shown on the left side of Fig. 3. The figures give the power level in bels for loud speakers in a medium-sized room. On the right side are given various other sounds for comparison. Thus, what is here called quiet radio music is on the same level as

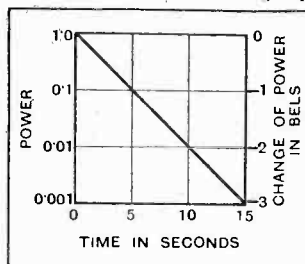

Fig. 1.—As the vibrations of a tuning-fork die away, the emitted power at any moment follows a straight line law.

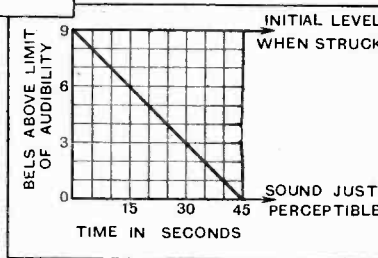

Fig. 2.—Chart which converts a tuning-fork into an instrument for measuring the power level of a loud speaker

Sound Intensities.—

ordinary conversation, while loud radio music is as loud as a heavy peal of thunder.

An interesting feature of this ladder of sound is that sound at any level is, roughly speaking, reduced to inaudibility by a competing sound at the level of the next rung above. Thus, while thunder may drown loud radio speech, the same speech drowns ordinary conversation. It also appears that if a lion should wander into the hall his voice would with difficulty prevail over the efforts of an ambitious amateur who has harnessed his speaker to a Mazda A.C. pentode valve. The ear is remarkably insensitive to changes in the intensity of sound. If one speaker is radiating twice as much power as another it is just possible to say which is the louder. This corresponds to a change in level of 0.3 bel. In this connection the figures in the table giving the relation between power ratio and corresponding rises in level up to one bel will be of interest.

The lower numbers are, in fact, the logarithms of the upper numbers. The term decibel is often used to indicate a change in level of 0.1 bel, or just under a third of the distance from rung to rung. Thus, considering the loud and very loud radio music indicated in Fig. 3, we may pass from one to the other in a little more than three perceptible stages. For example, if we move the volume control till the sound is distinctly louder, and repeat the operation twice, with a trifle more for good measure, the new intensity (or power radiated) will be ten times the old.

The Efficiency of Loud Speakers.

The transformation of energy from alternating current in the power valve to sound waves in the air is performed with great inefficiency by the loud speakers commonly in use to-day. A re-

view of the many experiments which have been performed to ascertain the ratio of acoustic output to electrical input leads to the conclusion that an average value for this ratio, which is a measure of the efficiency of transformation, is round about 1 per cent. The remaining 99 per cent. of the power is used up in resistance losses in the coils and in frictional losses in the moving parts.

In fact, while it is easy to set the cone or diaphragm into motion, it is difficult to impart this motion to the air a little distance away. The speaker may be compared to a closed oscillatory circuit, which radiates but little of the power which it consumes until an aerial is attached. So far, with the exception of the exponential horn which will be presently mentioned, no effective acoustic aerial has been devised for the loud speaker.

One cause of inefficiency is lack of rigidity of the cone. The light material, which must necessarily be used in order to obtain sufficient amplitude of swing, breaks up into vibrating segments at all but the lowest frequencies, as shown in Fig. 4. Consequently, much power is dissipated in local circulation of air and less is available for radiation to a distance.

If we make the cone smaller it becomes more rigid, and the local circulation diminishes in importance. But, unfortunately, as shown in Fig. 5, another cause of inefficiency sets in even with a perfectly rigid piston when its diameter becomes small compared with the wavelength of the musical note which is emitted. As the piston moves to the right the adjoining air is compressed in front and rarefied behind, and local circulation takes place round the edge in order to even up the pressure. The piston is not effectively loaded by the air,

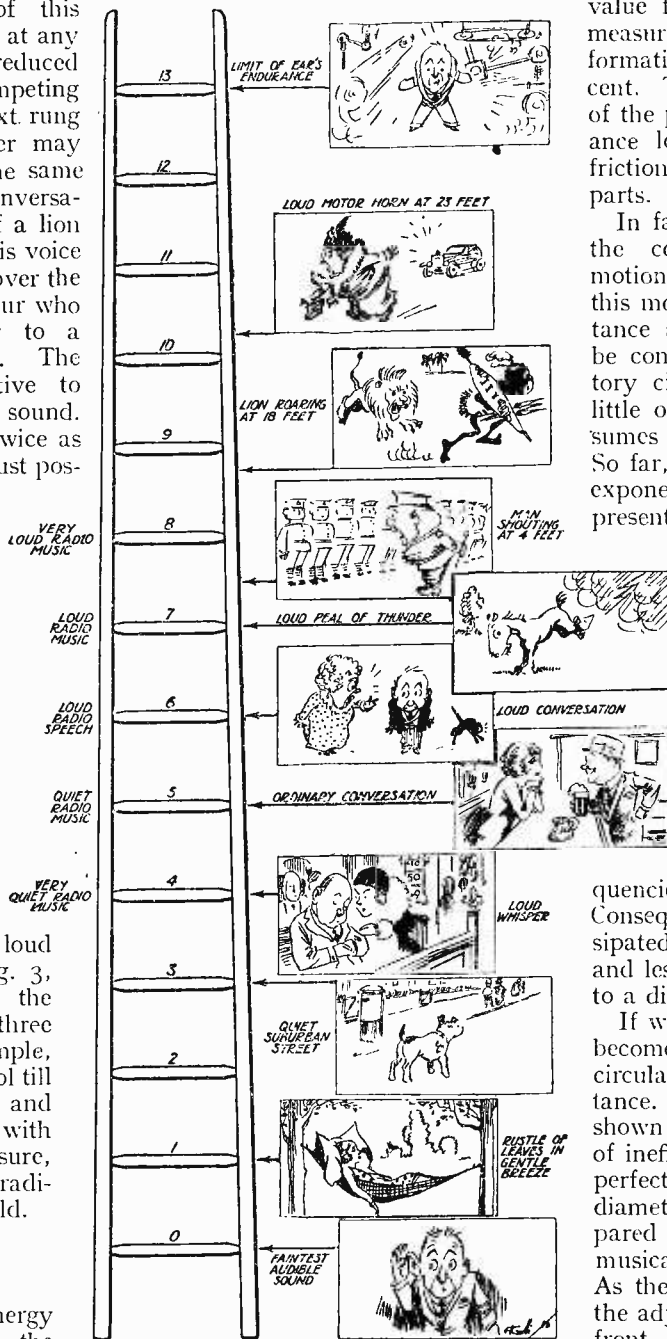

Fig. 3.—A sound almost overwhelms another when the volume difference amounts to one bel, i.e., when the sound increase is tenfold. In the ladder of sound we have a pictorial demonstration, each rung being at a level of one bel above the rung below.

Relative Power	1	1.26	1.58	2.00	2.51	3.16	3.98	5.01	6.31	7.94	10
Bels Up	0	0.1	0.2	0.3	0.4	0.5	0.6	0.7	0.8	0.9	1.0

Sound Intensities.—

but slips through it like a feathered oar in water. If we put a second piston B beside the first one A, as in Fig. 6, the backward wash of air from A impinges on the advancing face of B so that B has more resistance to push against and so is more heavily loaded than it would be if A were absent. Similarly, the wash from B helps the performance of A. This mutual reaction results in two adjacent pistons radiating four times as much power as one, while three pistons radiate nine times as much as a single piston, so that the radiation varies not merely as the total area, but as the square of this area, a law which holds until the diameter becomes comparable with the wavelength of the note emitted (at 1,000 cycles the wavelength is about one foot).

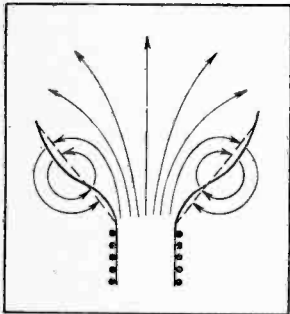

Fig. 4.—A cone diaphragm, whose normal shape is shown dotted, breaks up into vibrating segments at certain frequencies, and much wasteful circulation of air currents takes place.

If the diameter is large compared with the wavelength the edge effect is negligible and plane waves of sound are emitted. In these circumstances the efficiency would be quite large if a rigid and very light construction were feasible, but, unfortunately, with present materials these two qualities cannot be secured simultaneously.

We can, however, produce the plane waves of Fig. 7 from the small piston of Fig. 5 by fitting the latter with a suitable horn. A properly shaped horn with a 2in. diameter piston at the small end will deliver plane waves from the mouth, which may

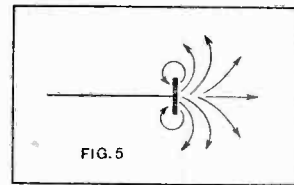

Fig. 5.—When a small piston vibrates much air simply slips round the edge.

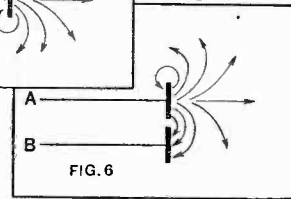

Fig. 6.—Two pistons, side-by-side, assist each other to set up useful radiation.

be 4ft. in diameter, so that the result is the same as if a perfectly rigid 4ft. piston were used.

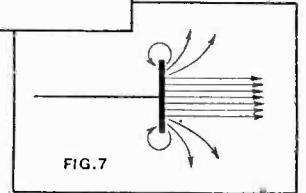

Fig. 7.—A large piston is the most efficient radiator.

The Western Electric Co. has made an exponential horn with an efficiency of 50 per cent., but since the length was 70ft. the device is not at

all suitable for use in the ordinary household! If the efficiency of our loud speakers could be transformed from 1 per cent. to 100 per cent.—a rise in power level of 2 bels—Fig. 3 shows that reproduction at whispering level would rise to that of ordinary conversation, while the announcer's voice as usually heard would rival a peal of thunder.

The Return of the "Superhet."

"The Revival of the Superheterodyne" was the title of a lecture given by Mr. E. Youle, of the Marconiophone Co., Ltd., at the last meeting of the Newcastle-upon-Tyne Radio Society. Mr. Youle gave his audience a complete summary of the history of superheterodyne design, and included some interesting descriptions of the methods used in ganging condensers with single control. The meeting ended with a brief discussion on *The Wireless World* superheterodynes.

Hon. Secretary, Mr. W. W. Pope, 9, Kimberley Gardeus, Jesmond, Newcastle.

○○○○

Wembley Society Closes Down.

Many amateurs in North-west London will regret the decision of the Wembley Wireless Society to discontinue its activities, at any rate for the present. The last meeting was held recently at Park Lane School. In a concluding speech the President, Mr. C. R. W. Chapman, expressed the fervent hope that some of the younger members would take it upon themselves to continue the Society's existence. Any communications on the subject would be welcomed and may be addressed to Mr. H. F. Faulkner, 40, Clifton Avenue, Wembley Hill. The cash balance in hand was handed over to the Wembley Hospital to defray the expenses of wiring the new wing for an extension of the existing radio equipment.

Waves.

Coloured drawings and diagrams on the blackboard, some technical and some humorous, added sparkle to an interesting lecture on "Carrier Waves" given before the Bristol and District Radio and Television Society on November 20th by the vice-chairman, Mr. A. E. Stephens (Radio GBVZ). The lecturer touched upon water, sound, light, and radio waves in sequence. Artificial aeriols, standing waves, polarisation, and modulation were among other points discussed.

Hon. Secretary: Mr. G. E. Benskin, 12, Maurice Road, St. Andrew's Park, Bristol.

CLUB NEWS.**"The Situation To-day."**

The first big meeting of the South Croydon and District Radio Society in their new headquarters at 19a, George Street, was the occasion for a lecture by the president, Mr. H. R. Rivers-Moore, who attracted curiosity by his title: "The Situation To-day." In this he outlined the general trend of progress which, so far as reception was concerned, was epitomised in the modern superheterodyne pentode output receiver with moving-coil loud speaker. To conclude the evening Mr. Rivers-Moore demonstrated his own receiver, the performance of which proved that "the situation to-day" represented a very high state of perfection.

Hon. Secretary: Mr. E. L. Chambers, 14, Campden Road, S. Croydon.

○○○○

A Successful Year.

Forty-nine meetings in one year was the proud record of Slade Radio (Birmingham), reported at the fourth Annual General Meeting held recently at the Society's headquarters in Brookfield Road, Erdington. At each meeting, if a lecture or demonstration had not been staged, some other fixture of interest had been arranged. The Society also held direction-finding tests, visits to places of radio interest, and also whist drives and dances.

It is fully expected that 1932 will offer equally good opportunities and that the membership will be still further increased. Full particulars may be obtained from the Hon. Secretary, 110, Hillaries Road, Gravelly Hill, Birmingham.

○○○○

Loud Speakers Compared.

The opportunity of hearing the whole range of Amplion loud speakers was seized with enthusiasm by members of the North Middlesex Radio Society at their last meeting, at which Mr. Hope-Wilson, representing the firm, demonstrated this formidable array of speakers, with

the aid of three receivers. Each loud speaker was operated in turn, thus enabling the members to judge the relative merits of the different examples, ranging in price from 15s. upwards.

On a recent Saturday a visit was paid to the Cosmos Lamp Works, under the guidance of Mr. G. Parr, of the Ediswan Company. Members were able to witness the manufacture of Mazda valves, from the early stages to the completion of the article ready for sale.

The winter syllabus of the Society, which includes many attractive features, is now ready, and copies will be gladly forwarded on application to the Hon. Secretary, Mr. P. Young, 40, Park View, N.E.1.

○○○○

Home Recording Demonstration.

A demonstration with the Kingston Home Recorder, used in conjunction with a paraphrase amplifier, was the important feature of the meeting of the Hackney and District Radio Society on November 16th. A Marconi Reiss microphone had been loaned for the occasion.

On November 23rd Mr. C. G. Lemon, of Messrs. Tungsram, lectured on "Radiant Energy," while on November 30th Mr. C. C. Devenny, of the B.T.H. company, dealt with the highly topical subject of "Interference."

Hon. Secretary, Mr. G. T. Ratcliff, 10, Balfour Road, Highbury New Park, N.3.

○○○○

Demonstrating the Stenode.

The fact that the meeting of the Southend-on-Sea and District Radio Society on Friday, November 6th, did not conclude until an unusually late hour furnished testimony to members' interest in the "Stenode Radiostat," which provided the subject of an interesting talk by Mr. Hale, of Radio Instruments, Ltd. The lecturer gave his hearers a thorough grasp of the principles employed in this novel receiver.

On November 20th the Society listened to a lecture by Mr. A. W. Hambling, A.M.I.E.E., on "Short Waves." The lecturer gave many circuits for short-wave sets and adaptors, and paid special attention to the use of the superheterodyne.

Hon. Secretary, Mr. F. J. Waller, 49, Fermoyn Road, Thorpe Bay, Essex.

NEW MOVING COIL MICROPHONE

Uniform Response up to 10,000 Cycles.

By A. DINSDALE.

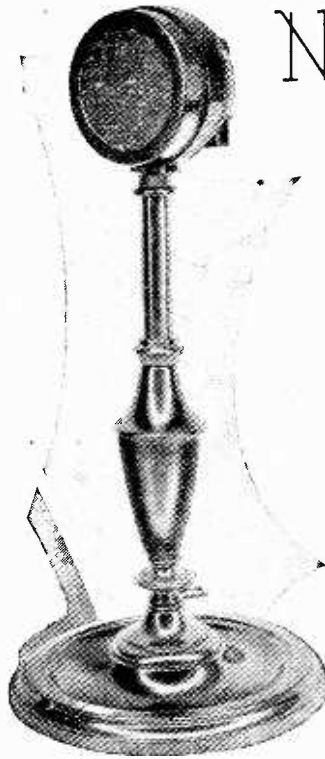

The table model is small and inconspicuous.

phone Laboratories. The new instrument—an improvement on the old B.B.C. magneto-electric type—is essentially similar to a moving coil loud speaker, with permanent magnet, rearranged, however, so as to transform sound waves into electrical impulses, instead of *vice versa*, as is done by the loud speaker. The details of construction are shown in the cross-sectional view in the accompanying diagram. The diaphragm A is dome-shaped in the centre, and is supported at its peri-

FOR a long time there has been a demand for a broadcasting microphone which would be impervious to atmospheric conditions, unaffected to any great extent by nearby electrical circuits, capable of use at some distance from its associated amplifier, and which, besides combining these advantages, would be reasonably robust, whether "alive" or "dead."

It is claimed that the demand has been met by the Western Electric Company, which announces a new type of microphone developed for it by the Bell Tele-

up by the central pole of the permanent magnet. Thus, as the diaphragm vibrates under the influence of speech or music, electric currents are generated in the coil.

The design of this new microphone, and the theoretical principles involved, are reminiscent of the mechanical gramophone sound box produced by the same laboratories for the "Orthophonic Victrola," and described in these pages some years ago by the present writer.* In both cases analogies have been drawn between the necessary mechanical components and the equivalent components of an electrical network or filter circuit designed to transmit the required band of frequencies.

The constancy of the response characteristics of the new microphone is secured by a design which adjusts the stiffness and mass of the diaphragm and the mechanical characteristics of small air chambers and passages to the



The standard model of the new Westinghouse moving coil microphone, which is designed both electrically and mechanically to give a straight characteristic up to 10,000 cycles.

acoustic pressures acting on the transmitter. The air space directly below the dome of the diaphragm has narrow passages connecting it to the small central air chamber, S₃, and to the large chamber, S₂. The accurate proportioning of these chambers and passages, combined with the stiffness and mass characteristics of the diaphragm itself, result in a frequency response curve that is practically uniform up to 10,000 cycles.

The moving-coil microphone, which is more sensitive and physically much smaller than the condenser type, can be used at some distance from the amplifier. At its first public trial, when two instruments were employed, one on either side at the back of the first balcony (dress circle), a distance of 150-200 feet from the orchestra, the results were highly successful, and the quality of reproduction beyond reproach. The instrument has the advantage of being unaffected by weather conditions.

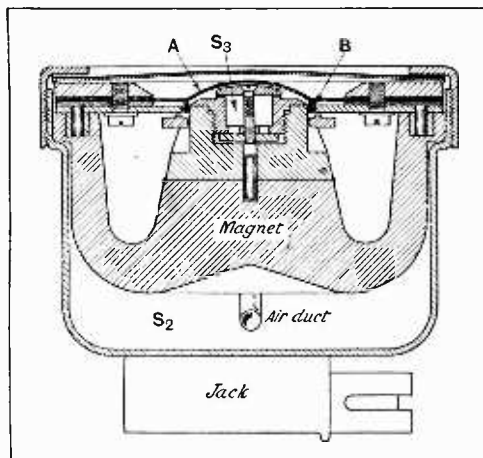

A cross-sectional view of the microphone showing the dome-shaped diaphragm and the specially designed air chambers.

phery by an annular clamp. Around the periphery of the underside of the "dome" there is a small annular coil B, which projects into the radial magnetic field set

* See "Wireless and the Gramophone," by A. Dinsdale. *The Wireless World*, Sept. 15th, 1926.

Wireless World

SINGLE DIAL SUPERHETERODYNE

(Concluded from last issue.)

Wiring-Up and Testing.

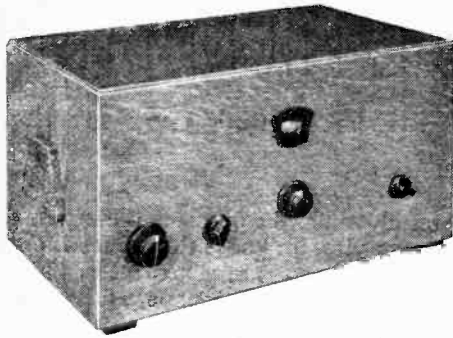

IN last week's issue the underlying principles of single dial control in superheterodynes were discussed, and we are now concerned with constructional details and notes on operation and performance. Using the underside practical wiring view as a guide, the leads are easily attached. The distance between points is measured off along the sleeving, which is then slipped over the wire. Particularly guard against fraying of the sleeving at the few points where it passes through the holes in the plate, and, as a precaution, one might slip an odd bit of sleeving of slightly larger size over the special small-gauge sleeving. Use the spare heads removed from the cathode terminals of the valve holders for clamping earth wires on the projecting ends of the bolts. Take particular note that the junction points marked "f" in the practical wiring diagram do not connect to the base-plate, but are free. Cut-down screws should be used at these three points, and, as a precaution, the condenser tags are bent upwards so as to remove the danger of contact with the plate. Where the small tag condensers engage on the coil terminals it will be necessary to open out the holes slightly, using, say, the shank end of a file for the purpose. Care is needed in fitting up the wander plugs to the battery, particularly where two leads enter to pick up a negative potential of 1.5 volts. Screw the indicating heads down as tightly as possible. The positive of the G.B. battery connects directly to a bolt on the metal plate. A danger point in the assembly is where the 50,000 ohm resistance connects to the anode terminal of the P.T.2 valve. When tightening this terminal see that the tag on the resistance does not contact with the holding down screw on the valve holder. Take care also that the extension of the condenser tag terminal on L₁ (K.21) does not contact with terminal 2 on the coil. Do not

insert the plugs into the bias battery until the wiring is finished, testing perhaps with a low-reading voltmeter or milliammeter to see that there is no current flow between a plug and its associated battery tapping. Carefully identify the battery-cable leads, or a mistake may result in the H.T. being applied to the valve filaments. The negative H.T. connection is not run in the cable, but consists of a wire joining the negative terminals of the H.T. and L.T. batteries.

Join up the L.T. only, and determine that the current flows when operating the switch. After making sure that the anode leads to the two S.G. valves are correctly joined up, plug in the H.T.-battery connections with caution, remembering that H.T.2, the screen lead of the pentode, *must always be joined up last and disconnected first*. Likewise, it is equally important, in protecting the pentode valve, not to run the set with the loud speaker disconnected. The loud speaker should either be of the type specially designed to work with the pentode valve (Ormond or Celestion), or, if of the ordinary type, an output transformer of suitable

ratio must be introduced.

Matching the loud speaker to the valve is of first importance, and poor quality will result if any departure is made from the correct requirements. If good quality is not obtained the trouble is almost certain to be traced to the matching of the

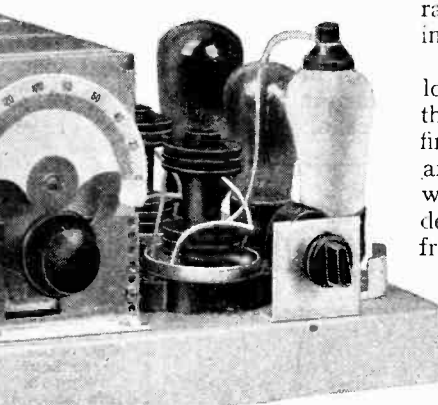

The screening boxes have been removed from the tuning coils and intermediate couplings for this general view of the new superheterodyne.

speaker, the impedance of which is incorrect.

The range-change switch should be set for the medium waveband, and a weak station tuned in on as short a wavelength as possible. The four trimmers on the intermediate-frequency transformers should then be adjusted for the maximum response, keeping the coils well apart. The three trimmers on the gang condenser must next receive attention, and these should again be adjusted for the loudest signals; while carrying out this

PRACTICAL WIRING DIAGRAM OF THE SINGLE DIAL SUPER.

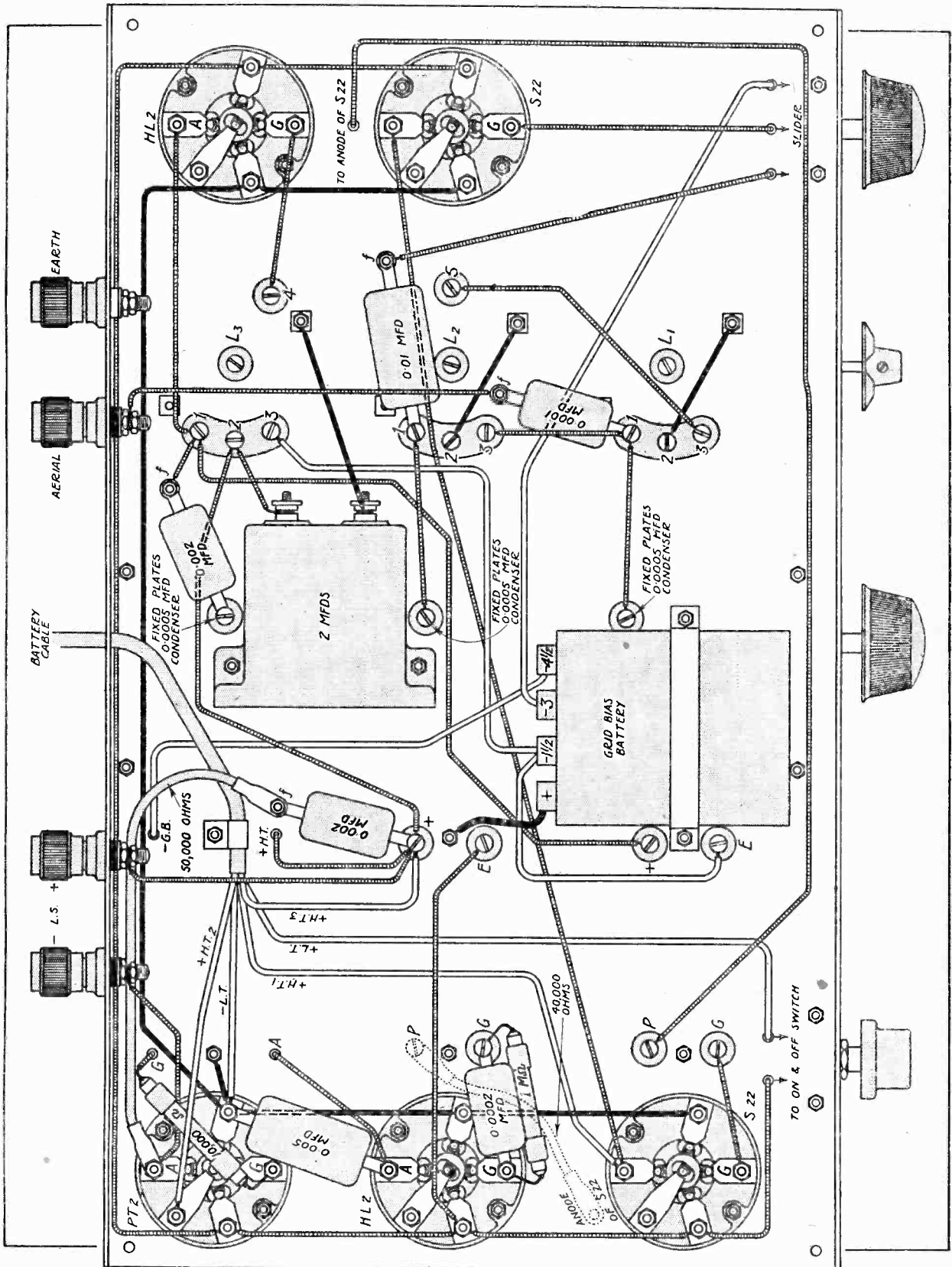

WIRING DETAILS. Where more than one lead connects to a single screw, do not terminate the wire but continue on through to the next point. When wiring, support the set on the three-section tuning condenser, using a cloth covering to avoid damage. No. 24 tinned copper wire is used carried in special 1/2 mm. yellow silk sleeving. The grid battery connections are of light rubber-covered flexible wire.

Single Dial Superheterodyne.—

adjustment, however, it may be found necessary slightly to retune with the main tuning dial.

The adjustment of the receiver is completed by setting the coils in the intermediate-frequency transformers to the best position. This adjustment requires some little care, for the selectivity is greatest when they are as far apart as possible, whereas there is definitely an optimum position for quality. The signal strength will also vary with their setting. In general, it is recommended that they be set for the best quality, and the usual adjustment for this is with the coils in the first transformer well apart and those in the second transformer fairly close together.

While carrying out this coil adjustment it may perhaps be found that at certain coil positions the I.F. valve starts to oscillate. The stage is designed to work fairly closely to the oscillation point in order to secure the maximum sensitivity. Valve characteristics vary somewhat, however, and so it may be found that in some cases actual instability is present. It should be noted, therefore, that if such instability is found it is readily cured by inserting a 40,000-ohms resistance in the anode lead to the I.F. valve. This resistance should be of the spaghetti type, and replaces the plain-wire connection between the valve anode and the I.F. transformer, and is therefore easily fitted. A reduction in the screen-grid voltage will also tend to reduce any regeneration. The trimming of the intermediate appears to be critical in respect of the tag control exposed at the front of the set.

The Selectivity Problem.

The selectivity of the set is such that any stations not actually heterodyning one another can be separated, except, of course, in the case of those adjacent to a powerful local station. Actually Muhlacker and the London Regional can be separated in North London. Second-channel interference will render a few stations unreceivable when the set is used close to a powerful transmitter. It should be noted that second-channel interference is readily recognisable, since both the distant station and the local can be heard together, and accompanied by a heterodyne whistle, the note of which changes with the setting of the tuning dial. This type of interference is only evident on a very few stations, and is almost inevitable.

The sensitivity is sufficiently high to allow of many foreign stations being consistently received, even on the medium band in daylight, while the quality of reproduction is good provided that the output valve is worked within its limits. Budapest is received in London during daylight. The output is large, considering that the total drain of the set on the H.T. battery need hardly exceed 12 mA.

The receiver has been tested within nine miles of Brookmans Park on an outdoor aerial, and the selectivity proved adequate. Algiers, which is spaced only 18 kc. from the London Regional, could be received without interference, but for the separation of Muhlacker the I.F. transformer coils were set for the maximum selectivity. The tuning control is best operated with

the left hand on the volume adjustment, advancing it only to the required degree of sensitiveness.

A specimen receiver is on view at the Editorial offices, 116, Fleet-street, London, E.C.4.

A WELCOME ANNUAL.

THE B.B.C. Year Book for 1932 fully maintains the high standard of interest set up by its predecessors. Considerable space is rightly and expectedly devoted to a description of Broadcasting House, and this includes a short article by Lt.-Col. Val Myer, the architect, in which he indicates a few of the problems encountered and overcome in the design of the building. The chapter headed "The Old Order Changeth" recalls pleasant memories of the early days of broadcasting, when there was a feeling of more intimate personal relationship between the staff at Savoy Hill and the comparatively small body of listeners, which inevitably tends to disappear as the growth on both sides of the microphone increases. The section devoted to licence statistics includes a comparison of the different methods adopted in various European countries, and the international section gives a brief summary of the progress of broadcasting abroad, with special reference to the United States and Germany.

The principal events broadcast during the past year are dealt with in the Programme section, while the Technical section contains articles on the New High-power Stations, Empire Broadcasting, Designing of Studios, Control of Transmissions, Reception, etc. A useful Appendix gives the personnel of the Advisory Committees, Councils, Musicians, Singers, etc., connected with the various educational and musical branches of the B.B.C., and the Balance Sheet and Revenue Account for 1930.

The book is profusely illustrated, and is published at the very modest price of 2s.

BOOKS RECEIVED.

Radio Telegraphy and Telephony. A complete textbook for students of wireless communications, by R. L. Duncan and C. E. Drew, 2nd edition, revised and enlarged, additional chapters having been written on Receiving Apparatus, Wireless as used in Aviation, and Broadcasting, while those on Valves, Commercial Transmitters, etc., have been enlarged and brought up to date. Pp. 1046+xi, with 529 diagrams and illustrations. Published by John Wiley and Sons, Inc., New York, and Chapman and Hall, Ltd., London, price 45s. net.

o o o o

Photograms of the Year 1931, edited by F. J. Mortimer, F.R.P.S. 64 Plates. Containing full-page or half-page reproductions of the leading photographic pictures from all parts of the world, with articles on the progress in many different countries, and a Directory of British Photographic Societies, Camera Clubs, and Amateur Cinematograph Societies. Published by Iliffe and Sons Ltd., London, price 7s. 6d. in cloth boards or 5s. in paper covers.

o o o o

The Motor Cyclist's Workshop, by "Torrens," of *The Motor Cycle*, with a section on Tuning for Speed and Efficiency written in collaboration with C. W. G. Lacey. An invaluable book for the motor cyclist who has a workshop of his own and is a good amateur mechanic. Pp. 136, with frontispiece depicting the ideal workshop and 94 illustrations. Published by Iliffe and Sons Ltd., London, price 2s.

A CURE FOR DETECTOR DAMPING

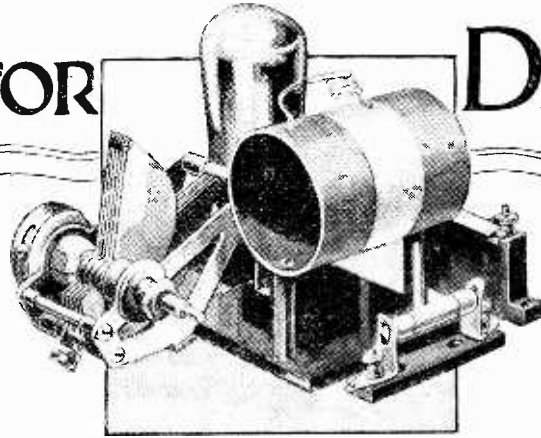

By C. H. SMITH,
B.Sc., A.M.I.E.E.
(Research Department, The British
Broadcasting Corporation.)

IN all respects but one the grid detector is satisfactory enough. The trouble lies in the loss of signal strength and selectivity occasioned by the serious load impressed on the preceding tuned circuit. Readers will welcome a new and inexpensive method of minimising this effect.

Using a Variable Grid-coupling Condenser.

THE grid-leak detector is generally admitted now to be a satisfactory rectifier when used under suitable conditions. It suffers, however, from the serious disadvantage that it imposes a considerable amount of damping on the radio-frequency tuned circuit that precedes it. This effect has been shown to be due to the anode load of the detector valve reflected by the anode-grid capacity c_a to the grid circuit of the valve, and may even produce damping in this circuit equivalent to a parallel resistance as low as 10,000 ohms, resulting in serious loss of selectivity. (See *The Wireless World*, July 30th, 1930, p. 100.)

These losses may obviously be neutralised by reaction, but in modern screen-grid sets this adjustment could often be dispensed with if the above-mentioned

condenser. There exists always an effective capacity between the grid and filament of a valve shown as C_1 in Fig. 2, and a little consideration of this figure will make it obvious that this condenser and the grid-coupling condenser (marked C_2 in the figure), together constitute a potential divider whose effect is to reduce the detector damping on the input tuning circuit. Normally, the grid-coupling condenser is made considerably greater than the grid-filament capacity, so that practically the whole of the damping is imposed on the tuned circuit.

Better Time Constant.

If, however, we reduce the capacity of the grid-coupling condenser, we obtain a reduction in damping identical with the effect obtained by tapping down the coil, with the added advantage that the time constant of the discharge circuit of the grid rectifier is decreased considerably, giving less high-note cut-off in the detector, or, alternatively, the grid leak may be increased correspondingly to give more nearly linear rectification at small inputs.

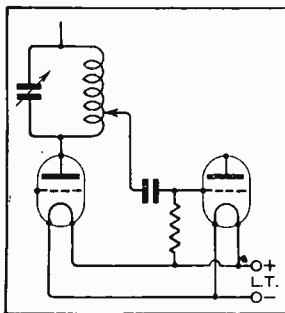

Fig. 1.—By tapping the grid down the preceding tuned circuit, the selectivity can be improved.

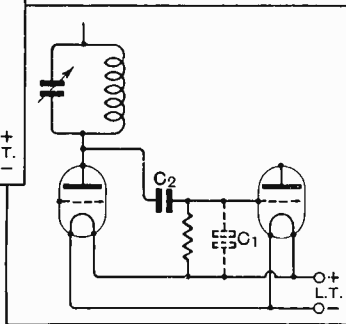

Fig. 2.—There is always an effective grid filament capacity in every valve. It is here shown as C_1 and together with C_2 a potentiometer is formed.

source of loss could be avoided. A partial cure consists of increasing the anode by-pass condenser, but it is not generally possible by this means to produce more than a slight improvement before the added capacity begins to exert a detrimental effect on the L.F. response curve. On occasion it has been the practice to connect the grid condenser to a tapping point of the preceding tuned circuit, as shown in Fig. 1, and this method provides a satisfactory means of increasing selectivity.

An alternative and preferred method, however, consists very simply of reducing the size of the grid-coupling

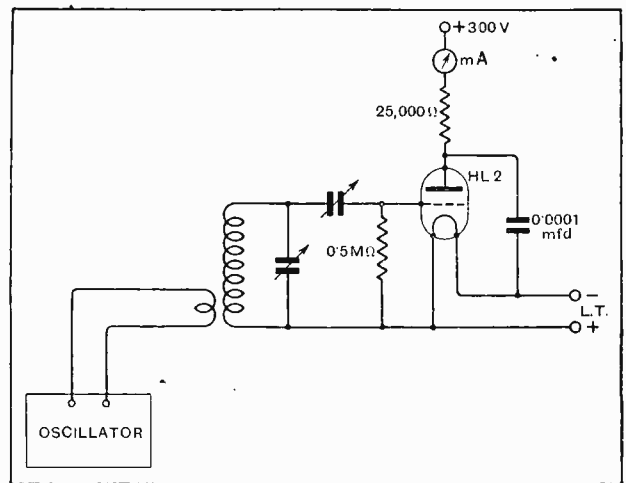

Fig. 3.—Experimental detector circuit coupled to oscillator. Note the variable grid condenser.

A Cure for Detector Damping.—

Simple experiments have been made to determine practically the effect of reducing the grid-coupling condenser. The circuit used is shown in Fig. 3, and consists of a detector circuit, conventional except for the variable grid condenser, coupled very loosely to an oscillator.

Measuring the Detector Load.

The detector load was measured by the detuning method, using a General Radio standard condenser, Type 222, capable of being read to less than $0.1 \mu\text{mf}$. Values of rectified current were observed, and from these and the previously determined rectification characteristic of the valve the radio-frequency potentials on the grid of the valve were obtained. Finally, the curves in Fig. 4 were drawn, showing the change in effective coil damping and sensitivity (i.e., volts

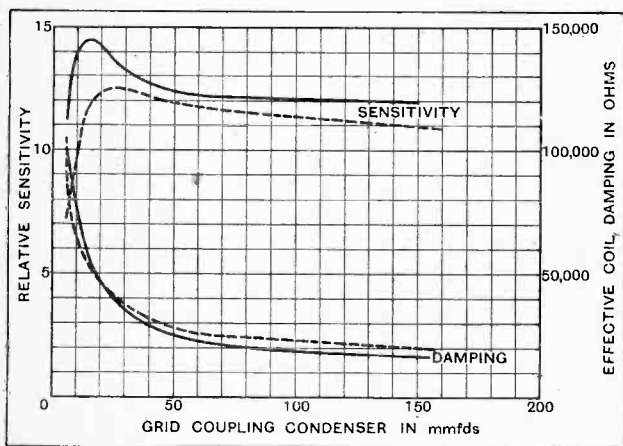

Fig. 4.—Showing the change in effective coil damping and sensitivity for various values of grid condenser. The full line curves were taken at 250 metres whilst those represented by broken lines were at 500 metres.

actually on the grid of the valve with constant coupling to the oscillator) for various values of grid-coupling condenser at wavelengths of 250 and 500 metres.

The results are instructive, for they show that a reduction of the grid-coupling condenser from the normal value of about 0.0002 mfd. to the comparatively low value of 0.00002 mfd. increases the selectivity of the input circuit in both cases by about three times, and even produces a small but perceptible increase in sensitivity.

It is not necessarily true that such a small value of grid-coupling condenser is to be recommended in every case, but home constructors would be well repaid by replacing the conventional 0.0002 mfd. grid-coupling condenser by one of the pre-set type with a maximum value of about 0.0005 mfd. This condenser should be adjusted to the smallest value at which no appreciable loss of signal strength is noticeable, and a considerable increase in selectivity should then be obtained. The added cost when substituting a variable grid condenser for one of the fixed type must be considered negligible when the total cost of a set is taken into account.

NEW BOOKS.

"TALKING PICTURES." By B. Brown, B.Sc. Pp. 305 + xi. With 161 illustrations and diagrams. Publishers: Sir Isaac Pitman & Sons, Ltd., London. Price 12s. 6d. net.

THIS book, while not being highly technical, explains to the layman the principles and a number of practical details of making and reproducing talking pictures, and generally shows the evolution of recording and reproducing technique up to about the end of 1930, which is highly commendable in a book dealing with a comparatively new and rapidly expanding subject.

The author shows that he has had a thorough practical experience with at least one main reproducing system, and the book is written in such a way that the layman with an elementary knowledge of wireless can understand most of the difficulties involved.

There are one or two very minor mistakes in the case of systems with which the author is not familiar, but these do not detract from the value of the book.

One of the most valuable chapters is that on theatre acoustics. There is often trouble due to the properties of the auditorium and not to the talkie set at all, and Chapter VI explains the principles of correction.

To conclude, this book is thoroughly to be recommended as an up-to-date non-technical *résumé* of progress in making and reproducing talking pictures.

o o o o

A. P. C.

RADIO CONSTRUCTION AND REPAIRING. By J. A. Moyer and J. F. Wostrel. (3rd edition.) Pp. 386 + ix. With 179 Figures. Publishers: McGraw Hill Publishing Co., Ltd., London. Price 15s.

IN the third edition of this book a considerable portion of the old matter has been revised and rewritten, while more space has been devoted to the design and construction of modern superheterodyne receivers and to short-wave equipment, especially that designed for broadcasting and television.

Testing and repairing receiving sets occupies 84 pages, and contains much useful advice, though from the point of view of the British amateur the fact that the book is written by Americans for Americans may prove a slight drawback, as, naturally, the valves specified and many of the components mentioned are those in use in the United States, and may be unknown in this country.

Next Week's Issue.**LOOKING BACK :****Recollections and Reflections.**

An exclusive contribution by Sir John Reith, of the B.B.C., in which he describes his early contacts with wireless amateurs and turns to his diary for a record of his impressions of the early days of broadcasting.

A SUPERHET ADAPTOR FOR ULTRA SHORT WAVES.

A Unit for use with either Battery, D.C. or A.C. receivers, and deriving its current from the "Parent" set.

SPECIAL ARTICLES DEALING WITH SHORT WAVE RECEPTION

AND

A LIST OF SHORT WAVE BROADCASTING STATIONS OF THE WORLD WITH A MAP SHOWING THEIR LOCATIONS.

Current Topics.

Radio Paris Surprise.

THE mystery concerning the erratic transmissions from Radio Paris, the strength of which varies from day to day, is cleared up by the official announcement that during the present tests listeners must expect to hear "sometimes the new transmitter and sometimes the old one."

o o o o

Vatican to Try the "Ultra-shorts."

THERE can be no further doubt that the engineers at the Vatican short-wave station intend to keep abreast of the latest radio practice. We learn from our Italian correspondent that Marchese Marconi's recent experiments have prompted a decision to install an ultra-short-wave station at the Vatican for communication with the Papal villa at Castel Gandolfo, 15 miles distant. The transmitters and receivers are already under construction, and should be in operation early in the spring.

o o o o

An Oscillatory Threat.

A THREAT that "one hundred reaction detectors will set Paris a-ringing" has been made by French Communists, who promise to adopt a campaign of this nature if any attempt is made to drown the broadcast transmissions from Moscow, as suggested in one of the weekly reviews.

The Communists are, we fear, just a little optimistic in claiming that 100 oscillators would put a stop to all radio reception in Paris. However, much can be done with a few kilowatts.

o o o o

America's 16 Million Radios.

THE biggest revelation in the U.S. Census Bureau's newly published report is that nearly every other home in the country now has a wireless set. The exact number of "radios" on April 1st, 1930, when the count was taken, was 12,078,345, or 40.3 per cent. of the total number of American households, which are calculated at 29,980,145.

o o o o

"Small Ads."

IN view of the alterations in our printing arrangements, due to the Christmas holidays, it is necessary that Miscellaneous Advertisements intended for *The Wireless World* of December 30th should reach us not later than first post on Wednesday next, December 23rd.

o o o o

Televising an "Eclipse."

AMERICAN scientists paid their highest compliment to television on December 2nd, when, rather than view an eclipse of the sun, they witnessed a "mechanical duplication" of the phenomenon transmitted from the Jenkins television studio in New York. The spectacle was witnessed on an 8ft. television

screen in the American Museum of Natural History while the actual eclipse was taking place, a running commentary being supplied by the famous ex-member of the Federal Radio Commission, Mr. O. H. Caldwell.

o o o o

Interference "War" in France.

THE man-made static nuisance in France has reached such a stage that it is to receive the attention of the Conseil d'Etat, the supreme tribunal for interpreting administrative questions falling outside the province of the ordinary courts. The case for the amateur, we understand, will be submitted by a committee specially appointed by the united

Hidden Advertisements.

THE prize-winners in the Hidden Advertisements Competition in our issue of December 2nd are as follows:—

1st prize (value £7 10s.): Mr. L. J. Trott, 5, Lancaster Street, Leves, Sussex; 2nd prize (value £5): Mr. L. P. Smith, 5, Critchmere Vale, Haslemere, Surrey; 3rd prize (value £2 10s.): Mr. C. D. Newman, Stormcrest, Easton-in-Gordano.

Consolation prizes (each of the value of £1) are awarded to the following: Mr. H. O. Guest (Redcar, Yorks), Mr. James Barclay (New Barnet, Herts), Mr. James Maccabe (Blackhall, Midlothian), Mr. P. R. Crimp (Sheffield), and Mr. C. F. Simons (Antwerp, Belgium).

Here is the correct solution:—

- (1) Britannia Batteries, Ltd. (Pertris).
- (2) Lanchester Laboratories, Ltd.
- (3) Lectro Linx, Ltd.
- (4) Telsen Electric Co., Ltd.
- (5) Jackson Bros.

(6) Tannoy Products, Ltd.

Police Radio.

THE German police have an official long-wave transmitter in Munich which transmits daily from 0700 to 0800, and 1900 to 2000 on 1,340 metres. The Paris police "poste" can be heard on wavelengths ranging from 44.74 to 1,140 and 1,200 metres. And now Hungary has established a radio arm of the law; in Budapest an 800-watt transmitter is in touch with stations throughout the country.

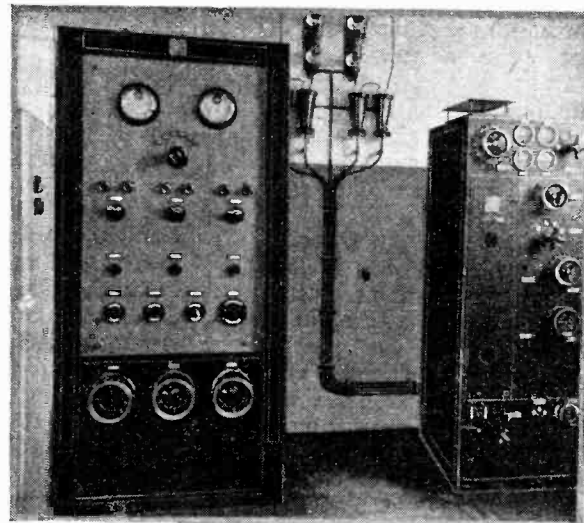

SHORT WAVES FOR THE POLICE. The Hungarian police force has established a wireless organization which includes a number of low power transmitters and more than 230 receivers. The upper picture shows the 800-watt transmitter at Budapest. Below is a typical receiving room.



wireless clubs, and it is hoped that the Conseil will be moved to enforce regulations to control the amount of interference which at present makes the French ether a pandemonium.

o o o o

How They Listen.

THE Postmaster-General states that of the 4,101,000 wireless receiving licences in force on October 31st last, 3,682,000 had been taken out by English listeners. There were 244,000 licences current in Scotland, 140,000 in Wales, and 35,000 in Northern Ireland.

Non-stop Flight.

SQUADRON-LEADER GAYFORD will start his non-stop flight from England (Cranwell) to Cape Town on Tuesday next, December 22nd, in a monoplane carrying a radio transmitter operating on 33.71 metres. The transmissions, which will be given every two hours, commencing at 0500, will take the form of "CQ, CQ, CQ v. GEZAA," followed by the position.

Messages received may be posted to the Air Ministry, Kingsway, W.C.2, but it is requested that distress calls be telephoned immediately to Holborn 3434.

AMPLION

'SIX'

WHEN the Amplion Six was first announced, just before this year's Olympia Exhibition, it seemed almost too good to be true. This self-contained A.C. receiver, with six British valves, albeit with only four stages (two of the valves are in the push-pull output circuit and another is a rectifier), with refinements such as a band-pass filter, ganged tuning, and wavelength calibration, to say nothing of a built-in moving-coil loud speaker, set quite a new standard of value.

After having had an opportunity of carrying out an extensive test, the opinion has been formed that the receiver lives up to its early promise in every respect, and, indeed, in the matter of selectivity, is rather better than might reasonably be anticipated. A set produced under commercial conditions is naturally subject to limitations in various directions, but almost every difficulty seems to have been overcome in a very satisfactory way.

Although designed primarily to operate with an external aerial-earth system, the Amplion Six is fitted with a built-in capacity aerial, which is, very modestly, stated to be mainly for short-distance reception. In point of fact, this miniature aerial, which consists

GENERAL: Self-contained A.C. mains receiver for operation with external aerial or built-in capacity aerial. Moving-coil loud speaker.

CIRCUIT: Band-pass input filter; two tuned-anode H.F. stages; optional power grid or anode bend detector; transformer-coupled push-pull output stage. Full-wave valve rectifier.

CONTROLS: (1) Ganged tuning. (2) Wave-range switch. (3) Combined volume control and on-off switch.

PRICE: 20 guineas complete.

MAKERS: Graham Amplion, Ltd., St. Andrew's Works, Slough, Bucks.

merely of a metal plate measuring about 7in. by 12in., mounted under the top of the cabinet, provides about as much signal pick-up as is needed by a large number of listeners; as an example of what it will do—and also as an index to the high sensitivity of the set—it may be stated that Radio Paris is receivable at full strength with its help under fair average conditions.

The basic circuit is a 2-V-1 combination, with band-pass input filter, two H.F. stages, power

grid detector, and push-pull output. Plain inductive coupling is employed between the filter circuits, but it is stated that a certain amount of capacitive coupling is intentionally introduced through the capacity of the wiring. Trimming of the primary circuit is done by

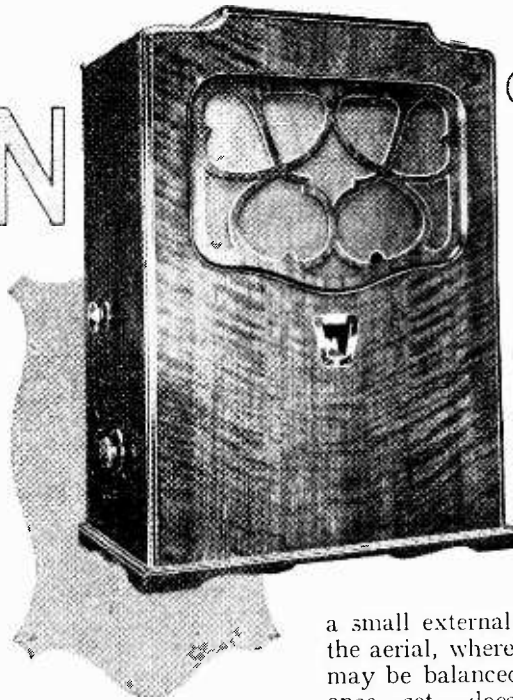

An Inexpensive
Long-range
Self-contained
A.C. Receiver
of Ambitious
Design.

a small external condenser in series with the aerial, whereby differences in capacity may be balanced out; this control, when once set, does not need subsequent adjustment. Simple tuned-anode couplings, controlled by ganged condensers with segmented end vanes and earthed rotors, are employed for linking together both the H.F. stages and the detector. The tuned oscillatory circuits are completed through large condensers, and also act as by-pass capacities in conjunction with anode decoupling resistances.

A pre-detection volume control of the double-acting type is fitted; this operates both by over-biasing the H.F. grids and by partially short-circuiting the aerial input circuit at the same time. These operations are carried out in a very simple manner by means of a single potentiometer; as the sliding contact is moved progressively from "maximum" to "minimum," negative bias is increased, and the resistance shunted across the aerial circuit is simultaneously reduced.

After the H.F. amplifier comes a power grid detector, operating with some 150 volts on its plate. This valve is convertible into an anode-bend detector by the simple expedient of open-circuiting a bias resistance included in its cathode circuit by means of an external switch. It is intended that anode rectification should be used mainly to improve selectivity where necessary, and also for short-distance work.

In the anode circuit of the detector there is a complete H.F. filter, of which the choke coil is entirely screened. Coupling between this valve and the push-pull output stage is by means of a transformer with the usual centre-tapped secondary; another transformer is used to link the output valves to a moving-coil loud speaker.

The power supply circuits are fairly conventional, the process of rectification being carried out by a standard B-type rectifier, of which there is a sufficient margin of voltage output to allow for adequate anode decoupling throughout the set. That part of the rectified output which feeds the push-pull stage is smoothed by a choke,

THE AMPLION SIX: DETAILS OF THE RECEIVER UNIT.

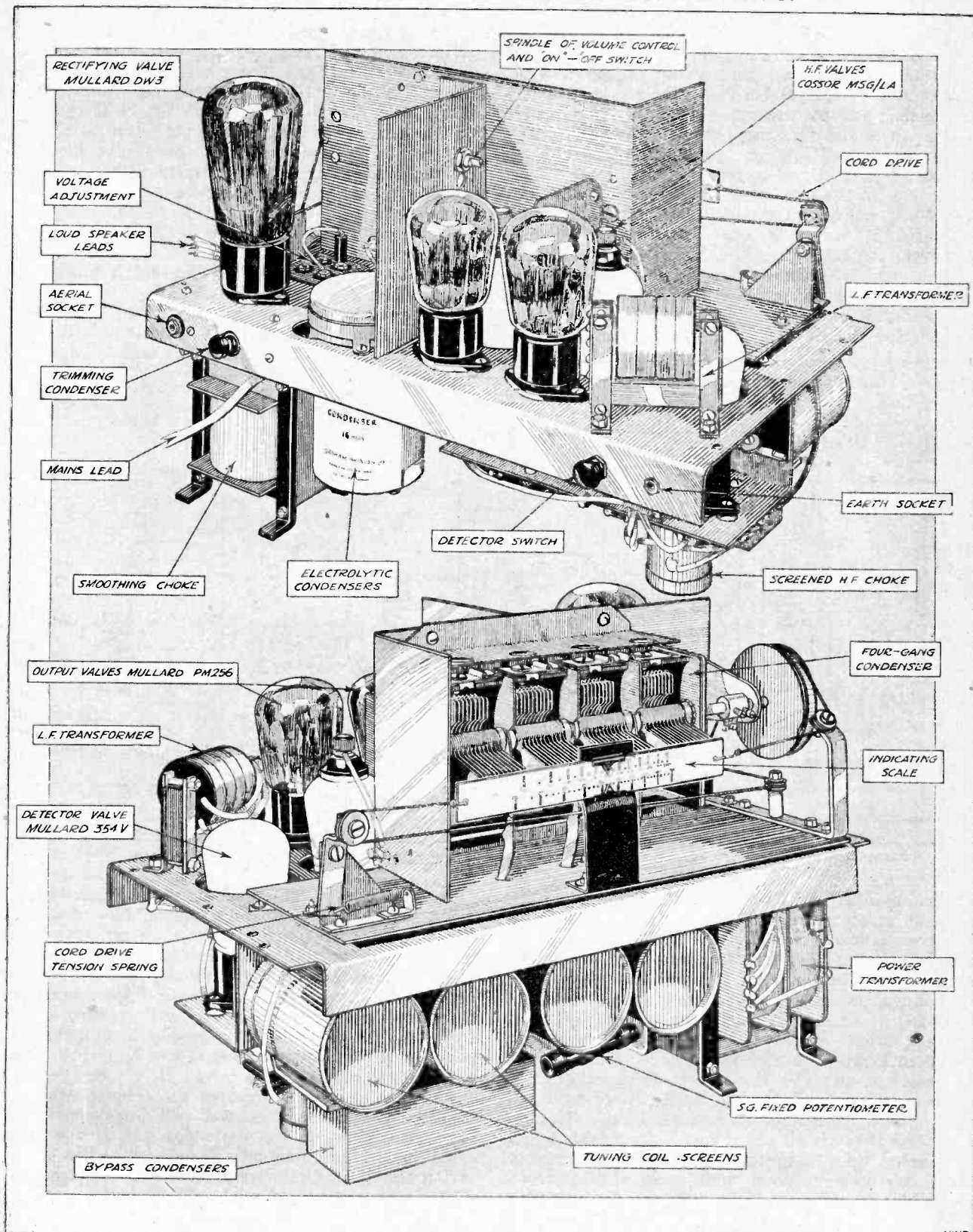

The chassis, as seen from both front and rear. All apparatus except the loud speaker is included in this unit.

Amplion 'Six.'—

in conjunction with a pair of high-capacity electrolytic condensers, which, incidentally, are built into a single case; feed current for all other valves is smoothed in addition by the loud speaker field winding; current for the screening grid potentiometer, which is of unusually low resistance, and thus provides good voltage regulation, is also passed through this winding, so there is an adequate magnetising current.

Operation of the receiver is simplified by combining the volume potentiometer control with that of the on-off switch, which is operated by a trip-action mechanism. Among other mechanical features are an ingenious spring-tensioned cord drive for the tuning condensers, combined with a horizontal wavelength scale, and also sponge-rubber suspension for the H.F. and detector valve-holders. All components, except

and as no reaction control is fitted, it is obvious that regeneration plays an insignificant part.

With regard to selectivity, it is hardly necessary to say more than that the tuning control "chops off the stations" in the real band-pass fashion. Interference from a local station at ten miles distance is confined to a much narrower band than usual, even for a four-circuit set of comparable type, while the other kind of interference—between two more-distant stations operating on adjacent frequency channels—is hardly ever encountered. When it is, recourse to anode bend detection will generally dispose satisfactorily of the interference, but will cause a reduction in signal strength, as this system of rectification is much less sensitive than the power grid method.

Loud speaker output is well maintained from about 100 cycles to nearly 2,500 cycles, after which there is

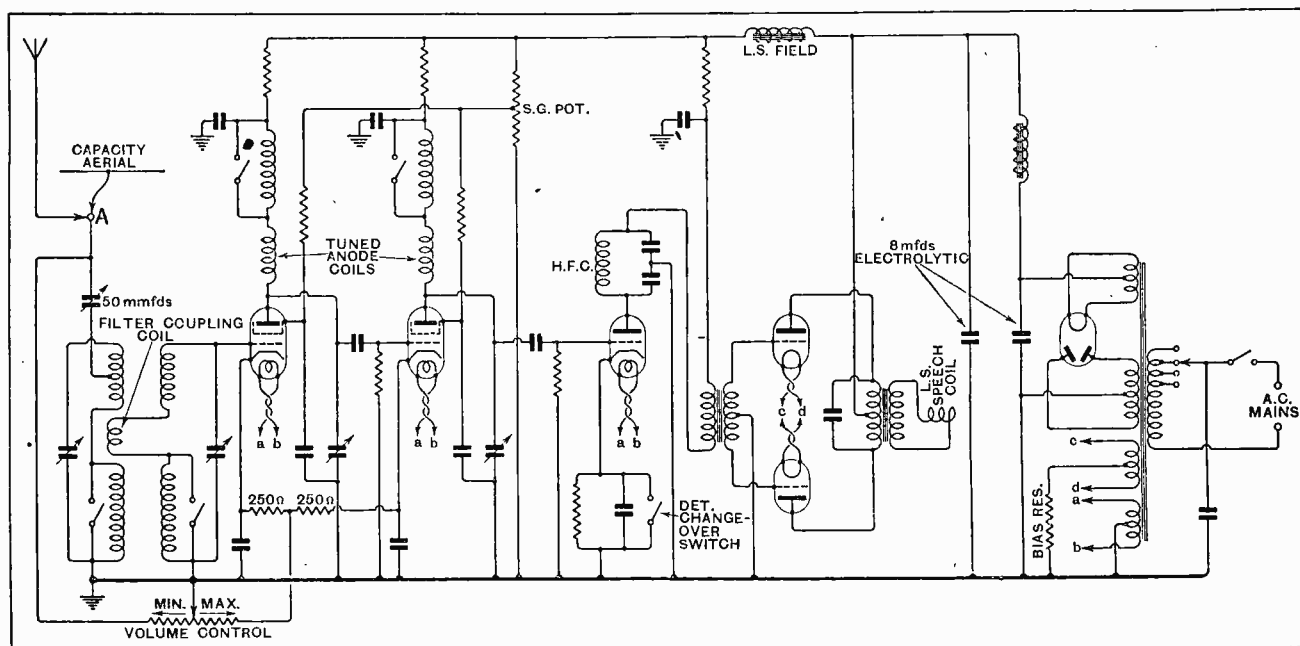

Complete circuit diagram, showing clearly the operation of the double-acting volume control. A 250-ohm resistor is permanently in series with each H.F. valve cathode.

the loud speaker and its transformer, are mounted on an easily removable metal chassis, which is fitted into the lower part of the cabinet. The lay-out is quite neat, and accessibility for purposes of test or replacement is much better than is usual nowadays. The wave-range switches, which are always examined critically, as troubles are so often caused by faulty contacts, are of extremely simple but robust design, and seem likely to stand up to their work indefinitely.

A receiver with two H.F. stages is expected to be in the long-range class, and in the matter of sensitivity the Amplion Six is fully up to expectations. It is not a set that depends on exceptionally favourable conditions or on skilful adjustment; many Continental stations on both medium and long wavebands are receivable in broad daylight, and as for operation, there is literally nothing to do but to set the volume control at maximum and then to turn the condenser knob. There is no sign of incipient self-oscillation,

distinct falling-off. This limitation of high-note output is not enough to prejudice the intelligibility of speech, and has the very practical advantage nowadays that it prevents a great deal of heterodyne interference. There is a noticeable resonance at about 200 cycles, which gives an effect that is pleasing rather than otherwise; also another, much less evident, in the upper middle register. The push-pull output stage provides volume to spare, even for a large room.

No unfavourable criticism can be directed against the design or general finish of the cabinet, which is of walnut, and compares well with many of those supplied with much less ambitious sets at about the same price. An unusually good instruction book, giving almost all the information that the average user is likely to need, is supplied with the set.

Next Week's Set Review:

H.M.V. CABINET RADIO RECEIVER.

UNBIASED

BY FREE GRID

Take Your Characteristic.

A READER with a morbid turn of mind has written to me asking how many volts are needed to kill a person. Whether he is desirous of ridding himself of his relations or some other obnoxious form of fauna, I do not know; but the answer is that it's the current that kills—not the voltage, as the prisoner in the Sing Sing "chair" remarked when explaining to the authorities that, owing to his abnormally high body resistance, they couldn't kill him without going outside the legal voltage limits.

I am given to understand that the voltage which is prescribed by law in certain American States varies between 1,500 and 1,800 R.M.S. volts, this apparently being adequate to force the necessary killing current through all but the most abnormal bodies. What the current is I cannot say, but it is more than a few milliamperes which an electrical engineer of a dogmatic turn of mind once asserted to me was all that was necessary. Anyone can prove this by putting himself and a milliammeter in the plate circuit of the out-

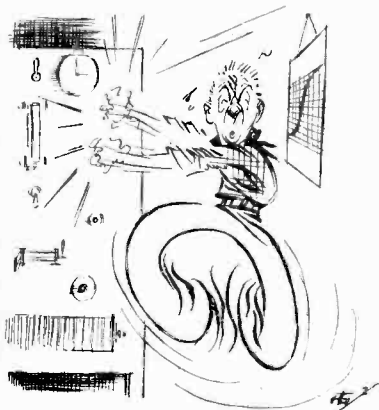

His characteristic curve.

put valve. In my own case I find that with a Mazda AC/Pen. taking a normal plate current of 30 mA., the current only drops to 26 mA. when I put myself in series by dis-

connecting one lead to the milliammeter and linking up the circuit with my hands.

I should be very glad if any reader could let me have some data on this matter. It is my belief that the human body has a critical threshold voltage beyond which the resistance rapidly declines, the characteristic curve being somewhat like that of a carborundum crystal, except, of course, that the voltages are infinitely greater. Everyone, therefore, has his own characteristic curve; why not take yours?

Carpet Beating.

I AM constantly inundated with letters from readers of this journal who want to know which is the best receiver on the market, and, as I have mentioned previously, I cannot undertake to satisfy them on this point for three reasons, which are: (a) I don't know; (b) If I did know I should not say; (c) There is no such thing as a "best" set on the market, any more than there is a "best" breed of dog or hippopotamus.

I cannot escape my relations so easily, however, and at the Olympia Show I ran straight into a particularly repulsive aunt of mine who disliked me from the day I was born.

Bewildered.

She had decided, so she said, to buy a "wireless," and having, in the Parish Magazine, seen a reference to a radio exhibition, had come up alone to make her choice. She had soon got bewildered by the vast array displayed, and was therefore more pleased to see me than I was to see her. Knowing that she had A.C. mains available, and that she had more than her fair share of filthy lucre, I jotted down a list of what I considered to be the best half-dozen sets in the Show.

A few weeks later, when I spoke to her on the 'phone, she informed me rather tartly that five out of the six sets I had suggested were per-

fectly appalling, as they produced no bass at all, but that the sixth was delightful, except that it was a little indistinct on speech. Why not, she suggested, invent a set that combines clear speech with good bass? Seriously perturbed at her statement concerning the lack of bass from the



Had decided to buy a "wireless."

five sets, which I had understood were first-class in every way, I hurried to her place of abode.

The Truth.

As I approached the house I was horrified to hear sounds as of a carpet being beaten vigorously; this I recognised as the "trade mark" of a particular type of American receiver. So, fearing the worst, I was surprised at being received with unexpected cordiality, my aunt apparently being highly delighted with the dreadful noise which the set was giving forth. "You can hear the thump of the bass all over the house!" my aunt exclaimed gleefully. "In fact, the set sounds better at a distance." With this opinion I heartily agreed. To cut a long story short, I told her plainly that there was a fault in the set and I would get the instrument changed for her. But do you think that I could induce her to let it go? On the contrary, I made the melancholy discovery that she actually liked the carpet-beating. Ye gods! What is the use of striving for improved reproduction?

Practical

Hints & Tips

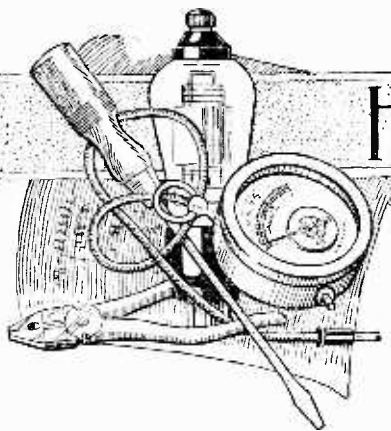

THE adjustment of turns on a reaction coil so as to provide adequate reaction over the whole tuning range is normally considered an easy task. So it is, sometimes, but

**INEFFECTIVE REACTION :
A Simple Cure.**

there are sets which entirely refuse to behave in a rational manner. Moreover, the frequency of misbehaviour is greater than it used to be some years ago, for the higher efficiency of modern valves tends to bring into prominence troubles that do not so readily arise with valves of older type.

A not unusual symptom is that although rotation of the reaction condenser causes oscillation, as evidenced by a "plop" as oscillation starts, and a change in anode current accompanying the "plop," no increase in signal strength is found when the position of oscillation is approached, and heterodyne "whistles" are not heard when the receiver is oscillating. Reaction appears to be fully present, as judged by all the technical tests, but it does no good.

In such a case it will usually be found, if the trouble is carefully traced out with all the equipment of the laboratory, that oscillation is taking place at the frequency to which the reaction coil, tuned by the reaction condenser, the by-pass condenser, and the various stray capacities, happens to resonate; to help in building up signals, oscillation is required to occur at the frequency to which the grid-current of the valve is tuned, which is, of course, that of the desired signal.

An effective cure for this undesired oscillation is to insert a resistance (which must be non-inductive, lest worse things happen) in series with the reaction coil, as shown in the accompanying diagram. If the trouble is foreseen from the beginning, and it is desired to ensure that it shall not happen, the reaction coil

**Simplified Aids to
Better Reception.**

may very profitably be wound with resistance wire. This will make the additional resistance unnecessary, and as the resistance of the reaction coil is, from the point of view of the wanted signals, in series with the A.C. resistance of the valve, it cannot possibly have any detrimental effect on efficiency.

In practice, it is found that the unwanted oscillation is most likely to occur when the reaction coil is so proportioned that it can be made to do duty on both long and short wave-ranges; it is strongly recom-

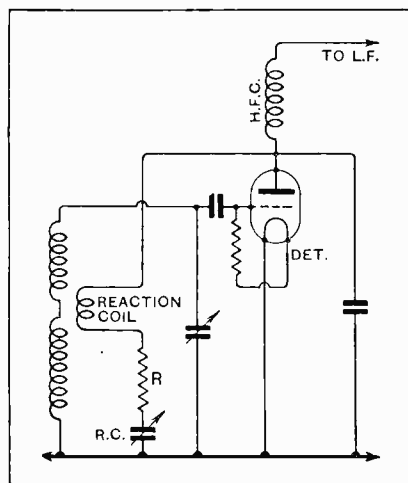

Fig. 1.—A non-inductive resistance (R) of from 100 to 1,000 ohms is usually a complete cure for parasitic oscillations in receivers with reaction.

mended that whenever the construction of a reaction coil is started with this in mind resistance wire should be used. A suitable gauge is No. 44 s.w.g.

LAST week attention was drawn in these columns to the possibilities of a modified type of two-circuit aerial tuner with separate tuning controls for each circuit, but with auto-

BAND-PASS AND TONE CORRECTION.

matic control of inter-circuit coupling. It should, perhaps, be made quite clear that, by arranging for optimum coupling (from the point of view of energy transference) between the circuits, the advantages of a band-pass filter in the way of retaining the higher modulation frequencies are inevitably lost; the type of tuner described, as compared with a plain single-tuned circuit, is much more selective, but will be no better in the matter of preventing high-note loss.

All this is, or should be, fairly well known, but the question of using highly selective two-circuit tuners in conjunction with tone correction does not seem to have received any great amount of attention. There is not the slightest reason why this type of circuit should not work in conjunction with the method of tone control described in *The Wireless World* for September 2nd, 1931.

It should, perhaps, be pointed out that any conventional type of band-pass filter can be arranged, by reducing inter-circuit coupling, so that the usual double-humped, or broadened, tuning is no longer present. Altered in this way, the device is no longer a band-pass filter, as it gives maximum response to a single definite frequency rather than to a band. The heading to this note is, admittedly, open to criticism on the grounds of academic exactitude.

In further elaboration of last week's note, it may be pointed out that the tuner in question can be controlled by a double-ganged condenser if desired; the use of separate controls was suggested merely because the arrangement is a good one

to employ when remodelling an existing receiver which is deficient in selectivity; the original tuning condenser may be retained if cost must be considered.



IT is probable that there is no simpler way of testing the relative "goodness" of tuned circuits than the absorption method described in these

columns a few weeks ago. The same method, apart from its usefulness in testing a com-

**TUNING COILS
COMPARED.**

plete tuned circuit and its adjuncts, is also applicable to comparative tests of tuning coils only, always provided that their inductance values are roughly the same; discrepancies of 10 per cent. or so will not greatly affect its accuracy.

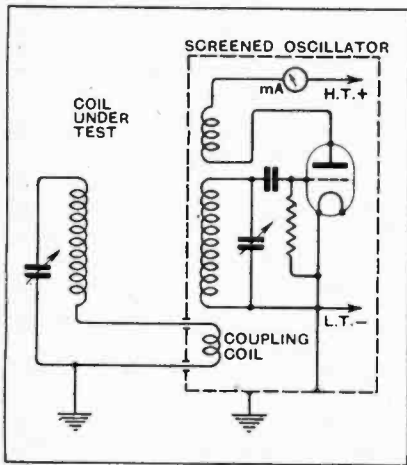

Fig. 2.—The efficiency of tuning coils having roughly the same inductance value may be compared by the absorption method.

In order to make a test, the coil is wired in series with a tuning condenser and a coupling coil (of five or six turns), which is linked magnetically to the tuned coil of a valve oscillator. A milliammeter in the anode circuit of the valve serves as an indicator.

The principle on which the method of testing depends is that the "best" circuit will absorb the greatest amount of energy from a valve oscillator, and will therefore cause the greatest change in anode current, as registered by the meter, as the test circuit is tuned through resonance. If all other test conditions, such as

coupling, tuning capacity, etc., and, indeed, everything but the coil under test, are unchanged, the meter gives a direct comparative indication of coil "goodness."

It is almost essential that no stray coupling should exist between the oscillator coil and the coil under test; this, in practice, means that either one of them should be properly screened; this point, as well as other circuit details, are illustrated in Fig. 2.



VERY large proportion of moving-coil loud speakers, especially the new smaller type that have

**MOVING THE
OUTPUT
TRANSFORMER.**

only recently made their appearance in this country, have speech-coils of low resistance, and so require a step-down transformer to link them to the set. In most cases this transformer is built into the speaker to form a single unit.

In all normal cases, where the speaker is built into the set or is to be used quite close to it, there is no point in interfering with this transformer, and it may very well be left where the makers fixed it. Occasions do arise, however, when it is desired to have the speaker in a room remote from the set; it may be that the usual speaker is to be removed temporarily to the bedroom of an invalid, or perhaps the long leads are required for an extra speaker to serve the needs of kitchen or nursery.

The long leads necessitated by this are not at all unlikely to introduce a very considerable loss of the higher notes of music, which implies also a loss of the clarity of the consonants in speech, with a resulting diminution in intelligibility. If such a loss in quality is found, or anticipated, it can readily be avoided by detaching the output transformer from the speaker, and connecting its primary to the set in the usual way by quite short leads. The long distance between set and speaker is then spanned by a length of twin wire connecting the secondary of the transformer with the speech coil. With this arrangement loss of high notes will not occur.

The reason for the precaution will be seen if it is remembered that the loss of high notes is due to the capacity of the connecting wires, which provide a path of moderately low impedance by which the higher notes can, in effect, take a short cut across the speech-transformer without passing through the windings. If this low-impedance path is in parallel with the primary of the transformer, which has a fairly high impedance, quite a noticeable proportion of the higher notes may pass through it, thereby avoiding their duty of actuating the speaker. The secondary of the transformer, on the other hand, has so low an impedance, even to high notes, that the alternative path through the capacity of the wire has a high impedance in comparison, and so offers no counter-attraction to the currents.

With a transformer of step-down ratio 20 to 1, a capacity of 0.005 mfd. across the primary is equivalent to a capacity of 2 mfd.

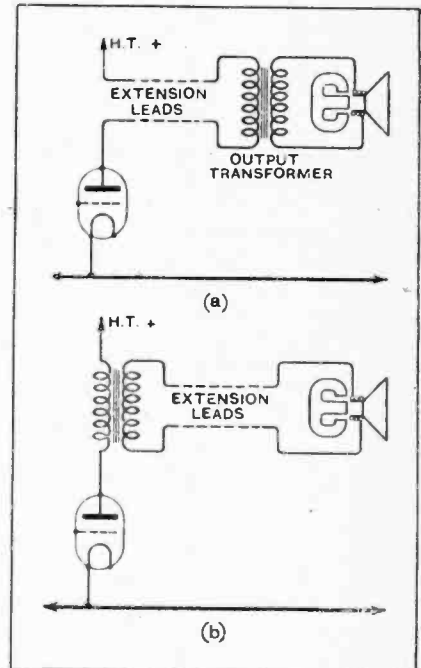

Fig. 3.—A loss of high notes due to long loud speaker leads (a) may be avoided by mounting the output transformer in the receiver (b).

across the secondary; it is quite evident, therefore, that unwanted capacities must be placed across the secondary where they will do no appreciable harm.

Laboratory Tests on New Apparatus.

Review of Recent Radio Products.

CHESTER MAINS TRANSFORMERS.

These transformers are made by Chester Bros., 495, Cambridge Road, London, E.2, who are specialists in this class of component, manufacturing a wide range of both mains transformers and L.F. chokes.

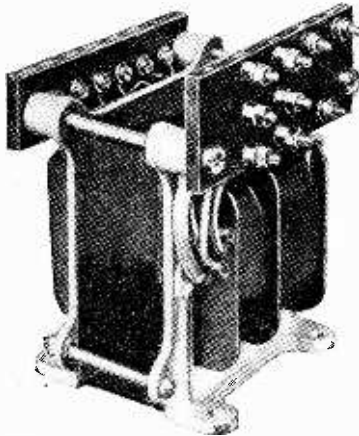

Chester mains transformer, Type N.8, for use with a valve rectifier.

The sample tested is a standard model designed for use with a valve rectifier, and designated Type N.8. It has three secondary windings, rated at 250-0-250 volts at 50 mA., 4 volts at 1 amp., and 4 volts at 4 amps. The primary winding has five tapings, so that the transformer can be used on any standard A.C. supply of 50 cycles, from 200 volts up to 240 volts.

The rectified output using a Marconi U.10 rectifier was measured at various current loads up to 60 mA., the A.C. voltage across one half of the secondary being measured at the same time. The curves reproduced here show the D.C. regulation and also the voltage drop in the secondary under load. During these tests the 4-volt 4-amp. winding was loaded to its maximum capacity of 4 amps.

Under full load conditions the rectifier

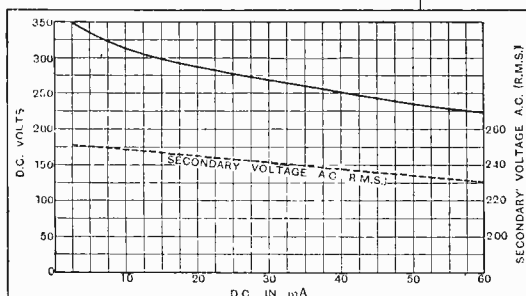

filament received 3.8 volts, while that across the loading resistance connected to the 4-amp. winding was 3.92 volts, the D.C. output—unsmoothed—being 222 volts at 60 mA.

The transformer runs perfectly cool

and is satisfactory in every respect. The voltages are well maintained and are sufficient to meet the requirements of an average receiver employing up to four valves. After smoothing the H.T. output there will be about 200 volts at 60 mA., but since in the majority of cases about 40 mA. will suffice, a smoothed D.C. of about 230 volts will be available.

The price of this model is 34s.

o o o o

CODD L.T. CELLS.

The Codd cell is a primary battery consisting of carbon and zinc electrodes immersed in a solution, the basis of which is ferric chloride. Since recharging is a simple process, for it is necessary only to renew the solution and change the zinc electrode, they are ideal for country use

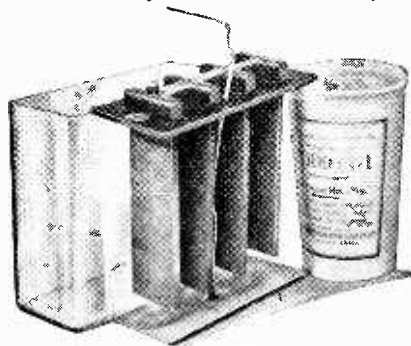

Codd L.T. cell and carton containing special electrolyte crystals.

in addition to being equally satisfactory elsewhere. The electrolyte is non-corrosive, which is a point in its favour.

It is made in two sizes, viz., 36-amp. hour and 72-amp. hour capacities, the discharge rates being 0.125 amp. continuous or 0.25 amp. intermittent for the first mentioned, and 0.25 amp. continuous or 0.5 intermittent for the larger size.

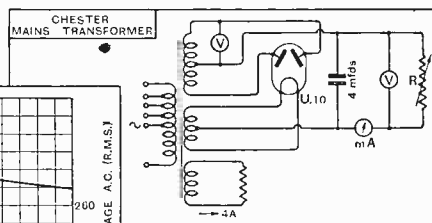

Regulation curve of the unsmoothed H.T. output from the Chester mains transformer using a Marconi U.10 rectifier and a 4 mfd. condenser. A resistance passing 4 amps. is connected across the 4-volt winding.

The initial potential is 1.5 volts per cell, but this falls rapidly during the earlier stages of discharge, and soon settles down to a fairly steady state at about 1.2 volts. From thence onwards the fall in voltage is gradual, and the end

point is reached when the potential is down to approximately one volt.

Some samples are at present undergoing a test, and when this is concluded we shall be in a position to give further information regarding these cells under working conditions.

The prices of these cells are 5s. 6d. and 8s. 9d. complete for the 36-amp.-hour and 72-amp.-hour sizes respectively. Special wooden crates to hold two 36-amp.-hour cells cost 1s. 3d., while one to accommodate four cells is available at 1s. 6d. The corresponding crates for the larger cells cost 1s. 9d. and 2s. respectively.

The makers are the British Insulated Cables, Ltd., Prescott, Lancashire.

o o o o

KINVA SCREENED H.F. CHOKE.

Although the practice of screening the H.F. chokes is not widely adopted to-day, there are so many points in its favour that this course will assuredly be followed in the not-too-distant future. The Kinva screened models bid fair to point the way in this new development, for, despite their small size—they measure 1½ in. high and 1½ in. in diameter—it has been found possible to attain a high inductance value without increasing the self-capacity unduly.

The choke is wound in five sections on a skeleton ebonite former 1 in. long and 1 in. in diameter, which is totally enclosed in a well-finished brass case. There are two styles available—a stan-

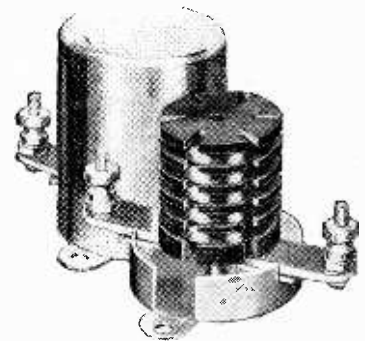

Standard model Kinva screened H.F. choke for baseboard mounting.

Standard model fitted with terminals, and a manufacturer's model, styled the type "M," which has two lugs arranged for sub-baseboard wiring.

Measurements made with a sample standard model give the self-capacity as approximately 7.5 mmfds., and the inductance, at radio frequencies, as 102,000 microhenrys, which is sufficiently high to assure that its resonant wavelength, when inserted in a normal circuit, will be well above the highest broadcast wavelength used at the present time.

This choke is particularly suitable for use in H.F. stages where the tuned-grid coupling is employed, and it will be found equally efficacious in detector

stages either as an H.F. filter or as a deflector when reaction is used.

The makers are Postlethwaite Bros., Church Hill, Kinva, Stourbridge, and the price of the standard model is 2s. 9d.

o o o o

FORMO GANG CONDENSERS.

The two models which are dealt with in this review are described as the Dual Gang Condenser and the Triple Gang Condenser; both models are fitted with illuminated drum dials, 0.0005 mfd. condensers, and embody mechanism for rocking the stators for the purpose of final adjustment.

The Triple Gang model is housed in a die-cast case, and, although each unit is not completely enclosed, the screening is adequate for all practical purposes. The rotors and the metal case are electrically connected. The two left-hand condensers

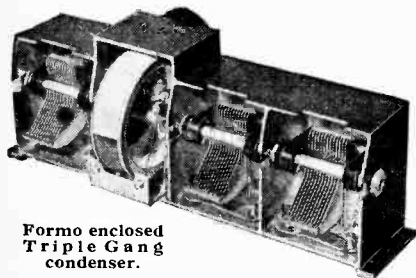

Formo enclosed Triple Gang condenser.

are fitted with small trimmers and their stators can be moved through an arc of about 36 degrees, which is equivalent to twenty divisions on the 0-100 scale. A concealed pointer throws a shadow on the illuminated dial and serves as an indicator for the setting of two stators.

The right-hand condenser is not provided with a trimmer, and its stator is fixed so that the required adjustment for trimming must be made on the two other members of the unit. The price of this model is 30s. It can be supplied with the rotor of the right-hand condenser insulated, selling at 31s. 6d.

The Dual Gang condenser is an un-screened model and includes many of

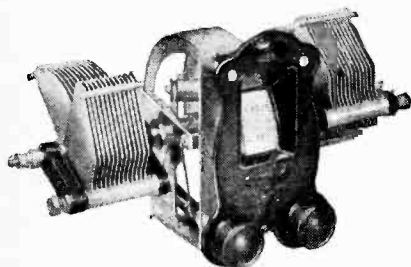

Formo unscreened Dual Gang condenser.

the features embodied in the Triple Gang unit. For instance, one stator can be rocked, it has a concealed pointer to show the setting of this stator, and is fitted with an illuminated dial. In this model both condensers are completely insulated, and the price is 18s. 6d.

The makers are Arthur Preen and Co., Ltd., Golden Square, Piccadilly Circus, London, W.1.

B 35

B.T.H. "MINOR" PICK-UP AND TONE ARM.

The curved tone arm of this new model is of particularly attractive design, and consists of a one-piece hollow moulding, to which the pick-up movement is attached from the underside by a single fixing screw. The movement is built up on a



B.T.H. "Minor" pick-up and tone arm.

metal baseplate which is connected to the earthed braiding of the pick-up leads. Thus the pick-up is effectively screened from electrostatic fields arising from the gramophone motor.

The movement is of the half-rocker type, and damping is effected by means of a short rubber filament fitting into a hole drilled in the armature.

The average output is of the order of 0.5 volt, and a good response is obtained up to 7,000 cycles on open circuit. With a volume control having the recommended resistance of 10,000-20,000 ohms the high-frequency response would show less irregu-

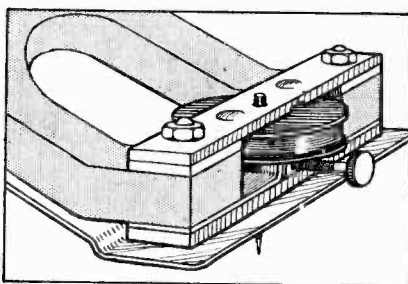

Constructional details of B.T.H. "Minor" pick-up movement.

larity and the possibility of needle-scratch would be reduced.

The unit shows no evidence of record wear and follows the wide amplitude standard frequency records without difficulty down to 75 cycles. Excellent needle track alignment is provided by the curved tone arm, which sets the pick-up head at the theoretically correct angle.

The price of the "Minor" pick-up is 27s. 6d., and supplies are obtainable from The Edison Swan Electric Co., Ltd., 155, Charing Cross Road, London, W.C.2.

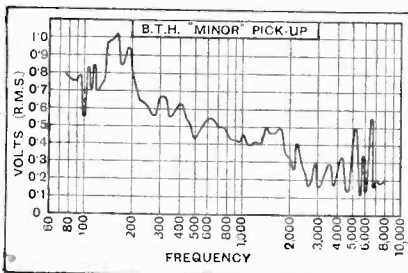

Open circuit voltage output characteristic of the B.T.H. "Minor" pick-up with H.M.V. "loud" needle.

PEGASUS, LTD.

We are informed that Messrs. Pegasus, Ltd., Radio Engineers, of Victoria Street, Chapel Allerton, Leeds, will be occupying new premises early in the New Year at Old Mill Lane, Wortley, Leeds.

This move has been made necessary as the result of expansion of business, and the firm is confident that, with the better facilities, they will be in a position to meet the increasing demand for their products promptly.

o o o o

CLARKE'S ATLAS MAIN UNIT, Model A.C. 290.

At the maker's request we have tested another sample of the A.C. 290 mains unit, and find that the output voltage is maintained at a higher level than that shown in the original curve on page 537

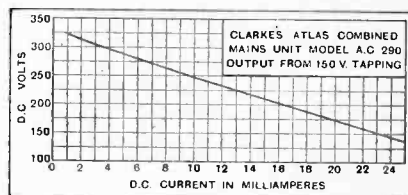

D.C. output from 150-volt tapping on Clarke's Atlas mains unit. Model A.C. 290.

in our issue of November 4th last. The revised curve is reproduced here for purposes of comparison.

o o o o

Catalogues Received.

Dayzile, Ltd., 17, Lisle Street, Leicester Square, London, W.C.2.—104-page illustrated catalogue for the 1932 season, dealing with the products handled by this firm. A most comprehensive publication, since it covers all wireless requirements from a terminal to a multi-valve superheterodyne. Also descriptive folder of the Musikon Portable Talking Picture Outfit.

o o o o

A. F. Bulgin & Co., Ltd., 11, Cursitor Street, Chancery Lane, E.C.4.—Illustrated catalogue dealing with the wide range of components and accessories made by them. A section is devoted to explanatory matter illustrated by circuit diagrams, showing the various uses of their principal components.

o o o o

Wingrove & Rogers, Ltd., Arundel Chambers, 188-189, Strand, London, W.C.2.—1931-1932 catalogue of "Polar" condensers and components.

o o o o

London Electric Wire Co. & Smith's, Ltd., Church Road, Leyton, London, E.10.—44-page illustrated catalogue describing their new season's radio products.

o o o o

Wright & Weaire, Ltd., 740, High Road, Tottenham, London, N.17.—Illustrated broadsheet dealing with the new range of Wearite components.

WIRELESS ENCYCLOPEDIA

No. 8

Brief Definitions
with Expanded
Explanations.

DECOUPLING. Name for the provisions which are made for preventing feed-back effects in multi-valve receivers due to impedances or resistances common to the anode or grid circuits of two or more of the valves.

IN any ordinary type of receiver the anode circuits of all valves are fed from a common source of H.T. supply, such as a battery or a battery eliminator operating from the electric light mains. When this source of high-tension current possesses any degree of internal resistance, the amplified alternating components of current in the anode circuits of the later stages of the receiver set up an alternating voltage between the terminals of the H.T. source. A portion, or all, of this voltage is then fed back through various paths to the grid circuits of earlier valves unless provision is made to prevent it. Without such precautions the set is liable to break into continuous self-oscillation at a frequency or frequencies determined by the constants of the circuits.

To illustrate the principles involved, a three-valve circuit, with H.F., detector, and output stages, is chosen as an example. Fig. 1 gives an arrangement requiring a minimum of component parts, but the conditions are about as bad as they can be as regards instability arising from resistance in the H.T. battery or eliminator. In the diagram the resistance R denotes the internal resistance of the H.T. battery.

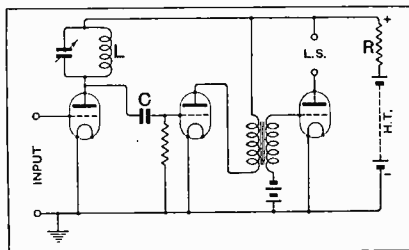

Fig. 1.—Simple 3-valve circuit in which no precautions are taken to prevent feed-back. Resistance in the H.T. battery is liable to cause oscillation.

The relatively large loud speaker currents pass through this resistance and set up an alternating voltage between the positive H.T. lead and the

earthed negative lead. A certain fraction of this voltage is impressed, via the tuned anode coil L and coupling condenser C , on to the grid of the detector valve. Whether this will result in continuous oscillation or not depends, in the first place, on which way round the L.F. transformer windings are connected, and then on the value of R . If the L.F. transformer is connected to oppose self-oscillation, the effect of the feed-back will be to reduce the effective amplification.

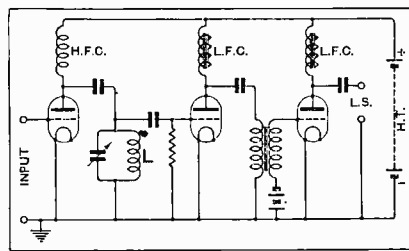

Fig. 2.—Parallel-feed circuit, less liable to instability than that of Fig. 1. Alternating currents are diverted from the H.T. battery.

In Fig. 2 the loud speaker and the main coupling components are removed from the anode to the grid circuits and arranged so that, as far as possible, all alternating components of current are passed directly to the earthed filament circuit without going through the battery. Chokes are connected in the anode-feed circuits to offer high impedance to the alternating currents, and the condensers are to prevent the short-circuiting of the H.T. battery.

The modified circuit of Fig. 2 would be quite satisfactory for a battery-operated receiver, providing, of course, that the H.T. battery is in good condition. But when a mains-operated H.T. battery eliminator is used, even this arrangement is inadequate to prevent excessive feed-back. The necessary smoothing circuits possess a considerable amount of resistance through which

the feed current to the valves has to pass, and the usual tendency is for violent oscillations of a very low frequency to be generated, the effect being commonly referred to as "motor boating." The frequency of this type of oscillation is determined chiefly by the natural period of the eliminator circuits.

Prevention of Motor Boating.

To secure stability under these conditions any voltage variations set up at the eliminator terminals must be prevented from reaching the anodes of all valves preceding the output stage. Accordingly, "feed resistances" R_1 and R_2 , and decoupling condensers C_1 and C_2 , are included in the manner shown in Fig. 3. The efficiency of these decoupling circuits is directly proportional to the values of the resistances and of the capacity. The fall of voltage permissible in each resistance sets a limit to its value in practice, and so condensers of large capacity are employed, one or two microfarads being usual.

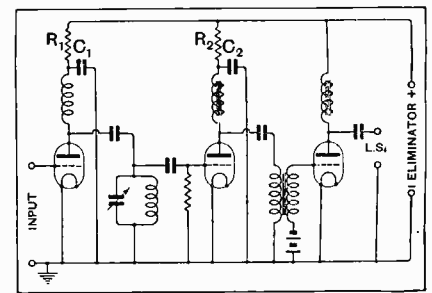

Fig. 3.—Special feed resistances R_1 and R_2 , and decoupling condensers C_1 and C_2 are necessary when an H.T. battery eliminator is employed.

The same principles can be applied to the decoupling of grid circuits with even greater ease, because there are usually no direct current components to contend with.

Broadcast Brevities

By Our Special Correspondent.

CRITICS are bewailing the "fact" that the economy campaign is affecting the B.B.C. programmes. I can say at once that, at the moment, there is no such fact. Most of the present programme material is built on contracts which were arranged before the economy measures took effect.

My fear is that this time next year the critics may really have something to wail about.

50 Per Cent. Cut.

It will be in the financial year beginning in April next that the effect of the B.B.C.'s sacrifice of £50,000 will definitely show itself, both in the lighter and more serious sides of the Corporation's work.

One producer who has hitherto been allowed a generous latitude in expenditure on his broadcast shows has already arranged to cut down his outlay by 50 per cent.

One-show Contracts.

Feature "series" will be avoided, and no artiste, however important, is likely to get a contract covering more than one broadcast, which, however, may be "diagonalised," to use an irritating word for that irritating practice of repeating the same show twice.

Quality or Quantity?

The time is coming, unless the economic position improves, when listeners may have to decide which they prefer: mediocre alternatives or first-class programmes without a choice. I believe that the B.B.C. will do their best to stave off the evil day as long as possible, if they do not avert it altogether, but considerable dexterity will be needed, and they may have to extend the use of the gramophone.

A New Talks Policy?

IT is an open secret that all has not been well in the B.B.C. Talks Department since the Corporation was criticised some months ago for over-frankness in controversial matters. The recent resignations, which everyone deplores, followed upon the decision that all debatable talks must in future undergo the censorship of the highest authorities at Savoy Hill.

An Opportunity.

The new situation is fraught with danger. Much depends upon who is chosen to succeed Miss Hilda Matheson in the position of Talks Director. The B.B.C. is now offered an opportunity of installing in this onerous post someone who, while being fully aware of his responsibilities to an august body, is not afraid to instil a little showmanship into the job.

Educationists to Take Charge?

Yet the indications are that the mantle of authority will fall upon one of those gentlemen in the B.B.C. whose outlook on life is didactic. Among the possible Talks Directors of the future are Mr. C. A. Siepman and Mr. R. S. Lambert.

Both have done good work with the B.B.C., but both, be it noted, came to Savoy Hill after years of association with educational work at the Borstal Institution.

Wanted: A Broad Mind.

As a very ordinary listener with no special malformation of the brow, I should welcome the arrival of a Talks Director who combined the scholarship of Origen with the common-sense of Plato and the showmanship of Shakespeare. However, "I can call spirits from the

on the Chairman of the Governors and the Director-General.

But this is a morbid topic.

High Lights of Radio Drama.

HIGH entertainment is promised in the New Year for those who enjoy radio drama. Each week something fresh will come along, or, if it is not fresh in the sense of being new, will have retained the freshness of a former broadcast.

"Love One Another" is the title of the radio play, by L. du Garde Peach, which will be broadcast on January 3rd.

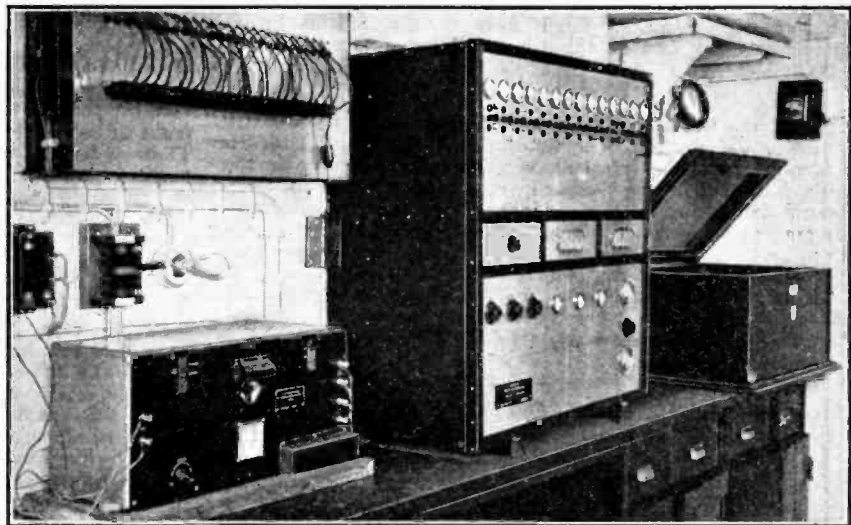

BROADCASTING AT SEA. The most elaborate system of musical reproduction in any ship has been installed by the Marconi Company on the new Furness Withy luxury liner "Monarch of Bermuda." In this photograph of the "control room," the broadcast receiver is seen on the extreme left. In the centre is the amplifier, the input of which can be selected from microphones in the hand enclosures, from the wireless set or from the gramophone on the right. Above the broadcast receiver are line connections to individual cabins.

vasty deep . . . but will they come?" In the absence of such a "discovery," I should plump for a man with the broad outlook of a good journalist. After all, talks are only spoken journalism.

The Powers That Be.

Mr. Whitley, it is understood, will himself censor talks touching upon political questions—a task for which he is peculiarly fitted, as a result of his long experience as Chairman of the House of Commons. Sir John Reith intends to scan manuscript dealing with other subjects of contention.

Who Takes Responsibility?

The special significance behind this new move concerns the question of who would be responsible if the Corporation committed an indiscretion involving an action for libel or slander. In the case of a newspaper, the editor and the printer have to face the consequences; in the B.B.C. no one, it seems, has yet been appointed official scapegoat, but the belief is held that responsibility devolves

"Bring Out Your Dead."

Here is a little playbill:—
January 10th: "BJ One," by King Hall.

January 17th: "Rope," by E. Hamilton.

January 24th: "The Taming of the Shrew," by W. Shakespeare.

February 1st: "Catastrophe," produced by Lance Sieveking.

February 14th: "Escape," by John Galsworthy.

February 21st: "Bring Out Your Dead," by Daniel Defoe.

Read in succession, these titles seem to have a weird significance. Do you notice it?

Emotional Broadcasting.

"DICK" SHEPPARD, more than any other clergyman, I think, has the art of putting emotion across the microphone. He is to speak to National listeners at a studio service on December 27th.

CORRESPONDENCE

The Editor does not hold himself responsible for the opinions of his correspondents.

Correspondence should be addressed to the Editor, "The Wireless World," Dorset House, Tudor Street, E.C.4, and must be accompanied by the writer's name and address.

INTERFERENCE TROUBLES.

Sir.—The question of interference seems to have been overlooked in one quite new development—coil ignition on the average motor car.

Once upon a time I got this interference only when I was on the short waves in the early morning, when a certain type of unmentionable car came round with the milk.

Gradually the Lewis gun accompaniment to a passing car has spread to the broadcast band, and now even to the long waves.

Surely the car makers might have thought of this before putting so many cars on this type of ignition.

Deal, Kent.

WM. B. WEST.

Sir,—I see from your Editorial that you regret the absence of legislation dealing with interference troubles. I don't. I merely regret the interference. The main difficulty is the small man with limited capital, who cannot afford to scrap serviceable apparatus. For instance, a very small accumulator-charging plant (commercial) costs about £50 to £80, if of the static rectifier type, whereas a satisfactory motor generator of about 1-kw. output can be obtained for about £20 to £30.

No, Sir, the only satisfactory solution of the problem is more and more power to the broadcasting stations and shorter and shorter aerials to the receivers. NUGENT C. A. GILDERS.

Romford.

A VALVE-MATCHING SUGGESTION.

Sir,—Allow me to congratulate you on your issue of November 11th. The information on the variable-mu screened-grid valve is worth a year's subscription itself.

Referring to your issue of August 5th and the article therein about push-pull balancing problems I find that, using indirectly heated valves biased as under, I can get very good matching with not too widely dissimilar valves.

The valves can be matched aurally, and milliammeter tests show the ear is not a bad judge. I have had good results with indirectly heated pentodes as shown in the diagram in push-pull, although these valves seem to vary a good deal in their individual anode-current requirements.

Johnstone.

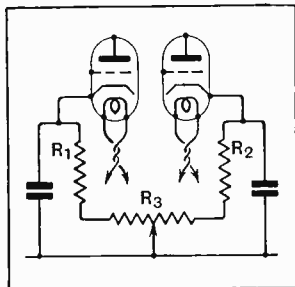

R_1, R_2 , bias resistances; R_3 potentiometer 10 to 40 ohms.

W. GALBRAITH, JUNR.

THE REGIONAL SCHEME.

Sir,—The Regional scheme has been with us for some time, and it is now that we have to ask ourselves, and the B.B.C., if it is the wonderful idea that it pretends to be. With the present cry for economy and the shortage of wavelengths in the middle band, should we continue with the twin transmitters? What percentage of listeners in these islands utilise the lower of the two transmissions, say, of London, when Daventry 5XX is radiating the same programme? The shorter of the two wavelengths is admitted by the B.B.C. to give good service to only a small area of the country; and does it? I have heard it said that the London National transmitter is not well received in North London; and I think that the receiver at the Science Museum is designed to receive only the Regional and Daventry 5XX. Why? From per-

sonal experience I can say that the London National can be received fairly well in North Devon, either day or night, but then fading—I admit that we are outside its service area—prevents good reception.

No, sir. Let us give up these shorter waves and so save money in building transmitters and also help to relieve the jamming problem.

To touch another subject, can anybody tell me when it was that broadcasting stations ceased to have their call signs in the form of a group of letters after a number, and why?

Mortehoe, North Devon. H. STEVENSON BALFOUR.

COMPONENT SIZES.

Sir,—Would it be too much to ask manufacturers advertising new components to specify the dimensions of their products? Some firms—makers of nidget transformers—do give the sizes. Perhaps it is that some firms are a little ashamed of their massive products. For instance, variable condensers are more or less as big as a nice medium-sized barn.

The Americans can make satisfactory nidget variable condensers, why cannot the British do the same?

Southport. ST. LOUIS MISSOURI.

FILM GRAMOPHONE REPRODUCTION.

Sir,—Surely "Free Grid," in his article in the October 28th issue, had in mind the *very* distant future when he postulated the use of a film for gramophone reproduction in a recent article.

Surely, again, the next, and to my mind long overdue, step is the slow-speed record.

We are all more or less conscious of the mild irritation induced by the necessity for frequent changing, and this greatly offsets the enjoyment obtainable.

Long-playing records necessitate no alteration to existing apparatus beyond the actual motor, and offer no practical difficulties which cannot easily be surmounted, and if manufacturers had concentrated their efforts in this direction instead of producing complicated and expensive machinery to make eight records last as long as one or two should, we might be more in a position to appreciate what a gramophone can be.

West Drayton, Middlesex. H. A. HUNTER.

B.B.C. ENTERPRISE.

Sir,—Capt. Eckersley's analogy to the telephone system, in his letter in your issue of November 4th, cannot be applied to broadcasting. It is obvious that since each subscriber is *connected* with an exchange, the characteristics of his apparatus should be such that they will operate efficiently, and so not be something for the P.O. to worry about.

In broadcasting, the function of the station is to radiate the programmes. It *cannot* control the operation of a receiver, and is not affected by the misuse or fault developing in the receiver. Hence, why should the transmission engineers worry about the standard of reception obtained by the subscribers? So long as the station is working properly, that is all that should matter.

Does a power station worry if you use electricity for lighting, or heating, or running a machine? No, that is, if you are running the apparatus according to their rules. But what I mean is that they have no control to stop you connecting what you like to their mains. You pay for the power you use. It's there to be used.

If the users worked separately in attaining their ideals, better results would be obtained. It would be easy for the transmission people to design their own receiver so as to cover up any defects in the transmitter. Two rival groups of workers will bring more definite results.

London, N.16.

S. GOLDSTEIN.

Readers' Problems.

Readers' technical enquiries are not replied to through the post, but in these pages replies to questions of general interest are dealt with week by week.

Three-point Sockets.

READERS whose houses are equipped with three-point electric supply sockets, which include an earth connection, have asked whether the latter could be employed as an "earth" for a receiver.

We expect that the earth socket is generally wired to the ultimate earthing point by a circuitous route, and, from the point of view of efficiency, it is unlikely that it would be as effective as a well-made direct connection. Further, there is the probability that the earth lead would pick up an unnecessarily great amount of interference from the mains.



Where Screened Coils are Unnecessary.

IT is asked whether any advantage is likely to result from the use of screened coils of modern type in a simple detector-L.F. receiver.

With the exception of sets with band-pass tuning—where intercircuit screening may only be omitted when simple magnetic coupling is employed—screening is quite unnecessary in most cases. As a rule, the matter of direct pick-up by the coils may be dismissed as being of no practical importance.



Superheterodyne Tests.

IT is sound advice to offer to anyone in trouble with his set that if nothing obviously wrong can be discovered time should not be wasted in an aimless search, but a logical sequence should be carried out in making stage-by-stage tests.

So far as "straight" receivers are concerned, the right procedure is fairly well known, but, due to the operation of frequency changing, a somewhat different method is necessary when dealing with a superheterodyne. One or two requests have been received as to the best way of dealing with *The Wireless World* superheterodynes recently described; in such cases the following plan is to be recommended. In essentials, it is applicable, with fairly obvious modifications, to any receiver of this type.

As a start, the first detector, including the input filter, etc., may be tested by interposing a pair of phones in its detector anode circuit, all other valves being inoperative. In *The Wireless World* receivers the best position for the phones is at the point marked X (Fig. 1), where it is also in series with the oscillator valve anode. Operated in this way, the set should give very fair signals from a near-by station, but no high degree of sensitivity is to be expected, even if every-

thing is working in an unexceptionable manner.

Having made any adjustments that may be necessary, and with the phones still in the same position, the oscillator may be tested by observing whether a heterodyne note with the local transmission is produced as oscillator tuning is varied.

The frequency changer as a whole may next be checked, without too many complicating factors, by eliminating the I.F. amplifier entirely; this is done by joining the secondary of the first intermediate-frequency transformer directly to the grid of the second detector. The necessary wiring alteration for this test is shown by a dotted line in Fig. 1; note that the bias cell should be disconnected and its leads short-circuited. The phones, of course, are transferred to the second detector anode circuit, and in practice may conveniently be bridged across the coupling resistance. Again, signals of great strength should not be expected, but the set should respond to the effects of tuning both the input filter circuit and the oscillator, the adjustment of the latter being very critical.

If everything is found to be in order so far, it can be assumed, almost with cer-

strength" only when the phones are in the second detector anode circuit are magnified to loud speaker volume when this stage is put into operation.



Automatic Bias Changes.

IT has been asked whether an ordinary triode output valve could be substituted for the special pentode that was recommended for the "Band-pass Pentode Three" (October 28th). It is realised, of course, that the special output choke and tone correction device will no longer be needed, but there seems to be some uncertainty as to whether any other alteration will be necessary.

With hardly any exceptions, the set as it stands may be modified in the way suggested, but occasionally the need will arise for altering the value of the automatic bias resistance R_{12} , across which bias voltage for the H.F. valve is developed. This value of resistance was chosen on the assumption that the total anode consumption of the set would amount to about 12 milliamperes; if, for example, the triode output valve of the P.240 class were substituted, consumption might rise to some 20 milliamps or more,

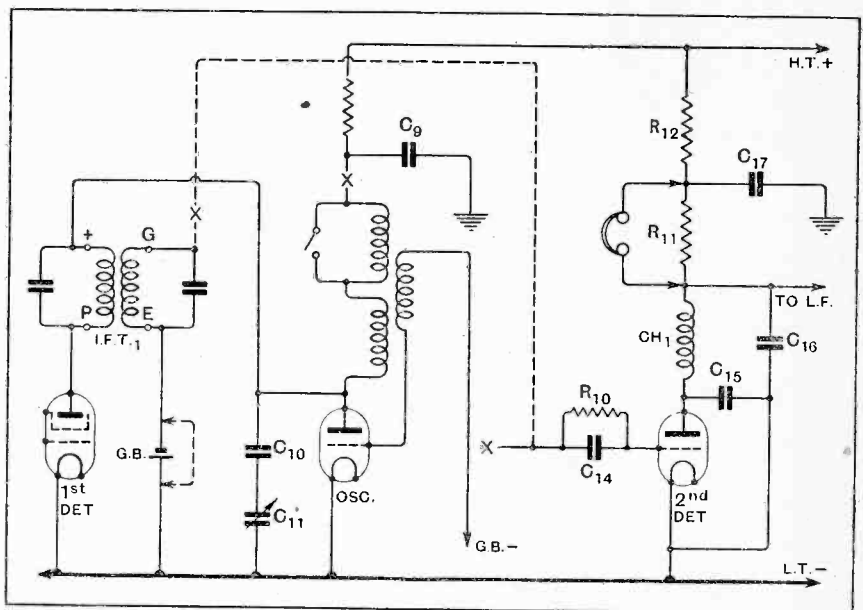

Fig. 1.—Stage-by-stage tests of a superheterodyne. The battery-operated "Super-selective Five" is taken as an example.

tainty, that the intermediate frequency amplifier is at fault, or at any rate it is out of adjustment.

Finally, the effectiveness of the L.F. stage is tested roughly by noticing whether signals that are of "telephone

with the result that the bias applied to the H.F. valve would be increased from about 1 volt to at least 1.6 volts. This is rather on the high side, and so a bias resistor of about 50 ohms should be substituted in such a case.

Hum Frequency Halved.

A READER has found that his moving-coil loud speaker, though highly satisfactory generally, has a marked resonance at about 100 cycles, and in consequence tends to accentuate unduly the small residue of hum that filters through the smoothing circuits of his mains-operated receiver. A comparative test made with other loud speakers of the same type, and even of the same make, proves conclusively that this background of hum is due to the resonance of his own particular instrument.

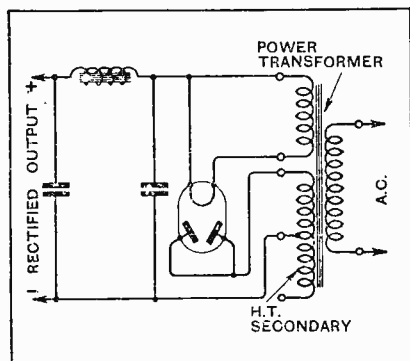

Fig. 2.—Modified circuit arrangement for half-wave rectification with a full-wave rectifying valve.

Having read that the ripple frequency of a half-wave rectifying valve is half that of the full-wave rectifier at present in use, he asks whether it would be permissible to try the experiment of temporarily converting his own power equipment for half-wave rectification by joining together the two anodes of the valve. It is also asked whether there is any risk of damaging the apparatus as a result of making this change.

It is quite logical to assume that in this particular case a half-wave rectifier might provide a more silent background, and this alteration might certainly be tried experimentally. Only one half of the power transformer H.T. secondary will be used, and the circuit will be rearranged as in Fig. 2.

A slight reduction in output voltage is to be expected, but this falling-off might be counteracted to a great extent by adding slightly to the value of the capacity already shunted across the rectifier output.



*Superheterodynes and Open Aerials.

THOSE who have noticed that most modern superheterodyne receivers work with a conventional aerial-earth system sometimes ask whether their receivers, originally designed for a frame, could not be modified so that the pick-up of a full-sized aerial could be employed.

Although the problem of introducing suitable modifications might at first sight appear to be simple enough, there are actually several important considerations to be taken into account. Apart from technical problems, there are the ethics

of the matter to be considered; most receivers without a preliminary stage of H.F. amplification include an oscillator coupled in such a way that radiation would take place to such an extent that the reception of near-by listeners would be impaired.

The main technical difficulty to overcome is the loss of selectivity brought about by the substitution of an open aerial for a frame. Unless a good band-pass input filter is fitted, it is certain that second channel interference will become serious.

In brief, modifications of this nature should be undertaken only by those who are willing to face the need for fairly extensive modifications.



Mains Interference.

IT would appear that a few readers, although they have an electrical supply, are still using batteries for the reason that a certain amount of electrical interference is noticed, and they fear that by using the mains to work their sets this interference will be accentuated. Their attitude in this matter is logical enough, but experience shows that this is not a valid reason for denying themselves the benefit of an "all-mains" supply. Most of the irregularities that cause interference are filtered out quite satisfactorily by the smoothing devices that are always included in eliminators. Even in the most unfavourable situations, where "man-made static" is a serious handicap to good reception, background noises are seldom any worse with a mains-operated set than with a battery set of equal sensitivity.



Oscillator Anode Current.

SEVERAL readers seem to be perturbed by the fact that, on inserting a milliammeter in the oscillator valve anode circuit of their superheterodyne receivers, a considerable change in current is observed when passing from one end to the other of the tuning scale; the same effect is often observed on switching over to another waveband.

Actually, these symptoms do not indicate that anything is wrong. The effectiveness of a fixed anode-grid coupling, which is invariably fitted, changes as the inductance-capacity ratio of the circuits is altered in the process of tuning, and the mean anode current as registered by the meter will vary in sympathy.



A "Variable-mu" H.F. Amplifier.

QUESTIONS have been asked as to whether the design of the H.F. amplifier of the "Variable-mu Three," recently described in this journal, might form part of sets having different detector-L.F. arrangements. Most of these questions are asked by those who wish to use existing apparatus and valves as far as possible, or who need exceptionally large volume—more than that provided by a combined detector-output valve.

With one or two special provisos, the two H.F. stages of the new set may be

considered as suitable for almost any A.C. receiver. In the first place, the voltage distribution of the set is carefully worked out, and any reader who proposes to modify his apparatus will be well advised to save himself the trouble of computing values of resistances, etc., by adopting in its entirety the feed arrangement exactly as described. Of course, it will be necessary to arrange matters so that a maintained H.T. voltage of about 200 is supplied to the H.F. amplifier.

There is a possibility that with a succeeding detector and L.F. stage of conventional design, which is bound to be more prone to "motor-boating" troubles than the "Variable-mu Three," it will become necessary to fit more extensive decoupling, at any rate in the anode circuit of the second H.F. valve.



Essentially for Batteries.

THE question of converting the "Wireless World Two" and the "Band-Pass Pentode Three" for either A.C. or D.C. mains operation is often raised. But it should be made quite clear that these sets are essentially for operation with the new high-efficiency type of pentode, of which the great advantage is economy in anode current. When a mains supply is available, the reason for this economy no longer exists.

But it so happens that the sets in question are simple and straightforward, and, with fairly obvious modifications to the output stage, lend themselves quite as readily as any others to modification in the way desired. The question of modifying any battery set for mains operation is now rather too involved to be treated briefly and in general terms.

FOREIGN BROADCAST GUIDE.

REYKJAVIK (Iceland).

Geographical position: 64° 08' 18" N.; 21° 57' 24" W.

Approximate airline from London: 1,170 miles.

Wavelength: 1,200 m. Frequency: 250 kcs. Power: 21 kW.

Standard time: Greenwich Mean Time less one hour.

Standard Daily Transmissions.

19.30 G.M.T., sacred service (Sun.); 20.30, news, weather; 21.00, time signal (clock, gong and chimes); 21.05, talks; 21.30, news; 22.00, concert or play; dance music until 1.0 a.m. (Sats. Sun.). Occasionally relays programme from Copenhagen.

Opening call: *Utværpsstad Islands i Reykjavik*, abbreviated between items to *Utvær Reykjavik*.

Announcer: Woman.

Closes down with good-night greetings (*Goda Nott*) followed by an old Icelandic hymn.

The Wireless World

AND
RADIO REVIEW
(19th Year of Publication)

No. 643.

WEDNESDAY, DECEMBER 23RD, 1931.

VOL. XXIX. No. 26.

Editor: HUGH S. POCOCK.

Editorial Offices: 116-117, FLEET STREET, LONDON, E.C.4.

Editorial Telephone: City 9472 (5 lines).

Advertising and Publishing Offices: DORSET HOUSE, TUDOR STREET, LONDON, E.C.4.
Telephone: City 2846 (15 lines).

Telegrams: "Ethaworld, Fleet, London."

COVENTRY: Hertford St. BIRMINGHAM: Guildhall Bldgs., Navigation St.

MANCHESTER: 260, Deansgate.

GLASGOW: 26B, Renfield Street, C.2

Telegrams: "Cyclist, Coventry."
Telephone: 8210 Coventry.

Telegrams: "Autopress, Birmingham."
Telephone: 2970 Midland (3 lines)

Telegrams: "Liffie, Manchester."
Telephone: 8970 City (4 lines).

Telegrams: "11 fls, Glasgow."
Telephone: Central 4557.

PUBLISHED WEEKLY.

ENTERED AS SECOND CLASS MATTER AT NEW YORK, N.Y.

Subscription Rates: Home, £1 1s. 8d.; Canada, £1 1s. 8d.; other countries abroad, £1 3s. 10d. per annum.

As many of the circuits and apparatus described in these pages are covered by patents, readers are advised, before making use of them, to satisfy themselves that they would not be infringing patents.

EDITORIAL COMMENT.

Supply and Demand.

YEAR after year it is a matter of regret to us that it should be necessary to call attention to the distressing extent to which the wireless industry falls behind in meeting the demand for wireless equipment at this season.

Complaints of delay in deliveries are, if anything, more numerous this year than ever before. It would seem to us that the inability of manufacturers to meet the demand for their products indicates a serious lack of confidence on their part in the articles which they produce. There is still, we feel, too much of the "wait and see" attitude adopted, particularly by the set manufacturers, who appear to decide on their production programmes only after the public taste has been disclosed and consequently the probable demand assessed at the annual Olympia Show.

We believe that, provided the products are satisfactory and the prices right, no manufacturer is justified in delaying his production programme until after the Show. What extra expenditure in advertising might be necessary would be more than offset by the increased business done as a direct result of the ability to meet the demand promptly. Advertising, however effective, cannot reap its full reward when full advantage cannot be taken of the demand thereby created.

It has been suggested that, in the case of set manufacturers, delay in organising production is due not to any lack of confidence on the part of the producers, but to the fact that set manufacturers are dependent, up to the last moment before the busy season commences, on the types of new valves which the manufacturers of these controlling components may produce. If the trouble lies here, then to know the cause is half way to effecting a remedy. It should be possible to distin-

guish between "experimental" and "production" types of valves, and to issue the former through the retail market only until their suitability has been proved before releasing them to the trade for use in commercial broadcast receivers.

Seven-metre Broadcasting.

IT is interesting news that the B.B.C. has decided to follow the lead of certain Continental countries and conduct experiments in broadcasting on wavelengths of the order of seven metres.

It will be remembered that *The Wireless World* has previously reported on other experiments of this nature, notably those conducted in Berlin. The case made out for justifying such attempts is that it will be possible to provide a supplementary service in very congested areas, and that because wavelengths of this order follow optical laws—that is to say they do not radiate beyond the horizon—they enable broadcasting to be conducted over limited areas without interference farther afield.

We are glad to see that the policy as outlined by the chief engineer of the B.B.C., in an interview reported in this issue, is to treat the tests as private for the present and not to create a situation where the public will begin to demand that their receivers for broadcast reception must include ability to receive on wavelengths of this order. Although we consider that any branch of the technique of broadcast transmission is a proper subject for investigation by the B.B.C., we are not of the opinion that seven-metre broadcasting should be hastily adopted as an additional "service." Rather we would suggest that these wavelengths should, if possible, be used for some communication services which are at present utilising the wavelengths just above the medium broadcasting band, in order to release wavelengths to enable the broadcasting band to be extended here.

Looking Back

Recollections

and Reflections.

By SIR JOHN REITH,

Director-General of the B.B.C.



MY first introduction to wireless was early in 1917 in America. I was, I believe, the first British officer who had been wounded in the War to go to that country. As such I was the object of more friendly curiosity and hospitality than was altogether conducive to the comfortable discharge of the very onerous work which I had been sent there to perform.

I established myself in a peaceful and amazingly amiable locality, some 12 miles from Philadelphia, although unable to spend as much time in that great city as I should have wished. On a certain Sabbath Day (and, incidentally, the entire population seemed to go to Church—the one half Presbyterian, the other Quaker) I was invited to accompany a college youth, some four years my junior, upon what he termed a “bird hike.” In the course of two hours in adjacent woods he drew my attention to the oral or visible presence of thirty-eight different types of birds. I accepted his word for it all. I was unable to check up on him. That part of my education had been neglected. I found it extraordinarily romantic, though somewhat discomfiting, but I derived a certain satisfaction by dilating upon the rapturous and voluptuous song of the English nightingale, which he had, naturally, never heard. After church I re-

paired to his parents' house for supper, and thereafter, as a signal mark of favour—recognised as such by me, my own school days not being so very far removed—I was invited by a younger brother, aged sixteen, to visit his sanctum at the

THE Author describes his first contacts with wireless amateurs and turns to his diary for a record of his impressions of the early days of broadcasting.

top of the house. In the corner by the window were contraptions that were quite strange to me—in fact, a primitive wireless set, upon which, at 9 p.m., I was invited to listen to the time signal from Arlington, Virginia, three hundred miles away. I was duly impressed and somewhat humiliated by my own ignorance, but here again I maintained a certain degree of self-respect by tapping out on his key a message in Morse at a speed which was too great for him to follow.

So the United States, the English nightingale, and wireless were associated together in my mind in 1917.

Very early in the history of the B.B.C., in fact, in December, 1922, before I had quite realised what broadcasting was, I was introduced to the Radio Society of Great

Britain. The circumstances of this introduction were not particularly cordial or friendly. The R.S.G.B. appeared suddenly and unexpectedly in the scheme of things, indicating that they had hitherto had the ether, or, at any rate, a considerable part of it, and in particular that part upon which broadcasting was thrusting itself, more or less to themselves. They had been occupying themselves on this ground for some years; it was of vital importance that they should be left unmolested, at least for a convenient and considerable part of the day, and they viewed the etheric activities of the B.B.C. with growing distaste and apprehension.

A Daniel in the Lions' Den.

I THOUGHT the best plan would be to attend the next meeting of the Society and to hear exactly what they thought of us. It was certainly interesting—even exciting. I felt like Daniel in the den of lions—and said so! It was made abundantly clear to me that we were interlopers—a horrid embarrassment—in fact, that the world for them would be a much happier place if we had never been born.

I hope I am not exaggerating. I am not making aspersions on anybody or any body. This was the impression I received, and I think it was the one I was meant to

Looking Back.—

receive. I do not suggest that they wanted to stop us, nor even to inconvenience us. But they did not wish us to stop nor inconvenience them, at least not beyond a point. The trouble was where that point was to be put.

Having recalled the early differences of opinion between the B.B.C. and the amateurs and "genuine experimenters" it would be misleading and discourteous to leave it without adding that our differences were never serious, and that in a very short time they were amicably adjusted to the satisfaction, I believe, of all parties. The respect in which the B.B.C. hold the R.S.G.B. is, I am sure, on the technical side at least, reciprocated.

What ancient history it is, and what a far cry from those days and those circumstances to these!

*On Keeping a
Diary.*

I WONDER if the Editor keeps, as I do, a diary? Mine begins in 1910, and I am only sorry that I left it so late as that. The keeping of a diary is a habit and a practice which, from every point of view, I judge to be profitable. I commend the habit and the practice to the readers of this journal, as a New Year resolution, irrespective of their occupation and position in life, and almost irrespective of their age. It is not a great burden. It is a salutary and stimulating exercise, and should be the source of much satisfaction in later years. It must not be a mere recital of events, however important they may be. It must contain something of the writer's own personality, the more the better, his opinions and feelings. It is well worth while, and, in a life as busy as that of most people, I have experienced little difficulty in maintaining it—giving it a place of priority next to work. Having survived the strain of life at the

Front, feverish munitions activities in the United States of America and at home, and above all the early years of the B.B.C., it is not likely to be abandoned now, and it has been abundantly worth while. So there is a piece of advice, given, like so much else that is not worth while, gratis.

**First Contact with "The
Wireless World."**

My diary reminds me that it was at that fateful meeting with the R.S.G.B. that I first met the Editor of *The Wireless World*; not that we have failed to meet periodically since then—and sometimes on a subject

similar to that which occasioned the first meeting—literary and journalistic encroachments, however, as distinct from etheric ones.

In May of the present year, within an hour of landing in New York, at 6.30 p.m., the first item of American broadcasting which I heard—on a loud speaker in our sitting-room of the hotel—was a nightingale from home, 10.30 p.m., British summer time. I hoped that my bird expert friend and his wireless expert brother heard it, too. It was an interesting greeting and a rather extraordinary bridging of the gulfs, oceanic and temporal. I heard about this nightingale all over the country,

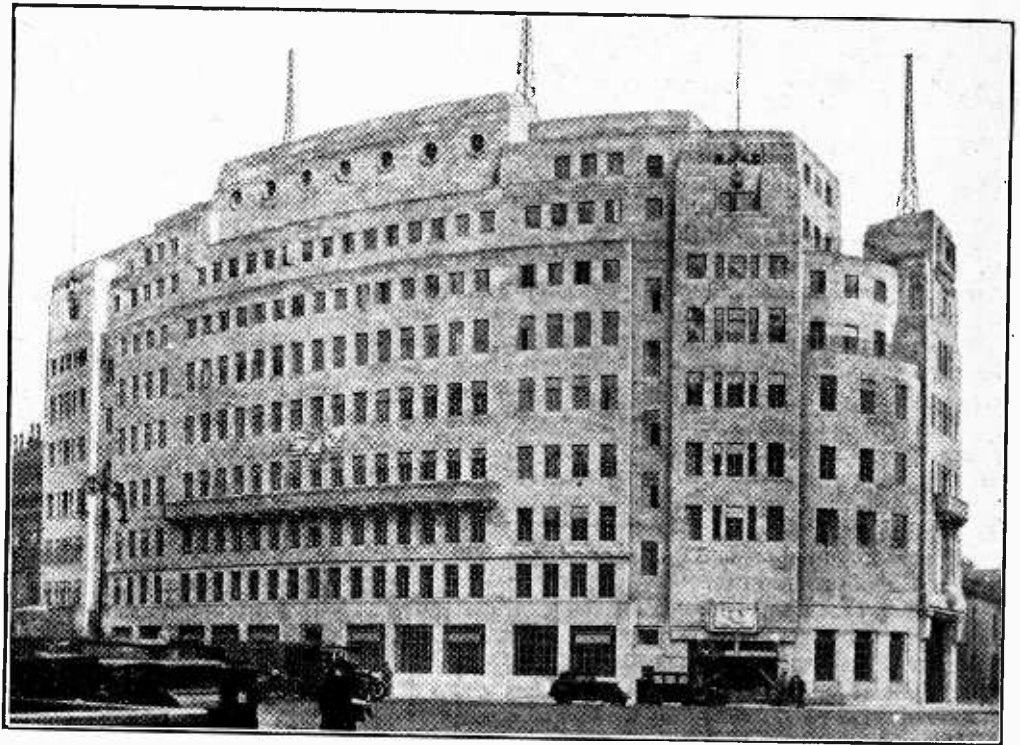

THE NEW HOME OF THE B.B.C.—After nine years of brilliant achievement, the destinies of British broadcasting are still controlled by Sir John Reith.

To All Our Readers.
Heartiest good
wishes for Christ-
mas and the New
Year, from the
Editor and staff of
"The Wireless
World."

It had a profound effect. Perhaps the little things of this order do as much to create international understanding and goodwill as those more deliberately planned and more extravagantly organised. We know already, for instance, how great is the effect throughout the British Empire of the tones of Big Ben, and one of the most satisfactory reflections for us of the B.B.C. this Christmas is that by Christmas 1932 a proper Empire Broadcasting Station should be in operation.

The "SUPER SELECTIVE"



RECEIVERS *and* THE SHORT WAVES

Constructional Details of a Short-wave Adaptor for Superheterodynes.

By W. T. COCKING.

MOST modern receivers are designed to cover the range of wavelengths between 200 metres and 2,000 metres, for the majority of European and American broadcasting stations are included within this band.

There is a number of stations, however, which work on very short wavelengths, of the order of 15 metres to 50 metres, and which are situated in all parts of the world. The range of these stations is phenomenal, for they can be received thousands of miles away at good loud speaker strength with quite simple apparatus. Atmospherics are not usually troublesome on the ultra-short waveband, and so it is perhaps the most suitable for very long-distance reception. Unfortunately, however, considerable fading occurs, and reception conditions are not reliable, but change almost from hour to hour. Stations working on these extremely low wavelengths, therefore, cannot be relied upon to give programmes of entertainment value at all times.

It was for this reason that no direct provision for short-wave reception was made in the "Super-Selective" series of superheterodyne receivers lately described in *The Wireless World*. In response to a number of requests, however, an adaptor has been designed to convert these receivers for short-wave reception, and to convert them in such a way that no modification whatever is needed to the standard superheterodynes. Additional valves are not required, for it has been arranged that certain of the receiver valves are used in the adaptor, while the necessary power supply is taken from the set by a plug connection.

The circuit diagram of the adaptor for use with

the A.C. receiver, the Super-Selective Six,¹ is shown in Fig. 1, and it will be seen to consist of a single screen-grid autodyne frequency changer. This directly precedes the I.F. amplifier of the normal superheterodyne, and four valves only are used on the short wavelengths. The signal frequency tuning circuits and the oscillator of the Super-Selective Six are not used on the short waveband, for they are replaced by the adaptor. The anode of the screen-grid valve, therefore, is taken through the H.F. choke Ch. to the P terminal of the first intermediate frequency transformer in the set by means of a flexible lead terminating in a spring clip.

The aerial is connected to the grid of the screen-grid autodyne valve through the neutralising condenser C_1 , and the tuned circuit consists of a screened coil with a built-in waveband switch, so that the range of 16 metres to 60 metres is covered in two sections with the 0.00035-mfd. tuning condenser C_2 . The reaction winding is in the anode circuit of the oscillating detector, and its effect is controlled by the 0.00015-mfd. condenser C_3 . Both these condensers are fitted with high-ratio, slow-motion dials, and any good condenser or dial is suitable, provided that the moving vanes have a pigtail connection.

The screen voltage is obtained from the adjustable 25,000-ohms potentiometer R_1 , which is decoupled by the 1,000-ohms resistance R_2 and the 0.1-mfd. condenser C_4 ; a by-pass condenser C_5 of 0.1-mfd. is connected between the screen grid and

earth, while a further condenser C_6 of the same capacity joins cathode and earth. It should be pointed out that

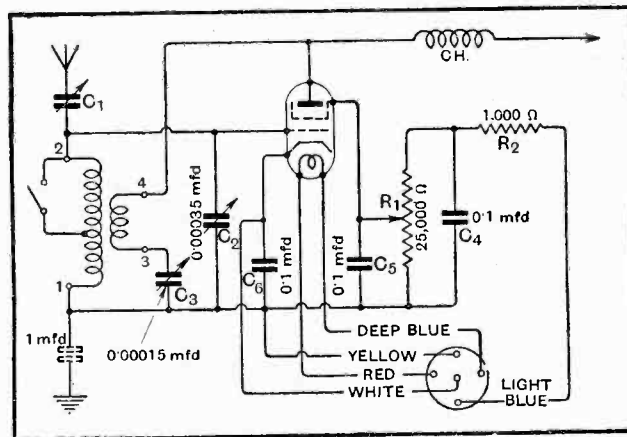

Fig. 1.—Both the A.C. and the D.C. mains adaptors are built to the above circuit; the 1 mfd. earth condenser for the D.C. unit only is shown dotted. C_1 is a neutralising condenser, of 50 mmfd. max., while C_2 , C_3 and C_6 are 0.1 mfd. non-inductive condensers. Ch is short-wave H.F. choke.

¹ The Super-Selective Six, June 3rd and 10th, 1931.

The "Super Selective" Receivers and the Short Waves. — these are the minimum values of capacity advisable, but there is no harm in using larger values; it is important, however, that the condensers be all of the non-inductive type, otherwise the receiver may become unstable.

Apart from the anode connection of the screen-grid valve, which has already been mentioned, the only other connection between the adaptor and the receiver is the five-wire cable terminating in a five-wire plug to fit into what is normally the oscillator valve-holder in the set. The two heater pins in the plug are used to pick up the heater current for the frequency changer valve, while the grid pin is used to provide the negative H.T. connection. The anode pin provides the H.T. voltage for the screen grid, and the cathode pin connects the cathode of the

ONE of the most important characteristics of the superheterodyne is its adaptability to reception on any desired wavelength. Merely by changing the signal frequency and oscillator tuning circuits, any desired wavelength can be received, while maintaining the full selectivity, sensitivity, and quality of reproduction. Constructional details are here given of a single screen-grid autodyne frequency changer for short-waves specially designed to precede the "Super-Selective" sets lately described in this journal.

clipped on to the P terminal of the first I.F. transformer, taking care that the clip does not short-circuit to the screening cover. The AC/HL oscillator valve is removed from its holder, and the five-pin cable plug inserted in its place.

The adaptor for use with the D.C. Super-Selective Five² is identical with that just described, except that a 1-mfd. condenser is included in series with the earth lead to prevent short-circuiting the mains to earth. The connections between the two units are the same, and are carried out in the same manner; the DC/HL oscillator valve,

however, cannot be removed entirely from the receiver, since this would break the continuity of the heater circuit. It is therefore placed in the first detector socket when receiving short waves.

With D.C. mains the best position for the earth lead must be found by experiment, as it varies in different cases. While testing the adaptor it was found that in one case reception was impossible with the earth connected to the terminal on the adaptor on account of background noise. Good results were obtained with the earth connected to the earth terminal on the superheterodyne itself, however, but the best results were obtained with no earth connection at all.

The Battery Adaptor.

The adaptor for use with the battery superheterodyne, the Super-Selective Five³, is slightly different, since grid

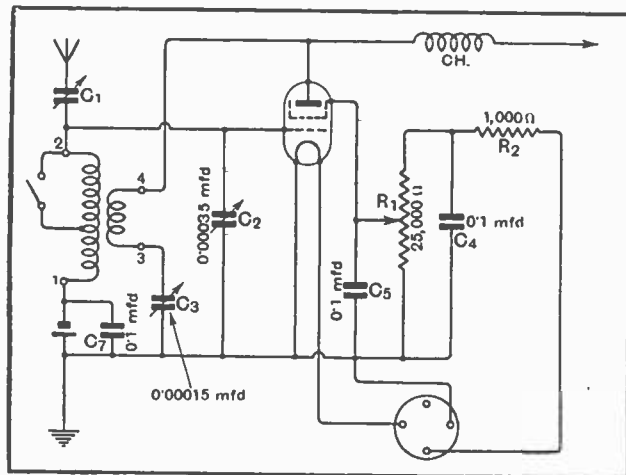
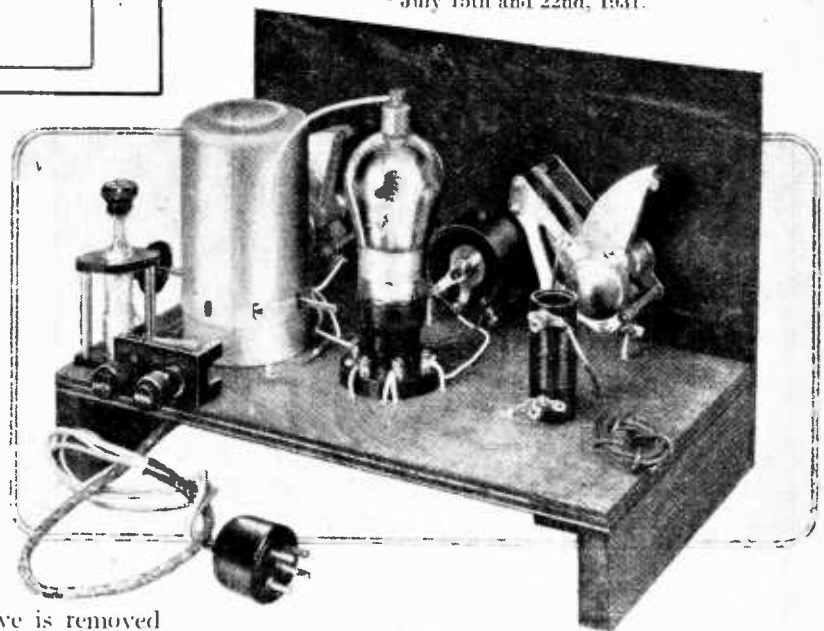

Fig. 2.—The circuit of the battery adaptor differs little from the mains models. The components have the same values but C₁ is not fitted; instead a similar condenser C₇ of 0.1 mfd. capacity is used to shunt the 1.5-volt bias cell.

S.W. valve to negative H.T. through a resistance built into the set (the oscillator bias resistance), and so provides the necessary negative grid bias. The fact that various coils and components in the set are connected in series with some of these leads does not affect the results, and no anxiety need be felt on this score.

The D.C. Mains Adaptor.

In use, therefore, the aerial and earth wires are removed from the receiver and connected to the two terminals on the adaptor. The AC/SG first detector valve is removed from its socket and inserted into the valve-holder in the adaptor, and the lead from the H.F. choke is



The short-wave adaptor covers a wave-range from 16 to 60 metres. It is specially designed to precede the "Super-Selective" receivers.

² August 12th and 19th, 1931.

³ July 15th and 22nd, 1931.

LIST OF PARTS.	
1 Variable condenser, slow motion, SLF or Log Law, 0.00015 mfd. (J.B., Utility, Cydon, Igranic, Formo, Polar, Ormond)	1 Short-wave H.F. choke (Igranic)
1 Variable condenser, slow motion, SLF or Log Law, 0.00035 mfd. (J.B., Utility, Cydon, Igranic, Formo, Polar, Ormond)	1 Short-wave coil with screen (Colvern KSW)
1 Neutralising condenser (J.B., Gamblell)	3 Fixed condensers, 0.1 mfd., non-inductive. (T.C.C., Type 50, Dubilier, Type No. 9200)
1 Wire-wound potentiometer, 25,000 ohms. (Watmel, Colvern, Electrad, Truvolt, Regentone, Bulgin, and Clarostat)	1 Resistance, 1,000 ohms, "Spaghetti" type (Lewcos, Ready Radio, Varley, Magnum, Igranic, Bulgin)
1 Valve holder, 5 pin. (W.B., Burton, Telsen, Clix, Lotus, Lissen, Wearite, Benjamin)	
	1 Plug, 5-pin (Bulgin, P3)
	2 Terminals (Belling-Lee, Igranic, "Eelex-Eastick," Burton, Clix)
	1 Terminal Mount (Belling-Lee, Junit)
	1 Cable 5-way (Burton, Bulgin, Belling-Lee Ready Radio, H. & B. Radio)
	1 Bakelised panel, 12x8x1/4.
	1 Baseboard, 12x7, multi-ply.
	Screws, wire sistoflex, wood, copper foil, etc.

bias is now supplied from a 1.5-volt dry cell secured beneath the baseboard. Only a three-wire cable for the connection between the two units is then needed, but great care should be taken to see that the filament leads are wired the right way round. The circuit is shown in Fig. 2, and the few small modifications to the practical wiring diagram, which is for the mains model, can readily be made.

Construction and Operation.

In all cases the constructional work is simple and readily carried out; the layout of the original should be adhered to, although minor modifications will not seriously affect the results. It is important that the specified type of tuning coil and H.F. choke be employed,

but other components may be changed in accordance with constructor's own preferences.

There is nothing difficult about the operation of the receiver on the short wavebands, and the only controls are the two condensers and the potentiometer on the adaptor, and the volume control and mains switch on the superheterodyne proper. The reaction condenser and screen-grid potentiometer require only occasional adjustment, and so the receiver is virtually single control. At the lower end of the 30-50 metres waveband the reaction condenser should be set at about 40° (with a 180° dial) and the potentiometer about half-way round; tuning is then carried out by rotating the 0.00035-mfd. condenser very slowly. Each station will be found to come in at two different settings, some 2° to 10° apart,

THE SHORT-WAVE ADAPTOR FOR THE "SUPER-SELECTIVE" RECEIVERS.

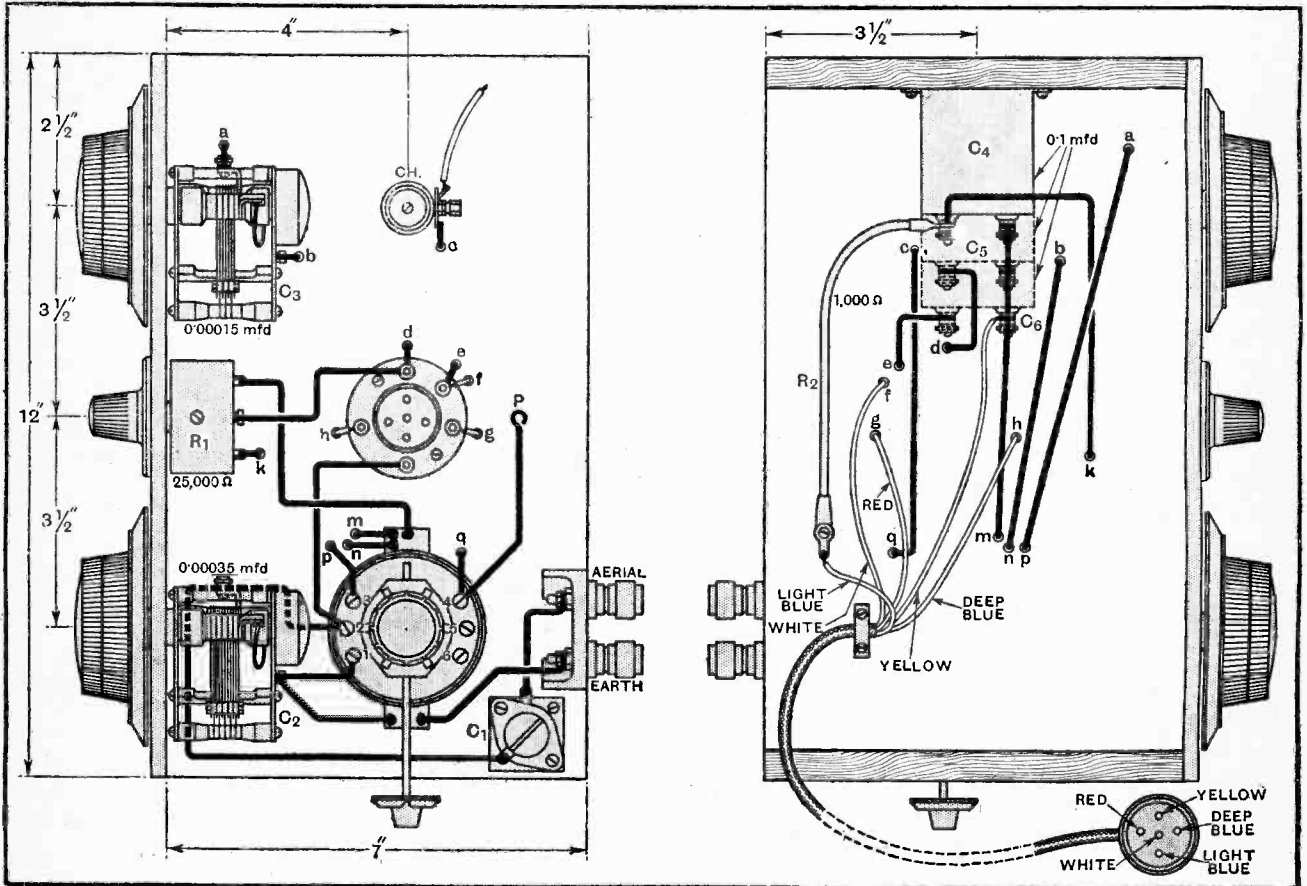

Layout of the components and general wiring plan.

The "Super Selective" Receivers and the Short Waves. — according to the wavelength. In this connection the calibration curve of Fig. 3 will be found of help, although it does not show the actual wavelength for a given dial setting, but the wavelength at which the valve is oscillating. That is to say, a station will be received at settings a few degrees higher and lower than that shown by the chart.

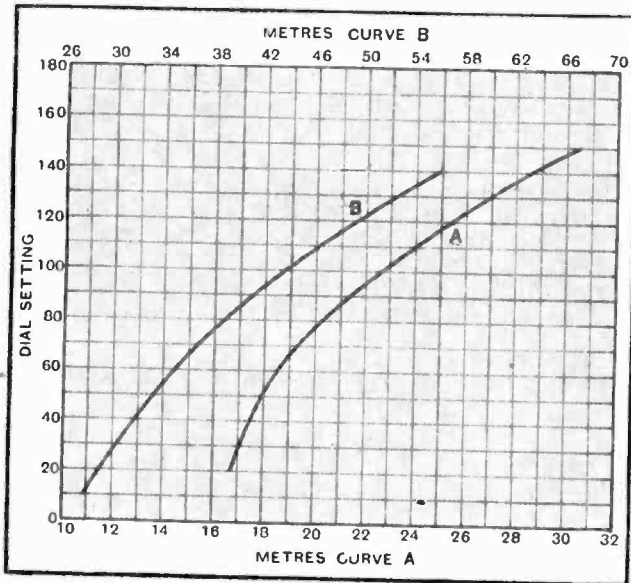

Fig. 3.—The approximate calibration curves of the adaptors are shown. They do not refer to the actual dial setting for a particular wavelength, but give the wavelength at which the valve is oscillating. The actual station settings are a few degrees higher and lower.

Towards the higher end of the upper waveband the reaction condenser setting will need increasing in order to maintain oscillation, until nearly the full capacity is required for wavelengths above 50 metres. On the lower waveband, however, very little reaction will be needed, and for dial settings about 90° the reaction condenser can be set at zero. Over this band it will be found that the setting of the screen volts potentiometer R_1 is quite critical. Too low a voltage will give poor signal strength, whereas an excessively high voltage will make the set howl. The optimum position for the control knob is just short of the howling point.

The setting of the neutralising condenser C_1 can be carried out once and for all; it should be adjusted so that at no point in the tuning range is a sudden large increase in the reaction condenser setting necessary to maintain oscillation.

On test, the two mains models were found to give an identical performance, but, as one would expect, signal strength was less with the battery adaptor owing to the poorer characteristics of the valves employed. Nevertheless, it was found possible to receive 2XAD at full loud speaker strength with the latter unit, so that no fear of an inadequate range need be experienced.

It should be pointed out that conditions on the ultra-short waveband are very variable, and sometimes result in an almost complete absence of signals. One should not be disappointed, therefore, nor assume that there is

some fault in the set if one can receive little or nothing when first trying it out. During the last few weeks conditions have been extraordinarily bad, and on some nights it has hardly been possible to receive anything.

An Experience.

An example of the conditions experienced while testing these units may be of interest. At about six o'clock in the evening faint and unintelligible speech was heard on about 19 metres. The strength gradually increased during half-an-hour's listening, until it was sufficient to overload the output valve; the quality was then good, and, in spite of considerable fading, the talk could be followed with ease, and the station definitely identified as 2XAD. After reaching this maximum strength the signal commenced to die away again, and at seven o'clock it was again an unintelligible whisper; throughout the evening it got steadily weaker and weaker until, finally, no trace of it could be found.

On that particular evening, therefore, 2XAD was only receivable for one brief period of about a quarter of an hour, and not only was 2XAD affected in this way, but all stations below about 23 metres were similarly affected. It has been the writer's experience that reception on these wavelengths is at its best about sunset, and is usually rather poor after darkness has fallen; the higher wavelengths, however, in the neighbourhood of 30-50 metres, seem to be subject to far less variation, and are good for both day and night reception.

The adaptor is available for inspection at the Editorial Offices, 116-117, Fleet Street, London, E.C.4.

HIGH-VOLTAGE VALVES.

AN indirectly heated valve for direct connection across the mains is distinctly attractive, particularly so far as D.C. supplies are concerned; for A.C. work it is easy and economical enough to step-down the voltage to the usual low value employed in heater and filament circuits.

We have recently had an opportunity of examining some of the high-voltage valves which are manufactured in Austria under the name of "Ostar." A number of different types are produced, and all have heaters rated for operation on voltages between 110 and 250 volts; consumption varies between 4 and 6 watts. As the valves may be wired in parallel it is obvious that they are ideal for use in a converted battery set. The English representative is Mr.



Eugen Forbat, of Ilona House, Greenhill Road, Farnham, Surrey.

The Short Wave Band

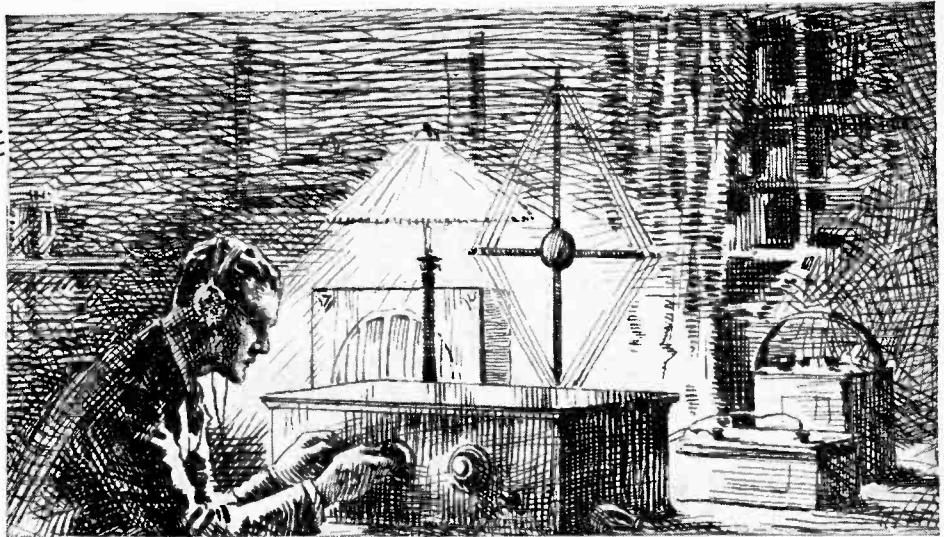

A Fresh Field and How to Explore It.

By A. H. LAWSON.

THERE are still numerous people keenly interested in wireless to whom the higher frequencies are as yet unexplored. It is for these, chiefly, that this article is written. Some of them will probably remember the days (some six years ago) when they used to listen to the amateur transmitters' gramophone records—and sometimes “family talent”—coming “over the air” on Sunday mornings on the 440-metre waveband. It is also possible that some of them sent welcome reports to those amateurs, a large percentage of whom are still active, but now operating on shorter wavelengths—the highest band now allotted to amateur transmitters being 150 to 170 metres.

Objections to short-wave reception given by various people when the subject has been broached are: lack of stations transmitting telephony, exceptional care necessary in building a short-wave receiver, and need for special components. Then it is often suggested that there is necessity for two separate sets, a short-wave and a broadcast receiver, and that there is the difficulty of tuning.

Anyone who examines the list of short-wave 'phone stations given elsewhere in this issue will immediately see that, besides the very large number of com-

mercial telephony stations, there are numerous ones transmitting very fine broadcast programmes. The stations at Zeesen (Berlin), Schenectady (N.Y.), Melbourne and Sydney (Australia), and Moscow Trade Unions should not be missed. For listeners abroad there is also our own short-wave broadcasting station, G5SW, at Chelmsford, which is to be replaced shortly by a more modern one at Daventry.

Now to consider the question of special components. The majority of, if not all, broadcast receivers in use now employ capacity control of reaction, and probably all of them would, with very slight alterations, function on short waves.

Considering the set employing a triode detector, the three usual circuits, which differ only slightly, are the old “throttle” circuit with variable condenser from the output end of the reaction coil to the cathode, and modifications of the Hartley and Reinartz circuits, in which the reaction coil and condenser are in series between the anode and cathode. These have been tried many times, and there is little, if anything, to choose between them in performance. In the Hartley the reaction coil is connected direct to H.T. nega-

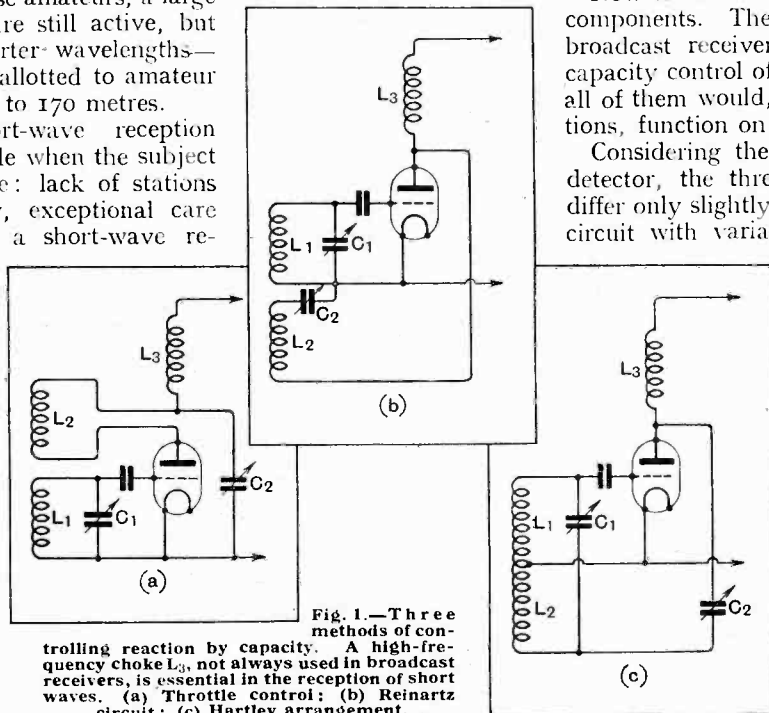

Fig. 1.—Three methods of controlling reaction by capacity. A high-frequency choke L_3 , not always used in broadcast receivers, is essential in the reception of short waves. (a) Throttle control; (b) Reinartz circuit; (c) Hartley arrangement.

The Short Wave Band.—

tive instead of H.T. positive as in the others. This is a point in favour of the Hartley circuit, as in short-wave working the coils are generally wound with bare wire, and there is no chance of doing damage by accidental contact of grid and reaction coils—in fact, the two coils are very frequently wound as one continuous winding, the cathode being tapped on near the middle. The essentials of the three circuits mentioned above are shown in Fig. 1, in which L_1C_1 is the grid tuning circuit, and L_2 and C_2 are the reaction coil and condenser. In each case L_1 and L_2 are inductively coupled.

Aerial Harmonics.

An important point in the short-wave receiver is the H.F. choke in the anode lead of the detector valve, as shown at L_3 in the diagrams. This is often omitted in sets designed for broadcast reception, the choking action of the output circuit being considered sufficient. With short-wave signals there would be a high-frequency loss without it, causing possible distortion and reducing the amount of reaction.

A screen-grid stage of H.F. amplification is very advantageous down to about 20 metres, as it stabilises the set considerably and cuts out the dead spots due to the harmonics of the aerial system.

The use of an S.G. valve as detector in place of the usual triode is becoming more popular, and results in a considerable improvement in performance. The R.S.G.B. "Short-Wave-Two" incorporates such a detector, together with a Pentode L.F. amplifier, and results are as good as the average three-valve equipment on both short and ordinary broadcast waves.

The superheterodyne receiver is, of course, applicable to short waves, and is probably the best receiver—especially in the matter of selectivity. Mention of selectivity brings up another important point; the average listener thinks a great deal about selectivity on the broadcast waveband, but does not consider it important outside this band. On short waves the frequency separation between stations is certainly greater, generally, than on broadcast waves; but, owing to greater losses in tuned circuits at high frequencies, the selectivity of an ordinary short-wave receiver is not usually good. Good selectivity is certainly necessary, as it frequently happens that there is a high-powered commercial station operating on a wavelength not very different from that of the lower-powered broadcast stations. This is where the superheterodyne scores over the ordinary type.

In superheterodyne reception the incoming signal is heterodyned by a local oscillator to give a frequency usually considerably lower—certainly so for short-wave work. For the happy owners of *The Wireless World* "Super-selective" broadcast receivers, there is de-

scribed in this issue a suitable adaptor for short waves, thus giving the required selectivity without the complications of designing a tuned circuit to do the job at high frequencies.

In the matter of components for use on short waves "low-loss" is certainly the key to success in an efficient set; but unless required for ultra-short wave working (i.e., below 18 metres) it will be found that standard components are quite satisfactory. Care should be taken to space parts well—especially in the H.F. part of the circuit even at the expense of longer wiring. These remarks apply equally to sets for reception at any frequency, but bad design does not make itself noticeable on short waves.

Rubbing contacts should be avoided, especially in the aerial and grid-tuning condensers, as they cause scratching noises or "home-made atmospherics." Practically all variable condensers are now fitted with a pigtail, connecting the moving vanes to the terminal, so that trouble from this cause need never be experienced.

Coming now to the matter of tuning, a 0.0003 mfd. condenser with a good slow-motion dial is very suitable, and even a 0.0005 mfd. condenser can be used after a little practice. Tuning, per degree of condenser movement, is, of course, much sharper than on ordinary wave-

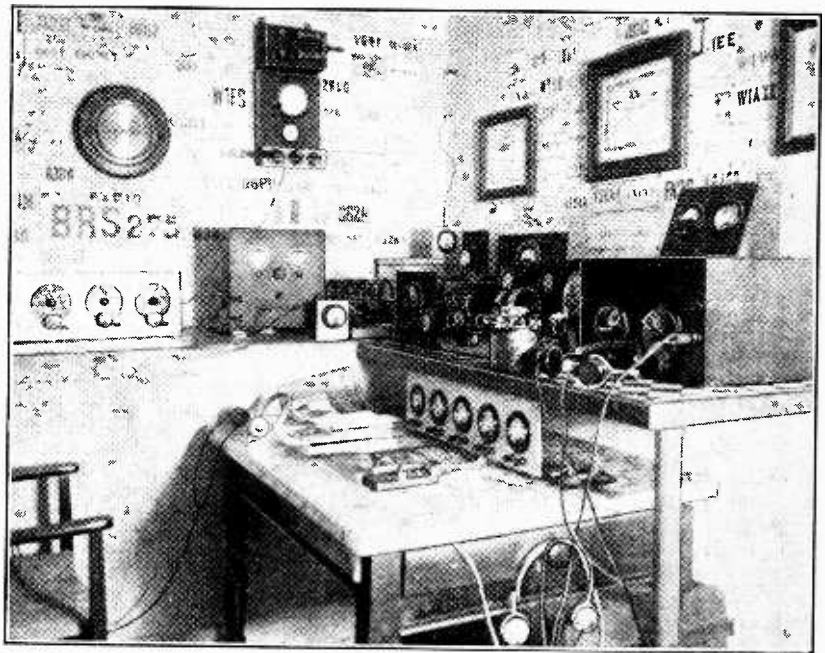

A "British Receiving Station" belonging to a member of the Radio Society of Great Britain. A well-equipped station of this kind can render invaluable service to distant transmitters.

lengths, as it must be realised that a large range will be covered. A 0.0005 mfd. tuning condenser will cover a range of 30 to 80 metres. When expressed in terms of wavelength this does not seem excessive, but when converted to frequency we see that this is equivalent to 10,000 kc. to 3,750 kc., a range of 6,250 kc.

A short-wave transmitter radiates two waves—a ground wave and a sky wave. The former, as its name implies, is radiated more or less parallel to the ground, and is quickly absorbed. The sky wave is transmitted

The Short Wave Band.—

from the aerial at an angle to the earth, depending on various factors, and it is refracted by, or reflected from, the Heaviside layer (or both), and strikes the earth again at some considerable distance from the transmitting station.

A station may thus be heard within a radius of, say, fifty miles, due to the ground wave, and may not be audible again within perhaps 500 miles. There is thus a large gap within which the station will be practically inaudible.

If the Heaviside layer is considered as a layer of ionised gases, it can be realised that all kinds of factors, such as atmospheric or solar disturbances, may affect it, and thus change the conditions for reception. Fading is experienced very considerably on short waves, and is especially noticeable about sunrise or sunset. This may

be considered to be due to distortion of the ionised layer of gas by the sun's rays striking it at a small angle.

Very little is yet known of the conditions governing good reception of a given transmitting station, and a great deal of useful work is being done at the moment by the amateurs of the world, and especially by those of our own country, in trying to solve this problem.

For listeners whose chief delight lies in the picking up of programmes there is a great satisfaction in being able to tune-in the broadcasting stations of our own colonies, and on three valves to bring them in at good loud speaker strength, although there is the possibility of some fading. The class of listener who revels in searching the ether cannot fail to get many thrills on hearing amateur stations testing in distant parts of the Empire, and these stations are always pleased to receive accurate reports on their transmissions.

TRANSMITTERS' NOTES.**Morse Practice.**

FOLLOWING the suggestions made by various District Representatives during the recent Convention, the R.S.G.B. has arranged a regular series of Morse Practices on Sundays. Each District will be responsible for a thirty-minute transmission, which will be divided as follows:—

1st, ten minutes on 1.75 megacycles (172 metres).

2nd, ten minutes on 3.5 megacycles (86 metres).

3rd, ten minutes on 7.0 megacycles (42.8 metres).

Each ten-minute period will be divided into two sections, in the first of which a speed of six to eight words per minute will be used, while in the second five minutes the speed will be increased to eight to twelve words. Telephonic announcements will probably precede the Morse transmissions, and the call will be "Morse test de G . . . District . . ."

On alternate Sundays the transmissions will be given from Districts 1 to 8, beginning with No. 1 at 9 a.m. and finishing with No. 8 at 12.30-1 p.m. On the other alternate Sundays the transmissions will be from Districts 9 to 15 and Scotland A and B, starting at 9 a.m.

o o o o

Districts and Managers.

THE following is a brief summary of the Districts into which the counties of Great Britain have been grouped by the R.S.G.B., and the District Manager in charge of each:—

DISTRICT 1.—North Western (Cumberland, Westmorland, Cheshire, Lancashire): Mr. S. Higson (G2RV), Wallasey, Cheshire.

DISTRICT 2.—North Eastern (Yorkshire, Durham, Northumberland): Mr. L. W. Parry (G2PY), Barnsley, Yorks.

DISTRICT 3.—West Midlands (Warwickshire, Worcester, Staffordshire, Shropshire): Mr. V. M. Desmond (G5VM), Moseley, Birmingham.

DISTRICT 4.—East Midlands (Derbyshire,

Leicestershire, Lincolnshire, Northants, Notts. and Rutland): Mr. H. B. Old (G2VQ), Mapperley, Nottingham.

DISTRICT 5.—Western (Herefordshire, Gloucestershire, Oxfordshire, and Wilts): Capt. G. Courteney Price (G2OP), Cheltenham.

DISTRICT 6.—South Western (Cornwall, Devonshire, Dorsetshire, Somerset): Mr. H. A. Bartlett (G5QA), Exeter.

DISTRICT 7.—South Eastern (Berkshire, Hampshire, Kent, Surrey, Sussex): Mr. J. Drudge Coates (G2DC), Farnborough Park, Hants.

DISTRICT 8.—Eastern (Cambridgeshire, Huntingdonshire, Norfolk, Suffolk): Mr. C. E. Runeckles, Needham Market, Suffolk.

DISTRICT 9.—Home Counties (Bedfordshire, Buckinghamshire, Essex, Hertfordshire): Mr. F. L. Stollery (G5QV), Clacton-on-Sea, Essex.

DISTRICT 10.—South Wales and Monmouth (Breconshire, Glamorganshire, Monmouthshire, Cardigan, Carmarthen, Pembrokeshire): Mr. R. J. E. Forsyth (G6FO), Newport, Mon.

DISTRICT 11.—North Wales (Anglesey, Carnarvon, Denbighshire, Flintshire, Merioneth, Montgomery, Radnorshire).

DISTRICT 12.—London, North: Mr. S. Buckingham (G5QF), Whetstone, N.20.

DISTRICT 13.—London, South: Mr. A. D. Gay (G6NF), Norwood, S.E.27.

DISTRICT 14.—London, East: Mr. T. A. St. Johnston (G6UT), Chingford, E.4.

DISTRICT 15.—London, West, and Middlesex: Mr. H. V. Wilkins (G6WN), Hanwell, W.7.

SCOTLAND.—Mr. J. Wyllie (G5YG), Newlands, Glasgow.

NORTHERN IRELAND.—Mr. C. Morton (G15MO), Belfast.

o o o o

New Call Signs and Changes of Address.

G2CO N. Cookwell, 34, Woodbine Terrace, Blyth, Northumberland.

G2IM E. R. Radford, 33, Whitehall Park, London, N.19 (Change of address).

G2NV H. Littley, "Radiohm," Bridgnorth Road, Wollaston, Staffs. (Change of address).

G2XA M. Griffin, 87, The Crossways, Heston, Middx. (Change of address).

G2YU M. H. Wilkinson, "Southerlea," The New Way, Tranmere Park, Guiseley, Leeds (Change of address).

G5CN (ex 2AJD) F. M. Caine, 75, Warren Drive, Wallasey, Cheshire.

G6CP C. R. Plant, 1, Albert Road, Northenden, Manchester.

G6CS G. R. M. Garratt, 26, Fellows Road, South Farnborough Hants. (Change of address).

G5FJ F. J. Jackson, "The Ringles," Headcorn, Kent (Change of address).

G5GZ G. L. Gridale, 39, Ranelagh Gardens, Ilford, Essex.

G15HV W. H. Martin, 45, Bawnmore Road, Belfast (Change of address).

G5IX P. H. Dutton, 8, Somersby Grove, Skegness, Lincs.

G5KA (ex 2AAL) F. J. Postlethwaite, 41, Kinfauns Road, Goodmayes, Essex.

G5LH F. Thompson, 235, Wingrove, Avenue, Newcastle-on-Tyne (Change of address).

G5LP E. Williams, 14, Wall Street, Ebbw Vale, Mon.

G5ML F. W. Miles, "Tudor Lodge," Gilbert Hill, Nr. Kenilworth (Change of address).

G5MP B. W. F. Mainprise, 48, Earlsfield Road, Hythe, Kent.

G5MR V. G. Mellor, Sele House, Hertford (Change of address).

G5NL N. G. Nolan, 1, Langley Cottages, Staines Road, Bedford, Middx.

G5NP W. J. Crawley, 1, Pisgah House Road, Broomhill, Sheffield.

G5QC G. Colley, "Hillingdon," Stallord Road, Oxley, Wolverhampton.

G6CJ F. Charman, 96, Cotswold Gardens, Hendon Way, London, N.W.2 (Change of address).

G6DB (ex 2BSJ) D. N. Bittcliffe, 41, Church Street, Morley, Leeds.

G6DC D. C. Clark, 179, Wood Street, Chelmsford.

G6PC C. D. Price, "Ardath," Park Lane, Wednesbury, Staffs.

G6PK W. G. Pike, "Keswick," Brunswick Road, Kingston Hill, Surrey.

G6XO J. Nixon, 33, Seaview Road, Gillingham, Kent.

2AKN R. K. Sheargold, "Glenmore," Manygate Lane, Shepperton, Middx.

2AOY L. C. Heddon, 31, Medhurst Road, London, E.3.

2AQU E. A. Bellamy, 10, Mapperley Hall Drive, Nottingham.

2BCF F. Robinson, 4, Cranford Gardens, Acklaur, Middlesbrough.

2BFT A. Read, 124, Fillebrook Road, Leytonstone, E.11.

2BKF L. O. Rogers, The Cottage, Hambutts, Painswick, Glos.

2BZW S. Cook, 2, Queen's Avenue, Snodland, Kent.

2BZZ J. T. Shrouder, Beech Lea, Maghull, Lincs.

The B.B.C. and Ultra Short Waves

AN INTERVIEW WITH THE CHIEF ENGINEER.

By OUR SPECIAL REPRESENTATIVE.

WHAT is the truth, and the whole truth, about the B.B.C.'s intentions in regard to ultra short-wave broadcasting? This question has exercised more than one apprehensive mind in the last few weeks, although it is worth remarking that, popular faith in the wise conservatism of the B.B.C. being at high-water mark, no attempt has been made to stampede listeners into imagining that a new era of receiver design is at hand, and that existing sets must be scrapped.

In an exclusive interview at Broadcasting House last week, Mr. Noel Ashbridge, Chief Engineer of the B.B.C., gave *The Wireless World* an outline of the work which it is proposed to undertake with the ultra short-wave apparatus now nearing completion at the Marconi Company's Chelmsford works.

"It must be clearly understood," said Mr. Ashbridge, "that these experiments will not in any way affect the ordinary broadcasting system nor the development of the regional scheme. The ultra short waves, even if they came into regular use, would give only a supplementary service."

The function of such service, in the eyes of the B.B.C., would be to ensure reception in populous centres where, for a variety of reasons, such as fading and heterodyning on the medium and long wavebands, listeners cannot rely on good reception.

No Schedule at First.

The one-kilowatt transmitter, the component parts of which are already being tested, will be erected within the next two months on the roof of Broadcasting House, this site in the heart of London having been chosen because, in Mr. Ashbridge's words, "it provides the worst possible conditions for broadcasting!" It would have been difficult to find another spot where the proximity of high buildings, intricate steelwork and other effective absorption devices could give the ultra short waves a better opportunity of proving their real worth. The di-pole aerial will be attached to one of the lattice masts, originally intended for ornamental purposes, which now adorn the roof of the new B.B.C. building some 100 feet above street level.

Amateurs who hope for a regular schedule of ultra short-wave transmissions must possess themselves in patience for at least a few months. The first tests, which will be essentially of a private nature, will be carried out by the B.B.C. in conjunction with the Marconi Company, and will probably not begin until April or May. Transmission times will be erratic, as well as the choice of frequencies, the intention being to vary the wavelength between six and nine metres. Probably the most effective wavelength will be found between seven and eight metres.

Mr. Ashbridge has an open mind on the subject of ultra short-wave receivers, but the superheterodyne



Mr. Noel Ashbridge in a recent photograph.

and super-regenerative types will both be used in the initial experiments in addition to adaptors and circuits of the "straight" type. The sets will be not only mobile, *i.e.*, mounted on cars, but also portable to enable the engineers to carry out severe tests in steel buildings and other unpromising situations.

Questioned on the subject of range, the Chief Engineer declined to make any definite prophecies. The fact that the range of ultra short waves is limited to an optical path constitutes their principal virtue at the present time, and the B.B.C. will be satisfied with distances up to seven or eight miles. But these are only average figures. Mr. Ashbridge considers that results will vary largely in different districts, and that reception may prove "patchy" as regards signal strength.

Amateurs and the Tests.

When the field strength in the London area has been carefully mapped out, the transmitter will be taken to other centres, but it has not yet been decided which towns shall be the next to be visited. No doubt the B.B.C. will soon have to consider many claims! Ultimately transmitters may be set up in a number of populated areas as permanent additions to the B.B.C.'s distribution scheme. But the Chief Engineer impresses this fact on all enquirers: an ultra short-wave service would supplement, not supplant, broadcasting on the medium wave.

Asked whether amateurs would at any time be invited to co-operate in the tests, Mr. Ashbridge said:

"We shall carry out very careful tests ourselves, but the time may come when we may ask amateurs for their experiences."

With this courteous encouragement, what reader of *The Wireless World* need hesitate to construct his ultra short-wave adaptor?

PRACTICAL HINTS AND TIPS.

SIMPLIFIED AIDS TO BETTER RECEPTION.

IN discussing and comparing detectors, whether of the power-grid or any other variety, it is customary to quote the output voltage that, at 100 per cent. modulation, would be developed across the resistance or other component in the anode circuit when the grid is supplied with the signal voltage that gives the greatest freedom from detector-distortion. While this mode of expressing the behaviour of the detector is both scientifically sound and extremely convenient for purposes of comparison, the reader must be warned that it does not, by itself, provide complete data for receiver design.

DETECTOR OUTPUT.

Practical experience shows that if a valve with a 50,000-ohm anode resistance will give, at 100 per cent. modulation, an output of 20 volts, it is not of the slightest use to couple it by this resistance to an output valve that requires 20 volts of signal to operate it at full strength, because the output valve will never get anything like the required strength of signal. It is found by experiment that the output valve will not be given signal enough for the occasional overload that most people expect unless a transformer of ratio 7 or 8 to 1 is interposed between it and the detector. It would appear from this that although the B.B.C. reserve the right to modulate up to 100 per cent., they practically never do it; for which, since detector distortion increases with modulation, we may be very thankful.

From the point of view of set design we conclude that if we decide to divide the theoretically possible output of our proposed detector by about eight, and to follow it by an amount of amplification based on this reduced output, the set, when finished, will contain just about the right amount of low-frequency amplification. Detector and output valve will, in fact, overload practically simultaneously as signal strength

is increased, the chances being slightly in favour of the output valve overloading a little before the detector.



IN the current number of our sister journal, *The Wireless Engineer*, there is described a patented device

CONSTANT AERIAL LOADING.

that should have a useful application to band-pass input filters, although it is intended primarily for other purposes.

Briefly, it consists of a differential capacity control of aerial coupling, matters being so arranged that tuning is disturbed to a negligible extent by this operation. As pointed out in the specification, the reduction of aerial loading that accompanies a reduction in coupling may sometimes be responsible for instability, and it is to prevent this that means are provided for the artificial insertion of resistance in order to maintain a sensibly constant load on the tuned circuit.

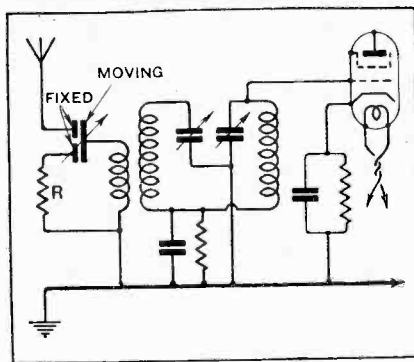

Fig. 1.—Automatic compensation for the reduction of input circuit damping that is normally caused by reducing aerial coupling.

In a band-pass filter circuit we are not usually troubled by instability as a result of removing aerial loading, but it is a matter of common knowledge that the symmetry of the resonance curve is disturbed if the load on either member of the filter be changed. To obviate this, the circuit might be arranged as in Fig. 1, where the artificial aerial

resistance is marked R. A value of from 25 to 30 ohms is suggested.

It will be appreciated that when the moving vanes of the differential condenser are fully enmeshed with the stator that is joined directly to the aerial, this resistance is entirely inoperative; its action is progressively increased as the rotor is engaged with the second stator.

The usual balancing condenser may be used in conjunction with this arrangement in order still further to avoid disturbances in tuning.



MATCHING the minimum capacities in two or three tuned circuits by means of the

ADJUSTING THE TRIMMERS.

trimmers is sometimes made more difficult by hand-capacity effects. If a "live" wire, carrying high-frequency currents, happens to run near the operating screw of the trimmer, it is often found that after the correct adjustment has been found, the removal of the hand from the proximity of the trimmer upsets this adjustment again. In such a case one is tempted to use a screwdriver or other handy tool to turn the trimmer, but it must not be forgotten that the metal of the blade runs up close to the hand, so that the screwdriver may prove to be of no assistance. The difficulty is readily surmounted by using, in place of the screwdriver, a piece of ebonite, paxolin, or even wood, having a shape that permits it to be used for the adjustment.

For the same reason, which is that the trimmer must be adjusted with the set *exactly* as it is going to be used, it is necessary to have any screens that there may be on the set in position when the trimming process is going on.

Although it is no longer a question of trimming in the usual sense, much the same precautions have to be taken when adjusting the tuning of intermediate-frequency stages in a superheterodyne receiver.

New Year Message from Pa.

There is an optimistic flavour in the announcement of the Anglo-American Radio Society, intended for listeners in Britain, that a New Year message will be transmitted at 2 a.m. G.M.T. on January 1st from WJAC, Johnstown, Pa., U.S.A., on 228.9 metres, with a power of 100 watts. Readers who pick up WJAC are asked to send their reports to the European Secretary at 11, Hawthorn Drive, Willowbank, Uxbridge, Middlesex, England.

○○○○

Sad Case.

Wireless has yielded a few touching stories in its time, but none more so than that of the elderly debtor in the Leeds Bankruptcy Court last week, who declared that: "I cannot, in my old age, grasp the idea of radio." His trouble was that he had tried to make a living as a radio dealer.

○○○○

Physical and Optical Societies' Exhibition.

The "discourses" given each day during the run of the Exhibition of the Physical and Optical Societies are always provocative of interest. On January 5th, the first day of the Exhibition at the Imperial College of Science and Technology, South Kensington, S.W.7, Mr. C. C. Paterson, O.B.E., F.Inst.P., M.I.E.E., will lecture on "Photocells: The Valves Which Operate by Light." This address will be illustrated by experiments. On January 7th Sir Oliver Lodge will give his "Reminiscences." The Exhibition will be open on January 5th, 6th, and 7th from 3 to 6 p.m. and from 7 to 10 p.m.

○○○○

Ham.

The famous Baconian controversy is of less importance to radio amateurs than that which centres round "ham." This term, which receives praise and blame in about equal proportions, has perhaps its champion apologist in Mr. Kenneth B. Warner, the well-known American amateur, who is now contending that "ham," far from being derogatory in its meaning, is a title of which any amateur can be proud. "Ham" actually stands, he asserts, for "unprofessionalism" in the best sense

○○○○

Broadcasting in Holland.

We are glad to be able to add a correction to our reference in Current Topics of December 2nd to the existing broadcasting system in Holland. Mr. F. H. Gusdorf, of Delft, informs us that while four of the five broadcasting associations are political or religious in their aims the largest—known as the A.V.R.O.—is entirely non-political and secular in scope and depends for its existence upon the free subscriptions of its members. The Association has prepared a scheme of common-wave transmitters or low-power relay stations, and only Government consent is required to put the scheme into practice.

B 15

Current Topics.

News of the Week in Brief Review.

A Radio Race.

In a contest organised by the American Radio Relay League on December 5th, twenty-four amateur "mystery" stations, divided equally between the east and west coasts of the United States, released a secret official despatch from the League headquarters. The lowest amateur frequency band, viz., that lying between 1,715 and 2,000 kc., was used, and the object of the test was to see how many of the messages could be relayed across the Continent and back to their starting point within twelve hours. The results are not yet published, but it is believed that all previous records were beaten.

○○○○

A Veteran Retires.

Mr. Andrew Gray, who is retiring from the position of Chief Engineer to the Marconi Companies, is a well-known figure in commercial wireless circles. He joined



MR. ANDREW GRAY, who is retiring from the position of Technical General Manager of the Marconi Companies, is well known to radio engineers all over the world. He joined the original Marconi concern in 1899.

the Marconi Company in 1899, after considerable experience in cable laying, and in due time was entrusted with the organisation of the ship and shore wireless system of the Marconi International Marine Communication Company. Mr. Gray was appointed Chief Engineer of the Parent Company in 1910, and since then he has supervised much of the practical side of the company's work. He was appointed Joint General Manager in 1923 and Technical General Manager in 1928. Among the many patents to his credit is the "Gray" tubular steel mast, which superseded the old wooden ship type. Some two hundred of these masts are now standing in various parts of the world and, according to a gay statistician, their total height is 60,000 feet!

Awkward Questions.

If there is one disadvantage in being a reader of *The Wireless World* it is that friends, anxious for a technical hint or two, are prone to ask questions which not even a Faraday or a Marconi could answer on the spur of the moment. In such contingencies it is useful to refer to *The Wireless World* Diary, with its wealth of handy information. Copies are 1s. 6d. each, or 1s. 7d. post free, from the Publishers, Dorset House, Tudor Street, London, E.C.4.

○○○○

Free Speech by Radio.

A remarkable fight on the issue of "free speech on the air" is being fought by the Rev. R. P. Shuler, of Los Angeles, whose station, KGEF, was recently suppressed by order of the U.S. Federal Radio Commission. The charge was that Mr. Shuler had used his station to "incite religious strife and antagonism," with the result that the transmissions were undesirable and obnoxious to the listening public. Shuler contends that the Commission's action is a direct challenge to the right of free speech guaranteed by the constitution of the United States, and he is prepared, if necessary, to take the case to the Supreme Court. Meanwhile, KGEF is silent, and its spirited owner, in order to collect funds to conduct his case, must perforce make his appeal from the pulpit.

○○○○

A Radio Battle.

Radio field days, however much personal vexation they may occasionally cause, are generally peaceful affairs, but Italian broadcasting authorities infused a decidedly warlike element into the radio rally held in the neighbourhood of Milan on December 6th, 7th, and 8th. In co-operation with the military authorities, the broadcasters organised a "barrage of waves" against an imaginary enemy proceeding on Milan from the direction of Lombardy. On the first day the forces concentrated, but on the two other days the radio artillery dealt out imaginary death and disaster for 4½ hours per diem. We prefer chasing hidden transmitters!

○○○○

His Master's Voice.

A happy reversal of the now old device whereby the cries of a baby at the top of the house can be heard on a loud speaker in the basement is reported from Greenwich, Conn., U.S.A. According to a correspondent, a canine enthusiast has been having trouble with his dogs barking in the night and wakening the neighbourhood; the kennels being some distance from the house, he has installed a microphone at his bedside and amplifiers and loud speakers in the "dog houses." A general admonition from the bedroom becomes a crisp, commanding shout in the kennels and is quickly obeyed.

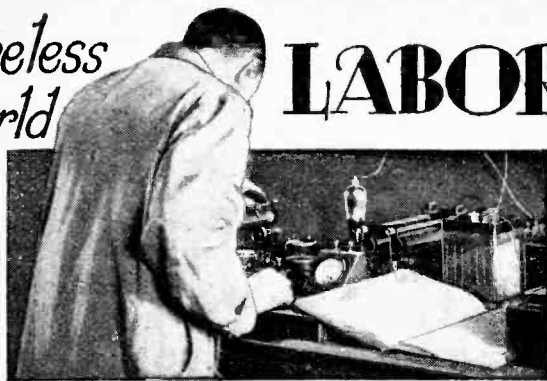
Wireless
World

LABORATORY TESTS

Review
of New
Radio
Products.OLDHAM H.T. BATTERY, GREEN
BAND SERIES.

The dry-cell H.T. battery dealt with in this review is one of the new type introduced recently by Oldham and Son, Ltd., Denton, Manchester, and officially described as the Green Band Series. They are made in various sizes, ranging from 60 volts to 120 volts; the price of the first mentioned is 5s. 6d., while the 120-volt model costs 11s. This series has been introduced to meet the demand for a reliable H.T. battery for moderate discharge work at a popular price, and it would seem that the makers have fully attained their object in this respect.

The sample tested—a 120-volt battery—was subjected to short periods of discharge, with equal time intervals for recuperation, but in the curve reproduced here the rest periods have been omitted, and only the actual working hours shown. It is significant that the end-pocket of the battery, assuming that it is kept in use until the potential falls to 0.75 volt

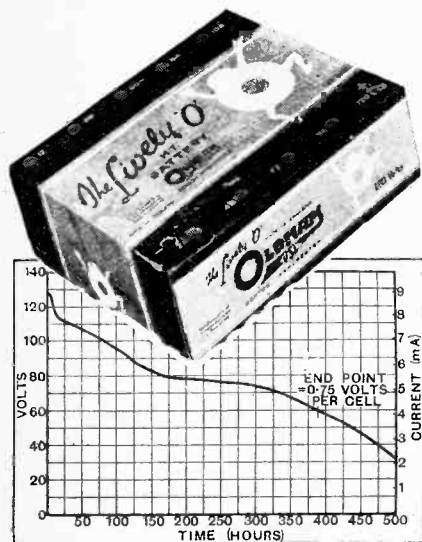

The 120-volt battery in the Oldham "Lively O" Green Band Series with its discharge curve.

per cell, approximately coincides with what would seem to be the natural cut-off, for beyond this point the voltage falls rapidly until the battery is exhausted.

Furthermore, the voltage is maintained at a satisfactory level right up to the end-point of the battery. The initial discharge current was a little high for this class of battery, but since the curve is so satisfactory despite this, we feel that under working conditions, if the current taken is of the order of 7 to 8 mA., the battery will show a potential of between 80 and 90 volts for the major part of its useful life.

Under the exacting conditions imposed by our test, a working life of some 390 hours can be expected, and, if the discharge rate is not so high, we feel confident that the battery would retain its "lively O" qualities well into the 400 hours region. For a battery costing but 11s. this is an exceptionally good performance.

○○○○

IGRANIC "PARVO" L.F.
TRANSFORMER.

This miniature intervalve transformer has been designed especially for use in the parallel-feed type of circuit, and, as the primary will normally not be passing a D.C. current, the use of a high-permeability alloy is permissible for the core. Furthermore, the magnetic material could be reduced to an exceedingly small amount, but in the case of the "Parvo" provision has been made for the primary to carry a few milliamps of D.C., thus enabling the transformer to be used in the normal manner providing the steady current does not exceed 3 mA.

Despite this, the component is exceedingly compact, the overall dimensions being 2½ in. × 1½ in. × 1¼ in., and it weighs about 4 oz. It is enclosed in a neat, mottled-brown bakelite case, and the terminals are clearly marked.

With no D.C. flowing, a very high primary inductance can be obtained under certain operating conditions, measurements showing that with 6 volts A.C. across the primary an inductance of 83 henrys is available. This condition would obtain when a power grid detector was used; indeed, this figure is often exceeded, and with higher A.C. potentials an increase in the primary inductance will ensue.

There is a rapid falling-off in inductance when quite small amounts of D.C. are passed through the primary, as can be seen by an examination of the curve reproduced here. Whenever possible, the

parallel-feed system should be adopted, as this enables the high primary inductance to be employed to the best advantage, giving an excellent amplification over the whole of the musical scale.

The nominal ratio is 1:3, but various ratios can be obtained by auto-coupling in a parallel-feed circuit.

The makers are the Igranic Electric Co., Ltd., 149, Queen Victoria Street, London, E.C.4, and the price is 7s. 6d.

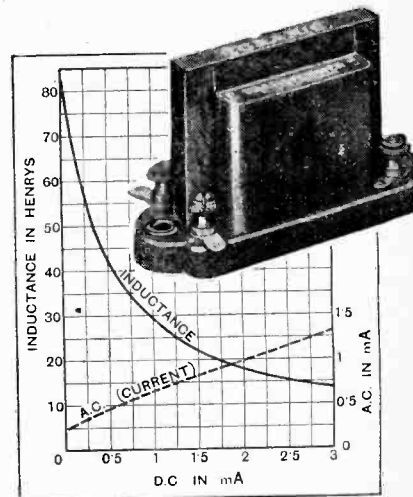

Inductance curve of Igranic "Parvo" L.F. transformer, with D.C. flowing in the primary. Inset is the miniature transformer, which is for parallel-fed circuits.

○○○○

VARLEY JUNIOR MULTI-CELLULAR
H.F. CHOKE.

The "Junior" model is wound on a moulded former 2½ in. long and 1½ in. in diameter, having twelve sections. These sections are not identical, but vary in thickness and in diameter, and it would seem that the reason for this is to obtain a high inductance with a very low self-capacity. In this the designers can be said to have attained their object, since the inductance is stated to be of the order of 120,000 microhenrys, and the self-capacity as low as 4 mmfds.

The actual values obtained by measurement at radio-frequencies gave the inductance as 127,000 microhenrys, and the self-capacity as approximately 3.5 mmfds.

When fitted in a normal circuit, the choke will be shunted by a capacity of not less than 10 mmfds., which is represented by the valve, its holder, and associated wiring, and as a consequence the resonant wavelength will be well above the highest wavelength covered by the average broadcast receiver.

Its high inductance and low self-capacity render the choke particularly suited for use in the tuned-grid type of H.F. circuits, but it is no less efficacious

in detector circuits, since the filtering effect will be exceptionally good, and very little H.F. will find its way into the L.F. portion of the set.

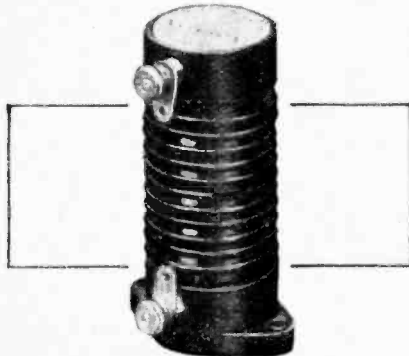

Junior model of the Varley Multi-Cellular H.F. choke.

The makers are Varley, Oliver Pell Control, Ltd., 103, Kingsway, London, W.C.2, and the price is 3s. 6d.

o o o o

WATES LOW-TENSION PRIMARY CELL.

Although the primary cell was one of the first generators of current evolved, for many years it possessed the serious drawback that heavy currents could not be taken from the cell for lengthy periods. Frequent intervals had to be allowed for recuperation, consequently this style of battery did not find favour as a source of L.T. for wireless purposes. Recent research has overcome most of the inherent drawbacks, and to-day this type of battery can well take its place side by side with any other device developed for a similar purpose.

The new "A.D." cell is a case in point, and currents up to one ampere can be drawn from the battery for many hours at a time. It does not employ a corrosive fluid, the electrolyte consisting of an ammonium chloride solution, or sal-ammoniac, as it is more commonly

"topped up" with water, as slight evaporation will take place.

At the end of this period a new zinc electrode will be required, also fresh electrolyte, and the battery will then continue to function for a further similar period. The carbon elements have a life of about 4½ years. Spread over this period, upkeep costs are very small indeed.

When first put into use, each cell shows an E.M.F. of 1.5 volts; this rapidly falls to about 1.3 volts, after which there is a very slow drop in voltage. It is stated that after about 600 hours of use each cell will show about 0.9 volt. Two cells will suffice, therefore, when 2-volt valves are employed, but a small variable resistance will be required to bring the voltage down to the working value in the first case.

A sample "A.D." cell is at present undergoing a life test, and when this is completed we shall be in a position to give some first-hand information on the actual performance of the batteries under conditions simulating those obtaining in a practical case.

These cells are made by the well-known Le Carbon Organisation, and the sole concessionaires for Great Britain and most of her colonies is the Standard Battery Co., 184-188, Shaftesbury Avenue, London, W.C.2, and the price is £2 each complete.

o o o o

WATMEL BAND-PASS FILTER UNIT. TYPE BPMFR.

This filter unit, comprising two screened coils mounted on a metal base and embodying waveband switches, is intended to be employed as a dual-capacity coupled band-pass filter, its special feature being a constant peak separation throughout the range covered. To complete the unit one 0.05 mfd. and one very small capacity semi-variable condenser are required.

The small variable condenser is connected between the high potential ends of the coils, while the 0.05 mfd. fixed condenser joins the low potential ends. The adjustment of the semi-variable condenser

and if the value is too high the peaks will be rather widely separated at the shorter wavelengths.

In view of this, it is possible that the makers will include a suitable condenser in the unit, thus assuring that the minimum capacity will be sufficiently small to give the correct spacing of the peaks.

The second coil in the unit has a reaction winding to be used when an H.F. stage is not employed. A differential reaction condenser must be fitted, and its capacity should not exceed 0.00015 mfd., as otherwise there may be a slight detuning effect, which would affect in an adverse manner the performance of the filter.

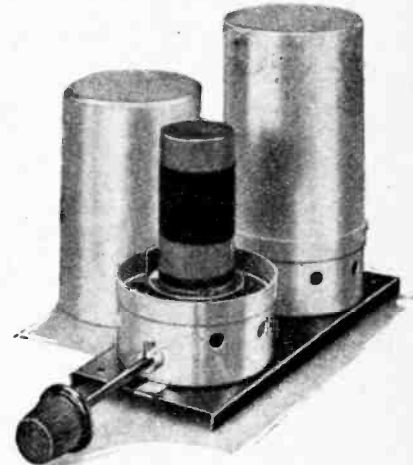

Watmel dual-capacity coupled band-pass filter coils.

The makers are Watmel Wireless Co., Ltd., Imperial Works, High Street, Edgware, Middlesex, and the price of the unit in its present form is 17s.

o o o o

Catalogues Received.

Ormond Engineering Co., Ltd., Ormond House, Rossbery Avenue, London, E.C.1.—Well-illustrated catalogue describing their receivers, loud speakers, condensers and components.

o o o o

Siemens-Schucker (Great Britain), Ltd., 30/34, New Bridge Street, London, E.C.4.—Illustrated leaflets dealing with Siemens & Halske 1,500-volt test condensers, fixed resistances and "Eshalite" 500- and 750-volt test condensers.

o o o o

Dubilier Condenser Co. (1925), Ltd., Ducon Works, Victoria Road, North Acton, London, W.3.—Broadsheet illustrating and describing the Dubilier range of components.

o o o o

The Benjamin Electric, Ltd., Tariff Road, Tottenham, London, N.17.—Illustrated handbook dealing with the latest Benjamin radio products.

o o o o

Watmel Wireless Co., Ltd., High Street, Edgware, Middlesex.—Descriptive folder, well illustrated, dealing with screened coils, tuner units, and other Watmel components.

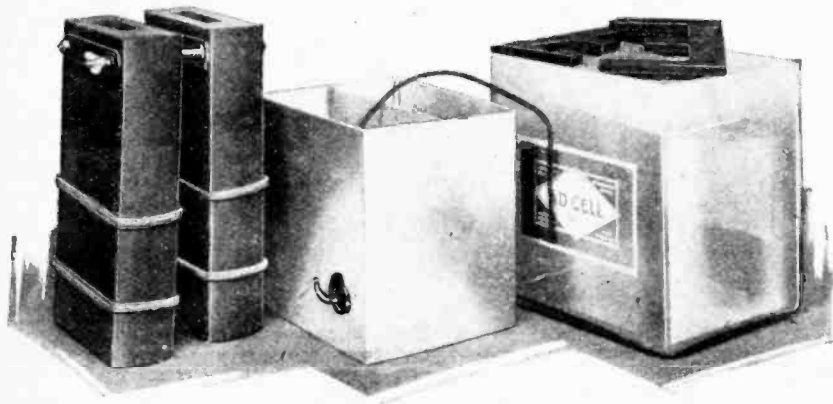

"A.D." low-tension primary cell giving up to one ampere of current.

known. On intermittent discharge a battery of these cells will have a useful life of about a year with very little attention. Occasionally they should be

is very critical, and, furthermore, it is essential that its minimum capacity should be very small indeed. The total capacity required is of the order of 5 mfd. only,

PRINCIPAL SHORT-WAVE BROADCASTING STATIONS OF THE WORLD.

Positions of the Stations are given in the Map on the Opposite Page.

Times of Transmission are approximate only and represent G.M.T.

Wave-length Metres.	Frequency Kilo-cycles.	Call-Sign.	Station.	Wave-length Metres.	Frequency Kilo-cycles.	Call-Sign.	Station.
14.28	21,018	OKI	Podebrady (Czechoslovakia)	37.2	8,060	OUIII	Vienna (Mon., Thurs., 21.30)
14.55	20,618	PMB	Malabar (Java) (Daily, 10.00-15.00)	38.0	7,890	PK3BK	Soerabaja (Java) (Tues., Fri., Sat., 11.40)
15.5	19,350	—	Nancy (France) (Daily, 21.00-22.00)	39.4	7,612	X26A	Nuevo Laredo (Mexico) (Daily, 14.00, 16.00, 18.00, 21.00 and 00.00)
15.5	19,350	VK2ME	Sydney (Australia) (Irregular)	39.7	7,556	KKF	Bogotá (Columbia) (Westinghouse Labs)
15.93	18,830	PLE	Bandoeng (Java) (Tues., 13.40-15.40)	41.0	7,320	HSP2	Bangkok (Siam) (Daily, ex. Mon., 12.30)
16.3	18,400	PKK	Kootwijk (Holland) (Daily, 16.00)	41.5	7,230	JIB9D	Zurich Radio Club (Switzerland) (1st and 3rd Sun., 12.00-19.00)
16.32	18,380	FZA	Saigon (Fr. Indo China) (Sun., 18.00-20.00)	41.5	7,230	—	Budapest (Techn. Sch.) (Hungary) (Daily, 07.30-08.10)
16.57	18,105	W9XAA	Chicago Ill. (U.S.A.) (Relays WCFL)	41.6	7,211	EAR58	Teneriffe Radio Club (Canary Islands)
16.85	17,804	PCV	Kootwijk (Holland) (Sat., 15.40)	41.7	7,195	VSIAB	Singapore (Mon., Wed., Fri., 11.30)
16.9	17,750	HISJ	Bangkok (Siam) (Sun. and Tues., 21.00)	42.0	7,143	VK2HR	Sydney (Australia) (Mon., Tues., Wed., Thurs., 09.00; Fri., 11.30; Sat., 01.30; Sun., 03.00)
18.4	16,300	PCF	Kootwijk (Holland) (League of Nations Station) (Sat., 13.40-14.00)	42.9	6,991	CTIAA	Lisbon (Portugal) (Fri., 22.00)
19.0	15,790	EAJI	Barcelona (Spain) (Irregular)	43.0	6,970	EAR110	Madrid (Spain) (Tues., Sat., 22.30)
19.56	15,340	W2XAD	South Schenectady N.Y. (U.S.A.) (Relays WG Y)	43.0	6,970	PK3BK	Soerabaja (Java) (Tues., Thurs., 11.10)
19.68	15,244	FYA	Pontoise (France) (Colonial Station E-W) (11.30-17.30)	43.75	6,865	F8LH	"Radio Vitus," Paris (Daily, 18.45)
19.72	15,210	W8XK	East Pittsburg Pa. (Relays KDKA)	45.0	6,667	FMSKR	Constantine (Algeria) (Mon. and Fri., 23.00)
19.84	15,120	HVJ	Vatican State, Rome (Daily, 10.00)	45.0	6,667	PL3CH	Soerabaja (Java) (Mon., Wed., 12.40)
20.5	14,630	XDA	Chapultepec (Mexico) (Daily, 19.30)	46.6	6,438	REN	Moscow (Relays Trades Union Station)
20.79	14,430	VPD	Suva (Fiji) (Irregular)	46.69	6,425	W3XL	Bound Brook, N.J. (Relays WJZ)
21.5	13,950	YOI	Bucharest University (Roumania) (Wed. and Sat., 19.00-22.00)	48.0	6,250	CN8MC	Casablanca (Morocco) (Relays Rabat)
23.8	12,605	—	Rabat (Morocco) (Sun., 11.30-13.00)	48.35	6,205	HKC	Bogota (Colombia) (Daily 15.00)
25.2	11,900	FYA	Pontoise (France) (Colonial Station N-S) (18.30-20.30)	48.62	6,170	HRB	Tegucigalpa (Honduras) (Daily, ex. Sun., 00.00-04.00)
25.25	11,880	W8XK	East Pittsburg Pa. (U.S.A.) (Relays KDKA)	48.65	6,167	XIF	Mexico City (Mexico)
25.27	11,870	VUC	Calcutta (India) (Daily 11.00-11.00)	48.85	6,145	VE9CL	Winnipeg, Manitoba (Canada) (Daily, 23.30-03.00)
25.34	11,840	W9XAA	Chicago Ill. (U.S.A.) (Relays WCFL)	48.86	6,140	W8XK	East Pittsburg, Pa. (U.S.A.) (Relays KDKA, Wed. and Sat., 22.00-05.00)
25.4	11,810	2RO	Prato Smeraldo, Rome (Daily, 16.00 and 19.30)	49.0	6,122	F3ICD	Saigon (Fr. Indo China) (Daily, 11.30)
25.5	11,763	XDA	Chapultepec (Mexico) (Daily, 20.00)	49.02	6,120	W2NE	Long Island, N.Y. (Relays WABC)
25.53	11,750	G5SW	Chelmsford (Daily ex. Sat. and Sun., 12.30-13.30 and 18.45-21.00)	49.18	6,100	W3XAL	Bound Brook, N.J. (Relays WJZ)
25.63	11,705	FYA	Pontoise (France) (Colonial Station E-W) (21.00-23.00)	49.22	6,095	VE9GW	Bowmanville, Ont. (Canada) (Daily, 11.45 and 22.00)
26.22	11,440	—	Nauen (Fri., Sat., Sun., 22.00)	49.34	6,080	W9XAA	Chicago, Ill. (U.S.A.) (Relays WCFL)
28.2	10,365	PLR	Bandoeng (Java) (Daily, 11.00-15.00)	49.34	6,080	W2XCX	Kearny, N.J. (U.S.A.) (Relays WOR)
28.98	10,350	LSX	Buenos Aires (Argentina) (20.30-00.30)	49.4	6,072	ZTJ	Jolannenburg (Daily 15.30-20.30)
29.3	10,238	TI4NRH	Heredia (Costa Rica) (10.00 and 14.00)	49.43	6,069	VE9CS	Vancouver B.C. (Canada) (Daily, 2.00)
30.0	10,000	—	Belgrade (Yugo Slavia) (Mon. 20.00)	49.46	6,065	—	Motala (Sweden) (Relays Stockholm)
30.75	9,756	—	Agen (France) (Tues. and Fri., 21.00)	49.5	6,060	W3XAU	Philadelphia, Pa. (Relays WCAU)
31.28	9,590	PCJ	Eindhoven. Transmissions suspended for six months from Nov., 1931	49.5	6,060	W8XAL	Mason, Ohio (U.S.A.) (Relays WLV)
31.28	9,590	VK2ME	Sydney (Australia) (Sun., 10.00-14.00 and 18.00)	49.5	6,060	VQ7LO	Nairobi (Kenya Colony) (Daily 16.30)
31.3	9,582	W3XAU	Philadelphia Pa. (U.S.A.) (Daily ex. Thurs. and Fri., 20.00-07.00)	49.67	6,042	W2XAL	Coytesville N.J. (Relays WRNY)
31.35	9,570	W1XAZ	East Springfield, Mass. (U.S.A.) (Relays WBZ)	49.7	6,040	PK3AN	Soerabaja (Java) (Daily, 11.40)
31.35	9,570	SR1	Posen (Poland) (Tues., 18.45; Thurs., 18.30)	49.83	6,020	W9XF	Chicago, Ill. (U.S.A.) (Relays WENR)
31.38	9,560	—	Zeesen (Germany) (13.00 onwards)	50.0	6,000	EAR25	Barcelona Radio Club (Sat., 20.00)
31.48	9,530	W2XAF	Schenectady N.Y. (Relays WGY)	50.0	6,000	—	Bucharest (Roumania)
31.51	9,520	OXY	Skamlebaek (Relays Copenhagen)	50.0	6,000	RW59	Moscow (Russia) (Relays Trades Union Station) (Daily 20.00)
31.55	9,510	VK3ME	Melbourne (Wed. and Sat., 10.00)	50.0	6,000	ZL3ZC	Christchurch (New Zealand) (Wed., 03.00; Sat., 07.30)
31.75	9,450	—	Rio de Janeiro (Brazil) (Daily, 21.30)	51.22	5,857	XDA	Chapultepec (Mexico) (Daily, 15.00)
31.86	9,430	PLE	Bandoeng (Java) (Tues., 13.10-15.40)	50.26	5,970	HVJ	Vatican City (Rome) (Daily, 19.00)
32.26	9,300	—	Rabat (Morocco) (Sun., 19.00)	54.52	5,502	W2NBH	Brooklyn, N.Y. (Relays WCGU)
32.85	9,130	H9OC	Zurich (Switzerland) (11.50-22.00)	58.0	5,172	OK1MPT	Prague (Czechoslovakia) (Tues., Fri., 19.30)
33.00	9,090	—	Paris, Radio LL.	62.5	4,800	W2XAV	Long Island, N.Y. (U.S.A.) (Fri., 22.00)
34.68	8,650	W2XV	Long Island N.Y. (U.S.A.) (Fri., 23.00)				
36.92	8,125	PLW	Bandoeng (Java) (Daily, 11.00-15.00)				

SHORT - WAVE BROADCASTING MAP.

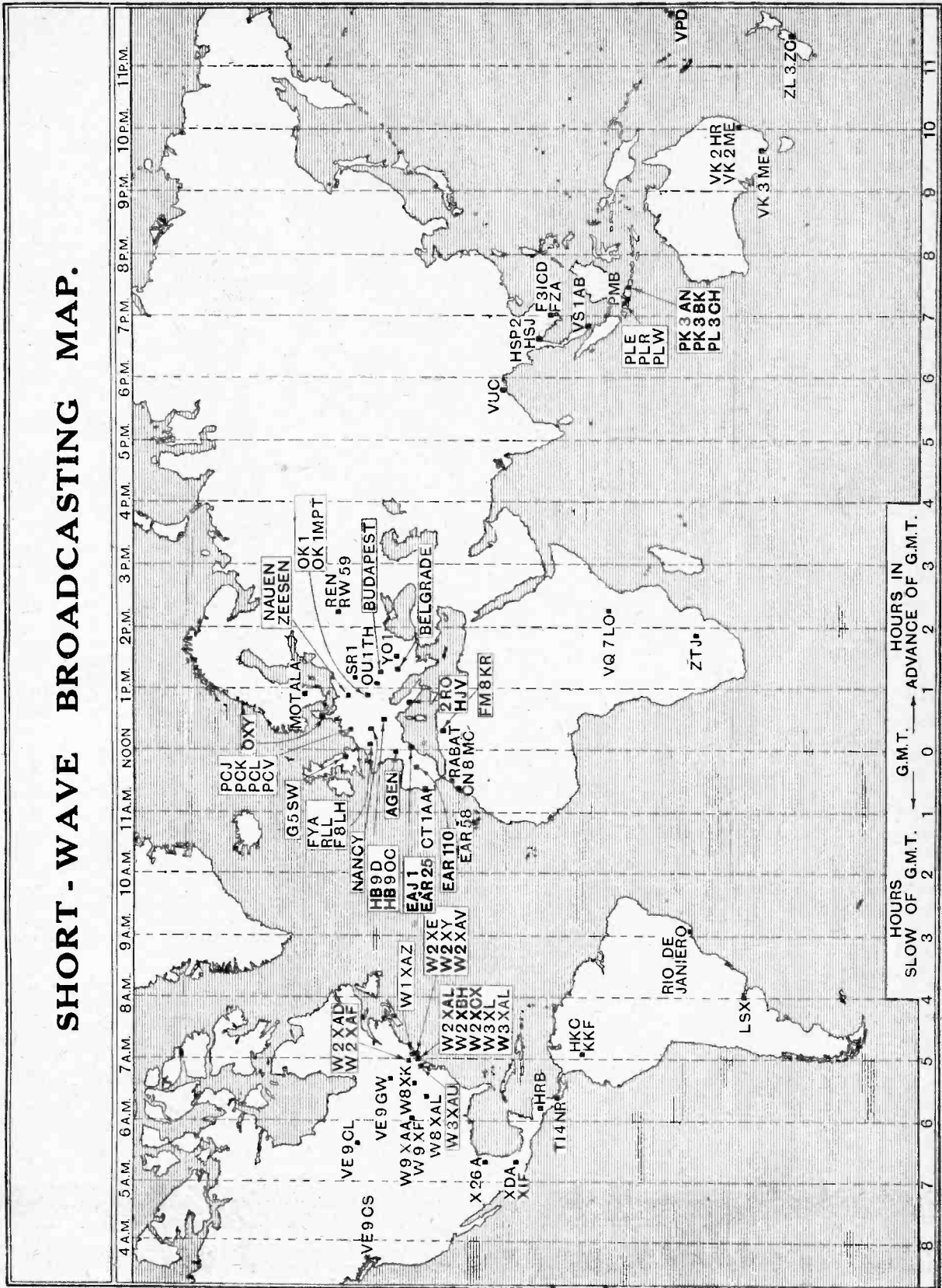

The time in any part of the world can be easily seen at a glance from the hour scales shown at the top and bottom of the map.

H.M.V. CABINET RADIO RECEIVER

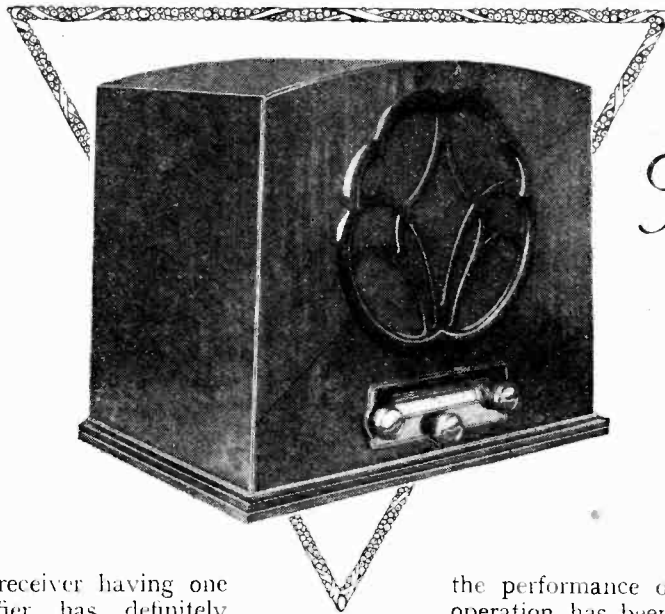
Model
435A Table Model
Three-valve
A.C. Receiver—A.C.
Three-Valve—With Self-
contained
Loud Speaker.

SINCE the three-valve receiver having one high-frequency amplifier has definitely established itself as the most popular general-purpose type in this country, it is but fitting that the first broadcast receiver, other than a radio-gramophone, to be produced by the Gramophone Company should take this form. The new set is described as Model 435, and operates entirely from the A.C. mains. It employs a valve rectifier and is fitted with a permanent-magnet-type loud speaker. Provision is made for gramophone reproduction in the same general form as adopted in their combined instruments.

The circuit arrangement comprises a capacity-coupled band-pass input filter, a screen-grid H.F. valve coupled by a tuned-grid circuit, arranged in the form of an auto-transformer, to a power grid detector. This is followed by a parallel-fed high-ratio L.F. intervalve transformer working into a pentode valve capable of giving a large power output. Three alternative aerial connections are provided; one joins direct to the tapping on the input coil and is intended for use with a relatively short aerial. When a long aerial is employed, one or other of the alternative aerial connections should be used, as these interpose small series condensers and considerably enhance the selectivity. A mains aerial is provided for use where range is not demanded and the immediate needs can be met by the choice of a limited number of alternative programmes.

Practically every modern feature likely to enhance

the performance of the set and simplify its operation has been incorporated. All circuits are adequately decoupled, with the result that absolute stability is assured, but not at the expense of sensitivity, which is well above the average for a receiver of this type. Excessive damping of the tuned-grid coil is avoided by connecting the valve across that portion of the coil which is used as the primary, so that the switch, which changes over the anode lead from the H.F. valve, makes the required changes to the detector grid circuit also.

The L.F. intervalve transformer is wound on a high-permeability core, and, having a step-up ratio of one to seven, affords sufficient amplification to load the pentode valve fully, even when the set is tuned to some of the more distant broadcast stations. This becomes evident, when using the set, by the extent to which the volume control has to be backed off to keep the volume within reasonable bounds.

This control is effective on both radio and gramophone. It is linked up with the reaction condenser, a variable resistance, and a potentiometer. The resistance controls the voltage on the screen-grid in the H.F. valve, while the potentiometer is the volume control for gramophone reproduction. Starting from the position of minimum volume, the initial rotation of the knob increases the screen potential, and after travelling through about two-thirds of a revolution the reaction condenser comes into play.

The practice of assigning to one control as many

FEATURES.

GENERAL: Self-contained A.C. mains receiver for use with external or "mains" aerial. Sockets for gramophone pick-up, electric motor and external loud speakers. Universal mains transformer. 40-100 cycles. 95 to 164 and 190 to 260 volts.

CIRCUIT: Band-pass input filter, one H.F. stage coupled by tuned-grid system to power grid detector. Transformer coupling to pentode output valve. Full-wave rectifying valve.

CONTROLS: (1) Single-knob tuning; (2) volume control incorporating reaction; (3) combined wave-change and mains switch.

PRICE: 22 guineas complete.

MAKERS: The Gramophone Company, Ltd., 363-367, Oxford Street, London, W.1.

H.M.V. CABINET RADIO RECEIVER.

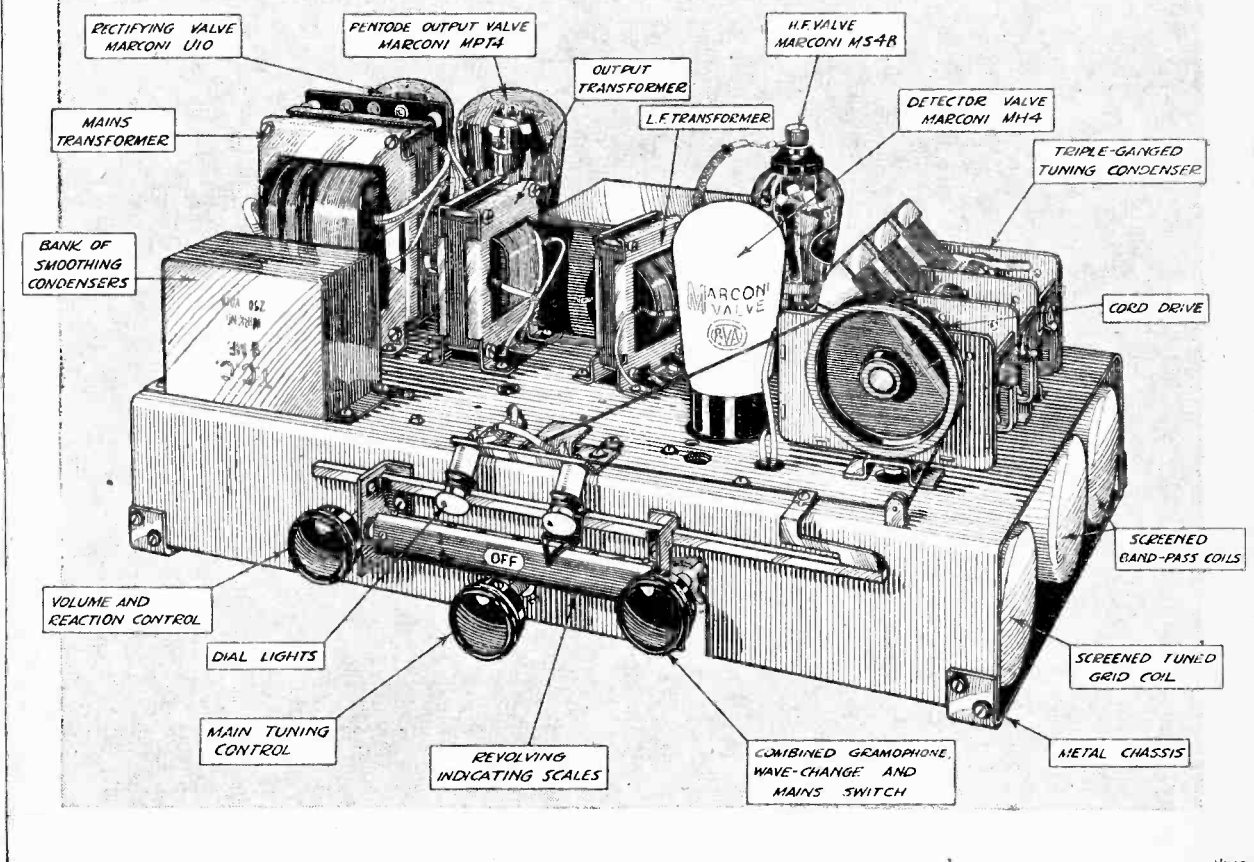
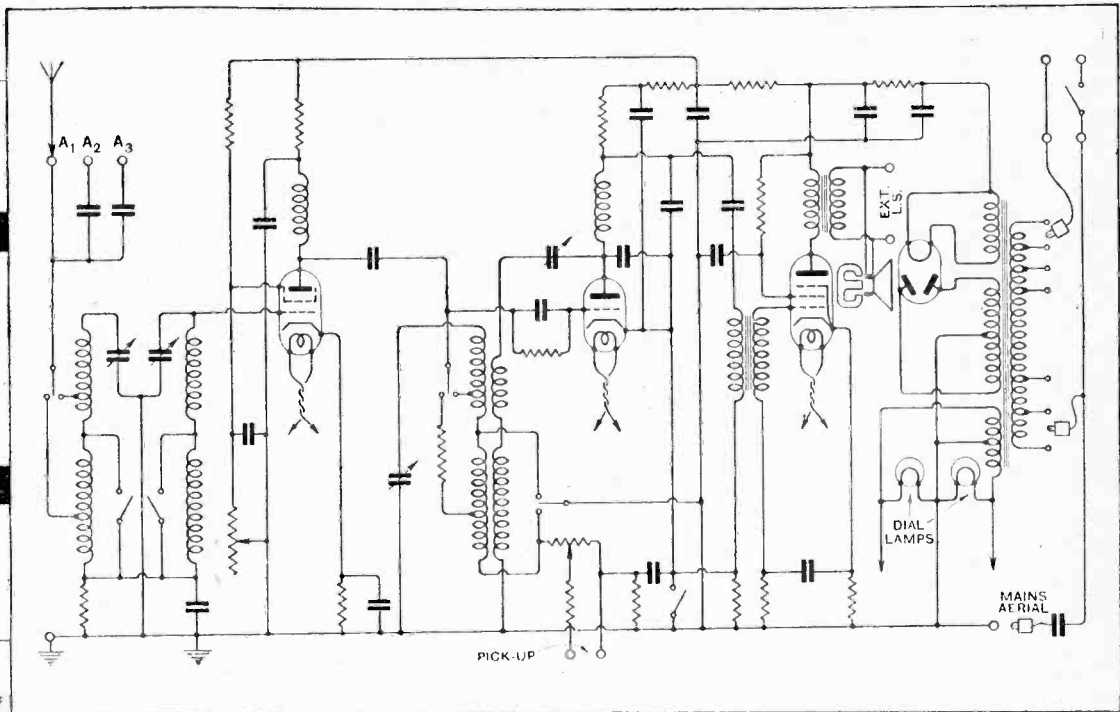

Circuit diagram and chassis assembly. The loud speaker is mounted separately in the cabinet.

H.M.V. Cabinet Radio Receiver.—

functions as can be reasonably expected has been extended, also, to the switching control. One knob is made to serve the triple purpose of wave-change, radio to gramophone, and on-and-off switch. Simultaneous with making these changes it actuates a revolving indicating drum located behind a longitudinal aperture bringing into view either an appropriate wavelength scale or a suitable indication of the changes made in the circuit by the switches.

Separate tuning scales are provided for both wavebands, and as these are scaled off in metres the tuning-in of distant stations is greatly facilitated. We found the calibration quite accurate and very helpful. All scales are illuminated by concealed lamps lit from the four-volt winding on the mains transformer.

Ingenious Condenser Drive.

The tuning control, which occupies the centre position immediately below the illuminated scales, operates a triple-gang condenser through a six-to-one reduction gear. A cord drive is used as the condenser unit is mounted on the extreme right of the chassis so as to bring it in close proximity to the coils. These are located immediately below the condensers on the underside of the metal base-plate, and each coil is individually screened.

As there are two main controls only, for, apart from the tuning, occasional adjustment of the volume control is required, the set is delightfully simple to operate. Tests were made some twelve miles from Brookmans Park, using an aerial of average size, and we found that the best compromise between selectivity and range was afforded by the intermediate aerial socket.

Receiving conditions were far from favourable on the particular evening chosen, but even so a dozen English and Continental broadcast stations were easily tuned-in on the medium waveband. Numerous other carrier waves were heard, a few of which could be resolved by careful manipulation of the volume control. If conditions had been more propitious we feel sure that this number would have been augmented by fifty per cent. at least.

Reaction Control.

Reaction is inclined to be a little fierce, but there is no backlash, and it only requires careful handling, when the set is in its most sensitive state, to bring quite weak signals up to good strength.

When searching for distant stations, the characteristic sharp cut-off of band-pass tuning was quite evident by the way signals quickly attained maximum intensity and the rapid decline to inaudibility beyond the normal setting. The long waveband provided eight alternative

programmes, all at good volume. Königswusterhausen, between Daventry 5XX and Radio Paris, was not affected by the proximity of these stations, although the last mentioned was exceptionally strong.

An Accessible Chassis.

During our tests we occasionally experienced a slight slipping of the cord on the driving spindle operating the tuning condensers, which resulted in the pointer coming to rest at varying distances from the upper end of the scale. This is the only mechanical fault in an otherwise excellent design.

The sensitivity of the set to weak signals is, in some measure, accounted for by the excellence of the loud speaker fitted. It is a permanent-magnet model with a low-resistance speech coil of small diameter carefully centred in a very narrow gap in which the flux density is some 6,000 lines per square centimetre. A specially prepared linen diaphragm is fitted, and, being celluloid finished, it has exceptional stiffness for its weight.

The quality of the reproduction is well up to the standard expected from an H.M.V. product, with the output nicely balanced and the bass well in evidence without being overpowering or obscuring the upper register, the reproduction of which is good.

As the pentode valve is capable of giving between 1.5 and 2 volts of undistorted power, it is possible to operate two additional loud speakers in conjunction with the built-in unit. But these must be of the low-resistance type. Two sockets are fitted on the back, into which the extension leads can be plugged.

Accessibility, with which goes ease of servicing, is a marked feature of the Model 435 receiver. To withdraw the chassis, first

remove the three control knobs; then take out the four screws passing through the base of the cabinet, and detach the loud speaker leads from the soldering tags on the output sockets. This is essential, for the loud speaker is fixed to the inside of the cabinet and not mounted on the chassis. The high-frequency unit can be removed without disturbing the remainder of the set.

These matters are of small concern to the user, but the service agent will fully appreciate their significance, since, should a fault develop, the defective part can be returned to the works for repair or replacement. Modern sets do not, as a rule, give much trouble, but no man-made article is perfect and minor faults do occur now and again.

The new model is housed in a well-finished walnut cabinet measuring 15½ in. high, 18½ in. wide, and 11½ in. deep, the loud speaker being mounted in the upper compartment. The set is economical to operate, requiring about 35 watts only, and the price is 22 guineas.

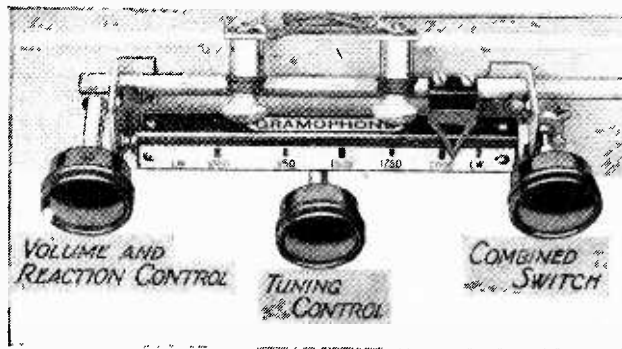

Details of the three controls showing the revolving drum indicator scales which are marked in actual wavelengths on both broadcast bands.

DAYS on the treadmill would be happier than those promised for talks' listeners in the New Year—if much that has been written and said about the new talks policy comes within shouting range of the truth. Happily, I believe that there has been exaggeration and misrepresentation.

The Maiden Aunt.

A Savoy Hill official let drop a remark last week to the effect that all listeners must be considered; that no one must be shocked; that the family circle includes small children. "And their aunt?" prompted a voracious enquirer. "Yes, and their aunt" was the pardonably weary rejoinder. Thus was it blazoned abroad that the B.B.C. is out to please the maiden aunt.

Strong Meat.

It was a poor gibe at the best, but it embodied a truth which is at once the glory of the B.B.C. and the thorn in its side. Unlike a newspaper, the B.B.C. must cater for all, including maiden aunts, old soldiers, and small children, for it cannot rely on what powers of discrimination may be found among such a mixed audience.

Apparently some recent talks have been pretty strong meat for the delicate, so the diet must be lightened. For the knowledgeable and blasé this may be a pity, but, after all, there is always the railway bookstall.

Music and Morals.

Fortunately, perhaps, no one troubles to moralise about music; I have seen a maiden aunt listen to the erotic melodies of negroid swamps without dropping a stitch.

Perpetual Youth?

The B.B.C. Governors have found at least some wisdom in the multitude of counsellors, and I understand that last-minute efforts may be made to instil a little more "devilry" into the coming talks campaign. The Board does resent remarks, however witty, upon the ages of its members, and efforts may be made to show the world that the B.B.C.'s outlook is still youthful.

Broadcasting by the Scottish Orchestra?

MMUSICALLY minded Scots will watch with eagerness the negotiations now in progress to save the Scottish Orchestra, which is, perhaps, the leading musical organisation north of the Tweed. I understand that the B.B.C. will shortly make an offer whereby the orchestra, now in grave financial difficulties, may be saved from extinction. At present Savoy Hill declines to make a definite statement.

Lord Snowden's Appeal.

THE Christmas Night appeal on behalf of the British Wireless for the Blind Fund will be made by Lord Snowden.

Broadcast Brevities

By Our Special Correspondent.

Illustrious Spokesmen.

This annual appeal will be made between 9.5 and 9.20 p.m., just at the time, one imagines, when listeners will be disposed to cast a thought towards those less fortunate than themselves.

Viscount Snowden is fourth in a line of illustrious pleaders for this cause, his predecessors having been the Prince of Wales, Mr. Winston Churchill, and Captain Ian Fraser.

18,000 Sets.

I hear that up to a few days ago no less than £38,307 had been subscribed, but the whole sum has already been expended, with the exception of £500, in supplying 18,000 sets.

A sum of £4,500 is still needed to carry out the original purpose of the scheme, to provide every blind person in this country with a wireless set. About 2,000 sets are still required.

The Announcer Pays.

ASK a policeman" is good advice on most occasions, but in matters of pronunciation it must always be: "Ask an announcer." For the announcer, poor man, is the only one who must actually memorise those long lists of dubious words issued by the Advisory Committee on Spoken English. I doubt whether any member of the Committee could be guaranteed to give the right answer every time.

Sibilants.

In the early days when microphones—fashioned so slenderly—had to be handled so tenderly, the B.B.C. supplied announcers with a list of words which could be substituted for those containing undesirable sibilants. But the latest list sparkles with sibilance. "Anæsthetist" is there with a "rhapsodic subpæna," and "Cesarewitch" rubs shoulders with "Salome."

Theatre's Broadcast Studio.

ON December 20th a broadcasting studio will be opened at the Birmingham Repertory Theatre for the transmission of short plays to Midland Regional listeners. This will be the first theatre in the world to have its own permanent studio.

Landscapes by Wireless.

WHILE waiting for the perfection of television the B.B.C. is not wasting its time. On January 4th Regional listeners will hear a novel type of programme by Mr. H. Allen, in which they will be helped to visualise a "Winter Landscape—a Snow Scene."

Extracts from the works of ten well-known authors will be given by three speakers and a singer, while Ernest Lush will play harpsichord music. Other musical accompaniments will be provided.



THE AUSTRALIAN "B.B.C." This popular station, 40G at Brisbane, is one of those which will come under the control of the new Australian broadcasting organisation modelled on B.B.C. lines.

Breakfast Music.

FOR some unexplained reason that hardly annual—the request for broadcast music at breakfast time—always blossoms forth at this time of the year when the mornings are at their darkest and breakfast is at its fastest. Now, there are things I can adore at midnight and hate at breakfast; among these things are cocoa and music. I am glad that the B.B.C. will, in the mornings, supply neither.

High Lights of the Year.

KALEIDOSCOPIC flashes from a year of broadcasting programmes should give sparkle to the special show which the B.B.C. are putting out on New Year's Eve. Every device, including the Blattnerphone (Stille system) will be used to recall past events just as they were broadcast during 1931.

The year was not a bumper one, perhaps, but it yielded a fair assortment of excitement and talent, so it should be possible to make a good selection.

Governors Calling?

I wish the august B.B.C. of to-day could unbend occasionally and give us the staff parties which were such a success a few years ago. In those days members of the staff could occasionally forget their worries and responsibilities.

The next best thing to a staff party I imagine, would be a programme planned by the Governors. What about it?

CORRESPONDENCE.

The Editor does not hold himself responsible for the opinions of his correspondents.

Correspondence should be addressed to the Editor, "The Wireless World," Dorset House, Tudor Street, E.C.4, and must be accompanied by the writer's name and address.

THE PENTODE.

Sir,—I have read with interest the article in your issue of November 4th entitled "The New York Radio Show."

I think that the paragraph which reads: "The pentode valve has found wide use in the output stage of the 1932 set, due to cost savings, but unfortunately the noticeable distortion, due to odd harmonics, rules out this type of valve for the better-class sets," needs either some explanation or qualification. Does the writer intend that remark to be applied to pentode valves in general or to the American valves in particular?

If the former, then some explanation is necessary as to why the leading English manufacturers, such as H.M.V. and Columbia, to mention but two, and also Philips in Holland, use pentode valves in their productions, which receivers are noted for good-quality reproduction, and to which *The Wireless World* has testified in test reports from time to time. If the reference is to American pentodes, then the remark is understandable, as American valves, with one or two exceptions, are definitely below the English standard.

My personal experience of the pentode dates from its introduction to the public by Mullards, and the early articles in *The Wireless World* by N. W. McLachlan, D.Sc., and embraces all types to my latest amplifier incorporating P.M.24D valves. It is my experience that, correctly used, the pentode can give as good quality and better frequency response than the best triodes, but that a suitable circuit and apparatus are more difficult to design and more costly to manufacture than for triodes. In any case, pentodes may be worked very well in push-pull, given a suitable output transformer, when harmonic distortion is reduced to practically nil, except at peak grid swing.

The review of prize-winning exhibits in *The Wireless World* ballot last year dealt with the Mazda A.C./PEN valve, and showed that provided the correct anode load was used second and third harmonics did not exceed 3 per cent., whereas Messrs. Ferranti in their laboratories have shown that a comparable triode, the P.X.4, with a correct load, introduces 5.2 per cent. harmonic distortion.

In my opinion, the use of a suitable output transformer is the secret of good-quality reproduction with a pentode, and a first-class transformer is neither easy to design nor cheap to produce. The pentode is particularly sensitive to incorrect loading and to poor transformers, the effective ratio of which may easily vary considerably with variations of L.S. impedance, thus aggravating the effect. Further, a transformer, irrespective of its self inductance, may have too high a flux density, and thus introduce a considerable amount of third harmonic distortion, which defect I have found in commercial examples.

Eastcote, Middlesex.

BERNARD F. FOGARTY.

INTERFERENCE.

Sir,—With reference to Mr. Rowe's letter contained in your issue of December 2nd, wherein he gives details of interference caused by traffic signals being situated in close proximity to his receiver, the probable source of trouble is that these signals are operated by lamps of the gas-filled type, which create considerable current-surge at the moment of switching-in the circuit (and often vice versa).

It is my opinion that these parasitic interferences are more usually reproduced through direct "pick-up" on the aerial.

As Mr. Rowe explains, however, that he has disproved my suspect cause, I will pass on to the next possible origin.

This may be by reason of the fact that at so short a distance (i.e., house from signals) the continued interruption of energy to the lamps may cause a "surge" or "ripple" in the mains sufficiently strong to be noticeable in the mains-operated receiver. On this assumption, and assuming also that the supply authorities are using a three-wire supply system, in which neighbouring consumers are usually linked to opposite sides of the supply, for balancing purposes, Mr. Rowe and the traffic signals might be using a common supply, whilst his

neighbour is being serviced from the other side of the main—the latter thereby being free from interference. As an aid to solution of the problem I would suggest that Mr. Rowe prevails upon his neighbour to permit the installation of a pair of temporary supply-leads for energising the receiver, and that when these are linked with the latter Mr. Rowe then completely isolates his own house-wiring by placing his main switch in the "off" position, replacing this in the "on" position before disconnecting the receiver. This would then prove whether the interference was being caused by (1) the origin of supply, (2) in the house-wiring, or (3) whether direct "pick-up" was responsible.

In the event of (1), I would suggest the employment of a more comprehensive "smoothing" equipment.

If (2), the installation of a metal-covered house-wiring system efficiently "bonded" and "earthed" (if such is already installed, this should be tested for "continuity" and "earth").

If (3), I fear I must leave the cure of this to Mr. Rowe's further patient trial and error.

As a last word. Should the cause of trouble be traced entirely to the supply mains, and no alteration to the mains-receiver equipment prove effective, I have no doubt that for a consideration the supply authorities would be willing to transfer Mr. Rowe's service to the same side of the main as that of his more fortunate neighbour.

Hastings.

W. M. PHILLIPS.

Sir,—One would be tempted to think that in these days of S.G. valves and stable H.F. amplification the need for using reaction on to the aerial circuit would have disappeared.

But the fact remains that on many nights of the week reception of many distant transmissions is made impossible by the squeaks and howls of people using obsolete gear. What is the use of my building a supersonic, endeavouring to enjoy a programme from Stuttgart, and then finding reception ruined by somebody trying to separate it from London Regional with (I should imagine) a plain reacting detector?

The mentality of these people is certainly a little difficult to understand, for, even supposing they eventually do alight on the silent point, it is fairly evident that neither the volume or quality would be of a sufficient standard for enjoyment of the programme. Or do they merely twist knobs for fun?

One may, I think, safely assert that in 1931 oscillation on the broadcast band is definitely unnecessary, and some sort of educative campaign is obviously indicated.

London, S.W.12.

LEONARD G. HURRELL.

IDENTIFICATION OF WIRELESS STATIONS.

Sir,—May I be allowed to express my gratification on finding that the identification panels in *The Wireless World* give the musical notation of the interval signals, when they are musical?

The identification panels published in book form by the B.B.C. do not give information in musical form; but I have reason to believe that steps are being taken to supply what is wanting in future editions.

My view is that the majority of owners of receiving sets are not technically minded, and do not plot curves. They consequently find it very difficult to identify stations with which their sets happen to be tuned. Moreover, few of us are linguistically minded, and are much in doubt when trying to identify by means of spoken call signals. Almost everyone, on the other hand, can recognise a tune when he hears it. If, for instance, he has once played over—or heard played over—the music of the Cologne interval chimes, he would always afterwards be able to say: "Those are the Cologne chimes." I would go farther, and recommend that the national anthems and other melodies, and whatever can be reproduced in musical notation, be set out in all publications dealing with the identification of stations.

Perhaps in this way one of the troubles of the ordinary user of the receiving set may be overcome and his pleasure in listening to foreign programmes increased.

London, W.9.

F. J. GRAY (Major).

Readers' Problems.

Readers' technical enquiries are not replied to through the post, but in these pages replies to questions of general interest are dealt with week by week.

Battery Valves.

A YEAR or two ago it was always urged that 4- or 6-volt valves should be employed in preference to those with 2-volt filaments whenever the extra expense of a larger accumulator could be tolerated.

Nowadays the position is changed entirely, and those readers who have asked whether the performance of recently described battery sets could not be improved by using, say, 6-volt valves, may be reassured by the statement that in every case the best possible valves have been chosen by the designer, and that no improvement whatsoever may be expected as a result of making a change.

The energies of manufacturers are concentrated on the problem of improving the characteristics of 2-volt valves, and, with the possible exception of the output stage, there is never any point in using valves with a higher filament voltage rating. Apart from this, there are sound technical reasons why a valve with a short filament is in some respects more desirable.



Not a Radio-Gramophone.

IN spite of the fact that it was definitely stated in the article describing the "Variable-mu Three" that this receiver is unsuitable for use with a gramophone pick-up, readers have asked whether it could not be modified fairly simply for the reproduction of gramophone records. It is sometimes suggested that adequate volume could be obtained by choosing the most sensitive type of pick-up on the market. This, we fear, is quite impossible; no pick-up of which we have any knowledge would give a sufficient voltage output. If one could be devised, its use would probably be disastrous from the point of view of record wear.

The only satisfactory way of modifying the set for this purpose is to employ an L.F. stage, which would call for very considerable alterations.



Tuning Range.

COMPLAINTS are sometimes received to the effect that the tuning range of a receiver (expressed as the difference in metres between the minimum and maximum wavelength to which it may be tuned) is considerably narrower than anticipated, and also less than that shown, for example, in the Tuning Chart Supplement to our issue of October 28th.

Sometimes this restriction of wave range is directly attributable to the use of a tuning condenser with a much smaller maximum capacity than 0.0005 mfd., which is almost universal nowadays, and which was taken into account when the chart in question was prepared. Another

possible cause is excessive residual capacity; one cannot over-emphasise the need for reducing "strays" as much as possible if it is desired to cover a wide range of wavelengths.

Again, the trouble may merely be due to the use of a tuning coil having an unduly small inductance value—in other words, too few turns. The discrepancy in this case is accentuated by the fact that we are dealing with wavelengths, and not estimating in terms of frequency.



Double Oscillation.

A READER states that the single H.F. stage included in his receiver is normally quite stable, but at the lower end of the medium waveband the H.F. valve goes into self-oscillation when reaction is applied between plate and grid circuits of the detector valve. By the use of a milliammeter it has been proved that this takes place before the detector valve itself goes into self-oscillation. As this state of affairs is obviously unsatisfactory, our correspondent asks what inference can be drawn from the result of his experiment.

We think it safe to assume that screening or decoupling of the H.F. tuned circuits are inadequate, or else—but it is unlikely—that the tuned circuits are too "good" for complete stability.

What we expect is happening can best be appreciated by considering Fig. 1, which shows the circuits in question in simplified form. L.C. is the tuned grid circuit of the H.F. valve, while L₁

reached where the H.F. stage becomes unstable. On increasing reaction beyond this point the detector valve itself would naturally go into self-oscillation.

The natural inference is that the H.F. stage is almost on the border-line between stability and instability. The remedy, of course, is to provide more thorough screening and decoupling; possibly some of the high-potential connecting wires might also be screened with advantage.



Our Favourite Subject.

WITH an apology for raising our national topic of conversation—the weather—a correspondent complains that his reception has lately been affected by interference from a high-voltage overhead power line, which passes close to his home. The interference is never very serious, and is only present at times when atmospheric humidity is high. It has been especially prevalent during the recent spell of damp weather.

It is asked whether, in a case like this, directional reception with a frame aerial could be depended upon to provide complete immunity from interference. If this is so, it is intended to assemble a fairly simple three-valve frame aerial set, mainly for reception of the local station, which is about twenty-five miles distant.

Power-line interference of this sort is generally caused by a brush discharge over the insulators, which takes place during damp weather, and our experience goes to show that it can as a rule be eliminated entirely by the suitable use of a frame

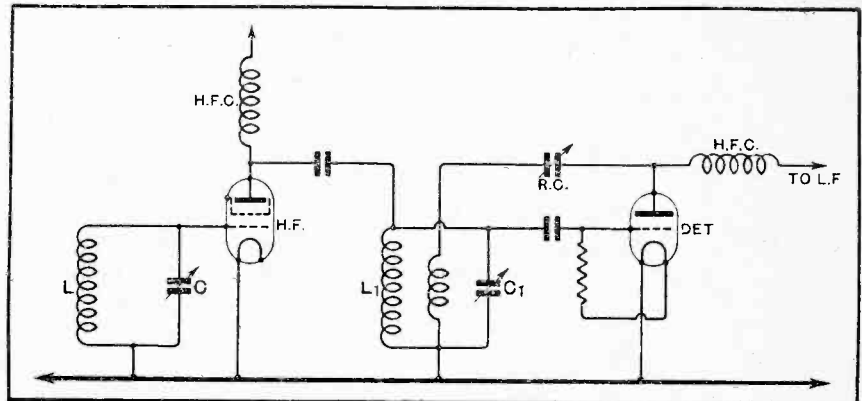

Fig. 1.—The tuned inter-valve circuit of a typical "1-H.F." set is also the grid circuit of the succeeding detector valve; thus, the application of reaction, by reducing the circuit losses, may destroy the stability of the H.F. stage.

C₁, virtually in the anode circuit, is also in grid circuit of the detector valve. Without reaction the working dynamic resistance of these circuits at any point of the tuning scale is not high enough to provoke self-oscillation, but as the damping imposed on L₁, C₁ is progressively removed by applying reaction, a point is

aerial. But it is conceivable that if two of the pylons are roughly equidistant from our correspondent's house it might be impossible to eliminate the interference from both sources, and therefore we suggest it would be worth while to make a test with improvised apparatus before going to the trouble of building a complete receiver.

Maintaining a Balance.

IN order to simplify wave-range switching an aerial-grid coil is often arranged as in Fig. 2 (a). For medium-wave reception the aerial is joined to a tapping point on the smaller coil, generally in such a position that from one-third to a quarter of its total number of turns are included in the open circuit. As no provision is made for changing over this connection to a corresponding position on the long-

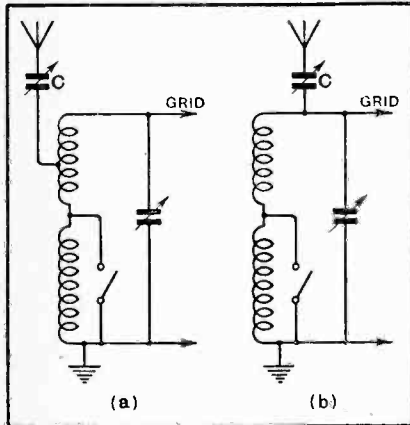

Fig. 2.—Two simple aerial grid circuits compared. In the first (a), the proportions of aerial capacity that are transferred to the tuned circuit are different for each waveband.

wave coil, it follows that, on switching over, a much greater proportion of the aerial capacity is transferred to the tuned circuit.

This is not a matter of any great importance in many sets, but when gauged tuning is employed long-wave efficiency may suffer, particularly if the aerial be long and of high capacity.

This is probably what is happening in the "one-dial" set of a reader, who complains that the long-wave National transmission is heard at two distinct settings of the tuning condenser, unless an appropriate change be made in the capacity of the aerial feed condenser (c in the diagram). It is suggested that this might be avoided by connecting the aerial directly to the high-potential end of the coil (see diagram [b]); if this is done, a series condenser of much smaller capacity than originally should almost invariably be used.



Curbing the Pentode.

EMPHASIS has often been laid on the fact that a pentode cannot be regarded as being interchangeable with a triode output valve unless the appropriate circuit alterations are made. The result of an indiscriminate change is almost always poor quality manifesting itself by a shrill over-emphasis of the higher notes, and, as often as not, there is little apparent increase in sensitivity unless proper precautions are taken.

The problem of matching, which is all important if the full benefits of making a change are to be obtained, has been

dealt with from time to time, and the essentials may be repeated for the benefit of those readers who have brought forward specific questions. Briefly, the scheme most usually advocated is to use a centre-tapped output choke, and to join the loud speaker (in series with a large-feed condenser) between the centre tapping of the choke and earth. The tendency towards over-emphasis of high notes is curbed satisfactorily by shunting the choke with a correcting device consisting of a condenser of about 0.01 mfd. in series with a variable resistance of some 25,000 ohms, which gives some latitude for adjustment.

Certain highly specialised pentode valves may need different values of correcting components.



Valve Data.

MANY valves have been known under the same type letters or numbers for a number of years, but it must not be thought that because their designations are unchanged their characteristics remain the same. In practically every case great improvements have been made, and so the information given in the latest "Wireless World" Valve Data Sheet does not apply to out-of-date specimens.

This point is brought up by a querist, who has an out-of-date valve which was rated by its makers to be operated with a maximum H.T. voltage of 120, and, under amplifying conditions, with a grid bias of $1\frac{1}{2}$ volts: the modern counterpart is rated to work with 150 volts on the anode and a bias of $4\frac{1}{2}$ volts, and it is asked whether the old valve might be operated in this way.

In this particular case the valve would not be damaged by applying the extra H.T. voltage, as anode current would be kept within bounds by excessive negative bias, but distortion and general inefficiency would result from making the change.



Not for General Consumption.

A NUMBER of those who have highly efficient Litz-wound coils, of the type popular some years ago, are apparently attracted by the idea of using these windings in a band-pass filter, and have asked for advice on the subject.

Although it cannot be denied that there are certain advantages to be gained by using this type of coil in a filter circuit, it should be emphasised that the practical difficulties in the way of such a course are considerable.

Inter-circuit screening and gauged tuning are the main troubles. If the efficiency of the windings is not to be impaired unduly, large-sized screening boxes are essential, and, due to the low H.F. resistance of the windings, tuning of the component circuits has to be much more accurate than when small coils of the type most popular nowadays are employed.

The first difficulty can obviously be overcome by sacrificing compactness, but extreme care and the very best type of gauged condenser are necessary in setting up a satisfactory single-knob tuning system, which, of course, is virtually essential for a filter of any type.

Settling Down.

USERS of superheterodyne receivers have noticed that after a few minutes' working—sometimes even after a longer period—it becomes necessary to make a minute change in the setting of the oscillator tuning condenser in order to maintain maximum signal strength. This effect is particularly marked in sets employing A.C. valves, and is due entirely to a slight change in oscillator frequency brought about by small alterations in the valve characteristics which take place as it warms up. It is not unusual to find that a valve of this type does not settle down finally to stable working conditions for some time, and it is worth while trying the effect of a readjustment after the set has been tuned to the same transmission for a quarter of an hour or so.

FOREIGN BROADCAST GUIDE.

KALUNDBORG (Denmark).

Geographical position: 55° 40' 18" N.; 11° 04' 20" E.

Approximate airline from London: 554 miles.

Wavelength: 1153.8 m. Frequency: 260 kcs. Power: 7.5 kW.

Standard time: Central European (coincides with B.S.T.).

Standard Daily Transmissions.

06.30 G.M.T., physical exercises (07.30 Sun.); 07.30, sacred service (09.00, Sun.); 11.00, chimes and time signal; 12.00 foreign languages (Sun.); 13.00, gramophone records; 15.30, concert; 16.00, sacred service (Sun.); 19.00, chimes, time signal and concert; 22.00, dance music (Sun., Mon., Thurs., Fri., Sat.); 23.00, chimes and time signal from Town Hall, Copenhagen.

Announcers: Man and woman, the latter only during afternoon hours.

Announcements are made in Danish only except when foreign conductors or artists contribute to programme or when the broadcast is of international interest. On these occasions other foreign languages are also used.

Call: *Kobenhavn-Kalundborg og Danmarks Korbølgesender.*

Interval signal; musical box melody as under:



End of transmission is frequently marked by one stroke on a gong.

Closes down with the words: *Hermed er programmet slut for iaften* (herewith we close our to-day's programme). *Vi meddeler dem programmet for imorgen* (we give you to-morrow's programme). On some evenings the Danish National Anthem (*Der er et yndigt Land*) is played.

Relays: Copenhagen, 281 m. (1,067 kcs) 1 kW; Skamlebaek (OXY), 31.51 m.; (9,520 kcs), 0.5 kW.

The Wireless World

4^D

AND RADIO REVIEW

The Paper for Every Wireless Amateur

Wednesday, December 30th, 1931.

THE NEW
COLVERDYNE
PRICE 12/6

Band Pass Intermediate
Frequency Transformer
for Super Heterodynes.

Write for Colvern Booklet and
Leaflet No. 9.

**COLVERN
LIMITED**

Advt. Colvern Limited, Mawneys Road, Romford.

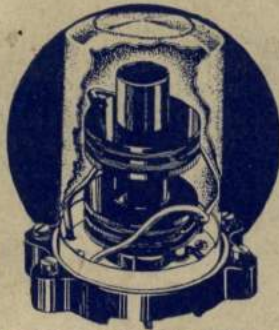

Make this New Year Resolution now — that in 1932 you will scrap batteries and enjoy trouble-free radio by using an Ekco Power Unit

Start the New Year well

Start the New Year well by writing to E. K. Cole, Ltd., Dept. W., Ekco Works, Southend-on-Sea.

EKCO
ALL-ELECTRIC RADIO

When you see this symbol

IT MEANS

Utility

WILKINS & WRIGHT, LIMITED
Utility Works, Holyhead Rd., BIRMINGHAM

Use a

T.C.C.
ALL-BRITISH
CONDENSER

Here is an upright type Mica Condenser with Grid Leak clips. Made in capacities from .00005 to .25 mfd. Prices from 1/6 to 18/-.

Telegraph Condenser Co., Ltd., Wales Farm Road., N. Acton, London, W.3.

9606



Build your eliminator with a *metal* rectifier

Ever since Metal Rectifiers for home-constructors' use were first introduced, they have increased steadily in popularity; and there are many reasons for this.

They are remarkably easy to use—the circuits* are simpler than for any other kind. A less expensive transformer may be used with the metal rectifiers than that required for other types. And—most important—they are very economical, as they do not burn out or deteriorate (rigorous tests made in this connection with units which have been in continuous service for over five years reveal no falling-off in output).

*"The All Metal Way" contains a great deal of information concerning the operation of radio sets from A.C. mains. It gives full details of how to use the various types of Westinghouse Metal Rectifiers, together with tested circuits. The booklet will be sent to you if you forward the coupon with threepence in stamps.

WESTINGHOUSE **METAL RECTIFIERS**

THE WESTINGHOUSE BRAKE & SAXBY SIGNAL CO., LTD.,
YORK ROAD, KING'S CROSS, LONDON, N.1. Phone: NORTH 2415

WESTINGHOUSE PUBLICITY, 82, York Road, King's Cross, London, N.1. Please send me your booklet, "The All Metal Way," for which I enclose 3d. in stamps.

PLEASE WRITE IN BLOCK LETTERS.

NAME

ADDRESS

W.W.30.12.31.

Mention of "The Wireless World," when writing to advertisers, will ensure prompt attention.

MAGNAVOX

CONSTRUCTIONAL TALKS — No. 3

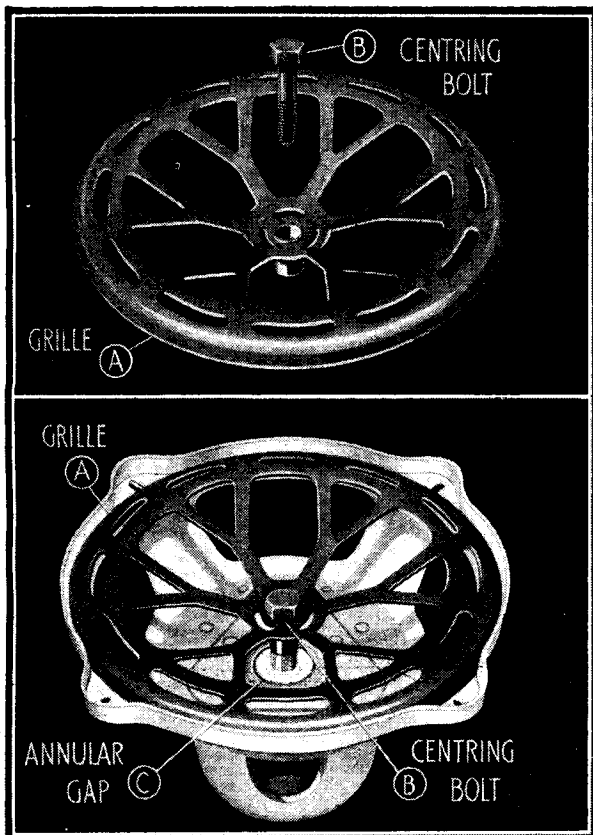

MAGNAVOX British Made Moving Coil Loud Speakers have been chosen as the result of exhaustive tests to form part of the standard equipment of the most important Receivers and Constructors' Kits in the country.

THE GRILLE

The Grille of the Magnavox Moving Coil Loud Speaker plays a part of considerable importance.

It consists (see A) of a heavy gauge steel pressing so designed as to possess great rigidity and strength. It has three distinct functions. First it serves to protect the cone from damage, secondly it grips the cone evenly throughout its entire periphery, and thirdly it serves, by means of the Centring Bolt (B), to clamp the complete assembly of magnet system and cone housing together. This highly important feature enables the cone of the Magnavox Speaker to be assembled in such a manner that the moving coil former is strictly concentric with the annular gap in the magnet system (C). Once the former has been so set, the centring bolt is keyed up and the cone will preserve its true alignment indefinitely.

It should be noted that the mathematical accuracy both of the grille and of the cone housing ensure the cone's being gripped tightly all round the edge, while the sturdiness of both these members forms an adequate safeguard against any distortion. A true piston movement devoid of any appreciable lateral play is thus imparted to the coil and there results that distortionless reproduction for which the Magnavox Speaker is so notable.

Each model of Magnavox Speaker is supplied in two types. Type "H" for voltages of 190 to 250 and type "L" for voltages of 110 to 190.

D.C.140 (7" cone) Model "H" £2-12-6.

D.C.142 (8 $\frac{3}{4}$ " cone) Model "H" £2-17-6.

D.C.143 (10 $\frac{3}{4}$ " cone) Model "H" £3- 2-6.

Model "L" £2-10-0.

Model "L" £2-15-0.

Model "L" £3- 0-0.

Universal tapped transformer matching either triode or pentode valve included.

Write for full literature.

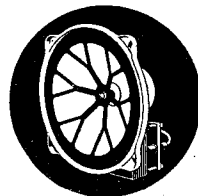

MAGNAVOX

MAGNAVOX (GREAT BRITAIN) LTD., 89, KINGSWAY, LONDON, W.C.2.

FOURTH EDITION

HANDBOOK OF TECHNICAL INSTRUCTION for Wireless Telegraphists

By H. M. DOWSETT, M.I.E.E., F.Inst.P., M.Inst.R.E.,

Author of "Wireless Telegraphy and Telephony," etc.

THIS work constitutes a complete text-book for the use of wireless telegraphists and others interested in the subject. In addition to dealing fully with general theory, the book describes in detail the various types of marine wireless equipment, and gives also much practical information on maintenance. The subject matter of this new edition has been entirely recast and the scope of the book has been widened to meet the more exacting requirements of the operator's duties of to-day. Twenty-six Spark and Valve Transmitters are described, and thirty-three Receivers and Direction Finders. There are more than 450 diagrams and illustrations.

A leaflet giving full particulars of the volume and a synopsis of chapters will be sent on request.

This volume provides a complete theoretical course for the P.M.G. certificate.

Price 25/- net. By post 25/9

From all leading Booksellers or direct from the Publishers

ILIFFE & SONS LTD., DORSET HOUSE, TUDOR STREET, LONDON, E.C.4

w.w.96

THE ELEMENTARY PRINCIPLES OF WIRELESS TELEGRAPHY AND TELEPHONY

By R. D. BANGAY.

Third Edition. Revised by O. F. BROWN, B.Sc.

FOR many years this volume has been the standard book of instruction for wireless beginners and students. The progress of wireless during recent years has made necessary the New Edition, which covers the whole subject in a clear and simple style and deals thoroughly with modern developments. Attention is given to the theoretical elements of electricity and magnetism, the dynamo and the properties of waves.

Many new chapters have been added and descriptions of modern circuits have also been included.

A leaflet giving full particulars of the volume and a synopsis of chapters will be sent on request.

**THIRD
EDITION**

Price 10/6 net. By post 11/-

From all leading Booksellers or direct from the Publishers:

ILIFFE & SONS LTD., DORSET HOUSE, TUDOR STREET, LONDON, E.C.4.

w.w.97

QUALITY WINS!

Amazing Tributes to the NEW F.I. M.C. Loud Speaker Unit

Nothing but unstinted praise from all parts of the country —

CALL FOR DEMONSTRATION
60, Paddington Street, W.1.

"Nothing approaches it."
"Streets ahead of anything we have ever heard."
"You should call your new unit 'The Wizard'—it's simply marvellous."
"I systematically buy every speaker that comes along—but I have never heard anything like your L.S. 4 unit."

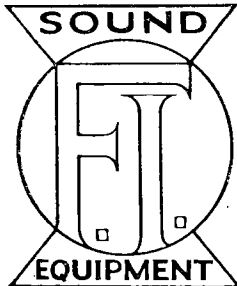
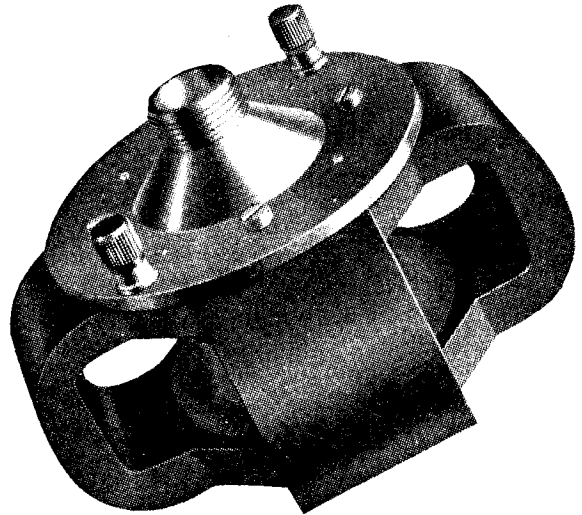

TEST IT YOURSELF

Prove to your own satisfaction that the F.I. Moving Coil Unit is all that we claim it to be. Fill in this coupon—enclose your remittance and we will send you an F.I. Unit. You may give this Unit a thorough test under your own condition of working for 7 days. Test it against any speaker—on radio—on gramo' or how you will. If you are not satisfied your money returned in full.

ABOVE IS THE DOMESTIC UNIT L.S. 4
A larger unit, the L.S. 5, is also available for Public Address and Cinema use.
Price - - £15 15 0. **£5-5**



To **FILM INDUSTRIES, Ltd.** 60, Paddington Street, W.1

Dear Sirs—Please send me one of your L.S.4 (Domestic) Unit Loudspeakers at £5. 5 0, for which I enclose remittance. This purchase is made subject to your 7 days' trial offer.

Name.....

Address.....

W.W. 30-12-31.....

FILM INDUSTRIES LTD

LONDON

IF YOU'RE BUILDING AN ELIMINATOR!

Freedom from breakdown is the main feature of Dubilier Condensers. They are manufactured by the most up-to-date methods and the quality of the materials, together with the strict attention paid to every detail, ensures absolute reliability. Dubilier Condenser Blocks are available in various capacities and working voltages, and we shall be pleased to send you particulars of these on request.

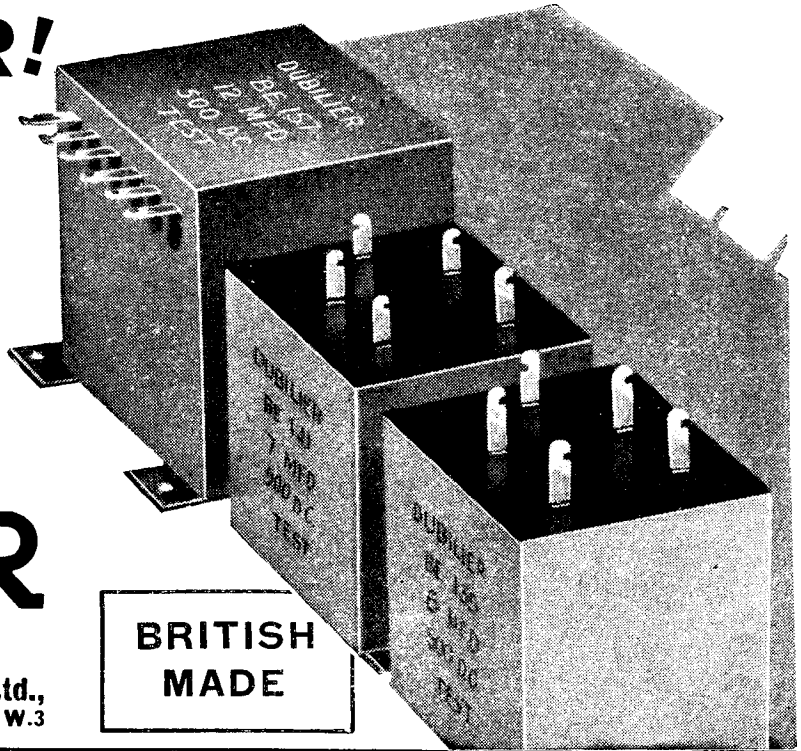

BRITISH MADE

BUILD WITH DUBILIER PAPER CONDENSERS

Dubilier Condenser Co. (1925) Ltd.,
Ducon Works, Victoria Rd., N. Acton, London, W.3

Seven-point suspension

Mica Bridge Mounting

both these advanced constructional features are incorporated in this
Cossor 2 volt special Detector Valve

SPECIALLY designed for use as a Detector the Cossor 210 DET incorporates all the most advanced constructional features. By the use of Seven-point suspension and Mica Bridge Mounting complete freedom from microphonic noises is obtained (a feature of special interest to users of portable sets). Due to its grid current characteristic distortionless rectification is ensured.

The use of this Cossor special Detector valve for either leaky grid or anode bend rectification will ensure complete elimination of microphonic noises and a marked improvement in tone.

A new edition of the Cossor Station Chart is now available, price 2d. Ask your Dealer for a copy of this useful novelty, or write us enclosing 2d. stamp.

Send for a copy of the 72 page Cossor Wireless Book—free on application to A. C. Cossor Ltd., Melody Dept., Highbury Grove, London N.5.

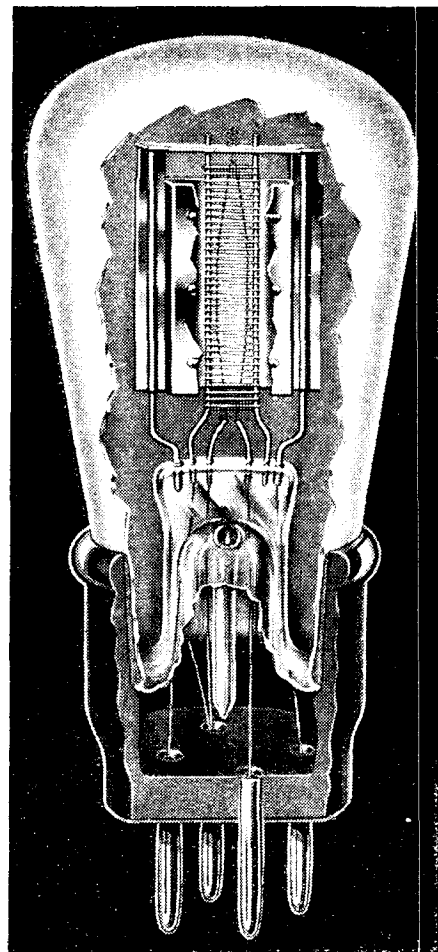

The Cossor 210 DET. 2 volts, .1 emp.
Impedance 13,000. Amplification
Factor 15. Mutual Conductance
1.15 ma./v. Normal working
Anode Voltage 90-150. Price **8/6**

THE
COSSOR
BRITISH MADE
210 DET

DEFINITELY FREE FROM MICROPHONIC NOISES

A. C. COSSOR, LTD., Highbury Grove, London N. 5. Depots at Birmingham, Bristol, Glasgow, Leeds, Liverpool, Manchester, Newcastle, Sheffield & Dublin. ♥

Mention of "The Wireless World," when writing to advertisers, will ensure prompt attention.

The Wireless World

AND
RADIO REVIEW
(19th Year of Publication)

No. 644.

WEDNESDAY, DECEMBER 30TH, 1931.

VOL. XXIX. No 27.

Editor: HUGH S. POCOCK.

Editorial Offices: 116-117, FLEET STREET, LONDON, E.C.4.

Editorial Telephone: City 9472 (5 lines).

Advertising and Publishing Offices: DORSET HOUSE, TUDOR STREET, LONDON, E.C.4.

Telephone: City 2846 (15 lines).

Telegrams: "Ethaworld, Fleet, London."

COVENTRY: Hertford St. BIRMINGHAM: Guildhall Bldgs., Navigation St.

MANCHESTER: 260, Deansgate. GLASGOW: 26B, Renfield Street, C.2.

Telegrams: "Cyclot, Coventry."
Telephone: 5210 Coventry.

Telegrams: "Autopress, Birmingham."
Telephone: 2970 Midland (3 lines)

Telegrams: "Iliffe, Manchester."
Telephone: 8970 City (4 lines).

Telegrams: "Iliffe, Glasgow."
Telephone: Central 4557.

PUBLISHED WEEKLY.

ENTERED AS SECOND CLASS MATTER AT NEW YORK, N.Y.

Subscription Rates: Home, £1 1s. 8d.; Canada, £1 1s. 8d.; other countries abroad, £1 3s. 10d. per annum.

As many of the circuits and apparatus described in these pages are covered by patents, readers are advised, before making use of them, to satisfy themselves that they would not be infringing patents.

Editorial Comment.

A New Information Bureau.

WE are pleased to be able to announce that a new Information Bureau has been established by *The Wireless World*, which undertakes to deal through the post, by letter, with readers' individual technical enquiries.

Until comparatively recently the paper has endeavoured to give a free service of replies through the post, but the constantly increasing demand upon the time of the technical staff to deal with the correspondence received necessitated the curtailment, and, finally, the suspension, of this service. So many enquiries have, however, been received, urging us to reconsider this decision and to reinstate a service on payment, that we have decided to endeavour to meet the wishes of our readers in this way.

The Information Bureau will remain under the control of the Editor, and all enquiries should be addressed to *The Wireless World* Information Bureau, Dorset House, Tudor Street, E.C.4, and accompanied by a fee. Rules and conditions of the service offered are included elsewhere in this issue. It is hoped that the arrangements which we have made will enable us to deal promptly with all enquiries, but readers are reminded that the efficiency of the service, and our ability to handle enquiries with despatch, will largely depend upon the manner in which the problems are presented; conciseness of wording and legibility of writing are, therefore, most important.

It is necessary to point out that in no circumstances can personal interviews be given regarding technical enquiries to callers at the offices of *The Wireless World*, nor can the Information Bureau undertake to deal with enquiries over the telephone. All communications must be by letter.

Those who do not wish to pay a fee are still invited to send in enquiries to the Information Bureau, to be considered as suitable matters to deal with in the Readers' Problems pages of *The Wireless World* week by week, or to form the subject of special articles when of sufficient importance.

Post Office Relay Proposals.

THE Post Office are reported to be actively engaged in the consideration of a scheme whereby subscribers will be able to obtain a choice of wireless programmes through the medium of the Post Office telephone. The proposal is, we understand, that the subscriber should be supplied with a loud speaker to connect to his existing telephone line, and that he should be able to call up or dial for a number which would connect him to one of a number of super wireless receiving stations to be set up by the Post Office, each individual station being permanently tuned for reception of some British or Continental transmitter.

It is interesting to find the Post Office pioneering so up-to-date a scheme calculated to enhance the value of the telephone to the public. We do not desire to be pessimistic in regard to the proposals, but at the same time we cannot help feeling that the Post Office has yet a very long way to go in improving the telephone service itself and eradicating line interference and interruptions before a broadcast programme conveyed to us under the same conditions can be attractive, or even tolerable. The scheme, in theory, will work, and the general idea has long been known, but we cannot imagine that, with the present state of imperfections of the telephone service, a relay broadcasting scheme can seriously be contemplated at any early date as an additional burden to the system.



BACKGROUND NOISES

Causes and Alleviation.

By

W. T.
COCKING.

AT the present time background noise is one of the greatest problems which confronts the set designer. It is obviously desirable that high-quality reproduction of speech and music should be unaccompanied by a background of hiss and scratching noises, but, unfortunately, this can only be relied upon in the case of the local station. Even then background noise is not entirely absent; it is so small in comparison with the signal, however, that it is usually unnoticeable.

It can be stated quite definitely that there is no known way of eliminating background noise, and all that we can hope to do is to keep it small in comparison with the desired signal. Much can be done on these lines, and we shall be well repaid by an investigation into the causes of this undesirable accompaniment to signals.

The Ratio of Noise to Signal.

In the first place, a certain amount of noise is present in the signal itself. Microphones, microphone amplifiers, land lines, and the transmitter circuits all introduce a certain amount of noise which modulates the carrier and gives rise to an audible hiss in the speaker. That this hiss is not objectionable, however, is borne out by listening to the local station with a suitable receiver; the hiss can only be heard during intervals in the programme, and even then a quiet room is necessary for it to become apparent. It is fortunate, therefore, that we can neglect it, for it is not within our control.

A greater amount of background noise is usually evident with foreign station reception, however, and this is due partly to atmospheric conditions. This source of background noise can be very serious indeed, and it is unfortunate that nothing can be done at the receiver to eliminate it. In fact, the only remedy is an increase in the power of the transmitting station; because of the general increase in station power recently, therefore, atmospheric noises are now less apparent than they were some time ago. They are readily recognisable, for

they are of the crackling and scratching variety, and, moreover, their intensity usually varies from day to day, and they are more prevalent in summer than in winter.

Valve Noises.

It is chiefly the noises introduced by the receiver itself with which we are concerned, however, for these are to some extent under the control of the set designer. There are two main sources of noise—the valves and the circuits. It is fairly generally understood that a valve can introduce noise, and, provided that the valve is in good condition, the amount of noise which it introduces is largely governed by its cathode design and operating potentials. It has been shown¹ that it is desirable for the cathode to emit more electrons than are necessary to maintain the anode current flow, so that a certain space charge is formed around the cathode. This has the effect of minimising the anode current fluctuations which cause the background noise.

Here, we are largely in the hands of the valve manufacturer, but we can obtain some measure of control by our choice of operating conditions. In general, the maximum rated value of heater potential should be applied, and the screen-grid voltage should be kept as low as possible consistent with good results, for these factors tend to keep the space charge at a maximum.

Grid emission is a prolific source of background noise; it need not concern us here, however, for it is a definite sign of a faulty valve. There should be no trace of grid emission with a good modern valve. Rectification in H.F. valves increases background noise, since it permits the noise potentials to modulate the carrier of the incoming signal. In this respect, therefore, variable-mu tetrodes are a great improvement on older types of screen-grid valves, and tests have shown that the reduction of background noise is one of the most striking characteristics of these new valves.

We now come to circuit noise, and by this we are not referring to the noise caused by faulty connections,

If we cannot eliminate all extraneous sounds under modern reception conditions, it is still possible, as this article shows, to cut down some of the disturbance by careful attention to circuit design.

¹ "Noise Generation within Radio Receivers," by Rinaldo de Cola. *Radio Engineering*, August, 1931.

Background Noises.—

but to that due to thermal agitation in the wires themselves. This type of noise has only recently become evident, and, of course, is only noticeable in very sensitive receivers. It is improbable that it would cause any trouble in receivers of the two H.F. class, but it may prove serious in sensitive superheterodyne sets.

There is little, if anything, which can be done to reduce this noise. We are not directly concerned with the amount of noise, however, but with the ratio of noise to signal strength, and so we can make the effective noise as small as we like by increasing signal strength. We cannot do this by amplification, however, for the noise is introduced chiefly by the tuned circuit preceding the first valve in the set. Either the power of the station must be increased, therefore, or we must arrange the circuit so that the signal impresses as great a voltage as possible on the grid of the first valve. The former is again not within our control, and so we have to use as efficient an aerial as possible, together with an efficient circuit for coupling it to the first valve.

Now, to obtain an efficient transfer of energy between the aerial and valve means that we shall have to employ a single-tuned circuit with a low-resistance coil, as shown at L_1L_2 in Fig. 1. It is possible with such circuits to obtain a step-up between the aerial and valve grid of some thirty-forty times, but a large-diameter Litz-wound coil is then required, and this is inconvenient. A more usual figure with the type of coil now commonly used is a step-up of about fifteen-twenty times.

In most modern receivers, however, it is customary to employ a band-pass filter for the coupling between the aerial and the first valve (L_1 and L_2), as shown in Fig. 2. The step-up between the aerial and first valve will now be much less, and usual figures are between five and ten. In other words, background noise due to thermal agitation in the wire will be from two to four times as great in a set with band-pass input as it is in a receiver with a single-circuit aerial tuning system.

There is another point to be considered, however, for an efficient aerial circuit means that less amplification will be required for the same results. Not only is noise due to thermal agitation reduced, therefore, but also noise introduced by the valves, and so there is an all-round gain in using an efficient aerial circuit.

Practical Cases.

In the majority of straight H.F. sets receiver noises are unimportant, largely because the selectivity is not high enough for the full amplification to be used under ordinary circumstances. It is with the superheterodyne that background noises are usually felt, and they are blamed upon the type of receiver, whereas the true reason is that such receivers are usually very much more sensitive than straight sets, and the selectivity is high enough to allow of full use being made of the sensitivity. It is true that the super-

heterodyne has one additional source of noise, namely, the oscillator valve, but this need cause no trouble provided that the amount of intermediate-frequency amplification is not excessively high.

It is largely for these reasons that the use of a frame aerial, or a small indoor aerial, is definitely detrimental to good long-distance results with any receiver. Such aerials are so inefficient that a large amount of amplification has to be employed; as just explained, this means that the ratio of valve noise to signal is increased, and that the ratio of circuit noise to signal is also increased, the net result being a very noisy background to reception.

To obtain a minimum of background noise with a superheterodyne, therefore, we should arrange for the screen-grid voltages to be as low as possible consistent with good results, and we should arrange for as efficient a transfer as possible of the energy in the aerial to the first valve. We cannot normally omit the input band-pass filter, however, for in most cases it is found that this results in making the receiver unusable on account of second-channel interference.

We must content ourselves, therefore, with making the filter as efficient as possible, and in this connection it is well to point out that the ganging is important. A poorly ganged filter does not usually make much difference to the station-getting properties of a superheterodyne, since this type of set is so sensitive, but it may greatly reduce the input to the first valve, and so lead to increased background noise.

In a well-designed receiver all these factors are taken into account, and, except for the accuracy of ganging, do not affect the user. The designer's calculations are

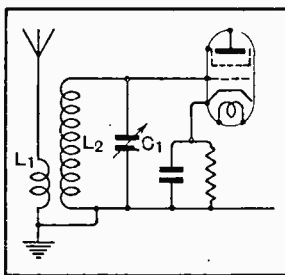

Fig. 1.—A method of increasing the ratio of signal strength to noise by ensuring an efficient transfer of energy between aerial and valve.

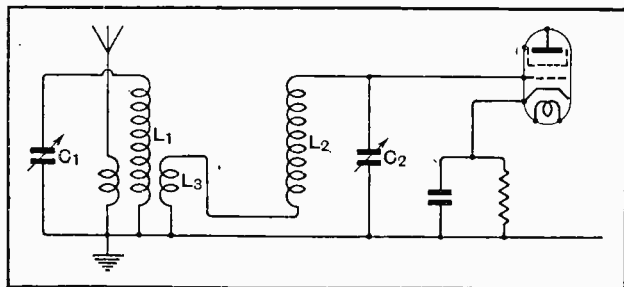

Fig. 2.—With band-pass tuning the circuit noises due to thermal agitation in conductors is likely to be greater than in single circuit aerial tuning systems.

upset, however, if a faulty valve be employed. It is unfortunate that most faulty valves do not prevent the receiver from functioning, but usually increase the background noise enormously. Such valves normally suffer from grid emission or poor insulation between heater and cathode, and the earlier their position in the set the worse is their effect upon the results. The first detector is the usual offender, and specimens should be chosen rather for their quietness in operation than for their efficiency. Poor connections in the early stages of the set can also cause a considerable amount of hiss.

COMMERCIAL WIRELESS



A
Record
of the
Year's
Progress

By LT.-COL. CHETWODE CRAWLEY, M.I.E.E.

THE spectacular development which demands first place in any summary of the advances made in 1931 has not yet entered the field of commercial communication.

This development is the use of very short waves for telephonic communication. During 1930 experiments had been in progress in various countries, but it was not till March, 1931, that the first public demonstration was staged by the International Telephone and Telegraph Laboratories, Incorporated, of Hendon, in co-operation with the laboratories of Le Matériel Téléphonique, of Paris. At this demonstration, which was described in *The Wireless World* at the time, good telephone communication was carried on across the Channel, between St. Margaret's Bay and Cap Gris Nez, on a wave of 18 cms., using reflectors, a power of only half a watt, and aerials of less than an inch long.

During the last few months, too, Marchese Marconi, as recently reported in this journal, has given several demonstrations in Italy of a similar nature, using waves of between half a metre and ten metres. The broadcasting authorities in various countries have also been experimenting with these very short waves.

The Matériel Téléphonique, of Paris, has also given some interesting demonstrations of short-wave telephony on a single side band system. Such a system has well-known advantages, and has been in use on the long-wave transatlantic circuit for several years, but it was only during this last year that it was shown to be applicable to short-wave working, where the technical difficulties are much more serious.

"Rugby Radio"—famous throughout the seven seas—is operated from this desk at the Central Telegraph Office, London.

Secret Telephony.

LONG-range telephony on short waves has continued to advance rapidly. At the beginning of the year the president of the Institution of Electrical Engineers, at his home in Hertfordshire, gave a lantern lecture to the Engineering Institute of Canada in Montreal.

In July, a commercial service was opened by the Post Office between this country and New Zealand, at a minimum charge of £6 15s. for three minutes' conversation. New Zealand has not yet erected a station powerful enough for direct communication, so that calls are set up by connecting, at Sydney, the wireless telephone circuit between Great Britain and Australia, and that between Australia and New Zealand. Later on, no doubt, the service will be extended to America.

The transatlantic circuit is now fitted with secrecy devices, so that the messages, if intercepted, are quite unintelligible. It has been extended to various places at both ends, the latest European extension being made to Roumania in November.

Several new services, including those between England and Brazil, and between Australia and Argentina, have been inaugurated during the year. South Africa, Canada, and India are yet to come.

Though the telephone service with Atlantic liners on waves round about 23 and 70 metres, being to a great extent a luxury service, has naturally suffered much from the financial depression, it has been made available to many new places. In November it was ex-

Commercial Wireless.—

tended to Australia, and the first conversation took place *via* England by wireless, between the editor of a newspaper in Sydney and a passenger in the "Olympic," which was in mid-Atlantic on passage to England.

The fitting of wireless telephony on longer waves, between 150 and 200 metres, in fishing vessels and other small craft, has made considerable progress. The great advantage of this form of communication is that with specially designed simple sets the expense of carrying a trained wireless operator in the ships can be avoided. This ship-and-shore telephone service for small ships can hardly yet be considered as having made a start commercially, but inter-ship telephony between fishing vessels has in fact made a real commercial start this year, though it is many years since the Marconi Company, who were the pioneers in this business, began to fit whalers with wireless telephony.

New Radio Telegraphy Services.

PPOINT-TO-POINT wireless telegraph services over great distances have gone on expanding during the year, but not nearly so rapidly as would have been the case if financial conditions had been favourable. The service with Kenya was transferred from the Post Office to Imperial and International Communications, Ltd., in July, and some important new services have been opened throughout the world, such as those between the U.S.A. and Austria, the U.S.A. and China, and between Argentina, Holland, and Belgium.

Progress in ships' telegraphy has been directed largely towards the improvement of short-wave sets. The number of British ships so fitted has increased during the year from about sixty to ninety, the number fitted throughout the world being now well over 300.

The long-wave sets, and the ordinary spark and I.C.W. sets, call nowadays for little improvement except in detail, but a good deal of work has been done during the year in improving the ease of working of D.F. installations, which will become part of the compulsory equipment of ships of 5,000 tons and over under the

new Safety Convention, which, it is expected, will shortly be embodied in an Act of Parliament. About 150 new D.F. installations have been fitted in British ships, bringing the total to about 1,300 out of 3,700 British ships fitted with wireless installations.

As regards ships' services, a new one, called the ship

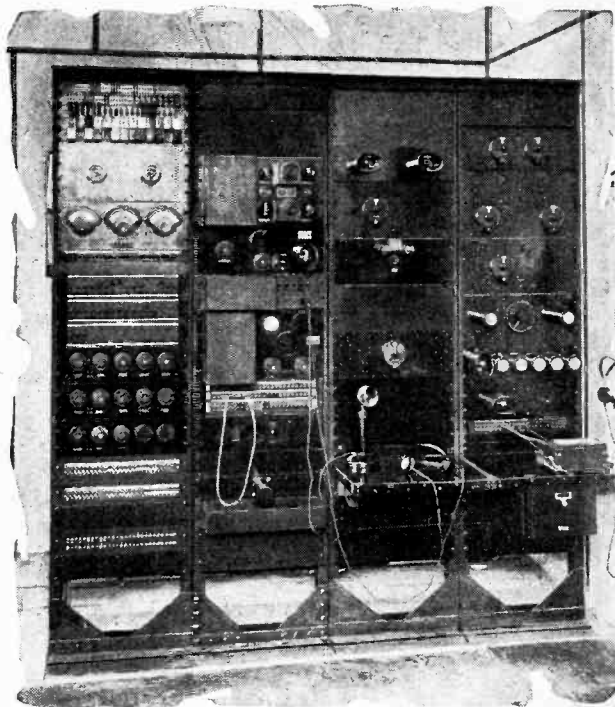

Much of the reception side of Post Office radio is carried out at Baldock. Here is a typical receiver used in ship-to-shore telephony.

letter telegram service, was opened in June in this country. The service is available from the ship to the shore only, at an inclusive charge of 3d. a word (as against the usual full-rate telegraphic charge of 11d. a word), with a minimum of 6s. 3d. for twenty-five words. In this service the messages are forwarded from the wireless station to the addressees by letter post instead of by telegraph as in the case of the normal wireless services with ships.

A number of new all-round wireless beacons for the use of ships have been fitted round our coasts during the year, but the rotating beacon at Orfordness still remains unique in this country. The talking beacon of the Clyde Lighthouse Trustees at Little Cumbrae was brought into action in January, and has been giving useful service. In this beacon, miles of cables are counted out by a broadcasting wireless trans-



No fewer than eight Marconi beam transmitters are housed in this hall, from which direct communication is maintained with U.S.A., South America, Egypt, Japan and the Far East.

Commercial Wireless.—

mitter automatically from a gramophone record, and the distance which the ship hears by wireless at the moment when she hears the end of the third blast of the sound fog signal is her distance from the beacon. The beacon, which uses 40 watts and works up to five miles, is used in foggy weather when the fog sound signal is in operation, and is the first of its kind in the world.

A very interesting sideline in wireless apparatus for ships, called the Echometer, has been fitted by the Marconi Company in many ships during the year. It is the latest type of depth sounding device, and is held to be a great improvement on former similar systems, especially for use in small ships, as the only source of power required is a four-volt accumulator, no motor or other running machinery being necessary, as in other types. The waves transmitted through the water by the projector at the bottom of the ship are of supersonic frequency. The projector is a quartz crystal between two steel plates. The vibrations of the outer plate impart through the water a wave motion which is

reflected back from the sea bottom, as in other systems. The apparatus can be used simultaneously with the D.F. set, and its silent operation makes it very suitable, too, for the larger types of passenger ships.

Wireless communication with aircraft on the Continent has at last entered the commercial field during the year. German, Czecho-Slovakian, and Austrian aircraft can now send commercial traffic through their airport stations at a charge of 1 Reichmark a word, and French aircraft can send or receive commercial traffic to or from French aeronautical stations at 4.25 francs a word. Commercial services of this sort are not provided in England.

Great advances have been made in the use of wireless signalling for service work with aircraft, not only for communication purposes but for guiding them on their routes, and at the moment a new form of wireless automatic guide is being installed at Croydon which should be of great assistance to aircraft when approaching or leaving the aerodrome.

THE FIRST VARIABLE-MU VALVE FOR BATTERY SETS.

**A New Cossor Screen-grid
Amplifier—the 220 VSG.**

HITHERTO, only those possessing A.C. lighting mains have been able to enjoy the many advantages of the variable-mu screen-grid valve. For those who are less fortunate and have to rely on battery-driven sets, there is now available a two-volt model manufactured by Cossor and styled the 220 VSG.

The construction of the grid is such that the application of a comparatively small negative grid potential will reduce the volume of local signals adequately, and the bias battery required for the output valve, which can be pressed into service for the dual function of biasing both output and H.F. valves, will probably have sufficient voltage. With two H.F. stages 12 volts bias are required, and for one stage 9 volts



The new Cossor battery variable-mu S.G. valve—the 220 VSG. Note the letter E marked against the filament pin which is connected to the metal coating.

are ample. It is quite a simple matter to add another bias battery in series with the original if a higher voltage is required.

A convenient volume control consists of a 50,000-ohm potentiometer connected across the bias battery or batteries, the slider being taken to the grid return circuit of the 220 VSG and also connected to earth via a 2-mfd. condenser.

The characteristic curve of the valve does not follow an exponential law, as it has been found that the control of volume is smoother when a curve following a somewhat complicated law is employed. The maximum anode voltage is 150 and the best screen voltage 60—the latter being obtained either from a tapping on the battery or from a potential divider connected across the source of H.T. supply.

For a battery valve the mutual conductance of 1.6 is extremely high, and the interelectrode capacity very low allowing a stage gain of nearly 100 with the diminutive screened coils now in vogue. The general characteristics of the 220 VSG are set out below under the same heading as those of *The Wireless World* Valve Data Sheet of December 2nd. The valve is an important addition to the range of H.F. amplifiers, making it now possible to design a single pre-H.F. volume control for the battery set which is distortionless, will not affect ganging, but which reduces valve amplification as the volume is decreased.

Type.	Filament.		Max. Anode Voltage.	Optimum Screen Voltage.	Average Anode Current (mA).†	Amplification Factor.	A.C. Resistance (Ohms).	Mutual Conductance.	Anode Grid Capacity (μF.).	Price.
	Volts.	Amps.								
Cossor 220 VSG.	2.0	0.2	150	60	5.0	180	110,000	1.6	0.001	20/-

†At 150 volts anode, 60 volts screen, and zero volts negative grid bias.

Unbiased — *by* "FREE GRID" —

Taking Its Temperature.

A FRIEND who has recently acquired an all-mains receiver buttonholed me the other day as I was leaving Savoy Hill, and poured forth a tale of woe concerning his receiver. It appeared that the performance was all that could be desired, but he was worried by the fact that the interior of the receiver became excessively hot, and he asked me what was the normal temperature for the particular mains set he mentioned. Frankly, I didn't know, but, naturally, was not such a fool as to lower my prestige in his eyes by admitting this, and so, pleading a pressing engagement, I hurriedly entered my car and was driven off.

Now it so happened that Mrs. Free Grid had recently presented me with a commercial all-mains set in fulfillment of a threat which she made to me last winter. I am, as a matter of fact, not allowed to interfere with this receiver, and seldom do so. Upon arriving home, however, I managed to find an opportunity of thrusting the bath thermometer into the innards of the set when she was not looking.

After a reasonable interval I withdrew it, and found that it read 116 degrees Fahrenheit, the room temperature being 58 degrees Fahrenheit



Not forgetting the pulse.

at the time. I found that it was not possible to press the hand firmly on the lid of the set without considerable discomfort. The makers of this particular set appear to make no provision for ventilation whatever, but I must admit that this does

not appear to affect its performance in any way.

I should be extremely interested if owners of mains-driven sets would take the temperature inside their instruments and let me know the results. If the space inside the set is very restricted, I suggest that a small thermometer of the type sold by photographic dealers be used.

Later I held the bulb of the instrument in contact with the glass envelope of the power rectifying valve, and the thermometer, which was only scaled up to 135 degrees, promptly burst, with the result that, owing to the absence of this useful household appliance, the smallest of the grid leaks nearly came to an untimely end by being scalded that night in his bath.

On the Spot.

IN my daily postbag there is usually a plentiful supply of bricks and bouquets—more of the former than of the latter, I fear—mixed up with enquiries on almost every subject under the sun, but occasionally I get an utterly incomprehensible letter. I have just received one of this latter type, and it is such a strange missive that I am publishing it herewith.

"Dear Free Grid,—I wish to place on record my appreciation of your remarks the other day about people who are going to impede the Post Office engineers in the execution of their duty. You can have no idea of the state of affairs in this part of the country.

"The other morning a Post Office mystery van drove up and took up its position at the side of the curb almost opposite my house; the driver got down, lit a cigarette and started a conversation with a milkman. Almost at once the frame aerial on the roof of the van started to turn round in a jerky fashion as the engineers (who, I presume, were inside the van) started to search round for pirates. (By the way, why is it that these vans always have their engines running slowly when tracking a pirate? I should have thought it would have inter-

ferred with the instruments which, I read in the newspaper, are so delicate that the engineers have to wear bone collar studs owing to the upsetting effect of metal ones.)

"Presently, at the far end of the street I saw a huge lorry coming along at a furious pace and lurching from side to side as though the driver was drunk. The next minute



Seized the engineers.

it had crashed into the small Post Office van, and, without pausing, had continued its riotous career up the street.

"The driver and several of the neighbours rushed forward with me to rescue the engineers from the wreckage of the van, but to our surprise they were gone, and the delicate instruments were gone too. The roof of the car was intact, but the funny thing was that the frame still kept on turning round in an irregular manner, being driven by some clockwork fixed on the underside of the roof. (This was to save the engineers trouble, I suppose, as they would have their hands full adjusting the delicate instruments.)

"The car had hardly stopped a second after the crash before speeding off, but the pirates must have leaped out, seized the engineers (not forgetting the delicate instruments), and made off. Now, whether I get taken for a ride or not, I want to say that this state of affairs is disgraceful, and questions ought to be asked in Parliament. These radio pirates are so desperate round here that they stick at nothing, and any other Post Office mystery van that comes round here will probably get bumped off the same as the other, and the engineers (not forgetting the delicate instruments) taken for a ride.—Yours, etc., —."

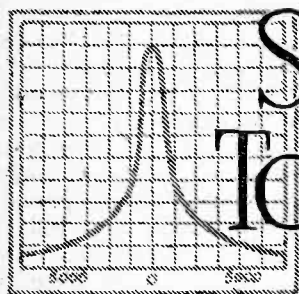

SELECTIVITY *and* TONE CORRECTION

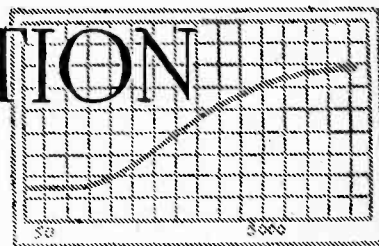

By F. M. COLEBROOK, B.Sc., D.I.C., A.C.G.I.

Audio-frequency Compensation for Highly Selective Tuned Circuits.

IN the issue of *The Wireless World* dated September 2nd there was published an article by the present writer under the title, "Band-pass or Tone Correction?" It showed how the side-band attenuation associated with broadcast reception on a highly selective circuit could be exactly compensated by a suitably designed audio-frequency amplifying stage, thus making it possible to obtain the advantages of high selectivity without sacrifice of the quality of reproduction.

In correspondence that followed the publication of this article it was suggested that any correcting device which had the effect of restoring the intensity of the received modulation of a desired transmission to its original unattenuated value would of necessity be equally effective in relation to interfering transmissions, thus cancelling the selective action of the tuned circuit. In consequence, a highly selective tuned circuit followed by perfect tone correction would be, it was argued, no more selective overall than a circuit sufficiently flat in tuning to give a substantially uniform response over the whole side-band range.

This argument seems to be based on sound common sense, thus showing once more that in scientific matters common sense is not always a reliable guide. It is desirable that the actual facts of the case, as far as they are known at present, should be clearly understood, for it is quite possible that the combination of high selectivity and tone correction may play an important part in the future design of receivers.

The writer has already given some account of the

matter in mathematical and experimental form in an article published in *The Wireless Engineer* in January, 1931. In a later issue of the same journal (May, 1931) Moullin gave a valuable critical commentary on the above-mentioned article, simplifying the analysis in a way which emphasised a number of important practical conclusions. The present article is largely based on these publications, and seeks to give a brief exposition of the essential facts in language as nearly non-mathematical as may be.

For simplicity of description, the actual complexity of a speech or music modulated wave will be reduced to the fundamental element of such a system, namely, a carrier wave of a certain radio-frequency f (for example, one thousand kilocycles per second) modulated by a pure tone of audio-frequency n (for example, five kilocycles per second). The ratio n to f , which is equal to 0.005 in the example given, has been called by Moullin the fractional modulation frequency. It is certainly desirable that it should have an agreed name, because it is of fundamental importance in selective reception.

It will further be assumed—or, rather, stated baldly as a fact of experience—that such a modulated wave is indistinguishable, as far as all the phenomena of reception are concerned, from a trinity of pure radio-frequency waves of frequencies $f-n$, f , and $f+n$ (995, 1,000, and 1,005 kc./sec. respectively in the example given.) Of these, the centre one will be referred to as the carrier wave and the others as side waves. The side waves are equal in amplitude, and the ratio of the amplitude of each to that of the carrier wave is one-half the modulation percentage. Thus, with 100 per cent. modulation the amplitude of

HERE, from the pen of an acknowledged authority, is a refutation of the argument that tone correction, in restoring the audio-frequencies lost in modern selective tuning methods, also brings back the unwanted interference.

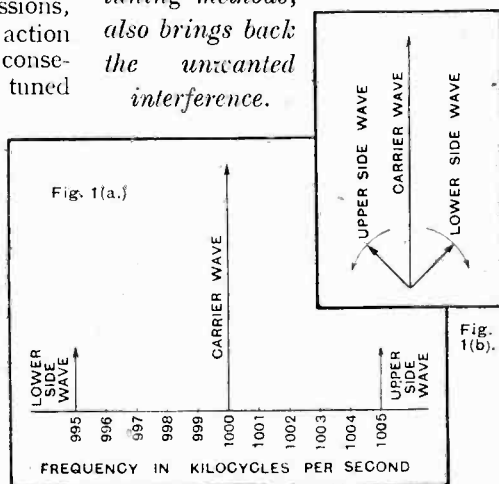

Fig. 1(a).— A modulated wave can be considered as consisting of three pure radio-frequency waves. The centre is called the carrier wave and the others the two side waves which are equal in amplitude. Assuming 50% modulation, the side waves each have a quarter the amplitude of the carrier wave. Fig. 1(b) The side waves are symmetrical both in amplitude and phase with respect to the carrier.

Selectivity and Tone Correction.—

each side wave is one-half that of the carrier; with 50 per cent. modulation, one-quarter, and so on. The spectrum of the modulated wave taken as an example, and assuming 50 per cent. modulation, is therefore as shown in Fig. 1 (a). There is, however, a further and very important distinctive feature of this group of waves which is not shown in the spectrum, namely, that at any given instant the side waves are equally in advance of and behind the carrier wave in phase. Thus, the instantaneous vector diagram for the three components will be as shown in Fig. 1 (b). These vectors are, of course, rotating with different angular velocities corresponding to their different frequencies, so that if the centre one is thought of as stationary, those corresponding to the side waves must be thought of as rotating in opposite directions, as shown, at n revolutions per second. The important point is that at any given instant the picture is symmetrical, i.e., the side waves are symmetrical both in amplitude and phase with respect to the carrier.

Tuned Circuit may produce Harmonic Distortion.

This much is probably quite familiar to readers of this journal, but it is, perhaps, less generally realised that any tuned system employed in reception should disturb this symmetry as little as possible, for any departure from symmetry, whether in amplitude or in phase, will produce a corresponding deviation from pure sine wave form in the envelope of the equivalent modulated wave, producing the effect of some small degree of harmonic distortion in the modulation wave form. The letter by Moullin, referred to above, gives a specific example of this effect when a circuit is tuned to one of the side waves. Thus, a tuned circuit alone, and considered quite apart from any form of rectification, can under certain conditions produce harmonic distortion. It is a matter of which the practical significance has not yet been fully investigated, and is only mentioned here as a point of general interest in relation to reception.

The outstanding advantage of the side-band representation of a modulated wave is that it simplifies the understanding of what happens when such a wave is received by means of a tuned circuit.

We will consider the simplest form of tuned circuit, namely, a frame aerial with a rectifier connected across the terminals of the tuning condenser. The conclusions arrived at will not be limited to this type of receiving arrangement but will be general in application. In order

to emphasise the effects under consideration it will be assumed that the effective resistance of the frame aerial has been reduced to a very small value by means of retroaction. Readers of this journal will be familiar with the term "coil magnification factor," or other equivalent name, and will know that by careful design as high a value as two or three hundred can be obtained for this. With a high degree of retroaction a figure of 1,000 is not impracticable, and will be assumed in the following description. The reciprocal of the magnification factor is called the power factor. Thus we assume a power factor of 0.001. This corresponds to a degree of selectivity which would seriously impair the quality of broadcast reception if used without tone correction.

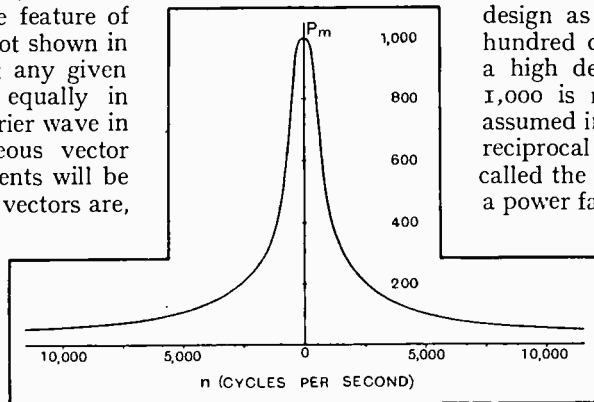

Fig. 2.—Showing resonance curve of a tuned circuit with a coil having a magnification factor of 1,000 (power factor 0.001). At resonance an induced e.m.f. of 1 millivolt will give 1 volt across the condenser.

The physical interpretation of the curve is as follows: The circuit is supposed to be tuned to some given frequency f and an e.m.f. with a frequency $f+n$ is induced in the coil. The height of the curve shows the ratio of the resulting condenser potential difference to the induced e.m.f. and the way in which this depends on n , the frequency difference from resonance. In the present case the induced e.m.f. is assumed to be proportional to frequency, which will actually be true for frame aerial reception. The main features of the curve can be described quite simply in words. The height OP_m is the coil magnification factor (1,000 in the present case). This means that at resonance an induced e.m.f. of one millivolt will give rise to a condenser potential difference of one volt.

Along the skirts of the curve the height does not depend on the resistance of the circuit at all, but only on the frequency ratio f/n . In fact, the height is given by $f/2n$, or the reciprocal of twice the fractional modulation frequency. This is not exactly true, but is very approximately true for all values of n such that the square of n/f is large compared with the square of the power factor of the coil. In the present case, taking f as one thousand kc./sec., the height of the curve is $f/2n$ for all values of n greater than 1,500 cycles/sec. At 5,000 cycles/sec. the height of the curve is $1,000 \text{ kc.} / 2 \times 5 \text{ kc.} = 100$, or one-tenth of the height at resonance.

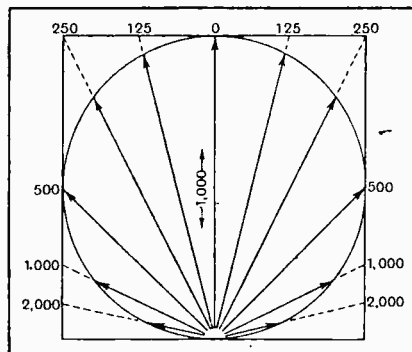

Fig. 3.—The resonance curve of Fig. 2 can be shown as a vector diagram. Both amplitude and phase of the potential difference across the condenser can be seen.

(Those who are able to appreciate vector diagrams may be interested in an alternative way of representing the resonance curve, shown in Fig. 3. This tells us both the amplitude and phase of the condenser potential difference, the phase being relative to that of the maximum or resonant potential difference. This diagram

Selectivity and Tone Correction.—

brings out the phase and amplitude symmetry of the simple type of receiving circuit under consideration.)

With the aid of the resonance curve of the circuit we can easily interpret the effect on the circuit of a modulated wave such as that having the spectrum shown in Fig. 1. The e.m.f. induced by the carrier wave is magnified a thousandfold by resonance, but the side waves, as shown above, are magnified only a hundredfold. The vector diagram shows that the original symmetry of phase is not impaired by the receiving circuit, and there will therefore be no harmonic distortion of the modulation waveform, but it is clear that there will be a considerable reduction of the modulation percentage. In fact, since the carrier wave e.m.f. is magnified ten times as much as the side wave e.m.f.s, the modulation percentage of the condenser voltage wave will be only a tenth of that of the original wave.

To put the matter generally, since the carrier wave e.m.f. is multiplied by M (the coil magnification factor) and the side wave e.m.f.s corresponding to a modulation frequency n are multiplied by $f/2n$, the modulation percentage is reduced in the ratio of $f/2n$ to M . or, in other words, is multiplied by the fraction $(f/2n)/M$ or $(f/2M)(1/n)$. This, of course, is only strictly true under the conditions of approximation already mentioned. For

frequencies below about 1,500 cycles/sec. it would be necessary to use the more accurate formula given in the original article on tone correction.

Subject to this reservation, we have the simple result that the modulation percentage is reduced by the selective action of the tuned circuit to an extent which is inversely proportional to the modulation frequency. Therefore, to restore the modulation frequency output to that equivalent to its original value, it is necessary to have an audio-frequency amplifying stage which gives an amplification proportional to frequency. Such a stage is, of course, very easy to design.

Another general result should also be noted. The reduction in modulation percentage can be written alternatively as proportional to the ratio of the power factor of the coil to the fractional modulation frequency. Thus, in receiving a transmission at, say, 200 kc./sec., corresponding to 1,500 metres in wavelength, the fractional modulation frequency is five times as large as at 1,000 kc./sec., so that for the same degree of side-band cut-off the power factor would have to be five times as large, i.e., the circuit would have to be five times as flat in tuning. This is all we need to know at present about the reception of the transmission to which the circuit is tuned.

(To be concluded.)

“THE WIRELESS WORLD”

Information Bureau.

THOSE seeking information on wireless matters are invited to address their enquiries to the new *Wireless World* Information Bureau, which is now conducting a special postal-reply service to readers.

For the guidance of those utilising the service, the following general instructions should be observed.

CONDITIONS OF SERVICE.

(1) The service is intended primarily for readers meeting with difficulties in the construction, adjustment, operation, or maintenance of wireless receivers described in *The Wireless World*, or those of commercial design which from time to time are reviewed in the pages of *The Wireless World*. Every endeavour will be made to deal with queries on all wireless matters, provided that they are of such a nature that they can be dealt with satisfactorily in a letter.

(2) Communications should be addressed to *The Wireless World* Information Bureau, Dorset House, Tudor Street, E.C.4, and must be accompanied by a remittance of 5s. to cover the cost of the service. The enquirer's name and address should be written in block letters at the top of all communications.

(3) The fee of 5s. covers the reply to any wireless technical difficulty, but in special cases, where the nature of the enquiry may involve a considerable amount of investigation, an increased fee may be necessary. In such cases a special quotation will be made.

(4) Questions should be clearly written and concisely worded in order to avoid delay. Where enquiries relate to trouble experienced in receivers built to specifications in *The Wireless World* a complete account should be given of the trouble, and especially the symptoms.

(5) Where reference is made to published articles or descriptions of apparatus, the title of the article, the date of publication in *The Wireless World*, and the page reference number should be given, in order to facilitate reply.

(6) Full circuit diagrams, constructional details of apparatus, or values of components for home-designed receivers cannot normally be supplied, but circuit diagrams sent in with queries will be checked and criticised.

(7) Particular makes of components cannot, in general, be recommended, but advice will be given as to the suitability of an individual component for a particular purpose.

TELSEN

100% BRITISH RADIO COMPONENTS

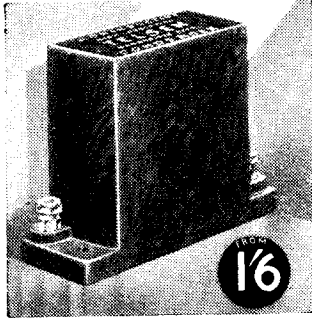

MANSBRIDGE TYPE CONDENSERS
Capacities from .01 to 2.0 mfd.

1/6

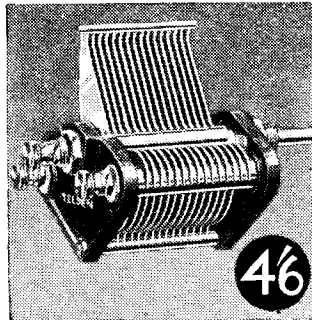

VARIABLE CONDENSER.

4/6

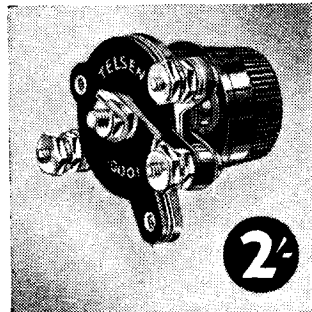

BAKELITE DIELECTRIC CONDENSERS

Differential Condenser—Cap. .0003, .00015, .0001, 2/-. Reaction Condenser—Cap. .0003, .00015, .0001, 2/-. .00075, .0003, 2/6. Tuning Condenser—Cap. .0003, .0003, 2/-. .

2/6

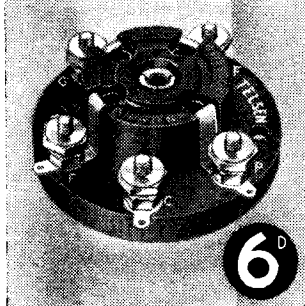

6^d

VALVE HOLDERS (Prov. Pat. No. 20258/30). The Telsen four- and five-pin valve-holders embody patent metal spring contacts, which are designed to provide the most efficient contact with split and non-split valve legs, and are extended in one piece to form soldering tags. Low capacity and self-locking.

Telsen 4-pin Valve Holder ... Price 6d.
Telsen 5-pin Valve Holder ... Price 8d.



9^d

GRID-LEAKS. Telsen Grid-leaks are absolutely silent and non-microphonic, and practically unbreakable. They cannot be burnt out and are unaffected by atmospheric changes. Telsen Grid-leaks are not wire wound and therefore there are no capacity effects. Their value is not affected by variation in the applied voltage. Made in values from 1.5 megohms.

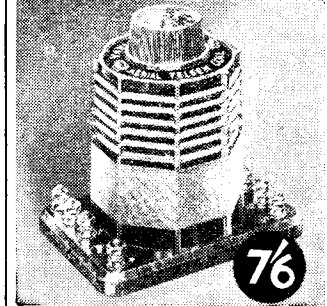

DUAL-RANGE AERIAL COIL with variable series condenser, 7/6. H.F. Transformer and Aerial Coil, 5/6.

7/6

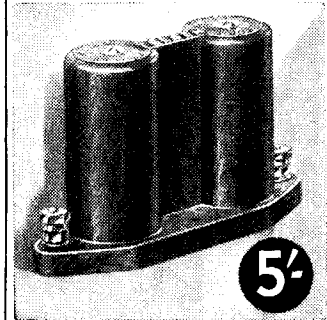

BINOCULAR H.F. CHOKE.

5/6

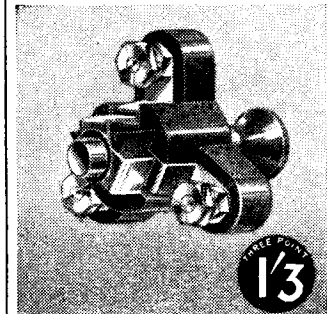

PUSH - PULL SWITCHES
(Prov. Pat. No. 14125/31).

Two-point 1/-
Three-point 1/3
Four-point (2 pole) 1/6

1/3

Advt. of The Telsen Electric Co., Ltd., Aston, Birmingham.

CV8-126

BUY "The Wireless World" Pocket Diary. Price 1/6 net. By post 1/7. 80 pages of facts and figures.

BUILT FOR BEST RESULTS

Practically every modern circuit uses gang tuning: but results depend entirely on the accuracy and construction of the Gang Condenser used.

That is why the new J.B. "R" Type Gangs are being specified in so many leading circuits. They are precision instruments, built for best results. J.B. "R" Type Gangs (Capacity .0005). Thoroughly shielded. Neat pressed aluminium clip-on dust-proof covers.

Very easily fitted—only round panel holes to cut. .0001 Trimmers (for adjustment once only) in each stage.

Complete with Vernier Disc Drive and Bakelite Panel Plate.

- Type "R" 2 (2-gang) as illustrated .. 21/-
- Type "R" 3 (3-gang) 29/6
- Type "R" 4 (4-gang) 37/-

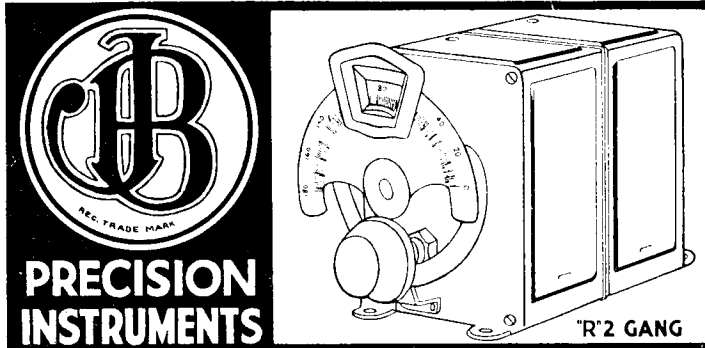
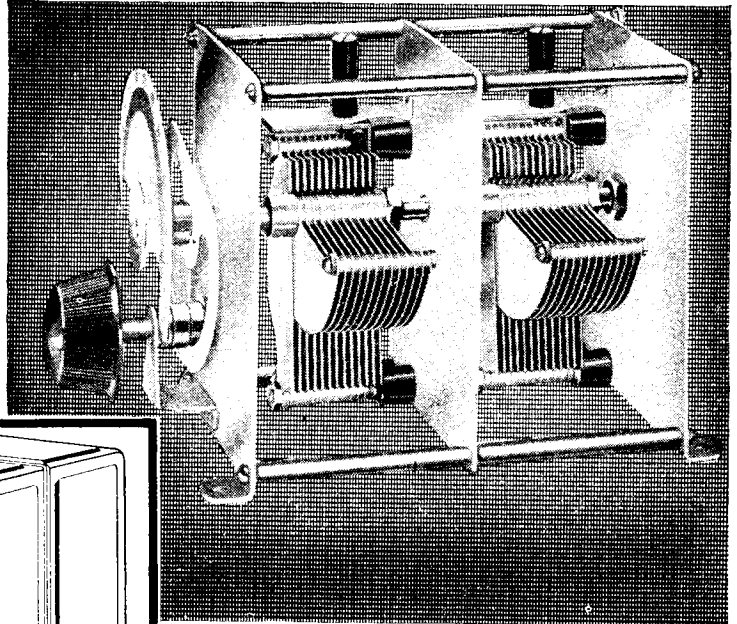

Advertisement of Jackson Brothers, 72 St. Thomas' Street, London, S.E.1

J.B. "R" 2 GANG WITH COVERS REMOVED.
 WIRELESS WORLD'S CHOICE
 for the SINGLE DIAL SUPER
 J.B. GANG TYPE R3W. 29/6
 Telephone: Hop 1837

Say
 Player's
 please

They always do!

N.C.C.60

Hear Radio at its Best by incorporating in your set an IGRANIC TRANSFORMER

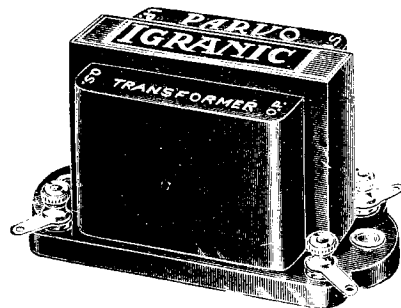

**IGRANIC "PARVO"
 TRANSFORMER**

For Parallel Feed
 Circuits.

Weight only 4 oz.
 Size 2 1/2" x 1 1/2" x 1 1/2"

PRICE 7/6

**IGRANIC
 "MIDGET"
 TRANSFORMER**

A Wonderful instrument
 at a very low price.

Ratio 3 : 1 and 5 : 1

PRICE 10/6

*If you are unable to
 obtain Igranic Com-
 ponents locally, send
 to Dept. U.326. We
 will send C.O.D.*

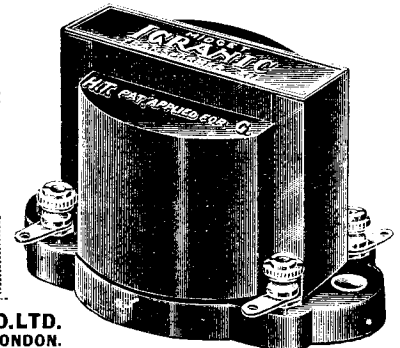

IGRANIC ELECTRIC CO. LTD.
 149, Queen Victoria St., LONDON.

Events of the Week

CURRENT
TOPICS

In Brief Review

A Radio Relic.

MR. BRANLY'S original coherer—the first practical wireless detector—has been handed over to the Museum of *Arts et Metiers* in Paris.

o o o o

Cheers in Czecho-Slovakia.

FOLLOWING the opening of the new high-power broadcasting station at Prague, Czecho-Slovakia is rejoicing over the biggest monthly increase in receiving licences recorded this year. The total rose from 343,869 in October to 355,492 in November. In January, 1925, the number was 1,554; a year later it was 17,000, and in January, 1927, it had reached 175,081.

o o o o

Wireless at the B.I.F.

NEARLY twenty wireless firms have already booked space in the London section of the British Industries Fair, to be held in February next.

o o o o

Iceland Wants to Know.

IF you should hear Reyjavik transmitting its daily programme on 1,200 metres between 11 a.m. and 1 p.m. (G.M.T.) it would give great delight to the station authorities to receive a report. Icelandic listeners are rather "out of it" so far as ordinary broadcasting is concerned, but, considering the troubled state of the European ether, we are not sure that they deserve any sympathy!

o o o o

Two Men in a Boat.

A RADIO test which may last a year begins on January 1st, when Captain J. E. Boyd and Captain Carl Justice leave Daytona Beach, Florida, in a 40ft. sailing boat on a 37,000-mile trip round the earth. Their boat is provided with two complete transmitting sets, and arrangements have been made with the American Radio Relay League whereby the little boat will be in constant touch with various amateurs throughout the voyage. It is understood that a definite schedule of transmitting times will be arranged.

o o o o

German Gramophone "War."

THE German gramophone "war" has ended. It will be remembered that the gramophone manufacturers sent an ultimatum to the broadcasting authorities forbidding the use of gramophone records in the programmes after December 6th. In an agreement just concluded the use of records is authorised on condition that gramophone concerts do not absorb more than two hours per day. Records may be freely used to illustrate talks, but the gramophone companies are determined that their records shall not be used for the compilation of "whole programmes."

B 13

The New Year in Germany.

NEW Year's Eve, generally an occasion of special broadcasting festivities in Germany, will be marked by an unusually solemn atmosphere this year in view of the existing crisis. In place of the customary jovial programme will be a speech by President Hindenburg, a performance of Beethoven's Ninth Symphony, and, at midnight, the chimes of Cologne Cathedral.

The occasion will be specially gloomy to the various station officials, all of whom have had formidable salary cuts.



RADIO AND THE ARCHITECT.—This glimpse in the first-class smoking room of the new S.S. "Monarch of Bermuda" shows how artistically the Marconi loud speaker has been incorporated in the ceiling decorations.

Non-stop Flight.

FOR the third time Squadron-Leader Gayford's projected non-stop flight to Capetown has been postponed owing to unfavourable weather conditions. We understand that the flight, which should offer exceptional opportunities to amateurs in logging radio messages from a long-distance plane, will be started on January 19th.

o o o o

Louder Signals from Turin.

IMPORTANT improvements are taking place at the Turin broadcasting station. The aerial power is to be increased from 8.7 kW. to 10.5 kW., and the modulation is to be raised from 70 to 100 per cent. Crystal frequency control is also being introduced.

o o o o

Have You Heard Liège?

TEST transmissions are being carried out by the new Belgian broadcasting station "Liège Regional" on a wavelength of 215 metres. The transmissions are made between noon and 1.30 p.m. and from 4 to 5 p.m. daily.

o o o o

Where Carpets Dazzle.

TURKEY apparently holds the record as regards wireless "pirates," for, according to the latest estimate, the pirates outnumber the licence-holders by 300 per cent. Actually there are some 5,000 persons holding Turkish licences, but it is believed that the number enjoying radio programmes is in the neighbourhood of 20,000.

The pirates' principal excuse seems to be that reception in Asia Minor is extraordinarily poor. According to a correspondent, "the Stamboul and Angora Stations have carpets that dazzle the visitors much more than do their programmes."

o o o o

Five-metre Work in America.

PALISADES, New Jersey, is a stronghold of the five-metre persuasion among American transmitting amateurs. According to a statement of the Amateur Radio Relay League, at least fourteen amateurs in that city hold duplex communication nightly within a radius of twenty-five miles. "Each is able to hear all the others as saying, and can chime in when he wishes; alternately, he can move aside with some other amateur and hold a quiet and undisturbed private conversation. . . . The whole thing is indescribably intimate and friendly."

At the headquarters of the League laboratory work on new ultra-short-wave developments are continually proceeding, and it is confidently predicted that "a new form of radio technique will shortly make its appearance," based on researches which have been primarily undertaken by amateurs.

Gramophone Novelties.

MR. J. H. A. WHITEHOUSE, of the Gramophone Company, Ltd., is giving a lecture at the Kingsway Hall on Wednesday, January 6th, at 5.30 p.m., in aid of the King Edward's Hospital Fund.

The lecture, which is entitled "The Magic of the Gramophone," should appeal to all interested in radio and gramophones. It will contain many novelties, and records have been obtained from all parts of the world for the occasion. A number of discs never before heard will be played, including unique records of historical interest. Some members of the audience will be invited to make a record to take home.

Tickets are obtainable at the door, price 1s., while numbered and reserved seats, price 2s., are obtainable from all branches of Alfred Hays, Ltd. (no booking fee). Parties of ten or more—half price.

o o o o

New Zealand's "B.B.C."

AN act placing the control of broadcasting in New Zealand in the hands of an appointed board was passed by the New Zealand Parliament recently, and the four main stations will be taken over from the Radion Broadcasting Co., Ltd., on January 1st, when the company's five years' licence expires. The general policy to be adopted will be very similar to that of the British Broadcasting Corporation. The board consists of three members, who will appoint an advisory committee at each station and also an advisory council of eight members, who will be nominated by various listeners' organisations. It is understood that the board will consider the possibility of taking over a dozen of the existing "B" class stations now operated by business houses in various parts of the country, and may institute a relay system on lines similar to that of the B.B.C.

o o o o

New Rules for U.S.
Broadcasters.

HIGH praise for the technical side of American broadcasting is contained in the annual report of the Federal Radio Commission for 1931. General Charles Sultzman, the chairman, declares that the last year has seen almost a complete revolution in the type of equipment used. Complying with a technical order of the Commission, all stations are now supposed to have equipment capable of better than 75 per cent. modulation.

On June 30th last there were exactly 612 broadcasting stations in the United States.

The report calls attention to the new set of rules and regulations which will be promulgated within the next few weeks. Among them will be relaxation of the present rigid requirements regarding the description of recorded programmes or "electrical transcriptions," though their character must still be made clear to the listening public. Call letters may now be announced at thirty-minute intervals instead of every quarter of an hour.

FIVE-METRE TESTS BY THE POST OFFICE.

Disclosures at the Telephone
Exhibition.

WIRELESS transmissions on a wavelength of five metres, a loud speaker telephone system in which the microphones are not affected by the sounds from the loud speakers, a seven-electrode valve, and an electric gramophone with push-button frequency control: these are among the attractions which the Post Office will "release" on January 5th, the opening day of the Young People's Own Telephone Exhibition at the Imperial Institute, South Kensington.

specting Post Office direction-finding sets. One of the unusual exhibits will be the experimental gramophone originally developed by Post Office engineers for line testing. By means of a special tone-control system, operated by switches, visitors will be able to eliminate certain bands of audio-frequencies so that voices and instruments can be deprived of their ordinary tone colour. Sopranos, for instance, will be made to sound like tenors—an operation which many broadcast listeners have often wished to perform. Another exhibit of great interest will be the new Post Office teleprinter for private use.

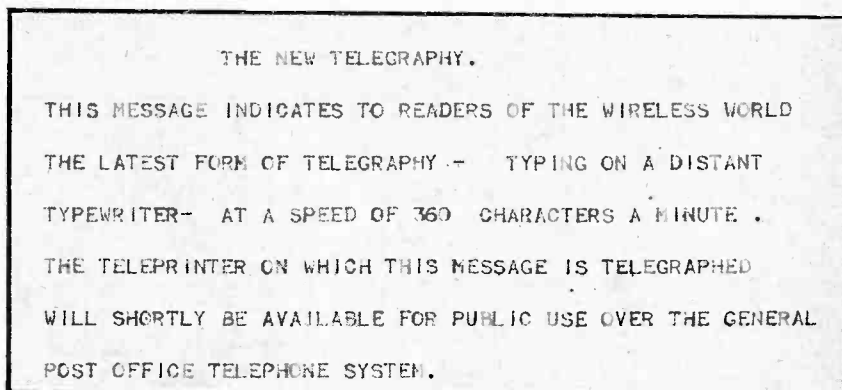

A facsimile message, slightly less than actual size, as received on the teleprinter. The instrument should be easily adaptable to radio transmission.

In an interview, an official of the General Post Office hastened to assure *The Wireless World* that, despite its title, the Exhibition will be open free to people of all ages. Its object is, primarily, to make the youth of the land "telephone conscious," and to fulfil this function no pains are being spared to include everything that is likely to be of interest. It is natural, therefore, that wireless should absorb a large amount of the display.

It is hoped that the five-metre transmitter, specially developed by the Post Office engineers, will actually be on test, so that messages can be exchanged from one end of the hall to the other. Visitors for whom long-distance radio telephony has a greater appeal will be able, at certain times of the day, to speak to Australia and New Zealand over the beam system.

Wireless "pirates" will derive a melancholy satisfaction from in-

Although not of direct wireless interest at the moment, this instrument should be easily adaptable to radio transmission. It has been in general use in Post Office telegram work for some time past, but the intention to-day is to introduce it into offices and private houses, subscribers being able to type their communications for direct printing at the receiving end. Ultimately it is hoped to establish a central teleprinter exchange. The teleprinter employs a simple telephone circuit, the transmitted characters being controlled by frequency changes.

In the historical section two interesting exhibits will be the original Fleming valve and Sir Oliver Lodge's electric impulse magnifier, patented in 1898.

The exhibition will be open daily (Sundays excepted) from 11 a.m. to 8 p.m., and admission will be free. The closing date is January 23rd.

INSTABILITY in H.F. AMPLIFIERS

Unsuspected Sources of Feed-back.

By C. H. SMITH, B.Sc., A.M.I.E.E.
(Research Department, The British Broadcasting Corporation.)

THE two principal methods of obtaining stability in radio-frequency amplifiers, by decoupling battery circuits and by screening resonant circuits, are well known and generally practised. There are, however, other possible sources of retro-action, the existence of which is not always realised.

It is not unusual to find that *The Wireless World* figures for theoretical maximum unneutralised amplification per stage are unobtainable in practice, and that instability occurs with coils whose figure of merit is considerably below the theoretically critical value. With mediocre coils indifferent screening may suffice, but where high values of amplification are desired complete screening in the mechanical sense may show obvious electrical imperfections.

A common constructional fault is shown in plan in

cuted turns coupling together the grid and anode coils. Cases have occurred in which the presence of the back screen actually produced instability. A much more satisfactory method of screening is shown in Fig. 2, in which each screening box is complete in itself and makes contact only with the cathode which it encloses.

A long earth lead may be a potential source of trouble, particularly where screening is incomplete. Each set of plates of a variable condenser has an appreciable self-capacity, distinct from the inter-plate capacity, which

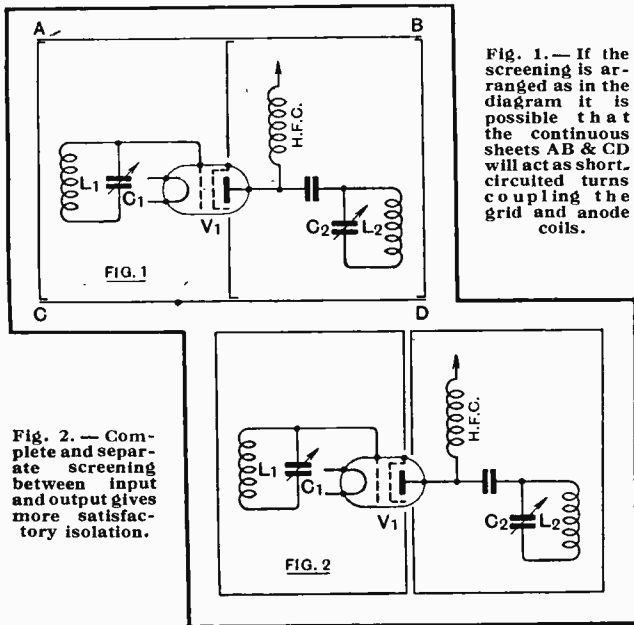

Fig. 1.— If the screening is arranged as in the diagram it is possible that the continuous sheets AB & CD will act as short-circuited turns coupling the grid and anode coils.

Fig. 2.— Complete and separate screening between input and output gives more satisfactory isolation.

Fig. 1, in which continuous sheets of metal AB and CD form a common back and front of two screening boxes. If the coils are disposed within the partitions so that their axes are parallel to the sides AC and BD, the back and front of the partitions will act as large short-cir-

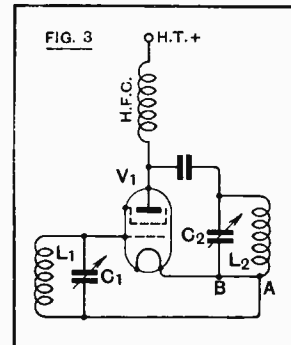

Fig. 3.— If the grid circuit is returned to point (A) the inductance of the wire AB which is common to both anode and grid circuits may cause instability.

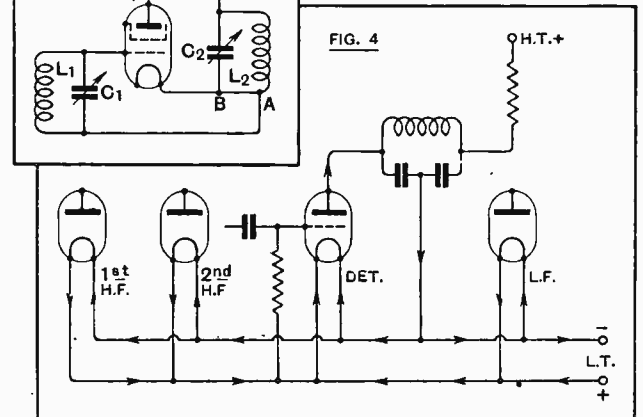

Fig. 4.— Skeleton circuit of a four-valve set with arrows showing the paths of the high-frequency anode currents.

is effectively its capacity to earth if there is no screening. The self-capacity of the "live" side of each condenser, in series with the inductance of the earth lead, forms a shunt circuit across the inter-plate capacity, and all such circuits have the earth lead inductance as a common impedance. If, for example, the self-capacities of the "live" sides of the condensers and associated wiring in two circuits are each 5 micro-microfarads and the inductance of the earth lead is 5 microhenrys, they will produce at 300 metres a coupling between the two resonant circuits whose coefficient k is of the order of 0.001, quite an appreciable figure.

The method of wiring a receiver can have a considerable effect on stability, and Fig. 3 illustrates a fault to be avoided. The grid circuit in this drawing has been connected to the point A of the wire AB, joining the coil and condenser of the anode circuit, while the fila-

Instability in H.F. Amplifiers.—

ment is connected to the point B. The circulating current through the wire AB is many times the value of the anode current fluctuation, and it may produce across the small inductance of the wire a voltage whose introduction into the grid circuit due to the method of wiring will produce appreciable effects. To ensure stability each circuit should be connected separately to the valve cathode.

A further elusive source of trouble is due to the fact that cathode connections are normally taken to the negative side of the filament of directly heated valves, although the effective source of electrons may be taken to be a point somewhere near the filament centre. There are a variety of conducting paths between the negative end and the centre point of each valve filament, as is illustrated by the arrows on Fig. 4, which show the various ways in which the high-frequency currents in the anode circuit of the detector valves in a four-valve set may find a return path to the filament centre-point. In a 6-volt s.g. valve the resistance between filament negative and filament centre is about 30 ohms, and so appreciable back coupling may occur, due to the presence of these stray currents. A palliative is to connect with very short wires between the L.T. - and L.T. + leads

a condenser having a very low impedance at radio frequencies, the best position being found by experiment, but the most satisfactory solution, since valves with a centre-tapped filament are not produced, is to use indirectly heated valves of the 4 volt 1 amp., or 6 volt 0.5 amp. class.

Summary.

The following precautions should always be taken in the design of a high-efficiency multi-valve H.F. amplifier:—

(1) Make each screening box complete in itself and insulated from adjacent ones.

(2) Screening boxes sufficiently large to contain all associated components may be better than coil covers when aiming at high amplification.

(3) When wiring connect the earthy sides of all tuned circuits, decoupling or filter condensers, leaks, and also the screening boxes directly and independently to the cathode of the valve with which they are associated, and let this wire be the only connection to the screening box; insulate every condenser from the metal panel, even though one side is at filament potential, and remember that the valve cathode is the true earth point, not the metal front or screening box.

(4) Use valves having equipotential cathodes.

GARRARD GRAMOPHONE MOTORS.

This season's range of electric motors and turntables comprises three types, as follows:—

Type 201 (Heavy Duty Induction).—This motor is of the slow-speed type in which the rotor revolves at turntable speed. It is of exceptionally massive construction, and as the moving parts are reduced to a minimum it is specially suitable for prolonged use, not only in the home but in hotels, cafés, etc. Link connectors are provided for adjusting the voltage for 100-130 or 200-250 volt mains. Current consumption, 0.13 amp. Price, £4 17s. 6d.

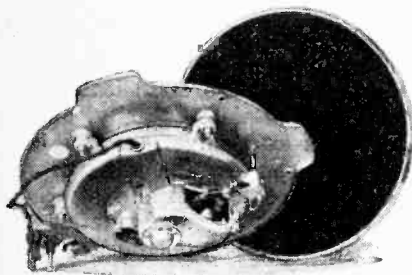

Garrard Type 201 heavy-duty induction motor.

Type 202 (Popular Induction).—The turntable is gear-driven by a compact induction motor of the so-called high-speed type. It gives the

very excellent torque of 20.8 ft.-lb. per minute, which is more than twice that required to play a heavily recorded 12in. record. The current

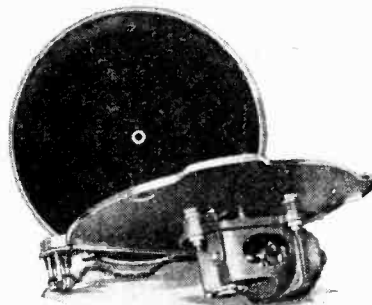

Garrard Type 202 popular induction motor.

consumption is approximately 0.07 amp., and the temperature rise after three hours running is 15 deg. C.

Price, £2 18s. 6d. Voltage range, 100-130 and 200-250 at 50-60 cycles.

Type E (Universal).—The turntable is driven through a flat belt under spring tension by a totally enclosed universal commutator motor and is controlled by a governor geared to the vertical turntable spindle. A resistance box is supplied which can be adjusted to all mains (A.C. or D.C.) from 100 to 250 volts. Special motor windings

can also be provided where the supply is less than 100 volts or higher than 60 cycles. The average current is 0.18 amp. Price, £5 15s.

All three motors are fitted with the well-known Garrard automatic trip switch, designed to function with all types of record throw-off grooves. The lubricating points are accessible (in the type 201 oil is fed through the hollow turntable spindle), and the materials and quality of workmanship are of the same high standard as in the Garrard clock-work motors.

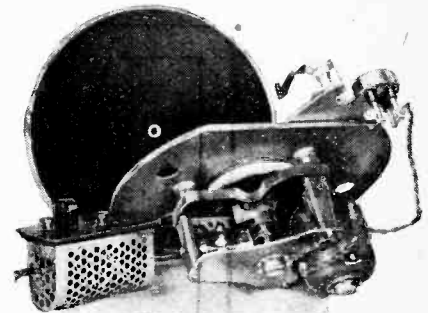

Garrard Type E Universal motor for A.C. or D.C. supplies.

Makers: The Garrard Engineering and Manufacturing Co., Ltd., 17, Grafton Street, London, W.1, and Newcastle Street, Swindon, Wilts.

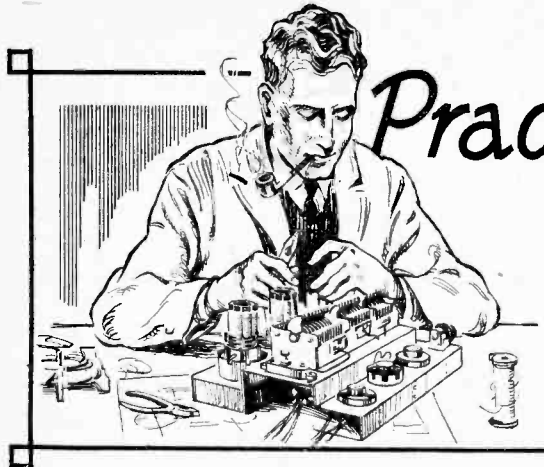

Practical Hints and Tips

Simplified Aids to Better Reception.

MANY sets, especially those of simple design, bring in the two local stations simultaneously at the bottom of the long-wave scale when they are used in the North of

CROSS-TALK AT 980 METRES.

London. The cause of this is often our old friend—or enemy—cross-modulation arising from rectification by the screen-grid valve. Whether, in any specific case, this really is the true cause, or whether it must be put down entirely to unselective tuned circuits, can be determined by a simple experiment.

Find a time when only one of the two local stations is transmitting, and tune to the point on the long-wave band where the interference is found. If the interference is not heard, cross-modulation is the probable cause. If, when the second local station starts its carrier preparatory to a transmission the signals from the first station are heard, the probability rises nearly to a certainty, final proof being afforded by the arrival of the programme from the second station as soon as it starts to modulate.

London National works on a frequency of 1,148 kilocycles, London Regional on a frequency of 842 kilocycles. If signals from both are present at the grid of a valve which is rectifying, a beat note, formed in the same way as is the intermediate frequency of a superheterodyne, is produced, this beat note having a frequency equal to the difference of the two original frequencies, and carrying the modulation of both.

The difference-frequency in the case under consideration is 306 kilocycles, corresponding to a wavelength of 980 metres. If the remaining tuned circuits in the set are tuned to this wavelength, signals from both the stations will be passed through the set on the locally formed carrier. The set has, in fact, unintentionally been turned into a superheterodyne, each

of the two stations acting as oscillator to the other.

Re-reading the second paragraph of this note in the light of the last remark should suffice to make the mechanism of the interference entirely clear, and show plainly the reasons underlying the test.



THE connections of an L.F. coupling transformer, when it is inserted directly in the detector anode circuit, are quite straightforward, but confusion seems to arise

THE DETECTOR ANODE CIRCUIT.

when the transformer is parallel-fed by means of a resistance and condenser, and also when the detector is linked to the succeeding stage by means of a simple resistance-capacity or choke-capacity coupling.

The L.F. feed lead seems to be the stumbling block, and many amateurs seem to fall into the error of thinking that it should always be joined directly to the anode of the detector valve, even when an H.F. choke is included in the circuit. It seems likely that this error is responsible for various peculiar effects, such as erratic reaction control and even more serious troubles due to the action of H.F. energy in the L.F. amplifier.

As a rule, it may be taken that the L.F. feed lead should be joined, not to the anode, but to the junction between the H.F. choke and whatever type of L.F. coupling impedance may be used. The reaction lead, of course, is joined directly to anode, as is any by-pass condenser that may be employed to improve detector efficiency (or, more correctly, to prevent anti-reaction feedback to the grid circuit). If this capacity be connected to the wrong end of the choke it will become almost entirely ineffective.

Correct and incorrect connections of the leads in question are clearly shown in Fig. 1.

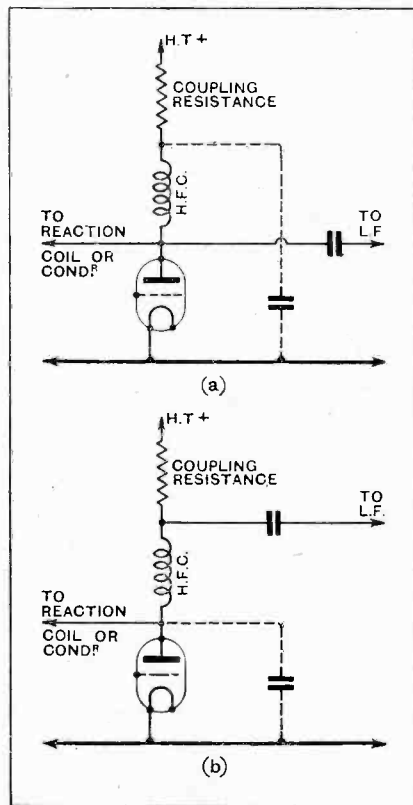

Fig. 1.—Common errors in the detector anode circuit connections are shown in diagram (a); these have been corrected in diagram (b).

THE calculation of the correct values of the two resistances that make up the potentiometer feeding

**SCREEN-GRID
POTENTIOMETERS.**

the screening grids of screen-grid valves is quite a tricky business if one sets about it the wrong way; rightly tackled, however, it offers no difficulty at all to anyone who has a nodding acquaintance with Ohm's Law.

Suppose that it is desired to supply a fixed 80 volts to the screens of the two valves shown in the figure, and that the main H.T. supply from which this voltage has to be derived is 200 volts. Since we want 80 volts on the screens, and have to drop 120 volts across R_1 , it would appear that R_1 must have 120/200ths of the total resistance, while R_2 has the remaining 80/200ths. One might, therefore, make R_1 120,000 ohms, and R_2 80,000 ohms, or, as an alternative, halve these values and use 60,000 and 40,000 ohms respectively for the two positions.

It is indicated on the diagram, however, that the screens of the two valves draw, between them, a current of 2 milliamps at the required 80 volts; in the preceding calculation this has not been allowed for, nor does there appear any convenient place in the calculation to insert this extra condition. The working out just done will, in fact, lead to quite a wrong voltage appearing on the screen; owing to the current drawn, it will be decidedly too low. Actually, the external voltage necessary to provide 80 volts on the screens with the resistances just suggested is 440 volts for the first pair, and 320 for the second, whereas the calculation was intended to be correct for an external voltage of 200 volts.

The working-out has to be done backwards, in the following way: The total current that has to flow is 2 milliamps for the screens plus the current that 80 volts will drive through whatever resistance we choose to insert for R_2 . We then have to find a value of R_1 that will drop the required 120 volts when taking this total current.

Suppose we have a potentiometer of resistance 30,000 ohms that we wish to make use of in the position

R_1 . Then the total current is 80/30 milliamps (=2.7 mA.) through R_2 plus 2 mA. for the screens, making 4.7 mA. in all. To drop 120 volts at 4.7 milliamps the necessary resistance is 120/4.7 or 25,500 ohms. The nearest stock figure is 25,000 ohms, which in this particular case is certainly going to be near enough to the value found by calculation.

From the theoretical point of view it is of no importance what value of resistance we choose for R_2 ; in practice, since the current drawn by the screens is likely to be known only approximately, it is advisable to swamp any small variations that may arise here by so selecting R_2 that it takes, at the required voltage, a current which is at all events not less than that which we expect the screens to consume. In the example given this has been done; the required 80 volts would have

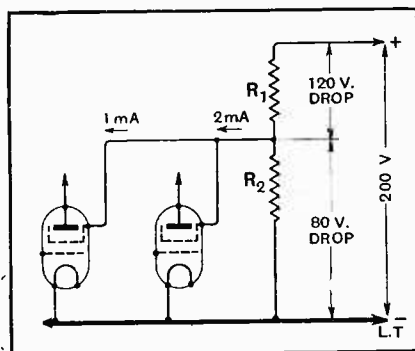

Fig. 2.—A screening-grid potentiometer: in estimating the values of R_1 and R_2 it is necessary to allow for screen current.

been more independent of screen current if R_2 had been given a resistance of perhaps 15,000 or 20,000 ohms. Those who are not quite sure they have grasped the method of calculation with sufficient completeness to be able to solve their own problems might like to work out the values of R_1 required to accompany each of these values; they should find that R_1 requires to be 16,350 ohms for $R_2=15,000$ ohms, and 20,000 ohms for $R_2=20,000$ ohms.

It is of no importance to the calculation whether R_2 is intended to be variable, thereby giving a volume-control by variation of screen-volts, or fixed, as would be the case if control of volume were supplied by other means. In the former case, although it would be difficult to forecast the screen-volts

reached for every different position of the slider on R_2 , owing to the continual variation of screen-current, we have no need to do so; it is quite clear that if the screen-volts are correct at their maximum value, and can be reduced to zero when the slider is at the bottom end of R_2 , every intermediate voltage is reached at some intermediate point on the control.



THE purpose of the small trimming condensers attached to the main tuning condensers of a

**A NOTE ON
TRIMMING.**

ganged set is to make it possible to adjust just the minimum capacity across each tuned circuit to the same value. If this is done successfully, the various circuits should remain exactly in tune with one another over the whole tuning range, the responsibility for the exactitude of this lying mainly with the coils, which need to be accurately matched.

Since the trimmers take care of the minimum capacity, it is only reasonable to adjust them with the main tuning condensers set nearly at minimum, so that the capacity of the trimmers may be a large proportion of the capacity in circuit. When making the adjustment it is advisable to arrange matters so that one of the trimmers is almost at the lowest possible capacity, since the dielectric in the average trimmer is not entirely free from losses. If a setting is found that gives good ganging, but which involves screwing all the trimmers in a good way, the trimmer which is found to require least capacity should be screwed right out, and the others should be brought out until satisfactory ganging is again attained.

When there are only two condensers ganged together it is often easier to adjust one trimmer only, swinging the main tuning dial back and forth, at the same time, to keep the signal in tune. Generally speaking, it is safe to say that ganging two tuned circuits is child's play, but ganging three requires some care if the most satisfactory results are to be obtained.

Broadcast Brevities.

By Our Special Correspondent.

News for the Empire.

THE first step towards the development of the new Empire broadcasting scheme will be taken on Monday next, January 4th, when 5SW will begin a service of special news bulletins.

I understand that the bulletins will be given three times daily, i.e., at noon, 6 p.m., and midnight, and that they will be arranged by Reuter's Agency, with a view to their suitability for overseas listeners.

An Acceptable Service.

This is the phase of Empire broadcasting which it is thought will be most acceptable in the Colonies. The arrangement follows in plan the temporary service which was given just before the Colonial Conference in London in 1930, in order that the delegates coming to this country should already have a grasp of the possibilities of an Imperial broadcasting service.

It was then estimated by the B.B.C. that a news service of the kind now established would cost £2,000 per annum.

A Ceremony at Portland Place?

THE *Wireless World* was the first journal to draw attention to the unnecessary modesty of the B.B.C. in not arranging an opening ceremony for Broadcasting House. Even now, however, I believe that some sort of "send-off" may be arranged. In the last few days discussion at Savoy Hill has centred around the advisability of a religious dedication, and it is now quite probable that a special service of consecration may be conducted by the Archbishop of Canterbury.

That D'ary.

SIR JOHN REITH'S personal diary, to which he made reference in last week's *Wireless World*, is one of the most coveted of documents so far as the B.B.C. staff are concerned. For its pages register the Director-General's real thoughts and opinions upon the world and affairs.

Day by day the chronicle is added to, and, as the "Diary" attained its majority this year, it crystallises the impressions of an unusually penetrating mind over nearly eight thousand days.

Will the "D.G." ever be persuaded to publish extracts?

Growing Pains?

LISTENERS in the Midlands show hyper-sensitiveness in complaining that the Midland Regional station does not get its full share of publicity and original programme material. As a matter of fact, their station, from being a pure experiment years ago, is now one of the most reliable in the B.B.C. chain. And this is

not all. Negotiations are now in progress for enlarging the Midland Regional Headquarters in Broad Street, Birmingham.

What is there to grumble about?

Bright Colours at Falkirk.

THE transmitting hall at the Scottish Regional Station is to be gayer in appearance than those at Brookman's Park and Moorside Edge. I hear that the interior decorations are to be carried out in Acquainta—a washable distemper which lends itself to beautiful colouring.

I shall be disappointed if the B.B.C. fail to take advantage of this. When I go to Falkirk I shall expect to find the place rigged out in tartan.

Testing in May?

The station is well on the way to completion now, and it is hoped that public tests will be started in the late spring.

What the B.B.C. engineers are rubbing their hands over is the fact that the roof went on before the beginning of the winter storms.

A Mystery—

A DESOLATING discovery will be made in the near future. The voice of an eminent broadcaster will bring a

covey of reporters from Fleet Street to Savoy Hill, all eagerness to interview the great one before he leaves the building.

"He will not leave to-night," the commissioner will say. "Nor to-morrow night, nor the next."

—and the Solution.

The reporters will nudge each other as the boldest, in solemn tones, declares that "Murder will out." "Nor the next, nor the next, nor the next . . ." the commissioner will be babbling on, until the *Daily* — reporter, always first in murder cases, downs the man and, kneeling on his chest, squeezes out the truth in one word: "Blattnerphone."

I may add that a portion of this prophecy has already been realised.

"Half the Wcr'd Away"

THE lesson that the B.B.C. will learn from the disappointing postponement of the "Half the World Away" programme intended for Christmas Day will be that it is better not to announce plans until it is reasonably certain that they can be carried out at the time specified.

Laugh, Clown, Laugh.

TOMMY HANDLEY is still as bright as ever, despite having been mistaken for me. For a few moments one morning last week you would have found us the sole occupants of that repository of dog-eared literature, the Savoy Hill waiting-room. Tommy was dog-eared the telephone directory when a messenger flew in. "Are you," he asked, addressing Tommy, "the radio man?"

"Raining? No, it isn't," said Tommy.



THE WORLD'S FIRST THEATRE STUDIO. A scene in the new broadcasting studio erected in the Birmingham Repertory Theatre. It has been built by Sir Barry Jackson in co-operation with the B.B.C.

PHOTO-CELLS and their APPLICATIONS.

No. 3.—Colour Comparisons.

THE fact that the sensitivity of any photo-cell varies in different parts of the spectrum naturally suggests that this property could be employed to detect changes in the colour of the light reaching the cell. As is well known, the potassium cathode has a maximum sensitivity to blue light and is practically insensitive to red, the reverse being the case with the caesium-silver oxide cell. With such a combination of cells the discrimination of red from blue is naturally quite easy. Such obvious and extreme differences,

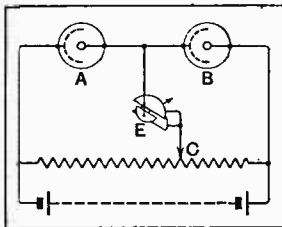

Fig. 1.—As cell A is blue sensitive and B red sensitive a change in the colour of the light reaching either cell will upset the balance previously obtained by the sliding contact C and resulting in an indication being obtained on the meter E.

however, are generally detectable by other methods and do not offer much difficulty.

the photo-cell is usually called upon to make discrimination of small colour differences as good as, or better than, that made by the eye, the problem most often being one which has successfully resisted all other methods of attack. Consequently, a complete solution of any particular problem may involve

elaboration which renders it impracticable in application. Colour problems usually resolve themselves into three groups:—

- The examination of liquids by comparison with a standard.
- Comparison of radiation from emitting sources.
- Matching of surfaces. The appearance, texture, and colour of materials.

The first group (a) generally permit of investigation by transmitted light, the comparison usually being between two liquids of similar nature, or between two samples of the same liquid, one of which may be regarded as the standard, it being required to operate some indicator when the second liquid differs in depth of colour from the first; or in the case of the process of mixing coloured solutions to cut off automatically the supply of one ingredient as soon as equality of colour has been attained. Actually, in such cases the problem becomes one of securing equality of transmitted light and the balanced two-cell circuit previously

Discriminating Small Colour Differences.

By R. C. WALKER, B.Sc.

described can be conveniently used. It is desirable to use vacuum cells of the same type whose cathodes are most sensitive to the colour absorbed by the solution. Preliminary experiments are usually necessary to decide this point as it has been found from experience

that visual judgment is nearly always too unreliable. Problems under heading (b) arise notably in connection with determination of temperature by colour as well as the brightness of light sources, and have been attacked by bridge circuits involving two photo-cells of different type having peak sensitivities at different parts of the spectrum. The primary emission of a photo-sensitive cathode to incident light of a definite wavelength is proportional to the intensity of that light, but the factor of proportionality differs with the type of cathode and with the wavelength of the light. If two cells, for which this factor is the same, are exposed to a source of light, and the light reaching one of the cells is adjusted by means of a shutter so that the currents in the two cells are equal, then the currents will continue to be equal when the source of light is changed for another of a different intensity or colour. If, however, the factor is different for the two cells, the currents will remain equal to one another only if the intensity changes while the colour remains the same, but they will not remain equal if the colour changes.

Bridge Circuits.

Thus, it is possible by detecting the out-of-balance current in a bridge circuit to determine whether two sources of light are of the same colour, though they may differ appreciably in intensity. This is illustrated diagrammatically in Fig. 1, A being a blue sensitive and B a red sensitive photo-cell, null deflection of the electrometer needle E being attained by sliding the movable contact C, both cells being exposed to the radiating source. More elaborate methods involving balanced cells have been developed¹ by the General Electric Co., Ltd., and applied to photometry and are now in use for the

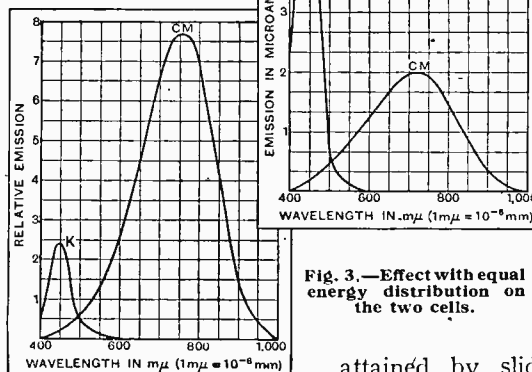

Fig. 2.—The curve "K" represents a measure of the effect of the light from a gas-filled lamp falling on a potassium cell. Curve "CM" shows the effect on a caesium cell.

Fig. 3.—Effect with equal energy distribution on the two cells.

¹ G. T. Winch, Journ. Sci. Inst., Vol. VI., No. 12, Dec., 1929, and Journ. I.E.E., Vol. 68, No. 401, May, 1930.

Photo-cells and Their Applications.—

accurate rating of lamps. Such methods furnish precision considerably in excess of that attainable by visual methods.

Comparison of surfaces under heading (c) perhaps includes the majority of colour problems in industry inasmuch as they so frequently occur in grading of all kinds of raw materials. The problem is generally to predetermine whether or not two surfaces will be judged alike when they are subsequently examined by the eye. The fundamental difficulty is that not only is it impossible to specify what is meant by a standard eye in respect of visual sensitivity throughout the spectrum, but also that the eye in judging a surface is influenced by factors other than colour. Thus, shade and depth of colour as well as texture of the surface all affect the final judgment, which is made by striking a balance of all these physical qualities. Two surfaces which appear alike may differ in all these qualities, and, conversely, objects of different appearance may differ in only one or in all three of these

ties. Machines which automatically sort cigars, coffee beans, eggs, etc., have been constructed and demonstrated, and mention has been made of them in the Press as interesting novelties, but the successful operation and adoption of such machines in industry is not borne out by facts. None, as far as is known, exist in this country.

If, of course, the surfaces under consideration do not differ appreciably in qualities other than colour, it frequently suffices to use the simplest method of all, viz., to measure the reflect-

ing power of the surface for white light with a single photo-cell. It can only be determined by trial whether the differences indicated are really those it is desired to measure. In any case, it is essential to ensure that no change in energy distributed occurs in the source of illumination by comparison of the sensitivity curves in Figs. 2 and 3. Fig. 2 is plotted for the radiation of a gas-filled lamp, and Fig. 3 for radiation with equal energy distribution. It is clear that for the two types of cell chosen the relative magnitude of their response is exactly opposite in the two instances. There is one special case of some

AN interesting application of the photo-cell is to the comparison of colour. This may be effected by the different colour sensitiveness of alternative types of cell or by the change in the behaviour of a cell when subjected to light of various colour when reflected from a surface under examination. In this connection the photo-cell has many industrial applications.

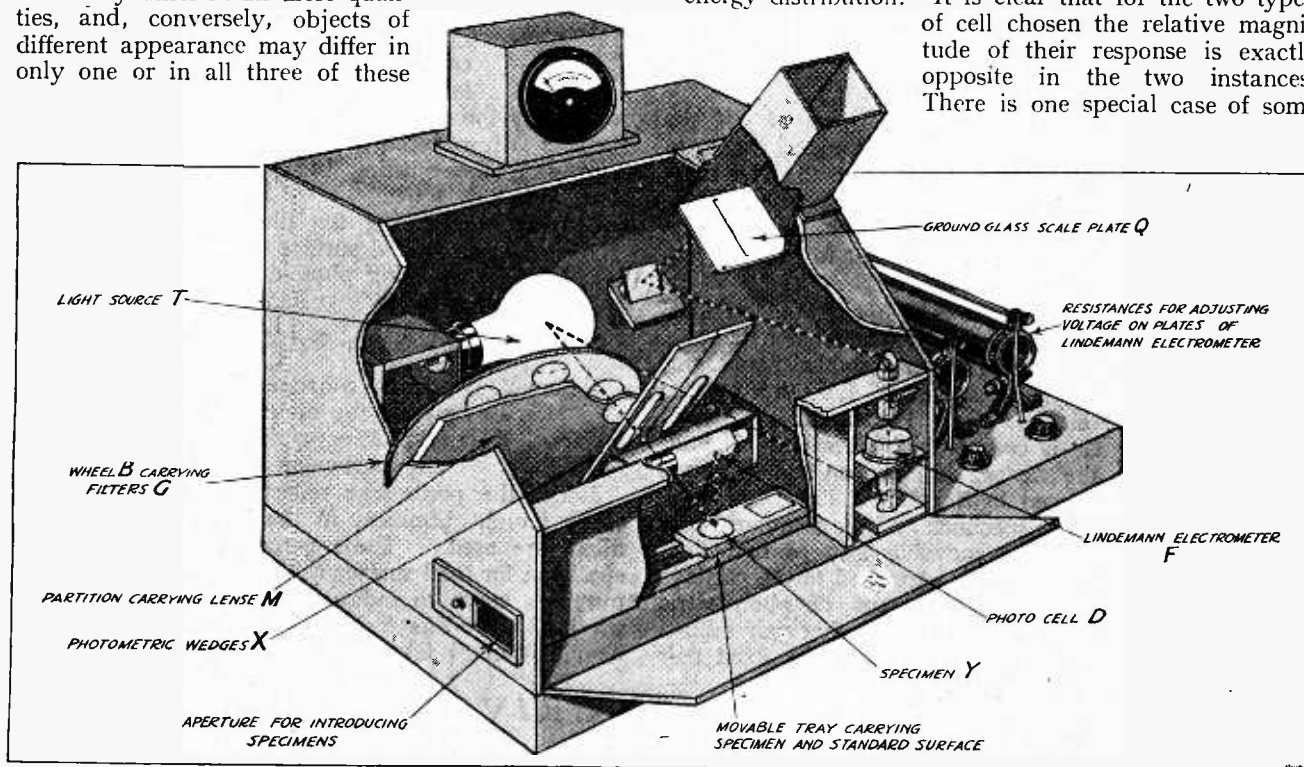

Fig 4.—Internal constructional details of the "Blancometer" used for the examination of fabrics, papers, and paints.

qualities. To decide, therefore, by physical measurement whether two surfaces will "look alike" is really an elaborate investigation and cannot generally be determined by any routine test. It will be appreciated, therefore, that the design of apparatus which has for its object the selection of materials and their separation according to shades of colour may involve great practical difficul-

considerable importance, namely, that of nearly white surfaces. It has been found that by using three appropriately chosen filters of quite broad transmission range the reflection or transmission coefficients relative to a standard white as determined for the three corresponding portions of the spectrum characterise the sample in a way which is extremely serviceable in

Photo-cells and Their Applications.—

industry and capable of discriminating differences not detectable by the eye.

An instrument termed the Blancometer has been developed on these lines by Messrs. Adam Hilger. Light from a lamp is reflected into a photo cell alternatively from the test surface under examination after passing through two fixed wedges and from a standard white magnesium oxide surface after passing through two adjustable wedges. The wedges consist of pairs of glass, wedge-shaped pieces of glass, so that the total thickness can be varied by sliding one over the other. The adjustable wedges enable equal deflections to be obtained in the two cases in an electrometer operating with the photo-cell. A similar determination using two magnesium oxide surfaces gives the zero position of the wedges. Equal deflection is obtained when the reflected lights are equal. If the gradation constant of the wedges is known, the ratio of the intensity of the reflected light in the two cases can be found. Colour screens adjusted to give definite spectral transmissions are inserted in the path of the light and enable readings to be taken for red, green, and blue, as well as white light.

Fig. 4 shows the internal and Fig. 5 the external arrangement of the apparatus. Light from a lamp T is divided into two beams by a suitable diaphragm, one beam illuminating the specimen, the other serving to illuminate the electrometer. The first beam passes through a filter G, is collimated by the lens M, and, passing through the wedges X, falls on the specimen Y at 45°, the reflected light entering the window D of the photo cell. The specimen and the standard white surface are placed on a movable tray so that light can fall on either as desired. Attached to the carriage holding this tray are the two pairs of photometric wedges, one pair being fixed and the other pair adjustable. The specimen is placed beneath the fixed pair

and the standard surface beneath the adjustable pair. The whole carriage is connected to the plate L (Fig. 5) which slides on the outside of the instrument. This plate L carries a graduated drum D which moves the adjustable wedges, complete revolutions being recorded on the counter S.

The second beam of light is reflected from two mirrors and passes into the Lindemann Electrometer F, the image of the needle being projected on to the scale Q by the optical system shown in Fig. 4. The adjusting screw Z (Fig. 5) projecting through the front of the case enables the electrometer needle to be kept in the field of view during large deflections. The sensitivity of the apparatus can be varied as desired by adjusting the voltages on the plates of the electrometer by means of resistances. Provision is

also made to enable the source T to be maintained constant. The wheel B which carries the filters projects through the left-hand side of the case and can be rotated by the observer. The tray containing the two surfaces is introduced through an opening close to the filter disc, the opening being constricted to exclude stray light.

If I_t = light reaching the photo-cell after reflection from tested surface

I_o = light reaching photo-cell from standard magnesium oxide surface.

Then it can be shown that $\frac{I_t}{I_o} = 10^{-Y(\beta-a)}$

Where Y = gradation constant of wedges.

a = zero reading of adjustable wedges.

β = any position giving equal deflections for any particular surface.

Hence the percentage reflection of the specimen is easily found. Similarly in the cases where the colour filters are used. These percentages characterise the specimen for total surface reflection and for all practical purposes serve to indicate the colour of any nearly white object. The instrument finds application in the examination of fabrics, papers, powders, and paints.

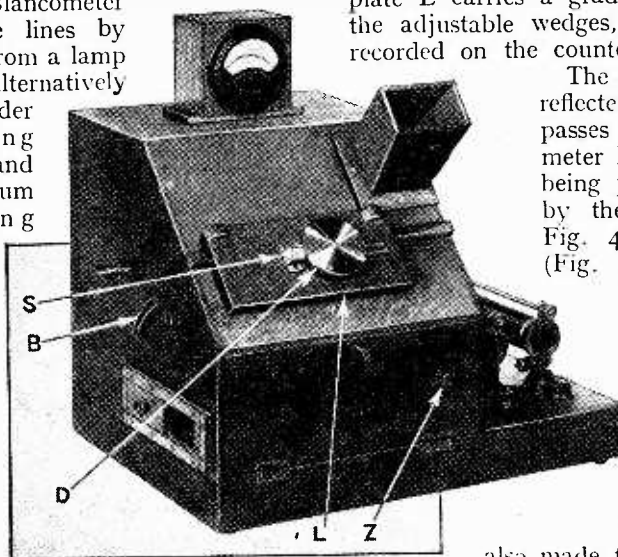

Courtesy Messrs. Adam Hilger, Ltd.

Fig. 5.—The "Blancometer" showing the external control.

BOOKS RECEIVED.

Radio Research Board Report for the period ended September 31st, 1930, and including Investigation on Propagation of Waves, Directional Wireless, Atmospheric, Aerials, Transmitting and Receiving Apparatus for Waves below 15 Metres, Development of Radio Frequency Standards, Electrical Measurements of Radio Frequencies, and list of Papers, etc., published between April, 1929, and December, 1930. Pp. 90, with 41 diagrams. Published by H.M. Stationery Office, price 2s. net.

o o o

Radio and Electronic Dictionary, compiled by H. P. Manly, comprising about 3,800 definitions of terms used in Radio Transmission and Reception, Phototelegraphy, Television, Sound Pictures, and Electricity and Magnetism as Applied to

Wireless. Pp. 300, with 550 illustrations. Published by F. J. Drake and Co., Chicago, U.S.A., price \$2.50.

Electricity: What It Is and How It Acts. Vol. II, by A. W. Kramer. The part played by the Electron in the propagation of light, radiation of heat, wireless waves, etc. Pp. 290+xiv, with 112 illustrations and diagrams. Published by Technical Publishing Co., Chicago, U.S.A. Price \$2.

Electricity in Our Bodies, by Bryan H. C. Matthews, M.A., Animal Electricity, the Sense Organs, Reflex Action, the Effect of Electricity on the Body, etc. Pp. 108, with 19 diagrams. Published by George Allen and Unwin, Ltd., London, price 6s. net.

WIRELESS ENCYCLOPEDIA

No. 9

Brief Definitions
with Expanded
Explanations.

DECIBEL. The practical unit of gain or loss in telephone and kindred circuits. It is one-tenth part of a "bel," which is the logarithm to the base 10 of the ratio of two powers to be compared in a given impedance. If, by a specified change of conditions, the power in a circuit or device is changed from P_1 to P_2 the number of decibels change is $10 \log. P_2/P_1$, being a gain if positive and a loss if negative.

IN line or radio telephony the ultimate object is the conversion of electrical variations into sound waves, and the response of the human ear to sounds of different frequencies and intensities presents considerable complexity when an attempt is made to give it numerical interpretation on a scientific basis. For instance, if the power imparted to the surrounding air by the diaphragm of a loud speaker is doubled, the increase in volume, as appreciated by the ear, is only just perceptible, and not doubled, as might be expected. The relative intensity of the sound does depend on the power ratio, but its effects on the ear are not directly proportional to it, and the decibel scale is one which enables a response curve to convey, through the medium of the eye, about the same effect as will be appreciated by the ear.

A tenfold increase in power represents a gain of one "bel," a unit named after Alexander Graham Bell. Now the common logarithm of 10 is 1, and for any other power-

is 2, because $100 = 10 \times 10$ or 10^2 . The reason why logarithms are chosen is that equal ratios are represented by equal distances on a linear scale, and so multiplications and divisions are reduced to additions and subtractions.

The decibel (db), as the name implies, is one-tenth part of a bel, and thus a gain or loss in decibels is ten times the logarithm of the power-ratio. When the power given to a circuit is doubled the number of decibels gain is just over 3, because the logarithm of 2 (which is the power-ratio) is 0.301.

Now, in dealing with amplifiers, gramophone pick-ups, etc., the gain or output is most conveniently calculated or measured in terms of the voltage. But a voltage ratio is not a power-ratio, and it is essential to know the latter before the gain or equivalent power level can be expressed in decibels. Fortunately, the process of conversion is simplicity itself, for the power in a given impedance is proportional to the square of the voltage. For instance, a tenfold increase of voltage represents a hundredfold increase of power, and so the number of decibels is ten times the logarithm of 100, the result being 20 db in each case. Thus the number of decibels change is equal to twenty times the voltage ratio. If a gramophone pick-up gives 0.2 volt at 1,000 cycles and 1 volt at some other frequency, the number of decibels gain over the 1,000-cycle value is twenty times the log. of the voltage ratio 5, being 20×0.7 or 14 db.

Figs. 1 and 2 are given to enable a curve drawn to the decibel scale to be compared with the same curve drawn to a linear scale of voltages. Fig. 1, drawn to a decibel scale,

illustrates at a glance a fairly true impression of the performance of a pick-up over the frequency range, the gain or loss in decibels being relative to the output at 1,000 cycles. Fig. 2, on the other hand, in which the actual voltage output is plotted against frequency, does not enable a true estimate of the actual state of affairs to be obtained, for, in the first place, the acoustic output at any frequency relative to that at 1,000 cycles depends on the square of the voltage ratio. And yet by plotting a curve of volts squared would make matters worse, for then the peak value at 60 cycles would be about 10 times greater than the 1,000-cycle value, so that the irregularities of the pick-up would be grossly magnified according to the interpretation of the eye. If, however, the values of voltage squared are plotted to a logarithmically ruled scale as is done for the frequencies in Figs. 1

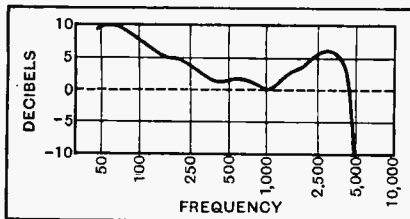

Fig. 1.—Gramophone pick-up response drawn to a decibel scale. This gives a true impression of performance, the gain or loss being relative to the 1,000-cycle output.

ratio the number of bels is represented by the logarithm of that ratio. The common logarithm of a number is simply the number of times that the base 10 has to be multiplied by itself to give the number in question. For instance, the logarithm of 100

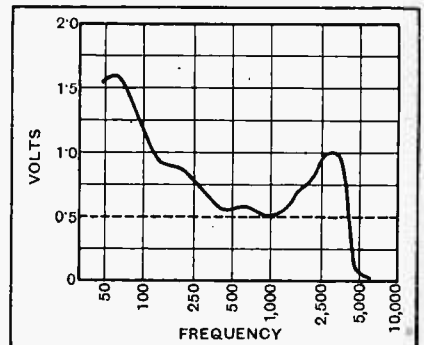
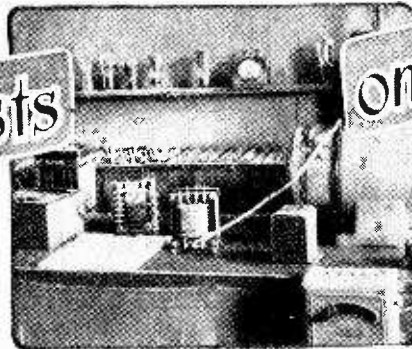

Fig. 2.—Voltage-frequency response of pick-up. An exaggerated estimate of performance is given by the curve.

and 2, the curve will have the same shape as in Fig. 1. Although this eliminates the calculation of decibel values it omits the main advantage that a multiplication or amplification is reduced to a simple addition.

Wireless World
Laboratory Tests



on New Apparatus

**BRYCE A.B.25
MAINS TRANSFORMER.**

The model A.B.25 mains transformer has been designed especially for use in the Variable-mu Three receiver described recently in this journal. Tappings are provided on the primary winding for supply voltages of from 200 to 240 at 40 to 60 cycles, and all secondary windings are centre-tapped. An iron core of generous size is used, and special cast



Bryce mains transformer Model A.B.25, intended for use in the Variable-mu Three receiver.

aluminium end-plates clamp the laminations together and serve, also, as fixing supports for the terminal board. The transformer can be mounted either vertically or in a horizontal position.

Tests were made using a "B" type full-wave rectifying valve (Mazda U.U.120-350), and with all windings loaded to simulate the conditions obtaining in the receiver the L.T. voltages were absolutely correct. Before smoothing the rectified output is 260 volts at 70 mA., and after smoothing the voltage will be brought down to the level required to operate the set.

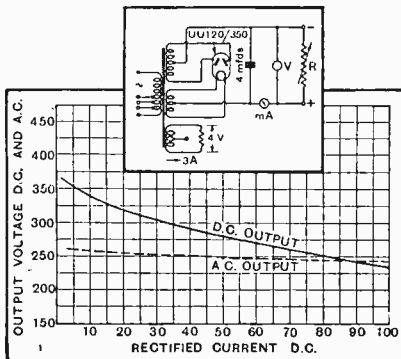

Regulation curves showing the output under full load conditions from Bryce mains transformer Model A.B.25.

Components Reviewed.

Voltage regulation is good throughout, the output from the H.T. secondary winding changing by only 6 per cent. between no load and full load conditions. Special attention is given to the insulation between windings, a material described as "Millimil" being employed. It has exceptionally good insulating properties, is virtually unaffected by high temperatures, and is non-inflammable. At boiling point it becomes soft, but hardens immediately on cooling without detriment to its insulating properties.

Its heat-resisting feature is interesting only in passing, for there is no noticeable temperature rise in the transformer under working conditions, and considerable overload can be tolerated for short periods without damaging the component in the slightest degree.

The model A.B.25 is a thoroughly sound job, and, at the price of 30s. 6d., is exceedingly good value for money. The makers are W. Andrew Bryce & Co., 54, Dawson Street, Bury, Lancs.

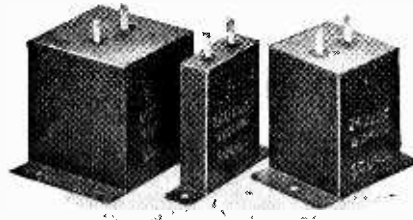

Sound Sales fixed condensers. A 4-mfd. 500-volt type; 4-mfd. and 1-mfd. in the 240-volt series.

SOUND SALES MAINS CONDENSERS.

A range of large-capacity fixed condensers made in 1-, 2-, and 4-mfd. sizes has been placed on the market by Sound Sales, Ltd., Tremlett Grove Works, Junction Road, Highgate, London, N.19. The best material only is used in the construction, and they are particularly well suited for use as smoothing and by-pass condensers in mains sets.

The normal working potential is 240 volts D.C., but the 2- and 4-mfd. sizes can be obtained for 500 volts D.C. working, the prices being 6s. 6d. and 11s. respectively. The lower voltage models cost 2s. 4d. for a 1-mfd. size, 3s. 2d. for a 2-mfd. size, and 5s. for a 4-mfd. size.

The condensers are housed in metal

cases with the soldering lugs protruding through the top. On test the condensers proved to be entirely satisfactory, and they are British made.

WEARITE SHORT-WAVE COMPONENTS.

Among some components sent in by Wright and Weaire, Ltd., 740 High Road, Tottenham, London, N.17, are two which would prove satisfactory in the special superheterodyne short-wave adaptor described in *The Wireless World* last week.

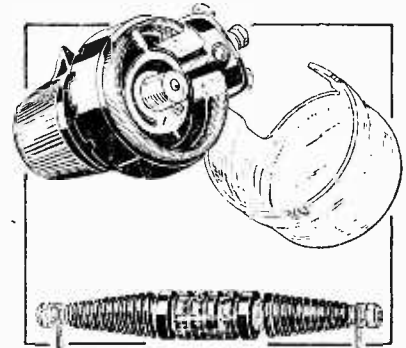

Wearite short-wave choke and 25,000-ohm potentiometer suitable for use in the recently described superhet adaptor.

One is an H.F. choke designed especially for short-wave circuits, and has the very low self-capacity of 3 mmfd. only. Its inductance is some 4,000 μ H., and the choke is effective from 10 to 150 metres approximately.

It is wound on an ebonite former in seven sections, with the last dozen turns wound in a tapered spiral groove at either end. The choke is comparatively light in weight, and it could be suspended on the wiring, but we understand that a special baseboard mount is available if this method of fixing is preferred. The price is 4s. 6d.

The other component is a 25,000-ohm wire-wound potentiometer, the resistance element of which is partially screened by an aluminium cover. It has a smooth action and is quite silent in operation. At the price of 4s. it represents excellent value for money.

CABINETS FOR TELSEN VICTOR 3 KIT SET.

There is now available a wide range of cabinets from which to choose for the popular Telsen Victor 3 Kit Set. Two models are made by Radio Cabinets (Walsall), Ltd., Stafford Street, Walsall. The "Dome" model, which costs 21s., has been designed to accommodate a loud speaker and the batteries in addition to the set, and it can be obtained finished either in mahogany or walnut.

A well-made cabinet for housing the set only, and finished either in mahogany or walnut, is obtainable from the same firm at 12s. 5d.

W. & T. Lock, Ltd., 11, Red Lion Square, High Holborn, London, W.C.1, are marketing an American-type cabinet for this set which, finished in oak, is available at the very reasonable price of 10s. 6d.

Those desirous of constructing a cabinet themselves will be interested in the special "Byldurone" parts marketed by J. J. Eastick & Sons, Eelex House, 118, Bunhill Row, London, E.C.1. The set of angle-pieces costs 4s. 6d. Ready-made, and covered in crocodile or lizard cloth, the cabinet can be obtained at the price of 9s.

o o o o

UNLIMITEX CONDENSERS AND SLOW-MOTION DRIVE.

These condensers are of French manufacture, and are designed on low loss lines. That is to say, the amount of metal in the frame has been reduced to the absolute minimum compatible with mechanical rigidity. The insulated supports for the fixed vanes consist of a transparent material, amber coloured, which appears to be pure bakelite, and as a consequence should possess exceptionally good electrical qualities. The general form of construction, coupled with the special plate shape adopted, assures a low minimum capacity.

There are two types available, viz., the type A and the type B. The first mentioned are fitted with adjustable spindles, and provision is made for ganging two or more condensers so that they can be driven by a single dial. They are made in 0.00035 mfd. and 0.0005 mfd. sizes, and cost 5s. each. A special short-wave model with double spacing and in sizes of 0.00015 mfd. and 0.00025 mfd., costs 6s. 9d. each.

The model B is fitted with a built-in fast- and slow-motion mechanism, giving a reduction of 30 : 1 in the case of the

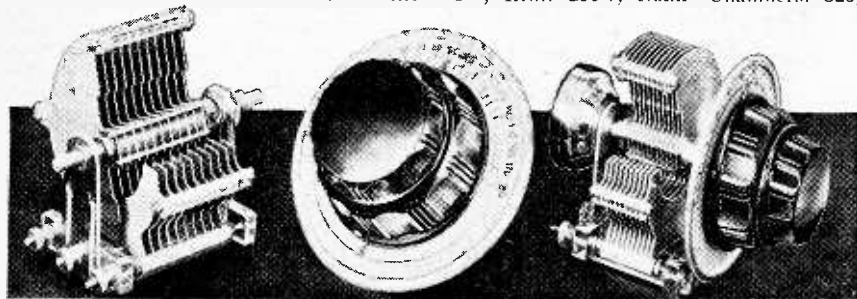

Unlimitex short-wave condenser, slow-motion dial and model B condenser of 0.0005 mfd.

normal standard capacities, and 60 : 1 in the case of the special short-wave models. The prices are 8s. 6d. each for 0.00035 mfd. and 0.0005 mfd. sizes, and 11s. 6d. for the short-wave type.

The fast- and slow-motion dial, with which is supplied an engraved aluminium scale, affords a 60 : 1 reduction drive, and costs 4s. It is available finished in either black or brown, and it is entirely free from backlash or slip.

B 25

These condensers are marketed by Wireless Supplies Unlimited, 278-280, High Street, Stratford, London, E.15.

CLARION CABINET FOR SINGLE DIAL SUPERHETERODYNE.

A specimen cabinet designed especially for the Single Dial Superhet described recently in this journal has been received from Clarion Radio Furniture, 28-38, Mansford Street, London, E.2. It is substantially made in oak and provided with a separate front panel, also in oak, with all the necessary holes drilled in their correct positions. A stout plywood base-board is included on which can be mounted the chassis.

Although the set may be fitted in a cabinet with a fixed front, the advantage of a separate control panel is that all constructional work and testing can be carried

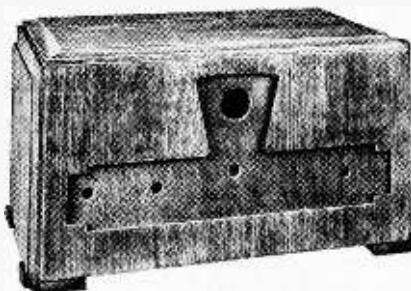

Clarion cabinet in polished oak for Single Dial Superhet.

out with the set in its most accessible form, and when final adjustments have been made the complete assembly pushed into the cabinet from the back without disturbing a single part. Finished in light oak and polished, the price is 25s. 6d. complete.

o o o o

FOTOS "NIPPER" TRANSFORMER.

These intervalle transformers are made in France, and distributed in this country by the Concerton Radio and Electrical Co., Ltd., 256-7, Bank Chambers, 329,

primary is 680 ohms. To obtain the best results the transformers should be preceded by a valve of comparatively low

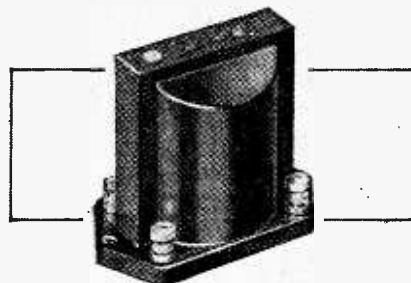

Fotos "Nipper" intervalle L.F. transformer.

A.C. resistance. The 1 : 5 ratio should be used in the second stage where two L.F. valves are employed.

o o o o

POLAR GANGED CONDENSERS.

We are advised by Wingrove and Rogers, Ltd., Arundel Chambers, 188-189, Strand, London, W.C.2, that ample stocks of Polar Tub 2, Tub 3, and Uniknob condensers are now available, and that immediate delivery can be assured.

Where difficulty is experienced in obtaining supplies from local dealers, customers are advised to communicate direct with the manufacturers.

Trade Notes.

A. F. Bulgin and Co., Ltd., 9-11, Cursitor Street, Chancery Lane, London, E.C.4, have been appointed the sole London agents for "Simplicon" condensers, manufactured by Williams and Moffat, Ltd., of Birmingham.

o o o o

The Rothermel Corporation, Ltd., 24-26, Maddox Street, London, have acquired more commodious premises at 1A, Willesden Lane, Kilburn High Road, London, N.W.6. The new telephone number is Maida Vale 5061.

Catalogues Received.

Lauchester's Laboratories, Ltd., Spring Road, Tyseley, Birmingham.—Illustrated booklet describing the Lauchester range of loud speakers and output transformers.

o o o o

Westinghouse Brake & Saxby Signal Co., Ltd., 82, York Road, King's Cross, London, N.1.—The All Metal Way for 1932; a useful handbook for those interested in the various applications of the Westinghouse metal rectifier.

o o o o

Baker's "Selhurst" Radio, 89, Selhurst Road, South Norwood, London, S.E.25.—Publications P.M.1 and E.M.1 respectively dealing with their range of permanent magnet and energised-type moving coil loud speakers.

o o o o

English Steel Corporation, Ltd., Vickers Works, Sheffield.—Illustrated brochure, "Magnets and Magnet Steels," giving technical data relating to the magnetic properties of Tungsten steel, Cobalt-Chromium steel, and sundry other similar alloys used in the construction of permanent magnets for radio and other purposes.

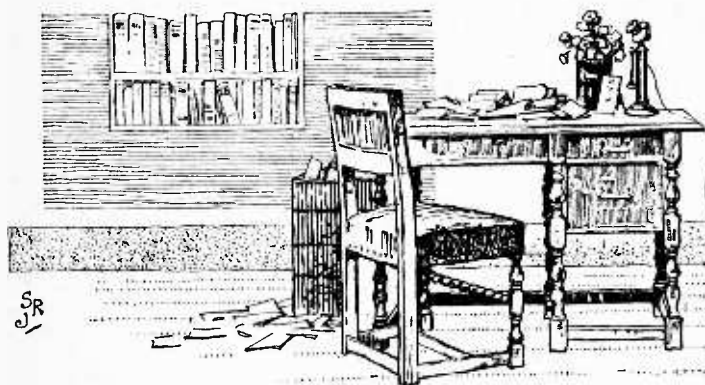

The Editor does not hold himself responsible for the opinions of his correspondents.

Correspondence should be addressed to the Editor, "The Wireless World," Dorset House, Tudor Street, E.C.4, and must be accompanied by the writer's name and address.

SLOW-SPEED RECORDS.

Sir,—In your issue of December 16th Mr. Huxter states that the next step in regard to gramophone reproduction is the long-playing record. I believe that a number of your readers will be interested to know that the long-playing record came in some years ago, and unfortunately faded out.

Having promoted the Southsea Gramophone Society, I do not think I am exaggerating when I claim to be the first to demonstrate the Pemberton-Billing device in the Portsmouth district. This consisted of a rubber-tired wheel running on the face of a record made on the slow-motion principle. The wheel and its carriage was fed inwards from the periphery by means of a worm. A governing device was mounted upon the whole, so that as the wheel traversed inwards its shortened path allowed the record to gradually gather speed, thus compensating the diminishing spiral, and affording throughout the record a constant tracking speed under the needle. A record of the twelve-inch size used to run for almost twenty minutes to the side.

Musically it was not as great a success as the ordinary disc. Being about the year 1923, we had not arrived at electrical recording. The discs themselves were on the expensive side, and the subject matter generally did not give the device a really fair showing. Another difficulty was the gramophonist's motor. Generally it was not strong enough to drive the two sets of governors, and I managed this by taking out the set belonging to the motor.

Dialogue, and the spoken word generally was quite perfect, and Fred Duprez's record of "Do Married Men Make the Best Husbands" was a sheer delight, and ran for twenty minutes.
London, N.W.8. FREDERIC JACKSON.

Sir,—I have just read with some interest the letter from Mr. H. A. Huxter in your December 16th issue.

I agree with him that the necessity for frequent changing of ordinary records can be annoying and that the "complicated and expensive machinery" of automatic changers is quite unnecessary with the slow-speed records available.

Messrs. Columbia, I believe, already issue quite a good series of 12in. records, playing at the slow speed of 33 r.p.m., but the radio-gramophone enthusiast is prevented from utilising these and similar records as there are no suitable motors for home use available. I recently communicated with nearly every English manufacturer regarding a suitable motor for home use giving both the normal speed of 78 and the slow speed of 33, only to receive replies indicating a complete lack of interest.
Norwich. M. C. LAMBERT.

INTERFERENCE TROUBLES.

Sir,—I certainly think your correspondent, Mr. Nugent C. A. Gilders, is looking at the interference problem from a very wrong angle. He mentions lack of capital; then let him digest this:—

I have for my private use one D.C. to D.C. rotary transformer, 250 volts input—15 volts 5 amps. output, which I use for charging my accumulators. Until recently it was quite impossible for me

to listen-in whilst charging, and a neighbour of mine whose set is about 12ft. away *via* a brick wall complained to me of the "crackling" he picked up. I knew it was due to my "charger," and so I wrote to the B.B.C. for expert advice. They referred me to the G.P.O., who sent a representative to me. He showed me how to make a filter for my type of machine, merely two 2-mfd. condensers across the mains input, to my charger. The condensers are in series with mid-point earthed.

I can now listen in comparative comfort to my own wireless, and, of course, my neighbour is absolutely satisfied. My set is about 15ft. from the charger and has all A.C. valves, although the filaments are heated by accumulators, and comprise 2-S.4.V.B.s choke-coupled to a 354-V. as detector, then 2-164V.s in push-pull, followed by 2-D.025s in push-pull and one large Epoch moving coil, *no* reaction.

I have to pay 6½d. per unit for my "juice," not having a power line, and it is still much cheaper than the "outside man" will do them for; also, it requires about 250 watts input to my charger to get the full load output of 75 watts.

What has your correspondent got to say about interference and lack of capital now?
London, E.C.2. J. HELPS.

Sir,—After reading Mr. Nugent C. A. Gilder's interesting, if not instructive, letter I was left pondering. Does he really suggest we should add one or two extra H.F. stages at 30s. upwards a stage to those we already gloat over—alternatively that we lose our sensitivity, thanks to our abbreviated aerial, and—the poor old B.B.C. has to spend more hard-earned thousands to help the "unselectivity" problem?

No! No! No! Nugent C. A. Gilder, this is a hard world, with "Progress" as its watchword (and its big expense). Your ingenuous solution (?) that we should spend our collective hundreds of pounds on such a basically unsound scheme to save a few pounds is dismissed. Let us forget it.
Cheshire. FRANKLIN JUDGE.

"THE WIRELESS ENGINEER"

A new volume commences with the January number of "The Wireless Engineer," which is a monthly technical journal for the radio engineer and advanced student. Besides its technical articles, the paper contains a monthly record of abstracts of the technical radio literature of the world.

If you place your order now with the publishers you have the advantage of commencing with the first number of the new volume.

Special articles in the January number include:—

Amplifier Tone Control Circuits.

Apparatus for Exhibiting Properties of Coupled Circuits.

The Gain Control and the Decibel.

Published from the offices of *The Wireless World*, Dorset House, Tudor Street, E.C.4. Annual Subscription, 32s., or Single Copy, 2s. 8d. post free.

Readers' Problems.

These columns are reserved for the publication of matter of general interest arising out of problems submitted by our readers.

Readers requiring an individual reply to their technical questions by post are referred to "The Wireless World" Information Bureau, of which full particulars, with the fee charged, are to be found elsewhere in this issue.

"Tuning-out" a Heterodyne.

IT has been asked whether a half-henry air-cored choke, made in accordance with the specification published in *The Wireless World* for November 11th, could be employed satisfactorily in an acceptor circuit for eliminating a steady heterodyne whistle, due to an interfering transmission. The query relates to a set including a two-stage resistance-coupled L.F. amplifier.

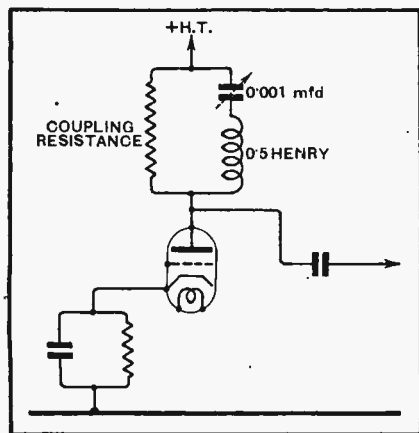

Fig. 1.—Tuned acceptor circuit shunted across a coupling resistance.

Within limits, a certain amount of relief from this form of interference can be obtained in the manner suggested, but the choke in question has a resistance which is perhaps rather on the high side for this particular purpose; it was primarily designed for use in a circuit where a certain amount of incidental resistance is not a matter of any importance.

At the worst, no harm will be done by trying this device, and it is suggested that the tuned acceptor should be connected across the coupling resistance of the first L.F. stage in the manner shown in Fig. 1. For tuning purposes the semi-variable condenser of about 0.001 mfd. maximum capacity should be about right.

An Unattractive Volume Control.

A CORRESPONDENT has found by experiment that signals from his local station, which are normally overpowering unless volume control is applied, can be reduced to a comfortable level of intensity by shunting the 0.01 mfd. coupling condenser used in his band-pass input filter with a condenser of 1 mfd. He asks whether there is any

theoretical objection to including this arrangement as a permanency by making provision for placing in circuit the extra condenser by means of a "local distance" switch.

By making the alteration described, our correspondent has in effect reduced the coupling between the component circuits of his filter to an extremely low value; indeed, they are probably linked only by stray coupling due to the wiring and to slight imperfections in the screening. We can well understand that a great reduction in signal strength will take place, but we feel bound to say that the arrangement is not one that appeals to us. It seems illogical to go to the trouble of setting up a comparatively elaborate filter circuit with the object of attaining selectivity without loss on sidebands, and then, for reception of the local station—from which the best possible quality is presumably desired—to throw away the main advantage of the filter by reducing inter-circuit coupling.

There are several other methods of volume control that are almost equally simple, and which have not this disadvantage.

Field Winding Connection.

THE moving-coil loud speaker specified for the "Wireless World A.C. Three" is fitted with alternative terminals for field exciting voltages of 110 and 220 volts. In the construction of the original model the panel carrying these terminals was removed and connection was made directly to the ends of the magnet winding.

Some confusion has arisen as to which terminal should be used in cases where the terminal board is retained. The answer is that connection should be made to the 110-volt terminal.

Matching Dissimilar Coils.

A READER who has been unfortunate enough to damage the windings of one of a set of matched tuning coils to such an extent that it became necessary to rewind it has found that the wire used, though of the same gauge as originally used, has apparently a thinner covering, with the result that a coil of the same number of turns takes up less space than previously.

As a result of making a test, it is found that the repaired coil cannot be "matched" with the others by the usual means, and advice is sought as to the simplest procedure that will give satisfactory results.

Although it is easy enough to match a set of coils that are physically similar, difficulties are likely to arise in the present case, and we think our best course is to refer the querist to the "Hints and Tips" section of *The Wireless World* for December 2nd, where, under the heading of "Matching Frame Aerials," a method was described that should be applicable where windings that are physically dissimilar are to be matched.

Although the procedure may appear to be somewhat complicated, we can assure him that perfect matching cannot be attained in any simpler way.

Milliammeter Connections.

ALTHOUGH the operation of ganging the "Wireless World A.C. Three" can be carried out quite satisfactorily by aural means, the use of a milliammeter in the detector anode circuit allows the necessary adjustments to be made with perhaps a greater degree of accuracy. It seems that there is some uncertainty as to the proper connections of the indicating instrument; in one or two cases instability has been produced by inserting it in circuit, while other reports would indicate that it has been connected in an incorrect position, with the result that current for the H.F. anode and pentode screen circuits has been passed through it, in addition to that consumed by the detector.

The correct method of connection is shown in Fig. 2 (a), from which it will be noted that it is joined in the H.T. feed lead at the low-potential end of the coupling resistance. Matters must be so arranged that the meter is at the "dead" side of the by-pass condenser C_{11} , otherwise the instability already mentioned will almost certainly become evident.

An examination of the receiver will show that in order temporarily to make the

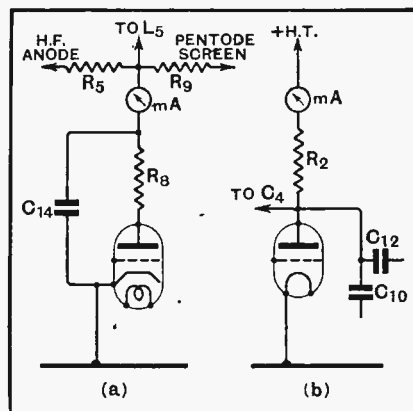

Fig. 2.—Correct position for a milliammeter in the detector anode circuit of the "Wireless World Three" (A.C. and battery models).

addition in question it will be necessary to make one or two minor alterations to the wiring. In the case of the battery-operated model of this receiver the meter should be connected as in Fig. 2 (b).

The "Single-dial Super."

REQUESTS have been received for information as to how a gramophone pick-up might be added to the "Single-dial Super" recently described in these pages. Doubts have been expressed as to whether this addition can be made to a superheterodyne receiver without difficulty; uncertainty on this point may be set at rest by saying that the superheterodyne is just as suitable as any other set for gramophone reproduction, and no

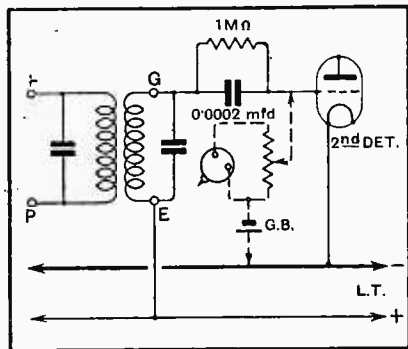

Fig. 3.—Connections of a gramophone pick-up in the second detector grid circuit of the "Single-dial Super."

greater difficulties are likely to be encountered in making slight alterations that are necessary. In the present case, the only limiting factor is the output available from the pentode valve.

The basic alterations necessary are shown in Fig. 3, which shows the simplest possible way of making the conversion. Additional wiring is shown in dotted lines. The constructor may suit his own convenience with regard to the details in carrying these alterations into effect. For instance, a switch may be fitted in order to place the pick-up in or out of circuit, or alternatively, a plug-and-socket arrangement may be devised if preferred.



An Automatic Safeguard.

A DRY-CELL H.T. battery of the best type can, when new, give a surprisingly heavy current, amounting to several amperes, but only for a short space of time. This many wireless users have proved to their cost by burning out the filaments of their valves, and so it is naturally concluded that an H.T. eliminator is equally a potential source of danger.

Fortunately this assumption is hardly correct, and in practice it is seldom that any damage is done to valve filaments through an accidental contact. There are so many incidental resistances in the rectifier and smoothing circuits that the maximum current that can be delivered is generally too small to do any serious harm.

The risk is somewhat greater in a D.C. mains set than in the case of an A.C. supply, but even here the smoothing choke is often of sufficiently high resistance to limit current to a sufficient extent. This explains the problem of a correspondent who states that although the H.T. leads were inadvertently joined across his series-connected $\frac{1}{2}$ -amp. valve heaters, no ap-

parent harm was done. Assuming a mains supply of 200 volts, a choke with a resistance of 400 ohms—not an abnormal value—would automatically keep down the current flow to the rating of the valves.



Looser Coupling Needed.

TO judge from our correspondence, the merits of a two-circuit tuner in the way of giving selectivity without any obvious loss of signal strength are now appreciated to a greater extent than ever before, but it is clear that full advantage of this highly satisfactory arrangement is not always obtained.

An analysis of the symptoms described in letters from readers who have failed to obtain entirely satisfactory results would suggest that in almost every case troubles are due to their failure to make provision for sufficiently loose coupling between primary and secondary circuits. One can never be certain that a two-circuit aerial tuner is working properly unless it is possible to reduce coupling so much below the optimum value that a clearly perceptible falling off in signal strength can be observed.

In practice this means that when simple magnetic coupling between the two coils is employed, provision must be made for sufficient spacing between the windings; it is not always possible to reduce transference of energy to a sufficient extent merely by changing the relative axial positions of the coils unless they are well spaced.

Capacity-coupled tuners are perhaps more popular, due to the ease with which they may be assembled, and here excessive inter-circuit coupling is generally due to the use of a coupling condenser with a minimum capacity that is much too high, or to excessive stray magnetic coupling between the coils.



Metal Chassis Dimensions.

FOR the benefit of those who wish to mount the recently described "Single-Dial Super" in an existing cabinet, it may be stated that the overall width of the standard metal base-plate is 16in. Its depth (back to front) is 9 $\frac{1}{2}$ in., but it may be necessary in some cases to allow an extra inch for the projecting terminals at the back.

Questions have also been received as to the overall height; an allowance of 8in. will be sufficient for this dimension. Another question relates to the use of loud speakers other than those of the special types designed for operation with the new high-efficiency pentodes. In such cases the loud speaker must be matched to the output valve by a transformer or by a special choke, preferably of the multi-tapped variety. Both these devices are used in conjunction with a shunted tone corrector consisting of the usual resistance and condenser.

With regard to practical details, the extra output circuit component may conveniently be mounted on the inside of the back cover of the cabinet specified, connection being made to the output valve circuit by means of short flexible leads.

The "Band-Pass Pentode Three."

CONSTRUCTORS of this receiver have in some cases failed to obtain results on the long-wave band that are comparable with those on the medium band, and have asked for suggestions.

Disparity of performance between the two wavebands is almost invariably traced to the presence of parasitic oscillations in the detector circuit; no beat note will be heard, but the detector will be more or less paralysed. A certain indication of the presence of this trouble is afforded by inserting a milliammeter in the detector anode circuit, if current falls on switching over to the long-wave band, it will certainly be present.

A simple cure is afforded by the connection of a non-inductive resistance of 500 or 600 ohms in series with the reaction coil and reaction condenser.



A Sign of Instability.

SEVERAL recent letters dealing with "H.F." sets having a ganged tuning system contain statements to the effect that self-oscillation can be provoked by adjustment of the trimming condensers.

Our correspondents do not always seem to realise that this symptom denotes a very unsatisfactory state of affairs; it proves conclusively that the H.F. stage (or stages) are unstable, self-oscillation being produced as grid and plate circuits are brought closely into tune. It should be realised that the effect is precisely the same as that encountered in an unstable set with separate tuning controls for each circuit, and the remedy is the same. The usual causes of instability are inadequate screening or insufficient decoupling.

FOREIGN BROADCAST GUIDE.

PALERMO (Italy).

Geographical position: 38° 06' N.; 13° 20' E.
Approximate airline from London: 1,135 miles.

Wavelength: 542.5 m. Frequency: 553 kcs. Power: 4 kW.

Standard time: Central European (one hour in advance of G.M.T.)

Standard Daily Transmissions.

09.50 G.M.T., sacred service (Sun.); 12.30, gramophone records; 19.00, variety, news; 20.00, time signal, concert or operatic relay; 21.55, news.

Announcers: Man and woman.

Opening call: *Ente Italiano Audizioni Radiofoniche, Stazione di Palermo*, abbreviated between items to E.I.A.R. (phon: *Eh-yah*), *Radio Palermo*.

Opening signal: Gramophone record (organ, bells, etc.). Closes down with opening call to which is added *Fine della trasmissione* and good-night greetings (*Stenori, Buona notte*) followed by Italian National Anthem and Fascist hymn (*Giovinetta*).

THE · SET · YOU · WILL · EVENTUALLY · BUILD

DUX

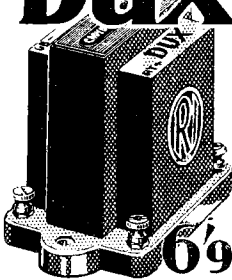

The Reliable Low Priced Transformer with the amazing performance. Its primary inductance is **30 HENRIES** and it has a performance that is guaranteed by the full technical data given with it.

Ratio 1-3½ (standard) and 1-4½ (auto-connection).



ROY. O.S., ENGLAND.

SINGLE DIAL SUPER
made possible by

COLVERN COILS



Components	Specified
Set of 3 coils, K21, K22, K23, Complete with screens (patent pending)	37/6
Two Colverdynes. Type 110	12/6 each
Variable Colverstat, S.T.10, 50,000 ohms	5/6

COLVERN LTD., MAWNEY RD., ROMFORD.

Wireless World's Choice . . .

J.B. GANG CONDENSER

TYPE R3W
29/6



PRECISION INSTRUMENTS

Advt. of Jackson Brothers, 72, St. Thomas' St., London, S.E.1.
Telephone: Hop 1887.

Ready Shortly:

THE HAYNES A.C. SINGLE DIAL SUPER

Another leader in design.

For complete details **REGISTER** your name on our Mailing List.

A queries service is now at your disposal. 2/6 each communication.

THE Wireless World **SINGLE DIAL SUPER**

BY F.H.HAYNES AND W.T. COCKING.

MAZDA PEN 220

THE SOLUTION TO THE OUTPUT STAGE PROBLEM IN BATTERY OPERATED SETS.

THE AMAZING

MAZDA THE BRITISH VALVES

EDISWAN RADIO

Advt. of THE EDISON SWAN ELECTRIC Co. Ltd. V.153

SPECIALISTS IN PRESSED METAL CHASSIS WORK.

ALUMINIUM CHASSIS

Complete with brackets and screws as specified, **10/-** (postage 1/-)

WHITE BROS. & JACOBS, Ltd.
46, Chalk Farm Rd., N.W.1. *Quiliver 5146*

T.C.C. ALL-BRITISH CONDENSERS SPECIFIED EXCLUSIVELY!

Yet again T.C.C. has proved the choice of the expert. Yet again T.C.C. are specified exclusively for a "star" receiver. Be sure your "Single Dial Super" is a "star performer" — by using only the designers' selection — T.C.C. Condensers.

9572

Belling-Lee terminals are used in all Good Sets.

HAYNES · RADIO · SAFEGUARDS · THE · CONSTRUCTOR

HIGHLY SUCCESSFUL RESULTS ASSURED. TESTED COMPONENTS. SERVICING TEST, CALIBRATION and QUERIES.

Complete Kit, including valves and all components **£10.19.6** carriage paid. Trade supplied.

HAYNES RADIO, 57, HATTON GARDEN (Clerkenwell end), E.C.1. Telephone: Chancery 8023.

MISCELLANEOUS ADVERTISEMENTS.

NOTICES.

THE CHARGE FOR ADVERTISEMENTS in these columns is 12 words or less, 2/- and 2d. for every additional word.

Each paragraph is charged separately and name and address must be counted:

SERIES DISCOUNTS are allowed to Trade Advertisers as follows on orders for consecutive insertions, provided a contract is placed in advance, and in the absence of fresh instructions the entire "copy" is repeated from the previous issue: 13 consecutive insertions 5%; 26 consecutive, 10%; 52 consecutive, 15%.

ADVERTISEMENTS for these columns are accepted up to **FIRST POST ON THURSDAY MORNING** (previous to date of issue) at the Head Offices of "The Wireless World," Dorset House, Tudor Street, London, E.C.4, or on **WEDNESDAY MORNING** at the Branch Offices, 19, Hertford Street, Coventry; Guildhall Buildings, Navigation Street, Birmingham; 260, Deansgate, Manchester; 26a, Renfield Street, Glasgow, C.2.

Advertisements that arrive too late for a particular issue will automatically be inserted in the following issue unless accompanied by instructions to the contrary. All advertisements in this section must be strictly prepaid.

The proprietors retain the right to refuse or withdraw advertisements at their discretion.

Postal Orders and Cheques sent in payment for advertisements should be made payable to **ILLIFFE & SONS Ltd., and crossed** Notes being untraceable if lost in transit should not be sent as remittances.

All letters relating to advertisements should quote the number which is printed at the end of each advertisement, and the date of the issue in which it appeared.

The proprietors are not responsible for clerical or printers' errors, although every care is taken to avoid mistakes.

NUMBERED ADDRESSES.

For the convenience of private advertisers, letters may be addressed to numbers at "The Wireless World" Office. When this is desired, the sum of 6d. to defray the cost of registration and to cover postage on replies must be added to the advertisement charge, which must include the words Box 000, c/o "The Wireless World." Only the number will appear in the advertisement. All replies should be addressed No. 000, c/o "The Wireless World," Dorset House, Tudor Street, London, E.C.4. Readers who reply to Box No. advertisements are warned against sending remittance through the post except in registered envelopes; in all such cases the use of the Deposit System is recommended, and the envelope should be clearly marked "Deposit Department."

DEPOSIT SYSTEM.

Readers who hesitate to send money to unknown persons may deal in perfect safety by availing themselves of our Deposit System. If the money be deposited with "The Wireless World," both parties are advised of its receipt.

The time allowed for decision is three days, counting from receipt of goods, after which period, if buyer decides not to retain goods, they must be returned to sender. If a sale is effected, buyer instructs us to remit amount to seller, but if not, seller instructs us to return amount to depositor. Carriage is paid by the buyer but, in the event of no sale, and subject to there being no different arrangement between buyer and seller, each pays carriage one way. The seller takes the risk of loss or damage in transit, for which we take no responsibility. For all transactions up to £10, a deposit fee of 1/- is charged; on transactions over £10 and under £50, the fee is 2/6; over £50, 5/-. All deposit matters are dealt with at Dorset House, Tudor Street, London, E.C.4, and cheques and money orders should be made payable to Illiffe & Sons Limited.

SPECIAL NOTE.—Readers who reply to advertisements and receive no answer to their enquiries are requested to regard the silence as an indication that the goods advertised have already been disposed of. Advertisers often receive so many enquiries that it is quite impossible to reply to each one by post. When sending remittances direct to an advertiser, stamp for return should also be included for use in the event of the application proving unsuccessful.

RECEIVERS FOR SALE.

SCOTT SESSIONS and Co., Great Britain's radio doctors; read advertisement under Miscellaneous [0264]

HIRE a McMichael Portable Set, 3/6 daily, or from 15/- weekly.—Alexander Black, Wireless Consultant, 55, Ebury St., S.W.1. Sloane 1655. [0328]

McMICHAEL, Dimic S.G. Three, battery model, recently overhauled and fitted new valves, 46; Blue Spot speaker, oak cabinet, 25/-; or £7 the lot. Martin Smith, Blackheath, Guildford. [6556]

"NEW RADIOS FOR OLD!" BE UP TO DATE

WE TAKE YOUR OLD SET IN PART EXCHANGE FOR ANY 1932 MODEL BEST ALLOWANCE GIVEN

Here is an example:
OLD COSSOR SET AND ELIMINATOR. (Original cost approx. 12 guineas)
EXCHANGED for 1932 Ekco R.S.3 model. (List price 24 guineas)
ALLOWANCE GIVEN £9.0. BALANCE paid £15.15.0
Difference payable Cash or Instalments.

Send full particulars of present set and new set you require, enclosing 1d. for reply. No necessity to send your set for inspection. You use it until we deliver the new one.

RADIALADDIN LTD.,
The largest Radio exchange firm in U.K. (Dept. V)
47, Berners St., W.1. Museum 1821, 4141.

QUALITY AMPLIFIERS for ALL PURPOSES REPAIRS and MODIFICATIONS TO EXISTING APPARATUS

We specialise in the design and installation of special high quality amplifiers and receivers for Hospitals, Schools, Yachts, Country Houses, etc. All designs and installations are by competent engineers under expert supervision. We invite enquiries for our special superheterodynes for long range short-wave reception.

SCOTT SESSIONS WISHES A HAPPY NEW YEAR TO ALL.

**SCOTT SESSIONS
RADIO ENGINEERS
MUSWELL HILL, N.10
TUDOR 5326.**

Contractors to H.M. Office of Works

Receivers for Sale.—Contd.

SEND £3/3 Deposit for the R. G. Greatrex All-electric Portable, with Magnavox moving coil speaker.

SEND 10/- Deposit for any one of the Range of Atlas Eliminators.

SEND 11/- Deposit for the Ready Radio Kit.

SEND Your Orders for Smith's Electric Clocks to R. G. Greatrex and Co., 184, Regent St., London. Phone: Regent 3575. [6408]

"**WIRELESS WORLD**" A.C.3, magnificent instrument, embodying several special features ensuring perfect fidelity of reproduction; £13.- Further particulars Box 2097, c/o *The Wireless World*. [6558]

4-VALVE Philips Portable; cost £25 6 months ago, accept nearest £15; reason selling bought mains set.—Box 2085, c/o *The Wireless World*. [6545]

BUY via Appleby's, where radio part exchange began nearly 13 years ago.

THE Service is as follows:—Straightforward and definite; we can supply practically all the leading lines of radio apparatus on the market (excluding trivial sundries) at current list prices; if so desired we can accept in part exchange, and make liberal and reasonable allowance for modern high grade components, loud-speakers, portable receivers, all-electric receivers, and all electric radio-gramophones; valves and tuning coils cannot be accepted in part exchange except by special arrangement, as their second-hand value is often regrettably low.

IN View of the Difficulty of Making Fair and Definite Offers for Material that we have not inspected, it is requested that apparatus tendered for part exchange be kindly forwarded to us for valuation; no business can be proceeded with in relation to part exchange until material tendered has been examined; in this connection there need be no fear, material is sent to us from all over the world, not a single item of customers' property has ever been lost or mislaid; rejected offers from Christmas, 1929, amount to only three.

APPLICATIONS for Quotations of Approximate Allowances must be Accompanied by two 1d. Stamps.

TERMS of Part Exchange Business: A minimum of 50% of the value of an order plus carriage charge where due, is payable in cash, unless the value is below £1, when a minimum of 10/- is payable; should the part exchange allowance exceed 50% of the total value of new requirements, the difference will be credited against future orders; material may be deposited against a credit note, which may be utilised at a later date; the maximum amount allowed to stand to the credit of any one individual is £200; allowances on material are entirely determined by the demand for individual articles, considering also their condition and production age; amateur constructed receivers cannot be accepted in part exchange as receivers, their value lying wholly in the components contained in them; only modern apparatus, not more than two years old, is accepted in part exchange; material is not purchased by us for cash.

THESE Terms have been Made to the Lowest Economic Minimum, to give the customer the best value possible, while enabling us to maintain the standard required of this business, all British, for those who care to know.

APPLEBY'S, Chapel St., Edgware Rd., Oxford St., London. Tel: Paddington 8828 (5 lines). [6165]

UNWANTED Xmas Gift.—Murphy 3-valve A.C. mains receiver, 200-250v., 40-60 cycles. Offers to Box 2098, c/o *The Wireless World*. [6566]

ACCUMULATORS—BATTERIES.

CONDENSERS—T.C.C., 2 mid., 500 volts, new, 1/6 each; 6 mid, 3/6, 8 mid, 5/-, 10 mid, 7/- each.—Electradix Radios, 218, Upper Thames St., E.C.4. [0360]

CHARGERS AND ELIMINATORS.

TANTALUM for A.C. Rectifiers; blue prints for T. inexpensive I.T. and L.T. chargers. Blackwell's Metallurgical Works, Ltd., Garston, Liverpool. [5086]

ELIMINATOR Components for Home Constructors; stamped addressed envelope brings eliminator diagrams with prices of complete range of Mains components.—Mains Power Radio, Broadway Works, Eastern Rd., Romford, E.-sex. [0364]

BUY British.—The Tonic self generating trickle charger kit enables everybody to keep their 2-volt L.T. accumulator fully charged at home, ideal for remote places, obtainable only from maker; 7/- each, postage 9d.—Williams, Netherend, Cradley, Birmingham. [6422]

MAINS Transformers, 250-250, 4 volt, 1 amp., 4 volt, 4 amp., 23/-; 200 volt, 4 volt, 4 amp., 20/-; repairs and rewinding. G. McDaniel, 154, Hainault Rd., Romford. [6576]

Mention of "The Wireless World," when writing to advertisers, will ensure prompt attention.

ELECTRADIX
NEW FULTOGRAPH PICTURE RECORDER
BARGAINS

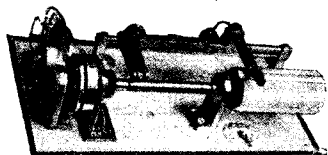

Complete brand new £22 kits, unwired, 27/6, with diagrams.
Sets ready for use, complete with instructions, 45/-.
Recorder Kit only, less amplifier and wiring, with diagram. Easily adapted to record any signals, 19/6.

FULTON SPARES. Gramo. Motor, double spring with speed control and handle, 6/6. Stylus on carriage with guide, 2/6. Magnetic clutch with contacts, gear drive stop magnet and cover, 9/-.
Shift fine thread steel-head screw with 2 bearings, 2/6. Cylinder, aluminium, 4" x 2", 1/6. Transformer, 6:1 ratio, 3/-.

MICROPHONES

You will find our Microphones remarkably cheap and efficient for all purposes. We have all types from 1/- to £20. Pendant; No. 11, single, 6/6; No. 7 (special panel), 12/6; No. 10 (pulpit), 12/6; No. 8 (hand), 15/-; No. 4 (pedestal), 17/-; Nos. 1 or 5 (announcer's P.A.), 65/-.

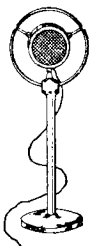

Micro Transformers, 3.6, 5-, 7.6, and 10-; Three-valve Amplifiers for P.A. off D.C. mains (Panatrop), £3 15s.; three-valve portable type, £2 15s., fitted mike transformer.

METERS. Biggest Stock at Lowest Prices in London. Panel A.C. Hot Wire to 1/2 amp., 5/-; to 1 1/2 amps., 6/-; B.T.H. 50 m/a. Mr. 2", 8/6. Mov. Coil, flush nickel W.E. to 5 m/a., 12/6; 1 1/2" dial flush Mr., 0-20 m/a for H.T., 7/6. Cirscale M.C., 0-3v. and 0-30v., 2 scales, 25/-; Megger Cell Test, 3-0-3v., 30/-; Thermo Junt. M.C. 1 1/2 amps., 6 amps. or 9 amps., 30/-; 2-Range M.C. Westons, 0-30v., 0-300v., 35/-; E. & T. Ammeters 2 1/2" M.C., 5 amps., 10 amps. and 20 amps., 25/- each; Weston Micro Ammeters, 45/-; Elliott Multi-range E108, 35/-, a fine tester. G.P.O. V.M. Testers, 45/-; H.T. Electrostatic Panel to 2,000 volts, 40/-; Switchboard 6" meters, from 12/6. Galvo, Vertical Telegraph, 4/-; Horiz. Silvertown C3, 7/6. Tinsley Lab. reflecting, 60/-; Magneto-meters, Gauss law, 12/6. 3" Milit. Compass, 3/6. Ohmmeters, £8-10-0.

CONDENSERS. Best British 400 volts, 2 mfd, 1/6 only. Smooth out hum and crackles X-ray Valves, 7 in. diameter, 37/6 each. All good.

TELESCOPES. Ross Gunsight X 2 1/2, 2 1/4" long, heavy, screw focus. In wood case, 15/-; Small Wey-Cooke ditto, with range finder attachment, 17/6.

Stamped envelope for Dec.-Jan. Sale List.

ELECTRADIX RADIOS

218, UPPER THAMES STREET, LONDON, E.C.4
Phone: CITY 0191.

CRESSALL RESISTANCES

"Cressall" Asbestos-Wire Woven Resistance Nets for voltage absorbing on D.C. Mains Receivers, Mica-Wound Resistance Units, Sliding Resistances. Resistance Wires.

Please write for Lists.

CRESSALL MANUFACTURING CO.
31-32, TOWER STREET, BIRMINGHAM

The AMATEUR PHOTOGRAPHER
& CINEMATOGRAPHER

The Journal for Everybody with a Camera

EVERY WEDNESDAY 3d. w.w.37

Chargers and Eliminators.—Contd.

VORTEXION Transformers and Chokes Wound to Any Specification, highest grade British material and British manufacture throughout.

VORTEXION Shrouded Transformers, type P.T./B, input 200v.-220v.-240v., 50 cycles, output 350 0-350v. 120 m.a., 4v. 2 amps., centre tapped, 4v. 4 amps., centre tapped, price £27/3; type P.T./C, input 200v.-220v.-240v. 50 cycles, output 250 0-250v. 60 m.a., 4 volts 2 amps., centre tapped, 4 volts 2 amps., centre tapped, 4 volts 4 amps., centre tapped, price £1/18.

VORTEXION Shrouded Chokes, 30 henries, 120 m.a., price 19/6; 40 henries, 60 m.a., price 19/6.

VORTEXION Open Frame Chokes, 20 henries, 100 m.a., price 11/6; 30 henries, 30 m.a., price 9/6.

VORTEXION Bakelite Bobbins, die cast, T section aluminium clamping frames, cadmium plated clamping bolts and nuts, bakelite terminal strips, enamelled, D.C.C. and D.S.C. wire, genuine stallio stampings, 0.014in thick, insulated.

ALL British.

WRITE for Fully Illustrated List for "The Home Constructor," List No. 1.

VORTEXION, Ltd., 150, The Broadway, Wimbledon, S.W.19. Tel.: Wimbledon 2814. [0439]

MAINS Transformers, smoothing chokes, and eliminators, for valve or metal rectification; prices from 7/6; guaranteed 12 months; write us your enquiries or phone Romford 1464. Albany Radio Products, 56, Osborne Rd., Romford, Essex. [6482]

TRIX Mains Transformers and Chokes Give Highest Quality Results at Moderate Cost.

TRIX Transformer, V220/30B, 220x220v. 30 m.a., 4v. 1 amp., 4v. 2 amps., all centre tapped; 18/6.

TRIX Transformer, 275/60A, for Super Selective Six, 275x275v. 60 m.a., 5v. 1.6 amp., 4v. 5 amps., 4v. lamp, all centre tapped; 30/-.

TRIX Transformer, 350/80A, for "The Wireless World" Three A.C. model, 350x350 volts 80 m.a., 4 volts 3 amps., 4 volts 2.5 amps., all centre tapped; 37/6.

TRIX Chokes—30 m.a., 11/-; 55 m.a., 14/6; 60 m.a., 15/-.

TRIX—Many other types available; send for lists; every transformer fully tested and guaranteed; goods sent on 3 days' approval against remittance.

TRIX—Manufactured by Eric J. Lever (Trix) Ltd., 8-9, Clerkenwell Green, London, E.C.1. Phone: Clerkenwell 3014-5. [5491]

SOUND SALES Take This Opportunity of Thanking Their Numerous Customers, home and abroad, and have the pleasure to wish

A HAPPY New Year, with better radio and brighter prospects, to all home customers, trade and retail. To foreign customers

A HAPPY New Year South Africa, especially readers of "Q.T.C."

A HAPPY New Year to Our Buyers and Agents in Hong Kong, Egypt, Singapore, Persia, Norway, Finland, India, France, not forgetting Irish Free State.

OUR New Year's Resolution: To achieve a bigger output of all British radio productions.

YOUR New Year's Resolution: To obtain "Sound Sales" latest lists.

SOUND SALES, Ltd., for transformers, mains, output, special inter-valve, chokes for all purposes, condensers, home constructors' parts, and special manufacturers' components, made to rigid specifications and specified by the experts.

SOUND SALES, Ltd., Trentlet Grove, Junction Rd., N.19. Phone: Archway 3871. [0366]

CABINETS.

DIGBY'S Radio-Gramophone Cabinet; from £4.

DIGBY'S Cabinets—Pedestal model, with separate battery components; from 55/- to £12.

DIGBY'S Cabinets Made to Customers' Own Designs.

DIGBY'S Cabinets—Write for new 28-page art catalogue, enclose 3d. stamps. F. Digby, 9, The Oval, Hackney Rd., E.2. Phone: Bishopsgate 6458. [0129]

KAY'S Cabinets—The most comprehensive range of radio and radiogram cabinets in the Kingdom; keenest trade prices; illustrated lists free.—H. Kay, Cabinet Manufacturer, Mount Pleasant Rd., London, N.17. Phone: Walthamstow 1626. [5687]

MANUFACTURERS of Special Casework—Longley Radio Manufacturing Co., 63, Longley Rd., Harrow. [5711]

DYNAMOS, ETC.

TWELVE Only New Shop Sailed M-L Anode Convertors, 6 volt, in 120 volt out. £3/10; one M-L motor generator 220 volt D.C. in 500 D.C. out, complete with smoothing equipment and cut-out, £5.—Euston Ignition Co., Ltd., 329, Euston Rd., N.W.1. [6541]

1 h.p. 50 volt Crypto Motor, had little use and in good order; £1/5.—Martin Smith, Blackheath, Guildford. [5557]

PILOT
AUTHOR'S
KITS

Exact to Specification

IMMEDIATE DELIVERY.

SINGLE DIAL SUPER

FREE FULL SIZE BLUE PRINT
with every Pilot Author's Kit.

● **COMPLETE SET OF PARTS EXACTLY AS SPECIFIED**

CASH or C.O.D. £7-2-0

or 12 monthly payments of 13/-
Complete Kit "A" as above, including set of specified valves, but less cabinet.

CASH or C.O.D. £10-19-0
or 12 monthly payments of 20/-.

● **READY ASSEMBLED CHASSIS**

Chassis only, built exact to specification. Aerial Tested — Royalties Paid. Cash or C.O.D. **£9-15-0**

Or 12 monthly payments of 18/-.

● **FINISHED INSTRUMENT**

In solid Oak Cabinet, with built-in Ormond 4-Pole Balanced Armature Unit Speaker (1Z) and specified Valves. Cash or C.O.D. **£15-15-0**

Or 15 monthly payments of 23/7.

As above, but with Magnavox Permanent Magnet Moving Coil Speaker. **£17-17-0**

Or 15 monthly payments of 27/-.

● **"WIRELESS WORLD" A.C.3**

KIT "A" Author's Kit, less valves and cabinet. Cash or C.O.D. **£10-7-10**. Or 12 monthly payments of 19/1. Set of Valves **£4-0-0**. Cabinet with Chassis 37/6.

● **"W.W." BAND-PASS PENTODE 3**

KIT "A" Author's Kit, less valves and cabinet. Cash or C.O.D. **£7-15-1**. Or 12 monthly payments of 14/3. Set of Valves **£2-8-6**. Cabinet 17/6

● **"WIRELESS WORLD" TWO**

KIT "A" Author's Kit, less valves and cabinet. Cash or C.O.D. **£2-11-5**. Or 12 monthly payments of 4/9. Set of Valves **£1-8-6**. Cabinet 12/6.

Any part for W.W. Sets supplied separately. If value of 10/- carriage paid. C.O.D. we pay Post charges. See our advertisements in previous issues.

SEND 3d. POSTAGE FOR NEW CATALOGUE.

PETO-SCOTT

CO. LTD.

77, CITY RD. LONDON, E.C.1

Tel.: Clerkenwell 9406-7-8-9. and 62, HIGH HOLBORN, W.C.1. Tel.: Chancery 8266.

A REAL ENGINEERING JOB

BOTH

ELECTRICALLY AND MECHANICALLY

Cool Working. Highly Efficient.
Absolutely Correct Voltages.

A Mains Transformer you will be proud to show your friends.

Challis Mains Transformers and Chokes.

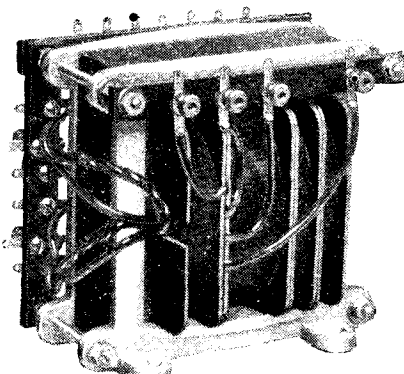

Mains Transformers made to specification at short notice.

1931-2 Lists now ready.

Let us build your eliminator and save you trouble.

We can supply B.T.H. R.K. Speakers from stock.

Special attention to export orders.

Illustrated List on application.

O. M. CHALLIS, 22, Park Road, RUGBY.

Wholesale & Export Service

for all standard apparatus as described in the "Wireless World" and elsewhere.

LEONARD HEYS, FARADAY HOUSE, BLACKPOOL.

(Strictly Wholesale Only.)

EPOCH MOVING COIL SPEAKERS

Send to-day for full details of Epoch Moving Coil Speakers.

Booklet WS 5 free.

EPOCH RADIO MANUFACTURING CO. LTD.

Exmouth House, Exmouth St., London, E.C.1

At the Junction of Rosebery Avenue and Farringdon Road

The RADIO TRAINING INSTITUTE OF GREAT BRITAIN

can help you to Achieve a Permanent Position in the Radio or Talking Picture Profession. Send for our booklet, "Progress," containing full particulars of unique "home-study" courses for "Certificate of Proficiency," free. We guarantee successful training. **RADIO TRAINING INSTITUTE OF GREAT BRITAIN, 10, Union Bldgs., St. John Street, Newcastle-on-Tyne.**

The Autocar **EVERY FRIDAY, FOURPENCE**

GRAMOPHONES, PICK-UPS, ETC.

NEW Electric Gramophone Motors, 5-guinea models, suit A.C. or D.C. complete with 12in. turntable, switch, regulator, etc.; blueprint instructions, money return guarantee; 40/- each.—King, 1, Kingsley Rd., Hounslow, Middlesex. [6416]

NEW Harle Motor, 100-250 volts A.C.; listed £3/15, sell £2; purchased in error.—Newth, 31, George St., Hanover Sq., W.1. [6553]

B.T.H. Pick-up and Tone Arm, good condition; 15/-; A.F.6, 12, 6. E. Brook, Grinstead, Gilling East, York. [6562]

LOUD-SPEAKERS.

BAKER'S SELHURST RADIO 36-page Booklet, "Sound Advice is Yours for the Asking"; write now for new edition; see displayed advertisement on page 10. [6231]

VINCENT Exponential Diaphragm, with Farrand inductor chassis "Wireless World"; "Frequency response remarkably uniform, 50 to 8,000 cycles, above the average."—Write for catalogue, "Realistic" Speakers, 72, Penton St., London, N.1. [6357]

MOVING Coil Speakers, various makes, from 10/- to 30/-, with input transformer, brand new, 6 to 240 volts A.C. or D.C. and P.M.—Write Plater, 92, Umfreville Road, Harringay, N.4. [6497]

LANCHESTER Senior Permanent Magnet Moving Coil Chassis; 40/-;—227, Chamber Rd., Oldham. [6547]

MARCONIPHONE Latest P.M. Unit. £4/12/6; 6-volt field unit Camco cabinet, £2.—Wilmshurst, 32, Victoria St., S.W.1. [6543]

ROLA's, brand new, boxed, manufacturers surplus, American, J.M.90, field resistance 1,950 ohm, speech coil 13 ohms, complete with base and transformer; listed £6, sell 25/- each (12 only).—Newth, 31, George St., Hanover Sq., W.1. [6552]

VALVES.

O/20, O/10B, L.S.5, L.S.5A., 50/-, or offer.—G2RO, 94, Wilberforce Rd., Leicester. [6559]

COMPONENTS, ETC., FOR SALE.

BELLING-LEE Panel Fittings are Designed to give an Expert Finish to any Home-constructed Set; catalogue post free.—Belling and Co., Queensway Works, Ponders End, Middlesex. [6018]

TRANSFORMERS, stampings, instrument wire, etc.; cheap; lists free.—Lumen Electric Company, 9, Scarisbrick Av., Litherland, Seaforth, Lanes. [6496]

NEW High Class Moving Coil Milli-amperes, 0.5 and upwards. 16/6; double range, 10/100, 18/6; A.C. and D.C. voltmeters, double range, 8/240, 7/6; meter repairs of every description.—The Victoria Electrical Co., 47, High St., S.W.11. [6355]

EXPERIMENTAL Surplus, condition guaranteed; Colvern coils, dual wave, pair matched, 10/-; Cosmos R.C. units, 2, with V.H., 2/6 each; ditto 2, without V.H., 2/- each; 2 Met. Vick elastic aerial units, 3/- each; Ducon aerial, 2/-; 5 Lewcos screens and bases, 2/- each; 2 pairs Lewcos 5-pin coils, 2/6 pair.—Martin Smith, Blackheath, Guildford. [6555]

FREE. Free list; accumulators, 2v. 150a., 9/6; screen grid valves, 7/-; 8-pole Kolster speaker and chassis, 16/9.—Armstrong, 46, Lambert Rd., London, E.16. [6546]

A.P.5, 12/-; Colvern 25,000 ohm potentiometer, 4/-; various other components, condensers for mains units.—26, Grassmere Rd., Purley, Surrey. [6544]

AMATEUR'S Death.—Ferranti O.P.M.3, 17/-; S4V.B., 18/-; J.L.610, 8/6; pair P.M.5264, matched, 14/-; Cosor 2H.F., 5/-; Tannoy mains transformers, 210-230, 175v. at 25 m.a., 4v. 6 amps., 25/- each; Ormond 0.0005 V.C. dial, 3/9; Bowyer Lowe 0.0005, 0.0005, central A.B., 100 megohms, 2 electrods, 500,000 megohms, 3 regentone 120,000; wire wound 100 ohms, 4/-; Lotus relay, 9/3; Hara ill. vernier dial, 12 Bulgin toggles 1a., 250v., 2/9; clarostat, 7/-; Gleed, 28, Wandle Rd., Mitcham. [6458]

MAINS Transformers, 200 unused, 230 volt, 50 cycles, sec., 200 volts 20m. amps. c.t., 4 volt 1 amp. c.t., clamped aluminium end plates, terminals; 8/9, post free or c.o.d.—Wood, 19, Lennox Av., Blackpool. [6549]

CONDENSERS, 1 nfd., 2,000 D.C. test, working voltage 1,000 D.C., 1- each, or 10/- per dozen.—Newth, 31, George St., Hanover Sq., W.1. [6554]

OLDHAM 240-volt Battery, in 40-volt sections, with cases, type L.H.F.L., Marconi M.C. 100-volt field.—Goodyear, Crook House, Great Barr, Staffs. [6561]

MARCONI Electric Turntable, A.C. or D.C., any voltage, model B; list £2/15 new, £2; Ferranti 2-, 4- or 6-volt trickle charger, 15 amp., as new, £2.—Box 2100, c/o The Wireless World. [6568]

ROLA Midget Loud Speakers (6in. diaphragm), tested, O.K., one for 220v. A.C., with metal rectifier and output transformer, 37/6; two for 200-250v. D.C., with output transformer, 22/6 each; unused; Climax mains transformer, input 200-240v. A.C., output 250 volts, 100 m.a., boxed, new, 18/-.—Munro, 3, Parliament Hill, Hampstead, N.W.3. [6565]

SOLD ALL THE GOODS ADVERTISED— AND MANY MORE

Through "THE WIRELESS WORLD"

"I recently inserted an advert. in your paper with the following results.

I received more than five pounds worth of orders before I had even received the paper from my newsagent.

Yesterday (26 days later), I received an enquiry for some of the goods advertised.

I have sold all the goods advertised and many more. I may add that previous adverts. have put me into touch with many countries abroad, including the Irish Free State and the Transvaal. I think this speaks well for your circulation."

Trevor Pepper
48, Wake Green Rd.
Moseley
Birmingham

W.W. 8

WIRELESS DIRECTION FINDING

& Directional Reception

By R. Keen, B.Eng. (Hon.)

Second Edition (1927)

THIS volume describes the principles of Direction and Position Finding in this country, and is invaluable to wireless engineers tackling this field of work for the first time. Well illustrated from photographs and diagrams.

PRICE 21/- net.
By Post 21/9

From Leading Book-sellers or direct from

LILIFFE & SONS LIMITED
Dorset House
Tudor Street, London, E.C.4
W.W.68

The IDEAL SET with a tuning range of 15 to 2,000 Metres

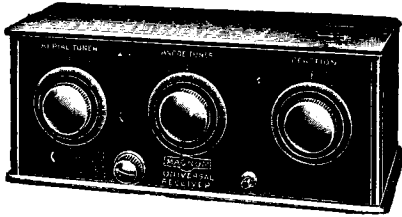

MAGNUM UNIVERSAL THREE

A truly versatile set, equally selective on Ultra Short, Broadcast and Long Wave reception. The "Universal Three" is *not* an experiment, but a sound, efficient, unique receiver that has *proved* itself supreme in every detail. It has been found impossible to improve on the design of this marvellous set, which is particularly suitable for the overseas user. Complete with valves and coils. Royalty paid. **£15**

We specialise in all models the "Wireless World Three" and other "Wireless World" Sets. Full particulars with list of leading short wave stations—Free on request.

BURNE-JONES AND COMPANY LIMITED,

"Magnum" House, 296 Boro' High Street, London, S.E.1
Telephones: Hop 6257 & 6258.

Scottish Agent: ROSS C. WALLACE, 54, Gordon St., Glasgow, C.1

HERE IT IS—

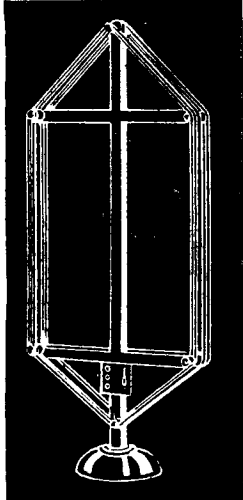

The EELEX Frame Aerial

A wonderful frame aerial at an amazingly low price. This aerial was especially designed for use with Super-het receivers, but can also be employed in any circuit with or without centre tap.

The Eelex Frame Aerial has a definite minimum silent point.

PRICE 20/-

EELEX Short Wave Converter.—Just put the Eelex Short Wave Converter in front of your set—no alteration necessary—and you will then get stations on the 16-60 metre band. Additional coil for the 140-190 metre band 5/- extra. All Mains model 65/- complete, plus additional coil 5/-.

Write for List C21.

J. J. EASTICK & SONS,
Eelex House, 118, Bunhill Row, London, E.C.1.

Phone: Metropolitan 0314 5 6.

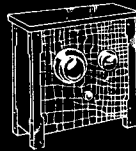

ONLY 60/- COMPLETE
A.C. MAINS VERSION 65/-

Components, Etc., for Sale.—Contd.

R.

SELECTED Parts for Sale, as new; any c.o.d. or "Wireless World" deposit system, which we recommend if in doubt as to the splendid value offered; we take risk of damage in transit to customers; all goods tested for callers, and guaranteed, however low priced.

J.B. R.3 Screened Triple Gang, with disc drive, 20/-; Polar twin tub, 14/9; Lotus twin, screened, with disc drive, 16/9; Lotus 0.0005 brass variable, 3/-; Lissen drum drive, new, with pair Lotus 0.0005 brass condensers, 10/-; J.B. universal log. 0.0005, new, 5/- each; Ormond log. No. 3, 1/9; 0.0005 Ormond log. No. 4, S.M., 0.0005, 7/9 pair; Formo 0.00025, 1/6; Ferranti 2 m.f. fixed condensers, 500v. test, 2/-; ditto L.X.L., 2/6; ditto, 1.000v. test, 3/6; Lissen c.m.f., 1/6; various, 0.1 and 0.01 Mansbridge, 9d.

WEARITE Junior Frame Ariel, new, 12/-; Eelex ditto, 12/9; Varley S.P. coils, boxed, as new, 10/-; Colvern coil screens, 2/- each; set three T.G.S.C., T.G.S.R. coils, 15/-; Colvern; Colvern 6-pin formers, 1/6; Colvern 6-pin bases, 6d.; Tunewell D.R. coils, 2/3; R.I. Pkersley tuner, new, 10/-; Formo D.R. coils, with base, 4/9; pair Copex S.G. coils, 2/6; Dubilier Toroid coils, 2/3 each, with bases, red; Challenge Four D.R. coils, 1/6 each.

MAZDA A.C.P., unused, last 4, 10/- each; A.C. S.G., 14/6; Mazda P.E.N.425, 8/6; P.M.24, 8/6; P.M.22, 8/6; P.M.24A., 10/6; P.M.154V., 4 pin, 5/-; Cossor S.G.410, 8/6; Lissen H.L.210, 2/3; Tritron C.2, 5/6; Lissen P.P.22, 5/6; P.M.26, 5/6; Cossor 4.L.P., 3/6; Cossor P.T.230, 8/6; Mulard 154v, 5 pin, 8/-; P.M.14, 6/6; P.M.054, 8/6; Tritron U.D.2, new, unused, 4/9; Tritron A.N.4, 4/9; S.N.4, H.F., 4/9; P.M.256, 4/-; D.E.II.610, D.E.II.410, Cosmos D.E.55, Radion P.625, Cosmos S.P.G., Dario 4vL., Cunningham 6v. G.P. valves, American bases, 1/3 each, all guaranteed full emission.

PORTABLE Cases, 15x12x8 approximately, in red and light leather, 5/- to clear; Lissen and Telsen L.S. units, latest, 3/9; Telsen 0.0005 variable, 3/-; Wavemaster ditto; Kinva screened H.F. chokes, 2/-; Igranic midjet L.F. transformer, 6/9; A.E.D. 15 meg. volume, 3/9; Bulgin 50,000, with switch, 4/6; Formo H.F. choke, 5/6; Formo 0.00015 differential, 2/-; Pae, 2/9; Wavemaster, 1/9; R.I. 50,000 Unigrad volume, 5/6; Formo S.M. dials, 1/6; all new.

A VOMETER, perfect in every respect, listed £8 8/- offered for £5 18; Weston microammeter, 0-7, £5 5; listed £11; Weston 0.10 m.a., in oak case, No. 45, mirror scale, £5 5; Weston model 301 0.50 m.a., flush, 25/-; ditto, projecting, 0.300 m.a., 20/-; ditto, 0.15 amp, 17/6.

W.M.R. H.T.1, with Ferranti transformer, 200-210v. input, 50/-; A.F.6, 18/6; A.F.7, 18/6; A.F.5, 18/6; O.P.m.3, 17/6; A.F.5c., 21/6; A.F.4, 8/-; A.F.3, 7/9; R.I. Hipermu., 12/- and 14/6, new; Niore L., 13/6; Marconi heavy duty L.F. chokes, 9/-; Bulgin 20H, and 32H L.F. chokes, 8/9.

LAST Few.—Hydra 5 m.f., 500v. A.C. test, 375v. working, 5/-; 2 m.f. Bakelite, 2/6; 1 m.f. Bakelite, 1/9; not repeatable; T.C.C. block condensers, 14 m.f., 500v. test, 250v. working, 2.4 m.f., 2.2 m.f., 2.1 m.f., used, 7/9; O.K., unused 10/9; Arrow mains toggle switches 1/-, 750v.

R.I. Filament Transformer, 200-250v. input, 4v. 4 amp., 6v. 9 amp., 7.5v. 6 amp., 15/-; Parmeco, 110v. input, 250v., 4v. 5 amp., 4v. 1 amp. output, C.T., 15/6; Igranic, 200-250v., 175v. output and 4v. 4 amp., 5v. for U.S. 15/-; Fosters, input 200-250, output 200v. 20 m.a., etc., half wave, 7/6; Savage half wave, input 200-250, output 300v. 60 m.a., 4v. 2 amp., 4v. 1 amp., unused, 10/9 each.

CALLERS, please note address carefully; nearest Tube Lambeth North, bus stop outside door; alight Fitzalan St.—G. A. Ryall, 182, Kennington Rd., London, S.E.11.

R. [6560]

A.F.5 Transformer, 20/-, The following valves, as new: 2 SAV.A., 1 SAV.B., 8/6 each; 354V, 6/6; P.M.24B, 10/-;—Box 2102, c/o *The Wireless World*, [6569]

MISCELLANEOUS.

ALEXANDER BLACK,

THE Original Wireless Doctor, will call (London and Home Counties) and cure your set.

CONSULTATIONS by Appointment, sets installed, maintained, and brought up to date; amplifiers and portable sets on hire.

55, Ebury St., Victoria, S.W.1. Sloane 1655. [0277]

EASY Payments.—We supply, by easy payments, components, accessories, and sets, any make; 10% down, balance spread over 11 months.—Send list of requirements to London Radio Supply Co., 11, Out Lane, London, E.C.2. [0337]

PORTASS Lathes; 45/- to £20; from 6/- with order. —Gregory and Taylor, 9, Howard St., Sheffield. [0361]

It's not an alternative It's specified again

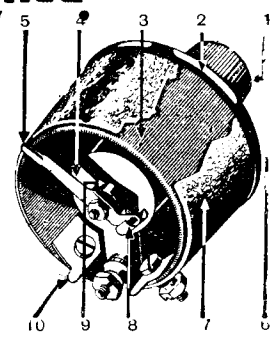

Watmel 25,000 ohms Wire-wound Potentiometer specified for the "Wireless World" "Short Wave Superheterodyne Attachment."

1. Polished Pointer Knob.
2. Engraved Bakelite front plate.
3. Wire Wound Former. *N.B. The resistance is wire; NOT composed with wire contacts, and is specially wound on a tapered former.*
4. Insulating bush to insulate spindle from panel.
5. Contact finger Phosphor Bronze.
6. One-hole fixing—brass bearing; bush resulting in perfect bearing.
7. Bakelite case—protecting winding.
8. Back self-cleaning contacts.
9. Large contact plate.
10. Stops at end of wiring.

WATMEL SCREENED COILS

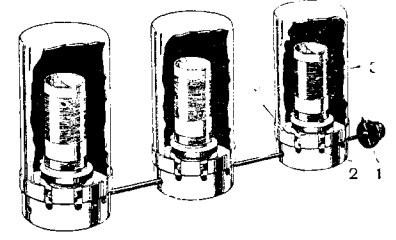

Recommended by "Wireless World."
Types S.S.6 A.C. Battery
" S.S.5 " " " D.C.
" S.S.5 " " "

These coils were specified for the "Wireless World" Super Selective Six A.C. Super Selective Five Battery and Super Selective Five D.C. Watmel coils can be adapted to nearly every circuit, including such popular circuits as the Mullard, Cossor, etc.. Just drop us a line stating what you require, and we will send you circuit-free of charge.

- 1 Band Pass Coil and Screen.
- 1 Secondary Band Pass. Coil and Screen.
- 1 Oscillator Coil and Screen.

Set of Three:—Complete with Switch Rod. Price 27/6

Also 1 Slab Coil Price 3/-

The Advantage of Using Watmel Coils.

Our coils have been specially designed in view of modern broadcasting conditions. A high degree of selectivity is assured by using these coils, as they are specially screened to prevent direct pick-up or interaction between the various units. Information on other types of coils—Band Pass Aerial Units, etc.—may be had on application.

WRITE FOR FREE COMPONENT CATALOGUE.

If you have any difficulty in obtaining Watmel components, write direct to us.

Trade Enquiries Invited.



COMPONENTS

"GET THE BEST OUT OF ANY SET"
WATMEL WIRELESS CO., LTD.,
IMPERIAL WORKS, HIGH ST., EDGWARE
Telephone: Edgware 0923 (M.C.552)

Price 1/6. By post 1/7.

Miscellaneous.—Contd.

SCOTT SESSIONS and Co., Great Britain's radio doctors, officially appointed as wireless repairers by Joint Committee of the (Inc.) Radio Society of Great Britain and Wireless League; old sets of every type repaired, rebuilt, modernised; send set for immediate quotation.

SCOTT SESSIONS and Co.—New sets constructed with your or our components, guaranteed finest workmanship; we specialise in "The Wireless World" circuits; remember we have satisfied customers throughout the British Isles and in three Continents; if you so desire, we will design and construct high grade apparatus to suit your especial circumstances for quality, range, and selectivity.—Tel.: Tudor 5326. Muswell Hill, London, N.10. [0262

ENGINEERS! 200 page book free!—Do you realise that there are examinations open to you that lead definitely to jobs carrying salaries rising from £4 10s. to as much as £20 per week, and that no particular experience is required? Our handbook explains these things and more. It gives details of B.Sc., A.M.I.C.E., A.M.I.Mech.E., I.E.E., A.M.I.A.E., G.P.O. Matric, and all examinations, outlines Home-Study Courses in all branches of civil, mech., elec., motor, wireless, aero, "talkie," eng., etc., and shows how our unique appointments department operates. Don't stay in the rut—get our 200-page handbook to day, free (state subject).—British Institute of Engineering Technology, 87, Shakespeare House, 29-31, Oxford St., London. [6377

SECOND-HAND Syphon Recorder (Telegraph Machine Co.), complete with electric motor drive, 6 volts, good condition; £5.—Box 1655, c/o The Wireless World. [5903

PATENT AGENTS.

PATENTS and Trade Marks, British and foreign.—Gee and Co. (H. T. P. Gee, Member R.S.G.B. and A.M.I.R.E., 51-52, Chancery Lane, London, W.C.2. Phone: Holborn 1525. [0001

REPAIRS.

SCOTT SESSIONS and Co., Great Britain's radio doctors; read advertisement under Miscellaneous column. [0263

REPAIRS.—Single ratio L.F. transformers, loud speakers (except Blue Spot) or headphones within 48 hours; 12 months guarantee; 3/9 post free; terms to trade.—Transformer Repair Co., 953, W. Garratt Lane, London, S.W.17. [5448

LOUD Speaker Unit Rewinding and Repairs; 3/- any type except Blue Spot, Blue Spot 4/—G. McDaniel, 154, Hainault Rd., Romford. [6571

EXCHANGE.

BOSTOCK and STONNILL for Exchanges.—Now in our third year of *Wireless World* advertising; components, units, speakers, complete sets, etc., taken in part payment for new apparatus; also tested and guaranteed second-hand goods for sale on 7 days' approval; our prompt attention to correspondence and delivery of new goods assured.—Bostock and Stonnill, 1, Westbourne Terrace, S.E.23. [6564

WANTED.

WANTED. Cossor valves, 680P, 680XP.—Nicoll, 15, Manchester Rd., Burnley. [6551

NEW or Second-hand Wireless Wanted for Cash; send yours, stating reasonable price, cash by return; will call London districts.—24, Mildmay Grove, London, N.1. [6542

A NODE Converter, 6 or 12v. to 250-300v., 50-60 m.a., give particulars and price.—Wharton, The Gables, Kendal. [6563

FINANCIAL PARTNERSHIPS.

GRAMOPHONE Recording and Radio Engineer requires Partner with Small Capital; good propositions.—Box 2080, c/o The Wireless World [6540

SITUATIONS VACANT.

EXPERIENCED Moving Coil Loud Speaker Designer Required for Experimental and Development Work for Large Radio Factory near London.—Write, giving full particulars, Box 2078, *The Wireless World*. [6538

FOREMAN Superintendent Required by Large Radio Factory near London to Take Complete Charge of Assembling Moving Coil Speakers; applicants must have had production experience and be capable of designing own jigs and fixtures.—Write Box 2079, c/o *The Wireless World*. [6539

WANTED, outside salesman; commission only; Croydon.—Box 2099, c/o *The Wireless World*. [6567

For Wireless Engineers and Experimenters

"THE WIRELESS ENGINEER" is a monthly magazine catering for the professional engineer, and the wireless enthusiast who is anxious to increase his knowledge both in theoretical and practical directions.

Month by month the latest radio developments are recorded, and authoritative technical and scientific information, bearing upon varied aspects of wireless experiment and research, is presented in a clear and instructive manner.

The correspondence columns, which are open to all, provide a forum for the discussion of readers' problems and experiences.

SUBSCRIPTION:

32/- per annum, post free

The WIRELESS ENGINEER

AND EXPERIMENTAL WIRELESS MONTHLY 2/6 By Post 2/8

The Journal of Radio Research and Progress

ILIFFE & SONS LIMITED

Dorset House, Tudor Street, LONDON, E.C.4 W.W.2

SOLD AT ONCE

THROUGH "THE WIRELESS WORLD."

"I recently advertised two articles in your small advertisement columns and, as a result, both were sold within twenty-four hours of publication. One enquiry was actually received before my copy of "The Wireless World" had reached me.

This was my first experience of your advertising service, and pays eloquent tribute to its effectiveness."

W. J. Pickthorn

Grapes Hill

NORWICH

w.w.3.

MAKE IT TANNOY FOR 1932!

MAKE YOUR RADIO a SUCCESS in 1932 by USING

TANNOY MAINS UNITS

TYPE G.B.1. Pat. No. 353875.

H.T. 150 v. at 15 m/a or 120 v. at 20 m/a.

G.B. 3 tapings up to 12 v.

L.T. 2, 4 or 6 v, Trickle Charger.

9/2 and 11 payments of 8/8 or cash £4 : 15 : 0.

A model with larger output is available . . . **TYPE G.B.3.**

Write for particulars.

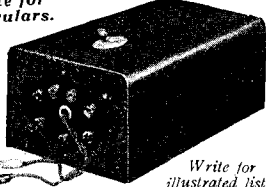

Write for illustrated list.

DALTON St., West NORWOOD, S.E.27
Streatham 67312.

MAKE IT TANNOY FOR 1932!

RUN YOUR SET FROM THE MAINS.

SEND FOR ILLUSTRATED CATALOGUE SHOWING COMPLETE RANGE OF M.P.R. MODELS TO SUIT ANY SET. A.C. MODELS FROM £2 : 2 : 6.

ADAPTUS CO., 12, ALBERT ROAD, ROMFORD, ESSEX.

Repairs to Everything Radio

Loud Speakers & Pickups, 3/6. Blue Spot & Balanced Armatures, 4/6. Transformers, 3/6 to 4/6. Headphones, 3/-.

All repairs remagnetised free. Tested and guaranteed, and delivered within 24 hours. Discount to Trade, 8 years' experience.

LONDON RADIO ELECTRIC CO., 224, CLAPHAM ROAD, S.W.9. Tel.: 1407.

Hexa MAINS TRANSFORMERS AND CHOKES

We supply any required value, our prices unequalled for quality of material used; write for lists.

Sole Manufacturers:
F. C. HILL & CO., 154, Compton Road, Wolverhampton.
Phone 2239.

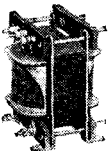

Mention of "The Wireless World," when writing to advertisers, will ensure prompt attention.

An ENQUIRY from INDIA

The following letter was recently received by H. Panagakis of Liverpool in reply to his announcement in the small advertisement columns of "THE WIRELESS WORLD"

"I noticed in 'The Wireless World' of the 24th December last, that you were advertising for sale some receivers at bargain prices. Could you procure for me a good second-hand receiver, which must be of at least 5 valves, more if possible, as the nearest broadcasting station (Bombay) is over 700 miles away."

J. M. BAKER
JHANSI
INDIA

W.W. 12

A SINGLE "WIRELESS WORLD" ADVERTISEMENT STIRS UP BUSINESS ALL ROUND

The following letter registers both surprise and pleasure

"We take this opportunity of expressing our satisfaction with the results from our recent advertisement, the volume, not only of enquiries, but of orders, was very satisfactory. We are still (two months later) receiving these, and the astounding part is the distance from which some of these enquiries come: in addition, the number of trade enquiries are also surprising."

From Bon Marche Ltd. Brixton

W.W. 11

FOR A.C. & D.C. MAINS SETS

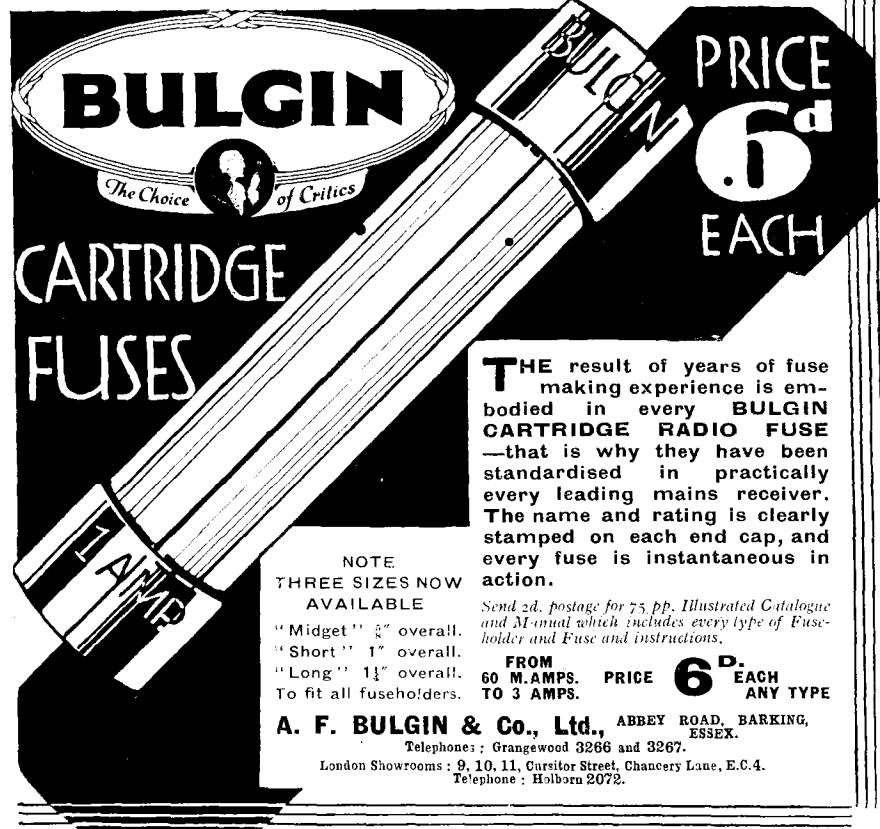

BULGIN

The Choice of Critics

CARTRIDGE FUSES

PRICE 6^d EACH

THE result of years of fuse making experience is embodied in every BULGIN CARTRIDGE RADIO FUSE—that is why they have been standardised in practically every leading mains receiver. The name and rating is clearly stamped on each end cap, and every fuse is instantaneous in action.

NOTE
THREE SIZES NOW AVAILABLE
"Midget" 3/4" overall.
"Short" 1" overall.
"Long" 1 1/4" overall.
To fit all fuseholders.

Send 2d. postage for 75 pp. Illustrated Catalogue and Manual which includes every type of Fuseholder and Fuse and instructions.

FROM 60 M.A.MPS. PRICE 6^d EACH TO 3 AMPS. ANY TYPE

A. F. BULGIN & Co., Ltd., ABBEY ROAD, BARKING, ESSEX.
Telephones: Grangewood 3266 and 3267.
London Showrooms: 9, 10, 11, Cursitor Street, Chancery Lane, E.C.4.
Telephone: Holborn 2072.

WATES ROTARY CONVERTERS

OVER 25% INCREASE IN OUTPUT

This popular converter, now with increased output, is by far the most efficient you can buy. It is a boon to all those who wish to operate an A.C. set. See your dealer about it right away.

Stocked by all dealers

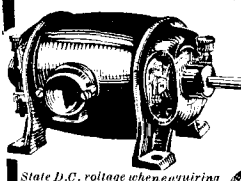

State D.C. voltage when enquiring. Any size made, special quotations for large models and odd voltages from

STANDARD BATTERY CO. 184-188, SHAFTESBURY AVENUE, W.C.2

From D.C. to A.C. NO Increase in Prices.

Model A. Output 80 Watts D.C. from 200-250 volts to 220 A.C. 50 cycles. For receivers with up to 9 valves. Rotary Converter Price £7.10 Smoothing Box £1.5 or complete in new soundproof cabinet with handle £10.15
Model B. Output 100 Watts D.C. from 200-250 volts to 220 A.C. 50 cycles. Rotary Converter Price £9.0 Smoothing Box £1.5 or complete in new soundproof cabinet with handle £12.5

REPAIRS IN 48 HOURS 1 YEAR'S WRITTEN GUARANTEE

Any make of single ratio L.F. Transformer. Headphones or Loudspeaker (except BlueSpot)

POST FREE 3/9

TRANSFORMER REPAIR CO. 953 W. GARRATT LANE, LONDON, S.W.17.

Terms to trade. Quotations for Inductors. Cash with order.



THE SILENT D.C. A.C. CONVERTER
FOR OPERATING A.C. RECEIVERS & RADIOGRAMS FROM D.C. MAINS.

GUARANTEED SILENT. INTERFERENCE FREE

Supplied with filter and sound-proof cabinet. Can be run by side of radio set. Recommended and used by H.M.V., Philips Lamps, Kolster-Brandes, Majestic, Brunswick, etc., etc.

Prices from £10
9 sizes listed up to 600 watts

Also Anode Converters
ELECTRO DYNAMIC CONSTRUCTION CO. LTD.
DEVONSHIRE GROVE, LONDON, S.E.15

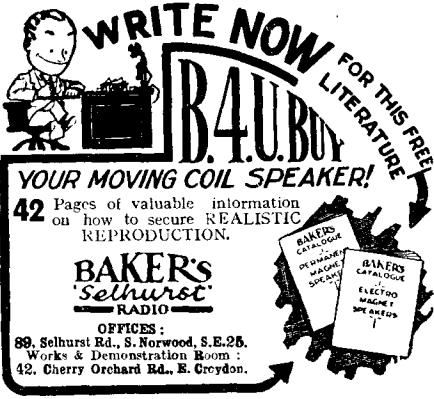

WRITE NOW FOR THIS FREE LITERATURE

BAUBY

YOUR MOVING COIL SPEAKER!

42 Pages of valuable information on how to secure REALISTIC REPRODUCTION.

BAKER'S 'selhurst' RADIO

OFFICES:
89, Selhurst Rd., S. Norwood, S.E.25.
Works & Demonstration Room:
42, Cherry Orchard Rd., E. Croydon.

INDEX TO ADVERTISEMENTS.

	PAGE		PAGE		PAGE
Adaptus Co.	12	Electradix Radios	9	Peto-Scott Co., Ltd.	9
Baker's "Selhurst" Radio	13	Electro Dynamic Construction Co., Ltd.	13	Players	6
Belling & Lee, Ltd.		Epoch Radio Manfg. Co., Ltd.	10	Postlethwaite Bros.	
Bennett College, Ltd.		Film Industries, Ltd.	3	Radialadin, Ltd.	8
Birmingham Sound Reproducers		Formo Co.		Radio Training Institute	10
British Blue Spot Co., Ltd.		General Electric Co., Ltd.		Ready Radio	14
British Ebonite Co., Ltd.	14	Gilbert, J. C.	14	Reproducers & Amplifiers, Ltd.	
British Insulated Cables, Ltd.		Graham Amphion, Ltd.		Rotax, Ltd. (M.L. Equipment)	
British Radiophone, Ltd.	14	Gramophone Co., Ltd.		Scott Sessions & Co.	8
Bulgin, A. F., & Co., Ltd.	13	Gripso Co.		Smith, Arthur	
Burne-Jones & Co., Ltd. (Magnum)	11	H. & B. Radio Co.		Standard Battery Co.	13
Carrington Manfg. Co., Ltd.		Haynes Radio	7	Star Engineering	
Celestion, Ltd.		Heys, Leonard	10	Swift-Levick & Sons, Ltd.	
Challis, O.	10	Hill, F. C., & Co.	12	Tannoy Products	12
Clarke, H., & Co. (Mer.), Ltd.		Igranite Electric Co., Ltd.	6	Telegraph Condenser Co., Ltd.	Cover i.
Cole, F. K., Ltd.	Cover i.	Jackson Bros.	6	Telsen Electric Co., Ltd.	5
Coburn, Ltd.	Cover i.	Jewel Pen Co., Ltd.		Transformer Repair Co.	13
Cossor, A. C., Ltd.	4	Jimit Radio, Ltd.		Walmel Wireless Co., Ltd.	11
Cressall Manfg. Co.	9	Lowse Radio Co., Ltd.		Westinghouse Brake & Saxby Signal Co., Ltd.	Cover ii.
Darwins, Ltd.		London Radio Elect. Co.	12	White Bros. & Jacobs, Ltd.	
Dubilier Condenser Co. (1925), Ltd.	3	Lotus Radio, Ltd.	Cover iv.	Wilburn & Co.	
Eastick, J. J., & Sons	11	Lyons, Claude, Ltd.		Wilkins & Wright, Ltd.	Cover i.
Edison Swan Electric Co., Ltd.		Magnavox (Great Britain), Ltd.	1		

5 GOOD REASONS

for using RADIOPHONE GANGED CONDENSERS

- 1 GUARANTEED ACCURACY**—maximum error of only $\frac{1}{2}$ m.f.d. plus $\frac{1}{2}\%$.
- 2 ROBUST CONSTRUCTION**—a sound engineering job.
- 3 PERFECT SPINDLE ROTATION**—constant tension and smooth movement.
- 4 NO ENDWISE MOVEMENT**—an important point in true ganging.
- 5 NONE BETTER** when specified—the best alternative when not specified!

2-Gang 18/-
Dustproof Cover 3/-
3-Gang 28/-
Dustproof Cover 3/6
4-Gang 38/-
Dustproof Cover 4/-
Oxidised Silver
Escutcheon and
Drive Assembly
with pilot lamp
attachment . . 5/-

Write for descriptive
brochure.
Prompt deliveries
are assured!

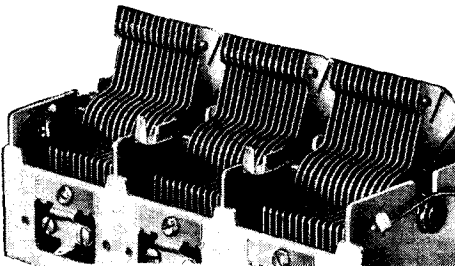

RADIOPHONE GANGED CONDENSERS

THE BRITISH RADIOPHONE LTD., Aldwych House, Aldwych, W.C.2.

BECOL LOW LOSS FORMERS LEADING

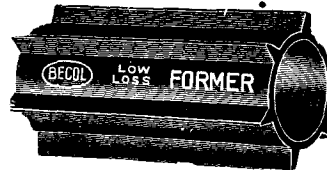

Others following.
Quality First.

UNPRECEDENTED DEMAND.
Tested before despatch.
SHEET, PANELS, TUBES, RODS.

Sole Makers:
THE BRITISH EBONITE Co. Ltd., Hanwell, London, W.7.

High-Grade RADIO GRAMOPHONE CABINET

of exclusive modern design, hand-made and polished on Queen Anne legs.
Figured Oak £5 - 5 - 0
Figured Walnut or Mahogany £5 - 19 - 6
Carriage paid.

The ACME of CRAFTSMANSHIP.
Radio Gram. Cabinets from £3 - 19 - 6 to £21.

Wireless Cabinets from 11.6.
Photographs and 30-page illustrated catalogue free.
Cabinets made to order a speciality.
Furniture at Makers' prices.

GILBERT, Cabinet Maker, SWINDON.
Estimates free. Estd. 1866.

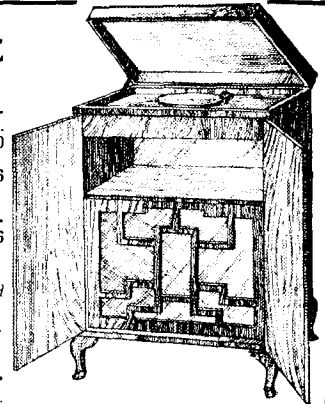

INSTANT MAT CHING

Connect an Instamat Output Transformer between your output terminals and loud-speaker. It gives six different ratios and enables you to match your receiver with speaker whilst you are actually listening.
Instamat. For all loud-speakers except low-resistance moving-coils £1 7 6
Instamat Major. For low-resistance moving-coil loud-speakers £1 17 6
Write for full details to

OF VALVE & SPEAKER WITH THE 'INSTAMAT' OUTPUT TRANSFORMER

Ready Radio

Eastnor House, Blackheath, S.E.3
Telephone: Lee Green 5878

The Yachting World

and Motor Boating Journal

The Leading British Yachting Journal

"THE YACHTING WORLD" deals with yachts and boats of all types and tonnages, whether on the sea or inland waters. Every aspect of yachting and motor boating is covered in an attractive and interesting manner.

Every Friday 6^D.

ILIFFE & SONS Ltd., Dorset House, Tudor St., London, E.C.4

Be sure you get

The
Wireless
AND
RADIO REVIEW **World**

*The only Diary published which is compiled
by the Staff of "The Wireless World."*

DIARY
for **1932**

THIS handy little pocket volume is now in its eighth year of publication. As a convenient source of information on many aspects of wireless theory and practice it is unique. In addition to the usual Diary pages—one week at an opening—there are 80 pages of facts, figures and explanations to which wireless amateurs make frequent reference. These include a series of 16 up-to-date circuit diagrams, dealing among other things with Band Pass Filters, Input Volume Controls, Eliminators and Rectifiers, and Methods of using Reaction.

LIST OF CONTENTS

Regulations Controlling Receiving Licenses—Broadcasting Stations of Europe—Dial Settings for European Stations—Principal Short-Wave Broadcasting Stations of the World—A Series of Abacs—Copper Wire Tables; Sizes, Weights and Resistance—Conversion Tables—Symbols in Common Use—Symbols Used in Wireless Diagrams—Circuit Diagrams and Notes—Coil Construction Data—Practical Hints and Tips—Matching Output Valve and Loud Speaker—Morse Code—Valve Data.

Price 1/6

By Post 1/7

From all Booksellers, Stationers and Bookstalls or direct from the Publishers

ILIFFE & SONS LIMITED, DORSET HOUSE, TUDOR STREET, E.C.4

w.w.86.

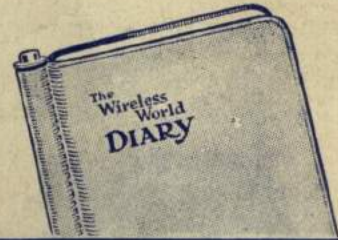

Size $3\frac{1}{2} \times 4\frac{1}{2}$ inches, 192 pages. Bound leather cloth, backloop with pencil, round corners and gilt edges.

RADIO DATA CHARTS

A SERIES OF ABACS

providing most of the essential Data required in Receiver Design

By **R. T. BEATTY, M.A., B.E., D.Sc.**

(1930)

Reprinted from "The Wireless World"

"Radio Data Charts" provide designers of wireless apparatus with a ready and convenient means of solving problems without having recourse to complicated formulæ and mathematics.

By the use of the charts it is possible to tackle all the more familiar problems in radio receiver design; such as, for example, finding the relationship between inductance capacity and frequency, and working out the design of high frequency transformers. All keen amateurs will appreciate this helpful book.

Price 4/6 net

By post 4/10

(39 CHARTS and more than 50 Diagrams)

From all leading booksellers or direct from the Publishers

Published from the Offices of "THE WIRELESS WORLD"

ILIFFE & SONS LTD., Dorset House, Tudor St., London, E.C.4

W.W. 93

Now Ready. "The Wireless World" Pocket Diary. Price 1/6 net. By post 1/7.

good news for constructors

*New LOTUS anti-microphonic
valveholder at amazingly low price!*

Now you can buy **SPRUNG** valve holders of the renowned **LOTUS** quality at a price that defies competition.

There is nothing sacrificed to price about this new **LOTUS** Valveholder Type **VHK**. It comprises two highly finished bakelite mouldings of excellent dielectric quality. These are assembled together by means of four resilient phosphor bronze combined sockets, springs and tags.

Special attention has been given to provide ample current-carrying capacity and the nickel-plated terminal nuts are accessibly placed.

Also the **LOTUS** 4-pin Anti-Microphonic Valve Holders, Type **VH/27** with Terminals and Type **VH/28** without Terminals. Price 1/- each. Rigid Valve Holders for 4 or 5 pin valves. Type **VH/30** without Terminals, 9d. Type **VH/31** with Terminals, 10d.

FREE CATALOGUE

**LOTUS RADIO LTD.,
Mill Lane, Liverpool.**

Please send me free copy of the **LOTUS** Component Catalogue.

Name.....

Address.....

W. W. 30/12.

LOTUS
RADIO COMPONENTS
LOTUS RADIO LTD., MILL LANE, LIVERPOOL

4

for the Publishers, **ILIFFE & SONS LTD.**, Dorset House, Tudor Street, London, E.C.4, by The Cornwall Press Ltd., Paris Garden, Stamford Street, London, S.E.1.

Colonial and Foreign Agents:
 U.S.A.—The International News Co., 331, Varick Street, New York. FRANCE—W. H. Smith & Son, 248, Rue Rivoli, Paris; Hachette et Cie, Rue Réaumur, Paris.
 ENGLAND—W. H. Smith & Son, 78, Mitre Lane, Herbes, Brussels. INDIA—A. H. Wheeler & Co., Bombay, Allahabad and Calcutta. SOUTH AFRICA—Central News Agency, Ltd.
 AUSTRALIA—Gordon & Gotch, Ltd., Melbourne (Victoria), Sydney (N.S.W.), Brisbane (Queensland), Adelaide (S.A.), Perth (W.A.), and Launceston (Tasmania).
 —The American News Co., Ltd., Toronto, Winnipeg, Vancouver, Montreal, Ottawa, St. John, Halifax, Hamilton; Gordon & Gotch, Ltd., Toronto; Imperial News Co.
 Toronto, Montreal, Winnipeg, Vancouver, Victoria. NEW ZEALAND—Gordon & Gotch, Ltd., Wellington, Auckland, Christchurch and Dunedin.