

The Wireless World

AND RADIO REVIEW

4^D

The Paper for Every Wireless Amateur

Wednesday, December 4th, 1929.



NEEDS
WIRELESS
P.M.
TONES
VOLUME
DISTANCE
PUT NEW LIFE
INTO YOUR RECEIVER

Mullard
THE MASTER VALVE

Public Opinion
(“Wireless World” National Ballot)

VOTED
E.K.C.O.

POWER SUPPLY UNITS
1ST Place for Mains Supply Units

Write for Free Booklet on “All-Electric” Radio to:
E. K. COLE, LTD., Dept. W, “Eko” Works, Leigh-on-Sea.

AWARDED THE CERTIFICATE OF THE INSTITUTE OF HYGIENE FOR QUALITY AND PURITY

Superfine Quality

Trelleborgs

GUARANTEED
FINE EBONITE

25% REDUCTION ON RETAIL PRICES

120000 VOLTS PER MM
National Physical Lab. Report

TRELLEBORG EBONITE WORKS LTD.,
Union Place, Welis Street, W.1

Green for Safety!

T.C.C.
CONDENSERS

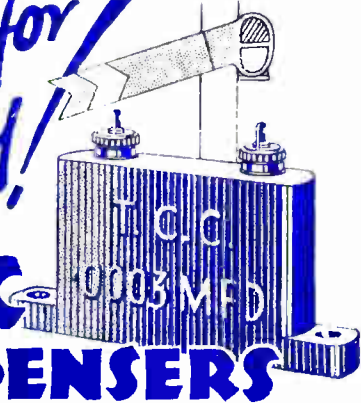

Advt. Telegraph Condenser Co. Ltd.,
Wales Farm Rd., N. Acton, London, W.3.

2585

for SELECTIVITY SELECT.



Actual
Size

The ORMOND SMALL LOG LAW CONDENSER *with Pointer Dial*

Prices:

With Friction Control (as illustrated).

Cat. No. R 370, Cap. .00025, 9/-

Cat. No. R 371, Cap. .00035, 9/3

Cat. No. R 372, Cap. .0005, 9/6

Without Friction Control.

Cat. No. R/373, Cap. .00025, 6/6

Cat. No. R/374, Cap. .00035, 6/9

Cat. No. R/375, Cap. .0005, 7/-



Made with that precision for which Ormond products are famous—the Ormond Small Log Law Condenser enables an exactness which is invaluable in securing the more distant stations.

In addition easier, clearer and finer readings than before are made possible with the Pointer Dial—a new departure in radio.

This Small Log Law Condenser is exactly similar in design to our standard model small Log Law Condenser, but is constructed mainly of aluminium. The Pointer Dial is a metal disc with a gold finish marked plainly in a 0-180 degree scale.

Dial readings are shown by the pointer, the spindle of condenser being controlled by the smaller knob. The upper knob is the slow-motion adjustment on friction control condensers.

Owing to the fact that the pointer dial can only be used with condensers with a modified spindle, it is not supplied separately.

THE ORMOND ENGINEERING CO., LTD.

Ormond House, Rosebery Avenue, London, E.C.1.

Telephone: Clerkenwell 5334-5-6.

Telegrams: "Ormondengi, Smith."

British through and through—and 'ORMOND' too!

Mention of "The Wireless World," when writing to advertisers, will ensure prompt attention.

EVERYTHING



ELECTRICAL

It's costly to test valves after you've bought

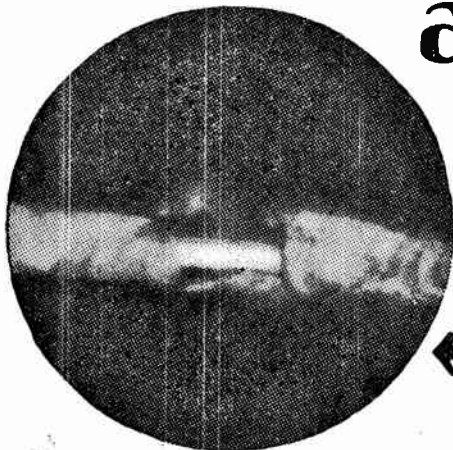

**YOU
MAY BE
GETTING
THIS**

A GOOD Filament WITH

"TENACIOUS COATING"

This reproduction shows the coating typical of all OSRAM VALVES. Notice the absolute evenness of the coating. There are no gaps, the coating clings, so that the full benefit of the coating is maintained. The secret is the startling discovery of the scientific process of "TENACIOUS COATING."

A BAD Filament WITHOUT

"TENACIOUS COATING"

Reproduction from an untouched microphotograph showing part of the filament of a badly coated valve before use, showing a serious gap in the coating. A gap such as this starts the valve off in its life with a poor performance. The valve then prematurely falls.

**YOU GET
THIS IN
OSRAM VALVES**

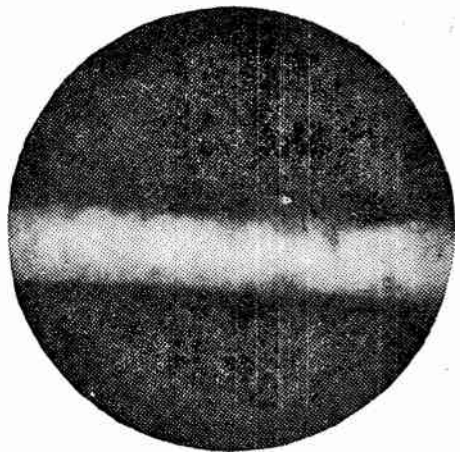

MADE IN ENGLAND.

SOLD BY ALL WIRELESS DEALERS.

WRITE for booklet "OSRAM WIRELESS GUIDE" (1929 edition) giving full particulars of the full range of OSRAM VALVES with the "TENACIOUS COATING." Also helpful wireless information of importance to every listener. Sent post free.

Osram Valves

with the

"TENACIOUS COATING"

Advt. of The General Electric Co., Ltd., Magnet House, Kingsway, London, W.C.2

At Advertisements for "The Wireless World" are only accepted from firms we believe to be thoroughly reliable.

WHAT IS IT?



THE NOVOTONE
McLachlan Tone Compensator
(Patents Pending).

BOOKLET
"W.W."
FREE ON
REQUEST

- that** TURNS HUGE LOSSES INTO GAINS.
- that** INCREASES OVERALL AMPLIFICATION.
- that** PUTS IN TRUE BASS WITHOUT BOOM.
- that** CAUSES AN APPRECIABLE STRENGTHENING OF THE HIGHER NOTES.
- that** IMPROVES REPRODUCTION BEYOND BELIEF OVER THE WHOLE MUSICAL SCALE.
- that** RESULTS IN A BRILLIANCE OF REPRODUCTION NEVER BEFORE OBTAINED.

THE NOVOTONE COMPENSATOR

This marvellous invention of Dr. N. McLachlan makes good electrically (without the use of extra valves or apparatus) all the huge losses which are inherent in records, pick-ups and amplifier, and thereby makes possible for the first time realistic reproduction of records.

EVERY USER OF AN ELECTRICAL PICK-UP SHOULD ASK HIS DEALER TO DEMONSTRATE THE NOVOTONE.

GAMBRELL RADIO LTD.,
6, BUCKINGHAM STREET, STRAND, LONDON, W.C.2.

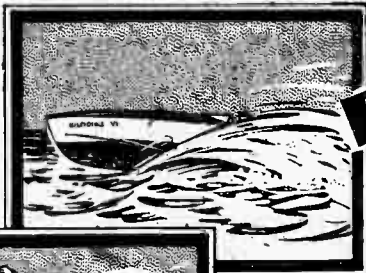

FAST & SLOW MOTION with POLAR



Write for the
Polar
Catalogue (W).

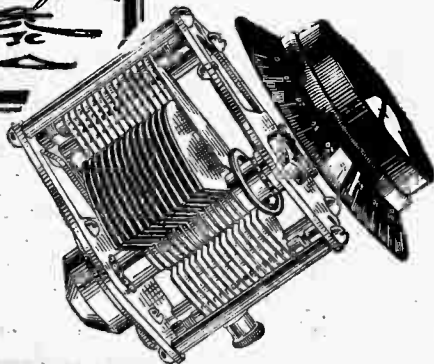

You will find a wonderful difference in the way you can pull in stations which are separated by only a metre or two, when you employ "Polar" Fast and Slow Motion Condensers.

Polar Condensers make just that difference in selectivity that adds a few more stations to your list of those "worth hearing"; and they also improve the quality of reception by giving you "dead on" tuning.

THE POLAR "IDEAL."

This is one of the most popular types of condensers because it can be used most effectively with practically any modern circuit.

'0005 - 12/6 '00035 - 12/3 '0003 - 12/-

The Polar "Ideal" DRUM CONTROL CONDENSER is supplied in capacities as above, and costs only 2/6 extra. Ask your dealer to show you one.



WINGROVE & ROGERS, LTD., 188-189, STRAND, LONDON, W.C.2.



Get in the Modern Movement — Make it “All-Electric”

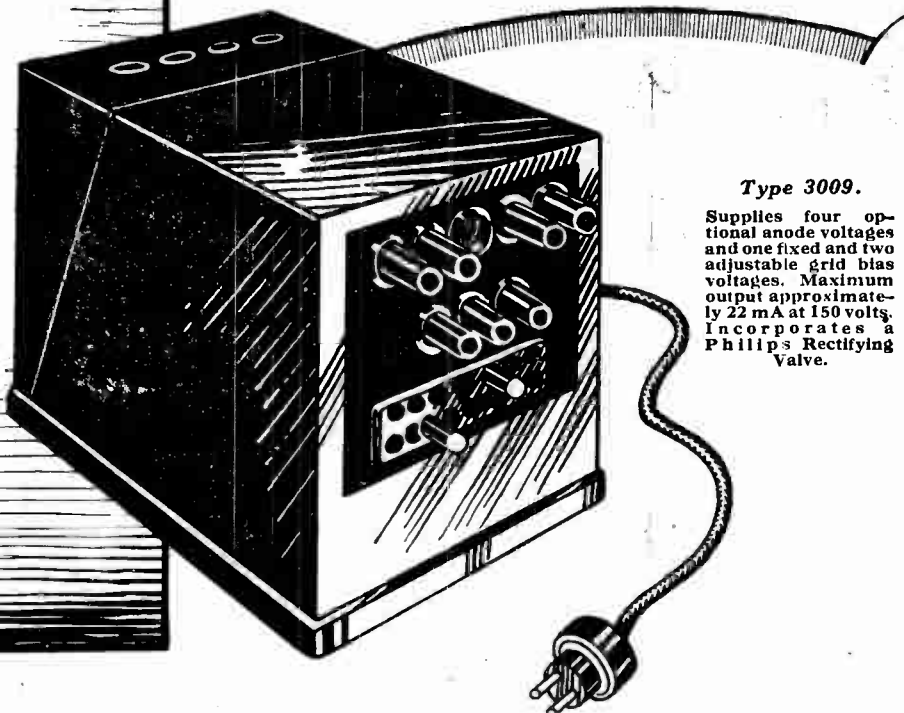

Type 3009.

Supplies four optional anode voltages and one fixed and two adjustable grid bias voltages. Maximum output approximately 22 mA at 150 volts. Incorporates a Philips Rectifying Valve.

Put your radio receiver on the same basis as modern types—make it All-Electric. Philips Battery Eliminator will supply High Tension current direct from the electric mains and Philips Trickle Charger will keep your accumulators always charged. Then you are not bothered with replacement and recharging bills and your set will be far more efficient in operation. Make your receiver All-Electric from now on. Install a Philips Battery Eliminator and a Philips Trickle Charger.

Philips Battery Eliminator Type 3009 for A.C. Mains only £5 15 0, or on Hire Purchase Terms for 10/- down. Also type 3005 for D.C. Mains at £3 17 6, or for 10/- deposit.

PHILIPS for Radio

MADE BY THE MANUFACTURERS OF THE FAMOUS PHILIPS ARGENTA LAMPS.

PHILIPS RADIO, PHILIPS HOUSE, 145, CHARING CROSS ROAD, LONDON, W.C.2.

A3 Advertisements for "The Wireless World" are only accepted from firms we believe to be thoroughly reliable.

CUT OUT
BATTERY
BILLS
AND
BREAKDOWNS

FERRANTI

MULTI-RANGE TEST SET

A quality instrument for every direct current measurement up to 25 amps. 250 volts, with an almost unlimited range above this by the use of external shunts and resistances. The Test Set comprises two Ferranti Radio Meters—an ammeter and a voltmeter—mounted side by side in a moulded bakelite case with terminals so arranged that current and voltage readings may be taken simultaneously.

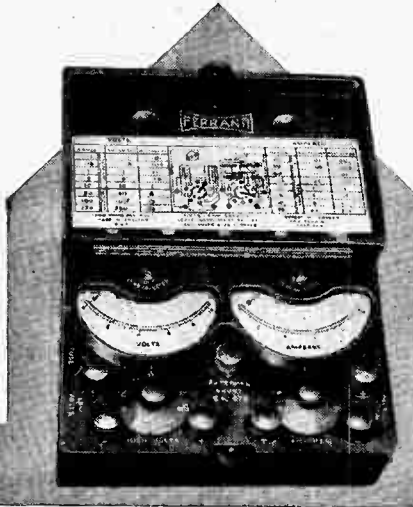

By means of rotary switches mounted on the instruments a wide range of readings is obtainable, namely:—

VOLTS.		AMPERES.	
0-0.1	0- 10	0-0.01	0- 1
0-0.5	0- 50	0-0.05	0- 5
0-1	0-100	0-0.1	0-10
0-5	0-250	0-0.5	0-25

Size $5\frac{1}{2}'' \times 4\frac{1}{2}'' \times 1\frac{1}{2}''$. Weight only 1 lb. 14 ozs.

PRICE. For Set only .. £7:15:0

Complete with case, together with plugs and leads to facilitate measurements in Radio Receivers .. £9: 5:0

Extra for Resistance Box to increase range to 500 volts .. £1:10:0

Resistance 1,000 ohms per volt precisely.

FERRANTI LTD.

HOLLINWOOD

LANCASHIRE

The Wireless World DIARY for 1930

AND RADIO REVIEW Full of Useful Information!

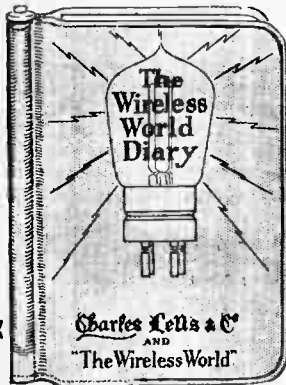

A Suggestion for Christmas?

“The Wireless World” Diary for 1930 makes an admirable little gift to a wireless friend, and will prove of use and value throughout the coming year.

“The Wireless World” Diary, now in its sixth year of publication, contains facts and figures to which wireless amateurs constantly refer, together with ample space for memoranda and notes concerning individual sets and other radio matters.

PRINCIPAL CONTENTS:

Summary of Regulations and Commercial Stations of Relating to Amateur Transmitter and Receiving Licences. Conversion Tables. English measures to metric and *vice versa*. Decimal and metrical equivalents of fractions of an inch. Broadcasting Stations of Europe with their Call-Signs and Wavelengths. Principal Short-Wave Broadcasting and Commercial Stations of the World. Nationality Prefixes used by Amateurs. Morse Code. Symbols used in Wireless Diagrams, Typical Wireless Receiver and Eliminators:— Fourteen Different Circuits with Diagrams. Valve Data, giving the characteristic features of standard valves.

From All Booksellers and Stationers

Published jointly by

“THE WIRELESS WORLD,” LONDON, E.C.4 and CHARLES LETTS & CO.

PRICES: Cloth Board, 1/- net. By post 1/1. In Leather Case, with pockets, pencil and season ticket window, 2/6 net. By post 2/7.

Mention of “The Wireless World,” when writing to advertisers, will ensure prompt attention.

ACCUMULATORS L.T. SUPPLY CAR LIGHTING Etc.

Type "Y" 2/30.

Glass Storage Cell 2 volts.

Celluloid Case.

Type "G.Z." 2/40 Glass Case.



Type "C" Crate Celluloid Case.

Unspillable type for Portables

ASK your dealer to show you an **EVER READY** Accumulator and note its clean and substantial construction. **EVER READY** were the first batteries made for wireless and are still unapproached for consistent quality and guaranteed service.

Let your next accumulator be an **EVER READY** and ensure satisfaction.

Obtainable Everywhere. Write for illustrated list to the manufacturers :

The Ever Ready Co. (G.B.) Ltd., Hercules Place, London, N.7.

STANDARDS PHILIPS

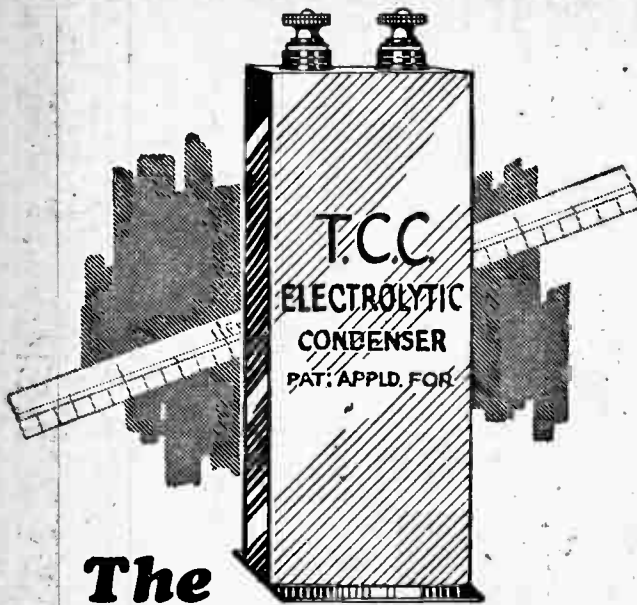

The "YARD STICK" and T.C.C.

ALL yards—if they are true yards—are exactly the same length as the "Yard Stick"—a standard of length confirmed by Statute. A true three yards of cloth is exactly three times the length of the standard yard—the "Yard Stick."

Accuracy in anything demands a standard, and among condensers that standard is T.C.C. Whenever you see a condenser marked "T.C.C." you are assured that it is true to type—that it is a standard by which all others are judged, whether for accuracy, dependability or service. The considered opinion of all who know what a good condenser should be, have recognised in T.C.C. the standard. Use T.C.C. wherever a condenser is specified, and know that you are safe.

The illustration above shows an Electrolytic Type Condenser. These are made in three capacities, viz. :—Single Type 2,000 mfd. 12 volts D.C., price 15s. od. Double Type 4,000 mfd. 12 volts D.C., price 27s. 6d., and the new Single Type 500 mfd. 40 volts D.C. price 2cs. od.



Adv. Telegraph Condenser Co. Ltd, Wales Farm Road, N. Acton, Lond n, W.3.



2584



RECTIFYING VALVES

For:

- Reliable H.T. Supply
- Dependability
- Long Life
- High Efficiency
- Output easily varied and smoothed

The rectifier that has stood the greatest of all tests—**TIME.**

Representative Types

TYPE 506

Full wave. Filament voltage 4 volts. Anode voltage 2 x 300 v. R.M.S. Maximum rectified current 75 mA. Price 20/-

TYPE 2506

Full wave. Filament voltage 4 volts. Indirectly heated. Anode voltage 2 x 300 v. R.M.S. Rectified current 40 mA. Price 22/6

TYPE 505

Half wave. Filament voltage 4 volts. Anode voltage 400 R.M.S. Maximum rectified current 60 mA. Price 15/-

TYPE 373

Half wave. Filament voltage 4 volts. Anode voltage 220 R.M.S. Maximum rectified current 40 mA. Price 15/-

Obtainable at all Radio dealers.

PHILIPS for Radio

Advert. of PHILIPS RADIO, PHILIPS HOUSE, 145, CHARING CROSS ROAD, W.C.

Mention of "The Wireless World," when writing to advertisers, will ensure prompt attention.

CA SPEAKING LIKENESS

Whether it's vocal or instrumental music, whether it's the "News Bulletin" or a Broadcast "talk," the McMichael Super Range Portable Four Receiver can be relied upon to reproduce with perfect fidelity every tonal variation. So clear is the reproduction, so fine the tuning and so accurate the construction of the McMichael Super Range Portable Four that it has become world famous for efficiency. So simple to tune in—so easy to cut out unwanted stations, and so convenient to carry from place to place without effort. High in quality—low in price, this luxury Portable is extremely economical in battery consumption.

The McMICHAEL SUPER RANGE PORTABLE FOUR

Owing to the high degree of selectivity in this, and our other Screened Grid Portable Receivers, we are able to guarantee complete selectivity between all main B.B.C. stations under the new scheme of wavelengths.

Ask your dealer for a demonstration of this wonderful receiver or call at our London Showrooms, 179, Strand, W.C.2, for a demonstration without obligation.

CASH PRICE 22 GNS. (Including all Equipment and Royalties)

or if desired it can be purchased by means of our special "Deferred Payments on Hire Purchase Terms" system, £5 down and 10 monthly payments of £2.1.0.

THE McMICHAEL SUPER RANGE FOUR (TABLE MODEL)

Contains the same circuit as the McMichael Super Range Portable Four, but is made as a table model in handsome Walnut. It is mounted on a turntable, and has a most efficient frame aerial fitted inside the Cabinet. The use of additional aerial and earth can be used to add to the normal and very remarkable range.

Cash Price **26 Gns.**
Including all Equipment and Royalties.

L.M. MICHAEL LTD

Manufacturers of Wireless and Scientific Apparatus
WEXHAM ROAD, SLOUGH, BUCKS.

Telephone: Slough 441-442. Telegrams: Radiether, Slough.
London Showrooms: 179, Strand, W.C.2. (Telephone: Holborn 2466)

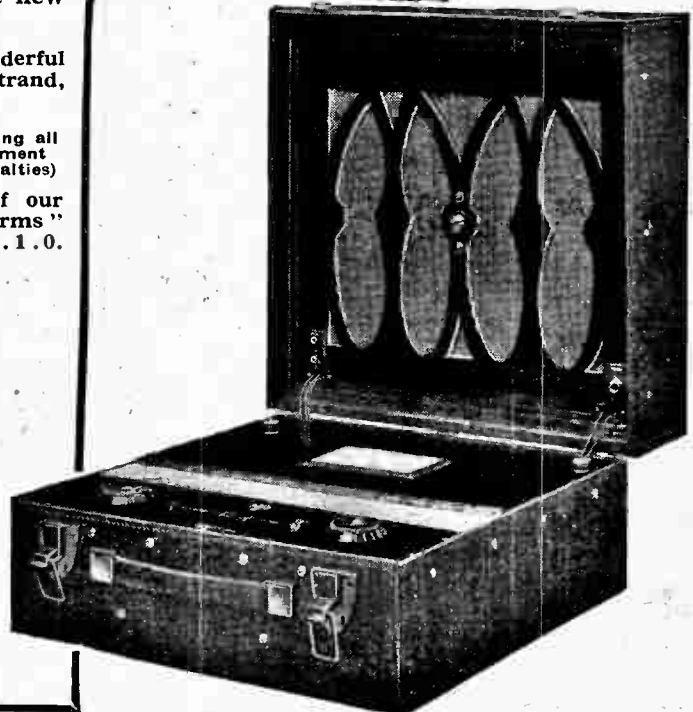



The latest & best in H.T. Accumulators

This entirely new range of C.A.V. H.T. Accumulators has many unique features to commend them to all radio users. They are supplied in separate 10-volt blocks and assembled 30-volt units, the latter comprising three 10-volt blocks air spaced from each other and assembled in a carrying tray. All-moulded acid proof material so popularly used for car batteries, is employed for the cell containers and trays, the polished surface giving an attractive appearance.

10 VOLTS **6/3** 5000 MILLIAMPS

Also supplied in 2,500 & 10,000 Milliamp Hrs.

Specify the C. A. V. Jolly Acid Battery—The Perfect L.T. for all Portables.

WRITE FOR CATALOGUE T5.

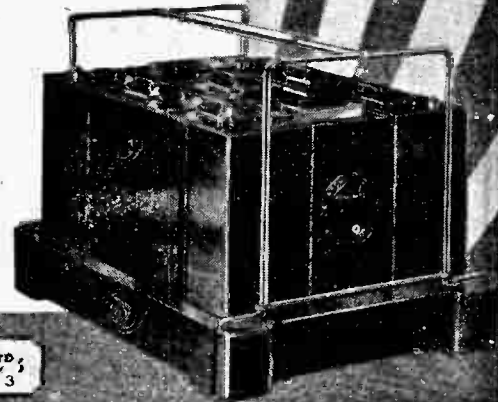

C.A.V. Vandervell & Co., Ltd.
ACTON, LONDON, W 3

Superior A.C. POWER TRANSFORMERS

and **CHOKES** for the **MAINS** from 35/- each
for ALL INPUTS and OUTPUTS.

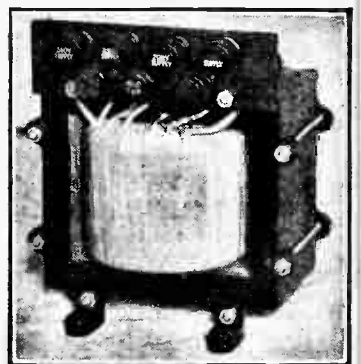
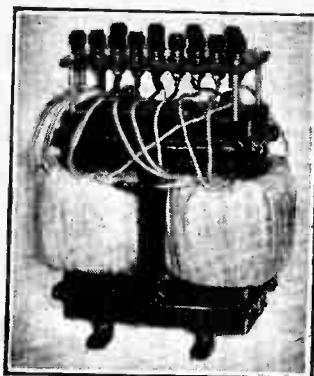
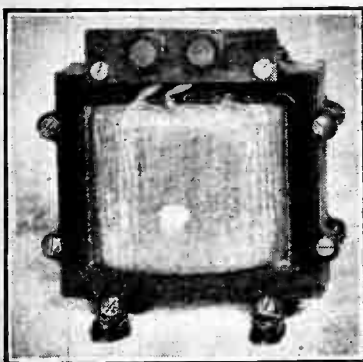

Special Audio-Frequency Chokes and Transformers, and Smoothing Chokes for all purposes.

WILLIAM BAYLISS LTD., Sheepcote Street, BIRMINGHAM.

Telephone: Mid. 1409.

Telegrams: "Drawbench B'ham."

Mention of "The Wireless World," when writing to advertisers, will ensure prompt attention.

GENTLEMEN OF THE JURY



**THE FIRM'S CLAIM
OF "MELODY OUT
OF THE MEDLEY"
IS MORE THAN
JUSTIFIED**

and, Gentlemen, I would urge you and your friends to always use Telsen Transformers in preference to others if you desire to obtain the utmost performance and the acme of perfection. In my opinion I consider their claim justified—so writes an enthusiastic user of Telsen Transformers. Fit Telsen Transformers now and avoid those costly errors of judgment.

**A GOOD JUDGE ALWAYS
FITS TELSEN TRANSFORMERS**

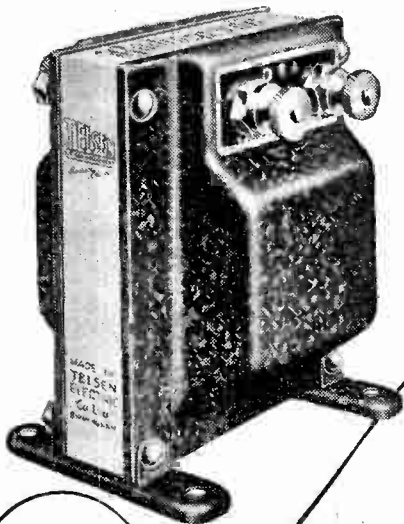

RADIOGRAND

12/6

Ratios 5-1 or 3-1

TELSEN TRANSFORMERS

TELSEN ELECTRIC CO., LTD., MILLER STREET, BIRMINGHAM.

READ THIS!

14, Beechwood Crescent,
High Street, Edgware, 30th Sept., 1929.
Burley, Leeds.

Messrs. Watmel's,
Dear Sirs,
I have already purchased one of your units and is giving splendid results on a 5" floating cone. I am now curious to see what sort of cone you recommend, so please forward me your literature to buy that the thing that persuaded me to buy your unit is the way it is constructed. You are evidently not afraid of letting anyone see how it is made, and not boxing it up like most cone units on the market.

Yours truly
(signed) A. DAVISON.

PRICE
18/6

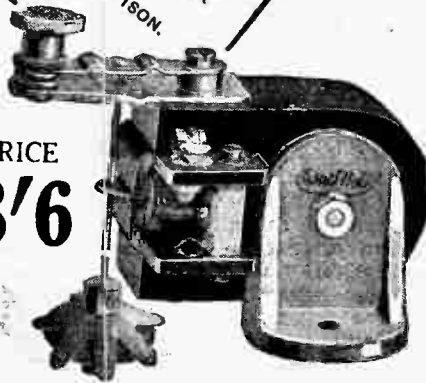

Q This bears out our claim that the Watmel is "the best of the British units" Try one—or better still, buy the Watmel Cone Speaker Kit (including cabinet) at 55/-, and make up your own Speaker, using this Unit!

Full particulars and instructions on application.

Watmel

WATMEL WIRELESS CO. LTD.,
Imperial Works, High St., Edgware, Mx.
Telephones: Edgware 0323.

P. & T.

DUBILIER FOR STAUNCH RESISTANCES

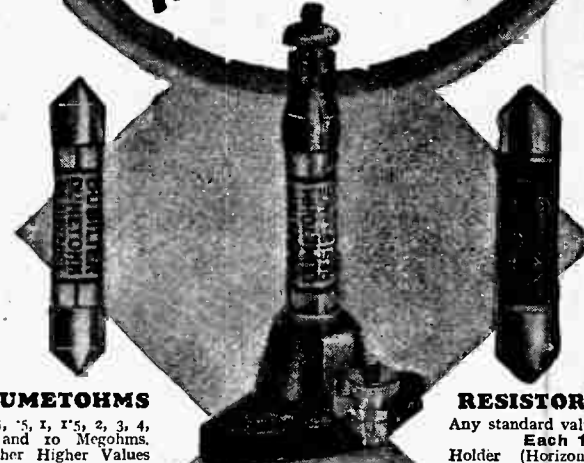

DUMETOHMS

25, 5, 1, 1/5, 2, 3, 4, 5 and 10 Megohms.
Other Higher Values specially to order.
Each 2/6

RESISTORS

Any standard value
Each 1/-
Holder (Horizontal or Vertical).
Each 1/-

Vertical Holder
Each 1/-

Horizontal Holder
Each 1/-

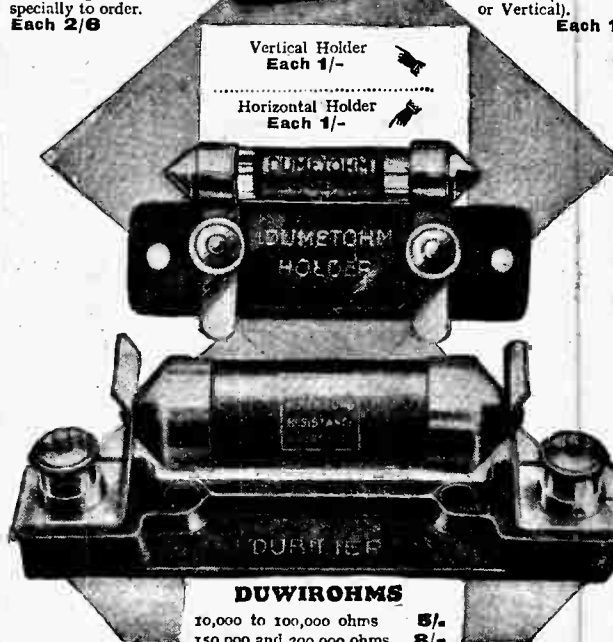

DUWIROHMS

10,000 to 100,000 ohms	5/-
150,000 and 200,000 ohms	8/-
250,000 ohms	9/9
300,000 ohms	11/6
Holder for Horizontal type	1/6

If unobtainable from your dealer write direct to us giving his name and address.

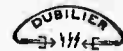

Free for the asking—"A Bit about a Battery." There's a copy for you at your dealer's.

DUBILIER RESISTANCES

Dubilier Condenser Co. (1925) Ltd., Ducon Works, Victoria Road, N. Acton, London, W.3.

Mention of "The Wireless World," when writing to advertisers, will ensure prompt attention.

BC 250/R
A10

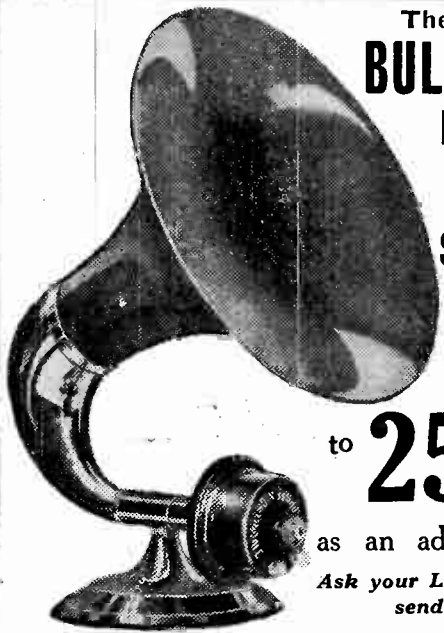

The Famous
**BULLPHONE
DE LUXE
LOUD-
SPEAKER**

Reduced
from 55/-

to **25/-** 1000 only
as an advertisement.

Ask your Local Dealer or
send direct.

**CUT OUT
THE NEW
STATION**
with the
**BULLPHONE
DUAL RANGE
COIL**

12/6

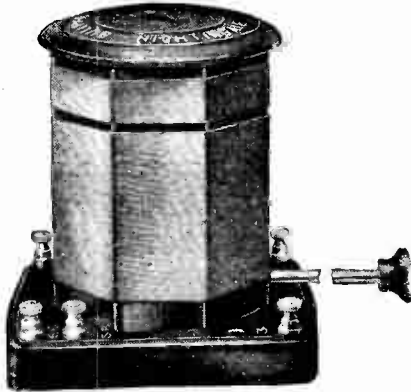

BULLPHONE

4-Pole
Adjustable
Tone

CONE UNIT

15/-

Adjustable
Cone Chassis,
suitable for
any Cone
Unit,

per **3/-** pair

Obtainable from your Local Dealer or direct from:

BULLPHONE, LTD.

38, HOLYWELL LANE, LONDON, E.C.2

AK6! FOR A
**BRASS-VANED LOG
CONDENSER**

Just a typical example
of Graham-Farish
value. A brass-vaned
log-mid-line variable
condenser using Bake-
lite as a dielectric.
Robust in construction,
and ideal for
portable sets. Can be
mounted for either
drum or ordinary dial
control, with one hole
fixing with special
claw panel grip.
•0005, 4/6; •003,
4/3; •00015, 4/3.

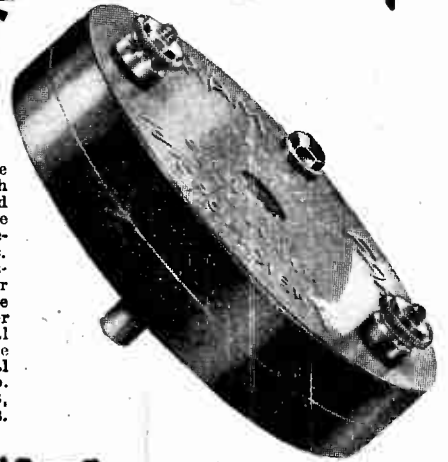

5/-
each.



2/3
each.

The "MULTIWAVE"
H.F. CHOKES designed
for modern valves. By
employing solenoid wind-
ing followed by sectional
windings, high impedance
is obtained with low D.C.
resistance. Also very
effective for use in H.F.
stopper or filter circuits.
With Base 5/- each.

The famous
"OHMITE"—a
new process
Moulded Resistance
with a value that re-
mains constant. Infinite-
ly better than wire-wound.
Hermetically sealed in Bake-
lite. Noiseless and efficient.
Negligible self capacity, so that
the high notes are retained. Also
fitted with terminal ends. All
values 1,000 to 500,000 Ohms.
2/3 each. Holders for above 6d.

**GRAHAM
FARISH**

BROMLEY



KENT

LISENIN

POSITIVE GRIP TERMINALS

(Patented)

Scientifically constructed, both electrically and mechanically, they hold the wire, but grip the flex covering. All stresses and strains are removed from the conductors, and once a connection is made it stays put, and without any unsightly frayed ends of leads, the bane of all fans.

Write for **FREE** copy of our latest descriptive leaflet "W.W." Post free, of course.

POSITIVE GRIP SAFETY PLUG AND SOCKET
(Registered Design).

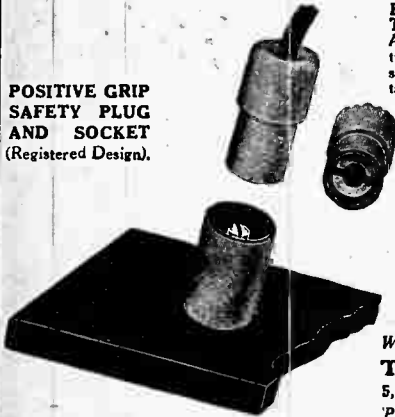

POSITIVE GRIP Banana Type PLUG & SOCKET.
A great advance on all other types of plug. A silky, dead smooth contact is NOW obtainable. Price 4d. complete.

LISENIN POSITIVE GRIP ALL MAINS PLUG AND SOCKET (Registered Design).
The Lisenin Mains Plug and Socket is totally insulated and is equally as valuable on sets working off batteries as those from the electric supply. The leads may be dropped with impunity and there is no chance of a short circuit. Instantly assembled with the aid of a screwdriver. **NOTE THE PRICE.** 6d. each, complete as illustrated.

WRITE to-day for our new descriptive folder, mentioning this paper.

We have moved to larger premises. Note new address:—
THE LISEININ WIRELESS CO.,
5, Central Buildings, HIGH ST., SLOUGH, Bucks.
Phone: Slough 652. T. Address: POSGRIP SLOUGH.

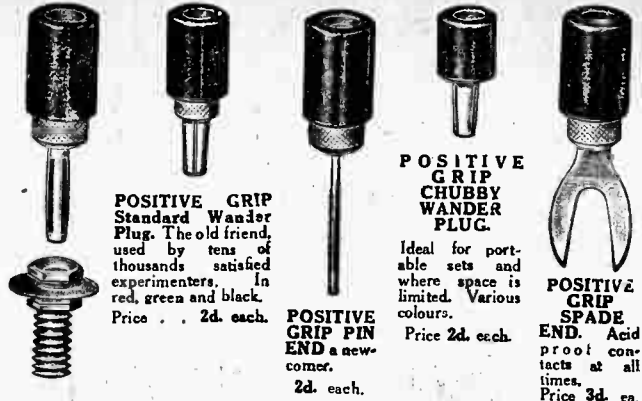

POSITIVE GRIP Standard Wander Plug. The old friend, used by tens of thousands satisfied experimenters. In red, green and black. Price . . . 2d. each.

POSITIVE GRIP CHUBBY WANDER PLUG.

Ideal for portable sets and where space is limited. Various colours. Price 2d. each.

POSITIVE GRIP PIN END a new-comer. 2d. each.

POSITIVE GRIP SPADE END. Acid proof contacts at all times. Price 3d. ea.



Look for the Lisenin Show Case on your Radio Dealer's Counter.

DONOTONE

THE BEST LOUD SPEAKER

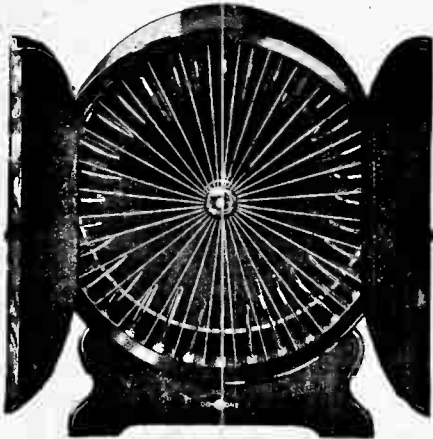

FROM 5 GNS.

The wonderful Loud Speaker with the tuned gongs which impart crispness and brilliance together with real purity and increased volume.

DEMONSTRATIONS DAILY.

THE DONOTONE (Regd.) LOUDSPEAKER,
Dept. C 40, Farnival Street, Holborn, London, E.C.4.
Phone: HOLBORN 0523.

HOW TO BUILD AND OPERATE

The Wireless AND RADIO REVIEW World

MOVING COIL LOUDSPEAKER

(as described in "The Wireless World")

Complete
Constructional Details
and Dimensional
Drawings

By F. H. HAYNES

Assistant Editor: "THE WIRELESS WORLD."

Second Edition, Revised.

WITH the moving coil type of loudspeaker the most faithful reproduction can be obtained. This booklet gives complete instructions for building an instrument, at a moderate cost, whose output is suited to home conditions. The design has been developed to form a standard for amateur workers, as, when once adopted, the dimensions cannot easily be modified.

Price 1/8 post free.

From the offices of "THE WIRELESS WORLD,"
Dorset House Tudor Street, London, E.C.4.
w.w.70

ABSENT MINDED DOCTOR TO PATIENT :-



"Say-er-...."

Player's
Please!"



N.C.C. 756A

Radio's Supreme Power



ARE YOU PROUD
OF YOUR NEW SET?
DO IT JUSTICE
AND FIT THE BEST
POSSIBLE BATTERY

Grosvenor Batteries give continuous and satisfactory service because they incorporate a new vitalising element which is unique to Grosvenor.

66 v. from 7/6 Super Capacity for Multi-Valve Sets 66 v. 20/-
99 v. .. 11/6 99 v. 32/6

The Grosvenor Battery

BRITISH MANUFACTURE

GROSVENOR BATTERY CO., LTD., 2-3, White St., MOORGATE, LONDON, E.C.2. Phone. Met. 6865

A13 Advertisements for "The Wireless World" are only accepted from firms we believe to be thoroughly reliable.

LOTUS LOGARITHMIC CONDENSERS

pass the test

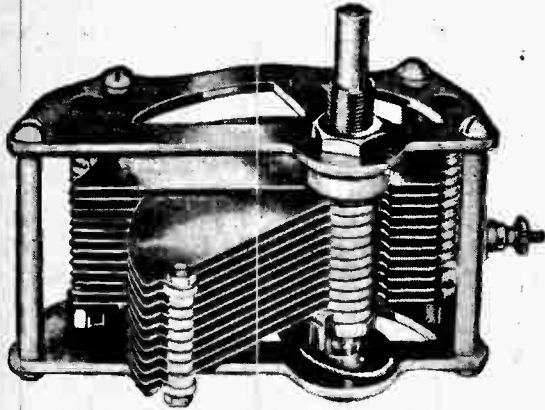

Technical writers, the press and the leading manufacturers of circuits are constantly recommending Lotus Logarithmic Condensers. Why not use these proved condensers in your set?

The ball bearings and the chemically-cleaned special brass vanes and end plates ensure a smooth, firm movement and perfect conductivity, and the ample spacing prevents any chance of short circuiting of the vanes.

Every Lotus Component, from a variable condenser to a simple switch, is the product of experience and experiment—a masterpiece of mechanical perfection. Make a point of building your next set with Lotus Components.

- .0005 Condenser 5/9
- .00035 Condenser 5/7
- .0003 Condenser 5/6
- .00025 Condenser 5/3
- .00015 Condenser 5/-

FROM ALL RADIO DEALERS.

LOTUS

VARIABLE CONDENSERS

Made in one of the most modern radio factories in Great Britain.

You can get these Condensers fitted to the Lotus Dual and Single Drum Dials—Ask your Dealer.

Garnett, Whiteley & Co., Ltd., Liverpool

One of the outstanding successes of Olympia

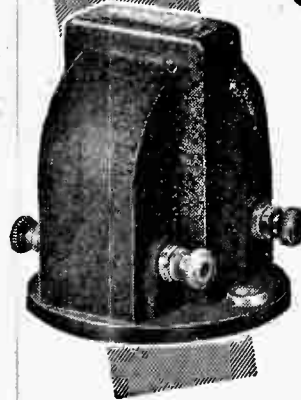

The new British General Midget Transformer created remarkable interest. In accordance with modern practice of economising in weight and space this transformer has been produced in a remarkably small size. The core is of the latest Nickel Alloy (specially treated) and the performance is as good as many transformers at three times the price.

11'6

From all dealers of repute or direct from the manufacturers.

The British General Manufacturing Co., Ltd.
Brockley Works, London S.E.4.

An entirely new M-L production for the ALL ELECTRIC RECEIVER, the D.C. to A.C. Converter.

40 WATT Model
£13-0-0

85 WATT Model
£19-0-0

Power Supply Units our Speciality.

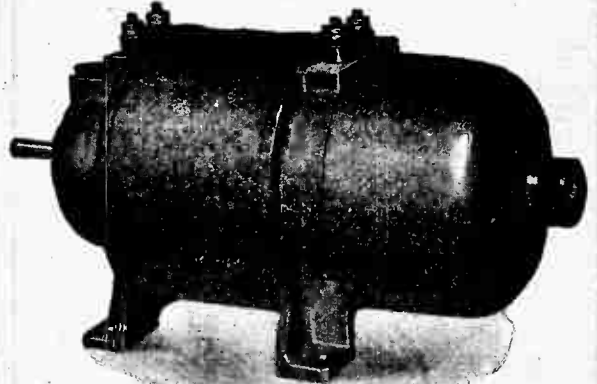

IF YOU ARE ON D.C. MAINS employ the above machine for running your ALL ELECTRIC RECEIVER. The only safe way to operate receivers from D.C. Mains. Suitable for well-known makes of Receivers

M-L MAGNETO SYND. Ltd.,
Radio Dept., COVENTRY.

Telephone: 5001.

Mention of "The Wireless World," when writing to advertisers, will ensure prompt attention.

Now!
**The
 WORLD
 FAMOUS
 BENJAMIN
 COMPONENTS**



5 PIN VALVEHOLDERS
 For 5-pin valves with centre leg, anti-microphonic one-piece springs, perfect contact, price 1/9.



PENTODE VALVEHOLDERS
 A Standard Clearertone Valve holder with Pentode attachment, price 2/3.



ROTARY BATTERY SWITCH
 All insulated "on and off" indicating dial and pointer knob, price, 1/9.



VIBROLDER
 Last season's most successful accessory. Self-aligning positive contact, price 1/6.



CLEARERTONE VALVEHOLDERS
 The original Benjamin Anti-microphonic valve holders price 2/-.

Write for illustrated leaflet No. 2,000 for full description of all components.

**BENJAMIN
 RADIO PRODUCTS**

THE BENJAMIN ELECTRIC Ltd. Brantwood Works' LONDON, N.17

We Don't wish
 to worry you
 But:—
 Do you appreciate

that within the next two weeks you will make a decision as to what music you will have for Christmas? Whether it is for your Club or your Home, you will require some instrument to entertain your friends, and why not make it a Radiogramophone and be up to date?

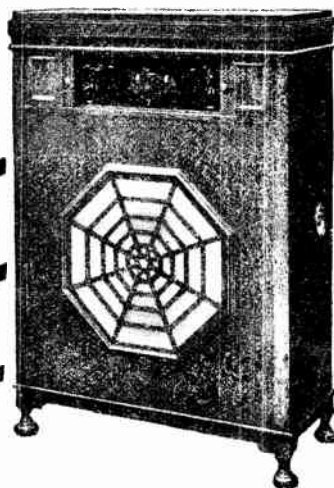

**The R.G.D.
 Radiogramophone.**

An entirely new six-valve instrument giving the highest possible quality for both radio and record, with ample volume, incorporating the latest design of moving coil speaker, operates entirely from electric mains, A.C. any voltage, or D.C. 200 volts or over.

£75 in Oak. **£80** Mahogany.

Place your order now to ensure delivery, to avoid disappointment.

Literature on application to

**The Radiogramophone Development
 St. Peter's Place, Co.
 Broad Street,
 BIRMINGHAM.**

THE
WESTINGHOUSE
METAL RECTIFIER

STYLE A3
 FOR LOW TENSION

D.C. Output, 9 volts, 1 amp.

23/6

MADE IN ENGLAND BY

The Westinghouse Brake &
 Saxby Signal Co. Ltd.,
 82 York Road, King's Cross, London, N.1.

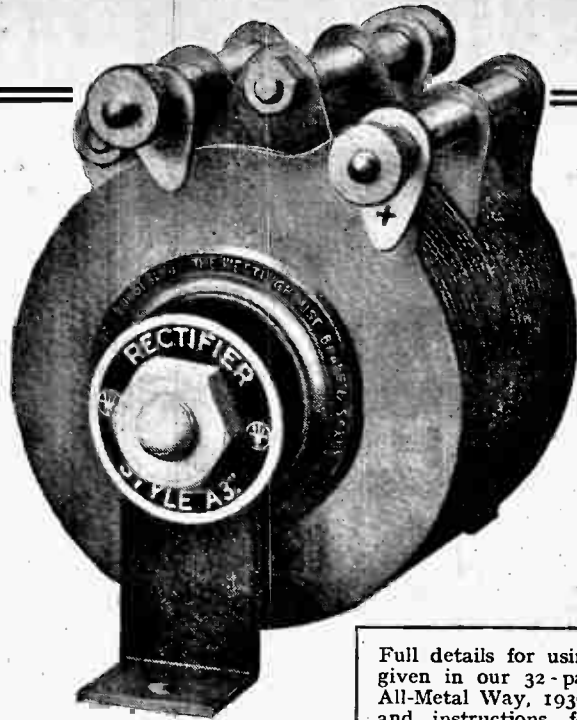

Full details for using this unit are given in our 32-page book, "The All-Metal Way, 1930," with circuits and instructions for building all types of A.C. mains units, high and low tension.

Send 2d. stamp for a copy.

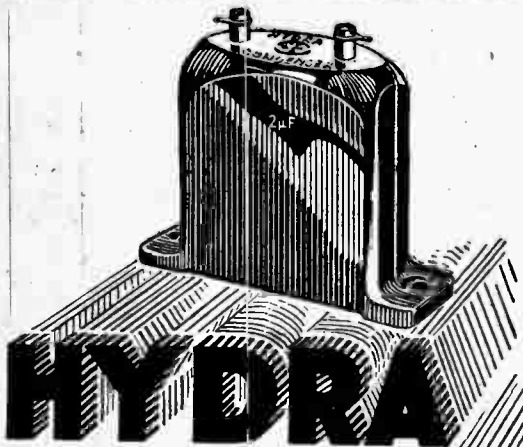

**THE STRONG POINT
 IN ANY MAINS UNIT!**

The impregnable insulation of the paper dielectric in a Hydra Condenser is the "strong point" in any eliminator. When you put Hydra into the circuit, you cut out once and for all the risk of condenser-trouble—you safeguard your set and all who handle it.

The best eliminators you can buy contain Hydra Condensers—write for list of makers' names.

LOUIS HOLZMAN, 37, Newman Street, London, W.1.

Mention of "The Wireless World," when writing to advertisers, will ensure prompt attention.

ELECTRAD

**TRUVOLT
 Resistances**

Truvolt wire-wound potentiometers simplify the construction of H.T. Eliminators and do away with all guesswork. The resistance element is a nickel alloy wire. There is no iron to rust or zinc to oxidise. Truvolts are air-cooled and give a positive and lasting service. All Truvolts are rated at 25 watts.



REDUCED PRICES.

Type T.5	500 ohms.	224 m.a.	8/6 each
" T.10	1,000 "	158 "	8/6 "
" T.20	2,000 "	112 "	8/6 "
" T.25	2,500 "	100 "	8/6 "
" T.30	3,000 "	91 "	8/6 "
" T.50	5,000 "	71 "	8/6 "
" T.75	7,500 "	58 "	8/6 "
" T.100	10,000 "	50 "	8/6 "
" T.200	20,000 "	25 "	8/6 "
" T.250	25,000 "	32 "	8/6 "
" T.500	50,000 "	22'5 "	8/6 "

Write for our new 68-page Catalogue and Audio Manual. It tells you all about the uses of Electrad resistances. Post Free 6d.

THE ROTHERMEL CORPORATION LTD.,
 24, Maddox Street, London, W.1.

'Phone: Mayfair 0578/9.

"the most efficient choke"—

The Industrial Progress Ltd.'s report upon the Lewcos H.F. Choke.

"The Lewcos H.F. Choke is the most efficient Choke we have tested, there being no sign of instability even when using 150 Volts H.T. on the anode of the S.G. Valve. The construction is massive and well finished, and its design places it in the front rank of high-class components."

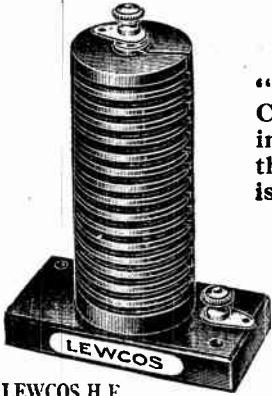

LEWCOS H.F. Choke 20-2000 m. Price 7/9.

LEWCOS RADIO PRODUCTS



LEWCOS POTENTIOMETER Patent No. 740579.

The Lewcos Fixed Potentiometer gives perfectly smooth re-action control on all Radio Receivers. Price 4/9 without Grid Leak.

GLAZITE
BRITISH MADE REGD.
COLOURED
CONNECTING
WIRE
6d. per 10 ft. coil.



LEWCOS BINOCULAR COILS

Patent No. 277876.

For use in multi-stage receivers without screening.

Prices:

Aerial Coils - - 8/6
H.F. Transformers - 8/6 to 12/6

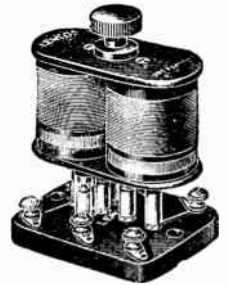

THE LONDON ELECTRIC WIRE COMPANY AND SMITHS LIMITED, CHURCH ROAD, LEYTON, LONDON, E.10

THE LONG LIFE BATTERY WITH NO CRACKLE!



Never again need you suffer from H.T. "crackle," due to battery exhaustion. Get "Pertrix" batteries which, having no sal-ammoniac electrolyte cannot develop these annoying sounds. "Pertrix" moreover actually gives

60% LONGER LIFE —

PERTRIX

PATENT H.T. BATTERY.

PERTRIX LTD., Britannia House, Shaftesbury Ave., London, W.C.2
Factory: Britannia Works, Redditch, Worcs.

WEBB'S PAY MONTHLY SYSTEM IS FOR YOUR CONVENIENCE.

You spend only so much now and yet obtain full use and enjoyment of just what you want while paying for it in a comfortable, well managed manner that just suits your pocket.

<p>EKCO ALL-ELECTRIC 2-VALVE RECEIVER. Detector and Pentode. For D.C. mains. Model P.2. Send only 30/- and then 12 monthly payments of 2/1.</p>	<p>OSRAM MUSIC MAGNET KIT. Complete with valves and cabinet. Full instructions. Send only 20/- and then 12 monthly payments of 14/2.</p>
<p>PHILIPS ALL-ELECTRIC 2-VALVE RECEIVER. Detector and Pentode. For A.C. mains. (As Nationally advertised.) Send only 30/- and then 12 monthly payments of 19/6.</p>	<p>MULLARD ORGOLA KIT. Exact to specification, including valves, cabinet and full instructions. Send only 20/- and then 12 monthly payments of 17/3.</p>
<p>PHILIPS ALL-ELECTRIC 2-VALVE RECEIVER. Screened grid, Detector and Pentode. For A.C. mains. (As Nationally advertised.) Send only 60/- and then 12 monthly payments of 35/4.</p>	<p>AIR CHROME SPEAKERS. Type F. Ideal for powerful signals and radio gramophone use. Send only 10/- and then 12 monthly payments of 6/7. All other models in stock.</p>
<p>EDDYSTONE SCIENTIFIC SHORT WAVE THREE CONSTRUCTIONAL KIT. 18-100 metres. Including Royalty. Send only 20/- and then 12 monthly payments of 14/7.</p>	<p>CELESTION LOUD SPEAKER. Type Z20. Mahogany. We consider this the best value in the Celestion range. Send only 20/- and then 12 monthly payments of 12/10. Oak finish is slightly cheaper.</p>
<p>MAGNOVOX X CORE MOVING COIL SPEAKER. 10 1/2" core for D.C. mains. The latest dynamic principle speaker made by the original makers. Send only 20/- and then 12 monthly payments of 12/10. Smaller size core and A.C. mains models also in stock.</p>	<p>GAMBRELL NOVOTONE PICK-UP COMPENSATOR, as advertised and described in "The Wireless World." Send only 10/- and then 12 monthly payments of 8/-.</p>

We stock all leading makes of receivers, portables, and latest components for constructional kits. Send us list of your requirements and let us quote.

WEBB'S

RADIO ELECTRIC STORES,
164, CHARING CROSS RD., LONDON, W.C.2
(Near Tottenham Court Road),
133, NEW STREET, BIRMINGHAM.
"EDDYSTONE" SERVICE DEPOT.

"RITHO" METAL CABINETS

for the
"1930
EVERMAN
FOUR"
"KILOMAG 4"
& "RECORD 3"



Complete with Wood Base and two Small Aluminium Screens. Beautifully finished in ROSEWOOD, WALNUT or JACOBEEAN effects.
£3:0:0 Finished IMITATION LEATHER effect,
£2:16:6 Carriage and Box—2/6 extra.



IMPORTANT:— These Cabinets are exactly as submitted to "The Wireless World" and are thoroughly electrically sealed.

WRITE TO-DAY.

Eliminator Cases and High Grade Metal Cabinets of every description in various artistic finishes. Screening Boxes, Containers, etc.

RITHERDON & CO., LTD.
Metal Workers,
North Bridge Mills—BOLTON.
Phone: 1024.

A NEW "PARMEKO" TRANSFORMER

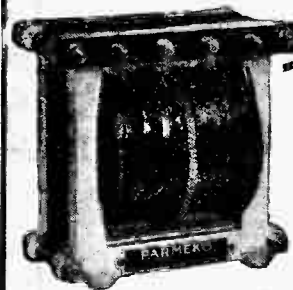

Transformer for all 4-volt indirectly heated valves, giving 5 amps. max. at 4 volts, centre tapped, made for all mains voltages.

30/- each.

PARMEKO Transformers, Chokes and Eliminators are designed by technical experts and made by skilled workmen from materials of the highest quality. Evidence of their excellence is found in the fact that PARMEKO components are used by some of the largest Radio-Gramophone and Talking-Picture Companies. The range covered is exceptionally wide, but we make a speciality of apparatus to your own specification. Don't be satisfied with the nearest, send us your requirements and we will quote by return for the exact.

Write for price list of Wireless Main's Apparatus.

PARTRIDGE & MEE Ltd.,
26, DOVER STREET, LEICESTER. 74, New Oxford Street, LONDON, W.C.1.



HERE IS THE REASON WHY

your choice should be a Burndept Screened Portable. The diagram below shows all the technical details and unique features which make it the finest of all portable receivers.

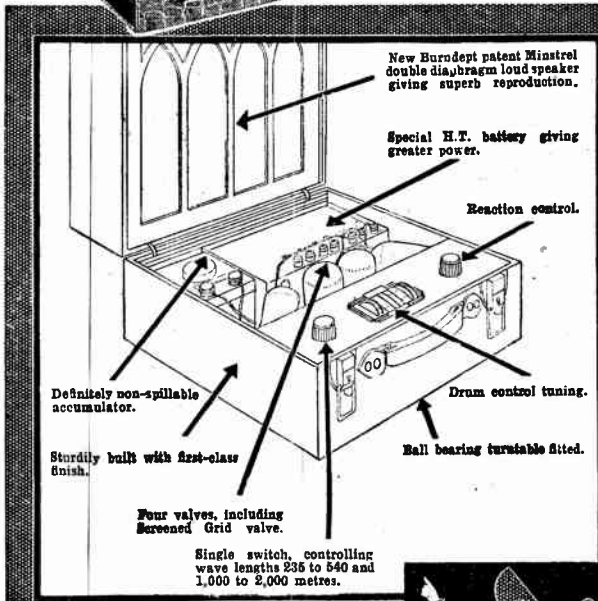

And consider the price... complete, including valves and royalty, 19 gns., or on generous hire purchase terms of £2 down and 12 monthly payments of £1.11.5.



Burndept SCREENED PORTABLE

For the new Burndept Catalogue giving full specification, write direct to

Burndept Wireless (1928) Ltd., Blackheath, S.E.3.

London Showrooms:—
Roxburghe House, 283, Regent Street, W.1.
and 15, Bedford Street, Strand, W.C.2.

WHY PAY more than 5/6 FOR A UNIVERSAL VALVE

- 1 New Glass Bulb, Finer yet Tougher
- 2 New Super Strength Grid
- 3 New Non-microphonic Filament with Special Coating
- 4 New Large Size Anode, Easier Flow of Electrons

NEW 1930 TYPES!

NEW 1930 PRICES!

WRITE FOR FREE FOLDER!

TWO VOLT	
Universal	.1 amp. . . 5/6
Resistron	.1 amp. . . 5/6
Super H.F.	.15 amp. . . 5/6
Super Power	.18 amp. . . 7/6
Hyper Power	.3 amp. . . 9/6
Pentodion	.3 amp. . . 18/6

From your Dealer or direct:

FOUR VOLT	
Universal	.075 amp. . . 5/6
Resistron	.075 amp. . . 5/6
Super H.F.	.075 amp. . . 5/6
Super Power	.1 amp. . . 7/6
Hyper Power	.15 amp. . . 9/6
Pentodion	.15 amp. . . 18/6

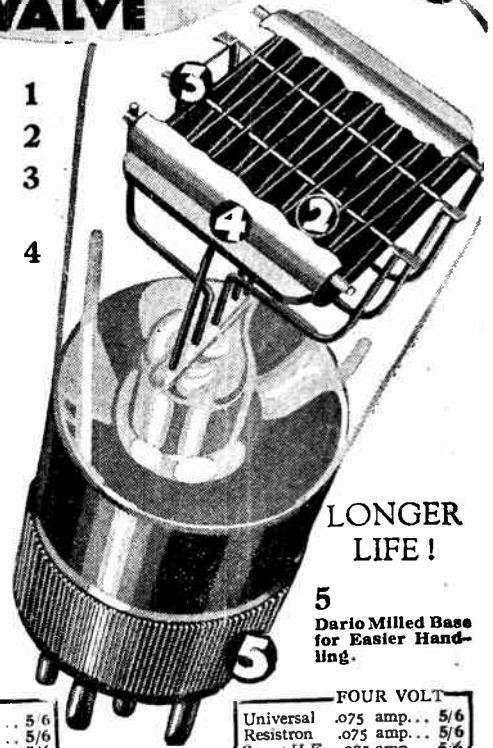

LONGER LIFE!

5 Dario Milled Base for Easier Handling.

DARIO VALVES

Best way to all Stations

IMPEX ELECTRICAL, LTD., DEPT. C,
538, HIGH ROAD, LEYTONSTONE, LONDON, E.11

WELDED JOINTS!



STRENGTH!

POWER!

LONG LIFE!

Because every joint is electrically welded, the elements of the *NEW* Cossor Screened Grid Valve have exceptional strength. And because they are built under the exclusive Cossor Interlocked Construction system, they are absolutely rigid. Even the hardest blow cannot mar their perfect alignment. For strength, for uniformity and for long life use the *NEW* Cossor in your Screened Grid Receiver. No other Screened Grid Valve has Interlocked Construction.

2-volt type now available.

The *NEW* Cossor 220 S.G. (2 volts, .2 amp.)
 Max. Anode Volts 150,
 Impedance 200,000,
 Amplification factor 200. **22/6**
 Price

Cossor 4 and 6 volt Screened Grid Valves are also available with similar characteristics at the same price.

The **NEW**
COSSOR
Screened Grid
Valve

The Wireless World

AND
RADIO REVIEW
(17th Year of Publication)

No. 536.

WEDNESDAY, DECEMBER 4TH, 1929.

VOL. XXV. No. 23.

Editor: HUGH S. POCOCK.

Assistant Editor: F. H. HAYNES.

Editorial Offices: 116-117, FLEET STREET, LONDON, E.C.4

Editorial Telephone: City 9472 (5 lines).

Advertising and Publishing Offices:

DORSET HOUSE, TUDOR STREET, LONDON, E.C.4.

Telephone: City 2847 (13 lines). Telegrams: "Ethaworld, Fleet, London."

COVENTRY: Hertford Street.

Telegram: "Cyclist, Coventry." Telephone: 5210 Coventry.

BIRMINGHAM: Guildhall Buildings, Navigation Street.

Telegram: "Autopress, Birmingham." Telephone: 2970 and 2971 Midland.

MANCHESTER: 260, Deansgate.

Telegram: "Hille, Manchester." Telephone: 8970 City (4 lines).

GLASGOW: 101, St. Vincent Street, C.2.

Telegram: "Hille, Glasgow." Telephone: Central 4857.

PUBLISHED WEEKLY.

Subscription Rates: Home, £1 1s. 8d.; Canada, £1 1s. 8d.; other countries abroad, £1 3s. 10d. per annum.

Entered as Second Class Matter at New York, N.Y.

As many of the circuits and apparatus described in these pages are covered by patents, readers are advised, before making use of them, to satisfy themselves that they would not be infringing patents.

CONTENTS OF THIS ISSUE.

	PAGE
EDITORIAL VIEWS	009
MEASURING THE INTER-ELECTRODE CAPACITY OF SCREEN GRID VALVES.	
By T. H. KINMAN	610
VALVE DATA	614
OPERATING FILTER CIRCUITS. By H. F. SMITH	618
CURRENT TOPICS	620
WIRELESS THEORY SIMPLIFIED. PART XI. By S. O. PEARSON	622
MAINS SETS AND GRID BIAS. By F. H. HAYNES	625
NEW APPARATUS REVIEWED	628
THE PENODE UNDER WORKING CONDITIONS	630
CORRESPONDENCE	633
BROADCAST BREVITIES	636
READERS' PROBLEMS	637

VALVE DATA SUPPLEMENT.

WITH this issue we publish as a separate sheet a Valve Data Supplement, giving technical and other information regarding representative radio receiving valves on the British market.

Readers will find that the information published is very much more complete than anything which has hitherto been attempted, as, for instance, the inclusion of a column giving the A.C. power output in milliwatts of some eighty-five different valves. This information has not been available previously and should prove of very great value to those concerned with the design of receivers. The inter-electrode capacities of most of the screen grid valves are given and the maximum attainable stage gain of these valves, calculated on the basis of the inter-electrode capacity.

The inclusion in this issue of an article having special bearing on the Valve Data Supplement provides, it is believed, all the assistance necessary to readers who wish to make the best use of the information which the supplement contains.

VALVE SUPPLIES.

MANY readers have written to us stating that they have found it impossible to obtain certain valves of the new Mazda series, such as have been incorporated in the designs of recent *Wireless World* receivers, through the usual trade channels.

On enquiry from the manufacturers, we learn that the demand for these valves has been so great that it is impossible at present to issue adequate supplies to retailers, although we understand that the position is rapidly improving.

As a temporary measure, however, until production is able to cope with the demand, the manufacturers have kindly undertaken, at our request, to supply valves if readers of *The Wireless World* write direct to them at the Edison Swan Electric Co., Ltd., Service and Installation Department, 1A, Newman Street, Oxford Street, W.1, ordering the valves they require and stating for what *Wireless World* receiver they are to be used. It is essential that applicants should give the name and address of their local radio dealer. Valves will be despatched to readers by post, c.o.d., the charge being the usual retail selling price of the valves, plus cost of postage. Prompt application should be made for the valves by readers who wish to avail themselves of this opportunity, as this special arrangement can only be regarded as a temporary measure.

o o o o

THE HAGUE CONFERENCE.

AN interesting report has recently been received of a statement made by the Chairman of the U.S. Delegation to the recent Radio Conference at the Hague on his return to Washington.

The statement would lead one to suppose that the American delegates had things very much their own way at the Conference. In his report the Chairman says: "The proposals and studies prepared in Washington last summer and sent out by the U.S. to all nations were taken as the basis of discussion at the Hague, and in almost every case were adopted, not always with our original wording, but with our original intent." The Chairman is also reported to have stated, "I think, perhaps, the splendid technical contribution made by the U.S. Delegation at the Hague in 1929 will enable the next meeting at Copenhagen, in 1931, to dodge the troublesome 'English' questions by authorising the use of the 'American' language instead of 'English.'"

It would appear that the U.S. attaches more importance than other countries to the question of obtaining a dominating position in International radio discussions.



MEASURING THE INTERELECTRODE CAPACITY OF SCREEN-GRID VALVES



Details of the Apparatus Used.

By T. H. KINMAN

(Of the British Thomson-Houston Company's Engineering Laboratory at Rugby).

THE importance of reducing the interelectrode capacity between the anode and control grid in screen-grid valves in order to obtain a degree of stable amplification at high frequencies is well known and has been the subject of recent discussion.¹

A method of measuring this capacity was described by A. W. Hull and N. H. Williams in 1926,² and more recently another method has been described by N. R. Bligh, B.Sc.³ The method described in this article is based on the substitution method, outlined by Hull and Williams, in that the valve capacity is determined by observing the capacity change required in a standard condenser connected in parallel with the valve capacity when coupled between an R.F. source and amplifier to obtain the same amplifier output reading when the valve capacity is removed. The bare theoretical circuit

The three interelectrode capacities present in a screen-grid valve are represented in Fig. 2 by C_{as} , C_{gs} , and C_v , respectively, the value of C_v , which is desired, being but a small fraction of C_{as} or C_{gs} .

In testing this circuit it was found that the results obtained were not consistent with the above simple theory, the cause being traced to the shunting effect of the anode-to-screen capacity of the valve under test. The effect of this capacity when switched in or out of circuit is to react upon the R.F. source and alter the impressed voltage or frequency or both, so vitiating the readings. This effect was small with the early types of valves such as the Hull, or where the capacity C_v is relatively large, but with valves of the AC/S type, the anode-screen capacity is relatively larger and the coupling capacity C_v very small, therefore the effect of the former capacity must be taken into account.

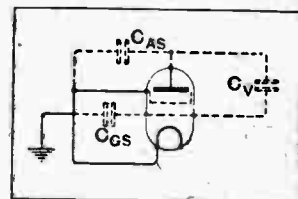

Fig. 2.—Equivalent circuit showing the three interelectrode capacities present in a screened valve.

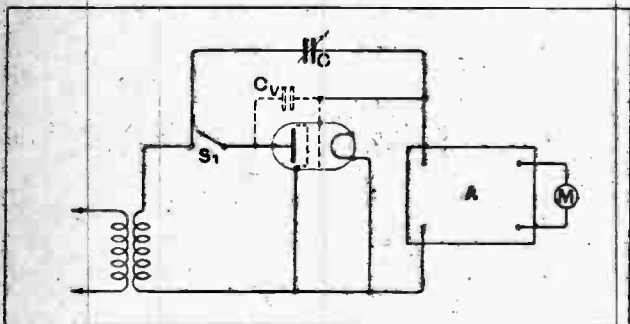

Fig 1.—Schematic diagram of apparatus used for the measurement of valve interelectrode capacities.

arrangement is shown in Fig. 1, in which the R.F. source is coupled to a screened amplifier A through the valve capacity C_v and standard variable condenser C. A meter M indicates the degree of coupling between the R.F. source and amplifier caused by the coupling capacities $C_v + C$.

The meter reading is noted when both C_v and C are in circuit. When S_1 is open C_v is removed from circuit and C is then increased until the original meter reading is obtained. The change in capacity to produce this effect is equal to the coupling capacity of the valve and can be determined from the known physical constants of the condenser C which will be described later.

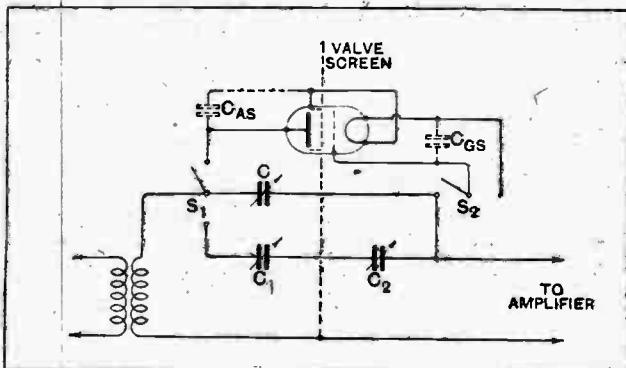

Fig. 3.—The circuit arrangement which was designed to overcome the shunting effect of the anode-to-screen capacity of the screened valve.

¹ See *Experimental Wireless*, June, 1929, page 293; also *The Wireless World*, July 24th, 1929, page 68.

² *Physical Review*, Vol. 27, April, 1926.

³ *Experimental Wireless*, June, 1929, page 299.

Measuring the Interelectrode Capacity of Screen-grid Valves.— ment. The coupling capacity C_v was, therefore, removed by means of switch S_2 , which disconnected the control grid from circuit, a small condenser C_2 being provided to compensate for the removal of the valve capacity C_{gs} , which is normally in shunt with the input circuit of the amplifier. C_3 can, however, be dispensed with, but a compensating adjustment on the input tuning condenser would then be necessary. It was found more convenient to use a separate condenser as indicated in Fig. 3 for this purpose.

It may be of interest to point out that whilst C_2 can obviously be made to equal C_{gs} in capacity, it will not usually include the H.F. resistance introduced by the valve, valve-holder, etc. The damping effect of C_2 on the input circuit of the amplifier will, therefore, be less than when C_{gs} is in circuit, and a larger output reading obtained. The magnitude of the reading for this adjustment is, however, immaterial, as will be explained later.

Description of Apparatus.

The complete circuit arrangement is given in Fig. 4. The H.F. oscillator needs no special description other

In this particular case the wire was coupled by an insulating link to the movement of a standard micrometer which not only provided a scale, but also gave a very fine and accurate adjustment. Fig. 5 shows the appearance of this condenser. The capacity change per centimetre of movement was calculated from the following

equation:— $C = 1/2 \cdot (\log_e \frac{R_1}{R_2})$; where C is the capacity change per cm. length; R_1 is the radius of tube electrode, and R_2 the radius of wire electrode.

In constructing such a condenser, certain precautions are necessary:—

(1) The electric field between the electrodes must be confined inside the tube. This is effected by suitable external screening.

(2) The "fringing" capacity between the ends of the tube and wire must be practically constant over the working range of the condenser, and must also be small compared with the true radial capacity between wire and tube, i.e., the tube must be long and the axial movement of the wire a fraction of its length within the tube.

It will be understood that the adjusting mechanism must be insulated and well screened from both electrodes, whilst the earth capacity of the wire which pro-

It is not overstating the case to say that the great strides made in stable H.F. amplification during the last year are, to a large extent, due to the advent of the screened valve with an interelectrode capacity of the order of one hundredth of a micro-microfarad or less. This progress has been greatly assisted by the design of highly specialised apparatus for measuring minute capacities. In the accompanying article an interesting description of such equipment is given.

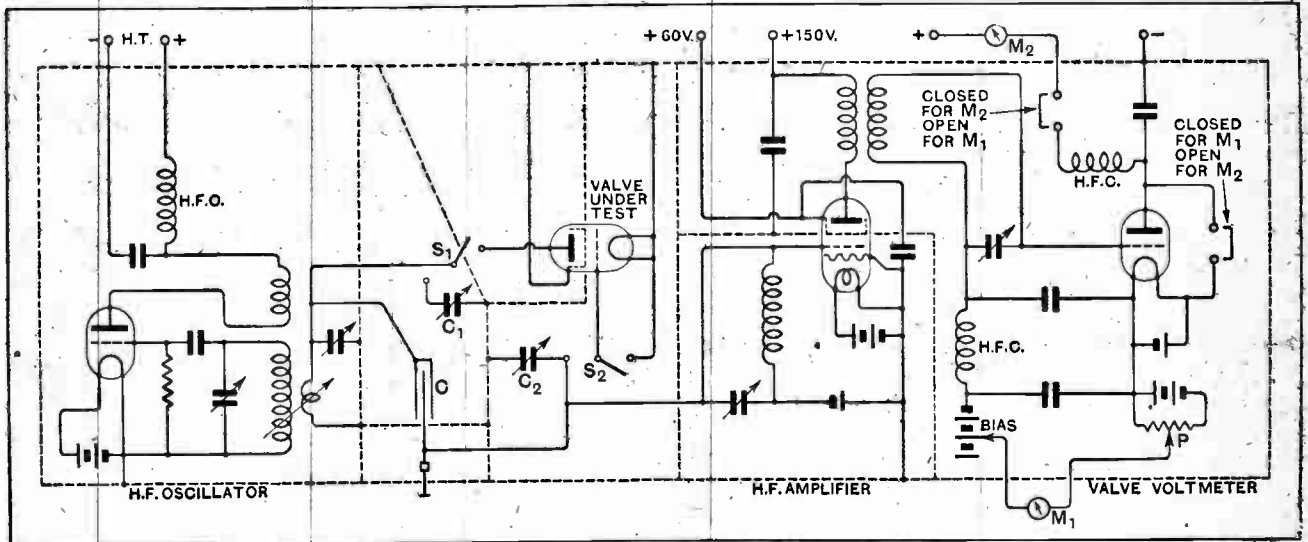

Fig. 4.—Complete circuit diagram of equipment containing essentially a valve voltmeter, H.F. amplifier, valve under test and an H.F. oscillator.

than that it provided a constant high-frequency and output voltage across the coupling coil to suit the particular H.F. amplifier employed. The frequency actually used in these tests was 750 kilocycles. The variable condenser C was specially constructed for the tests. It consists of a brass tube as one electrode and a thin wire as the other, the capacity change being obtained by moving the wire along the axis of the tube and measuring the displacement on some convenient scale.

jects outside the tube must be constant. The wire itself must also move without deviation along the true axis of the tube. The condenser shown in the photograph had a capacity change of 0.01075 cms. per revolution of the micrometer, and this was sub-divided to give a fine adjustment of 0.00043 cms. variation for 1/25th of a revolution.

The switch S_1 was of the so-called anti-capacity type, having the additional feature of a screening member

Measuring the Interelectrode Capacity of Screen-grid Valves.— between the moving contact and the fixed contact which connects to the anode of the valve under test. A slit was cut in this screening member to allow of the passage of the moving contact. The mounting of the valve under test required some attention to ensure that all the electrostatic coupling between anode and control grid was inside the valve. In practice, a metal partition is usually provided with a circular hole through which the valve is inserted, thereby screening the wire connection to the anode from that to the grid. In the present arrangement a double screen was provided to allow valves of differing lengths being used without alteration to the screening.

Certain types of valves, similar to the Hull construction, require an earthed metal screen over the entire bulb. In fact, the capacity C_v can be reduced to some extent in any valve by completely covering the bulb with tin-foil and earthing it. The external screen apparently neutralises the coupling effect of the magnesium coating inside the bulb, which may, in some cases, extend from the anode terminal round to the pinch to which the control grid is anchored. In some types of screen-grid valve the magnesium coating is earthed by the makers. When this is the case, an external bulb screen, as distinct from partitioning screen, will obviously be superfluous. The radio-frequency amplifier consisted of only one tuned H.F. stage and employed a Cosmos AC/S valve, which enabled a circuit amplification of well over 100:1 to be obtained. A multi-stage aperiodic amplifier would have certain advantages over the tuned type, providing the overall amplification was of the order mentioned. The indicating meter M_1 was a microammeter in series with the grid circuit of a negatively biased triode, and not only served as an indicator but also measured the voltage developed across the tuned circuit by noting the bias voltage required just to bring the meter pointer to zero.

A more sensitive indicator was found desirable when measuring valves of the smallest capacity, and this was provided by connecting the same or another microammeter M_2 in the anode circuit of the triode. This latter arrangement does not give a direct voltage reading without calibration, but removes the damping on the tuned output circuit by eliminating the necessity of grid current flow through M_1 . A greater output voltage will, therefore, result, apart from the added μ of the triode. The potentiometer P was used for adjusting the meter to some convenient setting on its scale whilst making the measurements.

Method of Operation.

The amplifier was tuned to the frequency of the oscillator and adjusted so that the maximum output

voltage and negative bias could be used on the valve voltmeter without overloading the H.F. amplifier. This was done with switches S_1 and S_2 closed to include the valve coupling capacity C_v , i.e., S_1 upwards and S_2 to left-hand contact. The next step was to adjust C_1 to the value of C_{as} . With S_1 closed to the anode (upwards) and S_2 on the right-hand contact, condenser C_2 was increased to replace C_v , until substantially the same meter reading was obtained. Switch S_1 was then closed to C_1 (downwards) and C_1 adjusted until the same meter reading was shown. This gave the correct setting for C_1 as a substitute for C_{as} . S_2 was then closed to the left and C_2 reduced to zero or to its original setting. The meter reading was now noted. Switch S_1 was now thrown up, putting the valve capacity C_v in parallel with C_1 , which was reduced until the previously noted reading was again obtained. The value by which

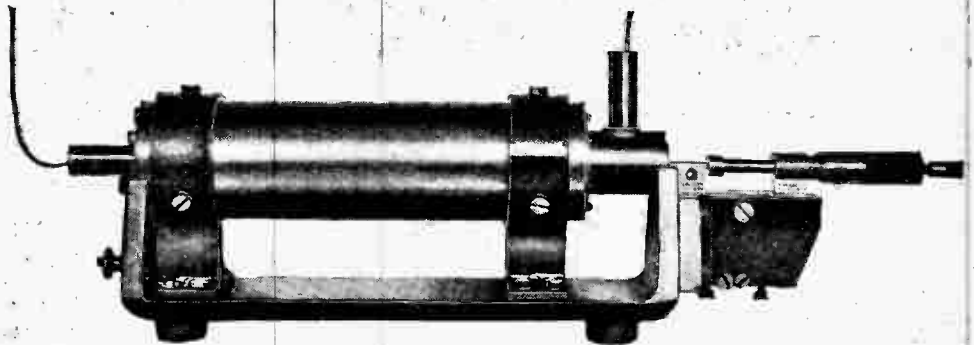

Fig. 5.—Standard micrometer condenser. The illustration shows the chassis supporting the condenser, and micrometer adjustment. The wire and tubular electrodes are inside and concentric with the screening tube seen in the photograph, and the terminal connections to the condenser are indicated by the two wires which project through the smaller screening tubes.

C had to be changed gave the required capacity of the valve.

Precautions were found to be necessary, as erratic or

TABLE I.

Valve.	No.	Capacity ($\mu\mu\text{F}$).
Mazda 215SG	1	0.0085
	2	0.0086
	3	0.0072
	4	0.0067
	5	0.0072
	6	0.0089
Cosmos AC/S	1	0.0072
	2	0.0072
	3	0.0067
	4	0.0076
	5	0.0074
	6	0.0065
U.S.A. Hull Type	1	0.012
	2	0.012
	3	0.010
Hull Type AC/S	1	0.0095

Since the capacity measurements shown in the above table were taken, the Mazda 215SG and the Cosmos AC/S (now called the Mazda AC/SG) valves have been altered in construction and the interelectrode capacities have been reduced respectively to 0.005 cms. and 0.0045 cms.

Measuring the Interelectrode Capacity of Screen-grid Valves.— inconsistent readings are sometimes caused by high resistance paths between the various electrodes inside the valve, and may even prevent the capacity of the valve being measured. It was, therefore, found advisable to subject each valve to a high voltage insulation test between the different pairs of electrodes before capacity measurements were attempted.

Results Obtained.

A large number of valves have been tested with the apparatus described, covering values from 0.100 cms. to 0.0017 cms. capacity, the accuracy obtained on the lowest figure being within 10 per cent. Table I gives results of measurements made on stock Mazda and Cosmos valves, and includes also capacities of some American type valves which may be of general interest.

An important point in connection with screen-grid

valves which does not appear to be generally realised is that the interelectrode capacity should be reasonably uniform between different valves of the same make and type, otherwise when a valve is replaced instability may result.

In conclusion, it may be stated that capacity measurements have been made also on other types of valves mentioned by Mr. Bligh, the results on which agree generally with his. In fact, a method similar to his has been tested, using only 100 volts input and employing a calibrated R.F. amplifier voltmeter to compensate for the low output voltage. The writer is grateful to Mr. R. C. Clinker for his useful advice regarding the construction of the standard condenser, and has to thank the British Thomson-Houston Company, Ltd., for permission to publish the results of the work done in the Engineering Laboratory at Rugby.

A Record Junk Sale.

An exceptionally large number of components were disposed of at the Junk Sale organised by Slade Radio (Birmingham) at their last meeting. The Society is now appealing for more members, and it is thought that there must be numbers of enthusiasts in the Birmingham district who may be unaware of the Society's existence. Application for particulars should be made to the Hon. Secretary, 110, Hillaries Road, Gravelly Hill, Birmingham.

o o o o

Stations While You Wait.

An entertaining demonstration was given before the South Croydon and District Radio Society on November 19th, when Mr. Taylor, a former member, showed the capabilities of the Philips All-Mains 4-valve set. Scarcely a station named by members proved out of reach of this fascinating receiver, its only apparent shortcoming being its inability to receive signals without an aerial. It was shown, however, that even the merest apology for an aerial would suffice, as, indeed, was proved when the chairman himself touched the aerial socket and provided the audience with the pick of Europe's radio! The receiver embodies two screen-grid H.F. valves, leaky grid detection, and a pentode stage to the loud speaker, all valves being indirectly heated by A.C.

Hon. Secretary, Mr. E. L. Cumberb, 14, Campden Road, South Croydon.

o o o o

New Society in Essex

The opening of the new Brentwood and Warley Wireless Club was celebrated in an auspicious manner on Wednesday last by a public debate on "The Merits and Demerits of the Brookmans Park Transmitter," which showed that the first of the regional stations is a subject of great interest to listeners in Essex.

New members will be warmly welcomed. The Hon. Secretary of the Brentwood Club is Mr. M. B. Edwards, 38, Junction Road, Brentwood.

o o o o

How Metal Rectifiers Work.

A cinematograph display illustrating the use of metal rectifiers was given in the course of a lecture before the Kensington Radio Society on November 14th by a representative of the Westinghouse Brake and Saxby Signal Co., Ltd. At the Society's meeting on December 12th Mr. R. Waldo Emerson will demonstrate a 6-valve receiver. The meeting will be held at 8.30 p.m. at 20, Penywern Road, S.W.5.

Hon. Secretary, Mr. G. T. Hoyes, 71a, Elsham Road, W.14.

o o o o

Valve Mysteries Explained.

Valuable technical data regarding the design of radio valves was given at the meeting of the Muswell Hill and District Radio Society on November 20th by a representative of the Mullard Company. The fundamental principles of the screen-grid and pentode valves were described, and members received some useful hints which cleared up several mysteries.

Hon. Secretary, Mr. C. J. Whit, Coniston Road, Muswell Hill, N.10.

o o o o

NEWS FROM
THE CLUBS.

Set Wiring Explained.

The Queen's Park and District Division of the Wireless League are resuming their series of monthly meetings on Thursday, December 5th, at 8 p.m., when it is hoped to demonstrate the wiring up of a well-known radio receiver. Amateurs are cordially invited to attend these meetings, which will be held on the first Thursday in each month at 37, Enbrook Street, Harrow Road, W.10.

Full particulars of these and other interesting events gladly supplied by the Local Secretary, Mr. P. Batho, at the above address.

o o o o

Sets of the Future.

Mr. Haynes, Assistant Editor of *The Wireless World*, recently lectured before a large audience of members of the Wembley Wireless Society, taking as his subject the question of selectivity.

In view of the interference now experienced from the new broadcasting station at Brookmans Park, Mr. Haynes's remarks were most helpful. Valuable suggestions were made for the cutting out of this station and receiving other stations quite near in the wavelength scale.

The lecturer also touched briefly on the forthcoming design of sets and outlined the modifications which will take place next year. From Mr. Haynes's remarks it was clear that we have not yet reached finality in the design of wireless receiving sets, and in the future their design and construction will call for considerable ingenuity from a mechanical as well as an electrical point of view.

Hon. Secretary, Mr. H. E. Comben, 24, Park Lane, Wembley.

o o o o

Anode Converters.

Anode converters and motor generators as applied to wireless and gramophone amplification were discussed by Mr. Woodall, A.M.I.E.E., of the M.L. Magneto Syndicate, at a recent meeting of Slade Radio (Birmingham). A number of anode converters, rotary transformers, and motor generator sets were on view. The evening concluded with a demonstration given with the assistance of the Radio Gramophone Development Co., who kindly supplied the necessary apparatus.

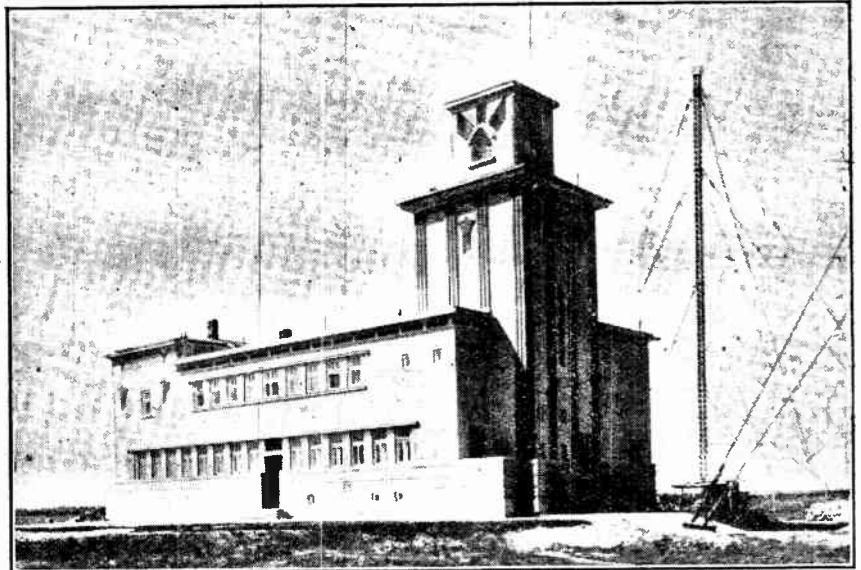

RADIO AND THE ARCHITECT.—Broadcasting has given architects a new outlet for original expression. The building shown above houses the Bucharest transmitter, which provides Hungarian listeners with all-day programmes on 550 metres. The power is 20 kW.

VALVE DATA

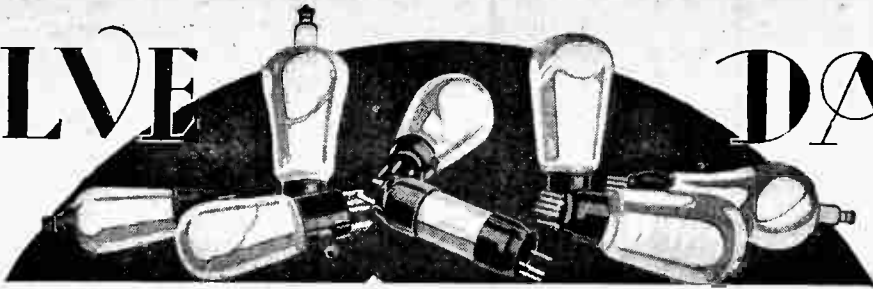

Interpreting the Information given in "The Wireless World" Valve Data Sheet.

PROGRESS in receiver technique depends to a large extent on progress in valve design. The set is built around its valves, and the hope of really successful performance can only be fulfilled if the various valve constants now so willingly given by the manufacturers are understood and applied to the best advantage. The separate valve data sheet accompanying this issue is wider in its scope than that which we published in February of this year. In it there are about 165 representative British valves classified under five main headings—a step rendered necessary by the growing list of special-purpose valves, no two classes of which can be easily categorised under the same sub-headings. It is the aim in these notes to explain briefly the various data in each section which will be taken *seriatim*.

○○○○

Screen-grid Valves.—

Certain data such as filament volts and amps. are omitted as they are obvious in nearly every case from the type name. The best performance will be obtained with the maximum anode and screen voltages specified, but anode voltages down to about 100 minimum may be used with a slight reduction in screen volts. Anode voltages below this figure may bring the operating point to the negative resistance "kink" in the characteristic which will result in uncontrollable oscillation.

A knowledge of anode current is necessary when it is desired to reduce the voltage from an H.T. eliminator. The value of the voltage-dropping resistance required, for instance, to feed the anode of a Marconi S.410 valve with 150 volts from an eliminator giving 230 volts is

$$230-150 \div 3.8 \text{ mA. (expressed as amperes)} = \frac{80}{0.0038} =$$

20,000 ohms approx. The average anode current figures given assume maximum anode voltage, optimum screen volts, and 0.9 volt negative bias for battery-fed valves and 1.5 volt bias for the indirectly heated A.C. type. There is very little "straight" portion in the grid volts-anode current curves of a screened valve—the mutual conductance and hence

signal strength increasing as the signal is impressed nearer and nearer to zero grid volts.

Taking into account the large H.F. stage gains now obtained and the limited grid swing acceptance of the detector, it is safe to allow about $\frac{1}{5}$ -volt as the largest signal which the valve preceding the detector will have to handle. The bias need not exceed a fraction of a volt provided that no grid current flows at zero grid volts. This condition obtains in the battery-fed S.G. valves,

and a bias of 0.9 volt is given as being conveniently obtainable from the special battery developed by Messrs. Siemens for *The Wireless World*. With indirectly heated A.C. valves, due chiefly to the fact that there is no voltage difference between the ends of the emitter, grid current may flow when the grid is quite a large fraction of a volt negative and a bias of $1\frac{1}{2}$ volt is desirable.

Screen current is not published, as it would be

unsatisfactory to obtain screen potential from a considerably higher voltage source by the use of a series resistance. A potentiometer should be employed passing 2 to 3 mA., which is about four times the screen current of an average S.G. valve. Mutual conductance is omitted in favour of an H.F. performance factor given

by $\frac{\mu}{\sqrt{R_0}} \times 100$. This shows a true figure of merit for an

H.F. valve used with an H.F. transformer of optimum ratio. For a given signal a valve with a performance factor of 80 will give twice the H.F. output as compared with one having a performance factor of 40. If a *Wireless World* type of transformer wound with Litz on a 3in. former with a fine wire primary is used as an inter-valve coupling—and such is to be recommended on the score of stability when the receiver is mains driven, it can be assumed that the dynamic resistance R of the secondary is about 250,000 ohms. The optimum trans-

former ratio is $\sqrt{\frac{R}{R_0}}$, which in the circumstances becomes 500 divided by the square root of the valve's A.C. resistance. Where the valve has a greater A.C.

THE supplementary valve data sheet which accompanies this issue contains a number of important new features which are the subject of discussion in these notes. The publication of the A.C. power output in milliwatts of some 85 valves should make the scientific design of the output stage of an amplifier considerably easier. The degree of unobjectionable distortion which is permissible is taken as 5 per cent. second harmonic. The tabular matter giving the maximum possible stage amplification of screen-grid valves taking into account interelectrode capacity will undoubtedly prove of assistance in constructing H.F. amplifiers. All symbols and formulæ used are explained in the appendix at the end of the article.

Valve Data.—

resistance than 250,000 ohms and a step-down ratio is theoretically correct, a 1 to 1 ratio is specified in the tables as being a compromise between tolerable selectivity and signal strength. The stage amplifications attained when using optimum transformer ratios are given by the expression $\frac{1}{2}\mu N$, but in nearly every case the figure exceeds the limit of stable amplification possible (compare cols. giving stage amp. neutralised and max. stage amp. unneutralised). This means that there are only one or two screened valves on the market which will not oscillate when used with a *Wireless World* type of transformer of optimum ratio unless neutralised.

Where selectivity is of the utmost importance, amplification must be sacrificed by using fewer primary turns on the transformer than are dictated by theory. When a 3 to 1 transformer, for instance, of the type already mentioned is used, stage amplification is given

by $\frac{N\mu R}{R+N^2R_0}$ and the results are given in the last column but one. The figures do not reach the limit of stable amplification, and neutralisation is therefore unnecessary. From this it will be seen that the removal of primary turns is conducive to greater stability and better selectivity, but signal strength is reduced.

We now come to the constant which makes or mars the screen-grid valve from the point of view of maximum stable amplification, namely, residual anode-grid capacity. By the expedient of arranging two screening grids in cascade or by using a cross-mesh screen the interelectrode capacity has been reduced in two or three cases to the low figure of approximately 0.005 $\mu\mu\text{F}$. Expression (a) in the appendix gives the maximum possible amplification before oscillation sets in due to the feed back through the small condenser formed by the grid and plate of the valve. This formula is solved for practically all the screen valves shown, and the figures obtained are given under the heading—Max. stage amplification unneutralised—which is next to the anode-grid capacity column. As an example of the influence of interelectrode capacity it will be seen that the Mazda 215 S.G. valve has a stable amplification of 153 with a capacity of 0.005 $\mu\mu\text{F}$.; had this been 0.05 $\mu\mu\text{F}$.—still a very low figure—expression (a) shows that

the amplification would drop to 60—rather less than that of the best neutralised triode. It is claimed that if copper gauze of fine mesh be wrapped round the bulb of the MS4 valve and earthed, the internal capacity is reduced from 0.0045 $\mu\mu\text{F}$. to 0.0025 $\mu\mu\text{F}$., provided that the valve is already contained within a screening compartment. This would increase the maximum unneutralised amplification to considerably over 200 times.

o o o o

Miscellaneous Valves.

—From these three-electrode valves having A.C. resistances greater than 13,000 ohms will be chosen the neutralised H.F. valves, certain anode and grid detectors, and early L.F. valves. As explained in the screen-grid section, if a *Wireless World* type of H.F. transformer is used the step-up ratio is obtained by dividing 500 by the square root of the valve's A.C. resistance. As an example let us take the Mazda

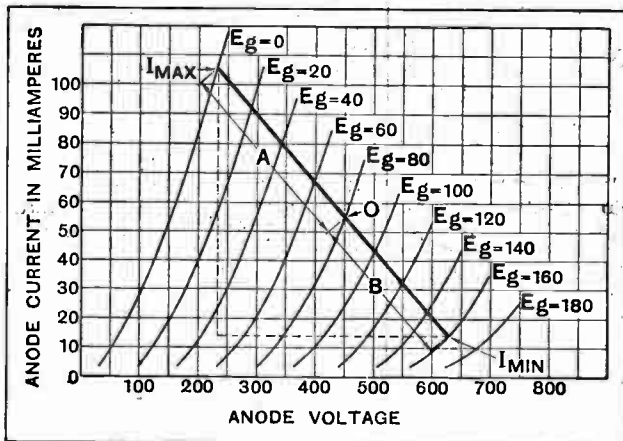

Fig. 1.—Anode volts-anode current curves for equal increments of grid voltage for a super-power valve. By pivoting the 5 per cent. second harmonic scale at the operating point O, the optimum load line (i.e. loud speaker impedance) and the power output triangle can be found for allowable distortion.

AC/HL; the step-up ratio would be $\frac{500}{\sqrt{13,500}}=4.3$ and the stage amplification $\frac{1}{2}\mu N = \frac{1}{2} \times 35 \times 4.3 = 75$. Similarly the Osram H.L.610 would require a step-up ratio of $\frac{500}{\sqrt{30,000}}=2.9$ and the stage amplification = $\frac{1}{2} \times 30 \times 2.9 = 43$. It would be as well not to choose a valve for this function that has an H.F. performance factor $\left(\frac{\mu}{\sqrt{R_0}} \times 100\right)$ less than 14. The grid bias given is for amplifying conditions, and should be doubled for anode bend detection using the same anode voltage. The average anode current figures are useful for calculating voltage dropping resistances when deriving current from the mains as explained earlier.

Anode bend detectors can be of two distinct classes; first, those chosen from among valves having A.C. resistances greater than, say, 15,000 ohms, which can only accept peak voltages of 2 or 3, and must be followed by resistance coupling, and secondly, those with A.C. resistances less than 10,000 ohms which will accept peak voltages up to, say, 10, and can be followed by an L.F. transformer provided that its primary inductance is of the order of 150 henrys under working conditions. The first type will be found among the valves under discussion, and will not throw any appreciable load on the

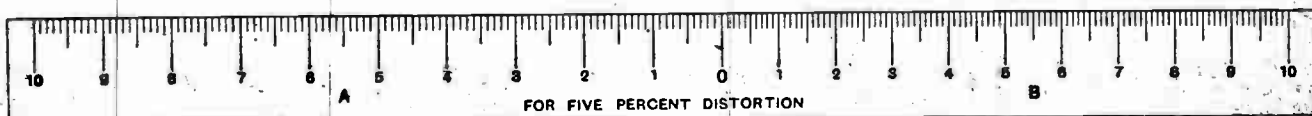

Fig. 2.—The 5 per cent. second harmonic distortion scale. The divisions on the left of zero are 11/9ths those on the right.

Valve Data.—

preceding tuned circuit, while the second type must be selected from the Output Valve section, and will load the tuned circuit to a certain extent. Suitable valves for this latter class are those having mutual conductances of about 2 and A.C. resistances of about 8,000 ohms.

o o o o

Output Valves.—This section contains valves with A.C. resistances less than 13,000 ohms, and as in the last series the grid bias figures are for amplifying conditions. The maximum undistorted output requires some explanation. This constant is extremely valuable in designing output stages under correct load conditions, and it is hoped that by the time our next data sheet is published the valve manufacturers will have agreed upon a standard basis of measurement. The figures given must be considered as a useful guide, but because two valves of obviously similar characteristics made by two different firms differ by, say, 10 per cent., the valve with the *slightly* higher output must not necessarily be considered superior. Valve makers differ in their method of fixing the bias point, there are indications in some cases of rather high biasing to obtain low anode currents; this contributes towards a slight disparity between valves of otherwise similar constants. A moving coil speaker for home use requires approximately a minimum of 1,000 milliwatts to give satisfactory volume, for public address work and large halls 5,000 milliwatts upwards is necessary, while a small cone loud speaker would give very good volume if it were fed with 500 milliwatts, and all the power that a portable set can give its loud speaker when 2-volt valves are used with 100 volts H.T. is about 150 milliwatts.

The graphical method of arriving at power output is probably the most accurate; it is, however, rather too laborious when 85 valves have to be examined! Typical valves of different classes have been checked by this method, and have been found to give sensibly the same figures as those derived from expression (b) in the appendix which has been used for column D. The graphical method which it is hoped will become standard is clearly described by K. S. Weaver in the November, 1929 issue of *QST*. The anode current-anode volts curves at a number of fixed grid voltages differing by equal increments are plotted as in Fig. 1. A scale is then made as in Fig. 2, such that each division on the left of 0 is $\frac{1}{10}$ ths that of each division on the right. The point of maximum anode current and voltage gives the operating point O on one of the grid voltage curves, and it now remains to pivot the zero of the scale on the operating point to obtain the best angle (load line or optimum loud speaker impedance) at which the scale gives the same reading on either side of zero where two

grid voltage curves are cut. Each of these curves must represent equal voltages either side of the operating grid voltage. For example, in Fig. 1 when the zero on the scale is pivoted at the operating point O on the grid voltage of 80, 10 on the left of zero will cut $E_g=0$, while 10 on the right cuts $E_g=160$ if the scale is held at the angle shown. In fact, A in Fig. 1 will be $\frac{1}{10}$ ths of B.

It will be noted that the distance between $E_g=160$ and $E_g=140$ is less than that between $E_g=0$ and $E_g=20$, and as the anode voltage swings up and down the load line, second harmonic distortion will take place. It is generally agreed that 5 per cent. second harmonic is the maximum unobjectionable distortion permissible. The scale in Fig. 2 obtains the necessary load line for this condition, and if the dotted sides of the triangle shown in Fig. 1 are multiplied together as volts \times amps. and divided by 8 the resultant figure is the A.C. power output in watts for 5 per cent. second harmonic distortion. Expression (b) in the appendix which is due to B. C. Brain² arrives at the same result from purely mathematical considerations. The mutilating effect on a pure sine wave by superimposing a second harmonic³

(twice fundamental frequency) of 50 per cent. amplitude is shown in Fig. 3. The case is, of course, exaggerated, but the ear can detect 5 per cent. distortion more easily than the eye. It is often suggested that the D.C. anode dissipation (i.e., col. A \times col. C) multiplied by 0.2 will give the maximum A.C. watts, but different classes of valves require a different factor—one must look up the answer first and then work out the problem!

In comparing power output figures it is only fair to examine the grid bias (col. B) to see what input is necessary, it is also interesting to note the anode voltage required. The PX4, P650 and the AC/P1 should give adequate volume with a moving coil loud speaker using only 200 volts H.T. An interesting point is brought forward in the article by B. C. Brain, namely, that the power output is proportional to the 2.5 power of the anode voltage. That is, if the anode voltage is doubled the power output increases by $2^{\frac{5}{2}} = 5.6$ times—the advantage of high anode voltages where these are possible is obvious. The output from two valves in parallel or push-pull is approximately double that of one valve provided that the load is halved and doubled respectively. There is a slight advantage in push-pull in that even harmonics tend to be cancelled out, but with mid-point biasing there is no serious gain.

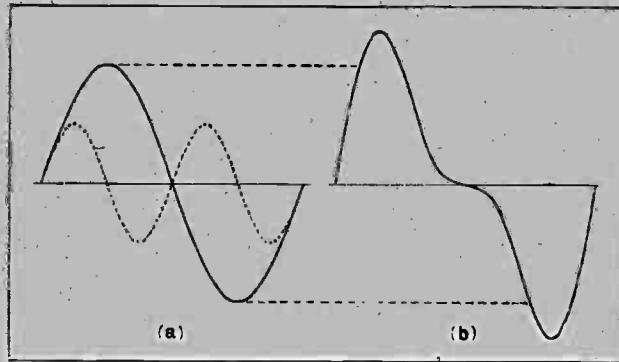

Fig. 3.—Second harmonic distortion. (a) Sine wave representing the fundamental and a 50 per cent. second harmonic (in dotted lines). (b) The two waves in (a) combined to form a distorted wave.

¹ See article entitled "The Pentode under Working Conditions" elsewhere in this issue.

² See *Experimental Wireless*, March, 1929.

³ See *Experimental Wireless*, July, 1926. Article entitled "Harmonics and their Effects on Wave Form," by J. F. Herd.

Valve Data.—

Pentode Valves.—It should be noted that out of 15 valves, 6 require a screen voltage less than that of the anode. This suggests a resistance to drop the necessary volts, and at the same time to decouple the screen circuit. The value of the screen current which is necessary to calculate this resistance is given in col. F. Amplification factor and A.C. resistance are omitted as they change considerably with small alterations in screen and control grid voltages, but the mutual conductance, which is given, remains fairly constant. In any case the A.C. resistance of perhaps some 40,000 ohms is no guide to the speaker impedance which should be about 7,000 or 8,000 ohms to avoid distortion and dangerous over-voltages as explained elsewhere in this issue. The power output in col. D is obtained graphically from a family of anode volts-anode current curves, and the limiting condition of distortion in this case is the third harmonic which again has to be reduced to 5 per cent. to become unobjectionable. In Fig. 4 a third harmonic of 33 1/3 per cent. amplitude (dotted curve) is shown combined with its fundamental. The resulting flat-topped wave (b) is particularly unpleasant. The formula in the appendix for power output cannot be used for pentodes. The enormous power output for small input grid swing is the feature of the pentode, as will be shown by an examination of the data sheet. There is an error in the valve data sheet in the pentode section; the grid bias sub-heading should read—for A and E—not—for A and C.

••••

Rectifying Valves.—In choosing a rectifying valve it is necessary to have the maker's regulation curve to see what voltage will be available at the terminals of the filter with the known load of the receiver. Connected across the output of a rectifying valve there must be a condenser which it is understood has been standardised at 4 mfd. by the manufacturers. This condenser, which

must be considered as part of the rectifier and not part of the filter, is necessary to improve power factor (rectification efficiency). The use of *considerably* more than 4 mfd. may damage the valve, while 2 mfd. would mean a reduced output. The reduction of rectified output must never be carried out by dimming the filament as this tends to saturate the valve and causes its early destruction; furthermore, the impedance rises and the regulation curve becomes steep. The absorption of excess volts should be carried out with series resistances and sub-potentiometers where the feeds are extremely small. The figures given for maximum unsmoothed

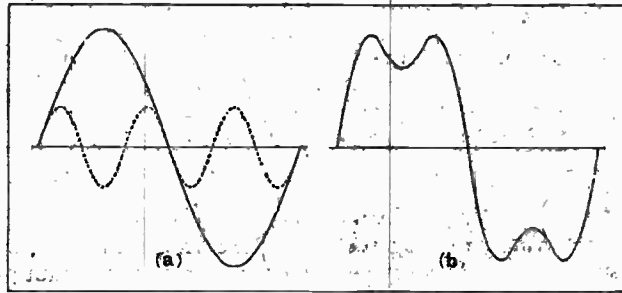

Fig. 4.—Third harmonic distortion. A wave of 33 1/3 per cent. amplitude and of 3 times fundamental frequency when combined with its fundamental gives a particularly objectionable flat-topped wave (b).

D.C. assume a 4 mfd. shunted condenser, but allowance is not made for any drop in output due to the resistance of smoothing chokes.

APPENDIX.

Max. stage amplification (unneutralised) with S.G. valves before threshold instability is reached at 200 metres taking into account anode-grid capacity is given by

$$A = \frac{-1 + \sqrt{1 + 2\mu R_0 \omega C_0}}{\omega C_0 R_0} \dots\dots\dots (a)$$

$$\text{Milliwatts output} = HK\mu \left(\frac{V_a}{\mu}\right)^2 \dots\dots\dots (b)$$

- A = Stage amplification.
 - C₀ = Anode-grid capacity in farads.
 - μ = Amplification factor of valve.
 - R₀ = A.C. resistance of valve (ohms).
 - R = Dynamic resistance (ohms).
 - ω = 2π × frequency (at 200 metres, ω = 10⁶ × 2π × 1.5).
 - N = Step-up turns ratio of H.F. transformer.
 - V_a = Max. anode volts.
 - E_g = Grid bias.
 - I_a = Anode current (mA.).
 - H = A coefficient depending upon the ratio of external to internal impedance in an output valve. If there is no watts dissipation limit, H = 0.041, but with large power valves the load impedance may have to be up to 4 times the A.C. resistance of the valve and H becomes a minimum of 0.032. See article by B. C. Brain already referred to.
 - K = A constant obtained from the maker's valve curves.
- $$= \frac{I_a}{\left(\frac{V_a}{\mu} - E_g\right)^2} \quad V_a \text{ is obtained from col. A; } E_g \text{ from col. B and } I_a \text{ from col. C.}$$

A COMPLETE INDEX TO RADIO LITERATURE.

THE December number of our sister journal, *Experimental Wireless*, completes the volume for the year, and contains an index to the technical articles on radio subjects which have appeared in all countries and in all languages during the past twelve months. From month to month *Experimental Wireless* issues with each number a service of abstracts and references to the world's wireless literature, and the December number contains the index to these abstracts for the year. The index is an invaluable

source of information, especially to those who happen to specialise in the study of any particular branch of the subject.

In addition to this index, the December number contains an article on the design and use of a new type of valve voltmeter by Manfred von Ardenne, and a study of the effect of the ground on downcoming plane space-waves; there is also an important contribution by R. Wilmotte on "A Comparison of the Power Factors of Condensers."

OPERATING FILTER CIRCUITS

Practical Hints on Applying an Improved Tuning System.

By H. F. SMITH.

BITTER complaints have already been registered by those whose long-distance reception has been eclipsed by the high-power transmissions from Brookmans Park, but it seems likely that the storm that has just subsided will renew itself with redoubled force when the twin station starts work. Over a wide area, listeners with out-of-date and unselective apparatus will find themselves in the unenviable position of being unable to receive even one programme without interference until their sets are altered.

Indignant listeners may even go to the length of demanding a refund of their broadcast licence fees, but it is certain that among the applicants there will be but few

the response (or H.F. voltage output relative to the audio-frequency component or modulation of an incoming carrier wave) of an ordinary "good" tuned circuit under actual working conditions. By linking together two such circuits with very loose coupling, no improvement is effected with regard to high-note retention, but selectivity is vastly improved.

Flattening Out Tuning Peaks.

As coupling between the circuits is made closer, there is a tendency for the composite circuit to give a maximum response to two different frequencies, and it is this property that is so valuable as an aid to obtaining real selectivity combined with good quality. Tuning curves of the kind provided by this arrangement are shown in Fig. 1 (b). The first (X) is what may be expected of low-loss circuits. It is not ideal, as a little consideration will show that, assuming a perfect detector and amplifier to be operated from the voltages developed, there would be over-emphasis of the higher audible frequencies. In actual practice, this might well be unobjectionable, if only because it is hard to avoid some high-note loss in the amplifier, but, to be on the safe side, it is well to aim at something more like curve Y, which is afforded by circuits of average "goodness," used without any abnormal precautions to avoid incidental losses.

The advantages of what is sensibly a flat-topped resonance curve can be realised by careful operation of the circuit given in Fig. 2, which represents an anode bend detector, transformer-coupled to an output valve. This

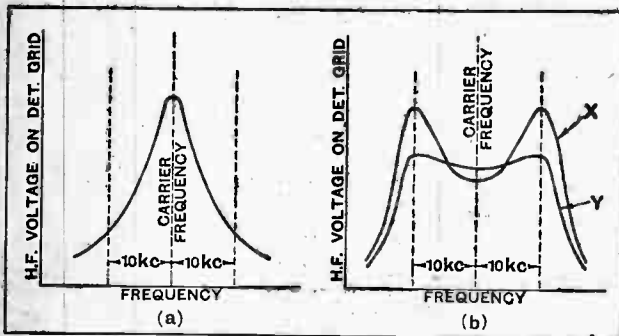

Fig. 1.—Resonance curve of conventional single circuit (a) compared with outputs obtainable from filter circuits.

Wireless World readers: to the true enthusiast, difficulties of this kind exist only to be overcome. Of the several possible lines of attack, none offers greater possibilities than the use of tuned filter circuits, which have already been discussed¹ at some length. It is suggested that an hour or two may profitably be spent in acquiring practical first-hand knowledge of the behaviour of these circuits in their simplest form before attempting to incorporate them in more complex and ambitious receivers. An attempt will be made in this article to show how apparatus already in the possession of the average set constructor may be pressed into service for setting up a receiver that will afford valuable experience, and, it is believed, convince even the most sceptical of the worth of this method of tuning.

Without retracing our footsteps over ground that has already been covered, the reader may be reminded that the kind of tuning we are now trying to avoid is that represented diagrammatically in Fig. 1 (a), which shows

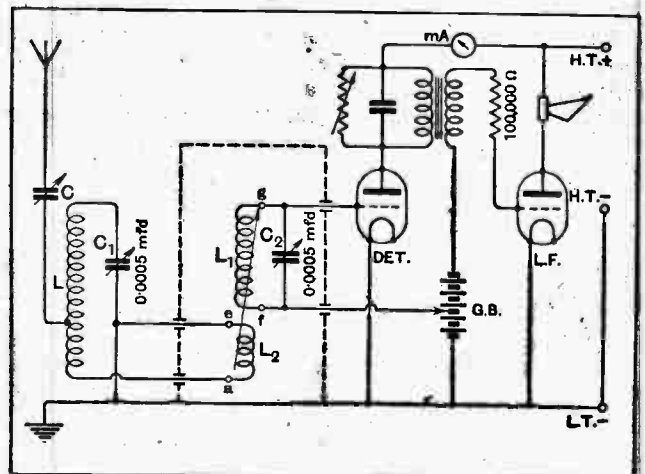

Fig. 2.—A simple local-station receiver for testing the effect of "double-humped" tuning. The anode bend detector valve should have a reasonably low impedance and an L.F. transformer with a large primary inductance should be used.

¹ *The Wireless World*, October 30th, 1929.

Operating Filter Circuits.—

combination can give really good loud speaker signals at a distance of a few miles, and it is primarily suggested to those living within "good crystal range" of a broadcasting station. For our present purpose we are concerned mainly with the tuning circuits, and considerable latitude is permissible with regard to the L.F. amplifier; for example, resistance coupling will serve quite well.

The secondary inductance L_1 may consist of about 56 turns of No. 24 D.C.C. wire on a 3in. former. Its coupling coil L_2 may have some 8 turns of finer wire wound on a sleeve which is an easy sliding fit on the main former, so that its distance from L_1 (and consequently the coupling) may be readily adjusted. A sectional sketch of these windings is given in Fig. 3; connections are indicated by lettering corresponding with Fig. 2. A more convenient form of coupling (from the mechanical point of view)

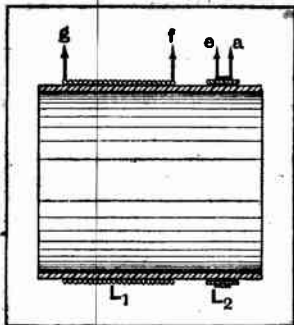

Fig. 3.—Construction of a coupler. Lettering of the terminal points refers to Fig 2.

can obviously be devised by those with the necessary facilities.

Any reasonably good input coil (L) that is to hand may be used. Failing anything else, a winding similar to that specified for L_1 , with a tapping at the 10th turn from the earthed end, will do admirably.

In order that inter-circuit coupling may be completely under control, the secondary winding and its coupling coil should be enclosed in a screening box, which may also accommodate the detector valve if space permits.

At very short range, some method of preventing detector overloading must be provided, particularly if the aerial system is efficient. A series aerial condenser (C) of some 0.00025 mfd., though not a perfect control, is effective enough, if one remembers that any variation in its setting will call for slight retuning. It is, perhaps, as well to state here that the whole essence of filter circuit operation is accurate tuning, and that the usual expedient of reducing incoming signal strength by detuning is quite out of the question.

Post-detection Volume Control.

Assuming that the input from the aerial is sufficient fully to load our detector, some means of preventing overloading of the subsequent valve must almost invariably be provided. For this purpose, a variable resistance of some 200,000 ohms may be connected across the L.F. transformer primary.

A sensitive milliammeter in the detector valve anode circuit is shown; this acts as an H.F. grid voltage indicator, and is a highly desirable refinement, but is by no means essential.

Having set up the circuit, local signals should first be tuned in accurately with the maximum possible separation between coils L_1 and L_2 , making quite sure that there is no tendency towards double-humped tuning. If

necessary, aerial input should be reduced, as it is much easier to work with a signal that is not overpoweringly strong. The setting of C_2 should be as critical as when "aperiodic" coupling is used, and a test may readily be made by temporarily joining the aerial to point a on L_2 after having removed the existing connection from this point. Coupling should be adjusted so that signal strength is changed as little as possible while making this comparative test.

Critical Adjustment of Coupling.

Reverting to the two-circuit tuner, we now come to the most critical operation—that of tightening coupling until the circuits begin to "pull" together and act as a true filter. If a detector anode meter is available, the simplest plan is to move the coupling coil towards the closed circuit winding until a maximum reading is indicated and then to make a further slight increase in the coupling until a definite but slight drop in current is registered. This is a sure indication that something approaching the desired results have been achieved, but a little experience is necessary to determine the best coupling for producing the proper degree of flatness. A good idea can be formed by noting the effect of rotating the condenser C_2 ; there should be little perceptible

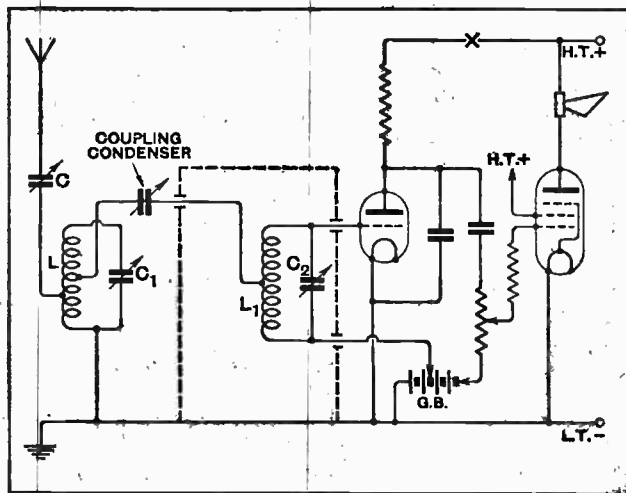



Fig. 4.—Another experimental receiver circuit with capacity coupling. A plate current galvanometer may be inserted at X.

change in signal strength (as indicated by the meter), as its dial is turned through at least a single scale division, or perhaps 2 degrees of a 0-180 scale.

If a meter is not available it is best to make progressive increases in coupling, "feeling" at each step for the desired broadening of tuning. In any case, it is essential that the variable condensers should be finally set exactly "in the middle of the signal," if the full benefit of a filter circuit is to be retained.

Where high selectivity is required, it is often necessary to adjust coupling so that the tuning curve "peaks" are rather closer together than shown in Fig. 1(b); in any case it is necessary at least to make provision for doing so when we come to deal with a long-range receiver with H.F. amplification.

CURRENT TOPICS



Events of the Week in Brief Review.

THE ROYAL CONSTRUCTOR.

H.R.H. the Duke of York is reported to have completed the construction of a wireless set in his "workshop" at 145, Piccadilly.

o o o o

NEARING THE THREE MILLION MARK.

In the House of Commons last week the Postmaster-General reported that the number of broadcast licences now issued was 2,869,000. The number was increasing, and he was confident that it would reach 3,000,000 before very long.

o o o o

THE ALL-SEEING EYE.

A wireless "pirate" fined at the Thames Police Court asked if he could be informed of the names of the people who gave information about him.

Magistrate: You are not entitled to the information, and you must assume that there is an all-seeing eye which sees these things.

INVENTORS, FORWARD!

Louis Graveure, a Berlin concert singer, is appealing to scientists to invent a means of broadcasting whereby the waves will only be available to subscribers.

o o o o

THE WIRELESS LEAGUE.

Members of the Wireless League are cordially invited to attend the annual general meeting, which will be held at the Royal Automobile Club, Pall Mall, S.W., on Friday next, December 6th, at 3 p.m. Sir Arthur Stanley will be in the chair.

o o o o

A NEW "KDKA."

KDKA, Pittsburgh, one of the pioneer broadcasting stations of the world, is to have a sister station at Saxonburg, Penn., early in 1930, according to the plans of the Westinghouse Electric Company. The new "KDKA" will concentrate on short-wave work, and for this reason the new site has been selected after an exhaustive search. The new station should make itself heard in Britain.

PHONE CONTROL FOR ELECTRIC GRAMOPHONES.

Dr. N. W. McLachlan, M.I.E.E., F.Inst.P., will give a lecture, with demonstration, entitled "Experiments in Tone Control for Electric Gramophones," at the annual general meeting of the Incorporated Radio Society of Great Britain, to be held on Friday, December 13th, at 6 p.m., at the Institution of Electrical Engineers, Savoy Place, W.C.2.

o o o o

WIRELESS PRIZE HUNT.

An observation test of unusual interest will be provided in next week's *Wireless World* in the form of a Hidden Advertisements Competition. Wireless apparatus amounting in value to £20 will be offered to successful entrants, who will be able to choose their own prizes from goods advertised in that issue.

While calling for no technical skill, this intriguing test will challenge the competitor's powers of observation and his ability to make the best use of the clues provided. Full details will appear in our advertisement pages next week.

o o o o

RADIO SOCIETY'S HOSPITAL GIFT.

The Sheffield Wireless Society is presenting a broadcast receiving installation to the Firth Auxiliary Hospital for Women.

o o o o

A TECHNICAL TEST.

A Nottingham listener fined for owning and operating a set without a licence pleaded that he was only testing it. He admitted that he had committed a technical offence.

o o o o

WIRELESS FROM THE WILDS.

Short-wave wireless messages transmitted by Mr. Hinds for Major C. Court-Treatt, the British explorer, from a portable Marconi equipment in the wilds of Sudan, have been received as far afield as the United States of America.

Pitching their camps in the least-known parts of the Western Sudan, Major and Mrs. Court-Treatt and Mr. Hinds were able to maintain communication with Sudan Government wireless stations throughout their twelve months' travels in the jungle, where they were making the British instructional film "Stampede."

Thus they were in regular touch with London through the Government stations and on a number of occasions their transmissions, on a wavelength of approximately 30 metres, were heard at a distance

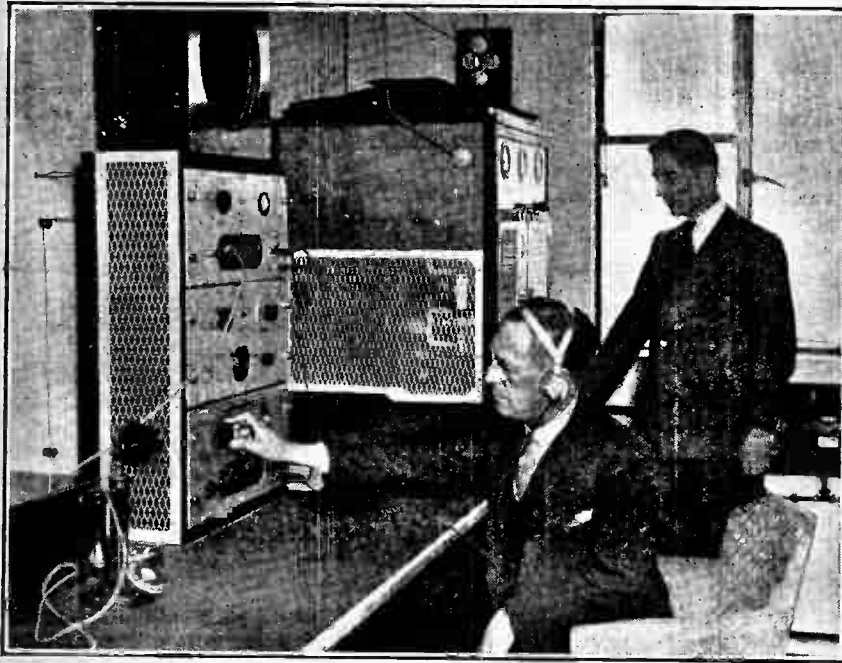

FLYING LESSONS BY WIRELESS. The new wireless installation at Heston Air Park School was officially opened last week by Sir Sefton Brancker, who is here seen adjusting the receiver. An illustrated description of the equipment appeared in "The Wireless World" of November 20th.

of more than 5,000 miles in Detroit, Michigan and Boston, Massachusetts.

The wireless transmitter used was a specially designed Marconi set of extremely small power and weight, the power being supplied by turning the handle of a small electrical generator.

MUSIC WHILE YOU WAIT.

A Paris taxi owner has equipped his cab with a broadcast receiver. The loud speaker is in the roof and is said to drown traffic noises very effectively. Traffic blocks are forgotten.

"SMALL ADS."

The return of the Christmas season makes it necessary to close for press earlier than usual with our issues of December 18th and 25th. Miscellaneous advertisements for inclusion in these issues can be accepted up to the first post on the Wednesday preceding the date of issue. Those for the issue of January 1st should be received not later than first post on Tuesday, December 24th.

THE STENODE.

At a demonstration on Thursday last, Dr. James Robinson exhibited a receiver of his own invention in which high selectivity is sought by utilising only a narrow waveband. It is claimed that the apparatus is capable of receiving the modulated signal when sharply tuned to the carrier frequency, the audio frequencies being reproduced at their correct relative amplitudes. The device is called the Stenode.

The use of a narrow waveband has always been contrary to the views of *The Wireless World* as being inimical to quality reception; it is, therefore, possible that Dr. Robinson is making an original contribution of the first importance to our knowledge of the properties of resonant circuits. Some scepticism must prevail, however, pending the disclosure of precise technical details.

The device is understood to employ a quartz crystal resonator in conjunction with a superheterodyne which converts the original frequency to the natural frequency of the crystal. Dr. Robinson states that it is possible to restrict reception to a given transmission avoiding interfering frequencies as close as 100 cycles to that of the carrier.

VALVE HOLDERS IN COURT.

In the Chancery Division of the High Courts of Justice on November 19th Mr. Justice Clausen delivered judgment in favour of the plaintiffs in the action brought by Benjamin Electric, Ltd., against Garnett, Whiteley and Co., Ltd. The plaintiffs sued for infringement by the defendants of two patents, No. 222,086 (Benjamin Patent) and No. 240,918 (Burndept Patent), which relate to anti-microphonic valve holders. In delivering judgment, his Lordship said it became clear in the course of the case that if the plaintiffs' Patents, setting aside two claims in the Burndept Patent (which the plaintiffs asked leave to disclaim as separate claims), were valid, the defendants had infringed them.

On the question as to whether the de-

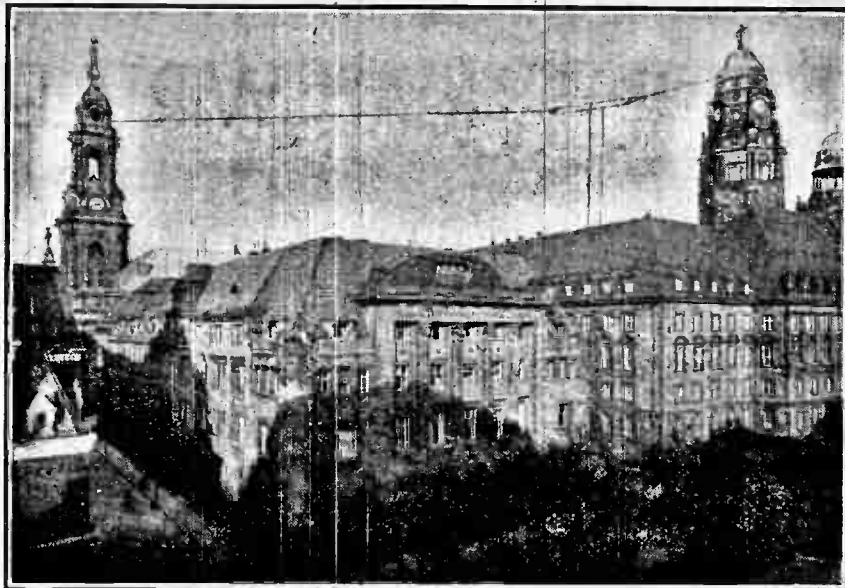

DRESDEN'S AERIAL. The aerial system of the Dresden relay station overshadows the bank and municipal buildings. The station relays Leipzig on a wavelength of 319 metres.

fence of no subject-matter was to prevail, his Lordship said: "It was said that the plaintiffs' device (the Benjamin valve-holder) is a combination of old features; and it may be true that each separate feature in the combination can be found in some previous device. It appears to me, however, that the combination of these separate features is not a mere juxtaposition of old features but has produced an article which operates as a whole and is a new and useful article."

WIRELESS AT WESTMINSTER.

(From Our Parliamentary Correspondent.)

A New Wireless Act?

During the Committee stage last week of the Expiring Laws Continuance Bill, Captain Bourne, a Unionist member, moved to omit from the scope of the Bill the Wireless Telegraphy Act of 1904. He explained that at the time the Act was passed no one dreamt that we should get the elaborate system of broadcasting that we had to-day. A new Act should be passed, he urged, which would bring the law up to date.

Replying to this and many other points raised, Mr. Lees-Smith, the Postmaster-General, said that there was to be a wireless international telegraphic conference in Madrid in two or three years, and that the conference was likely to adopt certain conventions which would need legislation in the Parliaments of the ratifying States, so that the Government might have to bring in a Bill on this subject in three or four years' time. They did not want two Bills.

Brookmans Park Tests.

In regard to the experiments at Brookmans Park, said the Postmaster-General, the station was still working on a single wave, and the great change would come when it worked on the double wave, which would be initiated in a few weeks' time. It would not be initiated all at once, but probably it would be increased as the public accustomed itself to the new development. On the subject of television, he said that the Baird Television Company now had the right to use the B.B.C. stations for half an hour on five days a week out of broadcasting hours.

As to evasion of the payment of wireless licences, that was being gradually reduced.

FORTHCOMING EVENTS.

WEDNESDAY, DECEMBER 4th.
Institution of Electrical Engineers, Wireless Section.—At 8 p.m. At the Institution, Savoy Place, W.C.2. Lecture: "Naval Wireless Telegraphy Communications," by Mr. G. Shearing, B.Sc., and Capt. J. W. S. Dorling, R.N.

Edinburgh and District Radio Society.—At 8 p.m. At 16, Royal Terrace. Auction Sale.

Queen's Park Radio Society.—At 8 p.m. At the Oddfellows' Hall, 593, Harrow Road, Paddington. Lecture by Messrs. W. F. Floyd, A.Inst.P., and E. J. Reid, B.Sc.

Muswell Hill and District Radio Society.—At 8 p.m. At Tollington School, Tetherdown, N.10. Lecture and Demonstration: "The Elementary Principles of Television," by Mr. T. Andrews.

North Middlesex Radio Society.—At 8 p.m. At St. Paul's Institute, Winchmore Hill, N.21. Debate: "Is the Moving Coil Loud Speaker Worth While?"

THURSDAY, DECEMBER 5th.
Uford and District Radio Society.—Lecture: "Operation from A.C. Mains," by a representative of the Marconi-Phone Co., Ltd.

FRIDAY, DECEMBER 6th.
Bristol and District Radio Society.—At 7.30 p.m. In the Geographical Lecture Theatre, University of Bristol. Lecture and Demonstration: "The Philips Four-Valve Set," by Mr. Cooper, of Philips Lamps, Ltd.

MONDAY, DECEMBER 9th.
Newcastle-upon-Tyne Radio Society.—At 7 p.m. In the Physics Theatre, Armstrong College. Demonstration of Commercial and Amateur Loud Speakers.

TUESDAY, DECEMBER 10th.
Ryde Radio Society.—Visit to the Sandown Radio Society.

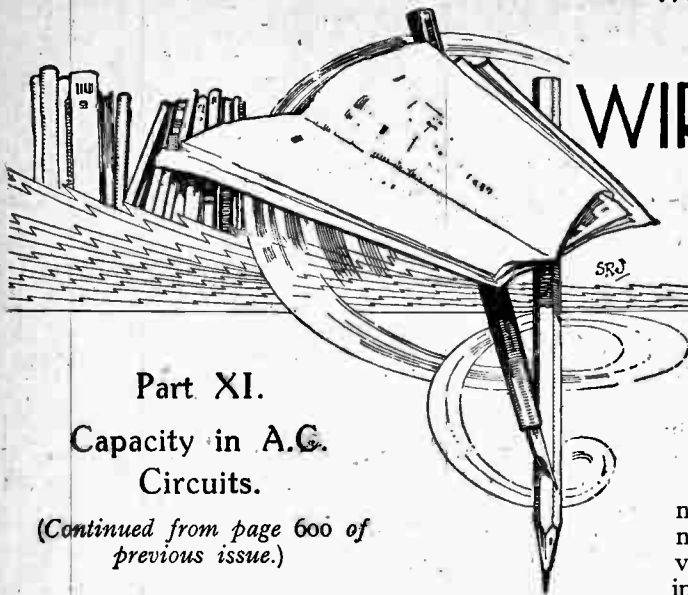

WIRELESS THEORY SIMPLIFIED

Part XI. Capacity in A.C. Circuits.

(Continued from page 600 of previous issue.)

By S. O. PEARSON, B.Sc., A.M.I.E.E.

Nature of the Charging Current

Suppose that a condenser of capacity C farads is connected through a switch S to the terminals of an alternator A as shown in Fig. 1. It will be assumed that the voltage at the terminals of the alternator varies according to the sine law so that when plotted as a curve to an angle base in the manner already described it gives a sine wave as shown by the full line curve of Fig. 2. Let E_m be the maximum value attained by the voltage every half cycle. Then the sine wave can be represented by a vector of length OE_m rotating about O at a speed of f revolutions per second, where f is the frequency. This means that the vector will have an angular speed of $2\pi f$ radians per second (see Part IV, October 16th issue).

Now suppose that the switch S is closed at an instant when the voltage is passing through one of its zero values and is increasing towards the positive maximum value. This instant is indicated by O in the graph of Fig. 2. Since the condenser C is now connected directly across the alternator terminals the voltage across it will be at every instant equal to the alternator voltage; and so, as the voltage rises, a charging current will flow round from one plate of the condenser to the other, being at every instant proportional to the rate at which the voltage is changing.

Clearly the voltage is changing at its greatest rate just as it passes through its zero values because the curve is steepest at these points. Therefore the charging current will have its maximum value when the voltage is zero.

THE behaviour of a condenser in an A.C. circuit is one of the most important aspects of our subject. Inductance and capacity together constitute the key to all radio communication. To those studying the effect of capacity in an A.C. circuit for the first time, some of the facts come as a complete surprise and others prove most intriguing and interesting. For instance, when it is known that no current can possibly flow through a condenser from one set of plates to the other on account of the insulating medium between them, it may come as a surprise to learn that on an A.C. source of supply a lamp can be made to light when connected in series with a condenser. To those new to the subject or those who have given the matter no thought, this must appear to be a contradictory state of affairs, because apparently we have an alternating current flowing round a circuit in which there is a gap across which no current can pass.

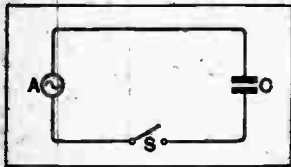

Fig. 1.—Simple circuit for connecting a condenser C across the terminals of an alternator A .

It is a very common practice to speak of an alternating current flowing through a condenser, but actually the current does not get through at all. It is only apparent. Our immediate object is to discuss this matter and see what really does happen.

It has already been shown that the rate at which the voltage between the plates of a condenser builds up is exactly proportional to the value of the charging current. If C is the capacity of the condenser in farads, the charging current at any instant is given in amperes by

$$i = C \times (\text{rate of change of voltage}) \dots \dots (1)$$

It will be realised that this relationship is of the same form as $e = I \times (\text{rate of change of current})$ for an inductive coil, as explained in Part V (page 407), and we can therefore apply the same reasoning for determining the relationship between current and voltage when a condenser is connected to a source of A.C. supply.

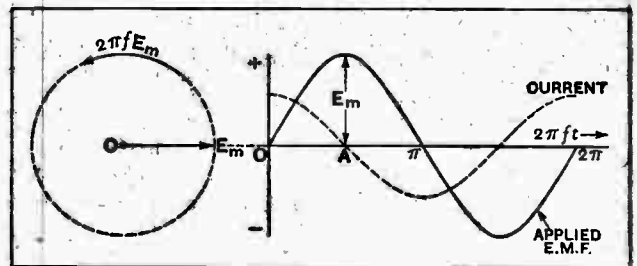

Fig. 2.—The speed of the end of the vector OE_m gives the maximum rate of change of voltage. The current taken by a condenser leads the applied voltage by a quarter of a cycle.

Just as the voltage is passing through its maximum value, it is neither increasing nor decreasing—its rate of change is zero—and therefore at this instant, denoted by A in Fig. 2, the condenser is being neither charged fur-

Wireless Theory Simplified.—

ther nor discharged—the charging current is zero. Beyond this point, when the voltage starts to fall again, the condenser begins to lose its charge, showing that the current must have reversed and is therefore negative.

Obviously, since the condenser is being charged up in opposite directions alternately by the alternator, the electrons representing the charges will be surging backwards and forwards round the external circuit, being first piled up on one plate by the action of the alternator, then withdrawn and piled up on the other, and so on. But none of them passes through the insulation between the plates. This surging backwards and forwards of the electrons constitutes an alternating current and would be indicated by an ammeter in the circuit. It has its maximum value when the voltage is zero and falls to zero when the voltage is a maximum as explained above.

A Condenser takes a Leading Current

We conclude then that the charging current is an alternating one *exactly a quarter of a cycle out of step* with respect to the voltage. Furthermore, this current will have a *positive* maximum value when the voltage is zero and increasing towards the positive value. So the current can be represented by another wave in the position shown by the dotted curve of Fig. 2. From these curves we see that the current reaches its maximum positive value a quarter of a cycle *earlier* than the voltage and we arrive at the extremely important conclusion that a condenser in an A.C. circuit takes a current which *leads* the voltage by exactly a quarter of a cycle or 90°. This is just the reverse of a pure inductance, which was found to take a current *lagging* by a quarter of a cycle. This opposition of phase angles is one of the things which makes tuning possible.

No Power Consumed by a Perfect Condenser.

The average power consumed by a perfect condenser in an A.C. circuit is zero for the same reason as that given in connection with a pure inductance, namely that the current and voltage are out of step by a quarter of a cycle, the power factor being zero. The energy put into the condenser during the first quarter cycle when it is being charged up is all recovered during the second quarter cycle, during which time it is completely discharged again, and so on. In practice some very small losses occur in the di-electric and plates, but except in special circumstances this may be entirely ignored.

The condenser and alternator combination of Fig. 1 can conveniently be compared, for purposes of mechanical illustration, with a pump and divided air cylinder similar to that described in Part IX, but in this case the pump must be of a type designed to drive the air first one way through the pipe, and then the opposite way alternately.

A possible arrangement of this sort is indicated in Fig. 3, where C is the main air reservoir divided into two equal compartments by a diaphragm D, and P is a reversible air pump which is reversed at regular intervals. In this way air is first withdrawn from compartment A and added to that already in B, so creating a pressure difference or back pressure between the two

sides. When the pump begins to slow down before reversing, the excess air in compartment A starts to flow back in exactly the same way that the condenser loses its charge when the alternator voltage is falling.

When the pump is reversed the pressure in compartment A falls below the normal and that in B rises, etc. And so as the pump is periodically reversed the air molecules will be surging backwards and forwards between the two compartments.

In exactly the same way the alternator may be looked upon as a sort of electron pump which causes some of the electrons in the circuit to surge backwards and forwards between the two plates of the condenser. A little

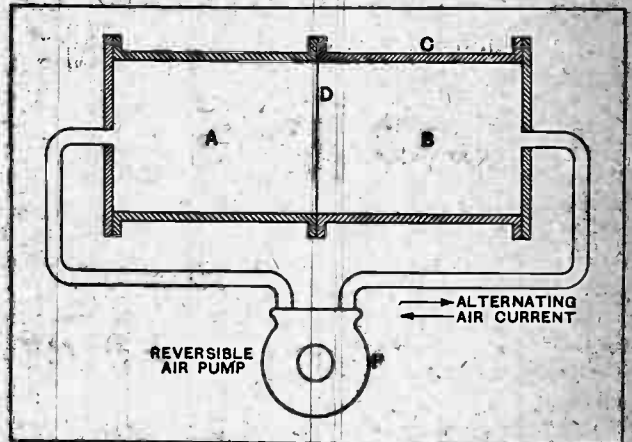

Fig. 3.—Divided cylinder and reversible air pump arrangement for illustrating the action of a condenser in an A.C. circuit.

consideration will show that the mechanical system and the electric circuit in question are also similar as regards stored energy, and as regards phase difference if we assume that the air pressure exerted by the pump obeys a sine law with respect to time. The current of air in the pipe stops flowing just as the pressure exerted by the pump reaches its maximum value in the same way that the charging current of the condenser ceases at the instant the alternator voltage reaches its maximum value.

Finding the Value of a Current.

Now that we know the phase relationship between current and voltage for a condenser we can find their relationship as regards magnitude, also by the aid of Fig. 2. The maximum value of the current will be $I = C \times$ (maximum rate of change of voltage) from equation (1) above. Now the maximum rate at which the voltage is changing is exactly equal to the actual speed of movement of the extremity of the vector OE_m , representing the E.M.F. wave as explained at some length on page 491 of October 30th issue in connection with the induced E.M.F. in an inductive coil. In the present case the speed, and therefore maximum rate of change of voltage, is $2\pi f \times E_m$ volts per second. Hence the maximum value attained by the charging current of the condenser will be:

$$I_m = C \times 2\pi f E_m = 2\pi f C \times E_m \text{ amperes.}$$

Wireless Theory Simplified.—

But for sine waves the R.M.S. value is 0.707 of the maximum value, and so to get the R.M.S. value of the current we multiply each side of the last equation by 0.707, namely:

$$I = 0.707 I_m = 2\pi f C \times 0.707 E_m$$

$$\text{or } I = 2\pi f C \times E$$

where E and I are R.M.S. values.

Reactance of a Condenser.

It should be remembered that the ratio of E.M.F. to current in a circuit is always expressed in ohms, but whether this ratio gives resistance, reactance or impedance depends entirely on the phase relationship between the current and voltage. If they are in phase their ratio is a resistance, if they are a quarter of a cycle out of step their ratio is a reactance, and if they are out of phase by any odd angle between zero and 90°, i.e., if they are out of step by some fraction of a cycle less than a quarter, their ratio gives the impedance.

Now we have seen that for a condenser the current and voltage are exactly a quarter of a cycle, or 90°, out of step, and hence the ratio $\frac{E}{I}$ is in the nature of a pure reactance. And so the reactance of a condenser is given

$$\text{by } X_c = \frac{E}{I} = \frac{1}{2\pi f C} \text{ ohms, where } C \text{ is the capacity in farads and } f \text{ the frequency.}$$

Comparison of Condensive Reactance with Inductive Reactance.

It is evident that both capacity and inductance in an A.C. circuit produce reactance; each of them introduces a phase displacement of a quarter of a cycle between the current and voltage. But in other respects they are fundamentally opposed: For instance, a condenser takes a current *leading* the voltage by a quarter cycle, whereas a pure inductance passes a current which lags behind the voltage by 90°. Hence if inductance and capacity are present simultaneously in the same circuit, one will have a neutralising effect on the other, and the results of this are to be discussed in the next part. On account of these opposing effects the reactance of a condenser must be considered negative with respect to that of an inductive coil when making calculations. To distinguish between them the one is called *condensive reactance*, and the other *inductive reactance*, denoted by X_c and X_L respectively.

Another aspect in which condensive reactance and inductive reactance are in contrast lies in the manner in which each depends on the frequency, and on the value of capacity and inductance respectively. Whereas inductive reactance is directly proportional to the frequency and inductance, being given by $2\pi f L$, the reactance of a condenser is inversely proportional to the frequency and capacity, being given by $\frac{1}{2\pi f C}$. This

means that if an alternating voltage of constant R.M.S. value E is applied to a condenser of capacity C farads, the current "through" the condenser will be directly proportional to the frequency, and if plotted as a graph against frequency will give a straight line passing upwards from the origin O as shown in Fig. 4, where the

reactance is also shown plotted against the frequency. These curves should be contrasted with those of Fig. 5 of Part VI (October 30th issue) for a circuit possessing inductance only.

Numerical Calculation.

From the results obtained so far we conclude that a condenser will pass no direct current at all but will allow alternating current to flow to an extent proportional to the frequency. As an example for numerical calculation we can take the case of a by-pass condenser connected between the plate and filament of the detector valve in a receiver. The object of the condenser is to provide an easy path to "earth" for the high-frequency component of the plate current, whilst at the same time preventing as far as possible the escape of the wanted currents of audible frequency.

Suppose that the by-pass condenser has a capacity of 0.0001 microfarad, the radio-frequency current has a frequency of 1,000,000 cycles per second (corresponding to a wavelength of 300 metres) and that the highest note frequency with which we are concerned is 5,000 cycles per second. In calculating the reactance the capacity must be expressed in farads, and is, therefore, $0.0001 \div 10^6$, or 0.0001×10^{-6} farad!

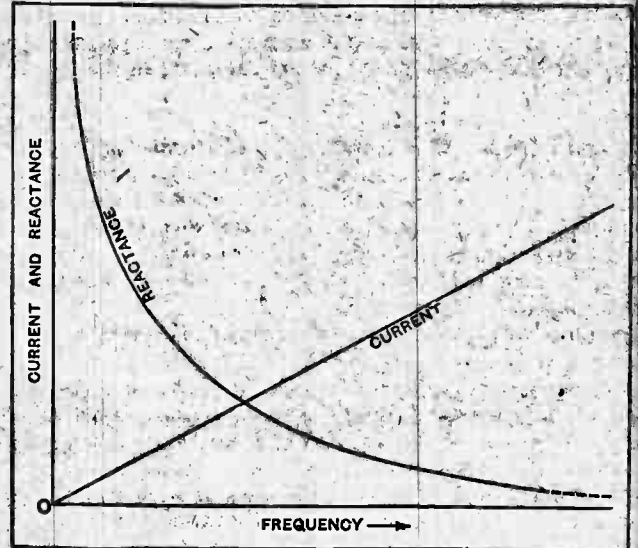

Fig. 4.—Curves showing how current and reactance vary with frequency for a condenser.

At a frequency of one million, or 10^6 cycles per second, the reactance is:

$$\frac{1}{2\pi f C} = \frac{10^6}{2\pi \times 10^6 \times 0.0001} = 1,590 \text{ ohms;}$$

and at 5,000 cycles per second the reactance is

$$X_c = \frac{10^6}{2\pi \times 5000 \times 0.0001} = 318,000 \text{ ohms.}$$

Thus if there were an anode resistance of 150,000 ohms in the plate circuit, about 99 per cent. of the high-frequency current would be conducted away "through" the condenser, whereas only just over 30 per cent. of the audio-frequency current would be lost in this way.

The next instalment will deal with the effects of capacity in A.C. circuits where resistance and inductance are also present. (To be continued.)



A New Problem and Some Suggested Solutions.

By F. H. HAYNES.

TROUBLE is certain to arise in a mains-operated set when the grid bias is produced by the inclusion of dry cells. We can be quite sure that the failure of the grid biasing cells will not be detected until impaired performance is suspected, by which time damage may have been sustained by the valves. Even in the battery-operated set the grid cells are neglected and in the mains set the possible existence of dry cells contained within the cabinet is entirely forgotten.

As an alternative to the use of cells, grid bias is derived by dropping part of the anode voltage across a resistance introduced into the filament (or cathode) side of the H.T. circuit (Fig. 1). This resistance, R , also forms part of the grid circuit, and the voltage set up across it is such that the filament is positive with regard to the grid or, taking the filament as being at zero potential, then the grid is negative. To determine a suitable value for this resistance it is only necessary to multiply the potential required by 1,000 and divide by the average anode current in milliamperes. As a rule only an approximate figure may be thus obtained, yet the result is sufficiently reliable and an error as high as 5 per cent. is not serious in view of the latitude in grid biasing values. It should be noted that the anode voltage is reduced by the amount of the grid bias taken, and for this reason it is not always economical to create in this way biasing potentials of 100 or more volts as required by super-power valves.

A resistance which forms a common path to both the grid and anode circuits of a valve produces a coupling between the output and input and may be responsible or contributory in the bringing about of instability in a high frequency amplifier or oscillation in a detector or low-frequency stage. This undesirable coupling is sufficiently removed by providing a path of low impedance to the signal currents across the biasing resistance by means of a shunt condenser. In a high-frequency circuit, including a screen-grid valve combined with coils of average resistance, a mica condenser of 0.01 mfd. should be regarded as the minimum capacity which can be safely adopted in a set tuning to both wavebands. For a low-frequency stage the shunt condenser will need to have a value of not less than 2 mfd. (Fig. 2). Coupling between

grid and anode may be further localised in the case of a transformer-coupled L.F. or output stage by using a filter feed anode circuit. For example, a voltage drop from 300 to 60 as required by a leaky grid detector is produced by an anode resistance of some 60,000 ohms so that it becomes possible to feed the primary of the intervalve transformer through a condenser connected to the anode, thus avoiding incidentally an excessive current being passed by the winding. The earth side of the primary must now be returned, not to the common H.T. —, but to the filament or heater circuit. Similarly, in an output stage, the return lead of a filter-fed loud speaker, instead of connecting to the H.T. —, likewise runs direct to the filament. In this latter case it is advisable to connect condensers in each of the speaker leads, for it will be seen that an earth connection or low insulation occurring on the loud speaker winding would produce a short circuit across the resistance which gives the grid bias.

When dealing with indirectly heated valves it is at once obvious that a resistance connected in the cathode lead will give the required biasing potential (Fig. 3). It will also be noted that a common source of heater current may be connected to the several valves while the biases may differ. While such an arrangement will prove quite satisfactory with certain valves, instances may arise where mains hum is experienced, due to the difference of potential which has been set up between heater and cathode. Considering for a moment the actual circuit of a screen-grid H.F. stage biased in this way, it will be noted that while the dangers of grid-anode coupling across a common resistance are still present, there is in addition, a difference of voltage between heater and emitter, these being in intimate contact within the valve. Many indirectly heated valves may, however, be successfully operated in this way without trouble from A.C. hum, and in arranging the biasing resistance it will be found worth while to make it pass the current of the screen potentiometer as well as the anode current (Figs. 3 and 4). By so doing, the value of the resistance will be reduced owing to the appreciable increase in current which is necessarily passed by the potentiometer and a more constant value of bias will result.

THE chief problem in the design of mains sets is that of providing "free" grid bias. Avoidance of feedback coupling as well as mains hum are the difficulties encountered. This article explains the development of receiver circuits in which bias for all valves is derived from a rectified anode current supply.

Main Sets and Grid Bias.—

Turning now to alternative circuits designed to avoid differences of potential between heater and cathode, it is pointed out that the use of a separate heater winding for each valve will prove inconvenient. In planning out a circuit one should start by joining the mid-point of the heater winding to a common return lead and to this lead also all the cathodes should be directly connected. As shown in Fig. 5; the grid biasing voltage is now produced across a resistance connected directly in the grid circuit, while no longer is the H.T.— taken to the common lead. Applying this principle to a tuned-grid circuit, it will be necessary to connect the resistance in series with the inductance while the tuning condenser may be taken from grid to earth (Fig. 6). The tuning condenser is shown in this way as in many sets its spindle will be common to other tuning condensers and will therefore be in contact through its bearings with the frame of the set. Further complication by way of the introduction of decoupling resistances has been omitted as it has been found in practice that the other factors present tending towards the setting up of self-oscillation are far greater in their effect than the common resistance with its by-pass condenser. It will be seen that this method can only be applied to two tuned stages when each requires the same bias. This is due to the biasing resistances being connected across common points in the circuit—the H.T.— and frame. Thus the biasing resistances are parallel-connected and the entire anode current of the stages will be distributed between them.

In an endeavour to devise yet another method, attention is turned to the possibility of passing the entire anode current required by the receiver through a resistance connected in the H.T. negative lead and stepping off biasing potentials as may be required by the various stages. Fig. 7 shows such an arrangement. By far the largest demand on the H.T. supply is made by the output stage, so that the omission of the detector and other amplifying stages from the circuit will not complicate a consideration of its principle. A correct grid bias, producing maximum signal, is obtained by the voltage drop across the resis-

tance which, by way of example, has been shown having a value of 20 ohms. In addition to this resistance is a 250-ohm potentiometer from which the bias for an anode-bend detector may be obtained or, alternatively, such a potentiometer may serve as a volume control. By means of this potentiometer, therefore, grid bias applied to the H.F. valves may be steadily increased up to the point of extinction of the signal. A resistance of 0.5 megohm interposed in each lead, carrying the bias to the several stages is effective for decoupling purposes when associated with a fixed condenser of 0.01 mfd. Several bias values are available by making tappings along the resistance connecting the H.T.— to the common return lead, and if the potentiometer prevents the provision of a tapping at a particular voltage, then another resistance may be connected in parallel so as to provide a convenient point of sub-division. Where several chokes are used for smoothing purposes there is no objection to the resistance of one of the chokes being used as a means of producing bias.

A mains-fed anode-bend detector circuit is shown in Fig. 8, and here again suitable bias is produced by connecting to the point X a lead from the main biasing resistance. Leaky grid detection involves no problems as regards bias. It is only necessary to connect the leak to the cathode. When the grid current characteristic, however, reveals that a definite application of positive bias is necessary it is best produced by a connection to a high-resistance potentiometer running from H.T.+ to cathode. Assuming a potential of 250 volts exists between these points, the positive bias of a volt will be obtained at the junction between a 500- and a 125,000-ohm resistance (Fig. 9).

When a gramophone pick-up is to be introduced, a well-insulated two-way switch may be fitted in the grid circuit of the detector, connection to either tuned circuit, or pick-up, while the earthed pick-up lead may be taken to a tapping on the negative biasing resistance. Wire-wound biasing resistances usually possess a safer margin of current-carrying capacity than those consisting of deposited resistance material. The latter type should be rated to dissipate at least 2 watts.

**Explanatory Notes on the Circuit Diagrams
reproduced on the opposite page.**

1. When an anode current I traverses the resistance R a bias $V = IR$ is applied to the grid.
2. Output stage in which the grid bias is produced by the voltage drop across a resistance. If the anode current is 20 mA. and the resistance has a value of 1,000 ohms then a bias of 20 volts will be applied to the grid. Note that the anode voltage is reduced by the amount of grid bias.
3. Biasing an H.F. stage. The cathode is connected to the H.T.— through the resistance R_1 and the voltage drop thus produced is applied to the grid. This resistance (R_1) forms part of the screen voltage potentiometer ($R_2 + R_3$). $V_1 = R_1(I_1 + I_2)$. $V_2 = \frac{R_3 \times \text{max. voltage}}{R_1 + R_2 + R_3}$ approximately. In determining V_2 the comparatively low resistance of R_1 may be neglected although it is carrying both the current of the potentiometer and the valve.
4. Practical circuit developed from Fig. 3 showing suggested values for the resistances.
5. Modified schematic circuit of an indirectly heated screen-grid valve in which the potential of the cathode is the same as the mean potential of the heater.
6. The circuit of Fig. 5 shown in practical form. As the ends of the resistance R_1 are connected to the common leads H.T.— and earth, care must be taken when introducing a second similarly biased stage.
7. In this arrangement the total anode current produces a voltage difference across the resistances R_4 , R_5 and various voltages as required may be passed to the several valve stages through suitable decoupling resistances (R_6). In this instance R_4 produces the correct grid bias for the H.F. stages, while R_5 arranged as a potentiometer serves as a volume control by increasing the bias. Other resistances may be placed in parallel with R_4 , R_5 to produce other biasing potentials such as may be required by an anode bend detector or when amplifying from a gramophone pick-up.
8. Anode bend detector circuit arranged to avoid difference of potential between heater and cathode. The point X is connected through a decoupling resistance to a point on the resistance R_5 of Fig. 7. Only when a reduction of anode voltage is required will the potentiometer R_7 , R_8 be necessary.
9. Leaky grid detector with positive bias. A high resistance potential divider is connected between H.T.+ and cathode return lead and a small positive potential applied to the grid through the leak resistance. It should be noted that the low voltage end of the potential divider must not connect direct to the H.T.— when negative biasing resistances are interposed.

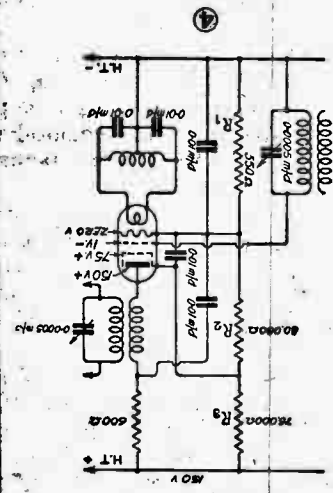
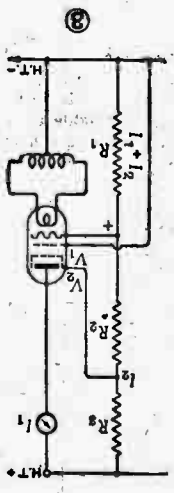
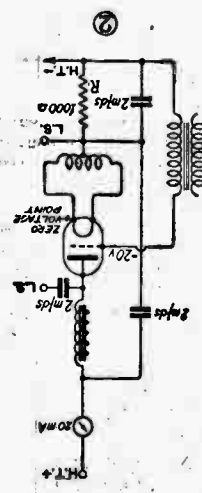
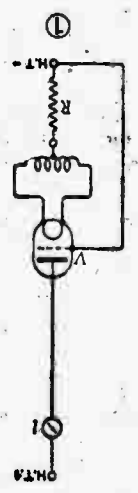
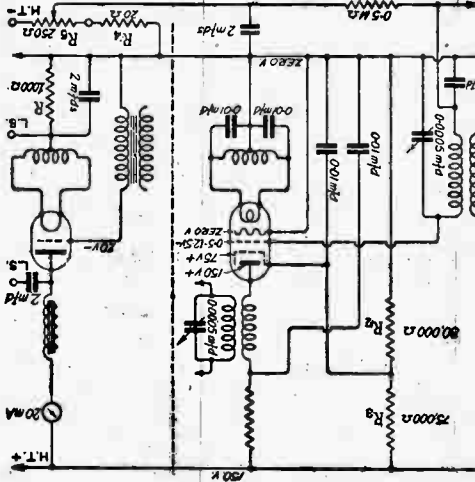
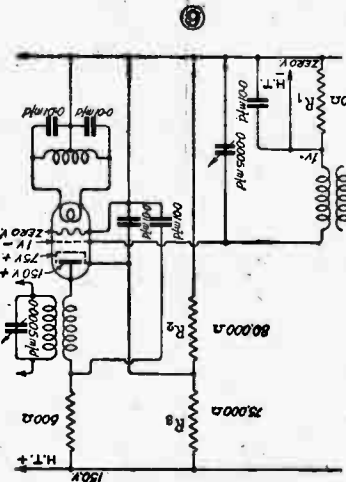
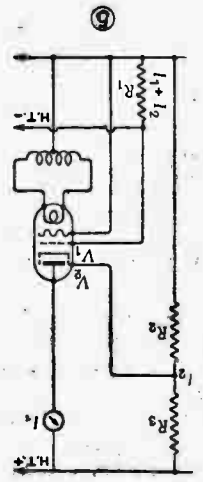
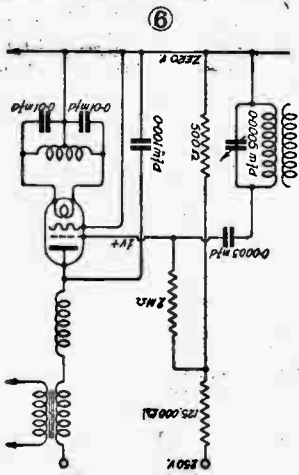
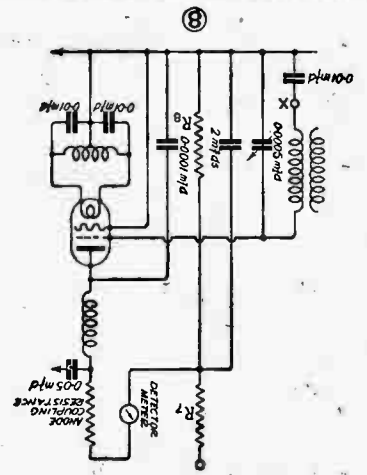

WIRELESS WORLD LABORATORY TESTS

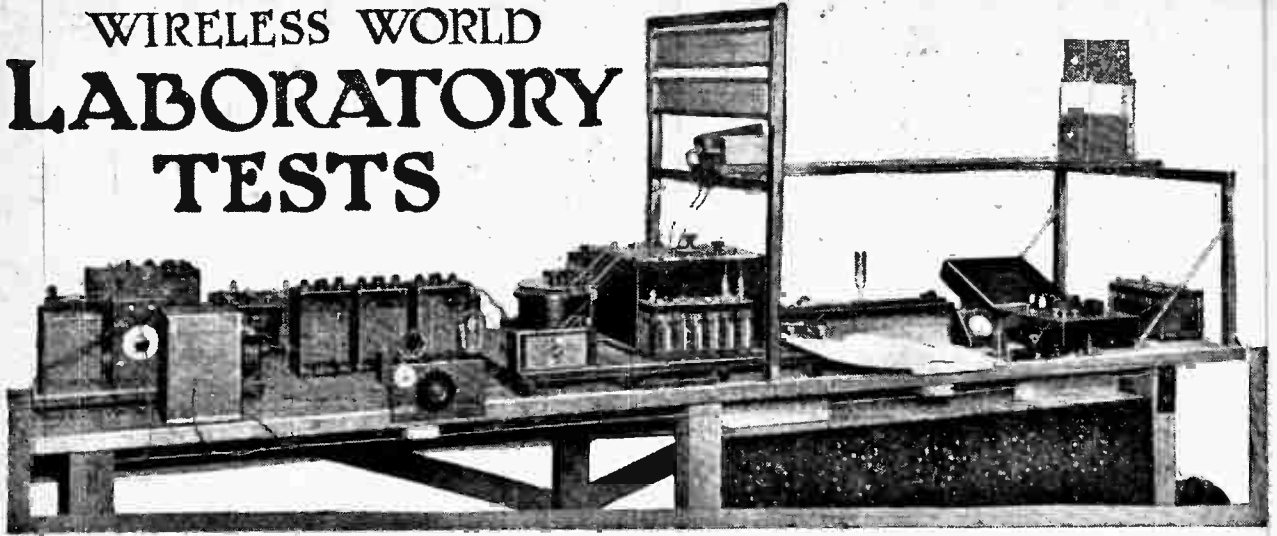

A Review of Manufacturers' Recent Products.

"WATCO" L.T. TERMINAL TAGS.

The restriction of space in portable, and transportable sets often necessitates accommodating the L.T. accumulator in a rather inaccessible position, with the result that one's patience is occasionally seriously taxed in making satisfactory connection between the L.T. leads and the cell. The operation of connecting and disconnecting the cell for recharging purposes can be made delightfully easy by fitting the extension lugs supplied by the Waterloo Tool Co., Ltd., 21 and 23, York Road, Lambeth, London, S.E.1. These are made from soft lead coated with non-corrosive paint and provided with a terminal at one end and shaped lugs at the

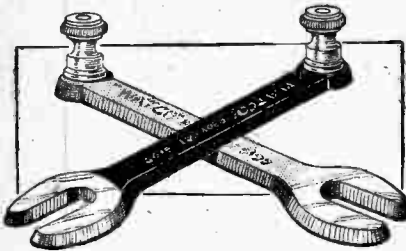

"Watco" extension terminal tags for use in portable sets where the L.T. cell is not readily accessible.

other for gripping under the terminals on the battery. They are supplied in red and black colours as a means of identifying the polarity of the battery. The price has been fixed at 6d. the pair.

AMPLION STANDARD CABINET CONE LOUD SPEAKER.

This new speaker, to be known as Model A.B.6, has been introduced to replace the earlier Models A.C.25 to A.C.29, and is the only balanced armature model loud speaker made by this firm. It occupies an intermediate position between the

Amplion Lion and the cheaper "Junior" types. It is housed in a handsome cabinet measuring 14½ in. x 14½ in. x 8 in. deep, with an ornamental front, and is acoustically

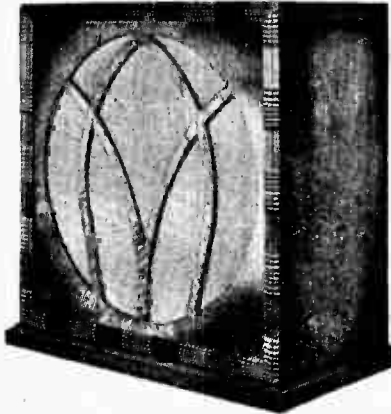

Amplion new Standard Cabinet Cone Loud Speaker, Model A.B.6, in polished oak case.

open at the back. Four large-diameter holes provide free egress for the sound-waves emitted from the back of the cone. The confining of these waves often leads to bad cabinet resonance and impairs reproduction.

A feature of special interest is the provision of three input terminals, which gives the choice of three different loud-speaker impedances, and enables that most suited to the particular output valve fitted to be employed. For test purposes the receiver used was fitted with an output valve having an A.C. resistance of 1,600 ohms and an output filter. With this arrangement the medium impedance winding gave the best all-round results. The high impedance winding should be used with valves of between 2,500 and 4,000 ohms A.C. resistance.

A practical test showed that with normal electrical inputs the frequency band to which the instrument gave good audible response was from about 150 cycles up to 4,500 cycles. The speaker favoured the frequencies below 800 cycles, and showed a noticeable cut-off at 150 cycles.

The instrument is sensitive, and will accept quite large inputs before showing signs of distress.

The makers are Messrs. Graham Amplion, Ltd., 26, Savile Row, Regent Street, London, W.1, and the price of the Model A.B.6 in a polished oak cabinet is £4 10s.

"GOLTONE" SPRING WANDER-PLUG.

Two parts only are used in this wander plug. The prong and wire anchorage are stamped in one piece from hard brass,

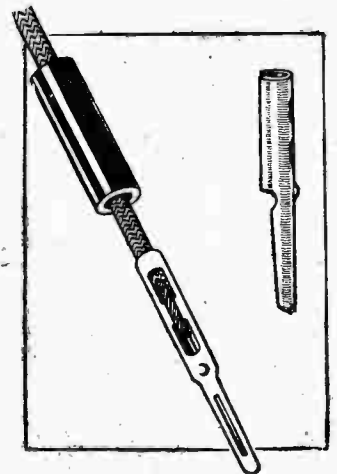

"Goltone" spring wander-plug.

and the bared end of the flex is gripped by first threading this through two holes

and pushing a sleeve of insulated material over the shank.

The prong is "D" shaped and given a slight taper to enable the plug to accommodate itself to different-sized sockets in the H.T. battery. To differentiate between positive and negative leads, sleeves in red and black coloured material are supplied. The makers are Messrs. Ward and Goldstone, Ltd., Frederick Road Pendleton, Manchester, and the price has been fixed at 1½d. each.

o o o o

BELLING-LEE "RADIO-LEGS."

A simple but effective device for converting a table type receiver into a pedestal model has been introduced recently by Messrs. Belling-Lee, Ltd., Queensway Works, Ponders End, Middlesex. This consists of a cleverly designed folding leg type table, but without the usual top. Attachment is a very simple matter, and the device is adjustable to accommodate most sizes of cabinets from a small loud speaker to that required to house a five- or six-valve set.

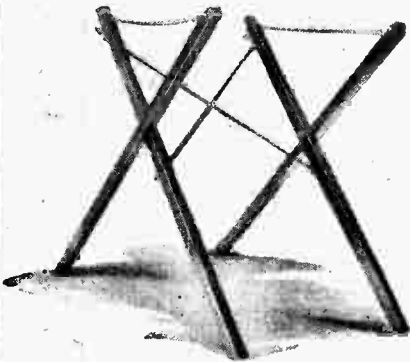

Belling-Lee "Radio-Legs" convert a table model set into a pedestal type and are adjustable to suit any sized cabinet.

The legs are first pulled out to the width of the cabinet and locked by the small nuts provided. Having opened out the cross legs to slightly more than the depth of the set, they are held temporarily in position by a chain at both sides. The set is then placed in the claws on the top of each leg, and two wing nuts tightened until the chains are taut. The set will then be rigidly attached to the legs and can be carried about with ease, at the same time possessing the advantage that it can be placed in any convenient corner.

These legs can be used also to support portable and cabinet type gramophones. They are available in oak or mahogany finish and sell at 15s. 6d. the set.

o o o o

RADIO-GRAMOPHONE CABINET.

The Premier Supply Stores, 165, Fleet Street, London, E.C.4, has introduced recently a radio-gramophone cabinet provided with spacious compartments for loud speaker, batteries, receiving apparatus and gramophone equipment. It will accommodate a set measuring 22in. long, 8in. high, and 16in. deep. The overall

dimensions of the cabinet are 36in. high, 24in. wide, and 19in. deep. A well is provided to accommodate the gramophone turntable and tone arm. The motor board is made of nine-ply wood.



Handsomely finished radio-gramophone cabinet by The Premier Supply Stores.

The cabinet is handsomely finished in polished oak and the price has been fixed at £4 19s. 6d. An ebonite panel, cut to size, finished and polished in either black or "mahoganite," and measuring 21 x 7in., can be supplied for an additional 3s. 6d.

o o o o

"TWIN-CONE" TWENTY.

Linen diaphragms mounted back-to-back, with their apices touching, have been found to give surprisingly good reproduction, the suppleness of the material preventing well-defined diaphragm resonance. Best results are obtained when the two cones are of dissimilar size.

The constructional work involved necessitates access to a well-equipped workshop, but now this need not deter the home constructor, since Messrs. Green and Faulconbridge, Ltd., Coventry, have placed on the market a kit containing all the parts required for the construction of a double-cone linen diaphragm.

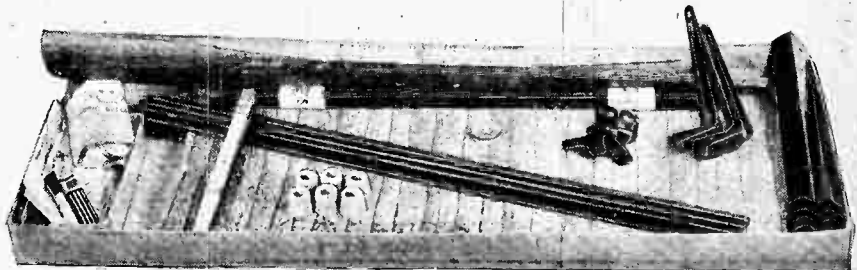

Complete set of parts contained in the kit of the linen diaphragm "Twin-Cone Twenty."

The kit consists of 17 packets and contains 149 parts. The main frame is assembled from iron bars, and the sides from stout cardboard finished to resemble grained wood. The finished article measures 20in. square and 8in. deep.

A cabinet is unnecessary, unless particularly desired, since the diaphragm material is not displeasing in appearance and the stout cardboard sides give the impression of a wooden case. Four rubber feet are included to prevent damage (and to absorb vibration) should the loud speaker be rested on a polished cabinet or table.

Provision has been made to enable most of the well-known cone movements to be used. However, the makers offer a special movement for building into the case: this is referred to as the "Twin-Cone" movement, and sells at 15s. The price of the kit is 21s.

A slight modification has been made in recent outfits. Lighter corner-pieces are now included as standard, and, as an alternative to the stout linen for the diaphragm, thinner material can be supplied. This renders the speaker more sensitive and is recommended when small power output valves are used.

o o o o

It has been brought to our notice that the price of the Pilot "Resistograd" reviewed in our issue of October 30th last should be 5s. and not 4s. 3d., as stated. The error on the descriptive leaflet was not notified in time to include the correct price.

o o o o

In our issue of October 30th last mention was made of the Calton Stewart H.F. choke under "Laboratory Tests." The address of the manufacturers should read 28, St. Enoch Square, Glasgow, and not as stated, the business having been transferred from Edinburgh some time ago.

o o o o

TRADE NOTE.

On November 18th, the Carrington Manufacturing Co., Ltd., opened their new showrooms and sales department at 24, Hatton Garden, London, E.C.1. The showrooms are open from 9.30 a.m. to 5.45 p.m. daily, with the exception of Saturdays, when they close at 12.30 p.m. Small stocks are kept for emergency purposes only. Orders should be sent, as hitherto, to the main depot at Camco Works, Sanderstead Road, South Croydon.

THE PENTODE Under Working Conditions

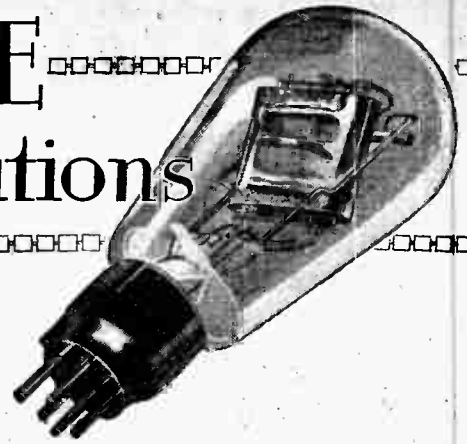

Calculating the Power Output of Triodes and Pentodes under Correct Load Conditions.

(Contributed by the Research Department of the General Electric Company.)

IN dealing with three-electrode valves from the point of view of the correct impedance to connect into the anode circuit to obtain the maximum output it is best to use curves in which ordinates are anode current and abscissæ anode volts with curves drawn for constant grid voltages; Fig. 1 shows such a set of curves for an LS5 valve.

Suppose a valve is connected up as in Fig. 2 to a resistance load with an inductance that has a much greater impedance and a condenser that has a much lower impedance than the load resistance.

Suppose now normally the H.T. voltage is 300 and the grid bias is -30. Then with no alternating voltage

THE intelligent operation of a loud speaker is dependent upon an understanding of the properties of the output valve. Thought must be given to the correct conditions of load necessary to obtain the maximum undistorted output. Attention is drawn in this article to the excessive voltages developed when using a pentode incorrectly.

on the grid the anode current will be 22.5 mA. and the point P on Fig. 3 will represent conditions in the valve as to anode current, anode volts and grid volts (assuming negligible D.C. voltage drop in the choke).

If now an A.C. voltage is applied to the grid, there will be an A.C. component of the anode current—if the anode current increases by δI amps the current through R will be δI amps; the voltage across R will be $R\delta I$, and hence the anode voltage will drop by an amount $R\delta I$. Thus, if on Fig. 3, a straight line is drawn through P such that its slope in

$$\frac{\text{volts change}}{\text{current change (amps)}} = R$$

then whatever voltage is applied to the grid the corresponding anode volts-anode current state will be determined by a point lying on this line.

In Fig. 3 XPY is the line through P corresponding to $R = 10,000$ ohms; this figure is checked, for by considering the points where the line cuts the axes it is seen that an increase of 520 volts causes a decrease of 52 mA.; hence the corresponding resistance is:

$$\frac{520}{0.052} = 10,000 \text{ ohms.}$$

Having our 10,000-ohm line through P we can now study what happens when the grid voltage is varied; when the grid has been swung from 10 volts+ from its normal biased condition of -30 volts its voltage will be -20 and the anode

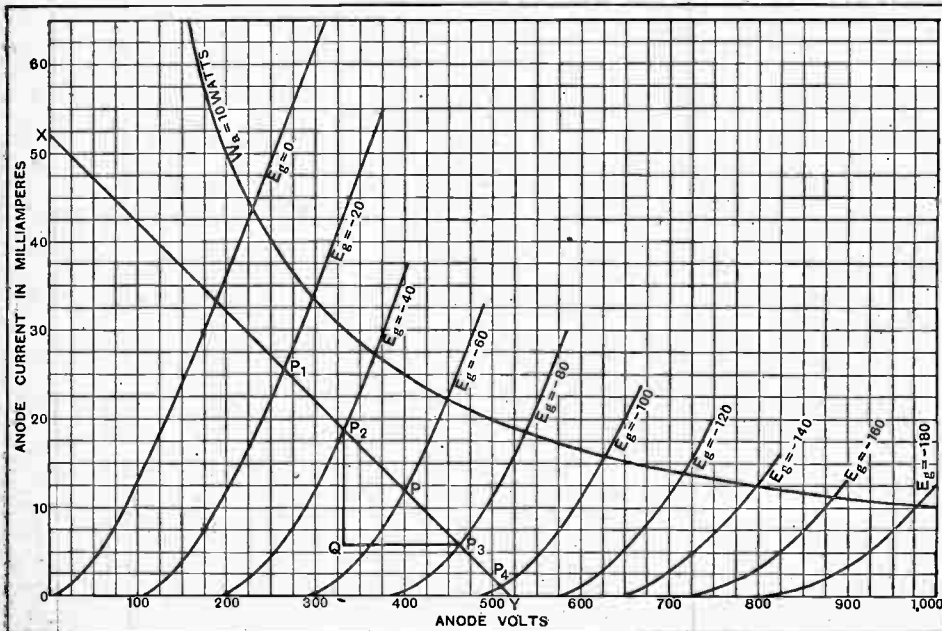

Fig. 1.—Anode current-anode voltage curves for an LS5 valve. The power output triangle P₂ Q P₃ represents only a fraction of the permissible output.

The Pentode Under Working Conditions.—

current and volts will be given by the point where the line XY cuts the -20 volts grid line, i.e., the point marked P₂.

Similarly, when the grid voltage has been increased by 30 volts, the grid voltage will be zero and the point P₁ where XY cuts the E_g=0 line will give the corresponding anode current and voltage.

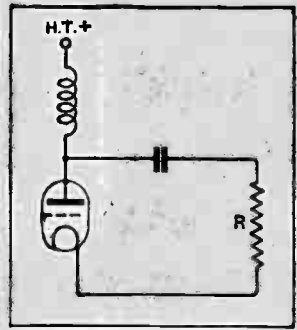

Fig. 2.—Circuit with load R connected to valve output. The inductance has an impedance greater than the load and the condenser impedance is less than the load.

Here we come up to a limitation, for if we swing the grid more positive still we shall have grid current which will cause distortion of the input voltage. Thus the useful portion of the line XY extends upwards from P to P₁; as the voltage applied to the grid will be symmetrical we shall require to swing the grid negative by an equal amount; since we are to swing upward from -30

to 0 we shall have to swing from -30 to -60 volts on the grid arriving at the point P₄. Thus with 30 volts bias we can swing the grid from 0 to -60 and our anode current and volts will follow the line P₁P₄. The total change in anode current will be the difference of the currents corresponding to the points P₁ and P₄ and will be 33-12=21 milliamps. This will be twice the peak value of the A.C. component of the anode current so that the R.M.S. A.C. current through

R will be $\frac{21}{2\sqrt{2}} = 7.5$ mA.

approximately. Similarly, the total voltage swing across R is the difference of the voltages corresponding to P₁ and P₄ and is 405-180=225, and here again to get the R.M.S. value we must divide by $2\sqrt{2}$; hence the

R.M.S. voltage is $\frac{225}{2\sqrt{2}} = 80$

volts approximately. Thus the power delivered to R is

$\frac{80 \times 7.5}{1000}$ watts = 0.6 watt.

We may note that if we draw a right-angled triangle P₁QP₄ the watts are proportional to the area of this triangle, and are in fact equal to one quarter of its area in volt amps. In the present case we note that each volt change on the grid as we pass from P₁ to P₄ along the line P₁P₄ produces equal changes in anode

current and voltage, thus the current through R is practically a distortionless replica of the grid volts. This may not be always so, for suppose as in Fig. 1 we had set the anode voltage at 400, the grid bias at -60 and as before take R=10,000 ohms. Then if we proceed as before we might say that we could swing upward from -60 to 0, but it is necessary now to consider the other half of the swing from -60 downwards.

It is seen at once that soon after the grid has swung more than an additional 40 negative volts to point P₄ difficulties arise in that there ceases to be any anode current at all, and further that during the part of the swing -80 to -100 between the points P₃ and P₄ the change in anode current per unit change in grid volts is less than throughout the portion P₁ to P₃ of the curve since the length P₃P₄ is less than P₁P₂, P₂P or PP₃. This will cause distortion and we can say with this setting that we should not swing past P₃. This limits us in the other direction and thus P₂ to P₃ is the extent of the distortionless part of the XY line that we may use.

In practice neither the settings given in Figs. 1 or 3 would be used, but we should by trial and error obtain a line so that the mean bias point P comes in the centre of the usable portion of the line XY, that is the part between the line E_g=0 and the point where distortion occurs due to the curvature of the lower parts of the characteristics.

For example, with a resistance of 10,000 ohms we

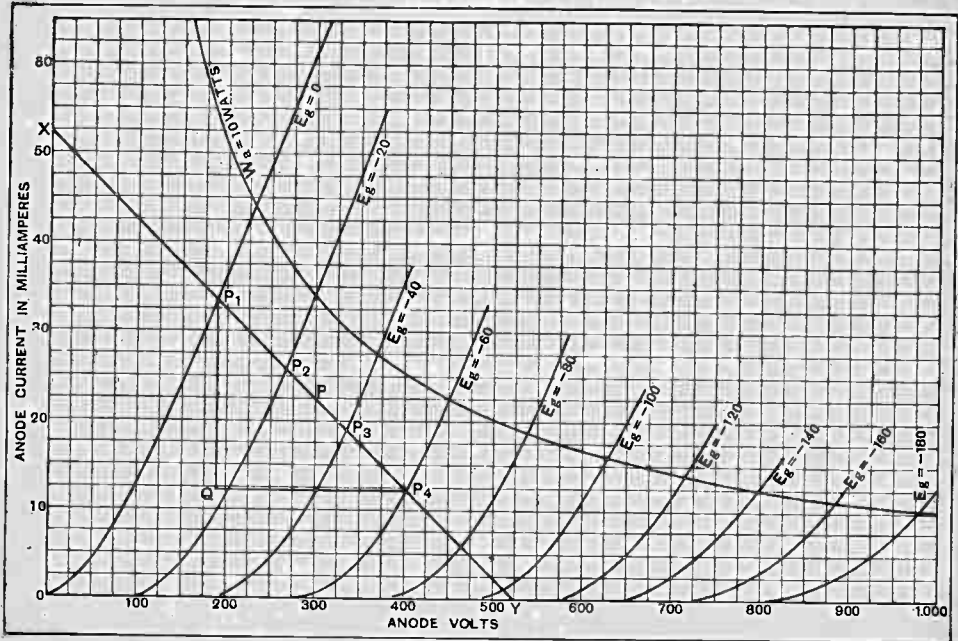

Fig. 3.—Operating conditions for an LS5 valve with 300 volts H.T. and 30 volts bias. Note that the 10 watt dissipation curve is not cut.

merely have to draw a number of lines on Fig. 3 parallel to the line XY and pick out the most suitable; this can be done for a number of values of resistance and the maximum watts on each case tabulated; we can then pick out the optimum conditions. When, as is the case with small valves, there is a limitation on the anode

The Pentode Under Working Conditions.—

volts usually the optimum resistance is about twice the internal resistance of the valve. With larger power valves and power modulators where there is a limitation on the standing anode watts loss, the optimum resistance may be much more than twice the valve resistance.

Pentodes.

Pentodes, which we shall now examine, however, give quite different results, for we shall find that the optimum load resistance is much less than the internal resistance of the valve.

Curves of a pentode are shown in Fig. 4 and we can proceed in an exactly similar way to determine the optimum condition.

In Fig. 4 the line XY is the line corresponding to a 60,000-ohm load with 150 volts on anode and screen and -9 volts grid bias.

Suppose we swing the grid voltage from -6 to -12, i.e., 3 volts on either side of the bias, then we note that the lengths intercepted on XY on either side of P are very unequal in swing up to -6 on the grid; the anode volt swings down from 150 to 42, a difference of 108 volts, but in swinging down to -12 volts the anode swings up to the point where the e = -12 volt line cuts the XY line; this is off the diagram, but is about 450 volts, so that the increase in anode volts is 450 - 150 = 300, nearly three times these

corresponding decreases when the grid swings to -6. Since the anode current changes are proportional to the anode voltage changes there is corresponding anode current distortion. A further examination shows that

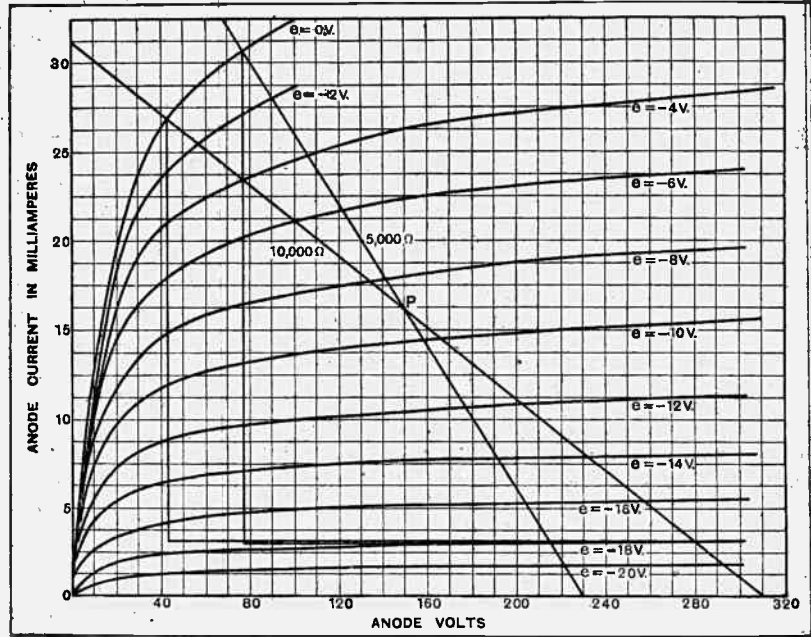

Fig. 5.—Pentode power output triangles for 5,000 and 10,000-ohm loads.

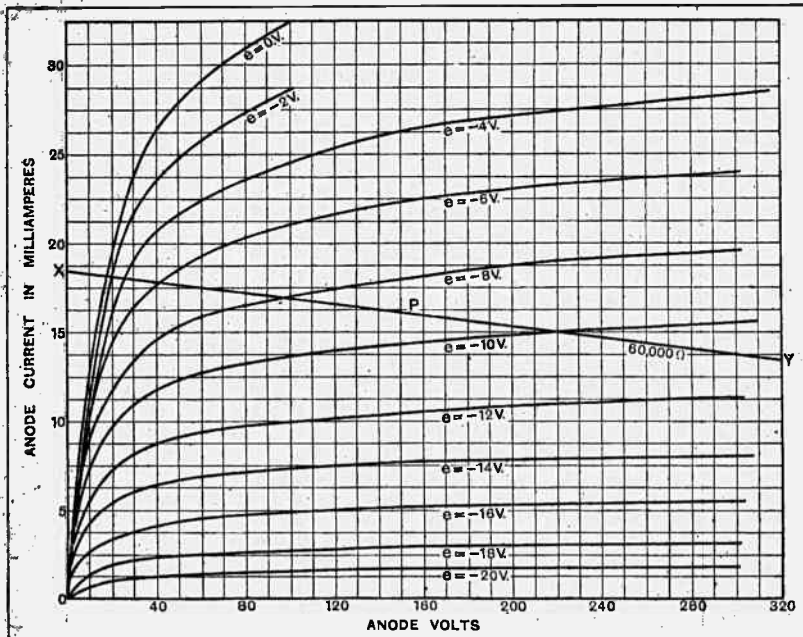

Fig. 4.—If a high resistance load is connected in the anode circuit of a pentode as shown at XY, dangerously high voltages are developed. The line XY would meet the -18 grid voltage line at about 1,100 volts H.T.

with this loading we ought not to swing the grid more than about 1½ volts above and below -9 volts if we are to avoid serious distortion. If we were to swing the grid from 0 to -18, then the maximum anode voltage would be the point where the $E_g = -18$ line cuts XY. This is well off the diagram and would be somewhere about 1,100 volts, entailing, of course, great distortion, besides being very dangerous. These high peak voltages can be readily observed by using a peak voltmeter.¹ Let us now draw a 10,000-ohm line as in Fig. 5 with the same initial conditions; we now see that we can swing from 0 to -18 without any very excessive distortion. It is true that the equal changes in grid volts do not cause equal changes in anode current and volts, but the variations are not excessive. Again in Fig. 5 the 5,000-ohm line is drawn, and here again we can swing from 0 to -18 without any very serious distortion.

The triangles giving the full power are drawn and for 10,000 and 5,000 ohms they are about for equal areas. If we decrease the load resistance below 5,000 ohms the area of the triangle and consequently the available output decreases. On the other hand, if we increase the

¹ Cf. Sims, *The Wireless World*, Jan. 10, 1929.

The Pentode Under Working Conditions.—

load much above 10,000 ohms we have to restrict the grid swing, and again the output goes down. Hence for such a pentode the optimum load is roughly between 5,000 and 10,000 ohms.

We have dealt only with resistance loads, whereas in practice the loud speakers are inductive. The treatment of the inductive load is considerably more complicated, but all that has been said about distortion applies equally well. Many loud speakers of the cone or horn type have impedances of 20,000 to 30,000 ohms or more at frequencies of 5,000 cycles, and if used directly with pentodes will give voltage peaks of 5 to 7 times the

H.T. battery voltage. These high peak voltages, apart from the unpleasant distortion, are more than the valve or loud speaker can reasonably be expected to withstand.

A suitable transformer in which the winding having the fewer turns connected to the valve and the winding with the larger number of turns to the loud speaker may be of service.

A transformer connected the other way round will, with most loud speakers, of course, give more "noise" for a very small input voltage; but if the signal is increased unpleasant distortion and dangerous over-voltages will occur.

CORRESPONDENCE.

The Editor does not hold himself responsible for the opinions of his correspondents.

Correspondence should be addressed to the Editor, "The Wireless World," Dorset House, Tudor Street, E.C.4, and must be accompanied by the writer's name and address.

B.B.C. TRANSMISSIONS.

Sir,—One of the most sensible and well-reasoned letters ever published in *The Wireless World* was that by Mr. McCormack on October 23rd last regarding B.B.C. transmissions. Any intelligent listener with a wireless set having a performance curve above the level of the first gramophone would agree with him when he says that the only "first-rate" transmissions are the direct or "local" ones, and that the majority of listeners (outside the London area, at any rate) receive as a rule third to tenth-rate transmissions.

It, therefore, causes me agony of soul to read the letter in your issue of November 13th by "Fair Play," of York, Yorks.

Mr. Fair Play's argument is: "Who are you, Sir, to criticise the B.B.C. unless you can first prove that your set and loud speaker are perfect? How dare a mere cutter, bobber, or shingler of side-bands talk of decent reproduction? Who are we—with our trivial bits of amateur apparatus—to stand up in the market place and deride the omnipotent B.B.C.?"

Now this is very quaint. My taste, hearing, sight, and sense of smell and touch are not what they used to be. I have lived, and smoked, and sat up late, and done many things which I should not have done; consequently, my senses are by no means perfect. We all suffer in this way when we have passed the age of callow youth. And yet . . . do I not know a good, succulent, well-done chop when I bite it? Do I not appreciate a well-sung song when I hear it? Do I not love the original water-colour better than the cheap reproduction? Do I not prefer the odour of real lavender water to the synthetic variety which comes from the penny-in-the-slot machine? Do I not respond to the feel of high-class woollies on a cold day? I do. I and my five senses may not be immaculate, but I flatter myself that I can separate the good from the indifferent and bad.

And so it is with my wireless set. It does not boast perfection. It is a thing, no doubt, of weird curves rather than splendid, manly, straight lines. It cuts off side-bands as ruthlessly as I cut off my own side-whiskers every morning of my life. But—in spite of all its terrible, almost-human imperfections—it can always tell me when a long land-line transmission is torturing a work of art. The Manchester Hallé Concerts, as disgorged by 2LO, cut me to the quick far, far more deeply than my set cuts the side-bands. The Bournemouth Orchestra (as relayed from the glass-and-iron concert hall in that delectable spot) makes me sigh for the melody of the first phonograph and the very, very first Edison-Bell record. And when 2LO gives me a poisonous dose of some remote spot like Plymouth, Cardiff, or Pwll-something-or-other, I feel so despondent that, but for my belief in silver linings, I should drink the acid in the accumulators and waft myself to the place where the music *would* be worth while.

An interesting but very harassing experiment which I sometimes try is to gather together the children (whose appreciation of good reproduction is by no means perfect), give them a few

minutes with the 2LO uncles and aunts, and then switch over to the Birmingham-via-5GB Children's Hour. They invariably ask me why the second lot of aunts talk with plums in their mouths. I reply, sadly, that this is due to "attenuation of the higher frequencies in the land-line" and *not* to side-band amputation. They are good children. They believe me—because they know from experience that Daddy always speaks the truth. Which he does!

It is a poor set which will not show the lack of brilliance, or the harshness, or the undercurrent of extraneous noise, or the surfeit of plums in female mouths, when a long land-line transmission is in full blast. (Eastbourne, for some peculiar reason, excepted!) And it is a very poor set which cannot make manifest the difference between a good transmission and an indifferent one.

Therefore, I say that Mr. McCormack's letter is sound commonsense, and Mr. Fair Play, of York, Yorks, is talking arrant nonsense. Let us not creep too humbly upon the earth's surface, or we shall get from the self-satisfied B.B.C. precisely what we shall deserve—third to tenth-rate junk.

Twickenham.

BERTRAM MUNN.

Sir,—Surely it speaks well for your broadminded attitude to your readers' views that you should print the letter from "Fair Play." What Mr. McCormack said was perfectly correct and not a bit exaggerated. If "Fair Play's" receiver is not capable of distinguishing between the first-rate transmissions from 5GP and 2LO, especially when the programs are from a local source, and the terrible noises that are sent out when a relay from most of the more-distant stations is attempted, either it is very poor indeed or his hearing is at fault. Of course there is some side-band attenuation at the receiving end in most cases, but nothing to compare with the horrible attenuation of even the medium high-frequencies that most land-lines give.

Until the advent of 5GB and the new 2LO, listeners in the Midlands were in the position of having receivers considerably in advance of the transmitters—or some of us had. Perhaps "Fair Play" has never heard a good receiver working on a good transmission?

If a gale puts the normal land-lines to Daventry out of commission we are given speech of a quality which, apparently, satisfies "Fair Play," but which we think horrible.

Birmingham.

F. G. SACKETT.

Sir,—The impression which the B.B.C. seems to wish to convey about the quality of their transmissions is that they are well-nigh perfect. One is driven to this conclusion: (1) By positive statements to that effect which appear from time to time; (2) by the fact that whilst their official organ contains pages of criticisms, often of a futile kind, about the subject-matter of their

programs, criticisms of the *quality* of their transmissions are absent; and (3) by the fact that when anybody is rash enough to comment on the transmissions in your valued journal, or elsewhere, somebody else immediately pops up and tells the critic that he should "look to his set."

That our receiving sets are imperfect, more or less, everybody who has the most elementary knowledge of wireless will be ready to admit. That is not, I would submit, really the point at all. The real point is this: When we hear horrid sounds proceeding from our L.S., are we bound to assume that the fault is always at our end? My submission is that most certainly we are not, if only for the reason that, though faults at the transmitting end are commonly discounted, nevertheless, in recent times, rather grudging admissions have appeared which urge difficulties associated with land-lines and "transients."

These admissions raise a number of questions, as, for example: What steps are being taken to get over the land-line trouble? What progress, if any, is being made in dealing with transients? And, thirdly, are land-line troubles and transients the only causes of the horrid sounds? As regards the third of these questions, let us take one or two examples:—

(1) The first few bars of a choral item are emitted by my L.S. They suggest that the singers have been dining on coarse fish and that some of the bones have stuck in their throats. Then there is a kind of rumpling sound from the L.S., and 90 per cent. of the fish-bones seem to have been swallowed. Was this rumpling sound due to the swallowing of the fish-bones or the swallowing of transients, or was it, perchance, due to a switch?

(2) A piano recital from the studio begins in such a way as to suggest that the pianist has, with his opening chords, broken 80 per cent. of the strings of the piano. Suddenly the volume is lowered by 300 per cent. and only about 10 per cent. of the strings appear to have been damaged. What is it that has brought about this curious change?

(3) I listen to a piano item from Queen's Hall. It is a remarkably good reproduction of "the real thing." The concert ends, the voice of a giant tells me what the weather has been like to-day. I tone down the giant with my volume control. In due course he finishes and is followed by the usual piano item. I observe that, though I am receiving this piano item at only about one-eighth of the volume of the item from Queen's Hall, nevertheless the studio item produces the broken string effect, whereas the Queen's Hall item did not—or only very slightly. How exactly is this explained in terms of land-lines and transients?

(4) The announcer states that Thir Thamel Thmith ith about to give one of hith thatinating dithcourtheth. Is the announcer speaking across a land-line from his bedroom, as depicted by Mr. Hammond, p. 334 of the B.B.C. Year Book? Or is it that my set is incapable of dealing with such high frequencies as the ss and ff? Well, I am forced to the conclusion that Mr. Hammond's picture of the announcer is not quite so innocent a joke as might appear at first sight. For when Sir Samuel begins, not only do the ss and fs appear clearly but the ss actually whistle!

Now, sir, criticism is of little use if not constructive. So here are some suggestions: (1) That you continue the good work of publishing letters commenting on the quality of the B.B.C. transmission. (2) That you let us have an article or series of articles showing the *kind* of faults which we may reasonably attribute to faulty transmission and not to our sets. (3) That if the B.B.C. are unwilling to undertake the work themselves and tell us about it, some other public body, equipped with all the necessary and expensive instruments—perhaps the National Physical Laboratory—should carry out periodical and exact tests of transmissions under varying conditions and publish the results. (4) That we amateurs should, somehow or other, get together and evolve a scheme whereby we can compare notes about the transmissions and so help each other to decide whether the faults we notice are to be attributed to our end or to the transmitting end. This last suggestion may be difficult to carry out, but surely it is not impossible. Perhaps some of your readers may be able to make helpful suggestions about it? E. C. RICHARDSON.

Sir,—Such touching faith as that expressed by "Fair Play" in his letter published in your issue of November 13th is, in these days, most refreshing.

Most of your readers will, however, not be prepared to accept

"Fair Play" as a competent judge, for he does not appear to be situated in such a position as to be able to take advantage of wireless reception under ideal conditions.

Situated as I am, less than two miles from 2ZY, I can, and do, use "high loss" coils which effectively prevent loss of sidebands, together with an amplifier which follows B.B.C. practice closely and which is admitted to amplify fairly evenly all frequencies between 25 cycles and 6,000-7,000 cycles, and I unhesitatingly endorse Mr. McCormack's comments on land-line transmissions.

One has only to hear a transmission from 2ZY of the Northern Wireless Orchestra (playing in the new studio) and to compare it with any land-line transmission from 2LO (of an orchestra, of course) to realise the enormous difference. In the case of the land-line transmission (whether from the London studio or from the Queen's Hall) the bass lacks "body," the drums are extremely poor, and violins are thin and lack the characteristic timbre of a violin.

But, apart from the technical aspect of the matter, why should London listeners benefit at the expense of that great body of provincial listeners, in numbers many times greater than listeners to 2LO?

Why should not the National Orchestra or B.B.C. Symphony Orchestra be formed in Manchester, where the finest body of orchestral musicians in this country resides and where, in addition, there is the finest broadcast studio in Europe?

Manchester.

JAS. HUDSON.

CONCERTS FROM RADIO PARIS.

Sir,—It will no doubt be of interest to your readers to know that we have arranged for a series of weekly recitals to be given each Sunday, broadcast from Radio Paris.

These recitals will last an hour and will consist of varied popular music, the concert for Sunday, Dec. 1st, for instance, was dance music played on Decca records by leading Decca dance bands from 2 to 3 p.m.

We believe that we are the first gramophone company to book an exclusive hour for the entertainment of listeners.

THE DECCA RECORD CO., Ltd.

London, S.W.9.

NON-RADIATING SETS.

Sir,—I would like to express my sympathy with Mr. Henry W. Moss.

I have had the same trouble for the last eighteen months and on all wavelengths covered by the "Everyman Four."

It is very seldom I can listen to a programme without interference of one kind or another, either "howling" or "silent-point" oscillation. (I reported the matter to the B.B.C. in June or July, 1928, and the G.P.O. has been dealing with it for over twelve months and can give me no hopes whatever.)

I also know of a road less than a mile from here where one listener switches off and another says he will give up wireless owing to interference.

I certainly think reaction ought to be prohibited, because I feel sure all this trouble is caused by people "playing" with their sets, and the quality of transmissions must be improved if the ether could be cleared of these "heterodyne howls."

London, S.W.8.

A. W. SNARE.

Sir,—Mr. Moss, in your issue of November 6th, proposed that legislation should be introduced prohibiting the use of reaction. I assume, of course, that he meant this to apply only to sets intended for reception on broadcasting wavelengths, since it would render amateur communication on short waves more difficult.

Although anyone who lives in a crowded district will heartily agree to it, this idea is too Utopian to be useful. If, as in France, the larger percentage of sets were commercially built, the legislation could be enforced by limiting manufacturers to circuits without reaction. But in England I think home constructors predominate. It would need an enormous (and incidentally expensive) army of men to go to every house having an aerial and examine the set.

There is another consideration. A man who is an inveterate

fiddler will, if he has no reaction control with which to play, adjust some other part of the receiver. The final result of his unskilled efforts will be further oscillation, and the situation will then be as bad as before.

"R.N."

Sir,—I read the letter from Henry W. Moss in your issue of November 6th with great sympathy.

My own set has a neutralised H.F. amplifier, and I am quite satisfied causes no interference. I would, however, willingly conform to such legislation as he suggests, and make the necessary alterations to my set, if such legislation would relieve me of the intolerable interference caused by the howls of my neighbours.

I recently sent a complaint to the B.B.C., and a P.O. official has visited the neighbourhood. Conditions were better for a few days, but are again becoming as bad as before.

Grimsbury. "FELLOW SUFFERER."

EMPIRE BROADCASTING.

Sir,—One has always understood that the purpose of the Empire Marketing Board was to stimulate the sale of Empire products, not to provide entertainment for Empire listeners.

May one make another suggestion—that Empire broadcasting be regarded as a matter for the Imperial Government, that the B.B.C. do the actual transmission, and that the money be provided by the Post Office; they keep plenty of it!

G. M. PART.

The following extract from a letter from a reader in Singapore was received by Mr. Gerald Marcuse, President of the Radio Society of Great Britain, and is published as of general interest.

Though I am not personally known to you, you are well known to me through your transmissions in the past, when I had a two-valve set. Now I am armed with a McMichael six-valve short-wave superhet, and I was extremely gratified this morning when I read your letter in *The Wireless World* of the 11.9.29 just to hand, promising us your excellent transmissions in the near future again.

Having no broadcast stations in this country, I went to the expense of getting the present set purely in the hope of getting 5SW in a satisfactory state, but all to no purpose. Twenty-five metres is in the midst of a nest of Morse stations, and its 15 kW. are simply swamped out. I and my family are sending you our grateful thanks for the trouble you, as an amateur, are

going to take for the benefit of us amateurs in the outposts of the Empire, devoid of all help. For my part, at least, I have been continually writing to the local papers in the hope that our lamentations may some day reach the local or home authorities. Will it not be possible for you to get someone in Parliament to put the question at one of the meetings as to this Empire Broadcast? The Dutch in North Indies and the Americans in the Philippines are gaining ground, and the British wireless trade is suffering. The other day I went to buy a potentiometer of 400 ohms. I had to come home with a German-made potentiometer of 600 ohms and fix it in my set! And this was the only kind obtainable at any price.

I have again written to the local Press to-day and mentioned also your promise. I shall send a cutting in a couple of days.

Kindly give us some notice before you start and state wavelength. I rather prefer you to stick to about 20, as there is too much atmospheric interference at 40. Of course, you are the best judge.

SUPERHETS.

Sir,—Your correspondent's article on the Paris Radio Show was very interesting. He gives three reasons why the superhet. is as universal over there as straight sets are here. Can anyone give me three reasons for the apparent unpopularity here?

SUPER HET.

TELEVISION.

Sir,—In reply to the last paragraph of your editorial of the 20th inst., I would say that the Television Society is alive to the desirability of a comprehensive survey being made with the object of establishing the reasons for the present situation, and, further, of clarifying the future prospects of television broadcasting. The Society feels, however, that very little can be done in this respect without the whole-hearted co-operation of the trade and commercial interests concerned, who should be prepared to meet in a round-table conference together with representatives of the B.B.C. and representatives of this Society. The Society would, I think, welcome such a conference as being in the very best interests of that branch of applied science for which we all share an interest.

I can say at once that the number of members of the Society who systematically receive the television broadcasts as at present arranged is very limited, and there are probably not more than ten of our members who do so.

The Television Society,
London, W.C.2.

W. G. W. MITCHELL,
Joint Hon. Secretary.

Hobbies, Ltd., Dereham, Norfolk.—Autumn edition of Fretworkers' Weekly Journal (October 5th, 1929), containing a design for a Pedestal Wireless Cabinet.

o o o o

Higgs Motors, Witton, Birmingham.—Stock list of 1-, 2- and 3-phase induction motors for 50-cycle supplies; also D.C. dynamos and motors. There is a wide range of small machines of less than one h.p.

o o o o

Mullard Wireless Service Co., Ltd., "Mullard House," Charing Cross Road, London, W.C.2.—Descriptive leaflets of P.M. Filament Transformer and P.M. H.T. Supply Unit for A.C. mains.

o o o o

The D.P. Battery Co., Ltd., Bakewell, Derbyshire.—Illustrated folder of D.P. Kathanode large capacity L.T. accumulators.

o o o o

The Varley Co., Kingsway House, 103, Kingsway, London, W.C.2.—Loose-leaf illustrated catalogue of Varley main sets and wireless components; also 15-page instructional book on the use and application of this firm's products.

CATALOGUES RECEIVED.

Messrs. C. A. Vandervell and Co., Ltd., Acton, London, W.3.—Illustrated catalogue of C.A.V. high- and low-tension accumulators for wireless uses; also folder dealing with non-spillable cells for portable sets.

o o o o

Messrs. Wingrove and Rogers, Ltd., Arundel Chambers, 188-9, Strand, London, W.C.2.—Illustrated leaflet of "Polar" differential reaction condenser.

o o o o

Messrs. J. H. Taylor and Co., Macaulay Street, Huddersfield.—Illustrated price list of proprietary wireless components stocked by this firm.

o o o o

Burne-Jones and Co., Ltd., Magnum House, 296, Borough High Street, London, S.E.1.—Descriptive folder of the "Magnum" short-wave converter. This is used in conjunction with the L.F. portion of the broadcast set, and includes short-wave detector and reaction circuit.

Marconi Wireless Telegraph Co., Ltd., Marconi House, Strand, W.C.2. Leaflets Nos. 1082/2, 1101, 1097 and 1103, illustrating and describing their 100-watt and 500-watt fixed wavelength telephone sets XMB1a and XMC2; the 500-watt telegraph transmitter types MCCa and MC8b, and the 1.5 kW. telegraph transmitter MC13.

o o o o

A. J. Dew and Co., 32-34, Rathbone Place, Oxford Street, London, W.1.—General wireless catalogue of proprietary receivers, components and accessories stocked for the season 1929-1930.

o o o o

Oldham and Sons, Ltd., Denton, Manchester.—32-page handbook entitled "Radio Power Problems," dealing with "Oldham" H.T. and L.T. accumulators and trickle chargers.

o o o o

L. McMichael, Ltd., Wexham Road, Slough, Bucks.—Illustrated and descriptive folders dealing with the "Super-Screened Portable Four," "Screened Dimic Three," and mains-operated receivers. Also full constructional details for the "Home Constructors' Screened Three" receiver.

BROADCAST BREVITIES



By Our Special Correspondent.

Progress at Portland Place.—Broadcasting in Parliament.—Christmas Programmes.

Broadcasting House.

The Portland Place site is now ready for the massive building designed by Col. Val Myer to house the B.B.C. headquarters. Tenders have now been invited for the constructional work and should be in the hands of the owning syndicate within the next week.

Building operations will occupy more than a year, and it is doubtful whether the opening ceremony can take place much before April or May, 1931.

○○○○

P.M.G. and Brookmans Park.

Seldom does the House of Commons spend so much time on wireless matters as it did on Tuesday of last week—Westminster's wireless day. Besides dubbing himself "the policeman of the ether," the Postmaster-General (Mr. Lees-Smith) had several interesting things to say regarding the activities of the B.B.C., and he made a new disclosure concerning future policy at Brookmans Park. The twin transmitter, which begins tests in a few weeks' time, will commence on low power, gradually increasing its output as the public habituate themselves to the new development. I understand that the first tests will probably not employ more than 5 kW.

○○○○

A Ticklish Question.

If the Postmaster-General's proviso is to be strictly observed, I imagine that the power increase of the twin transmitter will be exceedingly slow. Who is to say when the public have habituated themselves to a broadcasting system which calls for uncommonly selective sets and the virtual abolition of the crystal?

○○○○

B.B.C. to Borrow Money.

Another disclosure, which was not unexpected by those who have studied the B.B.C.'s present financial position, was contained in the Postmaster-General's remarks concerning the development of the regional scheme. Up to the present the Corporation has financed its stations from its reserves, but it is now anticipated that as the scheme develops it may be necessary for the B.B.C. to utilise its power to raise a loan.

The only alternative is to let the scheme hang fire until sufficient funds have accumulated from licence revenue, by which time the B.B.C. might have learnt too much about twin wave transmission!

Savoy Hill and the Pirates.

With a scarcity of funds looming ahead it is not surprising that Savoy Hill regards the "pirate" question with pathetic interest. Questions in the House evoked the P.M.G.'s statement that licence evasions were being gradually reduced, but Savoy Hill remains sad-eyed, the opinion there being that after seven years of broadcasting there should now be 4,000,000 set owners. Licencees number barely 3,000,000.

○○○○

Modulation of B.B.C. Transmitters.

A correspondent in last week's issue of *The Wireless World* pleaded for an equal degree of modulation from all B.B.C. transmitters. An official at Savoy Hill solemnly informs me that uniformity in this direction is always sought by the B.B.C. engineers, and that the degree of modulation never exceeds the boundaries of 2 and 30 per cent.

○○○○

A Disappearing Landmark.

The first and second 2LOs are both being dismantled. The Marconi House

plant is already in the last stages of dissolution and will not be long survived by the installation in Oxford Street, which will also lose its masts by the end of this month.

Thus Brookmans Park will have no standby.

○○○○

A Broadcast Christmas.

Seven Christmas seasons have been enriched with broadcasting, and now that we are approaching the eighth it needs an effort of memory to recall those prehistoric festivals when we had to make our own music or listen to the waits.

The Christmas element in the transmissions will begin on December 23rd with the broadcasting of the Nativity Play from St. Hilary's Church, Marazion, Cornwall. Two carol programmes will be given on Christmas Eve, while on Christmas morning 2LO and nearly all stations will broadcast the service from York Minster. Miscellaneous Christmas fare will make up the rest of the day's programme. In the afternoon Bransby Williams will give his well-known impression of Scrooge.

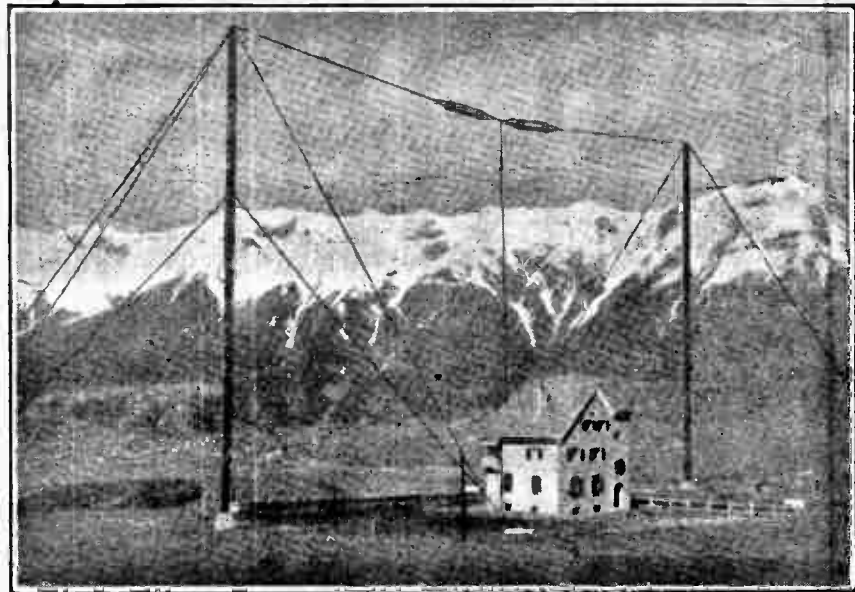

BROADCASTING IN THE AUSTRIAN TYROL.—The relay station at Innsbruck which distributes the Vienna programmes to mountain dwellers. The station is without a regular wavelength but is working provisionally on 287.4 metres.

READERS'

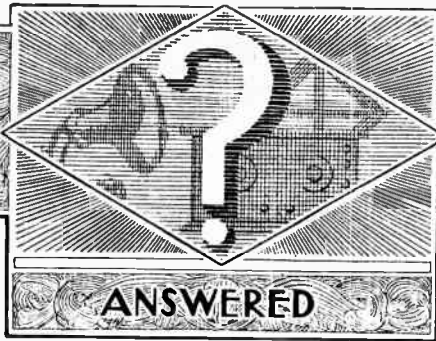

PROBLEMS

The Service is subject to the rules of the Department, which are printed below; these must be strictly enforced in the interest of readers themselves.

A selection of queries of general interest is dealt with below, in some cases at greater length than would be possible in a letter.

"The Wireless World" Supplies a Free Service of Technical Information.

Designing Tuning Coils.

Have you ever published information for designing inductance coils to specific H.F. resistance values? Inspired by a recent article, I am thinking of trying filter circuits: hence my question. E. B.

Simple graphs for the design of coils of different H.F. resistances were given in our issue of January 11th, 1928. The range dealt with should be sufficient for your purpose.

"Push-Button Regional Receiver."

With reference to your reply to "T. F. S." under the above heading in your issue of November 13th, I should like to know if it is possible to simplify the arrangement shown by using a tapping on each of the coils, instead of an extra semi-variable condenser for each tuned circuit.

T. C. W.

It might be possible to obtain satisfactory results from a simple arrangement of this kind, but it would be found that the operation of tuning by varying a tapping point on an inductance coil would be a very inconvenient procedure; indeed, it would be almost impossible in a set which, by the very nature of the work it is intended for, must have reasonably selective circuits.

Provision for continuous adjustment of inductance over a limited range can be made by winding a few turns of the coil

on a rotatable former (variometer fashion), but this would be no simpler and probably no cheaper than a second semi-variable condenser.

"Pentode Two" Conversion.

My "Pentode Two" receiver gave entirely satisfactory results up to the time when Brookmans Park started operations; now I find that interference is so bad that it is a difficult matter to receive any station except 5GB and one or two other transmissions in the neighbourhood of 500 metres on the normal broadcast band. It is found that spreading of signals can be minimised by fitting a smaller series aerial condenser, but reduction to a value that is really effective renders the set extremely insensitive. Can you suggest a method of altering the receiver? I should not object to rebuilding it in a larger cabinet, but do not care to go to the expense of "scrapping" a number of existing parts, and perhaps adding an H.F. stage. R. F. B.

We suggest that you should rebuild your receiver to the general circuit arrangement of the "Two-Circuit-Two" receiver, described in our issue of February 6th.

The two sets are not widely dissimilar, and you will find that all your present parts can be used, and that little additional apparatus will be required.

Testing a Variable Condenser.

I have reason to suspect an intermittent short-circuit between the vanes of one of my variable condensers, and, in order to make a test, connected a flash-lamp battery and dry cell across the terminals. The lamp glowed at, apparently, full brilliancy, irrespective of the position of the moving plates. Does this suggest that there is a short-circuit across the frame of the condenser, as the glow was observed when the moving plates were obviously clear of the stator vanes? H. C. F.

It may be that there is, as you say, a complete short-circuit in the frame of the condenser, but this would entirely prevent the reception of signals, and we are more inclined to think that you have forgotten the fact that, in a normal receiver, the

variable condenser is bridged by a tuning coil with windings of low ohmic resistance, and, consequently, your test lamp will glow whether the plates are making contact with each other or not.

Before making a test of this sort the tuning coil should be disconnected.

The "Foreign Listeners' Four."

When an indirectly heated valve is used as a grid detector, with an applied H.T. voltage not exceeding some 60 or 70 volts, I understand that there is no need to provide any positive bias for its grid. It is proposed to take advantage of this in introducing a slight modification to the "Foreign Listeners' Four"; consequently the grid leak will be connected directly to the valve cathode. With this arrangement it would seem that a very simple addition should make the set suitable for gramophone reproduction; will you please give me a circuit diagram showing how the necessary additions may be made, bearing in mind that I wish to get "free" grid bias if possible. W. G. L.

Your proposed scheme is quite sound, and, indeed, there is a good deal in its favour. We suggest the simple method

RULES.

- (1.) Only one question (which must deal with a single specific point) can be answered. Letters must be concisely worded and headed "Information Department."
- (2.) Queries must be written on one side of the paper, and diagrams drawn on a separate sheet. A self-addressed stamped envelope must be enclosed for postal reply.
- (3.) Designs or circuit diagrams for complete receivers cannot be given; under present-day conditions justice cannot be done to questions of this kind in the course of a letter.
- (4.) Practical wiring plans cannot be supplied or considered.
- (5.) Designs for components such as L.F. chokes, power transformers, etc., cannot be supplied.
- (6.) Queries arising from the construction or operation of receivers must be confined to constructional sets described in "The Wireless World" or to standard manufacturers' receivers. Readers desiring information on matters beyond the scope of the Information Department are invited to submit suggestions regarding subjects to be treated in future articles or paragraphs.

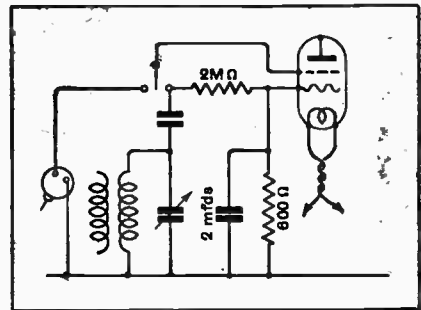

Fig. 1.—Connections of a gramophone pick-up in the detector grid circuit of the "Foreign Listeners' Four."

of connection shown in Fig. 1. This necessitates the addition of a biasing resistance in the cathode lead, and also of a grid circuit switch to make the appropriate changes for gramophone or radio reproduction; as usual, it is desirable that this switch should have very good insulation and low self-capacity.

Isolating the Aerial Circuit.

I am about to add a tuned aerial circuit to my receiver and to provide an H.T. feed from my D.C. mains (220 volts with positive earth). Some time ago it was stated in "The Wireless World" that the aerial circuit should, in these conditions, be isolated from the mains, and it has been suggested that a double-wound aerial transformer, with no metallic connection between primary and secondary, is of advantage: is it possible to bring about this isolation when using a two-circuit aerial tuner with capacity coupling? I have studied several circuit diagrams of this arrangement, but it seems to me that they all provide a direct path to earth for the mains.

C. R.

So far as isolation of the mains from the normal wireless "earth" is concerned, the capacity-coupled two-circuit aerial tuner does not confer any advan-

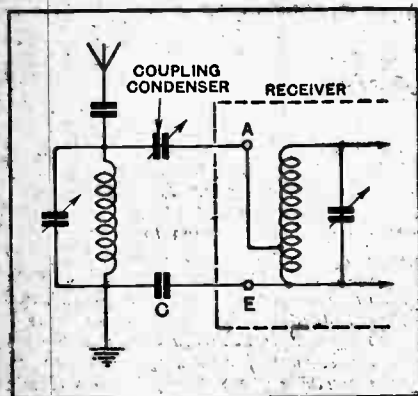

Fig. 2.—A safety precaution for D.C. mains users: a capacity-coupled tuned aerial circuit may be isolated from the supply leads by fitting an extra condenser.

tage over any other arrangement, and, if used in the ordinary way, it is necessary to fit the conventional "earth" condenser; to be on the safe side, a second condenser should be inserted in the aerial lead. The need for this can be entirely overcome by fitting a small mica condenser (of about 0.001 mfd.) between the earthed end of the aerial coil and the earth terminal of the set in the manner shown in Fig. 2, where the extra condenser is marked "C."

It may be added that this arrangement confers little benefit as compared with the more conventional method, but it does prevent the aerial coil and condenser from becoming "live"—a matter of some importance when these components are mounted outside the receiver cabinet.

○○○○

The Best Variable Condenser Capacity.

I am going to buy three high-grade variable condensers, with the idea of using them for experiments connected with H.F. amplification. What value of capacity do you consider to be the most generally useful? C. C. P.

It is rather difficult to dogmatise on this matter, but, on the whole, we think

you would be well advised to choose a value slightly over 0.0003 mfd.—say, 0.00035 mfd. This value is highly suitable for use in modern circuits, as it enables one to cover the normal broadcast waveband very satisfactorily, without depending too much on the lower end of the condenser scale.

By choosing condensers of 0.0005 mfd. you would be safe enough, as they would be suitable for use with coils of any reasonable inductance, but scale readings would be unnecessarily close together with the more popular arrangements.

○○○○

Mistaken Economy.

It is proposed to use a Mazda 2-volt S.G. valve in the H.F. position in my receiver, with 6-volt valves for detection and L.F. amplification. Instead of inserting a resistance in series with the filament of the H.F. valve, in order to absorb surplus voltage, would it not be more economical to feed it through an extra lead from the positive terminal of the first cell (counting from the negative end) of my 6-volt L.T. battery? S. M. E.

We are sure that it would be a mistake to adopt this plan, as the need for recharging your L.T. battery will be determined by the condition of the cell from which most energy is taken. In your case this will be the first one, from which, with your proposed method of connection, more current will be drawn than from the others. Unless special precautions are taken in recharging, individual cells are likely to be either over-charged or under-charged.

○○○○

A Simple Bias Rule.

Is it to be assumed that the correct value of negative grid bias of an amplifying valve is dependent upon impedance, and that an increase in impedance automatically implies a reduction in negative grid bias, all other conditions being unchanged? P. R. R.

Generally speaking, this is a safe rule to follow, both with regard to amplifying valves and anode bend detectors. It should not be applied too hastily when dealing with H.F. amplifiers, which are seldom required to accept any very considerable input voltage. It is usual to take advantage of the improved characteristics resulting from the application of the smallest bias necessary to prevent the flow of grid current.

○○○○

A Point of Difference.

There seems to me to be very little difference between filter circuits and loosely coupled separately tuned aerial circuits of the type with which we are all familiar. Possibly, however, there is some difference between the two that I have overlooked; will you please give me a few words of explanation? T. W. M.

Basically there is no real difference, but the term "filter circuit" is conveniently applied to an arrangement of two coupled circuits in which a deliberate attempt is made to avoid loss of high notes (or side-band cutting) by so arrang-

ing the coupling between them so that something approaching a "double-humped" resonance curve is produced.

○○○○

An Apparent Inconsistency.

After reading a recent article on the subject of H.F. transformer design, I was interested enough to compare the optimum ratios between primary and secondary windings given there with those used in recent receivers described in your journal. I was rather surprised to find that in hardly a single instance are the primaries of these sets as large as theoretical considerations would indicate that they might be; this would suggest that it is considered desirable to sacrifice a certain amount of amplification, but possibly there is some other explanation? C. S. G.

This is another case of compromise, and a good deal depends on the designer's views, although careful consideration will show you that there is something approaching unanimity on this question. The problem of selectivity is at the root of the matter; generally speaking, it is considered best to sacrifice a certain amount of amplification in order to improve the performance of the receiver with regard to the elimination of interference.

In some cases screening enters into the question, and, where complete isolation of the circuits cannot be easily and economically arranged, it is sometimes necessary to forgo amplification to attain complete stability.

FOREIGN BROADCAST GUIDE.**MOSCOW KOMINTERN
(Russia).**

Geographical position: 55°42' N. 37°39' E.
Approximate air line from London: 1,552 miles.

Wavelength: 1,481 m. Frequency: 202.5 kc. Power: 40 kW.

Time: Eastern European (2 hours in advance of G.M.T.).

Standard Daily Transmissions.

G.M.T. 4 a.m. and 5.15 a.m. physical exercises followed by gramophone records; 14.10 gramophone records; 16.15 music lesson; 18.00 main evening concert; 20.00 dance music (Sundays only); 21.55 relay of noises from the Red Square followed at 22.00 by time signal and midnight chimes (to the melody of the *Internationale*) relayed from the Spassky Tower, Kremlin.

Male announcer. Call: *Sloeschaitje! Sloeschaitje! sdie goworit Moskwa.*

Interval call: Radio Moskwa.

On most evenings after 22.00 G.M.T. news bulletins are broadcast; they are read slowly and repeated, in order to allow of transcription.

Under the heading "Foreign Broadcast Guide," we are arranging to publish a series of panels in this form, giving details regarding foreign broadcast transmissions.

THE NEW **BA2** **21**

**AN
AMPLION
PRODUCT**



A balanced armature movement of great sensitivity able to handle considerable volume and reproduce with high efficiency all audio frequencies. Adaptor plate to fit varied chassis types, and fitted with terminals for three alternative values of impedance. Gives splendid results in combination with any valve set, and can be used with pentode valve without special transformer.

**NO SPECIAL
TRANSFORMER
NEEDED WITH
PENTODE VALVE**

GRAHAM AMPLION LIMITED
25/26, Savile Row, Regent Street, W.1



A Pick-up of Distinction

The R.G.D. is something different.

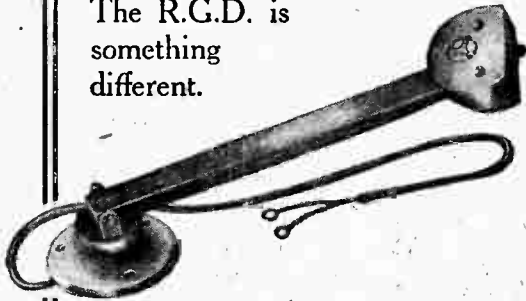

The R.G.D. Magnetic Pick-up is designed after years of experiments, and we believe it to be as perfect as possible. No record wear, perfect tracking, a scientific instrument, specially developed for moving coil speaker reproduction. Price £3 in bronze, £3-3-0 in oxidised silver.

Literature on application.

The Radio Gramophone Development Co.,
St. Peters Place, Birmingham.

Fit the DUBILIER BATTERY

Fitted with the long-life Dubilier Battery, your Set will give better quality performance over a longer period. 66 volts And it costs less! 7/9 Other Voltages Available.



Ask your dealer for a copy of the Dubilier Booklet—"A Bit about a Battery."

DUBILIER CONDENSER CO., LTD.,
SER. CO. (1925), LTD.,
Ducon Works, Victoria Road,
North Acton, London, W.3.

★—it is Cheaper than others—has longer life, and is British Made.

Clearer B22



11/6 down and they are yours to use and enjoy!

All LOEWE RADIO products amounting to an aggregate sum of not less than £5 can be obtained on attractive H.P. terms. Full details from your dealer.

You can now secure the wonderful new LOEWE RADIO Reaction Receiver together with the LOEWE RADIO Loud Speaker for a first payment of 11/6 only! Purchase completed in 9 monthly payments of 12/6. Ask your dealer for full particulars.

LOEWE RADIO

The LOEWE RADIO CO., LTD.,
4, Fountayne Road, Tottenham, N.15. 'Phone: Tottenham 3911/2.

BRITKAM SUPER QUALITY EBONITE IN SHEETS, RODS, AND TUBES.

PANELS cut to any size and thickness. Matt or polished surface. Guaranteed against surface leakage. Immediate delivery. Prices on application.

Trade enquiries invited.
BRITKAM-EBONITE (Britannia Rubber & Kamptulicon Co. Ltd.)
7, Newgate Street, London, E.C.1.



USE THE



"MAJOR" CABINET for your RADIO-GRAM

Especially suitable for MULLARD ORGOLA; OSRAM MUSIC MAGNET,

and for panels up to 18" x 8". Loud Speaker compartment is 18" x 18" x 18 1/2".

Oak £7:10:0 Mahogany £7:15:0 Call and see full range of Camco cabinets at new London Showrooms.

CARRINGTON MANUFACTURING CO., LTD. NEW SHOWROOMS: 24, Hatton Garden, London, E.C.1.

Complete with 16 1/2" baseboard and removable baffle board.

Mention of "The Wireless World." when writing to advertisers, will ensure prompt attention.

MISCELLANEOUS ADVERTISEMENTS.

NOTICES.

THE CHARGE FOR ADVERTISEMENTS in these notices is:

12 words or less, 2/- and 2d. for every additional word.

Each paragraph is charged separately and name and address must be counted.

DISCOUNTS are allowed to Trade Advertisers allows on orders for consecutive insertions, provided a contract is placed in advance, and in the absence of fresh instructions the entire "copy" is repeated from the previous issue: 13 consecutive insertions 5%; 28 consecutive, 10%; 52 consecutive, 15%.

ADVERTISEMENTS for these columns are accepted up to **FIRST POST ON THURSDAY MORNING** (previous date of issue) at the Head Offices of "The Wireless World," Dorset House, Tudor Street, London, E.C.4, or **WEDNESDAY MORNING** at the Branch Offices Hertford Street, Coventry; Guildhall Buildings, Fenchurch Street, Birmingham; 260, Deansgate, Manchester; 101, St. Vincent Street, Glasgow, C.2.

Advertisements that arrive too late for a particular issue will automatically be inserted in the following issue as accompanied by instructions to the contrary. All advertisements in this section must be strictly prepaid. The proprietors retain the right to refuse or withdraw advertisements at their discretion.

Postal Orders and Cheques sent in payment for advertisements should be made payable to **ELLIOTT & CO.** Notes being acceptable if lost in transit should not be sent as drafts.

Letters relating to advertisements should quote the number which is printed at the end of each advertisement, and the date of the issue in which it appeared.

The proprietors are not responsible for clerical or printers' errors, although every care is taken to avoid mistakes.

NUMBERED ADDRESSES.

For the convenience of private advertisers, letters may be addressed to numbers at "The Wireless World" Office. In this is desired, the sum of 6d. to defray the cost of postage and to cover postage on replies must be added to the advertisement charge, which must include the "Box 000, c/o 'The Wireless World.'" Only the number will appear in the advertisement. All replies should be addressed No. 000, c/o "The Wireless World," Dorset House, Tudor Street, London, E.C.4. Readers who do not wish to have their names advertised should send a separate letter through the post except in registered envelopes; such cases the use of the Deposit System is recommended, the envelope should be clearly marked "Deposit System."

DEPOSIT SYSTEM.

Readers who hesitate to send money to unknown persons deal in perfect safety by availing themselves of our Deposit System. If the money be deposited with "The Wireless World," both parties are advised of its receipt. A time allowed for decision is three days, counting from receipt of goods, after which period, if buyer does not retain goods, they must be returned to seller. If a sale is effected, buyer instructs us to remit to seller, but if not, seller instructs us to return to depositor. Carriage is paid by the buyer, in the event of no sale, and subject to there being no arrangement between buyer and seller, each pays his own way. The seller takes the risk of loss or damage in transit, for which we take no responsibility. For transactions over £10, a deposit fee of 1/- is charged; on transactions over £10 and under £50, the fee is 2/6; over £50/-, all deposit matters are dealt with at Dorset House, Tudor Street, London, E.C.4, and cheques and postal orders should be made payable to Elliott & Sons Ltd.

SALE OF HOME-CONSTRUCTED UNLICENSED APPARATUS.

A Service to our Readers.

We have made an arrangement with the Patentees whereby readers who wish to dispose of a home-constructed apparatus not licensed under the patents made use of, can have the set by means of the Deposit System referred to. The person desiring to sell, in sending us particulars for advertisement, will in every case make use of a Box and should add to the price which he requires the amount of royalty customarily paid by manufacturers. The purchaser is satisfied with his purchase, the sum sent will be forwarded to the seller, less the amount in respect of royalties, which amount will be paid by "The Wireless World" to the owners of the patents concerned, and a certificate will be handed on to the purchaser of the set.

SPECIAL NOTE.—Readers who reply to advertisements receive no answer to their enquiries are requested to be silent as an indication that the goods advertised are already disposed of. Advertisers often receive so many enquiries that it is quite impossible to reply to one by post.

B & J

ALL WIRELESS WORLD COILS

1930 EVERYMAN FOUR	47/6 set
KIT SET, Coils with Switches ..	45/- set
NEW KILOMAG	45/- set
REGORD III	45/- set
FOREIGN LISTENERS 4 B.B.C.	30/- set
5XK 37/6 set	
METAL CABINETS	38/6 to 46/6
5 1/2" DRUM DIALS with Escutchcons ..	5/6
WAVE TRAP, Litz Wire	10/6 each

B & J. Wireless Co.

2, 3, & 4, Athelstan's Mews,
Stroud Green Road, N.4.

Archway 1695

"THERE IS A WHALE OF DIFFERENCE"

APPLEBY'S

THE ORIGINATORS OF RADIO PART EXCHANGE

For Moleira High-grade Material Only.

CHAPEL ST., LONDON, N.W.1

OPEN TILL 7 P.M. SAT. 1 P.M.

Phone: Paddington 8828 (3 lines).

TANNOY Mains Units

ELECTRIFY YOUR PRESENT SET for £2 - 7 - 6

We have now come to the time when everyone requires PERFECT RADIO, with the least amount of trouble.

Constant H.T. means a great deal towards this.

Fit a TANNOY H.T. mains unit into your present set instead of buying your next dry battery.

H.T. mains unit for A.C. 22 17 6
Combined H.T. and L.T. 25 12 6

Write for leaflets RW/MR.

THE TULSEMERE MFG. CO.,

1-7, Dalton Street, West Norwood, S.E.27.

Phone: Streatham 6731.



HANG OR STAND PLAQUE LOUD SPEAKER

This beautifully finished Loud Speaker, mounted on oak or mahogany baffle, is surprising in the richness of its tone. Despite the low price, efficiency has not been sacrificed. Send for one to-day!

12/6 carr. fwd.



SPECIAL BARGAIN HART ACCUMULATORS

Type M-E 6 v. 30 amp. actual.

A special purchase of these accumulators enable us to offer them at a very low price. Every one guaranteed new and in perfect condition.

Orders executed in strict rotation.

GARRATT STORES

193, Garratt Lane, London, S.W.18
Phone: Battersea 0453.

15/- carr. fwd.

IMPORTANT NOTICE.

Owing to the Christmas Holidays, the issue of "THE WIRELESS WORLD" for December 18th must be closed for press earlier than usual.

The **MISCELLANEOUS ADVERTISEMENTS** for insertion in that issue can be accepted up to **FIRST POST, WEDNESDAY, DECEMBER 11th.**

RECEIVERS FOR SALE.

SCOTT SESSIONS and Co., Great Britain's Radio Doctors.—Read advertisement under Miscellaneous. [0264]

3-VALVE All-wave Receiver, latest type, powerful, perfect; £4.—V. Taylor, 57, Studley Rd., Stockwell, London. [0274]

RECEIVERS for Sale.—Portable 5-valve, unit case type, complete, as new, perfect; £9/17/6.—N. Taylor, 57, Studley Rd., Stockwell, London. [0323]

5-VALVE Portable, complete, long range; £12, cost double.—Bracey, Factory Sq., Streatham. [7202]

WIRELESS is a Fascinating Subject, but makes heavy demands upon the purses of its devotees. For one who is determined to keep abreast of the times, there are always new components to be bought, and sets and loud-speakers to be superseded.

AT the Same Time, the would-be buyer is often deterred from buying because he knows that there will be still one more piece of apparatus left on his hands, to add to those already in the junk box.

WE Have Opportunities of Disposing of Semi-Obsolete Apparatus to those who are not fortunate enough to be able to afford the latest type, and will take such apparatus or components, providing they are in saleable condition, in part exchange for any new set, loud-speaker or component required.

ALL We Ask is that You should Send Along a List of Your Old Apparatus, together with your new requirements, or, better still, send the apparatus to us to inspect, when we will make you a fair offer.

IF You Approve of this You can Send Your Remittance for the Balance, and we will forward the apparatus required; if you have sent your old apparatus and you do not approve of our offer, we will return carriage paid.

The Principal of this Firm, who has been a professional wireless engineer since 1910, and has been manager for the Sterling Telephone Co., radio expert to the General Electric Co., and Chairman of the Technical Committee of the National Association of Radio Manufacturers, will willingly give advice to those who are desirous of purchasing apparatus; we are entirely unbiased and will recommend the best apparatus for your particular purpose; you save money by having genuine expert advice.

DONT Forget We Will Take Your Old Receiver or Components in Part Exchange.

WE Will Also Install Sets Anywhere in the British Isles; sets modernised; send for estimates.—Scientific Development Co., 51, Fishergate, Preston. Tel.: 1364. [0225]

WIRELESS Portable Sets with 5 New-Cosor Valves for 9 Guineas; less than components cost, comparable with any set double this price; beautiful suit case, 2 aerial windings, English batteries and accumulators, all inclusive; efficient sets. Royalty paid, a magnificent Xmas gift; if you are in London may I fix an appointment? If you are not in London may I send you particulars?—G. Hodgson, 53, Windsor House, Victoria St., Westminster. [7293]

EVERYMAN Four, complete in mahogany cabinet, with Philips A.C. eliminator, type 3002, Celestion mahogany speaker, 3 spare valves, Exide accumulator, all in perfect order; £18; would separate.—Jacobs, 106, Anson Rd., Cricklewood. [7401]

B.R.O. Five, 2 screened H.F. valves, detector, 2 L.F.; £25.—Davies, 1a, Stanwell Rd., Penarth, Glam. [7400]

COSSOR Screen Grid Three, complete with valves and accumulator. £5; Marconi H.T. eliminator, 200 or 240 A.C. mains. £3/5; Philips trickle charger, A.C., 200 or 240 mains, £2/5; moving coil loud-speaker, with baffle, £3.—W. H. Oates, 195, Hammersmith Rd., W.6. [7397]

BURNEDEPT Ethophone S.G. Pentode, with valves; £8.—Dryland, 25, Beaufort Mansions, Chelsea, S.W.3. [7386]

Advertisements for "The Wireless World" are only accepted from firms we believe to be thoroughly reliable.

Universal Three
15-2,000 metres.



The most perfect receiver yet designed for Ultra Short Wave, Broadcast, and Long Wave reception. Including Valves, Coils and Royalty £18.0.0d.

Convert your present Set into a Short Wave Receiver.

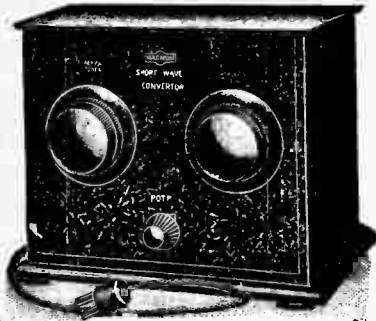

Magnum Short Wave Converter.

This Converter is adaptable to any valve set by simply removing the detector valve from set and inserting it in the valveholder of converter, the plug of converter taking the place of the detector valve. In crystalline metal cabinet, with 2 Coils 20/40 and 40/80 metres. Plug and Adaptor £4.10.0d. inclusive.

Magnum Receivers are now obtainable on Easy Payment Terms.

We specialise in all apparatus described in "Wireless World."

Lists on application.

BURNE-JONES & CO., LTD.
296, BOROUGH HIGH ST.,
LONDON, S.E.1.

Receivers for Sale.—Contd.

WHAT Offers?—McMichael 5-valve superonic unit, complete with 2 auto oscillators and Eddystone dual frame aerial, to-day's list price £9/8/6, perfect condition; Western Electric power amplifier, complete with valves, as new, cost £17/17.—Mox [7382] c/o *The Wireless World*.

4-VALVE T.M.C. Set, selective, modernised, Regentone eliminator, 240v., A.C., loud-speaker, all accessories; best offer secures.—44, Victoria Road, Edmonton, N. 18. [7381]

7-VALVE Experimental Receiver, in fine inlaid bookcase cabinet, 7ft.x3ft., beautiful piece of furniture; £12, or near offer.—45, Villiers Rd., Southall, Middlesex. Southall 0057. [7403]

3-VOLT A.C., all mains (240v. 25a. 50 cycles), 200-3,200 wave band, mahogany case, excellent condition; cost £28, sell 12 guineas.—Box 4066, c/o *The Wireless World*. [7414]

MEGAVOX Three Components, as specification, £10/10; Ferranti O.P.1 transformer, 14/-; Bailey, 12, Marlborough Crescent, Bedford Park, W.4. [7409]

3-VALVE Marconiphone Model 32, with valves, used demonstration only, £8; also 3-valve Cromwell pedestal receiver, unused, £5/10.—Oakthorpe Garage, Palmers Green, N.13. [7405]

G.E.C. World Wide Four, cabinet model, height 3ft., complete valves, long and short wave aerial, cost £34/7, accept £17; Tungar trickle charger, cost £1/15, accept £1; new Atla A.C.50 eliminator, cost £12/17/6, accept £7/10; Ekco D.C. 5T60 eliminator, unboxed, cost £4/15, accept £3/5; latest type D.C. Marconi moving coil speaker, cost £5, accept £3/5; Junior R.K. amplifier A.C. operated, eliminator (all mains), amplifier Senior R.K. speaker, less cabinet, cost £33, accept £15; will have exchanged for any voltage or D.C.; selling as owner going abroad.—Apply Burnett, 21, Clarges St., London, W.1. [7389]

SIMMONDS BROS.—Receivers constructed to your own or any published design; also repairs, reconstructions; and modernisations at moderate charges; best materials and workmanship guaranteed; numerous testimonials; quotations free.—Address, Shireland Rd., Smethwick. [5882]

1929 Everyman Four Cabinet, with panel, coils, and condensers, also Marconi Ideal 6-1, £5; Blue Spot 66 K, with chassis, 30/-; near offers; seen after 6 p.m.—B. 70, Chelverton Rd., Putney. [7344]

SILVER Marshall Superhet, complete with Thoraderson push-pull L.S.5 valves, Radielle eliminator, R.K. model, 120 amps. actual, Exide, tremendous power range; £30.—H. Lousada, 9, Aubert Park, Highbury, London. [7472]

MARCONIPHONE, transportable, as new, under guarantee, cost 28 guineas; offers.—Box 4067, c/o *The Wireless World*. [7468]

ROLLS 1928 All-range Model; a bargain.—Box 4066, c/o *The Wireless World*. [7467]

XMAS.—What about a portable? Splendid 5-valvers, combining aerial, batteries, loud-speakers, valves, etc., from £9/9, really portable, take wherever you go; constructional kits, £7; performance guaranteed, all parts supplied.—Box 4061, c/o *The Wireless World*. [7462]

QUICK Disposal, several new and second-hand sets and components; half price.—Fox, 71, Buckingham Rd., Aylesbury. [7463]

PHILIPS 4-valve All-wave Receiver, 10-2,460, complete, perfect; £20, or offers.—Box 4066, c/o *The Wireless World*. [7461]

2-VALVE Set, with coils and valves, £3; also useful parcels of experimenter's surplus, 6/-; postage paid.—N. Hodgson, Wireless Depot, Mareham-le-Fen, Boston, Lincs. [7452]

LANGHAM Portable Five, new, £36/15 model; £15/15, near offer.—4, Queen's Gardens, W.2. 5942 Paddington. [7450]

PHILIPS All Electric 3-valve, 210 volts; cost £23, bargain, £18; scarcely used, demonstration worthily given.—Brooks, 3, Croxsted Rd., Dulwich. [7449]

READ and **MORRIS, Ltd.**, the mains pioneers, who in 1925 equipped the hospital with mains sets, still supreme in all-mains receivers and units.

LOW Tension A.C. Eliminators, permanently replacing batteries, now only £5/15; electrolytic condensers, 2,000 m.f., as used in above, 13/-; including postage.

BARGAINS.—Second-hand sets, units, meters, speakers.—Read and Morris, Ltd., 31, Eastcastle St. (facing back of Warrings), Oxford St., W. [7445]

NATIONAL Portable Radio, 5 valves, almost new; 10 guineas, cost 15 guineas.—Write S. H. P., 131, Lorrimore Rd., S.E.17. [7443]

HALCYON 5-valve Portable 1928 Cabinet Model, in perfect condition, with spare accumulator; first 15 guineas secured.—Lawson, 95, Goldhurst Terrace, Hampstead, N.W.6. [7438]

MULLARD Orgola Kit, exactly as specified, no cabinet or valves; £5, post free.—G. Hutson, Wide Bargate, Boston. [7428]

REDUCED PRICES



AMAZIN BARGAIN IN STEEL MAST

26ft. STEEL MAST, tapering 1 1/2" to 1". Carriage: London, 1/6; Midlands, 2/6; Elsewhere, 3/6. Weighs 28 lbs. 8/

30ft. Tapering 1 1/2" to 1". Carriage: London, 2/-; Midlands, 3/-; Elsewhere, 4/- Weighs 36 lbs. 10/

34ft. Tapering 1 1/2" to 1". Carriage: London, 2/-; Midlands, 3/-; Elsewhere, 4/-; Weighs 40 lbs. 11/

40ft. Tapering 1 1/2" to 1". Carriage: London, 2/6; Midlands, 3/6; Elsewhere, 4/6 Weighs 50 lbs. 16/

A super mast.

OUTFIT with MAST. Mast rings, ample galvanneal, Solid Metal footrest and strong galvanneal stay fastenings. Note.—Our Masts are stayed at 4 ground points (not 3) which ensures safety.

ACCESSORIES. Best Manila Rope Halyards (will suit 1/8" to 1/4" mast), 60 ft. 1/6, 100 ft. 2/6. Special Anti-rust paint (sufficient for mast), 1/6. Coppered earth tube, 1/9. C.P. Special Aerial, has 14 strands of No. 28 galvanized steel wire, 100 ft. 3/6. Money refunded if mast returned intact and carriage paid within 7 days.

C.P. MAST CO.
48E, HIGH STREET, PENGE, S.E.20

PAREX

A.C. 3 KIT SET

Bakelite Drum Dials with Escutcheons

5/6 (from stock)

All Metal Cabinet with oak base and plinth **42/6**

Coils per set, as specified **60/-**

Cabinets, Coils, Valve Holders, etc., for New Kilo-Mag 4 and 1930 Everyman 4.

Order direct from:

E. PAROUSSI,
10, Featherstone Buildings, High Holborn, W.C.1
Phone: Chancery 7010.

Have you got this Catalogue?

BULGIN RADIO PRODUCTS

A. F. BULGIN & Co.,
9/11, Currier St., Chancery Lane, London, E.C.4.

BOOKS on WIRELESS

Write for complete list to
ILIFFE & SONS LTD.,
Dorset House, Tudor St., London, E.C.4.

COMPLETE ELIMINATOR TRANSFORMER

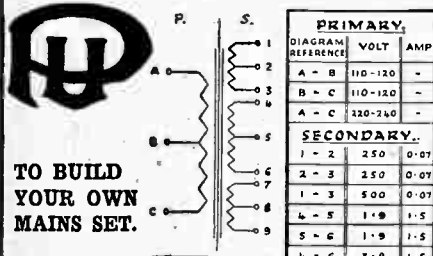

TO BUILD YOUR OWN MAINS SET.

Well designed, and current for 5 valves. **20% CARR PAID**

PUGH BROS., 95/101, Holloway Road, N7

Mention of "The Wireless World," when writing to advertisers, will ensure prompt attention.

Receivers for Sale.—Contd.

GRAM Magnet Set (1928), new valves, wired, complete, as new; bargain.—Smith, West Cottingwood, Morpeth. [7421]

MULLARD S.G.P.3, with all batteries and long and medium wave coils, just new; nearest offer.—McEwcn, 17, Craven Rd., London, W.2. [7390]

PHILIP'S All Electric 3-valve Set, cost £23; also Celestion speaker, cost £5/12/6; what for?—Box 4041, c/o *The Wireless World*. [7391]

COMPLETE Kit of Mullard Orgola 3-valve Set Parts, never taken out of maker's packings; 6 guineas, accept first cheque for £5; parts as fitted by Mullards.—M. Godfrey, 37, Ombersley, Bedford. [7383]

BATTERIES.

D.E.S. Accumulator Hire and Maintenance Service (5 mile radius)—98, Cherry Orchard Rd., Croydon. [6374]

WET H.T. Replacements—Sacs (capped or uncapped), highest grade, No. 1, 10d. per doz.; No. 1/9 per doz.—See below.

INCS.—Best quality (wired), No. 1, 8d. per doz.; No. 2, 9d. per doz.; orders valued 5/- carriage paid, otherwise 6d. for postage.—British Battery Co., London Rd., Watford, Herts. [0258]

ENCODE Users—Write for details of new size self-charging wet battery; 20,000 milliamps, 6d. per lb.; illustrated catalogue giving data, post free.—Ullor, 57, Studley Rd., Stockwell, London. [0273]

STANDUP Wet H.T. Battery will Always Improve Your Reception; its capabilities to feed your area with pure D.C. current over exceptionally long roads, combined with its low running costs, appeal to any listener; list free.—Scottish Batteries, Braehead, Hall Station. [6852]

WET H.T. Batteries—Parts per dozen, jars, No. 1, 2 1/2 x 1 1/2 square, 1/3; No. 2, 1 1/8; zincs, No. 1, 1/3; No. 2, 1/4; sags, No. 1, 1/2 dozen; No. 2, terminals, 8d., 10d.; dozen cells (18 volts), come with bands and electrolyte, No. 1, 4/1; No. 2, post 9d.; high efficiency, long life, self charging, deep small; send 6d for sample unit; illustrated booklet free, carriage free orders 10/-; write for free wireless bargains, trade supplied.—W. Taylor, 87, Mley Rd., Stockwell, London. [0039]

WE Guarantee the Best Accumulator Maintenance in South London; slow rate circuits and expert attention; meticulous attention is given to topping, cleaning and drying of H.T. accumulators; trouble-free collection and delivery; the service includes hire Oldham H.T. and L.T. batteries.—Official Oldham Station, Anelay Radio (associated with Anelay ducts), 36, Hindmans Rd., East Dulwich, S.E.22. New Cross 4074. [7074]

BRITANNIA Accumulators, 2-volt, 20 amps, 7/3; 30, 9/3; 40, 11/3; actual capacities, H.T. plates, up, 1/6; 1 1/2, 2/3; 2, 3/6 per dozen; all post free. Okill, 82, Dean St., Soho, W.1. [7371]

KIDE H.T. Batteries, 120v., excellent condition; 45/-, or near offer.—Broad, 30, Asnans Place, Bakers Green, N.W.11. [7432]

CHARGERS AND ELIMINATORS.

DETENTION Transformers, chokes, etc., wound to any specification; write or phone for quotation; quality components only.—Vortexion, 72, Merton Wimbledon, S.W.19. Tel.: Wimbledon 2814. [0319]

TRANSFORMERS and Chokes for Battery Eliminators, and for all wireless purposes, receiving or emitting; enquiries invited.—Chester Bros., 244, Toton Lane, London, E.8. [6138]

PLAS Eliminators, D.O. £11/17/6, A.C. £3/17/6; Nesper trickle chargers, 29/6. Phone: Gerrard 3 for demonstration.—Greatrex and Co., 184, Regent London. [6451]

ANTALUM and Lionium for A.C. Rectifiers; make up your own inexpensive chargers; blue prints H.T. and L.T., 1/- each; Lionium electrodes fitted terminals, 2-3 amps. and 5-8 amps.—Blackwell's Allurgical Works, Ltd., Speke Rd. Works, Garston, Liverpool. Phone: Garston 980 (2 lines). [6282]

HERBROS.—Chebros for all types of transformers and chokes, high grade instruments at a very moderate price; enquiries invited.—Chester Bros., 244, Toton Lane, London, E.8. [5290]

NEW Improved Uniflex A.C. H.T. Eliminator Kit, gives 120 volts and 60 volts at 15 milliamps; [6451]

NIFLEX Eliminator Kits are the Cheapest in England and sold all over the world; 30/-.

NIFLEX Eliminator Kits are All Ready for Wiring, mounted on baseboard, with panel, instructions, 30/-.

NIFLEX Eliminator Kits are Guaranteed, satisfaction or money refunded; hundreds of testimonials.

NIFLEX Kit Sent c.o.d. Post Free 30/-; state town voltage and cycle, also if Phillips 373 rectifying valve is to be sent, 15/- extra.—Liverpool Radio Supplies, Uniflex Works, Myrtle St., Liverpool. [7247]

EGGS! No. 2 AND THE



CLAROSTAT

Some Variable Resistances, just like Eggs, are unknown quantities. To secure a good, fresh egg it is advisable to purchase only from an old-established and reliable source, or to consult an expert.

"Clarostats" have been "hatched" 5 Years! Over 4 million are in regular use the World over. They are backed by a firm Established May 1918—before "Broadcasting." Any Wireless Expert will confirm that they are still the best of the "brood." They are fully guaranteed to give you satisfaction.

There are now so many imitations at a little less money that you should make sure that by saving a few coppers you do not—like Foolish Freddie above—purchase "a bad egg!"

THERE'S A "CLAROSTAT" FOR EVERY RESISTANCE PROBLEM!

- STANDARD, 18 WATTS, for Eliminators .. Was 10/6 NOW 9/6
- STANDARD, 18 WATTS, BRASS FINISH MODEL. .. Was 9/6 NOW 8/6
- VOLUME CONTROL, 100-500,000 Ohms .. Was 8/6 NOW 7/6
- POWER CLAROSTAT, 35 WATTS Was 15/- NOW 13/6
- POWER TYPES, Brass Finish Were 12/6 NOW 11/6
- "NUM-DINGERS," all Types NOV 4/-
- SUPER-POWER CLAROSTAT, 250 WATTS .. (A New Model) 30/-
- TABLE TYPE (Distant Volume Control) .. Was 13/6 NOW 12/-

36-PAGE ART BOOKLET CONTAINING 47 Illustrations, 27 Diagrams, 3 Scale Drawings of H.T. Units, etc., FREE and POST FREE, from:



CLAUDE LYONSTM
76 OLDHALL ST.
LIVERPOOL

Chargers and Eliminators.—Contd.

PHILIPSON'S Safety High Tension Battery Eliminators.
10/- Down and the Balance in Easy Monthly payments secures the finest high tension supply available.
PHILIPSON'S Safety Eliminators are Guaranteed for 12 Months.
PHILIPSON'S Safety Eliminators are the Cheapest to Install and the Cheapest to Run; prices: Model A.C.5 £4/17/6, A.C.7 £3/17/6, complete with full wave rectifiers; D.C.4 37/6, D.C.5 45/-.
ALL Models Obtained for 10/- Deposit; take advantage of this and get constant high tension immediately.
WRITE for Our Booklet, "Radio Power" to Philipson and Co., Ltd., Radio Engineers, Astley Bridge, Bolton. Phone: 2038. Grams: Safety, Bolton. Est. over 50 years. [0318]

POTENTIAL Dividers, wire wound, variable tappings, ideal for eliminators and rectifying units; price 6/6, post free.—Below.

POTENTIAL Dividers, standard 20 m.A. type, 5 variable tappings, supplied in all values; a first class job; price 2/6.—Abingdon Wireless Supplies, Abingdon, Berks. [7287]

FEL-ECTRIC RADIO Eliminator Kit, transformer, choke, valve holder, valve, 3 condensers, variable resistance, insulated terminals, sleeving, wiring diagram; 37/- complete; output 15 m.a. at 120 volts; send for lists.—Fel-Ectric Radio, 56, Garden St., Sheffield. [7411]

SAVAGE'S Specialise in Wireless Power from the Mains, reliable apparatus at reasonable prices.
SAVAGE'S Transformer Laminations and Bakelite Bobbins; intending home constructors should write for list.
SAVAGE'S Reliable Smoothing Condensers—1,000 volts D.C. test, 2 mid. 3/-, 4 mid. 5/3; 500 volts D.C. test, 1 mid. 1/6, 2 mid. 2/3, 4 mid. 3/9.
SAVAGE'S Super Smoothing and Output Chokes—Many types available, write for list.
SAVAGE'S Mains Transformer for Westinghouse Rectifiers—H.T.4, 18/6; A.3, 17/-; A.4, 20/-.
SAVAGE'S Mains Transformer for Westinghouse H.T.4 Unit, with additional winding, 4 volts 3 amps; 23/-.
SAVAGE'S Mains Transformer—V.T.31, 200-0-200 volts 60 m.a.mps., 2+2 volts 2 amps., 2+2 volts 3 amps.; 28/-.
SAVAGE'S Mains Transformer—B.T.3 500-0-500 volts 120 m.a.mps., 3.75+3.75 volts 3 amps., 3+3 volts 3 amps., 2+2 volts 3 amps.; 51/-.
SAVAGE'S Mains Transformers and Power Chokes are carefully and individually constructed from first class materials with an exceptionally generous margin of safety.
SAVAGE'S, 146, Bishopsgate, London, E.C.2. Phone: Bishopsgate 6998. [6808]

RADIELLE Eliminator, type C.P., D.C. output 150 volts, 40 m.a., for A.C. mains, brand new, unused; cost £9/17/6, sacrifice at £5/15.—Box 4062, c/o *The Wireless World*. [7464]

200V. A.C. Crypto Charging Plant, complete, switchboard, meters, rotary rectifier, transformer, tapped 12, 25, 50, 100 volts, new condition; offers.—BM/EDGR, W.C.1. [7451]

RADIELLE Eliminator, model R.K., output 350 volts, 80 milliamps, and 2 variable tappings, input 200-240 volts, 50 cycles; list price £13/10, will take £6/10; perfect condition.—Rogers, 21, New Rd., Brentwood, Essex. [7422]

CABINETS.

ARTCRAFT Radio Cabinets are Britain's Best Value. [0313]

DIGBY'S Cabinets—Table models in solid oak and mahogany; from 11/6 to 71/-.

DIGBY'S Cabinets, fitted with Radion or Resiston ebonite if required.

DIGBY'S Cabinets—Pedestal model, with separate battery compartments; from 56/- to £12.

DIGBY'S Cabinets Made to Customers' Own Designs.

DIGBY'S Cabinets—Write for new 16-page art catalogue.—F. Digby, 9, The Oval, Hackney Rd., E.2. Phone: Bishopsgate 6458. [0128]

ARTCRAFT Radio Cabinets are Britain's Best Value. [0309]

KAY'S Cabinets, the greatest range of pedestal cabinets in the kingdom; original creative designs at prices 50% lower than elsewhere; quotations for specials by return; delivery at short notice guaranteed; moving coil, portable, baffle, vignette, radiogram, electric pick-up, television, etc.; illustrated lists free.—H. Kay, Wireless Cabinet Manufacturer, Mount Pleasant Rd., London, N.17. Phone: Walthamstow 1626. [6464]

HORNS for Cabinets, portables, etc.; illustrated list.—Maddison, 1, Chapel St., Edgware Rd. [6192]

Cabinets.—Contd.

ARTCRAFT Radio Cabinets; Britain's best value; lowest prices consistent with highest quality; illustrated list free from actual manufacturers.—Artcraft Co., 156, Cherry Orchard Rd., Oraydon. Phone: Croydon 1981. [0040]

CABINETS, 16 1/2 in. x 7 1/2 in. x 11 in., hand mahogany finished 7/6. unpolished 5/6; oval front, 10 1/2 in. x 6 1/2 in., 6d. extra; baseboard, 6d.; carriage free.—F. W. Ramsey, 63, Shaftesbury St., London, N.1. Clerkswell 7139. [6145]

ARTCRAFT Radio Cabinets are Britain's Best Value. [0311]

CABINETS, metal, for S.G.3 receiver, complete with baseboard and screen; 9/6.—Allsop, 69, Great Hampton St., Birmingham. [7380]

FINEST American Types, astonishing value, special offer oak cabinets, hinged lid, baseboard, highly polished, take 12 in. x 6 in. panel; sample, carriage paid, 6/6; trade discounts for quantities.—Mag-Radio, 112, Warstone Lane, Birmingham. [2665]

ARTCRAFT Radio Cabinets are Britain's Best Value. [0310]

LOUD-SPEAKER Cabinets, extraordinary offer, oak cabinets, handsome fret front, highly polished, 13 in. square, 6 in. deep, finished moulding, take all ordinary units; sample, carriage paid, 6/6; trade discounts for quantities.—Mag-Radio, 112, Warstone Lane, Birmingham. [2666]

COILS, TRANSFORMERS, ETC.

600-OHM Decoupling Resistances for New Kilomag Four, foreign listeners' four, and all "Wireless World" circuits, hand made and tested in our own workshops; improved model wound with Constantan wire, 1/6 each, post free.—Groves Bros., St. Mary's Place, Shrewsbury. [7361]

1,000-OHM Decoupling Resistances for "Wireless World" Circuits, 1/6 each, post free.—Groves Bros., St. Mary's Place, Shrewsbury. [7362]

SIMMONDS BROS.—Berclif coils. Record Three, 50/- pair; new kilo-mag. four, 50/- set; foreign listeners' four, low, 30/-; long wave, 37/-; screened grid Regional, 40/-; Mullard G.E.P. dual range coils, 30/- pair; Berclif standard coils, for new all-wave four, standard four, A.O. three, Everyman four, etc., 63/6 set of 4, with bases; the same coils for the Lodestone series ("Wireless Magazine"). 65/9 set of 4, with bases; Titan unit, 15/-; decoupling resistances, 600 ohm, 1/6; 1,000 ohm, 2/-; all "Wireless World" and similar coils in regular production by the leading specialists; lists free; trade supplied.—Simmonds Bros., Shireland Rd., Smethwick. Tel.: Smethwick 751. [6314]

FOREIGN Listeners' Four Boxes, 19/- set of 4; coils, 37/6 set.—Stott. [7363]

RECORD III Coils, 35/-; Kilo-Mag 4 coils, 33/-; decoupling resistances, 1/3. [7364]

KIT Set Coils and Switches, 37/6; dials and plates, 5/- pair.—Stott. [7365]

1930 Everyman Coils, 42/6 set; all special parts to order; trade supplied. [7366]

METAL Cabinets, in oak or mahogany, with moulded wood top and base; Record III, K.M., and 1930 Everyman, 45/-; Kit set, 35/-; metal box only, 32/6 and 27/6 respectively.—Arthur T. Stott, 1a, Duke St., Rochdale. [7323]

NEW Kilo-Mag Four Coils, 37/6 set; ebonite formers (slotted), for winding, 12/6 set of 3; all post free.—Groves Bros., St. Mary's Place, Shrewsbury. [7446]

KIT Set Coils for New A.C. Model, 50/-, complete with switches; 1930 Everyman Four coils, 50/-.—R. Kilby, 51, Lyndhurst Grove, Peckham, S.E. [7434]

RADIOGRAPH.—W.W. coils, Record III, 35/-; new Kilomag Four, 33/-; S.G. Regional, 37/6; foreign listeners' Four, 37/6 set; Europa Portable, 21/-; Europa III, 18/6; S.G. multi-valve portable, 22/6; new Everyman Four, 42/6. [7447]

RADIOGRAPH.—Litz wire, 9/40, 1/6; 27/42, 2/6 dozen yards; Redfern's deep ribbed or Becol tube, 5d. per inch, slotting 1/6 extra. [7448]

RADIOGRAPH, Ltd.—W.W. cabinets, 4 compartments, 44/6; 2 compartments, 38/6; crackle enamel and oak finish.—Station Rd., Handsworth, Birmingham. [7441]

GRAMOPHONE PICK-UPS, ETC.

EXPONENTIAL Horns for Cabinet Gramophones and Wireless, metal and wood; list.—Maddison, 1 Chapel St., Marylebone, N.W.1 [6141]

B.T.H. Pick-up, latest model, off-set tone arm, new, 35/-; Brown speaker unit, type V, perfect, 10/-.—Osborne, 6, Belgrave Terrace, Bath. [7387]

BROWN Pick-up, adapter and kushette arm, little used; post paid, 18/6.—Baker, Wanford, Beccles. [7408]

DYNAMOS, ETC.

DYNAMO by G.E.O., output 150 volts 1 1/2 amps., 1,500 r.p.m., unused; cost £12, what offers?—29, Brudenell Rd., Leeds. [7424]

Dynamos, Etc.—Contd.

CHARGING Generators for Sale; bargain clear exceptional offer of B.T.H. and Mackie high speed and low tension charging dynamos, giving 2 pairs of 200 to 300 volts 100 milliamps, and 8-12-5 amps. shunt wound, brand new; all charging stat should purchase one; worth £15 each, our price clear, with guarantee, 50/-.

C.A.V. Shunt Wound Charging Dynamos, 30 volts 100 amp., ball bearing, 4-pole, new condition, we 60 lb.; price 50/- each.

FINAL Clearance of Crompton Dynamos, 50-75 and 20-30 amps., shunt wound, 4-pole, in new condition; £7.

NEWTON Slow Speed Dynamo, 110 volts 20 amp. and 200 volts 20 amps., ball bearing, shunt wound, price £10; compound wound, £12.

MARCONI Charging Boards, containing shunt resistance, 2 double pole change over switches, wavy series parallel switch and fuses and battery terminals, etc., mounted on polished slate in iron frame; bargain clearance, 20/- each.

THESE are Only a Few of Our Many Bargains; we have a large stock of all size A.O. and L.M. motors, all size dynamos, cables, meters, etc.; to your requirements; we can quote you the lowest market prices.

T. W. THOMPSON and Co., 1, South St., Greenwich, S.E.10. Phone: Greenwich 1259. [7370]

DYNAMOS, L.T. charging.—W.W. 20 volts, 6 amp. 50/-; L, 12 volts, 8 amps., 45/-; Ct, 18 volt, 8 amps., 65/-; 50 volts, 25 amps., 27/10; 80 volt, 20 amps., £8 10s.; and others. Motor generators: volts A.C. to 100 volts, 100 m.a. D.C., 70/-; dynamos: 100 volts, 1 amp., 25/-; 100 volts, 4 amp., 36/-; 250 volts, 4 amps., £3/10. H.P. anode M. 100 volts D.C. to 250 volts, 250 m.a., £10; 220 volt D.C. to 400 volts D.C., 200 m.a., £12; fine new comm. G.E.O. Aircraft generators: 950 volts, 60 m.a. and 6 volts, 5 amps., £10; 600 volts, 100 m.a. and volts, 5 amps., £5; fine Newton H.T. generators, kW, 2,000 volts, £50; slow speed 1 kW, 2,000 volt £40; 2kW, 2,000 and 4,000 volts, £52; large E.C. Megger hand generators 1,500 volts, £8; medium 600 volts, £5; hand magnetos, 80 volts, 50 m.a. 6/- each; H.T. 4,000 volts, 1/2 mfd. mica condens 10/-; 0.01 Dubilier 1,000 volts, 6d. each.

50 Petrol Electric Generating Sets, Air Force, 70 volts, 20 amps., £27; 150 electric belt and portable 110- and 220-volt drills, £5.

SWITCH Gear.—Slow motion geared slide Rheos, 30 watts, 7/6; 147 S.P. plug boards, 9-way, 10-amp 2/-; Lucas 8-way switch boxes, mahogany, with brass cover; 6 S.P., 1 D.P., 1 C.O. switches, 3/6; S.P.C. switches, 1/6; H.T. send receiver, 2/6; hundreds other switches and controllers; send for list.

ELECTRADIX RADIOS, 218, Upper Thames St. E.C.4. [7371]

LOUD-SPEAKERS.

HORNS of All Descriptions for Loud Speakers and Gramophone Units.—H. Maddison, manufacturer of the Allwoodorn, 1, Chapel St., Paddington, N.W. [7372]

YOUR Old Loud-speaker Taken in Part Payment for the Latest Type; see our advert. under "Colours Receivers for Sale.—Scientific Development Co., Fishergate, Preston. [7373]

CELESTION Model C.10, oak, condition as new; no offers.—1, Hillworth Rd., Tulse Hill, London, S.W.2. [7374]

MOVING Coil Loud-speaker, suitable for work off 6-volt accumulator, as new; £4.—H. Louisa, 9 Aubert Park, Highbury, London. [7375]

RICE KELLOG B.T.H. Senior L.S., 240 volt, A.C. cost £40, price £20.—Saul, 8, Ansdell Rd., S. Ansdell, Lytham. [7376]

NIKOLA Cones, leather floats, felt fronted rings, a range of sizes and angles, manufacturers' type completely assembled from 3/6; complete chassis from 7/6; list.—Knight and Co., 6, Chapel St., London, E.C.2. [7377]

GREAT Bargains. GREAT Bargains.

GREAT Bargains.—Epoch model A moving coil speaker kit (or complete units), brand new large number of these famous instruments made a special order for use in talks, but not executed for credit reasons only; regular prices, £3/10, £4 and £5/17/6, to clear at 50/- for accumulator operation, 55/- for D.C. mains operation, 85/- for mains; kits comprising copper plated super magnet (weight 23 lb.), Crystallene frame, fully adjustable, moving coil, any impedance, paper, leather mounting rings, made up complete, if desired, extra.

GREAT Bargains. GREAT Bargains.—In fact, the greatest bargain ever offered! A number of Epoch model A kits at given away prices, guaranteed in perfect working order; early 1926 model, 35/-; latest model, 42 made up complete, if desired, 6/- extra.

ENJOY Marvellous Epoch Reproduction Ridiculous Cost; don't wait until they are gone, but secure one immediately by writing, "Phone telegraphing, or hurrying to Epoch, 3, Farringdon St. E.C.4. [7378]



You realise immediately that the Wates Star Duplex is definitely an advance on any other speaker, irrespective of price. The liquid beauty of the softer cadences blend with the verve and volume of the louder chords that is a joy to hear. Experts and the everyday listener acclaim it. Deliberately built above the standard of "built down to a price speakers"—whilst dearer in price—it becomes an investment in hours of happy entertainment and superlative reproduction.

Obtainable as a separate unit, or with special Double Cone Chassis, or as illustrated in complete Cabinet form in mahogany or oak.

Water Star Duplex complete Spc aker with Double-cone Chassis in Oak Cabinet £4.0.0 Mahogany £4.6.0

WATES STAR LOUD SPEAKER UNIT

The Wates Star Duplex Unit, double magnets, twelve poles, four coils .. 36/- Double-cone with brackets 12/-



THE SHAFTESBURY RADIO CO. (Dept. W.W.), 184-188, Shaftesbury Avenue, London, W.C.2. M.B.

If unable to obtain locally can be supplied direct.

THE LITTLE CELLS THAT SATISFY

Leyton Primary H.T. Battery, PI Porous Pot Cells, S1 & S2 Sac Cells. All complete for assembly.

P1 1-cell. 6-cell. 12-cell. 30-cell. S1 6d. .. 3/3 .. 5/9 .. 14/- 6d. .. 3/- .. 5/3 .. 12/-

Watch our notice for new type cell. "Easeful" Plier, 1 pint 1/-, pint 1/6, post free 3d. extra. Send 13d. stamp for booklet giving full particulars to:—

THE LEYTON BATTERY CO., 305 CHURCH ROAD - LEYTON - E.10

REPAIRS

Any make of L.F. Transformer, Loudspeaker or headphones repaired and dispatched within 48 HOURS—TWELVE MONTHS' GUARANTEE with each repair. 4/- Post Free.

Terms to Trade. TRANSFORMER REPAIR CO., Dept. W., 214, High Street, Colliers Wood, London, S.W.19

Mention of "The Wireless World," when writing to advertisers, will ensure prompt attention.

HELLESEN DRY BATTERIES



VERB. SAP.

RIDLEY told me at the Club last Monday that he had been consulted regarding the purchase of a Portable for a friend. There had been sixteen makes of set on his original list, but he had whittled the choice down to three when I saw him. What interested me, though, was that of the original sixteen; every one was fitted as standard with Helleesen's H.T. Batteries. "Naturally," he replied, when I remarked on this fact, "it's the first thing I look for. If a manufacturer standardises Helleesens, the odds are that the other components he fits will be up to the same high quality. And anyway, an H.T. Battery that has to fit a small space and yet supply four or five valves with juice for months on end needs to be a Helleesen's and nothing less."

"Verb. sap.," I thought.

PRICES

Standard Capacity.

- "Wiray" 9 volt Grid Bias Type 2/-
- "Wirin" 60 volt H.T. Type... 10/6
- "Wirup" 99 volt H.T. Type... 18/-
- "Wisol" 108 volt H.T. Type 20/-

Treble Capacity.

- "Kolin" 60 volt H.T. Type... 13/-
- "Kolup" 99 volt H.T. Type... 32/6

Your Dealer Sells Them.



HELLESEN DRY BATTERIES,
ELECTRICAL MEASURING INSTRUMENTS,
POLYMET MICA AND PAPER CONDENSERS,
HANDLAMPS, TORCHES, ETC. P.&T.

A. H. HUNT, LTD., CROYDON, SURREY.

Loud-speakers.—Contd.

EPOCH Moving Coil Speakers.

EPOCH.

EPOCH.

EPOCH.

EPOCH.

EPOCH.

EPOCH Moving Coil Speakers Speak for Themselves.

EPOCH.

EPOCH.

EPOCH.

EPOCH.

EPOCH—Test an Epoch against any other make. It will persuade you more than the best salesman.

EPOCH.

EPOCH.

EPOCH.

EPOCH.

EPOCH.

EPOCH—Ask any of the thousands of users of even the older models. Put this season's models! Well, let the speakers tell you themselves.

EPOCH.

EPOCH.

EPOCH.

EPOCH.

EPOCH.

EPOCH.

EPOCH—Please do test them against any or every make on the market—preferably with a quick switch over.

EPOCH.

EPOCH.

EPOCH.

EPOCH.

EPOCH.

EPOCH—Order one for 7 days' free trial.

EPOCH.

EPOCH.

EPOCH.

EPOCH.

EPOCH—Your deposit instantly refunded in full if you are not more than satisfied. No catch. No red tape.

EPOCH.

EPOCH.

EPOCH.

EPOCH.

EPOCH.

EPOCH.—The most comprehensive range of moving coil speakers in the world.

EPOCH.

EPOCH.

EPOCH.

EPOCH.

EPOCH—Send for catalogue W8.2.

EPOCH.

EPOCH.

EPOCH.

EPOCH.

EPOCH.

EPOCH—16 pages crammed full of real information. Post free.

EPOCH.

EPOCH.

EPOCH.

EPOCH.

EPOCH.

EPOCH.

EPOCH.

EPOCH.

EPOCH.

EPOCH.

EPOCH.

EPOCH RADIO MANUFACTURING Co., Ltd., are the manufacturers. City Office and Service Station, 3, Farringdon Avenue (Ludgate Circus end), E.C.4. Phone: Central 1971 (2 lines). Private Branch Exchange [6972]



It's acclaimed wonderful from Land's End to John o' Groat's

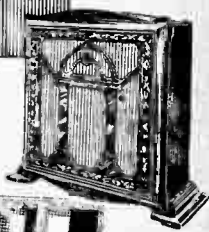

Model U14, illustrated in this advertisement, costs £5:5:0. It is the most wonderful speaker of the season. Below, Chassis Type "F" at £4:4:0.

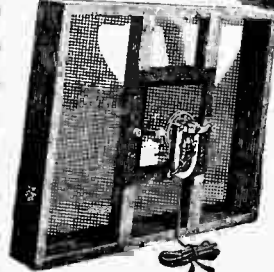

The Air Chrome complete breakaway from the conventional achieves wonders!

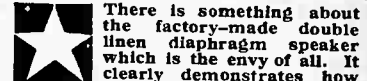

There is something about the factory-made double linen diaphragm speaker which is the envy of all. It clearly demonstrates how the job is done by the vast manufacturing resources of two continents. Do not envy the efficiency of the Ultra Air Chrome. It is not easily attained outside a modern factory equipped with every jot of research data and every manufacturing facility provided by the combined sciences of acoustics and electricity. If you would hear with your own ears, then visit your radio or music dealer. He will convince you in the twinkling of an eye.

IN CHASSIS FORM

Type L	12" x 10" x 3 1/2"	42/-
Type K	14" x 14" x 5 1/2"	52/-
Type F	18" x 23" x 5 1/2"	84/-
Type J	24" x 24" x 6 1/2"	105/-

Stocked by every radio and music dealer from Land's End to John o' Groat's.

ULTRA AIR CHROME

The Speaker with the double linen diaphragm

MODELS FROM 3/96

Ultra Electric Limited, 661, Harrow Road, N.W.10.

The accepted Rolls Royce of Radio is that great success DIX-ONEMETER

It is a Precision Instrument of universal use, with an ingenious system of multipliers which enable full-scale readings of any value to be made over a wide range. One millivolt to 2,000 v., or 50 ohms to 50 megohms. Mirror double scale, jewelled, knife edge. A £10 De Luxe model for only 50/-. Multipliers, 6/6 each.



New A.C. Model **ACONEMETER**. Model **VAC.3**. In case. Is a new Model for measurement of volts on Alternating Current, a 3-range instrument reading 0-150 v., 0-300 v., and 0-600 v. Price, inclusive of case, 75/-. Extra for 1,500 volt Multiplier, 44/-.
TEST SETS. 10 Ranges. Cromptons, Nalders, J. & P. or Evershed, 0-600 v. and 0-500 amps., 10 ranges, £8 10s. Fine 7-range Moving Coil in Case, B52, quite new, 55/-. worth double. **Valve Characteristic Test Cabinet**, 3 Moving Coil Meters on panel, 7 1/2 in. x 9 1/2 in. Socket for test valves, worth £10. Sale £4 each. **A.C. Testers**, 108/B21, 4 ranges, 120 v., 6 v., 200 m/a. and 4 amps., for 40-100 cycle mains, cheap at 45/-. **4-Range Westons**, 2 1/2 in. dial 0-6 a., 0-24 m.a., 0-120 m.a., 0-240 m/v. Cost £4. Sale 40/-. Ferranti Laboratory Sets, mov. coil, mirror scale, knife pointer, 5 ranges, Millivolts to 250 volts, 1/10 milli-amperes to 25 amperes, and all between. Half-price, £4 10s.

ANODE METERS, panel type for 20 m/a. H.T. output from Eliminators, 7/-.
LABORATORY. £50 Set of Sullivan Standard Galvo., Scale and Shunt, £15; 3-range Tinsley Micro Ammeter read to 1 micro., full scale 500, 60/-; Paul ditto, £5; Gambrell Onward, £4 10s.; Univ. Shunt Box, 35/-; Lab. Test Res. Box, plug, from 30/-; Capacity Bridge, .0001 to 10 mfd., £8; Marconi B-T Direction Finder, £5 10s. For rapid readings use a Megger 1,000 ohms to 10 megs., £15. **Get the Best out of your set by using a Dix Onemeter and a Wavemeter.** Paul Type 4-Dial 1 meg. Bridge and Galvo., £9 10s. G.P.O. Standard Bridge, £7 10s. Silvertown Sets, £8. Res. Units, 2/6, Standard Mfd. Units, from 8/-. Wheatstone Bridges, £2 5s., £6 10s. and £10. Campbell Inductometer, £17.

VOLTMETERS. 500 volts, 50/-; 1,000 volts, £3; 1,500 volts, £5; 2,000 volts, £6; 2,500 volts, £6 10s.; 5,000 volts, £7 10s. Large stock of odd Voltmeter and Milliammeters at reduced prices.

MORSE WIRELESS RECORDERS, £7 10s. Magnificent British work, solid brass case, fine finish. Mahogany case with drawer for tape reel. Cost £30.

H.T. GENERATORS, all sizes from 2 K.W., 4,000 volts to the famous 250 watt 500-cycle Alternators, complete with exciter, cost £30, for 70/-.
SPARK. 10in. Marconi Coils, £7; Cox X-ray, £10; 20,000 v., 8/6; 50,000 v., 17/6; Diathermy 1 K.W. 100 v. D.C. to 10,000 v. A.C., £15.

GRAMO PICK-UPS. Magnetic Earpiece Units for making your own 40/- reproducer. Adapted with a little work. Only 1/2 each. In metal case, 1/6. Adapted Brown A Pick-ups, 12/-. Marconi Wave Traps, 15/-.

WE HAVE A WONDERFUL STOCK OF RADIO AND SCIENTIFIC APPARATUS.

Bargain Sale now on.
ELECTRADIX RADIOS,
 218, Upper Thames Street, London, E.C.4

ELEX WANDER PLUGS
 MIDGET & STANDARD
 NICKEL PLATED—6 Colours 2d. each.
J. J. EASTICK & SONS
 "Elex House," 188, Bunhill Row,
 London, E.C.1. 'Phone, Clerkenwell 9282/3/4.

EVERYMAN FOUR, KILO-MAG AND RECORD THREE METAL CABINETS.
 35/- each, or with woodwork 46/6 each.
Kit-Set 27/6 and 38/6 each respectively.
 Finished crystalline Brown, Black or Blue.
 Trade enquiries invited.—Samuel Eaton & Sons (Manufacturers of Lighting Goods), 66/72 Barr St., Birmingham.

BAKERS SELHURST RADIO MOVING COIL SPEAKERS ARE BEST

Loud-speakers.—Contd.

SELHURST RADIO are the pioneer manufacturers of Moving Coil Speakers.

The New 36-page Booklet, "Sound Advice," is yours for the asking.

Our Speakers are of the Highest Grade Throughout, and of proved efficiency.

Get a Baker's Moving Coil Speaker, and you will not be disappointed.

Let Us Send You Our Free 36-page Booklet, "Sound Advice," a postcard will do.

Send To-day for a Baker's Speaker, on 14 days approval for comparative test.

Enjoy the Wonderful Realistic Reproduction Given by Baker's new Speakers.

The Advertisement on Page 29 Illustrates the Finest and most efficient Moving Coil Speaker made to-day.

BAKER'S SELHURST RADIO, Office, 89, Selhurst Rd., South Norwood, S.E.25. Works: 42, Cherry Orchard Rd., East Croydon (always open). [74231]

FINEST Suspension Leather, for fixing cones to moving coil or read units, as supplied to principal makers; 2/- sq. ft., 1/6 10in. square; segments up to 12in. cone sd. for 4; all post free; cash with order.—Dilley, 8, Ashby Rd., Essex Rd., N.1. Clissold 0736. [7458]

MAGNAVOX R4 Model, 6-volt field, heard by appointment; £3/15.—Mackenzie, Palmerston Rd., West Croydon. [7433]

WESTERN ELECTRIC Kone Speaker, 18in., perfect condition, £3/3, can be heard by appointment; Blue Spot 66A, unpacked, 17/6; Ferranti trickle charger, £2; carriage paid.—Williams, Kingswood, Hartford Rd., Bexley, Kent. [7431]

CONSTRUCTORS desiring balanced armature units for reproducers should enquire for complete lists and prices; all types.—F. C. Davies, 31, Abbey St., Tower Bridge, London, S.E.1. [7430]

NEW PUBLIC ADDRESS and Broadcasting MICROPHONE

The Ideal Instrument for addressing Audience through Loudspeaker, and for relaying Speech or Musical Entertainment to any distance.

Powerful Loudspeaker Reproduction without distortion

Highly sensitive Microphone, guaranteed free from distortion or microphonic noises; absolutely silent background; far superior to ordinary Microphone Transmitters; for use with Valve Amplifier or Valve Set (through lead of Gramophone Pick-up if desired) at Open-air Meetings, in Cinema, Theatre, or Concert Hall. Operates from 2 Volt tapping of L.T. Accumulator, through Microphone Transformer. Current consumption one-tenth Ampere. Provided with detachable sound collector and 9 ft. connecting cord, and fixed by rubber-cord suspension hinged nickel-plated frame, on pedestal, 11 in. high; for mounting on Speaker's Platform, in Palpit, on top of Camera Stand; or for suspension from ceiling, as illustration. 25/-

The above Microphone is rendered Directional by attaching the Sound Collector.

MICROPHONE TRANSFORMER

special design to obtain best possible result from sensitive Microphones when connected to high-resistance phones, Loudspeakers, Valve Set, or Valve Amplifier; best Transformer made for clear Speech with volume, modulation speech and music transmission, Publications, etc.; Prim. & Sec. terminal fitted; full directions for use of Microphone and diagrams of connections. Goods by return post. 6/-

FREDK. ADOLPH, Actual Maker, 27, Fitzroy Street, London, W.1. 'PHONE: Museum 8325

BONA FIDE TRADERS' GUIDE.

Send for our comprehensive Illustrated List. QUICK SERVICE. QUICK SERVICE.

THE QUALITY HOUSE.

PERSEUS MFG. CO., LTD. (Dept. W.W.)
 BRANSTONE RD., BURTON-ON-TRENT

BEAUTIFY YOUR SET! Radio Furniture De Luxe Batteries—Speaker—from £3 15s. to £11 11s. 8 ON APPROVAL—you may return at our expense if you wish to part with it. Used by Radio Press—3,000 clients.
PHOTOGRAPHS & LIST 3d.
 Pickett's Radio Furniture Works, W.W. Bexley House

CLEARING STOCKS SURPLUS STEEL MASTS

at below prices to clear.

- 26ft. STEEL MAST, tapering 1 1/2" to 1", Carriage: London, 1/6; Midlands, 2/6; Elsewhere, 3/6. Weighs 28 lbs. 8/-
 - 34ft. Tapering 1 3/4" to 1", Carriage: London, 2/-; Midlands, 3/-; Elsewhere, 4/-. Weighs 40 lbs. 11/-
 - 40ft. Tapering 1 3/4" to 1", Carriage: London, 2/6; Midlands, 3/6; Elsewhere, 4/6. Weighs 50 lbs. 16/6
- A super mast.

OUTFIT with MAST. Mast rings, ample galvanised wire (cut to lengths), Pulley, Cleat, Solid Metal footrest and strong galvanised stay fasteners. Note.—Our Masts are stayed at 4 ground points (not 3), which ensures safety.

ACCESSORIES. Best Manila Rope Haldraps (will not rot), 60 ft. 1/8, 100 ft. 2/6. Special Anti-rust paint (sufficient for mast), 1/8. Coppered earthing tube, 1/8. Special Aerial, has 14 strands of No. 28 gauge Enamelled high conductivity pure copper wire, 100 ft. 3/6. Money refunded if mast returned intact and carriage paid within 7 days.

ADELAIDE STEEL TUBE CO., LTD.,
 KENT HOUSE ROAD, BECKENHAM, KENT.

Mention of "The Wireless World," when writing to advertisers, will ensure prompt attention.

Loud-speakers.—Contd.

R.H. Rico-Kellogg Speaker, 6-volt, latest model, unused; £3/17/6, nearest offer.—28, Rawlins St., Erpohl. [7429]
AKER'S 6-volt Super Moving Coil, pentode winding, heard in use; £3.—Mountview 4414, or write Tuinell Park Rd., N., for appointment. [7419]
DOUBLE Linen Cone Speakers, made with patented chassis and fitted with first class unit, wonderful results; cut price, 42/- complete; carriage paid; now for Christmas; orders taken in strict rotation. Jomford and Co., Post Office Av., Southampton. [7416]

TRANSMITTERS.

CHEBROS. Chebros. Chebros transformers and chokes of all descriptions, special transformers for emitting and modulation; chokes a speciality; enquiries invited.—Chester Bros., 244, Dalston Lane, London, E.8. [5240]

VALVES.

Various Valves, used testing only, all makes and types, 5/- each; 3 Cosmos A.C./G., unused, 7/6 each; D.E.T.1, £2; clearing laboratory of apparatus; enquiries invited.—1, Stapleford Rd., Wembley. [7410]
AMPLIFIER Valve—If you require power you cannot do better than one of these:—
MILAMENT Volta 6, plate volts 400 (maximum), grid bias 84 volts (approx.), impedance 800 ohms, amplification factor 3.8, mutual conductance 55 m.a./volts; price £5/10; see article "The Wireless World," 24th July, 1929, then send to North London Valve Co., Ltd., 22½, Cazenove Rd., Stoke Newington, London, N.16. [7457]
MOSSOR (New Process) 2v. Pentode, unused; 17/—14, Vegal Crescent, Englefield Green. [7437]

WIRE.

WIRE of Every Size and Kind from The Beaver Engr. Co., 4, Upper Grosvenor Rd., Handsworth, Birmingham. [6897]

COMPONENTS, ETC., FOR SALE.

PELLING-LEE Panel Fittings are designed to give an expert finish to any home-constructed set; catalogue post free.—Belling and Lee, Ltd., Queensway Works, Ponders End, Middlesex. [7018]

Output Means Fresh Goods; fresh goods are better; you can rely on fresh materials from the retailer's, retail radio distributors with a wide market.
BRIEFLY—here is our service, simple, straightforward, fair. A not-too-dull brochure, more fully descriptive, will be sent to you, immediately, on request.

Supply Practically all the Leading Lines of Radio Apparatus at current list prices, and make no carriage charges, except on accumulators and batteries and exceptionally bulky articles.
If You Wish we will take in part exchange any branded receiver, component or loud-speaker for which you have no further use, providing such is reasonably modern and in workable condition.

Make Fair Offers we must see the material; on receipt of a parcel, which must contain a list of contents and name of sender, we will send our offer, which is as an allowance from an order for the requirements totalling not less than twice the allowance—but it is fair. In the unlikely event of agreement being reached, we will return your material carriage paid; you need have little fear for our returns in this respect have always been below the average per cent. We cannot execute part exchange orders of less than 10/- net cash value—that is, after part exchange allowance has been deducted.

Above Terms Exist that fair offers may be an economical possibility, and a sound standard maintained; particular points of questions are elucidated in a little folder, "The Ins and Outs of the Terms and Ins"; a copy post free on request.

PLEBY'S, specialists in distribution by mail and the originators of radio part exchange, No. Forty in Chapel St., Marylebone, London, N.W.1 (station opposite, Edgware Rd., Metropolitan Railway). [7316]

NYLANITE, the most artistic panel known; only 2/- and 3/- per sq. ft., according to pattern; particulars and samples free (1/4d. postage).—Marsh and Wright, 5, Royal Arcade, Weymouth. [7317]

YOUR Old Components Taken in Part Payment for Latest Type; see our advert, in column receivers for sale.—Scientific Development Co., 51, Shergate, Preston. [7028]

CLIMAX ALL-ELECTRIC RADIO



Climax H.T. Mains Units this Xmas. For your own set and to give to your friends. The best you can get—the best you can give. Popular prices. Every modern improvement. A.C. models have new metal rectifying units eliminating all valve trouble. Negligible upkeep costs. Ten Voltage Tappings. For all Mains Voltages 40/100 cycles.

A. C. Model U.20. Price £4. 5. 0
Up to 120v. H.T. Up to 20 milliamperes.

A. C. Model U.50. Price £5. 15. 0
Up to 200v. H.T. Up to 50 milliamperes.

Improved D.C. Model H.T. Unit—the most popular D.C. Mains Unit on the market—has ten voltage tappings. Output 50 m/a total, 10 m/a at tappings.

Price complete £1. 14. 0

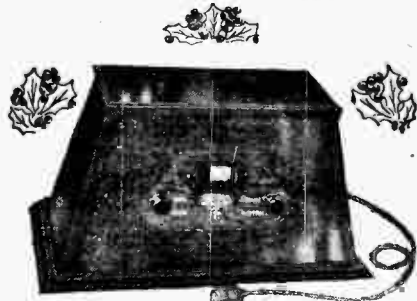

CLIMAX CHELLOSET.

an amazingly selective long range 2-valve all-electric receiver.

Many important features, one dial tuning, dual wave switch to eliminate coil changing, Westinghouse metal rectifier Volume control. No batteries whatever. Operates entirely from A.C. Mains. Walnut finished cabinet.

Price only £9. 17. 6.

complete with valves, royalties and full mains equipment. The finest value yet offered in all-electric receivers.

Obtainable from all radio dealers.

CLIMAX A YEAR AHEAD

Climax Radio Electric Ltd., Haverstock Works, Parkhill Road, Hamstead, London, N.W.3. Telephone: Primrose 1171-2.

Components, Etc., for Sale.—Contd.

VENER Wood Paper Converts Commonest Woods into Oak; 30in.x20in., 8d.—Burtenshaw, Hillsborough Terrace, Ilfracombe. [7351]

600-OHMS Decoupling Resistances; see advt. under Coils. — Groves Brothers (Manufacturers). [7175]

EXPERIMENTEE'S Surplus.—Large selection valves, coils, condensers, variable and fixed; send for list.—Irving, 15, Reddons Rd., Beckenham. [7363]

CONTROL Your Receiver from That Other Room by means of the Foolproof and Inexpensive Yarg Relay, no maintenance or attention, models for battery and mains operated sets; patent pending; single make and break, 10/6; double, 17/6; triple, 22/6; post free; stamp particulars.—"Yarg," 1, Eccles Old Rd., Manchester. [7248]

ZAMPA Cone Chassis, 4/-; Tefag cone unit, 15/6; Hegra moving coil 6v. 0.5 amp., 50/-; Tefag cone speaker, 19/6; Zampa aerial (uncr. 6/6; 6-pin coils, 2/3 each; Formo transformer, 5/- and 5-1, 3/- each; Watmel auto choke, 6/6; 2-volt 40 amp. accumulator, 10/6; gramophone pick-up, Acouston, 7/6; Hegra, 7/6; Igranic, with control, 12/-; Daru 4v. Pentode valve, 10/-; 6 Eagle and Triotron valve, 4v., 2/3 each; Mullard ½-wave rectifier, 9/-; eliminator transformer, full wave, 300v., 16/-; Saba push-pull transformer, 10/-; heating transformer, 3.5v. 2 amp., 7/6; mostly new condition; stamp reply.—Simpson, Jesmond Place, Leeds. [7323]

SALE—Marconi 6-volt M.C. speaker, 2 Osram P625 valves, matched for push-pull, Ferranti trickle charger, all perfect; offers invited.—"Pont-y-bren," Llysven Rd., Cyncoed, Llanishen, Cardiff [7379]

ELECTRICAL and Wireless.—What is it you require; write and let us quote; new or second-hand; quality with cheapness.—J.M. Supplies, 570, Woolwich Rd., S.E.7. [7385]

GRAMOPHONE-RADIO Surplus.—Ekco H.T. unit, A.C. 110 mains (220 volts 45 m.a., tapping 110), £3/10; D.C. unit (smoothing set) for H.T. direct from any D.C. mains, £2; R.A. Varley pick-up (new), 30/-; 2 L.S.5 valves (new), 15/- each; 2 H.M.6 C.A.V. 60-volt H.T. accumulators (6 months' service), 15/- each; Marconiphone 4.5-1 transformer, 12/6; J.B. var. 0.0003 condenser, 5/-; Dubilier 0.0005, 5/-; set of 4 Master Three coils with base, 10/-; wire-wound resistances (reliable makes), 150,000, 100,000, 80,000, 60,000, 40,000, 30,000, 20,000, 3/6 each.—Snow, Burnham Thorpe, Eton, Tel.: Windsor 62. [7393]

POTENTIAL Dividers 10,000, 15,000, 20,000, 25,000 and 30,000 ohms, 5 variable tappings; 2/- each.

POTENTIAL Dividers, heavy duty, wire wound, 15,000 and 20,000 ohms, 7 tappings, 5/6; 4 tappings, 3/9.

CONDENSERS, 2 mid., 2/3; 4 mid., 4/-; guaranteed; tested 500 volts.

CHOKES (L.F.)—Excellent for smoothing, up to 2 milliamps, 2/-; special heavy duty, 10 milliamps, 8/6.

ELIMINATORS, A.C., wired for half or full wave, complete with valve; £3/17/6.

H.F. Chokes; 3/-.

GRAMOPHONE Motors, well known make, double spring, silent, complete with fittings; 50/-.

SPECIAL Bargain—B.T.H. 40 henry chokes; 9/6; any article on approval against cash.—Huggins, Radio Engineer, Clacton-on-Sea. [7398]

FERRANTI L.T. Charger (200v.), 40/-; P.X.650 valve, 15/-; H.L.610, 6/-; P.M.5B, 6/-; 66K, 17/6; Burndep Ethovox, 40/-; R.I. 5-1, 15/-; oak cabinet, 26x26x9, 45/-; 2 0.0003 Dubilier, variable, 17/6; all perfect.—McMillen, 39, Malvern Rd., Walsley. [7399]

McMICHAEL Supersonic Unit, Broadcast wave length, £2/10; with 4 4v. valves, £3; also Mullard 0.40 valve, £1.—Tomkins, 238, Drakelet Rd., S.E.4. [7407]

CRESCENT 5-range Meter, 30/-; B.T.H. pick-up and arm, 24/6; Osram 8625, 10/6.—B.M./WSGF, London, W.C.1. [7404]

A TRANSPORTABLE Wireless Cabinet, 8 valves, 5 fixed resistors, and a few odd components, little used; price, in one lot, £1/1, carriage extra.—Box 4064, c/o The Wireless World. [7470]

VALVES, components, etc.; state requirements; offers.—Box 4065, c/o The Wireless World. [7466]

BROWN'S Vee Unit, 13/6; R.I. Hypermu transformer, unused, 11/6.—Box 4063, c/o The Wireless World. [7465]

L.T. Charger, valve rectifier, 2-4-6 volts at 1-1.5 amps., 200v. A.C., 35/-; Bodine tapped frame aerial, 10/-; set of Igranic S.W. coils, 5/-; postage extra.—B. F. Vaughan, 4, Ilford Av., Wallasey. [7459]

CUT Out that Unwanted Station with a Gordon Wave Trap; price 6/6, post free.—The Universal, 20, Victoria Rd., Peckham, S.E.15. [7455]

Brownie

2/6

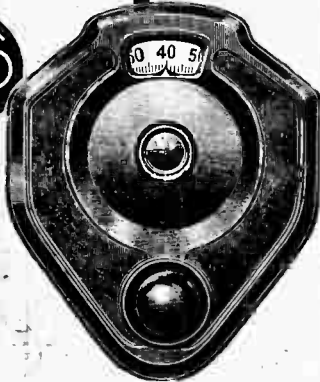

the 'DOMINION' Slow Motion Dial

A Vernier Dial at 2/3! Bring your set up to date by fitting this slow motion dial. The mechanism is of special non-backlash construction which makes very fine tuning easy. Finished in smooth black or beautifully grained mahogany, bakelite.

Brownie

wireless

NELSON ST. WORKS, LONDON, N.W.1.

A thoroughbred among panels!



Resiston Panels stand supreme! Beautiful in appearance—everlasting in strength. Fit a Resiston Panel to your Set and bring it right up to date. You'll make it look even better than many of the most modern Receivers. Ask your Wireless Dealer for particulars, or write direct.

RESISTON PANEL

American Hard Rubber Co. (Britain) Ltd., 13a, Fore Street, E.C.2.

2481

Components, Etc., for Sale.—Contd.

RADIO HOUSE, HUDDERSFIELD (13th winner).
EXTRAORDINARILY
LUCID
INFORMATION
ACCUMULATED
BRILLIANTLY
INSIDE
LIST.
ILLUSTRATED
TASTEFULLY.

YET This Mine of Information is Absolutely Free. A satisfied Littlehampton reader sent unsolicited testimonial: "Your firm is 'streets' ahead of some of the London houses for business." This unsolicited reputation we endeavour to uphold.

WHOMEVER
INQUIRES
RECEIVES
EXCELLENT
LACONIC
ENLIGHTENMENT.
SUPREME

SATISFACTION. So, when inquiring, endeavour submitting similarly composed advertisement, using the words "Reliability Wireless Guide," so as to encourage readers to apply for this list. Weekly change of matter desired. A 100-volt H.T. battery for each effort published, and useful consolation prizes given.

GIVES
UNFAILING
INTERESTING
DISCLOSURES.

EUREKA!—The Guide will be sent post free by J. H. Taylor and Co., 15, Radio House, Macaulay St., Huddersfield, to whom competition efforts should be submitted, indicating also if name and address publishable if successful. (Only 23 alternative words required, Radio House, Huddersfield, remaining. One word for each initial following). Prize-winner from Newport. [7471]

CELESTION C.L.20, oak, £6/10; Ostram Music/Magnet, £7/15; Ecco 3F.20 for A.C., £3/10; carriage paid; all unpacked; sickness causes sale.—34, Hanover St., Birmingham. [7454]

NEW 0.0005 Igranic Lokvane, 5/-; 2 new PM5X valves, 5/6 each.—BM/BP6B, London. [7453]

BURNDEPT Pick-up, 10/6; SP16G, 5/-; Amplion A.C.2, 11/6; Pye 20H, 7/-; wirewound, 20,000, 100,000, 2/-; mica, 0.05, 2/9; Lissen R.C., 2/-; S.W. kit, 15/-; guaranteed; lists.—Pepper, Wako Green Rd., Moseley, Birmingham. [7448]

CONDENSERS, Hegra and Dubilier Drum, 0.0005, 7/6; Loewe pick-up, 12/6; Watmel arm, 4/6; £5 Brown loud-speaker, 30/-; Ferranti trickle charger, 30/-; Mullard R.C. unit, 9/6; Precision testing set, 6 readings, 35/-; Titan coils, 9/6; Bradlyohm E10, 4/6; Sterling phones, 5/-—40, Cranleigh Rd., West Green, N.15. [7447]

R.I. Choke (14/7H), 14/6; R.I. RCC unit, 8/6; R.L. SM dials, 3/- pair; Marconi mains transformer C, 25/-; pair Lewcos SW coils, 7/6; Colvern aerial, 2/9; Lewcos SP aerial, 3/-; HFSS 3/9; all LW Lissen, EB Gambrell, 50, 75, 100, 1/-; Igranic, Frost rheostats, 1/-; Mullard WW, 100,000, 2/9, 250,000 3/9; Dimic 1A, with base, 3/-; Silvertown telephone transformer, 3/9; oak cabinets, 18x7, 15/-, or exchange these only.—G. Ryall, 182, Kennington Rd., London. [7442]

A.F.5, 17/6; P.M.14, P.M.24, 11/6 each; P.M.4D, 4/6; Royalty variable 500,000 potentiometer, 4/-—Saville, 25, Valleyfield St., Glasgow. [7435]

ORGOLA Parts.—Panel, condensers (gang, trimmer, reaction), coils, switches, brackets, S.G. holder, used 2 weeks, 57/6 the lot; Burndept D.P.D.T. switches, 2/3 each; Utility, 2/-; Elfin, 0.0001, 2/6.—55, Thornton St., Skipton, Yorks. [7427]

PM14, unused, £1; 8625, 10/-; Varley transformer for HT3, £1; coil formers, bases, condensers, etc.—5, Hopewell Terrace, Horsforth, Leeds. [7423]

THE Universal Gives the Biggest Value in Part Exchanges; write, phone or send what you have—what you require.—The Universal, 20, Victoria Rd., Peckham, S.E.15. [7456]

Say 99!

EPOCH

NEW MODEL 99 P.M.
MOVING COIL SPEAKER
will satisfy the most critical of listeners.

No accumulator, no mains,
no suspension, no adjustments—
7 days' free trial.

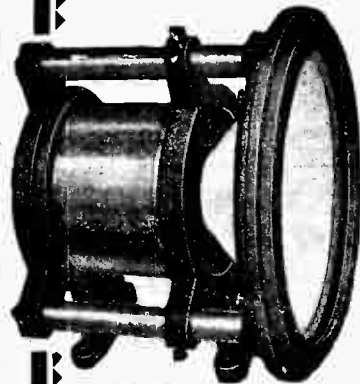

Send for new 16-page Catalogue of real information.

EPOCH RADIO
MANUFACTURING CO., LTD.,
3, Farringdon Avenue :: E.C.4.
Phone: CENTRAL 1971/2.

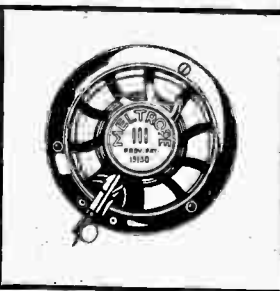

The Sound Box that never tires!

—“bring your old Gramophone up-to-date in time for Xmas!”

by fitting the new MELTROPE Sound Box, its greater definition, forward tone, and range being wider than many Sound Boxes costing more than double.

Suitable for all types of tone-arm.

PRICE 12/6

AMPLIFIERS LTD.,
Billet Road,
Walthamstow, E.17.

A New



MAINS UNIT FOR PORTABLES

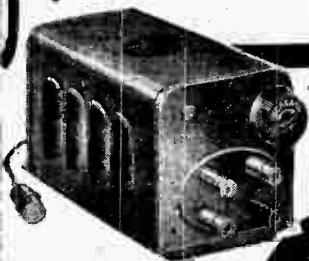

A.C. MODEL
£4 : 5 : 0
D.C. MODEL
£2 : 15 : 0

How you can run
your Portable off
the electric light!
(A.C. or D.C. Mains)

This new Regentone
H.T. Mains
Unit fits *inside* any
Portable Receiver,
and possesses all
the advantages of
our
Standard Models.

Write to-day for FREE
copy of our ART
BOOKLET "Radio
in the Mains,"
which gives full particulars
of all Regentone
Products—Mains
Receivers, Mains
Units, Trickle Chargers,
and Mains Comments—and includes
details of our Hire
Purchase Terms.

Treat yourself or your
best friend to a really
useful Xmas Present this
year—a Regentone Mains
Unit or Trickle Charger.



For Radio from the Mains

REGENT RADIO SUPPLY CO. 21 Bartlett's Bldgs
Holborn Circus, London, E.C.4 Telephone
2424, 2425

**IT
FITS
HERE**

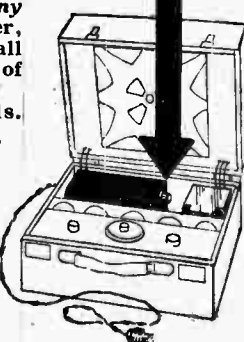

MISCELLANEOUS.

EXPONENTIAL Horns for Cabinet Gramophones and
Wireless, metal and wood; list.—Maddison, 1,
Chapel St., Marylebone, N.W.1. [6143a]

EASY Payments.—We supply, by easy payments,
components, accessories, and sets, any make; 10%
down, balance spread over 10 months.—Send list of
requirements to London Radio Supply Co., 11, Oat
Lane, London, E.C.2. [0097]

WIRELESS Notes.—A monthly service of informa-
tion for all those who want the very best in
wireless or gramophone reproduction; frank criticism
of receivers and components; immediate postal help
and advice in all difficulties; something new and
unique; you must have it if you want to know the
truth.—Full particulars free from Ernest H. Robin-
son, Langmead, Pirbright, Woking, Surrey. [6144]

ALEXANDER BLACK.

PLEASE Note New Address.

THE Original Wireless Doctor, will call (London and
Home Counties) and cure your set.

CONSULTATIONS by Appointment Without Obliga-
tion, sets installed, maintained, and brought up
to date, gramophone pick-ups, eliminators, and Web-
son moving coil speakers demonstrated; purity repro-
duction specialist.

55, Ebury St., Victoria, S.W.1. Sloane 1655. [0277]

SCOTT SESSIONS and Co., Great Britain's radio
doctors, officially approved as wireless repairers
by Radio Society of Great Britain and Wireless League;
old sets of every type repaired, rebuilt, modernised;
send set for immediate quotation.

SCOTT SESSIONS and Co.—Midland customers, please
send address to us and our Midland representative
will call.

SCOTT SESSIONS and Co.—New sets constructed
with your or our components, guaranteed finest
workmanship; we specialise in "The Wireless World"
circuits; remember, we have satisfied customers
throughout the British Isles and in three Continents;
if you so desire, we will design and construct high
grade apparatus to suit your special circumstances for
quality, range and selectivity.—Tel.: Tudor 5326. Mus-
well Hill, London, N.10. [0262]

YOUR Old Apparatus Taken in Part Payment for
Latest Type; see our advert. in column Receivers
for Sale.—Scientific Development Co., 51, Fishergate,
Preston. [0229]

PATENTS.

THE Proprietor of British Patent No. 176128 is
prepared to sell the patent or to license British
manufacturers to work thereunder. It comprises a
wireless signalling system having inductively coupled
2-loop aeriols.—Address Boulton, Wade and Tennant,
112, Hatton Garden, London, E.C.1. [7444]

PATENT AGENTS.

PATENTS and Trade Marks, British and foreign.—
Gee and Co. (H. T. P. Gee, Member R.S.G.B. and
A.M.I.E.E.), 51-52, Chancery Lane, London, W.C.2.
Phone: Holborn 1525. [0001]

REPAIRS.

TWELVE Months' Guarantee Accompanies all our
Repairs; any make of I.F. transformer, head-
phones, or loud-speaker repaired and despatched within
48 hours; 4/- post free; don't discard if burnt out;
terms to trade.—Transformer Repair Co. (Dept. W.),
214, High St., Colliers Wood, S.W.19. [0011]

REPAIRS Returned Post Free, and to ensure satis-
faction send remittance after approval of same.
—Leeds Wireless Repair Service.

LOUD-SPEAKERS, headphones, rewound to any
resistance and remagnetised, 3/-; transformers
rewound, 4/-; Blue Spots, Triotrons and 4-pole units,
4/6; work guaranteed.—Leeds Wireless Repair Service,
5, Boston Place, Green Rd., Leeds. [7250]

SCOTT SESSIONS and Co., Great Britain's radio
doctors; read advertisement under Miscellaneous
column. [0263]

KINGSTON-ON-THAMES.—Transformers, 'phones,
loud-speaker repairs; transformers wound to any
ratio.—Minter, 156, Cambridge Rd. [7269]

GUARANTEED Repairs by Experts.—Loud-speakers,
head phones, cone units, pick-ups, any type, re-
wound, remagnetised and adjusted, post free, 4/-;
transformers from 4/-.—Howell, 42, Potheringham Rd.,
Enfield, Middlesex. [7420]

WANTED.

"WIRELESS WORLD" from 1926 to 1928, bound
or unbound.—E. Thomas, Worsley St., Hulme,
Manchester. [7294]

WANTED for Cash, 2-valve all mains sets; or highest
price given in part payment for any new set.—
Oakthorpe Garage, Palmers Green, N.13. [7406]



AS BRITISH AS BRITANNIA

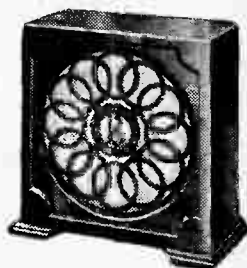

The Brown DUPLEX LOUD SPEAKER

An entirely new loud speaker. Gives
finer results due to new Brown "Vee"
Reed and Duplex Cone principles.
Pure tone and rich volume. In three
models: V.10, £5 10s; V.12, £7 10s.;
V.15, £12 10s.

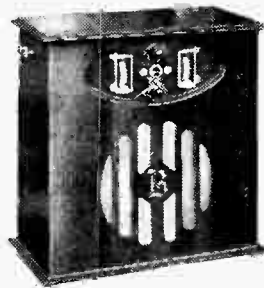

The Brown S.G. Receiver

The secret of the successful perform-
ance of the Brown Receiver (it gets
over 40 Stations in an hour) is the
honest value that is put into it. Only
the finest components that money can
buy are used. In 4 models: Type
A (for battery operation) £12 7s. 6d.
Type A.M. (for mains operation)
£20 10s. Types B. and B.M. £9 7s. 6d.
and £17 10s. respectively. All models
also supplied in kit form at slightly
lower prices.

Ask your Wireless Dealer for
particulars of Easy Payments.



From all Radio Dealers. Write for Catalogues
and full particulars, to Dept. D.

S. G. BROWN, LTD
Western Ave., North Acton, W.3.

The MIRACLE

World's Wonder Sets STATIONS ROLL IN

Sold at **FACTORY PRICES**, complete with **Cosmor Valves**, ready for listening-in, with Grand Model Cabinet Cone or Horn-type Loud Speaker. Yours for **5/-** deposit. Nothing more to pay for a month. Purchase completed by easy payments. **QUICK DELIVERY.**

£2 GRAMOPHONE Electric Pick-up

FREE to all who write NOW for Free Illustrated Art List and order WITHIN 10 DAYS.

Special Offer of **SCREENED GRID & ALL ELECTRIC MAINS SETS.**

5 DOWN SECURES a 2,3 or 4 VALVE SET



CONE or HORN-TYPE LOUD SPEAKER

Write for Lists **WORLD'S WIRELESS STORES,** Wallington Surrey.

AT LAST!

A Solution to All Trouble of Volume Control and at Moderate Price

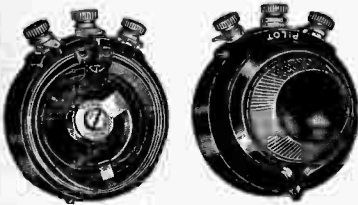

The PILOT VOLUMGRAD

This is a Smooth Action Variable Resistor especially designed for Volume and Oscillation Control. With One Turn of the Knob the Volume can be Adjusted from Zero to Maximum.

In Four Resistances:—
50,000 ohms. **EACH**
100,000 " **6'6**
200,000 " **6'6**
500,000 " **6'6**

Also all lines manufactured by the Pilot Radio and Tube Corporation of New York, the largest manufacturers of wireless parts in the world.

Write for a Catalogue to:—
THOMAS A. ROWLEY LTD.
59, Skinner Lane, Birmingham.
Sole Agents for Great Britain and Ireland.

Wanted.—Contd.

WANTED, B.T.H. pick-up and arm, Blue Spot unit, S410, U8, U5, or similar valves.—Newsomes, 12, Wolves Lane, Palmers Green. [7426]

WANTED, Ferranti multi-range valve Tester.—Browne, 6, Oban Rd., Bournemouth. [7440]

A.C. Eliminator Components: D.E.5A, megostat, H.F. L.F. chokes, Kisha arm, gramophone motor.—Shepherd, "Beltinge," School Rd., West Wickham. [7436]

BURNT-OUT Transformers Required; top prices paid.—Post to Radio Manufacturing Co., Talza Arcade, Southend-on-Sea. [7418]

EXCHANGE.

YOUR Old Apparatus Taken in Part Payment for Latest Type; see our advert. in column Receivers for Sale.—Scientific Development Co., 51, Fishergate, Preston. [0230]

THE RADIO EXCHANGE, Treville St., Plymouth, the exchange specialists; a trial solicited. [7324]

WE Accept in Part or Whole Exchange, any type of components or sets; write for quotation.—Radio Supplies, 138, High St., Shoreditch, E.1. [7415]

CONDENSERS, T.C.O., 2-6 m.f., 600 volts, exchange for anything wireless.—Hedges, 70, Chadwick Rd., Nottingham. [7394]

NINE Chinchillas, Bostock and Smiths, for valve set or kit.—Williams, Maker, Plymouth. [7388]

AGENCIES.

AGENTS Wanted Ideal H.T. Accumulators, 60 volt 32/-, 120 volt 58/6; good terms.—Pearson, 29, Midland Rd., Bournemouth. [6414]

AGENTS Wanted, spare time, wireless experience, to demonstrate and sell the world's best and cheapest 3-valve set.—Mag-Radio, 112, Warstone Lane, Birmingham. [2667]

BUSINESSES & PROPERTY FOR SALE, TO BE LET, OR WANTED.

WIRELESS Retail Business, in North Devon, growing rapidly, big scope, no opposition; £300, including fixtures, s.a.v.—Box 4054, c/o The Wireless World. [7412]

SITUATIONS VACANT.

WIRELESS Operating Appointments Assured; short qualifying course, day, evening; fees payable after appointment for boarding students; Morse classes.—Manager, Wireless School, 21, Manor Gardens, London, N.7. Archway 3694. [6379]

WANTED, wireless mechanic for reconstructing broadcast sets and assisting in shop work.—Apply S. E. Walker, Southgate, Sleaford. [7318]

SITUATIONS Guaranteed as Wireless Operators, age 15-29; day, evening, or postal courses; Morse classes.—School, 321, Mansfield Rd., Nottingham. [7360]

CHIEF Radio Engineer for Factory, components and receivers, capable executive man with expert knowledge up-to-date circuits, commercial experience essential; write full details education, training, experience, age, salary.—Box 510, Scils, Fleet St., E.C.4. [7384]

RADIO Engineer Required for Channel Islands, must have sound knowledge, practical experience of fault finding, repairing, and installation of all types of receivers.—Full particulars of experience, age, and salary required, Box 4055, c/o The Wireless World. [7413]

WANTED for Talking Pictures, young men (aged 21-30) to be trained as sound engineers; applicants must possess thorough knowledge of high-power amplifiers, general electrical work, and be capable of controlling volume of talking films in cinemas; also prepared to accept positions in provinces; only young men of good appearance and high standard of education need apply, by letter only, stating previous experience and salary required, to Sound Controller, New Gallery House, Regent St., W.1. Practical men only considered. [7396]

SITUATIONS WANTED.

WIRELESS Operator, over 10 years in charge ship stations, desires position ashore, wireless or anything electrical, sound technical and practical knowledge, good correspondent, would manage department, or suit sales, wireless or accumulator manufacturers.—Box 4042, c/o The Wireless World. [7392]

EX-WIRELESS Operator, 5 years' experience, desires employment as demonstrator, or other suitable; drive car.—Box 4059, c/o The Wireless World. [7460]

"B.A.T." 750 Watt "Q.M.B." SWITCH.

This miniature switch comfortably breaks 3 Amperes at 250 Volts. For H.F., L.F., H.T., L.T. Circuits. For A.C. Sets, Eliminators, Gramophones, and as Loud Speaker Field Switch, etc.



"WIRELESS WORLD" said (14.8.29) "functioned quite well on test and did not give any cause to justify doubt as to their ability to handle this wattage" (750 Watts!). "Ideal for use in portable sets and in all types of mains equipment."

"B.A.T." "Q.M.B." POWER SWITCH only 2/6 Each.

CLAUDE LYONS LTD.
76, OLDHALL STREET, LIVERPOOL.

These Cabinets are made by experts and are thoroughly electrically sealed with Fine Brass Gauze

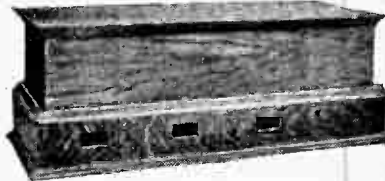

W.W. as specified **CABINETS.**
RIGBY & WOLFENDEN
10, Great North Wood, Millnrow Road, ROCHDALE. 'Phone 294

For the Best in Radio

WILL-DAY LTD.
(THE BEST IN THE WEST)
10 LITTLE STREET, LEICESTER SQUARE, LONDON, W.C.2.
Wholesale—10, Abchurch Lane, London E.C.4. Telephone, 2539.
OPEN TILL 7 P.M.
WRITE FOR OUR CATALOGUE
POSTAGE 6d FREE TO CUSTOMERS



MAKE A GRAMOPHONE BUY CABINETS FOR WIRELESS at a quarter shop prices. Order set as shown. British double spring motor, 12" velvet turntable, Swan Arm, Metal Soundbox, amplifier, needle cups, for £1-15-0 and build your own Cabinet. Machines sold by others at £10-£20 not contain better fittings. Motor from 8/6. Repair Parts. Lists free 64 pp. 1930 Catalogue, drawing how to make Gramos, 3d.

PORTABLE GRAMOPHONES: REGENT FITTINGS CO. (W.O.)
from 21/- Post 1/6. 120, Old Street, London E.C.1.

Your First Steps in Wireless

By **HUGH S. POCOCK**
Editor of "The Wireless World"

A most helpful little book for those who are beginning to study wireless. It explains technical difficulties by simple analogies.

Price 9d. By Post 11d.
From **ILIFFE & SONS LIMITED**
Dorset House, Tudor Street, London, E.C.4.
and leading booksellers. w.w. 14

Mention of "The Wireless World," when writing to advertisers, will ensure prompt attention.

BOOKS, INSTRUCTION, ETC.

VET H.T. Batteries are now a proved success; write for new illustrated booklet, giving cost and method building and maintaining free; mention paper-floor, 57, Studley Rd., Stockwell, London. [0077]

TEP by Step Wireless; a complete course of the theory of electricity in relation to the practical sign of wireless apparatus, eliminators, circuits, etc., with extracts from a designer's notebook, giving up-to-date practical application; issued weekly; send 1/- p.o. for first 4 weeks.—Clifford Pressland, A.M.I.E.E. Eng. apt. W.W., Hampton-on-Thames [0195]

INVENTOR'S Guide on Patents.—T. A. A., 253 (W), Gray's Inn Rd., London, W.C.1. [6373]

ACCUMULATOR Charging, Maintenance and Repair. By W. S. Ibbetson. A handy guide to the charging and upkeep of accumulator for wireless work motor cars; 3/6 net.—Of booksellers or Pitman's,arker St., Kingsway, London, W.C.2. [7068]

SET of Books, Famous Lives, in 3 Volumes.—Steel, 63, Parolles Rd., Ilighgate, London, N. [7439]

A First Class Mechanical and Electrical Designer

of Radio Sets and Apparatus IS WANTED

for large Works in London, S.W.

Thoroughly competent and energetic man with good experience and preferably about 30 years of age.

Write

Box No. 4015, c/o *The Wireless World*.

Applications will be treated as strictly confidential and should state full particulars as to age, past experience and salary required.

WORLD'S FINEST VALUE

Graves 'Vulcan' 2-Valve Wireless Set is the World's greatest achievement in Wireless Value and Efficiency. Even if you are only a beginner, this magnificent installation will enable you to start where others leave off; or if you are an experienced wireless operator, this superb set will give you a sense of power and command over the mysterious forces of the ether which will



TERMS Our Inclusive Bargain Price is for deferred payments. Send 10/6 now, and 14 Monthly Payments of 10/6 if satisfied after trying Outfit in your home. Money back if at all disappointed.

SPECIFICATION Cabinet (as illustrated below) of polished Oak, beautifully finished with hinged lid; all internal parts (including valves) easily accessible. Dull Emitter Detector and Power Valves of proved efficiency, anti-microphonic valve holders. No coils to change. Latest type H.T. Battery; 2-volt Accumulator, and complete Aerial Outfit. Cost of upkeep negligible. **The LOUD SPEAKER** (as illustrated) is of exclusive design Cabinet Type in Oak to match the Set. Finest tone and wide range of musical frequencies. The Unit being of the 'four pole' balanced armature type, with a large magnet, ensuring perfect reproduction. **Price complete and Carriage Paid £7. 17. 6**

ANOTHER WONDERFUL BARGAIN IS THE GRAVES SCREENED GRID THREE-VALVE WIRELESS RECEIVING OUTFIT

Complete in every particular. Wonderful range and amazingly good reception. Exclusive Oak Cabinet and Cabinet Loud Speaker. All components of highest quality. Carriage Paid **£12:15**

TERMS: 15 - with Order, & **15** - Monthly CATALOGUE POST FREE. Full Particulars and specifications of both Sets; also newest types of Portable Sets, and other varieties of high-class Receiving Apparatus.

J. G. GRAVES Ltd. SHEFFIELD

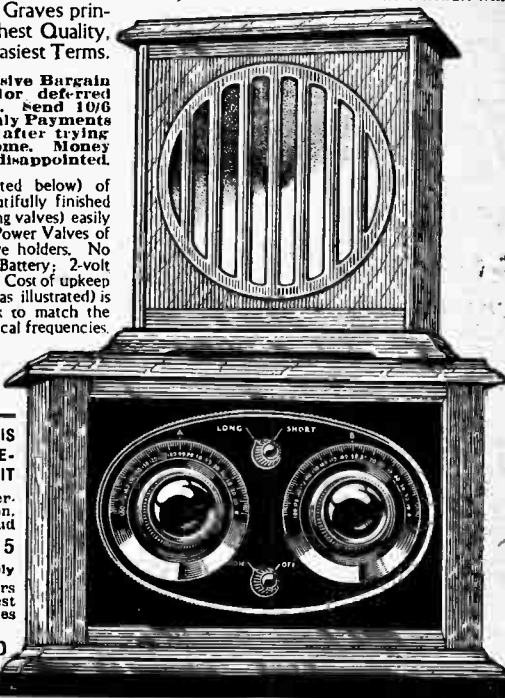

From a recent advertiser's letter:

"I must say your paper is a good advertising agency."

C. R. PEARCE,
St. Germans,
Cornwall.

W.W.46

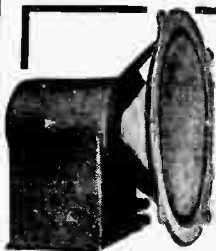

"THE MUSIC LOVER'S CHOICE"

Radio - Gramophone music and speech reproduced with amazing and uncanny realism. The most efficient speaker money can buy.

BAKER'S 'Selhurst' RADIO

SEND TO-DAY FOR OUR FREE 38-PAGE BOOKLET "SOUND ADVICE."

Offices: 89 Selhurst Road, S. Norwood, S.E.25.
Works: 42 Cherry Orchard Road, E. Croydon.

SOLVE ALL H.T. TROUBLES



Per doz.	No. 1.	No. 2.
Jars (waxed)	1 3	1 6
Bags	1 2	1 9
Zincs	10	11
Rubber Bands (24)	4	4
Terminals	8	10

Special sizes for Pentodes.



LONG LIFE: SILENT: ECONOMICAL

Sample doz. (18 volts), complete with bands and electrolyte. No. 1, 4/1; No. 2, 5/-; post 8d., terminals extra. No. 3, with terminals, 7/6 (10,000 milli-amps), sample unit 6d. Orders 10/- carr. paid. New illustrated catalogue post free.

FREE Bargain List of Receivers, Amplifiers and Components.

G. TAYLOR, 57, Studley Rd., Stockwell, London.

"Scientific" Radio-Gramophone Cabinets and Logarithmic Horns

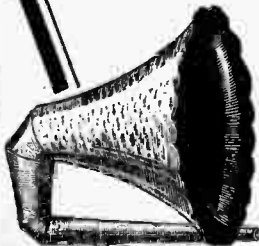

- No. 635 Length 5 feet, Flare 25" 19/6 carr. fwd.
- No. 635 Folded (as illustrated) 25/6 carr. fwd.
- No. C1 Length 4 feet, Flare 18" 15/6 carr. fwd.
- No. C2 Length 40", Flare 17" 12/6 carr. fwd.
- Western Pattern, Height 25", Flare 15" 6/9 post paid
- Western Pattern, Height 19", Flare 10" 4/9 post paid

These cabinets are built to accommodate a combined Radio-Gramophone, or a Radio Set or Gramophone separately as desired. Excellently finished in Oak, there is ample space to make your apparatus absolutely self-contained. We can supply all parts necessary to build a complete Radio Gramophone, 5 Valve Set, or Gramophone. Full building instructions given with each order. Dimensions overall: Height 39", Width 22", Depth 18". Receiver Compartment: 20" x 7" x 15" deep. Battery and L.S. Compartment: 21" x 16" x 15" deep. Platform for turntable etc.: 21" x 15" x 6". Cabinet only **£3:18:6**

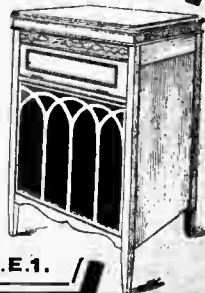

SCIENTIFIC SUPPLY STORES, 126, NEWINGTON CAUSEWAY, LONDON, S.E.1.

INDEX TO ADVERTISEMENTS.

PAGE		PAGE		PAGE	
Accumulators Elite	28	Ever Ready Co. (G.B.), Ltd.	5	Ormond Engineering Co., Ltd.	Cover 11
Adelaide Steel Tube Co., Ltd.	28	Exact Manf. Co.	5	Paroussi, E.	24
Adolph, Fredk.	30	Exide Batteries	5	Partridge & Mee, Ltd.	18
American Hard Rubber Co. (Britain), Ltd.	30	Fairfield Tube Co.	34	Perseus Manf. Co.	28
Amplifiers, Ltd.	30	Ferranti, Ltd.	4	Pertrix, Ltd.	17
Appley, E. Hetherington	23	Gambrell Radio, Ltd.	2	Phillips Radio	3 & 6
B. & J. Wireless Co.	23	Garnett, Whiteley & Co., Ltd.	14	Pickett Bros.	28
Baker's "Selhurst" Radio	33	Garratt Stores	23	Players	15
Bayless, W., Ltd.	8	General Electric Co., Ltd.	1	Potter, H. B. & Co., Ltd.	34
Beam, Ltd.	3	Graham Amplion, Ltd.	21	Premier Supply Stores	34
Belling & Lee, Ltd.	15	Graham Farish Manf. Co.	11	Pugh Bros.	24
Benjamin Electric, Ltd.	15	Graves, J. G., Ltd.	33	Radio Gramophone Development Co.	15 & 22
Black, Alexander	22	Grosvenor Battery Co., Ltd.	13	Regent Radio Supply Co.	31
Britannia Rubber & Kampulbeoa Co., Ltd.	22	H. & B. Radio Co.	14	Rigby & Wooltenden	32
British General Manuf. Co., Ltd.	14	Hayward, F. C. & Co.	34	Ritherdon & Co., Ltd.	18
British Insulated Cables, Ltd.	Cover iii	Holland, G. S. & Co.	16	Rothermel Corpn., Ltd. (Electrical)	16
Brownie Wireless Co. (G.B.), Ltd.	30	Holzman, L.	16	Rowley, Thomas A., Ltd.	32
Brown, S. G., Ltd.	31	Hughes, F. A. & Co., Ltd.	27	Scientific Supply Stores	33
Bulgin, A. F. & Co.	24	Hunt, A. H., Ltd.	37	Shaftsbury Radio Co.	26
Bullphone, Ltd.	11	Ideas Development Synd., Ltd.	24	Superstone Talkies	33
Burndept Wireless (1928), Ltd.	19	Impex Electrical, Ltd.	19	Taylor, G.	33
Burne-Jones & Co., Ltd.	24	Jackson Bros.	19	Telegraph Condenser Co., Ltd.	Cover i & p. 6
Burton, C. F. & H.	22	J.R. Wireless Co.	19	Telsen Electric Co., Ltd.	9
Carrington Manuf. Co., Ltd.	22	Lectro Link, Ltd.	26	Transformer Repair Co.	26
Clarke, H. & Co. (M/cr.), Ltd.	29	Lever, Eric J. (Trix), Ltd.	26	Trelleborg Ebonite Works, Ltd.	Cover i
Climax Radio Electric, Ltd.	29	Leyton Battery Co.	12	Tudor Accumulator Co., Ltd.	23
Cole, E. K., Ltd.	Cover i	Liscnin Wireless Co.	26	Tulsemere Manf. Co.	25
Cossor, A. C., Ltd.	20	Lock, W. & T., Ltd.	22	Ultra Electric, Ltd.	27
C.P. Mast Co.	24	Loewe Radio Co., Ltd.	17	Vandervell, C. A. & Co., Ltd.	8
Day, Will, Ltd.	32	London Electric Wire Co. & Smiths, Ltd.	17	Varley (Oliver Pell Control, Ltd.)	16
Digby, F.	12	London Radio Supply Co.	25 & 32	Ward & Goldstone, Ltd.	10
Donotone (Regd.) Loud Speaker	12	Lustrolux, Ltd.	25 & 32	Watmel Wireless Co., Ltd.	18
Dr. Nesper, Ltd.	10 & 22	Lyons, Claude, Ltd.	Cover iv	Webb's	18
Dubilier Condenser Co. (1926), Ltd.	10 & 22	Marconiphone Co., Ltd.	7	Westinghouse Brake & Saxby Signal Co.	2
Eastick, J. J. & Sons	28	McMichael, L., Ltd.	14	Wilkins & Wright, Ltd.	16
Faton, S., & Sons	28	M-M Magneto Synd., Ltd.	14	Wingrove & Rogers, Ltd.	2
Fairson Swan Electric Co., Ltd., The	28	M.P.A. Wireless, Ltd.	Cover i	Wolverhampton Die Casting Co.	32
Electradix Radios	28	Mullard Wireless Service Co., Ltd.	Cover iii	World's Wireless Stores	32
Ellison Manf. Co., Ltd.	30	O'Brien, Thos., Ltd.	Cover iii		
Epoch Radio Manf. Co., Ltd.	30	Oldham & Son, Ltd.	Cover iii		

RADIO-GRAMOPHONE CABINETS

Beautifully finished in highly polished OAK.

Will take sets
18" x 7" x 16" or 21" x 7" x 16".

Spacious compartment for speaker and batteries. Overall size 36" x 24" x 19".
9-ply motor board.

£4.19.6
(Mahogany Finish £5-15-0.)
Delivered free in England and Wales. Scotland 2/6 extra.

Send for our Illus. Catalogue.

Fitted complete with D.S. Motor, B.T.H. Pick-up and Arat, Ormond Unit and Chassis. £9-17-6

This is all you need to turn your present set into a modern RADIO-GRAMOPHONE.

PREMIER SUPPLY STORES
Radio & Gramophone Specialists,
165, Fleet St., London, E.C.4.
Phone: Central 2833

Large selection of Gramo. Motors and Pick-ups always in stock



HUGE STOCKS



AMAZING BARGAINS IN EFFICIENT STEEL MASTS

26ft. STEEL MAST, tapering 1 1/2" to 1". Carriage: London, 1/6; Midlands, 2/6; Elsewhere, 3/6. Weighs 28 lbs. **8/-**

34ft. Tapering 1 3/4" to 1". Carriage: London, 2/-; Midlands, 3/-; Elsewhere, 4/-. Weighs 40 lbs. **11/-**

40ft. Tapering 1 7/8" to 1". Carriage: London; 2/6; Midlands, 3/6; Elsewhere, 4/6. Weighs 50 lbs. **16/6**

A super mast.

OUTFIT with MAST. Mast rings, ample galvanised Cleat, Solid Metal footrest and strong galvanised stay fasteners. Note.—Our Masts are stayed at 4 ground points (not 3), which ensures safety.

ACCESSORIES. Best Manila Rope Halyards (will not Anti-rust paint (sufficient for mast), 1/6. Coppered earthing tube, 1/6. Special Aerial, has 14 strands of No. 28 gauge Enamelled high conductivity pure copper wire, 100 ft. 3/9. Money refunded if mast returned intact and carriage paid within 7 days.

FAIRFIELD TUBE CO.,
6, SOUTHEND ROAD, BECKENHAM, KENT.

'REGIONAL' STATION - ELIMINATOR

Doubles the Selectivity of Your Set.

Cuts out your Local or Powerful Regional Station (but not everything else) and brings in distant, weak and Foreign Stations 25% louder and clearer.

Fitted in 30 seconds. No alterations to your set.

Come and hear it operated in our Showroom.

Descriptive leaflet post free.

PRICE 10/6
Post Free.



I.D.S. 4, GOLDEN SQUARE (Piccadilly Circus), W.1.
Telephone: Gerrard 2437.

PARFAIT

THE PERFECT EBONITE

SUPPLIED IN SIX FINISHES

Semi-Polished Black	Semi-Polished Mahogany
Highly Polished Black	Highly Polished Mahogany
Matt	Cube Surface

Obtainable from most wireless dealers.

Advertisement of H. B. Potter & Co., Ltd., Station Buildings, ROOHDALÉ.

SCIENTIFIC 'EARTH'

AND BROOKMANS PARK.

10/6 Carriage paid.

The B.B.C. stated that the earth connection should be improved to get the best results from this station. You can do this by installing the above "earth," which has been universally proved the most efficient yet devised, because of its very low resistance to earth. Owing to the scientific facts underlying the principle of this "earth" no other type can hope to equal it, taking equal areas of contact.

Once installed, it never needs watering and is everlasting.

Ask your dealer for particulars, or write direct for illustrated pamphlet.

G. S. HOLLAND, A.M.I.E.E., & CO.
65, Wellesley Road, Chiswick, W.4.
Patent No. 273651.



FOR ELIMINATOR CIRCUITS

You cannot afford to use any but the best Condenser in an eliminator circuit.

HELSEBY CONDENSERS

are made and guaranteed by a firm with 30 years' experience in condenser making, from small telephone and radio condensers to Power Condensers weighing upwards of 2 tons.

Guaranteed working voltages :-

Type M	-	-	150 volts D.C.
Type 2A	-	-	350 volts D.C.
Type 3A	-	-	450 volts D.C.
Type 4A	-	-	600 volts D.C.

All Helsby Condensers are vacuum dried and impregnated with a special non-hygroscopic material which renders them moisture proof.

If unobtainable from your dealer, write to us giving his name and address.



BRITISH INSULATED CABLES LTD

PRESCOT - LANCS.

Makers of PRESCOT and HELSEBY cables

WHY BUY WASTE ?

Stop buying power that leaks away. Use OLDHAM H.T. Accumulators — they're "Air-Spaced" to save you money

If you use H.T. Dry Batteries you may pay for waste—for power you may never be able to use. Use obsolete smooth top accumulators and you may still be throwing money away—electrical leakage can sneak along their unbroken top, sapping away energy which should go to your Set. Oldham "Air-Spaced" H.T. Accumulators store up every pennyworth

of current put into them. Their "Air-spaced" construction definitely prevents electrical leakage and self-discharge. And the Oldham H.T. Accumulator has many other exclusive advantages — large vents — screw connectors — is simple to assemble. See an Oldham at your Dealers.

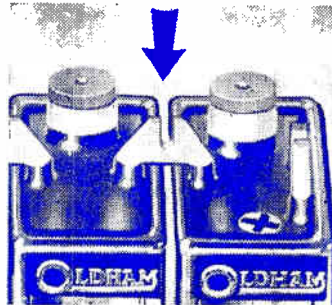

Not only between each cell but between each unit as well there is an "Air-gap" in Oldham H.T. Accumulators—see for yourself.

See the famous Oldham "Air-gap" which ended electrical leakage—the bug-bear of the old-fashioned smooth-top H.T. Accumulator.

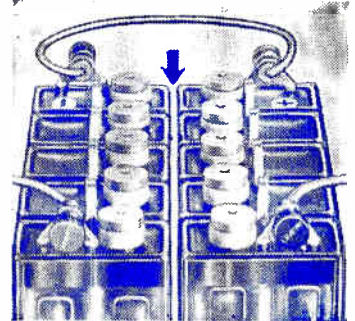

EXTRA LARGE CAPACITY.

(5,500 milliamps)
Per 10-volt Unit

6'9

Complete with two connectors and length of cable. Wooden trays extra if required. Ask your Wireless Dealer to show them to you.

STANDARD 10-VOLT UNIT.

Capacity 2,750 milliamps

5'6



The Pioneers of "Air-Spaced" H.T. ACCUMULATORS

Oldham & Son, Ltd., Denton. London Office: 40, Wicklow Street, Glasgow
Manchester. King's Cross, W.C.1. 200, St Vincent Street.
Telephone: Denton 301 (4 lines). Telephone: F. 7110-5 (4 lines). Telephone: Central 4915.

TRAWLER AGROUND!

**When danger is
greatest
MARCONI VALVES
come to the rescue**

80-MILE-AN-HOUR GALE! Seas like mountains! Tossing, wallowing, lightship rides it out. Anxiously, handful of men watch through night. Suddenly . . . light shows trawler aground on sandbank! At once, wireless to ships, lifeboat stations. Fair weather or foul, lightships protect shipping . . . summon aid, *through reliable Marconi Valves.*

Marconi Valves are used in all TrinityHouse lightships. For their reliability. For their wide range. For their long life. *They will make your radio set better.* Give you clearer tone, fuller volume. Cost not a penny more. Fit any set.

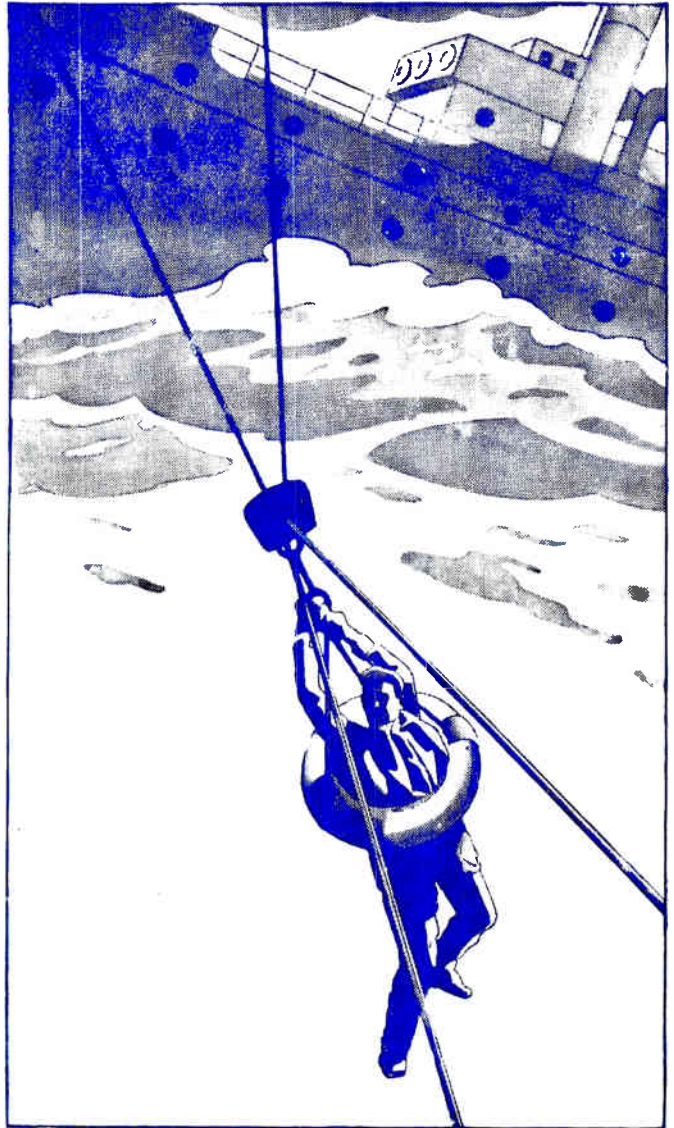

MARCONI VALVES



The first and greatest name in wireless

Write for an interesting valve catalogue to the Marconiphone Company Limited, 210-212 Tottenham Court Road, London, W.1

Printed for the Publishers, HUFFE & SONS LTD., Dorset House, Tudor Street, London, E.C.4, by The Cornwall Press Ltd., Paris Garden, Stamford Street, London, S.E.1.

Colonial and Foreign Agents:
 UNITED STATES—The International News Co., 131, Varick Street, New York. FRANCE—W. H. Smith & Son, 248, Rue Rivoli, Paris; Hachette et Cie, Rue Réaumur Paris.
 BELGIUM—W. B. Smith & Son, 79, Marche aux Herbes, Brussels. INDIA—A. H. Wheeler & Co., Bombay, Allahabad and Calcutta. NORTH AFRICA—Central News Agency Ltd.
 AUSTRALIA—Gordon & Gotch, Ltd., Melbourne (Victoria); Sydney (N.S.W.); Brisbane (Queensland); Adelaide (S.A.); Perth (W.A.); and Launceston (Tasmania).
 CANADA—The American News Co., Ltd., Toronto, Winnipeg, Vancouver, Montreal, Ottawa, St. John, Halifax, Hamilton; Gordon & Gotch, Ltd., Toronto; Impero News Co., Toronto, Montreal, Winnipeg, Vancouver, Victoria. NEW ZEALAND—Gordon & Gotch, Ltd., Wellington, Auckland, Christchurch and Dunedin.

The Wireless World

AND RADIO REVIEW

4^D

The Paper for Every Wireless Amateur

Wednesday, December 11th, 1929.



TELSEN
L.F. TRANSFORMERS

Radio's Choice

Have acquired a world-wide reputation for Quality and Value.

Built by Specialists in Transformer construction, they have set a Quality of Performance above reproach. Your Set will work better with a Telsen Transformer - - - Fit one now

TELSEN ELECTRIC CO. LTD.
Miller Street
Birmingham

RADIOGRAND
12/6

750-WATTS! THE BEST SWITCH YET.

LYONS "B.A.T." (Best-After-Test) "QMB" SWITCH comfortably breaks 3 Amps. at 250 Volts, yet it is extremely small and very robust and unconditionally guaranteed.

Cordially reviewed by "W.W." specified in the 1930 EVERYMAN FOUR, etc. Essential in 2-volt sets where switch resistance is fatal. Used by many leading set-makers.

USES:-

H.T. Units, A.C. Sets, L.T. Switch, for Portables, Gram-Motor Control, M.C. Speaker Field Switch, etc. Super-sedes noisy "push-pull" varieties and clearly indicates "ON" or "OFF." Nickel Finish.

ONLY
2/6



CLAUDE LYONS Ltd.,
76, OLDHALL STREET, LIVERPOOL.

"Utility" MITE

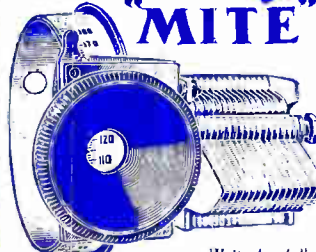

The famous "Utility" Mite Condenser and NEW DRUM DIAL.

The Component that created the keenest interest at Olympia Readings appear through the central aperture, simplifying easy tuning; saves valuable space. Supplied for left or right hand operation.

Cat. No.	Cap.	Price
W. 201	.0005	11/-
W. 202	.0003	11/-
W. 203	.0002	10/-

Write for fully illustrated Lists.

Prov. Pat. Nos.
37475/28 and
37476/28.

WILKINS & WRIGHT LTD
HOLYHEAD² *Utility* BIRMINGHAM

BurTON VALVE HOLDER



1/- each

Pentode
-Valve-
Holders
16 each

Patent No.
316708

MANUFACTURED BY
C. F. & H. BurTON

PROGRESS WORKS
WALSALL, ENG.

"BEAM" WITH PLEASURE!

Every purchaser of "Beam" Loudspeakers, H.T. Batteries and other components will be pleasantly surprised at their excellence. Buy "Beam" for yourself and your friends this Xmas.

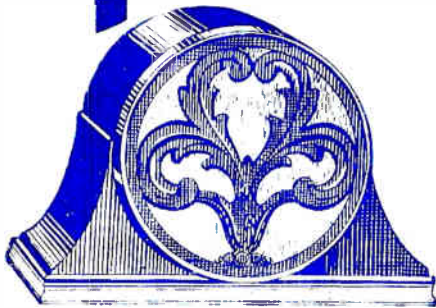

55/-
Complete with
flexible lead

"BEAM" SPEAKERS are constructed to give the finest possible reproduction on either weak or strong reception. The model illustrated is marvellous value, of excellent appearance, and harmonizes with all home surroundings.



"BEAM" H.T. BATTERIES are silent yet energetic workers. The elements of which they are built ensure steady flow of current without background noises.

All "Beam" products are obtainable from your dealer or direct

Beam Ltd. 35, Farringdon Road,
London, E.C.1

Telephone: Holborn 7843



FOR ELIMINATOR CIRCUITS

You cannot afford to use any but the best Condenser in an eliminator circuit.

HELSEBY CONDENSERS

are made and guaranteed by a firm with 30 years' experience in condenser making, from small telephone and radio condensers to Power Condensers weighing upwards of 2 tons.

Guaranteed working voltages :-

Type M	-	-	150 volts D.C.
Type 2A	-	-	350 volts D.C.
Type 3A	-	-	450 volts D.C.
Type 4A	-	-	600 volts D.C.

All Helsby Condensers are vacuum dried and impregnated with a special non-hygroscopic material which renders them moisture proof.

If unobtainable from your dealer, write to us giving his name and address.



BRITISH INSULATED CABLES LTD
PRESCOT - LANCs.
Makers of PRESCOT and HELSEBY cables

YOU CAN TAKE IT FROM US

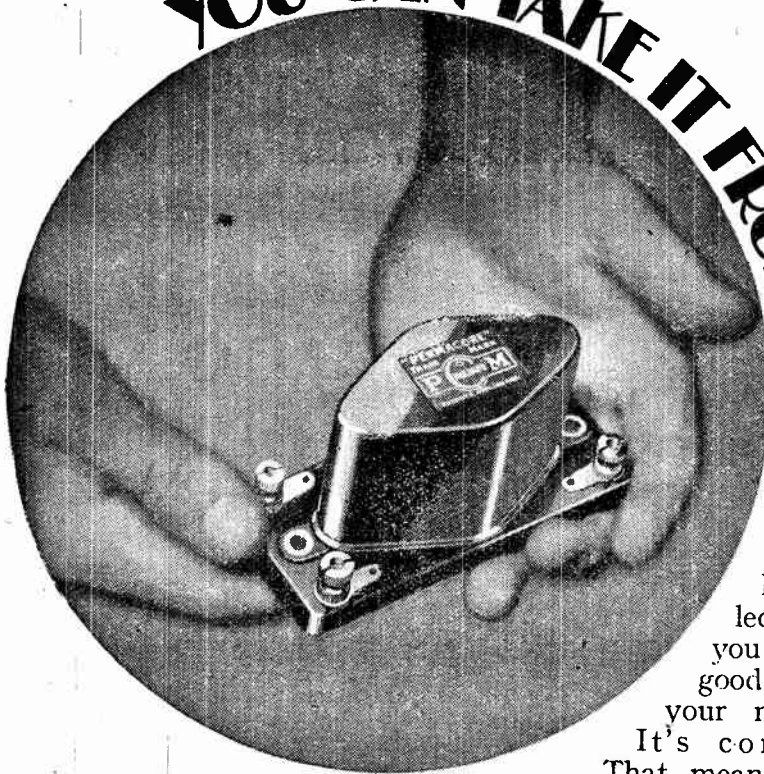

—secure
in the
know-
ledge that
you get a
good job for
your money.

It's compact.
That means simplified assembly and wiring. It's efficient. It does its work properly because of its special core, the silver wire of the primary, and the nickel-wound secondary.

Hear its performance and you'll remember its name—the Mullard PERMACORE L.F. Transformer. It has a step-up ratio of 3:1.

PRICE
25/-

Mullard

MASTER · RADIO

Agents, The Mullard Wireless Service Co., Ltd., Mullard House, Charing Cross Road, London, W.C.2.

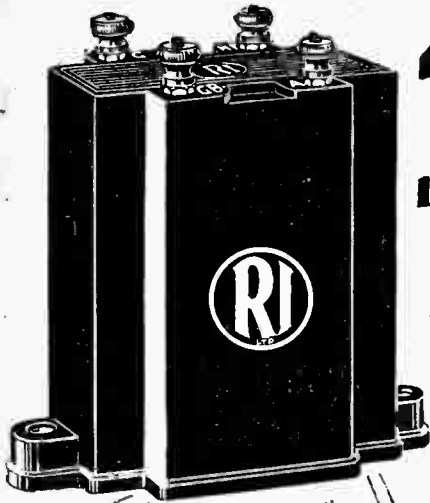

THE 'HYPERMU'
L.F. INTERVALVE TRANSFORMER
is included in the
1930
'EVERYMAN FOUR'

The fact that the Hypermu was specially chosen for inclusion in the circuit of the 'EVERYMAN FOUR' is proof positive of its pre-eminence as the most efficient transformer for L.F. amplification in all modern receivers.

Its famous N.P.L. curve which proved definite maximum amplification from

25 to 7,000 cycles

has now been augmented by

NEW AND STILL MORE WONDERFUL CURVES

taken in conjunction with the famous A.C.H.L., Cosmos, and other indirectly heated valves, and also the P.M. 4.DX. These curves present a straightness absolutely unequalled by any other transformer and reveal amplification of miraculous strength and uniformity. They completely eclipse any curves published by any other Radio Manufacturers throughout the world and are a splendid tribute to British research and enterprise.

Extract from
 "THE WIRELESS WORLD,"
 OCTOBER 16th, 1929.
 "An R.I. 'Hypermu' transformer was chosen to couple the first L.F. amplifier to the output valve, since this component, when connected as an auto-transformer and freed from direct anode current by means of a resistance-capacity filter, shows a marked rising characteristic (vide N.P.L. curves)."

THE "HYPERMU."

The first metal shielded transformer in a Bakelite case. Size 3" x 1 1/4" x 1 1/2" weight 14 ozs. ...

21/-

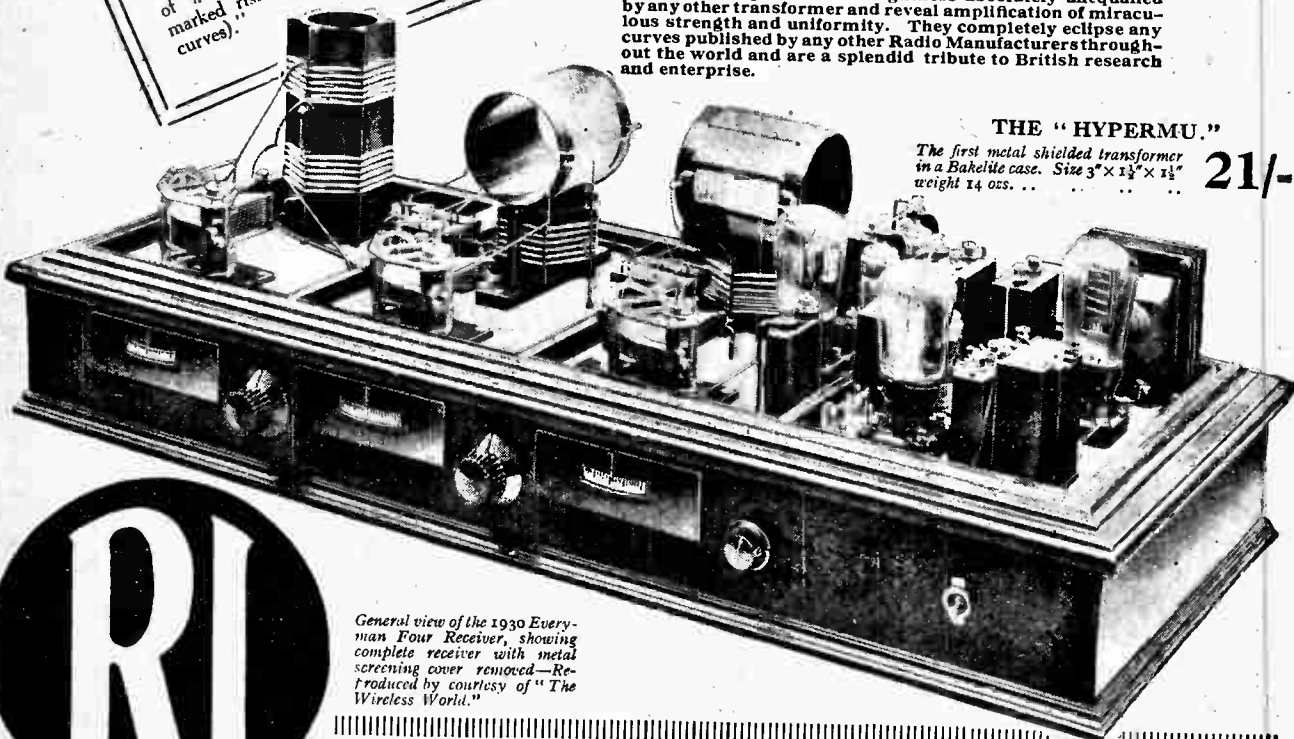

General view of the 1930 Everyman Four Receiver, showing complete receiver with metal screening cover removed—Reproduced by courtesy of "The Wireless World."

RADIO INSTRUMENTS LTD., SPECIALISTS IN SOUND REPRODUCTION.
 Sole Address: Offices, Showrooms and Works—12 HYDE STREET, LONDON, W.C.1

Mention of "The Wireless World," when writing to advertisers, will ensure prompt attention.

such **RADIO** makes **Xmas**

The 304 Columbia . . . **£33**
(all electric—A.C. or D.C. Mains)

Columbia Radio captures the Christmas spirit, and crystallizes it for the pleasure of your home. Volume for dancing. Tone vividly to portray song and story. Range that enables you to spend Christmas in all the capitals of Europe, sharing the Christmas of other nations.

Yet Columbia Radio easily bought, on deferred terms if you wish.

Five valves, including 3 screen grid.
Four tuning circuits ganged to work from one control, marked in wavelens; this.
Power unit built into set, works direct from electric light socket (A.C. or D.C.).
Only needs a Columbia Cone or Moving Coil Loud-speaker to complete.

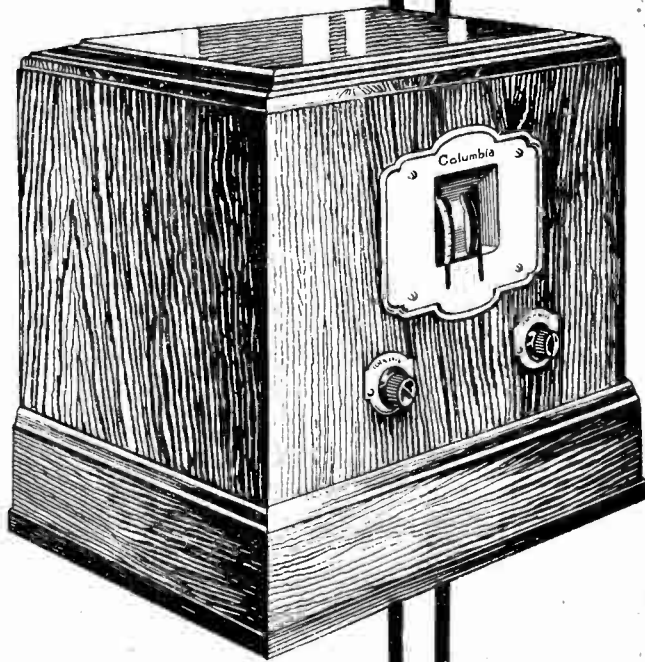

MADE BY THE
MAKERS OF
COLUMBIA GRAM-
OPHONES AND
RECORDS

This Coupon is valuable →

Columbia RADIO

Columbia Dealers everywhere.

W.W.1.

- * I would like to hear a
{ Columbia Portable Radio.*
{ Columbia Radio Table Model.*
playing in my own home. Please arrange
this without cost or obligation to myself.
- * I would like to have a catalogue of
Columbia Radio models.
- * I would like full particulars of Columbia
deferred terms.
- * Delete if not required.

NAME

ADDRESS

Cut this out and post it in an unsealed envelope bearing a 1d. stamp to:—
COLUMBIA, 102, Clerkenwell Road,
London, E.C.1.

**"ADOPT ..
ADAPT ...
IMPROVE ..."**

You have heard this message given to British Industry; you know who gave it. At Progress Works it is our constant aim to adopt, adapt and improve, as, indeed, the name of our factory indicates.

Adopt BurTon Components, adapt your set and you will improve your reception!

**BUY BY THE
BURTON!
NAME**

Burton Anti-capacity Switch
Maximum efficiency in minimum of space. Nickel Plated Finish.
One way, 4/-, 2 way, 5/-, 3 way, 6/-, 4 way, 7/-, 5 way, 8/-.

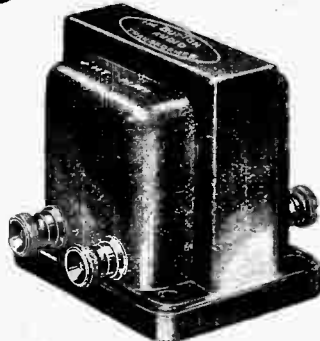
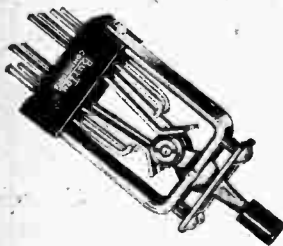

Burton L.F. Transformer.
Highest efficiency, high grade finish.
Price, 10/6.

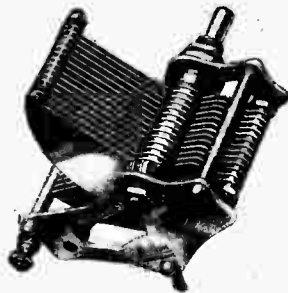

Burton Mid-Log Condenser.
Aluminium End Plates with Burton Friction Brake.
Price without dial, '0005, 5/3.
" " "0003, 5/-.

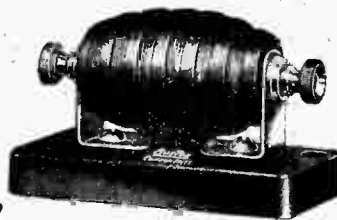

Burton H.F. Choke.
Wave band of 20-2,000 metres.
Price, 3/9.
Binocular choke, wave band 50-3,000 metres. Price, 5/9.

**BUY
BURTON
COMPONENTS**

O. F. & H. BURTON, Progress Works, Walsall.

**EVEN ON
CRYSTAL
SETS!**

PRICE
18'6



THE amazing sensitivity of the Watmel Unit can be gathered from the fact that a specimen selected from stock gave clear reproduction at six feet when connected to a crystal set at a distance of 15 miles from a broadcasting station. If you want a Loud Speaker of highly attractive appearance, that will give delightful reproduction of full round volume, write at once for our folder which tells you how you can in ten minutes build one up from a kit of parts costing only 55/-. To obtain the same reproduction elsewhere you would have to spend twice as much or more. Finally, remember that the Watmel Unit is so sensitive that it saves you money handsomely in the H.T. current you use—it saves an extra valve, in fact.

If your dealer cannot supply you with a Watmel Unit or Kit, write direct to us, giving his name and address.

WatMel

**WATMEL WIRELESS CO. LTD.,
Imperial Works, High St., Edgware, Mx.**

Telephone: Edgware 0323

P. & T.

Mention of "The Wireless World," when writing to advertisers, will ensure prompt attention.

The FERRANTI A.C. MAINS RECEIVER

Winter Warmth & Music

The Ferranti A.C. Mains Receiver Model 31 is really handsome in the sense that "handsome is as handsome does." Its beautiful cabinet work gives added grace to any scheme of furnishing, and its performance is very nearly true to life.

In combination with the Ferranti Moving Coil Speaker you are assured of such deep satisfaction from the programme of your choice that you are doubly glad of the exceptionally easy manipulation.

There is no need for a second thought about anything but the pleasure of listening. Simply plug in to the electric mains. No batteries to run down or require constant attention. Available for Alternating Current only, voltages 200 to 250; 50 cycles or over.

Price, including Valves:—

In Oak Cabinet	£25
In Mahogany Cabinet	£26
In Walnut Cabinet	£26

Royalty £1 extra.

NOTE: The Electric Fire illustrated above is the Ferranti Model 111. If you are interested in the luxurious comfort afforded by radiant heat write for the book of the Ferranti Fire.

FERRANTI LTD.

HOLLINWOOD

LANCASHIRE

PHILIPS



RECTIFYING VALVES

For:

- Reliable H.T. Supply
- Dependability
- Long Life
- High Efficiency
- Output easily varied and smoothed

The rectifier that has stood the greatest of all tests—TIME.

Representative Types

TYPE 506

Full wave. Filament voltage 4 volts. Anode voltage 2 x 300 v. R.M.S. Maximum rectified current 75 mA. Price 20/-

TYPE 2506

Full wave. Filament voltage 4 volts. Indirectly heated. Anode voltage 2 x 300 v. R.M.S. Rectified current 40 mA. Price 22/6

TYPE 505

Half wave. Filament voltage 4 volts. Anode voltage 400 R.M.S. Maximum rectified current 60 mA. Price 15/-

TYPE 373

Half wave. Filament voltage 4 volts. Anode voltage 220 R.M.S. Maximum rectified current 40 mA. Price 15/-

Obtainable at all Radio dealers.

PHILIPS

for Radio

Made by the manufacturers of Philips Argenta lamps and fittings.
Advert. of PHILIPS RADIO, PHILIPS HOUSE, 145, CHARING CROSS ROAD, W.C.

Mention of "The Wireless World," when writing to advertisers, will ensure prompt attention.

Here's how "J.B." do it

Follow the lights and see for yourself the improvements in the J.B. Drum Dial, one of the most popular models in the J.B. range. It is made in both a Bronze and Oxidised Silver finish and costs 10/6



All parts of the Dial are insulated from the condenser so that the drum becomes an anti-capacity shield and may be earthed.

The scale is Ivorine, reading 0-100, and is reversible so that reading may be altered to 100-0.

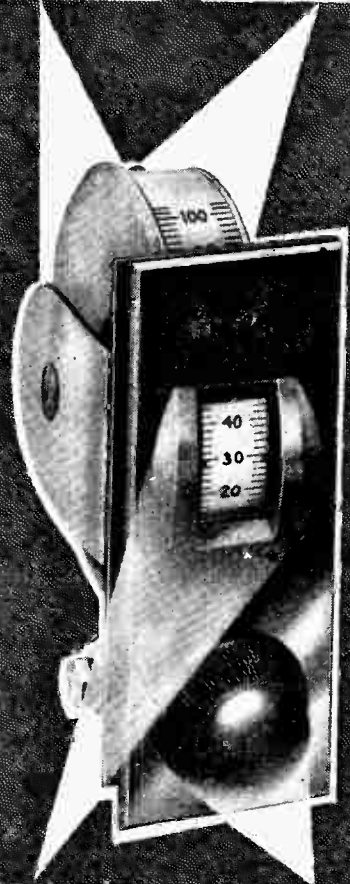

The scale is flush with the panel and may be read with ease. A powerful and positive friction drive is used which prevents backlash and slip.

By an improved method the Control Knob is placed immediately below the scale—the most convenient place for it.

Advertisement of Jackson Brothers, 72, St. Thomas' Street, London, S.E.1 Telephone: Hop. 1837

THE CURVE TELLS THE STORY!

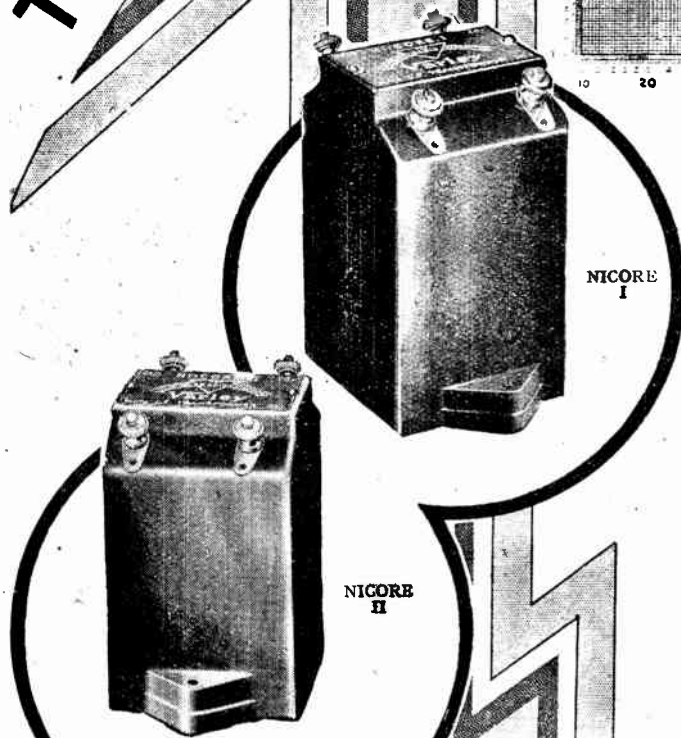
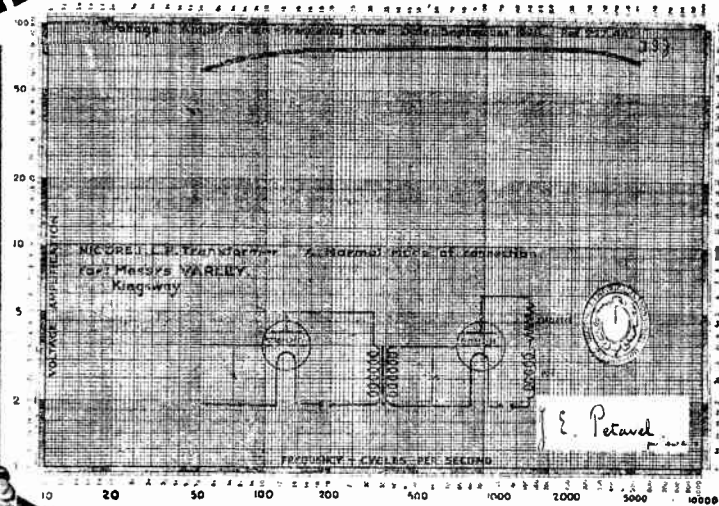

An amplification curve of almost 80—and a frequency response curve practically uniform over the whole audible frequency range—that's the story told by the National Physical Laboratory curve—the story of a really good L.F. Intervalve Transformer—the VARLEY Nicore I.

And this story is practically as true in the case of Nicore II—almost the same constant amplification over the whole range of musical frequencies—results infinitely better than many higher priced transformers of other makes.

The use of a nickel-iron alloy core coupled with long and varied experience in the winding of Transformer Coils enables VARLEY to produce Transformers of exceptional performance.

Remember that more than 30 years' research is behind a VARLEY product. That's why quality is assured when you specify VARLEY.

Extract from Test Report

("Modern Wireless," December).

"In any set where it is used the L.F. Transformer is a critically 'key' component By no means all nickel-iron core transformers have proved successful, and it is greatly to the credit of the Varley people—although in view of their reputation it is only what we suppose would be expected from them—that they have been able to produce such a component, as the Varley Nicore transformer."

For
RADIO
OLIVER PELL MANUFACTURE
Varley

Nicore I (List No. £1
D.P.1) Ratio 4 : 1 -
Nicore II (List No. 15s.
D.P.2) Ratio 4 : 1 -

Write for Section D of the Varley Catalogue.

Advertisement of Oliver Pell Control Ltd., Kingsway House, 103, Kingsway, London, W.C.2. Telephone: Holborn 5303.

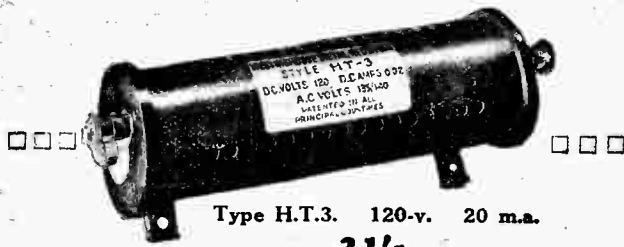

WESTINGHOUSE
METAL RECTIFIERS

have

No fragile filaments to limit their life and consume energy

and

A higher efficiency than any other type of small rectifier. Moreover this efficiency is maintained practically throughout their whole range of output.

Smoothing is easier than with any other type of rectifier, owing to the truer nature of their output wave form.

Westinghouse Metal Rectifiers are now used in the MAJORITY of modern mains receivers and eliminators, designed and marketed by experts who are satisfied as to their reliability, and whose aim has been to provide **TROUBLE-FREE RADIO EQUIPMENT.**

You should have Westinghouse Metal Rectifiers to work *your* set. The best way of using them is fully set out in our booklet "The All-Metal Way, 1930"—32 pages of circuits and information on A.C. Mains operation. Send a 2d. stamp for a copy:—

The Westinghouse Brake & Saxby Signal Co., Ltd.
82, York Road, Kings Cross, London, N.1.

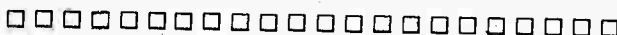

Mention of "The Wireless World," when writing to advertisers, will ensure prompt attention.

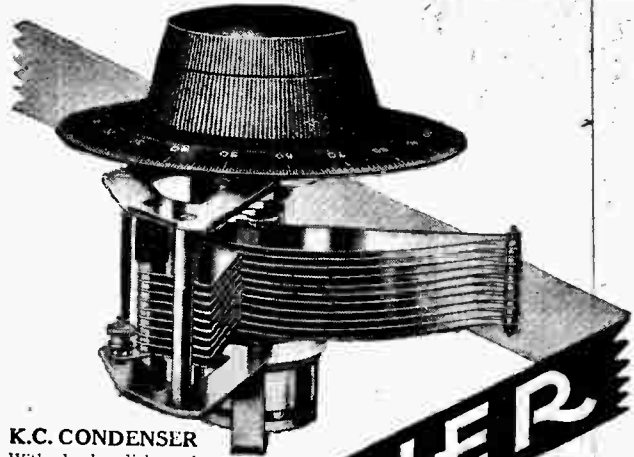

K.C. CONDENSER

With knob, dial and slow-motion device, .0003 or .0005 12/-
Without knob, dial or slow-motion device .0003 or 8/-

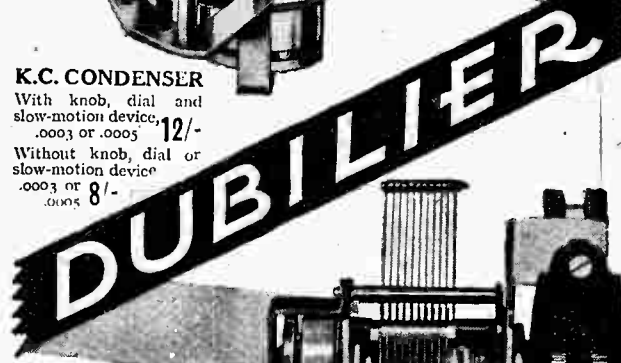

K.C. DRUM CONTROL CONDENSERS

With Drum Control and slow-motion device, .0003 or .0005 15/6
Triple K.C., each condenser .0003 or .0005 38/6
Triple K.C. Combinations of .0003 & .0005 40/-

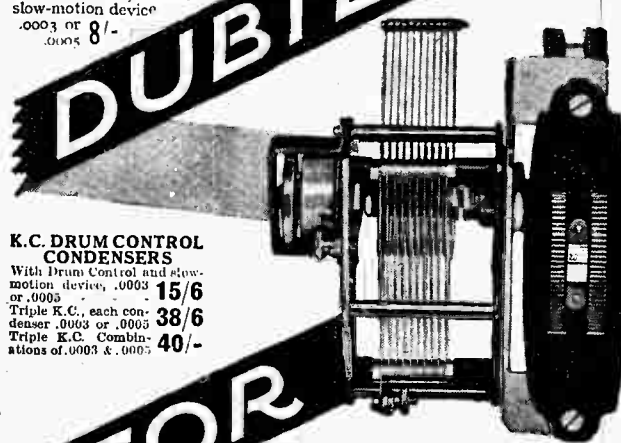

MIDGET CONDENSER

A small variable condenser for panel mounting .0005, 5/6 .0001 or .0002



DUBILIER
VARIABLE CONDENSERS

Ask your dealer for the Dubilier Booklet "A Bit about a Battery"—it's free.



Dubilier Condenser Co. (1925) Ltd., Ducon Works, Victoria Road, N. Acton, London, W.3

BC 249/17

Another Essential Point dealt with

By
Mr. Full O'Power

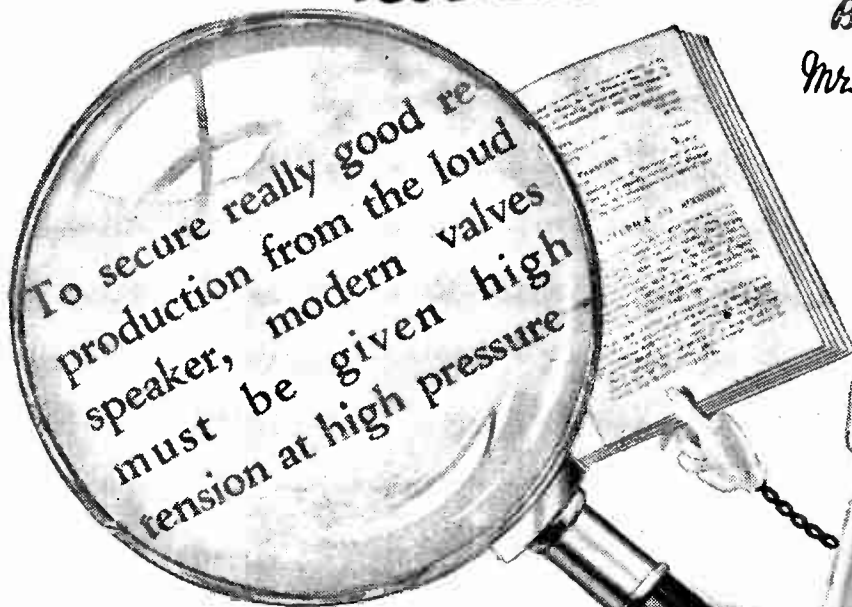

THE need for High Tension at high pressure if the best results are to be obtained from modern valves is not always recognised. This point is dealt with in Mr. Full O'Power's booklet,

"INSIDE KNOWLEDGE"

(on the correct use of Radio Batteries),

a Free copy of which may be obtained from your dealer or direct from Siemens Brothers & Co., Ltd., Woolwich, S.E.18.



PRICES.	
Popular Type.	
No. 1200	60 volts, 8/-
No. 1202	100 volts, 13/-
Power Type for Power Valves.	
No. 1204	"Power" 60 volts 13/6
No. 1206	"Power" 100 volts 22/6
Grid Bias.	
No. G.9.	9 volts 1/6

SIEMENS BROTHERS & CO. LTD., WOOLWICH, S.E.18.
Telephone: Woolwich 1161.



Put your wander plugs into the wonder battery

Unbelievable is the saving until you have had actual experience of "Pertrix" — the super-battery without sal-ammoniac, and therefore without the defects that sal-ammoniac inevitably involves. No loss when not in circuit; no crackle at any stage or age; and

60% longer life

PERTRIX SUPER DRY BATTERIES

PERTRIX LIMITED,
Britannia House, Shaftesbury Avenue, London, W.C.
Factory—Britannia Works, Redditch, Worcs.

LISENIN

POSITIVE GRIP TERMINALS (Patented)

Scientifically constructed, both electrically and mechanically, they hold the wire, but grip the flex covering. All stresses and strains are removed from the conductors, and once a connection is made it stays put, and without any unsightly frayed ends of leads, the bane of all fans.

Write for **FREE** copy of our latest descriptive leaflet "W.W." Post free, of course.

POSITIVE GRIP SAFETY PLUG AND SOCKET
(Registered Design)



POSITIVE GRIP Banana Type PLUG & SOCKET. A great advance on all other types of plug. A silky, dead smooth contact is NOW obtainable. Price 4d. complete.

LISENIN POSITIVE GRIP ALL MAINS PLUG AND SOCKET (Registered Design). The Lisenin Mains Plug and Socket is totally insulated and is equally as valuable on sets working off batteries as those from the electric supply. The leads may be dropped with impunity and there is no chance of a short circuit. Instantly assembled with the aid of a screwdriver. **NOTE THE PRICE, 6d. each, complete as illustrated.**

WRITE to-day for our new descriptive folder, mentioning this paper.

We have moved to larger premises. Note new address:—
THE LISENIN WIRELESS CO.,
5, Central Buildings, HIGH ST., SLOUGH, Bucks.
Phone: Slough 652. T. Address: POSGRIP SLOUGH.

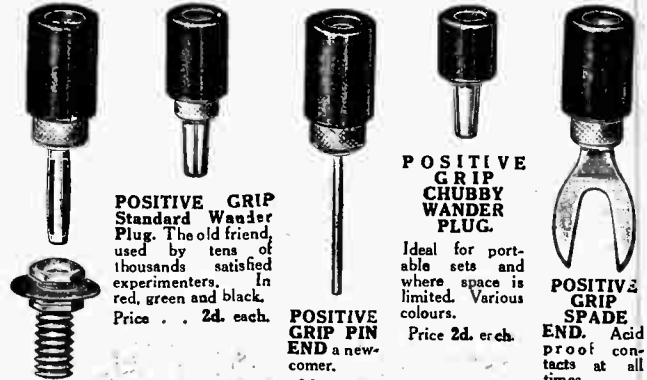

POSITIVE GRIP Standard Wander Plug. The old friend, used by tens of thousands satisfied experimenters. In red, green and black. Price . . . 2d. each.

POSITIVE GRIP CHUBBY WANDER PLUG.

Ideal for portable sets and where space is limited. Various colours. Price 2d. each.

POSITIVE GRIP PIN END a new-comer. 2d. each.

POSITIVE GRIP SPADE END. Acid proof contacts at all times. Price 3d. ea.



Look for the Lisenin Show Case on your Radio Dealer's Counter.

BUILD YOUR OWN RADIO - GRAMOPHONE

AND OBTAIN GLORIOUS QUALITY OF REPRODUCTION FROM
RECORD OR RADIO.

Since the public had the opportunity of hearing the wonderful results from the "C.A.C." Coupler at our Demonstration Room facing Olympia during the recent Radio Exhibition, we have been inundated with enquiries from all over the country for wiring diagrams incorporating this marvellous device.

It is our intention, therefore, from time to time to give in these pages a variety of circuits to suit every individual requirement.

The secret of the wonderful quality of reproduction lies in the method of amplification employed exclusively by us, and which entirely supersedes any other known method, known as

THE "C.A.C." LOW FREQUENCY COUPLER. THE HEART AND SOUL OF PERFECT REPRODUCTION.

All "G.R.A." instruments, from the small battery-fed receiver to the powerful Talking Film Amplifiers installed in many Cinemas throughout the country, embody exclusively this Low Frequency Coupler as the sole method of amplification.

We have sold thousands of these Couplers as a result of our Olympia demonstration, for not only do they give results which cannot be hoped for by any other method, but the actual construction of such an instrument as shown here is simplicity itself by the use of this component.

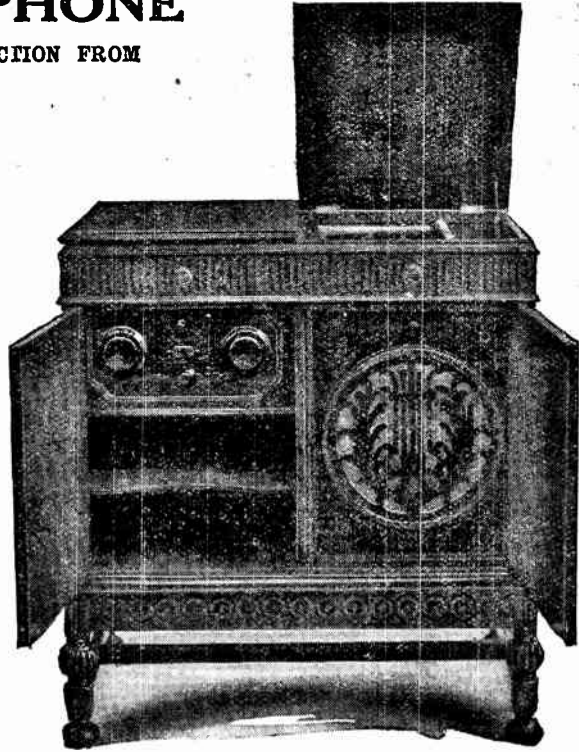

PRICES:

BATTERY OR D.C. MAINS TYPE

Two Stage 35/-
Three Stage 52/6

A.C. MAINS TYPE FOR INDIRECTLY HEATED VALVES

Two Stage 45/-
Three Stage 60/-

Guaranteed for Two Years.

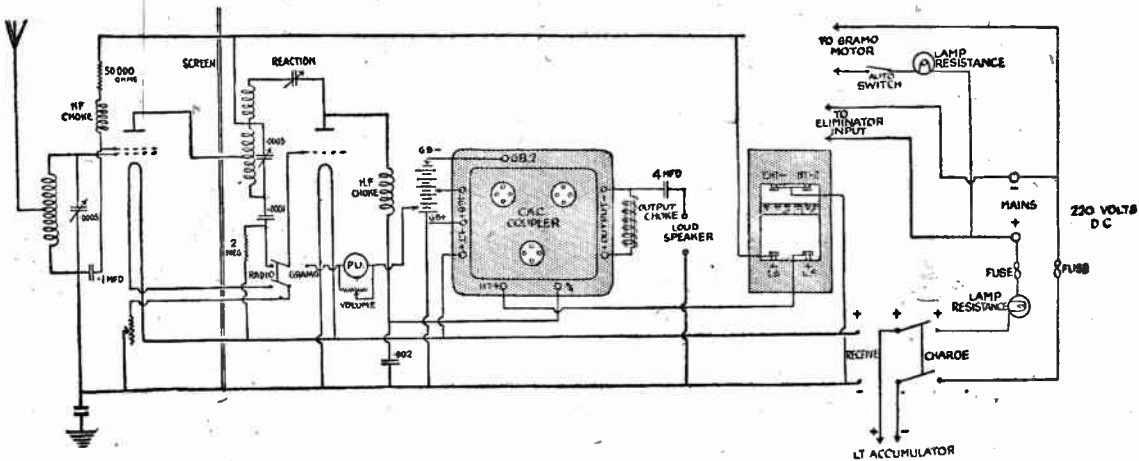

WIRING DIAGRAM OF RADIO-GRAMOPHONE WORKING FROM D.C. MAINS. COMPLETE SPECIFICATION ON REQUEST
CIRCUITS FOR A.C. MAINS OPERATION SUPPLIED ON RECEIPT OF STAMPED ADDRESSED ENVELOPE.

*We cordially invite all those interested in Perfect Musical Reproduction to hear
this wonderful Coupler under working conditions at our address below.*

GRAMO-RADIO AMPLIFIERS, Ltd., 1a, NEW LONDON STREET, E.C.3
(facing Fenchurch Street Station).
Royal 4300.



**INDISPENSABLE to the WIRELESS
Experimenter,
Retailer &
Factory—**

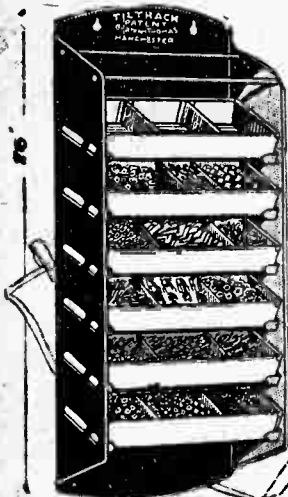

"TILTRACK" (Junior)
Price 30/- Post Free

Ideal for the Experimenter for storing Nuts, Bolts, Screws, Washers, Condensers and Small Components.

THE "BENCHRACK."
(Tiltrack Principle.)

Made to stand on the work bench; thus all small parts needed for the job in progress are immediately to hand. The trays are provided with patent hinging partitions, and the front face of each tray is rounded to facilitate quick removal of the goods in the tray. This rack is a tremendous time saver.

"TILTRACCESSORIES"

ACCESSORIES to "TILT-BACK" TRAYS, for "JUNIOR" and "SENIOR."

These are square boxes for fitting into the "Junior" and "Senior" Trays. Extremely useful for small details as screws, washers, etc. The illustrations below show the boxes as fitted to the "Senior" Trays.

FOR the "SENIOR"

Particulars from Manufacturer & Patentee:—
BERTRAM THOMAS, Worsley Street, Hulme, MANCHESTER.

London Office & Showroom:— 28, Victoria Street, S.W.1.



"TILTRACK" (Senior)
The ideal stores for the Retailer and Factory—

Goods found in minimum time with minimum trouble. Patent adjustable partitions to trays. Maximum illumination. No danger of Fire. Great Storage Capacity.

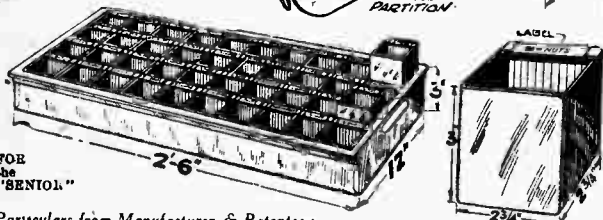
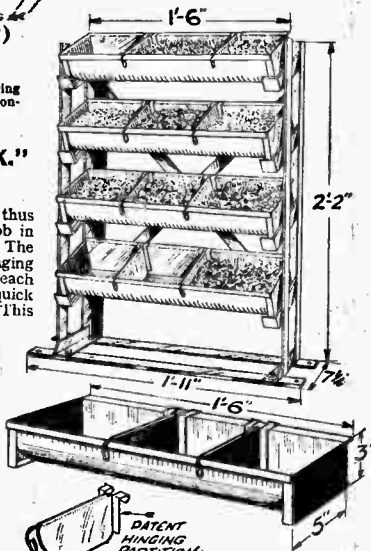

You can now purchase your MAGNAVOX X-CORE dynamic speaker unit complete with a handsome genuine walnut firescreen baffle which will harmonise with any kind of furnishing. The Belvedere Fire-Screen Baffle has been correctly designed in order to give the very best results in conjunction with either a Magnavox Standard or special model X-Core moving coil unit. The combination of a Magnavox X-Core Unit and Belvedere Baffle will enable you to secure the finest reproduction possible. What a splendid Xmas gift.

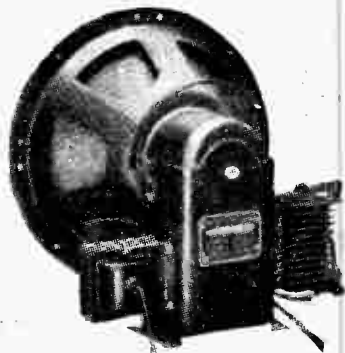

Standard Model Unit 10 1/2" Cone Complete with Belvedere Baffle

No. 107.	110-180 volts D.C.	£12 5s. 0d.
" 109.	180-300 " D.C.	" 12 5s. 0d.
" 201.	6-12 " D.C.	" 12 0s. 0d.
" 401.	110 v. 50 cy. A.C.	" 15 0s. 0d.
" 405.	200-240 v. 50 cy. A.C.	" 15 0s. 0d.

Special Model Unit 7 1/2" Cone Complete with Belvedere Baffle

No. 106.	110-180 volts D.C.	£10 0s. 0d.
" 108.	180-300 " D.C.	" 10 7s. 6d.
" 200.	6-12 " D.C.	" 10 0s. 0d.
" 400.	110 v. 50 cy. A.C.	" 12 5s. 0d.
" 404.	200-240 v. 50 cy. A.C.	" 12 5s. 0d.



Write for the new 68-page "Great Voice" Booklet. It tells you all about the operation of moving coil speakers, electrical gramophones, volume controls, eliminators, etc. This new enlarged edition should be in the hands of all 'Wireless World' readers. Send 6d. in stamps for postage.

The Rothermel Corporation, Ltd.,
24, Maddox Street, London, W.1.
Phone: Mayfair 0578/9.

HEAR HOW GOOD YOUR SET CAN BE



Type 2016
Price
£2.10.0



Type 2007
Price
£5.5.0

MAKE the most of your radio receiver by using it in conjunction with a Philips Loudspeaker and Battery Eliminator. Philips Loudspeakers give the most perfect reproduction while Philips Battery Eliminators ensure the utmost efficiency. They eliminate all trouble caused by battery voltage-drop, and the expense of renewing rapidly wasting batteries.

Philips Loudspeaker, Type 2007. Price - - £5.5.0

Philips Moving Coil Loudspeaker, Type 2013 (for use with Philips de Luxe 4-valve All-Electric Receiving Set, Type 2511). Price £14.14.0

Philips Moving Coil Loudspeaker, Type 2011 (with step-down Transformer). For universal use. Price - - £15.15.0

Philips Seven-Cornered Loudspeaker, Type 2016. Price - - £2.10.0

Philips Battery Eliminators, Type 3009. For A.C. Mains. Price - - £5.15.0

Type 3002. For A.C. Mains. Price - - £5.10.0

Type 3005. For D.C. Mains. Price - - £3.17.6

For 10/- down you may have any of these Battery Eliminators on Philips Hire Purchase System.

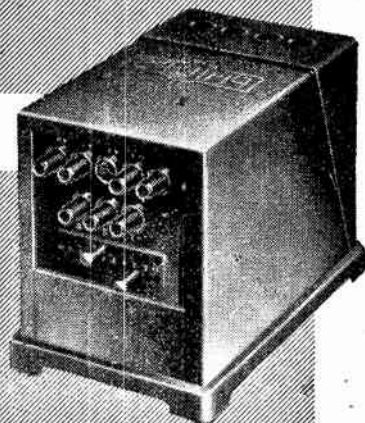

Type 3009
Price
£5.15.0

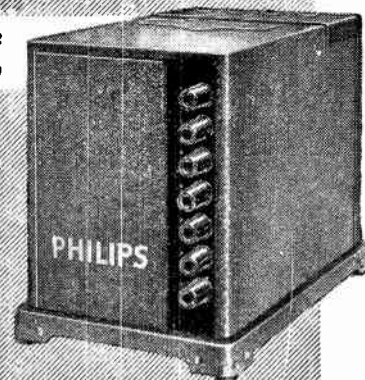

Type 3002
Price
£5.10.0

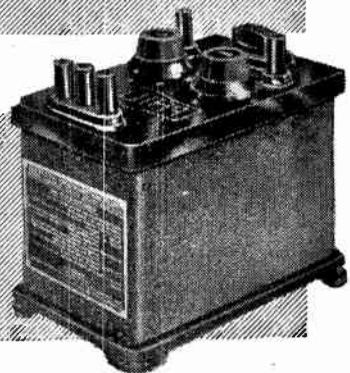

Type 3005
Price
£3.17.6

Makers of the famous Argenta Lamps and Fittings.

PHILIPS

for Radio

PHILIPS RADIO, PHILIPS HOUSE, 145, CHARING CROSS ROAD, LONDON, W.C.2.

B5 Advertisements for "The Wireless World" are only accepted from firms we believe to be thoroughly reliable.

A Scientific Instrument for 2/3



The famous "OHMITE" — a Moulded Anode Resistance with a value that remains constant. Infinitely better than wire-wound. Hermetically sealed in Bakelite. Noiseless and efficient. Negligible self capacity, so that the high notes are retained. Also fitted with terminal ends. All values, 1,000 to 500,000 Ohms.

2/3 each.

Holders. Horizontal or Vertical. 6d.

No wonder we've sold millions!

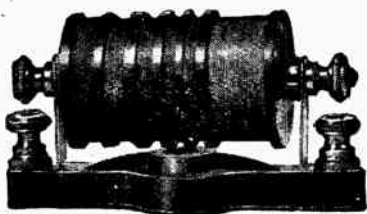

5/- each.

The New "MICRO-FICIENT" Condenser, a brass-vaaned log-mid-line variable condenser using Bakelite as a dielectric. Robust in construction, and ideal for portable sets. Can be mounted for either drum or ordinary dial control. .0005 4/6. .0003 4/3. .00015 4/3.

The "MULTIWAVE" H.F. CHOKE designed for modern valves. By employing solenoid winding followed by sectional windings, high impedance is obtained with low D.C. resistance. Also very effective for use in H.F. stopper or filter circuits. With Base.

GRAHAM FARISH



BROMLEY

KENT

136

THE NEW CELESTION LOUDSPEAKER

Z.20.

Holds undisputed rank as the finest of all Loudspeakers

"Finest loud-speaker I have heard . . . sets entirely new standard . . . worth every penny it costs." *"Help Yourself" Annual.*

"Nearest approach to the ideal that I have yet heard." *"Sphere."*

"Most critical musician could not find fault . . ." *"Evening Chronicle."*

Sets a standard. Amazingly true reproduction. Low frequencies as well as high." *"Daily Mirror."*

"Renowned for brilliancy and quality . . . speech and music particularly good . . . a handsome instrument." *PERCY HARRIS in "Wireless Constructor."*

Designed specifically to give the finest possible results with any set from a Two-Valver to a Power Amplifier. Crowned with the Celestion hallmark — a beautifully designed and hand-polished cabinet.

In Oak £7 : 15 : 0,

Mahogany £8 : 5 : 0,

Walnut (to order) £9 : 0 : 0.

Other Celestion models from £3 : 15 : 0.

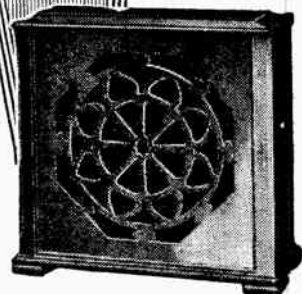

WRITE FOR AN ABSORBING FREE BOOK ON "SOUND RE-CREATION"

CELESTION

The Very Soul of Music

London Showrooms: 106, Victoria Street, S.W.1.

Write to: Celestion Ltd., Dept. C. Kingston-on-Thames.

FOREMOST NAME IN SOUND REPRODUCTION

Mention of "The Wireless World," when writing to advertisers, will ensure prompt attention.

B6

EVERYTHING



ELECTRICAL

“The
Christmas
Spirit”



Treat
yourself
and
your
friends
to a
set of

**Osrain
Valves**

MADE IN ENGLAND
Sold by all Wireless Dealers.

Advt. of The General Electric Co., Ltd., Magnet House, Kingsway, London, W.C.2

Advertisements for "The Wireless World" are only accepted from firms we believe to be thoroughly reliable.

Gift it with "Ekco!"

There's a wonderful treat in store for those who receive "EKCO" this Christmas! There is an "EKCO" Power Supply Unit for every type of battery-operated set, whether the electric supply is from D.C. or A.C. Mains, guaranteeing you a continuous source of plentiful power at a negligible maintenance cost.

Battery sets are completely electrified with an "EKCO" All Power Unit, or H.T. and L.T. batteries are eliminated with an "EKCO" H.T. or L.T. Unit respectively, whilst an "EKCO-LECTRIC" Radio Receiver gives modern radio at its very best.

An "EKCO" Power Supply Unit was placed **FIRST** by **PUBLIC** in "The Wireless World" **NATIONAL BALLOT!**

H.T. UNIT
D.C. 1V. 20
(S.G. 0-150:
120/150
volts),
£2-10-0

H.T. UNIT, A.C.
2A-10 (60 and
120 volts), £3-10-0.

Ask your dealer,
or write for Free
Booklet on
"All - Electric"
Radio.

"EKCO"

E. K. COLE, Ltd.,
Dept. W,
"Ekco" Works,
Leigh-on-Sea.

H.T. UNIT
A.C. 8P. 2
(S.G. 0-60
120/150
volts),
£3-10-0

TRICKLE
CHARGER,
£2-12-6.

"EKCO-LECTRIC" RADIO RECEIVERS "Plug-in-That's all!" AND POWER SUPPLY UNITS

THE WONDERFUL NEW GOLDEN P. R. VALVE

By a special process employing an extremely rare element in minute and precise quantities, in the coating of our Golden Series, we have been able to turn out a valve of extraordinary efficiency.

ABNORMAL SELECTIVITY and VOLUME

Although the L.T. Filament consumption has been kept more or less to our standard to secure robustness, the emission has been increased **BY OVER 50 PER CENT.** For selectivity and volume, we believe a better valve cannot be obtained anywhere with such a low consumption of H.T. and L.T. The glass bulbs are of a distinctive golden colour and each valve has a golden guarantee band.



4/6

Postage 4d.

INSIST ON THE GOLDEN P.R.

Ask your Trader for a Golden P.R. Valve, and do not be put off with any other. You will be positively amazed at the greatly increased efficiency of your set. Remember, insist on the Golden P.R.

GET PERFECT RESULTS OR GET YOUR MONEY BACK

Each valve has attached to it a written guarantee covering 7 months. In the event of the valve losing emission or becoming inefficient in any way during this term, a new valve will be supplied under the terms of the guarantee. If not fully satisfied that the valves received are equal to any they should be returned within a week; full refund will be made by return of post.
Sent C.O.D. if desired. Ask your dealer for them. Accept no other. Matched Valves 1/- extra per set.

P.R. PRODUCTS
29, P.R. HOUSE, NEWGATE STREET,
LONDON, E.C.4.

LIST OF P.R. SUPER GOLDEN SERIES.						
4/6	Type.	Fil. volts.	Amp.	Imp. ohms.	Amp. fac.	
EACH	GPR 2	2	.095	24,000	13.5	H.F. Det.
Post 4d.	GPR 3	2	.095	12,000	9	L.F.
POWER	GPR 4	2	.095	40,000	32	R.C.
7/6	GPR 9	3.5-4	.09	22,000	14.5	H.F. Det.
EACH	GPR 10	3.5-4	.09	10,000	9	L.F.
Post 4d.	GPR 11	3.5-4	.09	44,000	41	R.C.
SUPER-POWER	GPR 17	5-6	.14	20,000	17.5	H.F. Det.
EACH	GPR 18	5-8	.14	11,000	9.5	L.F.
Post 4d.	GPR 19	5-8	.14	75,000	41	R.C.
12/6	GPR 20	2	.15	6,000	7	Power
EACH	GPR 40	4	.15	6,000	7	"
Post 4d.	GPR 60	8	.15	6,000	7	"
Screened Grid	GPR 120	2	.3	3,000	4.5	Super Power
15/- Each	GPR 140	4	.2	3,500	4.5	"
Post 4d.	8G 25	2	.2	220,000	150	S.G.

2 Valves or more sent **POST FREE.** Matched Valves 1/- extra per set.

(Opposite G.P.O. Tube Station.) Telephone: 0171 3788.

Mention of "The Wireless World," when writing to advertisers, will ensure prompt attention.

£20 in Christmas Present Prizes

Simple Competition
for Readers of "The Wireless World"

HIDDEN ADVERTISEMENTS

Below will be found six reproductions of fragments taken from the Advertisement pages of this issue of "The Wireless World." Each fragment is a clue. Can you from these clues identify the Advertisements? Eight prizes will be awarded to the first eight readers who send us correct solutions. No technical skill is required, merely observation. There are no restrictions or entry fees and the conditions are simple.

First Prize

An order entitling the winner to purchase goods as advertised in this number of "The Wireless World" to the value of

£7. 10s.

for the first correct solution opened.

Third Prize

An order entitling the winner to purchase goods to the value of

£2. 10s.

for the third correct solution opened.

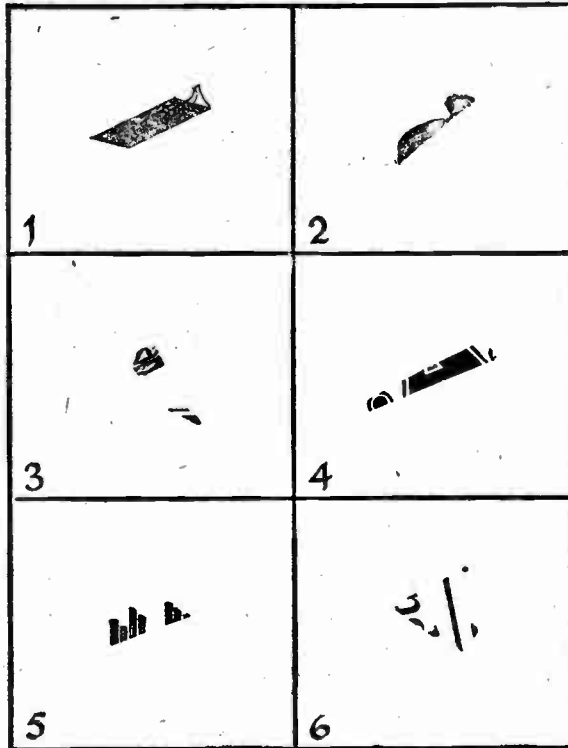

Second Prize

An order entitling the winner to purchase goods to the value of

£5

for the second correct solution opened.

5 Consolation Prizes

of goods to the value of

£1 each

for the next five correct solutions opened.

CONDITIONS

1. All solutions must be written on the special coupon appearing on an advertisement page in this issue and addressed to *The Wireless World*, Dorset House, Tudor Street, London, E.C.4, and marked "Hidden Advs." in bottom left corner.

2. Clues will not, of necessity, appear in the same way as in the advertisement page, but may be inverted or placed in some other position.

3. In order that town and country readers may compete on equal terms, solutions will not be dealt with until 10 a.m. on Monday, December 16th. All solutions received before that date will be retained until Monday morning. Competitors may submit

any number of entries. Erasures or alterations on a coupon will disqualify the entry.

4. The first prize of £7. 10s. will be awarded for the first correct solution opened; the second prize of £5 for the next correct solution; the third prize of £2. 10s. for the third, and five consolation prizes of £1 each for the next five correct answers. In the event of no readers sending correct solutions the prizes will be awarded to the competitors whose solutions are most nearly correct.

5. The decision of the Advertisement Manager of *The Wireless World* is final and no correspondence can be entered into. Competitors enter on this distinct understanding. No member of the staff of the paper is permitted to compete.

FOR HEAVY WORK!



At Christmas time your wireless set is kept working for many hours on end. Everybody's enjoyment depends upon the quality of reception maintained. And the purity of reception depends largely upon the low tension supply, which is forced to carry a much heavier load.

Buy a Tudor Monolt Battery and, however heavy the current consumption of your set, you can be sure of uninterrupted reception combined with purity of tone and powerful volume.

Here are a few attractive Tudor features: Mono-bloc clear glass container. Charge indicators. Wood separators. Positive plates, very substantial, which means longer life! Large spray-proof ebonite vents and a detachable carrier, making a bulky wooden crate unnecessary. These are the reasons why the Tudor Monolt Battery is so frequently specified by the technical press.

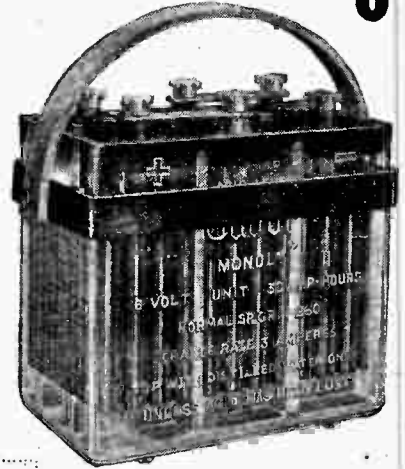

Tudor Monolt Unit.
6v. 34a.h.
40/-
Complete with Carrier.

Tudor ACCUMULATORS

COUPON.
Please send me full particulars of Tudor Wireless Batteries.
Name
Address
Tudor Accumulator Co., Ltd., 2, Norfolk Street Strand, London, W.C.2.

Advt. of Tudor Accumulator Co., Ltd., 2, Norfolk Street, Strand, W.C.2.

M.C.46

The Wireless World COUPON for "HIDDEN ADVT." COMPETITION

The latest time for receiving this Coupon is 10 a.m., Monday, December 16th, 1929.

Clue No.	Name of Advertiser.	Page
1		
2		
3		
4		
5		
6		

I enter the above solution subject to the published rules.

Name
(Please write clearly)

Address



THE PERFECT PORTABLE — AT A PRICE YOU CAN PAY

No aerial troubles—no loose wires to contend with—no connections to make, enjoy care-free broadcast reception with a "Chakophone" Junior Portable Four or Five Receiver, a handy suit-case model that can be carried from room to room, or wherever you wish, and be a constant source of entertainment. "Chakophone" Portables make ideal Xmas gifts within the reach of moderate purses by reason of their exceptionally low prices.

THE JUNIOR PORTABLE FOUR is capable of giving excellent reception with full volume for all near stations. Complete including Royalty .. **£13.13.0** or 30/- down and 11 monthly payments of 25/-.

THE JUNIOR PORTABLE FIVE, recommended for longer range reception. A perfect Portable. Complete including Royalty .. **£14.14.0** or 39/- down and 11 monthly payments of 26/-.

BUY BRITISH



THE EAGLE ENGINEERING COMPANY LTD.

EAGLE WORKS, WARWICK.

Full particulars and name of nearest agent on request.

Mention of "The Wireless World," when writing to advertisers, will ensure prompt attention.

B10

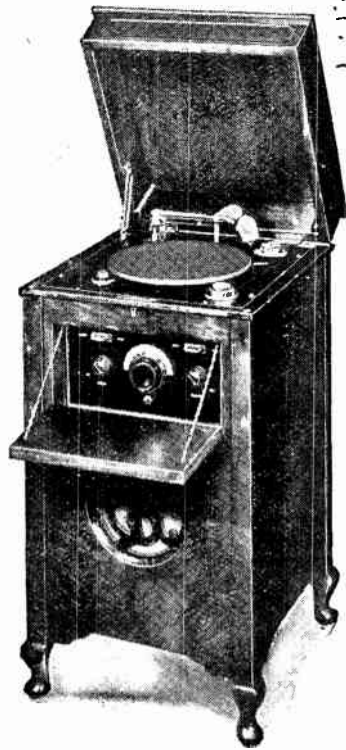

The 'CLARITH' REPRODUCER combines a 3-valve Radio Set with a high-class electrically reproducing Gramophone, entirely mains operated. The Speaker is of the Moving-Coil Type and gives perfect reproduction. Price:

A.C. ... 49 Guineas.

D.C. ... 59 Guineas.

*Send To-day for
Illustrated Folder.*

Opera or Drama Music or Speech...

'Clarith' gives life to speech and music either from the Radio or the Gramophone. Sit cosily at home whilst from the speaker comes the very essence of the performance So wonderful that it must be heard to be believed. Ask your dealer to demonstrate 'Clarith.' If he cannot write us, please.

Clarith

RADIO-GRAMOPHONE

CLARITH REPRODUCERS LIMITED, East Street Mills, LEEDS

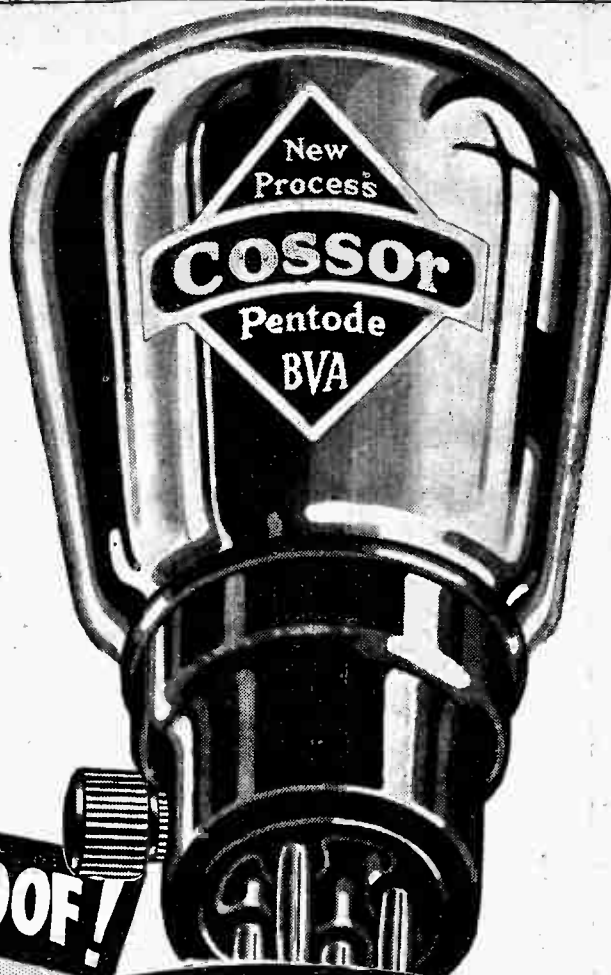

SHOCK-PROOF!

THE ONLY PENTODE

NOISE-PROOF!

VALVE WITH INTERLOCKED

BREAK-PROOF!

CONSTRUCTION!

THE elements of the NEW Cossor Pentode are double locked in position—braced to a girder-like rigidity. This exclusive Cossor system of construction definitely prevents individual movement. Even the hardest shock cannot mar their perfect alignment, and because of their rigidity they cannot vibrate and so cause microphonic noises. For power and for long life use the NEW Cossor Pentode in your Receiver. No other Pentode Valve has this wonderful system of Interlocked Construction.

2 volt type now available
 The NEW Cossor 230 P.T.
 (2 volts, .3 amp Impedance
 20,000. Amplification Factor
 40. Anode volts 100 to
 180. Price 25/-

Cossor 4 volt Pentodes are
 also obtainable from all
 Wireless Dealers.

The **NEW**
COSSOR
PENTODE

A. C. Cossor Ltd. Highbury Grove, London, N.5.

Mention of "The Wireless World," when writing to advertisers, will ensure prompt attention.

2760



The Wireless World

AND
RADIO REVIEW
(17th Year of Publication)

No. 537.

WEDNESDAY, DECEMBER 11TH, 1929.

VOL. XXV. No. 24.

Editor: HUGH S. POCOCK.

Assistant Editor: F. H. HAYNES.

Editorial Offices: 116-117, FLEET STREET, LONDON, E.C.4

Editorial Telephone: City 9472 (5 lines).

Advertising and Publishing Offices:

DORSET HOUSE, TUDOR STREET, LONDON, E.C.4.

Telephone: City 2847 (13 lines). Telegrams: "Ethaworld, Fleet, London."

COVENTRY: Hertford Street.

Telegrams: "Cyclist, Coventry." Telephone: 5210 Coventry.

BIRMINGHAM: Guildhall Buildings, Navigation Street.

Telegrams: "Autopress, Birmingham." Telephone: 2970 and 2971 Midland.

MANCHESTER: 260, Deansgate.

Telegrams: "Dife, Manchester." Telephone: 8970 City (4 lines).

GLASGOW: 101, St. Vincent Street, C.2.

Telegrams: "Dife, Glasgow." Telephone: Central 4857.

PUBLISHED WEEKLY.

Subscription Rates: Home, £1 1s. 8d.; Canada, £1 1s. 8d.; other countries abroad, £1 3s. 10d. per annum.

Entered as Second Class Matter at New York, N.Y.

As many of the circuits and apparatus described in these pages are covered by patents, readers are advised, before making use of them, to satisfy themselves that they would not be infringing patents.

CONTENTS OF THIS ISSUE.

	PAGE
EDITORIAL VIEWS	639
ON CHOOSING A SET	640
THE PARALLEL-FED L.F. AMPLIFIER. BY F. AUGHTIE AND W. F. COPE	644
THE ROBINSON "STENODE RADIOSTAT"	647
HOW WE HEAR. BY R. T. BEATTY	649
BROADCAST BREVITIES	653
WIRELESS THEORY SIMPLIFIED. PART XII. BY S. O. PEARSON	654
CURRENT TOPICS	657
MODERN SHORT-WAVE BROADCASTING. BY A. J. HALL	659
CORRESPONDENCE	662
READERS' PROBLEMS	663

A RADIO CHRISTMAS.

ONCE again Christmas is approaching, and with it, naturally, come thoughts of entertainment round the fireside. To-day winter evenings round the fireside can scarcely be regarded as up to date unless wireless is present to complete the picture. In the matter of giving presents, wireless offers great attractions by reason of the fact that there is so much that is new from which a choice can be made, whilst the variety of apparatus and sets makes it possible to make a selection to suit every pocket.

o o o o

OURSELVES.

WE feel that it would be ungrateful on our part if we neglected to express our very keen appreciation of the way in which our readers have reacted to our decision to increase the price of *The Wireless World* from 3d. to 4d., following the announcement which appeared in our issue of November 27th. We had no reason to expect communications approving of our policy, so that to have received quite a large post

conveying expressions of opinion from readers which amount almost to congratulations on our decision is extremely gratifying.

We think it would be of interest to quote from a representative few of the letters which we have received. "I do not think any reasonable person would grumble at the increased price of your journal. Some people have wondered how such a well-produced technical weekly could have been published at 3d.—R. B. Smith, Tyr Pwll, Abergavenny." "Don't, for goodness sake, drop the quality of *The Wireless World*, even at the cost of 6d. It is the only paper worth while in the opinion of really interested people.—R. T. Ashton, Hanley, Staffs." "Regarding the increased price of *The Wireless World*, I believe the great bulk of your subscribers will willingly pay the small addition . . . I feel sure you are taking the right course . . . Those whose sole criterion is cheapness, will always be able to indulge it.—A. F., Southampton." "I have often wondered how much longer we were to have our favourite journal for 3d. Here is one only too pleased to pay 4d. or more if required. More power to your elbow.—L. H. Pepler, Ipswich." "I observe that the price of *The Wireless World* is to be increased to 4d. May I say that if it were treble the amount it would still be the best available value for money? *The Wireless World* caters for a large section of the wireless community for whom other periodicals are valueless.—C. J. Carter, Chalfont St. Giles."

One must find an exception to prove the rule, and up to the time of writing we have received only one letter condemning us for our action. This comes from Mr. E. H. Brown, of South Norwood, who disagrees with our statement as to the time and care required before we are able to give publication to the design of a modern receiver. Our critic states, "If you had, say, a fortnight's work in the experimental workshop with the manufacturers' co-operation, plus the services of a draughtsman to make a drawing of it, it would sound feasible." We are told that in regard to our technical information service we should pass over the bulk of our queries "to component manufacturers, who are only too pleased to give technical information, as I have often proved." This communication concludes with the assurance that "further editions at 4d. per copy can remain on the bookstall so far as I am concerned." We must express regret at the loss of a reader, but we feel, at the same time, that Mr. Brown could never have been warmly attached to a paper of which he appears to have so poor an opinion.

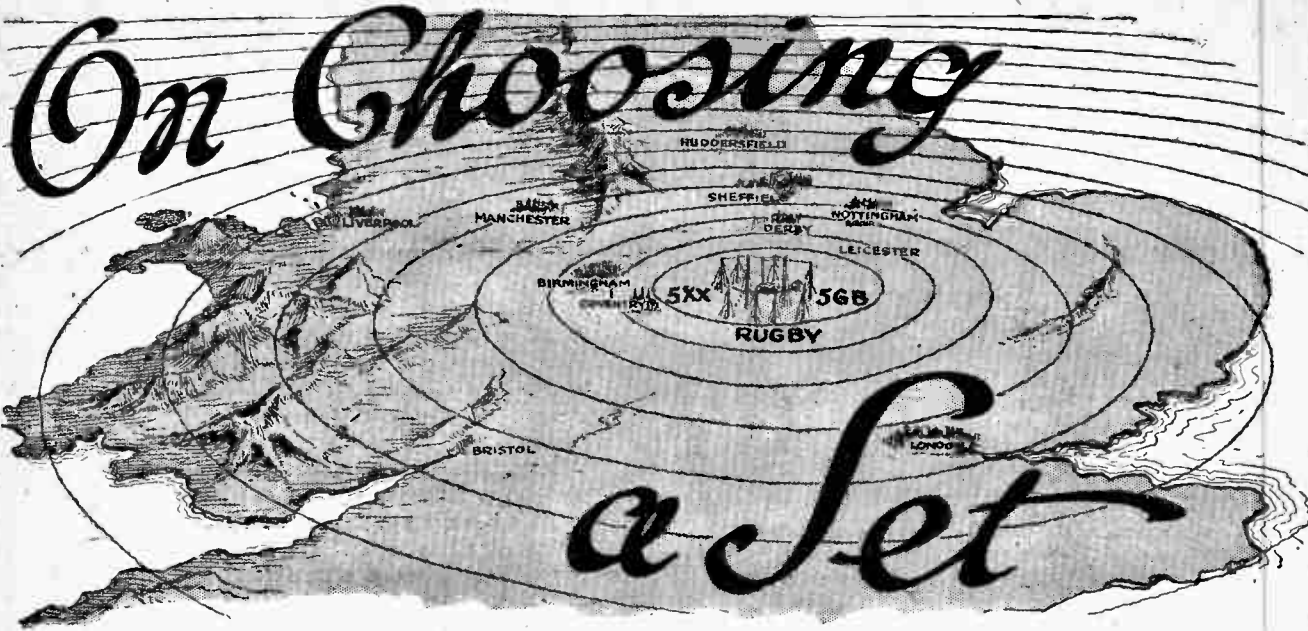

How Decisions are Affected by Changing Conditions.

BROADCASTING technique in this country is passing through a period of transition, and it behoves everyone who is faced with the task of deciding upon the desirable features of a new set, no matter if it is to be bought ready-made or assembled at home, to keep an eye on probable developments of the near future. Naturally, this applies equally to those who, at this season of the year, are giving wireless apparatus as presents, or who are acting in the capacity of adviser to those who are less well informed on the subject.

It is hardly necessary to remind the reader that if present plans come to maturity the whole country will be served, within a couple of years or so, by alternative programmes radiated from powerful twin stations in London (Brookmans Park), at Daventry, on the Lancashire-Yorkshire border, in Scotland, and on the Bristol Channel. These stations are expected to provide signals strong enough to be practically immune from fading difficulties or any ordinary form of interference within a radius of up to 80 miles, and considerably more in the case of 5XX, whose long wavelength is subject to less attenuation.

Choice of a suitable set for given requirements is

much more a matter of geography than is generally appreciated—at short ranges, a few miles more or less in distance from the local station makes a world of difference in the “spreading” of its signals—and it might seem at first sight that this opportunity might profitably be used to discuss the best circuit arrangement for operation in various areas. Unfortunately,

such a course is impossible, for the very good reason that there is still nothing approaching unanimity as to what is best even for the least complex set of conditions imaginable. The writer cannot hope to do more than deal with general considerations that should be taken into account, avoiding as far as possible a superfluity of “ifs” and “buts” that are apt to be so wearisome when one attempts briefly to discuss a number of points.

Before attempting to make a choice it is wise to devote some thought to forming a fairly clear idea of what is required of the

apparatus. Many of us, influenced perhaps in the early days of broadcasting by ill-informed and ill-advised pronouncements as to what a wireless set should do, have set an unduly high standard; it is more than ever difficult to combine superlative quality reproduction with long range in one simple piece of apparatus, and

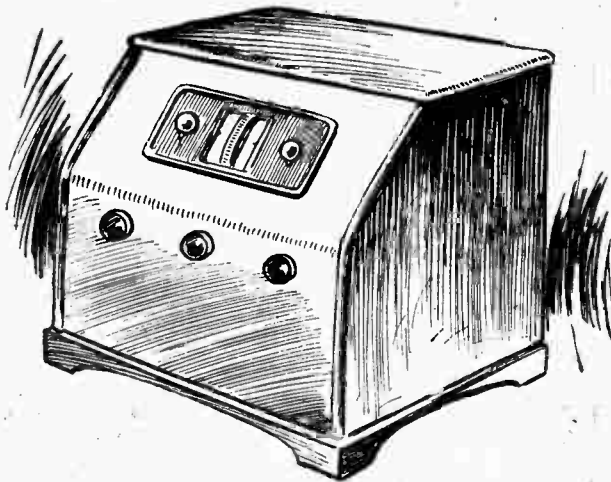

A three-valve H.F.-det.-L.F. set is a safe choice for satisfying average requirements, as it combines reasonable selectivity and sensitivity with enough volume for ordinary needs.

On Choosing a Set.—

there may be a tendency for the popular general-purpose set—jack of all trades and master of none—to give way to more highly specialised circuit combinations.

Be this as it may, it seems likely that a new type of listener will arise, asking for nothing more than the alternative programmes from his local station. Except when he lives on the borderland between the service areas of two regional stations his requirements are easily satisfied. Much has been written on the need

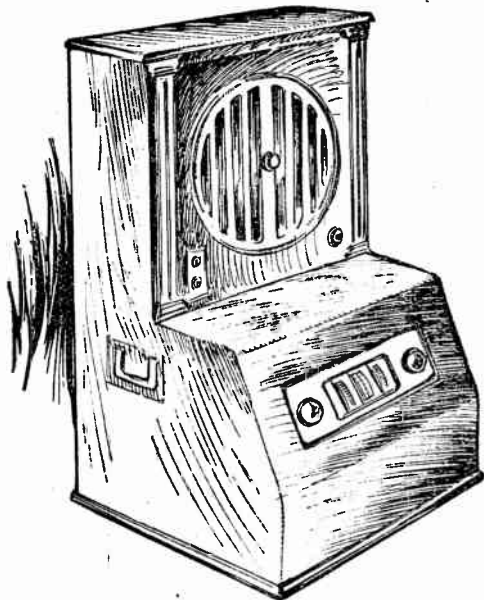

The table portable set—completely self-contained, with built-in loud speaker and frame aerial—is one of this season's innovations, and is proving increasingly popular. Mains-fed models are available.

for selectivity that will manifest itself when the twin stations come into being, but it is always tacitly assumed that other transmissions will be required; if they are not, the problem resolves itself into one of reducing input from the aerial.

Imagine a listener living at a distance of a mile from Brookmans Park; a comparatively crude 2-valve receiver will provide volume only limited by the capabilities of the type of output valve customarily fitted without allowing any mutual interference between the transmissions. All the user has to do is to try various short lengths of aerial until a sufficient, but not excessive, input to the detector is obtained. Of course, similar results may be attained by the use of a fixed aerial and a suitable input volume control.

Disproportionate Cost of an Extra Programme.

Briefly, the position may be summed up by saying that a set with sufficient selectivity to separate the two stations at its maximum range is bound to be capable of separating them at any distance, however short, provided that aerial input can be reduced to simulate conditions existing at a distant point. This proviso implies that the direct pick-up of coils and wiring is negligibly small, or at any rate can be made so by screening.

But let our hypothetical listener try for signals from Daventry 5GB, some 60 or 70 miles away—at first sight a modest enough addition to the repertoire of his set. This station may be within its range; but, to obtain sufficient sensitivity, he must increase the dimensions of his aerial—or its coupling, which comes to very much the same thing if a large aerial is normally used—to such an extent that serious interference from the local station will almost certainly make itself felt. This interference can be eliminated only by adding a complicated system of extra tuned circuits, in conjunction with at least one H.F. amplifying valve, and our ideal of a simple and inexpensive receiver is at once shattered in order that a trifling gain may be achieved.

Admittedly this is an extreme case, but it goes to prove that, under anticipated conditions, the reception of anything beyond the local twin transmissions will often be accomplished by considerably increased expense and complexity. In circumstances anything like those envisaged the possibilities of the purely two-station receiver should not be ignored, even if it is used only as an auxiliary to a long-distance outfit which may, of necessity, be rather too elaborate for everyday use.

Laments from Potters Bar.

Influenced no doubt by the minority who loudly voice their complaints regarding interference and the Regional Scheme, one is apt to place undue emphasis on the trials and tribulations of those living in the wipe-out areas surrounding the new stations—existing or projected. No one will grudge them their share of the limelight, and it is only right that their peculiar difficulties should have attention focused on them, although actually they will always be in a minority, and most wireless users will find that the better sets of present design are amply selective. Before attempting to discuss any particular circuit arrangement it is as well to consider one or two general principles about which there has recently been some revision of ideas.

There are still those who profess a distrust of mains-operated receivers, and until quite lately one is bound to admit that there was some justification for their attitude. But now, thanks to a fuller appreciation of

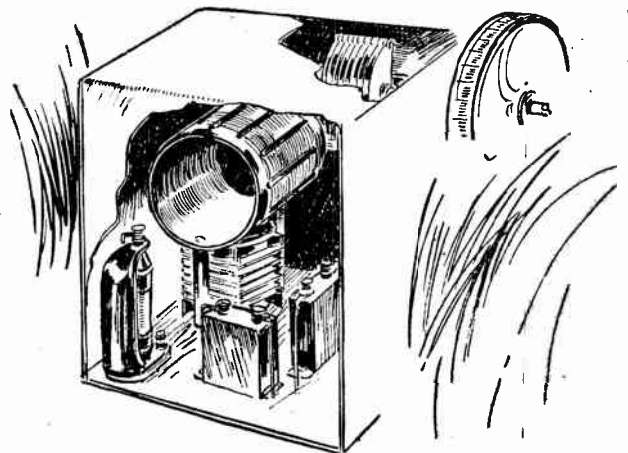

The single highly efficient H.F. stage, with complete metallic screening, scores largely on the grounds of low upkeep cost.

On Choosing a Set.—

the principles underlying power rectification, smoothing, and, most important of all, the "decoupling" of individual circuits, the general performance and reliability of "mains" sets leaves little to be desired; indeed, it is now considered that battery users are almost precluded, by financial and practical limitations, from obtaining the realistic volume that is so readily available to those with access to a mains supply.

The above applies more particularly to alternating current circuits; although very satisfactory D.C. sets have been produced, it is by no means unusual to depend on the mains for H.T. current, and perhaps for grid bias as well, using an accumulator for filament supply. Incidentally, two-volt valves are now so extraordinarily good, as compared with those of a year or two ago, that there is a noticeable tendency to use them even in the case of quite ambitious sets where 6-volt filaments would previously have been chosen. The upkeep of a "D.C." set with no other battery than a single large L.T. cell is a very simple matter.

Some Eliminator Considerations.

The days when a receiver and an eliminator intended to work together were bought separately and more or less at random are almost over; indeed, the tendency of to-day is to combine the two. If the eliminator is not specifically designed to work with the set concerned, the prospective purchaser should assure himself that the necessary interconnections to the various anode circuits can be readily made.

In the matter of price the mains-fed receiver scores

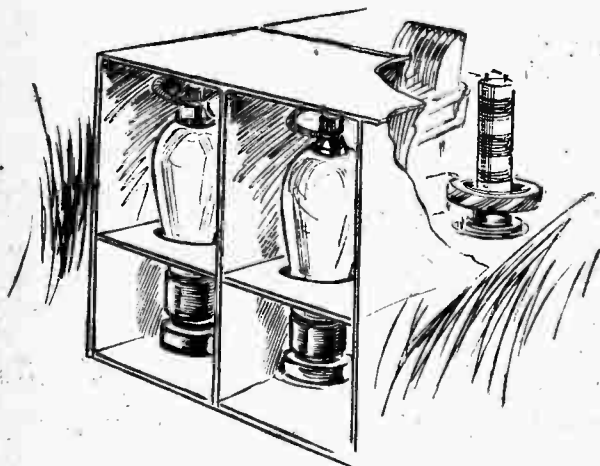

Typical arrangement of components in a multi-stage H.F. amplifier, as included in the most ambitious receivers. Separate screening for the valves is usually provided.

heavily when maintenance expenditure is considered, although its initial cost is apparently disproportionately high until all the factors concerned are properly considered.

This is not the place to discuss the relative merits of "portable" and fixed receivers; the weaknesses of the former are well known, but there is sometimes a tendency to over-emphasise these weaknesses and to ignore the many advantages of a completely self-contained receiver. In any case, the great British public

has signified its approval of this type of set in an almost unqualified manner, so it must have a very real appeal. Possibly it will eventually be displaced by the "mains transportable," which, with obvious limitations, has its advantages without its handicap of a limited power output and a rather heavy upkeep cost.

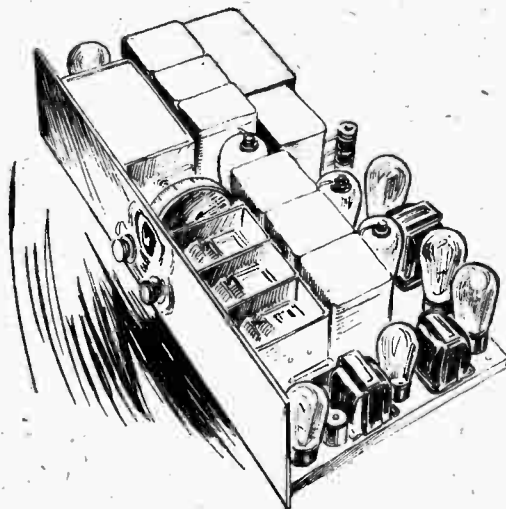

The possibilities of "chassis" receivers, suitable for mounting in existing pieces of furniture, etc., should not be overlooked. Several examples of this type of construction are available commercially.

Recent articles dealing with the trend of modern receiver design show that a three-valve combination of H.F. amplifier, detector, and L.F. valve—very often a pentode is provided in the latter position—is the most popular circuit arrangement of to-day—at any rate for fixed receivers. It will be generally agreed that public taste is thoroughly well justified in this matter, and that for average requirements such a set is a safe choice. It has inherent freedom from serious L.F. instability, is at least reasonably selective, by virtue of its two or sometimes three tuned circuits, and is sufficiently sensitive for use almost anywhere for reception of the nearer stations with a consistent "programme" value, while the better designs can be depended upon for long-distance reception when conditions are reasonably favourable, particularly after dark.

Desirable Points in Design.

A four-valve receiver, with one H.F. amplifier and two L.F. stages, will have a greater reserve of amplification and is consequently to be recommended for more difficult situations and more exacting requirements. It is nowadays considered almost essential that such a set should have a post-detection volume control whereby the very considerable magnification afforded by its two L.F. stages may be reduced. Similarly, it is desirable that specific precautions should be taken to prevent undesirable interaction between the various anode circuits: at the best, such interaction will be productive of more or less serious distortion, and, at the worst, will cause motor-boating or L.F. oscillation. To minimise the possibilities of these troubles there is a tendency to rearrange the valves, and to provide two H.F. amplifiers with a single L.F. stage. Sets of this

On Choosing a Set.—

type are rather more difficult to design and operate, but are more sensitive to weak inputs, and also much more selective. On the other hand, the H.F.-det.-2 L.F. combination scores where a very great power output is required. Sets with parallel or push-pull output valves come in this category, as they include the same number of stages.

The "two-H.F." set considered above is quite suitable for use with a frame aerial, and should have ample sensitivity for reception of stations near enough and powerful enough to provide consistently good signals. Due to the comparatively poor pick-up of this type of collector, regular long-distance reception implies either two stages of exceptional efficiency, or, better, of three H.F. valves. This brings us to the luxury class of set, whether for open aerial, frame, or

short indoor aerial, with a multi-stage high-frequency amplifier having comparatively flat circuits, and, more often than not, a system of mechanically linked variable condensers. For consistent long-distance reception, this is unquestionably the best type of receiver.

Reverting to the question of selectivity, mention should be made of a point likely to be overlooked in deciding upon a receiver for operation near a twin regional station. This concerns input volume control; it is highly desirable that some means of regulating the signal voltage applied to the first valve should be provided. Detuning may not be permissible, due to the fact that a sufficient variation of the condenser capacity would probably bring in the unwanted alternative station. The ideal input volume control does not seem to exist, but very effective regulation can be arranged by providing variable coupling for the aerial.

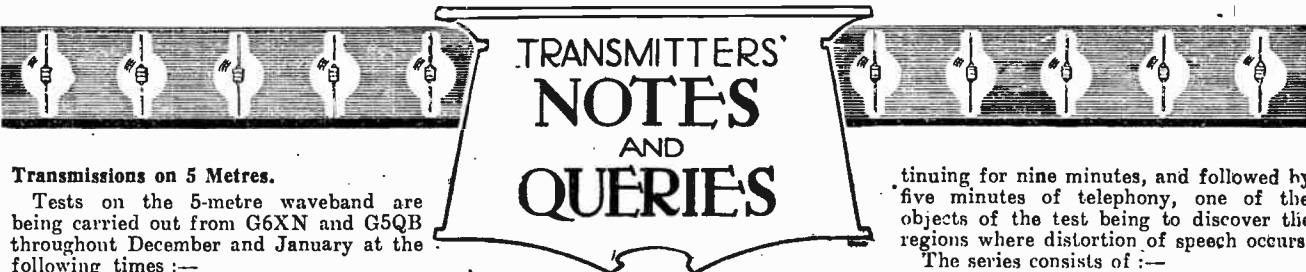

TRANSMITTERS' NOTES AND QUERIES

Transmissions on 5 Metres.

Tests on the 5-metre waveband are being carried out from G6XN and G5QB throughout December and January at the following times:—

Each Sunday, 10.00-10.10, 10.30-10.40, 11.00-11.10, 11.30-11.40, 14.00-14.10, and for ten minutes past each subsequent hour and half-hour until 22.40 G.M.T.

Transmissions will take place alternatively from G5QB and G6XN, and will consist of series of Vs followed by the call-sign, or of the word "Test" followed by the call-sign, and an announcement of the frequency.

In addition, automatic signals will be sent from G5QB between 9 p.m. and 10 p.m. on each weekday from Monday to Friday inclusive.

Reports should be sent direct to G6XN, 5, Pembroke Mansions, Canfield Gardens, London, N.W.6, or to G5QB, 120, Mill Lane, London, N.W.6.

Paris Experimental Station.

A French short-wave station which is now being heard in Great Britain is Paris Experimental Radio. Transmissions of gramophone records and speech are made on 31.65 metres (9479kC.) with a power of 1 kilowatt, four days a week at the following times: 10.00-11.30 a.m. G.M.T. Sunday, 21.30 Tuesday, 18.00-19.15 Thursday, and at 19.00 on Friday. The interval signal adopted is that of a metronome with 120 beats per minute. The station closes down with the playing of the well-known French military march, "Entre Sambre et Meuse."

Federated Malay States.

Mr. G. D. Forbes (VS 2AT), writing from Kinta Kellas Estate, Batu Gajah, tells us that a Radio Society is being formed in the Federated Malay States, and that it is hoped to institute a broad-

casting service. We gather from the correspondence which has passed between us that experimenters in the Malay States are few in number and somewhat widely scattered, but that their enthusiasm is almost unbounded.

South Africa.

With reference to the note on page 417 of our issue of October 9th, we hear that Mr. E. R. Cook (ex G6UO) has been allotted the call-sign ZUIJ, and that his present address is 6, Annandale Street Gardens, Cape Town. He generally works on the 21-metre waveband every Wednesday at about 16.00 G.M.T., and would greatly appreciate reports from anyone hearing him in this country.

French Experimental Transmissions.

The French National Meteorological Office, in collaboration with the Administration of Posts and Telegraphs, transmits twice in each month a series of signals on various wavelengths for the purpose of obtaining records of the signal-strength of the respective wavelengths in different parts of the world. The transmitting stations are Lyons FYS, with an aerial output of about 500 watts; Lyons FYR, with 6 to 10 kW., and Paris FLE, with about 1 kW.

The December series is from Paris only; the transmissions on December 12th will comprise only the 1st, 3rd and 6th groups, and that on December 14th the complete series. Each transmission will consist of repetitions of the signal . . . interspersed with groups of five figures, con-

tinuing for nine minutes, and followed by five minutes of telephony, one of the objects of the test being to discover the regions where distortion of speech occurs.

The series consists of:—

- 1st group, 11.40-11.54 G.M.T. on 24 metres, 11.55-12.09 on 36 metres, 12.10-12.24 on 56 metres, and 12.25-12.39 on 95 metres.

The succeeding groups are similar. The second group will be transmitted from 13.40-14.39, the third from 15.40-16.39, the fourth from 17.40-18.39, the fifth from 19.40-20.39, the sixth from 21.40-22.39, and the seventh from 23.40-00.39.

On January 11th and 18th of next year both the Lyons and Paris stations will transmit, this time on telegraphy only, the signals being repetitions of . . . interspersed every two minutes with the call-sign and an indicating group of five figures. The programme for the first group will be:—

- 12.00-12.10 G.M.T. Lyons FYS on 38 metres
- 12.10-12.20 Lyons FYR on 38 metres
- 12.20-12.30 Paris FLE on 36.7 metres
- 12.30-12.40 Lyons FYS on 25.75 metres
- 12.40-12.50 Lyons FYR on 25.75 metres
- 12.50-13.00 Paris FLE on 73.5 metres
- 13.00-13.10 Lyons FYS on 15.1 metres
- 13.10-13.20 Lyons FYR on 60 metres.

The succeeding three groups will be similar, and will be transmitted at the following times: 2nd group at 14.00-15.20; 3rd group, 16.00-17.20; 4th group, 17.30-18.50. The 5th group at 19.20 and the 7th at 23.30 will comprise Lyons FYR on 60 metres, Lyons FYS on 38 metres, Lyons FYR on 38 metres, Paris FLE on 36.7 and 73.5 metres, Lyons FYS on 25.75 metres, and Lyons FYR on 25.75 metres, each transmission lasting ten minutes; the 6th group at 21.20 will omit transmissions from Paris. The tests on January 11th will only include groups 1, 3 and 6, but those on January 18th will be in full.

THE PARALLELFED LEAMPLIFIER

How Resistance=condenser
Coupling Affects the
Transformer Characteristic.

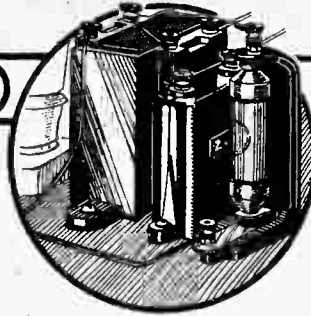

By F. AUGHTIE, Ph.D., M.Sc.,
and
W. F. COPE, B.A.

THE modern tendency in the design of receivers is towards simplification of external connections and improvement of the quality of reproduction. The introduction and increasing use of the anode feed resistance scheme has contributed to both of these by eliminating the need for tappings on the H.T. supply and reducing the back coupling caused by its resistance. In the case of high-power receivers, the resistance plays a further part in that it reduces the voltage of the H.T. from the high value required for the last stage, to a value more suitable for the earlier valves.

When a valve is followed by a transformer and the H.T. voltage is such as to permit (or demand) the use of a resistance in series with the H.T. supply, an improvement of the results obtained may be given by rearranging the actual components used, together with a more exact choice of their values.

The actual circuit of the rearrangement is shown in Fig. 2b. Contrasted with Fig. 1, which shows the usual layout, it will be seen that the only wiring changes are as follows:—First, the lead from the resistance to the transformer is transferred from one terminal to the other, giving Fig. 2a; secondly, the order of the condenser and transformer is reversed. This second change has no effect on the electrical constants of the circuit, and is made solely to isolate the transformer from the H.T. supply: it can be omitted if desired. But the change from Fig. 1 to Fig. 2a, while simple on paper, profoundly alters the performance of the assembly in ways which it is the purpose of this article to explain.

First of all, it should be noted that in Fig. 2a the D.C. feed current of the valve flows only through the resistance and *not* through the primary of the transformer as well. The immediate result of this is that the

primary self-inductance of the transformer is not reduced from its "open circuit" value, as is the case when the steady current flows through the primary, and as a consequence—quite apart from other effects which will be discussed later—the amplification is maintained down to a lower frequency. In other words, the lower "cut-off" frequency is reduced in value.

With modern transformers tolerating little—if any—polarising current, and modern valves taking larger and larger anode currents, this factor alone is sufficient to warrant serious consideration for the change.

But there is a second effect which even further improves the performance at low frequencies. It is well known that a valve when amplifying may be regarded as a source of (alternating) E.M.F. in series with a resistance equal to its anode slope resistance ("impedance"). This permits us to draw the circuit of Fig. 2 in the form of Fig. 3, where the voltage μe in series with a resistance R_a replaces the valve. Now ignoring for a moment the effect of the resistance R , it will be

seen that the transformer primary and the condenser are in series across the valve; the resistance R representing the transformer primary resistance. We see that we have our old friend the tuned circuit once more with all quantities much larger than are encountered in ordinary (R.F.) tuned circuits. The first impression therefore is that the arrangement will be selective, amplifying one frequency very strongly and

others weakly. This will be so if the components are wrongly chosen, but by a suitable choice of values (all practicable) quite a different result may be obtained.

The ideal result is that, for a constant input voltage to the grid of the valve, the voltage applied to the grid of the succeeding valve shall be the same at all

LOW-FREQUENCY intervalve transformers with high permeability cores are becoming increasingly popular, due to good performance combined with small physical dimensions. The steady anode current must, however, be deflected from their primary windings by a suitable resistance capacity filler, the practical study of which forms the subject of this article. The small disadvantages of the arrangement are undoubtedly outweighed by the advantages, not the least of which is freedom from motorboating.

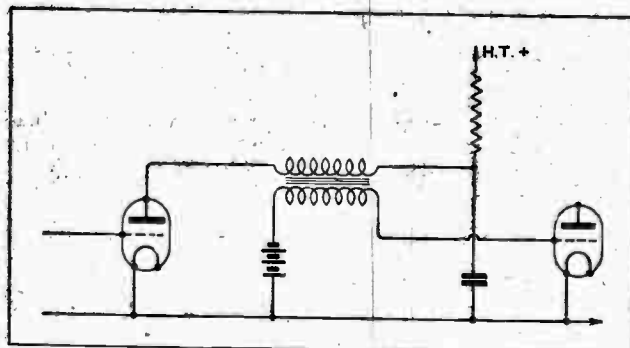

Fig. 1.—The conventional anode-feed resistance or decoupling scheme applied to a L.F. transformer stage to prevent feedback.

The Parallel-fed L.F. Amplifier.—

frequencies: this means that (for medium and low frequencies with which we are solely concerned in this treatment) the voltage across the primary must be independent of frequency. This is obtained if the (audio-frequency) current is inversely proportional to the frequency. This occurs with the normal circuit (over the usual frequency range) by letting the current be limited by the impedance of the primary, which, of course, increases with frequency, that is, by making R_a small compared with the impedance of the transformer primary. This is merely a long way of saying that the voltage across R_a must always be small.

The amplification can be maintained at its steady

and this can be made to compensate to a considerable extent for the drop of voltage across R_a , which, of course, also increases as the current increases.

This all looks so much like getting something for nothing that the reader is probably wondering "Where is the catch?" The catch is simply that the amplification is slightly reduced—unless an unlimited H.T. voltage is available! This is due to the resistance R now being a shunt with the primary of the transformer. We can see its effect by forgetting for the moment the condenser and transformer primary; re-drawing the circuit (Fig. 4), it is seen to be the usual resistance coupling arrangement, of which is known to be $\frac{\mu e R}{R + R_a}$ which is

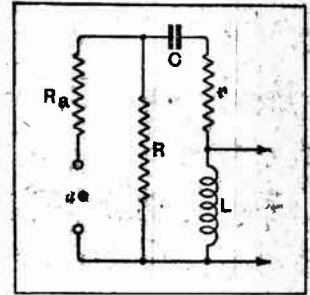

Fig. 3.—A valve when amplifying should be regarded as a source of alternating E.M.F. in series with a resistance equal to its anode A.C. resistance. The equivalent circuit of Fig. 2 is here shown.

obviously less than μe . Now, looking at the complete diagram once more we see that it is this reduced voltage which is applied to the transformer through the condenser. As the "boosting" effect of the condenser only affects the low frequencies it is clear that at medium frequencies the amplification is reduced.

The loss of amplification can be made small by making R large, but unfortunately this means using large H.T. voltages, and in practice a compromise has to be made. The average reduction is 20 per cent., an amount which is too small to be detected by the average ear.

Avoiding a Resonant Circuit.

Hanging over our heads all this time is the "tuned circuit" threat mentioned at the commencement. Fortunately the mathematical analysis of the circuit shows how this can be avoided and gives quite a simple formula connecting the constants of the circuit. The full analysis is somewhat beyond the scope of the present paper. The design formula is given in the Appendix.

Note that the steady value of the amplification over the useful range is $\frac{1}{B}$ times that obtained with the usual circuit. When the constants of the circuit satisfy this relation the amplification curve rises smoothly up to the value at medium frequencies without rising above this value, i.e., there is no hump in the curve. It is important to note that the value of L to insert in the formula is the open-circuit inductance of the transformer primary. This is the value usually

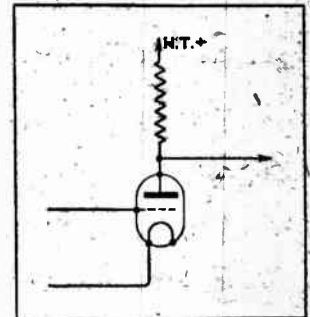

Fig. 4.—The normal resistance coupling arrangement in which the stage amplification must be less than the amplification factor of the valve.

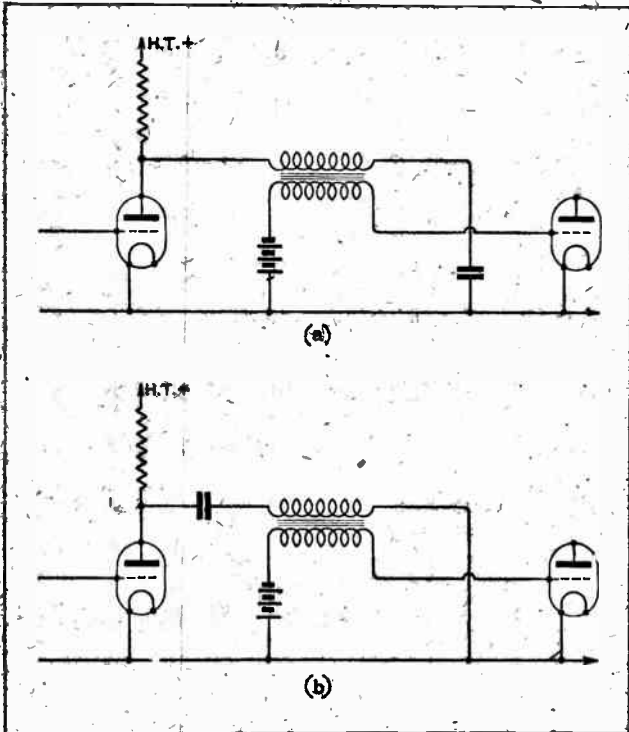

Fig. 2.—(a) The first step in the conversion of the circuit of Fig. 1 to a resistance filter-fed stage where the D.C. is prevented from passing through the transformer primary. (b) The complete conversion.

value down to a lower frequency if as the frequency is reduced an extra voltage be applied to the transformer primary additional to that at the output terminals of the valve. Now this is just what the condenser does in the circuit of Fig. 2, since when a condenser and inductance are placed in series across an alternating voltage, this applied voltage is the (arithmetic) difference between the voltage across the condenser and inductance respectively. Hence at least one (and not infrequently both) are greater than the applied voltage.

Looking at the performance from another point of view, the condenser reduces the impedance of the circuit and thereby permits a larger current; this gives an increased voltage across the transformer. The reduction of the impedance given by the condenser increases as the frequency decreases (down to a limiting point),

The Parallel-fed L.F. Amplifier.—

given in the maker's specification unless otherwise stated.

In practice the values of the constants will deviate from their "nominal" values given by the makers; fortunately this causes no serious modification of the

As the usual tendency is for R_a to be greater than the rated value, and L to be less, a smaller value of condenser than that given by the formula is often satisfactory. This is cheaper and causes no serious modification of the curve. A value of three-quarters of that

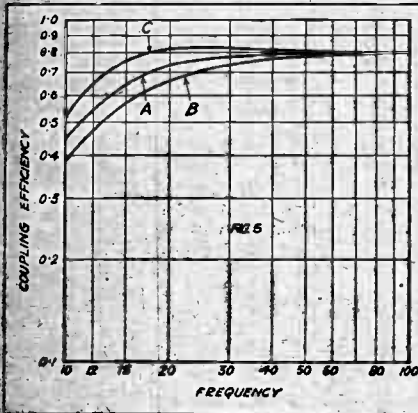

Fig. 5.

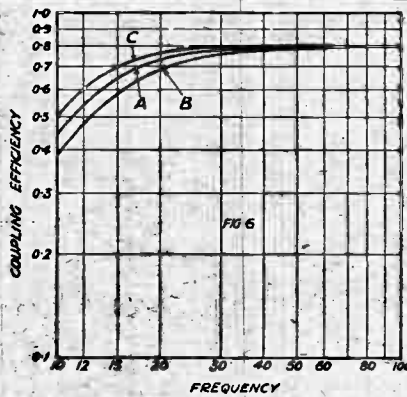

Fig. 6.

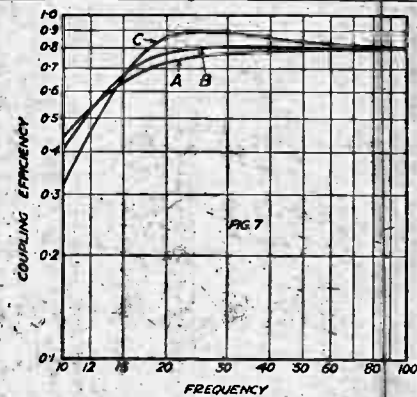

Fig. 7.

Figs. 5, 6 and 7.—Coupling efficiency-frequency characteristics. In Fig. 5 the effect of varying valve resistance is shown. Curve A is for a nominal resistance of 5,000 ohms; curve B for 20 per cent. increase and curve C for 20 per cent. reduction (i.e. 6,000 and 4,000 ohms respectively). $C = 4$ mfd.; $L = 45$ henrys; $R = 20,000$ ohms. Fig. 6.—The effect of varying inductance. Curve A = 45 henrys; B = 11 per cent. reduction = 40 henrys; C = 11 per cent. increase = 50 henrys. $R_a = 5,000$ ohms; $R = 20,000$ ohms; $C = 4$ mfd. Fig. 7.—Varying capacity values. Curve A = 4 mfd.; B = 25 per cent. reduction = 3 mfd.; C = 50 per cent. reduction = 2 mfd. $R_a = 5,000$ ohms; $R = 20,000$ ohms; $L = 45$ henrys.

coupling efficiency-frequency curves, as may be seen from Figs. 5, 6 and 7, which shows the effect of such deviation from the nominal values as are likely to occur in practice.

given by the formula is suggested as being satisfactory in most cases.

To facilitate design, in Fig. 8 a number of curves have been prepared showing the correct coupling

condenser for various primary inductances and valve resistances.

A further set of curves, Fig. 9, gives the corresponding cut-off frequencies. The cut-off frequency is defined as the frequency at which the amplification has fallen to 70 per cent.

$\left(\frac{I}{\sqrt{2}}\right)$ of its value at medium frequencies.

It will be noted that figures are given for low-resistance valves; this is because the circuit is particularly suitable for the penultimate stage of a high-power receiver where considerable grid swing is required for the output stage.

There is one other feature of the circuit to which reference may profitably be made. It can be shown that the magnitude of the audio-frequency current flowing through the H.T. supply falls as the

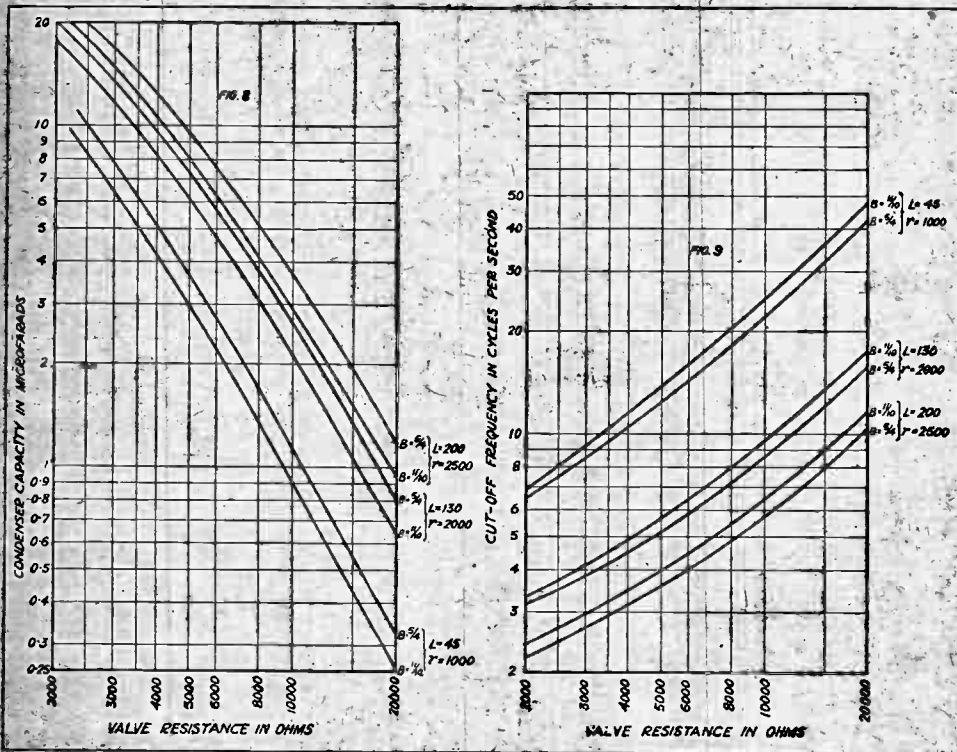

Fig. 8.

Fig. 9.

Fig. 8.—Showing the correct coupling condensers for various primary inductances and valve resistances. Fig. 9.—How varying valve resistance affects cut-off frequency.

The Parallel-fed L.F. Amplifier.—

frequency is reduced down to the cut-off frequency. This is of importance because the internal impedance of practically all eliminators rises as the frequency is reduced. The circuit shown is therefore free from "motorboating" under ordinary conditions, but the usual choke-filter should be retained in the last stage.

Cut-off Frequency Considerations.

The rise of audio-frequency current through the H.T. supply for frequencies below the cut-off is of little importance because the amplification is very small at these frequencies. There is therefore no tendency to oscillate at a frequency below this value.

THE ROBINSON "STENODE RADIOSTAT."

A Receiving Set Designed to Separate Two Stations One Kilocycle Apart.

THE WIRELESS WORLD has recently been afforded an opportunity of inspecting a remarkable receiving set designed by J. Robinson, D.Sc., the former head of the Wireless Section of the Royal Air Force, embodying a new circuit system for selective reception known as the "Stenode Radiostat." It is understood that, owing to the patent situation, details cannot be disclosed at present, but the performance of the apparatus seems to show that Dr. Robinson has succeeded in producing a device of unusual selectivity combined with good quality of reproduction.

The set consists of two cabinets, one of which is sealed, while the other is fitted with a variable tuning condenser for coarse adjustment, and a small fine-control air condenser for accurate setting. The maximum variation possible with the latter is only about

6 mmfd., and a change of a fraction of 1 mmfd. brings in 2LO strongly, so that the selectivity is enormous. In spite of the great selectivity, the quality of reproduction is as good as could be desired.

In order to test the effect of an interfering transmitting station, a local oscillator was set up to give a heterodyne note with 2LO. This note could be clearly heard on an ordinary receiver, but no trace of it appeared with Dr. Robinson's set, even when the local oscillator was tuned to a frequency only 1 kilocycle off 2LO. It was not until the heterodyne note dropped to a frequency of 300 or 400 that it began to cut into the broadcast.

Partial Explanation.

Dr. Robinson has supplied a few details, which amount to a hint as to the method which he uses rather than an explanation. If we construct a tuned circuit containing a coil whose ratio of reactance to resistance is very large, say 3,000 (the amateur's usual figure is 150), then the signal will build up slowly, and the circuit will continue to ring after the incoming signal has ceased (Fig. 1, curve A). If, however, we chop the wave into equal sections and reverse the phase in each alternate section, the energy which builds up in the receiving tuned circuit during one section will be completely destroyed during the next, owing to the phase reversal (Fig. 1, curve B). The circuit evidently remains as selective as ever, that is, the shape of the usual resonance curve is unaltered, but the sluggishness has been greatly reduced as curve B shows, while the amplification is smaller.

Fig. 2 shows how the incoming wave is chopped. Two screen-grid valves in parallel receive the incoming signal in opposite phases. This arrangement would, of course, neutralise the signal, and no effect would be transmitted to the detector valve. A device is added which is the essence of the affair. *The*

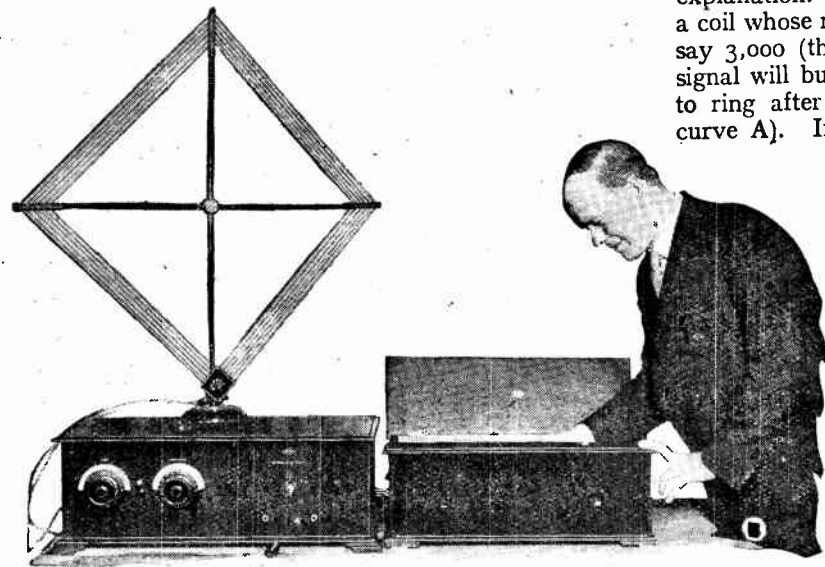

The selectivity produced is demonstrated by a superheterodyne provided with a fine-tuning condenser of exceedingly small capacity connected across the oscillator control. An interfering signal from an H.F. oscillator while producing a heterodyne note on a normal receiver is readily removed and a broadcast transmission received with good quality. Dr. Robinson is seen examining the crystal controlled unit.

The design formula is:—

$$C = 2L \left(\frac{B}{A} \right)^2 \quad \text{Where } A = R_o + r + \frac{R_o r}{R}$$

$$= R + Br$$

$$B = r + \frac{R}{R}$$

The amplification at any frequency is given by

$$\mu \cdot \sigma \frac{\omega L}{\sqrt{A^2 + B^2 \left(\omega L - \frac{1}{\omega C} \right)^2}}$$

Where in addition to the above:— $\omega = 2\pi \times$ frequency, $\mu =$ amplification factor of valve, $\sigma =$ voltage ratio of transformer.

Except at high frequencies the product $\mu \cdot \sigma$ is constant, and thus we are concerned mainly with the third factor. This is conveniently termed the "Coupling Efficiency."

The Robinson "Stenode Radiostat."

two screens are wobbled up and down at supersonic frequency, and hence the valves come into action alternately. A train of waves is transmitted by one valve

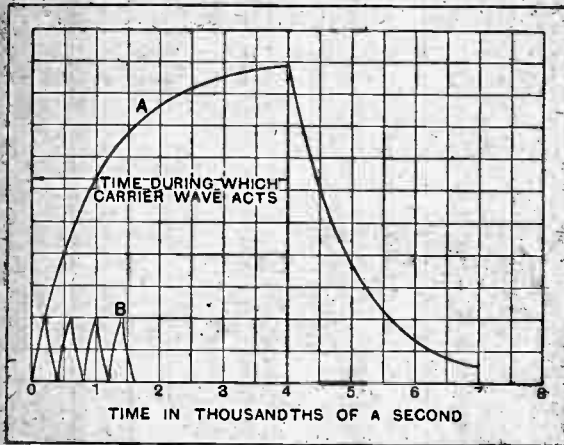

Fig. 1.—(a) Signal given by a tuned circuit of magnification 3,000 when receiving waves on 300 metres. (b) Signal produced by the same circuit when the incoming wave is chopped with reversal of phase at each interruption.

when its screen is up; on the next wobble this valve shuts down, and the waves come through the other valve with a reversal of phase.

Still a Mystery.

The above explanation certainly discloses an ingenious method by which ringing might be prevented on a set of high selectivity, but it does *not* explain why the sidebands in broadcast transmission get through on such a set. We are still puzzled by the result that an inter-

fering station 1 kc. away is cut out, while the quality of reproduction would suggest that sidebands up to 5 kc. away may be getting through. It is to be hoped that Dr. Robinson will explain this phenomenon at an early date.

While this new circuit system appears to have numerous important applications, Dr. Robinson claims that it is now possible to establish some fifty broadcast stations in an area where only one transmitting station can operate under existing conditions. Broadcast

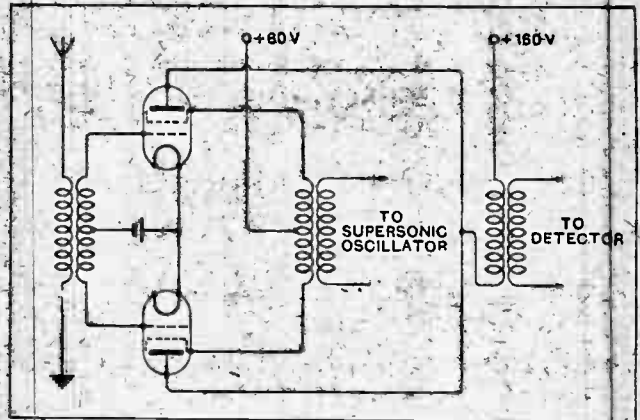

Fig. 2.—The signal is received in opposite phase by two parallel-connected screen-grid valves. A supersonic oscillator connected in the leads to the screen grids upsets the balance and brings the valves alternately into action. In the demonstration apparatus the screen-grid valves follow the intermediate amplifier of a superheterodyne receiver, and the supersonic oscillator is a piezoelectric crystal.

receivers, it is stated, can be constructed at popular prices which will receive existing programmes without mutual interference.

CHRISTMAS RECORDS.**A Good Selection of Seasonable Music.**

THE increasing number of readers who employ electrical methods for the reproduction of gramophone music adds special interest at this season to the selection of Christmas records which have just been issued by Columbia. We have had the opportunity of testing a number of these, and consider that they are a most attractive series.

An exceptionally fine record is one entitled "An Organist's Yuletide," which is contributed by Mr. Quentin MacLean, the organist of the Regal Cinema, London. It is a fine example of modern recording, and consists of a delightful Christmas medley, including snatches of carols and traditional tunes.

Savoy Christmas Medleys, a record which has had great popularity in the past, has been remade this season by Debroy Somers' band.

A particularly fine record by the Ketelby Concert Orchestra, with W. G. Webber playing the organ of Westminster Central Hall, and Nellie Walker singing with a full chorus, is "A Dream of Christmas." The

theme is that it is Christmas Eve, and the mother has been relating bedtime stories to her little child, who afterwards falls asleep and dreams of the carol singers and fairies.

The Christmas list of new records includes some of the most popular carols and hymns, beautifully rendered by the St. George's Singers. They are six in number, and include "We Three Kings of Orient Are," "Wassail Song," "What Child is This," "The Moon Shines Bright," "I Saw Three Ships," and "The Holly and the Ivy." Three carols are contained on each record. All are sung unaccompanied, and those who have heard the madrigal records of this talented body of singers will not need to be told how beautifully the carols have been performed. The B.B.C. Choir and Wireless Military Band have also contributed to the Christmas vocal list with "Once in Royal David's City" and "While Shepherds Watched," and the fullness of tone produced by choir, band and organ makes an interesting contrast to the simplicity of the St. George's singers.

21

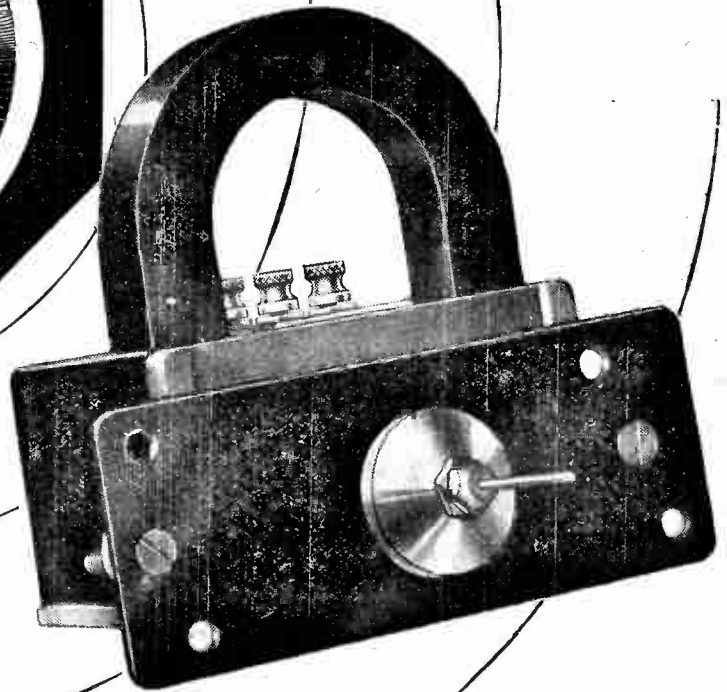
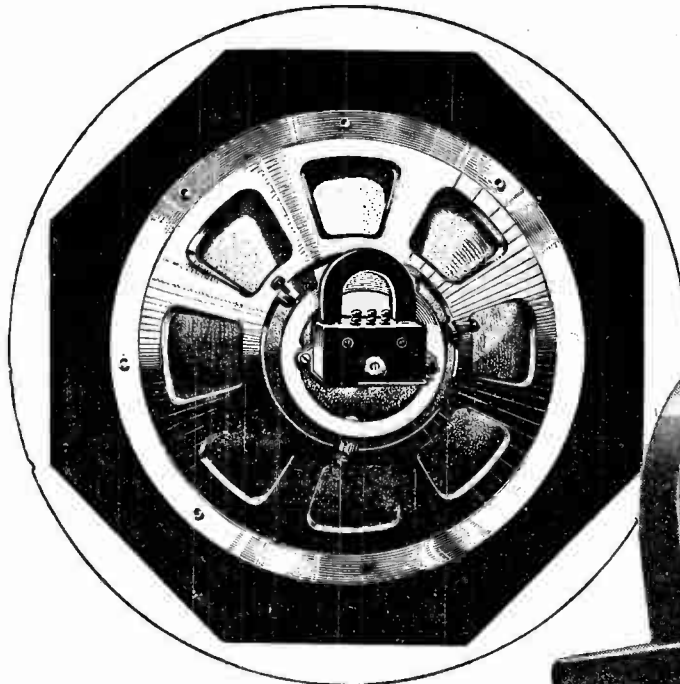

THE SOUL OF THE SPEAKER

Fit the new Amplion B.A.2 unit to any chassis and you fit quality, life, sensitivity and volume handling capacity—you put heart and soul into the speaker. Note the following points:—

- (1) Strong and robust construction with neat compact design and workmanlike appearance.
- (2) Designed for normal chassis. Adaptor plate is supplied for use on other types of chassis.
- (3) Sensitivity far above the normal, combined with adequate volume handling capacity.
- (4) Three terminals giving alternative values of impedance.
- (5) Equally suitable for use with power valves of low or medium impedance or with pentodes.

Your dealer will gladly demonstrate.

GRAHAM AMPLION LIMITED, 25/26, SAVILE ROW, LONDON, W.1. . . . WORKS: SLOUGH

THE BA 2

BALANCED ARMATURE SPEAKER UNIT

AMPLION®

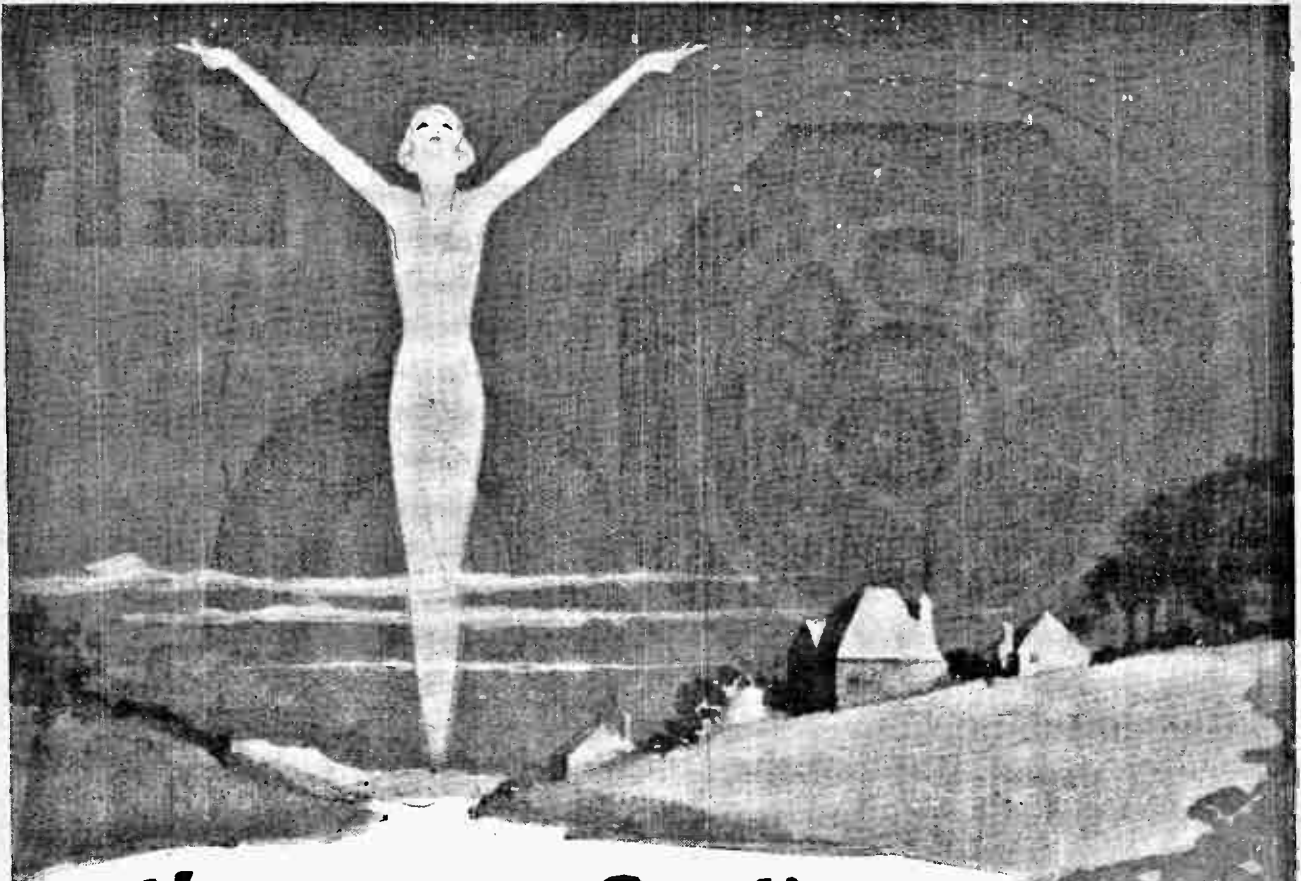

..then came Radio.

A lonely outpost of the British Empire—a lonely farmhouse in the Highlands—a cottage in the distant valley—lonely places all—and then came radio and the long lonely evenings became times of joyous entertainment.

At the very beginning of radio, McMichael Receivers were known for their paramount supremacy. To-day McMichael Receivers are still triumphant—far ahead of all others in perfection of reproduction.

THE McMICHAEL

SUPER RANGE FOUR (TABLE MODEL)

is a set of absolute efficiency, reliability and sound value. Comprising the latest Screened Grid Amplification, Single Dial Tuning, Volume Control, simple switch over from long to short waves. Beautifully toned loud-speaker.

The set is specially designed for use in the home where an outdoor aerial and earth are not convenient or necessary. Its handsome Walnut cabinet contains a highly efficient frame aerial and earth, and is fitted with a turntable to ensure the best "directional results." The aid of additional aerial and earth can be used to add to the normal and very remarkable range.

Owing to the high degree of selectivity in this, and our other Screened Grid Portable Receivers, we are able to guarantee complete selectivity between all main B.B.C. stations under the new scheme of wavelengths.

Ask your dealer for a demonstration of this outstanding receiver—a receiver which gives the widest possible range of stations with low upkeep cost.

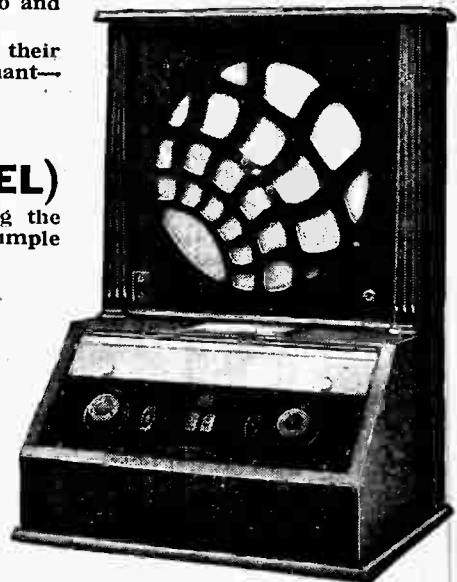

Telephone:
SLOUGH
441-442

L.M^cMICHAEL LTD

Manufacturers of Wireless and Scientific Apparatus
WEXHAM ROAD, SLOUGH, BUCKS.

London Showrooms: 179, STRAND, W.C.2 (Phone: Holborn 2466)

Telegrams:
RADIETHER
SLOUGH.

CASH PRICE 26 GNS.

(Including all Royalties and Equipment.)

or by "Deferred Payments on Hire Purchase Terms."

Mention of "The Wireless World," when writing to advertisers, will ensure prompt attention.

How we Hear



Can the Principles of Mechanism by which the Ear Detects Sounds of Varied Amplitude and Frequency be Applied in Radio?

By R. T. BEATTY, M.A., B.E., D.Sc.

IF a committee of scientists and engineers were asked to design an instrument which would be sensitive to all audible tones, which would detect a change in pitch of less than a sixtieth of a semitone over most of the range, and register changes in loudness of the order of 10 per cent., which would be capable of operating a relay in response to the chirp of a cricket or the roll of thunder, and, lastly, work day by day for some fifty years without attention, executing its own repairs, keeping itself clean, and costing a penny per day for running expenses, what sort of machine would the committee recommend to satisfy these terrifying demands embracing so many exacting conditions?

No such machine would be produced.

But if thought were taken for the first four conditions only, a solution could be arrived at. One would imagine that it would take a form of long racks carrying some twenty thousand resonators—64 to the semitone over the musical range—with a tiny coil of heated wire in the neck of each resonator to be alternately warmed and chilled by the throb of sound. Each coil would be connected to a valve amplifier, and the output wires would be led through a maze of switches to an inconceivable number of relays.

The whole affair would cost a million pounds; it would be served by thousands of operators, and would fill the great hall at Olympia.

Nature's Curious Device.

Nature, working by her savage formless methods over a space of many million years, advancing by trial and error, with life or death to mark success or failure, has solved the problem. Those who have ears to hear are drawing their royalties on Nature's invention.

What, then, is her solution?

It is the little affair like a snail shell with a bundle of nerve fibres passing from it to the brain; the whole

thing could be enclosed within the shell of a hazel nut, and the nerve bundle with its thousands of fibres could be threaded through a tube of macaroni.

It is music's analyser; the brain is its interpreter; and the partnership is one of the sweetest gifts which has been given to man.

The snail shell, or cochlea, consists of a hollow tube of bone coiled into a spiral of $2\frac{1}{2}$ turns and filled with liquid. In all mammals, with but one exception, this spiral shape is found, but if we imagine that man, who is distinguished for the number of convolutions in his

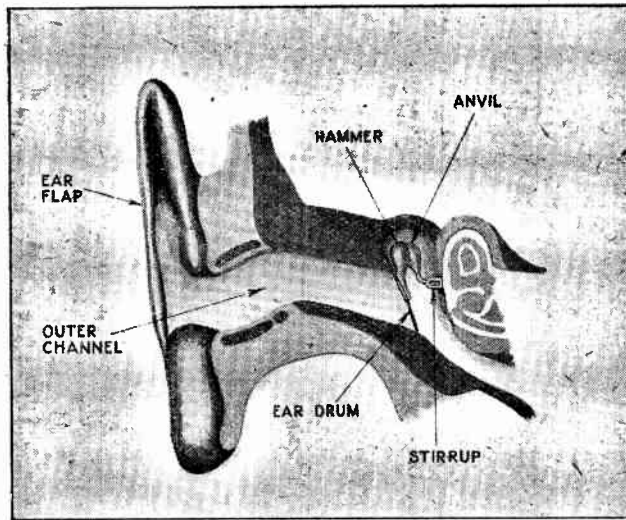

Fig. 1.—Sound is collected by the ear flap, passed along the outer channel, and transmitted via the ear drum and the hammer, anvil, and stirrup, to the oval window shown in Fig. 2.

How We Hear.—

brain, is similarly favoured by possessing the greatest number of turns in his cochlea, we are at once humiliated by the fact that pride of place must be given to the common pig, with $3\frac{1}{2}$ turns.

The cochlea if uncoiled would appear as a straight tube 30 mm. long with an average internal diameter of 1.5 mm. This tube is divided lengthwise into two parts by a tightly stretched membrane, the basilar membrane, which runs along its entire length.

One end of the long tube is enlarged and is fitted with two thin membranous windows; one of these, the oval window, carries a piston which conveys the vibrations of sound from the outer ear; the other, the round window, relieves by its motion the pressure set up in the fluid by the motion of the piston.

Man's Miniature Harp.

Under the microscope the basilar membrane is seen to consist of some 24,000 tightly stretched fibres running crosswise, each fibre being held in tension by ligaments. These fibres are connected to each other by a thin membrane, and they increase in length from 0.13 mm. near the piston to 0.4 mm. at the other end of the tube. The whole structure irresistibly suggests a set of tuned

down the outer channel to the ear drum which actuates a chain of three bones—the hammer, anvil, and stirrup—the three forming a lever system with a reduction in amplitude of $1\frac{1}{2}$ to 1. The end of the stirrup is inserted

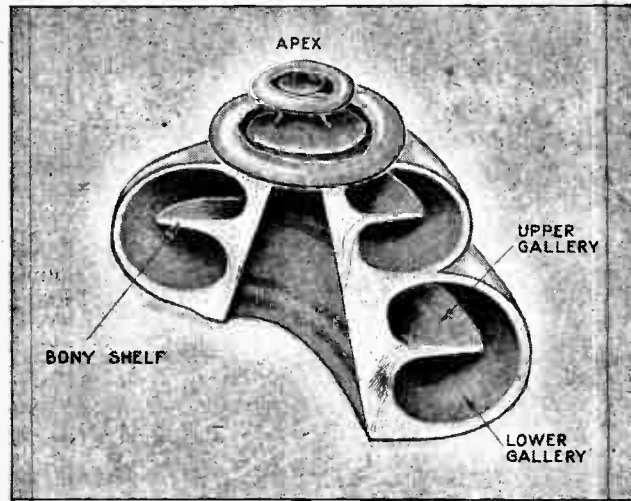

Fig. 3.—Cross-section of the bony cochlea; the basilar membrane is not shown.

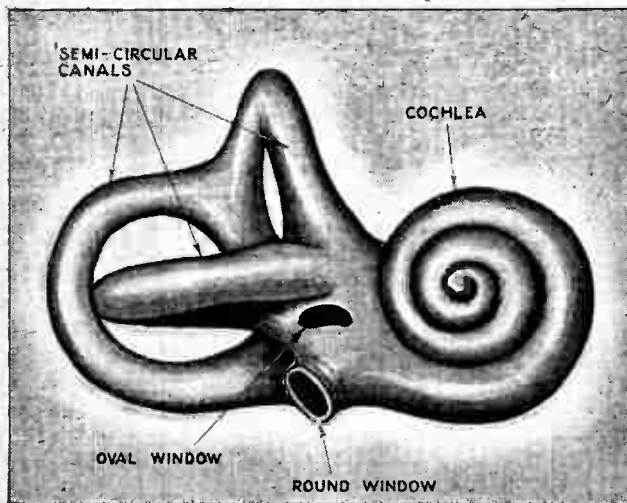

Fig. 2.—The stirrup (Fig. 1), which is attached by a membrane to the oval window, transmits vibrations to the fluid filling the cochlea, across the basilar membrane, and back along the cochlea to the round window.

strings, and all the facts patiently unearthed by anatomists and physicists confirm the conviction that this is indeed Nature's harp which, by the resonance of its strings, analyses the vibrant messages from the external world. Thousands of years before the first savage crouched to evoke rude music from his bowstring, this marvellous instrument lay fully developed in the ears of mankind ready to interpret the rustle of leaves, the song of birds, the roar of the carnivore, to the still lowly brain, deaf as yet to all but material needs.

The Ear as a Whole.

The ear flap (Fig. 1), which is now but a rudimentary collector of sound waves, compared with the large mobile ears of the horse or the dog, passes the sound

into the membrane which closes the oval window (Fig. 2) of the bony labyrinth. In addition to the cochlea three curious formations will be noticed looking like handles. These have nothing to do with hearing, but give us information about our position in space, and guide our movements in turning, leaping, or bending. They form the oldest part of the ear; they are found, but with no cochlea attached, in fishes, which do not need to hear, but whose life depends on their ability to make accurate and well-timed movements.

A cross-section of the bony cochlea is shown in Fig. 3. A spiral tube winds upwards to the apex, and is almost divided in two by a spiral bony shelf; one end of the basilar membrane is attached to the edge of this shelf (Fig. 4), and stretches across to the opposite side where it is held in tension by a strong ligament, so that the spiral tube is actually divided into an upper and a lower gallery.

The Simplified Ear.

A mechanical model, Fig. 5, may be constructed to represent what is generally believed to be the mode of action of the ear. When a puff of air strikes the outer ear the drum and the lever system move forward so that the stirrup transmits pressure to the liquid in the upper gallery; the motion is communicated through the opening at the apex to the lower gallery, and the round window bulges slightly in consequence. In addition, of course, the pressure may be partly relieved by yielding of the basilar membrane, and if a pure tone of given frequency is used we would expect that any portion of the basilar membrane which is tuned to this frequency would be set into resonance, and convey a message to the brain by the nerves which are attached to it. This indeed was the original brilliant suggestion of Helmholtz, and is a remarkable instance of scientific foresight. He recognised that the only known way of analys-

How We Hear.—

ing complex sounds was by the use of resonators, and that the transverse fibres of the basilar membrane, with their progressive variation in length, might act as a system of this kind.

Three Points which Support the Resonator Theory.

As we pass along the spiral tube of the cochlea from base to apex, we find that the fibres of the basilar membrane increase in length from 0.13 mm. at one end to 0.40 mm. at the other. Further, the spiral ligament which holds the membrane taut decreases in bulk from base to apex; near the apex, indeed, it consists of only a few thin fibres. Again, when resonance is set up in any section of the membrane, the mass moved is not only that of the membrane, but also that of the double column of liquid, as shown in Fig. 6, so that the loading of the fibres increases from base to apex.

Now, the formula for the frequency of vibration of a stretched string is:—

$$\text{Frequency} = \frac{1}{\text{twice length}} \sqrt{\frac{\text{tension}}{\text{mass per unit length}}}$$

and we have just seen that in going from base to apex length and mass increase while tension diminishes. It appears, then, that all three factors vary as they should

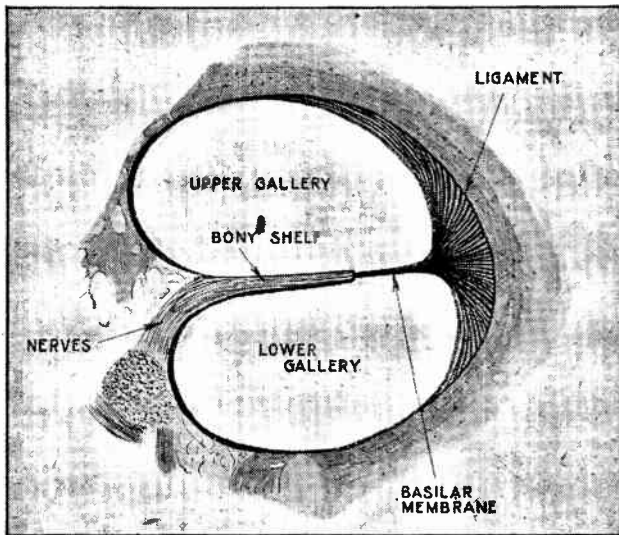

Fig. 4.—Cross-section of the cochlear galleries: the basilar membrane is held in tension by strong ligaments, and nerves run from it through channels in the bony shelf and are led away through the central opening shown in Fig. 3.

if the bass strings are to be located at the basal end and the treble strings at the apical end of the cochlea. Helmholtz was aware of but one of these factors; had the other two been known in his time few can doubt that the resonator theory would have been established so firmly that no rival theories would ever have emerged.

Can the Fibres Stand the Required Tension ?

The greatest tension will be needed for the strings tuned to the highest audible frequency, which is about 30,000 cycles per second. Since we can find the length and mass from microscopical observations we can calculate the tension from the formula given above. It works out that we require a tension of 44 milligrammes

to tune a single fibre to this note, taking the diameter of a fibre as 0.003 mm.

Now, it is found from experiments on animal tendons and fibres such as human hair or silkworm gut that

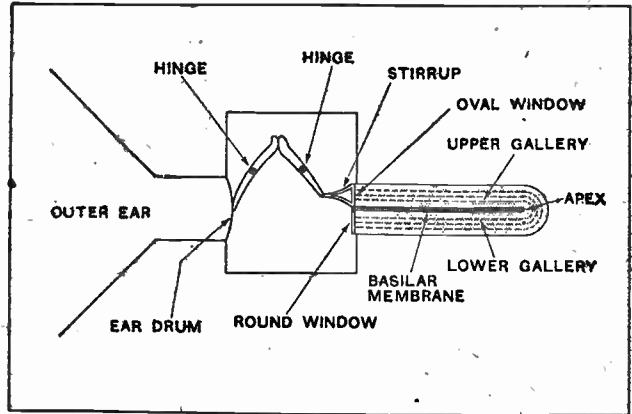

Fig. 5.—The action of the ear demonstrated by means of a mechanical model.

their breaking stress for the same cross-section is from four to eight times the figure just given. It seems, then, that the theory makes no impossible demands on the strength of the resonating elements.

Those who think in terms of the piano or harp may still, however, feel that an instrument on the cochlear scale is unworkable. The deepest string of the piano is several feet long, while the longest string of the cochlea is only 0.4 mm.; how can these ridiculously different lengths be tuned to the same note?

The answer is that the dimensions of the piano are large because the instrument is required to deliver a large volume of sound. The cochlear strings, on the other hand, need only vibrate through a few millionths of a millimetre to excite the nerve endings with which they are connected. Scale has nothing to do with the question of resonance; if we compensate for decreased length and mass by decreased tension we can pass to an instrument whose smallness is only limited by the size of the molecules themselves.

Experimental Evidence for the Resonator Theory.

Twenty years ago a remarkable experiment was carried out on the guinea-pig, which has a well-developed cochlea of four turns. A loud note was sounded close to the animal's hutch and maintained for many hours. The guinea-pig was then killed and its cochlea examined under the microscope, whereupon

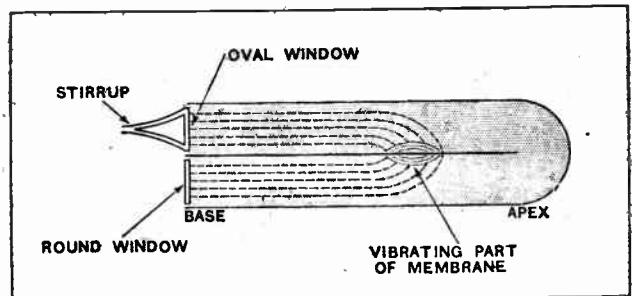

Fig. 6.—From this mechanical model it is seen that not only the membrane vibrates but also a double column of liquid, so that the loading of the fibres increases from base to apex.

How We Hear.—

a portion of the basilar membrane was found to have degenerated, the same being true for the nerves attached to it. Similar experiments were carried out with notes of different pitches, and in all cases the position of the injured part depended only on the pitch of the note which had been used. Fig. 7 represents a section of the cochlea of the guinea-pig, and the positions of the injured areas are marked corresponding to the exciting frequencies. Below are shown the four turns of the basilar membrane uncoiled with the damaged portions shaded.

This experiment, through indicating that the membrane is differentiated for frequency along its length and that low notes affect the region near the apex, is not quite convincing, since in each case a long strip is injured, whereas we should expect the damage to extend over a few fibres only. However, the notes were excessively loud, so that probably a great many fibres were set into forced oscillation in addition to those which vibrated with their own natural frequency.

Last year results of a much more definite nature were obtained in a Leipsic laboratory. A very fine drill, only

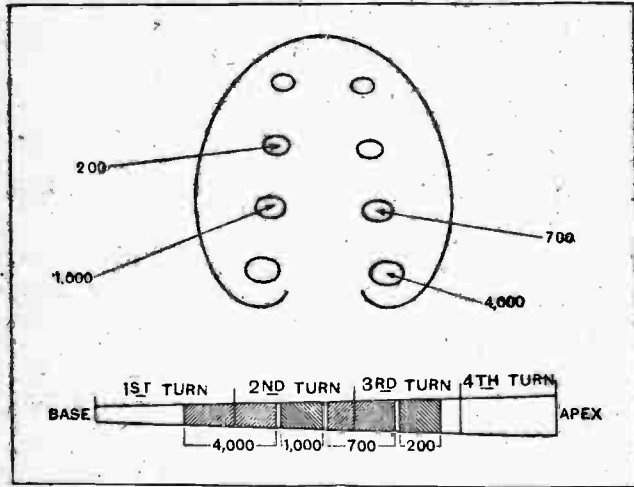

Fig. 7.—Section of a cochlea of a guinea pig; showing how different portions may become damaged by sounding notes of particular frequencies.

$\frac{1}{10}$ mm. in diameter, was used to bore a hole into the wall of the bony cochlea so as to break some threads of the ligament which exerts tension on the basilar membrane (Fig. 8). Subsequent microscopical examination showed that neither the membrane itself had been injured nor the nerves which pass from it and leave the cochlea on the opposite side from the point of entry of the drill. The tension, and consequently the natural frequency of the membrane, must, however, have been decreased.

It has long been known that the guinea-pig responds to any note within its range of hearing by a tremor of its ear muscle. Previous to the operation the animal responded in this way to all the notes of a series of tuning forks spaced a semi-tone apart from a frequency of 1,000 to 40,000 cycles per second.

After the operation a region of deafness was found whose position varied with the location of the drilled

hole and which extended over a frequency breadth *not exceeding a single tone*. The positions of the holes in different experiments are shown at the bottom of Fig. 8 with the corresponding frequencies where deafness was noted by the absence of the ear muscle reflex.

It will be seen that the positions agree with the theory that the fibres are tuned to higher and higher frequencies as the base of the cochlea is approached.

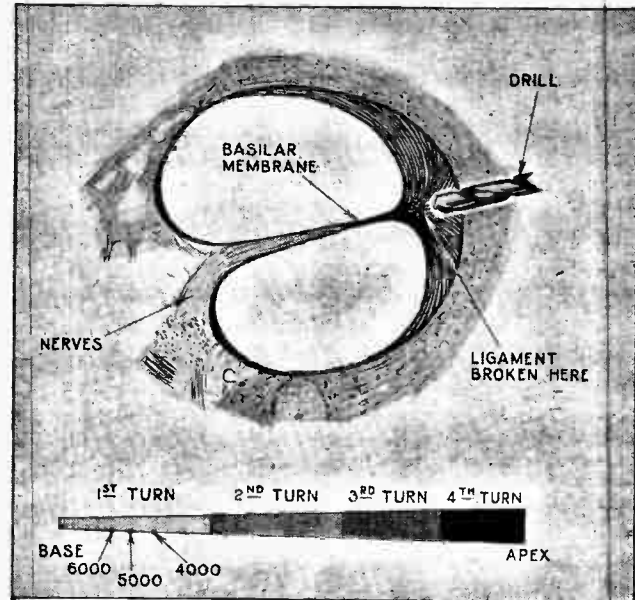

Fig. 8.—Breaking of some of the threads of the ligament which exerts tension on the basilar membrane produces a deafness over narrow bands of frequency.

The most remarkable fact of all is that the narrow band of deafness disappeared after three weeks. The ligament must have recovered its former tension, but that it should have done so, and applied exactly the right amount of pull to the corresponding elements of the membrane, seems to be a marvellous thing.

The Telephone Theory.

Though the resonator theory is so attractive and so powerfully supported by the facts which have been already cited it is not universally accepted. There are some who hold that the basilar membrane has no power of analysis, but that it faithfully follows every change in pressure of the sound waves and by its motion as a whole transmits messages to the thousands of fibrils which make up the auditory nerve. These fibrils accordingly act like telephone wires in parallel, and the onus of analysing the messages is thrown entirely on the brain.

If we accept this theory we must be puzzled by the complex structure of the basilar membrane; a much simpler device would seem to be adequate if no analysis is performed till the brain is reached: a few nerves attached to the ear-drum might suffice.

But a more formidable difficulty arises from the recent discoveries of physiologists as to the response of nerves to rapid impulses.

(To be concluded.)

Broadcast Brevities

By Our Special Correspondent.

Twin Transmission on Trial.—The Modulation Question.—Appeal to Pirates.

Regional Scheme on Trial.

Before these lines appear the behaviour of the Brookmans Park transmitters working in double harness will have been ruthlessly scrutinised by legions of listeners. The B.B.C. is on trial; and I should be surprised if there were any recommendation for mercy if the scheme proved to be beyond the technical resources of the populace.

Is 261 Metres Too Low?

For one hour and a half daily (Mondays to Fridays) the normal London programme is being broadcast on the wavelength of 261 metres, and many listeners have never yet descended to such a depth. The importance of becoming familiar with this wavelength is realised when one notes that it will be used for the "general interest or national programme."

The B.B.C. are wise in limiting the alternative transmission to speech; and it is also a shrewd move to allow an hour's transmission daily on the shorter wavelength without the encumbrance of the 356 metre signal.

When to Listen.

The full schedule of tests, until further notice, is as follows:—

MORNING:	
11.30 a.m. to 12 noon (Monday to Friday inclusive).	5XX Programme on 261 metre wavelength.
12.30 p.m. to 1.0 p.m. (Saturday only).	* Special programme on the 261 metre wavelength and 5XX.
12.0 noon to 1.0 p.m. (Monday to Friday inclusive).	The normal published programme on the 261 metre wavelength.
1.0 p.m. to 2 p.m. (Saturdays only).	Special programme on the 356 metre wavelength.
1.0 p.m. onwards (Monday to Friday inclusive).	} The 356 metre wavelength returns to the normal published programme.
2.0 p.m. onwards (Saturday only).	

EVENING:	
First half-hour of dance music period.	Dance music as published on the 261 metre wavelength only.
Remainder of dance music period.	Dance music as published on the 261 metre wavelength and special programme on the 356 metre wavelength.

* 5XX at all times does its normal published programme, in addition to the special programme on Saturday mornings

There will be no test transmissions on Sundays, Christmas Day and Boxing Day, but the usual programme will be radiated on 356 and 1554 metres.

A Springtime Service.

The length of the tests is still a matter for debate in B.B.C. engineering circles,

but I think that my original prediction, that we shall have the season of spring and portables upon us before regular twin programmes, will not be far wrong.

Over-modulation.

The question of the modulation of B.B.C. transmitters, recently raised in *The Wireless World*, has excited considerable interest at Savoy Hill. That the B.B.C. stations are models of rectitude in this direction is proved, say the officials, by the news that the Union Internationale de Radiodiffusion is holding up the B.B.C. as an example to transgressors on the Continent. It appears that much of the trouble with the Prague Plan is definitely ascribed to over-modulation by European broadcasters. To those who froth over the Union says: "Look at 5GB and Brookmans Park. Mark the delightful manner in which they are received abroad."

The Clapham Test.

At its Clapham research station on a recent Saturday, the B.B.C. conducted a little experiment in self-vindication, selecting the transmission of Radio Toulouse for the purpose. Radio Toulouse is an 8 kW station with an estimated aerial power of 5 kW. Signal measurement tests revealed a strength at Clapham of 0.8

millivolts per metre. Now, says the B.B.C., one of our stations operating on the same power would not yield a higher signal strength than 0.25 millivolts at such a distance. Therefore Radio Toulouse is over-modulating. Q.E.D.!

The Decline of the Oscillator.

That the old breed is slowly dying out is shown by some revealing figures collected by the B.B.C. anent oscillation complaints. In October and November, 1927, complaints of oscillation numbered 2,204. In the corresponding period of 1928 the figure dropped to 1,603. This year it is only 1,551. The figures as they stand tell less than the truth, for in October, 1927, there were only 2,337,733 licenses as compared with 2,852,924 two years later.

To the Radio Pirates of the World.

Oscillators and pirates are all nuisances, but in most cases there is a chasm of moral difference between the two classes.

The ordinary methods of overcoming piracy being rather slow, the B.B.C. might take a tip from the Polish broadcasting authorities, who are seeking to overwhelm the pirate by an appeal to his better nature. To-morrow (Thursday) the Vilna broadcasting station will broadcast a programme addressed to "the radio pirates of the world." In a special address to this ignoble fraternity, condemnation will be tempered with exhortations to repent. What stony-hearted knob-twiddler could stand this?

British and German Licence Figures.

The human element asserted itself distressingly in a recent paragraph in which I stated that the increase in British receiving licences amounted to 17,025 in the previous quarter. This figure actually represents the *monthly* increase, so the comparison with the German quarterly advance of 16,941 sheds a yet more glorious light on the popularity of the B.B.C. programmes.

The Microphone in Fleet Street.

Readers who wonder what Fleet Street is like and how a newspaper is produced should listen to the broadcast from 2LO and 5XX on December 16 of a tour of a newspaper office.

The Editor's room, the news room, the composing department, the foundry and the machine room will be visited.

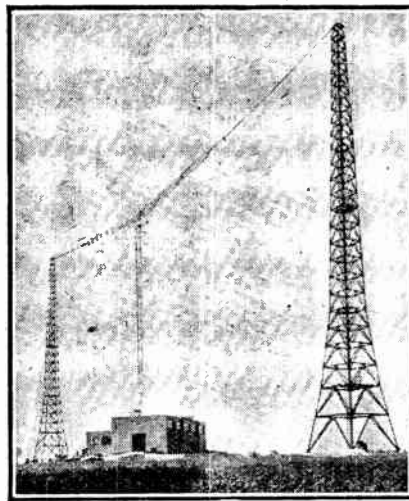

HAVE YOU HEARD THIS ONE? The Czech station at Moravska-Ostrava, which is not difficult to receive in this country. The power is 10 kW and the wavelength 263 metres.

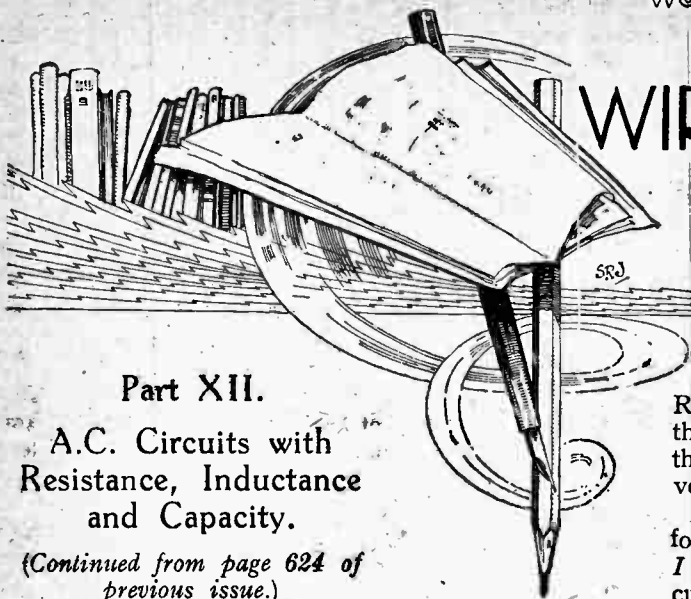

WIRELESS THEORY SIMPLIFIED

By S. O. PEARSON, B.Sc., A.M.I.E.E.

Part XII.

A.C. Circuits with Resistance, Inductance and Capacity.

(Continued from page 624 of previous issue.)

UP to the present we have dealt with resistance, inductance and capacity singly and have discussed the laws applying to each as regards alternating currents. We have also considered the combined effects of inductance and resistance in series, where impedance and power factor introduced themselves. We have now to take into account those circuits in which capacity is present together with one or other, or both, of the constants resistance and inductance. As we have learned all the rules applying to each of the three constants individually, the solving of a circuit where two or all three of them are present merely resolves itself into combining the effects according to the known laws of each. In simple series or parallel circuits this is quite an easy matter, but for circuits where there are both series and parallel portions it is sometimes very difficult. Fortunately we need only concern ourselves with the simpler circuits to enable us to understand and deal in a practical manner with the great majority of circuit arrangements in a modern wireless receiver.

Capacity and Resistance in Series.

In the first place let us consider a circuit consisting of a resistance R in series with a condenser of capacity C as shown in Fig. 1 (a). Suppose that it is desired to drive an alternating current whose R.M.S. value is I amperes through the circuit. Then the total voltage required will be made up of two components, namely, that necessary to drive the current through the resistance

R and that required to drive the current "through" the condenser C . (N.B.—The same current flows through each element of a series circuit.) Denote these voltages by E_1 and E_2 respectively, as shown in Fig. 1.

We have then $E_1 = IR$ volts, being in phase with I (rule for a pure resistance), and $E_2 = IX_C$ volts, lagging behind I by a quarter of a cycle, because for a condenser the current leads the voltage by 90° . X_C is the reactance

of the condenser, its value being $\frac{I}{2\pi fC}$ ohms.

So if we draw a simple vector diagram for the circuit we must draw the lines OE_1 and OE_2 at right-angles to each other, as shown in Fig. 1 (b), where OE_1 is in line with the current vector OI . The total voltage required between the ends of the circuit is then given by the length of the diagonal OE . Thus

$$E = \sqrt{E_1^2 + E_2^2} = \sqrt{(IR)^2 + (IX_C)^2} = I\sqrt{R^2 + X_C^2} \text{ volts.}$$

It will be realised that this is the same expression as used for resistance and inductance in series, except that in the present case we have the condensive reactance in place of the inductive reactance. $\sqrt{R^2 + X_C^2}$ is the impedance Z of the circuit in ohms. A further difference lies in the fact that the current leads the applied voltage by an angle ϕ , where $\cos \phi = \frac{R}{Z}$ as

before. For the inductive circuit it was a lagging angle. The impedance triangle for the circuit is shown at (c) in Fig. 1, the reactance line X_C being drawn vertically downwards this time because condensive reactance is negative with respect to inductive reactance.

To illustrate the calculation of such a circuit as that of Fig. 1 (a) in practice, suppose that the resistance R has a value of 500 ohms and the condenser C a capacity of 10 microfarads and that we require to know the current taken when 100 volts (R.M.S. value) at 50 cycles per second is applied to the ends of the circuit. The reactance of the condenser

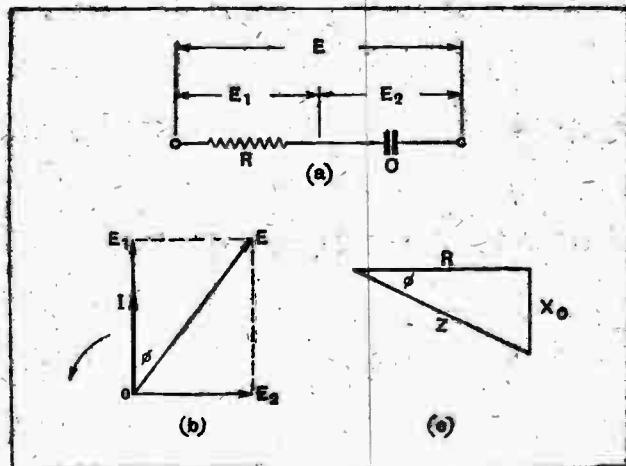

Fig. 1.—(a) Circuit with resistance and capacity in series. (b) Vectors showing the phase angles of the various voltages. (c) The impedance triangle for the circuit.

Wireless Theory Simplified.—

is then $X = \frac{I}{2\pi f C} = \frac{10^6}{2\pi \times 50 \times 10} = 318$ ohms. The impedance Z is therefore $\sqrt{500^2 + 318^2} = 583$ ohms, and so the current will be $I = \frac{E}{Z} = \frac{100}{583} = 0.1713$ ampere. This current leads the voltage applied to the circuit by an angle whose cosine is $\frac{R}{Z} = \frac{500}{583} = 0.857$, and this is the power factor of the circuit. Hence the power absorbed is $P = EI \cos \phi = 100 \times 0.1713 \times 0.857 = 14.7$ watts; or by another method: $P = I^2 R = 0.1713^2 \times 500 = 14.7$ watts.

Condenser and Resistance in Parallel.

In a circuit where the components are connected in parallel the same voltage is applied to each, and the best way to treat such a circuit if the applied voltage is known is to calculate the current through each branch separately, and find its phase relation to the voltage. The currents can then be added together in the proper manner, taking the phase differences into account. It is perhaps not out of place to remind the reader that currents or voltages must always be added by the parallelogram method when there are phase differences between them. Let us take as an example a circuit consisting of a 500-ohm resistance connected in parallel with a 10-microfarad condenser and assume that 100 volts at 50 cycles per second are applied to the ends of the circuit, as shown in Fig. 2 (a). We shall calculate the current and power taken by the circuit as a whole. Let I_1 be the current in the resistance branch, I_2 the current in the condenser branch and I the total current taken by the circuit. Then the current I_1 in the

resistance will be $\frac{E}{R} = \frac{100}{500} = 0.2$ ampere, and this will be in phase with the voltage. Similarly the current in the condenser branch will be $I_2 = \frac{E}{X_c}$. But X_c for a 10-mfd. condenser at 50 cycles per second was found to be 318 ohms in the previous calculation: So the current in the condenser branch is $I_2 = \frac{100}{318} = 0.314$ ampere, and this leads the voltage by a quarter of a cycle.

How to Use Vectors.

Knowing the value of each current and the phase angle of each with respect to the voltage, we could draw to scale a simple vector diagram as shown at (b) in Fig. 2. First draw the voltage vector OE of any convenient length, not necessarily to scale, and in any position. Since there is only one voltage value in a parallel circuit we take the voltage as the starting point. Now draw the current vector $OI_1 = 0.2$ ampere in line with OE and to a suitable scale of, say, 1 inch = 0.1

ampere so that OI_1 would be 2 inches long. Then draw OI_2 at right angles to OE to the left, because it is a current leading the voltage by 90° . Its length to the same scale will be 3.14 inches. On completing the rectangle, the length of the diagonal OI will give the value of the total current to the same scale. It leads the voltage by the angle ϕ which can be read off in the ordinary way with a protractor.

On the other hand the value of the current can be very easily calculated, since $OI = \sqrt{(OI_1)^2 + (OI_2)^2}$. Hence $I = \sqrt{0.2^2 + 0.314^2} = 0.372$ ampere. The impedance of the circuit is thus $Z = \frac{E}{I} = \frac{100}{0.372} = 269$ ohms, and

it should be noted that this is less than either the resistance or the reactance of the respective branches. From the diagram we see that the cosine of the angle of lead of the current is $\cos \phi = \frac{I_1}{I} = \frac{0.2}{0.372} = 0.538$, being the

power factor for the circuit as a whole. But the power factor is not given by $\frac{R}{Z}$ as it was for the series circuit. It happens to be $\frac{R}{Z}$ this time, but this must not be taken as a general rule for a parallel circuit.

There are two methods of calculating the power in this particular circuit:

(a) By multiplying together the volts, amps. and power factor for the complete circuit in the usual manner, or (b) by calculating the power in each branch separately and adding the values together to get the aggregate. By the former method the power is $E \cdot I \times (\text{power factor}) = 100 \times 0.372 \times 0.538 = 20$ watts. Now in employing the second method we know that a condenser takes no power, and therefore that the whole of the power taken by the circuit is absorbed by the resistance, where the current was found to be 0.2 amp. Hence power = $0.2 \times 100 = 20$ watts as before.

Resistance, Inductance and Capacity.

Next we come to one of the most important circuits as far as wireless is concerned, namely, one in which all three constants, resistance, inductance and capacity are present. Under certain conditions, as every reader knows, such a circuit can be made to respond strongly to one particular frequency whilst giving but feeble response to other frequencies. We shall treat a series circuit first in a general way, and then lead on to the theory of the tuned circuit.

Suppose that a resistance of R ohms, an inductance L henrys, and a capacity C farads are all connected in series as shown in Fig. 3 (a), and that we desire to find what voltage E will be necessary to drive a current of I amperes through the circuit when the frequency is f cycles per second. The resistance R and inductance L might very well belong to a single coil, but for the sake of clearness we can imagine them separated.

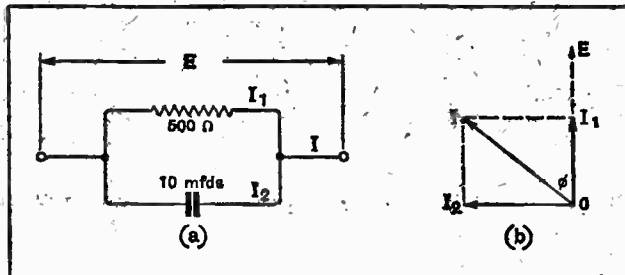

Fig. 2.—(a) Circuit with resistance and capacity in parallel. (b) Vectors giving the currents in the branches and the total current. $OI_1 = 0.2$ amp., $OI_2 = 0.314$ amp., $OI = 0.372$ amp. when $E = 100$ volts at 50 cycles.

Wireless Theory Simplified.

So R stands for the resistance of the whole circuit.

In the first place the same current I flows through each part of the circuit, and so we can write down the value of the voltage required by each portion separately, in terms of the current and the "constant" of that part. For instance, the voltage E_1 required to drive the current I through the resistance R is given by $E_1 = I.R$ volts, and this is *in phase* with the current. In drawing the diagram of vectors the current vector OI is drawn first, in any position, and the voltage vector OE_1 for the resistance portion of the circuit is drawn in line with OI as these two are in phase. The complete vector diagram for the circuit is given in Fig. 3(b).

The reactance of the inductive portion of the circuit is $X_L = 2\pi fL$ ohms, and the voltage required to drive the current through it is $E_2 = IX_L$ volts. Since the current lags for an inductance it follows that this voltage E_2 must be ahead of the current by a quarter of a cycle. So in the vector diagram the vector OE_2 is drawn at right angles to OI to the left (see Fig. 3 (b)).

For the condenser the reactance is $X_C = \frac{I}{2\pi fC}$

ohms, and the voltage required to drive I amperes "through" it will be $E_3 = IX_C$ volts, and this lags behind the current by 90° because a condenser takes a leading current. Hence in the vector diagram the vector OE_3 is drawn to the right.

Now the total voltage E required by the whole circuit will be equal to the sum of the separate voltages E_1 , E_2 and E_3 . But these three voltages are all at different phase angles, and in adding them the phase angles must be taken into account. However, the addition is a fairly simple one because the two voltages E_2 and E_3 are in direct opposition, one leading the current by 90° and the other lagging by 90° . Hence we can combine these two first, by the simple process of subtraction—the one has its maximum positive value

at the same instant that the other has a negative maximum value. So the voltage required to drive the current through the inductance and capacity of the circuit, apart from the resistance, is $E_2 - E_3$ or $E_3 - E_2$ according to which of the voltages is the larger.

Power Factor for Series Circuit.

They might be equal, but for the present we shall assume that E_2 is larger than E_3 , and therefore the voltage required by the inductance and capacity together will be $E_2 - E_3$, this voltage still being a quarter of a cycle out of step with respect to the current, as shown by the vector diagram of Fig. 3 (b). $E_2 - E_3$ may be called the total reactive voltage of the circuit.

Now we must add to this the voltage E_1 required by the resistance R. Since E_1 is in phase with I it is out of phase by 90° with respect to the reactive voltage $E_2 - E_3$. Hence the total voltage for the complete circuit is given by the diagonal vector OE, its value being $E = \sqrt{E_1^2 + (E_2 - E_3)^2}$ volts.

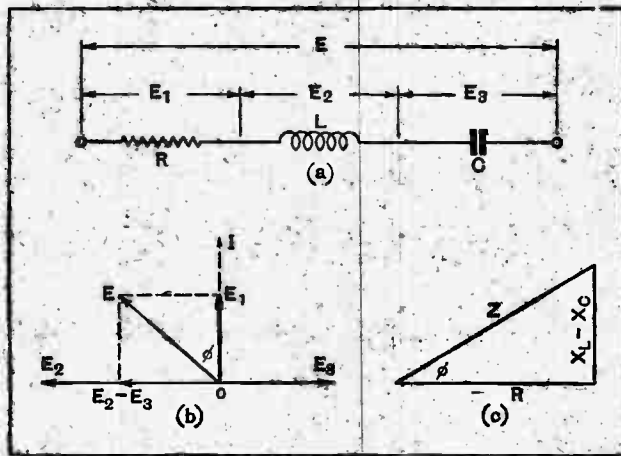

Fig. 3.—(a) Series circuit with resistance, inductance and capacity. (b) Vectors giving the phase angles of the various voltages. (c) Impedance triangle for the circuit.

But $E_1 = IR$, $E_2 = IX_L$ and $E_3 = IX_C$; and so $E = I \sqrt{R^2 + (X_L - X_C)^2}$ volts. From this we get the impedance of the complete circuit, namely, $Z = \frac{E}{I} = \sqrt{R^2 + \left(2\pi fL - \frac{I}{2\pi fC}\right)^2}$ ohms.

This is the fundamental equation for a circuit in which all the constants are present in series. The quantity $\left(2\pi fL - \frac{I}{2\pi fC}\right)$ is the resultant reactance due to the combined effects of

inductance and capacity in series, and if we denote it by X we arrive back at our original equation $Z = \sqrt{R^2 + X^2}$ ohms. The impedance triangle for the circuit is given in Fig. 3 (c), and by its aid we see that the power of $\cos \phi$ is given by $\frac{R}{Z}$, also in agreement with our previous results. From this we can conclude that the power factor is $\frac{R}{Z}$ for any series circuit.

(To be continued.)

J. J. Eastick and Sons, 118, Bunhill Row, London, E.C.—"Eelox Radio Bulletin" for October, 1929.

Keith Prowse and Co., Ltd., 159, New Oxford Street, London, W.1.—Illustrated catalogue of proprietary portable and transportable sets now stocked.

Igranic Electric Co., Ltd., 149, Queen Victoria Street, London, E.C.4.—Illustrated loose-leaf catalogue of radio com-

Catalogues Received.

ponents for 1930. Also descriptive folders dealing with the "Neutrosonic Short Wave Receiver," embodying the superheterodyne principle, and particulars of the Igranic "A.C.3," an all-electric broadcast receiver.

Garnett, Whiteley and Co., Ltd., Lotus Works, Mill Lane, Liverpool.—Illustrated catalogue of "Lotus" components with

special reference to their remote control system for mains operated receivers.

Claude Lyons, Ltd., 76, Old Hall Street, Liverpool.—Descriptive booklet of the "Grassmann" moving coil speaker.

Standard Wet Battery Co., 184, 188, Shaftesbury Avenue, London, W.C.2.—Illustrated folder dealing with tests that can be made with the Wates Volt-Amp. meter.

EVER READY

REGD. TRADE MARK

BRITAIN'S BEST BATTERIES

You know that in your Ever Ready Dry Battery you have all power necessary to operate your set efficiently

COMPACT—CONVENIENT—EVER READY

Not only does Ever Ready give a purer and more perfect reception than any other form of current supply, but it is

CHEAPER BOTH IN INITIAL COST AND UPKEEP.

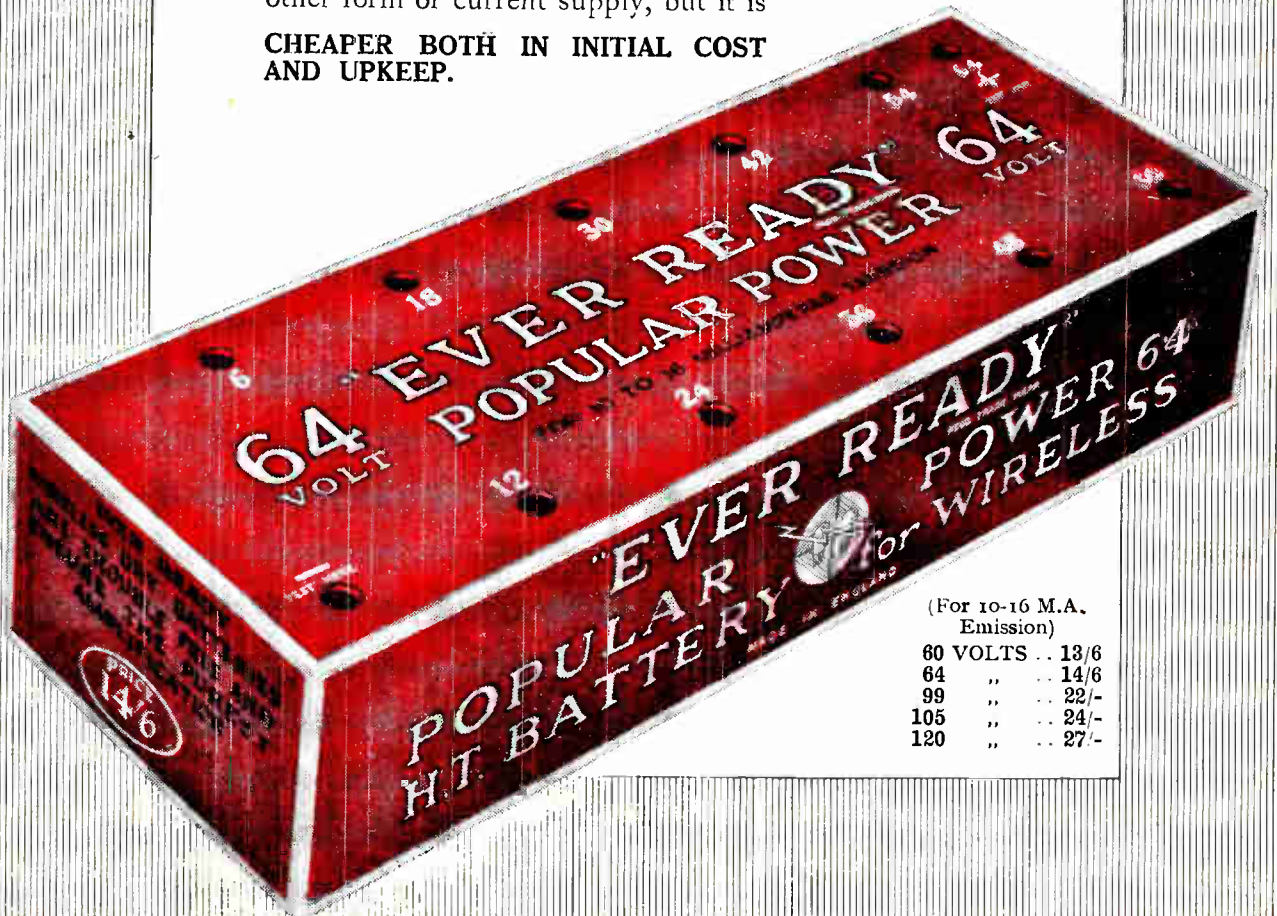

(For 10-16 M.A. Emission)

60 VOLTS	..	13/6
64	"	14/6
99	"	22/-
105	"	24/-
120	"	27/-

An Old Musician ~



appreciates music
that he himself has
played to thousands.

No greater testimony for Telsen Transformers could be found than the artistic sense of a Musician who writes to us of the wonderful balance of tone these Transformers give throughout the entire musical scale—which has now made it possible for him to hear as he once played to thousands. Try one in your set—and have music in all its reality!

**RADIO'S CHOICE AND
A MUSICIAN'S, TOO**

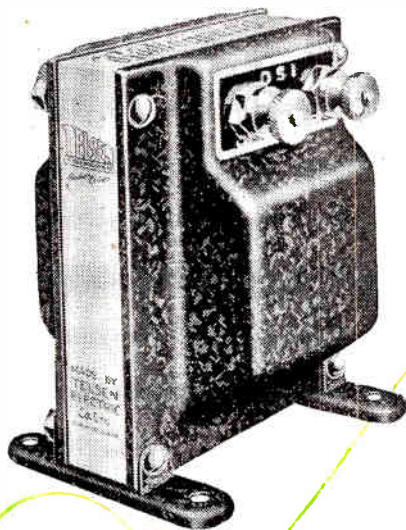

RADIOGRAND
12/6
Ratios 5-1 or 3-1

TELSEN

TRANSFORMERS

TELSEN ELECTRIC CO., LTD., MILLER STREET, BIRMINGHAM.

Mention of "The Wireless World," when writing to advertisers, will ensure prompt attention.

"Green for Safety"

Whatever the Circuit

In multi-valve sets, in single valve sets, in amplifiers—eliminators—in fact, wherever a condenser is specified use T.C.C. and be safe.

Sometimes the circuit demands a capacity that is critical—sometimes an ability to stand up to sudden high voltages—often the circuit demands both these things; then, for the sake of the circuit—for safety's sake—use the condenser in the green case.

Remember this, too—there is a quarter of a century's experience behind every T.C.C. Condenser—and now, with the reduced prices, they cost no more than ordinary condensers.

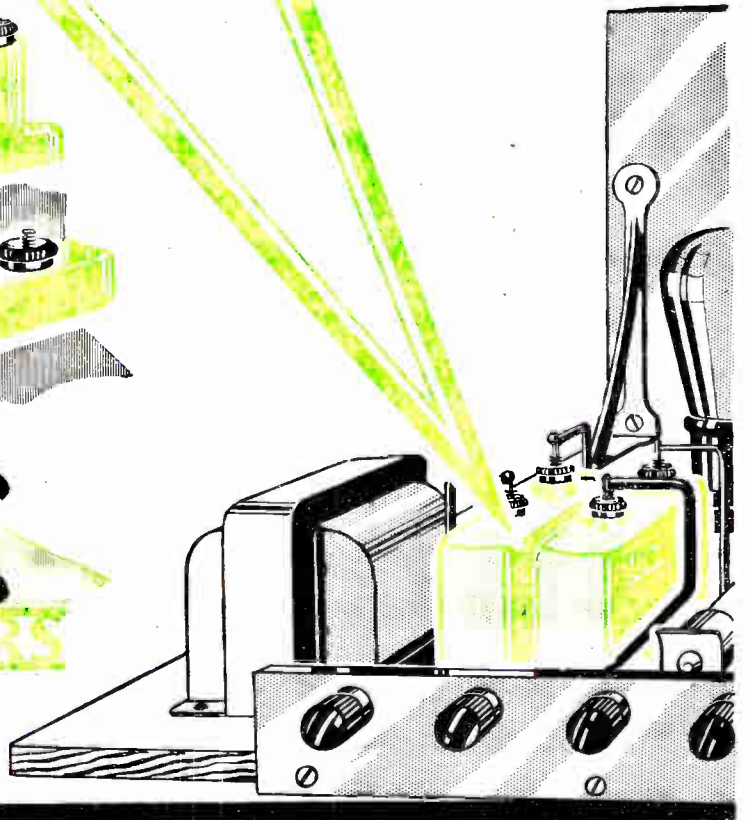
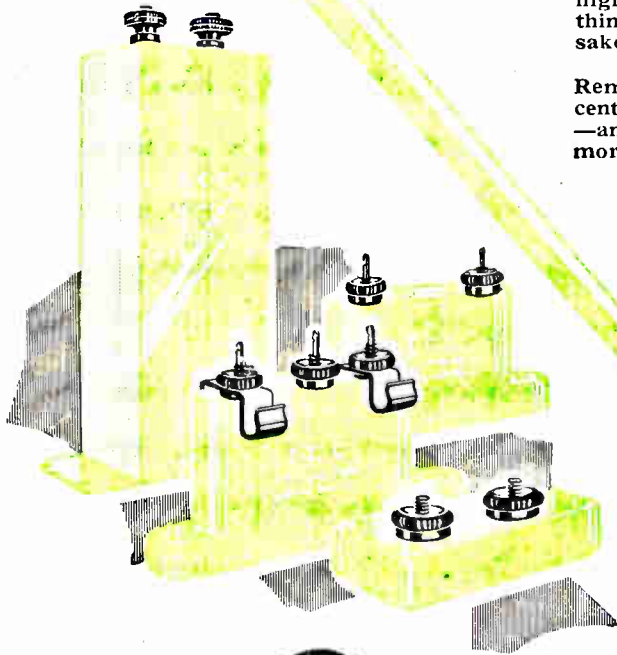

T.C.C.

CONDENSERS

Adv.
The Telegraph Condenser Co. Ltd., Wales Farm Rd., Acton, W. 3.

The

KUKOO

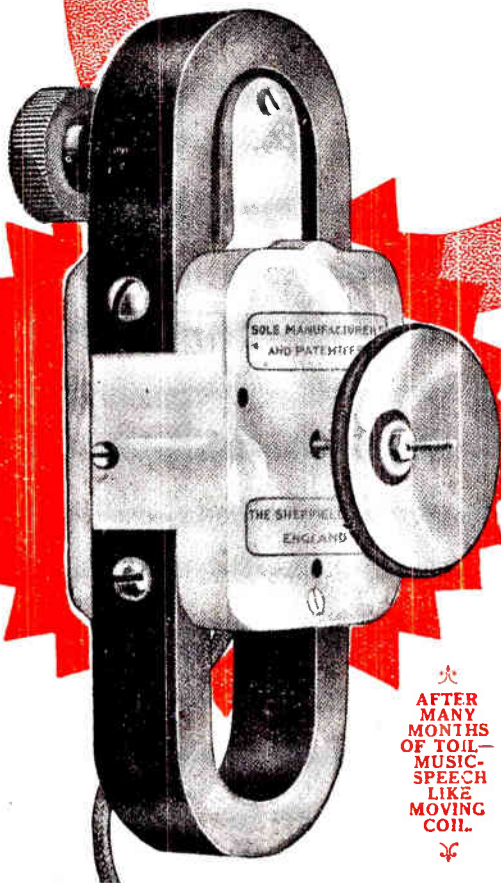

THE OUTSTANDING UNIT AT MANCHESTER

THE reproduction given by the "KUKOO" is remarkable, reaching the extreme frequencies. Its purity and volume are equal to that hitherto only associated with the most expensive moving-coil Speakers. The "KUKOO" has earned, and well deserves, the unstinted and unsolicited praise which has been given to it by numerous radio experts and musical critics. Every unit is accompanied by detailed instructions for making cones of diameters varying from 6 ins. to 12 ins., so that a novice can produce a complete speaker in an hour.

SECRETS OF SUCCESS.

The "KUKOO" incorporates two Cobalt Steel Magnets of high magnetic efficiency, which provide enormous flux density across the ends of an *uniquely suspended armature*, which has *sensitive* and "stay-put" adjustments. Will last a lifetime. Best quality British made materials used.

★
AFTER
MANY
MONTHS
OF TOIL—
MUSIC-
SPEECH
LIKE
MOVING
COIL.
✧

The Unit that realises the capabilities of your set. You do not know what your set is capable of until you have tried the "KUKOO"!

SOLE MANUFACTURERS AND PATENTEES:—

THE SHEFFIELD MAGNET Co.
BROAD LANE :: SHEFFIELD.



Phone: 20866 Sheffield.

Cables and Grams: "MAGNET," 20866 Sheffield.

POSTAGE

EXTRA.

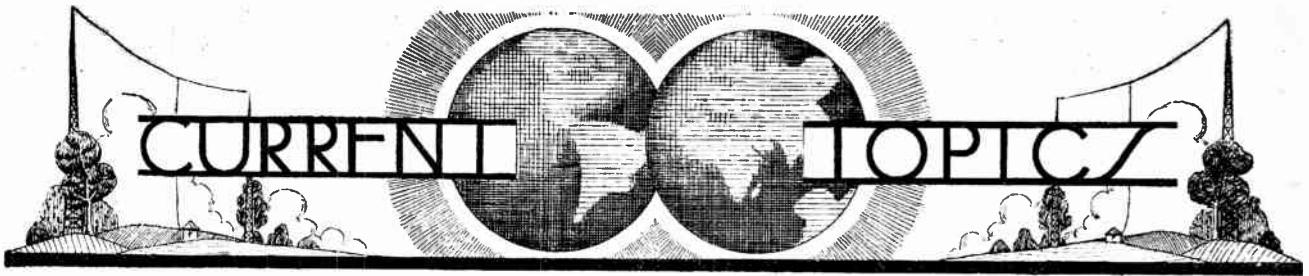

Events of the Week in Brief Review.

GWTC.

No known station hears this call-sign, but the letters are a useful memory jogger on shopping expeditions, meaning, of course, "Give Wireless This Christmas."

○○○○

THE WIRELESS TREASURE HUNT.

An invitation to participate in a search for "buried treasure" is extended to readers in our advertisement pages this week, prizes amounting in value to £20 being offered to successful entrants. The winners choose their own prizes.

○○○○

THIS WIRELESS AGAIN.

"Wireless in Court" was the description applied by several daily newspapers to recent experiments in Bow Street Police Court with a microphone and speech amplifier system.

○○○○

CHALLENGE TO DENMARK.

Sweden is now runner-up in the world's race for leadership in the percentage of wireless sets per head of population. According to a Stockholm correspondent, licensed listeners in Sweden on October 1st numbered 416,865, representing 68.3 to every 1,000 inhabitants. Only Denmark exceeds this proportion.

○○○○

'PHONE CALLS FROM THE ATLANTIC.

On Sunday last, December 8th, the Atlantic liner *Leviathan* opened a public ship-to-shore telephony service with equipment similar to that which will shortly be installed on the *Berengaria* and *Majestic*. The manufacturers are the Bell Telephone and the American Telephone and Telegraph companies.

○○○○

A TWO-METRE CLAIM.

Transmission tests with waves of three metres are referred to in the German amateur periodical, "CQ," which states that success on these high frequencies has been attained by Dr. Karl Stoye by means of a special arrangement of super-regeneration circuits. Transmitters and receivers functioning very efficiently on "the 3-3.40-metre waveband" are reported to be constructed with ordinary commercial apparatus, while a 2-metre wave is said to be attainable with the use of special valves.

○○○○

CHEER UP, ETHIOPIA.

Whereas the United States contains 9,640,348 wireless receiving sets, Ethiopia has only two, says the U.S. Department of Commerce. Britain is second in the list with nearly three million, followed

by Germany and France. Japan is fifth with 550,000.

Licence fees are highest in Lithuania, where the listener must pay £2 12s. 5d. annually.

○○○○

IRISH BROADCASTING DELAYS.

Anxiety is being felt by listeners in the Irish Free State as a result of rumours that the project for a high-power broadcasting station is being shelved by the Government. The scheme aims at the establishment of a station in the centre of the Free State with sufficient power to cover the whole of the country. "Who will pay the piper?" is the question which the Government has to face.

○○○○

"ANARCHISTS OF THE ETHER."

Certain French amateurs who are distracted by oscillators and other "anarchists of the ether" are considering the initiation of a campaign similar to that of the Dutch Radio Union, writes our Paris correspondent. The sufferers in Holland are preparing for a systematised "day and night struggle" with all forms of radio disturbance, personal and otherwise. A permanent office has been established where complaints

will be received and action taken under legal advice.

○○○○

A WIRELESS UTOPIA.

A Utopian dream has been realised by the U.S. Bureau of Standards in the acquisition of Pleasant Valley, Fairfax, Va., as an open-air radio laboratory. The site, covering 100 acres of abandoned pasture land, is flat and relatively free from trees, and is believed to be almost ideal for its purpose, viz., the study of fading.

Ordinary overhead aerials are to be dispensed with, the antenna system being limited to a vertical rod about 55 feet high and a number of direction-finding loops. To obviate "man-made-static," the power line for replenishing batteries from the mains can be disconnected.

The Bureau of Standards is retaining its field laboratory at Kensington, Ind, for investigation into radio echo phenomena.

○○○○

PARIS CRITIC OF THE WIRELESS WORLD.

In our esteemed French contemporary, *La Parole Libre en T.S.F.*, M. René Sudre makes a spirited reply to the remarks of *The Wireless World* regard-

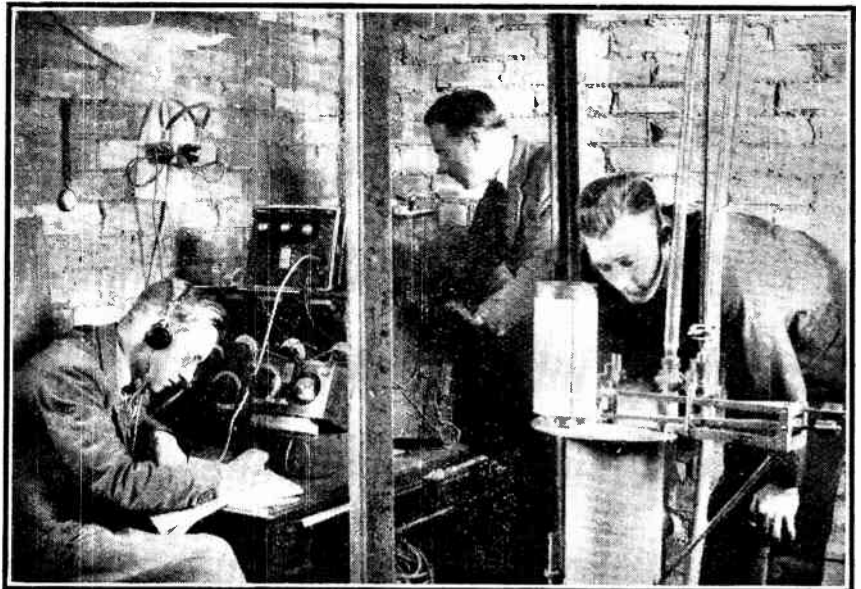

AN IMPROMPTU WIRELESS STATION. Temporary gear in use at Howden Aerodrome, Yorks, for the collection of weather data in preparation for the flight of the airship R.100 to the mooring mast at Cardington.

ing the Paris Radio Salon and the inextinguishable popularity of the super-heterodyne.

"Instead of attributing this to the French desire for good broadcasting," says M. Sudre, "the critic of *The Wireless World* concluded that the patent question is the true cause of the reign of the superheterodyne. . . . On the day that we have a good radio organisation it is possible that we shall go to London for the fashion of our receivers as well as for the cut of our lounge suits. But it is also possible that we shall remain faithful to the frequency changer, reduced to its five, or even four, valves. It is a truly French system which combines elegance of conception with perfection of result."

○○○○

"SMALL ADS." AT CHRISTMAS.

Christmas causes delightful havoc to our ordinary printing arrangements, and it is therefore necessary to close for press earlier than usual with our issues of December 25th and January 1st. Miscellaneous advertisements for inclusion in the former can be accepted up to the first post on Wednesday, December 18th; those for January 1st should be in our hands not later than first post on Tuesday, December 24th.

○○○○

WIRELESS ON NON-STOP FLIGHT.

In its attempt to beat the world's non-stop record for distance by flying from Britain to South Africa, the Fairey Napier Lion monoplane will carry a small wireless transmitter for sending out messages at hourly intervals indicating its position. Wireless is considered

more necessary on this flight than on the Fairey monoplane's non-stop trip to India, which covered a route served by aerodromes at regular intervals.

The transmitter, with the call-sign GEZAA, works on 33.71 metres. Reception reports should be sent to the Signals Branch, Air Ministry, Kingsway. The flight is scheduled to start on any date from December 18th onwards.

○○○○

BELGIAN BROADCASTING.

The new Belgian Wireless Bill has passed successfully through the Chamber of Representatives and is now awaiting the approval of the Senate. The Bill gives the postal administration complete control of broadcasting, which will be directed by a National Wireless Institute, operating two high-power stations broadcasting in French and Flemish respectively. The council of control will include a number of independent personages, including four technical authorities, and will be presided over by the Belgian Postmaster-General.

○○○○

GRAMOPHONE TONE CONTROL.

Dr. N. W. McLachlan will give a lecture-demonstration on "Tone Control for Electric Gramophones" at a meeting of the Incorporated Radio Society of Great Britain on Friday next, December 13th, at 6 p.m., at the Institution of Electrical Engineers.

○○○○

STANDARD BATTERY COMPANY.

We hear that the official title of the Standard Wet Battery Company has been changed to "The Standard Battery Company."

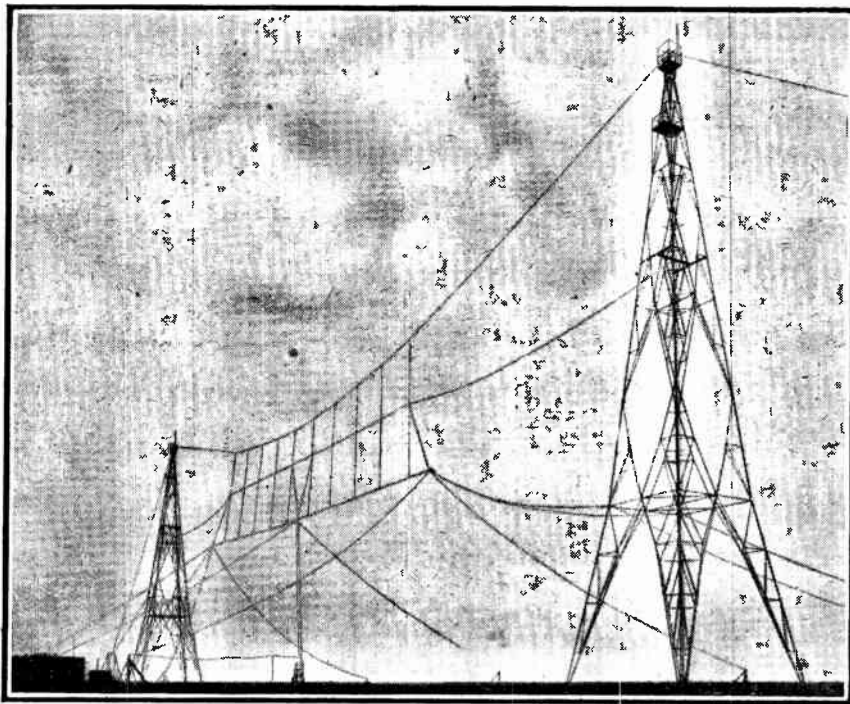

HOLLAND'S NEW SHORT-WAVE STATION. The aerial system of PHI at Huizen. The equipment is described in the following pages.

CLUB NEWS.

Invitation to Birmingham Enthusiasts.

A review of the past year's activities of Slade Radio (Birmingham), was given by the chairman, Dr. C. H. Harcourt, at the second annual general meeting held recently. The Society has apparently overcome the difficulties which are often encountered towards the end of the second year, and is entering its third year with confidence.

An appeal is now made for more members, and anyone who is interested in wireless is invited to get in touch with the Hon. Secretary, 110, Hilliards Road, Gravely Hill, Birmingham who will gladly forward details of the Society. An open invitation is also given to attend one of the Society's meetings any Thursday at 8 o'clock at the Parochial Hall, Broomfield Road, Slade Road, Erdington, Birmingham.

○○○○

An All-electric Receiver.

Mr. A. J. Hall, G2NU, of Philips Lamps, Ltd., has been engaged for some considerable time on research work on all-electric receivers, so his lecture and demonstration before the Muswell Hill and District Radio Society on November 27th were of more than usual interest. To convert the local D.C. supply to A.C. in order to run the A.C. demonstration receiver a special A.C. generator, driven off the D.C. mains, was used, and proved quite satisfactory. The lecturer pointed out the numerous advantages of all-mains sets over battery-driven ones, and gave a demonstration of one of his firm's well-known receivers, upon which a large number of Continental broadcast stations was logged at very good strength, despite the poor antenna system available.

Hon. Secretary, Mr. C. J. Witt, 39, Coniston Road, N.10.

○○○○

"Talkie" Secrets Disclosed.

Mr. Hawker, of the Western Electric Company, visited the Wembley Wireless Society recently and gave a lucid description of the method of production and reproduction of "talkie" films.

The lecturer, who has been actively engaged in the preparation of some recent famous talking pictures, let the members of his audience into many secrets of the "talkie" studio.

It was stated that "talkie" films were introduced many years ago but that owing to the reluctance on the part of the film producers the invention was not seriously taken up until quite recently.

At the Society's next meeting on December 13th Messrs. Hart and Perry will continue their "Practical Hints and Tips" demonstration, dealing with the best way to use a soldering iron.

Hon. Secretary, Mr. H. E. Comben, B.Sc., 24, Park Lane, Wembley.

○○○○

Varied Fare.

A vigorous debate on the respective merits of the moving-coil and balanced armature types of loud speaker was one of the recent features of the Golders Green and Hendon Radio Society's programme. Mr. Bremner, B.Sc., championed the former, while Mr. Maurice Child upheld the latter.

Programme problems were discussed by a representative of the B.B.C. at a recent meeting, and a lecture of absorbing interest was that given by Mr. H. T. Barton Chapple, B.Sc., on the subject of television.

The Society's future fixtures include lectures on such varied topics as "talkie" films, colour photography, all-mains receivers, and metal rectifiers. The next club dance will be held on December 27th.

Hon. Secretary, Lt.-Col. H. A. Scarlett, D.S.O., 60, Pattison Road, N.W.2.

○○○○

Query Night at Tottenham.

Knotty points of theory in the working of certain portions of a typical radio receiver were explained by Mr. Bodemeid at the last meeting of the Tottenham Wireless Society. The lecturer had previously obtained from members particulars of points which they had found rather difficult of explanation, and these were worked through one by one. Among the points dealt with were the explanation of the working of a detector valve, the nature of the current before and after detection, and the reason why the rectified current can operate transformers and pass through condensers, etc. The lively discussion which was maintained during the whole of the evening indicated the great interest taken by the members in this type of meeting.

Hon. Secretary, Mr. W. Bodemeid, 10, Bruce Grove, N.17.

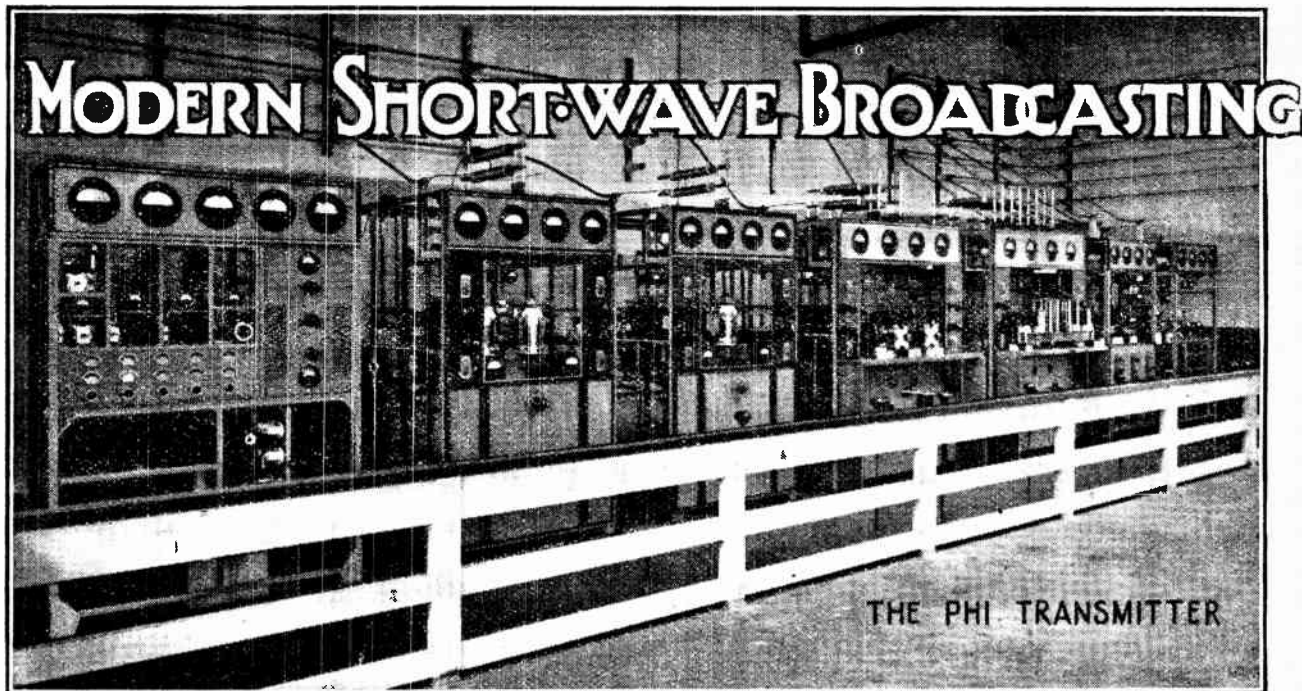

The New Station at Huizen.

By A. J. HALL (of Philips Radio).

THE experience gained by the engineers who designed the Philips experimental short-wave station PCJ, has been very liberally drawn upon in the development of the new Dutch short-wave transmitter PHI, located at Huizen.

Even accustomed, as we are, to the very rapid developments in the technique of radio transmission and reception, it can still seem strange that the energy passed to the aerial of this gigantic transmitter is effectively controlled by a piece of quartz comparable in size with a halfpenny!

A glance at the illustration on this page, showing the seven frame-type panels, will indicate the progressive increase in the power handled in succeeding stages of the transmitter.

Commencing with the first panel (stage No. 1)—on the extreme left—the upper portion of this houses the "crystal oscillator." A piezo-electric crystal, ground to oscillate at a frequency of 2,222 kilocycles, is used in conjunction with a 4-volt receiving valve. The purpose of this stage is merely to furnish an output at a dead-constant frequency, to ensure strict adherence of the transmitter to its assigned wavelength. The feeble output of this piezo-electric oscillator is fed to the compartment immediately beneath, which contains two small transmitting valves of 10-watt rating, arranged in push-pull. The constant frequency signal is thus magnified to a suitable value for passing to the next stage.

In the third and fourth positions of this same panel, two operations are performed, viz., frequency doubling and amplifying. Whilst the input to the third position is at a frequency of 2,222 kc., the output circuit is

tuned to double this frequency, and a suitably amplified output at 4,444 kc. is available from position number four.

The next operation again doubles the frequency, at the same time amplifying the signal at such frequency, giving a resultant of 8,888 kc., from which it will be seen that a wavelength of 33.75 metres has been reached (positions Nos. 5 and 6). The anode feed to the initial stages, thus far, is at 400 volts. Special precautions are taken with respect to electrical screening, for such a step is found necessary if feed-back trouble in the crystal oscillator stage (the effect of which is promptly to shatter the small quartz crystal) is to be avoided. In the sixth position valves fed at 2,000 volts are used.

The second panel unit incorporates two valves of 1½-kilowatt rating, again connected in push-pull formation, making position No. 7. It is in this stage that the final frequency doubling operation is carried out, resulting in the working frequency of 17,778 kilocycles, corresponding to a 16.88-metre wavelength being produced.

Position No. 8—shown in the photograph as the third panel—performs an amplifying operation in which 1½-kilowatt valves are again used, this time, however, fed at an anode voltage of 4,000. At this juncture, the water-cooled type of valve can be more conveniently used, and succeeding stages, therefore, embody valves of this type, which are capable of taking up to 12,000 volts anode tension.

The ninth operation is again amplifying, the stage comprising two water-cooled valves of 10-kilowatt

Modern Short-wave**Broadcasting.—**

rating. The fourth panel in the illustration depicts this stage. In the tenth operation the power dealt with is no less than forty kilowatts, handled by two valves. Even this does not represent the maximum that can be dealt with, for an anode feed current as large as six amperes at an applied voltage of 10,000 has actually been recorded.

It may here be said that such a comparatively large power input is really an accomplishment in the present stage of ultra-high frequency technique, for the operation of valves at such powers, when handling ultra-high frequencies, presents difficulties not encountered in the generation of frequencies corresponding to the usual broadcast wavelengths. It is known that when dealing with ultra-high frequencies, capacitive currents—which can attain surprisingly large values—flow in certain conductors, and there are necessary precautions to be taken to minimise the effects of such parasitic currents. The signal energy has now reached the stage at which modulation takes place, and

in the anode feed circuit of the valves incorporated in this fifth panel unit the necessary modulating transformers are installed.

The modulating unit proper is embodied in the sixth panel, and is equipped with two modulating valves of 15 kw. rating for each of the three transformers. The seventh panel, equipped with four amplifying valves,

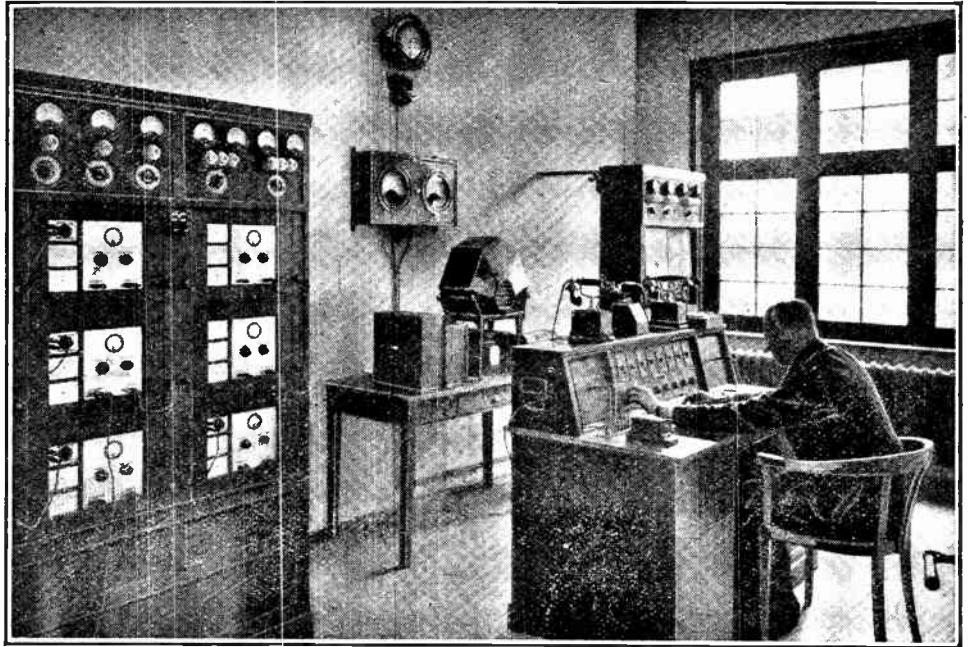

The studio control room at Huizen. A special land line connects the station with Amsterdam, enabling the celebrated concerts in that city to be relayed.

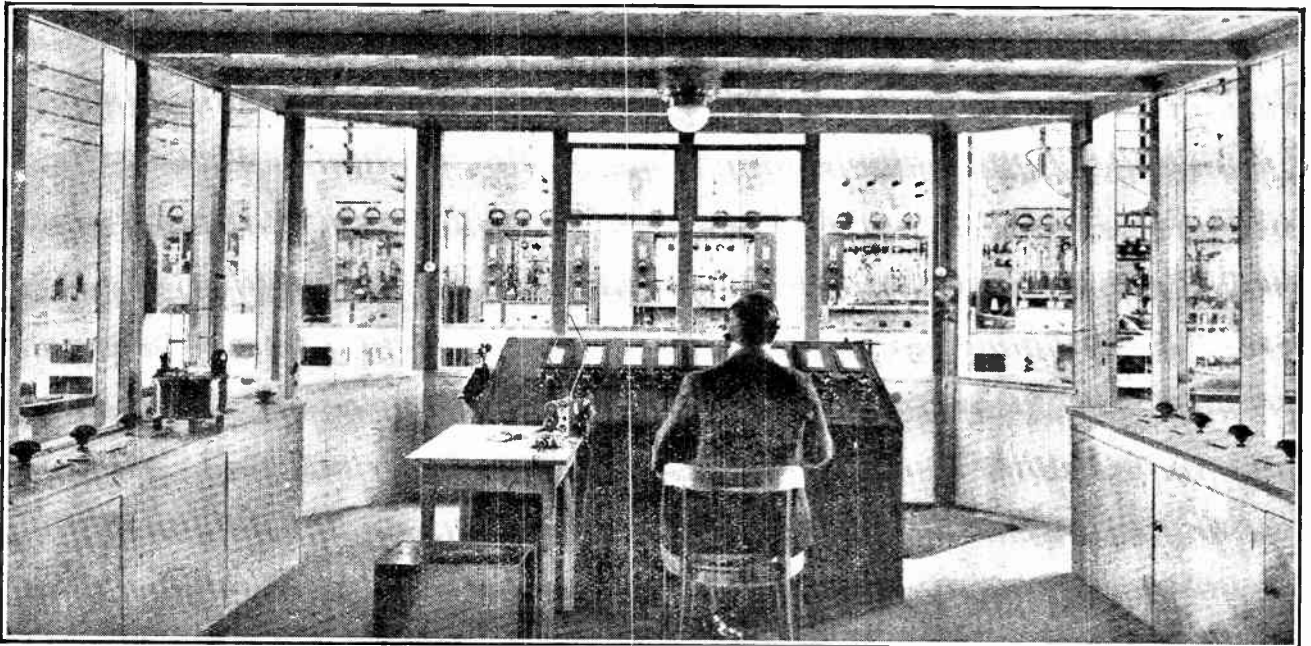

From the vantage point of the engineer's control desk, shown above, every portion of the transmitter is under constant observation. The motor generators in the engine room are operated by a remote control device.

Modern Short-wave Broadcasting.—

is the final stage, the output being fed to the aerial. The overall power input is no less than 130 kilowatts, and naturally the supply of this amount of energy at several different voltages presents no small problem.

Reference to the photograph of the high-power rectifier unit will show how the supply is obtained. The main rectifying bank, shown in the picture, furnishes an output of up to 12,000 volts for the higher-powered stages of the equipment, and it will be observed that the water-cooled type of rectifying valve is used.

The medium-power rectifying bank using air-cooled valves operates on an 8,000 volts polyphase supply, whilst the water-cooled bank rectifies a six-phase supply at 14,000 volts.

The smoothing problem is very much simplified by the use of six-phase alternating current.

A comparatively small value of capacity shunted on the output of such a rectifier will yield an output having no trace of ripple, a very necessary feature in a telephony transmitter.

The accompanying photograph shows the Duty Engineer's control position. Necessary indicating meters are conveniently placed, and the operation of the entire transmitter, from the crystal stage to the aerial input, is thus under constant surveillance.

A check on the outgoing signal is maintained by means of the monitor, with its single-turn loop aerial, to be seen on the immediate left of the Duty Engineer. The engine-room is also linked up by remote control with the Duty Engineer's desk.

The filament lighting load, in itself, represents quite a formidable power load, very close regulation of which is essential. Immediately adjacent to the guard rails, in front of the seven panels, can be seen the filament controls which permit adjustments to be made during operation of the transmitter, without necessitating a near approach to any of the apparatus under voltage. The scales of the meters are so disposed as to be visible at a distance of several feet.

The studio microphone is connected to the "A" amplifier rack in the adjoining main control room, the panel incorporating no fewer than six amplifiers equipped with necessary gain controls.

A special land-line connects the control-room with

Amsterdam, thus permitting the well-known concerts from that city to be relayed to the far-distant audience of the station.

The aerial used is of the Beam type, and is supported between two masts about 200ft. in height. The orientation of the aerial is such that the strongest signal is placed in territories on a line joining Huizen and the Dutch East Indies.

The choice of wavelengths is governed by several considerations, an important one being the mean noise

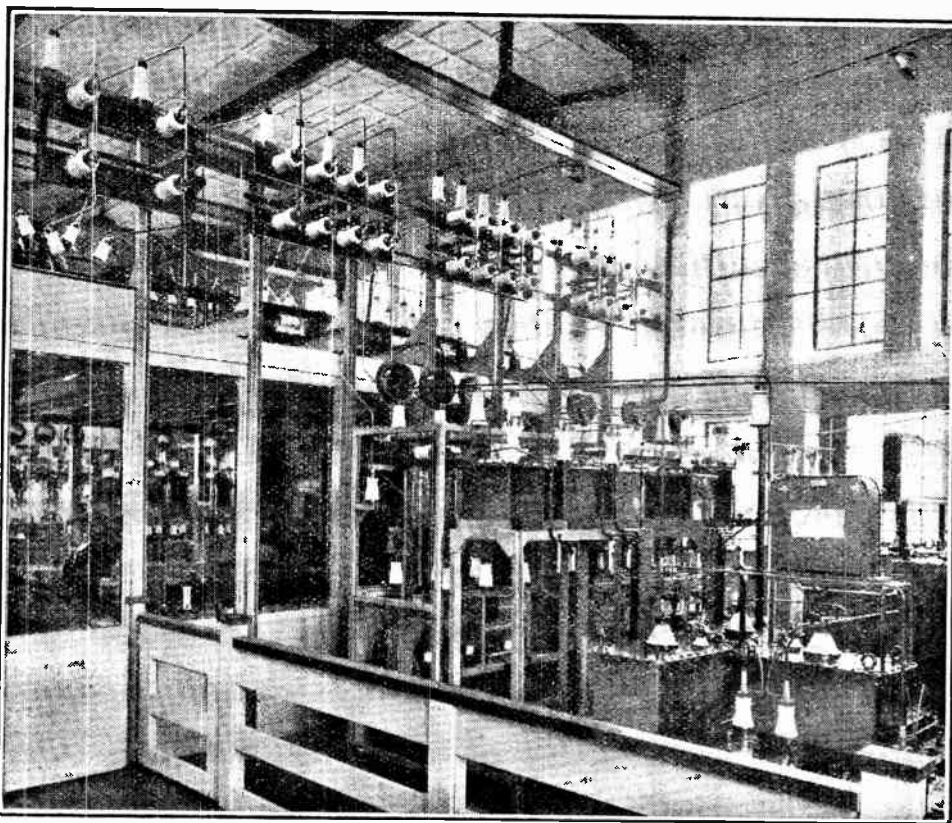

The high-power rectifying plant at Huizen. The main rectifying bank, seen in the picture, gives an output up to 12,000 volts. Water-cooled valves are used in this stage.

level from atmospheric disturbances in the location in which the reception is desired. In certain parts of the world there are periods during the year when radio reception on any wave greater in length than about 40 metres—sometimes less—is impossible, due to the severe atmospheric disturbances. With the choice of a wavelength as low as about 17 metres, the atmospheric bugbear will be very much less in evidence, and "all-the-year-round reception" will, therefore, become almost a certainty.

At the present time, the Huizen short-wave transmitter is not operating to standard programme times, but it is expected that the station will go into scheduled operation in the near future.

Reports from many places speak with enthusiasm of the excellent reception and outstanding quality of the transmissions from this new station, which bids fair to establish a name even surpassing that of PCJ.

CORRESPONDENCE.

The Editor does not hold himself responsible for the opinions of his correspondents.

Correspondence should be addressed to the Editor, "The Wireless World," Dorset House, Tudor Street, E.C.4, and must be accompanied by the writer's name and address.

RECEPTION OF CONTINENTAL STATIONS.

Sir,—As I, too, have been a wireless enthusiast since the early days of broadcasting, and take a keen interest in long-distance reception, I was very interested in the letter from Mr. A. W. Scott in your issue of November 27th.

I cannot, however, agree with his assertion that "the 'enjoyment' of foreign transmissions is an absolute myth" and his description of reception from foreign stations as "awful noises—transmission plus mush, atmospheric, heterodynes, fading and morse."

All stations (irrespective of whether they happen to be British or foreign!) are liable to the forms of interference mentioned by your correspondent, and whether the interference is seriously disturbing or not depends very largely on the ratio of interference to strength of received signals.

On a reasonably efficient set incorporating a screen-grid H.F. stage, I am able to receive upwards of twenty Continental stations at good loud-speaker strength on most evenings from dusk onwards. A smaller set (detector and L.F.) enables me to get a similar number of stations on headphones. I do not claim that all these stations afford consistently reliable results, but on any given night I can invariably select, from this wide choice of programmes, several Continental transmissions which, apart from slight fading, are receivable with a volume and quality that compares favourably with reception from Daventry 5GB. It is manifestly absurd to describe these foreign transmissions as "awful noises" merely because they happen to originate on the other side of the Channel or the North Sea!

As the regular reception of foreign wireless programmes by a large number of listeners is calculated, directly and indirectly, to help in bringing about a better understanding between people of different nationalities, it seems rather a pity to discourage it in any way, but of course one appreciates that the B.B.C. cannot be expected to hamper the development of our own broadcasting service on this account. W. OLIVER.
London, S.W.18.

Sir,—The letter over A. W. Scott's signature, in my opinion, voices the feeling of many, if not the majority of licence holders. The B.B.C.'s main duty is obviously to supply the British public, and the reception of foreign programmes is no concern of theirs. I agree that the latter would be worth listening to if they could be received as transmitted, but with the multiplicity of foreign stations this is now a hopeless proposition. Years ago much pleasure could be derived from them, but now it is definitely better to rely on our own programmes, which on the whole are satisfactory.

Mr. Baggs in his letter voices a real grievance in his complaint of London programmes being relayed. My own set, a "Wireless World" screened-grid five, gives excellent reception of 2LO, 5XX, 5GB, and Manchester, but as a general rule this gives only two programmes from four stations, with the inevitable military band from one.

I do hope when the second programme from 2LO is radiated it will give an alternative programme, and that the Northern Regional Station will give a third choice.

This, I understand, was the whole idea underlying the Regional Scheme.

It is up to the ordinary listener to make himself or herself heard on this point, but the apathy of these people is such that it lulls the B.B.C. into a sense of complacency which is definitely to the detriment of all concerned. L. N. GROVER.

Eastwood, Notts.

B.B.C. TRANSMISSIONS.

Sir.—The letter appearing in your issue of November 13th over the pseudonym of "Fair Play" contains a number of

errors and misrepresentations of which I ought, perhaps, to take notice.

In my letter in your October 23rd issue I did not imply that all distortion occurs in B.B.C. land lines and/or transmitters. I implied, on the contrary, that the defects of any one transmitter were not sufficient to impair the satisfactory quality of direct transmission. Sources of error in my set would not prejudice my point, which was that my apparatus, such as it is, gave me satisfactory results with direct but not with other transmissions. Defects in reception would affect all transmissions alike.

A perfect or elaborate set is not needed to make obvious the deficiencies of land-line and wireless-link transmissions. If "Fair Play" can get near enough to a suitable transmitter, a crystal set and a pair of telephones ought to enable him to differentiate for himself between the various transmissions. The problem he sets for my solution, the old problem of obtaining both quality and selectivity, is therefore in this particular connection quite irrelevant. The lines, however, on which it may be satisfactorily solved he will find indicated for him in recent pages of *The Wireless World*.

It is an error to suggest that the human ear is not the final judge as to quality of reproduction. The sole aim of wireless is to give the normal ear a sufficiently approximate duplicate at one end of the process of what it would hear were it at the other. Scientific tests and measurements serve their purpose. They reveal and localise defects and indicate the direction and degree in which improvement is required. They show also that the ear does not demand perfection but will, within limits, tolerate defects. This tolerance, however, far from invalidating an adverse judgment by the ear, only confirms it and puts it beyond question.

It is quite improbable that the B.B.C. would claim that all their radiations were as good as any set reproducing them. (I use here "Fair Play's" imperfect method of expression.) It is to be observed, too, that "Fair Play" finds it convenient to forget that the B.B.C. themselves, in one of their methods of transmission, make use of a receiving set.

The Chief-Engineer does not require proof of the serious defects of land-line transmissions, nor even to have them brought to his notice. In regard to such defects, he has the evidence of his own ears and also, I believe, a certain quantity of technical data. The following passage is taken from a letter from Mr. A. L. Barham published in *The Wireless World* of January 19th, 1927.

"By great courtesy of B.B.C. engineers I spent a very fascinating afternoon at Savoy Hill a week or so ago and was shown some actual curves of frequencies passed by various land lines let by the G.P.O. to B.B.C. Most of them were most irregular in the way the sonic frequencies were passed, generally looking more like malarial temperature charts than any instrument response. One comparatively short line had a complete cut-off above 3,000 cycles! As different lines are used at different times the practical difficulties in compensating can be imagined."

Any improvement in land-lines and land-line technique during the past three years has not sufficed to effect any noticeable amelioration in the quality of land-line transmission.

The Chief Engineer is unable completely to rectify land-line errors. He gives us at present the best he is capable of in the way of land-line transmission and he can do no more.

There is no reason why we should not all have, at least occasionally—I mean, of course, in the provinces—concerts of the same merit as those from Queen's Hall by direct transmission from our local stations.

I admitted nowhere in my letter that Daventry 5XX was available as an alternative to Newcastle. Daventry 5XX can be easily heard here, but its reception is too liable to interference by various forms of "mush" for it to be accepted as giving an adequate alternative service.

Newcastle-on-Tyne.

K. McCORMACK.

READER'S

THE WIRELESS WORLD SUPPLIES A FREE SERVICE OF TECHNICAL INFORMATION

PROBLEMS

The Service is subject to the rules of the Department, which are printed below; these must be strictly enforced in the interest of readers themselves.

Tracing Power Circuit Interference.

I am occasionally troubled by cracklings and other intermittent noises, which I believe come from the electric power wiring in my neighbourhood, or perhaps from my own house wiring. Can you suggest a simple test which will enable me to determine whether this interference is due to the latter wiring, or to an external source?
S. T. A.

This test should be easy to carry out. All you have to do is, at a time when the interference is particularly noticeable, to take out your main switch, which will certainly be of the double-pole type. If, on doing this, there is no appreciable change in the character of the interference, you may justifiably assume that it is entirely from an outside source.

It will be hardly necessary to add that this test should be repeated several times, preferably with the help of an assistant if the set is at some considerable distance from the main switch.

o o o o

Screening S.G. Valves.

I have some well-made copper screening boxes, measuring 8in. x 8in. x 7in. high, and should like, if possible, to use them in the construction of a receiver on the general lines of the "New Kilo-Mag Four." Would there be any harm done if the H.F. valves were mounted vertically in the first and second compartments?
W. S. W.

We would strongly dissuade you from adopting this course, unless you are willing to be satisfied with an overall

magnification much less than the maximum attainable. If the design of most modern multi-stage H.F. amplifiers is carefully considered, it will be found that it is usual practice to take some pains both to screen individual grid and plate circuits and to isolate the valves themselves from stray fields.

We suggest that you should either mount the valves on "outriggers" behind the screening boxes, as in the original "Kilo-Mag Four," or perhaps better, if the overall width of the receiver is not a matter of great importance, that the boxes should be mounted on the baseboard with a space of some 2in. separating them, thus allowing the valves to be mounted between the screening compartments. This method was exemplified in the "Foreign Listeners' Four."

A selection of queries of general interest is dealt with below, in some cases at greater length than would be possible in a letter.

actually a considerable capacity between the aerial wire and earth; the whole system may be represented as Fig 1 (a), where this external capacity is shown by dotted lines.

A similar explanation applies to the series grid condenser (C in Fig 1 (b)). It must be remembered that there is a small but definite capacity between grid and filament (denoted by C_g), and that this constitutes a second condenser through which the circuit is completed in the manner shown in Fig. 1 (c).

When the plate A of condenser C is given a negative charge, it apparently attracts a positive charge to, but actually drives negative electrons away from, plate B. These are sent across to plate X of condenser C_g , and constitute the counterpart there of those electrons which have been drawn off from plate Y by the

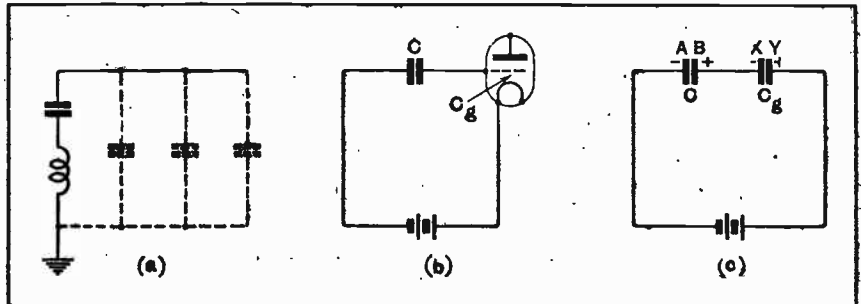

Fig. 1.—The interposing of a condenser in an aerial (a) or grid (b) lead does not constitute a break in the circuit as the condenser is merely connected in series with an existing capacity.

Electrons and Condensers.

With reference to your series of articles, "Wireless Theory Simplified," I have found it quite easy to understand how an electron flow through a condenser is brought about, but cannot quite grasp how this takes place in such practical cases as that of an aerial with a series condenser or of a valve with a condenser in series with its grid. In neither case does there appear to be electrical continuity between the two plates of the condenser.

A few words of explanation would be greatly appreciated. W. T. T.

As you suggest, a condenser cannot be charged unless there is an external circuit, but in both cases instanced this condition obtains, although the circuit is actually completed through another condenser in series with the first.

In the case of the open aerial there is

battery. For further explanation of the subject of condensers in series we would refer you to our issue of November 27th.

Still referring to Fig. 1 (c), it should be realised that the voltage applied by the battery is divided between the condensers in the inverse ratio of their capacities, and where the capacity of one of the condensers is very small compared with the other, practically the whole of the voltage is set up across the smaller one. If C has a value of 0.0003 mfd. (or 300 mfd.) and C_g a value of 10 mmfd., the voltage will be divided in the ratio of 300 to 10 between the condensers. Thus if the E.M.F. of the battery is 10 volts, the voltage across C will be $\frac{10}{310} \times 10 = 0.322$, and that across C_g will be $\frac{300}{310} \times 10 = 9.678$.

Plates B and X are at the same potential, since they are joined; the signs indicate distribution of electrons only.

RULES.

- (1) Only one question (which must deal with a single specific point) can be answered. Letters must be concisely worded and headed "Information Department."
 - (2) Queries must be written on one side of the paper, and diagrams drawn on a separate sheet. A self-addressed stamped envelope must be enclosed for postal reply.
 - (3) Designs or circuit diagrams for complete receivers cannot be given; under present-day conditions justice cannot be done to questions of this kind in the course of a letter.
 - (4) Practical wiring plans cannot be supplied or considered.
 - (5) Designs for components such as L.F. chokes, power transformers, etc., cannot be supplied.
 - (6) Queries arising from the construction or operation of receivers must be confined to constructional sets described in "The Wireless World" or to standard manufacturers' receivers.
- Readers desiring information on matters beyond the scope of the Information Department are invited to submit suggestions regarding subjects to be treated in future articles or paragraphs.

The "Selectivity-Quality" Problem.

In Fig. 1 of the above article in your issue of November 27th, a fixed resistance of 60,000 ohms is shown as being connected between one side of R_1 and the filament of the detector valve. It seems to act more or less as a short-circuit across the H.T. supply leads. Will you please explain its purpose? S. J. E.

This resistance forms one arm of a potentiometer, of which R_1 is the variable element. The voltage applied to the detector anode will be determined largely by the relationship between the values of these two resistances.

In the receiver under discussion there is a very considerable difference between the main H.T. input voltage and that suitable for the detector, and in these circumstances it is desirable to ensure a sensibly constant voltage feed by fitting a potentiometer device instead of a simple series resistance.

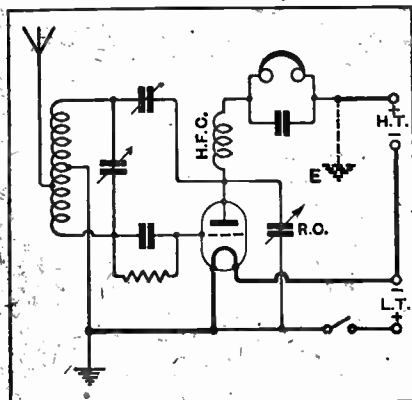

Fig. 2.—When the positive L.T. lead is earth connected there is a possible risk of burning out the valve filament. Short-circuit path is shown in heavy lines.

Still Another Way of Burning Out Valves.

Some little time ago I made up a single-valve detector set with throttle-controlled reaction on the general lines of a circuit shown in your journal, but with one or two minor modifications. As the set was built into a small metal cabinet the positive terminal of the L.T. battery was "earthed" to the case, in order that an existing on-off switch (of which one terminal was in metallic connection with the fixing bush) could be used. Negative terminals of high- and low-tension batteries were connected together, as is always recommended.

In view of the fact that these precautions were taken, I had hoped that the set would be as "safe" as could be expected, but I have actually burnt out the valve on two separate occasions by allowing the high-tension positive lead accidentally to make a momentary contact with the metal container.

Is this particular circuit arrangement especially prone to this trouble, or have I made a mistake in "earthing" the positive side of the low-tension battery? L. H.

Much space has been devoted in this journal to the subject of "safety" valve filament connections; your own arrangement most definitely does not come under this category.

We expect that your circuit is that shown in Fig. 2. We have added an earth connection (marked E), which represents what takes place when the H.T. positive lead makes accidental contact with the metal work. If you consider the diagram carefully you will see that this connection provides a "through" circuit, via the valve filament, across the H.T. battery, provided that the on-off switch is open.

The throttle control reaction circuit need introduce no more risk of damage to valves than any other, provided that proper precautions are taken in arranging the filament wiring, etc. o o o o

Parallel Feed L.F. Amplifier

In a set on the lines of the 1930 Everyman Four, but with a power valve in the first L.F. position, would it not be preferable to replace the anode resistance by a high-inductance choke? I ask this because it seems that when using a low-impedance valve taking a considerable anode current, there would be an excessive loss of voltage in the resistance. C. B. N.

In a case of this sort we think it would be a mistake to use a choke in place of a resistance, as by doing so there is a risk of upsetting the characteristics of the transformer. In any case, it must be realised both that the inductance of the choke would be considerably reduced were a heavy current to be passed through it, and that there is a tendency for the grid volts/anode current curve of a valve to straighten out when a resistance is connected in its anode circuit. Assuming a fairly conventional arrangement, with reasonable H.T. voltage, we think you need have no fear that the first L.F. stage, if arranged as in the 1930 Everyman Four, will deal with a sufficient input. o o o o

Filter Output as Stabiliser.

I have just replaced a choke filter arrangement by an output transformer, with the result that the set, which was previously quite stable, is now totally unmanageable, and produces violent L.F. oscillation. Is this a usual effect, and, if so, will you please suggest a cure? L. B. G.

An output filter, of the type in which one side of the loud speaker is earthed, acts as a decoupling device by virtue of the fact that speech frequency currents are largely diverted from the common source of H.T. current by the anode choke, which almost invariably has a much higher impedance—at any rate to currents corresponding to the upper range of audible frequencies—than the alternative path.

The fact that you have noticed this effect would point to the need for inserting decoupling resistances in the anode circuits of detector and 1st stage L.F. valves. This should provide a cure, and

enable you to use your output transformer with satisfactory results, but if stability is still lacking please send us a circuit diagram of your receiver, with details of the source of H.T. current supply. o o o o

Considerations in Design.

In the design of the Record III, an attempt was avowedly made to attain the maximum possible amplification consistent with the retention of sidebands: I am puzzled as to why a 4in. diameter litz coil, similar to the H.T. transformer secondary, was not used for the H.F. grid coil. Is it not a fact that a high-inductance coil of low H.F. resistance could with advantage be used in this position, providing still greater amplification and less sideband cutting? W. M. T.

Tuned circuits having a large inductance and a small capacity contribute comparatively little to the overall selectivity of a receiver, and on these grounds alone it would probably be injudicious to include a second one of this type in the receiver. Further, a high-inductance coil cannot usefully be employed unless all possible steps are taken to reduce incidental capacity across it, and consequently its use would necessitate "decapping" of the H.F. valve as well as of the detector, which was considered to be undesirable. o o o o

FOREIGN BROADCAST GUIDE.**EIFFEL TOWER**

(Paris, France).

Geographical Position: 48° 51' 30" N. 2° 17' 43" E.

Approximate air line from London: 214 miles.

Wavelength: 1,444 m. Frequency: 205.76 k.c. Power: 12 kW.

Time: Greenwich Mean Time.

Relays main transmissions from the Ecole Supérieure (PTT), Paris.

Standard Daily Transmissions.

8 a.m. news and time (from PTT, Paris); 12.15—13.30 concert interspersed with short news bulletins; 13.30—15.40 news, talks, etc.; 17.45 concert; 19.20 (Sun. 19.50) concert followed by relay of PTT Paris.

Male announcer. Call (when own transmission): Ici le Poste National de la Tour Eiffel (repeated). (When relaying PTT Paris): Ici les émissions de T.S.F. du Réseau Français de Radio-diffusion des stations de l'Ecole Supérieure et de la Tour Eiffel.

Opening signal: Seconds counted in the French language.

Time signal (when relaying PTT Paris): Carillon de Fontenay (clock with chimes).

Under the heading "Foreign Broadcast Guide," we are arranging to publish a series of panels in this form, giving details foreign broadcast transmissions.



MOVING-COIL

by PETER GRASSMAN

£4-17-6

The lightest and finest Moving Coil made. Now you can enjoy the advantages of a Moving Coil—the purity and clearness of speech and song—realistic reproduction that only the Peter Grassman speaker can give you—and at a price which you can afford to pay.

The Peter Grassman A.C. model, according to laboratory tests, has infinitely superior frequency curve and operates considerably quieter than any other make.



You must hear it. Just send us a post-card, and we will arrange an immediate demonstration in your own district through your own dealer. The following models are available.

220-volt D.C.

PRICES

6-volt, 110-volt and

£4 17 6

240 volt A.C. models

£8 5s. each.

The ROTOR INDUCTIVE DYNAMIC LOUD-SPEAKER UNIT

No better value because no unit to equal it!

Obtainable from good dealers everywhere. In case of difficulty write for name of nearest dealer.

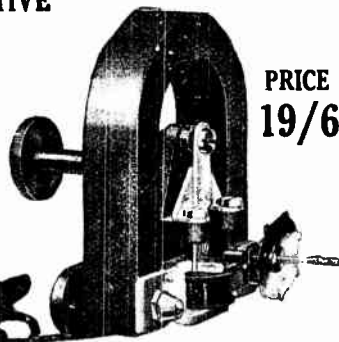

PRICE 19/6

This is a typical Peter Grassman product. You can use this 4-pole Balanced Armature to build any type of cone speaker—it has a fine adjustment, and so will handle a very large volume without rattle or chatter. Extremely easy to mount, compact and of robust construction. You can build the best linen diaphragm loudspeaker and you will find that from deepest bass to highest treble it reproduces faithfully and fully.

ROTOR ELECTRIC LTD.,

2/3 Upper Rathbone Place, London, W.1. Telephone: Museum 2641-2

The CRESCENT METER

The famous Crescent Moving Coil Meters are produced to meet the public's demand for a precision instrument at a popular price.

The men who make them are specialists in delicate clock and watch work—accustomed to the microscopic adjustment of the fine jewel movements such as Crescent Meters have.

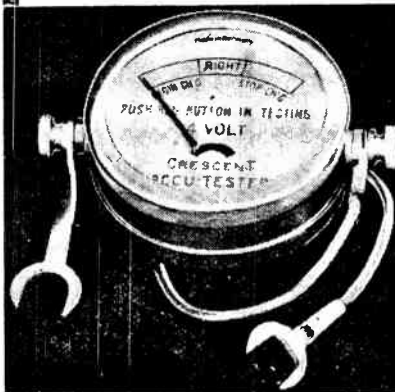

Insist on "CRESCENT"

CRESCENT ACCU-TESTER

Supplied for 2, 4, 6 or 12-volt Batteries.

IT tells you the condition of your accumulator instantly, can be applied permanently across Terminals of L.T. Accumulators, will show if battery needs charging, when right and when to stop charging.—No more messy hydrometers! When ordering state voltage.

Price 6/6

CRESCENT MULTI-READING METER



A simple instrument consuming only 4 m.a. on full scale. Precise within 1% measures 0-10, 0-100, 0-1000 m.a. 0-10 volts, 0-200 v. and resistances 0-100,000 ohms. The 2 screw Terminals serve for all three methods of measuring, the wander plug connecting up the appropriate shunts or resistances for any particular full scale reading required. Resistance 250 ohm. per volt.

PRICE 45/-

If unable to obtain from your dealer order direct from

LOUIS HOLZMAN, 37, Newman Street, London, W.1.

Telephone: Museum 2641-2.

CHRISTMAS GIFTS

Build a Radio-Gramophone for Christmas

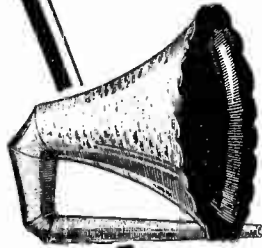

LOGARITHMIC HORNS

- No. 635 Length 5 feet, Flare 25" 19/8 carr. fwd.
- No. 635 Folded (as illustrated) . . . 25/8 carr. fwd.
- No. C1 Length 4 feet, Flare 18" 15/8 carr. fwd.
- No. C2 Length 40", Flare 17" . . . 12/8 carr. fwd.
- Western Pattern, Height 25", Flare 15" 6/8 post paid
- Western Pattern, Height 19", Flare 10" 4/8 post paid

CABINETS

Excellently finished in Oak, there is ample space to make your apparatus absolutely self-contained. We can supply all parts necessary to build a complete Radio-Gramophone, comprising self-contained 5-Valve Set and a Super Gramophone.

TWO SUPER INSTRUMENTS IN ONE. A complete Radio-Gram. of the most modern type can be built for less than £18. Complete instructions. Full Service. Results Guaranteed.

Cabinet Dimensions: Height 39", Width 22", Depth 19". Receiver Compartment: 20" x 7" x 15" deep. Battery and L.S. Compartment: 21" x 16" x 15" deep. Platform for turntable, etc.: 19 1/2" x 10 1/2". Cabinet only £3 : 18 : 6

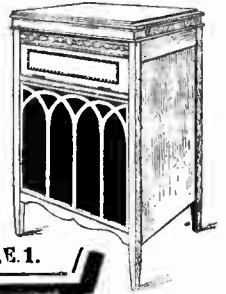

Terms arranged to suit customers' convenience if desired.

SCIENTIFIC SUPPLY STORES, 126, NEWINGTON CAUSEWAY, LONDON, S.E.1.

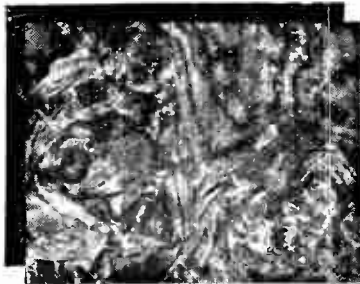

Give a Trolitax Panel

Here is an original idea—give components this year to your constructor friend and include a Trolitax panel. He will appreciate your foresight in giving him a panel which not only possesses excellent insulating properties but is of handsome appearance.

Your wireless dealer stocks Trolitax in a variety of finishes, including some entirely new wood finishes. Trolitax will please the recipient by its high standard of performance and its ease of working . . . you cannot do better than a Trolitax panel.

TROLITAX

F. A. HUGHES & CO., LIMITED

204-6, Great Portland St., London, W.1. Phone: Museum 8630 (4 lines).

Distributors for Northern England, Scotland and North Wales H. C. Rawson (Sheffield and London) Ltd., 100, London Road, Sheffield. (Phone: Sheffield 20006.) 22, St. Mary's Parsonage, Manchester. (Phone: Manchester City 3329.)

Your Christmas SPEAKER:— THE

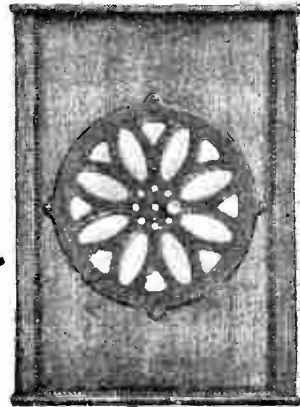

1930 "WHITE SPOT" GIVING MOVING COIL RESULTS

AN artistic speaker Chassis in oak, fitted with the famous "White Spot" Chassis with the fabric suspended cone, it will give really wonderful results. It can be supplied to take either of the following units: Amplion B.A., Brown Vee Movement, Blue Spot, Triton and Ormond. Insist on having a genuine "White Spot" and ensure satisfaction and value for money.

Prices and full literature from—

The WOLVERHAMPTON DIE CASTING Co.,
Gt. Hampton Street, Wolverhampton.

WHY BUY FOREIGN VALVES?

—BRITISH VALVES ARE CHEAPER!

BRITISH MADE AND GUARANTEED ALL RING VALVES REPAIRED. Price as follows:—

For any and every circuit, including SCREENED GRID and "WIRELESS WORLD" sets.

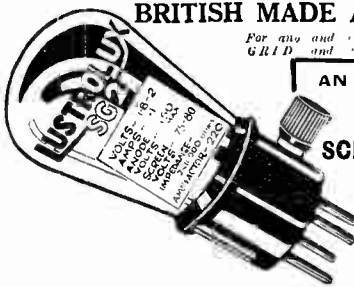

AN OUTSTANDING SUCCESS— The S.G.2 SCREENED GRID VALVE

Proved, Tested and Adopted by all. A Splendid Valve. Try one.

2 volts only **15/-** each.

QUICK

From your Dealer or Direct—

LUSTROLUX

Lower House Mills, West Bollington, Nr. MACCLESFIELD. London Agent: E. R. MORTON, Ltd., 23, Bartlett's Buildings, Holborn Circus, E.C.4. Scottish Agent: Messrs. Bothwell Elec. Co., 54, Eglinton Street, Glasgow.

OUR LATEST— "Super" Type, Pipless.

2, 4 & 6 volts	"A" Type. H.F. L.F. R.C. POWER	5/- Each	2, 4 & 6 volts	"Super" Type, Pipless. H.F. L.F. R.C. POWER	5/- Each 7/- Each
----------------	--------------------------------	----------	----------------	---	----------------------

L.F. H.F. R.C. - 5/3 ORIGINAL
Power Valve - - 6/3 CHARACTERISTICS
Screened Grid - 11/3 GUARANTEED.

CHRISTMAS GIFTS

We're giving Father a new H.T. for *our* radio



I'm sure nothing will please him better—or us! From the time that we first had the wireless set Dad has continually preached the virtues of what he calls a wet H.T. of the C.A.V. make; how it will improve reception by cutting out those funny crackling noises, and then he goes on to talk about less trouble, constant volume and all that.

Anyway, if all the things are true that he said about the new C.A.V. type, the one which he says is “built like a car battery” it will be a good investment. So we have taken the hint, and I'm certain that the improvement will make it worth while, for Dad does know what he is talking about on the subject of wireless.

The new **CAV** of course!

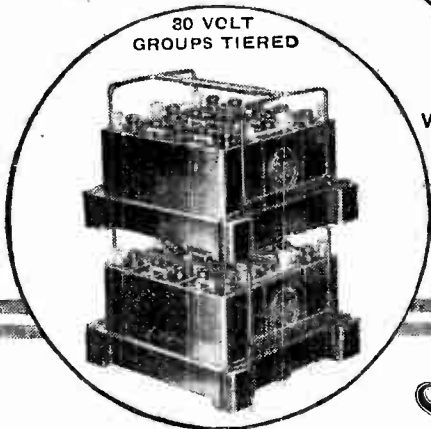

80 VOLT GROUPS TIERED

10 VOLTS **6/3** 5000 MILLIAMPS

ALSO IN 2500 & 10,000 MILLIAMPS

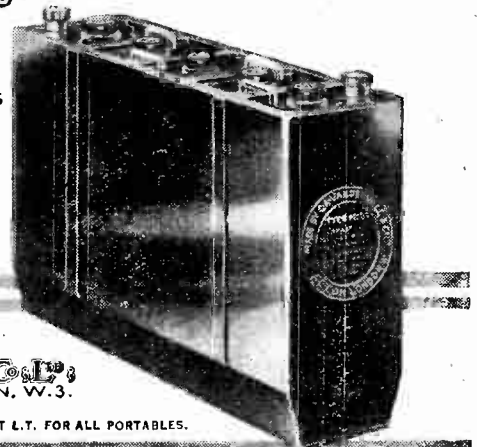

WRITE FOR CATALOGUE T3.

CAVandervell & Co. Ltd.
ACTON, LONDON, W.3.

SPECIFY THE C.A.V. JELLY ACID BATTERY—THE PERFECT H.T. FOR ALL PORTABLES.

CHRISTMAS GIFTS

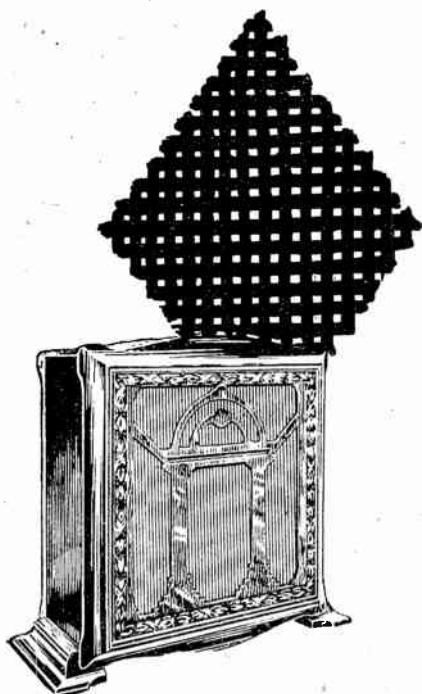

The Christmas Tonic for your Radio Set !



However long ago you bought your radio receiver the Ultra Air Chrome Speaker will give it new life, increased brilliance and realistic vitality. Last season's receivers become transformed by the amazing tone sensitivity of this wonderful double diaphragm linen speaker, which, since its introduction, has taken musicians, technicians, dealers, radio enthusiasts, and ordinary listeners by storm. Give your radio receiver this magic tonic—it will respond, magically. No other speaker will reveal such glorious tone quality, such faithful reproduction of the high notes and such realistic response to the very low notes in the familiar receiver that for many months past has served you so well. Remember the name at your dealer's—the Ultra Air Chrome. Cabinet models from £3 : 19 : 6; Chassis types from £2 : 2 : 0

ULTRA
AIR CHROME SPEAKER

*fitted with the double
linen diaphragm*



*Buldry Ad. U 111



The
**LIFE of the
CHRISTMAS PARTY**

Think how this Bowyer-Lowe Portable Five would brighten your home this Christmas ! Everything you could desire in a Portable is here. Pure reception—beautiful reproduction—amazing volume—very low upkeep. Entirely self-contained in a handsome dark oak cabinet. Hear this superb set to-day. Have it delivered before Christmas. You can pay by easy monthly instalments if you wish. See your dealer now.

£16-16s

Complete including royalties.

Ask your Wireless Dealer about the comprehensive range of Bowyer-Lowe Sets and Components, or write for illustrated literature.

BOWYER-LOWE

In association with



Recordaphones Ltd.

Head Office and Works:
RADIO WORKS, LETCHWORTH, HERTS.

Mention of "The Wireless World," when writing to advertisers, will ensure prompt attention.

CHRISTMAS GIFTS

THE GIFT FOR XMAS



The new

SURE-A-LITE

BRINGS MOST IN - GIVES MOST OUT

60 VOLTS - 6/9
100 " - 11/3

GRID BIAS.

9 Volt	1/3 each
18 1/2 "	2/6 "
18 " (square)	3/- "
22 1/2 "	3/9 "
30 "	4/6 "

The last three are made specially for Eliminators.

All Types have 1 1/2 volt tappings.

Type	Capacity	66 Volt	108 Volt
Supra	8 m.a.	7/11	13/8
Senior	10/12 m.a.	9/6	15/6
		60 Volt	100 Volt
Power (Trebble)	15/20 m.a.	13/6	22/6
		66 Volt	72 Volt
Super (Quadruple)	25 m.a.	19/-	23/-

Flashlamp Batteries .. 6d.

Practical gifts are always better appreciated. This new size SURE-A-LITE meets the need for a moderate size battery at a moderate cost. Like all SURE-A-LITE BATTERIES, this new model can be absolutely relied upon. For silence and consistent output they are unequalled. Give yourself one for Xmas, too.

THE BATTERY CO., 92, HURST STREET, BIRMINGHAM.

Telephone: Midland 3333.

Telegrams: "UNLIMITED."

SEND P.C. FOR NEW LIST NOW READY.

CHRISTMAS GIFTS

Radios' Supreme Power



**ARE YOU PROUD
OF YOUR NEW SET?
DO IT JUSTICE
AND FIT THE BEST
POSSIBLE BATTERY**

Grosvenor Batteries give continuous and satisfactory service because they incorporate a new vitalising element which is unique to Grosvenor.

66 v. from 7/6	Super Capacity for Multi-Valve Sets - - -	66 v. 20/-
99 v. „ 11/6		99 v. 32/6



The
Grosvenor
BATTERY

BRITISH
MANUFACTURE

GROSVENOR BATTERY CO., LTD., 2-3, White St., MOORGATE, LONDON, E.C.2. Phone Met. 6865



An entirely new M-L production for the **ALL ELECTRIC RECEIVER**, the **D.C. to A.C. Converter**.

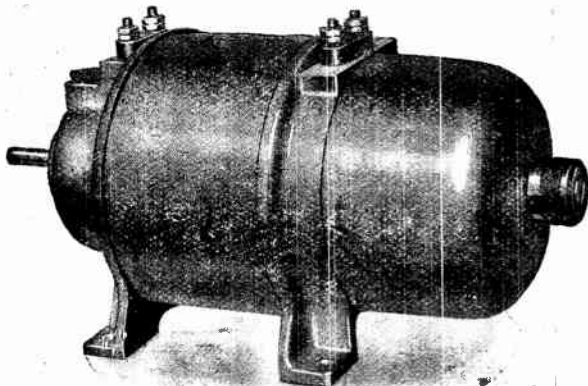

See *The Wireless World*,
Page 375,
October 2nd, 1929.

40 WATT Model
£13-0-0

85 WATT Model
£19-0-0

Power Supply Units our Speciality.

IF YOU ARE ON D.C. MAINS employ the above machine for running your **ALL ELECTRIC RECEIVER**. The only safe way to operate receivers from D.C. Mains. Suitable for well-known makes of Receivers.

M-L MAGNETO SYND. Ltd., Radio Dept., COVENTRY.
Telephone: 5001.

CHRISTMAS GIFTS

A Radiogramophone for me! says the Expert:—this XMAS.

What is more appreciated in the Home or Club at the Festive Season than Christmas Music, and what a suitable gift . . . a Radiogramophone or Loud Speaker . . . a Gift of Utility, Quality, and Beauty.

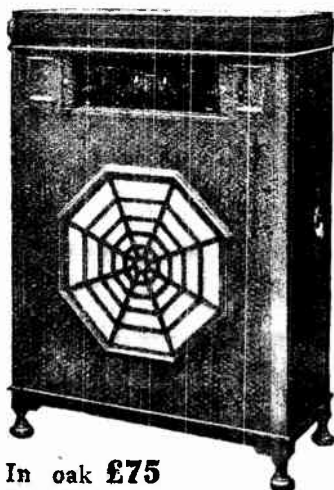

In oak £75

THE
R
G
D

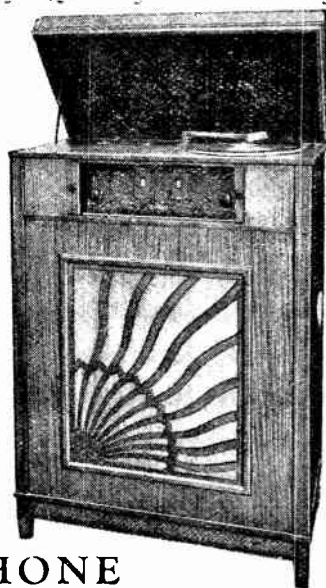

Mahogany
£80

RADIOGRAMOPHONE

For the highest possible quality and tone for both radio and record, with ample volume, incorporating the latest developments in moving coil speaker, operates entirely from electric mains, A.C. any voltage, or D.C. 200 volts or over.

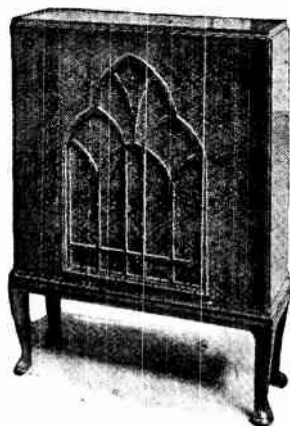

The R.G.D. Moving Coil Loudspeaker finished in Walnut, Oak or Mahogany 2 ft. 6 ins. high, 3 ft. 6 ins. wide—an exceptionally High-class Instrument for D.C. mains, £20
Can be supplied with equipment for A.C. mains.

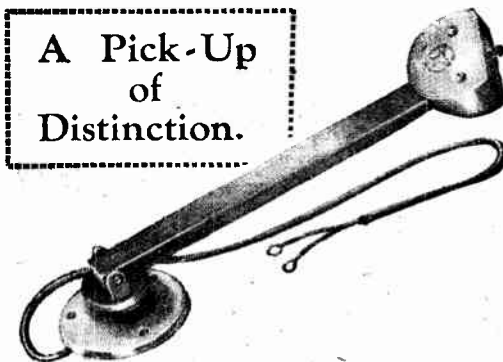

A Pick-Up
of
Distinction.

The R.G.D. Magnetic Pick-up is designed after years of experiments, and we believe it to be as perfect as possible. No record wear, perfect tracking, a scientific instrument, specially developed for moving coil speaker reproduction.
Price £3 in bronze, £3-3-0 in oxidised silver.

Place your order now to ensure delivery, and we shall be pleased to supply literature on application.

The RADIOGRAMOPHONE DEVELOPMENT Co.,
ST. PETER'S PLACE, BROAD ST., BIRMINGHAM.

CHRISTMAS GIFTS

... "I received my Eliminator A.C.16, and had my Set working inside ten minutes with marvellous results" ...

The above is an extract from a letter which has reached us, and is typical of many we are receiving daily from delighted users of our New Super H.T. Battery Eliminator—Model A.C.16.

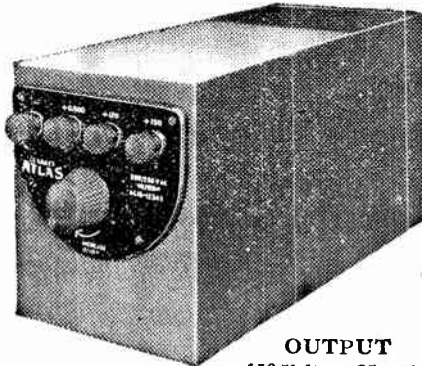

OUTPUT
150 Volts at 25 m/A.

Model A.C.16,

for Alternating Current. Provides three Tappings, two fixed of 120 and 150 Volts respectively, and one variable of 100 Volts. This is the finest H.T. Unit yet produced at the price, and is suitable for any Set from one to five Valves, and specially caters for Sets using Screen-Grid, Detector and Pentode Valves. It is also ideal for use with any Portable Set when used in the home. It is yours for

Get your High Tension Supply from the Mains.

Using this "ATLAS" Eliminator, you can get all the High Tension you require for your Set from the mains—constantly powerful and at practically no cost.

All you have to do is to connect it to a lamp socket or wall plug, attach the terminals to the Set in the same way as a Battery, and switch on.

Imagine what it means to you to have this everlasting H.T. Unit—never runs dry and never needs renewing. Compare the cost of H.T. Batteries—using them on a 3 or multi valve set you must be incurring an expense of anything from 50s. to £6 per annum, and tolerating anything but the best from your Set.

Whatever your needs are, there is a Model in the "ATLAS" Range to meet them. Our new Folder No. 44 gives full details. "ATLAS" H.T. Units can be obtained from any Wireless Dealer.

10% DOWN

(less than the cost of an H.T. Battery). The balance you pay in nine monthly easy instalments.

CASH PRICE £4-10-0

CLARKE'S "ATLAS" BATTERY ELIMINATORS.

POST THIS COUPON NOW!

Messrs. H. CLARKE & Co. (M/CR), Ltd., (Dept. 3D), Atlas Works, Old Trafford, Manchester.

Please send me your New Folder No. 44, along with particulars of your easy payment scheme.

NAME

ADDRESS

in unsealed 4d. stamped envelope.

Please use **BLACK LETTERS.** W.W.4.

The Famous **BULLPHONE DE LUXE LOUD-SPEAKER**

Reduced from 55/- to **25/-** 1000 only as an advertisement.

Ask your Local Dealer or send direct.

CUT OUT THE NEW STATION

with the **BULLPHONE DUAL RANGE COIL**

12'6

BULLPHONE

4-Pole Adjustable Tone **CONE UNIT**

15'-

Adjustable Cone Chassis, suitable for any Cone Unit, per 3'-pair

Obtainable from your Local Dealer or direct from:

BULLPHONE, LTD.
38, HOLYWELL LANE, LONDON, E.C.2

Mention of "The Wireless World," when writing to advertisers, will ensure prompt attention.

CHRISTMAS GIFTS

13 electrical instruments in 1

The
AVOMETER
TESTS OUT
CIRCUITS,
CURRENTS,
ACCUMULATORS,
BATTERIES,
INDICATORS,
VALVES,
LAMPS,
MOTORS,
ETC, ETC,

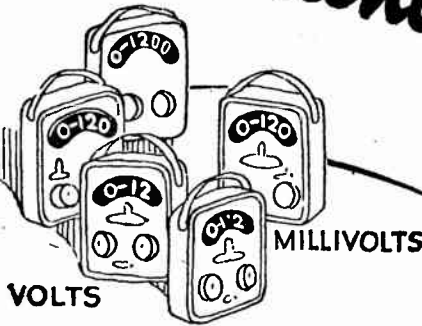

AMPERES **V**OLTS **O**HMS

The AVOMETER (New Model) is a portable, self-contained combination electrical measuring instrument giving direct and accurate readings (D.C.) of Current, Pressure, and Resistance. These readings come well within the margin of error allowed for first-grade instruments by the B.E.S.A. A novice can use it, so simple and clear is its operation. A single switch fitted with a spring click controls all ranges. A knob is clearly marked with each range, while an arrow-head indicates the one in use.

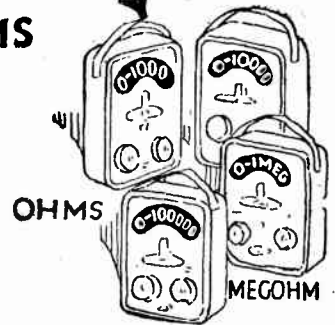

ONLY ONE PAIR OF TERMINALS USED

Direct readings. No calculating. No external shunts or multipliers.

Write for the NEW "AVOMETER" Folder K.

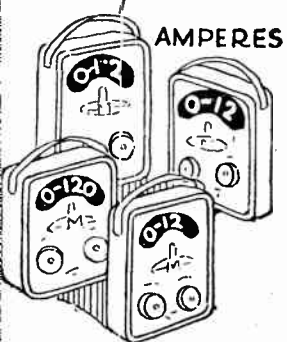

AMPERES

MILLIAMPS

THE AVOMETER WEIGHS ONLY 5lbs. BRITISH THROUGHOUT

The readings shown in the windows of the thirteen miniature "Avometers" pictured above are as follows:—

- | | |
|------------------|-----------|
| 0—12 Milliamps | } AMPERES |
| 0—120 Milliamps | |
| 0—1.2 Amperes | |
| 0—12 Amperes | |
| 0—120 Millivolts | } VOLTS |
| 0—1.2 Volts | |
| 0—12 Volts | |
| 0—120 Volts | |
| 0—1,200 Volts | } OHMS |
| 0—1,000 Ohms | |
| 0—10,000 Ohms | |
| 0—100,000 Ohms | |
| 0—1 Megohm | |

PRICE £8'8'0



The
AVOMETER

(REGD TRADE MARK. PATENTED IN ALL COUNTRIES)

THE AUTOMATIC COIL WINDER & ELECTRICAL EQUIPMENT CO., LTD.,

Dept. K, "Winder House," Rochester Row, London, S.W.1.

TELEPHONE: VICTORIA 4350.

CHRISTMAS GIFTS

**Solve Hubbie's
Accumulator Worries**

Buy him a
**"GUARDIAN"
TRICKLE CHARGER.**

*5 amp. for 2, 4 or 6 volt Batteries.
Absolutely safe. Silent and efficient.
Consumption negligible.

Price **37/6**

Larger types available.

A "CIFEL" PRODUCT.

Enquire of your dealer or
direct from

FONTEYN & CO.,

LTD.,
2-6, Elandford Mews,
Baker St., London, W.1



High-grade
**QUEEN ANNE STYLE
FIGURED OAK CABINET**

Height 3 ft. 3 ins. Depth 1 ft. 3 ins.
For Panels up to 21 ins. x 7 ins.
Baseboards up to 11 in.

£5.5.0 Carriage Paid

Prices of other sizes in proportion.
Manufacturer of all types of wireless cabinets
and furniture of every description.

Illustrated lists free.

**GILBERT,
CABINET MAKER,
SWINDON.**

Estimates Free.

Estd. 1866.



BUY YOUR SET A PRESENT!

WHETHER IT BE A PORTABLE OR EMPLOYS AN AERIAL

MODEL P.2 A.C.
For Portable Sets.

120 volts at 15 m.a.
60 volts at 2 m.a.

Metal Rectifier.
£4 : 17 : 6

THE
ELLISON

GUARANTEED ELIMINATORS

WILL

IMPROVE RESULTS

SAVE MONEY

ELIMINATE BATTERY WORRY

LAST A LIFETIME

MODEL P.1 D.C.
For Portable Sets.

Universal Voltage
Detector and Power
Tappings.

£2 : 10 : 0

MODEL A.C.1.

120 volts at 20 m.a.
60 volts at 2 m.a.

Ideal for all standard
sets taking not more
than 20-25 m.a.

£3 : 15 : 0

IMPROVE RESULTS

SAVE MONEY

ELIMINATE BATTERY WORRY

LAST A LIFETIME

MODEL A.C.2.

For Screen Grid Sets.

120 volts at 30 m.a.
Variable S.G. Tapping
60-70 volts for De-
tector.

£4 : 10 : 0

THE ELLISON MFG. CO., LTD., DRAGON WORKS, HARROGATE.

HEAYBERD

The leading All-Mains Transformer.

Three selections from our Dec. List —

W.14.

135 v., 70 ma.
4 v., 4 amps.

Price 21/-

W.15.

135 v., 70 ma.
12 v., 1 1/2 amps.
45 v., 50 ma.

Price 28/6

W.16.

135 v., 70 ma.
0.8 v., 4 amps.

Price 21/-

HEAYBERD Power Transformers refuse to break down, give constant and exact voltage, are made in every conceivable variety, give no trouble, and are **WORTH THEIR WEIGHT IN GOLD.**

Full lists Free.

F. C. HEAYBERD & CO., 10 Finsbury St., E.C.2.

(One minute from Moorgate Station.)

PARFAIT
THE PERFECT
EBONITE PANEL
ONE QUALITY ONLY
— THE BEST —

SUPPLIED IN SIX FINISHES | Matt Cube Surface | Semi-Polished Mahogany | Highly Polished Black | Highly Polished Mahogany | Semi-Polished Black.

Stocked by most Wireless dealers. If any difficulty in obtaining locally, write for name of nearest stockist to:
H. B. POTTER & Co., Ltd., Station Buildings, ROCHDALE.

Mention of "The Wireless World," when writing to advertisers, will ensure prompt attention.

CHRISTMAS GIFTS

DONOTONE

THE BEST LOUD SPEAKER

This Speaker with its wonderful tuned gongs will make AN IDEAL XMAS GIFT which will give pleasure all the year round and be a daily reminder of your kindly act.

FROM **5** GNS.

DEMONSTRATIONS DAILY.

The DONOTONE (Regd.) LOUD SPEAKER,
Dept. "C,"
40, Furnival Street, Holborn, London, E.C.4.

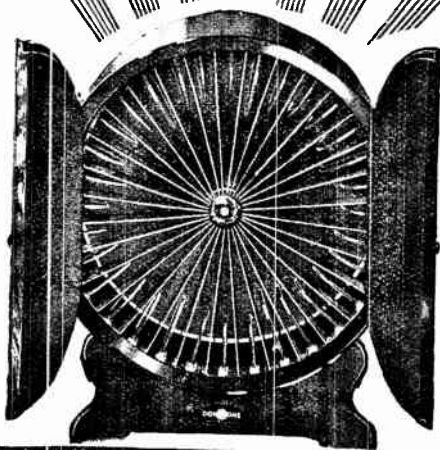

for XMAS - RADIO CONNECTIONS

Overhaul your set for Xmas to make sure of good results. See that every connection is perfect. Replace old connections with the acknowledged best — Belling-Lee engraved Terminals, Wander Plugs, Spade Terminals, Plugs and Sockets, Anode Connectors, Twin Connectors, Fuses, etc.—all are the last word in safety and efficiency, and improve the appearance and convenience of any set.

Thousands give Belling-Lee "radio connections" as Xmas presents. Few such low-priced gifts are so acceptable. How about pleasing your friends this Xmas with these useful little products?

Ask your Dealer, or send to us for Belling-Lee Handbook, "Radio Connections."



FUSE
Complete with Adaptor to fit Wander Plug, etc., 1/-
Spare Fuse, 6d.

PLUG & SOCKET 9d.
Panel portion 3d.
Flex portion 6d.

TERMINALS.
Type "B" . . . 6d.
Type "M" . . . 4d.
Type "R" . . . 3d.

SPADE TERMINAL
4d.

WANDER PLUG
4d.

ANODE CONNECTOR 6d.

BELLING-LEE
FOR EVERY RADIO CONNECTION

Advt. of Belling & Lee, Ltd., Queensway Works, Ponders End, Middlesex.

CHRISTMAS GIFTS

THE GOLIATH OF LOUDSPEAKERS

The "Goliath" of the Blue Spot range makes an ideal gift for the lover of true reproduction. Because the Blue Spot "Goliath" is all that a speaker should be, it reproduces all that is broadcast, but no more; its tone is superb . . . its appearance will please the ultra-critical.

Hear it first at your dealer's.

Price £6-6-0

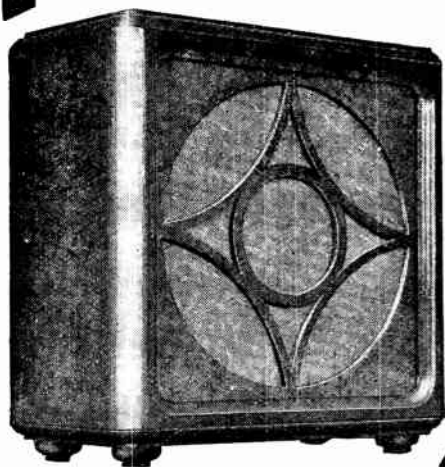

F. A. HUGHES & CO., LIMITED
204-6 Great Portland Street, London, W.1.

'Phone: Museum 8630 (4 lines).

Distributors for Northern England, Scotland and North Wales:
H. C. RAWSON (Sheffield and London), Ltd., 100 London Road,
Sheffield ('Phone: Sheffield 26006), and 22 St. Mary's Parsonage,
Manchester ('Phone: Manchester City 3329).

LOTUS LOGARITHMIC CONDENSERS

pass the test

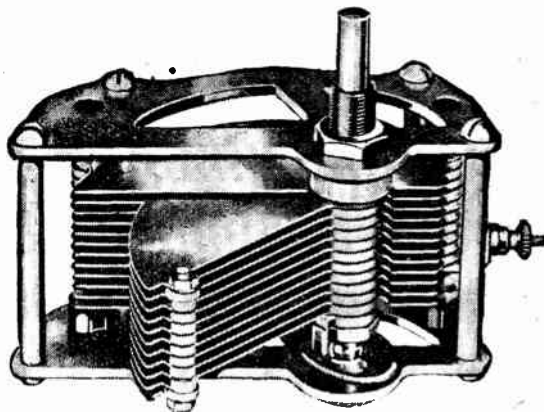

Technical writers, the press and the leading manufacturers of circuits are constantly recommending Lotus Logarithmic Condensers. Why not use these proved condensers in your set?

The ball bearings and the chemically-cleaned special brass vanes and end plates ensure a smooth, firm movement and perfect conductivity, and the ample spacing prevents any chance of short circuiting of the vanes.

Every Lotus Component, from a variable condenser to a simple switch, is the product of experience and experiment—a masterpiece of mechanical perfection. Make a point of building your next set with Lotus Components.

.0005 Condenser	5/9
.00035 Condenser	5/7
.0003 Condenser	5/6
.00025 Condenser	5/3
.00015 Condenser	5/-

FROM ALL RADIO DEALERS.

LOTUS

VARIABLE CONDENSERS

*Made in one of the most modern
radio factories in Great Britain.*

*You can get these Condensers
fitted to the Lotus Dual and Single
Drum Dials—Ask your Dealer.*

Garnett, Whiteley & Co., Ltd., Liverpool

Mention of "The Wireless World," when writing to advertisers, will ensure prompt attention.

CHRISTMAS GIFTS

With Indicating Floats
 P.G.F.5 11/9
 20 a.h. 2v. (as illustrated)
 P.G.F.7 13/9
 30 a.h. 2v.
 P.G.F.9 18/9
 40 a.h. 2v.



Non-Indicating
 P.G.5 9/-
 20 a.h. 2v.
 P.G.7 11/-
 30 a.h. 2v.
 P.G.9 13/-
 40 a.h. 2v.
 P.G.11 15/-
 50 a.h. 2v.

I know when my L.T. will run out

"My Peto & Radford P.G.F. Accumulator never discharges without warning me of its condition.

Its three indicating floats—white, green, red—take care of that.

When the accumulator is fully charged these rise to the top. Soon after I 'switch on' the white float sinks to the bottom. At half discharge down goes the green, and not until the red falls is recharging necessary."

Like every other Peto & Radford Battery the P.G.F. is

Guaranteed for 6 months

It embodies these further special features. The plates are sturdy. Paste is held in by interlocking grids. The lid is of crack-proof, acid-proof Dagenite, hermetically sealed at the edges. Terminals have acid-proof glands, and, because of their different diameters, they cannot be reversed. There is ample acid-room, and plates are held in place by glass keyways in the box.

Send a postcard for a Catalogue to:—

PETO & RADFORD,
 93, Great Portland Street,
 London, W.1.

(Telephone: Langham 1573).

Glasgow Depot: 45, Clyde Place.

P AND R

London Sales & Repair Depot: 107a, Finsbury R.I. S.W.1.

PETO & RADFORD

ACCUMULATORS

The beginning and the end in

POWER

W.R.5

This announcement is issued by
THE NATIONAL ACCUMULATOR CO., LTD.

An acceptable gift
 The
IGRANIC-PACENT PHONOVOX
 Pick-up.

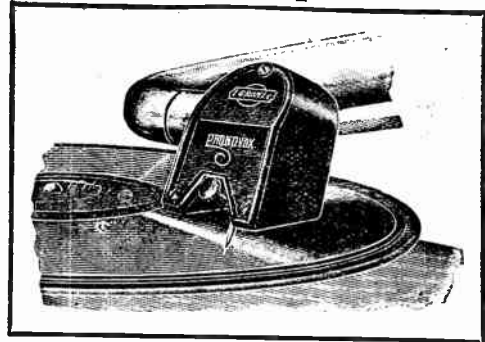

Supersedes the old sound box. Makes the gramophone electrical, and gives unexpected beauty in records, and rich, pure tone even from an old gramophone. The Phonovox Pick-Up offers a new joy to the lover of music. Fitted in a moment, and worked with a radio set. With an Igranic Phonovox an old gramophone becomes as modern in reproduction as the most up-to-date expensive gramophone.

Price 21/-

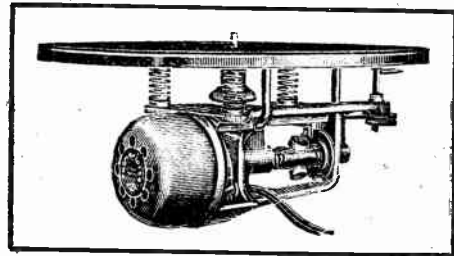

IGRANIC-PACENT PHONOMOTOR

The Igranic-Pacent Phonomotor is a silent single-phase induction motor, which is extremely economical in power. It is the ideal motor for electric gramophone. Supplied in two models only, 110 volt and 220 volt A.C.

Price £6:6:0



Write to Dept. U. 302 for Leaflets.

CHRISTMAS GIFTS

Referee, pleadingly:

“Now . . . just
a minute . . .

*Player's
please*



N.C.C. 765A

*They all place Polar
behind their panels*

When it is a question of efficiency and economy there is no condenser more worthy of being placed behind your panel than the Polar No. 3.

It is highly efficient on normal and ultra short-wave reception. It is low in price and it economises on space because its overall size is only 3½" wide when fully open and 2¼" deep behind panel. One hole fixing.

Constructed entirely of chemically cleaned hard brass. Perfect electrical contact at all points. Smooth yet precise action. Robustly built throughout.

Note: Knob-dial or dial as illustrated which matches that used on Polar "Ideal," 1/- extra.

Get a copy of the Polar Catalogue (W)

**YOU WILL BE PLEASED WITH
POLAR BEHIND YOUR PANEL**

WINGROVE & ROGERS LTD., 188/9, STRAND, LONDON, W.C.2

Polar Works: Mill Lane, Old Swan, Liverpool.

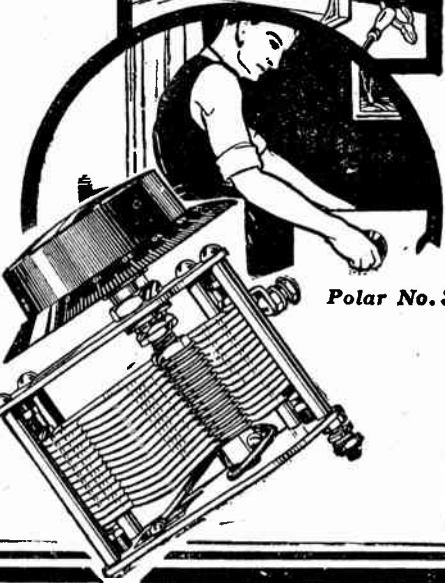

Prices:
•0005 - 5/8
•0035 - 5/7
•0003 - 5/6
without dial.

Polar No. 3

CHRISTMAS GIFTS

Performance is the only test.

PILOT COMPONENTS THIS WEEK.

PILOT TRANSFORMERS

USED ALL OVER THE WORLD. ENSURE PERFECT RECEPTION. 2—1 and 3½—1 ratio.

BAKELITE CASE + 11/6

METAL CASE - - 9/6

PUSH - PULL TRANSFORMERS.

12/6

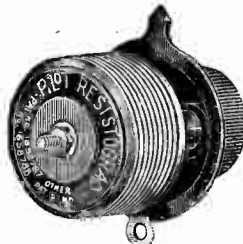
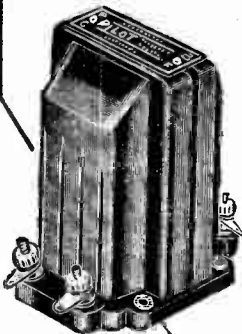

ABOVE ALL—THE **PILOT RESISTOGRAD**

A perfect resistance. A 'jumpless' range from 40 ohms to 10 meg-ohms. Non-inductive and free from packing. For all Eliminator work 5/-

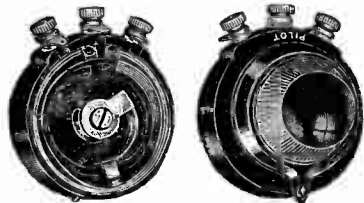

For Volume and Oscillation Control the

PILOT VOLUMGRAD

has no equal. Volume can be adjusted from zero to maximum with one turn of the knob.

In 4 Resistances—50,000 ohms } 6/6
 100,000 "
 200,000 "
 500,000 "

West of England Distributors:—

F. BURRIS & SONS, 7 to 16, REDCLIFFE STREET, BRISTOL.

Write for Catalogues to:—

T. A. ROWLEY, LTD., Sole Agents for Great Britain and Ireland for the PILOT Radio and Tube Corporation of New York, 59, SKINNER LANE, BIRMINGHAM.

A Revelation in 4-Pole Units



Acclaimed by All as the **FINEST UNIT YET PRODUCED!**

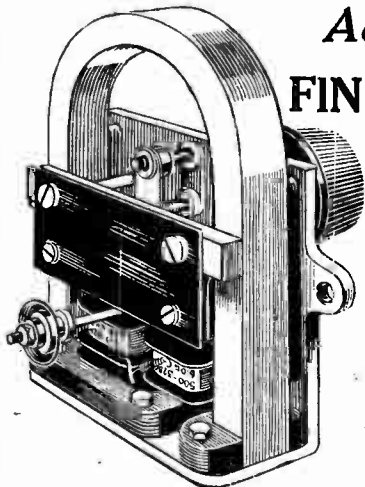

Price **15'6**

THIS new Super Power balanced-armature unit has the power, quality and tone of the best moving-coil loud speaker.

Get one for Christmas and enjoy perfect reproduction

Hearing is believing. Ask your dealer for a demonstration.

TELEPHONE BERLINER (LONDON) LTD., Colindale Avenue, Hendon, LONDON, N.W.9.

CHRISTMAS GIFTS

Some Christmas Presents
which all wireless
friends will
appreciate!

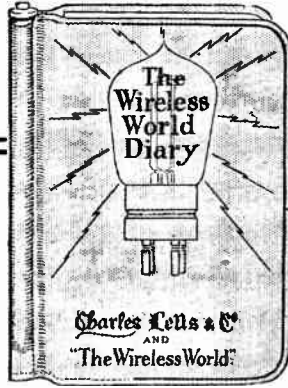

The
Wireless
AND
RADIO REVIEW **World**

DIARY for 1930

Full of useful information for all wireless amateurs, a copy of "THE WIRELESS WORLD" Diary for 1930 makes an admirable Christmas present. It contains facts and figures frequently required, and ample space for memoranda and notes concerning radio matters.

PRINCIPAL CONTENTS:

Summary of Regulations Relating to Amateur Transmitter and Receiving Licences. Conversion Tables, English measures to metric and *vice versa*. Decimal and metrical equivalents of fractions of an inch. Broadcasting Stations of Europe with their Call-signs and Wavelengths. Principal Short-wave Broadcasting and Commercial Stations of the World. Nationality Prefixes used by Amateurs. Morse Code. Symbols used in Wireless Diagrams. Typical Wireless Receiver and Eliminators.—Fourteen Different Circuits with Diagrams. Valve Data, giving the characteristic features of standard valves.

PRICES:

Cloth Board, 1/- net. By post 1/1. In Leather Case, with pockets, pencil and season ticket window, 2/6 net. By post 2/7.

FIFTY YEARS OF ELECTRICITY.

By Sir Ambrose Fleming, M.A.,
D.Sc., F.R.S.

A comprehensive review for the general reader of the chief triumphs of electricity during the last half-century. In this book Dr. Fleming covers practically every phase of electrical work, indicates the trend of present research, and suggests the course of future progress and development. The volume is very fully illustrated.

Price 15/- By post 15/9.

WIRELESS DIRECTION FINDING.

By R. Keen, B.Eng. (Hons.), Sheffield,
A.M.I.E.E.

This book deals with the principles of the subject and the constructional details of direction-finding installations. It describes the principles of Direction and Position finding in this country in such a way that the subject may be grasped easily by those who are tackling this field of wireless work for the first time. Numerous photographs and diagrams.

Price 21/- By post 21/9.

DICTIONARY OF WIRELESS TECHNICAL TERMS.

By S. O. Pearson, B.Sc., A.M.I.E.E.

This little volume contains concise definitions of terms and expressions commonly used in wireless telephony and telegraphy, and provides a useful guide to all those interested in wireless who come across unfamiliar words in their reading. It is well illustrated and cross-referenced to enable the required information to be readily obtained.

Price 2/- By post 2/2.

The above books may be obtained from the Publishers, ILIFFE & SONS LTD., Dorset House, Tudor Street, London, E.C.4. If desired, they will be sent direct to your friends upon receipt of remittance and an addressed label. Kindly say if you wish them to be dispatched on any particular date.

"RITHO" METAL CABINETS

for the
"1930
EVERYMAN
FOUR"

"KILOMAG 4"
& "RECORD 3"

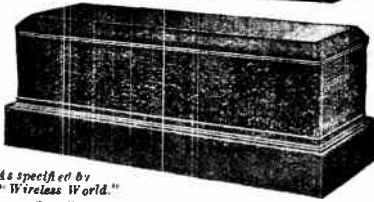

*As specified by
"Wireless World."*

Complete with Wood Base and two Small Aluminium Screens. Beautifully finished in ROSEWOOD, WALNUT or JACOBAN effects,
£3 : 0 : 0 Finished IMITATION LEATHER effect,
£2 : 16 : 6 Carriage and Box—2/6 extra.

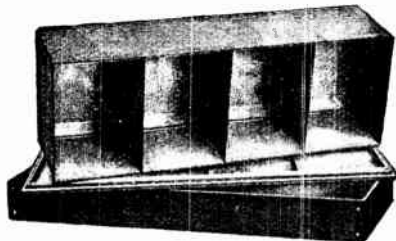

IMPORTANT :— These Cabinets are exactly as submitted to "The Wireless World" and are thoroughly electrically sealed.

WRITE TO-DAY.

Eliminator Cases and High Grade Metal Cabinets of every description in various artistic finishes. Screening Boxes, Containers, etc.

RITHERDON & CO., LTD.
Metal Workers,
North Bridge Mills—**BOLTON.**
Phone: 1024.

MINIMUM LOSS

Hard and tough, almost unbreakable, "Atlas" Pirtoid Tubing is a unique and far superior material for High Frequency Transformers, Aerial Coils, etc. Drills and taps like hard wood or bone. "Atlas" Pirtoid Tubing can be obtained in any usual diameter, thickness of wall and length.

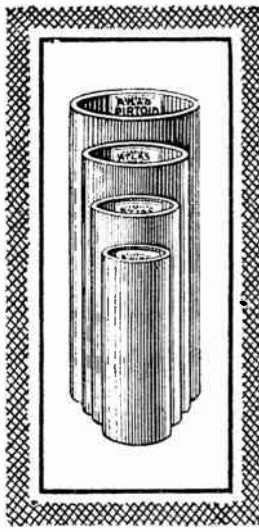

CLARKE'S "ATLAS" PIRTOID TUBING

Write for full particulars to the Sole Makers :
H. CLARKE & CO. (M/CR) Ltd.,
ATLAS WORKS,
OLD TRAFFORD, MANCHESTER.

Master Your Volume

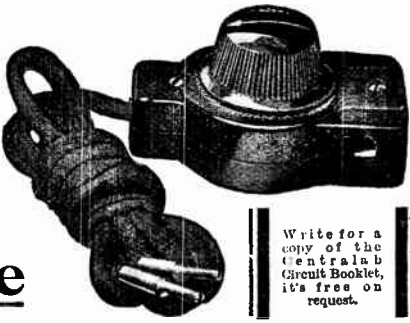

Write for a copy of the Centralab Circuit Booklet, it's free on request.

Do you realise that by detuning your receiver or dimming your filaments you are adopting hopelessly inefficient methods to control your volume? Such practice results in poor quality and is liable to cause unnecessary interference from other stations transmitting on nearby wave lengths. Centralab Modulator plugs obviate all these difficulties and enable you to control your volume from a mere whisper to full loud speaker strength without spoiling reception.

Just connect the two cords on the Centralab Modulator to your loud speaker terminals and then connect your loud speaker cord tips into the two receptacles in the side of the modulator. You can then master your volume by just turning the small bakelite knob on top of the modulator plug. If your set is equipped with an output jack there is another model modulator plug to suit.

- No. 2 type for sets with terminals for loud speakers - - 10/6 each
- No. 1 type for sets with jack for loud speakers - - 10/6 each
- No. 3 type has a 2 foot cord which enables you to control your volume from your armchair - - 12/6 each

Centralab

The Rothermel Corporation Ltd.
24/26, Maddox St., London, W.1. Phone: Mayfair 0578/9.

IDEAL GIFTS

No. 97B
Price 15/-

No. 101
Price 39/6

PRESENTS make the heart grow fonder!
This year make your friend a Christmas present of a Squire Gradle and Cone.

Those with keen musical ears say that they enjoy a constant delight in listening to a Squire Speaker coupled to a good receiver.

If your friend has a Unit, then our 97B Model, shown above, is suitable (it is universal in that it will take any Unit). If, on the other hand, you want to make a real present de-luxe, you can give one of our double "101" Speakers—the finest speaker of the day.

In either case you will be affording your friend such reproduction as he would only be able to obtain elsewhere for a very much greater expenditure.

FREDK. SQUIRE
24, Leswin Rd., Stoke Newington, N.16

THE CORRECT METHOD

of reducing volume is to put a



“VOLUVERNIA” in the Volume Control Circuit.

Reducing volume by detuning causes distortion. Reducing volume with the “Voluvernium” retains purity of reproduction and graduates volume smoothly from maximum to a mere whisper. Splendid for all multiple receivers and excellent for control of volume when records are reproduced by gramophone amplifiers and pick-ups.

Price
6'9

Send for the *Gambrell Components Booklet.*

GAMBRELL RADIO LTD.,
6, BUCKINGHAM STREET, STRAND, LONDON, W.C.2.

Weston sets the world's standard



Model 528, Pocket Size
A.C. Tester

A small and reliable instrument essential to maintain accuracy and efficiency in Voltage control. The sensitivity is remarkably high, 6 m.a. for 600 volts with self-contained resistance. The Scale is very legible and the damping excellent. This instrument is capable of continuous service at full load.

Prices from
£3 . 10 . 0 to £4 . 15 . 0

WESTON
ELECTRICAL INSTRUMENT
CO., LTD.

15, Great Saffron Hill, London, E.C.1
A.1

Write for your copy of “Radio Control,” which explains simply the electrical operation of a radio set. Sent free on receipt of a postcard addressed to:—

REDFERN'S REG. NO. 469456. **Ebonart** NON-METALLIC SURFACE EBONITE **RADIO PANELS**

Recommended for “FERRANTI” S.G. RECEIVER.

MAXIMUM INSULATING PROPERTIES AND LEAK-FREE SURFACE.

Consider an “EBONART” Panel a necessity, especially when constructing a set employing H.F. STAGES. Supplied in Black and Mahogany colours. One side Polished Surface or Moire Silk Design.

REDFERN'S RUBBER WORKS Ltd.—Hyde, Cheshire

Give your Short Wave Pals a treat this Xmas!



12/6

A PAIR—AND WELL WORTH IT!
120, 2,000 and 4,000 ohms.

All DX workers have a pair of Ericsson Super-sensitive on the bench—for their wonderful response to all tonal frequencies the B.B.C. use them in their studios to test quality.

Astonishing sensitivity to weakest signals. Crystal users find them a wonderful aid on Brookman's Park reception.

At all good dealers or direct:
ERICSSON TELEPHONES LTD.,
67/73, Kingsway, London, W.C.

Ericsson

SUPERSENSITIVE TELEPHONES.

BE SURE OF YOUR PANEL



EBONITE IS GENUINE

Tested to 104,000 volts.
USE THE PRIZE WINNING LOW LOSS FORMER.

LOOK FOR TRADE MARK.

Write for Handbook on Windings and Circuits, Post Free 4d.
THE BRITISH EBONITE CO., LTD., HANWELL, LONDON, W.7.

MISCELLANEOUS ADVERTISEMENTS.

NOTICES.

THE CHARGE FOR ADVERTISEMENTS in these columns is:

12 words or less, 2/- and 2d. for every additional word.

Each paragraph is charged separately and name and address must be counted.

SERIES DISCOUNTS are allowed to Trade Advertisers who follow on orders for consecutive insertions, provided a contract is placed in advance, and in the absence of fresh instructions the entire "copy" is repeated from the previous issue: 13 consecutive insertions 5%; 26 consecutive, 10%; 52 consecutive, 15%.

ADVERTISEMENTS for these columns are accepted up to **FIRST POST ON THURSDAY MORNING** (previous date of issue) at the Head Offices of "The Wireless World," Dorset House, Tudor Street, London, E.C.4, or on **WEDNESDAY MORNING** at the Branch Offices: 9, Hertford Street, Coventry; Guildhall Buildings, Navigation Street, Birmingham; 260, Deansgate, Manchester; 101, St. Vincent Street, Glasgow, C.2.

Advertisements that arrive too late for a particular issue will automatically be inserted in the following issue unless accompanied by instructions to the contrary. All advertisements in this section must be strictly prepaid.

The proprietors retain the right to refuse or withdraw advertisements at their discretion.

Postal Orders and Cheques sent in payment for advertisements should be made payable to **ILLIFFE & Co.** Notes being traceable if lost in transit should not be sent as remittances.

All letters relating to advertisements should quote the number which is printed at the end of each advertisement, and the date of the issue in which it appeared.

The proprietors are not responsible for clerical or printers' errors, although every care is taken to avoid mistakes.

For further particulars see previous issues.

IMPORTANT NOTICE.

Owing to the Christmas Holidays, the next two issues of "THE WIRELESS WORLD" are closing for press earlier than usual.

In accordance with the Notice that appeared last week, the latest date upon which Miscellaneous Advertisements could be accepted for the issue of December 18th was **WEDNESDAY, December 11th.**

For the issue of December 25th advertisements for these columns can be accepted up to **FIRST POST, WEDNESDAY, December 18th.**

RECEIVERS FOR SALE.

SCOTT SESSIONS and Co., Great Britain's Radio Doctors.—Read advertisement under Miscellaneous. [0264]

5-VALVE All-wave Receiver, latest type, powerful, perfect; £4.—V. Taylor, 57, Studley Rd., Stockwell, London. [0274]

RECEIVERS for Sale.—Portable 5-valve, suit case type, complete, as new, perfect; £9/17/6.—N. Taylor, 57, Studley Rd., Stockwell, London. [0323]

MAS.—What about a portable? Splendid 5-valvers, combining aerial, batteries, loudspeakers, valves, etc., from £9/9, really portable, take wherever you go; constructional kits, £7; performance guaranteed, all parts supplied.—Box 4061, c/o The Wireless World. [7462]

QUICK Disposal, several new and second-hand sets and components; half price.—Fox, 71, Buckingham Rd., Aylesbury. [7463]

READ and MORRIS, Ltd., the mains pioneers, who in 1925 equipped the hospital with mains sets, still supreme in all-mains receivers and units.

LOW Tension A.C. Eliminators, permanently replacing batteries, now only £5/15; electrolytic condensers, 2,000 m.f., as used in above, 13/-; including postage. [7464]

BARGAINS.—Second-hand sets, units, meters, speakers.—Read and Morris, Ltd., 31, Eastcastle St. (facing back of Warrings), Oxford St., W. [7445]

5-VALVE Receiver, with valves, H.T., L.T., L.S., self-contained, decoupled, gang control guaranteed; £8.—17, Chepstow Crescent, Notting Hill, W.11. [7511]

VERY Slightly Shop Soiled but Carrying Makers' Guarantees.—3-valve receiver, £4/4; 2-valve receiver, £3/3; royalties paid; 7 days' approval against sb.—Bostock and Stonnill, 1, Westbourne Terrace, E.23. [7530]



ALL WIRELESS WORLD COILS

1930 EVERYMAN FOUR	47/8 set
KIT SET, Coils with Switches	45/- set
NEW KILOMAG.	45/- set
RECORD III	45/- set
FOREIGN LISTENERS 4 B.B.C.	30/- set
5XX 37/8 set	
METAL CABINET	33/3 to 46/8
5 1/2" DRUM DIAL with Escutcheons	5/6
WAVE TRAP, Litz Wire.	10/8 each

B&J Wireless Co.

2, 3, & 4, Atheistans Mews,
Stroud Green Road, N.4.

Archway 1695

"END OF YEAR CLEARING."

APPLEBY'S

FOR BARGAINS WATCH

Phone: Paddington 8828 (3 lines).
THE MISCELLANEOUS COLUMNS THIS MONTH.

For Modern High-grade Material Only.

CHAPEL ST., LONDON, N.W.1

OPEN TILL 7 P.M. SAT. 1 P.M.



A.C. 3 KIT SET



Bakelite Drum Dials
with Escutcheons

5/6

(from stock).

All Metal Cabinet with oak base and plinth 42/6

Coils per set, as specified 60/-

Cabinets, Coils, Valve Holders, etc., for New Kilo-Mag 4 and 1930 Everyman 4.

Order direct from:

E. PAROUSSI,

10, Featherstone Buildings, High Holborn, W.O.1

Phone: Chancery 7010.

RADIO-GRAMOPHONE CABINETS

Beautifully finished in highly polished OAK.

Will take sets
18" x 7" x 16" or 21" x 7" x 16".

Spacious compartment for speaker and batteries. Overall size 36" x 24" x 19".
9-1/2 motor board. £4. 19. 6

(Mahogany Finish £5-15-0).
Delivered free in England and Wales. Scotland 2/6 extra.

Send for our Illus. Catalogue.
Fitted complete with D.S. Motor, B.T.H. Pick-up and Arm, Ormond Unit and Chassis. £9-17-6

This is all you need to turn your present set into a modern RADIO-GRAMOPHONE.

PREMIER SUPPLY STORES

Radio & Gramophone Specialists,
165, Fleet St., London, E.C.4.
Phone: Central 2833

Large selection of Gramo. Motors and Pick-ups always in stock

Receivers for Sale.—Contd.

WIRELESS is a Fascinating Subject, but makes heavy demands upon the purses of its devotees. For one who is determined to keep abreast of the times, there are always new components to be bought, and sets and loud-speakers to be superseded.

AT the Same Time, the would-be buyer is often deterred from buying because he knows that there will be still one more piece of apparatus left on his hands, to add to those already in the junk box.

WE Have Opportunities of Disposing of Semi-Obsolete Apparatus to those who are not fortunate enough to be able to afford the latest type, and will take such apparatus or components, providing they are in saleable condition, in part exchange for any new set, loud-speaker or component required.

ALL We Ask is that You should Send Along a List of Your Old Apparatus, together with your new us to inspect, or, better still, send the apparatus to us to inspect, when we will make you a fair offer.

IF You Approve of this You can Send Your Remittance for the Balance, and we will forward the apparatus required; if you have sent your old apparatus and you do not approve of our offer, we will return carriage paid.

THE Principal of this Firm, who has been a professional wireless engineer since 1910, and has been manager for the Sterling Telephone Co., radio expert to the General Electric Co., and Chairman of the Technical Committee of the National Association of Radio Manufacturers, will willingly give advice to those who are desirous of purchasing apparatus; we are entirely unbiased and will recommend the best apparatus for your particular purpose; you save money by having genuine expert advice.

DO NOT Forget We Will Take Your Old Receiver for Part Exchange.

WE Will also install Sets Anywhere in the British Isles; sets modernised, send for estimates.—Scientific Development Co., 51, Fishergate, Preston, Tel.: 1364. [0226]

SIMMONDS BROS.—Receivers constructed to your own or any published design; also repairs, re-constructions; and modernisations at moderate charges, best materials and workmanship guaranteed; numerous testimonials; quotations free.—Address, Shireland Rd., Smethwick. [5882]

4-VALVE Portable Wireless Set, Geophone, with 2 extra accumulators, latest model, perfect condition, almost new, foreign stations; cost 25 guineas, accept half.—Write Box 295, c/o Dixons, 195, Oxford St., W.1. [7517]

4-VALVE Wireless Set, giving excellent results, Marconi cone speaker, H.T. and L.T. accumulators, complete with charging board, transformers, etc., suitable for 110 or 240 A.C.; cost complete just under £50, in perfect condition; £17, or near offer.—Robertson, The Cottage, Westway, Pinner. [7507]

NATIONAL Portable, 5-valve, unused; accept £11 quick sale, no offers.—80, Cloughton St., St. Helens, Lancs. [7505]

ORMOND Transportable, 5-valve, oak cabinet, used November—only demonstrations, absolutely as new, £10/10; Listener Three, double diaphragm speaker, in 24in. oak cabinet with Blue Spot unit, cost £25/5, perfect, 50/-.—Clemens and Taylor, Wireless Engineers, Pershore. [7503]

1929 Everyman Four, one valve in parallel, 5 valves and D.C. eliminator, wonderful set; bargain, £12.—Williams, 104, Upper Walthamstow Rd., E.17. Phone: Walthamstow 2151. [7502]

5-VALVE National Portable, perfectly new condition, new H.T. fitted, £10; 5-valve Pembroke suitcase portable, new and perfect, £10; 1929 Cosmo Melody Maker, complete with new valves, £5.—A.R.19 Amplion speaker, £1/10; 30/- new Sferavox cone speaker, 20/-; almost new 3-valve Ekco all cletric D.C. set, complete, £13; new Ekco H.T. mains unit, 55/- model, 25/-; new 3-valve G.E.C. receiver, perfect, 50/-.—Walbro, 49, High St., Saffron Walden. Phone: 45. [7484]

BURNDIPT Ethophone IV, fitted screened valve, 200-4,000 meters, 2-volt accumulator, Ferranti trickle charger, 120-volt high tension accumulator (6 weeks old), Philips valve high tension charger, large type Amplion horn speaker, the whole outfit making complete all mains set for 200-250 A.C. 50 cycle, absolutely like new, £15 the lot, worth treble; Fillograph wireless pickup receiver, used demonstration only—complete and unscratched, £15.—Cedric King, Tweedale St., Roebdale, Tel.: 2507. [7482]

MARCONIPHONE Type 35 Screened Grid Detector and Pentode, guaranteed as new, only 5 months' use, complete (without batteries); £10, no offers.—Box 4092, c/o The Wireless World. [7477]

MARCONI Model 61, 3 valves, 3 S.G. det. and 2 R.C. stages, frame aerial, extremely powerful and selective. The Wireless World, September, 1929, states: Expensive but of superlative performance. Cost £60, together with Marconi moving coil (mahogany) loud-speaker for A.C. mains cost £17, perfect condition; great bargain, 30 guineas.—Box 4176, c/o The Wireless World. [7586]

OSRAM Music Magnet (new model), demonstration set, as new; £7/10, offers.—G. Alderson, Dorridge, Birmingham. [7582]

GENUINE Mullard Master Three Receiving set, G complete with valves; £5, or offer.—Box 4169, c/o The Wireless World. [7576]

OBETA

H.T. BATTERIES

as a

Xmas Gift

will ensure a

Gratifying Reception

STANDARD

60 Volt 8/- 105 Volt 13/6

POWER

60 Volt 10/3 105 Volt 16/6

Your Wireless Dealer can obtain them from—

F. L. LESINGHAM,
13, Victoria St., LONDON, S.W.1

PORTABLE CASES

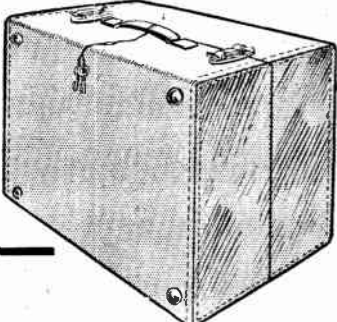

BEST QUALITY
ALL FITTED WITH PAKAWA HANDLES, PATENT FASTENERS AND LOCKS

14½" x 12" x 4½" LID. 4½" DEEP

LEATHER - - 34/-

REXINE - - 22/6

14" x 14" x 5" LID. 4" DEEP

BLACK REXINE - - 20/-
Carriage Extra.

HENRI & CO.,
79, ROCHESTER ROW, VICTORIA, S.W.1
Tel.: VIC. 4361.

Receivers for Sale.—Contd.

IGRANIC, Neutrosonio Seven Transportable, complete, less H.T. batteries, but with Eko. D.C. eliminator, £30; hide Radiogram portable S.G. Pentone, £12.—Box 4168, c/o *The Wireless World*. [7575]

MARGONI Straight Eight, with H.T. eliminator, excellent condition: £20, absolute bargain.—Northboy, 37, Belvedere Rd., Coventry. [7565]

MARGONI 28-guinea Portable, new; will accept 21 guineas.—Vincent, Military Rd., Chatham. [7554]

POWER Amplifier, two stage, transformer, R.C., P.M.5B, P.625A., milliammeter, voluvernina, eliminator (1 fixed, 2 variable), accumulator and charger (200-220 A.C.), complete; £10.—19, Gourcock Rd., Iltham, S.E.9. [7550]

COSSOR A.C. Mains Kits; we can deliver for Christmas.—A. S. Hales, 62, Chalk Farm Rd., N.W.1. [7548]

SUICASE 5-valve Portable, Mullard circuit, less accumulator; £8, or offer.—Ritchie, 127, Blythe Rd., W. Kensington. [7547]

MULLARD Raleigh 5-valve Set, with valves; £8/10; heard evenings.—Mack, 58, Thornton Av., Streatham Hill, S.W.2. Streatham 2454. [7522]

KOLSTER-BRANDES 1930 All Mains £14 Model, K.B.169, complete; also 1930 speaker, K.B.135, £6; both guaranteed perfect condition; only used few hours; either on approval.—Box 4139, c/o *The Wireless World*. [7497]

SALE—7-valve Igranic Neutrosonio receiver, also frame aerial, sensitive and powerful set, practically new; cost £45, take £20; also H.T. unit and trickle charger for above, cost £13, take £8.—Box 4135, c/o *The Wireless World*. [7490]

BATTERIES.

G.D.E.S. Accumulator Hire and Maintenance Service (5 mile radius).—98, Cherry Orchard Rd., Croydon. [6374]

WET H.T. Replacements.—Sacs (capped or uncapped), highest grade, No. 1, 10d. per doz.; No. 2, 1/9 per doz.—See below.

ZINCS.—Best quality (wired), No. 1, 8d. per doz.; No. 2, 9d. per doz.; orders valued 5/- carriage paid, otherwise 6d. for postage.—British Battery Co., Clarendon Rd., Watford, Herts. [0258]

PENTODE Users.—Write for details of new size self-charging wet battery; 20,000 milliamps, 6d. per volt; illustrated catalogue giving data, post free.—U. Taylor, 57, Studley Rd., Stockwell, London. [0273]

WET H.T. Batteries.—Parts per dozen, jars, No. 1, 2½x1½ square, 1/3; No. 2, 1/6; zincs, No. 1, 10d.; No. 2, 11d.; sacs, No. 1, 1/2 dozen; No. 2, 1/9; terminals, 8d., 10d.; dozen cells (18 volts), complete with leads and electrolyte, No. 1, 4/1; No. 2, 5/-; post 9d.; high efficiency, long life, self charging, nickel amalgam, and 6d. for sample unit; illustrated booklet free, carriage free orders 10/-; write for free list wireless bargains, trade supplied.—W. Taylor, 57, Studley Rd., Stockwell, London. [0039]

WE Guarantee the Best Accumulator Maintenance in South London; slow rate circuits and expert personnel; meticulous attention is given to topping, cleaning and drying of H.T. accumulators; trouble-free collection and delivery; the service includes hire of Oldham H.T. and L.T. batteries.—Official Oldham Service Station, Ansoy Radio (associated with Ansoy Products), 36, Hinmans Rd., East Dulwich, S.E.22. Tel.: New Cross 4074. [7074]

OLDHAM (130v. H.T.) Accumulator, D.C. charger, as new; £3.—24, Camberwell Rd., S.E.5. [7519]

ACCUMULATORS, 2-volt 20, 5 plates, celluloid, 2in x ¼in. x 5in.; 4/9, post paid.—Rowner, 170, Lordship Lane, S.E.22. [7480]

TEN Sample Accumulators, never been used, three 2-volt, five 4-volt, one 24-volt, one 60-volt; for sale to the first £2 postal order received.—Box 4166, c/o *The Wireless World*. [7574]

OLDHAM 120v., 25/-; 3 Elite 60-volt units, 17/6 each; all fully charged.—2, Green Lane, New Eltham, S.E. Eltham 1654. Avenue 5308. [7561]

TUDOR Monolt 6v. 30 a.h. at 3 amps., charged, condition as new; 15/-.—L. Phillips, 11, Poultry, E.C.2. [7569]

CHARGERS AND ELIMINATORS.

VORTEXION Transformers, chokes, etc., would to any specification; write or 'phone for quotation; best quality components only.—Vortexion, 72, Merton Rd., Wimbledon, S.W.19. Tel.: Wimbledon 2814. [0319]

ATLAS Eliminators, D.O. £1/17/6, A.O. £3/17/6; Nesper trickle chargers, 29/6. 'Phone: Gerrard 6268 for demonstration.—Grentrex and Co., 184, Regent St., London. [6451]

TANTALUM and Lionium for A.C. Rectifiers; make up your own inexpensive chargers; blue prints for H.T. and L.T., 1/- each; Lionium electrodes fitted with terminals, 2-3 amps. and 5-8 amps.—Blackwell's Metallurgical Works, Ltd., Speke Rd., Works, Garston, Liverpool. 'Phone: Garston 980/2 lines. [6282]

PHILLIPS Trickle Charger, 240 volts; 30/-.—Shill, 4, The Broadway, St. Margarets, Middlesex. [7556]

MULLARD H.T. Eliminator, complete, perfect; £4; M approval deposit.—Ashburton, Chisnal Rd., Chelmsford. [7496]

IT COSTS 5/6 BUT IT'S WORTH DOUBLE the price!!



The TRIX H.F. CHOKE

since its redesign in winding now positively the last word in choke construction. It is suitable for all wavelengths from 5 to 3,000 metres. Sturdily constructed, 1" bobbin and base are cut from one piece of highest-grade ebonite with brass parts heavily nickel plated. Guaranteed for 2 years, too. Simply nothing to approach for price and performance. See that you have one without delay.

Manufacturers:
ERIC J. LEVER (TRIX) LTD
8/8, Clerkenwell Green, London, E.C.3.
'Phone: Clerkenwell 3014/5.

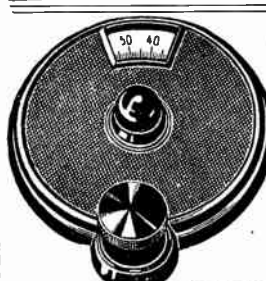

BABY JUNIOR 2½" - 2/4

BABY 3" - 2/6

STANDARD 4" - 2/8

In Black or Brown.

"ISO" DIALS

"Iso" Dials have a definite grip. They do not slip.

ISOMONA 70 PRECISION

SIZE PRICE
3" 4/-

HAW & Co. Ltd.
10, CHEAPSIDE, London, E.C.3.
Tel.:—CITY 3510.
Sole Distributors for "Iso" Products.
Cone Units, Transformers, Chokes, Condensers, Trickle Chargers, Eliminators etc.

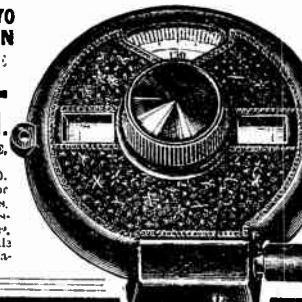

Mention of "The Wireless World," when writing to advertisers, will ensure prompt attention.



**AS
BRITISH
AS BRITANNIA**

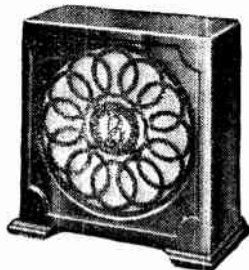

**The Brown
DUPLEX
LOUD SPEAKER**

An entirely new loud speaker. Gives finer results due to new Brown "Vee" Reed and Duplex Cone principles. Pure tone and rich volume. In three models: V.10, £5 10s; V.12, £7 10s.; V.15, £12 10s.

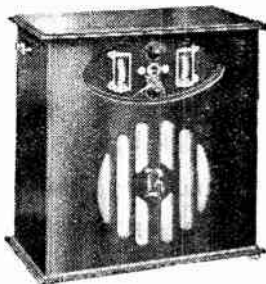

**The Brown
S.G. Receiver**

The secret of the successful performance of the Brown Receiver (it gets over 40 Stations in an hour) is the honest value that is put into it. Only the finest components that money can buy are used. In 4 models: Type A (for battery operation) £12 7s. 6d. Type A.M. (for mains operation) £20 10s. Types B. and B.M. £9 7s. 6d. and £17 10s. respectively. All models also supplied in kit form at slightly lower prices.

Ask your Wireless Dealer for particulars of Easy Payments.

Brown

From all Radio Dealers. Write for Catalogues and full particulars, to Dept. D.

S. G. BROWN, LTD

Western Ave., North Acton, W.3.

Chargers and Eliminators.—Contd.

NEW Improved Uniflex A.C. H.T. Eliminator Kit, gives 120 volts and 60 volts at 15 milliamps; 30/-

UNIFLEX Eliminator Kits are the Cheapest in England and sold all over the world; 30/-

UNIFLEX Eliminator Kits are all Ready for Wiring, mounted on baseboard, with panel, instructions, etc.; 30/-

UNIFLEX Eliminator Kits are Guaranteed, satisfaction or money refunded; hundreds of testimonials.

UNIFLEX Kit Sent c.o.d. Post Free 30/-; state town voltage and cycle, also if Philips 373 rectifying valve is to be sent, 15/- extra.—Liverpool Radio Supplies. Uniflex Works, Myrtle St., Liverpool. [7247]

PHILIPSON'S Safety High Tension Battery Eliminators.

10/- Down and the Balance in Easy Monthly payments secures the finest high tension supply available.

PHILIPSON'S Safety Eliminators are Guaranteed for 12 Months.

PHILIPSON'S Safety Eliminators are the Cheapest to install and the Cheapest to Run; prices: Model A.C.5. £4/17/6. A.C.7. £3/17/6, complete with full wave rectifiers; D.C.4 37/6. D.C.5 45/-

ALL Models Obtained for 10/- Deposit; take advantage of this and get constant high tension immediately.

WRITE for Our Booklet, "Radio Power" to Philipson and Co., Ltd., Radio Engineers, Astley Bridge, Bolton. Phone: 2038. Grams: Safety, Bolton. Est. over 50 years. [0318]

CHEBROS.—Chebros for all types of transformers and chokes, high grade instruments at a very moderate price; enquiries invited.—Chester Bros., 244, Dalston Lane, London, E.8. [5290]

POTENTIAL Dividers, wire wound, variable tappings, ideal for eliminators and rectifying units; price 6/6. post free.—Below.

POTENTIAL Dividers, standard 20 m.A. type, 5 variable tappings, supplied in all values; a first class job; price 2/6.—Abingdon Wireless Supplies, Abingdon, Berks. [7287]

FEL-ELECTRIC RADIO Eliminator Kit, transformer, choke, valve holder, valve, 3 condensers, variable resistance, insulated terminals, sleeving, wiring diagram; 37/- complete; output 15 m.a. at 120 volts; send for lists.—Fel-Electric Radio, 36, Garden St., Sheffield. [7411]

SAVAGE'S Specialises in Wireless Power from the Mains, reliable apparatus at reasonable prices.

SAVAGE'S Transformer Laminations and Bakelite Bobbins; intending home constructors should write for list.

SAVAGE'S Reliable Smoothing Condensers.—1,000 volts D.C. test, 2 mfd. 3/-, 4 mfd. 5/3; 500 volts D.C. test, 1 mfd. 1/6, 2 mfd. 2/3, 4 mfd. 3/9.

SAVAGE'S Super Smoothing and Output Chokes.—Many types available, write for list.

SAVAGE'S Mains Transformer for Westinghouse Rectifiers.—H.T.4, 18/6; A3, 17/-; A4, 20/-

SAVAGE'S Mains Transformer for Westinghouse H.T.4 Unit, with additional winding, 4 volts 3 amps; 23/-

SAVAGE'S Mains Transformer.—V.T.31, 200-0-200 volts 60 m.amps., 2+2 volts 2 amps., 2+2 volts 3 amps.; 28/-

SAVAGE'S Mains Transformer.—B.T.3 500-0-500 volts 120 m.amps., 3.75+3.75 volts 3 amps., 3+3 volts 3 amps., 2+2 volts 3 amps.; 51/-

SAVAGE'S Mains Transformers and Power Chokes are carefully and individually constructed from first class materials with an exceptionally generous margin of safety.

SAVAGE'S, 146, Bishopsgate, London, E.C.2. Phone: Bishopsgate 6998. [6808]

MAINTEN MANUFACTURING Co., Ltd., invite you to consider this unequalled value, viz.:-

MAINTEN Special Unit, including 2 variables, 0-80, 0-100, 120, 150, and 200 volts at 50 m.a., full wave Westinghouse rectification and heater transformer for A.C. valves up to 3 amps., in handsome metal cabinet; £6/10, or without heater transformer £5/15.

MAINTEN Model A.C.M.100, H.T. only with similar M. voltages to A.C. Special, but with 100 m.a. output, complete with Westinghouse rectifiers; £8.

MAINTEN A.C. Low Tension Unit, giving 2, 4, 6 and 6 volts up to 1 amp.; £5.

MAINTEN A.C. and D.C. Portable Units, which will go right inside any portable or transportable receiver; A.C. model £4, D.C. model £2/10.

MAINTEN Eliminators may be Purchased on Easy M. Payments.

MAINTEN Eliminators are Guaranteed for 12 Months, and are subject to 7 days' approval; write for latest literature on complete units and radio-mains accessories.

MAINTEN MANUFACTURING Co., Ltd., Portland Rd., Hove, Sussex. Phone: Hove 1519. [0326]

GOLTON De Luxe D.C. 220/40v. Eliminator, unused; cost 60/-, price 25/-; would exchange for good transformer or components.—Watkins, "Cambria," Oakfield Rd., Blacon, Cheshire. [7509]

EXIDE Combined H.T. and L.T. Charger, almost new; £3/10; seen by appointment only.—Davies, 11, Crestway, Rochampton, S.W. [7481]

EKCO A.C.2 All-Mains Unit for Sale, H.T., L.T., and G.B.; £7/15; guaranteed.—36, Bushey Hill Rd., Peckham Rd., Camberwell. [7539]

**CLIMAX
ALL-ELECTRIC RADIO**



Climax H.T. Mains Units this Xmas. For your own set and to give to your friends. The best you can get—the best you can give. Popular prices. Every modern improvement. A.C. models have new metal rectifying units eliminating all valve trouble. Negligible upkeep costs. Ten Voltage Tappings. For all Mains Voltages 40/100 cycles.

A. C. Model U.20. Price £4 . 5 . 0
Up to 120v. H.T. Up to 20 milliamperes.

A. C. Model U.50. Price £5 . 15 . 0
Up to 200v. H.T. Up to 50 milliamperes.

Improved D.C. Model H.T. Unit—the most popular D.C. Mains Unit on the market—has ten voltage tappings. Output 50 m/a total, 10 m/a at tappings.

Price complete £1 . 14 . 0

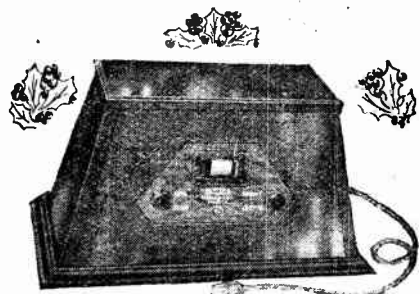

CLIMAX CHELLOSET.

an amazingly selective long range 2-valve all-electric receiver.

Many important features, one dial tuning, dual wave switch to eliminate coil changing, Westinghouse metal rectifier Volume control. No batteries whatever. Operates entirely from A.C. Mains. Walnut finished cabinet.

Price only £9 . 17 . 6

complete with valves, royalties and full mains equipment. The finest value yet offered in all-electric receivers.

Obtainable from all radio dealers.

**CLIMAX
A YEAR AHEAD**

Climax Radio Electric Ltd., Haverstock Works, Parkhill Road, Hamstead, London, N.W.2. Telephone: Primrose 1171-2



"THE 1930 EVERYMAN FOUR"

Cabinet, as specified in "Wireless World," Oct. 16, made to exact design of "Wireless World" and supplied in various wood finishes.

OAK BASE—Jacobean Finish 57/6
 MAHOGANY BASE—Mahogany Finish 63/-
 Also suitable for the New "KILOMAG 4" and "W.W. RECORD III."

These Cabinets are made by experts and are thoroughly electrically sealed.

KIT-SET Metal Cabinet 54/-

Every description of Wireless Cabinet supplied. Screening Boxes, Eliminator Cases, etc.

Send Direct to:—

RIGBY & WOLFENDEN

Sheet Metal Workers,

Millarow Road, ROCHDALE.

'Phone 2948.

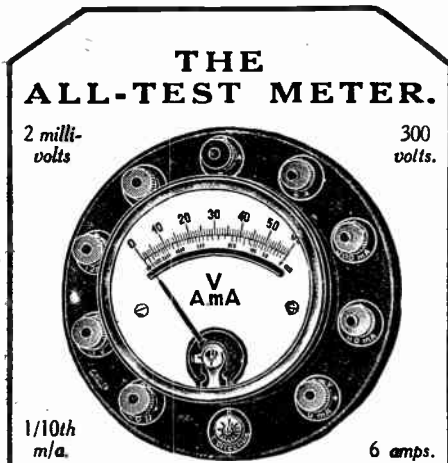

THE ALL-TEST METER.

2 milli-volts

300 volts.

1/10th m/a.

6 amps.

A NECESSITY!

No experimenter's bench is complete without this Ten-in-one Meter. Enables innumerable tests and calculations to be made. A beautifully finished moving coil instrument having a resistance of 200 ohms per volt.

PRICE 60/- ONLY.

ELECTRIC (GRAFTON) COMPANY

54, GRAFTON ST., TOTTENHAM COURT RD., LONDON, W.1.

Museum 0241.

Chargers and Eliminators.—Contd.

TRANSFORMERS and Chokes for Battery Eliminators and for all wireless purposes, receiving or transmitting, enquiries invited.—Chester Bros., 244, Dalston Lane, London, E.8. [7587]

CABINETS.

ARTCRAFT Radio Cabinets are Britain's Best Value. [0513]

DIGBY'S Cabinets.—Table models in solid oak and mahogany; from 11/6 to 71/-.

DIGBY'S Cabinets, fitted with Radion or Resiston ebonite if required.

DIGBY'S Cabinets.—Pedestal model, with separate battery components; from 56/- to £12.

DIGBY'S Cabinets Made to Customer's Own Designs.

DIGBY'S Cabinets.—Write for new 16-page art catalogue.—F. Digby, 9, The Oval, Hackney Rd., E.2. 'Phone: Bishopsgate 6458. [0128]

ARTCRAFT Radio Cabinets are Britain's Best Value. [0509]

KAY'S Cabinets, the greatest range of pedestal cabinets in the kingdom; original creative designs at prices 50% lower than elsewhere; quotations for specials by return; delivery at short notice guaranteed; moving coil, portable, baffle, vignette, radiogram, electric pick-up, television, etc.; illustrated lists free.—H. Kay, Wireless Cabinet Manufacturer, Mount Pleasant Rd., London, N.17. 'Phone: Walthamstow 1626. [6461]

ARTCRAFT Radio Cabinets are Britain's Best Value. [0511]

HORNS for Cabinets, portables, etc.; illustrated lists.—Maddison, 1, Chapel St., Edgware Rd. [6142]

ARTCRAFT Radio Cabinets; Britain's best value; lowest prices consistent with highest quality; illustrated list free from actual manufacturers.—Ardcroft Co., 156, Cherry Orchard Rd., Croydon. 'Phone: Croydon 1981. [7040]

FINEST American Types, astonishing value, special offer oak cabinets, hinged lid, baseboard, highly polished, take 12in. x 6in. panel; sample, carriage paid, 6/6; trade discounts for quantities.—Mag-Radio, 112, Warstone Lane, Birmingham. [2666]

ARTCRAFT Radio Cabinets are Britain's Best Value. [0510]

LOUD-SPEAKER Cabinets, extraordinary offer, oak cabinets, handsome fret front, highly polished, 13in. square, 6in. deep, finished moulding, take all ordinary units; sample, carriage paid, 6/6; trade discounts for quantities.—Mag-Radio, 112, Warstone Lane, Birmingham. [2666]

STEEL Cases for Eliminators, size 11in. x 5in. x 4 1/2in. deep, ventilated lid, clearance hole for valve, side cut for panel, finish black or green; 6/6, post free.—Adams, 20, South Quay, Great Yarmouth. [7493]

WIRELESS Cabinets, 3ft. high, to suit any panel, hinged lid, 4 doors, polished; approval.—Wooler and Son, Robertown, Liversedge, Yorks. [7476]

CABINETS, 16 1/2in. x 7 1/2in. x 11in., hand mahogany finished 7/6, unpainted 5/6; oval front, 10 1/2in. x 6 1/2in., 6d. extra; portable cabinets, 16 1/2in. x 16 1/2in. x 8in., 21/5; baseboard, 6d.; carriage free.—F. W. Rumsey, 63, Shaftesbury St., London, N.1. Clerkenwell 7139. [7584]

CABINETS.—A fine gift, something new: Combined loud-speaker cabinet, bookshelf, newspaper rack and occasional table, 30in. high, take any unit up to 18in. x 17in., handsome cabinet, well made, superior finish; solid oak 35/-, solid mahogany 40/-.—Below.

ANOTHER New Line.—Handsome fire screen loud-speaker, 31in. high, brown enamelled frame, 3-fold, covered with best quality sateen, strongly wired, complete with baffle and shelf, take any unit up to 14in. x 14in.; price 15/-.—Below.

PEDESTAL Cabinets, Radiogram, etc., from 55/-; table and loud-speaker cabinets from 15/-; above in solid oak, selected materials, hand polished; send for illustrated list.—Thos. Eastham (Dept. 5), Cabinet Works, Thornton, Blackpool. [7573]

COILS, TRANSFORMERS, ETC.

600-OHM Decoupling Resistances for New Kilomag Four, foreign listeners' four, and all "Wireless World" circuits, hand made and tested in our own workshops; improved model wound with Constantan wire, 1/6 each, post free.—Groves Bros., St. Mary's Place, Shrewsbury. [7361]

1,000-OHM Decoupling Resistances for "Wireless World" Circuits; 1/6 each, post free.—Groves Bros., St. Mary's Place, Shrewsbury. [7362]

NEW Kilomag Four Coils, 37/6 set; ebonite formers slotted, for winding, 12/6 set of 3; all post free.—Groves Bros., St. Mary's Place, Shrewsbury. [7446]

RADIOGRAPH.—W.W. coils, Record III, 35/-; new Kilomag Four, 33/-; S.G. Regional, 37/6; foreign listeners' Four, 37/6 set; Europa Portable, 21/-; Europa III, 18/6; S.G. multi-valve portable, 22/6; new Everyman Four, 42/6.

RADIOGRAPH.—Litz wire, 9/40, 1/6; 27/42, 2/6 dozen yards; Redfern's deep ribbed or Becol tube, 6d. per inch, slotting, 1/6 extra.

RADIOGRAPH, Ltd.—W.W. cabinets, 4 compartments, 44/6; 2 compartments, 38/6; crackle enamel and oak finish.—Station Rd., Handsworth, Birmingham. [7441]



MAHOGANY RADIO GRAMOPHONE CABINET.

Hand French polished, satin finish. Will take gramophone, any set up to 22" x 10" x 16", and loud-speaker and battery compartment 18" high, 22" wide and 16" deep.

Prices - - - £8
 With doors over front of set and baffle - £7.10

Deliver free England and Wales. Scotland 2/6 extra. Crata 7/6 extra, returnable.

F. DIGBY, 9, The Oval, Hackney Rd., London, E.2. 'Phone: Bishopsgate 6458



PORTABLE GRAMOPHONE from 21/- Post 1/6.

MAKE A GRAMOPHONE OR LUX CABINETS FOR WIRELESS at a quarter shop prices. Order set as shown. British double price motor, 12" velvetturntable, Swan Arm, Metal Soundbox, amplifier, needle cups, for £1-18-0 p.p. and build your own Cabinet. Machines sold by others at £10-20 do not contain better fittings. Motor from 3/6. Repair parts. Lists free. 64 pp. 1930 Catalogue, drawing and how to make Gramos, etc.

REGINA FITTINGS CO. (W.O.) 120, Old Street, London, E.C.1.

BONA FIDE TRADERS' GUIDE.

Send for our comprehensive Illustrated List. **QUICK SERVICE. QUICK SERVICE.**

THE QUALITY HOUSE.

PERSEUS MFG. CO., LTD. (Dept. W.W.), BRANSTONE RD., BURTON-ON-TRENT.

For the Best in Radio

WILL-DAY LTD.

(THE BEST IN THE WEST)
 10 LISLE STREET, LEICESTER SQUARE, LONDON, W.C.2.
 OPEN TILL 7 P.M.
 WRITE FOR OUR CATALOGUE
 POSTAGE 6d. FREE TO CALLERS

The WILLIS WORLD-TIME INDICATOR

or Almanac of the Hours, shows world times everywhere any instant; and when to tune in all foreign programmes or events being anywhere broadcast, or when to time cables 'phone calls, and all international intercourse. The idea, Gift. As essential to the world of to-day as an almanac of the days. Reviews: "A remarkable device." "Of inestimable value." "Unique."

Of dealers or **WILLIS & CO., IPSWICH ROAD, NORWICH.** Price 1/6. By post 1/8. Refunded if unapproved.

ORMISTON'S

LITZEN

as used **WIRE** by the
 27/42 SWG

"Wireless World"

IS THE BEST FOR TUNING COILS AND H.F. TRANSFORMERS.

Each individual strand is silk-covered, with an overall covering of silk. All other sizes supplied.

20 yds. 4/6 | 50 yds. 10/-
 25 yds. 5/6 | 60 yds. 12/-

Trade Terms on application.

P. ORMISTON & SONS, LTD. 79, Clerkenwell Road, London, E.C.1.

**13050 Lines
PER SQ. CM.**

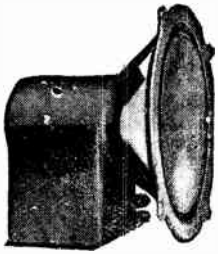

BAKER'S 1930 SUPER POWER MODEL

This highly efficient Moving Coil Speaker is ideal for all Music Lovers who demand the best possible quality reproduction of both speech and music.

The above is the flux density of a Standard Super Power Speaker. Full reports of tests of various models by the National Physical Laboratory, Teddington, are now available.

**BAKER'S
'Selhurst'
RADIO**

Offices:

89, SELHURST ROAD, S. NORWOOD, S.E.25.

Works and Demonstration Room:
42, CHERRY ORCHARD ROAD, E. CROYDON.

**XMAS
GIFTS!**

SIFAM

RADIO METERS

What do you think of these useful measuring instruments as Xmas Gifts? Decide on these sure-to-please gifts NOW. There are models from 78 upwards, and the range includes voltmeters and milliammeters of all readings, testing sets, radio fuses and three scale meters, etc., etc. Ask your dealer or write us, the name Sifam is your guarantee of quality.

DOURET MODEL
VOLTMETER.

716

0-6-120 volts.
Res. 4,000 ohms.

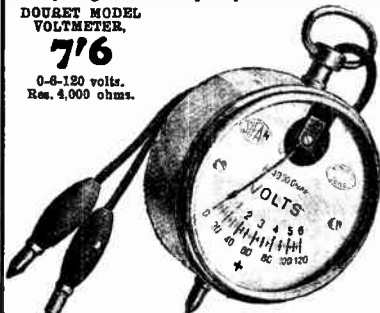

Write for interesting free leaflet:

THE SIFAM ELECTRICAL INSTRUMENT
COMPANY, LIMITED.

(Dept. W.W.)

Bank House, Aldwych, London, W.C.2.

Coils, Transformers, Etc.—Contd.

SIMMONDS BROS.—Berclit coils. Record Three, 50/- pair; new kilo-mag, four, 50/- set; foreign listeners four, low, 30/-; long wave, 37/-; screened grid Regional, 40/-; Mullard S.G.P. dual range coils, 30/- pair; Berclit standard coils, for new all-wave four, standard four, A.C. three, Everyman four, etc., 63/6 set of 4, with bases; the same coils for the Lodeston series ("Wireless Magazine"). 65/9 set of 4, with bases; Titan unit, 15/-; decoupling resistances, 600 ohm, 1/6; 1,000 ohm, 2/-; all "Wireless World" and similar coils in regular production by the leading specialists; lists free; trade supplied.—Simmonds Bros., Shireland Rd., Smethwick. Tel.: Smethwick 751. [6314]

GRAMOPHONE PICK-UPS, ETC.

EXPONENTIAL Horns for Cabinet Gramophones and Wireless, metal and wood; list.—Maddison, 1 Chapel St., Marylebone, N.W.1. [6141]

B.T.H. Pick-up Only, new; £1, cost 27/6.—Box 4170, c/o The Wireless World. [7577]

B.T.H. Pick-up and Tone Arm, new; 35/-.—Goad, 43, Rolt St., Deptford S.E.8. [7549]

CELESTION Woodroffe, £4/4 model, unused; any reasonable offer accepted.—Satchell, 33, Redesdaie St., Chelsea. [7535]

LISSEN Pick-up, 10/-; Edison tone arm, 2/6; as new; wanted, microphone and transformer to suit same.—Lloyd, 72, High St., Cheadle, Staffs. [7529]

B.T.H. Pick-up, latest model, off-set tone arm, new, 35/-; Brown speaker unit, type U, perfect, 10/-.—Osborne, 6, Belgrave Terrace, Bath. [7387]

WOODROFFE Pick-up, 37/6; Amplion, 13/-.—Box 4173, c/o The Wireless World. [7580]

LOUD-SPEAKERS.

HORNS of All Descriptions for Loud Speakers and Gramophone Units.—H. Maddison, manufacturer of the Allwoodon, 1, Chapel St., Paddington, N.W.1. [6143]

RICE KELLOG B.T.H. Senior I.-8. 240 volt A.C.; cost £40, price £20.—Saul, 8, Ansdell Rd., S. Ansdell, Lytham. [7417]

BROWN Speaker Unit, type T, perfect, 10/-.—Osborne, 6, Belgrave Terrace, Bath. [7387]

YOUR Old Loud-speaker Taken in Part Payment for the Latest Type; see our advert. under column Receivers for Sale.—Scientific Development Co., 51, Fishergate, Preston. [0227]

NIKOLA Cones, leather floats, felt fronted rings, full range of sizes and angles, manufacturers' type, completely assembled from 3/6; complete chassis from 7/6; list.—Knight and Co., 6, Chapel St., London, E.C.2. [7328]

GREAT Bargains.

GREAT Bargains.

GREAT Bargains.—Epoch model A moving coil speaker kit (or complete units), brand new; a large number of these famous instruments made for a special order for use in talks, but not executed, for credit reasons only; regular prices, £3/10, £4/2, and £5/17/6, to clear at 50/- for accumulator operation, 55/- for D.C. mains operation, 85/- for A.C. mains; kits comprising copper plated super magnet-pot (weight 23 lb.) Chrysalene frame, fully adjustable, moving coil, any impedance, paper, leather and mounting rings, made up complete, if desired, 6/- extra.

GREAT Bargains.

GREAT Bargains.—In fact, the greatest bargains ever offered! A number of Epoch model A used kits at given away prices, guaranteed in perfect working order; early 1928 model, 35/-; latest model, 42/6; made up complete, if desired, 6/- extra.

ENJOY Marvellous Epoch Reproduction at Ridiculous Cost; don't wait until they are all gone, but secure one immediately by writing, phoning, telegraphing, or hurrying to Epoch, 3, Farringdon Av., E.C.4. [7077]

600 ALUMINIUM Chassis, with leather suspended super cone, wonderful bargain; 12in. cone, 7/-; 9in., 5/9; post free; refund if not satisfied.—"Elite," 306, High Holborn, W.C. [7520]

MOVING Coil Speaker by Webson, large ornamental cabinet, perfect condition, wonderful tone, including transformer, 6-volt accumulator; £4/17/6.—2, Green Lane, New Eltham, S.E. Eltham 1654. Avenue 5308. [7514]

MOVING Coil Loud-speakers, 6-volt winding; take 30/- each.—L. Barford, 34, Shakespeare Rd., Bedford. [7512]

BARGAINS, excellent condition, cheap; Brown, Amplion, Ediswan units, Brown cone.—Box 4134, c/o The Wireless World. [7488]

AMPLION Oak Flare Speaker, original case; £2.—Simmons, below.

CABINET Cone Speakers, 12in., 25/-; 14in., 32/-; full volume, superb tone, all worth double; power cone units, 12/-.—Simmons Radio, 9, Iffracombe Av., Southend, Essex. [7495]

DOUBLE Linen Cone Speakers, made with patented chassis and fitted with first class unit, wonderful results; cut price, 42/- complete; carriage paid; buy now for Christmas; orders taken in strict rotation.—Bomford and Co., Post Office Av., Southport. [7416]

BROWN Mascot and Baker's Moving Coil Speaker, 6-volt; £2 each.—19, Sternhold Av., Streatham Hill. [7474]

**Here are the ideal
Xmas Presents
for MUSIC LOVERS!**

**HEAR
these
wonderful
Moving
Coil
SPEAKERS
at
our new
Demon-
stration
Room
at**

**42
CHERRY
ORCHARD
ROAD,
EAST
CROYDON**

**15
MINUTES
NON-STOP
from
LONDON
BRIDGE
or
VICTORIA
STATIONS**

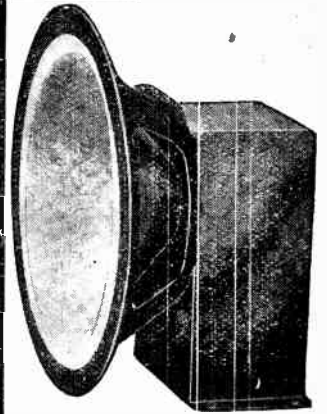

1930 "SUPER" MODEL
Obtainable on 14 days' approval.
Light, Compact, Powerful.
Reproduces with wonderful
realism.

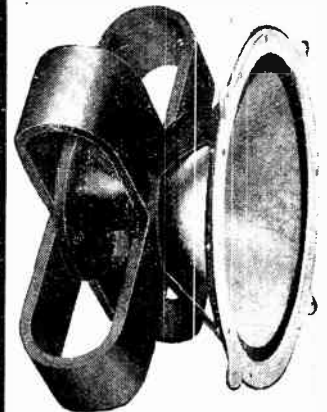

1930 PERMANENT MAGNET
MODEL
Obtainable on 14 days' approval.
No accumulators or house current
required.
Reproduces with the same excep-
tional quality as the Super Model.

**WRITE NOW FOR NEW 36-PAGE BOOK-
LET, "SOUND ADVICE," GIVING
"WIRELESS WORLD" CIRCUITS AND
FULL INFORMATION OF ALL OUR WELL-
KNOWN MOVING COIL SPEAKERS.**

**BAKER'S
'Selhurst'
RADIO**

The leading manufacturers of Moving Coil Speakers

Offices:

89, SELHURST ROAD, S. NORWOOD, S.E.25

Works and Demonstration Room:

42, CHERRY ORCHARD ROAD, E. CROYDON

REDUCED PRICES

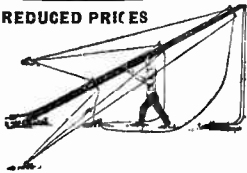

AMAZING BARGAINS IN STEEL MASTS

26ft. STEEL MAST, tapering 1 1/2" to 1". Carriage: London, 1/6; Midlands, 2/6; Elsewhere, 3/6. Weighs 28 lbs. **8/-**

30ft. Tapering 1 1/2" to 1". Carriage London, 2/-; Midlands, 3/-; Elsewhere, 4/-. Weighs 35 lbs. **10/-**

34ft. Tapering 1 1/2" to 1". Carriage London, 2/-; Midlands, 3/-; Elsewhere, 4/-. Weighs 40 lbs. **11/-**

40ft. Tapering 1 1/2" to 1". Carriage London, 2/6; Midlands, 3/6; Elsewhere, 4/6. Weighs 50 lbs. **16/6**

A super mast.

OUTFIT with MAST. Mast rings, ample galvanised wire (cut to lengths), Pulley, Cleat, Solid Metal footrest and strong galvanised stay fasteners. Note.—Our Masts are stayed at 4 ground points (not 3) which ensures safety.

ACCESSORIES. Bes Manilla Rops Halyards (will not rot), 60 ft. 1 1/4, 100 ft. 2/8. Special Anti-rust paint (sufficient for mast), 1/8. Coppered earthing tube, 1/9. C.P. Special Aerial, has 14 strands of No. 24 gauge Enamelled high conductivity pure copper wire, 100 ft. 3/9. Money refunded if mast returned intact and carriage paid within 7 days.

C.P. MAST CO.,
48E, HIGH STREET, PENGE, S.E.20.

ELECTRIFY YOUR SET
with
"TANNOY" MAINS UNITS.
H.T. & L.T.
from **£2-7-6**

Write or 'Phone:—

THE TULSEMER MFG. CO.
1-7, DALTON STREET, WEST NORWOOD, S.E.27.
'Phone: Streatham 6731.

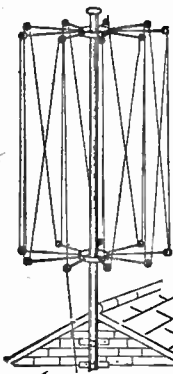

ASHTON PERFECT AERIAL SPREADERS
15/- New Model 15/- Per Set.
WONDERFUL RECEPTION



8-10, Bulls Head Chambers, Hopwood Avenue, Manchester.

Loud-speakers.—Contd.
EPOCH Moving Coil Speakers.

EPOCH. Moving Coil Speakers Speak for Themselves.

EPOCH.—Test an Epoch against any other make. It will persuade you more than the best salesman.

EPOCH.—Ask any of the thousands of users of even the older models. But this season's models? Well, let the speakers tell you themselves.

EPOCH.—Please do test them against any or every make on the market—preferably with a quick switch over.

EPOCH.—Order one for 7 days' free trial.

EPOCH.—Your deposit instantly refunded in full if you are not more than satisfied. No catch. No red tape.

EPOCH.—The most comprehensive range of moving coil speakers in the world.

EPOCH.—Send for catalogue W.S.2.

EPOCH.—16 pages crammed full of real information. Post free.

EPOCH RADIO MANUFACTURING Co., Ltd., are the manufacturers. City Office and Service Station, 3, Farringdon Avenue (Ludgate Circus end), E.C.4. 'Phone: Central 1971 (2 lines). Private Branch Exchange. 16972

ASSEMBLED IN 3 MINUTES

NEW & NOVEL

The Patent "DORIC" Cabinet is of high-class and superbly finished. Its sectional construction allowing it to be assembled in a few minutes without aid of nails or screws. Perfectly ready when assembled, forming a cabinet for the housing of the most costly receiver. Packs flat in card box when by post, thus minimising risk of damage to suit any circuit.

BUILD YOUR OWN CABINET FRENCH POLISHED MAHOAGANY OR OAK WITH HINGED LID



Prices—Loose Base Board included:

Panel	Depth	Price
12" x 7" x 7"	21"	net 18" x 7" x 10" 33/- net
16" x 7" x 9"	27/6	net 21" x 7" x 9" 30/- net
18" x 8" x 8"	Special	for Music Magnet, 30/- net.

Any size made to order at proportionate price.
Postage 1/- extra. Cash with order or C.O.D.

Trade enquiries welcomed. Quotations given for Special Cabinets.
Manufactured only by—
Thomas O'Brien Ltd., Slater St., Seel St., Liverpool

"REGIONAL" STATION ELIMINATOR

DOUBLES THE SELECTIVITY OF YOUR SET

Cuts out your Local or Regional Stations and brings in distant, weak and foreign Stations 25% louder and clearer.

PRICE 10/6
Post Free.

Brookmans Park—5GB—or Local Station cut out in 2 degrees (but NOT everything else)

Fitted in 30 seconds.
NO ALTERATIONS TO YOUR SET.
Come and see it demonstrated in our Showroom.

I.D.S. 4, GOLDEN SQUARE (Piccadilly Circus), W.1.
Telephone: Gerrard 2437.

THE LITTLE CELLS THAT SATISFY

Leyton Primary H.T. Battery, Pl Porous Pot Cells, S1 & S2 Sac Cells. All complete for assembly.

1-cell.	6-cell.	12-cell.	30-cell.
P1 6/d.	3/3	5/9	14/-
S1 6/d.	3/-	5/3	12/-

Watch our notice for new type cell.
"Baseful" Filler 1 pint 1/-; pint 1/6, post free 3d. extra.
Send 1/4d. stamp for booklet giving full particulars to:—
THE LEYTON BATTERY CO.,
305 CHURCH ROAD - LEYTON - E.10

REPAIRS

Any make of L.F. Transformer, Loudspeaker or headphones repaired and dispatched within **48 HOURS—TWELVE MONTHS' GUARANTEE** with each repair. 4/- Post Free.

Terms to Trade.
TRANSFORMER REPAIR CO.,
Dept. W.
214, High Street, Colliers Wood, London, S.W.19

Mention of "The Wireless World," when writing to advertisers, will ensure prompt attention.

HELLESEN
DRY BATTERIES



AMPS-HOURS-PENCE!

"YOU know," remarked Baxter as we hailed a taxi after the meeting of our Wireless Club, "buying H.T. Batteries is very apt to be like buying a pig in a poke." "Explain, O! cryptic one," I rejoined. "Well, you pay your money down and then trust to luck as to how many hours' service you are going to get; the rate per milliampere-hour seems to vary surprisingly." I objected. "There is no need for that to happen if you buy a battery of reliable make. Next time get yourself a Helleesen, get a Double or a Triple Capacity, if you can; not only are Helleseens amazingly consistent, but there is no battery which gives so good a return for the money."

PRICES

Standard Capacity.

- "Wiray" 9 volt Grid Bias Type 2/-
- "Wirin" 60 volt H.T. Type. 10/6
- "Wirup" 99 volt H.T. Type. 18/-
- "Wisel" 108 volt H.T. Type 20/-

Treble Capacity.

- "Kolin" 60 volt H.T. Type. 12/-
- "Kolu" 99 volt H.T. Type. 32/6

Your Dealer Sells Them.

HUNTS

HELLESEN DRY BATTERIES,
ELECTRICAL MEASURING INSTRUMENTS,
POLYMET MICA AND PAPER CONDENSERS,
HANDLAMPS, TORCHES, ETC.

P.A.T.

A. H. HUNT, LTD., CROYDON, SURREY.

Loud-speakers.—Contd.

BAKER'S

BAKER'S

SELHURST RADIO Moving Coil Speakers are of the Highest Grade and Proved Efficiency.

BAKER'S

BAKER'S

SELHURST RADIO Moving Coil Speakers Obtained on 14 Days' Approval for Comparative Test.

BAKER'S

BAKER'S

SELHURST RADIO Moving Coil Speakers Used by Music Lovers Throughout the World.

BAKER'S

BAKER'S

SELHURST RADIO Moving Coil Speakers.—Write now for new 36-page booklet, "Sound Advice."

BAKER'S

BAKER'S

SELHURST RADIO Moving Coil Speakers Reproduce both Speech and Music with Wonderful Realism.

BAKER'S

BAKER'S

SELHURST RADIO Moving Coil Speakers can always be Heard at the New Demonstration Room.

BAKER'S

BAKER'S

SELHURST RADIO Moving Coil Speakers.—The new 36-page booklet is full of truthful information.

BAKER'S

BAKER'S

SELHURST RADIO Moving Coil Speakers are the Best that Money can Buy; ideal Xmas presents.

BAKER'S

BAKER'S

SELHURST RADIO, the leading manufacturers of high grade coil speakers.

OFFICE: 88, Selhurst Rd. Phone: Croydon 1618. Works and Demonstration Room (always open): 42, Cherry Orchard Rd., Croydon, S.E. (15 minutes non-stop Victoria or London Bridge). [0231

ELECTRADIX
LONDON
DISPOSAL DEPT.

LOUD SPEAKERS. R.K. Cones, fitted B.T.H. Moving Coil, 100 surplus at only 7/6 each. Marconi L.S. Magnet Pots, 6v. for Moving Coil Cones, 20/-. Gramo-Motor, genuine Panatone Motors, run direct off supply mains, fitted turntable, etc., few only, £3 10s. each; worth £3 10s.

CHOKES. For feed from power amplifiers, latest Model, 17/6. Ironclad Chokes, 1.6. H.F. Chokes, Silk Wound, 1/-.

CONDENSERS. Dubiler, .01 mfd., 11s, 7/- each; sale, 7/- doz. New Strling 2 mfd., genuine Mansbridge Condensers to 410 volt at reduced price of 2, 10 only; Ex W.D., 2 mfd., 1/6. Bass Loud Speaker Condensers, .03, with 5 Taps, 5/-; Mains Smoothing 2 mfd., 1/8. Khouite Case Condensers, any from .0001 to .0011, 8d. each.

TELEPHONES. Brown's, 4,000 or 3,000 ohm pairs, headband and cord, 35/- per pair; 1,600 ohm ditto, 20/-; 120 ohm ditto, 15/-; Sullivan L.R., 3/- pair. Single Brown A. Receiver, 60 or 750 ohms, 7/6; 2,000 ohms, 14/-. Western or Ericsson Receivers for Pick-ups, 1/6. Wireless Micros, 12/6. Public Address Hand Microphones, 15/-. Speech Buttons, 1/-; Carbon Micros, Insets, 8d. Skinderviken, 2/-; Bobbins, 8d.

BROADCAST RECEIVERS. New R.A.F. 3-Valve semi-portable, 1 Det. 2 L.F., 3 anti-pong Holders, Remote Control, Variable Condenser and Rheostat, and tested on Broadcast, 27/6, or with Cabinet Hornless Loud Speaker, 42/6; R.A.F. 5-Valve ditto, with 1 Valve, £3 10s; or fitted in well mahogany cabinet with S.M. Dials, £6 10s. 2-Valve L.F. Amplifier, 30/-. Twin Loud Speaker Wire, 3/- per 100 yds. 2-Fin Wall Plugs and Sockets, 10d. Remote Tuning Controls, fitted long cord and two Variable Condensers and Rheostat, 2/-.

METERS. Milliammeters, B.T.H. panel, 15/-; 0 to 500 volts, 45/-. Weston Meters, to 1,600 volts, 1 Volt and other Testing Set, E.108, 4 ranges, amps. and volts, 45/-. G.E.C. Hot Wire, amp., 4/-. Silvertown Galvos, 7/6. Relays, 7/6. Wind Speed Meters, 5/-. Torpedo Gyroscopes, 15/-.

WHEATSTONE BRIDGES. G.P.O. and Dial types, £7 10s. Mirror Galvos Reflecting Beam, by Paul, Gambrell, Sullivan and Tinsley, £3. Standard Resistance Boxes and Universal Shunts, 35/-. Electrostatic Voltmeters to 5,000 volts, £8. Capacity Bridges, £8. Meggers and Bridge Meggers, cheap.

TRANSMITTING VALVES. 6-volt, 40 watts, 4/6; 250 watts, 45/-.

WAVEMETERS by Townsend, Paul, Silvertown and Gambrell. Marconi Region Wave Triaps, 15/-. Heterodynes, all ranges cheap.

TRANSMITTERS. With A.T.I. and all fittings in case, cost £13. 2-Valve Aircraft with Osram Valves, Speech or Morse, 40/-. Tapping Keys, No. 1, with massive contacts, 6/- each. Transmitting No. 41KD, with aluminium cover, double contact, fine work 7/6 each. Morse Practice Sets, with Buzzers and Key on mahogany panel, 8/6 each. Spark Gaps, 2/-.

DYNAMOS. L.T. Charging. Aero, 12 volts 250 watts, with auto cutout, 25/-; W.W., 20 volts 5 amp., 50/-; L., 12 volts 8 amps., 45/-; C.L., 18 volts 8 amp., 65/-; 30 volts 25 amps., £7 10s.; 60 volts 20 amp., £8 10s., and Four 100v. motors, 10/-. High Tension Charging Motor Generators: 230 volts A.C. to 100 volts, 100 m/a., D.F., 70/-; Dynamos: 100 volts 4 amps., 25/-; 250 volts 2 amp., £3. Weston T. Anode Motor Generators: 100 volts D.C. to 250 volts, 250 m/a., £10; 220 volts D.C. to 400 volts D.C., 200 m/a., £12. G.E.C. and B.T.H. 2-con. Aircraft Generators: 350 volts 60 m/a., and 8 volt 5 amp., £10; 600 volts 100 m/a. and 3 volts 3 amp., 55/-. Fine Newton H.T. Generators, 1kW., 2,000 v., £60; Slow Speed Motor Generator, 1kW., 2,000 volts, £24; 2kW., 2,000 and 4,000 volts, £52. Large E.V. Megger Hand Generators: 600 volts, £6. Hand Magnets, 10 v. 50 m/a., 6/-; H.T., 4,000 v. 1 mfd. Mica Condensers, 10/-; 2,000 v. Varia, 15/-.

SWITCH GEAR. Mains Set Glass Fuses, 2 amps., 3d. Slow-motion Geared-Slide Rheos., 250 v., 7/6. 147 S.P. Plug Boards, 9-way, 10 amp., 2/-. Lucas 8-way Switch Boxes, mahogany, Brass Cover, 6 S.P., 1 D.E., 1 C.O., 8 S. 8 P.C.O. Switches, 1/6. H.T. and resist., 2/6; Lucas Car Instrument Cutouts, 7/-; and hundreds of other Switches and Controller-Charging Boards built to order.

GUN POCKET TORCHES. with new "Ever-Ready" Batteries, 2 S. Airship Safety Lamps, 2 v., 7/6; 25 v., to 200 v. Candle Lamps, 6d. Hand Lanterns, ditto, 4/6. Radiator 2 amp. 110-volt Lamps for charging, 2 S., 1,000 ohm Res. Bulbs, 8d.

ELECTRIC FLASHING SIGNAL LAMPS: Ails, 14/6; C.A.V., 12/6; 3-Colour Hand, 8/-; Leather Cases, 10 x 5 x 6in., with Strap, 5/-. Aerial Halliards, 8d. Aerial Winches, with Brake, 1/6. Airship Safety Lamps, 15/-.

MISCELLANEOUS. Geared Condenser Dials, 1/6; Shock Coils, 6/6 and 8/6. Voltmeter, 0-6 v. and 0-120 v., 4/6 only. Loud Speaker Magnets, 1 S. each. H.T. Batteries, 90 v., 5/6. Gramophone Pickups, 14/-. Valve Boxes, 5-cell padded, 1/8. Double Protractors in Leather Case, 5/-. Instrument Cases, mahogany, with Handle, Lid and Front Panel, 7 x 8 x 5 1/2 in., each 2/6. Plated Angle Terminals, 10 C.A., 1d. each. Mahogany Cases, with Lid and Ebony Panel, with 5 Brass Sockets for H.T., 3 x 4 x 1 1/2 in., 2/-. Earth Spikes with Terminals, 1/2. Tons of other goods unclassified. Send cash with order plus postage or your enquiries.

Latest Edition of our Surplus Bargains in Radio and Electrical Goods ready. Send addressed envelope for Bargain List.

SAVES RADIO USERS POUNDS.

ELECTRADIX RADIOS,
218, Upper Thames St., E.C.4

Blackfriars Stn., Underground Rly.

City 091.

WATCH "Radielle"

MID-WINTER ANNOUNCEMENT. SEASON 1929-30.
"W.W.S." TRANSFORMER. Price 39/6.
Wound, to "Wireless World" specification, with Secondary voltages adjusted as follows:—

- (a) 210-0-210 volts to carry 40 m.a. for plate Rectifying Valve.
- (b) 5 volts 1.6 amps. (centre-tapped) for filament Rectifying Valve.
- (c) 4 volts 3 amps. L.T. Raw A.C. for heater elements of three indirectly heated cathode valves.
- (d) 5.5 volts 1 amp. (centre-tapped) L.T. Raw A.C. for filament of output valve.

"C.A." CHOKE. Price 12/6.

For use in the smoothing circuit of the rectifying unit incorporating "W.W.S." Transformer. Inductance of approximately 35 henries at maximum D.C. load of 50 m.a. Resistance 380 ohms.

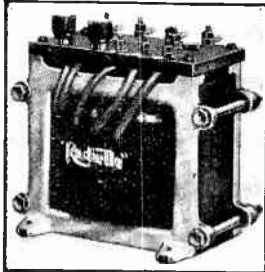

"RADIELLE"
Transformer
Type "T.1"
for H.T.
Power Unit
up to 50 m.a.
and supply
L.T. Raw A.C.
4 volts
4 amps.
37/6

THE RADIELLE COMPANY LIMITED
18a Haverstock Hill, Chalk Farm, London, N.W.3
(facing Chalk Farm Tube Station).

Telephone: Hampstead 1934

"POPULAR" TRANSFORMER BROWNE WIRELESS

The Brownie POPULAR Transformer is every bit as good as it looks. Its purity of amplification gives vivid clarity throughout the full musical range, while its sturdy British construction ensures that it will give this quality of reproduction not just now and then, but always. It costs only 9/6, and does the work of transformers at double its price.

BROWNE WIRELESS CO. (G.B.) LTD.
Nelson Street Works, London, N.W.1



Mention of "The Wireless World," when writing to advertisers, will ensure prompt attention.

Loud-speakers.—Contd.

BAKER'S SELHURST RADIO MOVING COIL SPEAKERS

SELHURST RADIO are the pioneer manufacturers of Moving Coil Speakers.

The New 36-page Booklet, "Sound Advice," is yours for the asking.

Our Speakers are of the Highest Grade Throughout, and of proved efficiency.

Get a Baker's Moving Coil Speaker, and you will not be disappointed

Get Us Send You Our Free 36-page Booklet, "Sound Advice," a postcard will do.

Send To-day for a Baker's Speaker, on 14 days approval for comparative test.

Enjoy the Wonderful Realistic Reproduction Given by Baker's new Speakers.

The Display Advertisement in This Issue Illustrates the Finest and Most Efficient Moving Coil Speaker made to-day.

BAKER'S SELHURST RADIO, Office, 89, Selhurst Rd., South Norwood, S.E.25. Works: 42, Cherry Orchard Rd., East Croydon (always open). [0231]

PHILIPS Speaker for Sale; cost £5/5, sell £4, or nearest; used 5 weeks only.—Coombs, Lower Moor Worcester. [7475]

50 Different Makes of Loud-speakers in Stock; your old one taken in part payment, high allowances made; your enquiry will receive prompt attention.—Bostock and Stonnill, 1, Westbourne Terrace, S.E.23. [7531]

AMPLION Lion Chassis, L14 (£8); £3/15, or offer.—24, Hammersley St., Hanley, Stoke-on-Trent. [7553]

SCREW-ON Reed Extensions, complete with drilled bush, nuts, and washers; state make of unit.—J. Hindle, 5, Coronation St., Blackpool. [7544]

C14 Celestion, £14/10, unsoiled; £8/10.—43, Buckleigh Rd., S.W.16. Phone: Streatham 1358. [7555]

PHILIPS Loud-speaker, 25/-; Brown H3, 15/-; Hebra unit and cone, mounted, 7/6; R.I. tuner and 2 anode units, 10/6 lot.—Fell, Meadow View Rowley Grove, Stafford. [7543]

The NEW Wilson WATCH-TYPE MICROPHONE

MICROPHONES for the MILLION



For transmission of speech or music—private or public use—the New Wilson Watch-Type Microphone will amplify whispers to an amazing volume without the aid of valves.

Eminently suited to wireless experimenter. These microphones can also be used in connection with any wireless receiver.

Apart from the practical application of these instruments, they can be used for experiments and for amusement. Price, Post Paid 8/6



The NEW Wilson SPECIAL SPEECH MICROPHONE

For powerful amplification of speeches, concert music, sermons etc. As efficient as microphones costing many pounds.

Note the Price 16/- Post Free.

THE IMPROVED WILSON MICROPHONE & ELECTRIC CO., LTD.
182, Holland Park Avenue, LONDON, W.12
L & S.

THE GREAT DEMAND

for C.D.M. components has compelled larger premises to be taken. When sending for goods, please note new address, to save delay.

C.D.M. H.F. CHOKES, suitable on 15 to 2,000 metres, 5/- and 4/- each. MOTORBOATING STOPPER - 7/- each

FIXED MICA CONDENSERS.
00005 to 002 - 1/3 each
0025 to 006 - 1/9 "
01 - 2/9 "

C.D.M. DUONATOR.
0003 and 2 meg. combined - 2/- each

WAVE TRAP - 7/6 each
REJECTOR - 8/6 "

RESISTORS, all prices upon application.

C. D. MELHUISH

NEW ADDRESS:
MAXWELL WORKS,
Conewood St., Highbury, London, N.5

Your First Steps in Wireless

By HUGH S. POCKOCK
Editor of "The Wireless World"

A most helpful little book for those who are beginning to study wireless. It explains technical difficulties by simple analogies.

Price 9d. By Post 11d.

From ILIFFE & SONS LIMITED

Dorset House, Tudor Street, London, E.C.4
and leading booksellers. W.W. 14

100 Guarantee

If found unsatisfactory and returned within seven days of purchasing from us direct, we guarantee to return your money in full or forfeit the sum of £100. A similar arrangement can be made with our dealer.

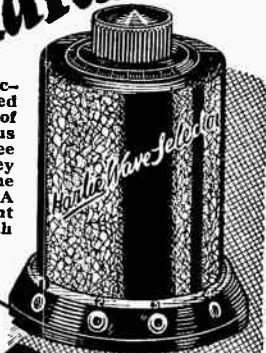

LOCAL STATION CUT OUT
UNWANTED STATION CUT OUT
DISTANT STATIONS WITHOUT INTERFERENCE
INCREASED VOLUME FROM FOREIGN STATIONS

TWO MODELS.
A. 200-700 metres (for 2L0, 5GB, etc.)
B. 700-2,000 metres (for 5XX, etc.)

If desired either model will be sent on receipt of 12/6 or per C.O.D. upon receipt of Post Card.

12/6 ONLY

Brookman's Park cut out at will. No alterations set. No Valves to burn out. No drilling. Easily plugged in between aerial and set.

Harlie WAVE SELECTOR

A MOVING COIL Speaker at half price!



Produces every note. Patent 10 inch abolishes drumminess and chatter. Absolutely human and lifelike.

Harlie MOVING COIL Loud Speaker

Reproduce Realism from your Records!

Pick-up—Tone Arm—Vol. Cont. £1.17.0
Without Volume Control £1.15.0
Pick-up only £1.7.6
Tone Arm and Vol. Control 9s. 6d.
Without Volume Control 6s. 9d.

Harlie GRAMOPHONE PICK-UP and TONE ARM

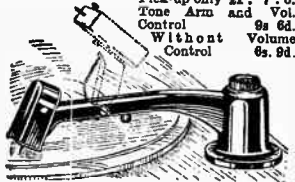

Write for particulars to: EARLIE BROS., Dept. D.1, 10tham Rd., Edmonton, London, N.9. Tel.: Tottenham 3446.

Loud-speakers.—Contd.

B.T.H. Model C2, horn type, perfect condition; 30/-.—Write Box 3986, c/o The Wireless World. [7369]

SELF-CENTRE Ball and Socket Device, when fitted to your cone unit, will relieve driving rod of all undue side stress, centering the cone in relation to driving rod improving results; all round; provisional patent applied for; price 2/6; c.o.d. terms available.—Weedon, 80, Lonsdale Av., London, E.6. [7487]

TRANSMITTERS.

CHEBROS. Chebros. Chebros transformers and chokes of all descriptions, special transformers for transmitting and modulation; chokes a speciality; enquiries invited.—Chester Bros., 244, Dalston Lane, London, E.8. [5240]

VALVES.

AMPLIFIER Valve.—If you require power you cannot do better than one of these:—

FILAMENT Volts 6, plate volts 400 (maximum), grid bias 84 volts (approx.), impedance 800 ohms., amplification factor 3.8, mutual conductance 4.35 m.a./volts; price £5/10; see article "The Wireless World," 24th July, 1929, then send to North London Valve Co., Ltd., 22½, Casnové Rd., Stoke Newington, London, N.16. [7457]

A.C./S., 15/-; A.C./G., 8/-; A.C./P1, 12/-; unused.—Wilmshurst, 4, Enmore Gardens, S.W.14. [7516]

TWO Matched P625 Valves, £1; 1 P.M.14 valve, 14/-.—Francis, 1, Park Crescent, Southend-on-Sea. [7513]

THREE Six-Sixty Valves, one 210 H.F., one 210 P., one 215 S.P., new, unused; will exchange for Brown vac unit.—A. Hart, 3, Lord St., Bacup, Lancs. [7483]

PANEX, PM6, PM252 (2-volt Super-Power), Marconi DEH610, DES, and Ampliton 6-volt detector; what offers? useful exchanges considered.—Evans, Penlan House, Penclawdd, Swansea. [7552]

U5 Osram, double wave rectifier; 8/-, post free.—108, Milton Rd., W.7. [7545]

COSSOR Valves, 7H.F., 2P, 1R.C., Mullard 6PM3, 1.3A, 1.4, 4/6 each; one P.M. 254.6/-, all 4-volt; 9D.C. 2-volt Osrams, 3/6 each; 3 S.P. Cosmos for 7/-; 5 4-volt new Cleartrons for 10/-.—Hazelwood, Lower Hare Park, Newmarket. [7527]

COSSOR 610H.F. and 610X.P. (unused); also 8-volt Osram H.F. and Met. Vick L.F.; 25/-, or separate.—Ratcliffe, 21, Ashbourne Rd., Eccles. [7537]

WIRE.

APOLOGY!—M. A. Frost regrets delay, Christmas rush, snowed under with orders.—54, Olerkenwell Rd., E.C.1. [7571]

COMPONENTS, ETC., FOR SALE.

BELLING-LEE Panel Fittings are designed to give an expert finish to any home-constructed set; catalogue post free.—Belling and Lee, Ltd., Queensway Works, Ponders End, Middlesex. [0018]

CYLANITE, the most artistic panel known; only 2/- and 3/- per sq. ft., according to pattern; particulars and samples free (1/6d. postage).—Marsh and Wright, 5, Royal Arcade, Weymouth. [7317]

VENEER Wood Paper Converts Commonest Woods into Oak; 30in x 20in., 8d.—Burtenshaw, Hillsborough Terrace, Hfracombe. [7351]

600-OHMS Decoupling Resistances; see advt. under Coils.—Groves Brothers (Manufacturers). [7175]

POTENTIAL Dividers 10,000, 15,000, 20,000, 25,000 and 30,000 ohms, 5 variable tappings; 2/- each. [7516]

POTENTIAL Dividers, heavy duty, wire wound, 15,000 and 20,000 ohms, 7 tappings, 5/6; 4 tappings, 3/9.

CONDENSERS, 2 mid., 2/3; 4 mid., 4/-; guaranteed; tested 500 volts.

CHOKES (L.F.).—Excellent for smoothing, up to 20 milliamperes, 2/-; special heavy duty, 100 milliamperes, 8/6.

ELIMINATORS, A.C., wired for half or full wave, complete with valve; £3/17/6.
H.F. Chokes; 3/-.

GRAMOPHONE Motors, well known make, double C spring, silent, complete with fittings; 30/-.

SPECIAL Bargain.—B.T.H. 40 henry chokes; 9/6; S any article on approval against cash.—Juggins, Radio Engineer, Clacton-on-Sea. [7398]

YOUR Old Components Taken in Part Payment for Latest Type; see our advert in column Receivers for Sale.—Scientific Development Co., 51, Fishergate, Preston. [0228]

CARRARD Motor, 11A, new, 30/-; Loewe pick-up, £10/-; Brown's A type, 16/-; milliammeter, 3/6; receiver and eliminator components wanted.—Brown, 73, Guild St., Burton-on-Trent. [7518]

INTERFERENCE.—Special two-section eliminator coil for making your own Brookman Park wavetrap; 3/3 each, post free, with diagram; made by Gordon Castagnoli, A.M., R.E., Castaphone Radio Service, Culver St., Colchester. [7510]

5 Guinea Mullard Speaker, P.M. 24-valve, used few hours; half price.—Legge, Park Rd. West, Wolverhampton. [7504]

= H. & B. = SETS, KITS, COMPONENTS

Buy the H. & B. Way. It's Easier. It's Better. No References. Strictly Confidential.

CLIMAX, All Electric A.C. Chelsoet, One dial tuning, Dual wave, Amazingly selective. In Walnut Cabinet. Cash Price £9.17.6, Valves included, or £2 down and 10 monthly payments 17/6.

COSSOR, 1930 Battery Kit, complete with Cabinet, Valves and full instructions. Cash Price £8.15.0, or 16/- down and 11 monthly payments 15/10.

PYE POPULAR TWO, Remarkable efficient Two, One dial tuning, Dual range. Cash Price £4.17.0, or 15/- down and 10 monthly payments 9/-.

PYE, All Electric 3, S.G., Handsome Cabinet in Walnut, Gramophone pick-up plug. Including Valves and Royalties. Cash Price £25, or £5 down and 12 monthly payments 36/8.

ELIMINATORS

PHILIPS A.C. Model 7 tappings will work any set up to 5 valves. Cash Price £5.10.0 or 10/- down and 10 monthly payments 10/6

PHILIPS D.C., H.T. Unit 2 variable tappings and 2 fixed. Cash Price £3.17.6 or 10/- down and 10 monthly payments 7/-.

EKCO A.C. Eliminator. 3 F.20, S.G., 60O-120 120/150. 10/- down and 8 monthly payments 9/8.

M.P.A. popular Cabinet speaker, Oak Cabinet Cash Price 45/- or 5/- down and 9 monthly payments 5/-.

BROWN'S VEE Units and Chassis. The perfect speaker. Cash Price 40/- or 8/7 down and 4 monthly payments 8/7.

BULGIN Valves Emission Tester. Test your valves. Every amateur should have one. Cash Price 42/- or 5/- down and 8 monthly payments 5/-.

AMPLION A.C.4. Oak Cabinet Speaker. Splendid tone, handsome appearance. Cash price £3 or 15/- down and 5 monthly payments 10/-.

H. & B. 1930 115 page catalogue now ready, Price 9d. Refund on first order over 5/-.

We can supply any set described in this issue for cash or upon our gradual payments system.

Write for full details of the set you are interested in. Carriage Paid on all orders.

C.O.D. Charges Paid over 11.

WE CAN SUPPLY ANYTHING RADIO.

H. & B. Radio Co. 34, 36, 38, Beak Street, Regent St., W.1, London

Phone: Gerrard 2834.

Components, Etc., for Sale.—Contd.

R.I. Input and Output, push-pull power transformers, 30/- the pair; one Cosor 210 L.F. valve, 7/-; one P.M.4, 4/-; carbundum crystal detector, 3/-; 44, Miles Rd., Epsom, Surrey. [7508]

SET (4) McMich:cl Superhet Transformers, 35/-; Climax folding frame aerial, 15/-; two new B.T.H. headphones 7/6 each; Amplion A5 loud-speaker unit, 15/-; Loew pick-up, 7/6; all perfect.—Covington 20, St. Alban Rd, Bedford. [7506]

CLIMAX Folding Frame Aerial and Stand, with loading coil, ranges 200-2,000 metres, 18/-; R.I. H.F. choke, 5/6; Igranit L.F. transformer, 5/-; Ormond rheostat, complete, 1/6; new Igranit ditto, 2/-; 250 ohm Burndept potentiometer, 2/-; 0-8 volt dead beat pa 2 meter 6/-; R.I. 6-terminal transformer, 15/-; all guaranteed; deposit.—Box 4147, c/o The Wireless World. [7501]

GECOPHONE Broadcast Wavemeter, accurate, 50/-; vibrator instrument, with graph; exchanging good loud-speaker balanced armature unit.—Box 4146, c/o The Wireless World. [7500]

APPLEBY'S.

AN Unusual Advertisement.—In view of the enormous amount of business we have on hand at the moment, and the approaching end of year clearing, we are forced to give notice that fresh part exchange business will be suspended until further notice, from to-day; current business will, of course, follow through in the usual routine.

END of Year Clearing means big work, and big bargains; you will do well to watch these columns during the next few weeks; hundreds upon hundreds of pounds worth will be turned out, of all classes of radio material, preparatory to reorganisation and extension.

APPLEBY'S, Number Forty-four, Chapel St., Marylebone, N.W.1 (4 minutes from Oxford St., London). [0316]

POWER Chokes, substantially built, for smoothing circuits in eliminators dealing with currents 100-300 milliamperes, inductance 30 henries; 8/6 each; guaranteed 12 months.—Transformer Repair Co. (Dept. W), 214, High St., Colliers Wood, S.W.19. [0327]

TWO Cosmos A.C./R. Valves, 8/- each; one A.C./S., 12/6; one A.C./G., 7/6; one B.T.H. 2: 1 transformer, 6/-; all unused; lot £2.—Box 4093, c/o The Wireless World. [7478]

P.625A, 7/6; P.M.4.D.X., 5/-; P.M.24, 17/-; 2 0.003 Utility, 3/- each; aerial coil and base for Foreign Listeners 4, 3/6.—BM/SFLC, London, W.C. [7562]

SALE, experimental wireless, complete, £4; 3 Pye .0005, 7/6 each; Dimics S.W.4, S.W.3, O.A., 1, 1, 1A, 3, 3A, and 2 bases, £1; 3 microstats, 1/- each; Loewe condensers, .0002, .0005, .001, and .002, 1/3 each; Cosmos A.C. valveholder, 1/-; Ormond fixed, .00005, .00005, .0001, and .0003, 1/- each; Burndept buzzer, 3/-; the lot £8.—Cope, 18, Cambridge Rd., Teddington. [7560]

ALL Parts, made into S.G.V.1 set, valves, H.T., A.L.T., accumulators; £6.—23, Shelbourne Rd., Tottenham. [7558]

TWO L.S.S.A Valves, and 1 B.T.H. pick-up; £2 the lot.—Dyer, 34, Ackroyd Rd., Forest Hill, S.E.23. (Letters only.) [7551]

FOR Sale, McMichael super het unit, 5 valve set, 2 .0005 variable condensers, with slow motion dials, 1 frame aerial, £3; 2 R.I. reactive anode units, centre tapped, new, listed 25/- each, 10/- each, or offer; 1 Colvern dual coil, with circuits, new, 8/-; 1 Dubilier variable grid leak, new, 4/-; 2 Burndept variable full resistances, new, 2/- each; 1 Igranit variable 3 terminal condenser, 2/6; 1 B.T.H. Anti-Mobo unit, new, 5/-; 1 Brown's Type 2 loud-speaker, £15/15 list, as new, £5; several 2-volt valves at 4/- each. 37 Moore St., Rochdale. [7546]

CYLDON Log Mid Line.—.0003, 3 at 9/6 each; ditto, dual .0003, 2 at 14/- each; 2 Ferranti A.F.3, 15/- each; Gecophone .0005, S.M. dial, 9/-; Mullard 100,000 ohms W.W. resistance, with base, 4/-; Climax H.F. choke, 5/-; Formo L.F., 5.1, 4/-; Lotus 2-way coil holder, 3/6; 2-way coil holder, 2/-; coils, Igranit, 50, 1/-; 75, 1/-; 100, 1/3; 300, 1/6; 400, 2/-; Finstone, 55, 75, 175, 3/- lot; pleated diaphragm speaker, Brown's "A" earpiece, 9/-; Brown's "A" earpiece, 6/-; 2 pairs earphones, 2/9 each.—Rigby, Manor Avenue, Penwortham, Preston. [7542]

UNUSED Sifam Flush Type C2-ma., £1; P.M.24, emission as new, 15/-; old type Baker's M.C. speaker, 200v., 25/-.—Smith, 10, Parade, Felixstowe. [7541]

McMICHAEL Super Het Block Unit, with long and short wave oscillators, potentiometer, and instructions, 20/-; McMichael twin range frame aerial, 15/-; 2 Gecophone slow motion condensers, suitable for above, .0005, .0005, 5/- each; McMichael R.C. unit, 3/6; new dials, Igranit, 3/6; R.I. Baby, 2/6; Wate's voltmilliammeter, 4/6; Kone (Western Electric) speaker, 40/-; all in good condition.—Ellis, Aingarth, Bramhope, Leeds. [7540]

MARCONIPHONE Type C. Power Transformer, 27/-; P.M.256, 5/-.—Barnes, 84, The Drive, Ioughton, Essex. [7538]

NEW Cone Speaker Unit by M.P.A., 6/-; R.I. aerial tuner, with reaction, 200-4,000 metres, cost 39/6, 15/-; or offer; new Climax G.B. unit, 10 tappings, cost 15/-; 7/-; R.I. H.F. anode reactance, 200-4,000 metres, 3/-.—Blookey, 'Knowle Mount, Burley, Leeds. [7534]

Mention of "The Wireless

The MIRACLE

World's Wonder Sets STATIONS ROLL IN

Sold at FACTORY PRICES, complete with **Cosor** Valves, ready for listening-in, with Grand Model Cabinet Case or Horn-type Loud Speaker. Yours for 5/- deposit. Nothing more to pay for a month. Purchase completed by easy payments. QUICK DELIVERY.

£2 GRAMOPHONE
Electric Pick-up
FREE to all who write NOW for Free Illustrated Art Lists and order WITHIN 10 DAYS.

Special Offer of **SCREENED GRID & ALL ELECTRIC MAINS SETS.**



Write for Lists
WORLD'S WIRELESS STORES, Wallington, Surrey.

A RANGE OF GOOD VALVE HOLDERS

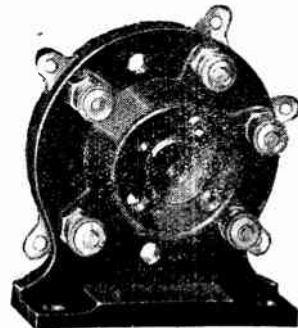

The W.B. Universal model is shown here. Equally suitable for 4- or 5-pin valves and for either vertical or horizontal use. This grips both solid and resilient pins and costs only 1/3. Other types include an ordinary 5-pin and an antiphonic model, 1/3, and also a Rigid Valve Holder, 1- with terminals, 9d. without.

★ Two W. B. 5-pin (baseboard mounting) and two W. B. Universal 5-pin Valve Holders were specified for the Kit Set A. C. Mains model, described in Wireless World, Nov. 27th issue. ★

W.B.

The W.B. Conc Unit, by reason of its 4-pole Balanced Armature, achieves remarkably good results. Central adjustment—cobalt steel magnet—best bakelite casing, 12/6.

WHITELEY BONEHAM & CO., LTD., Nottingham Rd., Mansfield, Notts. Telephone: Mansfield 762. Telegrams: "Whitebon Mansfield." London Office: 21, Bartlett's Buildings, Holborn Circus, E.C.4 Telephone: Central 6669.

Components, Etc., for Sale.—Contd.

COMPONENTS, guaranteed as new.—Wearite Eye man coils, bases, medium, 8/-; long wave, 11/- pair; set, 16/8; A.F.5, 17/6; Marconi Ideal Jun: 5/-; Cylidon .0005 dual, 7/6; single, 5/-; 2 Burnd Ethovneria, complete, 5/- pair; R.I.28/14 L.F. cho 10/6; Hydra 4 mfd. condensr, 2/6; 3 Dubilier Bakel 2 mfd., 1/6 each; .05 Alica Bakelite, 2/6; .05, 1 .0001.610, .0001.620, .01.620, 1/- each; 2 Ufil S.P.C.O. switches, plated, 2/- each; Two-range Fo 17/-; volume control, 3/6; M.I.L. binocular H.F. cho 1/6; 3in. aluminium panel brackets, 1/3; 8 new B ebomite terminals, 2/-; Cosor P.610, Marconi, D.E. H., I.L.L., I.L.L.610, 5/- each; P.625, P.625A, 7/6 each (the lot 35/-; everything 4/6.5.—Coward, 11, Carl Boulevard, Eastham, Cheshire. [75]

TWO A.F.5s, £1 each (as new in box); P.M.4D. 5/-; A.C.R., 9/-; Sifam voltmeter, 5/-.—10, P. more St., Ilasland, Chesterfield. [75]

IGRANIO Type J Transformers, ratio 3-1 and 6-1 9/- each.—Box 4174, c/o The Wireless World. [75]

ASTOUNDING Testimonials.—H.F. choke, 2/-; turns-in segments, each surrounded by air, low self-capacity, even choking; 2/- by post.—Cait Stewart, 28, St. Enoch Sq., Glasgow. [75]

OFFERS Wanted.—Brown H.2 speaker, Igranit ditto control, potentiometer, Neutrodyne condens Sterling 0.0005.—Potts, 16, Queen's Drive, Mossley II, Liverpool. [75]

ALMOST New Varley Super Transformer, 10/-; H. choke, 4/-; .0001 Ormond reaction condens 2/-; Clarton dualwave coils, 5/- each.—Baybut, Hainault Rd., Chadwell Heath, Essex. [74]

RADIO HOUSE, HUDDERSFIELD (14th Winne

ENSURES

LISTENERS

INCOMPARABLE

ADVANTAGES.

BARGAINS

INNUMERABLE,

LIBERAL

IRRESISTIBLE

TERMS.

YEA, tis true; a Littlehampton client was satisfied that he sent unsolicited testimonials "Your firm is 'streets' ahead of some of the London Houses for business." This unsolicited reputation we endeavour to uphold.

WHENEVER

INCOMES

REQUIRE

ECONOMY

LESSENED

EXPENSES

SUPPLY

SOLUTIONS.—So, when applying for Guide end your submitting similarly composed advertisements, using the words "Reliability Wireless Guide" so as to encourage readers to apply for this Weekly change of matter desired. A 100-volt battery for each effort published, and useful construction prizes given.

GEOGRAPHICALLY

UNFAVoured,

UNIABITANTS,

DERIVE

ENCHANTMENT from the list, which will be sent post free by J. H. Taylor and Co., Radio House, Macaulay Street, Huddersfield, to whom competitors' efforts should be submitted, indicating also if name and address publishable if successful. (Only 23 alternative words required, Radio House Huddersfield, remaining, one word for each item following.) Winner: Mr. A. Hart, Belvedere Road, Liverpool. [74]

MAGNAVOX R.4, 6-volt Field, perfect, £3/12

M Regentone trickle charger, with L.T. couple 28/-; Centralab Pot, 500.000 ohms, 5/6.—27 M Hill Av., Leeds. [75]

GUARANTEED, money returned if unsatisfactory.

B.T.H. 2-1 transformer, 6/-; Marconi 2.7 7/6; Marconi 4-1, 7/6; Ferranti A.F.3, 9/6; Metv I.L.T. transformer, 18 6; Metrick A and B, 20/-; B Spot unit, 12/6; Blue Spot cone, 5/-; Blue Spot pi up, volume control type, 19/6; Loewe gramophone pick-up, 9/-; B.T.H. pick-up, gramophone tone and model, 16/-; Cosmos 100 heavy choke, 7/6; Cosr S.P.55R, valve, 5/-; S.P.55R, 5/-; A.C./S., 12 A.C./G., 8/-; A.C./R., 7/6; A.C./P.1, 8/6; S.P.42 9/6.—Box 4172, c/o The Wireless World. [74]

UNFAVoured,

UNIABITANTS,

DERIVE

ENCHANTMENT from the list, which will be sent post free by J. H. Taylor and Co., Radio House, Macaulay Street, Huddersfield, to whom competitors' efforts should be submitted, indicating also if name and address publishable if successful. (Only 23 alternative words required, Radio House Huddersfield, remaining, one word for each item following.) Winner: Mr. A. Hart, Belvedere Road, Liverpool. [74]

MAGNAVOX R.4, 6-volt Field, perfect, £3/12

M Regentone trickle charger, with L.T. couple 28/-; Centralab Pot, 500.000 ohms, 5/6.—27 M Hill Av., Leeds. [75]

GUARANTEED, money returned if unsatisfactory.

B.T.H. 2-1 transformer, 6/-; Marconi 2.7 7/6; Marconi 4-1, 7/6; Ferranti A.F.3, 9/6; Metv I.L.T. transformer, 18 6; Metrick A and B, 20/-; B Spot unit, 12/6; Blue Spot cone, 5/-; Blue Spot pi up, volume control type, 19/6; Loewe gramophone pick-up, 9/-; B.T.H. pick-up, gramophone tone and model, 16/-; Cosmos 100 heavy choke, 7/6; Cosr S.P.55R, valve, 5/-; S.P.55R, 5/-; A.C./S., 12 A.C./G., 8/-; A.C./R., 7/6; A.C./P.1, 8/6; S.P.42 9/6.—Box 4172, c/o The Wireless World. [74]

UNFAVoured,

UNIABITANTS,

DERIVE

ENCHANTMENT from the list, which will be sent post free by J. H. Taylor and Co., Radio House, Macaulay Street, Huddersfield, to whom competitors' efforts should be submitted, indicating also if name and address publishable if successful. (Only 23 alternative words required, Radio House Huddersfield, remaining, one word for each item following.) Winner: Mr. A. Hart, Belvedere Road, Liverpool. [74]

MAGNAVOX R.4, 6-volt Field, perfect, £3/12

M Regentone trickle charger, with L.T. couple 28/-; Centralab Pot, 500.000 ohms, 5/6.—27 M Hill Av., Leeds. [75]

GUARANTEED, money returned if unsatisfactory.

B.T.H. 2-1 transformer, 6/-; Marconi 2.7 7/6; Marconi 4-1, 7/6; Ferranti A.F.3, 9/6; Metv I.L.T. transformer, 18 6; Metrick A and B, 20/-; B Spot unit, 12/6; Blue Spot cone, 5/-; Blue Spot pi up, volume control type, 19/6; Loewe gramophone pick-up, 9/-; B.T.H. pick-up, gramophone tone and model, 16/-; Cosmos 100 heavy choke, 7/6; Cosr S.P.55R, valve, 5/-; S.P.55R, 5/-; A.C./S., 12 A.C./G., 8/-; A.C./R., 7/6; A.C./P.1, 8/6; S.P.42 9/6.—Box 4172, c/o The Wireless World. [74]

UNFAVoured,

UNIABITANTS,

DERIVE

ENCHANTMENT from the list, which will be sent post free by J. H. Taylor and Co., Radio House, Macaulay Street, Huddersfield, to whom competitors' efforts should be submitted, indicating also if name and address publishable if successful. (Only 23 alternative words required, Radio House Huddersfield, remaining, one word for each item following.) Winner: Mr. A. Hart, Belvedere Road, Liverpool. [74]

MAGNAVOX R.4, 6-volt Field, perfect, £3/12

M Regentone trickle charger, with L.T. couple 28/-; Centralab Pot, 500.000 ohms, 5/6.—27 M Hill Av., Leeds. [75]

GUARANTEED, money returned if unsatisfactory.

B.T.H. 2-1 transformer, 6/-; Marconi 2.7 7/6; Marconi 4-1, 7/6; Ferranti A.F.3, 9/6; Metv I.L.T. transformer, 18 6; Metrick A and B, 20/-; B Spot unit, 12/6; Blue Spot cone, 5/-; Blue Spot pi up, volume control type, 19/6; Loewe gramophone pick-up, 9/-; B.T.H. pick-up, gramophone tone and model, 16/-; Cosmos 100 heavy choke, 7/6; Cosr S.P.55R, valve, 5/-; S.P.55R, 5/-; A.C./S., 12 A.C./G., 8/-; A.C./R., 7/6; A.C./P.1, 8/6; S.P.42 9/6.—Box 4172, c/o The Wireless World. [74]

UNFAVoured,

UNIABITANTS,

DERIVE

Components, Etc., for Sale.—Contd.

T.H. Pick-up, 30/-, new; Sifam Eliminator, 200 volts 100,000 ohms, £1; B.T.H. R.K. speaker, and new, £4; B.T.H. valve pick-up amplifier, with res. new, £3/5; B.T.H. 21-A transformer, 9/-; sen Radiogrand 5-lt 8/-; Blue Spot unit and ssis, 25/-; Marconi Ideal 100 m.a. choke, 13/6; ins transformer primary, 220 volts, sec 2x200v. 1 4v., 12/-; 30 m.a. choke, 6/-; Trickle charger, amp., 25/-; valves, all new, 1 Cossor S.G. 2-volt, £; Mullard P.M.12, 14/-; 2 Marconi H.L.210, 5/9 h; P.M.4, 8/-; Ostram P.625A, 9/-; Marconi E.L.210, 5/9.—Box 4167, c/o The Wireless World.

WIRELESS Transmitting Sets for Morse Telegraphy or distant Code of Models, etc., 1in. spark in, condenser, spark gap, helix, etc., very compact, complete and ready for use, 12/6; high note buzzer in heavy Morse key, very high quality, 7/6.—Below. ELECTRIC Motors, 1/2h.p. to 1/2h.p., 110v. and 220v. D.C., silent running, carbon brushes, in best condition and working order, suitable for gramophones, television, or any small power uses, 1/-; a few with overheated windings, if rewound to good dynamos for I.L.T. accumulators, 6/-.—Below.

COMPLETE Portable Telephones, ready for use, high class instruments, 17/6; hand telephones, 4/6; 100 ohm choke coils, 1/-; Dewar switches, 1/-; earphones, 1/3; Morse keys, 4/-.—Below. HIGHLY Sensitive Microphones for Transmissioin of Speech or Music or Sensitive Amplifying, 2/6; microphone transformers to suit, 2/6; microphone dynamos, 1/-; G.P.O. relays, 2,000 ohms, very sensitive, very low operating current, 6/6.—Below.

IN. Spark Coils, 11in. x 7in. x 6in., complete with contact breaker and condenser, 12/6; 1in. spark coils, 4in. x 4in. x 5in., fully complete, 6/-; Ford ignition coils, 3in. spark, complete, 4/-.—Below. DYNAMOS, shunt wound, for charging or lighting, 50v. 4 amp., ring oiler bearings, carbon brushes, 100v. 3 amp. ditto, 50/-; 110v. 3 amp., ball bearing, carbon brushes, 55/-; 110v. 2 amp. ditto, 45/-.—Below.

ELECTRIC Motors, all ball bearing and carbon brushes, 1/2h.p. to 1/2h.p., 110v., 30/-; 6-volt car motor, 107/-; 12-volt ditto, 12/6; 110v. motor belt coupled to air blower, mounted on iron bedstead, 1/2h.p. motor, 45/-.—Below. PARTS, please state requirements; starter regulators make good field magnets for dynamos, carry 2 amps., 7/6, to carry 5 amps. 10/-, to carry 10 amps. 12/6.—Below.

LI. Above Goods Guaranteed, cash with order, or c.o.d. all goods 3 days' approval from date of delivery; all letters answered.—Galpin, Binfield Heath, or Henley-on-Thames. [7570]

HILIPS J.T. Charger, 200v. A.C., 45/-; A.F.3, 12/6; Ampion Dragon, oak, 25/-; all perfect.—Hessell, 6, Groveland Av., Norbury, S.W.16. [7567]

EXPERIMENTERS.—A limited number only moving coil loud-speaker Magnet units and castings, well known firm, to be cleared cheap.—Particulars in E. B. Wardle, 41, Lower Mosley St., Manchester. [7566]

F.3 Transformer, 16/-; Marconi Ideal Junior, 10/-; Ideal Senior, 14/-; Harley wave trap, 8/-; Cos ditto, 8/6; Met-Vick elastic aerial unit, 8/-; Bakken D.C. battery charger, 17/6; Wearite H.F. ke, 3/9; Lewcos Q.A. coil, 7/6; Q.S.G. transformer, 12/6; Cylidon L.M.L. 0.0005 condensers, 6/-; Ambrell Peto Scott McMichael neutralising condenser, 3/-; Ecko eliminator, 1V.A.20, £2/17/6; Ecko eliminator, 15/-; Blue Spot unit and frame, 30/-; White Spot frame 12/6; Ormond S.M. dials, 3/-; Burndict ditto, 3/-; others, 1/6 to 3/-; Michael all mains screened Dimic Three, as new, 10/-; Loewe cone speaker, 30/-; Brandes table cone, 10/-; R.I. Varley pick-up and arm, 50/-; M.P.A. cone speaker, 20/-; Ampion pick-up, 15/-; G.E.C. 10, 10/-; Elphonic ditto, 10/-; general radio 20 set, new, with valves, 45/-; Dubilier R.C.C. unit, 10/-; R.I. Varley, 8/-; Mullard ditto for Orgola, 11/-; H. ditto, with valve holder, 6/-; aero short wave 30/-, very fine; Ictanic neutro regenerative, 10/-, with extra coils, £3/10/-; A.F.4 transformer, pair P.625 valves, matched, as new, 17/6 pair; 25A 17/6; Cossor S.G.220, 12/-; Ostram S.G.215, 12/-; Pentone P.M. 22, 14/-; Pentone P.M.26, 14/-; 5A., 10/-; another, as new, 13/6; all valves guaranteed in full emission; S.P.42U. rectifier, 12/-; 1 ditto, 9/-; also many other parts too numerous list; send requirements.—Scientific Development Co., 51, Fishergate, Preston. Tel.: 1364. [7564]

ESTON Model 301, milliammeters, ammeters, and voltmeters, 21/- each; hot wire ammeters 0-1 4/-; 0-0.5 amp., 3/-; instrument repairs and alterations; send for list.—The Victoria Electrical Co., High St., Battersea, S.W.11. Established 1910. [7563]

MISCELLANEOUS.

ASY Payments.—We supply, by easy payments, components, accessories, and sets, any make; 10% a balance spread over 10 months.—Send list of requirements to London Radio Supply Co., 11, Oat St., London, E.C.2. [0097]

IRELESS Notes.—A monthly service of information for all those who want the very best in less or gramophone reproduction; frank criticism and component information; immediate postal help and advice in all difficulties; something new and useful; you must have it if you want to know the latest.—Full particulars free from Ernest H. Robinson, Langmead, Firbridge, Woking, Surrey. [6144]

TONEX HAVE PRODUCED IT

THE TONEX UNIBOX



Price 30/- Each

UNIBOX is to the screened-grid circuit what TONATUNA is to the detector L.F. circuit. It is an absolutely complete shielded coil unit for a screened-grid valve receiver and is the very thing that has been wanted for a long time. All the coils are enclosed in a metal case attractively finished in crystalline enamel. The screened-grid valve itself fits into the case—and in addition an extra shield can be fitted for isolating the aerial tuning condenser from the rest of the circuit. The coils cover long and short wave broadcasting bands and a self contained change-over switch is provided. The UNIBOX contains all the essential parts of the screened-grid circuit, the addition of tuning condensers and a few other components being all that are required to build a complete receiver.

THE TONEX H.F. CHOKE



A choke that defies competition. Sectional windings enclosed in a handsome moulded Bakelite case. Handy terminals with screw-driver slots are fitted, and soldering tags are provided also. Fixing holes are metal bushed.

Table with 2 columns: Range (10-90 metres, 30-3,000 metres, Centre Tapped) and Price (3/6, 4/6, 5/6).



Price 21/-

THE TONEX TONATUNA

The well-known tuning coil that has achieved remarkable popularity. No coils to change and a simple turn of the centre knob switches over from short waves to long waves. Aerial coil is centre tapped for increased selectivity. Range 240 to 520 metres and 1,100 to 2,000 metres.

If your dealer does not stock, write direct giving his name and address—

THE TONEX Co. WALKER STREET, BLACKPOOL.

Alexander Black The Original Wireless Doctor WILL CALL AND CURE YOUR SET (London and Home Counties.) Consultations by appointment—no obligation. Personal Attention to all Clients' Sets, Eliminators, Pick-ups, "Webson" M.C. Speakers Demonstrated, Installed, Maintained and Brought Up to Date. Purity Reproduction Specialist. NOTE NEW ADDRESS: 55, EBURY STREET, VICTORIA, S.W.1. Sloane 1655.

ORDER YOUR CABINET FOR XMAS (Delivery from Stock) "The Wireless World" A.C. Kit Set Metal Cabinet and Base Complete £2 15 0 1930 EVERYMAN FOUR METAL CABINETS 46/6 each (or without woodwork 35/- each). KILLO-MAG & RECORD THREE METAL CABINETS. 35/- each, or with woodwork 46/6 each. Kit-Set 27/6 and 38/6 each respectively. Finished crystallins Brown, Black or Blue. Trade enquiries invited.—Samuel Eaton & Sons (Manufacturers of Lighting Goods), 66/72, Barr St. Birmingham

A CATALOGUE that Saves you Money! EVERY RADIO ENTHUSIAST SHOULD SEND FOR IT! Send 3d. in stamps for this 56-page Catalogue. Scores of Ready-to-assemble Wireless Cabinets and Special Osborn Offers. CHAS. A. OSBORN (Dept. W.W.), The Regent Works, Arlington Street, London, N.1. Telephone: Clerkenwell 6095. Open from 7.30 p.m. Saturdays 4.30 p.m. And at 21, ESSEX ROAD, ISLINGTON, N.1. Open until 3 p.m. 9 p.m. SATURDAYS. Phone: Clerkenwell 6031.

MUCH IMITATED CLAROSTAT NEVER EQUALLED REDUCED PRICES! STANDARD. WAS 10/6 NOW 9/6 VOLUME. " 8/6 " 7/6 POWER TYPES, WERE 15/- " 13/6 FREE 40 Page Illustrated Booklet with Scale Drawings all types mains apparatus etc. CLAUDE LYONS LTD. 76, OLDHALL ST., LIVERPOOL.

Say 99!

EPOCH

NEW MODEL 99 P.M.
MOVING COIL SPEAKER
will satisfy the most critical
of listeners.

No accumulator, no mains,
no suspension, no adjustments.
7 days' free trial.

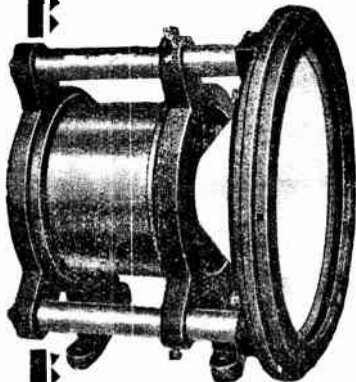

Send for new 16-page Catalogue of
real information.

EPOCH RADIO
MANUFACTURING CO., LTD.,
3, Farringdon Avenue : E.C.4
Phone: CENTRAL 1971-2.

City of London.

THE SIR JOHN CASS TECHNICAL INSTITUTE,
Jewry Street, Aldgate, E.C.3.

Principal: Geo. Patchin, A.R.S.M., M.I.M.M.
The following special evening course of instruction will be given during the Second Term (January to April, 1930):—

ALTERNATING CURRENTS AND ELECTRICAL OSCILLATIONS
by D. Owen, B.A., D.Sc., F. Inst.P.

A course of ten lectures, with practical demonstrations, intended for those interested in the higher developments of this subject, especially in its application to radio-telegraphy and telephony. Tuesdays, from 7 to 8.30 p.m., commencing January 14, 1930.

Details of the above course may be had upon application to the PRINCIPAL.

BERCLIF COILS

1930 EVERYMAN	57/-	the Set.
NEW KILO-MAG	50/-
RECORD III	50/-

CABINETS AND DIALS.
SHIRELAND ROAD. SMETHWICK.

EXACT TUNERS
250 to 2,000 metres.

No further coils are required, tuning is as simple as A.B.C., see "Wireless World," January 25th. We can strongly recommend these tuners. Send postcard for particulars and Circuit FREE for

THE EXACT MANUFACTURING CO.
Croft Works, Priory Place, COVENTRY.

BOOKS on WIRELESS

Write for complete list to
ILIFFE & SONS LTD.,
Dorset House, Tudor St., London, E.C.4.

Miscellaneous.—Contd.

EXPONENTIAL Horns for Cabinet Gramophones and Wireless, metal and wood; list.—Maddison, 1, Chapel St., Marylebone, N.W.1. [6143a]

ALEXANDER BLACK.

PLEASE Note New Address.

THE Original Wireless Doctor will call (London and Home Counties) and cure your set.

CONSULTATIONS by Appointment Without Obligation, sets installed, maintained, and brought up to date, gramophone pick-ups, eliminators, and Web-son moving coil speakers demonstrated; purity reproduction specialist.

55, Ebury St., Victoria, S.W.1. Sloane 1655. [0277]

SCOTT SESSIONS and Co., Great Britain's radio doctors, officially approved as wireless repairers by Radio Society of Great Britain and Wireless League; all sets of every type repaired, rebuilt, modernised; send set for immediate quotation.

SCOTT SESSIONS and Co.—Midland customers, please send address to us and our Midland representative will call.

SCOTT SESSIONS and Co.—New sets constructed with your or our components, guaranteed finest workmanship; we specialise in "The Wireless World" circuits; remember, we have satisfied customers throughout the British Isles and in three Continents; if you so desire, we will design and construct high grade apparatus to suit your special circumstances for quality, range and selectivity.—Tel.: Tudor 5326. Muswell Hill, London, N.10. [0262]

YOUR Old Apparatus Taken in Part Payment for Latest Type; see our advert. in column Receivers for Sale.—Scientific Development Co., 51, Ffhergate, Preston. [0229]

IF You Live in London and are interested in Any Receiver, loud-speaker, eliminator, etc., write, phone or call, making an appointment for us to demonstrate the article in your own home; terms and exchanges arranged confidentially.—Bostock and Stonhill, 1, Westbourne Terrace, S.E.23. Sydenham 2336. [7532]

1 Balloons, paper hats and carnival novelties for Xmas radio parties; send to-day for free list.—W. Sweeney, 217, Belsize Rd., London, N.W.6. [7557]

PATENT AGENTS.

PATENTS and Trade Marks, British and foreign.—Gee and Co. (H. T. P. Gee, Member R.S.G.B. and A.M.I.R.E.), 51-52, Chancery Lane, London, W.C.2. Phone: Holborn 1525. [0001]

KING'S PATENT AGENCY, Ltd., 146a, Queen Victoria St., E.C.4.—Free advice and handbook on patenting inventions and registering trade marks by registered agent with 43 years' experience. [0002]

REPAIRS.

TWELVE Months' Guarantee Accompanies all our Repairs; any make of L.F. transformer, headphones, or loud-speaker repaired and despatched within 48 hours; 4/- post free; don't discard if burnt out; terms to trade.—Transformer Repair Co. (Dept. W.), 214, High St., Colliers Wood, S.W.19. [0011]

REPAIRS Returned Post Free, and to ensure satisfaction send remittance after approval of same.—Leeds Wireless Repair Service.

LOUD-SPEAKERS, headphones, rewound to any resistance and remagnetised, 3/-; transformers rewound, 4/-; Blue Spots, Triotrons and 4-pole units, 4/6; work guaranteed.—Leeds Wireless Repair Service, 5, Boston Place, Green Rd., Leeds. [7250]

SCOTT SESSIONS and Co., Great Britain's radio doctors; read advertisement under Miscellaneous column. [0263]

KINGSTON-ON-THAMES.—Transformers, phones, loud-speaker repairs; transformers wound to any ratio.—Minter, 156, Cambridge Rd. [7269]

GUARANTEED Repairs by Experts.—Loud-speakers, headphones, cone units, pick-ups, any type, rewound, remagnetised, and adjusted, post free, 4/-; transformers from 4/-.—Howell, 42, Fotheringham Rd., Enfield, Middlesex. [7523]

WANTED.

WANTED, 2 or 3-valve set.—Box 4136, c/o The Wireless World. [7489]

SPLIT Primary, Reinartz transformer, B.B.O. and 5XX, 2 bases (Lewcus), A.F.5; cheap.—Box 4096, c/o The Wireless World. [7486]

MAINS Transformer, step-up, 105 volts to 135.—Frost, 54, Clerkenwell Rd., E.C.1. [7572]

WANTED, Amplion Lion loud-speaker, H.T. eliminator, Ferranti, B.E.M.I., or Regentone, W.I.A. S.G., 240V, 50 cycles.—Box 4175, c/o The Wireless World. [7585]

WANTED, Indigraph dials, A.F.5c, Utility switches, P.M.14, P.M.41X, pick-up, Kilo-mag parts. Sell: Kone speaker, I.S.5As, A.F.3, Marcophone 6-1 hand microphone, Brown's microphone amplifier, H2 speaker, 120W. A phones, phone transformer, T.V.T. unit, Weston relays, Weston 100 m.A. meters.—Box 4171, c/o The Wireless World. [7578]

EXCHANGE.

YOUR Old Apparatus Taken in Part Payment for Latest Type; see our advert. in column Receivers for Sale.—Scientific Development Co., Ffhergate, Preston. [0230]

CLIX

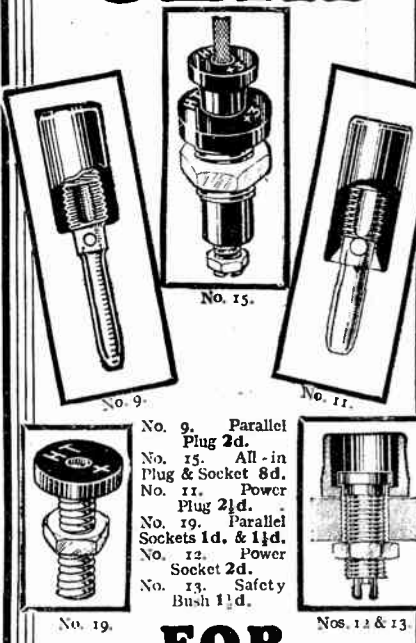

FOR CONTACT

LECTRO LINX Ltd., 254, Vauxhall Bridge Rd., S.W.

NEW PUBLIC ADDRESS and Broadcasting MICROPHONES

The Ideal Instruments for addressing an Audience through Loudspeaker (via Valve Amplifier or L.F. Stages of Wireless Set), and for relaying Speech and Musical Entertainment to any distance. Powerful Loudspeaker Reproduction with perfect Purity Hand Type.

Highly distance-sensitive, yet guaranteed entirely free from distortion or microphonic noises, absolute silent background; far superior to ordinary Microphone Transmitters for use with Valve Amplifier or Valve Set (through leads of Gramophone Pick-up if desired) at Open-air Meetings, in Cinema, Theatre or Concert Hall. Operates from 2 Volt tapping of L.T. Accumulator, through Microphone Transformer. Current consumption one-tenth Ampere. Provided with detachable Sound Collector, handle, hook for suspension, and a soft silk connecting cord.

16/6

Pedestal Type.

Highly Sensitive Microphone as above described, provided with detachable sound collector and a soft silk connecting cord but fixed by rubber-cord suspension in nickel-plated frame on pedestal 11in. high; for mounting on Speaker's Platform, in Pulpit, on top of Camera Stand, or for suspension.

25/-

The above Microphones are rendered Directional by attaching the Sound Collector.

Microphone Transformer, special design to obtain best possible results from sensitive Microphones when connected to high-resistance phones, Loud Speaker Valve Set, or Valve Amplifier; best Transformer made for clear speech with volume, modulation speech and music transmission, Public Address Microphones, etc.; Prim and Sec. terminals fitted; full directions for use of Microphone and diagrams of connections free. Goods by return post.

FREDK. ADOLPH, Actual Maker,
27, Fitzroy Street, London, W.1. PHONE: MUSEUM 8329.

Mention of "The Wireless World," when writing to advertisers, will ensure prompt attention.

Exchange.—Contd.

THE RADIO EXCHANGE, Treville St., Plymouth. the exchange specialists; a trial solicited. [7324]
WE Will Accept Your Surplus Apparatus (making you a high allowance) in part payment for your new apparatus; your enquiry will be dealt with promptly.—Bostock and Stonnill, 1, Westbourne Terrace, S.E.23. [7533]
EXCHANGE Unused Pentone for O.P. Transformer; wanted, Dimic modified S.W. coils.—Webster, 96, Marshall Rd., Sheffield. [7599]

AGENCIES.

AGENTS Wanted, spare time, wireless experience, to demonstrate and sell the world's best and cheapest valve set.—Mag-Radio, 112, Warstone Lane, Birmingham. [2667]

SITUATIONS VACANT.

WIRELESS Operating Appointments Assured; short qualifying course, day, evening; fees payable after appointment for boarding students; Morse classes.—Manager, Wireless School, 21, Manor Gardens, London, N.7. Archway 3694. [6379]

RADIO.—Young engineers required for research laboratories in the Midlands.—Applicants should give full particulars, age, education, experience, salary required, Box 546, Sells, Fleet St., E.C.4. [7515]

WIRELESS Manufacturers Require Smart Young Man for Office, thorough knowledge of office routine and correspondence essential, one with business acumen who can soon make his services valuable; must have class technical and some mechanical knowledge in wireless circuits would be a recommendation; salary commencing 50/-; Sydenham district.—Box 4140, c/o The Wireless World. [7498]

WIRELESS Valve Manufacturers Require Immediately Fully Qualified Technical Manager to take control of coated filament production; commencing salary £750 per annum, with interest in profits.—Write for absolute confidence Managing Director, Cleartron Tubes, Ltd., 21, Cumberland St., Birmingham. [7479]

SITUATIONS Guaranteed as Wireless Operators, age 15-29; day, evening, or postal courses; Morse classes.—School, 321, Mansfield Rd., Nottingham. [7526]

SITUATIONS WANTED.

MAN Requires Situation, charge accounts, well conversant with radio trade; in situation, but desiring improvement.—Box 4137, c/o The Wireless World. [7491]

YOUNG Man, fluent German, knowledge German wireless and motor trades, seeks opening.—Box 48, c/o The Wireless World. [7492]

YOUNG Man, 23, first class P.M.G. Certificate, 2½ years' sea experience, sound knowledge of design construction of all types of receivers, requires situation.—Box 4087, c/o The Wireless World. [7473]

MARTON, 69a, High St., Deal.—Wanted, situation as wireless mechanic, 6 years' experience, repairing, constructing, all types of receivers. [7485]

WIRELESS Operator (young) Requires Position, London, good knowledge electricity, wireless, any work.—Piercer, 11, Aldred Rd., West Hampstead. [7521]

BOOKS, INSTRUCTION, ETC.

BEST H.T. Batteries are now a proved success: write for new illustrated booklet, giving cost and method of building and maintaining free; mention paper.—Editor, 57, Studley Rd., Stockwell, London. [0077]

STEP by Step Wireless; a complete course of the theory of electricity in relation to the practical design of wireless apparatus, eliminators, circuits, etc.—Extracts from a designer's notebook, giving up-to-date practical application; issued weekly; send 1/- p.o. for first 4 weeks.—Clifford Pressland, A.M.I.E.E. Eng., 1, W.W., Hampton-on-Thames [0195]

FREE: Inventor's Guide on Patents.—T. A. A., 253 (W), Gray's Inn Rd., London, W.C.1. [6373]

LOUD-SPEAKERS, by C. M. R. Balbi.—A practical handbook for wireless amateurs on the selection, construction and performance of loud-speakers, with notes on the detection and remedying of faults; 3/6 each.—Booksellers or Pitman's, Parker St., Kingsway, London, W.C.2. [7069]

TRANSFERS
 for marking Wireless Sets and Components

Send particulars of your requirements to—
 The British Transfer Printing Co., Ltd.,
 Quinton Road, Coventry.

600 OHMS DECOUPLING RESISTANCES
 SPECIFIED FOR "NEW KILOMAG" FOUR and "Foreign Listeners Four"

1/6 EACH POST FREE. Manufactured by GROVES BROTHERS, ST. MARY'S PLAGE, SHREWSBURY. 1,000 ohms, 1/6 each.

WORLD'S FINEST VALUE

Graves 'Vulcan' 2-Valve Wireless Set is the World's greatest achievement in Wireless Value and Efficiency. Even if you are only a beginner, this magnificent installation will enable you to start where others leave off; or if you are an experienced wireless operator, this superb set will give you a sense of power and command over the mysterious forces of the ether which will astonish you. The Graves principle stands for Highest Quality, Lowest Price, and Easiest Terms.



TERMS Our Inclusive Bargain Price is for deferred payments. Send 10/6 now, and 14 Monthly Payments of 10/6 if satisfied after trying Outfit in your home. Money back if at all disappointed.

SPECIFICATION Cabinet (as illustrated below) of polished Oak, beautifully finished with hinged lid; all internal parts (including valves) easily accessible. Dull Emitter Detector and Power Valves of proved efficiency, anti-microphonic valve holders. No coils to change. Latest type H.T. Battery; 2-volt Accumulator, and complete Aerial Outfit. Cost of upkeep negligible. **THE LOUD SPEAKER** (as illustrated) is of exclusive design Cabinet Type in Oak to match the Set. Finest tone and wide range of musical frequencies, the Unit being of the four pole balanced armature type, with a large magnet, ensuring perfect reproduction. **Price complete and Carriage Paid £7.17.6**

ANOTHER WONDERFUL BARGAIN IS THE GRAVES SCREENED GRID THREE-VALVE WIRELESS RECEIVING OUTFIT

Complete in every particular. Wonderful range and amazingly good reception. Exclusive Oak Cabinet and Cabinet Loud Speaker. All components of highest quality. **Carriage Paid £12:15**

TERMS: 15/- with Order, & 15/- Monthly CATALOGUE POST FREE. Full Particulars and specifications of both Sets; also newest types of Portable Sets, and other varieties of high-class Receiving Apparatus.

J. G. GRAVES Ltd. SHEFFIELD

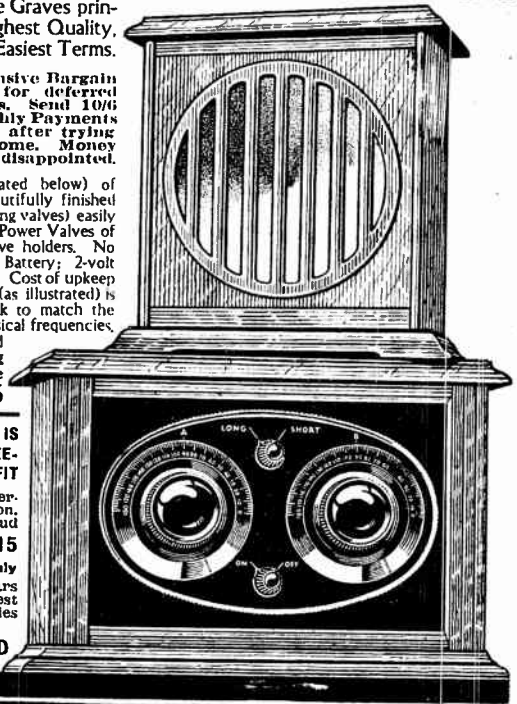

E E L E X

SPADES PINS EYES

Specially designed to meet every requirement of the enthusiast. All parts are interchangeable, made with coloured sleeves and cost but 2d. each. Write for List x89.

2d. each.

J. J. EASTICK & SONS,
 Eelex House, Bunhill Row, E.C.1.

Telephone: Clerkenwell 9282/3/4.

CABINETS KABILOK OF DISTINCTION

?

BUILDING THE Orgola, Magic 3 or a set described in "Wireless World" and other radio publications?

Select a **KABILOK CABINET** of distinction. **Illustrated Catalogue Free on request.**

W. & T. LOCK LTD.
 ST. PETER'S WORKS, LONDON: 11, Red Lion Square W.C.1.

WEBBSON

STILL LEADING

Convincing Proof

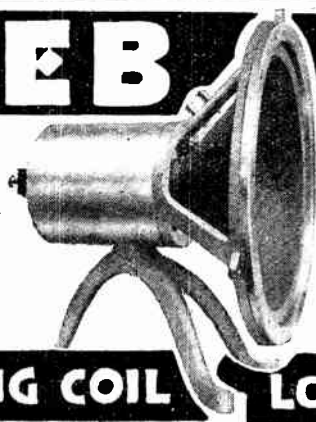

Model B.S.7

MOVING COIL LOUD SPEAKER

November 5th, 1929.
 Messrs. Star Engineering Co.,
 Didsbury, Manchester.
 Dear Sirs,
 I feel I should like to tell you that your B.S.7 Loud Speaker is the finest Speaker I have yet tried, and I have tested almost every make.

Yours faithfully, George H. Toser,
 Vice-President the South Croydton and District Radio Society.

Send for particulars to:
STAR ENGINEERING
 Didsbury, Manchester. Phone: Didsbury 11:83

INDEX TO ADVERTISEMENTS.

Adolph, Fredk.	Sup. xxx.	Gambrell Radio, Ltd.	Sup. xviii.	Paroussi, E.	Sup. xix.
Appleby, E. Hetherington	Sup. xix.	Garnett, Whiteley & Co., Ltd.	Sup. xii.	Partridge & Mee, Ltd.	Sup. xix.
Asitoo, Harold	Sup. xxiv.	General Electric Co., Ltd.	15	Perseus Radio Manf. Co.	Sup. xxii.
Automatic Coil Winder and Electrical Equip. Co., Ltd.	Sup. ix.	Gilbert, J. C.	Sup. x.	Pertrix, Ltd.	10
B. & J. Wireless Co.	Sup. xix.	Grafton Elec. Co., Ltd.	Sup. xxii.	Peto & Radford, Ltd.	Sup. xii.
Baker's "Selhurst" Radio	Sup. xxiii.	Graham Ampton, Ltd.	21	Phillips Radio	6 & 13
Battery Co., Ltd.	Sup. v.	Graham Parish	14	Player's	Sup. xiv.
Bayliss, W. Ltd.	Cover iii.	Graves, J. G., Ltd.	Sup. xxii.	Potter, H. B. & Co., Ltd.	Sup. x.
Beam, Ltd.	Cover ii.	Grosvenor Battery Co., Ltd.	Sup. vi.	P.R. Products	Sup. 16
Belling & Lcc, Ltd.	Sup. xi.	Groves Bros.	Sup. xxxi.	Premier Supply Stores	Sup. xix.
Black, Alexander	Sup. xxix.	H. & B. Radio Co.	Sup. xxvii.	Radielle Co., Ltd.	Sup. xxvi.
Bowyer-Low Co., Ltd.	Sup. iv.	Harlie Bros.	Sup. xxvii.	Radio Gramophone Development Co.	Sup. vi.
British Ebonite Co., Ltd.	Sup. xviii.	Haw & Co., Ltd.	Sup. xx.	Radio Instruments, Ltd.	Sup. xvii.
British Insulated Cables, Ltd.	Cover ii.	Heayberd, F. C., & Co.	Sup. x.	Radern's Rubber Works, Ltd.	Sup. xxii.
British Transfer Printing Co., Ltd.	Sup. xxxi.	Henri & Co.	Sup. xx.	Regent Fittings Co.	Sup. xxii.
Brownie Wireless Co. (G.B.), Ltd.	Sup. xxvi.	Holzman, L.	Sup. xx.	Rigby & Woolfenden	Sup. xxii.
Brown, S. G. Ltd.	Sup. xxi.	Hughes, F. A., & Co., Ltd.	Supa. ii. & xii.	Ritherdon & Co., Ltd.	Sup. xvii.
Bullphone, Ltd.	Sup. xvii.	Hunt, A. H., Ltd.	Sup. xxv.	Rothermel Corp., Ltd. (Centralab) 12,	Sup. xvii.
Burton, C. F. & H.	Cover i. & p. 4	Ideas Development Synd., Ltd.	Sup. xxiv.	Rowley, Thomas A., Ltd.	Sup. xv.
Cass, Sir John, Institute	Sup. xxx.	Igranic Electric Co., Ltd.	Sup. xiii.	Scientific Supply Stores	Sup. ii.
Celestion, Ltd.	14	Impex Electrical, Ltd.	Sup. xiii.	Sheffield Magnet Co.	Colour p. 28
Clareth Reproducers, Ltd.	19	Improved Wilson Microphones & Electric Co., Ltd.	Sup. xxvii.	Siemens Bros. & Co., Ltd.	9
Clarke, H., & Co. (M'er.), Ltd.	Supa. viii. & xvii.	Jackson Bros.	6	Sifam Elec. Inst. Co.	Sup. xxiii.
Climax Radio Electric, Ltd.	Sup. xxi.	Lectro Linx Ltd.	Sup. xxx.	Simmonds Bros.	Sup. xxx.
Cole, E. K., Ltd.	16	Lever, Eric J. (Frix), Ltd.	Sup. xx.	Squire, Fredk.	Sup. xvii.
Columbia Graphophone Co., Ltd.	3	Levton Battery Co.	Sup. xxiv.	Star Engineering	Sup. xxxi.
Competition Coupon	18	Lisenin Wireless Co.	Sup. xxiv.	Telegraph Condenser Co., Ltd.	Colour p. 25
Competition Page	17	Lock, W. & T., Ltd.	Sup. xxxi.	Telephone Berliner (London), Ltd.	Sup. xv.
Cosser, A. C., Ltd.	20	Lowce Radio Co., Ltd.	Sup. xxxi.	Telsen Electric Co., Ltd.	Cover i. & Colour p. 24
C.P. Mast Co.	Sup. xxiv.	London Electric Wire Co. & Smiths, Ltd.	Sup. xxxii.	Thomas, Bertram	12
Dag, Will, Ltd.	Sup. xxii.	London Radio Supply Co.	Sup. xxxii.	Tonex Co.	Sup. xxix.
Digby, F.	Sup. xxii.	Lustroux, Ltd.	Sup. ii.	Transformer Repair Co.	Sup. xxv.
Donotone (Regd.) Loud Speaker	Sup. xi.	Lyons, Claude, Ltd.	Cover i. & Sup. xxix.	Tre'borg Ebonite Works, Ltd.	Sup. xxxii.
Dr. Nesper, Ltd.	Sup. xi.	Marconiphone Co., Ltd.	Cover iv.	Tudor Accumulator Co., Ltd.	18
Dubilier Condenser Co. (1926), Ltd. 8 & Cover iii.		McMichael, L., Ltd.	22	Tulsemoro Manf. Co.	Sup. xxv.
Eagle Engineering Co., Ltd.	18	Melluish, C. D.	Sup. xvi.	Ultra Electric, Ltd.	Sup. iv.
Eastick, J. J., & Sons	Sup. xxxi.	M-L Magneto Synd., Ltd.	Sup. vi.	Vandervell, C. A. & Co., Ltd.	Sup. iii.
Eaton, S., & Son	Sup. xxix.	Moore & Co.	1	Varley (Oliver Pell Control, Ltd.)	7
Electradix Radios	Sup. xxv.	M.P.A. Wireless, Ltd.		Ward & Goldstone, Ltd.	
Ellison Manf. Co., Ltd.	Sup. x.	Mullard Wireless Service Co., Ltd.	1	Wamel Wireless Co., Ltd.	4
Epoch Radio Manf. Co., Ltd.	Sup. xxx.	O'Brien, Thos., Ltd.	Sup. xxiv.	Westinghouse Brake & S'ady Signal Co., Ltd.	8
Eriesson Telephones, Ltd.	Sup. xviii.	Oldham & Son, Ltd.	Sup. xxii.	Weston Electrical Instrument Co., Ltd.	Sup. xviii.
Ever Ready Co. (G.B.), Ltd.	Colour page 23	Ormiston, P. P. & Son	Sup. xxii.	Whiteley, Boneham & Co. Ltd.	Sup. xxviii.
Exact Manf. Co.	Sup. xxx.	Ormond Engineering Co., Ltd.	Sup. xxii.	Wilkins & Wright, Ltd.	Cover i.
Kixide Batteries		Osborne, Chas. A.	Sup. xxix.	Willis & Co.	Sup. xxii.
Ferranti, Ltd.	5			Wingrove & Rogers, Ltd.	Sup. xiv.
Fenteyn & Co., Ltd.	Sup. x.			Wolverhampton Die Casting Co.	Sup. ii.
Formo Co.	Sup. xxxii.			World's Wireless Stores	Sup. xxviii.
				Wright & Weaire, Ltd.	Cover iii.

THE BEST PANELS—NOW THE CHEAPEST.

Trelleborg Ebonite Works, Ltd., Union Place, Wells Street, London, W.1

Highly Polished 3/16" Black or Wavy, 2064, sq. in., 6x9, 2/6; 7x14, 4/6; 7x18, 6/-; 7x21, 7/-; 8x12, 4/6; 8x16, 6/- . . . Highly Polished, 3/16" Mahogany, 1 1/2 Black or Wavy, 24, sq. in., 6x9, 3/6; 7x11, 6/3; 7x18, 8/-; 7x21, 9/3; 8x12, 6/-; 8x16, 8/- . . . Highly Polished, 1" Mahogany, 14, sq. in., 6x9, 4/6; 7x14, 8/2; 7x18, 10/6; 7x21, 12/8; 8x12, 8/-; 8x16, 10/8.

HIGH GRADE RADIO APPARATUS ON Easy Terms

We SPECIALISE in the supply of all Good Quality Radio Sets, Components and Accessories on Easy Terms. We will give you efficient service.

Any of the new "Wireless World" Receivers built to order. Carefully wired and tested and fully guaranteed by us. Moderate Charges.

Send us your list of requirements and a quotation will be sent by return.

LONDON RADIO SUPPLY COMPANY,
11, Oat Lane, Noble St., London, E.C.2. National 1977.

THE FINEST VERNIER DIAL OBTAINABLE

MECHANICALLY PERFECT, POSITIVE BRASS CONTACT drive on SOLID BRASS SCALE ensuring smooth movement, with absolutely NO BACK-LASH. ROBUST in Construction and Trouble Free. SMALL, EXTREMELY ELEGANT, EFFICIENT.

3/-

TUNING WITHOUT IRRITATING UNCOMFORTABLE CROUCH OR STOOP.

As pictorially shown, the scale and aperture are inclined at an angle of 30° from perpendicular, thereby permitting convenient unobstructed view of scale without need to crouch or stoop.

If unable to obtain from dealer please communicate with us. Full Catalogue sent post free on receipt of post card.

THE FORMO CO., CROWN WORKS, CRICKLEWOOD LANE, LONDON, N.W.2

Mention of "The Wireless World," when writing to advertisers, will ensure prompt attention.

Superior A.C. POWER TRANSFORMERS

and **CHOKES** for the **MAINS** from **35/-** each
for ALL INPUTS and OUTPUTS.

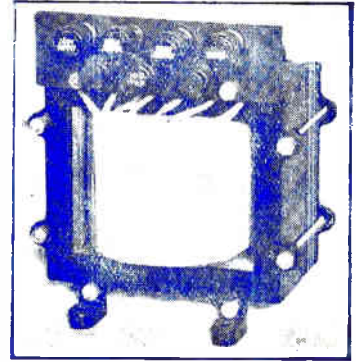
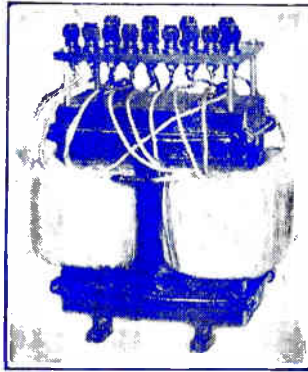
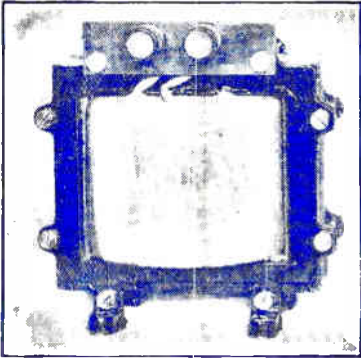

Special Audio-Frequency Chokes and Transformers, and Smoothing Chokes for all purposes.

WILLIAM BAYLISS LTD., Sheepcote Street, **BIRMINGHAM.**

Telephone: Mid. 1409.

Telegrams: Drawbench. B'ham.

Get improved
reception with
this long-life
BATTERY

66 Volts
7'9

SUPERIOR (Single Capacity)	
9 volts	1/6 99 volts .. 11/9
63	7/6 108 .. 12/9
66 .. (with G.B. Tappings)	7/11
SUPREME (Treble Capacity)	
60 volts	13/6
63	14/3
100	22/-

Get Dubilier's Booklet—"A Bit about a Battery"—from your Radio dealer



BRITISH
MADE

DUBILIER

H.T. BATTERIES

DUBILIER CONDENSER CO. (1925) LTD Ducon Works,
Victoria Rd. North Acton, London. W.3. B.E.

WEARITE COMPONENTS

1930 EVERYMAN FOUR

Coils per set £2-7-6

NEW KILOMAG FOUR.

Coils per set £2-5-0

WIRELESS WORLD KIT SET.

Coils per set £2-5-6

DECOUPLING RESISTANCES.

500 or 600 ohms .. 1s. 6d.

Fixed resistances wire wound

1,000-5,000 10,000 15,000 20,000 25,000 ohms

2 - 2/6 3 - 3/6 4 - each

FOREIGN LISTENERS FOUR.

B.B.C. Coils, per set of 3 £1-2-6

5XX Coils, per set of 3 £1-17-6

Coil Bases, per set of 3 £0-7-6

Write for illustrated lists:

WRIGHT & WEAIRE, LTD.

740, HIGH ROAD, TOTTENHAM, N.11.

Telephone: 2011 (4 lines) 247 2 125



Reliable as your Electric Light!

*This mains unit—made by
Marconiphone—supplies constant
power once and for all*

IN HOUSES where there is electric light, people are doing away with batteries and accumulators altogether, and running their radio from a Marconiphone Mains Unit—the unit designed out of the greatest radio experience in the world.

So much more convenient! No accumulators to be recharged. No batteries to be replaced. Your set *always* ready. Cheaper, too; for a Marconiphone

Mains Unit uses only the minimum of current.

Any dealer will supply you with the correct model to work your set. And once installed, it is there for a lifetime. For this is a *Marconiphone* Mains Unit.

It carries the most famous name in wireless as a guarantee of reliability and efficiency. Prices from £4. The Marconiphone Company Limited, 210-212 Tottenham Court Road, London, W.1.



The first and greatest name in wireless

MARCONIPHONE Mains Units

Printed for the Publishers, LIPPK & SONS LTD., Dorset House, Tudor Street, London, E.C.4, by The Cornwall Press Ltd., Paris Garden, Stamford Street, London, S.E.1.

Colonial and Foreign Agents:
 UNITED STATES—The International News Co., 121, Varick Street, New York. FRANCE—W. H. Smith & Son, 248, Rue Rivoli, Paris; Hachette et Cie, Rue Beaumur, Paris.
 BELGIUM—W. H. Smith & Son, 78, Marche aux Herbes, Brussels. INDIA—A. H. Wheeler & Co., Bombay, Allahabad and Calcutta. SOUTH AFRICA—Central News Agency, Ltd.
 AUSTRALIA—Gordon & Gotch, Ltd., Melbourne (Victoria), Sydney (N.S.W.), Brisbane (Queensland), Adelaide (S.A.), Perth (W.A.), and Launceston (Tasmania).
 CANADA—The American News Co., Ltd., Toronto, Winnipeg, Vancouver. MONTREAL, OTTAWA, ST. JOHN, HALIFAX, HAMILTON; GORDON & GOTCH, LTD., TORONTO; IMPERIAL NEWS CO. Toronto, Montreal, Winnipeg, Vancouver. VICTORIA. NEW ZEALAND—Gordon & Gotch, Ltd., Wellington, Auckland, Christchurch and Dunedin.

The Wireless World

4^D

AND RADIO REVIEW

The Paper for Every Wireless Amateur

Wednesday, December 18th, 1929.

Plug-in—That's all!

THIS YEAR.....GIFT IT WITH "EKCO"

AN "EKCO" POWER SUPPLY UNIT was VOTED FIRST by PUBLIC in Wireless World NATIONAL BALLOT

EKCO

Write for Free Booklet.

EKCO-ELECTRIC RADIO RECEIVERS AND POWER SUPPLY UNITS

E. K. COLE, Ltd., Dept. W, "EKCO" WORKS, LEIGH-ON-SEA.



RAJAH MULLARD VALVE

P.M.

**TONES
VOLUME
DISTANCE**

PUT NEW LIFE INTO YOUR RECEIVER

Mullard

THE MASTER VALVE

AWARDED THE CERTIFICATE OF THE INSTITUTE OF HYGIENE FOR QUALITY AND PURITY

Superfine Quality

Trelleborgs

GUARANTEED PURE EBNONITE

25% REDUCTION ON RETAIL PRICES

GLOSSY
HIGHLY POLISHED

20000 VOLTS PER MM
National Physical Lab Report

TRELLEBORG EBNONITE WORKS, LTD.,
Union Place, Wells Street, W.1



BLUE SPOT

LOUISIANA AIR UNIT

66K

BLUE SPOT 66K

25%

There is nothing better

PORTABLE SPOTLIGHTS EVER READY

BRITAIN'S BEST BATTERIES

A MODEL FOR EVERY MEMBER OF THE FAMILY.

Searchlights & Spotlights.

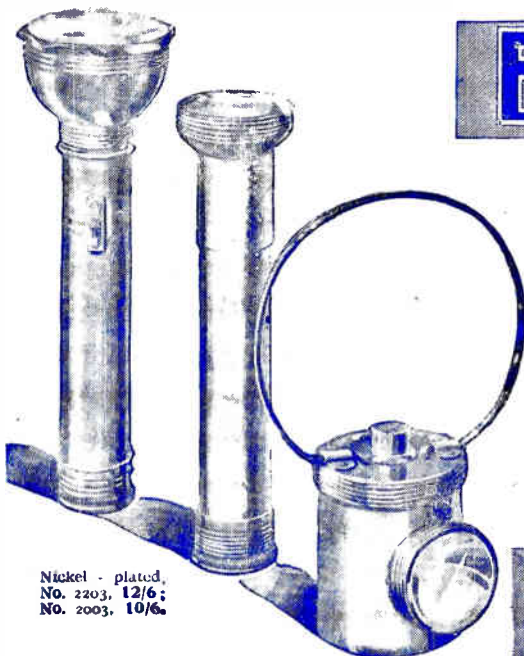

Nickel-plated,
No. 2203, 12/6;
No. 2003, 10/6.

Bull's
Lan-
tern, Nickel
plated, No. 1820,
12/6.

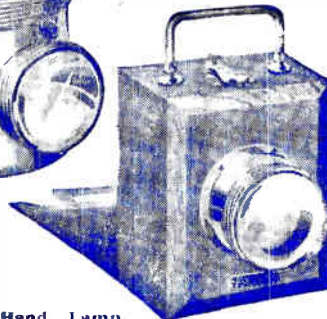

Hand Lamp,
oak case, No.
1360, 10/6.

Accumulators for
Wireless, Car, etc.,
Celluloid and Ebon-
ite Cells.



The Cell for
Your Bell, 2/-.



Cycle Lamp,
long life model,
No. 2036, 3/3.



Spotlight
Pocket Lamp,
leather-covered
and nickel-
plated, No. 2000,
3/6.



The H.T. Bat-
teries for Your
Portable
Wireless Set,
63 volts, 8/6;
108 volts, 15/-.

Grid Bias Bat-
teries, G.B.4, 9
volts, 2/-.



Refill Bat-
teries for Flash-
lamps, 1-cell,
No. 1689, 9d.

The "Small-
est Pocket
Lamp in the
World," No.
1679, 2/-.

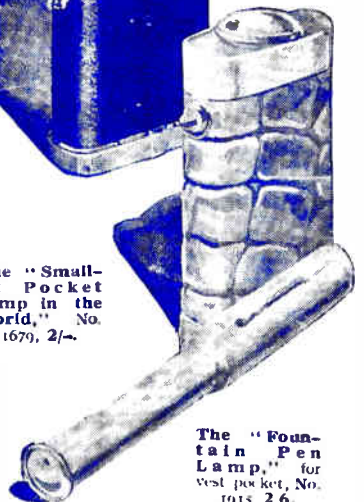

The "Foun-
tain Pen
Lamp," for
vest pocket, No.
1015 2/6.

Obtainable Everywhere. Write for Illustrated Catalogue to the Manufacturers:

THE EVER READY CO. (G.B.), LTD., HERCULES PLACE, LONDON, N.7.

Mention of "The Wireless World," when writing to advertisers, will ensure prompt attention.

TELSEN

TRANSFORMERS

Have acquired a world-wide reputation for Quality and Value.

Built by Specialists in Transformer construction, they have set a Quality of Performance above reproach. Your Set will work better with a Telsen Transformer — Fit one now!

RADIOGRAND

12/6

ACE

8/6

Both in Ratios 5 to 1 and 3 to 1.

TELSEN ELECTRIC CO., LTD.,
Miller Street, BIRMINGHAM.

RADIO'S CHOICE

TELSEN

RADIOGRAND

TRANSFORMER



THE WORLD'S FINEST TRANSFORMER VALUE



Clarith
RADIO-GRAMOPHONE.

The
**MIRROR
OF
MUSIC
and
SPEECH**

As the mirror reflects faithfully the movement and light of the form before it, so does the "CLARITH" reflect music and speech.

NEVER before has such reproduction been possible.—Never such life and colour in music.—Never such clarity of speech. Nothing we may say can really convey the remarkable purity and volume of the "CLARITH" Reproducer—It must be heard to be believed.

Ask your dealer to demonstrate—if he cannot, write us, please!

The "CLARITH" Reproducer combines a 3-valve Radio Set with a high-class electrically reproducing Gramophone, entirely mains operated. The Speaker is of the Moving Coil type, and gives perfect reproduction.

Price, A.C. - - 49 guineas.
D.C. - - 59 guineas.

Clarith
RADIO - GRAMOPHONE
CLARITH REPRODUCERS LTD.,
East Street Mills, LEEDS.

Send
To-day
for
Illustrated
Catalogue.

**CUT
OUT
2LO at will—**
and get better
reception from
other stations

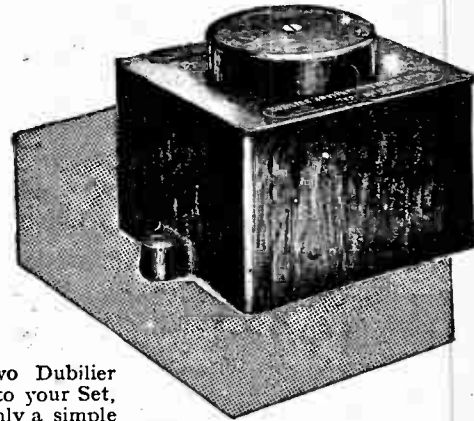

By fitting two Dubilier Wave Traps to your Set, even if it's only a simple receiver, you will be able to get good reception from other stations without the slightest interference from either of the two 2LO transmissions—as effectively as if you fitted high-frequency valves costing several pounds. If, however, you merely desire to receive one or other of the two transmissions from the London Regional Station at Brookman's Park, you will only require one Wave Trap, and in that case, unless your Set is already fairly selective, it is extremely unlikely that you will be able to receive any other than one of the two transmissions from Brookman's Park when they are broadcast simultaneously. The Dubilier Wave Trap has only to be connected between your aerial and your Set—that's all. It's ready tuned when you buy it, so there are no adjustments to make.

Available in two models for the two wavelengths of the London Regional Transmitter.

Type BR1 for 356.3 metres
Type BR2 for 261.3 metres

**PRICE
15/6
Each**

If your Dealer is unable to supply, please write to us giving his name and address.

**DUBILIER
WAVE TRAP**

Dubilier Condenser Co. (1925) Ltd., Ducon Works, Victoria R.L., North Acton, London, W.3.

EVERYTHING

The
G.E.C.
your guarantee

ELECTRICAL

“The
Christmas
Spirit”



Treat
yourself
and
your
friends
to a
set of

MADE IN ENGLAND
Sold by all Wireless Dealers.

**Osram
Valves**

Advt. of The General Electric Co., Ltd., Magnet House, Kingsway, London, W.C.2

Advertisements for "The Wireless World" are only accepted from firms we believe to be thoroughly reliable



The Famous
**BULLPHONE
DE LUXE
LOUD-
SPEAKER**

Reduced
from 55/-

to **25' -**
1000 only
as an advertisement.

Ask your Local Dealer or
send direct.

**CUT OUT
THE NEW
STATION**
with the
**BULLPHONE
DUAL RANGE
COIL**

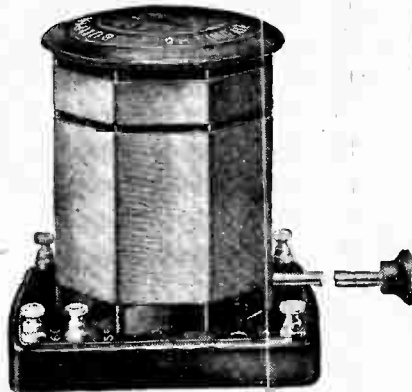

12'6



BULLPHONE

4-Pole
Adjustable
Tone

CONE UNIT

15' -

Adjustable
Cone Chassis,
suitable for
any Cone
Unit,

per **3' -** pair

Obtainable from your Local Dealer or direct from:

BULLPHONE, LTD.

28, HOLYWELL LANE, LONDON, E.C.2

**A HAPPY CHRISTMAS
A BRIGHT AND PROSPEROUS
NEW YEAR
AND A LONG LIFE TO
ALL USERS OF THE
EXIDE BATTERY**



It will be unnecessary to convey to present users of the Exide Battery the wish that their wireless reception be constant and clear and that their cars shall start quickly from cold.

Exide
**THE LONG LIFE BATTERY
FOR WIRELESS AND CARS**

Obtainable from all Exide Service Stations and reputable dealers
Exide Service Stations give service on every make of battery

EXIDE BATTERIES
London Sales & Service Depot, 215-229 Shaftesbury Ave., W.C.2

Christmas Gifts

A Radiogramophone for me! says the Expert:—this XMAS.

What is more appreciated in the Home or Club at the Festive Season than Christmas Music, and what a suitable gift . . . a Radiogramophone or Loud Speaker . . . a Gift of Utility, Quality, and Beauty.

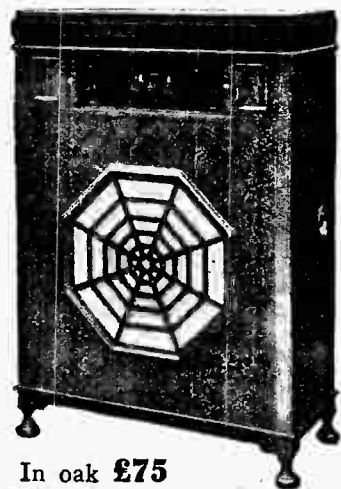

In oak £75

THE
R
G
D

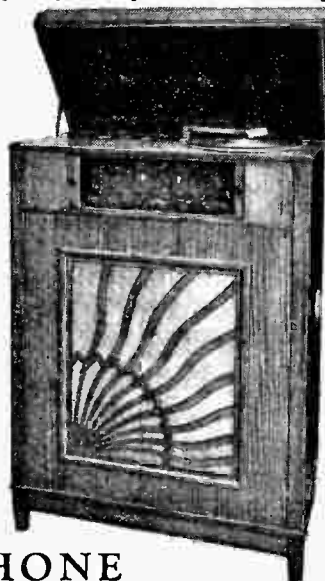

Mahogany
£80

RADIOGRAMOPHONE

For the highest possible quality and tone for both radio and record, with ample volume, incorporating the latest developments in moving coil speaker, operates entirely from electric mains, A.C. any voltage, or D.C. 200 volts or over.



The R.G.D. Moving Coil Loudspeaker finished in Walnut, Oak or Mahogany 2 ft. 6 ins. high, 3 ft. 6 ins. wide — an exceptionally High-class Instrument for D.C. mains, £20
Can be supplied with equipment for A.C. mains.

A Pick-Up
of
Distinction.

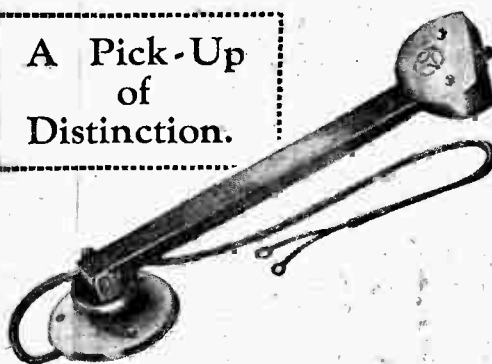

The R.G.D. Magnetic Pick-up is designed after years of experiments, and we believe it to be as perfect as possible. No record wear, perfect tracking, a scientific instrument, specially developed for moving coil speaker reproduction.
Price £3 in bronze, £3-3-0 in oxidised silver.

Place your order now to ensure delivery, and we shall be pleased to supply literature on application.

The RADIOGRAMOPHONE DEVELOPMENT Co.,
ST. PETER'S PLACE, BROAD ST., BIRMINGHAM.

**WHY
PAY more
than 5/6
FOR A UNIVERSAL
VALVE**

TWO VOLT

Universal .1 amp. . .	5/6
Resistron .1 amp. . .	5/6
Super H.F. .15 amp. . .	5/6
Super Power .18 amp. . .	7/6
Hyper Power .3 amp. . .	9/6
Pentodion .3 amp. . .	18/6

FOUR VOLT

Universal .075 amp. . .	5/6
Resistron .075 amp. . .	5/6
Super H.F. .075 amp. . .	5/6
Super Power .1 amp. . .	7/6
Hyper Power .15 amp. . .	9/6
Pentodion .15 amp. . .	18/6

DARIO VALVES

Best way to all Stations

**DARIO VALVES make Ideal
Christmas Gifts**

- New Glass Bulb, Finer yet Tougher 1
- New Super Strength Grid 2
- New Non-microphonic Filament with Special Coating 3
- New Large Size Anode, Easier Flow of Electrons 4
- Dario Milled Base for Easier Handling. 5

LONGER LIFE!

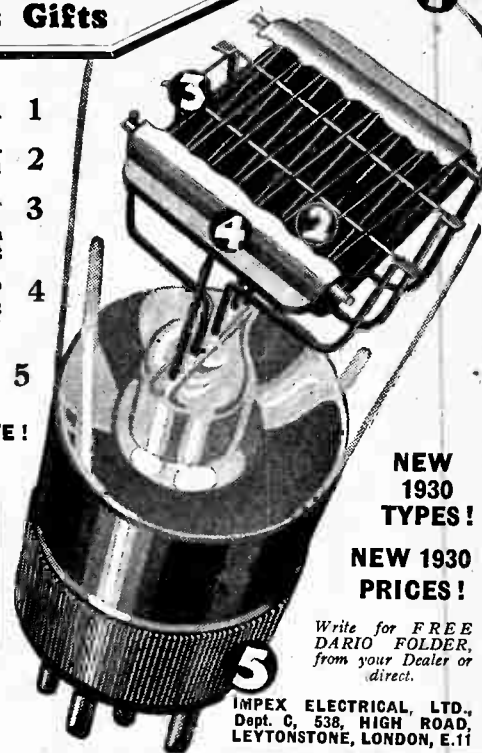

**NEW
1930
TYPES!
NEW 1930
PRICES!**

Write for FREE
DARIO FOLDER,
from your Dealer or
direct.

IMPEX ELECTRICAL, LTD.,
Dept. C, 538, HIGH ROAD,
LEYTONSTONE, LONDON, E.11

107

PRECISION CONDENSERS

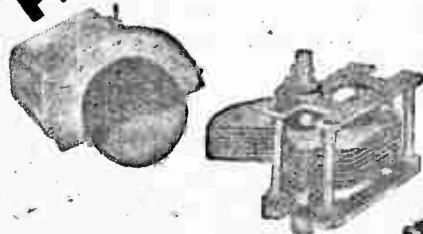

J.B. UNIVERSAL LOG.

.0005	..	9/6
.0003	..	9/-
.00025	...	8/9
.00015	..	8/9

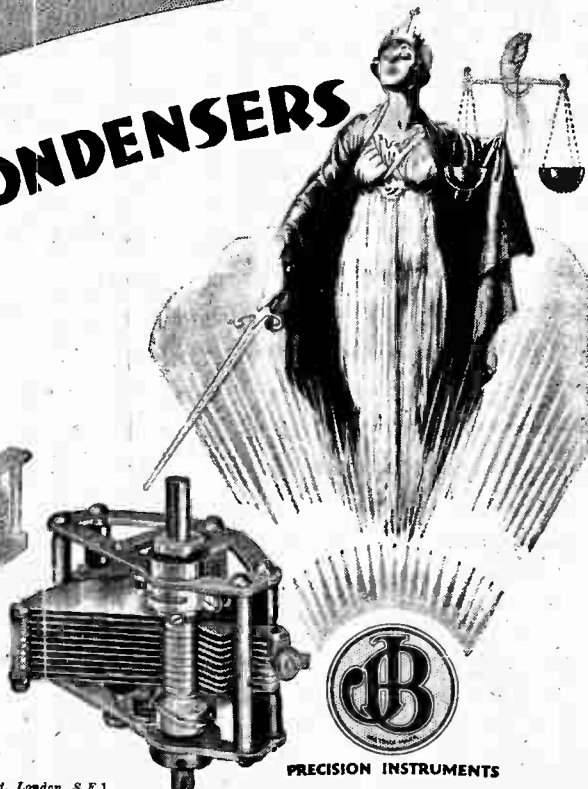

**now
as
always**

In a country where mechanical wonders are becoming more and more frequent, and the standard of workmanship is very high, J.B. Condensers still stand out as examples of precision and finish. Their design, as well as the accuracy with which they are made, have established for them a reputation that exists wherever Wireless is to be found.

PRECISION INSTRUMENTS

Advertisement of Jackson Bros., 72, St. Thomas' Street, London, S.E.1.

Telephone: Hop 1837.

Mention of "The Wireless World," when writing to advertisers, will ensure prompt attention.

ABSENT-MINDED CALLER SPEAKING TO SUPER—

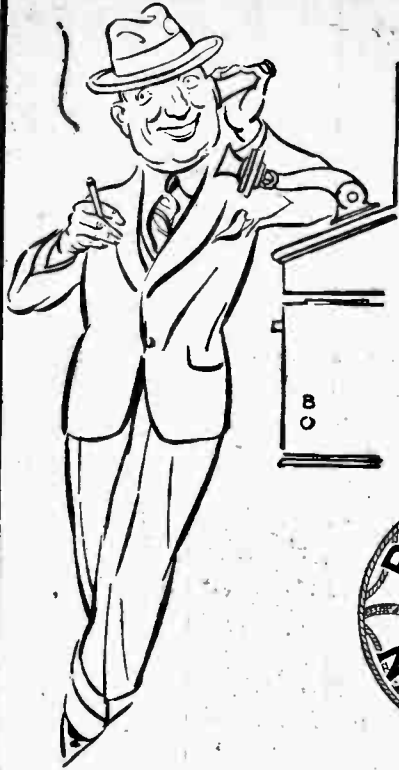

"IS THAT THE SUPERVISOR?
I WANT—

Player's
please

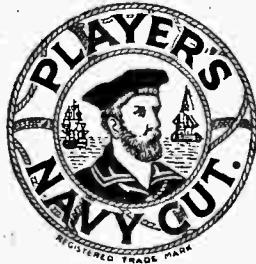

N.C.C. 767A



Put your wander plugs
into the wonder battery

Unbelievable is the saving until you have had actual experience of "Pertrix" — the super-battery without sal-ammoniac, and therefore without the defects that sal-ammoniac inevitably involves. No loss when not in circuit; no crackle at any stage or age; and

60% longer life

PERTRIX
SUPER
DRY BATTERIES

PERTRIX LIMITED,
Britannia House, Shaftesbury Avenue, London, W.C.
Factory—Britannia Works, Redditch, Worcs.

STANDARDS

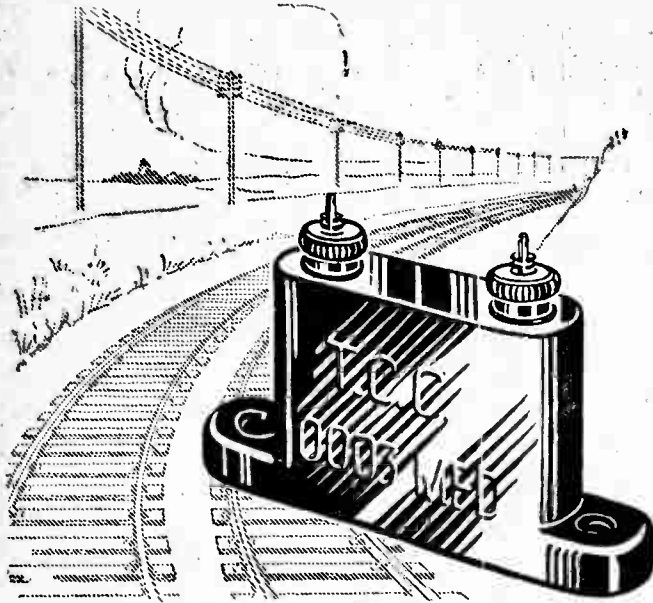

RAILWAY TRACKS and T.C.C.

ALL British railway tracks are of standard width or "gauge." To complete a journey without frequent changes—to run to schedule, to permit interlinking of the various groups, and to avoid chaos generally standardisation is essential.

It's the same with condensers—only by adhering to a definite standard can perfect working be assured. There can, however, be only one standard, and where condensers are concerned that standard is T.C.C. Whenever you see a condenser marked T.C.C. you know that it is a condenser designed and built to a standard—with a degree of accuracy and dependability approached by no other. It is, in a word, the standard by which all other condensers are judged.

Illustrated above is a .0003 mfd. T.C.C. Upright Type Mica Condenser. Price 1/6 each. Other capacities in this type are made from .0001 mfd. to .25 mfd. Prices 1/6 to 18/-



Adv. Telegraph Condenser Co Ltd., Wales Farm Road, N. Acton, London, W.3

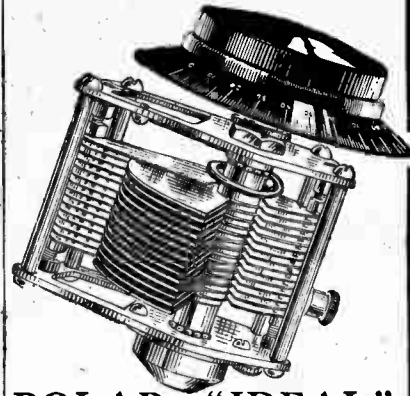

The Polar "Ideal" DRUM CONTROL CONDENSER is supplied in capacities as below, and costs only 2/6 extra. Ask your dealer to show you one.

Have you had a copy of the "Polar" Catalogue?

POLAR "IDEAL" CONDENSERS

Make just that difference in selectivity that adds a few more stations to your list of those "worth hearing"; and they also improve the quality of reception by giving you "dead on" tuning.

.0003 - 12/- .00035 - 12/3
 .0005 - 12/6

WINGROVE & ROGERS LTD.
188-189 STRAND, LONDON, W.C.2



ELECTRAD

TRUVOLT Resistances

Truvolt wire-wound potentiometers simplify the construction of H.T. Eliminators and do away with all guesswork. The resistance element is a nickel alloy wire. There is no iron to rust or zinc to oxidise. Truvolts are air-cooled and give a positive and lasting service. All Truvolts are rated at 25 watts.



REDUCED PRICES.

Type T.5.	500 ohms.	224 m.a.	8/6 each
" T.10	1,000 "	158 "	8/6 "
" T.20	2,000 "	112 "	8/6 "
" T.25	2,500 "	100 "	8/6 "
" T.30	3,000 "	91 "	8/6 "
" T.50	5,000 "	71 "	8/6 "
" T.75	7,500 "	58 "	8/6 "
" T.100	10,000 "	50 "	8/6 "
" T.200	20,000 "	25 "	8/6 "
" T.250	25,000 "	32 "	8/6 "
" T.500	50,000 "	22.5 "	8/6 "

Write for our new 68-page Catalogue and Audio Manual. It tells you all about the uses of Electrad resistances. Post Free 6d.

THE ROTHERMEL CORPORATION LTD.
24, Maddox Street, London, W.1.

Phone: Mayfair 0578/9.

FERRANTI

Fixed Condensers



Type C1 5/6
 Type C1T 5/-*
 *Terminals for soldering only.



Type C2 3/6
 Type C2T 3/-*
 *Terminals for soldering only.

Ferranti 2 Mfd. Fixed Condensers are wound with pure metal foil and not with metallised paper. They are specially designed for mains work and offer minimum resistance to H.F. currents. Adequately insulated and subjected to searching tests to eliminate any possibility of defect or failure.

FERRANTI LTD.

HOLLINWOOD

LANCASHIRE

"the most efficient choke"—

The Industrial Progress Ltd.'s report upon the Lewcos H.F. Choke.

"The Lewcos H.F. Choke is the most efficient Choke we have tested, there being no sign of instability even when using 150 Volts H.T. on the anode of the S.G. Valve. The construction is massive and well finished, and its design places it in the front rank of high-class components."



LEWCOS H.F.
 Choke 20-2000 metr. es.
 Price 7/9.



LEWCOS POTENTIOMETER
 Patent No. 740579.

The Lewcos Fixed Potentiometer gives perfectly smooth reaction control on all Radio Receivers.
 Price 4/9 without Grid Leak.

LEWCOS

RADIO PRODUCTS REGD.

THE LONDON ELECTRIC WIRE COMPANY AND SMITHS LIMITED,
 Church Road, Leyton, London, E.10.

Trade Counter : 7, Playhouse Yard, Golden Lane, E.C.1.



GLAZITE

COLOURED CONNECTING WIRE

6d. per 10 ft. coil.

Radio's Supreme Power



**ARE YOU PROUD
OF YOUR NEW SET?
DO IT JUSTICE
AND FIT THE BEST
POSSIBLE BATTERY**

Grosvenor Batteries give continuous and satisfactory service because they incorporate a new vitalising element which is unique to Grosvenor.

66 v. from 7/6	Super Capacity for Multi-Valve Sets - - -	66 v. 20/-
99 v. .. 11/6		99 v. 32/6



The Grosvenor Battery

BRITISH MANUFACTURE

GROSVENOR BATTERY CO., LTD., 2-3, White St., MOORGATE, LONDON, E.C.2. Phone: Met. 6866

THE BEST WAY

TO RUN YOUR MOVING COIL LOUD SPEAKER IS TO FEED THE MAGNETS FROM THE A.C. MAINS, THROUGH A



METAL RECTIFIER

The rectifier is constructed entirely of rigidly-fixed metal and has

- NO MOVING PARTS
- NO VALVES
- NO ELECTROLYTE

nor any part requiring renewal at any time.



Other types of rectifier units for use in L.T. battery chargers, trickle chargers, and H.T. eliminators and chargers are available.

The Westinghouse Brake & Saxby Signal Co., Ltd.,
82, York Road, King's Cross, London, N.1.

Full particulars, and circuits, showing how to use all types of Westinghouse Metal Rectifiers, are given in our 32-page book "The All-Metal Way, 1930". It includes a chapter of useful information on the running of moving coil speakers from the mains.

Send 2d. stamp for a copy.

EASIER TUNING

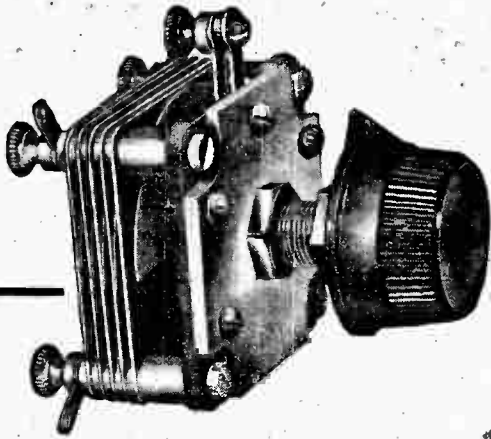

For accurate and easy tuning, use the Lotus Differential Condenser. To obviate the need for re-tuning, to simplify selectivity, and to reduce oscillation, this Lotus Condenser is incomparable.

The Condenser is reproduced here in actual size. It has two sets of fixed and one set of moving vanes, interleaved with bakelite discs of the highest possible dielectric qualities. All brass parts are chemically treated.

Available in any of the following capacities.

00007	- - - -	6/6
00013	- - - -	7/-
0002	- - - -	7/6
00027	- - - -	7/6
00034	- - - -	8/6

From all Radio Dealers.

LOTUS COMPONENTS

"Made in one of the most modern radio factories in Gt. Britain."

GARNETT, WHITELEY & CO. LTD., LIVERPOOL.

PHILIPS

RECTIFYING VALVES



For:

- Reliable H.T. Supply
- Dependability
- Long Life
- High Efficiency
- Output easily varied and smoothed

The rectifier that has stood the greatest of all tests—**TIME.**

Representative Types

TYPE 506

Full wave. Filament voltage 4 volts. Anode voltage 2 x 300 v. R.M.S. Maximum rectified current 75 mA. Price 20/-

TYPE 2506

Full wave. Filament voltage 4 volts. Indirectly heated. Anode voltage 2 x 300 v. R.M.S. Rectified current 40 mA. Price 22/6

TYPE 505

Half wave. Filament voltage 4 volts. Anode voltage 400 R.M.S. Maximum rectified current 60 mA. Price 15/-

TYPE 373

Half wave. Filament voltage 4 volts. Anode voltage 220 R.M.S. Maximum rectified current 40 mA. Price 15/-

Obtainable at all Radio dealers.

PHILIPS

for Radio

Made by the manufacturers of Philips electric lamps and fittings.
Advert. of PHILIPS RADIO, PHILIPS HOUSE, 145, CHARING CROSS ROAD, W.C.

LOCKED *for* **SAFETY!**

LOCKED *for* **RIGIDITY!**

LOCKED *for* **LONG LIFE!**

-INTERLOCKED!



**2-volt type
now available.**

The New Cossor 220 S.G.
(2 volts, 2 amp.) Max.
Anode Volts 150, Im-
pedance 200,000, Ampli-
fication Factor **22/6**
200. Price - - **22/6**

Cossor 4 and 6 volt Screened
Grid Valves are also available
with similar characteristics at
the same price.

Individual movement of the elements is impossible in the *NEW* Cossor Screened Grid. They are rigidly locked in position, definitely eliminating all risk of internal short circuit. And because they are braced to a girder-like rigidity they are proof against even the hardest blow. As a result the *NEW* Cossor has an exceptionally long life. Nothing short of complete destruction can mar its extraordinary sensitivity and range. Demand the *NEW* Cossor for your Screened Grid Receiver. No other make has Interlocked Construction.

The **NEW**
COSSOR
Screened Grid
Valve  2869

A. C. Cossor Ltd., Highbury Grove, London, N.3.

Mention of "The Wireless World," when writing to advertisers, will ensure prompt attention.

The Wireless World

AND
RADIO REVIEW
(17th Year of Publication)

No. 538.

WEDNESDAY, DECEMBER 18TH, 1929.

VOL. XXV. No. 25.

Editor: HUGH S. POCOCK.

Assistant Editor: F. H. HAYNES.

Editorial Offices: 116-117, FLEET STREET, LONDON, E.C.4.

Editorial Telephone: City 9472 (5 lines).

Advertising and Publishing Offices:

DORSET HOUSE, TUDOR STREET, LONDON, E.C.4.

Telephone: City 2847 (13 lines). Telegrams: "Ethaworld, Fleet, London."

COVENTRY: Herford Street.

Telegrams: "Cyclist, Coventry." Telephone: 5218 Coventry.

BIRMINGHAM: Guildhall Buildings, Navigation Street.

Telegrams: "Autopress, Birmingham." Telephones: 2970 and 2971 Millan.

MANCHESTER: 260, Deansgate.

Telegrams: "Hifo, Manchester." Telephone: 8970 City (4 lines).

GLASGOW: 101, St. Vincent Street, C.2.

Telegrams: "Hifco, Glasgow." Telephone: Central 4887.

PUBLISHED WEEKLY.

Subscription Rates: Home, £1 1s. 8d.; Canada, £1 1s. 8d.; other countries abroad, £1 3s. 10d. per annum.

Entered as Second Class Matter at New York, N.Y.

As many of the circuits and apparatus described in these pages are covered by patents, readers are advised, before making use of them, to satisfy themselves that they would not be infringing patents.

CONTENTS OF THIS ISSUE.

	PAGE
EDITORIAL VIEWS	665
GRID BIAS VALUES. BY W. I. G. PAGE	666
TELEVISION RECEPTION TESTS. BY F. H. HAYNES	669
KIT CONSTRUCTORS' NOTES. OSRAM MUSIC MAGNET	674
CURRENT TOPICS	676
HOW WE HEAR (CONCLUDED). BY R. T. BEATTY	677
NEW APPARATUS REVIEWED	682
WIRELESS THEORY SIMPLIFIED. PART XIII. BY S. O. PEARSON	683
CORRESPONDENCE	686
BROADCAST BREVITIES	687
READERS' PROBLEMS	688

THE MARCONI ROYALTY COMPROMISE.

A GREEMENT appears to have at last been reached between the Marconi Company and those manufacturers who were licensees under the Marconi patents. It will be remembered that negotiations for a modified licence agreement began as soon as the appeal of the Marconi Company had succeeded against an order by the Comptroller of the Patent Office under which the amount of royalty payable by licensees to the Marconi Company was reduced from 12s. 6d. per valve stage to 5s. for the first valve and 2s. 6d. on succeeding valves.

The effect of the success of the Marconi appeal against this order was to reinstate the position of the Marconi Company; the judgment deciding that the amount of the royalty could only be reduced by agreement with the Marconi Company, who were entitled to grant or refuse licences under their patents practically on what terms they pleased.

At the time that this judgment was given many months of arrears in royalties on the basis of 12s. 6d. per stage had accrued to the Marconi Company's credit, but so confident were the licensees that the new rate of 5s. and 2s. 6d. would apply that in many instances only this latter amount was taken into account in deciding upon the price at which receivers would be sold.

Had the full royalty of 12s. 6d. been demanded retrospectively by the Marconi Company, it is probable that a number of firms would have been unable to pay, and consequently it seemed highly desirable that some new agreement should be formed which would amount to a compromise to get over the difficulty.

A compromise has now been arrived at by which the royalty is agreed upon as 5s. per valve stage, irrespective of the number of stages, whether or not they utilise patents subject of the licence, with a further 5s. in the case of sets which include a battery eliminator employing any patent. Licensees must accept the agreement for the full period of the licence, which is from August 28th, 1929, to August 28th, 1933.

The licence is granted in respect of past and future patents of the Marconi Company and the Gramophone Company (which recently entered into an agreement to acquire the Marconi Company's interest in broadcast receiving apparatus).

Many of the more important patents held by the Marconi Company at the time of the old agreement have since expired, or will run out well within the new period to August, 1933, so that the Marconi Company benefits very largely by extending the period over which it is assured a substantial revenue from its patents, but the rate of 12s. 6d. over the period during which the question of royalties has been in dispute could legally have been insisted upon by the Marconi Company, so that licensees may well consider that to have avoided this full payment is a fair exchange for being made to continue to pay royalties over a longer period, perhaps, than would otherwise have been required of them. The Marconi Company, by virtue of its associations, is in a strong position to acquire future patents of importance, and these being in future at the disposal of the licensees is undoubtedly another attractive point in the terms of the agreement.

The new agreement is certainly a compromise but, taking into consideration the strong position created for the patent owners as a result of the successful legal appeal, it is satisfactory to the licensees from most points of view. Even an unsatisfactory agreement might have been better than a prolongation of the unsettled situation of the past months.

The Use of Anode
Current—Anode
Voltage Curves for—

GRID BIAS VALUES

— Determining In-
put and Output
Operating Conditions.

By W. I. G. PAGE, B.Sc.

WHEN we purchase a receiving valve there will probably be contained within the carton a slip reminding us how much we have spent and giving the conventional anode-grid characteristics. These will take the form of the upper part of Fig. 1, which has been traced from the official curves issued for a well-known small output valve. The grid bias recommended by the makers for 150 volts H.T. for amplifying conditions is 6 volts negative, which is marked X in the figure. Since grid current in power valves seldom flows to the left of zero grid volts—and even if it does the affected grid voltage is insignificant in value when compared with the total grid swing—it must be assumed that we are at liberty to allow the signal to swing to zero grid volts on the right (H) and to -12 grid volts on the left (K), for a signal voltage makes equal excursions on either side of the bias point.

Thus the permissible grid swing with an output valve can be safely taken as twice the recommended bias, unless it is expressly stated by the makers that the valve must be overbiased to prevent excessive heating of the anode. When applying the permissible 12-volt swing KH (Fig. 1) to the point X the anode current for the positive half cycle rises to L, or 10.8 mA.

from 2.6 mA., and drops from the latter figure to zero at the negative peak of the swing. The two output half-cycles will be extremely asymmetrical, and serious rectification and distortion will apparently take place. Has the valve manufacturer made a mistake or has he overbiased to be able to quote a low average anode current—such an important feature in portable sets?

The Bias Point and the Anode Load.

The answer is that the curves of Fig. 1 are of little use for bias considerations and must be redrawn in another form, taking into account the anode load. As the anode current increases there will be an increasing voltage drop across the load, the anode voltage will drop, and *vice versa*. The dynamic curve can then be found quite easily if it be assumed that the load (loud speaker impedance) is a resistance choke filter-fed in the ordinary way. *Every volt change on the grid means a simultaneous change*

both of volts and milliamps on the plate, so that an examination of the working conditions for a constant plate voltage as in Fig. 1 gives entirely erroneous results because the anode voltage is changing all the time and is only 150 volts for a fleeting moment when the signal makes the grid potential exactly 6 volts negative. Neither does the positive peak H cause the anode current to be 10.8 mA. (L), nor does the negative peak K mean a drop to zero.

How to Calculate Correct Bias.

By taking the points of intersection of each grid voltage marked and the four constant anode voltage curves (Fig. 1) a new set of characteristics can be drawn as in Fig. 2 giving anode current—

anode volts curves for constant grid voltages of equal increment. As an example the $E_g - 4$ curve intersections are D E F G in Fig. 1 and are shown again in Fig. 2 with the same lettering. In a similar way the other curves are drawn or in the case of $E_g - 12$ and $E_g - 14$ are, unfortunately, estimated.

In our early discussion of Fig. 1, in which static conditions were assumed for the plate circuit, no account was taken of the effect of A.C. on

the load. We are now concerned with peak voltages which may have an instantaneous value very much greater than the steady voltage of the H.T. battery (or eliminator). If the anode characteristics of Fig. 2 are to give a complete interpretation of working conditions we must ask the valve manufacturers for curves of plate voltages up to at least twice the maximum battery voltage; in the case in question 300 volts.

We can fix the mean working point in Fig. 2 as O, which is the same as X in Fig. 1 (6 volts bias, 150 volts H.T. and 2.6 mA); this point will represent the state of affairs when no signal is being impressed on the grid. When the total permissible grid swing (12 volts) as limited by the 6 volt bias is applied, the working line will start at $E_g = 0$, cut O and terminate at $E_g - 12$, and the angle of this line will depend on the A.C. resistance R of the load. By Ohm's law R (ohms) = $\frac{\text{change of volts}}{\text{change of amps}}$

*THE author pleads for the publication by valve manufacturers of anode current—*anode voltage curves rather than the more conventional grid voltage—*anode current characteristics. It is shown that only with such curves is it possible for the grid potential to be properly adjusted to give the minimum distortion with the greatest possible amplification. There is also considerable information in this article with regard to the effect on grid bias of the early flow of grid current with indirectly heated valves and the alteration from normal bias that has to be made when the filaments of power valves are directly fed with raw A.C.*

Grid Bias Values.

and we may hazard the guess, since the valve's A.C. resistance under working conditions is some 10,000 ohms, that the best load will be about 20,000 ohms. The line AB has been so pivoted at O that 100 volts anode change is accompanied by 5 mA. (0.005 amp.) change in anode current, making $R = \frac{100}{0.005} = 20,000$ ohms. Other angles of AB, that is other values of R, may be tried but it will be found that the greatest output for the minimum distortion will be obtainable with the load value already referred to.

If AO is not more than $\frac{11}{9}$ ths of OB, the second harmonic distortion will not exceed 5 per cent., which is unobjectionable. For further details of the 5 per cent. distortion scale which is shown against AB, the reader is referred to an article entitled "Valve Data," which appeared in the issue dated December 4th. Had the bias point been fixed originally at -8 volts, the load line of 20,000 ohms from $E_g = 0$ passing through O to $E_g = -16$ would not only give serious distortion as checked by the distortion scale, but a region of zero anode current would be entered. If the bias has been fixed at -4 volts as is suggested by the type of curve (Fig. 1) issued by the maker, the valve would be underloaded and the power output would be more than halved, although the bias had only been reduced by 2 volts. Thus the manufacturer has gone to some pains to arrive at the optimum bias point for maximum undistorted output, but the curves supplied give no clue to working conditions and are liable to mislead all but those who have taken the trouble to convert them to the type in Fig. 2. Besides giving the bias point for an output valve for minimum distortion with best value of load, these curves show the A.C. milliwatts developed in the load by making AB the hypotenuse of a right-angled triangle and multiplying together AC and CB as milliamps. and volts and dividing by 8 (in this case about 60 milliwatts).

There appears to be a very urgent need for the publica-

tion of anode current—anode volts curves up to high values of H.T., for it is only with their help that many phenomena can be studied both in radio- and audio-frequency circuits. For example, an anode-bend detector when followed by a suitable L.F. transformer provides an extremely small capacitive load to H.F. and the load line can be taken as approximately vertical ($R=0$ when change in volts = 0). In Fig. 2 M O N represents such a condition and as the working characteristic swings up and down a constant anode voltage, there would seem to be here an isolated case where the bias can be fixed from the curves of Fig. 1. Even so, the curves of Fig. 2 would be more helpful in determining rectification efficiency and the percentage harmonic distortion with varying depths of modulation. With output valves we have accepted the load as a pure resistance, actually it is usually inductive, and, because the current will lag behind the voltage, the upward swing of the working characteristic will not coincide with the downward swing resulting in an ellipse (see Fig. 3).

With screen-grid valves it is essential to use the anode volts—anode current curves, for without them the limits of safe anode swing without encroaching upon the negative resistance "kink" cannot be seen. In Fig. 4 curves of one of the new S.G. valves are shown. The working characteristics should apparently be within the dotted rectangle to ensure linear amplification without rectification. An excursion to the left of the rectangle where the $E_g = 0$ curve shows the valve to have a comparatively

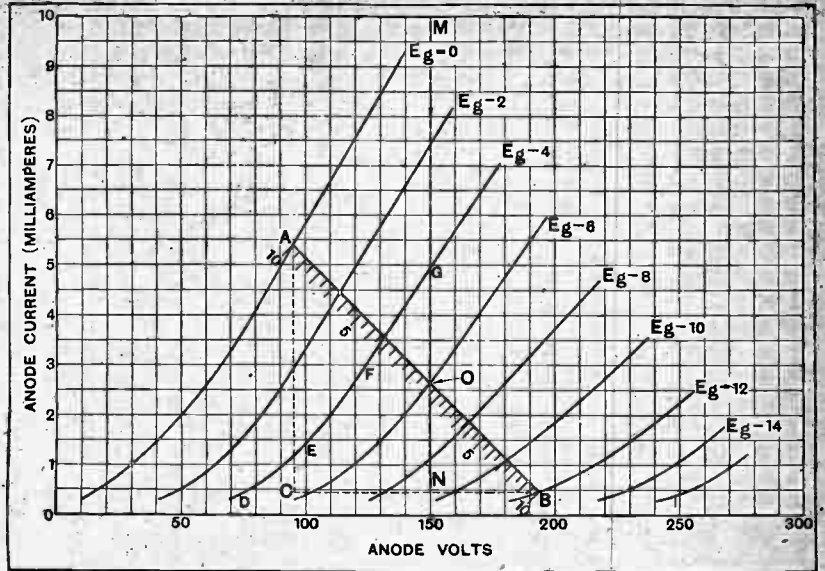

Fig. 2.—Anode current—anode volts curves for equal increments of grid volts (E_g) plotted from Fig. 1. From this family of characteristics the working conditions are easily followed. The bias of 6 volts can be seen to give practically no rectification and the best output load can be calculated from the angle of A B. The actual undistorted A.C. watts developed are measurable from the area of the triangle A B C.

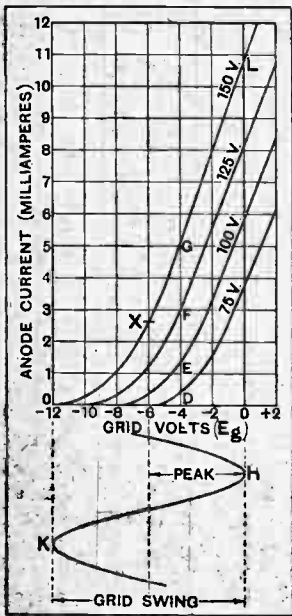

Fig. 1.—Conventional grid voltage—anode current curves for a popular small output valve. Although an optimum bias of 6 volts for 150 anode volts is given by the manufacturers for amplifying conditions, it is seen that a 12-volt grid swing KH would be seriously rectified if operating conditions are viewed from these characteristics.

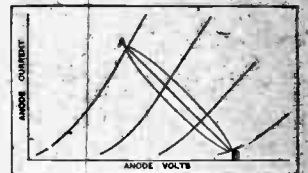

Fig. 3.—With an inductive load the anode current— anode volts characteristic swings up and down in the form of an ellipse AB since the current lags behind the voltage. As an approximation the axis of the ellipse can be taken to represent the load line.

Grid Bias Values.—

low impedance might affect selectivity. The load line shown represents a coupling with a dynamic resistance of about 40,000 ohms at resonance—indeed a poor inductance with the losses of a bad plug-in coil. If a load of about 250,000 ohms (a good Litz coil) were drawn with its operating point at $E_g - 1.5$, the line would be nearly horizontal, suggesting an extremely limited grid swing for 150 anode volts. Further study of such curves might reveal the cause of the mysterious lack of selectivity with S.G. valves when used with H.F. transformers of optimum ratio.

With pentodes the production of dangerous anode voltages up to seven times that of the H.T. battery, and the fact that very low impedance loads must be used, would not have been brought to light without a careful study of the anode characteristics.¹ In brief it may be said that the bias point and general operating conditions for triodes, pentodes and screen-grid valves can only be found by an examination of the anode curves plotted for constant grid volts, and the author feels that his plea for the general publication of such curves is justified.

It has already been stated earlier in this article that with output valves, if there is any flow of grid current to the left of zero grid volts, it affects such a proportionately small amount of the total grid swing that the bias need

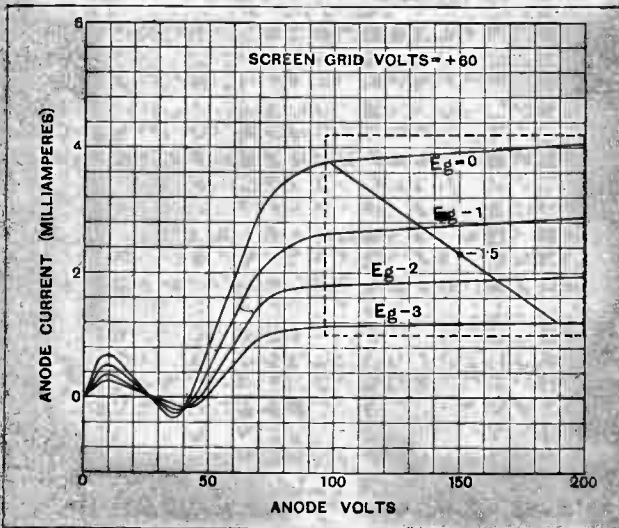

Fig. 4.—Anode characteristics of one of the new screen-grid valves. To avoid rectification the load line should be restricted to the area within the dotted rectangle.

hardly be increased. With H.F. valves and detectors accepting but small inputs the position is different. The increasing popularity of all-mains receivers has led to the widespread use of indirectly heated A.C. valves in which grid current may flow at negative grid voltages. The reason is that electrons are shot off from a cathode or filament just as irregularly as steam is emitted from a saucepan of boiling water. Some electrons start with sufficient velocity to overcome a very small negative voltage on the grid, others have but a small initial velocity and will not form part of the grid current. When there is a voltage drop down the filament, as with the

battery-fed type of valve for 2-, 4- and 6-volt accumulators, the positive end of the filament is at a considerably more positive voltage with respect to the grid than the negative end of the filament.

If the grid is connected to the negative end of the filament in a 6-volt valve such as the P.625, the grid is at a potential which is 6 volts negative with respect to the positive end of the filament and only a small portion of the negative end of the filament will produce grid current which will start to flow on the right of zero grid volts (see Fig. 5). In a valve with an indirectly heated cathode there is no potential difference between the ends of the emitter and the whole surface of the latter contributes towards grid current, which will probably start on the left of zero grid volts (see curves on the left in Fig. 5).

Grid current curves start at about the same point on the grid base for varying anode voltages, but less current will flow the higher the H.T. pressure, since the plate will begin to rob the grid of the electrons which it has claimed at the lower voltages (Fig. 5). While it is important in the interests of maximum signal strength to bias H.F. valves (neutralised triodes and S.G. valves) as near to zero grid volts as possible, it is desirable to apply a minimum of $1\frac{1}{2}$ volts negative to H.F. valves with independent A.C. cathodes. With an ordinary filamented triode a fraction of a volt is enough. An A.C. valve usually has sufficient grid current flowing at zero grid volts to allow of its use as a leaky grid detector without any applied positive bias, provided the anode volts are kept low (40-60 volts).

The prevailing practice of employing in the last stage of a mains receiver a power valve directly heated with A.C., suggests a few notes on the problems of bias in the circumstances. Assuming that the grid return is taken to the electrical mid-point, we must use a greater bias than is correct for D.C. because (1) we have actually altered the "static bias" on the grid by removing the steady potential drop along the filament and we have also slightly increased the effective anode voltage by the same means; (2) assuming the grid current to start originally at zero grid volts, we have now to take care that the grid does not in effect swing positive, due to the peak value of the A.C. voltage on the filament. The bias which we have to add must compensate for whichever of the above two effects is the greater. The changes in (1) will be taken care of by making the bias more negative by an amount $E_f/2 + E_f/2\mu$ where E_f is filament voltage and μ the amplification factor of the valve. The change of bias due to the removal of the steady drop along the filament is compensated for by $E_f/2$, while $E_f/2\mu$ cares for the effective increase of anode voltage. The potential change alluded to in (2) will be $\sqrt{2} \times E_f/2$, i.e., $E_f/\sqrt{2}$. When these two effects are equal we have $\frac{1}{2} + \frac{1}{2}\mu = 1/\sqrt{2}$ that is, $\mu = 2.4$ approximately. Thus if μ exceeds 2.4 the additional bias is $E_f/\sqrt{2}$.

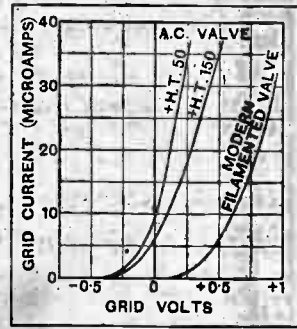
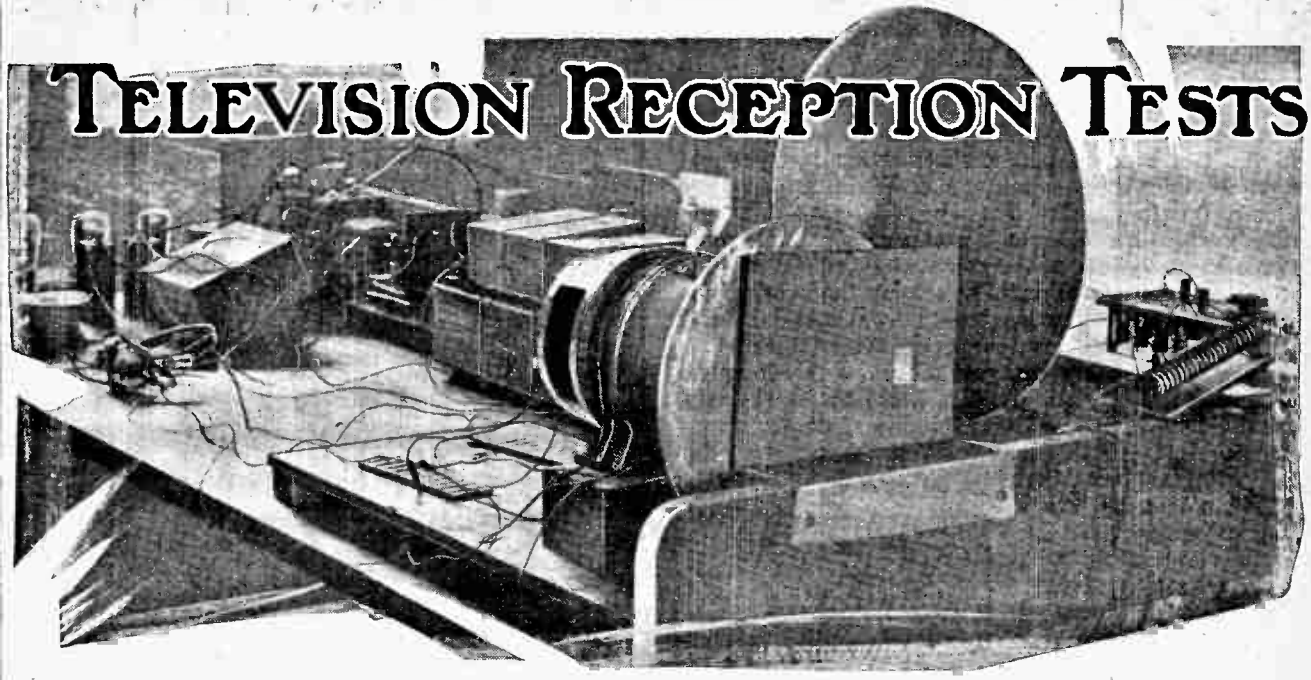

Fig. 5.—Grid current curves for A.C. and ordinary filamented valves.

¹ See *The Wireless World*, December 4th, 1929, page 630.

TELEVISION RECEPTION TESTS



An Endeavour to Receive the Television Broadcast, with Details of the Apparatus Used.

By F. H. HAYNES.

BUT for the fact that an experimental television broadcast is being conducted from the London regional station there would have been no justification for this article. So limited is a technical study of the apparatus now used in television that, in reviewing the present situation, a few words must necessarily be devoted to the Baird organisation, which is responsible for the transmissions, and the part played by the Post Office and the B.B.C. As a determined experimenter not to be deterred from his objective by the failure or criticism of others, Mr. John L. Baird has earned for himself the highest praise. His early apparatus was first described in the issues of this journal of May 7th, 1924, and January 21st, 1925, which, while revealing little that was new and an advance on the work of earlier experimenters, showed that he was intensively applying himself to the practical side of the problem. A mechanical analyser was used consisting of a disc carrying a spiral of lenses, the carrier frequency was introduced by a serrated wheel, and the light sensitive device was said to be coloidal. Valve amplifi-

cation was a new factor, so that it became possible for him to use a neon tube as a source of image-forming light at the receiver. Since that time another contribution of vital importance to television has been the perfecting of the photo-electric cell, and we can say that the valve amplifier, the neon lamp, and the photo cell have made the demonstration of television possible; yet the application of these new devices is but an obvious modification.

Knowing that the real difficulty in television is that of synchronising the revolving mechanism at transmitter and receiver, no inventor can claim success who does not first put forward a solution to this problem. In his earliest apparatus Baird used A.C. synchronising, such as had been adopted previously in several systems, and was described by Campbell Swinton. In this respect the Baird gear represented no advance on the work of others. Synchronising by A.C. consists of feeding a common A.C. current to both transmitter and receiver which, with the aid of a synchronous motors, tuning forks or relays, effectively holds

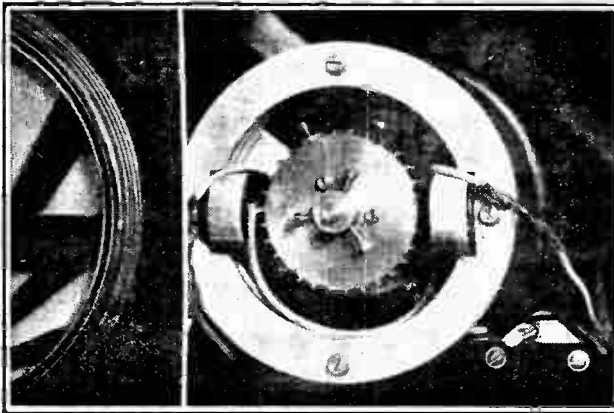

The toothed-wheel synchroniser fitted in the Baird television receiver.

Television Reception.—

the rotating parts in step. This method demands an additional channel between transmitter and receiver in order that both the picture-forming and synchronising signals may be separately conveyed. In spite of the existence of this all-important problem of synchronising and the fact that no patent specification has yet appeared in which a new solution is disclosed, it is thought in many quarters to-day that television is making vast strides towards becoming an accomplishment as familiar as broadcasting. We now know that Baird had no important contribution to make in solving the synchronising problem. The situation might have remained unchanged following the early experiments of Baird had not financial assistance been sought and a development company formed to convert the Baird apparatus into a marketable article. More recently a larger company acquired the Baird interests in this country, the principal object being that of manufacturing television reception gear for use in conjunction with our broadcasting service. In this connection another almost insurmountable problem presents itself.

The Frequency Limitation.

When analysing a picture into a number of points of light of varying intensity, an enormous number of individual signals are formed, and we

the image, and the extent or "fineness" of analysis, the number of signals to be transmitted within a second far exceeds in value the highest audio frequency that can be dealt with in broadcast. So long as the picture

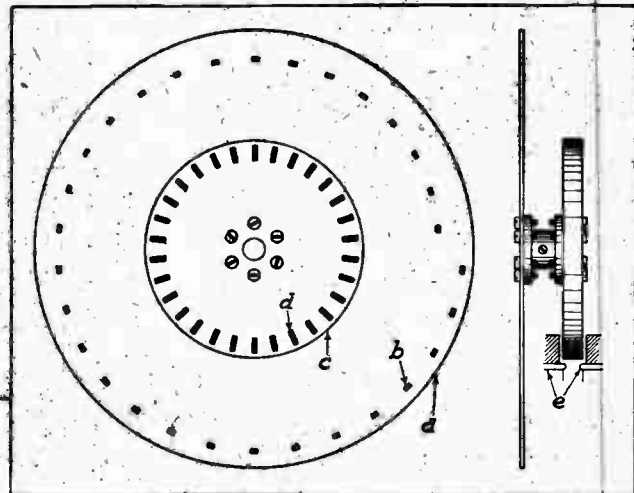

Constructional details of scanning and synchronising discs.

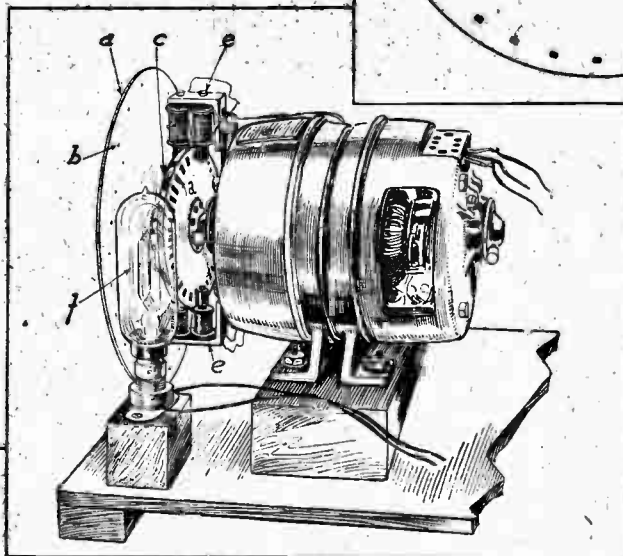

Experimental television receiver. (a) scanning disc, (b) spiral of 30 holes, (c) light fibre synchronising disc, (d) soft iron segments, (e) magnets carrying the picture signals, (f) the neon lamp.

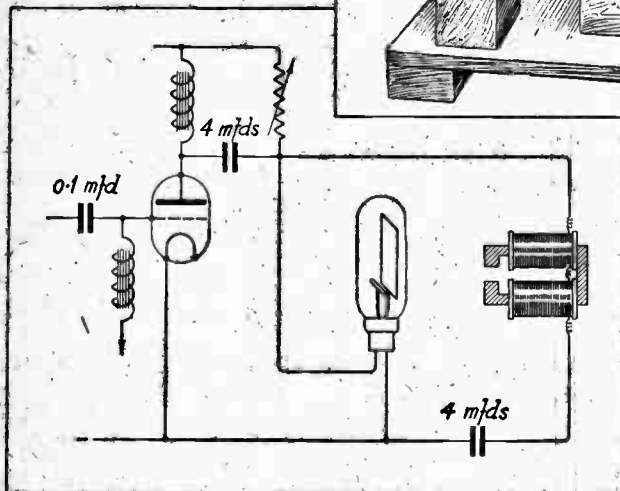

Circuit arrangement of an output stage in which the picture signals are passed to an electromagnet in order that the current peaks may produce synchronising.

know that the complete image must be transmitted in a period of time not longer than one-tenth of a second if a moving picture effect is to be produced. Unless a very severe limit is imposed, therefore, on the size of

is kept small and a coarse degree of analysis used, radio transmission is possible, assuming, of course, that a solution is found to the difficulties of synchronising.

We remember the publicity given to the negotiations between the Baird Company and the broadcasting authorities concerning the inclusion of television transmissions in our broadcast programmes. From the statements issued it appeared that the B.B.C. was opposed to being a partner in such an undertaking, this attitude being based upon technical considerations. Negotiations were pursued, however, and on the intervention of the Post Office we now have the experimental television broadcast service. Transmissions are made from 11 a.m. to 11.30 a.m. daily, Saturdays and Sundays excepted. It is understood that this series of television transmissions is now being extended to include, in addition, two nights a week after broadcasting hours.

Enquiries are being made in many quarters as to the success of these transmissions, which have now been in progress for some eight weeks. Listeners ask where suitable receiving gear can be obtained, and radio enthusiasts seek technical details of experimental apparatus with which to participate in the tests. Can this television broadcast be successfully received, and, if so, what is the quality of the pictures? It was with

Television Reception.—

the object of answering these questions that the apparatus to be described came into being.

Details of the Baird method of synchronising were made public last September. The apparatus was shown to be extremely simple, and to consist of a toothed wheel mounted on the shaft of the motor driving the analysing ("scanning") disc. Just clearing the teeth are the poles of an electromagnet, the signal currents being applied to the magnet winding. A very similar arrangement of phonic wheel has already been described in this journal when reviewing the Mihály system of television.¹ Assuming that a break exists between each successive picture, then a similar moment of no signal must likewise occur after the formation of each transverse picture-forming strip. With a number of teeth equal to the number of holes in the disc and the poles of the magnet engaging the teeth during the

period of no signal, it is thought possible that the picture signals may be used as a means of synchronising. Thus at a time of no current through the magnet windings the teeth will travel unimpeded past the poles. Should, however, the disc be running slightly too fast the picture-forming current will be energising the magnet pending the interval of no signal being reached. There will thus be a retarding action tending to correctly regulate the speed of running and the precise position of the disc at any interval of time. Whether or not the toothed wheel is controlled by an interval of no signal between each image-forming picture strip or is, in fact, pulled into position by the current representing a bright line across the picture is immaterial. What most probably is the intention is that the bright parts of the picture representing successive peaks of current with each traverse have an accelerating or retarding action upon the rotation.

Unless a generous bank of power valves be used for energising the electromagnet its influence will be inadequate to control the rotation. Whether the power thus available is sufficient to control the disc will depend upon the weight and speed of the revolving parts and the amount of correction required. When one considers that the initial driving power is

supplied by a motor running at a speed of over 700 r.p.m., and that the restraining influence of the synchronising current is only applied for a brief interval of time, it will be readily realised that considerable energy will be needed to check even a small variation. Lightness of moving parts and a minimum of friction

for the motor to overcome are the aims in setting up the apparatus, while provision must be made to regulate very critically the speed of the motor. A slow-speed motor with ball-race bearing having an armature and commutator of the smallest permissible diameter was selected after making several tests. As to the scanning disc itself, which measured $11\frac{1}{8}$ in. in diameter, sheet aluminium was adopted, a little more than $\frac{1}{16}$ in. in thickness, after tests had been made with another and much lighter material.

Instead of the iron-toothed wheel, as recommended by Baird, one of fibre was constructed

slightly larger in diameter than was indicated, so as to provide a more critical control and yet possessing quite moderate weight. To avoid the windage of projecting teeth, which it was quickly realised was appreciable at the normal running speed, small iron bars were pressed into a fibre disc, and their ends turned down flush with the faces. Precise details of the disc can be gleaned from the illustrations. Every care was taken to ensure correct spacing between the bars and that they passed through the disc at exact right angles to the faces. Maximum

magnetic flux for the watts available was thus produced by the short magnetic circuit when these bars passed between the poles of an electromagnet. Two magnets were actually used in order to get the strongest magnetising effect without saturating the iron. As there was no end play on the motor shaft, exceedingly small clearances were possible between the poles and the disc, and this is, of course, an important condition, seeing that the

watts used to produce a given magnetic flux increase approximately as the square of the width of the gap increases. So small were the clearances, in fact, that when the signal currents were applied a slight pulling in of the poles occurred, and, in order to prevent rubbing, it was necessary to insert wooden wedges between the end cheeks of the bobbins.

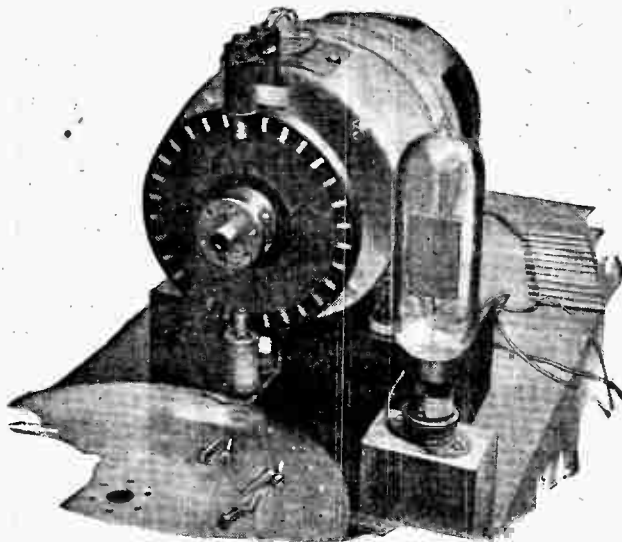

View showing the method of mounting the synchronising disc and its associated electromagnets. The critical speed-adjusting field rheostat can be seen on the right.

IS it possible to receive in the average home the television broadcasts now taking place from 2LO? The test apparatus made up with a view to answering this question is here described together with details of the results obtained. Unlike most scientific achievements uncertainty exists as to whether the claims of success have been substantiated.

The recent announcement that 1,000 receiving sets will shortly be available, and that the television transmissions are being extended has created a demand for precise technical information concerning the apparatus and its performance.

¹ Television by the Mihály System, July 3rd, 1929.

Television Reception.—

A brass bush coupled the synchronising and scanning discs. In the absence of published information it became necessary to conduct some preliminary tests in order to discover the direction of the spiral of holes in the scanning disc, the pitch of the spiral, together with the size and position of the image. Quickly it was realised that reasonable precision was necessary in the positioning of the holes, and that a small error in the setting out of any one hole produced a dark strip when the disc was rotated before a source of light. It was noted also that for uniformity of illumination when receiving a picture that the holes should not be precisely round, and that their exact shape, which more probably approaches a rectangle, can, no doubt, be readily calculated, bearing in mind also the hole-shape used in the scanning disc at the transmitter.

Speed Regulation.

Critical speed control was arranged by variable resistances in the field and armature circuits of the motor, so that an almost correct running speed was maintained with a minimum of current. Part of the resistance controlling the field was brought out to a short-circuiting switch in accordance with popular American practice, so that the speed could be critically checked while watching the formation of the image. Such a method of speed

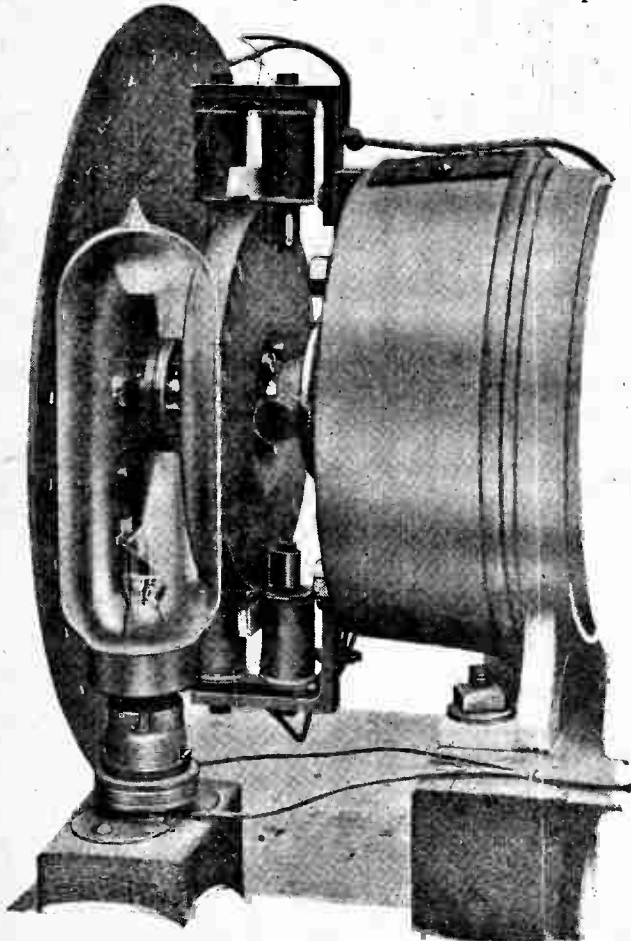

The complete apparatus as assembled on the end of the motor.

control, while being crude and entirely unsatisfactory in a commercial product, is as helpful as anything in the hands of the experimenter. Attention was particu-

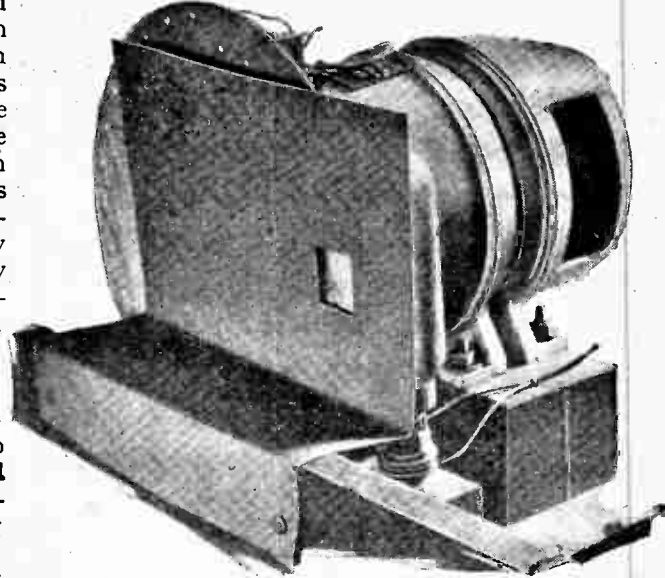

A card is used to "frame" the image while a magnifying lens was improvised so that the details could be more carefully examined.

larly turned to an endeavour to successfully operate the synchronising device. With a power output valve such as the P.625, which can be run from a normal source of H.T. supply, it cannot be seen how sufficient control of the disc can be obtained. By fully loading its grid with an alternating current, and experimentally adjusting the impedance of the magnet so as to obtain a maximum power output at the given frequency, the control provided by a valve of this class proved entirely inadequate. In making this observation it must be borne in mind that the magnets are only acting at brief intervals.

Tests with Generous Output Stage.

The next step was to arrange a generous output power stage, and the arrangement finally set up consisted of no fewer than three of the new LS6A valves with fully loaded grids, as revealed by microammeter and milliammeter, and working with the maximum rated anode voltage of 400. Even so generous an output stage as this proved insufficient to produce stable and automatic synchronising. When the grids of the output valves, however, were fed with alternating current, the effect was different, and, in spite of the comparatively high speed of rotation, synchronising with the A.C. voltage was at once possible, as was to be expected from previous experience with a phonic wheel. Owing probably to the irregular wave-shape of the picture-forming signal this type of synchronising, as suggested by Baird, cannot be regarded as satisfactory. Maybe by mere coincidence the regional scheme will provide an acceptable solution to the problem, in that while one transmitter will convey the picture signals, the other can provide an alternating current controlled by the analysing disc at the transmitter. Such a proposal differs vastly from the existing claims as to the possibilities of a television broadcast

Television Reception.—

service, and would entail the use of a twin receiving equipment.

As to the results obtained it may be stated that pictures were received within the first ten minutes of using the apparatus, but the synchronising was not automatic and success depended upon the very careful manipulation of the field regulating switch, combined with frequent frictioning of the disc. For the most part the successive pictures appeared as parallelograms rising and falling before the aperture. With the rising or falling string of pictures one soon learns how to speed up or retard the disc, yet an apparatus demanding such a procedure possesses no commercial merit. The neon tube functioned well, and after critically adjusting the threshold and signal voltages the contrast of the image was brought down from the harshness which it possessed at the commencement of the tests. Detail was poor, due, perhaps, in some measure to small inaccuracies in the location of the holes and to the continuously changing position of the picture. Two types of tube were tested, with equal success, one a product of the General Electric Company and the other a Raytheon Kino-lamp (Rothermel).

It is probable that the scanning disc used was incorrectly divided in that the pitch of the spiral was excessive as compared with the mean circumference. In the absence of information it is suggested that some 50 per cent. of the signal is taken up by the synchronising mechanism so that the height of the picture is only about one-half the distance between successive holes. This reduction in the height of the image demands a smaller pitch for the spiral in order to maintain the correct height to width ratio. Actually the holes in the disc were very much smaller than they appear in the illustrations, the apparent large size being due to countersinking. Assuming that nearly half the signal energy is thus applied to the windings of the magnets, and this would seem to be the case from these tests, the successful working of the apparatus can be anticipated. A bright margin observed between successive pictures indicates the inclusion in the transmission of a definite synchronising signal.

In addition to the apparatus referred to here other forms of gear were tested. An attempt was made to rotate a light paxolin disc with a powerful audio-frequency oscillator adjusted closely to the picture fre-

quency and to which the picture signals were coupled. It was the hope that the peaks in the signals would drag the oscillator precisely into step. Insufficient power, however, was produced to maintain the high speed of rotation, while practical difficulties in combining an incoming signal with the local oscillator made the arrangement unworkable.

Transmission but no Reception.

Against the observations recorded here may be quoted the fact that successful public demonstrations have been claimed. Other than at the Olympia demonstration and that which is frequently given at the Baird studios, where in both instances the transmitting and receiving equipments are set up in adjoining rooms, no details can be gleaned of successful television reception possessing commercial possibilities and operating under conditions similar to those existing in the home of the broadcast listener. While much is being written on the obscure electrical and light problems involved in television the writer is unaware of any single instance of an experimenter coming forward claiming successful results and inviting investigation. We will be better able to judge the fulfilment of the claims made when Baird receiving equipments become available, and one cannot but draw attention to the extraordinary position which exists under which the transmissions have come into being without even the standards of transmission being disclosed to the public or a single specimen instrument being procurable. Television receiving sets are to be available shortly, and, according to a statement by the Baird Company, one thousand instruments will be completed during the month of January, and whilst one must assume that machines already exist it has not been the good fortune of the writer to be favoured with an early specimen in order that its successful working might be endorsed. "Television is here" has so long been the cry that failure in its fulfilment is sufficient contradiction of its truth. It has long been hoped that in television the amateur will find a new field of experiment, and with the introduction of receiving equipments in the course of the next few weeks an opportunity will be afforded to judge its potentialities. In the meantime a statement from the B.B.C. as to the nature of the reception, which, one must assume, they are investigating, would be welcomed.

Elements of Radio Communication, by J. H. Morecroft. A text-book for students giving the general principles of wireless telegraphy and telephony in a concise form and without the use of advanced mathematics, comprising the simple laws of the electric circuit; special laws for radio circuits; general idea of radio communication; the valve and its uses; telegraphy; telephony; and typical receiving sets. Pp. 269+x, with 170 illustrations and diagrams. Published by J. Wiley and Sons, Inc., New York, and Chapman and Hall, Ltd., London. Price 15s. net.

○○○○

The Fundamentals of Radio, by Prof. R. R. Ramsey, Ph.D. of Indiana University, U.S.A.

BOOKS RECEIVED.

A text-book for students, comprising the general theory of electricity and the principles and practice of radio telegraphy and telephony. Pp. 372+xi, with numerous illustrations and diagrams.

Published by the Ramsey Publishing Co., Bloomington, Indiana, U.S.A., price \$3.50.

○○○○

A.T.I. (Annuaire Téléphonique International).—The first edition of the International Telephone Directory in English, French and German. Containing the charges for long-distance telephone con-

versations between Continental towns and a list of 12,120 names, addresses and telephone numbers of manufacturers, hotels, traders, etc., in 1,485 towns of 27 different European countries. These are classified under their trades, but a further alphabetical index of their names is provided in which they are grouped according to their respective countries. The directory is published in Copenhagen, and the editors, while admitting that this first edition naturally falls far short of the objects they have in view, hope that its utility will be so universally recognised by firms doing foreign business that subsequent editions will become more and more complete. The sole agents for Great Britain are Messrs. Rassey Bros., 28, Basinghall Street, London, E.C.2.

KIT CONSTRUCTORS' NOTES

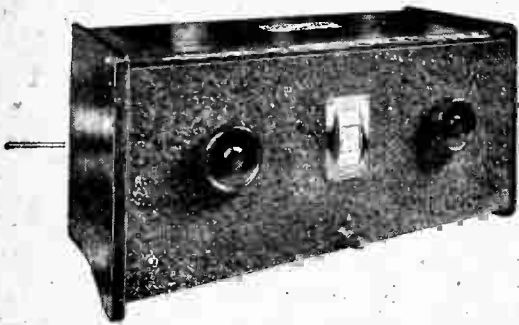

The New Osram Music Magnet.

THAT the basic essential features of the original Osram Music Magnet have been found suitable to be included in their entirety in this season's model must surely be a matter for justifiable self-congratulation on the part of those responsible for it. In a rapidly developing art such as ours, no better proof of excellence exists than that a design—particularly one of an ambitious and unconventional kind—should not only survive, but actually flourish, after the acid test of a year's trial.

It must be a pleasant task—it is certainly still a comparatively unusual one—for a wireless set designer to be relieved of the necessity for producing something entirely new, and to be able to concentrate all his energies on improving his original conception in detail. However carefully the job may have been done in the first place, experience nearly always shows minor crudities or imperfections to be smoothed away, and desirable additions to be made.

The set under review provides an example of what can be done when working on these lines. Although it is externally similar to its prototype, critical examination shows that hardly a single detail remains unchanged.

Alterations are found in the arrangement of the filament wiring; originally, there was considerable risk of burning out valves by an accidental short-circuit, but, by connecting H.T. negative to L.T. negative and fitting an on-off switch (insulated from the metal panel) in the positive L.T. lead, the receiver is rendered as safe, and even fool-proof, as is possible. As an extra precaution, a safety fuse is inserted in the H.T. negative lead.

An improved mounting for the H.F. valve is provided; although it is still carried in a spring holder, a fairly rigid metal spring is used for making connection with the anode terminal.

The coil assemblies have been simplified, and now consist of two concentric formers, the inner carrying the medium-wave inductance and the outer the long-wave coil; there is also a third section which, as the coils are interchangeable in grid or anode circuits, functions as either "aperiodic" aerial or reaction winding. The coils have a very limited external field, as each of the tuned inductances comprise two windings in opposite direction. For working on the long waves, one section only is used, while for the medium band, both are placed in parallel by the action of built-in roller switches. One is apt to criticise the position of these switches on the score of inaccessibility—the lid of the box must be opened to change wavebands—

but any other plan would introduce undesirable complications.

Complete ganging of the two tuned circuits is, of course, still a leading feature of the design, and an important innovation this year is the provision of direct wavelength calibration; indications are marked on the dial every 50 and 200 metres for the medium and long wavebands respectively. This is a most attractive and valuable feature.

It will be unnecessary to enumerate all the details in which the present set differs from the original, but mention should be made of the improved condenser friction drive, which operates well and is quite easy to set up, and of the

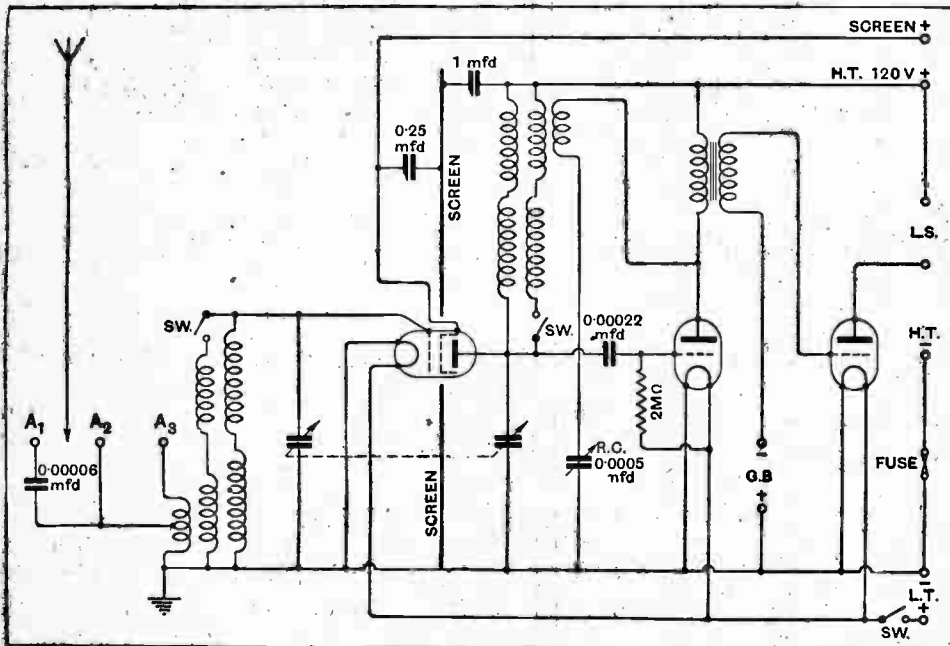

Circuit diagram, showing details of waveband switching.

Kit Constructors' Notes.—

fact that a good-looking polished oak cabinet, supplied in sections ready for easy assembly, is now included in the set of parts. The efficient L.F. transformer is of a new type, with high-permeability core.

The diagram given shows that the circuit is a fairly conventional arrangement of H.F. amplifier, detector, and one L.F. stage. Aerial coupling is through a double-wound transformer with three optional connections for varying selectivity. By joining the aerial to A_3 , the complete primary winding is in circuit and signal strength is (almost invariably) at a maximum; greater selectivity but generally less sensitivity is afforded by changing to A_2 ; in this position the number of aerial coupling turns is reduced. The third terminal, A_1 , is joined internally to the tapping point on the coupling coil through a very small condenser, and provides high selectivity with considerably weaker signals.

H.F. coupling is through a tuned anode arrangement, and the detector operates on the grid principle. For reaction control, a commendably large value of variable condenser is used, and it should be noted that the primary winding of the L.F. transformer is relied upon to deflect sufficient energy through the feed-back circuit, the usual choke being omitted.

Assembly and wiring of the "kit" submitted for test took precisely 2 hours 55 minutes; this allowed sufficient time to make connections neatly and properly. Prospective constructors may be interested to know that it is wise implicitly to follow the sequence of operations as laid down in the instructional pamphlet, and that apparent short cuts may involve the risk of having to remove parts already assembled. In general, accessibility of the components is excellent, and all the holding down holes register accurately with their counterparts on the sheet aluminium chassis. Care should be taken to see that the lead between terminal No. 4 of the anode coil assembly and the reaction condenser is led well clear of the roller switch in such a way that it does not interfere with its operation. A small spanner is useful for tightening up the various nuts, particularly those on the terminals; the condenser spanner supplied might with advantage be made double ended so as to serve for this purpose.

Satisfactory Ganging.

One's initial impression that the design of the set is particularly well balanced is confirmed on testing it. The H.F. resistance of the coils seems to be just high enough to ensure entirely satisfactory operation of the single-knob tuning control and low enough to afford reasonable

sensitivity; with regard to this latter quality, the set behaves every bit as well as many popular receivers with independent tuning condensers.

To obtain high selectivity it is necessary to make full use of the variable coupling provided by the three aerial terminals, and it would be more convenient if these were replaced by sockets. Over most of the tuning scale, there is naturally a considerable drop in volume as coupling is loosened, but this is not so marked when receiving the lower wavelengths on either band. Operated on an indifferent aerial in central London, Brookmans Park was just audible on the setting corresponding to the proposed twin station (261 metres) with the aerial connected to A_3 (least selective adjustment). This slight interference was entirely removed by applying reaction. There was very little spreading of local signals with the weaker coupling provided by connection to A_1 or A_2 .

On the medium band, reaction control was found to be smooth, progressive, and almost free from overlap; on the longer waves it was not quite so good, but still

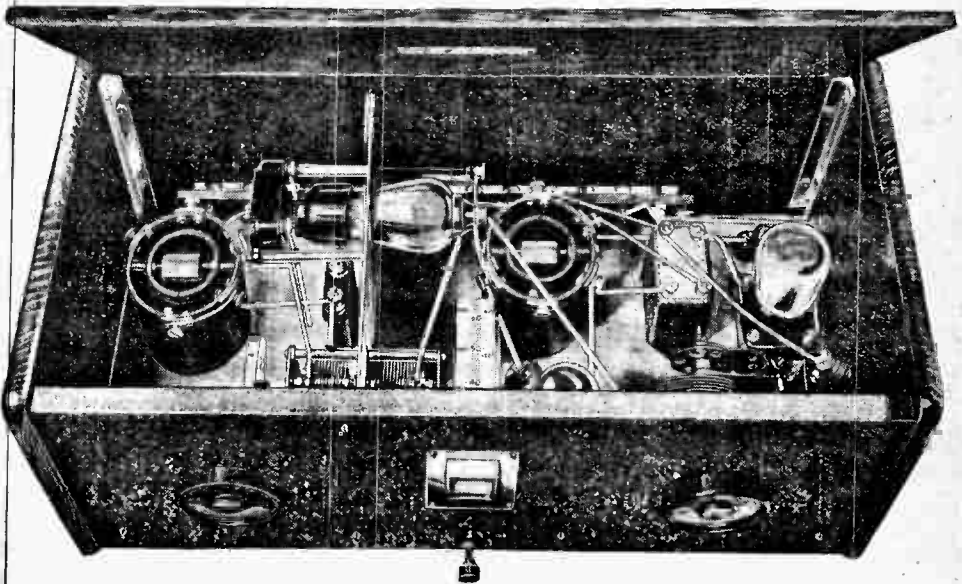

Interior view, showing dual astatic coils and positions of the more important components.

satisfactory. Thanks largely to the new L.F. transformer, quality of reproduction is distinctly superior to that of the original model, and, with a super-power L.F. valve in place of the Osram P.215 normally supplied, a still greater undistorted output is obtainable—but, of course, at the expense of an increased H.T. consumption.

Two years ago it would have been considered almost impossible to produce an inexpensive 3-valve set with H.F. amplification, ganged tuning, and wavelength calibration, even under factory conditions, where tests can be applied at various stages of manufacture. It is something of an achievement to have devised means whereby these advantages can be offered to the home constructor in such a way that he is virtually assured of success, provided he applies reasonable care and common sense in assembly and wiring. The complete kit, including valves and cabinet, costs £9, and may fairly be considered as good value for money.

**U.S. FOOTHOLD IN CANADIAN
ETHER.**

While Britain continues to dally with the project for an Empire broadcasting service, the United States has secured a new mouthpiece for national and commercial propaganda in Canada by the inclusion of station CKGW, Toronto, in the National Broadcasting Company's network. CKGW broadcast its first N.B.C. programme on the American Thanksgiving Day (November 28th), and will in future relay to Canadian listeners regular programmes from New York, Washington, and other cities of the United States.

WORLD TALKS FROM THE VATICAN.

Work has now begun on the erection of the Papal wireless station in the Vatican City. The apparatus is being built by the Marconi Company.

RAIN-MADE "STATIC."

During the rainy spell many listeners have imagined that atmospheric have been on the increase. In most cases it has been found that the supposed static has been due to faults in aerial insulation disclosed by the damp.

**FRANCO-TURKISH WIRELESS
SERVICE.**

A public radio service to Turkey has been opened by the French Post Office. Private and commercial telegrams marked "Voie T.S.F." are sent by this route at the ordinary rates.

POLICE WIRELESS IN FRANCE.

A network of fifty-one police wireless stations distributed throughout France is provided for in the Budget of the Ministry of the Interior for 1930. The central transmitter will be the Eiffel Tower, says

**CURRENT
TOPICS.**

The Daily Telegraph, and the calls will be made at an hour's interval during a certain part of the day. Photographs and finger-prints will be included in the transmissions. The receiving stations will be specially equipped for short-wave reception, and their duties will include watching foreign transmissions and searching for illicit stations.

OUR CHRISTMAS-DAY ISSUE.

Special arrangements have been made whereby the issue of *The Wireless World* dated December 25th, will be on sale on Saturday, December 21st.

**PHYSICAL AND OPTICAL SOCIETIES'
EXHIBITION.**

Sir Ambrose Fleming, M.A., D.Sc., F.R.S., lecturing on "Television, Present and Future," will provide one of the attractions of the twentieth annual exhibition of the Physical and Optical Societies.

The exhibition is to be held on Tuesday, Wednesday, and Thursday, January 7th, 8th and 9th, 1930, at the Imperial College of Science, Imperial Institute Road, South Kensington, and will be open in the afternoon from 3 to 6, and in the evening from 7 to 10 p.m.

Over eighty firms have accepted the invitation to exhibit in the trade section at this exhibition, and in addition a group of research and experimental exhibits is being arranged, which will be shown by Fellows of the societies and others, and a number of research laboratories and other institutions. Some interesting historical exhibits will also be included.

Sir Ambrose Fleming's lecture will be given at 8 p.m. on January 9th.

TREE RENT.

Listeners who have used trees in Enfield Town Park Estate, Middlesex, to support their aerials, are to pay a shilling a year to the Town Council as "rent."

NEW YEAR "SMALL ADS."

Special holiday printing arrangements make it necessary to close for press earlier than usual with our issue of January 1st. Miscellaneous advertisements for inclusion in that issue should be in our hands not later than first post on Tuesday, December 24th.

MAZDA VALVES.

In our issue of December 4th we drew attention to the special arrangement of the Edison Swan Electric Co., Ltd., whereby customers who were unable to obtain valves of the new Mazda series from their local dealers could be supplied direct on application to the company. Owing to the large response, the Edison Swan Electric Co., Ltd., regret that this offer must now be withdrawn. Every effort is being made to overtake the demand.

"WIRELESS FOR THE BLIND" FUND.

With the object of providing every blind person in the United Kingdom and Northern Ireland with a wireless set a Fund has been established, with H.R.H. The Prince of Wales as President. Whole-hearted support is being given by the B.B.C., and one of the first moves in the broadcast campaign will be a microphone appeal, to be made by the Rt. Hon. Winston Churchill, M.P., at 9.20 p.m. on Christmas Day from all B.B.C. stations.

It is estimated that 15,000 blind people throughout the country need sets.

All donations to this Fund should be sent to the Rt. Hon. Reginald McKenna, Hon. Treasurer, British "Wireless for the Blind" Fund, 226, Great Portland Street, London, W.1.

MAN'S INGRATITUDE TO MAN.

That broadcasting for love is a thankless task is the discovery of the Radio Club of Burma, which has received numerous complaints from Rangoon that its programmes do not come up to the expected standard. More in sorrow than in anger, the president of the club is asking the Government to erect a powerful station which can be heard all over the province. The Radio Club's transmitter has a power of only 750 watts, and funds are scarce owing to the fact that the club, unlike the broadcasting companies, draws no revenue from the wireless import duties.



FOR THE WORLD'S FASTEST LIFEBOAT.—The totally enclosed wireless telephony transmitter and receiver installed by the Marconi Company in the new Dover lifeboat, the fastest in existence. Known as the type XMB.1., the set uses a transmitting power of 100 watts on a wavelength of 900 metres, and is designed for work under the roughest conditions. The lifeboat is specially equipped for aircraft rescue work,

HOW WE HEAR

The Ear Corrects certain Loud Speaker Defects and Acts as an Amplifier, Rectifier and Frequency Analyser.

By R. T. BEATTY, M.A., B.E., D.Sc.

(Continued from page 652 of previous issue.)

PHYSIOLOGISTS find that both motor nerves (those which transmit orders from the brain) and sensory nerves (those which transmit messages to the brain) behave exactly alike. Messages pass along both kinds of nerve at an average speed of 100 metres per second, or 220 miles per hour—a rate which is too slow to be of an electrical nature and which is ascribed to chemical action; this action is, however, accompanied by an electrical effect, which can be amplified and recorded by a string galvanometer. These records reveal a most curious result; the amplitude of the disturbance is always the same (Fig. 9). The only difference between

neighbouring strings affected in rather smaller measure.

The Ear Makes Its Own Overtones.

In addition we sound a feebler note of different pitch it may be drowned by the louder tone unless its strength is sufficient to cause a subsidiary peak on the main resonance curve (Fig. 13). This drowning, or *masking*, effect might be expected to be greater when the two notes are close together than when they are far apart. Fig. 14 shows results on masking obtained by Fletcher in 1923. He measured the strength of a just audible tone when sounding alone; then he ascertained how many times that strength required to be multiplied for audibility in presence of a second stronger tone. In curve A, Fig. 14, a tone of 800 cycles/sec. was sounded continuously. The ordinates give the multiplying factor required to make any weaker tone audible: the factor is seen to be symmetrical on either side of 800 cycles/sec. with a kink at the maximum due to complications arising from beats when the tones are nearly equal in pitch, and we may conclude that the ear strings vibrate symmetrically on either side of the reson-

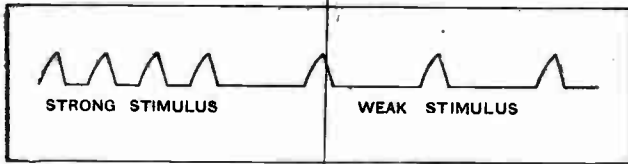

Fig. 9.—A strong or weak stimulus is conveyed by a nerve as a variation in the frequency of the impulses. The amplitude of the disturbance is always the same.

the effects of a strong or a weak stimulus applied to the nerve is that in the former case more pulses are produced in the nerve per second than in the latter. Further, it is found that the passage of a pulse leaves the nerve in a refractory condition for about 0.003 second, during which time no further pulse can pass, so that the nerve can transmit no more than 300 pulses per second. If the nerve passes through a ganglion (a swelling on the nerve which acts as an amplifier of the pulse) the number is still further reduced.

Here, then, a fatal objection arises to the telephone theory: how can a nerve convey the sensation of a note of 20,000 cycles per second when it can transmit but a few hundred pulses per second?

How Our Ears Deceive Us.

When the tuned strings in our ears respond to the throb and pulse of sounds which reach them they may play strange tricks at times: they may actually generate tones, phantom tones, which do not exist save in the ear itself: out of two sounds they may create a third; out of a single sound they may create a multitude.

When a tuning fork gives out its single pure tone we should expect the strings of the basilar membrane to vibrate most strongly near the resonance point, with

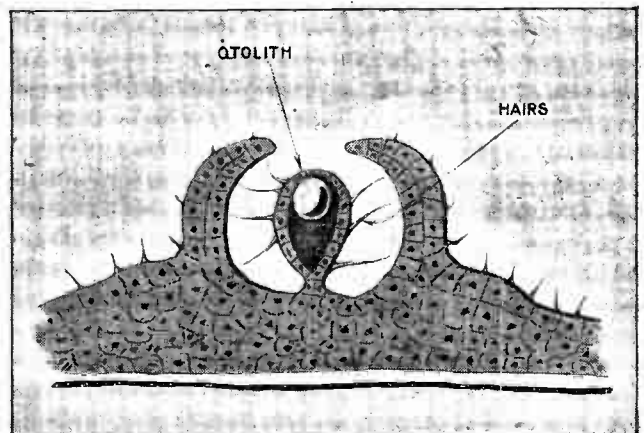

Fig. 10.—While a fish has no powers of hearing, it is equipped with a device that detects violent vibration. It takes the form of a tiny stone which is carried in a sensitive cavity.

ance point as imagined in Fig. 12. But the story changes when the continuous tone is made 4 times as strong (as in curve B), or 8 times as in C. The curve becomes unsymmetrical, the masking is greater on the

Now We Hear.—

high frequency side, and new kinks show the presence of overtones, which are harmonics of the 800-cycle note, as is evident since their relative frequencies are as 2, 3, 4, etc.

The Ear is an Unsymmetrical Receiver

How come these overtones? It is idle to say that they arise in our consciousness or that they are figments of the brain incapable of analysis: science has taught us little if we cannot better such explanations.

A hint is given by the behaviour of vibrating bodies when the amplitude is so large that the strain exceeds the elastic limit or when the load is unsymmetrical, as when a diaphragm is loaded with a wax pellet on one side. Theory shows and experiment agrees that in such cases overtones will appear and will become relatively stronger as the amplitude is increased. Now many unsymmetrical structures occur in the ear; for example, in the arrangement of the muscles which bear on the ear drum, in the ear bones, and in the structures connected to the strings themselves. Hence we have good reason to expect the overtones which Fig. 14 shows to be present. *The ear has the faults of the early microphones used in broadcasting or of a badly designed loud speaker.*

Difference Tones.

But theory goes farther and predicts that when two

pure tones excite an unsymmetrical receiver a third tone will be generated with a frequency equal to the difference between the first two. When the middle C of a piano and the G above, whose frequencies are as 2 3,

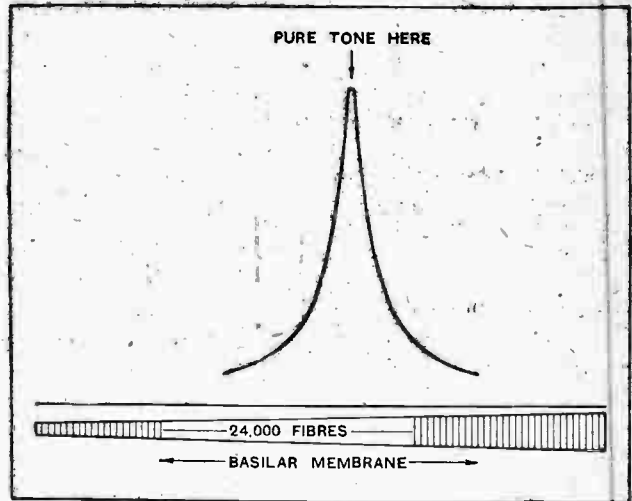

Fig. 12.—Hypothetical amplitude of vibration of the ear strings when a pure tone is sounded.

are sounded together, using the loud pedal, the C an octave below, whose relative frequency is 1, will be heard. We cannot say, however, that this tone is generated only in the ear, for on opening up the piano it will be found that a lower C string is vibrating strongly: the difference tone has been produced by the unsymmetrical frame of the piano. But when the experiment is repeated with tuning forks placed on separate tables with no connection save air, the same difference tone is heard and can be made to give beats with a third fork of nearly the pitch of the difference tone. This tone cannot be picked up by a resonator and so has no existence outside the ear.

Fundamental Tone Suppressed—No Change in Pitch.

When a vowel is sung, and a record taken on an oscillograph and analysed, the constituents of the complex sound are as shown in Fig. 16: the vowel can be faithfully reproduced by using a series of valve oscillators and loud speakers, one for each partial tone. Now comes a truly remarkable result: if the fundamental tone be suppressed the vowel will sound exactly the same: if in addition the first overtone be silenced the pitch on which the vowel is sung will seem unaltered though a very slight change of quality will appear, as if the same note had been taken up by a different voice. With

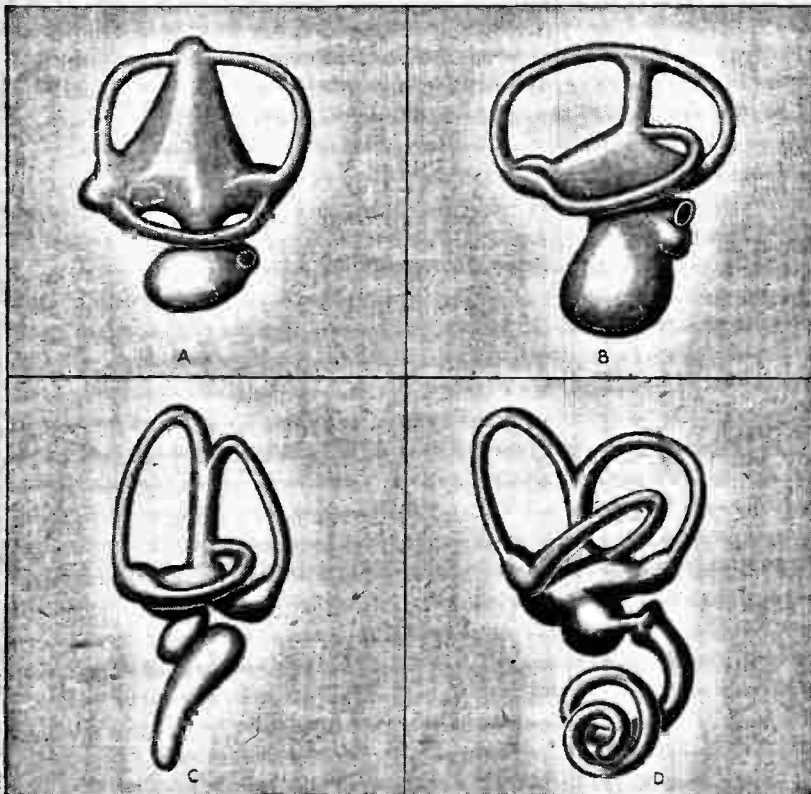

Fig. 11.—The evolution of the cochlea from fish to mammal. A, fish, no cochlea; B, frog, a slight swelling on the right indicates the beginning of the cochlea. C, bird, slightly curved cochlea; D, mammal, spiral cochlea with several turns.

How We Hear.—

so many overtones present the ear has manufactured the difference tone corresponding to the fundamental with an intensity so great that the presence or absence of that tone in the air makes practically no change, the same being true to a smaller extent of the first overtone.

Does the Loud Speaker Cut-off Matter?

Those who use loud speakers which fail to reproduce below 250 cycles/sec. must have been astonished to hear bass voices, cellos, and bass viols coming through almost unimpaired. The reason is now evident: the low notes, though lost in reception, have been re-created in the ear. We must not conclude that the fundamental tone of any sound will reappear, for if the overtones are not harmonic, the difference tone will not coincide with the fundamental: thus drums, cymbals, and xylophones sound unnatural when the lower tones are cut off.

The Ear is a Rectifier.

The author well remembers how difficult it was fifteen years ago to get the theory of difference tones across the lecture table to second-year students. To-day it is only necessary to give the analogy of the anode bend rectifier and the explanation becomes clear and unforgettable.

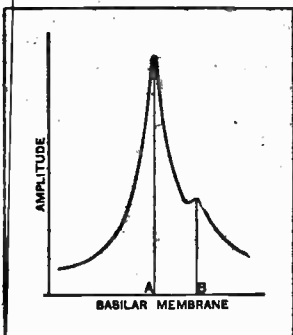

Fig. 13.—A second tone at B is audible if it causes an extra peak on the main resonance curve due to a tone at A.

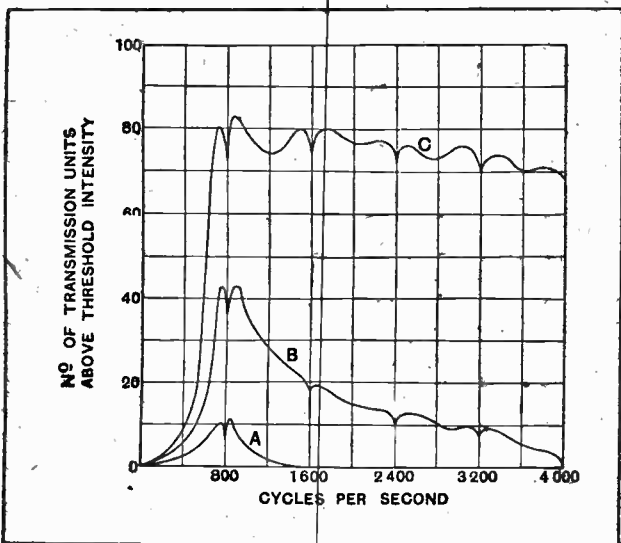

Fig. 14.—Masking of one tone by another: the ear introduces overtones when a note is loud.

For the anode bend rectifier is an unsymmetrical structure. Though the grid voltage may swing up and down by equal amounts the anode current will show unequal changes. When two carrier waves act on the

rectifier a heterodyne note (difference tone) is produced: without the rectifier the compound note could only be resolved into its two H.F. constituents and no difference tone would appear. As the carrier waves are made stronger the heterodyne note becomes relatively stronger.

The ear gives precisely these results, and the analogy is made closer by the experimental fact that when two notes above the audible range are produced by two bird calls an audible difference tone can be heard, as was shown many years ago by Lord Rayleigh.

Do Beats Merge into a Difference Tone?

Beats are the periodic waxing and waning of sound heard when two pure tones of nearly the same pitch are produced. If the pitch of the higher tone be gradually raised the beats become more rapid and finally pass into a new tone—the difference tone. Whether the beats and the new tone are identical has been a controversial question for fifty years, but on the resonator theory of the ear's action we should say that they are entirely different. Our explanation would be that when, as in Fig. 18, the two tones are close together, the two resonating strings suffer fluctuations of amplitude twenty times per second and that the corresponding nerves carry to the brain information

that each string is vibrating with a varying amplitude: at the same time a vibration of twenty cycles per second is produced, but is inaudible because no ear string is tuned to such a low frequency. On raising the pitch of the upper note to 2,100 c.p.s. beats are still heard, but the difference tone of 100 c.p.s. is now picked up by a string and becomes audible as a tone: if this string were absent we should hear the beats but not the tone; if the two upper strings were absent we should hear the difference tone but not the beats. Finally if the upper note is raised to 2,500 c.p.s. the beats are so rapid that the nerves cannot convey news of the fluctuations: the beats disappear and the difference tone of 500 c.p.s. is heard alone.



Fig. 15.—Overtones generated in the ear as the bass C is sounded more and more loudly. The sizes of the notes indicate roughly their intensity.

The Sense of Direction.

Familiar sounds like voices, footsteps, or the barking of dogs, can be located without effort: it is easy to say whether they come from front or rear, from right or left. In trying to account for this sense we naturally enquire what happens in the simpler case when the sounds are pure tones such as those produced by a tuning fork.

Suppose a tuning-fork sounding in the middle of a large meadow on a dark night. It is found that if one ear is stopped up an observer has no idea of the position of the fork: if he uses both ears he can easily tell when the fork is on his right or on his left, but he is unable to distinguish a fork in front from one in rear.

How We Hear.—

Thus we have a clue to the cause of our sense of direction. Sound waves from the fork are diffracted by the head and reach one ear in advance of the other, and so differences of phase and intensity are set up. If the direction of the waves makes an angle A with the fore and aft line of the head we can calculate the phase difference P between the waves arriving at the two ears; in Fig. 19 this relation is shown for tones of different frequencies; thus when we face north and a tone of frequency 310 c.p.s. comes from the north-east the phase will lead by 65° at the right ear.

An Experiment with Headphones.

Now we can try the following experiment: Two telephone magnets are set up, as in Fig. 20, with wires leading from their coils to two ear-phones, and a toothed iron wheel rotates rapidly as shown. A phase difference will be set up between the alternating currents which circulate in the two coils and consequently in the ear-phones; if the phase difference is zero the sound seems

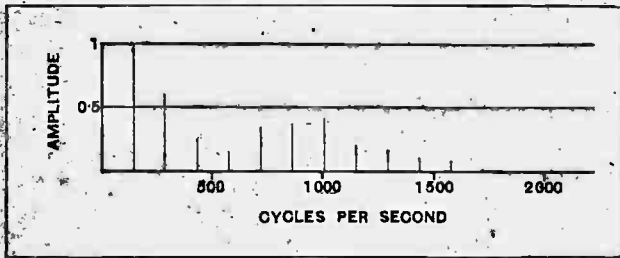

Fig. 16.—Showing the vowel "ah" sung on d.

to come from a point in front, but if the current leads in the right ear-phone the apparent source is displaced to the right through an angle which agrees with that given in Fig. 19. This is a striking confirmation of the theory and so we conclude that the string affected in the right ear leads its opposite number in the left ear in phase, that this lead is preserved in the pulses

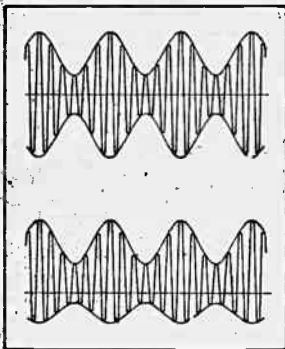

Fig. 17.—Any unsymmetrical receiver will produce partial rectification of a wave: the unsymmetrical structure of the ear must cause a similar effect.

set up in the pair of corresponding nerve fibres, and that the brain translates this lead into a judgment that the sound is coming from a point to the right of the line of sight.

So much for relative phase, but what about the relative intensity at the ears? Experiment shows that relative intensity is comparatively ineffective in helping to form a judgment as to direction. This result leads us into difficulties, for a strong stimulus causes more

How, then, do we keep a sense of direction? No doubt the physiologists will eventually supply the answer, but in the meantime we may hazard the guess that the nerve pulses are not continuous but form intermittent trains,

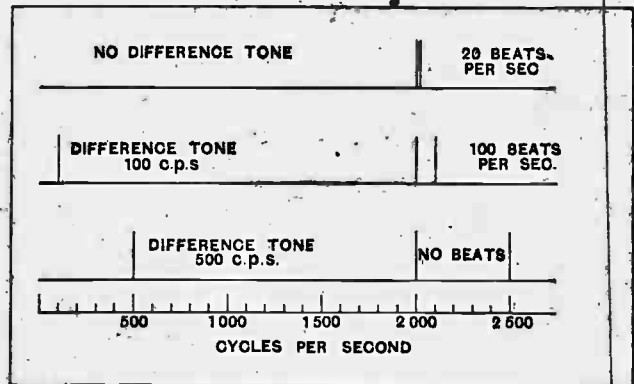

Fig. 18.—How beats merge into a difference tone.

the leading pair of pulses in each train maintaining a constant phase difference; thus the required lead would exist at the beginning of each train, though it would rapidly disappear after a few pulses have passed (Fig. 21).

Multiple Images.

For sounds of high frequency the sound may appear to be in two or more positions at the same time. Thus at 930 c.p.s. let the phase be made to lead by 150° at the right ear; this is the same thing as if the phase were to lead by 360° - 150° = 210° at the left ear. From Fig. 19 we see from the curve corresponding to 930 c.p.s. that phase differences of 150° and 210° corre-

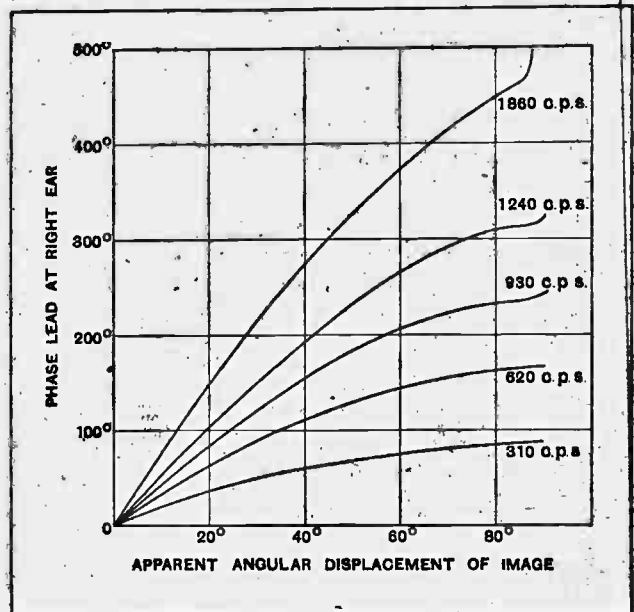

Fig. 19.—The sense of direction of sound depends upon a phase difference between the waves arriving at the two ears. This illustration shows such phase difference for tones of different frequencies.

How We Hear.—

spond to apparent displacements of the image of 39° to the right and 62° to the left. Obviously the location of the sound is going to be made much more difficult if it seems to come from more than one point, and most observers find that their judgment breaks down for frequencies higher than 1,000 c.p.s.; the chirp of a cricket, for example, seems to come from all directions at once.

The Evolution of Hearing.

We believe that all living beings may trace their descent from the life which began in the warm seas of some thousand million years ago. The fishes of to-day inherit an unbroken tradition of environment over this vast reach of time. What have we discovered about the hearing powers of fishes?

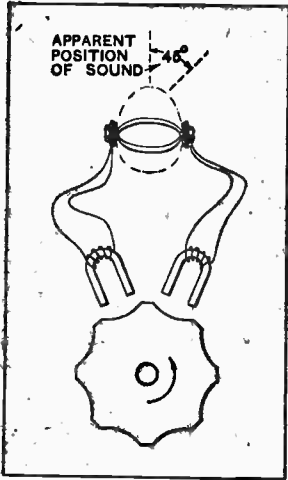

Fig. 20.—This experiment with earphones strikingly confirms the contention that sense of direction depends upon phase difference.

Well, with one or two exceptions, fish seem quite unable to hear. They are indifferent to sounds from a submerged buzzer, loud speaker, or submarine bell. A slight response is shown to violent shocks due to striking the wooden end of a small aquarium by a heavy hammer; this response has been traced to a structure in the head of the fish (shown in Fig. 10) composed of a tiny stone enclosed in a sac which is furnished with hairs. Vibration causes the stone to quiver, and the hairs, striking the sides of the cavity, bend

and initiate messages along the nerves attached to them. The chief purpose of such stones (or otoliths) is to give the direction of gravity, and so enable the fish to swim on an even keel. A certain species of prawn carries its otoliths, not in the head, but in an open cavity in the joint of its antenna, and when the stones drop out the prawn replaces them with grains of sand which it picks up with its forceps. When the prawn was put in an aquarium where iron filings had been placed, it soon became equipped with these magnetic otoliths, and when a magnet was brought near it changed its position as if it mistook the pull of the magnet for the pull of gravity.

As fish emerged from the silent ocean in which their deafness was no handicap, they found new enemies on land, but these were not the noiseless, darting hunters of the deep—their approach was always heralded by sounds, by footsteps, by rustle of reeds or trembling of twigs.

And so the emigrants from the sea began to develop a new sense; the full story is not yet known, but it appears that in amphibia and reptiles like the alligator which never quite forsook the water, and in birds which made the air their own, a tube (Fig. 11) has grown out from the original labyrinth, curved like a sickle, furnished with parallel fibres; in animals which have chosen the dry land this tube has developed into the spiral cochlea, and reaches its highest development among the carnivores and the deer-like tribes, the hunters and the hunted, for whom delicate hearing is a supreme necessity in the daily struggle for existence.

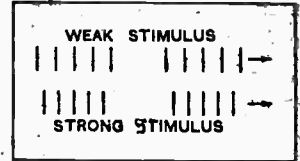

Fig. 21.—Nerve pulses may possibly not be continuous but may take a form of intermittent trains. The leading pair of pulses in each train may maintain a constant phase difference.

nished with hairs. Vibration causes the stone to quiver, and the hairs, striking the sides of the cavity, bend

All About Metal Rectifiers.

Mr. S. A. Stevens, of the Technical Department of the Westinghouse Brake and Saxby Signal Co., Ltd., visited the Bec Radio Society on Tuesday, 10th November, lecturing on "Metal Rectifiers" with the aid of an extensive range of lantern slides and the explanatory film which his company have produced.

The lecturer made it clear that the metal rectifier is virtually a cold electronic valve, and an enlarged drawing was shown on the screen giving the manner of assembly of such a unit.

A detailed explanation of the meaning of half-wave and full-wave rectification followed, and an instructive collection of slides included diagrams showing the "centre-tap," "bridge," and "voltage-doubler" methods of obtaining full wave rectification.

The outstanding event of the lecture was the display of the company's film, in which one saw upon the screen living pictures of the performance of alternating and direct currents.

Hon. Secretary, Mr. A. L. Odell, 171, Tranmere Road, S.W.18.

o o o o

A Modern Receiver.

An interesting set embodying an indirectly heated A.C. screened grid valve with a magnification factor of 1,200 was demonstrated by Mr. Remington at the last meeting of the South Croydon and District Radio Society. The H.F. amplifier was followed by an anode bend detector, and the last low frequency stage embodied two L.S.5a valves in parallel. The set was operated from the mains. The design was made clear by means of diagrams on the blackboard, members being given full details of the

CLUB NEWS.

transformers, the design of the moving coil loud speaker, and the wiring arrangements.

Hon. Secretary, Mr. E. L. Cumbers, 14, Campden Road, S. Croydon.

o o o o

New Club's Success.

The recently formed Sevenoaks and District Radio Club is already proving its value to wireless enthusiasts in the district. At the last meeting a powerful set constructed by one of the members was demonstrated. Interesting tests have also been carried out with a radio-gramophone. New members and visitors are cordially invited. Full particulars of the club can be obtained from the Hon. Secretary, Mr. E. M. Dent, Cornwall Lodge, Dunton Green, Kent.

o o o o

Demonstrating Transmission.

The Muswell Hill and District Radio Society has among its membership no fewer than seven "hams," one of whom, Mr. J. Hum, G5UAM, demonstrated his 171-metre transmitter before that Society on December 4th. In order to avoid interfering with broadcast listeners no radiating system was used, but the transmitter was put in an oscillating condition and the wave picked up on a receiver placed on an adjacent table. The lecturer dealt briefly with

the principles of crystal control, power supply, and various types of transmitting valve, and then proceeded to show, with the help of the transmitter, the advantages of using crystal control from the point of view of steadiness of wave and purity of note.

Hon. Secretary, Mr. C. J. Witt, 39, Coniston Road, London, N.10.

o o o o

Soldering Aluminium.

The soldering of aluminium has always been a *bête noir* to the amateur, but two enthusiasts, Messrs. Hart and Perry, recently demonstrated to members of Wembley Wireless Society that the task can be robbed of its terrors. They also demonstrated brazing, silvering, and ordinary soldering. The Society is at present holding an interesting exhibition of historical wireless apparatus, and the Committee invites members to contribute with any gear which they may believe to have an antique value. The first half of the winter session was concluded on Friday last and meetings will be resumed early in January. An attractive list of fixtures has been arranged. A syllabus of meetings will be forwarded on application to the Hon. Secretary, Mr. H. Comben, 24, Park Lane, Wembley.

o o o o

Lectures by Club Members.

Several items of unusual interest appear in the forthcoming programme of the Wigan and District Technical College Radio Society, which will resume meetings on January 14th.

An interesting feature includes lecturettes and demonstrations by members themselves. Hon. Secretary, Mr. M. M. Das, B.Sc., Library Street, Wigan.

LABORATORY TESTS.

A Review of Manufacturers' Recent Products.

LOUD SPEAKER Baffle BOARD.

To obtain the maximum acoustic output from a cone-type loud speaker it is necessary to prevent circulation of the sound waves from the front to the back of the cone. The neutralising effect due to this cause is more devastating on the very low notes than on the higher frequencies. A large baffle board, some 3ft. square, helps to overcome the harmful effect, but, unless well finished, it is rather an eyesore, especially in a drawing room.

Recently the Morogoro Trading Corporation, Ltd., 7, Union Court, Old Broad Street, London, E.C.2, has placed on the market a handsomely finished baffle measuring 30in. x 30in., and mounted on three ornamental legs. The three-cornered design permits standing the baffle cross-wise in a corner of the room.

An 8in. diameter opening is provided in the centre of the board, behind which will be mounted the diaphragm and movement. A supporting platform must be made up, but as the nature of this will depend on the chassis used, whether moving-coil or reed-type, the makers have left this to the constructor.

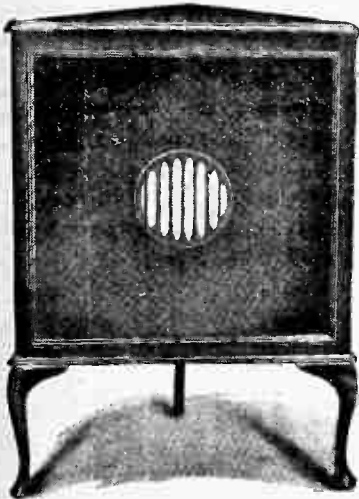

Morogoro three-cornered baffle board for cone loud speaker construction.

The price of the baffle in polished mahogany is 42s., and in oak 38s.

o o o o

"ASHTON" AERIAL SPREADER. NEW MODEL.

Where facilities are not available for the erection of a suitable sized outdoor aerial of the orthodox pattern, satisfactory reception can be had by using a vertical wire with a cage-type collector at the top. The construction of this alternative device is rendered simple by the new model "Ashton Perfect Aerial Spreader." This consists of two spider-type supports, which are attached to a pole, or iron tube, and spaced about 3ft. apart. They are

clamped to the pole by three screwed studs carried on the ring boss of each spider. On the end of each arm is a small porcelain bobbin. The wire is wound in zig-zag fashion, commencing from a top bobbin and finishing at one of the lower ones.

To assure that the device will not sustain damage in the post it is supplied in the form of a set of parts which can be assembled in about fifteen minutes.

The makers are Messrs. Harold Ashton, 8 and 10, Bull's Head Chambers, Hopwood Avenue, Market Place, Manchester, and the price has been fixed at 15s.

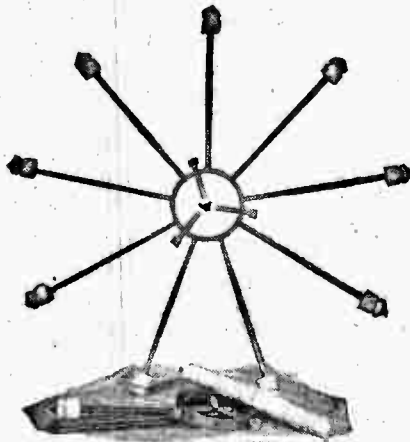

One of the spiders, assembled, for the "Ashton Perfect Aerial Spreader"; note the parts for the other.

o o o o

ROTOROHMS.

A wide range of variable high resistances and potentiometers are included in the list of Rotorohms marketed by Rotor Electric, Ltd., 2-3, Upper Rathbone Place, London, W.1. These components, admirably suited for use as volume controls, are available with resistance values ranging from 0 to 2,000 ohms up to 0.1 to 7 megohms. There are eleven models in all, the price being 6s. 6d. for the potentiometer and 5s. 9d. for the variable resistance.

Two specimens were tested, the type H, maximum resistance 25,000 ohms, and the type L, a 500,000 ohms potentiometer. The measured resistance of the first-mentioned model was 36,000 ohms. A graded resistance is adopted, the value changing slowly at first when the knob is rotated in an anti-clockwise direction, but later showing a more rapid rate of change for the same angular movement. This feature is exhibited in the other model. In this case the maximum resistance was found to be 700,000 ohms.

For control of volume, using a potentiometer in the input circuit of a valve, it is desirable that the resistance should change more rapidly at first and those

that follow the logarithmic law generally prove most successful. It would appear that Rotorohms have been designed to



The resistance in Rotorohms is protected by a wire-wound track over which the variable contact rides.

meet these conditions, so that, used for this purpose, they should prove uniform in action.

TRADE NOTES.

The Loewe Radio Co., Ltd., 4, Fountain Road, Tottenham, London, N.15, announce that their products can now be obtained on the hire-purchase system.

Full particulars of the scheme will be provided on application to the company.

o o o o

Lisenin Wireless Co., 5, Central Buildings, High Street, Slough, Bucks.—Descriptive folder dealing with H.T. and L.T. connectors. Insulated plugs and sockets for use in mains-operated sets are listed also.

o o o o

Messrs. Ferranti, Ltd., Hollinwood, Lancs.—Descriptive leaflet Wb 419, dealing with the Ferranti Model 31 A.C. mains receiver.

o o o o

In the Buyers' Guide 1929-30 list of receiving sets published in our issue of November 20th last, the price of the "Empire 3" receiver made by Messrs. C. F. and H. Burton was stated to include valves and royalties. This is, unfortunately, incorrect; valves and royalties are not included in the prices stated for the two models.

o o o o

On page 565 of the same issue the price of the Philips set, Model 2502, should read £12 10s., and not £15, as stated.

o o o o

We learn that in some quarters the impression prevails that the "Ekco" Model C.2A. A.C. complete battery eliminator, described on page 537 in our issue of November 13th last, is made for alternating current supplies only. This is, of course, incorrect, as a D.C. unit, also styled Model C.2A., is available for use on D.C. mains. This particular unit was reviewed on page 81 under "Laboratory Tests" in our issue of July 24th last.

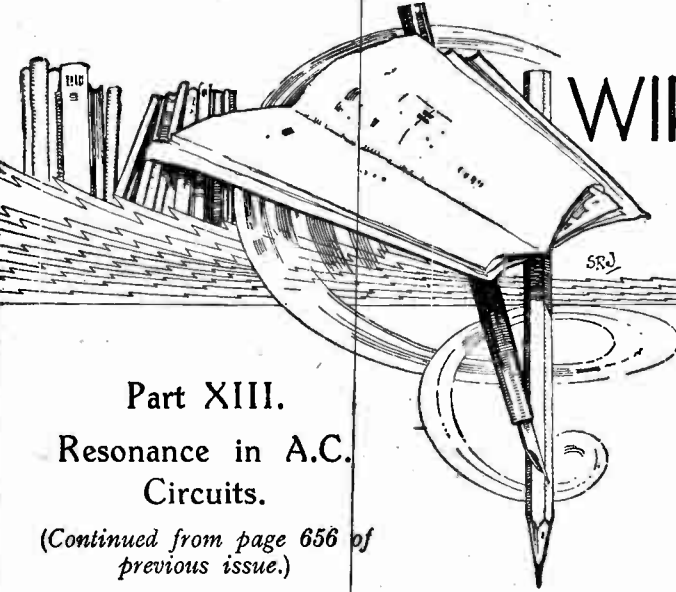

WIRELESS THEORY SIMPLIFIED

By S. O. PEARSON, B.Sc., A.M.I.E.E.

Part XIII.

Resonance in A.C. Circuits.

(Continued from page 656 of previous issue.)

AT the end of the previous instalment the impedance was obtained for a simple circuit with resistance inductance and capacity in series. The value of this impedance was found to be $\sqrt{R^2 + X^2}$ ohms, where R is the resistance of the circuit and X the resultant reactance, at a frequency f cycles per second, due to the combined effects of inductance and capacity. The value of X itself was found to be $(2\pi fL - \frac{I}{2\pi fC})$ ohms, where L is the inductance in henrys and C the capacity in farads. $2\pi fL$ is the inductive reactance and $\frac{I}{2\pi fC}$ the condensive reactance.

Since the resultant reactance X is equal to the difference between the inductive and condensive reactances, it is clear that the last two partially neutralise each other if they are unequal, and one will completely neutralise the other if they are equal. When this happens the impedance of the circuit becomes

$$Z = \sqrt{R^2 + 0} = R \text{ ohms.}$$

That is to say, when $2\pi fL = \frac{I}{2\pi fC}$, the circuit behaves as though it were a non-inductive resistance as far as the relationship between current and voltage is concerned, but in some other respects its behaviour is phenomenal.

The value R ohms is obviously the lowest possible value of impedance the circuit can have, because no matter whether the resultant reactance X is positive or negative, the square of this quantity is always positive and therefore always goes to increase the impedance above the value R, or, in other words, the impedance of the circuit can never be less than R ohms.

Frequency of Resonance.

Now since the inductive reactance $2\pi fL$ is proportional

to the frequency and the condensive reactance, $\frac{I}{2\pi fC}$ is inversely proportional to the frequency, it follows that at very low frequencies the condensive reactance will be greater than the inductive reactance, whereas at very high frequencies the inductive reactance will be the greater. Clearly, then, there must be one particular frequency for which the reactances will be equal and opposite. This is called the *resonant frequency* of the circuit, and at this frequency the circuit is said to be in complete resonance with the applied frequency. Although the resonant frequency is sometimes called the "natural frequency" of the circuit, this is not strictly correct—a point to be discussed later.

In Fig. 1 the reactance of the coil and that of the condenser are plotted as curves against frequency, ranging upwards from zero. At the point where the curves cross each other the reactances are equal, and this point gives us the value of the resonant frequency. It must be remembered that the condensive reactance is negative with respect to the inductive reactance and, therefore, at the point where the curves cross, the resultant reactance is zero. By finding the difference between the two curves at a number of frequency values we can obtain the curve of resultant reactance against frequency.

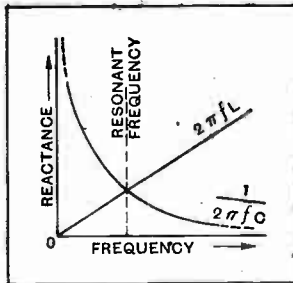

Fig. 1.—Curves showing how the inductive reactance and the condensive reactance vary simultaneously in a series circuit as the frequency is changed.

Value of the Resonant Frequency.

For the condition of complete resonance we have $2\pi fL = \frac{I}{2\pi fC}$, where f is the resonant frequency, and from this we derive the fundamentally important expression

$$f = \frac{I}{2\pi\sqrt{LC}} \text{ cycles per second.}$$

for calculating the resonant frequency, L and C being in henrys and farads respectively.

In tuning a wireless circuit to a given frequency we are simply adjusting the condensive reactance to neutralise completely the reactance of the tuning coil.

Now we must see what is actually happening in a series circuit when a voltage having a frequency equal to the resonant frequency is applied to its ends. The circuit is shown in Fig. 2 (a), and the condition for resonance is that the reactance of the condenser is exactly equal to that of the inductance. Therefore the voltage E_r re-

Wireless Theory Simplified.—

quired to drive the current against the back E.M.F. of the coil is equal to the voltage E_3 required to drive it "through" the condenser. But since E_2 was seen to lead the current by 90° and E_3 to lag by 90° the two voltages in question are always in direct opposition and so cancel each other out between the ends of the circuit. The complete vector diagram for the condition of resonance is shown in Fig. 2 (b).

Now as the two reactance voltages balance out completely it follows that the applied voltage E between the ends of the circuit is only employed in driving the current through the resistance portion of the circuit. Hence the applied voltage is simply $E = E_1 = IR$. This is in agreement with the previous discovery that the impedance of

dealing with the parallel circuit as it can be more simply applied in that case.

Calculation of an Actual Circuit.

As it is very important to know how a resonant circuit behaves not only at the resonant frequency itself but also at neighbouring frequencies, it will be best to consider an actual circuit and calculate the numerical values of impedance and current over a band of frequencies ranging from well below the resonant frequency to well above it, and then to plot the results as curves.

Accordingly let us suppose that we have a coil whose inductance is 2532 microhenrys, that is 2532×10^{-6} henry, in series with a condenser of capacity 0.00025 microfarad. Let the resistance of the coil be 500 ohms. It was pointed out in a previous part that a coil possessing both resistance and inductance is equivalent to a series circuit with resistance and inductance separated. This high value of resistance is chosen to simplify the calculation and the effects of varying the resistance will be discussed afterwards.

The resonant frequency of the circuit will be

$$f = \frac{1}{2\pi\sqrt{LC}} = \frac{1}{2\pi\sqrt{2532 \times 10^{-6} \times 0.00025 \times 10^{-6}}} = 200,000$$

cycles per second or 200 kilocycles per second, and at this frequency the impedance of the circuit will be numerically equal to its resistance, namely 500 ohms, because the reactances balance out.

Now let us calculate the impedance at a frequency just double that of the resonant value, that is, at 400 kilocycles. At this frequency the reactance of the coil will be $X_L = 2\pi fL = 2\pi \times 400,000 \times 2532 \times 10^{-6} = 6364$ ohms. The reactance of the condenser is

$$X_C = \frac{1}{2\pi fC} = \frac{10^6}{2\pi \times 400,000 \times 0.00025} = 1591 \text{ ohms.}$$

Thus the total reactance of the circuit at 400 kilocycles per second will be $X = X_L - X_C = 6364 - 1591 = 4773$ ohms, and the impedance is therefore

$$Z = \sqrt{R^2 + X^2} = \sqrt{500^2 + 4773^2} = 4803 \text{ ohms.}$$

If we choose a frequency below the resonant value, say 120 kilocycles per second, we find that the condensive reactance is greater than the inductive reactance, so that we get a negative value for the resultant reactance X . It works out to -3394 ohms and the impedance is therefore

$$Z = \sqrt{500^2 + (-3394)^2} = \sqrt{500^2 + 3394^2} = 3432 \text{ ohms.}$$

The impedance is always positive by its very nature.

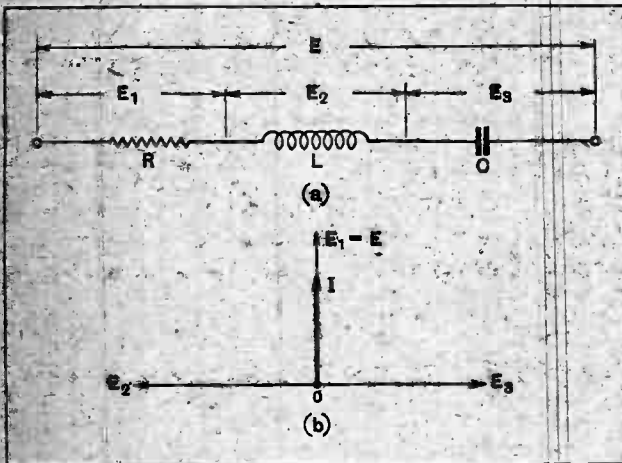

Fig. 2.—When a series circuit is tuned to complete resonance the inductive reactance is wholly neutralised by the condensive reactance. The voltages E_2 and E_3 are equal and opposite, and balance out.

the complete circuit is R ohms at the frequency of resonance. The vector diagram indicates the equally important fact that at this particular frequency the applied voltage and current are exactly in phase.

It would seem then that we are driving the current through the two reactances of the circuit in series without the aid of any E.M.F. from the external source. The secret lies in the fact that once the alternating current has been started and has reached a steady R.M.S. value, neither the inductance nor the condenser absorb any power from the source of supply. When the current is falling from one of its maximum values to zero the voltage across the condenser is building up from zero to a maximum and therefore during this time the whole of the stored energy coming from the collapsing magnetic field is being transferred to the condenser and vice versa. Hence the stored energy in the circuit is merely oscillating backwards and forwards between the condenser and the coil and no call is made upon the source of supply for assistance. A mechanical analogy for resonance in an A.C. circuit will be given in

Frequency—Kilocycles per sec.	$X_L = 2\pi fL$	$X_C = \frac{1}{2\pi fC}$	$X = (X_L - X_C)$	$Z = \sqrt{R^2 + X^2}$	Current = E/Z
0	0	∞	∞	∞	0
20	318	31,820	-31,502	31,510	0.317 ma.
40	636	15,910	-15,274	15,284	0.650
80	1,273	7,955	-6,682	6,692	1.49
120	1,909	5,303	-3,394	3,432	2.92
160	2,550	3,978	-1,428	1,512	6.62
200	3,182	3,182	0	500	20.00
240	3,818	2,651	+ 1,167	1,267	7.89
300	4,773	2,121	+ 2,652	2,699	3.70
350	5,568	1,818	+ 3,750	3,785	2.64
400	6,364	1,591	+ 4,773	4,803	2.08

Wireless Theory Simplified.—

In this manner the impedance of the circuit has been worked out for a number of different frequencies ranging from zero to 400 kilocycles per second and the results are given in full in the table, the values being in ohms.

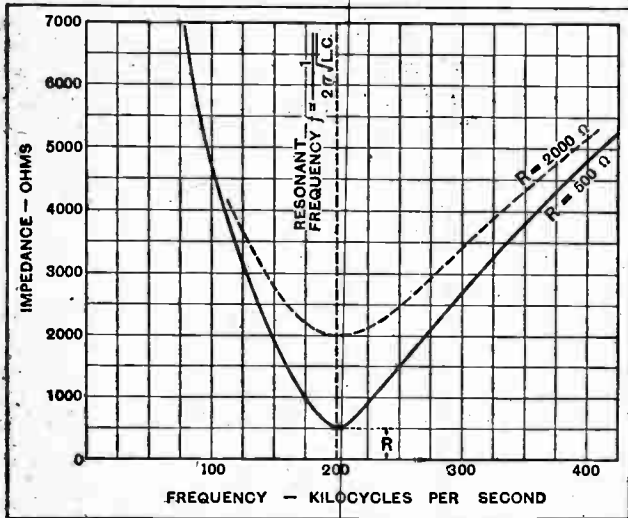

Fig. 3.—Curves showing how the impedance of a series circuit with inductance and capacity varies with frequency. $L = 2532$ microhenrys, $C = 0.00025$ μF .

An examination of the table will show that, as the frequency is increased from zero, the inductive reactance X_L rises in value from 0, whereas the condensive reactance X_C starts from an infinitely great value (∞) and falls as the frequency is raised, and further, that the two reactances are equal when the frequency is 200 kilocycles per second (this corresponds to a wavelength of 1500 metres). As regards the impedance of the circuit it will be seen that this has high values at each end of the frequency range chosen and falls to a minimum of 500 ohms at the resonant frequency.

The calculated impedance values given in the table have been plotted as a graph, shown by the full line curve in Fig. 3, to enable the reader to see at a glance how the impedance of a series circuit with inductance and capacity varies with frequency.

It will be observed that at frequencies far removed from the resonant value, the resistance of the circuit has a negligible effect on the value of the impedance—in these cases the impedances are nearly equal to the resultant reactances which are themselves very high. At frequencies very close to the resonant value however, the resistance is the controlling factor and at the resonant frequency itself the resistance is the only thing that counts.

The height of the lowest point of the impedance curve above the frequency axis is equal to the resistance of the circuit and to show the effect of changing the resistance value of the circuit without altering the inductance and capacity, the dotted curve has been included in Fig. 3, giving impedance values when the resistance is 2000 ohms. If the circuit could be imagined to have no resistance at all the impedance curve would actually touch the base line.

Resonance Curves.

In the last column of the table are given the values of current taken by the circuit at the various frequencies, assuming a constant E.M.F. of 10 volts R.M.S. value to be applied to the ends of the circuit. At any one frequency the current is obtained in amperes by dividing 10 volts by the impedance at that frequency, then multiplied by 1000 to give the result in milliamperes.

The values of current so obtained have been plotted as a curve against the frequency in Fig. 4 and from this curve we can judge at a glance the general behaviour of the circuit. The curve shows that as the frequency increases and approaches the resonant value of 200 kilocycles per second, the current increases very gradually at first and then very rapidly for frequencies between 150 and 200 kilocycles per second. It reaches a maximum value of 20 milliamperes at the resonant frequency and then begins to fall rapidly again when the resonant frequency is exceeded.

Selective Effect of Tuned Circuit.

The main feature is that the circuit allows much greater currents to pass if their frequencies are at or near the resonant value than if they have frequencies far removed from the resonant value. The circuit is thus seen to have the property of selecting currents whose frequencies lie within a comparatively narrow band of values in the neighbourhood of the resonant frequency, and of choking back currents whose frequencies are outside this band.

The curve of Fig. 4 is called the *resonance curve* of the circuit, and from its shape and the sharpness of the peak the performance of the circuit can be judged. It should be noted that the peak of the resonance curve has a rounded top; this is so because the impedance of the circuit is equal to the resistance R at the resonant frequency, and any very small change of frequency will only introduce a small amount of unbalanced reactance,

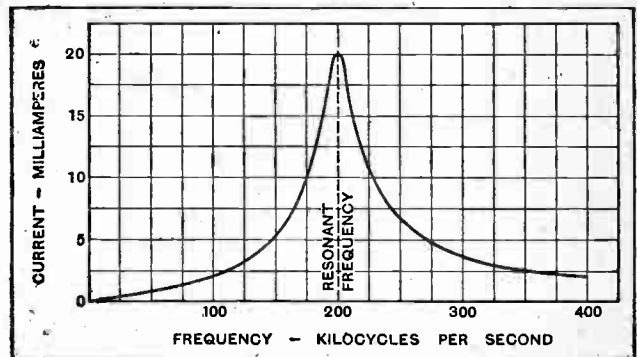
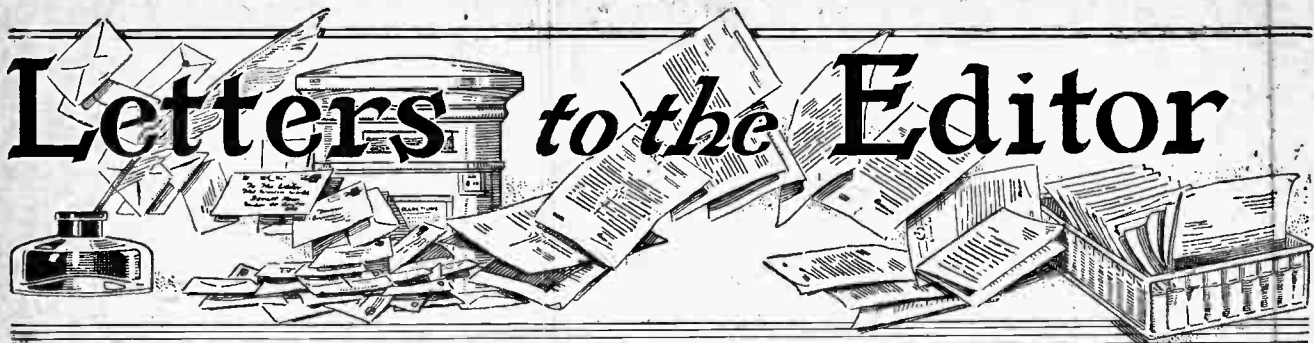

Fig. 4.—Resonance curve for a series tuned circuit where $L = 2532$ microhenrys, $C = 0.00025$ mfd. and $R = 500$ ohms.

negligible with respect to the resistance; and so the current curve must have a horizontal portion just at the top. Another point is that the peak of the curve is not symmetrical in shape.

The degree of selectivity of a tuned circuit and its general efficiency depend upon a number of factors and a discussion of them will constitute the subject of the succeeding instalment.

(To be continued.)



The Editor does not hold himself responsible for the opinions of his correspondents.

Correspondence should be addressed to the Editor, "The Wireless World," Dorset House, Tudor Street, E.C.4, and must be accompanied by the writer's name and address.

THE THIRST FOR POWER.

Sir,—As a reader of your paper, and one who has so far been in agreement with its opinions, I must take exception to the leading article, "The Thirst for Power," in the last issue. There are a very large number of wireless listeners in this country who pay their licence fee and yet do not get the type of programme they want. Moreover, here there are very large gaps on Sunday in which no transmission takes place and what is given is severely restricted in type.

Continental stations give programmes all day on Sunday and their week-day evening transmissions give an alternative source of enjoyment in the form of splendid orchestral concerts, operas, etc., to the interminable series of talks, jazz music, chamber music, etc., which we are given here. I venture to say that the ordinary man, when he returns home in the evening and sits down, likes to listen for a couple of hours to an uninterrupted programme of lively music, or a concert, such as are regularly broadcast abroad. At present an efficient three-valver will, with foreign transmitters working on 7 to 20 kW., give good results on a loud speaker. Those who possess more selective and powerful sets—mine is one of your four-valve circuits—get still better results, and I find stations like Turin, Vienna, Bratislava, etc., come through as well as, and generally better than, 5GB. Now, sir, when more powerful stations are working, such as Rome and Oslo soon will be, on 50 kW., they will give L.S. results in this country, judging from my experience, practically as good as ZLO. Listeners here, therefore, who have to go abroad for their entertainment owing to the restricted and classical type of programme that is given will in no way feel alarmed, but will welcome such increase of power. I am unable to understand why your correspondent, A. W. Scott, gets such "mushy" results. I can assure him that there are at least ten foreign stations, including those I have mentioned, which I receive regularly every evening at tremendous strength on a M.-C. speaker. They drown out all mush, Morse and background noise. Fading is, of course, sometimes present, but increased power will minimise this and present better reception for the weaker set. I trust you will find space to publish this letter as I am sure many thousands of listeners hold these views.

J. CHANDLER.

Upminster, Essex.

FOREIGN STATION RECEPTION.

Sir,—I deeply sympathise with Mr. A. W. Scott, of Chipstead, Surrey. He must, indeed, have been bitterly disappointed, after having gone to the trouble and expense of making a "reasonably up-to-date" set of "your own excellent design," to find that all he can receive of the ten to fifteen foreign stations which are available almost any night is a mixture of "transmission plus atmospherics plus heterodynes plus fading plus Morse."

I am very sorry for him; but I do consider that he is unreasonable in supposing that the majority of other listeners (more than 99 per cent. of them, in fact) can get no better results than he can.

Surely Mr. Scott must be almost unique if he experiences troublesome fading on the long waveband; and surely if his neighbours are as relentless with their oscillating as to heterodyne continuously all his fifteen stations, his best course would be to send an appeal to the Postmaster-General.

My own experience of foreign reception is admittedly far less disturbing to the nerves. No doubt it is not advisable to amplify foreign programmes to concert-room loudness: to reproduce them with powerful moving-coil speakers; but for all that there are, even in London, a large number which can be received and which can be enjoyed. Not every one every night, it is true, but there is rarely a night on which more than one cannot be well heard.

On a four-valve portable set of a well-designed (and, admittedly, rather expensive) type I can usually get conveniently enjoyable reception from Huizen, from Radio Paris, from Warsaw, from Motala, from Kalundborg, from Hilversum (on its long wavelength), or from Königswusterhausen on the long waveband; and from Budapest and Vienna (though sometimes entangled with Morse), Berlin, Frankfurt, Toulouse, Breslau, and many others on the shorter waves.

I find that in the country (unless near the sea) I can get many more.

I may add in conclusion, in case Mr. Scott should think that my standards of reproduction are perverted, that for local reception of the London programme I use a very carefully designed set, employing in the last stage two L.S.5A valves, running on 300 volts, and feeding a well-made moving-coil speaker.

C. K. HERBERT.

London, S.W.1.

Sir,—I read with interest the letter of Mr. A. W. Scott (27/11/29) criticising your attitude to the Regional Scheme, and as my own experiences of "foreign listening" are similar to his I fully endorse his views.

Situated three miles N.E. of Glasgow, I can pick up most of the leading European stations at loud-speaker strength, but after three years of "foreign listening" I have decided that distance and quality seldom go together, for reception is more than often marred by statics on the long waves and fading and heterodyning on the short waves. In fact, I could easily count the number of nights on which a "distant programme" was received without some kind of extraneous Morse or interference. Even 5XX is not free from static on some occasions, and although the volume and quality of Brookmans Park are good there is periodic fading.

So the local station only remains, and even it is not above reproach, for about 80 per cent. of the programme comes over 400 miles of land-line before being transmitted. So until Scotland has its own regional station, and one transmission does not require the assistance of the land-line, then only can we hope to have first-class quality.

So may the regional station for Scotland materialise and the scheme prosper.

K. M. TOPPING.

Glasgow.

Broadcast Brevities

By Our Special Correspondent.

Listeners' Reports on Twin Transmissions.—Mains Sets for Schools.—Money and Music.

Listeners and the Twin Transmitters.

Mr. Noel Ashbridge, the B.B.C.'s Chief Engineer, is agreeably surprised at the number of listeners who have taken the trouble to report favourably on the twin transmissions from Brookmans Park. Profiting by earlier experience, however, he refuses to be beguiled by the first batch of letters. Those who first take up the pen are the enthusiasts—the people who have good sets; the smaller fry who have only a hazy notion of what the scheme is all about are probably just discovering that additional selectivity is now necessary.

○○○○

Erratic Modulation.

From my own experience I would say that it will be easier to judge how comfortably the two stations can be separated when the 261-metre transmitter settles down to a fairly uniform output. Modulation appears to be erratic and there are times during the late dance music when the new transmitter suddenly spreads itself out in a manner which must cause pain to many listeners living within 5 miles of Brookmans Park.

However, it is too early to criticise. Who knows what a week may bring forth?

○○○○

L.C.C. and School Wireless.

"Mains Sets for Schools" seems to be the new slogan of the London County Council. I hear that the question of school sets appeared on the agenda at last week's meeting of the Council, following upon an inspection in several schools where battery-operated receivers were proving costly and difficult to maintain.

As an indication of the importance which the L.C.C. attaches to broadcast lessons it is significant that steps are to be taken to ensure that only the best and latest design of receivers are to be used for the work, with power supply from the electric mains.

○○○○

School Sets Need Supervision.

According to the B.B.C. at least 3,000 schools up and down the country are known to be taking one or more of the broadcast courses. Little information is forthcoming regarding the type of quality of the sets employed, though the B.B.C. engineers undertake to inspect sets and give advice when requested to do so. Is this good enough? Some responsible authority should surely be commissioned to see that scholars are ensured decent, distortionless reception. The schoolmaster

entrusted with the management of a class cannot be expected to pay attention to grid bias and H.T. battery voltage at the same time.

The L.C.C. is acting wisely in the matter, and it is to be hoped that other educational authorities will also tackle the question.

○○○○

The "Early 'o Bed" Station.

Two main programmes nightly in water-tight compartments will be the principle adopted by 2LO, 5GB and other stations early in the New Year.

Beginning on January 6th, 5GB will start its first programme at 6.30 p.m. and its second at 8.35, and a noteworthy feature will be the introduction of a nightly talk at 8 o'clock—the first serious attempt to introduce talks from the experimental station. The station will close down at 10.30 each evening.

○○○○

Original Programmes from Regional Twin?

2LO, 5XX and other stations will start their two main programmes at 7.45 and

9.45 respectively. Comparing these times with those of 5GB, it will be seen that the experimental station will provide light relief during the 7 to 7.45 talks period from the other stations.

What of the programme from the twin station at Brookmans Park? I am asked to understand that an original programme will be provided, but I retain the belief that the provincial stations may help to contribute.

○○○○

The European Network.

A step forward towards that European relay network to which reference was made recently is indicated by the news that the B.B.C. now prepares a list of attractive musical features to be broadcast six weeks ahead. This list is sent to broadcasting authorities in Germany and Belgium, i.e., countries in which the land lines are favourable for musical transmission. I understand that the courtesy is reciprocated.

○○○○

Matters Musical.

Dr. Adrian Boult's appointment as musical director of the B.B.C. is to be deferred until May 15th next. This will enable Mr. Percy Pitt, the present holder of the post, to prove that an artist's powers of expression do not frizzle up immediately their possessor attains the age on which the B.B.C. sets the seal of superannuation.

○○○○

An Expensive Orchestra.

Meanwhile the future of Sir Thomas Beecham's "National Orchestra" is coming up for discussion. It is an open question whether this experimental combination which Sir Thomas is conducting will become a permanent institution, as was suggested during its formation, although no changes are likely before next autumn. In the interval, of course, the B.B.C. is faced with its liabilities in regard to a number of the players who will be drawing anything between £15 and £25 per week from Savoy Hill for the next three years.

In view of this expenditure of listeners' money, the public will want to hear a good deal more of the orchestra between now and 1932.

○○○○

The Truth.

"The Truth About the B.B.C." was the striking title of an article published a few days ago. Some doubt is expressed as to whether this is the 254th or the 255th time that this striking title has been employed.

CHRISTMAS PROGRAMME FEATURES.

London and Daventry (5XX).

DECEMBER 23RD.—Nativity play relayed from St. Hilary's Church, Cornwall—"Bethlehem," by Bernard Walke.

DECEMBER 24TH.—Carols relayed from St. Mary's, Whitechapel.

DECEMBER 25TH.—"Cox and Box," comic opera, by Burnand and Sullivan.

DECEMBER 26TH.—"Cinderella," a pantomime, by Ernest Longstaffe.

DECEMBER 28TH.—"Rupert of Hentzau," a play by Anthony Hope.

Daventry Experimental (5GB).

DECEMBER 24TH.—Light orchestral programme and solos.

DECEMBER 25TH.—"Cinderella," a pantomimic, by Ernest Longstaffe.

DECEMBER 26TH.—"The Messiah" (Handel).

DECEMBER 27TH.—"Rupert of Hentzau," a play by Anthony Hope.

Cardiff.

DECEMBER 23RD.—Carols relayed from the Exchange, Cardiff.

DECEMBER 27TH.—"A Visitor for Christmas," a Yuletide playlet, by F. Morton Howard.

Manchester.

DECEMBER 24TH.—"Christmas Eve at Browns," by Edwin Lewis.

DECEMBER 25TH.—Christmastide request orchestral programme and songs.

Glasgow.

DECEMBER 24TH.—"No Room at the Inn," a Christmas morality play, by David Cleghorn Thomson.

DECEMBER 27TH.—Tullytassie Hogmanay Gathering—grand soiree and concert, followed by an assembly in the Burgh Hall, Tullytassie.

Belfast.

DECEMBER 24TH.—"Christmas Eve in Ballinacaghey."

READERS'

PROBLEMS.

"The Wireless World" Supplies a Free Service of Technical Information.

The Service is subject to the rules of the Department, which are printed below; these must be strictly enforced, in the interest of readers themselves. A selection of queries of general interest is dealt with below, in some cases at greater length than would be possible in a letter.

Moving the Reaction Condenser.

My detector—2 L.F. set—would be quite satisfactory were it not for the fact that hand capacity effects are troublesome when operating the reaction condenser. I am told that this is because the condenser is connected in such a way that both its moving and fixed vanes are at high potential; this seems to be correct, as an experimental reversal of connections does not have any noticeable effect.

I am sending you a circuit diagram of the receiver. Will you please tell me if there is any easy way of overcoming the difficulty?

G. P. S.

Your diagram (of which the part in question is reproduced in Fig. 1) shows that the reaction condenser is connected between the detector valve anode and the high-potential end of the reaction coil: in this position hand capacity effects are likely to be evident, particularly if the condenser is unscreened, and if its operating knob is of such dimensions that the operator's hand comes into close proximity to the "live" spindle.

We suggest that the condenser should be moved to the position indicated by "X" in the diagram, the existing connections being, of course, joined together. Although this sounds easy enough, it may possibly be necessary to rebuild the coils if interchangeable plug-in inductances are

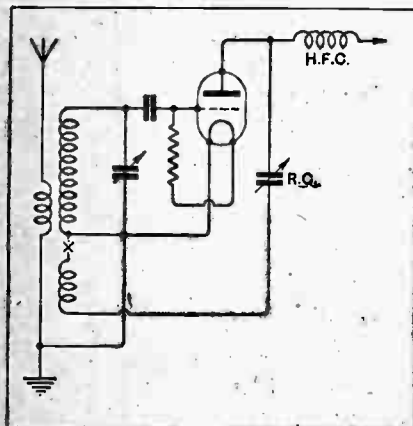

Fig. 1.—Hand capacity effects in a regenerative detector valve circuit may generally be overcome by transferring the reaction control condenser to the position marked X.

fitted, or, alternatively, if waveband switching is used, to elaborate the switch change-over connections. This is because an extra connection must be led out from the coil assembly to enable you to work with an "earthed" reaction condenser.

o o o o

Modified "A.C.2."

My "A.C.2" receiver, as described in "The Wireless World" for August 22nd, 1928, was sufficiently selective until the new 2L.O started working; now I find that this station tends to "spread" very seriously unless a value of series aerial condenser sufficiently small to cause considerable diminution of signal strength is inserted. Would it not be possible to alter the tuned circuits of this receiver to conform with the arrangement included in the "Two-Circuit Two" ("The Wireless World," February 6th, 1929)? It is realised that the cathodes and heaters will be connected in the conventional manner; is any other alteration necessary, and do you anticipate that any difficulty will be encountered? W. R. N.

There is no reason why your proposed alteration should not be effected, and no alterations other than the obvious ones will be necessary. Due to the high efficiency of the detector valve as compared with battery-heated types, there will be an increased tendency towards self-oscillation, but this can be overcome by suitably setting the relative values of the reaction feed condenser and the reaction control condenser.

o o o o

Simple Pick-up Connection.

I believe that it is possible to convert the "Everyman Four" for gramophone reproduction simply by connecting a pick-up by means of a length of flex to an ordinary coil plug, and inserting this plug in the socket normally occupied by the long-wave loading coil. Please tell me if this is correct.

J. le G. L.

The answer to this question depends on whether it relates to the original "Everyman Four" or to the model with potentiometer control of detector grid bias, as described in the last edition of the "Everyman Four" booklet.

It is quite in order to connect a pick-up to the modified receiver in the manner that you describe, but some form of

volume control will be required; this should not be "later" in the chain of amplification than in the grid circuit of the first L.F. valve. Of course, the value of negative bias normally applied to the detector must be reduced when this valve is made to function as an amplifier; this is easily done by giving a partial turn to the potentiometer knob.

o o o o

Two Eliminators.

I am about to rebuild my receiver, and intend to add a push-pull output stage requiring much more energy than can be supplied by my existing eliminator, which is quite satisfactory except only in the matter of power output.

In order to save trouble and expense, it is proposed to use the original eliminator for feeding the H.F. valve, detector, and first-stage L.F. amplifier, and to build a new power unit for the output valves only. Is there likely to be any unforeseen difficulty in doing this? Current is A.C. at 250 volts. G. D.

There is no reason whatsoever why this plan should not be adopted successfully. It can only be criticised on the grounds that it involves the upkeep of two separate rectifiers; in all probability there would be sufficient surplus output from the proposed new power unit to feed the earlier stages of the receiver.

RULES.

(1.) Only one question (which must deal with a single specific point) can be answered. Letters must be concisely worded and headed "Information Department."

(2.) Queries must be written on one side of the paper and diagrams drawn on a separate sheet. A self-addressed stamped envelope must be enclosed for postal reply.

(3.) Designs or circuit diagrams for complete receivers cannot be given; under present-day conditions justice cannot be done to questions of this kind in the course of a letter.

(4.) Practical wiring plans cannot be supplied or considered.

(5.) Designs for components such as L.F. chokes, power transformers, etc., cannot be supplied.

(6.) Queries arising from the construction or operation of receivers must be confined to constructional sets described in "The Wireless World" or to standard manufacturers' receivers.

Readers desiring information on matters beyond the scope of the Information Department are invited to submit suggestions regarding subjects to be treated in future articles or paragraphs.



Ormond scores again!

A GAIN Ormond have produced a new and cleverly designed Loud Speaker. Like all Ormond products, it is not only essentially reliable but at the remarkably low price of 17/6 offers amazing value. The Ormond Plaque Loud Speaker is a combination of the famous Ormond 4-Pole Adjustable Unit with a Cone of entirely new design, proving remarkably successful and achieving wonderful tone and volume. It forms an attractive wall ornament and is unsurpassed for excellence of reproduction.

Write for descriptive leaflet.

The
**ORMOND ENGINEERING
CO., LTD.,**
ORMOND HOUSE, ROSEBERRY AVENUE,
LONDON, E.C.1.

Telephone:
Olerkenwell 5334-5-6 and 9344-5-6.

Telegrams:
Ormondengi, 5mth.

THE ORMOND PLAQUE LOUD SPEAKER

17/6

COMPLETE



**For PUNCH
POWER
& PURITY**

The **Wireless** **World** **DIARY** **for** **1930**
 AND **RADIO REVIEW**

A Suggestion for a Christmas Gift!

Full of useful facts and figures for wireless users, with ample Diary pages for memoranda: a little book that makes a much appreciated present to a wireless friend at Christmas time.

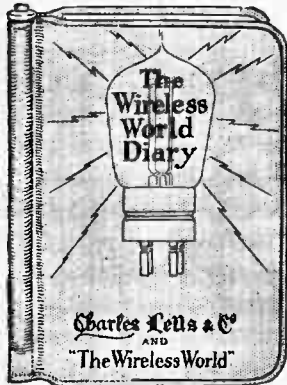

PRINCIPAL CONTENTS:

Summary of Regulations Relating to Amateur Transmitter and Receiving Licences. Conversion Tables, English measures to metric and *vice versa*. Decimal and metrical equivalents of fractions of an inch. Broadcasting Stations of Europe with their Call-Signs and Wave-lengths. Principal Short-Wave Broadcasting and Commercial Stations of the World. Nationality Prefixes used by Amateurs. Morse Code. Symbols used in Wireless Diagrams. Typical Wireless Receiver and Eliminators:— Fourteen Different Circuits with Diagrams. Valve Data, giving the characteristic features of standard valves.

PRICES: Cloth Bound 1/- net. By post 1/1. In Leather Case, with pockets, pencil and season ticket window, 2/6 net. By post 2/7.

From All Booksellers and Stationers.

Published jointly by

"THE WIRELESS WORLD," LONDON, E.C.4,
 and CHARLES LETTS & CO.

Give your Short Wave Pals a treat this Xmas!

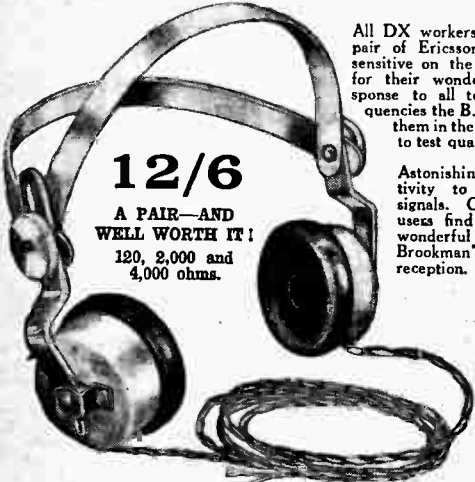

12/6

A PAIR—AND WELL WORTH IT!
 120, 2,000 and 4,000 ohms.

All DX workers have a pair of Ericsson Super-sensitive on the bench—for their wonderful response to all tonal frequencies the B.B.C. use them in their studios to test quality.

Astonishing sensitivity to weakest signals. Crystal users find them a wonderful aid on Brookman's Park reception.

At all good dealers or direct:
ERICSSON TELEPHONES LTD.,
 67/73, Kingsway, London, W.C.

Ericsson
 SUPERSENSITIVE TELEPHONES.



IDEAL GIFTS

No. 97B
 Price 15/-

No. 101
 Price 22-2-0
 Royalties included.

PRESENTS make the heart grow fonder! This year make your friend a Christmas present of a Squire Cradle and Cone.

Those with keen musical ears say that they enjoy a constant delight in listening to a Squire Speaker coupled to a good receiver.

If your friend has a Unit, then our 97B Model, shown above, is suitable (it is universal in that it will take any Unit). If, on the other hand, you want to make a real present de-luxe, you can give one of our double "101" Speakers—the finest speaker of the day.

In either case you will be affording your friend such reproduction as he would only be able to obtain elsewhere for a very much greater expenditure.

FREDK. SQUIRE, Ltd.,
 10, Leswin Place, Stoke Newington, N.16

Mention of "The Wireless World," when writing to advertisers, will ensure prompt attention.

WONDERFUL RESULTS

with the MULLARD "ORGOLA" 3 Circuit, using
"GOLSTONE" COMPONENTS
 and Mullard Valves.

Supplied in sealed Kit with diagrams of wiring and instructions. Do you realise the extraordinary range and volume of this Screened Grid Set? You can tour Europe, one station after another coming in with purity and maximum strength. Let us send you our Radio catalogue with particulars of Kit for easy construction in an evening.

"Orgola" Kits from **£5'5'**-

Full particulars on request.

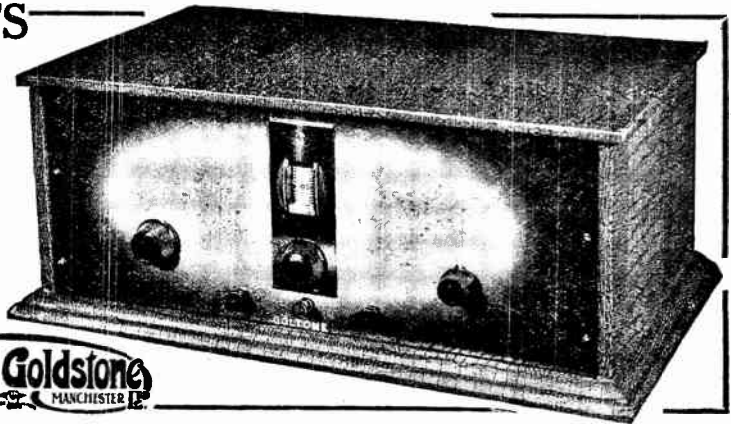

HYDRA



**THE OUTSTANDING
 FEATURE OF A
 GOOD MAINS UNIT!**

Look at any good mains unit! See how often Hydra Condensers are incorporated! The best manufacturers and the wisest amateur constructors know that Hydra Condensers provide the greatest margin of safety—because Hydra are built to stand up to overloads and have never been known to break down under normal conditions.

LOUIS HOLZMAN
 37, Newman Street,
 London, W.1.

Telephone:
 Museum 2641.

Fit the

DUBILIER
long-life
BATTERY

66 Volts
7'9

BRITISH MADE

and improve
 the quality
of your
 reception

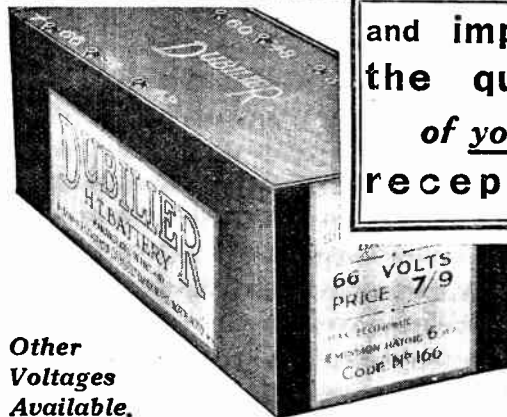

*Other
 Voltages
 Available.*

Ask your dealer for a copy of the Dubilier Booklet — "A Bit about a Battery."

Dubilier Condenser Co. (1925), Ltd., Ducon Works, Victoria Road, North Acton, London, W.3.

Clearer B31

**Solve Hubbie's
 Accumulator Worries**

Buy him a

**"GUARDIAN"
 TRICKLE CHARGER.**

'5 amp. for 2, 4 or 6 volt Batteries.
 Absolutely safe. Silent and efficient.
 Consumption negligible.

Price **37/6**

Larger types available.

A "CIFEL" PRODUCT.

Enquire of your dealer or
 direct from

**FONTEYN & CO.,
 LTD.,**

2-8, Blandford Mews,
 Baker St., London, W.1



BRITKAM

**SUPER QUALITY
 EBONITE**
 IN SHEETS, RODS,
 AND TUBES.

PANELS cut to any size and thickness.
 Matt or polished surface. Guaranteed
 against surface leakage.
 Immediate delivery. Prices on application.

Trade enquiries invited.

BRITKAM-EBONITE (Britannia Rubber &
 Kamptulicon Co. Ltd.)
 7, Newgate Street, London, E.C.1.

MISCELLANEOUS ADVERTISEMENTS.

NOTICES.

THE CHARGE FOR ADVERTISEMENTS in these columns is:

12 words or less, 2/- and 2d. for every additional word.

Each paragraph is charged separately and name and address must be counted.

SERIES DISCOUNTS are allowed to Trade Advertisers as follows on orders for consecutive insertions, provided a contract is placed in advance, and in the absence of fresh instructions the entire "copy" is repeated from the previous issue: 13 consecutive insertions 5%; 26 consecutive, 10%; 52 consecutive, 15%.

ADVERTISEMENTS for these columns are accepted up to **FIRST POST** on **THURSDAY MORNING** (previous to date of issue) at the Head Offices of "The Wireless World," Dorset House, Tudor Street, London, E.C.4, or on **WEDNESDAY MORNING** at the Branch Offices 19, Hertford Street, Coventry; Guildhall Buildings, Navigation Street, Birmingham; 260, Deansgate, Manchester; 101, St. Vincent Street, Glasgow, C.2.

Advertisements that arrive too late for a particular issue will automatically be inserted in the following issue unless accompanied by instructions to the contrary. All advertisements in this section must be strictly prepaid.

The proprietors retain the right to refuse or withdraw advertisements at their discretion.

Postal Orders and Cheques sent in payment for advertisements should be made payable to **ILIFFE & SONS Ltd., and crossed & Co.** Notes being untraceable if lost in transit should not be sent as remittances.

All letters relating to advertisements should quote the number which is printed at the end of each advertisement, and the date of the issue in which it appeared.

The proprietors are not responsible for clerical or printers' errors, although every care is taken to avoid mistakes.

NUMBERED ADDRESSES.

For the convenience of private advertisers, letters may be addressed to numbers at "The Wireless World" Office. When this is desired, the sum of 6d. to defray the cost of registration and to cover postage on replies must be added to the advertisement charge, which must include the words Box 000, c/o "The Wireless World." Only the number will appear in the advertisement. All replies should be addressed No. 000, c/o "The Wireless World," Dorset House, Tudor Street, London, E.C.4. Readers who reply to Box No. advertisements are warned against sending remittance through the post except in registered envelopes; in all such cases the use of the Deposit System is recommended, and the envelope should be clearly marked "Deposit Department."

DEPOSIT SYSTEM.

Readers who hesitate to send money to unknown persons may deal in perfect safety by availing themselves of our Deposit System. If the money be deposited with "The Wireless World," both parties are advised of its receipt.

The time allowed for decision is three days, counting from receipt of goods, after which period, if buyer decides not to retain goods, they must be returned to sender. If a sale is effected, buyer instructs us to remit amount to seller, but if not, seller instructs us to return amount to depositor. Carriage is paid by the buyer, but in the event of no sale, and subject to there being no different arrangement between buyer and seller, each pays carriage one way. The seller takes the risk of loss or damage in transit, for which we take no responsibility. For all transactions up to £10, a deposit fee of 1/- is charged; on transactions over £10 and under £50, the fee is 2/6; over £50, 5/-. All deposit matters are dealt with at Dorset House, Tudor Street, London, E.C.4, and cheques and money orders should be made payable to Iliffe & Sons Limited.

THE SALE OF HOME-CONSTRUCTED UNLICENSED APPARATUS.

A Service to our Readers.

We have made an arrangement with the Patentees whereby readers who wish to dispose of a home-constructed receiver not licensed under the patents made use of, can license the set by means of the Deposit System referred to above.

The person desiring to sell, in sending us particulars for his advertisement, will in every case make use of a Box No., and should add to the price which he requires the amount of royalty customarily paid by manufacturers.

If the purchaser is satisfied with his purchase, the sum realised will be forwarded to the seller, less the amount due in respect of royalties, which amount will be paid by "The Wireless World" to the owners of the patents concerned, and a certificate will be handed on to the purchaser of the set.

SPECIAL NOTE.—Readers who reply to advertisements and receive no answer to their enquiries are requested to regard the silence as an indication that the goods advertised have already been disposed of. Advertisers often receive so many enquiries that it is quite impossible to reply to each one by post.



ALL WIRELESS WORLD COILS

1930 EVERYMAN FOUR	47/3 set
KIT SET, Coils with Switches	45/- set
NEW KILOMAG.	45/- set
RECORD III	45/- set
FOREIGN LISTENERS 4 B.B.C.	30/- set
	5XX 37/6 set
METAL CABINET	38/3 to 48/3
5 1/2" DRUM DIALS with Escutcheons	5/6
WAVE TRAP, Litz Wire	10/6 each

B & J. Wireless Co.

2, 3, & 4, Athelstana Mews,
Stroud Green Road, N.14.

Archway 1695

"END OF YEAR CLEARING."

APPLEBY'S

FOR BARGAINS WATCH Phone: Paddington 5829 (3 lines).

THE MISCELLANEOUS COLUMNS THIS MONTH.

For Modern High-grade Material Only.

CHAPEL ST., LONDON, N.W.1

OPEN TILL 7 P.M. SAT. 1 P.M.

TANNOY



FOR YOUR SET

—don't be let down by dry batteries, maintain constant and perfect H.T. and L.T. by using TANNOY mains units, which are cheaper, better and trouble-free.



H.T. from
£2: 17: 6.



L.T. from
£2: 12: 6.

The TULSEMERE MFG. CO.,

1-7, Dalton Street, West Norwood, S.E.27.

Telephone: Streatham 673r.

Mains Units

Our 1830 Super Power Model.



"THE MUSIC LOVER'S CHOICE."

Radio - Gramophone music and speech reproduced with amazing and uncanny realism. The most efficient speaker money can buy.

BAKER'S 'selhurst' RADIO

SEND TO-DAY FOR OUR FREE 36-PAGE BOOKLET "SOUND ADVICE."

Offices: 86 SELHURST ROAD, SOUTH NORWOOD, S.E.25.
Works and Demonstration Room:
42 CHERRY ORCHARD ROAD, EAST CROYDON.

IMPORTANT NOTICE.

Owing to the Christmas Holidays, the next issue of "THE WIRELESS WORLD" (dated December 25th.) is closing for press earlier than usual.

In accordance with the Notice that appeared last week, the latest date upon which Miscellaneous Advertisements could be accepted for the above issue was **FIRST POST WEDNESDAY, December 18th.**

For the issue of January 1st, advertisements for these columns can be accepted not later than **FIRST POST, TUESDAY, DECEMBER 24th.**

RECEIVERS FOR SALE.

SCOTT SESSIONS and Co., Great Britain's R. Doctors.—Read advertisement under Miscellaneous.

3-VALVE All-wave Receiver, latest type, powerful, perfect; £4.—V. Taylor, 57, Studley Rd., Stockwell, London.

RECEIVERS for Sale.—Portable 5-valve, snit type, complete, as new, perfect; £8/17/6. Taylor, 57, Studley Rd., Stockwell, London.

READ and MORRIS, Ltd., the mains pioneers, in 1925 equipped the hospital with mains still supreme in all-mains receivers and units.

LOW Tension A.C. Eliminators, permanently placing batteries now only £5/15; electronic condensers, 2,000 m.f., as used in above, 13/-; inc. postage.

BARGAINS.—Second-hand sets, units, me speakers.—Read and Morris, Ltd., 31, Eastern St. (facing back of Warrings), Oxford St., W.

WIRELESS is a Fascinating Subject, but many heavy demands upon the purses of its devotees. For one who is determined to keep abreast of times, there are always new components to be bought and sets and loud-speakers to be superseded.

AT the Same Time, the would-be buyer is often deterred from buying because he knows there will be still one more piece of apparatus left in his hands, to add to those already in the junk box.

WE Have Opportunities of Disposing of Semi-Complete Apparatus to those who are not fortunate enough to be able to afford the latest type, and take such apparatus or components providing they are in saleable condition, in part exchange for new set, loud-speaker or component required.

ALL We Ask is that You should Send Along a list of Your Old Apparatus, together with your requirements, or, better still, send the apparatus to us to inspect, when we will make you a fair offer.

IF You Approve of this We can Send Your Return for the Balance, and we will forward the apparatus required; if you have sent your old apparatus and you do not approve of our offer we return carriage paid.

THE Principal of this Firm, who has been a professional wireless engineer since 1910, and been manager for the Sterling Telephone Co., expert to the General Electric Co., and Chairman of the Technical Committee of the National Association of Radio Manufacturers, will willingly give advice to those who are desirous of purchasing apparatus; are entirely unbiased and will recommend the apparatus for your particular purpose; you save money by having genuine expert advice.

DON'T Forget We Will Take Your Old Receivers or Components in Part Exchange.

WE Will Also Install Sets Anywhere in the British Isles; sets modernised; send for estimates. Scientific Development Co., 51, Fishergate, Preston, Tel.: 1364.

SIMMONDS BROS.—Receivers constructed to your own or any published design; also repairing constructions; and modernisations at moderate charges. Best materials and workmanship guaranteed; numerous testimonials; quotations free.—Address, Shireland Smethwick.

WIRELESS Portable Sets with 5 New Costor Valves for 9 Guineas; less than components cost, comparable with any set double this price; beautiful case, 2 aerial windings, English batteries and eliminators, all inclusive efficient sets; Royalty paid magnificent Xmas gift; if you are in London I fix an appointment; if you are not in London I send you particulars?—G. Hodgson, 53, Westminster, Victoria St., Westminster.

PYE Presentation Two, with battery, valves, eliminator, and Celestion speaker enclosed, new, months ago; cost £12, accept reasonable offer; Marconi 6-volt type moving coil speaker, cost £8; offer; seen by appointment only.—J. Annesley, 22, Mead Rd., Beckenham.

Mention of "The Wireless World," when writing to advertisers, will ensure prompt attention.

Receivers for Sale.—Contd.

E.O. World Wide Screened Grid Four, Celestion loud-speaker, Philipson's safety eliminator, Exide inductor, 2 spare screened grid valves, a first class lens selective set, in perfect condition and working (privately owned); worth about £35, will accept suitable offer; demonstration evenings.—J. Bennett, 'Endle Rd.', Stratham, London. [7637]

VO Aeonic V Valve Transformers, latest models; £12/10 each, or best offer; one Aeonic V valve, case, 1928, complete with new battery, £8/10, new fitting, perfect order.—George Slater, Chemist, doctry, Banfshire. [7600]

OLLS 5-valve Portable Receiver, extra accumulator, new batteries, tone and condition good; £12; never going abroad.—On view at 62, Kinnerton St., Ton Place, S.W.1. [7598]

ECOPHONE Portable, 2 months old, as new, £20, or near offer; also Maglo 3C, £6.—E. Adams, 97, Rylands Rd., W.9. [7590]

ADIO-GRAMOPHONE, in fiddle-back mahogany cabinet (screened grid 5), including Ferranti push-button scheme and incorporating Baker's 1930 model dynamic moving coil speaker, B.T.H. pick-up, all latest elements, entirely A.O. mains driven; demonstration evening after 7.30; price £38.—Mayer, 25, John's Hendon, N.W.4. [7589]

REBE Short Wave Receiver, complete with 2 valves, 5 coils, etc., nearly new, excellent reception, from 200 metres; cost £25, will accept nearest offer to—H. O. N. Shaw, 114, Wardour St., W.1. [7636]

CHRISTMAS Bargains.—4-valve (S.G.) portable, practically new, worth £20, take £13; Amplion A.C.2 (fully used) 15/-; portable gramophone cases, few left, clear, 7/6 each.—B.M/ZNTN, London, W.C.1. [7630]

VALVE Superhet, complete with Amplion speaker, all stations; cost £40, for quick sale £15, offer on 1 week only.—Phone: Beckenham 1106. 57, The Avenue, Beckenham. [7644]

PHILIP'S 3-valve All Mains Receiver, cost £23, unused, £17; Celestion pick-up, 35/-; B.T.H., 15/-; inductor, 14/-; Marconi D.F.P.240, 7/6; or offers.—Box 226, c/o The Wireless World. [7647]

O. Mains 3-valve Receiver, new, Marconi components, excellent results; £15, complete.—6, Haverock Rd., S.W.11. [7619]

930 Cossor Set, unopened carton; post free, £7/15.—L. Phillips, 11, Poultry, E.C.2. [7668]

ACCUMULATOR HIRE.

DON'T Buy Accumulators or Dry Batteries, join our C.A.V. low- and high-tension accumulator hire service, the largest and best in London; better and cheaper reception with no trouble; regular deliveries within 12 miles of Charing Cross; no deposit, payment by delivery or by subscription; over 10,000 satisfied customers; explanatory folder post free; phone or write day.—Radio Service (London), Ltd., 105, Torrington Rd., N.W.5. 'Phone: North 0623-4-5. [7596]

D.D.E.S. Accumulator Hire and Maintenance Service (5 mile radius)—98, Cherry Orchard Rd., Croydon. [6374]

BATTERIES.

WET H.T. Replacements.—Sacs (capped or uncapped), highest grade, No. 1, 10d. per doz.; No. 1/9 per doz.—See below.

INCS.—Best quality (wired), No. 1, 8d. per doz.; No. 2, 9d. per doz.; orders valued 5/- carriage paid, otherwise 6d. for postage.—British Battery Co., Wrenford Rd., Watford, Herts. [0258]

ENTUDE Users.—Write for details of new size self-charging wet battery; 20,000 milliamps. 6d. per cell; illustrated catalogue giving data, post free.—U. Taylor, 57, Studley Rd., Stockwell, London. [0273]

WET H.T. Batteries.—12arts per dozen, jars, No. 1, 2 1/4 x 1 1/4 square, 1/3; No. 2, 1/6; zincs, No. 1, 1d.; No. 2, 1 1/2d.; sacs, No. 1, 1/2 dozen; No. 2, 1/3; terminals, 8d., 10d.; dozen cells (18 volts), complete with hands and electrolyte, No. 1, 4/1; No. 2, 3/6; post 9d.; high efficiency, long life, self charging, keep small; send 6d. for sample unit; illustrated booklet free, carriage free orders 10/-; write for free wireless bargains, trade supplied.—W. Taylor, 57, Studley Rd., Stockwell, London. [0039]

XIDE 2,500 m.a. 10-volt Units, 16 for sale, filled; write only.—Kennedy, 17, London Rd., S.E.23. [7601]

WHAT Offers? Wet H.T., 4 trays, 60 volts each, zincs 1/4in. thick (70 squares), quantity sal., would barate.—Dodge, 9, Kemphead Rd., Cumberwell, S.E.5. [7606]

XIDE H.T., 120v., in 2 crates, charged, excellent condition; 25/-.—176, Valley Rd., Stratham. [7596]

100-VOLT Exide, 100-volt Oldham H.T., 5,000 m.a., charged; 55/-.—Tipper, 385, Rotherhithe Wd., Rotherhithe, S.E. [7622]

LDHAM H.T. Batteries, 60v., new, 5,500 milliamp. capacity; 35/- each.—Kircher, 47, Federation Rd., Ley Wood. [7635]

CHARGERS AND ELIMINATORS.

ORTEXION Transformers, chokes, etc., wound to any specification; write or phone for quotation; quality components only.—Vortexion, 72, Merton Wimbledon, S.W.19. Tel.: Wimbledon 2814. [0319]

EGGS! No. 2 AND THE



CLAROSTAT

Some Variable Resistances, just like Eggs, are unknown quantities. To secure a good, fresh egg it is advisable to purchase only from an old-established and reliable source, or to consult an expert.

"Clarostats" have been "hatched" 5 Years! Over 4 million are in regular use the World over. They are backed by a firm established May 1918—before "Broadcasting." Any Wireless Expert will confirm that they are still the best of the "brood"! They are fully guaranteed to give you satisfaction.

There are now so many imitations at a little less money that you should make sure that by saving a few coppers you do not—like Foolish Freddie above—purchase "a bad egg"!

THERE'S A "CLAROSTAT" FOR EVERY RESISTANCE PROBLEM!

STANDARD, 18 WATTS, for Eliminators .. Was 10/6 **NOW 9/6**

STANDARD, 18 WATTS, BRASS FINISH MODEL .. Was 9/6 **NOW 8/6**

VOLUME CONTROL, 100-500,000 Ohms .. Was 8/6 **NOW 7/6**

POWER CLAROSTAT, 35 WATTS .. Was 15/- **NOW 13/6**

POWER TYPES, Brass Finish .. Were 12/6 **NOW 11/6**

"HUM-DINGERS," all Types NOV/7 **4/-**

SUPER-POWER CLAROSTAT, 250 WATTS .. (A New Model) **30/-**

TABLE TYPE (Distant Volume Control) .. Was 13/6 **NOW 12/-**

36-PAGE ART BOOKLET CONTAINING 47 Illustrations, 27 Diagrams, 3 Scale Drawings of H.T. Units, etc., FREE and POST FREE, from:



CLAUDE LYONS LTD.
76 OLDHALL ST.
LIVERPOOL

Chargers and Eliminators.—Contd.

ATLAS Eliminators, D.C. £11/7/6, A.C. £3/17/6; Nesper trickle chargers, 29/6. 'Phone: Gerrard 6268 for demonstration.—Greatrex and Co., 124, Regent St., London. [6451]

TANTALUM and Lionium for A.C. Rectifiers; make up your own inexpensive chargers; blue prints for H.T. and L.T., 1/- each; Lionium electrolytes fitted with terminals, 2-3 amps. and 5-8 amps.—Blackwell's Metallurgical Works, Ltd., Speke Rd. Works, Garston, Liverpool. 'Phone: Garston 980 (2 lines). [6282]

PHILIPSON'S Safety High Tension Battery Eliminators.

10/- Down and the Balance in Easy Monthly payments secures the finest high tension supply available.

PHILIPSON'S Safety Eliminators are Guaranteed for 12 Months.

PHILIPSON'S Safety Eliminators are the Cheapest to install and the Cheapest to Run; prices: Model A.C.5 £4/17/6, A.C.7 £3/17/6, complete with full wave rectifiers; D.C.4 37/6, D.C.5 45/-.

ALL Models Obtained for 10/- Deposit; take advantage of this and get constant high tension immediately.

WRITE for Our Booklet, "Radio Power" to Philipson and Co., Ltd., Radio Engineers, Astley Bridge, Bolton. 'Phone: 2038. 'Grams: Safety, Bolton. Est. over 50 years. [0318]

CHEBROS.—Chebros for all types of transformers and chokes, high grade instruments at a very moderate price; enquiries invited.—Chester Bros., 244, Dalston Lane, London, E.8. [5290]

POTENTIAL Dividers, wire wound, variable (tappings), ideal for eliminators and rectifying units; price 6/6, post free.—Belov.

POTENTIAL Dividers, standard 20 m.A. type, 5 variable tappings, supplied in all values; a first class job; price 2/6.—Abingdon Wireless Supplies, Abingdon, Berks. [7287]

FEL-ECTRIC RADIO Eliminator Kit, transformer, choke, valve holder, valve, 3 condensers, variable resistance, insulated terminals, sleeve, wiring diagram; 37/- complete; output 15 m.a. at 120 volts; send for lists.—Fel-Ectric Radio, 56, Garden St., Sheffield. [7411]

MAINTENANCE MANUFACTURING Co., Ltd., invite you to consider this unequalled value, viz.:

MAINTENANCE Special Unit, including 2 variables, 0-80, 0-100, 120, 150, and 200 volts at 50 m.a., full wave Westinghouse rectification and heater transformer for A.C. valves up to 3 amps., in handsome metal cabinet; £6/10, or without heater transformer £5/15.

MAINTENANCE Model A.C.M.100, H.T. only with similar voltages to A.C. Special, but with 100 m.a. output, complete with Westinghouse rectifiers; £8.

MAINTENANCE A.C. Low Tension Unit, giving 2, 4, and 6 volts up to 1 amp.; £5.

MAINTENANCE A.C. and D.C. Portable Units, which will go right inside any portable or transportable receiver; A.C. model £4, D.C. model £2/10.

MAINTENANCE Eliminators may be Purchased on Easy Payments.

MAINTENANCE Eliminators are Guaranteed for 12 Months, and are subject to 7 days' approval; write for latest literature on complete units and radio-mains accessories.

MAINTENANCE MANUFACTURING Co., Ltd., Portland Rd., Hove, Sussex. 'Phone: Hove 1519. [0326]

TRANSFORMERS and Chokes for Battery Eliminators and for all wireless purposes, receiving or transmitting; enquiries invited.—Chester Bros., 244, Dalston Lane, London, E.8. [7587]

SAVAGE'S Specialise in Wireless Power from the Mains, reliable apparatus at reasonable prices.

SAVAGE'S Transformer Laminations and Bakelite Bobbins; intending home constructors should write for list.

SAVAGE'S Reliable Smoothing Condensers.—1,000 volts D.C. test, 2 mid. 3/-, 4 mid. 5/3; 500 volts D.C. test, 1 mid. 1/6, 2 mid. 2/3, 4 mid. 3/9.

SAVAGE'S Super Smoothing and Output Chokes.—Many types available, write for list.

SAVAGE'S Mains Transformer for Westinghouse Rectifiers.—H.T.4, 18/6; A3, 17/-; A4, 20/-.

SAVAGE'S Mains Transformer for Westinghouse H.T.4 Unit, with additional winding, 4 volts 3 amp; 23/-.

SAVAGE'S Mains Transformer.—V.T.31, 200-0-200 volts 60 m.amps., 2+2 volts 2 amp., 2+2 volts 3 amp.; 28/-.

SAVAGE'S Mains Transformer.—B.T.3 500-0-500 volts 120 m.amps., 3.75+3.75 volts 3 amp., 3+3 volts 3 amp., 2+2 volts 3 amp.; 51/-.

SAVAGE'S Mains Transformers and Power Chokes are carefully and individually constructed from first class materials with an exceptionally generous margin of safety.

SAVAGE'S, 146, Bishopsgate, London, E.C.2. 'Phone: Bishopsgate 6998. [6808]

REGENTONE Eliminator, model W.1, giving 190v. R. at 60 m.a. (listed £10), £6; also Regentone lamp trickle charger (listed 65/-), £2; both A.C. 200-240 volts.—Nixon, Higher Drive, Banstead. 'Phone: Epsom 9695. [7646]



REGENTONE

MAINS COMPONENTS

↓

MAINS UNITS

↓

MAINS RECEIVERS

Treat yourself or your best friend to a really useful Xmas Present this year—a Regentone Mains Unit or Trickle Charger. Write for free copy of our Art Booklet, "Radio from the Mains"



for Radio from the Mains.

REGENT RADIO SUPPLY CO. 21, Bartlett's Bldgs., Holborn Circus, London, E.C.4. Telephone Central 9661



The Sound Box that never tires!

—“bring your old Gramophone up-to-date in time for Xmas!”

by fitting the new MELTROPE Sound Box, its greater definition, forward tone, and range being wider than many Sound Boxes costing more than double.

Suitable for all types of tone-arm.

PRICE 12/6

AMPLIFIERS LTD.,
Billet Road,
Walthamstow, E.17.

Chargers and Eliminators.—Contd.

REGENTONE W1 Eliminator, 220-30 volts, 50 cycles, output 200 volts, 100 milliamps, list £13/10, perfect; bargain. £7.—Gordon, 3, Cowper St., Leeds. [7594]

TUNGAR Rectifier, A.C. 110-125, charging H.T. and L.T., variable to 7 amps., excellent condition; carriage paid, £4/10.—121, Lulworth Rd., Preston. [7613]

EXIDE Trickle Charger, combined H.T. and L.T., 200-250 volts, A.C. mains, few months old, under makers guarantee; cost £8, accept £4.—3, Belfield Rd., Didsbury, Manchester. [7633]

EKCO Combined H.T., L.T., and G.B. Eliminator, D.C. model, C2, condition new; cost over £6, accept £2/10.—3, Belfield Rd., Didsbury, Manchester. [7634]

HIGH Tension Power Unit, G.E.C., 200-260 volts, A.C., 50-100 cycles, 20 milliamp type, brand new, cost £5/5 sell £3 15, or near offer; also trickle charger (Tekade), 2 and 4-volt, £1, bought all-mains; also Marconi H.T. unit, 210-250-volt, A.C., 100 cycles, what offers?—Box Z.X.660, c/o Deacons, Fenchurch Av., E.C.3 [7624]

CABINETS.

ARTCRAFT Radio Cabinets are Britain's Best Value. [0313]

DIGBY'S Cabinets.—Table models in solid oak and mahogany; from 11/6 to 71/-.

DIGBY'S Cabinets, fitted with Radion or Resiston ebonite if required.

DIGBY'S Cabinets.—Pedestal model, with separate battery components; from 56/- to £12.

DIGBY'S Cabinets Made to Customer's Own Designs.

DIGBY'S Cabinets.—Write for new 16-page art catalogue.—F. Digby, 9, The Oval, Hackney Rd., E.2. 'Phone: Bishopsgate 6458. [0128]

ARTCRAFT Radio Cabinets are Britain's Best Value. [0309]

KAY'S Cabinets, the greatest range of pedestal cabinets in the kingdom; original creative designs at prices 50% lower than elsewhere; quotations for specials by return; delivery at short notice guaranteed; moving coil, portable, baffle, vignette, radiogram, electric pick-up, television, etc.; illustrated lists free.—H. Kay, Wireless Cabinet Manufacturer, Mount Pleasant Rd., London, N.17. 'Phone: Walthamstow 1626. [6461]

ARTCRAFT Radio Cabinets are Britain's Best Value. [0311]

HORNS for Cabinets, portables, etc.; illustrated list.—Maddison, 1, Chapel St., Edgware Rd. [6142]

ARTCRAFT Radio Cabinets; Britain's best value; lowest prices consistent with highest quality; illustrated list free from actual manufacturers.—Arrcraft Co., 156, Cherry Orchard Rd., Croydon. 'Phone: Croydon 1981. [9040]

WIRELESS Cabinets, 3ft. high, to suit any panel, hinged lid, 4 doors, polished; approval.—Wooller and Son, Robertown, Liversedge, Yorks. [7476]

ARTCRAFT Radio Cabinets are Britain's Best Value. [0310]

CABINETS, 16 1/2 in. x 7 1/2 in. x 11 in., hand mahogany finished 7/6, unpainted 5/6; oval front, 10 1/2 in. x 6 1/2 in., 6d. extra; portable cabinets, 16 1/2 in. x 8 in., £1/5; baseboard, 6d.; carriage free.—F. W. Ramsey, 63, Shaftesbury St., London, N.1. Clerkenwell 7139. [7584]

CABINETS.—A fine gift, something new: Combined loud-speaker cabinet, bookshelf, newspaper rack and occasional table, 30in. high, take any unit up to 18in. x 17in., handsome cabinet, well made, superior finish; solid oak 35/-, solid mahogany 40/-.—Below.

A **NOTHER** New Line.—Handsome fire screen loud-speaker. 31in. high, brown enamelled frame, 3-fold, covered with best quality sateen, strongly wired, complete with baffle and shelf, take any unit up to 14in. x 14in.; price 15/-.—Below.

PEDESTAL Cabinets, Radiogram, etc., from 55/-; table and loud-speaker cabinets from 15/-; above in solid oak, selected materials, hand polished; send for illustrated list.—Thos. Eastham (Dept. 5), Cabinet Works, Thornton, Blackpool. [7573]

FINEST American Types, astonishing value, special offer oak cabinets, hinged lid, baseboard, highly polished, take 12in. x 6in. panel; sample carriage paid, 6/6; trade discounts for quantities.—Mag-Radio, 112, Warstone Lane, Birmingham. [2665]

LOUD-SPEAKER Cabinets, extraordinary offer, oak cabinets, handsome fret front, highly polished, 13in. square, 6in. deep, finished moulding, take all ordinary units; sample, carriage paid, 6/6; trade discounts for quantities.—Mag-Radio, 112, Warstone Lane, Birmingham. [2666]

COILS, TRANSFORMERS, ETC.

600 OHM Decoupling Resistances for New Kilomag Four, foreign listeners' four, and all "Wireless World" circuits, hand made and tested in our own workshops; improved model wound with Constaton wire, 1/6 each, post free.—Groves Bros., St. Mary's Place, Shrewsbury. [7361]

1,000 OHM Decoupling Resistances for "Wireless World" Circuits; 1/6 each, post free.—Groves Bros., St. Mary's Place, Shrewsbury. [7362]

So Many Replies

A recent advertiser in "THE WIRELESS WORLD" writes as follows:

"I HAVE received so many replies to my advertisement in 'The Wireless World,' which appeared under a Box Number that I am sending herewith stamps to the value of 6d. as further payment towards your postage expenses. Thanking you for the quick despatch of all replies."

R. W. CAPEWELL,
52, Chapel Terrace,
Trent Vale,
Stoke-on-Trent.

STUPENDOUS!

A recent advertiser in "THE WIRELESS WORLD" writes as follows:

"As the results from my advertisement in 'The Wireless World' were stupendous, I shall be glad if you will cancel my advertisement in next week's issue as I am cleared out.

I might add that 'The Wireless World' is the best journal I have read."

W. F. Macbeth,
"Breinar,"
Ballymena, Ulster.

Mention of "The Wireless World," when writing to advertisers, will ensure prompt attention.

Coils, Transformers, Etc.—Contd.

NEW Kilo-Mag Four Coils, 37/6 set; ebonite formers (slotted), for winding, 12/6 set of 3; all st free.—Groves Bros., St. Mary's Place, Shrewsbury. [7446]

RADIOGRAPH.—W.W. coils, Record III, 35/-; new Kilo-mag Four, 33/-; S.G. Regional, 37/6; foreign teners' Four, 37/6 set; Europa Portable, 21/-; Europa III, 18/6; S.G. multi-valve portable, 22/6; w Everyman Four, 42/6.

RADIOGRAPH.—Litz wire, 3/40, 1/6; 27/42, 2/6 dozen yards; Redfern's deep ribbed or Becol bc. 5d. per inch, slotting 1/6 extra.

RADIOGRAPH, Ltd.—W.W. cabinets, 4 compartments, 44/6; 2 compartments, 38/6; crackle enamel and oak finish.—Station Rd., Handsworth, Birmingham. [7441]

JIMMONDS BROS.—Berolif coils, Record Three, 50/- pair; new kilo-mag, four, 50/- set; foreign listeners ur, low, 30/-; long wave, 37/-; screened grid Regional, 39/-; Mullard S.G.P. dual range coils, 30/- pair; Berolif standard coils, for new all-wave four, standard four, C.O. three, Everyman four, etc., 63/6 set of 4, with bases; the same coils for the Loekstone series ("Wireless Magazine") 65/9 set of 4, with bases; Titan unit, 3/-; decoupling resistances, 600 ohm, 1/6; 1,000 ohm, 1/-; all "Wireless World" and similar coils in regular production by the leading specialists; lists free; trade applied.—Simmonds Bros., Shireland Rd., Smethwick. [6314]

FOREIGN Listeners' Four Boxes, 19/- set of 4; coils, 37/6 set.—Stott.

RECORD III Coils, 35/-; Kilo-Mag 4 coils, 33/-; decoupling resistances, 1/3.

KIT Set Coils and Switches, 37/6; dials and plates, 5/- pair.—Stott.

950 Everyman Coils, 42/6 set; all special parts to order; trade supplied.

METAL Cabinets, in oak or mahogany, with moulded wood top and base; Record III, K.M. and 1930 Everyman, 45/-; Kit set, 35/-; metal box only, 32/6 and 27/6 respectively.—Arthur T. Stott, Duke St., Rochdale. [7651]

DYNAMOS, ETC.

M-L. Motor Generator, perfect, input 200v.-210v. 50 cycles, output 6v. 3a., 350v. 80 m.a., smoothing unit for H.T. and L.T., cut-out for floating accumulators; £17/17.—Nutter, 245, Selhurst Ed., Norwood Junction, S.E.25. Thornton Heath 2848. [7623]

DYNAMOS, L.T. charging.—W.W. 20 volts, 5 amps., 50/-; L. 12 volts, 8 amps., 45/-; Ct. 18 volts, 10 amps., 65/-; 50 volts, 25 amps., £7/10; 80 volts, 40 amps., £8/10; and others. Motor generators: 230 volts A.C. to 100 volts, 100 m.a. D.C. 70/-; Dynamos: 100 volts, 1 amp., 25/-; 100 volts, 4 amps., 38/-; 250 volts, 4 amps., £3/10. H.T. anode M.G., 200 volts D.C. to 250 volts, 250 m.a., £10; 220 volts D.C. to 400 volts D.C., 200 m.a., £12; fine new 2-amm. G.E.C. Aircraft generators: 950 volts, 60 m.a. and 6 volts, 5 amps., £10; 600 volts, 100 m.a. and 6 volts, 5 amps., £5; fine Newton H.T. generators, 1/2 kw., 2,000 volts, £30; slow speed 1 kw., 2,000 volts, £40; 2kW., 2,000 and 4,000 volts, £52; large E.V. regger hand generators, 1,500 volts, £8; medium, 800 volts, £5; hand magnetos, 80 volts, 50 m.a., 1/- each; H.T. 4,000 volts, 1/2 mfd. mica condensers, 10/-; 0.01 Dubilier 1,000 volts, 6d. each.

50 Petrol Electric Generating Sets, Air Force, 50 70 volts, 20 amps., £27; 150 electric bench and portable 110- and 220-volt drills, £5.

SWITCH Gear.—Slow motion geared slide Rheos, 250 watts, 7/6; 147 S.P. plug boards, 9-way, 10-amp. /-; Lucas 8-way switch boxes, mahogany, with brass cover; 6 S.P., 1 D.P., 1 C.O. switches, 3/6; S.P.C.O. switches, 1/6; H.T. send receiver, 2/6; hundreds of their switches and controllers; send for list.

ELECTRADIX RADIOS, 218, Upper Thames St., E.C.4. [7639]

GRAMOPHONE PICK-UPS, ETC.

EXPONENTIAL Horns for Cabinet Gramophones and Wireless, metal and wood; list.—Maddison, Chapel St., Marylebone, N.W.1. [6141]

LOUD-SPEAKERS.

HORNS of All Descriptions for Loud Speakers and Gramophone Units.—H. Maddison, manufacturer of the Allwoodon, 1, Chapel St., Paddington, N.W.1. [6143]

RICE KELLOG B.T.H. Senior L-S., 240 volt A.U.; cost £40, price £20.—Saul, 8, Ansdell Rd., Ansdell, Lytham. [7417]

YOUR Old Loud-speaker Taken in Part Payment for the Latest Type; see our advert. under column Receivers for Sale.—Scientific Development Co., 51, Fishergate, Preston. [0227]

CELESTION Loud-speaker G14, cost £11, sell £7; B.T.H. pick-up, cost £2.5, £1/10, as brand new.—Lang, 14, Herryfield Rd., Penton Place, Kennington Park Rd., S.E.17. [7612]

MAGNAVOX and B.T.H. M/O Speakers, 100-250 watts J.G., new condition; £3.—2a, Salisbury Rd., Seven Kings, Essex. [7611]

BAKER Moving Coil (1929), 6v., mounted baffle; 45/-.—Nixon, Higher Drive, Banstead. Phone: 969m 9695. [7645]

There's time yet to give your set this magic tonic

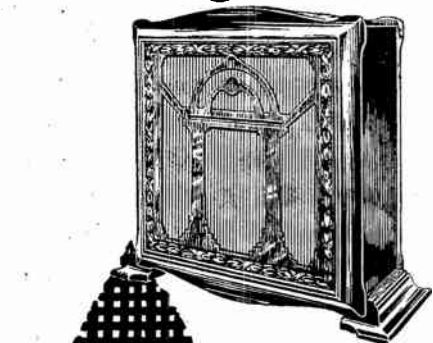

This is Model U14 listed at £55.0, incorporating a 14" x 14" Ultra Air Chrome Chassis.

The Double Diaphragm Principle is the subject of British Patent No. 295,625, controlled by Ultra Electric Limited.



Radio via Ultra Air Chrome has definition and character. It is selective at audio-frequency. Radio sets operated by the factory-made double linen diaphragm speaker possess high selectivity at audible frequencies, reproducing music, song and speech with brilliance, with virility, and with the vital temperament of individual instruments and voices. End the search for natural radio now. Though your set be old, give it the chance to reveal hidden tone qualities. Enjoy it under the ideal and laboratory conditions produced by the Ultra Air Chrome Speaker. There is ample time yet before Christmas. Visit your local dealer to-night. Take home an Ultra Air Chrome, it is the magic tonic—sets old and new respond to it magically.

Cabinets from £3.19.6
Chassis from £2.2.0

Demonstrated and sold by all radio and music dealers in the country.

ULTRA AIR CHROME SPEAKER

fitted with the double linen diaphragm



Baldry Ad. U 116

Loud-speakers.—Contd.

EPOCH Moving Coil Speakers.

EPOCH.
EPOCH.
EPOCH.
EPOCH.
EPOCH.
EPOCH Moving Coil Speakers Speak for Themselves.
EPOCH.
EPOCH.
EPOCH.
EPOCH.
EPOCH.
EPOCH.
EPOCH.—Test an Epoch against any other make. It will persuade you more than the best salesman.
EPOCH.
EPOCH.
EPOCH.
EPOCH.
EPOCH.—Ask any of the thousands of users of even the older models. But this season's models? Well, let the speakers tell you themselves.
EPOCH.
EPOCH.
EPOCH.
EPOCH.
EPOCH.—Please do test them against any or every make on the market—preferably with a quick switch over.
EPOCH.
EPOCH.
EPOCH.
EPOCH.
EPOCH.
EPOCH.—Order one for 7 days' free trial.
EPOCH.
EPOCH.
EPOCH.
EPOCH.
EPOCH.
EPOCH.—Your deposit instantly refunded in full if you are not more than satisfied. No catch. No red tape.
EPOCH.
EPOCH.
EPOCH.
EPOCH.
EPOCH.—The most comprehensive range of moving coil speakers in the world.
EPOCH.
EPOCH.
EPOCH.
EPOCH.
EPOCH.—Send for catalogue W 5.2.
EPOCH.
EPOCH.
EPOCH.
EPOCH.
EPOCH.—16 pages crammed full of real information. Post free.
EPOCH.
EPOCH.
EPOCH.
EPOCH.
EPOCH RADIO MANUFACTURING Co., Ltd., are the manufacturers. City Office and Service Station, 3, Farringdon Avenue (Lucas's Circus end), E.C.4. Phone: Central 1971 (2 lines). Private Branch Exchange. [6972]

Say 99!

EPOCH

NEW MODEL 99 P.M.
MOVING COIL SPEAKER

will satisfy the most critical of listeners.

No accumulator, no mains, no suspension, no adjustments, yet it is the finest Moving Coil Speaker on the Market.
7 days' free trial.

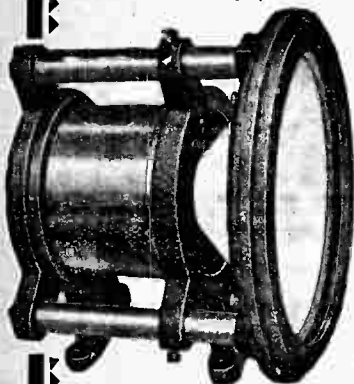

Send for new 16-page Catalogue of real information.

EPOCH RADIO
MANUFACTURING CO., LTD.,
3, Farringdon Avenue :: E.C.4.
Phone: CENTRAL 1971/2.

BARGAINS!

Never before has such wonderful value been offered.

BURDEPT Slightly used Leather Suitcases: Type Portable Cabinets. Inside measurements 14 1/2 in. x 14 1/2 in. 12/6 each.

BURDEPT Polished Mahogany Suitcase Type Portable Cabinets. Inside measurements 14 1/2 in. x 14 1/2 in. Condition as new. 25/- each.

BURDEPT Brand New Cone Speakers, complete with fret front to fit lid of above portable cabinets. 30/- each.

BURDEPT Oak Portable Cabinets (not suitcase type), complete with inside frame aerials and battery compartments. As new. 25/- each.

BURDEPT H.T. Eliminator Cabinets, oak. Inside measurements 13 1/2 in. x 7 1/2 in. x 8 in. deep, with hinged lid. Condition new. 7/6 each.

BURDEPT 3-Valve Mahogany Cabinets, open front, hinged top, for panel 11 1/2 in. long, 8 1/2 in. deep, and 8 1/2 in. baseboard. 14/6 each.

BURDEPT 4-Valve Cabinets, mahogany, open front, hinged lid, for panel 16 in. x 10 in. As new. 25/- each.

Loud-speaker Bargains: Amplion A.C.9 mahogany cone, as sold at £5, our price, 65/-; Type A.C.5 Oak Speaker, 59/-; Type A.C.5 Oak Speaker, 56/-; Type A.R.38 Horn Speaker, 25/-.

Every brand new. **Horn Type Loud-speaker Units**, brand new. A.U.4, 8/6; A.U.5, 10/6; A.R.88 bases, as sold with horn at 5 guineas, bases only with complete unit, 8/-; ditto, type A.R.58, 7/-.

Loud-speaker Cabinets. Amplion type A.C.9 cone cabinets, mahogany. Size 16 1/2 in. high x 17 1/2 in. x 7 1/2 in. base. Takes 12 in. cone. 17/6 each.

Loud-speaker Units, complete with chassis and cone, genuine Amplion, and will fit any cabinet. Type A.C.16, with 9 in. cone, 16/-; Type A.C.10, with 12 in. cone, 19/-.

Brand new, in original cartons, all Amplion lines.

BURDEPT Low-Loss Variable Condensers, totally enclosed, capacity 100 p.f., can easily be altered to any lower capacity as vanes are easily dismantled. Price 3/- each.

Genuine Western Electric 2-Valve "Kone" Amplifiers, brand new, in original cartons, ready for use, but less valves. Each amplifier contains two transformers, one being tapped to volume control switch on panel; also one output transformer, etc. 20s. each. Worth more than treble if broken up.

ALL GOODS CARRIAGE PAID.

HUGHES & SONS,

149, CHEPSTOW ROAD, NEWPORT, MON.

Mention of "The Wireless World," when writing to advertisers, will ensure prompt attention.

Loud-speakers.—Contd.

BAKER'S

BAKER'S

BAKER'S

BAKER'S

BAKER'S

BAKER'S

BAKER'S

BAKER'S

BAKER'S

BAKER'S

BAKER'S

BAKER'S

BAKER'S

BAKER'S

BAKER'S

BAKER'S

BAKER'S

BAKER'S

BAKER'S

BAKER'S

SELHURST RADIO Moving Coil Speakers are of the Highest Grade and Proved Efficiency.

SELHURST RADIO Moving Coil Speakers Obtained on 1: Days' Approval for Comparative Test.

SELHURST RADIO Moving Coil Speakers Used by Music Lovers Throughout the World.

SELHURST RADIO Moving Coil Speakers.—Write now for new 36-page booklet, "Sound Advice."

SELHURST RADIO Moving Coil Speakers Reproduce both Speech and Music with Wonderful Realism.

SELHURST RADIO Moving Coil Speakers can Always be Heard at the New Demonstration Room.

The new 36-page booklet is full of truthful information.

SELHURST RADIO Moving Coil Speakers are the Best that Money can Buy; ideal Xmas presents.

SELHURST RADIO, the leading manufacturers of high grade coil speakers.

OFFICE: 89, Selhurst Rd., South Norwood, S.E.25. Phone: Croydon 1618, Works and Demonstration Room (always open): 42, Cherry Orchard Rd., Croydon, S.E. (15 minutes non-stop Victoria or London Bridge).

SUPER-MICROPHONES

New, highly sensitive, made on the latest principle, a vast improvement over all other types: will pick up whispers words from a distance of several yards, also strongly amplify and transmit speech and music over a distance, through Loud-speaker or Headphones. Splendid instruments for making Detachable, Hand-aid, LOUD SPEAKING TELEPHONE, Announcements through Loud-speaker, Amplifier or Crystal or Valve Sets. Electric Sound Detector, Experiments.

NO OTHER MICROPHONE OF EQUAL SENSITIVENESS KNOWN; each instrument finely black enamelled and fitted with a 3 ft. silk connecting cord. Despatched by return post. 8/6

SPECIAL MICROPHONE TRANSFORMER for connecting Super-Microphone to Radio Headphones, Loud-speaker, Valve Set, or Valve Amplifier 6/-

SMALL 10 OHMS EARPIECE for use with Super-microphone as a HIGHLY EFFICIENT DEAF-AID, or Detachable, etc.; this 3-ft. silk connecting cord fitted. Earpieces finely black enamelled. Full Directions for use of Super-Microphone for many purposes and Diagrams of connections free.

NEW PUBLIC ADDRESS MICROPHONE

The Ideal Instrument for addressing an Audience through Loud speaker (via Valve Amplifier or L.F. Stages of Wireless Set), and for relaying Speech and Musical Entertainment to any distance. Powerful Loudspeaker Reproduction with perfect Fidelity.

Highly distance-sensitive, yet guaranteed entirely free from distortion or microphonic noises, absolutely silent background; far superior to ordinary Microphone Transmitters and obsolete Government surplus; for use with Valve Amplifier or Valve Set (through lead of Gramophone Pick-up if desired) at Open-air Meetings, in Cinema, Theatre, or Concert Hall. Operates from 2 Volt Tapping of L.T. Accumulator, through Microphone Transformer. Current consumption one-tenth Ampere. Provided with detachable Sound Collector, handle, hook for suspension, and a 9 ft. silk connecting cord, as illustration. 16/-

Microphone Transformer for the above 6/- DIAGRAM OF CONNECTIONS FREE.

FREDK. ADOLPH, Actual Maker, 27, Fitzroy Street, London, W.1. Phone: MUSEUM 532

THE Scientific Logarithmic Horn



Length 5 feet. Flare 25 inches. Specially designed for home use. Inconspicuous and of pleasing appearance. Can be suspended in corner of room and will harmonise with all furnishings.

Crisp definition with marvellous depth of tone, remarkable volume, equal reproduction on all frequencies. Equalled only by a good moving coil speaker. Will satisfy the most critical ear.

Horn with Baldwin Type Balanced Armature Unit. Complete £2:0:0. Horn with Brown U/GA Unit. Complete £2:18:6. A combination making the finest loud speaker obtainable. Satisfaction guaranteed. On 5 days' approval against cash. 19/6

SCIENTIFIC SUPPLY STORES, 126, Newington Causeway, London, S.E.1

These Cabinets are made by experts and are thoroughly electrically sealed with Fine Brass Gauze.



W.W. as specified CABINETS. RIGBY & WOOLFENDEN, Sheet Metal Workers, Millnrow Road, ROCHDALE. Phone 294

Loud-speakers.—Contd.

REAT Bargains.
REAT Bargains.
REAT Bargains.—Epoch model A moving coil speaker kit (or complete units), brand new; a number of these famous instruments made for special order for use in talkies, but not executed, credit reasons only; regular prices, £3/10, £4/2, £5/17/6, to clear at 50/- for accumulator operation, 55/- for D.C. mains operation, 85/- for A.C. mains; kits comprising copper plated super magnets (weight 23 lb.) Chrystalcne frame, fully adjustable, moving coil, any impedance, paper, leather and iron rings, made up complete, if desired, 6/- extra.
REAT Bargains.

REAT Bargains.—In fact, the greatest bargains ever offered! A number of Epoch model A used as at given away prices, guaranteed in perfect working order; early 1923 model, 35/-; latest model, 42/6; made up complete, if desired, 6/- extra.
ENJOY Marvellous Epoch Reproduction at Ridiculous Cost; don't wait until they are all gone, but secure one immediately by writing, phoning, telegraphing, or hurrying to Epoch, 3, Farringdon Av., E.C.4. [7077]

MARCONIPHONE Moving Coil Speaker, in oak cabinet, accumulator model, practically new; cost 10, bargain £5.—Meibes, 144, Great Portland St., W.1. [7603]

NET Moving Coil Quality Linen Diaphragm Speaker, 20in. square, varnished ply case, 17/-; polished mahogany, 25/-; units supplied; free fitting.—Parke diagrams, 79g, Turnpike Lane, London, N.8. [7597]

MPLION Lion Chassis L14 (£6), used 8 weeks; £3/10.—Box 4217, c/o *The Wireless World*. [7649]

ULTRA Air-chrome Chassis, 18x23, list £4/4, unused, had to take double delivery; £3/10.—Atter L. Laimson, 154, Jerningham Rd., New Cross, S.E.14. [7621]

ELF-CENTRE Ball and Socket Device, when fitted to your cone unit, will relieve driving rod of all due side stress, centering the cone in relation to driving rod improving results all round; provisional patent applied for; price 2/6; c.o.d. terms available. Weedon, 80, Lonsdale Av., London, E.6. [7487]

TRANSMITTERS.

CHEBROS. Chebros, Chebros transformers and chokes of all descriptions, special transformers for smitling and modulation; chokes a speciality; enquiries invited.—Chester Bros., 244, Dalston Lane, London, E.8. [5240]

AMP. A.C. Motor, coupled to Mackie 60-watt generator, £10; heterodyne wavemeter, calibrated 65-0, by "Experimental Wireless," 25/-.—G5UB, 16, High St., Wetherby. [7608]

AMERELL 3-valve 20-watt Transmitter, telenhony and keyed, latest pattern, complete with Mullard 10 type transmitting valves, guaranteed in perfect order as delivered by makers; cost £30, accept £12 tick sale.—5DJ, 56, Furzehill Rd., Plymouth. [7633]

VALVES.

AMPLIFIER Valve.—If you require power you cannot do better than one of these:—

FLAMENT Volts 6 plate volts 400 (maximum), grid bias 84 volts (approx.), impedance 800 ohms, amplification factor 3.8, mutual conductance 15 m.a./volts; price £5/10; see article "The Wireless World," 24th July, 1929, then send to North London Valve Co., Ltd., 22½, Cazenove Rd., Stoke Newington, London, N.16. [7457]

TWO Cossor 415X.P., matched, push-pull, few hours' use, perfect, changing to mains; 24/-.—Laxton, Inceess Rd., Bournemouth. [7604]

TWO AG/Gs, 10/6; AC/R. 12/-, month old; 8625, new, 13/-; OPM3C, 15/-; BTHRK, £4.—132, Millax Rd., Bradford. [7626]

COMPONENTS, ETC., FOR SALE.

PELLING-LEE Panel Fittings are designed to give an expert finish to any home-constructed set; catalogue post free.—Belling and Lee, Ltd., Queensway Works, Ponders End, Middlesex. [0018]

ENEREER Wood Paper Converts Commonest Woods into Oak; 30in.x20in., 8d.—Burtenshaw, Hillsborough Terrace, Ilfracombe. [7351]

00-OHMS Decoupling Resistances; see advt. under Coils.—Groves Brothers (Manufacturers). [7175]

OWER Chokes, substantially built, for smoothing circuits in eliminators dealing with currents 0-300 milliamperes, inductance 30 henries; 8/6 each; guaranteed 12 months.—Transformer Repair Co. (Dept. 1), 214, High St., Colliers Wood, S.W.19. [0327]

VESTON Model 301, milliammeters, ammeters, and voltmeters, 2/- each; hot wire ammeters 0-1 up, 4/-; 0-0.5 amp., 3/-; instrument repairs and alterations; send for list.—The Volta Electrical Co., High St., Battersea, S.W.11. Established 1910. [7563]



26
THE DOMINION
VERNIER
DIAL

Only Brownie's huge production enables them to offer this really splendid dial for 2/6. The special non-backlash design makes hair-breadth tuning a matter of delightful ease, while its handsome appearance (black or beautifully grained mahogany bakelite) will add to the good looks of that new set you are building.

BROWNIE WIRELESS COMPANY (G.B.) LIMITED,
NELSON STREET WORKS, LONDON, N.W.1.

BROWNIE
WIRELESS

FEEL THE SNAP OF IT !



THE PILOT QUICK 2/6 ACTION SWITCH

It will handle 3 amperes at 220 volts. Especially suitable for Mains Sets.

Write for Catalogues to:
THOMAS A. ROWLEY LTD.,
59 Skinner Lane, Birmingham.

Sole Agents for Great Britain and Ireland for all lines manufactured by the **PILOT** Radio and Tube Corporation of New York.
 West of England Distributors:—**F. BURRIS & SONS, 7 to 10, Redcliffe Street, Bristol.**

Components, Etc., for Sale.—Contd.

RADIO HOUSE, HUDDERSFIELD (14th Winner), ENSURES LISTENERS INCOMPARABLE ADVANTAGES. BARGAINS INNUMERABLE, LIBERAL IRRESISTIBLE TERMS.

YEA, tis true; a Littlehampton client was so satisfied that he sent unsolicited testimonial: "Your firm is 'streets' ahead of some of the London Houses for business. This unsolicited reputation we endeavour to uphold."

WIENEVER INCOMES REQUIRE ECONOMY LESSEND EXPENSES SUPPLY SOLUTIONS.—So when applying for Guide endorsement submitting similarly composed advertisements, using the words "Reliability Wireless Guide," so as to encourage readers to apply for this List. Weekly change of matter desired. A 100-volt H.T. battery for each effort published, and useful consolation prizes given.

GEOGRAPHICALLY UNFAVoured, INHABITANTS, DERIVATIVE ENCHANTMENT from the List, which will be sent post free by J. H. Taylor and Co., 15, Radio House, Macaulay Street, Huddersfield, to whom competition efforts should be submitted, indicating also if name and address publishable if successful. (Only 23 alternative words required, Radio House, Huddersfield, remaining, one word for each initial following.) Winner: **Mr. A. Hart, Belvedere Road, Liverpool.** [7499]

APPLEBY'S.
END of Year Clearing.—As announced last week, due to the enormous amount of business we have on hand, we have been forced to give notice that fresh part exchange business has been suspended until further notice; current business will, of course, follow through in rotation.

END of Year Clearing.—The broom begins its work; the following material is offered for clearance this week, the first of an enormous collection of part used material, which will be offered for disposal during the course of the next few weeks; watch these columns!

END of Year Clearing.—The following slightly used material is offered subject to sale; when as new, it will appear marked with an asterisk; every article will be severely tested before despatch, and guaranteed in workable condition; no part exchange allowance can be made against any of the following, as the lowest cash prices are quoted; carriage is forward, but packing is free, on the following articles, in order to keep down the nett figure.

END of Year Clearing.—McMichael screened Dimio Three receiver, in oak, with set of 3 tested valves with additional S.W. coils, used 3 days, £16/18/6; another similar, in oak, used about 4 weeks, £14/15/-; another similar, used about 2 months, £12/15/-; Marconi 5-valve receiver, with all mains drive, for 100/125v. A.C. mains, a fine domestic receiver, of handsome appearance, £19/19/-, with set of 5 tested valves; Philips 2-valve all-electric receiver, for 240v. A.C. mains, with tested valves, £9/17/6/-; Geophone World Wide 2/6 four aerials, with set of 4 tested valves, and requisite leads, etc., £17/10/-; Marconi 5-valve portable receiver, complete with valves and batteries (new ones), £14/15/-; Burnrdpt Screened Four Portable, crocodile finish, complete with new valves and batteries, £15/10/-; Geophone 8-valve super heterodyne receiver, with set of 8 new tested valves, and frame, £16/18/-; a few more will be unearthed next week; every one of the foregoing may be definitely relied upon; they will not leave us unless we are satisfied as to their efficiency.

APPLEBY'S. Number Forty-four, Chapel St., Marylebone, N.W.1 (4 minutes from Oxford St., London). [0316]

SET of 3 Fada H.F. Neutrodyne Transformers, with matched condensers and Apex slow motion dial; also Fada neutrodyne condensers and instruction book; accept £3.—Bloxam, 55, Park Rd., Hampton Hill, Middx. [7591]

**For Xmas, New Year and
All Times
THE IDEAL GIFT
IS A
DIX-ONEMETER**



The Precision Instrument of universal use, with an ingenious system of multipliers which enable full-scale readings of any value to be made over a wide range. One millivolt to 2,000 v., or 50 ohms to 50 megohms. Mirror double scale, jewelled, knife edge. A £10 De Luxe model for only 50/-. Multipliers, 6/6 each.

New A.C. Model **ACONEMETER**. Model **VAC.3**. In Case. Is a new Model for measurement of volts on Alternating Current, a 3-range instrument reading 0-150 v., 0-300 v., and 0-600 v. Price, inclusive of case, 75/-. Extra for 1,500 volt Multiplier, 44/-.
WHEATSTONE BRIDGES. G.P.O. and Dial types: £7 10s. Mirror Galvos Reflecting Beam, by Paul Gambrell, Sullivan and Tinsley, 43. Standard Resistance Boxes and Universal Shunts, 35/-. Electrostatic Voltmeters, £4. Capacity Bridges, £8.

FOCUSING ARC LAMPS, 60/-. Indoor Projectors, with lenses fitted 100-watt focus lamp, 39/6. Xmas 14 lamp Festoons, 220 v., 12/6. Torpedo Spring-driven Gyroscopes, 15/-. Neon Tubes, 2/6. Holders, 8d. Osram B.E. Power Valves, for Eliminators, 4/6. Selenium Cells up to 200 v., ratio 30-1, 15/-. Double Scale Taylor-Hobson Projectors, double arm, 5/6. Radio Picture 2-valve Amplifiers, 40/-. A.C. or D.C. Motors for Drive, 35/-. Wonderful 200-watt Alternators, Watford A.C., self-exciting, cost £30; great bargain, £3. Porcelain encls. 250-v. Fuses, 3a, to Protect mains sets, 3d. each. Photoelectric Cells, 60/-.
ACCUMULATORS. If you are tired of your dry battery being always dry, try an H.T. Accumulator, Monobloc, new, ebonite case, 1,000 m/a hours, 60 v., 19/-. 90 v., 28/-.
L.T. Celluloid, 4 volt, 10/20 amp., 6/3; 4 volt, 20/40 amp., 11/-. 4 volt, 30/60 amp., 12/6. 3-volt Inert Dura, 1/3. Cell Fillers, 1/6. Hydrometers, 1/-. Petrol Testers, 2/6.
HOUSE TELEPHONES, 12/6 set of two complete stations.
LOUD-SPEAKERS. R.K. Cones, fitted B.T.H. Moving Coil, 100 surplus, at only 7/6 each. Marconi L.S. Magnet Pots, 6 v., for Moving Coil Cones, 20/-. Ampion L.S. Unit with base A.R.58, 7/6.
THE VIOLINA CABINET LOUD-SPEAKER DELUXE. Wonderful reproduction, complete tonal range. Beautifully polished mahogany. List, £5. Sale price, 22/6. Moving-coil Loud-speakers, £3 10s.
TRANSMITTERS. With A.T.1 and all fittings in case, cost £15. 2-valve Aircraft with Osram Valves, Speech or Morse, 40/-. Tapping Keys, No. 1, with massive contacts, 6/- each. Transmitter No. 51KD, with aluminium cover, double contact, fine work, 7/6 each. Morse Practice Sets, with Buzzer and Key, on mahogany panel 8/6 each. Morse Recorder Mechanisms, for making picture receivers, 15/- each. Spark Gaps, 2/-.
3-VALVE POWER AMPLIFIERS, D.C. Mains Panatropie model, 65/-. 3-valve Receivers, 27/6.



CONDENSERS. W.D. 250 volts 2 mfd. 1/6. 4 mfd. 5/6. 6 mfd. 7/6 New Sterling Smoothing for up to 400 volts 2 mfd. 2/1s. 4 mfd. 5/6. 6 mfd. 7/6. 500 mfd. Dry 12 v. for Mains Supply L.T. Filters, 10/-. Dubilier .01 Type 577 1000 v. List 7/-. Sale 1/-.
WE HAVE A WONDERFUL STOCK OF RADIO AND SCIENTIFIC APPARATUS.

If you cannot call at our showrooms, send addressed envelope for our illustrated list to

ELECTRADIX RADIOS,
218, UPPER THAMES STREET, E.C.4.
Phone: City 0191.

Components, Etc., for Sale.—Contd.

POTENTIAL Dividers 10,000, 15,000, 20,000, 25,000 and 30,000 ohms, 5 variable tappings; 2/- each.
POTENTIAL Dividers, heavy duty, wire wound, 15,000 and 20,000 ohms, 7 tappings, 5/6; 4 tappings, 3/9.
CONDENSERS, 2 mfd., 2/3; 4 mfd., 4/-; guaranteed; tested 500 volts.
CHOKES (L.F.).—Excellent for smoothing, up to 2 milliamps, 2/-; special heavy duty, 10 milliamps, 8/6.
ELIMINATORS, A.C., wired for half or full wave, complete with valve; £3/17/6.
H.F. Chokes; 3/-.
GRAMOPHONE Motors, well known make, double spring, silent, complete with fittings; 30/-.
SPECIAL Bargain.—B.T.H. 40 henry chokes; 9/6; any article on approval against cash.—Huggins, Radio Engineer, Clacton-on-Sea. [7398]
INTERFERENCE.—Special two-section eliminator coil for making your own Brookman Park wave-trap; 3/3 each, post free, with diagram; made by Gordon Castagnoli, A.M., R.E., Castaphone Radio Service, Culver St., Colchester. [7510]
YOUR Old Components Taken in Part Payment for Latest Type; see our advert. in column Receivers for Sale.—Scientific Development Co., 51, Fishergate, Preston. [0228]

CONTROL Your Receiver from That Other Room by means of the Foolproof and Inexpensive Yarg Relay, no maintenance or attention, models for battery and mains operated sets; patent pending; single make and brass, 10/6; double, 17/6; triple, 22/6; post free; stamp particulars.—"Yarg," 1, Eccles Old Rd., Manchester. [7248]
SURPLUS.—P.M.5B, new, 8/-; Cosor H.F., 4-volt, 2/6; Ormond drum dial, 2/6.—Robertson, College Gate House, Bury St. Edmunds. [7610]

FERRANTI A.F.5C, £1; O.P.1, 10/-; Western Electric, 3:1 ratio, 10/-; Igranic megostat, 4/-; Priestler, 46, Glasslyn Rd., Crouch End, London, N.8. [7605]
KELVIN Electrostatic Voltmeter, 0-150 v., 25/-. Grompton potentiometer, 50/-; 6in. moving coil instruments, 0-150 and 260v., 12/6; 0-100 millivolts, 10/-; 0-8v., 10/-; 0-0.8 milliamps, 10/-.—Bohus, 5, Friar's Rd., Coventry. [7599]

LIBERTY Superhet Kit, complete, 26/-; set frame aerials, 50/-; 4 matched valves, £1.—Capper, 20, Parker's Rd., Sheffield. [7592]

SURPLUS, Experimenters.—The following terrific bargains are offered; I must sell, room wanted: B.T.H. pick-up, 35/6; Sigan 200 m.a. meter, 7/6; Philips pick-up, 35/-; Ferranti A.F.4, 13/6; Collura gram motor, 50/-; moving coil speaker, 6-volt, £6; another, 230 A.C. main, £7; Burndopt S.G. and Pentode 3-valve set, £9; Philips 2514/230 volt A.C. set, £17; Karphones 4000, 5/-; Hegra pick-up, 10/6; potentiometer, 6/-; Anode resistances; 3/-; Bullphone transformer, 7/6; Autobot 230v. A.C., 25/-, etc., etc.; send for my list; all guaranteed O.K. or your money back.—Schouten, 30, City Rd., E.C. [7625]

A.F.3, case scratched, 10/-; Marconi 2-7-1, new, 10/-; Varley H.F. choke, 5/-.—29, Haig Rd., Cambridge. [7627]

EXPERIMENTER wishes to Dispose of Surplus Components of Every Description, all in excellent condition; complete list will be sent on application.—Steel, Oak Orchard, Lanark. [7632]

SOLODYNE Coils (wound Mazdas), 15/9; other components half price.—Gleed, Optician, Raynes Park. [7641]

MISCELLANEOUS.

EASY Payments.—We supply, by easy payments, components, accessories, and sets, any make; 10% down, balance spread over 10 months.—Send list of requirements to London Radio Supply Co., 11, Oat Lane, London, E.C.2. [0097]

EXPNENTIAL Horns for Cabinet Gramophones and Wireless, metal and wood; list.—Maddison, 1, Chapel St., Marylebone, N.W.1. [6143a]

ALEXANDER BLACK.

PLEASE Note New Address.

THE Original Wireless Doctor, will call (London and Home Counties) and cure your set.

CONSULTATIONS by Appointment Without Obligation, sets installed, maintained, and brought up to date, gramophone pick-ups, eliminators, and Webson moving coil speakers demonstrated; purity reproduction specialist.

55, Ebury St., Victoria, S.W.1. Sloane 1655. [0277]

WIRELESS Notes.—A monthly service of information for all those who want the very best in wireless or gramophone reproduction; frank criticism of receivers and components; immediate postal help and advice in all difficulties; something new and unique; you must have it if you want to know the truth.—Full particulars free from Ernest H. Robinson, Langmead, Pirbright, Woking, Surrey. [7607]

**How
to sell
a Portable!**

For the sale or purchase of Portable or other Receivers use the Miscellaneous Columns of "The Wireless World." A recent advertiser writes as follows:

"I am very satisfied with the results obtained. The Portable set was sold the same day, and I had over twenty other replies, including prepaid Telegrams. I also had a large number of callers and altogether am very pleased with the pulling powers of your valuable paper."

M. A. FROST,
54, Clerkenwell Road,
London, E.C.1.

W.W.#5

**EGYPT
NATAL
SOUTH AFRICA
MALTA**

High Value!

"You will be pleased to learn that from my last advertisement in 'The Wireless World,' letters reached me from EGYPT, NATAL, SOUTH AFRICA, and goods were sold to a person residing in MALTA. This undoubtedly proves the high value of your paper."

WILLIAM WINFIELD,
4, ARTHUR ST.,
HULL ROAD,
YORK.

W.W.#3

Miscellaneous.—Contd.

JOTT SESSIONS and Co., Great Britain's radio doctors, officially approved as wireless repairers Radio Society of Great Britain and Wireless League; sets of every type repaired, rebuilt, modernised; 1 set for immediate quotation.

JOTT SESSIONS and Co.—Midland customers, please send address to us and our Midland representative call.

JOTT SESSIONS and Co.—New sets constructed with your own components, guaranteed finest craftsmanship; we specialise in "The Wireless World" suits; remember, we have satisfied customers throughout the British Isles and in three Continents; you so desire, we will design and construct high de apparatus to suit your especial circumstances for dily, range and selectivity.—Tel.: Tudor 5326, Mual Hill, London, N.10. (0262)

OUR Old Apparatus Taken in Part Payment for Latest Type; see our advert. in column receivers for Sale.—Scientific Development Co., 51, shergate, Preston. (0230)

ENGINEERS.—Can't we get together? All we ask is the chance to prove that you can earn £300, 00, £500 per year and more. Other men are doing and you can do the same. We have an unrivalled and-vice organisation waiting to help you, whether you are a novice or expert. If you wish for something more on a bread-and-butter job you owe it to yourself investigate our service. Our handbook, "Engineering Opportunities," has pointed the way to better things to over 20,000 of your fellows. It contains details of A.M.I.Mech.E., A.M.I.C.E., A.M.I.E.E., M.I.A.E., A.M.I.Struct.E., C. & G., G.P.O., etc., exams, and outlines home study courses in all branches Electrical, Mechanical, Motor and Wireless Engin- ing. In a brilliant article Professor A. M. Low tells clearly the chances you are missing. The book and our advice are quite free. We guarantee No Pass— Fee. Don't miss this opportunity; send a postcard— w (state branch, post or exam.).—British Institute Engineering Technology, 87, Shakspeare House, 29, ford St., London, W.1. (7640)

PATENT AGENTS.

PATENTS and Trade Marks, British and foreign.— Gee and Co. (H. T. P. Gee, Member R.S.G.B. and M.I.R.E.), 51-52, Chancery Lane, London, W.C.2. Phone: Holborn 1525. (0001)

REPAIRS.

TWELVE Months' Guarantee Accompanies all our Repairs; any make of L.F. transformer, head- phones, or loud-speaker repaired and despatched within 48 hours; 4/- post free; don't discard if burnt out; come to trade.—Transformer Repair Co. (Dept. W.), 4, High St., Colliers Wood, S.W.19. (0011)

JOTT SESSIONS and Co., Great Britain's radio doctors; read advertisement under Miscellaneous column. (0263)

INGSTON-ON-THAMES.—Transformers, 'phones, loud-speaker repairs; transformers wound to any io.—Minter, 156, Cambridge Rd. (7269)

GUARANTEED Repairs by Experts.—Loud-speakers, headphones, cone units, pick-ups, any type re- tuned, remagnetised, and adjusted, post free 4/-; transformers, iron 4/-.—Howell, 91, Morley Hill, En- field, Middlesex. (7617)

WANTED.

WANTED, Gambrell, Philips, or other 3- or 4- valve all-electric, voltage 105 A.C., with loud- speaker, inside aerial, first class condition, trial ap- proval.—Box 4215, c/o The Wireless World. (7616)

ELIMINATOR, 250v. A.C., output 10-15 m.a. 120v., 1/2 Lissen or similar.—Greensill, 71, Watling St., Edgworth, Cannock. (7629)

WANTED, Blue Spot loud-speaker unit, also cabinet loud-speaker, 220-volt D.C. eliminator, Climax transformer.—Block, 38, Abercorn Rd., Londonderry. (7631)

WANTED pointer microammeter, 0-100 microamps approximately.—Haigh, 50, Algernon St., Limby. (7618)

WANTED, all components for Record III.—Box 4227 c/o The Wireless World. (7622)

EXCHANGE.

THE RADIO EXCHANGE, Treville St., Plymouth, the exchange specialists; a trial solicited. (7324)

OUR Old Apparatus Taken in Part Payment for Latest Type; see our advert. in column receivers for Sale.—Scientific Development Co., 51, shergate, Preston. (0229)

EXCHANGE.—Send us your enquiries; satisfaction guaranteed.—Midland Wireless Supplies Co., 5 and 7, Oxford Rd., Peterborough. (7614)

AGENCIES.

AGENTS Wanted, spare time, wireless experience, to demonstrate and sell the world's best and cheapest valve set.—Mag-Radio, 112, Wurstone Lane, Birming- ham. (2667)

SITUATIONS VACANT.

WIRELESS Operating Appointments Assured; short qualifying course, day, evening; fees pay- able after appointment for boarding students; Morse classes.—Manager, Wireless School, 21, Manor Gardens, London, N.7. Archway 3694. (6379)

Universal Three
15-2,000 metres.



The most perfect receiver yet designed for Ultra Short Wave, Broadcast, and Long Wave reception. Including Valves, Coils and Royalty £18 J. 0d.

Convert your present Set into a Short Wave Receiver.



Magnum Short Wave Converter.

This Converter is adaptable to any valve set by simply removing the detector valve from set and inserting it in the valveholder of converter, the plug of converter taking the place of the detector valve. In crystalline metal cabinet, with 2 Coils 20/40 and 40/80 metres, Plug and Adaptor £4.10.0.1. inclusive.

Magnum Receivers are now obtainable on Easy Payment Terms.

We specialise in all apparatus described in "Wireless World."

Lists on application.

BURNE-JONES & CO., LTD.
296, BOROUGH HIGH ST.,
LONDON, S.E.1.

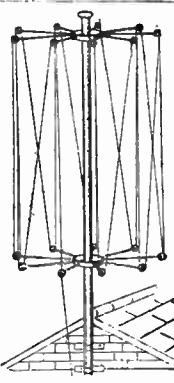

ASHTON PERFECT AERIAL SPREADERS
15/- New Model 15/-
Per Set

WONDERFUL RECEPTION



From Dealers or
8-10 Bull's Head Yard,
Manchester.

BOOKS on WIRELESS
Write for complete list to
LIFFE & SONS LTD.,
Dorset House, Tudor St., London, E.C.4.

Situations Vacant.—Contd.

SITUATIONS Guaranteed as Wireless Operators, age 15-29; day, evening, or postal courses; Morse classes.—School, 321, Mansfield Rd., Nottingham. 17526

WIRELESS Mechanic Wanted, capable of wiring up complicated sets from circuit diagrams; state age, experience, salary required.—Write Box 4214, c/o The Wireless World. (7606)

A FIRST Class Electrical Designer of High-tension Eliminators and Wireless Apparatus required by Manchester Firm, must be thoroughly competent, energetic, and have had good experience in designing transformers, chokes and wireless apparatus; state in confidence full particulars of past experience, age and salary.—Box 4187, c/o The Wireless World. (7602)

YOUTH Required for Test Room Work with Radio Engineers; Central London; state age, experience and salary required.—Box 4224, c/o The Wireless World. (7648)

WANTED for Editorial Office, youth of good education and with fair theoretical knowledge of wireless.—Send full particulars to "Editor," Box 4218, c/o The Wireless World. (7642)

WELL Established Radio Firm, with international connections, requires, at an early date, services of a fully trained lecturer to organise and conduct radio classes and undertake public lectures, permanent engagement, with good salary and prospects, to suitable applicant.—Write Box 4219, c/o The Wireless World. (7643)

THE NORTH-EASTERN SCHOOL OF WIRELESS TELEGRAPHY (Established 1911), Radio House, York Rd., Bridlington, E. Yorks. Phone: Bridlington 2625.—Young men from 15 upwards, required to train for positions in the wireless service; all successful students of the past year have been placed in remunerative positions; tuition fees after appointment for student boarders if desired; special terms for operators requiring coaching for 1st Class Certificate (1927 Convention).—Apply for prospectus, Principal, M. W. G. Russell, M.I.R.E. (7650)

BOOKS, INSTRUCTION, ETC.

WET BILT Batteries are now a proved success; write for new illustrated booklet, giving cost and method of building and maintaining free; mention paper.—Taylor, 57, Studley Rd., Stockwell, London. (0077)

STEP by Step Wireless; a complete course of the theory of electricity in relation to the practical design of wireless apparatus, eliminators, circuits, etc., with extracts from a designer's notebook, giving up-to-date practical application; issued weekly; send 1/- p.o. for first 4 weeks.—Clifford Pressland, A.M.I.E.E. Eng., Dept. W.W., Hampton-on-Thames (0195)

FREE: Inventor's Guide on Patents.—T. A. A., 253 (W.) Gray's Inn Rd., London, W.C.1. (6373)

A GUIDE for the Crystal User.—"Successful Crystal and One-valve Circuits," by J. H. Watkins, tells you how to improve the performance of your receiver and gives diagrams of many well-tested circuits; 3/6 net, of booksellers, or Pitman's, Parker St., Kingsway, London, W.C.2. (7070)

CITY of London.
THE SIR JOHN CASS TECHNICAL INSTITUTE,
Jewry Street, Aldgate, E.C.3.
Principal: Geo. Patchin, A.R.S.M., M.I.M.M.
The following special evening course of instruction will be given during the Second Term (January to April, 1930):—
ALTERNATING CURRENTS AND ELECTRICAL OSCILLATIONS
by D. Owen, B.A., D.Sc., F.Inst.P.
A course of ten lectures, with practical demonstrations, intended for those interested in the higher developments of this subject, especially in its application to radio-telegraphy and telephony. Tuesdays, from 7 to 8.30 p.m., commencing January 14, 1930. Details of the above Course may be had upon application to the PRINCIPAL.

TILTRACK
Patent-STEEL STORES-System
For the Wireless Experimenter, Factory, and Retailer.
Full Particulars from Sol. Manufacturer and Patentee.—
BERTRAM THOMAS, Worsley Street, Hulme, MANCHESTER.

1930 EVERYMAN FOUR COILS 50/- SET
NEW KILO-MAG FOUR - - 45/- SET
WAVETRAP FOR NEW REGIONAL SCHEME, LITZ WIRE WOUND - 12/6
R. KILBY,
51, LYNDBURST GROVE, PECKHAM, S.E.

INDEX TO ADVERTISEMENTS.

	PAGE		PAGE		PAGE
Adolph, Fredk.	20	Ever Ready Co. (G.B.), Ltd.	Cover ii	Potter, H. B. & Co., Ltd.	24
Amplifiers, Ltd.	18	Exide Batteries	4	Premier Supply Stores	24
Appleby, E. Hetherington	16	Ferranti, Ltd.	9	Radio Gramophone Development Co.	5
Ashton, Harold	23	Fonteyn & Co., Ltd.	16	Regent Radio Supply Co.	20
B. & J. Wireless Co.	16	Garnett, Whiteley & Co., Ltd.	11	Rigby & Woolfenden	18
Baker's "Selhurst" Radio	16	General Electric Co., Ltd.	3	Ritherdon & Co., Ltd.	8
Bate, Jabez, & Co.	24	Grosvenor Battery Co., Ltd.	10	Rothermel Corp'n., Ltd. (Electrad)	8
Bayliss, W., Ltd.	24	Holzman, L.	15	Rowley, Thomas A., Ltd.	21
Britannia Rubber & Kamptulicon Co., Ltd.	15	Hughes, A. E., & Sons	20	Scientific Supply Stores	20
British Insulated Cables, Ltd.	Cover iii	Hughes, F. A., & Co., Ltd.	Cover i	Squire, Fredk., Ltd.	14
Brownie Wireless Co. (G. B.), Ltd.	21	Impex Electrical, Ltd.	6	Telegraph Condenser Co., Ltd.	8
Bulgin, A. F., & Co.	21	Jackson Bros.	6	Telsen Electric Co., Ltd.	8
Bullphone, Ltd.	4	Kilby, R.	23	Thomas, Bertram	23
Burne-Jones & Co., Ltd.	23	London Electric Wire Co. & Smiths, Ltd.	9	Transformer Repair Co.	24
Cass, Sir John, Institute	23	Lyons, Claude, Ltd.	17 & 24	Trelleborg Ebonite Works, Ltd.	Cover i
Clarith Reproducers, Ltd.	2	Marconiphone Co., Ltd.	Cover iv	Tudor Accumulator Co., Ltd.	1
Cole, E. K., Ltd.	Cover i	M.P.A. Wireless, Ltd.	1	Tulsemere Manf. Co.	19
Cossor, A. C., Ltd.	12	Mullard Wireless Service Co., Ltd.	Cover i	Ultra Electric, Ltd.	16
Day, Will, Ltd.	24	Olham & Son, Ltd.	Cover iii	Vandervell, C. A., & Co., Ltd.	15
Dubilier Condenser Co. (1925), Ltd.	2 & 15	Ormond Engineering Co., Ltd.	13	Varley (Oliver Pell Control, Ltd.)	15
Eastick, J. J., & Sons	24	Pensens Manf. Co.	24	Wain & Goldstone, Ltd.	15
Electradix Radios	22	Pertrix, Ltd.	7	Westinghouse Brake & Sarby Signal Co., Ltd.	10
Epoch Radio Manf. Co., Ltd.	20	Phillips Radio	11	Wingrove & Rogers, Ltd.	8
Ericsson Telephones, Ltd.	14	Player's	7		

**"B.A.T." 750 Watt
"Q.M.B." SWITCH.**

This miniature switch comfortably breaks 3 Amperes at 250 Volts. For H.F., L.F., H.T., L.T. Circuits. For A.C. Sets, Eliminators, Gramo-Motors, and as Loud Speaker Field Switch, etc.

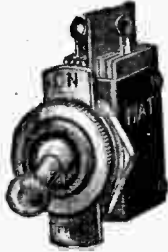

"WIRELESS WORLD" said (14.8.29) "functioned quite well on test and did not give any cause to justify doubt as to their ability to handle this wattage" (750 Watts!). "Ideal for use in portable sets and in all types of mains equipment."

"B.A.T." "Q.M.B." POWER SWITCH only 2/6 Each.

**CLAUDE LYONS LTD.,
76, OLDHALL STREET, LIVERPOOL.**

**RADIO-GRAMPHONE
CABINETS**

Beautifully finished in highly polished OAK.

Will take sets
18" x 7" x 16" or 21" x 7" x 16".
Spacious compartment for speaker and batteries. Overall size 36" x 24" x 19".
9-ply motor board.

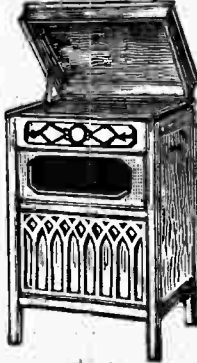

(Mahogany Finish £5-15-0)
Delivered free in England and Wales. Scotland 2/6 extra.
Send for our Illus. Catalogue.
Fitted complete with D.S. Motor, B.T.H. Pick-up and Arm, Ormond Unit and Chassis... £9-17-6

This is all you need to turn your present set into modern RADIO-GRAMPHONE.

PREMIER SUPPLY STORES
Radio & Gramophone Specialists,
165, Fleet St., London, E.C.4.
Phone: Central 2833
Large selection of Gramo. Motors and Pick-ups always in stock

BONA FIDE TRADERS' GUIDE.

Send for our comprehensive Illustrated List
QUICK SERVICE. QUICK SERVICE.

THE QUALITY HOUSE.

**PERSEUS MFG. CO., LTD., (Dept. W.W.)
BRANSTONE RD., BURTON-ON-TRENT**

REPAIRS

Any make of L.F. Transformer, Loudspeaker or headphones repaired and dispatched within **48 HOURS—TWELVE MONTHS' GUARANTEE** with each repair. 4/- Post Free.

Terms to Trade.

**TRANSFORMER REPAIR CO.,
Dept. W.**

214, High Street, Colliers Wood, London, S.W.13

For the Best in Radio

WILL-DAY LTD.

(THE BEST IN THE WEST)
19 LISLE STREET, LEICESTER SQUARE, LONDON, W.C.2.
Telephone: Holborn 8101 and 8022. Telegrams: Willday, London.
OPEN TILL 7 P.M.
WRITE FOR OUR CATALOGUE
POSTAGE 6d FREE TO CALLERS

Have you got this Catalogue?

BULGIN
RADIO PRODUCTS

A. F. BULGIN & Co.,
9/11, Currier St., Chancery Lane, London, E.C.4.

56 PAGES
2d POST FREE

BATE'S MILLION
EARTH TUBE

1/6 EACH
A REAL EARTH TUBE
24" LONG X 1" DIA.
ALL DEALERS SUPPLY.

JABEZ BATE & CO
VERONA WORKS BIRMINGHAM

E.ELEX

WANDER PLUGS
MIDGET & STANDARD
NICKEL PLATED—6 Colours 2d. each.

J. J. EASTICK & SONS
"Eelex House," 188, Bunhill Row,
London, E.C.1. Phone, Old Kentwell 9282/3/4.

PARFAIT
THE PERFECT EBONITE

SUPPLIED IN SIX FINISHES
Semi-Polished Black
Highly Polished Black
Matt
Semi-Polished Mahogany,
Highly Polished Mahogany
Cube Surface

Obtainable from most wireless dealers.

Advertisement of H. B. Potter & Co., Ltd., Station Buildings, HOODDALE.

Mention of "The Wireless World," when writing to advertisers, will ensure prompt attention.

EXPERIMENTAL WIRELESS
& The WIRELESS ENGINEER

The Journal for Professional Engineers and Advanced Wireless Experimenters

Monthly 2/6 net. Annual Subscription 32/- post free.

ILLIFFE & SONS LTD., Dorset House, Tudor Street, London, E.C.4.



FOR ELIMINATOR CIRCUITS

You cannot afford to use any but the best Condenser in an eliminator circuit.

HESBY CONDENSERS

are made and guaranteed by a firm with 30 years' experience in condenser making, from small telephone and radio condensers to Power Condensers weighing upwards of 2 tons.

Guaranteed working voltages :-

Type M	-	-	150 volts D.C.
Type 2A	-	-	350 volts D.C.
Type 3A	-	-	450 volts D.C.
Type 4A	-	-	600 volts D.C.

All Helsby Condensers are vacuum dried and impregnated with a special non-hygroscopic material which renders them moisture proof.

If unobtainable from your dealer, write to us giving his name and address.



BRITISH INSULATED CABLES LTD

PRESCOT - LANCs.

Makers of PRESCOT and HESBY cables

use ALL the power you pay for !

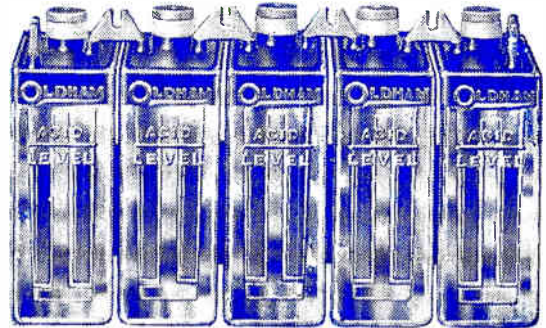

Obsolete mass type H.T. Accumulators can constantly discharge themselves—day in and day out their unbroken tops permit power—paid for power—to leak away.

In Oldham H.T. Accumulators the AIR SPACES form an impassable barrier to electrical leakage. Buy an Oldham H.T. Accumulator today and you'll get more listening, less recharging and better radio for less cost.

Ask your dealer to show you these money-saving accumulators.

EXTRA LARGE CAPACITY.

(5,500 milliamps)
Per 10-volt unit

6'9

STANDARD 10-VOLT UNIT.

Capacity 2,750 milliamps

5'6

Complete with two connectors and length of cable.
Wooden trays extra if required.



The Pioneers of "Air-Spaced"

H.T. ACCUMULATORS

Oldham & Son Ltd., Denton, London Office: 40, Wicklow Street, Glasgow: 209, St. Vincent Street, Manchester, King's Cross, W.C.1.
Telephone: Denton 701 (4 lines), Telephone: Fournival 4446 (3 lines), Telephone: Central 4016.

CA 2882

Every word . . .

every note . . .

natural,

flawless!

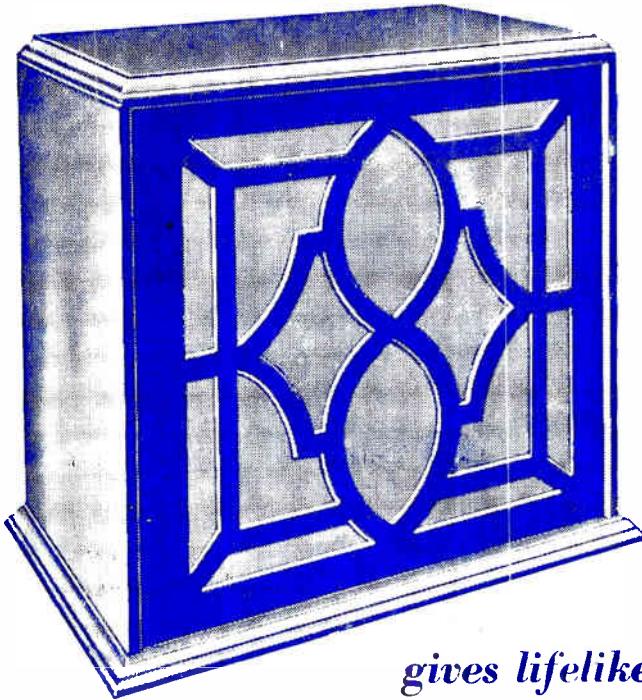

With this speaker you hear the whole programme and nothing but the programme. Nothing missed . . . nothing distorted.

This new moving coil speaker gives lifelike reproduction at your fireside

NOW—you can hear the world's greatest musicians, famous singers, leading figures in national events—just as though they were actually in your room.

Never before has a loud speaker captured so wide a range, such delicate shades of tone. The Marconiphone Moving Coil speaker brings everything to life! In music—from lowest bass to highest treble. In speech—all the expression of the voice.

Boundless power — yet so sensitive!

And so great is the range of volume that it can be adjusted to the needs of your drawing-room or the largest hall. The highly accurate

centring of the moving coil makes this speaker almost uncannily sensitive. The special diaphragm, pressed from a single piece of new non-resonant fibrous material, gives every note its real value—no more, no less.

Moving Coil Units for home construction from £4 10. 0. Cabinet models for working from 6-volt accumulator—£7; for D.C. mains—£7 10. 0; for A.C. mains—£12 12. 0 (including Rectifier Unit and Valve).

Hear these speakers at any dealer's. If there is no dealer near you, write to the Marconiphone Company Limited, 210-212 Tottenham Court Road, London, W.1.



The first and greatest name in wireless

MARCONIPHONE Moving Coil SPEAKERS

Printed for the Publishers, LITTLE & SONS LTD., Dorset House, Tudor Street, London, E.C.4, by The Cornwall Press Ltd., Paris Garden, Stamford Street, London, S.E.1.

Colonial and Foreign Agents:

UNITED STATES—The International News Co., 131, Varick Street, New York. FRANCE—W. H. Smith & Son, 248, Rue Rivoli, Paris; Hachette et Cie, Rue Racine, Paris. BRITAIN—W. H. Smith & Son, 78, Marsh Lane, London; W. H. Wheeler & Co., Bombay, Allahabad and Calcutta. SOUTH AFRICA—Central News Agency, Ltd. AUSTRALIA—Gordon & Gotch, Ltd., Melbourne (Victoria), Sydney (N.S.W.), Brisbane (Queensland), Adelaide (S.A.), Perth (W.A.), and Launceston (Tasmania). CANADA—The American News Co., Ltd., Toronto, Winnipeg, Vancouver, Montreal, Ottawa, St. John, Halifax, Hamilton; Gordon & Gotch, Ltd., Toronto; Imperial News Co., Toronto, Montreal, Winnipeg, Vancouver, Victoria. NEW ZEALAND—Gordon & Gotch, Ltd., Wellington, Auckland, Christchurch and Dunedin.

ALTERNATIVE PROGRAMME RECEIVER

4^D

The Wireless World

AND RADIO REVIEW

The Paper for Every Wireless Amateur

Wednesday, December 25th, 1929.

BurTON VALVE HOLDER

SELF-LOCATING



1/- each

Pentode - Valve - Holders 16 each

Patent No. 216708

MANUFACTURED BY C. F. & H. BurTon

PROGRESS WORKS WALSALL, ENG.



TELSEN

L.F. TRANSFORMERS

Radio's Choice

Have acquired a world-wide reputation for Quality and Value.

Built by Specialists in Transformer construction, they have set a Quality of Performance above reproach. Your Set will work better with a Telsen Transformer - - - Fit one now!

RADIOGRAND 12/6

TELSEN ELECTRIC CO. LTD., Miller Street, Birmingham.



Natural Radio - via Air Chrome

Radio sets operated by the factory-made double linen diaphragm speaker possess high selectivity at audible frequencies, reproducing with brilliance, with virility, and with the vital temperament of individual instruments and voices.

Cabinet Types from £3.19.6. Chassis Types from £2.2.0. Demonstrated and sold by all dealers.

ULTRA AIR CHROME SPEAKER

with the double linen diaphragm

ULTRA ELECTRIC LIMITED, 661-663, Harrow Road, London, N.W.10.

LOW IN PRICE - EFFICIENT IN PERFORMANCE

THE RADIO-GRAMOPHONE YOU HAVE WAITED FOR

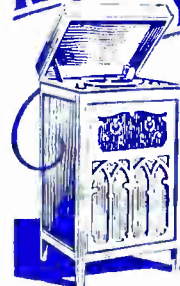

GIVES PERFECT RADIO & GRAMOPHONE MUSIC ON ONE INSTRUMENT

FOR BATTERY OR MAINS OPERATION

The CRAIGWEIL RADIO-GRAMOPHONE

Write for Particulars The British Radio Gramophone Co Ltd 77, City Road, London EC1

"BEAM" WITH PLEASURE!

Every purchaser of "Beam" Loudspeakers, H.T. Batteries and other components will be pleasantly surprised at their excellence. Buy "Beam" for yourself and your friends this Xmas.

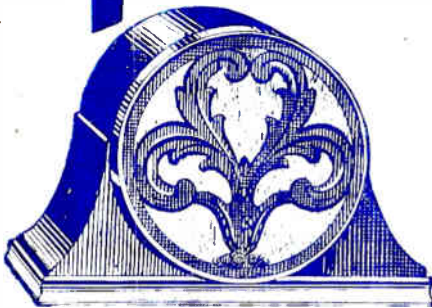

55/-
Complete with flexible lead.

"BEAM" SPEAKERS are constructed to give the finest possible reproduction on either weak or strong reception. The model illustrated is marvellous value, of excellent appearance, and harmonizes with all home surroundings.



"BEAM" H.T. BATTERIES are silent yet energetic workers. The elements of which they are built ensure steady flow of current without background noises.

All "Beam" products are obtainable from your dealer or direct.

Beam Ltd. 35, Farringdon Road, London, E.C.1

Telephone: Holborn 7048

DUBILIER FOR DURABILITY

R.C. COUPLING UNIT. Complete with Dumet-7/- ohms

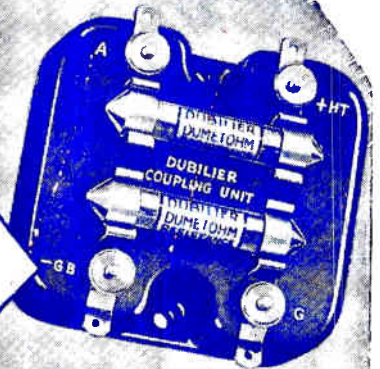

COMBINED R.C. COUPLING UNIT AND VALVE HOLDER. Complete with Dumetohms 7/-

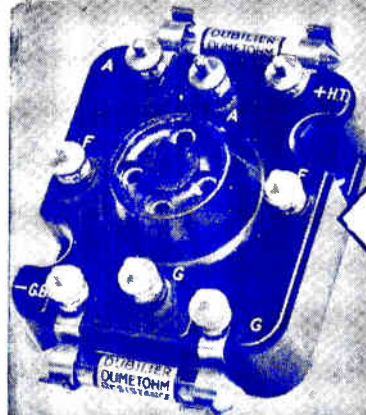

H.F. CHOKE. Four Types to meet all uses. Each 4/6



If unable to get from your dealer, write direct to us giving our name and address

DUBILIER RADIO PRODUCTS

Have you got the Booklet—"A Bit about the Battery"? If not, ask your local dealer for a copy.



Dubilier Condenser Co. (1921) Ltd., Ducou Works, Victoria Road, N. Acton, London, W.3

HC 2510

Mention of "The Wireless World," when writing to advertisers, will ensure prompt attention.

PERFORMANCE PROVES THE P.M. FILAMENT.

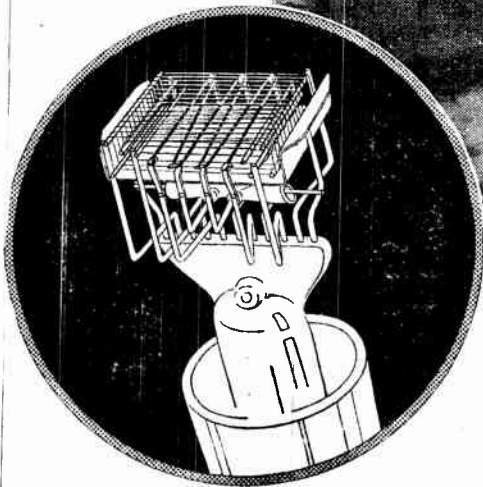

— that's how the enormous development and research on the P.M. principle can make itself known to you — through the results you obtain from your receiver with Mullard valves. Such technical improvements on the P.M. filament as —

- ★ Increased Emission
- ★ Greater Efficiency
- ★ Improved Characteristics
- ★ Greater Mechanical Strength

mean incisive reception and vivid tonal purity. Act on this tangible evidence and plug a set of Mullard radio valves into your receiver to-day.

Mullard

THE • MASTER • VALVE

Advt. THE MULLARD WIRELESS SERVICE CO., LTD., Mullard House, Charing Cross Road, London, W.C.2.

Advt. Advertisements for "The Wireless World" are only accepted from firms we believe to be thoroughly reliable.



The MIRROR of MUSIC and SPEECH

The croon of the Saxophone—the beat of the drum—the trill of the violin and the ring of the harp—all are faithfully reflected by the “CLARITH” Reproducer.

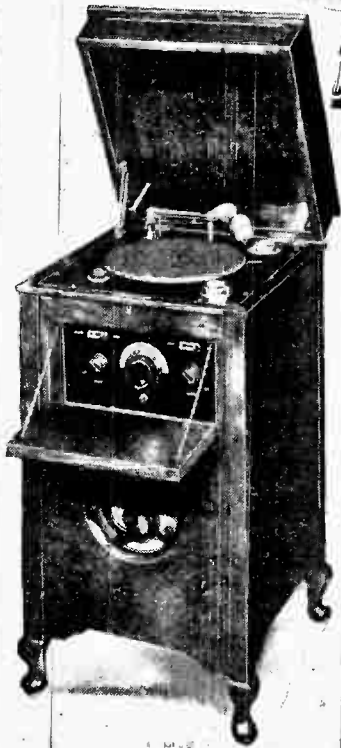

LIFE—sheer life—colour—movement in music and speech are faithfully reproduced by the “CLARITH,” just as the mirror reproduces the form, colour, and movement of that which is before it.

We cannot convey to you in mere words the quality and richness of this Radio Gramophone—you must hear to believe. No batteries to run down—no expense of charging accumulators—just plug in to the lighting socket and the “CLARITH” is working.

Either Record or Radio, a switch changes over. The same volume control is used for both.

The Radio Set embodies a 3-valve circuit of unusual merit—and it brings in the stations. The same specially designed Moving Coil Speaker is used for the Radio Set and the Gramophone, which is also electrically operated—the reproduction is “mirror clear.”

The Cabinets used in the “CLARITH” are masterpieces of the craftsman’s art and are supplied in Oak, Walnut and Mahogany. These Cabinets enhance the appearance of any home.

Price A.C. 49 Guineas.
D.C. 59 Guineas.

All we ask is, let your dealer demonstrate “CLARITH”—if he cannot—write us please, and we will make an appointment.

Clarith

RADIO-GRAMOPHONE

CLARITH REPRODUCERS LIMITED, East Street Mills, LEEDS

Send To-day
for Illustrated
Catalogue,
Post Free.

**THE
POPULAR
LOTUS
ALL ELECTRIC
RECEIVER**
for
£19-9
DOWN

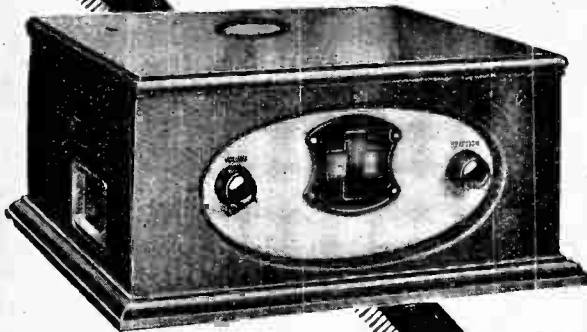

Easily operated by connecting to any A.C. Mains light socket—no batteries needed—this Lotus All Electric 3 valve S.G.P. Set is highly selective and covers a good range of British and Continental stations.

CASH PRICE

£21

(Royalties paid and including valves) or £1 19s. 9d. down and eleven similar monthly payments. See and hear it at any wireless dealer's or write for the Lotus Sets catalogue and Hire Purchase terms.

LOTUS
**ALL ELECTRIC
RECEIVER**

Gets the best reception.

Made by the makers of the famous Lotus components in one of the most modern radio factories in Great Britain.

GARNETT WHITELEY & CO., LTD., Dept. W.W.4,
Lotus Works, Mill Lane, Liverpool.

Gauston

Mention of "The Wireless World," when writing to advertisers, will ensure prompt attention.

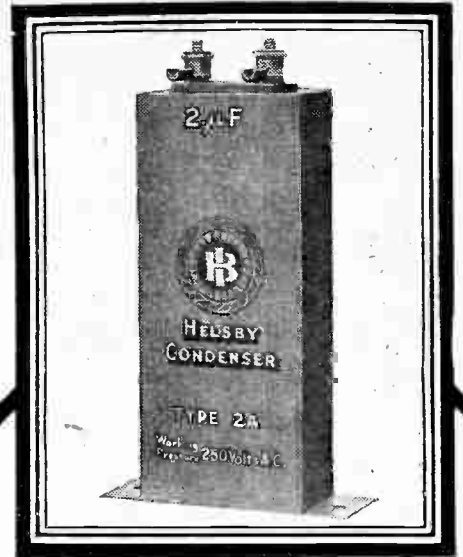

FOR ELIMINATOR CIRCUITS

You cannot afford to use any but the best Condenser in an eliminator circuit.

HELSBY CONDENSERS

are made and guaranteed by a firm with '30 years' experience in condenser making, from small telephone and radio condensers to Power Condensers weighing upwards of 2 tons.

Guaranteed working voltages :-

Type M	-	-	150 volts D.C.
Type 2A	-	-	350 volts D.C.
Type 3A	-	-	450 volts D.C.
Type 4A	-	-	600 volts D.C.

All Helsby Condensers are vacuum dried and impregnated with a special non-hygroscopic material which renders them moisture proof.

If unobtainable from your dealer, write to us giving his name and address.



BRITISH INSULATED CABLES LTD
PRESCOT - LANCs.

Makers of PRESCOT and HELSBY cables

RADIOGRAND
12'6

ACE
8'6

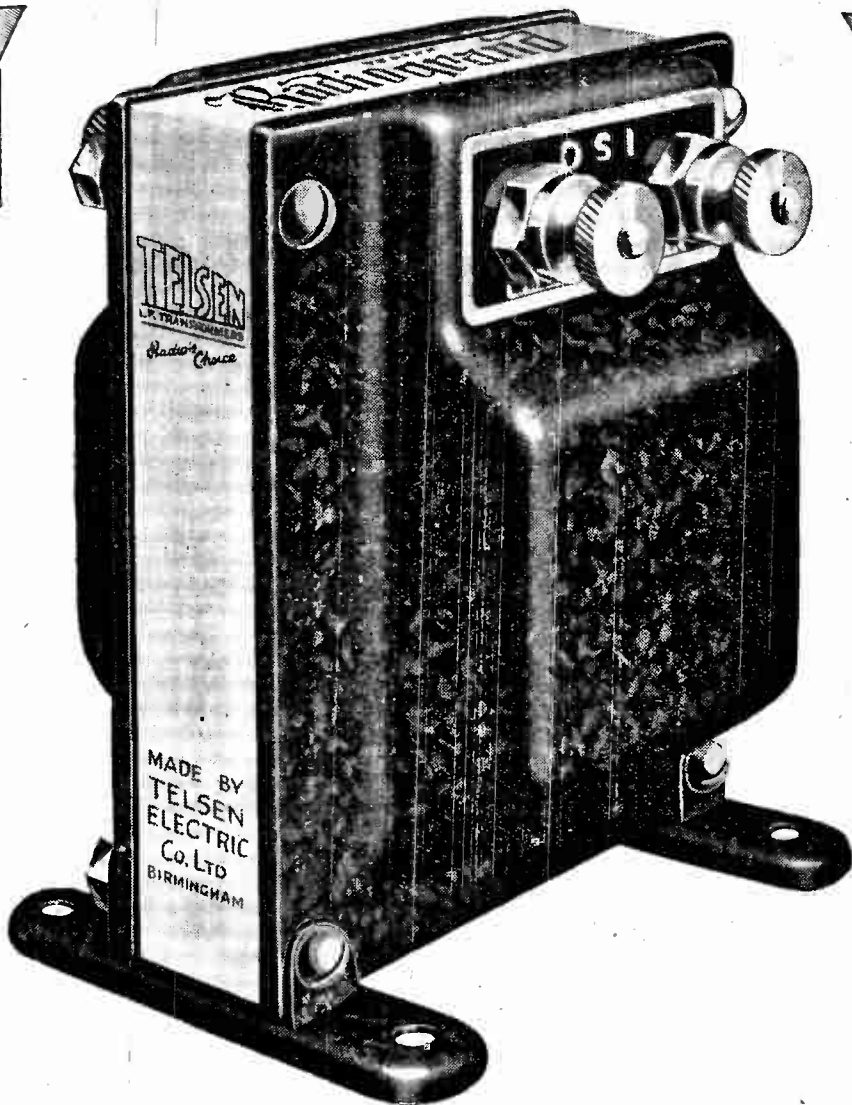

FOLLOW THE LEAD OF THE
SET MANUFACTURER

If popularity is proof of performance, there are none to compare with T E L S E N Transformers. Manufacturers standardise them. Experts specify them, and Amateurs are enthusiastic over the amazing quality of reproduction made possible by T E L S E N Transformers.

TELSEN

Specialized manufacturing facilities, plus the finest materials procurable, have resulted in the production of a high-grade article at the lowest cost. Remember, whenever a Transformer is specified, you can with confidence fit T E L S E N.

TRANSFORMERS

TELSEN ELECTRIC Co. Ltd., MILLER STREET, BIRMINGHAM
London Distributors: The Sel-Ezi Wireless Supply Co., Greek St., Soho, W.1

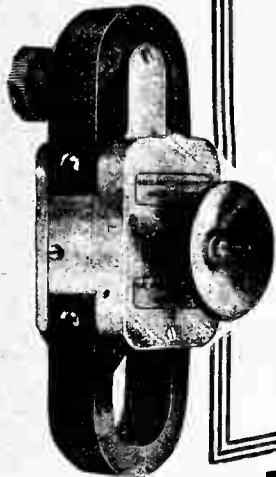

The
**SUPER
 CONE
 SPEAKER**
 that is in the
**MOVING
 COIL
 CLASS**

KUKOO

CONE UNIT

Unsolicited Testimonial

24, Upper Brook Street,
 C. on M.,
 Manchester.

"Gents,

Have fixed the KUKOO L.S.
 (Baffle Board 36) and have *obtained*
absolutely Moving Coil results.
 Wonderful. Thanks."

Yours, etc.,
 Tom Prendergast.

*We understand the above
 results were obtained on a
 Mullard Master Three set,
 with 120 H.T.*

*Mr. Prendergast is in no
 way connected with us;
 neither is he known to us.*

FROM YOUR DEALER OR DIRECT
 From Sole Patentees and
 Manufacturers.

The SHEFFIELD MAGNET

Phone
 Sheffield
 20866

Co., Broad Lane,
 SHEFFIELD.

Grams
 Magnet 20866
 Sheffield

Postage 9d. extra.



**Very Pleased with Results
 of advertising**

COMPLETE SETS

in The
Wireless
 AND
 RADIO REVIEW
World

Read this letter
 from a recent advertiser!

Dec. 2nd, 1929.

Dear Sirs,

You may be interested to hear
 that I was very pleased with the
 results obtained through the half
 page advertisement I recently in-
 serted in "The Wireless World."

I had always understood that
 "The Wireless World" was not a
 good medium for advertising com-
 plete Sets, and I must admit that
 this is the reason why I have not
 used your space before.

It is therefore very illuminating
 to find that, although my half page
 was for two Portables only and one
 of these a very high priced instru-
 ment, I received a large number of
 enquiries every day for at least 10
 days from all parts of the Country.

I can definitely credit "The Wire-
 less World" with these enquiries, as
 the cheaper Portable was advertised
 for the first time, and no one could
 have known of its existence from
 any other source.

I may say I have entirely changed
 my opinion regarding your paper
 now, and will certainly avail myself
 of its pages in the future.

Yours truly,
 (Signed) C. HOLT.

EMPIRE ELECTRIC CO.,
 10, Fitzroy Street, London, W.1.

Full particulars of advertising
 in "The Wireless World," and
 Advertisement Tariff, will be
 sent on request.

ILIFFE & SONS LTD.,
 DORSET HOUSE, TUDOR STREET, LONDON, E.C.4.

WISE WIRELESS USERS PREFER BATTERIES

BECAUSE—

pure H.T. current comes only from a dry battery, for it contains steady, direct current and does not depend upon humming generators for its source of supply.

Batteries are handy, portable and safe, too; and cheaper in the long run—no expensive valves or windings to burn out.

Buy a battery and get the best in EVER READY, the battery that has stood the test for 25 years.

Use an EVER READY
refill battery for your
Electric Hand Lamp.



**The Popular Batteries
for Portable Sets.**

- PORTABLE 1.
63 volts, 6x5x3". 8/6
- PORTABLE 2.
99 volts, 9x5x3". 13/6
- PORTABLE 3.
108 volts, 10x5x3". 15/-

CUT OUT THAT CRACKLE!



LONGER **60%** LIFE

ALL SAL-AMMONIAC batteries develop "crackle" sooner or later. "Pertrix" cannot, for it contains no cell-corroding electrolyte—and in this respect "Pertrix" is unique. On every test, "Pertrix" shows 60% longer life, and no loss of power when out of circuit. Try "Pertrix" once, and you will never go back to the sal-ammoniac type again.

PERTRIX SUPER LIFE H.T. BATTERIES

PERTRIX Ltd., Britannia House, Shaftesbury Avenue, London, W.C.2
Factory—Britannia Works, Redditch, Worcs.

IN THE NEW YEAR

Whatever new components you use for your 1930 set you will not go far wrong with a Trolitax panel.

Trolitax has already proved itself to be thoroughly reliable, and with its high insulating properties and its ease of working it is the ideal panel material. Your wireless dealer stocks Trolitax in a variety of finishes which can be cut to any size required.

Ask to see the range of wood finishes.

TROLITAX

F. A. HUGHES & CO., LIMITED
204-6, Great Portland Street, London, W.1

Phone: Museum 8630 (4 lines).

Distributors for Northern England, Scotland and North Wales:
H. C. Rawson (Sheffield and London), Ltd., 100, London Road,
Sheffield. Phone: Sheffield 26006. 22, St. Mary's Parsonage,
Manchester. Phone: Manchester City 3329.

An entirely new M-L production for the ALL ELECTRIC RECEIVER, the D.C. to A.C. Converter.

40 WATT Model
£13-0-0

85 WATT Model
£19-0-0

Power Supply Units our Speciality.

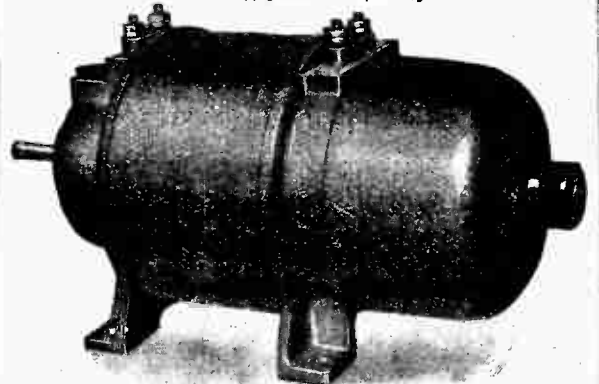

IF YOU ARE ON D.C. MAINS employ the above machine for running your ALL ELECTRIC RECEIVER. The only safe way to operate receivers from D.C. Mains. Suitable for well-known makes of Receivers

M-L MAGNETO SYND. Ltd.,
Radio Dept., COVENTRY.

Telephone: 5001.

Mention of "The Wireless World," when writing to advertisers, will ensure prompt attention.

VARLEY
 Maintain the lead
 in L.F. Intervalve
 Transformers!

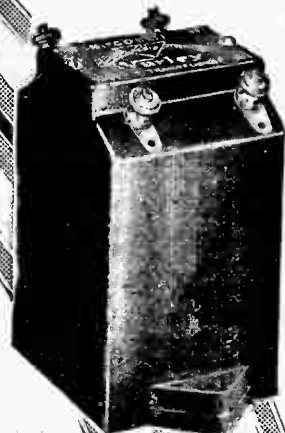
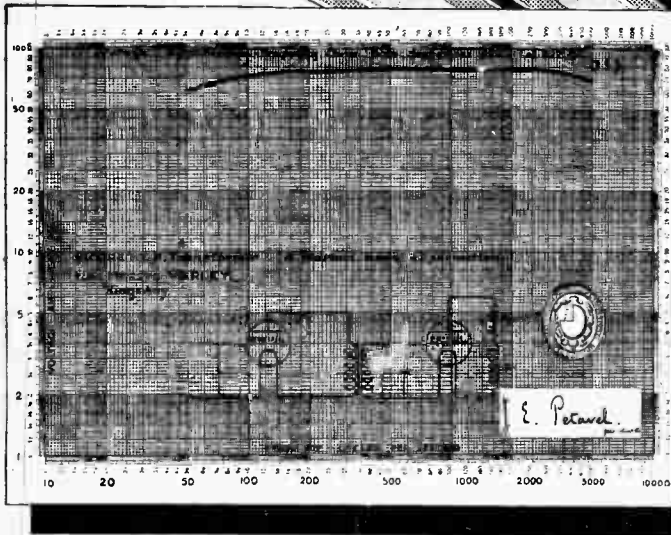
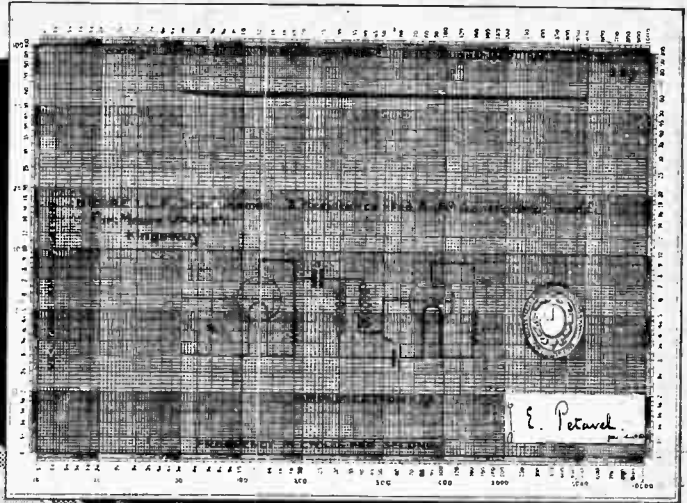

You have only to look at these curves to see that for yourself. They show what the curves of no other transformer can show—perfect amplification of the deep bass notes, together with constant response at all frequencies from 50 to 5,000 cycles. These curves have been taken using ordinary valves. If the curves were taken with A.C. Valves, then naturally a much better performance would be apparent. As, however, the majority of constructors have not facilities for using A.C. Valves, obviously it is of far more general interest to publish N.P.L. Curves obtained with the valves which are in almost universal use to-day. Curve "A" is that of Nicore I, used in the ordinary transformer arrangement, showing an amplification of the order of 80 between 100 and 5,000 cycles and over 60 at 50 cycles. Curve "B" is that of Nicore I used in the resistance feed auto-transformer arrangement, showing an amplification of 60 and a perfectly straight line between 50 and 5,000 cycles. No attempt has been made to retain inaudible side-band frequencies; the discerning public will not be slow to realise that our efforts have produced curves which are—like everything else connected with Varley—perfectly straight.

Write for Section D of the Varley Catalogue.

Nicore I (List No. **£1**
 D.P.1) Ratio 4:1



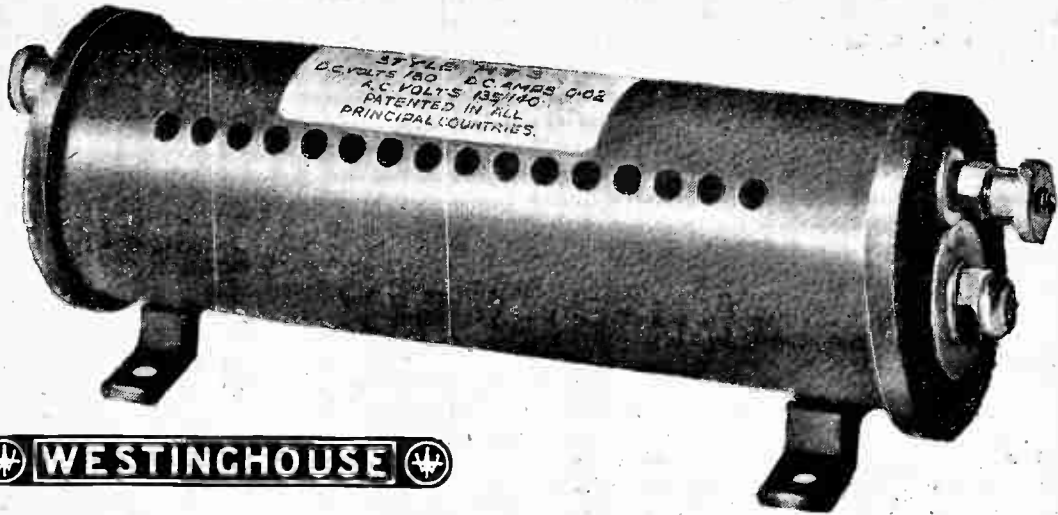

**METAL RECTIFIER
STYLE H.T. 3
FOR HIGH TENSION
D.C. OUTPUT 120 V., 20 M.A.**

Price 21/-

Full details and circuits for this unit, and our other types, are given in our 32-page booklet "The All Metal Way—1930." If you are interested in A.C. mains units, you should have a copy.

Send a 2d. stamp with your name and address.

Made in Eng'and by:—

The WESTINGHOUSE BRAKE & SAXBY SIGNAL Co. Ltd.
—82, York Road, King's Cross, London, N.1—

**Master
Your
Volume**



Write for a copy of the Centralab Circuit Booklet, it's free on request.

Do you realise that by detuning your receiver or dimming your filaments you are adopting hopelessly inefficient methods to control your volume? Such practice results in poor quality and is liable to cause unnecessary interference from other stations transmitting on nearby wave lengths. Centralab Modulator plugs obviate all these difficulties and enable you to control your volume from a mere whisper to full loud speaker strength without spoiling reception.

Just connect the two cords on the Centralab Modulator to your loud speaker terminals and then connect your loud speaker cord tips into the two receptacles in the side of the modulator. You can then master your volume by just turning the small bakelite knob on top of the modulator plug. If your set is equipped with an output jack there is another model modulator plug to suit.

- No. 2 type for sets with terminals for loud speakers - - - 10/6 each
- No. 1 type for sets with jack for loud speakers - - - 10/6 each
- No. 3 type has a 2 foot cord which enables you to control your volume from your armchair - - - 12/6 each

Centralab

The Rothermel Corporation Ltd.
24/26, Maddox St., London, W.1. 'Phone: Mayfair 0578/9.

**DICTIONARY
of WIRELESS
TECHNICAL TERMS**
Compiled by S. O. Pearson, B.Sc.

Issued in conjunction with "THE WIRELESS WORLD."

THIS volume contains concise definitions of terms and expressions commonly used in wireless telephony and telegraphy, and serves as a guide to all those interested in wireless who come across, from time to time, unfamiliar words in their reading. Well illustrated and cross-referenced.

Price 2/- net. By post 2/2.
From leading booksellers or direct from

ILIFFE & SONS LTD.,

W.W.48. Dorset House, Tudor Street, London, E.C.4.



**THE
BEST
PANELS
—NOW
THE
CHEAP-
EST.**

Trelleborg Ebonite Works, Ltd., Union Place, Wells Street, London, W.1.

Highly Polished 3/16" Black or Wavy, 9/16d. sq. in. 6x9, 2/8; 7x14, 4/8; 7x18, 6/-; 7x21, 7/-; 8x12, 4/8; 8x16, 6/-; Highly Polished, 3/16" Mahogany, 1/2" Black or Wavy, 3d. sq. in., 6x9, 3/8; 7x14, 6/3; 7x18, 8/-; 7x21, 9/3; 8x12, 6/-; 8x16, 8/-; Highly Polished, 1/2" Mahogany, 1d. sq. in., 6x9, 4/8; 7x14, 8/2; 7x18, 10/8; 7x21, 12/3; 8x12, 8/-; 8x16, 10/8.

Mention of "The Wireless World," when writing to advertisers, will ensure prompt attention.

With Indicating Floats
 P.G.F.5 11/9
 20 a.h. 2v.
 (as illustrated)
 P.G.F.7 13/9
 30 a.h. 2v.
 P.G.F.9 15/9
 40 a.h. 2v.

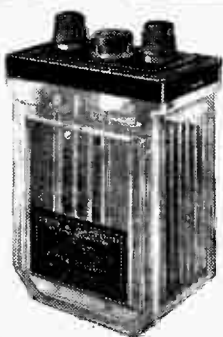

Non-Indicating
 P.G.5 9/-
 20 a.h. 2v.
 P.G.7 11/-
 30 a.h. 2v.
 P.G.9 13/-
 40 a.h. 2v.
 P.G.11 15/-
 50 a.h. 2v.

How much current have I left?

You've asked yourself this question for the last time, having once put the Peto & Radford P.G.F. into service. Let us explain. The P.G.F. Accumulator has three little floats which rise to the surface at recharging and fall in turn as discharge proceeds. Thus you are able to tell at a glance just how much current you have left. No guessing—no worry.

As simple as telling the time

Eleven and ninepence for a 20 amp. hour accumulator, guaranteed for six months of perfect service—that is the Peto and Radford P.G.F. 5. Now consider these features. The capacity—20 amp. hours—is the real, valve-working capacity. The plates are sturdy with interlocking grids to hold the paste. Terminals have acid-proof glands and cannot be reversed. Plates are held in place by glass key-ways. Vent is large, splash-proof and spray-tight, and screws in. The lid is made of crack-proof Dagenite and is hermetically sealed to the box. There's no better value than this.

Send a post card for a Catalogue to:—
PETO & RADFORD,
 93, Great Portland Street,
 London, W.1.
 (Telephones: Langham 1473.)

Glasgow Depot:
 45, Clyde Place.

P AND R

London Sales & Repair Depot:
 107a, Pimlico Rd.
 S.W.1.

PETO & RADFORD

ACCUMULATORS.

The beginning and the end in

POWER

W.R.4

This announcement is issued by
THE NATIONAL ACCUMULATOR CO., LTD.

R.G.D.

—We desire to—
 —wish all our—
 —Patrons and—
 —prospective—
 —Customers—
A MERRY XMAS
 AND A
HAPPY NEW YEAR

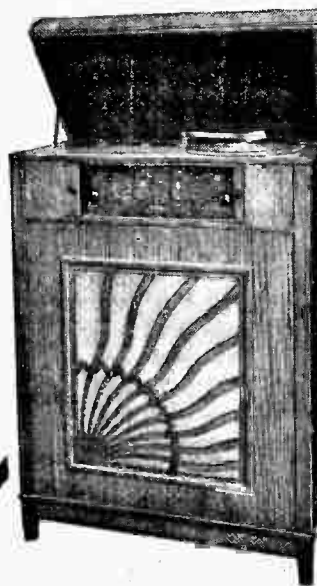

and look—
 —forward to—
 —meeting them—
 —again at Olympia—
 —and our Showrooms—
 — IN —
 — 1930 —

The Radiogramophone Development
St. Peter's Place, Co.
Broad Street,
BIRMINGHAM.

USE IGRANIC FOR RELIABILITY

—and maintain maximum efficiency throughout your sets



IGRANIC TAPPED "C.C." OUTPUT UNIT

protects your loud-speaker windings, gives better quality, and often is the remedy for L.F. howls and "motor-boating." The Igranic Tapped "C.C." Output Unit contains a choke and condenser of the correct proportions and is provided with tappings so that a step-up or step-down auto transformer effect can be obtained.

PRICE 21/6



IGRANIC L.F. CHOKE Type "F"

This high-grade component is equally suitable as an inter-valve coupling choke or an output filter choke.

The winding is in two sections, so that one or both may be used as desired.

PRICE 15/-

Apply to your dealer or write direct to Dept. U.303.



REDFERN'S Ebonart

REG. NO. 469456.
NON-METALLIC SURFACE EBONITE

RADIO PANELS

Recommended for "FERRANTI" S.G. RECEIVER.

MAXIMUM INSULATING PROPERTIES AND LEAK-FREE SURFACE.

Consider an "EBONART" Panel a necessity, especially when constructing a set employing H.F. STAGES. Supplied in Black and Mahogany colours One-tile Polished Surface or Aotse Silk Design

REDFERN'S RUBBER WORKS Ltd.—Hyde, Cheshire

Fit the DUBILIER BATTERY

Fitted with the long-life Dubilier Battery, your Set will give better quality performance over a longer period. **66 volts** And it costs less! **7/9** Other Voltages Available.



Ask your dealer for a copy of the Dubilier Booklet—"A Bit about a Battery."

DUBILIER CONDENSER CO. (1925) LTD., Ducon Works, Victoria Road, North Acton, London, W.3.

—it is Cheaper than others—has longer life, and is British Made.

Cleaver B22

BE SURE OF YOUR PANEL



EBONITE IS GENUINE

Tested to 104,000 volts. USE THE PRIZE WINNING LOW LOSS FORMER.

LOOK FOR TRADE MARK.

Write for Handbook on Windings and Circuits, Post Free 4d. THE BRITISH EBONITE CO., LTD., HANWELL, LONDON, W.7.

Use a **NON-SPILLABLE** battery in your home ~

It is so fatally easy for a few drops of acid to spill when changing over ordinary low tension accumulators. You may already have experienced the vexation of discovering damage to carpet or furniture on which acid has dropped.

The C.A.V. Non-spillable accumulator contains acid—but in a jellied form. You cannot spill it, and it does not flow, so you can use it in any position.

Because of its advantages over the free-acid type of non-spillable accumulator, its compactness, its safeness, it is the ideal battery for portable receivers. It is also the battery to relieve you of all anxiety. Why not use one with your home receiver?

Our latest Radio Battery catalogue No. T3 will gladly be forwarded upon application.

We have recently introduced an entirely new range of rechargeable high tension accumulators—built like car batteries. May we send you details?

C.A.V. Vandervell & Co. Ltd.
ACTON, LONDON, W.3.

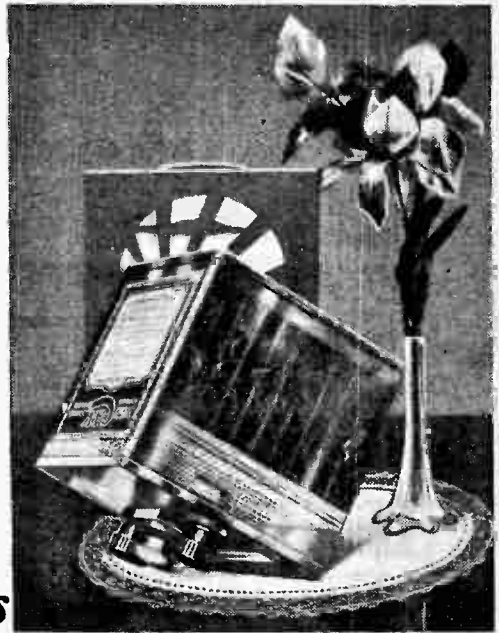

All Position-Non Spillable Batteries

The Original Jelly Acid Battery Perfect for Portables

"TILTRACK" Registered Trade Mark Patent-STEEL STORES-System

"A PLACE FOR EVERYTHING"

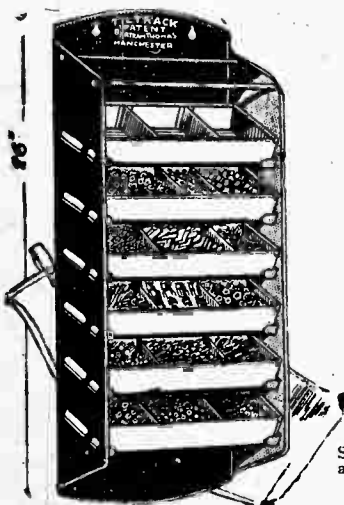

"TILTRACK" JUNIOR 30/-
Post Free.
For the Experimenter for storing Nuts and Bolts and small components.

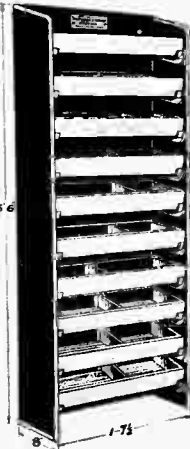

"TILTRACK" TWEENIE
Something between the "Junior" and the "Senior." Very compact with great storage capacity.
Price 70/- each f.o.r. M/cr.



"TILTRACK" SENIOR
The ideal stores for the Factory, Factor and Retailer.
STORES FOR WIRELESS PARTS.

"Tiltracks" save Time, Money, Trouble, Labour. The Experimenter will do his jobs much quicker and with greater pleasure if all parts are to hand. The Factory, Factor and Retailer will save many pounds per year by cutting out the time now lost in looking for goods that are in stock but "nobody knows where." Far superior to old-fashioned wooden shelves.

Full Particulars from Manufacturer and Patentee :—
BERTRAM THOMAS,
Worsley Street, Hulme, MANCHESTER.
London Office and Showrooms :—28, Victoria Street, S.W.1.

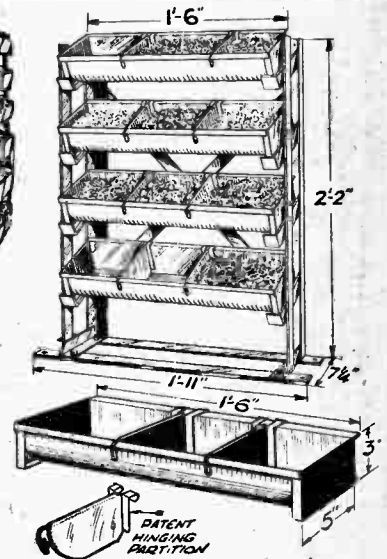

THE "BENCHRACK."
(Tiltrack Principle.)

Made to stand on the work bench; thus all small parts needed for the job in progress are immediately to hand. The trays are provided with patent hinging partitions, and the front face of each tray is rounded to facilitate quick removal of the goods in the tray. This rack is a tremendous time saver.

Use
a Pentode
you can trust!

RIGID!
SAFE!
LOCKED!



Use the *NEW* Cossor Pentode — **RIGID** — because its elements are firmly braced top and bot'om—because every joint is electrically welded. **SAFE**—because of the rigidity of its elements which makes individual movement impossible. **LOCKED**—secure because of its wonderful Interlocked Construction System — an exclusive Cossor development which ensures uniformity of characteristics throughout its exceptionally long life. In *your* Receiver use the *NEW* Cossor Pentode, no other has such strength, rigidity or power.

The **NEW**
COSSOR
PENTODE

The *NEW* Cossor 230 P.T. (2 volts, .3 amp.)
Impedance 20,000. Amplification Factor 40. Anode Volts 100-180. Price **25/-**

Cossor 4 volt Pentode: are also stocked by all Wireless Dealers.

The Wireless World

AND
RADIO REVIEW
(17th Year of Publication)

No. 539.

WEDNESDAY, DECEMBER 25TH, 1929.

VOL. XXV. No. 26.

Editor: HUGH S. POCOCK.

Assistant Editor: F. H. HAYNES.

Editorial Offices: 116-117, FLEET STREET, LONDON, E.C.4
Editorial Telephone: City 9472 (5 lines).

Advertising and Publishing Offices:

DORSET HOUSE, TUDOR STREET, LONDON, E.C.4.
Telephone: City 2847 (13 lines). Telegrams: "Ethaworld, Fleet, London."

COVENTRY: Hertford Street.

Telegrams: "Cyclist, Coventry." Telephone: 5210 Coventry.

BIRMINGHAM: Guildhall Buildings, Navigation Street.

Telegrams: "Autopress, Birmingham." Telephone: 2970 and 2971 Midland.

MANCHESTER: 260, Deansgate.

Telegrams: "Hille, Manchester." Telephone: 3970 City (4 lines).

GLASGOW: 101, St. Vincent Street, C.2.

Telegrams: "Hille, Glasgow." Telephone: Central 4857.

PUBLISHED WEEKLY.

Subscription Rates: Home, £1 1s. 8d.; Canada, £1 1s. 8d.;
other countries abroad, £1 3s. 10d. per annum.

Entered as Second Class Matter at New York, N.Y.

As many of the circuits and apparatus described in these pages are covered by patents, readers are advised, before making use of them, to satisfy themselves that they would not be infringing patents.

CONTENTS OF THIS ISSUE.

	PAGE
EDITORIAL VIEWS	689
TWIN-STATION TWO. By H. F. SMITH	690
PICK-UP VOLUME CONTROL. By F. L. DEVERREUX	695
CURRENT TOPICS	697
THE PROGRAMME DIFFICULTY. By HUMPHRY MACCALLEN	698
WIRELESS THEORY SIMPLIFIED, PART XIV. By S. O. PEARSON	702
BROADCAST BRIEVITIES	705
THIS YEAR'S PROGRESS IN COMMERCIAL WIRELESS. By LT.-COL. CHEWROE CRAWLEY	706
ADMIRAL SIR HENRY JACKSON	710
CORRESPONDENCE	710
READERS' PROBLEMS	712

A MINISTRY OF BROADCASTING.

IN the House of Commons some days ago a Member drew the attention of the Speaker to the fact that when he handed in a question complaining of the broadcasting service in the East of Scotland he was informed that there was no department to which he could address it, nor could he address it to the Prime Minister. He asked how the grievance of people who by law paid 10s. a year for receiving instruments could be ventilated. The Speaker said that it was one of the rules governing questions that they must be put to a Minister on subjects for which Ministers had some responsibility. In the matter of broadcasting he understood there was no such Minister. The Postmaster-General stated that he understood that in the matter of broadcasting the Post Office had a responsibility for questions of general policy but no responsibility for questions in detail. Sir W. Mitchell-Thomson, Postmaster-General in the late Government, stated that he had always refused to answer questions

relative to broadcasting on particular details as not being himself responsible.

As long ago as November 24th, 1926, writing in *The Wireless World* at the time that publication was given to the new Charter for the Broadcasting Corporation, we chose "A Ministry of Broadcasting" as the title for our leaderette, and, after commenting on the scope of the Charter and referring to the importance with which the subject of broadcasting was treated in a debate in the House of Commons, we concluded by saying "This brings us to the question of how long the Broadcasting Service will remain under the thumb, so to speak, of the Postmaster-General. Probably it will always be necessary for the Service to obtain its licence to operate the stations from the Postmaster-General, but it seems that at a comparatively early date all justification for the Postmaster-General to have authority in other directions will have disappeared, and, to judge by the ever-growing national importance of the Broadcasting Service, it seems to us highly probable that in the not far distant future the appointment of a Ministry of Broadcasting will be regarded as just as essential as other Ministries which have been created to control various other activities of a national character."

If in 1926 there was sufficient evidence to suggest a good case for the formation of a Ministry of Broadcasting, how much stronger a case could be put forward to-day! Had broadcasting in this country remained as in America, largely in the hands of private enterprise, then there would have been no occasion for considering such a step, any more than it could be justified in this country in connection with the Press; but seeing that our national broadcasting service is firmly established under Government control, and taking into account its importance as a national influence, it seems incongruous that this organisation should be without a spokesman in the House of Commons.

o o o o

OBITUARY.

OUR readers will have learned, with sorrow, of the loss of one of the greatest of our pioneers of practical wireless telegraphy through the death of Admiral Sir Henry Jackson. Admiral Jackson's career has been a long record of service to his country, and his personality had endeared him to everyone who came in contact with him.

Elsewhere in this issue we record some of the activities of Admiral Jackson's career, which will ensure for him undying recognition in the annals of British history.

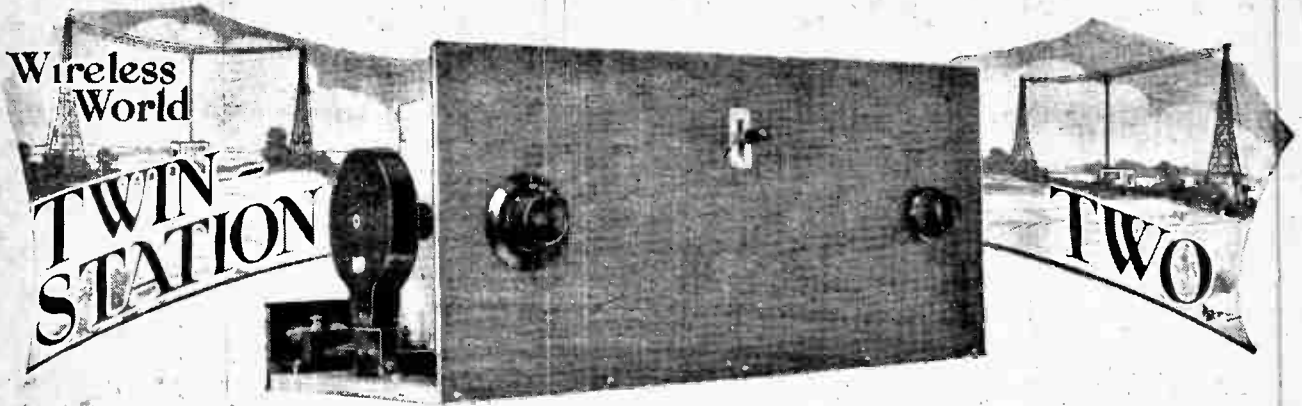

Alternative Programmes Without Retuning.

By H. F. SMITH.

CONTRIBUTORS to these pages have more than once put forward the suggestion that we are all inclined to expect rather too much of our radio receivers, and have hinted that in many cases more enduring satisfaction would result from the use of a set designed for a definite and strictly limited performance under a fairly rigidly defined set of conditions.

It would be futile to suggest that such a rule should be universally applied, and that, having decided exactly what programmes we want to hear, we should design, have designed, or buy ready-made a receiver capable of satisfying these requirements—no more or no less—in our own particular locality. Except in special cases it would be technically impossible to do so.

Although the general-purpose set is perfectly satisfactory for average requirements and localities, there is at least one body of wireless users who should seriously consider the use of a specialised type of receiver. Under

this category are included those who live within a few miles of Brookmans Park (or, of course, of any similar twin regional station that may be built). These unfortunate people—or perhaps fortunate; everything depends on one's point of view—will need, for anything like satisfactory distant listening, a highly selective and ambitious receiver—so ambitious that to use it merely for local reception would savour of cracking nuts with a steam-hammer. They will probably either satisfy themselves with local programmes only, or will have two separate receivers, one of which will be designed exclusively for long-distance work.

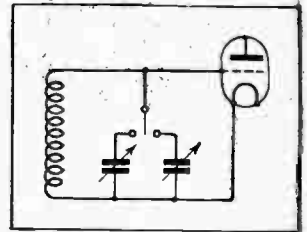

Fig. 2.—Another method of wave switching.

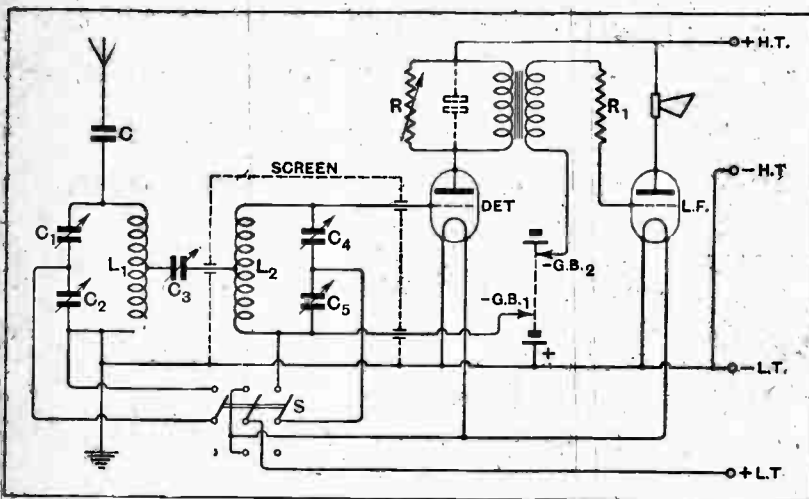

Fig. 1.—Complete circuit diagram. The condenser shown in dotted lines is built into the L.F. transformer. C, aerial shortening condenser, 0.0002 mfd.; C₁, C₂, C₃, tuning condensers, min. 0.0002 mfd., max., 0.001 mfd. (depending on wavelength); C₄, coupling condenser, 0.0001 mfd. L₁, plug-in aerial coil; L₂, secondary coil (see text); R, volume control resistance; R₁, H.F. stopping resistance, 100,000 ohms. S, combined wave-changing and on-off switch.

Quick-change Reception.

If either of these courses is decided upon it will be readily agreed that the local-station set should be as simple in construction and operation as is possible, and, to avoid the need for constant retuning, a quick and easy change-over from one alternative programme station to the other is clearly desirable. The receiver to be described in this article represents one of the many ways in which these features may be combined in a satisfactory manner. As it is intended for use in a strictly restricted area, it follows that the design as it stands will be suitable for an equally restricted number of readers, but it is hoped that those living outside this area who are interested in the undoubtedly attractive feature of quick-change, programme-to-programme switching will be able to glean some suggestions applicable

Twin-station Two.—

to their own needs and geographical situation.

When it is said that the basic circuit diagram comprises an anode-bend detector without reaction, transformer-coupled to an output valve, it will be realised that the set is most distinctly not for long-range work, or even for medium distances. This point should be emphasised, as there is nothing more unsatisfactory than a receiver without sufficient sensitivity—one should say a reserve of sensitivity—for the purpose it is intended to serve. The set gives good results only where signals are really strong: sufficiently strong, say, for a crystal set to operate headphones loudly enough to be audible several inches away from the ear. Of course, the aerial plays its part, and its effectiveness must be increased as we move farther away from the transmitting station.

In order that adequate selectivity for any locality may be obtained, a two-circuit aerial tuner is provided, with variable capacity coupling which serves both as a pre-detection volume regulator and selectivity control. From the circuit diagram given in Fig. 1 it will be seen that the coupling condenser C_3 is connected

Rear view, from the output end.

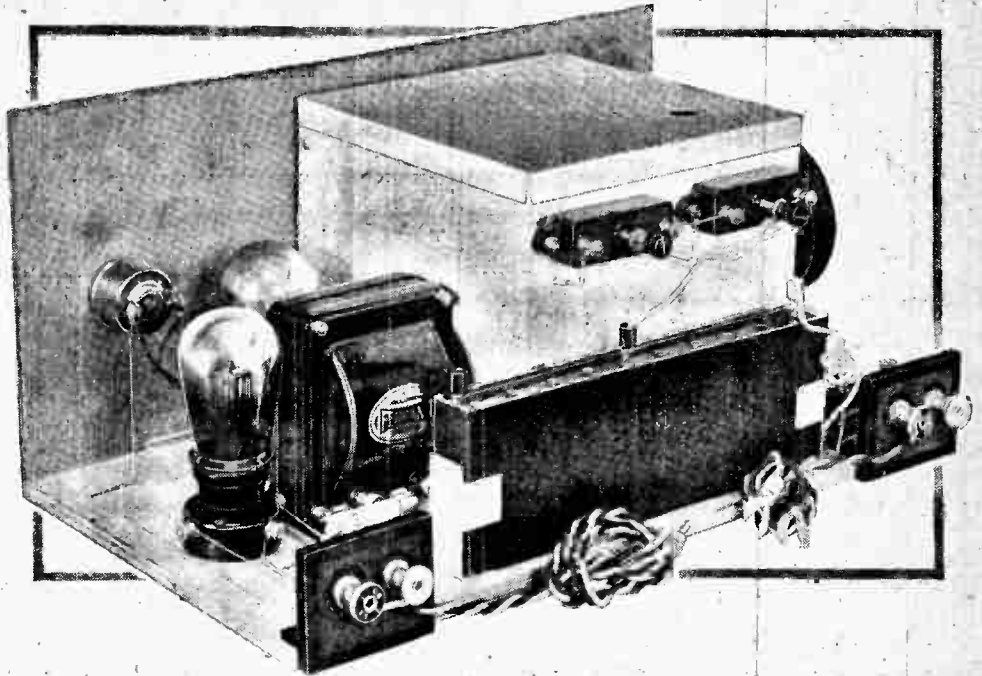

between the centre points of aerial and grid coils; adequate linkage of the circuits is obtained by these means with a condenser of standard capacity range, and the disturbing effects of coupling changes are less evident than when it occupies the usual position between the high-potential ends of the coils.

The connection of the tuning capacities C_1 , C_2 , and C_3 , together with the wave-changing switch, may at first appear complicated, but the matter is really quite simple if it is realised that a pair of semi-variable condensers are joined across each circuit, and that one unit of each pair is short-circuited when it is desired to receive the longer of the two twin-station wavelengths. The shorter wave is tuned-in by opening the short-circuiting switches and, without disturbing the settings already obtained, adjusting the remaining condensers. Having once found the right values, programme selection should be merely a matter of throwing the switch to the appropriate position: one condenser of each pair short-circuited for longer wave and both in series for shorter wave. The centre pole of the switch breaks

Rear view, from the input end.

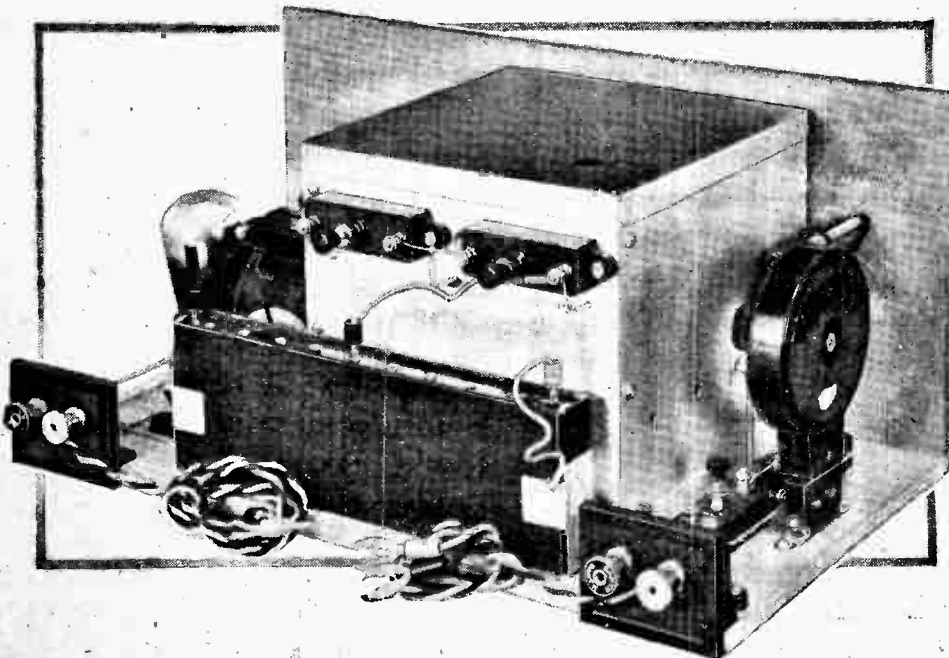

Twin-station Two.

the filament supply circuit when in the intermediate position, and so switches off the set.

This series connection of tuning condensers has one or two minor advantages, as compared with the alternative method of wave switching shown in Fig. 2. For one reason, it allows the use, if necessary, of the simplest single pole on-off switches.

The remainder of the circuit arrangement is so simple and conventional that it calls for little comment. The grid coil L_2 is screened in an aluminium box in order that coupling between it and the aerial coil L_1 may be almost entirely through the intermediary of the condenser C_3 , and consequently under proper control. A post-detection volume regulation may seem rather superfluous in a two-valve set, but it was considered best to fit a variable resistance across the transformer primary, as overloading of the ordinary power valve will set in before the detector grid circuit is fully loaded. An H.F. stopping resistance R_1 is inserted in series with the output valve grid.

Regarding details of construction, it will be seen that the semi-variable condensers C_1 and C_3 , which tune the secondary or grid circuit, are mounted on the back of the screening case. Holes coinciding with their control knobs, and of from $\frac{3}{8}$ in. to $\frac{1}{2}$ in. diameter, should be drilled through the back of the containing cabinet so that a screwdriver may be inserted for initial adjustment or at

any subsequent time if necessary. The remaining tuning condensers are on the baseboard, and are also set with the help of a screwdriver.

Coil-winding Details.

The plywood front panel carries H.F. input and L.F. output volume controls, and a combined on-off and wave-changing switch. In order that the lid of the screening box may be removed when required, it is necessary that the box itself be set back about $\frac{1}{16}$ in. to $\frac{1}{8}$ in. from the rear surface of the panel by interposing a distance piece in the form of a thin strip of wood, ebonite, fibre, or some similar material; the switch lever and securing screws are passed through this strip.

For the aerial circuit a centre-tapped plug-in No. 40 coil is used, as shown, while the secondary inductance L_2 is a simple, home-made coil consisting of fifty turns of No. 24 D.C.C. on a Pirtoid former measuring $3\frac{1}{2}$ in. long by 3 in. in diameter. A tapping is brought out from the centre point (25th turn). The winding should be started about $\frac{1}{2}$ in. from the upper end of the tube, the lower end of which is secured to the wooden sub-base of the screening box with the help of a wooden disc or in any other convenient manner.

"Junit" terminal blocks, screwed to the rear edge of the baseboard in the manner shown, carry terminals for aerial, earth and loud speaker, while

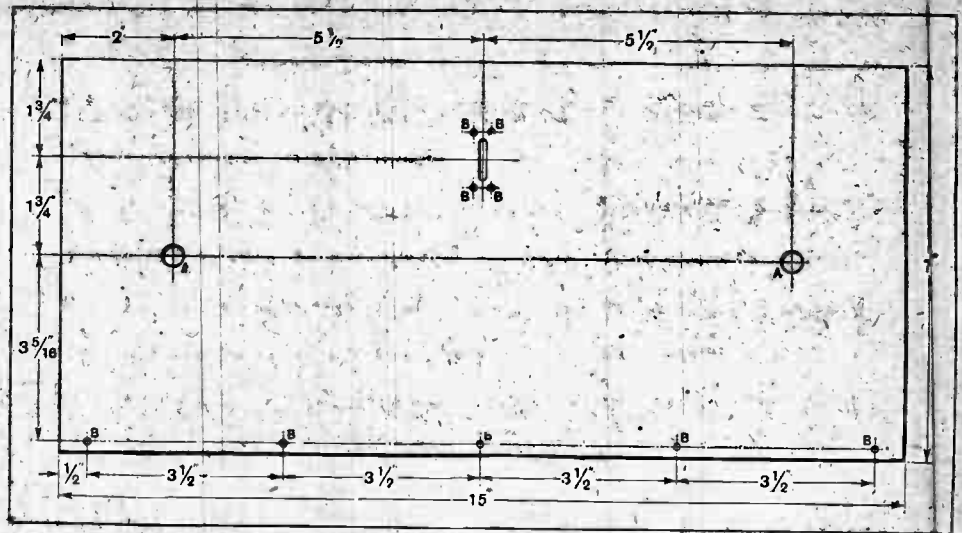

Fig. 3.—Drilling details of the front panel. A, $\frac{1}{4}$ in. dia.; B, $\frac{1}{8}$ in. dia.

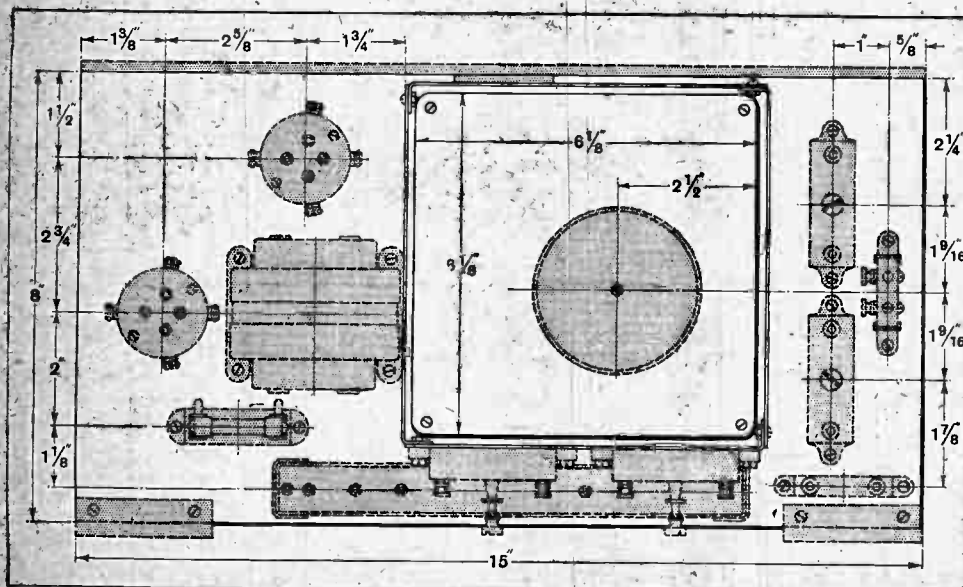

Fig. 4.—Layout of components on the baseboard. Note distance piece between screening box and panel.

LIST OF PARTS.

1 Wood panel, 3-ply, 15×7in.
 1 Wood baseboard, 5-ply, 15×8in.
 1 Screening box, aluminium, 6½×6½×6in. high.
 1 Inductance coil former, 3½×3in. dia. (Pirtoid).
 1 L.F. transformer (Ferranti, A.F.5).
 2 Valve holders (Burton, Midget).
 1 Switch, 3-pole change-over (Burton).
 1 Reaction condenser, 0.0001 mfd. (Burton).
 1 Variable resistance (Standard Clarostat).
 1 Single coil-holder (Lotus).
 1 Coil, No. 40, centre-tapped (Lewcos).
 4 Semi-variable condensers, 0.001 max. (Formodensers, Type G).

1 Resistance, 100,000 ohms (Ediswan).
 1 Holder for above (Bulgin).
 1 Fixed condenser, 0.0002 mfd. (Trix).
 2 Terminal mounts (Junit).
 4 Terminals: "Aerial," "Earth," "LS+," "LS-" (Ealex).
 1 Grid bias battery, 15 volts (Ripaults).
 1 Pair bias battery clips (Bulgin).
 5 Wander plugs (Clix).
 2 Spade terminals (Clix).
 Sisto-flex, wire, screws, etc.

Approximate cost, £1 2s. 6d.

In the "List of Parts" included in the descriptions of *THE WIRELESS WORLD* receivers are detailed the components actually used by the designer and illustrated in the photographs of the instrument. Where the designer considers it necessary that particular components should be used in preference to others, these components are mentioned in the article itself. In all other cases the constructor can use his discretion as to the choice of components, provided they are of equal quality to those listed, and that he takes into consideration in the dimensions and layout of the set any variations in the size of alternative components he may use.

flexible leads for connection to L.T. and H.T. batteries are led out through holes provided in these blocks.

One can hardly go wrong in the wiring of a simple set of this type, particularly with the help of the diagram given in Fig. 5, but some attention should be paid to the connections between tuning condensers and switch, the leads being run parallel and close together in pairs, as clearly indicated both in the diagram and in the illustration on this page. This is to minimise stray inductive coupling due to the fact that the aerial circuit wiring at this point is of necessity passed into the secondary circuit screening compartment.

Apart from permissible modifications in design, a certain amount of latitude is allowable with regard to the choice of components. Semi-variable tuning condensers operate best towards the minimum end of their capacity range, as in this position a given rotation of the control knob brings about a much smaller capacity change than at the other end of the scale. To cover the wavelengths of the alternative London stations, Formodensers rated at 0.0002-0.001 mfd. (but actually with a slightly lower minimum) are accordingly used. Obvious adjustments as to values can be made when dealing with other wavelengths.

A transformer used for linking an anode-bend detector to a succeeding L.F. valve should be of first-class design, and must have a high primary inductance, which implies a low step-up ratio. Unless a high-grade transformer is used, it does not pay to employ this circuit arrangement. The detector valve itself should be one of the types specially designed for this particular func-

tion, and should have a rated impedance not appreciably greater than 10,000 ohms—preferably less. Marconi or Osram "D.E.L.," or Mullard "D" types are suitable. There is no need to discuss the output valve, of which the choice will, as usual, depend on current supply facilities and requirements as to volume.

While dealing with the question of volume it should

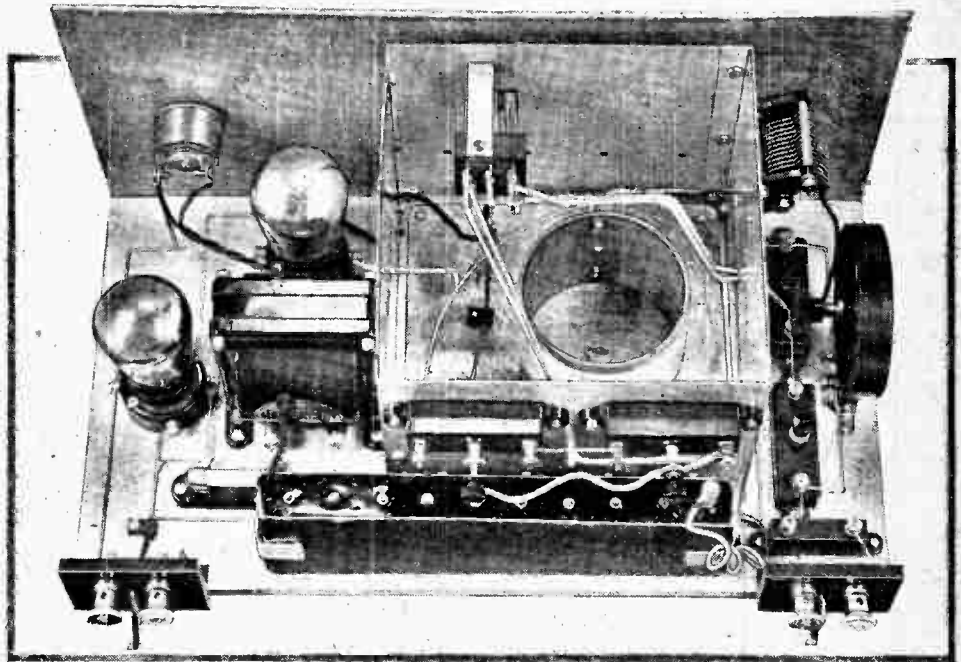

Plan view. The separate pairs of tuning condensers are wired with parallel side-by-side conductors. Holes with an ample clearance are drilled to pass wires through the screening box.

be made quite clear that a simple set of this type can produce a really large output, always provided that sufficient energy is picked up by the aerial; and it must be remembered that extraordinarily high signal voltages are developed at a few miles' distance from the present high-power stations. A recent article¹ showed that an arrangement similar to that under discussion, with a P.M.6D. valve with 150 volts H.T. and 10½

¹ "The Valve as an Anode Bend Detector," *The Wireless World*, March 27th, 1929.

Twin-station Two.

volts bias, fed with maximum possible signal voltage consistent with avoidance of grid current, will provide a peak output of 110 volts (total swing), implying a bias of 55 volts for the L.F. valve. This is, of course, a much greater output than is ordinarily required, but it should be made quite clear that it is only attainable

As a good deal of attention has lately been devoted to the question of operating two-circuit tuners, it is quite unnecessary to give lengthy instructions, but it should be emphasised that efforts should first be concentrated on the longer of the two wavelengths to be received, tuning with the condensers C_1 and C_4 , while C_2 and C_5 are "shorted" by means of the switch.

When making the short-wave adjustment with switch open and condensers in series, it will be found that the tuning of condensers C_2 and C_5 is now apparently "broad"; this is because their effective capacity range is reduced. This represents one of the advantages of the series method of connection when compression-type tuning condensers are used. The stations should first be tuned in with a very weak coupling (i.e., with a low-capacity setting of the condenser C_3), afterwards increasing strength if necessary by tightening coupling to the optimum value.

Except at very short ranges volume control will normally be effected by operation of the variable resistance R . With exceptionally large aerial inputs, distortion may be evident, even though this resistance may be set to such a low value that L.F. valve overloading is obviously impossible. These symptoms will indicate that the detector itself is overloaded, and the remedy is to reduce H.F. input to it by weakening coupling, afterwards bringing up intensity to the required level by rotation of the knob controlling R .

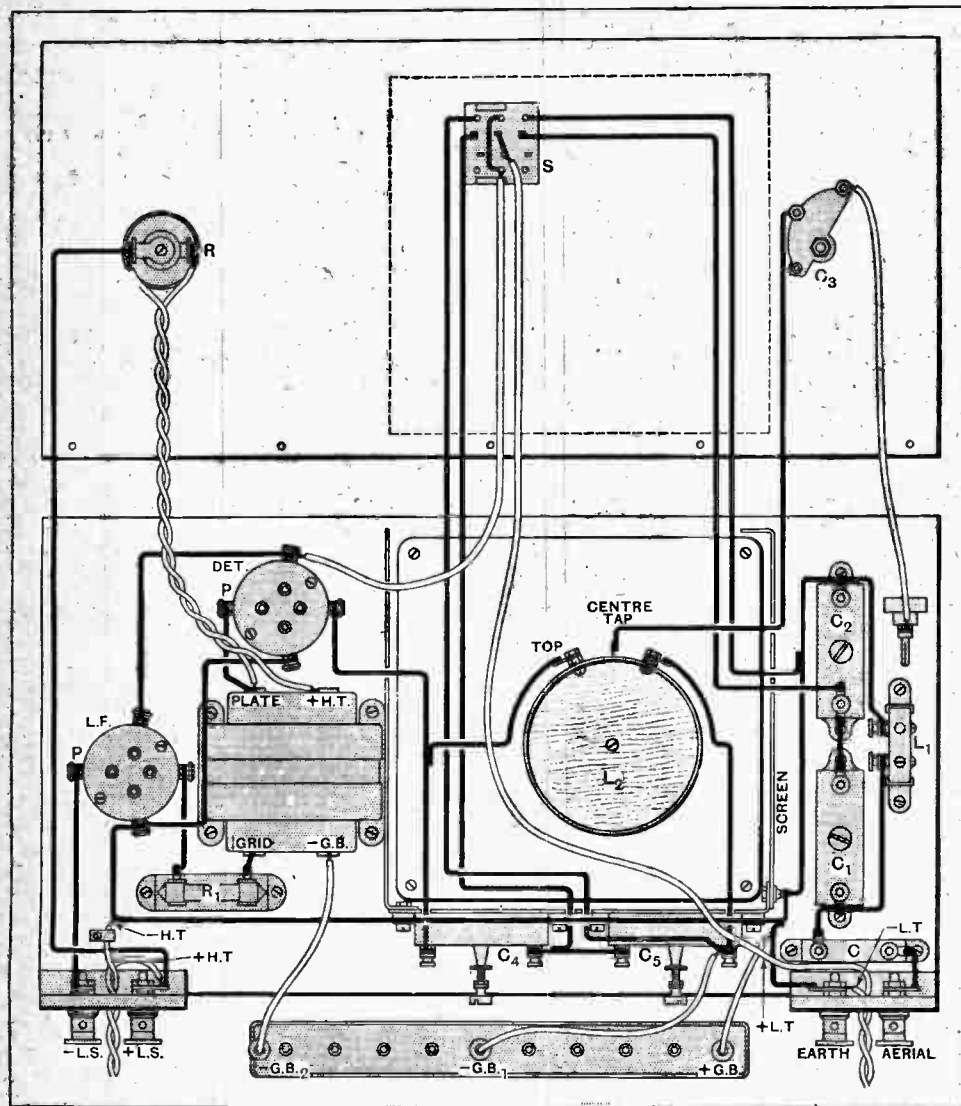

Fig. 5.—Practical wiring plan. Rigid conductors are used except where clearly shown to the contrary.

at a very short distance from the transmitting station.

With regard to the question of H.T. voltage, it is hardly fair to expect good results with a pressure of less than 100 volts; normally 120 volts may be regarded as a minimum. This may be increased to 150 volts with the usual gain, but if the supply is considerably greater than this it is as well to provide a separate connection for feeding the output valve. The receiver is not prone to troubles brought about by interaction, and consequently it may be fed from a simple—even a crude—eliminator.

In situations where greater sensitivity than that afforded by the set described is necessary a stage of H.F. amplification may be added, with its tuned coupling controlled in the manner discussed. Generally speaking, it will be possible to omit the separately-tuned aerial circuit. Where a grid detector with reaction, followed by L.F. amplification, is preferred to an "H.F." set, the Hartley circuit, or one of its variants, is to be recommended, as it lends itself readily to easy wave-change switching with separate coils and condensers for each wavelength.



PICK-UP VOLUME CONTROL

Potentiometer and Variable Shunt Resistance Methods Compared.

By F. L. DEVEREUX, B.Sc.

THE voltage output from an electromagnetic pick-up is frequently in excess of the maximum input for which the associated amplifier has been designed. Further, the general level of output from records of different types varies between wide limits. A continuously variable volume control is, therefore, an essential component of any electrical gramophone equipment.

The simplest and most generally favoured method is to connect some form of variable resistance across the pick-up terminals in order that the voltage may be reduced to the required level before it reaches the grid circuit of the first amplifying valve. Properly applied, this method is quite sound, but there are one or two serious pitfalls to be avoided.

Matched Impedance.

Strictly speaking, an electromagnetic device such as a pick-up should be designed to work into an impedance of known value, e.g., the primary winding of an input transformer. When this is done, the correct procedure is to apply the volume control by means of what is known to telephone engineers as a "T" network. The opportunities of applying this method are, however, few, since the majority of commercial pick-ups are designed—or rather intended—to be connected direct to

across the pick-up terminals as in Fig. 1 (a). For simplicity we will assume that the impedance of the pick-up windings is mainly inductive, in which case the equivalent electrical circuit will be as shown in Fig. 1 (b). The inductance L and resistance R will form a series circuit, and the alternating E.M.F. (E)

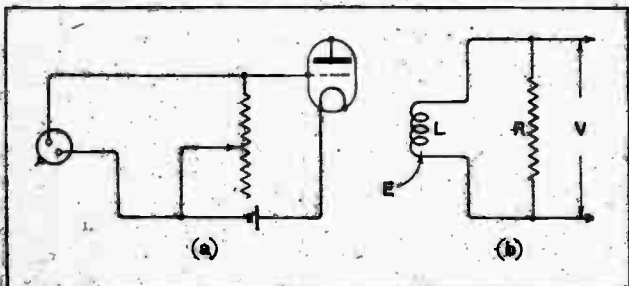

Fig. 1.—(a) Variable shunt resistance volume control producing high-note loss and (b) equivalent circuit.

the grid circuit of the first amplifier valve, i.e., to work into an infinite resistance or open circuit. In these circumstances the connection of a resistance across the pick-up terminals may result in serious high-note loss as the following examples show.

Let us suppose that a variable resistance R is shunted

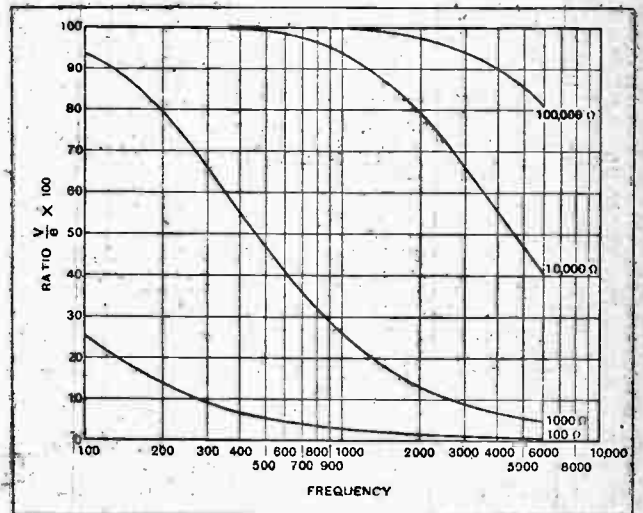

Fig. 2.—Calculated curves showing high frequency cut-off for various values of R in Fig. 1. It is assumed that the pick-up impedance is purely inductive and an inductance of 0.6 henry has been taken as a basis for calculation.

generated by the movement of the armature may be represented as being injected into the inductance L . The voltage drop V across R will be the voltage output to the first valve of the amplifier. For distortionless reproduction the relationship between V and E should remain constant for all frequencies. Unfortunately, the higher the frequency the higher becomes the impedance of L , until at very high frequencies R may represent only a small fraction of the total impedance of the circuit. Consequently, V at high frequencies is only a small fraction of the total E.M.F. (E) in the circuit.

The curves in Fig. 2 show that, as might be expected, the high-frequency loss is greater the lower the shunt resistance. For simplicity the D.C. resistance of the winding has been neglected; its effect will be considered later.

Pick-up Volume Control.—

The curves of Fig. 3 are the result of actual measurements on a pick-up having an inductance of approximately 0.6 henry. Unfortunately, the mountainous

accounted for by the resistance of the pick-up windings which was not taken into account in calculating the curves of Fig. 2.

It may therefore be taken for granted that the variable shunt resistance as a method of volume control is definitely bad. This leaves us with the alternative potentiometer scheme as shown in Fig. 5, which gives, without high-note loss, provided the total resistance of the potentiometer is sufficiently high, a range of volume from zero to maximum. Investigation of a number of representative commercial pick-ups indicates 0.25 megohm (250,000 ohms) as a good average value. In general the total resistance across the terminals should not be less than 100,000 ohms, but in the unlikely event of a pick-up being found with an excessive high-frequency output a lower value might be usefully employed to correct matters.

In conclusion, a word about the correct method of connecting a potentiometer. Many components of this type

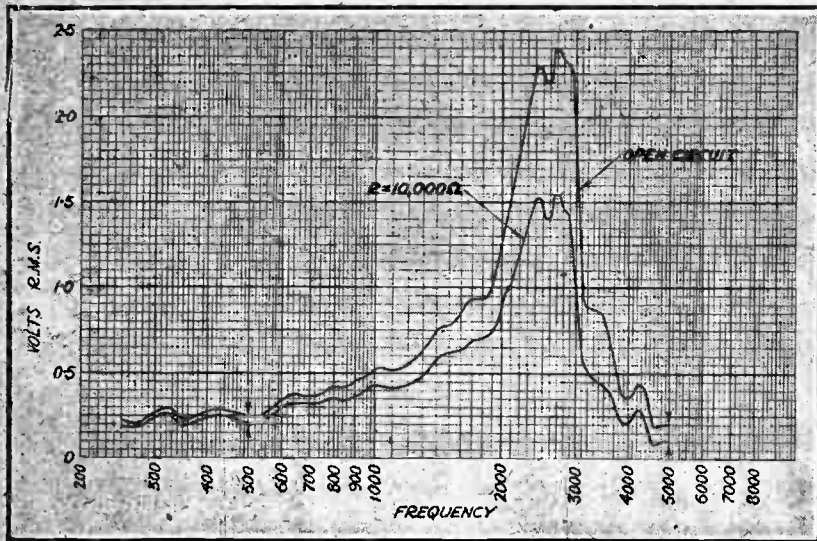

Fig. 3.—Characteristics of experimental pick-up with 10,000-ohm shunt and on open circuit. Comparison of the curves at 500 and 5,000 cycles where the output level is of the same order shows that the shunt resistance produces a greater reduction of output at the higher frequency.

nature of the curve somewhat obscures the progressive high-note loss. By comparing the difference in the height of the two curves at 500 cycles with that of 5,000 cycles, where the general level is approximately the same, it will be seen that whereas the 10,000-ohm shunt produces a reduction of only 20 per cent. at 500 cycles, the loss at 5,000 cycles is at least 50 per cent. Incidentally, these curves show that the resonance in the pick-up is mechanical, not electrical; otherwise the shunt resistance would have the effect of flattening the resonance peak.

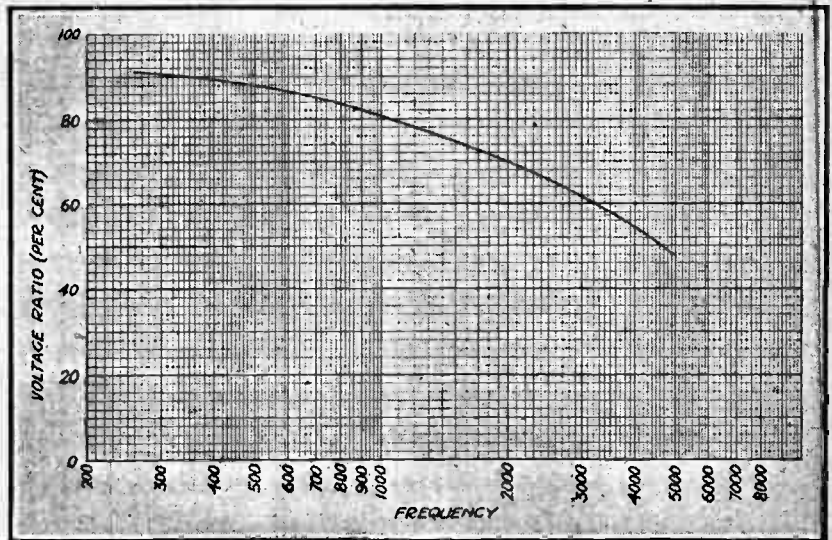

Fig. 4.—Curve derived from Fig. 3 showing percentage reduction of output with frequency due to 10,000-ohm shunt.

The percentage difference in voltage output between the two curves, irrespective of variations in amplitude, is shown in Fig. 4. Comparing this with the 10,000-ohm curve in Fig. 2, it will be seen that they are in agreement at 5,000 cycles where the inductive impedance is high compared with the resistance. The practical curve, however, fails to reach the 100 per cent. line. This is

have a logarithmic distribution of resistance. In other words, the resistance change for a given angular movement of the contact arm is greater at one end of the scale than at the other. The reason for this is that the acoustic output from the loud speaker is proportional to the square of the input voltage from the pick-up. If the potentiometer resistance is divided logarithmically the sound output is evenly distributed over the range of movement of the contact arm. It is essential, however, to connect the ends of the resistance the right way round, otherwise the range of control will be crowded to one end of the scale. The low-resistance end should be connected at A in Fig. 5, and the high-resistance end at B.

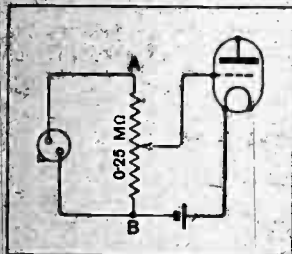

Fig. 5.—Potentiometer volume control. The high-note loss is negligible provided the total resistance of the potentiometer exceeds 100,000 ohms.

CURRENT TOPICS.

Events of the Week in Brief Review.

THE COMPLIMENTS OF THE SEASON.

To all readers of *The Wireless World* from the Arctic to the Antarctic we extend our best wishes for a Merry Christmas and a Happy New Year.

CHRISTMAS GREETINGS BY WIRELESS.

Special facilities for sending Christmas messages to ships at sea are announced by the Postmaster-General. From Rugby Radio greetings can be addressed to "ships on all seas" at 1s. 6d. a word. Ships up to five days from any British port can be reached via British and Irish land stations at 1ld. a word.

BROADCAST "STUDIO" ON POLISH TRAIN.

The first of the wireless-equipped trains on the Warsaw-Cracow line is now ready, writes a correspondent. Each seat is fitted with a receiving point fed from a central receiver in a special "studio" which includes a microphone for announcements and a gramophone amplifier. Passengers pay a small fee for the hire of headphones, which are disinfected after use.

FRENCH BROADCASTING "WAR": ANOTHER STAGE.

The "Broadcast Defence Committee" is the name of an organisation formed in Paris by the minority party who are in favour of complete State control of broadcasting, writes our Paris correspondent. It is unlikely that the Committee will exert much influence on the progress of the broadcasting Bill, but as this intricate piece of legislation can

hardly take practical shape before the autumn of 1930, the minority still hope that its terms can be modified. The Bill aims at creating a semi-State monopoly on the lines of the B.B.C.

FRANCE WINS "SUPERHET" CLAIM.

M. Lucien Levy, the French wireless worker, has received official advice from the American Patent Office admitting his claim as the inventor of the superheterodyne. The claim was also recognised recently by the German Patent Office.

WHAT IS YOUR WAVELENGTH?

"Every man has his own wavelength," declares Dr. Moineau, a French scientist, who claims to have invented an animal wave-meter. He states that human beings radiate waves of between 22 and 45 millimetres. The new police radio organisation in France should make a note of this.

5SW RELAYED IN AMERICA.

5SW, the short-wave broadcast station at Chelmsford, and the Post Office telephony station at Rugby, both transmitted Marchese Marconi's speech from a B.B.C. studio on December 12th when the inventor described his first experiments in Transatlantic wireless telegraphy twenty-eight years ago. The 5SW transmission was selected by the Radio Corporation of America for relaying to listeners in the United States. Many enthusiastic reports have been received.

HIDDEN ADVERTISEMENTS COMPETITION.

A large number of readers entered for the Hidden Advertisements Competition in our issue of December 11th, and the following are the prize-winners:—

1st Prize (value £7 10s.): Herr Robert Käubler, Jordanstr 31, Dusseldorf, Germany.

2nd Prize (value £5): Mr. Alfred Jackson, 48, Fenwick Road, Peckham, S.E.15.

3rd Prize (value £2 10s.): Mr. Maurice R. Guy, 70, Cambridge Road, New Malden, Surrey.

Consolation prizes (each to the value of £1) are awarded to the following: Mr. S. H. Lewis (Guildford), Mr. R. de S. Stawell (Falmouth), Mr. R. Harrison (London, S.E.3), Mr. J. Lovell (Brigg, Lincs), and Mrs. M. Martin (Edinburgh).

WORLD BROADCASTING ON FIFTEEN WAVELENGTHS.

Long-distance listeners who are seeking fresh worlds to conquer can begin with the New World by picking up the G.E.C. transmissions from Schenectady (New York). Some fifteen channels are now in use, ranging from 790 kilocycles (380 metres) to 23,080 kilocycles (13 metres), the last-named being that of W2XAW.

For broadcast to foreign countries, considerable use is made of W2XAF, 31.4 metres (9,530 kC.), and W2XAD on 19.6 metres (15,340 kC.), but experimental

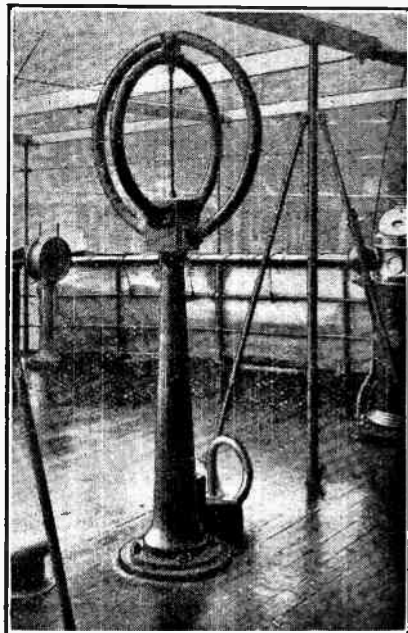

DIRECTION FINDING IN THE ANT-ARCTIC. The Marconi direction-finder aerial on the bridge of "Discovery II."

transmissions are also carried out on 187.4 metres (1,604 kC.), 125 metres (2,398 kC.), 100 metres (3,256 kC.), 62.6 metres (4,795 kC.), 46.7 metres (6,425 kC.), 34.7 metres (8,650 kC.), 23.4 metres (12,850 kC.), and 17.3 metres (17,300 kC.).

The following call-signs are used indiscriminately, viz., W2XAZ, W2XAH, W2XX, W2XAC, W2XO, W2XAH, and W2XAK, in addition to W2XAW already mentioned.

Television tests are conducted on about 139.5 metres with the call-letters W2XCW. All telephony tests with aircraft are carried out on 130.4 metres (230.2 kC.) and 97.3 metres (3,076 kC.) with the call-sign W2XCH.

RADIO MANUFACTURERS' ASSOCIATION.

Captain J. W. Barber, of the Brownie Wireless Co. of Great Britain, has been elected chairman of the Radio Manufacturers' Association in succession to Mr. John T. Mould. The new vice-chairman is Mr. R. M. Ellis, of Climax Radio Electric.

THE PARALLEL-FED L.F. AMPLIFIER.

It is regretted that an error occurred in the appendix to the article "The Parallel-fed L.F. Amplifier" on p. 647 of our issue of December 11th. The design formula should read thus:—

$$C = 2L \left(\frac{B}{A} \right)^2 \quad \text{Where } A = R_a + r + \frac{R_p}{R} \\ = R_a + Br \\ B = 1 + \frac{R_a}{R}$$

Lines 31, 32, 33, second column, p. 644, should therefore be read: "... the resistance r representing the transformer primary resistance."



SOUTHWARD HO! Operating the Marconi direction finder in the chart room of "Discovery II," the Royal research ship which left London on December 14th for a three years' scientific research voyage in the Antarctic.

...d their reserva-... out from... part, who had all... he happy, the two of... Letty nodded again... she could think

TO-DAY'S WIRELESS PROGRAMMES.

LONDON.—9.0: 842kc/s. (856.3m.) A... DAVENTRY.—6XX, 193kc/a. (1,554.4m.)... 10.16 a.m. Service... 10.30, Time, Weather... 10.45, Keeping Back the Years, by Mrs. Williams... 11 (Daventry) ... 11-11.30 (London), Television... 12. Vyvyan Lewis, cello; Norman Fraser, piano... 12.30, Organ, played by Leonard H. Warner, from St. Boniface... 1-2, Gramophone... 2.25 (Daventry), ... 3.0, Selections from ... 3.55, Interlude... 4. Peoples of the World and their Homes... 4.55, Events on Athletics and Games... 5.40, Interlude... 5.45, Schools; Sybil Eaton String Quartet; Sybil Eaton, 1st violin; Pierre Tas, 2nd violin; Raymond Jeremy, viola; Allan Ford, cello... 6.30, Moschella and his Orchestra, from the May Fair Hotel.

5.15, Children: How Wireless Came to Toy-Town (S. G. Hulme Beaman), as a dialogue story, with incidental music by the Gershwin Parkington Quintet... 6. Some New Ways of Cooking Haddock, by Miss Marjorie Guy... 6.15, Time, Weather, News... 6.30, Ministers of Agriculture... 6.45, ... 7.15, ... 7.25, Letty and the Ordinary Reader, the Rev. M. R. Ridley... 7.45, Leslie Weston, comedian; Betty Warren in impersonations; Tommy Hand... comedian; Hungarian Gipsy Band; ... the Bayan Vocal... Ango, Baudelaire, Shadows, who scene by Valerie Wood; B.B. ... 9. Weather, News... 9.15, Topical Talk... 9.30 (Daventry), ... Fat Stock Prices... 9.35, Roland, a ... ing, effects composed and produced by Peter Cree... 10.35, Super... 10.50, Teddy ... and his Band, from the ... Club.

DAVENTRY.—5GB EXPERIMENTAL: 626kc/s. (1792m) 3. Organ played by Leonard H. Warner, from St. Boniface's; Organ; Mary ... 4. ... 5. ... 6. ... 7. ... 8. ... 9. ... 10. ... 11-11.15, Jack Harris's Grosvenor House ...

... arrived ... Park of the ... collection at ... They stand ... the male hav ... whilst those ... shorter and ... These wild ... of the "Ba ... hunter in the ... inaccessible c ... always on wa ... to approach ... lean down a tree ... Owing to the ... sidered safe to ... wild sheep and ... terances, and ... prepared for the ... following ... y's issue o ... Patterns of ... kets. H ... "Gift Pre ... stamps ... Illustrated ... Illustrated ... Page 4 ... Copy of ne ... Sample bot ... for the ... of ... rough ... Booklet, ... Dre ... A ... An in



A Low-power Synchronised Transmission Scheme.

By HUMPHRY MacCALLUM, B.Sc.

ONE of the advantages of the gramophone, as compared with radio, is that, within the limits of your means or your foresight or your borrowing capacity, you can listen when you like to what you like; one of the limitations of radio is that you cannot do so. If you have a gramophone and access to records of all sorts you can make your own programmes and you can make them just when you want them. But with radio you have a limited choice, since you can listen only to what is in the programmes of those stations that are broadcasting at the moment and happen to be within range.

Radio can give quality reception which is beyond serious criticism, quality which can be relied upon to please the discriminating ear of the music critic, and indeed of the musician himself—provided he is satisfied to forgo long-distance reception and to rely almost entirely upon the fare offered by the B.B.C. But at present this is not an altogether attractive prospect. The most enthusiastic supporter of the B.B.C. is forced to recognise that there are periods during which individuals or groups, if not whole classes, of listeners are thoroughly bored. On some occasions, indeed, listeners are transported beyond the boundaries of boredom to the regions of exasperation.

One cannot blame the B.B.C. programme department for this. They have done more than well with the

limited facilities at their disposal, for they have at least succeeded in providing programmes which, on the whole, have been sufficiently attractive to make broadcasting a feature in the lives of the people.

It is quite definitely impossible to please everyone with one programme, or even with two programmes, though the availability of an extra programme is an immense step in the right direction. If you remove the church service to please the radio dealer, who does not want to talk shop to an accompaniment of the Psalms, you will most certainly upset a large body of serious-minded listeners, and if, in response to the clamour of the afternoon dance enthusiast, you discontinue the fading out of so-and-so's orchestra which prefaces the friendly "Good afternoon, scholars," you will upset another, perhaps larger, body of serious-minded listeners. Clearly you can't do much with one programme. In present circumstances the alternative programme is, as a rule, either inaccessible to the listener or is received at diminished volume, and in any case it is rarely a true alternative, which, of course, detracts immensely from its value.

The scheme of broadcasting suggested in this article is designed to ensure that the listener will receive a true alternative which is, to an extent, of his own selection, and that he will not find himself asked to listen to some-

THE writer, who was intimately associated with British broadcasting in its earliest days, suggested the sites for the original chain of 1½ kw. stations which has held sway, with modifications, for the last seven years. While "The Wireless World" disclaims responsibility for the views expressed in this article, it is felt that they are worthy of more than passing attention.

The Programme Difficulty.—

thing he does not want to hear. If it is adopted, our dance enthusiast will not have his dance music faded out to give place to the unexpected and unwanted voice of the scholar's mentor. The susceptibility of the religiously inclined will not be shocked by the change from a religious address to a secular concert. The earnest scholar will have facilities for gleaning the knowledge he so assiduously seeks. The highbrow will have his heights and the lowbrow his depths. Mayfair and Kensington, Peckham and Tooting, Mile End Road and Dockland, will have programmes to their liking, and all these not at arbitrary times fixed by the B.B.C. but, as far as possible, continuously available at the will of the listener.

The Listener to Choose His Fare.

The means by which these alternatives can be provided appear to be quite practicable, and it is somewhat remarkable that they have not previously been suggested. They will be dealt with shortly. In the meantime it will no doubt be universally agreed that the provision of alternatives in the manner indicated is eminently desirable. It would even seem that the introduction of a scheme providing such facilities would result in radio receiving an impulse of the most powerful kind and that, because of the new possibilities, its future prospects as a means of entertainment and education, as well as an industry, would be considerably greater than has hitherto been considered to be the case.

The essential point in the suggested scheme is that the listener shall himself be able to select what class of entertainment he is to listen to, and to change at will to a true alternative programme. An individual listener does not always want to listen to the same type of entertainment. While detesting talks, Brown, who is an enthusiastic motorist, may be anxious to hear an address by Sir Henry

Segrave. Jones, who, as a rule, considers the News a waste of time, may tune in to see whether Compston has beaten Hagen at golf, though normally he would wish to listen to dance music at that time of the evening. Robinson is a bee expert and of musical taste as well. He usually listens to symphony concerts and the like, but a talk on bees will lure him away from his normal vogue. And so on and so forth.

Now if Brown and Jones and Robinson have the choice of, let us say, four programmes which we may call A, B, C, and D respectively, and if—and this is the essence of the proposition—they all know that talks on bees can only be heard from station D, and that sym-

phony music can only be heard from station B, that golf reports emanate from station C, from whence also comes Sir Henry Segrave's address, and so on, then every listener by tuning in to one or other of the four alternatives, will make sure of hearing at any rate the class of broadcast he wishes to hear at that particular time.

Common Wavelengths Synchronised.

To make this perfectly clear we can assume a hypothetical table of programme classification as follows:—

Station A.—Broadcasts only "popular" entertainment.

Station B.—Broadcasts only "highbrow" entertainment.

Station C.—Broadcasts Time, News, Weather, Politics, Talks (other than educational), etc.

Station D.—All Educational and Religious broadcasts from this station.

This classification is merely by way of suggestion in order to fix ideas. That eventually adopted would, no doubt, be the result of a somewhat interesting research carried out by the programme department of the B.B.C. on the lines indicated.

The four-programme scheme might have been introduced in 1922, when what became the B.B.C. chain of stations was under consideration. Four high-power stations grouped together at, say, Daventry, would have filled the bill. But in those days the authorities were hard-hearted on the subject of power, which was limited to $1\frac{1}{2}$ kW. There are obvious drawbacks to this method, however, and in any case the time for its adoption is past, if only because there now exists a large body of listeners who regard themselves as having a vested interest in their own particular local station. Any scheme which does not meet this difficulty cannot be considered seriously.

An alternative four-programme scheme with fewer drawbacks, and one which appears to have the merit

of novelty, is based upon the use of one wavelength for a number of stations sending out simultaneously the same programme.

Recent research has disclosed the fact that although the common use of one wavelength by stations sending out different programmes is unsatisfactory, if not unworkable, excellent reception over a limited area surrounding each station can be assured when two or more perfectly synchronised stations are sending out the same programme. The attempt at sharing common wavelengths with Continental stations was doomed to failure because the programmes differed and because synchronisation was imperfect. Where all the stations taking part



FIRST STEPS IN BROADCASTING. A photograph taken in the tiny studio at Marconi House in 1922. In the early days the technical novelty of broadcasting overshadowed programme considerations.

The Programme Difficulty.—

in the scheme are under one control, as in the case of the B.B.C. stations, conditions are favourable for best results in regard to synchronisation, and the B.B.C. engineers have shown that it is possible to maintain stations permanently synchronised under practical conditions. The provision of identical programmes is mainly a matter of land-line facilities, though in certain cases a radio link becomes possible without increasing the number of wavelengths in use.

The scheme now put forward is based upon the use of low-power stations using four wavelengths but, to

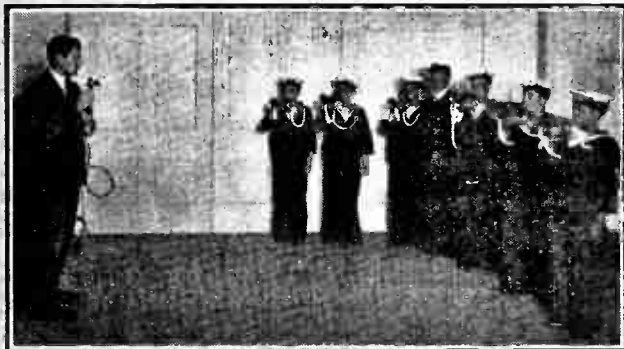

AN EARLY "SURPRISE ITEM." Boys of the training ship "Exmouth" broadcasting a bugle call from Marconi House.

meet certain limitations, two additional stations of high power, operating on two extra wavelengths are suggested. The total number of wavelengths required for the whole country would, therefore, be six, one of which might be the existing 5GB wave, and another the 5XX wave.

One Station, Four Wavelengths.

At present we are using ten wavelengths; there is therefore a saving in this direction which would allow for extra wavelengths for television or other services, or alternatively, would allow for wider spacing between the used wavelengths and therefore less liability of interference.

The main scheme provides only for densely populated districts. The two extra stations are intended to provide for the sparsely populated areas, the inhabitants of which, under the new scheme, would have the choice of two British programmes only and, of course, such Continental programmes as their apparatus enabled them to pick up. The sparsely populated districts will suffer by comparison with the centres of population, but this is only relative, and owing to considerably improved programmes and less interference the listeners in these districts will really be better off than at present.

Listeners at centres of population will have a full choice of four alternative programmes classified in the manner suggested, and available at good strengths and of ideal quality. For them at any rate, i.e., for the vast majority of the population, the scheme would appear to provide a complete solution to existing programme difficulties.

What can we find against this ambitious scheme?

The technical difficulties do not appear to be insur-

mountable. We know it is possible to send out four programmes on four different wavelengths from one broadcasting centre, and Captain Eckersley has published results from which we are entitled to deduce that such centres can be duplicated or multiplied within reason as required without increasing the number of wavelengths in use.

The Financial Aspect.

Is the scheme financially unsound to a degree that would put it out of court? Will it cost too much to broadcast four waves from each important centre of population? Will it cost too much to provide four classes of programme continuously? Figures are not available, but it would seem reasonable to suppose that a very greatly increased revenue from licences would result from the introduction of the scheme, and that this would more than provide for any increased expenditure. Each centre of population would, in a sense, become self-supporting. The larger centres, like London, Manchester, etc., might be expected to contribute, through the medium of licences, sufficient funds to cover the provision of the four simultaneous broad-



SATISFYING THE PIONEER LISTENER. In 1922 the only instrument which was faithfully reproduced throughout its range of frequencies was the set of tubular bells seen in the picture. Listeners were delighted!

casts at appropriate power, whereas smaller centres, though less important financially, might be expected to contribute funds sufficient to provide for the needs of the districts which would be met by a simultaneous broadcast on reduced power.

It is possible that the scheme might be developed along these lines to an extent which would enable quite small centres of population to come in economically, and by a low-power local broadcast add one or more programmes to those already received from the high-power stations, without increasing the number of wavelengths in use. A series of such stations held at the disposal of the Educational Authorities, and paid for

The Programme Difficulty.—

by Government grant would give free scope for educational activities and avoid the necessity for interfering with the two high-power programmes.

It will be realised that the cost of producing programmes is not likely to increase abnormally, since four only are required for the whole country. Each may be the very best of its class, and fees will be correspondingly heavy, but a counterbalancing economy results from the fact that there is no duplication as at present with the large number of stations in existence.

The scheme suffers from the drawback that it fails to provide for the programme of purely local origin. The best of the "local" items will find their outlet, however, in the appropriate national programmes.

A further, though not very serious, disadvantage of the suggested scheme lies in the possibility of items of equal attraction to the individual listener running concurrently in different programmes. Robinson's "talk on bees" might conceivably coincide with his favourite symphony, and he would perhaps be annoyed at not being able to hear both. But this class of fault is surely outweighed by the many good points of the scheme, which may be summarised as follows:—

(1) A greater choice of programmes than has hitherto been possible is provided at good strength at all important centres of population. Every listener at these centres has available, at equal strength, and all the time during broadcasting hours, four different classes of programme.

(2) Considerable economy in wavelength is obtained, the whole country using six waves only for home broadcasting purposes.

(3) The cost of programmes is reduced and/or their quality improved, since only one first-rate programme of each class is required instead of some half-dozen second-rate programmes, as at present.

(4) Long-distance listening, with its unavoidable unreliability, is discouraged by the provision of reliable near-by transmissions of the very best quality, offering a choice of programme unobtainable elsewhere. As a result of this, radio is likely to assume a popularity far in excess of that held by it at present, and, indeed, in excess of the wildest dreams of its most ardent supporters.

(5) Although the scheme provides continuous and unlimited entertainment of a type suited to every class of listener, it also provides uninterrupted scope for pro-

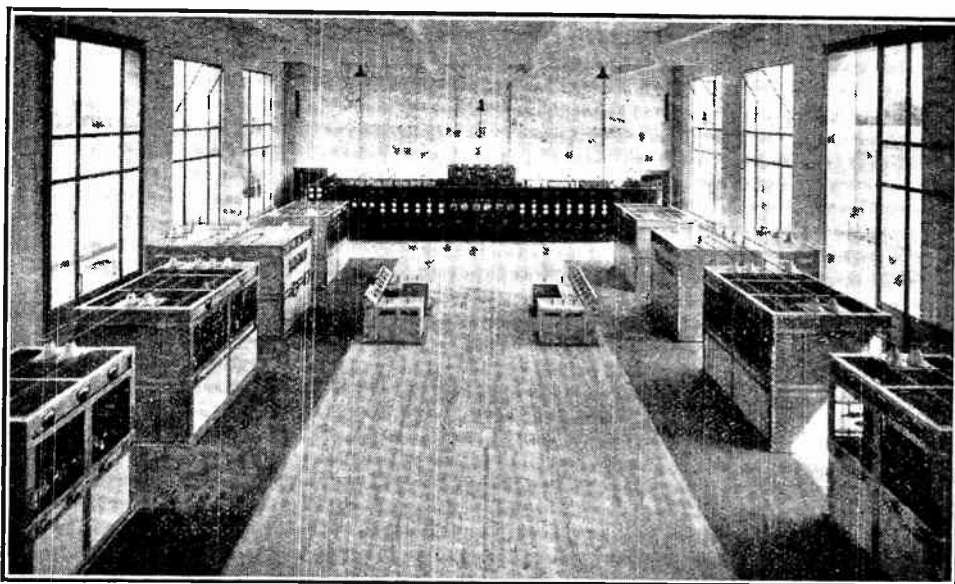

IS THIS TYPE OF TRANSMITTER NECESSARY? The twin transmitters at Brookmans Park, which, if our contributor's scheme were to materialise, would be the biggest white elephants in the zoology of the ether.

grammes of an instructional, educational, political, and religious type. The conflict of interest between the various sections of thought regarding the provision of programmes automatically comes to an end since each section has a free choice of sufficient alternative programmes at adequate strength.

It would seem that the scheme carries with it so many important advantages that it is at least worthy of serious consideration, and, should it prove to be practicable, its introduction by the B.B.C. will exterminate for ever the persistently recurring slander anent the intention of that body to provide what it considers to be good for the people rather than what the people consider to be good for themselves.

The Marconiphone Co., Ltd., 210-212, Tottenham Court Road, London, W.1.—Publication No. 585a, revised edition of new catalogue containing full description of the Marconiphone range of receiving sets, loud speakers and gramophone pick-ups.

o o o o

The Halcyon Wireless Co., Ltd., 313-319, Regent Street, London, W.1.—Illustrated folder dealing with two new 4-valve transportable receivers recently introduced.

CATALOGUES RECEIVED.

Cambridge Instrument Co., Ltd., 45, Grosvenor Place, London, S.W.1.—Illustrated leaflet of the Cambridge Surface Pyrometers, an instrument to provide accurate and convenient means of determining the inside temperature of bakelite and other moulding material during the process of manufacture.

Tungstone Accumulator Co., Ltd., 3, St. Bride's House, Salisbury Square, London, E.C.4.—24-page book describing and illustrating the construction of the paste-filled lead-grids used in Tungstone batteries. Also illustrated folders of H.T. and L.T. batteries for wireless use.

o o o o

The Mainten Manufacturing Co., Ltd., Portland Road, Hove, Sussex.—Descriptive folders dealing with the range of battery eliminators, all-mains receivers, and metal cabinets manufactured by this firm.

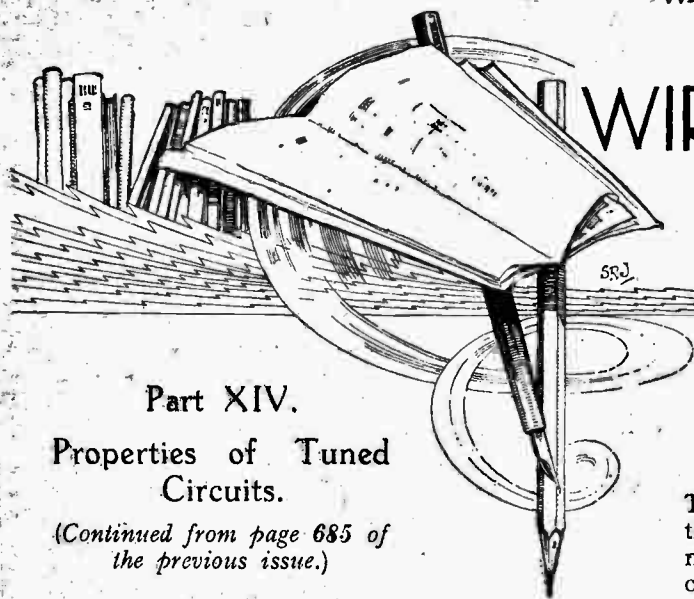

WIRELESS THEORY SIMPLIFIED

Part XIV.

Properties of Tuned Circuits.

(Continued from page 685 of
the previous issue.)

IT was shown last week how a series of circuit possessing inductance and capacity was capable of selecting currents whose frequencies were near the resonant frequency of the circuit whilst choking back currents with frequencies outside this band. Since the circuit allows maximum current to flow at the resonant frequency it is sometimes called an "acceptor circuit." It will be seen later that the parallel circuit has the reverse effect, and it is referred to as a "rejector circuit."

The resonant frequency of a series circuit is quite independent of the resistance, being determined by the product of inductance and capacity only, its value being $f = \frac{1}{2\pi\sqrt{LC}}$ cycles per second, but the amount of current passed at this frequency is determined by the resistance alone for a given applied voltage, because the respective reactances due to the inductance and capacity neutralise each other's effects completely at the resonant frequency.

The Closed Circuit.

To study the properties of a tuned circuit profitably we must do so from a practical point of view; that is to say, we must know the conditions under which the circuit is going to be used in practice and then find out the conditions in the circuit which will make for the highest efficiency.

The commonest example of a series tuned circuit in a wireless receiver is the ordinary tuned grid circuit preceding the first valve, where the aerial is inductively coupled to the tuning coil as shown in Fig. 1 (a).

By S. O. PEARSON, B.Sc., A.M.I.E.E.

The alternating current in the aerial coil, produced by the signals being received, causes an alternating magnetic field to be linked with the coil L of the tuned circuit, and this in turn induces an alternating E.M.F. in the latter coil. Let the R.M.S. value of this voltage be E. This voltage will, of course, drive an alternating current round the closed circuit, R, L, C and the value of this current will be $I = \frac{E}{Z}$ amperes, where Z is the total impedance of the circuit.

Clearly we should get exactly the same effect if, instead of inducing the voltage E into the closed circuit by mutual induction, we were to connect a generator giving E volts at the same frequency anywhere in the circuit. This means that our closed circuit with applied E.M.F. induced in the coil is electrically equivalent to a series circuit with the voltage E applied to its ends as shown at (b) in Fig. 1. This is a point of fundamental importance; any closed circuit where the applied E.M.F. or energising E.M.F. is induced into it is equivalent to a series circuit; the current round the closed loop is simply given by $\frac{E}{Z}$, where Z is the impedance due to R, L and C in series.

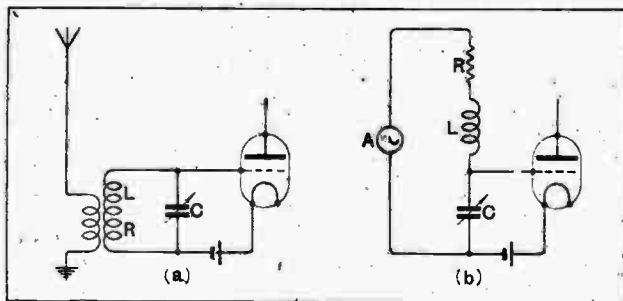

Fig. 1.—(a) Typical tuned grid circuit inductively coupled to the aerial. The tuned circuit is electrically equivalent to the series circuit shown at (b), where A is the source of alternating E.M.F. energising the circuit.

Voltage on the Grip of the Valve.

The valve depends for its action on the application of an alternating voltage between the control grid and filament and does not consume any current other than the small fraction of a microamp required to charge and discharge the grid when the valve is working under proper conditions. So the valve has its grid and filament connected across the condenser (or across the coil) of the tuned circuit as shown in Fig. 1 (a).

Now the voltage across the condenser is $I \times \frac{1}{2\pi f C}$ volts, where I is the current in the closed circuit and

Wireless Theory Simplified.—

$\frac{1}{2\pi fC}$ ohms is the reactance of the condenser. Thus the voltage applied to the valve is proportional to the current in the closed circuit and inversely proportional to the frequency. Obviously then the performance of this stage of the receiver will depend on the general characteristics of the resonance curve obtained by plotting the voltage across the condenser against the frequency rather than on the simple current resonance curve found previously. The required voltage resonance curve can be found very simply from the current curve merely by multiplying the current at a number of different frequencies by the condenser reactance at the respective frequencies.

The voltage resonance curve is necessarily not quite the same shape as the current curve, because in obtaining it we are multiplying the current values by a variable quantity—the frequency. In order to show the difference the values of voltage across the condenser have been worked out for the same circuit constants which were used before, namely, $L = 2532$ microhenrys, $C = 0.00025$ microfarads, and $R = 500$ ohms. But this time the voltage applied to the circuit is taken as 0.1 volt instead of 10 , that is to say, in the circuit of Fig. 1 (a), 0.1 volt is induced into the coil L , so that the current values shown in the last column of the table given in Part XIII are just a hundred times greater than in the present case.

The resonant frequency is 200 kilocycles per second and at this frequency the current in the closed circuit is a maximum, being $\frac{E}{R} = \frac{0.1}{500}$ ampere or 0.2 milliampere, and the reactance of the condenser is $X_c = 3182$ ohms. Hence at the resonant frequency the voltage applied to the grid of the valve is $E_c = IX_c = 0.0002 \times 3182 = 0.636$ volt. Note that this is 6.36 times greater than the voltage induced into the circuit by the aerial current even though the tuned circuit has the abnormally high value of 500 ohms.

Frequency Kilocycles per sec.	Condenser Reactance.	Current Milliamp.	Voltage across Condenser.
20	31,820	0.00317	0.101
40	15,910	0.0065	0.103
80	7,955	0.0149	0.119
120	5,303	0.0292	0.155
160	3,978	0.0662	0.263
200	3,182	0.200	0.636
240	2,651	0.0789	0.209
300	2,121	0.0370	0.0785
350	1,818	0.0264	0.048
400	1,591	0.0208	0.033

At the moment we are concerned with the shape of the voltage resonance curve and will return to the voltage step-up effect later.

The table gives the values of current, the reactance of the condenser, and the voltage across it for various frequencies between 20 and 400 kilocycles per second, the other conditions being as given above.

In order to make it easy to compare the shape of the voltage curve with that of the current curve, instead of plotting the actual values of current and voltages against the frequency, each is plotted as a percentage of the maximum value to a common base line denoting frequency values in Fig. 2. For instance, at 160 kilocycles per second the current is 0.0662 milliampere or 33.1 per cent. of the maximum value of 0.2 milliampere. By adopting this expedient the peaks of the curves are made to coincide.

The current curve is shown as a full line and the voltage curve as a broken line.

Although it can be shown mathematically that the

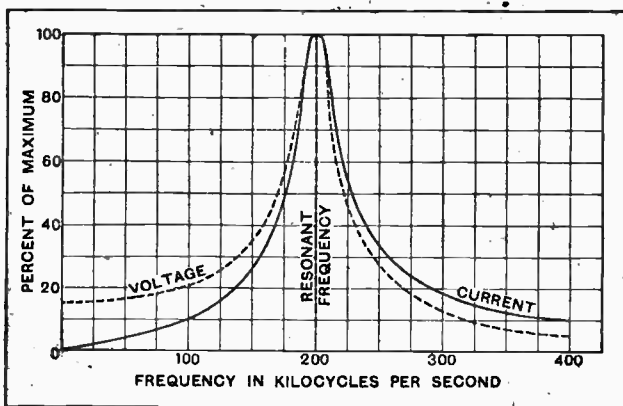

Fig. 2.—Current and voltage resonance curves for a series circuit. The values of each are plotted as a percentage of the maximum value to facilitate comparison. $L = 2532$ microhenrys. $C = 0.00025$ mfd. $R = 500$ ohms.

peaks of the two curves do not occur exactly at the same frequency they are so close together for all normal values of circuit resistance that we can assume that they coincide at the resonant frequency. But it is clear that for frequencies far removed from the resonant value the two curves are rather widely separated; but even so, they are very similar in shape.

Conditions for Maximum Signal Strength.

From the resonance curves of Fig. 2 we see

quite definitely that the voltage applied between the grid and filament of the valve will be a maximum when the current in the closed circuit is greatest at the resonant frequency. As explained, this current is determined alone by the resistance of the circuit and so from the point of view of obtaining the greatest signal strength it is of prime importance to make the resistance of the tuned circuit a minimum. At high frequencies the resistance of the tuning coil depends not only on the size of wire with which it is wound, but on other factors to which a section will be devoted at a later date.

In the actual circuit we have been discussing a resistance of 500 ohms was chosen to simplify the calculations and to accentuate the effects of the resistance relatively to the other constants. Even with a resistance as high as 500 ohms, in a circuit where $L = 2532$ microhenrys and $C = 0.00025$ microfarads, the voltage built up across the circuit at the resonant frequency was seen to be 6.36 times greater than the E.M.F. induced into the circuit. If the resistance were reduced to 50 ohms, a more practical value, the current in the circuit would be increased tenfold at the resonant frequency and the voltage across the condenser would be 63.6 times greater than the incoming

Wireless Theory Simplified.—

voltage. The importance of keeping the resistance down will thus be evident.

To show the important effect of resistance in this direction a number of current resonance curves are given in Fig. 3 for a circuit with the same inductance and capacity values as before but with different values of resistance as marked on the individual curves. It will be seen that the peaks of the curves have varying heights according to the resistance, but that they are all about the same width near the bottom. The values are worked for a voltage of 0.1 induced into the coil.

How the Values of L and C Affect the Signal Strength.

It was shown that the voltage applied to the valve grid at the resonant frequency is not only proportional to the current in the circuit but also inversely proportional to the capacity of the tuning condenser. Now since the

frequency to which the circuit is tuned is given by $\frac{1}{2\pi\sqrt{LC}}$ cycles per second it follows that the resonant frequency is determined by the product of inductance and capacity. Hence, if the inductance were doubled and the capacity halved the product would still be the same and the circuit would still be tuned to the same frequency. Furthermore

if the resistance were not increased in the process the value of the current circulating round the circuit at the resonant frequency would be unchanged and so the voltage across the condenser would be doubled.

The inference is that for high voltage step-up in a tuned series circuit the ratio of inductance to capacity should be kept as high as possible. But of course a coil of higher inductance necessarily incurs an increase of resistance as more turns, usually of thinner wire, are required and so the gain in voltage is partly off-set by a reduction of the current. In practice we must strike a compromise which gives the optimum voltage step-up effect. The tuning condenser is usually a variable one, the inductance being fixed and in normal practice the value of inductance

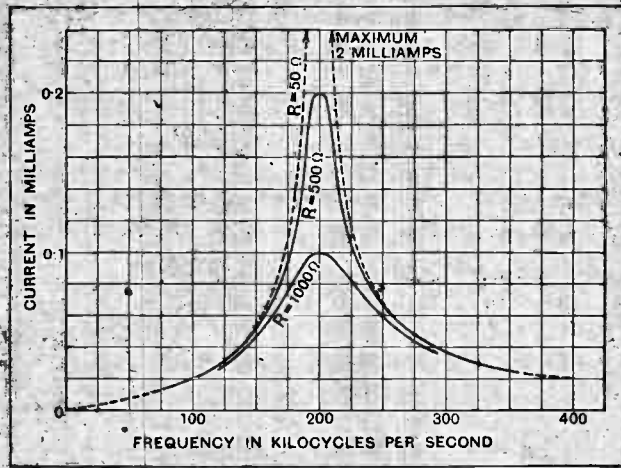

Fig. 3.—Current resonance curves for series circuit showing the effects of resistance. L = 2532 microhenrys. C = 0.00025 mfd.

is so chosen that the maximum wavelength or minimum frequency to which the receiving set is required to tune calls for a variable condenser whose maximum value of capacity is of the order of 0.00025 to 0.0005 microfarad.

A tuned circuit where a variable condenser is employed gives the greatest voltage step-up effect at the higher end of the frequency scale or lower end of the wavelength band when the condenser is set to low values of capacity.

(To be continued.)

How Mains Sets Work.

The Philips 4-valve receiver was the subject of a lecture given by Mr. Cooper, of Philips Lamps, Ltd., on Friday, December 6th, before the Bristol and District Radio Society in their Club Room at Bristol University. By means of blackboard diagrams, the lecturer clearly explained how the A.C. mains were utilised for the working of wireless receivers.

The Annual Meeting of the Society will be held on January 24th, when it is hoped that all members will be present. Full details of the Society may be obtained from the Hon. Secretary, Mr. S. T. Jordan, 1, Myrtle Road, Cotham, Bristol.

Valve Manufacture Described.

A lecture on valves given by Mr. W. L. Hartshorne, of Messrs. Cosson, Ltd., was the chief item of interest at a recent meeting of Slade Radio (Birmingham). Many important details of manufacture were explained, while samples of the various parts exhibited were submitted to a searching examination by a group of interested members.

Details of the Society's activities may be obtained from the Hon. Secretary, 110, Hilaries Road, Gravelly Hill, Birmingham.

An Amplion Demonstration.

A large and enthusiastic gathering greeted Mr. P. K. Turner, of Graham Amplion, Ltd., for his lecture and demonstration of one of the Amplion A.C. mains receivers before the Muswell Hill and District Radio Society on December 11th. The necessary alternating current for the set was obtained from an A.C. generator running off the D.C. mains. Mr. Turner dealt with numerous points of design in the receiver and showed how good quality

CLUB NEWS.

had been secured despite the use of reaction; though the judicious use of the latter, together with a screened grid valve, suited the set admirably for distant reception, as was proved in the subsequent demonstration, when numerous Continental stations were picked up at excellent strength with only an apology for an aerial.

Hon. Secretary, Mr. C. J. Witt, 39, Coniston Road, London, N.10.

Photo-electric Cells.

Photo-electric cells were described and demonstrated by Mr. Walker, of the General Electric Co., at the meeting of the Tottenham Wireless Society on December 3rd. With the aid of lantern slides the lecturer explained their theory and present-day use, concluding with a demonstration showing their capabilities in street lighting control.

Hon. Secretary, Mr. W. Bodemeald, 10, Bruce Grove, Tottenham, N.17.

Mains Set Operation.

The operation of radio receivers from the mains formed the subject of a constructive lecture given by Mr. Wyborn, of Messrs. Ekco, Ltd., at the last meeting of the Southend and District Radio Society. The lecturer started with the simplest form of high tension eliminator for direct current mains. He pointed out difficulties in operating sets arising from

this elementary apparatus. From this he proceeded in stages to a final high efficiency type suitable for powerful and complicated receivers used on the roughest of mains.

Hon. Secretary, Mr. F. J. Waller, Lyntonhorpe, Grange Gardens, Southend-on-Sea.

H.F. Amplification: Old and New.

A practical lecture on high frequency amplification was given by Mr. C. Neems-Stanley at a recent meeting of the Tottenham Wireless Society. The lecturer first reviewed the methods in general use for obtaining H.F. amplification prior to the advent of the screened grid valve. Some interesting comparisons were drawn between the efficiency of the early methods as compared with those of to-day. Practical hints were given for the construction of coils for use with modern valves.

Cutting Out Brookmans Park.

The problem of interference from the new Brookmans Park transmitter was fully dealt with in a lecture at the last meeting of the North Middlesex Radio Society. The speaker, Mr. E. H. Laister, dealt especially with the case of the simple unselective receiver which is in such extensive use at the present time. The use of a loose-coupled circuit was advocated as the simplest and probably most effective modification which could be made, and it became obvious, from the speaker's remarks, that the separation of stations of fairly close wavelengths was not the intricate task that many people imagined. Wave-traps were denounced owing, said the lecturer, to their disconcerting propensity for cutting out the wanted station as well as the unwanted.

Hon. Secretary, Mr. E. H. Laister, "Wind flowers," Church Hill, Winchmore Hill, N.21

BROADCAST

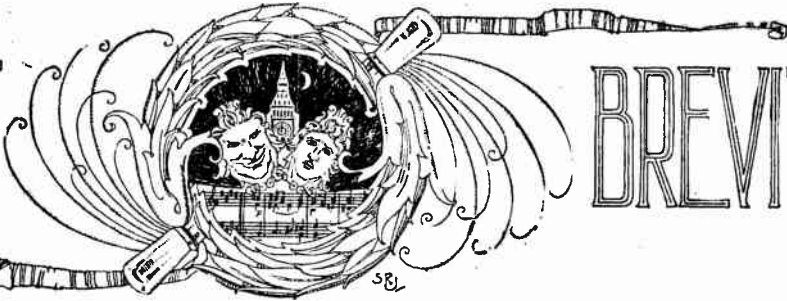

BREVITIES

By Our Special Correspondent.

New Test for "B.P." Listeners.—European Programme Exchanges.—Greeting the New Year.

A Mixed Post.

"A spate of letters," to use the vigorous phrase of the B.B.C. Correspondence Department, has occurred in regard to the Brookmans Park twin transmission tests. A few are congratulatory, but the majority are plaintive. Most plaintive of all are those from listeners who wish to know what has become of London's late dance music. Apparently, in spite of the torrent of publicity, there are people unaware of the existence of twin transmission tests!

o o o o

Tuning Out Twin Tunes.

The most fruitful cause of complaint is of inability to separate the two transmissions. Sufferers under this head may have further reason for lamentation in a week or two, for I hear that those unobtrusive talks from the 356-metre transmitter are to be replaced by music; European ether searchers know how much more difficult it is to separate two tunes than a tune and a talk.

As I prophesied last week, many of the general public are finding the 261-metre wavelength beyond their technical resources.

o o o o

Brookmans Park Uses Wireless Link.

An unpleasant message from the Post Office awaited the B.B.C. engineers when they rolled up for duty at 9 o'clock on the morning of Saturday, December 14th. A technical catastrophe at Holloway had resulted in a complete break in all the five lines which connect Savoy Hill with Brookmans Park. Throughout the day, therefore, the London Regional station had to pick up its material by wireless from Daventry 5XX, which explains the B.B.C.'s polite apology for the unusual amount of atmospherics.

o o o o

Europe Makes Merry.

New Continental landlines are to have their first real test on January 3rd, when the B.B.C. will co-operate with the German and Belgian broadcasting authorities in an original "give and take" relay from 8 to 9.15 p.m. The first portion of the programme will come from Cologne, and will consist of Haydn's "Fourth London Symphony." This will be followed by a relay from Brussels of the works of Gretry, and the feature will conclude with a B.B.C. transmission of Henry Purcell's "Fairy Queen."

Listeners in Germany, Belgium and Britain will hear all three portions.

Sunday Education.

Up till now the B.B.C.'s educational campaign has been limited to six days in the week. In 1930 it is to wave its standard on Sundays as well. The transmitter involved will be 5GB, which will send out a talk every Sunday from 5.45 to 6.15 on subjects of interest to students of the theology. The speaker will be Dr. E. S. Waterhouse.

o o o o

A Programme Quandary.

If Savoy Hill wishes to proclaim the general high standard of programmes there is no better way than to draw attention to the quandary in which it finds itself over National Radio Week. This week of rejoicing begins on Sunday, January 12th, and the original intention was that the B.B.C. should prepare special "star" programmes for the occasion. But the programme people feel that the "star" standard has now been attained with un-failing regularity for months past. How can they improve perfection?

In all seriousness, can anyone suggest a really original feature?

o o o o

The Grand Good Night.

For the fifth year in succession the B.B.C. will bid a Grand Good Night to

everybody on New Year's Eve, and this time it is hoped that nobody will be forgotten. One year this unique message, for which Mr. J. C. Stobart is responsible, was intended to greet all the great towns and cities of Britain, but Dundee was unintentionally omitted, and Savoy Hill very soon heard about it. Another dreadful omission occurred last year when a greeting to men of all trades and professions left out the firemen.

This year a special greeting will go out to the National Broadcasting Company of America.

o o o o

"Exit 1929."

The birth of the New Year will be celebrated by the B.B.C. in a radio sequence on December 31st-January 1st. The people of those countries which keep Central European time will hold their festivities one hour in advance of Great Britain. The clocks in Holland, which observe an independent time, will strike midnight approximately twenty minutes before Big Ben. When the Old Year has died in London it will still have five hours of life in New York.

o o o o

Celebrating on the Continent.

Hence the programme sequence will be on the following lines:—At 11 p.m. British listeners will hear midnight in Cologne, followed by dance music by Jack Hylton and his Band relayed from the Kit-Cat Restaurant. At 11.10 p.m. the celebrations in Paris, Copenhagen, Hamburg, Vienna, Frankfurt, Buda Pesth, Brussels, Madrid, Milan and Turin will be heard, with more dance music by Jack Hylton's Band. At 11.35 p.m. a relay of the bells of St. Vitus, Hilversum, will usher in midnight in Holland.

o o o o

"Good Morning, Everyone."

At 11.50 p.m. the B.B.C.'s own celebration will include a message for 1930 by Canon W. H. Elliott and the singing of the hymn, "O God Our Help in Ages Past," while the bells of St. Michael's, Cornhill, will "ring out the old." The striking of midnight will be relayed from Big Ben, followed by the bells of Southwark Cathedral, rung by the Ancient Society of College Youths. "Auld Lang Syne" will be sung before the lingering sounds of the Old Year are heard from New York. Then comes the Grand Good-night and a closing salutation at approximately 12.10 a.m. of "Good Morning, Everyone."



AS OTHERS HEAR THEM. Students of broadcast technique at the Berlin School of Music listening to their own microphone efforts by means of a magnetised wire recording instrument.

This YEAR'S PROGRESS in COMMERCIAL WIRELESS

By Lieut.-Colonel
CHETWODE CRAWLEY,
M.I.E.E.



Privacy in Transatlantic Telephony.—The Radiotelegraph Convention.—Less Broadcast Interference.—Wireless Beacons.

PUBLIC attention has been focused on commercial wireless communications in 1929 as it never has been before, at any rate so far as this country is concerned, with the possible exception of 1913, when the first scheme for Imperial communications, better known under the old halfpenny Press heading of "The Marconi Scandal," was under discussion in the House of Commons. Again the interest has been caused by our Imperial communications, in connection this time with the merging of the cable and wireless interests as a result of the report of the Imperial Wireless and Cable Conference which was published in July, 1928.

It will be remembered that this conference, at which the whole Empire was represented, was appointed to examine the situation which had arisen as a result of the competition of the beam wireless telegraph services with the submarine cable services. The conference recommended that the Government cable and wireless services for Imperial communication be transferred on certain terms to private enterprise, being merged with the Eastern Telegraph and its associated companies and the Marconi Company so as to amalgamate in one commercial undertaking, with a certain amount of Government control, all the cable and wireless interests conducting communications between the various parts of the Empire. These recommendations were accepted by all the Governments concerned, and the Government services were transferred to the merger on the 30th of September last.

This great communication merger, with a capital of over £53,000,000, consists of two new associated companies, the Imperial and International Communications Co., Ltd., which deals with the traffic, and Cables and Wireless, Ltd., which deals with the manufacturing side of the business.

This is the first great combination of cable and wireless interests that has taken place in the world, but

during the year similar ideas have taken strong root in the United States of America, and efforts are being made to get rid of the ban imposed by law in that country upon mergers of interests dealing with wire, wireless and cable communications.

Wireless Telephony.

Wireless telephony has been specifically omitted from the British merger, and the British Post Office reserves the right to conduct the external telephone services of Great Britain and makes terms with the company when it uses the company's stations for telephone purposes. So far, no commercial telephone service has been opened on the beam system between England and the Dominions, though several interesting demonstrations took place during the year, notably that of broadcasting the Thanksgiving Service for the recovery of the King on July 7th. The service was transmitted from London to Bodmin by land-line, thence by beam telephone to Montreal, Canada, and again by beam telephone to Sydney, Australia. This service was rebroadcast, and was heard well all over Canada and Australia.

On the same day, and by the same route, conversation was held between England and Australia. This was the first time that duplex telephone conversation had been held between the two countries.

Another interesting experiment in long-distance telephony took place between Sweden and America, including the England-America wireless link. The total length of route traversed was about 14,000 miles, including the wireless link of 3,200 miles; this constitutes a record in distance for telephone communication.

The latest important wireless telephone link on the directive system was opened on October 12th between Spain and the Argentine. This is the longest wireless telephone circuit yet working, but by far the most extensive and important telephone link in the world is the Transatlantic circuit which was originally opened

This Year's Progress in Commercial Wireless.—

between London and New York in January, 1927.

The use made of this Transatlantic wireless telephone circuit has increased considerably during the year, and there are now three short-wave channels working in addition to the long-wave channel. The traffic at present averages about 45 calls per day, the duration of each call being about six minutes. Ninety-five per cent. of the inward traffic comes from the United States, 4 per cent. from Canada and 1 per cent. from Cuba and Mexico. Of the outward traffic, 53 per cent. is from Great Britain, 34 per cent. from France, 7½ per cent. from Germany and 5½ per cent. from other European countries. The circuit suffered from the fact that it was possible to overhear conversations, but methods of imparting a high degree of privacy have recently been developed.

Short Waves.

This year has been notable for the almost universal adoption of short waves for long-range wireless

A valve panel at the Rugby station.

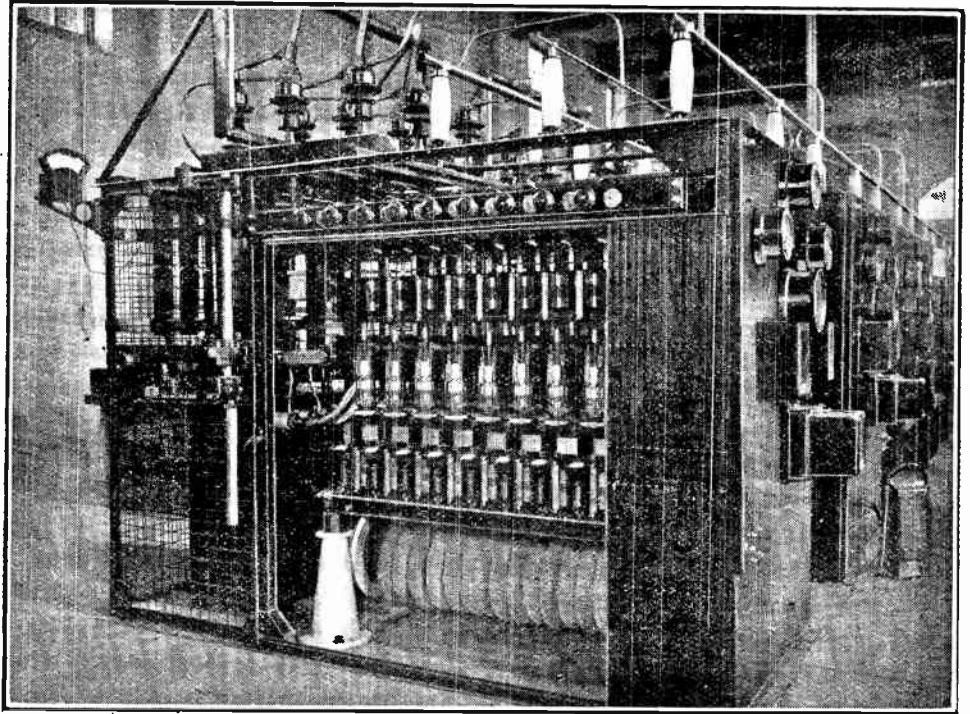

telegraph circuits, and probably more new circuits have been opened than in any former year. The volume of traffic dealt with by wireless telegraphy has continued its rapid increase which began when the Imperial beam circuits came into operation three years ago, and by September, when these circuits were transferred to the merger company, they were dealing with some 900,000 words a week with this country.

The Radio-Telegraph Convention.

As regards the wireless communications of ships, the most important events of the year were the coming into force on the 1st January of the new International Radio-Telegraph Convention, which resulted from the international conference held in Washington at the end of 1927, and the holding in London in April and May of an international conference on the Safety of Life at Sea.

The most important regulations brought into force by the Convention concerned the distribution of wavelengths amongst

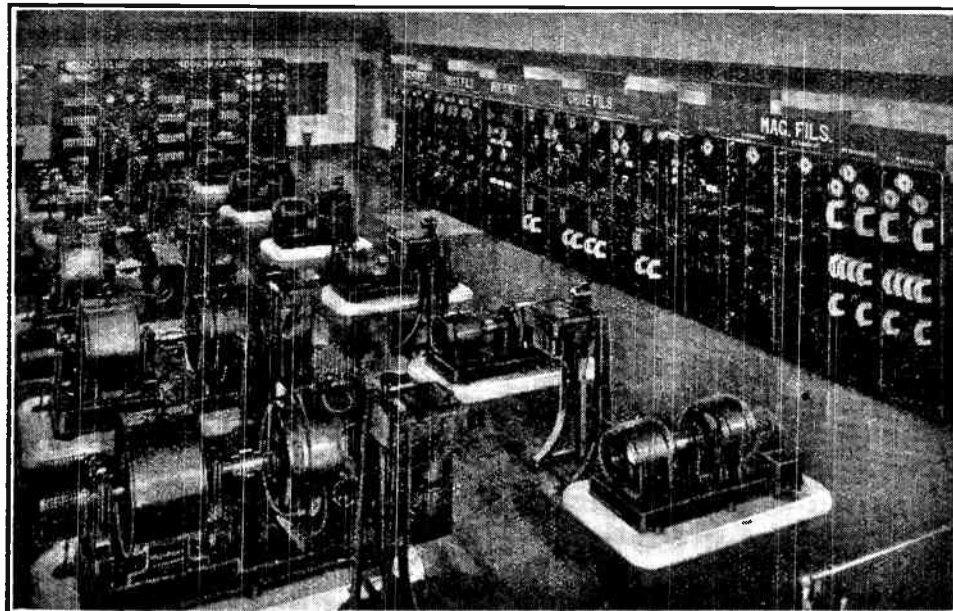

The machine room, Tetney beam station.

This Year's Progress in Commercial Wireless.—

the various services; ships, aircraft, fixed, broadcasting and experimental. The use of the 300- and 450-metre waves, which had been extensively employed by small ships, has been curtailed in the interests of broadcasting, and is now practically abolished. For the same reason, spark sets at coast stations are being replaced by interrupted continuous wave installations, except in the case of very small ships' sets, in accordance with the regulations of the Convention. The qualifications required of ships' operators have been overhauled, and new regulations introduced in connection with distress and similar signals.

This regulation of wireless services throughout the world was long overdue as the provisions of the previous Convention of 1912 were quite inadequate and out of date, but it is surprising how well we had managed to get along since the War on a policy which had nothing behind it but goodwill and common sense.

The Safety Convention.

The same might be said of the regulations governing the installation and use of wireless in ships in connection with the safety of life at sea. The only international convention dealing with this aspect of wireless signalling was produced in 1914, but owing to the War was never ratified by any of the countries concerned. Regulations were indeed introduced in this country just after the War on the general lines of those in the Convention, but, on the whole, the regulations in other countries were much less stringent. The new Convention, which will come into full force in 1931, will bring all other maritime countries into line with our present technical regulations, and will introduce several

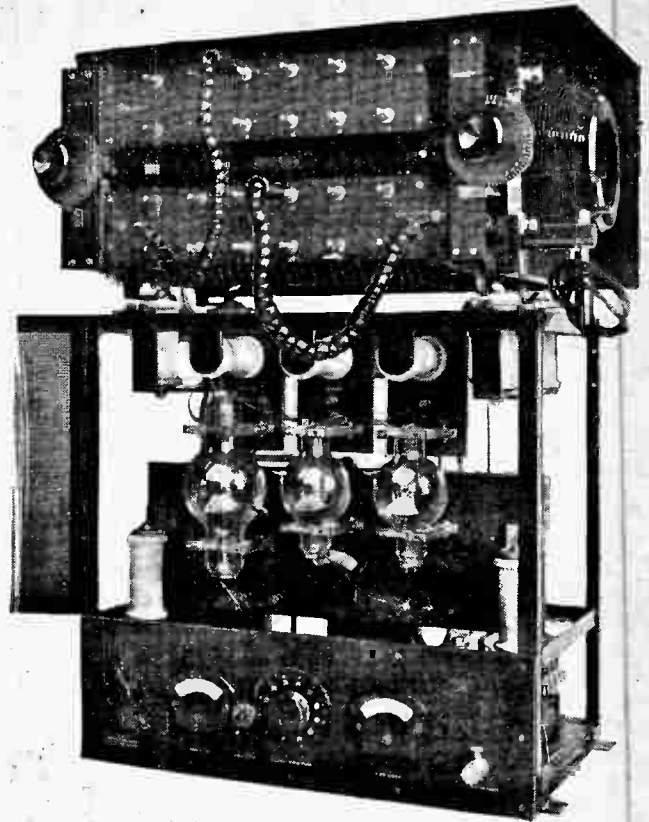

A ship's long-range transmitter.

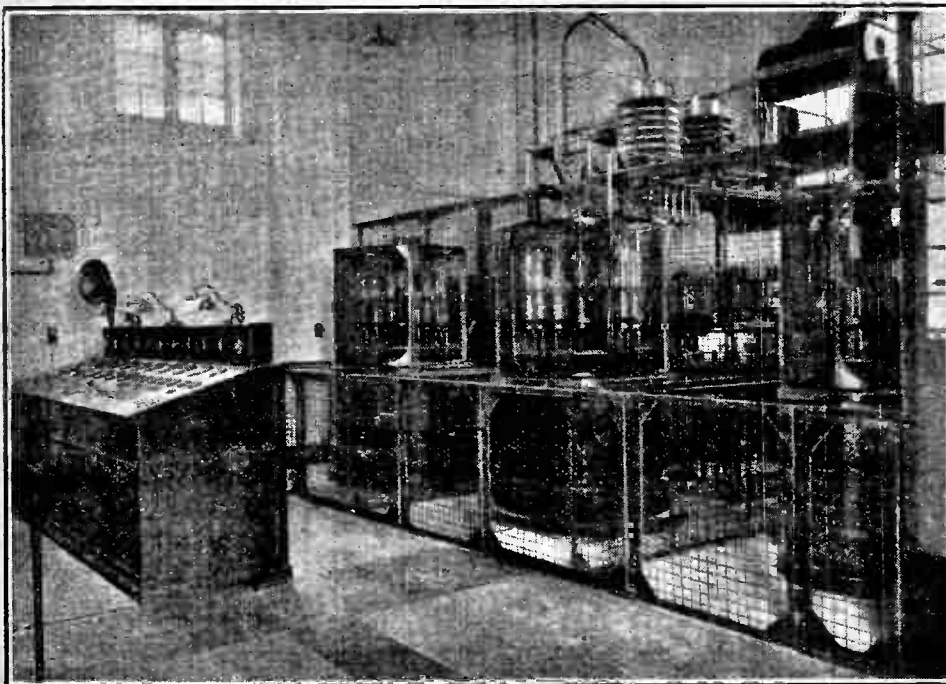

Telephone transmitter, with control table in foreground, at the Rugby station.

new important rules. For two years before this conference we alone had been using automatic apparatus for the reception of the alarm signal, and it was satisfactory that the conference recognised internationally the practical advantage of this apparatus for keeping a safety watch, and laid down watch-keeping rules for the ships in which it is fitted.

This will be, too, the first Convention to recognise the desirability of fitting directional receivers for safety purposes, and it stipulates that every passenger ship of 5,000 tons gross and upwards shall be provided with approved directional apparatus. The importance of wireless in connection with the dissemination, collection and distribution of meteorological data is fully recognised for the first

This Year's Progress in Commercial Wireless.—

time, and co-operation between the various Governments with this end in view is arranged for on general lines. The watches to be kept in different classes of ships for safety purposes are also laid down.

Ships' Wireless.

The chief advances made in ship-and-shore signalling apparatus include the substitution of I.C.W. for spark sets in many ships and coast stations, and the continued increase in the number of ships fitted with automatic receivers for the alarm signal and with directional receivers. The number of automatic receivers now fitted in British ships is over 1,000, and the number of directional receivers over 800.

A number of new all-round wireless beacons have been installed at various points on the coast, and a directional beacon, from which ships not fitted with directional receivers can obtain bearings has been installed experimentally at Orfordness in Suffolk.

The increase in long-range short-wave sets in ships has been marked. About 80 sets were working throughout the world at the beginning of the year, whereas about 180 are working now.

Wireless telephony, too, is at last beginning to emerge from its long chrysalis state so far as ship communications are concerned. Previously only a very few ships, mostly fishing vessels, were fitted, but during the last few months some of the large liners have been fitted, and experiments with short-wave telephony with the object of a commercial service are now in hand.

In Germany a commercial service connecting with the telephone system of the country is being tried experimentally with some small ships. A few lifeboats have been fitted with wireless telephony for the first time during the year.

Experiments have been carried out with the facsimile transmission of weather charts to ships, but no commercial service has yet been commenced.

The Hague Conference.

This last year has been notable for international regulations for the control of wireless communications, as in addition to the coming into force of the International Radio-Telegraph Convention of Washington, and the holding of the international conference for the safety of life at sea in London, there was held an international conference in Prague for the regulation of broadcasting

services, and an international conference at the Hague to advise on various technical matters which had arisen out of the regulations framed by the Washington Conference.

The Prague Plan for the international regulation of broadcasting wavelengths is rather outside commercial wireless, and has been already fully dealt with in this journal, but we might glance at some of the principal recommendations of the Hague Conference.

Most of the recommendations referred to methods of measurement, and technical problems which require further study. The terms long and short waves have always given rise to a certain amount of confusion, and the conference recommended that waves be classified as follows: Below 100 kcs. (over 3,000 metres), long waves; 1,500 to 100 kcs. (200 to 3,000 metres), medium waves; 6,000 to 1,500 kcs. (50 to 200 metres),

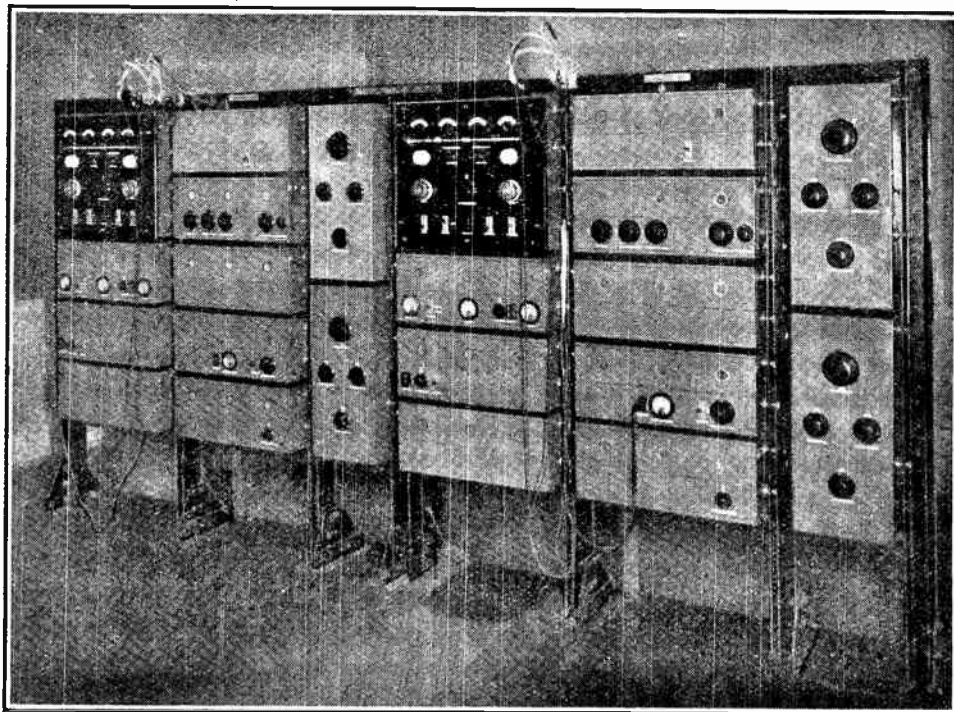

The Indian and Australian receivers at the Skegness beam station.

intermediate waves; 30,000 to 6,000 kcs. (10 to 50 metres), short waves; above 30,000 kcs. (below 10 metres), very short waves. Waves between 50 and 13 metres are to be reserved in principle for long distances, 50 to 85 metres for moderate distances, 85 to 200 for the shorter distances.

It was agreed that in practice a separation of 0.1 per cent. frequency is desirable to avoid interference. This is the great problem which confronts the development of wireless communication, viz., how is it possible to crowd into the ether, without causing mutual interference, a sufficient number of waves to meet the demand? As the year closes, claims are being made that a new method has been devised to deal with this problem, but we must wait for next year to see how far these claims are justified.

A WIRELESS PIONEER.

The Late Admiral Sir Henry Jackson.

THE world of wireless has lost one of its most notable personalities by the death, on December 14th, of Admiral of the Fleet Sir Henry Bradwardine Jackson, G.C.B., K.C.V.O., F.R.S., D.Sc., M.I.E.E. A career of distinguished naval service, culminating in an

of Hertzian waves. It was in 1893 that Sir Henry, while commanding the *Edinburgh*, conceived the idea of utilising electro-magnetic waves for signalling purposes. His experiments principally consisted of exciting a circuit which included a filings coherer tapped by the hammer of a high-resistance trembling bell. In 1896 Sir Henry met the young Marconi, and the two collaborated in experiments, which finally proved to a reluctant Admiralty Signals Committee that wireless was to supersede all other methods of communication at sea.

Sir Henry Jackson remained responsible for the progress of wireless telegraphy in the Navy until 1906, when he became a Rear-Admiral. Lord Fisher had already recognised his special scientific ability by selecting him, in 1905, for the office of Third Sea Lord and Controller of the Navy. A spell of service afloat was followed by an Admiralty appointment, and when, in 1915, Lord Fisher left the Admiralty, Sir Henry was appointed First Sea Lord. In December, 1916, after rendering invaluable service, he retired from this post; he was promoted G.C.B. in the same year, and on July 31, 1919, was advanced to the rank of Admiral of the Fleet. In 1920



The late Admiral Sir Henry Jackson in his wireless laboratory. This photograph was taken soon after the war.

This photo-

appointment to the highest rank during the War, would in itself provide the material for an engrossing biography, but it is the late Admiral's untiring devotion to the cause of wireless from the earliest days which must appeal to every amateur and experimenter.

Born at Barnsley on January 21st, 1855, Henry Bradwardine Jackson entered the Navy in 1868. After service abroad he joined the torpedo school ship *Vernon* in 1881 and quickly demonstrated those scientific talents which were later to be applied to the study

he was appointed Chairman of the Radio Research Board. He retired from the Navy in July, 1924.

The late Admiral, who always showed a deep interest in amateur experimental research, in 1922 occupied the Presidential Chair of the then Wireless Society of London and was a frequent figure at the meetings of the Radio Society of Great Britain. Sir Henry was elected a Fellow of the Royal Society in 1901. He was a member of the Institute of Electrical Engineers, Hon. D.Sc. of Oxford and Leeds, and Hon. LL.D. of Cambridge.

CORRESPONDENCE.

The Editor does not hold himself responsible for the opinions of his correspondents.

Correspondence should be addressed to the Editor, "The Wireless World," Dorset House, Tudor Street, E.C.4, and must be accompanied by the writer's name and address.

THE "STENODE RADIOSTAT."

Sir,—The brief description of the action of the Robinson "Stenode Radiostat," given in your current issue, appears to me to carry one rather farther in the explanation of the apparently paradoxical performance of this device than is indicated in the article in question. I refer to the words: "The above explanation certainly discloses an ingenious method by which ringing might be prevented on a set of high selectivity, but it certainly does not explain why the sidebands in broadcast transmission get through on such a set." Is this not rather a contradiction?

For convenience modulation is thought of in terms of sideband frequencies, the principal reason being that the system

used for obtaining selectivity invariably employed in present practice is a resonant circuit, which has the property of becoming more and more slow to respond to changes of applied e.m.f. by corresponding changes of current, as the selectivity is increased by reducing the damping. But I see no *prima facie* reason why this should be an inherent property of all selective systems. Thus, if a telephony transmission is regarded as an oscillation of constant frequency and variable amplitude, the ordinary tuned circuit, if made so selective as to respond substantially only to this single frequency, must necessarily be of such low damping that the variations in the amplitude of the signal e.m.f. are not matched by corresponding variations in the current

in the circuit (and corresponding e.m.f. available for operating the receiver). In other words, the modulation is cut off, leaving only the carrier. The high modulation frequencies obviously suffer first.

On the other hand, if Dr. Robinson has been able to produce a highly selective system which is able to respond to changes in amplitude at audio frequencies (and why should he not?), it is obvious that it would have the properties claimed for the "Radiostat."

This conclusion is arrived at without assuming any knowledge of Dr. Robinson's system, or any fallacy in existing theory, but simply by discarding the popular but unwarrantable assumption that all selective systems must have the same properties as the particular one commonly used.

Lee, S.E.12.

M. G. SCROGGIE, B.Sc., A.M.I.E.E.

Sir,—I was interested in your description of the above, and venture to give an explanation of how it was possible to receive the sidebands up to 5 kilo-cycles and yet eliminate an interference frequency difference of 1 kilo-cycle.

It is well known that a tuned circuit is not symmetrical about the point of tune. For example, the response to a frequency, say, 1 kc. below the resonant frequency is less than the response 1 kc. above. This difference is far more marked on longwave-tuned circuits such as the intermediate stages of a superhet., and when several stages are used the effect is greatly increased. The result is to give a superhet. a response curve extremely steep on the lower side and a more gradual falling off on the other side.

With such a tuning curve it is possible to tune in the signals in such a way that the carrier frequency and one sideband only is received. If then the interference frequency is such that it comes within the sideband which is dropped, it will not be apparent in the audio-frequency output.

With regard to the low-resistance circuit, your implication that such remains selective when frequencies are applied for an exceedingly short time, does not seem correct.

An example is the super-regenerative receiver in which, when actually receiving and amplifying, the resonant circuit has negative resistance.

Yet such receivers are very unselective.

Sheffield.

R. E. RAYNER.

Sir,—Re the Robinson "Stenode Radiostat" described in the December 11th issue of *The Wireless World*, it appears that the chopping up of the signal to neutralise the lag of a H.F. circuit is enough to explain the result described. This is because the H.F. circuit does not amplify the higher frequency modulation when the lag is present, and it appears that the sidebands have no objective existence, but are obtained by Fournier

Series only. So that when the lag is eliminated, the circuit may be made as selective as possible. R. SUGDEN.
London, W.11.

OURSELVES.

Sir,—I can only crave your pardon for taking up your valuable time with this letter—let its subject matter be at once its excuse and its justification.

It was with pain and indignation that I read in your Editorial views in to-day's issue the criticism of Mr. Brown, of South Norwood, of your policy in increasing the price of your paper, and I feel so keenly the attitude of this gentleman that I cannot resist writing to express my resentment.

How puerile are Mr. Brown's ideas! Does he not, for example, give any thought to the fact that although he may be able to obtain technical advice from the manufacturers of components (I have not been similarly fortunate!) the replies published each week to readers' queries are absolutely invaluable to others who have exactly similar problems? I could mention numbers of instances where I have been helped by these published replies. Does not Mr. Brown further realise that successful wireless reception can only be obtained by most careful quantitative analysis and experiment? And where will he obtain such technical articles, by such experts in this most technical of all subjects, except in your paper?

There is a stage which we amateurs reach at which we begin to realise how little we know, and how extraordinarily efficient your contributors are. It is at that stage that we appreciate the fact that your paper is the only one which will help us. Were you to double or even treble the price of *The Wireless World* it would still be cheap by comparison with the quality of its technical articles.

Perhaps you will kindly accept seasonable greetings from a staunch supporter.

H. D. McCLENAGHAN.

Dublin.

Sir,—I beg to point out that my letter has been misquoted in your Editorial. I said "the bulk of the queries that you receive could no doubt be accurately replied to by the mechanic or draughtsman in the experimental workshop."

Fair play, please! Thanks for your letter.

South Norwood.

E. H. BROWN.

The complete sentence in Mr. Brown's original letter read: "The bulk of the queries that you receive could, no doubt, be accurately replied to by the mechanic or draughtsman in the experimental workshop. The rest you can refer to the component manufacturers, who are only too pleased to give technical information, as I have often proved."

It is regretted that in our editorial we misquoted Mr. Brown by implying that he proposed "the bulk of the queries" should be referred to manufacturers instead of "the rest."—ED.

Electrical Wiring and Contracting.
Edited by H. Marryat, M.I.Mech.E.
Parts 2 to 4, which complete the first volume, include drawing—with useful illustrations indicating the generally accepted symbols used in electrical diagrams and the conventional section lining to denote various materials—electricity and magnetism, A.C. work and index to Vol. I.

Parts 5 to 8, which comprise Vol. II, include D.C. and A.C. generators and motors, testing and measuring instruments, wires and cables, also a section on mathematics as applied to wiring and contracting.

Each part pp. 64, with numerous diagrams and illustrations. Published by Sir Isaac Pitman and Sons, Ltd., London. Price 1s. per part.

A general notice of this publication and the contents of Part I appeared in our issue of October 23rd, page 474.

BOOKS RECEIVED.

Radio Traffic Manual and Operating Regulations, by R. L. Duncan and C. E. Drew. A handbook primarily intended for the use of operators and amateur transmitters in U.S.A. and comprising instruction in Morse, operating rules and regulations of the Radio Marine Corporation of America, International Radiotelegraph Convention of Washington and the Regulations attached thereto, U.S. Radio Act of 1927, Ship Act of July 23rd, 1912, and regulations governing the issue and renewal of operators' licences in U.S.A. Pp. 187, with 15 illustrations, examples of operators' abstracts, logs, etc. Published by J. Wiley and Sons, Inc., New York, and sold by Chapman and Hall, Ltd., London. Price 10s. net.

Handbook for Wireless Telegraph Operators (Revised 1929), issued by the G.P.O. The principal additional matter in this revised edition relates to the classification of Radiotelegrams, especially those in code or cypher, and the charges for five-letter code words. Published by H.M. Stationery Office. Price 6d. net.

o o o

Modern Gramophones and Electrical Reproducers, by P. Wilson, M.A., and G. W. Webb, with a foreword by Compton Mackenzie.

A comprehensive text-book on the theory and practice of gramophone construction and the various problems involved in the recording and reproduction of sound. Pp. 272+xvi, with 116 illustrations and diagrams.

Published by Cassell and Co., Ltd., London, price 10s. 6d. net.

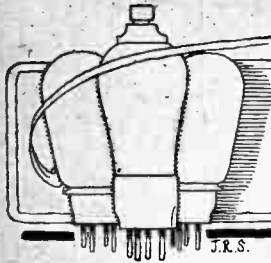

J.R.S.

READERS' PROBLEMS.

"The Wireless World" Supplies a Free Service of Technical Information.

The Service is subject to the rules of the Department, which are printed below; these must be strictly enforced, in the interest of readers themselves. A selection of queries of general interest is dealt with below, in some cases at greater length than would be possible in a letter.

Uncontrollable Oscillation.

I have just completed construction of a detector-2 L.F. receiver, using a commercial two-range tuner which includes a reaction winding. So far, results have been disappointing; on the medium waveband, uncontrollable oscillation is produced unless the reaction control condenser is disconnected. On the long-wave side, it is impossible to stop oscillation even in this way unless H.T. voltage is reduced to a ridiculously low value. Can you tell me how to put matters right?

H. G. S.

It seems that the tuning unit is designed for a small reaction condenser having a lower minimum value than that of the condenser you are using; this would account for the behaviour of the set on the medium band, while H.F. choke resonance is probably responsible for the trouble on the long waves.

Removal of a few turns from the reaction winding (or windings), combined with the substitution of another choke for the existing component, would almost certainly effect a cure, but we think that your best plan is to try the effect of connecting a small fixed condenser (of about 0.0001 mfd. or even 0.0002 mfd.) between anode and negative filament terminals of the detector valve. This addition will almost certainly overcome the tendency towards uncontrollable self-oscillation, and

RULES.

(1.) Only one question (which must deal with a single specific point) can be answered. Letters must be concisely worded and headed "Information Department."

(2.) Queries must be written on one side of the paper, and diagrams drawn on a separate sheet. A self-addressed stamped envelope must be enclosed for postal reply.

(3.) Designs or circuit diagrams for complete receivers cannot be given; under present-day conditions justice cannot be done to questions of this kind in the course of a letter.

(4.) Practical wiring plans cannot be supplied or considered.

(5.) Designs for components such as L.F. chokes, power transformers, etc., cannot be supplied.

(6.) Queries arising from the construction or operation of receivers must be confined to constructional sets described in "The Wireless World" or to standard manufacturers' receivers.

Readers desiring information on matters beyond the scope of the Information Department are invited to submit suggestions regarding subjects to be treated in future articles or paragraphs.

will improve detector efficiency—probably to a very noticeable extent. The addition of this capacity may possibly modify the frequency characteristics of the L.F. amplifier, but is hardly likely to do any harm.

○○○○

Where D.C. Resistance is Unimportant.

I am going to make up a small battery eliminator (to work on my A.C. supply) for providing grid bias potentials for a large amplifier. Will you tell me if the primary and secondary winding of a disused L.F. transformer are likely to be satisfactory for smoothing purposes in this piece of apparatus, or would it be safest to order a special choke? Of course, the windings will be joined in series.

G. H. C.

There is no reason why the windings of a reasonably good L.F. transformer should not be quite satisfactory for this purpose. Their ohmic resistance is likely to be considerable, but it should be an easy matter to ensure that this value will be low compared with that of the potentiometer across which the biasing potentials are developed.

○○○○

The Baby Alarm.

Please do not consign this letter to the waste-paper basket before reading it through; my query is a perfectly serious one, and I am emboldened to ask it as I seem to remember that a similar problem was treated in your pages some years ago.

Now for the question. Is it possible to install a microphone over a baby's cot in a distant room, and to connect the instrument to a receiver so that the child's cries will be superimposed on the broadcast programme? My set is an H.F.-det.-L.F. combination, with grid detection and transformer coupling; if this addition can be made to it, will you please show me how to proceed?

T. S. W.

You need have no fear that your query will be treated as frivolous; hardly a week goes by without our receiving a request for information on this subject. Many harassed parents seem to feel a very real need for means of knowing that all goes well with their slumbering progeny while

they themselves are listening to the evening programmes.

Fortunately, it is by no means difficult to arrange that any sounds indicative of untoward happenings in the child's bedroom may be amplified by the set and heard through the loud speaker. As a rule, at least two magnifying stages are

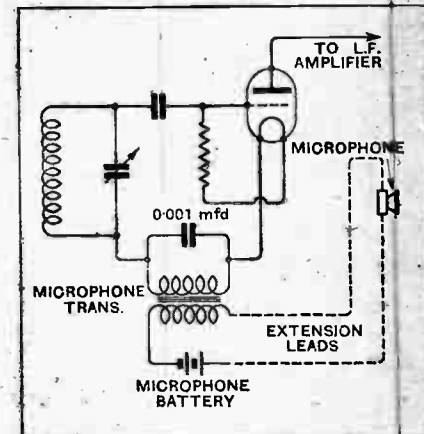

Fig. 1.—Where distortion can be tolerated, the detector valve may be made to work as an extra amplifier in a microphone circuit.

necessary, so in your case the detector valve must be made to amplify; rectification will, of course, introduce distortion, but this should not matter.

The secondary winding of a microphone transformer is inserted in the grid return lead of the detector valve in the manner shown in Fig 1, and should be shunted by a fairly large H.F. by-pass condenser. Connection is made between the transformer primary and the distant microphone through extension leads, a small battery being interposed; very often it is possible to use the receiver L.T. cells for this purpose. Some method of breaking the microphone circuit must be provided to prevent waste of battery current.

Microphone and transformer should be obtained from the same source, and it is desirable that these pieces of apparatus should be designed for working together.

May we express the wish that you will have no cause to test the functioning of the apparatus during the Christmas festivities?

The FERRANTI *A.C. Mains Receiver*

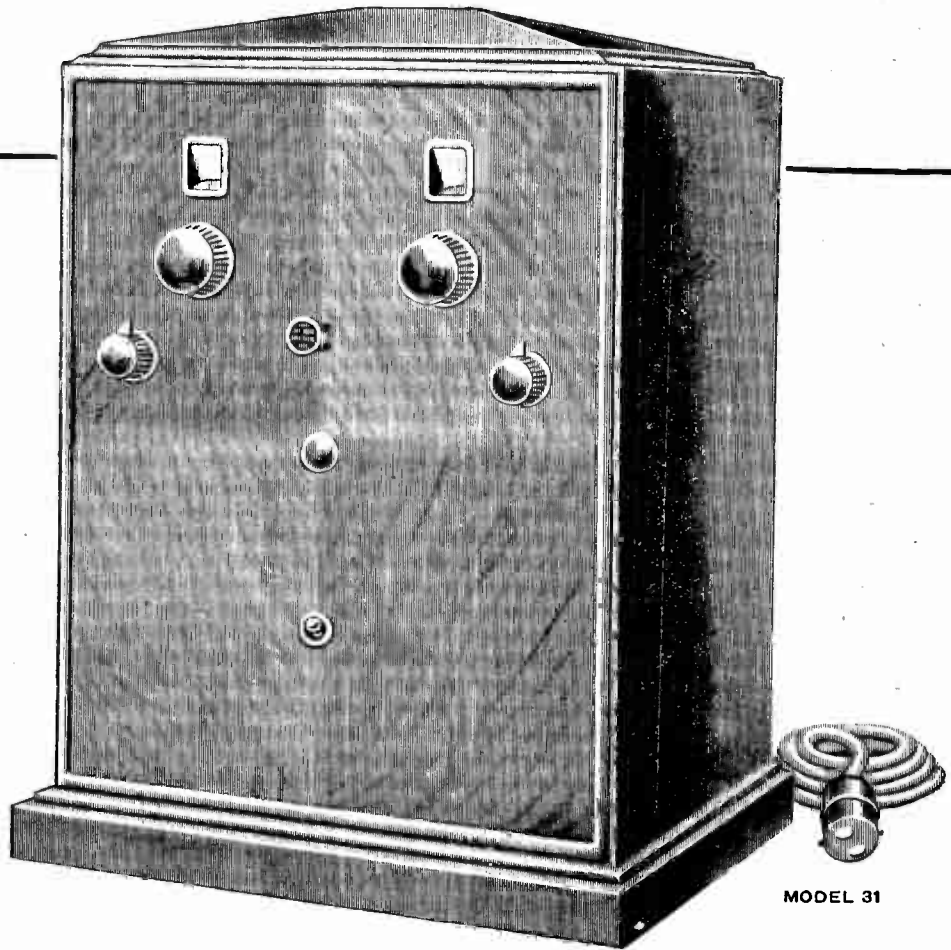

In Oak - - - £25
In Mahogany - £26
In Walnut - - £26
Royalty £1 extra.

A Set which, once installed, requires no second thought. Enjoy the pleasure of listening to reproduction which is very nearly true to life.

FERRANTI LTD.
HOLLINWOOD
LANCASHIRE

Available for Alternating Current only. Voltages 200/250: 50 cycles or over.

PHOTOGRAMS

OF THE YEAR

THE ANNUAL REVIEW FOR 1930 OF THE
WORLD'S PICTORIAL PHOTOGRAPHIC WORK

Edited by F. J. MORTIMER, F.R.P.S.

Editor of "The Amateur Photographer and Cinematographer."

This year's edition of "PHOTOGRAMS OF THE YEAR" is now on sale, and lovers of pictures made by the camera will give it a warm welcome.

A literary section provides reports of photographic progress at home and overseas, and a useful Directory of British Photographic Societies is included.

For keen photographers the annual volume of "PHOTOGRAMS" is an inspiration; for those to whom camera pictures appeal it is a book which gives lasting pleasure.

PRICES:
Paper Covers
5/-
Cloth Boards
7/6

Postage 6^d.
extra.

"PHOTOGRAMS" contains reproductions of the most striking and representative pictures from the principal photographic exhibitions of the year, selected from the work of the leading pictorial photographers of the world.

From all leading booksellers or direct from the Publishers:

ILIFFE & SONS LTD., Dorset House, Tudor Street, London, E.C.4.

What the
Pacific Engineering
Laboratory Co. (U.S.A.) thinks
of

**EXPERIMENTAL
WIRELESS**
& The WIRELESS ENGINEER

"This is one of the
best technical wireless
journals we have
read and we heartily
recommend it to
everyone."

MONTHLY 2s. 6d. net.

Subscription: 32s. per annum, post free.

ILIFFE & SONS LTD.,
Dorset House, Tudor St., London, E.C.4

w.w. 37

WIRELESS DIRECTION FINDING and DIRECTIONAL RECEPTION

By R. KEEN, B.Eng. (Hons.).

Second Edition: Revised and Enlarged.

THIS volume deals with the principles of the subject and the constructional details of direction-finding installations, and includes some information concerning aircraft installation. It describes the principles of Direction and Position Finding in this country in such a way that the subject may be grasped easily by engineers tackling this field of wireless work for the first time. Numerous photographs and diagrams are included.

Price 21/- net. By post 21/9.

*From leading booksellers or
direct from the Publishers:*

ILIFFE & SONS LIMITED,
Dorset House, Tudor Street, London, E.C.4

w.w. 68

MISCELLANEOUS ADVERTISEMENTS.

NOTICES.

THE CHARGE FOR ADVERTISEMENTS in these columns is:

12 words or less, 2/- and 2d. for every additional word.

Each paragraph is charged separately and name and address must be counted.

SERIES DISCOUNTS are allowed to Trade Advertisers as follows on orders for consecutive insertions, provided a contract is placed in advance, and in the absence of fresh instructions the entire "copy" is repeated from the previous issue: 13 consecutive insertions 5%; 26 consecutive, 10%; 52 consecutive, 15%.

ADVERTISEMENTS for these columns are accepted up to **FIRST POST** on **THURSDAY MORNING** (previous to date of issue) at the Head Offices of "The Wireless World," Dorset House, Tudor Street, London, E.C.4, or on **WEDNESDAY MORNING** at the Branch Offices (19, Hertford Street, Coventry; Guildhall Buildings, Navigation Street, Birmingham; 260, Deansgate, Manchester; 101, St. Vincent Street, Glasgow, C.2.

Advertisements that arrive too late for a particular issue will automatically be inserted in the following issue unless accompanied by instructions to the contrary. All advertisements in this section must be strictly prepaid.

The proprietors retain the right to refuse or withdraw advertisements at their discretion.

Postal Orders and Cheques sent in payment for advertisements should be made payable to **ILLIFFE & SONS Ltd.,** and crossed **& Co.** Notes being untraceable if lost in transit should not be sent as remittances.

All letters relating to advertisements should quote the number which is printed at the end of each advertisement, and the date of the issue in which it appeared.

The proprietors are not responsible for clerical or printers' errors, although every care is taken to avoid mistakes.

NUMBERED ADDRESSES.

For the convenience of private advertisers, letters may be addressed to numbers at "The Wireless World" Office. When this is desired, the sum of 6d. to defray the cost of registration and to cover postage on replies must be added to the advertisement charge, which must include the words Box 000, c/o "The Wireless World." Only the number will appear in the advertisement. All replies should be addressed No. 000, c/o "The Wireless World," Dorset House, Tudor Street, London, E.C.4. *Readers who reply to Box No. advertisements are warned against sending remittance through the post except in registered envelopes; in all such cases the use of the Deposit System is recommended, and the envelope should be clearly marked "Deposit Department."*

THE DEPOSIT SYSTEM.

Readers who hesitate to send money to unknown persons may deal in perfect safety by availing themselves of our Deposit System. If the money be deposited with "The Wireless World," both parties are advised of its receipt.

The time allowed for decision is three days, counting from receipt of goods, after which period, if buyer decides not to retain goods, they must be returned to sender. If a sale is effected, buyer instructs us to remit amount to seller, but if not, seller instructs us to return amount to depositor. Carriage is paid by the buyer, but in the event of no sale, and subject to there being no different arrangement between buyer and seller, each pays carriage one way. The seller takes the risk of loss or damage in transit, for which we take no responsibility. For all transactions up to £10, a deposit fee of 1/- is charged; on transactions over £10 and under £50, the fee is 2/6; over £50, 5/-. All deposit matters are dealt with at Dorset House, Tudor Street, London, E.C.4, and cheques and money orders should be made payable to Illiffe & Sons Limited.

THE SALE OF HOME-CONSTRUCTED UNLICENSED APPARATUS.

A Service to our Readers.

We have made an arrangement with the Patentees whereby readers who wish to dispose of a home-constructed receiver not licensed under the patents made use of, can cease the set by means of the Deposit System referred to above.

The person desiring to sell, in sending us particulars for its advertisement, will in every case make use of a Box No., and should add to the price which he requires the amount of royalty customarily paid by manufacturers.

If the purchaser is satisfied with his purchase, the sum realised will be forwarded to the seller, less the amount due in respect of royalties, which amount will be paid by "The Wireless World" to the owners of the patents concerned, and a certificate will be handed on to the purchaser of the set.

SPECIAL NOTE.—Readers who reply to advertisements and receive no answer to their enquiries are requested to guard the silence as an indication that the goods advertised are already being disposed of. Advertisers often receive so many enquiries that it is quite impossible to reply to each one by post.

B&J

ALL WIRELESS WORLD COILS

1930 EVERYMAN FOUR	47/6 set
KIT SET, Coils with Switches	45/- set
NEW KILOMAG.	45/- set
RECORD III	45/- set
FOREIGN LISTENERS 4 B.B.O.	30/- set
METAL CABINETS	5X 37/8 set
5 1/2" DRUM DIALS with Escutcheons	5/6
WAVE TRAP, Litz Wire	10/6 each

B&J. Wireless Co.

2, 3, & 4, Athelstan's Mews,
Stroud Green Road, N.4.
Archway 1695

"END OF YEAR CLEARING."

APPLEBY'S

FOR BARGAINS WATCH THE MISCELLANEOUS COLUMNS THIS MONTH. Phone: Paddinton, 823 (3 lines)

For Modern High-grade Material Only.

CHAPEL ST., LONDON, N.W.1

OPEN TILL 7 P.M. SAT. 1 P.M.

TANNOY

WHAT'S BEHIND YOUR SET?

Are you working from a dry battery and accumulator? Think how really insignificant they are compared with the electric mains, where the voltage never varies. Mains units give better tone, more volume, and greater selectivity, because they are always constant.

H.T. from £2 : 17 : 6
L.T. £2 : 12 : 6

Combined H.T. & L.T.,
£5 : 12 : 6 (complete).

The TULSEMERE MFG. CO.,
1-7, Dalton Street, West Norwood,
S.E. 27. Phone: Sireatham 6731.

Mains Units



ELEX

WANDER PLUGS



The plugs that fit firm in their sockets. Fitted with grub screw for holding the lead. All nickel-plated, with 6 different coloured sleeves. Standard size 2 D.W. or Midget, 2d. each.

Write for List X90

J. J. EASTICK & SONS.

EELEX HOUSE, 118, BUNHILL ROW, E.C. 4
Tel.: Clerkenwell 9282/3.

RECEIVERS FOR SALE.

SCOTT SESSIONS and Co., Great Britain's Radio Doctors.—Read advertisement under Miscellaneous. [0264]

3-VALVE All-wave Receiver, latest type, powerful, perfect; £4.—V. Taylor, 57, Studley Rd., Stockwell, London. [10274]

RECEIVERS for Sale.—Portable 5-valve, suit case type, complete, as new, perfect; £9/17/6.—N. Taylor, 57, Studley Rd., Stockwell, London. [0323]

READ and **MORRIS**, Ltd., the mains pioneers, who in 1925 equipped the hospital with mains sets, still supreme in all-mains receivers and units.

LOW Tension A.C. Eliminators, permanently re-energising batteries now only £5/15; electrolytic condensers, 2,000 m.f., as used in above, 13/-; including postage.

BARGAINS.—Second-hand sets, units, meters, speakers.—Read and Morris, Ltd., 31, Eastcastle St. (facing back of Waring's), Oxford St., W. [7445]

WIRELESS Portable Sets with 5 New Cossor Valves for 9 Guineas; less than components cost, comparable with any set double this price; beautiful suit case, 2 aerial windings, English batteries and accumulators, all inclusive efficient sets, Royalty paid, a magnificent Xmas gift; if you are in London may I fix an appointment; if you are not in London may I send you particulars?—H. Hodgson, 53, Windsor House, Victoria St., Westminster. [7293]

TWO Aeonic V Valve Transformers, latest models; £12/10 each, or best offer; one Aeonic V valve, suitcase, 1928, complete with new battery, £8/10, new condition, perfect order.—George Slater, Chemist, Pindochty, Banffshire. [7600]

5-VALVE Transportable (3 S.G., det., and Pentode), £5 as new, complete with makers' guarantee, receives 40 stations; owner going abroad; cost 40 guineas, accept 30 guineas.—Burnett, 21, Clarges St., W.1. [7679]

MULLARD 1930 New Receiver, including valves, loud-speaker, batteries; £5/10.—18, St. George's Buildings, Elephant and Castle. [7673]

3-VALVE Set, accumulator, valves, no cabinet, £3/15; R.T.H. C2 speaker, 25/-; Brown's double microphone amplifier (equale to 2 valves), £3/10, cost £20; 9-range moving coil test set, Healy's, £4/10; many other bargains.—Send requirements or call, Clark, 78, Lavender Sweep, S.W.11. [7674]

5-VALVE Freed-Eisemann Neutrodyne Set, specially selective, fitted Osram valves, anode rectifier, resistance transformer L.F.s, super power output, fine reproduction, range 200-600 metres, suitable London district, sound set; no approval; £15.—Postlethwaite, Church Hill, Kinner, Stourbridge. [7675]

MULLARD Screened Grid Pentode 3-valve Parts, cost £6/10, accept £3/10; Brandes table talker, 10/6.—80, Cloughton St., St. Helens. [7670]

CONSOR (1928) 3-valve Set, complete with new H.T. batteries, L.T. accumulators, and B.T.H. loud-speaker; what offers.—G. A. Costain, Leighton Park, Reading. [7667]

SALE.—Complete set parts for McMichael screened grid three, including valves and coils; £6.—White, Gilstead, Cudry, Cheshire. [7662]

1930 Cossor Kit (unused gift); £7/10.—Sylvester, 107, Brook St., Kennington. [7659]

SIMMONDS BROS.—Receivers constructed to your own or any published design; also repairs, reconstructions; and modernisations at moderate charges; best material and workmanship guaranteed; numerous testimonials; quotations free.—Address, Shireland Rd., Sineathwick. [5826]

AMERICAN Samson-Cotton Superhet, with English valve holders, complete with valves, battery leads and two frame aerials; seen by appointment; £7.—Colonel Kennard, 2 Adelphi Terrace, W.C.2. [7696]

MULLARD Mikado 2, in handsome cabinet; 30/-.—Box 4273, c/o The Wireless World. [7704]

G.E.C. 7-valve Supersonic Portable Receiver, complete with valves, L.T. battery, and H.T. unit (A.C.), as new; reasonable offer accepted.—T. Bridger and Son, High St., Slough. [7710]

LOOK!—5-v. lve (2 H.F. choke coupled detector with reaction, 2 L.F., R.C.C., transformer) specially designed, carefully assembled, portable model, a wonderful set! Excluding valves and batteries, but Marconi royalties paid; bargain, 6 guineas; first letter with remittance secures!—Address, C., 75, Gascony Av., W. Hampstead, N.W.6. [7716]

MULLARD Orgola A.O. Mains Kit, complete, including latest 5-pin, A.C. valves and filament heater transformer, all brand new; £7/10.—Ashman, 1, King's Rd., Brislington, Bristol. [7706]

FERRANTI S.G.3, with cabinet, Osram valves, A.P.5 transformer; £8.—28, Kingscote Rd., Edgbaston, Birmingham. [7693]

MARCONIPHONE Type 35 Screened Grid 3-valve Sets, brand new; £9, with valves; hire purchase arranged; only a few at this price.—Hall, 91, Fove St., Edmonton. [7722]

Receivers for Sale.—Contd.

WE Offer You the Following Inducements to Purchase Your New Receiver or Other Apparatus from us.

FIRSTLY.—Unbiased advice. The Principal of the firm has twenty years' professional wireless experience, having been at Government Experimental Stations in 1910. He has been Manager for the Sterling Telephone Co., radio expert to the G.E.C., and Chairman of the Technical Committee of the National Association of Radio Manufacturers. His advice has saved our clients many thousands of pounds, for, as everybody knows, there is no hobby on which more money is wasted on useless apparatus by the uninitiated.

SECONDLY.—We take your old apparatus in part exchange for new. Send us a list of your old apparatus, or, better still, send us the apparatus, and state your new requirements. We will then make our offer for your goods, and if you do not approve, which is unlikely, we will return the parcel, carriage paid.

IF You are in Doubt as to the Make of Receiver or other Apparatus you should Purchase, write to us, and we will advise you; we have no leaning towards any particular maker, and will tell you the particular instrument you should buy for your purpose.

SCIENTIFIC DEVELOPMENT CO., 51, Fishergate, Preston. Tel.: 1364. [0226

SILVER Marshall Superhet, Thordarson push-pull, L.S.5 valves, Radielli eliminator, Exide 6V, 120 amps. actual, moving coil loud-speaker; £30.—H. Lonsada, 9, Aubert Park, Highbury, London. [7688

MARCONIPHONE Model No. 22 Receiver, as new; 90/- (no H.T.), a bargain; owner left district.—Broomhead, 9, Marylebone Mews, New Cavendish St., W. [7689

PYE 3-valve All Mains Receiver, 200-250v. A.C., in perfect order and condition; £14/14.—Below.

SELECTOR 7-valve Portable Receiver, in mahogany, complete with all valves, batteries and waterproof cover, hardly used; £17/10, cost 54 guineas.—Powell, 54, High St., Tunbridge Wells. [7697

MARCONIPHONE 5-valve Portable Receiver, type 53, absolutely brand new, unused, accumulator not yet charged; £19, cost 28 guineas.—21, Arandel Rd., Tunbridge Wells. [7698

MARCONIPHONE 82 Superhet, 8-valve, complete, 105 cone speaker, new 120v Exide H.T., new 6v. 100 amp. L.T.; cost £70, offers.—White Bros. Epsom 434. [7725

GREAT Opportunity.—Having many requests for famous Royal Air Force 3-valve receivers, we have now procured limited number; these receivers give excellent loud-speaker reception, each set specially tested before delivery to ensure satisfaction, all are guaranteed brand new and perfect; the original cost of these sets was £18; special travelling case with each set; we are sacrificing at the absurdly low price of 32/6.

GUARANTEED and Absolutely New McMichael Superonion Kit's, including mahogany cabinet, book instructions, blue prints; clearance price only £3; these sets can get the whole world; without cabinet, price £2.

J. B. HUMPHREYS and Co., 23, College Hill, Cannon St., London, E.C.4. [7718

ACCUMULATOR HIRE.

DON'T Buy Accumulators or Dry Batteries, join our C.A.V. low- and high-tension accumulator hire service, the largest and best in London; better and cheaper reception with no trouble; regular deliveries within 12 miles of Charing Cross; no deposit, payment on delivery or by subscription; over 10,000 satisfied users; explanatory folder post free; phone or write to-day.—Radio Service (London) Ltd., 105, Torrington Av., N.W.5. Phone: North 0623-4-5. [7596

C.D.E.S. Accumulator Hire and Maintenance Service (5 mile radius)—98, Cherry Orchard Rd., Croydon. [6374

BATTERIES.

WET H.T. Replacements.—Sacs (capped or uncapped), highest grade, No. 1, 10d. per doz.; No. 2, 1/9 per doz.—See below.

ZINCS.—Best quality (wired), No. 1, 8d. per doz.; No. 2, 9d. per doz.; orders valued 5/- carriage paid, otherwise 6d. for postage.—British Battery Co., Clarendon Rd., Watford, Herts. [0258

PENTODE Users.—Write for details of new size self-charging wet battery; 20,000 milliamps, 6d. per volt; illustrated catalogue giving data, post free.—U. Taylor, 57, Studley Rd., Stockwell, London. [0273

WET H.T. Batteries.—Parts per dozen, jars, No. 1, 2 1/4 x 1 1/4 square, 1/3; No. 2, 1 1/8; zincs, No. 1, 10d.; No. 2, 11d.; sacs, No. 1, 1/2 dozen; No. 2, 1/9; terminals, 8d., 10d.; dozen cells (18 volts) complete with leads and electrolyte, No. 1, 4/1; No. 2, 5/-; post 9d.; high efficiency, long life, self charging, upkeep small; send 6d. for sample unit; illustrated booklet free, carriage free orders 10/-; write for free list wireless bargains, trade supplied.—W. Taylor, 57, Studley Rd., Stockwell, London. [0039

PEYO and RADFORD'S 50-amp. 6-volt Accumulator, in perfect order; £1.—Colonel Kennard, 2, Adelphi Terrace, W.C.2. [7695

'POPULAR' TRANSFORMER

Make your new set a better set with the Brownie POPULAR Transformer. Although it costs only 9/6, its purity of amplification gives a more vivid clarity of reproduction throughout the musical scale, while its sturdy British build ensures that once it is fitted the words "transformer troubles" can be eliminated from your list of worries.

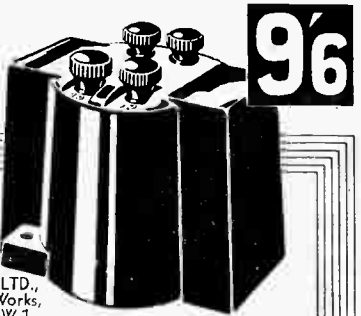

BROWNIE WIRELESS CO. (G.B.) LTD., Nelson St. Works, London, N.W.1.

BROWNIE WIRELESS



"THE 1930 EVERYMAN FOUR"

Cabinet, as specified in "Wireless World," Oct. 16, made to exact design of "Wireless World" and supplied in various wood finishes.

OAK BASE—Jacobean Finish 57/6
MAHOGANY BASE—Mahogany Finish 63/-
 Also suitable for the New "KILOMAG 4" and "W.W. RECORD III." These Cabinets are made by experts and are thoroughly electrically sealed.

KIT-SET Metal Cabinet 54/-

Every description of Wireless Cabinet supplied. Screening Boxes, Eliminator Cases, etc.

Send Direct to—

RIGBY & WOOLFENDEN

Sheet Metal Workers, Millnrow Road, ROCHDALE. Phone 2948.

CHARGERS AND ELIMINATORS.

VORTEXION Transformers, chokes, etc., wound any specification; write or phone for quotation best quality components only.—Vortexion, 72, Mert Rd., Wimbledon, S.W.19. Tel.: Wimbledon 2814. [03

ATLAS Eliminators, D.C. £1/17/6, A.C. £3/17/6. Nesper trickle charger, 29/6. Phone: Gerra 6268 for demonstration.—Grettrex and Co., 184, Rege St., London. [64

TANTALUM and Liumium for A.C. Rectifiers; make up your own inexpensive chargers; 1/6s. price for H.T. and L.T. 1 1/2 each; Liumium electrodes fit with terminals, 2-3 amps. and 5-8 amps.—Blackwell Metallurgical Works, Ltd., Speke Rd. Works, Garston Liverpool. Phone: Garston 980 (2 lines). [62

PHILIPSON'S Safety High Tension Battery Eliminators.

10/- Down and the Balance in Easy Monthly payments secures the finest high tension supply available.

PHILIPSON'S Safety Eliminators are Guaranteed for 12 Months.

PHILIPSON'S Safety Eliminators are the Cheapest to Install and the Cheapest to Run; prices Model A.C.5 £4/17/6, A.C.7 £3/17/6, complete with full wave rectifiers; D.C.4 37/6, D.C.5 45/-.

ALL Models Obtained for 10/- Deposits; take advantage of this and get constant high tension immediately.

WRITE for Our Booklet, "Radio Power" by Philipson and Co., Ltd., Radio Engineers, Astley Bridge, Bolton. Phone: 2038. Grams: Safety Bolton. Est. over 50 years. [031

CHEBROS—Chebros for all types of transformers and chokes, high grade instruments at a very moderate price; enquiries invited.—Chester Bros., 244 Dalston Lane, London, E.8. [529

FEL-ETRIC RADIO Eliminator Kit, transformer, choke, valve holder, valve, 3 condensers, variable resistance, insulated terminals, sleeving, wiring diagram; 37/- complete; output 15 m.a. at 120 volts; send for lists.—Fel-etric Radio, 56, Garden St., Sheffield. [741

TRANSFORMERS and Chokes for Battery Eliminator sets and for all wireless purposes, receiving or transmitting; enquiries invited.—Chester Bros., 244 Dalston Lane, London, E.8. [755

240 A.C. Charger, cost £7, charges 2, 4, or 6 volt at 0-10 amp., also 15, 45 volt H.T. at 0.2 amp., a really good job, will guarantee; £3/10.—Spencer, 92, Untriville Rd., Harringay, N.4. [766

SAVAGE'S Specialise in Wireless Power from the Mains, reliable apparatus at reasonable prices.

SAVAGE'S Transformer Laminations and Bakelite Bobbins; intending home constructors should write for list.

SAVAGE'S Reliable Smoothing Condensers.—1,000 volts D.C. test, 2 mfd. 3/-. 4 mfd. 5/3; 500 volt D.C. test, 1 mfd. 1/6, 2 mfd. 2/3, 4 mfd. 3/9.

SAVAGE'S Super Smoothing and Output Chokes.—Many types available, write for list.

SAVAGE'S Mains Transformer for Westinghouse Rectifiers.—H.T.4, 18/6; A3, 17/-; A4, 20/-.

SAVAGE'S Mains Transformer for Westinghouse H.T.4 Unit, with additional winding, 4 volt 3 amps; 23/-.

SAVAGE'S Mains Transformer.—V.T.31, 200-0-200 volts 60 m.amps., 2+2 volts 2 amps., 2+2 volt 3 amps; 28/-.

SAVAGE'S Mains Transformer.—B.T.3 500-0-500 volt 120 m.amps., 3.75+3.75 volts 3 amps., 3+3 volt 3 amps., 2+2 volt 3 amps; 51/-.

SAVAGE'S Mains Transformers and Power Chokes are carefully and individually constructed from first class materials with an exceptionally generous margin of safety.

SAVAGE'S, 146, Bishopsgate, London, E.C.2. Phone: Bishopsgate 6998. [680

HEYBEARD'S Overnight Charger, 2-4-6 volts, with spare valve, in perfect condition; £1.—Colons Kennard, 2, Adelphi Terrace, W.C.2. [7699

CABINETS.

ARTCRAFT Radio Cabinets are Britain's Best Value [031

DIGBY'S Cabinets.—Table models in solid oak and mahogany; from 11/6 to 71/-.

DIGBY'S Cabinets, fitted with Radion or Resistor ebonite if required.

DIGBY'S Cabinets.—Pedestal model, with separate battery components; from 56/- to £12.

DIGBY'S Cabinets Made to Customer's Own Design.

DIGBY'S Cabinets.—Write for new 16-page art catalogue.—F. Digby, 9, The Oval, Hackney Rd. E.2. Phone: Bishopsgate 6458. [012

ARTCRAFT Radio Cabinets are Britain's Best Value. [030

KAY'S Cabinets, the greatest range of pedestal cabinets in the kingdom; original creative design at prices 50% lower than elsewhere; quotations in special by return; delivery at short notice guaranteed; moving coil, portable, bañle, vignette, radiogram, electric pick-up, television, etc.; illustrated list free.—H. Kay, Wireless Cabinet Manufacturer, Mount Pleasant Rd., London, N.17. Phone: Walthamstow 1626. [646

Mention of "The Wireless World," when writing to advertisers, will ensure prompt attention.

How to sell a Portable!

For the sale or purchase of Portable or other Receivers use the Miscellaneous Columns of "The Wireless World." A recent advertiser writes as follows:

"I am very satisfied with the results obtained. The Portable set was sold the same day, and I had over twenty other replies, including prepaid Telegrams. I also had a large number of callers, and altogether am very pleased with the pulling powers of your valuable paper."

M. A. FROST,
54, Clerkenwell Road,
London, E.C.1.

Wonderful Response!

A recent advertiser in "The Wireless World" writes:—

"I should like to inform you of the wonderful response to my advertisement in 'The Wireless World.' I have received no less than 20 applications for the Ferranti and Marconi Transformers and most of the other goods have been sold."

W. H. Trevett,
80, High Street,
Erith, Kent.

W.W.S.

Cabinets.—Contd.

ARTCRAFT Radio Cabinets are Britain's Best Value. [0311]

HORNS for Cabinets, portables, etc.: illustrated list.—Madison, 1, Chapel St., Edgware Rd. [6142]

ARTCRAFT Radio Cabinets; Britain's best value; lowest prices consistent with highest quality; illustrated list free from actual manufacturers.—Artraft Co., 156, Cherry Orchard Rd., Croydon. Phone: Croydon 1981. [0040]

CABINETS, 16½in. x 7½in. x 11in., hand mahogany finished 7/6, unpainted 5/6; oval front, 10½in. x 6½in., 6d. extra; portable cabinets, 16½in. x 16½in. x 8in., £1/5; baseboard, 6d.; carriage free.—F. W. Ramsey, 63, Shaftesbury St., London, N.1. Clerkenwell 7139. [7584]

CABINETS.—A fine gift, something new: Combined loud-speaker cabinet, bookshelf, newspaper rack and occasional table, 30in. high, take any unit up to 18in. x 17in., handsome cabinet, well made, superior finish; solid oak 35/-. Solid mahogany 40/-.—Below.

ANOTHER New Line.—Handsome fire screen loud-speaker. 31in. high, brown enamelled frame, 3-fold, covered with best quality sateen, strongly wired, complete with baffle and shelf, take any unit up to 14in. x 14in.; price 15/-.—Below.

PEDESTAL Cabinets, Radiogram, etc., from 55/-; table and loud-speaker cabinets from 15/-; above in solid oak, selected materials, hand polished; send for illustrated list.—Thos. Eastham (Dept. 5), Cabinet Works, Thornton, Blackpool. [7573]

FINEST American Types, astonishing value, special offer oak cabinets, hinged lid, baseboard, highly polished, take 12in. x 6in. pane; sample, carriage paid, 6/6; trade discounts for quantities.—Mag-Radio, 112, Warstone Lane, Birmingham. [2665]

ARTCRAFT Radio Cabinets are Britain's Best Value. [0310]

LOUD-SPEAKER Cabinets, extraordinary offer, oak cabinets, handsome fret front, highly polished, 13in. square, 6in. deep, finished moulding, take all ordinary units; sample, carriage paid, 6/6; trade discounts for quantities.—Mag-Radio, 112, Warstone Lane, Birmingham. [2668]

COILS, TRANSFORMERS, ETC.

600-OHM Decoupling Resistances for New Kilo-mag Four, foreign listeners' four, and all "Wireless World" circuits, hand made and tested in our own workshops; improved model wound with Constantan wire, 1/6 each, post free.—Groves Bros., St. Mary's Place, Shrewsbury. [7361]

1,000-OHM Decoupling Resistances for "Wireless World" Circuits; 1/6 each, post free.—Groves Bros., St. Mary's Place, Shrewsbury. [7362]

RADIOGRAPH.—W.W. coils, Record III, 35/-; new Kilo-mag Four, 33/-; S.G. Regional, 37/6; foreign listeners' Four, 37/6 set; Europa Portable, 21/-; Europa III, 18/6; S.G. multi-valve portable, 22/6; new Everyman Four, 42/6.

RADIOGRAPH.—Litz wire, 9/40, 1/6; 27/42, 2/6 dozen yards; Redfern's deep ribbed or Beccol tube, 5d. per inch, slotting 1/6 extra.

RADIOGRAPH, Ltd.—W.W. cabinets, 4 compartments, 44/6; 2 compartments, 38/6; crackle enamel and oak finish.—Benton Rd., Handsworth, Birmingham. [7441]

A.F.S., 15/-; Ident 6 to 1, 9/-; Igranit old type 5.1, 2/6; Croix 5-1, 2/-; Cosmos H.F. choke, 2/6; Lissen L.F. choke, 2/-; Liversidge, 5, Eastfield Rd., Benton, Northumberland. [7680]

FERRANTI A.F.S.C. O.P.3C, 2 100,000 ohms resistances, never been used; 45/-.—Burley, 47, Stowe Rd., Shepherd's Bush, W.12. [7656]

SIMMONDS BROS.—Berclif coils, Record Three, 50/- pair; new kilo-mag, four, 50/- set; foreign listeners' four, low, 30/-; long wave, 37/-; screened grid Regional, 40/-; Mullard S.G.P. dual range coils, 30/- pair; Berclif standard coils, for new all-wave four, standard four, A.C. three, Everyman four, etc., 63/6 set of 4, with bases; the same coils for the Lolesstone series ("Wireless Magazine"), 65/9 set of 4, with bases; Titan unit, 15/-; decoupling resistances, 600 ohm, 1/6; 1,000 ohm, 2/-; all "Wireless World" and similar coils in regular production by the leading specialists; lists free; trade supplied.—Simmonds Bros., Shireland Rd., Smethwick, Tel.: Smethwick 751. [6314]

STANDARD Four Type Coils, set of 4, with bases, 30/-; Netrovernier, 3/-.—Bowden, 28, Knighton Rd., Plymouth. [7714]

MARCONIPHONE Ideal Junior Transformers, formerly 18/- clearing at 12/6; Marconiphone Popular transformers, formerly 12/6, clearing at 9/6; both post free; guaranteed new, in makers original boxes.—Hull.

MARCONIPHONE Power Transformer, 200-240v., gives 150 H.T. at 30m.a. with U5 valve and 4v. A.C. up to 8 amps.; formerly 37/6, clearing at 18/9; all new, in original boxes.—F. J. A. Hall, 91, Fore St., Edmonton, N.18. [7721]

GRAMOPHONE PICK-UPS, ETC.

EXPONENTIAL Horns for Cabinet Gramophones and Wireless, metal and wood; list.—Madison, 1 Chapel St., Marylebone, N.W.1. [6141]

B.T.H. Pick-up and tone arm, almost unused; 28/6.—Box 4233, c/o The Wireless World. [7653]

NEW Philips Pick-up for Sale; 32/6, cost 50/-.—Ellis, 28, Redhill Drive, Edgware. [7658]

"ELECTRADIX" RADIO TESTER TO GET EXACT RESULTS

The DIX-ONEMETER

is the Highest Grade possible. Used in Admiralty, L.C.C., G.P.O., and the "Varsities." Price: "DIX-ONEMETER," IN CASE, READING MICROAMPS. PER DIV. WITH 6 MULTIPLIERS.

£4 : 10 : 0

A Wonderful Stock of Radio and Scientific Apparatus.

Send us your Inquiries for Moving Coil Speakers, Mains Sets, Chokes, Gramo-motors and Amplifiers, Microphones, Recorders, Relays, Special Apparatus for Transmission and Testing Dynamos and Motors, all sizes. Bridges, Galvos, Switch and Control Gear of every description in stock.

NOW READY, NEW EDITION OF 72 PAGE ILLUSTRATED CATALOGUE, 4d.

Send Stamped Addressed Envelope for November Sale List.

218 Upper Thames Street, London, E.C.4

Telephone: City 0197



Our 1930 Super Power Model.

"THE MUSIC LOVER'S CHOICE."

Radio - Gramophone music and speech reproduced with amazing and uncanny realism. The most efficient speaker money can buy.

BAKER'S
Selhurst
RADIO

SEND TO-DAY FOR OUR FREE 36-PAGE LOOKLET "SOUND ADVICE."

Office: 59 SELHURST ROAD, SOUTH NORWOOD, S.E.25.
Works and Demonstration Room:
42 CHERRY ORCHARD ROAD, EAST CROYDON.

BONA FIDE TRADERS' GUIDE.

Send for our comprehensive Illustrated List. QUICK SERVICE. QUICK SERVICE.

THE QUALITY HOUSE.

PERSUS MFG. CO., LTD. (Dept. W.W.), BRANSTONE RD., BURTON-ON-TRENT.

POLAR CONDENSERS

GIVE BETTER TUNING.

POLAR "IDEAL"

·0005, 12/6. ·00035, 12/3.
·0003, 12/-.

Ask your Dealer for Polar.

POLAR

BERCLIF COILS

1930 EVERYMAN 57/- the Set.
NEW KILG-MAG 50/- " "
RECORD III 50/- " "

CABINETS AND DIALS.
SIMMONDS BROS.,
SHIRELAND ROAD, SMETHWICK.

So Many Replies!

A recent advertiser in "THE WIRELESS WORLD" writes as follows:

"I HAVE received so many replies to my advertisement in 'The Wireless World' which appeared under a Box Number that I am sending herewith stamps to the value of 6d. as further payment towards your postage expenses. Thanking you for the quick despatch of all replies."

R. W. CAPEWELL,
52, Chapel Terrace,
Trent Vale,
Stoke-on-Trent.

STUPENDOUS!

A recent advertiser in "THE WIRELESS WORLD" writes as follows:

"As the results from my advertisement in 'The Wireless World' were stupendous, I shall be glad if you will cancel my advertisement in next week's issue as I am cleared out.

I might add that 'The Wireless World' is the best journal I have read."

W. F. Macbeth,
"Bræmar,"
Ballymena, Ulster.

Loud-speakers.—Contd.

HORNS of All Descriptions for Loud Speakers and Gramophone Units.—H. Maddison, manufacturer of the Allwoodorn, 1, Chapel St., Paddington, N.W.1. [6143]

AMPLION Mahogany Speaker; £6, sell £2; splendid instrument.—BM/FZ3, London, W.C.1. [7684]

MAGNAVOX M Type Speaker. 25/-; Baker H.R. moving coil speaker, 110 volts, 25/-; 50 and 100 milliamps Jewel meters, 10/- each.—Col. Bayldon, Beaulieu, Hants. [7685]

B.T.H. Rice Kellogg, 6 volt, perfect; 50/-, near offer.—70, Dayncourt Gardens, Upminster, Essex. [7671]

SELF-CENTRE Ball and Socket Device, when fitted to your cone unit, will relieve driving rod of all undue side stress, centering the cone in relation to driving rod improving results all round; provisional patent applied for; price 2/6; c.o.d. terms available.—Weedon, 80, Lonsdale Av., London, E.6. [7487]

GREAT Bargains.

GREAT Bargains.

GREAT Bargains.—Epoch model A moving coil speaker kit (or complete units), brand new; a large number of these famous instruments made for a special order for use in talkies, but not executed, for credit reasons only; regular prices, £3/10, £4/2, and £5/17/6, to clear at 50/- for accumulator operation, 55/- for D.C. mains operation, 85/- for A.C. mains; kits comprising copper plated super magnet-pot (weight 23 lb.) Crystalline frame, fully adjustable, moving coil, any impedance, paper, leather and mounting rings, made up complete, if desired, 6/- extra.

GREAT Bargains.

GREAT Bargains.—In fact, the greatest bargains ever offered! A number of Epoch model A used kits at given away prices, guaranteed in perfect working order; early 1928 model, 35/-; latest model, 42/6; made up complete, if desired, 6/- extra.

ENJOY Marvellous Epoch Reproduction at Ridiculous Cost; don't wait until they are all gone, but secure one immediately by writing, phoning, telegraphing, or hurrying to Epoch, 3, Farringdon Av., E.C.4. [7077]

6-VOLT 1/2-amp. M.C. Speaker; list £6 new this year; 29/6; "days approval against cash.—Brew, Pytchley, Kettering. [7708]

MARCONIPHONE Popular Horn Loud-speakers, adjustable unit, dark mahogany crystalline finish, absolutely new, in makers' original sealed boxes; formerly 42/-, clearance price 15/- each, postage 1/-.—F. J. A. Hall, 91, Fore St., Edmonton, N.18. [7720]

MARCONIPHONE Type 105 Cone Speaker, brand new, not yet unpacked; £2/17/6, cost £5/5.—Below.

MARCONIPHONE Moving Coil Speaker Unit, 6 volt, or 100-200v. D.C. type; £3/10, original price £6/6.—Powell, 54, High St., Tunbridge Wells. [7699]

CELESTION C24, mahogany, unused; cost £21, accept £12.—"Kalua," Chorley Wood Rd., Rickmansworth. [7690]

LINEN Diaphragm Speaker, in 24in. oak cabinet; can be heard after 7.30 p.m.; £3/10, or nearest offer.—Preston, 140, Brooke Rd., N.16. [7687]

MOVING Coil Speaker, 250 volts, 50 cycles for 25 to 1 transformer, complete, £6; Linen diaphragm speaker, with Blue Spot, £2/10; carriage paid.—Box 4268, c/o The Wireless World. [7686]

R.K. Moving Coil Speaker, practically new, 200 volt D.C. field, with transformer; £4, cost £8/5.—Gedfrey, 68, Elsham Rd., Kensington, W.14. [7723]

R.K. Moving Coil Speaker, 6-volt accumulator model, with transformer; £4; practically new, cost £8/5.—Blackford, 70, Addison Gardens, West Kensington. [7724]

TRANSMITTERS.

CHEBROS. Chebros, Chebros transformers and chokes of all descriptions, special transformers for transmitting and modulation; chokes a speciality; enquiries invited.—Chester Bros., 244, Daiston Lane, London, E.8. [5240]

NEWTON D.C. Generator, 1,500 volts 100 milliamps, direct coupled to 1/2 h.p. D.C. motor, with starter and field regulator on slate switchboard, £12/10; 0-1,500 moving coil voltmeter, £2/10; 2 D.E.T. valves, 30/- each; Sterling 2-button hand microphone, £21; 0-150 Western milliampmeter, £2.—Wilkin, Osborne St., Colchester. [7677]

VALVES.

ALL New Varley Ni-core 1, 15/-; Osram P625, 8/-; P625A, 8/-.—Box 4234, c/o The Wireless World. [7654]

AMPLIFIER Valve.—If you require power you cannot do better than one of these:—

FILAMENT Volts 6, plate volts 400 (maximum), grid bias 84 volts (approx.), impedance 800 ohms, amplification factor 3.8, mutual conductance 4.35 m.a./volts; price £5/10; see article "The Wireless World." 24 h July, 1929, then send to North London Valve Co., Ltd., 22 1/2, Cazenove Rd., Stoke Newington, London, N.16. [7702]

Alexander's Black

The Original Wireless Doctor

WILL CALL AND CURE YOUR SET
(London and Home Counties.)
Consultations by appointment—no obligation.

Personal Attention to all Clients' Sets, Eliminators, Pick-ups, "Webson" M.C. Speakers Demonstrated, Installed, Maintained and Brought Up to Date.

Purity Reproduction Specialist.
NOTE NEW ADDRESS:
55, EBURY STREET, VICTORIA, S.W.1.
Sloane r655.

A CATALOGUE that Saves you Money!



EVERY RADIO ENTHUSIAST SHOULD SEND FOR IT!

Send 3d. in stamps for this 56-page Catalogue. Scores of Ready-to-assemble Wireless Cabinets and Special Osborn Offers.

CHAS. A. OSBORN (Dept. W.W.),
The Regent Works, Arlington Street, London, N.1.
Telephone: Clerkenwell 5093. Open to 7.30 p.m. Saturdays 4.30 p.m.
And at 21, ESSEX ROAD, ISLINGTON, N.1. Open until 9 p.m. SATURDAYS. Phone: Clerkenwell 6884.

MUCH IMITATED

CLAROSTAT

NEVER EQUALLED

REDUCED PRICES!

STANDARD. WAS 10/6 NOW 9/6

VOLUME. " 8/6 " 7/6

POWER TYPES. WERE 15/- " 13/6

FREE 40 Page Illustrated Booklet with Scale Drawings all types mains apparatus etc.

CLAUDE LYONS LTD.
76, OLDHALL ST., LIVERPOOL.

ORDER YOUR CABINET NOW

(Delivery from Stock)
"The Wireless World"
A.C. Kit Set
Metal Cabinet and Base Complete £2 15 0
1930 EVERYMAN FOUR METAL CABINETS
46/6 each

(or without woodwork 35/- each).
KILO-MAG & RECORD THREE METAL CABINETS.
35/- each, or with woodwork 46/6 ea. h.
Kit-Set 27/6 and 38/6 each respectively.
Finished crystalline Brown, Black or Blue.

Trade enquiries invited.—Samuel Eaton & Sons (Manufacturers of Lighting Goods), 88/72, Barr St. Birmingham

Valves.—Contd.

S. 625, 10/6; P.M.5A, P.M.5, P.M.256, lot 11/6; full emission.—Hanson, Verwood, Dorset. [7692]
OSRAM Screened Grid 270/15/1; Marconi 4-volt super power, 10/-; both equal new.—Bolter, Naunton, nr. Cheltenham. [7691]

COMPONENTS, ETC., FOR SALE.

BELLING-LEE Panel Fittings are designed to give an expert finish to any home-constructed set; catalogue post free.—Belling and Lee, Ltd., Queensway Works, Ponders End, Middlesex. [0018]

600-OHMS Decoupling Resistances; see advt. under Coils.—Groves Brothers, Manufacturers. [7175]

POWER Chokes, substantially built, for smoothing circuits in eliminators dealing with currents 100-300 milliamperes, inductance 30 henries; 8/6 each; guaranteed 12 months.—Transformer Repair Co. (Dept. W), 214, High St., Colliers Wood, S.W.19. [0327]

WESTON Model 301, milliammeters, ammeters, and voltmeters, 21/- each; hot wire ammeters 0.1 amp., 4/-; 0.0-5 amp., 3/-; instrument repairs and alterations; send for list.—The Victra Electrical Co., 47, High St., Battersea, S.W.11. Established 1910. [7563]

POTENTIAL Dividers 10,000, 15,000, 20,000, 25,000 and 30,000 ohms, 5 variable tappings; 2/- each.

POTENTIAL Dividers, heavy duty, wire wound, 15,000 and 20,000 ohms, 7 tappings, 5/6; 4 tappings, 3/9.

CONDENSERS, 2 mid., 2/3; 4 mid., 4/-; guaranteed; tested 500 volts.

CHOKES (L.F.)—Excellent for smoothing, up to 2 milliamps, 2/-; special heavy duty, 10 milliamps, 8/6.

ELIMINATORS, A.C., wired for half or full wave, complete with valve; 3/17/6.

H.F. Chokes; 3/-.

GRAMOPHONE Motors, well known make, double spring, silent, complete with fittings; 30/-.

SPECIAL Bargain.—B.T.H. 40 henry chokes; 9/6; any article on approval against cash.—Huggins, Radio Engineer, Clacton-on-Sea. [7598]

A.F.5, 19/6; 4 Mansbridge type 2 mid. condensers, 2/- each; 2 P.M.14 (screened grid valves), 12/6 each; P.M.4, 5/6; McMichael 6-point switch, 2/6; also binocular H.F. choke, 3/-; Lewcos 5-pin I.F. transformers for screened grid valve, B.B.C. and D.1. variety, 12/- pair; Ferranti 50,000 ohm anode resistance, 3/-.—Oswald Chippindale, Wedderburn, Harrogate. [7683]

CLIMAX Mains Transformer, 200-240v., 18/-; 1) U.10 valve, 7/6; D.E.8 L.F., 5/-; Mullard 250,000 resistance, 4/-; Sterling Baby, 17/6; Woba L.S. unit, 5/6.—The Lindens, Cobden Rd., Peterborough. [7668]

DUAL Condensers, 4 0.0005, 1 0.0003, 4 in dimic coils, complete, neutralising condensers, baseboard-panel type, all as new.—Boyns, Tudor Av., Hirwain, Glam. [7665]

UNUSED Igranite Potential Divider, E.B.H. Elkon rectifier, Varley Elkon power transformer; lot 22/15.—Pepperdeane, 131, Brecknock Rd., Tunfell Park. [7657]

G.R. Super Het Kit, 3 oscillators and aerial coils, 70/-; Baker's super speaker, 6-volt type, 2 spare diaphragms, 70/-—80, Grosvenor Place, Murgate. [7664]

BLUE Spot Pick-up, volume control, tone arm, 35/-; Mullard speaker unit, 32/-; Cosmos H.F. choke, 5/-; P.M.2, 6/-; Marconi P240, 6/-; Cosmos 525 H.F., 5/-, list of many other parts: 1 1/2 stamp.—Martin Woodroffe, Campden, Gloucestershire. [7655]

EXPERIMENTER Has for Sale Host of Wireless Parts, new and second-hand, 2 large accumulators, charger, speakers, transformers, R.C.C. units, pick-up, etc., all at half price; what a gift.—Spencer, 92, Umfraville Rd., Harringay, N.4. [7661]

YOUR Old Components Taken in Part Payment for Latest Type; see our advert in column Receivers for Sale.—Scientific Development Co., 51, Fishergate, Preston. [0228]

AMPLION Lion Power Chassis, in use 3 months, 24/15; B.T.H. pick-up and tone amp., 25/-; Mullard D.F.A.9, 10/-.—Box 4276, c/o The Wireless World. [7719]

PAIR Orgola Coils (Colvern), 11/-; Mullard 84V, 18/6; P.M.24, 18/6; all new.—Allen, 136, Southfield St., Nelson, Lancs. [7711]

NEW Westinghouse Rectifier, type R.4.2.1, 17/6; Ferranti 3-range portable, with switch, 0-7 1/2; 0-150 volts, 0-30 u.a., 37/6, new; O.P.M.4 and O.P.M.2, 14/- each, new; Marconi 2.7/1 Ideal, 10/-.—73, Crown St., Rochdale. [7709]

PORTABLE Cabinet, rexine, 15/-; A.F.3, 14/6; A.F.5, 21/-; two Blue Spots, 66a., 12/- each; with Wolhampin, portable chassis, 6/- extra, as new; some used Triotrons, 5/6—41, Earlham Grove, E. 7. [7705]

BANKRUPT Stock, new and guaranteed.—Transformers, Telec. Radiogram, 9/-; R.I. Hypermi, 15/-; Varley Nicore I, 12/6; Nicore II, 7/6; Ready Radio selectivity units, 15/-; Marconi A.C. moving coil units, 24/15; terms, cash with order; satisfaction or money refunded.—Spencer, Sheep St., Northampton. [7707]

SUPER-MICROPHONES

New, highly sensitive, made on the latest principle, a vast improvement over all other types; will pick up whispered words from a distance of several yards, also strongly amplify and transmit speech and music over a distance, through Loud-speaker or Headphones. AMAZING VOLUME WITHOUT THE AID OF VALVES

Splendid instruments for making Detectors, Head-sets, LOUD-SPEAKING TELEPHONE Announcements through Loud-speaker, Amplifier for Crystal or Valve Sets, Electric Sound Detector, Experiments.

NO OTHER MICROPHONE OF EQUAL SENSITIVENESS KNOWN; each instrument finely black enamelled and fitted with a 3 ft. silk connecting cord. Despatched by return post. 8/6

SPECIAL MICROPHONE TRANSFORMER for connecting Super-Microphones to Radio Head-phones, Loud-speaker, Valve Set, or Valve Amplifier 6/-

SMALL 10 OHMS EARPIECE for use with Super-microphone as a HIGHLY EFFICIENT DEAF-AID or Detector, etc.; thin 3-ft. silk connecting cord fitted. Earpiece finely black enamelled. 6/- Full Directions for use of Super-Microphones for many purposes and Diagrams of connections free.

NEW PUBLIC ADDRESS MICROPHONE The Ideal Instrument for addressing an Audience through Loud-speaker (via Valve Amplifier or L.F. Stages of Wireless Set), and for relaying Speech and Musical Entertainment to any distance. Powerful Loud-speaker Reproduction with perfect Fidelity.

Pedestal Type. Highly Sensitive Microphone, guaranteed entirely free from distortion or microphonic noises, absolutely silent background; far superior to ordinary Microphone Transmitters; for use with Valve Amplifier or Valve Set (through leads of Gramophone Pick-up if desired) at Open-air Meetings, in Cinema, Theatre, or Concert Hall. Operates from 2 Volt tapping of L.T. Accumulator, through Microphone Transformer. Current consumption one-tenth Ampere. Provided with detachable Sound Collector and a 5ft. silk connecting cord, and fixed by rubber-cord suspension in nickel-plated stand 11in. high; for mounting on Speaker's Platform, in Pulpit, on top of Camera Stand, or for suspension from ceiling, as illustration. 25/-

MICROPHONE WITHOUT STAND 16/- The above Microphones are rendered Directional by attaching the Sound Collector.

Special Microphone Transformer for the above 6/- DIAGRAM OF CONNECTIONS FREE.

FREDK. ADOLPH, Actual Maker, 27, Fitzroy Street, London, W.1. 'Phone: MUSEUM 8320

BABY JUNIOR 2 1/2" - 2/4
BABY 3" - 2/6
STANDARD 4" - 2/9
In Black or Brown.

"ISO" DIALS
"Iso" Dials have a definite grip. They do not slip.

Model I.K. 3" - 3/4
4" - 4/-
In Black or Mottled Mahogany.
HAW & Co. Ltd.
20, CHEAPSIDE, London, E.C.2.
Tele.—CITY 9510.
Sole Distributors for "Iso" Products, Cone Units, Transformers, Chokes, Condensers, Triotrons, Changers, Eliminator, etc.

Components, Etc., for Sale.—Contd.

APPLEBY'S. THIS Opportunity We Take to Express to Several Thousands of Customers, following many calling in this and distant countries all over the world, our old time greetings.

GOOD Wishes FOR Christmas. FOR the New Year. FROM Those Who Constitute the Functioning of That Which You Know as Appleby's. FROM, also, E St. J. Hetherington Appleby, London, N.W.1. N.W.10, and S.W.19. [031]

RADIO HOUSE, HUDDERSFIELD (15th Winner), EXCELS LIKE

ITS ADVERTISEMENTS, BY INTERESTING LISTENERS INVESTING THIS

YULETIDE. So impressed with our values was Littlehampton reader that he sent an unsolicited testimonial, "Your Firm is 'streets' ahead of some of the London Houses for business." This unsolicited reputation we endeavour to uphold.

WHILE IT REALLY ENCOURAGES LEADS EXPECTING SOME

SAVING, it provides an interesting, remunerative competition, so why not submit similarly composed advertisement, using the words "Reliable Wireless Guide," so as to encourage readers to apply for this list? Weekly change of matter desired, a 10 volt H.T. battery for each effort published, and useful consolation prizes given.

GENERALLY USED IN DECIDING

EXPENDITURE by Those Familiar with the List, so make sure of a copy, which will be sent post free by J. H. Taylor and Co., 15, Radio House, Macaulay St., Huddersfield, to whom competing efforts should be submitted, indicating also in name and address publishable if successful. (Only 23 alternative words required, Radio House, Huddersfield retaining. One word for each initial following Prize winner this week from Edinburgh. [77]

WOODRUFF Pick-up, hardly used, 35/-; Marconi phone L.F. choke (21-), brand new, 12/-; 400 condensers, Sterling make, 3 mid., 4/-, 6 mid., 10 mid., 10/-; Marconi phone popular transformer, used, 8/6; output transformer, 9/-; Philips L.T. battery charger, 220v A.C., 11/15, was 24/4; R. amplifier, Junior model, and moving coil speaker, 27/-; P. Powell, 54, High St., Tunbridge Wells. [77]

MISCELLANEOUS.

EXPONENTIAL Horns for Cabinet Gramophones a Wireless, metal and wood; list.—Maddison, Chapel St., Marylebone, N.W.1. [514]

ALEXANDER BLACK. PLEASE Note New Address.

THE Original Wireless Doctor, will call (London and Home Counties) and cure your set. CONSULTATIONS by Appointment Without Obligation, sets installed, maintained, and brought to date, gramophone pick-ups, eliminators, and Wireless moving coil speakers demonstrated; purity reproduction specialist.

55, Ebury St., Victoria, S.W.1. Sloane 1665. [02]

Miscellaneous.—Contd.

ASY Payments.—We supply, by easy payments, components, accessories, and sets, any make; 10% in, balance spread over 10 months.—Send list of requirements to London Radio Supply Co., 11, Oatford St., London, E.C.2. [0097]

WIRELESS Notes.—A monthly service of information for all those who want the very best in wireless or gramophone reproduction; frank criticism of receivers and components; immediate postal help in all difficulties; something new and unique; you must have it if you want to know the latest.—Full particulars free from Ernest H. Robinson, Langmead, Pirbright, Woking, Surrey. [7607]

COTT SESSIONS and Co., Great Britain's radio doctors; officially approved as wireless repairers; Radio Society of Great Britain and Wireless League; sets of every type repaired, rebuilt, modernised; and set for immediate quotation.

COTT SESSIONS and Co.—New sets constructed with your or our components, guaranteed finest workmanship; we specialise in "The Wireless World" suits; remember, we have satisfied customers throughout the British Isles and in three Continents; if you so desire, we will design and construct high class apparatus to suit your special circumstances for quality, range and selectivity.—Tel.: Tudor 5326. Muswell Hill, London, N.10. [0262]

ENGINEERS.—Can't we get together? All we ask is the chance to prove that you can earn £300, £500, £1000 per year and more. Other men are doing it and you can do the same. We have an unrivalled and world-wide organisation waiting to help you, whether you are a novice or expert. If you wish for something more than a bread-and-butter job you owe it to yourself to investigate our service. Our handbook, "Engineering Opportunities," has pointed the way to better things to over 20,000 of your fellows. It contains details of A.M.I.Mech.E., A.M.I.C.E., A.M.I.E.E., M.I.A.E., A.M.I.Struct.E., C. & G., G.P.O., etc., exams, and outlines home study courses in all branches.

Electrical, Mechanical, Motor and Wireless Engineering. In a brilliant article Professor A. M. Low shows clearly the chances you are missing. The book and our advice are quite free. We guarantee No Postage. Don't miss this opportunity; send a postcard—(state branch, post or exam.)—British Institute of Engineering Technology, 87, Shakespeare House, 29, Oatford St., London, W.1. [7640]

PATENTS.

The Proprietor of Patents Nos. 263752 and 263753, Variable Directional Electric Wave Generating Service and Directive Projecting and Receiving System for use in Wireless Telegraphy or Telephony is anxious of entering into arrangements by way of licence or otherwise on reasonable terms for the purpose of exploiting the same and ensuring its full development and practical working in this country. All communications should be addressed in the first instance to J. E. Evans-Jackson and Company, Registered Patent Agents, Bath House, 57 to 60, Holborn Viaduct, London, E.C.1, and 34, Dame Street, Dublin, Ireland. [7712]

PATENT AGENTS.

PATENTS and Trade Marks, British and foreign.—Gee and Co. (H. T. P. Gee, Member R.S.G.B. and M.I.R.F.), 51-52, Chancery Lane, London, W.C.2. Phone: Holborn 1525. [0001]

WING'S PATENT AGENCY, Ltd., 146a, Queen Victoria St., E.C.4.—Free advice and handbook on patenting inventions and registering trade marks by registered agent with 43 years' experience. [3002]

REPAIRS.

TWELVE Months' Guarantee Accompanies all our Repairs; any make of L.F. transformer, headphones, or loud-speaker repaired and despatched within 48 hours; 4/- post free; don't discard if burnt out; come to trade.—Transformer Repair Co. (Dept. W.), 4, High St., Colliers Wood, S.W.19. [0011]

COTT SESSIONS and Co., Great Britain's radio doctors; road advertisement under Miscellaneous column. [0265]

LONDON-ON-THAMES.—Transformers, 'phones, and loud-speaker repairs; transformers wound to any ratio.—Minter, 156, Cambridge Rd. [7269]

REPAIRS Returned Post Free, and to ensure satisfaction send remittance after approval of same. Leeds Wireless Repair Service.

LOUD-SPEAKERS, headphones, re-wound to any resistance and remagnetised, 3/-; transformers re-wound, 4/-; Blue Spots, Trictrons and 4-pole units, re-wound, work guaranteed.—Leeds Wireless Repair Service, Boston Place, Green Rd., Leeds. [7652]

GUARANTEED repairs by Experts.—Loud-speakers, headphones, cone units, pick-ups, any type, re-wound, remagnetised and adjusted; post free; transformers from 4/-.—Howell, 91, Morley Hill, End, Middlesex. [7713]

WANTED.

WANTED for A.C. 230 Volts, 50 cycles Burndept V.A.C. Seven Columbia 304, G.E.C. S.G.4, Marconi 56, Philips 2511, also mains M.C. speaker; cannot be more than trade.—Box 4240, c/o The Wireless World. [7676]

RECORD Three Metal Cabinet and Coils; cheap.—J. R., 73, Woodgrange Rd., E.7. [7669]



THE Scientific Logarithmic Horn

Length 5 feet. Flare 25 inches. Specially designed for home use. Inconspicuous and of pleasing appearance. Can be suspended in corner of room and will harmonise with all furnishings.

Crisp definition with marvellous depth of tone, remarkable volume, equal reproduction on all frequencies. Equalled only by a good moving coil speaker. Will satisfy the most critical ear.

Horn with Baldwin Type Balanced Armature Unit. Complete £2:0:0. Horn with Brown U/GA Unit. Complete £2:18:6. A combination making the finest loud speaker obtainable. Satisfaction guaranteed. On 5 days' approval against cash. **19/6**

HORN ONLY

SCIENTIFIC SUPPLY STORES,
126, Newington Causeway, London, S.E.1

HIGH GRADE RADIO APPARATUS ON Easy Terms

We SPECIALISE in the supply of all Good Quality Radio Sets, Components and Accessories on Easy Terms. We will give you efficient service.

Any of the new "Wireless World" Receivers built to order. Carefully wired and tested and fully guaranteed by us. Moderate Charges.

Send us your list of requirements and a quotation will be sent by return.

LONDON RADIO SUPPLY CO.
11, Oat Lane, Noble Street, London, E.C.2.
National 1977.

EPOCH MOVING COIL SPEAKERS.

The Epoch Radio Manufacturing Co., Ltd., wish the readers of "The Wireless World" A Merry Xmas.

REPAIRS

Any make of L.F. Transformer, Loudspeaker or headphones repaired and despatched within 48 HOURS—**TWELVE MONTHS' GUARANTEE** with each repair. 4/- Post Free.

Terms to Trade.

TRANSFORMER REPAIR CO.,
Dept. W.
214, High Street, Colliers Wood, London, S.W.19

Wanted.—Contd.

WANTED, Ferranti O.P.M.3C, exchange O.P.M.1C (new, unused) or P.M.24 and P.M.4D.X. valves (new condition); sell Pye 20H. choke.—Steel, 11, Tassie St., Glasgow, S.1. [7682]

WANTED, sensitive relay, Marconi P.T.625, Ferranti A.F.3, and copy of "Wireless Valve Transmitters."—12, Alexandra Villas, Flinsbury Park, N.4. [7703]

EXCHANGE.

YOUR Old Apparatus Taken in Part Payment for Latest Type; see our advert in column Receivers for Sale.—Scientific Development Co., 51, Fishergate, Preston. [0230]

AGENCIES.

ATWATER Kent All Mains Receiving Sets, in every way far ahead of all others, a wonderful line to handle; agents wanted.—Apply sole concessionaires, Fredk. J. Gordon, 92, Charlotte St., W.1. [7665]

AGENTS Wanted, spare time, wireless experience, to demonstrate and sell the world's best and cheapest 3-valve set.—Mag-Radio, 112, Warstone Lane, Birmingham. [2667]

BUSINESSES & PROPERTY FOR SALE, TO BE LET, OR WANTED.

OLD Established Radio Business in S.W. District, large shop, with living accommodation; vacant possession, long lease; stock, plant, and workshops; a bargain.—Box 4248, c/o The Wireless World. [7678]

FOR Immediate Disposal, large convenient workshop in West End, completely equipped with modern machine tools electrically driven throughout, offices, stores, etc., suitable for any form of light engineering.—Particulars of Leopold Farmer and Sons, Factory Specialists and Auctioneers, 46, Gresham Street, E.C.2. [7715]

SITUATIONS VACANT.

WIRELESS Operating Appointments Assured; short qualifying course, day, evening; fees payable after appointment for boarding students; Morse classes.—Manager, Wireless School, 21, Manor Gardens, London, N.7. Archway 3694. [6379]

COMMUNICATIONS Invited from Young Men, preferably single, holding first class P.M.G., able to instruct in wireless telegraphy, and invest between £170-£200; extension of present business.—Box 4250, c/o The Wireless World. [7681]

BOOKS, INSTRUCTION, ETC.

WET H.T. Batteries are now a proved success; write for new illustrated booklet, giving cost and method of building and maintaining free; mention paper.—Taylor, 57, Studley Rd., Stockwell, London. [0077]

STEP by Step Wireless; a complete course of the theory of electricity in relation to the practical design of wireless apparatus, eliminators, circuits, etc., with extracts from a designer's notebook, giving up-to-date practical application; issued weekly; send 1/- p.o. for first 4 weeks.—Clifford Presland, A.M.I.E.E.Eng., Dept. W.W., Hampton-on-Thames [0195]

FREE: Inventor's Guide on Patents.—T. A. A., 253 (W), Gray's Inn Rd., London, W.O.1. [6379]

AN Introduction to Wireless Telegraphy and Telephony, by Professor J. A. Fleming, M.A., D.Sc.—An interesting account of the principles of wireless telegraphy and telephony for the listener-in and wireless experimenter; 3/6 net, of booksellers, or Pittman's, Parker St., Kingsway, London, W.C.2. [7071]

PAREX



Bakelite Drum Dials
with Escutcheons

5/6
(from stock).

Cabinets, Coils, Valve Holders, etc., for New Kilo-Mag 4 and 1930 Everyman 4.

Order direct from: **E. PAROUSSI,**
10, Featherstone Buildings, High Holborn, W.C.1.
Phone: Chancery 7010.

FOREIGN LISTENERS 4 Set of 6 Coils . . . 37/6
SCREENING BOXES . . . 5/- each; . . . 19/- set.
RECORD III Coils 35/- set. **KILO-MAG 4 Coils** 33/- set.
1930 EVERYMAN Coils. 42 8 set. **METAL BOXES—**
4 Compartments. 32/6 Complete Cabinets . . . 45/-
W.W. KIT SET Coils and Switches, mounted . . . 37/6
Metal Boxes . . . 27/6 Complete Cabinets . . . 35/-
SEND ALL YOUR ENQUIRIES. TRADE SUPPLIED.
A. T. STOTT, 1a, Duke St., ROCHDALE.
 (Late 63, Syke Road.)

The **Wireless**
AND **Radio Review**
World

INDEX TO ADVERTISEMENTS.

	PAGE		PAGE		PAGE
Accumulators Elite	22	Garnett, Whiteley & Co., Ltd.	4	Rothermel Corporation, Ltd. (Centralab)	10
Adolph, Fredk.	20	Graves, J. G., Ltd.	2	Rowley, Thomas A., Ltd.	20
Alderson & Smith	17	Grosvenor Battery Co., Ltd.	22	Scientific Supply Stores	23
Appleby, E. Hetherington	17	Haw & Co., Ltd.	22	Sheffield Magnet Co.	8
B. & J. Wireless Co.	17	Hayberd, F. C., & Co.	22	Sifam Electrical Instrument Co.	19
Baker's "Selhurst" Radio	19	Holland, G. S.	2	Simmonds Bros.	19
Bayliss, Wm., Ltd.	Cover iii.	Holzman, L.	2	Standard Wet H.P. Battery Co.	23
Beam, Ltd.	Cover ii.	Hughes, F. A., & Co., Ltd.	8	Stott, A. T.	23
Black, Alexander	21	Igranic Electric Co., Ltd.	12	Telegraph Condenser Co., Ltd.	Cover 1 & p. 5
British Ebonite Co., Ltd.	12	Lectro Linx, Ltd.	23	Telsen Electric Co., Ltd.	13
British Insulated Cables, Ltd.	4	London Radio Supply Co.	21	Thomas, Bertram	23
British Radio Gramophone Co., Ltd.	Cover i.	Lyons, Claude, Ltd.	8	Transformer Repair Co.	10
Brownie Wireless Co. (G.B.), Ltd.	18	Marconiphone Co., Ltd.	Cover iv.	Trelleborg Ebonite Works, Ltd.	17
Bullphon, Ltd.	Cover i.	M.L. Magneto Synd., Ltd.	6	Tudor Accumulator Co., Ltd.	17
Burton, C. F. & H.	3	M.P.A. Wireless, Ltd.	1	Tulsemere Manf. Co.	Cover i.
Clarith Reproducers, Ltd.	14	Mullard Wireless Service Co., Ltd.	21	Ultra Electric, Ltd.	15
Cossor, A. C., Ltd.	14	Osborn, Chas. A.	23	Vandervell, C. A., & Co., Ltd.	9
Dubilier Condenser Co. (1925), Ltd.	12	Paronssi, E.	19	Varley (Oliver Pell Control, Ltd.)	10
Eastick, J., & Sons	21	Persens Radio Manf. Co.	8	Westinghouse Brake & Saxby Signal Co., Ltd.	2
Eaton, S., & Sons	19	Pertrix, Ltd.	11	Weston Electrical Instrument Co., Ltd.	19
Electradia Radios	23	Peto & Radford	11	Whiteley, Boneham & Co., Ltd.	24
Epoch Radio Manf. Co., Ltd.	7	Phillips Radio	11	Wilkins & Wright, Ltd.	19
Ever Ready Co. (G.B.), Ltd.	15	Radiogramophone Development Co.	12	Wingrove & Rogers, Ltd.	
Exact Manf. Co.	24	Radio Instruments, Ltd.	12	Wolverhampton Die Casting Co.	
Ferranti, Ltd.		Redfern's Rubber Works, Ltd.	18	World's Wireless Stores	
Formo Co.		Rigby & Woolfenden			



THE FINEST VERNIER DIAL OBTAINABLE

MECHANICALLY PERFECT, POSITIVE BRASS CONTACT drive on SOLID BRASS SCALE ensuring smooth movement, with absolutely NO BACK-LASH. ROBUST in Construction and Trouble Free. SMALL, EXTREMELY ELEGANT. EFFICIENT.

TUNING WITHOUT IRRITATING UNCOMFORTABLE CROUCH OR STOOP.

3/-

As pictorially shown, the scale and aperture are inclined at an angle of 30° from perpendicular, thereby permitting convenient unobstructed view of scale without need to crouch or stoop.

If unable to obtain from dealer please communicate with us. Full Catalogue sent post free on receipt of post card.

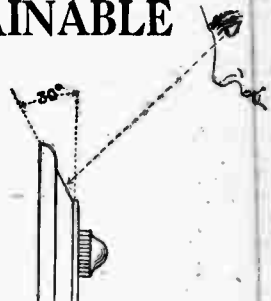

THE FORMO CO., CROWN WORKS, CRICKLEWOOD LANE, LONDON, N.W.2

YOU need the "MITE"
-a "Utility" Product!

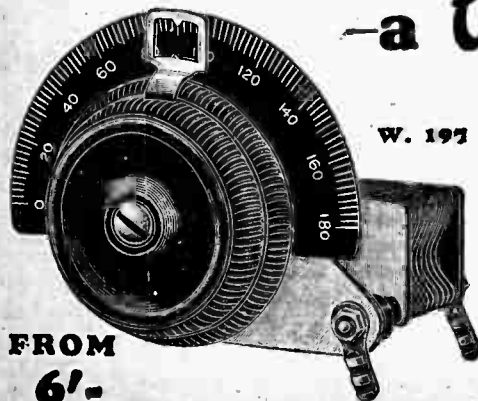

FROM 6/-

W. 197

And fully guaranteed for efficiency and finish! The small Receiver is the vogue of to-day—this diminutive Condenser will help you to eke out the scant space available behind the panel. It is just one "Utility" product—write NOW for a complete List and be sure that you insist your dealer supplies "Utility," the best value irrespective of price.

WILKINS & WRIGHT LTD
HOLYHEAD? *Utility* BIRMINGHAM

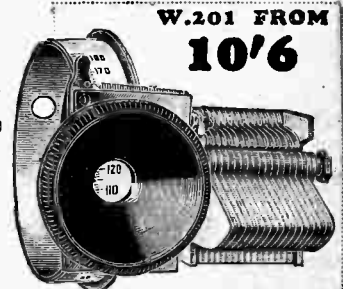

W.201 FROM 10/6

The "Mite" is supplied with new Drum Dial as above in 3 capacities—0002-3-5, or with Micro Dial in 4 capacities—0001-2-3-5.

Mention of "The Wireless World," when writing to advertisers, will ensure prompt attention.

Superior A.C. POWER TRANSFORMERS

and CHOKES for the MAINS from 35/- each
for ALL INPUTS and OUTPUTS.

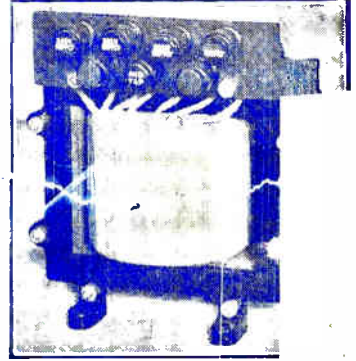
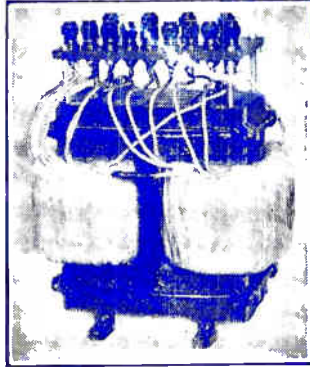
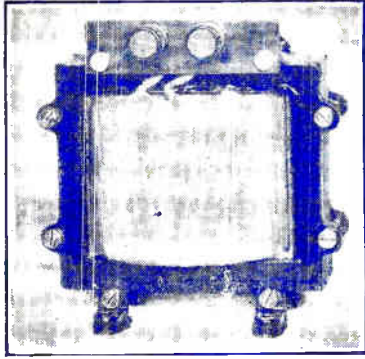

Special Audio-Frequency Chokes and Transformers, and Smoothing Chokes for all purposes.

WILLIAM BAYLISS LTD., Sheepcote Street, BIRMINGHAM
Telephone: Mid. 1409. Telegrams: "Drawbench, B'ham"

Be Prepared! — for the Year that Lies Ahead!

Get
your
Copy of

The
Wireless
AND
RADIO REVIEW **World**
DIARY
for 1930

"The Wireless World" Diary contains 80 pages of useful facts and figures for wireless users, together with ample space for memoranda and personal notes on radio matters.

PRINCIPAL CONTENTS:

Summary of Regulations Relating to Amateur Transmitter and Receiving Licences. Conversion Tables, English measures to metric and *vice versa*. Decimal and metrical equivalents of fractions of an inch. Broadcasting Stations of Europe with their Call-Signs and Wavelengths. Principal Short-Wave Broadcasting

and Commercial Stations of the World. Nationality Prefixes used by Amateurs. Morse Code. Symbols used in Wireless Diagrams. Typical Wireless Receiver and Eliminators:— Fourteen Different Circuits with Diagrams. Valve Data, giving the characteristic features of standard valves.

From All Booksellers and Stationers.

Published jointly by
"THE WIRELESS WORLD," LONDON, E.C.4
and CHARLES LETTS & CO.

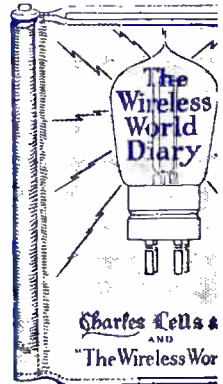

PRICES
Cloth Board, net. By post. In Leather Case with pocket and sea ticket wind 2/6 net. By 12/7.

Today's most brilliant loud speaker

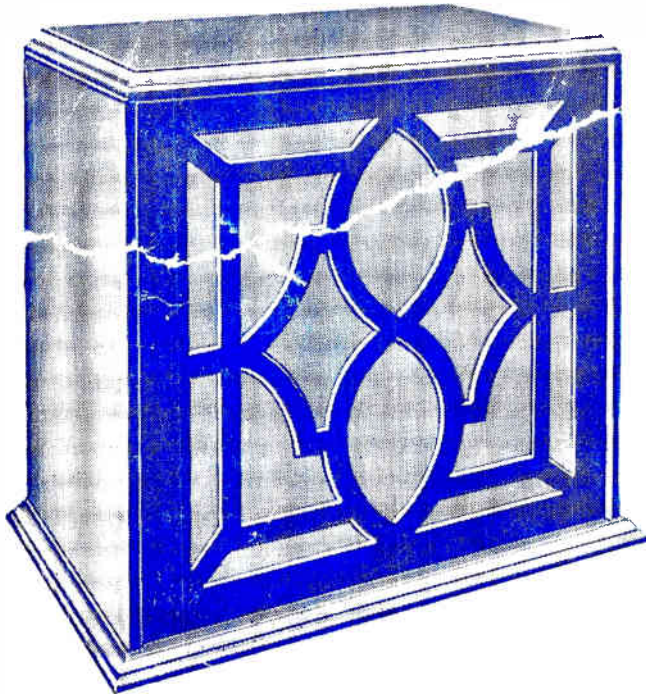

*carrying the most
famous name in wireless!*

In almost every room there is a niche awaiting this splendid speaker. A single hearing will convince you of its extraordinary range and fidelity.

A **S**UBTLE harmony in the strings . . . an elusive quality in a singer's voice . . . effects that add the final, individual touch to a perfect performance . . . the Marconiphone Moving Coil Speaker brings them all out flawlessly!

Missing nothing, exaggerating nothing, it reproduces every note exactly as it is made. Yet so perfect is the volume control that it can fill a dance hall or be hushed to the intimate atmosphere of a drawing-room.

Wonderfully sensitive . . . for all its power
This fine speaker gives perfectly even response at all stages throughout the musical scale, from

deepest bass to highest treble. Every shade of expression, however slight, is faithfully rendered. And in the design of this up-to-date moving coil speaker there is all the experience of the Marconiphone engineers!

Cabinet models for working from 6-volt accumulator — £7. For D.C. mains — £7.10.0. For A.C. mains — £12.12.0 (including rectifier unit and valve). Moving coil units from £4.10.0.

Any dealer will demonstrate this new speaker. Or if there is no dealer near you, write to the Marconiphone Company Limited, 210-212 Tottenham Court Road, London, W.1.

MARCONIPHONE

Moving Coil Speakers



*The first and
greatest name
in wireless*

Printed for the Publishers, LITTLE & SONS LTD., Dorset House, Tudor Street, London, E.C.4, by The Cornwall Press Ltd., Paris Garden, Stamford Street, London, S.E.1.

Colonial and Foreign Agents:
UNITED STATES—The International News Co., 131, Varick Street, New York. **FRANCE**—W. H. Smith & Son, 248, Rue Rivoli, Paris; Hachette et Cie, Rue Beauvau, Paris.
BRITAIN—W. H. Smith & Son, 78, Mark Lane, London. **INDIA**—A. H. Wheeler & Co., Bombay; Allahabad and Calcutta. **SOUTH AFRICA**—Central News Agency, Ltd., Johannesburg.
AUSTRALIA—Gordon & Gotch, Ltd., Melbourne (Victoria); Sydney (N.S.W.); Brisbane (Queensland); Adelaide (S.A.); Perth (W.A.), and Launceston (Tasmania).
CANADA—The American News Co., Ltd., Toronto, Winnipeg, Vancouver, Montreal, Ottawa, St. John, Halifax, Hamilton; Gordon & Gotch, Ltd., Toronto; Imperial News Co., Toronto, Montreal, Winnipeg, Vancouver, Victoria. **NEW ZEALAND**—Gordon & Gotch, Ltd., Wellington, Auckland, Christchurch and Dunedin.