

The Wireless World

AND
RADIO REVIEW
(17th Year of Publication)

No. 510.

WEDNESDAY, JUNE 5TH, 1929.

VOL. XXIV. No. 23.

Editor: HUGH S. POCOCK.

Assistant Editor: F. H. HAYNES.

Editorial Offices: 116-117, FLEET STREET, LONDON, E.C.4
Editorial Telephone: City 9472 (5 lines).

Advertising and Publishing Offices:
DORSET HOUSE, TUDOR STREET, LONDON, E.C.4.
Telephone: City 2847 (13 lines). Telegrams: "Ethaworld, Fleet, London."

COVENTRY: Hertford Street.
Telegram: "Cyclist, Coventry." Telephone: 5210 Coventry.

BIRMINGHAM: Guildhall Buildings, Navigation Street.
Telegram: "Autopress, Birmingham." Telephone: 2970 and 2971 Midland.

MANCHESTER: 260, Deansgate.
Telegram: "Liffe, Manchester." Telephone: 8970 City (4 lines).

GLASGOW: 101, St. Vincent Street, C.2.
Telegram: "Liffe, Glasgow." Telephone: Central 4857.

PUBLISHED WEEKLY.

Subscription Rates: Home, 17s. 4d.; Canada, 17s. 4d.;
other countries abroad, 19s. 6d. per annum.

Entered as Second Class Matter at New York, N.Y.

As many of the circuits and apparatus described in these pages are covered by patents, readers are advised, before making use of them, to satisfy themselves that they would not be infringing patents.

CONTENTS OF THIS ISSUE.

| | PAGE |
|--|------|
| EDITORIAL VIEWS | 573 |
| THE MODERN PORTABLE | 574 |
| CURRENT TOPICS | 578 |
| REPRESENTATIVE PORTABLES REVIEWED | 579 |
| BUYERS' GUIDE TO PORTABLE SETS, 1929 | 585 |
| HINTS AND TIPS FOR PORTABLE USERS | 600 |
| BROADCAST BREVITIES | 601 |
| APPARATUS REVIEWED | 602 |
| PORTABLES NEED NO APOLOGIES. By B. H. DAVIES | 604 |
| LETTERS TO THE EDITOR | 606 |
| READERS' PROBLEMS | 608 |

ARE AERIALS OUT OF DATE?

MANY of the earliest portables which appeared on the market in this country were not the products of the established radio manufacturing firms, and the explanation for this may probably be found quite readily in the fact that the engineer dislikes compromise of any kind, and would rather sacrifice convenience than put forward for production a design which he considers to be technically inadequate.

This was the state of affairs a year or so ago. Unless one was prepared to employ many more valves than were economic or strictly necessary for satisfactory reception it was not a practical proposition to dispense with the outside aerial. But to-day a new situation has arisen. If one uses an outside aerial the employment of two stages of H.F. amplification is very desirable as a means of attaining the selectivity necessary in these days of crowding of stations and high power local transmitters. Now, having admitted that for best results we should use two tuned H.F. stages, we find that with an outside aerial we have at our command amplification far

in excess of what is really necessary, and it becomes desirable to reduce the efficiency of the H.F. amplification in such a receiver in order that the detector stage shall not be overloaded. This all means that we have reached a position where an outside aerial becomes unnecessary and, apart from its inconvenience, it may be even quite undesirable to employ it, because with a set giving high amplification the outside aerial brings in a great deal of interference which can be, to a certain extent, reduced by the employment of a frame aerial, largely on account of its directional properties.

From the point of view of convenience, there is much to be said in favour of the portable, and it is not surprising that statistics show a very pronounced increase in the demand for portable types of receivers during the past few months.

Aerials Superseded by H.F. Amplification.

Reverting to the question of the outside aerial, its history can be traced from the early days when coherers, and later, crystals, were the only detectors available, and when amplification was unknown. The advent of the valve changed the position considerably but, even so, until H.F. amplification was introduced one could not dispense with an outside aerial except in the case of long-wave and very high-power transmitters, without an entirely uneconomical extension of low-frequency amplification. For a year or so past when using sets employing, say, one good H.F. stage, it has been the practice of those seeking for selectivity to reduce the size of their outside aerials very considerably, and the more efficient the H.F. stage the smaller the aerial which was necessary for the degree of amplification required and the better the selective properties of the receiver.

The well-designed set of to-day employing two stages of screened-grid H.F. amplification can comfortably afford to dispense with an outside aerial altogether, and so we see the increase in the popularity of the portable as a direct result of the great advances which have been made in H.F. amplification. It seems likely that as time goes on the unsightly outside aerial will disappear almost entirely from the chimneys and the back gardens, and those that remain will brand the user as the owner either of a crystal set or a very inefficient valve receiver. In fact, the demise of the outside aerial, which would probably take place in any event as a direct result of technical developments, will be hastened by reason of that same characteristic of human nature which registers dislike at driving a car preceded by a starting handle in these enlightened days of electric self-starters!

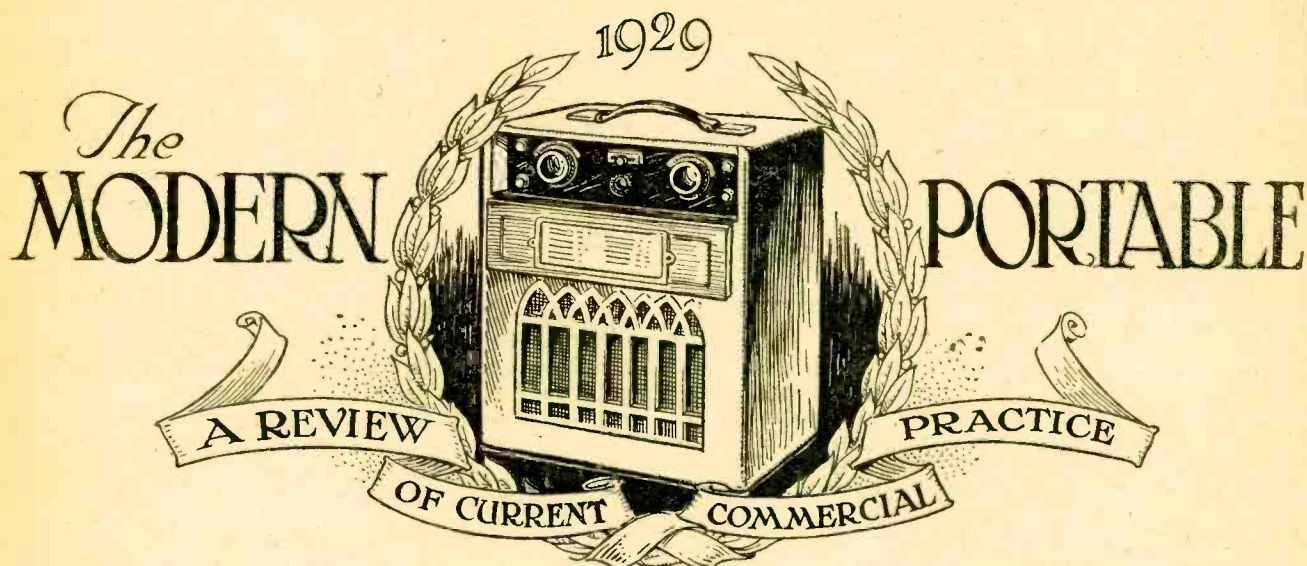

NO longer is the portable set the synonym of outdoor reception. It has passed from the position of the least satisfactory of radio receivers to one of omnipotence. Out-of-doors use with the picnic party or in the car, so generally visualised as the purpose of the portable, is now but a minor application.

The fact which has made the portable the typical receiver of to-day is that it can be built without need for undue compromise in design which might prejudice performance while giving the great advantage of a self-contained set devoid of external connections. A concentration on the production of portables by practically all manufacturers has been regarded in many quarters as a passing phase; yet we are forced to admit that it now holds the field as the leading type of radio receiver. Valve improvement is the foundation on which the portable builds. With the best valves of a year or so ago, such as the .06 and D.E.5 classes, portable receiver designs suffered from many defects. It is not unduly difficult with the valves

of to-day to build a stable H.F. amplifier giving such a high degree of magnification that the use of a small frame is preferred to the elevated outdoor aerial. Ample low-frequency amplification can now be obtained without the sacrifice of quality, while the apparatus employed is less heavy and more compact than formerly.

Most important of all is that concurrent with the advance of the portable comes the commencement of the regional scheme. London listeners will shortly be within the shadow, almost, of a station of 5GB dimensions, and it is safe to predict that attention will be turned to the self-contained frame aerial receiver. That

we shall have two outstanding types of receiving sets is a safe prediction—the generous all-mains quality receiver with moving-coil loud speaker and, as its junior, the more modest self-contained set which up to the present has been known as the portable.

In that progress is revealed by change of practice we find many interesting facts in comparing receivers of this season with those of a year ago. We look first for any wide disparity in a summary of the features of the designs, and next for examples of new and outstanding practice. As there is not a downward trend

in the number of amplifying stages used in this year's portables as expressed by a percentage representing those sets fitted with five valves it might be thought that the single efficient H.F. stage as well as the pentode have not yet found their way into portable receiver design. Actually several manufacturers in adopting the pentode output have replaced their five-valve receivers with four-valve models. Because there are more sets

this year than last, the number of five-valve sets has increased to 75 per cent. of the total for all types, yet this year there are 18 per cent. sets in which the pentode is fitted either as standard practice or will be supplied if required, as against last year without a single instance. Particular two- and three-valve sets of last year have disappeared, whilst new ones incorporating the pentode have maintained a figure of 10 per cent. for receivers of this class.

It was surmised last year that there would be a tendency to simplify tuning in the direction of a reduction in the number of sets fitted with two-dial con-

No longer is the portable a specialised class of receiver involving compromises in design that may impair its performance. Neither is the portable any longer regarded as an out-of-doors set but rather as the ideal popular receiver for home use. The high-power London station at Brookmans Park which is shortly to replace the 2LO equipment will further encourage the use of the self-contained set with enclosed frame aerial.

Present-day practice is carefully analysed in this article and the facts disclosed should prove helpful to the amateur, the set builder and the designer. Portable set designs are arrived at only after considerable experimental work combined with careful testing, and the result of much experience is here revealed.

PORTABLES of 19/29

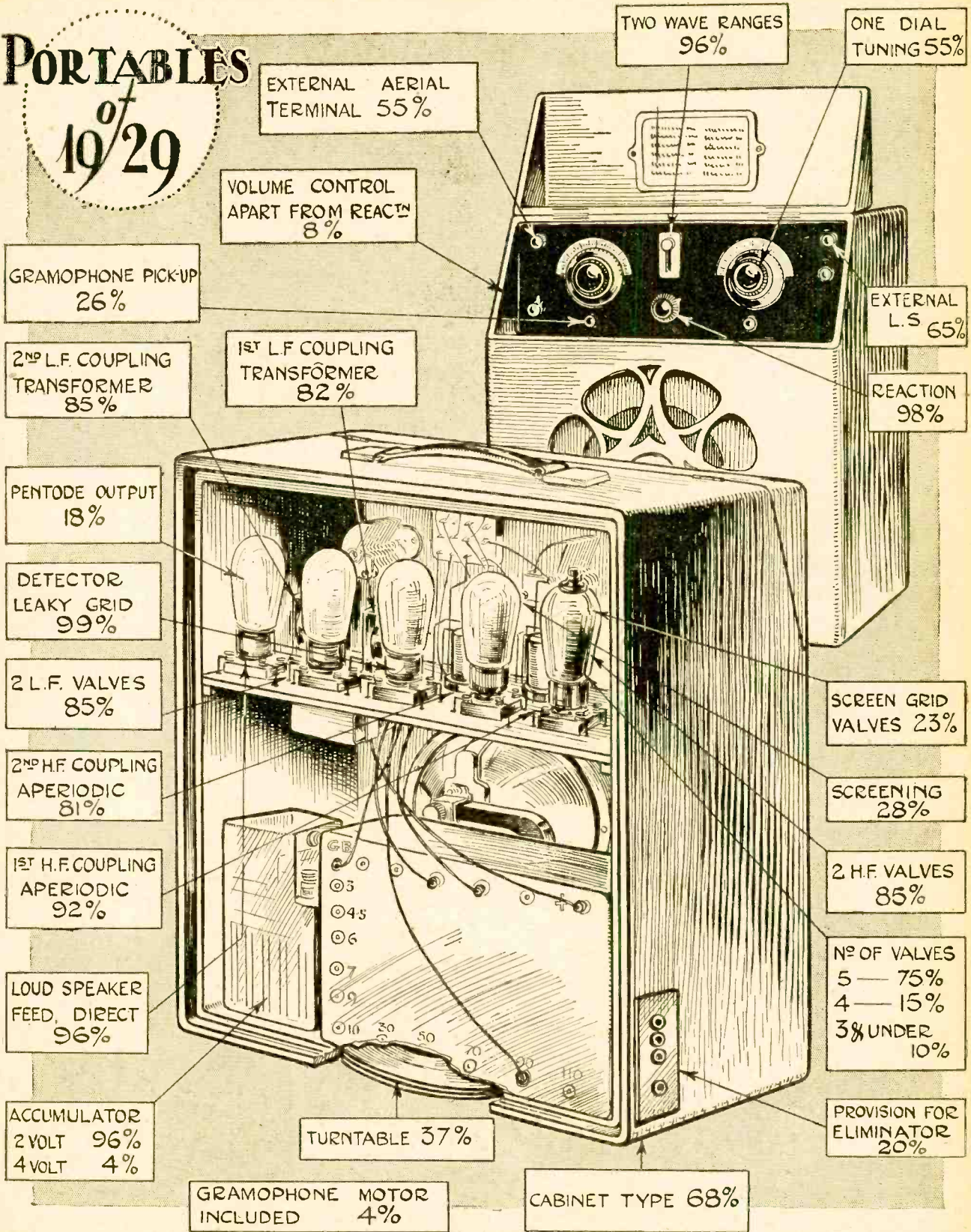

TWO WAVE RANGES 96%

ONE DIAL TUNING 55%

EXTERNAL AERIAL TERMINAL 55%

VOLUME CONTROL APART FROM REACT'N 8%

GRAMOPHONE PICK-UP 26%

EXTERNAL L.S. 65%

2ND L.F. COUPLING TRANSFORMER 85%

1ST L.F. COUPLING TRANSFORMER 82%

REACTION 98%

PENTODE OUTPUT 18%

DETECTOR LEAKY GRID 99%

SCREEN GRID VALVES 23%

2 L.F. VALVES 85%

2ND H.F. COUPLING APERIODIC 81%

SCREENING 28%

1ST H.F. COUPLING APERIODIC 92%

2 H.F. VALVES 85%

LOUD SPEAKER FEED, DIRECT 96%

N^O OF VALVES
5 — 75%
4 — 15%
3^{OR} UNDER 10%

ACCUMULATOR
2 VOLT 96%
4 VOLT 4%

TURNTABLE 37%

PROVISION FOR ELIMINATOR 20%

GRAMOPHONE MOTOR INCLUDED 4%

CABINET TYPE 68%

The Modern Portable.—

trol. The trend has been otherwise, however, for whereas last year more than four-fifths of the total number of sets had one-dial tuning, we find that only

in two-dial tuning, there is likewise a decrease in the use of an aperiodic coupling preceding the detector. Significant is the increase in the use of screening, now to be found in more than a quarter of the total number of

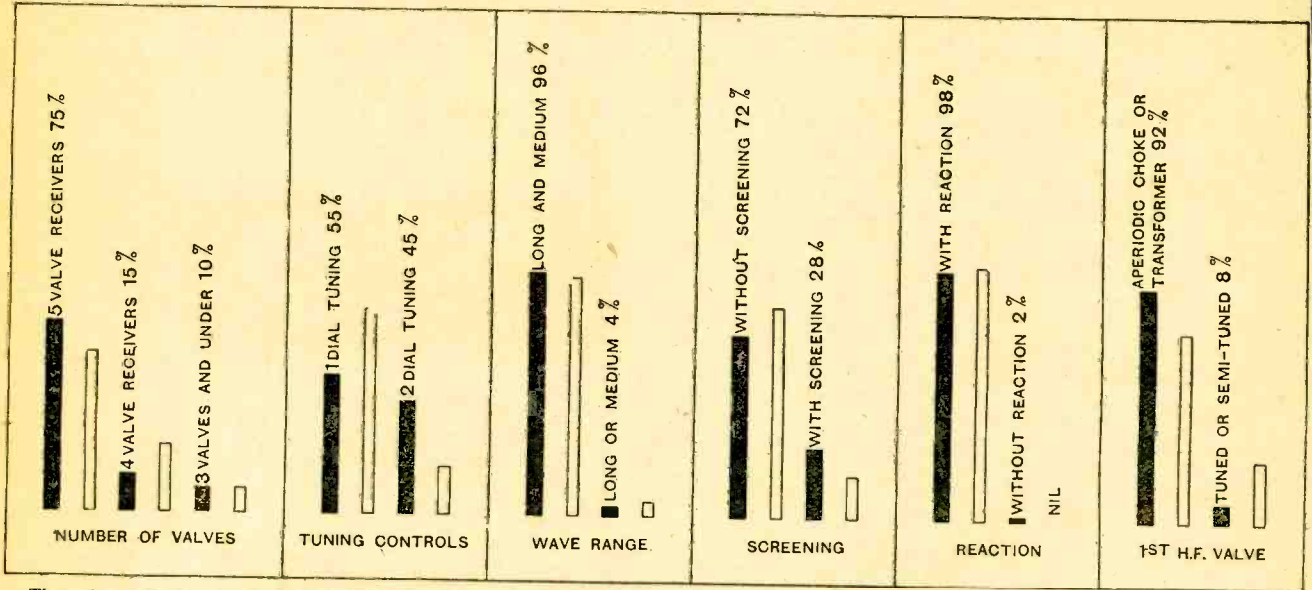

The columns in black refer to this year's portables while the open columns afford a comparison with the sets of last year. Significant in this section is the decline in single dial tuning and the increase in the use of screening.

just over one-half are so arranged. This change is important and marks the introduction of tuned H.F. stages as giving better performance than the all-aperiodic H.F. amplifier formerly so extensively used. This change is due to the more extensive use of the screen-grid valve, while practically no manufacturer claims the use of intentional neutralising as a means of providing stability. As to the actual forms of H.F. couplings used, it is revealed that there is a slight increase in the adoption of the aperiodic choke as against tuned anode or tuned transformer in the case of the first H.F. stage. Consistent with the increase

receivers as against an estimate of 17 per cent. for last year. This fact also reveals the extending adoption of the screen-grid valve. Manufacturers have not shirked the difficulties arising out of two-range tuning so as to give reception on both the broadcast and the higher wave band. Fewer sets are now to be found which are capable of receiving only on the broadcasting band or 5XX.

Improved H.F. Amplifiers.

As far as can be ascertained, there was no single instance in the records of last year of a set that was not provided with reaction. In this year's data there are

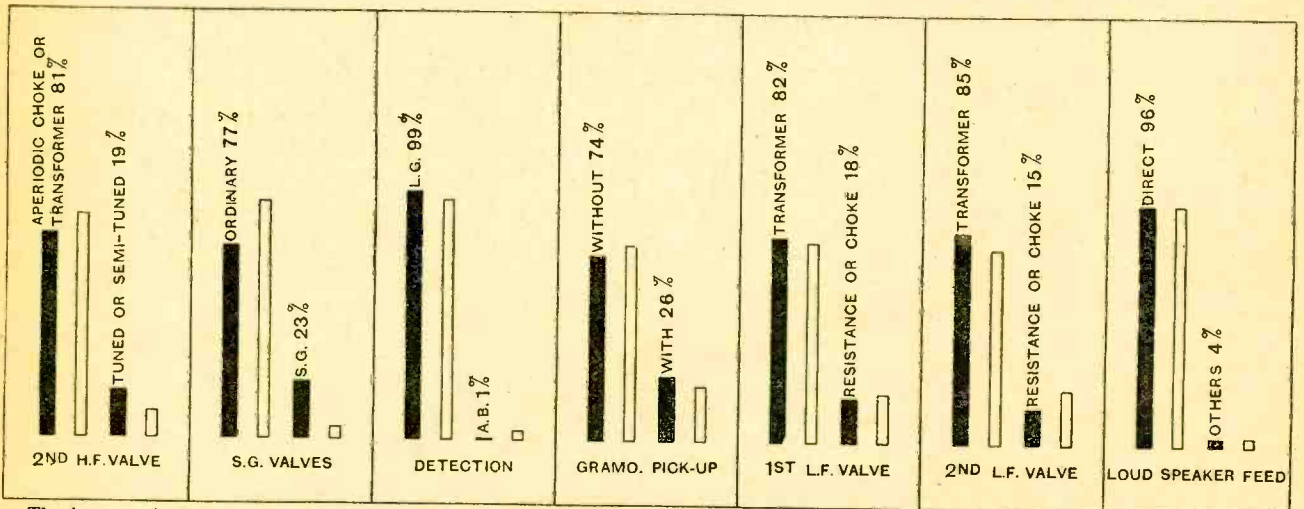

The increase in the number of tuning controls and the use of screening as compared with last year arises out of the larger number of sets now fitted with screen-grid valves. While there is an increase in the number of sets using aperiodic H.F. coupling after the first H.F. valve there is a decline in the use of aperiodic second stage amplifiers.

The Modern Portable.—

several definite instances where reaction is not included and where unintentional reaction does, probably, not occur. From this we see the improvement which is taking place in the efficiency of the H.F. amplifier which is not unassociated with the increase from 5 per cent. to 23 per cent. in the number of sets fitted with screen-grid valves.

Decline of the Anode Bend Detector.

Better H.F. amplification might suggest an increase in the use of anode bend detection. Experience, however, reveals the advisability of using leaky grid detection, and whereas last year there were several examples of the inclusion of an anode bend detector, the practice has now almost disappeared, and this in spite of the declining use of reaction.

Of radically new features there are few. That in 4 per cent. of the sets this year the 4-volt accumulator is adopted for filament heating must have arisen from the improved results that the particular 4-volt valves chosen provide. It is the 4-volt pentode valve that probably accounts for this change. There is good reason to believe that the rendering of accumulators unspillable by glass wool packing or jelly electrolyte is unsatisfactory as revealed by the almost unanimous adoption of celluloid cells with acid-locking vents. Another growing tendency is that in no less than 20 per cent. of the sets attention has been given to the external connection of filament and anode current leads. Thus, not only can the portable be operated from batteries of more generous dimensions than those fitted, but where mains are available connection can readily be made to a battery eliminator.

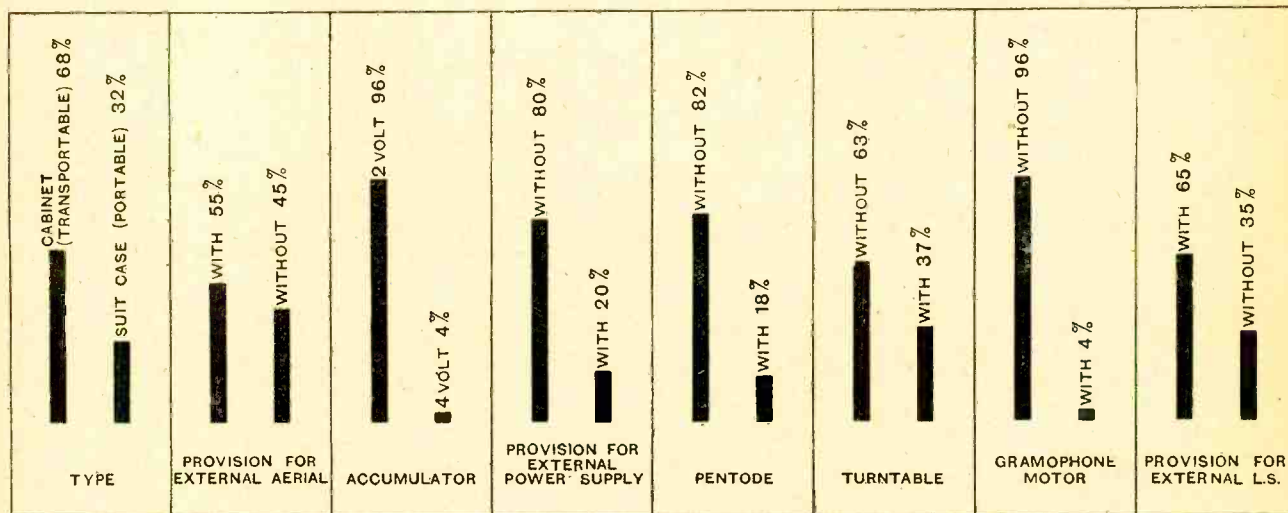

These columns refer to new details of design or to particulars of which no previous data are available by way of comparison. Observe the use of the 4-volt accumulator and the high proportion of sets which are available with pentode output valve.

An examination of the L.F. amplifier reveals the interesting point that there is a decline in choke and resistance couplings with a corresponding increase for the transformer. Figures calculated for this year and last show practically no change as to the number of sets fitted with gramophone pick-up or in the method of feeding the loud speaker. More than 50 per cent. of the sets have aerial and earth terminals. That all sets are not so fitted suggests unsatisfactory results by way of flatness of tuning when an aerial wire is connected, while indicating absolute confidence in the performance of the set without resorting to the aid of an elevated aerial. It is possible with more than half the total number of sets to connect an auxiliary loud speaker. The figure is slightly less than last year, however, as many manufacturers are of the opinion that to provide for plugging in a pair of telephones is unnecessary. There is just the consideration, however, that a portable not so fitted cannot be used for picture reception. Little mention has been made previously of the fact that many sets are now fitted with a turntable for rotating the set. This accessory must almost be regarded as an essential and is, in fact, present in nearly 40 per cent. of the sets.

A somewhat ambitious development is that of combining within the limited space of the portable a gramophone motor and turntable either to function essentially as a gramophone or with the aid of a pick-up as an electrically reproducing gramophone.

The Portable a British Product.

Although many manufacturers offer receivers of both cabinet and suitcase type, the percentage for the former shows an increase for this season. Little success has been met with by way of making sets less heavy. Cabinet work may be lighter, but the dominant weight lies in the batteries and no endeavour should be made to reduce their capacity.

This year's analysis shows that progress has been made to an extent that has changed the status of the portable. Elsewhere in this issue are technical specifications of no less than 150 standard British made portables. Foreign instruments have not been excluded, and the fact that there are none is significant. The high efficiency portable is of entirely British origin, and is not to be found among the products of other European and American manufacturers.



Events of the Week

in Brief Review.

THE ULTRA-PORTABLE.

The Elgin Watch Company, of Illinois, is devising a radio watch "that will tick in its owner's pocket although its power plant is miles away," says a Washington message. Progress has been reported to the Institute of Radio Engineers, but it is stated that the work is still in the research stage.

THAT SPARE WAVELENGTH.

Norway has decided that it has no immediate use for the wavelength of 1,070 metres allotted to it by the Prague Conference. The wavelength is therefore being retained by Hilversum.

SHORT WAVES FOR S.A.?

The South African Broadcasting Company is being urged to experiment with a short-wave station to discover whether by this means reception conditions can be improved. The company's service has to cover a very wide area which is never entirely free from fading and atmospherics.

Mr. ERIC DUNSTAN.

Rather novel circumstances surrounded the resignation, on Election night, of Mr. Eric Dunstan, the well-known B.B.C. announcer. In a Press interview Mr. Dunstan said: "I expected to do all the General Election announcements. For some reason Sir John Reith (the Director-General) decided that he would do the announcements himself, and although there were hundreds of telephone calls from all parts of England to say that he was speaking too fast, Sir John Reith decided to continue announcing. I decided immediately to resign my position."

Mr. Dunstan, who was one of the early members of the B.B.C. staff, became General Manager of the Indian Broadcasting Company in 1927, but resigned in October last, with several other European members of the I.B.C. staff, owing to lack of financial support for the company's efforts.

HONOUR FOR LEE DE FOREST.

Dr. Lee de Forest, "the man who put the grid in the valve," has been awarded the John Scott medal by the Franklin Institute, Philadelphia, in recognition of his service to science.

LIFEBOAT WIRELESS.

The importance of wireless even after a ship has gone down is emphasised by

the International Conference on Safety of Life at Sea, which recommends that when more than a certain number of lifeboats are carried, one or more should be motor boats fitted with wireless and searchlights.

ARE BROADCASTING STATIONS A NUISANCE?

Argentina has issued a national decree requiring all broadcasting stations to remove to points outside city limits before December 31st, 1929. Let this be a lesson to the B.B.C.!

STRAIGHTENING OUT BELGIAN BROADCASTING.

The new Belgian Wireless Act, which has just become law, creates a State monopoly in broadcasting and promises to put an end to illicit listening. At the present time it is estimated that licence fees have been paid on only one-tenth of the wireless sets in use, of which there are believed to be 200,000. The annual licence fee will be about 6s. 9d. The administration of broadcasting is to be entrusted to a National Broadcasting Institute on the lines of our own B.B.C.

MORE LISTENERS IN GERMANY.

At the end of March, 2,837,894 wireless receiving licences were current in Germany, an increase of 603,162 in twelve months.

"RADIO"—REGISTERED TRADE MARK.

An effort to register the word "Radio" as a trade mark in Brazil with the idea of creating a monopoly has been thwarted by the U.S. Radio Manufacturers' Association, says a New York correspondent. The American wireless trade, which regards Brazil as a fruitful market, approached the Brazilian Government through the American Embassy at Rio de Janeiro and obtained an assurance that "radio" was common property.

PRIVATE YACHT WIRELESS.

Sir William Berry's motor yacht, "Sona," has been equipped with a Marconi 1½ kilowatt valve transmitter. This has been designed to transmit on interrupted C.W. between 600 and 800 metres, with extra provision for transmission on C.W. between 1,800 and 2,600 metres. The valve receiver for the telephone ser-

vice covers a wavelength range of from 320 to 27,000 metres.

A four-valve broadcasting receiver is also carried, working from a separate aerial.

THE BIG FIGHT.

The sentence, "Your book takes second place!" in a recent advertisement of a well-known wireless firm has drawn protests from the bookselling trade, members of which are urged to take arms to fight the suggestion.

CHAMPION OF WIRELESS DEALERS.

Sir Harry Brittain is the new president of the Wireless Retailers' Association.

THE INCOME TAX ANALOGY.

"No doubt you understand all the sections in connection with the Wireless Telegraphy Act. . . . If you do, you are very wise, because they are as bad as the income tax forms," said the chairman of the Heywood magistrates a few days ago in imposing a fine of 4s. on a Manchester billposter for working a set without a licence.

LISTENERS' SURVEY OF U.S. BROADCASTING.

Ten thousand picked listeners are to combine in a grand survey of American broadcasting now being organised by the Federal Radio Commission, writes a Washington correspondent. These "expert listeners," who have been chosen from districts all over the States, will be required to answer a questionnaire regarding signal strength, fading, atmospherics, etc., with a view to discovering the degree of success attained by the wavelength allocations of last November.

BROADCASTING IN FRANCE.

The Bill regularising French broadcasting was signed by the President of the Republic on Tuesday of last week. While the Government stations will be controlled by a National Bureau, the private stations will continue under their present owners, who will be granted concessions to broadcast on their own responsibility.

A scale of licence fees has been prepared, valve set owners being required to pay about 9s. per annum. Crystal users will pay about 3s.

REPRESENTATIVE PORTABLES REVIEWED

Notes on the Performance of Typical 1929 Designs.

THE student of design wishing to assess the general improvement in portable receivers that has taken place during the past year will find most of the information he requires in the Buyers' Guide in another part of this issue. Statistics extracted from the specifications have also been discussed in an article entitled "Modern Portables," and from these two sources the reader will be able to discover the general trend of circuit development and improvements in constructional details.

Owing to the large number of sets involved the specifications must be brief, and the statistics are, of necessity, subject to broad generalisation. It is thought, therefore, that reviews of a few representative portables in greater detail would serve a useful purpose in supplementing the aforementioned information, more particularly in showing the advance in performance which has been achieved during the past twelve months.

Selected Examples.

It should be clearly understood that there is no implication that the sets chosen are necessarily better than others in their respective class; their choice rests on the fact that they are typical. To emphasise this point we would refer to the case of the Halycon and Burndept sets. In view of the importance of this new and growing class of portable it was decided to deal with more than one specimen. The tests revealed a striking similarity in the performance, not only as regards range and selectivity, but also in the general "feel" of the controls. As is only to be expected there are differences which give each receiver its individual character, but it is significant that in each case the performance as a whole conformed to a type.

Conservative practice in employment of two H.F. stages with a periodic coupling is represented by the Pye Portable, the performance of which is proof that this well-tried system is by no means played out. The Trix shows what can be done with only two valves at a price within the reach of most pockets, while the McMichael is an example of the super portable which is springing up to challenge the best indoor sets that work on an outdoor aerial.

To give the sets a fair trial as regards selectivity, and in order that the conditions might approximate as closely as possible to those under which a portable is usually operated, they were taken into the country to a place approximately twenty miles from 2LO. During the outward journey each set was subjected to an unpremeditated, but none the less severe, test of mechanical strength and rigidity, for the van used for transport had seen better days and was sprung for heavy loads. It is gratifying to record that without exception the sets came through the test with flying colours; not a valve was broken nor a wire displaced.

There can be no doubt that the trade as a whole has now really got down to the fundamentals of portable set design. Without using more than 7 or 8 mA.

of H.T. battery current they have succeeded in combining range and selectivity with a very high standard of quality in reproduction. All the established makes of 4- and 5-valve sets can be relied upon to give at least four foreign transmissions on long waves in daylight, in addition to alternative programmes from the B.B.C., while after dark the score is supplemented by from 6 to 10 reliable transmissions at good loud speaker strength on the short-wave band. It is difficult, if not impossible, in this year of 1929 to buy a really bad new car, and the same applies to portable sets, provided one patronises well-established firms with a reputation among radio manufacturers themselves.

The Set of the Future.

The general improvement in range, quality of reproduction and reliability has put the portable set in a position seriously to challenge the permanently installed receiver working on an outdoor aerial.

In the matter of selectivity, a factor which is likely to become of increasing importance, the portable has distinct advantages, for not only can advantage be taken of the directional properties of the frame, but there is no damping due to an aerial and earth system. Add to this the obvious advantage of mobility, and there can be no longer any doubt that the portable is the set of the future.

TYPES REPRESENTED.

1. **The Miniature Portable.** Inexpensive two and three-valve sets intended primarily for local station reception.
The Trix Portable Two.
o o o o
2. **The Aperiodic Two-H.F. Portable.** Five-valve receivers conforming to the well-established practice of using two H.F. valves with aperiodic choke or transformer coupling.
The Pye No. 25 Portable.
o o o o
3. **The Screen Grid Portable.** Generally a four-valve set with one stage of screen-grid H.F. amplification involving two tuned circuits with reaction.
The Burndept Screened Portable.
The Halycon de Luxe Screened Four.
o o o o
4. **The "Super" Portable.** Receivers of outstanding performance employing two stages of H.F. amplification with screen-grid valves.
The McMichael Super Screened Four.

THE PYE PORTABLE

A Well-made and Reliable Receiver with
Aperiodic H.F. Coupling.

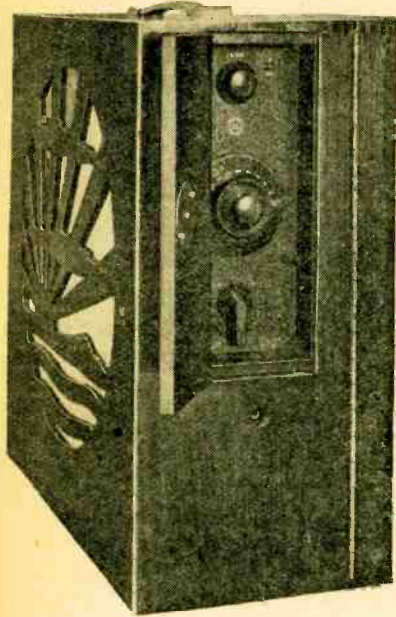

IN spite of the large increase this year in the number of portable sets employing screen-grid, high-frequency valves, receivers with two aperiodic H.F. stages continue to hold their own. There is much to be said for the older of the two methods of H.F. amplification. The overall amplification of the two stages is at least equal to one screen-grid stage. Complicated screening is unnecessary, and it would appear to be easier to repeat performance with greater uniformity than is at present possible with screen-grid valves. There is little to choose between the two systems on the score of current consumption, but the screen-grid valve with its two tuned circuits has greater possibilities in the matter of selectivity. At the present stage in the development of the screen-grid portable, the selectivity is only slightly better than that of the aperiodic amplifier with reaction, but, whereas the latter method has reached the limit of its resources in this direction, the screen-grid valve still has reserves upon which to draw should the necessity for improved selectivity become more acute.

Long-wave Selectivity.

There is room for improvement in the long-wave selectivity of the Pye, but on short waves it can hold its own with most other portables, and

at a distance of twenty miles north of London, 2LO and 5GB do not spread for more than 5 or 6 degrees on either side of their normal dial settings. 5XX, on the other hand, can be heard faintly at all parts of the dial unless reaction is critically adjusted, and there is some difficulty in receiving Radio Paris without a slight background from 5XX. East or west of London this difficulty would not arise, as it would be possible to make use of the directional properties of the frame. In the south, too, conditions would be easier owing to the increased distance from 5XX and the decreased distance from Radio Paris.

The sensitivity of the Pye is excellent, and its range is uniformly good on long and short waves. The sensitivity on short waves is of rather a peculiar quality. Even when reception conditions are bad it is possible on any evening to log at least twenty stations on the short-wave band. Variations in atmospheric conditions seem to govern the number of stations available at enjoyable loud speaker strength, but the total number receivable remains fairly constant. On an average evening six or eight of the twenty odd stations available can be enjoyed from a programme point of view. On long waves it is equally good. The writer has tuned in 5XX at Land's End on a Pye portable at full loud speaker strength with plenty in reserve, and Radio Paris has been enjoyed in the open on Exmoor. At least five other stations can be relied on irrespective of reception conditions on long waves.

The general layout and mechanical construction of the Pye are in keeping with the reliability and simplicity of the H.F. coupling system employed. The three essential controls—tuning, reaction and wave-range switch—are mounted on a crystalline-enamelled panel let into one end of the cabinet. The back is hinged, and gives access to the valves, batteries, and loud speaker adjustment. Sponge rubber strips on the hinged back and in the valve compartment prevent damage to the valves in transit.

Quality and Volume.

The quality of reproduction is good up to the volume required for outdoor conditions. It is possible to produce overloading, but adequate volume is obtained before this state is reached.

The receiver depends a good deal for its success on the judicious use of reaction, and it is pleasant to find that this control is unusually smooth in operation. The reaction coil rotates inside a damping ring, and is driven through a reduction gear. The set goes into and out of oscillation with perfect smoothness, and it is an easy matter to adjust the circuit to its most sensitive condition at each setting of the tuning dial.

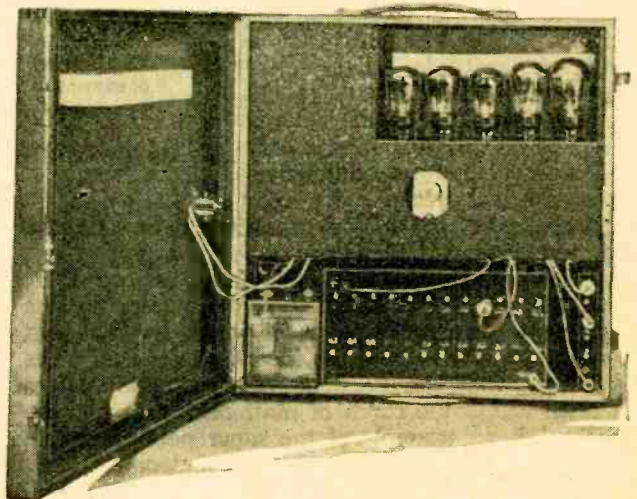

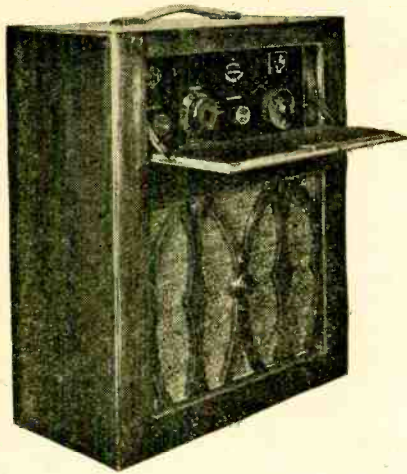

MCMICHAEL SUPER SCREENED FOUR

Exceptional Range and Selectivity with Two
Screen-grid H.F. Stages.

HAVING regard to the difficulty of stabilising two high-frequency stages with screen-grid valves even in a receiver working from an outdoor aerial, considerable interest attaches to any attempt to use two screen-grid valves in a portable where the damping effect of an aerial and earth is absent. There is the additional problem of tuning controls which must necessarily be multiplied in a circuit of this type. In the McMichael set both these difficulties have been overcome and the result is a receiver which sets a new standard in portable set performance. Perfect stability has been attained throughout the whole wavelength range of the set by very careful and complete screening, and the use of aperiodic coupling for one H.F. stage and the introduction of an ingenious ganging device for the remaining circuits has reduced the tuning virtually to a single control.

The performance is of a quality which has rarely, if ever, been attained before in a portable receiver. Foreign stations come in with a drive and incisiveness usually associated with ultra-efficient H.F. amplification on a good outdoor aerial.

On long waves the performance is as good as we have heard on any receiver, irrespective of type. Even in daylight the volume of at least five long-wave stations is so great that it is necessary to tone the set down, not only by dispensing with reaction, but also by reducing the filament current of the screen-grid valves. The long-wave selectivity is well above the average, and there is no difficulty in separating Radio

Paris from 5XX at a distance of 50 miles from the latter station. Königswusterhausen can also be received clear of 5XX if the set is rotated to the position of minimum signal strength from 5XX. This position may not be favourable for the reception of Königswusterhausen, but, provided it does not coincide with the absolute minimum for that station, the exceptional sensitivity of the set when making use of reaction enables full loud speaker strength to be obtained without a trace of 5XX. Incidentally, it is possible to obtain a perfect minimum with an absolutely silent point.

Range on Short Waves.

On short waves the performance, although perhaps less phenomenal than on the long range, is none the less far above the average. Although the total number of stations receivable after dark is no greater than with other high quality portables, the proportion received at good loud speaker strength is higher and the process of tuning-in requires less concentration and effort. At a first sitting, 20 miles north of London, twelve stations were picked up, one after the other, at full loud speaker strength, while an equal number of carrier waves and faint transmissions was noted for future reference. It is this easy logging of stations without constant resort to the use of reaction which constitutes one of the chief charms of the set, a feature which is a strong argument in favour of two screen-grid stages. Incidentally, reaction is very uniform over the tuning scale, and need not be touched unless critical adjustment is required for a weak transmission.

Selectivity on the lower wavelengths is of a high order, and at 20 miles from 2LO and 50 from 5GB, neither station spreads more than three or four degrees.

On the mechanical side by far the

most interesting feature is the dual condenser unit and single-knob control. The condensers are controlled by a compound tuning knob the front disc of which drives both condensers through worm gears. This disc is provided with finger holes in the front and is the part of the dial normally used when searching for stations. When a station is picked up the next step is to place the fingers on the outer knurled edges of both dials and rotate them together. This automatically stops one condenser and rotates the other, so that the two tuned circuits may be brought into exact resonance. Having once mastered the principle the control is delightfully simple to operate and is one of the most ingenious tuning mechanisms that has yet been produced.

The sectioned screening box is a beautiful piece of instrument making, and not the least interesting of its fittings are the hinged valve-holders for the screen-grid valves.

The McMichael Screened Four scores full marks on all the points which go to make the perfect portable—range and selectivity, ease of control, quality of reproduction, battery economy and workmanship.

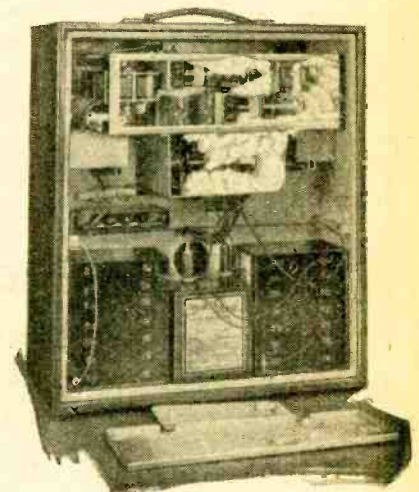

BURNDEPT SCREENED PORTABLE

A Typical Example of a New and Promising Type.

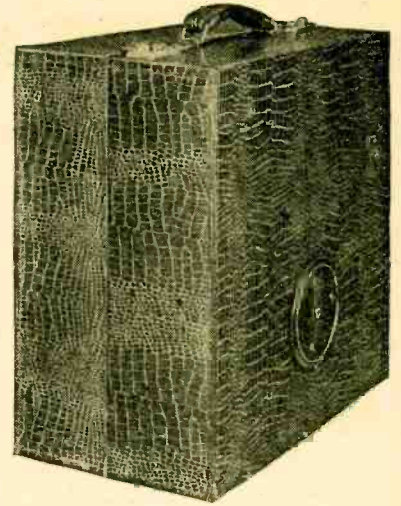

THE four-valve portable employing a single screen-grid valve with tuned intervalve coupling in place of the more common two-stage aperiodic amplifier is steadily gaining in popularity with the leading firms of the wireless industry. Last year only 5 per cent. of the total number of portables on the market were equipped with screen-grid valves, but the statistics this season show that the proportion has already risen to well over 20 per cent.

The Burndept Screened Portable is typical of this new and flourishing class and is representative both in construction and performance. It is of the popular suit-case type with the valves fitted accessibly in a well in the tuning panel. Outwardly there

is little evidence of screening, but underneath the tuning panel a complete system of screening is provided for the tuned anode circuit of the screen-grid valve. The H.F. valve itself is unscreened, but an interesting feature is the use of an armoured lead from the anode terminal of the valve to the tuned circuits inside the screen.

Reaction is applied to the tuned anode circuit and can therefore be used without fear of energising the frame aerial.

The L.F. Stages.

The makers have sufficient confidence in the amplification from the H.F. stage to use resistance coupling in the first L.F. stage, a measure which sacrifices L.F. amplification but is conducive to quality. Transformer-coupling precedes the last stage which employs a P.M. 252 super power valve.

The system of battery connections deserves special mention. The sockets in the combined H.T. and grid battery, instead of being marked with numbers representing voltage, are identified by means of coloured discs. The wander plugs are coloured to correspond with the sockets, and there can be no possibility of error when renewing the battery.

There are four alternative positions for the grid bias wander plug (grey) for the last valve so that a compromise between battery economy and quality of reproduction can be made to suit the individual. As the plug is moved from left to right the quality improves and the H.T. current increases.

Actually, the grid bias voltages with their equivalent H.T. currents (measured) are as follow: 18v., 5.4 mA.; 16½v., 7.2 mA.; 15v., 8.4 mA.; 13½v., 9.7 mA. The L.T. consumption turned out to be 0.66 amp from the 24 amp.-hour 2-volt accumulator.

The quality of reproduction is characterised by crispness and clearness, which may be attributed to lack of bass, or, alternatively, to good reproduction of high notes. Whatever the cause, the result is to give unusually good diction when reproducing speech.

The Burndept Etholog dials are calibrated at the works in wavelengths, both long and short ranges being covered. This is of great assistance not only in searching for stations but in helping to identify unknown transmissions.

The range is good both on long and short waves. In addition to 2LO and 5GB, six stations were received at full loud speaker strength after sunset; approximately 20 stations in all could be logged, though the strength in most cases was hardly sufficient for the proper enjoyment of the matter broadcast. The long waves provided four reliable stations in addition to 5XX, all of which could be enjoyed in daylight.

Finally, the Burndept Screened Portable seems to be affected less by atmospherics than most sets—a distinct advantage, since portables are used most in the summer months when atmospherics are at their worst.



HALCYON DE LUXE SCREENED FOUR

A High-class Suit-case Portable giving Exceptional Quality of Reproduction.

ALTHOUGH from its appearance one would at first classify this set as a suit-case portable, a closer inspection reveals that it has many of the characteristics of the cabinet type portable. The case is of solid polished walnut, the lid containing the loud speaker is deeper than usual and is decorated with an elaborate grille. The weight of the set complete with batteries is 33lb., so that it really falls between the portable and transportable categories. The cabinet's locks and fittings are of unusually good quality, and the general finish is of a high standard.

Electrostatic Screening.

Externally the layout follows the conventional practice of the suit-case portable. The valves are situated in a well between the tuning panel and the battery compartment. Actually the tuning panel covers a very complete system of aluminium

screening compartments. The detector, too, is provided with a separate compartment to itself, as will be seen in the photograph of the open set.

The screen-grid valve is coupled to the leaky grid detector by a H.F. transformer to which reaction is applied through the usual capacity control. Taken individually the circuits are not sharply tuned, but the overall selectivity is of a higher order than that usually associated with portables employing aperiodic H.F. coupling.

A high-magnification first L.F. valve is transformer-coupled to the output valve—a two-volt super-power valve. Decoupling resistances are included in the H.T. leads to the H.F. and first L.F. valves as a precaution against low-frequency oscillation. All the valves are mounted in anti-microphonic valve-holders, but a slight tendency to microphonic reaction was observed; however, this may have been due to the particular valves fitted to the receiver under test.

To get the best results the reaction control should be used with care. It is somewhat critical, and the set emits a warning howl if the threshold of oscillation is overstepped.

The sensitivity of the receiver is rather better on short than on long waves if the degree of reaction required is any guide. However, there is very little in it, and in any case the long-wave performance is quite satisfactory. Four stations other than 5XX were received at good volume, and no difficulty was experienced in separating Radio Paris and 5XX.

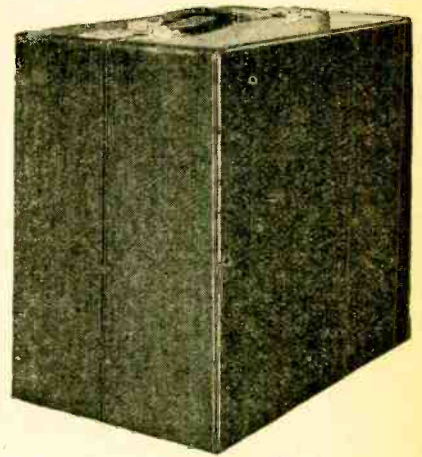

A test after dark on the short-wave band produced nine stations at good loud speaker strength, which is somewhat above the average performance of the class of receiver to which it belongs. Many of these stations were received in daylight but not at full loud speaker strength, and only with very close adjustment of the reaction control. Selectivity on the short-wave band is surprisingly good, and few, if any, stations are lost through interference from the local station.

High-quality Reproduction.

We now come to what is undoubtedly the outstanding feature of the set, namely, the unusually high standard of reproduction. The richness and fullness of tone is the first thing to attract attention when switching on the set for the first time. The loud speaker is a 12-inch Celestion mounted inside the lid of the case. Possibly the solidity of the woodwork in the case has something to do with the tone. Credit must also be given to the design of the L.F. amplifier and the transformer used for coupling the L.F. valves. The quality is all the more surprising when one takes into account the fact that the H.T. voltage is only 99. The measured H.T. current for the particular receiver tested was exactly 10 mA.

To sum up the leading features of the Halcyon set we would say that its range, when careful use is made of reaction, is above the average, and for quality of reproduction it stands in a class by itself.



TRIX PORTABLE TWO

Loud Speaker Results with Two Valves.



THIS receiver is representative of a type which has recently sprung up to challenge the monopoly of the four- and five-valve portable. No one would suggest that the same range is possible with two as with five valves, but not everyone wants foreign stations or even an alternate programme, and to this class of listener the two-valve portable should make a strong appeal on account of its low price, compactness and economy.

Compactness and Low Weight.

The Trix Portable Two measures only $13\frac{1}{2} \times 13\frac{1}{2} \times 7$ in., and its weight complete with batteries does not exceed 16 lb.; it is just as easy to carry as an attaché case. The loud speaker, valves and batteries are mounted as a single unit in a light wooden frame which fits inside the outer case. The hinged back carries a small inspection door which gives access to the tuning controls.

To ensure the highest possible efficiency, the frame aerial is space-wound with Litz. Leaky grid rectification is employed, but the damping effect on the frame is not serious, since the grid-filament circuit is connected only across one half of the winding. The centre-tapped frame is also used to obtain reaction effects through a small condenser connected between the free end of the frame and the anode of the detector valve. Actually this condenser is of the small neutralising type mounted on the control panel and marked "Reaction."

The detector is transformer-

coupled to the output valve, which is a type 230 PP Six-Sixty pentode. The high amplification factor of this valve contributes largely to the success of the receiver, and it is doubtful whether adequate loud speaker strength would be otherwise obtainable.

Another factor which contributes to the general efficiency of the set is the 12-inch cone loud speaker. The movement is adjustable and should be set with the armature just off the pole pieces if the full possibilities of the receiver are to be realised.

The H.T. voltage is 105, and the total H.T. current is from 5 to 9 mA, depending on the grid bias setting. A $16\frac{1}{2}$ -volt bias battery is provided, and experiments with grid bias values from $13\frac{1}{2}$ to $16\frac{1}{2}$ volts are well worth while in order to arrive at a compromise between quality, sensitivity and battery economy. A safety fuse in the form of a flash-lamp bulb is fitted in an accessible position near the pentode valve holder. Filament current is drawn from a 2-volt, 15 ampere-hour unspillable accumulator. Care should be taken when replacing the batteries that the leads do not touch the loud speaker cone, as this may cause chattering.

The set was first tried out in a car in the London area, and everywhere excellent loud speaker volume was obtained from 2LO—quite sufficient to be heard above traffic noises in the busiest streets. Encouraged by the first success, the next test was made at a distance of 20 miles from 2LO and 50 miles from 5GB. This proved a little too severe, however, and while both stations

could be tuned-in, the volume even indoors was hardly satisfactory. At a distance of 8 miles from 2LO, however, the loud speaker strength out of doors, whilst not overpowering, was satisfactory up to a distance of 10 or 15 ft. from the set.

As is only to be expected with a Litz-wound frame of low resistance, tuning is somewhat critical, and but for the slow-motion dial there would be some possibility of over-shooting the station when working the set at distances near its limiting range.

Evidence of Efficiency.

However, the sharpness of tuning can be regarded as evidence that the maximum efficiency is being obtained from the tuned circuit. There can be no doubt that the low-frequency valve is pulling its full weight, and with a sensitive 12-inch loud speaker to make the most of its output we have a portable set which conclusively proves that loud speaker results are possible with two valves. While the reserve of power is hardly sufficient for outdoor picnics outside a 10-mile radius of 2LO, it is more than adequate for town use, and the set should make a strong appeal to flat dwellers on account of its compactness and low cost.

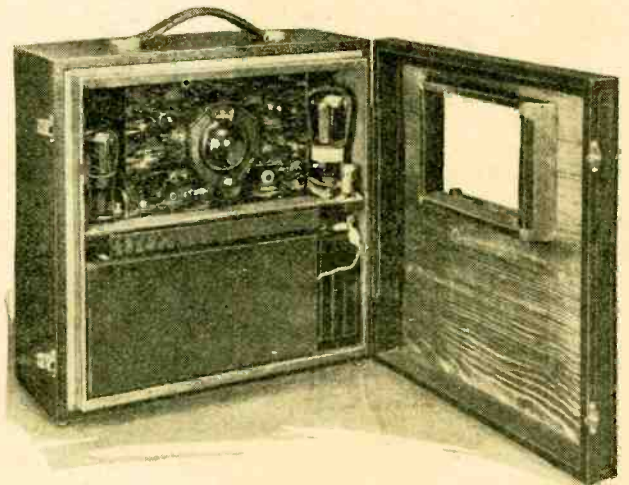

Buyers' Guide to Portable Sets

1929



Abridged Specifications
of
Self-contained Receivers.

IF the prospective buyer of a portable set has any definite opinions as to the best circuit arrangement for his own particular needs, the information contained in the following pages will enable him to narrow down his field of search; even if he has no concrete ideas on the subject, the specifications given will at least be helpful when read in conjunction with other articles in this issue.

At one time there was a fairly clear line of demarcation between "portable" and "transportable" sets; the first type was generally mounted in a leather-covered suitcase type of container, and was thus intended mainly for use out of doors or when travelling, while the title

of "transportable" was allotted to sets in upright wooden cabinets of an appearance and of dimensions suitable for use in the home. Nowadays there is a tendency for these distinct types to merge together, and we find many sets in good-looking cabinets which are at the same time designed for portability, and, as often as not, provided with a turntable to assist in the orientation of the frame and a removable cover to protect them during their excursions abroad.

Except where stated to the contrary, it is to be assumed that both wavebands are covered, and that the price quoted is for the set complete with batteries and royalties.

ADVANCE.

Five-valve Portable.

Specification: First H.F. valve resistance-coupled; second H.F. valve choke-coupled, grid detector followed by two transformer-coupled L.F. stages. Reaction applied to frame aerial. One-dial tuning. Dimensions 16x17x9in. Weight 30 lb. £16 16s.



Advance Five-valve Portable.

The set is suitably wired for a gramophone pick-up, and an external loud

speaker can be used at will. A turntable is fitted as standard, and assists in orienting the frame aerial. An Exide 2-volt unspillable accumulator of 26 amp-hours capacity is supplied. The H.T. voltage is 108.

Three-valve Portable.

Specification: Regenerative grid detector followed by two transformer-coupled L.F. stages. Battery specification as for five-valve portable. Reaction applied to frame aerial. One-dial tuning. Dimensions 16x17x9in. Weight 28 lb. £14 10s.

Provision is made for using a gramophone pick-up and external loud speaker. The output valve is directly coupled to the loud speaker.

The "Advance" Radio Co., Carlton House, Lower Regent Street, London, S.W.1.

o o o o

AEONIC.

Transportable Five.

Specification: Two choke-coupled H.F. valves and grid detector followed by transformer- and resistance-coupled L.F. stages. Single tuning control and reaction. Dimensions 15x16x7½in. Weight 30 lb. £16 16s.

In walnut upright-type cabinet. Exide 2-volt accumulator, 23 A.H. capacity, and Ever-ready 108-volt H.T. battery.

Suitcase Five.

Specification: As for "Transportable Five," but dimensions 15x12x8½in. Weight 27 lb. £16 16s.



Aeonic Upright Transportable.

In real hide suitcase. Exide 2-volt A.H. accumulator fitted.

**Buyers' Guide to Portable Sets, 1929.—
Screened Grid Four.**

Specification: S.G. high-frequency valve, transformer-coupled to leaky grid detector and followed by two transformer-coupled L.F. amplifiers. Reaction between detector anode and H.F. coupling. Two tuning controls. Dimensions 15x12x8½in. Weight 26 lb. £18 18s. In antique hide suitcase. Type S.215 screen-grid valve. Two-volt Exide

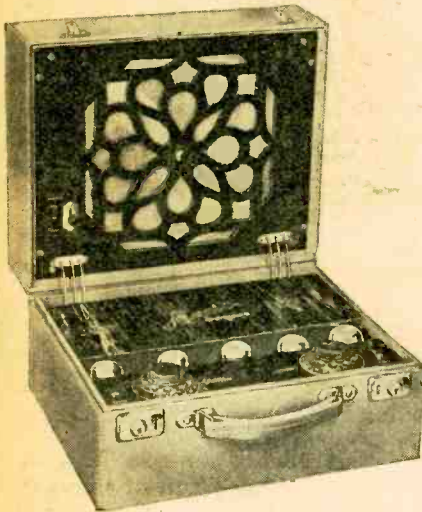
**Aeonic Suitcase Model.**

accumulator and 108-volt Exide H.T. battery.

Aeonic Radio, Ltd., 90, Regent Street, London, W.1.

○○○○

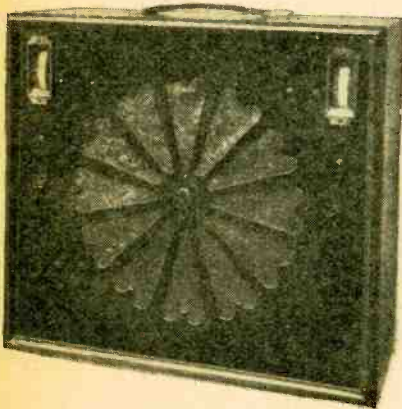
AUTOMOBILE ACCESSORIES.**P.D. Melody Portable Five.****P.D. Model Five.**

Specification: Two aperiodic H.F. stages, grid detection, and two transformer-coupled L.F. amplifiers. Single tuning control with reaction. Dimensions 18x16x7½in. Weight 28 lb. £15 15s.

In figured oak cabinet, with ample space for 100-volt H.T. battery of standard capacity. Frame aerial is mounted above the battery compartment.

Automobile Accessories (Bristol), Ltd., Sion Road, Bedminster, Bristol.

**B. AND J. WIRELESS.
Transportable.**

Specification: Two choke-coupled H.F. valves, grid detector, and two transformer-coupled L.F. stages. Single tuning control with reaction. Dimensions 15x15x8in. Weight 30 lb. £20.

**B. and J. Transportable.**

In polished oak case with turntable. Set proper may be removed from the case as a complete unit; thus all components are readily accessible. Fitted with Hart 2-volt 30 A.H. accumulator and two Ripault's 60-volt H.T. batteries.

B. and J. Wireless, Ltd., 2 and 3, Athelstane Mews, Stroud Green Road, London, N.4.

○○○○

BERENDSEN.**Uwana Portable.**

Specification: Five valves (Mullard 2-volt); two aperiodic H.F. stages, detector followed by R.C.-coupled first L.F. stage and transformer-coupled second stage. Reaction applied to frame aerial. One-dial tuning. Dimensions 15½x15½x7¼in. Weight 26 lb. £16 16s.

The loud speaker which is directly coupled to the output valve has an elliptical floating-cone movement. The voltage of the H.T. battery is 100, and the total anode current about 7mA. Provision is made for the use of an external battery eliminator, and there are connections for a gramophone pick-up.

S. Berendsen, Ltd., 10, Philpoy Lane, London, E.C.

○○○○

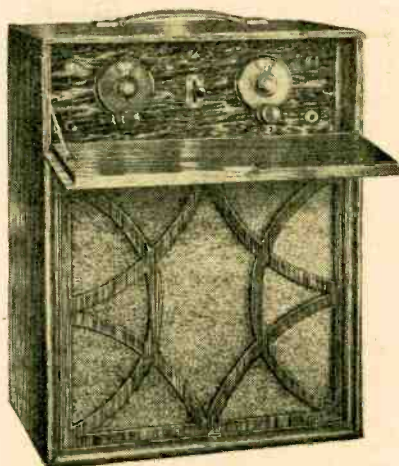
BRITISH RADIO GRAMPHONE.**British Radiogram Portable.****British Radiogram Portable.**

Specification: Two aperiodic H.F. amplifiers, grid detector, and two transformer-coupled L.F. stages. One tuning dial with reaction. Dimensions 18½x14½x9in. Weight 31 lb. £21 15s. Provision is made for attachment of gramophone pick-up, and an external aerial and earth may be connected. Oak or mahogany case, mounted on turntable.

British Radio Gramophone Co., Ltd., 77, City Road, London, E.C.1.

○○○○

BURGOYNE.**Transportable de Luxe.**

Specification: Five valves; two aperiodic H.F. stages, detector followed by two transformer-coupled L.F. stages. Reaction applied to frame aerial. Loud speaker fed direct from last valve. One-dial tuning. Dimensions 16½x17½x8¾in. Weight 36 lb. £31 10s.

A double-capacity H.T. battery of 124 volts provides the total anode current of approximately 11mA. A Rowland Edwards 2-volt unspillable accumulator of 30 amp.-hours capacity is supplied. The loud speaker unit is made by Mullard.

Pentode Portable.

Specification: Five valves; two aperiodic H.F. triodes, grid detector followed by R.C.-coupled first L.F. stage and transformer-coupled second stage to pentode. One-dial tuning. Volume control by means of reaction condenser. Dimensions 15x12½x8in. Weight 26 lb. £23 2s.

**Five-valve Suitcase Portable by
Burgoyne.**

The H.T. battery is 99 volts; total anode current 8mA. The filaments are supplied by a 2-volt unspillable accumulator of 20 amp.-hours capacity. Provision is made for the use of an external loud speaker if extra volume is required.

Model A Portable.

Specification: Five valves; two aperiodic H.F. stages, detector, first L.F. stage R.C.-coupled, second stage transformer-coupled. The output valve is directly coupled to the loud speaker. H.T. 99 volts. Total anode current 8mA. Dimensions 15x12x8in. Weight 26 lb. £21.

Both wavebands are covered and tuning is effected by one dial. Volume is controlled by a condenser which feeds back energy to the frame aerial. A Mullard Permucore transformer is used.

Burgoyne Wireless, Ltd., 34A, York Road, King's Cross, London, N.1.

○○○○

BURNDEPT.**Screened Portable.**

Specification: S.G. high-frequency amplifier, coupled by tuned anode to leaky grid detector;

Buyers' Guide to Portable Sets, 1929.—

resistance- and transformer-coupled L.F. amplifiers. Two tuning controls with reaction. Dimensions 15x15x8½in. (closed). Weight 29 lb. Price in crocodile-grained hide or mahogany, £25 12s. 6d.; in blue morocco, £30.



Burndept Screened Portable.

Suitcase portable type. Dials are directly calibrated in wavelengths for both medium and long broadcasting bands. Two-volt, 24 A.H. accumulator, and 108-volt Grosvenor H.T. battery. Super-power P.M.252 output valve.

Burndept Wireless (1928), Ltd., Eastnor House, Blackheath, London, S.E.3.

○○○○

BURNE-JONES.

Magnum Portable.



Burne-Jones Magnum Five.

Specification: Two aperiodic H.F. stages and grid detector followed by transformer- and resistance-coupled L.F. amplifiers. Single tuning control, with reaction. Dimensions 15x15x9¾in. Weight 27 lb. £18 18s.

A 27

Suitcase portable type. Amplion cone loud speaker, Exide 18 A.H. accumulator, and Hellesen H.T. battery are fitted. Leatherette covered case. Provision is made for optional connection of external aerial-earth system.

Magnum Transportable.

Specification: As Magnum Portable, but dimensions are 18x17x8¾in. Weight 28 lb. £18 18s.

In upright polished mahogany cabinet, with carrying handle.

Burne-Jones and Co., Ltd., Magnum House, 296, Borough High Street, London, S.E.1.

○○○○

CANTOPHONE.

Attaché-case Portable.

Specification: Two valves for headphone reception only. Regenerative grid detector transformer-coupled to L.F. stage. Reaction applied to frame aerial. One-dial tuning. Dimensions 12x9x5in. Weight 10 lb. £10 10s.

This lightweight set is capable of operating a loud speaker up to 5 or 6 miles. Two Ever Ready H.T. batteries of 22½ volts are connected in series for the H.T. supply. The total anode current is 1.5mA. The 2-volt unspillable accumulator has a capacity of 10 amp.-hours. Both wave ranges are covered.

The Cantophone Wireless Company, Remo House, 310-312, Regent Street, London, W.1.

○○○○

CASTAGLIONI.

Castaphone Uni-Four.

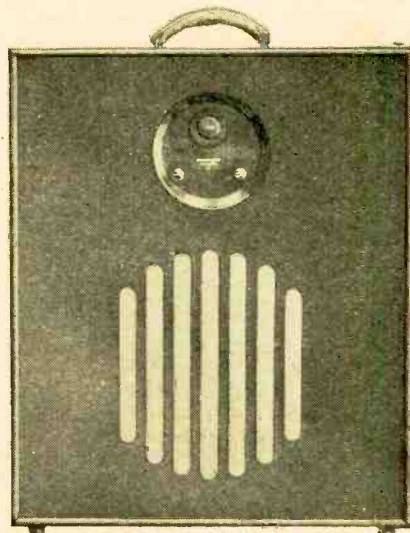

Castaphone Uni-Four.

Specification: One choke-coupled H.F. valve and leaky grid detector, followed by resistance- and transformer-coupled L.F. amplifiers. Single tuning control with reaction. Dimensions 16x16x8in. Weight 26 lb. £12 12s.

For reception of long broadcasting waveband only. Fitted with "Kathanode" 2-volt, 30 A.H. accumulator, and Ripault's "Utex" 99-volt H.T. battery.

Castaphone D.W./4.

Specification: As for Castaphone Uni-Four, but covers both medium and long wavebands. Same accessories are included. £14 14s.

Gordon Castaglioni, M.I.R.E., Castaphone Radio Works, 71, Culver Street, Colchester, Essex.



Castaphone D.W./4.

○○○○

CATESBYS.

Five-valve Portable.

Specification: Two aperiodic choke-coupled H.F. amplifiers, detector, first L.F. transformer-coupled, second L.F. R.C. coupled. Reaction applied to frame aerial. Dimensions 12½x8x15½in. Weight 25 lb. £15 15s.



Catesbys Attaché-case Five-valve Portable.

The five Six-Sixty 2-volt valves are fed from an Edwards unspillable accumulator of 20 amp.-hours capacity. A Pertrix 100-volt H.T. battery is supplied; the total anode current is 7mA. The receiver is tuned with one dial.

Catesbys, Ltd., 64-67, Tottenham Court Road, London, W.1.

○○○○

CAVENDISH.

All-mains Portable Three.

Specification: A.C. screen-grid H.F. valve aperiodically coupled to a grid detector which is followed by a pentode. One-dial tuning. Reaction applied to H.F. coupling. Provision for a gramophone pick-up. Dimensions 14x12x9in. Weight 26 lb. £28 10s.

The receiver contains a balanced armature loud speaker choke-filter fed from the pentode. The A.C. eliminator which provides both H.T. and L.T. is contained within the cabinet; the latter can be finished in walnut or mahogany or in various shades of hide, lizard or crocodile.

Buyers' Guide to Portable Sets, 1929.—

Portable Three.

Specification: Screen-grid H.F. valve linked by neutralised tuned anode coupling to grid detector which is transformer-coupled to a pentode. Reaction applied to H.F. coupling. Connection for gramophone pick-up. Dimensions 14x12x9in. Weight 25 lb. £24 17s. 6d.

The 2-volt valves are supplied with filament current from an Exide unspillable cell of 26 amp.-hours capacity. A Pertrix H.T. battery of 100 volts delivers the anode current, which totals 9mA.

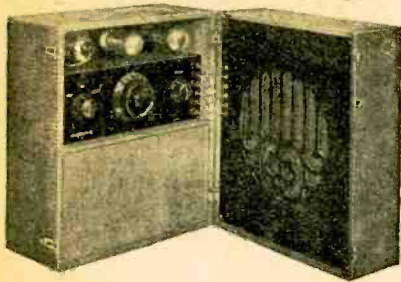

Cavendish Three-valve Portable.

A balanced armature loud speaker is supplied, which is choke-filter fed from the pentode.

The Cavendish Trading Co., Ltd., 5A, Palace Chambers, Bridge Street, London, S.W.1.

o o o o

CELEBRITONE.

Celebro.

Specification: Two choke-coupled H.F. amplifiers, grid detector, and two L.F. stages (transformer- and resistance coupled). One tuning dial and reaction. Dimensions 15½x12½x9½in. Weight 25 lb. In hide, £16 16s.; in rexine, £15 15s.

Suitcase portable receiver, fitted with Grosvenor H.T. battery, 108 volts, and 20 A.H. accumulator. Loud speaker and wave-change switch mounted in lid.



Celebritone Portable Receiver.

Celebritone, Ltd., Commerce House, 72, Oxford Street, London, W.1.

o o o o

CHAKOPHONE.

Screened Grid Three Table Grand.

Specification: S.G. high-frequency, coupled through a transformer to the detector, which

is followed by a pentode output valve. Tuning by two thumb-control dials. Reaction to inter-valve coupling. Dimensions 17x17x9in. Weight 30 lb. £25 8s. 6d.



Chakophone Table Screened Three.

A self-contained "home" receiver of the transportable type in walnut cabinet. Frame aerial and loud speaker are mounted in the lid. Exide 18 A.H. accumulator and 90-volt double-capacity H.T. battery are fitted.

Warwick Portable Five.

Specification: Two aperiodic H.F. stages, followed by detector and two L.F. amplifiers, all transformer-coupled. Single tuning control with reaction. Dimensions 17x13x7in. Weight 28 lb. £16 16s.

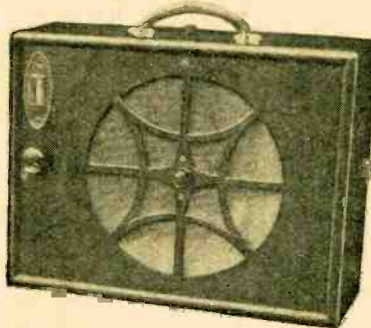

Chakophone Warwick Five.

Falls between the "portable" and "transportable" classes, being mounted in a dull polished walnut container of "suitcase" shape, and is thus convenient for carrying. Fitted with 48 A.H. capacity accumulator and 108-volt double-capacity H.T. battery.

The Eagle Engineering Co., Ltd., Eagle Works, Warwick.

o o o o

CLASSIC.

"Ariel" Five-valve Portable.

Specification: Two aperiodic choke-coupled H.F. stages, detector followed by two transformer-coupled L.F. stages. Pertrix 99-volt H.T. battery. Rowland Edwards 2-volt unspillable accumulator of 18 amp.-hours capacity. Reaction applied to frame aerial. Dimensions 15½x13x8in. Weight 26 lb. Price in cowhide, £17 17s. In rexine, £16 16s.

For extra volume plugs can be specially fitted for an external loud speaker. One-dial tuning is employed.

Classic Radio and Gramophone Co.,

Ltd., Components House, 25, Eccleston Street, London, S.W.1.

o o o o

CLIFTOPHONE.

Cliftophone III.

Specification: One choke-coupled H.F. valve, grid detector, and one transformer-coupled L.F. amplifier. Single tuning control with reaction. Dimensions 17½x17x7½in. Weight 28 lb. £14 14s.

Three-valve transportable set in upright cabinet. Medium broadcast waveband only.

Cliftophone IV.

Specification: Resistance- and choke-coupled H.F. stages, followed by leaky grid detector and single transformer-coupled L.F. amplifier. One tuning control, with reaction. Dimensions 17½x17x7½in. Weight 30 lb. £21.

Four-valve transportable receiver, in upright cabinet.

Cliftophone V.

Specification: Resistance- and choke-coupled H.F. amplifiers, and grid detector, followed by two L.F. stages (transformer- and resistance-coupled). One tuning dial with reaction. Dimensions 17½x17x7½in. Weight 30 lb. £22 10s.

Transportable model, with provision for gramophone pick-up. Volume control by variable input resistance to 1st L.F. stage.

Cliftophone and Records, Ltd., 40, Bernandsey Square, London, S.E.1.



Classic "Ariel" Five-valve Portable.

o o o o

J. H. COOK.

Five-valve Transportable.

Specification: Two aperiodic choke-coupled H.F. stages, detector followed by two transformer-coupled L.F. stages. Reaction applied to frame aerial. One-dial tuning. Output valve directly coupled to loud speaker. Dimensions 17x16x9in. Weight 30 lb. Price, exclusive of valves, £5 17s. 6d.

A 2-volt unspillable Exide accumulator of 20 amp.-hours capacity is supplied. The H.T. battery is a "Sure-a-lite" of 108 volts and the total anode current is 10mA.

J. H. Cook and Co., 49-51, Monks Road, Lincoln.

o o o o

COOKS WIRELESS CO.

C.W.C. Popular.

Specification: Two "aperiodic" H.F. stages and grid detector, followed by resistance and transformer-coupled L.F. amplifiers. One tuning dial, with reaction control. Dimensions 18x16x7½in. Weight 27 lb. £15 15s.

Buyers' Guide to Portable Sets, 1929.— Self-contained transportable receiver, in upright oak cabinet. Turntable and waterproof cover included. Fitted with Fuller accumulator, 20 A.H., and Rip-a-ult's H.T. battery, 99 volts.

C.W.C. Portable.

Specification: Two aperiodic H.F. stages, grid detector, and two transformer-coupled L.F. amplifiers. Single tuning control and reaction. Dimensions 15x15x7½in. Weight 28 lb. £22 10s.

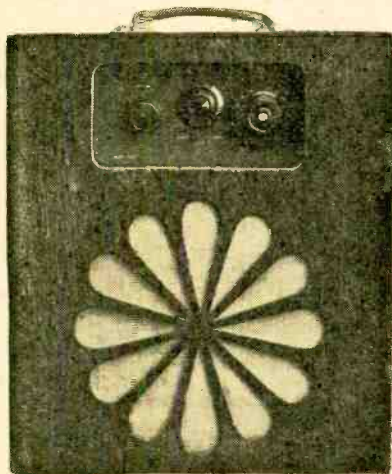

C.W.C. Receiver.

Transportable model, in oak or mahogany cabinet. Ediswan portable accumulator of 20 A.H. capacity, and "Sure-a-Lite Supra" 108-volt H.T. battery are fitted. Price includes turntable, waterproof cover, and carrying strap.

Cook's Wireless Co., Ltd., 25, St. Helen's Street, Ipswich.

o o o o

DAVEX.

Five-valve Portable.

Specification: Aperiodic H.F. stages followed by grid detector. Ediswan non-spillable L.T. accumulator Mullard loud speaker. Weight 28 lb. £15 15s.

One-dial tuning is employed, and reaction, which is applied direct to the frame aerial,



Davex Five-valve Portable.

A 29

is capacity-controlled. The two low-frequency stages are transformer-coupled, and the loud speaker is fed directly from the last valve.

St. Mary's Motor Company, Market Harborough.

o o o o

DUBILIER.

Westminster Radio-Gramophone.

Specification: Two screen-grid H.F. valves, linked by tuned grid and aperiodic couplings (in that order). A grid detector is followed by a pentode output valve. Gramophone turntable, motor, and pick-up are included. Two tuning dials and reaction control. Dimensions 20x18x9½in. Weight 58 lb. £30 9s.

Transportable radio-gramophone in walnut cabinet with oxidised fittings. Double-capacity H.T. battery of 120 volts and 20 A.H. L.T. accumulator are fitted. Space is provided for storing record turntable, pick-up, and winding handle inside the cabinet when not in use. A direc-



Dublier Westminster Radio-Gramophone.

tional turntable is also fitted. There is a potentiometer input control for regulating volume of gramophone reproduction.

Dublier Condenser Co. (1925), Ltd., Ducon Works, Victoria Road, North Acton, London, W.3.

o o o o

DUNHAM.

Portable de Luxe.

Specification: Five valves two transformer-coupled H.F. stages, detector and two transformer-coupled L.F. stages. One-dial tuning. Reaction applied to H.F. coupling. Dimensions 18x18¼x9¾in. Weight 31 lb. £21 15s.

A turntable is fitted as standard, and jack connections provide for the use of a gramophone pick-up, external loud speaker, and outside aerial and earth. The anode battery has a voltage of 102 and the total anode current is 9mA. Price in oak, £21 15s.

Portable de Luxe.

Specification: Five valves; two transformer-coupled H.F. stages, detector and two transformer-coupled L.F. stages. One-dial tuning. Reaction applied to H.F. coupling. Dimensions 12½x15¼x9in. Weight 27 lb. £20 14s.

A turntable is supplied as a standard fitting and terminals are arranged for connecting an external battery eliminator if desired. Provision is made for an external loud speaker and a gramophone pick-up. The H.T. battery has a voltage

of 102 and the L.T. 2-volt Exide unspillable accumulator a capacity of 22 amp.-hours.

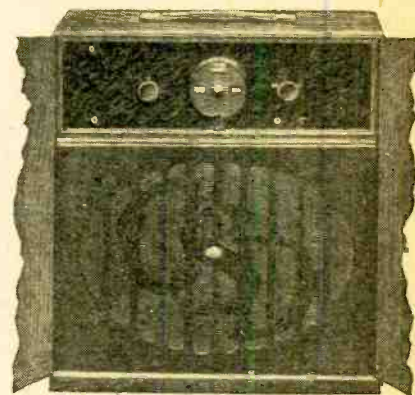

Dunham Transportable de Luxe.

Five-valve Transportable.

Specification: Two transformer-coupled H.F. stages, detector followed by R.C. coupled 1st L.F. stage and transformer-coupled 2nd stage. One-dial tuning. Reaction applied to H.F. coupling. Dimensions 18x18¼x9¾in. Weight 30 lb. Price in oak £18 12s.

An external loud speaker and battery eliminator can be used with this set. A turntable is fitted as standard, and the front of the set is enclosed by double doors which can be locked.



Dunham Portable de Luxe.

Suitcase Portable.

Specification: Five valves, two transformer-coupled H.F. stages, detector, 1st L.F. stage resistance-coupled and 2nd stage transformer-coupled. One-dial tuning. Reaction applied to H.F. coupling. Dimensions 12½x15¼x9in. Weight 25 lb. £17 11s.

An external loud speaker and battery eliminator can be connected if desired. An "Ecco" 102-volt H.T. battery is fitted. The total anode current is 7mA, and the capacity of the 2-volt L.T. accumulator 22 amp.-hours.

C. S. Dunham, Elm Works, Elm Park, Brixton Hill, London, S.W.2.

Buyers' Guide to Portable Sets, 1929.— EDDYSTONE.

Scientific Portable Three.

Specification: S.G. high-frequency valve, coupled by tuned transformer to grid detector, followed by L.F. transformer-coupled pentode. Two tuning controls with reaction between detector anode and intervalve coupling. Dimensions $15\frac{1}{2} \times 15\frac{1}{2} \times 10$ in. Weight 34 lb. £28.



Eddystone Scientific Portable Three.

A portable receiver, obtainable in suitcase type of container either in oak or hide. Fitted with triple-capacity H.T. battery of 100 volts, Exide 32 A.H. accumulator, and Celestion loud speaker.

Stratton and Company, Ltd., Balmoral Works, 58, Bromsgrove Street, Birmingham.

o o o o

EDISON BELL.

Picnic Portable.

Specification: Five valves; two aperiodic choke-coupled H.F. stages, detector and two L.F.

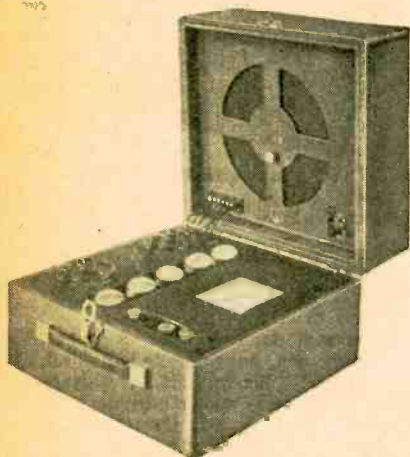

Edison Bell Picnic Portable.

stages the last being transformer-coupled. Two-dial tuning. Reaction applied direct to frame. Provision for connecting external loud speaker. Dimensions $13\frac{1}{2} \times 13\frac{1}{2} \times 10$ in. Weight 26 lb. £15 15s.

For greater sensitivity an outside aerial and earth can be used. A Fuller 2-volt accumulator of 35 amp.-hours capacity is employed, while an Edison Bell H.T. battery of 108 volts supplies the total anode requirement of 9mA. The loud speaker is direct-coupled to the last valve.

Five-valve Portable.

Specification: Two aperiodic H.F. stages, detector, resistance-coupled 1st L.F. stage and transformer-coupled 2nd stage. Two-dial tuning. Reaction applied direct to frame. Dimensions $17 \times 17 \times 7\frac{1}{2}$ in. Weight 34 lb. Price in walnut case £20 5s.

The panel with the control dials is protected by a folding flap and a nickel-plated grille covers the loud speaker.



Edison Bell Five-valve Portable.

Provision is made for the use of an external aerial and earth, also a separate loud speaker.

Edison Bell, Ltd., 62, Glengall Road, Peckham, London, S.E.15.

o o o o

EMPIRE ELECTRIC.

"Metropolis" Portable.

Specification: Five valves; super-heterodyne circuit. The first detector is a screen-grid valve. Screen-grid intermediate amplifier. The 2nd detector and the oscillator are triodes and the L.F. valve a pentode. Volume control by H.F. damping. Two-dial tuning. Dimensions $13 \times 12 \times 8$ in. Weight 22 lb. £31 10s.

Two Rowland Edwards unspillable 2-volt accumulators of 15 amp.-hours capacity are supplied. A small voltmeter on the panel indicates the H.T. voltage, while the housing of the accumulator is so arranged that contact is made to its terminals without any wiring being needed.

Challenger Portable.

Specification: Three valves; choke-coupled H.F. stage, grid detector followed by transformer-coupled L.F. stage. One-dial tuning. Reaction applied to frame aerial. Dimensions $18 \times 16 \times 5$ in. Weight 16lb. £10 10s.

Connections are provided for the use of an external loud speaker. Thumb control tuning is embodied and both wavebands are covered. The set is automatically switched on by opening the door



"Metropolis" Five-valve Super-heterodyne Portable.

covering the loud speaker. The accumulator makes automatic contact when placed in its housing.

Empire Electric Co., 10, Fitzroy Square, London, W.1.

o o o o

FALK STADELMANN.

Blenheim Screened Four.

Specification: S.G. high-frequency valve, coupled by tuned anode to grid detector followed by resistance- and transformer-coupled L.F. stages. Two tuning dials, with reaction control. Dimensions: height $18\frac{1}{2}$ in., width $15\frac{1}{2}$ in., depth $8\frac{1}{2}$ in. Weight 30 lb. £26 15s.

Transportable model, in upright polished mahogany cabinet. Waterproof cover sup-

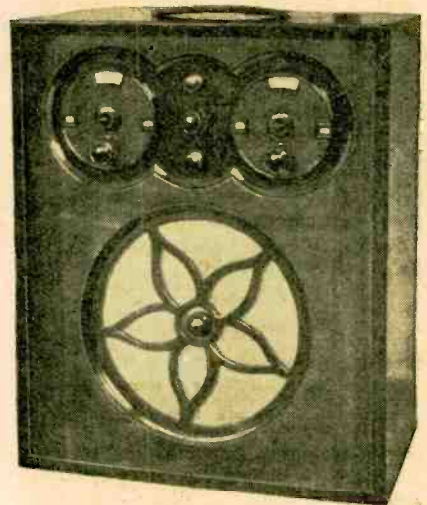

Blenheim Screened Four.

plied as an extra at 15s. Optional use may be made of an outdoor aerial.

Falk Stadelmann and Co., Ltd., 83-93, Farringdon Road, London, E.C.1.

o o o o

FARDEX-SERAPHONE.

Faradex Portable Five.

Specification: Two choke-coupled aperiodic H.F. stages, detector followed by two transformer L.F. stages. Two tuning controls and a reaction control to frame aerial. Dimensions $15\frac{1}{2} \times 12\frac{1}{2} \times 8\frac{1}{2}$ in. Weight 27 lb. Price, including Ediswan pick-up, £16 16s.

Provision is made for the use of a gramophone pick-up which is connected to the last two valves. The loud speaker is fed directly from the output valve. Sixty valves are employed and are fed from an Exide 2-volt unspillable accumulator and a Pertrix 99-volt H.T. battery. The total anode current is 8.5mA.

**Buyers' Guide to Portable Sets, 1929.—
Seraphone Five-valve Portable de Luxe.**

Specification: Two choke-coupled H.F. stages, detector followed by a transformer-coupled first L.F. stage and R.C.-coupled second stage. Two-dial tuning. Capacity reaction on to frame aerial. Dimensions 14x17x8in. Weight 37 lb. £26 5s.

Tuning is facilitated by thumb controls placed close together. The swinging of the set for directional purposes is facilitated by a ball-bearing turntable. A waterproof cover is included in the price.

Junior Five-valve Portable.

Specification: The high-frequency stages are choke-coupled and the low-frequency valves are transformer- and resistance-coupled respectively. Two-dial tuning. Capacity-controlled reaction to frame aerial. Dimensions 14½x15½x8in. Weight 17 lb. £15 15s.

A 2-volt Edwards unspillable accumulator of 30 amp.-hours is fitted, and the H.T. supply is from a Grosvenor 102-volt battery. The total anode current is about 5mA. Cosmos valves are used, the last of which is direct-coupled to the loud speaker.

Faradex-Seraphone Co., Ltd., 189, Regent Street, London, W.1.

o o o o

G.E.C.

Gecophone Portable Screen-grid Four.

Specification: S.G. high-frequency valve, coupled by tuned anode to the detector, which is followed by two transformer-coupled L.F. stages. Two tuning dials and reaction, the latter being controlled by an edgewise dial. Dimensions, 15¼x15½x10in. Weight 35 lb. £27 10s.

A portable type of receiver, contained in a leatherette-covered suitcase, coloured either antique red or Cambridge blue. A large balanced armature loud speaker is mounted in the lid, while a 30 A.H. capacity accumulator and a 100-volt H.T. battery are included. Osram valves are fitted throughout, including a super-power D.E.P.240 in output position.

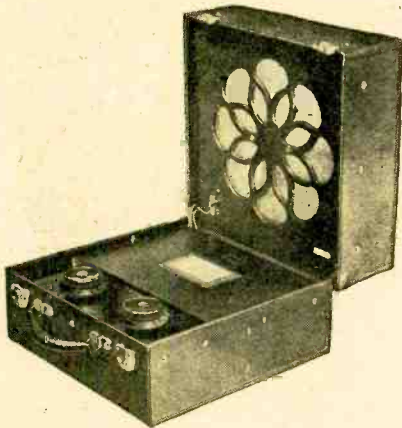

Gecophone Portable.

General Electric Company, Ltd., Magnet House, Kingsway, London, W.C.2.

o o o o

GODWINEX.

De Luxe Transportable.

Specification: Two "untuned" transformer-coupled H.F. stages, followed by grid detector and resistance- and transformer-coupled L.F. amplifiers. One tuning control with reaction. Dimensions 17½x17¼x8in. Weight 32 lb. £25 15s.

Transportable receiver, supplied either in oak or mahogany upright cabinet mounted



Godwinex de Luxe.

on turntable base. Waterproof cover obtainable at 15s. extra. H.T. battery of 120 volts and Exide accumulator of 13 A.H. capacity are fitted.



Godwinex Five.

Godwinex "Junior."

Specification: As for "De Luxe Transportable," but dimensions 16x16x7in. Weight 25 lb. Fitted with "Godwinex" cone loud speaker. £19 19s. in oak, £20 9s. in mahogany.

J. Dyson and Co., Ltd., St. Stephen's House, 2, Coleman Street, London, E.C.2.



Burlington Five-valve Portable.

GREENWOOD PAGE.

Burlington Five-valve Portable.

Specification: Two aperiodic H.F. stages and detector, followed by transformer and resistance-coupled L.F. amplifier. Single tuning control with reaction. Dimensions 15¼x13x8¼in. Weight 25 lb. £15 15s.

In blue crocodile-covered suitcase. A magnetic compass is fitted as an aid to frame orientation. Supplied with Exide 24 amp.-hours accumulator and Pertrix 99-volt H.T. battery

Greenwood, Page and Co., Ltd., 3-5, Burlington Gardens, London, W.1.

o o o o

H.P.L.

Super Five Portable.

Specification: Two aperiodic choke-coupled H.F. stages, detector followed by transformer-coupled first L.F. stage and R.C.-coupled second stage. Reaction applied direct to frame aerial. Two-volt unspillable accumulator of 30 amp.-hours capacity. Dimensions 18x15½x6½in. Weight 23 lb. £19 15s.

The set is mounted on a light turntable, and is supplied with a slip-over waterproof cover. The H.T. voltage is 100 and the total anode current 6mA. There is provision for a gramophone pick-up.

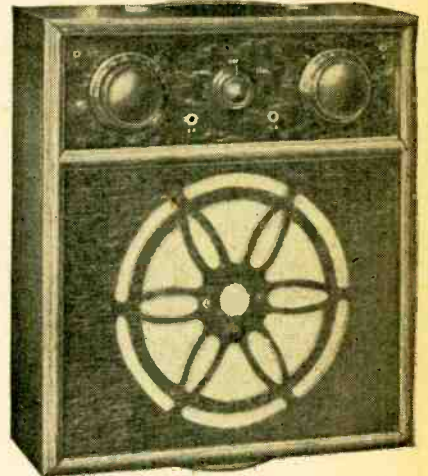

H.P.L. Super Five Portable. Note the turntable.

Super Three Portable.

Specification: Leaky grid detector followed by two transformer-coupled L.F. stages. Volume control by means of reaction condenser. One-dial tuning. Dimensions 16½x14x6½in. Weight 22¼ lb. £12.

A jack connection is provided for using an external loud speaker. The high-tension voltage is 100, and the total anode current 7.5mA. The wave-range is the medium broadcast band only. A turntable is fitted to assist in the orientation of the frame.

Heath Plugs, Ltd., 2 and 67, Sancroft Street, Kennington Cross, London, S.E.11.

o o o o

HALCYON.

De Luxe Cabinet Five.

Specification: Two semi-aperiodic transformer-coupled H.F. stages, detector followed by two transformer-coupled L.F. stages. Reaction to frame aerial is capacity-controlled. One-dial tuning. Dimensions 18x14¼x8¼in. Weight 36 lb. £34 13s.

An external loud speaker can be connected at will. The self-contained loud speaker is a 12in. Celestion which is directly coupled to the last valve. A

Buyers' Guide to Portable Sets, 1929.—

turntable is fitted as standard, and a small pilot lamp on the panel indicates when the filaments are alight. All sets are sent out calibrated on six broadcasting stations.

De Luxe Lightweight Five.

Specifications: Two semi-aperiodic transformer-coupled H.F. stages, detector followed by two transformer-coupled L.F. stages. Reaction applied to H.F. coupling. Loud speaker directly fed from last valve. £34 13s.

The 4-volt valves are fed from an L.T. accumulator of 15 amp.-hours capacity. The total anode current of 10mA. is supplied by a Hellesen 99-volt battery. The set is fitted in a crocodile leather suitcase, and a 12in. Celestion cone loud speaker is built in.

De Luxe Screened Grid Four.

Specification: One tuned H.F. stage followed by detector and two transformer-coupled L.F. stages. Reaction applied to H.F. coupling. Last valve coupled direct to loud speaker. Dimensions $15\frac{1}{2} \times 16\frac{1}{4} \times 10\frac{1}{4}$ in. Weight 33 lb. £31 10s.

**Halcyon de Luxe Screened Grid Four.**

Two-volt Six-Sixty valves are used and are fed from an Exide unspillable accumulator of 16 amp.-hours capacity. Comprehensive screening is applied to the detector valve and its associated components. The receiver is sent out calibrated on six broadcasting stations.

De Luxe Cabinet Three.

Specification: One H.F. stage semi-aperiodic transformer-coupled followed by leaky grid detector, which is transformer-coupled to a pentode. Reaction applied to H.F. coupling. One-dial tuning. £21.

The 2-volt valves are fed from an L.T. accumulator of 38 amp.-hours capacity. The H.T. voltage is 72 and the total anode current 6 milliamperes. A turntable and panel pilot light are included.

The Halcyon Wireless Co., Ltd.,
313-319, Regent Street, London, W.1.

o o o o

HART COLLINS.**Screened Grid IV. Receiver.**

Specification: S.G. high-frequency valve, detector, and two L.F. stages. Two tuning dials and capacity-controlled reaction. Dimensions $14\frac{1}{2} \times 12 \times 8\frac{1}{4}$ in. Weight 25 lb. £21.

A portable receiver of suitcase type, fitted with thumb controls. Frame aerial and loud speaker are mounted in the lid.

**Hart Collins Screened Grid IV.**

Hart Collins, Ltd., 38A, Bessborough Street, Westminster London, S.W.1.

o o o o

HENDERSON.**Type "T."**

Specification: Two choke-coupled H.F. stages, detector, and two L.F. amplifiers (resistance- and transformer-coupled). Single tuning control and reaction. Dimensions $15\frac{1}{4} \times 12\frac{1}{2} \times 9\frac{1}{4}$ in. (when closed). Weight 28 lb. £17 17s.

Portable type of receiver, fitted with Hellesen 99-volt H.T. battery and 25 A.H. capacity L.T. accumulator.

Type "R."

Specification: As for Type "T." but dimensions $15 \times 13\frac{1}{4} \times 7\frac{1}{2}$ in. Weight 23 lb. Celestion loud speaker movement is fitted. £26.

Type "P."

Specification: As for Type "T." but dimensions $14\frac{1}{2} \times 13\frac{1}{4} \times 7\frac{1}{2}$ in. Weight 24½ lb. £26.

Transportable receiver in upright polished mahogany case. Lid is fitted over control panel.

**Henderson Transportable.****Type "S."**

Specification: As for Type "T." but dimensions $17\frac{1}{4} \times 12\frac{1}{4} \times 9\frac{1}{4}$ in. Weight 31 lb. £28.

A complete Celestion loud speaker is built into this model. Its L.T. accumulator has a capacity of 30 A.H.

W. J. Henderson and Co., Ltd., 66A, Farringdon Street, London, E.C.4.

**Henderson Suitcase Model.**

o o o o

IGRANIC.**Universal Portable.**

Specification: Two S.G. high-frequency valves, with one tuned and one aperiodic coupling, followed by detector and two L.F. amplifiers (resistance- and transformer-coupled, in that order). One tuning control, with reaction. Dimensions $16\frac{1}{2} \times 17 \times 8\frac{1}{4}$ in. Weight 46 lb. £33 4s. 6d.

**Igranic Universal.**

Two 54-volt H.T. batteries, of sufficiently large capacity adequately to supply a total anode current of 12 milliamperes. An Igranic Phonovox pick-up, plug adaptor, and volume control may be used for gramophone reproduction. The two tuned circuit controls are "ganged" and operated from a single knob.

Igranic Electric Co., Ltd., 149, Queen Victoria Street, London, E.C.4.

o o o o

LISSEN.**Five-valve Portable.**

Specification: Two aperiodic stages, both choke-

Buyers' Guide to Portable Sets, 1929.—

coupled, the first with a grid choke and the second with a grid resistance, followed by detector and two transformer-coupled L.F. amplifiers. One tuning control, with reaction. Dimensions 15¼×16×8½in. Weight 30 lb. £19 19s.

A suitcase type of portable receiver, supplied in oak, mahogany, or real hide container. Provision is made for connection of external aerial-earth system if desired. Fitted with 16 A.H. capacity accumulator and 108-volt H.T. battery.

Competition Five-valve Portable.

Specification: Circuit details and dimensions as for above model. Weight 28 lb. £16 16s.

Provision is made for connection of aerial-earth system and gramophone pick-up to be fitted. Container covered in red



Lissen Portable.

leatherette; crackle red-black finish on metal control panel.

Lissen, Ltd., Friars Lane, Richmond, Surrey.

○○○○

LIVERPOOL RADIO.

Screened-Grid Portable.

Specification: Choke-coupled screen-grid H.F. stage, detector followed by two transformer-coupled L.F. stages. Reaction applied direct to frame aerial. One-dial tuning. Dimensions 18×20×7in. Weight 34 lb. £15.

Special attention has been paid to the easy removal of the L.T. battery for charging. An eliminator can be used if desired. The H.T. battery used has a voltage of 120 and the total anode current is 10 mA.

Liverpool Radio Supplies, 64, Myrtle Street, Liverpool.

○○○○

LOCK ATKINSON.

LAW Five-Valve.

Specification: Two aperiodic H.F. stages, detector and two L.F. amplifiers (resistance and transformer-coupled). Single tuning control with reaction. Dimensions 15¼×15¼×7¼in. Weight 26 lb. £18 18s.

Portable receiver, either in polished mahogany or burr walnut container, mounted on ball-bearing turntable. Provision is made for using a gramophone pick-up, and an Eliptoid floating-cone loud speaker is fitted. The L.T. accumulator is rated at 2 volts 20 A.H.; H.T. battery is 100 volts.

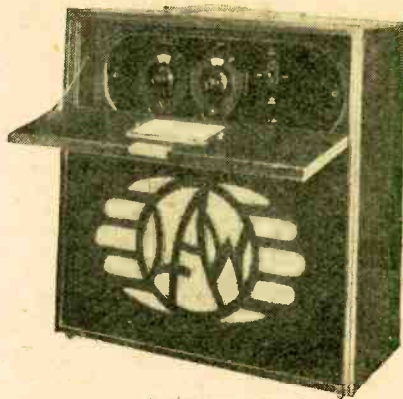

LAW Receiver.

UWANA-LAW Portable Radio-Gramophone.

Specification: Two aperiodic H.F. stages, followed by detector and two L.F. amplifiers (resistance and transformer-coupled). Single tuning control with reaction. Dimensions 15¼×15¼×8in. Weight 30 lb. Price from 24 guineas to 35 guineas, depending on finish.

A portable type radio-gramophone. A pick-up, together with turntable and motor, are included, a single three-position switch being arranged to make the necessary circuit alterations for medium- or long-wave reception or gramophone reproduction. Special provision is made for easy access to batteries. The highest-priced model has oxidised silver fittings and is mounted in antique leather-covered case.

Lock Atkinson Wireless, 95, Great Titchfield Street, London, W.1.

○○○○

LOTUS.

Suitcase Portable.

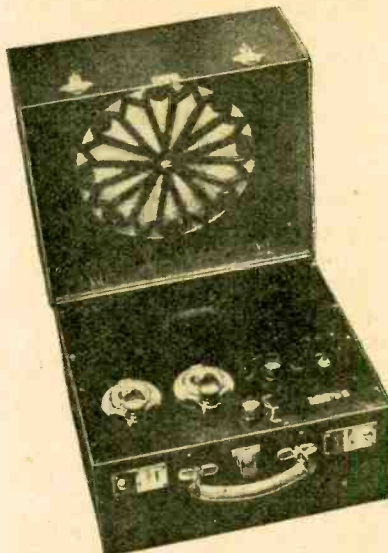

Lotus Suitcase Portable incorporating four valves.

Specification: Four valves: 1st H.F. stage screen-grid choke-coupled, 2nd H.F. stage screen-grid tuned anode, detector coupled to a pentode by a transformer. Reaction applied to H.F. coupling. Loud speaker directly coupled to last valve. Dimensions 15×13×12in. Weight 35 lb. £24 13s. 6d.

Two tuning dials are employed, one for

the frame aerial and one for the second screen-grid amplifier. An Ediswan H.T. battery of 103 volts is used, and the total anode current is 10mA. The filaments of the 4-volt valves are supplied by an accumulator having a capacity of 15 amp-hours. An external loud speaker can be connected for extra volume.

Screened-Grid Transportable.

Specification: Four valves: 1st H.F. stage screen-grid choke coupled; 2nd H.F. stage screen-grid tuned anode, detector coupled to a pentode by a transformer. Reaction applied to H.F. coupling. Loud speaker directly coupled to last valve. Dimensions 20×16×9in. Weight 40 lb. Price in oak £24 3s. 6d., in mahogany or walnut £25 4s.

Two tuning dials are provided, and a capacity control of reaction gives a means of changing the volume. Four-volt valves are incorporated.

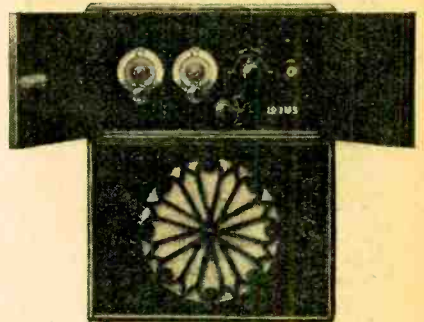

Lotus Transportable Screened-grid Receiver.

Garnett, Whiteley and Co., Ltd., "Lotus Works," Broadgreen Road, Old Swan, Liverpool.

○○○○

LUTONIA.

Five-valve Portable.

Specification: Two aperiodic H.F. stages, detector, and two L.F. amplifiers. Single tuning control with reaction. Dimensions 15¼×12½×8¼in. Weight 26½ lb. £17 6s. 6d.

Supplied in two distinct types, one with circular dials and exposed valves, and the

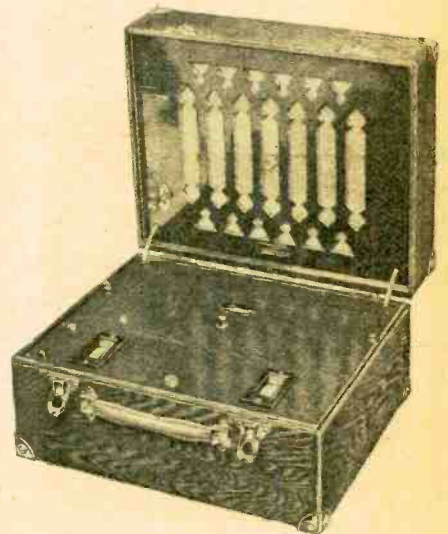

Lutonia Suitcase Receiver.

Buyers' Guide to Portable Sets, 1929.—second with drum controls and enclosed valve compartment. Either model supplied in oak or crocodile finish covering. Gramophone pick-up may be used.

Five-valve Transportable.

Specification: Two aperiodic H.F. stages, detector, and two L.F. amplifiers. Single tuning control with reaction. Dimensions 9x18x14in. Weight 30 lb. £15 15s.



Lutonia Five-valve Transportable.

A transportable set in upright oak cabinet. Fitted with 100- or 120-volt H.T. battery and "Three Star" accumulator, 20 A.H. capacity.

Lutonia Radio Supplies, 1, Wade's Place, Mile End, London, E.1.

o o o o

MARCONIPHONE.

Model 53.

Specification: Two aperiodic H.F. stages, detector, and two L.F. amplifiers, all transformer-coupled. Single tuning control with reaction. Dimensions 18x16½x7½in. Weight 30 lb. £29 8s.

A receiver falling between the conventional "portable" and "transportable" classifications; it is built into a matt finish walnut upright case in a form convenient for transport. 108-volt H.T. battery and 28 A.H. capacity L.T. accumulator are



Marconiphone Portable.

fitted. Winner of *The Wireless World* 1928 Readers' Olympia Ballot in the 5-valve class.

The Marconiphone Co., Ltd., 210-212, Tottenham Court Road, London, W.1.

o o o o

McMICHAEL.

Super-screened Four.

Specification: First H.F. (screen-grid) valve has a tuned grid coupling. Second H.F. stage aperiodically choke-coupled, grid detector transformer-coupled to pentode. One-dial tuning with differential ganging. Reaction applied to H.F. coupling. Dimensions 18x15¼x7in. Weight 38 lb. £36 15s.

The control of volume is effected by a filament rheostat in circuit with the screen-grid valves, also by capacity-controlled reaction. There is provision for connecting an external battery eliminator if desired. An important feature of this receiver is the comprehensive screening of the H.F. stages. The set is supplied complete in a polished walnut cabinet fitted with a turntable.

Five-valve Portable.

Specification: Two aperiodic choke-coupled H.F. stages, grid detector followed by two transformer-coupled L.F. stages. Reaction applied to frame aerial. Exide 2-volt accumulator of 18 amp-hours capacity. Hellesen 99-volt H.T. battery. Total anode current 6mA. Dimensions 15½x12¼x8¾in. Weight 35 lb. £28 7s.



McMichael Five-valve Portable Receiver.

One-dial tuning is employed. The set is housed in a leather attaché-case with Celestion loud speaker built into the lid. An external loud speaker can be connected if required.

Super-range Portable Four.

Specification: First H.F. stage (screen-grid) is tuned; second stage (screen-grid) aperiodically coupled to grid detector. L.F. stage is transformer-coupled. One dial tuning. Volume control by reaction and filament control of screen-grid valves. Dimensions 15x15x8¾in. Weight 28 lb. £23 2s.

A compensated tuning device permits ganging of two tuning controls at any setting. The high tension battery voltage is 120 and the total anode current 8mA. There is provision for connecting an external battery eliminator.

L. McMichael, Ltd., Wexham Rd., Slough, Bucks.

o o o o

MELPHONIC.

Five-valve Portable.

Specification: Two aperiodically coupled H.F. valves. One-dial tuning (slow motion). Re-

action applied to frame aerial. Provision for gramophone pick-up. Dimensions 15½x14x7¾in. Weight 26 lb. £16 16s.
Drage's, Ltd., 231, High Holborn, London, W.C.1.

o o o o

MONTAGUE.

Beethoven Portable.

Specification: Three high-frequency valves, detector, and pentode. One tuning control with reaction. Dimensions 19½x13½x8¾in. Weight 34 lb. £38 17s.

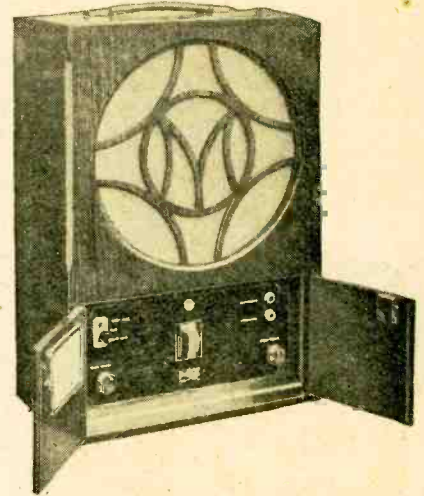

Beethoven Portable.

In upright cabinet, of oak, mahogany, or Chinese lacquer. Control panel is mounted below the loud speaker, and, in addition to switches and dials, etc., carries a filament pilot lamp. The circuit arrangement is the subject of a patent application.

Provision for gramophone reproduction (including volume control) is made, and the set is supplied complete with waterproof cover and turntable.

Montague Radio Inventions and Development Co., Ltd., 117-119, Regent Street, London, W.1.

o o o o

NATIONAL.

Five-valve Portable.

Specification: Two aperiodic H.F. stages, detector, and two transformer-coupled L.F. amplifiers. Single tuning control with reaction. Dimensions 15¼x8x12in. Weight 27lb. £15.
Portable receiver, contained in polished

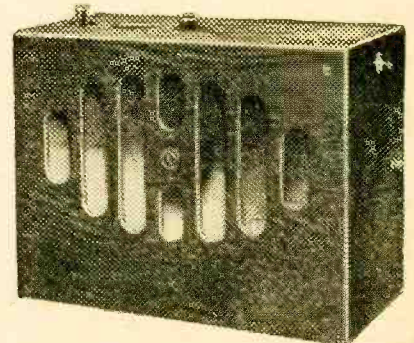

National Five-valve Portable.

Buyers' Guide to Portable Sets, 1929.— oak container of suitcase shape, provided with loose waterproof cover and carrying strap. Large oval cone loud speaker with external adjustment is fitted. Double-capacity Siemens H.T. battery of 125 volts and 18 A.H. accumulator are provided.
National Electric Co., 10, 12, 14, Beak Street, Regent Street, London, W.1.

NEOPHONE.

Type A.
Specification: Five valves; single tuning control with reaction. Dimensions 15½×13×9½in. Weight 28 lb. Price: in oak £15 15s. in mahogany £16 5s.
Suitcase type of receiver, with Ever-ready H.T. and L.T. batteries. Fitted with Neophone seamless vulcanite cone loud speaker.
Neophone Engineering Co., 9 and 10, Little St. Andrew Street, London, W.C.2.



Neophone Type A.

NULLI SECUNDUS.

Reliance Transportable.
Specification: Five valves; two aperiodic H.F. stages, detector followed by two L.F. valves, the last of which is a pentode. Reaction applied to H.F. coupling. One-dial tuning. H.T. battery 99-volt Ripault. L.T. battery Exide 2-volt, 25 amp.-hour capacity. Weight 30 lb. £26 5s.
There is provision for a gramophone pick-up, and terminals are arranged so that an external loud speaker can be connected. The receiver is suitably wired to be used with a battery eliminator. A ball-bearing turntable is fitted as standard.
Screened Grid Portable.

Specification: Five valves; the first H.F. valve (screen-grid) is tuned, the second H.F. valve is an untuned triode. There are two L.F. valves, transformer-coupled. Two-dial tuning. Reaction applied to H.F. coupling. Dimensions 14¾×11¾×5¾in. Weight 29 lb. £23 2s.
A Ripault H.T. battery of 99 volts provides a total anode current of 8mA., while an Exide 2-volt unspillable accumulator of 18 amp.-hours capacity heats the filaments. There are connections on the panel for a gramophone pick-up and an external loud speaker. The receiver is suitably wired to be driven by an external battery eliminator.

Universal Portable.

Specification: Five valves; first H.F. valve is choke-coupled and the second transformer-

coupled. One-dial tuning. Volume control by capacity reaction to H.F. coupling. Dimensions 14¾×11¾×5¾in. Weight 28 lb. £18 18s.
Provision is made for using a gramophone pick-up, outside aerial and earth, and an

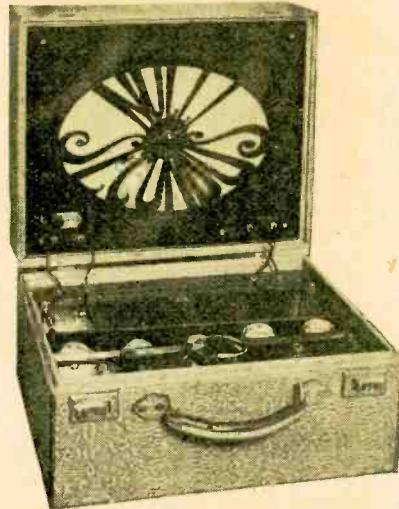

Nulli Secundus Portable Five.

external loud speaker if desired. The H.T. and L.T. battery specification is the same as that for the Screened Grid Portable.
C. Creswick Atkinson, 35b, High Street, Bedford.

ORMOND.

Attaché-case Five.
Specification: Five valves; two aperiodic H.F. stages followed by leaky grid detector and transformer-coupled first L.F. stage and R.C.-coupled second stage. Two-volt L.T. accumulator. 24 amp.-hour capacity. Ormond 108-volt H.T. battery. Total anode current 6mA. Dimensions 13½×16¼×9¾in. Weight 28 lb. £15.
The volume control employed is a reaction condenser coupled to the frame aerial, and only one tuning dial is used. A light leatherette case confers the benefit of extreme portability.

Attaché-case Portable Five (Leather).
Specification: Five valves; two aperiodic choke-coupled H.F. amplifiers, followed by leaky grid



Attaché-case Portable Five, by Ormond.

detector and two transformer-coupled L.F. stages. One-dial tuning. Capacity-controlled reaction on to frame aerial. Dimensions 13½×16¼×9¾in. Weight 28 lb. £27 19s. 2d.
If desired, an external loud speaker can be jack-connected. An Ormond Standard 108-volt H.T. battery is included in the set; the total anode current is 8 mA. The attaché-case is of real crocodile leather.

Transportable Five.

Specification: Five valves; two aperiodic choke-coupled H.F. stages, detector, followed by transformer-coupled first L.F. stage and R.C.-coupled second stage. Capacity-controlled reaction on to frame aerial. Dimensions 18½×14½×8½in. Weight 30 lb. £15 in oak. £15 15s. in mahogany.

The last valve is coupled directly to the loud speaker. A turntable can be provided as an extra fitting. An Ormond Standard 108-volt H.T. battery is employed, and the total anode current is 6mA. The 2-volt C.A.V. L.T. accumulator has a capacity of 30 amp.-hours.



Ormond Transportable Five.

Self-contained Transportable.

Specification: Five valves; two aperiodic choke-coupled H.F. stages, detector, followed by two transformer-coupled L.F. stages. Volume control by means of reaction on to frame aerial. Dimensions 18×14×9in. Weight 32 lb. £25 8s. 9d.
To assist in orienting the frame aerial a turntable is provided at 6s. extra. An Ormond Standard 108-volt H.T. battery is fitted. Total anode current, 8mA. A 2-volt C.A.V. unspillable accumulator of 30 amp.-hours capacity provides the filament current. The loud speaker is directly coupled to the last valve.

The Ormond Engineering Co., Ltd., Ormond House, Rosebery Avenue, London, E.C.1.

ORTH-O-DYNE.

Five-valve Portable.

Specification: Two aperiodic H.F. stages, detector and two transformer-coupled L.F. amplifiers. Single dial tuning with reaction. Dimensions 15×12½×10in. Weight 30 lb. £16 16s.

Buyers' Guide to Portable Sets, 1929.—

A portable receiver in hide suitcase of conventional type. The loud speaker and wave-range switch are mounted in the lid. Accessories include D.P. accumulator,



The Orth-o-dyne Five.

Hellesen dry batteries, and Osram valves. *The Orth-o-Dyne Radio and Electric Co., 63, Shaftesbury Street, New North Road, London, N.1.*

o o o o

PANDONA.

Five-valve Portable.

Specification: Two aperiodically coupled H.F. valves. Thumb control reaction condenser with slow motion gear. One-dial tuning with slow motion drum drive. Dimensions 17½×13½×7in. Weight 28 lb. £16 16s.



Pandona Five-valve Portable.

Pandona, Ltd., 87, Edmund Street, Birmingham.

o o o o

PERSONIC.

Upright.

Specification: Five valves; single dial tuning with reaction. Dimensions 16¼×14½×8in. Weight 31 lb. Price, in oak, £15 15s.; in mahogany, £16 16s.

Fitted with Edwards accumulator, 30 A.H. capacity, and Pertrix or Siemens 100-volt H.T. battery. Price includes a waterproof cover and turntable. Provision is made for connection of a gramophone pick-up.

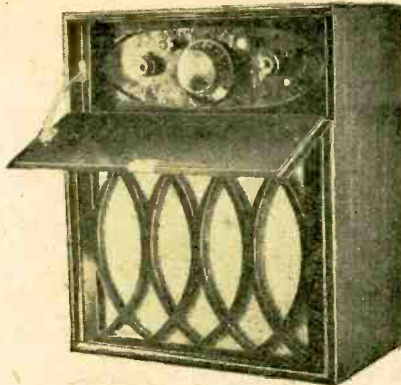

Personic Upright Receiver.

Personic, Ltd., Peebles Works, Polmerston Road, Kilburn, London, N.W.6.

o o o o

PETO-SCOTT.

The Rover Portable.

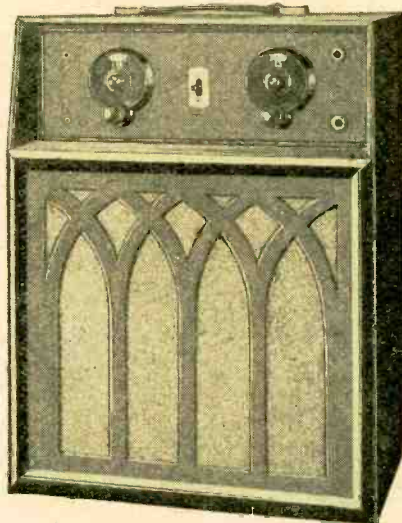

Peto-Scott "Rover" Portable.

Specification: Five valves; two aperiodic H.F. stages followed by leaky grid detector and transformer-coupled L.F. stages. Volume control by means of capacity-controlled reaction on to frame aerial. Two-dial tuning. Loud speaker fed direct from last valve. Dimensions 18½×14½×9in. Weight 31 lb. £16 16s. in oak, £17 17s. in mahogany.

A jack connection is provided for gramophone pick-up. To assist in orienting the frame aerial a turntable is provided as a standard fitting. For extra sensitivity an outside aerial and earth can be connected. *The Peto-Scott Co., Ltd., 77, City Road, London, E.C.1.*

o o o o

PORTADYNE.

Junior.

Specification: Two aperiodic H.F. stages, detector and two L.F. stages (resistance and transformer-coupled). Single tuning control with reaction. Dimensions 19¼×14½×14in. Weight 28 lb. £19 19s.

Suitcase type of receiver, with container covered in lizard or Oxford blue. Fitted with Hellesen H.T. battery, 99 volts, and 25 A.H. Peto and Radford accumulator.

Transportable.

Specification: Circuit arrangement as in "Junior" model. Dimensions 19¼×15×11in. Weight 35 lb. £26 5s.

Self-contained receiver in upright cabinet. Accessories as in "Junior" model.



Portadyne Transportable.

De Luxe.

Specification: Circuit arrangement as in "Junior" model. Dimensions 13¼×15×9¼in. Weight 28 lb. £23 2s.

Portable "suitcase" type of receiver, supplied in hide, lizard, crocodile, suede, etc.

Whittingham, Smith and Company, Ltd., 110, Kew Green, Kew, Surrey.

o o o o

PYE.

Type 25 Portable.

Specification: Two aperiodic H.F. stages, detector, and two transformer-coupled L.F. amplifiers. Single-dial tuning with reaction. Dimensions 16¼×16¼×8½in. Weight 30 lb. £23 10s.

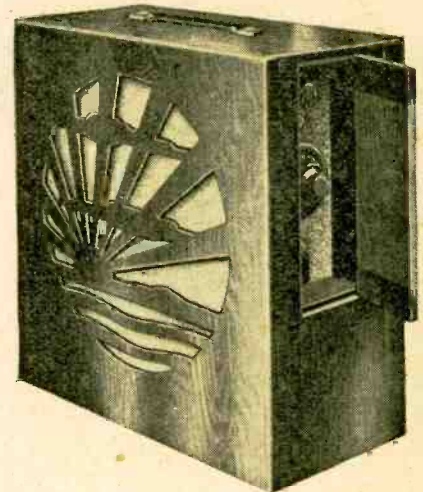

Pye Portable.

In polished walnut upright cabinet with control panel covered by a door at side. Fitted with Exide 18 A.H. accumulator, Ever-ready 108-volt H.T. battery, and Pye Senior or Celestion cone and speaker. *Pye-Radio, Ltd., Paris House, Oxford Circus, London, W.1.*

**Buyers' Guide to Portable Sets, 1929.—
RADIOCRAFT.**

Consol Transportable.

Specification: Single stage screen-grid amplifier followed by anode bend detector and pentode. Two dial tuning. The H.F. amplifier is stabilised and no reaction is employed. Provision for gramophone pick-up. Balanced armature loud speaker. Two-volt Exide accumulator, 40 amp.-hour capacity. Total anode current 10mA. Dimensions 36x15x15in. Weight 72 lb. £26 5s. in oak, £28 7s. in mahogany. An eliminator can be supplied if desired. The anode bend detector is coupled to the pentode by a Ferranti AF3 transformer. The loud speaker is filter fed from the pentode, which has 128 volts H.T. applied to it.

Radiocraft, Ltd., Arcade, Walsall.

READ RADIO.

Reaco Portable de Luxe.

Specification: Five valves; two aperiodic H.F. stages, followed by detector and two L.F. amplifiers. One-dial tuning. Hellesen 99-volt H.T. battery. Oldham 2-volt 20 amp.-hour L.T. accumulator. Dimensions 14x16x7½in. Weight 21 lb. £22.

The loud speaker is transformer-coupled to the last valve, and provision is made for connecting an external loud speaker if desired

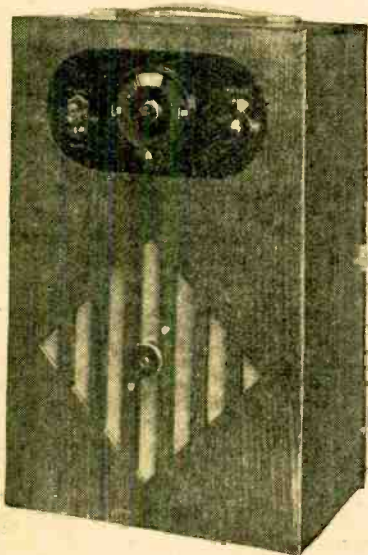

Reaco Popular Portable.

Reaco Five-valve Popular Portable.

Specification: Two aperiodic H.F. stages, followed by detector and two L.F. amplifiers. Two-dial tuning. Dimensions 11x17x8in. Weight 21 lb. £12 12s., royalties extra. A 2-volt 20 amp.-hour accumulator is supplied, also a Hellesen 99-volt H.T. battery. The last valve is transformer-coupled to the loud speaker.

Read Radio, Ltd., 32, Newman Street, London, W.1.

REES MACE.

Super Eight.

Specification: Supersonic heterodyne, with S.G. aperiodic signal-frequency amplifying valve, first detector, 3 I.F. stages, transformer-coupled and preceded by filter, followed by second detector and L.F. amplifier. Three tuning controls without reaction. Dimensions 17½x16½x8½in. Weight 34 lb. £50 8s.

A light-weight superheterodyne, fitted

with Peto and Radford or Edwards 28 A.H. accumulator and Hellesen 99-volt H.T. battery. Potentiometer volume control is provided.



Rees Mace Receiver.

Twin Baby.

Specification: Two screen-grid H.F. valves with tuned transformer couplings, detector, and two transformer-coupled L.F. amplifiers. Two tuning controls, no reaction. Dimensions 15¼x14½x8½in. Weight 34 lb. £35 14s.

An interesting receiver with an unconventional circuit arrangement. Provision is made for connection of a gramophone pick-up and volume control; for wireless reception, intensity is reduced by dimming H.F. valve filaments. Supplied with turntable and baize cover; waterproof cover extra. Tuning of H.F. stages is "ganged."



Rees Mace Twin Grand.

Twin Grand.

Specification: Similar to that of "Twin Baby" model. Dimensions 20½x19½x8¾in. Weight 40 lb. £37 16s. A larger "transportable" version of the "Twin Baby" receiver.

Rees Mace Manufacturing Co., Ltd., 39a, Welbeck Street, London, W.1.

REPRODUCTION, LTD.

Rhapsody Twin.

Specification: Five valves; two aperiodic H.F.

stages, leaky grid detector followed by two transformer-coupled L.F. stages. Potentiometer volume control across transformer. Reaction applied to H.F. coupling. Dimensions 16x16x10½in. Weight 40 lb. £40 19s.

A portable radio-gramophone is included in the equipment. When the pick-up (B.T.H.) is put in circuit two valves only are used for amplification. The total anode current for radio is 15mA.



Rhapsody Twin Five-valve Suitcase Portable.

Reproduction, Ltd., 5, 6, 7, Dysart Street, London, E.C.2.

RIALTON.

Rialton Portable.

Specification: Two choke-coupled H.F. stages, detector and pentode output valve. Single tuning control with reaction. Dimensions 13½x12½x9¾in. Weight 26 lb. Price from £19 19s. to £22 1s., depending on finish.

Supplied in leatherette (two optional colours), polished oak, or mahogany. Provision for connection of external aerial and earth is made. Accessories include Brown loud speaker, Hart 30 A.H. accumulator, and 108-volt H.T. battery. Calibrated in condenser settings.

Melva.

Specification: Three S.G. high-frequency valves, followed by detector and pentode output valves. Two tuning controls; no reaction. Dimensions 18x18x10in. Weight 40 lb. Price from £42 to £51 9s., depending on finish.

Supplied with turntable permanently fitted to cabinet, which is made in several distinct finishes—quartered mahogany, quartered burr walnut, and lacquer. Brown loud speaker, Hart L.T. accumulator, and large-capacity H.T. battery are fitted. Four-volt valves are used in this model.

Rialton Radio, 27, Old Bond Street, London, W.1.

RICARDA.

Five-valve Portable.

Specification: Two-dial tuning. Reaction applied to frame aerial. Output valve choke-filter fed to loud speaker. Dimensions 17½x14¼x8½in. Weight 28 lb. Price in lacquer £23 2s., in mahogany or walnut £21.

A Siemens 99-volt H.T. battery and a Peto and Radford 2-volt 30 amp.-hour accumulator are used. The total anode current is 8½mA.

Buyers' Guide to Portable Sets, 1929.—



Ricarda Transportable Receiver.

Screened Grid Four.

Specification: H.F. stage (screen-grid) aperiodically-coupled to grid detector. The first L.F. stage is transformer-coupled to the second stage. One-dial tuning. Reaction applied to H.F. coupling. Dimensions $15\frac{1}{2} \times 12 \times 8\frac{1}{4}$ in. Weight 26 lb. £19 19s.

The steady anode current of the output valve is prevented from passing through the loud speaker by means of a choke-filter feed. The capacity of the Exide 2-volt accumulator is 24 amp.-hours, and the voltage of the Siemens H.T. battery 99.

Ricarda Electric Co., 16, Holbein Place, Sloane Square, London, S.W.1.

ROLLS CAYDON.

Phantom Regional.

Specification: Two S.G. high-frequency valves, grid detector, and pentode output valve. Three tuning controls with reaction. Weight 45 lb. £44 2s.

Transportable model in crocodile-grained covered suitcase. Two 60-volt Hellesen triple capacity H.T. batteries and 2-volt 30 A.H. accumulator. Celestion loud speaker with filter feed. Osram or Six-Sixty valves.



Rolls Caydon Regional.

Phantom de Luxe.

Specification: Two aperiodic H.F. stages, grid detector, and two L.M. amplifiers. Single tuning control with reaction. Weight 32 lb. £37 15s.

Suitcase portable model, in lizard-grained case, fitted with Celestion loud speaker.

Ranger Type D.

Specification: S.G. high-frequency stage, grid detector, and two L.F. amplifiers. Single tuning controls with reaction. Weight 29 lb. £27 6s.

Suitcase portable model; case covered in material chosen for hard-wearing qualities. Celestion loud speaker fitted.

Regional.

Specification: Two aperiodic H.F. valves, grid detector and two L.F. amplifiers. Single tuning control with reaction. Weight 26 lb. £16 16s.

Portable model, supplied in four optional colour finishes. Fitted with Celestion loud speaker. Provision is made for attachment of external aerial and earth.

Rolls-Caydon Sales, 77, Rochester Row, Victoria Street, London, S.W.1.

○○○○

ROYAL.

Royal Five Portable.

Specification: Two aperiodic H.F. stages, detector and two L.F. amplifiers (resistance and transformer-coupled). Single tuning control and reaction. Dimensions $15\frac{1}{2} \times 12\frac{3}{4} \times 8\frac{3}{4}$ in. Weight 25 lb. £16 16s.

Portable receiver in hide suitcase. Provision is made, by means of a jack, for



Royal Five.

connection of a gramophone pick-up; insertion of plug automatically breaks H.F. filament circuits. An outside aerial may be used. Accessories include Grosvenor 108-volt H.T. battery, Litanode 25 A.H. accumulator, and special floating reinforced linen cone loud speaker with C.E.C. unit.

Royal Radio Co., 4-5, Dorset Mews North, Upper Gloucester Place, London, N.W.

○○○○

SELECTORS.

Screened Grid Four Portable.

Specification: One tuned screen-grid H.F. stage, detector and two L.F. stages. Two-dial tuning. Hellesen 108-volt H.T. battery, Exide 2-volt unspillable accumulator. Dimensions $13 \times 15\frac{1}{2} \times 8\frac{3}{4}$ in. Weight 26 lb. £33 12s.

Provision is made for the use of a gramophone pick-up and for an external loud speaker if desired. A turntable is fitted as standard, and calibration charts are fitted to the doors which enclose the panel when the set is not in use. The

L.T. battery can be trickle charged without removing it from the receiver.



Selectors Screened Grid Portable Receiver.

Screened Grid Four Cabinet Model.

Specification: Valves and couplings the same as those shown in the Screened Grid Four Portable model. Dimensions $13 \times 17 \times 7\frac{1}{2}$ in. Weight 26 lb. £33 12s.

Super-Seven Portable.

Specification: Superheterodyne circuit. Two-dial tuning. Litanode 2-volt unspillable accumulator of 40 amp.-hour capacity. Dimensions $18\frac{1}{2} \times 17\frac{3}{4} \times 7$ in. Weight 56 lb. £54 12s.

The L.T. accumulator can be trickle charged without its removal from the receiver. A somewhat unusual feature in a portable set is the inclusion of an 80-volt H.T. accumulator which delivers a total anode current of 18mA. An external loud speaker and gramophone pick-up can be connected if desired.

Screened Grid Three.

Specification: One tuned screen-grid H.F. stage, detector followed by one L.F. stage. Dimensions $12\frac{1}{2} \times 16\frac{1}{2} \times 7$ in. Weight 26 lb. £21. A 99-volt Hellesen H.T. battery delivers 11mA. to the anodes of the three valves, and a 2-volt unspillable Litanode accumulator heats the filament.

Selectors, Ltd., 1, Dover Street, London, W.1.

○○○○

W. SMITH.

Five-valve Economy Portable.

Specification: Two aperiodic H.F. stages, detector, and two L.F. stages. Single tuning control with reaction. Dimensions $13 \times 12\frac{1}{2} \times 7$ in. Weight 26 lb. £21.

A suitcase type of portable receiver; container is covered with leatherette. Peto and Radford accumulator and Hellesen H.T. battery are fitted.

W. Smith and Son, The Esplanade, Weymouth.

○○○○

STEVAL.

Five-valve Portable.

Specification: Two aperiodic choke-coupled H.F. stages, grid detector followed by two transformer-coupled L.F. stages. One-dial tuning. Reaction applied to frame aerial. Dimensions $14 \times 16 \times 8$ in. Weight 26 lb. £15 9s.

The total anode current of $7\frac{1}{2}$ mA. is supplied by a 99-volt Ripault battery. The filaments of the 2-volt valves are heated by an Oldham unspillable accumulator of 30 amp.-hours capacity. There is provision for a gramophone pick-up.

**Buyers' Guide to Portable Sets, 1929.—
Super Three.**

Specification: The H.F. stage (triode) is semi-aperiodically coupled by a transformer to the grid detector, which in turn is coupled to a pentode. Reaction applied to H.F. coupling. One-dial tuning. £13 4s. 6d.

An extra loud speaker can be connected if desired. The total anode current of 6mA. is delivered by a Pertrix 60-volt battery, and the filaments are heated from a 2-volt Exide accumulator of 16 amp.-hours capacity.

Steval, Ltd., "Swan House," 133, Oxford Street, London, W.1.

○○○○

SYMPHONY.

Transportable Five.

Specification: Two aperiodic H.F. stages, detector followed by two transformer-coupled L.F. stages. One-dial tuning. Reaction applied to frame aerial. Dimensions 11x19½x18in. Weight 54½ lb. £25.

An Exide 2-volt accumulator of 50 amp.-hours capacity is included, while the H.T. current supply is obtained from a Columbia 120-volt battery. A special L.F. transformer with nickel iron core is embodied in the receiver.

Portable Five.

Specification: The same as that given for the Transportable Five, with the following exceptions: Dimensions 15¾x12x8in. Weight 27 lb. £17 10s.

The set is supplied in a polished mahogany case and a waterproof cover is provided. An interesting feature is the oval cone loud speaker.

Symphony Gramophone and Radio Co., Ltd., 23-24, Warwick Street, Regent Street, London, W.1.

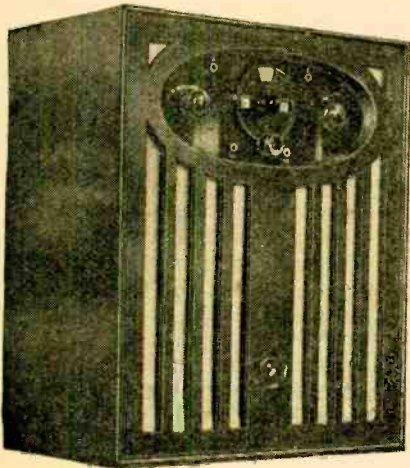

Truphonic Melo-Set.

○○○○

TRITONE.

Radio Gramophone Portable.

Specification: Two aperiodic H.F. stages, detector, and two L.F. amplifiers, both transformer-coupled. Single tuning dial with reaction. Weight 25 lb. £18 18s.

Gramophone turntable, motor, and pick-up are included, together with a variable resistance for volume control.

Five-valve Portable.

Specification: As for "Radio-Gramophone Portable," but apparatus for gramophone reproduction is omitted. £14 14s.

A 39

Three-valve Portable.

Specification: Grid detector and two transformer-coupled L.F. stages. Single tuning control with reaction. £12.

Two-valve Portable.

Specification: Grid detector, transformer-coupled to pentode output valve. Single tuning control with reaction. Dimensions 12x12x8in. Weight 11 lb. £8 8s.

A 2-valve detector-pentode combination, fitted with Exide accumulator, 10 amp.-hour capacity, and Grosvenor H.T. battery, 99 volts.

Tritone, Ltd., 41, Wigmore Street, London, W.1.

○○○○

TRIX.

Portable Five.

Specification: Two aperiodic H.F. stages, detector followed by R.C. coupled first L.F. stage and transformer-coupled second stage. Reaction applied direct to frame aerial. One-dial tuning. Dimensions 16¾x15½x8¾in. Weight 29 lb. Price, in walnut or mahogany, £18 13s. 10d.; in solid leather, £19 16s. 4d.

An H.T. battery of 105 volts is provided; the total anode current is 8mA. A switching scheme is arranged to connect



Trix Portable Five.

either an external battery eliminator or the internal batteries at will. There is provision for a gramophone pick-up.

Portable Two.

Specification: Leaky grid detector, transformer-coupled to two-volt pentode. Reaction applied direct to frame aerial. Pentode directly coupled to loud speaker. H.T. voltage is 105, and the total anode current 5mA. Dimensions 13½x13½x7in. Weight 16 lb. £10 17s. 6d.

For greater sensitivity an outside aerial and earth can be connected. A 2-volt Rowland Edwards unspillable accumulator of 15 amp.-hour capacity is supplied. One-dial tuning is used, and the lower broadcast band only is covered.

Trix Portette.

Specification: One valve. Regenerative leaky grid detector. Two-volt unspillable Exide accumulator of 7 amp.-hour capacity. H.T. voltage 36; total anode current 1mA. Dimensions 6x6x8in. Weight 6½ lb. Price, in mahogany, £5 10s.; in Rexine, £6 1s. 6d.

It is claimed that this is the smallest portable set in the world. The lower broadcast band only is covered. Head-phones are supplied.

Eric J. Lever (Trix), Ltd., 8-9, Clerkenwell Green, London, E.C.1.

○○○○

TRUPHONIC.

Melo-Set.

Specification: Five valves; two aperiodic choke-coupled H.F. stages; grid detector; first L.F.

stage transformer-coupled; second stage R.C. coupled. One-dial tuning. Dimensions 18x16x8in. Weight 26 lb. £16 15s.

A gramophone pick-up can be connected if desired, and should greater sensitivity be required an outside aerial and earth can be used. An H.T. battery of 100 volts provides the total anode current of 6½mA.

Truphonic Wireless Company, 137, Regent Street, London, W.1.

○○○○

WORLD'S WIRELESS STORES.

Miracle.

Specification: Five valves; two aperiodic H.F. stages, detector, and two L.F. amplifiers. Single tuning dial with reaction. Dimensions 16½x12½x8¾in. Weight 30 lb. £16 16s.



World's Wireless "Miracle."

Suitcase type of receiver with loud speaker, frame aerial, and switch mounted in lid. Exide 24 amp.-hours accumulator and 100-volt H.T. battery are fitted.

World's Wireless Stores, Wallington, Surrey.

CATALOGUES RECEIVED.

Pye Radio, Ltd., Paris House, Oxford Circus, London, W.1. 8-page illustrated booklet of the Pye Portable Receiver.

○○○○

Dubilier Condenser Co. (1925), Ltd., Ducon Works, Victoria Road, North Acton, London, W.3. Illustrated leaflet of Dubilier components. Midget variable condenser, vertical grid leak holders, and other small-sized compact components are suitable for use in portable sets.

○○○○

Fredk. Squire, 24, Leswin Road, Stoke Newington, London, N.16. Illustrated leaflet describing aluminium cradles for assembling cone type loud speakers. Eminent suitable for fitting to portable sets

○○○○

TRADE NOTE.

The Halcyon Wireless Co., Ltd., Canberra House, 313-319, Regent Street, London, W.1, have recently acquired a large modern factory at Slough to cope with the demand for their portable sets.

The service department remains at 27a, Pembroke Villas, Notting Hill Gate, London, W.11, and all correspondence relating to repairs should be sent to this address.



HINTS AND TIPS

for Portable Users

Points in the Operation of Frame-aerial Sets.

THE expenditure of a few shillings on a turntable, which may easily be screwed on to the underside of the portable set cabinet, is an investment which will generally pay for itself by preventing damage to polished table tops, etc. Orientation of the frame aerial is at best a clumsy procedure unless some device of this sort is fitted; without it, one cannot take full advantage of the directional properties of this method of reception.

When attempting to receive transmissions on a wavelength close to that of the local station, the correct procedure is first to set the frame to the position of *minimum* response to the near-by signals. Admittedly, if the "wanted" station lies in the same plane as the local, it will not be heard, but this is a rare case, and if selectivity is inadequate in the ordinary way it must be taken that the directional properties of the set will confer no benefit.

A voltmeter, preferably of the two-range type, is just as useful for the portable set as for any other; it shows if failure to obtain signals is due merely to exhausted batteries, and, moreover, gives an indication when L.T. and H.T. cells are becoming due, respectively, for recharging or replacement. It is generally possible to find room for the instrument in the cabinet; in any case, it should accompany the set during any prolonged absences from home.

There is a good deal of uncertainty as to whether filaments should be switched off when making internal adjustments to a receiver with its H.T. batteries connected. It is not possible to be dogmatic on this question, but in certain cases the battery connections are such that it is safer, from the point of view of avoiding accidental burn-outs, and, contrary to the usual belief, to leave the switch in the "on" position. A possible exception to this rule exists in the case of the output valve; to avoid the passage of a high anode current, it is as well to extinguish its filament before breaking its grid circuit.

To use two H.F. stages for reception of a station two or three miles away is like employing a steam hammer to crack a nut. When the set is mainly used for short-distance work, it is worth while to investigate the possibility of temporarily cutting out the conventional two-valve "aperiodic" high-frequency amplifier. This can sometimes be done quite easily by removing the frame aerial connection from the grid terminal of the first valve, and transferring the lead to the detector grid condenser—of course removing the existing wire from this point.

Small flashlamp bulbs, consuming a current that is quite negligible in comparison with that taken by the valve filaments of the average set, are now readily available. It is a good plan to mount one of these behind a hole drilled through the control panel or in some other convenient and conspicuous position; if the lamp holder is wired across the filament terminals of any valve holder it will serve as an indicator when the set is switched "on."

Some manufacturers provide a theoretical diagram of connections with their receivers; this is an invaluable aid in the quick location of any fault that may arise, and to prevent its loss it may well be pasted inside the container or on the underside of the battery compartment cover. Even if the user himself is unfamiliar with circuit diagrams, the task of a professional repairer to whom the set is entrusted will be lightened if its technical details are clear to him.

When removing the accumulator for its periodical recharging, see that its connecting leads are placed so that their ends cannot make accidental contact with conductors that may possibly be connected to the H.T. battery. As drops of acid in the wrong place may cause a good deal of damage, always wipe over a recharged accumulator before replacement.

Few portable sets include provision for headphone reception, but there are occasions when this method of listening has its advantages. If the loud speaker is eliminated, the total magnification ordinarily provided is generally excessive, and, if only in the interests of economy, the output valve may be removed from its holder, the phones being connected across the L.F. transformer primary terminals, which afford convenient points of attachment.

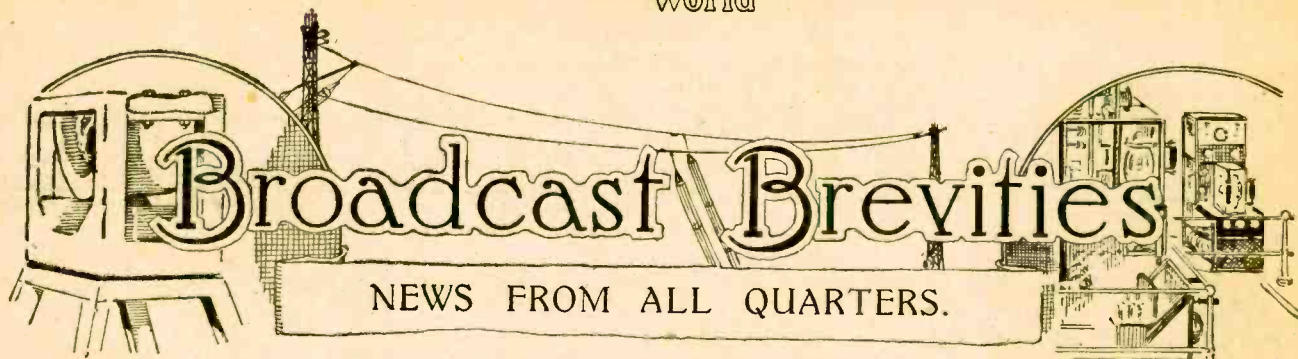

By Our Special Correspondent.

The Announcer's Job.—Dance Music Surprises.—New Permanent "O.B." Site.

Portable Sets for Announcers.

If there is one class of individual who might be expected to look on broadcast reception with disfavour, it is the announcer. Yet Mr. Derek McCulloch, who has just returned to Savoy Hill after a three-months' spell of announcing at Belfast, tells me that he listened to British and Continental broadcasting not only during his spare time in Belfast, but on the journey back to London!

His constant companion is a well-known five-valve portable (pre-screen-grid variety) on which, in Belfast, he was able to tune in Königswusterhausen, Radio Paris, Brussels, and a bevy of others every evening. London and the two Daventrys simply romped in.

Boredom in the Studio.

It may be cruel to suggest that every announcer should carry a portable set, but there is no doubt that certain of the tribe would benefit from hearing the efforts of their colleagues. In regard to their pronunciation and enunciation, I imagine that the B.B.C. announcers are without serious competitors anywhere in the world; but once or twice of late particular announcers have given an impression of supercilious boredom. Now, like almost every kind of work, announcing must have its moments of desolation, but it is an atrocious thing for an announcer to communicate his private feelings to the listener.

Weather Forecasts are Not Funny.

This sophisticated attitude has been specially remarked in the broadcasting of weather forecasts. Some announcers, it would seem, have never recovered from the "depression over Iceland" joke, and forget that meteorological news which may be of no consequence to themselves may be of vital importance to farmers and the men at sea, not to mention the vast host of amateur gardeners.

Jack Payne and the Armchair Listener.

All honour to Jack Payne, of the B.B.C., for being the first dance band leader to consider the needs of the listener who remains seated. Great plans are afoot for widening the scope of the B.B.C.'s dance band, and one of these is for the evolution of new Terpsichorean music which will give all the satisfaction of the dance to him who sits. Another scheme is

to tackle and harness music which no other dance band has ever dared to syncope.

The band has recently been augmented, and now consists of fourteen players, in addition to Jack Payne himself. And so versatile are these players that during one performance they handle forty different instruments. This is economy. Could Aberdeen ask for more?

Well-deserved Honours.

Not one of the recent recessionists from the B.B.C. staff could complain that he was "unwept, unhonoured, and unsung." But the best tokens of esteem have come to Capt. A. G. D. West, always one of the most popular among the B.B.C. staff. A few days ago his fellow-workers presented him with a silver loving cup, and at the same ceremony he received a silver salver from the Corporation.

Permanent Lines at Aldershot.

The second outdoor site to be permanently fitted with land lines and microphone points for broadcasting purposes is the Rushmoor Arena, Aldershot, from

which the Torchlight Tattoo will be relayed on June 18th. (The other permanent "O.B." site is, of course, the Cenotaph.)

The work of laying the lines at Rushmoor has been carried out by sappers of the Royal Engineers, the B.B.C. supplying the lines. Four pairs of cables have been buried.

During the display the "O.B." van containing the amplifiers will be concealed behind trees on the edge of the arena. The Tattoo provides a stirring and exciting broadcast, and the news that it is to become an annual programme event will be welcomed.

Empire Thanksgiving.

5SW, the Chelmsford short-wave station, will share in the great "S.B." on June 16th, when the Thanksgiving Service for the King's recovery is relayed from Westminster Abbey. No new technical arrangements will be required for this broadcast, as the Abbey is already equipped with microphones and cables, which are used for the broadcasting of Evensong on Thursday afternoons.

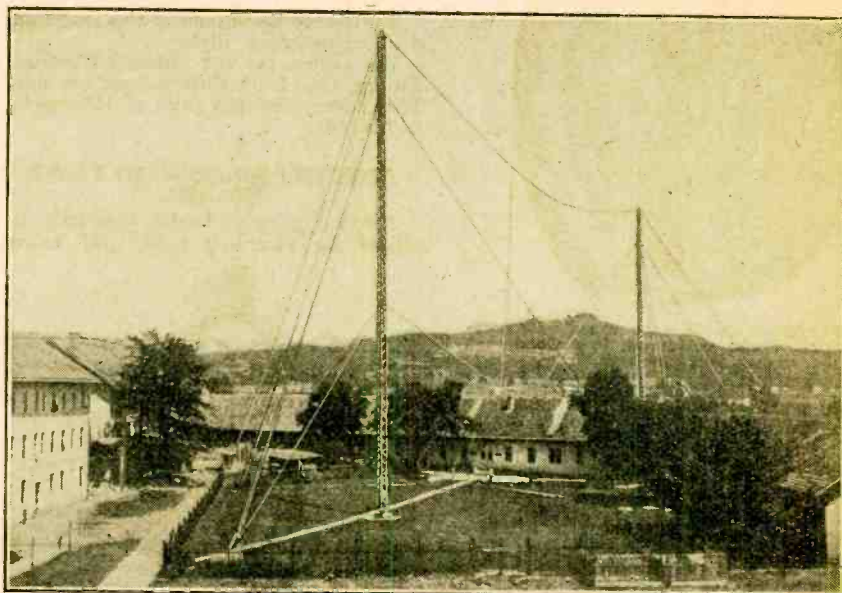

KLAGENFURT CALLING.—A well-known Austrian broadcasting station which usually relays the programmes of Vienna. The wavelength is 456 metres

APPARATUS REVIEWED

Components for Portables

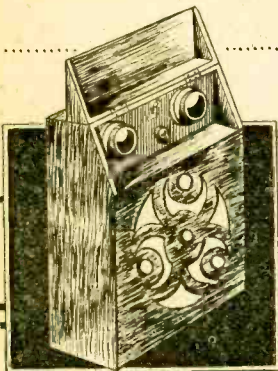

GOODMANS PORTABLE SET CONE UNIT.

This accessory has been designed especially for use in portable sets, and its main features are lightness and small bulk. The maximum depth required is 4in., and the overall diameter is 9½in. The chassis consists of a cast aluminium ring with a holding attachment for the loud speaker movement. The periphery of the cone is virtually free, but is lightly damped by resting against a ring of cotton wool glued to the aluminium chassis.

A broad cardboard guard ring encloses the unit and serves to protect the cone against trailing wires that might otherwise rest on the diaphragm and cause chatter. The design permits of the use of a wide range of loud speaker movements. The unit fitted to the model illustrated is a Goodmans four-pole movement. The cone assembly, without the

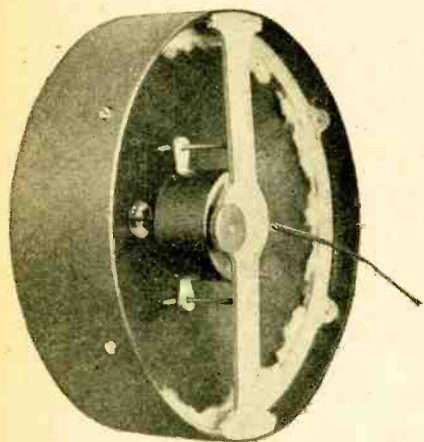

Goodmans special cone chassis for portables. The movement is a Goodmans four-pole unit.

loud speaker movement, is offered at 10s. 6d., and the makers are Messrs. Goodmans, 27, Farringdon Street, London, E.C.4.

o o o o

EXIDE UNSPILLABLE ACCUMULATOR.

The two-volt cell illustrated is the type WPC-3 18-amp.-hour size, which has been designed especially for suitcase-type portable sets. An ingenious arrangement

of compartments ensures that the plates are always covered by the electrolyte, both in the carrying position and the working position, these being generally in planes

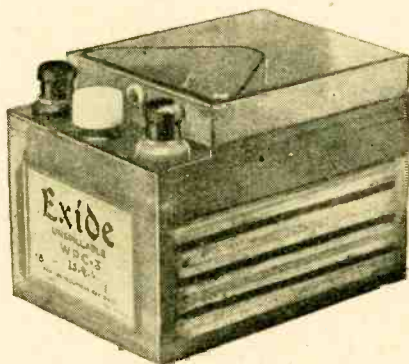

Exide unspillable accumulator for attaché case portable sets.

at right angles to each other. Furthermore, a special acid trap prevents leakage even though the cell is turned upside down or carried in any other position.

The overall dimensions of this model are 4½in. x 3½in. x 3½in. high.

The makers are the Chloride Electrical Storage Co., Ltd., Clifton Junction, near Manchester, and the price of this model is 15s. 6d.

o o o o

AERMONIC SCREEN-GRID VALVE HOLDER.

A new type valve holder, especially designed for mounting screen-grid valves

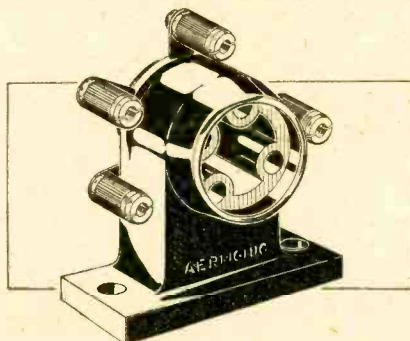

Aermonic screen-grid valve holder. A useful component for portable sets.

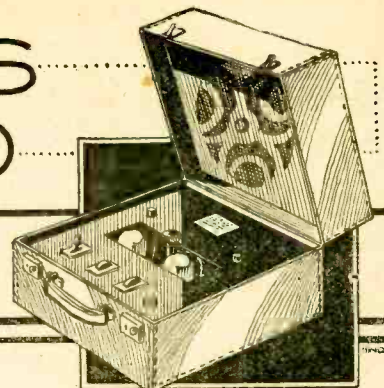

horizontally to the baseboard, has been put into production by Messrs. James Christie and Sons, Ltd., 246, West Street, Sheffield, and is offered at 1s. 3d. with screws and tags, and at 1s. 6d. with terminals. It is particularly suitable for use in portable sets, as it is compact, takes up very little baseboard space, and gives just sufficient clearance for the valve to justify using a screen with an inverted "U" opening in place of a circular hole. Those who have difficulty in cutting a hole 1½in. in diameter will appreciate this point.

It is made in one piece with the valve sockets and contact tags moulded in. The centre is open and leakage should be practically negligible. Tests showed the insulation resistance to be higher than 150 megohms.

o o o o

"CAMCO" RIVERSIDE PORTABLE CASE.

This is a conventional suitcase pattern container for portable sets made by the Carrington Manufacturing Co., Ltd., Camco Works, Sanderstead Road, South

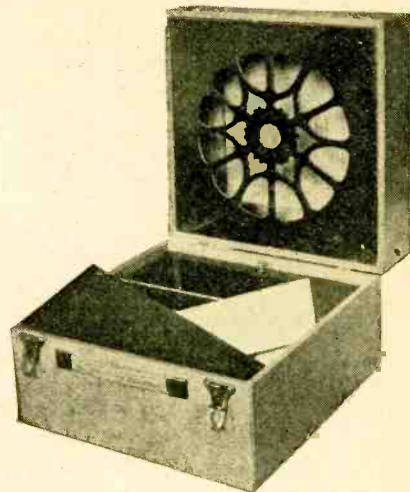

"Camco" suitcase portable set container.

Croydon. The panel space allowed is 14in. x 6in., and depth below panel (allowing 1½in. clearance for control knobs) is 3½in. approximately. The battery com-

partment, which is at the back of the case and measures 14in. x 5½in. x 4½in. deep, is fitted with a polished cover held in position by a concealed button.

Accommodation for a cone loud speaker and frame aerial is provided in the lid, the ornamental grille carrying the skeleton framework for supporting the aerial winding.

The outside dimensions of the case are 14½in. x 14½in. x 9½in. deep, and the finish is in imitation leather. All necessary interior partitions, panel battens, etc., are included, and the price is £2 5s.

o o o o

EDWARDS PORTABLE SET ACCUMULATORS.

Two types of portable set accumulators are made by Messrs. Rowland Edwards & Co., Ltd., Southampton House, 317, High Holborn, London, W.C.1. The "S.8" is a two-volt 30-amp.-hour (actual) cell of conventional shape and suitable for fitting into cabinet-type portable sets. A well-designed acid trap prevents leakage of the electrolyte even if the cell is resting on its side. This model sells at 14s. 9d.

The "E.F.A." type is a two-volt 18-amp.-hour cell designed especially for suitcase portables. In this model the plates are horizontal when in the working position and vertical when carried. An

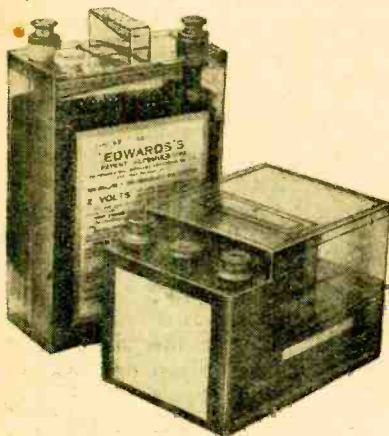

Two types of Edwards unspillable accumulators for portable sets. The "square" type is for suitcase portables.

arrangement of compartments, carefully chosen as regards volume, ensures that the plates are always covered by acid in both the normal working and carrying positions. Wet acid spray cannot escape from the vent, and the electrolyte will not spill in any position of the cell. This particular model is offered at 16s. 6d., but there are larger capacities in this type available. Prices will be quoted on application to the makers.

o o o o

BURNDIPT TURNTABLE.

It is essential that means should be provided for readily rotating a portable. The critical adjustment that is invariably needed is difficult to obtain unless the set can be turned with little effort, and it is to meet this need that the turntable now fitted to many modern portables has been introduced. Used out of doors the turn-

table provides a base upon which to stand the instrument, while for home use it avoids the inconvenience caused by dragging the instrument to a position of maximum signal strength. Incidentally, one of the best methods of volume control is obtained by the use of a turntable.



Burndipt ball-bearing turntable.

By fitting a turntable to the set it becomes a simple matter to orientate the receiver, but there are many who regard this as rather unsightly. The turntable made by the Burndipt Wireless (1928), Ltd., Eastnor House, Blackheath, London, S.E.3, and offered at 5s. 6d., would be well worth considering, since it measures only 4½in. in diameter and protrudes ½in. from the side. It is particularly suitable, therefore, for the attaché case type of portable. It runs on ball bearings, and the action is delightfully smooth even when supporting a heavy load.

o o o o

GECOPHONE LOUD SPEAKER MOVEMENT.

This adjustable reed cone loud speaker movement has been introduced by the General Electric Co., Ltd., Magnet House, Kingsway, London, W.C.2, for use in portable sets. The movement is the same small type as incorporated in this firm's Junior Plaque loud speaker, and is now being offered separately at 15s. It consists of two bar-magnets with a single pole piece at one end, the magnetic circuit being completed through the armature which is fixed at one extremity and measures 2½in. x ½in. wide.

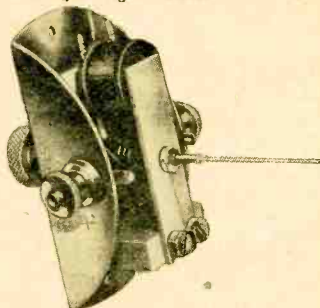

Gecophone adjustable reed, cone type loud speaker movement.

The cone spindle is attached to the centre of the armature, the fixing bush extending below this and forming the top support for a stout helical spring which is attached, at the other end, to a thumb-screw-controlled anchorage. This provides the adjustment of the distance between armature and pole piece.

The two input terminals are mounted,

in insulating bushes, one on each side of the supporting frame.

o o o o

FORMO "1928" LOG CONDENSERS.

With vanes fully extended, these condensers occupy a panel space of 3½in. x 3½in., and 2in. in depth. The vanes are constructed from aluminium, and the skeleton frame from a bakelite moulding and brass. The weight is 4½ ozs. only for the largest size, so that these are eminently suitable for use in portable sets. The ordinary type, as illustrated, has one end bearing only, but this is of generous size and there is no trace of whip. Vibration will not displace the vanes. They are available in three capacities: 0.00025 mfd., 0.00035 mfd., and 0.0005 mfd., the price being 5s. in each case. The plates are so arranged that the capacity change follows a logarithmic law.

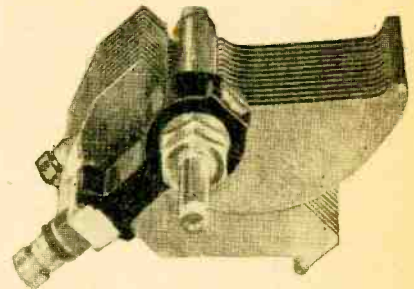

Range of "Formo" log condensers.

De luxe models with two end bearings are available at 6s. each; these, however, require more depth, the largest size measuring 2½in. back to front. Four capacities are available: 0.00015 mfd., 0.00025 mfd., 0.00035 mfd., and 0.0005 mfd. This type could be used where space is not so valuable as in the average suitcase portable.

Single-hole fixing is provided, and the makers are the Formo Company (Messrs. Arthur Preen & Co., Ltd.), Crown Works, Cricklewood Lane, London, N.W.2.

o o o o

"COLTAGS."

Since portable sets are not generally provided with battery terminals, it is desirable to adopt some method of marking whereby the various leads can be distinguished readily. The S. H. Collett Manufacturing Co., 60, Pentonville Road,



Collett's clip-on battery lead tags.

London, N.1, have recently placed on the market a range of clip-on aluminium tags, suitably engraved, and these are ideal for this purpose. Clearly marking each lead will save a lot of time and tedious tracing should the battery plugs jolt out during transit. "Coltags" are offered at 9d. a dozen.

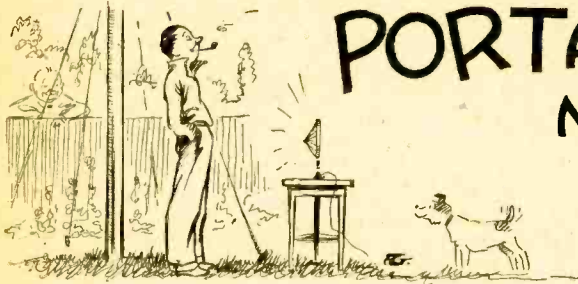

PORTABLES NEED NO APOLOGIES



An Enthusiast Challenges the Experts.

By B. H. DAVIES.

THE wireless enthusiast who takes *The Wireless World* every week is apt to regard portable receivers with a genial scorn. He is well aware that in what are sometimes called "luxury streets" it is impossible to sell anything else. The old ladies of the South Coast towns, living in flats and boarding houses, moving from place to place as they exhaust a neighbourhood, and possibly spending a month or two of each year at some cheapish Continental resort—they, of course, won't touch sets which require a G.P.O. aerial. But the listener who possesses a little knowledge is fidgeted at the idea of using four or five valves when three will do. An 18in. frame wound inside a leather bag or a walnut case is a poor collector of energy compared to a 40ft. mast at the bottom of the garden. If you have an efficient receiver, why not push into it all the input which you can get? After all, a hank of 7/22 copper wire only costs a shilling or two. And fancy returning in the year of grace 1929 to a tiny 10 ampere-hour accumulator, and one of those nasty little black 66-volt dry batteries, which begins to get noisy after six weeks of hard use, and anyhow won't supply a decent power valve even when it is brand-new?

All of which is perfectly true, and very sound reasoning, as far as it goes. The man (or woman) who spends all his life in one house, as a snail abides in its shell, would be a fool to buy or build a portable. The stationary wireless enthusiast, anchored by circumstances to a fixed habitation, is easy to cater for. He needs a good G.P.O. aerial, a *Megavox* three-valve receiver, an output filter, and sufficient wallplugs upstairs and downstairs all over his house to cover any possible emergencies, so that his wife may have music in her bedroom to drown the wails of the newest baby, and he can have the loud speaker in the kitchen when she has gone to her mother, and he is pigging it like the March Hare and the Mad Hatter with unwashed crockery all over the dirty table.

Nevertheless, a great many technical and semi-technical men either build or buy portables, and find them most amazingly pleasant and convenient in certain circumstances. *Moi, qui vous parle*, have constructed two or three hundred sets, have figured as director of a small wireless company, but count myself maimed and incomplete when there is no portable standing in my wireless den, ready for any emergency which the day may bring forth. And during the last five years there have been innumerable occasions when the portable has solved the situation. There was one eight weeks ago, when a fierce south-westerly gale coincided with a soggy lawn, wrenched out the S.W. picket of my 50ft. steel mast, and wreathed the G.P.O. aerial all over the tennis netting just when the

B.B.C. transmitted one of those rare items which no self-respecting listener can afford to miss. There will be another when this article is in type; for polling night will find me sleeping in a strange bed 300 miles from home. There may be a receiver in the village where I shall sleep on that date, but I shan't risk it. The portable will be packed in the stern sheets of the car, and at bedtime it will be placed on a chair beside my bed. The *Radio Times* will presumably tell me at



A portable brightens hotel life.

what hour the final results will go forth; an alarm clock will awake me at 4 a.m. or whatever it is; a sleepy finger will turn the switch to "On!" I shall marvel, and rejoice or curse, as the case may be. Not for worlds would I go there without a portable, since it is the sort of place where yesterday's paper arrives at noon to-morrow.

Home News in English.

There are not many places in Great Britain where one cannot now get a morning paper of sorts at breakfast time. But my job takes me across the Channel two or three times a year, often with a motor car. I am no great linguist; but when I can decipher the unsatisfying paragraphs of a French or German or

Portables Need No Apologies.—

Italian newspaper, it never tells me anything I want to know. The English daily papers are seldom obtainable promptly at the sort of place which I frequent; and the American journals, which seem to be much more accessible, stir me to rage. They tell me that Hiram Q. Snooks and family have arrived at the Majestic, that the White Sox beat the Bowery Brutes, that Babe Ruth has had another rise of 5,000 dollars, that there have been several matrimonial reshuffles in the Upper Ten at Hollywood. My portable is preferable; it brings in 5XX, and so gives me the racing, the cricket, and the political news from home, which is all I want. Contrary to general supposition, it is quite easy to take a British portable through foreign Customs, provided one has a motor car. (I have never tried without a motor car.) In fact, to betray a precious secret, if you have a car, you can take anything you like through any foreign *douane*, even the Italian, because the officials are so terrified of letting you camouflage an illegal motor car, import or export, that they never look at anything but the car. However, in this case the special tip is to enter the portable set on the *carnet* of the motor car, as if it were an indispensable accessory of motoring, as indeed it almost is; and that regularises everything. Neither does the portable set object to the bucketing which a car administers; in five years of carting such sets about on cars, covering perhaps 15,000 miles, I have fractured one connection, and corroded one frame aerial with spilt acid; even in the latter event a rather prehistoric type of accumulator was the culprit. The packing of the set must, of course, be sensible. The flat pattern of set, usually assembled in a leather case, carries best, as it can be laid on the floor of the boot or the rear cockpit. But, as a matter of fact, most of my travel has been done with vertical sets in wooden cases; they stand on the boot of the back compartment, and are jammed tight against the cushion of the seat with the aid of other luggage.

I have laid this emphasis on the value of a portable in foreign travel because the average Briton develops such a frenzy for news after a week or two's exile from his daily paper, but the traveller at home will find a good portable set equally serviceable. A stern employer has a nasty knack of keeping me busy on all the great national festivals. Derby Day, for example, is not an automatic holiday in my profession; but ever since the B.B.C. took their microphones to Epsom I have attended the great race in spirit and in mind, if not in body. When I do take a holiday it is often of the camping type. It is generally stated that there are two great snags about tent life. The one is rain, the other is insects. But in my opinion the real snag is the complete absence of anything to do after dusk. The wise camper pitches his tent in some gorgeous place, and after supper and washing up he is well content to

lie outside his tent with a pipe and a tankard till sunset. But the sun may set about 9 p.m. It is far too early to go to bed, and there is nothing to do. So out comes the portable; and if there are young people and a moderately level patch of turf, dancing begins—perhaps by moonlight, perhaps illuminated by lamplight from the car. On any holiday the B.B.C. weather forecasts are of genuinely inestimable value. I well remember rather a vivid case in point. I had raved for years about the magnificent scenery at Applecross beyond Loch Carron in the West of Scotland; and three years ago my companions at Inverness remembered these ravings, and decided we must visit this famous "Pass of the Cattle." I have been there many times, and five times out of six it has been so swathed in mist and driving rain that the visibility was limited to twenty yards, and the inevitable picnic meal (for there is no inn) was a dreariness in the flesh. We had the choice of six days for the long motor trip, and we picked our day with the aid of a Selector Super and the weather forecast, to be rewarded by twenty miles of visibility instead of 20 yards.

Portable sets are gradually becoming much cheaper; and perhaps with the aid of two or three more years of inventiveness they will grow lighter. Then everybody who frequents hotels will take a portable on their travels. Every night in the year the hotels, and perhaps more especially the commercial rooms, of Great Britain are full of solitary men, with nowhere to go and nothing to do. There is the bar and the billiard room, and in the street a cinema or a cheap flirtation, but there is nothing else. Already many men who travel by car take portables with them. When a long range portable weighs less, railway travellers will use them increasingly. The Bowyer-Lowe people sell a one-valve portable which weighs only a few pounds, and is packed in an attaché case. It operates off roof. of flex, draped round the picture rail of the bedroom, or dropped out of the window. It is a pleasant companion for a solitary traveller, subject to the drawback that it must be used in a bedroom, for one cannot very well start draping roof. of flex round a public room.

This Year Next Year ?

I think the designers of portable sets, in conclusion, deserve a very hearty vote of praise for the really excellent quality which they contrive to produce nowadays under the handicaps of an output valve which none of us would select for stationary loud speaker work, especially as weight limitations compel them to feed it from a small dry battery. The tone of many of the 1929 portables is so good that genuinely musical people find no fault with it.

Altogether, I find myself in a minority amongst knowledgeable wireless folk in regarding a portable as an essential part of my equipment, but I expect to find myself in a majority some day.



Eliminating the petty irritations of foreign travel.

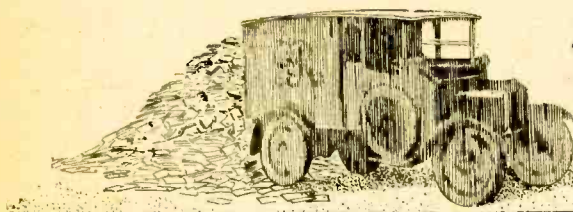

The Editor's Mail



The Editor does not hold himself responsible for the opinions of his correspondents.

Correspondence should be addressed to the Editor, "The Wireless World," Dorset House, T. dor Street, E.C.4, and must be accompanied by the writer's name and address.

EMPIRE BROADCASTING.

Sir,—May I be permitted to compliment you upon your leading article, "Empire Day, 1929," in to-day's issue of *The Wireless World* (22nd inst.)?

The reasons for the deplorable delay in modernising the technical and programme arrangements for the Empire Station can only be those stated in your leader, with the consequence that "5SW" is really nobody's baby.

You will recall my earnest endeavours to accelerate the Empire Service, when, in connection with my visit to Africa and Australia, it was contended by the Press of those Dominions that the Home authorities should not grudge a pittance for providing an efficient service. It was considered to be in the natural order of things that the Mother Country would see to it.

Then there is the case of the Pioneers in the "Bush." A relative handful perhaps, but it is to be presumed that we wish those backblocks to become more civilised, especially with the congestion at home. I have met two acquaintances during the last fortnight, from Malaya and India respectively, who also "stand and wait" (*vide* your amusing article also in to-day's issue). They, too, rely upon Holland and America for news!

Is it too much to hope that the new Government will fulfil the responsibility that is essentially ours?

London, W.6.

H. ANTHONY HANKEY.

H.F. AMPLIFICATION ON SHORT WAVES.

Sir,—We read in your issue of May 22nd a very comprehensive review of the Philips type 2802 receiver.

In the course of the text we notice the statement:—

"That an H.F. stage should be used in a short-wave set is an unusual feature, and this is the first instance in which the adoption of an H.F. amplifier is to be found in a commercially built short-wave set arranged for home reception."

This caused us no little surprise, as we felt sure that you were acquainted with the activities of this company in the development of H.F. amplification on short waves as far back as 1925-27, when the Igranic Neutro-Regenerative Receiver was developed, which tunes from 15 to 2,000 metres. We also recollect that you have had first-hand experience of this receiver by arrangement with our London office.

Further, at the Olympia Exhibition last year an Igranic short-wave receiver was shown incorporating a screened grid valve in a carefully developed H.F. circuit which pre-dates the Philips receiver by almost a year.

A. H. CURTIS,
Igranic Electric Co., Ltd.

Sir,—While it is only in accordance with British traditions of fair play to review foreign products as favourably in relation to their merits as those of the home country, we feel sure that in affirming on page 542 of *The Wireless World* for May 22nd, that a certain foreign receiving set "is the first instance in which the adoption of an H.F. amplifier is to be found in a commercially-built short-wave set arranged for home reception," it has escaped the memory of the reviewer that the Burndept "Empire Screened Four," of which a description appeared in *The Wireless World* on March 20th, was on the market some nine months earlier than the set now referred to.

M. G. SCROGGIE, B.Sc., A.M.I.E.E.,
Chief Engineer.

Burndept Wireless (1928), Ltd.,

S.G. VALVES AND SHORT WAVES.

Sir,—May I take advantage of your correspondence columns to ask any of your readers who have carried out experiments with H.F. amplification on short wavelengths if they will be good enough to inform me if their tests have indicated that there is any advantage to be gained by incorporating a S.G. high-frequency valve in a short-wave receiver for 15-100 metres?

From those whose experiments have shown improved results I would very much like to know (a) whether the tuned grid, compared with choke controlled, input to the H.F. valve warrants the extra control; (b) if parallel or series feed to anode of H.F. valve gives best results; and (c) whether the H.F. valve working under the best of the foregoing conditions actually amplifies signal strength or if it simply gives improved control of reaction due to the removal of aerial damping from the detector circuit. It is understood that efficient screening and de-coupling wiring should be employed and that neutralisation of the S.G. valve should be resorted to.

My aim in making these enquiries is to reduce mush by employing a shorter and lower antenna and to minimise fading, whilst keeping up signal strength.

I would like to add to this letter a small contribution of thanks from overseas for *The Wireless World's* persevering campaign for establishment of the Empire Station. It is decidedly satisfying to know there is one member of the wireless Press which can spare a thought for those a long way from home.

Las Palmas, Canary Islands.

M. V. BLAKE

April 24th, 1929.

"SCRAPPY" PROGRAMMES.

Sir,—On reading this correspondence, one is struck by the attempts of some of your contributors to say "smart" or sarcastic things at the expense of the B.B.C. Now sarcasm and leg-pulling have their uses, but lose their force when combined, as they so often are in this connection, with exaggeration and unreasonableness. I write as a regular listener to one station only. There is much in the programmes which I dislike, and much which I thoroughly enjoy. There are things which I think I am going to dislike, or which will bore me, but which, after a few minutes' hearing, compel me to "remain in" till they are finished. Not to prejudice the question, I will not say what my likes and dislikes are. The point is, would more continuous and solid chunks of any particular kind of broadcast really meet with the approval of even a bare majority? Would the listeners who complain about the types of broadcast matter be willing to sacrifice listening entirely for two or three nights a week so as to get full, undisturbed programmes of what they prefer on the other three or four evenings? Not so, if one may judge from the tone of their letters. Probably a large number would demand half their licence money back. The fact appears to be that good sets are now so prevalent that we are getting too expectant, both of what the set itself can do and of what manner of broadcast these good receivers will convey. If we are willing to spend more and more money on good receivers, should we not expect to pay more for our programmes, if we wish them also to be better or more varied? Probably in suggesting such a thing I am a voice crying in a wilderness, and one does not seriously expect the cost of receiving licences to go up. As things are, and until the advent of alternative programmes from twin regional stations, I maintain that the present division of time and kind of broadcasting is honestly designed to give "the greatest good for the greatest number."

The most interested listener can seldom enjoy more than two uninterrupted hours of the same kind of entertainment. The simplest amendment to the present order of things would be the relegation of the second news bulletin, etc., until 10 p.m., thus permitting a straight programme from 8 till 10 p.m. Finally, what does "Howard Roberts (Captain)" mean by his reference to the old "company" programmes? Were they less scrappy? To adapt Milton rather broadly, my own impression is that "corporation is but old company writ large."
Beckenham.
W. C. BURBRIDGE.

Sir,—Mr. Bertram Munn's able letter in your issue of April 24th diagnoses the position correctly, though I do not accept his assumption that a taste for "scrappiness" is either peculiarly British or specially fostered by the conditions of the age in which we live. In every age and in all countries the number of people capable of "sustained effort or prolonged artistic appreciation" has always been pitifully small, even among the leisured class; whilst the poor, for countless generations denied the opportunity of any entertainment at all, and only quite recently equipped with the very scantiest rudiments of education, have fallen an easy prey to all the shoddy and flashy allurements to which Mr. Munn refers. Yet are not these people, having duly paid their whack to the B.B.C., quite as entitled to expect from it such amusement as their unformed minds are capable of appreciating as I am to demand an integral performance of "Tristan und Isolde"?

The B.B.C. tries to be fair to both sides, but succeeds only in exasperating both by attempting the impossible task of pleasing everybody simultaneously. Would it not be a more promising policy to let 5XX and 5GB transmit completely highbrow and completely lowbrow programmes on different and alternate evenings?

Speaking on behalf of highbrows, I think that most of us would prefer to confine broadcasting to music only: almost everything else which interests us can either be got from books and the better newspapers or else appeals purely to the eye. As regards the music, the B.B.C. orchestra is improving, and on the way to becoming reasonably good; but only one of the conductors deserves to hold his job. We sorely need one very important thing—a permanent and fine string quartet; and a competent vocal quartet would not come amiss. We do not desire a military band. We should prefer all vocal music to be sung in its original language; and we should like singers and other soloists not to be so placed as to swamp the piano or even the orchestral accompaniment.

As to the requirements of the lowbrows I do not feel competent to speak.

I have never met anyone who was satisfied with Sunday broadcasting, nor am I likely to do so until the B.B.C. shows itself ready to face the fact that the kind of entertainment a man enjoys and will listen to on Sunday is precisely the same as he enjoys on other days; moreover, having more leisure on Sunday, he wants a longer, not a shorter, entertainment. Furthermore, to disseminate by wireless the doctrines of the Church of England on the very day of the week when every communicant in the country is enabled, thanks to that body's highly complete organisation, to partake of spiritual nourishment is obviously a wasteful duplication of effort, with the result that the working-man's receiver remains switched off during all but a very small part of the only day on which he might, under a more enlightened régime, derive full enjoyment from it.
Marlow.

ERNEST KANN.

Sir,—I have always thought that the "one programme per night" policy was best. The B.B.C. themselves used to work on these lines, but since they changed their policy to one of providing for everybody in one night my interest and enjoyment of the programmes has somewhat slackened.

I personally do not wish to accuse the B.B.C. of having hats too small, whatever may be their shortcomings, but I do think that there must be some persons connected with the programme department who have their own ideas as to what is most suitable for the listener. I suppose the millenium will have arrived when these persons with ideas come down to earth from the clouds and realise what the general listener really enjoys and desires.

Another fear that I have, connected with the present policy of the B.B.C. programme department, is that, with their "two programme per night" policy (which means *practically* that half of each provincial station's time per night is taken by a London programme), local stations' programmes will suffer. My reason for thinking this is that on perusing the programmes for my own local station (Manchester) in a recent *Radio Times* I find the Northern Wireless Orchestra giving such snippety bits as three-quarters of an hour of waltzes old and new, and half an hour or so of marches, this after London has monopolised nearly a whole evening. What an occupation for a combination of musicians, which, when it was formed, was looked upon as an orchestra with few superiors (according to the Press reports). What insignificant work for this orchestra to play waltzes and marches from 10.20 p.m. to 11 p.m. as a stop-gap. I do not want to find fault, but does it not appear that London's programmes *must* have first place? I am sure that with the "one programme per night" policy the local stations would demonstrate much more the capabilities of the resources which they have at their command.

I do not doubt that London has great talent and more resources, but I do think it is a mistake to make a rule of providing at least 50 per cent. of local stations' evening programme material.

I hope that your efforts to persuade the B.B.C. to drop the present "scrappy programmes" will bear fruit.

Manchester.

L. FOX.

RE NEEDLE TRACK ALIGNMENT.

Sir,—Mr. Finglass, whose letter on the subject of needle track alignment was published in the April 24th issue of your paper, is wrong in supposing that, when records are made, the stylus travels in an arc from the outer to the inner edge of the record; in the modern electric method the path followed by the recording stylus is a straight line along the radius.

That some authoritative information on the subject is very necessary was demonstrated a few weeks ago, when one of your contemporaries instructed its readers to adjust the tone arm so that the needle point when at the middle of the record was exactly over the centre, a condition which precludes the possibility of correct alignment with the usual swinging arm.

By designing and placing an ordinary swivelling arm correctly, the error in alignment can be reduced to within 2°, and it is important that the error should not be greater than 5° if record wear is not to be excessive. With regard to the type of pick-up carrier in which the pick-up is fixed to a carriage which rolls on a rail above the record, it was pointed out in *The Gramophone* for April that these do not necessarily give perfect alignment and that other troubles may arise due to other causes peculiar to this arrangement.

Kennington, S.E.11.

ROBERT J. PARRIS.

VALVE OUTPUT.

Sir,—In these days we are offered by the manufacturers a large range of super-power valves. In only one case, however, does the maker state the actual A.C. power output. This enlightened firm, however, contents itself by publishing this all-important data for one type only.

Recently I purchased a power valve of well-known make only to find that a rival maker claimed that their valve gave a greater power output. I accordingly went to the makers of the valve I had bought and asked them the actual output of their valve. They stated that their valve gave twice the output power of that of their rival.

On further enquiry, I discovered that each firm obtained their figure from a different formula, hence the discrepancy in the answers I received. Would it not then be possible for the makers to agree on a formula to be used and to publish this data in addition to that already given, i.e., mutual conductance, impedance, etc. It would, of course, be understood that the figure they gave would be that of the valve working under its best conditions.

London, S.E.13.

R. L. SOPER.

May 8th, 1929.

READERS PROBLEMS

"The Wireless World" Supplies a Free Service of Technical Information.

The Service is subject to the rules of the Department, which are printed below; these must be strictly enforced, in the interest of readers themselves. A selection of queries of general interest is dealt with below, in some cases at greater length than would be possible in a letter.

A Good "Portable" Circuit.

I propose to make up a three-valve portable set (S.G. high-frequency amplifier, grid detector, and pentode output valve), the general arrangement to be rather on the lines of the "Multiple Valve Portable" described recently. It would seem highly desirable to include reaction, as a leaky grid detector is to be used; will you suggest a simple method of arranging for this?
F. M.

If you use an H.F. transformer similar to that described for the set to which you refer, we think that the best way of avoiding complication is to make the primary windings act also in the capacity of reaction coils. To do this, they must be wound in the opposite direction to the secondaries, and impulses from the plate circuit of the detector can then be induced to its grid coil by passing back H.F. current through a reaction condenser to a tapping on these primaries. The best position for these tapings should be determined by trial, but assuming you to be using a reaction condenser of about 0.00025 mfd. (a good value), junction should be made to the tenth and twenty-fifth turns respectively on medium- and long-wave primaries.

In order to make the necessary change in the connection of the reaction condenser it will be necessary to use a three-pole

switch connected in the manner shown in Fig. 1, which, for the sake of completeness, is drawn to show the complete receiver. Except where specially marked,

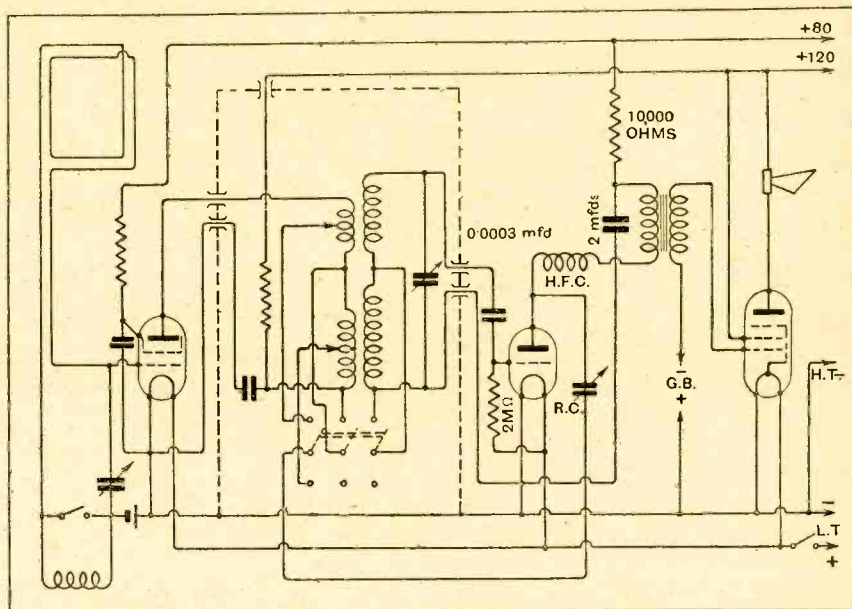

Fig. 1.—Circuit for H.F.-det.-pentode frame aerial receiver, in which H.F. transformer primaries are used as reaction coils.

RULES.

(1.) Only one question (which must deal with a single specific point) can be answered. Letters must be concisely worded and headed "Information Department."

(2.) Queries must be written on one side of the paper, and diagrams drawn on a separate sheet. A self-addressed stamped envelope must be enclosed for postal reply.

(3.) Designs or circuit diagrams for complete receivers cannot be given; under present-day conditions justice cannot be done to questions of this kind in the course of a letter.

(4.) Practical wiring plans cannot be supplied or considered.

(5.) Designs for components such as L.F. chokes, power transformers, etc., cannot be supplied.

(6.) Queries arising from the construction or operation of receivers must be confined to constructional sets described in "The Wireless World" or to standard manufacturers' receivers.

Readers desiring information on matters beyond the scope of the Information Department are invited to submit suggestions regarding subjects to be treated in future articles or paragraphs.

components may have the values assigned to them in the original design.

It might be necessary to insert an H.F. stopper in the form of a resistance of about 100,000 to 250,000 ohms in the grid circuit of the pentode valve.

o o o o

Megavox Loose Coupler.

In a reply to "W.G." in "The Wireless World" for May 8th, you describe a method of adding a separately-tuned aerial circuit to the Megavox receiver. The circuit diagram given shows the connections to the medium-wave aerial-grid transformer; how should one proceed in altering the long-wave coupling? C. M. T.

An auto-coupled aerial-grid coil is used in this receiver for long-wave reception; instead of joining the loading coil to a tapping on the present aerial winding as

in the case of the short-wave transformer, you must join it to a point on the long-wave grid coil of about 5 or 6 turns above its earthed end. In practice, the connection between the pin of the coil and the tapping will be made permanently (after the best position has been determined by trial), and the necessary connections will automatically result when the coil is inserted in its holder.

o o o

Charging the Feed Condenser.

Is there a simple explanation for the fact that a distinct "click" is produced when I join my loud speaker to its terminals, even though the filaments are not switched on? This effect was not noticed in my original set, so I take it it is due to the fact that the new receiver has a choke-filter output. C. P. S.

We expect that your choke filter is so arranged that one side of the loud speaker

is connected to the common H.T. and L.T. negative lead. If this is so, you will see that the high-tension battery circuit is completed through the L.F. choke, feed condenser and loud speaker; on connecting the latter there will be a flow of charging current into the condenser, and a click will be produced.

o o o o

Decoupling Resistances.

It seems that wire-wound resistances are almost invariably used for "decoupling" schemes. Is there any reason why composition resistors should not be substituted? T. D. J.

Provided the resistance has a suitable current-carrying capacity, its exact nature is unimportant, but it should not be subject to appreciable changes in value, nor to any form of intermittency likely to produce crackling.

The Wireless World

AND
RADIO REVIEW
(17th Year of Publication)

No. 511.

WEDNESDAY, JUNE 12TH, 1929.

VOL. XXIV. No. 24.

Editor: HUGH S. POCOCK.

Assistant Editor: F. H. HAYNES.

Editorial Offices: 116-117, FLEET STREET, LONDON, E.C.4
Editorial Telephone: City 9472 (5 lines).

Advertising and Publishing Offices:

DORSET HOUSE, TUDOR STREET, LONDON, E.C.4.
Telephone: City 2847 (13 lines). Telegrams: "Ethaworld, Fleet, London."

COVENTRY: Hertford Street.

Telegrams: "Cyclist, Coventry." Telephone: 5210 Coventry.

BIRMINGHAM: Guildhall Buildings, Navigation Street.

Telegrams: "Autopress, Birmingham." Telephone: 2970 and 2971 Midland.

MANCHESTER: 260, Deansgate.

Telegrams: "Hiffe, Manchester." Telephone: 8970 City (4 lines).

GLASGOW: 101, St. Vincent Street, C.2.

Telegrams: "Hiffe, Glasgow." Telephone: Central 4857.

PUBLISHED WEEKLY.

Subscription Rates: Home, 17s. 4d.; Canada, 17s. 4d.;
other countries abroad, 19s. 6d. per annum.

Entered as Second Class Matter at New York, N.Y.

As many of the circuits and apparatus described in these pages are covered by
patents, readers are advised, before making use of them, to satisfy themselves
that they would not be infringing patents.

CONTENTS OF THIS ISSUE.

| | PAGE |
|--|------|
| EDITORIAL VIEWS | 809 |
| SMALL MAINS TRANSFORMERS. BY T. W. RIDGE | 610 |
| PORTABLE DIRECTION-FINDER. BY R. L. SMITH-ROSE AND E. L. HATCHER | 614 |
| THE DESIGN OF H.F. TRANSFORMERS (CONCLUDED). BY A. L. M. SOWERBY | 617 |
| CURRENT TOPICS | 622 |
| NEW APPARATUS REVIEWED | 624 |
| BROADCAST BREVITIES | 626 |
| RADIO AT THE PARIS FAIR | 627 |
| LETTERS TO THE EDITOR | 629 |
| READERS' PROBLEMS | 631 |

IS ALL WELL WITH THE B.B.C. ?

WE are all interested in anything which affects the progress of the development of broadcasting in this country, and so, quite naturally, the central authority of broadcasting—the B.B.C.—is a constant subject of comment. Any little incidents are made much of in gossip and in the daily Press, so that on mature reflection one is often disposed to discount the importance of much of the criticism which is levelled at the Corporation and its activities.

But recently, even if one makes full allowance for these things, it seems that there must be more than coincidence in the number of resignations from the staff of the B.B.C. which have taken place during the past few weeks, and the last to date—and the most important—is, of course, the departure of Capt. P. P. Eckersley, who has been the popular Chief Engineer of the Corporation since the beginning of its existence. To us it would appear that the position might be cleared up and many rumours killed if the Board of Governors would see their way to make a statement on the matter.

This is a step which we think the Governors owe to themselves, because naturally if all is not well the public looks to the Board of Governors as the body responsible.

Is the cause of these resignations due to internal friction between individuals, or is it possible that the B.B.C. is suddenly alive to the fact that it may be over-staffed, and do the resignations come from those officials who feel that more active work awaits them elsewhere?

Somehow the impression has got about during the past months that the policy of the heads of the B.B.C. is to suppress personalities in the various departments of the organisation, and that as a consequence those officials of the B.B.C. whose names are well known to the public have at least met with no discouragement from resigning if the opportunity has presented itself. The public would like to have an explanation of these things, and we venture to think that in other Government Departments such a succession of resignations could hardly take place without an enquiry being made into the cause.

Are the future prospects inside the B.B.C. less alluring than they were, or is the Civil Service atmosphere so enveloping the B.B.C. organisation that those who have not the temperament for it find the new order of things intolerable? We find it difficult to reconcile recent events with the enthusiasm which pervaded the B.B.C. organisation in its early days. We well recollect repeated occasions when we have heard Sir John Reith publicly express his admiration for the enthusiasm and co-operation of the whole staff which, working in perfect harmony and with no thought but for the good of the broadcasting organisation, achieved the self-imposed task of establishing those ideals which it cherished, and on which British broadcasting has been built up.

We wonder if Sir John Reith could to-day speak with the same conviction of a united front and a common endeavour throughout the organisation of the British Broadcasting Corporation.

EUROPEAN BROADCASTING.

THE problem of obtaining full co-operation between all the European powers in the matter of controlling broadcasting and arriving at common agreement as to wavelengths and power of stations is so important to the future development of broadcasting in Europe that it is extremely gratifying that the French Government has at long last taken up active membership of the International Broadcasting Union. The organisation has been in existence for nearly five years, and we learn that now for the first time the French Government has joined officially in its deliberations.

SMALL MAINS

TRANSFORMERS

How to Design A.C. Mains Units for Supplying Anode and Filament Current.

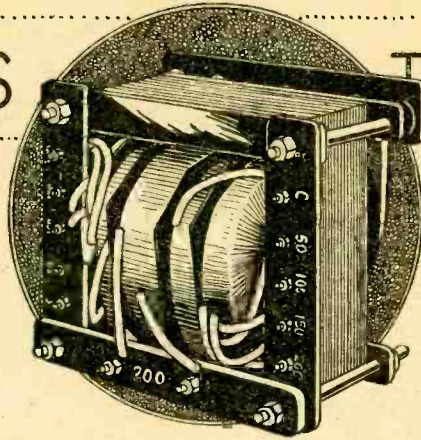

Data for the Home Constructor.

By
T. W. RIDGE.

THE great majority of houses being built to-day are equipped with an electricity supply, and more and more of the older houses are being connected. With a cheap and steady service of supply on tap, it is little wonder that the mains unit is gaining in popularity over the accumulator with its attendant expensive upkeep and uncertain voltage.

Eliminators and parts for making them up can be purchased, but very often a transformer with just the right tappings or capable of supplying the right voltage or current is unobtainable. For the ordinary wireless amateur who has a few tools and a little ordinary electrical knowledge there is no reason why he should not spend some pleasant evenings and save money in the making of his own transformers and choke coils just to his special requirements. The designing for such small power as is required for wireless need only be a matter of quite ordinary arithmetic, and all details for the theory and construction of an eliminator will be given, so that for those who do not wish to copy this design other figures can be substituted to meet the case.

As is generally known, the transformers consist of an iron core built up of laminations on which is wound two or more coils, the primary, to which the mains are connected, and the secondaries, from which supplies are taken at the particular voltages required. The current flowing in the primary winding magnetises the iron core, and this induces a current in the secondary windings of a voltage higher, equal to, or lower than that of the primary, in the same proportion as the numbers of turns in the windings.

Now, the first part of the transformer we must consider is the iron for the core, and this is often the most difficult part to obtain, as, of course, the amateur only

requires such a small quantity. To make the best and simplest job, the core should be made from stampings of the shape shown in Fig. 1, and for highest efficiency these should be made of Stalloy, a special transformer steel alloy made by Messrs. J. Sankey and Sons, Ltd. Certain standard sizes of stampings are stocked by them, and can be purchased quite cheaply in small quantities, Fig. 1 being their No. 4 pattern. Any stampings can be made to order, but, as this involves the special setting up of machines, the price, where perhaps only one gross is required, works out too high; but transformer cores can be made up from strips of "Stalloy," or even ordinary sheet iron, as shown in Figs. 2 and 3, only with this arrangement greater care must be taken

that the core is very tightly clamped, or the plates will vibrate and cause a continual hum when the transformer is put on load.

Core Considerations.

For those who wish to make up a cheap core and do not mind the extra trouble, strip iron of No. 26 s.w.g. or thinner, as used for packing cases, can be cut to the requisite lengths with shears and built up as shown in Figs. 2 and 3, and will be found quite satisfactory for the amateur's purpose. Of course, proper core plates are coated on one side so that when built up they are insulated from one

another to reduce eddy current loss, but when using ordinary sheet or strip iron the coating of oxide will serve as an insulator, and for our purpose any extra loss will be negligible.

Having decided on the type of core that can be obtained, we must, if we propose using a standard pattern, endeavour to arrange the windings to suit. The amount of power that we wish to take from the transformer must now be considered, so that the size

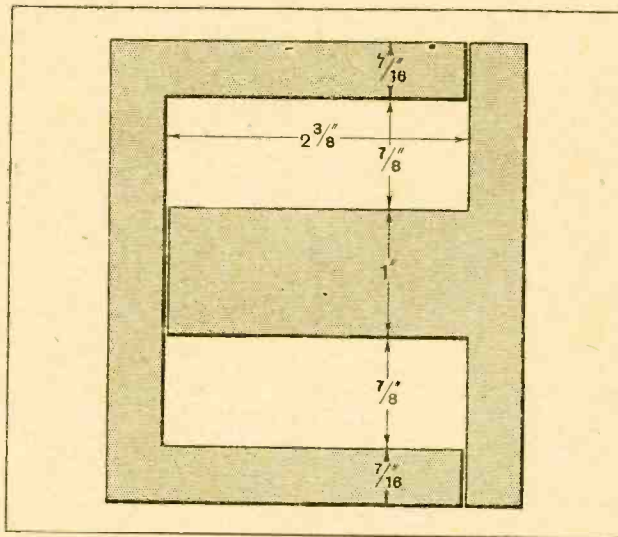

Fig. 1.—Showing the dimensions of standard Stalloy stamping No. 4.

Small Mains Transformers.—

of wire for the various windings can be found. In the transformer in question we require 2 amps. at 4 volts for the filament of the full wave rectifying valve (Cosmos SP42U), and 4 amps. at 4 volts for the filaments of 4 Cosmos A.C. valves in the set—that is, 4 volts × 6 amps. = 24 watts in the L.T. secondary coils, and for the H.T. of the set we will allow for 50 milliamps

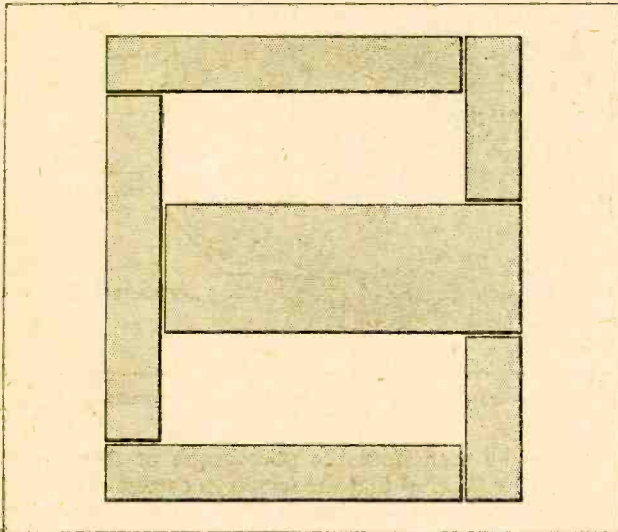

Fig. 2.—Shell-type laminations made up from pieces of strip iron or Stalloy. The outer limbs are half the width of the centre limb.

at 200 volts—that is, 200 volts × 0.05 amp. = 10 watts in the H.T. secondary coils. Now the primary winding has to carry the total power delivered by the secondaries plus the losses due to the iron and the resistance of the copper. So we will allow 6 watts for the losses, making a total load of 40 watts.

Flux Density.

The formula connecting the magnetic flux, number of turns in the winding, and voltage of either primary or secondary winding, is as follows:—

$$V = 4.44 n TN \times 10^{-8}$$

Where V = virtual voltage of winding.

n = frequency of supply in cycles per second.

T = number of turns in winding.

N = total magnetic flux.

This formula can be rearranged in a more convenient manner for designing as follows:—

$$\frac{V}{T} = \frac{ABn}{3.49 \times 10^6}$$

Where $\frac{V}{T}$ = Volts per turn in both primary and secondary windings.

A = cross-sectional area of core in sq. in.

B = magnetic flux density in core, in lines per sq. cm.

n = frequency of supply in cycles per second.

We will assume that the reader has some conception of the magnetisation of iron, the strength of which is

expressed as a flux density of so many lines per square centimetre cross-section of core. The iron losses increase with the flux density according to the quality of iron, and with big power transformers using modern transformer steel it should not be higher than 14,000 lines per sq. cm., but with the very small transformers which we are considering, where the iron losses are always higher and with perhaps ordinary iron for the core, this flux density should be kept down to about 6,000 to 8,000 lines per sq. cm. We now have some definite figures with which to work, and we can make use of the formula to find how many turns of wire are required in the winding. It was decided that standard No. 4 Stalloy stampings would be used if possible for the core, and that a 1/16 in. thickness, making 1 sq. in. cross-sectional area (ignoring the insulation for our purpose) would be tried.

Turns per Volt.

The electricity supply will probably have a frequency of 50 cycles. We can now fill in these figures, and the formula becomes:—

$$\frac{V}{T} = \frac{1 \times 6000 \times 50}{3.49 \times 10^6}$$

$$\therefore \frac{V}{T} = \frac{300,000}{3,490,000} = \frac{1}{11.6} \text{ approx.}$$

or 11.6, say 12 turns, per volt.

So we must wind twelve turns for every volt in all the windings, primary and secondary. On roughly

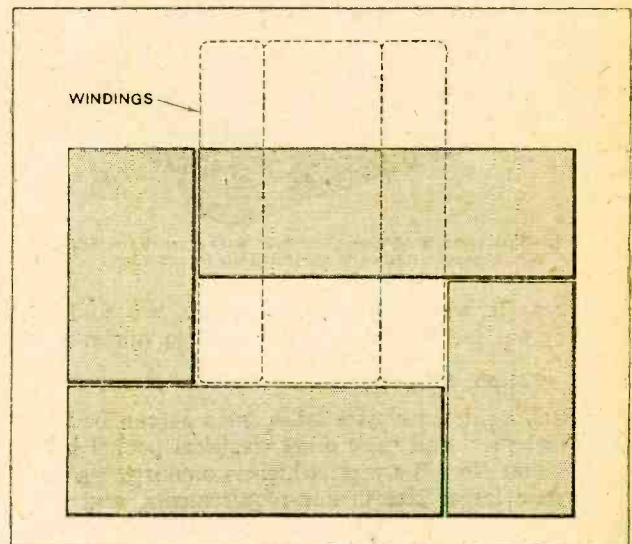

Fig. 3.—Core-type lamination from pieces of strip iron or Stalloy. All limbs have the same width.

working out the coils with this number of turns it was found that there was insufficient room to accommodate the wire between the limbs of the stampings, so a smaller number of turns per volt was necessary.

It will be seen from the formula that if the number of turns are reduced the flux density becomes higher unless the cross-section of the core is increased. This was done, and the pile of laminations was increased to

Small Mains Transformers.—

1½ in. thick, making the core about 1.5 sq. in. cross-section.

$$\frac{V}{T} = \frac{1.5 \times 6000 \times 50}{3.49 \times 10^6} = \frac{45}{349}$$

i.e., $\frac{1 \text{ volt}}{8 \text{ turns}}$ approx., or 8 turns per volt.

We can now consider each winding separately and decide the gauge of wire required and the number of turns. Commencing with the primary we found that it would take 40 watts. The voltage in our case is 200,

then $\frac{40 \text{ watts}}{200 \text{ volts}} = \frac{I}{5}$ or 0.2 amp. will have to be carried

by this winding. We obtain the gauge of wire necessary to carry this current from the knowledge that to carry 1,200 amps. 1 sq. in. of copper is required.

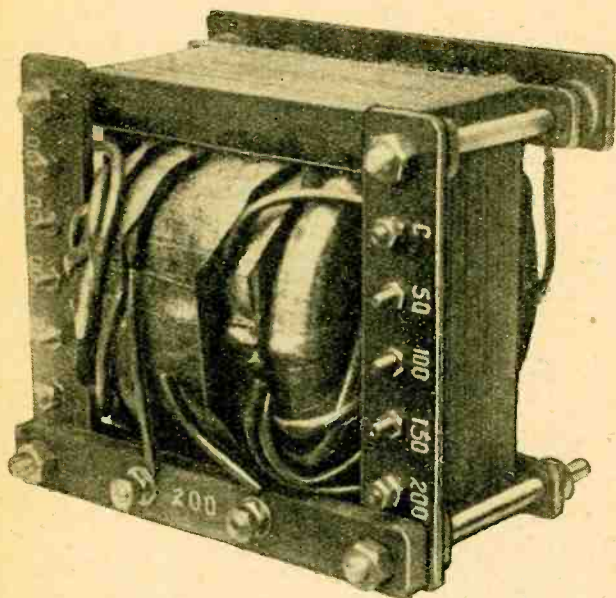

Fig. 4.—The completed transformer. Note that the windings are separate flat coils threaded on to the core.

Therefore, if we divide 0.2 by 1,200, we find that 0.000167 sq. in. (approx.) is required in our case.

Cotton, Silk, or Enamel Covered Wire?

On looking down a wire table, such as can be found in "Fowler's" and most other electrical pocket books, we find that No. 28 s.w.g., which is 0.000172 sq. in. is the nearest larger size to our requirements, and is the one we shall use. It is now known that the primary winding will consist of 200 × 8 turns per volt, i.e., 1,600 turns of No. 28 s.w.g. wire. Now, the insulation of the wire may be silk, cotton or enamel. Silk-covered wire is good but expensive, so we will rule that out. Cotton covering is quite good, and should be used for wire thicker than about No. 26 gauge, but for thin wires enamel will be found quite satisfactory as long as care is taken not to chafe it when winding, and it takes up less room, and is much cheaper than cotton or silk-covered wires. We will decide then to use No. 28 s.w.g. enamelled wire for the primary.

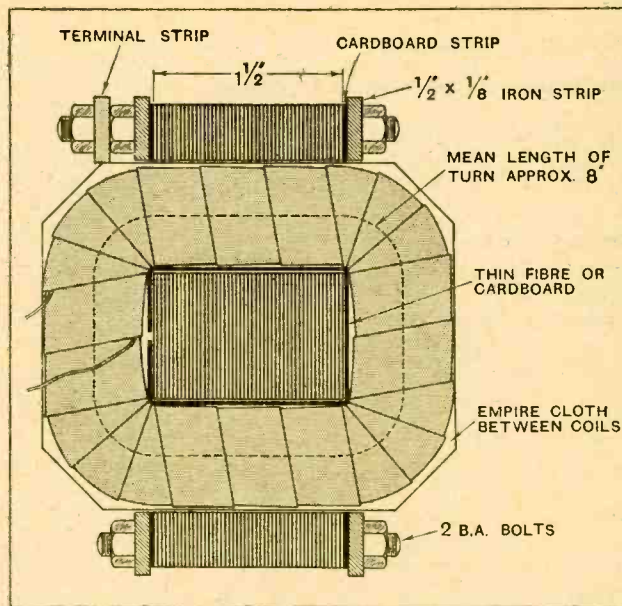
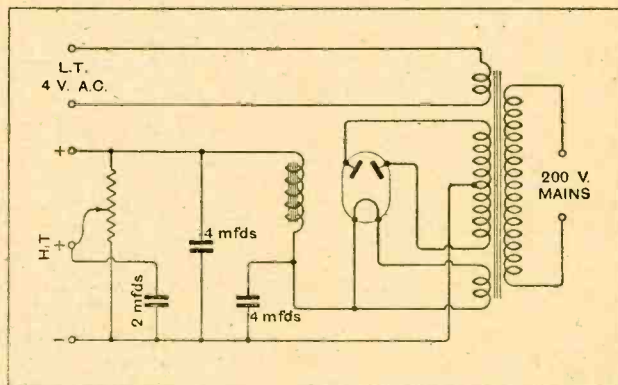

Fig. 5.—Cross-section of transformer giving dimensions. The mean length of turns is about 8in.

It will be seen from the photograph of the finished transformer (Fig. 4) that the windings consist of separate flat coils taped up and threaded on to the core. These coils are as large in diameter as the stampings will permit, and their individual thickness varies according to the number of turns and gauge of wire used. We must now measure the stampings, and, allowing for insulation, find the depth of the winding space available for wire. From the drawing of the stamping (Fig. 1) it will be seen that there is a space of 7/8 in. between the centre and outer limbs, and, allowing for tape and a wrapping of thin fibre or cardboard to protect the coils from the sharp corners of the core, we have a winding depth of 3/4 in.

Calculating the Quantity of Wire.

The remaining details of the windings can now be obtained. The primary has 1,600 turns of No. 28 s.w.g. enamelled wire. No. 28 s.w.g. is 0.0148 in. dia. plus 0.002 in. for insulation = 0.017 in. dia. Therefore,



The circuit diagram.

Small Mains Transformers.—

the number of layers we can wind is $\frac{0.75}{0.017} = 44$ layers;

we shall require, then, $\frac{1600}{44} =$ about 37 turns per layer, and the width of the coil will be $37 \times 0.017 = 0.63$ in. plus 25 per cent. for paper between layers and uneven winding, etc. = 0.8 in. We must now find the quantity of wire required and the resistance of the winding. The mean length of the turns will be seen to be about 8 in. (Fig. 5).

Now $\frac{1600 \times 8}{36} = 356$ yards approx.

From the wire tables we find that No. 28 s.w.g. has a weight of 1.989 lb. per 1,000 yards. We shall, therefore, require $\frac{1.989 \times 356}{1000} = 0.71$ lb. The resistance of No. 28 s.w.g. is 139.8 ohms per 1,000 yards, so our coil will have a resistance of $\frac{139.8 \times 356}{1000} = 50$ ohms approx.

Due to this resistance there will be a voltage drop in this winding when the transformer is on full load of 0.2 amps \times 50 ohms = 10 volts. This figure must be taken into account in the secondary winding.

(To be concluded.)

Short-wave Notes.

G 6TW, Mr. J. Noden, Coppice Road, Willaston, Nantwich, is transmitting regularly every evening from 2020 to 2030 G.M.T.; every Saturday from 1300 to 1330 G.M.T., and on Sundays from 1000 to 1030, 1300 to 1330, and 1730 to 1800 G.M.T. on the 5-metre waveband. His signals were picked up by Mr. E. T. Somerset at Burgess Hill, Sussex, on May 19th, who reports "QRK R1 to R2, QSS very bad." Mr. Noden has won the prize offered by Mr. Somerset, as mentioned in our issue of April 3rd, for the first communication of over 10 miles on 5 metres.

o o o o

Unlicensed Stations.

We understand that, possibly on account of the difficulty in satisfying the G.P.O. authorities on the question of the "other approved type" of wavemeter, there are a considerable number of unlicensed stations now on the air. Two at present operating on the 7 mC. band without permits are using the call-signs G 5RO and EI 2BX. We are asked to publish this information to deter licensed amateurs from replying to these calls.

o o o o

The New "Berne List."

The International Bureau of the Telegraph Union is this year issuing the well-known "Berne List" in five separate parts instead of in one somewhat cumbersome volume as hitherto.

Part I contains a list of commercial and official fixed and land stations of the world, both on long and short waves.

Part II is a list of stations performing special services, direction-finding, radio beacons, time signals, meteorological information, Press messages, etc.

Part III: Ship stations of all countries.

Part IV: Aircraft stations.

Part V: Broadcasting stations.

Part I is now published and may be obtained from the International Bureau of the Telegraph Union, Berne, Switzerland, for 7.50 francs (Swiss), post free, and including the monthly supplements as published. It gives the name, call-sign, geographical position, wavelength, normal power, nature and hours of service of each station, with notes, where necessary, on any special feature connected with the working of individual stations.

The column devoted to waves gives first the type, classified according to the regulations of the Washington Conven-

TRANSMITTERS' NOTES AND QUERIES.

tion, viz.: A1—C.W. Telegraphy; A2—I.C.W. Telegraphy; A3—Telephony; B—Spark, and, secondly, the frequency and corresponding wavelengths of the transmissions. The two following columns give (1) normal radiation power expressed in metre-amperes which, as regards Great Britain, is expressed by the figure representing maximum height of aerial, in metres \times input at base, in amperes, though we understand that some countries have their figures on the effective mean height of the aerial; (2) as an alternative, the

height of aerial and intensity of the current are given separately.

For some reason, which does not appear in the preface, no particulars are given of Australian, Spanish or Portuguese stations. We presume, however, that these were not ready when the book went to press, and that they will appear in a future supplement.

Several familiar call-signs have been altered owing to the fact that combinations beginning with the letters A and B are now reserved for the geographical part of the International Code. Thus the Java stations ANC, AND, etc., are now PLE, PLF, etc., while Nauen takes call-signs beginning with the letters DF, DG, or DH, and Königswusterhausen is allotted DIA to DIZ. The British naval stations which formerly had call-signs beginning with the letter B now adopt the initial letter G.

Amateurs using this list will doubtless wish that it had been found practicable to separate the short-wave from the long-wave stations, but this would probably have entailed too much labour in compiling. The remaining Parts II to V should be ready very soon, as well as the corresponding alphabetical index of call-signs.

o o o o

Nationality Prefixes.

The prefix VP has now definitely been adopted by Ceylon. India uses, at present, both VT and VU, but we are told that the latter will soon be adopted by all Indian amateur stations.

o o o o

QSL Service.

With reference to the note on page 348 of our issue of April 3rd, we understand that the R.S.G.B. will now undertake to forward QSL cards to anyone, whether he is or is not a member, who will send a supply of stamped addressed envelopes to their headquarters at 53, Victoria Street, London, S.W.

o o o o

Short Waves in Austria.

UOXY, a Vienna experimental amateur, transmits regularly every Saturday and Sunday from 1400-1700 B.S.T. on a wavelength of 10.6 metres. The actual text sent reads as follows: "CQ, CQ, CQ Ten de UOXY UOXY UOXY QRH 10.6 m. pse qsl via RW," the last two letters standing for Radio Welt, an Austrian wireless journal (11 Rudeingasse, Vienna 3).

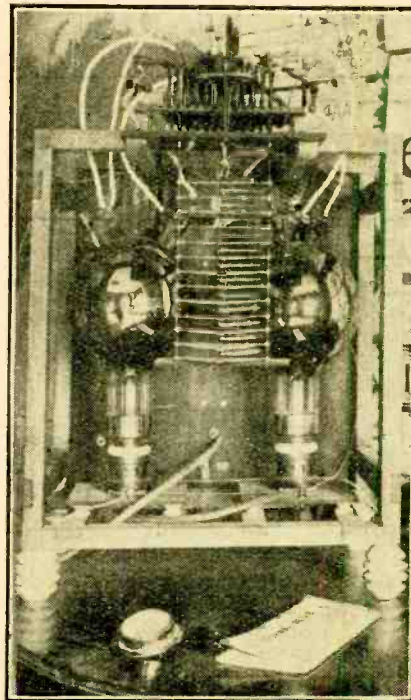

AN ACTIVE FRENCH STATION. FIM at Bourges has been in touch with most parts of the world on 7 and 14 megacycles. The input is about 40 watts to two "Fotos" valves. The station will shortly be working on the 10-metre waveband.

PORTABLE DIRECTION FINDER

Wide Range combined with Sensitivity and Accuracy.

By R. L. SMITH-ROSE, D.Sc., Ph.D., A.M.I.E.E., and E. L. HATCHER.

THAT most important virtue in a wireless direction finder for field work, viz., "transportability," is not more easily attained when the designer also aims at increased sensitivity, accuracy and range of working wavelengths. All these desiderata have been sought in the instrument shown on this page.

In the first part of a former article¹ the principles of the operation of the single frame-coil direction-finder were described in some detail, and the newcomer to the subject may be referred to that article for information on the chief sources of error in a direction-finding in-

strument and on the methods of screening employed to overcome these drawbacks. In the second part of the same article² a description was given of the general arrangement and constructional details of a direction-finder suitable for experimental purposes, employing a three-valve receiver and having a wavelength range of from 120 to 240 metres.

The present instrument makes use of a supersonic heterodyne seven-valve receiver, and has a working wavelength range of from 40 to 3,000 metres. To cover this range of wavelengths two separate frame coils are employed, as it is not considered

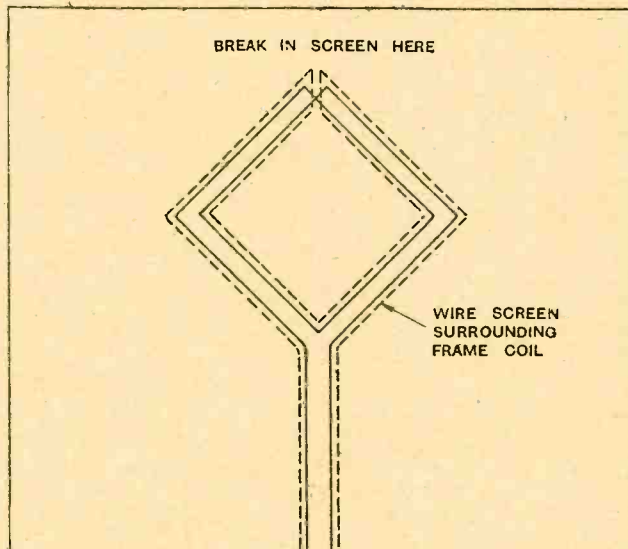

¹ The Wireless World, August 15, 1928.

² The Wireless World, August 29, 1928.

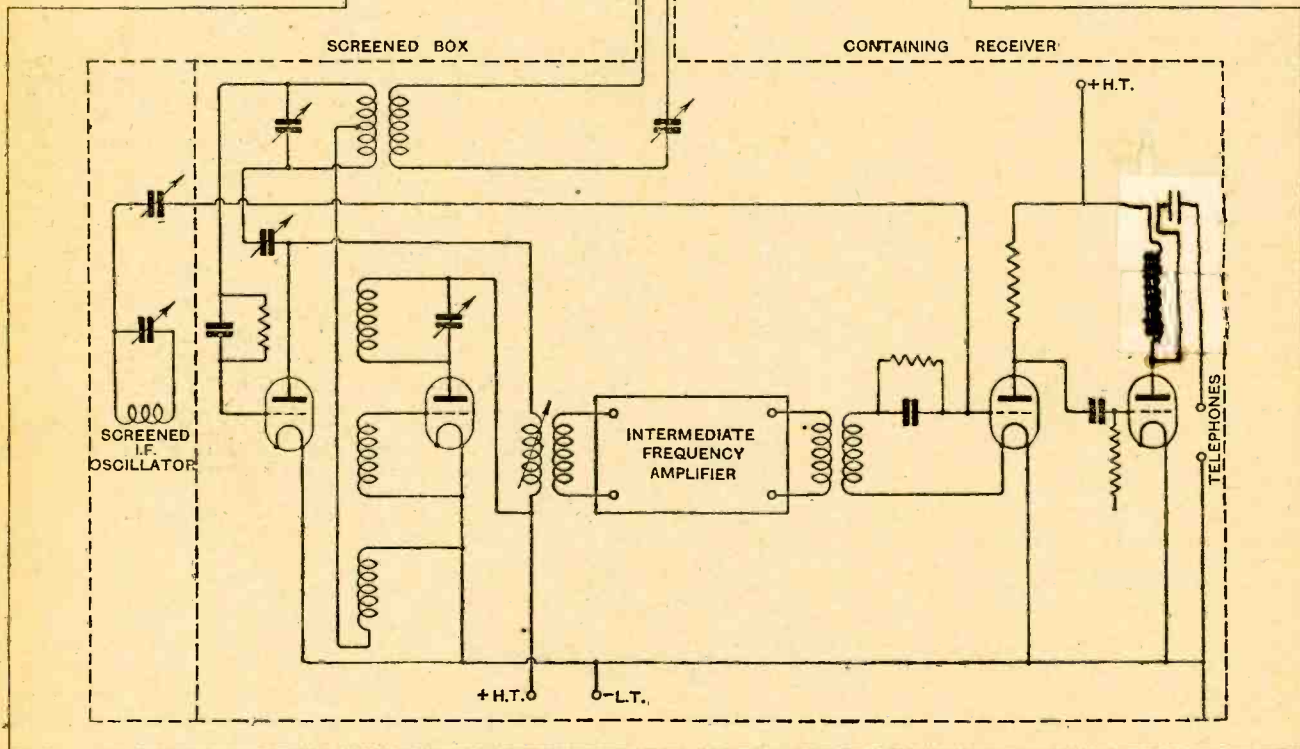

The abbreviated circuit showing the use of separate oscillator and reacting detector.

Portable Direction Finder.—

desirable to arrange for any alteration of the number of turns to be carried out on the coil itself. These frame coils are constructed in a manner sensibly similar to the design indicated in Fig. 7 of the earlier article. The length of side of the square coil employed is 1ft. 10in., one coil consisting of two turns of No. 16 S.W.G. tinned copper wire, and the other of six turns of No. 49/31 phosphor-bronze wire. Each coil is surrounded by an open wire electric screen of twelve wires supported on keramot spacing plates as formerly described, and the centre point of the receiving loop is connected to the screen. The ends of this loop are terminated on a simple two-pin plug which fits into a socket in the brass tube forming the main axis of rotation of the system, thus making the coils quickly and easily interchangeable. The screening wires terminate in a brass tube which is clamped into this supporting tube, thus rendering the whole system mechanically rigid and electrically continuous. This supporting tube contains the two leads from the coil; these terminate in two slip rings which, with the appropriate brush gear, form the connections to the primary circuit. The coil can, therefore, rotate without altering the capacity between any leads. It is important to ensure good contact between brushes and slip rings, and in this case the slip rings were of brass $\frac{1}{2}$ in. in width, and double brushes of spring phosphor-bronze were used with adjustable tension. The rotating coil system is supported by a brass bearing in a metallic tripod fixed to the top of the screened receiving box, which contains the whole of the valve receiver and its associated batteries.

An abbreviated circuit diagram is given on the previous page, from which it will be seen that the receiving coil or loop is connected to a tuning condenser and a primary coupling coil. To this closed circuit is coupled a secondary coil tuned by a second condenser. This secondary coil is centre-tapped, and connected to the first detector valve of the superheterodyne receiver in such a manner as to provide capacity retro-action. A separate oscillator valve is used in this receiver as the local source to change the frequency of

the incoming oscillations to the intermediate frequency, at which three stages of amplification are employed. These stages are followed by a second detector and one audio-frequency stage. For the reception of continuous-wave signals a second local oscillator is employed to change the signals from the intermediate to a suitable audio-frequency. The whole receiver, while having the advantages of stability and ease of operation, has a moderately high sensitivity, the overall voltage amplification at the intermediate frequency being about 2,000.

The instrument described is a successful attempt at improving the "transportability" of a direction finder as compared with that of earlier models, while striving for greater accuracy and sensitivity. A seven-valve super-sonic heterodyne receiver is employed, and the working wavelength range extends from 40 to 3,000 metres.

The screened box containing the receiver was specially constructed of three-ply wood coated on both sides with tinned iron sheet, and measures 2ft. 6in. by 12in. high by 1ft. 4in. in depth. The box is divided into two compartments, each of which is provided with an inner "lid" panel which fits on a flange provided for it at $1\frac{1}{2}$ in. below the opening of the box. Each of these panels is attached in a vertical position to a horizontal base-board, and the combination carries the whole of the receiver and batteries, with the exception of the primary circuit, as shown in the photograph below.

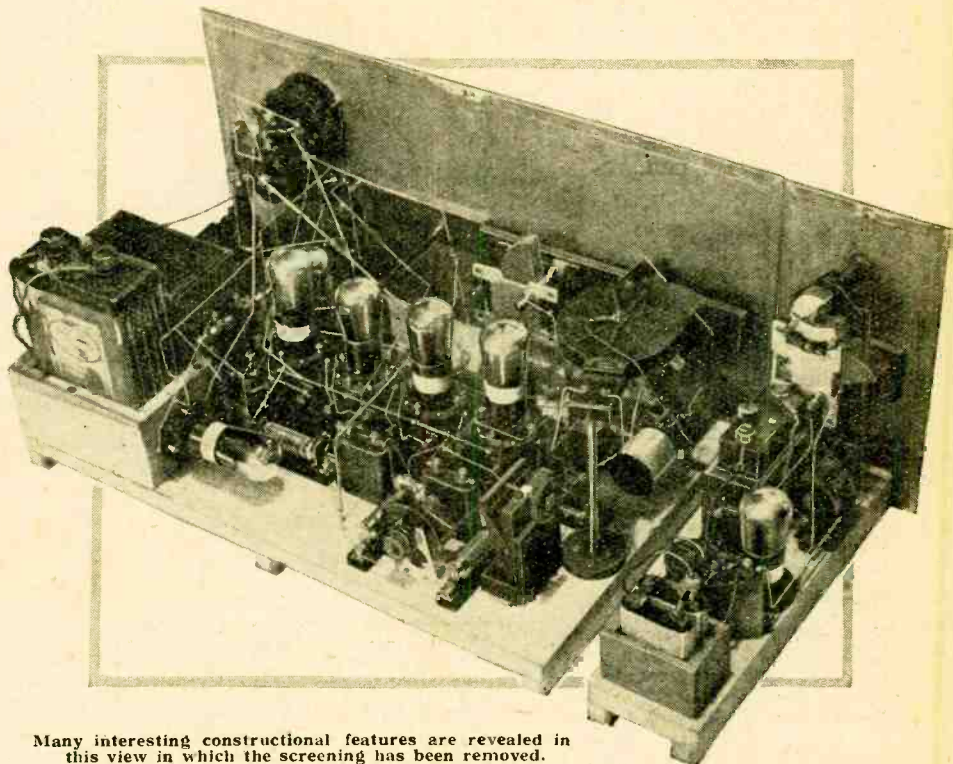

Many interesting constructional features are revealed in this view in which the screening has been removed.

The primary coupling coil and the primary tuning condenser are mounted on the inside at the top of the screened box, the primary tuning dial having a sliding drive enabling the receiver to be withdrawn without disturbing either the primary coil or condenser.

Portable Direction Finder.—

A useful addition is an instrument reading H.T. and L.T. voltages and anode current, controlled by a switch, thus enabling the operator to ascertain the state of the batteries without withdrawing the receiver. It has been found a great advantage in field work to have the whole apparatus mounted in the manner described, so that it may easily be withdrawn from the screening box for inspection and repairs. The variable condensers mounted on the panels have had insulated sections inserted in their spindles to avoid the spurious introduction of signals to the interior of the box from the external dials. This is considered to be an important detail of screening technique, and after it was carried out it was found that the receiver was very efficiently screened when the panels were bolted home to their flanges, although all necessary controls were available on the outside of the box. A further improvement in the screening efficiency is the use of a choke-capacity coupled output shown in the diagram, by means of which one of the telephone leads is connected to the screen, thus making a screened telephone lead unnecessary.

Taking Bearings.

The smaller compartment to the left-hand inside of the box in the view of the complete equipment contains the second oscillator operating at the intermediate frequency. This is screened from the remainder of the receiver, and is very loosely coupled to the second detector by a small variable condenser. The necessity

for having pure intermediate frequency oscillations and for having control of their amplitude was emphasised in a recent contribution in *Experimental Wireless*.¹ As an additional precaution in the matter of screening, and also to provide protection during transport, the whole receiver is provided with a single outer lid covering the whole box. The set is provided with a convenient hand-wheel for rotating the coil, while two pointers are provided which are adjustable to exactly 180° apart, so that direct and reciprocal bearings may be taken in succession without change of position of the observer.

Degree of Accuracy.

On signals of adequate strength the signal minima used for bearings can be read off to about 0.5°, although for reasons which have been explained previously it is not often that observed D.F. bearings are reliable to this accuracy. On the two-turn frame coil the operating wavelength range of the instrument is from 40 to 150 metres, with suitable changing of the coupling coils, which are of a standard plug-in type, while on the six-turn coil wavelengths of from 120 to 3,000 metres can be covered in a similar manner. For experimental direction-finding over moderate distances the portable transmitter previously described² is very useful as a source of transmissions, and the combination of direction-finder and transmitter provides the means for carrying out a very interesting series of experiments.

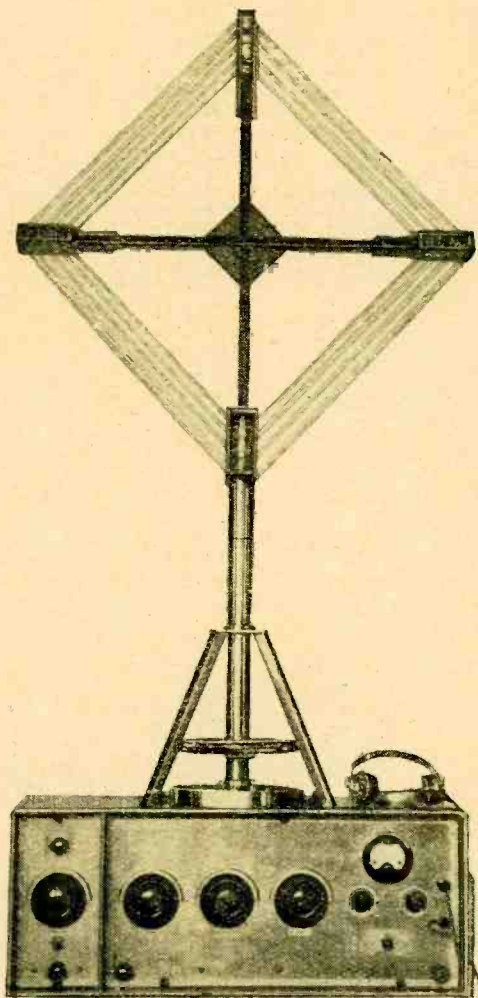

The complete transportable equipment.

¹ *Experimental Wireless*, December, 1928.

² *The Wireless World*, October 18th, 1928.

The use of an automatic time-switch for closing the filament circuit of a valve set at a specified time, corresponding to the beginning of a particular transmission, and for automatically switching-off at the conclusion of the item or programme, savours perhaps of unnecessary luxury. At the same time it certainly does prevent the valves from being left on all night through carelessness. In certain circumstances such a device would prove distinctly useful, in connection, for instance, with a special subscription service of Stock Exchange

PROGRAMME TIME-SWITCHES.

prices and similar items of commercial intelligence broadcast at definite intervals throughout the day.

A time-switch of this type has, in fact, recently been patented by a Hungarian inventor (Patent No. 281320). It consists of an ordinary clock fitted with a

third hand, to be adjusted normally on the clock dial to point to the hour at which the set is to be switched on. Special switch segments are selected to determine the duration of reception. The L.T. circuit of the set is connected to terminals on the clock, so that at the selected time a contact on one of the wheels of the clock-train rides on to the switch segment and lights up the valves. Simultaneously a branch circuit is energised to ring a warning bell or to light a flash-lamp to show that reception is about to commence.

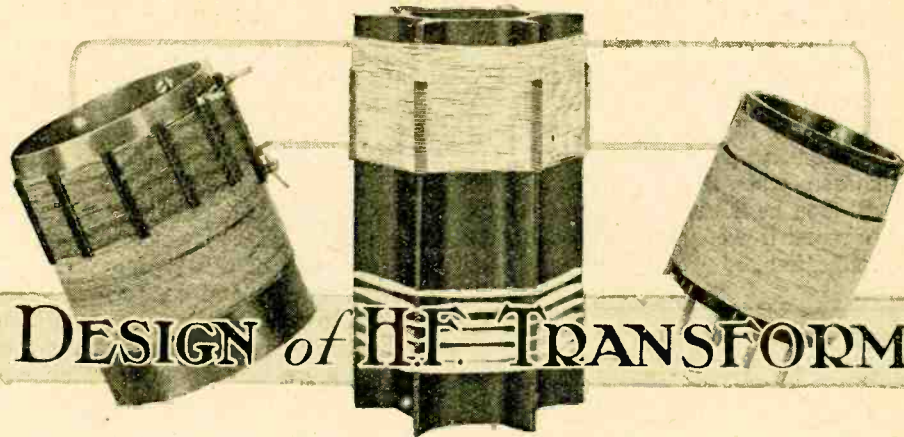

The DESIGN of HIGH-FREQUENCY TRANSFORMERS

Some Experimental Data.

By A. L. M. SOWERBY, M.Sc.

(Concluded from page 552 of May 29th issue.)

IN the first part of this article definite conclusions were reached, on a theoretical basis, as to the most favourable dimensions for the primary of a high-frequency transformer, and in the process of arriving at this result it was stated that maximum power is transferred to the transformer when the primary has a resistance to high-frequency currents (of the frequency to which the transformer is tuned) equal to the A.C. resistance of the valve in the plate circuit of which the transformer is connected. It has occurred to the writer that many readers would accept this statement more readily if it were substantiated with some experimental results.

Now it so happens that experimental results primarily intended to demonstrate this point also offer a very simple means for measuring, by an indirect method, the high-frequency amplification afforded by a stage, and can be repeated, by anyone who is interested, with his own valves and tuned transformers. No instruments are necessary other than a low-reading milliammeter, which need not even be calibrated, so that the measurements may be made even if one is not supported by the resources of a laboratory full of elaborate high-frequency measuring instruments.

Before reaching the experimental results it will be interesting to draw a curve, based on purely theoretical considerations, showing the way in which the power transferred to the transformer varies with the primary dynamic resistance. We shall then be able to check our theory by comparing the curve so obtained with that derived from experiments.

Such a theoretical curve is shown in Fig. 6; it shows the connection between the dynamic resistance of the primary and the power transferred to it from the valve. It is worked out on the supposition that the valve in whose plate circuit it is connected has an internal resistance of 28,000 ohms, and it will be seen that, as stated, the maximum power is transferred to the primary when the dynamic resistance of this is also equal to 28,000 ohms. On either side of this optimum value of primary resistance the power put into the transformer falls off, and this corresponds in a practical receiver, as one would expect, with reduced signal strength.

Agreement Between Theory and Practice

In the form in which it is here plotted, the curve is not suitable for direct comparison with experimental results, for in these the dynamic resistance of the primary is not directly known, though it may easily be calculated. Since variations of primary resistance are normally produced by varying the number of turns, one would naturally plot primary turns (in place of primary dynamic resistance) against signal strength. By making use of the relationship between R_p and R_s that has already been given, viz., $R_p = \frac{R_s}{n^2}$ and assuming for R_s , the dynamic resistance of the secondary, the value of 28,000 ohms found at 300 metres for the 68-turn Litz coil, for which figures have already been given, we can find the step-up ratio, and hence the number of turns on the primary, corresponding to any value of R_p . We can then draw a fresh curve,

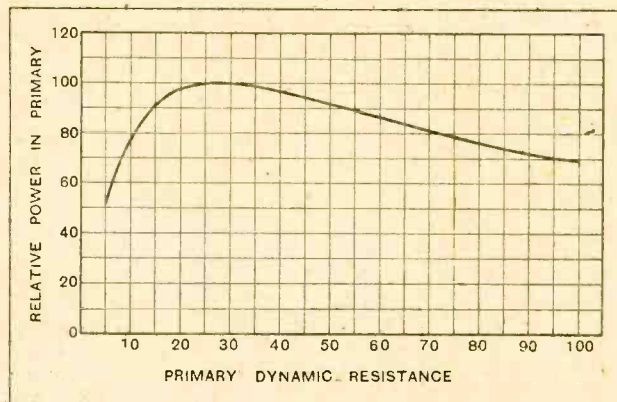

Fig. 6.—This curve, which is based on a calculation, shows how the power transferred to the primary of a high-frequency transformer varies with the dynamic resistance of the primary. The power is greatest when this resistance equals the internal resistance of the valve preceding the transformer. The primary dynamic resistance scale is in ohms × 1000.

The Design of H.F. Transformers.—

representing exactly the same figures that have already been plotted in Fig. 6, but showing the theoretical relationship between the number of turns on the primary and the power transferred to it by the valve. This is given as the upper curve of Fig. 7, and shows again the characteristic maximum, which is seen to occur, for the particular case chosen, when the primary has some 22 turns. This should then be the best number of turns to employ for the primary if we are endeavouring to attain maximum amplification.

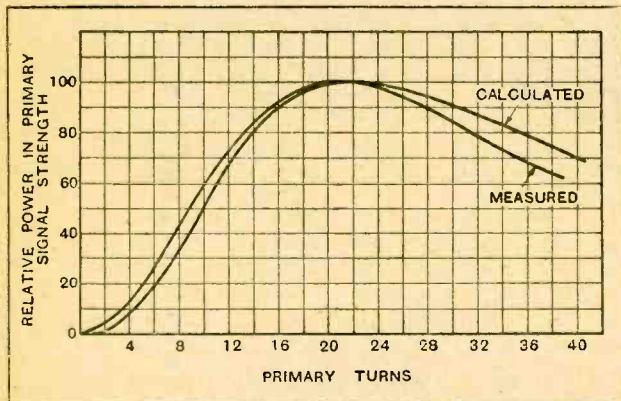

Fig. 7.—Here the upper curve is a repetition of that of Fig. 6, and is theoretical. The lower curve is obtained from measurements made with the valve and transformer secondary for which the upper curve was calculated. Observe that in both cases maximum signal strength is attained when the primary contains 22 turns.

It will further be noticed from the shape of the curve that the power transferred to the primary, which, roughly speaking, represents signal strength (audio-volts) in a practical receiver, falls off more rapidly if the primary is made too small than if it is made too large. Quite wide variations in either direction from the best number of primary turns can, however, be made without affecting signal strength appreciably, five turns more or less than the best number reducing the signal strength only to some 95 per cent. of the highest attainable value. It now remains to be seen how far these theoretical predictions are borne out by practical measurement.

The experimental investigation of the relationship between primary turns and signal strength was made with the aid of apparatus arranged as in the diagram of Fig. 8. Three valves are involved; of these the first serves as a generator of oscillations, and provides the "signals" on which the

measurements are made. The circuit used here is about the simplest possible, so that change of wavelength range can be made by changing a single coil. For most of the measurements in the present series the oscillator was set to a wavelength within a few metres either way from 300 metres.

The second valve, V_2 , is the valve the amplification of which, in conjunction with the tuned transformer, is being investigated. In order to rule out any possibility of reaction effects, which are very liable to render measurements of this type quite unreliable, its grid circuit is untuned, and consists of a two-turn coil loosely coupled to the oscillator. The oscillator and the rest of the apparatus were separated by a considerable distance so that there was no measurable error introduced by direct action of the oscillator on the tuned circuit. In the plate circuit of V_2 is connected the primary of the transformer, which is tapped to allow of the connection in circuit of a greater or smaller number of turns. The secondary, tuned by a slow-motion condenser, is connected between grid and filament of a third valve adjusted as an anode-bend detector. This valve has a sensitive meter in its plate circuit to enable the variations in plate current caused by rectification of the amplified high-frequency "signals" applied to its grid to be detected and recorded. The deflection of the meter is approximately proportional to the power dissipated in the tuned circuit, and this in turn is proportional to the square of the voltage developed across that circuit. Minor details of the circuits are given below the diagram.

Checking Results with a Simple Meter.

The secondary of the tuned transformer used in making the measurements about to be detailed consisted of 68 turns of 27/42 Litz on a paxolin former 3in. in diameter, and the tuned circuit, with tuning condenser and measuring valve, was found to have a dynamic resistance of

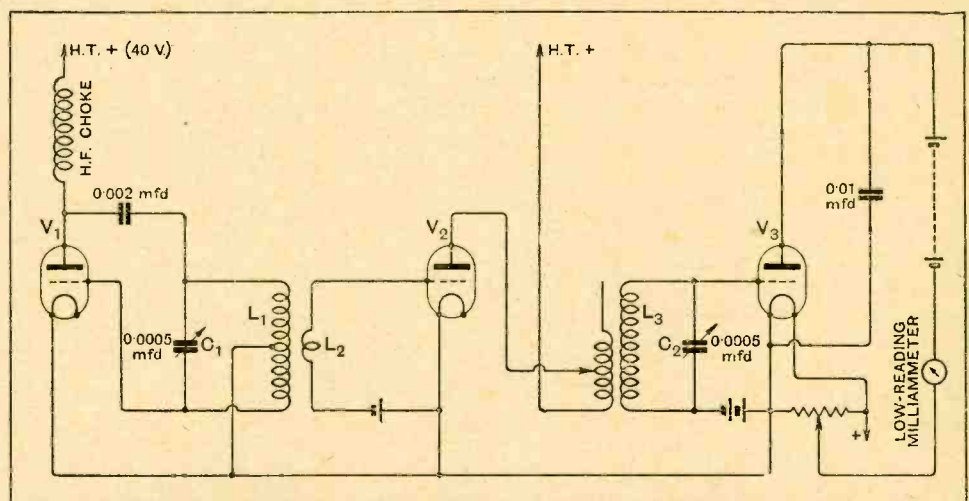

Fig. 8.—The equipment used for measurement. V_1 is a DE5B valve, V_2 the valve under examination (in the measurements quoted an HL610), while V_3 may be a PM6D or DEL610. In this case a milliammeter reading to 1 or 1½ mA. will be found highly suitable. The inductance L_1 is a centre-tapped Gambrell coil, L_2 a two-turn coupling coil, and L_3 the H.F. transformer, which is being examined in conjunction with V_2 . A common L.T. battery may safely be used for all valves, but each should have its own individual anode battery. The leads joining L_2 to V_2 must be long and twisted together; 6 feet of ordinary twin flex is suitable. There must be no measurable interaction between L_1 and L_2 , so that wide separation between these coils is essential. Very fine adjustment to C_2 is necessary, since the greatest deflection on the meter has to be read, as L_2C_2 is tuned.

The Design of H.F. Transformers.—

280,000 ohms at 300 metres. The primary was wound on ebonite spacers, and consisted of some forty turns of 30-gauge wire tapped in a number of places.

Using for V_2 a valve (Marconi HL610) which had a measured A.C. resistance (at $E_a=150v.$, $E_g=-1\frac{1}{2}v.$) of 28,000 ohms—which, it will be noted, was the figure

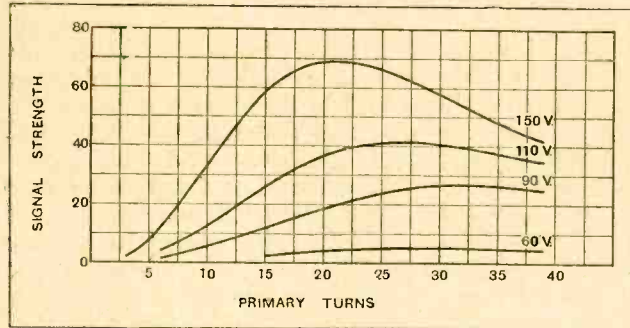

Fig. 9.—Curves for HL610 valve, with $-11v.$ on grid, and various plate voltages. See also Fig. 10.

assumed for the theoretical case to which refer the curve of Fig. 6 and the upper curve of Fig. 7—the deflection of the meter was found for each of the tappings on the primary. The results are given in the lower curve of Fig. 7, in which deflection is plotted against primary turns.

The two curves, theoretical and practical, have artificially been made to be the same height at their maximum point for the sake of comparison, but apart from this treatment, which is only a matter of choosing the vertical scale, they have not been "retouched" in any way. The vertical scale is, of course, arbitrary. The close agreement between the two curves throughout their length shows that the simple theory which has been put forward as representing the behaviour of the high-frequency transformer is a very good approximation indeed to the truth as determined by practical measurements over the whole range of primaries investigated. We have been chiefly concerned, however, with the theory as a means of deciding the number of turns for the primary winding; on this point the agreement between theory and practice is more than merely approximate, for the maxima of the two curves coincide exactly.

Measuring Stage Gain

Since the results of measurement can be so closely predicted by simple calculation, there would be but little point in carrying the measurements further than this one curve, were it not for the fact that the calculation implies a knowledge of the dynamic resistance of the tuned circuit, which is difficult to measure without rather elaborate equipment. By means of the measuring apparatus shown in Fig. 8 it is possible to determine experimentally the correct number of primary turns for any given combination of valve and tuned circuit in about ten minutes, without having any previous knowledge either of the characteristics of the coil used for the tuned secondary, or of the valve that goes with it. This fact at once takes the task of designing a high-frequency stage from the realm of precision laboratory work to that which is

practicable in any wireless den, for curves such as that shown in Fig. 7 can readily be taken by anyone who possesses a low-reading milliammeter.

Further, such measurements, as well as providing the necessary information that will enable valve and transformer to be suited to one another, offer a very simple method for the indirect determination of the high-frequency amplification to be expected from the stage. It has already been mentioned that the amplification is given by the simple expression $A = \frac{1}{2} \mu n$ for the case where the optimum primary is in use. When the correct number of turns has been determined experimentally by the method of Fig. 8, it is only necessary to find the step-up ratio and multiply it by half the amplification factor of the valve to obtain the overall amplification of the stage. For the case discussed, in which the primary has to have 22 turns, as shown by the curves, and for which the secondary had 68 turns, the ratio is $\frac{68}{22} = 3.09$. The amplification factor of the valve in question is 30, so that the amplification to be anticipated is $\frac{1}{2} \times 30 \times 3.09 = 46.4$ times. Thus it is possible to determine within reasonably close limits, the amplification of an H.F. stage, which is normally considered quite a difficult measurement, in a very simple way indeed.

Valve Resistance Varies with Grid and Plate Voltages.

By this method we may also study the effect on the amplification of variations in the grid and plate voltages applied to the valve. These have a far greater in-

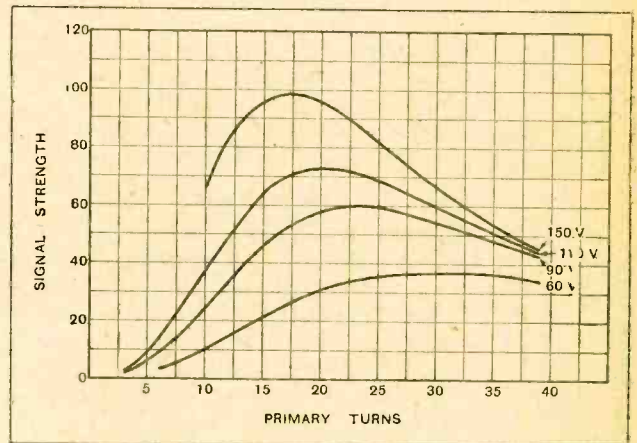

Fig. 10.—Curves for HL 610 valve, with zero grid bias and different plate voltages. These may be compared with Fig. 9, as all conditions other than the operating voltages of the amplifying valve were held constant while taking the curves of both figures.

fluence than is generally recognised, owing to the changes in valve resistance to which these alterations in operating voltages give rise. It should be emphasised that all these results are susceptible of calculation if we have full and complete information about both the transformer secondary and the valve; but it is normally much easier to measure the deflections produced in the meter of Fig. 8 for various numbers of primary turns than to find the necessary data and make the calculations.

The Design of H.F. Transformers.—

With the circuit of Fig. 8 measurements were continued, using the same standard Litz coil as the transformer secondary. Still with the Marconi HL610 valve, a number of different anode voltages were tried, the grid-bias being kept fixed at $-1\frac{1}{2}$ volts, which is the voltage of a single dry cell. The results so obtained are plotted as curves in Fig. 9; the number of turns in the primary are plotted horizontally, as before, while the vertical scale is in terms of the deflection of the

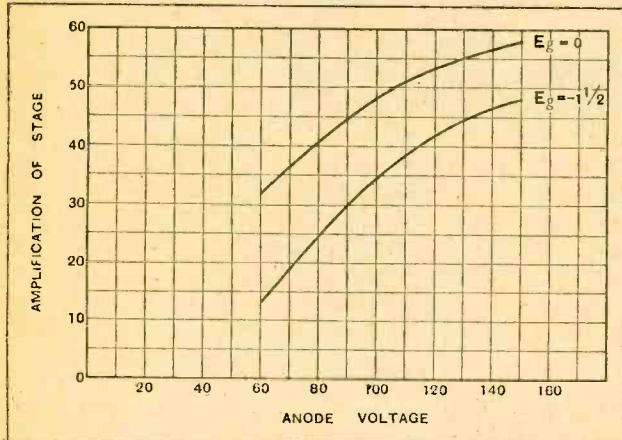

Fig. 11.—Amplification attained with an HL610 valve in a single stage, using the H.F. transformer described. Note how the amplification varies with the operating voltages.

meter in the plate circuit of the rectifying valve. Since the high-frequency input supplied to V_2 was kept constant throughout the series, the height of the curve above the baseline represents to a close approximation the square of the high-frequency voltage on the transformer secondary. Assuming an anode rectifier, this is proportional to the strength of the rectified signals, and the scale is consequently so labelled.

Minimum Bias Advisable.

The curves show a steady increase in height, together with a steady shift of the maximum in the direction of fewer primary turns, as the anode voltage is raised to the limit (150 volts) set by the makers of the valve. There is no doubt whatever that one is handsomely repaid by using the highest anode voltage that the valve will stand, for when using 150 volts we get about fourteen times the signal strength that we get with 60 volts. The correct number of primary turns varies, as the plate voltage is raised, from at least 38 for 60 volts to 20 for 150 volts. So large a variation shows that it is very desirable when designing a set to take into consideration the operating voltage to be used on the valves.

A similar set of curves was taken with zero grid-bias; as might be expected, the lowering of valve resistance brought about by doing away with grid-bias had the effect of raising very considerably the amplification attained; at the same time it reduced the optimum number of primary turns to 17. These curves are shown in Fig. 10; comparison may be made between the signal strength found here with that in Fig. 9, as the

same high-frequency input was used throughout both series.

From the maxima of the two sets of curves the amplification attained by the stage under the various operating conditions was calculated, and the two curves of Fig. 11 show the results so obtained. The great importance of using the highest permissible anode voltage, together with a grid-bias only just sufficient to prevent the flow of grid-current is very clearly shown by these curves.

As a check on these figures, the actual amplification afforded by the stage was measured at 300 metres by a direct method, taking the case of zero grid-bias and 150 volts on the anode of the HL610 valve. The figure so found was 55, which compares quite reasonably well with the value 58 calculated from the curves given. The lower value attained in practice may be attributed to the fact that our calculations have all been based on the supposition that the coupling between primary and secondary of the transformer is infinitely close, whereas in practice this condition is not quite perfectly fulfilled. Nevertheless, the discrepancy is small enough to warrant the use of the reasonably straight forward calculations that this simplifying assumption permits as a basis for practical receiver design.

Effect of Wavelength.

The effect of the variation of the A.C. resistance of the valve in altering the number of turns required on the primary is already fairly well shown by the curves for the HL610 valve, the resistance of which alters from 17,000 ohms at $E_a = 150$ v., $E_g = 0$ to 70,000 ohms at $E_a = 90$ v., $E_g = -1\frac{1}{2}$ v. In order to extend the measurements over a wider range, readings were also made using other valves, but the data are hardly interesting enough to reproduce

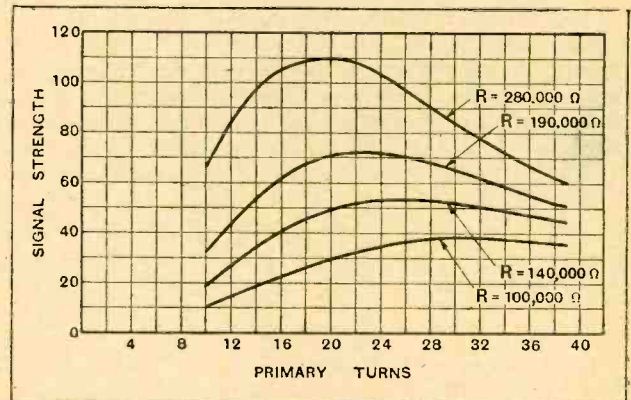

Fig. 12.—These curves show the effect of changes in the dynamic resistance of the secondary on both amplification and choice of primary turns. The valve is an HL610; R_0 is 23,000 ohms and μ is 30. Wavelength of test, 300 metres. The input is the same for all curves.

here. In every case in which it has been tried, a check calculation shows that the best size of the primary, as found experimentally from the position of the maximum of the curves, agrees within a turn, or two turns at most, with that calculated from the ratio obtained as already

described from the formula $n = \sqrt{\frac{R}{R_0}}$

There remain to be considered two other factors which

The Design of H.F. Transformers.—

have so far been omitted from our experimental results. The first of these is the effect produced by changing the dynamic resistance of the secondary of the transformer. This was done experimentally by introducing a known series resistance into the tuned circuit, and repeating the measurements with the HL6ro valve, which for this series had $R_0 = 23,000$ ohms. Curves of the results are given in Fig. 12, in which the dynamic resistance of the secondary is indicated for each curve. The input to the valve was kept constant throughout this series of

We have still to consider whether the best number of turns for the primary varies to any great extent with the wavelength to which the secondary is tuned. As we have already seen, the primary turns depend on the ratio of the internal resistance of the valve to the dynamic resistance of the secondary, and the second only of these quantities depends on wavelength. In the first instalment of this article some figures were given for the dynamic resistance of a typical tuned circuit at different wavelengths, and reference to the curve of Fig. 3 will show that the variation over the normal tuning range is not large. We should, therefore, feel safe in predicting that a primary designed for any one wavelength would be very nearly the best possible for any other. This point too, has been the subject of measurement, and the curves of Fig. 13, each of which refers to a different wavelength, confirm this anticipation, for the maximum occurs at nearly the same number of primary turns in all cases. The relative heights of the different curves are not significant in this series, as no attempt was made to keep the input from the oscillator the same at the different wavelengths.

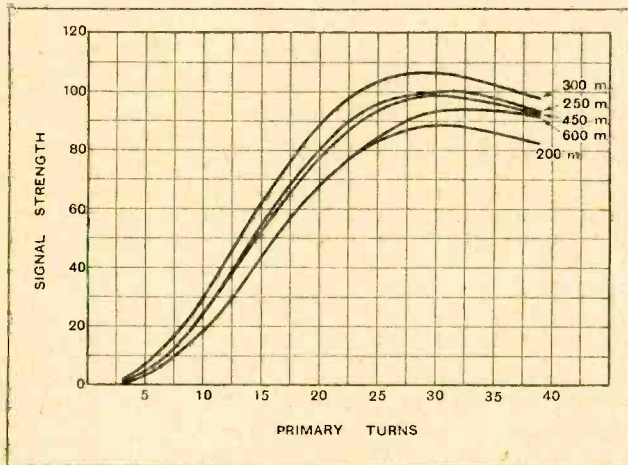

Fig. 13.—These curves, each of which refers to a different wavelength, show that the number of turns required for the primary is much the same over the whole wavelength range.

measurements, so that in addition to showing by the shift of the maximum the variation in the optimum number of primary turns, the relative height of the maxima in the different cases gives a measure of the signal strength attained. The very considerable increase in amplification brought about by the use of a secondary of high dynamic resistance is sufficiently great to require no stressing.

Summary.

In conclusion, we may say that the simple theory of the high-frequency transformer presented in the first of these articles is well borne out in practice at every point at which it has been tested by experiment, and that the inaccuracies imported into it by the simplifying assumption of infinitely close coupling are negligible, at least with the type of winding adopted. We

may, therefore, use the equation $n = \sqrt{\frac{R}{R_0}}$ for determining the ratio for any transformer of which the secondary characteristics are known. Having found the ratio n , either by calculation or by the method of measurement described, we can take $A = \frac{1}{2} \mu n$ as a reliable estimate of the amplification to be expected from the stage when transformer-coupling is used in a high-frequency amplifier.

The Standard Wet Battery Co., 134-8, Shaftesbury Avenue, London, W.C.2. 15-page illustrated handbook describing latest developments in their sac Leclanché H.T. and L.T. batteries, also 8-page booklet dealing with assembling, maintenance, and use of these batteries. Copies will be sent free of charge on application to the above address.

The Ormond Engineering Co., Ltd., 199-205, Pentonville Road, London, N.1. Illustrated leaflet of 3-point push-pull panel mounting switch.

Messrs. W. G. Pye and Co., Granta Works, Montague Road, Cambridge. Revised illustrated folder of components, with particulars of a new output transformer for pentode valves.

The Jewel Pen Co., Ltd., 21, 22, Great Sutton Street, London, E.C.1.—Radio List RD9, a revised eight-page catalogue of "Red Diamond" components.

**CATALOGUES
RECEIVED.**

The Britannia Reproducers, Ltd., Farnival Road, Sheffield. Descriptive booklet of Britannia moving coil loud speaker and parts for home construction.

The Improved Liquid Glues Co., Ltd., Imperial House, 15, 17 and 19, Kingsway, London, W.C.2.—Illustrated folder describing the "Croird" home outfit which simplifies the use of Croird glue.

Messrs. E. K. Cole, Ltd., "Ekco" Works, London Road, Leigh-on-Sea, Essex.—Illustrated leaflet describing the "Ekco-Electric Straight Three" mains-operated receiver for D.C. and A.C. supply mains.

Messrs. J. Dyson & Co., Ltd., 2, Coleman Street, London, E.C.2.—Illustrated list of "Godwinex" D.C. and A.C. H.T. battery eliminators, portable sets and "Airmax" coils and chokes.

Messrs. E. K. Cole, Ltd., Ekco Works, London Road, Leigh-on-Sea. Illustrated folder No. L.F.5, dealing with A.C. and D.C. supply units, also mains-driven 3-valve receivers.

The Mullard Wireless Service Co., Ltd., Nightingale Lane, Balham, London, S.W.12.—Illustrated leaflets of the "type E Pure Music" cone loud speaker and "Permacore" L.F. transformer.

Messrs. Peto-Scott, Ltd., 77, City Road, London, E.C.1.—A 32-page illustrated catalogue describing the special scheme of deferred payments inaugurated by this firm to assist the prospective purchasers of any of the receivers illustrated.

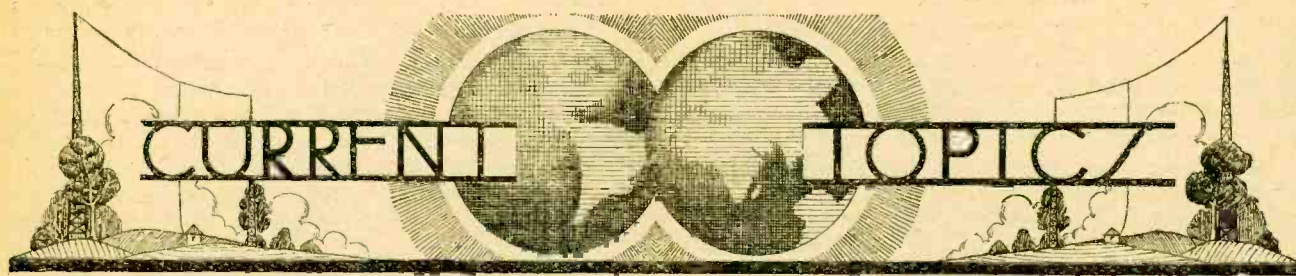

Events of the Week in Brief Review.

TRAIN WIRELESS.

"Radio-Fer" is the name of a new limited liability company in France "to exploit the installation of wireless on trains."

○○○○

5-METRE PRIZE WON.

The silver cup offered by Mr. E. T. Somerset to the first member of the Radio Society of Great Britain to achieve transmission over 10 miles on a wavelength of 5 metres has been won by Mr. J. Noden, of Nantwich. Details appear under "Transmitters' Notes" in this issue.

○○○○

PARIS RADIO SALON.

The Paris International Wireless Salon is to be held this year from September 27th to October 13th, coinciding with the famous Automobile Salon which brings visitors to Paris from all parts of Europe. The offices of the organisers of the wireless show are at 100, rue Réaumur.

○○○○

LOUD SPEAKERS IN THE PARK.

The London County Council hopes to economise in band music for parks by the use of Marconiphone loud speakers. Band selections played at the County Hall, Westminster, were recently relayed by land-line to Brockwell Park, Herne Hill, and reproduced by public address equipment.

○○○○

SHORT-WAVE RESEARCH.

A campaign in search of fresh data concerning short waves has been launched by M. G. Auger (F8EB), an official of the French Amateur Transmitters' League, who has circularised all the members with special log-cards for recording signal strength of short-wave transmitters at varying distances and under different atmospheric conditions.

○○○○

THE POPE AND THE PRAGUE PLAN.

"When the Papal station is working, all other stations will be silenced," says the Paris correspondent of the *Daily Mail* in reporting the arrival of engineers at Rome to install the Pope's new broadcasting station. The transmitter, it seems, will have an initial power of 50 kW., which can be increased in a few minutes to 100 kW. and then to 200 kW.

We wonder whether the sponsors of the Prague Plan have taken this station into account, and also whether Europe will have due warning before the Papal station begins transmitting

TRUTH IN ADVERTISING.

From a French radio journal: "For sale, a receiver, super-heterodyne, does not function; might suit amateur."

○○○○

WEATHER BROADCASTS FROM CROYDON.

Croydon radio station is conducting a trial service of broadcast weather reports at frequent intervals to all aircraft within range.

○○○○

"APPALLING ACCURACY."

The Master of a foreign steamer trading regularly to North Sea ports has

BELGIAN RADIO SHOW.

Belgium will hold her Third International Wireless Exhibition at Liège during September.

○○○○

PUBLIC WIRELESS TO SIAM.

A new direct wireless service to Siam has been opened by the Marconi Company. The rate for ordinary messages is 1s. 11d. a word, and for "deferred" 1½d. a word.

○○○○

ROOM FOR DEVELOPMENT.

Out of a white population in South Africa of nearly 2,000,000, only 16,710 held wireless receiving licences at the end of 1928, according to a *Times* correspondent, who reports that there is an urgent demand for more selective sets than those at present obtainable. Super-heterodyne sets have a large sale.

○○○○

PRIZES FOR PORTABLES.

Money prizes from £23 downwards are offered to amateurs by the *Manchester Evening Chronicle* for the design and construction of a lightweight portable receiver for headphone reception of 5XX and 2ZY. Every scope is allowed in regard to circuit and design generally, but the organisers suggest a maximum of 16 lb. weight for the receiver, including batteries. A month is given to constructors to complete their sets, but intending competitors are advised to send their names and addresses at once to the Radio Editor, *Evening Chronicle*, Withy Grove, Manchester.

The judging will be conducted in the open air on a Saturday afternoon early in July.

○○○○

RADIO-CHARTING THE ATLANTIC.

Transmissions from 2LO are being used in a "radio-survey" of the Atlantic now being carried out by the American wireless firm, Chas. Freshman, Inc., New York. Representatives of the company left New York on the *Ile de France* on June 1st, taking with them two C. A. Earl receivers equipped with milliammeters, which give a tape record showing signal strength. One set is permanently tuned to 2LO, and the other to WJZ, New York, the tuning dials of both sets being sealed before the commencement of the trip. Similar measurements are being made on the return journey, which begins in a few days' time.

The object of the test is to discover "just where American programmes begin

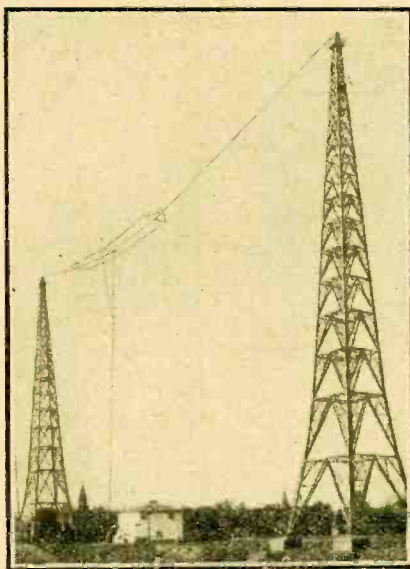

A WELL-KNOWN "DEUTSCHLANDER." The masts of Königsburg, the 4 kilowatt broadcaster which operates on 280 metres.

written to the Marconi International Marine Communication Co., Ltd., complementing them on the "appalling accuracy" of the Marconi Direction Finder. He reports that reliable readings were obtained in fog and bad visibility from stations 100 miles away.

○○○○

INDIA LISTENS TO HOLLAND.

The Government radio station at Bandung, Java, relays the transmissions of the Philips station, PHOHL, Huizen, Holland, every Thursday for a period of two hours on 37 metres. The relays are enjoyed by listeners in India

to fade and just where European programmes become a constant feature," and it is hoped that the data obtained will be useful in preparing plans for Transatlantic broadcasting. A similar test on short-wave transmissions is to be carried out during the autumn.

2LO "CUT OFF."

Soon after 10 o'clock on Thursday evening last a fire in a Post Office cable tunnel on the Victoria Embankment resulted in the telephonic isolation of the Savoy Hill control room, all provincial stations, including 5XX and 5GB, being left to pursue "their own sweet will." In no case, however, was there more than a few minutes' delay in connecting up an alternative programme from the West End Dance Hall, Birmingham. The transmission from 2LO was not affected.

WIRELESS ON THE "FLYING SCOTSMAN."

Through the courtesy of the London North-Eastern Railway Co. and Messrs. L. McMichael, Ltd., passengers on both the up and down "Flying Scotsman" were able to hear the B.B.C.'s running commentary on the Derby.

Messrs. McMichael installed their Super Range Portable Receivers in both trains, and tickets giving the results of the race were handed out to the passengers who were unable to get into the dining cars to hear the loud speakers.

At six o'clock the wireless picture apparatus, which was also installed on the train, was coupled up to the McMichael Super Range Receiver, and, with the train travelling at over a mile a minute, except for slight interference, perfect pictures were received, one showing Trigo passing the post, and the other of the winner being led in.

HOW U.S. NAVY RECEIVES SHORT WAVES.

A specification for the most efficient directional receiving aerial for short waves has been issued by the U.S. Navy Department.

"The antenna," says the U.S. Navy, "should consist of a single copper wire strung on posts at a height of 4 to 6 feet from the ground, approximately five half-

wavelengths long, and pointed in the direction of the transmitting station. The end pointing to this station should be grounded through a variable non-inductive resistance of 100 to 200 ohms. At the receiver end a variable 0.00015 mfd. air capacitor should be placed in series with the antenna for tuning and to avoid grounding that end. . . .

"As reception will be greatly improved on the three subharmonics of the frequency only one antenna, based on the

high dynamic resistance. These figures were based on the measurements made on an advance sample of the valve, which was the only one available at the time the article was written.

It now appears that this particular valve is by no means up to the standard of those now on the market, and with the latest valves examined an amplification of well over 500 times has been actually measured, with no assistance from reaction, at 300 metres.



FOR THE BLIND LISTENER. Broadcasting puts the blind listener on practically equal terms with his more fortunate brethren, especially when he is equipped with the "Braille Radio Times," which is published weekly by the National Institute for the Blind.

highest frequency employed, is necessary for reception within any one of the three subharmonic bands."

MORE AMPLIFICATION FROM SCREEN-GRID VALVES.

In a recent article under the above title figures were given for the theoretical amplification attainable on the broadcast band using the Cosmos AC/S valve in conjunction with a special tuned circuit of

COMPULSORY D.F. ON SHIPS.

Eighteen nations have signed the new convention for the safety of life at sea, arising out of the meetings of the International Conference which has just concluded its sittings in London. Among the provisions relating to wireless is a clause making the fitting of direction-finding apparatus compulsory on all passenger ships of 5,000 tons gross and upwards.

CUSHIONS AND ACOUSTICS.

WHAT are the ideal acoustic conditions for a concert hall? Are they the same as should obtain in the House of Commons? Could the system of stretched wires that one sees occasionally in an auditorium conceivably produce any useful effect? Is the reverberation period of the room in which you are accustomed to listen to wireless too long or too short, and how many rugs or cushions would be needed to perfect it? Could fifty thousand cushions make the

Albert Hall tolerable in those parts where it is now intolerable? Answers to these questions (except the last) are to be found in this book, whose authors are already well known for their acoustic work at the National Physical Laboratory.

The pioneer work of the late W. C. Sabine in raising the difficult subject of acoustics from an art (practised by scarcely any artists) to something approaching an exact science is accorded full recognition, and there are many good illustrations of his methods. A short section on churches is full of interesting information.

Studies of the shape of an auditorium are usually carried out by the sound-pulse or ripple-tank methods. Readers of this journal will recall the article by Dr. Davis

on this subject in a recent issue. The concluding chapters deal with the sound-proofing of rooms and the measurement of sound transmission through partitions.

The book is well illustrated, and the authors have evidently intended it as a text-book for the architect and the general reader. Some of the information relating to small experimental details is not quite up to date in describing a sound-generating and measuring apparatus; for instance, the authors speak of the "size and cost" of the oscillator coils necessary to produce tones of low frequency. The type of oscillator here referred to may have been common in 1927, but the heterodyne method is now practically universal.

R. P. G. D.

"The Acoustics of Buildings," by A. H. Davis, D.Sc., and G. W. C. Kaye, O.B.E., M.A., D.Sc., F.Inst.P. Bell & Sons, 1927. 15s. net.

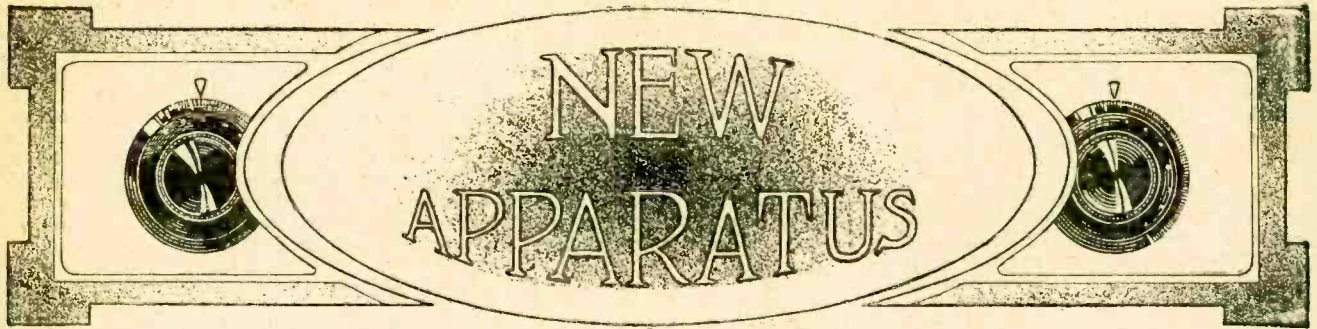

A Review of Manufacturers' Recent Products.

NORTON MOVING COIL SPEAKER.

The Norton moving coil loud speakers are of the electro-magnetic type, and are supplied with field windings for 220 volts or 6 volts as standard, but the makers are prepared to supply alternative windings to suit special requirements. The

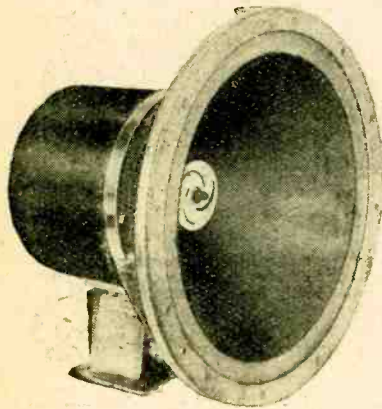

Norton moving coil loud speaker.

same applies to the moving coil; while the standard models have high resistance coils; special coils will be supplied if required.

The model sent in for test was fitted with a high-resistance coil and 220-volt field winding. When connected to the D.C. supply mains of this voltage a current of 100 mA. flowed; 22 watts were dissipated, therefore, in the magnet winding.

As a small gap is used, it is necessary to provide a centring device, and this takes the form of a thin cardboard web glued to the coil former and fixed to a brass rod let into the centre pole of the pot. Parallel movement without side play is assured, and the coil can oscillate at a large amplitude without touching the sides of the gap. The edge of the cone is provided with a supple leather surround, which is mounted on an aluminium casting bolted to the pot, holes being provided for attachment of a baffle.

The performance of this loud speaker is extraordinarily good, and no signs of resonance could be detected. Tests were made with a 3ft. baffle. High notes were reproduced with power, and the base drums were in evidence, but not over-

powering. On the whole the reproduction was surprisingly faithful. A feature of this model is its sensitivity.

The makers are Norton's Garage, 232, Bristol Street, Birmingham, and the price of the standard model is £6 complete and ready for attachment to a baffle or mounting in a cabinet. ○○○○

BAYLISS POWER CHOKES.

These power chokes have been designed for use in heavy-duty H.T. eliminators and are made in two inductance values, viz., 30 and 80 henrys. The 30-henry choke is stated to carry a maximum

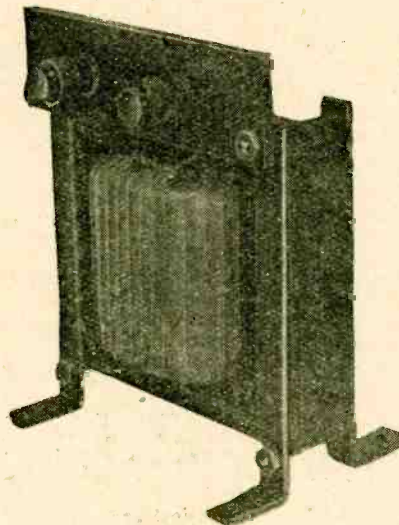

Bayliss power choke for heavy-duty smoothing equipment.

current of 500 mA. The 80-henry model has a maximum carrying capacity of 150 mA, the normal current being 100 mA.

The iron core is generous in size and built up from thin laminations insulated on one face. The winding is accommodated on the centre limb, and ample cooling surface is provided for radiation of any heat that may be generated. On test the temperature did not rise appreciably even when carrying the maximum load, and it will be perfectly safe to mount these chokes in close juxtaposition to other components.

The chokes are marketed at 35s. each, and the makers are Messrs. William Bayliss, Ltd., Sheepcote Street, Birmingham.

PHANESTRA LOUD SPEAKER.

This loud speaker is housed in an attractive and well-finished cabinet and appears to be of promising design. A 12-inch cone is used which is mounted on a small baffle fitting snugly behind an ornamental cloth-covered front. The driving mechanism consists of a massive balanced-armature unit provided with a substantial horseshoe magnet. This proved on test to be very sensitive, and comfortable volume could be obtained with a relatively small electrical input. The loud speaker will handle quite large inputs without showing signs of distress, but if driven too hard shows a tendency towards over-emphasis of the bass notes; which may be due to cabinet resonance, since this is not acoustically open at the back. On the whole the response is very good, but a critical ear might find reason to comment on the slight reluctance to bring out the very high audible frequencies in correct proportion having regard to the response to the lower tones.

These loud speakers are being sold at prices ranging from £6 6s. upward, ac-

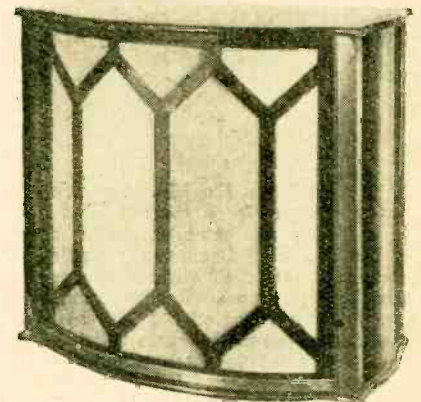

Phantestra cabinet cone loud speaker with balanced movement.

cording to the type of cabinet. They are supplied by Phantestra (Renn's Gramophones and Wireless, Ltd.), 22½, Cazenove Road, London, N.16.

ELECTRAMONIC D.C. H.T. ELIMINATOR.

The Electramonic H.T. battery substitute for use on D.C. supply mains is well worthy of a place among the best eliminators, since it provides a wide range of output voltages in addition to a power supply. A reference to the voltage regulation curves will bring to light the very satisfactory performance of the power supply under load, and it will be seen that the output voltage is practically unaffected by the current drawn from this tapping. Measurements showed that the power voltage dropped very slightly, even though a current of the order of 25 mA. was drawn from this tapping; and, moreover, the power load had negligible effect on the voltages appearing at the intermediate tappings. This is explained by the fact that the power supply is derived from a direct connection to the mains through a series resistance provided with three tappings allowing independent adjustment of this output.

The intermediate voltages are obtained from a potential divider, and, as is inevitable with this arrangement, show some interdependence on the current loads in each case.

Three intermediate voltage terminals are provided, and each has a wander lead and plug for insertion in any of the eight tapping sockets on the potential divider.

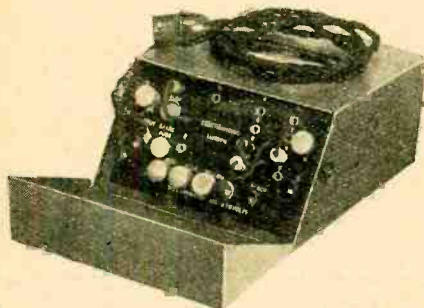

This Electramonic D.C. H.T. eliminator provides three intermediate output voltages as well as a power supply.

The same distinguishing colours are given to the wander plugs and terminals with which they connect. A small flash-lamp bulb is fitted as a safety fuse, and a spare supplied in case of accidents. The usual earthing terminal, and terminal for attaching a wire from the earth of the set, is incorporated.

The unit is enclosed in a metal case with a lid which protects the live terminals, ebonite bushes being provided to prevent input and output leads from being damaged by the sharp edges of the holes in the sides of the container. The makers are The Electramonic Co., Ltd., Bear Gardens, Park Street, Southwark, London, S.E.1, and the price is £3 3s.

"CARCO" SWITCHES.

Switches play an important part in a modern receiver since interchangeable coils are now regarded as out of date and switch-over circuits are now fashionable. Especially in portable sets does this

arrangement figure, as it simplifies the operation, and, if high-class switches are used, rarely introduces losses. "Carco" switches are admirably suited to this use, since the action is positive and there is not the slightest possibility of the switch lever changing its position, even though subjected to violent vibration. This is particularly important with combined wave-change and filament control switches, especially with respect to the neutral position.

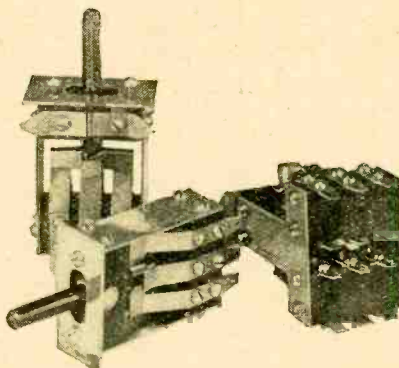

Range of "Carco" switches.

These switches are made in various types, and prices are as follows:—

Type 202—two-way two-pole, 4s. 6d.

Type 212—two-way two-pole with filament circuit control, 5s. 6d.

Type 204—two-way four-pole, 7s. 6d.

Stout phosphor-bronze springs are fitted, and the insulation is of a high order throughout. The makers are Messrs. Greenwood, Page & Co., Ltd., 3-5, Burlington Gardens, London, W.1.

o o o o

MAGNUM AUTO FUSE.

An H.T. fuse will inspire a feeling of confidence, and since portable sets are subject to much more vibration than stationary receivers, this safety device

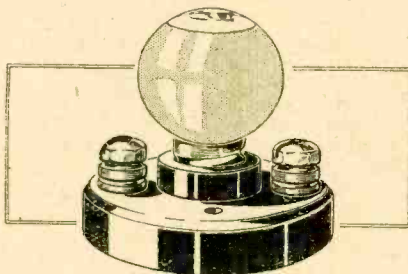

Magnum auto fuse.

should be fitted. The "Magnum" auto-fuse has this advantage over others of similar type now on the market; should the fuse "blow" and a spare not be available immediately, the contacts on the holder can be short-circuited by unscrewing the bulb. The price of this useful accessory is 1s. 3d., including lamp, and spare bulbs, rated to fuse at 0.06 amp., are available at 6d. each.

The makers are Messrs. Burne-Jones and Co., Ltd., Magnum House, 296, Borough High Street, London, S.E.1.

"HYPERMU" TRANSFORMER.

The "Hypermu" L.F. transformer is made by Radio Instruments, Ltd., 12, Hyde Street, Oxford Street, London, W.1, and is offered at 21s. One of its principal features is its size; it measures 3in. x 1½in. x 3in. high, and weighs 13ozs. only. This is made possible by using a special alloy for the core, which has a much higher permeability than is generally associated with transformer iron used in radio mains units.

Since one of the factors governing the inductance of any iron-cored coil is the permeability of the magnetic circuit, it follows that by using this special alloy a large primary inductance can be attained with considerably less wire, and hence a reduction in the size of the component. Owing to the special nature of the core, it will tend to reach magnetic saturation much earlier than ordinary iron, and particular attention must be given to the probable effect of the steady anode current in the primary.



R.I. "Hypermu" L.F. Transformer.

Measurements show that quite a small current causes a lowering of the permeability, and this is reflected in the amplification, particularly of the lower audible frequencies. Constant amplification can be made possible from about 30 cycles up to 4,000 cycles by passing the H.T. to the valve via a resistance and feeding the transformer through a 2-mfd. condenser. This blocks off the D.C. component and allows the A.C. component only to pass to the transformer.

Above 5,000 cycles the amplification increases, and beyond this a decline follows, but even at 7,000 cycles the amplification is slightly greater than at 2,000 cycles. These results were obtained with an 8,000 ohms valve preceding the transformer, a 30,000 ohms anode resistance, and a good power stage following.

Used in the normal manner, the amplification tails off below 200 cycles, but is sensibly constant from 200 to 4,000 cycles. The most suitable valve to precede the transformer under these conditions is one having an A.C. resistance of between 20,000 and 30,000 ohms.

The transformer is enclosed in a black moulded container, inside which is an iron case with provision for earthing.

BROADCAST

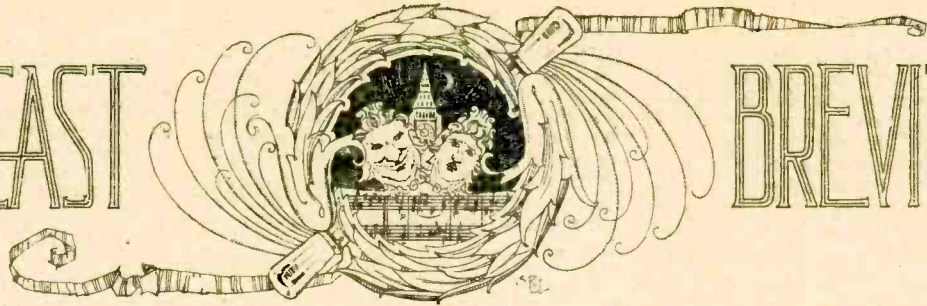

BREVITIES

By Our Special Correspondent.

Captain Eckersley.—Broadcasting House.—The Twins of Brookman's Park.

The Chief Engineer's Resignation.

Captain P. P. Eckersley follows the ecclesiastical precedent in placing himself, as its most illustrious member, at the end of the long procession from Savoy Hill. Whether he is indeed the last is open to conjecture, for the time has come when the reasons for all these retirements should be investigated. A little ventilation of the real facts might set a few more pilgrims on their feet.

Who Will Succeed "P.P."?

Although he renounces his official position at the end of September, Captain Eckersley will continue to advise the B.B.C. in regard to the regional scheme. This is as it should be, for the regional scheme is the Chief Engineer's own "child," and it is still his ambition to make the British broadcasting system a model for other nations to follow.

On the question of a successor to Captain Eckersley, I am unable to obtain a statement from the B.B.C. The Assistant Chief Engineer is Mr. Noel Ashbridge. However, it would be in keeping with the B.B.C.'s new doctrine of anonymity if the next chief were to labour in obscurity.

Broadcasting House.

The wilderness at the south corner of Portland Place, London, will wear a different aspect in a few weeks' time, when Messrs. Holland and Hannen and Cubitts, Ltd., who made the successful tender, get to work on the foundations of Broadcasting House. The architect's drawing, which appears below, shows certain modifications in the original design. While the height of the building is slightly reduced, fuller and more practical use is made of the available space.

Studio to Seat a Thousand.

The whole of the studios and allied departments remain intact as originally conceived, enclosed within their insulating brick tower, but more room is allowed for the administrative side. The super-studio or concert hall, capable of accommodating nearly a thousand people, remains an integral part of the plans.

Tweediedum and Tweedledee.

In the B.B.C.'s announcement of the new wavelengths to be taken up by British stations under the Prague Plan on June 30th the most interesting feature is

the allusion to the Brookman's Park transmitters. "London 1" will operate on 356 metres (842 k.c.) while its twin brother, "London 2," will be heard on 261 metres (1,148 k.c.) giving a kilocycle separation of over 300. Whether this is sufficient will only be known towards the end of the year, when the twins begin simultaneous operation for the first time.

A Local Tyrant.

A friend who is mightily afraid that his home comes within the "wipe out" area of Brookman's Park, tells me that his only remaining comfort is the thought that a low wavelength like 261 metres should give good quality of reproduction. But the genuine ether searcher (and he is one) will always fume at the tyranny of a too-powerful local station, however good the B.B.C. programmes may be in days to come.

Anticipatory Praise.

The B.B.C. is wondering whether to accept as a good omen a letter which helped to swell last week's mail. "I have been listening," says the writer, "to your new 2LO (Brookman's Park?) and find that the

music and speech are much louder and clearer than that from Savoy Hill."

The International Broadcasting Union.

The annual General Assembly of the Union Internationale de Radiodiffusion, the international broadcasting union, which concluded its sessions at Lausanne last week, elected Vice-Admiral C.D. Carpendale, C.B., Comptroller of the British Broadcasting Corporation, to be its President for the fifth year in succession.

This Assembly was notable, among other things, for the fact that for the first time the French Government took up active membership. Practically all European broadcasting organisations are now within the Union, which has become the recognised centre for all broadcasting questions of an international character.

The Master Regulator.

Armed with its new authority the Assembly has adapted the former statutes to the new conditions and has provided for the management and finance of the wavelength checking centre at Brussels. This centre has now been officially made the master-regulator for Europe.



THE BROADCASTING OF TO-MORROW. The new modified design of "Broadcasting House," the construction of which is to be started in the near future.

RADIO AT THE PARIS FAIR

Super-heterodyne Still Foremost.

THE general Trade Fair which is held annually near the Porte de Versailles in Paris during the month of May has included during the past few years a section devoted to radio, and this section has steadily grown in dimensions from year to year.



A radio-gramophone cabinet by Radio-Meuble, Paris.

from offering anything in the way of surprises in the matter of novelty.

An Out-of-season Show.

Most of the apparatus exhibited, therefore, shows comparatively little evidence of progress since the exhibits of last autumn's radio show, which we reviewed in these pages. There are, however, one or two general observations which can be made regarding the radio apparatus exhibited. We feel convinced from our inspection of apparatus and the opportunities which we have had from time to time of listening to what, in France, is considered good reproduction that radio sets there must sell more on the merits of their appearance than their standard of performance. The cabinet work and general design of the better sets show an originality and finish which is not attained by British manufacturers at anything approaching an equivalent price, and, in any case, even if attained would not apply to standard products. The cabinet makers who have specialised in producing the furniture in which the radio set is to be housed appear to have taken far more trouble to employ competent designers of furniture than is apparent with the products of our own radio cabinet firms, who, for the most part, supply little more than a box with, at

times, a certain amount of additional decoration. But on the interiors of the sets, which, after all, we must regard as the essentials, we cannot compliment the French manufacturer on showing evidence of real progress, nor even, we would say, of keeping abreast of the times.

To examine the receivers at a French Exhibition makes one wonder whether the number of valves in the set is not one of the salesman's strongest points of argument, for there the average number of valves in receivers seems to increase rather than diminish, whereas here the efforts of manufacturers are always in the direction of making the utmost use of every valve in the set and so reducing the total as far as possible. We

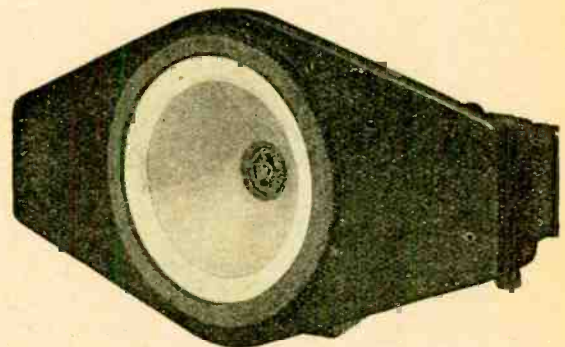
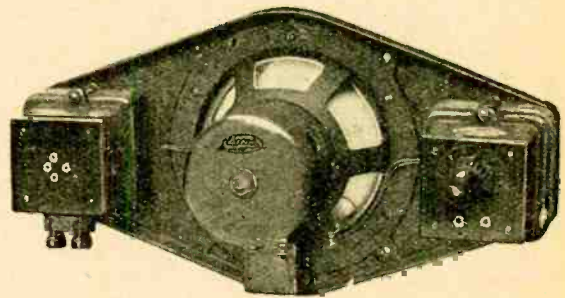

"Elcosa" moving coil speaker Unit.

believe that the designer is handicapped to a certain extent through lack of a choice of French valves giving performances equivalent to those available here.

The Super-heterodyne Still Leads.

Frame aerial receivers are still, as they always have been in France, much more in evidence than they have ever been in this country. The French designer does not appear to have yet appreciated fully the possibilities of efficient straight H.F. amplification, and consequently the many-valved super-heterodyne still leads the field amongst the French receivers.

Radio at the Paris Fair.—

From the point of view of initial care in the design of the receiver unit we think that the firm of "Sicra" still sets an example to many of its competitors, although we fear that there may be a tendency with this firm to sacrifice circuit improvements in order to avoid any radical change in the general planning of the sets, the standardised chassis being an all-metal framework.

A well-designed moving coil loud speaker was shown by Electro-Constructions, S.A., mounted on a metal framework, which also carries a transformer and rectifying valve for the field winding, and a volume control. The instrument is shown in the illustration, which gives a front and back view of the complete unit. Other stands also exhibited moving coil speakers, showing that this speaker is beginning to gain favour.

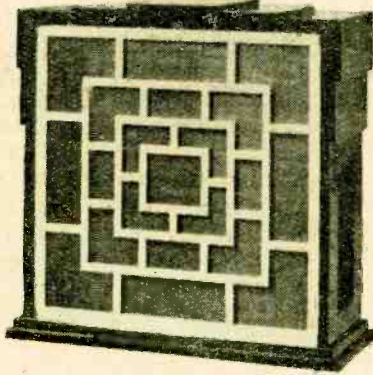

A Gaumont moving coil speaker.

Progress in Electric Gramophones.

Considerable attention is being paid to electric gramophone reproduction, and a number of firms are showing models of machines at various prices. Etablissements Gaumont are pioneers in apparatus of



The Gaumont "Elgéphone," an all electric gramophone equipment.

this type, and show models of all-electric machines entirely self-contained.

A leather finish to sets on the lines of that familiar to those of our readers who know the Philips' range of receivers is now fairly common practice with French models, particularly the lower priced sets.

A number of suit-case and other portables were to be seen, though it is noteworthy that with the better class portables the tendency appears to be to accom-

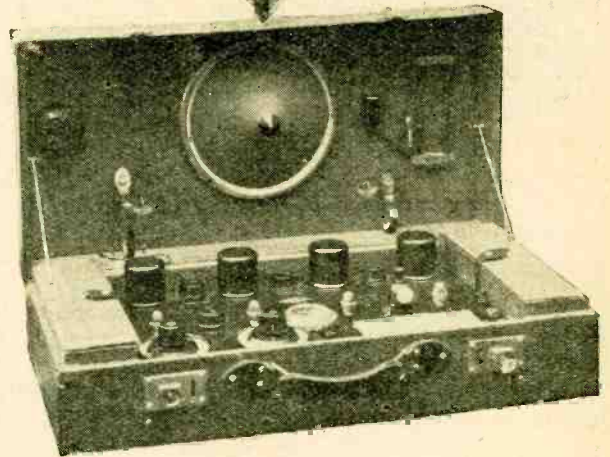
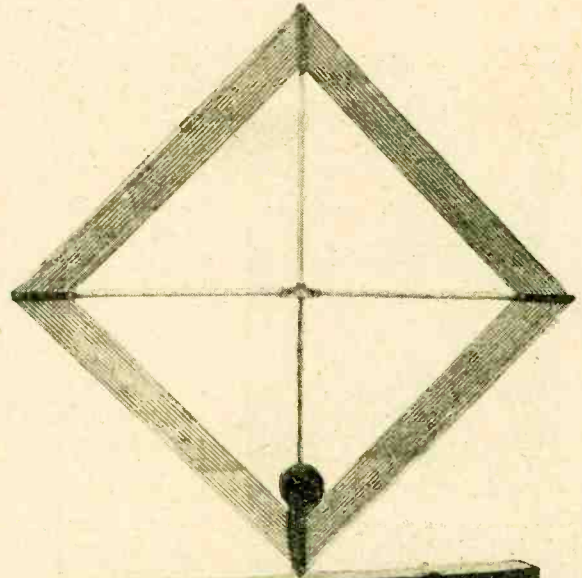

The "Stellor" portable.

modate the batteries in a separate container. This may be merely as a matter of convenience, but it is, perhaps, also accounted for by reason of the fact that the weight and bulk of batteries suitable for super-heterodyne receivers might prohibit their inclusion in the set itself, as this would add so much to the bulk and weight, and the great majority of the portables were multi-valve super-heterodynes.

A somewhat new style in general design was noticed in the "Stellor" portable which we illustrate. This receiver is of proportions rather unusual for a portable set, and the shape seems to us to be distinctly preferable to a square design which may be cumbersome to

Radio at the Paris Fair.—

carry. Unfortunately, we did not have an opportunity of a demonstration of this receiver, but certainly its general appearance was attractive.

Accessories.

Amongst accessories the "Sutra" motor generator unit for supplying high tension and low tension shown by Soci t  C.A.S.E. was of interest, particularly in view of the way in which the complete unit was accommodated in a soundproof case. The apparatus is designed in two models, the first supplying   amp. at

4 volts and 160 volts plate current at 35 mA., and a larger model, 1 amp. at 4 volts, and 160-200 volts at 100-120 mA.

An attractive design of loud speaker was shown by "Brunet," and this is illustrated in the photograph. It consists of an oxydised art metal framework carrying a

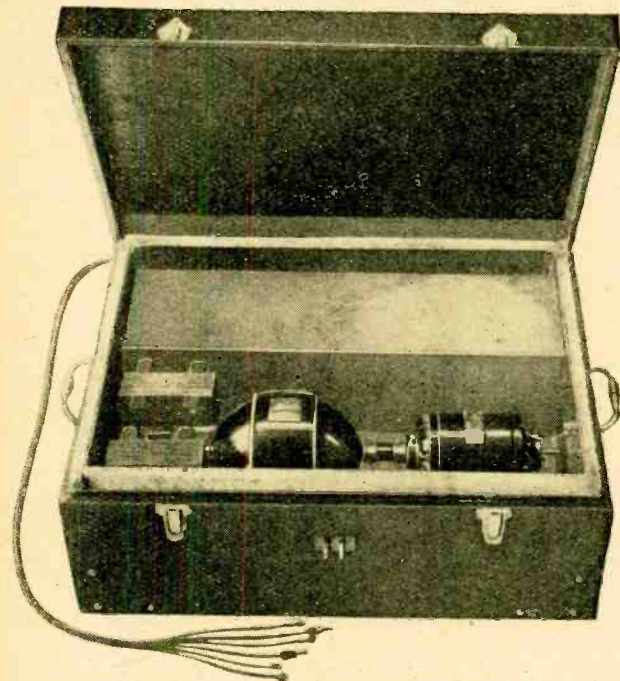

A motor generator unit for H.T. & L.T. in soundproof case.

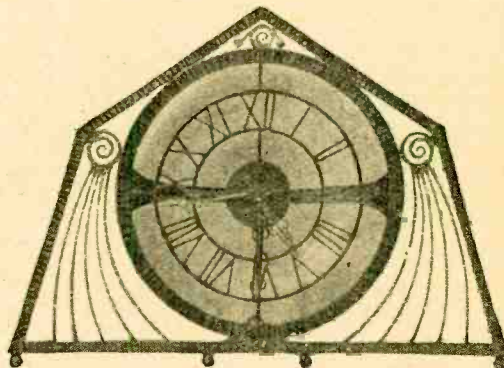

An attractive design of loud speaker incorporating a clock.

clock in the centre, and behind is the transparent cone with the loud speaker unit mounted at the back. In appearance the speaker passes as an artistically designed timepiece, and only a close inspection reveals the further utilitarian object.

Great strides may be expected in the radio industry in France as soon as broadcasting in that country is established on a lasting and satisfactory basis. At present those firms which are conducting transmissions are in the unfortunate position of having no guarantee of the permanency of their licences to broadcast, and this naturally has a depressing effect upon the home trade. New legislation now pending is expected to remove this unstable state of affairs and establish French broadcasting for the first time on a truly permanent basis.

CORRESPONDENCE.

The Editor does not hold himself responsible for the opinions of his correspondents.

Correspondence should be addressed to the Editor, "The Wireless World," Dorset House, Tudor Street, E.C.4. and must be accompanied by the writer's name and address.

SHORT-WAVE RECEPTION.

Sir,—I have read with interest the description of various short-wave beam transmitters described from time to time in your publication.

I have, however, been very puzzled by the results I have got here. My position is approximately 6 .05 min. North and 0 .50 min. West.

The transmissions of the Nauen beam station come in here very well (on about 15 metres), as do also the Paris and Buenos Aires telephony service on about 15 and 15.50 metres respectively. As I am in the line of the beams of these stations this is quite natural.

I have also heard Rocky Point on 16 metres, and the higher-wave New York transmitter on about 22 metres (this latter late at night), and also the Canadian station on about 32 metres. These stations should not be audible here so far south, as I am well out of the line of the beam, but nevertheless it is just possible that the beam is not too carefully adjusted, and spreading makes these stations audible here.

Lastly, the most incomprehensible results I have got are the reception of the East and West beam transmitter of Huizen on 16.88 metres, and the Dutch telephony transmitter on 18 metres. Huizen comes in here more regularly and at better strength than any other station, yet I am due south of this station, who officially announces that his beam is East and West!

Can any of your readers give me an explanation of these results? It would seem that beam transmitters ("so called") are not nearly as directional as they are supposed to be.

c/o Postal Agent, Kade, via A. G. FAITHFULL
Takoradi, via Tarhusa, Gold Coast,
West Africa.

"SCRAPPY" PROGRAMMES.

Sir,—Please pardon my further intrusion in this ferocious controversy, but honour demands that I defend my fair name and reputation from the base attack made on it by Mr. J. E. Kemp in your issue of May 8th.

I will admit, with pride, that I have considerable charm and that I have even displayed it in Manchester. Furthermore, I will admit that I have met, at various times and places, many gentlemen by the name of Kemp. But never have I had the pleasure of meeting Mr. J. E. Kemp, and never, never, never have I been a member of the B.B.C. staff.

This was the unkindest cut of all. It is humiliating enough to think that there may be one other Bertram Munn on earth; but it is indeed terrible to think of his being a member of the concern which is adding still more scraps to the general serappiness of life. To convince Mr. Kemp of my sincerity I herewith publicly challenge any member of the B.B.C. staff who bears exactly the same full name as myself to come forth from his lair and fight me with any weapons I may choose. It must be a real fight—and no mere “scrapping.”

Twickenham. BERTRAM MUNN,

[With reference to Mr. Kemp's letter published in our issue of May 8th, we find on enquiry that some confusion has arisen as a result of similarity of names of the writer of the above letter and the official of the B.B.C. referred to in Mr. Kemp's letter.—Ed.]

THE MILLIAMMETER.

Sir,—Your article in *The Wireless World* on the use of the milliammeter on other ranges by the use of additional shunts is interesting. Obviously the best method is to use an instrument of the necessary capacity on each circuit, but though it is a policy of perfection it is expensive, and, furthermore, tends to make the set in appearance resemble a central station!

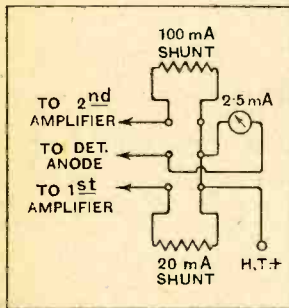

A couple of years ago I schemed out a switching method of doing the job—I may say that I love switching problems, they are as good as chess—but I finally used separate instruments.

I have torn the sketch from my scribble book and enclose it in the hope that it may interest you. It has the defect that when checking up on the other loads allowance has to be made for the detector circuit. The switch is a Burndept two-pole.

- Lever central=Detector.
- Lever up=1st amplifier.
- Lever down=2nd amplifier.

ARTHUR C. BANFIELD.

London, W.1.

RADIO FOR THE DEAF.

Sir,—A note of warning should be sounded about the article entitled “Broadcast Receiver for the Deaf” in the 8th May issue of *The Wireless World*.

The apparatus mentioned is suitable for a great number of cases of deafness, but not all, and unless this is pointed out it may cause a great deal of disappointment to those cases to which it is not applicable.

In the audition area of many deaf ears there are smaller areas where a pure note is not heard as such, but only as a noise. Such an area I have marked on the diagram. In this case tones of a frequency between about 700 and 3,000 falling in this area would be heard as a noise, and as the fault lies in the ear no apparatus can make them hear properly. Of course, if the area is small its effect is small also and may pass unnoticed.

These noise areas are mostly met with in cases of nerve deafness. The chances of anyone suffering from any degree of nerve deafness of hearing with this or any other electric apparatus are small.

I am a licensee, under the Marconi-Reisz patents, for the use of the Reisz microphone in thermionic deaf aids, and have developed, independently, a form of this instrument which is

particularly applicable to such apparatus. It is, of course, heavy and fairly expensive, but it gives results that no other deaf aid on the market can give. It is particularly useful to

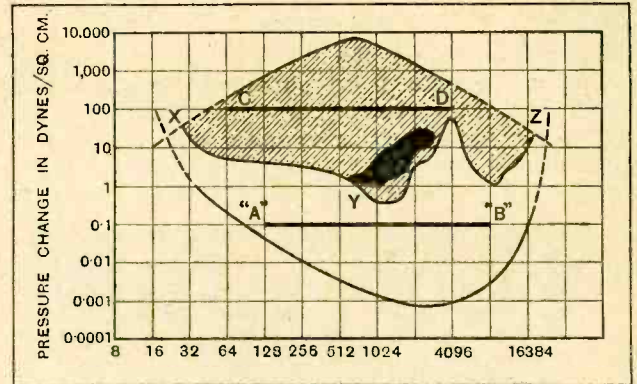

those people who are fond of music. With it most people suffering from middle ear deafness—even those classed as “Very deaf”—can go to any concert and really hear.

As I am such a case myself I speak with experience.
Croydon. R. G. KENNARD.

Sir,—Thank you for forwarding to me a copy of Mr. Kennard's letter; my comments in regard to this are as follows:—

When a deaf person, in addition to his deafness, has a malady such as tinnitus, which I presume is what Mr. Kennard is referring to, it is advisable for the person to seek medical advice about its treatment.

I hope that my omitting to make reference to such cases in my article does not imply that the instrument I described was suitable for everyone who had some complaints connected with his hearing. In fact, I thought that reference to the medical side of such a question would be out of place in such a publication as *The Wireless World*.

I am very much obliged to Mr. Kennard for pointing out this matter in case there are any others who may think the instrument a panacea for all forms of deafness.

All I wished to point out in my article is that the instrument I described is capable of dealing with much louder “signals” without distortion than the ordinary headphone, therefore the deaf may take full advantage of the clear reception from a modern broadcast receiving set without being limited to the distorted reception that would be obtained if ordinary headphones were used. It can be stated that in at least nine cases out of ten a receiver that will handle a large volume without distortion is found to be of great value to those who are hard of hearing.
S.W.1. CHARLES M. R. BALBI.

IS ALL WELL WITH THE B.B.C.?

Sir,—The recent departures of various members of the staff of the B.B.C. for other fields of activity, together with the recent episode in connection with the Election results announcements, tempts me to ask the above question.

As one who remembers the first transmission of the old Broadcasting Company (and even the old Writtle days) I cannot help wondering what is really happening. We have, as regards the resignations, the usual reasons, but many, I think, will agree with me that the campaign of anonymity which seems to have been entered upon may be carried too far. Those of us who remember the early days of the B.B.C. and came to consider the various “uncles” and “aunts” as our personal friends, cannot but regret the changing of the old order.
PERTURBED.

Lee, S.E.12.

READERS' PROBLEMS

"The Wireless World" Supplies a Free Service of Technical Information.

The Service is subject to the rules of the Department, which are printed below; these must be strictly enforced, in the interest of readers themselves. A selection of queries of general interest is dealt with below, in some cases at greater length than would be possible in a letter.

Courting Failure.

I have a commercial receiver with two H.F. stages, anode bend rectifier, and one transformer-coupled output valve. Do you think that it would be possible to wire the filaments in series, so that they could be fed direct from D.C. mains? I should, of course, make provision for shunting the filament of the detector valve, which takes less current than the others, with a suitable resistance.

A. C. D.

The problem of modifying any set with two H.F. stages should be approached with some diffidence, and we can hardly recommend your proposed scheme; unless anode and grid circuits are fully "decoupled," it is more than likely that, by connecting the filaments in series, instability will be produced.

Two Super H.F. Stages.

With reference to the article on "Doubling Screen-Grid Amplification," I should like to know if there is any reason why two neutralised S.G. valves should not be used in cascade.

H. V.

There is no theoretical barrier against the use of two high-amplification neutralised stages, but the practical realisation of a set including them would be a matter of some little difficulty. Overall amplification might well be in the neighbourhood of 10,000 times; this means that the most meticulous care would have to be taken to prevent any feedback of energy from the output to the input end of the amplifier.

Overall amplification of this order can hardly ever be usefully employed in an "open aerial" set, but it would not be excessive if the receiver were operated in conjunction with a frame.

Continuously Variable Aerial Coupling.

I am thinking of rebuilding my receiver (H.F.-det.-2 L.F.) to include a loosely coupled and separately tuned aerial circuit. As waveband switching is to form part of the scheme, I should like to include an arrangement on the lines of the auto-coupled circuits that you have recently published, but wish to have provision for continuous adjustment of aerial coupling. Will you suggest a simple scheme? L. S. M.

We think that the arrangement shown in Fig 1 should meet your needs. As you will see, the switching arrangement is

similar to that included in several recent Wireless World receivers, but, instead of joining the loaded aerial direct to a tapping on long- or short-wave grid coils, it is connected to earth through small coupling coils— L_1 for long waves and L_2 for short waves—in variable inductive relation with the corresponding grid windings.

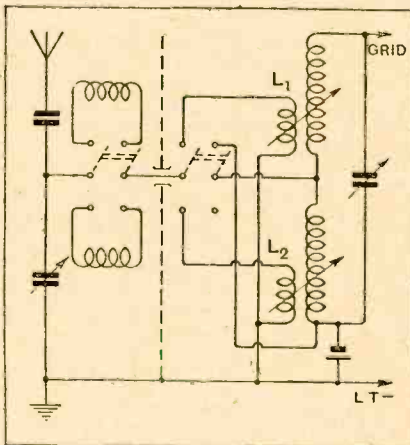

Fig. 1.—Connections of two-circuit aerial tuner with variable coupling and waveband switching.

These coils may have respectively five and twenty turns each, and may conveniently be mounted inside the coil formers in such a manner that they may be rotated with respect to the secondaries. If

RULES.

- (1.) Only one question (which must deal with a single specific point) can be answered. Letters must be concisely worded and headed "Information Department."
 - (2.) Queries must be written on one side of the paper, and diagrams drawn on a separate sheet. A self-addressed stamped envelope must be enclosed for postal reply.
 - (3.) Designs or circuit diagrams for complete receivers cannot be given; under present-day conditions justice cannot be done to questions of this kind in the course of a letter.
 - (4.) Practical wiring plans cannot be supplied or considered.
 - (5.) Designs for components such as L.F. chokes, power transformers, etc., cannot be supplied.
 - (6.) Queries arising from the construction or operation of receivers must be confined to constructional sets described in "The Wireless World" or to standard manufacturers' receivers.
- Readers desiring information on matters beyond the scope of the Information Department are invited to submit suggestions regarding subjects to be treated in future articles or paragraphs.

their disposition is such that it is not possible to obtain a tight magnetic coupling in the "maximum" position, it will be necessary slightly to increase the number of turns we have suggested.

Improving the Hartley Circuit.

I believe that it is possible to improve the sensitivity of a receiver having a "Hartley" detector valve by adding a fixed condenser in addition to the 0.0001 mfd. variable used for reaction control. If this is correct, will you tell me where the extra condenser should be inserted, and specify a suitable capacity? N. S. L.

It is a fact that a noticeable improvement in sensitivity can often be obtained by joining a fixed capacity of from 0.0001 mfd. to 0.0003 mfd. directly between plate and negative filament of the detector valve.

When this addition is made you will find that a considerable increase in the capacity setting of the reaction condenser must be made in order to obtain oscillation as compared with the normal adjustment. You must take care that the added condenser is not sufficiently large to prevent your obtaining adequate reaction control.

Reversed Coil Connections.

I am in trouble with my "Kilo-Mag Four" receiver, which has just been completed; the aerial grid circuit does not seem to tune below about 480 metres. A certain number of stations, rather below this wavelength, are received with the first condenser set at zero, and quite a number of transmissions on higher wavelengths are heard, but selectivity is extremely poor.

From this information, can you tell me what is wrong? A. L. J.

We think it almost certain that your medium-wave aerial-grid coil is incorrectly connected; it seems probable that the leads to the ends of the windings have been reversed, with the result that the aerial is tapped to a point only a few turns below the end in connection with the first H.F. grid. The result is, practically speaking, a directly coupled aerial, which will account for poor selectivity. Due to the addition of aerial capacity, this misconnection will also be responsible for the fact that the circuit will not tune to the lower wavelengths.

Short-wave "Everyman Four."

Would it not be possible to receive ultra-short wavelengths on the "Everyman Four" by replacing the present coils by special aerial-grid and intervalve H.F. transformers? If so, will you please give me the necessary winding data? C. A. C.

As far as we are aware no satisfactory short-wave H.F. coils have been evolved for this type of set, and we are confident in saying that its design does not lend itself to modification for this kind of reception.

○○○○

Valve Holder Connections.

Referring to the practical wiring plan of the "Kilo-Mag" receiver, it would appear that the H.F. stopping resistance *R* is connected to the filament terminal of the output valve holder. Surely this is an error, as, according to the theoretical circuit diagram, it should be in series with the grid. W. M. R.

We think that this matter will be cleared up when we point out that the terminals of the Sterling anti-microphonic valve holders actually used in the construction of the set, and illustrated in the practical wiring plan, are somewhat different from those usually adopted, external plate and grid connections being adjacent. The diagram is correct.

○○○○

Charging in Sections.

Is it a practicable plan to charge a 120-volt accumulator H.T. battery in sections of 40 volts? I ask this question because I have a battery of that size, and also a 50-volt household lighting plant. My idea is to divide up the H.T. battery into 40-volt sections, and to charge one section per week in rotation. E. R. N.

We can see no objection to your proposed scheme, particularly if you take the trouble to make a small switchboard, by means of which each section of the battery may be put on "charge" or "discharge." Unless you disconnect the H.T. cells from the set when they are put on charge, a short-circuit may take place if the household supply happens to be "earthed."

○○○○

Failing Filaments.

When my set was first built a milliammeter connected in the anode circuit of the output valve registered 13 milliamperes; now, with batteries in the same condition as before, and the same valve, the current has dropped to 8 milliamperes, and quality is not so good as originally. What do you think is wrong? B. J. D.

If we can take it that all the battery voltages (H.T., L.T., and grid bias) are within a few per cent. of the original values, it can be stated almost definitely that the filament of the output valve has lost a good deal of its emission, and that it is due for replacement. Of course, it

is just possible that there is an excessive resistance in the output anode circuit; but this is hardly likely, and in any case the fault would probably be revealed by a simple test.

○○○○

Superabundant Energy.

Is any advantage likely to be gained by using Litz wire in a reaction coil? At present my aerial grid coil is wound with 9/40 stranded cable, but the reaction winding is of very fine silk-covered wire, which I suppose has considerable H.F. resistance.

G. P.

There is no point in using a coil of specially high efficiency as a reaction winding; here we are dealing with superabundant energy, and the use of heavier wire will probably have the opposite effect to that you desire, as its capacity with respect to the grid winding will be greater than if finer wire were used.

○○○○

A Correction.

With reference to the "Flat Dwellers' A.C. Three" set, I notice that in the inscription under Fig. 6 the wire for the grid coils is specified as 9/40 Litz, while in the "List of Parts" mention is made of 9/42 cable. Which is correct? L. W. P.

The correct wire for these windings is 9/40 Litz, each strand S.S.C., with a D.S.C. covering over all. Consequently the "List of Parts" is incorrect in this respect. We regret this error.

quite impracticable; if you consider the diagram carefully, you will observe that there is a considerable difference of potential between the filaments of the valves in the set proper and that of the eliminator rectifier valve. Consequently, it is essential that this latter should be supplied from a separate winding.

○○○○

The D.C. Junior Eliminator.

The circuit arrangement of my receiver comprises an S.G. high-frequency valve, transformer-coupled to an anode bend detector, which is followed by a single transformer-coupled L.F. valve. A common H.T. voltage of 120 is applied (from dry batteries) to the anodes of all the valves, and a separate tapping is provided for the screening grid voltage supply. The set is, in fact, very much on the lines discussed in several recent articles in "The Wireless World," and is arranged on "safety-first" principles in the matter of unwanted interstage couplings. I assume, therefore, that it should be possible to supply it from a simple eliminator, such as the "D.C. Junior" described in your issue of May 22nd, and should be glad to know how this unit may be modified in order that screening grid voltage may be accurately adjusted. My supply voltage is 220. N. D. F.

We suggest the arrangement shown in Fig. 2, in which the "+1" feed is replaced by a "two-element" potentiometer.

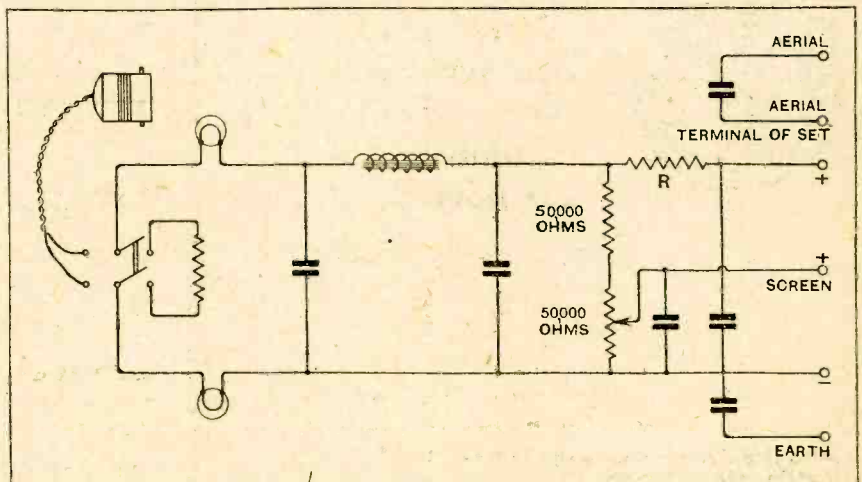

Fig. 2.—Simple D.C. eliminator with single anode voltage output and critical control screening grid supply.

Short-circuited H.T. Supply.

I have an A.C. power transformer with a centre-tapped high-tension winding, and also a single separate winding rated as being capable of delivering 5 amps. at 4 volts. Would it be possible to use this in building the "Flat Dwellers' Three," modifying the original design by feeding the filaments of both receiving and rectifying valves from the low-voltage winding? J. M. S.

No, we are afraid that this plan is

meter, consisting of one fixed resistance and another with a sliding contact. Except where marked, the values of components are as in the original unit as described.

The value of the resistance *R* will depend on the total current consumed in the three anode circuits; if your valves are of the type customarily used in a set such as you describe, we suggest a value of about 5,000 ohms, which should give a suitable output voltage—slightly higher than you are using at present.

The Wireless World

AND
RADIO REVIEW
(17th Year of Publication)

No. 512.

WEDNESDAY, JUNE 19TH, 1929.

VOL. XXIV. No. 25.

Editor: HUGH S. POCOCK.

Assistant Editor: F. H. HAYNES.

Editorial Offices: 116-117, FLEET STREET, LONDON, E.C.4
Editorial Telephone: City 9472 (5 lines).

Advertising and Publishing Offices:
DORSET HOUSE, TUDOR STREET, LONDON, E.C.4.
Telephone: City 2847 (13 lines). Telegrams: "Ethaworld, Fleet, London."

COVENTRY: Hertford Street.

Telegrams: "Cyclist, Coventry." Telephone: 5210 Coventry.

BIRMINGHAM: Guildhall Buildings, Navigation Street.

Telegrams: "Autopress, Birmingham." Telephone: 2970 and 2971 Midland.

MANCHESTER: 260, Deansgate.

Telegrams: "Hife, Manchester." Telephone: 8970 City (4 lines).

GLASGOW: 101, St. Vincent Street, C.2.

Telegrams: "Hife, Glasgow." Telephone: Central 4857.

PUBLISHED WEEKLY.

Subscription Rates: Home, 17s. 4d.; Canada, 17s. 4d.;
other countries abroad, 19s. 6d. per annum.

Entered as Second Class Matter at New York, N.Y.

As many of the circuits and apparatus described in these pages are covered by patents, readers are advised, before making use of them, to satisfy themselves that they would not be infringing patents.

CONTENTS OF THIS ISSUE.

| | PAGE |
|--|------|
| EDITORIAL | 633 |
| ALL ELECTRIC AMPLIFIER. BY A. P. CASTELLAIN | 634 |
| IS THE PRAGUE PLAN SOUND? BY J. GODCHAUX ABRAHAMS | 638 |
| KIT CONSTRUCTORS' NOTES. MCMICHAEL SCREENED THREE | 641 |
| DANISH BROADCASTING. BY P. O. LANGBALLE | 643 |
| CURRENT TOPICS | 645 |
| NEW APPARATUS REVIEWED | 647 |
| SMALL MAINS TRANSFORMERS (CONCLUDED). BY T. W. RIDGE | 649 |
| BROADCAST BREVITIES | 653 |
| VALVES WE HAVE TESTED. THE OCTRON SERIES | 655 |
| LETTERS TO THE EDITOR | 656 |
| READERS' PROBLEMS | 659 |

AMATEUR STATUS IN BRITAIN.

WE have often asked ourselves why it is that in this "free" country the wireless amateur who takes an interest in transmitting as a hobby has been consistently and persistently suppressed by the authorities, whilst in other countries—notably in America—the State does all in its power to encourage the amateur and help him to be efficient as well as useful in his hobby.

When war broke out in 1914 the amateurs of this country provided a very important nucleus of trained men with a practical knowledge of wireless apparatus, and their usefulness to the country has never been denied. After the war was over it was only with the utmost difficulty, and after prolonged effort on the part of the radio societies, that facilities were renewed by the Post Office so that amateurs could again become the owners of transmitting sets, but as the number of amateurs grew it would seem that the Post Office regretted having granted facilities, for new regulations have been imposed upon the amateur so cumbersome

and so exacting as almost to preclude the possibility of any but thoroughly experienced or extremely enthusiastic transmitters to retain their licences.

Now let us see by comparison what is the attitude of the State towards amateur activities in America. In the United States there has existed since 1925 an army-amateur radio organisation described as "The Affiliation of the Signal Corps and the Transmitting Radio Amateurs of the United States." The first section of the official terms of the affiliation is so striking as to be worth quoting in full. It reads as follows:—

1. The Signal Corps desires to co-operate with the transmitting radio amateurs throughout the country for the following purposes:—

(a) To provide additional channels of communication throughout the continental limits of the United States that can, in time of emergency, be used to augment or replace the land lines, both telephone and telegraph, that may be seriously damaged or destroyed by flood, fire, tornado, earthquake, ice, riots or insurrections.

(b) To place at the disposal of military commanders of all components of the Army of the United States and of the Red Cross such amateur radio channels of communication as may be developed under this plan.

(c) To provide civilian radio operators with a knowledge of Army methods of radio procedure and of the basic principles of using radio in the field.

(d) To establish contact with a considerable number of civilian radio operators, acquainting them with the Signal Corps and its activities, and securing their aid in experimental work, tests, etc.

(e) To render such encouragement and assistance as may be desirable to firmly establish and perpetuate the American amateur.

The American Government would not, we think, go to this trouble unless it was realised that it was well worth while to do so. If such an organisation is of value there it must surely be equally applicable in our own country or extend to the Empire. There are only, as far as we can see, two objections to the encouragement of the amateur here. They are, first, that the Post Office holds a monopoly for communication in this country and might suspect amateurs of utilising their transmitters to avoid paying for telegrams, and, secondly, because it might be argued that the extension of facilities to amateurs would tend to increase the ether congestion.

There would seem to be a satisfactory reply to both of these objections. In the first place, suitable controlling regulations can easily be formulated, and secondly, America has demonstrated that there is still plenty of room for small power transmitters on the short wavelengths without any serious reason to anticipate congestion.

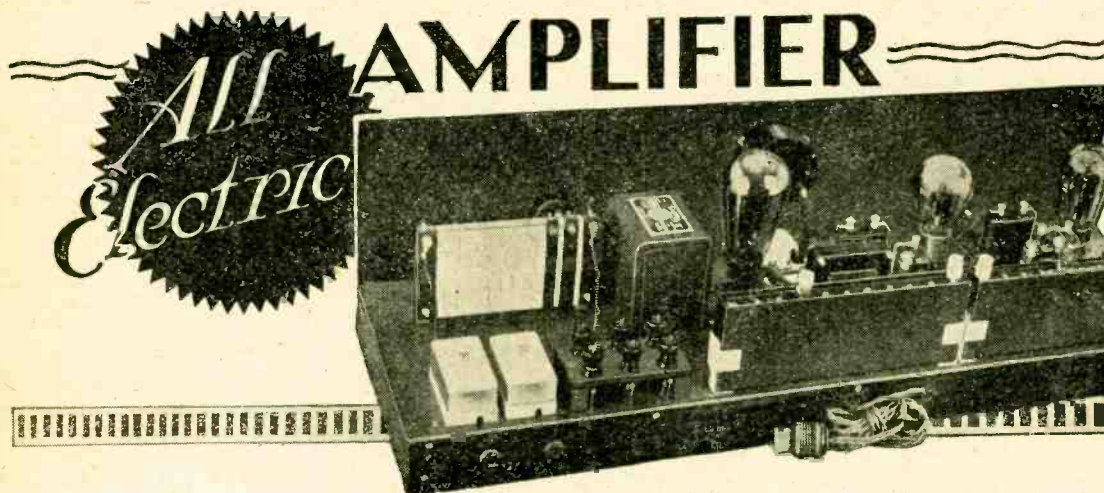

High Quality Reproduction of Gramophone Records.

By A. P. CASTELLAIN, B.Sc., A.C.G.I., D.I.C.

ONE of two broad principles can be followed in designing electrical apparatus for the reproduction of speech and music, whether these are of the "live" variety (radio or public address) or the "canned" (talking films or the gramophone). The first consists in trying to make each essential unit of the complete system as perfect as possible, so that the whole shall be good; while the second consists in making the units complementary to each other, so that deficiencies in one may be compensated for in the others, and vice versa. Which course should we follow?

Consider the case of the electrical reproduction of speech and music from gramophone records. There are three essential units: (a) a mechanical-electrical converter, usually known as the pick-up; (b) an elec-

avoidable defects. For example, if the best pick-up available has a marked resonance in the range required for reproduction, this would be corrected by a suitable filter incorporated with the pick-up circuit, though, of course, it is the aim eventually to produce a pick-up which in itself is perfect (i.e., which has no resonances and behaves as a resistance only, both electrically and mechanically).

On the second principle, the pick-up, amplifier and loud speaker would be so chosen and designed that deficiencies or resonances in one or more were compensated by the reverse in the remainder.

The writer prefers to follow the first principle, even though it may involve the use of more apparatus with electrical-acoustic and mechanical-electrical devices as they are at present, because each unit is complete in itself, and may be dealt with separately, whereas in the second case changes in any one may involve changes in some or all of the others.

D.C. Mains, A.C. or Battery-operated.

Before it is possible to consider the design of an amplifier, it is necessary to know what are the terminal conditions, i.e., what is the maximum input voltage and the input impedance, and also what is the impedance of the loud speaker, and what volume of undistorted output is required. Further, the supply voltages and the range of valves available must be known. The amplifier to be considered is intended to be operated from D.C. mains or from batteries, and is arranged so that, with fairly simple modifications, it may be run from A.C. mains with a suitable eliminator.

If the amplifier is used on D.C. mains, with the filaments also supplied from the mains, the choice of valves for the last stage is rather limited unless excessive power consumption is not objected to. Valves handling the necessary power for our present purpose on 200-240 volts may be found in the 0.25 ampere filament class, such as the P625, P625A and PV625X valves, and this filament consumption means a wattage

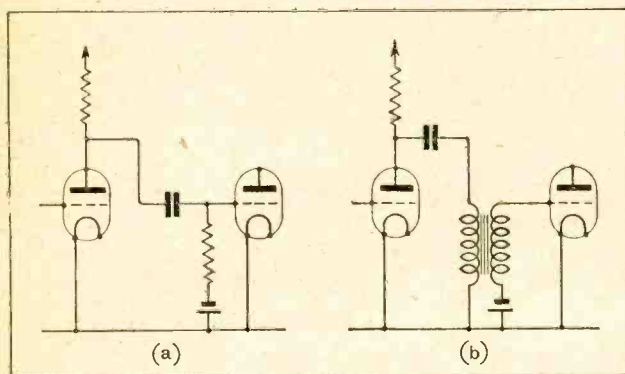

Fig. 1.—The conventional circuit used with resistance-capacity coupling is shown in (a). With high-efficiency Mu-metal intervalve transformers it may be advantageous to filter away the D.C. component to prevent reduction of primary inductance as in (b).

trical amplifier; and (c) an electrical-acoustic converter or loud speaker. On the first principle, each unit—the pick-up, the amplifier and the loud speaker—will be made as perfect as possible, with incorporated corrective devices where necessary to deal with un-

All Electric Amplifier.—

of 50 to 60 for the filament supply alone. However, 60 or 70 watts total cannot really be considered excessive for a mains supply.

Three stages are used in this amplifier in order to obtain really good overall characteristics. Two stages only might have been used, but, as will be seen, a rather greater number of components would have to be used in order to obtain the same gain, while the overall characteristic would not be quite so good.

The main sources of loss varying with frequency in an amplifier are (1) the input coupling from pick-up, (2) the intervalve couplings and (3) the output coupling to the loud speaker. In general, the main source of this loss will be in the output coupling, and invariably arises owing to a question of cost and size of components: The input and output couplings will be dealt with separately, so that the above statement must suffice for the moment.

The Valve's Input Impedance.

It is advisable, therefore, to use such intervalve couplings that the loss both at the very low frequencies and at the very high audio frequencies is really negligibly small, and, now that modern high mutual conductance valves are available, resistance capacity coupling becomes very suitable. Intervalve couplings have been dealt with many times in the pages of *The Wireless World*—especially resistance coupling—so that only a brief outline of the sources of loss will be given.

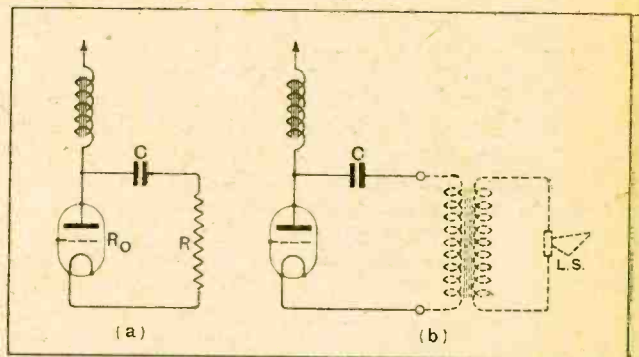
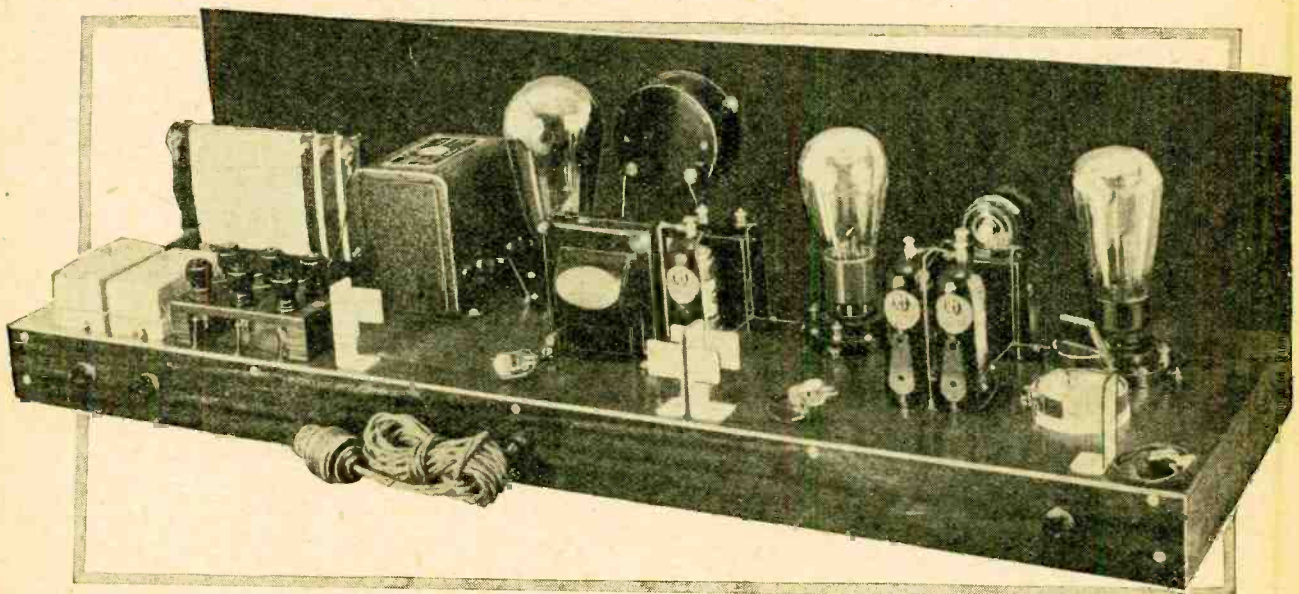

Fig. 2.—The equivalent output circuit (a). The A.C. resistance of the valve is represented by R_0 , while R is the loud speaker considered as a pure resistive impedance.

on the second grid) on to a grid leak, and it is the A.C. voltage developed across the latter which is the actual voltage passed on. The capacity of the coupling condenser must be sufficiently high so that its impedance is small compared with the resistance of the grid leak at the lowest frequency required to be transmitted (30 cycles)—thus the higher the value of grid leak the smaller the condenser required.

At high audio frequencies, however, there is another source of loss—due this time to the following valve. This valve, having a resistive (or inductive) impedance in its plate circuit, will have quite a large capacitive input impedance—especially if it has a high amplifica-



Rear view of the amplifier (without grid batteries). The 960-ohm tapped resistance can be seen on the left.

These losses may be dealt with in two parts, (1) those at very low frequency, (2) those at very high audio frequency, since they are due to separate causes.

With resistance (or choke) capacity coupling the A.C. voltage developed across the resistance in the plate circuit of one valve is passed on to the next valve through a coupling condenser (to stop D.C. potentials

tion factor, i.e., there will be an appreciable capacity between grid and filament, which will limit the maximum value of the grid leak that may be used, while still obtaining a negligible change of amplification at 10,000 cycles due to this input capacity. Partly for this reason the writer prefers to use a grid leak of not more than 0.5 megohm with ordinary valves with ampli-

All Electric Amplifier.—

fication factors up to about 15, and not more than 0.25 megohm for high amplification valves. The coupling condensers should then be at least 0.05 mfd, and 0.1 mfd. respectively if several stages are being used, the loss per stage at 30 cycles being very small indeed for 0.5 megohm-0.05 mfd. coupling. The amplifier here described has 0.5 megohm-0.1 mfd. coupling.

The resistance in the plate circuit of the previous valve should be fairly low compared with the following grid leak so that loss at the higher frequencies may be completely ignored—and in these days of valves with a high mutual conductance this is easily catered for.

Using transformer coupling, on the other hand, it is desirable to use valves of low impedance to obtain small losses at the lower frequencies, but it is unfortunate that such valves naturally have quite large, steady plate currents which, if allowed to flow direct through the primary of the transformer, will effectively reduce its inductance (especially in the case of the modern small

are likely to be serious changes in amplification at the higher audio frequencies.

Transformers made by first-class manufacturers are fairly satisfactory when so used, but, although more gain per stage is possible, the extra gain does not equal that obtained by one extra stage of resistance coupling.

When considering the input conditions it may be objected that the input impedance of the amplifier has been left rather indeterminate. Unfortunately this is unavoidable in a general specification, since there is *no transformer on the market* which may be loaded with a resistance on the secondary side of, say, 0.25 megohm or less so as to determine the primary impedance definitely, which then has good overall characteristics.

Output Coupling.

It has been mentioned before that the output coupling to the loud speaker forms the greatest source of loss at the low frequencies in the whole amplifier. Here choke-capacity coupling is used, the choke having low D.C.

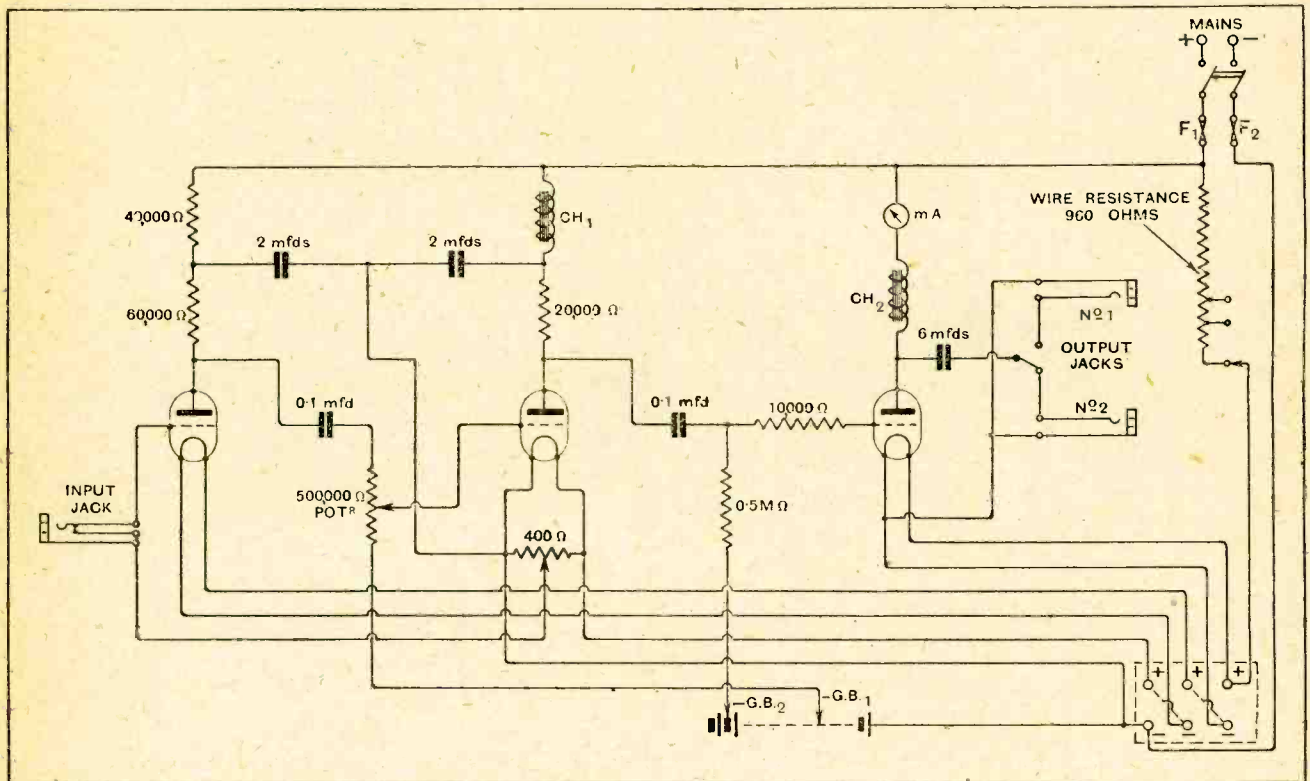

Fig. 3.—The circuit diagram of the complete amplifier. Note the comprehensive anode decoupling scheme.

high-efficiency "Mu-metal" transformer) and thus introduce serious losses at the very low frequencies. What might be done here, of course, is to filter out the D.C. from the transformer primary by using a choke or resistance capacity coupling to the transformer, as shown in Fig. 1 (b). In Fig. 1 (a) is shown normal resistance coupling. A further point with transformer coupling is that the secondary of the transformer must be correctly designed to work with a capacitive load corresponding to the input capacity of the valve it is feeding, or there

resistance and thus permitting the mean plate potential of the last valve to be very nearly equal to the supply voltage. In Fig. 2 (a) is shown the equivalent output circuit, where R_0 represents the A.C. resistance of the valve, R the loud speaker impedance (considered as purely resistive) and C the coupling condenser. As in the case of intervalve couplings, the impedance of the condenser should be low compared with the following resistance R . Here R should be of the same order as R_0 , being, with the type of valve used, rather larger

All Electric Amplifier.—

than R_0 for maximum power output—in the amplifier considered it is taken as 3,000 ohms for a P625 valve or 2,000 ohms with a P625A valve.

Taking the first valve, the loss with 4 mfd. or the second with 6 mfd. will be about 10 per cent., which is very reasonable. The greater loss in the output circuit will generally be due to the output choke. This choke has to carry the heavy plate current of the last valve and still have enough henrys inductance to have an impedance large compared with R at 30 cycles. In the case considered about 40 henrys are required at 30 to 40 mA.

The speaker impedance has been taken as 3,000 or 2,000 ohms—actually it may be very different from this. In the case of a moving-coil speaker it may be, say, 30 ohms, so that a step-up transformer having an impedance ratio of $\frac{3,000}{30}$ or $\frac{2,000}{30}$ will be necessary. In general, a transformer having an impedance ratio of $\frac{3,000}{R_s}$

or $\frac{2,000}{R_s}$ will be required, according to the output valve used, where R_s is the speaker impedance. The transformer ratio that is usually given is the *voltage* or *turns* ratio, which is the square root of the impedance ratio. Thus, suppose $R=3,000$ ohms and $R_s=30$ ohms, the impedance ratio required is $\frac{3,000}{30} = 100$, and the

turns ratio will therefore be $\sqrt{100}=10$, i.e., a 10:1 transformer is required. In Fig. 2 (b) a choke-filtered output transformer is shown.

In any amplifier designed for speech reproduction it is essential (a) that no valve may be overloaded when the rated output power is being given, and (b) that when overloading does occur it *must* occur in the output stage first, and preferably well first. The first consideration calls for some form of volume control early in the amplifier, while the second means that the first and second valves must be so chosen that their undistorted voltage output will easily feed the following valve with some to spare.

A suitable form of volume control, which may be incorporated between the first two stages, consists of a 500,000-ohms potentiometer in place of the 0.5 megohm grid leak. It is unlikely that the first valve will be overloaded by the pick-up.

A Comprehensive Decoupling Scheme.

The circuit of the complete amplifier is given in Fig. 3. Plate circuit filters have been provided in stages 1 and 2, both for hum elimination when D.C. mains are used, and for stabilising (decoupling) purposes. It will be noticed that a 10,000-ohms resistance is put in series with the grid of the last valve—this is to stop

any possible chance of this valve oscillating at radio frequency, which may occur with a valve of very high mutual conductance.

A change-over switch has been provided on the output for comparing loud speakers. It must be confessed, however, that this was only incorporated in the first place so as to get a good symmetrical layout on the panel, although it is useful for comparison and is not merely ornamental. The overall characteristic of the amplifier is shown in Fig. 4, and, as will be seen, it

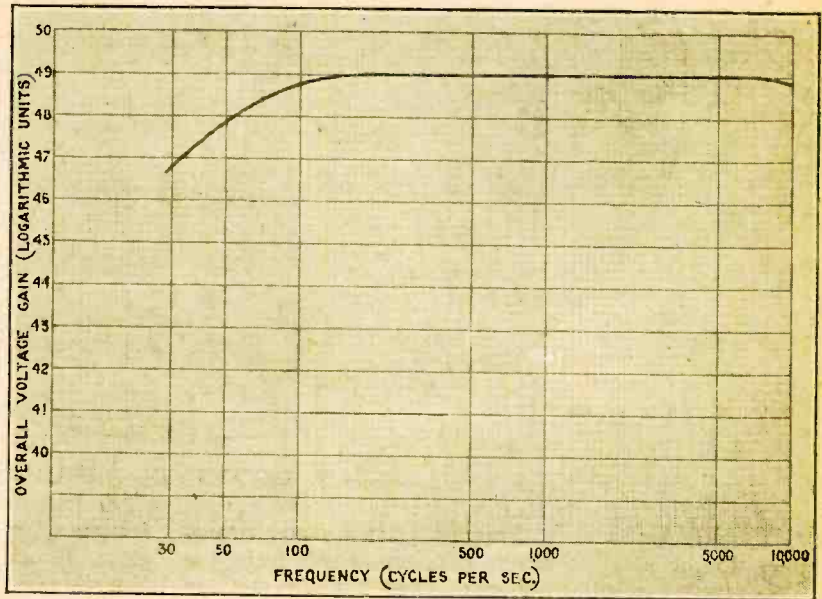

Fig. 4.—The overall characteristic of the amplifier with 2000-ohm input and output impedances. Logarithmic units are used.

is extremely good over the whole audio-frequency range of 30 to 10,000 cycles.

(To be concluded.)

o o o o

USEFUL DATA CHARTS.

“A First Course in Nomography.”

THE next in the series of useful data charts which has been appearing in *The Wireless World* will deal with the subject of “The Design of Non-Cored Chokes Carrying D.C.”

Since we commenced the publication of this series of Useful Data Charts a number of our readers have written to us asking for information on how such charts are compiled, but we have had to reply that it would not be possible to devote the space in *The Wireless World* which would be necessary to give in detail the principles of nomography.

For the benefit, however, of those who wish to make a further study of the subject, we think it may be helpful to mention that “A First Course in Nomography,” by S. Brodetsky, published by Messrs. G. Bell & Sons, Ltd., at 10s., will be found a very useful introduction to the whole subject.

Is the Prague Plan Sound?



A general view of Prague.

Photo: Czechoslovak Travel Bureau.

By J. GODCHAUX ABRAHAMS.

GENEVA, Brussels, Prague! Are we any nearer to the solution of the problem which faces the ever-growing number of broadcasting stations in Europe? Will the present Prague plan, timed to come into operation on June 30th, sweep away the innumerable difficulties with which the *Union Internationale de Radiophonie* at Geneva has had to contend during the past three years?

The *Plan de Genève* and the subsequent *Plan de Bruxelles*, which was established with a view to a correction of errors made by its predecessor, were tentatively put forward by the European Broadcasting Union at Geneva; but the new plan has assumed a more official nature, being based mainly on decisions taken by the Governments of the world at the 1928 Washington Conference, and at a subsequent general discussion at Prague.

On January 13th, 1929, European listeners were unpleasantly surprised by the putting into operation of the *Plan de Bruxelles*, and the only consolation offered to them was the promise that a further conference would take place later in the year, when, acting on the experience gained in the interval, measures would be taken to end the chaos in the ether.

In the list of countries represented at the Prague Con-

ference (April 4th-13th) we find Egypt, Belgium, Bulgaria, Denmark, Germany, Esthonia, Finland, France, Greece, Great Britain, Holland, Irish Free State, Iceland, Italy, Jugo-Slavia, Latvia, Norway, Austria, Palestine, Poland, Roumania, Sweden, Switzerland, Soviet Russia, Spain, Czecho-Slovakia, Turkey and Hungary, all interested in established or prospective broadcasting systems. To these were added representatives of public and other wireless services, including

Compagnie Générale de T.S.F. (Paris), Compagnie Radio France (Paris), International Telephone and Telegraph Corporation, Italo Radio (Milan), Marconi Wireless Telegraph Company (London), Radio Austria (Vienna), Sté. Radio Suisse (Berne), Transradio (Berlin), and the League of Nations (Geneva). Moreover, the International Committee of Aerial Navigation,

the Netherlands-Indies Telegraph Administration, and the United States of America also took part in the discussions.

That the decisions taken at the Washington Conference were drastic ones is indicated by a remark passed by one of the German delegates at Prague: "We are trying to cook the soup which Washington has so liberally spiced, and it does not taste good!"

No comparison could be drawn between conditions

What many authorities are beginning to recognise as a serious flaw in all existing plans for reducing interference in the European ether is the absence of any provision for the adequate "spacing" of high power stations. The Plan de Prague, which comes into operation on Sunday week, June 30th, allots wavelengths not to stations, but to countries, each country being free to distribute its particular group of wavelengths regardless of the arrangements of its neighbour. The author contends that a central authority should be empowered to allot frequencies to individual stations having regard to the scheme as a whole.

Is the Prague Plan Sound?—

in Europe and those governing North America, for while, in the latter case, one land and one language had to be dealt with, in the former it was necessary to deal with some thirty separate countries, possessing almost as many tongues, and all imbued with the laudable ambition of running a number of broadcasting transmitters which should include in each case at least one high power station capable of disseminating its "kultur" over the entire Continent.

Recalcitrant Countries.

At previous conferences it had been found impossible to discover a happy solution, inasmuch as some countries, including France, Holland and Russia, would not abide by the wishes expressed by the general assembly. At the Prague Convention, apart from other serious problems appertaining to the wireless services of nations, the members were called upon to legislate on the allocation of wavelengths as well as to broadcasting as a whole, and although individual claims in some cases were upheld, the measures adopted were planned to benefit these services in general; the success of a carefully worked out scheme could not be endangered by altering it in parts to suit the desires of any nation in particular. The plan had its limitations, for broadcasting was to be permitted in certain zones only of the frequency band, and between the boundaries of these frontiers it was necessary to make provision for an almost incalculable number of transmitters.

It is understandable, therefore, why, in some individual cases, unfairness has been pleaded against the allocators, and that as a result in some European States considerable antagonism has arisen against what would appear to have been the preferential treatment of more favoured countries.

What concerns us solely to-day is the fate of the European broadcasting stations which are called upon to accept decisions taken at Washington, and a study of the plan which sets out the allocated wavelengths will show the difficulties which beset the scheme.¹

Now, what are the limits of the total broadcast telephony wave band? From 110-160 kilocycles, or 2,725-1,875 metres, the ether is fully booked with mobile

telegraphy services, one broadcaster only being found in that region, namely, Kovno on 2,000 metres. As interference is caused to a British Government station there is a possibility of this transmitter working on 1,935 metres (155 kc.), but it is still in a forbidden portion of the band. 1,875 metres (160 kc.) to 1,340 metres (224 kc.) was originally destined to aerial navigation services, but as these use mainly 1,500 metres (200 kc.) and 1,400 metres (214.3 kc.) a slight alteration to 1,471 metres (204 kc.) and 1,382 metres (217 kc.) would still permit the entry of a number of broadcasters. In this range, 1,875 metres (160 kc.) to 1,340 metres (224 kc.), we therefore find Huizen, Lahti, Radio-Paris, Königswusterhausen, Daventry 5XX, Moscow Komintern, Eiffel Tower, Warsaw, Motala and Kharkov. Note, however, that, with perhaps the exception of Huizen, all these transmitters are broadcasting on high power, and that, with the exception of Daventry and Königswusterhausen, their separation is under 9 kilocycles.

The zone 1,340 metres to 1,200 metres (224-250 kc.) is exclusively reserved to the flying services, but here we find Kharkov (1,304 metres), Stamboul and Reykjavik (1,200 metres). In the band 1,200-1,050 metres (250-285 kc.), although no room could be found, Kalundborg (1,153 metres) and Norway had to be housed.

Although the section 1,050-950 metres (285-315 kc.) was never intended for broadcasting, many positions have been usurped, e.g., Lenin-grad on 1,000 metres (300 kc.) and Basle, 1,010 metres (297.1 kc.). Between 950 and 850 metres (315-350 kc.) the Soviets have placed a 75-kilowatt transmitter actually working on 925 metres (324.5 kc.). Up to the present 850-830 metres (350-360 kc.) had

been barred to broadcasters, but Rostov (Don) works on 848 metres (354 kc.). The section 830-770 metres (360-390 kc.) is reserved to direction-finding stations. Here we find Moscow on 825 metres (364 kc.); Geneva and Lausanne respectively on 760 metres (395 kc.) and 680 metres (461 kc.), which, provisionally, are to remain as they are.

Trespassing.

Again, 650-545 metres (460-550 kc.) is reserved to mobile radio services, but smaller stations have been allowed within its boundaries. Buda-Pest, however, has been called upon to reduce its wavelength to 550 metres (545 kc.) to prevent interference.

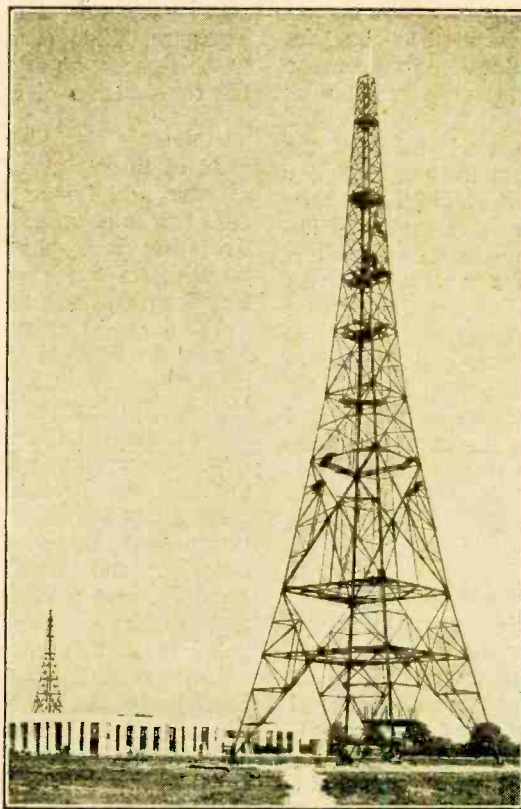

HIGH POWER BROADCASTING. A new view of the London Regional station at Brookman's Park, which will begin occasional transmissions on 356 metres at the end of July, and finally supersede the existing 2LO.

¹ See *The Wireless World*, April 24th, 1929.

Is the Prague Plan Sound?—

Now, the actual broadcasting band, viz., 550 metres (545 kc.) to 200 metres (1,500 kc.) contains one hundred and seven exclusive wavelengths, ten common waves, one to be shared by Monaco, Nice and Corsica, and one (200 metres) which is free to any applicant. If we look at a detailed list of recognised and unofficial broadcasting stations—of the latter there are many in France—we find that this band must contain some *one hundred and seventy* different transmitters, either in operation, in course of establishment, or in perspective. This number *does not take into account* either the Russian transmitters or those erected in Algeria, Tunisia or Morocco. Roughly speaking, throughout the scale there exists a uniform separation of 9 kilocycles, although on the lower part of the waveband an extra kilocycle has been found possible.

These various wavelengths were allotted to countries and not to transmitters; the final allocations were made to the individual stations by the respective national or other broadcasting associations.

Herein, it would appear, lies a weak point of the scheme, for, in view of the fact that the power of the individual stations varies greatly, it would have been wiser to leave the allotment of the wavelengths to the separate stations in the hands of a central committee, which would be in a better position to view the plan as a whole. By individual allocation on the part of the countries the question of power cannot be taken into consideration to the same degree, and the share-out which may suit one country may not, in view of the divergent power of the transmitters, work in well with the general plan. The separation of 9 kilocycles must be a minimum one, and the close proximity of, say, two 10-kilowatt stations largely destroys the possibility of their transmissions being clearly received in any but their own immediate districts.

The Thirst for Distance.

It might be pointed out that if the Prague plan will even achieve this result it must be considered successful; possibly, but apart from the B.B.C. stations, whose sole aim would appear to be that of assuring a local service, it must be borne in mind that most of the foreign broadcasters are anxious that their entertainments should be well heard by listeners in neighbouring and even more distant countries. If this were not the case we should not observe the ardent desire shown by certain foreign States to possess super-power transmitters, whereas stations of a lesser energy would adequately satisfy the wants of their radio population.

Most certainly, if a careful study of the *Plan de Prague* be made, the grievances expressed by some countries appear to be justified.

Belgium, a country whose area can be compared with that of Yorkshire, has been given three exclusive wavelengths, viz., 509 metres (590 kc.), 339 metres (887 kc.), and 208 metres (1,440 kc.), as she has successfully put forward the plea that she must broadcast not only in French and Flemish, but also in German, the latter language being required for districts conceded to her on her eastern frontier at the end of the War.

On the other hand, France, which lags far behind most other European countries in the matter of broadcasting, has been allotted *sixteen* wavelengths, whereas Germany and Great Britain, which have done most of the pioneering work, have received only fifteen and ten respectively. France, according to the most optimistic statisticians, does not boast of more than one million listeners! (Unfortunately for the private interests, the French Posts and Telegraphs have commandeered most of these allotments.) France at present possesses the following stations:—Alpes-Grenoble, Lyons PTT, Marseilles PTT, Nice-Juan-les-Pins, Paris PTT (École Supérieure), Petit Parisien, Radio Agen, Radio Beziers, Bordeaux-Lafayette, Limoges PTT, Montpellier PTT, Radio LL (Paris), Radio Lyons, Nimes, Normandie, Radio Paris, Lille PTT, Rennes PTT, Bordeaux-Sud-Ouest, Radio Toulouse, Vitus (Paris), Toulouse PTT, Eiffel Tower, to which must be added Rheims PTT, Strasbourg PTT, the construction of which is contemplated.

Trouble Brewing.

As of these sixteen wavelengths the French Ministry of Posts and Telegraphs retains the bulk and only parts with two to private transmitters (Radio Paris and Radio Toulouse) it would appear that some seven private transmitters will be called upon to share the common wavelength of 220 metres!

What will be the result? Experience shows that the French private broadcasters have had few scruples regarding any interference they may cause to neighbouring "friendlies" and have, in the past, adopted the positions in the ether which have suited them best. Regarding their future policy, it may be pointed out that the French State has passed a new broadcasting law which, contemplating the placing of most transmitters under its sole control, regularises the situation and should bring order out of chaos. Possibly, and possibly not, for it is not the first time that ineffective radio legislation has been promulgated in that country.

In the meantime—for much water may flow under the Seine bridges before the law can be brought into effect—the despoiled stations will merrily rove up and down an already congested waveband in their efforts to squeeze themselves in somewhere, and these nightly wanderings are likely to upset the entire scheme.

Are There Too Many Stations?

The Prague plan must surely be a provisional measure only, subject to further amendments and alterations at a subsequent conference. But June 30th and the following week will show whether an improvement or not has been achieved, and we must wait until that date before a final verdict can be passed on the failure or success of the scheme.

From opinions already freely expressed in Continental countries, this constant juggling with the wavelengths must prove but an inefficient remedy, and the only practical way out is a drastic reduction in the number of broadcast transmitters operated by each European State. This conclusion will be arrived at after a few more conferences. The question is, How many?

KIT CONSTRUCTORS' NOTES

The McMichael Home Constructors' Screened Three.

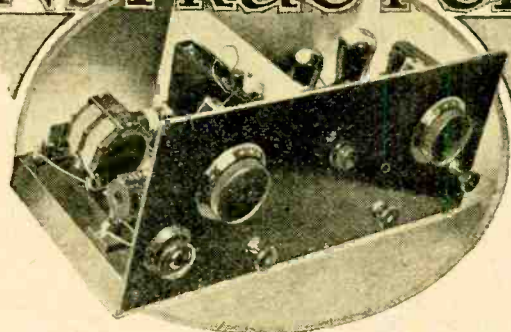

It is a mistake to assume that a three-valve set with a pentode output should be directly comparable with receivers having the same number of ordinary valves. On account of the high magnification obtainable from the five-electrode valve it should be more closely akin, in the matter of performance, to a standard four-valve combination with H.F. amplifier, detector, and two low-frequency stages. If the circuits are properly designed the resulting receiver will certainly be less prone to L.F. reaction troubles than in cases where the detector is followed by two triodes; this is often considered to be one of the greatest advantages of the pentode. For the Screened Three use of this valve is optional, although it seems to be generally preferred; it may be substituted for an ordinary triode (which is shown in the accompanying diagram) in a few moments.

The McMichael firm can fairly claim to be pioneers of the popular type of receiver having a screen-grid H.F.

valve followed by a detector and pentode: the "Screened Dimic Three," a complete manufactured set to this specification, was described in these pages nearly a year ago. The subject of this article is basically similar, and may be regarded more or less as an adaptation of it for the home

constructor. Its circuit arrangement, given in Fig. 1, is fairly conventional; the aerial is coupled to the centre point of a medium-wave input coil through a small fixed condenser, and a long-wave loading coil is thrown in or out of circuit by means of a single-pole "shorting" switch. The three circuits associated with the S.G. valve—grid, screening grid, and plate—are all tied down to earth by means of large by-pass condensers.

"Tuned grid" H.F. coupling is used, and consequently anode current is fed through a choke across which H.F. voltages are set up and impressed on the tuned circuit through a blocking condenser. Wave-range switching is so arranged that the well-known "Dimic" coils serve the purpose both of tuning inductances and reaction coil. Referring to the diagram, L_2a and L_2b represent the two sections of the medium-wave coil; for long-wave reception the winding L_3 is

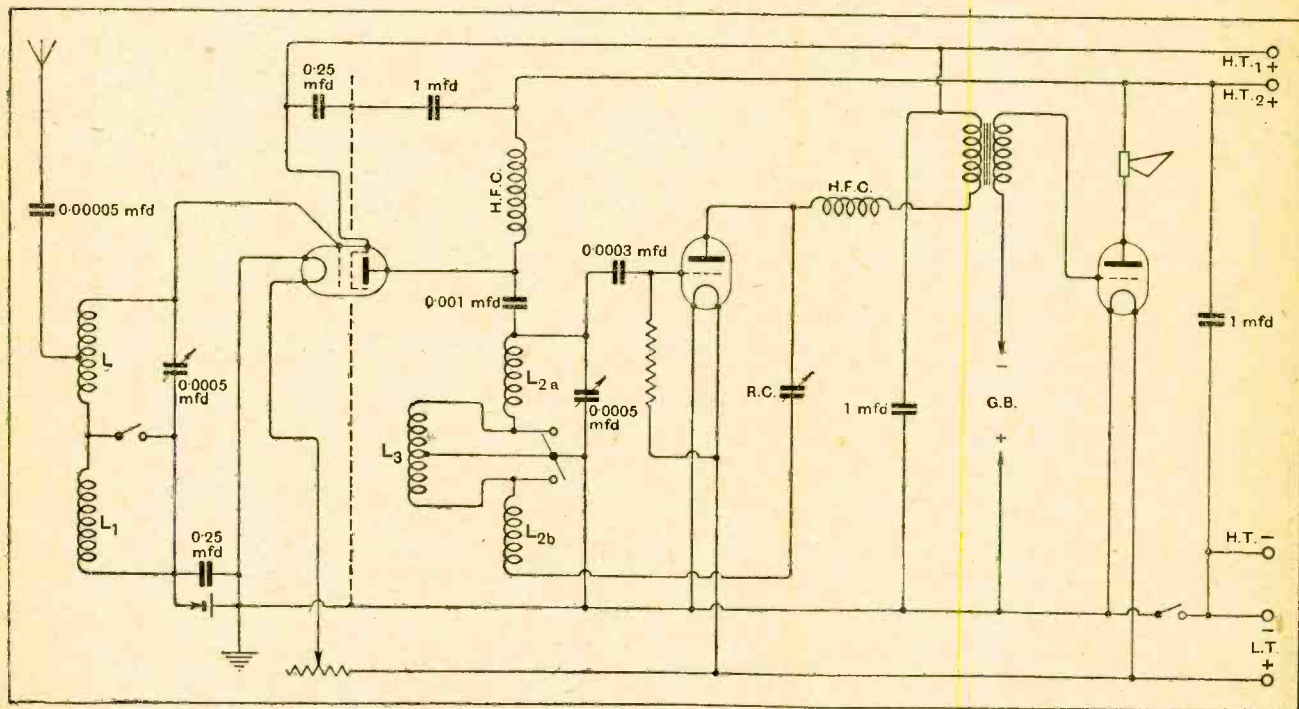

Fig. 1.—Circuit diagram of the receiver, simplified by omission of pick-up connections, which are explained in the text.

Kit Constructors' Notes.—

inserted at the centre point, and is completely short-circuited when not in use. It will be observed that the tuning condenser is connected across one-half of the windings—or across half of both windings in series for long-wave reception—and that the remaining sections serve merely as reaction coils. In consequence, the total inductance for a given wave-band must be considerably greater than when Dimic coils are used in more conventional ways, as, for instance, in the grid

this adjustment is made must be kept near its minimum setting on account of the large inductance of the medium- and long-wave reaction coils.

It will be seen that the on-off battery switch is inserted in the common H.T.-L.T. negative lead; this form of connection, although not unusual in "Kit" sets, is open to criticism, as it engenders a false sense of security in the mind of the user, who may imagine that both batteries are disconnected when the switch is "off." Actually, the negative H.T. lead will still be joined to the filament bus bar (positive side) through the L.T. cells, and a high-tension short-circuit to, say, the metal screen may be responsible for burning out all the valves.

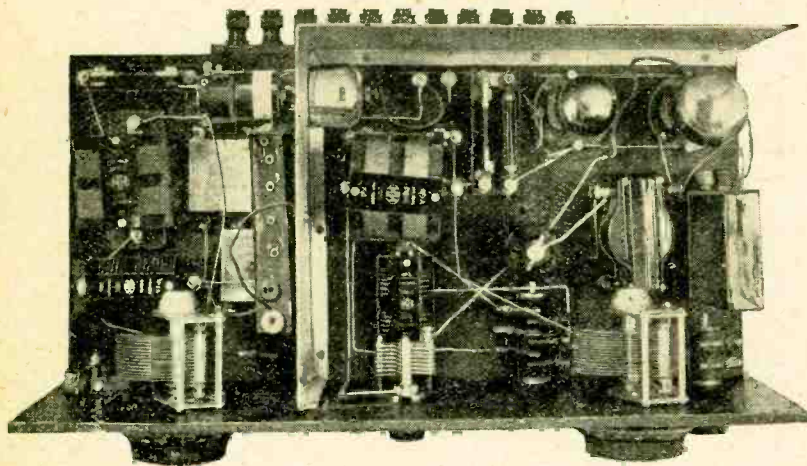

Fig. 2.—Plan view showing back screen and horizontal mounting of H.F. valve.

KIT CONSTRUCTORS' PROBLEMS.

The Information Department Service has been extended to deal with problems encountered by builders of "kit" sets discussed in these pages. Receivers already treated are the "New Cossor Melody Maker," Osram "Music Magnet," Mullard "Master Three Star," Six-Sixty "Mystery Receiver," Ferranti "Screened Grid Three," Formo "Screened Grid Three," and the Dubilier "Toreador Screened Grid Four." The service is subject to the rules printed in the "Readers' Problems" section.

Grid Leak Failure.

A fault seems to have developed in my "Cossor Melody Maker" ; signals are fairly good as long as the reaction condenser is set at minimum, but when I attempt to increase sensitivity music and speech are heard in waves of varying intensity. Can you suggest what is wrong?

F. P. R.

It appears likely that the grid leak for your detector valve has developed a fault, or possibly it may be making imperfect contact with its holder, with the consequence that charges accumulated on the grid condenser cannot leak away. The remedy is obvious.

o o o o

Loud Speaker Connections.

I have a Marconiphone moving coil loud speaker, which, as you will know, has a built-in transformer for connection to the output terminals of the set. As I am thinking of building a Ferranti Screened Grid Three, will you tell me if the set should be modified in any way to make it suitable for operating with this loud speaker?

F. G.

Your best plan is to omit the specified output transformer and one of the output terminals. The remaining pair should be joined, internally, to the anod- of the last valve and to H.T.+, and externally to the loud speaker input terminals.

o o o o

Follow the Specification.

I am thinking of building the Osram "Music Magnet" described in your issue of February 20th. To simplify construction I propose to use a metal panel with a wooden baseboard, and also to include the components detailed on the enclosed list if you consider that it is permissible to do so.

S. T. D.

As a general rule there is little need to adhere slavishly to a specification, except in special cases where the ill-effects of using components other than those recommended will be fairly obvious. But the set in question is of a highly specialised design, and, most important of all, it includes "gang" control of its two tuning adjustments; it is therefore almost essential that components having exactly the same characteristics as those specified should be used. Substitution of a wooden baseboard would tend to impair screening.

circuit of the present receiver; suitable inductances are specified in the makers' pamphlet of instructions, which, by the way, are both complete and lucid.

Provision for use of a gramophone pick-up—a matter of some little difficulty when it is to be connected to a valve normally acting as a grid detector—is made in an unusual but nevertheless perfectly effective and very simple manner, two terminals being joined respectively to the negative side of the H.F. bias cell and to the detector grid.

Short-wave Possibilities.

Another attractive "extra" is the adaptability of the set for ultra short-wave reception, which is attained simply by inserting suitable Dimic coils in the holders provided for the medium-wave inductances. Although there is no evidence of any great amount of pure high-frequency amplification on the very high frequencies, the performance of the set on this band is very satisfactory. On normal broadcasting wavelengths it is fair to say that both selectivity and sensitivity are rather above the average standard of receivers of this class, and one is at once attracted by its complete stability. It seems that the very small capacity chosen for the aerial feed condenser is responsible for some reduction in voltage input to the H.F. grid circuit, and in situations where local interference is not a serious problem it is worth while trying a somewhat larger capacity; experiments in this direction are facilitated by the use of McMichael clip-in condensers.

Reaction control is smooth and is certainly more constant than usual, although the small condenser by which

DANISH BROADCASTING

A Story of Amateur Effort.

By P. O. LANGBALLE.

IF we judge by the proportion of licensed listeners to the total population, Denmark has made a greater success of broadcasting than any other country in the world; and it is a significant point that the present system in Denmark owed its inception and early growth almost entirely to the work of wireless amateurs.

The natal cry was heard at the Government station Lyngby OXE, near Copenhagen, in 1922, when surprised listeners distinguished something like the scratching of an old gramophone. However, the music (*sic*) was not intended for their benefit, all private reception being strictly forbidden; the tests were conducted simply with a view to the establishment of a wireless telephone service between the mainland and the island of Bornholm, using a Poulsen arc C.W. transmitter.

Overcoming Amateur Restrictions.

A regular service being established, it was soon found that private reception could no longer be suppressed. A provisional Bill was, therefore, passed by Parliament permitting general reception "until further notice," but private transmission was still strictly *verboten*, and this led to the formation of the Danish Radio Club, a body composed of wireless amateurs who were determined to secure the same privileges as were enjoyed by fellow-enthusiasts in other countries.

Meanwhile broadcasting abroad, especially in Great Britain, had developed to such an extent that the Lyngby plant soon became out of date. This gave the amateurs their chance. Lyngby was replaced by a modern valve transmitter at the military station at

Ryvangen, just outside Copenhagen, and, although the plant was supplied by the State, its operation and maintenance were entrusted to the Danish Radio Club. That the amateurs made hay while the sun shone is shown by the fact that the fame of Ryvangen spread to listeners throughout the country as well as in parts of Sweden. Having secured the confidence of the Government, the Club had no difficulty in obtaining permission to erect a really first-class broadcasting station in Copenhagen itself.

Once again the amateurs were privileged to operate the new station, funds being provided by the State and a few private subscribers. Extensive programme developments followed.

And then the inevitable happened. Reared so lovingly and on so sumptuous a scale, the child outgrew the resources of its parents. Hitherto many of the incidental expenses of broadcasting had been borne by private members of the Club, but it now became necessary to secure support from listeners. Accordingly

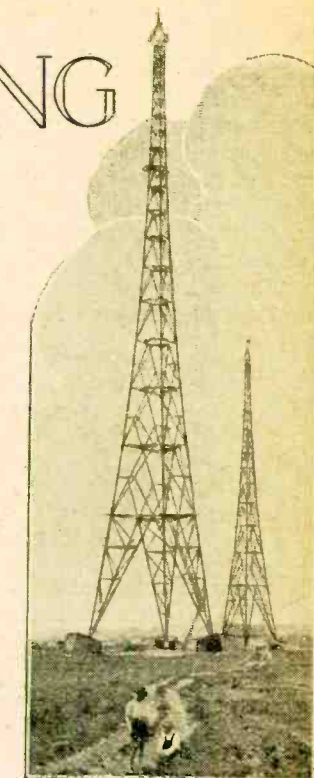

DENMARK'S "DAVENTRY," Kalundborg, which distributes the Copenhagen programmes.

the State assumed control, and a wireless Bill was passed whereby listeners were required to pay for their entertainment, valve owners being taxed 15 crowns per annum and crystal users 10 crowns. (All listeners are now taxed at the uniform rate of 10 crowns per annum.)

The demands of country listeners now led to the establishment of a relay service which must be regarded as unique in the history of broadcasting. Several passenger steamers between Copenhagen and Jutland were fitted with broadcast transmitters and

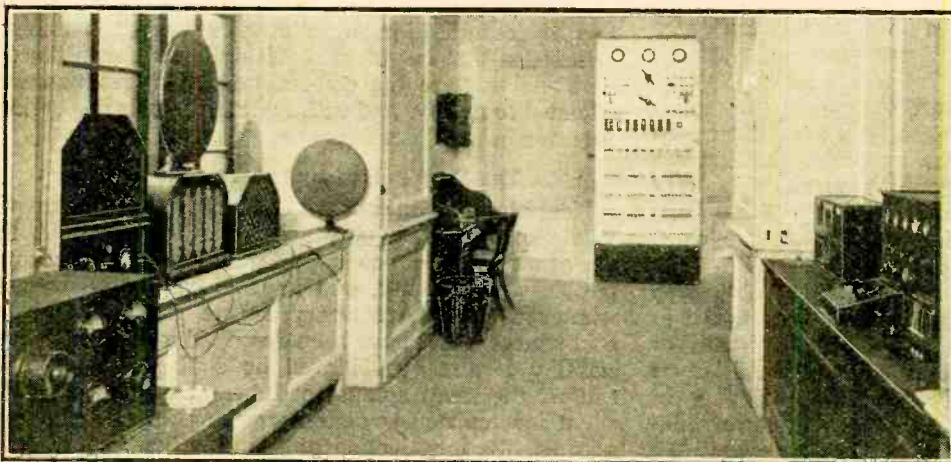

THE CONTROL ROOM at Axelborg, Copenhagen, through which the majority of Danish programmes are conducted. Note the array of loud speakers!

Danish Broadcasting.—

receivers; they became, in fact, floating relay stations, picking up the Copenhagen programmes by wireless link. Their range was necessarily limited, but the steamers played their part well until, in 1927, the broadcasting authorities came to the conclusion that "fewer stations, higher power" was the real solution to the problem of giving everyone a satisfactory service. It was, therefore, resolved to build a new high power station at Kalundborg on the western coast of Seeland.

Kalundborg is now recognised as one of the big stations of Europe. It is ideally situated in the centre

of Denmark, on an unscreened site surrounded by the sea and open country. British listeners will be interested to learn that, while the machines are mostly of Danish manufacture, the entire transmitting plant is a product of the Western Electric Company, London.

Although Danish broadcasting is framed on the lines of the British Broadcasting Corporation, the authorities at Copenhagen refuse to regard as their ultimate aim merely the satisfaction of listeners in Denmark. Broadcasting is deemed to be international in scope, and, for this reason, nothing gives greater pleasure at Copenhagen than the appreciation from listeners abroad.

WHY WE NEUTRALISE.

When Neutralisation Helps — and When It Hinders.

IF we wire up a tuned-anode circuit, and use for amplification an ordinary triode valve, it is found that the tendency towards oscillation, caused by the feed-back of amplified currents from plate to grid through the plate-grid capacity of the valve, its holder, and the associated wiring, makes it impossible to achieve any useful degree of amplification. In an endeavour to check oscillation we may introduce heavy damping into the grid-circuit by connecting a resistance in series or parallel with it, when there is no difficulty in allowing the valve to develop its full amplification. This gain, however, is completely offset by the low efficiency of the tuned circuit, so that while we have gained amplification we have now a far fainter signal to operate the receiver.

Valve Capacity Limits Amplification.

By careful adjustment of the damping we may arrange that the source of reaction mentioned just keeps the effective high-frequency resistance of the grid circuit at its original value. On one wavelength only this is a complete solution of the difficulty, but since the reaction effect varies from one wavelength to another, it is a solution satisfactory only where but one station is to be received, where grid, filament and plate voltages are all adjusted to a fraction of a volt, and where a valve is used that never alters its characteristics or grows old. It being awkward in most cases to fulfil these conditions a neutralised circuit, where the feed-back voltages are balanced out by the introduction of a special subsidiary circuit, has generally been preferred. By this means retro-action from plate to grid is completely removed.

If a screen-grid valve is used the position is a little different—but in degree only, not in kind. With such a valve the interelectrode capacity has been reduced to an extent which permits the use of tuned circuits of moderate damping, such as is found with multi-layer coils or astatically wound solenoids of fairly fine wire, in a similar tuned-anode circuit. The tendency to oscillation in such a stage is such as to reduce appreciably the damping due to these moderately inefficient coils, so that they, with the aid of the inevitable traces of reaction

that remain, are approximately equivalent over the waveband for which the set is designed to a coil of considerably lower losses. Since the amount of reaction varies with the tuning of the stage, and since valves vary slightly from one another in their characteristics, a margin of safety has to be left in designing a receiver to ensure stability, so that only at one point at most in the wave-band will the coils approach the efficiency of really low-loss coils. Owing, however, to the considerably better characteristics of the screen-grid valve as compared with the triode, such a stage is almost exactly equivalent over most of its wavelength range to a neutralised triode stage employing coils of high efficiency, and over some of the range it is better. It is on these lines that most screen-grid receivers have been designed.

If coils of high efficiency are used we return to the conditions of the triode, for the residual interelectrode capacity again causes instability to limit amplification, and we are again compelled to invoke the aid of neutralisation. It will thus be seen that neutralisation, whether of ordinary or screen-grid valves, is only required when instability limits amplification. Where, on the other hand, coil losses limit instability, the introduction of neutralisation, by wiping out the small amount of reaction that has already been allowed for in the design, will replace the coil-resistance that reaction was intended to nullify, and will, therefore, result in a serious decrease in amplification.

The Part Played by Inherent Reaction.

Neutralisation, in fact, whether used with screen-grid valves or triodes, is only useful in that it permits the use of more efficient coils than would otherwise be compatible with stability, and in itself confers no benefits whatever. On the contrary, where, as in all screen-grid receivers that have been described in these columns, stability is already achieved by setting off coil-losses against the small amount of inherent reaction that the slight incompleteness of the screening in the valve still permits, the introduction of neutralisation in any form will result in a very definite falling off in the overall efficiency of the receiver.

A. L. M. S.

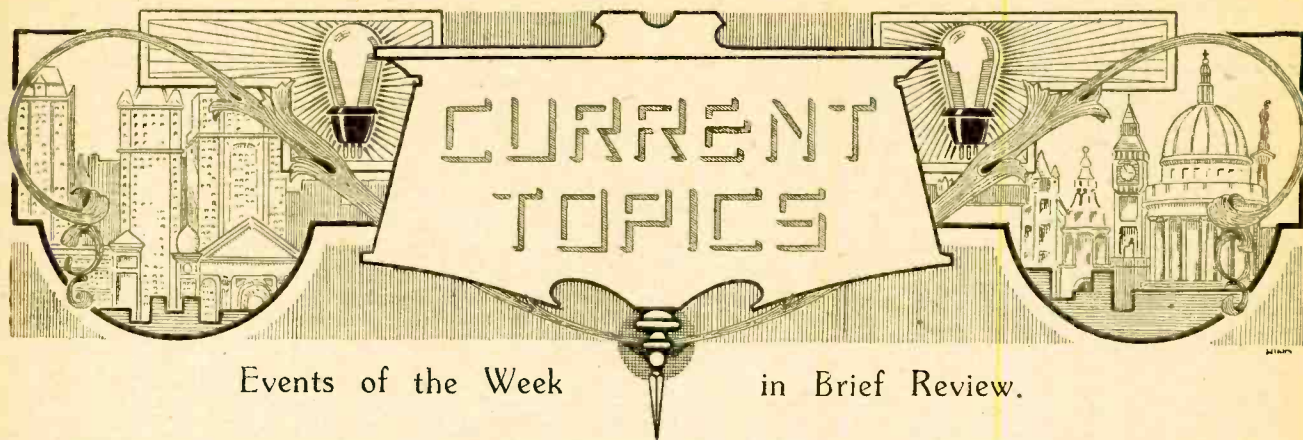

Events of the Week in Brief Review.

GERMANY'S LICENCE LEAD.

The number of licensed listeners in Germany at the end of March was 2,837,894, as compared with 2,234,732 in March, 1928. The British licence figure at the end of March last was 2,731,968.

○○○○

60-KILOWATT SHORT WAVE.

Stated to be the most powerful of its class in the world, a new short-wave station owned by the Philips Company is now testing at Huizen on a wavelength of 16.88 metres with the call-sign PHI. The station is intended for communication with the Dutch Indies.

The transmitter is divided into seven groups, giving a maximum anode output of 60 kilowatts.

○○○○

FORERUNNER OF THE VALVE.

Jubilee celebrations extending over five months are being held in the United States to mark the fiftieth anniversary of the perfection of the incandescent electric lamp by Thomas Alva Edison. The first of a series of "light festivals" was held at Atlantic City at the beginning of this month and the celebrations will culminate on October 21st with a national tribute to the inventor. The jubilee committee is headed by President Hoover in the rôle of honorary chairman.

Edison's announcement of the perfection of the incandescent lamp for commercial purposes was made from his laboratories at Menlo Park, New Jersey, on October 21st, 1879.

○○○○

FRANCO-GERMAN WIRELESS ALLIANCE.

Two famous wireless organisations, the Compagnie Générale de Telegraphie sans Fils, of Paris, and the Telefunken Company, of Berlin, have submitted a joint estimate for the construction of a League of Nations broadcasting station. Their only rival at the moment appears to be the Swiss Marconi Company, which is reported to have taken steps with a view to building a world-wide transmitter for the League.

An obstacle to the scheme has hitherto been presented by the Swiss Government, which is desirous of having a proprietary interest in any station erected on Swiss soil. On behalf of the League, it is urged that the station should be entirely neutral.

CONDENSER MANUFACTURERS, FORWARD!

A Nottingham inventor, according to Press reports, has applied the principle of the automatic telephone to wireless receivers. Tuning is eliminated, as the listener has only to "dial" the number of the required station. Any number of stations can be obtained, "the only limitation being the number of the tuning condensers in the receiver, as each station on the dial must have its own condenser."

○○○○

WHALE CATCHING WITH WIRELESS.

The Norsk Marconikompani, which owns the well-known Stavanger station, is celebrating the tenth anniversary of its establishment. One of the most important activities of the company has been the fitting of wireless installations on the Norwegian whaling fleet.

○○○○

SHORT WAVES THREATEN U.S. TELEGRAPHS.

A projected chain of 110 short-wave wireless stations covering the United States, is threatening the prosperity of the Western Union and Postal Telegraph services. This short-wave network is promised for 1932 by the Universal Wireless Communications Co., which was recently granted forty exclusive frequencies by the U.S. Federal Radio Commission. The service will be open to the general public for ordinary telegraph traffic.

FEWER "BLACK-HEARERS" IN GERMANY.

Records prepared by the German Post Office show that the number of unlicensed listeners prosecuted in 1928 was 1,263, as against 2,836 in 1927. The German "pirate" is known as a *Schwarzhörer*, literally "black-hearer."

○○○○

BIG BEN OBLIGES AT ALDERSHOT.

Big Ben is making his first appearance at the Aldershot Tattoo this year. A special record of his famous chimes has been made by the Gramophone Company (H.M.V.), and is electrically reproduced through an installation of Marconiphones at 11 o'clock each night.

○○○○

PUBLIC TELEPHONES ON TRAINS.

Within three months' time the express trains on the Canadian National Railways system between Toronto and Montreal will be equipped with telephony apparatus giving passengers two-way communication with any point on the North American continent. The carrier current system will be employed, utilising the telegraph wires at the side of the track.

○○○○

FOR BLIND LISTENERS.

The Braille Radio Times, a photograph of which appeared in our last issue, is published every Friday by the National Institute for the Blind, 224-8, Great Port-



WIRELESS RECRUITS. Boys of the Army Training Signal Corps at Catterick, Yorks, receiving instruction in the use of a portable transmitter and receiver. Note the sectional mast.

land Street, London, W.1, and has a circulation of nearly 2,000. It contains an authoritative résumé of programmes broadcast from British stations, and is produced by permission and with the co-operation of the B.B.C. The subscription is 6s. 6d. per annum, 3s. 6d. per six months, and 2s. per three months (minimum), post free, inland and abroad.

BUYERS' GUIDE TO PORTABLES.

We regret that an error occurred in the printed specification of the McMichael Super-Range Portable Four, appearing on page 594 of our issue of June 5th. This receiver incorporates one stage of screen-grid H.F. (tuned), not two as stated, and is followed by a detector and two stages of L.F. amplification.

The address of Messrs. W. J. Henderson and Co., Ltd., makers of the Henderson portable sets, is 351, Fulham Road, South Kensington, London, S.W.10, and not as given on page 592 of our June 5th issue.

TELEGRAPHY BROADCASTS TO SHIPS.

A new service of world-wide broadcasting by wireless telegraphy for the benefit of mariners is announced in the Board of Trade Half-yearly Book for foreign going ships, published on June 1st. The intention is to create a service for use when news of special importance should reach all ships as quickly as possible. In normal circumstances the scheme will operate only in the first week in January and July of each year for trial purposes.

The messages will be broadcast from (a) Rugby W/T station on 18,740 metres at 00.00 and 12.00 G.M.T. immediately preceding the British Official Wireless News; (b) certain medium- and high-power stations abroad on 2,000 and 3,000 metres; and (c) certain stations operating commercial traffic on 600 metres.

AMERICA AND CABLE-WIRELESS MERGERS.

The whole field of communications in the United States is to be investigated by the Inter-State Commerce Committee of the Senate with a view to discovering whether the present U.S. policy against mergers of wire, wireless, and cable interests should be revised. Colonel Behn, president of the International Telephone and Telegraph Company, declares that the U.S. policy is in singular contrast to that of equally important nations in the communications field and that it may be harmful in world competition.

BROADCASTING ENTERPRISE IN SWEDEN.

The Swedish Government is rejoicing over the rapid development of State controlled broadcasting. According to a Stockholm correspondent, the number of licensed listeners now exceeds 400,000, which means that there are sixty-six receiving sets per 1,000 inhabitants. There are thirty-one broadcasting stations, the most important being the internationally famous station at Motala, which supplies a large number of relays and can be heard all over Europe.

OSCILLATOR HUNT AT BIRMINGHAM.

The difficulty of discovering the whereabouts of an oscillator by means of direction-finding equipment was amply shown during a novel test held at Sutton Park on June 9th by members of Slade Radio, Birmingham. The "oscillators" were Mr. C. H. Young (G2AK) and Mr. T. S. Craig (G16TC), who operated a concealed transmitter on a wavelength of 168 metres. The search began at 11.40 a.m., when the competitors, each equipped with a portable set and frame aerial, set out individually. Although on several occasions competitors passed within a hundred yards of their prey, the oscillator was not located until 1.10 p.m., when Mr. C. Smart caught the offenders in the act.

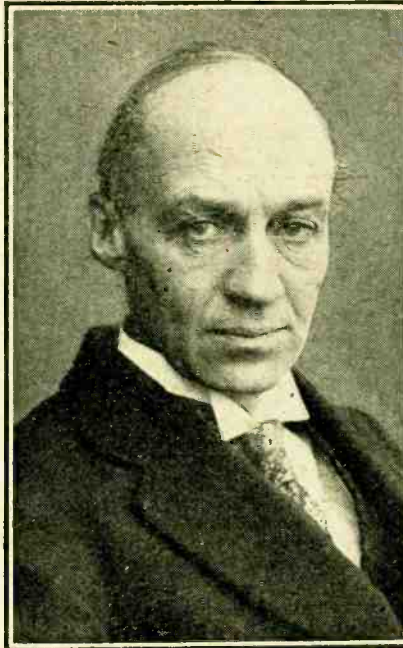

THE NEW "P.M.G." Mr. H. B. Lees-Smith, who, as Postmaster-General in the new Labour Government, has the last word in matters affecting wireless and broadcasting.

Mr. Reuben Heaton, who secured second prize, arrived five minutes later.

This was the first "Oscillation Test" held by the society. The experience gained on this and future tests of a similar nature should go far towards the elimination of oscillation nuisance in the Birmingham area. Unfortunately, however, the real oscillator seldom sins long enough at one sitting to enable accurate bearings to be taken!

DISTRESS CALLS AT SEA.

Amended procedure to be followed by ships' wireless operators in sending out distress calls is outlined in "Notices to Mariners" issued by the Board of Trade.

The Distress Signal consists of SOS made as one sign, while the automatic alarm signal, which, if used, should precede the SOS, comprises a series of 12 dashes sent in one minute. Attention is called to the fact that any three consecutive dashes are capable of actuating the

auto-alarm device if made at the abnormally slow rate of about three words a minute, but that there is no possibility of a TTT signal having this effect unless the transmission is intentionally timed at the slow rate.

It is strongly emphasised that the SOS signal must only be used in cases of immediate danger; where the danger is not immediate the "urgency" signal should be used. This consists of three X's.

PRIZES FOR PORTABLES.

Entries for the portable set competition organised by the *Manchester Evening Chronicle* will be judged early in July. The prizes will mainly consist of wireless gear, not cash, as stated in our last issue, and will include a complete Fultograph picture receiver (first prize), presented by Messrs. A. Franks, Ltd., Deansgate. Among the other prizes will be a B.T.H. "Resister 3" receiver, "Music Magnet" kit, "Music Master" loud speaker, and other valuable instruments and accessories.

The prize winning competitors will have shown their ability to design and construct a lightweight portable set for headphone reception of 5XX and 2ZY, the weight of the receiver not exceeding 16 lbs. Intending competitors should communicate at once with the Radio Editor, *Evening Chronicle*, Withy Grove, Manchester.

NEW CALL-SIGNS AND STATIONS IDENTIFIED.

GREAT BRITAIN.

- G2KU A. J. Selby, 12 and 13, Borough Rd., Burton-on-Trent. (Change of address.)
 G2WL A. T. Wilson, c/o Mayfair Enterprises, Ltd., 5-6, Cork St., Bond St., London, W.1. (Change of address.)
 G5CL M. Shaw, Jnr., 11, Ascog St., Crosshill, Glasgow, S.2.
 G5CM T. H. Streeter, School House, Alford, nr. Billingshurst, Sussex.
 G5JF (ex BRS 170), G. Webster, Jnr., 311, Bolton Rd., Darwen, Lancs, transmits on 170, 42, and 21 metres and will welcome reports on signal-strength and modulation.
 2AOZ (ex 6JS), Percy R. Solder, 6, Churston Gdns., Blake Rd., New Southgate, London, N.11. (New call sign and address.)
 2ASA John H. Hopkins, Kilgare, Winscombe, Somerset.
 2AVR E. R. Cook, 122, Archer Rd., Millhouses, Sheffield. (Also owns 4UO.)
 2AWH J. Armstrong, 109, Rupert St., Bolton.
 2AZQ R. J. Fox, De Grey House, Grosvenor Rd., Batley, Yorks.
 2AZU H. J. Stannard, 18, Winnopole Mews, Weymouth St., Portland Pl., W.1.
 2BOQ H. E. Bottle, 27, Stormont Rd., London, S.W.11.

CEYLON.

- 4VX R. C. Scott, Ottery Estate, Dickova.
 5VX A. M. Rahim, "Rillington," Wellawatta, Colombo.
 6VX L. W. Gaul Hamlin, "Kingsland Lodge," Colpetty, Colombo.
 7VX G. H. Jolliffe, Frocester, Govinna.
 8VX F. H. Pitkin, Box 197, Colombo.
 9VX James C. White, "St. Helens," Havelock Town, Colombo.
 1VY P. Warren-Harvey, Rosset, Demodera.
 2VY P. L. Harbour, "Iveiton," Bagatelle Rd., Colombo.
 3VY A. C. MacLacklan, Sheen, Pundaluoya.
 4VY W. H. W. Coultas, North Pundaluoya.

FRANCE.

- F8DD J. Rodoui, 75 Avenue de la Republique, Pateaux (Seine).
 F8LT A. Renault, 21 Rue Luis Thuillier, Amiens.

JAVA.

- PK1XM P. Moens, c/o Malabar Radio, Weltevreden, Java, D.E.I.



A Review of Manufacturers' Recent Products.

"POLYMET" TUBULAR CONDENSERS.

The feature of special interest in connection with these fixed condensers is the manner whereby connection is made between the plates and the contact lugs. The construction allows for direct electrical contact between the entire banks of tinfoil forming the two sides of the condenser and the external contact. This makes for very low A.C. resistance, and the larger capacities will be particularly

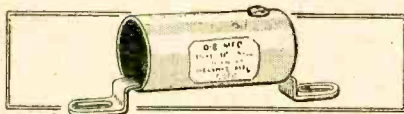

"Polymet" tubular-type paper dielectric fixed condenser.

suitable for use in decoupling circuits where a path of low H.F. resistance is really essential if the arrangement is to be effective in combating back-coupling.

In spite of the fact that paper dielectric is used, the working voltages are extraordinarily high. Type "A" condensers are stated to withstand a difference in potential of 300 volts D.C.; the test voltage being 900 D.C. and the working voltage 200. These are listed in capacities from 0.01 mfd. to 0.5 mfd. and the prices are as follows:—

| | s. | d. |
|-----------------------|----|--------|
| 0.01 to 0.02 mfd. ... | 1 | 6 each |
| 0.03 " 0.04 " ... | 1 | 8 " |
| 0.05 " 0.1 " ... | 1 | 9 " |
| 0.25 mfd | 2 | 0 " |
| 0.5 " | 2 | 6 " |

Type "B" condensers are tested at 1,500 volts D.C.; the normal working voltage being 600 D.C. and 300 volts A.C. These are a little dearer than the lower voltage type, and prices can be obtained on application to Messrs. A. H. Hunt, Ltd., H.A.H. Works, Tunstall Road, Croydon.

o o o o

SCOTT'S DUAL-RANGE COIL.

Since present-day practice in receiver design favours the use of switch-over devices in preference to the antiquated arrangement of interchangeable coils,

every new device of a dual-range coil unit must necessarily incite curiosity regarding its "goodness" and usefulness for this purpose. Scott's dual-range aerial unit consists of a single layer-wound coil tapped for attachment of the aerial, a long-wave leading coil, wound in slots, and a reaction winding. All three coils are carried on a single six-ribbed former 3in. in diameter and 4in. long, fitted with clearly marked terminals and feet for fixing to the baseboard. A panel-mounting push-pull switch is supplied for short-circuiting the long-wave leading coil when receiving on the 200-600-metre waveband. There is supplied, also, a suitably engraved switch cover plate for the front of the panel, indicating the correct position of the switch knob for each waveband.

A practical test revealed the necessity for connecting a small fixed condenser in series with the aerial to achieve a satisfactory degree of selectivity within two to three miles of a main broadcast station. Possibly this could be omitted under less exacting conditions.

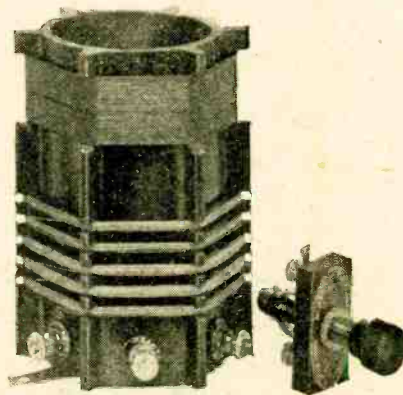

Scott's dual-range aerial coil with panel switch.

The tuning range, with an average sized receiving aerial and using a 0.0005 mfd. variable condenser across the grid coil, was 208 to 580 metres on the medium waveband and 930 to 1,920 metres on the Daventry waveband. These coils are

made by S. W. Scott and Co., 67A, Lothian Road, London, S.W.9, and the price is 10s. 6d., including switch.

o o o o

SIFAM H.T. FUSES.

The special fuses made by the Sifam Electrical Instrument Co., Ltd., Bush House, Aldwych, London, W.C.2, should meet practically all requirements of the average radio equipment, as they are available in various grades arranged to

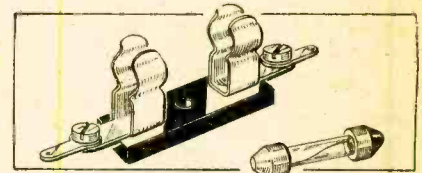

Sifam fuses take up little space, but afford adequate protection.

fuse from 100 mA. to 5 amperes. Two samples were tested: one with a normal rating of 130 mA. and stated to blow at 200 mA.; the other with a normal rating of 1 amp. and fusing at 1.5 amps. The first sample blew at 205 mA., and the second at 1.5 amps. These fuses will give, therefore, adequate protection to the set, and the user can rest assured that no damage will be done to the components in cases of accidental short circuits.

The fuse is enclosed in a small glass tube fitted with brass end caps, and the prices vary according to the fusing current. For example, a 150 mA. (fusing current) fuse costs 2s. 6d. complete with clip; spare cartridges are 1s. 6d. each. From 750 mA. up to 5 amps. the price is 2s. with clip, and 1s. for a spare fuse.

o o o o

"OBETA" H.T. BATTERIES.

"Obeta" H.T. dry-cell batteries are of foreign make and are supplied in this country by Messrs. F. L. Lesingham, 13, Victoria Street, London, S.W.1. Two types are available, a standard size, which sells at 13s. 6d. for 105 volts, and a double-capacity size at 17s. for the same voltage. One of the larger type was tested by discharging intermittently for

periods of 4 hours, with 4-hour periods of rest, until the battery was exhausted.

In this particular case the initial current was set at 12.9 mA. The terminal voltage to commence with was 123. It has been found generally that a rapid drop in voltage occurs during the first 20 or 30 hours, when the steady state is reached and maintained for a considerable period after. In the present case,

advantage will accrue in keeping the battery in service until the voltage drops to 0.75 volts per cell, as this adds only a matter of 30 hours more to its life. The performance of the battery is extraordinarily good considering its small physical size; the dimensions are 10 $\frac{1}{4}$ in. \times 5in. \times 3 $\frac{1}{2}$ in. high, and it compares favourably with many costing considerably more.

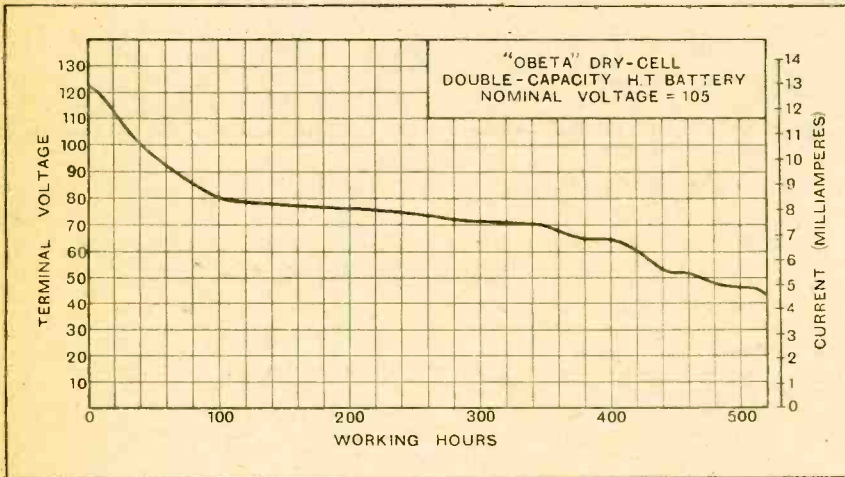

Discharge curve of the "Obeta" dry-cell H.T. battery, double-capacity size.

however, the decline was more gradual, and the steady state was not reached until the battery had been on discharge

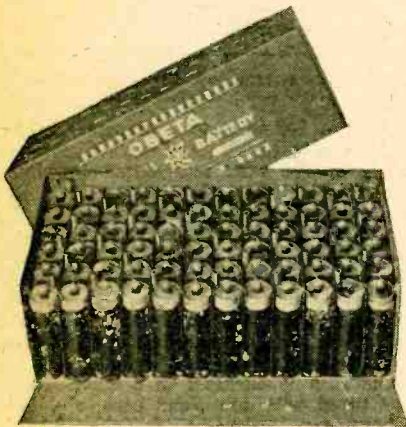

"Obeta" large size H.T. battery, with cover and side removed. Note the clean appearance after discharge.

for 100 hours (actual working time). The voltage had then dropped to 80. This value was maintained with only a very slight fall for the next 250 hours, after which the voltage fell steadily at first and then more rapidly until the battery was exhausted.

It will be seen by reference to the discharge curve that a rapid decline occurs after 400 hours' useful work, and this corresponds to a drop to 0.9 volt per cell; the battery contains 71 small cells. In view of the marked fall in voltage after the 400-hour mark is passed, no

TRIOTRON LOUD SPEAKER UNIT.

This unit consists of a massive horseshoe magnet supporting four pole-pieces between which the reed moves on the differential principle. The armature is anchored at one end and is adjustable. A generous clearance is provided between the armature and the pole-pieces, so that the unit can be expected to handle large electrical inputs without chattering.

The weakest link in a cone type loud speaker is generally the apex of the cone, and this often leads to disappointing results due to breaking under the influence of the thrust and pull of the armature. This defect should not occur with the Triotron unit, since the makers supply large cone washers—1 $\frac{1}{2}$ in. in diameter—which will give adequate strengthening.

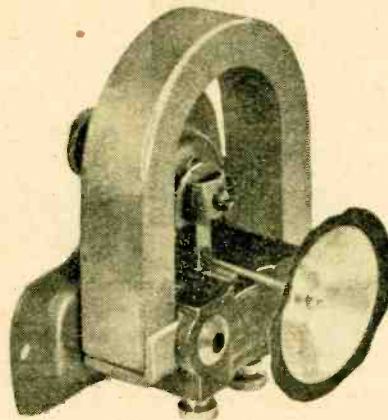

Triotron four-pole, differential movement, loud speaker unit.

The unit is supplied by the Electric Lamp Service Co., Ltd., 39/41, Parker Street, Kingsway, London, W.C.2, at the price of 17s. 6d.

o o o o

IGRANIC SCREENED CONDENSER.

This variable condenser has been designed for use in circuits where both sets of plates would be at high oscillating potential and where difficulty might be experienced in tuning due to hand capacity effects. Both banks of vanes are well insulated from the cover, these being mounted on a bakelite moulding which also carries the single bearing for the moving vanes. This assures that the plates are well spaced from the metal casing, and makes for a low minimum capacity. The measured minimum was

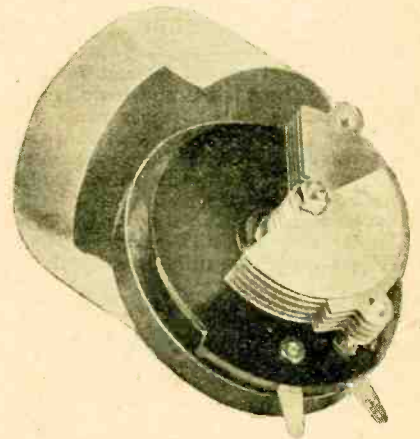

Igranic screened condenser; an ideal component for short-wave sets.

found to be 8 micromicrofarads only with the screened cover earthed. The maximum capacity, which is stated to be 0.00015 mfd., was found, by measurement, to be 0.000156 mfd. An insulated spindle is fitted, but as this is $\frac{3}{8}$ in. in diameter, a special dial, or knob, will be required.

Although this component was designed primarily for use in any of the multitudinous variations of the Reinartz circuits as a reaction condenser, the happy choice of the maximum capacity renders it eminently suitable for incorporation in short-wave sets, and it is, perhaps, in this field that its greatest utility lies.

The makers are the Igranic Electric Co., Ltd., 149, Queen Victoria Street, London, E.C.4, and the price is 9s. 6d.

o o o o

Catalogues Received.

Radio Instruments, Ltd., 12, Hyde Street, New Oxford Street, London. W.C.1. 40-page illustrated catalogue of R.I. components. Many pages are devoted to transformers, L.F. and mains A.C. type.

o o o o

Messrs. Fredk. J. Gordon and Co., Ltd., 92, Charlotte Street, London, W.1. 30-page illustrated catalogue of the Atwater Kent Manufacturing Co. (U.S.A.). D.C. and A.C. mains receivers.

SMALL MAINS TRANSFORMERS

Constructional Details of Complete Eliminator.

By T. W. RIDGE.

(Concluded from page 613 of previous issue.)

WE will now proceed in a similar manner with the secondary windings. The winding to supply the filaments of the valves in the set must be a separate one from that which heats the filament of the rectifying valve, although in our case both require the same voltage. The reason for this can be seen from the wiring diagram, Fig. 8, where the filament of the rectifying valve forms the H.T. positive and the filaments in the set H.T. negative, so that a short circuit would occur across the H.T.

For the valves in the set we require 4 amps at 4 volts. At 8 turns per volt we require $8 \times 4 = 32$ turns, and at 1,200 amps per sq. in. we require $\frac{4}{1,200} = 0.0033$ sq. in., or No. 16 s.w.g. The diameter of No. 16 s.w.g. is 0.064 in., plus 0.012 in. for the double cotton covering which we shall require for this thick wire = 0.076 in. diam. Therefore, in the $\frac{3}{4}$ in. winding space we can wind $\frac{0.75}{0.076} = 9$ layers, and we shall require 4 turns per layer, so the width of the coil will be $4 \times 0.076 = 0.304$ inches, and as we can see to wind this thick wire quite evenly, about a third of an inch will accommodate it. The length of wire required

for this coil will be $\frac{32 \times 8 \text{ in.}}{36} = 7.11$ yds., the mean length of the turns being the same in all coils, i.e., 8 in.

From the wire tables it can be seen that the weight will be $\frac{7.11 \times 37.2}{1,000} = 0.26$ lb.,

and the resistance will be $\frac{7.11 \times 7.48}{1,000} = 0.053$ ohms.

The voltage drop due to this will be $0.053 \times 4 = 0.212$ volts, and, in addition, due to the voltage drop in the primary, we shall get a drop in the secondary proportional to its voltage, i.e., $\frac{10}{200} \times 4 =$

0.2 volts, making a total drop of 0.412 volts at 4 amps.

Now we can compensate for this by winding extra turns, so that if we add two turns, making a total of thirty-four, the voltage at no load will be 4.25, and with the load of 4 amps. it will be about 3.8. This variation will not generally be found excessive, but, if desired, thirty-five turns may be used, making the full load voltage about 3.95, or wire of lower resistance could be used. The winding for the filament of the rectifier,

which only requires 2 amps., may be wound with No. 18 s.w.g. D.C.C. wire, but another coil with 34 turns of No. 16 s.w.g. similar to above can be used.

Calculating the H.T. Secondary.

Now the H.T. secondary will be calculated in exactly the same manner. We require 50 mA. at 200 volts, therefore, $200 \times 8 = 1,600$ turns, and wire of $\frac{0.05}{1,200} = 0.000042$ sq. in. cross section, so No. 36 s.w.g. will do. The diameter of No 36, allowing for the enamel, is 0.0096 in. Therefore, in the $\frac{3}{4}$ in. winding depth we can get $\frac{0.75}{0.0096} = 78$ layers, and the turns per layer will be $\frac{1,600}{78} = 21$. The width of the coil then will be $21 \times 0.0096 = 0.2$ in. plus 25 per cent. for paper between layers = 0.25 in. The length of wire required will be $\frac{1,600 \times 8}{36} = 356$ yards about. The weight of this will

be $\frac{356 \times 0.5249}{1,000} = 0.186$ lb., and the resistance $\frac{356 \times 530}{1,000} = 188$ ohms.

The voltage drop due to this resistance will be $188 \times 0.05 = 9.4$ volts, and, in addition, there will be the drop due to the primary, which in this case will be 10 volts the same, this winding being for 200 volts as the primary. So altogether we must wind additional turns to compensate for 20-volt drop (i.e., 10 per cent.), the total number of turns required being 1,600 plus 160 = 1,760.

The H.T. secondary of the transformer described is arranged with tappings at 60, 100, and 150 volts. These are very little extra trouble to make while winding, and often come in very useful for experimenting, so, if required, they should

be brought out at 528, 880, and 1,320 turns. Now, as the transformer is required for full wave rectification, another H.T. secondary coil must be made exactly the same as the first, with tappings brought out at the same points.

Having worked out all the details, we can purchase the quantities of wire required and proceed with the actual making. A winding machine of some kind is required but it need only be quite simple and with a

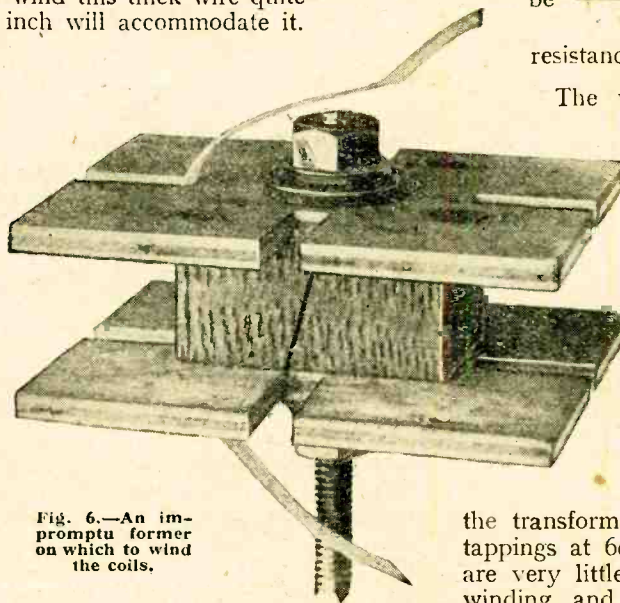

Fig. 6.—An impromptu former on which to wind the coils.

Small Mains Transformers.—

little ingenuity it is possible to rig up a hand drill in the vice with an arrangement to count the turns such as a cyclometer. It will be necessary to make up a former on which to wind the coils, and Fig. 6 shows how this is easily arranged. It consists of two cheeks of three-ply wood of the size of the finished coil, in this case $3\frac{1}{2}$ in. \times $2\frac{3}{8}$ in., with a centre piece between $1\frac{1}{16}$ in. \times $1\frac{1}{16}$ in. and of the thickness required to accommodate the winding. A $\frac{1}{4}$ in. hole is drilled through the centre so that they can be clamped together between two nuts on a long screw, which can be held in the chuck of the winding machine.

The four slots in each of the cheeks are for the purpose of placing four narrow tapes (one is shown in position in photograph Fig. 6) so that when the coil is wound the ends of the tapes can be brought up and tied, thus holding the coil together while the nuts are loosened and the cheeks removed and the coil drawn off the centre piece ready for its final taping. The same cheeks are used for all the coils, but we shall require three centre pieces 0.8 in. thick for the primary, $\frac{1}{2}$ in. for the L.T., and $\frac{1}{4}$ in. for the H.T. secondaries.

When the centre pieces have been made to the correct size and the centre hole drilled it is advisable to cut each piece into two with a diagonal saw cut to facilitate their removal from the centre of the coils. This will be made clear by examining Fig. 6. The four tapes for tying can now be placed into position and a layer of empire cloth wrapped round and the winding proceeded with, the spool of wire being mounted on a smooth rod between two pieces of wood so that the wire runs off easily. As each layer is finished a piece of very thin paper of the width of the coil should be run on to separate it from the next and to keep the coil in shape. A supply of strips of the required width should have been prepared beforehand. In the case of the L.T. coils which are wound with 16 s.w.g. D.C.C. these separating papers will be unnecessary.

Varnishing the Coils.

When winding the two H.T. secondary coils great care must be taken to wind both in the same direction and to note the beginning end, the order of each of the tappings, and the finishing end, and to make this clear the beginning should be brought out of one of the slots on, say, the left of the tappings and finish out on the right of the former. As these coils are wound with thin wire, i.e., 36 s.w.g., the ends and taps should be soldered to pieces of wire of about No. 26 s.w.g. to act

as connectors, the soldered joint being carefully insulated with a piece of paper.

Having wound all the coils, which should have been carefully removed from the former after tying the four tapes, they can now be taped up with $\frac{1}{2}$ in. wide tape (keeping the positions of the ends in place) and be given a coat of shellac varnish and placed in an oven or a warm place to dry.

While the coils are drying we can prepare four strips of $\frac{1}{2}$ in. by $\frac{1}{2}$ in. iron $\frac{1}{4}$ in. long and four pieces of 2B.A. threaded rod for clamping the core. The piece of sheet fibre which is to be used to protect the coils from the core (as shown in Fig. 5 in the first instalment of this article) should now be carefully marked with a knife and folded to its form of a square tube. On the centre of the tube should be placed the primary coil; on either side of this must be placed a piece of empire cloth in the shape of a large washer (Fig. 5) to insulate it thoroughly from the two H.T. secondary coils which will come next, one on each side of the primary. The H.T. secondary

coils must be placed in such a manner that their windings are in opposite directions to one another, i.e., the beginning ends of both should be towards the centre and the tappings and finishing end away from the centre. The two L.T. coils can now be placed one at each end on the outside with another empire cloth washer between it and its neighbour. We can now proceed to build up the core by pushing in the "Tee" stampings from alternate ends and then interleaving with "U" pieces. The clamps can then be put on, placing a strip of cardboard between the $\frac{1}{2}$ in. by $\frac{1}{2}$ in. clamping strip and the core plates to act as a cushion and to insulate the core from the clamps. It now remains to make up terminal strips of $\frac{1}{8}$ in. thick ebonite which are carried on the clamping bolts and to connect the respective coils to complete the transformer. When first testing it it is advisable to connect a lamp (about 60 watts) in series with the mains. This should not glow, or if at all, only dimly, until a load is applied to the secondary. The inexperienced should be careful; the 200-volt mains can be dangerous.

Having made the most complicated part of our eliminator the remaining details can be more brief. Whilst the winding gear is at hand the choke coil had better be made up. This is arranged in the same manner as the transformer, and is on a core of the same No. 4 stallo stampings, but is only 1 in. thick. The coil consists of 6,000 turns of No. 30 s.w.g. enamelled wire (about 1 $\frac{1}{2}$ lb.) and it is made in two sections of 3,000

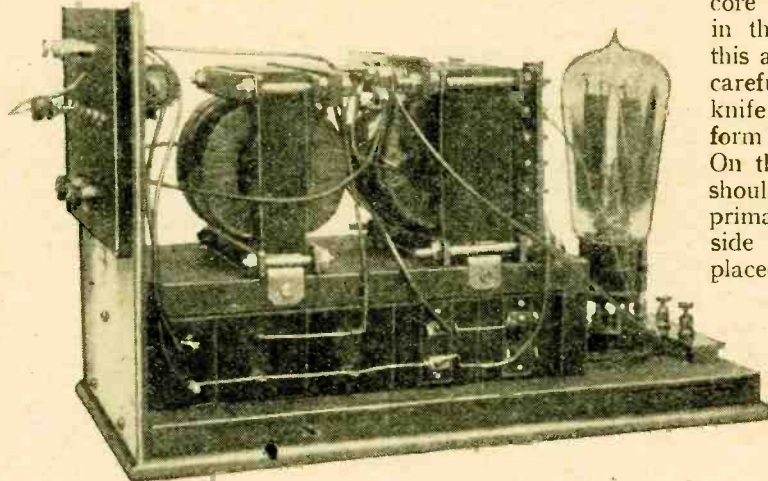

Fig. 7.—The eliminator with full wave rectifying valve and smoothing equipment.

Small Mains Transformers.—

turns each for convenience of handling. The same former can be used for winding, but the centre piece must be $1\frac{1}{16}$ in. by $1\frac{3}{16}$ in. and $\frac{1}{16}$ in. thick. This choke will have an inductance of approximately 100 henrys when carrying 50 milliamperes, and as its resistance is 233 ohms there will be a voltage drop of only about 12 volts with the full 50 m.a. passing.

When assembling care should be taken to place both coils on the core the same way round so that the windings go in the same direction, then the end of one coil is connected to the beginning of the other. The finished choke can be clearly seen in the photograph (Fig. 7). Regarding the assembly of the transformer, choke, condensers and rectifying valve little will be said, for the layout will depend on the particular make of condenser used, and as long as the wiring is correct it matters little how the components are placed, for we are not troubled with capacity effects as in the radio-frequency amplifier of an ordinary wireless set.

As can be seen in the photograph (Fig. 7) the set described is provided with terminals for the mains at one end and at the other with a small ebonite panel which has a pair of terminals at the bottom for the 4-volt L.T., and three terminals at the top for the H.T., the centre terminal being connected to the wander plug, which can be connected to either of the six sockets from a potential divider. There is a sheet-iron cover which shuts the components in and prevents risk of contact with the mains. The potential divider is not now made use of, the main H.T. only is taken to the set, and resistance capacity feed is provided to each valve in the latest approved manner so that it is probably not worth while for those building an eliminator to-day to incorporate a main potential divider, but sub-potential

dividers may be necessary for screen voltage and for the feed to an anode bend detector.

The wiring diagram, Fig. 8, should give the rest of the details required to complete the eliminator.

Some readers may require to design choke coils of a size other than that given and will therefore require the formula, which is as follows:—

$$L = \frac{1.25 \times a \times \mu \times N^2}{l \times 10^8}$$

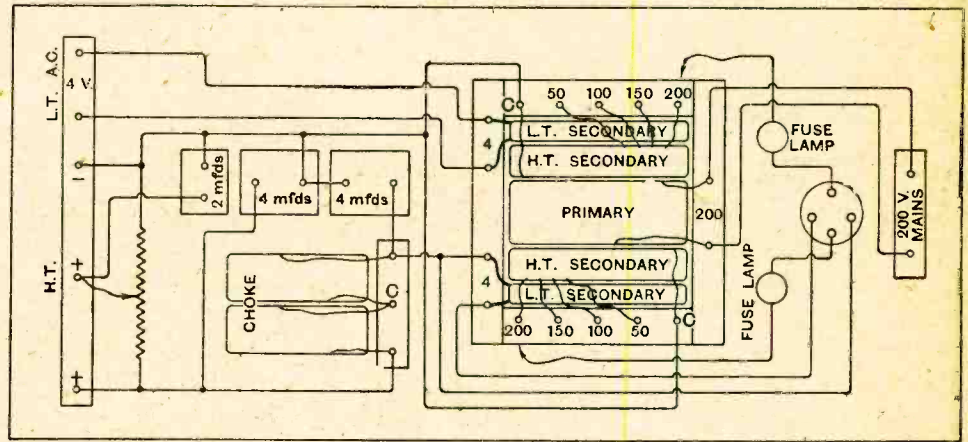

Fig. 8.—The wiring diagram of the complete unit.

- L = being inductance in henries.
- a = cross-sectional area of core in sq. cms.
- N = number of turns of wire.
- l = length of magnetic path in cms.
- μ = permeability of the iron of core which is dependent upon the quality of the iron and the flux density which varies with the amount of current flowing through the coil.

$\mu = \frac{B}{H}$, which is the magnetic induction for the particular variety of iron divided by H which = 1.25 ampere turns per cm. length of magnetic path.

A permeability curve is issued by most manufacturers of magnetic iron showing the relationship of B to H for their particular iron. It will be seen that it is very difficult to obtain the inductance of an iron-cored choke coil accurately, but it can be obtained quite accurate enough for practical purposes.

Some figures obtained from a BH curve for a transformer steel are tabulated below, and will serve our purpose:—

| H | B | μ |
|----|--------|-------|
| 8 | 10,800 | 1,350 |
| 12 | 11,800 | 990 |
| 16 | 12,400 | 775 |
| 20 | 12,800 | 640 |
| 24 | 13,300 | 555 |
| 30 | 13,700 | 457 |
| 38 | 14,300 | 376 |

Taking as an example the choke coil as described for the eliminator:—

a = cross-sectional area of core = 1 sq. in. or 6.45 sq. cms.

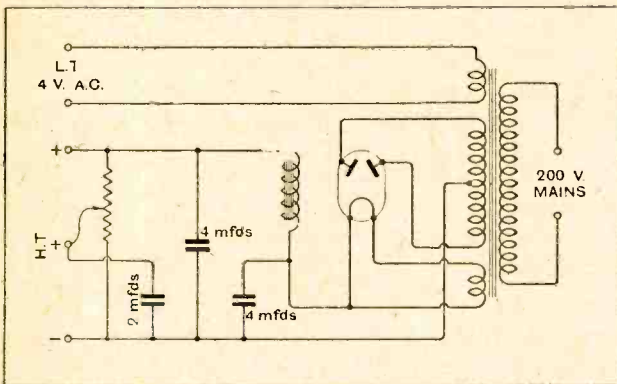

Fig. 9.—The circuit diagram.

Small Mains Transformers.—

N=number of turns=6,000.

l=length of magnetic path=about 20 cms.

Then, with 50 m.a. $H = \frac{1.25 \times 0.05 \times 6,000}{20} = 18.7.$

Therefore, from table μ =about 700 and inductance =

$$L = \frac{1.25 \times 6.25 \times 700 \times 6,000^2}{20 \times 10^8} = 98.7$$

If the current were increased to 100 m.a. H would be

doubled, becoming $\frac{1.25 \times 0.1 \times 6,000}{20} = 37.5.$ The permeability μ would now be (from the table) 376, and the

inductance $L = \frac{1.25 \times 6.25 \times 376 \times 6,000^2}{20 \times 10^8} = 53,$ or little

more than half the original value. It can now be seen that when stating the inductance of an iron-cored choke the value of the steady current passing through it must also be given.

AN ELECTRIC "PICK-UP" PROBLEM.

When amplifying from gramophone records, especially for a public audience, it is an advantage to be able to change over from one record to the next automatically, or without any noticeable interval. This can be effected, for instance, by using two turntables and causing each stylus at the end of its working path to operate two switches, the first cutting in

Patent Novelties.

triangular in cross-section. Triangular holes are similarly punched out in the flanges of the plates P as shown. In

passes from Tetrode to Pentode and then to the multiple-stage amplifiers of Dr. Loewe. An American inventor—Mr. A. Mavrogenis—is responsible for a further development—this time along somewhat different lines. His object is to produce a valve capable of being plugged in directly to the alternating-current mains, and containing, in the same glass bulb as the amplifier proper, special rectifying and smoothing devices for ensuring a steady D.C. voltage for the plate supply.

The general arrangement is illustrated in the figure. The filament is in the form of an inverted V, the upper part F1

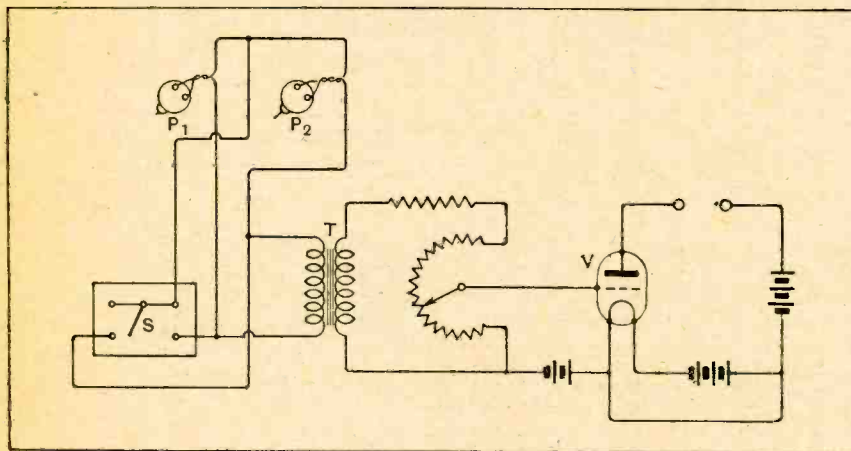

Switching scheme for bringing two pick-ups successively in circuit.

the new record and the second cutting out the old.

The diagram shows an alternative switch-over arrangement for connecting the two pick-ups P1, P2 successively in circuit with an amplifier V. When the switch arm S is on the left-hand contact, the pick-up P1 feeds the primary of the input transformer T, whilst on the right-hand side the pick-up P2 is brought into circuit. The pick-ups are, of course, engaged with the records by hand, in preparation for the change-over. In the case of a cinema or like installation, both turn-tables might be driven continuously from the same motor, or a separate motor could be switched into operation, as required, by the control switch S. (Patent No. 298,249.)

o o o o

MOUNTING CONDENSER PLATES.

An ingenious yet simple method of assembling condenser plates in alignment upon their supporting rods, recently patented by the Igranic Co., is illustrated in the figure. A series of slots S are first cut in regular succession along the length of the rods R, which are

assembly the plates are held in a jig at the correct spacing, and the rods R are threaded through, until the slots coincide with the holes. The rods are then twisted through a right-angle so that the straight edges of each triangular

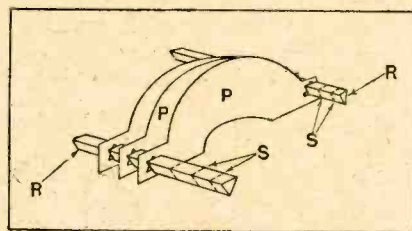

New method of assembling condenser plates.

hole bite into its respective slot. In order to effect a permanent grip, the slots are slightly tapered from top to bottom. (Patent No. 301,586.)

o o o o

A SELF-CONTAINED VALVE.

The internal complications of valve design appear to be without end. One

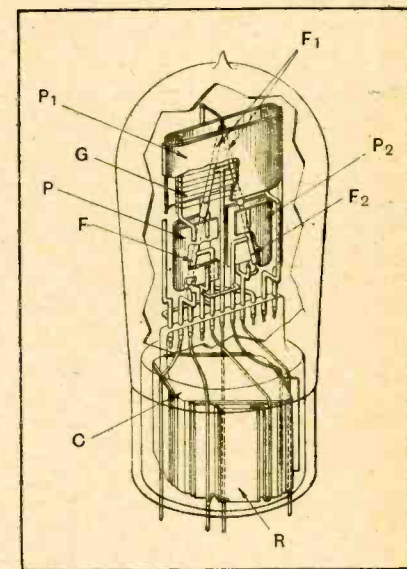

An A.C. valve of new design.

acting as a cathode to the grid G and plate P1. One of the lower legs F2 co-operates with a separate plate P2 to rectify the A.C. supply. The second leg F, in combination with a third plate P, imposes a saturation limit to the rectified current, and so acts to smooth out pulsations. A special filter condenser C is housed inside the turned-up flange of the glass bulb. The D.C. output from the unit F, P is fed to a resistance element R, from which the plate voltage is tapped off to P1. The filament F, F1, F2 consists of a thin high-resistance wire, enclosed first in a quartz tube, and then in a nickel tube coated with Barium oxide. (Patent No. 298296.)

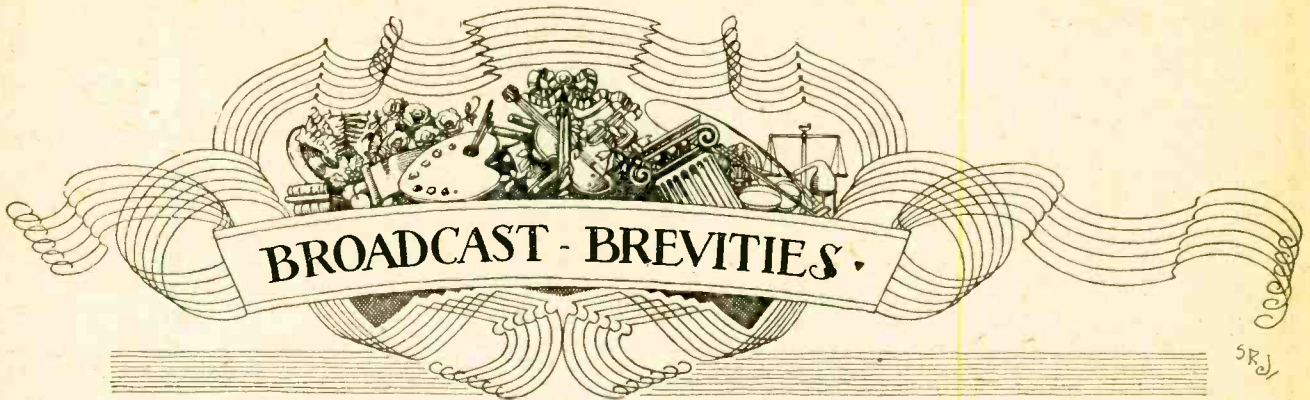

By Our Special Correspondent.

**The Money Question.—Captain Eckersley's Future.—The New Chief.—The Kiloherzt Departs.—
Scottish Grievances.—Labour and the B.B.C.**

Financial Reward.

If in trouble, make an emphatic statement. Let it be accurate if possible, but emphatic at all costs. This seems to be the practice nowadays, and a very effective one. Last week the B.B.C., cornered over the question of resignations, produced a genius who said: "Financial reward is not, and can never be, the sole, or even the main attraction of the broadcasting services."

o o o o

Payment to Artists.

More than two and a half million licence holders pay a very large sum of money each year in return for what they hope will be the finest talent available. The finest talent demands, and surely deserves, the best possible payment. Yet the B.B.C. seems to imagine that the listening public will acquiesce in an endeavour to extract service from artists and everyone else connected with broadcasting at a cost lower than could be obtained in a commercial undertaking.

o o o o

Competition Needed?

The fact that broadcasting in this country happens to be under State control is a mere accident so far as emoluments to artists and staff are concerned, and if the B.B.C. intends to, use its monopoly as an excuse for homilies of the "art for art's sake" variety, then the sooner a competitive broadcasting system is inaugurated the better it will be for the listening multitudes. Only poets with private incomes can afford to work for love. And generally they don't.

o o o o

"P.P." as Lecturer.

Captain Eckersley has no intention of dwelling in seclusion when he leaves Savoy Hill at the end of September. Already he is "booked" to appear on the lecture platform at frequent intervals during the winter as "Faraday Lecturer" for the Institution of Electrical Engineers. In the course of the session he will visit the I.E.E. centres at Newcastle, Manchester, Leeds, Liverpool and Edinburgh, in addition to headquarters, at Savoy Place, London.

The New Chief.

Mr. Noel Ashbridge, B.Sc., who becomes Chief Engineer of the B.B.C. as from September 30th, was Captain Eckersley's right-hand man during the famous pioneer days of "2 Emma Toc," the Marconi test station at Writtle. Later he became chief of the experimental section, remaining at Writtle until Savoy Hill claimed him. He has been assistant chief engineer to the B.B.C. since 1925.

o o o o

Early Experience.

Mr. Ashbridge received his engineering training at King's College, London, and obtained practical experience with the



CAPTAIN ECKERSLEY'S SUCCESSOR. Mr. Noel Ashbridge, who becomes Chief Engineer of the B.B.C. as from September 30th next. He is a "pioneer" of the early days, having assisted in the test transmissions from Writtle.

British Thomson-Houston Company and the Lancashire Dynamo Company. During the War he served as wireless officer with the Royal Engineers both in France and England. He entered the service of the Marconi Company in 1919.

o o o o

The Passing of the Kiloherzt.

Who can withhold a tributary tear from the bier of the "Kiloherzt"? One morning in January last the kilohertz awoke to find itself famous. Now, after one crowded hour of glorious life, it returns to the vile dust from which it sprung. For the B.B.C., in common with other European broadcasting organisations, has decided to abandon "kilohertz" and revert to its equivalent, "kilocycles per second."

o o o o

R.I.P.

Although it had moved in polite text book circles for many years, the kilohertz was unknown even to a good many wireless engineers when it flamed out in the public announcement of the Brussels broadcasting scheme on January 13th of this year. At once it became unpopular. It had a lethal sound, and may be said to have given a phonetic forecast of the death pains of the Brussels scheme. And, of course, there was always that little difficulty about its plural. Some said "kilohertz's" and others . . . but what does it matter, now? *The Wireless World* of January 23rd said: "If it hertz, kill it."

o o o o

Scots Wha Ha'e.

Scotland is not altogether happy just now over the question of regional broadcasting, the fear being that the victory of trousers over kilts is to be repeated in the realm of song and story.

As plans stand at present, the existing stations at Glasgow, Aberdeen, Edinburgh and Dundee are all to be replaced with a single high-power regional station in the neighbourhood of Glasgow. On the programme side the changes are already taking place, Glasgow and London providing most of the programme material, with the other stations acting as relays.

"Londonising" Aberdeen.

Popular feeling is most acute in Aberdeen and the "Nor'east." The B.B.C., it is alleged, are endeavouring to "Londonise" the Highlands, but Aberdonians decline the honour, preferring to have their own fare from 2BD, which broadcasts a considerable amount of local talent.

○○○○

The B.B.C. Reply.

The B.B.C., of course, disclaims any intention of turning Scotsmen into Cockneys (as if it could!). In an interview, a B.B.C. official explained to me that the object of the regional scheme was to give scope for "local aspirations and interests," while providing listeners in any one area with a widely selected programme drawn from many sources.

Some reduction in local effort will be called for, but the B.B.C. declares that there has never been a sufficiency of talent in the provinces to keep a station busy for ten or twelve hours a day, and that every provincial station has found it necessary to "tap" London.

○○○○

Not "Local."

Speaking of London, my informant mentioned a point which may be overlooked even by the shrewd Aberdonian, i.e., that London programmes are not "local" in the provincial sense. Artistes come to London from all parts, yea, even from Aberdeen itself, knowing where they will find the best market.

○○○○

Mass Production.

But I am not convinced that the Highlanders have no cause for alarm. Call it what you will, the regional scheme carries with it a hint of mass production, and it is difficult to see how, in trying to please everybody, the B.B.C. can pos-

sibly hope to give satisfaction to individual communities.

○○○○

Eleven Different Programmes!

On the programme side the work entailed will be colossal. I am told that each of the five regional stations may send out two *original* programmes daily, and that 5GB will contribute yet another. Where is this inexhaustible fountain of talent?

FUTURE FEATURES.**London and Daventry.**

JUNE 24TH.—Covent Garden Opera.

JUNE 26TH.—"The Swallow," an opera by Puccini.

Daventry Experimental (5GB).

JUNE 23RD.—Service from Birmingham Cathedral, conducted by the Rev. R. D. Richardson.

JUNE 27TH.—Covent Garden Opera.

JUNE 29TH.—Excerpts from "A Midsummer-Night's Dream," by Shakespeare.

Cardiff.

JUNE 23RD.—Favourites from Oratorio.

Manchester.

JUNE 26TH.—Band Concert from Southport.

Newcastle.

JUNE 26TH.—Running Commentary on the Northumberland Plate.

Glasgow.

JUNE 24TH.—"Wee MacGregor," Acts 1 and 2, a comedy by J. J. Bell.

Aberdeen.

JUNE 28TH.—A National Gaelic Concert.

Belfast.

JUNE 28TH.—"The Black Sheep," a comedy by F. Morton Howard.

Labour and the B.B.C.

Whatever is said for or against the Prime Minister's use of the microphone on June 8th to return thanks to the electorate, the gesture can be accepted as a definite sign that the Labour Party places a high valuation on broadcasting as a means of reaching the multitudes. Considering that Labour has a smaller

Press than any other party, it seems likely that the new Government may seek further opportunities to broadcast. This will raise many delicate questions which for the moment it might be wiser not to discuss.

○○○○

More Educational Broadcasts.

Hitherto there has been little suggestion of "Government interference" with broadcasting, but it would not surprise some people if the accession of Labour to power were followed by signs of an augmented educational policy at Savoy Hill. It is common knowledge, of course, that the *savants* are only awaiting a fuller development of the regional scheme before launching a much more comprehensive educational plan than anything yet attempted.

National education is a prominent feature in the Labour programme; nor can we forget that one of the most active members of the B.B.C. Governors is Mrs. Philip Snowden, wife of the new Chancellor.

○○○○

A 2LO Thriller.

"Ingredient X," a thriller by L. du Garde Peach, will be broadcast from 2LO on July 11th.

○○○○

Gerhardi Writes a Broadcast Play.

A play by William Gerhardi, entitled "Lord Brute," which has been written for broadcasting, will be transmitted from 5GB on July 10th and from 2LO and other stations on July 11th.

The hero took the title because his wife called him a brute on the day his name appeared in the Honours List, but the authorities made him accent the "e."

○○○○

Oscar Wilde at His Best.

Plays that are "nearly all talk" are rarely successful, whether on the stage or in the broadcasting studio. An undoubted exception is Oscar Wilde's "The Importance of Being Earnest," which sparkles with effervescent dialogue and is therefore specially suited to the microphone. Its popularity with listeners in the past is sufficient excuse for another broadcast of the play from 5GB to-morrow evening (Thursday).

○○○○

H.R.H. The Prince.

The Prince of Wales's speech at the Royal Institute of International Affairs dinner, in honour of Sir A. Bailey, will be relayed from the Mansion House to 2LO on July 8th.

○○○○

Programme Criticism.

Not long ago the B.B.C. was lamenting the absence of Press criticisms. It seemed as if too much sweetness was being wasted on the desert air. In the last few months, however, the weekly Press, if not the daily, has shown a quite serious concern over the programmes, many of which are given as much constructive criticism as the first performance of a play.

The French radio papers now draw attention to the splendid publicity given to broadcasting in the British Press, and lament the fact that the lay Press of France ignores wireless altogether.

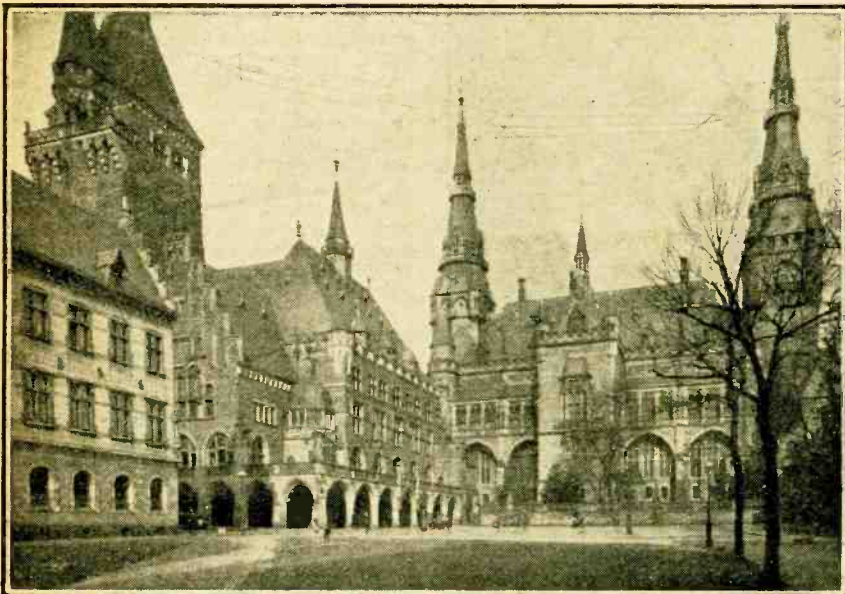

AT AIX-LA-CHAPELLE. If a competition were inaugurated to discover the world's most picturesque broadcaster, this German relay station would probably come high in the list. Aix-la-Chapelle relays Langenberg on 456.3 metres.

VALVES WE HAVE TESTED



THE OPTRON SERIES

Low-priced Range in 2-, 4- and 6-volt Types.

THESE valves are supplied by Optron, Ltd., Charlotte Street, Birmingham, and they are made in 2-, 4- and 6-volt types. The prices have been fixed at 5s. for the H.F., R.C. and L.F. types in each class. The super-power valve in the 2- and 4-volt series costs 8s., and the 6-volt power valve 6s. 9d.

Vertical hairpin filaments are fitted in the 4- and 6-volt series, but a short, straight, vertical filament is used in the 2-volt valves.

H.F.2.

The H.F.2 can be regarded as the general-purpose valve in the 2-volt

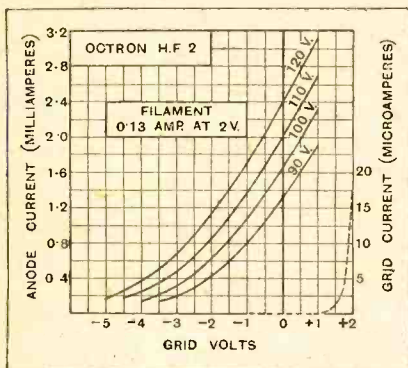

Average values under working conditions: A.C. resistance, 28,600 ohms; amplification factor, 17.4; mutual conductance, 0.6mA/volt.

class, since its rated characteristics are, A.C. resistance 30,000 ohms, amplification factor 15, and mutual conductance 0.5mA. per volt.

The sample tested was heavily gettered, and the untarnished appearance of the interior indicated that it was pumped hard before the magnesium was flashed. No trace of softening, as indicated by reversed grid current, could be detected. Measured characteristics agreed sensibly with the makers' figures. At 100 volts H.T. and zero grid bias the A.C. resistance was found to be 26,600 ohms; the amplification factor 18.2, and the mutual conductance 0.68mA. volt. These values changed very slightly under normal working conditions. At 120 volts H.T. and minus 1½ volts grid bias the measured values were: A.C. resistance, 28,600 ohms; amplification factor 17.4, and mutual conductance, 0.6mA. per volt. Grid current started at +1 volt grid bias; a characteristic common to all the 2-volt series dealt with.

The rated and measured values of some of the other valves in the same class are tabulated below.

P.P.4.

The P.P.4 is the star valve of the 4-volt class, since it shows a mutual conductance of 1.5mA. per volt according to the makers' rating. Our measurements on the specimen tested were sensibly in agreement with

2-Volt Series.

| Type. | Makers' Rating. | | | Measured Values at 100 v. H.T. and Zero Grid Bias. | | |
|-------|------------------------|-----------------------|---------------------|--|-----------------------|---------------------|
| | A.C. Resistance. Ohms. | Amplification Factor. | Mutual Conductance. | A.C. Resistance. Ohms. | Amplification Factor. | Mutual Conductance. |
| R.C.2 | 50,000 | 25 | 0.5mA/V. | 36,400 | 20 | 0.5mA/V. |
| L.F.2 | 15,000 | 9 | 0.6mA/V. | 9,000 | 7 | 0.8mA/V. |

these figures at 100 volts H.T. and zero grid bias.

Makers' Rating.

| | | |
|----------------------|----|-------------|
| A.C. resistance | .. | 2,700 ohms. |
| Amplification factor | .. | 4 |
| Mutual conductance | .. | 1.5mA/volt. |

Measured Values.

| | | |
|----------------------|----|-------------|
| A.C. resistance | .. | 2,640 ohms. |
| Amplification factor | .. | 3.7 |
| Mutual conductance | .. | 1.4mA/volt. |

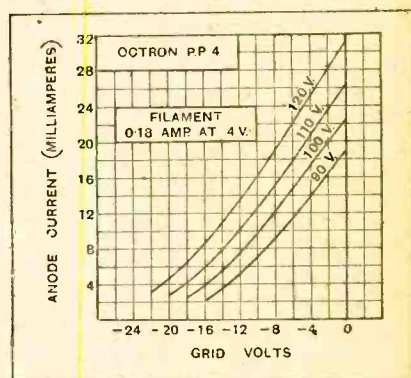

Average values under working conditions: A.C. resistance, 2,640 ohms; amplification factor, 3.7; mutual conductance, 1.4mA/volt.

The anode current is not unduly high for a super-power valve, as will be seen from the following measurements taken at various grid potentials and with 120 volts on the anode.

P.P.4.

| Grid Bias. | Anode Current. |
|--------------|----------------|
| - 10½ volts. | 15.4mA. |
| - 12 " " | 13.4 " " |
| - 13½ " " | 11.5 " " |
| - 15 " " | 9.8 " " |

Valves we have Tested.—

Nevertheless, it would be advisable to include a choke-capacity output circuit, or a transformer, since even this comparatively small current is too much to pass through the windings of the average loud speaker.

The rated and measured characteristics of the remaining valves in the 4-volt class are given below.

In all cases where a better conductance was obtained we found the filament current to be in excess of the makers' rating. For example, the L.P.4 should take 0.15 amp. at 4 volts, whereas the sample tested consumed 0.185 amp. at this voltage.

The 6-volt range consists of four types only—H.F., R.C., L.F., and power-valves.

L.P.6.

This is a valve of the small power class, but cannot be regarded as a "super" type, since its nominal A.C. resistance is 6,700 ohms, amplification factor 6, and mutual conductance 0.9mA. per volt.

The measured characteristics, which were taken at 100 volts H.T. and zero grid bias, were: A.C. resistance 5,800 ohms, amplification factor 5.3, and mutual conductance

rent at various grid bias voltages was found to be as follows:—

L.P.6.

| Grid Bias. | Anode Current. |
|-------------|----------------|
| — 7½ volts. | 7.2mA. |
| — 9 " | 5.8 " |
| — 10½ " | 4.6 " |
| — 12 " | 3.5 " |

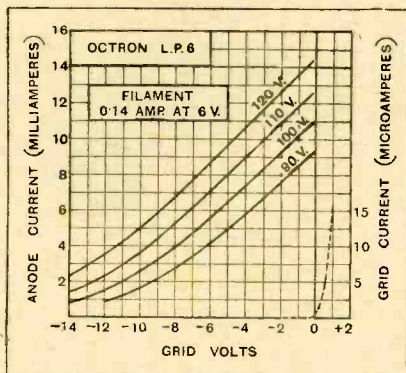

Average values under working conditions: A.C. resistance, 6,650 ohms; amplification factor, 5.2; mutual conductance, 0.8mA/volt.

0.9mA. per volt; these are in reasonable agreement with the makers' figures.

At 120 volts H.T. the anode cur-

The optimum grid potential under working conditions with this value of H.T. will be about -9 volts, and since the anode current is less than 6mA. it would be admissible to dispense with the usual output devices and connect the loud speaker in the anode circuit of the valve. The L.P.6 is not a super-power valve, but it should give a sufficiently large output to operate the loud speaker at moderate volume in an average-sized room.

A few of the samples tested showed a slight trace of reversed grid current at zero grid bias, but this cleared after the valve had been run for a short period.

4-Volt Series.

| Type. | Makers' Rating. | | | Measured Values at 100 v. H.T. and Zero Grid Bias. | | |
|-------|------------------------|-----------------------|---------------------|--|-----------------------|---------------------|
| | A.C. Resistance. Ohms. | Amplification Factor. | Mutual Conductance. | A.C. Resistance. Ohms. | Amplification Factor. | Mutual Conductance. |
| R.C.4 | 45,000 | 27 | 0.6mA/V. | 57,200 | 33 | 0.58mA/V. |
| H.F.4 | 24,000 | 18 | 0.75 " | 17,800 | 15.5 | 0.87 " |
| L.F.4 | 10,000 | 9 | 0.9 " | 8,730 | 9 | 1.0 " |
| L.P.4 | 6,000 | 6 | 1.0 " | 3,850 | 5 | 1.3 " |

CORRESPONDENCE.

The Editor does not hold himself responsible for the opinions of his correspondents.

Correspondence should be addressed to the Editor, "The Wireless World," Dorset House, Tudor Street, E.C.4, and must be accompanied by the writer's name and address.

MORSE INTERFERENCE.

Sir,—It was very refreshing at last to read, in your issue of May 15th, an intelligent and correct treatment of the above subject by G 2VV (Mr. Roe).

As one who used to read *The Wireless World* at the time when it was solely devoted to topics of the commercial and sea-going operators, I thought it rather a shame to read the long series of reckless letters which have appeared in your columns, all directed against so-called "Government Morse"—mostly letters written obviously by listeners with no knowledge of the Morse code, who therefore could not know from which stations and upon which wavelengths the messages were being worked.

As far as Londoners are concerned, the only Morse interference which should be encountered on the broadcast band is that from:

(a) Ships docking in London or Tilbury and calling GNF (North Foreland) to announce that they are shutting down their radio. (This only occurs at fairly long intervals, and is a transmission of one to two minutes' duration at the most.)

(b) Boulogne Radio (FFB), whose power is very large, and

who causes more trouble to the ships' operators than to listeners. Even when FFB works on 800 metres he jams 600-metre traffic, so that he is a nuisance to commercial and private stations alike.

So that London listeners who get perpetual Morse jamming must blame the lack of selectivity in their sets.

Everyone sympathises, of course, with those unfortunates who live in close proximity to a coast spark station. The authorities are doing their utmost to assist listeners by the following means:

- (1) Abolishing traffic on 300 and 450 metres.
- (2) Converting spark stations to I.C.W., though this is probably making the lot of the ship's operator harder as far as receiving is concerned, as it is very difficult to read I.C.W. through other I.C.W. jamming.
- (3) Working as much traffic as possible to Class A ships on 1,800, 2,100, and 2,400 metres by C.W. so that mostly only ships with rather low-power spark sets operate on the 600-metre wave.
- (4) Transferring long messages or lengthy traffic from spark-fitted ships to 800 metres instead of 600.

I should like to add that recently, whilst aboard a passenger ship in the North Sea, the operator, who was trying to work out a radio for me, was scarcely able to receive the coast station on account of broadcast interference from Budapest! So there is another side to the question, too!
South Woodford. STUART F. MEEK.

OLD LAMPS FOR NEW.

Sir,—We heartily agree with your Editorial remarks, and as traders we should be glad if manufacturers would seal their valve boxes, and also that a slip should be enclosed in each box saying that if found faulty the valve should be returned to the makers direct by the purchaser. We trust that your remarks may be brought to the notice of manufacturers and acted upon in due course.
Bournemouth.

BOSCOMBE RADIO CO.
(L. Gastrell Eades).

Sir,—May I support your correspondent, Mr. Duff, whose little outburst in your columns on the question of valves from the ordinary customers' point of view has my strongest sympathy! I would also suggest that the ordinary customer who buys a valve is in an unfortunate position, anyway. The valve is delivered to him presumably in perfect condition. If he finds that the filament is broken or that the valve refuses to emit directly he gets home he cannot probably get it exchanged. But generally, in my experience, troubles occur too late for this remedy. They develop with use. Microphonic noises occur, or the grid sags on to the filament, or emission gradually grows smaller or beautifully less. Some of the best known makes are sad offenders. I have tried to get such replaced, but have never had any luck. Am I exceptionally unlucky, or do others have the same experience?
Littleport.

W. BONARIA HUNT.

REGIONAL SCHEME AND SCRAPPY PROGRAMMES.

Sir,—The question of "scrappy" or "solid" programmes will soon assume an importance far greater than it has had so far.

The regional scheme should soon offer me a choice of five programmes with existing outfit in my present location, a double-barrelled London, a Cardiff of the same calibre, and a one-string Daventry.

My opinion is that the B.B.C. should put on five solid British joints—none of your Continental cookery—and leave me to sail round and carve off where the fancy strikes me. In other words, under the regional scheme the listener becomes the programme designer instead of the B.E.C. Or am I to have the privilege of dipping into five (or less) specially prepared brews?
Deal, Kent.

WM. B. WEST.

PROGRAMMES.

Sir,—I have been much interested by the correspondence which has taken place in your columns on the subject of the B.B.C. programmes. Very little of it, however, has been constructive criticism, and it is to be hoped that this letter differs in this respect.

I am of the opinion that the B.B.C. is very much more in the dark as to what the mass of the people really wants to hear than it imagines itself to be. And not only what it wants to hear, but when it wants to hear it.

Practically all the Corporation has to go on is the correspondence which it receives which may probably be divided into two classes, either from those who are extremely satisfied or extremely disgusted. The volume of this correspondence is most likely insignificant compared with the total number of listeners, the bulk of whom are for the most part totally apathetic. (Personally, I have been listening since the inception of broadcasting, and this is the first time I have ventured to express any views on paper.)

The remedy to my mind is in some form of census. Your correspondent, Mr. Shearman Dyer, asks for such a scheme, but is unable to find a practical application of it. I therefore suggest the following as being easily carried out without greatly adding to the expenses of the Corporation.

The postcard which is sent out by the Post Office should be a double card folded in half, one half being as at present,

and the other half appropriately set out for voting on a variety of subjects, together with the times of the day on which the receiving set is most frequently used, and a space for general comments. The completed cards could be handed into the post office when renewing the licence and passed on by them to the B.B.C. for analysis.

Furthermore, the scheme should be a permanent one in order that the B.B.C. may be kept up to date with the changes in public taste.

The idea should not be costly to carry out and might help us to get something more mutually satisfying than the present programmes.
C. W. A. RAY.

Brixton Hill, S.W.2.

Sir,—Mr. Ernest Kann, while he admits he is not in a position to speak of the likes and dislikes of "low-brows," is generous enough to admit that the poor (and, I think, others) should be provided with some form of amusement which they are capable of appreciating. And then he contradicts this by saying bluntly that "we do not desire a military band." I think it will be generally agreed that military band music is one class of entertainment that is enjoyed by quite a large proportion of the poor with their "unformed minds," and most of the "middle-brows" too. Mr. Kann makes the mistake of telling us what he wants cut out of the programme (he surely has an "on-off" switch on his set) instead of keeping to his own likes. In particular the Wireless Military Band is responsible for the switching-on of many sets which are silent while "Tristan and Isolde" are disturbing the ether.

He would prefer to hear Italian songs sung in Italian, and, apparently, rendered as though the singers were a minor part of the orchestra. If the words are not to be distinctive and intelligible, what is the use of a singer at all? It would seem that the addition of another instrument would do just as well.

As for his remarks on Sunday programmes, we should certainly appreciate longer transmissions, but to say that he has never met anyone who is satisfied with them suggests that Mr. Kann does not mix very much with his fellow-men, as I am personally acquainted with several people who would miss any other item in the programme rather than the Sunday Service or the Epilogue.
Chelmsford

F. C. CHAMBERLAINE.

Sir,—*Re* recent correspondence in your columns about the ever-important question of programmes.

I recently had a couple of days "off," and it struck me what nice programmes are given all day, particularly from 5XX until the tea hour comes around.

11 a.m.—Concert till 1. 1 to 2.—Restaurant music (this is the best, especially Frascati's). 3.30 to 5.15.—More concert, nearly continual.

Unfortunately, I, in common with most people, get home from work, normally, after 5 p.m. So we miss all the nice music.

Starting with the children's hour at 5.15, the whole evening seems nothing but ten- and fifteen-minute whiffs of music sprinkled with ten- and fifteen-minute whiffs of moral uplift and other rubbish. Surely the B.B.C. Programme Committee could put the "moral uplift" people on early in the day, and let the workers—brawn and brain—listen to some of the nice music in their few hours of recreation.

Nobody listens to the talks, anyway, at least, very few. If some of the professors and doctors could hear the clicks of the receivers being switched off when they are switched on, it would sound like a hail storm.

I noticed the B.B.C. switched off the *Daily Mirror* Children's Sing-song from the Albert Hall in their usual ill-mannered and drastic manner at 5.15 the other Saturday to put on the children's hour. Surely the children must have been disappointed to lose the Gug Nunc sing-song to listen to well-meaning aunts and uncles trying to be funny.
Llanely, S. Wales.

WM. J. LAW.

THE REGIONAL SCHEME.

Sir,—In your Editorial of May 15th issue you unduly stress the value of reception of Continental stations.

In this locality we are anticipating the opening of Brookman's Park and are hoping that the medium wavelengths

will then be available to us without a prohibitive amount of spark interference as at present.

The extra power will be, in my opinion, of very great benefit to the majority of listeners, comparatively few of whom trouble at all to time in Continental broadcasts. These few, of course, are enthusiasts and make themselves heard, whilst the very much greater number say nothing unless it is to grumble at heterodyning of the British stations by the more powerful Continental ones.

The question of crystal reception does not arise here, as there are no crystal sets in use, and, indeed, I do not think you would find many more than ten miles from the transmitter.

The B.B.C. serve the whole country and not these very limited and congested areas only or even mainly, and a very great increase of power seems to be the only way to give undisturbed reception to all.

Margate.

ARTHUR HOBDAV.

VALVE OUTPUT.

Sir,—Mr. R. L. Soper's letter published in your issue dated June 5th should remind valve manufacturers that published data in connection with power output for L.F. valves is long overdue.

The valve purchaser is entitled to know the comparative loud speaker outputs he is likely to get from various valves under given conditions, and with the exception of the valve list of the B.T.H. Company no information is at present available.

The following formula, I believe, is generally accepted as giving the maximum undistorted output in milliwatts when the maximum permissible signal grid swing is applied to the valve at maximum H.T. voltage. It is assumed that the speaker impedance is equal to or a little greater than that of the valve:—

$$\frac{\mu^2 \times G.B.^2}{8R_0} = \text{milliwatts undistorted output.}$$

where μ = amplification factor of valve.

G.B. = maximum negative grid bias volts.

R_0 = A.C. resistance of valve in thousands of ohms.

If this catches the eyes of the valve manufacturers it will be interesting to note whether they agree to the formula and whether they will be prepared to publish output characteristics accordingly.

Leatherhead.

R. H. REEVES.

Sir,—Mr. R. L. Soper, in his letter published in your issue of June 5th, states that he has had great difficulty in arriving at the true A.C. output obtainable from various makes of super power valves, and that in his dealings with two rival valve manufacturers, each claimed that his valve gave more power than that of his rival, in one case twice as much. It seems incredible that such a discrepancy should arise from the use of different formulas, and although I agree that all makers should publish in their advertisements the amount of undistorted A.C. power their valves can produce, this figure is easily obtainable from the characteristics normally given by making use of the formula of which I give a proof below, and the correctness of which I suggest will

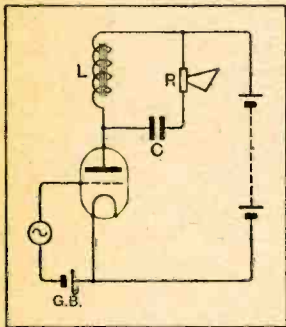

not be questioned by any of the manufacturers.

The sketch shows a valve working under ideal conditions. The loud speaker R is matched with the valve so that it offers the same resistance to A.C. of voice frequency as does the valve. The choke L is considered to be of sufficiently high inductance for its shunting effect on R to be negligible. Similarly, the condenser C is sufficiently large for its impedance to currents of voice frequency to be negligible.

Now the watts expended in R, when the maximum permissible A.C. voltage is applied to the grid of the valve, represent the maximum undistorted power that the valve can handle.

Let G be the difference between the grid bias voltage and the grid voltage at which grid current commences to flow. (This latter is usually at zero volts.) Then the maximum A.C. voltage R.M.S. that can be applied to the grid is $G/\sqrt{2}$. Now if I equals the valve impedance which is equal to the impedance of the loud speaker, and A is the amplification factor, the volts R.M.S. on the anode under the above conditions will be:—

$$\frac{G}{\sqrt{2}} \times A \times \frac{I}{I+1} = \frac{G \times A}{\sqrt{8}}$$

and the current through R will be:— $\frac{G \times A}{\sqrt{8} \times I}$ amps.

Therefore the power expended in R will be:—

$$\frac{G \times A}{\sqrt{8}} \times \frac{G \times A}{\sqrt{8} \times I} = \frac{G^2 \times A^2}{8 \times I} \text{ watts.}$$

That is to say, for an ordinary valve where grid current commences to flow at zero volts on the grid, the maximum watts undistorted output equals the square of the Grid Bias multiplied by the square of the Amplification Factor divided by eight times the Impedance.

It is hoped that this will not encourage manufacturers to overstate the grid bias required by their valves, and thus indicate a fictitious power. The correct value of bias will allow a "full load" signal just to avoid distortion at the bottom bend in the characteristic curve on the negative swing, and just to avoid causing grid current distortion on the positive swing.

Ilford, Essex.

ED. A. H. BOWSHIER.

IS ALL WELL WITH THE B.B.C.

Sir,—I was very interested to see your leader of June 12th on the subject of the B.B.C., and also the letter by "Perturbed" in the same issue.

When we look for an explanation of the apparent falling off in enthusiasm amongst some (we will not say all) of the members of the B.B.C. staff, is it not likely that we shall find it in the fact that in the early days Sir John Reith led his staff, and through his personality inspired each member of the staff to an unusual degree of enthusiasm, whereas a state of affairs has been reached to-day where he is to a large extent deprived of initiative because the organisation is now headed by a sedate board of governors who cannot have the same enthusiasm for the task as directed the early efforts of the B.B.C. under Sir John Reith.

As Capt. P. P. Eckersley said in an article which I read in the "Evening Standard" of June 12th, speaking of the old days, "The letters 'B.B.C.' blazed on the broadcasting horizon and I followed the *gloriam*. What days! Mr. Reith (now Sir John Reith), inspirer, mentor, friend, leader, negotiator, in one whirl of energy . . ."

One would think, to judge from the present state of affairs, that the days are over when enterprise and leadership of the B.B.C. are necessary, but surely they were never more needed than at the present juncture when public confidence in the B.B.C. seems to be waning, and even some of the best brains of the Corporation are departing as if they felt they were leaving a sinking ship.

Totteridge.

MAC.

Sir,—I am sure many people must have felt surprised that when the official announcement was made of the resignation of Capt. P. P. Eckersley from the B.B.C. there was not even a suggestion of regret in the statement, nor even an appreciation of the work that he has done since the days of Writtle in building up the technical side of the broadcasting organisation.

Much criticism is directed to the programmes and the policy of the B.B.C., but one very seldom comes across criticism of the way in which the technical side has been conducted, and, however much Capt. Eckersley may have been supported by able assistants, that makes no difference to the fact that the credit for what has been done is his.

Yet officialdom announces his resignation as if it meant nothing to the public nor to the B.B.C. as an organisation.

Carlisle.

R. WILSON.

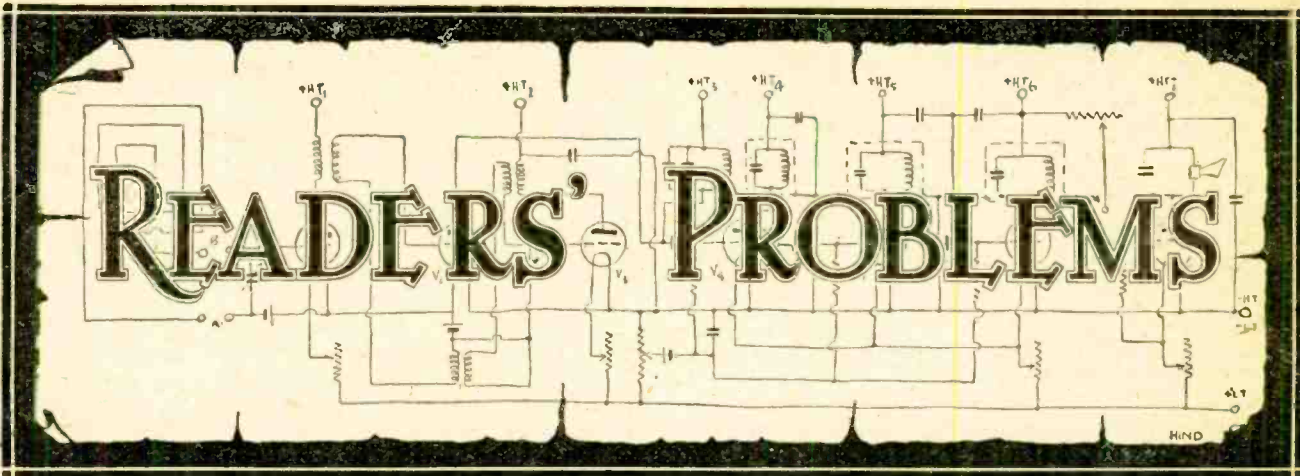

"The Wireless World" Supplies a Free Service of Technical Information.

The Service is subject to the rules of the Department, which are printed below; these must be strictly enforced, in the interest of readers themselves. A selection of queries of general interest is dealt with below, in some cases at greater length than would be possible in a letter.

Limitations of Selectivity.

I am rather disappointed in the selectivity of my receiver, particularly on the long waves; as an instance, I find it impossible to separate Daventry and Königswaterhausen (Zeesen), although there is a difference of 85 metres between the wavelength of these stations. Surely a good set should do better than this? F. W.

If you consider this matter in terms of frequency, you will find that there is a difference between the two transmitters mentioned (according to the latest list) of something less than 10 kilocycles; consequently, it is a more than difficult matter to separate them completely, unless the circuits of the receiver are so sharply tuned as to cause a good deal of high-note loss. The problem, from a practical point of view, is made much more difficult by the fact that your distance from Daventry station is much less than that separating you from the foreign transmitter, and it is hardly likely that you will be able to receive the latter, unless you use a very ambitious set

Primary-cum-Reaction Windings.

I am interested in the method of reaction control suggested in a reply to "F. M.," which appeared in your issue of June 5th under the heading of "A Good Portable Circuit," and am thinking of using something on these lines in my projected receiver. My trouble is that I cannot quite understand the connections of the combined primary and reaction winding; the circuit diagram given in Fig. 1 is complicated by switching. Will you please help me by giving a simplified skeleton diagram of the H.F. coupling and its connections?

L. P. T.

We think that the diagram given in Fig. 1 will make the matter clear to you. It will be seen that the only addition to the normal transformer-

RULES.

- (1.) Only one question (which must deal with a single specific point) can be answered. Letters must be concisely worded and headed "Information Department."
- (2.) Queries must be written on one side of the paper, and diagrams drawn on a separate sheet. A self-addressed stamped envelope must be enclosed for postal reply.
- (3.) Designs or circuit diagrams for complete receivers cannot be given under present-day conditions justice cannot be done to questions of this kind in the course of a letter.
- (4.) Practical wiring plans cannot be supplied or considered.
- (5.) Designs for components such as L.F. chokes, power transformers, etc., cannot be supplied.
- (6.) Queries arising from the construction or operation of receivers must be confined to constructional sets described in "The Wireless World" or to standard manufacturers' receivers. Readers desiring information on matters beyond the scope of the Information Department are invited to submit suggestions regarding subjects to be treated in future articles or paragraphs.

coupled arrangement is a tapping on the low-potential end of the primary coil; this tapping is joined to the reaction condenser.

You may regard the turns between the tapping and the "earthed" end of the

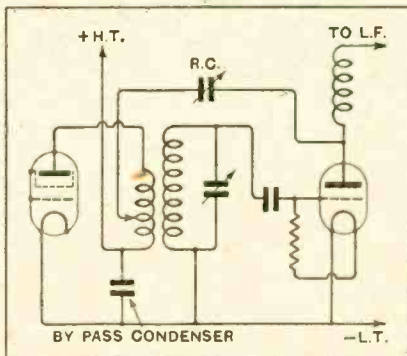

Fig. 1.—Simple method of applying reaction in a transformer-coupled H.F. amplifier: part of the primary winding acts as a reaction coil.

primary as fulfilling the function of reaction coil in addition to its normal rôle.

We should stress the point that, as stated in our reply to "F. M.," the "sense" of the primary and secondary windings must be correct, or reaction effects will not be obtainable.

o o o o

Voltage Drop.

I have fitted a regulating resistance for the first L.F. valve of my set, which is supplied with anode current from the D.C. mains through an eliminator; this was done with the object of preventing "motor-boating," and seems to be quite successful. I am not sure whether the resistance chosen is of the correct value, and understand that it is impossible to measure the actual voltage supplied without taking special precautions. I have a sensitive and accurate milliammeter; would it not be possible to use this for measuring the current taken by the valve, and then to calculate the voltage reduction due to the resistance? C. F. S.

Yes, provided you know the supply voltage, and the values of the reducing resistance and any other resistances (such as smoothing chokes, etc.), it is quite possible to obtain a sufficiently accurate idea of the actual voltage applied to the valve by the simple use of Ohm's law.

Having measured the current passed by the valve under working conditions, you should multiply this figure (expressed as a fraction of an ampere) by the resistance (in ohms). This will give you the voltage absorbed by the resistance, and, of course, if this figure is subtracted from the supply voltage, you will obtain the actual pressure applied to valve; or, more accurately, to whatever coupling device may be inserted in its anode circuit.

Eliminating an L.F. Stage.

With reference to your reply to "W. H. D." in "The Wireless World" for May 22nd, on the subject of "Safe L.F. Switching," is it not a fact that when cutting out the first L.F. valve, it will become necessary to alter the positions of the plugs on the grid bias battery?

J. M.
Yes; almost invariably some alteration will be necessary. Careful consideration of the diagram will show you that when the terminals A and D are bridged, with the result that the normal first L.F. valve is cut out, the output valve will be biased through the grid leak resistance, which was formerly associated with a valve of presumably much lower impedance. Consequently, this battery tapping should be moved to the socket normally occupied by the grid bias connection for the output valve.

Parallel-Feed H.F. Couplings.

If you consider the idea to be practicable I intend to build a two-stage screen-grid H.F. amplifier, using a parallel feed circuit on the lines of that included in the "Flat-Dwellers' A.C. Three."

I have a three compartment screening box with sufficient room to accommodate the coils and tuning condensers with adequate spacing, and propose to mount the valves externally. Will you please give me a circuit diagram showing how the various parts should be disposed in the screening compartments?

M. L.

The diagram you require is given in Fig. 2. You do not say if you are using

Anode Bend Detection.

Since reading your recent articles on "The Valve as an Anode Bend Detector," I have fitted a low-reading milliammeter in the plate circuit of the detector valve of my "Kilo-May Four." It is found that a rectified current of 1.2 milliamperes (or even considerably more) is readily obtained when tuned to a number of transmissions, but even before this figure is reached loud speaker signals are excessively loud, and obvious overloading is taking place. Can you give me a hint as to how I can make best use of the meter, mentioning any modification that may be desirable?

M. F. A.

We take it that you are using a detector valve of the comparatively low-impedance, high-efficiency type discussed in the article in question: if this is so, a reading of one millampere or slightly over (depending on anode voltage, etc.) will show that the detector is fully loaded, and consequently working under best conditions.

Assuming average modulation at the transmitting station, it follows that a "rectified" detector anode current of this order will give rise to very large L.F. voltage variations on the grid of the L.F. valve, and unless this is of the "super-power" variety, with exceptionally high plate voltage and commensurate grid bias, it will inevitably be overloaded unless some method of reducing its input is available. Of course, you could reduce the signal voltage applied to the detector (and consequently its anode current) either by detuning or by dimming the H.F. filaments, but this is defeating your

maximum value of something between 100,000 ohms and 250,000 ohms) across the primary of the L.F. transformer as suggested in the article already referred to. This is an addition that can be thoroughly recommended.

o o o o

A Mechanical Problem.

My set is a Det.-2 L.F. combination; in this locality it is necessary as a rule to use a good deal of reaction for the reception of either Daventry transmission at adequate volume, but when deeply modulated musical transmissions are taking place I often feel the need for some method of reducing volume by slackening reaction coupling, without the necessity of going to the set. Is there any simple way of fitting a remote control of reaction?

M. B.

We do not think that there is any simple solution of your problem. In practice, it would not be possible to extend the reaction control leads to a point at a distance from the set, and the only way out of the difficulty would be to use a relay system; this would be a rather complicated electro-mechanical problem. On the whole, we think you would be well advised to choose some other form of volume control, and perhaps we should add that, at your considerable distance, a set with a stage of H.F. amplification would be more satisfactory, both from the point of view of the fitting of remote control and all-round performance.

o o o o

Frame Aerial Details.

Will you please tell me if the long- and short-wave frame aerials for the "Flat-dwellers' A.C. Three" should be connected in series when receiving long waves? Is it essential that the frames used should be exactly as shown in the illustrations?

S. C. E.

It is intended that entirely separate frames should be used for the two wavebands; the aerial in use is inserted into its base on the top of the receiver and is connected to the terminals on the front panel.

It is by no means essential that the original design should be followed; in this matter you may suit your own conditions and requirements, remembering that the "pick-up" of a frame aerial increases with its dimensions.

o o o o

Reducing Aerial Loading.

It is often stated that the sensitivity of a set may be improved by inserting a small condenser in series with the aerial. I have tried to improve the performance of a friend's set by making this addition, but the only result is uncontrollable oscillation when the two condensers are brought into tune. Why is this?

W. D.

We expect that the set is of obsolete design; it probably makes use of an unneutralised H.F. valve as an H.F. amplifier, and is normally stabilised by aerial loading. When this loading is reduced by insertion of a condenser instability will naturally result.

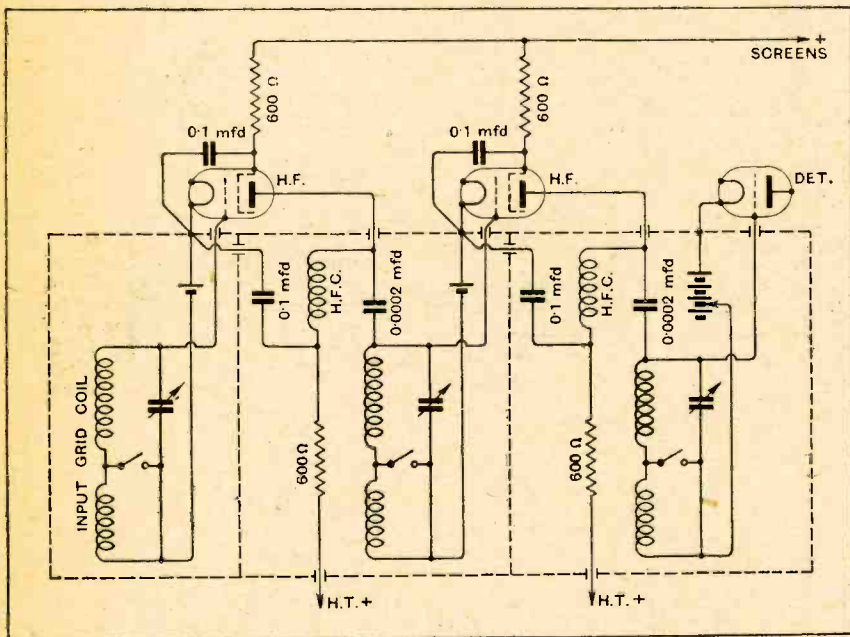

Fig. 2.—Arrangement of a two-stage H.F. amplifier with anode feed through H.F. chokes.

A.C. screen-grid valves as in the receiver to which you refer, but if you are, the necessary alterations will be obvious.

object; to obtain the advantages of a fully loaded detector, we suggest that you should fit a variable resistance (with a

The Wireless World

AND
RADIO REVIEW
(17th Year of Publication)

No. 513.

WEDNESDAY, JUNE 26TH, 1929

VOL. XXIV. No. 26.

Editor: HUGH S. POCKOCK.

Assistant Editor: F. H. HAYNES.

Editorial Offices: 116-117, FLEET STREET, LONDON, E.C.4

Editorial Telephone: City 9472 (5 lines).

Advertising and Publishing Offices:

DORSET HOUSE, TUDOR STREET, LONDON, E.C.4.

Telephone: City 2847 (13 lines). Telegrams: "Ethaworld, Fleet, London."

COVENTRY: Hertford Street.

Telegrams: "Cyclist, Coventry." Telephone: 6210 Coventry.

BIRMINGHAM: Guildhall Buildings, Navigation Street.

Telegrams: "Autopress, Birmingham." Telephone: 2970 and 2971 Midland.

MANCHESTER: 260, Deansgate.

Telegrams: "Hiffe, Manchester." Telephone: 8970 City (4 lines).

GLASGOW: 101, St. Vincent Street, C.2.

Telegrams: "Hiffe, Glasgow." Telephone: Central 4657.

PUBLISHED WEEKLY.

Subscription Rates: Home, 17s. 4d.; Canada, 17s. 4d.;
other countries abroad, 19s. 6d. per annum.

Entered as Second Class Matter at New York, N.Y.

As many of the circuits and apparatus described in these pages are covered by patents, readers are advised, before making use of them, to satisfy themselves that they would not be infringing patents.

CONTENTS OF THIS ISSUE.

| | PAGE |
|---|------|
| EDITORIAL VIEWS | 661 |
| DESIGNING THE L.F. AMPLIFIER. BY T. R. LUPTON | 662 |
| BROADCAST RECEIVERS. THE REES MACE TWIN SCREENED GRAND | 667 |
| USEFUL DATA CHARTS, NOS. 25A AND 25B | 668 |
| NEW APPARATUS REVIEWED | 672 |
| CURRENT TOPICS | 674 |
| BROADCAST BREVITIES | 676 |
| ALL ELECTRIC AMPLIFIER (CONCLUDED). BY A. P. CASTELLAIN | 677 |
| READERS' PROBLEMS | 683 |

WIRELESS PATENTS.

The Marconi Judgment.

ELSEWHERE in this issue we give a report of the judgment delivered by Mr. Justice Luxmoore in the Chancery Division of the High Court of Justice, allowing the appeal of the Marconi Company from the order of the Comptroller-General of the Patent Office, under which order the royalties payable to the Marconi Company on valve receiving sets were reduced from 12s. 6d. per stage to 10 per cent. on the wholesale selling price of the receiver, subject to a minimum charge of 5s. on the first valve and 2s. 6d. on each additional valve stage included in the apparatus sold. The effect of this judgment is to put back the position to what it was prior to the application by the Brownie Wireless Company to the Comptroller-General of the Patent Office for a compulsory licence under certain Marconi patents.

Too Much Optimism.

We cannot ourselves profess that the High Court judgment comes in any way as a surprise to us, for although

we have looked forward to the possibility of a reduction in the royalties and had not in any way wished to interfere with the policy of the Association of Manufacturers in their whole-hearted support of the Brownie Company in their action, we have throughout felt that too much optimism on the part of the licensees of the Marconi Company was in evidence, and that it would have been a wiser course to have made provision for the possibility of the full royalty payment until the issue was definitely decided.

In our issue of February 6th this year we commented on the matter, and although we were taken somewhat to task for our attitude, we feel that in the light of the present position we were fully justified in suggesting, as we did on that occasion, that the facts of the case did not warrant excessive optimism.

Unfortunately, the wireless industry as a whole has been inclined to assume that the reduction in royalties would stand and that the decision of the Comptroller would not be upset on the appeal of the Marconi Company to the High Court. So to-day many manufacturers find themselves in the position of having reduced their prices in anticipation of the royalty reduction, but are now liable for the full royalty of 12s. 6d. a valve stage retrospectively over a number of months.

The Need for an Amicable Settlement.

It is understood that the manufacturers who are licensees of the Marconi Company will negotiate with the Marconi Company with a view to reaching an amicable settlement of the present situation, and although the judgment indicates that legally the Marconi Company is entitled to extract the full royalty of 12s. 6d. a valve stage, one may reasonably express the hope that some compromise will be reached, in view of the fact that this rate of royalty has for a long while been generally considered high and a hindrance to the marketing of cheaper receivers. Moreover, since the anticipated reduction of royalties brought about a reduction in prices, sales, it is understood, have increased substantially.

Readers may recollect that the general agreement under which the Marconi Company licences manufacturers, known as the A.2 agreement, is in respect of thirteen patents owned by the Marconi Company, and another consideration which should, we think, have considerable influence in bringing about a reduction in the present royalty charge is that two of what may be regarded as the principal patents in this group expire this year, one (that known as the "Reaction" Patent) having, in fact, already expired, and the other (known as the "Grid Leak" Patent) expires in October.

DESIGNING the L.F. — — AMPLIFIER

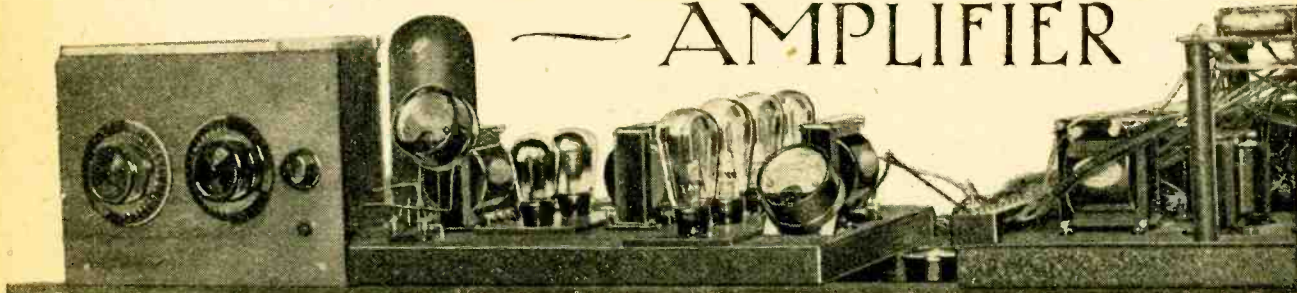

Choosing the Intervalve and Output Coupling Components.

By T. R. LUPTON, M.Sc.

(of the Ferranti Radio Research Laboratories).

IN the matter of the design of a low-frequency amplifier, it may appear at first sight to be rather illogical to deal primarily with the output end of the set, but one must at the outset decide what is intended to be done with the receiver, or, in other words, the amount of output which is necessary. To take two extremes, a set designed to feed a small horn type speaker will be much different from that required to fill a large hall with music or speech. Here a large proportion of set builders meet a stumbling block, for many have asked the following question: "I intend giving a demonstration in a small hall—how many valves and what type shall I use?" As in many other walks in life, experience is here the best guidance, but it can be taken that for a *small* hall two L.S.5A valves with 400 volts on the anodes, feeding to a moving coil speaker, will be necessary. For an ordinary large-sized room two valves of the B.T.H. PX.650 type with 200 volts on the anode will give a reasonable margin of safety against overloading on peaks when using a moving coil speaker. This is a point which unfortunately for the good name of wireless has been overlooked in the past.

A Plea for Adequate Power Output.

It has been customary to work practically every wireless component to its limit. Indeed, up to a very recent date most valves used were atrociously overloaded, and even at the present time overloading of valves is one of the most frequent sources of distortion, which becomes distressingly evident when a really good speaker is used. When it is intended to use a cone speaker of the moving iron type or a horn speaker, it is desirable to use a super-power type of valve. The smaller power valves, from a quality point of view, are somewhat inadequate as output valves, and should only be considered as a dry battery man's power valve, because the volume obtainable from the loud speaker with such a valve when not overloading can only be

described as a "tinkle" due to the small power output. The figures which will be given later merely as an example of an amplifier, will be based on an output stage of two valves of the PX.650 type with 200 volts on the anodes. Even though a large number of people regard this as a large available output it is not so in reality, as although the *total* power available is certainly not necessary to handle the *average* volume issuing from the speaker, it is there in order to take care of large peaks which occur at times, such as a particularly high soprano note, drums, or, in a play, the shriek of the heroine or the bang of a door. On most sets these do not sound natural, and although the lack of reality is very often attributed to faulty transmission, this is only partly so, and is to a much larger degree due to the momentary overloading of the output stage of the amplifier. So much, therefore, for the necessity for a liberal output stage.

Personal Safety Necessary.

In passing it may be as well to draw attention to the voltages specified above—400 volts is mentioned as suitable for a small hall, but only 200 for an ordinary room. Too much emphasis cannot be laid upon the danger of handling 400 volts; the careful experimenter who has constructed the set may with due caution handle it, but in the hands of the inexperienced such high voltages are to be deprecated. It is, moreover, advisable in the case of a family set in which the anode voltage is even of the order of 200, to equip it with an automatic switch which cuts off the current when the cabinet doors are opened or the lid is raised.

The next point which arises is the method of connecting the output stage. The various means available are shown in Fig. 1. The simplest scheme for connecting a speaker to a set is to insert it in series with the lead from the positive H.T. supply to the anode of the last valve, as shown in Fig. 1(a). There are various objections to this: first, with large output valves the current through the speaker will be large and may affect

Such a multiplicity of methods exists for coupling low-frequency valves and for connecting the loud speaker to the last stage that readers will welcome a treatise on this subject couched in simple terms. Disappointing signal quality can often be accounted for by a lack of knowledge of the factors controlling the relative impedance values of the speaker and the last valve; this article supplies valuable information on the subject.

Designing the L.F. Amplifier.—

its operation, though as to whether this is audible or not depends entirely on the type of loud speaker employed. The making or breaking—generally the breaking—of the current gives rise to a high voltage across the terminals of the speaker, so that the insulation between turns is subject to a high voltage stress resulting often in the breakdown of the insulation. The moving coil type of speaker cannot be operated with a steady D.C. current flowing through its speech coil, since this pushes the coil right out of the magnetic field, so that isolation from the anode direct current is absolutely essential in this case. Again, most loud speakers are designed with terminals which are easily accessible. This is done for convenience in connecting up, but if a high voltage is used on the anodes of the power valves the speaker terminals will be at a high potential. Thus there is a slight possibility of a person moving a loud speaker and touching a terminal in doing so, and at the same time touching a good earth with some other part of the body. This can prove dangerous and is a remote contingency which must be guarded against.

Isolating the Speaker from D.C.

The last disadvantage of direct connection of the loud speaker to the power valve anode circuit is that the majority of people find it desirable for various reasons to place the loud speaker at a distance from the set. With a good amplifier the length of lead to the speaker is sufficient to cause back-coupling to the input, which results in a high pitched whistle, generated by virtue of this coupling.

Fig. 1 (b) shows a single valve with choke-capacity output; the single valve must be taken as being merely diagrammatic, as the stage may actually consist of two or more valves in parallel. Here it is seen that the anode current flows through the choke to the valve or valves and should therefore be of a very low resistance, otherwise with large anode current there will be a considerable voltage drop, so that the voltage actually on the power valve anode is less than the maximum available with a consequent reduction of available output. The other essential of the choke is that it must offer a high impedance to low frequencies, an impedance which should be at least five or six times—preferably more—the impedance of the loud speaker, thus diverting the major portion of the low-frequency current through the loud speaker. The condenser, however, serves to keep any current from the H.T. source from flowing through the speaker. The return lead of the speaker is connected to L.T. negative, thus preventing low-frequency currents from the power valve from flowing through the H.T. battery, which decreases the tendency to back-coupling.

As has been described previously in *The Wireless World* back-coupling can be caused through the low-frequency current circulating through the H.T. source, passing potential back to previous valves in the amplifier, which thus becomes re-amplified, appears again at the output, is passed back and re-amplified until the whole set becomes unstable and either howls or "motor boats," which is really a very low frequency oscillation, the frequency actually depending on sizes of chokes and condensers used.

Fig. 1 (d) shows two valves in push-pull with centre-tapped choke. A condenser in each arm isolates the speaker from the H.T. supply. The advantage of this arrangement is that the anode currents to the two valves flow in opposite directions to each other, thus balancing out magnetically, with the result that in order to obtain a certain inductance the choke can be made much smaller than in the case where a single valve or valves in parallel are used, or, alternatively, the same size choke can be used with an enhanced inductance under working conditions, for it must be remembered that as the iron core becomes more and more magnetised so the inductance of the choke is gradually decreased.

Fig. 1 (c) shows an

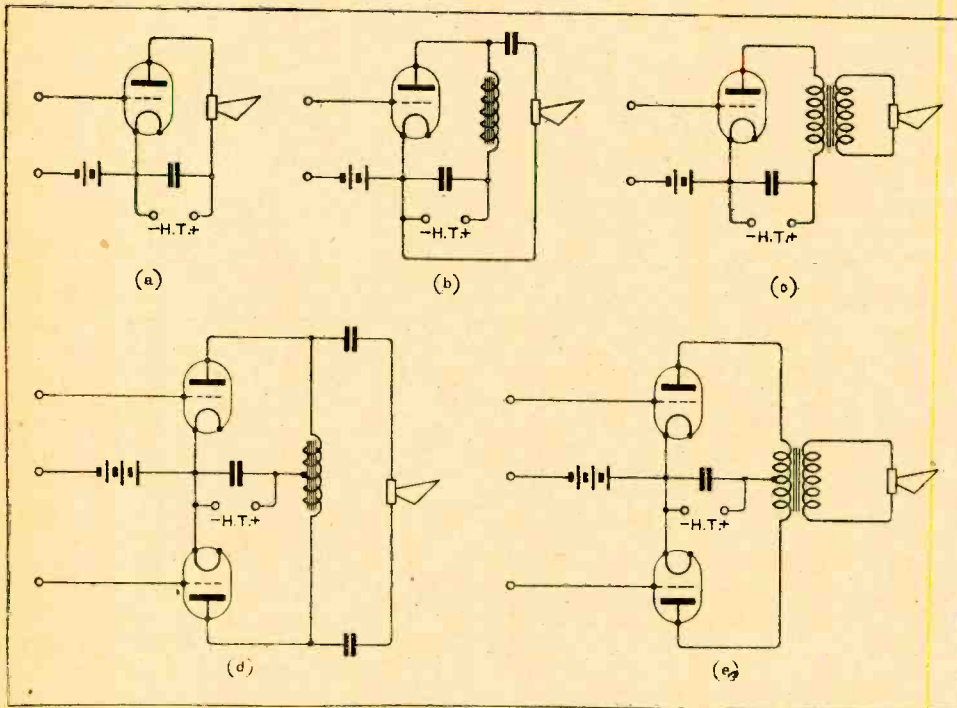

Fig. 1.—Various methods of coupling the loud speaker to the output stage. Direct coupling is shown in (a); Choke-filter output (b); Output-transformer-coupling (c); push-pull choke output (d); push-pull transformer output (e).

¹ "Battery Resistance and Distortion," *The Wireless World*, April 25th, 1928.

Designing the L.F. Amplifier.—

ordinary single output valve with a transformer in the anode circuit, and is simply inserted for the sake of completeness. Although it is quite suitable for use with small power valves, it is not recommended for large valves, as an ordinary output transformer becomes increasingly difficult to design as the primary current becomes large. It has, however, the advantage over choke-capacity coupling that it serves the purpose by reason of its ratio when suitably chosen of adapting the speaker impedance to the impedance of the valve. The all-important question of matching of impedance is dealt with later.

Fig. 1 (e) shows a push-pull output stage with the necessary push-pull transformer in the anode circuit.

The question of whether to connect the valves in parallel or in push-pull is mainly bound up with the question of the output device. If one used choke-capacity output then the speaker must be so designed that its impedance is approximately equal to twice that of the valve combination. "Valve combination impedance" is, for valves in parallel, equal to the impedance of one valve divided by the number of valves in parallel, but when two valves are used in push-pull with mid-point bias the impedances to L.F. currents are in series, and therefore the effective impedance becomes twice that of a single valve. Until recently it was accepted that in order to obtain maximum output the effective load impedance must be equal to that of the valve combination, but latterly it has been shown mathematically, and to the author's knowledge checked up experimentally, that the condition for maximum output is that the speaker impedance must be rather greater than or even twice that of the valve combination.

Curvature or Mid-point Biasing for Push-pull?

The original method of using push-pull was to bias the valves so that the bottom bend of the anode current-grid voltage characteristic was reached. Thus, while no signal was being received very little current was taken by the output valves and as one valve was operative the other was inoperative.

The reasons that this method is not popular at the present time are: first, in order to obtain a certain output approximately twice the grid swing is necessary compared with that required in the method to be described. Secondly, in order to avoid distortion the valves must have characteristics which are very similar

towards the bottom bend. This is a part of the characteristic which is an extremely variable quantity, and would thus need careful measurements to obtain the best results, since one must have the valve biased at the mid-point of the curvature. Finally, as one valve is in use while the other is idle with a reversal for the next half cycle, there is flow of current at an audio frequency from the H.T. supply, and when large outputs are concerned additional risk of back-coupling through the supply device is incurred.

The method more commonly in use at the present day is to bias practically the mid-point of the straight part of the characteristic. Under push-pull conditions half the signal is fed to the grid of one valve, the other half being fed at the opposite potential to the other grid simultaneously. Thus, as one grid is a certain amount positive, the other grid is an equal amount negative. Now, following the action through the output valve, this positive grid will cause a certain increase of current to flow in the anode circuit of that valve, while the anode current of the other valve will be decreased by an equal amount because of its negative grid. We thus see that the total feed to the two valves has remained

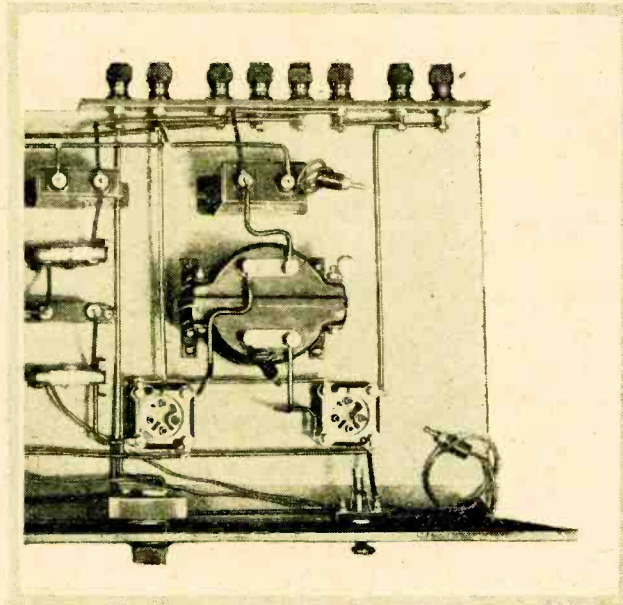

Showing a typical layout of components in a low-frequency amplifier. Note that the last valve is directly coupled to the loud speaker.

unchanged, and there is in effect a circulation of A.C. signal from one filament to the anode through the output transformer primary to the second anode and back to the filament. This has involved no flow of current through the H.T. supply source, so that there is no signal component in that source with consequent reduction of interaction in the amplifier. This fact together with the cancellation of magnetisation due to the current flowing in opposite directions through the two halves of the primary of the output transformer is the true advantage of the push-pull arrangement.

As mentioned previously, if one considers the design of a transformer to carry the current to two large power valves in parallel it is an awkward proposition, because the transformer must have an ample core section in order that it shall not saturate magnetically. This means that it becomes unduly bulky, and also, which is an important point in practice, the co-efficient of coupling between primary and secondary begins to depart from unity, which is objectionable. If, however, the valves are arranged in push-pull, the anode currents through the two halves of the primary winding flow in such directions that the magnetic effect of the one neutralises that of the other, so that the only limit to the current which a push-pull output transformer will carry is that fixed

Designing the L.F. Amplifier.—

by the size of the wire, and usually becomes evident by a reduction of the anode voltage rather than by heating. Under these conditions the primary retains its high inductance, the transformer can be kept small, and thus the coupling between windings maintained at a very high value.

Avoiding Distortion in Push-pull.

While it is desirable to use valves with characteristics as similar as possible, it is not essential that they should be exactly matched. This is easy to understand, for suppose that the mutual conductance of one is slightly smaller than that of the other, then for a given input signal the one with the smaller mutual conductance will produce a smaller change of milliamps than the other. The result is that a small portion of the audio signal has to return either by the anode supply lead or by way of the two-microfarad by-pass condenser which ought to be attached to the positive H.T. terminal, that is, to the centre tap of the primary of the transformer. The signal is represented by the change of milliamps of the one valve flowing through half the transformer primary plus the change of milliamps in the other valve flowing through the other half of the transformer. Thus the milliamps multiplied by turns for one-half of the transformer is different to that of the other half, but since this holds for any portion of the cycle it does not cause distortion. Another point which arises in connection with push-pull output is that in the past many people

have been disappointed with the volume obtainable, the effect being coupled with a severe form of distortion. In a number of cases this has been traced to self-oscillation of the output stage, and in many cases has been caused by the user of the set. Super-power valves have been used with much higher anode voltages than that for which they were designed, so that slight softening resulted which was sufficient to cause parasitic oscillation. A palliative is to use a high resistance in series with each grid, but the correct thing to do is to use the

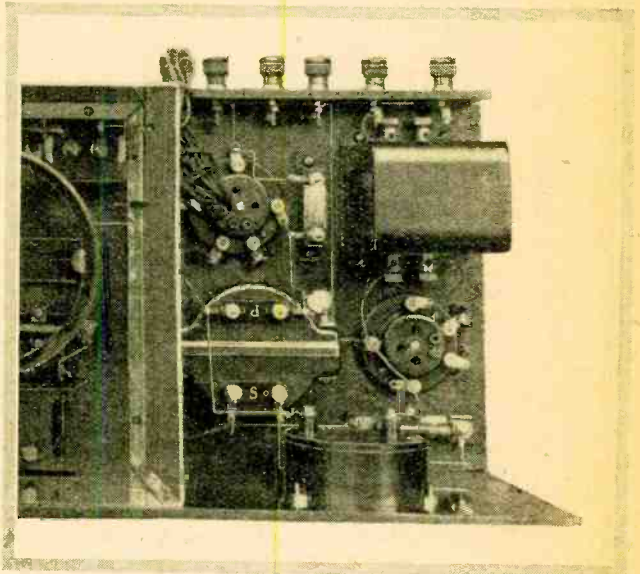

The low-frequency amplifier layout in a set built for A.C. valves. An output transformer to match the speaker and output-valve impedances can be seen on the right.

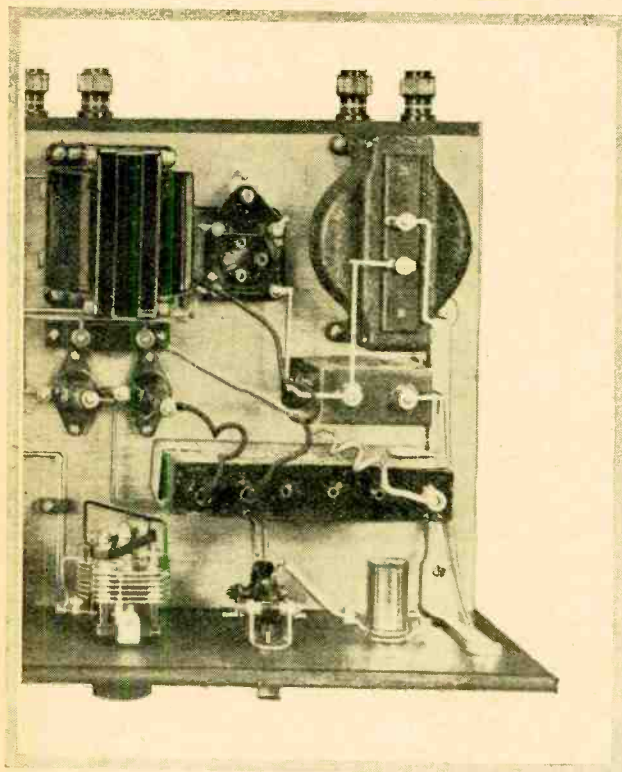

The choke-filter output circuit of the "Megavox Three" receiver. The steady direct anode current is prevented from passing through the loud speaker windings.

valves at an anode voltage not higher than that specified by the makers, and bear in mind always to switch off the filaments when taking out the grid bias wander plug in order to adjust the bias.

It must not be thought that push-pull is a panacea for all output troubles. Many writers have stated that push-pull enables a lower value of H.T. to be used. Such a statement is hardly correct without qualification. With a given H.T. two valves will give identical output whether used in push-pull or in parallel. It may be mentioned that in order to obtain maximum output from the valves in push-pull twice the grid input signal is required that would be necessary with a single valve, whereas with valves in parallel the same signal is required as with the single valve. This hardly ever causes any difficulty, as an ordinary set can usually easily overload the output stage.

The importance of the correct ratio of the output transformer cannot be over-emphasised.² This has been the reason for much of the disappointment when push-pull output has been used for the first time. It is easily seen that the impedance of two valves in push-pull is four times the impedance of the same two valves used in parallel. Thus the ratio of the output transformer

² See "Letters to the Editor," *The Wireless World*, Jan. 16th, 1929. Also *Experimental Wireless*, August, 1926.

Designing the L.F. Amplifier.—

should be $\sqrt{4}$ times as large as it was before, that is, twice as large. A great difficulty arises when using any ordinary horn or moving-iron type of speaker, for it was mentioned earlier that the impedance of the speaker must be stepped up by means of a transformer to be equal to twice that of the valve combination. However,

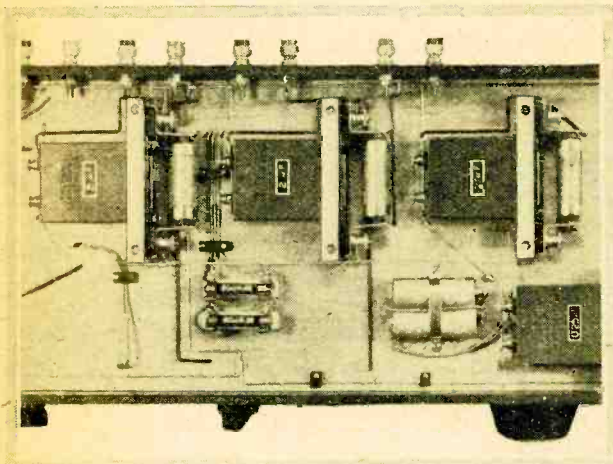

A convenient method of mounting anode decoupling resistances and condensers on the under-baseboard. A complete battery filter for each valve can thus be accommodated without crowding the baseboard.

with the types of speaker just mentioned, the impedance varies at different frequencies, in some speakers approximating to a definite law, but in others in a quite haphazard manner. The question therefore arises as to the frequency at which the impedance must be considered. At the best one can only compromise, with the result that some frequencies will be over-emphasised while others may be slightly lacking. However, if a good moving coil speaker is used its impedance remains fairly constant over a large range of frequencies, with usually a large resonance towards the lower frequencies and a high rise of impedance at the upper end of the audible range due to the natural increase of impedance of an inductance with frequency. One can thus accommodate such a speaker more accurately than other types.

The transformer ratio N is given by

$$N = \sqrt{\frac{2 \times \text{Valve Impedance}}{\text{Speaker Impedance}}}$$

This matching of the loud speaker to the valves is one which in the majority of cases can only be carried out by means of a transformer. In other words, the choke capacity output arrangement is only suitable for use when the speaker impedance happens to be approximately equal to twice the valve combination impedance. If this is not so, as in the vast majority of cases, then a transformer is practically essential.

(To be concluded.)

New "Call Book."

The "Radio Amateur Call Book" for June is now published, and the lists of call-signs of amateur and experimental stations in all parts of the world has been brought up to date as far as possible. We presume that the book had to go to press before it was feasible to amend the Argentine call-signs which are mainly the old signs transposed and with the nationality prefix LU. Thus AH4 now becomes LU4AH. The published lists we have seen in Argentine papers give the stations in the alphabetical order of the names of their respective owners, and it will be a somewhat lengthy and tedious task to rearrange them in the order of their call-signs to conform with the remainder of the Call Book, though we presume that this will be done in time for the next edition.

The book contains the revised "Q" code, and authorised abbreviations, the nationality prefixes and a useful list of short-wave stations.

○○○○

Berne Lists.

With reference to the note on page 613 of our issue of June 12th, we understand from the International Bureau of the Telegraph Union that Parts II and III (stations performing special services and ship stations) are now in the press and will be published in a few days, and that Parts IV and V should be ready in four or five weeks' time. The alphabetical list of call-signs will then follow. This will contain the call-signs of all stations comprised in the five international lists,

TRANSMITTERS' NOTES.

and must necessarily await the completion of these. The nature of each station in the alphabetical list will be indicated by the letters specified in Article 13, par. 10 of the Washington Convention, so that there will be no difficulty in determining which of the five lists contains the particulars of any station.

○○○○

Russian Amateurs.

The following corrections should be made to the list of Russian amateurs published on page 528 of our issue of May 22nd:—

| | | |
|-------|-------------|----------------------|
| EU5AR | should read | EU5AL, M. Tetelbaum. |
| EU5AL | " | EU5AC, M. Skotcki. |
| EU5AB | " | EU5AW, M. Aaronov. |
| EU5AC | " | EU5AS, M. Wolfenzon. |

Mr. A. Lambourne, who sent us the original list, regrets the errors which were occasioned by transcribing Russian letters into English script.

○○○○

Field Day with a Portable.

The Southend-on-Sea and District Radio Society held the first of this year's series of field days on Sunday, June 16th, at Rochford. Their portable station, G5QK, uses for the transmitter a single-valve Hartley circuit, the power being drawn from dry batteries at 240 volts and the three-valve receiver was of the detector, L.F. and power type, all constructed by members of the Society.

Successful two-way communication was established with G5SN at Westcliff, G2LZ at Wickford, G6PA at Chatham, and G2MI at Margate, whose own transmissions were received at good loud speaker strength. The portable station was operated under the supervision of Mr. H. C. Revell.

The next outing will be on Sunday, July 21st, and the hon. secretary, Mr. F. Waller, Lynthorpe, Grange Gardens, Southend-on-Sea, will be glad to hear from any other society similarly engaged on that day with a view to exchange of signals.

○○○○

QSL Cards Destroyed.

Mr. J. W. Tyrrell (G2BLX) tells us that his valued collection of QSL cards has been burnt (possibly in the course of those barbaric sacrificial rites known as "spring-cleaning"), and wishes to appeal to all transmitters who have in the past sent him their cards to forward him duplicates, which will be most gratefully acknowledged. Among the foreign amateurs whose cards were destroyed are EB4TO, 4CK and 4AI, EAR10 and 55, Danish 7RL and various stations in the Irish Free State. Cards should be addressed to Signalman J. W. Tyrrell, "D" Coy., Royal Corps Signals, Catterick Camp, Yorks.

○○○○

Call-Sign Relinquished.

Mr. F. Charnley asks us to state that he no longer operates station G5AZ at 43, Reads Avenue, Blackpool. This call-sign is now allotted to Mr. H. Hazelden, 41, Oakhurst Grove, London, S.E.22.

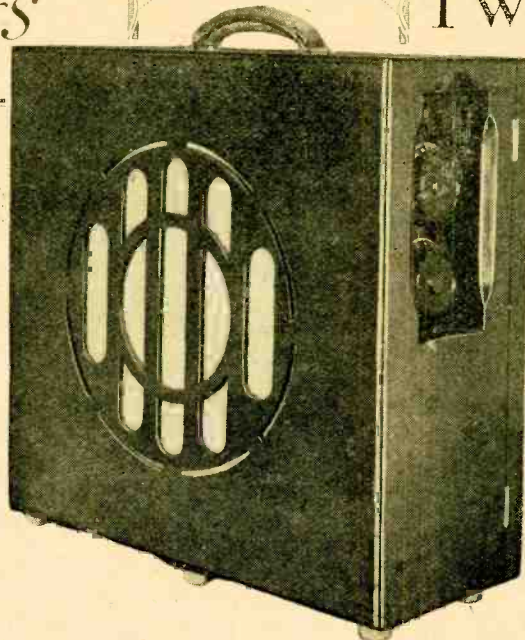
Broadcast
ReceiversREES—MACE
TWIN SCREENED
GRANDA Receiver
in which the Best Circuit
Practice is Materialised in
Portable Form.

THE Rees Mace "Twin Screened" portables, although employing essentially the same circuit, are made in two types, the "Baby" and the "Grand." The former falls well within the weight and size limits of the "portable" type, but the latter must be classed as a transportable. It is intended for clubs and dance rooms where plenty of volume is required but where the advantages of mobility are also appreciated. The case measures 20½ in. by 19½ in. by 8½ in. and is constructed of solid mahogany. Taking into account the fact that two AF5 transformers are incorporated in the L.F. amplifier it will be appreciated that the weight is above the average portable.

The generous dimensions of the case, however, permit the use of a large diameter cone loud speaker and a more logical disposition of the component parts of the circuit than is usually possible in a portable of conventional dimensions. The photograph of the interior shows that there is no cramping, everything is accessible and valves and batteries can be changed with the minimum of difficulty.

The Circuit Arrangement.

The circuit comprises five valves, the first two stages being devoted to H.F. amplification. The two P.M.12 screen-grid valves and their associated couplings are completely screened. The detector is an H.L.210, functioning as a leaky grid rectifier, and is mounted in the right-hand screening compartment together with the anode circuit of the second screen-grid valve. In this compartment are also to be found by-pass condensers and a H.F. choke for suppressing the H.F. component of the rectified current before it passes out to the L.F. amplifier. The screen-grid valves are coupled by means of H.F. transformers tuned by means of ganged condensers mounted in each compartment. The transformers are of the simplest possible construction, the primary and secondary windings filling adjacent slots in formers built up from ebonite discs. Though no one would venture to claim that this

form of winding is efficient, it has many advantages when applied to a two-stage amplifier of this type. The adjustment of turns is easy to carry out, and any damping present is conducive to stability, while comparative flatness of tuning in individual circuits is not of serious consequence where there are three tuned circuits in cascade. Indeed, this can be regarded as an ideal arrangement inasmuch as a good overall selectivity is obtained without undue cutting of the sidebands carrying the higher audio frequencies. No reaction is employed, so that this property of the circuit is in no way impaired.

Transformer coupling is employed for both the L.F. stages, the transformers being of unusually high quality for a portable set. The first L.F. valve is a D.E.L.210 and the output valve a D.E.P.240 biased to -18 volts. Such a luxury is inevitably paid for in H.T. current consumption, and it is not surprising to find that the total H.T. current for the set is 18.5 mA. However, the energy is expended to good effect, for the volume and quality of reproduction is quite exceptional for a self-contained receiver.

Unusual Cone Assembly.

Having taken great pains to perfect the L.F. stages, the designers have realised that a really good loud speaker is necessary if the cost of the L.F. transformers, etc., is to be justified. Accordingly they have produced a cone loud speaker of a unique type which, judging by results, does full justice to the L.F. amplifier. The drive is of the adjustable reed type and is rigidly mounted on a stout wooden upright. The reed is attached to a compound diaphragm consisting of two cones of different diameter. The outer cone is reinforced, has an obtuse angle and is 1¼ in. in diameter, while the inner cone has a diameter of 7 in. at the periphery and is acute. The results would seem to justify this form of construction, for not only is the upper register well in evidence, but the low notes are better reproduced than in any commercial portable we have so far tested. This was convincingly demonstrated

Broadcast Receivers.—

during an organ recital in which the lower frequencies are well in evidence in the pedal notes.

In the absence of reaction, and with ganged H.F. stages, the controls are few in number and easy to manipulate. There are two tuning dials; the upper dial (C1) actuates the ganged condensers inside the screening boxes, while the lower dial (C2) tunes the frame aerial. The combined on-and-off and wave-range switch is situated in the top left-hand corner of the panel and is balanced on the right by a volume control which takes the form of a rheostat for the screen-grid valve filaments.

The performance on long waves is particularly good. There was complete freedom from the "mush" which mars many 2 H.F. sets on long waves, and reception from four Continental stations was crisp and clear. No difficulty was experienced in separating Radio Paris and 5XX, and Königswusterhausen could be received without interference by making use of the directional properties of the frame. As a guide to the sensitivity on short-waves, it may be mentioned that the volume control has to be used when receiving 5GB

in London. Even so, the station is inaudible 5 degrees on either side of its normal dial setting. After dark the short-wave band is alive with stations, particularly near the lower end of the range, where sensitivity appears to be highest. In daylight, however, 2LO and 5GB are the only reliable stations, at all events in the vicinity of London.

The Twin Screened Grand, then, is a receiver in which no pains have been spared to achieve selectivity and range without detriment to quality. In our opinion the makers have succeeded in this effort to a marked degree and have produced in portable form an instrument embodying the best receiver practice. The only possible criticism is that the current drawn from the H.T. battery is considerably greater than the economic discharge rate, but presumably this will be considered a minor point among the clientele for whom the set has been designed. The price of the model under review is 36 guineas, while the same essential circuit is available in more compact form at 34 guineas (Twin Screened Baby). The makers are the Rees Mace Manufacturing Co., Ltd., 39a, Welbeck Street, London, W.1.

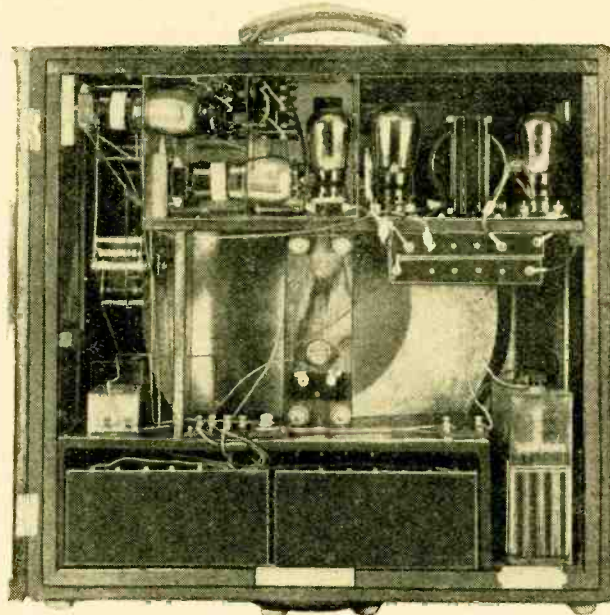

The dimensions of the case permit the use of a 14in. loud speaker diaphragm and give the designer a free hand in arranging the layout of components.

USEFUL DATA CHARTS. (Nos. 25 (a) & 25 (b).)

The Design of Iron-cored Chokes Carrying D.C.

IRON-CORED chokes are required in the smoothing circuits of battery eliminators and in the output stage of L.F. amplifiers, and it is important that the magnetisation of the iron due to the D.C. ampere-turns should not approach the saturation point, otherwise the inductance of the choke to superposed A.C. will fall off.

Such excessive magnetisation can be prevented by using a sufficiently large core section, but the same result can be obtained more cheaply by introducing an air gap in the magnetic circuit. We use the following symbols:

- L = A.C. inductance of choke in henrys.
- I = D.C. current in amps.
- V = Volume of iron in cubic inches.
- N = Total number of turns.
- l = Length of magnetic path in inches.

It is known that when the best air gap is used in each case a curve can be drawn¹ connecting LI^2/V and NI/l .

Fig. 1 shows this relation for stalloy,² and the curves form the basis of abac 25 (a).

Example.

We wish to design a smoothing choke whose A.C. inductance is to be 30 henrys, the D.C. flowing through it being 50 mA., and the frequency 50 c.p.s. Let us try a stalloy core such as that given in connection with abac 24,³ in which the volume of iron is 9.15 cub. in. and the length of magnetic path 6.8in. Then on going through abac 25 (a) and using $L=30$ henrys, $I=50$ mA., $V=9.18$ cub. in., we find turns/inch = 700. Curve (r) has been used: we shall see presently whether this choice was justified. The turns = $700 \times 6.8 = 4,760$: the winding area is 0.9 sq. in., and so we can find the largest gauge of wire which will allow 4,760 turns to be wound

² The data for these curves are taken from Symonds *Experimental Wireless*, September, 1928, p. 485.

³ *The Wireless World*, April 24th and May 22nd, 1929.

¹ *Experimental Wireless*, February, 1928, p. 49.

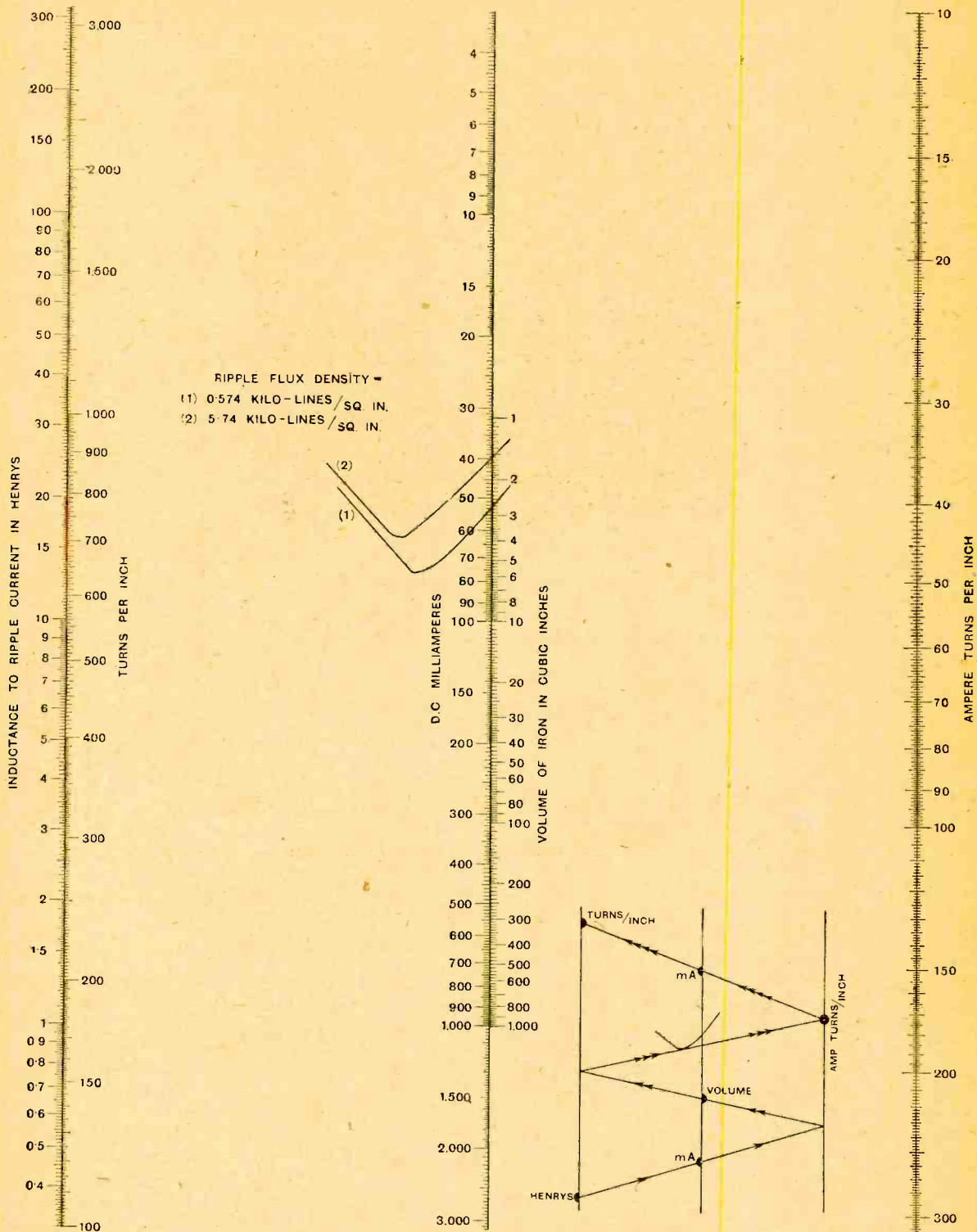

DESIGN OF IRON-CORED CHOKES CARRYING D.C.
 DETERMINATION OF TURNS PER INCH

W.W. ABAC

No 25 a

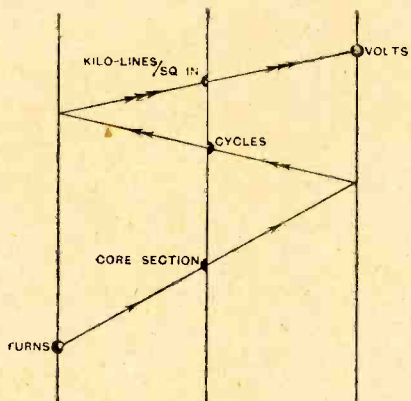
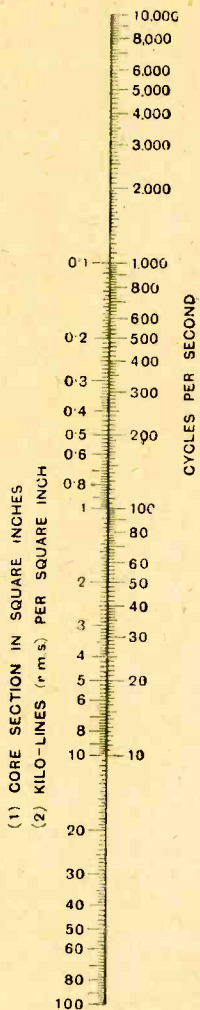

DESIGN OF IRON-CORED CHOKES CARRYING D.C.
RELATION BETWEEN A.C. FLUX PER SQUARE INCH AND A.C. VOLTS

W.W. ABAC

Nº 25 b.

Useful Data Charts (Nos. 25 (a) and 25 (b)) -

in this area from abac 24 (b), or if we prefer to calculate directly we have turns per sq. in. = $4,760/0.9 = 5,300$: the nearest gauge (S.S.C.) is No. 30, whose diameter is 0.0124 in. Since the average length of one turn is 8.2 in. the total length of wire is $\frac{8.2 \times 4,760}{36} = 1,080$ yds., and the D.C. resistance is $199 \times \frac{1,080}{1,000} = 216$ ohms.

The D.C. voltage drop across the choke is $216 \times 0.05 = 10.8$ volts, which is probably sufficiently small, and the D.C. watts dissipated are $10.8 \times 0.05 = 0.54$ watts, so that the heating is inconsiderable.

Ripple Volts Corresponding to Ripple Flux Density.

In abac 25 (a) we have chosen curve (1) corresponding to a rms ripple flux density of 0.574 kilo-lines per

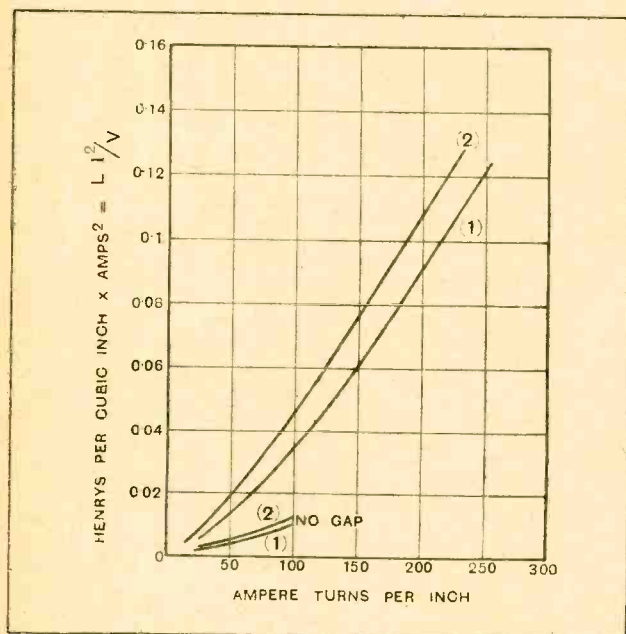

Fig. 1.—Curves showing the product of inductance and current squared plotted against ampere-turns per inch for optimum air gap using stalloy.

sq. in. In order to justify this choice we must find the ripple volts across the choke which would produce this flux density. We have ripple volts (rms) = turns \times core section in sq. in. \times cycles \times ripple kilo-lines per sq. in. $\times 2\pi \times 10^{-5}$ and abac 25 (b) enables us to work out this

value, or if we like to calculate it directly, ripple volts (rms) = $4,760 \times 1.5 \times 50 \times 0.574 \times 2\pi \times 10^{-5} = 12.9$. If curve (2) had been chosen the corresponding ripple volts would have been ten times as great, i.e. 129. Evidently in the case of a smoothing choke curve (1) is nearer the mark than curve (2): it is worth noting that the smaller the ripple volts the smaller is the ripple inductance, so

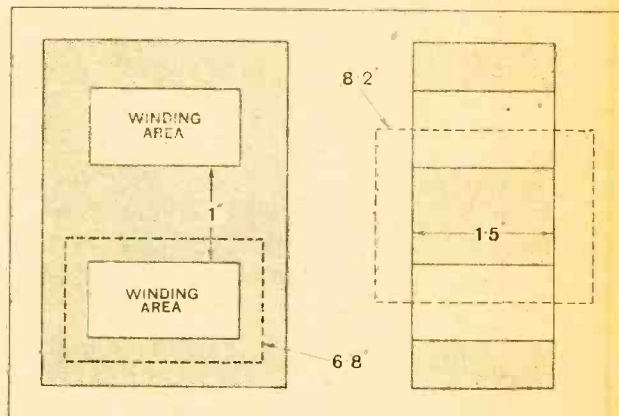

Fig. 2.—Core dimensions of a choke of 30-henrys ripple inductance.

with a chain of similar smoothing chokes in a filter the efficiency falls off with successive stages as the smoothing proceeds.

The Optimum Air Gap.

The calculations already made have shown that a choke of 30 henrys ripple inductance can be constructed with the core illustrated in Fig. 2 with a D.C. voltage drop of 10.8 and without excessive heating, and it now remains to find the best size of air gap. This is given by abac 25 (c), which will appear in a subsequent issue. The amp. turns per inch are 35 (as found from abac 25 (a)), and the corresponding air gap ratio is 0.0021: since the length of magnetic path is 6.8 in. the length of gap is $0.0021 \times 6.8 = 0.0143$ in.

This theoretical value is calculated on the assumption that no spreading of the magnetic lines occurs in the gap: actually, however, fringing takes place with the result that the gap should be made greater than the calculated value by an amount which depends on the shape and size of the magnetic circuit. For chokes similar in dimensions to the one described above, the gap should be from 20 to 30 per cent. greater than the value given by abac 25 (c).

The Service Area of Broadcasting Stations. By P. P. Eckersley. A summary of the papers read, by the author, before the I.E.E. on the design and distribution of broadcasting stations, the operation of such stations on the same wavelength, and similar subjects. Pp. 23, with 14 diagrams and 5 sheets of curves. Published by the British Broadcasting Corporation, Savoy Hill, London, W.C.2.

Die Internationale Regelung der Funktelegraphie und -telephonie. By H. Thurn. A treatise on the various radio-

BOOKS RECEIVED.

telegraphic conferences and regulations from the Berlin Conference of 1903 to the Washington Conference of 1927. Pp. 97. Published by Julius Springer, Berlin. Price R.M. 8.40.

Radio Receiving Tubes, including applications for distant control of industrial processes and precision measurements, by

J. A. Moyer and J. F. Westrel. The history, manufacture, testing and action of thermionic valves, with specifications of those in common use in U.S.A. Pp. 297, with 180 illustrations and diagrams. Published by McGraw-Hill Publishing Co., Ltd., London. Price 12s. 6d net.

Moderne Empfangsschaltungen. By Manfred von Ardenne. Twelve diagrams of receiver circuits, with notes. Pp. 43. Published by Rothgiesser and Diesing A.G., Berlin.

WIRELESS WORLD

LABORATORY TESTS

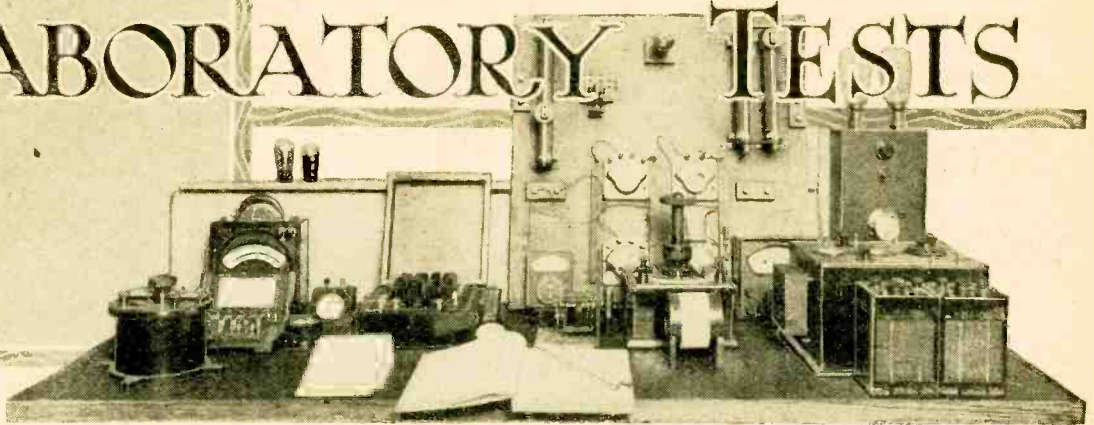

A Review of Manufacturers' Recent Products.

POLAR "IDEAL" DRUM CONTROL CONDENSER.

This is identical in construction with the "Ideal" condenser reviewed in our issue of August 15th last, but it is now fitted with a drum control. This takes the form of two milled edge drums, one of which carries the engraved ivorine

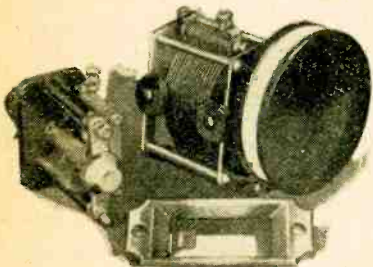

Polar "Ideal" drum control condenser and slow-motion reaction condenser.

scale and supplies the direct drive to the vanes, while the other provides a slow-motion drive with a 30:1 ratio. The drums are 3in. in diameter and together measure 3in. in width. Right-hand and left-hand types are available, and these can be mounted with the drum controls adjacent for semi-ganging of two circuits.

Prices have been fixed at follows:— 0.0005 mfd., 15s.; 0.00035 mfd., 14s. 9d.; 0.00025 mfd., 14s. 6d.; and 0.00013 mfd. and 0.0001 mfd., 14s. each.

The 0.0005 specimen tested had a maximum capacity of 0.00059 mfd. and a minimum of 22 micro-mfd.

A miniature slow-motion reaction condenser with the plates shaped to assure a low minimum capacity and mounted on a moulded frame is available in 0.000075 mfd. and 0.00005 mfd. capacities at 7s. 6d. each. A 0.000075 mfd. specimen was submitted for test and found to have the low minimum of 6 micro-

microfarads only, with a measured maximum of 0.000105 mfd.

The makers are Messrs. Wingrove and Rogers, Ltd., 188-189, Strand, London, W.C.2.

○○○○

NEW "HEGRA" LOUD SPEAKER UNIT.

In these columns on March 27th last we reviewed the "Hegra" unit, but subsequently a modified sample came to hand, in which adjustment is provided for the armature. The modified instrument, which otherwise closely resembles the original unit, is being offered at 22s. 6d. and is supplied by Messrs. Geo. Becker, Ltd., 39, Grafton Street, Tottenham Court Road, London, W.1.

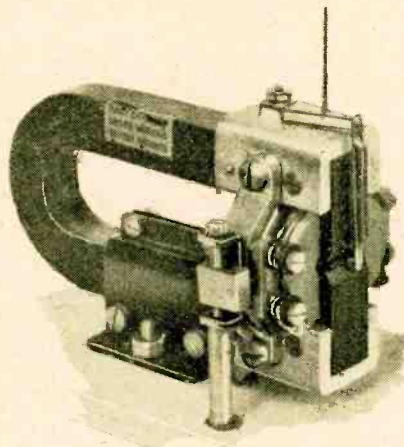

Modified "Hegra" loud speaker unit with adjustable armature.

○○○○

COSSOR L.F. TRANSFORMER.

This component was designed for the Cossor "Melody Maker," but has since been offered separately for general use at the price of 21s.

The transformer measures only 3in. x 3in. x 2in. high overall, and is enclosed in a brown crystalline finished metal case. These small dimensions are made possible by the use of a special alloy for the core. The steady current through the primary

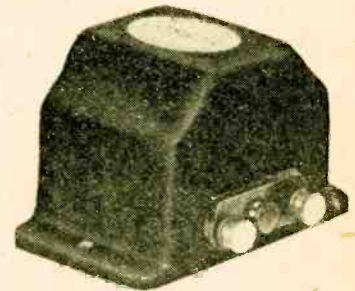

Cossor L.F. transformer. A diminutive component suitable for use in portable sets.

winding should not be allowed to exceed 3mA, otherwise the inductance will be greatly reduced. Practical tests show that the best valve to use preceding the transformer is one having an A.C. resistance of the order of 20,000 ohms.

The makers are Messrs. A. C. Cossor, Ltd., Cossor House, Highbury Grove, London, N.5.

○○○○

GECOPHONE H.T. DRY-CELL BATTERIES.

These batteries, which are made in two sizes, a standard capacity type and a "super" size, are built up from a number of interchangeable units, which can be replaced, should some sections run down sooner than others. This often happens when intermediate voltages are required for certain valves in the set. Furthermore, a battery of non-standard voltage can be acquired at less expense than otherwise would be the case.

The small-capacity size tested com-

prised four units in a cardboard container, rated at 66 volts nominal. To enable an average current of 5 mA. to be maintained during discharge, a resistance was chosen which would pass just over 7 mA. initially. The terminal voltage at the commencement of discharge

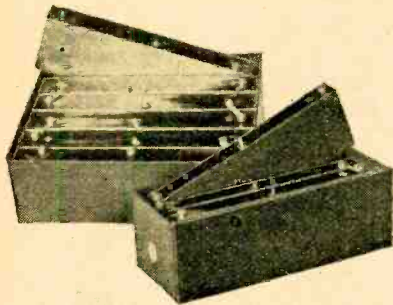

Gecophone H.T. dry batteries. Note the sectional assembly.

was 76.5 volts, but this fell rapidly, and eventually reached a steady state at about 60 volts. The current was well maintained for 150 hours, and then fell gradually until the battery was exhausted. If the battery is kept in use until the voltage per cell drops to 0.75, a life of 240 hours' actual working can reasonably be expected. The discharge curve for this battery is shown at B on the accompanying graph.

As regards the super-capacity type, which had a nominal voltage of 66, it was decided to commence the discharge at 12 mA., a reasonable figure for batteries of this size. The terminal voltage at the beginning was 79.5, but after the first few hours this reached a steady value at 65 volts approximately.

Very little change took place during the first 200 hours, but after this the current fell steadily until the battery was exhausted. In the absence of a natural cut-off, we will take the life of the battery up to the point where the voltage per cell has dropped to 0.75. In this case a useful working life of 400 hours can be expected. The discharge curve for this battery is shown at A on

the graph. If the current required by the set exceeds about 6 mA. the super-capacity size will prove to be more economical in the long run.

These batteries are made by the General Electric Co., Ltd., Magnet House, Kingsway, London, W.C.2, and the prices are as follows: Small size, 66 volts (L 4901), 18s. 6d.; 100 volts (L 4903), 21s.; spare sections, 3s. 6d. each. Six sections make up the 66-volt battery in this size.

o o o o

IGRANIC PUBLIC ADDRESS SYSTEM.

During the recent General Election widespread use was made of the microphone by all political parties as a medium for placing before the voters their claims for public support. Broadcast was not the only medium, and many candidates sought the assistance of public address apparatus during their campaign.

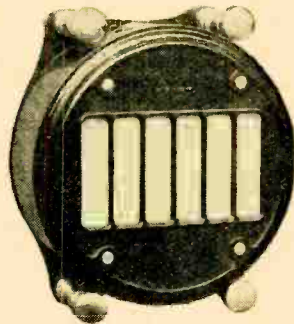

Igranic transverse current microphone.

The Igranic system was one that found favour and indeed was used extensively. It consists of a transverse current microphone, a control unit, and a power amplifier. A detailed description of the microphone was given in our review of the wireless section at the British Industries Fair in the issue of February 27th last.

The makers are the Igranic Electric Co., Ltd., 149, Queen Victoria Street, London, E.C.4.



Igranic public address system control unit.

o o o o

"NIPSIT" TIME-SAVING SCREW-DRIVER.

The "Nipsit" screwdriver is fitted with a reversible blade, both ends of which are suitably shaped and fit into a specially slotted handle. One end of the blade is split, forming a three-prong fork, which when sprung into the slotted head of a screw holds this firmly in a line with the blade. This will be more easily followed by referring to the enlarged drawing of the split end of the screwdriver.

Having started the screw, the blade should be reversed in its holder and the screw then driven home, using the plain end. This useful tool is manufactured by Messrs. R. E. Collingwood & Son, Ltd., March Street Works, Rochdale, and the price is 1s. 6d.



"Nipsit" screwdriver, showing blade removed from holder and enlarged view of split end.

o o o o

Catalogues Received.

Lectro Linx, Ltd., 254, Vauxhall Bridge Road, Westminster, London, S.W.1.—15-page illustrated booklet of "Clix" specialties.

o o o o

Dubilier Condenser Company (1925) Ltd., Ducon Works, Victoria Road, North Acton, London, W.3.—List No. 928, a 62-page catalogue, profusely illustrated, of Dubilier products. A section is devoted entirely to choice of condensers for receivers and mains equipment.

o o o o

Messrs. Ferranti, Ltd., Hollinwood, Lancashire.—Illustrated descriptive leaflets and booklets dealing with chokes, transformers, trickle chargers and H.T. supply units. Also constructor's broadsheet for H.T. unit No. 5.

o o o o

Philips Lamps, Ltd., 145, Charing Cross Road, London, W.C.2.—Descriptive folders of "All-Electric" receivers and Aerial Discharger.

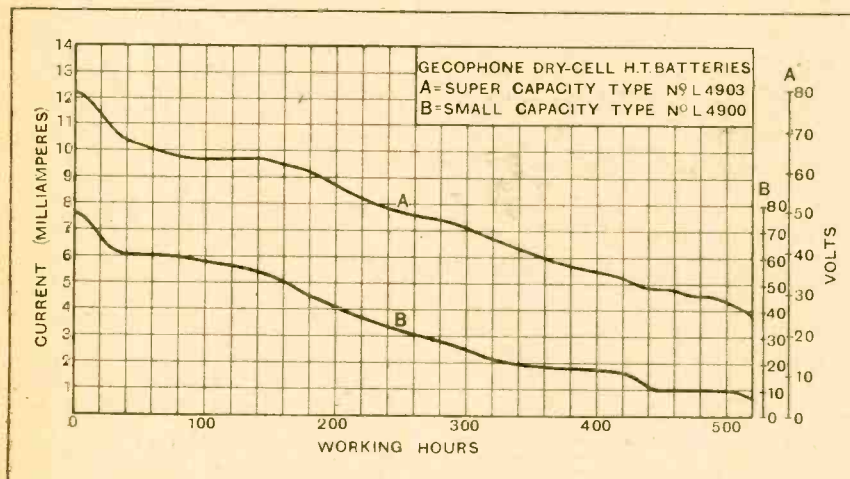

Discharge curves of the Gecophone small and super-capacity dry-cell H.T. batteries.

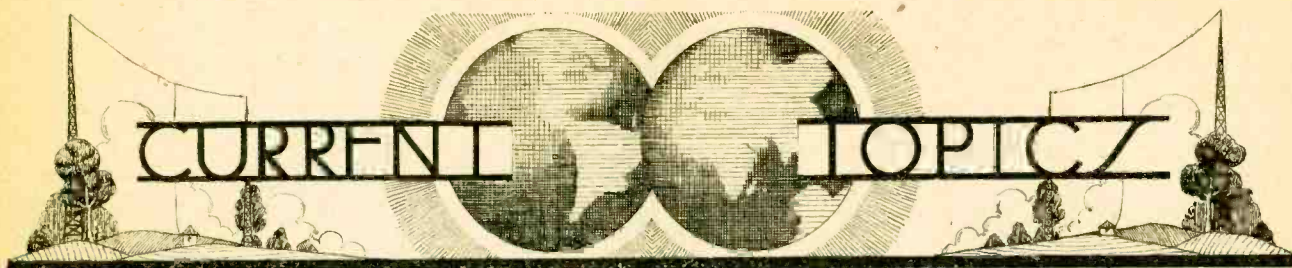

Events of the Week in Brief Review.

POLICE WIRELESS.

A wireless room will be included in the new headquarters of the City of London Police to be built within eighteen months on the site of the old police building in Old Jewry, E.C.

○○○○

MEXICAN NEWS ON SHORT WAVES.

Early risers will be interested to learn that the authoritative news bulletins issued by the Trens Agency through XDA, Mexico City, and referred to in a recent issue, are transmitted daily at 5.45 a.m. (G.M.T.) on 32 metres. Reports from readers will be welcomed.

○○○○

TELEPHONIC TEMPTATIONS.

An English domestic servant who had been in Canada only a week recently had a costly attack of homesickness, writes a Toronto correspondent. Putting through a Transatlantic telephone call to London she ran up a bill of £20 in five minutes, and the amount is being deducted from her wages.

○○○○

200 KILOWATTS FROM SCHENECTADY.

The General Electric Company at Schenectady has obtained permission from the United States Radio Authorities to increase the power of its transmissions to 200 kilowatts. Tests are to be carried out nightly from midnight until morning on 545.5 metres (550 k.c.), 455.9 metres (660 k.c.), 379 metres (790 k.c.), 260

metres (1,150 k.c.) and 200 metres (1,500 k.c.), with a view to ascertaining whether and to what extent this increased power will increase the range of a broadcasting station. Listeners in Europe picking up these transmissions will identify them by the call W 2XAG, Schenectady.

○○○○

DUTCH SHORT-WAVE STATIONS.

In view of the extended use made of the Holland-Dutch East Indies public telephone service new transmitters have been brought into operation. PLF, Bandoeng, works daily between 2.30 and 5.30 p.m. (B.S.T.) on a wavelength of 17 metres, and to cope with the traffic is being assisted by PLE on 15.74 metres, and the new station PLG on 18.8 metres. A fourth transmitter, PLR, on 27 metres, will eventually take over the entire night service. Most of these transmissions can be picked up in Great Britain, and a search should be made towards 1 p.m. (13.00) B.S.T. when previous to the opening of the public service, gramophone records are transmitted as a test.

○○○○

NAUEN TIME SIGNALS.

Up to the present the Nauen official time signals put out daily at 1 a.m. and 1 p.m. have been transmitted both on 3,100 metres and 18,050 metres. The signals will shortly be broadcast through

Norddeich, Nauen and Koenigswusterhausen according to the following schedule:—

0.55-1 a.m. Norddeich, 1,648 metres (182 k.c.).

Nauen, 18,050 metres (16.6 k.c.).

The midday signal, i.e., 12.55-1 p.m. (B.S.T.) will be transmitted through Koenigswusterhausen on 1,648 metres (182 k.c.), and again through Nauen on the higher wavelength.

○○○○

MAPS FOR WEATHER PROPHETS.

A map showing prevailing weather conditions throughout the British Isles is now broadcast twice weekly by the Hiltograph process from 5XX on Tuesdays and Thursdays between 2 and 2.25 p.m. The map, which is prepared by the Meteorological Office, should be of great value to those who have sufficient knowledge of the weather to be able to base forecasts upon it for their own locality.

We understand that should the experiment prove successful it may be possible to arrange similar transmissions earlier in the day.

○○○○

TECHNICAL RESEARCH SCHOLARSHIPS.

The Manchester Municipal College of Technology (University of Manchester) announces that a limited number of Research Scholarships in Technology (each of the value not exceeding £100) will be awarded in July. The scholarships, which are tenable during the academic year 1929-30, admit of research in a wide range of technical subjects, including electrical engineering. Applications must be received on or before July 6th, 1929. Forms of application, etc., may be applied for (in writing) to the Registrar of the College.

○○○○

HONOUR FOR SHEFFIELD ENTHUSIAST.

Among the recipients of honorary degrees to be conferred by the University of Sheffield at a congregation on July 6th is Mr. Frederic Lloyd, who will be given the degree of Master of Engineering. Mr. Lloyd and his son, Mr. Harry Lloyd (G 2UM), are regarded as the pioneers of wireless in the Sheffield district, having broadcast nightly programmes from their private station before the B.B.C. came into existence. Since then Mr. Lloyd has interested himself in the cause of hospital and school wireless, and has presented several wireless installations to schools in Sheffield.

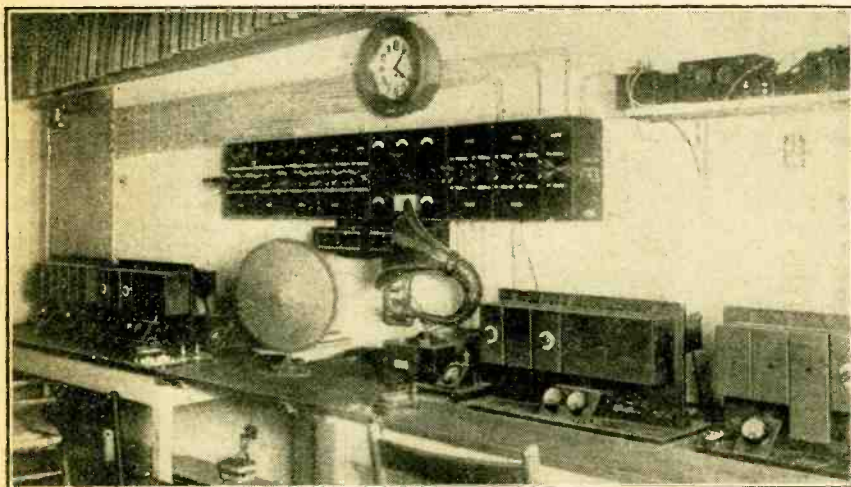

THE CONTROL ROOM AT OSLO. Norway's new broadcasting station supplies programmes to five relay stations. In accordance with the Prague scheme Oslo will transmit on 493 metres as from June 30th. The present wavelength is 496.7 metres.

A PARIS FIELD DAY.

A "radio rally" staged by the Paris Radio Manufacturers' Association in conjunction with the Automobile Club de France is to be held in the environs of Paris on Sunday next, June 30th. The main feature of the event will be a competition to gauge the capabilities of car owners in receiving transmissions from the Paris broadcasting stations at different control points, and the day will conclude with a "radio gynkhana" in which all the competitors will meet to give loud speaker demonstrations before a picked jury.

The prizes will include a valuable collection of wireless material.

WIRELESS "WAR" IN PARIS.

The organisers of the Paris International Wireless Show, which will be a contemporary rival to the Annual Radio Salon in September, have decided that the profits from the venture will be

handed over to charity (writes our Paris correspondent). No effort will be spared to set the international show "in a frame of extreme elegance," its object being to attract the public from the old-established exhibition and to demonstrate that French listeners will not be satisfied with a display which includes only the home product.

HOPES DASHED.

Dr. E. O. Hulburt, physicist at the U.S. naval laboratory, has delivered the opinion that communication with Mars is impossible on wavelengths below 100 metres owing to the density of the Martian atmosphere.

SENATORE MARCONI.

The announcement that the King of Italy has conferred on Senatore Marconi the hereditary title of Marquis will receive the unanimous approval of all wireless enthusiasts. Senatore Marconi is already the

holder of numerous honours. He was created a Chevalier of the Civil Order of Savoy in 1905, and on July 24th, 1914, King George bestowed upon him the honorary knighthood of the Grand Cross of the Victorian Order. In 1909 he was awarded the Nobel Prize of Physics.

WHERE LISTENING IS MOST POPULAR.

Argentina leads the world in the number of licensed broadcast listeners per hundred of the population with a percentage of 10.2, according to the Union Internationale de Radiophonie. The United States came next with a percentage of 10, followed by Denmark with 7.6. Other countries high in the list are: Australia, 6.7; Sweden, 6.3; Great Britain, 6; Austria, 5.7; New Zealand, 5.4; and Germany, 4.6.

Of the countries under review Italy and Soviet Russia make the poorest showing with a percentage each of 0.1.

WIRELESS PATENTS.

Marconi Appeals Allowed.

Brownie Wireless Action.

MR. JUSTICE LUXMOORE, in the Chancery Division of the High Court of Justice on Tuesday, June 18th, delivered his reserved judgment allowing the appeal of Marconi's Wireless Telegraph Company, Ltd., from the order of the Comptroller-General of the Patent Office of March 22nd, when the Comptroller-General decided that a compulsory licence should be granted to the Brownie Wireless Company to manufacture valve receiving sets on the terms that the royalties payable to the Marconi Company should be reduced from 12s. 6d. per valve stage to 10 per cent. on the wholesale selling price of the receiver, subject to a minimum charge of 5s. on the first valve and 2s. 6d. on each additional valve stage included in the apparatus sold. His Lordship held that there was no case for granting a compulsory licence.

Mr. Justice Luxmoore, in giving judgment, said that the appeal was brought by the Marconi Company from an order of the Comptroller-General of Patents that a licence should be granted to the Brownie Company as from September, 1928, in the terms of the order which was made on two separate applications by the Brownie Company for a compulsory licence to be granted under Patents No. 13636 of 1913, and No. 147148 of 1913.

His Lordship traced briefly the history of the Marconi General Licence and the development of the broadcasting industry, and also the history of the law which, since the Patents Act of 1883, had made it possible, under certain special circumstances, for the conduct of a patentee to be challenged in the exercise of his rights. His Lordship said, that in his judgment, in order to make out a case for a compulsory licence it was necessary to prove three things, (1) that the patentee had refused to grant to the applicant a licence on reasonable terms; (2) that the trade or industry of the United Kingdom or the trade of any person or class of persons trading in the United Kingdom or the establishment of any new trade or industry in the United Kingdom was prejudiced by the refusal of the grant; and (3) that it was in the public interest that the licence should be granted.

In addition, his Lordship dealt with other points connected with the terms of the Marconi Company's General Licence known as the A2 agreement, and contended that there was nothing in the various clauses of the agreement which was unreasonable. With regard to the question of the licence providing for the payment of royalties on non-patented articles, that again was not unusual, and in his Lordship's judgment there was nothing unreasonable in a patentee saying to a proposed licensee:

"I will grant you a licence in respect of my patent, but I want your wholehearted support in the development of my patent. I am only prepared to grant you a licence on such terms as will ensure that support."

The result, therefore, of the appeal was that the application to the Comptroller-General of the Patent Office by the Brownie Company for a compulsory licence ought to have been refused, and his Lordship held that the appeal should be allowed and the order of the Comptroller discharged.

The Loewe Radio Case.

Following the judgment in regard to the appeal of the Marconi Company in the case of the Brownie Wireless Company, Mr. Justice Luxmoore also allowed the appeal by Marconi's Wireless Telegraph Company from the decision of the Comptroller-General of the Patent Office allowing the application of the Loewe Radio Company, Ltd., for a licence to manufacture in this country treble and double valves for wireless sets on payment of stipulated royalties. The royalties which the Comptroller of the Patent Office decided that the applicants should pay to the Marconi Company was 10s. on each triple valve set and 7s. 6d. on each double valve set; in other forms of multiple valves the royalty was to be calculated on the basis of 5s. for the first valve and 2s. 6d. for each additional valve.

His Lordship said that in his opinion there had been no refusal on the part of the Marconi Company in negotiations between the Marconi Company and the Loewe Company to grant a licence and, therefore, the time had not arrived for the Loewe Company to be in a position to apply for a compulsory licence on the grounds that the licence was unreasonable because its terms had never been discussed. That finding was sufficient to dispose of the appeal. His Lordship, however, gave as his view that 12s. 6d. for each separate valve stage would, in all the circumstances of the case, be unreasonable, and that it was also unreasonable to treat each multiple valve as comprising a number of separate valves. The Comptroller had fixed the royalty at 10s. for each triple valve and 7s. 6d. for each double one, and his Lordship did not think that a royalty at that rate was unfair to the parties, provided the licence was limited to the manufacture of triple and double valves.

The order of the Comptroller in this case also was discharged, and the appeal of the Marconi Company allowed on the ground that there had been, in fact, no refusal to grant a licence.

BROADCAST



BREVITIES

By Our Special Correspondent.

Pole Moor.—New Plans for "Broadcasting House."—Better Studios.

Northern Regional.

On its romantic, tent-pitching side the business of obtaining a site for the Northern Regional station seems to have ended at Pole Moor, Slaithwaite (*Slewitt*, if you please), four and a half miles west of Huddersfield. Only the sordid details of purchase have to be gone through, and the prevailing impression at Savoy Hill is that the deal will be completed.

Pole Moor covers a spur of the Pennines and is the property of the Earl of Dartmouth.

The Search Ended.

I hear that, although the B.B.C.'s mobile station is still carrying out signal strength tests on the site, the engineers are practically satisfied that they have found the best spot for miles round. One thing is certain, no further sites are to be explored.

If and when Pole Moor becomes B.B.C. property, the special cables to Manchester, fifteen miles away, will be buried throughout the major portion of the distance so as to preserve the beauties of the moorland.

The Case of Newcastle.

The Pole Moor station (as it will probably be called in preference to "Slaithwaite") will have a service area covering the greater part of Northern England, but it will still leave Newcastle in the cold. For this reason 5NO will enjoy a unique existence as a comparatively high-power relay station when its fellow relays are tottering under the regional axe.

More Studios for "Broadcasting House."

There is no finality at present in the internal design of the new "Broadcasting House" at Portland Place. With regard to the studios, the latest plans provide for at least a dozen instead of the nine originally allowed for. This extension is in response to the claims of radio drama, for there is no saying how many studios may be required for the radio play of 1932. To-day Mr. Val Gielgud may commandeer as many as six studios for an hour's performance. If in three years' time a dozen studios are necessary, a pretty problem will arise when London is transmitting two plays simultaneously! Possibly some of

the "effects" could be shared, though if this were done many terrible mistakes could only be averted if a form of interlocking device were used, similar to that in railway signal cabins.

Studio Reforms.

One of the minor studio improvements will be the introduction of artificial daylight through dummy windows, which will also provide ventilation. This reform will be heartily welcomed, for few will deny that the studios at Savoy Hill are nearly all tomb-like and depressing, notwithstanding repeated and valiant efforts to make them inspiring.

Significant.

Extract from the Savoy Hill postbag: "I do know that since Mr. Rex Palmer left the reception of the transmissions has been rotten."

Greek Drama in the Studio.

The "Elektra" of Euripides, one of a budget of leading plays intended for the microphone during the coming months, is to be heard from 5GB on July 16th, and from 2LO, 5XX, and other stations on July 17th.

To Canada.

The B.B.C. will celebrate Dominion Day (July 1) with a special programme having the title of "A Sketch Portrait of Canada from East to West in Thirty Minutes."

Corks.

"Sensitive Suburbanite" writes: "I have no objection to the corking of aerials to save bird life, though the practice will not prevent the suicide of birds who are put off their notes on these long summer evenings by the back garden loud speakers. I think it is the loud speakers that need corking."

Broadcasting Silence.

Of a prolific conversationalist it was once said that "he occasionally favoured the company with eloquent bursts of silence." The B.B.C. is now being counselled to do the same. It is suggested that after a satisfying performance of a play listeners should be afforded a few minutes' silence in which to ruminate upon what they have heard.

But surely a listener who desires these moments of contemplation can switch off?

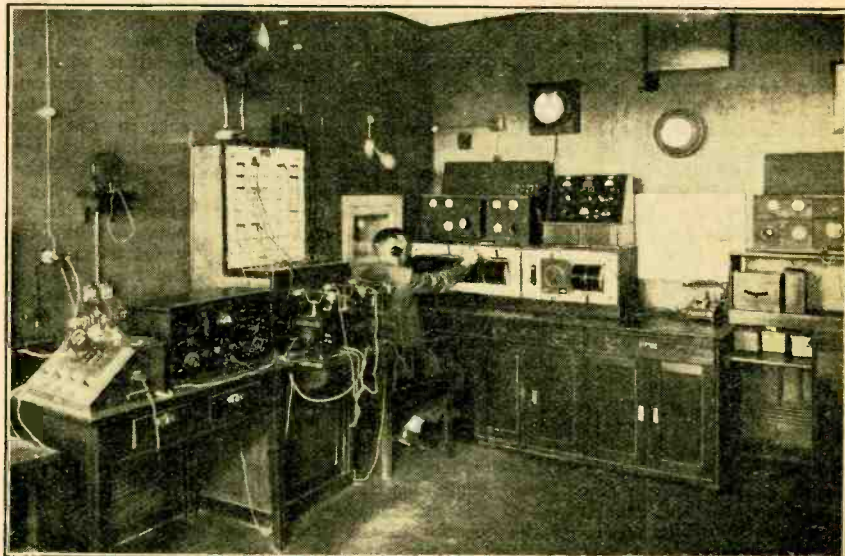

A GERMAN CONTROL ROOM. A photograph taken at Königsberg, which is well known to ether searchers. The station transmits on 280.4 metres but will change to 276 metres on June 30th when the Prague Plan begins to operate.

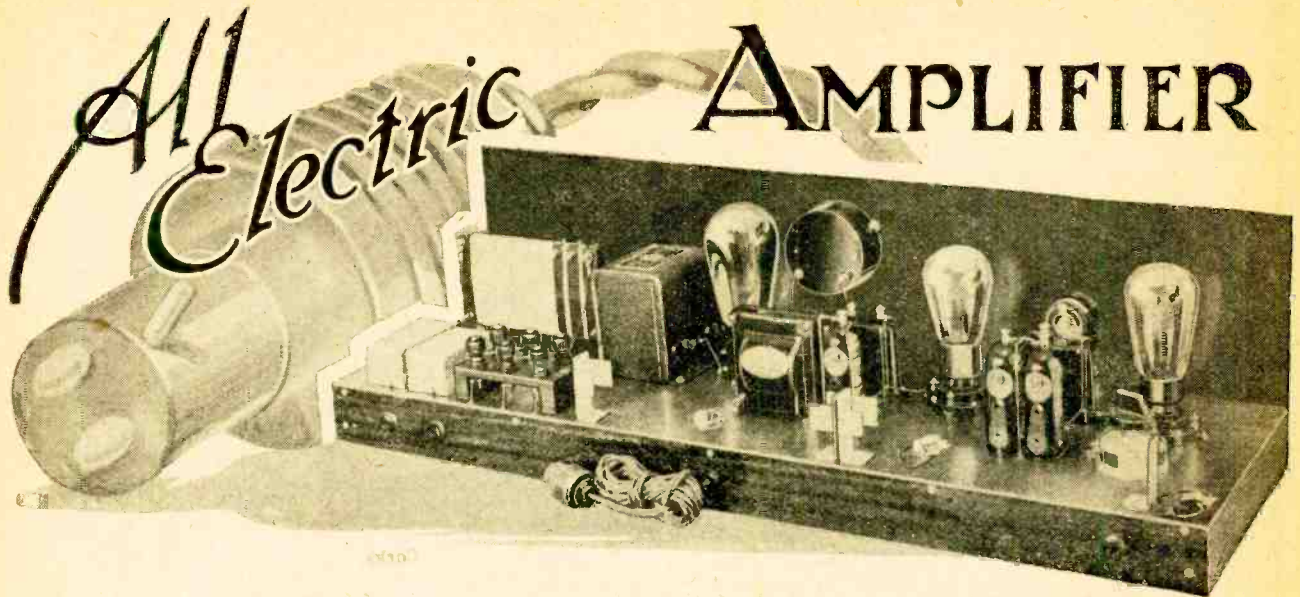

Practical Details of Construction.

By A. P. CASTELLAIN, B.Sc., A.C.G.I., D.I.C.
(Concluded from page 637 of previous issue.)

THE construction of the amplifier should not present very much difficulty, as both the layout and the wiring are quite straightforward. The details of the panel are given in Fig. 5, which shows the dimensions of the hole to be cut for the Ferranti milliammeter in the circuit of the output valve.

It will be noticed in the list of parts that the meter specified is one reading to 150 milliams., at full scale. The reason for using such a high-reading instrument with an output valve taking 30 mA. plate current is two-fold; first, on switching on with a loud speaker connected, the output condensers will charge up, and

this will be indicated by a very considerable "kick" on the meter; secondly, if at any time the amplifier is used on A.C. a heavy duty power valve may be used in the output stage with a much higher plate current, possibly of the order of 60 milliams., or more, depending on the H.T. supply.

Also to be found on the panel are the volume control, a loud speaker change-over switch, and, under the meter, the main switch. The type of switch used is the "push-on, push-off" variety sold with a metal cover plate. In the writer's opinion this metal plate connected, the output condensers will charge up, and

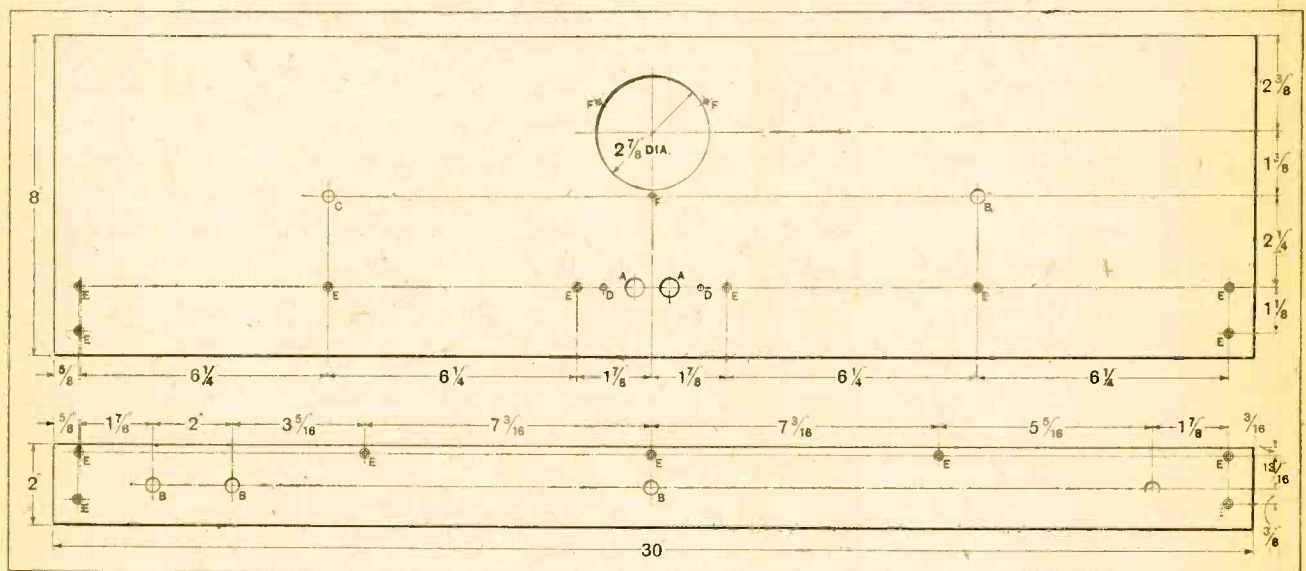
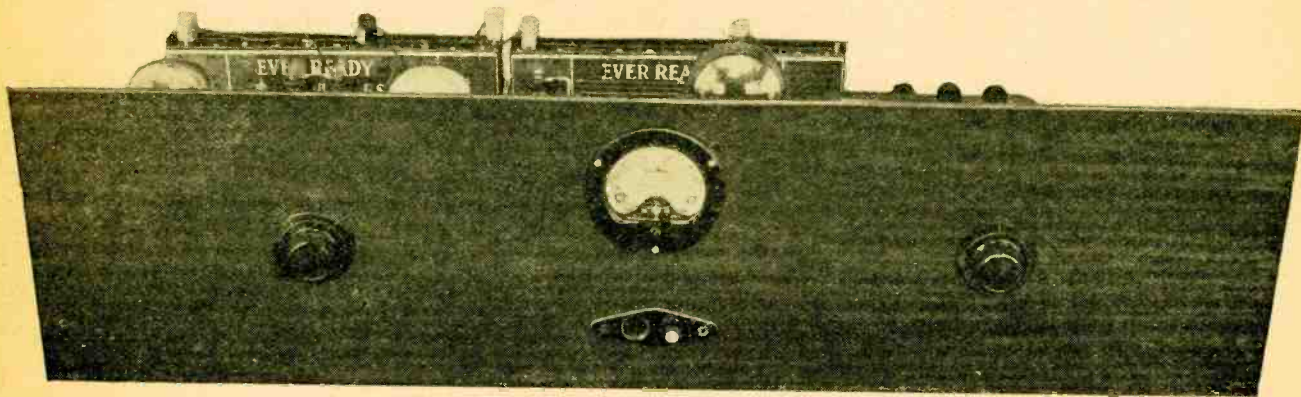

Fig. 5.—Drilling dimensions for the panel and terminal strip.

All Electric Amplifier—

obtrusive cover can be obtained by cutting a small diamond-shaped piece of $\frac{1}{16}$ in. ebonite fitted as seen in the illustrations. The terminal strip runs the whole length of the amplifier at the back of the baseboard, and carries the input jack and the two loud speaker jacks—

or amplifier, the writer prefers to use the "double-deck" method of wiring, i. e., all supply wires (filament, H.T. and grid bias leads) are taken below the baseboard, and all "live" wires (plate and grid leads) above the baseboard. Accordingly the amplifier now described has been laid out along these lines. The



The front panel of the amplifier.

the drilling dimensions for this are given in Fig. 5. Inside the amplifier is a small terminal strip carrying six L.T. terminals connected to the filaments of the three valves in the amplifier. By the use of two links the filaments may be connected in series for D.C. mains operation, or in parallel for battery or A.C. operation, as shown in Fig. 6, without any other alteration of the wiring.

In the construction of almost any type of receiver

baseboard is of very generous size, giving plenty of latitude in the arrangement of the components, but the layout shown in Fig. 7 will probably be found to be the most suitable. Since the amplifier is primarily intended for use on D.C. mains, a pair of fuses have been incorporated in a convenient position on the baseboard to function in the case of the remote possibility of a direct short circuit across the H.T. supply inside the amplifier. The wiring diagram of the amplifier is given in Fig. 8.

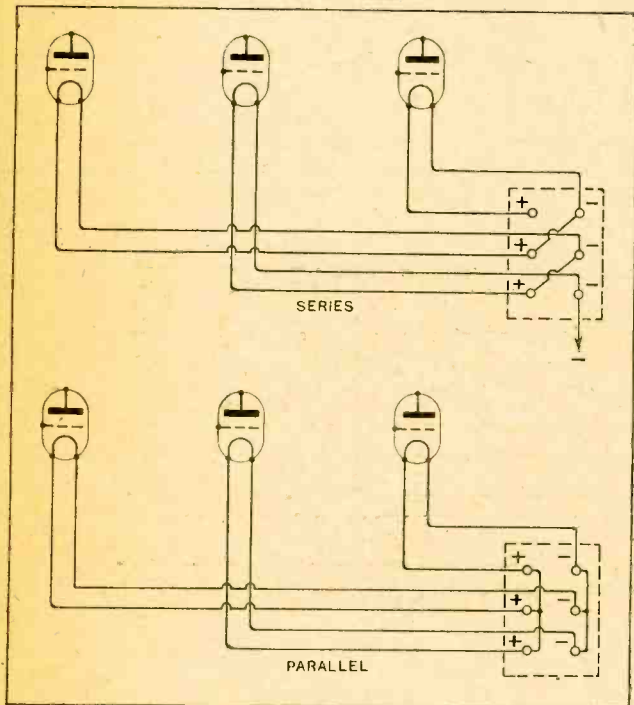

Fig. 6.—Circuit details for wiring the filaments in series or parallel.

Grid Bias Considerations.

If the amplifier is to be used on D.C. mains with filament supply also from mains (as shown in the theory diagram Fig. 3 of last issue) it will be necessary to run the filaments in series and to use a resistance to drop the mains voltage to a suitable value. With the valves suggested the filament current is 0.25 ampere, and as the valves are of the 6-volt type, the voltage to be dropped in the resistance is mains voltage - 18; thus the value of the resistance in ohms will be four times the voltage to be dropped. It is probably most convenient to use a wire-wound resistance—preferably a flat type mounted vertically to assist cooling. A suitable design is given in Fig. 9. There are 278 turns of wire on the large section, and fourteen turns on each of the small sections, making in all 306 turns of 34 D.S.C. Eureka.

Grid bias is not wholly obtained from D.C. mains for two reasons, viz., (a) grid bias batteries are cheap, last a long time, give no trouble with hum, and permit easy alteration of bias values; (b) the amplifier is intended to be able to run from batteries if required. However, as the filaments are connected in series, some of the bias is obtained from the mains. On following the wiring diagram (or the theoretical diagram) it will be found that the first valve obtains its bias from a potentiometer across the second valve, the arrangement of the

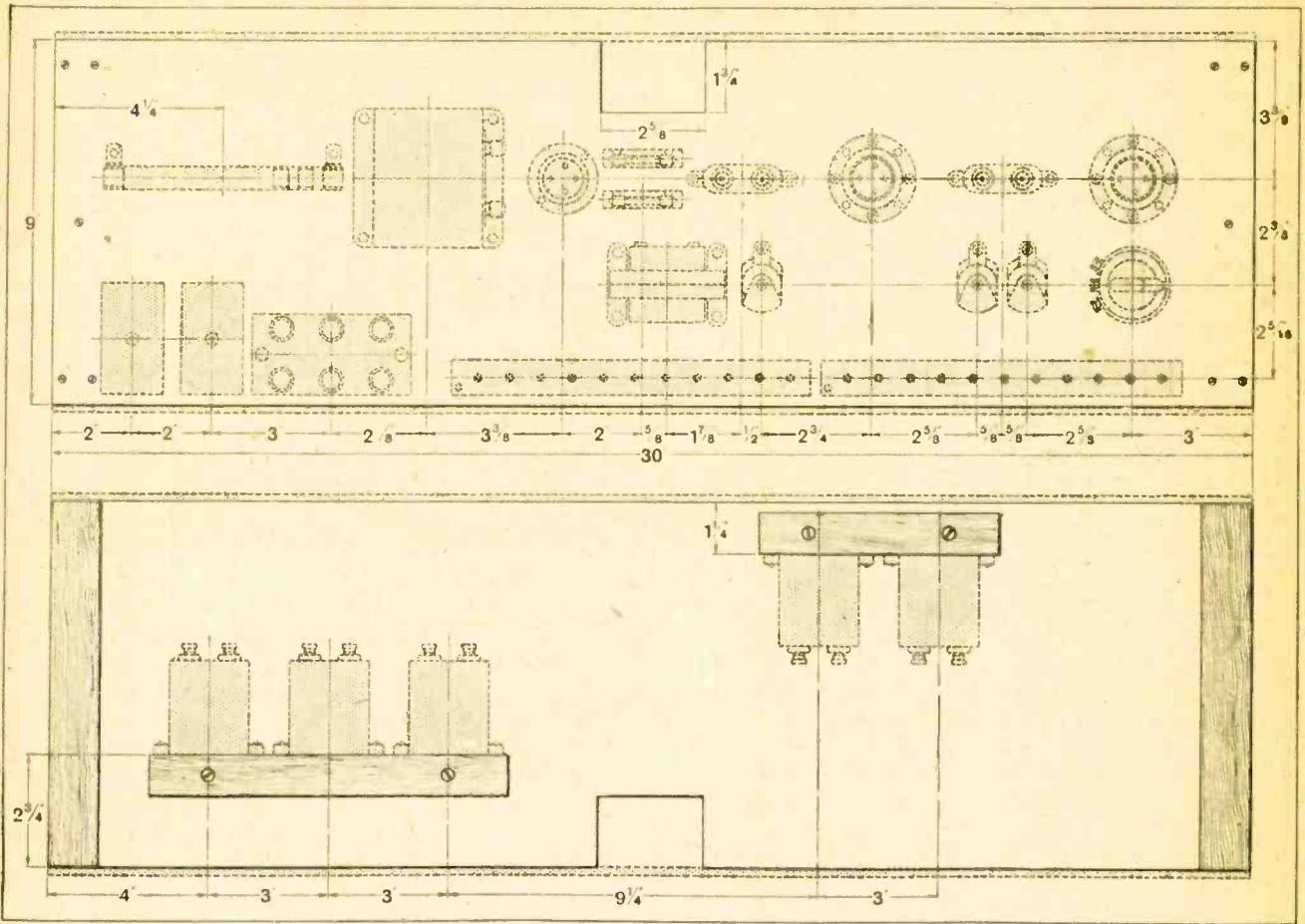
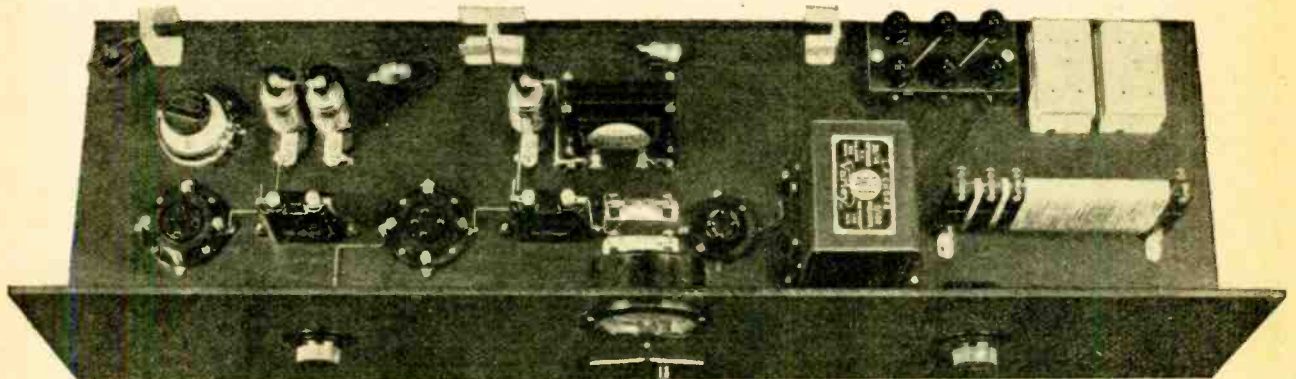

Fig. 7.—General layout of components on the baseboard and under-baseboard.

filaments being third, first and second in order of increasing negativeness, so that a bias up to -6 volts is available for the first valve. The second valve obtains all its bias from the battery (usually 10 to 12

on D.C. mains with the output valves specified, one 16-volt battery will be sufficient. Two 16-volt batteries have been allowed for in the amplifier described to deal with cases where the filaments are used in



Plan view of amplifier. By making use of the under-baseboard, crowding of the upper surface of the baseboard has been avoided

volts will be required), while the last valve obtains 12 volts from the other two filaments and the remainder from the battery. If the amplifier is only to be used

parallel, while there is sufficient space for four if necessary (for example, when using an L.S.5A on A.C.). It should be noted that when the filaments are used

All Electric Amplifier.—

in parallel the grid bias connection from the input jack should be taken to the grid bias battery and not to the potentiometer.

It is important that suitable condensers be used in this amplifier, and on *no account* should 200-volt (working voltage) condensers be employed, although

they are the cheapest, because there is very serious danger of their breakdown. The smallest type that should be used is that tested at 500 volts D.C., while the writer prefers always to run filter and output condensers, especially the latter, at much under their rated working voltage for the reason that peak voltages on switching may occur which are several times the normal

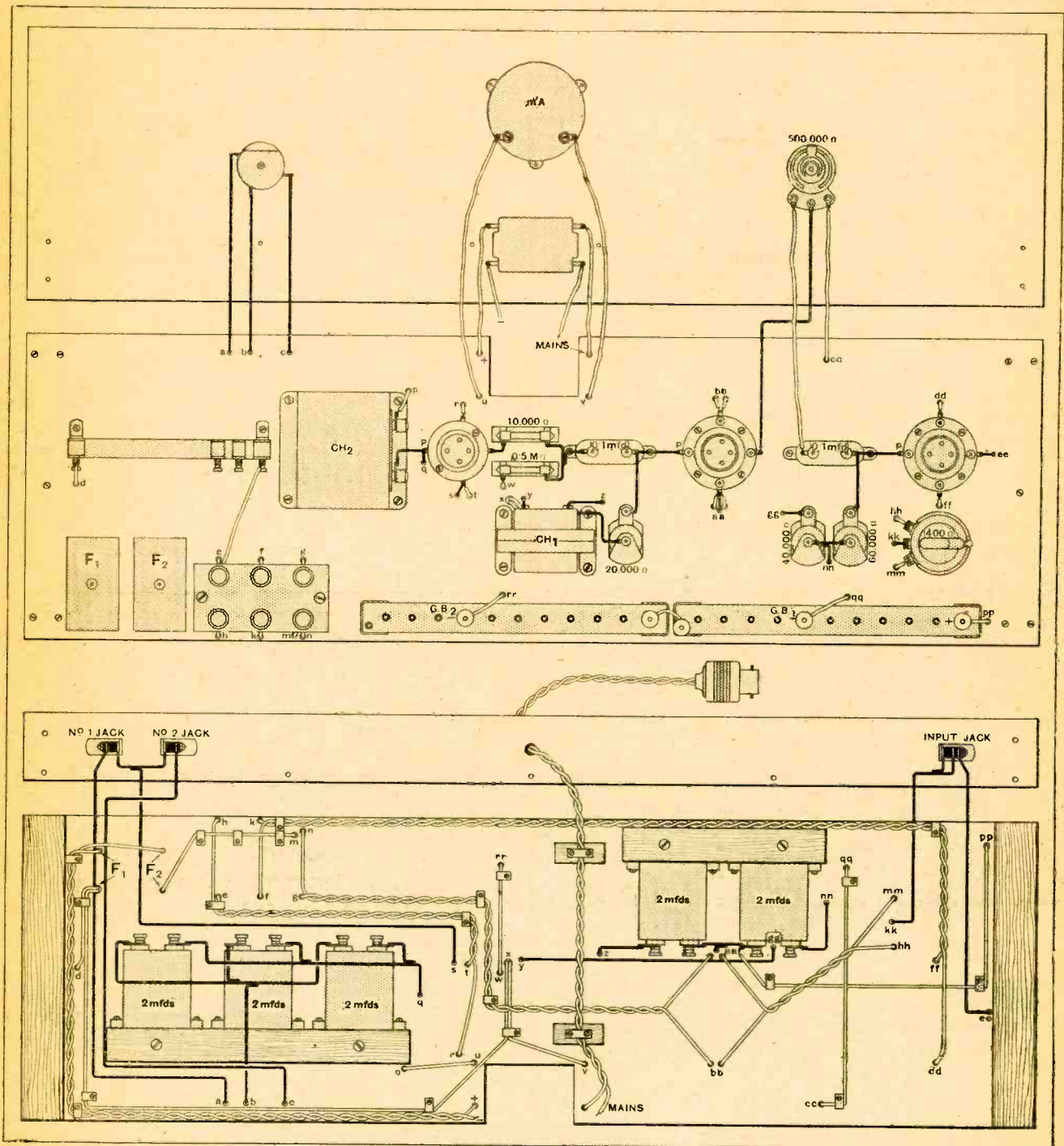

Fig. 8.—Practical wiring plan of the panel, baseboard, and under-baseboard.

LIST OF PARTS.

- 1 Baseboard, 30 x 9 in.
- 1 Panel, 30 x 8 x 3/16 in. (bakelised board).
- 1 Strip, 4 x 2 x 1/4 in.
- 1 Strip, 30 x 2 x 3/16 in.
- 2 Valve holders (Lotus).
- 1 Valve holder (Igranic).
- 2 Fixed condensers, mica, 0.1 mfd. (B775, Dubilier).
- 5 Fixed condensers, 2 mfd. 500 v. D.C. test (Dubilier). †
- 1 Resistance, 10,000 ohms (Loewe).
- 1 Grid leak, 0.5 meg. (Loewe).
- 2 Porcelain grid leak holders (Bulgin).
- 1 High resistance (variable), 500,000 ohms ("Megostat," Igranic).
- 1 Wire-wound anode resistance, 20,000 ohms, and holder (Varley).
- 1 Wire-wound anode resistance, 40,000 ohms, and holder (Varley).
- 1 Wire-wound anode resistance, 60,000 ohms, and holder (Varley).

- 1 Choke (B. 3, Ferranti).
- 1 Choke, 28/14 henrys, 200 mA. (R.I.).
- 1 Meter, 0 to 150 milliamps. (Ferranti).
- 1 Switch, D.P., 10 amp. 200 volts (S. 2,304, G.E.C.).
- 2 Fuse blocks, S.P., 5 amp. (S. 815, G.E.C.).
- 1 Adaptor.
- 2 Jacks (P. 61, Igranic).
- 1 Jack (P. 62, Igranic).
- 6 Terminals (Belling Lee).
- 1 1/2 oz. No. 34 S.W.G. Eureka resistance wire D.S.C., for potential divider.
- 2 Grid bias batteries, 16 v. (Ever Ready).
- 2 Pairs grid bias clips (Bulgin).
- 5 Wander plugs ("Springmore," Igranic).
- 1 Potentiometer, 400 ohms (Igranic).
- 1 Rotary switch, 1 pole 2-way (Pye).
- Wire, screws, systoflex, flex, etc.

Approximate cost of above parts, £9 19s. 0d.

In the "List of Parts" included in the descriptions of *THE WIRELESS WORLD* receivers are detailed the components actually used by the designer and illustrated in the photographs of the instrument. Where the designer considers it necessary that particular components should be used in preference to others, these components are mentioned in the article itself. In all other cases the constructor can use his discretion as to the choice of components, provided they are of equal quality to those listed, and that he takes into consideration in the dimensions and layout of the set any variations in the size of alternative components he may use.

working voltage, particularly in the case of the output condensers. The extra cost is not excessive, and there is a feeling of absolute safety in the use of the larger condensers. Condensers with a test voltage of 1,000 D.C. are suggested for the output and second filter condensers. The coupling condensers between the valves must have a mica dielectric, since even a very few microamps. leakage will upset the grid bias of the

For D.C. mains operation valves with 0.25-ampere filaments should be used. If lower consumption valves are used in the first two stages they must be shunted with a suitable resistance so that the total consumption is 0.25 amp. For example, if 0.1-amp. valves are used, the shunting resistance must take 0.15 amp. at 6 volts, which gives a value of 40 ohms for the resistance. A suitable type of resistance is the Burndept

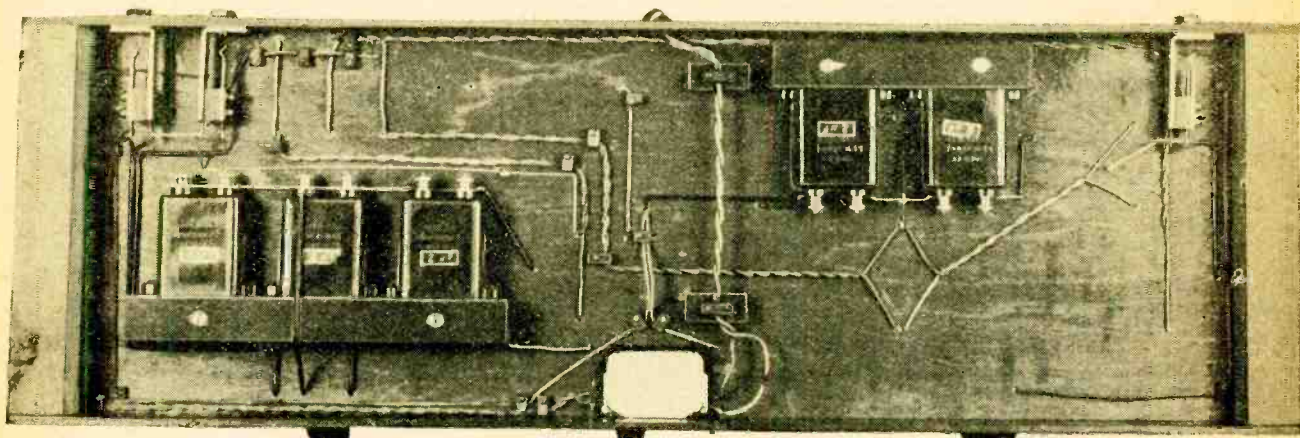

The general arrangement of components under the baseboard.

following valves, besides making the volume control noisy. For the latter reason, too, it is desirable to use a hard valve following the volume control so that there is no appreciable reverse grid current flowing through the potentiometer, a condition which would make it just as noisy as with a leak through the coupling condenser.

† This test voltage is the lowest permissible and it is preferable to use 1,000 volt D.C. test condensers for reasons explained in the text.

screw-in resistor. If these lower consumption valves are contemplated, two resistance holders and resistances should be incorporated in parallel with the first two filaments.

Choosing Suitable Valves.

The tables overleaf show valves suitable for various supplies; corresponding valves of other makers can, of course, be used.

All Electric Amplifier.—

| | D.C. MAINS. | | Remarks. |
|---------------|-------------|---------------|--------------------------------------|
| | Type. | Fil. current. | |
| Stage 1 | D.E.L.610 | 0.1 | 40-ohm shunting resistance required. |
| | H.L.610 | 0.1 | |
| | D.E.5B | 0.25 | |
| Stage 2 | D.E.L.610 | 0.1 | 40-ohm shunting resistance required. |
| | P.625 | 0.25 | |
| Stage 3 | P.625 | 0.25 | For mains over 200 volts. |
| | P.625A | 0.25 | For mains up to 200 volts. |

The above types of valve are suitable for battery operation with a 6-volt L.T. battery, though in this case the valves need not have the same initial filament current consumption.

For use as an A.C. amplifier the large resistance in series with the filaments must be disconnected, the grid bias positive connected to the sliding arm of the filament potentiometer, and the grid bias lead from the input jack taken direct to the bias battery since the filaments are in parallel. The bias values will be approximately as before plus three volts.

Suitable valves for A.C. are given below.

| A.C. MAINS. | | |
|------------------------------|----------------------------|--|
| Stage 1.—L.S.5B. A.C./G.* | Stage 2.—L.S.5 A.C./R.* | Stage 3.—L.S.5A. L.S.6A. A.C./R.* A.C./P2.* |

* If these valves are used with 6-volt filament supply a 2-ohm resistance to carry 1 ampere should be used in series with the heater.

The output from the amplifier in conjunction with a good moving coil loud speaker is considerably greater than from the ordinary type of gramophone, and the quality is very noticeably better. A similar amplifier

to that described has been used by the writer to supply dance music in a small hall, and has been found very suitable for this purpose.

A really good amplifier is undoubtedly an asset, for not only can it be used with a gramophone pick-up, but also it may be connected to a microphone. Further-

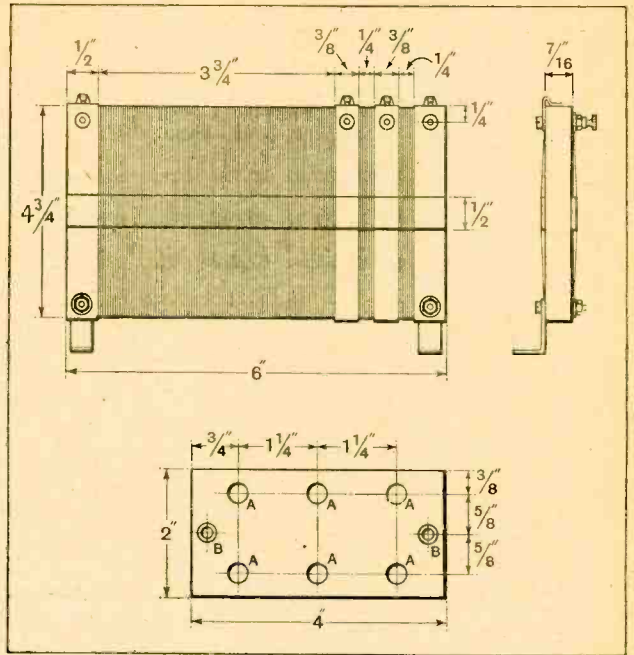
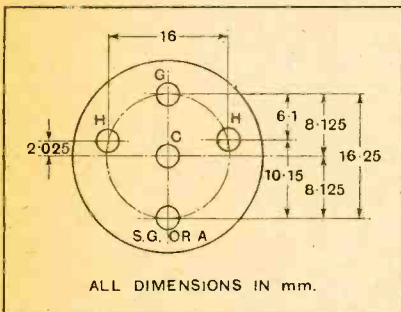

Fig. 9.—The upper diagram shows the mains voltage-dropping resistance, the large section of which contains 278 turns of No. 34 D.S.C. Eureka wire. The two small sections contain 14 turns each of the same resistance wire. The lower diagram gives the drilling dimensions for the small terminal panel.

more, where it is desired to receive local broadcast programmes a detector unit of quite unambitious design can be added.

MAINS-OPERATED receivers are to take a conspicuous place among next season's sets. The need to replace current from the accumulator by current from the mains is pressing the development of the indirectly heated valve. Incidentally, the liberal current supply available from the mains, as compared with the limited output of the accumulator, renders the indirectly heated valves as



Valve base dimensions showing the location of the new cathode pin.

THE NEW A.C. VALVES.

a class superior to those using accumulator heated filaments. An additional lead is required, which taking a place on the negative side of the valve circuit and remote from the anode, is now commonly referred to as the cathode. Connection to the cathode is made in the new valve bases by an additional pin centrally placed among the four pins of the standard socket, the former filament connections becoming the leads of the heater unit. Screen grid valves are to retain their top anode connection, the anode pin of the triode taking the screen lead. Indirectly heated output valves and pentodes are not essential to the all-mains operated set, as the heating of the filaments of these valves with A.C. is satisfactory. It is understood that all types of indirectly heated valves will, in due course, come into line with this new standard, which, by the way, permits of a suitably wired set being used with either filament or in-

directly heated valves without structural modification.

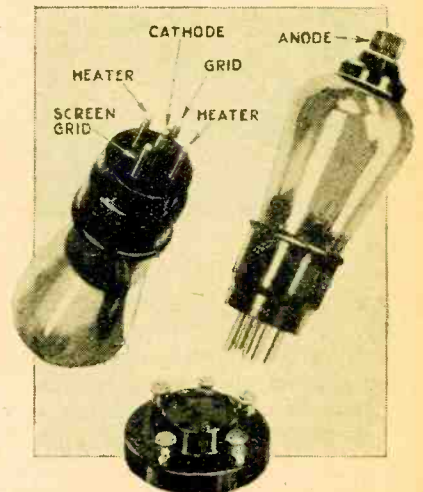

This system of connections permits of the interchanging of A.C. and D.C. valves.

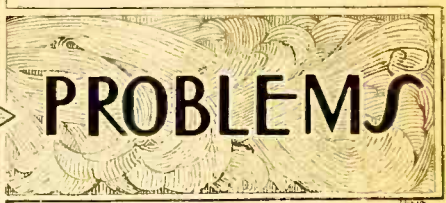
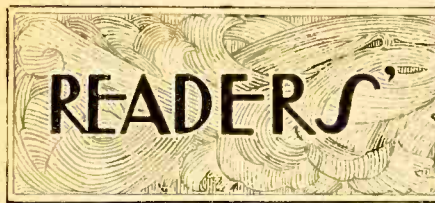

The Service is subject to the rules of the Department, which are printed below; these must be strictly enforced in the interest of readers themselves.

A selection of queries of general interest is dealt with below, in some cases at greater length than would be possible in a letter.

"The Wireless World" Supplies a Free Service of Technical Information.

Post-detection Volume Control.

I am thinking of making a receiver with two H.F. stages, anode bend detection, and two L.F. amplifiers. Do you think it is necessary to include some method of regulating L.F. magnification, or, at any rate, the input from the detector to the L.F. amplifier, which, I suppose, amounts to more or less the same thing?

S. T. S.

In the light of modern knowledge, some form of post-detection volume control must be considered as almost essential for a set such as you describe. When receiving loud signals (which should naturally provide reproduction of good quality), the use of two L.F. stages will almost inevitably result in overloading of the output valve, provided the H.F. input to the detector is sufficiently great to allow of efficient operation of this valve; consequently, some means should be provided to throw away excess low-frequency amplification. It may, of course, be argued that the total amplification provided should be just sufficient to load up the output valve when the detector is being operated under correct conditions; but if this is done there will be no reserve of amplification when receiving extremely distant stations under conditions where a certain amount of distortion is generally to be tolerated.

o o o o

A Slow Starter.

My three-valve set (detector and two resistance-coupled L.F. stages, fed from a D.C. eliminator) has worked well for some time, but recently seems to have developed a fault: on switching on, no signals are heard for a minute or so, and, after they become audible, there is a gradual increase in intensity. Can you tell me the probable cause of this effect?

T. W. H.

It seems almost certain that your trouble is due to a grid leak, which has probably developed an excessively high resistance. There will be two of these leaks in the set: you should test both with 'phones and battery, and, if either is found to give no click, or a very feeble click, it should be replaced.

A.C. High Frequency Valve.

If you consider that the idea is practicable, I propose to build a set on the general lines of the "S.G. Regional," but, as I need rather more sensitivity than an ordinary H.F. stage would provide, I am thinking of fitting an AC/S valve in the H.F. position, using ordinary battery valves elsewhere. Although my house is not connected to the main supply, battery charging is not a difficult problem, so the comparatively heavy consumption of L.T. current will not trouble me.

Will you please give me a circuit diagram showing connections of cathode and heater?

W. D. S.

Your proposed scheme is quite practicable; the required connections are given in Fig. 1, from which you will see that one side of the heater and the cathode are joined together and also to the L.T. negative bus-bar. This is a suitable procedure when an A.C. valve is fed from an accumulator battery.

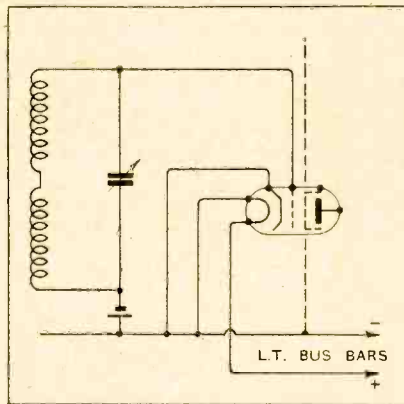

Fig. 1.—An indirectly heated S.G. valve, though designed for A.C. supply, may equally well be fed from an accumulator battery: how to connect the heater and cathode.

We have not shown any rheostat, as this will be unnecessary if you use 4-volt valves elsewhere in the receiver, with, of course, a filament battery of the same voltage rating, but in the event of 6-volt valves being used, it will be necessary to insert a resistance of 2 ohms in the positive heater lead.

Modified L.F. Transformer Connections.

I have seen a published circuit diagram in which H.T. current is fed to an L.F. valve through a resistance, an L.F. transformer primary, fed through a blocking condenser, being connected between the plate of the valve and L.T. negative. The object of this method of connection is apparently to prevent any reduction of primary inductance due to the passage of D.C. current through this winding.

Would it be worth while trying this form of connection in the anode circuit of a bottom bend detector valve? If there is no serious disadvantage that I have overlooked, it would appear that it should improve proportional amplification of the lower frequencies as compared with the more conventional plan.

L. W. W.

This parallel feed resistance scheme is certainly applicable to the coupling between an anode bend detector and the succeeding L.F. amplifier. Up to a point, your argument in favour of it is sound, but it must not be forgotten that in any case a valve functioning in this way does not pass a heavy direct current, and consequently when the transformer primary is connected in series in the ordinary way there is no very serious reduction in its effective inductance.

RULES.

(1.) Only one question (which must deal with a single specific point) can be answered. Letters must be concisely worded and headed "Information Department."

(2.) Queries must be written on one side of the paper, and diagrams drawn on a separate sheet. A self-addressed stamped envelope must be enclosed for postal reply.

(3.) Designs or circuit diagrams for complete receivers cannot be given; under present-day conditions justice cannot be done to questions of this kind in the course of a letter.

(4.) Practical wiring plans cannot be supplied or considered.

(5.) Designs for components such as L.F. chokes, power transformers, etc., cannot be supplied.

(6.) Queries arising from the construction or operation of receivers must be confined to constructional sets described in "The Wireless World" or to standard manufacturers' receivers.

Readers desiring information on matters beyond the scope of the Information Department are invited to submit suggestions regarding subjects to be treated in future articles or paragraphs.

Eliminator Voltage Measurement.

I am completely at a loss to know how to measure the voltage output of my eliminator. I have a moving coil voltmeter and a milliammeter; can you refer me to a book number containing an article showing how these instruments may be used?

T. P. L.

If your eliminator is designed to work in conjunction with your receiver, it is not absolutely essential that you should trouble yourself with the voltage measurements, as in all probability the pressures actually applied are sufficiently accurate. It must be remembered that, with a few exceptions, modern valves are not critical as to their requirements in this respect.

A simple method of measurement is explained in an article entitled "The Eliminator Output," which appeared in *The Wireless World* of May 2nd, 1928. If the eliminator makes use of series resistances, you should read our reply to "C. F. S." in last week's issue.

○○○○

"Decoupling" a Portable.

My five-valve portable (two H.F. valves, detector, and two transformer-coupled L.F. stages) gives quite pleasing quality when a new H.T. battery is fitted, but it deteriorates in this respect after a few weeks' working—it is assumed that this falling-off is due to increase in battery resistance. If this assumption is correct, I take it that quality will be improved by fitting a decoupling scheme; will you please give me a circuit diagram showing how the necessary feed resistances and by-pass condensers should be connected?

R. P. G.

Without full technical details of your set, it is not possible to make a definite

condensers (of 2 mfd. capacity) are shown at C.

You will probably find that at present provision is made for the application of a comparatively low H.T. voltage to the detector valve, but, as your proposed alteration will result in a considerable diminution of applied voltage, it will be as well to connect the feed resistance (R_1) for this valve to the main supply terminal.

With regard to the anode circuit of the first L.F. valve, it is unlikely that any very considerable voltage drop in the added resistance will be tolerable, and the value of R_2 must be kept as low as possible; we suggest that you try 10,000 ohms. It may be that you will find it necessary to reduce the grid bias applied to this valve. For R_1 , something between 20,000 and 30,000 ohms should be suitable.

○○○○

Short-circuited Neutralising Condenser.

On several occasions the windings of my H.F. transformer have been burnt out through a short-circuit in the neutralising condenser. Which is the best method of preventing this trouble?

J. C. H.

In the first place we would suggest that you should examine the condenser itself; a well-made and properly designed component should not be subject to repeated short-circuits. As a preventive measure, it is possible to insert a fixed condenser of something over 0.0001 mfd. (its exact capacity is unimportant) in series with the balancing condenser. This scheme is as satisfactory as any other, but as an alternative, you can connect the low-potential end of the neutralising windings, which is at present joined to the primary winding (and consequently to H.T.+) to the negative filament terminal of the H.F. valve holder; with this form of connection, a

Power Line Interference

High-voltage overhead cables are being erected behind my house, passing at a distance of about 150 yards. Can you tell me whether they are likely to interfere with my reception?

C. D. P.

It is not possible to give you a definite reply to this question, but we think it unlikely that you will suffer serious annoyance.

Any trouble that may arise is likely to be most pronounced at times when the insulators are wet and dirty, and at such times it is possible that there will be a certain amount of interference.

For a full discussion of this matter we would refer you to an article in our issue of May 8th, from which you will see that, in one instance, at a distance of 200 feet from the insulators of a 60,000-volt line, reception was spoiled by this cause.

○○○○

The Signal-frequency Amplifier.

Is there any inherent reason why a screen-grid valve should not be used as an H.F. amplifier (fundamental frequency) in a superheterodyne receiver? I cannot trace the published description of such an arrangement, but if you consider it to be practicable, I should like to include it in my set, which is in course of reconstruction.

L. D. M.

There is no reason whatsoever why an S.G. valve should not be used for this purpose; indeed, it would appear to be particularly suitable, and unless your present H.F. stage is of the most efficient type, you may fairly look for a considerable improvement, provided reasonable care is taken in making the alteration.

○○○○

Further Data Wanted.

I am sending you the circuit diagram of my proposed D.C. eliminator: will you please mark on it suitable values for the two voltage-dropping resistances, bearing in mind that I wish to have an output of 70 volts at the terminal marked H.T.1, and 150 volts on the other.

T. B. L.

We are afraid that you have set us an impossible task; everything depends on the current to be taken from the two terminals, and we could at best do no more than make a vague guess as to suitable resistance values.

If you know roughly the current taken by the various valves to be fed from the two terminals at the desired voltage, it is a simple matter for you to calculate the value of the resistance yourself. Knowing the voltage of the mains, you will divide the voltage to be dropped in the resistance (i.e., the difference between the required and supplied voltages) by the current to be consumed (expressed as a fraction of an ampere).

This calculation must be carried out with respect to both high- and low-voltage terminals, and if you propose to take a heavy current from the eliminator, it will be necessary to make a correction for voltage loss in the smoothing choke.

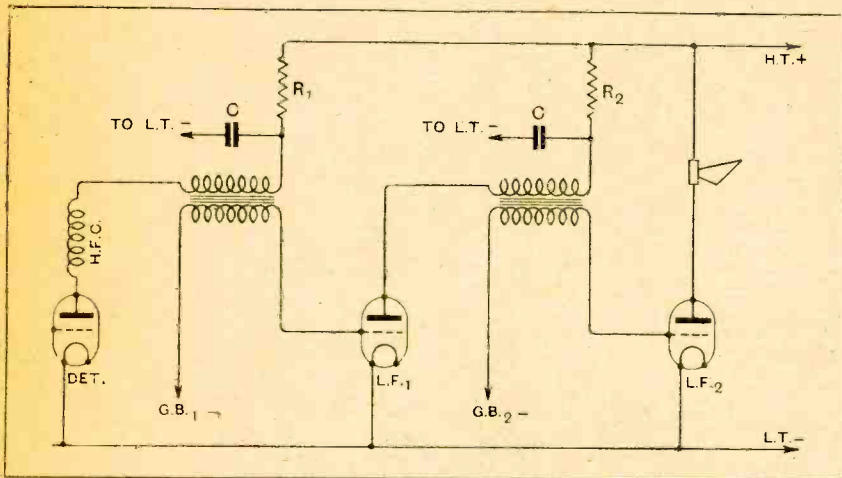

Fig. 2.—How to add decoupling resistances and condensers to a two-stage transformer-coupled L.F. amplifier.

statement as to whether the addition of decoupling resistances will cure your trouble, but in all probability it will effect an improvement. The necessary additions are shown in Fig. 2, in which R_1 and R_2 represent feed resistances; by-pass

battery short-circuit is impossible, even though the balancing condenser plates may make contact.

Thirdly, the connection of a fuse in the H.T. feed lead will prevent any ill effects, provided it is suitably chosen.