

The Wireless World

AND RADIO REVIEW

No. 321.

WEDNESDAY, OCTOBER 7, 1925.

VOL. XVII. No. 15.

Assistant Editor:
F. H. HAYNES.

Editor:
HUGH S. POCOCK.

Assistant Editor:
W. JAMES.

Editorial Offices: 139-40, FLEET STREET, LONDON, E.C.4

Telephone: City 4011 (3 lines).

Advertising and Publishing Offices: DORSET HOUSE, TUDOR STREET, LONDON, E.C.4.

Telephone: City 2847 (13 lines).

Telegrams: "Ethaworld, Fleet, London."

COVENTRY: Hertford Street.

BIRMINGHAM: Guildhall Buildings, Navigation Street.

MANCHESTER: 199, Deansgate.

Telegrams: "Cyclist, Coventry."
Telephone: 10 Coventry.

Telegrams: "Autopress, Birmingham."
Telephone: 2970 and 2971 Midland.

Telegrams: "Hiffe, Manchester."
Telephone: 8970 and 8971 City.

Subscription Rates: Home, £1 1s. 8d.; Canada, £1 1s. 8d.; other countries abroad, £1 3s. 10d. per annum.

As many of the circuits and apparatus described in these pages are covered by patents, readers are advised, before making use of them, to satisfy themselves that they would not be infringing patents.

CLOSING DOWN THE RELAY STATIONS.

THE second conference of European Broadcasting Engineers held recently in Geneva has recommended a course of action which is both courageous and satisfactory. To have ignored the chaotic state in which the present independent national arrangements for broadcasting were leading, would have resulted in the development of a state of affairs in the near future which it might have been next to impossible to remedy because matters would have gone too far for a remedy to be introduced.

The first Conference of Engineers in Geneva resulted, as we know, in a strenuous effort to rearrange the wavelengths of stations so as to avoid mutual interference, but the engineers admit that this scheme has failed.

Whilst nothing definite has been disclosed so far as to what precise steps will be taken to reduce the number of stations, and although Capt. Eckersley in his talk before the microphone last week—which is reproduced in this issue—did not go very far in taking his listeners into his confidence, yet it has since been made clear that the sacrifice which will have to be made in this country will be the closing down of the relay stations. If certain of the British stations have got to go, it is obviously the relays which must first be "axed," and it is equally apparent, as we have pointed out before, that if Europe is to be served by broadcasting stations in proportion to the population and the area of the various countries, then Great Britain already has more stations than its legitimate share.

The Geneva Bureau can only be effective so long as each European country receives equal treatment with the rest of Europe. However distasteful to those who reside in the areas now served by relay stations the pending abolition of these stations may appear, the facts must be faced, and it is useless to kick against the inevitable result which the progress of broadcasting has brought about.

CONTENTS.

	PAGE
EDITORIAL VIEWS	453
THE POST OFFICE BEAM STATION	454
"FIXED TUNING" RECEIVER	457
NOVELTIES FROM OUR READERS	461
REMOTE RECEIVER CONTROL	463
By A. R. Turpin.	
CURRENT TOPICS	467
EUROPE'S WAVELENGTH DIFFICULTIES	469
By Capt. P. P. Eckersley.	
EXPERIMENTAL STATION G2KF	471
BROADCAST BREVITIES	473
THE SELECTION OF A VALVE (Continued)	475
By N. V. Kipping and A. D. Plumlein.	
PRACTICAL HINTS AND TIPS	479
CRYSTAL DETECTORS	481
By F. M. Colebrook.	
NEW APPARATUS	484
DICTIONARY OF TECHNICAL TERMS	486
LETTERS TO THE EDITOR	488
READERS' PROBLEMS	489

Morse Interference.

Very welcome news reached us only recently of the decision to restrict ship communication to wavelengths outside the broadcasting band, except when out of range of likely interference. This, of course, is a very important step, but there is still room for improvement. On certain wavelengths on the broadcasting band in this country there are still Morse stations causing an immense amount of interference, and whilst not laying any specific charge against the Post Office in respect of the land stations which they operate, yet we believe that an astonishing improvement in broadcast reception all over the country, and particularly in certain areas, would be revealed if fate should bring about a temporary breakdown in certain of the

Post Office transmitting stations.

Sooner or later something will have to be done, therefore why not now? We have had an important enquiry at Geneva to deal with mutual interference by broadcasting stations; and we think that a further enquiry is overdue to investigate causes of interference with broadcast transmissions other than by stations operating for broadcasting.

The POST OFFICE BEAM STATION

Some Notes on the Mast and Building Erection now in Progress at Bridgwater.

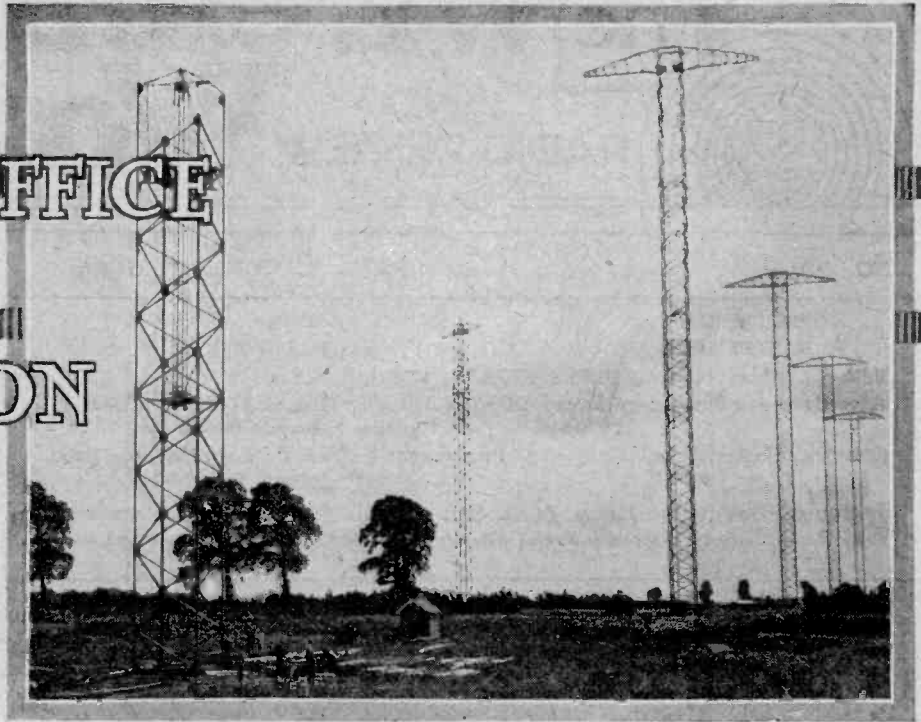

THE first long-distance station on the beam system to be erected in this country for the Government is the one which is now under construction for the G. P. O. by the Marconi Company at Bridgwater. The Bridgwater station, when completed, will comprise two separate and distinct receiving systems, each system consisting of five masts arranged in a straight line with cross arms at right angles to this line, as shown in the general view of the masts above. These two receiving systems are destined for use in communication with Canada and South Africa. The line formed by the four finished masts to be seen in the photograph and the partly finished mast

in the foreground will carry the aerial equipment for reception from the corresponding transmitting station which is now being erected in Canada. The central mast is one of the other system of five masts which will be for correspondence with South Africa.

Selection of the Site.

The site for this station has been selected with great care. For strategic purposes it was thought advisable that the stations should be well inland, so that the probability of bombardment from enemy warships, in the event of war, should be reduced to a minimum. It was also de-

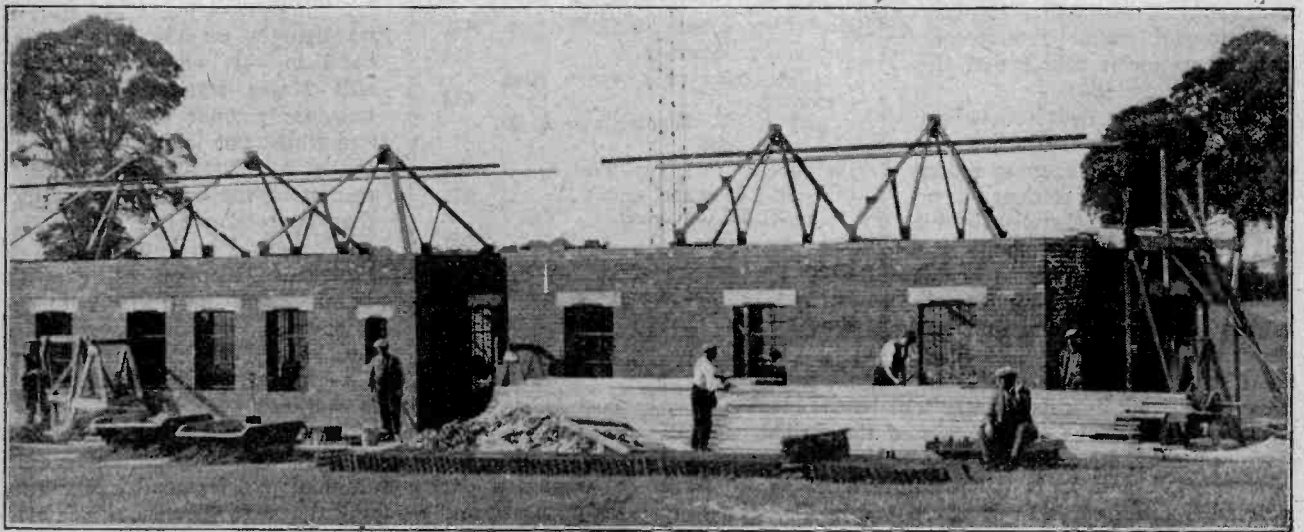

Fig. 1.—The receiving station buildings.

The Post Office Beam Station.—
sirable that the station should stand on high ground with a clear stretch between it and the distant sister station with freedom from hills and trees in the vicinity.

The masts, when finished, will support a flat reflector intended to concentrate wireless waves coming from the direction of the transmitter on to one receiver, provided that the wavelength is correct. By this means the received signal strength is that of the signals received in each of the many aerials added together. It is no

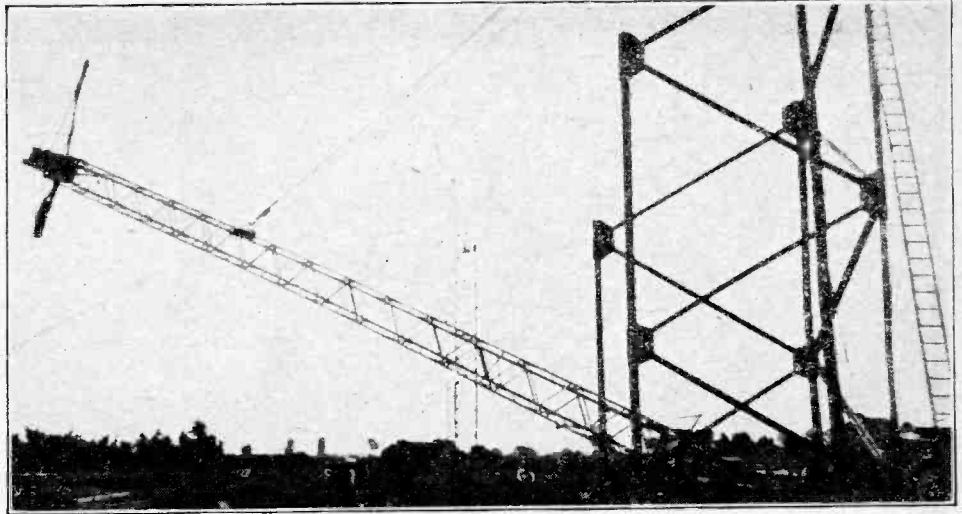

Fig. 2.—Derrick used for hoisting sections of the mast being raised into position.

longer found necessary to curve the reflector in order to obtain this effect, although in the early experimental work it was assumed, until experiments proved otherwise, that a wireless reflector would have to be curved in the same way as an optical reflector to bring the waves into focus.

The various photographs reproduced show the masts in the course of erection. No receiving apparatus is as yet installed, and it will be seen that the building itself is only partially completed. The masts are being erected under sub-contract from the Marconi Company, but under their supervision and to their design. The weight of each mast is approximately 50 tons, and the concrete anchors

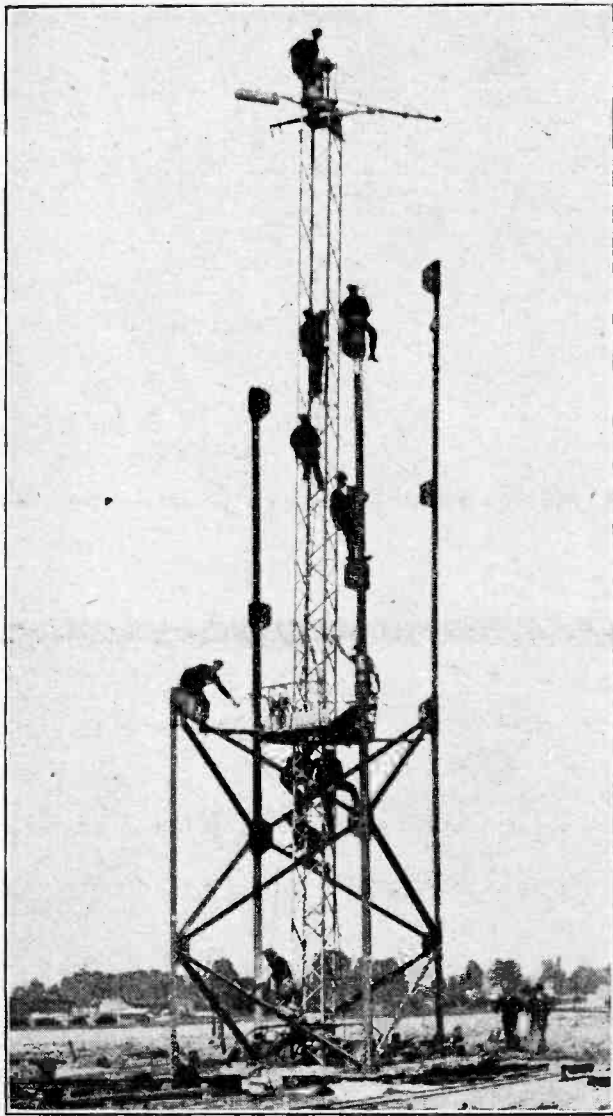

Fig. 3.—The derrick in position.

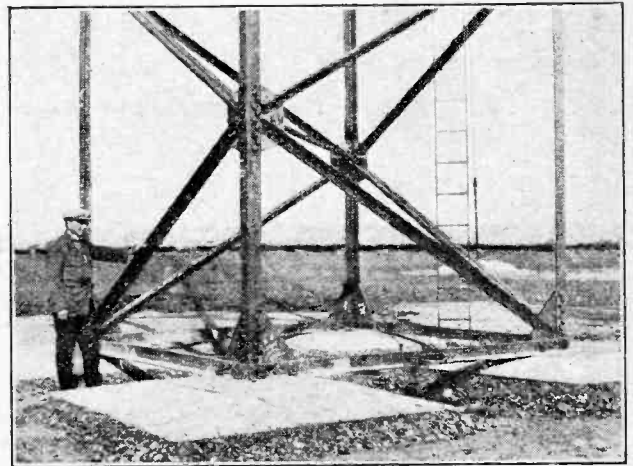

Fig. 4.—The foundations at the base of one of the masts.

for each stay, of which an illustration is given in Fig. 7, weigh more than 30 tons each. The most unusual point about the mast construction is the elaborate cross-piece at the top, forming a "T." This portion alone weighs 7 tons, and acts as a gigantic spreader to support the aerial system. The aerial system consists of a large number of vertical wires suspended on insulators, the lower end being attached by means of other insulators to special anchors in the ground. These anchors are so designed as

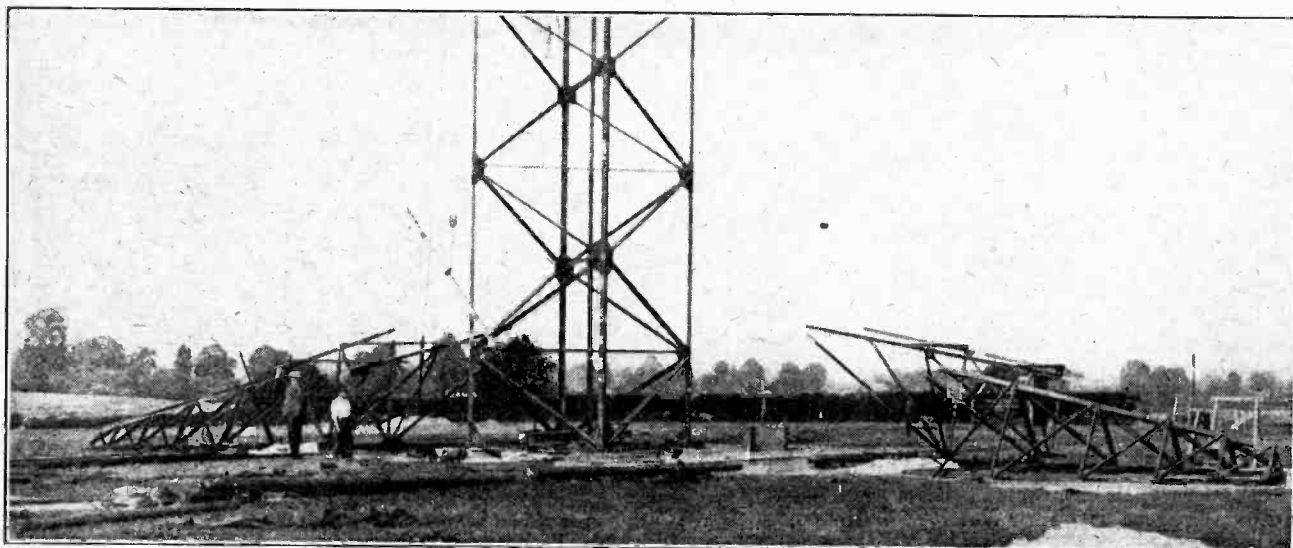

Fig. 5.—A cross arm in four sections ready to be hoisted to the masthead.

to maintain a constant pull on the aerial and keep it taut. The other end of the "T" section at the top of the masts is to support the reflector wires just behind the main aerial. These wires are identical with the aerial wires, and are arranged one behind each of the former.

Method of Erecting Masts.

It is very fascinating to watch the actual erection of these masts, because they are so different in character from ordinary masts, on account of the complication and weight of the cross section at the top. The method which is being employed in the erection of the masts is that, as soon as the foundations are ready, some of the lower sections and braces are set up and bolted into a vertical position, as shown in Fig. 2. A derrick is then moved into position with its base within the four corners of the tower, but with its weight resting in such a manner that the anchorage forms a hinge (see Fig. 3).

A block and tackle is made fast to a point about two-thirds of the way up the derrick, and by this means the

derrick is hoisted up from the ground. A working platform is then assembled inside the mast and surrounding the derrick.

With the lower sections, platform and derrick all in position, the steelwork for the next section of the mast is

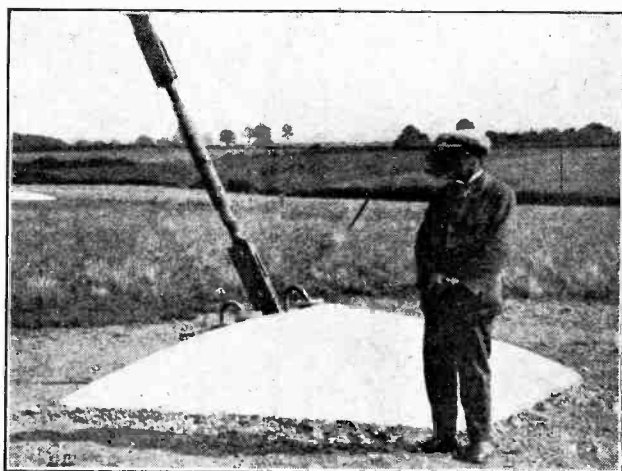

Fig. 7.—Concrete anchor to one of the stay wires.

hoisted into position piece by piece, and bolted into place. When this is completed, the whole derrick is raised up from the ground vertically, and made fast to the lower portion of the mast. More steelwork is built round it; then the derrick is again raised, so that eventually the derrick stands with its head projecting above the finished walls of the tower.

When the final stage is reached, auxiliary derricks are hoisted into place, and then the four great portions (shown in Fig. 5), which form the cross arms, are raised and bolted into place. Finally, the derricks are dismantled and lowered to the ground.

We are indebted to the "Western Daily Press," Bristol, for permission to reproduce the interesting series of photographs illustrating this article.

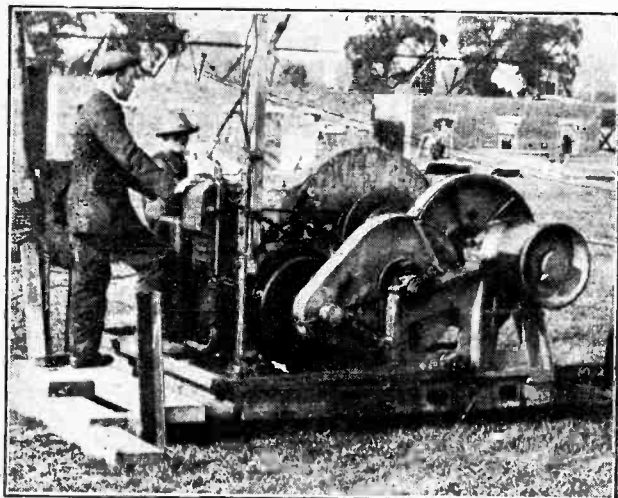
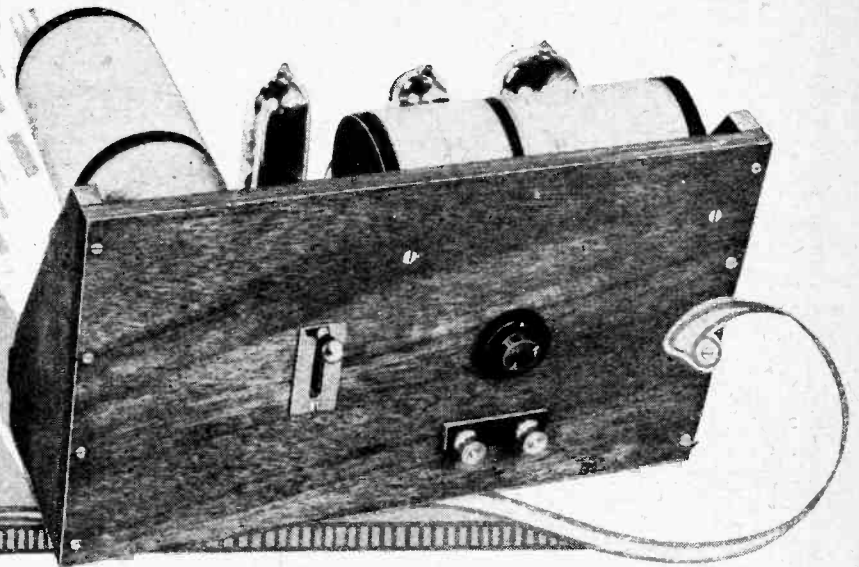

Fig. 6.—A winch used for mast erection.

FIXED TUNING

THREE VALVE SET

Receiver for Local
&
5xx Programmes
Without Controls.



Easily Constructed and Inexpensive Set for Loud Speaker Reception.

By F. H. HAYNES.

ALTHOUGH the process of tuning adds interest to wireless reception as a hobby, there is little doubt that the elimination of tuning controls from the receiving set would give rise to an increase in the number of listeners-in to broadcast programmes. The trend among the commercial designs is not towards simplifying the process of tuning, and whilst many wireless users appreciate the inclusion of adjustments which provide for getting "the very last ounce" out of a set, there is a class of would-be listener who merely desires to turn on a switch to bring the set into operation.

The omission of tuning adjustments more than halves the total cost of components, as well as greatly simplifying the actual construction, though certain difficulties arise in devising the circuit arrangement. It is to be assumed that the tuning of transmitting stations will remain perfectly constant and that changes of wavelength will not occur without notice. Exactness of tuning of the transmitting station can be expected, for no diffi-

culties stand in the way of keeping observation on the constancy of the wavelength. Recently, attention was drawn in this journal to the fact that the wavelengths used by several of the stations differed from the stated wavelengths, but it would appear that no observable change of wavelength has occurred in the case of the London station for a period of several weeks, during which period the transmitting apparatus has been often returned as a result of experiments carried out at other times than the usual broadcasting hours on other wavelengths.

Changes of Aerial Capacity.

An important factor to be allowed for in the design is the varying conditions of the aerial and, in particular, changes of aerial capacity. The principal cause of movement of the aerial comes about from shrinkage of the halyard rope when wet, though the reader may be surprised at the results which will be obtained from a few simple tests to investigate the changes of aerial capacity. For instance, if 50ft. of wire suspended between a chimney stack 28ft. above the ground and a mast 35ft. in height is connected to a non-oscillating receiver and is raised and lowered though with a distance of 10ft. at its centre, no change of signal strength results either from any variation of capacity or decrease in effective height. There is, however, a marked falling off in the signal of a distant station when the receiving set is very sharply tuned as a result of bringing it near the oscillatory point by the critical adjustment of reaction coupling. For reception from the nearest station, however, this latter condition does not apply.

In making these tests the aerial tuning condenser was connected across the inductance, and the apparent capacity of the aerial, as roughly determined by calculation from the wavelength obtained when loaded by an inductance coil, was 0.00018 mfd., while the setting of the condenser showed a parallel capacity value 0.00013 mfd.

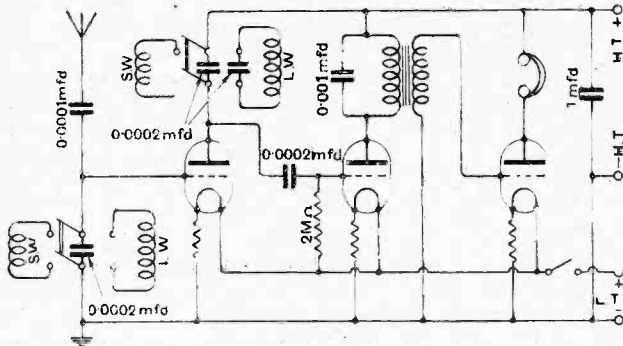

Fig. 1.—The circuit provides for fixed tuning with a doublewave range for reception from both the local station and Daventry by means of a 4-pole switch and a double set of tuning coils. Suitable grid bias is obtained by fixed filament resistances connected in the negative filament leads.

**"Fixed Tuning" Three Valve Set.—
Constant Aerial Tuning.**

The aerial tuning circuit can, however, be so proportioned as regards capacity that the small changes likely to be met with in the actual capacity of the aerial produce inappreciable changes of tuning within practical limits.

Bearing in mind that when a condenser has another of equal value connected in series with it the resultant capacity is half that of either of them, it will be seen that, by using a series aerial condenser, the effect on the total capacity of the circuit of aerial capacity changes will be lessened. For instance, when an aerial of capacity 0.00018 mfd. is connected in series with an aerial tuning condenser of 0.0001 mfd., the resultant capacity is 0.000063 mfd. Now if the aerial capacity increases to 0.000185, somewhat an excessive change, perhaps, the combined value becomes 0.000065 mfd.

This increase, already minimised by the series condenser, can be rendered still less significant by employing a parallel connected condenser across the tuning coil. The combined capacity of condensers connected in parallel is obtained by adding the individual capacities, and in the example it will be seen that minute variations in the combined capacity of aerial and series aerial condenser become inappreciable when added to the capacity of a parallel condenser of a normal value of 0.0002 mfd. The total aerial capacity now becomes 0.000263 mfd., and the increase in aerial capacity brings the value up to 0.000265 mfd.

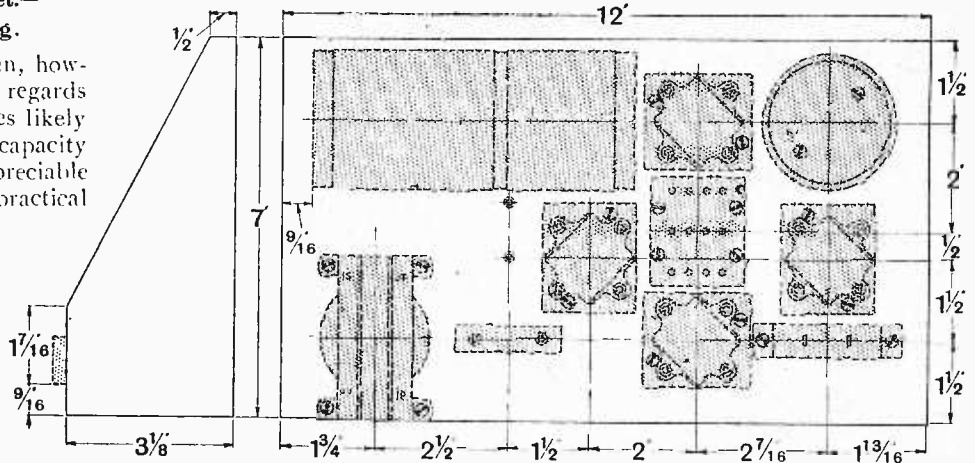

Fig. 2.—Dimensional drawings showing the relative positions of the component parts.

In tuning to a wavelength of about 360 metres, the apparent inductance value of the tuning coil will be about 140 microhenries. The increase in wavelength produced by the increase of aerial capacity is less than 2 metres with this coil, an almost significant value, as will be seen from the resonance curve of a tuned aerial circuit operating on broadcasting wavelengths when not stimulated into self-oscillation by reaction.

Were the capacity of the series-connected aerial condenser to be reduced to a lower value than 0.0001 mfd., or the parallel condenser increased beyond the value given of 0.0002 mfd., then changes of aerial capacity would be even less significant. These values are chosen with regard to signal strength and selectivity.

Valve Capacity.

The capacity presented between the electrodes of the valve constitutes another variable factor, although valves of similar type do not differ to any great extent. The maximum interelectrode capacity of receiving valves rarely exceeds 0.00001 mfd. (10 micromicrofarads), and the difference with valves of similar type is not likely to be more than one or two micromicrofarads. This small variation is rendered of no consequence by comparison with the capacity of the parallel tuning condensers which connect the grid and plate of the high-frequency valve to earth potential points in the circuit. The parallel condensers also are of sufficient capacity to prevent the set oscillating as a result of the grid plate capacity.

**Circuit and Points
in Design.**

Because no form of reaction coupling can be

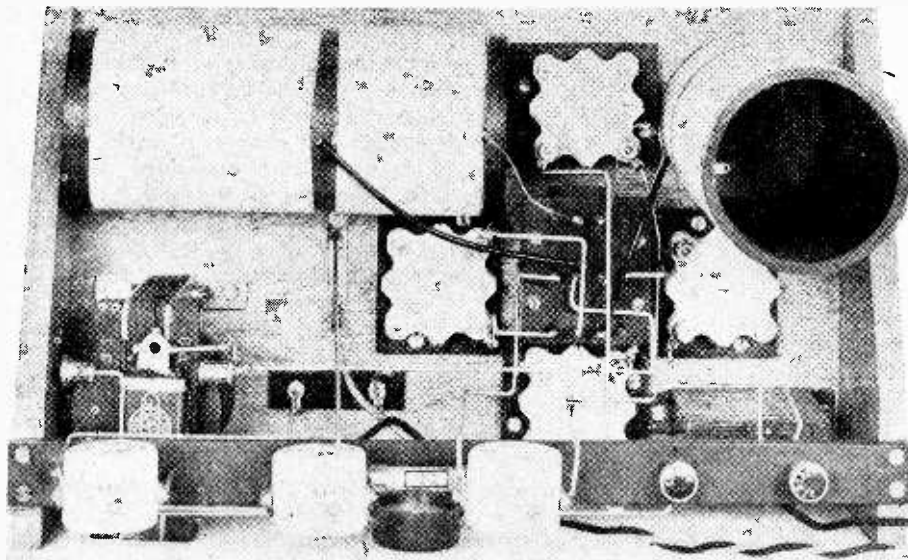

Fig. 3.—The layout of the components has been carefully considered to simplify the wiring and to render the leads as short as possible.

LIST OF COMPONENTS.

- 12½ in. ebonite tube, 2½ in. dia., ¼ in. wall.
- Planed wood, preferably mahogany, ¾ in. in thickness. The front panel is 7 in. × 12 in. and the ends are cut from a piece 7 in. × 7 in.
- Utility 4-pole switch, lever pattern.
- 3 Valve holders with clips (Athol).
- 3 Air condensers, 0.0002 mfd. (Ormond).
- 1 Air condenser, 0.0001 mfd. (Ormond).
- 4 Terminals.
- 1 mfd. Condenser (T.C.C.).

- Intervalve Transformer (Ormond).
- Grid condenser 0.0002 mfd. (Walmel).
- Grid leak, 2 megohms (Darco).
- Mica dielectric condenser, 0.0001 mfd. (Igranic).
- 4 ozs. No. 24 D.S.C. wire.
- 4 ozs. No. 30 D.S.C. wire.
- 4 ozs. No. 16 tinned copper wire.
- 2 yards flexible wire.
- Ebonite for strip 12 in. × ¾ in. × 5/16 in.
- On and off switch (R. A. Rothermel).

adopted to give good sensitivity, it becomes necessary to include a high-frequency amplifying stage. Moreover, the H.F. valve may be helpful for bringing in Daventry on the wavelength of which a high degree of H.F. amplification is obtainable. A valve detector followed by a single-stage low-frequency amplifier renders the sets suitable for operating a loud-speaker on both the transmission from the local station and Daventry. Grid condenser and leak rectification is made use of as greater signal strength results than with anode rectification. The grids are biased by the potential drop produced across the fixed

switch changes the coils in both the aerial and tuned anode circuits. The tuning condensers are of the air dielectric type. The filament current is controlled by a switch on the wooden front panel.

Construction.

Begin by making up the tuning coils. Ebonite tube, or cardboard well dried and impregnated with paraffin wax, 2½ in. in diameter, is cut off with a fine toothed back or hack saw to two pieces 6 in. in length. The ends of the tubes can be cleaned up by rubbing with a circular movement on medium-grade carborundum cloth laid flat on the bench. Four pairs of small holes for terminating the wire (about 1/16 in.) are made at distances of ¾ in., 1 5/16 in., 2 3/16 in., and 5 3/4 in. from one end of the aerial coil former, which is plugged with a bridging piece of ¾ in. wood. The anode coil former is attached to the front panel by means of two 1 in. by 4 B.A. countersunk brass screws with nuts and small spacing pieces of drilled ebonite ¼ in. thick. This former is drilled with pairs of holes for the wires at distances of ¼ in., 2 5/16 in., 2 3/8 in., and 5 3/4 in. for one end. The aerial inductance consists of a winding of No. 24 double silk-covered wire occupying a space of 1 3/4 in. on the former, leaving 6 in. of wire spare at the commencing end. For long-wave tuning, No. 30 double-silk-covered wire is used with a winding space of 3 1/2 in. The short and long wave coils are not connected together, but are brought into circuit separately.

The finished instrument shown in the accompanying illustration will be seen to consist of a wooden base-board carrying the coils, condensers, change-over switch, and intervalve transformer. The valves are supported by an ebonite strip 12 in. × ¾ in. × 5/16 in., which bridges the wooden end pieces. In making up the frame work, planed ¾ in. mahogany is used, with horizontal grain along the front panel, and vertical grain for the end pieces. Back saw and file are used to bring the wood down to the correct dimensions. The ebonite strip must be sawn off with care and filed down

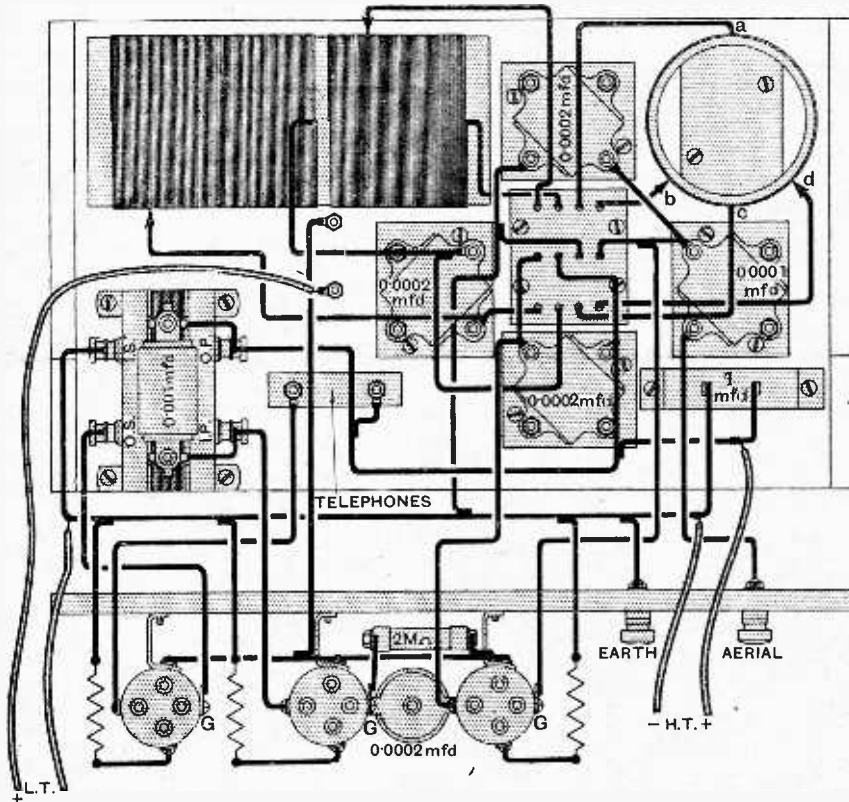

Fig. 4.—Practical wiring diagram, showing the actual points between which the leads are run. The lead (a) connects to the starting end of the smaller winding, (b) is the tapping point, (c) the starting end of the long-wave winding, and (d) the long-wave tuning tap.

filament resistances connected in the negative filament leads, and a single H.T. voltage of comparatively low value is common to all of the three valves.

The tuning circuits are entirely duplicated and carried on two formers assembled at right angles to each other to prevent inductive coupling. A four-pole, two-position

"Fixed Tuning" Three Valve Set.—

to size, examining all edges with straight edge and square. A good finish is obtained by rubbing down on medium carborundum cloth.

It is obvious that the layout of the components can be modified so that less work will be included in making up the set, but if compactness is required with short and direct wiring, the layout given should be accurately followed.

The relative positions of the components is decided entirely by the wiring, and they have been placed in positions so that connection can be made by means of short direct leads. Valve holders, for example, are spaced so that when bridged by the grid condenser, no additional wiring is needed. Filament resistances of fixed value and consisting of resistance wire spirals are connected between the negative filament lead and the filament sockets of the valve holders. No. 32 silk-covered Eureka wire is suitable for making up resistances for dull emitter valves, and for the D.E.R. type about roin. is required. The actual length can be adjusted before making a permanent soldered connection.

Making the Tuning Adjustments.

The best way of determining points on the tuning coils at which the connections are to be made is with the aid of a pair of ebonite rods about the size of pencils terminated at one end with sharp metal points. A 4 B.A. screw threaded into the end of a piece of $\frac{1}{4}$ in. ebonite rod with the head removed and brought to a point forms a suitable wander tapping point for determining the tuning adjustment. A flexible lead is run between the tapping point and the part of the circuit to which connection is to be made, and the point

is forced into contact with the turns of the inductance until maximum signal strength is produced. It is necessary, of course, to make adjustment simultaneously on both the aerial and anode coils.

Short and long wave inductances are tuned quite independently, and if, owing to using a large aerial, the tapping points are found to leave more than a few dead end turns, the surplus winding should be removed, leaving, of course, a few turns for future use when readjusting. A strong needle inserted under the turn to which con-

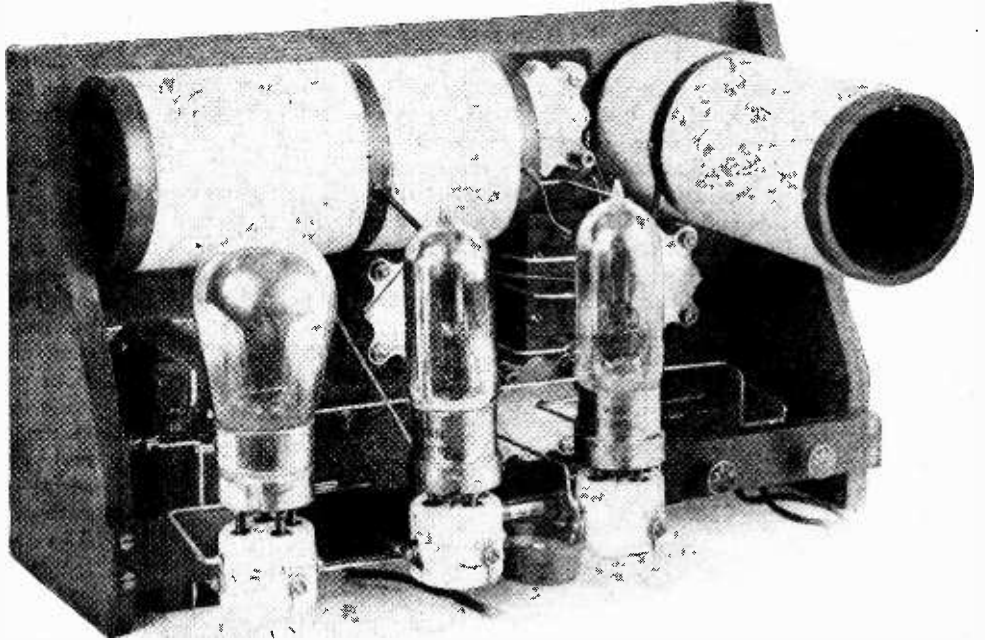

Fig. 5.—Another rear view of the finished instrument. The high and low tension batteries are connected up by means of flexible leads while terminals are provided on the ebonite strip for the aerial and earth connections. The telephone terminals are on the front of the set.

nection is to be made will stretch the wire sufficiently for a piece of wood or empire cloth to be slipped under the turn, so that a good soldered connection can be made.

In spite of the simple form of construction adopted, the receiver is capable of a very satisfactory performance. Connected up to an average amateur single-wire aerial at a distance of twelve miles from ZLO, good signal strength was obtained from an Amplion loud-speaker both from the local station and Daventry.

Cape Town, S.A.

(On 35 and 80 metres.)

U.S.A.:—8EX, 9EJ, 1AXA, 2XAF.
Great Britain:—5DH, 2LZ, 5MA.
France:—8SM, OCDB, YZ. Chile:—1EG.

(0-v-1.) All telephony.

J. S. STREETER (O.A4Z).

London, S.E.27.

Great Britain:—2BDQ, 2BDX, 2BH, 2BK1, 2DA, 2FO, 2NE, 2UY, 5BA, 6FQ, 6IZ, 6VP, 6SU, 5DA. Holland:—OXW, OPM, ORO. France:—8PAX, 8PPC.
Sweden:—SMXU, SMYV. Australia:—2CM.
New Zealand:—4AR, 2AC, Mexico:—1AA, 1B. Unknown:—11B.

L. F. ALDOUS (2ZB).

Calls Heard.**Extracts from Readers' Logs.****Monmouth.**

U.S.A.:—1AKZ, 1AUC, 1ADP, 1SL, 1JK, 1AJM, 2AXL, 2CXL, 3SB, 4CCB, 4SL (all on 90 metres). France:—8F1, 8ACA, 8PAX, 8RB, 8NN, 8YB. Various:—LAT, KY6, KY7, PB7, W1R, W1Z, WQN, SMTT, SGC, NOPX.

R. W. ARNOTT (G2AJL).

Thornton Heath.

(September 12th to 15th.)

Italy:—1AB, 1AS, 1BP, 1GN, 1NO.
Ireland (Free State):—7AR, 7OK.
Sweden:—SMTN, SMVL, SMZS.
Luxembourg:—L0OR. Varna:—NTT (U.S.S. "Scorpion"). Morocco:—Maroc (CQF MAROC). Mosul:—1DH. Brazil:—BZ1AB. U.S.A.:—1ALR, 1AVL, 1AXA, 1CKI, 1CKP, 1CNE, 2BBX, 2BUR, 2BUY, 2MM, 3BWJ, 4RM, 4XB, 8BR, 8EQ, 9XN, NKF, WIZ. Russia:—NRL. Miscellaneous:—N12BB, BP7, B4RE, BE2, BK2, BN2, BP2, BG6, FB1, 8ZZ3, 3AD.

(0-v-0.) On 30 to 50 metres.

W. A. J. WARREN.



A Section Devoted to New Ideas and Practical Devices.

TELEPHONE SWITCH.

The circuit given in the diagram shows how a 12-pole three-position Dewar switch may be used to give alternative connections for high and low resistance telephones or a loud-speaker.

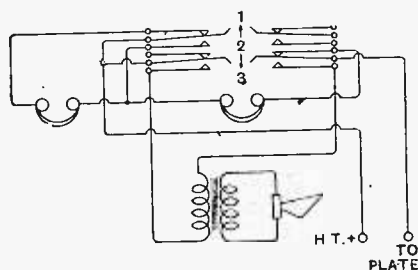

Connections for switching a loud-speaker and two pairs of telephones.

Switches of this type are obtainable from dealers in ex-Government wireless apparatus, and consist of two groups of six contacts mounted side by side. In the diagram the two halves of the switch have been left side by side for the sake of clearness. With the switch in position 1, two pairs of telephones are connected in series in the plate circuit of the last valve. In the central position 2, one pair of telephones is in circuit, while in position 3 the primary winding of the loud-speaker transformer is connected in the plate circuit.—K. H. C

o o o o

HYDROMETER HOLDER.

If frequent use is made of a hydrometer for testing the specific gravity of the acid in the L.T. batteries, there is a possibility of damaging carpets, etc., with drops of acid from the hydrometer when it is removed from the cell.

The photograph shows a method of supporting the hydrometer over the battery by means of a clip bent from

to

ordinary tinned copper connecting wire. When the battery is returned from the charging station, the hydrometer is held permanently in the position shown until the battery is ready for recharging. The specific gravity of the acid can, therefore, be examined at frequent intervals, and a close watch kept over the rate of discharge of the cell.—W. H.

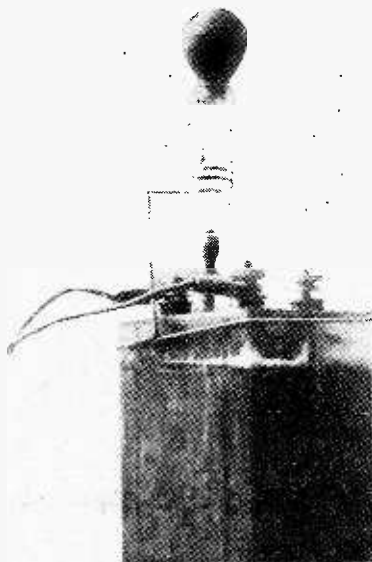

Specific gravity tests can be made at frequent intervals to ascertain the condition of the cells if the hydrometer is attached to the accumulator throughout the charging or discharging period.

o o o o

VERNIER CONDENSER.

By mounting a curved plate on a vertical spindle at the side of a variable condenser a vernier adjustment of the total capacity may be obtained by varying the distance between the plate and the fixed vanes of the condenser. The plate is cut from sheet metal in the shape shown at the right-hand side of the diagram, and the projections at the top and bottom are bent over at right angles after the

holes have been drilled. The plate is then clamped to a vertical spindle passing through a metal bush in the receiving panel. A small adjusting knob and pointer may be fitted together with a stop to prevent the auxiliary vane from touching the

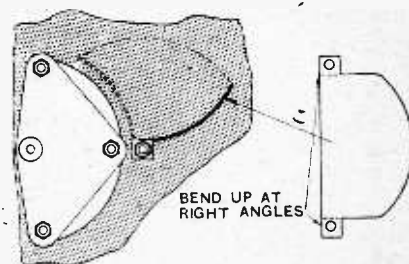

Vernier attachment for variable condenser.

main condenser. A flexible connection is then made between the top of the vane and the centre spindle of the main condenser.—S. P. S.

o o o o

REWINDING TELEPHONES.

The principal cause of failure in telephones rewound by amateurs is a breakage of the wire at or near the commencement of the winding. The pressure exerted by the upper layers of wire is sufficient to break off the wire near a badly made joint, and, even if the joint is satisfactorily made, it often happens that the thin wire is broken off just where it emerges from the bottom of the coil.

An excellent method of leading out the inner connection which does not occupy much winding space is shown in the diagram. A layer of waxed paper or other suitable insulation is first fixed to one of the inside faces of the bobbin. The end of the wire is then soldered to a narrow strip of thin brass or copper foil, which is laid on the surface of the insulation. After making a small S bend in the wire near the joint to relieve the joint

from possible tension, another layer of waxed paper is placed over it and stuck down by warming slightly. The winding of the coil may now be

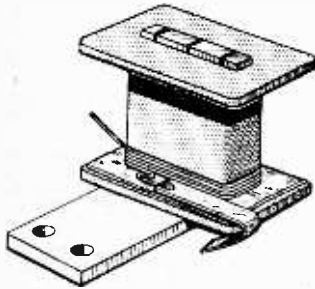

Internal connection for telephone winding.

proceeded with. When the coil is finished, the connecting strip will be quite firmly fixed, and connection can be made to it without fear of breaking the internal joint.—F. K.

NEUTRODYNE VALVES.

When adjusting the neutralising capacities in a neutrodyne receiver it is customary to insulate one of the filament legs by wrapping round it one or two layers of paper. This is rather a tedious method, and often results in trouble through the tearing of the paper when the valve is inserted.

If much experimental work is to be done with this type of circuit it may be an advantage to treat all the H.F. valves used for experiments in the following manner. One of the filament sockets of each valve is reduced in length by about $\frac{1}{4}$ in. When neutralising the valve is withdrawn until the shortened filament pin is out of contact with the socket. The remaining three legs are in contact, so that electrically the conditions for neutralising are fulfilled.—J. A. C.

KEY SWITCH.

Surreptitious use of reacting receivers during the absence of the persons usually responsible for their manipulation is undoubtedly the cause of much of the interference due

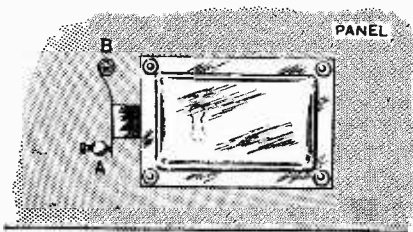

An inexpensive key switch.

B 14

to oscillation. Misuse of apparatus in this way can be effectively guarded against by using a key switch, the key being kept by the owner of the set.

A particularly cheap and simple switch can be constructed with a small cabinet lock, which can be obtained for a few pence from any ironmonger. The lock can be screwed to the back of the main panel of the receiver and arranged to close contacts connected in the I.T. circuit. The contacts from the vibrator of an old electric bell are admirably suited for this purpose, and could be mounted as shown in the sketch, the leads from the filament circuit being connected at A and B. The construction could be simplified by making one of the connections to the lock itself, but there is always the possibility of a noisy contact in the lock mechanism, and separate contacts are therefore to be recommended.—A. R. F. L. M.

Valves for Readers.

For every practical idea submitted by a reader and accepted for publication in this section the Editor will forward by post a receiving valve of British make.

KEYING A TRANSMITTER.

The difficulties of keying a transmitter are considerably increased when short wavelengths are employed. With any of the standard methods of keying, an unsteady note is produced by alteration of the filament temperature, hand capacity, and other well-known effects. The following method has been used with considerable success by the writer in a short-wave Colpitts transmitter.

A non-inductive resistance having a value of 40 to 50 ohms is connected between -H.T. and the filament, and the key is arranged to short-circuit it when depressed. The valve does not stop oscillating when the resistance is short circuited, but the wavelength is changed slightly, the difference being sufficient to render the beat note in the receiver inaudible during "spacing" periods when it is

tuned to the wavelength emitted during "marking."

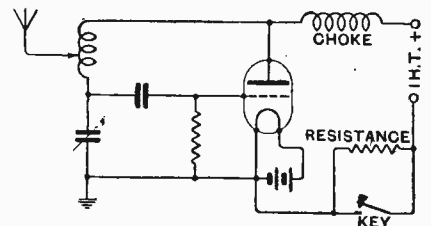

Connections for keying a short-wave transmitter.

A remarkably steady note is produced, and there is complete freedom from hand-capacity effects.—E. H. C.

LOW-CAPACITY VALVE MOUNTING.

Valves with 4-pin mountings may be used for short wave work if special precautions are taken to reduce capacities in the wiring after it leaves the "pinch." The valve pins and the metal base are carefully removed after unsoldering the wire connections, which are made just at the base of the valve pins. The valve is then mounted between ebonite clamps of the form shown in the diagram, and the wire connections from the "pinch" of the valve are soldered to tags on the two top clamps. The connections to the receiver are taken from the screws used to fix the soldering tags. The valve may be mounted behind an ebonite

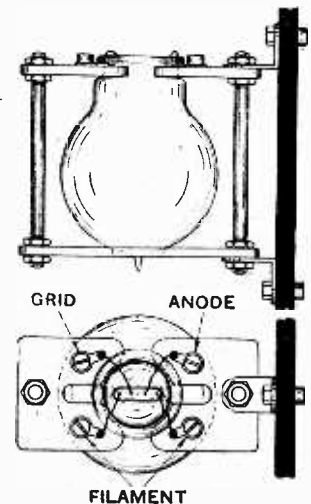

Low-capacity mounting for four-pin valves.

panel by fitting small brass angle brackets to one side of the holder. If desired, the unit may be insulated mechanically from the panel by means of sponge rubber.—A. R.

REMOTE RECEIVER CONTROL.

A System Providing Continuous Adjustments of Tuning and Filament Current.

By A. R. TURPIN.

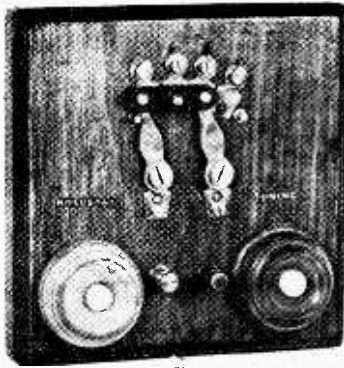

Control panel, showing reversing switch, pushers, switches and telephone terminals.

THERE have been described in this journal from time to time a number of remote controls for switching on the filament current, but most of these did so without the use of a rheostat, thus shortening the life of the valves considerably. Further, all of these acted only as a filament switching device, whereas that about to be described actuates the tuning control as well, and as far as the writer can ascertain, the only other control of this type is the Marconi, which is used

sary to run seven wires from the set to the switchboard. This latter drawback is not greatly detrimental, because if Sterling 7-way cable is used this does not entail any more labour than laying twin flex, and takes up about the same space. The number of this cable is W.7,401, and your local dealer will obtain it for you. The various wires in this cable each have a distinctive colour, so that the making of the correct connections becomes simplicity itself.

The writer does not bring forward this design as being perfect, because it was chiefly constructed from scrap that happened to be about the workshop, and those who possess no other tools than a screwdriver may still be able to construct it with the aid of a few Meccano parts and a little ingenuity.

The greatest difficulty was to keep the number of wires as low as seven, and eventually the arrangement shown in Fig. 1 was decided upon.

The Circuit.

It will be seen from the diagram that the field windings of the two motors are wired in series and the two free ends taken to the mov-

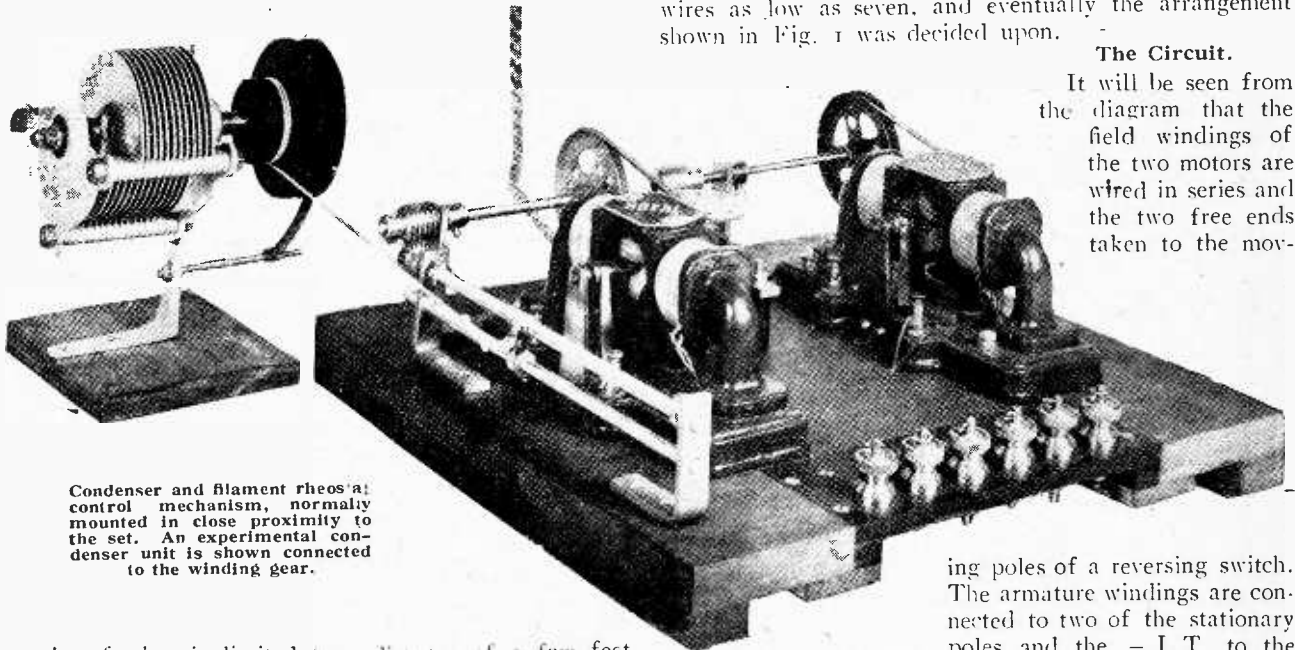

Condenser and filament rheostat control mechanism, normally mounted in close proximity to the set. An experimental condenser unit is shown connected to the winding gear.

on aircraft, but is limited to a distance of a few feet only.

The control, in main, consists of two model electric motors which can be purchased at any toy shop for a few shillings; one of these is used to operate a master rheostat and the other the tuning condenser. These are controlled at a distance by two miniature bell pushes and a reversing switch.

It might be said, however, that the apparatus has two drawbacks; firstly, it can only be used with receivers actuated by a single knob; and, secondly, that it is neces-

ing poles of a reversing switch. The armature windings are connected to two of the stationary poles and the - I.T. to the others, the former, however, first pass through two bell pushes to break the circuit.

The control works as follows: Having placed the reversing switch in the required position the button marked "Rheostat" is pressed, and this closes the circuit and allows the motor to rotate, which in turn is connected by a flexible metal Meccano belt to a pulley mounted on a shaft running in brass bearings. In the centre of this shaft is a worm gear which rotates a cog-wheel, D (Fig. 5), mounted on the rheostat shaft, thus

Remote Receiver Control.—

turning it on. To turn it off it is only necessary to change the position of the reversing switch.

The other motor is connected in the same way, but instead of driving a rheostat it rotates through the medium of the pinion C, a length of No. 2 B.A. rod, which carries a nut, B, so fixed that it cannot rotate, and will thus move along the rod in either direction according to the position of the reversing switch. Attached to this nut at A is a length of thin steel wire (T, Fig. 4) or catgut, which has its other end wound round a small ebonite drum fixed to the condenser shaft in such a manner that it may easily be adjusted. On the same spindle is fixed a light clock spring, S, so that as the nut moves towards the condenser the spring takes up the slack and rotates the moving vanes in the opposite direction.

Construction and Wiring.

The base-board measures 10 1/2 in. x 10 in. x 3/4 in., and on this should be mounted the two motors in the positions shown in Fig. 2. It will be found that the two halves of the field windings are connected in series, and one outside end goes to one of the terminals on the motor, and the other to one of the brushes. One of these should be connected to the same wire on the other motor, and the other end on each taken through two holes in the base-board.

Now drill seven holes to take No. 4 B.A. countersunk screws in the positions shown, and six more to take six terminals.

To the two right-hand screws connect by means of insulated wire the two ends of the field windings, to the next two the insulated commutator brushes, and from the next take a wire to the terminals marked -I.T. The two telephone terminals are joined to the remaining screws and + I.T. (Battery) to the uninsulated commutator

brushes. A wire is also joined from + I.T. (Receiver) to one terminal of the rheostat, and the other connected to + I.T. (Battery).

From the tuning motor a flexible steel belt (Meccano)

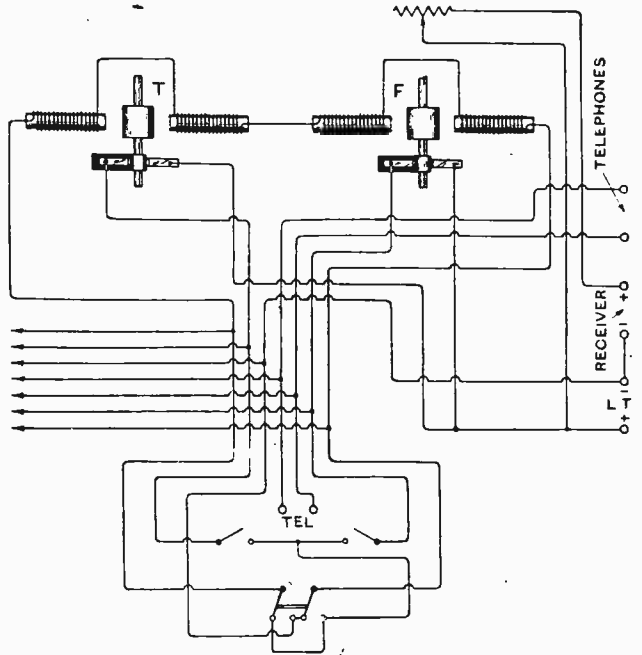

Fig. 1.—Circuit diagram. A second control panel may be connected to the seven leads at the left-hand side of the diagram if desired.

drives a pulley giving a ratio of 4 : 1. This pulley is mounted on a 3/8 in. brass shaft and held in bearings consisting of a "U" shaped Meccano stamping. On the other end is fixed a worm gear.

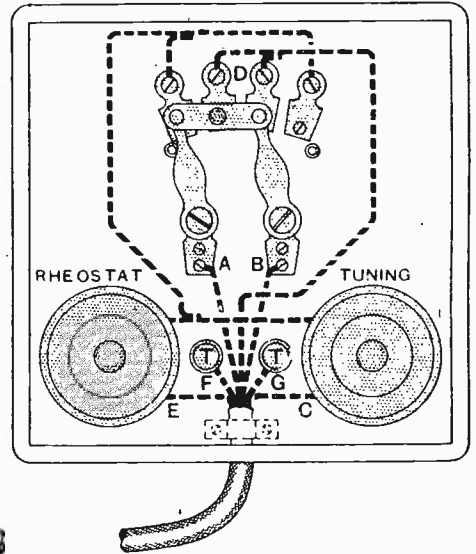
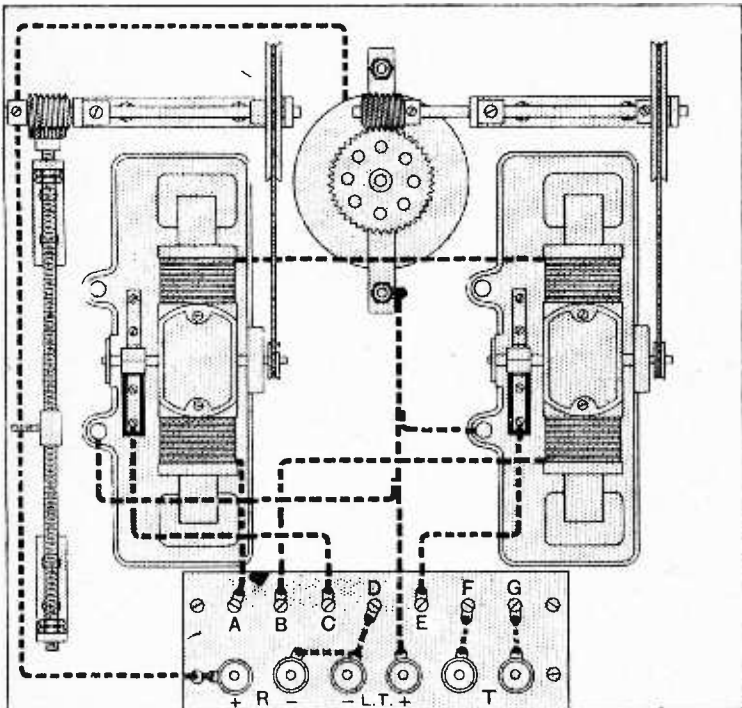

Fig. 2.—Wiring diagram. The ends of the seven-stranded cable are lettered A to G. It will be noticed that connections to the "earthed" brushes of the motors are made via one of the terminals on the iron frame of the motor.

COMPONENTS REQUIRED.

- 1 Baseboard, 10½ in. × 10 in. × ½ in.
- 1 Baseboard, 6 in. × 6 in.
- 2 Electric motors, 4 volt "Royal" (Gammages).
- 1 Rheostat, 5 ohm.
- 2 2 in. pulleys (Meccano).
- 2 Worm gears (Meccano).
- 1 19 tooth gear (Meccano).
- 1 30 tooth gear (Meccano).
- 6 in. 2 B.A. rod.
- 6 in. 4 B.A. rod.
- 2 Brass angle brackets, 1½ in.

- 2 Brass angle brackets, 2 in.
- 1 Meccano "U" shaped bracket, 1½ in.
- 1 Meccano steel shaft, 4 in.
- 1 3½ in. ¼ in. brass shaft.
- 2 Panel bushes.
- 1 Length of flexible steel belt (Meccano).
- Brass strip, 8 terminals, insulated wire.
- 1 D.P.D.T. reversing switch.
- 2 Bell push switches.
- Sterling W.7401 cable as required.

The bearings for the No. 2 B.A. rod consist of two 1½ in. brass angle brackets, to which have been soldered two panel bushes, a drill afterwards being passed through them to clear surplus solder and increase the size of the hole in the brackets, so that the rod will rotate freely. On one end of this rod is fixed a gear wheel with 19

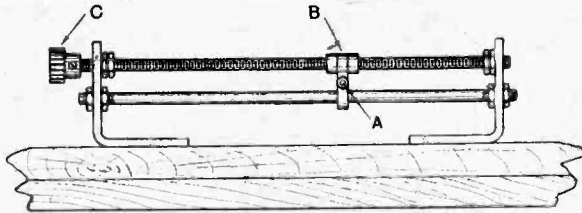

Fig. 3.—Details of winding gear for the tuning control.

teeth, giving a reduction from the worm wheel of 19 : 1, and on the other end are fixed two lock nuts.

For the travelling nut the writer tapped a half-inch length of ⅜ in. brass tube and used that.

In order to prevent this tapped tube from rotating, a length of No. 4 B.A. brass rod was passed through the lower holes already in the brackets, with a further ½ in. length of untapped brass tube threaded on to it. A piece of brass strip was then soldered between the threaded tube on the No. 2 B.A. rod and the plain tube on the No. 4 B.A. rod, thus locking them securely together.

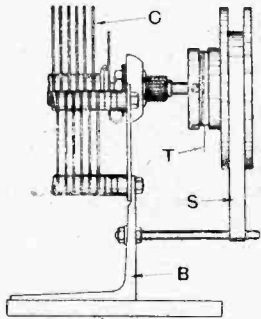

Fig. 4.—Details of the condenser mounting.

To a No. 6 B.A. screw fitted to the strip of brass at A is attached a length of catgut, the other end of which is wound round the ebonite drum on the tuning condenser spindle. This drum was constructed from a built-up H.F. transformer bobbin. The legs were removed and the boss drilled and tapped to take a No. 4 B.A. set screw, which secures the bobbin to the condenser spindle, which passes through a hole drilled in the centre of it.

Before mounting it on the shaft, it will be necessary to fix the clock spring in position between the flanges, and this is done as follows.

Remove the No. 2 B.A. set screw holding the flanges together, and replace the centre piece of ebonite by a plain tapped condenser bush into which has been screwed a short No. 6 B.A. screw with the head removed; place

the clock spring over this bush, so that the hole in the end of it catches in the protruding portion of the No. 6 B.A. screw, and then replace the flanges and fix to the condenser spindle. Now fix a length of No. 4 B.A. rod into the panel of the receiver, so that it protrudes out beside the spindle and just clears the bobbin; to this is attached the other end of the clock spring. To adjust, the set screw holding the bobbin on to the spindle should be loosened and the bobbin turned until the spring has just sufficient tension to return the vanes to an either fully out or fully in position, and then make a loop in the end of a length of catgut and pass it over the head of the set screw and take two or three turns round the drum, and from thence to the point A on the travelling nut.

I would mention here that the length of the No. 2 B.A. rod will depend on the diameter of the ebonite drum round

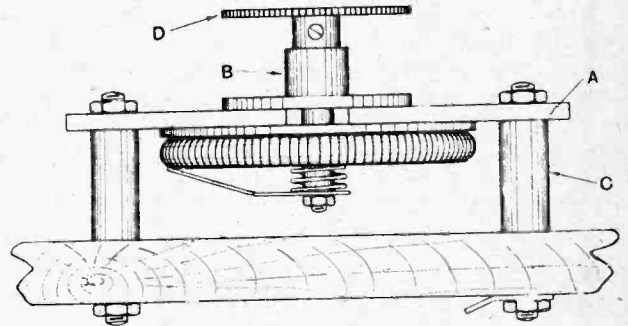

Fig. 5.—Method of mounting the filament rheostat. The rheostat is clamped by the bush B to the metal strips A, which are in turn supported from the base by the sleeves C.

which the catgut is wound. This length should be just over half the diameter, plus the length of the bearings and gear wheels.

Regarding the other motor, this drives a similar pulley and worm as previously described, which is directly connected to a toothed wheel on the rheostat spindle.

The rheostat shown in the photograph has rather an unusual method of mounting, and if the ordinary type is used a better way is shown in Fig. 5. In order to fit the pinion on to the spindle, it will be necessary to drill it out to the required size.

The switchboard requires no explanation, as the connections can be clearly seen from the diagram, but for neatness the use of a better class of switch is recommended.

Operation.

Place the base-board in such a position that the cat-

gut has a direct pull on the drum and so that the travelling nut is at one end of the shaft and the condenser vanes either fully in or out according to the way the drum has been wound.

Connect up the L.T. accumulator to the terminals marked L.T., and join those marked R to the set; then connect the phones and phone terminals.

Now press the switch marked "Rheostat," and this should start one motor, which will revolve the spindle and turn the valves on. It is as well to count the number of seconds this takes, so that the switch is not kept on longer than necessary.

To tune, press the switch marked "Tuning." This will cause the travelling nut to move along the No. 2 B.A. rod, thus pulling the catgut and revolving the condenser spindle. The station will gradually grow in strength until fully tuned in. If this point is over-shot, change over the reversing switch and repeat the process.

In the arrangement shown, the same accumulator is used to light the valves as that which works the control, but if dull emitter valves are used, the leads from the set to accumulator should be short and heavy, otherwise the current taken to actuate the control may dim the valves to such an extent that the signals completely fade out.

Switchboards may be placed in any number of rooms required by merely taking tappings at any convenient point.

In conclusion, the writer would state that the control is not meant to be used by those trying to break records of distant reception, but for those who, having the choice of two or three stations, may wish to tune in either by merely pressing a button and without moving from their armchair before the fire. Thus the receiver may be placed in the most convenient and efficient position near the point where the lead-in enters the house.

SHORT-WAVE TRANSMITTING STATIONS.

The following list of transmissions taking place on the wave band 20 to 150 metres will be found helpful in the calibration of short-wave receiving sets.

Wave-length.	Call Sign.	Location.	Wave-length.	Call Sign.	Location.	Wave-length.	Call Sign.	Location.
20.0	POX	Nauen, Germany.	76.0	POX	Nauen, Germany.	40.0	PPG	San Francisco, Calif.
20.0	NKF	Bellevue, D.C.	77.4	NFV	Quantito, Va.	40.0	NRRL	U.S.S. Seattle.
20.0	NAL	Washington, D.C.	80.0	NEL	Lakehurst, N.J.	40.0	NAJ	Great Lakes, Ill.
20.0	NFQ	U.S.S. Relief.	81.0	NPG	San Francisco, Calif.	40.0	NAS	Pensacola, Fla.
25.0	2YT	Poldhu, England.	81.5	NKF	Bellevue, D.C.	41.0	NKF	Naval Research Laboratory, Bellevue, Anacostia, D.C.
25.0	POY	Nauen, Germany.	83.0	RDW	Moscow, Russia.	43.0	NPG	San Francisco, Calif.
26.0	POX	Nauen, Germany.	84.0	NKF	Anascotia, D.C.	45.0	NPG	San Francisco, Calif.
30.0	2XI	Schenectady, N.Y.	85.0	SFR	Paris, France.	49.0	NPM	Honolulu, Hawaii.
30.6	NAL	Washington, D.C.	85.0	8GB	Paris, France.	49.0	WHD	Sharon, Pa.
32.0	2YT	Poldhu, England.	86.0	NQC	San Diego, Calif.	53.0	NPU	Tutuila, Samoa.
35.0	2XI	Schenectady, N.Y.	90.0	6XO	Kahuku, T.H.	54.0	NBA	Balboa, Canal Zone.
36.0	LPZ	Buenos Aires, Argentine.	90.0	1XAO	Belfast, Me.	57.0	WQN	Rocky Point, N.Y.
38.0	2XI	Schenectady, N.Y.	92.0	2YT	Poldhu, England.	68.0	NPO	Cavite, P.I.
40.0	1XAO	Belfast, Me.	94.0	2YT	Poldhu, England.	68.4	WRB	Miami, Fla.
40.0	NPG	San Francisco, Calif.	95.0	SFR	Paris, France.	68.4	WRP	Pinecrest, Fla.
40.0	NRRL	U.S.S. Seattle.	96.0	8XS	East Pittsburgh, Penna.	70.5	NQG	San Diego, Calif.
40.0	NPW	U.S.S. Mexico.	99.0	6XI	Bolinas, Calif.	71.0	NKF	Naval Research Laboratory, Bellevue, Anacostia, D.C.
41.6	NKF	Bellevue, D.C.	100.0	—	New Orleans, La.	71.5	NPL	U.S. Training Stn., San Diego, Calif.
43.0	WIR	New Brunswick, N.J.	100.0	POX	Nauen, Germany.	76.0	NAJ	Great Lakes, Ill.
43.0	NPG	San Francisco, Calif.	100.0	2XI	Schenectady, N.Y.	77.5	NFV	U.S. Marine Corps, Quantico, Va.
47.0	POZ	Nauen, Germany.	100.0	NAM	Norfolk, Va.	80.0	NEL	Lakehurst, N.J.
49.0	NPM	Honolulu, T.H.	103.0	WGH	Tuckerton, N.J.	90.0	KIO	Kahuka, Hawaii.
50.0	NKF	Anascotia, D.C.	105.0	WHU	S.S. Big Bill.	95.0	KEL	Bolinas, Calif.
53.0	NPU	Tutuila, Samoa.	107.0	2XI	Schenectady, N.Y.			○○○○
54.0	NBA	Balboa, C.Z.	112.0	1XAO	Belfast, Me.			
54.4	NKF	Bellevue, D.C.	115.0	FL	Paris, France.			
56.0	KFKX	Hastings, Nebraska.	119.0 to					
58.79	KDKA	East Pittsburgh, Penna.	149.0	NGF	U.S.S. California.			
60.0	1XAO	Belfast, Me.	119.0 to					
60.0	2YT	Poldhu, England.	149.0	NEDJ	U.S.S. West Virginia.			
62.0	KDKA	East Pittsburgh, Penna.	120.0	1XAO	Belfast, Me.			
67.0	8XS	East Pittsburgh, Penna.	146.0	6XO	Kahuku, T.H.			
70.0	POX	Nauen, Germany.	150.0	NITZ	U.S.S. Sturgeon Bay.			
70.0	NPO	Cavite, P.I.	17.0	NKF	Naval Research Laboratory, Bellevue, Anacostia, D.C.			
70.0 to								
84.5	NERM	U.S.S. Los Angeles.	20 to 30	NAL	Navy Yard, Washington, D.C.			
70.5	NQG	San Diego, Calif.	20.8	NKF	Naval Research Laboratory, Bellevue, Anacostia, D.C.			
71.5	NKF	Bellevue, D.C.	25.6	NKF	Naval Research Laboratory, Bellevue, Anacostia, D.C.			
71.5	NKF	Anascotia, D.C.						
71.7	NPL	San Diego, Calif.						
74.0	WIR	New Brunswick, N.J.						
75.0	SFR	Paris, France.						
75.0	WGN	Rocky Point, L.I.						
75.0	NUQB	U.S.S. Pope.						
75.0	NIRX	U.S.S. Canopus.	35.0	WQO	Rock Point, N.Y.			
76.0	NAJ	Great Lakes, Ill.	37 to 40	NPU	Tutuila, Samoa.			

CATALOGUES RECEIVED.

Messrs. Autoveyors, Ltd., have recently issued a new list of their radio specialities.

"The Readers' Bulletin," the bi-monthly magazine of the Coventry Public Libraries, contains an excellent selected list of wireless books to assist students in the study of the subject.

The 1925-1926 catalogue of C. S. Dunham, 234-6, Brixton Hill, London, S.W.2, is now available. It includes a complete range of receiving sets as well as several useful components and accessories.

CURRENT TOPICS

News of the Week — in Brief Review

RELAY STATIONS IN AUSTRIA.

Two relay broadcasting stations are being opened in Austria, at Salzburg and Klagenfurt.

o o o o

BROADCASTING STATION FOR AMSTERDAM?

Wireless enthusiasts in Amsterdam are stated to be agitating for a broadcasting station with a minimum power of 1½ kilowatts.

o o o o

AMPLIFIERS AT WESTMINSTER.

However poor the acoustics of the House of Lords may have been in the past, its illustrious members can no longer plead difficulty of hearing. Three microphones are now in position—two on the table and a third facing the woosack—and the Lords' benches are furnished with twenty single headphones on handles. The reporters in the Press Gallery will enjoy the use of the ordinary double headphones. Amplifiers are concealed in the basement.

o o o o

WHAT THE BELGIAN LISTENER WANTS.

A falling off in the popular taste for broadcast jazz music is one of the interesting facts elicited by the referendum recently instituted by "Radio Belgique" to determine the requirements of broadcast listeners.

A questionnaire was circulated among all licensed listeners, and from the replies received extremely useful information was obtained. The consensus of opinion was in favour of maintaining the existing arrangements in regard to classical and light music, literary talks, lectures, and news bulletins, while the voting revealed an increased demand for instrumental solos and operatic items.

o o o o

MAIDSTONE RADIO WEEK

Maidstone's Third Annual Wireless Exhibition, to be held in the Concert Hall, Corn Exchange, will be opened by G. Foster Clark, Esq., J.P., on Tuesday, October 15th, at 6.45 p.m. and will continue until October 17th.

Organised by the Maidstone and District Radio Society, the Exhibition promises to be a very successful event. An attractive programme has been arranged, and includes lectures by the B.B.C., the R.S.G.B., a Dance, a Concert

in aid of the Maidstone Hospital's wireless installation, and an open competition for the best home constructed crystal to a 3-valve set.

An imposing display of all up-to-date apparatus and accessories will be on view at the stands of the most prominent wireless firms of Maidstone, and demonstrations will be given by them each evening.

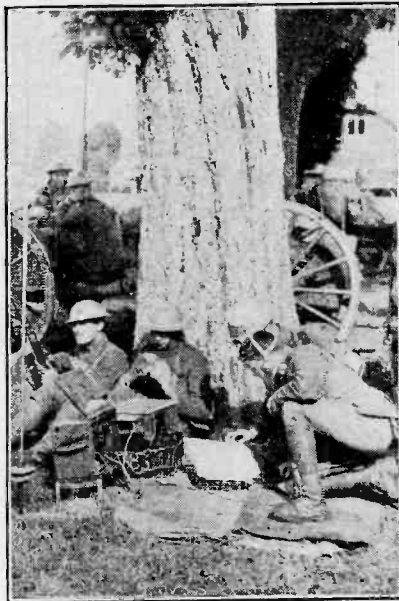

AN ECHO OF THE MANŒUVRES. A typical roadside listening post in the "war area." The aerial supports can be seen on the left.

There will also be a good display of amateur work.

Further particulars may be obtained from the Hon. Secretary, Mr. H. T. Cogger, 44, Postley Road, Maidstone.

o o o o

CAPTAIN ECKERSLEY ON "MICROPHONES."

Scottish readers will learn with interest that the subject of broadcasting finds a place in the programme for the winter session of the Institution of Engineers and Shipbuilders in Scotland. Among the papers submitted for discussion will be one entitled "Some Notes on Micro-

phones for Broadcasting," by Captain P. P. Eckersley.

Particulars may be obtained from the Secretary, Mr. Edward H. Parker, 39, Elmbank Crescent, Glasgow.

o o o o

JOHN HENRY ENTERTAINS THE WOUNDED.

The fifth season of weekly entertainments for wounded soldiers, under the direction of the Adair Wounded Fund, opened auspiciously on Sunday, September 27th, at the Wigmore Hall. One of the principal features of the entertainment was the presence of John Henry, the famous wireless comedian, who acted as M.C. As usual, there was no dearth of variety artists, who willingly gave their services for the cause. The prizes for the "Lucky Draw" were distributed by "Blossom," also of wireless fame.

o o o o

MARCONI BROADCASTING STATIONS IN ITALY.

Apropos of our recent note on the erection of a high-power broadcasting station at Milan by the Marconi Company, we are now advised by the Company that this information is incorrect and was circulated by them in error.

The actual facts are that the Marconi Company have received an order to construct a powerful broadcasting station in Rome, and it is understood that the 6-k.w. station which this will replace will be transferred to Naples.

o o o o

CONDENSER CALIBRATIONS FREE OF CHARGE.

At the forthcoming wireless exhibition at the Horticultural Hall, Westminster, a useful service will be rendered at the stand of Messrs. The Telegraph Condenser Co., Ltd. A member of the firm's technical staff will be present to calibrate, free of charge, any form of fixed condenser. Wireless enthusiasts who are doubtful whether their fixed condensers are of the correct value are invited to take advantage of this offer.

o o o o

AN ERROR.

Messrs. F. E. Wootten, Ltd., manufacturers and factors of wireless apparatus, 56, High Street, Oxford, draw attention to the fact that their address was erroneously given as Aston Road, Birmingham, on page 317 of our issue of September 9th.

BROADCASTING BROOKLANDS.

An Experiment by the B.B.C.

THE B.B.C. have at various times attempted the transmission of all sorts of noises. Their latest effort in this direction has been to give listeners an idea of the thrills of motor racing at Brooklands.

The first experiment of this nature was carried out on September 26th on the occasion of the Junior Car Club's 200-mile race. This is the Derby of motor racing, and of great importance both to motor racer and motor owner as well as to motor manufacturer, as the future of motor-ing depends to a great extent on the various types of cars and their performance at the Brooklands racing track.

The Microphone at the "Hairpin" Bend.

On this occasion the race was made more interesting by including two "hairpin" bends in each lap of the race, thus requiring that the cars should employ sufficient braking as well as exhibiting rapid acceleration and great speed on the level. So that listeners should appreciate all these points the B.B.C. microphone took up its station at the second "hairpin" bend, and was thus able to transmit the sounds of cars travelling at full speed towards the first "hairpin" as well as the sounds of braking and rapid acceleration in rounding the second "hairpin."

The conversations describing the race and its functions broadcast previous to the actual start were of great interest, and we are of the opinion that broadcasts of this nature are very valuable in stimulating interest in all forms of sport. Unfortunately, the severe Press restrictions, which handicap the B.B.C. very seriously in presenting broadcasts of this nature, do not allow of any refer-



Ca-ptain West, Chief of the B.B.C. Research Department, regu-lating one of the potentiometers used to control the strength of the signal passed to the line circuit connected with Savoy Hill.

ence to be made to anything which might be considered of real news value.

In spite of this, the broadcast itself was very realistic. The shrieks when the brakes were applied and the noise

of the engines, which were of various types, were extraordinarily well transmitted. It was, in fact, possible easily to distinguish between the exhaust of four- and six-cylinder cars and the twin-cylinder, air-cooled car entered for the race. One car actually backfired within a few feet of the microphone, but the 2LO transmitter appeared none the worse for it.

As regards the arrangements for the broadcast, we understand that no special microphones or amplifiers were used, but on account of the very strong wind blowing precautions were taken to prevent it affecting the microphone and thus introducing unwanted sounds.

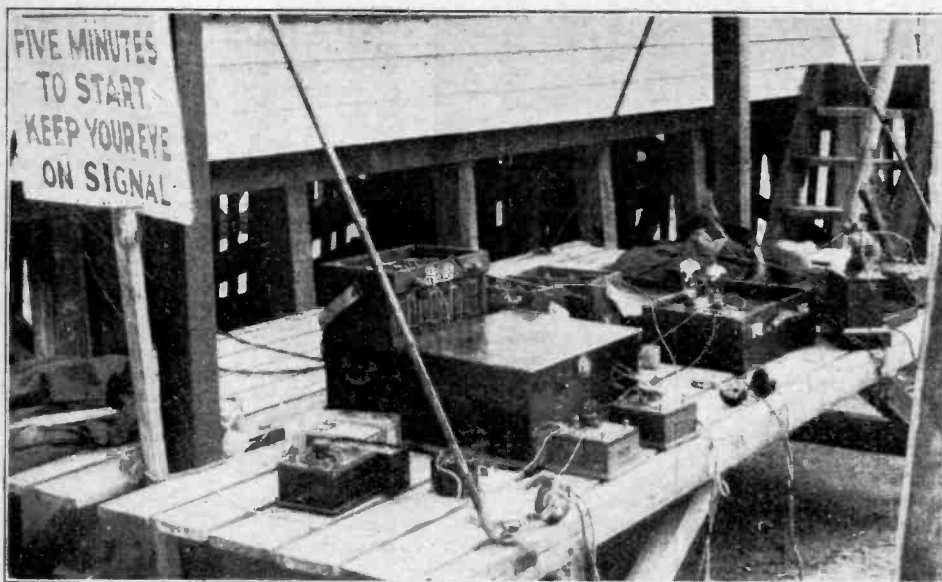

The amplifying equipment.

EUROPE'S WAVELENGTH DIFFICULTIES.

Geneva Proposals Outlined.

By CAPT. P. P. ECKERSLEY.

SOME highly important and startling conclusions as to the future of broadcasting were arrived at by the delegates to the International Wireless Conference when they met at Geneva to consider the results of the recent European wavelength tests.

The object of these tests was to discover to what extent interference between the transmissions of European broadcasting stations caused by the clashing of wavelengths could best be overcome.

The tests were based on a scheme by which the wavelengths of all European stations were scientifically allocated and placed under unified control, although in certain cases, as the plan was under trial, an attempt was made to make some stations work on the same wavelength.

As experiments, they illustrated beyond any doubt that the scheme in its fundamentals was sound, that only by common-sense efforts, which must be voluntary and involve all nations making sacrifices, can order be restored from the present state of international chaos.

But they revealed something of even greater importance, viz., that no matter what the broadcast authorities of Europe may do or how splendidly they may co-operate and strive together to put their affairs in order, circumstances as they exist to-day are so weighed against them that other means will have to be devised to solve the difficulty. What it actually amounts to is this:—

Too Many Stations.

Europe has more broadcasting stations than can be possibly fitted into any wave band coming within the most elastic limits which the Governments of Europe are ever likely to set aside for broadcast purposes.

The only solution of the problems is to get rid of some of them. The matter was not officially discussed, but the feeling of many of the delegates present favoured this step.

This does not mean that each country is to be asked to close down two or three of its stations immediately. Such an idea is unthinkable. Broadcasting has only just commenced, and services must be extended and not curtailed.

But there can be no permanent progress and development in anything if some integral part of a scheme becomes obsolete. That is the trouble with European broadcasting to-day.

We have reached a stage when the broadcast services as they have so far been built up have in some respects expanded beyond their initial usefulness.

Instead of having the present large number of comparatively low-power stations, Europe in the future must have fewer and more powerful transmitters.

It sounds, and, in fact is, a revolutionary idea, yet it is the agreed conclusion of all the experts who went to Geneva.

It is not always easy to admit awkward facts, though you know that sooner or later they must be faced.



Capt. P. P. Eckersley, Chief Engineer of the British Broadcasting Company.

The experts carefully weighed up the whole situation, and this is what they found. To give every existing broadcast station a separate place in the ether, all the space between 200 and 600 metres and also between 1,000 and 2,000 metres would be required. On the projected problems the wavelength would need to be, perhaps, 150-600 and 800-3,000 metres.

Obviously no Government would agree to this. No Government *could* possibly agree. After all, broadcasting only wants its fair share of the ether in conjunction with the requirements of other wireless services, government, maritime, and commercial.

No Further Wave Bands Available.

To put it another way, broadcasting is not likely to get any further allocation of wave channels beyond what it has now. The broadcasting authorities are grateful for the removal of certain maritime services from the recognised existing broadcast wave band which was announced only a few days ago.

The experts at Geneva realised—and they are to be congratulated on this point—that it was to their advantage to take the long view.

This was not an easy matter. For one thing, it meant the shattering of an idol. Low power and relay stations have long been regarded as a sound system of any broadcast service, together with a few very high-power stations here and there to meet certain definite arrangements which could not otherwise be catered for.

But ideals must give way to practical solutions; broadcasting is no exception to this edict.

Europe's Wavelength Difficulties.—

Thus it has come about—very fortunately in some respects—that the day of the small relay stations and low-power stations has passed.

In the initial stages of the development of broadcasting these stations served a very useful purpose. In the scheme of things they have entirely justified their existence. Those who designed and constituted them made no mistakes. What has happened is that broadcasting, considered in all its national and international aspects (as it must be at the present time), the situation is found to have grown out of all proportion to what anyone dreamed would be the case, in the short space of time since broadcasting started.

Failure of the Recent Efforts.

That is the state of affairs as shown by the recent European tests, and it was brought about in this way.

It was realised from the beginning that there were not sufficient separate positions in the broadcast wave bands to give every station a place.

Some stations had to be put on the same wavelengths. This part of the scheme was governed by geographical considerations, the power used by any two stations, and their distance apart.

All sorts of adjustments were made during the recent tests, but it must be admitted that this part of the plan was a failure.

All the scheming imaginable could not overcome the problem of getting two stations in the comparatively confined area of Europe to work on the same wavelengths. It is one of those things which cannot be done.

That is why the experts are in favour of fewer stations. Sooner or later each station *must* have its own wavelength.

After this it becomes a question of what power shall be used by the stations, for which there are places in the wave band.

This matter, of course, rests with the various Governments, though from the purely technical aspects there are no difficulties. A few good high-power stations can give as satisfactory and possibly much better results to listeners than a lot of low-power and relay stations.

There is no fear that these high-power stations would interfere with each other; crystal set users would probably be very pleased with the change.

Naturally, an extended series of tests would be necessary to devise the best way of doing it.

But even now one can anticipate the objections that will be raised when the disappearance of some relay station is threatened, if and when the cutting down in the number of stations is decided upon.

Towns will complain of their lost status; listeners will say that their programmes have been robbed of the local individuality, that their broadcast goodwill has been absorbed by whatever main station has its power increased to serve the affected area.

But a good deal of compromise is possible in all these instances. It may be decided to retain the local studios at those towns where stations are closed down and to give regular programmes by means of land lines from several towns connected up to whatever station takes charge of any particular district.

But these are schemes of the future, and which, in any case, can only be put into operation gradually.

Meanwhile, something must be done to keep the present cause of interference between the stations of Europe to the least harmful limits. The Conference at Geneva decided on a temporary plan which it is hoped will give these results.

The plan they adopted differs in many respects from that on which the recent tests were based.

Wavelengths must still be allocated to each station, as before, but instead of the former considerations by which places on the coveted band of between 300 and 500 metres were followed, other factors are now going to operate.

These are:—

Population of a particular country; the area of that country; length of time a broadcast service has been operating; and language difficulties (such as cases when two or more languages are spoken in one territory).

To accomplish this, further sacrifices will have to be made by all the nations represented at the Conference, but these they are mostly willing to make.

Some countries agreed absolutely to do whatever is required; others acquiesced tentatively.

For instance, Great Britain agreed with the reservation that some of the sacrifices must be of the future and not the immediate present. Germany agrees *in toto*, and France will probably come in. Austria, Czechoslovakia, Belgium and Holland, Finland, Norway and Sweden are all happy about the idea, but Italy may have to work a few stations on wavelengths which clash with those of other countries, although there is not expected to be much interference, owing to the careful selection of her stations.

Spain is a little uncertain, because her representative was unable to be present at the Conference.

The Effect of Geneva Proposals.

The expected results can be summarised in this way—that based on the experience of the recent tests, the new scheme, if adopted by all the nations, will eliminate a good deal of the present jamming.

The opinion of the Conference was that it is better to risk whatever this jamming may amount to, rather than continue with the present conditions, which would certainly lead to utter chaos during the coming winter.

The new scheme will come into operation about November 1st; the broad principles of it have so far been decided that no further negotiations between the various broadcasting authorities will take place in the meantime, but another meeting will take place in December.

Additional details of the scheme will be announced as they are arranged by the permanent staff at Geneva.

The only other point of interest concerns the construction of new stations. These will be given positions below 200 metres, because in any case this inflicts no hardship on anybody.

In this respect, the new Dublin station, which will commence operations this year, is very fortunate. The British representative at the Geneva Conference was able to arrange a position for the first station in the Irish Free State inside the coveted part of the wave band.

EXPERIMENTAL STATION G2KF.

Description of the Equipment of the Well-known Amateur Station with a World-wide Range.

DURING the past twelve months long distance communication between experimental stations has made remarkable progress, chiefly owing to the fact that developments have taken place in short wave transmission. A description of the apparatus used by one of the pioneer short wave stations, G2KF, will be of interest to readers, many of whom have no doubt heard the transmissions from this station.

At the end of 1924, when the 100 metre wave band was becoming a hotbed of interference from Continental stations, many of which used low periodicity A.C. as a source of plate current supply, attention was given to the design of sets that would operate on 40 metres. It was observed about this time that certain American stations were already operating on this wavelength, and that there was a tendency to abandon the 100 metre band for long distance work. It was decided that more attention should be given to the still shorter wavelengths, for it appeared that even greater possibilities presented themselves as regards long-distance working.

Developing the Short Wave Band.

About the middle of February of this year signals were received from American stations with a constancy and absence of fading never before experienced on the 100 metre band, and among the first stations to be heard were 1XV, 1BCR, 1CCX, 1NY and 1XAM. As soon as the necessary permit could be obtained from the Post Office experimental work on the development of short wave transmitting apparatus was commenced, and very soon resulted in two-way communication with the American station 1CMP on a wavelength of 23 metres. This suc-

cessful test took place at 6 p.m., whilst still daylight on this side, and it was, of course, mid-day in New York.

Two-way working with the United States had hitherto been impossible in daylight, and further experiments soon showed that whilst a wavelength of 23 metres was most useful for daylight working and for certain early hours of darkness, a wavelength of 45 metres was by far the better throughout the night.

Keying Problems.

Difficulty was experienced, of course, in tuning the transmitter to these short wave bands, and many different types of radiating systems were experimented with, the final arrangement being a single wire aerial and a similar counterpoise. The transmitting circuit found to be most satisfactory was the familiar arrangement of a simple oscillating valve circuit with loose coupled aerial. The method of keying, particularly on these short wavelengths and when using powers round about 100 watts, presents difficulty, and it has been found that when the H.T. supply is derived from a D.C. machine, it is best to key outside the oscillatory circuit so as to avoid unnecessary strain on the armature windings. A good procedure is to key in the counterpoise lead, which will, as a rule, produce a spacing wave, and providing that this is not too close to the marked wave, the result is an easily readable and steady signal. If accumulators are used for supplying current to the filament of the transmitting valve they should be insulated and present a minimum of capacity to earth. As a precaution the anode lead to the valve should not be allowed to sag on to the glass, as many valves have been damaged due to the glass cracking, an effect which is more noticeable as the wavelength is decreased. The development of circuits for telephony transmission is being proceeded with, and speech transmission from G2KF has been received clearly in Mosul, Iraq, and regular daylight tests have also been carried out with Belfast.

Reports of telephony reception have come to hand from America, and attempts are being made to establish two-way telephony working with the Antipodes. A point to be remembered, when working on the very short wavelengths is that coils and other apparatus not actually in use must be removed as far as possible away from

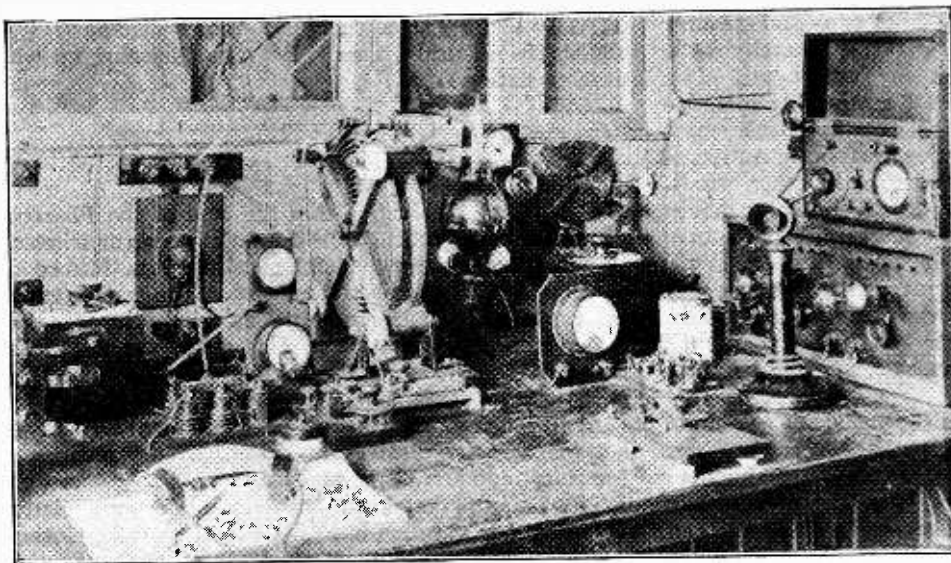

The transmitting apparatus has a simple layout and consists of few components.

Experimental Station G2KF.—the apparatus in the oscillatory circuits.

For reception on all wavelengths from 15 metres upwards the circuit is a simple one, consisting of a loose coupled detector valve with reaction and followed by a note magnifier. The writer can only endorse the fact that the more simple the receiver, the better the result on short waves. Complicated tuning arrangements are practically useless where quick searching is required, whilst high-frequency amplification on wavelengths below 100 metres, excepting when definite wavelengths are intended to be received, is not worth the trouble, and it is very doubtful if an increased range of reception is obtained. A practical point of interest is the fitting of a vernier condenser entirely apart from the secondary tuning condenser, as this will prove useful for making the small adjustment, which becomes necessary owing to variations in the wavelength of the transmitting station. Without this fine tuning control signals may be lost for intervals of some seconds. Experience shows that almost any valve can be used for reception on the shorter wavelengths, and it must not be assumed that the ordinary 4-pin type is not suitable.

Range and Wavelength.

A peculiar feature of the 45-metre wave band is the varying signal strength of stations up to 100 miles distance. For example, of two stations using approximately the same power, one being thirty miles away and the other just over one hundred, the latter station is generally found to be considerably stronger than the nearer one. On several occasions reports have been received of reception in England of signals from G2KF giving the strength as about R4, whilst at the same time a station in Antipodes has reported similar signal strength. In other words, the signal strength at 13,000 miles is the same as that at 30 miles. During the same transmissions reports have been received from American stations giving the signal strength there as R7 to R8, and yet another instance may be quoted of this peculiarity when during the recent working with CH1EG a listener in Kent reported the signals from the Chilian station as much stronger than those from G2KF.

Telephony on 45 metres at distances under 100 miles is received weakly for the most part, but stations in Wales and Cornwall are heard with great clarity in London, although their powers are very low. A listener in Birmingham using a single valve receiver has reported reception of telephony from G2KF without aerial or earth.

B 26

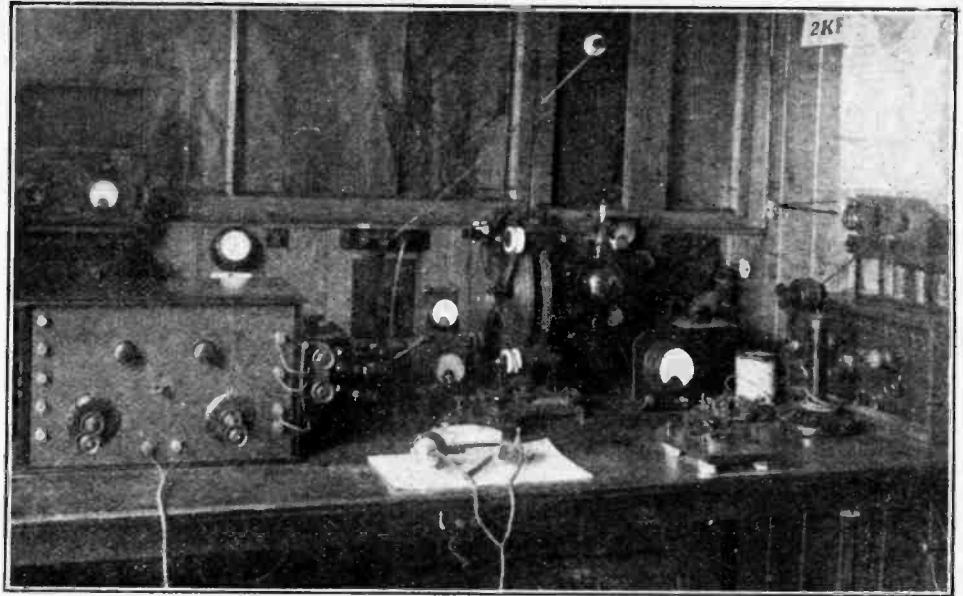

The station equipment at G2KF. The receiver is fitted with low loss interchangeable coils. Nos. of the components can be easily identified.

G2KF has communicated with most countries of the world on short wavelengths, and is in regular touch with America, Australia, and New Zealand. The countries still to be linked up with include: South Africa, India, Japan, and China, and as reports of reception are to hand from the two first-named countries, it will not be long before two-way communication is effected.

The approaching winter will undoubtedly prove the most interesting season for short wave working, and considering that the results recently achieved on 45 metres are the outcome of only a few short months of experimental work on this wavelength, still greater records will be set up, due to concentration on apparatus design.

G2KF is usually to be heard working with stations in the Antipodes in the early mornings, and Mr. Partridge is assisted in his interesting experimental work by Mr. F. H. Ledger, who may be heard signing "L," whilst Mr. Partridge uses "P" when finishing up with another station.

BROADCASTING IN EGYPT.

SIGNS are not wanting that the land of the Pharaohs will shortly react to the appeal of amateur wireless, in view of the news that a Union has been formed of Greek wireless enthusiasts in Egypt. The most interesting project of the Union is the establishment of a low power broadcasting station in Alexandria, the seat of the Union headquarters, for the delectation of the population in the city.

At the inaugural meeting of the Union Mr. L. P. Sclavounos was elected as President, Mr. E. Brouzos as Secretary, and Dr. Glyki as Treasurer.

The Union undertakes to answer all questions relating to the wireless situation in Egypt. The hoped-for Government permission will allow of the installation of a low power telephony transmitter for broadcasting purposes.

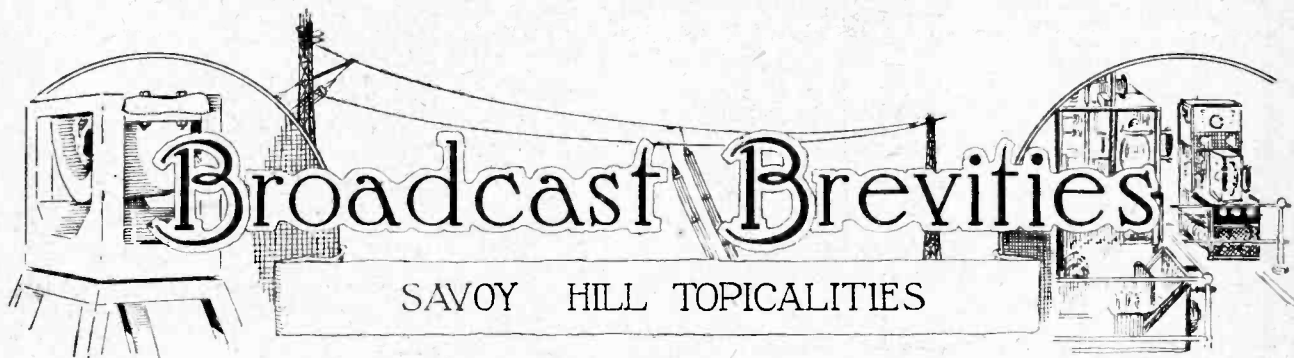

Sunday News.

Beginning on Sunday, October 11th, the general news bulletin will be broadcast at 9 p.m. on Sundays, thus dividing the broadcast service from the secular programmes. The latter will be timed to begin at 9.15 p.m.

○○○○

Leeds Relays.

The reorganisation of the land line system for the simultaneous broadcast services, to which reference was made some time ago, will be brought into operation on November 1st, when Leeds becomes the pivot controlling all the transmissions relayed between the South and the North.

○○○○

Rental Expense.

Hitherto land line connections between one broadcast station and another have been operated through London, except for a small inter-communication switchboard at Glasgow for linking all Scottish

stations. Separate lines have been used between London and practically all other stations, save in one or two cases where the stations were connected to 2LO via another broadcasting station. As the lines were all in duplicate, not only for the purpose of maintaining communication on administrative questions, but as a standby in case of breakdown during the broadcasting of programme items, the expense of renting the lines from the Post Office has been enormous.

○○○○

A Cumbersome Scheme.

One of the other patent disadvantages which may be mentioned is the broadcasting of, say, the Newcastle programme from Manchester having to be done by lines to and from London. To the engineers it is an unwieldy and cumbersome scheme, tending to create delays in the programmes, because at some time or other each evening all stations take some items from London. The quality of transmissions has suffered by the use

of several hundreds of miles of unnecessary land lines which produce distortion due to the impossibility of certain telephone lines working on variable frequencies.

○○○○

Stations to Feed Themselves.

From the beginning of November all stations north of Leeds will be linked up by land line to Leeds instead of to London. Between London and Leeds four special lines have been set apart by the Post Office for the use of the B.B.C. Generally speaking, only one will be wanted, but spares are provided for alternative programmes, control purposes and emergency use. The arrangements at Leeds to send out the programmes or items to Northern stations will be much more automatic than they have been from London. Instead of the engineers in the London control room feeding other stations, the stations depending on Leeds will help themselves, as it were. The distant station will make its own connection to Leeds by the manipulation of a single plug, which will also control the necessary amplifying apparatus.

○○○○

Amplifying the Signals.

The chief function of Leeds as a pivotal point will be to improve the quality of all items it receives from London to the same excellence as when they left London. Distortion and other faults will be corrected and weak signals will be given new life before they are passed on, so that listeners should get improved reception from many local stations, as well as a general speeding up in the S.B. part of the programme.

○○○○

Value of Land Lines.

The policy is to develop land line communication to the highest efficiency, and later on another pivot between London and the West Country will be installed, probably at Bristol. It is often asked why British stations are not linked up by wireless instead of by land lines, as is done in some other countries. Land line connections between stations have greater guarantee of success. The alterations in the system brought about by the improvements at Leeds will not only provide better reception, but lead to considerable economies in the hire of what are, after all, unnecessary miles of Post Office land lines.

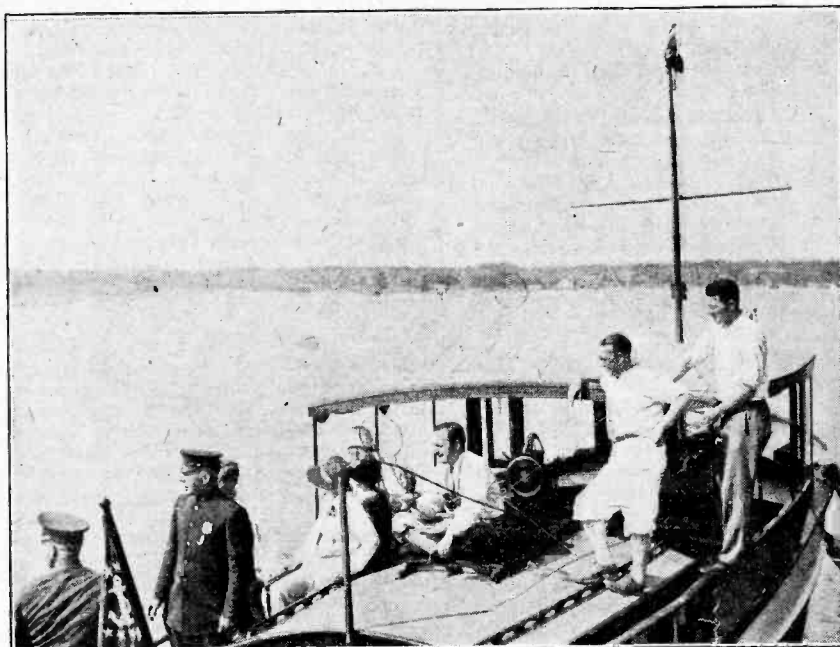

NEWS FROM THE COURSE. A graphic description of the recent Gold Cup motorboat race in America was broadcast by WAHG, Richmond Hill, New York. The photograph shows the announcer, microphone in hand, giving his "word picture" of the event. Note the businesslike cage aerial.

Tests for Receiving Sets.

In order to test the efficiency of receiving sets it is proposed that the B.B.C., as the transmission agent, should endeavour to put out transmissions dealing with all frequencies equal, i.e., without distortion. As I have already pointed out in these columns, the average receiver lags behind the progressive development of the transmitter very considerably and if tuning notes of different frequencies and of consistent strength were sent out at stated intervals, listeners would be enabled to test their sets by audible observations or by actual measurements. It would thus be possible for listeners to ascertain whether their sets were responding to these frequencies in the way they should.

○○○○

Trafalgar Day.

A special programme will be broadcast on Trafalgar Day, and will take the form of a continuous presentation, i.e., only a preliminary announcement will be made and the rest of the programme will be linked up with dialogue and occasional suitable excerpts. The programme, which is entitled "England Expects—" will include items by the 2LO band and the Wireless Choir, with Masefield excerpts: "A Longshore Farewell," and "A Glimpse of the Sea Road." It will include a dramatic episode "Outward Bound," specially contributed by Captain Frank Shaw. As far as it can be made so, this item will be a faithful representation of an old sailing ship leaving port for the deep sea. As the various duties incidental to its departure are performed, traditional sea chants will be sung by mariner members of the Seven Seas Club. Another dramatic episode will be a naval sketch in four parts of modern life on a man-o'-war, specially contributed by "Bartineus." October 21 will, therefore, be a real naval programme.

○○○○

Super Studio in Prospect.

Even with the new studios which will shortly be brought into service at 2LO, the accommodation will be severely taxed and will not, in fact, be adequate to cope with the new developments which are being considered. The construction of another studio of larger dimensions than any yet existing in the world is therefore projected. It will be specially fitted and adapted to keep pace with the experiments which are constantly being made with problems of acoustics and will be as nearly a replica of the outside hall to which an audience can be invited as it is possible to get.

○○○○

Speeding-up Programmes.

A feature of the studios which are nearing completion in the new section of the building at Savoy Hill is the installation of a silence cabinet about 4 ft. by 6 ft. in dimension, where the dramatic producer will have all the controls at his hand for the purpose of regulating the sounds coming out of the studio. In this cabinet four knobs will be fitted, three of which will control the microphones in the studios. Each microphone will contribute the amount of sound required and by

B 28

FUTURE FEATURES.**Sunday, October 11th.**

LONDON.—3.30 p.m., The Band of H.M. Royal Air Force.

BOURNEMOUTH.—9.15 p.m., A Mozart Evening.

GLASGOW.—9.15 p.m., Pianoforte Recital by Marcelle Meyer.

BELFAST.—3.30 p.m., Harvest Festival Service relayed from the Cathedral.

Monday, October 12th.

LONDON.—9 p.m., "The Mastersingers" (Act III.). 10.45 p.m., Max Darowski at the Piano.

MANCHESTER.—8 p.m., Chamber Music and Pianoforte Recital.

Tuesday, October 13th.

ALL STATIONS.—10.30 p.m., Ella Shields in a Farewell Performance.

BIRMINGHAM.—7.30 p.m., First Symphony Concert of the City of Birmingham Orchestra.

MANCHESTER.—1.15 p.m., Tuesday Mid-day Society's Concert.

LEEDS-BRADFORD.—8.15 p.m., "Tannhauser," Act II., performed by the British National Opera Company, relayed from the King's Theatre, Edinburgh.

Wednesday, October 14th.

5XX.—8.15 p.m., Music to "The Sleeping Beauty," relayed from the Royal Opera House, Covent Garden.

LONDON.—9 p.m., "Aida" (Act III.), performed by the British National Opera Company, relayed from the King's Theatre, Edinburgh. S.B. to other Stations.

CARDIFF.—8 p.m., The Piano and Song.

Thursday, October 15th.

LONDON.—8 p.m., Chamber Music Programme.

BIRMINGHAM.—7.30 p.m., The Oratorio, "Elijah" (Mendelssohn). Performed by the Birmingham Festival Choral Society. Relayed from the Town Hall.

NEWCASTLE.—8 p.m., "The Immortal Hour" (Rutland Boughton).

Friday, October 16th.

ALL STATIONS.—7.50 p.m., "Popular Wireless" Competition. 8.25 p.m., Speeches at the Inaugural Meeting of the B.N.O. Campaign, presided over by Lord Londonderry. 9.30 p.m. approx., Excerpts from the Musical Comedy, "Dear Little Billie."

Saturday, October 17th.

BOURNEMOUTH.—8 p.m., Second Anniversary of the Bournemouth Station.

MANCHESTER AND 5XX.—8 p.m., "The Lure of the Dance."

turning the knobs the dramatic producer will be able to vary the amount of echo. At the end of a broadcast he will fade out the knobs connecting the studio microphones and will use the fourth knob for announcing the next item, thus avoiding the delay between items which has caused a certain amount of irritation among listeners and has prompted the more impatient of them to suggest the need of a non-stop programme.

○○○○

Free Speech in the Studio.

While the dramatic producer is announcing the next item, the artists will be able to move about freely in the studios, as the microphones will be out of circuit and there will be no need for those present in the room to walk softly or speak in hushed tones so that their verbal asides shall not be broadcast. A green light will show outside the silence cabinet when the dramatic producer is broadcasting, and a red light will be shown when the microphones in the studios are working. A considerable speeding-up in the programme arrangements is anticipated when the innovation comes into operation.

○○○○

Duke of York Broadcast.

Certain of the speeches at the Law Society's Centenary Banquet on October 15 will be relayed from the Guildhall and broadcast from Daventry. The speakers will include the Duke of York, the Lord Chief Justice, the Attorney-General, the Lord Chancellor and Sir William Joynson-Hicks.

○○○○

More S.B.

A suggestion has been made in certain quarters that there should be a diminution in the amount of simultaneous broadcasting; the suggestion does not take account of the fact that the demand for simultaneous broadcasts has gained in volume. It is the fact that formerly local listeners had a strong predilection for local artists and preferred to hear someone who was fairly well known in his own locality but unknown throughout the rest of the country, rather than have in the local programme as an S.B. item some artist from outside the district, even though that artist might have a wide reputation.

○○○○

Better Winter Music.

During the winter months, more opera will be broadcast than in any previous season. This means that the stations will take the best that can be obtained in London, as well as in the Provinces. The best of the season's symphony concerts will also be drawn on for the benefit of listeners. The date, October 22nd, will mark the beginning of the new scheme. The first relay of the season from the Halle Orchestra Concerts in the Free Trade Hall, Manchester, will be given on that date. The overture, "The Mastersingers," with which Sir Hamilton Harty usually opens his series of concerts there, and the Brahms Symphony No. 1 in C minor, will be included.

THE 'SELECTION OF A VALVE.

Essential Characteristics of Amplifying and Detecting Valves.

By N. V. KIPPING and A. D. BLUMLEIN.

(Continued from page 149 of the September 30th issue.)

IN an amplifier, the true criterion of amplification is the step-up of power obtained—not of current or voltage taken alone. Consequently, m does not represent the ultimate criterion because it represents the voltage step-up, but says nothing about the current. The popular idea that amplification may be measured in terms of voltage step-up has arisen from the fact that in most cases the power absorbed by the grid circuit of a valve is negligible (as there is very little or no grid current), and that therefore the output of the valve depends upon the voltage applied to the grid. Theoretically, if the grid absorbs no power, an amplifier could be made to have infinite amplification by introducing a transformer into the output circuit having an infinite step-up. Actually, however, the grid always does absorb a certain amount of power, and also a limit is reached in the ratio obtainable with the transformer. After a certain time it becomes practically impossible to wind any more turns on the secondary, as the increased capacity becomes a shunt on the winding.

Although, therefore, the voltage step-up obtained may give a reasonably close idea of the amplification obtained, yet ultimately power must be the chief consideration, as it is only power that can be converted into sound.

Conditions for Maximum Amplification.

To obtain the maximum amplification from a valve, the output load should have the same impedance as R_o . This arrangement, however, will not decrease the slope of the grid voltage-plate current curve so much as with a higher impedance load, so that less variations in grid voltage can be allowed without distortion, but on the other hand maximum amplification is obtained. It is consequently a matter of compromising between maximum amplification and distortion. For the first stages of a L.F. amplifier, amplification may be given first place, as input voltages are, as a rule, small, and not likely to overlap the straight curve.

For late stages, however, where input voltages are high, distortion must be given first consideration. Many authorities consider that in early stages, the load impedance should equal R_o , and in later stages should be $\frac{3}{2} R_o$, or $2R_o$.

It is more or less safe, therefore, in preparing load curves, to take $R_L = \frac{3}{2} R_o$, unless, of course, one is working out a specific case.

Maximum amplification is obtained from a valve when the quantity $\frac{m^2}{4R_o}$ is a maximum.

This is arrived at as follows:—

The voltage input to the grid is limited by either (a) the output from a previous stage, if no step-up is used, or (b) the economic limit which exists for the impedance of the secondary of the input or intervalve transformer. The criterion of amplification is then output power per A.C. grid volt. That is to say, it is the product of plate current per grid volt, and plate volts per grid volt, when the load is connected to the valve. Assuming the load to have an impedance R_o , which is best from the power standpoint, these two quantities are $\frac{m}{R_o + R_o}$ and

$$\frac{m}{2}, \text{ and their product is } \frac{m^2}{4R_o}.$$

It will be seen that as R_L seldom exactly equals R_o , the above expression is not precise; even if R_L is $2R_o$, however, the amplification obtained only differs by 11 per cent. from $\frac{m^2}{4R_o}$. Thus, except for resistance

and choke couple amplifiers, where voltage step-up rather than power step-up is aimed at, this expression may be used as representing the amplification a valve will give. This shows that the ideal valve for amplification purposes is one having a high m and a low R_o .

Unfortunately, it is impossible in practice to obtain both these properties at the same time. The usual method of producing a valve with a high m is to place a closely meshed grid very close to the filament, and the plate a comparatively long distance away. This has the effect of giving the grid a very firm control over the current which flows to the plate, but placing the grid relatively close and making it a fine mesh results in grid currents flowing rather easily, and plate currents with difficulty. The smaller the plate currents, of course, the higher is R_o .

Compromise between Values of m and R_o .

The ideal not being attainable, it is possible at one time to have only some of the ideal properties at the expense of the others. Curve A, Fig. 4 (page 447 of the previous issue), for example, has a high m , but also a fairly high R_o . Curve C has a rather low m and a correspondingly low R_o . Curve B lies between the two.

Due to the fact that as m is increased, R_o is increased, the most desirable compromise will be different in each case. The best amplification is in general obtained when m is high, because m^2 increases more rapidly than R_o for a given type of valve, and the expression $\frac{m^2}{4R_o}$ is therefore increased when m is increased.

In the first part of this article appearing in the previous issue, a description was given of the methods of plotting valve characteristics. In concluding the article, the authors show how characteristics may be interpreted and summarise the points to look for when choosing a valve for any given purpose.

The Selection of a Valve.—

We have already explained that the load impedance of an amplifier is best equal to or greater than R_o .

This sets a limit to the value of R_o in transformer coupled amplifiers, because the primary of intervalve output transformers cannot economically be wound to a higher impedance than 20,000 or at a push 30,000 ohms. If a valve has a higher R_o than this, therefore, it will not be possible to connect it to a high ratio transformer, and the advantage of the higher m accompanying the high R_o will be largely lost.

L.F. Amplifiers.

It may be found that the choice of a valve for highest amplification will entail the use of a very high plate voltage to make use of the full straight line portion of the characteristic without the grid becoming positive. This may particularly be the case with a valve of high R_o , and is a point to be considered.

In view of the fact that distortion in an early stage is not likely to occur, the choice of a valve in this case rests almost entirely on high amplification. (The limitation of R_o already given must not, however, be forgotten.)

For later stages, it is usually necessary to sacrifice high amplification to obtain a lower R_o , as otherwise a high plate voltage is needed to obtain a sufficiently long straight portion of the characteristic over which to work without the grid becoming positive.

For late stages (or power amplifier stages), therefore, a valve with a long characteristic and hence low R_o is chosen, and an attempt made so to adjust matters that the same plate voltage may be used for this as for the early stages.

Where early stages are resistance or choke coupled, one is not limited by transformer design (and so by R_o), so that the chief consideration is to obtain a valve with a high m .

Push-full amplifiers are useful where valves have a square-law parabolic portion at the bottom of their characteristics, as the push-pull arrangement of two such valves can be made to give a resultant characteristic which is practically straight over a limited range. This combination of two curves has the effect of neutralising any even harmonics which might have been produced by one of them alone. It will not effect odd harmonics, such as are produced by evenly overlapping both the top and bottom curves of a characteristic. This method of amplification often permits a small economy in plate battery, and is frequently to be preferred to the use in power amplifier stages of two valves in parallel. The choice of a valve for such a stage may be made along the same lines as for an ordinary late L.F. stage, but it may be remembered that if the bottom curve of the characteristic is of what may be described as a wide, sweeping shape and is parabolic, it may be safely overlapped, thus allowing a lower plate voltage to be used. Grid bias is fixed accordingly.

Grid biases should be fixed in conjunction with the plate voltages, in the manner described in connection with the curves A, B, C, and D of Fig. 5 (page 448 of the previous issue), under the heading of "Distortion."

High-frequency Amplifiers.

Distortion is of less importance in this stage than in the low-frequency stages, because its effect on the high-frequency wave will be chiefly to alter its wave shape rather than to alter its amplitude, and hence its rectified shape. Consequently, although distortion should not be entirely neglected, it is usually of secondary importance to the difficulty of oscillation, which takes place very easily in the high-frequency stages due to inter-electrode capacity. This trouble is particularly prevalent for short wave working, and is commonly counteracted by permitting grid current to flow (by a low plate voltage and a suitable grid bias), thus reducing the amplification of the stage. The necessity for this in all except special circuits, such as the neutrodyne, limits very considerably any advantage which might attach to using a valve with a high m , as one would only have to limit the amplification, with its attendant oscillation troubles, by increasing the grid current. It is consequently usual to choose a valve for a high-frequency stage so that it has a medium m value (about 8).

Different arrangements of the H.F. stage are so numerous that it is scarcely possible to go more deeply than this into the choice of the best valve for each case.

In order to reduce as far as possible inter-electrode capacity in high-frequency stages, certain manufacturers have adopted a special form of mounting in which the electrodes are brought out to widely separated contacts. A glance at Fig. 7 will show the advantage of this type of mounting from the capacity standpoint over the more standard type, but the former type sometimes suffers from fragility and is rather inconvenient in form.

Valves for H.F. Amplification.

In an effort to reduce inter-electrode capacity, many manufacturers have so reduced the size of electrodes in valves intended as H.F. amplifiers as to increase considerably R_o , without producing a very high m . This will result in the quantity $\frac{m}{R_o} \times 10^6$ (being plate current in microamperes per grid volt) being small for an H.F. valve.

A high-frequency valve should be very "hard," *i.e.*, very highly evacuated. This is because the slight ionisation occurring in not very hard tubes, in addition to changing the form of the characteristic curve, produces a slight loss of energy which is due to the hysteresis lag of ionisation. This effect is not very serious at low frequencies, but in an H.F. valve may introduce considerable loss of power.

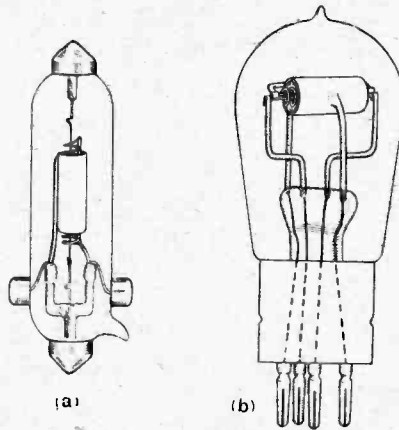

Fig. 7.—Arrangement of connections from the electrodes of (a) a special valve of low capacity, and (b) a standard receiving valve.

The Selection of a Valve.—

Detectors.

There are two methods by which a valve is commonly made to rectify :

(a) By operating on either bend of the plate current grid voltage curve.

(b) By operating on the grid voltage—grid current curve.

Whichever of these methods is used the sharpness of the bend will determine very largely the freedom from distortion which can be achieved. The ideal detector curve is shown in Fig. 8. curve A, in which the bend

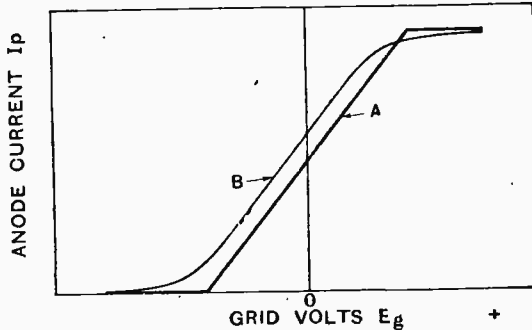

Fig. 8.—Ideal curve A for "anode" or "bottom-bend" rectification, and B the form of curve usually obtained in practice.

takes place in the minimum grid voltage range. Curve B is a practical case.

In Fig. 9 is shown the bottom part of a typical characteristic curve on a large scale. To this is introduced a small input voltage a . Relatively this wave does not appreciate the curvature of the characteristic, since the total change of slope, which is the important thing, is small over the voltage range of the wave. The output wave takes the form a' . In this, the top half of the wave is very little bigger than the bottom half, meaning very little rectification. The mean rectified current is represented by the line a'' .

With an input voltage such as b , however, the change of slope of the characteristic is relatively greater, due to the increased voltage range of the input wave and the output wave becomes b' . In this, there is a considerable difference between the two halves of the wave, and the mean rectified current is represented by the line b'' , which is comparatively much greater than a'' . The greater the amplitude of the input wave, the more nearly does the valve characteristic approach the ideal of Fig. 8A.

These curves demonstrate the uselessness of trying to rectify a very small input voltage; it is because of this that a high-frequency amplifier is so often essential; its omission often causes more distortion than its presence introduces.

With expert handling, perhaps the most efficient rectification can be obtained with a "soft valve" (which is not so highly evacuated as a "hard valve"). At a certain critical plate and grid voltage the ionisation of the gas in these valves suddenly increases, and the plate current correspondingly increases very rapidly with a change of voltage on the grid. Thus very sudden bends and sometimes kinks are produced in the characteristics,

which are almost ideal for rectification if they can only be accurately covered by the A.C. grid voltage wave. This rectification at the critical point of the valve is only possible for a very expert operator.

It will be appreciated, then, that one's first consideration in selecting a detector is the sharpness of the bend on which it is to be worked; often, with bright emitters, the sharper bend is that at the top of the plate current-grid voltage curve, and unless method (b) above is to be used for detection it may be found that this bend is the more satisfactory to use. With method (a) the bias of the grid is of the utmost importance, and should be fixed on the most curved portion of the characteristic. With method (b) the fixing of the grid bias may be described as semi-automatic; the selecting of a suitable grid leak is, however, largely a matter of trial and error.

To obtain this sharpness of bend, which is so necessary for detectors, the m is made high, so that the grid has a very firm control over the plate current, and consequently the curved portion of the characteristic is covered by only a small grid voltage range. The fact that a detector has a high m means that to some extent it has a high R_o . This should be kept as low as possible if a transformer coupling is to follow the valve.

Mechanical Considerations, Cost, and Convenience.

When buying a new valve, one is very largely prejudiced in favour of using battery valves which fit in with what one has; the importance of this is, of course, a matter to be decided by each individual, but there are one or two other considerations which are worthy of notice while considering the question. Amongst these may be mentioned the question of mechanical strength and rigidity of construction.

It is, as a rule, the very low filament consumption dull emitters (those consuming less than, say, 0.2 ampere filament current) which suffer most from fragility, which often results in "ponging"—a ringing noise caused by

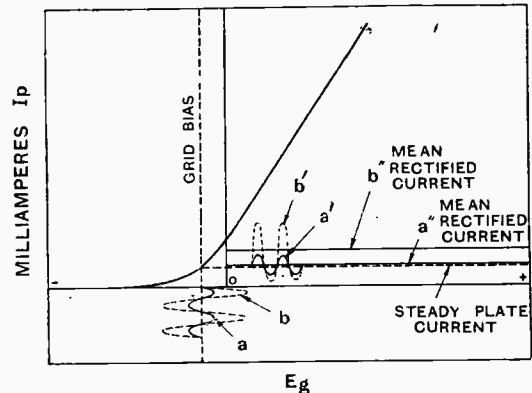

Fig. 9.—Diagram showing the relation between the efficiency of a valve rectifier and the amplitude of the incoming signal.

a mechanical vibration of the filament or other electrodes when the valve is jarred. Very small filaments also seem to be more or less incapable of constancy of emission, which results in their being "microphonic," a phenomenon which introduces the well-known frying noise. In general, medium power dull or bright emitters are comparatively free from these defects, as also are the higher power dull emitters.

The Selection of a Valve.—

Dull emitters as a class have longer working lives than bright emitters; although some very low filament consumption dull emitters are an exception to this. These latter valves, however, have been specially designed to meet the needs of a receiving set in which the use of accumulators may be avoided, and this is often so great an advantage that the not very vital defects of the very low filament consumption tubes are outweighed. Added to this, the need for portability or small size often prohibits the use of the larger valves.

In connection with cost, not only should the first cost of the valve be considered, but also its life and its cost in battery power.

Summary.

In conclusion it is proposed to suggest rules for the selection of a valve for each of the purposes dealt with above.

First of all, one's choice must be limited by the conclusions which have been reached regarding cost and battery power. This in turn will, as a rule, eliminate those valves which exhibit some undesirable mechanical or constructional feature. The following rules, which are given in the order of relative importance, may then be applied.

Low-frequency Amplifier.

(1) *Early Stages, Transformer Coupled.*—Highest m consist with R_0 not being greater than the 20,000 to 30,000 limit.

(2) *Early Stages, Resistance or Choke Coupled.*—Choose a high m value.

Last Stage.—(a) Choose so that the normal straight portion of the characteristic can be obtained of sufficient length, without an unduly high H.T. battery.

(b) The above requirement generally calls for a low R_0 value. R_0 must not be greater, and may be less than the load impedance.

(c) With the above limitations $\frac{m^2}{4R_0}$ should be a maximum.

High-frequency Amplifier.

(1) *Short-Wave Working.*—Without a specific circuit about which to talk, it is possible only to generalise on the choice of a H.F. valve, and, beyond the generalisations given, the final determination of the best valve can only be a matter of trial and error.

(a) Choose a valve having a medium or low m (say, about 8).

(b) Choose a hard valve having low inter-electrode capacity. *Note.*—In circuits containing devices for the neutralisation of inter-electrode capacity (such as the neutrodyne), a higher m may be used.

(2) *Long-Wave and Intermediate Frequency Working.*—Here inter-electrode capacity is of less importance provided the design of the H.F. stage is satisfactory and does not encourage oscillation. A valve of high m may therefore be chosen, which will give large amplification.

Detectors.

(a) Choose a valve having a very sharp bend to the characteristic which is to be used—*i.e.*, a bend occurring over as small a grid voltage range as possible.

(b) For transformer coupling, keep R_0 as low as possible, consistent with (a).

(c) Unless very expert, do not use a soft valve.

If the above method of selection results in several valves still being left in, a final choice may be made by applying the following analysis, weight being given to each consideration in the order given.

(a) Select the valves so that between the whole group a minimum number of different filament voltages are necessary.

(b) Select so that between the whole group a minimum number of different plate voltages are necessary.

(c) Consider any advantages which may attach to particular methods of mounting and to size.

(d) Consider the risk of mechanical breakage, due to weak construction, and consider the fact that overrunning is far more detrimental to the life of dull emitters than to the life of bright emitters. The former, however, often have initially longer lives than the latter.

General Notes.

We regret that in our issue of September 16th Mr. M. H. Wilkinson's call sign was given as 2YW. The correct call sign for his station at Southerlea, Batter Lane, Rawdon, near Leeds, is 2YU.

Mr. S. K. Lewer (G6LJ), 32, Gascony Avenue, West Hampstead, N.W.6, reports that at 8.30 a.m. on September 14th he heard A5BG (H. A. Kauper, 20, Gurney Road, Dulwich, South Australia) on about 37 metres, strength R6, and also established two-way communication with BZLAB (A. S. Freire, Echarahy, Nictheroy) earlier on the same morning.

Mr. R. C. Bradley, 205, Waverley Road, Reading, states that a short time ago he picked up SMUI, Mr. E. Aulin, Anderslöv, Sweden, on an 0-v-1 Reinartz receiver with a short indoor aerial and found, in answer to his QSL card, that Mr. Aulin was at that time using only a dull emitter receiving valve with 80 volts on the plate, as his usual transmitting valves were out of action. If this is so,

**TRANSMITTING NOTES
AND QUERIES.**

it seems an unusually long range for such low power.

Mr. N. A. Richardson, 68, Finchley Lane, Hendon, N.W.4, has been allotted the call-sign G5HJ. Mr. C. Warren, 19, Melville Road, Coventry (G6CI) is transmitting on 90 metres, and Mr. F. W. Goff, 102, Woodside Road, Bowes Park, N.22 (G6YG), on 45 metres. All these transmitters will welcome reports, and 6YG wishes to arrange tests with other stations.

Mr. A. E. Edwards (G6UU), 60-62, Wellhead Lane, Perry Barr, Birmingham, has reason to believe that someone else

is making use of his call-sign and will be glad of any information enabling him to trace the offender.

QRA's Identified.

We have received from various correspondents, to whom we tender our thanks, the following QRA's, which we trust will be of interest not only to those transmitters who specifically asked for them but to others of our readers:—
SMLZ, J. Lagercrantz, Svalnsvagen 18, Djursholm, Stockholm.

6YX, W. Macey, R.A.F., Bir Salm, Palestine (until lately used the call BSM).

SMRG, address Radio SMRG, Kristianstad, Sweden.

PI1HR, Lieut. H. P. Roberts, Fort McKinley, Manila, Philippine Islands.

PI1HK, H. Kidder, U.S.S. "Pope" (225), Asiatic Fleet, c/o Postmaster Seattle, U.S.A.

NW4X, Mr. Berven, Stavanger, Norway.

PRACTICAL HINTS AND TIPS

A Section Mainly for the New Reader.

MATCHING INTERMEDIATE FREQUENCY TRANSFORMERS.

CONSTRUCTORS of intermediate frequency transformers often have considerable difficulty in devising a simple method of matching these to a given wavelength. The exact wavelength is arbitrary; a divergence of several hundred metres or more will not affect the correct functioning of most designs of super-heterodyne set. What we have to aim at is to tune all the transformers to the same wavelength, and the use of the testing circuit shown in Fig. 1 will afford a simple and practical solution to the difficulty.

The components used (with the exception of the galvanometer, which can sometimes be dispensed with, as will be shown later) are such as most amateurs will already have in their possession. The valve V_1 functions as an oscillator, the wavelength being determined by the inductance of the coil L_2 and the capacity of the

The valve V_2 should be of the type which it is proposed to use in the actual amplifier, having in its grid-filament circuit a pick-up coil, L_3 , of high inductance, connected to flexible lead, so that it may be loosely coupled to the oscillator coil. In the anode circuit of this second winding of the transformer under test, valve will be inserted the primary

These components should be connected up on a baseboard, allowing very ample spacing (at least 18in.) between the oscillator windings and the transformer. A detector of high resistance, such as perikon or other combination of two crystals, should be used.

The measuring instrument is a sensitive galvanometer or micro-ammeter reading up to some 200 micro-amperes, and, of course, shows the direct current rectified by the crystal.

The oscillator should be set in operation and the pick-up coil placed near its grid inductance. The secondary of the transformer is then adjusted either by adding or taking off turns, varying the capacity of a semi-fixed condenser shunted across this winding, or a combination of both operations, until maximum deflection of the galvanometer is obtained. This will indicate resonance.

If no galvanometer is available, a pair of headphones may be used. It will be noticed that a grid condenser, shunted by a variable leak, is included in the oscillator circuit; this may be put into operation by opening the short-circuiting switch and adjusting the leak till an audible note is produced. The transformer is ad-

justed as indicated in the previous paragraph, till a note of maximum loudness is heard in the telephones.

While either of the methods described will enable the transformers to be matched with a fair degree of accuracy, no very useful conclusions may be drawn as to the relative efficiencies of different types of winding, ratios, etc. To conduct experiments in this direction, the use of a valve voltmeter, in place of the galvanometer and crystal combination, is almost essential.

STABILISING AN INTERMEDIATE FREQUENCY AMPLIFIER.

In cases where insufficient care has been given to the design of an intermediate frequency amplifier, it may be found that it oscillates uncontrollably, or, at the best, requires an excessive amount of positive grid damping applied by the potentiometer. As a temporary measure, at any rate, it is useful to remember that one of the intervalle coupling transformers may be replaced by an anode resistance of some 80,000 ohms, with coupling condenser (about 0.002) and grid leak. This substitution should be made in one of the middle stages, in order to break the sequence of tuned or semi-tuned circuits.

LOOSE COUPLING.

It is frequently stated that receivers must have a loose-coupled aerial circuit if a high degree of selectivity is to be obtained.

While this statement is true enough as far as it goes, the beginner who makes the necessary alteration to a set containing a stage of tuned high-frequency amplification will generally find that uncontrollable oscillations will be produced when the aerial coupling is loosened. The fact is that a valve with its grid and plate circuits tuned approximately to the same wavelength will normally oscil-

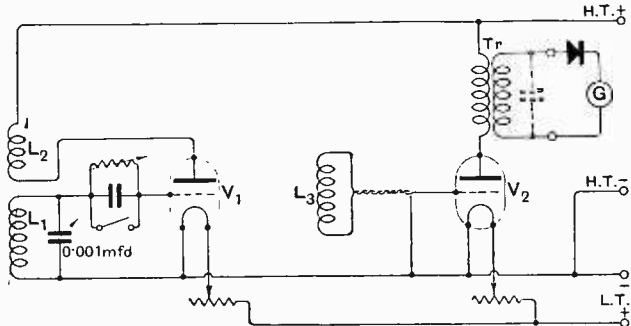

Fig. 1.—Matching I.F. transformers.

tuning condensers. It is suggested that plug-in coils of the standard type be used with an ordinary holder, the reaction coil being just sufficiently large to set up oscillations when fairly closely coupled. Reference to the coil makers' calibration curves will show the correct size of coil and capacity for the wavelength chosen with sufficient accuracy for our purpose.

late, unless some damping or balancing device is applied. Previous to making the alteration, the degree of damping necessary for stability was supplied by the load of the aerial-earth system connected across the grid inductance. Some form of stabilising device must, of course, be provided.

o o o o

LOCATION OF FAULTS IN MULTI-VALVE RECEIVERS.

A great deal of time is often wasted in locating faults in sets by failing to work in a methodical manner. When the usual obvious tests have failed to reveal the trouble, it is a good plan to test through valve by valve. To do this the wiring must generally be disturbed, but much more time will probably be wasted by proceeding in a haphazard manner.

Taking the case of a superheterodyne set which refuses to function, a pair of 'phones should be inserted in the anode circuit of the first detector, to make sure that this valve, together with any H.F. valves preceding it, are operating properly. The oscillator should next be tested by lighting the valve and noting whether a strong beat note is produced when varying its tuning through the wavelength of an incoming carrier wave, the 'phones still being connected to the detector. The first and second intermediate frequency valves may easily be tested by inserting a condenser with leak and a pair of telephones in respectively the grid and anode circuits of the latter valve. Having ascertained that everything is in order up to this point, the grid condenser and 'phones would be transferred to the next valve, and so on.

A similar plan should be adopted in dealing with other types of receiver; a little careful thinking will indicate a suitable method of procedure.

o o o o

TESTING FIXED CONDENSERS.

Although fixed condensers are generally taken on trust, and, indeed, this confidence is well justified in the case of most reputable makes, it sometimes happens that a fault exists, giving rise to troubles which many amateurs find difficult to locate. There are two possible causes: lack of insulation and internal disconnec-

tion. Luckily, these may be tested without elaborate apparatus by the use of a pair of 'phones and a 4- to 6-volt battery. Connect the 'phones, battery, and condenser in series, and, if in order, a click will be heard as the circuit is "made" (due to charging current flowing from the battery through the 'phones into the condenser). No click should be heard as the circuit is broken. This would indicate a short-circuit, or, at least, faulty insulation. If no click is heard at "make," a disconnection is indicated.

A large condenser will give a much louder click than will a small one; in fact, with practice, it is possible to

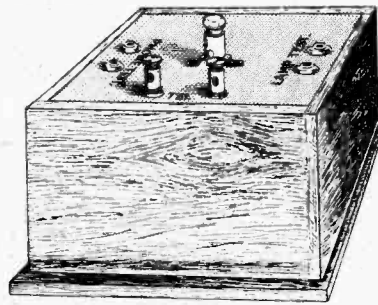

make quite a shrewd guess as to the actual capacity of the condenser under test.

Another method of testing the insulation of a condenser is to charge it up by connecting a battery across its terminals, and after a few seconds' interval discharging through a pair of telephones. If in order, a click will be heard, again depending in loudness on the capacity and degree of insulation of the condenser.

When making these tests, care should be taken that all contacts are clean, particularly those used for making and breaking, and that the insulation of the testing circuit is good throughout, avoiding partial short-circuits through the body of the operator.

o o o o

A SIMPLE TESTING BOX.

The above-mentioned condenser test, and many others necessary for determining the insulation and continuity of circuits and components, may be rapidly carried out with the help of the simple and inexpensive test box illustrated herewith. A circuit diagram is given in Fig. 2. Any experimenter not possessing a galvanometer or similar instrument will

find that the slight trouble involved in the construction of such a tester is amply repaid.

All the parts, including a $4\frac{1}{2}$ -volt dry battery, may be contained in a box about 4in. x 4in. x 4in., fitted with an ebonite panel, on which are mounted a couple of telephone terminals, four sockets, and a flashlamp holder, such as may be purchased for a few pence. Two insulated flexible leads should be made, fitted at one end with plugs to fit into the sockets on the panel, and at the other end with metal pins having an insulated sleeve, similar to the pin tags now sold.

To test the continuity of a circuit

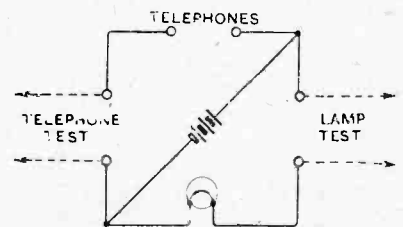

Fig. 2.—Circuit testing unit.

of low resistance, one would plug the leads into the sockets marked "lamp test," applying the pins across the component under suspicion. A glow would, of course, indicate continuity. High resistance circuits and condensers are tested by connecting 'phones to the terminals as shown, at the same time transferring the leads to the appropriate sockets.

o o o o

CONDENSERS IN SERIES.

Although the insulation of fixed condensers of the paper dielectric type is, considering their compactness, of an extremely high order, it is possible that there will be only a small margin of safety in the case of a coupling condenser of this pattern used in a resistance-capacity amplifier supplied with a high plate voltage. Mica condensers of suitable capacity are expensive and difficult to obtain. The plan of using two Mansbridge condensers in series solves the difficulty. If, for instance, two condensers of 0.25 mfd. are used, the actual capacity will be 0.125 mfd., and the total insulation resistance and dielectric strength will in each case be twice that of a single condenser.

CRYSTAL DETECTORS.

The Electrical Properties of Contact Rectifiers.

By F. M. COLEBROOK, B.Sc., D.I.C., A.C.G.I.

(Continued from page 409 of the Sept. 23rd issue).

FOR either of the two most common forms of crystal detector the relation between i_c , the continuous rectified current, and E , the high-frequency signal amplitude, will be of the kind shown in Fig. 18. Suppose now that the high-frequency amplitude, instead of being constant, is modulated with a single pure tone to the extent M . Assuming for a moment that the load in the detector circuit is a pure resistance, *i.e.*, one which is the same for a changing current as for a constant current, then this modulation of the high-frequency e.m.f. will cause a variation MM in the i_c line, and a corresponding variation AA in the magnitude of i_c . In other words, the variation of high-frequency amplitude by the amount M will produce an alternating component of rectified current of magnitude I_m as shown in Fig. 18. This is essentially, and in its simplest possible form, the explanation of the conversion of a modulated continuous wave into a modulation frequency current by means of a crystal detector.

In the two previous sections of this article the author discussed the form of the D.C. and C.W. characteristics of crystal detectors, and the effects on the characteristics of external loads. The present article deals with the choice of the best telephone resistance for different conditions of reception, and some sources of distortion, other than those introduced by the rectification process, are indicated.

current will be a faithful or undistorted copy of the modulation. The straightness of the rectification characteristic is therefore a very desirable feature of a detector. For moderately large signal amplitudes, *i.e.*, over about 0.4 or 0.5 volt, either of the more common forms of crystal detector will fulfil this requirement in a very satisfactory manner, which is the chief reason for the generally

acknowledged purity of reproduction of modulation given by a crystal.

The above must only be regarded as a very simplified introduction to the subject, which must be considered in rather fuller detail before practical conclusions can be drawn.

Rectification of Modulated Continuous Waves. Continuous Current Side.

It should be clear from a consideration of Fig. 18 that if the range of variation MM of the rectification characteristic is sensibly straight, the mean value of the continuous current will not be affected by the modulation. In fact, it can easily be shown that the alteration of the mean value of the rectified current, if any, is proportional to the curvature of the line MM . Moreover, if the modulation percentage, *i.e.*, the ratio of M to E , is small (in practice it will rarely exceed 20 per cent. or so), an appreciable curvature in the range MM will only produce a very small variation in i_c . To a fairly close approximation, therefore, the effective input conditions, *i.e.*, high-frequency resistance and input power, can be considered to be the same as for the unmodulated carrier wave. (More accurately, the input power will be increased by the modulation in the ratio of $(1 + \mu^2) : 1$, where μ is the ratio of M to E . Thus a 20 per cent. modulation will only produce a 4 per cent. change in the input power for a given carrier wave amplitude.) The variation of the input power with the d.c. resistance of the modulation frequency load (*e.g.* a pair of telephones) will therefore be of the same nature as already described in connection with the rectification of a pure continuous wave.

Rectification of Modulated Continuous Waves. Modulation Frequency Side.

The complete analysis of the crystal rectification of speech or music modulated continuous waves is an exceedingly complicated matter, since the modulation is of irregular and changing wave form, and the load impedance varies considerably with the audible frequency at which it operates. However, useful deductions can be made by considering the simple case of single pure tone modulation.

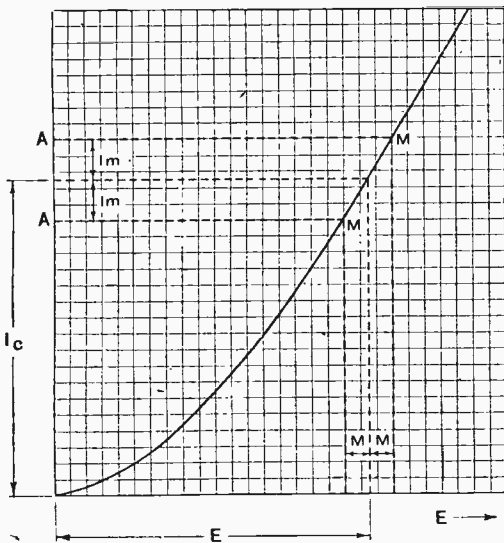

Fig. 18.—Relation between the continuous rectified current i_c and the amplitude E of the high-frequency e.m.f. applied.

One very important fact comes out from the inspection of this diagram. If the i_c line, *i.e.*, the "rectification characteristic," is not appreciably curved over the range MM , then, whatever the nature of the variation M , *i.e.*, whatever the wave-form of the modulation, the changes in i_c will be a faithful reproduction of it; *i.e.*, the modulation frequency component of the rectified

Crystal Detectors—

It was shown in the earlier part of the paper that in the rectification of a continuous wave with a d.c. load in series with the detector, the continuous current could be expressed in the form

$$i_c = \frac{E_c}{R_c + R}$$

in which E_c is an effective rectified e.m.f. and R_c an effective internal resistance of the crystal.

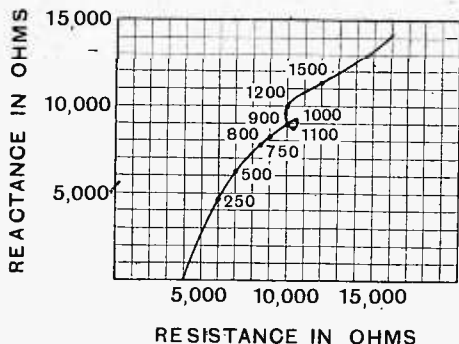

Fig. 19.—Curve showing the variation of impedance (reactance and resistance) of a pair of 4,000 ohm telephones. Frequencies are shown against the points on the curve.

In the same way it can be shown that for a modulation $m = M \sin nt$

and for a load whose impedance is represented at the given frequency by

$$Z_n = R_n + jX_n$$

the modulation frequency component of the current in the detector circuit can be expressed in vector form by

$$I_n = \frac{E_n}{Z_n + R_{cm}}$$

where E_n is an effective modulation frequency e.m.f. and R_{cm} is an effective internal resistance of the crystal. In scalar form the above is equivalent to

$$I_n = \frac{E_n}{\sqrt{(R_n + R_{cm})^2 + X_n^2}}$$

It is clear that from the present point of view the important quantities of the detector are E_n and R_{cm} , and it will be well to know something about their magnitude and variation.

As in the case of the corresponding quantities in the rectification of continuous waves, both the effective modulation frequency e.m.f. and the effective internal resistance will depend on the carrier wave amplitude, the d.c. resistance of the load, and with the type and the individual specimen of the crystal. Only a general idea of the magnitudes of these quantities can therefore be given.

The first, the effective modulation frequency e.m.f. is, for any given conditions, proportional to M , *i.e.* to the amplitude of the modulation. For either perikon or galena, and for all signal amplitudes up to about one volt or so it will probably be about 0.5 to 1.5 times M .

From the point of view of the circuit conditions, the effective internal resistance, R_{cm} , is the more important quality. This depends on the carrier wave amplitude, the d.c. resistance of the load in the detector circuit, and on the crystal. It will in general be of the same order

of magnitude as the quantity R_c , for no load under the same conditions of signal amplitude. Thus, for galena, at moderately large signal amplitudes, it may be anything from 70 to 300 or 400 ohms, increasing as the signal amplitude decreases and increasing with the load for any given amplitude. For perikon under similar conditions it may be anything from 300 to about 1,000 ohms. In both cases the effective internal resistance increases very rapidly as the carrier wave amplitude decreases from about 0.5 volt. Thus for galena it may be anything from 5,000 to 10,000 ohms for signal amplitudes less than 0.1, and for perikon under the same conditions it will probably be from 10,000 to 20,000 ohms. The figures are necessarily somewhat vague, but will suffice to indicate the order of the effective internal resistance to modulation frequency currents under the specified conditions. It should be mentioned that for any given carrier wave amplitude and d.c. resistance of the load the effective internal resistance appears to be independent of the amplitude or the frequency of the modulation.

We are now in a position to consider the crystal as a transformer of high-frequency power into modulation frequency power, and to discuss the circuit conditions appropriate to its operation.

Rectification of Modulated Continuous Waves. Crystal as Energy Transformer.

It has been shown that the modulation frequency current can be expressed in terms of an effective modulation frequency e.m.f. divided by the vector sum of the load impedance and an internal resistance.

The deduction of the most suitable telephone resistance from this fact is complicated by the circumstance that the impedance of the telephone will vary greatly with frequency. For instance, the curve of Fig. 19 shows the measured impedance of a pair of 4,000 ohm telephone receivers up to a frequency of about 1,500 cycles. (It might be mentioned in passing that this question of telephone impedance is one on which information is lacking. Kennelly's valuable work on this subject was mostly concerned with low resistance telephones of an early type, and the corresponding information about more modern varieties of higher resistance telephones does not appear to be available.)

As in the corresponding case of continuous wave rectification, the most suitable telephone resistance will depend not only on the detector, but on the input conditions. Thus, if a constant input potential could be assumed, *i.e.*, an input potential which was independent of the load imposed upon it, then the most suitable telephone resistance would be that which, over the most important part of the range of audible frequencies, gave an impedance comparable with the effective internal resistance of the detector. This would indicate the use of low resistance telephones (100 ohms or so) for moderately large signal amplitudes (*i.e.*, up to about ten miles from a B.B.C. station), and higher resistance telephones for small amplitudes, *i.e.*, for distant reception.

It has already been pointed out, however, that a constant input potential is certainly not the condition of direct crystal reception. The actual input condition will be discussed more fully later on, but it may be stated that the efficiency of transformation of high-frequency input

Crystal Detectors—

power into modulation frequency power is more likely to be the decisive factor in determining the best telephone load.

As an example, the following case has been worked out in detail. Carrier wave amplitude 1 volt, with 15 per cent. modulation: assumed that at some given frequency the impedance of the telephone load is four times its d.c. resistance, with a phase angle of 45° , i.e., equal resistance and reactance (see Fig. 19): galena detector. The curves of Fig. 20 show the variation of P_n , the modulation frequency power consumed in the telephones, with R, the d.c. resistance of the telephones, and also the variation of the transformation efficiency, i.e., P_n/P_1 under the same conditions. It will be seen that whereas P_n reaches a very pronounced maximum for a low value of R (about 100 ohms), P_n/P_1 reaches a maximum for a much higher value of R (about 450 ohms), the maximum in the second case being very much flatter than in the first.

This would suggest that telephone resistances of about 500 and 1,000 ohms respectively for galena and for perikon are suitable for operation at moderately large amplitudes. For small amplitudes, i.e., for fairly distant reception, it is probable that higher resistance telephones, up to about 4,000 ohms or even higher, could be used with advantage. In comparing different telephone resistances in any given receiving circuit, however, the effect of the telephone resistance on the input potential must be taken into account, and if possible compensated for in the manner to be described later.

Another feature of this variation of telephone impedance should be mentioned at this point. The efficiency of the telephone-detector combination depends on the relation between the telephone impedance and the internal resistance of the detector. Since the former varies greatly with the modulation frequency, the efficiency of the combination will vary with frequency. In general it will be higher at the lower frequencies. This will obviously result in a certain amount of distortion in the telephone reproduction of the modulation. Thus even crystal

reception is not free from distortion. This matter is further complicated by the response characteristic of the telephones, i.e., the variation of its acoustical efficiency with frequency, a matter on which information is lacking, but even if the telephones are free from any very pronounced natural resonance, this variation of the electrical efficiency described above will result in unequal treatment of frequency. Moreover, this variation with frequency

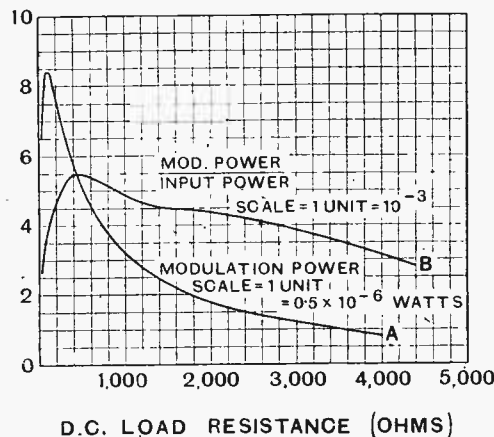

Fig. 20.—Curves showing the variation of modulation power P_n , and the transformation efficiency (the ratio $\frac{P_n}{P_1}$) with R, the D.C. resistance of the telephones.

will be a maximum in the neighbourhood of the optimum condition, so it is probable that an efficient telephone resistance will be associated with greater distortion than an excessive and therefore inefficient telephone resistance. This is, perhaps, a matter on which it is unsafe to speak definitely in the present state of our knowledge. It can be said, however, that the greater part of any distortion that occurs in crystal reception is due to the variation of the electrical and acoustical efficiency of the telephone-crystal combination, the rectification process itself being comparatively free from distortion.

(To be continued.)

Hackney and District Radio Society.

Greater facilities for experimenting are now enjoyed by the members, owing to the Society's move to the "Holy Trinity Institute," Mayfield Road, Dalston, E.8, where improved accommodation is available. A programme of considerable interest has been arranged for the coming session. On October 12th Mr. G. V. Colle will give a constructional lecture on "Crystal Receivers."

Hon. Sec., Mr. Geo. E. Sandy, King's Hall, Lower Clapton Road, E.5.

The Golders Green and Hendon Radio Society.

The opening meeting of the new session was held on Wednesday, September 23rd, when Mr. Maurice Child gave his first lecture of a series of six, entitled "The Fundamental Principles of Radio Reception." Mr. Child's lucid talk was greatly appreciated by beginners and advanced workers alike, and a number of interesting experiments were carried out

NEWS FROM THE CLUBS.

FORTHCOMING EVENTS.

WEDNESDAY, OCTOBER 7th.

Golders Green and Hendon Radio Society. At 8 p.m., at the Club House, Millfield Way. 2nd Lecture: "Fundamental Principles of Radio Reception." By Mr. Maurice Child.

FRIDAY, OCTOBER 9th.

Sheffield and District Wireless Society. At 7.30 p.m., at Headquarters. Annual General Meeting.

MONDAY, OCTOBER 12th.

Hackney and District Radio Society. At Headquarters. Constructional Lecture: "Crystal Receivers." By Mr. G. V. Colle.

WEDNESDAY, OCTOBER 14th.

Bolton and District Radio Society. Lantern Lecture: "Radio Ramifications."

illustrative of the lecturer's remarks.

The prizes won on the occasion of the Society's field day on July 19th were presented by Mr. Fogarty, who had also kindly acted as judge.

Mr. Donaldson received a handsome variable transmitting condenser, kindly given by Messrs. Dubilier Condenser Co., for his most efficient all-round station.

Mr. C. L. Thompson was awarded a pair of headphones, given by Mr. Fogarty, as a consolation prize.

The receiver tuning competition was won by Mr. Lynn, the prize consisting of a variable condenser, given by Messrs. Clark & Co., of Manchester. The winner of the Morse competition was Mr. C. L. Thompson, who received an ultra short-wave tuner, given by Messrs. Perrane & Co.

There still exist a few vacancies for new members, and applications for further particulars should be made at once to the Hon. Secretary, Mr. J. W. T. Crewe, 111, Princes Park Avenue, Golders Green, N.W.11.



A Review of the Latest Products of the Manufacturers.

BENJAMIN VALVE HOLDER.

During the past two years valve holder design has steadily developed and the type now which is universally adopted is one

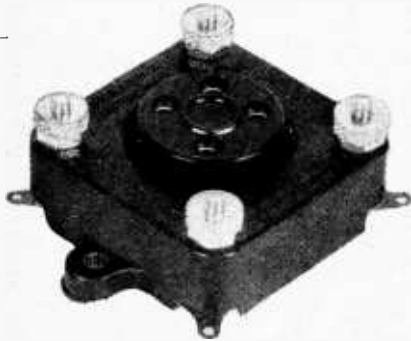

Benjamin anti-microphonic valve holder.

which can be screwed down to a wooden baseboard in the receiving set so that the valve is totally enclosed and behind the panel, and in which provision is made to prevent the transmission of mechanical shock to the filament.

The new valve holder, produced by the Benjamin Electric Co., Ltd., Brantwood Works, Tariff Road, Tottenham, N.17, is made in two pieces, one of which is the valve holder proper and the other a support carrying the terminals and fitted with extensions for screwing down. Four coiled spiral springs attach the valve holder to the mounting piece and render it perfectly free to vibrate. A most important feature is that the valve sockets, the springs and the connecting tags are all formed from one piece of metal, entirely removing any chance of intermittent contact occurring as may result when separate springs are linked between the tags and the sockets. The mouldings are particularly clean, giving the valve holder



The one-piece valve socket, spring and tag used in the construction of Benjamin valve holders.

B 40

an attractive appearance. The insulation and dielectric properties of this valve holder can be relied upon, as bakelite is used as the insulating material. It is a component which is likely to become very popular in amateur constructional work.

o o o o

NEW AMPLION LOUD-SPEAKERS.



New Amplion loud-speakers, types R S.1 and R.S.10.

The accompanying illustrations show two of the new type Amplion loud speakers. These instruments are undoubtedly attractive and the sound cavities have been carefully designed to maintain faithfulness of reproduction.

USEFUL RANGE OF BOX SPANNERS.

For tightening up small nuts, particularly those of the small B.A. sizes, there is no better method than to employ a box spanner.

A useful range of tubular spanners has been introduced by Fullers' United Electric Works, Ltd., Woodland Works, Chadwell Heath, Essex, in which a useful modification to the usual model of box spanner has been made. A slot is made in the side of the spanner through which a spring wire passes with sufficient pressure to make contact with one face of the nut, thus holding it in the small spring wire is fitted to retain the nut in the end of the spanner. The usefulness of this arrangement will be at once appreciated by the amateur constructor.

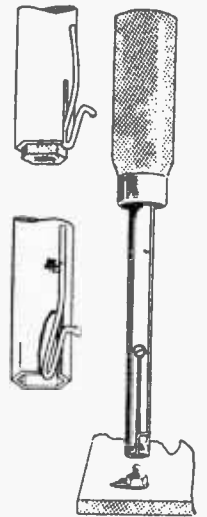

Box spanner for small B.A. nuts, in which a holding it in the small spring wire is fitted to retain the nut in the end of the spanner.

o o o o

SPADE TERMINAL WITH PLUG AND SOCKET CONNECTION.

Messrs. J. J. Eastick and Sons, 2, Dunstan's Hill, London, E.C.3., have recently introduced a spade connector fitted with a plug on which the flexible



Eastick spade terminal with plug connec'or

wire is terminated. By this modification terminal connections are converted to the plug and socket system. This useful accessory will probably find many applications when constructing and improvising experimental apparatus.

MAGNUM WANDER PLUG.

By connecting a spool of resistance wire in one of the leads from the high tension battery, accidental damage to the battery by short circuit is avoided, whilst the value of the resistance can be sufficiently high to limit the current to a value insufficient to burn out valve filaments. The resistance is best placed in circuit close up to the terminals of the high tension battery, and when wander

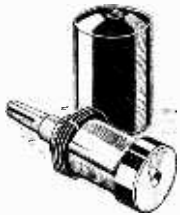

Magnum wander plug.

plugs are employed they can with advantage take the form of a spool of wire enclosed in the insulating handle of the plug. A plug of this type is manufactured by Messrs. Burne-Jones and Co., Ltd., Magnum House, 296, Borough High Street, London, S.E.1. It is well made and intended to replace one of the wander plugs of the high tension battery.

o o o o

STRAIGHT LINE FREQUENCY CONDENSER.

The first straight line frequency condenser to become available is now obtainable from Messrs. R. A. Rothermel, Ltd., 24 and 26, Maddox Street, Regent Street, London, W.1.

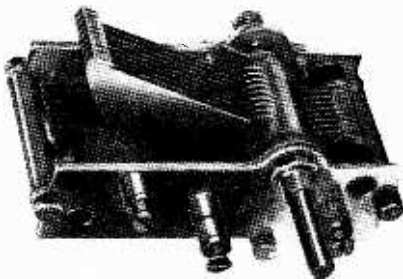

Straight line frequency condenser, obtainable from R. A. Rothermel, Ltd.

It is a well-constructed American product and electrically, as well as mechanically, the design leaves no room for criticism. The moving plates are in contact with the end mounting pieces, whilst the fixed plates are supported by insulating pieces in a manner that provides the best distribution of the electrostatic field. All plates are well bonded together and soldered into slots. The unusual shape of the moving plates can be seen in the illustration, and improved rigidity is obtained by the bridging piece which can be seen on the extreme end. It is probable that condensers of the straight line frequency type will, before long, be generally adopted.

VERNIER CONDENSER CONTROL.

Among the several systems of gearing now applied for obtaining critical condenser adjustment, the new component introduced by The Silvertown Company, Silvertown, London, E.16, is of particular interest. It can be fitted to almost any type of variable condenser, and consists of a toothed brass wheel, equal in diameter to the dial of the condenser, and

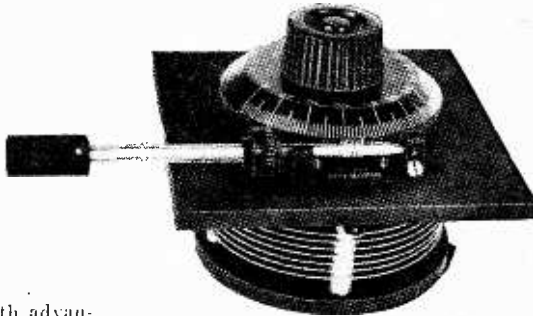

The Verniometer reduction gearing, a product of The Silvertown Company.

a bracket which serves as a bearing to a spindle carrying a worm wheel. The spindle is fitted with an engraved scale which provides a calibrated sub-division of the degrees on the condenser dial. For rapid adjustment the worm wheel can be taken out of mesh, or can be dropped into position, remaining against the edge of the toothed wheel by a snap action. Not only is the design ingenious, but this useful component possesses a high-class instrument finish.

o o o o

THE GRIPSO EARTHING CLIP.

A spring metal earthing clip of simple construction is manufactured by Messrs. L. H. Reid & Co., 52, Victoria Street, London, S.W.1. It is fitted with a terminal for attachment of the earth lead, while a pair of points on the inner face are provided to give good contact.



The "Gripso" push-on earthing clip.

This clip is convenient for rapidly making contact with a clean pipe.

o o o o

NEW SPADE TERMINAL.

An interesting spade terminal which we have had an opportunity of examining is that manufactured by Messrs. Partidges, Ltd., 115, Northwood Street, Birmingham.

It will be seen from the diagram that a small chuck is provided to grip the end of the connecting wire. This consists of a rotating sleeve, in the end of which is

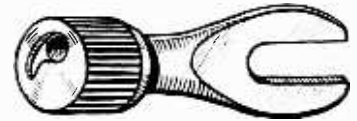

Spade terminal with rotating sleeve for gripping the connecting wire.

cut a tapering and eccentric hole. With the sleeve turned to the left the largest part of the tapering hole coincides with a circular hole in the shank of the terminal. The wire is then inserted and the sleeve turned to the right, when the connecting wire will be firmly gripped.

The wire shows no tendency to work loose, and the terminal is suitable for holding both solid and flexible wire.

o o o o

IGRANIC VARIABLE CONDENSER.

The majority of readers are probably already acquainted with the general appearance of the new type variable condenser made by the Igranic Electric Co., Ltd., 147, Queen Victoria Street, London, E.C.4. The moving plates, which are of brass, are held in position on the spindle by means of a pin, whilst the shaft itself is tapered and slotted, producing a very rigid form of mounting. The small well-finished ball race acts as a thrust bearing at one end of the spindle. Connection is made to the spindle by means of a spiral connector recessed into one of the adjusting nuts. The fixed plates are supported at two points only, and attached by means of brackets to pieces of ebonite rod held between screws in the end plates.

The condenser is fitted with a large diameter dial of attractive appearance, which is held in position on a plain shaft

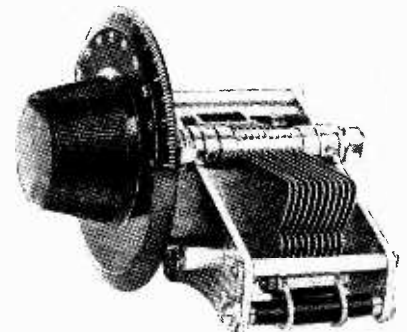

New type Igranic variable condenser.

by means of a grub screw. The system of one-hole mounting, which has become so popular, is not made use of, and a very secure fixing is obtained by means of three screws, the process of mounting being quite easy with the aid of a template which is supplied.

DICTIONARY OF TECHNICAL TERMS



Definitions of Terms and Expressions commonly used in Wireless Telegraphy and Telephony.

This section will be continued week by week and will form an authoritative work of reference.

"A" Battery. American term for the low voltage battery or accumulator used for heating the filaments of *thermionic tubes*, i.e., the *low tension battery*. Cf. "B" BATTERY.

Absolute Units. Units based upon the fundamental or primary units of Length, Mass and Time in the C.G.S. System, namely, on the Centimetre, the Gram, and the Second. Two systems of electrical units have been evolved based respectively on the electrostatic relations and the electromagnetic relations of the various quantities in electricity and called electrostatic units and electromagnetic units respectively. The practical units are convenient multiples or sub-multiples of the absolute units. *E.g.*, 1 volt = 10^8 electro-magnetic units or $1/300$ electrostatic units of *potential*.

Absolute Unit of Current, E.M.F., Resistance, etc. See CURRENT, E.M.F., RESISTANCE, etc.

Absorption (dielectric). When a condenser is charged the insulating medium between the plates is subjected to the influence of an *electric field*, and it is found that all media, other than gases, do not instantaneously acquire their maximum induction in an electric field. If a Leyden Jar or other condenser with solid *dielectric* be given a charge and its potential be measured by means of an electrometer, it will be found that the potential will fall for some time, but will eventually become constant. On discharging the condenser, the whole of the charge does not disappear immediately; successive discharges, gradually getting smaller, may be obtained, and are known as "residual charges." This time-lag in charging and discharging is said to be due to the absorption of part of the charge by the dielectric.

The phenomenon is very similar to that exhibited by various substances, such as glass, when subjected to torsional strain, and may thus be considered as a sort of imperfect electric elasticity. It is interesting to note that gases, which have perfect mechanical elasticity, do not exhibit any dielectric absorption and that, amongst solids, quartz (used for galvanometer suspensions) has the most perfect mechanical elasticity, and shows also the least dielectric absorption. The standard air condenser of the Bureau of Standards has the two sets of plates supported on quartz pillars.

When an alternating potential difference is applied to the plates of a condenser, the absorption causes a certain loss of energy (dielectric hysteresis) per cycle. Since the absorption depends on the time of charging, it follows that the dielectric losses due to absorption decrease with increase of frequency, and therefore these losses in a condenser become smaller as the wavelength is shortened. It is more important to guard against absorption losses in a condenser for use on long wavelengths than on short ones.

A.C. See ALTERNATING CURRENT.

Accumulator. A battery of storage cells or *secondary cells*. See SECONDARY CELL.

Acidometer. A hydrometer for measuring the *specific gravity* of accumulator acid.

Acoustic Waves. Ordinary sound waves in a gas, liquid, or solid, propagated by successive compressions and rarefactions of the medium. The velocity depends on the elasticity and density of the medium, being 1,090 ft. per second in air at 0° C., and barometer pressure of 30 inches of mercury.

Active Current. In-phase component or power component of an alternating current. The product of this current and the voltage give the *true power*. See ALTERNATING CURRENT and PHASE DIFFERENCE. Cf. WATTLess CURRENT and APPARENT POWER.

Active Material (of accumulator). That portion of the plates which is acted upon and changed chemically during charging and discharging. See SECONDARY CELL.

Adapter. An accessory which enables an extension lead to be run from an ordinary lamp holder. See VALVE ADAPTER.

Adjustable Condenser. See VARIABLE CONDENSER.

Admiralty Unit. Another term for the *Jar* unit of capacity. Equal to 0.0011 *microfarad*.

Admittance. The reciprocal of *Impedance*. It is a measure of the extent to which a circuit allows an alternating current to pass through it, being equal to the current divided by the voltage, irrespective of the *phase* relations. The unit of Admittance is the MHO. See and compare CONDUCTANCE.

Aerial. The system of wires or conductors suspended at a certain height above the ground and insulated there-

from except for a connection to *earth* (or Counterpoise) through certain components of the sending or receiving apparatus forming a direct path for *radio frequency oscillations* between the elevated wires and the earth. It is the elevated portion of the *antenna* used for radiating or receiving electrostatic and electromagnetic *ether waves*. See ANTENNA.

Aerial: Artificial, Balancing, Cage, Directional, Fan, Frame, Inverted "L," Loop, "T," Umbrella, Unloaded. See ARTIFICIAL AERIAL, BALANCING AERIAL, etc.

Aerial Circuit. The direct circuit through which the high frequency oscillations pass between *aerial* and *earth*. The circuit includes aerial and earth and all coils, condensers, instruments, etc., which make up the complete circuit.

Aerial Insulation. Refers to the insulation between the wires of the aerial and their supports, and not to any covering which the wires may possess. The wires are usually bare.

Aerial Insulators. Insulators made of porcelain, glass, or other insulating material, used for connecting the aerial mechanically to its supports but at the same time separating it electrically. To be effective the insulators must be so shaped as to reduce the surface leakage in wet weather to a minimum, and at the same time to be capable of withstanding considerable mechanical stress. The outside surfaces should be highly glazed in order to limit the deposition of conducting material such as soot.

Aerial Resistance. The resistance offered by an aerial system to the passage of high frequency currents is not a simple *ohmic resistance*, but is made up of three separate components. When an oscillatory current flows in the aerial system of a transmitter, the power delivered to the aerial is given by I^2R , where R is the effective resistance and I the aerial current.

The effective resistance may be split up into three components as follows:— (a) Radiation resistance, (b) Equivalent resistance accounting for *dielectric losses*, and (c) Ohmic resistance. Multiplying each of these by the square of the current gives respectively (a) the useful power radiated into space, (b) the dielectric losses, and (c) the power converted into heat in the wires themselves.

Dictionary of Technical Terms.—

The aerial resistance is not a constant quantity, but varies with the wavelength of the oscillations, usually having a maximum value at some particular wavelength. Taking the components separately, it is found that the ohmic resistance is fairly constant at all wavelengths; the radiation resistance reaches a sharp maximum at the *natural wavelength* of the aerial, and the dielectric losses are roughly proportional to the wavelength.

The most efficient aerial is that in which the radiation resistance is high compared with the ohmic resistance and dielectric losses. This applies both to transmitting aerials and to receiving aerials.

Aerial Switch. A change-over switch by means of which the aerial is connected either to the sending apparatus or to the receiving apparatus as required.

Aerial Tuning Condenser and Aerial Tuning Inductance. A variable condenser or inductance connected in the aerial circuit for the purpose of varying the *oscillation constant*; i.e., for *tuning* the aerial circuit to respond to a particular frequency or wavelength. Sometimes both are varied simultaneously, but it is more usual to have a variable condenser in conjunction with a fixed or tapped aerial coil.

Aether. See ETHER.

Air Condenser. A condenser of either variable or fixed *capacity* in which the *dielectric* or insulating material between the plates consists of air at ordinary atmospheric pressure. See also COMPRESSED AIR CONDENSER.

Air-Core Choke or Transformer. A choking coil or transformer whose *magnetic circuit* contains no iron or other magnetic material. An air-core choke is usually included in a circuit to offer a high *impedance* or opposition to the passage of *high frequency* current and a low impedance to current of *low frequency*. See CHOKING COIL AND TUNED ANODE.

Air-core transformers are used mostly for high frequencies, e.g., for transferring radio frequency energy from one valve to the next in a *radio frequency amplifier*. Used for low frequencies only in cases where it is necessary to maintain a constant *mutual inductance* between the two windings. See TRANSFORMERS and HIGH FREQUENCY TRANSFORMER.

Air Gap. In a magnetic circuit consisting of iron a gap is sometimes included in such a position that the *lines of magnetic force* have to pass a short distance through air. This is done so that the relationship between *magnetising ampere turns* and *magnetic flux* shall obey more approximately a linear law, i.e., to make the flux more nearly proportional to the *magnetising current*. This principle is sometimes applied to *interval transformers*.

The inclusion of the air gap considerably increases the *reluctance* of the magnetic circuit, and a greater

number of ampere-turns are required to produce the same *flux density*. An air gap results in the production of magnetic poles, N, S; one on each side of the air gap, which exert a *demagnetising* effect, and so reduce the *residual magnetism* to a minimum when the magnetising current is switched off.

Air Wires. Wires forming the elevated part of an *antenna*.

Alexanderson Alternator. A high-speed, high-frequency alternator used for supplying the high frequency currents in some high power *continuous wave* transmitting stations. The machine is of the *inductor type*, and can be made to give wavelengths from 3,000 metres upwards.

Alternating Quantity. An electric or magnetic quantity, such as current, voltage, flux, etc., which reverses its direction at regular time intervals, reaching successively the same maximum value in each direction, and repeating the same cycle in regular manner, is said to be "alternating" (as opposed to "continuous"). See ALTERNATING CURRENT.

Alternating Current (A.C.). An alternating current is one which flows first in one direction and then in the opposite direction round a circuit alternately. One way round the circuit is taken as positive and the other as negative. The time intervals for the two directions are usually equal, and the instantaneous values of the current are equal in magnitude but opposite in direction after the expiration of equal fractions of the intervals. Alternating E.M.F.'s and magnetic fluxes may be defined in a similar manner.

The sequence of values attained by the current in passing through one complete set of positive and negative values is called one *Cycle* (or *WAVE*, when the current is plotted as a graph to a time base). The time of one complete cycle is called the *PERIOD* or *PERIODIC TIME*, and the number of cycles passed through in one second is called the *FREQUENCY* or *PERIODICITY*.

The ideal alternating current is one which obeys a *sine law*, i.e., one which gives a *sine wave* when plotted as a graph. This is sometimes called a "Simple Harmonic Law." The instantaneous value of a sine wave of current is given by $i = I \sin 2\pi ft$, which $I =$ maximum value reached by the current, $f =$ the frequency in cycles per second, and $t =$ the time in seconds measured from the instant the current passes through its zero value and is increasing towards a positive value.

The *Effective Value* or *Virtual Value* of an A.C. is defined as the value of the continuous current which would have the same average heating effect in a given fixed resistance. Since the heating at any instant is given by $i^2 R$,

where i is the current at that instant and R is the resistance, it follows that the effective value of i will be $\sqrt{\text{mean value of } i^2}$. The effective value is for this reason sometimes called the "Root-Mean-Square" value (R.M.S. value). For sine waves the effective

value is $\frac{1}{\sqrt{2}}$ or 0.707 times the maximum value.

When two alternating quantities such as E.M.F., and current pass through their zero values at the same instant, and have their maximum positive values at the same instant, they are said to be "in phase." In all other cases they are "out of phase" (see PHASE DIFFERENCE).

Alternating Current Circuits. The relationship between voltage and current in an A.C. circuit depends not only upon the resistance of the circuit as in the case of *direct current*, but also upon the *inductance* and *capacity* of the circuit and the frequency of the current. (a) Only in the case of a circuit possessing pure resistance without the presence of inductance and capacity, is the current given by the voltage divided by the resistance (Ohm's Law) and the *true power* by the product of volts and amperes as for direct current. The same conditions as for D.C. hold here because the current and voltage are *in phase*.

(b) In a circuit possessing pure inductance without the presence of resistance and capacity, the current is given by $A = V / 2\pi f L$, where A and V are the *effective values* of the current and impressed voltage respectively, f is the frequency and L is the inductance in *henries*. The quantity $2\pi f L$ is called the "Reactance" (X) of the circuit and is measured in ohms. The current in this case lags behind the voltage by 90° (see PHASE DIFFERENCE). For a *condenser*, $A = 2\pi f C \times V$, where C is the capacity in *farads*, and the current leads the voltage by 90° . The

"Reactance" in this case is $\frac{1}{2\pi f C}$ ohms, and is sometimes called "Capacity Reactance," being negative with respect to "Inductive Reactance." When a circuit contains both inductance and capacity in series the resultant reactance is equal to $2\pi f L - \frac{1}{2\pi f C}$ ohms.

(c) In the general case where the circuit possesses both resistance and reactance in series the current is driven by

$$A = \frac{V}{\sqrt{R^2 + X^2}}$$

and is *out of phase* by an angle less than 90° . If the reactance is due to inductance the current lags, and if due to capacity it leads the voltage. The *tangent* of the angle of phase difference is equal to the ratio of reactance to resistance. The ratio of volts to amps. is known as the *Impedance* (Z) of the circuit, so that for the case considered, $Z = \sqrt{R^2 + X^2}$ ohms. (See POWER IN A.C. CIRCUITS.)

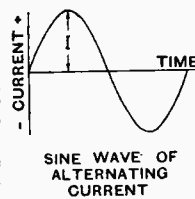

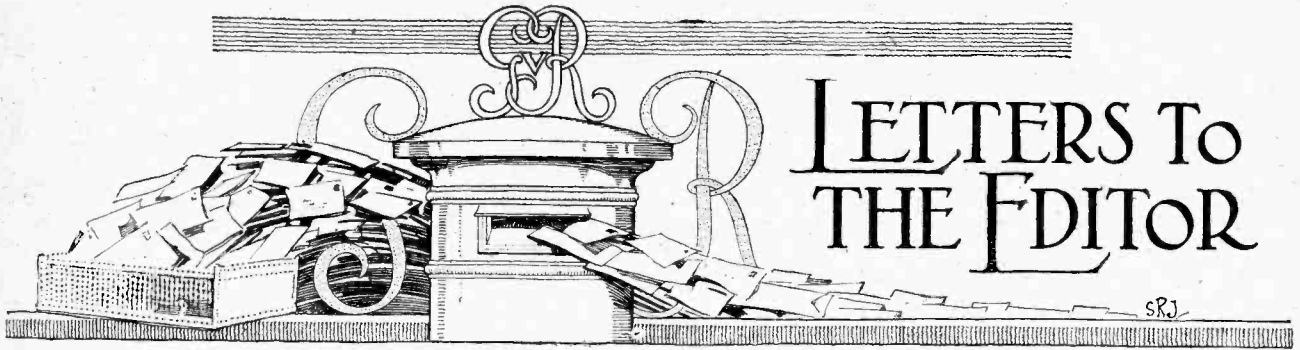

The Editor does not hold himself responsible for the opinions of his correspondents.

Correspondence should be addressed to the Editor, "The Wireless World," 139-140, Fleet Street, E.C.4, and must be accompanied by the writer's name and address.

SUPERSONIC v. NEUTRODYNE.

Sir,—Captain Round's letter in your issue of September 23rd removes a misunderstanding on my part of the significance of the paragraph which he himself quotes from his article, but I think in all fairness Captain Round must admit that the paragraph in question is a trifle misleading.

I am bound to confess that I concluded from what he had written that to construct a good supersonic heterodyne receiver it was necessary to precede the beat tone filter by a high-frequency filter which would reduce a near-by wave to $\frac{1}{1000}$ part of its intensity. This conclusion was depressing in the extreme, as the significance was apparently that a supersonic receiver was ineffective unless preceded by an equally selective neutrodyne.

I take it, from a perusal of Captain Round's letter, that the manoeuvre of "dodging from one position of the heterodyne to the other" is to be regarded as legitimate tactics in the case of a near-by station; at any rate I think that without this possibility even the two tuned H.F. circuits he specifies would be insufficient protection.

On this basis I am entirely in agreement that there are occasions on which something must be done to improve the selectivity of a plain supersonic set, and the reduction of a "second-channel" station to $\frac{1}{75}$ of its intensity at a corrected tuning is an excellent basis of reckoning which Captain Round has put forward.

With regard to the ways and means for attaining such selectivity I am bound to say that I prefer a high-frequency tuner with the usual "tune-stand by" arrangement to one in which both high-frequency circuits are always operative. I have spent a whole evening here working with a supersonic set having a considerably lower intermediate frequency than that specified by Captain Round, and have received a very considerable number of British and Continental stations without the slightest difficulty from "second-channel" interference. In this case the type of aerial I described in my previous letter is of great service, and presents no difficulties of construction which are worth considering in comparison with that of a mechanical connection between two condensers. At the same time, should a troublesome interference arise, a secondary circuit is available which will give an even greater selectivity than Captain Round's flat-tuned anode circuit.

Bedford.

P. W. WILLANS.

EARLY ELECTRICAL WIRE TRANSMISSIONS.

Sir,—Referring to a statement in the article on "Photograph Transmissions by Wire and Wireless," in your issue of August 5th, perhaps I may point out, as my father, the late F. C. Bakewell, invented the copying electric telegraph, that this was shown to the Prince Consort at Buckingham Palace in 1850, when excellent transmissions of his signature and of messages were effected. Later transmissions were carried out between London and Paris, and *vice versa*, and for the specimens exhibited at the Great Exhibition of 1851 my father was awarded the Council Medal.

B 44

The messages were written with non-conducting varnish and received electrically on specially prepared paper on the receiving instrument, the synchronisation of the sending and receiving cylinders being essential.

My father, Frederick Collier Bakewell, and not Mr. Bain, was the inventor. ARMITAGE BAKEWELL.
Plymouth.

"APERIODIC" AERIAL CIRCUIT.

Sir,—In the course of experimenting I have come across a circuit which I send herewith for the benefit of your readers, and which, I think, is rather novel; at any rate I cannot recall having seen anything like it. It will be seen that the grid coil is the secondary and is not connected electrically to the aerial, which is "aperiodic."

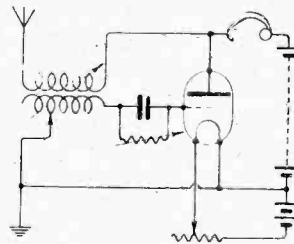

Aperiodic aerial circuit used by Mr. Reading.

I find with my aerial, which is about the average, that a tapped inductance with a total of, say, 80 turns in the secondary or grid coil gives loudest signals. The primary or aerial coil, connected direct to the anode, may be any size, according to coupling; in my case a No. 75 gives best results. It is better without a condenser across the telephones. The positive side of L.T. is earthed, but for broadcasting or short waves I get better results if the battery is disconnected altogether from earth.

Of course, in place of a tapped coil a No. 75 plug-in coil can be used, tuned with a 0.0005 mfd. condenser.

With larger coils 5XX comes in very well, but the L.T. battery must be earthed.

F. READING.

Manchester.

AMATEUR MORSE.

Sir,—With regard to the letter of G2BAS, I think all of us who are really trying to carry on some form of investigation, and not merely exchanging messages, will most heartily agree that well-spaced keying at 10-12 wpm, with QSZ in addition, usually saves time in the end and makes for accuracy. High speed keying is all very well for school-trained operators on the lower frequencies; but most of us have "picked up" our morse in more or less unorthodox ways, and we are operating in conditions where QSS and QRM in violent forms have to be contended with. If we want reports—and to most of us they are essential—slow sending and good spacing must be the rule. In answering "Test" and "CQ" calls it often pays to slow right down to 5 wpm. A steady slow call attracts attention when a faster one does not. That is one of the reasons why SOS is sent at five wpm by International rule.

Pirbright, Surrey. ERNEST H. ROBINSON (G5YM).

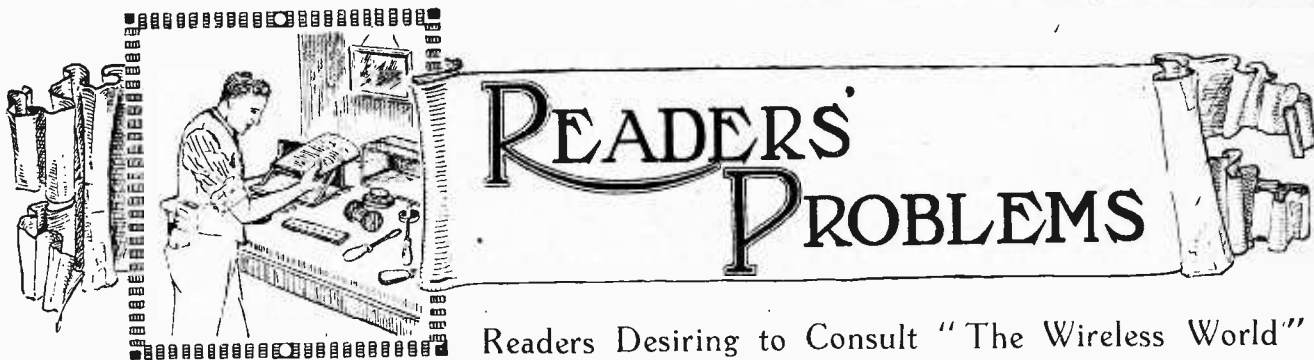

Readers Desiring to Consult "The Wireless World" Information Dept. should make use of the Coupon in the Advertisement Pages.

Volume Control.

I have attached a two-valve amplifier to my crystal set for loud-speaker work, but volume is slightly too great; but when one valve is cut out, signals are not nearly strong enough. How can I best control the volume from the two valves?

W.R. (Elstree).

One method would be to connect a variable grid leak of reliable type across the secondary of your second transformer. A second method would be to use a loose-coupled tuner in conjunction with your receiver. By this latter method interference could be minimised. On no account attempt to control volume by "detuning" or reducing your values of H.T. and L.T.

○○○○

Adding H.F. to a Superheterodyne.

Please criticise the attached diagram, which shows my effort at adding a high frequency amplifier to my superheterodyne. It has been a failure.

H. B. (Sheffield).

Our correspondent shows a tuned transformer of comparatively low resistance used as a coupling between the H.F. valve and the first detector. His failure to obtain results is almost certainly due to the fact that the former valve is oscillating. The damping of the circuits as shown by him, using a frame aerial, is low, and either artificial damping or balancing must be resorted to.

An untuned high resistance transformer could be used, or a better course would be to add a stage of neutralised high fre-

quency amplification. This will add another tuning control, which, however, from the operating point of view, might well be made fairly flat, by using fine wire coils. With this modification, neutralised transformers as described on page 370 of our issue dated September 16th, 1925. A circuit diagram is given in Fig. 1.

The grid return lead of the frame circuit, as shown by our reader could, of course, be connected through a potentiometer to L.T., thus stabilising the set, but we are sure that either of the other two alternatives suggested above would be productive of better results.

○○○○

Long-wave Neutrodyne.

I am thinking of constructing a neutrodyne receiver with provision for the insertion of loading coils for the reception of 5XX. Would this be better than to use interchangeable transformers? C.L.B. (Coulsdon).

The first alternative suggested would seem to be rather impracticable, while the second will, unless the design is carried out with extreme care, introduce complications. We would strongly recommend this reader, and others who wish to make or adapt standard neutrodynes for the longer waves, to confine themselves at present to the 250-550 metres waveband. At a later date, when it is felt that the receiver is thoroughly understood, one may begin to experiment in this direction. Incidentally, when comparing American and British designs, one should remember that the engineers of the former country have only concerned themselves with the usual broadcast waves.

Should it be regarded as essential that the receiver operates on the longer waves, our correspondent is referred to the article "H.F. Amplifier Design" in the issue of September 16th. The balanced H.F. amplifier-detector there is to be recommended. A one- or two-valve low fre-

quency amplifier may, of course, be added for loud-speaker work.

○○○○

A Short-range Loud-speaker Receiver.

I am situated less than 300 yards from 2LO. My crystal set already gives signals easily audible on a loud-speaker, but not quite loud enough for comfortable listening. Please recommend a simple circuit, using one valve and a good L.F. choke already in my possession, which will give the slight extra volume required. I wish to be able to still use the headphones, sometimes with and sometimes without the valve.

W.T.J. (London, W.)

The circuit given in Fig. 2 might be tried. The valve should be of a

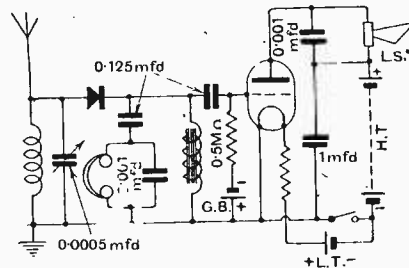

Fig. 2.—Crystal receiver with choke couple valve amplifier.

type capable of handling a fair amount of power, and having at the same time a good magnification factor.

○○○○

Accumulator Troubles.

My accumulator, which has given satisfactory service for several months, has suddenly commenced to froth. Can you give me any indication of the cause and cure?

H.A. (Hoxton).

The cause is due to certain impurities in the electrolyte, probably caused by "topping" with household tap water instead of using distilled water. The remedy is to empty away the electrolyte and thoroughly wash out the accumulator with distilled water, afterwards refilling with fresh electrolyte.

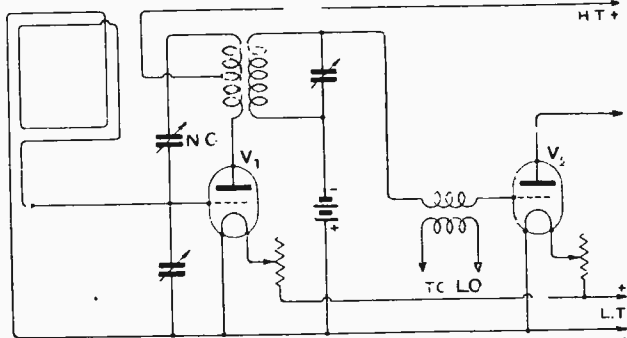

Fig. 1.—Neutralised stage of H.F. amplification preceding a superheterodyne receiver

Distant Control of Receiver.

I have constructed a set for loud-speaker work on the local station only and wish to place it upstairs near the lead-in. In order to switch on or off downstairs, can I extend the L.T. leads? W.D.B. (Twickenham).

The filament leads should not be extended, otherwise they will act as a counterpoise, and certainly in the case of some valves the voltage drop in the leads may be sufficient to necessitate the employment of a higher voltage accumulator. The correct procedure is to use a suitable relay.

o o o o

A Simple Two-valve Receiver with Jacks.

I require a moderately selective two-valve receiver (det. and L.F.), capable of working a loud-speaker on 2L0, and perhaps 5.X.X. Please give a circuit using plug-in coils, also jacks to change from one to two valves. Will this set give really sufficient volume, and also bring in other stations? I already have 120 ohm loud-speaker and headphones.

L.F.G. (Teddington).

Fig. 3 shows a suitable circuit. When the plug is withdrawn, both filaments are switched off. A simple tune-standby switch is fitted. If good components and suitable valves are used, sufficient volume for an ordinary room will be obtained from the local station, and, under moderately favourable conditions, particularly after dark, other

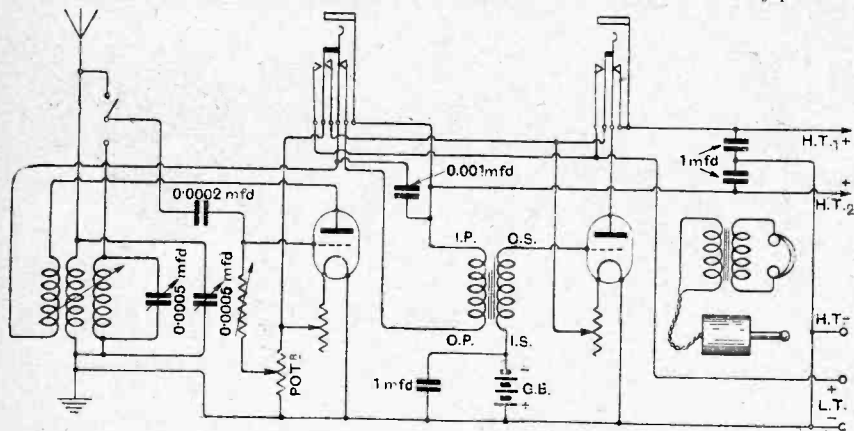

Fig. 3.—Two-valve broadcast receiver with jack switchings.

stations may be received on headphones. An output telephone transformer will, of course, be required for the low resistance loud-speaker or phones, and is shown connected to the plug.

Dry Cell L.T. Battery.

Is it possible to operate a small power valve consuming 0.25 amp. at 6 volts from dry cells?

R.A. (Manchester).

It is certainly possible to do this by obtaining four dry cells of the type recommended for use with the one-volt type of dull-emitter. The four cells should, of course, be connected in series. An accumulator would however, give more satisfaction.

BOOKS FOR WIRELESS BEGINNERS

Issued in conjunction with "The Wireless World."

"YOUR FIRST STEPS IN WIRELESS," by HUGH S. POCKOCK. Price 9d. net. By Post, 11d.

"WIRELESS TELEPHONY," by R. D. BANGAY. Price 2/6 net. By Post, 2/9.

"THE WIRELESS TELEPHONE," by P. R. COURSEY, B.Sc. Price 2/6 net. By Post, 2/9.

"CAPT. ECKERSLEY EXPLAINS," by CAPT. P. P. ECKERSLEY. Price 2/- net. By Post, 2/2.

"UNCLE JACK FROST'S WIRELESS YARNS ON GOOD RECEPTION AND HOW TO GET IT," by CAPT. C. C. J. FROST. Price 2/- net. By Post, 2/2.

"DICTIONARY OF TECHNICAL TERMS USED IN WIRELESS TELEGRAPHY," by HAROLD WARD. Price 2/6 net. By Post, 2/8.

Obtainable by post (remittance with order) from **ILIFFE & SONS LIMITED,** Dorset House, Tudor St., London, E.C.4, or of Booksellers and Bookstalls.

The By-pass Condenser.

I notice that in many published circuit diagrams a large fixed condenser is shown connected across the high-tension battery, while in others it is omitted. Is there any rule for this? J.W.S. (Bristol).

It may be taken that any set is improved by the addition of a by-pass con-

denser, the function of which is to afford a low resistance path to high- or low-frequency currents which would otherwise have to pass through the high tension battery. When new, the resistance of this latter is, or should be, negligible, and the shunting condenser is admittedly almost unnecessary. As the battery ages, its resistance may increase to quite a high value. It is merely for convenience in drawing diagrams that the condensers are sometimes omitted.

A study of the circuit diagram of certain types of multi-valve amplifier will show that voltages due to incoming signals would be set up across the high resistance battery and applied to the other valves in a manner not intended by the designer.

The need for providing an alternative path of low impedance is therefore apparent. The shunting condenser may have a capacity of 1 mfd. or more, but if only high frequency currents are being dealt with, 0.01 mfd. is sufficient.

o o o o

The Untuned Aerial.

Is there any real advantage in tuning the aerial circuit? I am surprised to see that an increasing number of modern receivers make use of the untuned system, and would expect a loss of efficiency.

M.V.H. (Cambridge).

Carefully conducted tests tend to show that, as far as the middle and lower broadcasting wavebands are concerned, there is very little, if any, advantage, as far as signal strength is concerned, in separately tuning the aerial circuit. The need for tuning, however, increases rapidly with the wavelength, and the method is unsuitable for waves over 600 metres.

A factor to be considered is that of practicability, and if a receiver can be made almost as efficient with one less control, it is likely to give better results in operation.

o o o o

H.T. from D.C. Mains.

One hears conflicting opinions as to the possibilities of using D.C. mains as H.T. supply. I am on a 110-volt circuit which is reputed to be noisy. I should like your views on the subject before embarking on the construction of a filter circuit unit. I use a crystal detector and two L.F. valves for reception of the local station only. H.L.S. (London).

It may be said that, broadly speaking, very satisfactory results may be obtained from this source of H.T. supply, although certain precautions must be taken. In the first place, a double filter with two chokes and three condensers is generally necessary. As there is often a difference of potential between the earthed main and the set "earth" it is necessary to use either a counterpoise or to use the mains as earth, for which purpose they are adequate when dealing with a strong signal. From the point of view of absolute quietness, this would seem preferable to the other expedient of connecting a large condenser in the earth lead. A set such as our correspondent describes should be admirably suited to this method, and we can recommend its adoption with considerable confidence. Main H.T. supply seems to be generally unsuitable for detector and H.F. valves. Luckily, these are generally of a type taking low anode currents, and can be adequately fed from dry batteries at a not too heavy expense. A very practical arrangement is to combine the two sources of supply, using the mains only for the L.F. valves. Our experience tends to prove that this source of supply works best when a crystal detector is used. Under suitable conditions it is impossible to hear any commutator hum, even with the ear near the loud-speaker.

The Wireless World

AND RADIO REVIEW

No. 322.

WEDNESDAY, OCTOBER 14, 1925.

VOL. XVII. No. 16.

Assistant Editor:
F. H. HAYNES.

Editorial Offices: 139-40, FLEET STREET, LONDON, E.C.4

Advertising and Publishing Offices: DORSET HOUSE, TUDOR STREET, LONDON, E.C.4

Telegrams: "Ethaworld, Fleet, London."

COVENTRY: Hertford Street.

Telegrams: "Cyclist Coventry."
Telephone: 10 Coventry.

Subscription Rates: Home, £1 1s. 8d.; Canada, £1 1s. 8d.; other countries abroad, £1 3s. 10d. per annum.

As many of the circuits and apparatus described in these pages are covered by patents, readers are advised, before making use of them, to satisfy themselves that they would not be infringing patents.

Editor:
HUGH S. POCOCK.

BIRMINGHAM: Guildhall Buildings, Navigation Street.

Telegrams: "Autopress, Birmingham."
Telephone: 2970 and 2971 Midland.

Assistant Editor:
W. JAMES.

Telephone: City 4011 (3 lines).

Telephone: City 2847 (13 lines).

MANCHESTER: 199, Deansgate.

Telegrams: "Liffe, Manchester."
Telephone: 8970 and 8971 City.

OUR INFORMATION SERVICE.

EXPERIENCE shows that it is a difficult if not impossible task to attempt to cover, solely by means of the articles appearing in this journal, all the likely problems with which a reader may be faced in the course of his experiences. On this account an information bureau may be regarded as an essential feature of the service which a wireless journal should provide for the benefit of readers.

Readers' Problems.

The *Wireless World* devotes a section to "Readers' Problems," and under this heading individual enquiries are treated, but only those which are of general interest receive publication. It has been our custom to deal with any question sent in by readers, and to forward the replies through the post, charging a nominal fee. This service has necessarily entailed a great deal of work, but we appreciate its importance to the reader, and our view is that our association with the reader should not end with the publication of the journal, but that we should give the utmost service possible in addition.

With this end in view, we have made special arrangements and have extended our information department so as to enable us to deal through the post with future readers' questions sent in to our Information Department without making any charge.

A Free Service.

We shall continue, as in the past, to publish such

questions and replies as in our opinion are of general interest, and, in addition, every question will receive a reply through the post.

In order to assist us in carrying out this work to the satisfaction of all readers, we hope that readers in turn will co-operate with us by wording their questions as

concisely as possible, and only one question should be sent in at a time, whilst each enquiry should be accompanied by a stamped addressed envelope.

o o o o

WIRELESS EXHIBITION.

THE Royal Horticultural Hall, where the products of no fewer than fifty manufacturers of wireless equipment and allied apparatus are to be seen, is again this year attracting the wireless amateur.

In addition to elaborate receiving sets, which are perhaps less in evidence here than at other exhibitions, the liberal display of new and original components is making a strong appeal. A selection is made from the exhibits, and the more interesting are described in detail elsewhere in this issue. Among the exhibitors will be found those manufacturers who in the past have endeavoured to provide

reliable components for the home constructor at moderate prices, and the steady development which is taking place in the design of receiving apparatus is bringing their products up to a high standard.

A perusal of the list of exhibitors will reveal that this exhibition is not a repetition of that recently held at the Albert Hall, and that much of the apparatus is of new design and has not been previously shown.

CONTENTS.

	PAGE
EDITORIAL VIEWS	491
SINGLE CONTROL TWO-VALVE RECEIVER	492
By F. L. Devereux.	
REALISTIC LOUD-SPEAKER REPRODUCTION	497
By H. Lloyd.	
WIRELESS FOG SIGNALS	501
By A. H. Morse.	
READERS' NOVELTIES	503
REVIEW OF APPARATUS AT THE WIRELESS EXHIBITION	505
CURRENT TOPICS	513
THE WIRELESS LEAGUE	515
By Sir Arthur Stanley.	
HINTS AND TIPS	517
H.F. AMPLIFIER DESIGN	519
By G. W. Sutton.	
EXPERIMENTS WITH LOOP AERIALS	522
By Leslie Miller.	
BROADCAST BREVITIES	523
DICTIONARY OF TECHNICAL TERMS	525
READERS' PROBLEMS	527

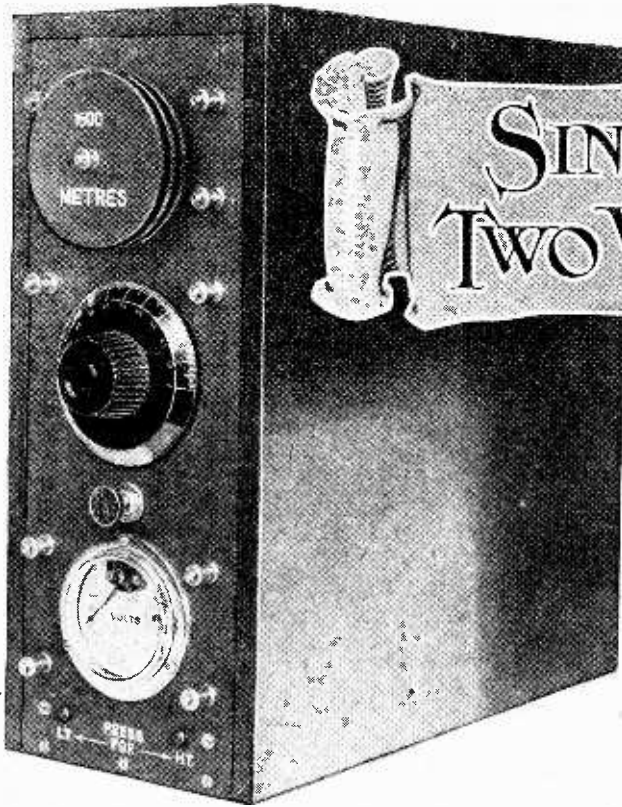

SINGLE CONTROL TWO VALVE RECEIVER

With Special Provision for Maintenance
of Valves and Batteries.

By F. L. DEVEREUX, B.Sc.

THERE are very few wireless receivers in existence at the present time that can be operated and maintained by a non-technical listener without advice and assistance from some outside source. The difficulty does not lie in the tuning controls; many receivers have been produced in which the tuning is confined to a single control and even in receivers in which the tuning is more complicated it is not long before the novice learns to recognise the effect on the strength and quality of reception produced by each adjustment and to tune automatically by ear with the precision of an expert.

When signals fail, however, and it is impossible to restore them by any tuning adjustment, it is necessary to call in the services of an expert to make a series of eliminating tests to locate the fault. The trouble will generally be found to lie in the H.T. or L.T. batteries or in the valves; it is only rarely that the trouble is located in the components or wiring of the receiver. If H.T. batteries and valves lasted indefinitely, it would only be necessary to have the L.T. battery recharged when signals failed, but with wireless receivers at their present state of development, a stoppage may result from any one of the three causes mentioned above.

Maintenance.

In the receiver about to be described, therefore, special provision has been made for isolating the cause of trouble in the event of failure of the receiver. A voltmeter is fitted on the front of the panel to indicate the voltage of either the L.T. or the H.T. battery, and the valves are mounted by themselves in a special compartment at the back of the receiver. Thus the operator has access

to the valves without being able to tamper with other components. When the receiver ceases to function, therefore, the voltage of the L.T. battery should be tested by pressing the left-hand stud below the voltmeter. If the voltage indicated is less than 1.8 volts per cell of the accumulator, the necessity of recharging is indicated. Assuming that this charge has been given and that signals are still absent, either the valves or the H.T. battery require attention. The voltage of the H.T. battery can be tested by pressing the right-hand stud of the voltmeter switch. The H.T. voltage can generally be reduced considerably before a diminution of signal strength can be detected, so that if the H.T. battery is at fault it will be at once indicated by the voltmeter. Having ascertained that the supply batteries are in good condition, the fault must rest either in the valves themselves or in the internal wiring of the receiver. The only satisfactory way of testing the valves which is available to the average listener is to substitute each valve by another of the same make, which is known to be in a good condition.

It will be seen that all these operations can be performed without any knowledge of wireless or even of electricity, and only in the event of failure of one of the components in the receiver is it necessary to call in technical advice. All the components other than the valves and tuning controls are housed in one compartment, which is normally sealed to prevent tampering with the wiring.

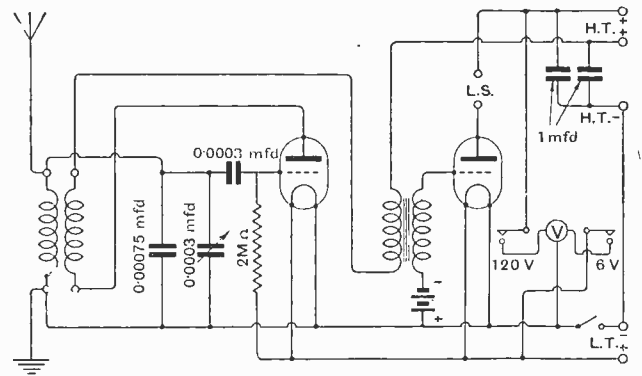

Fig. 1.—Circuit connections adopted in the receiver.

Single Control Two Valve Receiver.

A circuit diagram of the connections is given in Fig. 1. It will be seen that the first valve operates as a detector with fixed reaction coupled to the aerial tuning coil. The second valve operates as a power amplifier, and it is intended that a loud-speaker should be used exclusively with the set.

Reaction is incorporated with the object of economising filament current, as an additional stage of L.F. amplification would be necessary if the first valve were operated purely as a de-

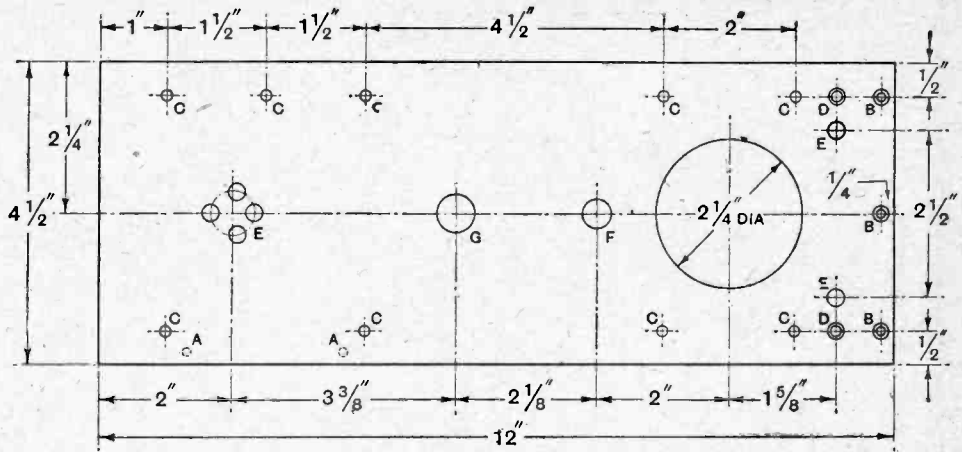

Fig. 2.—Drilling details of the front panel. Sizes of holes are as follow: A, drill and tap, No. 6 B.A. on underside; B, 1/8in. dia., countersunk for No. 4 wood screws; C, 5/32in. dia.; D, 5/8 in. dia., countersunk for No. 4 B.A. screws; E, 1/4in. dia.; F, 7/16in. dia.; G, 1/16in. dia.

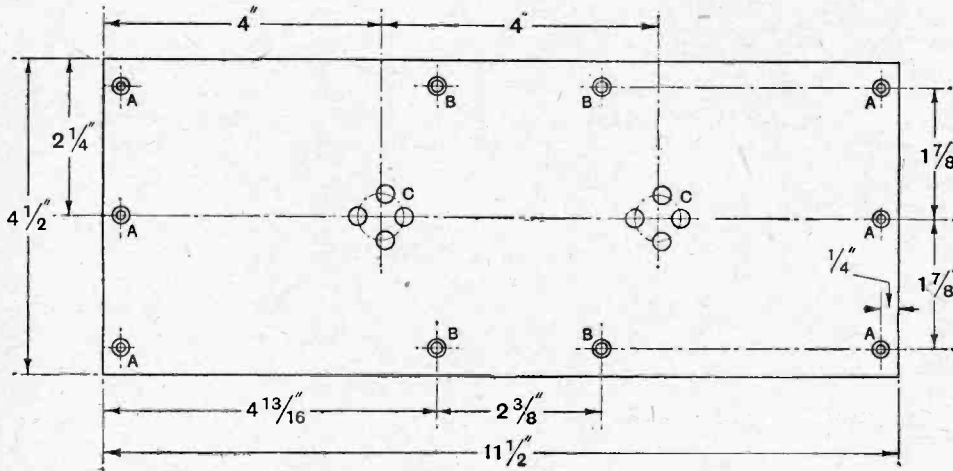

Fig. 3.—The valve panel. Sizes of holes are as follow: A, 1/8in. dia., countersunk for No. 4 wood screws; B, 5/32in. dia., countersunk for No. 4 B.A. screws; C, 1/4in. dia.

tector. The chief difficulty with fixed reaction is that the degree of reaction varies from point to point as the tuning condenser is rotated. The larger the capacity across the tuning coil the greater is the reaction coupling necessary to produce oscillation. Assuming then that the reaction has been adjusted with the condenser all out so that the set is just off the oscillation point, it will be found that reaction is very weak with the maximum capacity in circuit, and the set is therefore less sensitive than it might be. To overcome this difficulty a fixed condenser of 0.00075 mfd. capacity was connected permanently across the A.T.I., and the variable tuning condenser was given a capacity of 0.0003 mfd. Thus the change in capacity produced by a 180° movement of the condenser dial is only a small proportion of the total tuning capacity in circuit. This has a corresponding effect on the reaction which varies only slightly over the tuning range provided by the condenser. Thus it is possible to set the reaction so that the receiver is sensitive over the whole range of the tuning dial.

The aerial tuning and reaction coils are wound side by side in the slots of a unit similar to a H.F. transformer.

It is necessary to adjust the number of turns in both the coils to suit the constants of the aerial with which the set is to be used, and unless two stations happen to have wavelengths close to one another, separate units must be used for each station. It is intended that the receiver be used for Daventry and the local station with perhaps another B.B.C. station when favourably situated.

Filament resistances have been omitted, as these would introduce further variable factors. A push-pull filament switch is connected in the - L.T. lead for the purpose of switching the

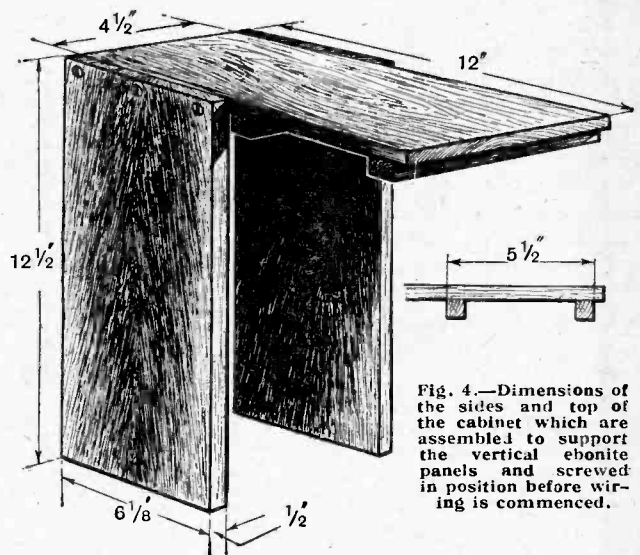
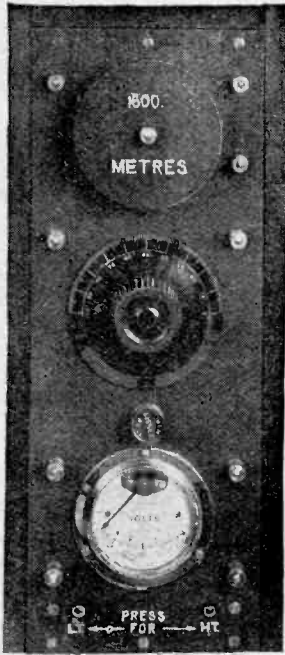

Fig. 4.—Dimensions of the sides and top of the cabinet which are assembled to support the vertical ebonite panels and screwed in position before wiring is commenced.



Front panel of the finished receiver.

receiver on and off. Two tappings are taken from the H. T. battery, one for the detector valve and the other, which includes the full voltage of the battery, for the amplifying valve. The connection to the voltmeter is taken to the latter tapping, as any falling off in the voltage of the supply to the detector valve would be at once indicated in the total voltage. The connections of the voltmeter and its associate switch are clearly shown in the diagram. The voltmeter is of the three-terminal type with a common negative terminal for both ranges.

Construction.

Most of the components are mounted on two vertical ebonite panels screwed to a wooden baseboard $11\frac{1}{2}$ in. \times $4\frac{1}{2}$ in. \times $\frac{1}{2}$ in. The front panel is illustrated in Fig. 2, in which details are given of the holes which it is necessary to drill to accommodate the components specified.

The valve panel (Fig. 3) is $\frac{1}{2}$ in. shorter in length, as

LIST OF COMPONENTS.

- 1 Ebonite panel, 12 in. \times $4\frac{1}{2}$ in. \times $\frac{1}{2}$ in.
 - 1 Ebonite panel, $11\frac{1}{2}$ in. \times $4\frac{1}{2}$ in. \times $\frac{1}{2}$ in.
 - 1 Variable condenser, 0.0003 mfd. ("Utility," Wilkins & Wright).
 - 1 Fixed mica condenser, 0.00075 mfd. (T.C.C.).
 - 1 Fixed mica condenser, 0.0003 mfd. (Igranite-Freshman).
 - 1 Grid leak, 2 megohms (Darco).
 - 2 Mansbridge type condensers, 1 mfd. (T.C.C.).
 - 1 Interval transformer (General Radio, Type 84).
 - 1 Moving coil voltmeter, double range 0-6 and 0-120, with common negative terminal (Sifam).
 - 1 Push-pull filament switch (Lissen).
 - 1 Grid bias battery (Siemens, G.I.).
 - 12 Flush fitting valve sockets.
- Wander plugs, terminals, wire, etc.
Mahogany, $\frac{1}{2}$ in. thickness, for container.

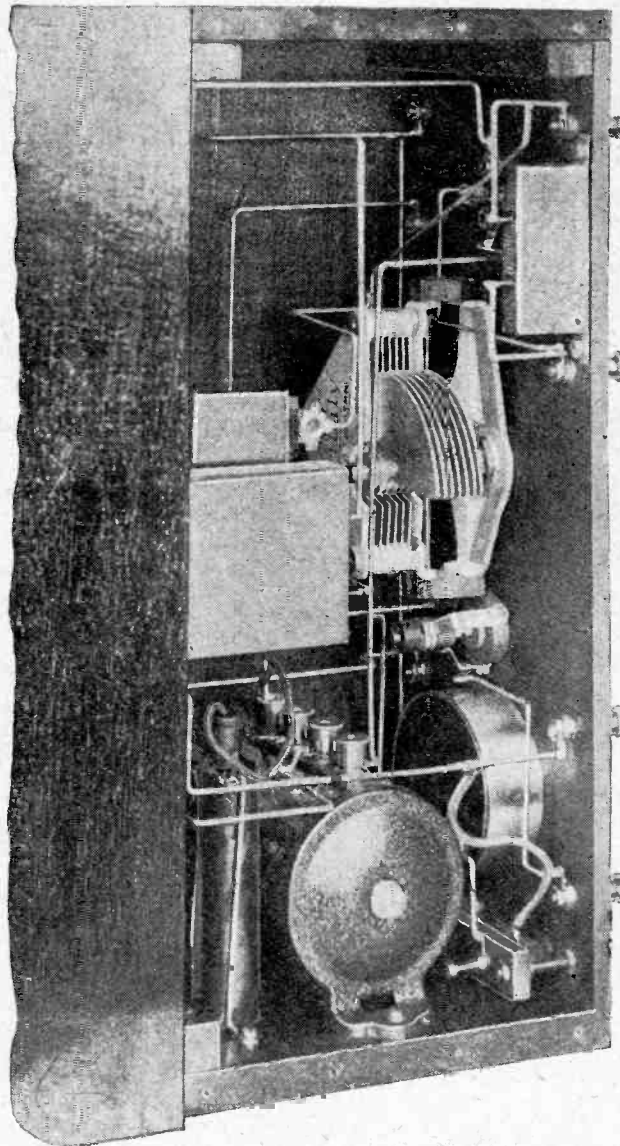

Interior view with the left-hand inspection panel removed.

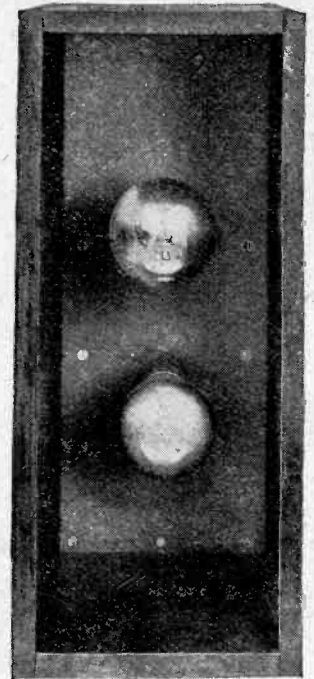

Interior of the valve compartment

it is screwed to a batten running across the baseboard at right angles to the sides at a distance of $5\frac{1}{2}$ in. from the front edge. Having screwed the panels to the base, it is necessary to construct the portion of the cabinet illustrated in Fig. 4. This, together with the baseboard, forms the compartment at the back of the cabinet for the valves, and also serves to strengthen the vertical ebonite panels which are screwed to battens on the underside of the top piece. The distance between the outside faces of these battens should be $5\frac{1}{2}$ in. to correspond with the spacing of the panels on the base.

Assembly.

With the exception of the interval transformer and the grid bias battery, the components are mounted on the two vertical panels. Flush-fitting valve sockets are employed throughout, for the valves and also for the tuner unit. The condenser is one-hole-fixing, as also is the "on-and-off" switch.

Single Control Two Valve Receiver.—

A moving coil voltmeter of good quality is recommended, and it is essential that the type chosen should have a common negative terminal; there are several types of

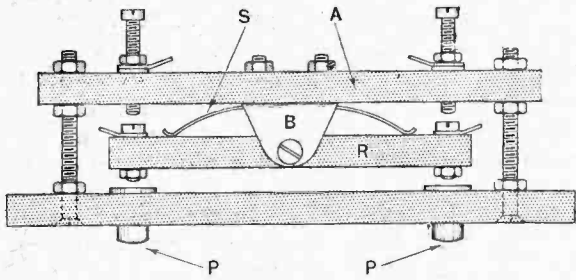

Fig. 5.—Details of voltmeter push switch.

double-range voltmeters on the market which employ a common positive terminal, but these cannot be used without modifying the internal wiring. The best method of cutting the hole for the voltmeter is to describe a circle $2\frac{1}{4}$ in. in diameter, and then to drill a series of holes

close together with the hand-drill. The holes should then be carefully broken into one another and the centre disc of ebonite pressed out. The positions of the holes for the set screws securing the voltmeter have not been shown, as these will be marked with a scriber when the voltmeter is in position. Details of the voltmeter switch are given in Fig. 5. This switch must be so designed that it is impossible to leave the voltmeter accidentally in circuit. A moving coil voltmeter of good quality consumes between 10 and 20 milliamperes—a current which would soon discharge a H.T. dry battery. It is, therefore, necessary to use a push switch, so that the voltmeter will be in circuit only while the button is pressed. If two independently operated switches of this type were used, however, it would be possible to short-circuit the H.T. battery by

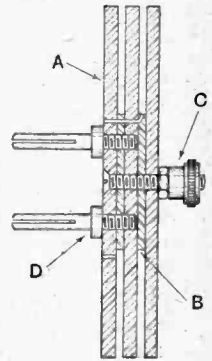

Fig. 7.—Sectional view of the type of former used for the tuner units.

pressing both the buttons at the same time. It was with the object of overcoming this difficulty that the switch illustrated in Fig. 5 was evolved. The two fixed contacts connected to the positive terminals of the voltmeter are mounted on an ebonite bar A which carries also a bearing bracket B. An ebonite rocker R is pivoted at its centre in the bearing bracket, and carries at each end contact studs connected respectively to +L.T. and +H.T. by means of short flexible leads. Silver or platinum contacts are unnecessary here, and if the heads of the screws are tinned with the soldering-iron, a perfectly satisfactory contact will be obtained. The switch is operated by two ebonite push-buttons P fitted in holes drilled in the front panel, and the rocker is kept normally in a horizontal position by a phosphor-bronze leaf-spring S. The switch can be assembled and adjusted on the base A before finally fitting to the panel.

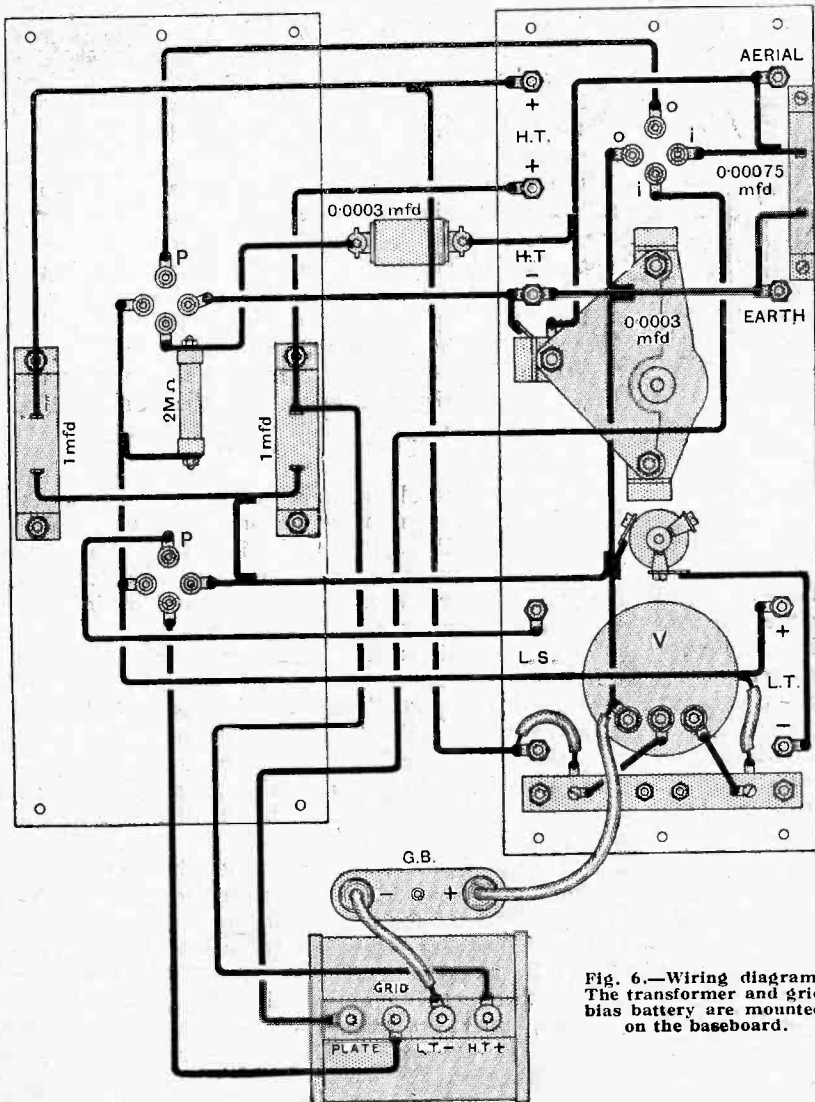

Fig. 6.—Wiring diagram. The transformer and grid bias battery are mounted on the baseboard.

The only other components carried by the front panel are the terminals and the fixed tuning condenser which is mounted in the position shown in Fig. 6, between the "Aerial" and "Earth" terminals. Blind holes were drilled at A in Fig. 2 for the purpose of securing this condenser, but countersunk screws fitted from the front of the panel may be used if the appearance of the heads of the screws is not objected to.

The 1 mfd. condensers connected across each section of the H.T. battery are mounted on the back of the valve panel with their

Single Control Two Valve Receiver.—

terminal contacts facing inwards towards the front panel.

The panels with their components in position are now finally screwed to the baseboard, and the section of the cabinet illustrated in Fig. 4 is screwed in position.

Wiring.

The wiring can now be proceeded with according to the diagram given in Fig. 6. The panels have been opened outwards in the diagram and laid side by side with the valve panel at the left-hand side and the front panel at the right-hand side of the diagram. The two components mounted on the baseboard, namely, the intervalve transformer and the grid bias battery, are shown at the bottom of the diagram.

The position of each component has been carefully chosen with the object of making the wiring as short and direct as possible. For instance, it will be noticed that the detector valve holder which is placed at the top of the valve panel, is opposite the tuning components on the front panel. The grid condenser, which has been specially chosen on account of its light weight, is suspended by the wires from the grid of the detector valve and from one side of the tuning condenser.

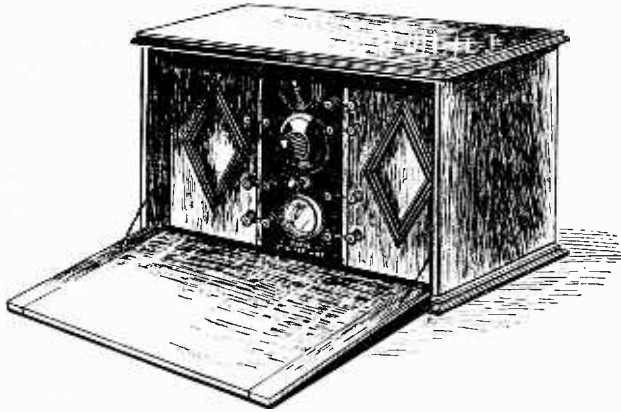

Fig. 8.—Suggestion for mounting the unit in a cabinet with H.T. and L.T. batteries in separate containers on either side. The aerial, earth and loud-speaker connections should be extended to the back of the cabinet.

The grid leak is provided with soldering tags, and there is no necessity for fitting special clips, as the leak can be soldered directly to the appropriate wires in the receiver. One tag is soldered to the grid socket connection of the detector valve and the other to the common + L.T. wire running between the filament sockets.

The low-frequency components, such as the intervalve transformer, are mounted on the baseboard near the lower valve holder. The wiring to these components is thereby localised at the base of the compartments, and does not interfere in any way with the high-frequency components and wiring in the top of the compartment. In the diagram the terminals of the L.F. transformer have been marked to correspond with the lettering on the actual instrument; it does not necessarily mean that leads from these terminals should be joined to the points indicated. As a matter of fact, the lead from the "Plate" terminal traverses the reaction coil before reaching the plate socket of the detector valve.

A 14

The leads for the wander plug connections to the grid battery are quite short, one being connected to the - L.T. lead, say, at the voltmeter, and the other to the appropriate terminal on the intervalve transformer.

The wiring is quite straightforward, and there is no necessity to wire any of the components before the panels are assembled.

Tuning Units.

The formers for the tuning units were built up with ebonite discs $2\frac{1}{4}$ in. in diameter. A section of one of the formers is given in Fig. 7, and it will be seen that three discs are used with spacing washers which form slots for the aerial and reaction coils. In the case of the short-wave units the thickness of the spacing washers was made only slightly greater than the diameter of the No. 26 D.C.C. wire used for the windings; thus each coil consisted of a single spiral. For Daventry, however, the width of the slots had to be increased to about $\frac{1}{8}$ in.

Four valve pins with the conventional spacing are arranged to take the connections from the ends of the coils, small holes being drilled near the "grid" and one of the "filament" pins for the inner ends of the reaction and aerial coils, respectively. The length of the screwed portion of the valve pins was only sufficient to clamp together two of the discs, and the third was held in position by a No. 4 B.A. countersunk screw passing through the centre of the former. A terminal head C fitted to this screw served as a handle when changing the unit.

The coils were wound on in the same direction as follows:—Holding the former by the pins in the left hand the wire is wound on in a clockwise direction until each slot is full. The inside end of the reaction coil which is farthest away from connecting pins is connected to the "grid" pin and the outside to the "plate" pin. The ends of the aerial coil are then connected to the "filament" pins, as indicated in the wiring diagram in Fig. 6. In making these connections the pins should face upwards to correspond with the wiring diagram.

Tests.

Having connected the aerial, earth, loud-speaker, and batteries to the appropriate terminals, the valves are inserted and the filament current switched on. Valves with filaments rated at 2, 4, or 6 volts, which do not require filament resistances, should be adopted, and low-impedance valves are recommended for both stages.

The tuner unit is then inserted with the reaction coil disconnected from the pins, and left on open circuit. The "grid" and "plate" pins are then short-circuited, and with the tuning dial set at the middle of the scale turns are taken off the aerial coil until the station required is tuned-in. The reaction coil is then connected, and turns taken off, until the set is just not oscillating at the zero end of the condenser scale.

For the particular aerial with which the set was tested, 21 turns of No. 26 D.C.C. were required for the aerial, and 35 turns for the reaction in order to tune in 2LO, while for Daventry 113 turns were necessary for the aerial and 50 for reaction.

Both these stations were received at full loud-speaker strength, and in the case of 2LO, a few miles away, no reaction was necessary. The quality from both stations was excellent.

13



Loud Speaker REPRODUCTION

Details of a Loud-speaker and Amplifier
Designed for Reception of Studio
Programmes.

By H. LLOYD.

by an electrical artifice, virtually to transport himself to the very spot occupied by the microphone at the origin of the transmission. This spot has been carefully chosen as the best point from which to hear the performance, from considerations of musical balance, echo effects, and absence of undesirable noises. The sounds reach the ear almost exactly as they arrive at the microphone, with practically nothing lost, and—which is important—with no embellishments. With a good "outside broadcast" the effect is strikingly realistic, but if the performance is taking place in a heavily draped studio, there is something lacking. Many people have pointed this out, but opinions on this matter are not entirely concurrent, and preference for public hall performances is by no means universal.

Echo Effects.

It would be interesting to know whether or not the advocates of outside broadcasts are to be found chiefly amongst the ranks of the listeners who use headphones exclusively. A consideration of this type of transmission on a loud-speaker will show this suggestion to be not unreasonable.

Loud-speaker reproduction places virtually at the microphone not the listener himself, but the loud-speaking device. The sounds issuing from it do not immediately reach the ear, but are projected into the room, there to be reflected and coloured by the resonance effects existing therein. This colouring of the sound may mar, or it may actually enhance the realism of the reproduction. If the transmission is an outside broadcast, it already contains the echo effects which one's ear has grown accustomed to associating with a large hall, and the superimposition of the very different echo effects of a domestic sitting room may easily spoil the illusion of actual presence at the performance. This, surely, is a case where headphone reception should be adopted, unless the enthusiasm and the facilities of the listener are great enough for him to fit up a blanketed room for the reception of such concerts on a loud-speaker. The writer has gone to the trouble of fitting up such a room as a matter of interest, and the results have certainly borne out the truth of this hypothesis.

PERFECT reception of broadcast transmissions will one day be an accomplished fact. Perfect reception may be taken to mean the reproduction in the immediate neighbourhood of the listener's ear of sound vibrations imperceptibly different from the original sounds transmitted. This article has as its object the brief examination of some of the difficulties encountered in attempting to satisfy a musically trained and critical ear—the ear of a person wishing to forget the existence of the medium in the appreciation of the final result, and not willing to make any allowances or accommodations of an aural nature, the strain of which, although perhaps only subconsciously present, might detract from the pleasure of listening.

Aural Accommodation.

The problem has its physical and its aesthetic sides, and the phrase "imperceptibly different" involves the satisfaction of psychological considerations as much as physical ones. With a crystal set and a pair of telephones a tolerant and imaginative person can close his eyes and, in listening to a concert from, say, the Albert Hall, experience almost the same pleasure that he would derive from an actual visit to the performance. To those with less imagination and with less interest in wireless as a science, the mere wearing of the telephones prevents the attainment of the desired effect, and the substitution of a loud-speaker, even though it may be concealed from view, introduces many other obstacles into the way of securing realism of effect in the mind of the hearer.

In assuming the headphones, the listener is enabled,

Realistic Loud-speaker Reproduction.—

If, on the other hand, the transmission is from a draped studio, the echo-free sounds which seemed so unnatural in the telephones may in many cases be improved in realism by the resonances of the room in which the loud-speaker is placed.

Echo in the Studio.

Whether this desirable effect will occur or not depends largely upon the matter being transmitted. If it is speech, a solo instrument accompanied by the piano, or chamber music, it will probably be improved, because it is of such a nature that it could conceivably be actually taking place in that room, and the types of echo and resonance introduced will be such as would be heard under those circumstances. Programmes composed of items like these will be rendered in a more pleasing manner by the use of a good loud-speaking receiver in an ordinary drawing room than by headphone reception. The hearer may thus be led to the hasty decision that studio transmissions are, without qualification, the best, whereas were he to hear the same programme through headphones he would notice a certain lifelessness compared with transmission from a public hall.

Now let us examine the effect of a different type of programme—one in which the original sounds are much louder, such as an organ recital, or the performance of a full orchestra or military band. By means of telephones, it is possible to convey direct to the ears a sound intensity of the same magnitude as would be experienced were the listener placed at an optimum position for hearing such music. If performed in a public hall, the result will again be realistic, but from a studio which is heavily draped there will be the same deadness as before. Loud-speaker reception in such cases does not bring about a suitable introduction of echo effect to give complete satisfaction, for several reasons. The outstanding one is the incongruity of the effect. By no stretch of imagination is it possible to conceive of a full orchestra playing within the comparatively narrow confines of a sitting room. Further, since it is not generally possible to place oneself at a similar distance from the loud-speaker as would be chosen when hearing the actual orchestra, the required sound intensity at the ear can only be obtained by adjustment of the total volume of sound from the instrument. The amount of toning down usually required is sufficient to reduce some of the finer details and softer passages to a strength which is below the threshold of audibility, giving rise to a "next-street-but-one" effect.

Loud-speaker Volume.

This brings us to the question of what strength of reproduction is to be employed with a loud-speaker. I

do not think there can be any doubt that, putting complicating factors on one side, the only way to get realistic reproduction is to make the receiver give out a sound intensity equal to that given by the original source of sound. Witness as an example of this the remarkably natural rendering of whistling solos, and of the flute, banjo, and concertina. It may be argued that the range of pitch of these instruments just happens to coincide with the optimum working range of the common forms of loud-speaker, and that this is responsible for the quality of the reception rather than the fact that they can readily be reproduced at their original strength. Such argument can be seriously shaken by listening to, say, a banjo solo on a receiver in which the volume can be varied over a wide range without altering the amplification-frequency characteristics. As the volume is gradually increased from zero, one begins with a distant impression, not unlike the banjo, perhaps, but nevertheless like listening to it through a closed door; passes through the realistic region where the sound intensity is about what one expects from the banjo, and then to the experience of some weird, gigantic instrument, whose nature baffles the imagination.

When to Use Headphones.

In view of the foregoing considerations, the writer has formed the opinion that outside broadcasts are best received on headphones, and has concentrated upon securing realism in the reproduction by loud-speaker of studio programmes of a comparatively simple nature, that is to say, speech and vocal items, and instrumental work involving only a few artists. Choral, orchestral, and band pieces, and outside broadcasts, whilst still being very pleasant to hear in this way, cannot be claimed to be quite like the real thing.

The loud-speaker is placed inconspicuously, and preferably in a different room from the receiving amplifiers, so that the presence of wireless apparatus shall not prejudice the artistically minded at the outset.

The type of loud-speaker most suitable for a room of ordinary size has been a difficult question, but, after trying various standard forms, it was soon found that, unless an inconveniently long horn was used, the lower notes were conspicuous by their absence. Although the low notes—i.e., those from 25 to 100 vibrations per second—may be delivered by the diaphragm, a horn responds but feebly to notes lower in pitch than the natural frequency of the air column within it. Consequently, an input energy which will give these notes out at sufficient strength will have the effect of hopelessly overloading the loud-speaker for the higher frequencies. As it was difficult, under the circumstances, to render inconspicuous a loud-speaker 8ft. long, attention was turned to the hornless type having a large diaphragm, and several of these were made, of various sizes. In testing these, another limiting factor was soon found, for in order to obtain repro-

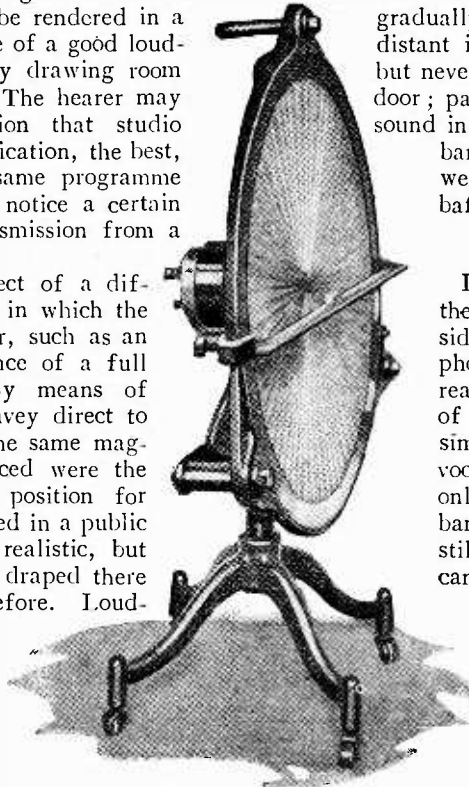

Fig. 1.—The loud-speaker fitted with cross-bar and rocking mirror for visual observation of the movement of the diaphragm.

Realistic Loud-speaker Reproduction.—

duction approaching the original in strength, the type of action using an iron armature or diaphragm had to be badly overloaded. With the large amplitudes necessary, it was obvious that the complex impedance characteristic of the device was introducing such distortion as would be difficult, if not impossible, to compensate for in the amplifier.

A moving coil action was therefore constructed to fit the magnet of a discarded Magnavox loud-speaker. It

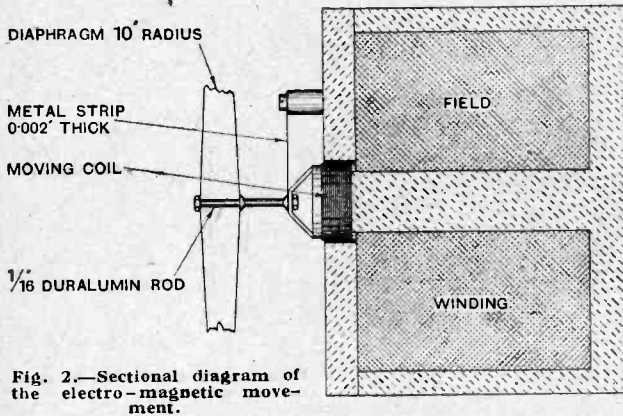

Fig. 2.—Sectional diagram of the electro-magnetic movement.

was connected to the centre of the diaphragm by a short duralumin rod, as shown in Fig. 2. To keep the coil practically concentric with the annular space between the pole-pieces throughout an axial range of movement of plus or minus 1 mm., a very thin tongue of foil prevented radial motion without applying undue restraint in an axial direction. The former itself was of thin bakelite tube, and was first wound with 36-gauge silk-covered aluminium wire to a resistance of about 10 ohms, but this winding was soon changed for a similar one of copper wire, on account of the difficulty of making reliable connection to the aluminium.

The Diaphragm.

With this action, diaphragms of the conical and the pleated types, in various grades of paper, have been tried, and an instrument which has been in regular use for the past nine months is shown in Fig. 1. It has a diaphragm 20in. in diameter, of thin wrapping paper treated with elastic varnish after being pleated, to obviate warping due to changes in humidity. It is housed in a heavy cast-iron frame. The restoring force on the coil is very small, being solely due to the rigidity of the pleated diaphragm. The natural frequency of the system is thus very low indeed, and the damping has been found sufficiently high to justify dispensing with the sponge rubber dampers originally fitted. A feature of its behaviour is the way in which it responds to the very low frequency currents sometimes accompanying land-line transmissions. Some of these, of the estimated order of fifteen to twenty vibrations per second, are quite inaudible in the conventional type of loud-speaker.

An illustration is shown (Fig. 4) of the magnet system of another loud-speaker of a similar type, having a moving coil action. In this case the magnet is of the permanent variety, made from cobalt magnet steel, six

specially shaped bars being clamped radially about the pole-pieces. The faces of the pole-pieces adjacent to the coil are slotted to eliminate energy losses due to eddy currents induced by the current in the coil. This instrument is not so efficient, on account of the lower flux density, which is only about 80 per cent. of that obtainable with the electro-magnet, but it has the virtue of requiring no field battery for its operation.

Details of the Transformer.

The transformer constructed for supplying these loud-speakers is illustrated in Fig. 4, and diagrammatically in Fig. 3, and has the following dimensions.

Core.—Stalloy, 20 mils. thick. Net cross-section, 7.25 sq. cm. Mean length of magnetic path, 27 cm.

Primary.—5,800 turns of No. 30 S.W.G. D.C.C. in four sections, tapped at each section, to use according to the anode impedance of the last stage of the amplifier.

Secondary.—Two windings of No. 26 S.W.G. D.C.C. each of 100 turns, connected in parallel.

The low-frequency amplifier itself, which follows a D.E.Q. detector valve, is of the wire-wound resistance-capacity coupled type, and has four valves of the B.4 class, followed by a final stage of one to three L.S.5 valves, according to the output energy required. These have recently been changed in favour of the L.S.5A type. The usual tone-raising and tone-lowering devices are applied to the first and second stages, and the third stage has a band filter by means of which any one noticeable resonance effect may be suppressed. The volume controls, of which there are two, are of the potential-divider type, applied to the first anode resistance and the last grid-leak respectively.

This arrangement will reproduce the full tone and

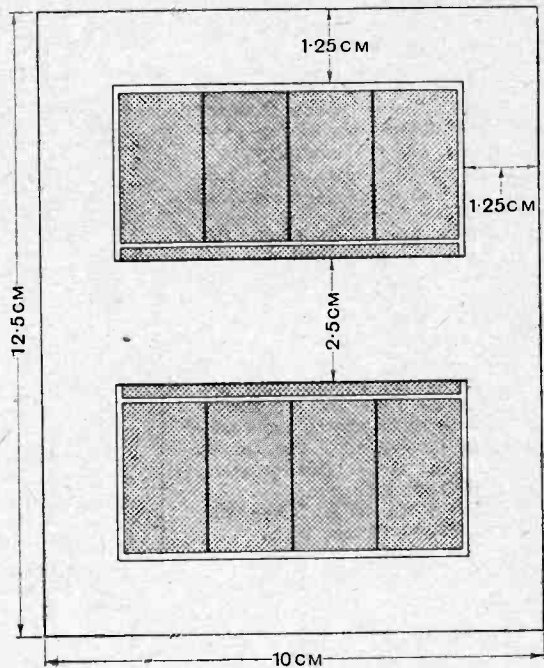

Fig. 3.—Dimensions of the output transformer core.

Realistic Loud-speaker Reproduction.—

volume of a piano over the full scale, without being overloaded at any point, and has deceived listeners in an adjoining room into thinking that the piano was actually being played.

After an item of music, the volume has to be cut down to deal properly with the announcer's voice, which is usually broadcast at the same level of loudness as the instrumentation. This is sometimes disconcerting, but it is a piece of broadcast faking that must be borne with in consideration of the crystal user, who would not hear the announcements clearly were they sent out at a strength relative to a fortissimo cadence by a brass band.

Naturalness in speech reproduction must not, however, be confused with intelligibility. With the trained voices of the announcers and of experienced public speakers, the one is synonymous with the other. But there are occasions when a speaker with an indifferent voice has something interesting to say, and a little judicious juggling with the amplification-frequency characteristics of the amplifier will considerably improve the clearness at the expense of obtaining an imperfect replica of the voice quality.

Frequently this is already done for us at the broadcasting control room, but it is an interesting point to note in passing. What is usually required is relatively to exaggerate the frequencies which comprise the consonantal sounds, i.e., those from 1,500 upwards. The voice loses much of its natural timbre, but the words themselves are grasped much more easily:

The search for realism of effect is a very fascinating one. It involves careful listening to actual music, and comparison with similar music as received by radio, and

a really trained ear provides a short cut to a stage of perfection otherwise attainable only by excessively laborious physical measurement. Design data for resistance amplifiers is capable of accurate computation, but measurements on loud-speakers are difficult to obtain, and when made, frequently neglect important factors contributing to the final effect on the ear. It is not advisable to work continuously with one particular loud-speaker, as the ear has a knack of accommodating itself to *consistent* shortcomings of reproduction, provided they are not too prominent.

It will be observed that the loud-speaker illustrated (Fig. 1) is fitted with a small rocking mirror to register

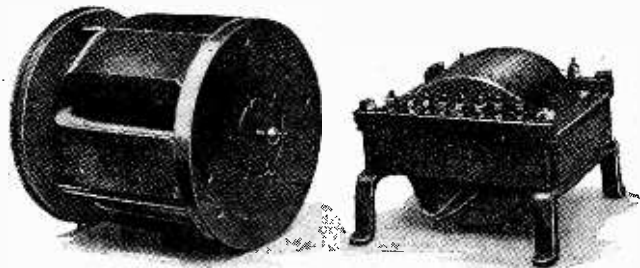

Fig. 4.—Loud-speaker movement with permanent field magnet, and (right) the output transformer.

the motion of the diaphragm. This has been used for demonstration purposes, in conjunction with a rotating mirror, but now that a sufficient degree of quality has been attained with certain kinds of music to deceive the ear, it is being calibrated for the purpose of examining the input-response characteristic over the whole audible range of the amplifier and loud-speaker taken as a unit.

Leyton Radio Association.

The association opened its winter programme on Wednesday, September 30th, when an interesting lecture was given by Mr. H. L. Kirke, a senior engineer of the British Broadcasting Company. Mr. Kirke took as his subject "Cutting out the Local Station" and "Long Distance Reception." The meetings of the association are held every Wednesday at 8 p.m. at headquarters, National Schools, High Road, Leyton, E.10. New members will be heartily welcomed.

Hon. Secretary, Mr. W. B. Clark, 102, Goldsmith Road, Leyton, E.10.

○○○○

North Middlesex Wireless Club.

On October 28th a special lecture will be delivered by one of the senior engineers of the British Broadcasting Co. on "Distortionless Reception of Broadcasting." All those interested are cordially invited to be present. The lecture will be at the Club Headquarters, Shaftesbury Hall, at 8.30 p.m.

Hon. Secretary: Mr. H. A. Green, 100, Pellatt Grove, Wood Green, N.22.

○○○○

Lewisham and Bellingham Radio Society.

A "wavemeter" night was held recently, members bringing many types of instruments, each being described by its owner. Each instrument was afterwards tested against a standard and accurately

NEWS FROM THE CLUBS.

calibrated wavemeter, and the results were surprisingly satisfactory. The most efficient wavemeters were those of Messrs. Kell and Lawrence.

The society is now actively engaged on the construction of a transmitter. The call sign of the new station will be 2BJK.

FORTHCOMING EVENTS.

WEDNESDAY, OCTOBER 14th.
Radio Society of Great Britain.—At 6 p.m. at the Institution of Electrical Engineers, Savoy Place, W.C.2. Informal Meeting. Mr. J. H. Reeves, M.A., will open a discussion on "Fine Wire Coils in connection with Crystal Reception."

Bolton and District Radio Society.—Lantern Lecture: "Radio Ramifications." By Mr. H. A. Hankey, Assistant Chief Engineer of the B.B.C.

MONDAY, OCTOBER 19th.
Hackney and District Radio Society.—Vest Pocket Lectures.

WEDNESDAY, OCTOBER 21st.
Golders Green and Hendon Radio Society.—At 8 p.m. at the Club House, Willifield Way, N.W.11. Third Lecture on "Fundamental Principles of Radio Reception." By Mr. Maurice Child.

Hon. Secretary: Mr. C. E. Tynan, 62, Ringstead Road, Cardiff.

○○○○

Streatham Radio Society.

The seating capacity of the Society's new headquarters was taxed to the uttermost on September 24th, when an "At Home" was held to all members of the South London League of Radio Societies. An enthusiastic meeting resulted. An interesting lecture entitled "Faithful Reproduction of Broadcast" was given by Mr. G. E. Minvalla (6BN), of the B.B.C. Research Department.

The manufacture of valves was dealt with in an interesting manner on October 1st, when a lecture was delivered by Mr. Goldup, of the Mullard Radio Valve Co., who brought with him a number of valves in various stages of manufacture.

About twenty members paid a visit to the Croydon Aerodrome on a recent Saturday afternoon. A profitable time was spent in visiting the wireless station and the Aerodrome buildings.

Hon. Secretary: Mr. N. J. H. Clarke, 26, Salford Road, S.W.2.

○○○○

Ipswich and District Radio Society.

The Society opened its winter session on October 5th, when Captain Frost, of the British Broadcasting Company, delivered a lecture entitled "Wireless."

Hon. Secretary: Mr. H. E. Barbrook, 55, Fonnereau Road, Ipswich.



WIRELESS FOG SIGNALS

A Much-needed Navigational Aid.

By A. H. MORSE, A.M.I.E.E., Mem.I.R.E.

IN the course of an address delivered to the Institution of Electrical Engineers on March 2nd, 1899, Mr. Marconi said: "There exists a most important case to which the reflector (wireless telegraph) system is applicable, namely, to enable ships to be warned by light-houses, light-vessels, or other ships, not only of their proximity to danger, but also of the direction from which the warning comes. If we imagine that A is a lighthouse provided with a transmitter of electric waves constantly giving a series of intermittent impulses or flashes, and B a ship provided with a receiving apparatus placed in the focal line of a reflector, it is plain that when the receiver is within range of the oscillator, the bell will be rung only when the reflector is directed towards the transmitter and will not ring when the reflector is not directed towards it. If the reflector is caused to revolve by clockwork or by hand, it will therefore give warning only when occupying a certain sector of the circle in which it revolves.

"It is, therefore, easy for a ship in a fog to make out the exact direction of point A, whereby, by the conventional number of taps or rings, she will be able to discern either a dangerous point to be avoided or the port or harbour for which she is endeavouring to steer."

Unfortunately, however, that was then possible only in theory; for there were no means of producing Hertzian waves of the persistency and frequency that were essential. The method and the means are two quite different things.

The same remark applies in almost the same degree to the proposal made by Stone in 1901, according to which "ships when approaching each other at sea may receive warning of their proximity to one another, and each ship may determine the bearing of the other, as well as such

other information as they may wish to communicate, as, for example, the course steered and the speed."¹

It was not until 1907 that Bellini and Tosi evolved a direction-finding method which could render any useful service to navigation with the means developed up to that time; and even that service was so greatly limited by the crudity of the means available, that it was scarcely worth while.

Finally, some seven years later, when, largely due to the ingenuity and perseverance of Round and Wright, the Bellini-Tosi method became of great value—particularly for military strategic purposes. However, its cost, delicacy, and intricacy are factors which are still detrimental to its general adoption as an aid-to-navigation.

It was the evolution of the triode, or thermionic valve, as an efficient receiving device, which made possible the practicable development of the Bellini-Tosi system; and it was the use of the same device as a generator of oscillations of very high frequency and unvarying persistence which opened the way in 1914² for the application of Marconi's proposal of 1899, and rendered possible the "beam" aid-to-navigation stations recently installed at Inchkeith and S. Foreland. It yet remains for someone to apply like means to Stone's proposal of 1901; and herein lies the point of this story.

Bridge-to-bridge Telephony.

No observant person who has been shipmates with a modern direction-finder will doubt its utility; neither will he question the general need of such a device. Yet

¹ See Specification of British Patent 27746/02.

² See *The Electrician*, July 31, 1914. In this year Meissner announced that, by means of the triode, he had been enabled to generate waves as short as 5 metres.

Wireless Fog Signals.—

few ships, comparatively speaking, are so equipped. The reasons are many, and one of them is that shipowners are loth to adopt devices which cannot be operated by their navigating officers; especially if such devices are of only limited use and are regarded as still in a process of evolution. There is, therefore, a great need of an equipment which will at once provide (a) automatic directional warning of the near approach of a ship, and (b) automatic warning to the approaching ship. Moreover, since the provision of such equipment now presents no technical difficulties, and the same equipment may be designed to provide also bridge-to-bridge telephony, there seems to be every reason why it should be forthcoming. The theory of such an equipment was outlined by John Stone some twenty-four years ago in the specification of U.S. Patent 716,955 (British Patent 28,509/02), and, as has been indicated, the means for putting it into effect have long since been available. It would be constituted as follows:

The transmitter should have a wavelength of about 5 metres and be rated at 50 watts, and a vertical self-supporting oscillator. The receiver would be connected between two vertical self-supporting aeriels, half a wavelength apart, mounted at equal distances on either side of the transmitting aerial and adapted to be rotated automatically about the latter

Operating Procedure.

On the approach of fog, the officer of the watch would start the transmitter, preferably by means of the same switch which is usually provided for starting the automatic steam fog-signal, which action would also start the rotation of the receiving aeriels and throw the associated gear into operation. A junior officer or apprentice would at once stand-by the receiver and either listen or watch for an incoming fog-signal—arrangements could readily be made for either sound or light signals—while watching

the progress of a pointer around a compass card. The pointer would indicate the angle made by the rotating aerial with the ship's keel. Upon receipt of a signal he would log it and its bearing, and report it to the officer of the watch, who would take steps accordingly. Obviously it would be advantageous if the transmitter were adapted automatically to signal the ship's course and speed, and this could readily be done.

Should the officer of the watch desire to speak to a ship whose warning signal he had received, he would simply speak into a microphone which would be coupled to his transmitter, the receiving aerial being stopped in the place of the observed direction of the ship to be spoken. For this purpose he would not be required to leave the bridge.

This equipment would also be useful in the event of a ship requiring to speak one of its own boats, in fog or otherwise; moreover, it would greatly help such boats to locate the ship in fog.

The efficiency of any scientific aid-to-navigation depends largely on the facility with which it is used and the confidence that may be placed in it. With the arrangement suggested herein, navigators would be holding bridge-to-bridge conversations every day, and would thus have ample opportunity for checking its accuracy and dependability.

Elimination of Interference.

If it were to be found that difficulties were involved in the simultaneous transmission and reception on the same wave, it would be a simple matter to alternate the functions rapidly, but there is no apparent reason why such difficulties should arise.

The equipment would take up very little room, and could be accommodated conveniently on almost any sea-going vessel. Moreover, its cost ought not to be great. We certainly need it, and we shall certainly have it; but why not now?

Funchal-Madeira.

(August.)

Great Britain:—2CC, 2DX, 6TM, 2LZ, 5XM, 5TZ, 5XY, 2KF, 5DH. *U.S.A.*:—1AHG, 1PL, 1ALW, 1ACI, 1ALZ, 1CKP, 5ZL, 3AHA, 3CM, 1ER, 2CTY, 1BGQ, 1AHG, 8LN, 1WL, 7TX, 1AAO, 4FM, WAP, 2HA, 2CTQ, 8PL, 1NT, 1UC, 9AOT, 8DIW, 8DON, 8BNH, 1BEE, 2WR, 1UW, 9BHT, 3AFQ, 8BF, 3QW, NVE, 3BHA, 4OI, 9XN, 2QW, 3OT, 8AY, 1CMF, 1ABP, 3CJN, 1CMP, 2LW, 1SE, 2CTH, 3BYA, 3BVA, 3CA, 3AUV, 2XBB, 2FO, 2BUR, 2JW, 4RL. *Canada*:—3AA. *France*:—8WTG, 8FW, *Brazil*:—1AF, 2SP. *Belgium*:—R2. *Sweden*:—SMYY. *Chile*:—1EG.

(0-v-1, Reinartz.)

A. C. DE OLIVEIRA (P3CO).

Cromer.

(30 to 100 metres.)

Great Britain:—5BA, 5OS, 5OK, 6AA, 6VG. *U.S.A.*:—1AM, 1NW, 4KY, 5KQ, 5RA, 8AUX, 8DGS, 8NNW. *France*:—4SR, 8BN, 8CI, 8CR, 8OV, 8FA, 8CA, 8KR, 8NOB, 8NU, 8PAX, 8PM, 8PU, 8QN, 8RRR, 8RG, 8TV, 8TIV, 8TK, 8UOZ, 8UO, 8VO, 8VU, 8XV, 8LN. *Holland*:—2PZ, OAS, OAM, OAU, OAR, OAW, OBX, OGN, OKG, OKM, OKV,

Calls Heard.

Extracts from Readers' Logs.

ONTR, ORE, ORM, ORER. Italy:—1AH, 1AU, 1BS, 1NU. *Belgian*:—2PZ, R2. *Germany*:—Y4, P5. *Argentina*:—A8. *Finland*:—5NF. *Switzerland*:—9NA. *Unknown*:—NST (about 95 metres, on Aug. 29th), KXH (about 60 and 80 metres. A. A. BARRETT (G2BJP). (0-v-0)

Mombasa, Kenya Colony.

(August.)

Great Britain:—2CC, 2LZ, 2KF. *Italy*:—1DO, 1AU. *South Africa*:—A4V, A4R (?A4F). *Cuba*:—Q, 2MK. *U.S.A.*:—WIR, NKF, WQN, WQK, WBZ, WIZ, WJB (? WJG Telephony), 1PZ, 1CRE, 1CKD, 1BQT, 1MN, 1ACI, 1KA, 1PC, 1ARR, BYX, 2HA, 2AGB, 2BEE, 2BG1, 2CFT, 2LU, 2AHG, 2WR, 4JE, 5AC1, 5ATV, 5JD, 5EW, 5AAQ, 5HE,

8XC, 8AVL, 8BEN, 8DAL, 9HP (? 95P). *Australia*:—3BD, 6DAB. *Unknown*:—4AWY, 9CH, OCDB, M, 1DH, 3KG, FTJ, HJD, 2MK, 5ZAI (? 5ZL), 5NJ, 6AFF, 6ZK, 8AY (? 8FY), 9XN, 9AAW, 9BHT, NOBQ, W1CEE, W8PC, NPO. (0-v-1.) 30 to 120 metres.

L. J. HUGHES (KY, 1VP).

Holland.

Great Britain:—5CT, 5ZR, 5QV, 5NW, 6RM, 2JB, 2ZB, 6VP, 5PW, 5DH, 2DY.

QSL to N.OAW via Radio Wereld, Amsterdam.

Godalming.

(August 15th to 30th.)

Great Britain:—21H, 2JU, 2KT, 2LZ, 2YQ, 5DH, 5HT, 5KT, 6AX, 6DN, 6GH, 6KA, 6MP. *France*:—7FP, 8AG, 8AL, 8AOA, 8BN, 8CT, 8FG, 8FMA, 8FQ, 8FW, 8HLL, 8JA, 8JC, 8NOO, 8RLH, 8SM, 8TOK, 8WAG. *Belgium*:—P2, R2, T2, ZK. *Holland*:—0HB, 0PM, 0ZA, 2PZ, 0CML, PCUU. *Switzerland*:—9AD, 9BA, 9BR, 9HB. *Italy*:—1AU, 1AY, 1GN. *Sweden*:—SMZS. *Germany*:—A8.

(0-v-0). All below 50 metres.

J. E. MONTGOMERY.

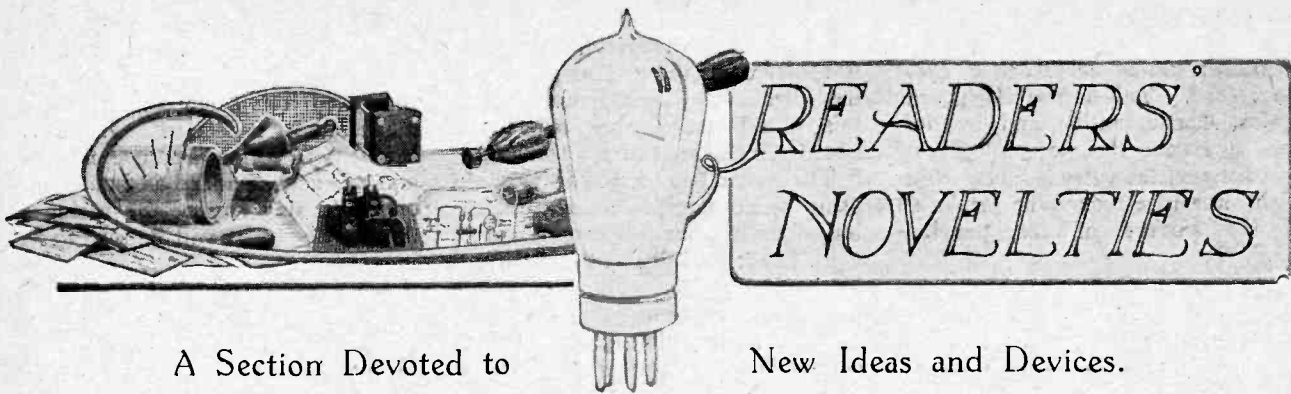

A Section Devoted to

New Ideas and Devices.

SELECTOR SWITCH.

The illustration shows a type of selector switch giving an improved electrical contact. A series of knife switch contacts is arranged radially, and a switch blade, which can be rotated and also moved up and down

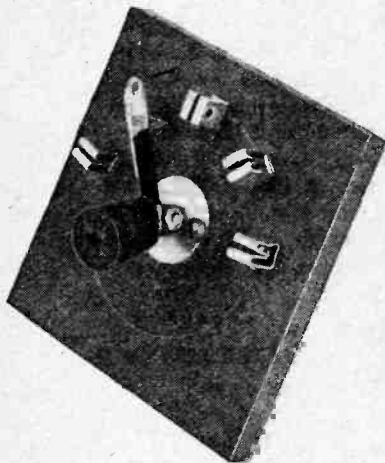

Selector switch with knife switch contacts.

in a vertical plane, is mounted on a spindle, passing through a suitable brass bush. The blade may be attached to the spindle with a knife switch contact of the same type as those used for making the tappings.—H. S. N.

o o o o

VALVES IN SERIES.

The advantages gained in the economical use of filament current by connecting valves in series are often counterbalanced by irregularities in the characteristics of the valve filaments themselves. Thus one of the valves may be near the end of its useful life, and will therefore require a slightly increased filament current to give the emission necessary for L.F. amplification, but since the current in both filaments is always the same, it

cannot be increased above the specified value without detriment to the normal valve. Further, if a different value of H.T. is applied to each valve, the filament current in the valve with the lower value of H.T. could be reduced without reducing signal strength or quality, and its useful life would thereby be increased. Here, again, the need for some method of introducing a slight difference in the filament currents in each valve makes itself felt. The difference required is only slight, and can be produced quite simply and efficiently in the following way.

A standard wire-wound potentiometer with a resistance element of approximately 300 ohms is connected across the outer ends of the pair of filaments when joined in series, and the third contact from the slider is connected to the mid-point between the two filaments. Normally the slider should be set in the electrical centre of the resistance, when, assuming that the resistances of the filaments are equal, the current in each will also be equal. Any movement of the slider on either side of the

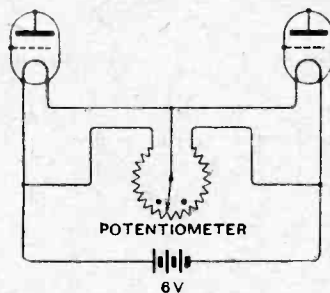

Potentiometer control of filament current in valves connected in series.

centre point will simultaneously increase the current in one filament and reduce it in the other, but the variation on either side must be small.

The reason for this will be apparent if we imagined the slider to have been moved to one end of the resistance; it will be seen that under these conditions one of the filaments will be short circuited, while twice the normal filament voltage is applied to the other. For this reason it is necessary to fit stops as shown in the diagram to limit the movement of the slider.

The method is particularly suitable for 0.06 type valves, with which the advantages of series connections are greatest. With a 300 ohm potentiometer the additional current is only of the order of 20 milliamperes.—G. H. K.

o o o o

VALVE PROTECTION.

If projecting brass valve sockets are used to mount valves, there is a

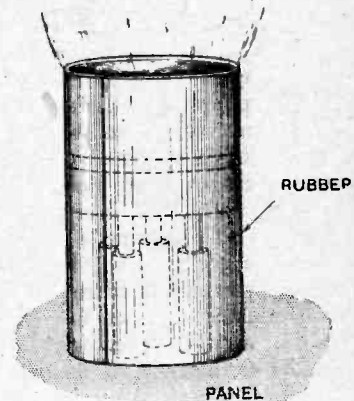

Rubber sleeve protection for valve sockets.

danger of short-circuiting the plate and filament sockets if a metal screw-driver is used to make an adjustment during the testing of the set. This would burn out the filament, and the same result would be produced if during subsequent use of the set one of the battery supply leads were to fall across the panel and touch the sockets.

To guard against this, the writer has fitted to each valve a short length of rubber tubing cut from a cycle inner tube. This effectively guards against short-circuiting, and, in addition, prevents the accumulation of dust between the valve sockets, which might otherwise reduce the insulation of the surface of the panel.—S. F. T.

o o o o

LEAD-IN INSULATOR.

When a simple ebonite tube lead-in is used, ample protection from the injurious effects of rain is provided by an ordinary shaving soap tin fitted as a cap over the end of the

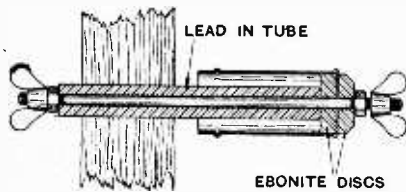

Protecting cover for lead-in tube.

tube. A hole is cut in the end of the tin large enough to clear the brass rod running through the centre of the ebonite tube, and the cover is located centrally and clamped firmly in position by two discs cut from 1/4 in. ebonite sheet.—W. M.

o o o o

NON-CORROSIVE FLUX.

The use of a solution of resin in methylated spirits or alcohol is well known as a non-corrosive flux for use when making soldered connections in electrical apparatus. Unfortunately the consistency of the solution is apt to vary through evaporation, and it becomes necessary from time to time to add more spirit. This often makes the solution so thin that it runs into places where it is not wanted. A few drops of glycerine added to the solution will prevent this, and to a certain extent will make for greater uniformity in the consistency of the flux.—E. J. H.

o o o o

EXPERIMENTAL TRANSFORMER.

In experimenting with low-frequency transformers for different types of amplifying valves it is necessary to vary the number of turns in both the primary and secondary windings. Tapped transformers are frequently used for this purpose, but they are seldom satisfactory on account of the self-capacity of the

turns which are not connected in the circuit. It is, of course, impossible to short-circuit these turns to obviate the effects of the self-capacity, as this would considerably reduce the effective inductance of the windings.

The writer has for some time been using sectionalised windings consisting of units wound in ebonite spools 2 1/4 in. in external diameter and 1/4 in. or 3/8 in. wide. The units are quite robust and can be assembled and dismantled without damage. With this system it is possible to build up a transformer of any given ratio having windings of any desired inductance.—M. R.

o o o o

PULLEY REPAIR.

The pulley at the top of a 40ft. steel mast having broken, the following method proved successful in replacing the aerial without the necessity of lowering the mast. The mast was stayed with guy wires, four of which were attached to the top mast, and no insulators were in this case inserted in the guy wires for the purpose of reducing eddy currents.

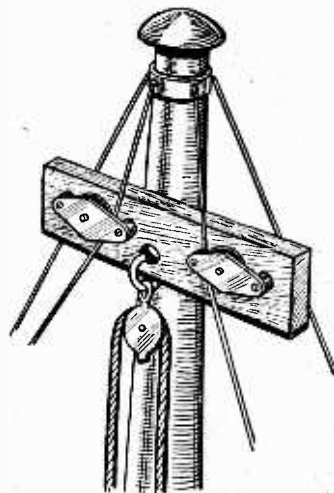

Broken aerial pulley replaced by means of guy wires.

Two small pulleys were screwed to a flat piece of hard wood, the aerial pulley being mounted between them. Two of the guy wires were then detached at their lower ends. These wires were then inserted through the pulleys and pulled outwards, with the result that the unit together with the pulley was raised to the top of the mast. The guy wires were then again anchored to the stakes driven into the ground, thus retaining the pulley unit in position.—J. O.

COUPLED TUNER UNIT.

When the construction of receivers with plain aerial tuning has been completed it is often discovered that the selectivity is deficient. A coupled circuit will often improve matters, and this may be added as a unit without disturbing any of the wiring in the receiver. It will be seen in the

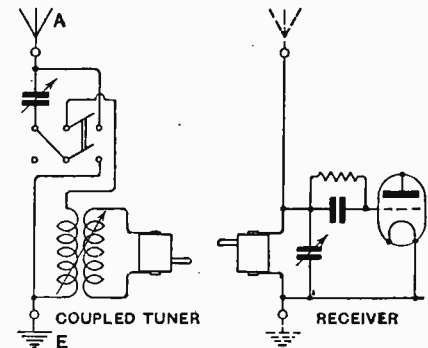

Loose-coupled tuner attachment.

diagram that the secondary coil of the tuner unit is connected to a coil plug fitting in the A.T.I. coil holder of the receiver. The new A.T.I. in the tuner unit is tuned by a condenser, which may be connected either in series or in parallel. Terminals are provided on the tuner for the aerial and earth, which are transferred from the set when the tuner is in use.—L. B. W.

o o o o

PANEL SUPPORTS.

When testing receiver panels before insertion in a cabinet or box, it is convenient to have some means of supporting them horizontally or vertically, which is not likely to be displaced if the panel is accidentally knocked.

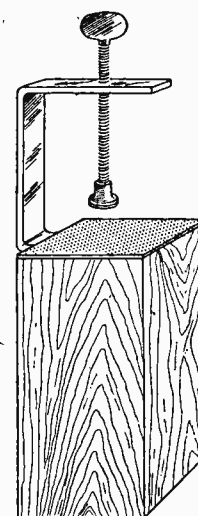

Supporting block for experimental panels.

It is possible to purchase simple iron clamps of the type illustrated in the diagram, which can be permanently screwed to a block of wood of convenient height. Two blocks will be necessary, one for each side of the panel.—A. S. C.

Wireless Exhibition

ROYAL HORTICULTURAL HALL



A Stand-to-Stand Review.

The following is a selection of the apparatus displayed on the stands.

EBONITE SHEETS, TUBES, Etc.

Stand No. 1.—F. W. Lowenadler, Audrey House, Ely Place, Holborn Circus, London, E.C.1.

Trelleborg ebonite, obtainable in sheets, rods, tubes, panels, blocks, and moulded articles. A special property of this ebonite is that it machines well, and, according to a report by the National Physical Laboratory on the insulation resistance when measured between two mercury electrodes 7.6 centimetres in diameter, the resistivity for the centimetre cube is over two hundred million megohms. The same material is obtainable with a red mottled finish.

"KLUTCH" TERMINALS.

Stand No. 2.—Simon Bros. (Engineers), Ltd., Broadmead House, 21, Panton Street, Haymarket, London, S.W.1

This spring clip terminal can be used in place of the ordinary screw-down type terminal, and facilitates the making of reliable and rapid circuit connections. When used in the place of telephone terminals, for example, several telephone tags of the spade or wire type can easily be fitted. Made in brass and nickel-plated.

HINDERLICH CRYSTALS.

Stand No. 3.—A. Hinderlich, 1, Lechmere Road, Willesden Green, London, N.W.2.

The range of crystals includes:—arzenite (detecting), arzenite (oscillating), bornite, carborundum, cassiterite, chalcopyrite, copper pyrites, galena, hertzite, iron pyrites, molybdenite, silicon, tellurium, zincite (red), zincite (yellow).

Arzenite is specially suitable for use in oscillating crystal circuits.

REFLEX COILS.

Stand No. 4.—Reflex Radio Co., Ltd., 198, Lower Clapton Road, London, E.5.

Among coils of the plug-in type in which the turns are self-supporting and arranged in a manner to produce low self-capacity is the Reflex type coil manufactured under Burndeft licence. The series includes nineteen coils, and covers a wave range of 180 to 30,000 metres.

"HARMO" PERMANENT DETECTOR.

Stand No. 5.—The Sclerine Crystal Company, 4a, Aubrey Road, Walthamstow, London, E.17.

Crystal receiving sets would be more generally adopted if the difficulties of maintaining the detector in a sensitive condition could be overcome.

The "Harmo" detector is totally enclosed under a nickelled cover entirely protecting the crystal contacts, which consist of elements specially treated to obtain a stable adjustment. No external adjustment is provided, and a two-pin mounting permits of the detector being easily removed from circuit. It is stated by the manufacturers that crystals of this type have been on test for many months receiving 2LO and 5XX at a distance of thirty miles from London, and have given complete success.

WIRELESS FURNITURE.

Stand No. 6.—The Reigate Radio Co., Leigh, Reigate.

The cabinets are constructed in various designs and woods—walnut, mahogany, oak, etc.—and are adapted to house any type of receiving equipment. The range of cabinets includes reproductions of antique models, and any suitable piece of furniture can be converted to serve as a wireless cabinet.

SQUARE LAW VARIABLE CONDENSERS.

Stand No. 8—Stella Products, Ltd., 13, Wybert Street, London, N.W.1.

A reliable condenser in all respects, offered at an exceedingly low price, constructed with moulded end plates, unbreakable bakelite knob and dial, one-hole fixing, and plates for square law tuning.

THE WEMBLEY LOUD SPEAKER.

Stand No. 8.—Stella Products, Ltd., 31, Wybert Street, London, N.W.1.

A low-priced yet reliable loud-speaker and suitable for use in a moderate-sized room. It is of British construction, and represents exceedingly good value.



Commander J. M. Kenworthy, M.P., who opened the Exhibition.

Wireless Exhibition.—

NEW TYPE T.C.C. CONDENSERS.

Stand No. 9.—Telegraph Condenser Co., Ltd., West Park Works, Mortlake Road, Kew Gardens.

The Mansbridge condenser, made by the Telegraph Condenser Co., is used extensively in the construction of receiving sets, and is well-known to the amateur. A recent addition is a series of small type condensers with mica dielectric. The form of mounting is a small moulded case with rounded corners, the condenser element being inserted from the bottom and sealed in. They are finished in green, to be uniform with other T.C.C. products, and are obtainable in capacities from 0.0001 to 0.004 mfd.

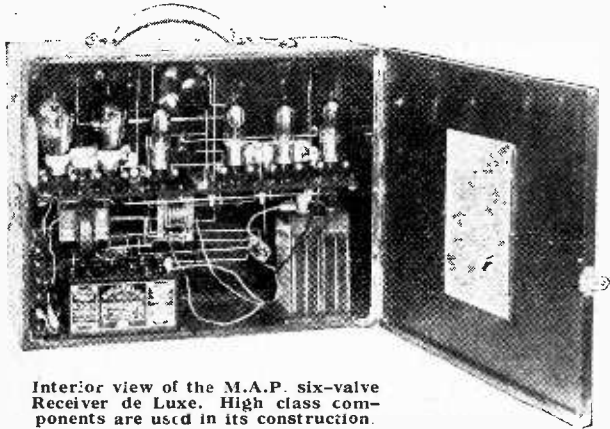

Interior view of the M.A.P. six-valve Receiver de Luxe. High class components are used in its construction.

The Mansbridge condenser consists of paper upon which a metallic coating has been deposited. The range of large capacity fixed condensers includes types in which waxed paper is used as a dielectric, the plates being of tinfoil.

Other condensers are available built to withstand high voltage, direct, and alternating currents, and are particularly suitable for use in transmitting circuits, one model withstanding 3,000 volts A.C. at a frequency of 50 cycles and having a capacity of 0.5 mfd.

Two other condensers from the range are designed to withstand potentials of 7,500 volts direct current with capacities of 0.002 and 0.01 mfd. Condensers are, of course, built to any required capacity.

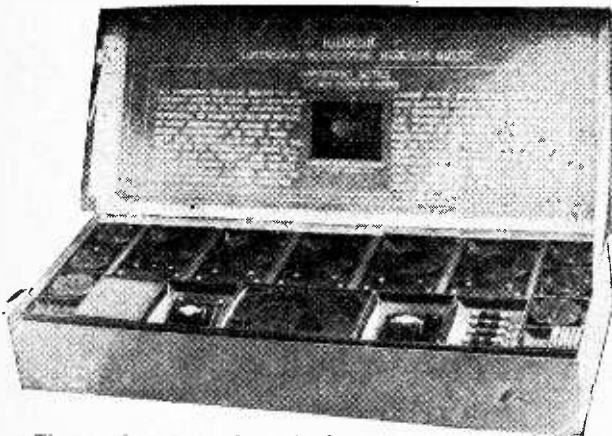

The new Superheterodyne Kit of the Igranic Electric Co., Ltd.

B 2

BROWN LOUD-SPEAKER. TYPES H.3 and H.4.
Stand Nos. 10, 11.—S. G. Brown, Limited, Victoria Road, North Acton, London, W.3.

The construction of the Brown loud-speaker, fitted with a conical aluminium diaphragm, and driven by

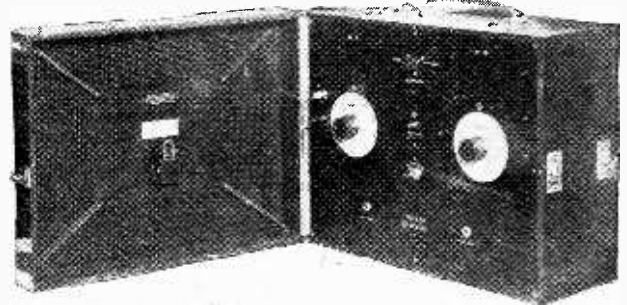

The front panel of the M.A.P. six-valve Receiver de Luxe has a clean and attractive appearance. The tuning dials rotate through a complete revolution.

means of a reed, is well known, and this form of construction has been applied to the new type instruments H.3 and H.4.

The new instruments are fitted with metal horn and flare, whilst an adjustment is provided for critically regulating the distance between the reed armature and the pole pieces. The outline of the base piece is entirely new. The smaller instrument, type H.4, which is inexpensive, is 10 in. in height, and the H.3, a larger model, is built on similar lines.

BROWN CABINET LOUD-SPEAKER.
Stand Nos. 11, 12.—S. G. Brown, Limited, Victoria Road, North Acton, London, W.3.

A beautifully proportioned cabinet type loud-speaker, which, being mounted in a rich rosewood shade of mahogany, will readily harmonise with any furniture. This pleasing design has been evolved to meet the prejudices of those to whom the more conventional horn models are distasteful.

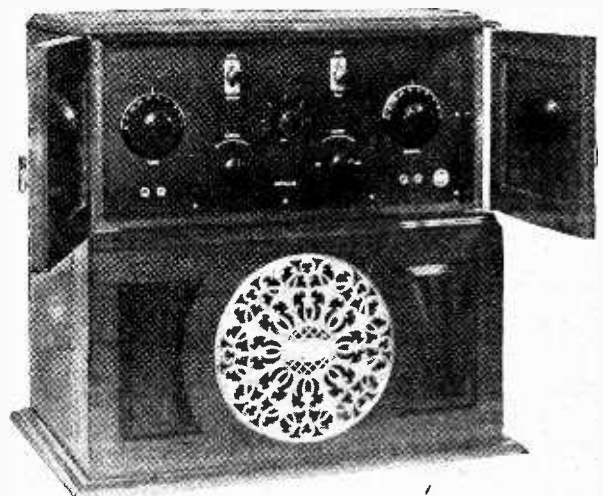

The Retola III, an entirely self-contained set made by Rectax Ltd. An interesting circuit arrangement is employed giving good selectivity, while a choice of two programmes is obtained by means of a two-way switch. The cabinet work is particularly well finished.

Wireless Exhibition.—

The front portion of this instrument is quartered, and the cabinet is finished in a most excellent manner. The totally enclosed horn is of cast-iron, and, with the other

rectification is produced by a carefully designed commutator. The standard model has an output of 2 amperes at 4 or 6 volts.

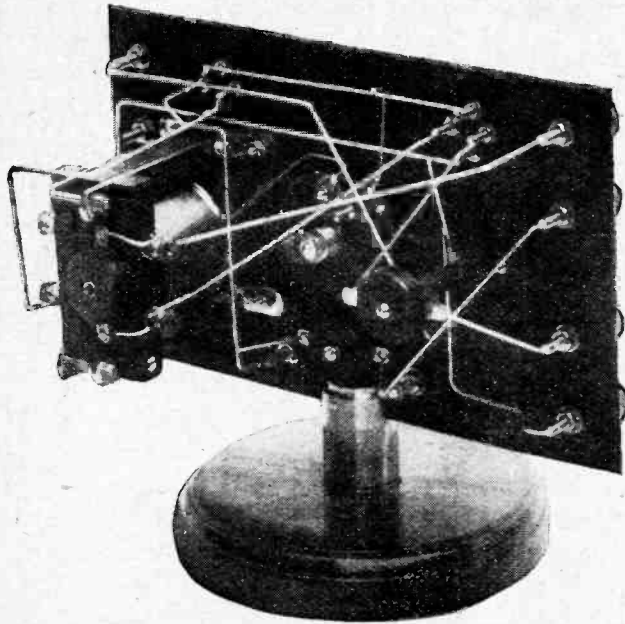

This instrument panel shows the several applications of Watmel products. The Watmel variable grid leak supports the new type fixed condenser, whilst another fixed capacity condenser bridges the transformer primary.

component parts, entirely fills the interior of the cabinet. It is a practically non-resonant instrument giving an exceedingly good tone.

FELLOWS ROTARY RECTIFIER.

Stand Nos. 12, 17, 18, 23.—Fellows Magneto Co., Ltd., Cumberland Avenue, Park Royal, Willesden, London, N.W.10.

The synchronous rectifier is one of the best solutions of the difficulty of charging accumulators from alternating current mains.

This rectifier, exceedingly simple in construction, consists of a polarised armature rotating in a field energised from the alternating current supply. The potential of the mains is stepped down through a transformer, and

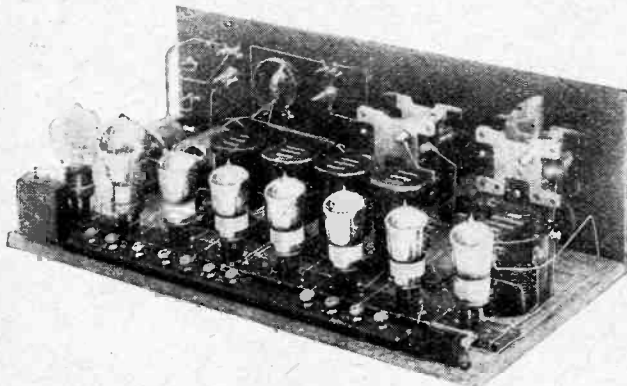

Eight valve superheterodyne receiver built from a set of parts supplied by Peter Curtis, Ltd.

FELLOPHONE "PORTABLE THREE."

Stand Nos. 12, 17, 18, 23.—Fellows Magneto Co., Ltd., Cumberland Avenue, Park Royal, Willesden, London, N.W.10.

The Fellows receiving sets are well-designed and constructed, and are offered at prices representing exceedingly good value.

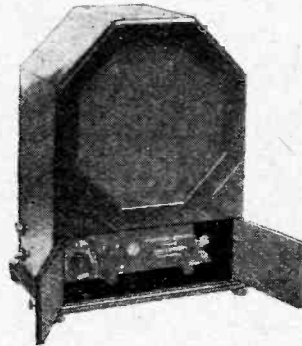

Elwell Statophone, a self-contained set with loud speaker.



One of the specimens of cabinet work exhibited by the Reigate Radio Co.



An interesting instrument shown by Read & Morris, Ltd., for deriving filament and plate current from public supply mains.

The portable set employs a dual amplification circuit which on test was found to be exceedingly stable, with a reaction adjustment that proved to be exceedingly smooth and easy to control. Tested in a screened position at a distance of four miles from Z.L.O., signals were strong enough to operate a small loud-speaker giving good quality reproduction. The frame aerial is enclosed in the lid of the instrument, so that it can be swung round to a position giving stronger signals. Batteries are included in the set, filament current being obtained from a non-spillable accumulator.

Wireless Exhibition.—

FELLOWS VARIABLE CONDENSER.

Stand Nos. 12, 17, 18, 23.—Fellows Magneto Co., Ltd.,
Cumberland Avenue, Park Royal, Willesden,
London, N.W.10.

An unusual form of construction is adopted in this instrument, the plates of which are so set up that by means of a cam, operated by the knob and spindle, they are moved towards the face of a copper strip. The latter is kept in tension by means of springs, whilst a strip of mica laid over the copper foil not only prevents short circuit, but makes this instrument suitable for operating at high potentials. The largest size, which has a capacity of 0.001 mfd., consists of two sections, whilst capacities of less than 0.0005 mfd. are obtained by reducing the width of the copper strip.

SETS OF PARTS FOR BUILDING RECEIVERS DESCRIBED IN CONSTRUCTIONAL ARTICLES.

Stand No. 14.—New Times Sales Co., 56, Ludgate Hill,
London, E.C.4.

A service which will be appreciated by many readers of wireless journals is conducted by this company, which not only provides all the components necessary for making up any particular set, but, when required, will arrange to supply on easy terms.

THE M.P.A. SIX-VALVE PORTABLE RECEIVER DE LUXE.

Stand Nos. 15, 16.—The M.P.A., 62, Conduit Street,
Regent Street, London, W.1.

This latest addition to the range of portable receiving sets in many respects marks progress in the design of portable outfits. An unusual feature is the inclusion of three high-frequency amplifying stages rendered control-



Bullphone
loud-speaker.

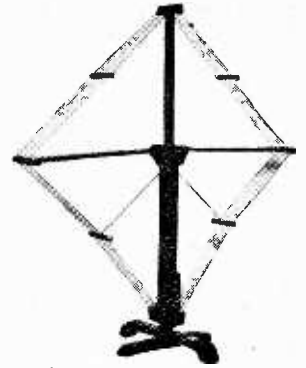

A large frame aerial which is easily dismantled—the Amplifex, a product of the Penton Engineering Co.



The new loud-speakers of S. G. Brown, Ltd. types H.3 and H.4.

lable by two tuning circuits which can, of course, be manipulated almost simultaneously. The tuning dials operate through gearing, and cover 360 degrees. A very attractive appearance is given by the dials, which rest symmetrically on a clean panel unobscured by a number of fittings. The valve detector is followed by two low-frequency amplifiers, the second amplifying stage being removed from the circuit by means of a break-jack, and in accordance with usual practice, the frame aerial is enclosed in the lid. The set is supplied complete, and the price quoted, including valves, batteries, and headphones. The well-finished cabinet, in polished mahogany, is provided with a waterproof cover. The set is brought into operation by means of a key switch.

THE SERENADA LOUD-SPEAKER.

Stand No. 19.—The Serenada Manufacturing Co., Ltd.,
22, Paper Street, London, E.C.1.

Although there is very little scope in the design of the trumpet type loud-speaker, a variance from the orthodox construction is the adoption of a new type of horn. The manufacturers state that the basis of the material used is a form of cloth, and although the finished product is rigid and tough, it possesses the property of reducing resonant effects from the trumpet itself.



Serenada
loud-speaker.

The Brandes loud-speaker and new type intervalve transformer.

Wireless Exhibition.—

"THERLA" CONDENSERS.

Stand Nos. 20, 21.—The "Sel-Ezi" Wireless Supply Co., Ltd., 6, Greek Street, London, W.1.

The various stages in the process of the construction of the Therla condenser are demonstrated, from the blanking out of the metal case which clamps the plates together, to the assembly by means of a jig and press. Specimens of the selected mica can be examined and samples are shown after splitting, grading, and cutting to size. In order to ensure that the condenser shall be constant in value, methods of extreme accuracy are adopted for the determination of the thickness of the sheets. An optical micrometer is used for this purpose, producing a magnification of 25,000. A valuable feature as far as the user is concerned is that all Therla condensers are certified to be true to value by the Faraday House Testing Laboratories. A capacity bridge set, fitted with a direct reading scale, is shown in operation.

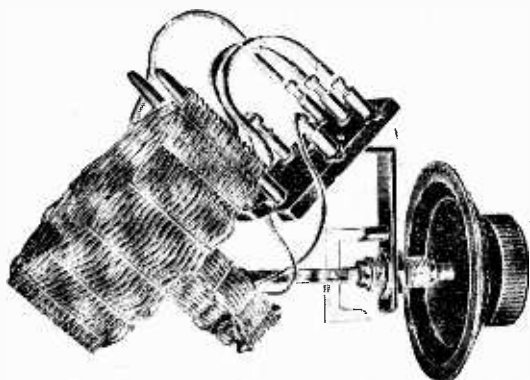

"Seagull" low loss tuner.

SEAGULL LOW LOSS TUNER.

Stand No. 24.—Seagull Limited, R.N. Works, Newcastle Place, Edgware Road, London, W.2.

The instrument consists of a pair of coupled coils wound as tubular basket coils and supported with a minimum of dielectric material. The smaller coil rotates through 180° by means of a bearing provided by a one-hole fixing, thus producing a variable coupling.

All the advantages of the interchangeable plug-in coil system are obtained in this tuner, for a series of coils are supplied which are held in position by a pair of ebonite pegs, the circuit connections being easily effected by means of plugs and sockets. A tuning range of from 50 to 2,000 metres is thus obtainable.

A useful feature is the inclusion of a tapping point on the tuning coil, so that it can virtually be employed as an aerial and secondary circuit with fixed coupling.

SUPERHETERODYNE KIT.

Stand Nos. 27, 28, 29.—Peter Curtis, Ltd., 75a, Camden Road, London, N.W.1.

The set of parts includes the aerial tuning inductances and oscillator coils, the input filter circuit and high-frequency transformers. It is a 7-valve set with separate valves as detector and oscillator and two intermediate high-frequency stages. By means of a two-way switch



The new variable condenser of the Formo Company.

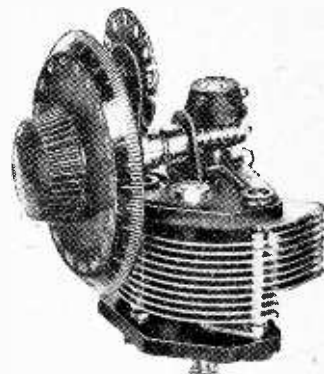

Colvern geared variable condenser with indicating dial, a new product of the Precision Screw Co., Ltd.

the lead to the grid circuit of the first detector valve can be transferred to the detector valve immediately in front of the low-frequency stages, so that the oscillator and intermediate amplifier are not in use. Capacity reaction is provided, and is adjustable from a knob on the front of the panel. The intermediate amplifier is stabilised by the use of a potentiometer.

LOTUS 2 AND 3-WAY COIL HOLDERS.

Stand Nos. 27, 28, 29.—Peter Curtis, Ltd., 75a, Camden Road, London, N.W.1.

The Lotus coil holders are well finished, clean ribbed mouldings being used for the insulating parts. The gearings which provide a reduction of 8 to 1, is totally enclosed, and consists of an intermediate two-wheel brass pinion operating in a segment. It can be mounted on the baseboard behind the panel or attached to the front of the instrument.

IGRANIC SUPERHETERODYNE KIT.

Stand Nos. 32, 33.—Igranic Electric Co., Ltd., 147, Queen Victoria Street, London, E.C.4.

The design of the various essential units contained in the outfit is such that the actual constructional work is rendered extremely easy, and may be accomplished by those possessing very little skill, with the aid of a few simple tools. Each unit is mounted upon a special base of moulded bakelite, and six of the bases are provided with means for mounting the Igranic anti-microphonic valve-holders, which are supplied. Metal strips, which are insulated from the angle brackets, serve the dual pur-



A new type of tuning coil designed by the Radio Reception Co.



The Energo coil.

Wireless Exhibition.—

pose of linking up the bases of the tuning units and forming bus-bars for carrying filament supply. The receiver makes use of six valves, the first valve acting as detector

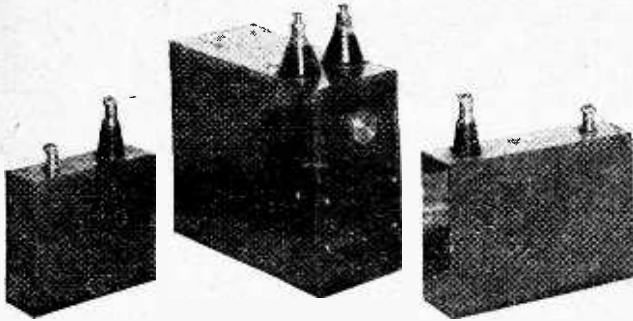

High tension smoothing and oscillatory circuit condensers made by the Telegraph Condenser Co., Ltd., and suitable for use in amateur transmitting circuits.

and oscillator. The intermediate high-frequency amplifiers are arranged to be self-stabilising, this system giving more efficiency than the usual potentiometer method, with its deliberate introduction of losses as a means of suppressing undesirable oscillation. All units are interchangeable, and the oscillator units are supplied in three sizes, tuning over a wave range of 215 to 4,500 metres. An instructional envelope is supplied, which gives complete details for making up the set and includes a full size drawing for wiring and drilling purposes.

INDIGRAPH DIAL.

Stand Nos. 32, 33.—Igranic Electric Co., Ltd., 147, Queen Victoria Street, London, E.C.4.

The upper half of the scale, which is divided in the usual manner, is visible through a window pierced in the dial cover. A similar window serves the same purpose in the lower half of the scale, and the index points situated at the centre of each window simplify the setting of the dial by showing both scale reading and the adjustment to tune to a given station or other predetermined position. The dial is obtainable in four sizes, from 1½ in. to 4 in. in diameter.

BRANDES LOUD-SPEAKERS.

Stand No. 34.—Brandes, Limited, 296, Regent Street, London, W.1.

The "Brandola" is a full-size loud-speaker incorporating many refinements and improvements, whilst the adjustable "Table Talker" model has not only been improved in design, but is reduced in price, and now sells at a very moderate figure.



Therla grid condenser and leak and bridging condensers

B 6

"ROTOLA III."

Stand Nos. 35, 36.—Rotax (Motor Accessories), Ltd., Rotax Works, Willesden Junction, London, N.W.10.

The main design has been to provide a sensitive set with a minimum number of controls. The circuit follows the standard design of a detector valve with two transformer-coupled amplifiers, and a useful addition is the inclusion of a rejector circuit. The tuning circuits are duplicated, so that a selection of two programmes is provided by the simple movement of a switch. The cabinet is a really well-finished job in polished mahogany with a lifting lid and double doors.

THE "KONE" LOUD-SPEAKER.

Stand Nos. 37, 38, 39.—Western Electric Co., Ltd., Connaught House, 63, Aldwych, London, W.C.2.

This loud-speaker has only recently been introduced, and operates by throwing into vibration a large-diameter cone by means of a drive applied at its centre. Richness and fullness of tone is obtained, and, being non-directional in character, there is no necessity for listeners to be grouped before the instrument, the distribution of sound in all directions being practically uniform.



The products of the Michrom Engineering Co. include an intervalve transformer of original design and a low capacity tubular condenser, for use as a vernier or for circuit balancing.

**EUREKA FRAME AERIAL.**

Stand Nos. 42, 43.—The Portable Utilities Co., Ltd., Eureka House, 8, Fisher Street, London, W.C.1.

The turns of wire are arranged in the form of a hexagonal frame extending to a height of 5 ft. and a width of 3 ft. 9 in. One movement opens or closes it, and when locked in position it is absolutely rigid. By an ingenious arrangement of "Clix" terminals, any number of turns can be included in the circuit, the unwanted turns being short-circuited.

SILVERTOWN WINDOW-PANE INSULATOR.

Stand Nos. 46, 47.—The India Rubber, Gutta Percha & Telegraph Works Co., Ltd., Silvertown, London, E.16.

As glass is such a good insulator, the most efficient method of bringing the aerial into a building is through the glass of a window. In taking advantage of the insulating properties of the glass, a form of "bushing" is necessary, and to meet this requirement an insulator has been produced in ebonite and is arranged to clamp on to the window. It consists of a double ebonite shed on one side and a single shed on the other, and rubber rings are provided which makes a watertight contact with the glass. Grinding a hole through a sheet of glass is quite a simple operation, requiring only a hand-drill, a

Wireless Exhibition.—

copper grinder, some carborundum powder, and a little turpentine. The grinder and necessary powder are supplied with the insulator, together with full instructions as to the procedure to adopt.



New type Enerco intervalve transformer.

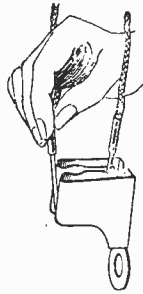

The "Clutch" terminal.

SILVERTOWN LOW FREQUENCY TRANSFORMERS.

Stand Nos. 43, 47.—The India Rubber, Gutta Percha & Telegraph Works Co., Ltd., Silvertown, London, E.16.

A reasonably heavy gauge of wire is employed and wound by a special process, producing a transformer of ample dimensions. The core is of "stalloy" stampings and is of large section for the purpose of reducing magnetic leakage and iron losses. Several types, differing in the arrangement of the windings, are available. Type B576 has a winding ratio of 4 to 1, and the B500 a ratio of 2 to 1. Type B572 is an interesting instrument provided with mid-point taps on both primary and secondary, which is, therefore, suitable for use in apparatus employing "push-pull" circuits. Another model, type B501, has a ratio of 5 to 1.

THE LOVELAND AUTOMATIC ACCUMULATOR CARRIER.

Stand No. 52.—Loveland & Co., Ltd., 4, Albion Parade, Norbury, S.W.16.

The accumulator is placed upon a wooden base, and, by the action of lifting on the handle, rubber-faced side members are brought into position, producing a secure hold. The carrier is supplied in three sizes, each covering a wide range, is light and strong, and folds flat when not in use. It is a most useful accessory, and its introduction will be welcomed by many amateurs who are not fortunately placed with regard to facilities for charging their accumulators at home.

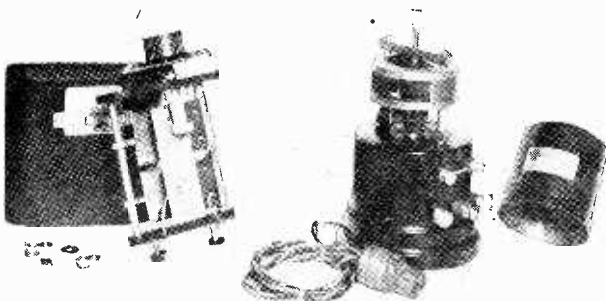

Products of the Fellows Magneto Co., Ltd. A new type variable condenser of unusual design and a rotary synchronous rectifier for battery charging.

"RECEPCO" LOW LOSS COILS.

Stand No. 56.—The Radio Reception Co., 110, Wilton Road, Victoria Station, London, S.W.1.

The turns of wire are given a side-by-side spacing, as well as a spacing between layers. Insulating strips resting on the layers provide spacing for subsequent layers. A special feature is that these insulating pieces consist of a hard core with a surface of pliable material. By this means the turns bed down into the soft outer surface and are held firmly in position, both turns and spacing pieces being unable to move. Readers who have made a study of coil design will no doubt appreciate the merits of this arrangement.

TROIDAL LOW FREQUENCY TRANSFORMER.

Stand No. 57.—Microhm Engineering Company, "Varsity Works," College Street, London, E.9.

This is a transformer of new and unusual design. The windings are arranged on an ebonite former, just over

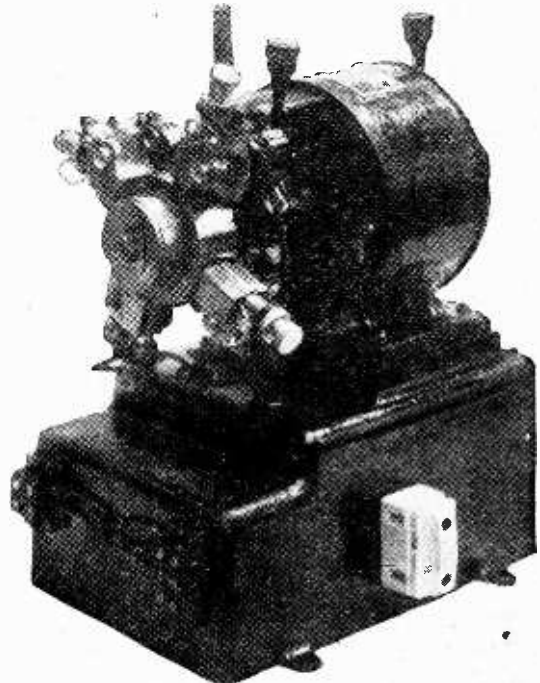

The M.W. rotary rectifier.

2in. in diameter and about 3/4in. in width. The core is formed in four sections, consisting of closed magnetic circuits embracing the coil at intervals. The winding ratio is 4 to 1.

PROGRESS IN EBONITE PRODUCTION.

Stand No. 59.—The St. Helens Cable and Rubber Co., Ltd., Slough, Bucks.

The standard arrived at in the production of high quality ebonite for wireless apparatus is well represented in the work of the St. Helens Cable and Rubber Co. Panels in all shapes and sizes are on view, together with specimens of turned ebonite, ebonite rods, and cylinders. An interesting feature is a display demonstrating, by means of specimens, the manufacture of ebonite from the raw rubber to the finished product.

Wireless Exhibition.—

"M.W." BATTERY CHARGING SETS.

Stand No. 64.—M. W. Woods, 15-16, Railway Approach,
London Bridge, London, S.E.1.

The "M.W." rectifier is a small synchronous alternating current motor, fitted with an interrupting commutator and three brushes carried on an adjustable brush-rocker. It is mounted on a cast-iron box, in which is



Demonstration of the winding process adopted in the manufacture of Energo transformers.

fitted an auto-wound transformer. Machines are available for operating on supply voltages of 50 to 250 at 50 to 60 cycles, and through a range of seven models voltage outputs are obtained of 8 to 80 and up to a maximum current of 20 amperes.

A very useful type of machine is the Rotary Transformer recently introduced, designed for battery charging from D.C. public supply mains. The machines are fitted

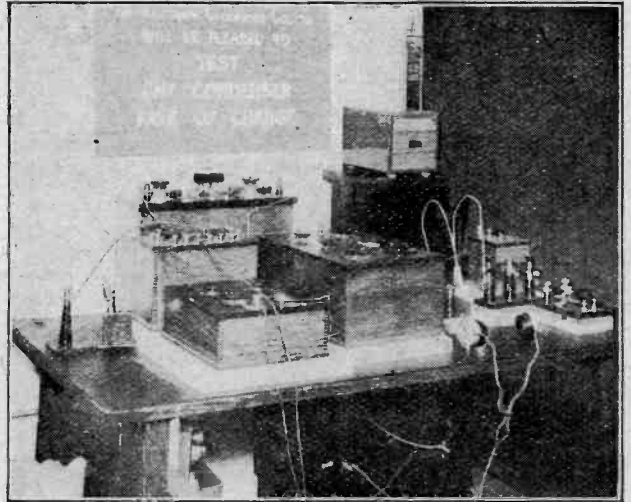

The Wien bridge capacity testing set of the Telegraph Condenser Co., Ltd.

with two commutators and made in six models, giving outputs from 24 to 400 watts. The smallest type, giving 8 volts at 3 amperes, or 6 volts at 4 amperes, should prove exceedingly useful for home accumulator charging, and has an efficiency far superior to the usual method of accumulator charging in which the supply voltage is dropped through a bank of lamps.

THE NEWEY VARIABLE CONDENSER.

Stand Nos. 67, 68.—Pettigrew & Merriman Ltd., 122-124,
Tooley Street, London, S.E.1.

The "Newey" Variable Condenser is of new and unusual design, both sets of plates being arranged to move and operate through a pinion attached to the instrument dial and segments secured to the spindles supporting the plates. The plates are of brass, finished bright, and welded together with a bonding strip and also to the supporting pillars. It is obvious that the form of construction adopted produces a condenser with exceedingly low minimum capacity, and the method of supporting the plates is one that will confine losses to a minimum. The dial moves through 360 degrees, thus providing critical control, and a square law capacity curve is obtained. The moving vanes are positively connected to the terminals by pigtail connections to eliminate the losses which may be set up by rubbing contacts. The end plates are bakelite mouldings.



Making and testing Thera condensers at the stand of the Sel-Ezi Wireless Supply Co., Ltd. The testing equipment is supplied by Faraday House.

CURRENT TOPICS

News of the Week — in Brief Review

THE GREAT JAM.

According to a recent computation there are 922 broadcasting stations in operation throughout the world. Readers who believe they have heard all these stations will kindly refrain from reporting the fact.

○○○○

RADIO ON THE GOODWINS.

Several of the lightships on the Goodwin Sands have been equipped with wireless installations. The Trinity House authorities will deal similarly with other ships round the coast as funds and opportunity allow.

○○○○

2NM AGAIN.

Another record has fallen to the key of Mr. Gerald Marcuse (G2NM), who has succeeded in establishing two-way communication with a station at Kohat, on the north-western frontier of India.

Signals were exchanged on 45 metres. Mr. Marcuse used Marconi Type T250 valves with 600 watts.

ANOTHER GERMAN BROADCASTING STATION.

The new German broadcasting station at Dortmund has begun experimental transmissions on a wavelength of about 265 metres.

○○○○

FREE STATE BROADCASTING COMMITTEE.

Mr. J. C. W. Reith, managing director of the B.B.C., and Sir Hamilton Harty, conductor of the Hallé Concerts, Manchester, have been appointed to the Selection Committee for broadcasting in the Irish Free State.

○○○○

NEW TELEFUNKEN STATION.

A wireless telegraph station, employing the Telefunken system, has been opened at Salinas, a point 70 miles east of Para, under the supervision of the Brazilian Telegraph Department. The charge for transmission to foreign vessels is one franc per word.

AMERICAN FARMERS AND WIRELESS.

According to a recent survey by the U.S. Department of Agriculture, the increase in the number of farms using wireless sets, from 365,000 in 1924 to over 550,000 in the present year, is due to the need for prompt market information in merchandising farm products, the educational value of wireless, and its entertainment features.

The greatest development in the use of wireless on farms is recorded in the corn belt States, the south having been slow to develop broadcasting as a source of current crop information, due to natural conditions hampering clear reception.

○○○○

WIRELESS "COMMERCIALLY IMPOSSIBLE."

Under the title "London in 1900," the *Daily Express* publishes regular extracts from the Editor's Diary of 25 years ago.

An entry under the date of October 5th makes interesting reading in the light of present-day developments in wireless.

"These Post Office people (runs the note) are very conservative. I heard Sir William Preece, the chief engineer of the Post Office, deliver himself to-day of an unequivocal statement that 'wireless telegraphy is not, and cannot be, a commercial success.' In spite of the delicate and interesting experiments of young Marconi, who is half Italian and half Irish, Preece held that 'wireless telegraphy cannot supersede the present wire system. It may be used under exceptional circumstances by the Army and Navy, but commercially it is impossible.'"

○○○○

THE LATE CAPTAIN RIALI SANKEY.

We regret to have to record the death, which occurred at Ealing on Saturday, October 3rd, of Captain M. H. P. Riall Sankey, C.B., C.B.E., R.E.

Captain Sankey, who was in his seventy-second year, was a director and consulting engineer of Marconi's Wireless Telegraph Co., Ltd., and a director of numerous other companies. He was a Past President of the Institute of Mechanical Engineers, and a Vice-President of the Institution of Electrical Engineers.

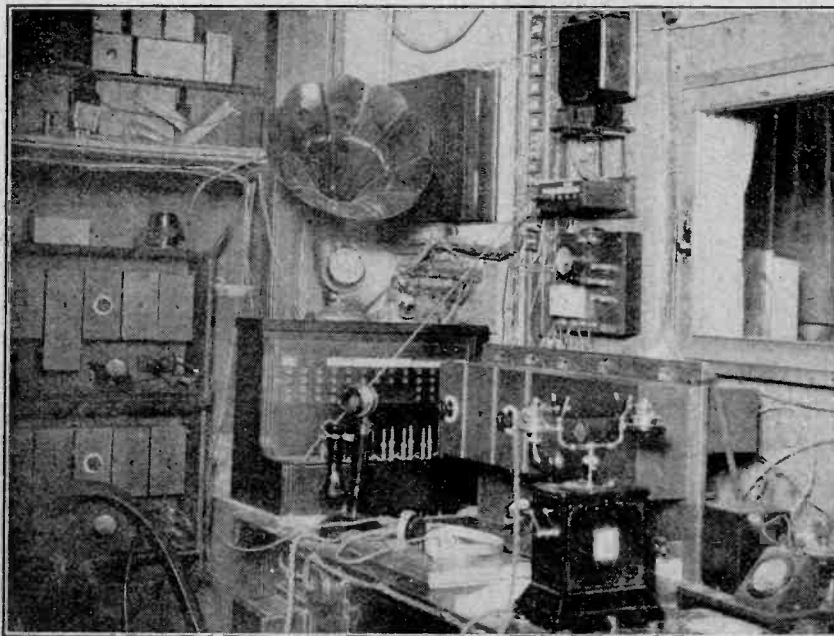

AT NEWCASTLE. A new photograph of the Control Room at 5NO. The "S.B." switchboard can be seen beneath the loud-speaker.

BRITISH-SOUTH AFRICAN DX.

The linking-up of South Africa and Great Britain by amateur wireless has long been a tempting objective for DX enthusiasts. The honours fall to Mr. F. A. Mayer (G2LZ), of Wickford, Essex, and Mr. J. Streeter (OA4Z), of Capetown, who effected two-way communication on Sunday, October 4th.

Mr. Mayer, who worked on 44 metres, was carrying out experiments with a new type of Osram transmitting valve. Mr. Streeter operated on 34 metres.

SOCIALIST PROPAGANDA BY WIRELESS.

The Socialist organisation in New York has been somewhat handicapped by the inability of its leaders to get its views published by the existing publicity agencies. A new avenue of propaganda is now being sought, viz., broadcasting, and a sum of \$350,000 yearly has been promised by the American Fund for Public Service to buy the control of one of the city's broadcasting stations for a few hours daily.

WIRELESS EXPENDITURE IN AUSTRALIA.

Australia's proposed loan expenditure for 1925-26 includes a large amount which is to be appropriated for the development

NEW VOLUME IN JANUARY.

The present volume of *The Wireless World* will be completed in December, in order that the new volume may commence with the first issue in January.

INCREASED POWER FOR AMERICAN BROADCASTING.

The attitude of the U.S. Chamber of Commerce towards high-power broadcasting stations is said to have changed during the past year. Fears were originally entertained that the licensing of stations with high power would mean interference with local reception. Recent tests appear to have altered this view, and a change of policy is shown by the fact that several stations have increased their power from 3 1/2 to 5 kilowatts.

RANGOON'S BROADCASTING STATION.

Slowly, but surely, India is building up a broadcasting system which should eventually cover the entire Empire. In consequence of the amalgamation of the radio

BROADCAST HELP FOR THE FARMER.

Appreciation of the B.B.C.'s weather forecasts to farmers is shown by a letter to *The Times* from an Essex farmer, Mr. J. F. Wilkes. The writer states that during his harvest, which extended from August 1st to September 6th, he lost six whole days due to bad weather; each wet day was accurately forecast in the B.B.C.'s bulletin and consequently warning was given in time. "Fine weather was also accurately forecast," wrote Mr. Wilkes, "so that my bailiff was able to have some reasonable idea beforehand how best to allot the harvest work in anticipation of a fine, wet, sunny, or cloudy day to follow."

GREENLAND-DENMARK WIRELESS LINK.

On September 22nd the new wireless station at Julianehaab, in South Greenland, established for the first time direct connection with the Lyngby station, in Denmark. The Julianehaab station is the largest of the four wireless installations which Denmark has been erecting during the past twelve months; it is intended for direct communication between Copenhagen and the Faroe Islands.

The wireless station at Angmagssalik, on the south-east coast of Greenland, was opened in July, and will be used for transmission of official messages via Iceland. The other two wireless stations in Greenland, viz., Godhavn and Godthaab, are local stations, intended for communication with Julianehaab. The former is already open, and that at Godthaab is expected to be completed very soon.

COSSOR VALVES.

The manufacturers of Cossor valves have drawn our attention to the fact that in the page of "Valve Data" published in our issue of September 30th we have incorrectly stated the application of certain of their types.

The P1 is designed not for H.F. amplification but as a detector or L.F. valve with filament voltage 4 to 4.5, being the same voltage as for other "P" type Cossor valves. The P3 is designed as a power valve, whilst the WR1 is suitable for detector and L.F. stages but not for high frequency amplification in addition, as indicated by us.

Readers will do well to make these alterations on the page of "Valve Data," which they will, no doubt, desire to keep by them for reference.

THE SELECTION OF A VALVE.

We regret that several clerical errors crept into the above article by Messrs. N. V. Kipping and A. D. Blumlein on page 449, September 20th issue. In the

sixth line below Fig. 6 — should read —
R_o 1
R_o R_o
1 m
and in the eighth line — should read —
R_o R_o

In the sixteenth line from the top, right-hand column, — volts should be —8 volts; in the eighteenth line 1.25 milliamperes should be 3 milliamperes; and in the twenty-fourth line —3.5 volts should be —9.5 volts.

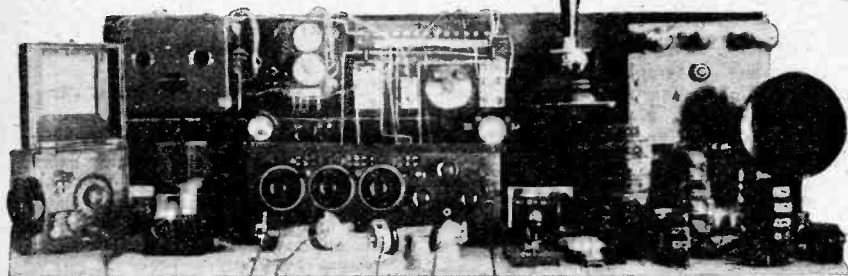

A BRITISH AMATEUR IN INDIA. Some of the apparatus at Indian 2BG, which is owned and operated by Mr. G. W. Benzie, of Cachar, who formerly conducted experiments in Scotland. The station being situated 350 miles N.E. of Calcutta, H.T. supply presents a problem, and a 600-volt hand generator has to be employed. 2BG would be glad to receive reports from amateurs in Britain. Transmissions are carried out on 100 metres, and a short-wave set is under construction.

of telephones, telegraphs, and other postal undertakings. An additional subscription of £200,000 to the capital of the Amalgamated Wireless is proposed, and the erection of wireless stations and other items bring the total postal vote to £6,200,000.

"RADIO RADIANCE" ON THE FILM

On a recent morning a chance visitor to the 2LO studio might have found himself in the glare of powerful sunlight arcs. The occasion was the filming of the "Radio Radiance" revue company actually performing before the microphone. Three cameras were used, and the film, which is being produced by Mr. Harry B. Parkinson in his series "Across the Footlights," will be shown to the general public from October 19th onwards at the new Capitol Theatre, Haymarket.

During the showing of the film music will be rendered to synchronise with the performance on the screen.

clubs in Burma, it has been possible by united effort to arrange for local programmes to be broadcast from Rangoon. Wireless enthusiasts there were previously obliged to listen to the distant transmissions of Calcutta, as Madras, although nearer, was too weak to be heard. The Calcutta programmes were frequently subject to atmospheric disturbances.

'PHONES IN THE KITCHEN.

The incursion of broadcasting into the culinary regions of the home is becoming a regular practice in the neighbourhood of Schenectady, New York, where WGY, the broadcasting station of the General Electric Company, provides a weekly fare of cookery recipes for harassed housewives. The scheme, albeit an excellent one, suggests alarming possibilities in the event of a mistake in a recipe, which might easily give indigestion to a whole town.

THE WIRELESS LEAGUE.

By SIR ARTHUR STANLEY.

At our invitation Sir Arthur Stanley, Chairman of the Wireless League, contributes the present article setting out the purpose of the Wireless League and the aims which it has in view. A meeting of the General Council took place on October 2nd, when the organisation for the future conduct of the League was approved.

WHEN a new movement springs into being it invariably happens that the need is found for some form of voluntary association to control or direct or support its activities. At the outset of the motoring movement the Royal Automobile Club came into existence, and later the Automobile Association. So now the Wireless League has come to life—obviously not to control the various forms of wireless activity which have suddenly developed as by enchantment, but to support them by all the means in its power and to ensure that they shall serve the highest interests of the community, and, indeed, of the whole world.

I have been asked by the Editor to explain the policy and objects of the Wireless League.

How the League was Formed.

The formation of the Wireless League was conceived in the first place by the very able brains of those men who direct the "Daily Express." They brought the League into existence, and when the time came that it should stand by itself as a distinct organisation, I was invited to take charge of it.

So I became the Chairman of the Wireless League—now absolutely independent of the "Daily Express," to which we are most grateful for our good start. I am sincerely proud of my new post, and I take this opportunity of thanking very cordially all those members of the Wireless League who have already shown me very great kindness, and who have most generously supported me in my efforts to organise the new association.

Provisional Committee.

My first step was to form a Provisional Committee. I wanted help in many different ways, and the Committee was formed with that object in view. It consisted of the following:—

Sir Arthur Stanley (chairman), Sir Lawrence Weaver (vice-chairman), Lord Montagu of Beaulieu, Sir Ernest Hodder-Williams, Sir Frederick Radcliffe, Sir Frederick Wise, M.P., Sir Landon Ronald, Sir Harry Brittain, Major Evelyn Wrench, Major L. Hore-Belisha, M.P., Mr. C. G. Ammon, M.P., Mr. H. W. Lonsdale, Mr. H. Munro Nelson, Mr. H. Y. Richardson, Sir Walter Windham, Mr. J. E. Kemp, the Rev. A. Tildsley.

It will be seen that we had secured excellent representation in the House of Lords and the House of Commons. We were also well represented in the musical world by Sir Landon Ronald; in the publishing world by Sir Ernest Hodder-Williams, and generally in every



Sir Arthur Stanley, G.B.E.,
C.B., M.V.O.

direction likely to be interested in the objects of the Wireless League. We also secured satisfactory representation of the provincial branches of the Wireless League.

We secured as our technical adviser Professor Low, who is well known to wireless enthusiasts, and our finances will, I hope, be looked after by those who watched so carefully and so successfully over the £22,000,000 raised by the British Red Cross and Order of St. John during the Great War.

The Composition of the Council.

The present governing body of the Wireless League is the General Council. This council is composed of representatives of the members of the Wireless League. In order to obtain this representation it was decided to divide England and Wales into fourteen areas, the branches in the areas each electing a number of representatives calculated on the estimated number of listeners in the areas.

The first meeting of the General Council, the controlling body of the Wireless League, towards the formation of which the efforts of branches and area organisations have been concentrated during the summer months, was held at the Royal Automobile Club on October 2nd.

There was a very large attendance of delegates representing the fourteen areas into which the United Kingdom and Ireland has been divided, and in addition the following members of the Provisional Committee, which had been managing the affairs of the League: Lord Montagu of Beaulieu, Sir Lawrence Weaver, Sir Frederick Wise, M.P., Sir Ernest Hodder-Williams, and Sir Walter Windham.

A feature of the meeting was the enthusiasm shown by the delegates. Every item of the long agenda was thoroughly discussed, the whole proceedings lasting over three and a half hours.

Sir Lawrence Weaver, the director of U.K. exhibits at the Wembley Exhibition, who has given the Provisional Committee considerable assistance, was elected as vice-chairman of the organisation, whilst the honour was done me of electing me as chairman.

A legislation committee, one of the functions of which will be to prepare evidence to be put before the Government Committee on Wireless, before which the League have been invited to appear, was also appointed, and a Technical Committee under the supervision of Professor A. M. Low was formed.

The appointment of a Rules and Constitution Committee, under the chairmanship of Sir Lawrence Weaver,

The Wireless League.—

was another matter which engaged the attention of the Council. A draft of the rules and constitution of the League was placed before the meeting, and with a number of amendments was duly carried.

With regard to subscriptions it was decided by the meeting after considerable discussion to keep this at the present very moderate figure of 2s., but to allow new members to be enrolled at a 1s. for the last six months of the financial year ending March 31st, 1926.

A neat little badge, the cost of which will probably be about 6d., was submitted to and approved by the Council.

Sir Ernest Hodder-Williams, who had gone very fully into the matter, made a brief statement regarding the prospects of the League being represented by a publication of its own, and suggested the time was not yet ripe for the adoption of such a scheme. It was thought advisable, however, to issue periodically a broad sheet which would give the latest news of the League's activities.

Objects and Policy.

We want to make the Wireless League of real use to its members. We all feel that an association of this kind is required, but when one is asked "What are you going to do," it is rather difficult to answer. One thing that we have arranged is free insurance for our members. We cover third party claims; damage to set due to lightning or any other cause up to a total of £30. Several claims have already been made and have been satisfactorily dealt with. Another is free legal defence. I hope that this will not be necessary in the case of many members as it is an expensive item, and it must be clearly understood that this legal defence is only in respect of litigation arising out of their use of wireless apparatus. We have already been able to help several of our members who were in difficulties of various sorts.

Then there is a new item, the granting of certificates to wireless repairers and the establishment of a corps of qualified maintenance agents. The whole wireless industry is of very recent growth, and as a result there are a good number of people setting up as wireless experts and repairers who know very little indeed about their job. For the protection of our members we shall enquire into the qualifications of repairers and give a certificate to those who can show that they are properly qualified to carry out the work.

But above all what we hope to do for our members is to make them realise that they—each one of them—has a definite personal

interest in the development of wireless in this country and in the whole world. In the early days of motoring it was necessary for the few motorists to bind themselves together in defence against a hostile public. That was the tie which held the Royal Automobile Club together in the first few years from 1898 when I first joined the Club. Such is not the case with wireless, because we have no enemies. We are hurting no one, and everyone is on our side. But there are dangers, nevertheless, and for that reason it is well to lay down at the outset the outlines of the policy we intend to pursue. These are as follows:—

1. To perpetuate, consolidate and extend the public service character of broadcasting in the British Isles, and with that object to support centralised executive control.

2. To exercise increasing vigilance to protect broadcasting from any lowering of its standards and ideals.

3. To safeguard the essential public service against any demand for broadcasting facilities, the granting of which would endanger Imperial defence.

4. To maintain the use of wireless broadcasting for educational as well as entertainment purposes.

5. To assist broadcast listener's in their efforts to secure efficient reception.

6. To bring to the notice of the broadcasting authorities such criticisms as may seem to be constructive, and generally to act as a link between the listening public and the authorities.

7. Generally to do all such things as are conducive to the efficiency of the service and the interests of listeners.

In concluding I wish to emphasise that the Wireless League has a great part to play in the development of the greatest movement that has ever been known in the history of the world. I maintain that of any invention that has raised us to the height of civilisation which we have now reached, none has ever had the potentialities of wireless. It has already bridged oceans, mountains and illimitable space, and I believe with all my heart that if we help to maintain the high standard that has already been set in this country, we shall do more than a dozen conferences at Versailles or

Geneva, or anywhere else, to bring the nations together in a general community of interest, thought and mutual comprehension which will make war unthinkable, and incidentally bring down the intolerable taxation under which we suffer at present, and which is the real and true cause of our sad industrial unrest.



AMATEURS IN CHINA. An interesting photograph showing members of the Shanghai branch of the International Amateur Radio Association of China.



A Section Mainly for the New Reader.

CAPACITY REACTION.

IN the design of enclosed sets where economy in space is of prime importance, it is often rather a problem to find room for a number of inductance coils. In Fig. 1 is shown a method whereby, in the case of a loose-coupled aerial-secondary circuit, a separate reaction coil may be eliminated, the aerial coil performing the two functions. A proportion of the H.F. anode current is fed back through the reaction condenser (RC in the diagram), and is applied to the grid through the magnetic coupling between the aerial and secondary coils. This coupling must of course be in the correct sense.

An obvious drawback is that a decrease in coupling between aerial and secondary also results in a weaker reaction coupling. At the same time, however, the damping of the grid circuit is reduced, and a lesser degree of

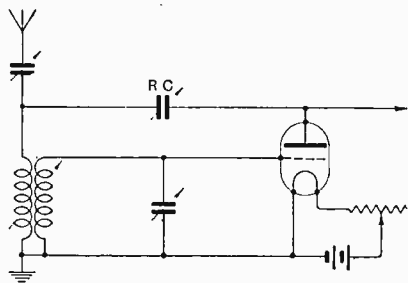

Fig. 1.—Coupled tuner adapted for capacity reaction.

reaction is necessary to bring the valve up to its most sensitive condition. It is thus possible to obtain quite steady and finely controlled reaction; the operation of a set making use of this arrangement is almost certainly no more difficult than that of the more conventional type.

The capacity of the reaction condenser will depend on the amount of damping present in the circuits, but will almost always be very small—a three-plate condenser will generally be

sufficiently large. An instrument having a very low minimum capacity should be used.

It will probably be necessary to insert a choke in the anode circuit of the valve to ensure that a proportion of the H.F. current is deflected through the condenser, which is, of course, operating here as a variable impedance.

RESISTANCE-COUPLED INTERMEDIATE FREQUENCY AMPLIFIERS.

Constructors of superheterodyne receivers are often tempted to replace the transformers used in the intermediate frequency amplifier by resistances and condensers. It may be said at once that there is a good deal to be said in favour of the practice, particularly as valves of high magnification factor with reasonably low impedance are available. One of the drawbacks is that the method in itself does not give any selectivity, and a much more serious one is that the whole amplifier is apt to act as a low-frequency magnifier, despite the small-capacity coupling condenser used.

In the case of a strong interfering signal, it is not unusual to find that very weak rectified pulses are applied to the grid of the first intermediate frequency amplifier. It should be borne in mind that, if such voltages are applied, they will inevitably be magnified, and the whole receiver will appear to be unselective. To overcome the difficulty it is advised that the non-inductive resistance in the

anode circuit of the last intermediate frequency amplifier be replaced by a tuned anode circuit, of as low D.C. impedance as possible (to keep down the voltages set up across it by low-frequency pulses). The coil may be tuned by a semi-fixed condenser.

A LONG WAVE ADAPTOR.

Constructors of the efficient type of receiver using a semi-a-periodic aerial coil tightly coupled to a tuned grid coil, with reaction feed-back through a condenser (Reinartz circuits), are often in difficulties as to the best method of adapting their sets for the longer wavelengths, including that of the high-power station. The following scheme can be recommended.

It is well known that the efficiency of the untuned aerial coupling falls off very rapidly as the wavelength is increased. In the unit to be described, of which the circuit diagram is given in Fig. 2, arrangements are therefore made to provide a tuned aerial circuit and to insert loading coils in series with both the grid and reaction coils. The short wave aerial coil is out of circuit. The

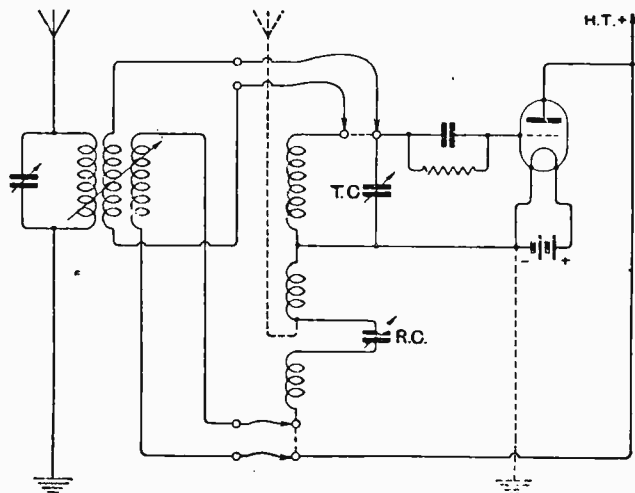

Fig. 2.—Converting a Reinartz receiver for long wavelengths.

loading coils are, for convenience, of the plug-in type, for which a three-coil holder is provided. Both grid and reaction circuits of the original set must be broken, the ends being taken to sockets for which short-circuiting links are provided, as shown in the dotted lines. The unit is preferably made up in a small case to match the receiver, to which it connects by four short flexible leads fitted with plugs. When the unit is in use the aerial and earth are of course connected directly to it.

Care should be taken that the choke usually fitted in the anode circuit is of sufficient inductance to act as a high impedance to the longer wavelengths.

o o o o

LOUD-SPEAKER REPRODUCTION.

A good deal of uncertainty seems to exist as to how great a voltage swing should be allowed for on the grid of the last stage valve of a low-frequency amplifier. The matter is of some importance, as, without definite knowledge of the maximum swing to be expected, it is not possible to make an intelligent choice of a suitable valve. The whole subject hinges on the question of personal opinion as to what adequate loud-speaker volume really is; therefore a very definite statement can hardly be made.

There is a fairly unanimous consensus of expert opinion that, at the least, provision should be made for variations up to a maximum of some six or seven volts. Accepting this statement, one is faced by the fact that, according to the manufacturers' published curves (which are unlikely to err towards under-rating the power-handling capacity of the product), very few of the so-called small power

valves are capable of handling this voltage. To make this quite clear, the curve of a typical valve of this class should be examined. If a straight edge is laid along the curve corresponding to maximum permissible H.T. voltage, it will be seen that it is only reasonably straight over applied grid voltages up to 10. In practice, then, we would bias the grid to 5 volts negative, and would get distortion on signal voltages over this value, a positive swing setting up grid currents and a negative one encroaching on to the bend. In either case amplification no longer in direct proportion to the input voltages would be produced.

The foregoing may lead to the conclusion that really good loud-speaker reproduction is not obtainable without the use of large power valves, taking an extremely heavy anode current, and this is true if considerable volume is required. However, for ordinary domestic use, it is found that an output valve biased to 4½ volts, and therefore handling without valve distortion voltage variations of that amplitude is capable of giving extremely good results. In the reproduction of music, certain deeply modulated notes will be slightly distorted, but if care has been taken at every stage of the design to ensure the highest attainable quality, there will be little to complain of. It is essential, however, to make certain that the average voltage variations applied to the last valve are not greater than it can deal with.

In this connection it should be noted that, all other things being equal, sensitivity in the loud-speaker itself is a very desirable quality, as a given volume will be produced from

a smaller output, thus making for more economical and efficient working.

o o o o

READING CIRCUIT DIAGRAMS.

Letters from our readers reveal the fact that a surprisingly large number of them are unable to read ordinary circuit diagrams. Many, indeed, end their tale of woe on this subject by saying that they will never be able to do so! In this, we feel sure that they are under-rating their own capabilities, and it is with a view to assisting this not inconsiderable minority that we commence at the foot of this page a series of what might be called "Wireless Circuit Films," with No. 1 "A Single-valver in Five Exposures."

It is admitted that the circuit diagram of a multivalve set, looked at as a whole, may appear rather terrifying to a novice; but, if considered by sections, as it should be, it will soon appear less formidable.

Consideration of the diagrams given below, in conjunction with the explanatory text, will show how the complete circuit is built up step by step, and will also suggest theoretical subjects on which further information is desired; a text-book may with advantage be used with them.

Perhaps some apology should be offered to our more advanced readers; we would ask them to bear with us in this matter, as they will realise that those for whom these "films" are intended will not derive much real interest from many of our articles until they master the simple art of reading circuit diagrams.

A desire to show the inherent simplicity of the subject is our excuse for the manner of presentation.

DISSECTED DIAGRAMS.

No. 1.—A Single-valve Receiver.

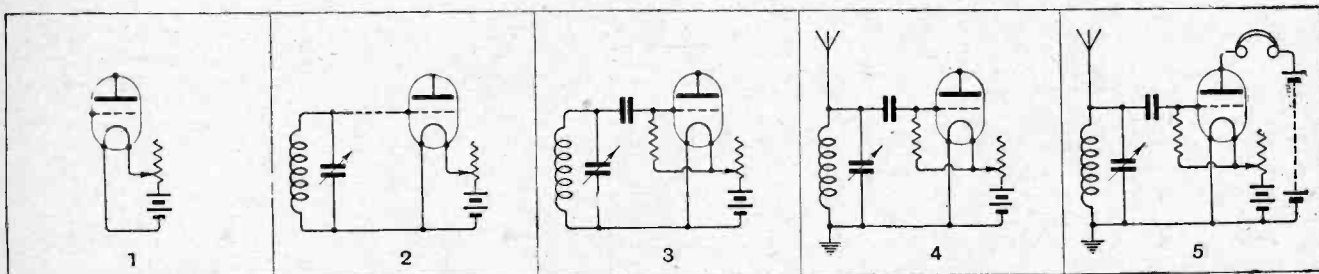

1 A valve, with its filament heated by an L.T. battery through a variable resistance—

2 —has connected between its grid and filament an oscillatory circuit—

3 —with a leaky grid condenser inserted to give rectification.

4 The addition of an aerial and earth system—

5 —with 'phones and H.T. battery in the plate circuit completes the receiver.

H.F. AMPLIFIER DESIGN.

Problems of Selectivity.

By G. W. SUTTON, B.Sc.

UP to the present we have only discussed the question of stability. This was purposely dealt with first as it is obviously the *sine qua non* of H.F. amplifiers. It was seen that stabilisation is a comparatively simple matter if the various factors influencing it are recognised and allowed for. If all experimenters could be induced to separate their open aerials and regenerative detecting valves by at least one stable H.F. amplifier, what a difference it would make to the ether—and, incidentally, to their own reception!

Probably the bulk of receiving stations are situated at an average distance of from 5 to 10 miles from one of the more powerful B.B.C. transmitters; and in such cases a high degree of selectivity is required if anything but the local station is to be received. The use of a "wave-trap" may be suggested as an alternative, but that entails considerable complication in tuning, and in any case does not help in separating more distant stations.

A factor limiting selectivity, and one which appears to be frequently overlooked, is what may be called the "transmission characteristic." In demonstrating a supersonic heterodyne receiver to friends quite recently, the writer was rather surprised by the number of them, who, when reception from a distant B.B.C. station was smothered by a spark set, remarked, "Oh! I thought with a set like this you could cut-out

such as those in Figs. 1 and 2. On the graph Fig. 1a the intensity of the ether disturbance, *not* the corresponding voltage which this induces in the aerial, is plotted to a base of frequency. Curve X represents the characteristic of a heavily damped spark station, and Y that of a valve-excited transmitting aerial. Although the wavelength to which X is tuned may be well removed from that of Y, the intensity induced on the latter's wavelength may be, and frequently is in practice, an appreciable fraction of that due to Y. It is, therefore, obviously impossible to separate the two transmissions (unless perhaps the direction of the two stations is markedly different), however selective the receiving aerial and set may be. In Fig. 1b the values of mean rectified current in the

detector circuit of a selective and an unselective receiver respectively are indicated, and serve to show the small advantage of the former under the transmitting conditions assumed.

It is assumed in Figs. 1b and 2b that the wavelength or frequency to which the receiver is tuned is held fixed, while that of the transmission is continuously varied through the range considered. Thus the response of the receiver to *all* wavelengths is shown, and its degree of selectivity can be roughly appreciated.

If a station X had a transmitting characteristic similar to Y, the result would have been as in Figs 2a and 2b.

In the two preceding sections of this article the principal causes of instability in H.F. amplifiers were enumerated, and standard methods of stabilising were discussed. Practical details were also given of a receiver with two stages of H.F. amplification designed to overcome the effects of stray capacity couplings. The present article deals with the question of selectivity, and includes the results of some measurements of the amplification and selectivity obtained with the above receiver.

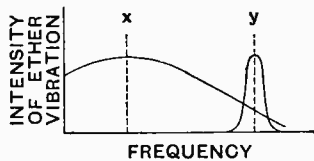

Fig. 1a.—Transmission characteristics of a spark station X and a C.W. station Y.

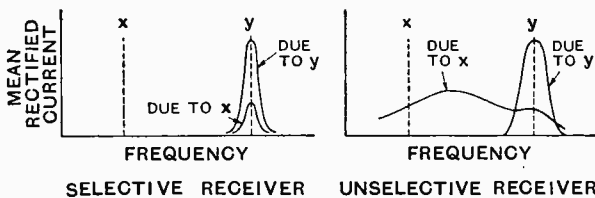

Fig. 1b.—Signal strengths induced in a receiver by the stations X and Y in Fig. 1a in selective and unselective receivers respectively.

anything!" In point of fact, the intermediate frequency amplifier was very sharply tuned; far too much so for good quality reception, and was preceded by a two-stage H.F. amplifier. The selectivity of the receiver could not therefore be called in question. It was entirely a matter of the relative intensities of the wanted and unwanted signals *at the exact frequency of the former.*

This important point is perhaps best illustrated, to those to whom it is new, diagrammatically, by sketches

Factors in Receiver Affecting Selectivity.

The selectivity of the receiving aerial system and amplifier is controlled by two factors:—

- (1) The amount of coupling between successive circuits, and
- (2) The effective resistance of those circuits.

Briefly, the looser the coupling and the lower the resistance the sharper the tuning. Weakening the coupling beyond a certain point, however, rapidly reduces the signal strength. The most convenient way, both from

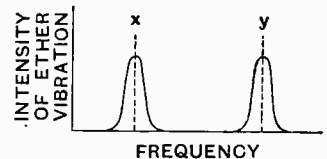

Fig. 2a.—Transmission characteristics of two C.W. stations X and Y of equal power.

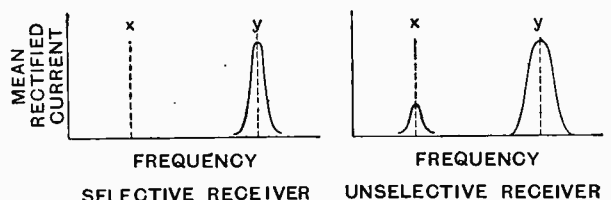

Fig. 2b.—Signal strengths induced in selective and unselective receivers by the stations X and Y in Fig. 2a.

H.F. Amplifier Design.—

the point of view of number of controls and bulkiness of the receiver, of obtaining loose coupling is to use between valve and valve a series of transformers, the primaries of which have about one-third or one-fourth of the number of turns on the secondary windings. The windings are arranged either within one another or side-by-side, and the secondary only is directly tuned. This type of coupling provides a grid circuit, the resistance

balance the effect. The experiment was repeated, using capacity instead of magnetic reaction, with exactly the same result. No distortion of the resonance curve could be detected.

Theoretically, reaction could be carried beyond the point indicated by the third curve of Fig. 3 and the selectivity increased to any desired extent. Apart from the question of the consequent effect on quality, however, the circuit then becomes unstable.

A Measure of the Selectivity of an Amplifier.

Resonance curves such as those shown in Figs. 3 and 4 are very readily obtained for stable amplifiers, and from them the degree of selectivity of the set may be easily expressed as a number. The magnitude of the mean rectified current in the detector valve circuit forms a suitable basis for such measurement and has been used as ordinate. It is suggested that the ratio of the mean rectified current at resonance to that at a frequency 10,000 cycles removed from resonance be called the "selectivity factor" of the set. Similarly, a measure of the quality of telephony reception possible would be expressed by the ratio of current at 5,000 cycles removed from resonance to that at resonance and could be called the "quality factor."

Owing to the variation of resistance with frequency, etc., the curves are not symmetrical about the resonance point, and values *above* the resonant frequency have been taken, as they give the smaller numbers and represent the less selective side.

The arrangement having a selectivity factor of 20, used on a large open aerial at a distance of about 5 miles from 2LO, receives the Bournemouth broadcasting station without interference from London, and Manchester with some interference. The strength of 2LO is such as to build up over 2 volts (R.M.S.) on an inductance coil of reasonable efficiency.

Amplification.

The results of one or two amplification measurements, which, although quite roughly taken, were satisfactorily

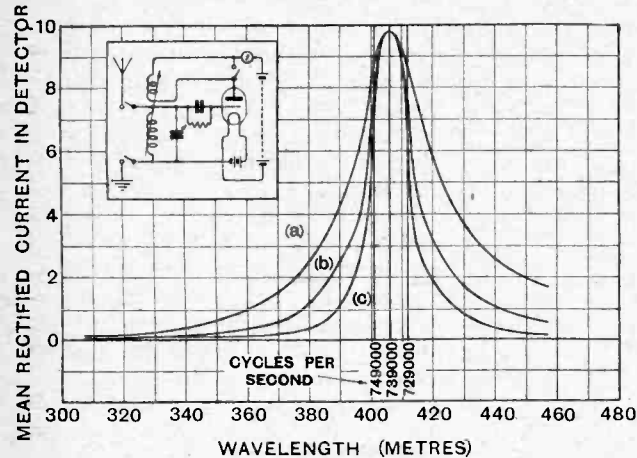

Fig. 3.—Results of an experiment to illustrate the effect of reaction on selectivity. (a) Tuned circuit with aerial and earth; (b) tuned circuit only, aerial and earth disconnected; (c) tuned circuit with aerial and earth with reaction introduced. Cumulative grid rectification employed in each case.

of which is practically only that corresponding to its own losses, and, of course, the grid-filament resistance of the succeeding valve. The latter can, unlike the anode-filament resistance, be made negligible in the case of amplifying valves; while that of the detecting valve may be neutralised by magnetic reaction. Regarding these coils as true transformers, the damping introduced into the tuned secondary by the anode-filament resistance in the primary circuit falls off as the square of the step-up ratio; consequently, with a 3:1 ratio transformer the effect is reduced to about one-ninth of what it would be with the popular "tuned-anode," or 1:1 ratio transformer.

Effect of Reaction on Damping.

It is generally assumed that the effect of reaction, both magnetic and capacity, is exactly equivalent to reducing the resistance of the circuit to which it is applied. On general theoretical considerations this appears to be justifiable, but the possibility of some distortion of the resonance curve sufficient to influence selectivity, and due to some factor not accounted for in the theory, could not be overlooked. The writer thought this might most readily be investigated experimentally.

A short experiment, the result of which is shown in Fig. 3, seems to indicate, however, that the effect of reaction may be regarded purely as the introduction of so many ohms of negative resistance into the circuit concerned. It will be seen that the resistance of the aerial materially flattens the resonance curve of the tuned circuit (already heavily damped by the detector valve), but that reaction may be adjusted to more than counter-

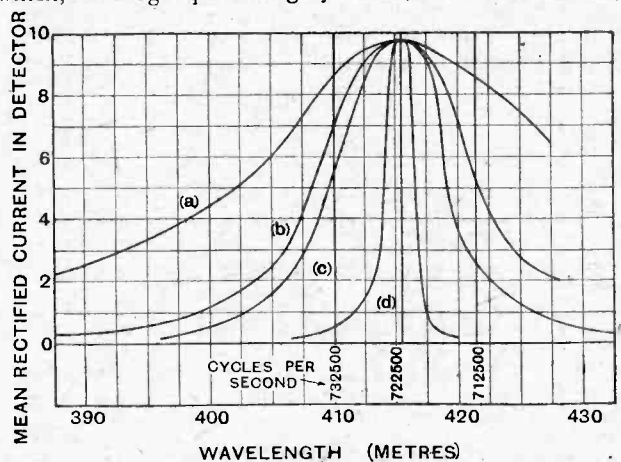

Fig. 4.—Resonance curves for a three-valve receiver with two stages of H.F. amplification. (a) Detector valve only on open aerial without reaction; (b) detector valve on open aerial with maximum permissible reaction (valve just not oscillating); (c) detector and one H.F. valve (no reaction); (d) detector and two H.F. valves (no reaction). Cumulative grid rectification was employed in each case, and the selectivity factors for each curve are as follow: (a) 1.1; (b) 1.4; (c) 1.9; (d) 19.5

H.F. Amplifier Design.—

repeated several times, may be of interest. A constant e.m.f. was induced in the aerial circuit from a shielded local oscillator. The amplification was measured in terms of change of mean anode current of the detector valve.

It was intended to compare the effectiveness of a detector valve with reaction, with that of one H.F. valve and detector, with and without reaction on the latter. In each case reaction was adjusted to be just short of oscillation. This could readily be done, of course, by means of the galvanometer in the anode circuit of the detecting valve.

The reading, when using the detector valve alone, with-

out reaction, roughly corresponded with what the writer (situated in south-east London) usually receives after dark from the Bournemouth B.B.C. station on one H.F. valve and detector. This ensured that the detector was working more or less over its normal range—obviously an important point in view of the rectification characteristic.

Reaction gave an amplification of just over 19; one H.F. valve without reaction only 10.5, and with reaction 25. The H.F. valve was, of course, "neutrodyned." Two H.F. valves gave very considerable further amplification, but the method employed could not justly be used for the measurement of such large values. Some means involving variable input would be necessary.

General Notes.

Mr. F. Sabrowsky, Gutenbergstr. 62, Stuttgart, who operates the O.F.V. Funkverein station KY5, transmits regularly on Wednesdays and Saturdays at 23.00 to 0200 Central European Time (1 hour ahead of G.M.T.) on 46.5 metres; also on Sunday morning and afternoon on wavelength between 20 and 50 metres, and will be glad if any British amateur will co-operate with him in his tests, or will report on his transmission.

Mr. O. Kruschwitz, Reilstr. 128, Halle a Saale, the authorised operator of KW1, states that an English lady will broadcast telephony from this station on a wavelength of 75 metres at 22.00 (presumably G.M.T.), and will welcome reports.

Mr. E. Montu, who operates the Radiogionale station, 11RG at Bellagio on Lake Como, transmits by telephony every Sunday on 18 metres at 15.00 G.M.T., and on 38 metres at 0600 and 1600 G.M.T., and will also welcome reports.

Mr. F. A. Mayer (G2LZ), Wickford, Essex, informs us that his signals on short waves have been received by the U.S.S. "Pillsbury" stationed at Chifoo, China. The operator, whose call-sign is NUQG, is transmitting on 40 metres, and would like to get into touch with British amateurs and to receive reports on reception of his signals, which should be sent to O. T. Cooper, U.S.S. "Pillsbury" (227), Asiatic Service, c/o Postmaster, Seattle, Washington, U.S.A.

Sergt. M. H. Figg, R.C.O.S., Royal Signals, Sialkot, Punjab, India, will be pleased to have reports from anyone picking up signals from A50 between 40 and 120 metres

Messrs. T. A. and F. C. Studley, 6, Rutland Road, Harrow, state that on Sunday, September 20th, within one hour between 6.45 and 7.45 a.m. B.S.T., they received:—*Argentine*:—BA1, AD1, BD1, CB8. *Australia*:—2CM, 3BQ. *Chile*:—2LD. *U.S.A.*:—Ship NISR. *New Zealand*:—4AV, 4AS, 2AQ, 2AE.

Mr. J. A. Sang (G6TB), Stranmillis Gardens, Belfast, who is transmitting on 23.45, and 150-200 metres, will welcome and acknowledge reports.

We understand that Nauen Station now uses the call-sign AGA in place of POZ for its normal wavelength, AGW for 21,000 metres, and AGO for 12,600 metres. Königwusterhausen also uses the call-signs AFP, AFT, etc., in place of LP.

TRANSMITTING NOTES AND QUERIES.

Through the courtesy of the Secretary, Réseau Belge, 11, Rue du Congrès, Brussels, we are able to give a list of the call-signs of Belgian transmitters arranged according to their respective localities:—

ANDERLECHT: C2, P8.
ANTWERP: BI, CI, DI, FI, HI, JI, KI, GI, MI, CH2, M3, V4, CH5, CH8.
ATH: T5.
ATHUS: L2.
AUDERGHEM: Q7, C9.
BEVERLOO: V2.
BINCHE: Z5.
BOITSFORT: M9.
BOURG-LEOPOLD: S6.
BRAINE-le-COMTE: D5.
BRUSSELS: T2, Z2, B3, D3, K4, D7, T7, W7, O8, T8, U8, W8 X8, A9, D9, O9, Y9, CH9, AI1, D11, E22, U22, X22, A23, A33, A38, A44, B44, A53, CEROUX-MOUSTY: A4.
COURTRAI: Z3, C4.
EMELGHEM: I6.
ETTERBEEK: S7, V7, Z22.
FLENU: U4.
FOREST: B2, I2, M2, W4, B7, M7, GHENT: M4, J6, L6, K6, M6, O6, A8, C8?, D8, E8, J9, I9, V9.
GEDINNE: G2, N9.
GILLY: A3.
GOYER: P6.
ICHTEGHEM: E6.
IXELLES: C3, U3, W3, W6, D7, E7, K7, Y7, F9, C9, C11, A22, R22.
JETTE-St-PIERRE: K2, R6.
LA LOULPE: M5.
LA HULVIERE: B4.
LEDEBERG: N6.
LIEGE: V1, X1, Y1, Z1, E2, H2, Y2, I4, W1.
LIERRE: L8.
LOKEREN: F8.
LOUVAIN: S2, A6.
MALINES: Y4.
MANHAY: G4.
MARCINELLE: R2, R3, V5, E4.
MONS: F5, R5, S5, Y5.
NAMUR: P9, Z9.
OOSTROOSEBEKE: V3.

OSTENDE: B6, C6, D6, F6, P7.
OTTIGNIES: G7.
PERONNE: U5.
PERUWELZ: W5.
RETINNE: S1.
ROULERS: G6, H6.
RUYEN: I9.
RUYSBROECK: E7.
SAVENTHEM: CH7.
ST. GILLES: D2, F2, P2, Q2, X2, N5, J7, Z7, Z8, B9, G9, T9, W9, X9, G11.
ST-JOSSE-TEN-NOODE: T3, Q8, S8, V8.
SCHAERBEEK: K5, O5, A7, F7, L7, N8, R8, E9, F11, C22, D22, C44.
TERVUEREN: H9.
THULIN: U2.
UCCLE: B5, O7, N7, X7, B8, R9, O22.
VERVIERS: N1, I3, K3, P4.
VILVERDE: S9.
WESEMBEK: H7.
WOLUWE-STOCKEL: A2, N2, F4, C7, I7, F9, K22, O44.

Addresses of Stations Wanted.

We shall be glad if any of our readers can give us the QRA's of the following stations. (In some cases it is inadvisable to publish the names and addresses, but any replies indicating that publication should be withheld, will be communicated in confidence to the enquirers):—

G2APU, G6LH, F8FW, F8TOK, OCTA, H9WWZ, H9AD, HGA (on 35 metres), Z1AF, Z2CA, Z2XA, M1B, BR22, RCRL, WAU (on 27 metres), I2BB, X3AD, H9BA, D7EC, B444, IZ, GCG, GCS.

G6RR, G6DT, G6ER (?) G5XO, G2APD, G2MK, GN2 (?), G5MQ, G5XO, G6DT, Q2MK, H9BR, M1K, M4HS, F8PRI, F8FIR, Z2AX, G2AZL, G2BDY, G2FO, F8ACA, F8FW, F8HU, F8VTI, NSMT (calling OKG), NOBX, NOBQ, U1AS, U2WR, U3NBS, U4M, WQN, BZ1AC, RBA1, Z4AS, NISR, 3K1K, FBL.

Nationality not stated, presumably French: OCKB, 8RR, 8RAT, 8NNN, 8YB (? Dutch), ORW, ORT, also 1NO, L1.

Misuse of Call Sign.

Mr. F. J. Hughes (2NL), 129, Wells Road, Bath, has reason to believe that some other transmitter is making use of his call sign, and will welcome any information enabling him to trace the offender.

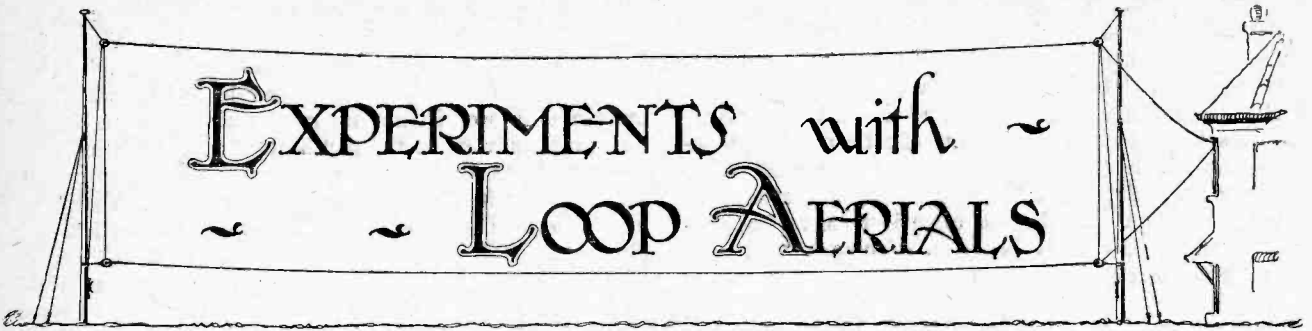

Comparisons with Elevated Aerial Systems.

By LESLIE MILLER, A.M.I.E.E.

THESE experiments were made with an aerial attached to an 18ft. pole at the far end of a suburban garden situated in a deep valley, 6½ miles from 2LO. There is another pole of the same height near the house, 70ft. away, and the usual down lead is brought into the receiving room. The poles are so placed that a line joining them would point in the direction of 2LO.

The object of the trials was to see if it would be preferable to use the aerial as a large loop instead of an inverted L aerial for receiving 2LO. Results proved the loop to be 50 per cent. more efficient than the inverted L aerial by measurement of the rectified carrier current. The writer is now wondering why others do not employ similar loops when they have the opportunity, and wish merely to receive broadcasting from one station. Farmers and others, with plenty of space at command, can easily make their loops accurately directional.

The loop is soon made. A shell insulator is attached to each pole at the top, and also at the bottom, about 18in. off the ground. The aerial wire is put through each insulator and pulled tight, thus forming a vertical rectangle averaging about 16ft. high and 70ft. long. The two ends, separated by a foot or so, are then brought into the house, near the ground, and joined to an adjust-

able 0.0005 or 0.001 mfd. condenser, as in the case of a small frame aerial. Across the condenser there is the usual shunt circuit, consisting of a rectifying crystal and a pair of 4,000 ohm telephones, with the addition of the microammeter, which reads from 0 to 40 microamperes, and has a resistance of 50 ohms.

The best adjustment of the condenser can be judged by the loudness of reception, but also with much greater ease and accuracy by seeing which setting gives the highest reading of the carrier current in the microammeter with a given contact on the rectifying crystal. In practice it is easy to find an adjustment of crystal and con-

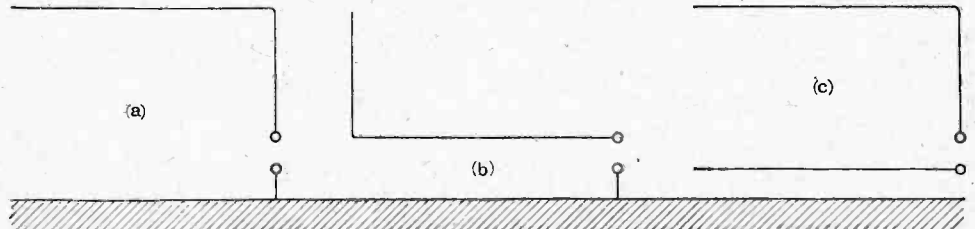

Other aerial systems tested during the experiments: (a) inverted L and earth connection; (b) L type aerial and earth connection; (c) inverted L and counterpoise.

denser, which gives the same high reading repeatedly, within narrow limits.

The results were as follow:—

Type of Aerial.	Average Current.
Loop, without any connection to earth	30 microamps.
Inverted L aerial and Earth Connection (buried tank) tuned with a sub-divided inductance	20 "
Inverted L aerial and counterpoise (bottom wire of the rectangle)	14 "
L type aerial and earth connection	8 "

The results obtained with the outdoor loop were so encouraging that it was decided to try the effect of converting an indoor aerial erected under the roof into a loop, as this was also roughly directional to 2LO. Here the superiority of the loop aerial was again demonstrated, for the rectifier current at resonance was increased from 15 to 23 microamperes.¹

In addition, the directional loop aerial is naturally much more free from interference from oscillation and other transmitting stations than the usual type.

¹ This indoor loop is a rectangle 32ft. long x 14ft. high. Daventry, about 80 miles away, can be easily understood when sending out the weather report.

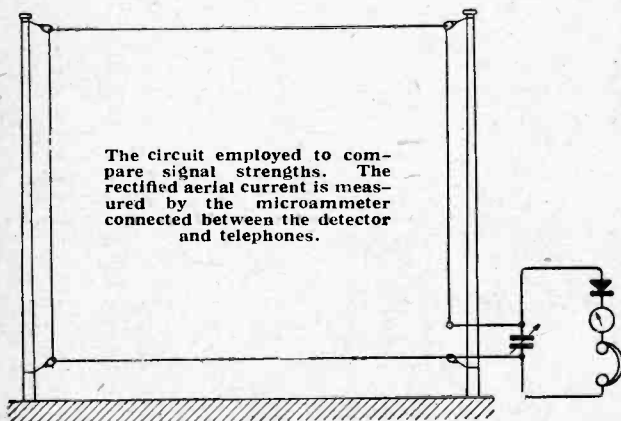

The circuit employed to compare signal strengths. The rectified aerial current is measured by the microammeter connected between the detector and telephones.



By Our Special Correspondent.

Daventry.

Complaints have been made by some listeners concerning interference with the morning transmissions from Daventry. Those who experience such trouble would be doing good service to others, as well as themselves, if they would report to the B.B.C. the nature of the interference, which has been already variously reported as automatic Morse and radio telephony.

o o o o

The Relay Station Scare.

Relay station areas have been greatly alarmed by the fear that the low-power stations are to be closed down almost immediately as the result of the policy of "fewer stations—higher power," discussed unofficially by the delegates to the Geneva Conference on Broadcasting. I can state on the highest authority that there is not the least likelihood that so drastic a step as the closing down of any relay station will be taken for a long time to come. Even if it were eventually found to be inevitable, I am told that the earliest date at which it would be put into effect is a year hence.

o o o o

Good for Listeners.

Listeners may further rest assured that they will not in any event be deprived

of a legitimate service. The assurance of Savoy Hill is given that every crystal user will, on the contrary, benefit if the relay stations are finally discarded and the stations remaining are raised to such power as will enable them to cover wide areas.

o o o o

A Mystery Solved.

Listeners noticed recently a rather curious noise like the sound of a gong during the transmissions from 2LO and 5XX. This, it is understood, was not due to any new experiment on the part of the engineers but was caused by a defective valve-holder. The fault has been rectified.

o o o o

The Studio Clock.

The ticking of a clock has also been audible at intervals. It is the studio clock that has been offending. In the new studios at 2LO a silent clock will be installed.

o o o o

"Interviews."

The microphone "interview" has proved so successful on the few occasions that it has been attempted that the Birmingham station intends to try a similar experiment on October 28th,

when Mrs. E. W. Barnes, the wife of the Bishop of Birmingham, will be interviewed before the microphone by a Birmingham journalist.

o o o o

A Complaint from Leeds.

In spite of the unofficial decision of the international broadcasting experts at Geneva that the time is approaching when some curtailment of the number of relay and low-power stations will have to be considered, a campaign is still being fostered in some localities with the object of getting relay stations to the status of main stations. Leeds, it appears, is a case in point.

The complaint seems to be that the programmes put out from the Leeds relay station are not so good as those from main stations. Leeds listeners take a pardonable pride in their own city, and would naturally like to get the best programmes obtainable. But so far as the status of Leeds is concerned, it may be recalled that the locale of the main stations was indicated by the then Postmaster-General to the House of Commons before broadcasting started, and the subsequent addition of relay stations to the list of eight main stations originally contemplated was an expression of the desire to concede as much as possible to other districts which were not included in the original scheme.

o o o o

Fading.

An impression exists that by raising the power of the main stations, one of the bugbears of the listener's life—i.e., fading—will be overcome. Apparently the broadcast engineers are not willing to accept this theory as the solution of the fading trouble, even if the power of the transmitting station were as high as fifty kilowatts. It is possible that high power might alleviate the difficulty, within limits; for example, if a weak station fades to one-fifth of its intensity at a certain point and a high-power station fades to the same relative extent at the same point, the signal from the latter station might be at any rate readable, although its value would be appreciably less than that of a signal from the same station when no fading takes place. - In cases where fading is very abrupt and intensive the distortion may affect the stronger and the weaker station alike. There can be no guarantee that high power will mean less fading.

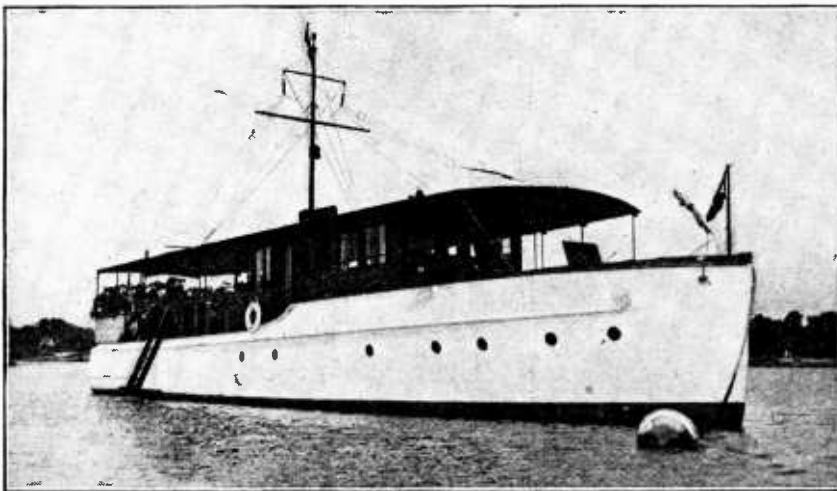

A FLOATING BROADCASTING STATION. The yacht "Muroma," which has been fitted with an experimental broadcasting plant by its owner, a wealthy Cincinnati resident.

Another Bells Broadcast.

The bells of Croyland Abbey, Peterborough, will be broadcast on October 25th as a prelude to the usual Sunday evening service transmission. This broadcast has been suggested partly as a result of the satisfactory transmission of Buckfast Abbey bells which took place recently, and the tests that have been carried out at Croyland Abbey indicate that the broadcasting of those bells should be quite as successful. Croyland is one of the most historic abbeys in the country and had a peal of bells as early as the year 960.

o o o o

Distant Reception of Daventry.

The wireless operator in one of H.M. ships which recently accompanied a fleet of tugs on a tour to Malta and back sends the following interesting account of the achievements of a single-valve straight detector circuit with aerial reaction, using a D.E. valve. The aerial was 60 ft. high and 69 ft. long.

"Daventry," he writes, "was heard after dark every night the whole voyage to Malta. The time signal was obtained 21.00 G.M.T. each night, followed by the News Bulletin. Chronometers were rated by this signal and the news obtained was very welcome, being circulated amongst the fleet of five naval tugs by Morse lamp afterwards. Even in a severe electrical storm off Cape Bon, Tunis, the time signal was received (at the risk of the only valve) quite clearly. On the return voyage not only Daventry, but Plymouth, Bournemouth, Cardiff, 2LO, and Madrid, and several other foreign stations were clearly audible after dusk, especially during the first test of Continental stations after midnight on August 31st-Sept. 1st, off Cape St. Vincent. Bournemouth was quite as audible as Daventry all along the Mediterranean from Cape Bon to Gibraltar."

o o o o

Barn Dance Broadcast.

"The Harvest Home" is the title of a special feature which will be included in the programme for October 23rd. It will be a representation of the entertainment which usually concludes the gathering-in of the crops. Old country songs and dances will be heard by broadcast as they are still heard in rural places even to this day, outside the pages of Thomas Hardy, and they will be accompanied by the shuffling of heavy boots in rustic dances on the bare floor. The success which has attended the broadcasting of the dance scene in "Radio Radiance" justifies, it is felt, the extension of the scheme of transmitting dance steps.

o o o o

"Stars."

"Is not the B.B.C. rather inclined to overwork its 'stars,' i.e., the people who helped to put broadcasting in the early days on a firm foundation?" was a question which the writer put to the officials at Savoy Hill the other day.

A 38

FUTURE FEATURES.**Sunday, October 18th.**

LONDON.—3.30 p.m., "Cockaigne. 9.15 p.m., Band of H.M. Grenadier Guards.
BIRMINGHAM.—3.30 p.m., Chamber Music.
BOURNEMOUTH.—9.15 p.m., Wagner.

Monday, October 19th.

LONDON.—10.30 p.m., English Folk Songs.
CARDIFF.—8 p.m., The Music of Russia.
ABERDEEN.—8 p.m., Wagner and Verdi.
SHEFFIELD.—7.30 p.m., The Opera, "Il Trovatore."

Tuesday, October 20th.

5XX.—8 p.m., "Ye Olde Manor House."
LONDON.—8 p.m., Une Heure Intime.
LEEDS-BRADFORD.—4 p.m., Band of the Royal Air Force, relayed from "Leeds Mercury" Better Housing Exhibition.

Wednesday, October 21st.

LONDON.—8 p.m., Trafalgar Day Programme, "England Expects."
MANCHESTER.—8 p.m., Trafalgar.
BELFAST.—7.30 p.m., Russian Music.
LEEDS-BRADFORD.—2.30 p.m., Speeches relayed from the Grand Nautical Exhibition.

Thursday, October 22nd.

LONDON.—8.50 p.m., Chamber Music and Poetry.
BIRMINGHAM.—8.5 p.m., "Judas Maccabeus."
MANCHESTER.—7.30 p.m., The Hallé Orchestra: Conductor, Sir Hamilton Harty. S.B. to other Stations.
GLASGOW.—8 p.m., Orchestral Programme.

Friday, October 23rd.

MANCHESTER.—8 p.m., Lancashire Night.
NEWCASTLE.—9.15 p.m., "Radio Radiance."

Saturday, October 24th.

BIRMINGHAM AND 5XX.—8 p.m., "Radio Fantasy."
ABERDEEN.—8 p.m., A Tale of Alsatia.

The reply admitted that such had been the tendency, but efforts were now being made to use broadcasting "stars" very sparingly, and to feature their appearances before the microphone in the same way as the appearance of "stars" of the theatre or concert hall would be featured. The vital fact that is being borne in mind is that a broadcast "star's" repertoire reaches saturation point very quickly and it is therefore wise policy to nurse him by limiting strictly his broadcast "turns."

Auditions.

Another matter of interest revealed to the writer at Savoy Hill was that if anybody who is really useful for broadcasting is discovered, every effort will be made to "star" him and to further his interests to the same extent as an established "star." But the standard required of the newcomer is higher than most people believe. A useful tip to those who have been offered an audition is that they should not fail to keep the appointment on the day and at the hour fixed. Several cases have occurred recently where applicants for auditions have written to say that the day arranged was inconvenient and they would attend at some other time. In view of the great number of applicants for auditions, this means that a person who has been given a date and has failed to keep to it will, in all probability, be put back for many weeks.

o o o o

Storms and Reception.

In outlying districts reception is frequently found to be much better during storms and high winds. A Stornoway listener, for instance, reports that when the wind is blowing with great velocity from the south-east or south-west he gets the best reception, with a total absence of atmospherics. West Country listeners observe a similar phenomenon in so far as south-westerly storms are concerned. In some northern districts, however, the near-by stations are obliterated when the storm is close, while those at distances come through well.

o o o o

A Birthday at Bournemouth.

Bournemouth Station will celebrate its second anniversary on October 17th, and a *résumé* of the past year's work will be included in the programme on that evening. Excerpts from the leading feature nights of the year will be given and for these, in most cases, the original artists have been chosen. Among the items to be given are the following: "Spain and Portugal," "Cheery Interludes," "Humour," "Sullivan and Cole-ridge-Taylor," "Old London," "Musical Comedy Favourites—Old and New," "Fun and Favourites," "Cross Word Puzzle," and "Night of Memories." In the morning of October 17th Mr. Arthur Marston, A.R.C.O., will give an organ recital from the Royal Arcade, Boscombe.

o o o o

A "London Symphony."

Some very attractive music has been written under the inspiration of London Town. One of the greatest of the orchestral pieces having characteristics of London is Vaughan-Williams' "London Symphony." This will be given from 2LO for the first time on October 18th, and will be played by the Wireless Symphony Orchestra, conducted by Mr. Dan Godfrey, who gave it from Manchester.

DICTIONARY OF TECHNICAL TERMS



Definitions of Terms and Expressions commonly used in Wireless Telegraphy and Telephony.

This section will be continued week by week and will form an authoritative work of reference.

Alternating Electro-magnet. An electro-magnet in which alternating current is passed through the magnetising coils so that the magnetic flux produced is an alternating one. It is usual for an alternating electro-magnet to have a *laminated core* in order to reduce the *eddy currents* in the iron. Since a piece of iron is attracted to a magnet pole, no matter whether it be a north pole or a south pole, it follows that an alternating electro-magnet will attract a piece of iron in exactly the same way as an ordinary permanent magnet, except that the pull will be varying rapidly between zero and a certain maximum value once every half cycle of the current. The iron is attracted every half cycle and *not* repelled when the magnetism reverses, the pull being proportional to the mean square of the magnetic flux density.

Alternation. A term sometimes used to signify one-half of a complete cycle of an alternating quantity, *i.e.*, that sequence of values from zero to maximum (positive or negative) and back to zero again.

Alternator. A dynamo or generator for producing alternating currents.

Aluminium Rectifier. See NODON VALVE.

American Morse. The Morse Code in general use in America differs slightly from the International Morse Code, some of the signal letters being a little shorter, and unequal spacing being employed. It needs rather more care in sending, but higher speeds can be obtained than with the International Morse Code.

Ammeter. The usual term for the word "Ampere-meter." An instrument for measuring current in *amperes*. The scale is graduated to read directly in amperes or a simple multiple thereof. (See SHUNT. See MOVING COIL AND MOVING IRON INSTRUMENTS).

Amp. Abbreviation for Ampere.

Ampere. The practical unit of *current* (named after the French physicist André Marie Ampère). The true ampere is equal to one-tenth of the C.G.S. *electro-magnetic unit* of current. See CURRENT.

Amperage. A term meaning "the current in amperes" in a circuit. Cf. VOLTAGE.

Ampere-hour.—The commercial unit of *quantity of electricity*. It is that quantity which passes when a current of one ampere flows for one hour, or its equivalent (*e.g.* half an ampere for two hours, etc.). See AMPERE-HOUR CAPACITY.

Ampere-hour Capacity. The output rating of an accumulator battery in *ampere-hours*. The rating is sometimes based on continuous discharge and sometimes on intermittent discharge (ignition). The former rating is the true one, the ignition rating being twice the actual capacity of the battery.

Ampere Meter. See METER.

Ampere-turns. The product of the number of turns in a coil and the number of amperes flowing through it. The *magnetic field strength* produced in a medium of constant *permeability* is proportional to the number of ampere-turns acting upon it, and therefore the ampere-turn makes a convenient unit of *magnetising force* for practical purposes.

Amplification. See AMPLIFIER.

Amplification Factor or Amplification Constant (of Three-Electrode valve). The ratio of the change of *plate voltage* necessary to bring about a given change of plate current, to the change in grid potential required to produce the same change in plate current; or the number of volts by which the plate potential must be lowered to maintain the plate current constant when the grid potential is raised by one volt. It is the maximum *voltage amplification* which the valve itself can give theoretically.

Example:—Suppose that at zero grid potential the plate current with 80 volts on the plate is 1.35 milliamperes. Now raise the grid potential by, say, +1 volt and adjust the plate voltage until the plate current is again 1.35 milliamps and suppose that the plate potential is now 74.5 volts. Thus a change of 1 volt in grid potential has an effect of 5.5 times that of a similar change in plate potential. The Amplification Factor is therefore 5.5.

Amplifier. An apparatus for strengthening or increasing the *amplitude* of (usually weak) electrical oscillations. In a wireless receiver an amplifier is used to increase the strength of the

signals received by the aerial before being delivered to the telephones or other instruments (such as recording relays, etc.). The actual energy delivered to the telephones (or loud speaker) is many times that received by the aerial, the additional energy being drawn from a local battery.

The function of an amplifier must not be confounded with that of a transformer, which amplifies the voltage at the expense of current and *vice versa*, so that, neglecting losses, the output is equal to the input. In the case of an amplifier the whole of the output is drawn from the local source of energy and may be many times greater than the input.

The received high frequency oscillations may be amplified before being *rectified*, in which case the amplifier is called a "Radio-frequency Amplifier"; or the signals may be amplified after *rectification* (Audio-frequency Amplifier). See THERMIONIC AMPLIFIER.

Amplifier: Cascade, Power, Speech, etc. See CASCADE AMPLIFIER, POWER AMPLIFIER, etc.

Amplitude. The maximum value attained by an *alternating quantity* in either direction (positive or negative), *e.g.*, an *alternating current*. Sometimes called the "peak value," especially when referring to voltage.

Anchor Gap. Small safety spark gap between *lead-in* of receiving aerial and earth to protect the receiving apparatus against powerful surges set up when transmitting. The high frequency oscillations induced in the receiving aerial pass across the gap instead of through the receiving apparatus.

Angle of Lag. See PHASE DIFFERENCE.

Anode. (a) Of cell: The *electrode* through which the current enters the cell; (b) of a thermionic valve: the plate of the valve. See THERMIONIC TUBE.

Anode Battery. The battery which maintains the *potential* of the anode or plate of a thermionic tube at a given value about that of the filament. See THERMIONIC TUBE.

Anode Characteristic. See STATIC CHARACTERISTICS.

Anode Circuit. See PLATE CIRCUIT.

Dictionary of Technical Terms.—

Anode Converter. A small electric machine with a single armature carrying two separate windings and two commu-

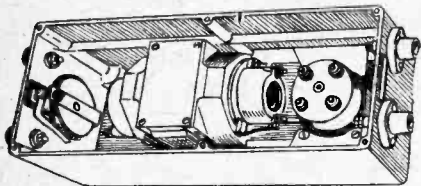

Anode Converter.

tators. One of the windings is designed for low voltage and the other for high voltage. The machine is run from a battery of accumulators (usually 12 volts) on the low voltage side and high voltage at reduced current is obtained from the other winding and used as the *high tension* supply to the anode circuit of a valve transmitter.

Anode Rectification. Refers to the use of a *three-electrode valve* as a rectifier or detector of electrical oscillations by operating the valve at one of the bends in the *static characteristic curve*. No *grid condenser* is employed, and the grid potential is adjusted so that the valve will operate at a point where the curvature of the static curve is greatest, usually at the lower bend in the curve. Then a given increase in grid voltage will cause an increase of plate current which is much greater than the decrease of plate current obtained when

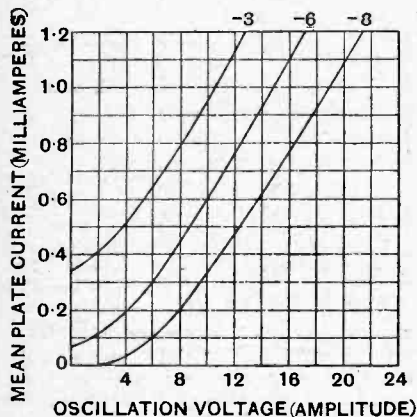

Anode rectification curves with mean grid voltages of -3, -6 and -8.

the grid voltage is decreased by the same amount, so that *rectification* takes place. This method is particularly suitable for the detection of strong signals but is not very sensitive on weak signals. Cf. GRID RECTIFICATION.

Anode Resistance. See RESISTANCE-CAPACITY COUPLING.

Antenna. The aerial system of a wireless station, including the "earth" or *counterpoise*, lead-in, etc. The word means "feeler," and was originally used to denote the aerial system of a receiving station, but is now commonly applied to both sending and receiving aerial systems.

Anticapacity Switch. A type of switch specially designed for use in high frequency circuits, the various parts being so spaced out that the capacity between the various circuits is reduced to a minimum.

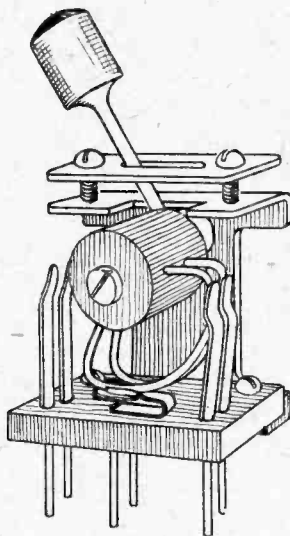

Anti-capacity Switch.

Antinodes. See NODES and LOOPS.

Aperiodic (circuit). An untuned circuit, *i.e.*, one which has no natural period or frequency of its own. A circuit in which the resistance is so high compared with the ratio of inductance to capacity that natural oscillations are impossible. This is the case in any circuit where R^2 is greater than $\frac{4L}{C}$

(where R is the resistance, L is the inductance in henries and C is the capacity in farads). See DAMPING. Cf. OSCILLATORY CIRCUIT.

Aperiodic Aerial. In some receiving circuits the aerial is inductively coupled to a tuned *oscillatory* circuit, no tuning arrangements being included in the aerial circuit itself. An aerial used in this way is often called "aperiodic," although this is not strictly true, since the aerial system is tuned to a fixed wavelength.

Apparent Inductance (of coils). When a condenser of capacity C microfarads is connected across a coil whose true inductance is L microhenries, the wavelength of the oscillatory circuit so formed would be $1885\sqrt{LC}$ metres if the coil had no self-capacity. If C_0 is the self capacity of the coil, the actual wavelength obtained would be $1885\sqrt{L(C+C_0)}$. Now the apparent inductance is that which would give the same wavelength as that measured assuming that no self-capacity existed. Thus, if the apparent inductance is denoted by L_a , the relation would be: wavelength $\lambda = 1885\sqrt{L_a C}$, where C is the capacity

across the coil and λ is the measured wavelength.

$$\text{Thus } L_a = \frac{\lambda^2}{1885^2 C}$$

Apparent Power. The product of volts and amperes in an alternating current circuit where these two quantities are not in phase. Only in the particular case where the current and voltage are *in phase* is the *true power* given by their product. See POWER IN A.C. CIRCUITS and POWER FACTOR.

Apparent Resistance. The ratio of voltage to current in a circuit where these two quantities are not in phase, *i.e.*, the *impedance* of the circuit. See ALTERNATING CURRENT CIRCUITS.

Applied E.M.F. or Applied Voltage. See IMPRESSED E.M.F.

Armstrong Circuit. See REACTION.

Artificial Aerial. An arrangement of coils, condensers and resistances used for testing sending apparatus. The values of the capacity, inductance, and resistance are adjusted to be the same as those in an actual aerial, so that the artificial aerial has similar characteristics as far as measurements are concerned. But whereas in an actual open aerial the *radiation resistance* is a large fraction of the total resistance, the radiation resistance of an artificial aerial is extremely small, so that with the latter arrangement very little radio-frequency energy is radiated out into space. See AERIAL RESISTANCE.

A.T.C. Abbreviation for *Aerial Tuning Condenser*.

A.T.I. Abbreviation for *Aerial Tuning Inductance*.

Atmospherics. Term for the irregular signals or disturbances received in wireless telegraphy due to stray electric waves set up by changes in the electrical state of the atmosphere or to flashes of lightning. A flash of lightning produces powerful etheric waves, which can be heard for thousands of miles on a sensitive receiver. Also called Strays, Static, and X's.

Audibility. The degree to which a given signal is audible in a telephone receiver. It is measured by ascertaining the resistance of a *shunt*, S, which must be connected across a telephone of resistance R to render the signal only just audible. The audibility is then given by $\frac{R+S}{S}$.

Audio-Frequency. A frequency of alternating current which can produce audible sounds in a telephone receiver, *i.e.*, within a range of from about 25 cycles per second to about 10,000 cycles per second. However, the range of frequencies used in ordinary telephony is only from about 100 to 3,000 cycles per second. Cf. RADIO-FREQUENCY.

Audio-Frequency Amplification. See LOW FREQUENCY AMPLIFICATION.

Audio-Frequency Transformer. See INTERVALVE TRANSFORMER.

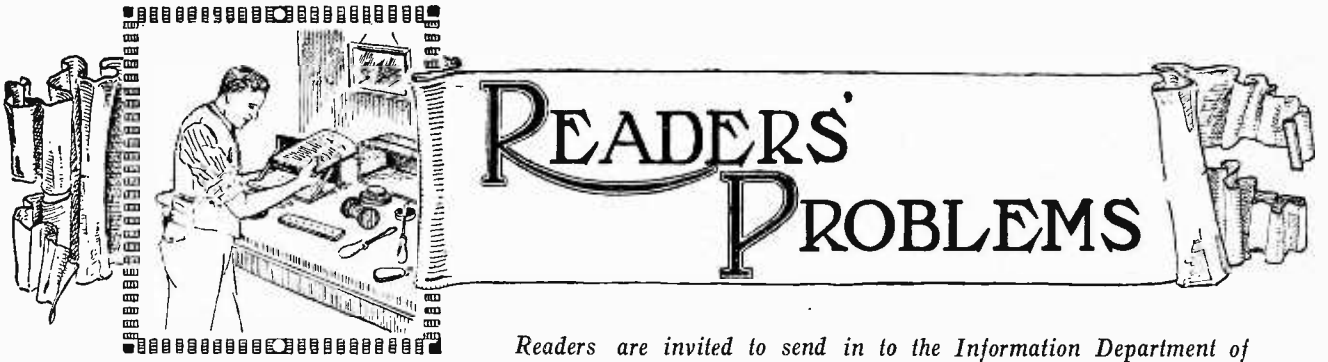

Readers are invited to send in to the Information Department of "The Wireless World," questions relating to their technical difficulties. Every question should be accompanied by a stamped addressed envelope for reply. No charge is made.

Microphonic Valves.

I have just built up a three-valve set (0-v-2), which gives excellent reproduction when the loud-speaker is held in the hand, but when it is placed on top of the cabinet a loud whistle is set up. I am using dull emitter valves throughout. Whistling sometimes occurs when the loud-speaker is stood on a table alongside the set.
F. B.

Our correspondent's trouble is undoubtedly due to the fact that the valves are microphonic, and that actual mechanical vibrations are being transmitted to them by the loud-speaker. The remedy is to fit good anti-microphonic valve holders, or else to mount the loud-speaker at some little distance from the receiver. It will be as well to direct the horn away from the set. Obscure cases of poor quality reproduction without actual howling are sometimes due to a similar cause.

o o o o

Indoor Aerial H.F. Receiver.

Please give me a good circuit, covering the broadcast wavelengths, with three valves (H.F., detector, and L.F.) for use on a very short indoor aerial and an earth consisting of copper gauze mat.
H. F. K.

As a very short aerial is to be used, with what practically amounts to a counterpoise, the grid circuit of the first valve will be lightly damped, and will

very probably oscillate uncontrollably. Our advice is that a set incorporating a neutralised stage of H.F. be made up. A suitable circuit is shown in Fig. 2. The H.F. transformer may be constructed in accordance with the instructions given in the issues of March 25th and April 1st.

lengths are considerable, and to enter into a full description of them is rather beyond the scope of this section. Moreover, the whole object of this type of receiver is to amplify effectively the higher frequencies, and it is not designed to function on long waves.

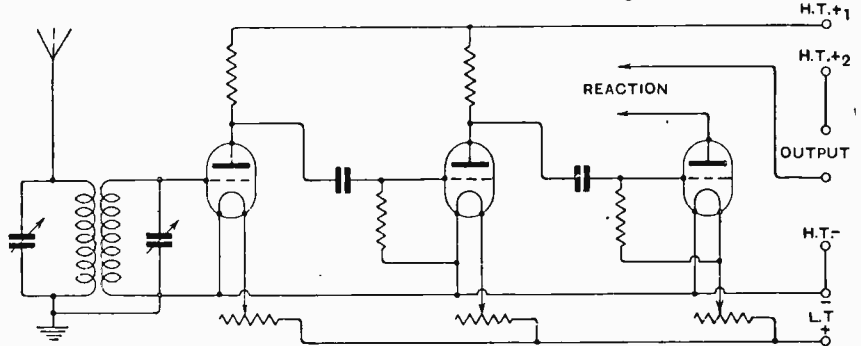

Fig. 1.—Long-wave H.F. amplifier-detector unit.

An All-wave Set.

I wish to make up a highly efficient superheterodyne receiver for the reception of both short- and long-wave stations on the loud-speaker. Please recommend one of your published designs, stating how the necessary modifications may be effected.
A. C. K.

The modifications necessary to adapt a superheterodyne set to the long wave-

In this case we would recommend that one of the supersonic sets recently described, without low-frequency magnification, be constructed, together with a two-valve low frequency amplifier and a long-wave H.F. amplifier-detector unit. If care is taken in design and suitable valves are used, this latter may make use of the resistance capacity method of intervalve coupling. A suitable circuit is shown in Fig. 1. All three units may be built into cabinets of similar height, with terminals arranged for easy interconnection. The L.F. amplifier will, of course, operate with either the long wave or supersonic sets.

o o o o

A Simple Instrument Board.

Please give me a design for an instrument board, using a three-range voltmeter and a double range milliammeter, suitable for general experimental work. I am thinking of adding a microammeter; please include this if you consider that it will be useful.
E. T. D.

It is rather difficult to design a distribution board, unless for some specific line of work. We think that our reader's best course would be to mount his meters in line on a wooden board, with an ebon-

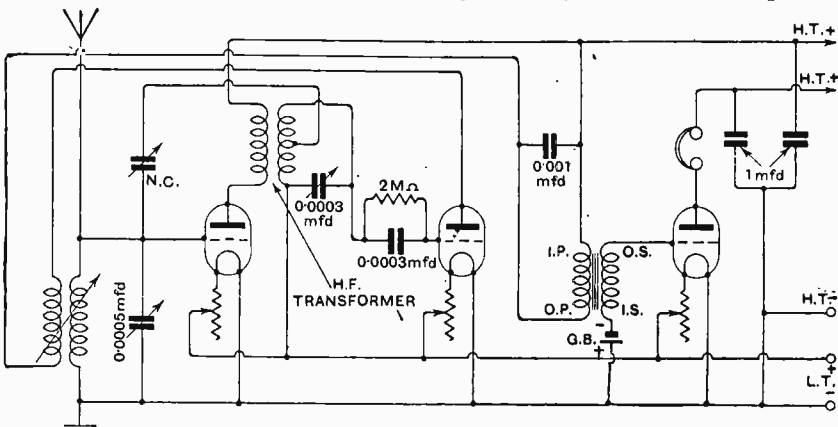

Fig. 2.—Three-valve receiver designed for use with a short indoor aerial.

its strip under them. On this strip would be fitted plug sockets, corresponding with the terminals of the various meters, to which they would be connected at the back of the board. The sockets should be suitably marked. A number of well-insulated flexible leads should be prepared, with a plug at one end to fit the sockets, and perhaps a spring clip or terminal tag at the other.

It will be found that a simple instrument board of this type will be very convenient in use; more so, perhaps, than one containing an elaborate system of switches and terminals.

Regarding our correspondent's enquiry respecting the utility of a microammeter, it may be said that a reliable instrument of this description will be found most useful. It can be used for plotting the grid currents curves of amplifying valves, and measuring high resistances and crystal outputs. A useful type is that having a sensitivity of about 5 microamps per scale division.

o o o o

Neutrodyne Tuning.

I have recently constructed the "Neutrodyne Four" described in issues of The Wireless World dated March 25th and April 1st, 1925. Although results both as regards selectivity and range are excellent, I am somewhat worried by the fact that the third condenser reads nearly 20 degrees higher on most stations than does the preceding one. The coils were carefully made to the instructions given. While this is perhaps not a very serious drawback, operation of the receiver is not so easy as if both dials read the same. How can I best remedy the trouble? C. M. A.

It seems certain that the trouble lies in the fact that the turns of the secondary winding of the third transformer have been too widely spaced. (In this design, a spaced winding was specified in order to ensure a part of the grid coil being in close inductive relation with the reaction coil.) We would recommend that the coil be rewound, with slightly less spacing than before, and, if the third condenser still reads low, a few more turns may be added. This procedure is not likely to have any bad effects. It is also possible that there are slight differences in the actual capacities of the two variable condensers.

o o o o

Trouble on Short Waves.

I have recently constructed a single-valve receiver for very short waves, and am unable to make it oscillate on any part of the tuning range when the aerial is connected. Kindly give me some indication of the probable source of the trouble. H. A. C.

It seems probable that the coupling between the aerial and grid coils is too tight. On wavelengths of 50 metres and below this coupling should be made extremely loose, both by using only one or two turns, and sometimes by actually varying the position of this coil in relation to the grid coil.

BOOKS FOR THE HOME CONSTRUCTOR

Issued in conjunction with "The Wireless World."

"THE HOME CONSTRUCTOR'S EASY-TO-BUILD WIRELESS SETS," by F. H. HAYNES. Price 1/6 net. By Post, 1/9.

"TUNING COILS AND METHODS OF TUNING," by W. JAMES. Price 2/6 net. By Post, 2/10.

"HOW TO BUILD AMATEUR VALVE STATIONS," by P. R. COURSEY, B.Sc. Price 1/6 net. By Post, 1/8.

"THE CONSTRUCTION OF AMATEUR VALVE STATIONS" by Alan L.M. DOUGLAS. Price 1/6 net. By Post, 1/8.

"THE HOME CONSTRUCTOR'S WIRELESS GUIDE," by W. JAMES. Price 3/6 net. By Post, 3/9.

"MAST AND AERIAL CONSTRUCTION FOR AMATEURS," by F. J. AINSLEY, A.M.I.C.E. Price 1/6 net. By Post, 1/8.

Obtainable by post (remittance with order) from
ILIFFE & SONS LIMITED,
 Dorset House, Tudor St., London E.C.4,
 or of Booksellers and Bookstalls

Another rather unusual source of trouble which we have encountered is due to the breaking of one of the strands of the usual 7/22 enamelled aerial wire, near the lead-in. This fairly well-insulated free wire imposes heavy damping on the aerial circuit, and might well be the cause of our reader's trouble, particularly as he is unable to obtain oscillations anywhere on the tuning scale.

o o o o

Adding H.F. to a Reflex.

I am thinking of rebuilding my single-valve reflex receiver, and, if it is practicable, at the same time adding a stage of high-frequency amplification. Please give me your opinion, and also a circuit diagram. W. P. L.

It is certainly quite possible to add a high-frequency amplifier to a receiver of this type. One of the easiest ways of

doing this is shown in Fig. 3. Various refinements, such as the addition of loose coupling and neutralised H.F., may be added.

It should be pointed out that this receiver requires some care in design and operation, but is capable of giving ex-

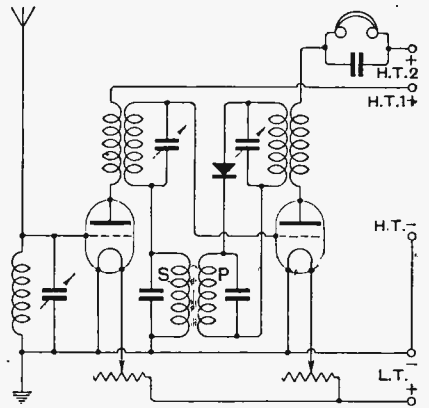

Fig. 3.—Reflex receiver preceded by a stage of H.F. amplification.

tremely good results. Particular attention should be given to the choice of valves, transformers (both H.F. and L.F.), and crystal detector, with a view to their working together in the most efficient manner possible.

o o o o

Reflex Difficulties.

I am having trouble with my single-valve reflex set, in that the crystal refuses to operate, signals being often as strong when the catwhisker is not in contact with the crystal. The latter is a good one, and works excellently in a plain crystal set. Any information which will help me to locate the fault will be appreciated. A. A.

There are several possible causes of this trouble. It may be that, due to incorrect H.T. voltage, filament brilliancy, or grid bias, the valve is functioning as a detector on the bend of the curve. The remedy here is obvious. Care should also be taken to ensure that the amplified high-frequency currents are being applied to the crystal in the most efficient manner possible. A test of this may most easily be made by connecting the telephones in series with the output circuit of the crystal—say between crystal and L.F. transformer primary. The receiver will then act as a plain H.F. valve followed by the crystal rectifier, and it will be found easier to judge the effect of any modification which may be made. It will, of course, be necessary to bridge the original telephone terminals of the set, in order that the valve may be supplied with H.T.

In spite of the fact that the L.F. transformer primary in a crystal-reflex set is not in the anode circuit, and consequently is not called upon to stand high voltages, the possibility of a breakdown here should not be overlooked; it would cause the symptoms mentioned in our correspondent's letter.

YOUR WIRELESS PROBLEMS

BEWARE! THE LONG BILL WRITE TO US

The Wireless AND RADIO REVIEW World

No. 323. WEDNESDAY, OCTOBER 21ST, 1925. VOL. XVII. No. 17.

<p>Assistant Editor: F. H. HAYNES.</p> <p>Editorial Offices: 139-40, FLEET STREET, LONDON, E.C.4</p> <p>Advertising and Publishing Offices: DORSET HOUSE, TUDOR STREET, LONDON, E.C.4.</p> <p>COVENTRY: Hertford Street. <i>Telegrams: "Cyclist Coventry." Telephone: 10 Coventry.</i></p>	<p>Editor: HUGH S. POCOCK.</p> <p>BIRMINGHAM: Guildhall Buildings, Navigation Street. <i>Telegrams: "Autopress, Birmingham." Telephone: 2970 and 2971 Midland.</i></p>	<p>Assistant Editor: W. JAMES.</p> <p>Telephone: City 4011 (3 lines). Telephone: City 2847 (13 lines).</p> <p>MANCHESTER: 199, Deansgate. <i>Telegrams: "Iliffe, Manchester." Telephone: 8970 and 8971 City.</i></p>
<p>Telegrams: "Ethaworld, Fleet, London."</p> <p>Subscriptions Rates: Home, £1 1s. 8d.; Canada, £1 1s. 8d.; other countries abroad, £1 3s. 10d. per annum.</p> <p><i>As many of the circuits and apparatus described in these pages are covered by patents, readers are advised, before making use of them, to satisfy themselves that they would not be infringing patents.</i></p>		

MORE PROBLEMS FOR GENEVA.

AS a first step taken by the B.B.C. towards meeting the recommendations made at the recent Broadcasting Conference at Geneva, there has now been installed, as most readers are aware, an experimental transmitting station located at Chelmsford, with call-sign 5GB, which is working within the normal broadcast band and with a power of approximately 10 kW. This power is much in excess of that of the average main broadcasting station. The object, as we understand from the B.B.C., is to test out experimentally whether an increase in the power of some of the British stations will result in any interference with commercial or Government communications. If no interference is reported, there is every probability that the Post Office will be able to authorise an increase in power of various stations throughout the country so as to pave the way for reducing the total number of B.B.C. stations, whilst, in effect, covering the same areas as satisfactorily as at present. This indicates that the B.B.C. intends to do whatever is possible to conform to the Geneva recommendations. But of what use will be this action if in the meantime other European countries do not follow suit?

More New Stations.

An announcement has just been made regarding a programme for the establishment of broadcasting stations in Spain, and it is there proposed that, during the years 1925, 1926, and 1927, a total of twenty-one broadcasting

stations shall be put into operation. This figure, of course, includes stations already giving service. The power of seven of the stations is to be rated at 4 to 8 kW. each, and the remaining stations will be 1½ to 2 kW.

If we consider the reasonableness of this programme in terms of the area to be covered, we find that, in comparison with the stations of Great Britain, Spain is entitled to approximately this number to complete a service throughout the country.

It would seem that the only possible solution is for very prompt action to be taken by Geneva to decide not only what shall be done to minimise the existing interference but also to find some method of meeting future requirements of the various European countries before Europe is involved in a tangle more hopeless than ever.

In reviewing the work of the Geneva Conference in our issue of September 23rd, we pointed out that there are still several countries where broadcasting has not developed to any considerable extent, and that, in our opinion, it is to these countries that a band of shorter wavelengths should be allotted. This would bring about the least dislocation of any existing organisations or industries.

Moreover, in these countries, where the manufacture of broadcast receivers as an industry has scarcely been entered upon, designers would be in a position to produce apparatus suited to the particular waveband selected.

There seems to be no other solution, but, unless immediate action is taken, the difficulties in the way of effecting even this remedy will be enormously augmented.

CONTENTS.		PAGE
EDITORIAL VIEWS	529	
TWO-VALVE NEUTRODYNE UNIT ...	530	
By W. James.		
INTRODUCTION TO WIRELESS THEORY ...	536	
By N. V. Kipping and A. D. Blumlein.		
ON HOLIDAY WITH A SUPER-HET. ...	539	
By Capt. Ian Fraser.		
CURRENT TOPICS	543	
CIVIL AVIATION WIRELESS	545	
By D. Sinclair.		
INTERNATIONAL OPERATING SIGNALS	550	
HINTS AND TIPS	551	
NEW APPARATUS	553	
BROADCAST BREVITIES	555	
DICTIONARY OF TECHNICAL TERMS.	557	
THE NEW YORK RADIO EXHIBITION	559	
LETTERS TO THE EDITOR	562	
READERS' PROBLEMS	563	

TWO VALVE NEUTRODYNE UNIT

How to Build a Non-Oscillating, Selective, High-Frequency Amplifier for 220-520 Metres.

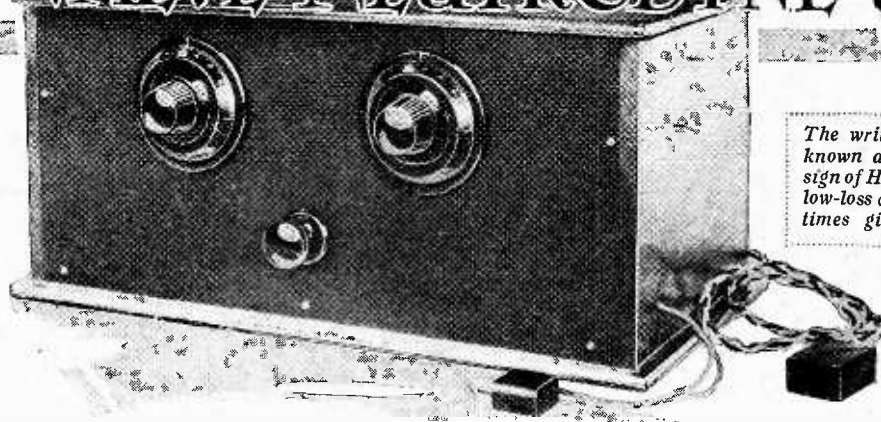

The writer, who is a well-known authority on the design of H.F. amplifiers using low-loss coils, has at different times given designs for a number of complete neutrodyne receivers. This article describes a unit which can be used with almost any existing set.

By W. JAMES.

THERE are many amateurs who, during the summer months, are content to receive the local and the high-power broadcast stations, and very excellent results can be obtained with a receiver comprising a detector and audio-frequency amplifier. These amateurs know that during the summer months atmospheric conditions are generally not favourable for the satisfactory reception of distant stations, and a good deal of dodging about has to be done before a distant station that is really worth listening to can be tuned in. From about this time of the year until the spring, however, excellent reception

an amplifier, it might be as well briefly to discuss the subject of high-frequency amplification.

Stabilising Tricks.

We are all familiar with the types of circuit illustrated in Figs. 1 and 2, where L_1, C_1 in each circuit is the tuner; C_2, L_2 , Fig. 1, a tuned anode circuit; and C_2, L_2, L_3 , Fig. 2, a tuned high-frequency transformer; and we know that such circuits tend to oscillate and to be quite unmanageable unless special precautions are taken to stabilise them. The majority of methods for stabilising these circuits are essentially methods for reducing the amplification to a figure where the amount of energy which passes back and excites the input circuit is insufficient to reduce the effective resistance of the circuits to the point where they become unstable. Usual methods are to damp the tuned circuits by introducing resistance, into the coils either by winding them of fine wire, by adding resistance, or by mounting the coils near metal objects, such as condensers; sometimes a resistance is put in series with the tuning condensers or across the tuning condensers. The effect in each case is the same, namely, so to reduce the amplification that the reaction effect is insufficient to produce a condition of instability. These stabilising tricks often destroy selectivity.

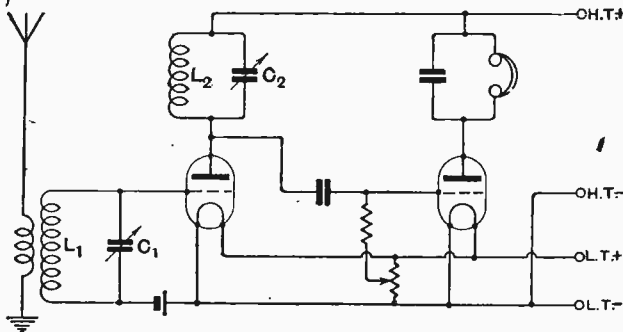

Fig. 1.—A receiver with a tuned anode coupled H.F. stage.

of distant stations can be had, provided the receiver is of suitable design. The requirements of a receiver for good distance work are selectivity and sensitivity, while a suitable receiver would be of the non-oscillating type, easily handled and not hard to build.

Some form of high-frequency amplification is a necessity, and it follows from the above remarks that it would be convenient if the high-frequency amplifier were a self-contained unit that could be connected to the existing detector and audio-frequency set when and as required. Fortunately, a non-oscillating selective high-frequency amplifier is not a difficult thing to make, neither is it expensive; but, before describing the construction of this

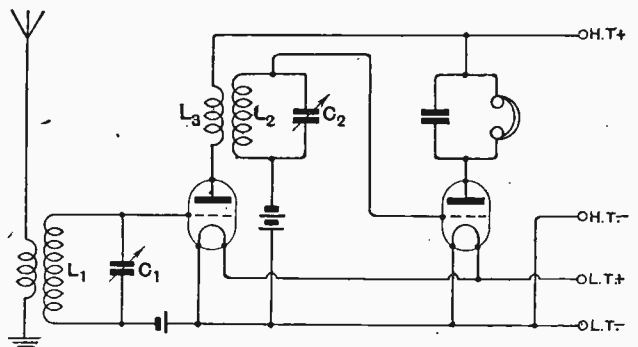
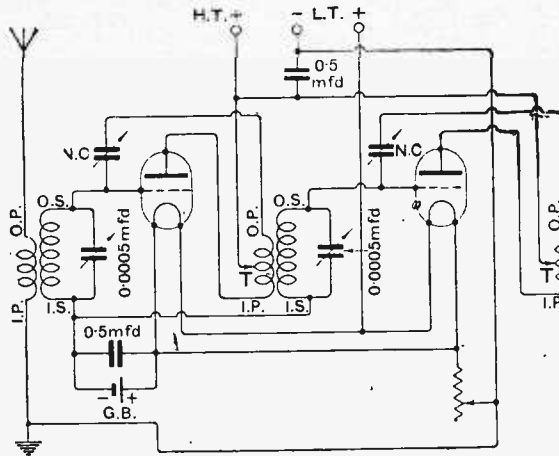

Fig. 2.—Connections of a set with a tuned H.F. transformer.

Two-valve Neutrodyne Unit.—

A further scheme is to increase the ratio of capacity to inductance in the Fig. 1 circuit. This increases the selectivity of the amplifier, but reduces the amplification



stance, on the type of valve and the position of the primary with respect to the secondary, on the size of wire and the spacing of the turns.
If the number of turns in the primary circuit is small,

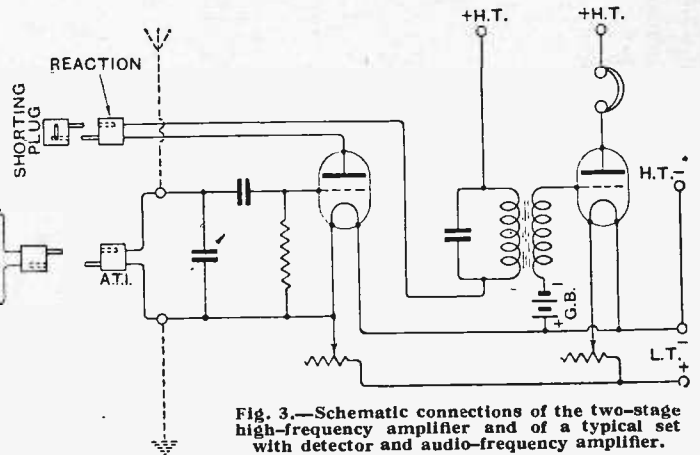

Fig. 3.—Schematic connections of the two-stage high-frequency amplifier and of a typical set with detector and audio-frequency amplifier.

and cannot be carried too far because the tuning range of a given coil is seriously reduced.

In the Fig. 2 circuit we can design coil L_2 to give the desired tuning range with C_2 , and procure stability and at the same time selectivity, by reducing the turns in coil L_3 . When the number of turns in this coil

is reduced below a certain value, the transformer I_3, L_2 no longer behaves as a true tuned H.F. transformer, as the condenser C_2 , while tuning L_2 to resonance, does not tune the primary to resonance. The circuit can be made very selective, however, by the simple process of reducing the turns in coil L_3 , but, unfortunately,

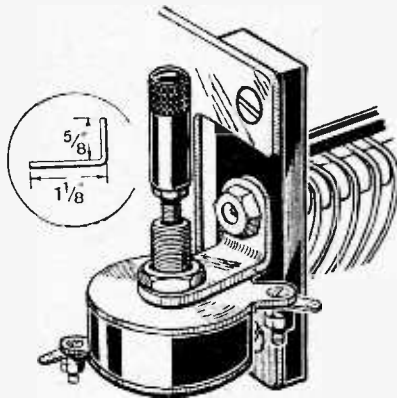

Fig. 4.—Method of mounting a neutralising condenser on the end of a tuning condenser.

the amplification suffers, and, if the set is made stable at the highest frequency at which it is to be used, the amplification at the lowest frequency is usually very poor indeed.

Design of Primary Windings.

In the receiver described below a good deal of care has been taken to secure a balance between the degree of amplification and selectivity required, in conjunction with valves of a certain type. The tuning range of the transformers depends mainly on the size of the tuning condensers and the inductance of the secondary coils, the mutual inductance due to the effect of the primary being negligible, to a first approximation.

The number of primary turns which can be used depends on quite a number of things. It depends, for in-

stance, on the type of valve and the position of the primary with respect to the secondary, on the size of wire and the spacing of the turns.
If the number of turns in the primary circuit is small, the voltage set up across it will be small, and therefore the voltage applied to the grid of the next valve will also be small. The primary winding must also be constructed in such a way that its self-capacity and its capacity with the secondary winding is very small. To secure this the primary may be wound with a fine gauge of wire, the winding being spaced from the secondary, and the wire lying directly over the spaces between the turns of the secondary.

The Circuit Used.

This unit uses a neutrodyne device, the circuits being balanced by means of small condensers; if the condensers are not properly set the circuits will oscillate violently. The circuit of the two-valve high-frequency amplifier is given in the left-hand portion of Fig. 3, the connections on the right-hand side being those of a typical set with a detector and audio-frequency magnifier.

The unit itself has three high-frequency transformers, one being connected between the aerial and the grid of the first valve, the second between the anode of the first

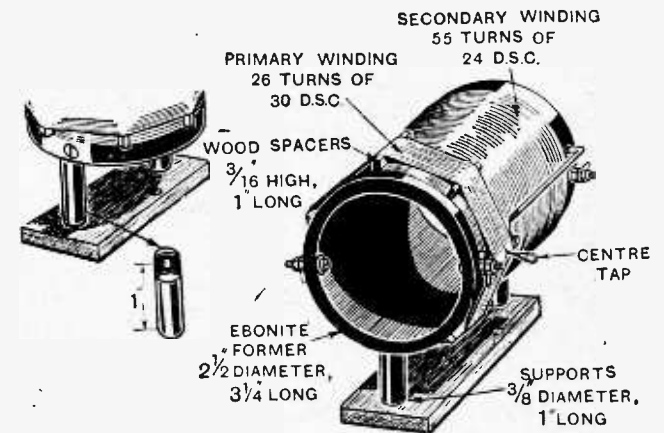

Fig. 5.—Showing the construction of the three high-frequency transformers.

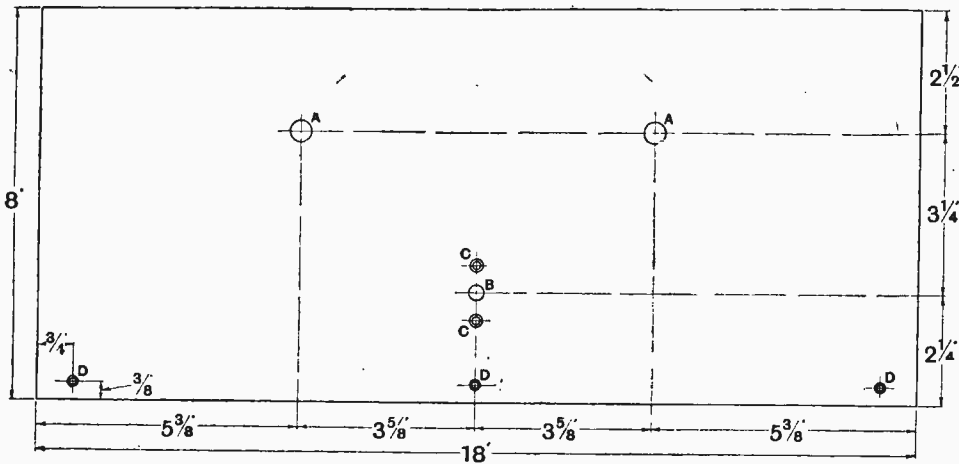

Fig. 6.—Details of the ebonite front panel: A, 7/16in. dia.; B, 5/16in. dia.; C, 5/32in. dia. and countersunk for No. 4 B.A. screws; D, 1/8in. dia. and countersunk for No. 4 wood screws.

valve and the grid of the second, while the primary of the third is connected to the anode of the second valve. A 0.0005 microfarad condenser is connected across the secondary windings of the first and second transformers to tune them. On the right-hand side of the diagram of the amplifier will be seen the secondary winding of the third transformer, the two ends being connected by two short lengths of flex to the contacts of a coil plug.

Referring now to the detector-audio-frequency set, it will be noticed that it is of the type having a two-coil holder, one holder being for the reaction coil and the other for the aerial coil. The aerial coil is tuned by a 0.0005 microfarad condenser connected across it.

When the H.F. unit is to be added, the coils are removed from the two-coil holder and the plug connected to the secondary of the H.F. transformer is plugged in the aerial (A.T.I.) socket. A short-circuiting plug is put in the reaction coil holder and the aerial and earth are taken off and connected to the H.F. amplifier. The aerial tuning condenser connected to the grid of the detector is now across the secondary of the third H.F. transformer, and is used to tune it to the same wavelength as the others.

In order to obtain the maximum amplification, and the highest degree of selectivity permitted by considerations of good quality, it is necessary so to construct the coils of the H.F. transformers that they are of low H.F. resistance. The secondary windings are therefore wound with a fairly thick wire (No. 24 D.S.C.), the turns are spaced, and thin ebonite formers are used. The coils have an inductance of 145 microhenries, and when tuned with a 0.0005 microfarad variable condenser have an actual tuning range of 220 to 520 metres. The tuning range is not quite what one would expect by calculation when using the known values of coil inductance and condenser capacity, because of the stray capacity in the circuit and the

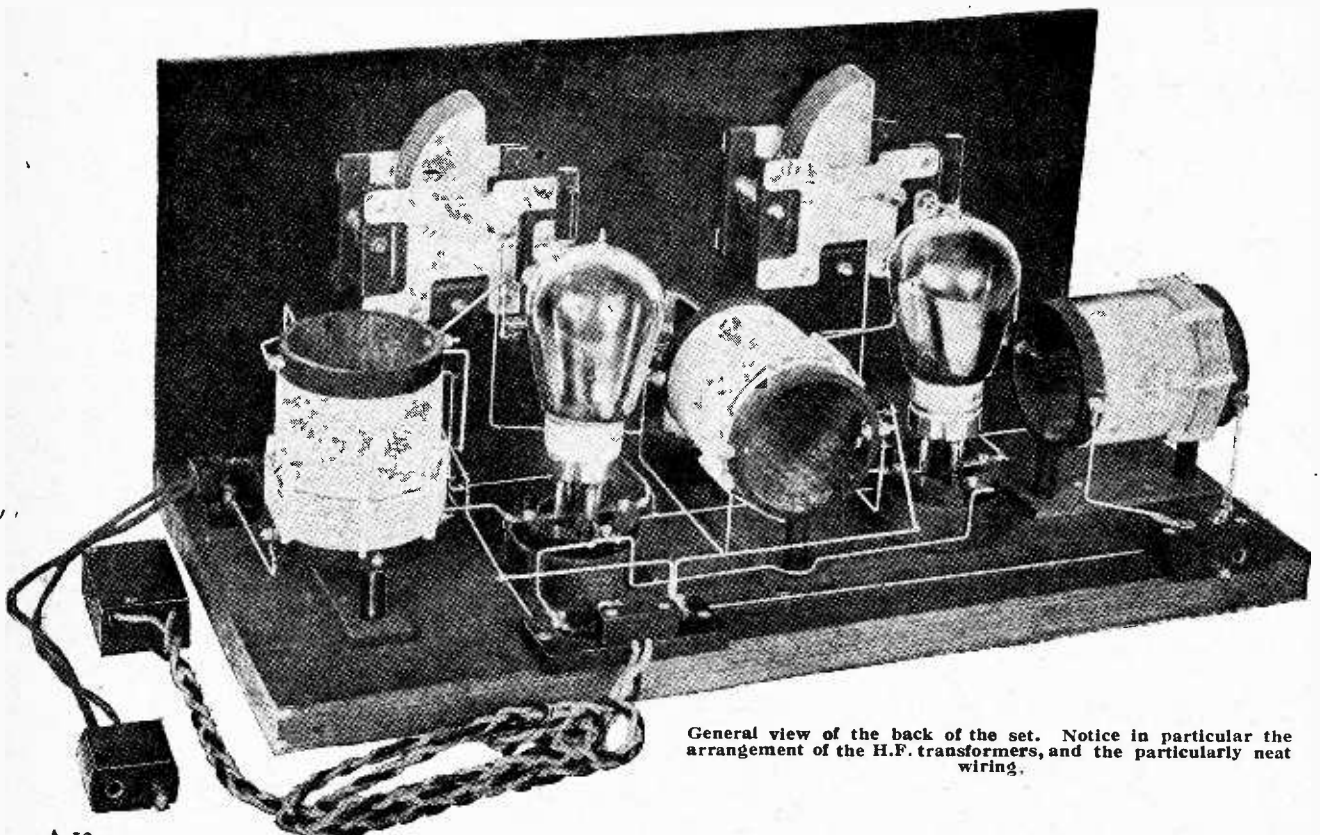

General view of the back of the set. Notice in particular the arrangement of the H.F. transformers, and the particularly neat wiring.

Two-valve Neutrodyne Unit.—

mutual inductance of the primary with the secondary. The gauge of wire was chosen as being one which, with the spacing adopted, gives an inductance of a little lower H.F. resistance for the size of coil than would be obtained by winding with a thicker wire.

The primary windings connected in the anode circuits

winding is $2\frac{1}{2}$ in., and the ends are soldered to tags held in position by screws and nuts. Over one end of each secondary winding is put the primary winding. In the case of the transformer connecting the aerial with the first valve the primary winding has 13 turns of No. 30 D.S.C., while the two remaining transformers have a total of 26 turns of No. 30 D.S.C., with a tapping at

Another view which shows the position of all the parts used in the construction of the set.

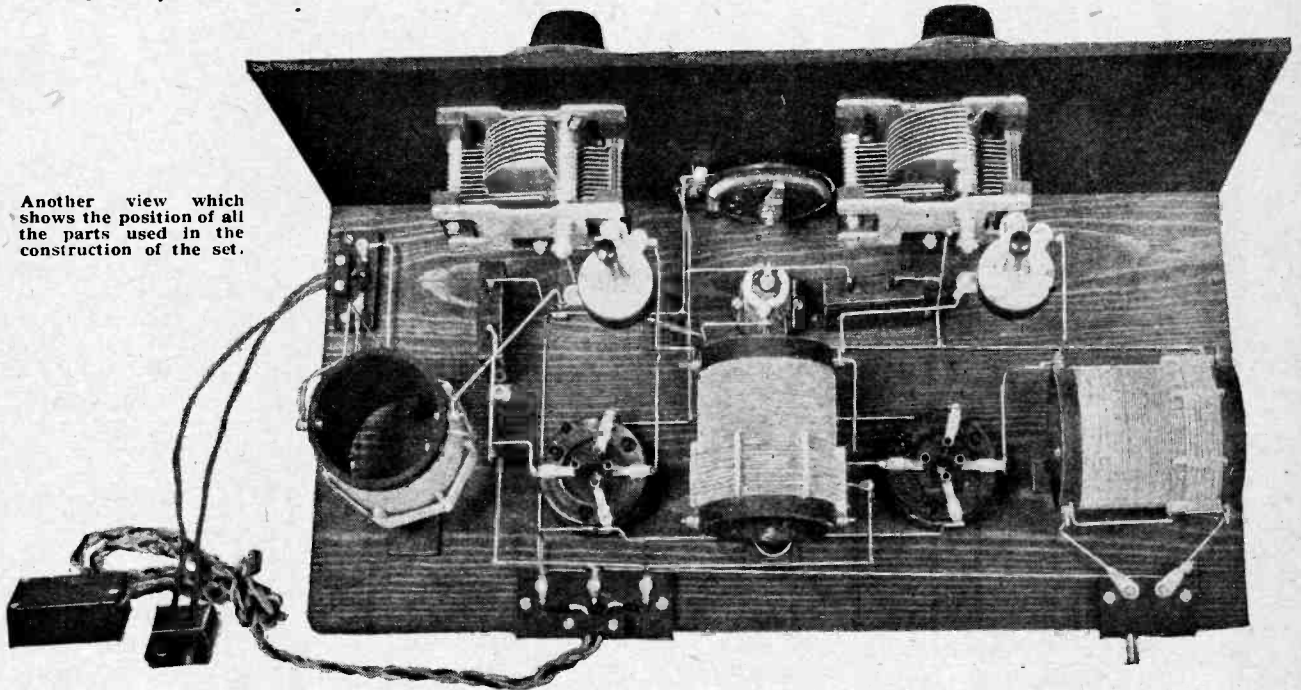

of the two high-frequency valves are of the double type popularised by the writer in the *Wireless World* for June 24th and October 1st, 1924, and a rather special form of construction is used.

Constructing the Coils.

The secondary windings have 55 turns of No. 24 D.S.C. wound on an ebonite tube $2\frac{1}{2}$ in. in diameter, $3\frac{1}{4}$ in. long with $\frac{1}{8}$ in. wall. The actual length of the

centre turn. The coils are all wound in the same direction.

The construction of the coils will be gathered from Fig. 5 and the photographs. It will be seen that the primary winding is wound on eight wood spacers $\frac{1}{8}$ in. high by 1 in. long laid on one end of the surface of the secondary, the spacers being held quite firmly by the wire. This spacing has been found to give a suitable degree of selectivity when D.E.5 (amplification factor 7, impedance 8,000 ohms) amplifying valves are used.

The coils are mounted in the peculiar manner shown in the photographs and in Fig. 7, the object being to minimise and, if possible, to prevent magnetic coupling between the transformers. The first and second transformers are mounted on a small base as shown in the right-hand sketch, Fig. 5. The lower piece of wood is $3\frac{1}{2}$ in. long by 1 in. wide, and the ebonite supports are 1 in. long and $\frac{3}{8}$ in. diameter. These are tapped and are screwed to the base and to the coil former.

The third transformer

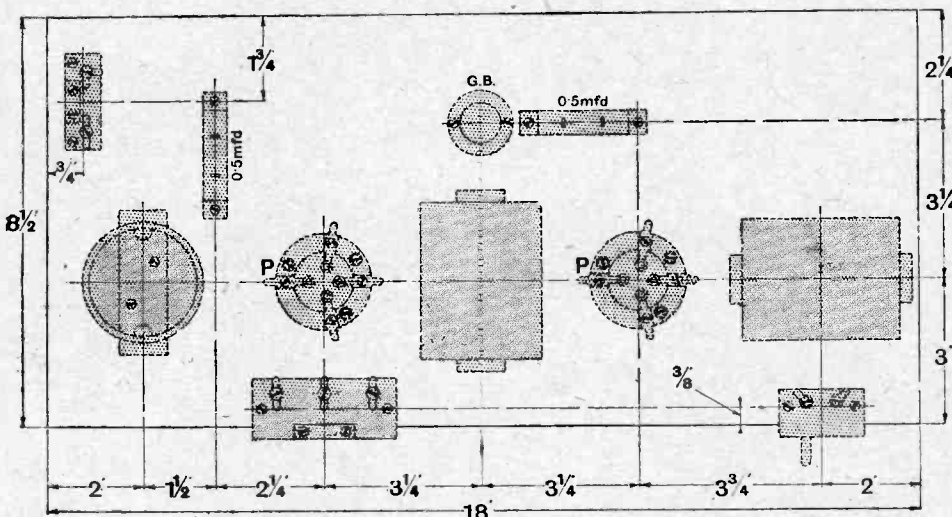

Fig. 7.—Arrangements of parts on the baseboard.

Two-valve Neutrodyne Unit.—

stands on end, and has a wooden base 3in. long by 1in. wide, and is raised by two ebonite supports, the construction of which may be gathered from the sketch in Fig. 5.

The Neutralising Condensers.

Referring to Fig. 3 for a moment, it will be noticed

condensers, the method adopted being shown in Fig. 4. A piece of brass strip was bent to the shape indicated and fastened to one of the insulating strips of the condenser by a nut normally used to hold the fixed plates; the top plates of the neutralising condenser, therefore, are electrically connected to the fixed plates of the tuning condenser. The side of the neutralising condenser which is con-

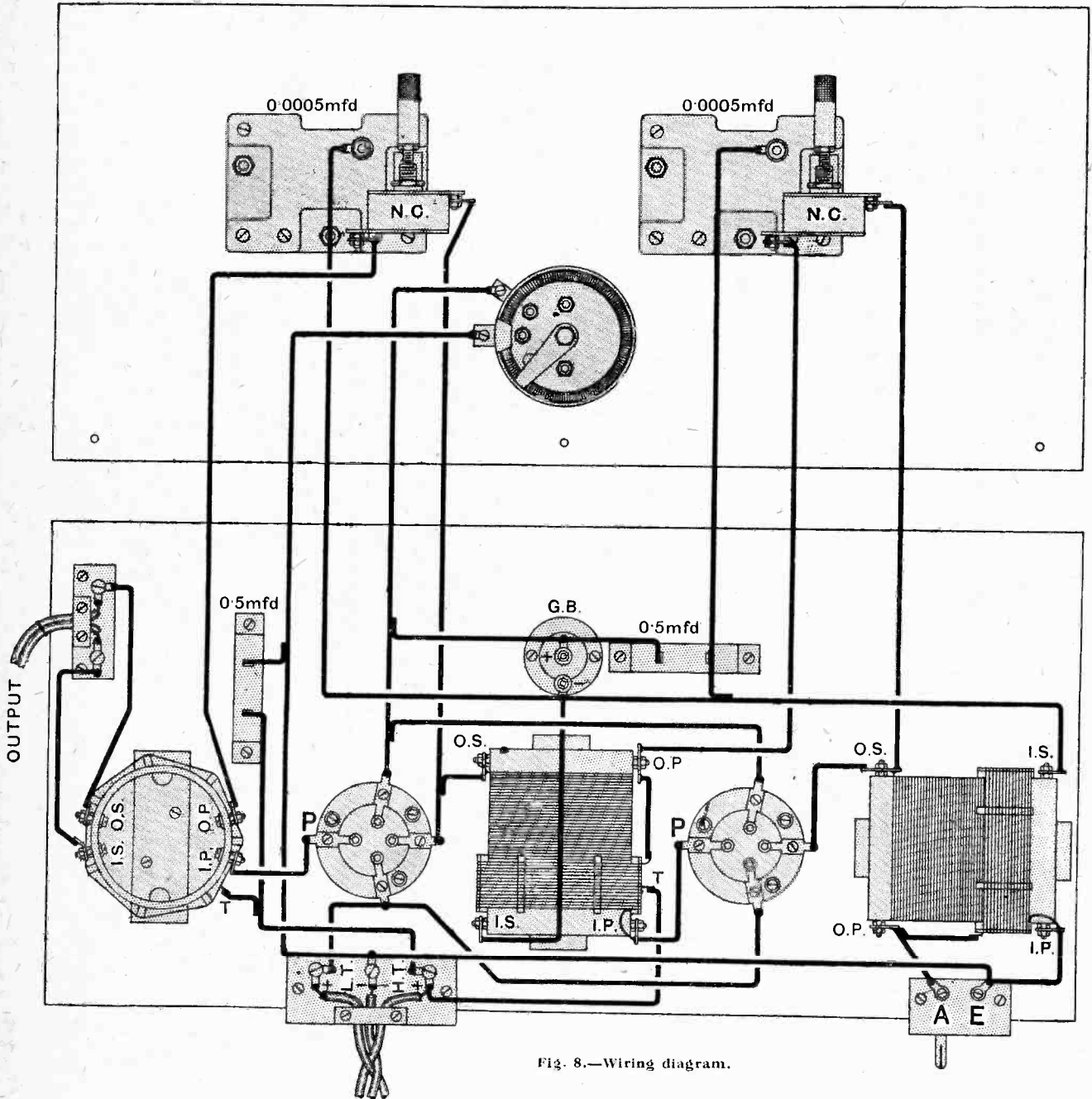

Fig. 8.—Wiring diagram.

that one side of each of the neutralising condensers (N.C.) is connected to the grid of the first and second valves respectively, and also to one side of the 0.0005 microfarad tuning condensers. The neutralising condensers were, therefore, mounted on the end of the tuning

connected to the fixed plates of the tuning condenser, should be noted when wiring up.

If the connections of the neutralising condensers, Fig. 3, are examined, it will be seen that if these condensers are short-circuited, positive H.T. is connected to the grids

COMPONENTS USED IN THE SET.

- | | |
|---|---|
| <p>1 Ebonite panel, 18in. × 8in. × ¼in. (Britannia Rubber and Kamptulicon Co., Ltd.).
 1 Baseboard, 18in. × 8½in. × ¾in.
 2 0.0005 mfd. square law tuning condensers (Ormond Engineering Co.).
 2 Neutrodyne condensers (Gambrell).
 1 6 ohms filament resistance (Burndept).
 2 0.5 mfd. fixed condensers (Telegraph Condenser Co.)
 1 1½-volt dry cell.</p> | <p>2 Anttpong valve holders (Bowyer-Lowe).
 2 Coil plugs (Burndept Wireless).
 2 Short circuiting plugs (Burndept Wireless).
 3 pieces of ebonite tube, 3½in. long, 2½in. diameter, ¼in. wall.
 1 Can't Cross Connector.
 2 Super Vernier dials, type B (Burndept Wireless).
 1 Piece of ebonite, 3in. × 1¼in. × ¼in.
 1 Piece of ebonite, 2in. × ¾in. × ¼in.
 1 Cabinet.</p> |
|---|---|

of the valves and to the filaments. With the type of neutralising condensers used, it was found desirable to place a disc of paper or mica between the moving and the fixed plate, to prevent any possibility of short circuiting taking place.

Building the Unit.

The unit is a particularly easy one to build, as the components are well spaced and are few in number. It has a panel which carries the two tuning condensers and filament rheostat, and a baseboard which carries the remainder of the components. Figs. 6 and 7 show the exact position of the parts, while the two illustrations give general views of the back of the set. The coil on the right-hand side is the one connected between the aerial and the first valve, while the secondary coil on the left-hand side is connected to a small connection strip of ebonite, and a coil plug by means of two short leads of flex. It is quite essential to space the coils as shown, for if attempts are made to operate a set in which the coils have been placed together without due regard to the effect of magnetic fields, it will not be found possible to stabilise the amplifier. The two valve holders are arranged in line with the three coils, and they are mounted on circular pieces of wood 1in. thick, the object of this being to simplify wiring and to reduce the length of the grid and plate wires.

The particular arrangement of the coils should be noted; for instance, the primary winding of the first transformer is on the right-hand side, while the primary of the second transformer is on the end remote from the panel. The third transformer has its primary on the end of the secondary nearest the baseboard. The two connection strips which can be seen are merely small pieces of ebonite having three and two screws respectively and a cleat to clamp the flexible connections. The longer of the two strips measures 3in. × 1¼in. × ¼in., while the second strip is 2in. × ¾in. × ¼in.

Wiring the Receiver.

The wiring diagram, Fig. 8, shows all the connections quite plainly, and, if compared with the photographs, it should be found quite an easy matter to wire in a neat and efficient manner. The filament wires are run, between the various points, along the baseboard; so is the earth wire and the + H.T. wires. The grid and plate wires should be run in as direct and short a path as possible, and should, of course, be quite clear of each other. Particular attention should be given to the wiring of the neutralising condensers, because, as previously explained, the neutralising condensers are mounted to the end of the tuning condensers and a common connection is, there-

fore, made with one side of the tuning condensers and one side of the neutralising condensers. It is very important to wire the coils exactly as indicated.

Operating the Set.

The aerial and earth should be connected to a coil plug, and this plug put into the holder provided on the set, and the battery plug which is connected to three wires (one H.T. + and one each for the L.T. battery) should be put in its holder. This holder can conveniently be screwed to the back of the existing set and wired in cir-

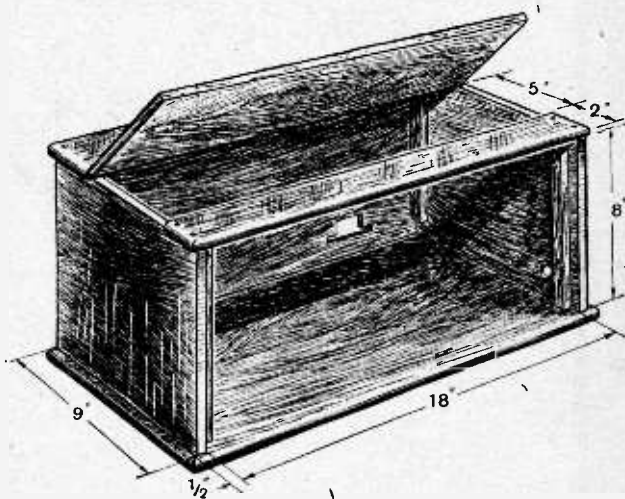

Fig. 9.—Details of a cabinet for the Unit.

cuit. Also put the output plug into the aerial socket of the existing receiver and short-circuit the reaction coil.

With two D.E.5 valves in the valve holders tune in the local station. To balance the set take out the first valve, put a piece of paper over the leg which fits in the socket connected with + L.T., put the valve back in the holder, and adjust the first neutralising condenser so that no signal is heard. If this stage is properly balanced, the signals should be heard quite loudly when the first valve is removed from the holder. Now restore this valve, and deal with the second valve and neutralising condenser in the same manner. If the neutralising condensers have been set carefully it should now be found possible to tune over the whole range without the set oscillating.

It is extremely important to remember that the amplifier is designed for D.E.5 valves; a design for valves of the high impedance class is being worked out and will be published shortly.

INTRODUCTION TO WIRELESS THEORY

Elementary Principles of Magnetism and Electricity.

By N. V. KIPPING and A. D. BLUMLEIN.

EXACTLY what electricity is has been worrying scientists for many years. Far more is known about what electricity can be made to do—that is to say, about its properties—than about what it is; but it is now thought to consist of very small particles, called electrons. These particles are much smaller even than atoms, and it is difficult to conceive them as single objects. Consequently, it is easy to think of an electric current as a flow of water. An electric current flowing in a wire is very like a flow of these electrons, and is very like a flow of water in a pipe.

Now, the reason why we have pipes through which water is intended to flow is because we want to direct the water along a certain course, and we know that the water cannot flow through the solid wall of the pipe, but only along the hollow interior. In just the same way electricity will flow easily along a metal wire, but the air surrounding the wire will stop it leaking out.

The wire is, therefore, called a conductor of electricity, and the air a non-conductor, or insulator. All substances can be divided broadly into the two groups of conductors and insulators (non-conductors); actually no known substance is a perfect insulator, as each will let electricity flow in it to some extent. The groups are divided according as a substance is most useful for providing a path for electricity to flow, or for preventing electricity from leaking out.

Conductors and Insulators.

Most metals are good conductors, and the earth itself is a fairly good conductor. Porcelain, paper, glass, rubber, ebonite, mica, and similar substances are good insulators when dry.

Now, there is one difference between a water system and an electric system—or electric circuit, as it is called. In a water system we can always add more water, or take away water from the system. An electric circuit, however, is always full of electricity, and we can neither add to nor take away from the total quantity. What we can do is to arrange that the electricity flows round a closed circuit, without the total quantity being altered. In order to get an idea of this it is easy to imagine a water system in which there is no way in or out for the water, the system being full of water.

For instance, in Fig. 1 we have a simple water circuit

with a paddle P for driving the water round. By making this paddle revolve, we can make the water circulate round the system. What causes the water to circulate round the system is the pressure exerted by the paddle. If the paddle ceased to exert pressure on the water, the water would cease to circulate, and, of course, the greater the pressure exerted by the paddle, the faster the water would circulate.

The electrical analogy to this is a wire connecting the two terminals of a battery. A battery is a device for exerting an electrical pressure, tending to make an electric current flow, so that, when a wire is connected across the terminals of a battery, current will flow round the closed circuit consisting of the wire and the battery. A battery is *not* a store of electricity, but merely a device which will push current round a circuit, just as the paddle will push water round a pipe system.

This electrical pressure is called electromotive force (abbreviated as e.m.f.), and loosely it is known as voltage, as it is measured in *volts*. Electromotive force is not a quantity of electricity, but is simply the pressure which is available to force a current round a circuit when the circuit is complete. It is possible to have an e.m.f. without any current flowing, just the same as a steam boiler may have a pressure of 100 lb. per square inch, even though all the steam exits are closed, and it is not being used at the moment. A battery by itself, with no wires connected to it, has a definite e.m.f. or a definite pressure which it exerts when called upon to do so.

The Unit of Electrical Pressure.

Volts, then, are the same kind of measure as pounds per square inch in a boiler. Voltage is one of the two most fundamental quantities met with in electrical engineering. The other is current, which is measured in *amperes*.

In an electrical circuit we are not interested in the total quantity of electricity which is present, but in the rate at which the electricity is flowing round the circuit. This rate of flow is called current. To understand this, think of

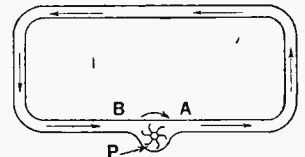

Fig. 1.—The flow of electricity under the influence of the e.m.f. of a battery is analogous to the flow of water circulating in a closed pipe under the action of a pump.

A knowledge of the fundamental laws of electricity and magnetism is necessary before it is possible to take even a passing interest in the theoretical aspects of broadcasting. In this series of articles these principles are presented in such a form that they may be readily understood by the beginner. The articles of necessity cover only a limited field, but with the introduction which they provide it will be possible for the amateur to understand the more specialised articles which appear in this journal from time to time.

Introduction to Wireless Theory.—

any pipe in which there is a steady, continuous flow of water. Now, during any second, the same quantity of water flows past any point in the pipe. Supposing the quantity which flows past a certain point in any second to be 7 gallons; then the rate of flow is 7 gallons per second. To say that the rate of flow in the pipe was 7 gallons would not mean anything; flow must be measured as a quantity in a given time, such as in gallons per second.

Factors Determining Rate of Flow.

In an electric circuit the flow is termed current, which is a measure of quantity in a given time. If we say that the current in a circuit is a certain number of amperes, we mean that a definite quantity of electricity passes a point in the circuit in a given time.

Returning to the water analogy of Fig. 1. Suppose that the pressure from the paddle were steady, then we should obtain a certain flow of the water. Now if we were to reduce the bore of a portion of the pipe, without altering its length or the pressure exerted by the paddle, then the flow of the water would be reduced, because of the extra resistance offered by the smaller pipe.

In just the same way, if the terminals of a battery are joined by a wire, and the battery exerts a steady pressure (or has a constant e.m.f.), then the current (or flow of electricity) in the wire and battery depends on the thickness of the wire. If we reduce the thickness of the wire, we shall at the same time reduce the current. We therefore see that the current in an electrical circuit is controlled not only by the e.m.f. of the battery, but also by the nature of the circuit.

Electrical Resistance.

This property of a circuit which controls the current is called resistance, and is measured in *ohms*. A resistance of 1 million ohms is called a *megohm*. Thin and long wires have a higher resistance than thick and short wires of the same material. Wires of equal thickness and length, but of different materials, have different resistances, because some materials are better conductors than others. Silver is the best conductor known, but copper is nearly as good, and is generally used for the sake of cheapness.

All parts of an electrical circuit have resistance. It is impossible to make any part of an electric circuit which has *no* resistance, but in many cases the resistances of some parts of a circuit are negligible as compared with the resistances of other parts. Batteries themselves have resistance, which limits the current in a circuit in just the same way as the resistance of the other parts of the circuit.

As we have said, resistance is measured in ohms, and the resistance of the ohm is such that an e.m.f. of 1 volt will drive a current of 1 ampere, through a circuit of 1 ohm resistance. This makes it easy to find the e.m.f. which will drive a certain current through a certain resistance. For example, if we require current of 2 amperes to flow through a circuit of 7 ohms resistance, we find that the e.m.f. necessary to drive this current is $2 \times 7 = 14$ volts. In the same way, if we have a battery whose

e.m.f. is $1\frac{1}{2}$ volts, and this is driving a current through a circuit of 3 ohms resistance, we know that the current is $\frac{1\frac{1}{2}}{3} = \frac{1}{2}$ ampere.

This very useful fact is known as *Ohm's Law*. It may be summed up by saying that e.m.f. = resistance \times current, or current = $\frac{\text{e.m.f.}}{\text{resistance}}$.

In Fig. 2 we have drawn a simple circuit, using the conventional symbols for the battery and resistances. This resistance might consist of a length of thin wire. Thick straight wires shown in circuits for joining different parts of the circuit together, have such a small resistance that it is generally neglected.

A Numerical Example.

In Fig. 2 we find that a battery of e.m.f. 5 volts is driving a current through a total resistance of $2 + 2 + 1 + 5 = 10$ ohms, and from Ohm's Law we know that the current in the circuit is 5 divided by 10, which equals $\frac{1}{2}$ ampere. Now, supposing that the resistance of 5 ohms is removed from the circuit, but that we still want a current of only $\frac{1}{2}$ ampere.

If no change in the e.m.f. of the battery were made we should get a current of 5 divided by $5 = 1$ ampere. To get the right current of $\frac{1}{2}$ ampere, we only need an e.m.f. of $\frac{1}{2} \times 5 = 2\frac{1}{2}$ volts, instead of the 5 volts which was needed when the extra 5 ohms resistance was included. It seems, then, that an e.m.f. of $5 - 2\frac{1}{2} = 2\frac{1}{2}$ volts was used up in driving the current through the 5 ohms resistance in the first case. This leads us to the conclusion that the e.m.f. is used up in various parts of the circuit, and that $2\frac{1}{2}$ volts is the pressure which is used up in driving $\frac{1}{2}$ ampere through 5 ohms, or, in other words, there is a difference of pressure of $2\frac{1}{2}$ volts between the two ends of the 5 ohms resistance.

Potential Difference.

In the same way there is a difference of pressure between the two ends of any part of an electrical circuit, in which current is flowing, and this difference of pressure is the pressure used up in driving the current through that part of the circuit. This pressure difference is called potential difference, or simply potential, to distinguish it from the total driving e.m.f. in a circuit. It is, of course, measured in volts.

Referring again to Fig. 2, we have a battery of e.m.f. 5 volts, and a steady current of $\frac{1}{2}$ ampere. From Ohm's Law we see that $\frac{1}{2} \times 2 = 1$ volt is required to drive the current of $\frac{1}{2}$ ampere through the 2 ohms internal resistance of the battery itself. This leaves us with a potential difference of $5 - 1 = 4$ volts to drive $\frac{1}{2}$ ampere through the external circuit of total 8 ohms. This is used up in three stages of $\frac{1}{2}$ volt, 1 volt, and $2\frac{1}{2}$ volts, in driving $\frac{1}{2}$ ampere through the 1 ohm, 2 ohm, and 5 ohm resistances respectively.

Now we have found that, although the battery in Fig. 2 exerts an e.m.f. of 5 volts, yet only 4 of these volts are

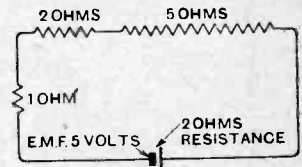

Fig. 2.—Simple electrical circuit in which the current is circulated by a 5-volt battery through resistances of 1, 2 and 5 ohms respectively, and its own internal resistance of 2 ohms.

Introduction to Wireless Theory.—

useful in driving current through the external circuit, as the other volt is previously used up in driving current through the internal resistance of the battery itself. Suppose the resistance of the external circuit were reduced to 3 ohms, then 2 volts of the total e.m.f. of 5 volts would be used up in the battery resistance, leaving us only 3 volts to drive current through the external resistance. This current would be $\frac{3}{3} = 1$ ampere. If we reduce the external resistance until it is so small as to be negligible by connecting a short, thick piece of copper wire across the terminals of the battery, then the total e.m.f. of 5 volts of the battery is used up in driving current through the internal resistance of 2 ohms. The current would be $\frac{5}{2} = 2\frac{1}{2}$ amperes, and is obviously the

greatest current that can possibly be driven by the battery. If the battery had a very low internal resistance, this maximum current would be large. When a part of a circuit has connected across it a wire of negligible resistance, it is said to be "short-circuited." A short circuit is very harmful to the battery, and is dangerous with batteries which have a small internal resistance, such as accumulators.

The opposite of short-circuiting is "open-circuiting" when a very high resistance is introduced into the circuit, so that the current flowing becomes negligible. If, for example, one of the wires is disconnected from a point in the circuit, or is broken, the resistance of the intervening air between the disconnected points is sufficiently high to reduce the current to a value which is negligible.

(To be continued.)

INTERFERENCE ON THE BROADCAST BAND.

THROUGH the courtesy of Captain Ian Fraser, and with the permission of H.M. Postmaster-General, we are able to print below, in full, correspondence which has passed between Captain Fraser and the Post Office on the important subject of ship interference on the broadcast wavelengths.

St. John's Lodge, N.W.1.
27th July, 1925.

Dear Wolmer,

As promised, I am writing you about one or two points which I raised in the House on the Post Office Debate.

My submission is that the time has come when a real effort should be made by the Post Office to give the Broadcasting Service a band of wavelengths free entirely from jamming. I am aware that you cannot, at present, free it from jamming due to harmonics of powerful arc stations, but, bad as this sometimes is, it does not by any means give the most trouble; the Direction Finding Stations and the Shore and Ship Traffic on 450 metres interferes, according to my own observation and information, very seriously with broadcasting. I submit that at least the time has come to call a halt in any increase in numbers of stations working on this wavelength, and that at the same time efforts should be made as quickly as possible to move these stations off this wavelength on to some other.

This may cost money; indeed, even a full technical inquiry such as I asked for in a recent question in the House might cost money, but I have suggested that the Postmaster-General is exceedingly lucky, for he need not use his own money for the purpose, but can use the money belonging to the listeners, which he has accumulated as the result of his share of their licence fees.

With the limited knowledge which any individual outside the Department can have, I do not submit these observations without being well aware that there may be circumstances which render my suggestions extremely difficult of fulfilment.

My plea is that at least the Post Office should accede to the demand to make a technical enquiry into the matter with a view to ascertaining precisely what trouble and expense would be caused were the B.B.C. given an adequate band, free from interference.

Shipping on 600 metres also interferes with broadcasting, but I do not suggest that anything immediate can be done about it, for I am well aware of the international complications and the vast amount of traffic on this wavelength. It is a fact, however, that ships and shore stations have to spread so far above and below 600 metres, and have to use the alternative wavelength of 450 so frequently, that there is evidence that sooner or later, and probably sooner, something will have to be done to avoid confusion in this sphere purely in their own interest, apart from that of broadcasting. I suggest that it should be considered as to whether or not regulations could be made which would have the effect of prohibiting the installation of new apparatus on ships which emit badly damped waves.

Yours sincerely,

(Sgd.) IAN FRASER.

To Viscount Wolmer, M.P., Assistant Postmaster-General.

General Post Office, London, E.C.1.

5th August, 1925.

My dear Fraser,

With reference to your letter of the 27th July to Viscount Wolmer, I am glad to have the opportunity of explaining to you what we have already done to ensure that the broadcast programmes shall, as far as possible, be immune from interference by other British services.

So far as the harmonics of Post Office stations are concerned, we have so far succeeded in suppressing the unwanted emissions at the Leafield wireless station that London broadcast programmes can now be received satisfactorily on a two-valve set situated immediately underneath the Leafield aerial. We have also fitted similar anti-harmonic appliances at Northolt.

The 450 metre wave has not for some months past been used for Direction Finding purposes in this country, as all such work has, with the co-operation of the Admiralty, been transferred to the 600 metre and 800 metre waves. The alteration suggested in your letter has thus been carried out, and, following on this alteration, the 440-460 metre band, which was originally excluded from the broadcasting band, has recently been placed at the disposal of the British Broadcasting Company.

There is, I can assure you, no intention of allotting waves in the 300-500 metre band in this country for any new services other than broadcasting; and, as you are aware, experimenters who are entitled to use the 440 metre wave at certain times are expressly forbidden to use it during broadcasting hours.

The question of the use of 300 and 450 metre waves by shipping and kindred questions will no doubt be considered at the International Radiotelegraphic Conference at Washington next year, and can, of course, only be regulated by international agreement.

Yours sincerely,

(Sgd.) W. MITCHELL-THOMSON.

Captain Ian Fraser, C.B.E., M.P.

BOOKS RECEIVED.

"The National Physical Laboratory. Collected Researches." Vol. XVIII. Pp. 456, with numerous diagrams. Published by H.M. Stationery Office. Price 17s. 6d. net.

"Kurze Wellen (Ausstrahlung, Ausbreitung Erzeugung und Empfang)." By Carl Lübben. Pp. 97, with 93 diagrams. Price 5.50 marks.

"Die Neuesten Empfangsschaltungen für die Radiotechnik. By Carl Lübben. Pp. 49, with 90 diagrams. Price 4 marks.

Being Parts IV. and VI. respectively of "Die Hochfrequenz Technik Heransgeber." Published by Hermann Meusser, Berlin.

ON HOLIDAY WITH A SUPER-HET.

Experiences with a Six-valve Set in Brittany.

By CAPTAIN IAN FRASER, C.B.E., M.P.

Captain Fraser, the blind Chairman of St. Dunstan's, is a member of the Council of the Radio Society of Great Britain, and is well known to amateurs as the first chairman of the present Transmitter and Relay Section of the Society. He represents the St. Pancras (North) constituency in Parliament, and is a member of the Broadcasting Commission recently appointed by the Government.

I HAVE just returned from a six weeks' stay at a French village called St. Lunaire, two or three kilometres from Dinard, in Brittany. I took with me a six-valve semi-portable supersonic heterodyne receiver, my experience with which I propose to describe.

To start with, let me emphasise my opinion that, unless you happen to be in the wireless trade and are by the end of July fed up with everything to do with it, you will find it well worth while taking such a set on a holiday. My "super" certainly gave me a good deal of amusement and not a little interest. I obtained a letter from the French Consulate in London to the Customs authorities in France, and subsequently filled in a form at Southampton, with the result that all difficulties which might have been anticipated were removed.

The instrument, which worked a loud-speaker with considerable volume from Daventry, using a three-foot frame, regularly gave us the news thirty-six hours before we could get it in print, allowed us to dance occasionally, and once, when the speaker was faced out of a window on the street, collected a crowd of forty or fifty exceedingly curious natives. Another valuable contribution of the "super" was the morning weather report, which we found exceedingly accurate when properly interpreted.

As will be seen from what follows, there is nothing very peculiar about the circuits which I adopted, though

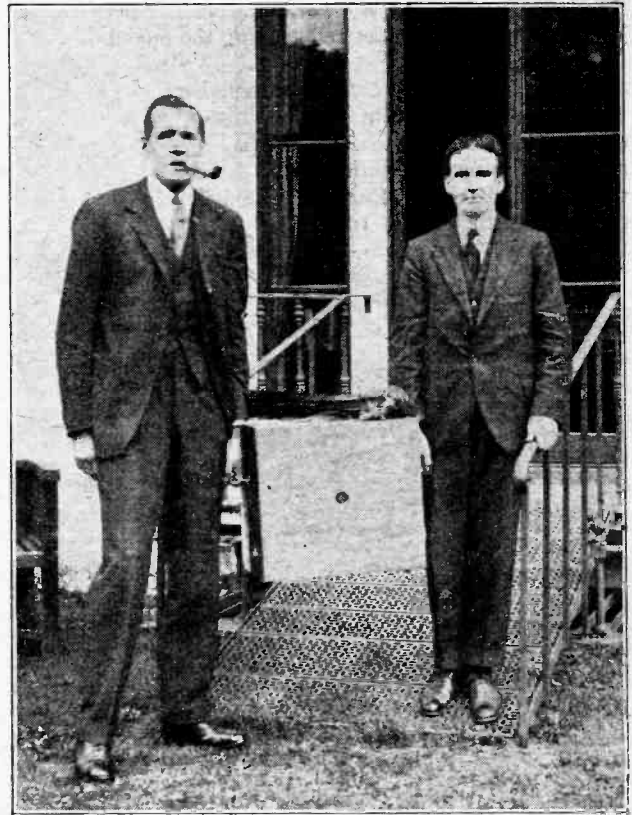

Fig. 1.—The author (left) with the self-contained set. The dismantled frame aerial can be seen lying on top of the case.

some of the constants used in the design of the completed instrument may be of interest. My object was to compress into the smallest possible amount of space

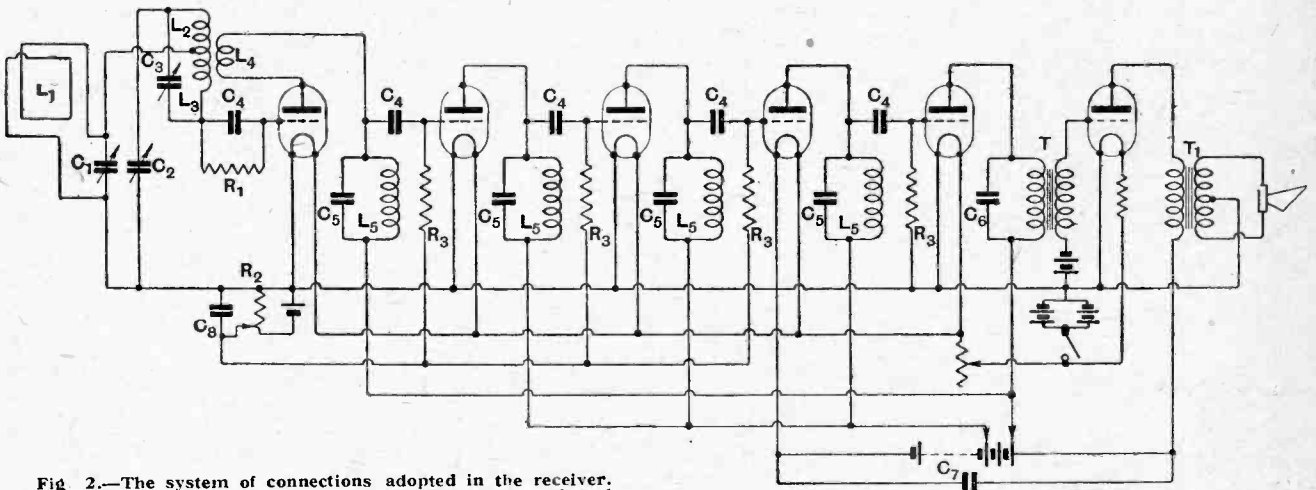

Fig. 2.—The system of connections adopted in the receiver. L₁, frame aerial; L₂, L₃, L₄, 1gramic coils Nos. 50, 50 and 25 (reduced to 16 turns); L₅, 100,000 mHs. C₁ and C₂ 0.0005 mfd.; C₃, vernier condenser; C₄, 0.0003 mfd.; C₅, 0.0005 mfd.; C₆, 0.003 mfd.; C₇, 2 mfd.; C₈, 0.01 mfd.; R₁, 1 megohm; R₃, 0.5 megohm; T, ratio 6 to 1.

On Holiday with a Super-Het.—

a self-contained set capable of giving good quantitative and qualitative loud-speaker results. This object has, I think, been moderately well achieved, since the whole instrument will sit upon a small table and can be carried without difficulty by two persons. The case is made of half-inch teak and is, I think, much heavier than necessary. If I were redesigning the model I should use plywood.

The whole of the receiver is mounted on a baseboard and ebonite panel, which in Fig. 3 can be seen occupying the top half of the case, while in the bottom half, from left to right, can be discerned a 15-volt grid battery, two 100-

volt anode batteries, and two 4-volt, 7-ampere-hour, non-spillable accumulators. There are only two controls—the oscillator condenser in the bottom centre of the panel, and the frame condenser above it and to the left. In addition, two adjustments are provided—one a rheostat, in the top right-hand corner of the panel, for the filaments of the first five valves, and the other a balancing condenser immediately below it, which, when once set, need not be touched. The function of this condenser, the electrical position of which can be seen from Fig. 6, is to prevent the transmission frequency and oscillator frequency circuits interfering with each other's tuning. This it very effectively does.

The Circuit.

The receiver should perhaps be called a super-sonic *autodyne*, for the first valve functions as both rectifier and oscillator. The oscillator circuit employs two standard plug-in coils joined in series in the grid-filament path, with a third coil in the anode circuit placed between them. This arrangement enables the oscillator inductance to be easily changed for different wavebands and avoids the necessity of making a special coil with a centre tapping.

The intermediate frequency amplifier comprises three valves associated with tuned anode circuits working a wavelength of some 13,000 metres. The use of this rather exceptionally high wavelength is conducive to stability and the highest magnification per stage. No qualitative complications ensue, since the corresponding oscillation frequency is still well above the audible band.

The Intermediate Amplifier.

The ratio of inductance to capacity in the anode circuits is an important consideration. If it is too low, the width of the (semi) flat-top filter system created by the three tuned circuits will be unduly narrow, and in consequence the amplifier may prove only partially responsive to the outer limits of the transmitted sidebands. If, on the other hand, the I/C ratio is too high, the maximum selectivity (consistent with faithful treatment of telephony) will not be achieved.

The I/C values indicated in Fig. 2 represent an attempt to effect the desideratum of cutting off amplification at the outer limits of the transmitted sidebands. In the particular case under review, compactness was an important consideration, hence the anode inductances were specially wound to small mechanical dimensions. Their value of 100,000 microhenries is closely duplicated by

Fig. 3.—Front view of the receiver, showing method of mounting loud-speaker in lid and (below) rear view of frame aerial mounting, terminal panel and hole in lid for loud-speaker adjustment. The auxiliary winding round the case of the instrument is for the 1,600 metre wave.

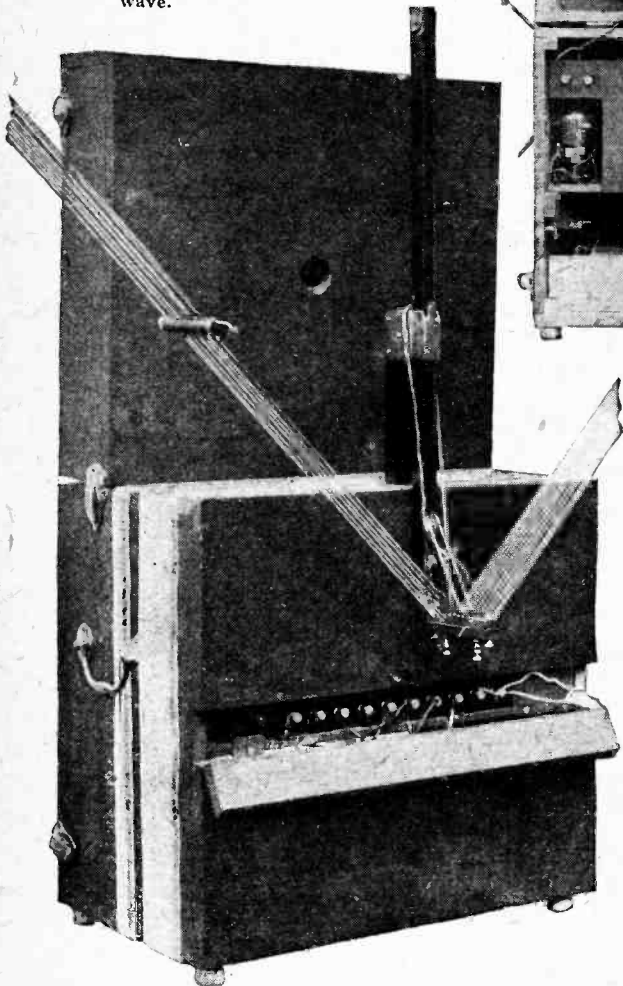

On Holiday with a Super-Het.—

Igranic Coil No. 1,250, the 5 per cent. difference being of no importance.

The stability of the intermediate frequency amplifier is such that it is possible to connect the grid returns of the three valves to the negative side of a single dry cell, thus imparting a negative bias of $1\frac{1}{2}$ volts and so avoiding rectification effects.

The fifth valve is a detector, and the sixth valve is a straightforward note magnifier. A step-down output transformer is used to couple the note magnifier to the loud-speaker in order that the windings of the speaker may be connected to a point at zero potential: this is an important factor in ensuring stability if a high ratio interval transformer is used and a good deal of magnification is obtained.

The two rectifying valves are Marconi D.E.3s, the three intermediate frequency amplifiers are D.E.3Bs, and the note magnifier is a D.E.4. The first five valves have one rheostat controlling their filament heating, and the note magnifier has a fixed resistance in its positive filament lead. All valves are mounted on shock-absorbing

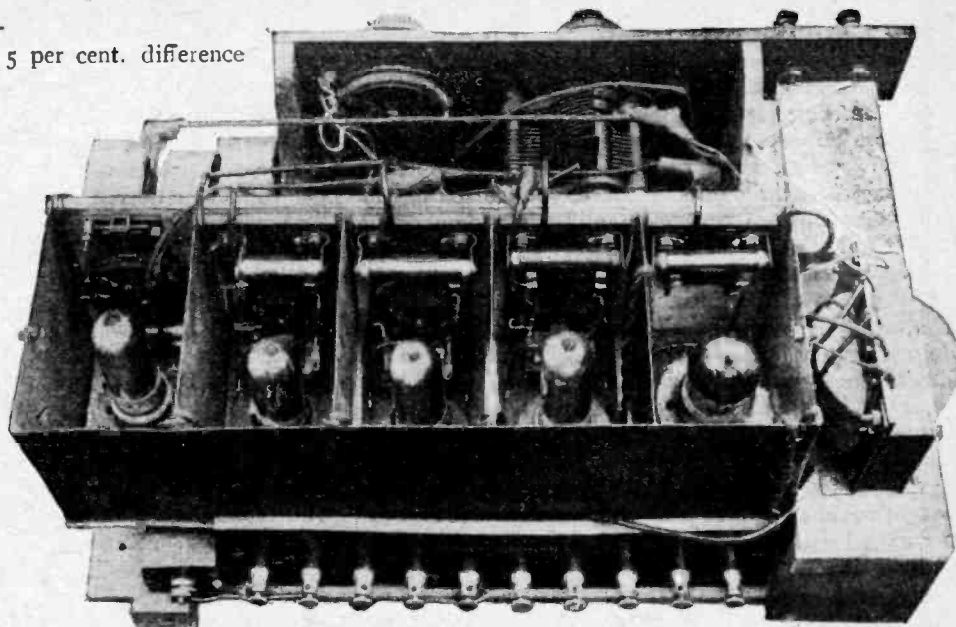

Fig. 4.—View indicating the layout of the screened valve compartments. The initial rectifying and oscillating stage, in the left-hand compartment, is followed by the three intermediate frequency stages, the right-hand compartment containing the final rectifier. The coupling condenser and grid leak in each intermediate frequency compartment is mounted directly above the associated long-wave coil and condenser.

holders, and were not removed from the set during the journey to or from France. In the case of the note magnifier it will be seen that there is a little wooden bracket on the top of the valve, having on its underside a piece of Sorbo rubber into which the pip of the valve sticks. This was necessary because, being a biggish valve, it was apt to bump against the transformer behind it.

Figs. 4 and 5, taken from the back of the receiver panel, shows the copper screening box, which is divided into five compartments, each containing a valve with its associated circuit components.

The metal partitioning pieces fit into grooves cut in a vertical wooden board (shown in Fig. 5), which is common to all the component panels. This method of unifying the various panels and making them mechanically independent of the screening box was resorted to in order to avoid having to deal with a separate panel for each compartment and the necessity of having to run wires through holes in the copper partitions; further, if any fault should occur, the panels can be lifted out *en bloc* from the screening box, and the whole circuit inspected without loss of time.

In practice the two rectifiers usually were given 80 volts; the three intermediate frequency amplifiers, 60 volts; and the

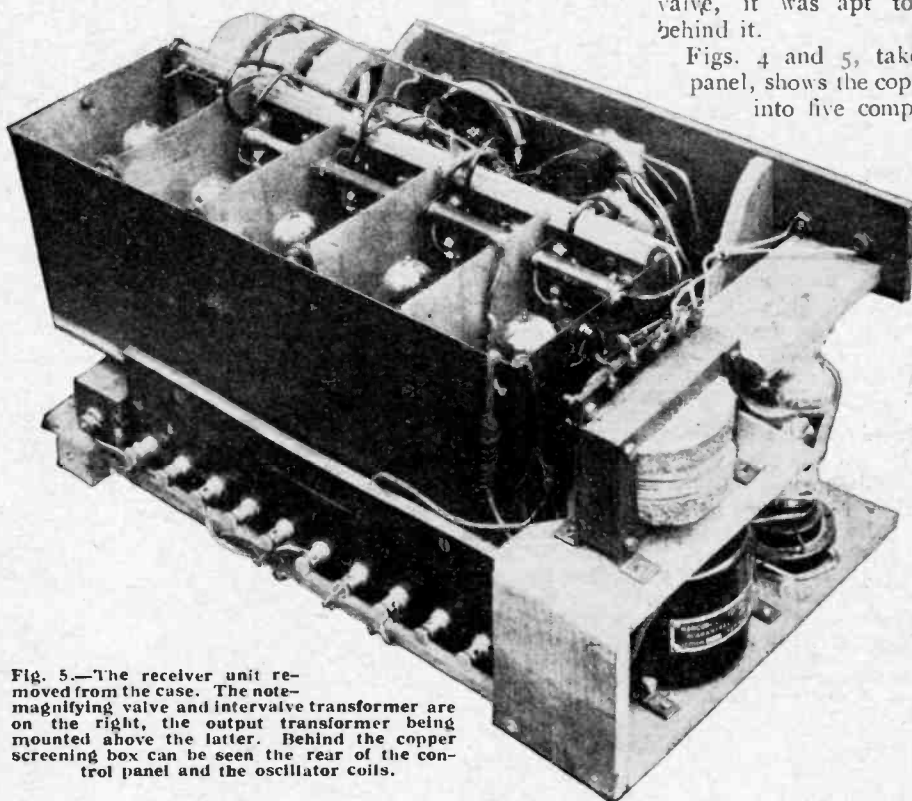

Fig. 5.—The receiver unit removed from the case. The note-magnifying valve and interval transformer are on the right, the output transformer being mounted above the latter. Behind the copper screening box can be seen the rear of the control panel and the oscillator coils.

On Holiday with a Super-Het.—

note magnifier, 200 volts. Since the photographs were taken, a potentiometer controlling the grid bias applied to the intermediate frequency amplifiers has been added. These grids, however, are never made positive, but are only varied between zero and $1\frac{1}{2}$ volts negative, which is found sufficient, with a suitable anode voltage setting, to bring the intermediate frequency amplifier in and out of an oscillating condition, and thus to secure maximum sensitivity when necessary.

The sensitivity of the set in France was such that many stations could be heard on the loud-speaker, Daventry, London, and Bournemouth all being as loud as one could possibly desire for an ordinary room. Even with the small frame, 17in. by 15in., which can be seen roughly wound round the outside of the case, Daventry was quite good on the loud-speaker in a quiet room.

The 200 volts employed on the final valve, with the consequent 15 volts negative grid bias, enabled loud signals to be handled without blasting, and the quality given by the Primax loud-speaker under these conditions was exceedingly good. This loud-speaker was chosen for no other reason than that it takes up extraordinarily little room. I prefer the quality of the pleated diaphragm type, but I should have used a horn-type instrument in this case

because of its greater responsiveness had it not been for the limiting question of size.

The selectivity of the set may be judged from the fact that at my home in London, which is almost exactly one mile north of 2LO, I can receive all B.B.C. stations while 2LO is working, save only the two whose wavelengths are immediately adjacent to that of the London transmitter, though, of course, not all of them work the loud-speaker—only Birmingham, Bournemouth, and Daventry do this really well.

I might mention that Daventry has already made a name for itself throughout the North of France, for, in conversation with both English and French listeners whom I met there, I found it was the most powerful and popular station.

The frame shown in the photograph of the complete instrument is a portable one, and has only ten turns, making it suitable for the ordinary broadcast wave-band. To receive Daventry on it I adopted the expedient of winding eighteen or twenty turns of bell wire on the outside of the existing frame and connecting the two windings in series. This is infinitely to be preferred to loading the frame with an inductance of small dimensions such as a plug-in coil, which latter arrangement picks up only a fraction of the available transmitted energy.

NEWS FROM THE CLUBS.

Swansea and District Radio Society.

The Society's annual general meeting, which also formed the first meeting of the winter session, was held on Monday, October 5th.

After the reading of the Society's report, which revealed a very sound financial position, the election of officers was proceeded with. Capt. Hugh Vivian was elected President and a number of vice-presidents were also elected. The Hon. Treasurer is Mr. W. H. Thomas, and the Hon. Secretary Mr. E. H. White, 100, Bryn Road, Swansea.

An attractive programme has been prepared for the ensuing meetings.

o o o o

FORTHCOMING EVENTS.**WEDNESDAY, OCTOBER 21st.**

Golders Green and Hendon Radio Society.
—At 8 p.m., at the Club House, Willifield Way, N.W.11. Third Lecture on "Fundamental Principles of Radio Reception." By Mr. Maurice Child.

FRIDAY, OCTOBER 23rd.

Radio Experimental Society of Manchester.
—Lecture: "High Frequency Measurements and Instruments." By Mr. A. N. Bentley.

MONDAY, OCTOBER 26th.

Hackney and District Radio Society.
—Lecture (with practical demonstration): "How a Valve Set Works." By Mr. A. H. Phillips.
Swansea Radio Society. — Lecture: "Measuring Instruments and their Functions." By Mr. H. K. Benson, A.M.I.E.E.

WEDNESDAY, OCTOBER 28th.

North Middlesex Wireless Society.—Lecture: "Distortionless Reception of Broadcasting." By a Senior Engineer of the B.B.C.

WHAT IS BEING SAID.**An Excuse for Radio Jargon?**

"You will notice that I have used the word 'ham' rather freely. I feel that I am justified in using this word, which lends itself so admirably to quick and expressive writing. 'Transmitter' is an ungainly word and one calling for much time and ink. 'Operator' is perhaps a better word, but somehow seems to lack meaning in the Radio sense. 'Ham' has long been used by our leading long-distance transmitters, and conveys a meaning to them which cannot be conveyed by our longer and cumbersome words. Therefore, although 'ham' may be distasteful to many, I use it not only to please myself and many readers, but

out of courtesy to our American cousins, whose welcome assistance in our tests and friendly co-operation we all appreciate.—*The Editor, T. and R. Bulletin.*

o o o o

The Case for the B.B.C.

"If a broadcasting station is erected by a private individual, it is put into operation primarily for the benefit of that private individual, afterwards for the benefit of the public; if it is erected by a non-profit-making organisation, it is erected for the public and only for the public.

"A public ownership of a broadcasting scheme ensures technically that the problem of serving a national is visualised as a whole, as a national not a parochial problem."—*Capt. P. P. Eckersley, in The Sunday-News.*

o o o o

A Weapon of Peace.

"Surely wireless will be a weapon of peace! Surely it will promote better understanding! Isolated groups of men developing insular prejudices fail to understand other groups; jealousies and misunderstandings arise, until they lead to the horrors of internecine strife and wholesale slaughter. . . . The commonwealth of nations often called the British Empire is peacefully disposed. They, with our cousins across the Atlantic, constitute the same race, speaking the same language; they are now welded together by this new method of communication. And if they only set their face to the right and determine to preserve the peace of the world they will succeed."—*Sir Oliver Lodge in "Talks about Wireless" (Cassell and Co., 5s.).*

Lewisham and Bellingham Radio Society.

"High and Low Frequency Amplification" was the title of a lecture given by Mr. R. Stanley on Tuesday, October 6th. The advantages of the various methods of obtaining radio and audio frequency amplification were discussed at length and many useful points were brought forward in connection with obtaining the greatest possible efficiency from the components employed.

During the winter months a progressive series of lectures will be given on the subject of Transmission, demonstrations being given on the Society's transmitting set. Prospective members are asked to communicate with the Hon. Secretary, Mr. C. E. Tynan, 62, Ringstead Road Catford, S.E.6.

CURRENT TOPICS

News of the Week — in Brief Review

LISTENERS IN GERMANY.

The total number of receiving licences issued in Germany at the end of August was in the neighbourhood of 839,000.

○○○○

WIRELESS ON AMERICAN TRAINS.

A multi-valve receiving set has been fitted on the Cincinnati and New Orleans express for the delectation of passengers. Headphones only are used, as it is feared that loud-speakers might disturb passengers who do not wish to listen.

○○○○

BRUSSELS STATION GATHERS FUNDS.

As a result of an "appeal to the people," the officials of the *Radio Belgique* broadcasting station have received sufficient funds to permit of transmissions twice weekly. Great appreciation is being shown of the operative transmissions from the "Theatre de la Monnaie" at Brussels.

RADIO TOULOUSE.

The programmes from Radio Toulouse, which is one of the most popular French stations with British listeners, are now transmitted on 432 metres, instead of 273.

○○○○

JAMMING IN FRANCE.

Despite the recent shuffling of broadcast wavelengths in Europe, listeners in the French provinces are lamenting their inability to pick out L'Ecole Supérieure, Paris, from the chaos of jamming which still persists. According to *La T.S.F. Moderne* the station cannot be heard at 100 kilometres from the French capital.

○○○○

DAVENTRY HEARD IN INDIA.

During a recent hunt for a "mystery station" in the neighbourhood of Bombay, an enthusiast in Poona heard 5XX distinctly. In his report he states that a pianoforte selection from Daventry was heard clearly on the telephones, and was just audible on the loud-speaker

WIRELESS-CONTROLLED TARGET SHIP.

The wireless-controlled target ship *Agamemnon* has been providing the British Mediterranean fleet with excellent gunnery practice at Malta. Without a man on board, the *Agamemnon* can manoeuvre, change course, increase or decrease speed—do everything, in fact, except hit back. All her movements are controlled by wireless from the destroyer *Shikhar*.

○○○○

LECTURES BY DR. J. A. FLEMING.

Beginning on October 28th, a course of six lectures on "Mercury Vapour Lamps and Mercury-Arc Rectifiers" is to be delivered by Professor J. A. Fleming, M.A., D.Sc., F.R.S., at University College, Gower Street, London, W.C.1. The lectures, which are open to members and non-members of the University, begin at 5 p.m. on Wednesdays, and the fee for the course is £1 11s. 6d.

○○○○

BRITISH SETS FOR DANISH EXHIBITION.

British amateurs are asked to exhibit apparatus of their own construction at a Danish Amateur Wireless Exhibition, to be held at Copenhagen from November 28th to December 6th. Both receiving and transmitting sets will be welcome. Full particulars, with details of Customs requirements, will be gladly forwarded on application to Mr. James Steffenson, "Dansk Radioklub," Hellerup, nr. Copenhagen. Expenses will be paid by the Dansk Radioklub.

○○○○

BROADCASTING BY THE SCORE.

No fewer than 21 broadcasting stations will be in operation in Spain by the end of 1927, if the plans of the *Société Union Radio* come to fruition. The scheme provides for the steady construction of stations during the next two years, and it is important to note that at least seven of the installations will have a power of between 4 and 8 kilowatts.

Such a project may be attractive to Spanish enthusiasts, but, in view of the present congested state of the European ether, listeners in other countries may not see things in such a rosy light. The tactful intervention of Geneva may be called for.

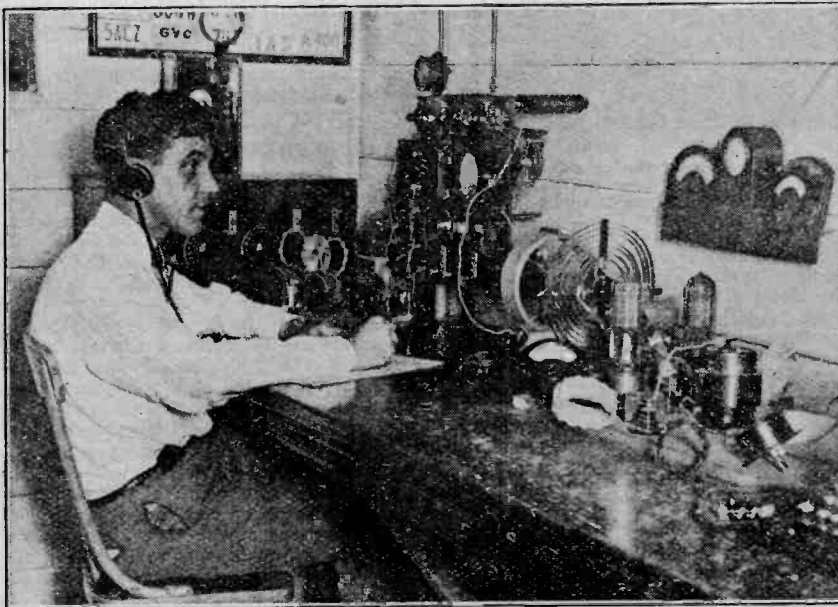

IN TUNE WITH THE ARCTIC. Mr. J. W. Brooklyn (U2DS), a New York amateur who holds nightly two-way communication with the MacMillan Arctic Expedition. The short-wave receiver, covering a band from 10 to 200 metres, can be seen on his left.

**BALTIMORE-BALUCHISTAN
CONVERSATION.**

On a wavelength of 33 metres the American amateur 3AJD, of Baltimore, has effected two-way communication with a station at Quetto, British Baluchistan, India. The distance covered was 11,000 miles.

○○○○

DX WITH BRITISH WEST INDIES.

Indications are not lacking that the season of DX records is upon us once more. Last week we chronicled amateur two-way working between Great Britain and South Africa. Now comes the news that Mr. N. G. Baguley (G2NB), of Newark, Notts, has established communication with BER, an amateur station at Bermuda, British West Indies.

BER was first picked up on a measured wavelength of 35.2 metres at 10.30 p.m. (G.M.T.) on October 8th, and communication between the two stations was maintained for two hours. Strangely enough,

**BROADCASTING STATION FOR
AMSTERDAM.**

The public demand for a broadcasting station at Amsterdam is being met by the construction of a 1½ kw. transmitter. The wavelength has not yet been fixed. Meanwhile the power of the Hilversum station is being increased from 3 to 10 kilowatts. It would appear that Dutch listeners will be adequately catered for during the coming winter.

○○○○

AUSTRIAN BROADCASTING.

A new Austrian relay station, to be erected at Innsbrück, will broadcast the programmes of Vienna and Gratz respectively on alternate evenings. The Gratz station now transmits its own programmes and is independent of Vienna.

○○○○

AUSTRALIAN WIRELESS CHAIN.

The erection of a wireless station at Wavehill, Northern Territory, 350 miles

NEW STATION FOR NORWAY.

The announcement is made that a large and well-equipped wireless station is to be erected at Trondhjem for the purpose of relieving the overtaxed cables between Northern Norway and the British Isles. The building of such a station has been under consideration for a considerable time, and a Government grant was voted as long ago as 1920, but the project has been deferred for various reasons.

○○○○

GERMAN AND U.S. SETS IN CHILE.

According to a message from Santiago, Chile, it is estimated that the total number of receiving sets in the Republic is 11,000. Of these, 75 per cent. are of U.S. manufacture. Germany supplied 12 per cent. Great Britain 9 per cent., and France 4 per cent.

The United States and Germany are said to hold the lead owing to price considerations, which weigh heavily with Chilean purchasers.

○○○○

**AMERICAN AMATEUR AND LOST U.S.
SEAPLANE.**

The discovery of the whereabouts of the American seaplane PN9 No. 1 and its heroic crew, after they had been adrift for several days off the coast of Hawaii, was hailed with delight by practically the whole civilised world. It may not be known, however, that it was an American wireless amateur who first communicated the good news to the U.S. Pacific Fleet.

Mr. A. H. Babcock (6ZD), of San Francisco, received the first news by telephone from Hawaii, and subsequently he was informed by the Naval Station NPG that it was unable to communicate the news to the Pacific Fleet, which was continuing the search. Thereupon Mr. Babcock endeavoured to communicate with NRRL, the short-wave station on board the U.S.S. "Seattle," and after a long battle with atmospherics and other disturbance succeeded in conveying his important message.

○○○○

ROUND THE WORLD IN A LIFEBOAT.

An interesting wireless installation is being fitted to the "Elizabeth and Blanche," the 40ft. lifeboat in which Captain G. E. Hitchens and four companions are to sail round the world, starting from London at the end of this month.

Captain Hitchens will investigate the requirements of a ship's lifeboat in the light of the "Trevessa" disaster, and will test the value of wireless equipment to a crew in such circumstances.

The Marconi ¼ kw. lifeboat set which is being fitted consists of a quenched gap transmitter and a valve receiver, the latter being arranged for directional reception. In actual transmitting tests with this equipment signals have been received by ships at distances up to 175 miles, and communication was maintained for one hour in daylight with a land station 300 miles away.

The progress of this little craft in its adventurous voyage will be eagerly followed by all wireless enthusiasts.

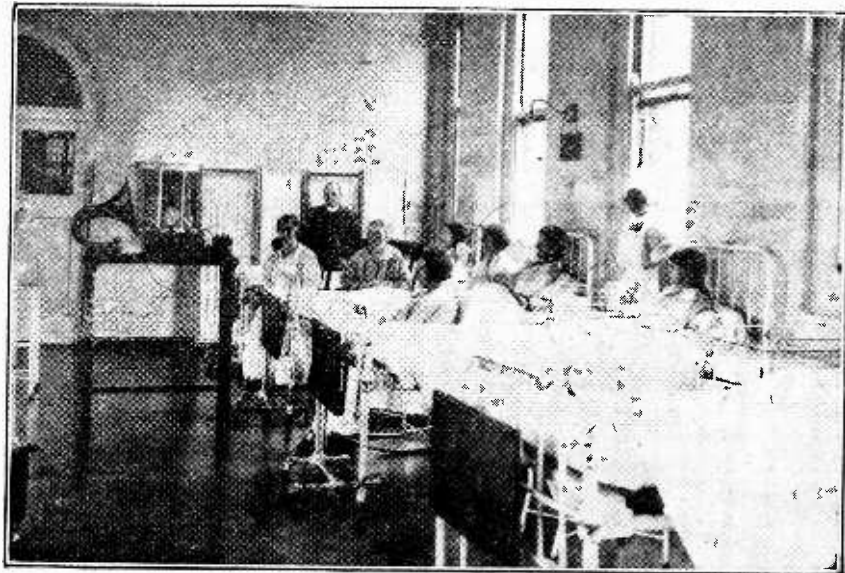

WIRELESS AND THE SICK. This photograph, taken in one of the principal London hospitals, gives a good idea of the pleasure which a broadcast receiver can bestow in a sick ward. The loud-speaker is one of the well-known Amplion range.

signals from BER faded noticeably as the night went on, and at 12.30 a.m. he was unreadable.

○○○○

GERMAN WIRELESS EXPORTS.

The general tendency of the German wireless industry, according to a Frankfurt correspondent of the *Times*, is in the direction of mass production and standardisation.

The possibilities in the direction of export trade are at present very favourable to Germany, because prices abroad are considerably higher. Even high duties do not constitute a serious obstacle, and consequently large quantities of components are exported to America. The export of telephones is remarkably high and there seems little doubt that attention will soon be given to loud-speakers and other component parts.

B 2

from Port Darwin, marks the first step in the establishment of an Australian inland wireless system designed to connect up the cattle stations and settlers with the coast. Another station at Camooweal, on the Queensland border, connects the land-line with the air mail.

The cost of the two stations is £10,000 as compared with £60,000 spent on land lines.

○○○○

SLOW BUT SURE.

Switzerland has never undergone a wireless boom to the same extent as many of her neighbours, but a steadily increasing interest is being shown in the development of broadcasting.

The bulk of the receiving sets at present in use have been imported, but a home wireless industry is gradually being built up.



CIVIL AVIATION WIRELESS.¹

The Development of Radiotelephony for Communication with Aircraft.

By DUNCAN SINCLAIR.

IT would appear that in aircraft transport we are confronted with a problem of the first magnitude as far as communications and signalling are concerned. It is an absolutely unique form of transport inasmuch as it differs from a railway system, where everything runs along hard and fast lines, or shipping, where definite routes are followed. Very much more is left to the initiative of the air pilots than is left to any marine master, for example.

Three main points appear to merit careful consideration in catering for any air transport scheme. Up to the present time nothing can compare with an aeroplane in the question of speed, and, that being so, we must devise a system of speedy communication which is far more rapid in operation than that needed anywhere else. The second point is the question of accuracy, which is really bound up with speed, since if we achieve a system which is inaccurate it means delay. Thirdly, we cannot rely upon any form of telephone line connecting the aircraft with the ground, nor can we rely at long ranges on a system of ground signalling.

The task then of the wireless engineer in ensuring the rapid exchange of information between the air pilot and the ground control is not easy.

We are reduced by force of circumstance to use wireless. Force of circumstance has also hitherto led us to use radiotelephony. Naturally all of us can talk, and if we are enabled to speak direct from ground to air, such a system seems naturally to be the most suitable for everyone concerned.

We might say, then, that the radio telephone was introduced mainly because of the simplicity of use, and such a system will stand us in good stead, provided that the spoken word is correctly understood, but if it is not correctly understood, then it is a more unsatisfactory proposition than the telegraphic message, which takes but few seconds longer to send, but about which there can be little or no misunderstanding.

It may be justifiably stated that the Cologne postal service was the first airway to be operated regularly, and, flying between London and Cologne, the aircraft were equipped with low-power telephony sets which were similar to those evolved by the British Royal Air Force during the last two years of the late war. The ground stations were able to communicate with the aircraft up to ranges of approximately 30 miles or sometimes more, dependent upon circumstances. Shortly afterwards the service between London and Paris came into operation, and from this nucleus the present comprehensive scheme has been developed. It is interesting to note that in the initial stages of development a wavelength of 400 metres was used, and something like 5,000 messages were exchanged during the first four or five months. At the conclusion of this stage, and while the first British companies were commencing to operate, the Marconi Company of Great Britain undertook the design and operation of commercial aircraft wireless apparatus, and has continued uninterrupted to carry out this work until the present date.

Wave-band Allotted to Aircraft.

It was recognised from the commencement that, in order to ensure thoroughly reliable communication between aircraft and ground stations, it would be necessary to arrange for a band of wavelengths entirely separated from any other wireless work in being, and subject only to the very minimum of interference. The wave-band from 850 to 950 metres was, therefore, allocated by mutual international agreement for this work, and, though in the early stages it was possible to allow point-to-point signalling between ground stations on the same wavelength, the pressure of traffic with aircraft has since proved so large and so important that all other work has been removed from this band. Point-to-point traffic between terminal

¹ Paper read before the Third International Air Navigation Congress, held at Brussels, Oct. 1925, and reproduced by courtesy of the Belgian Government.

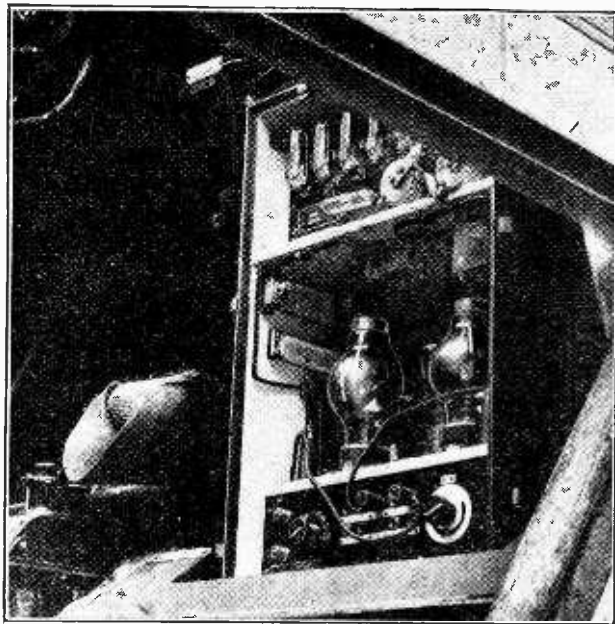

Combined wireless telephone transmitter and receiver installed in one of the Imperial Airways machines.

aerodromes has been for the last five years carried out regularly on the wavelength of 1,400 metres—that is to say, messages concerning the arrivals and departures and freights of the various aircraft in operation. Equally important to the air pilot is the question of weather, and, in order to keep the weather reporting service also as free as possible from interference, a third wavelength became necessary for the hourly exchange between all ground stations and aerodromes of weather conditions prevailing over the different routes. The wavelength set aside for this routine was 1,680 metres.

All this system has worked very effectively from the inception of commercial aviation. We are, however, now

beginning to experience certain difficulties which are increasing directly in proportion to the increase of air traffic. If we consider simply the problem of the number of machines arriving at, and departing from, the London Terminal Aerodrome daily, we find that the average number is in the neighbourhood of 70, this number including aircraft of every nationality operating regularly. Assuming that we have even 10 machines in the air at any given moment, perhaps five of which are in the British control area, it is not difficult to understand that with all the regular routine to be carried out, interference between machines and ground stations is bound to occur. Everyone knows that no matter what system of radio-telephony we use to-day, we are modulating by the human voice a continuous wave transmission and that, though this continuous wave is in itself a very sharply tuned wave, yet immediately it becomes modulated we change its condition and it resembles more the nature of the wave emitted by a spark transmitter, which is to say, that its tuning on any given receiver is not so sharp. Overlapping is the result, especially when all aircraft are supposed to be tuned to one single wavelength within the band, viz., 900 metres. An attempt to ease the position by placing the aircraft of one route on a different wavelength within the band from aircraft on another route can result only in the duplication of the number of ground stations employed, and economy being so necessary at the present time, this solution is ruled out. It has been possible to work with as many as five machines simultaneously from Croydon, but this result has only been obtainable by the extreme skill of the operators concerned.

Another difficulty is that under the original international agreement, messages handled by the contracting States on behalf of air operating companies should be only those falling strictly under the headings of safety of life and regularity of the services. It would seem highly essential, now that the public of all States is learning more and more to use air transport, that air transport in

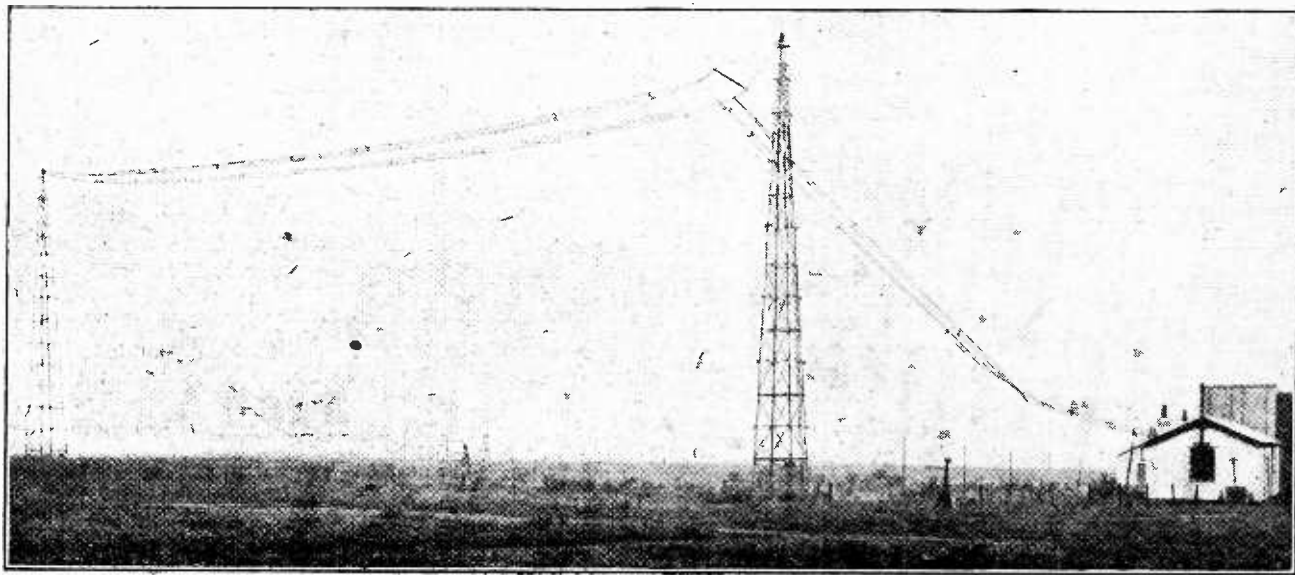

The main transmitting aerial at Croydon Aerodrome.

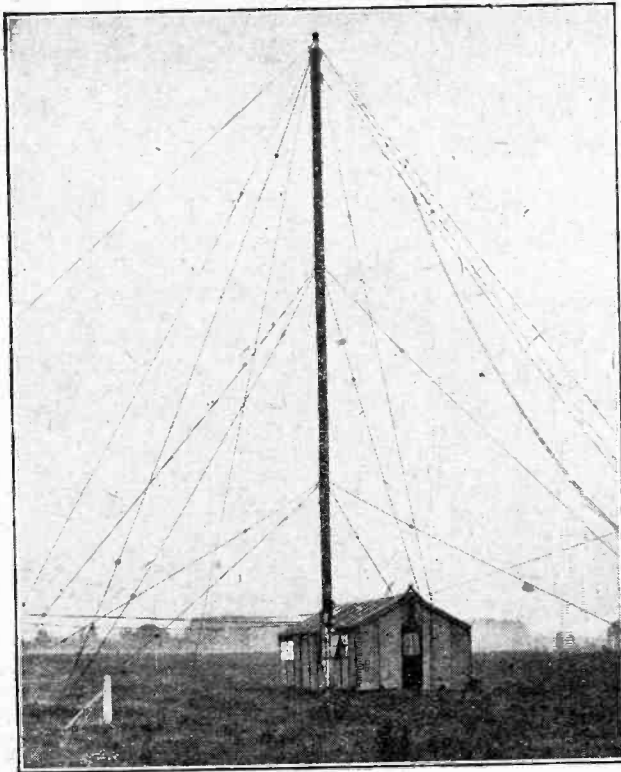

Collini-Tosi D.F. aerials at Croydon.

all its forms should be made more and more attractive. Let us ask ourselves the question whether we are or are not bound to consider one phase of attraction, viz., the affording of the facilities of private messages; that is to say, can we not now consider the possibility of allowing a private passenger the same facilities as he is allowed when he travels by sea. If we do so, it means a vast increase of the traffic exchanged between the aircraft and the aerodrome route stations, and on the face of it, it does not seem possible to meet such a demand with the present service employing radiotelephony.

The solution of these two difficulties appears to lie in the employment of telegraphic communication as opposed to telephonic communication. We have already said that the continuous wave emission is much more easily selected from neighbouring transmissions by a given receiver than if it were modulated and became a telephonic transmission. Using such a system we could reason-

ably expect to be able to work more aircraft within a given wave-band, but we are immediately confronted with a further difficulty still; we are confronted with the difficulty of the carriage of a skilled radiotelegraphist on board the aircraft. It does not appear either reasonable or just to expect the pilot to operate radiotelegraphy and to keep the radiotelegraphist's log-book during flight when he needs every one of his faculties to fly and navigate his aircraft.

This latter difficulty has been the subject of very extensive consideration, and the solution appears to be in the differentiation of the large aircraft from the small. If we have a large aircraft carrying a comparatively large number of passengers and no inconsiderable freight, the addition of an extra member of the crew is not such a serious proposition as it would be on a smaller machine, speaking comparatively, and the decision taken, one which will be put into effect nominally on January 1st next year is to divide aircraft into two categories. The larger aircraft is defined as one carrying ten or more passengers, the smaller as one carrying up to ten passengers.

It has been realised that the qualifications of an operator for the larger type of aircraft are higher than those needed for the ordinary Mercantile Marine or land station W/T operator.

To meet this a special syllabus has been drawn up for an examination for which British candidates will be able to sit at any future date on wishing to qualify for these appointments. The syllabus is in itself comprehensive and will contain theoretical and practical examinations in both elementary electricity and magnetism (with attendant knowledge of elementary mathematics) and technical wireless telegraphy. In the latter, special stress is laid on continuous wave work and on direction finding by all methods.

I suppose that the chief aid which can be given by

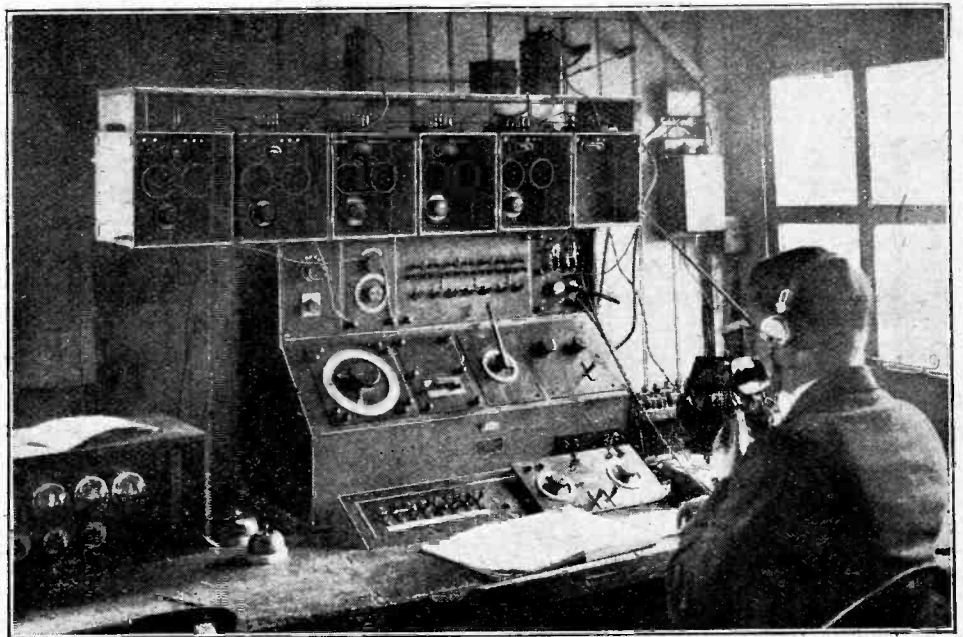

The receiving equipment at Croydon Aerodrome. The operator is also able to operate the transmitter, which is situated in another building, through a system of remote controls.

Civil Aviation Wireless.—

wireless to civil aircraft lies in the rendering of additional navigational facilities by direction finding. Direction finding stations of the Bellini-Tosi system have been in operation, purely for aircraft purposes, in Great Britain since 1920. These stations have been situated at the London Terminal Aerodrome, Croydon, and at Pulham, in Norfolk, and their efforts have met with such considerable success that a third station is about to be opened at Lympne. Meanwhile, as you must know, stations have been erected at Rotterdam, Brussels, and in the neighbourhood of Paris. For the past year experiments have been carried out by these latter stations with a view to ascertaining whether it would be possible to organise an international scheme for rendering D.F. assistance to any commercial aircraft in the vicinity, and,

accurate. It follows, of course, that direction finding by Bellini-Tosi methods is subject to certain errors, but the majority of these have been corrected for, and there now remain only the questions of coastal refraction and night error. Whether or not it will be possible to correct for these remains to be seen, continual research work is going on with this end in view.

Radio Beacons.

The alternative method of direction finding, to the Bellini-Tosi, is to use direction finding apparatus on the aircraft themselves, and to allow the navigator, or wireless operator, to take bearings of fixed stations along the route whose positions are accurately predetermined. This method seems to me far less subject to errors than the Bellini-Tosi system, and would appear to be worth while

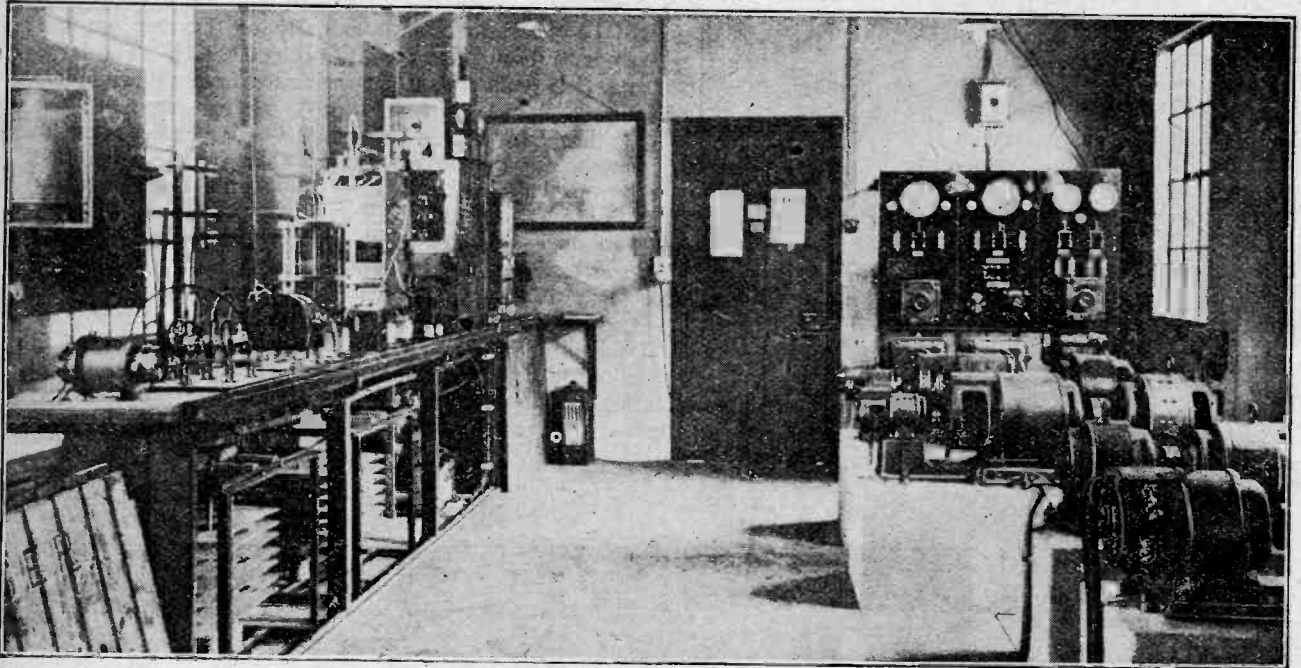

Transmitting equipment at the Croydon station.

as a result, we are now in a position to bring into being that scheme. Arrangements have lately been concluded whereby the Swiss stations at Geneva, Zurich, and Basle have also commenced operation, and there seems every likelihood of a general agreement being reached to include all these stations, and any others subsequently erected, in the scheme.

Direction and Position Finding.

Direction finding work hitherto has been confined to the rendering of either single bearings, from which the pilot of an aircraft could determine the course upon which he should fly to reach the station giving him the bearing or "positions"—that is to say, two or more bearings taken simultaneously of a single aircraft by different direction finding stations and laid off on a specially projected chart so that the position of the aircraft at the actual time of transmission could be determined. Both facilities have been freely offered and have proved highly

investigating very closely. Such a system has the disadvantage that extra weight would of necessity need to be carried in the aircraft, but it would mean a very considerable depreciation in the cost of initial outlay and annual upkeep of ground stations, to say nothing of a diminution of personnel concerned. The system would also, to my mind, have the advantage of placing the entire responsibility for the safety of the aircraft in the hands of the captain of the aircraft in the same manner that a ship is handled by its master mariner. There would be no division of responsibility between the pilot in the air and the traffic officer on the ground. Perhaps investigation will lead us to the installation of a system of radio beacons.

Recently much publicity has been given to phenomenal transmissions on very short wavelengths, vast distances having been covered with very small input powers. To date, I have seen no very conclusive evidence that work of this sort may be expected to be reliable throughout

Civil Aviation Wireless.—

every twenty-four hours of every day on any given wave, but for the comparatively shorter ranges over which we expect to work to and from commercial aircraft, there would certainly appear to be some benefit to be derived from the employment of a shorter wavelength. Before we can introduce any such scheme, however, there are one or two points to be considered. Firstly, for the smaller category of machine, will we be able to modulate for radiotelephony as successfully as we can on the higher waveband? Using a wave of the order 150-250 metres, the answer appears to be definitely in the affirmative. Secondly, using wavelengths of the same order, can we justifiably expect to achieve the same results in direction finding? There is no answer yet to this latter question.

Advantages of Short Waves.

The advantages lying in the employment of short waves would be that we should certainly be able to use a smaller aerial—probably one that is fixed permanently between convenient extremities of the aircraft—thereby obviating the use of that somewhat dangerous length of aerial which at present hangs beneath every commercial machine fitted with wireless, and we may expect to be able to reduce our input power and yet work over the same ranges. The latter point has one great advantage, in that, by reducing the transmitted energy of every single aircraft, we are bound to cut down much of the mutual interference. Shorter waves, moreover, will give us the possibility of many more stations working within a band than we could possibly work between 850 and 950 metres.

I have indicated quite briefly how we stand to-day and the possible trend of future development. For the rest it lies in our own hands to make the best we can out of these ideas and, if we can find still better ideas, to do so. I think we should remember that the whole of the future of civil flying depends upon the work that is being

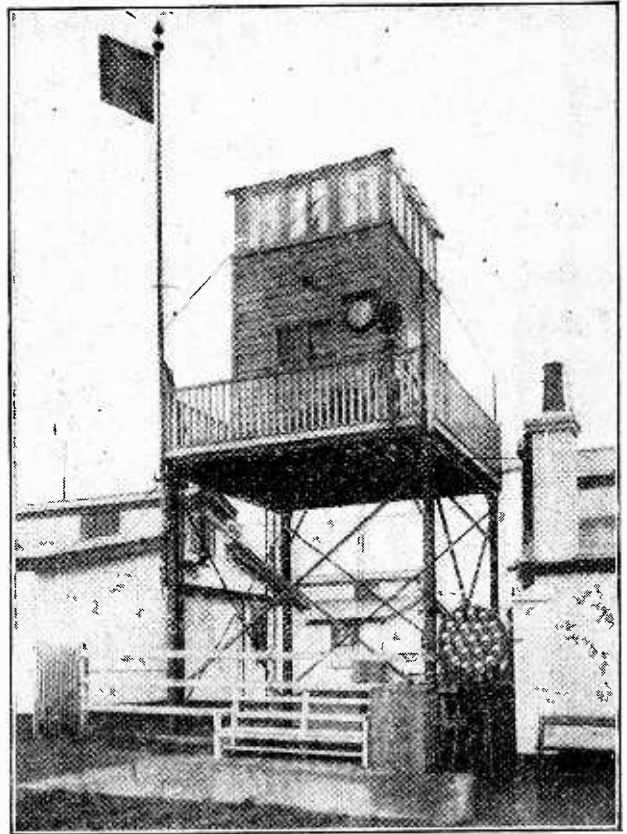

Control tower at Croydon Aerodrome.

done to-day. We should realise how very important a part wireless is playing, and is bound, more and more, to play in the future.

“Ever-Ready.”—The 1925-26 list of “Ever-Ready” products includes all types of flash lamps and batteries for every purpose. In addition, particulars and prices of “Ever-Ready” spring clip terminals, voltmeters and other accessories are included.

○○○

A “Reliability Wireless Guide” has been produced by Messrs. J. H. Taylor & Co., of Macaulay Street, Huddersfield. It contains the firm’s wireless price-list of goods despatched post free.

○○○

“Gecophone Wireless Receiving Sets.”—The General Electric Co., Ltd., of Magnet House, Kingsway, London, W.C.2, have issued a new list devoted entirely to their receiving equipments, including all types of crystal and valve receivers, as well as giving details of the new Gecophone six and eight-valve superheterodyne.

○○○

The complete range of Lamplugh receiving equipments and accessories is described in their radio catalogue for the season 1925-1926 just issued, and obtain-

**CATALOGUES
RECEIVED.**

able from Messrs. S. A. Lamplugh, Ltd., of Kings Road, Tyseley, Birmingham.

The radio catalogue just issued by Messrs. A. J. Dew and Co., 33-34, Rathlone Place, Oxford Street, London, W.1, is a complete guide to the wireless retailer, and includes almost every type of receiving set, component, or accessory at present on the market. Messrs. A. J. Dew and Co. are wholesalers only, but readers who are unable to obtain their wireless requirements from their usual trader may refer him to this catalogue, when their needs will probably be catered for.

○○○

Apart from giving particulars of a useful range of receiving sets, wave-meters, and other accessories, and a number of components of interest to the amateur, the booklet recently issued by

Goodchild and Partners, Ltd., 56-58, Eagle Street, Southampton Row, W.C.1, includes many pages of useful data and explanatory matter relating to broadcasting.

○○○

The new season’s catalogue of Radio Instruments, Ltd., of 12, Hyde Street, New Oxford Street, London, W.C.1, is now available, and includes a comprehensive range of receiving equipments, accessories, and component parts.

○○○

“Enterprise Manufacturing Co., Ltd.” (Electric House, Grape Street, London, W.C.2). Illustrated pamphlet describing the “Devicon” variable square law condenser.

○○○

“British L.M. Ericsson Manufacturing Co., Ltd.” (67-73, Kingsway, London, W.C.2). Booklet W.A.18 describing Ericsson components and circuits.

○○○

“Metro-Vick Supplies, Ltd.” (Trafford Park, Manchester). Illustrated catalogues relating to “Cosmos” receivers and radio valves.

INTERNATIONAL OPERATING SIGNALS.

List of Abbreviations Used in Amateur Transmissions.

AT the request of several of our readers we give below a list of the official abbreviations used in Morse signals. There are many others in common use, but as these are mostly abbreviations of English expressions, they can hardly be considered international.

Example—

QRK?=How are you receiving? QRK=I am receiving well.
QRW?=Are you busy? QRW XYZ=I am busy with XYZ.
Please do not interrupt.

PRB=Do you wish to communicate by means of the International Signal Code?

QRA=What is the name of your station?

QRB=How far are you from my station?

QRC=What are your true bearings?

QRD=Where are you bound?

QRF=Where are you coming from?

QRG=To what Company or Shipping Line do you belong?

QRH=What is your wavelength?

QRJ=How many words have you to transmit?

QRK=How are you receiving? (*Answer—*I am receiving well.)

QRL=Are you receiving badly? Shall I transmit— 20 times for you to adjust your apparatus?

QRM=Are you being interfered with?

QRN=Are atmospherics very strong?

QRO=Shall I increase my power?

QRP=Shall I decrease my power?

QRQ=Shall I transmit faster?

QRS=Shall I transmit slower?

QRT=Shall I stop transmitting?

QRU=Have you anything for me?

QRV=Are you ready?

QRW=Are you busy? (*Answer—*I am busy with — please do not interrupt.)

QRX=Shall I stand by? (*Answer—*Stand by, I will call you at —.)

QRY=What is my turn?

QRZ=Are my signals weak?

QSA=Are my signals strong?

QSB=Is my tone bad?

QSC=Is my spacing bad?

QSD=Let us compare watches. My time is —, What is your time?

QSF=Are the transmissions to be alternately or in series?

QSF=(*Answer*) Messages are to be transmitted alternately.

QSG=(*Answer*) Messages are to be transmitted in series of 5.

QSH=(*Answer*) Messages are to be transmitted in series of 10

QSJ=What is the rate per word to —?

QSK=Is the last message cancelled?

Time is denoted in Greenwich Mean Time expressed in four figures.

In the following list is given (except in a few cases) the meanings of the abbreviations in their interrogative form only, from which the answer or advice can easily be deduced, thus:—

QSL=Have you got the receipt? (*Answer—*Please give a receipt.)

QSM=What is your true course?

QSN=Are you communicating with land?

QSO=Are you in communication with another station (or, with —?)

QSO=(*Answer*) I am in communication with — (through the medium of —).

QSP=Shall I signal to — that you are calling him?

QSQ=Am I being called by —?

QSR=Will you despatch the message —?

QSS=Are my signals affected by fading?

QST=Have you received a general call?

QSU=Please call me when you have finished (or at — o'clock).

QSV=Is public correspondence engaged?

QSW=Should I increase the frequency of my spark?

QSX=Should I decrease the frequency of my spark?

QSY=Shall I transmit on a wavelength of — metres?

QSZ=(*Answer*) Transmit each word twice, I have difficulty in receiving your signals.

QTA=(*Answer*) Transmit each message twice (or, repeat the message you have just sent). Reception doubtful.

QTB=(*Answer*) Number of words not agreed, I will repeat the first letter of each word and first figure of each group.

QTC=Have you anything to transmit?

QTE=What is my true bearing?

QTF=What is my position?

QTG=Shall I transmit call-sign for one minute in order that D.F. bearing may be obtained?

73=Greetings, kind regards.

Signal strength as received by head telephones.

- R1 Signals unreadable.
- R2 Readable with difficulty.
- R3 Weak but readable.
- R4 Readable.
- R5 Easily readable.
- R6 Fairly strong.
- R7 Strong.
- R8 Very strong.
- R9 Loud-speaker strength.

PRACTICAL HINTS AND TIPS

A Section Mainly for the New Reader.

RESISTANCE STABILISING.

ALTHOUGH the "neutrodyne" system of stabilising tuned high-frequency amplifying valves is one of the most effective and widely used of the various methods at present available, there is some difficulty in adapting it to a set which is designed to operate over a wide band of wavelengths. Also, in the case of an existing tuned anode H.F. receiver, the selectivity of which it is desired to improve by the addition of a loosely coupled aerial circuit and neutralised tuned amplification, the alterations, involved would probably be considerable.

Another possible alternative capable of giving very good results is provided by the use of a variable non-inductive resistance in series with the tuned intervalve coupling circuit, as

compression filament rheostats will serve quite satisfactorily in this capacity. Individual specimens of the same make will be found, however, to vary considerably in the degree of smoothness with which adjustments of the higher resistance values can be made. A potentiometer will also generally be suitable for the purpose, as the winding is as a rule on a thin strip of insulating material, and will be sufficiently non-inductive. Of course, external connections are made to the variable contact and one end of the winding, the third terminal being idle.

In operating the set, grid and plate circuits are simultaneously tuned to the desired wavelength, and the amount of resistance is slowly reduced until the valve is in its most sensitive condition. This setting will, unfortunately, be correct only over a narrow wave-band, but, after a little practice, the adjustment of resistance necessary for stability on any wavelength will be easily made.

The degree of reaction may be closely controlled by fine adjustment of the variable resistance, and, in a set incorporating several high-frequency stages, it is certainly not necessary to provide any other reaction device.

The idea of including a high ohmic resistance in a tuned circuit may seem rather crude, but it will be realised that when this resistance is adjusted to such a value that the valve is just off the oscillation point, the actual effective resistance of the circuit is reduced to a very low figure.

An advantage of this method over the "positive grid damping" system is that the steady anode current is not increased; therefore, no extra demands are made on the H.T. battery.

ALTERNATIVE RECTIFICATION METHODS.

It will often be found that anode rectification gives much better quality reproduction of a strong incoming signal than does the more generally used grid method. The latter, however, is certainly much more sensitive

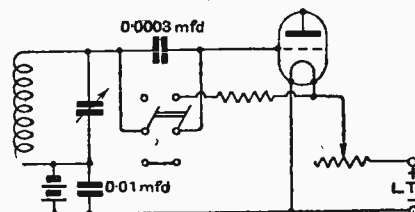

Fig. 2.—D.P.D.T. switch connected to provide either grid or anode rectification.

on a weak signal; this accounts for its great popularity. It is not, however, a difficult matter to adapt a receiver in such a way that either alternative may be used at will; one of the simplest ways of doing this is indicated diagrammatically in Fig. 2. The double-pole double-throw switch should have a low self-capacity, and great care should be taken, both in selecting its actual position in the receiver and in wiring it up. If these precautions are carefully observed, no appreciable loss of efficiency will result, as the incidental capacities of the switch and its connections are small compared with the other capacities in the circuit.

The grid bias battery provided for anode rectification is shunted by a large by-pass condenser; this is only necessary when its internal resistance increases with age. The battery may be permanently connected in circuit, as when the switch is up, the grid is insulated by the condenser, and its mean potential with respect to the filament is determined by the manner in which the lower end of the leak is connected.

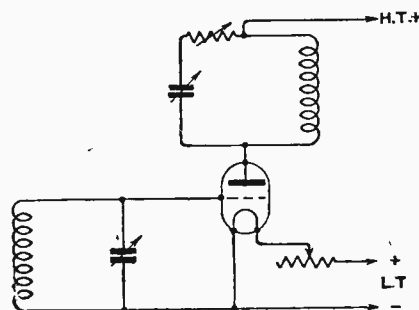

Fig. 1.—H.F. amplifying valve stabilised by means of a resistance connected in the anode circuit.

shown in Fig. 1. This is probably a more efficient method than that of damping the grid circuit by applying a positive voltage by means of a potentiometer, and is applicable to most sets with very little difficulty. The resistance should have a continuously variable value up to something like 200 ohms, and it will be found that some of the types of carbon

DIRECT REFLEXING.

It would seem that the valve-crystal direct reflex circuit due to Voigt, and described in this journal as long ago as August 22nd, 1923, might with advantage be revived now that high-amplification valves are in common use. The general arrangement of the circuit is shown in Fig. 3. It will be seen that the low-frequency impulses rectified by the crystal are fed back directly to the

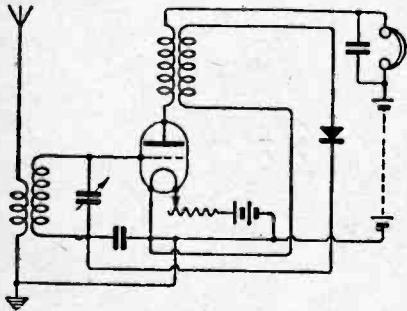

Fig. 3.—Simple reflex circuit dispensing with the L.F. transformer.

grid-filament circuit, and there is consequently no step-up voltage, as is the case in the more conventional arrangement, in which an L.F. transformer primary winding is connected in series with the crystal. When used with ordinary valves the amount of amplification obtainable by the direct method often seems disappointingly small, but the substitution of one of the type specially designed for resistance-capacity coupled amplifiers will generally result in a great increase in volume, and the addition of a single stage of low-frequency

magnification makes a receiver capable of supplying sufficient output for loud-speaker operation at quite a respectable range.

As suitable high-magnification valves normally have a high impedance, it will probably be best to couple the reflex stage to the low-frequency valve by means of a choke or resistance. The use of the former will simplify matters, as there is less risk of working the valve on the bend of its characteristic curve, due to the drop in voltage of a perhaps rather inadequate high-tension battery when the latter alternative is adopted. If both the valve and crystal are rectifying, the quality of reproduction will of course suffer, and amplification will be low.

In all circuits of this description, the effectiveness of the high-frequency transformer will largely decide the degree of efficiency obtainable. While an untuned coupling as shown can hardly be expected to give the greatest transfer of energy to the rectifier, its use certainly makes for a very practicable and easily operated receiver. No reaction control is shown in the diagram; both the capacity and magnetic methods are applicable, but the former arrangement seems to be preferable.

o o o o

NEUTRODYNE REACTION.

Users of receivers made to standard designs employing two stages of perfectly neutralised high-frequency amplification often feel, when working on the utmost limit of range

with a very weak incoming signal, that a certain amount of adjustable reaction would be desirable. In point of fact, it will generally be found that no very great advantage will be gained by the provision of this adjustment, as, in the case of a well-designed and really sensitive receiver, the extra sensitivity will hardly be necessary.

It is admitted, therefore, that conditions may exist where the extra sensitivity and selectivity provided by reaction will be of advantage, and the easiest way of providing this is to arrange for partial deneutralisation.

In practice, it is recommended that a smoothly adjustable neutralising condenser, with extension handle, be fitted in an accessible position on the panel, and connected in the usual manner in circuit with the second H.F. valve. Provided that the first valve is perfectly neutralised, oscillations in the second one will not be communicated to the aerial; it is therefore possible to search for distant stations by picking up the carrier waves by listening for the beat notes, without any risk of causing interference.

The same plan is also capable of adaption to a receiver containing only one H.F. stage, and, by its use, very good results are obtainable, without the complication of an additional reaction coil. In this case, of course, the usual precautions against interference by oscillations should be taken, as the set will naturally radiate as powerfully as will any other type when the first valve is in oscillation.

DISSECTED DIAGRAMS.

No. 2.—A Crystal Receiver with L.F. Amplifier.

For the benefit of those who have not yet acquired the simple art of reading circuit diagrams, we are giving week by week a series of sketches showing how the complete circuits of typical wireless receivers are built up step by step.

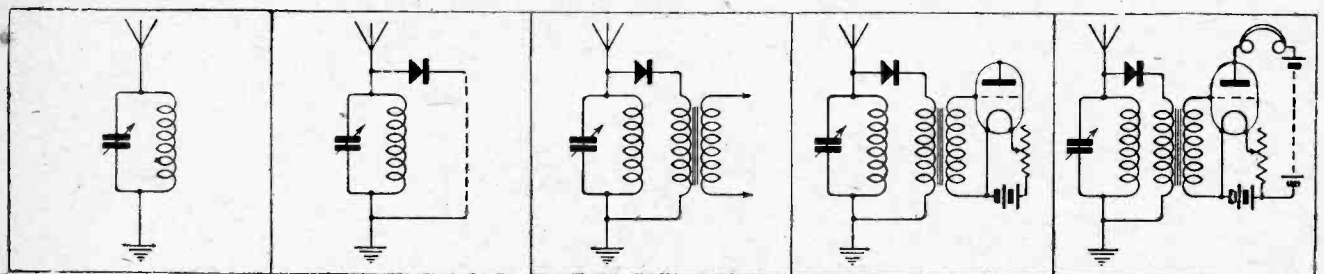

An oscillatory circuit, connected to aerial and earth. Voltages set up across it—

—are applied to a crystal detector. The rectified pulses are passed—

—through the primary winding of a step-up transformer, the secondary of which is connected across the grid-filament circuit of—

—an amplifying valve, having its filament heated by a battery through a variable resistance. Varying voltages on the grid cause—

—a sympathetic and magnified variation in the current flowing through the headphones from H.T. battery to plate.

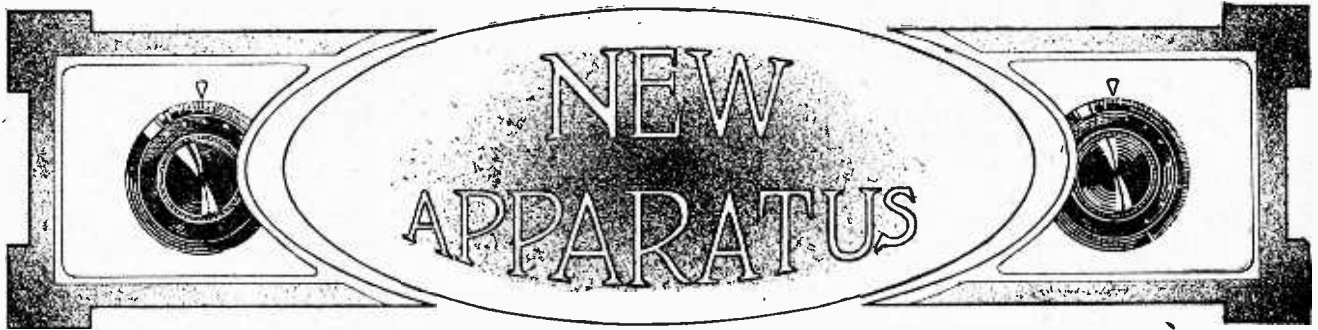

A Review of the Latest Products of the Manufacturers.

GECOPHONE VARIABLE CONDENSER.

The new type variable condenser recently introduced by the General Electric Co., Ltd., Magnet House, Kingsway, London, W.C., possesses many obvious points of merit.

The knob and dial are of distinctly attractive appearance; the milled portion which operates the vernier movement is 2½ in. in diameter and the dial itself 3 in. The knob operates a spindle passing right through the centre of the condenser and terminates on a small sharp-edged pinion which meshes between two stiff spring steel discs. These discs are carried by a spindle upon which is mounted

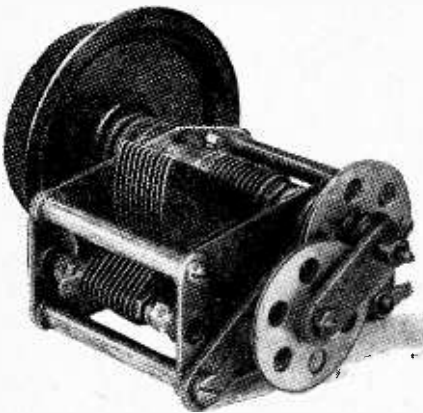

Gecophone geared variable condenser.

another small pinion similar to the first which again engages between a pair of steel discs on the main spindle of the condenser. This reduction gearing, which has a ratio of about 7 to 1, possesses the great advantage of absence of backlash as well as providing a particularly smooth movement, whilst the condenser will not be strained when the dial is operating through the reduction gear, which propels the plates to the limit of their movement.

The bearings on which the moving plates revolve are of very liberal dimensions, while the mechanism is robust and should give indefinite service. The moving plates are on the earth potential side of the condenser and the method of

securing the fixed plates consists of a pair of spindles with adjustable lock nuts engaging on small ebonite collets.

The metal parts of the condenser are of brass, and finished bright. The dial, with its clean engraving and polished finish, presents a very attractive appearance.

o o o o

ACME EBONITE PANELS.

The poor quality ebonite which has found its way into the wireless industry from time to time has brought about the need for the introduction of certain graded brands bearing definite trade names.

"Acme" ebonite is obtainable from Peter Curtis, Ltd., 75a, Camden Road, London, N.W.1, in panels of various sizes and thicknesses, with finished edges. It is supplied with surfaces either polished or matt in the black variety, and with polished finish in the mahogany variety.

A report of the National Physical Laboratory shows the insulation resistivity to exceed 50,000,000 megohms for a centimetre cube. The surface resistivity exceeds 100,000,000 megohms per centimetre as measured between two concentric rings placed on the surface of the material, observation being made after one minute's electrification at a pressure of 500 volts. The electrical strength is shown to be in accordance with Admiralty requirements, and a mechanical test applied in accordance with the Admiralty schedule shows its properties to be in every way up to standard.

o o o o

HUNT'S SPADE TERMINAL.

It is not always a simple matter to secure a multiple-strand flexible lead under a contact screw, and the new spade terminal of A. H. Hunt, Ltd., H.A.H.



Hunt's spade terminal.

Works, Tunstall Road, Croydon, is fitted with a spring clip into which the wire may be securely wedged. A single piece of flexible wire of 35 strands of No. 40 S.W.G. can be firmly nipped, and this connection will easily withstand a pull of seven or eight pounds. The use of spade terminals generally is a considerable improvement on the practice of twisting stranded flexible leads under screw terminals. The construction is simple and in consequence the connector is offered at a very low price.

o o o o

THE NEW B.W.R. COIL HOLDER.

Attention has recently been devoted to the design of two-way coil holders for mounting inside the receiving set with

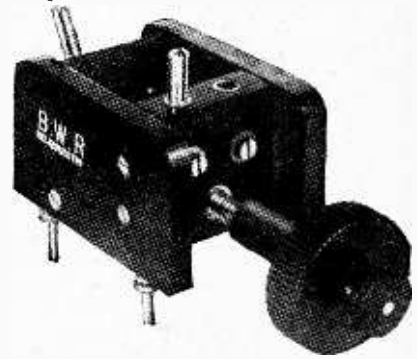

A new type of coil holder for mounting behind the instrument panel.

operating knob on the front of the instrument panel. The new B.W.R. two-way coil holder manufactured by Burge, Warren and Ridgley, Ltd., 91 and 92, Great Saffron Hill, London, E.C.1, consists of a plug and socket for the fixed coil mounted between two ebonite sides, with the moving holder pivoted between a pair of screws. The moving holder is operated by a pair of concentric knobs which provide for coarse and fine adjustment, the larger knob giving the quick adjustment through a coarse pitched thread and propelling the coil holder by means of a ball joint. Fine adjustment is produced by a spindle with a fine thread which passes up the centre of the coarse threaded spindle.

BRAMALL'S VALVE SOCKET.

Although the area of contact between the pin of a valve and its socket would appear to be liberal, intermittent contact is a common fault. To overcome this, difficulty the Bramall valve leg is cut through on one side and a strong bronze spring contact presses firmly into the recess. The contact thus made is very secure.



The Bramall valve socket fitted with a reliable spring contact.

Another advantage of this arrangement is that the actual tag to which soldered connection is made forms part of the spring which is in contact with the valve pin. Valve sockets of this type, when mounted on a piece of $\frac{3}{8}$ in. ebonite will form a really good low capacity valve holder.

o o o o

IGRANIC LOW-LOSS TRANSMITTING CONDENSER.

A variable condenser with liberal spacing between the fixed and moving plates has long been needed by the transmitting amateur, and is manufactured by the Igranic Electric Co., Ltd., 147, Queen Victoria Street, London, E.C.4. In this instrument the spacing of the plates is double that of the standard receiving con-

denser, which ensures the high degree of insulation necessary for transmission work, and prevents any possibility of a "flash-over." At the same time, losses are kept to a minimum by the avoidance of excessive dielectric strain. The method of supporting the fixed plates is the same as that adopted in the well-known Igranic receiving condenser, an arrangement which is particularly suitable when the condenser is required to handle appreciable energy at high radio frequencies. All metal parts are nickel-plated, and the general appearance and finish of the instrument leaves nothing to be desired.

o o o o

USEFUL CRYSTAL DETECTOR.

With the enormous popularity achieved by the galena and catwhisker type of detector, it is a relief to find that a perikon type of detector has recently been placed on the market by Auto Equipments, 184, Brearley Street, Birmingham. It is really a pretty job, consisting of a rigidly mounted cup into which a piece of bornite is secured by means of Wood's metal, the other contact, a small cup carrying a piece of zincite, being pressed into position by a spring, the tension of which has been carefully regulated.

In order that various points of contact may be sought out on the bornite crystal,

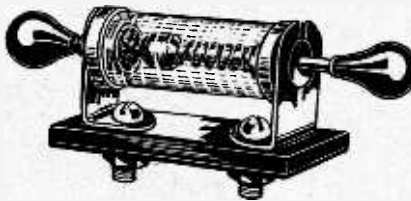

The double eccentric detector.

an eccentric mounting has been adopted. The detector occupies very little space on the instrument panel, and is shown in the drawing exact to size.

o o o o

ATHOL VALVE HOLDER BRACKET.

The porcelain valve holder manufactured by the Athol Engineering Co., Ltd., Cornet Street, Hr. Broughton, Manchester, is well known, and the introduction recently of a small brass angle bracket for attaching the holder to the instrument panel extends the application of this component.

The valve holder is designed for at-

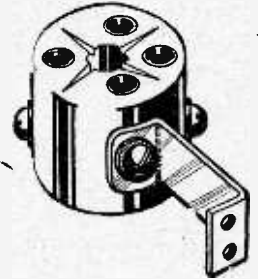

Athol valve holder and panel mounting bracket.

taching to a baseboard by means of a 6BA bolt passing through its centre. By using the new type bracket the baseboard can be dispensed with and the valve holder secured to the front panel. A pair of screws hold the bracket to the panel, and the bracket itself may serve as a circuit connection, for it is attached to the valve holder by one of the contact screws.

TRADE NOTES.**Changes of Address.**

Messrs. Sylver, Ltd., manufacturers of radio crystals and accessories, advise us that they have moved to 41, High Holborn, W.C.1.

Messrs. M. W. Woods, manufacturers of alternators, motor generators, rectifiers, etc., have moved their London offices to 3, Denman Street, London Bridge, S.E.1.

o o o o

New Amplion Scottish Depot.

The "House of Graham" has just opened a new Amplion depot at 101, St. Vincent Street, Glasgow. Showrooms for demonstrations to the trade and the public will be under the direction of qualified Amplion representatives.

o o o o

The Amplion in Canada.

Another link has been added to the chain of Amplion associated companies by the formation of the Amplion Corporation of Canada, Ltd., 130, Richmond Street West, Toronto, Ontario. Hitherto

Amplion business in Canada has been handled by Messrs. Burndept of Canada, Ltd., who still continue, for the time being, to act as wholesale distributors for the Amplion Corporation.

o o o o

The Long Life Battery.

Testimony to the enduring qualities of the Exide battery is given by a provincial wireless dealer who commenced repairing and recharging wireless batteries two years ago. In his report to the manufacturers he states that he has since repaired over 1,000 batteries of all shapes and sizes, but he has never yet had an Exide to repair, despite the fact that 50 per cent. of the batteries charged are Exides.

o o o o

The Radio Mail.

The above is the title of the monthly publication issued by Messrs. A. C. Cossor, Ltd. The September number includes an illustrated description of a tour round the machine shop of the Cossor factory

A Dubilier Dance.

The first carnival dance and whist drive of the Dubilier Condenser Company (1925), Ltd., was held on Friday, September 25th, at the Chiswick Town Hall, under the auspices of the Dubilier Athletic Sports Association.

Dancing and whist commenced simultaneously soon after 7.30 p.m., in the Town Hall and Hogarth Hall respectively, continuing until about 10 o'clock, when a halt was called for the distribution of whist prizes.

The success of the function was undoubted, and it is hoped to hold a similar evening in the near future.

o o o o

The Osram Bulletin.

In the "Osram Bulletin" for October equal prominence is given to the Osram valve as to the Osram lamp. In the first of a series of articles entitled "Opinions of Leading Amateurs," Mr. E. J. Simmonds (20D) describes some of his achievements with Osram valves.



By Our Special Correspondent.

London's Wavelength.

The alteration, last week, of 2LO's wavelength from 357.8 to 364 metres, brought reports of improved reception from listeners in Camberwell, Barnes, Newmarket, Bedford, Highbury, Barking and many other places. But the heterodyne position is now about as serious as it can be. One expert, in Central London, reported to Savoy Hill that 2LO was heterodyned at 8.50 every evening. In his opinion, a German station with a lady announcer was the offender. Other reports of continued heterodyning, even with the alteration in wavelength, have been received from Westcliff, Abthorpe (Northamptonshire, Polegate, Cambridge, and Slough. The B.B.C. is making every effort to trace the trouble to its source and to see that it is stopped.

o o o o

Improved Theatre Transmissions.

The broadcast from the Shaftesbury Theatre on October 16th, of an excerpt from "Dear Little Billie," was the first of a new series of engineering experiments in improving the quality of transmissions from theatres. Listeners have not been pleased with broadcasts of this kind in the past, owing to the echo effects and the absence of the right "balance" between orchestra and singers. The bad results are due mainly to reflection from the ceiling of the flies, which, in most theatres, are very high; and are not due to the auditorium itself. In the case of the recent opera transmissions, the "balance" between artists and orchestra has not been good. The charm of the music has been in the orchestration, and the voices of the singers have been lost.

o o o o

Several Microphones.

The solution of the problem lies in getting the microphone in a position to suit the characteristics of the theatre from which the broadcast is taking place. Several microphones will in future be used, according to methods recently tested by the engineers, who will also suggest ways in which the acoustics of the stage may be improved for the special purpose of securing good wireless transmission. The experiments in securing stereoscopic effects have recently been referred to in these columns.

5GB.

The experiments in higher power and medium wavelengths, which have attracted the attention of listeners to a transmitting station working with the call-sign 5GB, are being carried out by the B.B.C. under the authority of the Post Office. These tests are expected to go a long way towards solving the question whether or not fewer stations and higher power shall be the policy of broadcasting in the future.

o o o o

The Future of the Short Wave.

Further experiments will follow with short waves. Some engineers at Savoy Hill will tell you that the best method of broadcasting is that which has been used up to now; but with practically all the nations of Europe broadcasting, the ideal must give way to the practical, and subsidiary short waves may possibly be used for linking up distant countries.

Its Vagaries.

It is not certain that short waves will provide perfect linking; it may be that these elusive short waves will have to be abandoned and new methods adopted.

o o o o

Night Distortion.

Although the short waves get through very well in continuous working, the trouble of night distortion seems to set up an insuperable barrier. At certain times of the year, at undefined periods of the night, in unknown electrical conditions of the atmosphere, KDKA can be picked up with the utmost ease and the signals rebroadcast intelligibly. On the other hand, at times the B.B.C. may attempt to pick up this same station under apparently the same conditions and only succeed in broadcasting a succession of atmospheric with a possible travesty of the original thrown in.

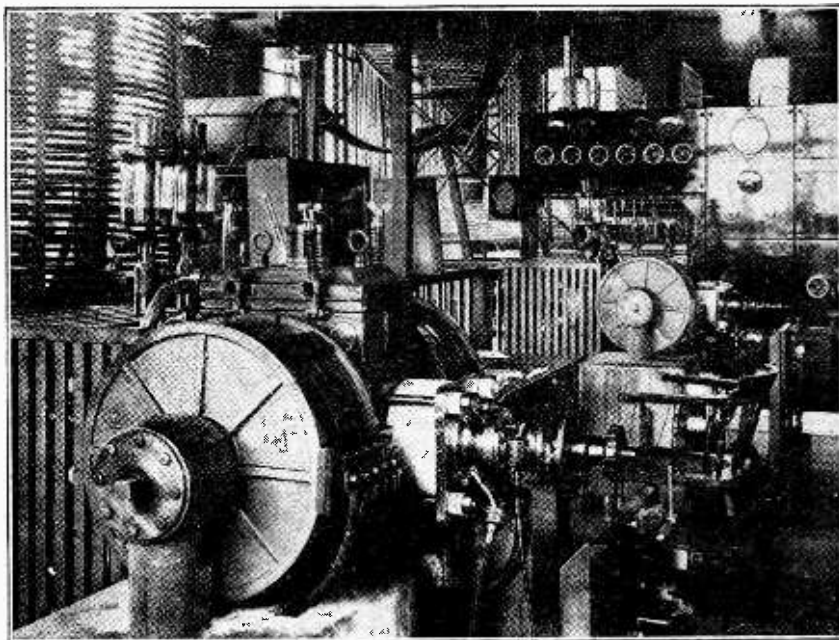

A SEAT OF INTERFERENCE. Many broadcast listeners in the London area complain of the "mush" created by the Post Office station at Northolt. This photograph shows some of the station's apparatus, with the arcs in the foreground.

Experiments at Hayes.

The super-receiving station at Hayes may be able to overcome this unreliable factor. The writer learns, however, that some definite experiments on this side are to be carried out, particularly with Europe, and it will shortly be known whether, say, twenty-five kilowatts with long wave is better than twenty-five kilowatts with short wave.

o o o o

Manchester's Afternoon Programmes.

The afternoon programmes of the Manchester station have been entirely reorganised, and on four afternoons of the week there is a short instructive talk to schools followed by a quarter of an hour of music. At 4.15 a tea-time concert is to be provided, and this terminates with the Children's Corner at 5.15. On Saturday afternoons the younger generation is being specially catered for with a "Thé Dansant."

o o o o

More Dance Music.

Throughout the winter an extended dance night will be arranged between the B.B.C. and several of the leading dance bands. The plan is to broadcast continuous dance music every Friday from 10.30 p.m. until 2.0 a.m. on Saturday. The music will be broadcast on alternate Fridays from 2LO and 5XX.

o o o o

Engineers' Bath at 5XX.

Several points have cropped up as the result of the broadcasting of the morning programmes from Daventry, and if the experiment is to be continued after this month the engineers will be faced with a good deal of extra expense in coping with the new situation. To take one of the many items, it has been found that the amount of cooling water is insufficient and the valves get too hot. The size of the tank will therefore have to be trebled. The tank will be rather in the nature of a lukewarm bath; but, as such, it may serve a useful purpose for the engineers, apart from its legitimate work of cooling the valves.

o o o o

For the Ladies.

For the special entertainment of women listeners a proposal is being considered to broadcast a talk once a week on Auction Bridge. If the suggestion is adopted the time of the broadcast will be from 4.0 to 4.15 p.m., and the problems of the game will be dealt with in an interesting way as possible.

o o o o

The Super Receiving Station.

Several features of the Hayes Receiving Station may now be explained more fully. A field was chosen so as to be as high as possible and as far away from civilisation as practicable, consistent with nearness to London. These conditions have been ideally satisfied and the results are respectively good reception, freedom from interference by local oscillators, and good landline facilities direct to London.

A 32

FUTURE FEATURES.**Sunday, October 25th.**

LONDON.—3.30 p.m., Symphony Concert.
BIRMINGHAM.—3.30 p.m., Symphony Concert. 9.15 p.m., Chamber Music.
MANCHESTER.—3.30 p.m., An Elizabethan Programme.
GLASGOW.—9.15 p.m., "The Transformation of Lachlan Campbell."

Monday, October 26th.

LONDON.—8 p.m., "Storm" and "Calm."
BOURNEMOUTH.—8 p.m., Winter Gardens Night.
MANCHESTER.—8 p.m., "The 7.30 Revue."
NEWCASTLE.—8 p.m., The Centenary of Johann Strauss.
ABERDEEN.—9.15 p.m., "Radio Radiance."
BELFAST.—8 p.m., St. Crispin's Day.

Tuesday, October 27th.

LONDON.—8 p.m., Programme provided by the "Daily Herald." S.B. to all stations except 5XX and Manchester. 10.30 p.m., Mass Telepathy. S.B. to all stations.

Wednesday, October 28th.

LONDON.—5.30 p.m., Earl Grey of Falloon: Lecture on "Bird Sanctuaries," relayed from University College, Gower Street. 8 p.m., "What is This?"
BIRMINGHAM.—9.15 p.m., "Radio Radiance."
CARDIFF.—8 p.m., The Spirit of Welsh Music.

Thursday, October 29th.

LONDON.—8 p.m., "Round the Continent." 9 p.m., Chamber Music.
EDINBURGH.—8 p.m., Classical Evening.
BIRMINGHAM.—8 p.m., Community Singing Concert, relayed from Lifford Hall, Broadway, Worcester.
GLASGOW.—8 p.m., Edward MacDowell.

Friday, October 30th.

LONDON.—8 p.m., "An Hour in a Mid-Victorian Drawing Room."
ABERDEEN.—8 p.m., "An Evening with the Composer Brahms."
BELFAST.—7.30 p.m., "Younger Days."

Saturday, October 31st.

LONDON.—8 p.m., Opening Concert of the Hastings Municipal Orchestra Season.
BIRMINGHAM.—8 p.m., "Old and New."
BOURNEMOUTH.—8 p.m., Musical Comedy, "The Rancee."

Beverage Aerial.

A large field was chosen for the reason that it would give full opportunity for making experiments with any type of aerial for reception, in particular for experiments with the Beverage type of aerial, which is very low and very long, and was so successful when it was first tried for the purpose of American reception for relaying purposes.

o o o o

Type of Standard Sets.

There have also been erected standard aeriels used in connection with standard sets which will give the engineer-in-charge an opportunity of estimating from time to time the relative performance of all stations on the Continent from the transmission point of view. One of these is an L single-wire aerial erected on two masts 50ft. high and 100 ft. apart. Another, to be erected later, is a T aerial (cage type) of the same height for longer wavelengths.

o o o o

A Variety of Receivers.

There will also be standard receivers of a simpler type and a special receiver for short wavelengths capable of great efficiency on any particular wavelength. Some of these receivers are:—

- (1) A neutrodyne with five high frequencies and one detector;
- (2) One high frequency and one detector for ordinary work;
- (3) A regenerative detector valve followed by a low frequency amplifier for searching purposes;
- (4) A receiver for short waves having four high frequency stages and one detector; and
- (5) Several low frequency amplifiers.

Others will be made according to requirements.

o o o o

Accuracy in Wavelength Tests.

The check on all European stations will consist first of all of a check on quality and secondly on wavelength. The use of a carefully designed wavemeter will enable wavelengths to be checked to a very high degree of accuracy. Thus not only will a watch be kept on British stations to see that they do not interfere with each other, but also on foreign stations, so that any possible interference with British programmes by such stations will be immediately spotted, and by measuring the wavelengths of the stations involved the one that is causing the offence will be found, and steps can then be taken to reduce the interference.

o o o o

Handicaps Overcome.

The method adopted for relaying European and American stations has so far been rather handicapped by the lack of a suitable set and suitable equipment. Now, however, an opportunity will be given of developing reception of such stations and of taking advantage of the co-operation so far offered by other stations, thus leading to greater reliability and better technical results in the relaying by British stations of programmes from distant stations.

DICTIONARY OF TECHNICAL TERMS

Definitions of Terms and Expressions commonly used in Wireless Telegraphy and Telephony.

This section is being continued week by week and will form an authoritative work of reference.

Audion. The name given by De Forest to the early form of three-electrode *thermionic tube* which was first used by him for receiving wireless signals. The term is used largely in America.

Autodyne. A self-oscillating valve circuit in which the grid and plate inductances form a common coil. Used extensively for transmission.

Auto-Heterodyne. See ENDODYNE.

Auto-Transformer. A transformer in which the *primary* and *secondary* comprise a single winding, some of the turns being common to both primary and secondary. For example, the input pressure might be applied across the whole coil and the output or secondary tapped from any part of it.

Auxiliary Anode. A term sometimes used for the *grid* of a *three-electrode valve*.

B.

"B" Battery. American term for the *high tension battery* used in the plate circuit of a *thermionic tube* or valve. Cf. "A" BATTERY.

Back-Lash. See OVERLAP.

Back E.M.F. A counter *electromotive force*. One which is acting in the opposite direction to the flow of current in a circuit, e.g., the induced E.M.F. of a motor or the polarisation voltage of a cell.

Balancing Aerial. An auxiliary aerial used for duplex telephony. It is usually placed at right angles to the receiving aerial and adjusted to balance out the effects of the transmitter on the receiving aerial so that signals can be received and sent simultaneously.

Balancing Capacity. See COUNTERPOISE.

B. and S. Gauge. The Brown and Sharpe or American wire gauge. (See STANDARD WIRE GAUGE.)

Banked Winding. A multilayer winding of inductance coils wound in a special manner to reduce the *self-capacity*. The successive turns do not form a continuous layer, but are "banked up" in groups. This type of coil has been largely replaced by the *honeycomb coil* for wireless purposes.

Barretter. An instrument for the measurement of small *high-frequency* currents by their heating effects. The current to be measured is passed through a fine wire resistance with a high *temperature coefficient*, and the effective value is

found by observing the change in resistance of this wire.

Basket Coil. A coil which is made by winding wire on a former consisting of an odd number of radial pegs. When the winding is complete the pegs are withdrawn, the coil being kept in shape by impregnation with wax or other insulating compound.

Beam, Wireless. See WIRELESS BEAM.

Beats. When two wave motions of slightly unequal frequencies are superimposed a pulsation is produced by the

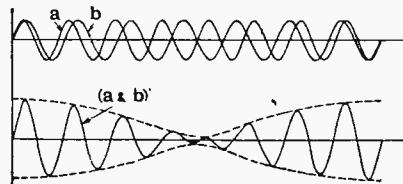

Curves showing the production of beats. The lower curve is formed by the addition of (a) and (b) above.

alternate coincidence and opposition of the waves. These pulsations or "beats" have a frequency exactly equal to the difference between the frequencies of the two superimposed wave motions. The principle is made use of in *heterodyne reception*. (See BEAT FREQUENCY and BEAT RECEPTION.)

Beat Frequency or Beat Note. The frequency of the beats or the note received in the telephones when using the *endodyne* or *heterodyne* method of reception of continuous wave signals. (See ENDODYNE and HETERODYNE.)

Beat Reception. The method of detecting continuous wave oscillations or signals by causing them to interact with locally generated oscillations of slightly different frequency, thus producing *beats* at an audible frequency in the telephones. Since the frequency of the beat note is equal to the difference between the frequencies of the local and received oscillations it is possible to vary the pitch of the note at will by varying the frequency of the local oscillations. (For methods of producing the local oscillations, see ENDODYNE and HETERODYNE.)

Bellini-Tosi System. See DIRECTION FINDER.

Beverage Aerial. See WAVE AERIAL.

B/H Curve. A graph showing the relation between the *magnetising force* (H) and the resulting magnetic *flux density* (B) produced (usually in iron).

The ratio B/H is the *permeability* of the material. For a material of constant permeability the B/H curve is a straight line passing through the origin. The correct name for the B/H curve is *magnetisation curve*.

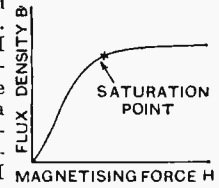

Form of the B/H curve for iron.

Bias. See GRID BIAS.

Billi Condenser. A tubular condenser of variable capacity capable of giving fine adjustments. A metallic tube slides over a tube of insulating material with an inner metallic lining.

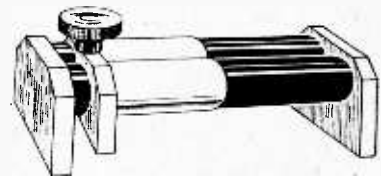

Billi condenser.

Binding Post. A *terminal*. Refers in particular to that type which is in the form of an upright pillar with a transverse hole to take the wire and with a central clamping screw, i.e., the type commonly known as a "telephone terminal."

Biotron. A combination of two *thermionic tubes* connected in such a manner as to produce a particularly steep *characteristic curve*.

Blasting. Term used to denote the distortion which takes place in loudspeaker or telephone signals on extra loud notes, due to working beyond the straight portion of valve characteristic. (See DISTORTION.)

Blind Spots. Places where wireless signals can only be received weakly although they can be heard with much greater strength at points further away from the transmitting station.

Blocking Condenser. A condenser of low fixed capacity usually included in a circuit to detune it with respect to some particular frequency.

Dictionary of Technical Terms.—

Blue Aura or Blue Glow. The bluish light which appears in *thermionic valves* of low vacuum (soft valves).

Bobbin. A coil of insulated wire as used for small electro-magnets of various kinds.

Bornite. A compound of copper, iron and sulphur used in conjunction with *zincite* as a crystal detector. (Chemical formula $3\text{Cu}_2\text{S.Fe}_2\text{S}_3$.)

B.O.T. Unit. Board of Trade Unit (of electrical energy). Equal to one kilowatt-hour, or the energy represented by a power of 1,000 watts operating for one hour.

Brake Horse Power. The actual useful output of a machine in horse power. (See HORSE POWER.)

Bridge. See WHEATSTONE BRIDGE.

Bridging Condenser or By-pass Condenser. A condenser of fixed capacity connected in *parallel* with part of a circuit in which both high frequency and low frequency currents are present. Since the reactance offered by the condenser is very much lower for the high-frequency component than for the low-frequency, most of the former passes through the condenser or is "by-passed," whereas the low-frequency component still passes more or less undisturbed through the other branch of the circuit. An example of this is the shunting of telephone receivers by a condenser of fixed capacity.

Bright Emitter. The ordinary type of thermionic valve in which the filament must be heated to a bright white heat before sufficient emission of *electrons* is possible. Cf. DULL EMITTER.

Brush Discharge. A pale blue luminous discharge which takes place from the surfaces of conductors which are raised to very potentials, e.g., from the ends of the aerials of high-power transmitting stations.

Bug Key. A special form of Morse transmitting key used to a large extent in America.

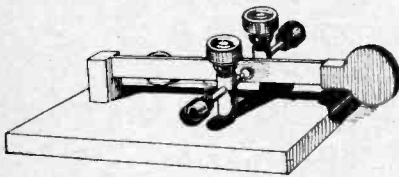

"Bug" key.

Bulb. A term sometimes used to denote a *thermionic valve*.

Bus Bar. Abbreviation for Omnibus Bar. A solid single conductor or bar which serves as a common connector for a number of instruments, machines, etc.

Buzzer. A device similar in operation to an electric trembler bell but not fitted with a gong, so that it produces a buzzing sound. It is often used to excite high-frequency oscillations in a tuned circuit for the purpose of test-

ing wireless receiving apparatus. The sudden breaking of the current through the buzzer coils is sufficient to set up high-frequency oscillations at the *natural frequency* of a tuned circuit when the latter is suitably connected.

Buzzer Wavemeter. A *wavemeter* which is excited by means of a buzzer and which therefore gives trains or groups of high-frequency oscillations. The number of such groups given out per second constitute a frequency within the audible range so that signals can be heard in an ordinary receiver without the necessity for *heterodyning*.

By-pass Condenser. See BRIDGING CONDENSER.

C.

"C" Battery. Notation sometimes used for the *grid battery* used for producing *grid bias*, i.e., for maintaining the potential of the grid of a *thermionic valve* at a given mean value above or below that of the negative end of the filament.

Cable. General term for stranded copper conductors for carrying electric currents.

Cage Aerial. An aerial in which a number of component wires are held in position round small star-shaped spreaders or round small hoops in such a manner as to form a "cage." This is done to reduce the *high-frequency resistance* of the aerial. At high frequencies the current density is always greatest near the outer surfaces of the conductors (skin effect), so that tube-like or cage-like conductors have a much lower H.F. resistance than solid conductors of the same cross-sectional area.

Capacitance. Another term for *capacity* used especially in America.

Capacity (of condenser). The capacity of a *condenser* is defined as the quantity of electricity (charge) which it contains when the electrical pressure between the two sets of plates is unity. In the practical system of units a condenser is said to have a capacity of 1 farad if it holds a charge of 1 coulomb (a coulomb being the quantity of electricity represented by a current of 1 ampere flowing for 1 second) when a pressure of 1 volt exists between the plates. Thus, if a condenser possesses a charge of Q coulombs when the pressure is V volts, the capacity, C , of the condenser is given by $C=Q/V$ farads. The farad is a very large unit, and for practical purposes the capacity of a condenser is usually expressed in *microfarads* (mfd.), i.e., in millionths of a farad. For some of the very small values of capacity met with in wireless even the microfarad is too large a unit, and the micro-microfarad or millionth part of a microfarad is used, and is usually denoted by mmfd.

The capacity of a condenser is directly proportional to the effective area of opposed surfaces of the two sets of plates, to the *specific inductive capacity* of the insulating medium between the plates, and inversely propor-

tional to the distance between the plates. The specific inductive capacity of dry air is unity and is greater than unity for all solids.

Capacity (of accumulator). Refers to the number of ampere-hours the accumulator is capable of giving out when discharged at the normal rate from the fully charged condition. This is known as the *actual ampere-hour capacity*. Accumulators are sometimes rated for ignition purposes where the discharge current is an intermittent one, the ampere-hour capacity being given as double the actual value as defined above. When purchasing an accumulator it is necessary to ascertain on which basis the rating is founded.

Capacity Coupling. See ELECTROSTATIC COUPLING.

Capacity Earth. See COUNTERPOISE.

Capacity Reactance. See CONDENSIVE REACTANCE.

Carrier Frequency. The frequency of the *carrier wave* of a telephonic transmission.

Carrier Wave. The high-frequency continuous waves or oscillations upon which the *audio-frequency* modulations or voice waves are superimposed in wireless telephony. See MODULATION.

Cascade Amplifier. A *multi-stage amplifier* or *multi-valve amplifier*.

Cascade Connection. Connection of a number of pieces of similar apparatus in sequence in such a manner that the output from one piece constitutes the input to the next, and so on. For example, in a *cascade amplifier* the valves are so arranged that the output from the plate circuit of the first is caused to operate the grid or input circuit of the next, and so on.

Cascade connection is sometimes used to express the ordinary series connection of apparatus such as resistances or condensers.

Cathode. (a) OF A CELL. The *electrode* through which the current leaves the cell.

(b) OF THERMIONIC VALVE. The filament or source of electron emission.

Cathode Ray Oscillograph. In a highly exhausted tube rays consisting of a stream of negatively charged particles are given off from the cathode when a high voltage is applied. A narrow beam of these cathode rays is made to fall on a fluorescent screen and thus make a visible spot of fluorescence. The beam passes through a field of two electro-magnets placed at right angles to one another, and excited proportionally to the voltage and current in the circuit under test. The deflection of the beam by the varying magnetic field causes the spot to trace out curves corresponding to the electrical oscillations in the circuit. This instrument may be used for the very high frequencies met with in wireless telegraphy.

Catwhisker. The fine wire which makes contact with the crystal in a *crystal detector*.

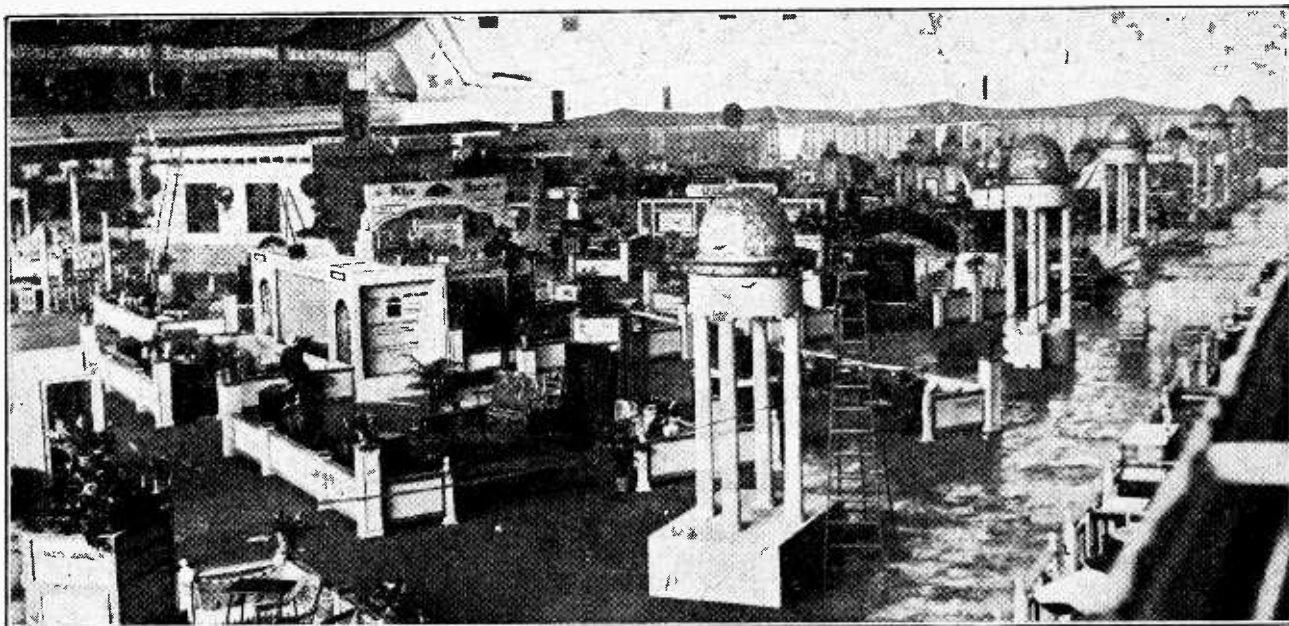

THE NEW YORK RADIO EXHIBITIONS.

Interesting Exhibits at the Radio World's Fair and the National Radio Exposition.

By A. DINSDALE.

THE night of September 19th saw the close of the two greatest radio exhibitions New York has ever seen. One, the Radio World's Fair, was held in the 258th Field Artillery Armory, the greatest extent of single floor space to be found in the city, and the other, the National Radio Exposition, was held at Grand Central Palace, in the heart of New York's shopping and theatre district.

Both exhibitions were remarkable for the large amount of business done by the exhibiting manufacturers, for the extensive display of new features, and for the vast attendance. At the Radio World's Fair, a general view of which is reproduced above the title of this article, it is estimated that at least \$100,000,000 worth of business was done, one independent valve manufacturer alone stating that he had scored a record of \$240,000 worth of business in a single afternoon! It is stated by the promoters that this Fair was visited by 150,000 people during the week it was open, and in the case of the National Radio Exposition 42,000 people crowded into Grand Central Palace on the last day alone.

The Radio World's Fair.

A unique feature of the Radio World's Fair was a complete broadcasting studio, set up in the middle of the Armory, and provided with large windows, so that the public could actually see the artists as well as hear them through giant loud-speakers disposed about the building. All the time the Fair was open programmes were broadcast from this studio through eight broadcast-

ing stations scattered all over the United States. These stations were all linked up through hundreds of miles of wire and controlled from a central switchboard. This feature was claimed to be the biggest broadcasting programme ever conducted from a single place.

During the progress of the Fair Mr. Bernays Johnson gave demonstrations of an oscillating crystal amplifier, which gave remarkable loud-speaker volume. The purity of reproduction was much admired by all who heard the set.

The Radio World's Fair closed with the presentation of a gold cup to Mr. Graham McNamee in recognition of his being the most popular announcer in the United States.

The National Radio Exposition.

The National Radio Exposition was opened on September 12th by an address transmitted by radio from London by the Duke of Sutherland. There were over 400 exhibits by the leading manufacturers, and these left no doubt in the mind of the visitor that radio has made great strides in the United States since the last exposition twelve months ago.

One of the most outstanding features was the extraordinary number of new types of loud-speaker and the fidelity of their performances. Another remarkable feature was the still further developed tendency of manufacturers to put their sets into handsome cabinets or pieces of furniture, so that they might harmonise with any surroundings. Many of these pieces of "radio furniture"

The New York Radio Exhibitions.—

were of remarkable beauty, and it is evident that the manufacturers acted wisely in taking this step; in this way they have developed what might be termed an "eye appeal" in radio.

In the matter of loud-speakers, the cone type appears to be in the ascendency, on account of its wonderful purity of tone and attractive appearance. As an example of the perfect quality which can be obtained from a loud-speaker, visitors to the Exposition were able to judge broadcast reception as delivered by two huge Hewlett induction type loud-speakers suspended over the side aisles.

These Hewlett loud-speakers have nothing to suggest the more usual type of instrument, for their spiral windings, supported on radial arms, and their concealed aluminium diaphragms, supported between the spiral windings, resemble more closely some decorative device than a reproducing instrument which is capable of filling a vast and crowded hall with pure, undistorted music.



Automatically tuned receiver entered in the competition for amateur constructors. By means of a series of push switches and magnetic relays any one of a series of broadcasting stations may be selected.

For some time past much thought has been devoted on the other side of the Atlantic to the development of devices for the elimination of all batteries in connection with radio receivers, and, judging from the exhibits at this Exposition, considerable success has been attained.

Battery Eliminators.

Lighting accumulators have been eliminated in two ways, one by the extensive development of dry cell valves, and the other by the development of appliances for lighting valves from the house-lighting mains, whether A.C. or D.C. In the States there will always be a demand for dry cell valves, or dull emitters, because there are in that country some six million farms still without electricity supply. They are also in demand for portable and semi-portable sets.

The demand for radio receivers which can be run off the house mains has been met by a wide variety of battery eliminators and battery rechargers. The latter have been developed into clean, attractive-looking units, employing chemical or valve rectifiers, and arranged to recharge the lighting battery at a slow rate. Such devices are called "trickle chargers" and are very economical, for they consume almost negligible current as compared with the usual more or less heavy-charge rate. By means of such a unit it is possible to recharge the lighting battery between operations, thus ensuring that it will at all times be ready for service and not give out at the critical moment as batteries charged in the more usual manner have an annoying habit of doing.

High-tension battery eliminators were also on show, most of them making use of special rectifier valves, transformers, and filter systems. That they are successful was amply demonstrated by the perfect operation of several receivers supplied with H.T. from such sources.

In one instance a complete superheterodyne, selling for

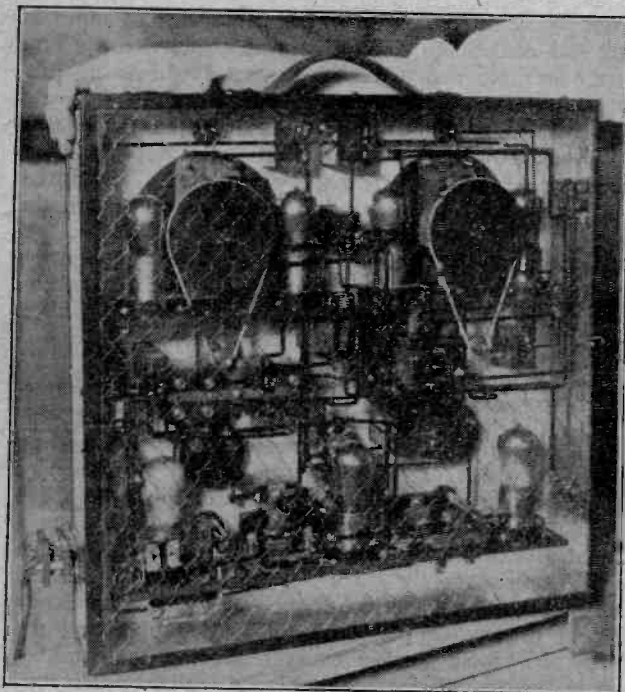

A fine example of amateur craftsmanship. A receiver built in an aluminium cabinet and entered by Mr. Irving Salzer in the competition for amateurs at the Radio World's Fair.

The New York Radio Exhibitions.—

nearly \$600, obtained all its current requirements direct from the supply mains, and operated perfectly without a trace of hum.

Components.

Examination of the component parts of the receivers on display revealed many refinements and improvements in details. In particular, there is evidence that American manufacturers are at last waking up to the fact that their L.F. transformers are totally unsuitable for broadcast reception. Until quite recently, American L.F. transformers have been a standardised article, designed originally, before the days of broadcasting, for purely telegraph work. Such instruments are small in size and have a high ratio, generally about 10 to 1. The impedance of the primary is also very low, even taking into consideration the fact that the average American valve has a lower impedance than the European valve.

Such transformers give great volume and satisfied those listeners whose principal craving was for noise; but that day is past. The American listener has at last become critical, and this is reflected in the design of many of the L.F. transformers exposed to view at this year's Show. They are much larger instruments, similar to the British article, containing much more iron in the core, more wire in the windings, and possessing a lower ratio.

In a further effort to improve the tonal quality of loud-speaker reproduction there was also a liberal display of special by-pass condensers, resistances, and other improved devices.

The necessity for sharper tuning has been recognised,

as was apparent from the many tuning refinements fitted to most of the better-class receivers. Variable condensers in almost every case were designed for straight-line frequency tuning, so as to spread stations out evenly over the dial. Such a condenser is becoming more and more necessary as the wavelength band employed for broadcasting purposes is brought lower and lower down the scale.

Receiving circuits employing high-frequency amplification in some form or other were to be seen everywhere, and it is apparent that high-frequency amplification has now found general favour in the States. The two most popular types of receiver in America to-day, if this exhibition can be taken as a guide, are the neutrodyne and superheterodyne. This is not surprising, in view of the simplicity of operation and excellent results obtainable with these types of receiver.

In place of the large-diameter tuning condenser dials with numbers engraved round the periphery, which were much in vogue at last year's exhibition, one finds this year tuning wheels with just the milled rim coming through a slot in the panel, or small knobs controlling verniers for extremely fine adjustments.

Besides the exhibits of radio sets and parts, many manufacturers of materials and apparatus used in radio receivers set up machinery in the exhibition hall and demonstrated to the public how ebonite panels are engraved, how valves, silk-covered wire, and aluminium condenser plates are made. Demonstrations were also given of the wireless transmission and reception of photographs, and how radiotelegrams are automatically sent and received across the Atlantic.

**TRANSMITTERS' NOTES
AND QUERIES.**

A French amateur, whose call sign is F8TBY, will welcome reports of his transmissions, and would like to arrange tests with British amateurs on any wavelength from 50-100 metres. He usually works on about 73 metres. Communications may be sent via Mr. C. Ayres (2BKD), 176, Denmark Road, Lowestoft, who will also forward cards to F8YNB and F8MCG.

Readers wishing to communicate with amateurs in South Africa may address QSL cards c/o S.A. Radio Relay League, "Myrtle Grove," Irwell St. Observatory, Cape Town, which is the address of OA4Z operated by Mr. J. S. Streeter.

Mr. J. Hanson, 56, Falstaff Gardens, Radford, Coventry, has been allotted the call sign 6YU. He transmits on 45 metres, and will welcome reports.

Mr. Rolf Horkheimer, Rottenburg a/Neckar, Germany, has been licensed to operate the station KY8 and will be glad to receive reports.

Prof. D. A. Rozansky, who is in charge of the short-wave station RCRL

at the Central Radio Laboratory, Lopukhinskaia 14, Leningrad, will welcome reports of transmissions. The station works on 38 metres, Morse and telephony, on Tuesdays from 3 to 8.30 p.m., and on Fridays from 8 a.m. to 1.30 p.m. This is, presumably, Russian time, two hours ahead of G.M.T.

Mr. J. Dunstan (A3JR), 7, Cameron Street, Ballarat East, Victoria, transmits on about 90 metres between 7 and 8 p.m. and between 10 and 11.30 p.m. Australian time, and will welcome reports.

Misuse of Call Signs.

Mr. W. B. Gillespy, The Hall Lodge, Elcheater, Co. Durham, has reason to believe that some other amateur is making use of his call sign 2BHC. As his station is only licensed for an "artificial aerial" he fears this misuse may jeopardise his chances of obtaining a full open licence.

Mr. A. L. Megson (G2GZ), Highway-side, Bow Green, Bowdon, Cheshire, also complains that someone else is making unauthorised use of 2HA, the call sign of his portable station. He has received reports from U.S.A., New South Wales, and other places, and also complaints from the Post Office that 2HA has been heard working on 39 metres. Mr. Megson states that he has not used his portable station (2HA) for more than two years. He welcomes reports of his short-wave transmissions from 2GZ.

Calls Heard.**Extracts from Readers' Logs.****Whitehead, Co. Antrim.**

(August.)

U.S.A.:—1AAY, 1ABP, 1ACI, 1AEP, 1ARE, 1ARH, 1AXA, 1BKE, 1BTR, 1BVL, 1BY, 1CAW, 1CKP, 1CMF, 1CMP, 1FH, 1PL, 1UW, 2AGB, 2BBX, 2BOX, 2BW, 2BY, 2CTH, 2SP, 3CKG, 3OT, 4ASK, 4OI, 4RL, 4SA, 4TV, 8BGN, 8SF. *Australia*:—3BD, 3BQ, 2CM, 2BB (?). *Various*:—WNP, NKF, NERKL, NTT, NRRL (in New Zealand), C1AR, CBS, RDW, M1DH.

Lichfield.

British:—6BD, 5LS, 2GY, 5SI, 5XO, 6MU. *French*:—8WAG, 8EE, 8TK, 8FW, 8BN, 8NN, 8RLH, 8TOK, 8UX, 8DTD, 8HLL. *Holland*:—0HB, N2PZ, 0PM. *Belgium*:—G6, Z2T2, 4RS. *Danish*:—7EC, 7OK. *Swiss*:—9AD, 9BR. *Sweden*:—SMTN, SMVH. *Italy*:—1BS, 1NO. *Spain*:—EAR21. *U.S.A.*:—8IQ, 3BVA, 1AXA, 2LV, 1ARH, 4XE, 1CKP, NKF, WAP, WIR, WQN. *N.Z.*:—4AR. *Australia*:—2CM. *Unknown*:—2ZA, KXH, FBI, 3AD.

G. S. SAMWAYE (G6OH).

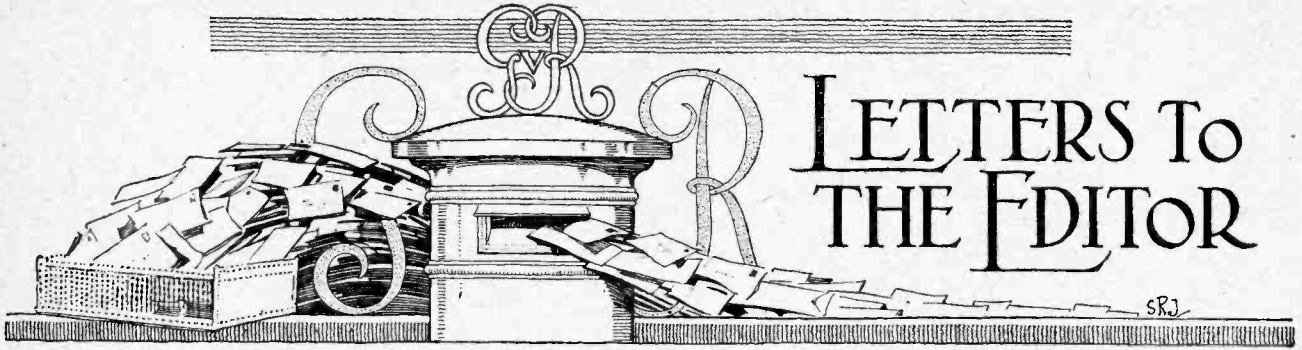

LETTERS TO THE EDITOR

The Editor does not hold himself responsible for the opinions of his correspondents.

Correspondence should be addressed to the Editor, "The Wireless World," 139-140, Fleet Street, E.C.4, and must be accompanied by the writer's name and address.

NEUTRODYNE v. SUPERSONIC.

Sir,—The following experiences bear out the contentions of Captain Round in his recent very interesting letter in your columns. The sets used for the tests were as follow:—

1. A well-known American supersonic set consisting of one H.F. stage (untuned), a first detector oscillating on the second harmonic principle, two beat frequency amplifiers (one of them reflexed), and a second detector followed by a note magnifier.
2. The above set with the addition of a carefully designed transformer coupled H.F. unit in a screened box, the secondary of this transformer being tuned by the frame tuning condenser of the supersonic set.
3. A selective neutrodyne set with three tuned H.F. circuits.

As some indication of their selectivity, it may be stated that all these sets will entirely cut out London within one mile from 2LO's aerial and bring in Bournemouth at loud-speaker strength.

The tests were conducted first in London and later in a remote part of Aberdeenshire. In London the supersonic set used with a small frame had a much more noisy background than the neutrodyne used with a large aerial. Harmonics of high power C.W. stations were apt to be troublesome on almost all wavelengths, Northolt (GKB) being a conspicuous offender. In addition to this, the amount of general mush was usually sufficient to prevent the enjoyment of distant broadcast programmes. The addition of the tuned and screened H.F. stage mitigated, but did not by any means cure, this trouble.

The neutrodyne receiver, on the other hand, working on a large aerial, had a notably quieter background all through the scale, was less troubled by harmonics and mush, and was quite distinctly superior from the listener's point of view.

In Aberdeenshire the chief difficulty in securing quiet reception was the presence for a time in the vicinity of a dynamo whose commutator created serious interference with the operation of the supersonic set on all wavelengths. The addition of the extra tuned H.F. stage did little to mitigate this.

The neutrodyne receiver brought in every main British station and many Continental transmissions with hardly a sign of dynamo interference, except in the neighbourhood of 270-290 metres, where some interference was experienced.

Curiously enough, in listening to Aberdeen, only about 35 miles distant, both sets brought in from time to time the harsh spark interference of Boulogne (FFB), which is so troublesome to listeners in the South of England who wish to receive 5IT or 2BD. Experience points to the advisability of cutting down to an absolute minimum the strength of any unwanted signals before the grid of the first detector is reached, as well as to careful shielding or the use of coils of the "toroidal" pattern with small external fields to minimise pick-up, and to the screening of the beat-frequency transformers. Subject to this, the arrangement suggested at the end of Captain Round's original article seems to be, as, indeed, he said, "ideal."

Dinnet, Aberdeenshire.

A. SHAW.

ATMOSPHERICS ON SHORT WAVELENGTHS.

Sir,—The following observations on the strength of atmospheric disturbance may interest readers of *The Wireless World*:

Observations were made on a 30ft. high, 25ft. horizontal wire aerial on the wave-band of 38-45ms. with o.v.l. Hartley circuit receiver. The strength of the atmospheric is determined with the aid of signals received, and I find it quite a simple method to compare the static strength with the signal strength and obtain results to a fraction of an "R."

The latter part of September produced very bad static, making even several local stations hard to read.

Observations were taken at about 2330 B.S.T., at which time static is generally at its maximum, generally falling off at about 0600-0700 B.S.T., when the air is generally pretty clear, but towards the end of the month the static apparently kept on, for at about 9600 it was just as bad as at 2300 the night before.

4, Glenhurst Avenue, London, N.W.5

R. POLLOCK.

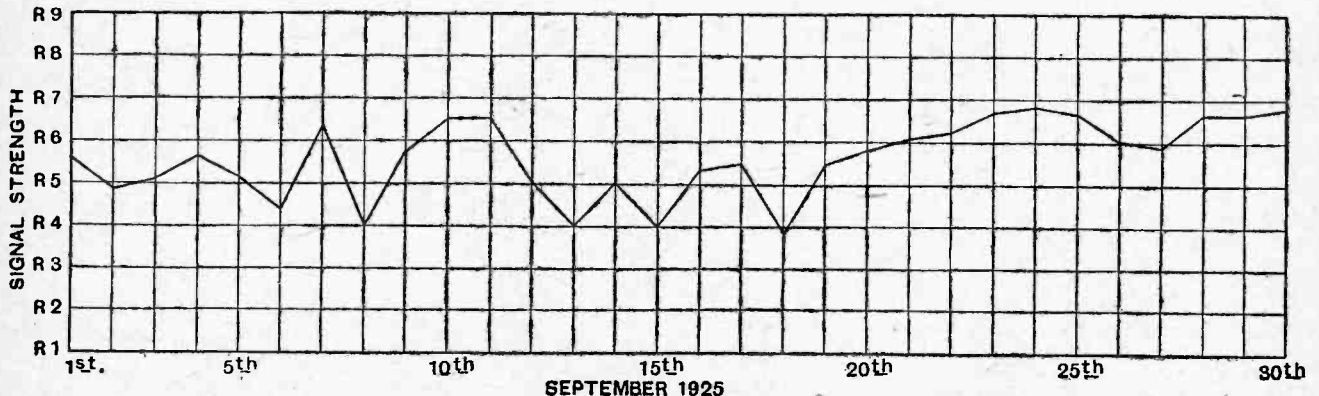

Observations on the strength of atmospheric taken daily at 2330 B.S.T. during the month of September.

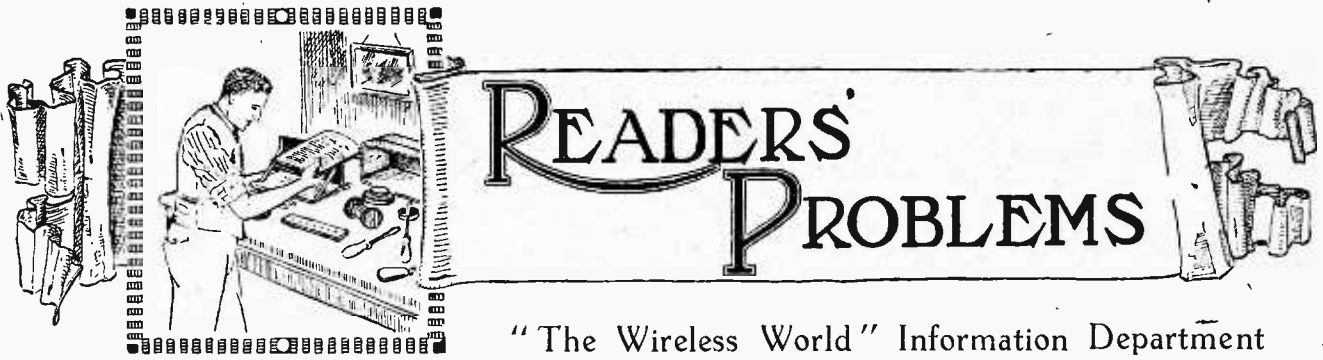

READERS' PROBLEMS

"The Wireless World" Information Department
Conducts a Free Service of Replies to Readers' Queries.

Questions should be concisely worded, and must be accompanied by a stamped addressed envelope for postal reply.

Stabilising H.F. Valves.

As suggested in your recent reply to my enquiry, I am thinking of improving selectivity by the addition of a coupled aerial circuit to my receiver. Am I to understand definitely that it is necessary to neutralise the H.F. valve if this scheme is adopted?

H.M.R.

It may be definitely stated when dealing with any system of tuned H.F. amplification on the shorter wavelengths, that if the coupling between the aerial coil and the grid coil of the H.F. valve is made loose enough to be effective, some form of artificial stabilising must be used. Neutralising is suggested as being probably the most efficient method at present known. Other alternatives are the use of positive potential on the grid of the valve, or the introduction of losses into grid or plate circuits by the insertion of resistances. It is also possible to damp the anode circuit by taking energy from it; this is a practical method when crystal detection is employed.

Detector Distortion.

I have a good single-valve receiver, but owing to my close proximity to the local station I experience distortion, presumably due to leaky condenser rectification when the receiver is tuned to the local transmission. Is there any method of curing this other than by using anode rectification?

H.A.R.

Quality can be considerably improved on these local transmissions by making use of a grid leak having a considerably lower value than is customarily used. A value of a quarter of a megohm should considerably improve quality, but at the same time, of course, a certain amount of signal strength will be lost, although in the case of the local station this point is not important.

Leaky Valve Holders.

I have built a resistance-coupled L.F. amplifier, but the quality obtained is disappointing. It appears immaterial whether grid bias is applied or otherwise. Can you indicate the possible cause of this?

P.C.H.

This phenomenon is more often than not due to a leakage between valve legs

either by reason of flux on the panel or faulty ebonite. Obviously a leak of this type will have the effect of partially "shorting" both grid leak and the grid biasing battery, thus multiplying the effect of any negative bias that may be applied, and causing distortion owing to the valve operating on an incorrect portion of its curve.

Extended Leads.

I am contemplating extending my loud-speaker leads for a considerable distance in order to give a demonstration in a small hall without the necessity of moving the receiver. Are any special precautions needed?

P.T.B.

You are advised to use a stepdown transformer and a low resistance loud-speaker. The reason for this is that if long extension leads are carried round the walls of a building, a considerable capacity will exist between the high potential wire and the earthed wall, which will have the same effect as connecting a large condenser across the loud-speaker, namely, giving a muffled tone to speech and music. Now, if a stepdown transformer is used, the effect of this added capacity will be approximately decimated, and no distortion will be introduced. Readers already in possession of high resistance loud-speakers, who contemplate using lengthy extension leads, should not carry both leads along the floor or walls

of a room, but should separate the leads, keeping the high potential lead isolated, as distinct from insulated, from all earthed objects such as walls, etc.

Three-valve Reflex Set.

I wish to construct a dual amplification receiver embodying three valves, in which only the centre valve acts in a dual capacity, the first and last valves acting as pure H.F. and L.F. amplifiers respectively. Rectification is to be accomplished by means of a crystal. Can you give me a suitable circuit?

P.R.B.

A circuit diagram suitable for this purpose is indicated in Fig. 1. It is necessary that a potentiometer be included to control the grid potential of the first valve, otherwise the set is apt to oscillate, even though all deliberate reaction devices are excluded. Needless to say, the final valve of this receiver must be a power valve if quality of reproduction is to be considered.

Loud-speaker Connections.

My loud-speaker has terminals marked + and -. Please state definitely the manner in which the loud-speaker should be connected to set.

Assuming that the telephone or loud-speaker terminals of the receiver are not marked, the internal connections of the receiver should be traced, and the + or

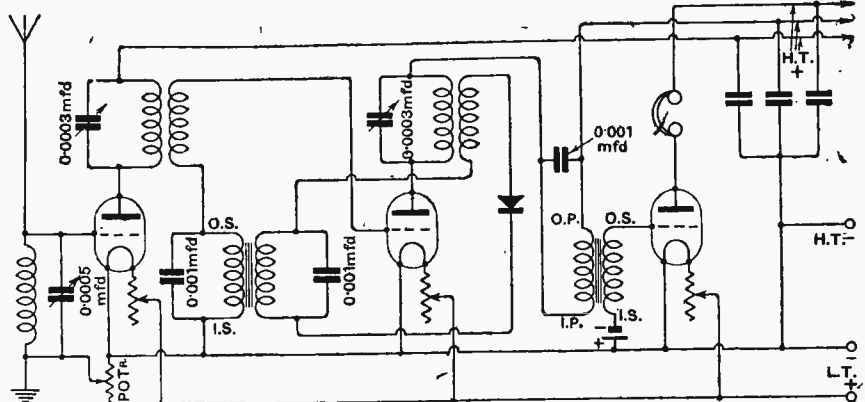

Fig. 1.—Three-valve circuit, in which the centre valve operates as a dual amplifier.

positive terminal of the loud-speaker should be connected to that output terminal of the set which is connected to the positive of the H.T. battery, the - or negative terminal of the loud-speaker attaching to the output terminal, which is internally connected to the anode of the final valve.

oooo

Eliminating Switches.

Understanding that it is highly inefficient to have switches of any description in the H.F. portions of a receiver circuit, I wish if possible to construct a receiver in which the H.F. stage can be eliminated when not desired in a manner least conducive to inefficiency. Can you indicate to me a suitable method? O.P.R.

By utilising the circuit diagram which we illustrate in Fig. 2, it is possible to

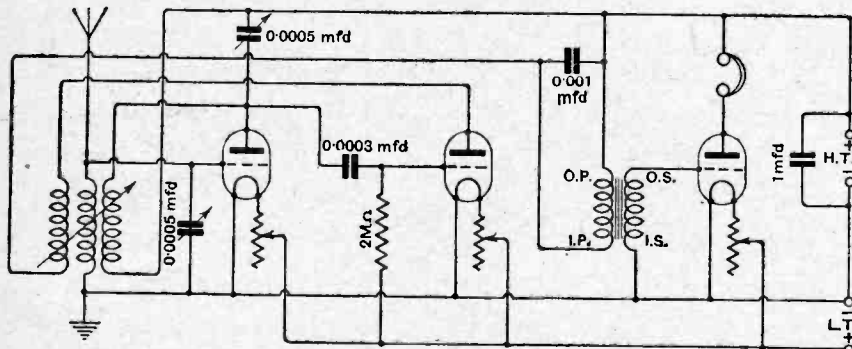

Fig. 2.—Three-valve circuit in which the H.F. valve may be cut out of circuit without the use of switches.

eliminate the H.F. stage without any switching whatsoever, it merely being necessary to turn out the filament of the H.F. valve. This is the fundamental circuit which contributes to the efficiency of *The Wireless World* "Four-Valve Combination Receiver."

oooo

Transformer Ratios.

Noticing recently in *The Wireless World* a statement that it was quite in order to use an 8 to 1 transformer following a galena crystal, provided that the transformer was of reputable make and possessing a telephone transformer of 9 to 1 ratio of the highest possible quality, I attempted to use this in a valve-crystal reflex receiver, but scarcely any amplification was obtained, and quality was appalling. Can you explain this? W.R.T.

A telephone transformer having a ratio of 9 or 10 to 1 must not be confused with a high ratio intervalve transformer. The latter, although containing a considerably less number of turns on its primary than a low ratio instrument, still possesses a much larger number of turns than the secondary of the telephone transformer you have been using as a primary, which contains comparatively few turns in order that its impedance may be equal to a pair of 120 ohm telephones with which

it is intended to be used. Consequently little or no amplification could take place, owing to the exceedingly low impedance of this winding.

oooo

Reservoir Condensers.

Does the 1 mfd. fixed condenser which it is customary to connect across the H.T. battery serve any other purpose than that of mitigating the crackling noises which are developed by senile H.T. batteries? E.L.G.

Yes, this condenser, by acting as a by-pass to all pulsating currents, whether of high or low frequency, reduces the tendency of the receiver to burst into oscillation. It must be remembered that the internal resistance of any H.T. battery, which is considerable, is in effect a high impedance common to the anode circuits of all valves. Consequently the current surges associated with each valve set up

various voltages across this impedance, which are naturally communicated to all valves, with resultant self-oscillation. The condenser, by offering a low impedance to these surges, prevents these undesirable voltages being set up across the H.T. battery.

BOOKS FOR THE WIRELESS STUDENT

Issued in conjunction with "The Wireless World."

"THE PERRY AUTO-TIME MORSE SYSTEM" by F. W. PERRY. Price 6d. net. By Post, 7d.

"MAGNETISM AND ELECTRICITY FOR HOME STUDY" by H. E. PENROSE. Price 6/- net. By Post, 6/6.

"THE ELEMENTARY PRINCIPLES OF WIRELESS TELEGRAPHY" by R. D. BANGAY. Price per part, 4/- net. By Post, 4/5. In one volume 7/6 net. By Post, 8/-.

"THE OSCILLATION VALVE—THE ELEMENTARY PRINCIPLES OF ITS APPLICATION TO WIRELESS TELEGRAPHY" by R. D. BANGAY. Price 6/- net. By Post, 6/3.

"ELECTRONS, ELECTRIC WAVES AND WIRELESS TELEPHONY" by Dr. J. A. FLEMING, M.A. Price 7/6 net. By Post, 8/-.

Obtainable by post (remittance with order) from **LILFEE & SONS LIMITED** Dorset House, Tudor St., London, E.C.4 or of Booksellers and Bookstalls

Short Range Reception.

I live within actual sight of the aerial of my local station. What is the best arrangement I can adopt for operating a loud-speaker at reasonable volume and the best possible quality? A.R.D.

The best method is undoubtedly to make use of a crystal rectifier followed by a good quality transformer, and a small power valve with suitable values of anode and grid potential. If galena is used, the transformer may be of 6 or even 8 to 1 ratio if of a reputable make, but in the case of perikon or carborundum a low ratio is preferable.

oooo

Superheterodyne Unit.

I am in possession of an ex-Government receiving instrument which is a multi-valve H.F. instrument designed for the reception of long waves, upon which it is remarkably efficient. Could I not take advantage of the efficiency of this long-wave amplifier by using it as the intermediate amplifier of a superheterodyne receiver? If possible, I should like to effect this by merely adding one extra valve. R.S.O.

It is quite a sound idea to make use of an efficiently constructed long wave receiver in the manner you describe. It can readily be converted to the superheterodyne by adding a combined detector-oscillator valve in accordance with the circuit diagram in Fig. 3. The grid coil, which should consist of about 60 turns, should be tapped in the centre. The plate coil should hold sufficient turns to produce smooth oscillation of the whole wavelength range covered by the grid coil and its associated tuning condenser. The two small balancing condensers on

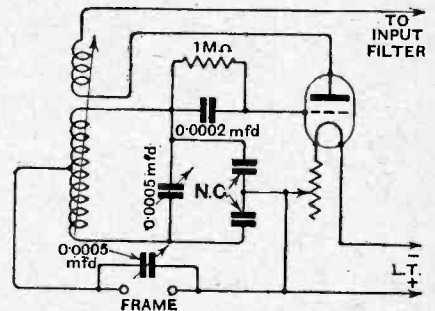

Fig. 3.—Autodyne unit for converting standard long-wave amplifier to superheterodyne receiver.

each side of the grid coil tuning condenser should be adjusted until an absolute balance of potential is obtained between the two points at which the frame is connected. In this manner the locally generated oscillations are prevented from entering the frame aerial and being re-radiated to the annoyance of others. Actually it is possible to employ an ordinary aerial and earth system without re-radiation, which is not possible with the ordinary superheterodyne. A large size neutrodyne condenser is suitable to use for the balancing condensers.

The Wireless World

AND
RADIO REVIEW
(13th Year of Publication)

No. 324.

WEDNESDAY, OCTOBER 28TH, 1925.

VOL. XVII. No. 18.

Assistant Editor:
F. H. HAYNES.

Editor:
HUGH S. POCOCK.

Assistant Editor:
W. JAMES.

Editorial Offices: 139-40, FLEET STREET, LONDON, E.C.4

Telephone: City 4011 (3 lines).

Advertising and Publishing Offices: DORSET HOUSE, TUDOR STREET, LONDON, E.C.4.

Telephone: City 2847 (13 lines).

Telegrams: "Ethaworld, Fleet, London."

COVENTRY: Hertford Street.

BIRMINGHAM: Guildhall Buildings, Navigation Street.

MANCHESTER: 199, Deansgate.

Telegrams: "Cyclist Coventry."
Telephone: 10 Coventry.

Telegrams: "Autopress, Birmingham."
Telephone: 2970 and 2971 Midland.

Telegrams: "Diffe, Manchester."
Telephone: 8970 and 8971 City.

Subscription Rates: Home, £1 1s. 8d.; Canada, £1 1s. 8d.; other countries abroad, £1 3s. 10d. per annum.

As many of the circuits and apparatus described in these pages are covered by patents, readers are advised, before making use of them, to satisfy themselves that they would not be infringing patents.

POST OFFICE COMPLACENCY.

AT a time when so much attention is being paid to the question of interference, especially between broadcasting stations in Europe, it is astonishing that serious causes of interference much less problematic of solution than some of those which beset the broadcasters should be allowed to continue apparently without any effort being made to effect a remedy.

During recent weeks interference has developed in the London area which makes reception of certain of the distant B.B.C. stations almost an impossibility, and, despite the fact that this interference can be traced almost definitely to the Northolt station of the Post Office, yet nothing is done to correct it.

We can imagine that very prompt measures would be taken by the Post Office if such interference were being caused by amateur, commercial, or even broadcasting stations in this country, but because the trouble appears to originate with one of the stations directly controlled by the Post Office, listeners and any other wireless users who are sufferers are apparently expected to tolerate the nuisance without complaint.

It is surely time that the Post Office should realise its responsibility and appreciate that its own stations should conform, equally with stations controlled by other interests, to the regulations for the avoidance of unnecessary interference which the Post Office itself has instituted.

This interference is not apparent to the local listener,

but every user in the North London area of a super-heterodyne or other receiver designed for distant reception has come within the influence of this interference which is practically continuous throughout the broadcasting hours.

Now that the winter months are approaching, attention

is being directed more and more to the enjoyment of distant reception, but of what use is it to do so if reception is rendered worthless, if not actually impossible, over a wide band of wavelengths well within the band allotted exclusively to broadcasting?

If the Post Office has any reason to doubt that the alleged offender is the station responsible, we suggest that the station should be closed for a brief period, observations being taken meanwhile, and we feel confident that the Post Office may count on many amateurs to offer their services as observers to assist in the detection.

The fact that this pronounced interference has only developed during the past few weeks is an indication that it is due to some fault which has developed, and which must consequently be equally capable of being corrected. It would satisfy listeners

provisionally to hear from the Post Office that efforts were being made to effect a remedy, but the continuance of the trouble, with no hint that the Post Office is taking action, whilst all other organisations controlling stations are making every effort to reduce interference is calculated to produce grave dissatisfaction amongst those who hitherto have looked to the Post Office to set an example.

CONTENTS.

	PAGE
EDITORIAL VIEWS	565
FIVE-VALVE NEUTRODYNE RECEIVER	566
By F. H. Haynes.	
WINTER CONCERTS FROM HOLLAND...	572
THERMIONIC RECTIFIER FOR BATTERY CHARGING	573
By J. F. Sutton.	
READERS' NOVELTIES	575
VALVES WE HAVE TESTED: THE COSSOR SERIES	577
CURRENT TOPICS	580
THE MANCHESTER WIRELESS EXHIBITION	582
RECENT INVENTIONS	583
HINTS AND TIPS	584
REVIEW OF APPARATUS	586
THREE-VALVE RECEIVER OPERATING FROM THE ELECTRIC MAINS	587
By Hugh S. Pocock.	
NEWS FROM THE CLUBS	593
BROADCAST BREVITIES	594
INTRODUCTION TO WIRELESS THEORY	596
By N. V. Kipping and A. D. Blumlein.	
LETTERS TO THE EDITOR	598
DICTIONARY OF TECHNICAL TERMS	599
READERS' PROBLEMS	601

A Special Wiring Supplement of this Set
accompanies this issue.

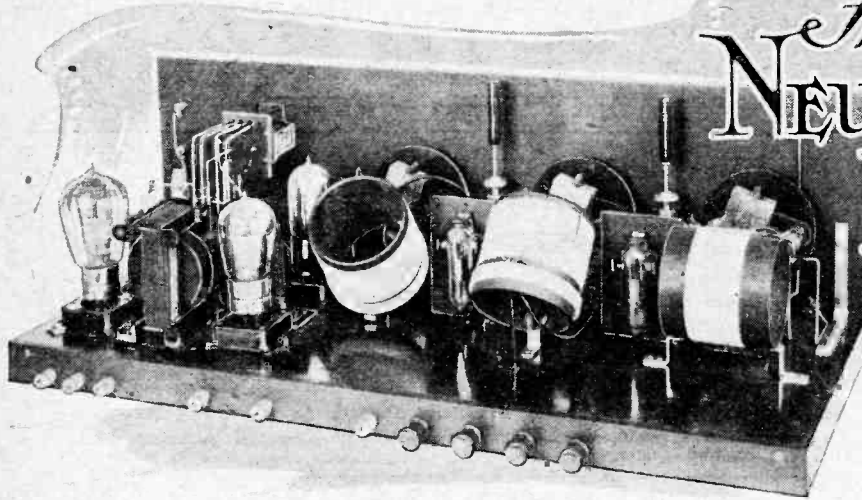

Five Valve NEUTRODYNE RECEIVER

An Easily Constructed
Long Range Broadcast Set
for Loud-speaker Reception
Made with Standard Com-
ponents.

By F. H. HAYNES.

WITH the coming of winter there will be many, no doubt, desiring to augment their present means of receiving broadcast transmissions. The receiving set of last year was required for bringing in the transmissions of the local station and, perhaps, one or two rather more distant British stations. The trend in design was, perhaps, towards producing a set capable of the best possible performance as regards short range reception. A large number of stations employing liberal power are now operating on the Continent, and with the interest taken in the Continental programmes, the merit of the set for the coming season will be judged by its range. Thus a highly sensitive type of receiver is needed, combined with a low-frequency amplifier for loud-speaker operation.

The other requirements applicable probably to the design of all-sets may be mentioned and in the receiver to be described have been rigidly adhered to. These points include a regard for cost in keeping with quality,

the employment only of standard component parts which can be fitted without alteration, a simplified wiring system, and the avoidance of cabinet work, which is one of the most difficult tasks the amateur constructor encounters.

Considerations in Design.

A single stage of high-frequency amplification used in a state of self-oscillation has, when followed by a power amplifier, a loud-speaker receiving range approaching a radius of 1,500 miles, assuming an average aerial in an unscreened position and transmitting stations with an input of not less than $1\frac{1}{2}$ kW. Such a receiver is, as a rule, far too unstable to give consistent results. Adjustment is exceedingly critical and reception intermittently broken up owing to lack of oscillation control. Stable high-frequency amplification must, therefore, be employed and two stages in which the stray capacities are neutralised is a good proposition.

Since the neutrodyne principle was first described, the solution of the many practical problems has been worked upon, and the best methods of applying negative capacity coupling arrived at. It will be seen in the circuit diagram that the neutralising condenser is connected to an additional winding instead of making use of the method in which a suitable potential is picked up by a tapping made on the H.F. transformer secondary. This arrangement possesses the merit that it is simple to set up and is more certain in its action. It is probably to be preferred to the linking across of the

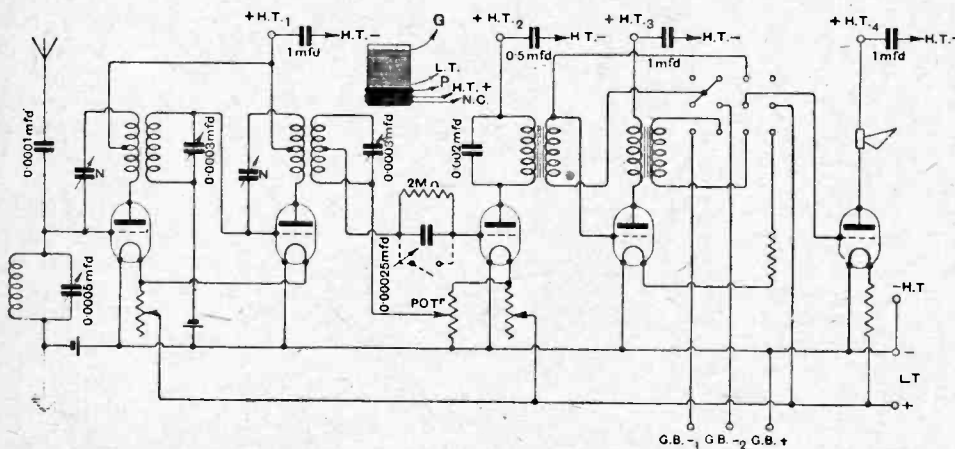

Fig. 1.—The two stage neutrodyne amplifier is followed by a valve detector for either grid leak and condenser, or anode rectification followed by a power amplifier. The first L.F. valve can be removed from circuit, and the switch provides for correctly maintaining the grid and plate potentials of the last valve. The method of connecting up the leads from the high frequency transformers is shown, primary and secondary windings being in the same direction.

Five Valve Neurodyne Receiver.—

tuned grid circuits, on the grounds that it is unwise to tamper with the tuning constants of the grid coil by connecting it up directly with the capacity of the neutralising condenser.

The loose coupled aerial circuit invariably shown in neurodyne circuits has been substituted by a direct coupling connected to the aerial through a fixed capacity air dielectric condenser (0.0001 mfd.), so as to avoid the need that would otherwise exist for specially designing the primary to suit the dimensions of the aerial. With the arrangement shown, the tuning of the aerial circuit does not vary a great deal with different aeri-als and the selectivity provided is at least as good as that given by the tight coupling of the usual neurodyne aerial coil.

The tuning range aimed at is the broadcasting band from approximately 260 to 525 metres, and if the tuning capacities are to be kept moderately low, which should be the aim, every care must be taken to guard against producing a coil with excessive self-capacity. Bearing in mind that the losses in the coils are in no way compensated for by the negative resistance effects of self-oscillation, damping due to dielectric losses must be eliminated as far as is possible. The tuning condensers of the intermediate transformers have maximum capacities of 0.00003 mfd., and they are specially chosen to have very low minimums. Employing the coils of easy construction shown in the set, the tuning range was found to be 292 to 525 metres, although with the special type of inductance shown in the photograph (Fig. 3), a tuning

denser and leak, though correctly it should be set to produce positive bias.

The essential provision of removing one of the low-frequency amplifiers from circuit is carried out by means

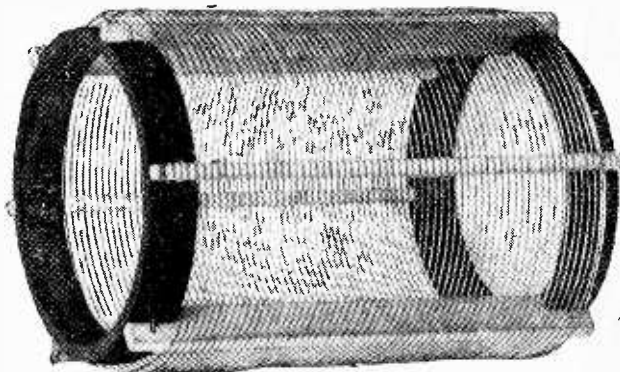

Fig. 3.—A special type of low loss coil not unduly difficult to construct and which may replace the coils shown in the set when the utmost efficiency is desired. The ebonite discs are 1/2 in. wide by 2 1/2 in. in diameter, and the six thin wooden strips which are tied on to the ebonite ends increase the diameter to 3 in. Indentations are made on the strips to hold the turns in place, and the wire is No. 26 hard drawn copper shaped by winding on a 2 in. cylinder and sprung in position. The primary winding is of similar construction, and carried on six strips which may be supported by the strips carrying the secondary winding.

of a switch connected in the grid circuits, which disconnects the first valve so that the power valve in the last stage is always utilised. It is necessary to use a four-pole switch so that the grid and plate potentials are correctly maintained.

Constructional Details.

Before proceeding with the constructional work the cabinet should be procured, and the dimensions specified are 2 1/4 in. x 8 in. for the front panel and a total external depth measured along one of the sides to the back of 9 3/4 in. The baseboard, which should be obtained with the cabinet, measures 2 1/4 in. x 9 in. x 1/2 in., and the end battens are 1 in. wide by 3/8 in. in thickness, producing a recess under the board 1 in. in depth. The ebonite terminal strip is 1 1/4 in. in width, and like the front panel is 5/16 in. in thickness, which,

although somewhat heavy, is necessary owing to the considerable length. The panel and terminal strip are ordered in polished ebonite with an additional 1/8 in. on length and breadth, and it is advisable to verify that the panel has been sawn square. A medium-cut file is used for truing up, and having made one edge perfectly straight, the edges are filed down to size, making use of square and straight-edge, though allowing for minor discrepancies in the squareness of the cabinet.

Making the Coils.

The formers for the coils, if of ebonite, are cut off with a fine-toothed saw at intervals of 3 1/16 in. along a 9 3/4 in. piece of 3 in. ebonite tube with wall thickness of 1/2 in. Carborundum cloth is used for rubbing down the ends. Reference to the lay-out of the baseboard will show that

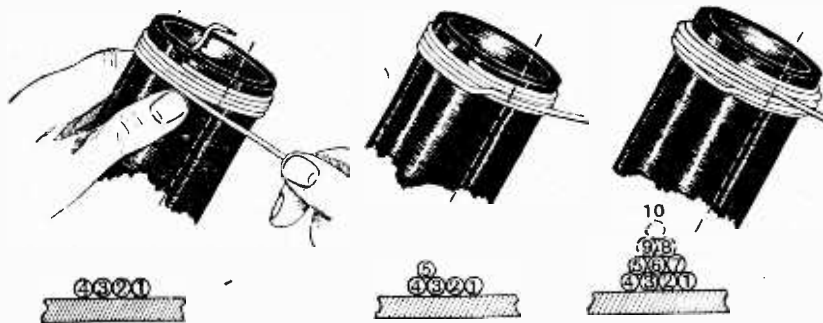

Fig. 2.—Steps in the process of pile winding. The starting end is connected to the neurodyne condenser, the junction being the first and second sections to the H.T. and the finishing end of the third section to the plate. A good tension must be kept on the wire, particularly during the winding of the first and second layers. No. 24 D.C.C. wire is most suited for the purpose.

range of 235 to 520 metres was produced, which represents an appreciable increase in the band of wavelengths occupied. For easy construction, however, the coils shown in the set wound upon ebonite or "Paxolin" formers (obtainable made to size to order from the Micanite Mfg. Co.) are entirely satisfactory.

The valve detector is provided with leaky grid condenser rectification, which produces more signal strength than the potentiometer method, and from a distortion standpoint scarcely warrants criticism. A potentiometer is, however, included in the design to give anode rectification if preferred, and the writer inserts a "QX" valve with an adaptor in place of the detector, short-circuiting the grid condenser by means of a piece of brass rod which replaces the grid leak. Very little effect is produced by the potentiometer when operating through the grid con-

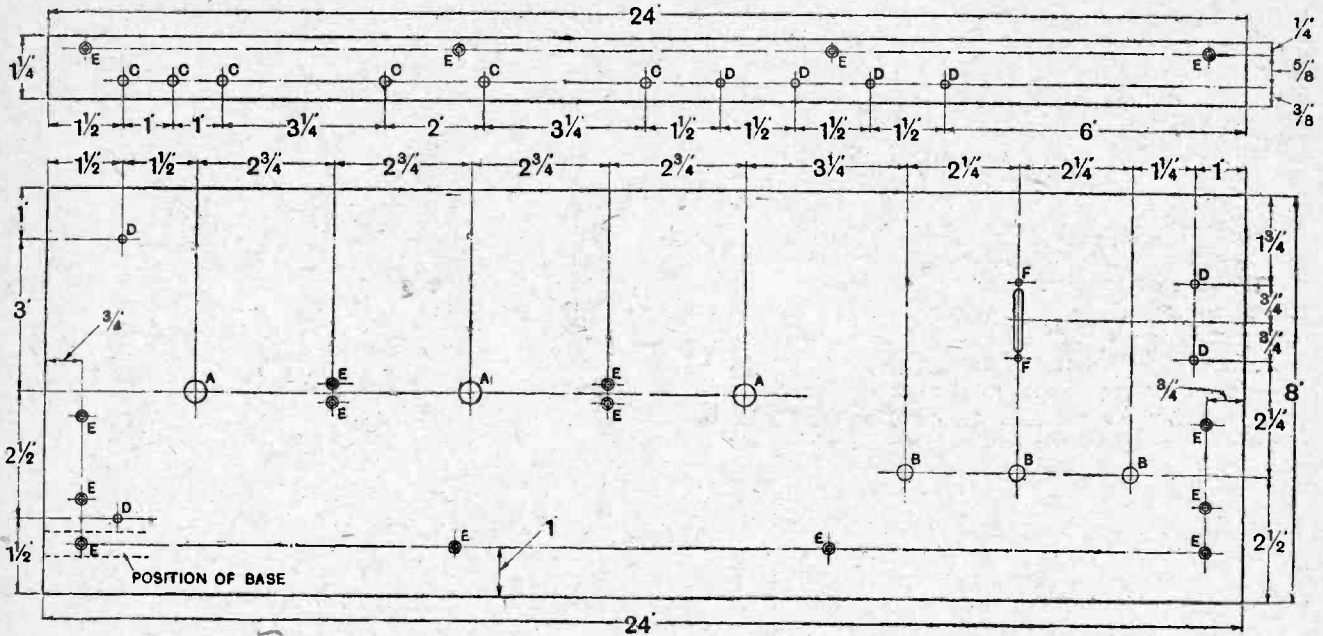

Fig. 4.—Drilling details of the front panel and terminal strip. A, 7/16in.; B, 5/16in.; C, 7/32in.; D, 5/32in.; E, 1/8in. and countersunk for 6BA and No. 4 wood screws; F, 1/8in. No tapped holes are required.

the aerial coil is mounted parallel to the front panel and it is best secured by two bent brass brackets made from No. 16 x 3/4 in. hard brass strip, which should be softened by making red hot and quenching in water before bending. Two 1/2 in. x 6 BA counter-sunk brass screws attach the brackets to the former, and 1/2 in. No. 4 round-headed brass screws secure the brackets to the baseboard. The other two formers are not mounted in the usual neutrodyne fashion, but are arranged to be at right angles to one another and at right angles to the aerial coil, so as to entirely avoid inductive coupling, for it must be remembered that the stabilising condensers only provide for neutralising stray capacity coupling and do not compensate for inherent magnetic coupling. Simple bent

pieces of brass will hold these coils in position with attachments at one end only. The brackets can, with advantage, be split at one end and forced open "Y" fashion and fixed to the ebonite by a pair of screws and nuts.

The aerial winding consists of 50 turns of No. 26 D.C.C., occupying a winding space of just under 1 1/2 in., and is terminated by threading through pairs of holes. The secondary winding on the other two formers consists of 65 turns of No. 26 D.C.C. in a winding space of 1 1/2 in., while the primary and neutralising windings are pile wound in three sections with No. 24 D.C.C. The first pile winding, built up as shown in an accompanying diagram and consisting of 10 turns, is eventually con-

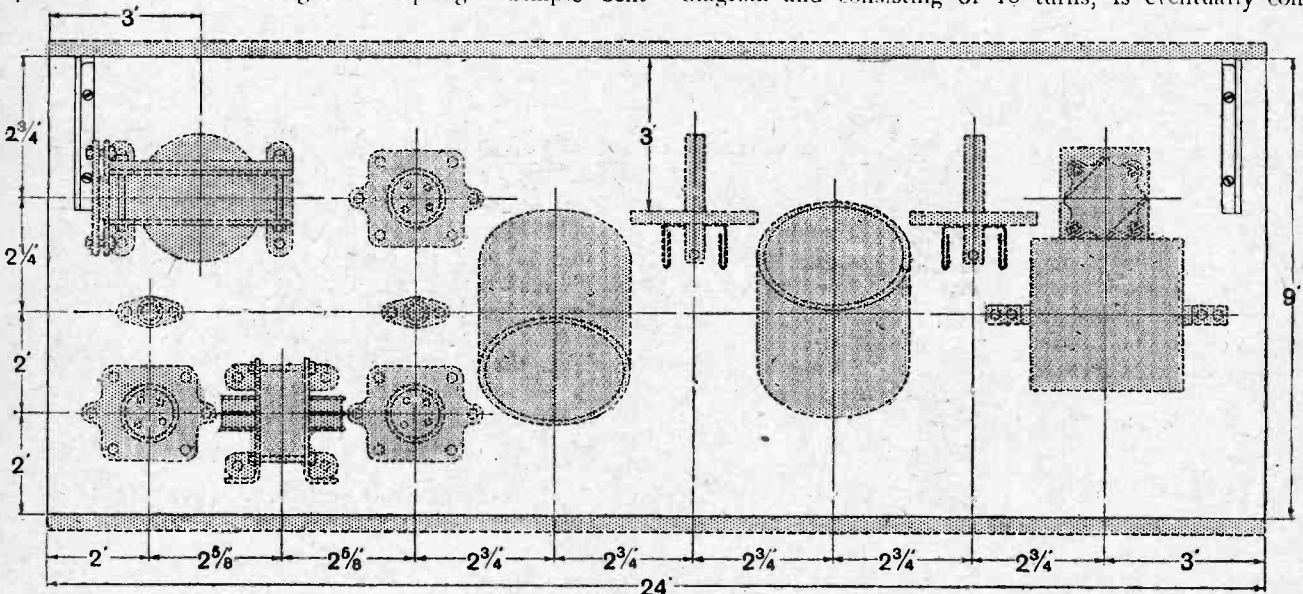

Fig. 5.—Layout of the components on the baseboard.

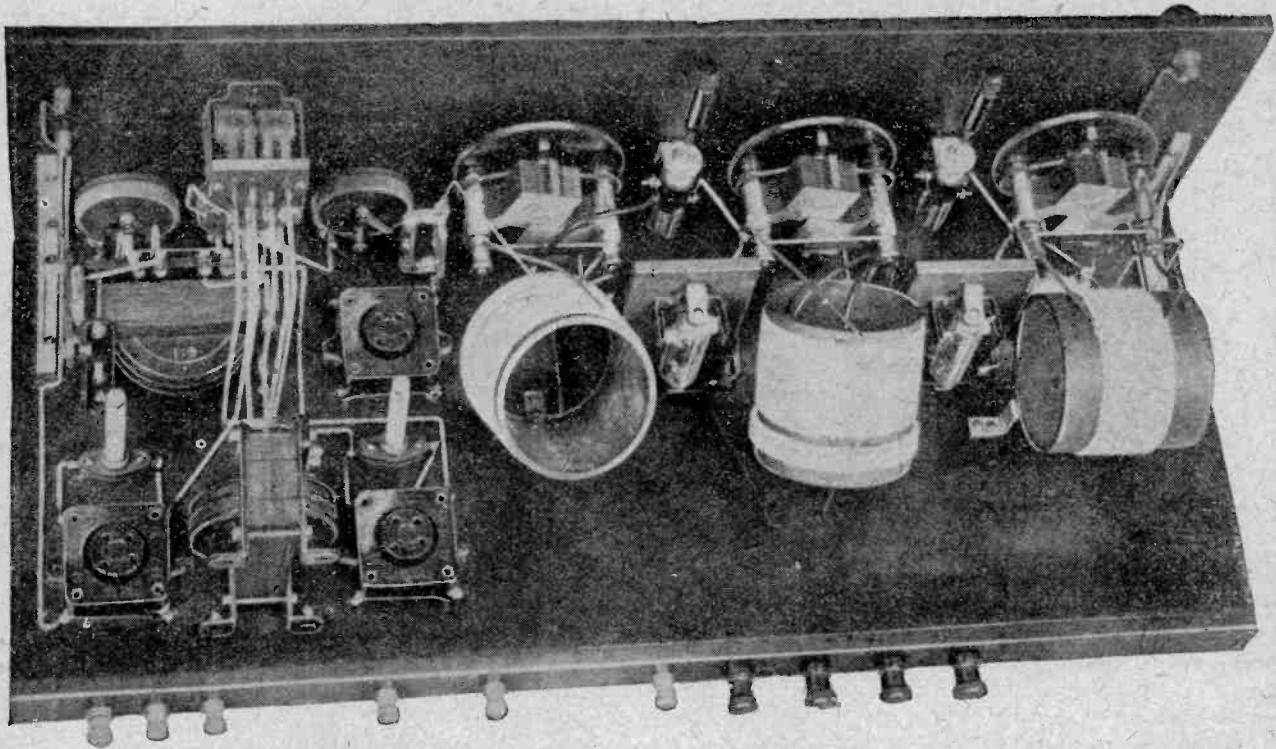

Fig 6 —Very little wiring appears on the completed set as many of the leads which do not form part of the tuning circuits are run beneath the baseboard, an arrangement which greatly simplifies wiring up and separates the H.F. leads from the earth potential parts of the circuit. The wire used throughout is No. 18 Indiarubber covered. A view of the front of the set with cabinet appears on the cover of this issue.

nected up with its starting end to the neutralising condenser, while a connection made to the junction with the second pile connects with the H.T. positive. The primary winding proper consists of 20 turns and the finishing end connects to plate. Primary and secondary windings are in the same direction, and it is the end of the secondary remote from the primary winding which connects to the valve grid. In winding put the secondaries on first, and in following the process of pile winding remember that success depends on keeping a good pull on the wire. A little shellac varnish may be applied to the cross-over points on the pile winding after it is completed. To reduce damping in the tuned circuit of the detector valve brought about by the flow of the grid current through the winding, a tapping point is made by inserting a pin under the centre turn, levering up the turn of wire causing it to stretch, and inserting a small wooden wedge to which a soldered connection is made when wiring up.

The Panel and Wiring.

Drilling the panel and assembling the other components in accordance with the drawings should prove

straightforward, though the following points may be mentioned. The neutrodyne condensers are held in position with their centres at $\frac{3}{4}$ in. from the back face of the panel by means of No. 16 S.W.G. brass brackets, $\frac{5}{8}$ in. in width. Alternatively, these condensers may be mounted straight through the panel with their centres $1\frac{1}{4}$ in. from the top edge, but it is better to house them inside as frequent adjustment is unnecessary. The holders for the V.24 valves are obtainable already made up and are mounted in the set by means of wooden angle-pieces. The condenser, which bridges the primary of the first low-frequency transformer, is held in position

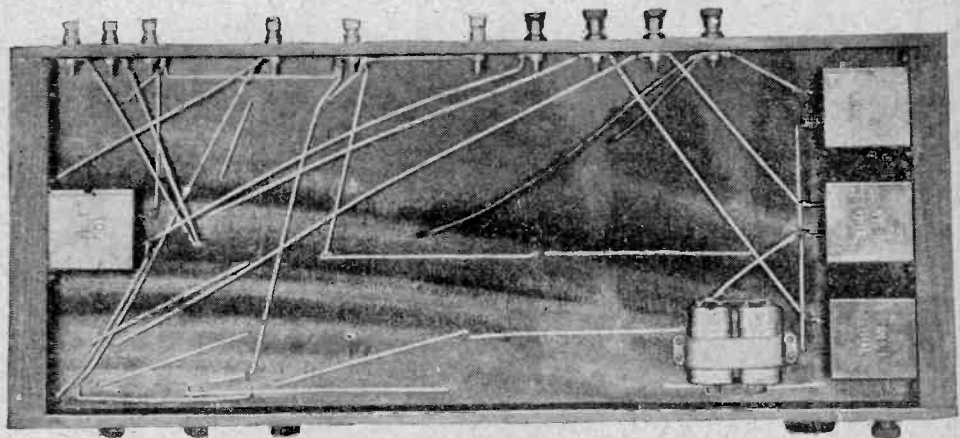

Fig. 7.—View of the underside of the baseboard. The bridging condensers and grid cells are carried in the recess provided for the wiring. On the practical wiring diagram the reference letters t, c, and b, indicate the leads connecting the top, centre, and bottom tapings of the primary windings, while f, p, and g are the H.F. valve connections.

Five Valve Neutrodyne Receiver.
by an ebonite strip and two 4BA screws with nuts passing through two of the alternative mounting holes of one of the transformers.

Simplified Wiring.

An endeavour has been made to simplify the wiring, and the large size practical wiring diagram which accompanies this issue shows the exact paths to be taken by the leads. The wire is No. 18 tinned copper with a vulcanised rubber covering, and other than the actual grid and plate leads associated with the tuned circuits, which are short and direct, the wiring is mostly carried out beneath the baseboard, the wires crossing and lying in contact. This method of connecting up is not only very much more easy than employing rigid No. 16, but is much neater as most of the wiring is hidden away. On the score of efficiency it

Fig. 8.—(Right) This close-up view shows clearly the details of construction and wiring of the low frequency amplifying equipment.

Fig. 9.—(Below) The high frequency amplifier section.

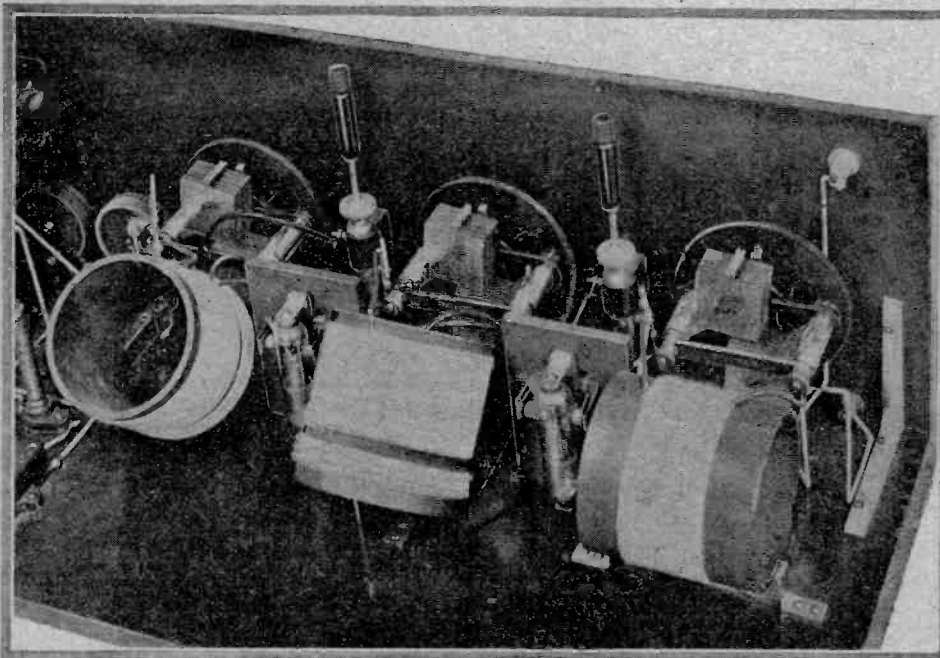
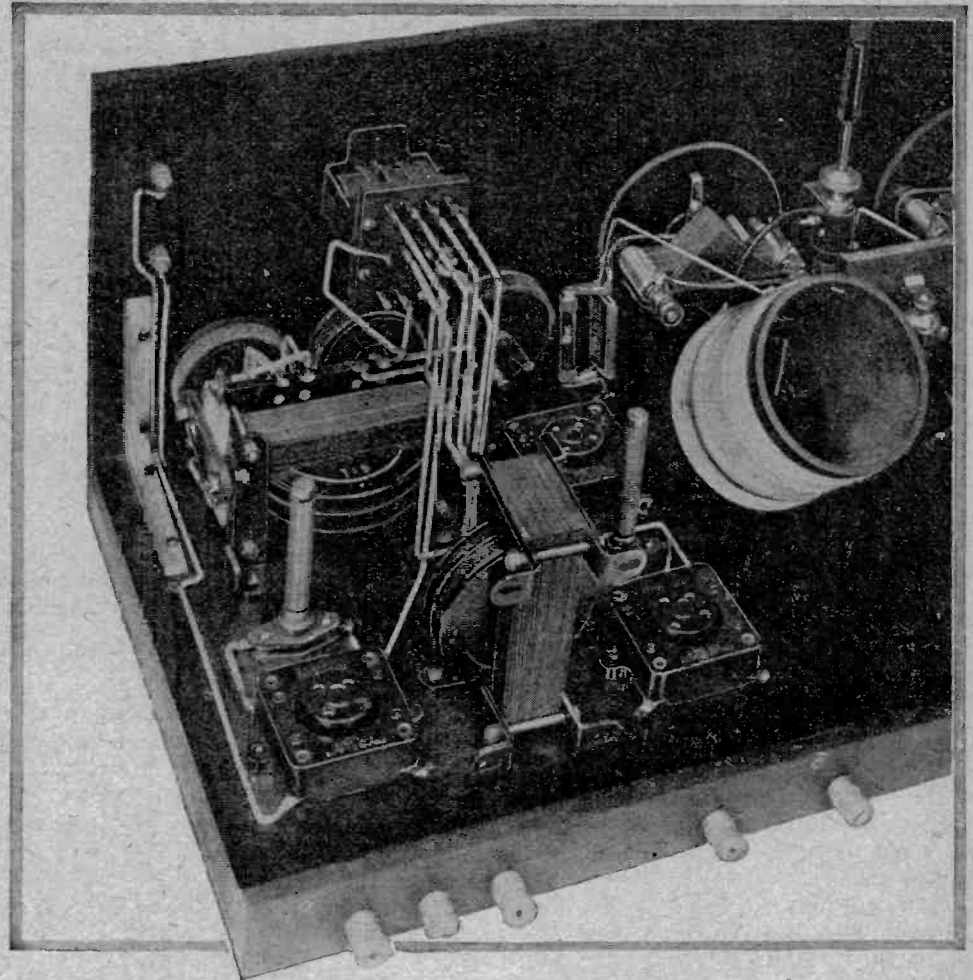

is, perhaps, superior for all leads which are not carrying radio frequency currents, can be taken directly through holes in the baseboard, leaving space among the components only for those leads in the high-frequency circuits which, for the correct operation of the set, must be short and well spaced.

The Balancing Condensers.

The space beneath the panel accommodates the bridging condensers and grid cells which would not add to the appearance of a set if distributed among other components. Small type "Ever-Ready" batteries are used as grid cells and their internal resistance reduced by connecting them up in pairs, thus obviating the need for shunt condensers.

LIST OF PARTS.

Cabinet and baseboard to details given. Mahogany, rosewood polished (Ashton & Mander, Albany Works, Teenmar Gardens, Willesden, N.W.10).

Front panel.

Terminal strip.

3in. diameter ebonite tube.

2 Cast aluminium brackets, 3in. (A. J. Dew).

2 "V.24" valve panels (Sterling) or 2 sets of clips.

3 Valve holders (Benjamin).

2 Filament rheostats, 8 ohms (Lissen).

2 Fixed "Resistors" and bases (Burndept type 734).

1 Potentiometer (Lissen).

3 Condensers, 0.0003 mfd. (Newey, Pettigrew & Merriman).

2 Neutralising condensers (Polar).

1 Air dielectric fixed capacity condenser, 0.0001 mfd. (Ormond).

1 Utility 4-pole switch, dull finish (Wilkins & Wright, Utility Works, Kenyon Street, Birmingham).

1 Grid condenser, 0.00025 mfd., and leak, 2 megohms (Therla, Selez Wireless Supply Co., 6, Greek Street, Soho).

1 Condenser, 0.002 mfd. (Therla).

2 Intervalve transformers, 4:1 Pye new type.

4 Ebonite-cased terminals for aerial, earth and loud speaker.

10 Labelled terminals (Belling and Lee).

3 Condensers, 1 mfd. (T.C.C.).

1 Condenser, 0.5 mfd. (T.C.C.).

2 Batteries (Ever-Ready type).

8 oz. No. 26 D.C.C.

4 oz. No. 24 D.C.C.

10 yds. No. 18 wire, rubber covered (Ripaults, Ltd., King's Road, St. Pancras, N.W.1).

Screws, brass for brackets, etc.

The set should first be tested out with the neutralising condensers set to zero and signals tuned in, observing that the set freely oscillates when the tuned circuits are brought into step. The leads from the first two coils to the grids of the high-frequency valve are then unsoldered, leaving the grids still connected to the neutralising condensers. With the earth lead connected to the set, the aerial is connected through a variable condenser to the grid of the detector valve and the signals of the local station tuned-in on the third condenser dial, the circuit then being a detector valve with one or two note magnifiers. Both the high-frequency valves, which may be of the "D.E.V." or "V.24" types, are placed in the clips with slips of thin paper wedged beneath the top contact to break the filament circuit. The aerial is then transferred to the lead joining the second H.F. valve to the balancing condenser. The signal previously tuned in will still be heard, the high-frequency current from the aerial taking a path partly through the grid plate capacity of the valve and partly through the neutrodyne condenser. From the circuit diagram it will be seen that the field produced by the current passed through the transformer primary *via* the valve is in the opposite direction to the field set up by the current through the balancing condenser. A position of balance can therefore be obtained when signal strength is at a minimum. Having thus set the second balancing condenser, restore the grid lead from the H.F. transformer, transfer the aerial lead across to the grid of the first valve, repeating the balancing process, and after a definite minimum has been found, resolder the grid lead from the aerial coil.

This method of balancing is to be preferred to others in which adjustments of the neutralising condensers appreciably alter the tuning and thus disguise the position of minimum signal by mistuning. If not correctly balanced, self-oscillation will occur in the process of tuning, and greatest signal strength accompanied, of course, with distortion, will be produced not at settings of resonance with the transmission, but at adjustments giving critical damping control.

The Question of Reaction.

The introduction of reaction into a neutrodyne receiver, either by direct magnetic coupling or tuning the plate circuit of the detector valve with variometer or condenser, in the hope of reducing losses, is a mistake, for not only will all the difficulties of manipulation of an unstable set result, but calibration will be rendered impossible. If self-oscillation is desired, it can be provided for by fitting a break switch on the panel directly in the lead to the second neutralising condenser.

Situated twelve miles to the north of London, the following Continental stations were tuned in, between October 15th and 19th, and operated an Amplion loud-speaker, type AR 19, giving loud clear signals without "mush," but with some ship jamming on certain wavelengths and key clicks from GFA harmonics:—Zurich, Berlin, Munich, Lyons, Ecole Superieure, Rome, Breslau, Münster, Madrid, Radio Iberica, Oslo, and Toulouse. Others were heard but could not be identified by transmission or wavelength. Many of the stations were tuned in precisely with the aid of a wavemeter emitting interrupted C.W. A circular paper scale mounted on the panel around each dial will readily give the tuning positions as indicated by 0° mark. The valves used were two "V.24," Ediswan R, D.E.5 and D.E.5A.

GOVERNMENT AND INDIAN BROADCASTING.

THE right to employ up to 10 per cent. of the total time devoted to broadcasting for the purpose of disseminating official information is the prerogative claimed by the Government of India in a recent announcement relating to the licensing of broadcasting stations in British India.

Included in the Government items broadcast would be

weather reports and forecasts, official notices and educational propaganda. Other stipulations are that a broadcasting station may be required to maintain a broadcast receiver for the use of the Government; that a complete or partial censorship of news may be imposed at any time; and that broadcasting stations must specify the sources of all news transmitted.

WINTER CONCERTS FROM HOLLAND.

The Hilversum Station and its Plans.

AN announcement which should specially appeal to wireless enthusiasts who are also music-lovers has been made regarding transmissions from the Hilversum broadcasting station. Every Thursday night a concert is to be broadcast from this well-known Dutch station by the celebrated "Concertgebouw" orchestra of Amsterdam, and strong hopes are held that the transmissions will be successfully received in England. Reports on reception from British listeners will be greatly appreciated and should be addressed to Messrs. Philips Lamp Works, Ltd., Eindhoven, Holland. The Hilversum station transmits on a wavelength of 1,050 metres with the call sign HDO.

Efficient Antenna System.

It is common knowledge that much of the expense in operating the Hilversum station has been borne by the famous Philips Valve Co., and the result of their assistance is shown to-day in the existence of a station comparing favourably with not a few of the better-known stations in Europe.

The two steel aerial masts, seen in the photograph, are

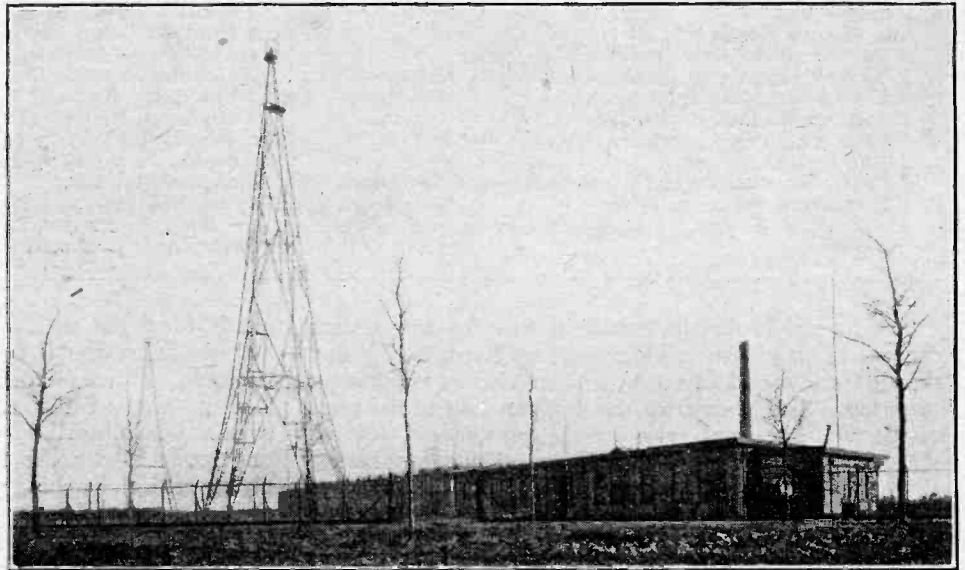

A general view of the Hilversum broadcasting station. The steel masts are 200 feet high.

each 200ft. high, providing an antenna system which might well provoke the envy of hard-worked engineers at many other broadcasting stations. The aerial consists of three wires, 600ft. long, and a counterpoise is formed by eight wires, 750ft. in length, supported at a height of 16ft. The entire transmitting plant was overhauled and enlarged at the beginning of the present year, and its efficiency is now enhanced by the addition of a Philips water-cooled transmitting valve. The transmitter makes use of the "choke control" method, used with such success in the B.B.C. stations, and is operated by a series of high-power Philips valves with a plate voltage derived from 50-cycle 3-phase A.C. with valve rectification.

The studio, transmitting room, and offices occupy four rooms in the works of the Nederlandsche Seintostellen Fabriek, which can be seen in the background in the upper photograph. It was by means of the experimental transmitter owned by this company that concerts were first broadcast, the necessary funds being collected by a group of enthusiastic amateurs. The transmitting power at that time was necessarily very limited.

The Search for Variety.

Hilversum being situated only twenty miles from Amsterdam, no difficulty is experienced in obtaining first-class talent for the programmes. The station authorities are, however, extremely anxious to introduce into the studio as much variety as possible, and any suggestions from listeners are warmly welcomed.

The quality of speech and music transmission is said to have improved very considerably in recent months, but judgment on this point must be left to those listeners who receive and report on the programmes.

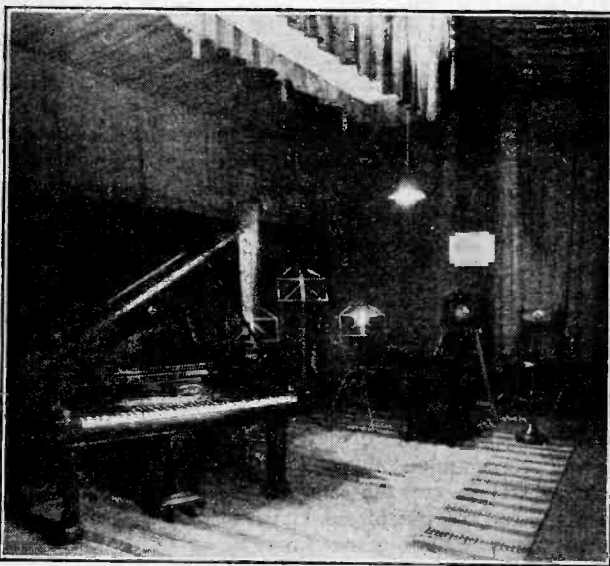

The studio at Hilversum. The microphone is of the Marconi-Sykes moving coil type.

THERMIONIC RECTIFIER FOR BATTERY CHARGING.

Tests on a New and Inexpensive Valve.

By J. F. SUTTON

THE widespread use and development of radio valves has now made it possible for manufacturers to produce a comparatively heavy current rectifying valve at a very reasonable price.¹ The writer has carried out some experiments with one of these valves designed for a maximum current of 1.3 amperes; and the results shown indicate that it makes a satisfactory and fairly efficient battery charger.

The valve is similar in shape to the ordinary tubular radio receiving valve, and has four prongs which fit the standard type of valve holder. As the inside surface of the glass is coated all over with a film of reflecting metallic substance, it was practically impossible to see the exact arrangement of the electrodes. The filament is, however, connected to the "filament" pins of the conventional three-electrode valve arrangement, and the two anodes are joined to the "grid" and "plate" pins respectively. Since there are two separate anodes, it is possible with a suitable transformer to obtain full-wave rectification, or the anodes can be joined together for half-wave rectification. With the former method a much heavier current can be taken from the valve, as will be shown later.

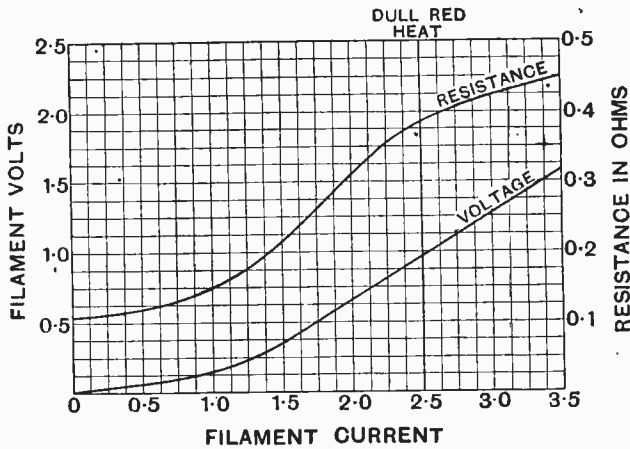
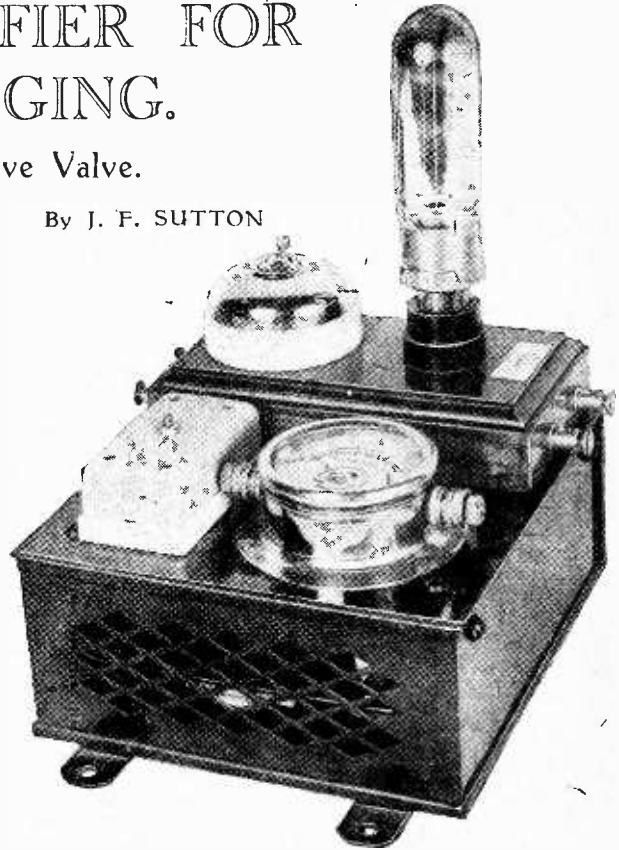

Fig. 1.—Curve showing relation between filament voltage, resistance and current in the Philips valve rectifier (1.3 amp. size).

A preliminary experiment was carried out to determine the voltage and current for heating the filament to a temperature high enough to start the arc. It was found that 2.5 amperes was the minimum value for the filament current, which could be increased to 3.5 without overheating the filament. Fig. 1 shows the relation between voltage and current, and resistance and current for the valve under test. The latter curve shows that the resistance increases considerably as the temperature rises. As soon as the arc is started and valve action takes place

there is enough heat generated to keep the filament red hot, so that the filament current can be switched off. It is evidently an advantage to have a thick filament capable of carrying a heavy current, as the anode current must pass through part of the filament, and it should, therefore, be strong enough to carry an overload on the anode plus the starting current.

When carrying out the experiments with D.C. to determine the characteristics it was found that the voltage drop from filament to anode was practically independent of the anode current, except in so far as it affected the temperature of the filament. Thus, with a filament current of 2.5 amperes, the anode current could be varied

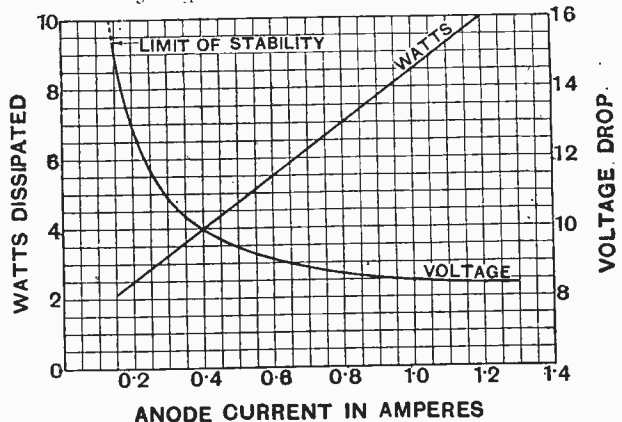

Fig. 2.—Anode current characteristics of the Philips valve rectifier.

¹ The Philips rectifier valve, now obtainable from the Mullard Radio Valve Co., Ltd., London, S.W.12.

Thermionic Rectifier for Battery Charging.—

from zero up to 1.1 amperes with a practically constant voltage drop of 8.5.

The next experiment was to determine the voltage drop under working conditions, *i.e.*, with the filament supply switched off. This gave the results shown in the graph Fig. 2. The minimum current at which the arc can be maintained is about 0.15 ampere. Even when the arc is out a very small current flows, about 8 or 9 milli-amperes, and this remains constant until the voltage is increased to about 125 volts, when flashing-over begins to occur. It would not, therefore, be safe to use this particular valve for charging voltages higher than 50, since at every alternate wave a peak voltage of over twice the charging voltage is obtained. From the characteristic curve, Fig. 2, it is evident that the valve is unstable to use alone, and a ballast resistance should be placed in series with it. If non-inductive resistance is used it should have a high temperature coefficient, *i.e.*, its resistance should increase as its temperature rises. Iron wire is suitable for this purpose, and it should be worked at a fairly high temperature.

Most house mains are supplied at 200 volts, so that it is necessary to use a transformer. The method of connection for half- and full-wave rectification is given in Figs. 3 and 4. In the first case only one half of the wave in the secondary winding is used, and in the second case both halves are used as

shown. Winding 1 is the primary of the transformer connected to the supply mains, winding 2 is the secondary, designed to suit the charging voltage required, and winding 3 is for heating the filament. Winding 4 in Fig. 4 is an additional secondary similar to 2.

A ballast resistance is shown, but it would be much more economical to use an iron core choke with variable tappings. If a moving coil and a moving iron ammeter are connected in series with a rectified alternating current, the readings on both instruments will not be the same. This is owing to the fact that moving coil instruments indicate the mean or average value of the current, that is to say, the current which is used in electrolytic effect in charging accumulators, and the moving iron instrument indicates the root-mean-square value, which is proportional to the heating value of the current. The ratio between these two is called the form factor, since it depends upon the shape of the wave. A peak-topped wave has a much higher form factor than a flat-topped wave. Since the useful work done in charging depends upon the *average* value and the heating losses, and consequently the maximum output of the valve upon the R.M.S. value, it is obvious that the form factor should be reduced to a minimum.

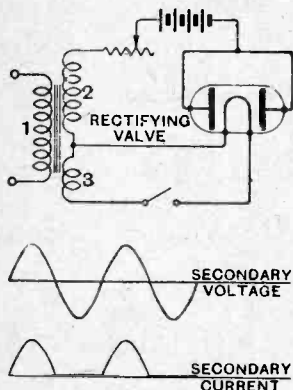

Fig. 3.—Connections for half-wave rectification. The transformer windings are as follows: 1, primary winding; 2, secondary winding; 3, filament winding.

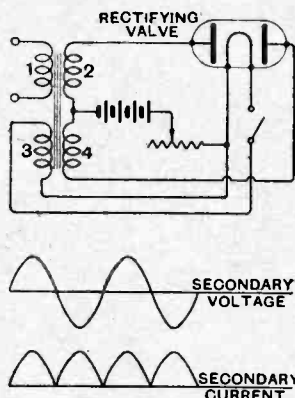

Fig. 4.—Connections for full-wave rectification. The transformer windings are as follows: 1, primary winding; 3, filament winding; 2 and 4 secondary windings.

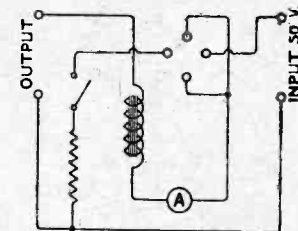

Fig. 5.—Practical connections of a half-wave rectifier designed for an input of 50 volts.

Form Factor of the Rectifier.

With single-wave rectification and a pure resistance load in series with the cells a form factor of about 1.5 is obtained, and with a complete wave rectification it is 1.1. The form factor is also reduced by putting a choke in series with the rectified circuit, since this has the effect of reducing the peak value.

The wiring diagram in Fig. 5 refers to the instrument illustrated in the title of this article, which the writer made up from an old Siemens A.C. motor starter. The input is supplied from a 50 volt tapping on a transformer, and a large resistance is used in series with this to heat the filament at starting. The value of this resistance is 17 ohms, and the impedance of the choke about 36 ohms at 50 cycles, but the power lost is not more than about 4 watts.

"Messrs. F. A. Hughes and Co., Ltd.," 204-206, Great Portland Street, London, W. 1. List of wireless panels and mouldings, knobs, dials, valve holders, etc., as well as "Trolite" in several varieties, including mahogany graining and a special surface panel with "wavy" design.

"A. J. Stevens and Co. (1914), Ltd.," (122-124, Charing Cross Road, London, W.C.2). Illustrated Sheet, giving details of A.J.S. receivers and components.

"MacFadden and Co., Inc.," (2,202 Arch Street, Philadelphia). Folder describing the MacFadden B power generator for operating any receiver.

CATALOGUES RECEIVED.

"London and Provincial Radio Co., Ltd (Colne, Lanes.). Pamphlet describing many useful components, valve receiving set and amplifier.

"Swedish General Electric Ltd.," (associated with Fuller Electrical and Manufacturing Co., 5, Chancery Lane, London, W.C.2). Stock price list, giving full particulars of D.C. and A.C. motors and dynamos, for immediate delivery.

"Economic Electric, Ltd.," (10, Fitzroy Square, London, W.1). Illustrated catalogue dealing with wireless apparatus, components and accessories.

"British Thomson-Houston Co., Ltd.," (Crown House, Aldwych, W.C.2). Pamphlet, illustrated in colour, describing the B.T.H. Table Lamp loud speaker and appropriately designed coloured shades.

"Portable Electric Light Company, Ltd.," (120, Shaftesbury Avenue, London, W.1). Fully illustrated catalogue describing "Ever-Ready" lamps, dry batteries, and high- and low-tension accumulators.

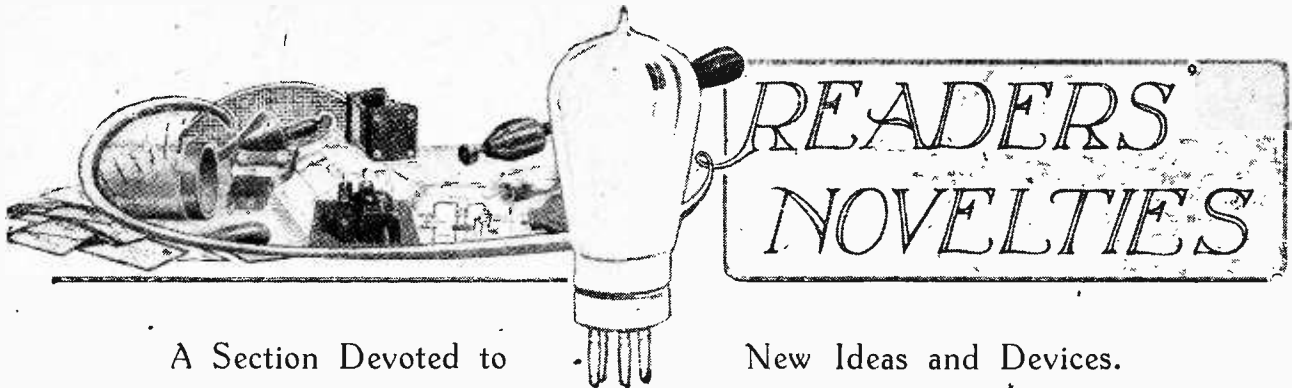

A Section Devoted to

New Ideas and Devices.

TIME INDICATOR.

It is very disconcerting to find at a week end that the L.T. accumulator has run down and that the receiver cannot be put into use.

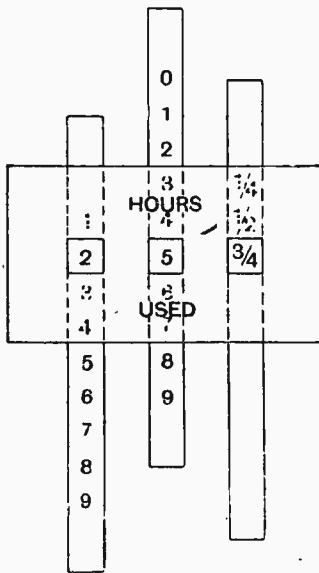

Time indicator for accumulator discharge.

The indicator illustrated in the diagram will be found invaluable in obtaining an indication of the condition of the cells. Three narrow strips of cardboard have marked upon them numbers for tens, units, and fractions, and are inserted in parallel slots cut in a rectangular piece of stiff cardboard. The material known as Bristol board is excellent for this purpose. The right-hand strip is used to denote fractions of an hour. Every time the set is used the indicator is moved forward by an amount equal to the time the valves have been running, so that the total number of hours taken from the battery since the last charge can be read off.

Experience will soon indicate the

average duration of a complete charge, and it will be thus a simple matter to estimate when the filament current is likely to fail.

It is best to rely on experience for an indication of the total time, as the ampere-hour capacity specified by the makers is generally obtained only under favourable conditions. This is particularly true of new cells which do not hold their charge until the plates have settled down after several charges and discharges.—R. F.

CRYSTAL DETECTOR HINT.

With many types of synthetic crystal it is found that after a short period of use the point of the catwhisker becomes coated with a film of oxide or sulphide due to chemical action between the metal and the surface of the crystal. This seriously impairs the efficiency of the detector, and is generally indicated by the inability to find a sensitive point anywhere on the surface of the crystal. In detectors of this type it is a good plan to insert a disc of fine emery cloth between the crystal cup and the end plate of the detector. When the

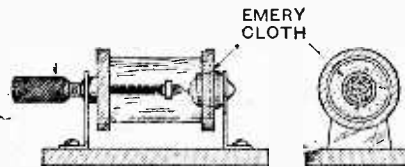

Disc of emery cloth fitted to crystal detector to clean catwhisker point.

point becomes oxidised it may be withdrawn from the crystal and rubbed on the emery cloth to remove the film. The method of clamping the disc of emery cloth between the cup and the end plate of the detector is clearly illustrated in the diagram.

—R. J. A

COIL FORMER.

The following is a valuable addition to the numerous methods which have been suggested for facilitating the removal of multi-layer tuning coils from the formers upon which they have been wound. A diagonal saw-cut is made in the cylindrical wooden former in the manner indicated in the diagram. It is essential to use a saw with a thin blade to make this cut; otherwise, the former when built up will not be perfectly cylindrical in shape.

The two flat surfaces formed by the saw-cut must be carefully filed or planed, and finally finished with

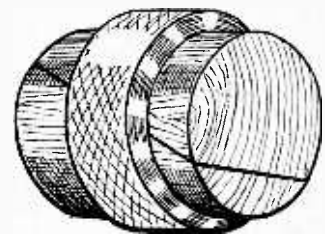

Coil former constructed in two halves to facilitate removal.

fine glass-paper to present a perfectly smooth surface. This is absolutely essential to the success of the scheme, otherwise the surfaces would bind and difficulty would be experienced in separating the two halves due to the pressure of the coil winding.

The securing screws may be inserted at each end through the thin ends of each half of the former, and when the coil is finished the two halves, after withdrawing the screws, are separated by a sharp tap at the narrow end of one of the pieces. If a strip of paper has been wound round the former before commencing the winding, the two halves will come away quite clean, and there will

be far less risk of damaging the windings than if it had been necessary to force them along the surface of the former.—A. F. F.

o o o o

VARIOMETER REACTION.

The application of reaction to a variometer tuned receiver presents a problem of some little difficulty. Probably the best method is to connect in series with the variometer a small coil to which the reaction coil may be coupled. In some cases, however, this method is impracticable, as it would increase the wavelength of the tuning variometer above the value required. In such cases a reaction coil of spherical form may be coupled to the variometer in the manner indicated in the sketch. The reaction coil winding is self-supporting, and may be wound by the method described on page 19 of the issue of July 1st.

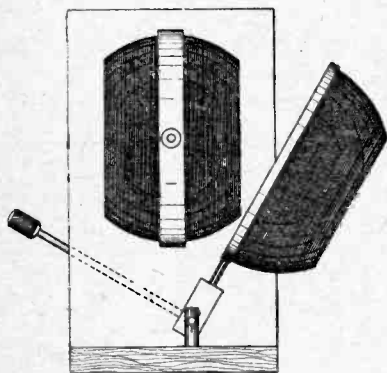

Spherical reaction coil for coupling to variometer.

An alternative method is to wind the coil on the domed top of a Winchester bottle of suitable size. The best method of supporting the coil is to fix it on a flanged ring of insulating material with shellac varnish as an adhesive. The ring is in turn supported by a short brass rod screwed to the edge at right-angles. The rod may be fixed in an ebonite plug mounted on a spindle parallel to the baseboard of the receiver and passing through a bearing in the front panel to an adjusting dial. A geared dial fitted with a friction device is recommended. If this is unobtainable, the brass bearing on the baseboard may be split and provided with a set screw to obtain a variable degree of pressure. An extension rod is suitable for use with this method of mounting.—G. W.

B 18

REMOVING VALVE CAPS.

Several methods of mounting four-pin valves for short wave work have been suggested from time to time in these pages. Most of these involve the removal of the metal cap on the end of the valve, and the following hints may, therefore, prove useful. Before proceeding to remove the cap the joints between the leads from the pinch of the valve and the base of the valve legs must be unsoldered.

If the valve cap is secured with a substance containing shellac, gentle heat must be applied from a Bunsen flame, the cap being at the same time eased off with a pair of tongs or pliers.

Where a substance such as a plaster of Paris has been used, the writer has found that the cement is readily softened by immersing the base of the valve for a few moments in alcohol or methylated spirits. After immersion a slight twist will easily free the cap from the glass bulb.—G. C. T.

o o o o

VALVE SAFETY.

An excellent method of protecting valves from excessive current from the H.T. battery in the event of a short circuit in the wiring of the receiver, is to connect a resistance of several hundred ohms in series with the H.T. supply.

The value of this resistance should be such that the voltage of the H.T. battery cannot drive through it a current in excess of the normal filament current of the valves.

An ordinary electric light lamp makes a cheap and effective resistance for this purpose. The value of the resistance offered by the lamp may be calculated from a knowledge of the voltage for which it has been designed and the power normally consumed in watts. Thus a 20-watt lamp designed for a 200-volt circuit would pass only 0.1 ampere at 200 volts,

Valves for Readers.

For every practical idea submitted by a reader and accepted for publication in this section the Editor will forward by post a receiving valve of British make.

and the current from an average H.T. battery of 100 volts would be 0.05 ampere. When using a protective resistance of this kind it is necessary to use a shunting capacity not less than 1 mfd. in parallel with the resistance and battery.—W. H. C.

o o o o

COIL MOUNTING.

When experimenting on long wavelengths with honeycomb or duolateral coils of different sizes, it is convenient to have some rapid method of supporting the coils and connecting them in circuit.

A plug-adaptor is generally favoured, as most experimental receivers are equipped with two- or three-coil holders specially designed for mounting plug-in coils. The sketch shows a system of mounting which the writer has used with great success for some little time.

The plug-adaptor was built up on an ebonite coil plug of the usual type. The top surface of the plug was filed

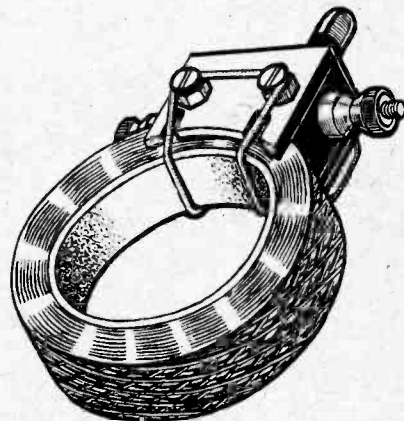

Experimental mounting for duolateral coils.

to form a shallow V to prevent the coil from "rolling" on what would otherwise be a flat surface. Two side pieces of 1/4 in. ebonite are then fixed to the coil plug by means of countersunk screws, which have previously been fitted with shallow lock nuts just below the countersunk head. The object of fitting these nuts is to provide a groove into which the elastic retaining band may be inserted. Vertical slots are cut in each side piece to pass the rubber band when coils of smooth depth are being used. The unit is completed by terminals fitted at each end, which make contact respectively with the plug and socket.—D. D. S.

21

VALVES WE HAVE TESTED

THE COSSOR SERIES.

All the valves of the well-known Cossor series have an arch-shaped filament which is supported inside a hood-shaped grid and anode. In this series are seven types of valves, three of them being designed to have their filaments heated off a two-volt accumulator, two off a two-, four-, or six-volt battery, while the remaining two types are bright emitters and work off a six-volt accumulator. Valves are provided for high-frequency amplification and for audio-frequency amplification or detection. In addition, there is a power valve in this series.

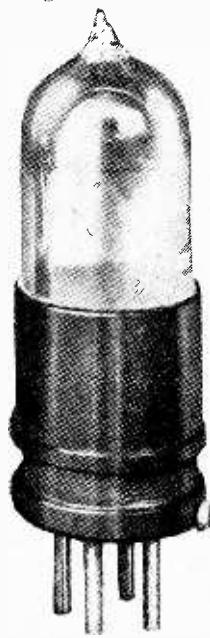

W.R. 1.

Tests Applied.

Specimens of these valves were supplied by the manufacturers, and we have tested them according to our usual methods. First, the filament characteristics are found—that is, readings of the filament current for several values of applied voltage are taken, and the results compared with the figures given by the manufacturers. Then several grid volts, anode current characteristics, are prepared, the anode voltages at which the figures were taken being within the range of voltage specified by the

manufacturers of the valve. From the readings so obtained the amplification factor and anode impedance are worked out at several values of anode voltage and grid bias. The figures given in our valve table are, therefore, extremely useful ones, because they show the constants of the valve under as nearly as possible its actual working conditions.

As the originators of this method of giving the results of valve tests, naturally we are pleased to see it being adopted enthusiastically by the valve manufacturers themselves, and, may we add, by our contemporaries as well.

Valves for Audio-Frequency Amplification or Detection.

The first of the valves designed for this work is known as the W.r. It is rated at 1.6-1.8 volts 0.3 ampere for the filament, and 30-120 volts for the



W.R. 2.

W. 1.

Audio Frequency and Detector.

Filament voltage, 1.5, 1.6, 1.7, 1.8. Filament current, 0.27, 0.29, 0.3, 0.315 ampere.

Anode Voltage.	Anode Current at Zero Grid Volts. Milli-amperes.	Actual Anode Current. Milli-amperes.	Grid Bias. Volts.	Amplification Factor.	Anode Impedance. Ohms.
122	5.1	3.05	-4	9	20,300
110	4.3	2.9	-3	8.9	21,000
98	3.65	2.75	-2	8.9	21,400
86	3.05	2.6	-1	8.9	21,600
48	1.45	1.45	0	8.9	25,500

Grid current starts at -0.5 volt. grid bias.

W.R. 1.

Audio Frequency and Detector.

Filament voltage, 1.5, 1.6, 1.7, 1.8. Filament current, 0.285, 0.3, 0.315-0.325 ampere.

Anode Voltage.	Anode Current at Zero Grid Volts. Milli-amperes.	Actual Anode Current. Milli-amperes.	Grid Bias. Volts.	Amplification Factor.	Anode Impedance. Ohms.
122	3.94	1.83	-5	9.6	28,100
110	3.37	1.74	-4	9.8	28,800
98	2.82	1.66	-3	10.0	29,300
86	2.3	1.56	-2	9.85	29,300
73	1.84	1.5	-1	9.45	29,300
48	1.0	1.0	0	9.1	28,000

Grid current starts at -1 volt grid bias.

P.1 RED TOP.

For Audio Frequency and Detector.

Filament voltage, 3.5, 4.0, 4.5. Filament current, 0.6, 0.735, 0.78 ampere. Total emission, 15.5 milliamperes. Filament efficiency, 4.4 mA per watt at 4.5 volts on filament.

Anode Voltage.	Anode Current at Zero Grid Volts. Milli-amperes.	Actual Anode Current. Milli-amperes.	Grid Bias. Volts.	Amplification Factor.	Anode Impedance. Ohms.
98	1.86	1.2	-2	12.3	37,200
73	1.13	0.81	-1	12.5	40,790
48	0.58	0.45	-0.5	12.9	44,400

Grid current starts at -0.5 volt grid bias.

W.2 RED TOP.

For H.F. and Resistance or Choke Capacity Coupling.

Filament voltage, 1.5, 1.6, 1.7, 1.8. Filament current, 0.262, 0.28, 0.295, 0.3 ampere.

Anode Voltage.	Anode Current at Zero Grid Volts. Milli-amperes.	Actual Anode Current. Milli-amperes.	Grid Bias. Volts.	Amplification Factor.	Anode Impedance. Ohms.
122	3.54	1.97	-4	13.1	33,300
110	3.05	1.5	-3.5	13.0	34,300
98	2.56	1.31	-3	12.8	34,300
86	2.12	1.29	-2	12.5	35,100
73	1.72	1.25	-1.5	12.5	37,800
61	1.33	0.98	-1.0	12.2	37,800
48	0.98	0.66	-0.5	12.2	40,000

Grid current starts at -0.5 volt grid bias.

Valves We Have Tested.—

anode. This valve has a black base which is rather larger than usual in other makes of valves, and the bulb is practically clear all over, while the bottom of the base is cut away to give a larger air space between the bottom of the valve pins. These pins are of the slotted type, and were found to make good contact in the valve holder fitted on the test board—a feature not always present, unfortunately.

From the table of test results given below for a filament voltage of 1.8, it will be observed that the filament characteristics are normal, while the amplification factor and anode impedance at the points tested remain fairly constant, averaging 8.9 and 21,000 ohms respectively. Grid current commences to flow at -0.5 volt grid bias, which is a point that should be remembered when estimating the ability of the valve to magnify without distortion.

The W.R.1.

The second valve of the type is the W.R.1, which is characterised by having a fixed resistance fitted to its base and a small screw with two screwed holes provided near one of the filament pins. This resistance is connected in series with the filament, and, when the valve is heated from a four- or six-volt accumulator, the screw should be put in the threaded hole nearest the marking 4-6 v. on the base of the valve. For use with a two-volt accumulator, the screw should be put in the hole immediately in front of the valve leg, as in this position the screw short-circuits the fixed resistance. Reference to the illustrations will show the position of the fixed resistance, it lying in the recessed portion of the base. The base is black in colour, and the glass bulb has the silvery appearance usually found with valves which have been "gettered" by the magnesium process. Tested in our usual manner, we obtained the figures set out in the table. The voltage amplification factor is seen to average 9.6, and the impedance 28,500 ohms.

W.R.2 RED TOP.

For H.F. and Resistance or Choke Capacity Amplification.

Filament voltage, 1.5, 1.6, 1.7, 1.8. Filament current, 0.275, 0.29, 0.3, 0.32 ampere.

Anode Voltage.	Anode Current at Zero Grid Volts. Milli-amperes.	Actual Anode Current. Milli-amperes.	Grid Bias. Volts.	Amplification Factor.	Anode Impedance. Ohms.
122	2.46	1.54	-3	11.5	41,400
110	2.15	1.3	-2.5	12.2	43,000
98	1.89	1.24	-2	18.1	44,400
86	1.52	1.15	-1.5	12.5	45,100
74	1.26	1.0	-1	12.0	46,200
61	0.95	0.82	-0.5	11.7	48,700
48	0.75	0.75	0	11.5	62,000

Grid current starts at -0.5 volt grid bias.

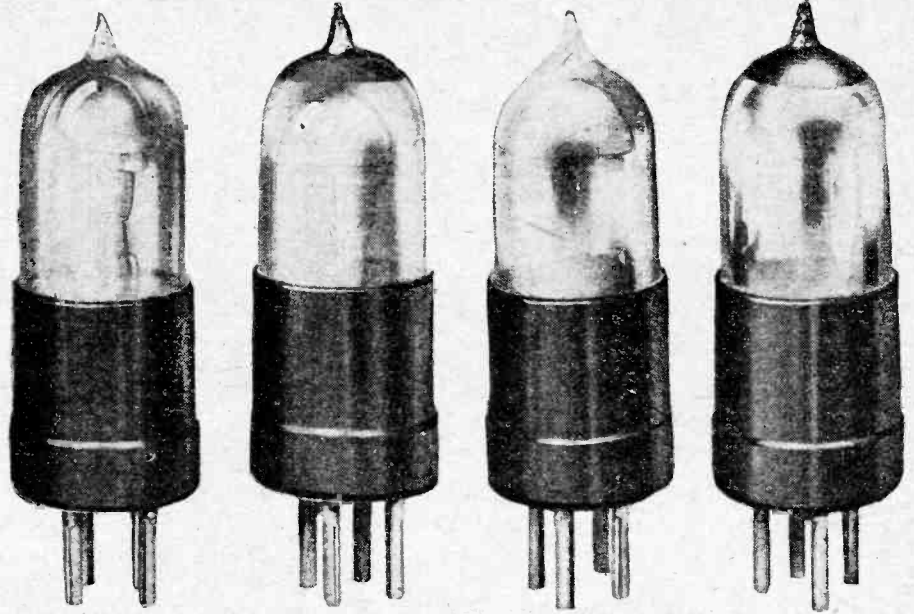

P.1.

P.2.

W.1.

W.2.

P.2.

For H.F. and Resistance or Choke Capacity Coupling.

Filament voltage, 3.5, 4.0, 4.5. Filament current, 0.65, 0.71, 0.76 ampere.
Total emission, 13.5 milliamperes. Filament efficiency, 4 mA/Watt at 4.5 volts on filament.

Anode Voltage.	Anode Current at Zero Grid Volts. Milli-amperes.	Actual Anode Current. Milli-amperes.	Grid Bias. Volts.	Amplification Factor.	Anode Impedance. Ohms.
122	5.02	2.51	-6	20.0	75,000
98	3.75	2.1	-4	20.4	75,000
72	2.38	1.65	-2	20.4	75,000
48	1.23	1.04	-1	21.0	73,800

Grid current starts at -1.5 volts grid bias.

W.3.

Power Valve.

Filament voltage, 1.5, 1.6, 1.7, 1.8. Filament current, 0.5, 0.525, 0.545 0.595 ampere.

Anode Voltage.	Anode Current at Zero Grid Volts. Milli-amperes.	Actual Anode Current. Milli-amperes.	Grid Bias. Volts.	Amplification Factor.	Anode Impedance. Ohms.
145	9.1	3.9	-7	10.9	15,150
122	7.3	3.68	-5	9.9	15,700
98	6.4	3.3	-3	9.6	16,300
74	3.6	2.3	-2	9.6	18,500
48	2.1	1.6	-1	9.5	20,000

Average impedance 12,000 to 15,000. Grid current starts at -1 volt grid bias.

The P.1.

This valve is a bright emitter—rated at 4-4.5 volts 0.75 ampere for the filament and 30-120 anode volts, it has a red base, and the glass bulb is clear. It gave a total emission of 13.5 milliamperes when the filament voltage was 4.5 and the anode 0.76 ampere. For the anode and grid voltage shown in the table, the average value of the amplification factor was found to be about 12.5 and the anode impedance 40,000 ohms.

These three valves, the W.1, W.R.1, and the P.1, are all good valves of their type when used in the first stage of an audio-frequency amplifier. An anode voltage of about 100 is suitable in each example, while the grid bias voltages to commence with may be of the values indicated in the tables. Experiment will show whether other voltages are more suitable for the particular set the valves are used in.

For detection an anode voltage of about 45 will be found a satisfactory one, and the grid leak may in all three examples be connected to the negative or positive side of the filament according to the value of the grid leak in use.

Valves for H.F. Amplification and for Resistance Capacity Coupled Circuits.

The three valves of the Cossor series designed for high-frequency amplification all have a distinguishing mark—a red top. These valves are otherwise similar in appear-

ance to the valves prepared for L.F. work, and they are known respectively as the W.2, W.R.2, and the P.2. They may also be used in L.F. amplifiers employing the well-known resistance or choke capacity method of coupling. The results of tests on sample valves appear in the accompanying tables, which show the valves to be good examples of their general class.

A Power Valve. W.3.

The power valve is designed to work off a two-volt battery, and takes a current of approximately 0.5 ampere, the exact filament characteristics being given in the table. The valve tested had an amplification factor of about 9.6 and an anode impedance of 16,000 ohms, and, used with an actual anode voltage of 120 and a grid bias of -5 volts, will give sufficient power to operate a loud-speaker quite comfortably. This valve can be recommended for use in the last stage of a power amplifier, and will give good results.

TRANSMITTERS' NOTES AND QUERIES.

We understand that the same call sign, 5UP, has inadvertently been allotted to two different amateurs—Mr. F. P. Devenish, 13, Marlboro Road, Bowes Park, and Mr. D. Graham Scott, 35, Alma Place, North Shields. It is believed that errors of this kind are very rare, but they may possibly account for some of the complaints regarding misuse of call signs.

We are informed that the prefix PR will in future be used instead of U by transmitters in Porto Rico.

Mr. L. W. Jones, 50, King Street, Cambridge, advises us that he has been allotted the call sign G5JO in place of 2ARY, and will welcome reports.

Mr. Stanley F. Evans, 3, Clarence Crescent, Whitley Bay, Northumberland, has been allotted the call sign G2BDY and will welcome reports on his transmissions.

Mr. E. G. Ingram, G6IZ, 18, Victoria Street, Aberdeen, is carrying out tests on 90 metres, with power from 2 to 10 watts, and would be glad of reports giving dates and times.

Mr. G. A. Massey (6GYQ), Holmside, Hillside, Prestatyn, North Wales, would also welcome reports of his transmissions.

Mr. H. Dean Poulton, 18, Albion Street, Cheltenham, has been allotted the call sign 6UG.

Mr. W. E. Coxon (A6AG), 5th Avenue, Inglewood, Western Australia, asks British stations to listen for his transmissions at 00.00 and 06.00 G.M.T.

Mr. R. J. Cottis (2LD), 4, Crondrace Road, Fulham, S.W.6, states that his call sign is being used by someone transmitting on about 48 metres, and, as his station is not licensed for short waves, this is likely to cause him some trouble.

Mr. G. A. Woods, 81, East Parade, Harrogate, keeps systematic records of all transmissions he hears on short wavelengths, and would be glad to arrange schedules with British or foreign amateurs and to take notes concerning temperature, the moon, clouds, fading, etc.

Stations Identified.

We have received from correspondents, to whom we tender our thanks, the following QRA's:—

H9XN.—M. Roesgen, Troinex, Geneva, Switzerland (who will undertake to forward cards for H9AD).

U1CME.—R. D. Kneeland, 63, Pond Street, Georgetown, Mass., U.S.A.

SMRG.—Gösta Siljholm, Kristianstad, Sweden.

BR22, B44, and other Belgian stations. —Communications should be sent via "Reseau Belge," 11, Rue du Congres, Brussels.

BZ1AC.—C. G. Lacombe, Rua Cosme Velho, 105, Rio de Janeiro.

F8TOK.—Communicate via G5XY, J. C. Harrison, Highcroft, Park Lane, Burnley, Lancs.

F8YB.—Communicate via "Journal des 8," Rugles, Eure, France.

I1NO.—Franco Marietti, Corso Dante 8, Turin.

M1B.—Manuel L. Perrusquia, Aveni da Morelos 27, Popotla D.F., Mexico.

M1K.—Juan C. Buchanan, Gabino Barreda, 56, Mexico, D.F.

Broadcasting in Portugal.

We understand that a private broadcasting station has been started in Lisbon, which transmits programmes and news on a wavelength of 320 metres. The call sign is PLAA, but we have not yet ascertained the time at which the station normally works.

International Abbreviations.

We regret an error on page 550 of our issue of October 21st. The meaning of the signal QRU is now "I have nothing to transmit." The original meaning, "Have you anything to transmit?" was allotted some time ago to the letters QTC.

Calls Heard.

Extracts from Readers' Logs.

Cassel, Germany.

(June to Sept.)

Great Britain:—2KZ, 2APU 2BDQ, 2NB, 2YT, 2OY, 2KF, 2OD, 2FO, 2IH, 5BA, 5BD, 5AR, 5DA, 5HA, 5IO, 5MA, 5OC, 5OK, 5PM, 5PZ, 5PD, 5RB, 5SI, 5XY, 5YK, 6BD, 6GF, 6MP, 6MPT, 6PM, 6RM, 6TD, 6VP, 6YX, 6ZK, GAX.
F. Noether (DE0038).

Sialkot, Punjab, India.

G6LF, G2DX, G2LZ, G5DH, G2KF, G2XY, F8SM, F8GB, ZZ, ZY, CB8, S1A, S2Y, W1Z, U2BG, U8DON, ARC, POX, POY, POF, POW, M1DH, OCDB, OCDJ, X6Y, SGC, A2CM, A2YG, Z2AC, GHH, GFP, D7EC, 6KB, 6ZK, NRL, 8UG, 8KF, X8Y, 8ZY, 9SW, N8Q, 8VF, KY5F, RDW, CHSTBN.
Sergt. M. H. Figg.

Lyons.

2CC, 2CF, 2DX, 2FM, 2GF, 2GY, 2KF, 2KZ, 2LZ, 2MA, 2MK, 2NB, 2NR, 2NL, 2OD, 2SZ, 2WJ, 2WY, 2XY, 5DA, 5DH, 5IG, 5LF, 5MA, 5OC, 5OK, 5PM, 5RB, 5SEE, 5XY, 5YI, 5YK, 6AH, 6AL, 6IS, 6JV, 6MP, 6GB, 6RM, 6TD, 6TM, 6VP, 6YX, 6YX, 6ZK.
(0-v-2) (Indoor aerial.) All on 20-150 metres.

E. Ayres,
176, Denmark Road,
Lowestoft
(QSL via G2BKD.)

Northampton.

Sept. 8th-28th.

Norway:—NW4X. Finland:—2NX, 2NL. Russia:—NRL, 1FL. Java:—ANE. Argentina:—AF1, BA1. Australia:—2CM, 2LO, 3BQ. Brazil:—1AB, 2SP, RGT. New Zealand:—4AL. India:—HBK.

P. H. Brigstock Trasler.

CURRENT TOPICS

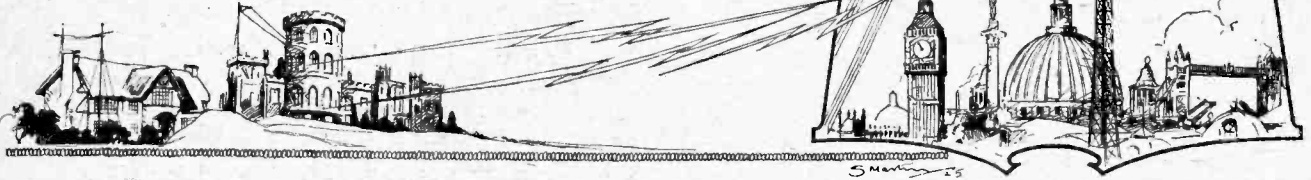

News of the Week in Brief Review.

MANCHESTER WIRELESS EXHIBITION.

The opening ceremony of the Manchester Wireless Exhibition, organised by the *Evening Chronicle*, took place yesterday in the City Hall. The Exhibition will remain open until November 7th.

"ELECTRIC NIGHT."

Twenty broadcasting stations throughout America joined in the observance of "Electric Night" on Wednesday, October 21st, this date marking the forty-sixth anniversary of the invention of the incandescent lamp by Thomas A. Edison.

THE THRALL OF RADIO.

In his attitude to broadcasting the Japanese boy is apparently as human as the British specimen. As a consequence, the Tokyo middle school authorities have issued orders forbidding students to listen-in during certain hours of the evening, which should be devoted to study. Investigations have shown that pupils neglected their school work for the attractions of the broadcast receiver.

DISSATISFIED DANES.

Dissatisfaction with the broadcasting system in Denmark is stated to be growing among amateurs in that country. A special meeting was recently called by one of the leading Danish radio clubs to consider methods of improving the service, and criticism was particularly directed at the broadcast programmes.

The chairman of the Government Broadcasting Central Committee announces that every effort is being made to improve the conditions that have received criticism.

PROPOSED BRITISH WIRELESS INSTITUTE.

The question of whether the proposed British Institute of Wireless Engineers should be brought into being is to form the subject of discussion at a general meeting to be held at the Hotel Russell, London, on October 31st. The chair will be taken at 2.30 p.m. by Mr. James Nelson, M.I.E.E., who is an ardent supporter of the scheme.

Tea will be served at 5 p.m., and the meeting continued till 7 p.m., if necessary. All interested in the question are cordially invited.

CHINESE WIRELESS PROPOSAL.

For the purpose of developing wireless communications for the benefit of China, the Japanese Legation at Peking urges the formation of an international committee including Great Britain and France.

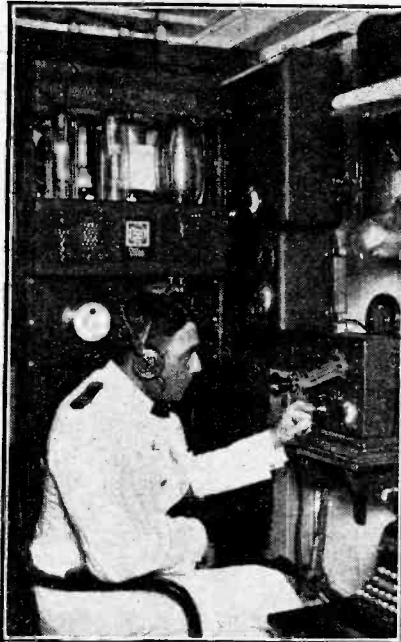

TELEPHONY AT SEA. An engineer on the North German Lloyd liner "Colombus" speaking on the 500-watt wireless telephone. Successful experiments which have been carried out with this apparatus between ship and shore indicate the possibility of a regular service for the benefit of passengers.

UNLICENSED BELGIAN TRANSMITTERS.

Serious attention is being given by the Belgian Ministry of National Defence, according to a Brussels report, to the question of unlicensed transmission. No doubt exists in the minds of the authorities that clandestine stations are in operation, and several projects are in hand for the purpose of detecting offenders. It is stated that several experiments in this direction have already been conducted without success.

THE IRRESISTIBLE ATTRACTION.

Thieves recently entered St. Isaac's Cathedral, Petrograd, climbed the belfry, and stole a wireless aerial.

TWO-WAY COMMUNICATION WITH CALIFORNIA.

Yet another record has been established in amateur two-way communication by the achievement of Mr. C. W. Goyder (G2SZ), of Mill Hill School, in exchanging signals with American amateurs in the Sixth District (Pacific Coast).

The Pacific seaboard has long been a tempting goal for British amateurs, but until October 18th two-way communication had not been secured with this part of America. Using a wavelength of 45 metres, Mr. Goyder first worked with U6VC at 7.5 a.m. (G.M.T.) and later with U6CTO at 7.50 a.m. Both these stations are in California.

On the same evening Mr. Goyder conversed by telephony with Indian HBK, a station which had first been communicated with by Mr. Gerald Marcuse (2NM) a fortnight previously.

WIRELESS ECHO OF THE WAR.

The announcement of the closing of the large American wireless station at Sayville, Long Island, N.Y., recalls a dramatic situation which arose in connection with the activities of this station just prior to the opening of the late war. At that time the Sayville station was under German ownership. Early in July, 1914, suspicion was roused among the authorities at Washington as to the genuine character of certain of the apparently innocuous messages which passed between Sayville and Berlin. In consequence a watch was kept on the station's activities, and one of the "sleuths," in the person of an American wireless amateur, Mr. Charles E. Apgar, secured phonograph records of cryptic messages sent on consecutive nights. The investigations revealed beyond doubt that the Sayville station was being put to "unneutral uses" by the German Imperial Government, the sequel being that the station was placed under American control. The full story of how the investigation was carried out appeared in *The Wireless World* of November, 1915.

WIRELESS LIFEBOAT IN LONDON.

The "Elizabeth and Blanche," the lifeboat in which Captain G. E. Hitchens and four companions are to sail round the world, is now lying in the Thames at Blackfriars. Reference was made in these columns last week to the very efficient wireless system which will be carried on the voyage. The Marconi $\frac{1}{4}$ kW. transmitter has been heard at a distance of 300 miles.

o o o o

WIRELESS FOG SIGNAL ON SPANISH COAST.

Spain's first wireless fog signal will come into operation on November 1st with the opening of an installation at Cape Silleiro, on the wild Galician coast. The letters OR will be transmitted in a musical note at a frequency of 800 per second. The signal will sound for 30 seconds every five minutes, and should be picked up by an ordinary ship's wireless at a distance of 30 miles. The wavelength will be 1,000 metres.

o o o o

FUTURE POLICY OF BROADCASTING.

The first meeting of the Committee appointed by the Postmaster-General to advise as to the future policy in regard to the broadcasting service will take place on November 19th, 1925, under the chairmanship of the Rt. Hon. the Earl of Crawford and Balcarres, K.T.

o o o o

FARMERS' COURSE BY WIRELESS.

Farmers in Kansas are hanging a new kind of certificate upon the walls of their homes. It certifies that the holder "has satisfactorily completed the work and passed the required examinations in the first regular college course to be given by radio" by the Kansas State Agricultural College.

Farming is not the only item included in the curriculum of the college, for the subjects range from law to the breeding of cattle, from the feeding of babies to the writing of business letters. The lectures are given on five nights a week during the collegiate year.

o o o o

TIME SIGNALS FOR SURVEYORS.

A pamphlet entitled "Wireless Time Signals for Surveyors" has been published by the Royal Geographical Society for the purpose of acquainting surveyors with the time signals transmitted for their benefit. The pamphlet states that changes will be made in the system of signals transmitted by the Bureau Internationale de l'Heure. The semi-automatic signals will be abolished, and the automatic will be modified. The rhythmic signals will be sent on a new system at standard times. It will be some time, however, before the changes will be made.

o o o o

NEW SECRET WIRELESS INVENTION.

The simultaneous transmission of eight or more messages from one valve on the same ten-metre wavelength and their reception on a single instrument was recently demonstrated before the U.S. Navy Department, according to a *Times*

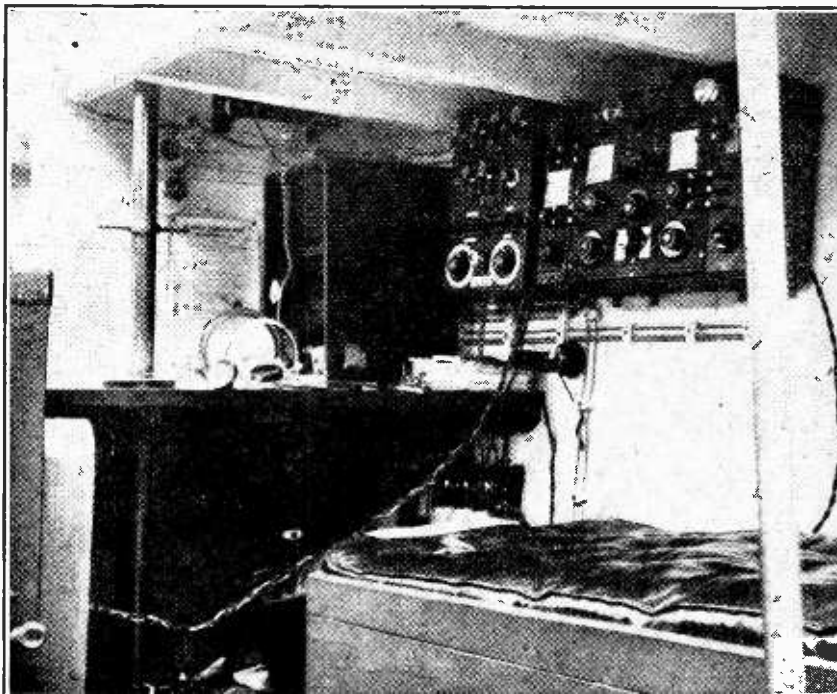

ROUND THE WORLD IN A LIFEBOAT. The wireless installation on board the "Elizabeth and Blanche," the forty-foot lifeboat which is about to start on a cruise round the world. The voyage is being undertaken to provide exhaustive tests of modern life-saving devices.

correspondent. The inventor is Mr. J. H. Hammond, Jun.

The general principle of the system is the projection of a short length carrier wave at the rate of, say, 30,000,000 vibrations per second, into which are impressed one or more "modulatory" waves at the rate of 27,000 vibrations per second and upwards. These modulatory waves produce periodic changes of intensity in the carrier wave. The Hammond receiver is designed to separate the frequencies of the complex incoming wave, having one circuit sensitive to the carrier wave and the other circuits sensitive to the frequencies of the modulatory waves. Only an operator knowing the frequencies which are being used can pick out incoming messages.

o o o o

TRUNK CALLS TO NEW YORK.

The imaginative speculations of the novelist and the newspaper Press as regards the possibility of a public telephone service between this country and America are nearing realisation. Transmission tests are likely to take place between the Rugby station and America within the next few days.

The International Western Electric Company, who have been responsible for the plant at Rugby, have now handed over the installation to the Post Office. The receiving station is situated at Chedzoy, in Somerset, and for several months messages have been successfully received from Long Island, N.Y.

According to the *Morning Post*, the charge for a three-minute call between

London and New York will probably not exceed £1.

o o o o

TROUBLE OVER AUSTRALIAN BEAM SYSTEM

According to messages from Melbourne, anxiety is growing in Australia over the delay in concluding arrangements for control and operation of the reciprocal beam wireless station in England communicating with Australia. The Commonwealth Government desires control of the English station as well as that in Australia, but it is understood that the British Post Office strongly opposes such a condition.

In support of its contention, the Australian Government points out that the Marconi Company is permitted to own stations in England for communication with Canada and foreign countries. If a private company, why not a Dominion Government? Moreover, foreign cable companies are permitted to operate land cables in Britain and six private cable companies are accepting traffic to Australia. It is feared that the vested interest of the cable companies will be favoured if the British Post Office retains control.

o o o o

"A TALK TO VALVE USERS."

The above is the title of an attractive and useful booklet which has been issued by Messrs. Metro-Vick Supplies, Ltd., with the object of explaining in simple language the various technical terms and data associated with valves. Copies may be obtained post free from the company at 4, Central Buildings, Westminster, London, S.W.1.

MANCHESTER WIRELESS EXHIBITION.

A Numerical Guide to the Stands.

Below we publish a list of the firms and organisations represented at the Manchester Wireless Exhibition, which was opened yesterday (Tuesday) at the City Hall. As in previous years, the Exhibition is under the able management of "The Manchester Evening Chronicle," and the success of last year's effort justifies the belief that the interest of the Mancunians in all matters pertaining to wireless will again be demonstrated during the next ten days. The Exhibition closes on Saturday, November 7th.

- Stand No. 1.—Trader Publishing Co., Ltd., 139-140, Fleet Street, E.C.4.
- No. 2.—F. W. Lowenadler, Audrey House, Ely Place, Holborn Circus, London, E.C.1.
- No. 4.—Manchester & District Association of Radio Societies. Hon. Secretary:—Mr. L. Gill, Hope House, South Reddish, Stockport.
- No. 5.—Manchester & District Association of Radio Societies, Worksop.
- No. 6.—Lancashire Dynamo & Motor Co., Ltd., Trafford Park, Manchester.
- Nos. 7 & 8.—Allied Newspapers, Ltd., Withy Grove, Manchester.
- No. 9.—A. & J. James, Maxwell House, Arundel Street, Strand, London, W.C.2.
- No. 10.—Gil-Ray Trading Corporation, Ltd., Sicilian House, Sicilian Avenue, London, W.C.1.
- No. 11.—Tutills, Ltd., 7-9, Swan Street, Manchester.
- No. 12.—Garnett, Whiteley & Co., Ltd., "Lotus Works," Broadgreen Road, Liverpool.
- No. 12a.—Nelson Electric Co., Ltd., 138, Kingston Road, Wimbledon, London, S.W.19.
- No. 14.—British Ebonite Co., Ltd., Hanwell, London, W.7.
- No. 15.—Ward & Goldstone, Ltd., Frederick Road, Pendleton, Manchester.
- No. 17.—Wholesale Wireless Co., The, 103, Farringdon Road, London, E.C.1.
- No. 18.—N. V. Webber & Co., Ltd., Vale Road, Oatlands Park, Weybridge, Surrey.
- No. 19.—L. Kremmer, 49a, Shudehill, Manchester.
- No. 20.—Silvertown Co., The (The India Rubber, Gutta Percha & Telegraph Works Co., Ltd.), Silvertown, E.16.
- No. 21.—Davidson & Baker, 371, Upper Street, Islington, London, N.1.
- No. 22.—Bretwood, Ltd., 12-18, London Mews, Maple Street, London, W.
- No. 23.—Burwood Electrical Supplies Co. (1924), 41, Great Queen Street, London, W.C.2.
- No. 24.—John Gaunt, Jay-Gee Specialists, 25, All Saints Street, Bolton.
- No. 25.—Radi-Arc Electrical Co., Ltd., Bennett Street, Chiswick, W.4.
- No. 26.—Tungstelite, Ltd., 47, Farringdon Road, London, E.C.1.
- No. 27.—C. J. Arrigoni & Co., Ltd., 8, Compton Passage, Clerkenwell, E.C.1.
- No. 28.—Stephens Bros., 83, Stretford Road, Manchester.
- No. 29.—S. T. Corry & Co., 52a, Southampton Row, London, W.C.1.
- No. 30.—Spectrome, Ltd., 39, Hilmarton Road, London, N.7.
- No. 31.—British Electrical Sales Organisation, 623, Australia House, Strand, London, W.C.2.
- No. 32.—Halliwell & Good, Ltd., 9-13, Miller Street, Manchester.
- No. 33.—Chloride Electrical Storage Co., Ltd., Clifton Junction, nr. Manchester.
- No. 34.—F. A. Hughes & Co., Ltd., 204-206, Great Portland Street, W.1.
- No. 35.—Wellworth Wireless Co., 8, Withy Grove, Manchester.
- No. 36.—Makerimporter Co., Melville Chambers, 50a, Lord Street, Liverpool.
- No. 37.—Ripaults, Ltd., 1, King's Road, St. Pancras, London, N.W.1.
- No. 38.—Radions, Ltd., Bollington, Macclesfield.
- Nos. 39-40.—Bliffe & Sons, Ltd., Dorset House, Tudor Street, London, E.C.4.
- No. 42.—Neutron, Ltd., Sentinel House, Southampton Row, London, W.C.1.
- No. 43.—Darimont Electric Batteries, Ltd., Darimont Works, Abbey Road, Park Royal, London, N.W.10.
- No. 44.—M.P.A. (Wireless), 62, Conduit Street, London, W.1.
- No. 45.—Wireless Components, 87, War-dour Street, London, W.1.
- No. 46a.—White Star Line Wireless Equipped Motor Lifeboat.
- No. 47.—Universal Electric Supply Co., Ltd., The, 4, Brown Street, Manchester.
- No. 48.—Sclerine Crystal Co., The, 4a, Aubrey Road, London, E.17.
- No. 49.—W. C. Barraclough, 49, Cross Street, Manchester.
- No. 50.—Richard Davies & Sons, Victoria Bolt & Nut Works, Bilberry Street, Manchester.
- No. 51.—H. Clarke & Co. (Manchester), Ltd., Radio Engineers, Atlas Works, Old Trafford, Manchester.
- No. 52.—Clayton Rubber Co., Ltd., The, Progress Works, Croft Street, Clayton, Manchester.
- No. 53.—F. H. Middleton, 13, St. John's Hill, Clapham Junction, S.W.11.
- No. 54.—Oldham & Son, Ltd., Storage Battery Makers, Denton, Manchester.
- No. 55.—Kelly Robert & Sons, Ltd., 47-49, Market Street, Manchester.
- Nos. 56 & 57.—Brownie Wireless Co., of Great Britain, Ltd., The, 310a-312a, Euston Road, London, N.W.1.
- No. 58.—Abro Motor Co., 184 & 186, London Road, Manchester.
- No. 59.—Rapinet, Ltd., Grotton Road, Earlsfield, London, S.W.18.
- No. 60.—Engineering Supplies Co., 235, Blackfriars Road, London, S.E.
- No. 61.—Carpax Co., Ltd., The, 312, Deansgate, Manchester.
- No. 62.—Hart, Collins, Ltd., 38a, Beesborough Street, London, S.W.1.
- No. 63.—Victoria Electrical (Manchester), Ltd., Oakfield Road, Altrincham, Manchester.
- No. 64.—Igranie Electric Co., Ltd., 147, Queen Victoria Street, London.
- Nos. 65 & 66.—Western Electric Co., Ltd., Connaught House, Aldwych, London, W.C.2.
- No. 67.—Palatine Wireless Co., The, 3, King Street West, Manchester.
- No. 68.—Price's Battery & Radio Co., Ltd., 11, Hart Street, New Oxford Street, London, W.C.1.
- No. 69.—J. A. Dearnley, 8, Belle Vue Street, West Gorton, Manchester.
- No. 70.—J. G. Ivory, 17, Whitcomb Street, Leicester Square, W.C.2.
- No. 71.—W. Bullen, 38, Holywell Lane, London, E.
- No. 72.—Parkside Electric Radio Supplies, The, 89-91, Rusholme Road, All Saints, Manchester.
- No. 73.—Walter Leigh, 21, Cannon Street, Manchester.
- No. 74.—Goodall Radio Mfg. Co., 18, Quay Street, Manchester.
- No. 74a.—Standard Insulator Co., Ltd., 41, Rathbone Place, London, W.1.
- No. 79.—Olhams Press, Ltd., 93, Long Acre, London, W.C.2.
- No. 80.—L. B. Sharp, 251, Stockport Road, Longsight, Manchester.
- No. 80a.—Collinson's Precision Screw Co., Ltd., Macdonald Road, Waltham-stow, London, E.17.
- No. 81.—Criterion Wireless Co., 69-70, Chalk Farm Road, London, N.W.1.
- No. 82.—Fuller's United Electrical Works, Ltd., Woodland Works, Chadwell Heath Essex.
- No. 83.—Seagull, Ltd., R.N. Works, Newcastle Place, Edgware Road, W.2.
- No. 84.—Barclays Advertising, Ltd., Bush House, Strand, London, W.C.2.
- No. 85.—Frank Tarpey, 537, Stratford Road, Manchester.
- No. 86.—H. Hudson, 118, Devon Street, Gallery, Ardwick, Manchester.
- No. 88.—C. N. Vernon & Co., 9, Halliwell Street, Manchester.
- No. 89.—X.L. Radio Supplies, 14, Handover Street, Shudehill, Manchester.
- Nos. 90 & 91.—Competitions Gallery.

RECENT INVENTIONS

Brain Waves of the Wireless Engineer.

Four-Electrode Valve Receiving Circuit. (No. 234,809.)

The object of this invention, by the British Thomson-Houston Co., Ltd., is to produce a reaction effect with a four-electrode valve without the use of an inductive feed-back coupling between the two grid circuits.

This result is attained by connecting the inner or space-charge grid B through an impedance L to a positive pole of the high-tension battery and adjusting the impedance so as to produce a reaction

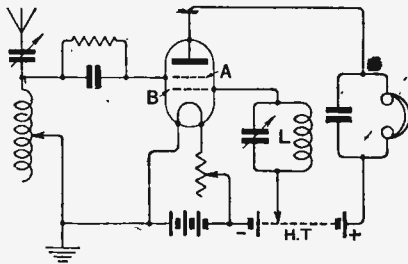

Reacting four-electrode valve circuit.
(No. 234,809.)

effect due to the capacity between the space-charge grid B and the control grid A.

The inductance L may be variable and tuned with a condenser, as shown in the circuit diagram, or it may consist of a variometer.

o o o o

Transmitting Apparatus. (No. 239,309.)

The invention, by G. W. Hale and Radio Engineering Co., Ltd., relates to apparatus for radio-signalling, such as radiotelephony, wherein use is made of electromagnetic waves modulated at an audible frequency, and more particularly to transmitting systems for radio signalling in which the filament or cathode of a valve generator of electrical oscillations is operated at a high-frequency potential relatively high to earth potential, instead of being operated at earth potential, as is more usual. The diagram shows a circuit diagram of one form of transmitter adapted for radiotelephony in which:

The oscillator valve A and the control valve B have their anode-filament paths connected in series with respect to the source of direct current high potential C, which supplies the anode circuits of both valves.

The choke coil K provides a path of relatively great high-frequency resistance across a portion of the main oscillatory

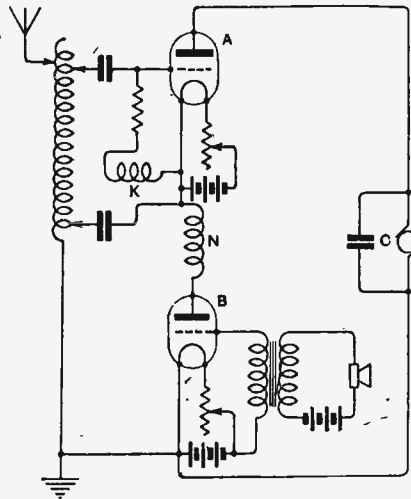

Telephony transmitter in which the anode circuits of the oscillator and control valves are connected in series. (No. 239,309.)

circuit, and the choke coil N prevents damping effects upon the oscillations generated by the oscillator valve A. The high-frequency by-pass condenser C is provided in order to prevent the high-tension supply current from escaping direct to earth.

o o o o

Variable Condensers. (No. 239,333.)

This patent, by C. E. Raeburn and W. E. Taylor, relates to variable condensers of the type in which the moving plate system is completely enclosed within the fixed system, except at the point

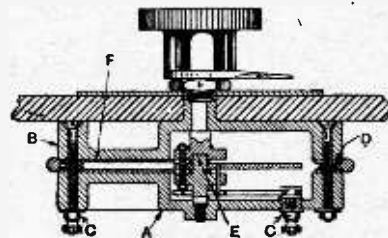

Enclosed variable condenser. (No. 239,333.)

where connection is made to the moving system, and in which the moving system is supported upon a rotary spindle of electrically insulating material.

The drawing shows a condenser having but a single moving plate. The casing of the condenser consists of a pair of machined castings A and B. Two layers of dielectric material such as mica are interposed between the two castings, and between the layers of mica resilient washers D are placed so that the maximum capacity of the condenser may be adjusted by tightening or loosening the nuts C.

The specification states that any number of moving and a corresponding number of fixed plates may be used, the moving plates being mounted on the spigot E, and the fixed plates being interposed between the mica plate F and the casting B.

o o o o

Plug-in Coils. (No. 239,267.)

This patent, by A. W. Sharman and Radio Acoustics, Ltd., relates to an aperiodic plug-in aerial inductance coil, the primary winding consisting of a few turns being untuned, while the secondary winding consisting of a greater number of turns is tuned with an external con-

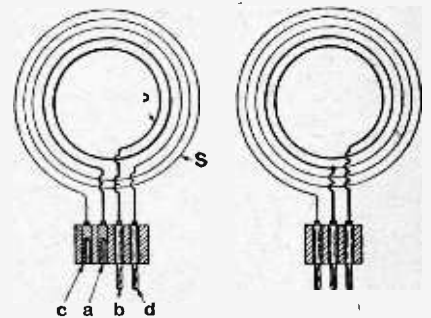

Plug-in coils with "aperiodic" tuning.
(No. 239,267.)

denser. The diagram shows the aerial coil P, consisting of a few turns terminating in plug and socket connections (a) and (b); and the secondary coil S, consisting of a greater number of turns terminating in plug and socket connections (c) and (d). In a modification shown at the right-hand side of the diagram, the unit may be formed as an auto-transformer coupling.

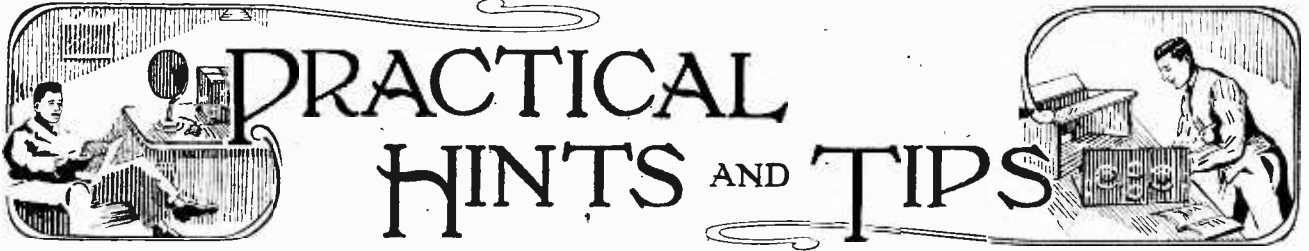

A Section Mainly for the New Reader.

THE CRYSTAL AS A VOLTAGE RECTIFIER.

It has recently been shown that the crystal detector is capable of acting as an efficient rectifier of oscillating potentials, as opposed to its more usual function of rectifying currents. As a matter of fact, it was so used in an arrangement disclosed in one of Lee de Forest's earliest patent specifications, in which a crystal was shown connected direct in the grid circuit of a three-electrode valve. The reasons for its operation do not, however, appear to have been very clearly understood at the time of publication.

With a few modifications, this property of the crystal may be pressed into service to meet modern requirements, and, in conjunction with a valve, will provide an effective, and, what is more important, practically distortionless amplifier under proper working conditions.

A suitable circuit for detector and L.F. amplifier is given in Fig. 1. It will be seen that the rectified

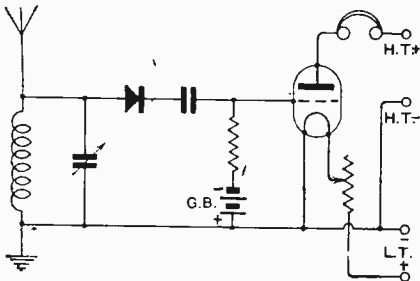

Fig. 1.—Direct amplification after a crystal detector.

potentials are applied to the grid through a large fixed condenser. A grid leak is provided in order that charges may not accumulate in this condenser, and a negative bias is impressed on the grid to prevent the flow of grid currents. The whole point of this system of connections is, of course, that practically no cur-

rent is flowing in the crystal output circuit.

The grid condenser should be well insulated, and may be of the type and capacity used in resistance-capacity inter-valve couplings, although in this case it is not called upon to withstand the voltage of the high-tension battery. The leak is of the usual value, depending on the capacity of the condenser chosen.

As the voltage magnification obtainable is determined by the amplification factor of the valve, this latter should be of the type sold for resistance coupling.

The addition of a second low-frequency stage to the circuit shown will give a receiver which can be highly recommended for pure loud-speaker reproduction of strong incoming signals. As the first valve will have of necessity quite a high impedance, it will probably be best to connect a resistance, rather than the primary of an L.F. transformer, in its anode circuit. The second valve should be capable of handling sufficient power for the satisfactory operation of the loud-speaker, and will consequently not give a very high degree of amplification. The overall magnification is, therefore, not very great, but is ample for ordinary purposes, provided that a really strong signal, such as is received from a station at a few miles distance, is being dealt with.

The construction of a receiver on these lines is a simple matter, and there is the additional advantage that no inherently expensive components are required. This does not mean that large losses may be tolerated; in particular, every effort should be used to ensure that the high-frequency voltages applied to the crystal are as high as possible. The aerial, earth, and tuning systems should, therefore, be as efficient as possible, except at the very shortest ranges.

ABSORPTION STABILISING.

In Fig. 2 is shown one of the many devices which are found to be efficacious in preventing the inherent tendency towards self-oscillation which is always present in tuned high-frequency amplifiers on the shorter wavelengths. A coil consisting of a few turns of wire is tightly coupled to the high-frequency transformer,

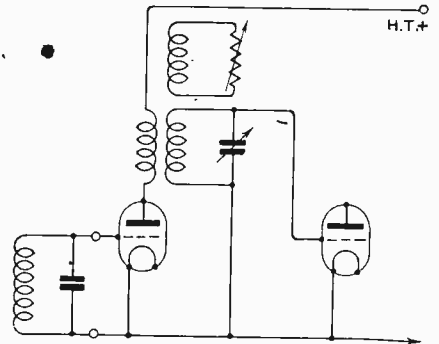

Fig. 2.—Stabilising an H.F. valve.

and has connected in series with it a continuously variable resistance; a good carbon compression rheostat will generally serve in this capacity.

The device operates by virtue of the fact that a certain amount of energy is induced into the stabilising coil, depending on the value of resistance in the circuit. In practice the variable resistance is reduced until sufficient energy is taken from the oscillatory circuits to give stability.

No definite instructions can be given as to the exact number of turns required for the stabiliser winding; this will be decided by various factors—among others the amount of resistance variation obtainable in the resistor itself. As a rough guide, it may be said that, in a certain H.F. amplifier designed to cover the 300-500-metre waveband, six turns were used with very satisfactory results.

TESTING FOR DISTORTION.

Amateurs are sometimes at a loss to know where to look for the causes of bad reproduction. A very usual method of detecting amplitude distortion, or, in other words, unequal amplification due to working off the straight part of the valve curve, is to insert a milliammeter in the anode circuit of the output valve. An excursion of voltage on to the lower bend of the curve will result in a momentary drop in the reading of the instrument. Grid bias and anode voltage should be adjusted until the needle is quite steady, or, at any rate, only shows a slight tremor. At first sight, it may seem that it should be in a continuous state of oscillation, but realising that speech and music frequencies are of the order of hundreds per

second, it will be realised that the instrument is quite incapable of following them, and it is only when a persistent series of heavy negative voltages is applied, with consequent rectification, that a noticeable deflection is produced.

Tests of this description should always be made on deeply modulated musical items.

o o o o

MEASURING H.T. SUPPLY FROM MAINS.

It should be realised that an ordinary voltmeter of comparatively low resistance is quite unsuitable for reading the actual voltages applied to the anodes of the valves when working from either filtered D.C. or rectified and filtered A.C. The reason is that

the meter requires quite a considerable current for its operation, and the resistance of the filtering circuit is probably greater than, or at least comparable with, that of the meter itself, and the latter will give a reading much below the true value.

Failing the use of a high-resistance meter taking a current approximating to that consumed by the valves, it will be necessary to calculate the actual voltage, having ascertained the current consumption of the voltmeter and D.C. resistance of the chokes. As far as ordinary valves with impedances far in excess of the resistance of the filter circuits are concerned, it is hardly necessary to go to this trouble, as the drop in voltage in the filter will seldom amount to more than some 10 or 15 volts.

DISSECTED DIAGRAMS.

No. 3.—A Cascade Transformer-Coupled Amplifier.

For the benefit of those who have not yet acquired the simple art of reading circuit diagrams, we are giving week by week a series of sketches showing how the complete circuits of typical wireless instruments are built up step by step.

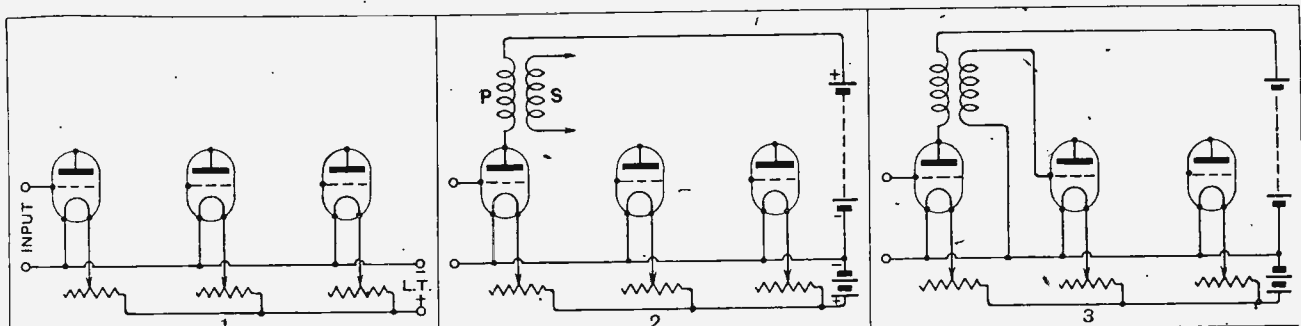

Three valves, with filaments heated through individual rheostats by current from common battery. The voltage variations (of an unspecified frequency) to be amplified are applied across grid and filament input terminals.

In the first anode circuit is connected the primary winding of a transformer suitable for the type of current to be dealt with. Pulsating or oscillating currents in this winding cause voltage variations across the secondary.

The secondary variations, already magnified by the first valve, are applied across the grid and filament of the second valve for a further stage of magnification.

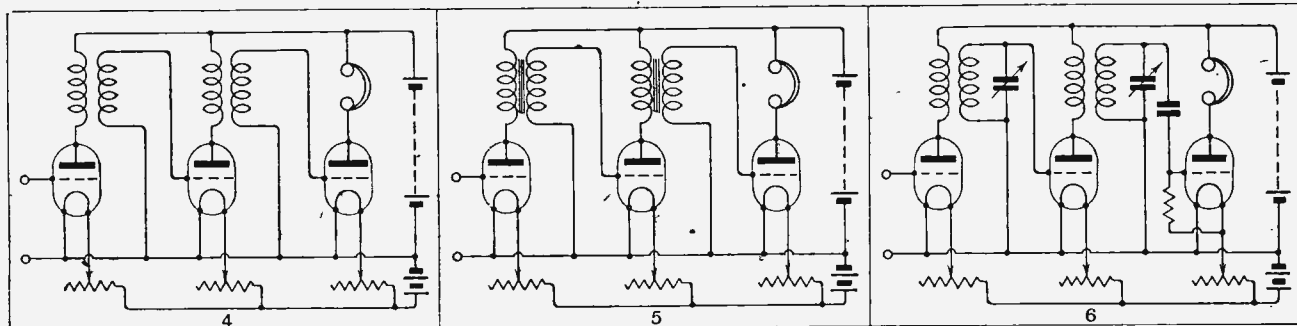

The same procedure is repeated in the anode circuit of the second valve and the grid circuit of the third valve, thus giving another stage of amplification. Some form of reproducer is connected in the anode (output) circuit, but—

—the phones shown in the previous sketch are of no practical use unless supplied with currents of a type with which they can deal. In this sketch the transformers are modified by the insertion of iron cores for low-frequency amplification—

—and here, by the substitution of tuned air-core transformers, the amplifier is adapted for dealing with high-frequency oscillations, and the magnified voltages are rectified by the action of the leaky grid condenser.

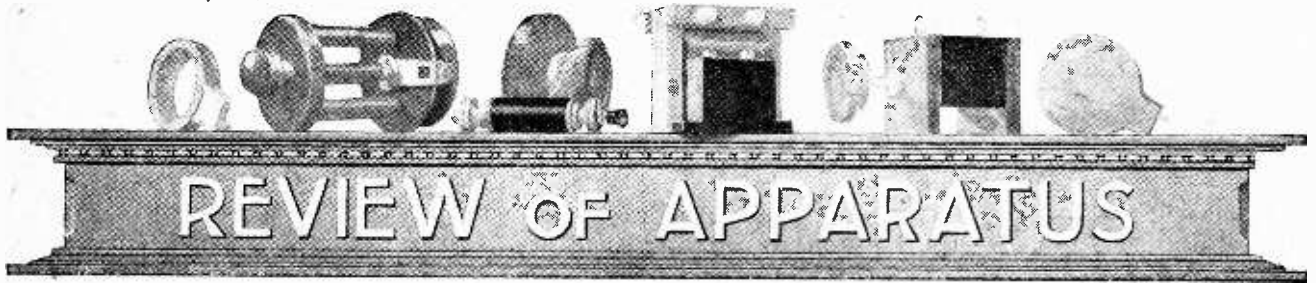

Latest Products of the Manufacturers.

NEW TYPE MANSBRIDGE CONDENSER.

This condenser is made by the Mansbridge Condenser Co., Ltd., under the regis of Mr. G. F. Mansbridge, the inventor of this type of condenser, and is tested and guaranteed by the Dubilier Condenser Co., Ltd., who are sole concessionaires to the Mansbridge Condenser Co., Ltd.

The new design is specially suited to the requirements of the experimenter, and



The new type Mansbridge condenser.

for ease of connection the condenser is now fitted with screwed nickel-plated terminals which are insulated from the all-metal case by Bakelite bushes. Connection can thus be made by means of connecting tags, or if a soldered connection is desired there is no danger of loosening the tag by over-heating it, as was the case with the earlier model.

For receiving apparatus the Mansbridge condenser is suitable for a working pressure of 300 volts D.C., but condensers for higher voltages are supplied when required.

o o o o

WIND-DRIVEN DYNAMO

In an endeavour to solve the problem of battery charging in districts where supply mains are not readily available, F. A. Wilkinson and Partners, Ltd., (Gretton, near Kettering, Northamptonshire, have produced a small wind-driven

dynamo with suitable mounting. Stated to be suitable for charging low-voltage batteries when the machine is set up in a strong wind and the outfit comprises a high-speed dynamo of the permanent magnet type mounted upon a swivelled platform with winged vane, so that the propeller is maintained in a position heading into the wind.

The auxiliary equipment includes a switchboard for wall mounting and fitted with ammeter, fuse, change-over switch, and cut-out, so that the set can be left unattended and will automatically switch in and out of circuit as the output fluctuates.

o o o o

EXCEL TERMINAL TAGS.

By using tags under screws and terminal contacts in preference to employing a loop in the connecting wire a larger area of contact is provided and a much neater appearance obtained.

Tags to suit various requirements are manufactured by The S. H. Collett Manu-

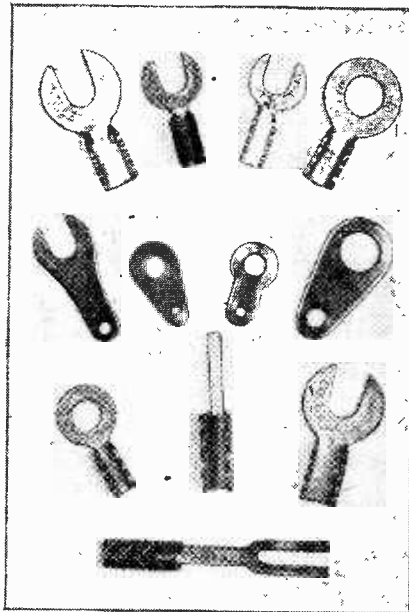

A selection from the range of connecting tags manufactured by the Collett Manufacturing Co

facturing Company, 52-54, Hampstead Road, London, N.W.1, and a selection is shown in an accompanying illustration. These are specially suitable for the wiring up of receiving sets, and stocks are carried by most of the dealers.

o o o o

HARKO VERNIER BASKET COIL HOLDER.

A mounted basket coil makes a cheap and efficient tuning inductance for use in an adjustable coil holder, and on the amateur station this form of coil has the great advantage that its

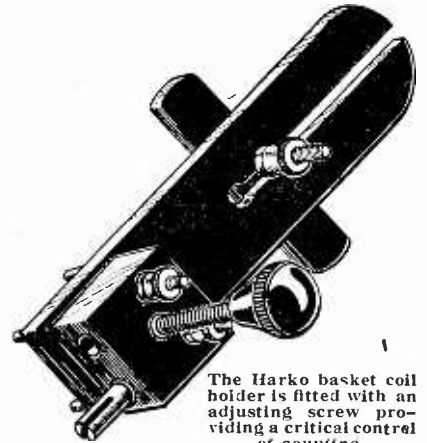

The Harko basket coil holder is fitted with an adjusting screw providing a critical control of coupling.

size can be carefully regulated for best results. The Harko basket coil holder is a robust job, and gives support to the winding by means of a small ebonite strip clamped in position with a screw and milled nut. By means of a slot the height of the coil from the holder can be regulated so that the basket coil can be arranged to be concentric with any of the standard commercial type inductances. A special feature is the inclusion of an adjusting screw which passes through the socket and gives a critical control of coupling, side play being prevented by four brass guide pins.

The pin connector can be withdrawn and inserted in either socket so that the holder can be turned round, bringing the adjusting knob in a convenient position for operating. This component is well finished and offered at a low price.

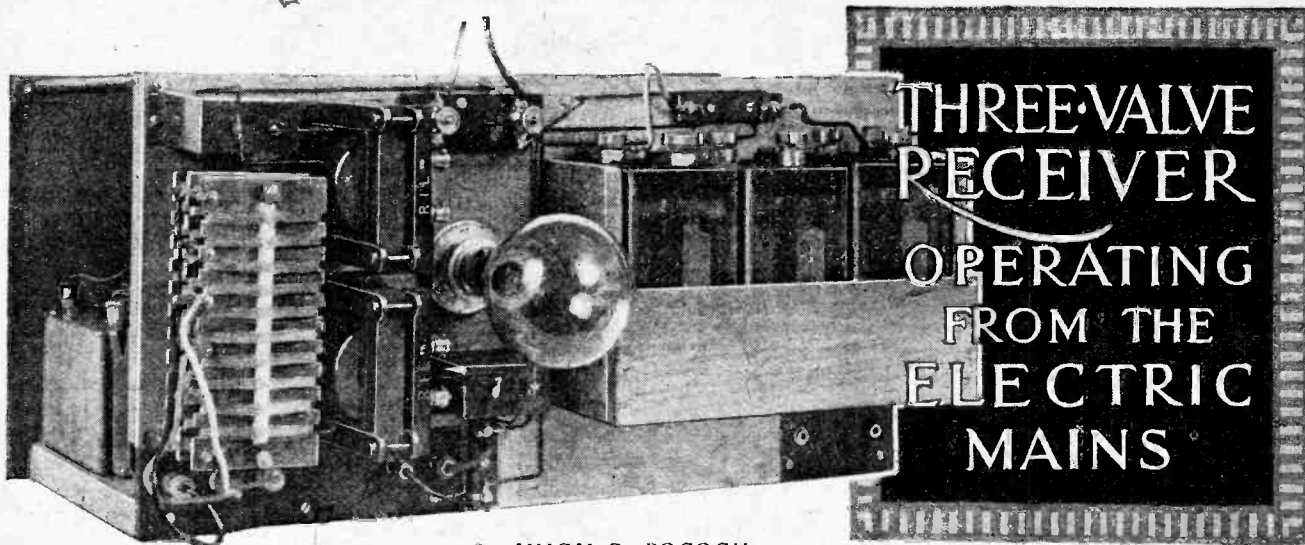

By HUGH S. POCOCK.

A Convenient Method for Obtaining H.T. and L.T. Supply.

THERE are several different methods possible for making use of the house-lighting D.C. mains for supplying the current necessary for operating a valve-receiver, both for the H.T. and L.T. current. It is surprising how many people who have D.C. current in the house still make use of batteries for H.T. current supply, and trouble to charge their accumulators periodically for filament heating when there is no practical difficulty in the way of discarding H.T. batteries altogether, and avoiding the trouble of accumulator charging. Too often it happens that had reception is found to be due to exhausted H.T. batteries or a discharged accumulator—perhaps just discovered when some specially good item in the programme is being looked forward to.

Some Advantages.

The advantage of using the mains for H.T. current is particularly apparent when a power valve is used for loud-speaker reproduction, or, in fact, whenever L.F. valves are used and good loud-speaker strength is required, on account of the fact that the current consumption becomes so considerable that only accumulator batteries, or

at least very large dry cells, will stand up to the service required for any length of time.

Various Methods.

If we assume that the D.C. voltage is 240, which is a very common voltage for house lighting, our first consideration must be how to drop the volts to the necessary value for the different voltages required for the anode circuits of the various valves of the receiver and for the filament heating. Some form of resistance must be introduced, and here several methods may be employed. The mains can be bridged by a series of electric lamps and connections taken off between the lamps where the voltages are suitable for our requirements for H.T. current. Another method is to use a Neon lamp, which will pass the requisite current and drop the voltage to a suitable value; but here it is necessary to use controlling resistances in addition, because it is impracticable to use two or more Neon lamps in series to bridge the mains, because the drop in voltage across one will be such as to prevent the next from lighting up and so passing the necessary current. A Neon lamp can, however, be made use of if tapings are not required to different valves. Another method, and probably the most convenient and the cheapest to set up, is to bridge the mains with a wire-wound resistance tapped at frequent intervals and capable of carrying something over the maximum anode current required for the valves in use. In this way, by choosing suitable tapping points, exactly the requisite voltage for each valve can be selected, and adjustments can easily and

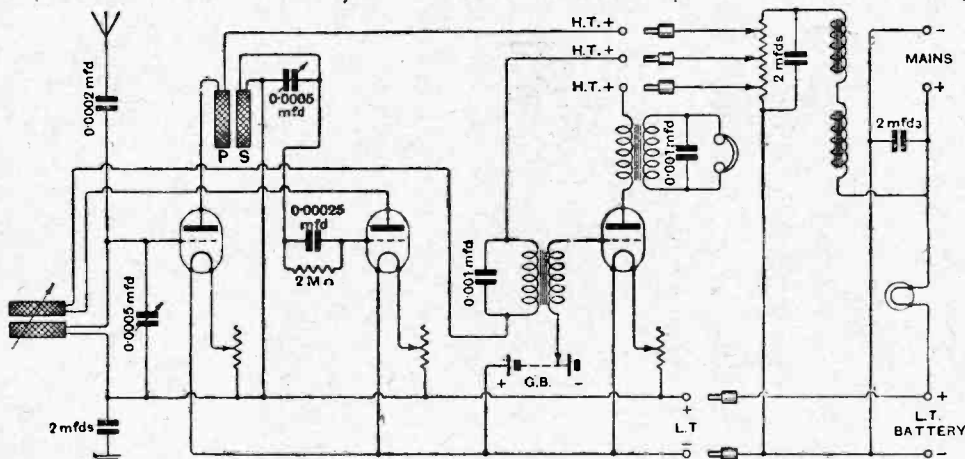

Fig. 1.—Circuit diagram, showing the connections of the receiver and the mains unit, with the method of connecting up the two.

prevent the next from lighting up and so passing the necessary current. A Neon lamp can, however, be made use of if tapings are not required to different valves. Another method, and probably the most convenient and the cheapest to set up, is to bridge the mains with a wire-wound resistance tapped at frequent intervals and capable of carrying something over the maximum anode current required for the valves in use. In this way, by choosing suitable tapping points, exactly the requisite voltage for each valve can be selected, and adjustments can easily and

Three-Valve Receiver Operating from the Electric Mains.—

quickly be made if different valves requiring varying anode potentials are used at different times.

For L.T. purposes the current passed must be limited to that at which the valves operate. Thus, if we have a three-valve set using valves which operate on, say, 0.3 of an ampere, we require to pass 0.9 of an ampere. For this purpose we should probably choose a lamp and use a variable wire-wound resistance for fine control.

Another method—and a very convenient one—is to bridge the mains by an accumulator of the voltage required by the valves in use, and to take leads to the L.T. terminals of the set from the "floating battery" in the ordinary way, each valve having the usual separate

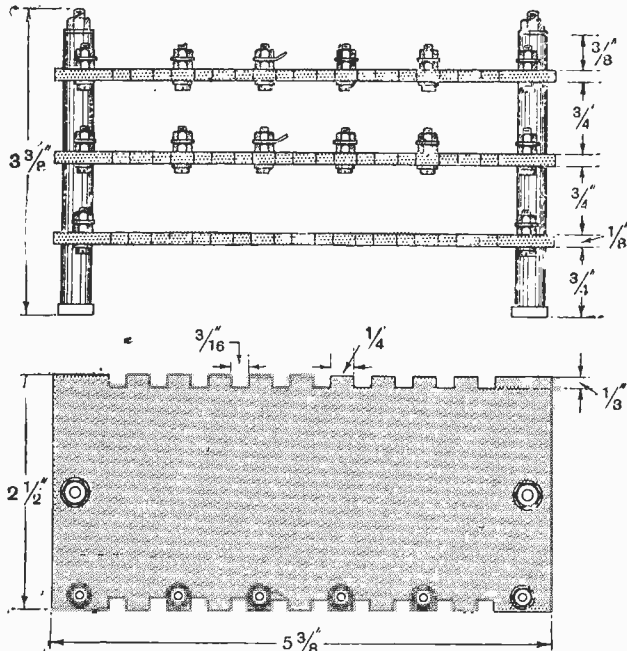

Fig. 2.—Details of the formers on which the wire resistance is wound.

resistance for independent control. The mains under such circumstances should be fed to the accumulator through a lamp in the positive lead, which will pass approximately the same current as the valves are consuming, and in this way the rate of discharge and charge of the battery will balance, and it will not be necessary to employ a battery of large capacity.

The purpose of this article is to describe the construction of a unit for supplying H.T. and L.T. current from D.C. mains, which has been in use for some considerable time, and has given every satisfaction. Incidentally, a typical set is incorporated with this unit, although the reader will readily see how any set he may have can be operated in the same way if certain necessary precautions are taken.

Details of the H.T. Supply.

The circuit diagram given in Fig. 1 shows theoretically the connections of the mains unit, and the receiver. The wire-wound resistance bridging the mains requires rather more care than the remainder of the construction, and may, therefore, be described first.

A sheet of micanite should be cut by means of a small saw into three strips, size $2\frac{1}{2} \times 5\frac{3}{8}$ in., and each of these strips should have notches cut as shown in the illustration, Figs. 2 and 3. There are ten notches or grooves cut in two of the strips of micanite. No tappings are required to the third strip. The two with notches should have holes drilled to take several small screws and nuts with terminal tags, as shown in Figs. 2 and 3. When these tags have been fixed, the strips are ready for winding. The wire used is No. 36 Contra resistance wire, and 12 yards should be wound into each groove, the wire being bared and connected to the tags after each groove has had 12 yards wound on. It will be seen from Fig. 3 that a strip of wood is inserted under the winding in the centre of the micanite on either side. The winding is done over this strip to ensure against the possibility of the wire warming up when it is passing current, which might occur if the winding were bunched up without ventilation. When the three resistance strips are completed, they can be built up by being held together with brass rod and nuts with ebonite tube holding the resistance strips at a suitable distance from one another as "spacing washers," as in Fig. 2. The resistance unit will now be ready for fixing to the remainder of the apparatus when this is assembled. The details of this resistance can best be understood from reference to the photograph of Fig. 3, which gives a close-up view.

To avoid confusion, the H.T. and L.T. supply unit has been designed so that it is entirely independent of the set itself, and has all been accommodated on the

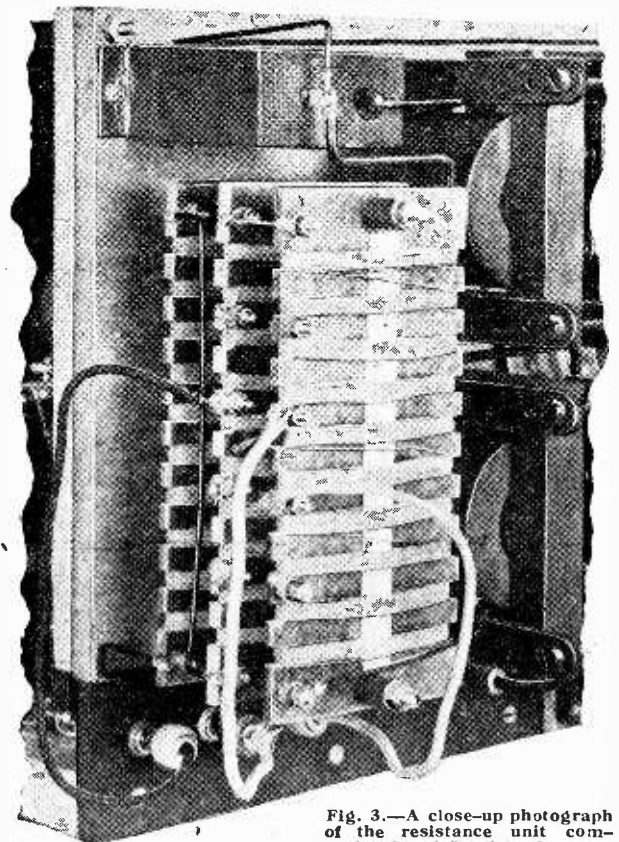

Fig. 3.—A close-up photograph of the resistance unit completed and fitted to the set.

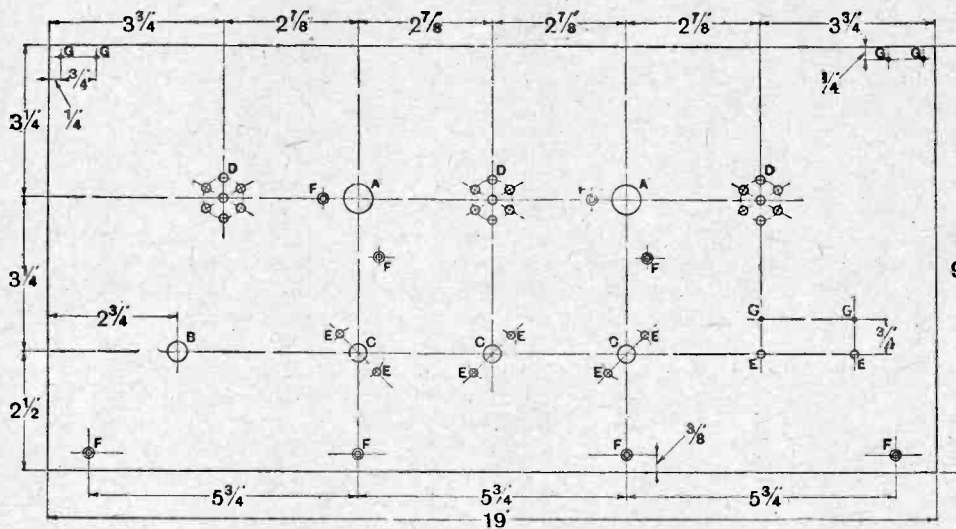

Fig. 4.—Drilling details for the panel of the receiver. F (bottom line), are holes for wood-fixing screws; D, are holes for providing valve windows.

wooden board fixed at the back of the set. Clix sockets and plugs are used for the H.T., L.T., and aerial and earth connections, these sockets being mounted on ebonite strips at the back of the baseboard of the receiver, details being given in Fig. 8, where A are the Clix sockets and B holes for wood-fixing screws. The plugs fit into these Clix sockets from their respective connections.

The apparatus to be mounted on the board consists of the H.T. resistance already described, two 2 - mfd. condensers, and

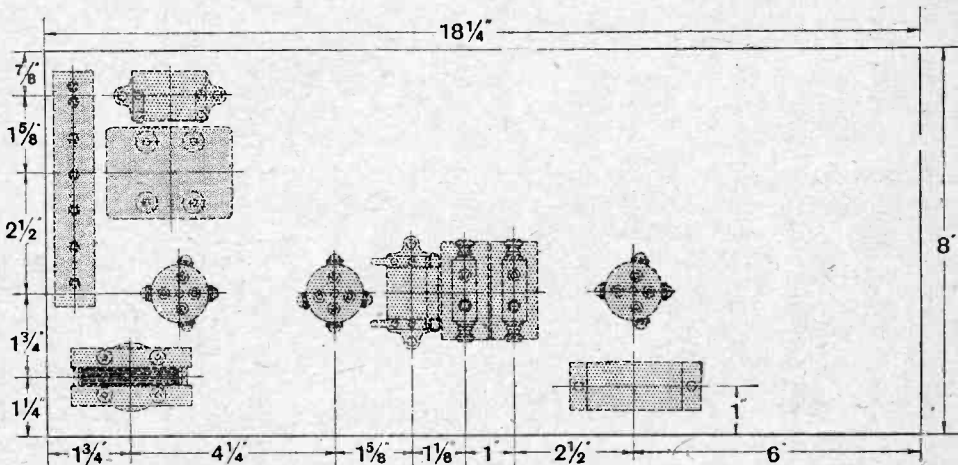

Fig. 5.—Spacing and location of the components of the receiver on the wooden baseboard.

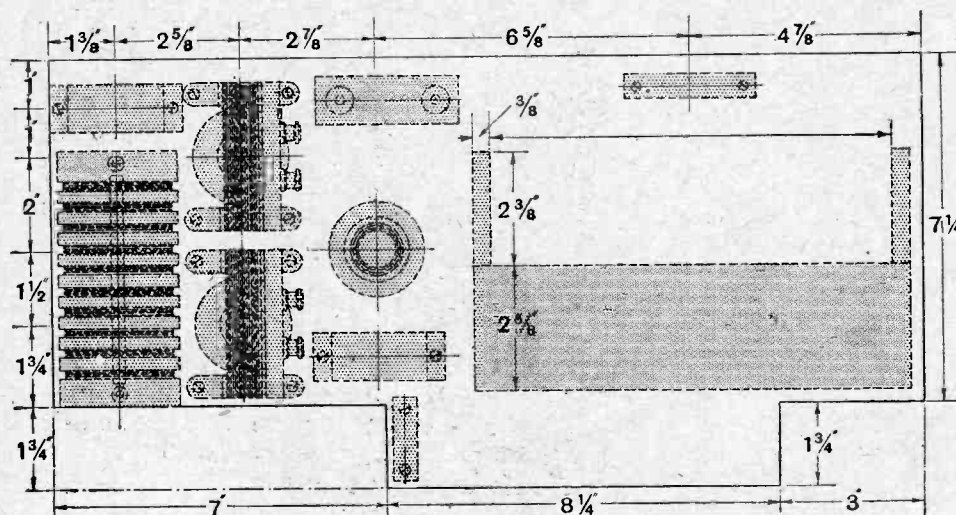

Fig. 6.—Spacing and location of the components of the mains unit on the wooden backboard.

chokes for eliminating machine noises of the D.C. supply, a lamp socket, a terminal strip to carry the two terminals to which the connection to the house-lighting mains is made, and a box which must be made up to accommodate three D.T.G. Exide accumulators, and details of the location of these parts with dimensions of the board are given in Fig. 6.

Smoothing Choke.

The value of the choke is not very critical, but it will usually have to be not less than 10 henries. In this particular set two R.I. chokes of about 6 henries each have been connected in series, but

the amateur must remember that although quite a number of manufacturers will supply chokes of the requisite value, it is important to be sure these are designed to pass the requisite current. If the current is estimated at 50 milliamps at 340 volts, this will give a good margin of safety.

When the various parts have been fixed to the board, the wiring is a very simple matter, which should give no trouble if Fig. 10 is followed carefully. The positions for the three tappings from the H.T. resistance can best be found after the set has been assembled, and

Three-Valve Receiver.—

they will, of course, depend upon the types of valves used and the grid bias used on the L.F. valve.

Construction of the Receiver.

As has been mentioned already, this H.T. and L.T. unit can be used with almost any ordinary type of receiver, but the description of the present receiver will be of interest to those who have not already got a suitable receiver for the purpose. If an existing set is used, certain precautions should be taken so as to avoid any risk of short-circuiting the lighting mains. In the first place, a small mica fixed condenser of, say, 0.0002 mfd. capacity should be inserted in series with the aerial lead-in, and similarly a large condenser, this time of 2 mfd. capacity, and dependable on 300 to 400 volts, must be inserted in the earth lead. Both these condensers are shown incorporated in this set (see diagrams, Figs 1 and 10), but if the set is required to be operated at some distance from where the aerial lead is brought in, it is better to insert the condenser near this point, and, similarly, the earth lead condenser not far from where the earth lead enters the house. A further precaution should be taken in the employment of a telephone transformer with the set, as otherwise the leads to

the loud-speaker will be in metallic contact with the house-lighting circuit.

The receiver to be described here incorporates these points, and consists of an H.F. stage with plug-in transformer coupling, detector valve, and one stage of L.F. amplification.

The particulars of the circuit are given in the diagram, Fig. 1, whilst the general layout is shown in Figs. 5, 9, and 10. The frame consists of a panel 9in. x 19in., and wooden base-board measuring 8in. x 18½in. Extra support is given to the backboard on which the mains unit is mounted by brass rods from the top of the ebonite panel through to the top of the board at the back, and held in place by nuts with washers. The brass rods can be covered by ebonite tube if desired, which will give a better appearance. The drawings of Figs. 4 and 5 show the arrangement of the components and the necessary drilling for the panel, whilst the wiring can easily be followed from Fig. 10, as this is not complicated.

Coils and H.F. Transformer.

For local reception it will always be found best to short-circuit the reaction coil either with a short-circuiting plug or a piece of wire, and the only tuning controls will then be the two variable condensers for the aerial circuit and the H.F. transformer respectively. For the broadcast stations the H.F. transformer coils should be Nos. 25 and 50 for the primary and secondary respectively, though for over 450 metres it will be found beneficial to

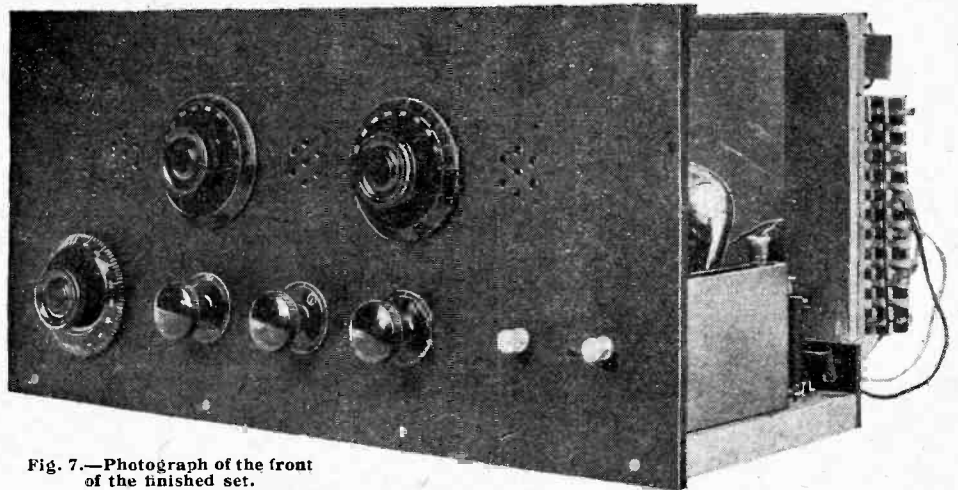

Fig. 7.—Photograph of the front of the finished set.

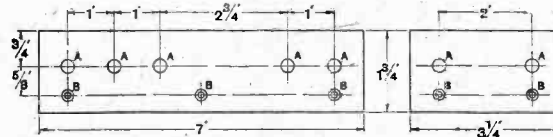

Fig. 8.—Details of the two ebonite strips carrying the terminals (Clix socket's) at the back of the set.

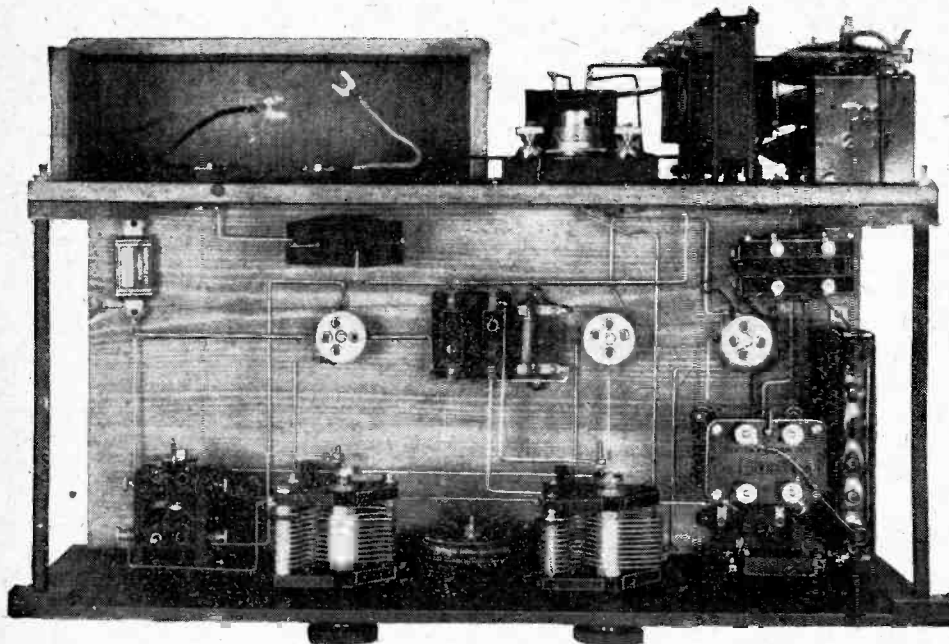

Fig. 9.—A view from the top, showing arrangement of the parts.

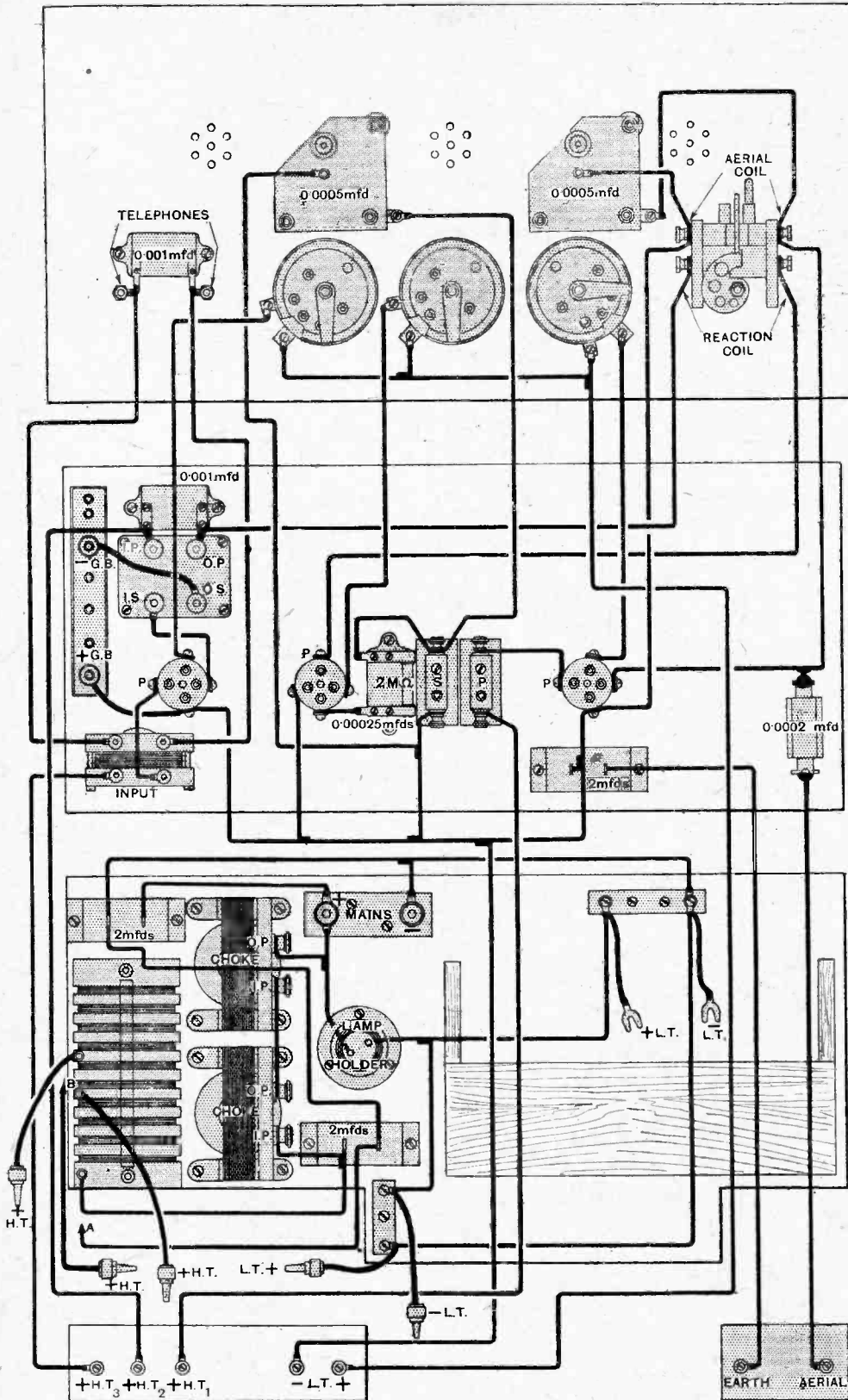

Fig. 10.—Complete details for wiring both the receiver and the mains unit.

substitute Nos. 50 and 75 coils, whilst the aerial coil with the variable condenser in parallel for tuning may be No. 50.

The Choice of Valves.

In the choice of valves we must consider what will be the current consumption in order that the lamp which we insert in the lamp socket of the mains unit may pass approximately the same cur-

COMPONENTS USED TO BUILD THE RECEIVER.

- 2 0.0005 mfd. variable condensers (A. J. Stevens).
- 1 2-coil holder (Woodhall).
- 2 Single coil holders, base mounting.
- 3 Valve holders (Athol).
- 3 7-ohm filament resistances (Burndept).
- 2 0.001 mfd. fixed condensers (Dubilier).
- 1 0.00025 mfd. fixed condensers (Dubilier).
- 1 0.0002 mfd. fixed condensers (Igranic Freshman).
- 3 2 mfd. reservoir condensers (T.C.C.).
- 1 2 megohm grid leak (Dubilier).
- 1 Batten type lamp holder (G.E.C.).
- 1 9 volt Hellesen grid battery (A. H. Hunt).
- 2 L.F. chokes (Radio Instruments).
- 1 Telephone transformer (Lissen).
- 1 L.F. transformer, ratio 4-1 (Ferranti).
- 3 Exide 2-volt D.T.G. batteries (Chloride & Electrical Storage Co.).
- 7 Clix plugs and sockets (Autoveyors).
- 4 Pillar terminals.
- ½ lb. No. 36 Contra (Ormiston).
- 3 Pieces micanite 5½ × 2½ in.
- Set of coils (those illustrated are Neatson type), sizes 38, 50, 50, 75).

rent. The set is intended for valves operating from a 6-volt accumulator, but if required the accumulator can be used as a 4-volt instead by simply cutting one cell out of circuit. If, for example, we use two Burndept H.L. 512 type and a L. 525 for the L.F. stage,

Three-Valve Receiver Operating from the Electric Mains.—

with a 6-volt accumulator, we shall require a lamp capable of passing 0.49 ampere, which on 240 volts will mean that a 50 candle-power carbon filament lamp will be required, which will pass half an ampere.

If, say, other types of valves are used, the same consideration must be given to see that the current consumption and charging rate approximate to the same. It will then require very little attention to keep the D.T.G. cells in order. From time to time the lamp may be taken out of circuit, so that the accumulators are gradually discharged whilst the set is in use, and they can be recharged again by inserting the lamp and leaving it in circuit for a time with the filament resistances turned off. Under normal conditions, however, the lamp will be in circuit whilst the set is in use, and the balance will be maintained. The accumulator should, of course, be topped up from time to time with distilled water as evaporation takes place. It should be remembered that the lamp will radiate a good deal of heat, so that if it is desired to box up the set it will be better to fix the lamp on the top of the set where heat radiated will not matter.

Connecting Up.

After the set has been assembled and is ready for use, the two terminals for connection to the mains should be connected to a length of flex, on the other end of which is a lamp fitting for an electric lamp socket. When the lamp socket has been placed in the holder and the switch turned on, the lamp at the back of the set should light up. The correct way round for the socket can be found by trial. The flexible connections to the accumulators should preferably be of different colours—red for positive and black for negative—or be otherwise suitably marked, so as to be sure that the batteries are connected up the right way round. Now see if, when the filament resistances are turned on, the valves light up correctly. If all is well, the current should be switched off and the three leads with Clix plugs inserted in the sockets should be connected up to tapping points on the resistance. Do not readjust the tapping points with the current on, but, as a precaution, turn it off each time when a change is to be made. It is quite a simple matter

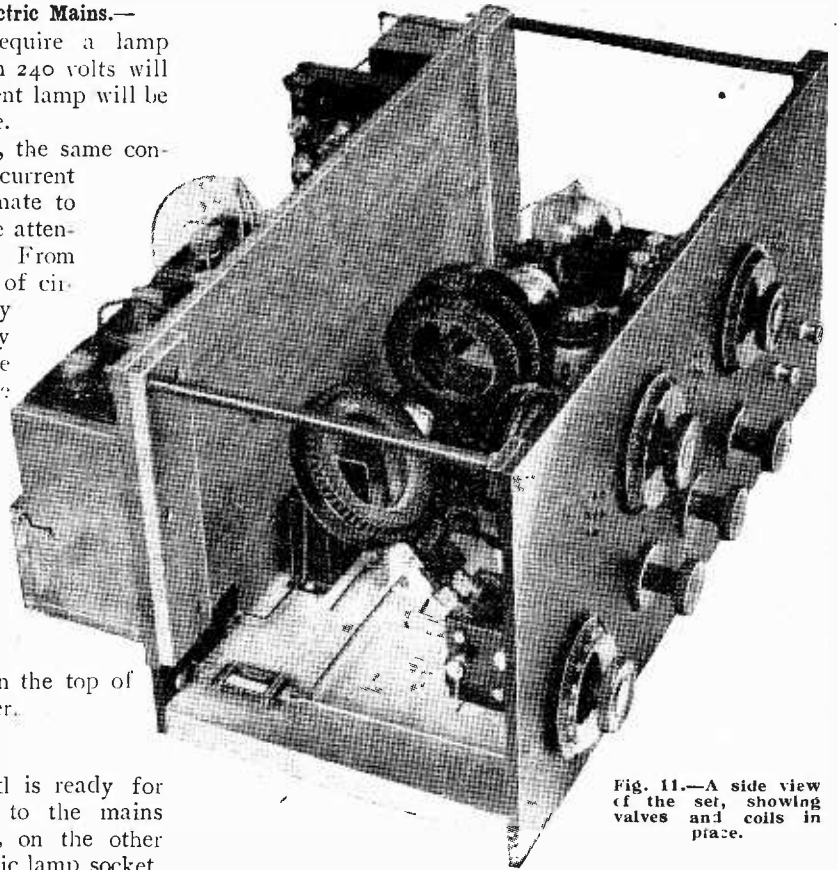

Fig. 11.—A side view of the set, showing valves and coils in place.

to find by trial the best positions, but, if a milliamperereading from, say, 0-10 milliamperes, is available, it is more convenient and quicker to insert this in between the Clix plug and the Clix socket of each valve in turn, and adjust the resistance tapping until the meter reads correctly. Thus, using Burndept valves again as an example and referring to the tables of page 430 of *The Wireless World* for September 30th, we see that for H.L.512 valves the plate current reading in milliamps given in the second column will indicate the plate voltage as given in the first column. For the last valve, which may be, say, an L.525, we refer to page 431, where we find that if our grid bias is, say, 8 volts negative and our milliammeter reads 4.15 milliamperes, then the plate voltage which we have tapped off is 100.

TREND OF GERMAN BROADCASTING.

THERE are to-day twenty broadcasting (including secondary) stations in Germany, with five or six more in prospect, says a correspondent of the *Radio Supplement*. How many stations, one after another, can be established without interference it is hard to say, but the subject perturbs the experts at present. Germany is linking up all her broadcasting stations so that local programmes, or items from programmes, may be transmitted over the whole country. While this linking up is progressing rapidly, the general opinion of those whose ideas are worth while is that, if it were possible to cover

the land effectively from one central broadcast station, so that even the simplest receiving set would get efficient service, this would be the best solution of the problem which is exercising the minds of many.

The sending stations in Germany are erected and maintained by the postal authorities, though the programmes are provided by private concerns. The German Post Office is paid through the manufacturers of wireless apparatus in such a way that the quality of the programmes and the development of radio depend on the numbers participating.



NEWS FROM THE CLUBS:



Secretaries of Local Clubs are invited to send in for publication club news of general interest.

All photographs published will be paid for.

Radio Experimental Society of Manchester.

The Society's winter session is now in full swing, an extremely interesting series of lectures having been arranged. Experimental work is also being carried on, the Society having acquired the nucleus of a wireless laboratory for that purpose. An extremely accurate wavemeter, capacity box, resistance box, microammeter, and milliammeter are all at the members' disposal to assist them in their experimental work, and advice and assistance will be willingly given to broadcast listeners in the district.

Transmission tests are being carried out bi-weekly on 150 to 200 metres during broadcasting hours, and reports will be welcomed by the Hon. Sec. (Call-sign 2FZ.).

Commencing on October 9th, "experimental" meetings will be held on alternate Fridays.

The Hon. Sec. will be pleased to give information to prospective members. Hon. Sec.: Mr. E. Butterworth, B.Sc., A.Inst.P., 102, Grenville Street, Stockport.

o o o o

St. Pancras 1925 Radio Society.

This new society has been formed to incorporate the Kentish Town and District Radio Society on the dissolution of the original St. Pancras Society.

The headquarters are at the L.C.C. Men's Institute at Carlton Road, Kentish Town, N.W., where there is a lecture hall to accommodate an audience of about 400. Lectures are given twice a week, on Mondays (theory and practice of wireless transmission and Morse) and Thursdays (electricity and magnetism, physics, elementary theory of wireless, and practical work). The hours are from 7.45 p.m. to 9.45 p.m.

Practical work can also be carried out by members during the rest of the week. There are metal, woodwork, and testing facilities, and material is also available for making up sets for experimental purposes.

The present membership is about 80, of which 20 are following regular lectures, and new members are cordially invited. Particulars of membership may be obtained from the Hon. Secretary: Mr. Ralph Judson, 34, Norfolk Street, Strand, W.C.2.

o o o o

Ilford and District Radio Society.

The last two fortnightly meetings of the Society have been of exceptional interest to experimenter and short-wave

advocate alike. Mr. Mayer (2ZZ), who has for some time been working to various parts of the globe on wavelengths from 27 to 45 metres, gave a careful account of his experiences. It was then disclosed that transmission on this waveband had so far succeeded as to allow frequent communication with the East, day or night, with very low power. Mr. Mayer's experiences were followed up at the next gathering of the Society on Oct. 13th by a discussion on the merits and demerits of existing commercial apparatus. Mr. Payne, Mr. Nickless (2KT), Mr. Ashton Cooper (5TR), Mr. Lassman (2PX) provided useful infor-

The Society has now obtained a transmitting licence, with the call sign 5WS, and progress is being made in the construction of a transmitter.

Hon. Secretary: Mr. H. J. South, 42, Greenvale Road, Eltham, S.E.

o o o o

Nottingham and District Radio Experimental Association.

The first meeting of the new session opened auspiciously with a large attendance on October 7th, when Mr. H. B. Old (2VQ) delivered a lecture on "Short Wave Work: 20-90 metres." The lecturer dealt essentially with the practical side of his subject, describing the two short-wave receivers that he employs. The first, built on conventional lines, consists of a detector and L.F. amplifier, with loosely-coupled aerial circuit, whilst the second embodies the Reinartz principle. The lecturer expressed a preference for the latter set for C.W. reception, but considered the ordinary receiver as more suitable for telephony.

At the close of his lecture Mr. Old gave an interesting demonstration of the two receivers in operation, and intercepted a number of Continental and American transmissions.

On November 18th Mr. Fielder, engineer at the Nottingham broadcasting station, will describe the new B.B.C. receiving station at Hayes.

Hon. Secretary: Mr. M. Allan, 71, Burford Road, Nottingham.

o o o o

Golders Green and Hendon Radio Society.

With reference to the prizes won on the occasion of the Society's field day on July 19th, the following awards were made, in addition to those referred to in *The Wireless World* of October 7th:

A pair of headphones each, presented by Mr. Leslie McMichael, were won by Messrs. MacCabe, Thorpe, and Bremner, jun., for the most rapid dismantling and re-erection of their station. Prizes given by the Radio Communication Co. and Portable Utilities, Ltd., will be competed for at a later date.

Mr. Maurice Child's lectures on "The Fundamental Principles of Radio Reception" are meeting with great appreciation. On October 7th members enjoyed a visit from Mr. P. K. Turner, who occupied the latter part of the evening with a fascinating description of his five-valve reflex supersonic heterodyne receiver.

Hon. Secretary: Mr. W. J. T. Crewe (2AKS), "The Dawn," 111, Prince's Park Avenue, N.W.11.

FORTHCOMING EVENTS.

WEDNESDAY, OCTOBER 28th.

North Middlesex Wireless Society.—Lecture: "Distortionless Reception of Broadcasting." By Mr. A. L. Kirke, of the B.B.C.

MONDAY, NOVEMBER 2nd.

Swansea Radio Society.—Exchange and Mart Night.

TUESDAY, NOVEMBER 3rd.

Lewisham and Bellingham Radio Society.—Lecture: "Low Loss Coils."

WEDNESDAY NOVEMBER 4th.

Institution of Electrical Engineers (Wireless Section).—Ordinary Meeting.

Golders Green and Hendon Radio Society.—Fourth Lecture: "Fundamental Principles of Radio Reception." By Mr. Maurice Child.

mation and advice to intending operators on the wavelengths referred to.

The secretary of this Society is organising closer working with kindred associations with a view to spreading the study of radio. The Society's address is 241, High Road, Ilford, Essex.

o o o o

Woolwich Radio Society.

An idea of the numerous activities of the Society was given in the Secretary's Report, read at the Seventh Annual General Meeting on October 7th. During the past year there have been 11 lectures, 10 short papers, discussions, and demonstrations, 5 visits to places of wireless interest, 5 inter-society visits, 3 field days, a club dinner, and a sale of surplus wireless gear.

New officers have been appointed for the ensuing season, but Mr. A. F. Bartle has been re-elected President.

The subscription has been increased by 2s. 6d. to meet additional expenses, and the resolution has been made to continue publication of the Society's monthly magazine, "The Oscillograph."

Broadcast Brevities

SAVOY HILL TOPICALITIES

By Our Special Correspondent.

Three Years of Broadcasting.

The third birthday of the B.B.C. falls on Saturday, November 14th, and efforts are being made to provide listeners with a festival week covering the period from the Sunday previous up to the anniversary day.

○○○○

A Gala Week.

The services of all the members of the staff will be requisitioned to make this a real gala week, although to guard against some of them falling short of expectations the broadcasts will be liberally besprinkled with "stars."

○○○○

Sunday.

On Sunday, November 8th, there may be a two hours' performance of a well-known musical play with an all-star cast, while in the evening the Bishop of St. Albans will preach from St. Martin's Church. We shall also hear De Groot.

Monday.

On Monday the broadcast in connection with the Lord Mayor's Show will take place. A microphone will be installed in a window in Fleet Street and a literary celebrity and some children may take part in the transmission. In the evening Sir Edmund Gosse will talk on humour in great books. The Guildhall Banquet speeches by the Prime Minister and other notabilities will also be broadcast.

○○○○

Tuesday.

Tuesday will be another all-star day and the B.B.C. hope to put on that famous trial scene "Bardell v. Pickwick," with real legal luminaries in the studio. Mr. Philip Snowden may also be expected to broadcast that evening.

○○○○

The Military Tattoo.

The Military Tattoo which was originally announced to take place on November

2nd, has been transferred to this Tuesday evening.

○○○○

Armistice Day.

Wednesday's broadcasts will include Sir Edward Elgar conducting "For the Fallen," and a special relay from Canterbury Cathedral with an address by the Archbishop of Canterbury. Captain Reginald Berkeley is also contributing a play, specially written for broadcast, in the evening of Armistice Day, entitled "The White Chateau," with music by Mr. Norman O'Neill. The "Roosters" will provide a special concert, and the dance music from the Hospital Ball at the Albert Hall will be broadcast from 11 p.m. till 2 a.m.

○○○○

Thursday.

On Thursday evening November 12th, the National Institute of Industrial Psychology is holding its annual festival dinner at the Trocadero. The speeches to be made by the Prime Minister and Mr. J. H. Thomas will be broadcast.

○○○○

Friday.

On Friday another "Round the Continent" broadcast will be given, and one of the most famous revue stars (of the male sex) will probably broadcast on that evening for the first time.

○○○○

Saturday.

On Saturday a staff concert will fill the programme. Miss Nellie Wallace will also appear before the microphone during the evening.

○○○○

British Wavelengths.

Several minor alterations in the wavelengths of British stations have recently been made, but they only amount to a metre or thereabouts in each case. They are adjustments effected for valid reasons, but it is well to note that they are liable to variation and must not be taken as constant. In the present difficult position as regards European jamming, the B.B.C. can never say precisely what a station's wavelength will be from day to day, and it has always been made clear that there is a margin of about one per cent. each way in connection with wavelengths as announced.

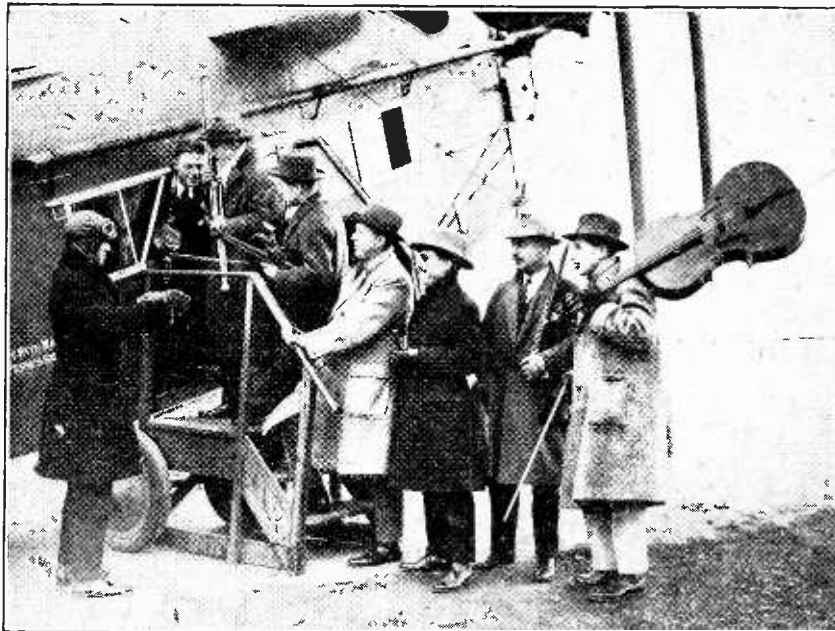

EXCELSIOR! Novelty is believed to be the aim of the latest broadcasting "stunt," in which the 2LO orchestra will give selections while flying. The photograph depicts members of the orchestra embarking for a trial trip.

Interference.

The basic consideration is that the interference problem in Europe has become so complicated as to render a published wavelength unreliable. If the wavelengths were strictly adhered to according to the published figures, some experimenters might be helped, but the broadcast service as a whole would suffer, since there is no doubt that transmissions would be seriously interfered with by foreign stations. Only after the further tests on the new wavelength allocations, to which reference has already been made in *The Wireless World*, have been definitely proved to be free from interference, will it be possible to say the exact wavelengths on which stations are transmitting.

○○○○

Do Storms Affect Reception?

A Scottish report to the B.B.C. stated last week that during high south-westerly winds or storms reception from near stations was very weak, while distant stations were received at very good strength. The captain of an Irish boat, who invariably listens during the crossing, now writes to say that he has had several experiences of a like nature, and on some occasions has been unable to pick up any British station, although he has had no difficulty in tuning in to Continental stations "all round the dial." The B.B.C. ask me to invite listeners to report to Savoy Hill what stations come in best during the next south-westerly gales. Information would be of particular use from Kent, Sussex, and Hants.

○○○○

Rev. Studdert Kennedy.

"Woodbine Willie," as the Rev. Studdert Kennedy was affectionately called during the War, when he was one of the most popular chaplains in the firing line, will broadcast from Bournemouth on November 8th.

○○○○

Stereoscopic Broadcasting.

Excellent reception was obtained at the first transmission of stereoscopic broadcasting in this country from the Shaftesbury Theatre. This broadcast was carried out through all stations, and was a preliminary test intended mainly for the guidance of the engineers. At the same time experiments were tried independently, with the view of improving the general results of this type of transmission. The result was that a marked difference was noticeable when "Dear Little Billie" was broadcast. The acoustic effect was about right, and objectionable echo which is usually due to the reflection of sound from the flies was eliminated.

○○○○

A Great Improvement.

Theatre broadcasts have usually indicated an absence of full, rounded sound. The effect has been that an acoustically flat sound picture was received, and the listener got no impression of the position occupied by the various artists or instru-

FUTURE FEATURES.**Sunday, November 1st.**

LONDON.—3.30 p.m., Light Russian Programme.

BIRMINGHAM.—3.30 p.m., Symphony Concert. 9.20 p.m., Instrumental Programme by the Olof Soloist Sextet.

CARDIFF.—9.15 p.m., Symphony Concert. Parry Jones (Tenor).

MANCHESTER.—9.15 p.m., The Casano String Octet.

ABERDEEN.—9.15 p.m., Amalgamated Musicians' Union Concert, relayed from the Music Hall, Aberdeen.

○○○○

Monday, November 2nd.

LONDON.—8 p.m., Military Tattoo.

MANCHESTER.—8 p.m., "A Fool's Paradise," by Sydney Grundy.

NEWCASTLE.—9.15 p.m., "The Burglar."

ABERDEEN.—8 p.m., "Les Cloches de Corneville" (Planquette).

○○○○

Tuesday, November 3rd.

MANCHESTER.—7.40 p.m., "Round the Table," a Discussion between Prof. T. H. Pear and Dr. Stanley H. Jackson.

○○○○

Wednesday, November 4th.

BIRMINGHAM.—8 p.m., Concert by the City of Birmingham Police Band.

BELFAST.—7.30 p.m., English and French Orchestral Music.

○○○○

Thursday, November 5th.

LONDON.—7.30 p.m., The Halle Orchestra, conducted by Sir Hamilton Harty, relayed from the Free Trade Hall, Manchester.

○○○○

Friday, November 6th.

BOURNEMOUTH.—8 p.m., Elgar, Stanford.

MANCHESTER.—8 p.m., Concert relayed from the Houldsworth Hall.

ABERDEEN.—8 p.m., "The Evolution of the Dance."

GLASGOW.—8.30 p.m., Scots Lecture Recital.

○○○○

Saturday, November 7th.

LONDON.—9 p.m., "Radio Radiance" (8th Edition).

GLASGOW.—7.30 p.m., Light Orchestral and Ballad Programme. Relayed to 5XX.

mentalists. In order to secure a similar effect to that received in the two ears of the listener, two microphones were installed to register intensity and tone values. By this means the listener got very much the same impression as if he had been standing in front of the footlights in the theatre with his eyes shut; that is, the reproduction so closely resembled the original that, judged by the faculty of hearing alone, the listener could not tell whether or not he was present at the actual performance.

○○○○

Two Receivers.

For the fuller development of this idea, it will presently be necessary to use two headphones, each connected to a different receiver, one tuned to 5XX and the other to the local station, and so adjusted that the strengths received are approximately equal. If loud-speakers were employed, an almost negative effect would be produced, as the sound intended for one ear would reach both ears. When the new type of transmission has been further perfected, listeners will be given an opportunity of tuning in, but in the meantime they should begin experiments on their own account, by employing two separate receiving sets. Further details will be given at the right time as to how they must use the sets to the best advantage.

○○○○

Outside Broadcasts.

One of the difficulties of outside broadcasts was demonstrated forcefully in connection with the transmission which had been arranged on the day of the Prince of Wales' return. A microphone was installed in the window of a Victoria Street stores with the object of picking up the sounds of the cheering crowds; but, unfortunately for listeners, His Royal Highness was fifteen minutes in advance of schedule time, and the microphone could not be switched on until his carriage had passed. This shows the vital importance of the time schedule in a broadcast of such a nature.

○○○○

Was it the Weather?

When, moreover, the microphone was brought into use, the noises of the multitude were very subdued. The adverse weather conditions, no doubt, had a dampening effect on the public's spirits.

○○○○

"Round the Table."

Starting in the first week of November, a series of discussions entitled "Round the Table," is being organised by Manchester station, with the co-operation of Professor T. H. Pear, Professor of Psychology at Manchester University. The first discussion is to take place between Professor Pear and Dr. Stanley H. Jackson at 7.40 on November 3rd. They have chosen as their subject: "What is Intelligence?" This will be followed by further debates in which women as well as men will take part.

INTRODUCTION TO WIRELESS THEORY

Power and Energy in Electrical Circuits.

By N. V. KIPPING and A. D. BLUMLEIN.

WE now come to the consideration of what is called "power." Let us return for this to our example of a water pipe and paddle (Fig. 1). In this the water will not flow continuously unless the paddle is turning, and the paddle will not turn unless some power is applied to it. Power is not merely "push," as one might say; it is a combination of "push" and the rate of pushing. That is to say, the same power might be used either to push a heavy thing slowly, or a light thing fast. The "push" of the paddle is usually known as "pressure," and the rate of pushing comes to the same thing as the rate of flow of the water. The power supplied to the paddle used in circulating the water round the pipe is measured by multiplying pressure by rate of flow. In the case of an electric circuit, then, the power supplied by the battery is measured by e.m.f. \times current. Power is talked about in "watts," and the watt has been chosen so that

$$1 \text{ watt} = 1 \text{ volt} \times 1 \text{ ampere.}$$

Calculation of Electrical Power.

For instance, if a battery of 3 volts is driving a current of 4 amperes through an electrical system, the power supplied by the battery is $4 \times 3 = 12$ watts.

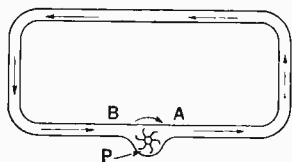

Fig. 1.—The power expended by the pump in forcing water through the pipe is proportional to the pressure exerted and to the rate of flow.

to light the lamp properly. From this we know that the current flowing through the lamp must be $\frac{30}{200} = 0.15$ ampere. Another way of saying this is to say that the lamp *absorbs* a power of 30 watts (when properly alight).

From this we can find the resistance of the lamp, because we know that an e.m.f. of 200 volts is driving a current of 0.15 ampere through it. This means that

the resistance is $\frac{200}{0.15} = 1,333$ ohms. This is the resistance of the very fine wire which is used for the filament of the lamp. Whenever a current flows through a wire, the wire gets hotter to some extent, depending on the current flowing and the resistance. In the case of the lamp, the very thin wire has a high resistance, and it is possible to choose a current which will cause it to become white hot and give out light. The resistance of the lamp

is calculated so that the current which will be pushed through it by the e.m.f. of the system is sufficient to make it white hot without melting it. If it is used on a system of a different e.m.f., the current pushed through it will either be greater or less than the right amount, and the filament will either melt or only glow dimly. If too much current flows through any part of a circuit, it may get dangerously hot and cause a fire, or, at any rate, be damaged itself. To prevent this, "fuses" are used.

A fuse consists of a small length of wire with a low melting point, the thickness of the wire being chosen so that as soon as the current in the circuit reaches too high a value for safety, the circuit is opened by the melting of the fuse.

While speaking of damage to circuits, it is worth mentioning that not only may conductors be damaged by too much current, but insulators by too much voltage. For instance, if a battery of sufficient voltage is connected to two separate wires lying side by side in the air, a spark will pass from one wire to the other across the air. The insulator (the air) is said to have broken down. This action is similar to the bursting of a boiler due to too great a steam pressure.

Transformation of Energy.

We have already said that the lamp absorbs power. If there were no current flowing in the lamp, no power would be absorbed, and the filament would not be heated. We get the idea, then, that the power is used in heating the filament. In fact, power can never be lost; it always appears again in some other form, if not in heat then as some other form of energy such as light or mechanical power. The power supplied whenever current flows

In this series of articles the fundamental principles of electricity and magnetism are presented in such a form that they may readily be understood by the beginner.

The nature of electrical pressure, current and resistance and their relation, as set forth in Ohm's Law, were dealt with in the previous issue. In this instalment the meaning of electrical power and energy is explained with numerous practical examples.

Introduction to Wireless Theory.—

through a resistance goes in heating the resistance, though in many cases the heating is so slight as not to be noticeable.

In electrical circuits, power is measured in watts, but other branches of engineering generally use "horse-power" as a measure of power. One horse-power is equal to 746 watts.

When we connect our lamp to a local electrical supply system, we are charged for using their power, but we are charged more for using 30 watts for an hour than for using 30 watts for a minute—in fact, sixty times as much. We are charged, then, not only for the power we use, but also for the length of time we use it. If we used a power of 30 watts for 1 hour, we should be charged as much as for 60 watts for ½ hour, because in each case we have used 30 watt-hours of energy. An amount of 1,000 watt-hours of energy constitutes one Board of Trade Unit.

We see, then, that energy is the name given to power used for a certain time. Now let us refer again to the simple circuit of a battery connected across a resistance, as in Fig. 2. Here the total resistance in the circuit is 10 ohms, and the e.m.f. is 5 volts, which gives us a current of ½ ampere. We are now able to say that the

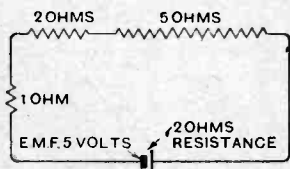

Fig. 2.—The power supplied by the battery in this circuit is 2½ watts, since a current of ½ ampere is being driven through the circuit by an e.m.f. of 5 volts.

power supplied by the battery is ½ × 5 = 2½ watts, and if the current flowed for 2 hours the energy expended by the battery would be 5 watt-hours.

As we have said before, in the circuit of Fig. 2 an e.m.f. of $2 \times \frac{1}{2} = 1$ volt is used in driving the current through the internal resistance of the battery. This

represents a power of ½ watt. The remaining 2 watts is used up in the 1-ohm, 2-ohm, and 5-ohm resistances in amounts of ¼ watt, ½ watt, and 1½ watts respectively, thus accounting for the whole of the 2½ watts supplied by the battery.

Power in Terms of Current and Resistance.

We now know that for a certain resistance with a certain current flowing through it we can calculate the driving e.m.f. or voltage across the resistance. Hence we can calculate the power absorbed by the resistance. The potential drop, or voltage across the resistance = resistance × current, and the power absorbed by the resistance = current × voltage.

Therefore the power equals current × current × resistance = current² × resistance. If I is the current and R the resistance, the power = I²R.

In Fig. 2, then, the power absorbed in the 5-ohm resistance = ½ × ½ × 5 = 1½ watts. Then, no matter what else is in a circuit, we can always calculate the power absorbed in a resistance forming a part of it, provided we know the current flowing through it. This power is changed into heat, and if the current is too large the value of I²R becomes too large for safety, causing damage to the circuit.

It is not only for lighting and room-heating purposes that the change of electrical energy into heat energy is useful. In a valve the heating of a wire by the passage of current is used to heat the filament of the valve and so accelerate the movement of electrons from it, as we shall see later.

Another interesting application is to be found in a simple little instrument for measuring current, called a hot-wire ammeter. In its simplest form this device consists of a fine wire stretched between two terminals. From the middle of this, a thread is stretched, tending to make the wire sag. This thread passes round a tiny pulley wheel and on to a fine spring, which keeps it taut. A pointer is fixed to the pulley wheel, so that if the sag of the wire increases, the thread will move, turn the pulley, and so move the pointer over a scale. Fig. 3a shows the arrangement schematically.

When a wire becomes hot, it expands, so that when a current passes through the wire of the ammeter it will expand by a certain amount, depending on how hot it gets, and, therefore, on the current flowing. The movement of the pointer, then, is a measure of the sagging of the wire, and so of the current flowing. The scale is so marked that the current can be read off directly in amperes.

A typical hot-wire ammeter, such as is often used for measuring aerial currents, is shown in Fig. 3b.

(To be continued.)

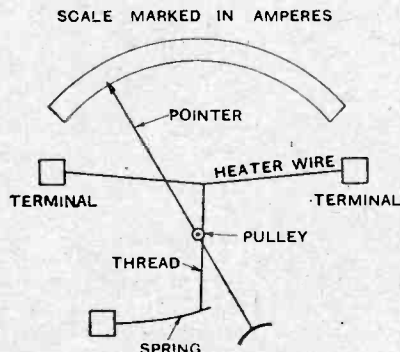

Fig. 3a.—Schematic diagram of the mechanism of a hot-wire ammeter.

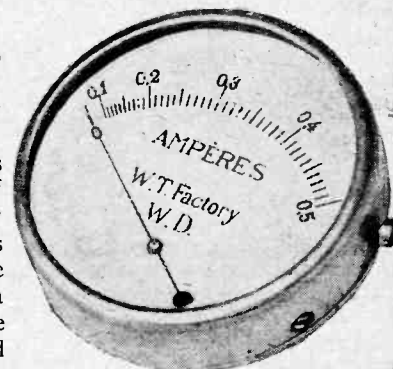
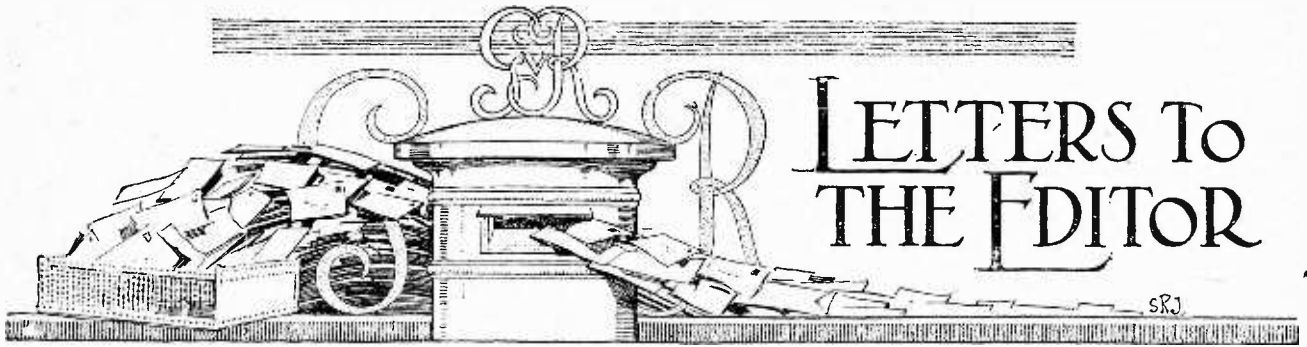

Fig. 3b.—Typical hot-wire ammeter in common use for measuring the aerial current of low-power transmitters.

OUR INFORMATION SERVICE.

So great has been the response to our invitation to readers to forward their technical problems to "THE WIRELESS WORLD" Information Department for replies free of charge, that we feel fully satisfied as to the need that has existed for such a service.

To assist us and to avoid delay, we ask our readers to head their questions "Information Dept.," and to limit themselves to one question at a time.



The Editor does not hold himself responsible for the opinions of his correspondents.

Correspondence should be addressed to the Editor, "The Wireless World," 138-140, Fleet Street, E.C.4, and must be accompanied by the writer's name and address.

SWEDISH SHORT-WAVE TESTS.

Sir,—Many will doubtless be interested to know that a special series of test transmissions for the further study of night effects, and particularly of "fading," will be sent out from the well-known amateur station SMXR (Sweden) every Friday from now onwards.

These transmissions will be on a wavelength of approximately 60 metres, and will commence at 10 p.m. (G.M.T.) with the call, "ILIDO DE SMXR," continued for five minutes and followed by other matter. The Morse system will be used, but to facilitate reports from all countries the well-known International Language ("Ido") will be employed. Reports should be sent and will be acknowledged in this language. Reception post-cards in this language can be obtained free by sending stamped addressed envelopes to the writer, and users are particularly desired to insert the "fading period."

These reports should be sent direct to Injeniore A. Lindstrom, Krokvgagen 12, Enskede (Sweden).

Although the tests will be made on low power, SMXR's signals are usually readable beyond Europe.

E. H. TURLE, Member I.R.E.,

Hon. Sek., Seciono Britania, Internaciona Ido-Radio-Klubo, Deerhurst, Beckenham, Kent.

AN "ALL-ROUND" WIRELESS EXHIBITION.

Sir,—I shall be glad of an opportunity of inviting the attention of your readers to the following points:—

During the last three years the National Association of Radio Manufacturers have organised a "Wireless Exhibition," and whilst these have been thoroughly well arranged there can be no doubt that it would be more appropriate to call the outcome of their efforts an "Exhibition of Popular Wireless Receivers and Accessories," since the apparatus shown is restricted to the kind which is of interest solely to those known, for want of a better name, as "Broadcast Listeners."

Exhibitions of the kind referred to do, of course, provide an opportunity for every manufacturer to see the products of certain competitors, but, on the other hand, the constitution of the organisers exclude many other manufacturers from exhibiting, and therefore the Exhibition cannot be regarded as completely representative, even of British manufacturers of broadcast receivers.

I would like to suggest to all parties concerned that it might be advantageous on some future occasion to organise a truly "Wireless Exhibition," open not only to manufacturers of receiving sets and accessories, but what is equally important, to the manufacturers of the plant and instruments required on the engineering or transmitting side of radio telephony and telegraphy.

It is generally admitted that the technical quality of radio telephony broadcast in this country is of a very high order, in consequence of which, manufacturers of transmitting, as well as receiving apparatus, have received many enquiries from abroad, from which fact we can assume with reasonable safety

that an exhibition covering every application of wireless telephony and telegraphy, both from the transmitting and the receiving side, would attract the attention, not only of the public and the manufacturers, but also that of prospective buyers from abroad.

An exhibition on these lines, therefore, would be certain of success, and might confer great advantages on this branch of the British engineering industry.

Incidentally, such an exhibition might help everyone concerned to realise that the prosperity and employment resulting from the extensive sale of receivers, accessories and journals, depends in the ultimate sense on the engineers who design the transmitting equipment, and when the complexity of the radio engineers' work is appreciated, it will be seen that these men need the widest possible training and experience.

Ruislip, Middlesex.

L. F. FOGARTY.

WIRELESS APPARATUS AND LIGHTNING.

Sir,—A few instances have been reported during the past summer of wireless apparatus being destroyed by lightning, but considering the number of aerials now in use the damage has been unexpectedly small. The extent to which aerials are affected by lightning discharge, and the results likely to arise therefrom are questions of practical importance to all users of wireless apparatus, and an attempt is being made to collect information relative to actual cases in which aerials and apparatus have suffered in this way. I should be glad if I may use the publicity of your columns to ask anyone, and everyone, whose apparatus has been damaged, to forward full information to me at the address given below. The data particularly required are:—

- The date and time of the occurrence.
- The position and approximate dimensions of the aerial.
- The nature and position of the earth connection.
- A brief description of surroundings, *i.e.*, position of adjacent houses, trees, telephone wires, etc.
- Whether the aerial was directly earthed or whether either receiving or transmitting apparatus were in circuit.
- The fullest possible description of the incident and the nature of the damage done.

CECIL L. FORTESCUE.

City and Guilds (Engineering) College,
Exhibition Road, S.W.7.

GERMAN AMATEUR TESTS.

Sir,—I have been advised by German KY5, Herr Fritz Sabrowsky, of Stuttgart, that he is transmitting on Wednesdays and Saturdays from 2300 to 0200 the following morning, on a wavelength of 46.5 metres, and would welcome reports. He uses 40 watts input (D.C.) on a 3-coil Meissner.

London, S.W.11.

C. W. PICKEN.

DICTIONARY OF TECHNICAL TERMS



Definitions of Terms and Expressions commonly used in Wireless
Telegraphy and Telephony.

This section is being continued week by week and will form an authoritative work of reference.

Centimetre (units of inductance and capacity) The dimensions (*i.e.*, the units expressed in terms of length, mass and time) of *inductance* in the C.G.S. electro-magnetic system and of *capacity* in the C.G.S. electrostatic system of units are both length, and for this reason the C.G.S. unit of each of these quantities is sometimes named the centimetre.

One centimetre of inductance is equivalent to 10^{-9} henry, or one *microhenry* equals 1,000 centimetres.

One centimetre of capacity is equivalent to $\frac{1}{30000000}$ of a microfarad. 1,000 centimetres = 1 jar.

C.G.S. Units. See ABSOLUTE UNITS.

Characteristic Curve. Any graph showing the relationship between two variable interdependent quantities such as E.M.F. and current. See STATIC CHARACTERISTICS (of valve).

Charge. (a) The quantity of electricity contained by a condenser or an isolated conductor.

(b) The number of ampere-hours which an accumulator can give out on being discharged.

Chatterton's Compound. An adhesive insulating compound which is easily melted by moderate heat.

Choke or Choking Coil. A coil wound to have a large reactance at a given frequency compared with its resistance. For use on low frequencies the coil is usually wound on an iron core, either fixed or movable, whereas for radio frequencies the coil is wound on a core of non-magnetic material. See ALTERNATING CURRENT CIRCUITS and AIR CORE CHOKE.

Choke Control. A system used in wireless telephony for modulating the high-frequency oscillations. Two valves are fed from the same source of H.T. supply through a highly inductive *choking coil*, one of the valves producing the continuous high-frequency oscillations. The audio-frequency oscillations are applied to and amplified by the second valve and by reason of the choke in the plate circuit these low-frequency oscillations are applied to the plate of the oscillator valve, causing the high-frequency oscillations to vary in amplitude at the audio-frequency. See MODULATION.

Chopper. See TICKER.

Circular Mil. The area of a circle one-thousandth of an inch in diameter. Sometimes used as a measure of the cross-sectional area of a wire.

Cleats. Porcelain insulators for fixing wires to walls, etc.

Click Method. Refers to a method for measuring the *wavelength* of a tuned circuit. When an oscillating valve circuit is loosely coupled to a tuned circuit it is found that the oscillations suddenly cease when the two circuits are brought into *resonance*. Thus by varying the tuning of one of the circuits so that it passes through the point of *resonance* with the other a click is heard in the telephones, exactly at the point of resonance, this click being due to the sudden cessation and recommencement of the oscillations.

Clicks. Name given to certain kinds of *atmospherics* which give sudden separate clearly defined sounds in the telephones; usually heard during the cooler seasons of the year.

Close Coupling. See TIGHT COUPLING and COEFFICIENT OF COUPLING.

Closed Core Transformer. A transformer with its *magnetic circuit* consisting entirely of iron, no *air gap* being included.

Coefficient of Amplification. See AMPLIFICATION CONSTANT.

Coefficient of Coupling. The ratio of the *mutual inductance* to the square root of the product of the individual *self-inductances* of two circuits which are inductively coupled together. If the mutual inductance between two coils is M and the individual inductances are L_1 and L_2 respectively, the coefficient of coupling is given by $\frac{M}{\sqrt{L_1 L_2}}$.

Coefficient of Mutual Induction. If two circuits are so placed that lines of magnetic force are linked with one of the circuits when current flows in the other, those two circuits are said to possess *mutual inductance*. The coefficient of mutual inductance denotes the number of "line linkages" (product of magnetic flux and number of turns linked with it) produced in one of the circuits when unit current flows in the other. The coefficient of mutual inductance is said to be one *henry* if 10^9 line linkages are produced in one of the circuits when one ampere flows

in the other. (Denoted by M .) Cf. COEFFICIENT OF SELF-INDUCTION.

Coefficient of Self-Induction. If a current when passed through a circuit produces a magnetic field linked with that circuit, the latter is said to possess *self-inductance*. The coefficient of self-induction is the measure of the self-inductance. A circuit is said to have a self-inductance of one *henry* if 10^9 "line linkages" (product of magnetic flux and number of turns of the circuit linked with it) are produced when a current of one ampere flows through it. (Denoted by L .) Cf. COEFFICIENT OF MUTUAL INDUCTANCE.

Coercive Force. The magnetising force which has to be applied in the reverse direction to a magnetised body in order to remove the *residual magnetism*. See HYSTERESIS LOOP.

Coherer. An early form of detector based on the imperfect contact between lightly packed metallic filings, which have the property of decreasing the contact resistance when subjected to more or less feeble high-frequency oscillations and remaining in this state of improved conductivity until disturbed.

Commutator. A device for reversing the direction of a current; a reversing switch. The drum built up of insulated copper segments connected to the armature winding of a direct current dynamo and from which the current is collected by the brushes.

Compressed Air Condenser. An *air condenser* in which the air dielectric is compressed, thus allowing much larger voltages to be used without the danger of a direct discharge taking place between the plates. The *dielectric strength* of air is much greater under compression than at normal pressure.

Condenser. An arrangement consisting of two sets of *conductors* of considerable surface, one set being insulated from the other by a comparatively thin *dielectric* and thus possessing an appreciable *capacity*. The two sets of plates or conductors may be fixed relatively to one another giving a fixed value of capacity, or one set may be movable with respect to the other in order to give a variable value of capacity.

If a steady potential difference is suddenly applied between the two sets of plates of a condenser a momentary

Dictionary of Technical Terms.—

current will flow, but as soon as the condenser becomes *charged* this current ceases. Thus a *direct current* cannot flow through a circuit in which a condenser is connected in series. When an *alternating potential difference* is applied the condenser becomes charged up alternately in both directions, the charging current passing from one plate to the other round the external circuit; so that a condenser does not prevent an alternating current from passing along a circuit of which it forms a part. It merely offers a certain amount of opposition depending on the capacity of the condenser and the frequency of the current. See CAPACITY, AIR CONDENSER, ALTERNATING CURRENT CIRCUITS.

Condensive Reactance. The opposition offered by a condenser to the passage of a current "through" it. If an alternating voltage V is applied to a condenser of capacity- C farads, the current is given in amperes by $A = \frac{V}{2\pi fC \times V}$, or $-\frac{1}{A} = \frac{1}{2\pi fC}$ ohms, where f is the frequency and the quantity $\frac{1}{2\pi fC}$ is the reactance of the

condenser at the frequency f , called condensive reactance or capacity reactance to distinguish it from *inductive reactance*. An alternating current through a condenser leads the voltage in *phase* by 90° . See ALTERNATING CURRENT CIRCUITS and REACTANCE.

Conductance. The reciprocal of *resistance*, the unit being the mho. For direct current the conductance may be defined as the ratio of current to voltage. For a circuit consisting of a number of branches connected in *parallel* the conductance is equal to the sum of the conductances of the individual branches.

Conductivity. The capacity of a material for conducting electric currents, and is sometimes used to denote the percentage which the conductivity of one substance is of that of a standard substance (e.g., pure copper). See SPECIFIC CONDUCTANCE.

Conductive Coupling. The connection of two circuits so that current flows between them by conduction. Cf. INDUCTIVE COUPLING.

Contact Breaker, or Contact Maker. An automatic switch for rapidly opening and closing a circuit, as in the case of a *buzzer* or the primary circuit of an induction coil.

Continuous Current. See DIRECT CURRENT.

Continuous Oscillations. **Continuous Waves (C.W.)** Oscillations or waves which persist with undiminished amplitude, i.e., undamped waves. Such waves are used in most of the later systems of wireless telegraphy and in all systems of wireless telephony. A high-frequency oscillation is said to consist of "pure C.W." if the amplitude remains absolutely constant whilst

it lasts. On the other hand, the continuous wave may be *modulated*, i.e., the amplitude may be varied in some desired way, as, for instance, in the case of wireless telephony, where the amplitude varies in conformity with the speech vibrations.

Control Valve. The *low-frequency* valve which is used in the *choke-control* method of wireless telephony transmission, for amplifying the audio-frequency oscillations before applying them to the *plate circuit* of the *oscillator valve*.

Converter. A single electric machine with moving parts, used for converting *alternating current* into *direct current* or *vice versa*, or to change the pressure of a direct current. See ANODE CONVERTER.

Co-Phasal. Of coincident *phase*.

Copper Loss. That portion of the energy which is wasted in any electrical apparatus by reason of the heating of the windings, etc., due to their *resistance*. The rate of loss of energy or the power lost is given by the product of the square of the current and the resistance. Thus, if I is the current and R is the resistance of the circuit, the power lost in watts is given by $W = I^2R$ watts.

Corona. The luminous discharge which takes place from transmitting aerials when working at very high voltages. Sometimes called a "brush discharge."

Cos ϕ (Greek letter "phi"). A term sometimes used for the *power factor* of a circuit, being equal to the cosine of the angle of *phase difference* between the current and the voltage. See ALTERNATING CURRENTS, POWER FACTOR and PHASE DIFFERENCE.

Coulomb. The practical unit of quantity of electricity, being that quantity represented by a current of 1 *ampere* flowing for one second.

Counter Electromotive Force. An E.M.F. which is opposed to the main or applied voltage in a circuit and due to some auxiliary cause. For instance, in an electric motor the rotation of the armature generates an E.M.F. which acts in the reverse direction to the applied voltage; similarly, in the case of an inductive circuit carrying an *alternating current*, the varying magnetic fluxes induce an E.M.F. which at every instant acts in opposition to the applied E.M.F. Sometimes called the "back E.M.F."

Counterpoise. A substitute for the usual "earth" connection in a wireless aerial system. It consists of a network of wires spread above the surface of the ground and insulated from it, these wires and the ground respectively forming the two plates of a large condenser. (Also called "balancing capacity" and "capacity earth.")

Coupled Circuits. Circuits arranged to affect one another either conductively, inductively, or *electrostatically*.

Coupler. An arrangement whereby electrical oscillations in one circuit are en-

abled to induce oscillations in another circuit or another part of the same circuit by *inductive coupling* between two coils, one of which is connected in each circuit. It is usual for the coupling to be variable. See LOOSE COUPLER and VARIOCOUPLER.

Critical Damping. *Damping* which is just sufficient to make oscillation at the natural period impossible. In an electric circuit containing inductance L and capacity C , oscillation at the natural frequency will be impossible if the re-

sistance is greater than $2\sqrt{\frac{L}{C}}$. This

is called the "critical resistance." See OSCILLATING CIRCUITS.

Crystal Detector. A *detector* of high-frequency oscillations depending on the *unilateral* or *unidirectional conductivity* of the contact between a suitable crystal and some other substance or another crystal of different composition. This unilateral conductivity has a rectifying effect on the trains of received high-frequency oscillations, and the unidirectional impulses of current so obtained can be made to produce audible sounds in a sensitive telephone receiver.

Cumulative Rectification. See GRID RECTIFICATION.

Current. The passage of electricity through a conductor. The magnitude of an electric current can be defined as the quantity of electricity which passes a given point in a circuit in one second. A current is detected by its physical effects, namely (a) its heating effect, (b) its electrolytic effect, and (c) its magnetic effects.

The absolute electromagnetic unit of current is based upon the magnetic properties, and may be defined as that current which, flowing in a conductor 1 centimetre long bent into an arc of a circle 1 centimetre in radius, will exert a force of 1 dyne on a *unit magnetic pole* at the centre of the circle.

The practical unit of current (the ampere) is equivalent to one-tenth of the absolute unit. The International ampere is defined as that steady current which will deposit by electrolysis 0.001118 gram of silver per second on a platinum cathode immersed in a 15% solution of silver nitrate, the anode being made of silver.

Current Density. The current in amperes per unit of cross-sectional area of the conductor carrying it; i.e., the ratio of the current in a conductor to the cross-sectional area of that conductor.

Current-Square Meter. A hot-wire or other type of ammeter where the scale reading is proportional to the square of the current, used for measurement of *aerial resistance* and other high-frequency resistances. If such an instrument is connected in a circuit in which oscillations are being induced and the reading is halved by the addition of a certain extra resistance in series, then the original *high-frequency resistance* of the circuit is equal to the added resistance.

READERS' PROBLEMS

"The Wireless World" Information Department Conducts a Free Service of Replies to Readers' Queries.

Questions should be concisely worded, and headed "Information Department." Each separate question must be accompanied by a stamped addressed envelope for postal reply.

A Reflexed Neurodyne Circuit.

Recently perusing a foreign radio journal I came across a reference to the Grimes Inverse Neuroflex circuit. Have you any information concerning this circuit?
R.C.F.

We reproduce this circuit in Fig. 1. It is, of course, a modernised form of the old Grimes Inverse Duplex circuit, in which the neurodyne principle has been introduced. As will be seen from the diagram, it consists fundamentally of two valves, both of which are reflexed and both of which are stabilised by the neurodyne method. Rectification is carried out by a crystal, and thus it may possibly be said that this circuit represents the utmost that may be done with two valves from the point of view of distance and volume. The special point about this circuit is that the valves are inversely reflexed in order that the valve which undertakes the greatest H.F. load (namely the second valve) is called upon to deal with the smallest L.F. load, the first valve acting as the first H.F. and final L.F. amplifier. If properly designed and constructed, a receiver of this

description should be capable of reception over very considerable distances. A lot depends on the design of the "neuroformers," and readers who contemplate experimenting with this circuit are advised to make their H.F. transformers exactly in accordance with the instructions given in the description of the two-valve neurodyne unit in the October 21st issue of *The Wireless World*.

Selective Receivers.

I wish to build a set which will bring in all B.B.C. stations on the loud-speaker. Two transformer coupled L.F. stages with suitable power valves will be used in any case. On the H.F. side I have narrowed my choice down to either a 2 H.F. neurodyne or a 3 I.F. superheterodyne receiver. Which do you advise me to build?
J. D. R.

It is by no means easy to give advice in a case of this description. From the point of view of sheer sensitivity the palm must be handed to the superheterodyne, but it is doubtful whether it

would be correct under all conditions to advise the building of a superheterodyne in preference to a neurodyne. From the point of view of sensitivity comparison, it is generally taken that a well constructed superheterodyne employing three well-designed I.F. stages gives results on the aerial fully equal to or slightly superior to a good neurodyne receiver employing two H.F. stages and operating on a normal aerial and earth system. This comparison is, of course, very rough and ready, and depends a great deal on individual circumstances. The superheterodyne possesses the advantages of requiring no outdoor aerial, and being more selective both inherently and because of the directional properties of a frame aerial. The neurodyne possesses the advantage of smaller initial and running costs, and of giving, from an actual practical standpoint, rather better quality than a superheterodyne. Both are excellent instruments if properly designed and constructed, and both are equal abominations if care is not taken in design and construction. The choice of either must necessarily in all cases depend on individual circumstances.

Comparing Signal Strengths.

I wish to make some sort of comparison between the signal strength obtained from the crystal receivers of various friends living in different suburban districts of the town in which my local station is situated, but am at a loss concerning the best method on which to set to work.
F. H. S.

The only satisfactory method of accomplishing this aim is to make use of a microammeter and measure the rectified current in each individual case, and so make a direct comparison. Another method, which is, however, very rough and ready, is to shunt the telephones with a calibrated variable resistance, and to decrease the value of this shunting resistance until all signals disappear, and then to note the resistance setting. By noting this signal disappearance point in different sets, a rough comparison between them can be made. Needless to say, the same pair of telephones should be used in every case. Unfortunately, of course, the human factor enters largely into this method.

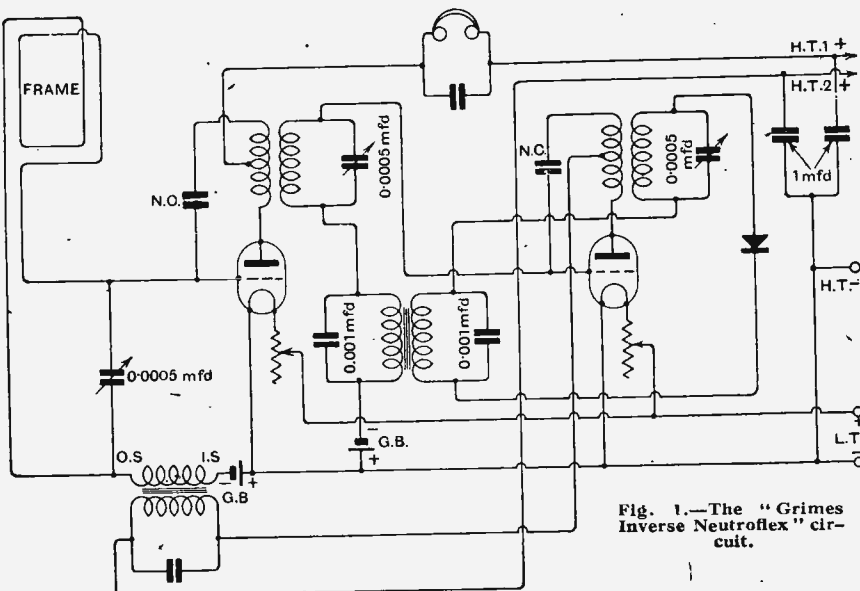

Fig. 1.—The "Grimes Inverse Neuroflex" circuit.

Restoring Crystal Sensitivity.

I have heard many conflicting opinions concerning the adverse effect on the sensitivity of a crystal which can be brought about by touching the mineral with the hands. Surely this statement is somewhat overrated, since I find my crystal which I have handled is fully equal to a new specimen. H. T. B.

The statement that crystals are completely ruined by handling is undoubtedly exaggerated by certain writers, and provided care is taken there is really no need to use tweezers every time a crystal is handled. At the same time, of course, unnecessary handling should be avoided. If a crystal has become insensitive owing to accumulation of dirt it may sometimes be restored to its former condition by washing in benzine. Petrol should never be used as it leaves a greasy deposit. Failing this, the crystal should be carefully fractured in order to expose a fresh surface.

o o o o

Converting to Anode Rectification.

I have constructed a superheterodyne receiver from which I have obtained excellent results. The intermediate amplifier consists of four resistance-coupled stages followed by a leaky grid condenser rectifier. I am desirous of improving quality by converting this detector to the anode rectification principle, using a D.E.Q. valve. Please give me a suitable diagram of conditions. A.O.C.

A suitable circuit is shown in Fig. 3. The grid coil, which can be of the plug-in type, should, of course, be of such a size that, in conjunction with the shunting 0.001 mfd. variable condenser, it will tune to the wavelength of the intermediate amplifier. The use of this tuned grid system will, of course, considerably assist in improving the selectivity of the intermediate amplifier. The choke in the anode circuit of the D.E.Q. valve must have a high impedance commensurate with the high impedance of this particular valve.

BOOKS FOR THE HOME CONSTRUCTOR

Issued in conjunction with "The Wireless World."

"THE HOME CONSTRUCTOR'S EASY-TO-BUILD WIRELESS SETS," by F. H. HAYNES. Price 1/6 net. By Post, 1/9.

"TUNING COILS AND METHODS OF TUNING," by W. JAMES. Price 2/6 net. By Post, 2/10.

"HOW TO BUILD AMATEUR VALVE STATIONS," by P. R. COURSEY, B.Sc. Price 1/6 net. By Post, 1/8.

"THE CONSTRUCTION OF AMATEUR VALVE STATIONS" by Alan L.M. DOUGLAS. Price 1/6 net. By Post, 1/8.

"THE HOME CONSTRUCTOR'S WIRELESS GUIDE," by W. JAMES. Price 3/6 net. By Post, 3/9.

"MAST AND AERIAL CONSTRUCTION FOR AMATEURS," by F. J. AINSLEY, A.M.I.C.E. Price 1/6 net. By Post, 1/8.

Obtainable by post (remittance with order) from ILIFFE & SONS LIMITED, Dorset House, Tudor St., London E.C.4, or of Booksellers and Bookstalls

L.F. Transformer Connections.

Is there any definite rule with regard to transformer connections? I notice that in different receivers it often happens that the same type of transformer is differently connected.

P. H. R.

No definite rule can be given, and although in many cases definite instructions are given by the makers, it is always as well to experiment with alternative connections, since different specimens of the same make and type of transformers have different characteristics. Usually, of course, the primary connections have a definite relationship to the secondary connections. That is to say, assuming that by careful experiments connections have been adopted which give best results, if the secondary windings are reversed, it will be found that a fall in volume, quality, or both, is experienced; whereas by reversing the primary the status quo is restored. Practice

shows that one of the best plans to adopt is to connect O.S. to grid and I.S. to negative side of grid bias battery, and then to experiment with the primary connections. Usually transformers will be more sensitive to the method of their connections when used in a reflex circuit than in a straight circuit.

o o o o

Reflexed Push-Pull Receiver.

Having experimented very considerably with push-pull amplifiers and obtained excellent results, I propose to construct a single-valve reflex receiver utilising the push-pull arrangement. Please inform me whether the diagram which I submit is suitable for my purpose. M.T.G.

Your diagram, which we reproduce in Fig. 2, is quite in order. Ordinary valves may be used throughout, there being no need for power valves. Owing to the

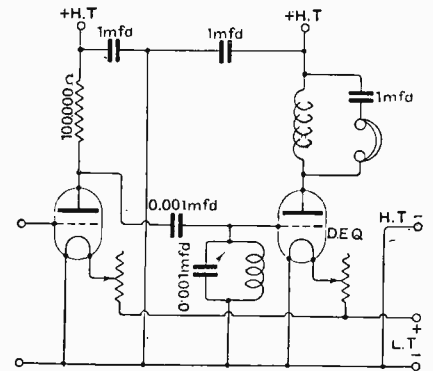

Fig. 3.—Circuit for converting the second detector in a superheterodyne receiver to anode rectification.

combination of crystal rectification and push-pull amplification, most excellent volume and quality should be obtained. The transformer following the crystal may be of 6 to 1 or even 8 to 1 ratio, if of reputable manufacture.

o o o o

Resonant Howling.

I find that when I turn my loud-speaker in the direction of my receiver a howl commences which gradually builds up into a roar. I am fully aware of the cause of this, having seen it explained many times in THE WIRELESS WORLD, but wish to know if there is any method of preventing it, other than by the substitution of anti-phonous valve holders.

L. O. R.

One method of overcoming this annoyance is to pack cotton wool round each individual valve. A simpler, but sometimes equally effective, method is to obtain a length of insulating tape and to pierce a small hole at one end in which is inserted the pip of the valve, the tape being also attached to the glass bulb by the adhesive matter on it. This tape is extended to the next valve, where a further hole is pierced for insertion of the valve pip, and so on, according to the number of valves in use.

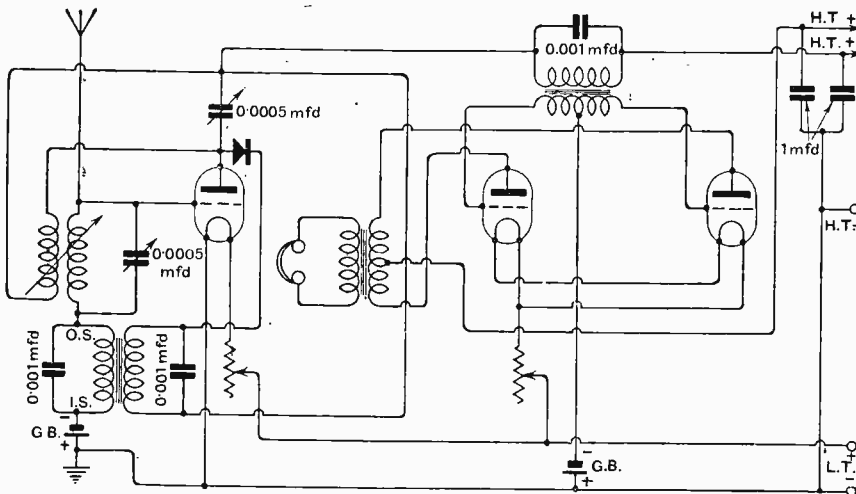

Fig. 2.—Three-valve and crystal receiver in which the first valve amplifies at high and low frequencies, and the second and third valves operate in combination as push-pull L.F. amplifiers.