

THE WIRELESS WORLD

AND
RADIO REVIEW



PRICE 4^D NET.

THE STORY OF
AMATEUR
COMMUNICATION
WITH
NEW ZEALAND

HETERODYNE
WAVE METER
FOR 60-250 METRES

No. 273 [No. 6
Vol. XV]

MORE COMPONENTS FOR THE UNIT RECEIVER

MARCONI VALVES

MADE AT THE OSRAM LAMP WORKS

For Resistance-Capacity Amplification

The D.E.5B

A companion valve to the Detector R5V and Power-Amplifier D.E.5 designed to give maximum amplification in the valve itself combined with minimum distortion in the Amplifier.

The well-known Resistance capacity method of coupling is eminently suitable for H.F. work on wavelengths of not less than 1,000 metres and is incomparable for low frequency amplifiers, eliminating all distortion common to iron core transformers.



Characteristics—

Filament Volts - - 5 to 6
Anode Volts - - - 100 to 120
Impedance- - - 30,000 ohms
Current Consumption 0.25 amps.

Amplification Factor 20

*To get the Right Results
the Right Valve Must be Used*

The D.E.5B

obtainable from all leading Wireless Dealers.

35/-

(WHOLESALE ONLY)

**The General Electric Co., Ltd.,
Magnet House, Kingsway, W.C.2.**

Get the Valve in the Purple Box!

THE WIRELESS WORLD AND RADIO REVIEW

THE OFFICIAL ORGAN OF THE RADIO SOCIETY OF GREAT BRITAIN.

No. 273. (No. 6 Vol. XV.) NOVEMBER 5th, 1924.

WEEKLY.

EDITOR:
HUGH S. POCOCK.

RESEARCH EDITOR:
PHILIP R. COURSEY, B.Sc., F.Inst.P., A.M.I.E.E

ASSISTANT EDITOR:
F. H. HAYNES.

QUESTIONS AND ANSWERS DEPARTMENT:
Under the Supervision of W. JAMES.

CONTENTS.

	PAGE
Radio Topics. By the Editor - - - - -	151
Heterodyne Wavemeter—60 to 250 Metres. By W. James - - - - -	152
A French Wireless Pioneer - - - - -	158
Readers' Practical Ideas - - - - -	159
Three-Valve Unit Receiver (<i>continued</i>). By R. H. Cook - - - - -	161
Wireless in the Midlands - - - - -	165
The Story of the New Zealand Successes - - - - -	167
Notes and News - - - - -	179
Broadcasting Table - - - - -	181
Calls Heard - - - - -	182
Among the Societies - - - - -	183
Correspondence - - - - -	184
Readers' Problems - - - - -	185

THE EDITOR will be glad to consider articles and illustrations dealing with subjects within the scope of the Journal. Illustrations should preferably be confined to photographs and rough drawings. The greatest care will be taken to return all illustrations and manuscripts not required for publication if these are accompanied by stamps to pay return postage. All manuscripts and illustrations are sent at the Author's risk and the Editor cannot accept responsibility for their safe custody or return. Contributions should be addressed to the Editor, "The Wireless World and Radio Review," 12 and 13 Henrietta Street, Strand, London, W.C.2.

SUBSCRIPTION RATES:
20s. per annum, post free. Single copies 4d. each or post free 5d. Registered at the G.P.O. for transmission by Magazine Post to Canada and Newfoundland.

As many of the circuits and apparatus described in these pages are covered by patents, readers are advised, before making use of them, to satisfy themselves that they would not be infringing patents.



EDITORIAL AND PUBLISHING OFFICES:

12 and 13 Henrietta Street,
Strand, London, W.C.2.
Telephone: Gerrard 2807-8.

ADVERTISEMENTS MANAGERS:

Bertram Day and Co., Ltd.,
9 & 10 Charing Cross, S.W.1
Telephone: Gerrard 8063-5.

Tune the Table-Talker with the "Matched Tone" Headphones

The Brandes Family Series.



AMARYLLIS dances. Once it was just now and then, but to young Bill that seems æons and æons ago. Now it's interminable—with the help of Brandes' Products. They are quick to define

naturally the intoxicating rhythm, the joyous lilt of saxophone wizardry. Young Bill grumbles, but why shouldn't she? That lithe young body, flushed cheeks and sparkling eyes—how hard to resist syncopated melody when the *Table-Talker* brings it with all its real tone and rhythmical fascination. "Joie de vivre, Bill!" she says, and somehow he forgets his grouse when *somebody else's* sister comes in to help "flay the carpet," as Father puts it. Ask your dealer for Brandes.

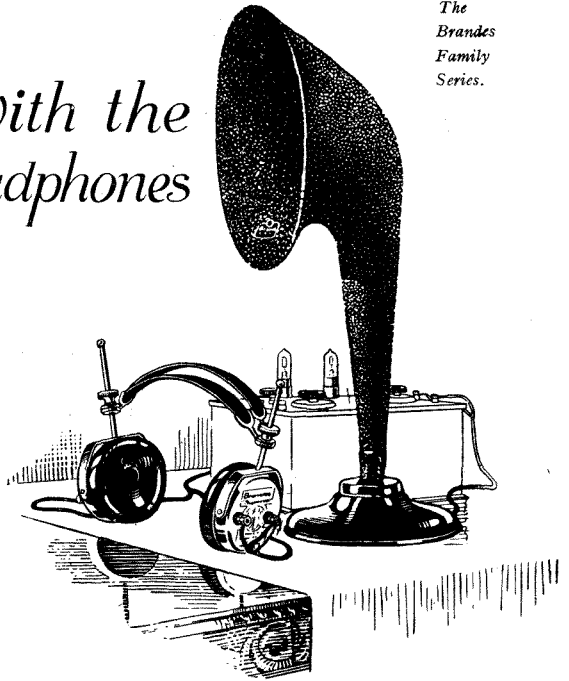

All Brandes products carry our official money-back guarantee, enabling you to return them within 10 days if dissatisfied.

The "Matched Tone" feature means that both your ears hear exactly the same sound at the same instant—and you learn a new beauty of tone. They are tested and re-tested for just this one vital point, and in addition their strength, long-wearing comfort and reliable efficiency make them undoubtedly **25/-** superior

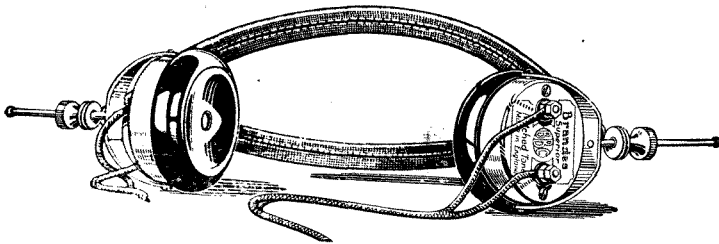

The *Table-Talker* is a Brandes quality product at a moderate price. The non-resonant, specially constructed horn is matched to the unit so that the air resistance produced will exactly balance the mechanical power of the diaphragm. This means beautiful sound-balance and remarkable tone qualities. It is twenty-one inches high, has a self-adjusting diaphragm, and is finished a **42/-** shade of neutral brown

Brandes

Result of 16 Years Experience

The name to know in Radio

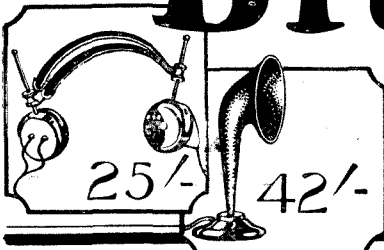

THE WIRELESS WORLD AND RADIO — REVIEW



RADIO TOPICS.

THE NEW ZEALAND SUCCESSES.

DUE to co-operation in true amateur spirit, we are able to publish in this issue first-hand accounts of communications with New Zealand from several of the principal contributors to these successes. These stories will, we feel sure, be read with the utmost interest and must act as a stimulus to further enterprise.

Mr. R. J. Orbell, the New Zealand amateur who owned the station **Z3AA**, has also contributed an account of amateur activities in New Zealand, and relates his experiences during his recent voyage to England *via* Cape Horn, when he operated an amateur station on short wavelengths throughout the voyage. On his arrival in England he was greeted with the news that direct amateur communication with New Zealand had been achieved, and, at the invitation of Mr. Goyder, of Mill Hill, he was able to take part himself in conversing by morse with his friends, from Mr. Goyder's station.

Apart from the successes which we recorded in our last issue, we have since received a number of additional reports of reception here of New Zealand stations, and also of reception there of British transmissions, whilst those who have effected two-way communication have repeated their results over continuous periods of as much as an hour and a-half.

Whilst recording these events we wish to draw attention to the fact that, apparently unwittingly, some amateur transmitting stations not taking part in these experiments have hampered communication with New Zealand by transmitting on wavelengths so very close to those employed for the New Zealand experiments that interference has resulted. It is hoped that, in

view of the importance of these experiments, those transmitters who are likely to cause interference will hold off during the test hours unless they are themselves participating.

As far as long distance working is concerned it is difficult to see in what direction the British amateur can now turn in order to beat his own record. We wonder what the Americans will have to say about this achievement, which is the goal for which they have worked unfruitfully for many months past. However ready we should have been to congratulate others if this success had fallen to them, a very natural satisfaction is felt that British amateurs were the first to set up a world's record.

At the meeting of the Radio Society of Great Britain, held recently, Mr. R. H. Barfield gave a lecture on "Unsolved Problems of Wireless." In the discussion which followed, interest centred around these long-distance transmission results, and many speakers pointed out the importance of obtaining comparative quantitative results on the strength of signals at great distances on different points of the globe, for it was only from the collection of such data as this, which the amateur is in the best position to provide, that any new light can be thrown on the problems connected with the propagation of wireless waves round the earth.

No doubt the Radio Society of Great Britain will take all possible steps to collect and record data already obtained, and any new information which may result from further tests. Unfortunately it too frequently happens that valuable scientific data is lost or recorded so unsystematically that it is of little value as evidence when required.

THE EDITOR.

THE CONSTRUCTION OF A HETERODYNE WAVEMETER 60 TO 250 METRES.

By W. JAMES.

Introduction.

THIS heterodyne wavemeter was designed to meet the requirements of those amateurs who are interested in the reception or transmission of short wavelength signals. To be of

instrument. Further, the variable condenser should be one having reasonably low losses, be rigidly constructed, and have a dial which is nicely engraved (in order that accurate readings may easily be taken) and which can be fixed securely to the shaft of the

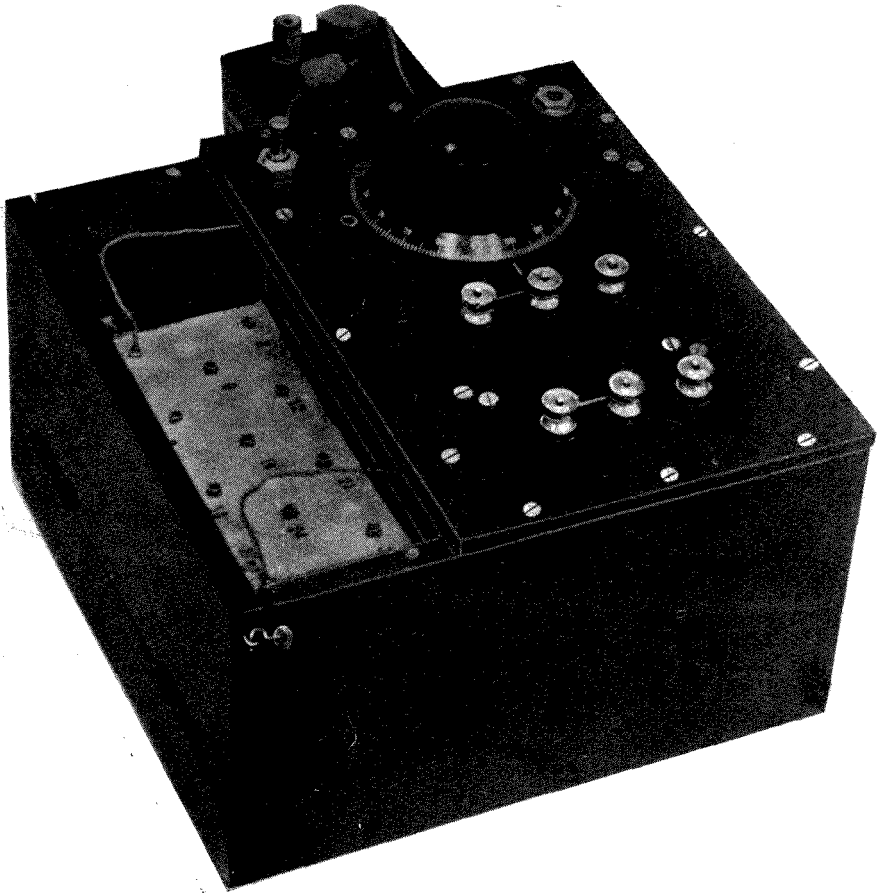

A view of the completed instrument.

value a wavemeter must be so designed that its characteristics do not change with use. Hence the coils must be well made from a mechanical as well as from an electrical point of view, in order that the turns shall not change their shape or their position on the formers, and be firmly secured in the

condenser. It is important to employ a well-made condenser, whose characteristics will not change with use.

The wiring should be carefully carried out, with thick, rigid wires, well soldered at the connecting points and arranged so that wires cannot change their position.

General.

The wavemeter is self-contained, and comprises a D.E.R. valve, a 2-volt accumulator (Exide, type DTG), two 15-volt dry cell units connected in series, a filament circuit (on and off) switch, a telephone jack (connected in the plate circuit), a variable condenser—maximum capacity 0.0005 microfarads (the one employed in this instrument is a Burn-dept standard condenser with screening case), a grid coil with one tapping, and a plate (reaction) coil with one tapping.

The illustration at the head of this article is a general view of the instrument. It will be seen that with the exception of the accumulator, everything is mounted inside the box. The accumulator rests on an extension of the base, and is situated here in order that it may readily be removed for charging.

The theoretical connections of the wavemeter appear as Fig. 1. It will be noticed that a tuned grid circuit is connected across the grid and filament of the valve. This circuit (mainly) fixes the wavelength of the oscillations which are generated.

No grid condenser and leak is employed. It was found that for the same applied filament and plate voltages the oscillations were much stronger when the grid return wire was connected direct to the negative side of the filament.

The capacity of the grid circuit is not, of course, localised in the tuning condenser. There is capacity between the elements of the valve, between connecting wires, and the coil has self-capacity. These stray capacities are in parallel with the tuning condenser. In addition, there is capacity between the grid and plate circuit coils. It is these capacities, added to the capacity of the tuning condenser (when set in the position of minimum capacity), which, for a given coil, decide the lowest wavelength of the oscillations which may be generated. Hence they should be reduced so far as possible.

The coil connected in the plate circuit is the reaction coil, and is in series with the plate battery and the telephone jack. Normally, that is, when the telephone plug is not in the jack, the plate circuit is closed through the long and short springs of the jack. When the telephone plug is inserted in the jack, the telephones are in series with the plate battery. High resistance telephones would normally be employed. A

fixed condenser, capacity 0.002 microfarad, is connected between the positive terminal of the plate battery and the negative side of the filament to provide a low impedance path for the oscillating currents.

The grid and plate coils are tapped, and the tappings are taken to the terminals mounted on the face of the instrument. Copper links or wires are employed to connect the appropriate terminals, according to the wavelength range required.

It might be thought that it would have been better had a variable condenser of the "square-law" type been used. The condenser actually employed was chosen because of its good electrical and mechanical properties. The moving plates of this condenser are connected to the metal end plates,

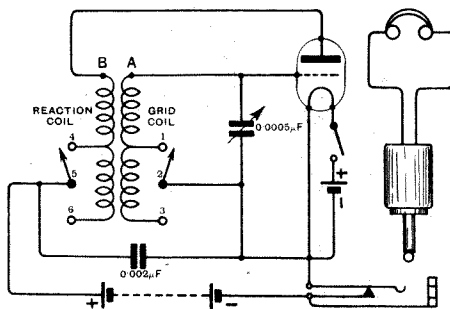

Fig. 1. Theoretical connections of the heterodyne wavemeter.

and the design is such that no flexible connection between the moving plates and a terminal is required.

As no grid condenser and leak is employed, the current taken from the plate battery is larger when the instrument is oscillating than when it is not. A simple method of determining whether or not the instrument is oscillating is by listening to telephones when the grid terminal of the valve is touched. If a click is heard when the finger is placed on the grid terminal and when it is removed, oscillations are being generated. When experimenting to determine the best size and spacing for the coils, a milliammeter was connected in the plate circuit, and readings taken when the circuit was oscillating at different wavelengths. First, a large reaction coil closely coupled to the grid coil was tried. It was found that strong oscillations were generated when the condenser

was set near its position of maximum capacity, but that as the wavelength was lowered, the strength of the oscillations fell off, and finally ceased. By gradually reducing the number of turns, a point was reached where the oscillations were strongest at the middle of the wavelength range, and only slightly less in strength at the minimum and maximum wavelengths.

effects were produced by the dead-ends, and concluded that as a multipoint dead-end switch is undesirable in a wavemeter, it would be better to employ the simple switching arrangements shown in the figures. As may be seen from the figures, the precaution was taken of separating slightly the plate and grid coils at the tapping point.

It is interesting to note that the wavelength

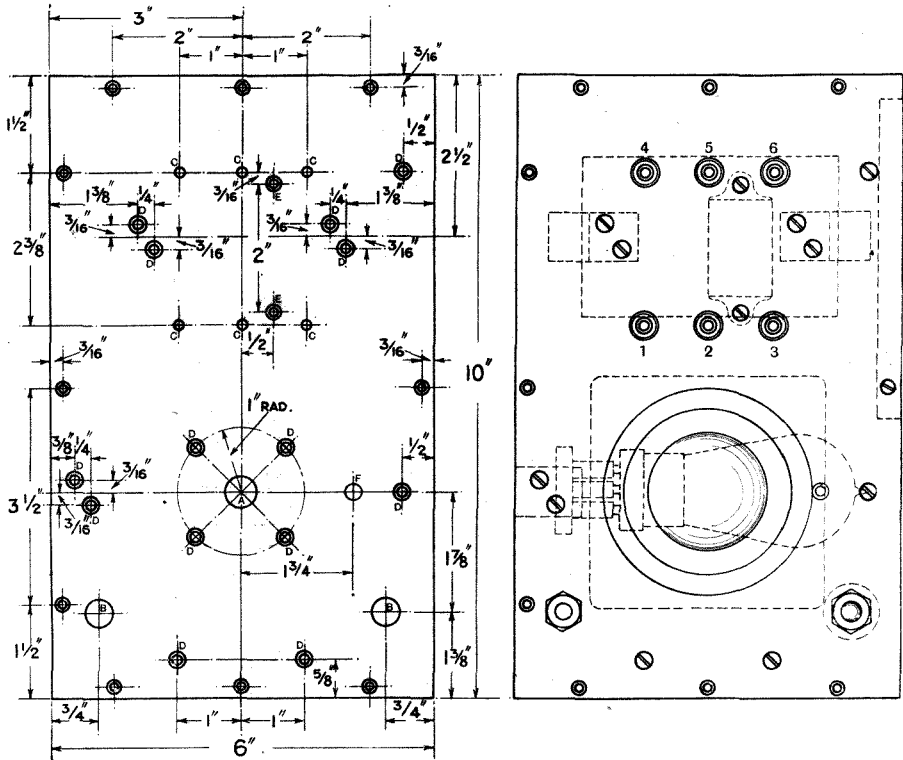

Fig. 2. The left-hand drawing gives the drilling details and the right-hand drawing the lay-out of the components. Drilling details, A, $\frac{1}{8}$ " dia.; B, $\frac{7}{16}$ " dia.; C, $\frac{5}{32}$ " dia.; D, $\frac{5}{32}$ " dia., and countersunk on top side for No. 4 B.A. screws; E, $\frac{1}{8}$ " dia., and countersunk on topside for No. 6 B.A. screws; F, $\frac{1}{4}$ " dia.

It was found essential to separate the grid and plate coils.

The plate coil which gave best results on the lower wavelength range was found not to give such good results as a larger coil on the higher wavelength range. Consequently a tapped plate coil was finally used. At first it was thought that the portions of the coils not in use when tuning over the lower wavelength band might give undesirable effects. The writer could not find that bad

ranges actually obtained are practically those predicted by simple calculations. Thus, the range of the condenser was assumed to be 0.0001 to 0.0005 microfarads, and the inductance between the end of the grid coil and the tapping 8.5 microhenries (No. 20 D.C.C., 7 turns per cm., 9 turns, former $2\frac{1}{2}$ ins. diameter), giving a wavelength range of 55 to 123 metres. The actual wavelength range was from a little above 60 metres to 126 metres.

Construction.

The wavemeter is contained in a box made of $\frac{3}{8}$ in. wood and measuring (outside) 10 in. by $8\frac{3}{8}$ in. by $5\frac{1}{2}$ ins. An ebonite panel 10 ins. by 6 ins. by $\frac{1}{4}$ in. carries the components, which are arranged as indicated in Figs. 2 and 5. The plate dry cell battery is situated in one end of the box, and the filament heating battery of one cell is carried on an extension of the bottom of the box. (Fig. 6.)

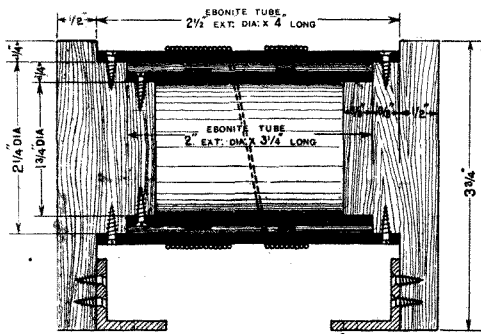

Fig. 3. A detailed drawing of the grid and reaction coils, and their supports.

The Coils.

The coil connected in the grid circuit is wound on a length of ebonite tube 4 ins. long, $2\frac{1}{2}$ ins. diameter and $\frac{1}{8}$ in. thick; the plate coil is wound on another tube which is $3\frac{1}{2}$ ins. long, 2 ins. diameter, and $\frac{1}{8}$ in. thick. As will be seen from the drawings and photograph, the plate coil is mounted inside the grid coil, and both coils are firmly held in position by means of two pieces of wood shaped to fit the ends of the coils. Details of these end pieces and the method of fixing the coils are given in Fig. 3. The end pieces are cut from a piece of wood about $\frac{7}{8}$ in. wide, and the projecting pieces rounded off to fit the inside of the tubes. Holes are provided in the ends of the tubes, and wood screws passed through them to secure the tubes to the end pieces.

Before winding the coils, provision is made for holding the end turns by drilling holes in the ends of the tubes, and No. 6 B.A. screws (to which are soldered the ends of the plate coil) are screwed in the outer tube. These details may be seen in Fig. 5.

Having constructed the former and supports, the coils may be wound. The coils

are wound in opposite directions. Commencing with the grid (outer) coil, start $1\frac{1}{8}$ ins. from one end, and wind 9 turns of No. 20 D.C.C. with the turns touching. Then wind the 10th turn half an inch away from the 9th turn, and continue winding until a total of 23 turns are wound. Solder a wire to the 9th turn at the point where it lies about half way between the two portions of the winding. When looking at the end of the coil nearest the side of the box, this winding should run in an anti-clockwise direction. For the plate circuit coil wind in a clockwise direction, starting $1\frac{1}{2}$ in. from one end of the tube, wind on 15 turns of No. 30 D.C.C., with the turns touching. Then wind the 16th turn three quarters of an inch away from the 15th turn, and continue winding until a total of 35 turns are wound. A wire is soldered to the 15th turn of the plate coil, and this wire and the two ends are finally brought through holes in the outer former and soldered to the No. 6 B.A. screws secured therein. Finally, dry and varnish the coils.

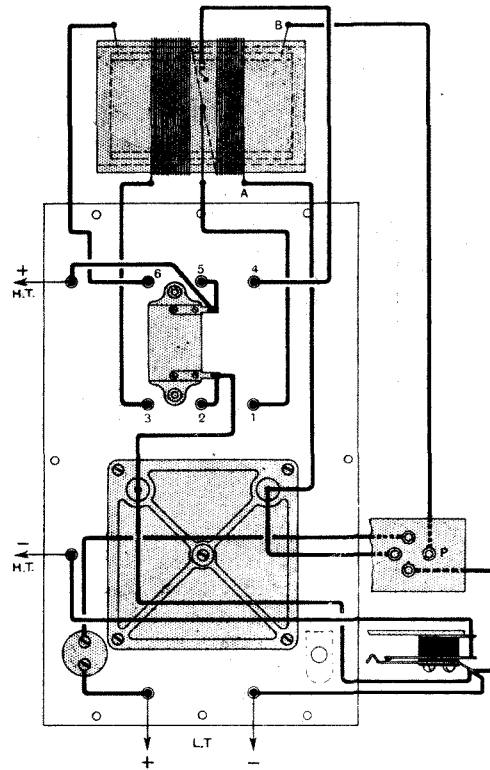

Fig. 4. The wiring diagram. The figures and letters correspond with those on the theoretical diagram.

Referring for a moment to the theoretical circuit, Fig. 1, the grid coil contains 9 turns between the grid and the tapping, (A and 1), and the plate coil 15 turns between the plate and the tapping (B and 4).

The Valve Holder.

The valve holder consists of a piece of ebonite $4\frac{1}{2}$ ins. by $1\frac{1}{2}$ ins. by $\frac{1}{4}$ in., carrying four valve sockets at one end, and a brass bracket at the other, as shown in Figs. 2 and 5. The bracket is screwed to the panel, and the side of the box cut away to permit the panel to fit flush. The valve, when in position, lies in the space between the bottom of the box and the bottom of the variable condenser.

that all the wires at low voltage are at one end of the instrument, and that the wires are provided with an insulating covering. It is an easy matter to wire the instrument from the wiring diagram of Fig. 4, but care must be taken to make each wire short and rigid. Flexible wires are connected to the terminal screws for the plate battery and the filament accumulator, the latter wires passing through holes in one side of the box. Special attention should be given to the wiring of the coils. As the windings are in opposite directions, the two ends (looking at one end of the coils) are connected to grid and plate respectively. If the coils were wound in the same direction, the two ends (from the same end

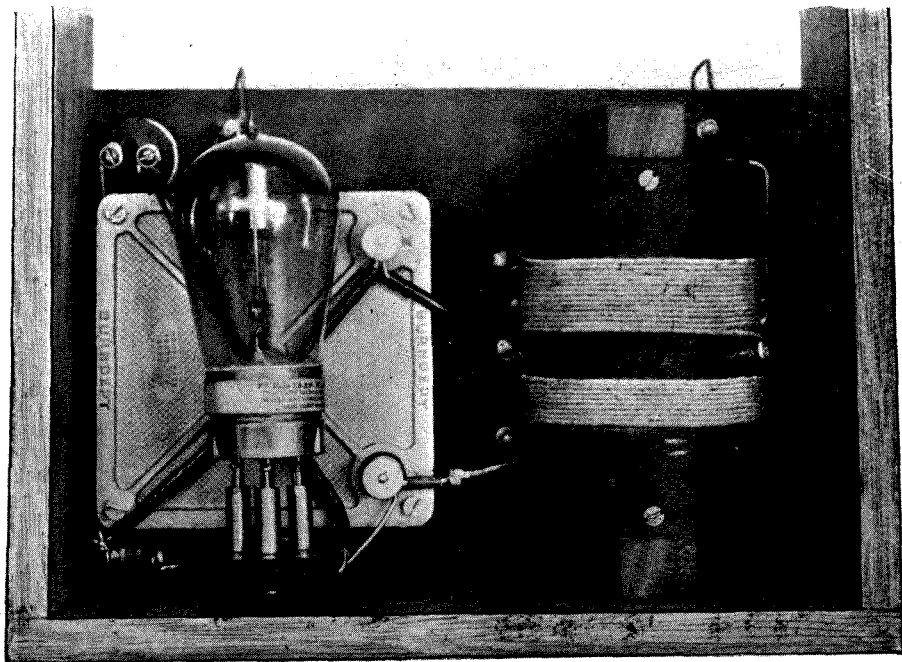

Fig. 5. A view of the wavemeter, looking at the underside with the bottom of the box removed.

Assembling and Wiring the Instrument.

Having constructed the coils and their supports and the valve holder, it is an easy matter to fit the terminals, the fixed condenser ($0.002 \mu\text{F}$), the jack, the switch, and the No. 4 B.A. screws which serve as connecting points for the batteries. The instrument is wired with No. 16 tinned copper wire, which is stretched and cut into suitable lengths. It will be observed from the figures

of the coils) should go to grid and plate battery respectively.

To prevent the plate battery moving, a piece of $\frac{3}{8}$ -in. wood is screwed to the edge of the panel, as may be seen from the illustration on page 152.

Using the Wavemeter.

For low wavelengths, connect grid terminals 1 and 2, and plate terminals 4 and 5,

and the plate and filament batteries. For higher wavelengths, grid terminals 2 and 3 and plate terminals 5 and 6 are connected. Calibrate the instrument in one of the well-known ways. The following figures, which are correct for the wavemeter illustrated here, show one what to expect.

Higher Range.		Lower Range.	
Wavelength Metres	Setting of Condenser	Wavelength Metres	Setting of Condenser
250	180	126	180
245	170	121.5	170
239	160	118	160
233	150	115	150
226	140	112	140
219	130	108	130
211	120	105	120
204	110	101	110
196	100	97	100
187.5	90	93	90
178	80	89	80
168	70	85.5	70
158	60	81.5	60
150	50	78	50
141	40	74	40
130.5	30	70	30
120	20	67	20
110	10	64	10
99	0	62	0

To measure the wavelength of a transmitter, put the telephone plug in the jack and tune the instrument until a beat note is heard in the telephones. The beat note is set up by the oscillations of the wavemeter combining with the oscillations induced in the coils of the wavemeter from the transmitter. Then adjust for the "zero beat" or "silent point." The wavelength of the wavemeter is then the same as the wavelength of the transmitter. This method is not always satisfactory when the transmitter is rated at over about 10 watts. Amateurs will find that a fairly reliable reading may be taken by employing a low power lamp in the tuned circuit, or by connecting a neon tube across the circuit. The instrument should be calibrated with the lamp or neon tube in circuit.

To determine the wavelength of a distant transmitting station heard on a receiver, carefully tune the receiver by letting it oscillate and adjust it for the "silent point." Then tune the wavemeter (the telephone plug may be removed from the jack of the wavemeter) until a note is heard in the telephones attached to the receiver. Now carefully adjust the wavemeter for the "silent point" condition; the wavemeter is now set at the same wavelength as the distant transmitting station.

It is advisable after calibrating the instrument to draw curves on squared paper to show the relation between the setting of the variable condenser and the wavelength. The reader will find that the calibration is affected by changing the valve or the batteries—in fact the calibration changes slightly as the batteries run down. However, a few tests will show to what extent the calibration is affected by changes of this sort.

A heterodyne wavemeter may be used, of course, in many measurements, but it is principally employed to determine the wavelength of the energy radiated from a transmitter, or to calibrate a receiver.

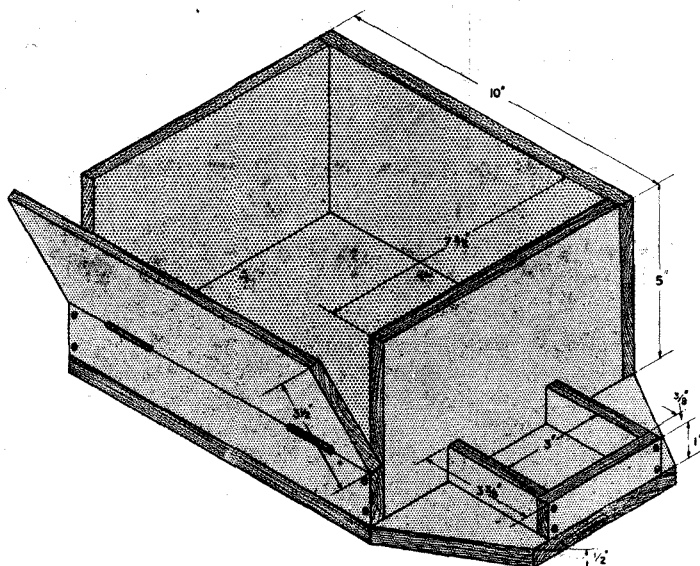

Fig. 6. The construction of the box

A FRENCH WIRELESS PIONEER.

BANQUET IN HONOUR OF PROFESSOR BRANLY.

ON Thursday, November 6th, a banquet will be given in Paris in honour of one of the pioneers of wireless, M. Edouard Branly.

The principal invention associated with the name of Branly is his famous "coherer," which contributed in no small measure to the success of Senatore Marconi's earliest experiments in wireless telegraphy. At that time the coherer was, in fact, the only practical rectifying device, and several years elapsed before it yielded place to the more stable crystal detector. In 1899, the first wireless message was transmitted across the Channel. It was addressed to Professor Branly, and ran: "Signor Marconi sends his respectful compliments by wireless telegraph across the

Channel, this admirable result being in part due to the remarkable work of M. Branly."

Educated at the St. Quentin and Henry IV. Colleges in Paris, M. Branly later became a Fellow of the University, a Doctor of Physical Science and Doctor of Medicine. His researches in wireless date back to about

1887, and in 1890 and 1891 he filed patents relating to the electrical conductivity of radio-conductors and to the operation of a local relay circuit from a distance.

It cannot be said that M. Branly's genius has been overlooked by his fellow countrymen. In 1900 the French Minister of

Public Instruction created him an Officer of the Legion of Honour, and some years later the French Press was instrumental in raising a public subscription for his benefit. When, a few years ago, the French Chamber voted him a grant of £800 per annum, he modestly declined, preferring to rely upon his own limited means.

Of recent years Professor Branly has been devoting his attention to various independent distributing devices

for producing tele-mechanical effects without wires. He is a tireless worker and, it is said, spends ten hours daily at his researches.

Professor Branly celebrated his 80th birthday on October 22nd, when he was the recipient of thousands of congratulations.

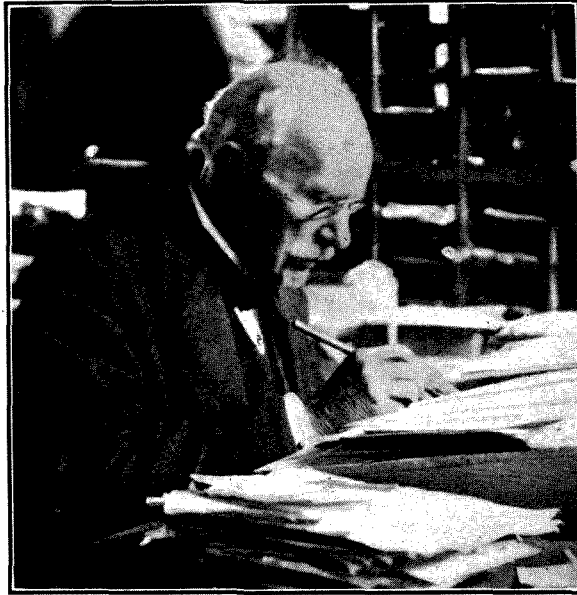

Professor Edouard Branly, the eminent French wireless engineer, who has just celebrated his eightieth birthday.

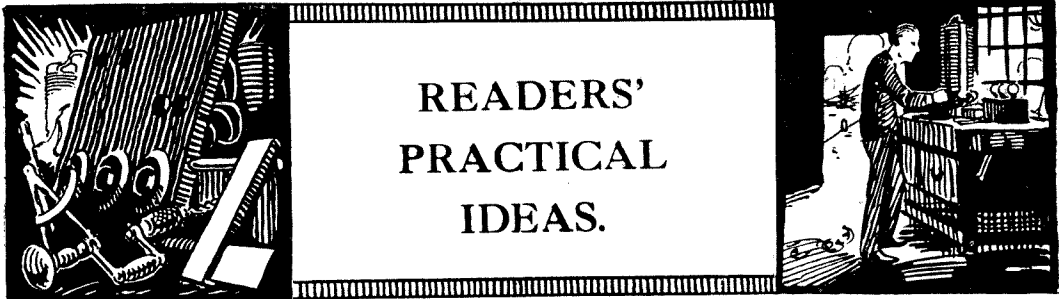

READERS' PRACTICAL IDEAS.

Protecting Valve Sockets.

THE type of valve holder which is built up from valve sockets is once more becoming popular, for experimenters are beginning to realise that this form of construction is simple and cheap, and what

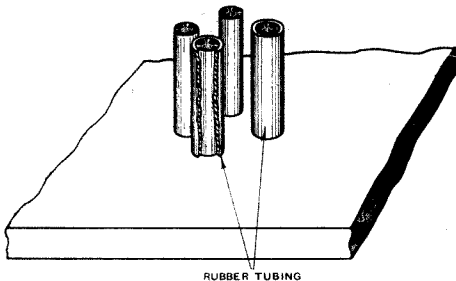

Rubber tubing slipped over the sockets eliminates the risk of a burnt-out filament.

is more important, produces a holder of low capacity. There is a danger with this type of holder, however, of making contact between the filament legs of the valve and the high tension potential of the plate battery. Risk of thus burning out the filament can be entirely eliminated by slipping pieces of india-rubber tubing over the sockets.

F. B.

A Novel Variable Coupling.

A THREE-COIL holder is probably the most generally used method of arranging for variable coupling between inductances, and its popularity is due to the convenience with which various sized coils can be readily interchanged.

When constructed, the coils are frequently of the single layer type, and a difficulty arises in devising a suitable method of variable

coupling. To avoid employing a pivotted coil, a sliding inductance will be found to give quite critical coupling, and is very useful when one of the coils is used to produce reaction effects.

The accompanying illustration shows how the moving coil may be set up, and this form of construction has the advantage that operation is effected by means of a rotating knob and dial. The diagram shows that a pulley is secured to a rod by the knob and dial, and in the two grooves of this dial is

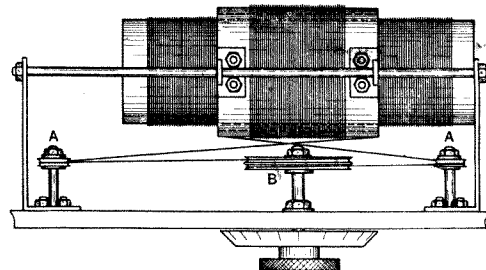
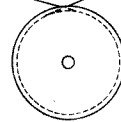
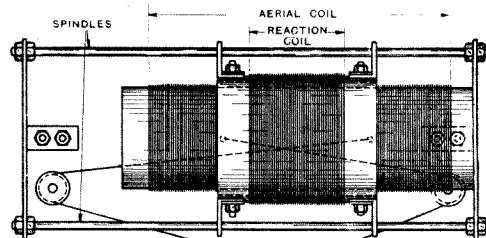

A novel method of effecting adjustable coupling between two coils.

wound a string which attaches to the moving coil. The string is actually tied to the pulley at one point so as to avoid slip. The two ends of the cord are terminated as shown, and the moving coil is set up to slide on two rods, which may be constructed from brass. If it is thought that the proximity of the metal rods to the winding gives rise to inefficiency the brass rods may be replaced by glass and secured at the ends by glueing into wooden supports.

J. L. H.

reached, when a strip of ebonite having a cross section of $\frac{1}{4}$ in. by $\frac{1}{4}$ in. is slipped under the wire and remains thus held until the

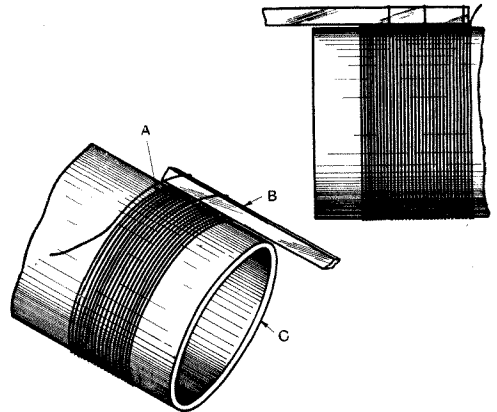

A convenient method of tapping a cylindrical coil in which an ebonite strip is used to raise the required windings.

On and Off Switch.

TO avoid the use of a number of switches for bringing the receiver into operation, the accompanying circuit shows a method by which all the necessary battery connections can be made by the movement of a single lever. It will be noticed that the arm of the switch closes circuits for grid cells, filament battery and high tension battery. When the set is not in use the lever connects the aerial to earth.

A. L. B.

next tapping point is required. It is then carefully slid along and serves to raise another turn out of contact with the former. This process is repeated till the end of the

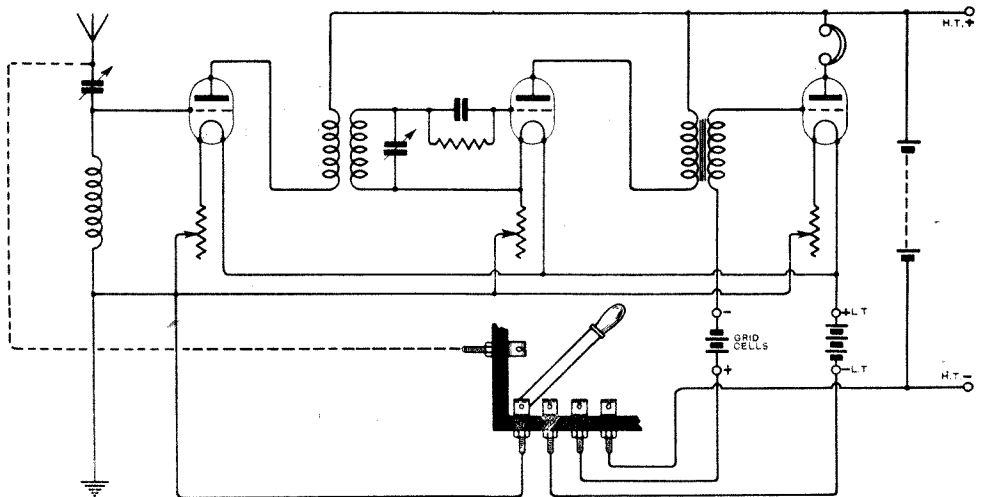

A combined switching arrangement for disconnecting the batteries and earthing the aerial.

A Neat Tapped Coil.

THE tappings on a single layer coil can be made by a variety of methods, but probably the neatest arrangement is that shown in the accompanying illustration. The preliminary turns are wound on in the ordinary way until the first tapping point is

coil is reached. The outside edges of the ebonite which are in contact with the wire should be slightly rounded to prevent damage being done to the insulation. It is now quite easy to scrape the insulation from the wire and make a good soldered connection.

C. N. G.

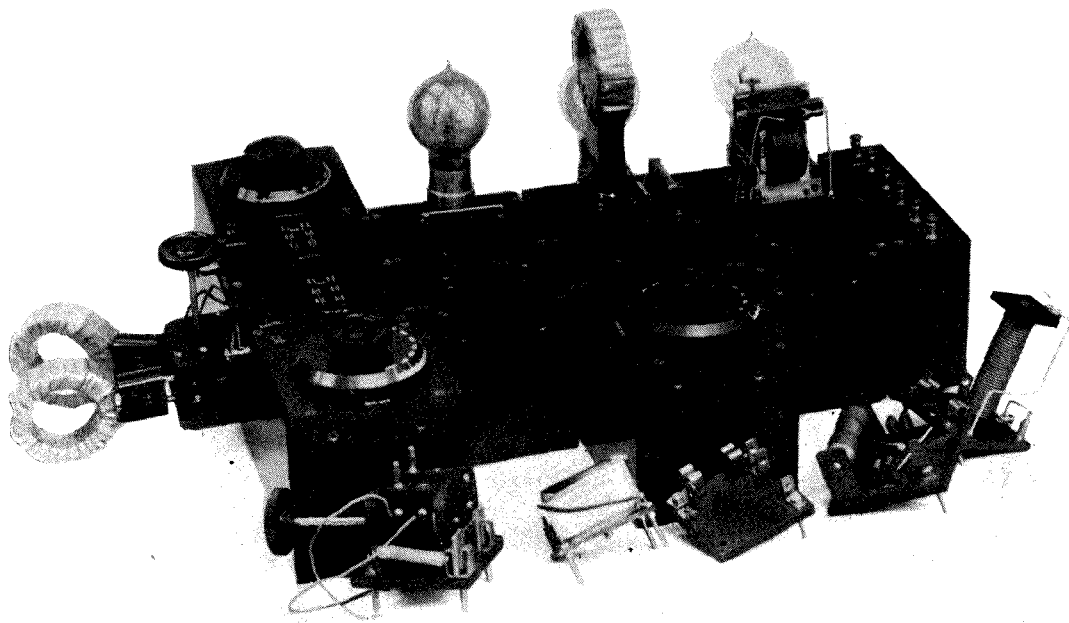

A THREE-VALVE UNIT RECEIVER.

In the first instalment of this article the author described the construction of the tuning and condenser units. He now describes the valve units, the terminal unit, and the coupling units.

By R. H. Cook.

(Continued from page 126 of previous issue.)

HAVING completed the tuning unit and the two condenser units, we may turn our attention to the amplifier and detector.

A number of three-valve circuits which may be tried with this receiver were given in the first portion of this article (page 124, October 29th issue). Fig. 6 gives a number of two-valve circuits. Fig. 6A shows the connections for two stages of high frequency amplification with transformer coupling and a crystal detector. Fig. 6B gives the connections with one stage of high frequency amplification, followed by a crystal detector and one note magnifier.

The next circuit, Fig. 6C, is that of a two-valve receiver having one stage of high frequency amplification with tuned anode

coupling, valve detector, and with the reaction coil coupled to the anode coil. Fig. 6D gives the connections of a receiver comprising a crystal detector and two stages of low frequency amplification, and Fig. 6E a valve detector with note magnifier.

THE VALVE UNITS.

The valve units are similar in every respect. Those who wish to employ three valves will, of course, construct three units. Each unit has a top panel of ebonite 6 ins. \times 4 ins. \times $\frac{1}{4}$ in. carrying a valve holder, a filament resistance and the adaptor sockets and pin (Fig. 8). The valve holder consists of the usual sockets screwed to the ebonite panel. Three sockets and one pin are mounted to form the adaptor socket. This

arrangement of sockets and pins is employed to prevent the possibility of inserting the

adaptor in an incorrect position. A fourth socket is mounted just below the pin. The position of the parts is clearly shown in Fig. 9.

Three side connection strips are employed, one on each of the long sides and the other on the front of the panel. The left-hand and front strips are fitted with sockets and the right-hand strip with pins. A dimensional drawing of the side strips was given in Fig. 3, page 125, October 29th issue. Side strips carrying pins and sockets in this way are employed in place of the usual terminals. To connect units it is only necessary to place them side by side and to fit the pins in the sockets. The front sockets are for plugging in a condenser to tune the unit when it is employed as a tuned anode or a H.F. transformer coupling.

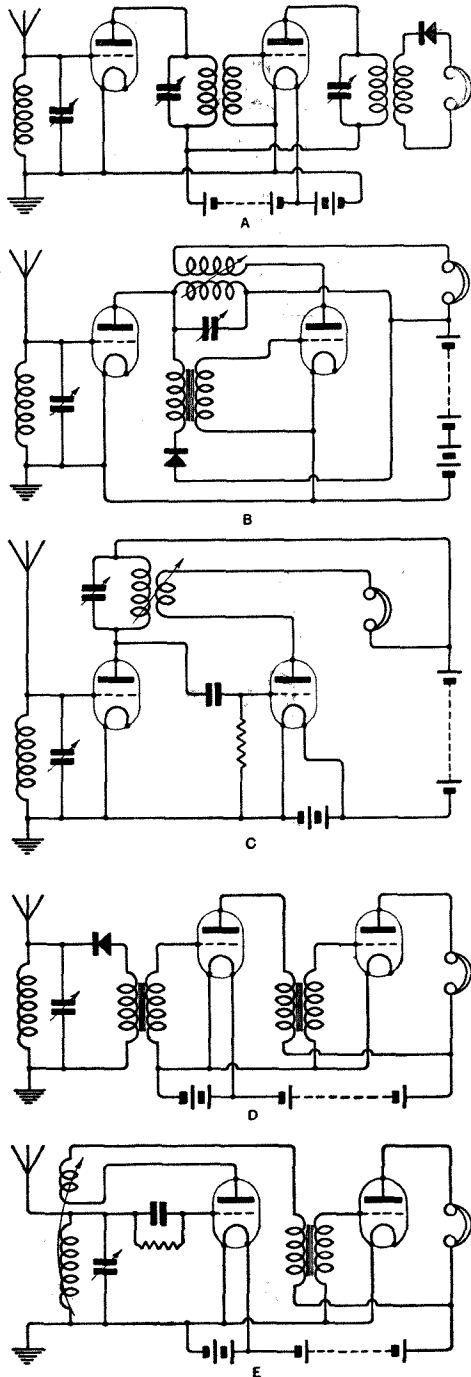

Fig. 6. Showing a number of methods of connecting two-valve receivers.

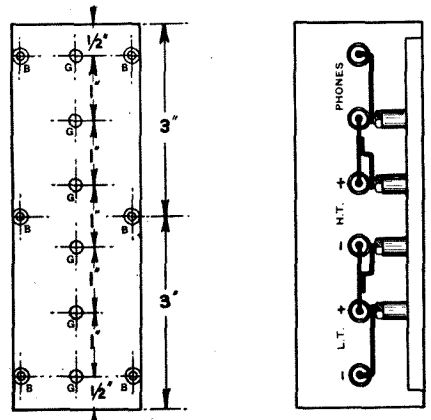

Fig. 7. Dimensions and wiring of the terminal unit. B, 5/32" and countersunk for No. 4 B.A. screws and wood screws; G, 5/32" dia.

The wiring of the panels is given in Fig. 8. It will be observed that the lower three pins and sockets are connected to the filament and plate circuits, the top left-hand socket to a socket of the adaptor and one of the sockets on the lower strip, and the top right-hand pin to the plate of the valve. The strips are secured to the panel by No. 4 B.A. countersunk screws; the centre screws seen in the drawings are wood screws which pass through the side strips and hold the panel and side strips to the box. The box is of course cut away on three sides to take the side strips.

THE CONDENSERS.

Those who construct three valve panels and propose to employ one or two stages of

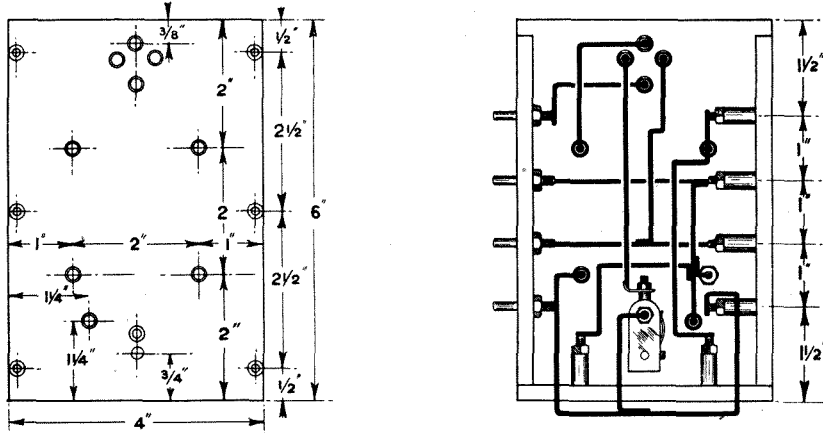

Fig. 8. Layout and wiring of a valve unit.

tuned high frequency amplification should also construct one or two condenser units respectively. The condenser units each consist of a box containing a 0.0002 μ F. tuning condenser connected to two pins fixed on a strip carried at one end of the

panel. These units are built up precisely as indicated in Figs. 4 and 5, page 126, October 29th issue.

THE TERMINAL UNIT.

This is a panel 6 ins. \times 1 $\frac{1}{2}$ ins. mounted on a box carrying six terminals for the various

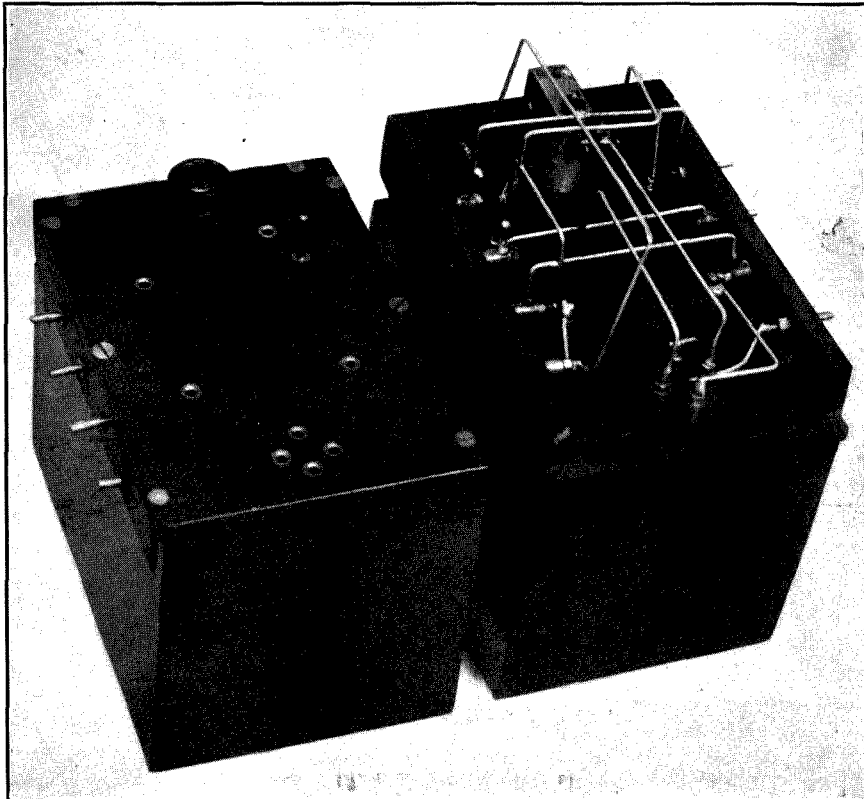

Fig. 9. Views of a valve unit.

connections and a side strip with six sockets. The terminal panel can be plugged in the last valve panel. Details of the construction appear in Fig. 7.

THE COUPLING UNITS.

The coupling units each comprise a small ebonite platform carrying pins and a socket to fit the corresponding sockets and pins in the valve panel, and the components which are required for the coupling.

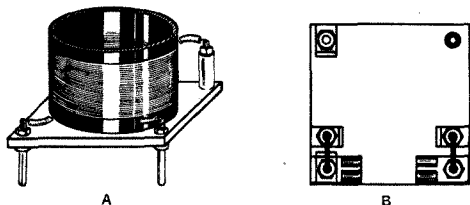

Fig. 10. (A) A sketch of a high frequency transformer unit; (B) The arrangement of a resistance-capacity unit which consists of an anode resistance, grid condenser, and grid leak.

Dealing with high frequency couplings first, we have in Fig. 10A details for the construction of a high frequency transformer unit and in Fig. 10B for the construction of a resistance capacity unit. The ebonite platform of the couplings is 3 ins. \times 3 ins. \times $\frac{1}{4}$ in., and the pins and socket are mounted at the corners of a 2 in. square to fit the corresponding sockets and pins provided on the panels. The high frequency transformer consists of two coils, wound on an ebonite tube and connected to the pins and sockets. Details of the winding will be given in the final instalment of this article. For the resistance-capacity coupling unit it is only

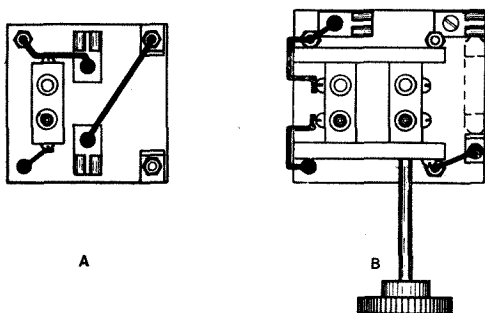

Fig. 11.

(A) A tuned-anode unit.

(B) A tuned-anode and reaction, or transformer unit.

necessary to provide clips for the anode resistance, the coupling condenser, and the grid leak.

The construction and connections for a unit which may be employed as a tuned

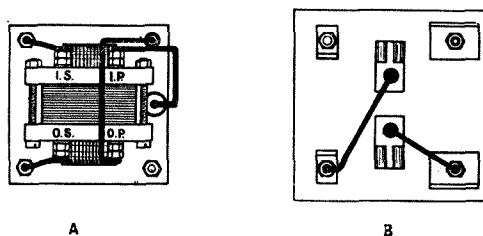

Fig. 12. (A) A transformer unit; (B) A resistance-capacity unit.

anode coupling are given in Fig. 11A and consists of a single coil mounting and clips for the fixed condenser and grid leak. A two-coil holder is mounted on the unit of Fig. 11B, with clips for a fixed condenser and grid leak. The fixed condensers referred to are the grid condensers normally employed with high frequency couplings and may have a capacity of 0.00025 mfd.

For the low frequency couplings, three units are provided—one for transformer

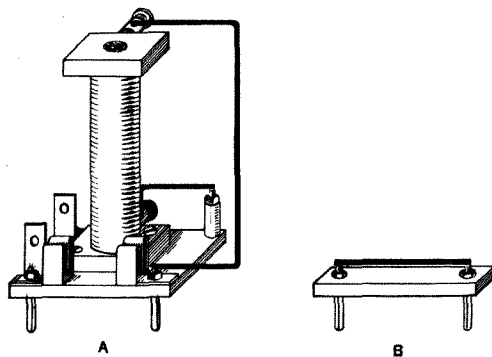

Fig. 13. (A) A choke-capacity unit; (B) A short circuiting unit.

coupling, one for resistance-capacity and the other for choke-capacity coupling. These units are sketched in Figs. 12A and B and Fig. 13A.

The resistance-capacity unit may have an anode resistance of 70,000—100,000 ohms, a coupling condenser of 0.05 μ F., and a grid leak of 0.5 megohms. In the choke-capacity unit a grid leak and coupling condenser of 0.5 megohms and 0.05 μ F. respectively may be employed, with an iron-cored choke coil.

The unit shown in Fig. 13B consists of a strip of ebonite carrying two pins which are connected together.

WIRELESS IN THE MIDLANDS.

SUCCESS OF THE MANCHESTER EXHIBITION.

MANCHESTER'S wireless exhibition, which was opened on October 14th, in the City Hall, Deansgate, by the Rt. Hon. Lord Colwyn, P.C., gave abundant proof of the enthusiasm with which the Manchester public have received wireless. Organised by the *Evening Chronicle*, the Exhibition exercised a wide appeal both popular and technical, and the fact that its doors remained open until the 25th of the month without any diminution in attendance, is proof that its aims were adequately realised.

To club members one of the principal features of the Exhibition was the grand rally of radio societies of the North of England on Saturday, October 18th, when an address was given by Dr. W. H. Eccles, F.R.S., President of the Radio Society of Great Britain. On other days, interesting lectures and demonstrations were provided by Mr. Philip R. Coursey, B.Sc., Research Editor of *The Wireless World and Radio Review*, Mr. F. H. Haynes, Assistant Editor of the same Journal, Mr. R. H. Wood, Engineer-in-Chief of **2 ZY**, and other well-known experts.



A corner of the City Hall, Manchester, during the recent wireless exhibition, which drew enthusiastic crowds for nearly a fortnight.

Ever since the inception of broadcasting, the *Manchester Evening Chronicle* has been among the foremost journals to foster public interest in the new art, and its regular contributions on the subject, together with constructional competitions, have found an increasing circle of readers and enthusiasts. As a promising experiment the Exhibition met with indubitable success, and its interest was considerably enhanced, not only by a number of entertaining lectures and demonstrations, but by many new and original exhibits.

A word must be said regarding the efficient technical organisation of the Exhibition, which was entrusted to the Manchester Radio Scientific Society. Excellent loud speaker demonstrations were carried out by the Society, whose labours in this direction were admirably supported by **2 ZY**, the Manchester Broadcasting Station, which transmitted appropriate instrumental music.

No fewer than 121 stands were occupied, both by local and "outside" firms, and in view of the immense variety of excellent material on show, it is difficult to single out any particular items for comment. Crystal and multi-valve sets were well represented, besides the increasingly popular loud speaker, but among novel and original items which deserve special mention must be included the interesting "Atlas" filament control exhibited by Messrs. H. Clarke & Co. (Manchester), Ltd. This makes use of piles of carbon pellets and provides for the most minute adjustment of filament temperature.

Another filament control device of interest was that shown by the City Accumulator Co., and illustrated on the next page. Designed by Mr. Alan L. M. Douglas, this filament resistance is specially intended for mounting on the face of a panel.

A full range of receivers manufactured by the Marconi Scientific Instrument Co., Ltd., was exhibited on the stand of Messrs. Halliwell & Good, Ltd., of Manchester, which appears in the foreground in the photo opposite.

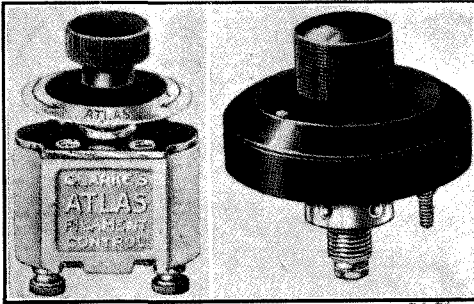

Two interesting filament rheostats on view at the Manchester Exhibition.

Left: A device making use of carbon pellets.
Right: The City Accumulator Co's product.

A useful accessory exhibited was the "Star" dustproof crystal detector, illustrated on this page. Besides affording protection from dust, the detector is fitted with rotary action, giving an almost unlimited choice of sensitive spots.

One of the most ingenious devices on show was the "Liberty" Safety Wander Plug, manufactured by the Radiac Electrical Co., Ltd. The current passed by this plug is sufficient to supply the

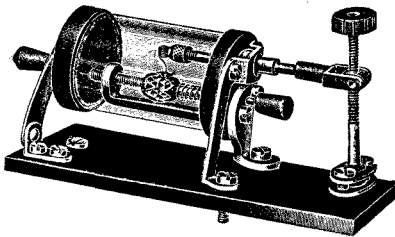

The "Star" dustproof crystal detector, with useful rotary control.

circuit, but insufficient to destroy the valve filament. The slogan of the manufacturers is, "Insure your valves for 2s. 6d." Another product of this company on view was the "Liberty" Tuner, embodying a novel form of variometer, the principle of which will be understood from accompanying illustration.

The problem of housing the newly-constructed set in a suitable cabinet is one that has confronted

every amateur constructor at some time or another. A stand almost entirely devoted to wireless cabinets of all grades and sizes, was that of Messrs. Henry Joseph & Co., Ltd., whose products extended from cases for the smallest crystal sets to handsome cabinets for multi-valve receivers.

As might be expected, the stand of the Manchester Radio Scientific Society was of exceptional interest to amateurs and experimenters. Messrs. Harold Green and L. Lomas both exhibited transmitting gear, and in addition much curiosity was aroused by a combined wireless and gramophone set constructed by Mr. Kemp.

Other items of more than usual interest were a combined lead-in tube and earthing switch by Messrs. W. H. Murad & Co. and the Ericsson low capacity key switch for H.F. circuits (exhibited by Palatine Wireless Equipment Co.).

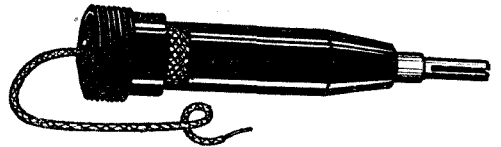

The "Liberty" Wander Plug, ensuring safety for filaments.

In addition great public interest was apparent in the realistic reproduction of a ship's cabin, equipped with a half-kilowatt quenched spark transmitter and standard Marconi receiving gear.

The outstanding impression gained by a London visitor to the Exhibition was the remarkably keen spirit which animates Manchester amateurs. The home constructor was in evidence everywhere, and it became increasingly apparent that with a natural aptitude for practical work the northern amateur combines a real appreciation of the value of theoretical knowledge, without which success can hardly be hoped for.

During the first four and a half days of the Exhibition 90,000 persons paid for admission.

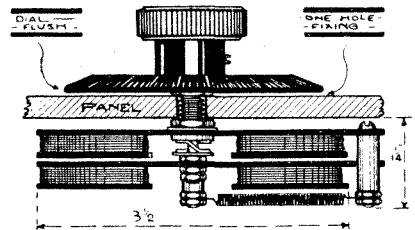

A novel variometer produced by the Radiac Electrical Co., Ltd.

THE STORY OF THE NEW ZEALAND SUCCESSES

The setting up of a world's record in amateur communication, as reported in our previous issue, has aroused considerable interest, not only to transmitters, but among all those who followed the development of wireless telegraphy. We are fortunate in being able to give publication below to a detailed report of the work carried out, compiled by the operators in this country who have participated. In addition, Mr. R. J. Orbell, an active experimenter in New Zealand, who has just arrived in this country, gives some details of the stations with which communication has been established. He records also the results of some interesting tests he has recently completed in the Southern Pacific in an effort to determine the distance over which the New Zealand and Australian stations can be worked. Although the tests were carried out with the hope of extending the range of the New Zealand stations, it would appear that any process of steadily increasing the distance would not apply, and that definite areas are to be found where communication is possible, while in other localities the conditions are less favourable. The field of research work thus opened by the amateur, places him in a position to investigate a problem of immense importance, and it is difficult to foresee the results to which this contribution to the science of wireless telegraphy may lead.

IN TOUCH WITH NEW ZEALAND.

By E. J. SIMMONDS

(G 2 OD).

IN view of the great interest aroused by the experimental two-way tests with New Zealand, it is thought that a short description of the incidents connected with the reception of the first New Zealand amateur station heard here, and the apparatus employed at **G 2 OD** in this and the subsequent two-way tests, may be of interest.

On October 16th last, at 0600 G.M.T., **U 5 MI** was strongly received sending **CQ**, and using code word "ALABAMA," and at the conclusion of this transmission, while searching around 80 metres, a station was tuned in calling **U 5 MI**, and signing **Z 4 AG**. The signals were of good strength, easily readable and very steady, the note being a low musical A.C. one.

At first the great importance of this reception was not fully realised, as it seemed so improbable that it really could be a New Zealand station. Shortly afterwards, however, at 0630 G.M.T., **Z 4 AG** was heard again, much stronger, calling **U 6 ARB**, but apparently was unable to connect with either of the American stations.

At this time the writer suddenly remembered that in a recent issue of *Q.S.T.* **U 6 ARB** was reported as the strongest U.S.A. station heard in New Zealand.

At once the transmitter at **G 2 OD** was started up, and **Z 4 AG** given several long

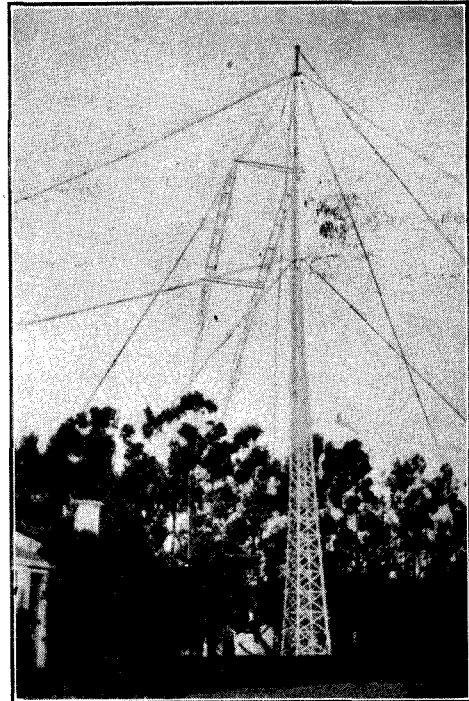

The aerial at the New Zealand station 4 AA, owned by Mr. F. Dillon Bell of Waihemo, Otago. In conjunction with English amateurs this station has established a world's record for long distance communication.

calls, but without result, the probable reason being that the New Zealand station was listening on the 75 to 80 metre band used by the Americans, and **G2OD** was transmitting on 95 metres.

The next day (Friday) careful watch was kept during the same period, but no New Zealand signals were logged, although frequent calls were transmitted from this station.

However, from evidence which has since come to hand, these calls were strongly

send out calls embodying a code word at sunrise for obvious reasons, and the word "Zinco" was the code word used at 0615 G.M.T. on Friday, October 17th.

There is a note in the log regarding the conditions on October 16th which may be of interest, and reads, "Temperature moderate, light QRN, steady air, and clear sky."

On October 19th, at 0615 G.M.T., **Z4AA**, with D.C. note, was logged QSA, working **G2SZ** and later **G2KF**, and on the 20th at 0715 G.M.T., two-way communication was

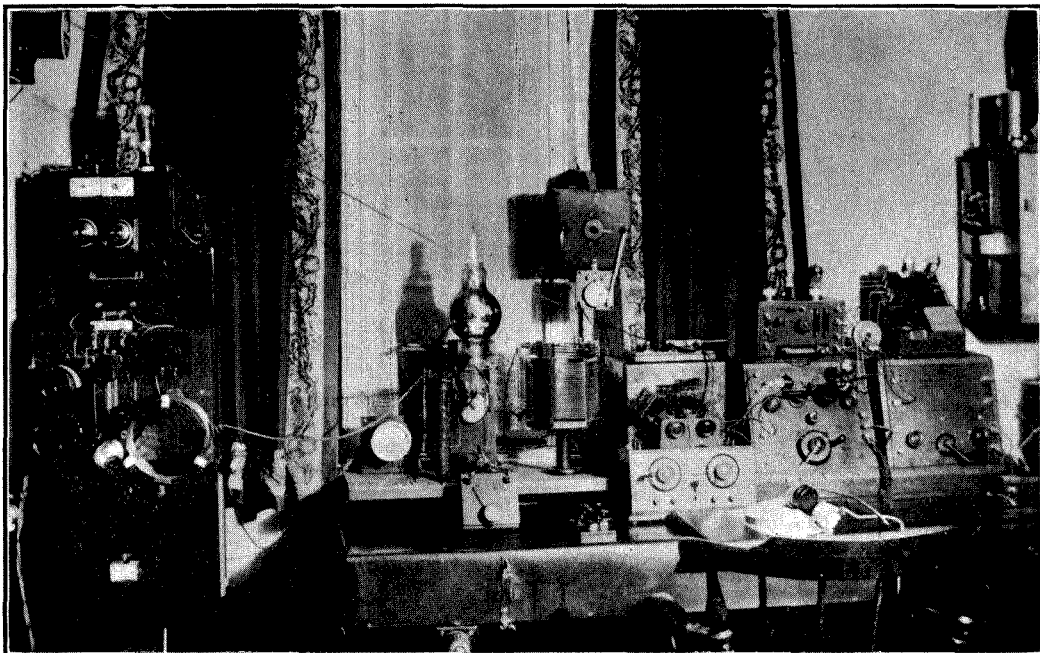

*The equipment at **2OD**, the station of Mr. E. J. Simmonds at Gerrard's Cross. Mr. Simmonds was the first English amateur to report the reception of signals from New Zealand. He heard **Z4AG**, operated by Mr. Ralph Slade at Dunedin, on the morning of October 16th, which was later confirmed by cable. He subsequently established two-way working. This station was the first English transmitter to be heard in the Antipodes.*

received in New Zealand by **Z4AA**, **G2OD** thus being the first English amateur station heard in the Antipodes. The telegram received from **Z4AA** confirming this reception reads as follows :—

"To E. Simmonds, Gerrard's Cross. Your signals loud calling Zinco and Americans Six-Thirty Friday Morning, Congratulations.

(Signed) "BELL, WAIHEMO."

It should be explained that it has been the practice at **G2OD** when operating to

established between **Z4AA** and **G2OD**, the British signals being reported QSA.

Up to the time of writing, this station has worked two-way with **Z4AA** four times, and **Z4AG** twice.

The strongest New Zealand signal here is **Z4AK**, using rough unrectified A.C. note, which is difficult to read through any interference.

A report has also been received that **G2OD** has been heard in Sydney, Australia, and logged by **A2DS** there, but full details are not yet to hand.

The transmitter used here is a master oscillator, the power supply being 50 cycles A.C., stepped up to 1,500 volts, and rectified by synchronous rectifier. The power amplifier is a Mullard O 250 C., with an anode input of 106 watts, and only 5.5 volts A.C. on the filament (12.5 volt rating), and it is a great tribute to the flexibility and efficiency of this valve. The receiver is a superheterodyne employing five valves.

The photograph shows, on the extreme left, the master oscillator panel and H.T. transformer; in centre, power amplifier and coupling transformer, also aerial series con-

changes that have been effected and are perhaps worthy of note.

Although the circuit itself remains as described and is the same as that employed for the first two-way communication with the United States late last year, the components forming this circuit have been modified with a view to reducing the losses so well known to exist on the shorter wavelengths. The tuning inductances have been replaced by spiral coils wound with copper strip and supported with cross arms, and all connections have been overhauled and carefully soldered. Specially spaced air dielectric low-loss con-

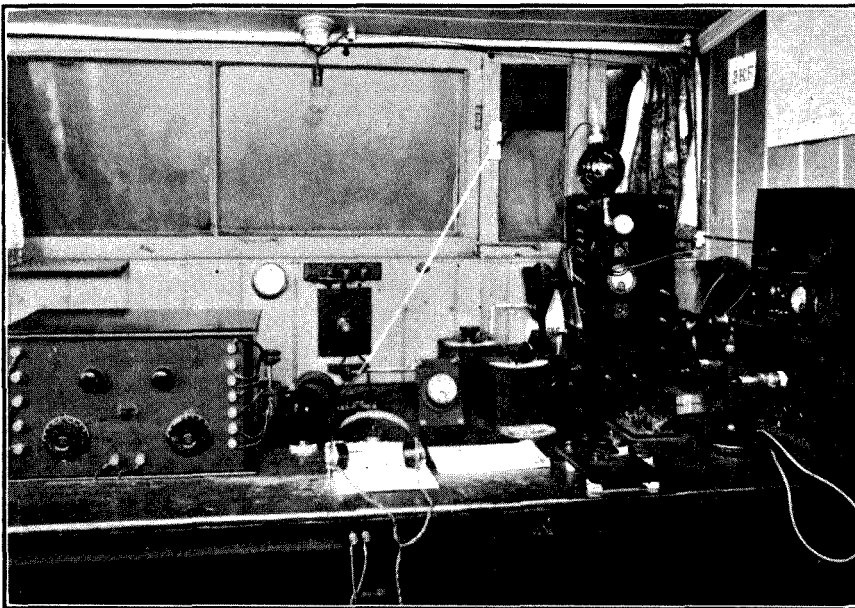

The apparatus at 2 KF. Mr. Partridge, who operates this station, will be remembered as the first British amateur to establish two-way working with the United States. He is now working with New Zealand.

denser; to left, superheterodyne and general purpose receivers. The aerial is a 6-wire cage, 72 ft. long including lead-in, 40 ft. high, badly screened by trees, and counterpoise six-wire fan, 48 ft. long and 9 ft. high.

THE WORK OF 2 KF.

By J. A. PARTRIDGE.

THE experimental equipment of this station has been previously described at some length and it is proposed to deal essentially with the several additions and

changes are now employed in the aerial and counterpoise leads, and all switch gear and supports have been overhauled to eliminate possible leakage and loss. Copper strip is used for connecting up the circuit wherever possible and it is interesting to note that an increase in aerial current for a given input was observed as soon as the set was rewired to this arrangement.

As to the receiving apparatus, an additional stage of L.F. amplification has now been fitted which is not used, however, when searching for distant C.W. transmitters such as the "Z" stations. The original aerial, which was a 3-wire inverted "L," has

* *Wireless World*, Vol. XIII, December 27th, 1923.

given way to a 6-wire cage with cage lead-in and the height of the supporting masts has been increased to 60 ft. The counterpoise consists of seven wires arranged in a fan-shaped formation and is suspended 7 ft. above the ground. Contact with the New Zealand Station **4 AA** was established at 6.25 a.m. on the morning of October 19th, and was thus the second successful two-way working with the Dominion. **Z 4AA** replied to the first call made by **2 KF** and he stated

of only one word and many comments were made as to signal strength. It is interesting to note that the New Zealander called **2 KF** by the name of its operator and this was indeed a surprise, coming as it did from over 11,000 miles away.

During the transmissions a message was received addressed to **G 2SZ**, the station of Mr. Goyder. This message was from the Prime Minister of New Zealand and another was received addressed to Sir James Allen,

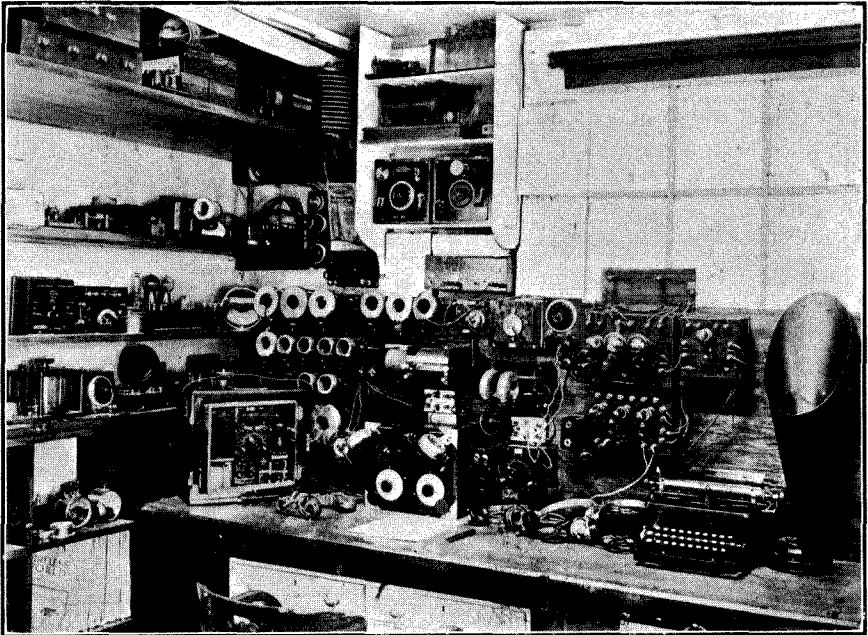

The receiving equipment at Z 4AA as it appeared about two years ago. It is interesting to observe that all of the apparatus is of British manufacture. The products of several well-known companies can be identified.

that he was receiving the English transmissions at good strength. Reliable communication was found to be possible until just after 7.15 a.m. G.M.T. Two messages* were passed each way, with the repetition

the High Commissioner of New Zealand in London. A reply to this latter message was successfully passed by **G 2KF** to **Z 4AA** two days later.

It would appear that at the present time

** Extract from Log.*

Text of some of the messages passed :—

No. 1. From **Z 4AA Waihemo, N.Z.**, to **G 2SZ** via **G 2KF**. Compliments from Prime Minister of New Zealand. Bell.

No. 2. From **Z 4AA Waihemo, N.Z.**, to Sir James Allen, Strand, London. Greetings from Home. Bell.

No. 1. From Radio Society of Great Britain to Radio Society of N.Z. via **Z 4AA**. Congrats on achievement and greetings from R.S.G.B. *G. 2KF*

The following message was sent in reply to **4 AA's** No. 2 or 19th to Sir James Allen.

No. 3. To **Z 4AA** from Sir James Allen. So far and yet so near. Congratulations.

the New Zealand stations experience little or no difficulty in reading the signals of the English stations. It rarely happens that a reply is not received immediately from one or other of the three "Z" stations when called during the hour or so when communication is possible.

At the time of writing only three New Zealand stations have been logged at **G 2KF** and these are **Z 4AA**, **Z4AG** and **Z4AK**. The former transmissions resembled what might be termed a pure D.C. note, while the other two used A.C. as a source of power, which renders their signals difficult to get when interference is experienced.

A strange observation, and one which is rather difficult to explain, is that the signal strength of the three stations varies and each in turn may be received quite strongly with the others barely audible. It is difficult to give a cause for this as the three stations are situated so close together, **4 AG** and **4 AK** being located in the same town of Dunedin. It is highly improbable that the power inputs of these stations would fluctuate in this manner, and more improbable still that the operators would introduce changes in their circuits having once established contact with this country. Another point of interest is the almost entire absence of American stations operating on a wavelength of 80

metres during the time that our stations are working with New Zealand.

It would appear, moreover, that our two-way working with the Antipodes is not intercepted in America, although our signals may be passing across their country. Again it has been noticed that when the signals

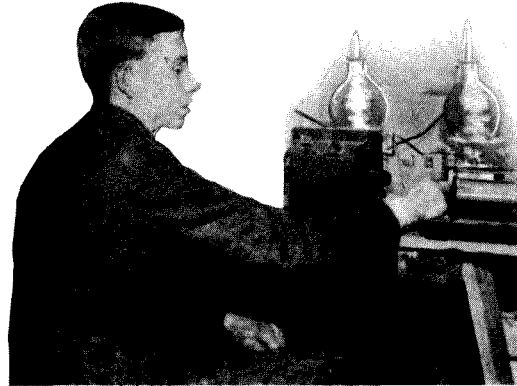

Mr. Goyder-(2 SZ) who was first to obtain two-way working between England and New Zealand.

from England become unreadable in New Zealand, the New Zealand station **Z 4AG** has been heard calling **CB8**, the Argentine station with whom it is understood the New Zealand stations carry out extensive tests.

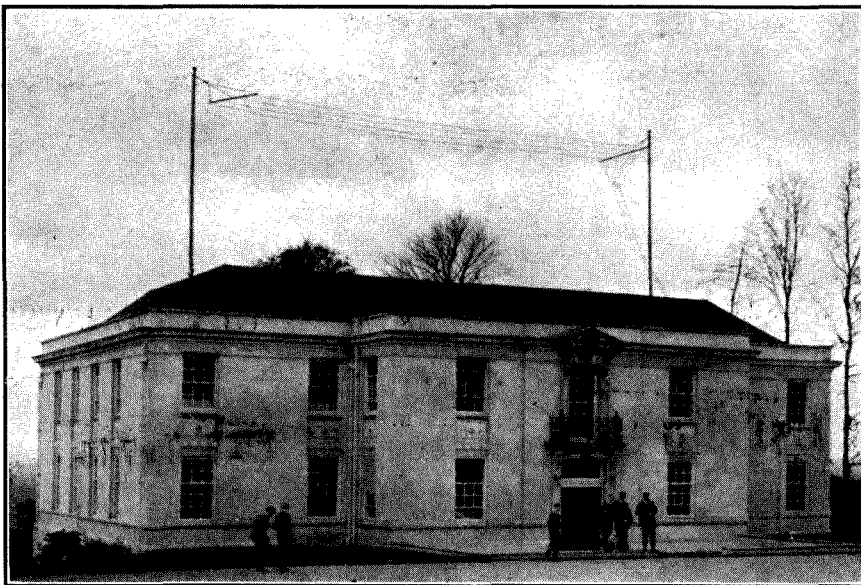

The aerial at the Mill Hill School (2 SZ) used for communicating with New Zealand.

Much interference is experienced in the London area from the several transmitters employing wavelengths between 80 and 90 metres, which is the band used by the New Zealand stations. The remedy is quite simple. Use wavelengths above 90 metres where the New Zealand stations will be searching and do not make a call until some indication has been received from the distant stations.

It might be added that the Australian station **2 DS** reports having heard the signals of **G 2OD** (Mr. E. J. Simmonds) and **G 5LF** (Mr. K. Secretan) and it would appear that we shall soon be satisfactorily working with the Australian Continent.

SOME OBSERVATIONS ON COMMUNICATING WITH NEW ZEALAND

By GERALD MARCUSE (2 NM.)

ENCOURAGED by the results obtained at my station from December to April, when two-way communication was carried out almost entirely with the United States and Canada, and profiting by the valuable data gained, I fully realised, as I have previously predicted, that this year would prove even more successful than ever so far as long distance amateur communication was concerned. During operations last winter it was found possible to work with forty-one Canadian and American amateurs, and the signals from **2 NM** were received North, South, East and West, throughout the American Continent. I do not propose to give full technical details here as these have been already published, but I will refer only to the alterations which have been introduced in the hope of improving the operation of the set.

A 25 ft. extension has been added to my 65 ft. steel lattice mast, making the height at the free end about 90 ft., while the height at the house is 65 ft. The aerial is an eight-wire cage, 2 ft. in diameter, with a six-wire lead-in, while the insulators for both aerial and counterpoise are further spaced from the earthed supporting wires by inserting them in plate glass squares. A source of high tension is obtained from a special generator built for me by Messrs. Mortly Sprague & Co., Ltd., which will deliver a current of 330 milliamperes at a potential of

3,000 volts, and when working on full power a current is obtained in my aerial system of 3 amperes, on the wavelength adjustment of 96 metres.

For reception a special low loss set was employed which was made up for me in Montreal, and is a two-valve set employing a detector and low frequency amplifier.

The many American and Canadian amateurs which had been worked, and from the reports gathered I could see that my labours were not altogether in vain, and when

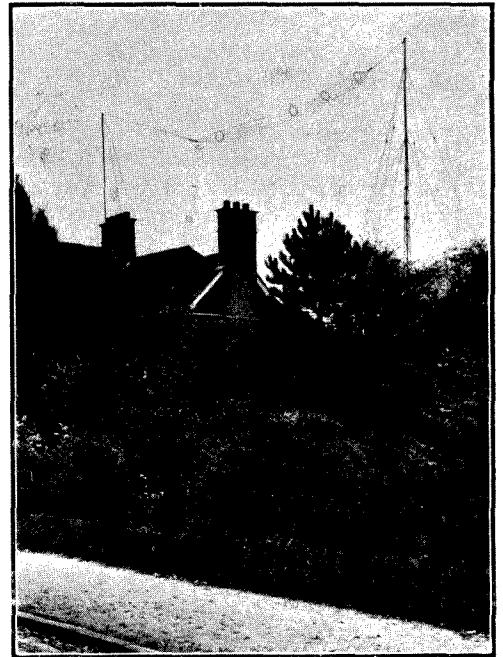

The aerial at 2 NM. It is an eight-wire cage 90 feet in height at the mast end.

using 300 watts and a Mullard O 250 valve as oscillator, communication was established with **1 HT**, which is an Italian destroyer, with an old friend, **ACD**, as operator. He told me that he had logged my signals well south of the equator. The Canadian Government steamer "Arctic" (**VDM**) also gave me a very encouraging report.

Unfortunately I was laid up when the New Zealand stations were first heard in this country, but when Mr. Goyder rang me up and told me the joyous news I was compelled to brave the doctor's orders. I crawled out of bed on the morning of October 19th and called up New Zealand, and was more than

gratified to hear **Z 4 AK** and **Z 4 AG** both calling me. Working was carried on with the latter station until his signals faded out, and during the course of this transmission the New Zealand station reported my signals to be of good strength. On October 21st my call was replied to by **Z 4 AK**, while on October 25th I again worked **Z 4 AG**, this time using about 900 watts, my previous working having been carried out with a

The reception of signals from New Zealand is rather curious. The signal strength may be fairly weak at the start, gradually increases, and then drops off again and gradually fades away. The period of audibility in this country seems to be about one hour, and on some occasions a little more, and is timed from 6.15 a.m. till 7.30 a.m. G.M.T.

Another observation of interest is that on

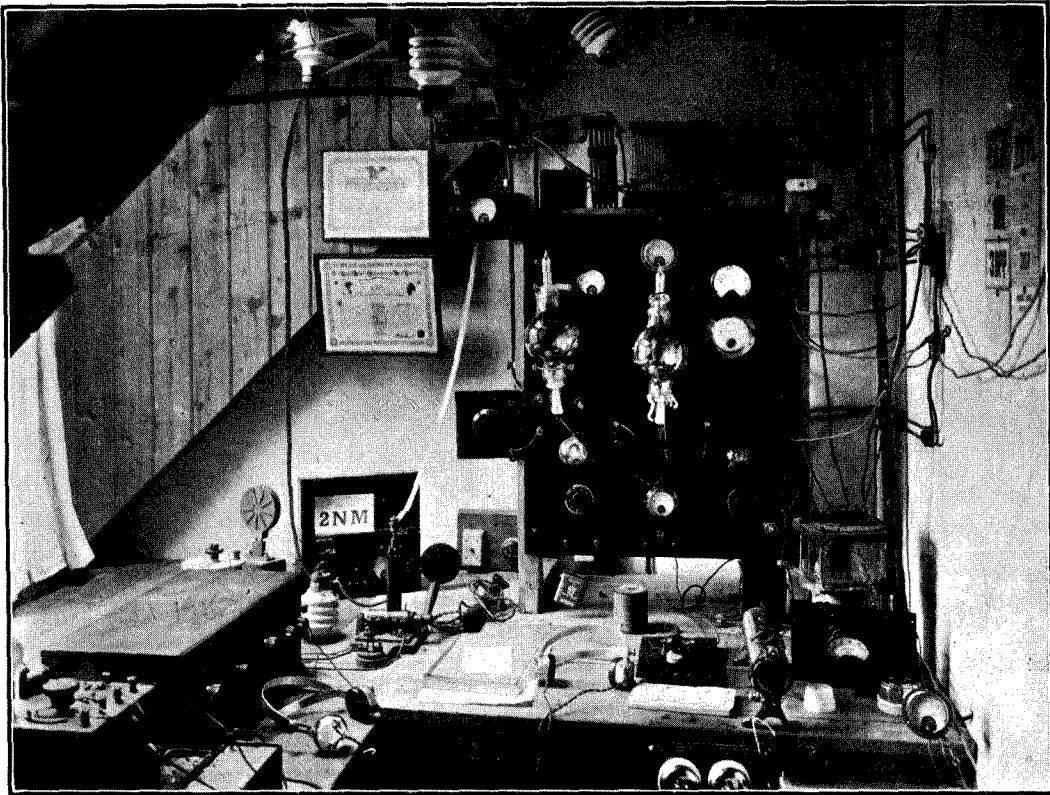

Mr. Gerald Marcuse operates 2NM and is actively engaged in working the New Zealand stations.

power of 300 watts. I also heard **Z 4 TE** calling, and although replied communication was not established. It is just as well to announce here that the New Zealand stations are testing with Australia between 5 and 6 p.m. G.M.T., while the Australian transmitters endeavour to establish communication from 6 to 7 p.m. G.M.T. In connection with these tests I have heard **Z 4 JA** calling during these hours. Those interested in short wave working should certainly make a point of listening-in to these tests.

Sunday morning, October 26th, the New Zealand station, **Z 4 AG**, sent out a general call, "CQ," and said that there was "nothing doing," although his strength here on two valves was the best I have yet heard from New Zealand. On the other hand, on Monday, 27th Oct., no signals were received from New Zealand, which is the first occasion for a week that this has occurred.

During the tests with New Zealand one observes that there would appear to be very little activity among the American and

Canadian stations, and so far as my own station is concerned, nothing has been heard in America since the Pan-American tests organised by the American Radio Relay League, extending from October 15th to 24th.

In recording the results of international communication it might be mentioned that very few American and Canadian amateurs have been heard calling the Argentine, although from letters received from Major Borrett and others in America **CB 8** is coming in well there, although two-way communication between Canada and the Argentine is not yet possible.

In a recent letter Canadian **IDD** (Major Borrett) states that **G 2 OD** (Mr. Simmonds), **G 2 KF** (Mr. Partridge), **G 5 LF** (Mr. Secretan), and my own station (**G 2 NM**), come in very well at his station, and that he has called us on 80 metres. Though I have listened very carefully for his signals I have heard nothing, and this is all the more curious as it is occurring at a time when the signals from New Zealand are coming in so well.

In conclusion, I would like, through these columns, to thank those gentlemen who have so kindly sent me telegrams and letters as a result of having overheard my two-way communication with New Zealand. I would like also to request those amateurs who are using wavelengths below 90 metres to refrain from doing so during this period, when communication with New Zealand is being developed, as they are very liable to interfere with the success of long range work.

AMATEUR RADIO IN NEW ZEALAND

R. J. ORBELL, B.E. (**Z 3 AA**).

COMING at a time when Imperial communication by wireless is such a widely debated subject, it is surely a significant fact that the honour of being the first to establish direct touch with the Antipodes should fall to the lot of a British amateur. This is more particularly the case when one considers the fact that communication was, and continues to be established using the remarkably low power of two hundred watts input. When one realises that the energy expended in covering the 11,000 miles to New Zealand is very little more than that consumed by an ordinary incandescent electric lamp, this feat appears even more remarkable, and one conjures up visions of what must

inevitably come in the near future. In a few years time, at the present rate of progress, anyone with a simple set such as those now used for listening-in to broadcasting, will no doubt be able to converse freely by word of mouth with a friend in any part of the world.

I have lately arrived in England from New Zealand, and the three amateurs in the latter country, who have already "got over" to England, are well known to me personally. I shall endeavour therefore to give a short description of their stations and of radio in New Zealand as a whole. I shall also describe briefly some two-way tests which I conducted on the s.s. "Port

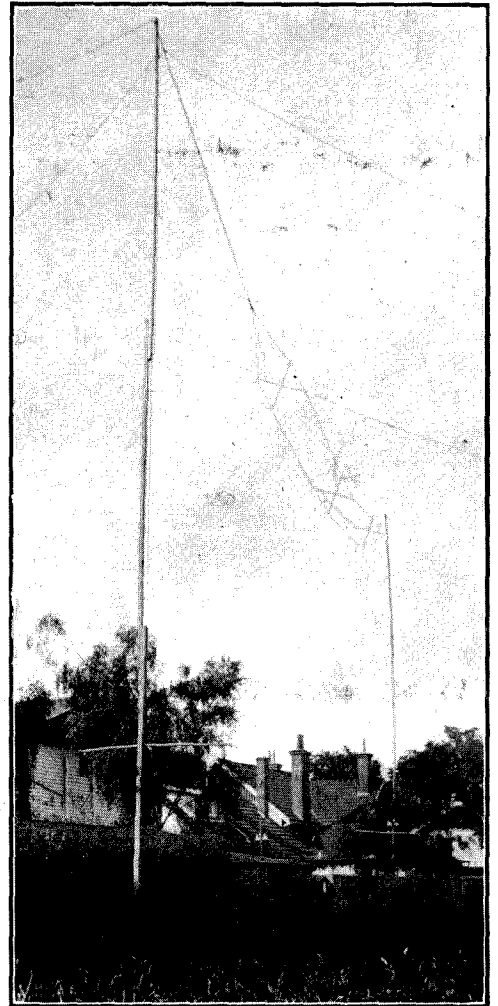

The aerial of Z 3AA at Christchurch, New Zealand.

Curtis" on the voyage to England *via* Cape Horn.

It was not until early in 1923 that the official ban on amateur wireless in New Zealand was raised, and regulations were framed giving the experimenter a reasonably free hand to carry on such work as he chose.

Although these regulations provided wavelengths ranging from 180 to 140 metres, no restrictions were imposed on the use of still lower waves, as it was then generally considered that waves in the neighbourhood of 100 metres were unworkable. Trans-

the call signs allotted are as follows:—Auckland District 1, Wellington District 2, Canterbury District 3, and Otago District 4. Other outlying Provinces are included in the above radio districts. Thus no calls have any figure greater than 4. The regulations are well thought out, and are also flexible as regards power and wavelength if special tests or experiments are to be conducted at any time.

For the first six months apparatus was exceedingly difficult to obtain, more particularly valves, as these all had to be im-

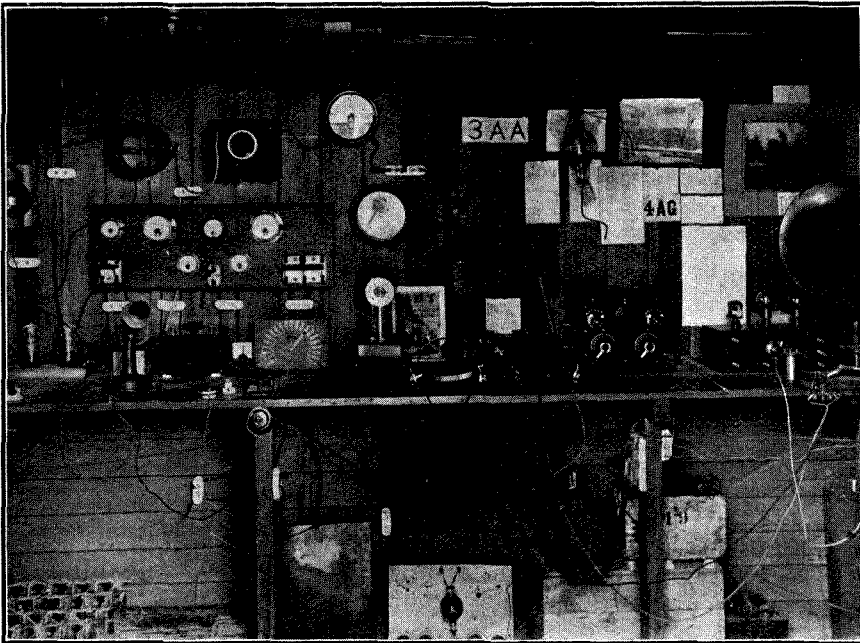

The equipment at 3 AA, the station of Mr. R. J. Orbell, a well-known New Zealand experimenter. He has just arrived in this country and he describes the New Zealand stations participating in the communication tests with this country.

mitting licences were divided into two classes—Grade 1 and Grade 2, the holders of the former being allowed fifty watts input and the latter five. To obtain a licence it was necessary to pass an examination embracing theory, morse code and the regulations. Ten words per minute were required for a Grade 1 licence and eight for a Grade 2. These licences were being revised when I left New Zealand and the intention was to have one grade only and eliminate Grade 2 altogether, thus allowing everyone the use of fifty watts. The figures prefixing

ported from either England or America, hence their chances of arriving intact were more or less uncertain. However, after a time various firms imported valves in bulk and this difficulty was overcome. Our experiments for the first year consisted for the greater part in "putting over" gramophone concerts which were not (as one might expect) of a very high class nature.

Then we began to hear amateurs in Australia, which is, on an average, about 1,400 miles from New Zealand. Tests were

arranged, first between individual stations in both countries and then between the Radio Society of Christchurch and the various Australian societies which had been formed. These tests proved quite successful, and eventually clear two-way conversations were made on both morse and speech. Low power working was tried and on one occasion Mr. Jack Davis, **A 2DS**, a prominent Sydney experimenter, got over to Mr. Bell, **Z 4AA** (now so well known to amateurs in England) with less than half of one watt input.

Signals from American amateurs had been heard in New Zealand and Australia for some

September there were many more transmitters working.

It occurred to me that if I installed my own transmitter and receiver on board the ship *en route* to England, and if a series of nightly tests were arranged, that an excellent opportunity would be afforded of determining just how far the New Zealand signals were reaching. The only reports to date which had come from outside Australasia were several from the United States which claimed reception of **Z 4 AA**, all of which reports, with the exception of one, did not correspond with the latter's log. However, Mr. O'Meara (**Z 2AC**) on May 24th worked Argentine (**RCB 8**) at 6,400 miles, this being at that time a world's record for two-way amateur communication.

Permission to install my set on the s.s. "Port Curtis" was kindly granted by Amalgamated Wireless, Ltd., the Marconi representatives in Australasia, and by the Post Office and shipping authorities. With the assistance of **Z 4 AA** and some other friends, I built a four-wire cage aerial 50 ft. long, and erected it from a point on one of the masts 50 ft. above the deck to a small pole lashed to the bridge. It was badly screened by the main ship's aerial and by numerous mast stays, etc., but was the best we could do under the circumstances. A lead-in was brought through a ventilator into the wireless cabin, where, through the kindness of Mr. Boorne, the ship's senior operator, we had arranged to place our gear. The apparatus was, however, necessarily rather cramped. The transmitter, which I had rebuilt for the purpose, was arranged to be attached to the wall, and occupied a space of only 15 ins. by 12 ins.

A shunt Hartley circuit was used with 600 volts H.T., supplied by a B.T.H. aeroplane generator. This latter was belted to a $\frac{1}{4}$ H.P. direct current motor run by the ship's supply mains. A 250 watt Marconi-Osram valve was operated on low power with an actual input of only 60 watts, as this was all that the generator would deliver. Better results were obtained in this way than by running several smaller valves in parallel. My receiver consisted of a detector and one note magnifier, with "low loss" inductances employing an aperiodic primary of four turns. When we put to sea it soon became evident that owing to "swinging" caused by the rolling

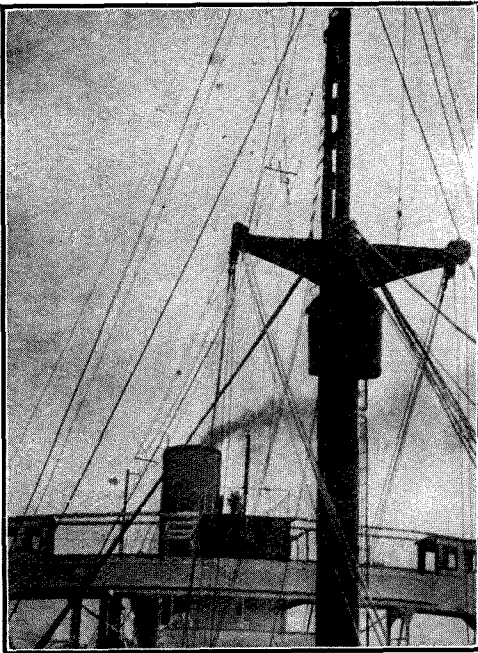

*The cage aerial fitted on the s.s. "Port Curtis" and used by Mr. Orbell for experimental work with Australian and New Zealand amateurs. It is 50 ft. above the deck. Little difficulty was experienced in working **A 2DS**, **A 3BQ**, **Z 4AA**, **Z 4AG**, **Z 4AK**, **Z 2AC**, up to a distance of 5,000 miles on the outward route from New Zealand to Cape Horn.*

time, but two-way tests arranged with the A.R.R.L. proved unsuccessful, although many American signals from all districts were received with great strength. Towards the close of 1923, about six New Zealand and ten Australian stations were in operation, all using an average input of about 30 watts. During 1924 considerable progress was made and when I left New Zealand early in

of the vessel it was impossible to use a wavelength lower than 125 metres, except during very calm weather. Hence this was used almost all the time.

The ship left Napier as its final port on September 4th, bound for Cape Horn. A schedule for working had been arranged, including that I should listen every night for New Zealand and Australian amateurs from 8 p.m. till 8.30 p.m. I was to reply at 8.30, giving calls heard, and then try to work anyone whose signals I heard. I decided to use my Christchurch call (**3 AA**), and in order that no confusion would be caused by the use of the "intermediate" **Z**, I substituted **X** instead. I kept a complete log of New Zealand and Australian calls heard and stations worked, but will mention here only the more important results obtained. Little difficulty was found in working **Z 4 AA**, **Z 4 AG**, **Z 4 AK**, **Z 2 AC**, and all the principal stations up to 5,000 miles, including **A 2 DS** and **A 3 BQ**, who were very consistent, the former using 25 watts input only. **Z 3 AL**, using 12 watts, was worked at 4,600 miles, and heard when we were rounding Cape Horn at 5,100 miles. I managed to work **Z 2 AC** every night till we arrived at Montevideo, at which place he reported my signals as being strong. This was a distance of 6,500 miles—just 100 miles further than the previous record by **Z 2 AC**. The latter tried modulation tests, and clear speech was received from him till the ship was approximately 300 miles S.W. from Montevideo. After leaving the latter port we experienced a period of very heavy atmospherics, which lasted for most of the remainder of the journey to Las Palmas. As we were now in tropical waters this was to be expected, and, as a result, two-way working with New Zealand became impossible.

However, **R CB 8** at Buenos Aires, whom I had worked every evening from Cape Horn onwards, and who had hooked up with **Z 2 AC**, now acted as a relay station, so I was still in touch though not directly. The New Zealand stations were still audible, but it was only during lulls in the bad weather that their calls were recognisable. **Z 4 AG** and **Z 4 AK** were occasionally heard till we were off Pernambuco, and **Z 2 AC** was the last one to be heard, distinctly calling **RCB 8** and myself, when the ship was 70 miles north of the equator, at a distance of nearly 10,000 miles. This latter call was

heard when the sun had been shining for over an hour, and the atmospherics had decreased as a consequence. A few days before this **Z 2 AC** had effected two-way communication with **R DB 2**, Dr. Cattaneo, of Bahia Blanca, whom I had also worked frequently when going up the coast. **R CB 8** and I arranged a schedule as far as Las Palmas, but atmospherics rendered signals unintelligible after we were about 3,000 miles apart.

British **G 2 KF** and **G 2 OD** were heard very strongly several times when we were passing Pernambuco, as was also Mr. Ducati, who was on the Italian warship "San Marco" **IHT** somewhere near the African coast. When we reached Las Palmas in the Canary Islands I dismantled the set in order to have it packed up ready for arrival in England some days later.

There were several rather interesting occurrences that were noticeable during the voyage. One was that the U.S. amateur signals which were constantly heard, reached a maximum strength about half-way across the South Pacific, and faded out very considerably later when the South American Continent intervened.

Later, in the Atlantic, near Las Palmas, they returned to nearly the same strength as previously. This appeared to point to a decided screening effect due to the land between us and the United States. Another noticeable effect was that as we became more and more distant from New Zealand, the fading of the New Zealand signals became gradually less noticeable, till at the maximum distance it almost entirely disappeared.

On my arrival in England on October 18th, it was indeed an agreeable surprise to find that **Z 4 AA** had actually been worked that same morning by Mr. Goyder at the Mill Hill School station **G 2 SZ**. That this was not merely due to "freak" conditions becomes increasingly evident, as several other stations at both ends have now been similarly successful, these others being, at the time of writing, **G 2 KF**, **G 2 NM** and **G 2 OD** in this country and **Z 4 AG** and **Z 4 AK** in New Zealand. Both **Z 4 AG** and **Z 4 AK** are using inputs in the neighbourhood of 250 watts. **Z 4 AA**, whose station I know intimately, he himself being a personal friend, is using from 100 to 150 watts in a close coupled shunt Hartley circuit.

He generally uses one UV 203 American valve rated at 50 watts output, supplied by a B.T.H. aeroplane generator similar to my own, with another machine in series, the total H.T. voltage amounting to about 1,200 volts. Power is derived from a 110 volt Delco lighting plant. The aerial is supported at one end by a wooden lattice tower 96 feet high, and at the other end by an Australian blue-gum tree 90 feet high stripped of its branches. The aerial itself is 30 feet long and consists of a double cage attached to spreaders. A cage lead-in is brought from the centre of the 30-ft. span, directly down to the operating room. The counterpoise is a multiple wire fan arranged directly below the aerial and about 15 feet from the ground. With this system, an aerial current of about 1.3 amperes is obtained on 100 metres.

While the station itself is on high ground over ten miles from the nearest town, Palmerston South, it is nevertheless enclosed on two sides by neighbouring hills of about 2,000 feet high.

It is a strange thing that, as far as I am aware, the only New Zealand stations reported to date are situated within a radius of 50 miles in the southern part of the country, while **Z 2 AC** and others in the North Island have not yet been heard in England. In this connection, it is interesting to note that the long wave high power stations in Europe are received much more strongly in the district where the successful stations are situated, than they are further north. This seems to suggest a possible concentration at certain points near the Antipodes of the waves from the various European stations. Another interesting fact is that these long wave European stations are received at maximum strength about 6 a.m. New Zealand time, corresponding to 6.30 p.m. Greenwich time, while amateur tests have so far been unsuccessful at this time. These are matters which can be elucidated only by constant and systematic experimenting.

REPORTS FROM A LISTENER IN FRANCE.

By J. L. MENARS, France. (F 8 FJ.)

DURING the period October 20th to 25th, signals from the New Zealand stations have been intercepted. Using a three-valve receiver the New Zealand

station **4 AA** comes in exceedingly loud and equal in strength to the strongest of the N. American amateurs.

A surprising thing is the ease with which the New Zealand signals can be received on a comparatively small aerial. The best time for working I find to be between 6 and 7 a.m. G.M.T., and, as to wavelength, I observe that **4 AG** is working on 80 metres, while **4 AA** employs a wavelength of 89 metres.

As regards the communication tests, the several European stations in communication would appear to be **2 OD** (Mr. Simmonds), **2 NM** (Mr. Marcuse), **2 SZ** (Mr. Goyder), **2 KF** (Mr. Partridge), and **5 LF** (Mr. Secretan), also the French station **8 BF** (M. Pierre Louis).

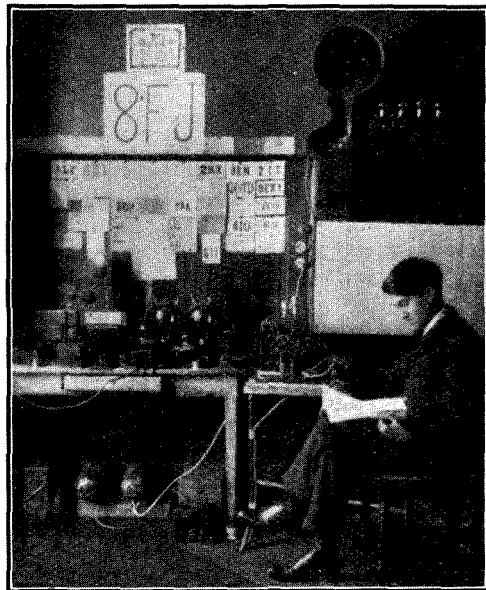

Mr. J. L. Menars, of Province Gan, a French amateur who is intercepting the New Zealand transmissions.

Mr. J. H. R. Ridley (**5 NN**) was heard in New Zealand on the morning of October 22nd by **Z 4 AA**. The wavelength used for the transmission was 99 metres.

Mr. Frederic L. Hogg (**2 SH**), using an aerial 40 feet in length and about 15 ft. in height, has been heard by **Z 4 AA**. Mr. Hogg reports reception of **Z 4 AA** and **Z 4 AG**.

Mr. R. L. Royle (**2 WJ**) worked with **Z 4 AA** on October 29th. He reports having heard **2 AC** working on a wavelength of 85 metres.

NOTES & NEWS



Satisfactory tests have been made from a new German broadcasting station at Bremen.

* * * *

Short-wave transmissions from **KDKA**, Pittsburgh, have been heard within 11 degrees of the North Pole by the operator of the Canadian Government steamship *Arctic*.

* * * *

The value of wireless apparatus manufactured in the U.S.A. during 1923 amounted to £8,692,000.

* * * *

The Ecole Supérieure station has again changed its wavelength, states our Paris correspondent, and now transmits on 458 metres. The *Petit Parisien* wavelength is now 346 metres.

* * * *

CAPTAIN IAN FRASER'S SUCCESS.

To wireless amateurs an interesting feature of the past election has been the returning to Parliament of Captain Ian Fraser, C.B.E., as Conservative member for North St. Pancras.

Captain Fraser, who was blinded on the Somme in 1916, is well known, not only as Chairman of St. Dunstan's, but as a keen wireless experimenter, a member of the Council of the Radio Society of Great Britain, and Chairman of the Transmitter and Relay Section. He is an active transmitter and owns the call sign **5 SU**.

RECORD LOOP AERIAL RECEPTION.

Broadcast reception with a loop aerial over a distance of 7,500 miles is reported from Johannesburg. On the night of September 27th, several experimenters, with a four-valve receiver and McMichael loop aerial heard the Pittsburgh station, **KDKA**. This appears to be a record for loop aerial reception in South Africa, and has roused great enthusiasm in the Press.

NEW SPANISH BROADCASTING STATIONS.

The Radio Iberica Co. of Spain has inaugurated a new broadcasting station at Seville, and concerts are to be sent out daily from 7 to 9 p.m. A low power broadcasting station is also to be installed at Barcelona, employing a Western Electric 100-watt transmitter. At present we have no information as to the call signs of these stations.

ITALIAN AMATEUR'S GOOD RECORD.

An Italian amateur station whose signals have become increasingly familiar to British listeners, is **1 FP**, the owner of which is Signor Franco Pugliese, of Milan.

We are indebted to Signor Pugliese for some interesting details of his work during the past summer. Although surrounded by very high mountains, **1 FP** has been heard in nearly all European countries, and Finnish **2 NM** has reported the Italian's signals as R 9 on two valves. Two-way working has been established with more than forty foreign amateurs. A new transmitter is now being designed for participation in the Transocean

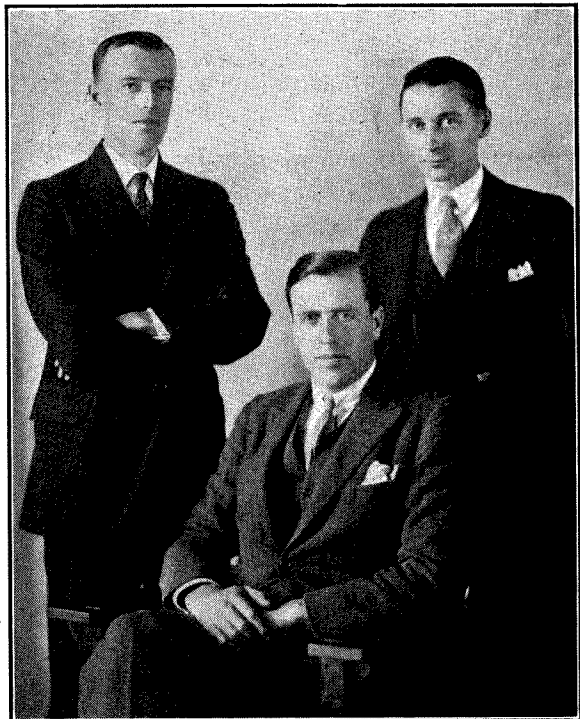

Captain P. P. Eckersley, Chief Engineer of the B.B.C., photographed while on his recent visit to America. On the left is Mr. A. J. Haynes, the well-known designer of receiving apparatus, and on the right Mr. Arthur Lynch, Editor of "Radio Broadcast," of New York, organising the international broadcasting tests on the American side.

Tests, and we hope that 1 FP will meet with the success which his previous record would seem to promise.

WIRED WIRELESS FOR BROADCASTING.

Much interest has been aroused in Germany by the successful application of "wired wireless" in connection with broadcasting. Preliminary experiments have been carried out in Saxe-Altenburg, and on October 23rd a programme was transmitted on this system to Rositz from Berlin *via* Leipzig. From Rositz it was sent out on the mains carrying a potential of 22,000 volts. The chief merit of the "wired wireless" system is its cheapness. A very low-powered transmitter can be employed, and the receiving apparatus is of usual design. Moreover, the primary functions of the power and conductors are not interfered with in any way.

2 NB.

The above call sign, originally the property of a Cheshire transmitter, is now owned by Mr. N. G. Baguley, of 94, Ribblesdale Road, Streatham, London, S.W.16. Mr. Baguley welcomes reports of his transmissions on short waves.

B.B.C. TO ENTERTAIN WOUNDED SOLDIERS.

It may come as a surprise to many readers to learn that in war hospitals round London there are

still 5,000 badly wounded soldiers. With the object of brightening the lives of these unfortunate sufferers, the *Adair Wounded Fund* has consistently, for nearly four years, provided them with weekly entertainments. Ninety-four of these entertainments have already been held in the Wigmore Hall, Palladium and elsewhere, but on the afternoon of Sunday, November 23rd, a "special" event takes place at the Palladium, when the British Broadcasting Company will act as hosts, providing the expenses for the entertainment and the tea. Over 600 wounded soldiers will be present to enjoy a "surprise" programme contributed by John Henry and "Blossom," Miss Isobel Elsom, Miss Phyllis Dare, Mr. Ben Lawes, and other popular artistes. This is one of the two yearly matinees to which the public are admitted, and to cover the inevitable "out-of-pocket" expenses (the artistes are giving their services free) it will be a gracious act if wireless folk turn up in force to support the kindly efforts of the B.B.C. Tickets, price 5s. 9d.,

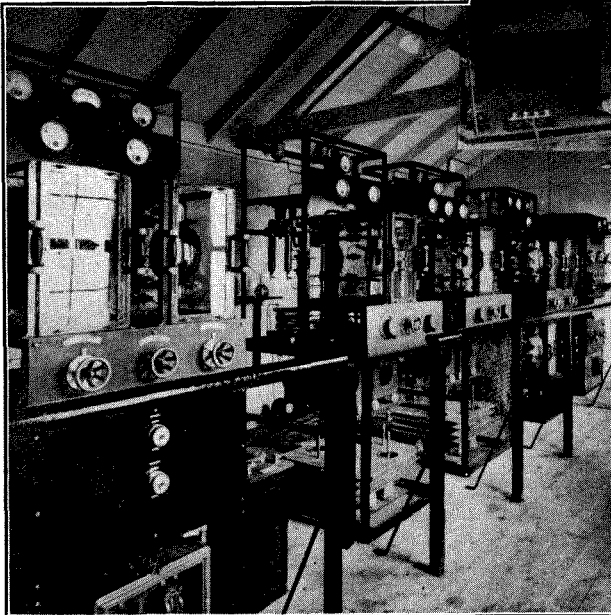
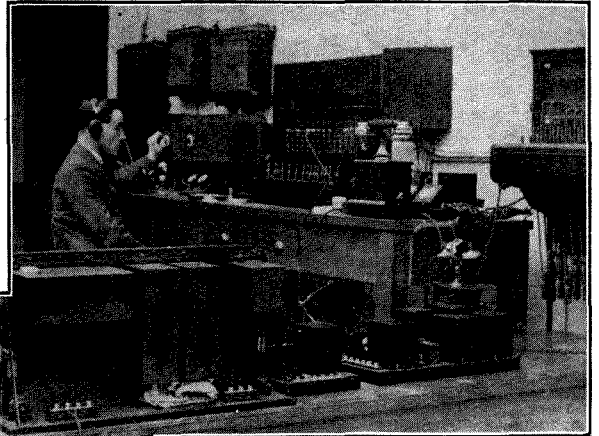

Two views of the Belfast Broadcasting Station, which was opened officially by the Duke of Abercorn at the end of October. Above: A scene in the control room. Below: The transmitting room.

3s. 6d., 2s. 4d. and 1s. 10d., may be obtained at the Wigmore Hall, or from the Hon. Secretary of the Fund, Basil F. Leskey, at Somerset House, New Barnet.

RUSSIAN WIRELESS FOR PERSIA.

The Electro Trust Company of Moscow has recently signed a contract with the Teheran Government for the construction of eight radio stations in Persia. Under the contract the work is to be carried out by Russian engineers, and only plant manufactured by the Russian Electro Trust is to be employed.

CALLS HEARD.

In order to cope with the increasing number of Calls Heard sent in, we shall be compelled to exclude English calls for the next few issues.



BROADCASTING.

REGULAR PROGRAMMES ARE BROADCAST FROM THE FOLLOWING EUROPEAN STATIONS :



GREAT BRITAIN.

CHELMSFORD 5 XX, 1,600 metres, Tests.
ABERDEEN 2 BD, 495 metres; **BIRMINGHAM 5 IT**, 475 metres; **BELFAST 2 BE**, 435 metres; **GLASGOW 5 SC**, 420 metres; **NEWCASTLE 5 NO**, 400 metres; **BOURNEMOUTH 6 BM**, 385 metres; **MANCHESTER 2 ZY**, 375 metres; **LONDON 2 LO**, 365 metres; **CARDIFF 5 WA**, 351 metres; **RELAY STATIONS: LEEDS-BRADFORD 2 LS**, 346 and 310 metres; **PLYMOUTH 5 PY**, 335 metres; **EDINBURGH 2 EH**, 328 metres; **NOTTINGHAM 5 NG**, 322 metres; **HULL 6 KH**, 335 metres; **LIVERPOOL 6 LV**, 315 metres; **STOKES-ON-TRENT 6 ST** 306 metres; **SHEFFIELD 6 FL**, 301 metres. Tuesdays, Thursdays and Fridays, 1.0 p.m. to 2.0 p.m. (2 LO only). Regular daily programmes, 3.0 to 7.30 p.m., 8.0 to 11.30 p.m. Sundays, 3.0 to 5.0 p.m., 8.30 to 10.30 p.m.

FRANCE.

PARIS ("Radio Paris"), **SFR**, 1,780 metres. 12.30 p.m., Cotton Prices, News; 12.45 p.m., Concert; 1.30 p.m., Exchange Prices; 4.30 p.m., Financial Report; 5.0 p.m., Concert; 8.30 p.m., News and Concert.

PARIS (Ecole Superieure des Postes et Telegraphes), 458 metres. 3.45 p.m. (Wednesday), Talk on History; 8.0 p.m. (Tuesday) English Lesson; 8.30 p.m., Concert; 9.0 p.m., Relayed Concert or Play.

PARIS (Station du Petit Parisien), 346 metres; 8.30 p.m., Tests.

BELGIUM.

BRUSSELS, BAV, 1,100 metres. At 2.0 p.m. and 6.50 p.m., Meteorological Forecast.

BRUSSELS ("Radio-Belgique"), 265 metres. Weekdays, 5.0 p.m. to 6.0 p.m., and 8.0 p.m. to 10.0 p.m.; Sunday, 5.0 p.m. to 6.0 p.m., and 8.30 p.m. to 10.0 p.m.

HOLLAND.

THE HAGUE, PCGG, 1,070 metres. 4.0 to 6.0 p.m. (Sunday), 9.40 to 11.40 p.m. (Monday and Thursday), Concerts.

THE HAGUE (Heussen Laboratory), PCUU, 1,050 metres. 10.40 to 11.40 a.m. (Sunday), Concert; 9.40 to 10.40 p.m., Concert; 8.45 to 9.0 p.m. (Thursday), Concert.

HILVERSUM, 1,050 metres. 9.10 to 11.10 (Sunday), Concert and News.

IJMUIDEN (Middelraad), PCMM, 1,050 metres, Saturday, 9.10 to 10.40 p.m., Concert.

AMSTERDAM, PA 5, 1,050 metres (Irregular), 8.40 to 10.10 p.m., Concert.

AMSTERDAM (Vas Diaz), PCFF, 2,000 metres, 9.0 a.m. and 5.0 p.m., Share Market Report, Exchange Rates and News.

DENMARK.

LYNGBY, OXE, 2,400 metres. 8.30 to 9.45 p.m. (Weekdays), 8.0 to 9.0 (Sunday), Concert.

SWEDEN.

STOCKHOLM (Telegrafverket), 440 metres. Daily, 12.45 to 1.0 p.m., Weather Report and Nauen Time Signal; Monday, Wednesday and Saturday, 8.0 to 9.0 p.m., Concert and News; Sunday, 11.0 a.m. to 12.30 p.m., Divine Service from St. James' Church.

STOCKHOLM (Radiobolaget), 470 metres. Tuesday and Thursday, 8.0 to 9.30 p.m., Concert and News.

GOTHENBURG (Nya Varvet), 700 metres. Wednesday, 7.0 to 8.0 p.m.

BODEN, 2,800 metres. Tuesday and Friday, 6.30 to 7.30 p.m., Sunday, 5.30 to 6.30 p.m., Concert and News.

GERMANY.

BERLIN (Koenigswusterhausen), LP, 680 metres. Sunday, 10.50 to 11.50 a.m., Concert; 2,800 metres, Sunday, 11.50 a.m. to 12.50 p.m., Concert.

EBERSWALDE, 2,930 metres. Daily, 1.0 to 2.0 p.m., Address and Concert; 6.0 to 7.30 p.m., Address and Concert; Thursday and Saturday, 7.20 p.m., Concert.

BERLIN (Vox Haus), 430 metres. 11.0 a.m., Stock Exchange; 1.55 p.m., Time Signals; 5.40 to 7.0 p.m., Concert; 7.0 to 8.0 p.m. (Sunday), Concert.

BRESLAU, 415 metres.

HAMBURG, 387 metres.

STUTTGART, 437 metres.

KONIGSBERG, 460 metres.

FRANKFURT-AM-MAIN, 467 metres. 7.30 to 10.0 p.m., Tests, Gramophone Records.

LEIPZIG (Mitteldeutsche Rundfunk A.G.), 452 metres.

MUNCHEN (Die Deutsche Stunde in Bayern), 485 metres.

CZECHO SLOVAKIA.

PRAGUE, PRG, 1,800 metres. 8.0 a.m., 12 a.m., and 4.0 p.m., Meteorological Bulletin and News; 4,500 metres, 10.0 a.m., 3.0 p.m., and 10.0 p.m., Concert.

KBELY (near Prague), 1,150 metres. Weekdays, 7.15 p.m. and 10.0 p.m., Sundays, 11.0 a.m. to 12.0 noon, Concert and News.

BRUNN, 1,800 metres. 10.0 to 11.0 a.m., Concert; 2.30 p.m., News.

SPAIN.

MADRID, PTT, 400 to 700 metres. 6.0 to 8.0 p.m., Tests.

MADRID (Radio Iberica), 392 metres. Daily (except Thursdays and Sundays), 7.0 to 9.0 p.m. Thursdays and Sundays, 10.0 to 12.0 p.m., Concerts.

MADRID, 1,800 metres. Irregular.

CARTAGENA, EBX, 1,200 metres, 12.0 to 12.30 p.m., 5.0 to 5.30 p.m., Lectures and Concerts.

PORTUGAL.

LISBON (Aero Lisboa), 370 to 400 metres. Wednesdays and Fridays, 9.30 to 12.0 p.m., Irregular Tests.

SWITZERLAND.

GENEVA, HB 1, 1,100 metres. Weekdays, 3.15 and 8.0 p.m., Concert or Lecture.

LAUSANNE, HB 2, 850 metres. Daily, 9.15 p.m., Concert and Address.

ZURICH, HBZ, 650 metres. 1.0 p.m., News and Weather Forecast; 8.15 p.m. to 10.15 p.m., Concert.

ITALY.

ROME, ICD, 3,200 metres. Weekdays, 12.0 a.m. to 1.00 p.m., 4.0 p.m. and 8.30 p.m., Tests, Gramophone Records.

ROME, 422 metres. Weekdays 7.30 to 9.30 p.m.

Calls Heard

Felixstowe, Suffolk (from September 7th).

French: 8 AL, 8 BC, 8 BO, 8 CN, 8 DP, 8 FC, 8 FI, 8 FM, 8 FVQ, 8 MU, 8 NS, 8 PA, 8 RBR, 8 RLL, 8 VV, 8 WL, 8 XH. Finnish: 1 FN, 1 NA. Danish: 7 ZM. Various: 1 MT, 2 CAA, 3 EA, 4 UU. (o-v-r.) (H. J. Wright.)

The Hague, Holland (from September 20th to October 20th).

French: 8 AB, 8 AG, 8 BN, 8 BP, 8 BRG, 8 CA, 8 CN, 8 DA, 8 DD, 8 EM, 8 EU, 8 EP, 8 FI, 8 FS, 8 FU, 8 GL, 8 JEL, 8 LMT, 8 ME, 8 MU, 8 NS, 8 OK, 8 PP, 8 QG, 8 SG, 8 TM, 8 UU, 8 VV, 8 WAL, 8 WL, 8 XH, 8 ZUT. Swedish: SMZP, SMZY, SMZZ. Belgian: 4 GP, 4 QS, 4 RS, 4 ZY, W 2. Italian: 1 FP, 1 MT, 1 HT. Swiss: 9 AD. Dutch: 0 II. Various: 3 XO, 3 CM, 7 EC, SA 2. (o-v-o Reinartz.) (Chas. Schneider.)

Workshop, Notts. (from August 17th to September 15th).

French: 8 AQ, 8 BD, 8 BF, 8 BO, 8 BV, 8 BRQ, 8 CM, 8 CN, 8 CO, 8 DA, 8 DS, 8 EO, 8 FH, 8 FM, 8 FSP, 8 FG, 8 KK, 8 ML, 8 MN, 8 NE, 8 NO, 8 OK, 8 PD, 8 PP, 8 QG, 8 RG, 8 RR, 8 RCR, 8 SR, 8 SM, 8 UU, 8 WAL, 8 XA, 8 WC, 8 XH, 8 ZM, 8 ZUT. Belgian: B 7, 4 C 2, 4 QS, 4 RS, P 1, W 2. Danish: 7 EC, 7 ZM. Dutch: 0 GC, 0 MS, 0 RM, 0 ZZ. Italian: 1 FP, 1 MT. Swedish: SMZY. Various: 3 AD, 3 XO, ICS, GB (o-v-r.) (I. Davidson.)

Strechford, Birmingham (September 17th to October 19th).

French: 8 BN, 8 BV, 8 CA, 8 CM, 8 CT, 8 DO, 8 DP, 8 DS, 8 EN, 8 FI, 8 FS, 8 FM, 8 KG, 8 MU, 8 PP, 8 QJ, 8 RG, 8 RM, 8 SG, 8 SR, 8 VE, 8 VV, 8 WL, 8 WZ, 8 XG, 8 XH, 8 ZM. Belgian: 4 ALS, 4 GP, 4 RS, 4 UU. Danish: 7 EC. Dutch: OLO, OMST. Italian: 1 MT, 1 DO. Swedish: SITTE. Various: P 1, IOZ. (o-v-r, Flewelling and one L.F.) (C. W. Wheeler.)

Weston-Super-Mare (September 15th and October 13th, all below 200 metres).

French: 8 AB, 8 BF, 8 BN, 8 BRW(?), 8 BP, 8 CA, 8 CM, 8 CN, 8 CZ, 8 DA, 8 DI, 8 DP, 8 EM, 8 EP, 8 EU, 8 EX, 8 FI, 8 FVQ, 8 GL, 8 JHL, 8 KBR(?), 8 LMT, 8 PA, 8 PD, 8 PP, 8 RBR, 8 RG, 8 RR, 8 SS, 8 UU, 8 VV, 8 WK, 8 WL, 8 XH, 8 ZH, 8 ZM, 8 ZUT, 8 ZZ. Dutch: OBA, OBJ, O II, O LO, O MV, O OK, O TR, O XF, O XP. Belgian: W 2, 4 RS. American: 1 CMP, 1 KC, 1 SZ, 1 XAV. Various: 4 YZ, 1 OKZ, 9 AD, 3 CA, 4 QEE, EUEU, PQ, 5 IER, IDO, EIER, U 1 CO, 1 TT, XKDD, A 4 FE, 15 T. (o-v-r.) (A. H. Giles.)

Weybridge (September 23rd to October 13th, on 150 to 210 metres).

French: 8 BN, 8 CA, 8 CT, 8 DD, 8 DP, 8 EU, 8 FV, 8 JH, 8 PF, 8 PP, 8 RD, 8 RW, 8 UU, 8 UC, 8 WA, 8 ZS. Dutch: 0 BA, 0 BN. Various: 4 YZ, 9 AD, JOCD. (o-v-r.) (Ronald J. Denny.)

Pirbright, Surrey (September 17th to October 15th).

French: 8 AG, 8 AL, 8 BA, 8 BC, 8 BF, 8 BN, 8 BP, 8 BR, 8 CM, 8 CN, 8 CZ, 8 DD, 8 DI, 8 DP, 8 EE, 8 EP, 8 EU, 8 FI, 8 FS, 8 FU, 8 GD, 8 GL, 8 GR, 8 HSM, 8 LMT, 8 MN, 8 MU, 8 MW, 8 OK, 8 PA, 8 PD, 8 PP, 8 QG, 8 RA, 8 RBR, 8 RG, 8 RM, 8 RN, 8 RR, 8 RZ, 8 SL, 8 SM, 8 SQ, 8 SS, 8 TM, 8 UU, 8 WL, 8 WM, 8 WZ, 8 YG, 8 ZM. Dutch: 0 BA, 0 FN, 0 II, 0 MS, 0 TB, 0 ZP. Swedish: SMZS. Various: 7 PG, 7 PH, 1 NT, 3 AF, 3 CA, 4 QO, 4 QZ, 9 AD, 1 DO, NBFN 2, P 1. (o-v-r Reinartz.) (E. H. Robinson, 5 YM.)

Cambridge (September 15th to October 10th).

French: 8 CG, 8 DQ 1, 8 DS, 8 EP, 8 GL, 8 GK, 8 PD, 8 RM, 8 SG, 8 UUZ, 8 VV, 8 XH, 8 ZST. Dutch: 0 BU, 0 II, 0 MD. American: 2 AN, 1 AA, 1 XAJ, 1 XAV. Swedish: SMZY, SMZZ. Finnish: 2 NM. Belgian: 1 OZ. Swiss: 9 AD. Various: 1 OKZ, YABO, 1 HT, 1 HU, 4 AA. (o-v-r.) (G. W. Thomas, 2 AQK.)

Chatham (September 5th to October 7th).

French: 8 AP, 8 BC, 8 BV, 8 BW, 8 CA, 8 DG, 8 DI, 8 DP, 8 FJ, 8 FY, 8 GL, 8 IP, 8 JH, 8 LM, 8 MK, 8 OK, 8 PN, 8 PP, 8 RM, 8 RR, 8 SM, 8 UU, 8 VV, 8 WE, 8 WI, 8 WK, 8 XH, 8 ZI, 8 ZM, 8 RBR. Dutch: 0 AB, 0 AG, 0 GC, 0 PG, 0 RM. Swedish: SMZY. Danish: 7 EC. Italian: 1 ER. Finnish: 1 NA. American: 2 CN, 8 DA. (A. Acland.)

Kirby Muxloe, near Leicester (September to October 10th).

French: 8 DS, 8 EK, 8 EY, 8 PQ, 8 RM, 8 RR, 8 UU, 8 WK, 8 WL, 8 WZ. Dutch: 0 BN, 0 QW. Belgian: U 2, P 1. Swedish: SMZY, AGA. American: 1 AUG, 1 XX, 2 ADJ, 3 OGG, 4 OA. Various: 4 RS, 4 YZ, 1 OKZ. (F. H. Tyler.)

Cobham, Surrey (September 11th to October 10th).

French: 8 AL, 8 BF, 8 BG, 8 BN, 8 BP, 8 BV, 8 CO, 8 DA, 8 DD, 8 DI, 8 DP, 8 ED, 8 EM, 8 EP, 8 FC, 8 FI, 8 FVQ, 8 GD, 8 GL, 8 JHL, 8 KBR, 8 KK, 8 LMT, 8 MN, 8 PP, 8 PQ, 8 RB, 8 RBM, 8 RBR, 8 RG, 8 RIL, 8 RM, 8 RO, 8 SR, 8 SSU, 8 UU, 8 VG, 8 WK, 8 XH, 8 ZM. American: 1 ABT, 1 AE, 1 AGL, 1 AR, 1 BFN, 1 BG, 1 BGN, 1 BGG, 1 BHN, 1 BQ, 1 BUN, 1 BX, 1 CCK, 1 CDP, 1 CKP, 1 CMP, 1 ER, 1 FDN, 1 II, 1 MTO, 1 QW, 1 RF, 1 SF, 1 SR, 1 SW, 1 TN, 1 XAV, 1 XW, 1 XZ, 1 ZT, 2 AAY, 2 AN, 2 ANA, 2 BG, 2 BGG, 2 BTA, 2 CDG, 2 PD, 2 RR, 2 XQ, 2 BG, 2 CDG, 2 HS, 3 KD, 3 KW(?), 3 UW, 3 VV, 4 MG(?), 4 RR, 4 SA, 8 XS, HCF, NFV, NKF. Dutch: 0 AA, 0 KN, 0 LO, 0 RE, 0 WN, 0 ZO, P 2. Belgian: 4 PS, 4 RS, 4 UU, 4 YZ, 4 ZY. Italian: 1 FP, 1 DO. Swedish: SMSV. Canadian: 1 AR. Brazilian: 1 HT. Various: 3 AD, 3 CA, 3 XO, P 2 NE, 1 OZ, CH 5 M, LIYZ, MM, OGDJ, SAZ. (o-v-r, Reinartz.) (E. J. Martin.)

Louvain, Belgium.

French: 8 BA, 8 BC, 8 BP, 8 BN, 8 CN, 8 DI, 8 DP, 8 EM, 8 EU, 8 GN, 8 PF, 8 RG, 8 SM, 8 WZ, 8 XR. Belgian: 4 GP, 4 QN, 4 QS, 4 RS, 4 UU, 4 YZ, 4 ZL, 4 ALS, B 7, W 2. Dutch: 0 GA, 0 GC. Various: D 7 EC, 9 AD, ILMT, ILFP, MMOZD, DE, OXE (o-v-o.) (A. L. Stainier.)

Failsforth, Manchester September 22nd to October 12th, on 100 to 180 metres).

French: 8 AP, 8 BN, 8 BR, 8 CS, 8 DD, 8 EU, 8 FS, 8 FV, 8 QG, 8 RG, 8 SG, 8 VV, 8 WL. Italian: 1 MT. Dutch: 0 MS. Swedish: SMZY. Various: FN 2 NCA, FN 2 NM, 3 DAX, 3 NB, 3 XO, 3 ZP, 4 QS, 4 RS. (J. Barnes.)

Blackheath, London (September to October).

French: 8 BA, 8 BN, 8 CM, 8 CZ, 8 DA, 8 DP, 8 EK, 8 EM, 8 EU, 8 MN, 8 PP, 8 RO, 8 SE, 8 SZ, 3 CA. Belgian: W 2, P 2, 4 OEEE. Dutch: 0 BA, 0 II, 0 YN, 0 MS. Danish: 7 EC. Finnish: 1 NA, 2 NM, 3 CE. Italian: 1 ER, 1 HT. Swedish: SMZY, SMZZ. Canadian: 1 AR. American: 1 AJW, 1 ARE, 1 XAV, 1 II, 1 BR, 1 SF, 1 XGO, 2 BRB, 2 GK, 2 MU, 4 SA, 6 XAD, 9 EM. (o-v-r Reinartz.) (R. W. H. Bloxam, 5 LS.)

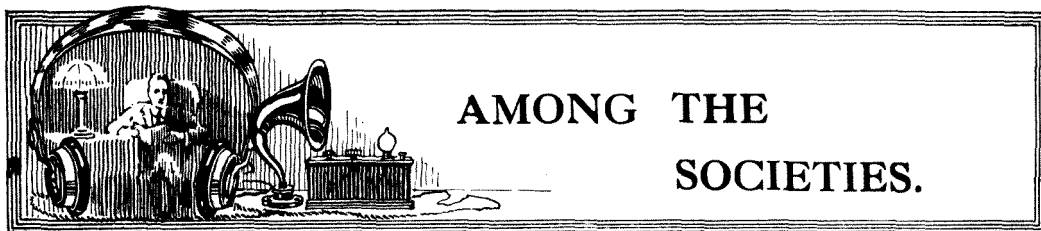

AMONG THE SOCIETIES.

Radio Society of Great Britain.

A talk on "2LO's Control Room" will be given by Captain P. P. Eckersley, at a meeting of the Transmitter and Relay Section to be held at 6.30 p.m. at the Institution of Electrical Engineers, on Tuesday, November 11th.

An informal meeting of the Society will be held at 6 p.m. at the Institution of Electrical Engineers on Wednesday, November 12th, when Mr. R. C. Clinker will demonstrate a dynamical model of an oscillating valve circuit.

HIGH TENSION CONDENSERS.

To those accustomed to the use of the small mica fixed condensers found in every receiving set, it requires some stretch of the imagination to picture a mica condenser weighing three tons. Such a condenser was illustrated on the screen by Mr. Philip R. Coursey, B.Sc., lecturing on "High Tension Condensers," before the Transmitter and Relay Section of the Society on October 24th.

In emphasising the increased importance of the high tension condenser since the days of spark transmission, Mr. Coursey illustrated a simple valve transmitting circuit in which at least five condensers were required. This number rapidly grew as the circuit was enlarged. The air dielectric condenser was excellent for certain purposes, said the speaker, but as its capacity increased so did its bulkiness. A way out of the difficulty was provided by the use of mica as a dielectric.

After a number of interesting slides had been shown depicting mica condensers in course of manufacture, the lecturer gave some instructive details of the methods of measuring capacities and voltage stresses. Most difficult of all is the measurement of the power factor, or the energy lost under working conditions. No really satisfactory system has been evolved, but at present more or less accurate results can be obtained by placing the condenser in a closed space of even temperature and submitting it to H.F. currents. Results are obtained by measuring the consequent increase in temperature over a number of hours.

Some confusion may have arisen through a typographical error which occurred in the Society's October letter to members. In the 6th line of the second paragraph, the word "Council's" should have read "Councils," thus substantially altering the meaning of the sentence.

Mr. H. Bishop, Assistant Chief Engineer of the B.B.C., lectured before the Stoke-on-Trent Wireless and Experimental Society on October 16th, taking as his title, "The Broadcasting Company and the Difficulties it has been up against."

After a brief outline of the Company's history, Mr. Bishop surveyed the present position, mentioning that about 21 broadcasting and relay stations were now in operation. An entertaining talk followed on the broadcasting methods in the studio and at the transmitting apparatus, and details were given of simultaneous broadcasting arrangements.

In conclusion the lecturer expressed the hope that broadcasting would soon be a necessity in every home.

* * * *

With the opening of its winter session, the West London Wireless and Experimental Association transferred its headquarters to the Belmont Road Schools, Chiswick. Among the subjects recently dealt with at the meetings have been "Aerial and Earth Arrangements," "Telephone Receivers," "Woodwork and Finishing," and "Ebonite Polishing."

A number of interesting lectures are to be delivered in the near future and intending members should enrol without delay.

* * * *

At least a dozen members of the Manchester and District Radio Transmitter's Society are taking part in the Transocean Tests.

On October 7th Professor E. W. Marchant, of Liverpool University, delivered an illustrated lecture on "The History of Radio Transmission," in which he described all the earlier methods and finally proceeded to valve operation.

An attractive syllabus has been prepared and all transmitters in the Manchester area are urged to strengthen the membership.

* * * *

The winter session of the Radio Society of Highgate opened on October 7th, when Mr. P. R. Coursey delivered a Presidential address. Taking as his subject the fascinating and little-explored question of short wavelengths, Mr. Coursey dealt with the design of transmitting and receiving apparatus for this class of work, and suggested some interesting lines of research.

* * * *

The City of Belfast Y.M.C.A. Radio Club opened the session on October 14th with an instructive

lecture delivered by Major Rupert Stanley, LL.D., M.I.E.E., who spoke on "The Electron Theory and the Fundamental Principles of Valve Action."

Having sketched the history of ether signalling by light waves through the ages, Major Stanley recounted man's efforts to create longer ether waves, and having created them, to detect them. In explaining the electron theory, he remarked that it was interesting to note that this theory was first propounded by Professor Storey in Belfast, in 1874. The lecture concluded with some useful hints on the construction of receivers.

* * * *

The Sunderland Wireless and Scientific Association opened the new session on October 11th, when the retiring President, Dr. Wilken, introduced his successor, Mr. E. Jeffrey, B.Sc., L.C.P.

In his inaugural address Mr. Jeffrey dealt interestingly with "Scientific Ideals."

The Association is applying for a transmitting licence, for the purpose of investigating fading by means of a portable receiver working with the transmitter over the surrounding country. New members are warmly welcomed and applications for membership should be addressed to the Hon. Secretary, c/o the Editor of *The Wireless World and Radio Review*.

A CORRECTION.

A slight error occurred in the advertisement of the Wireless Diary, appearing on page xxxii of our issue of October 29th. The price of the Diary in leather case, containing three pockets, season ticket window and pencil, is 2s. 6d.; cloth bound, 1s., and not as stated.

WIRELESS EXHIBITION AT MAIDSTONE.

Maidstone's Second Annual Wireless Exhibition is to be held in the Concert Hall, Corn Exchange, from November 11th to 15th, the opening ceremony being performed by G. Foster Clark, Esq., J.P. Organised by the Maidstone and District Radio Society, the Exhibition promises to be quite as successful as last year's event. Interesting competitions have been arranged and prizes will be awarded for the best home-constructed crystal, one, two, and three-valve sets. An imposing display of apparatus and accessories is promised by the leading wireless firms of Maidstone and an attractive feature of the Exhibition will be a wireless dance, to be held on Saturday, November 15th, from 10 p.m. till 12 midnight. At 7.30 on the same evening, Mr. H. Bishop (Assistant Chief Engineer of the B.B.C.) will give a talk on the work of the Broadcasting Company.

AN INDISPENSABLE ITEM.

Many an amateur, hearing an unknown call sign, worried by the questions of a novice, or perhaps involved in a tiresome argument, must have felt the urgent need of "finger tip" information, which would enable him to settle the matter "once and for all."

There is an abundance of this class of information to be found in the pages of "The Wireless Amateur's and Experimenter's Diary and Notebook for 1925," which has just been published by The Wireless Press, Ltd., in conjunction with Charles Letts & Co.

The early pages provide for personal memoranda, tunings for receivers and other useful entries. These are followed by illustrated wireless notes and circuits, specially prepared by Mr. W. James, dealing with a graduated variety of the most efficient receiver arrangements in general practice.

One of the most important sections is the comprehensive and up-to-date list of experimental transmission stations, containing many hitherto unpublished call signs, and occupying thirty pages.

The useful data section at the end of the diary provides tables for calculating gauges and turns of wire for coils, recognised formulæ, sizes of tapping and clearance drills for B.A. screws, coils sizes and other invaluable information.

The Diary and Notebook can be obtained from all booksellers, price 2s. 6d. in leather case, with pencil, season ticket window and three pockets, or cloth bound for 1s. It can also be secured direct from the Wireless Press, Ltd., 12-13 Henrietta Street, London, W.C.2., postage 2d. extra.

CORRESPONDENCE.

Oscillating Crystals.

To the Editor of THE WIRELESS WORLD AND RADIO REVIEW.

SIR,—With reference to the researches of Mr. O. Lossev. With the aid of the information he has placed at the disposal of the world, I have recently succeeded in generating good oscillations which have remained constant for hours, and can be started at will, from zincite-steel contacts. Your readers should therefore please consider my remarks about the difficulty of making practical use of crystal oscillations as withdrawn, at least as regards the combination in question.

LESLIE MILLER.

London, S.W.

FORTHCOMING EVENTS.

WEDNESDAY, NOVEMBER 5th.

Institution of Electrical Engineers (Wireless Section). At 6 p.m. (light refreshments at 5.30). At the Institution, Savoy Place W.C.2. Address by Mr. E. H. Shaughnessy, O.B.E. (Chairman).
Bristol and District Radio Society. Wireless Lecture No. 2. By Mr. W. A. Andrews, B.Sc.
Radio Research Society, Peckham. At 44 Talfourd Road. Lecture: "Relays." Discussion: "Measurement of Signal Strength."
Edinburgh and District Radio Society. At 8 p.m. At 117 George Street. Fourth General Meeting of Series.

THURSDAY, NOVEMBER 6th.

Bournemouth and District Radio and Electrical Society. At 7 p.m. At Canford Hall, St. Peter's Road. Lecture: "Special Forms of Coupling." By Mr. W. H. Peters.
Derby Wireless Club. Informal Discussion.
Luton Wireless Society. At 8 p.m. At Hitchin Road Boys' School. Lecture by Mr. C. C. Atkinson.
Kensington Radio Society. Lecture: "The Working of a Telephone Exchange."
West London Wireless and Experimental Association. At Belmont Road Schools. "Constructional Details. Part II." By Mr. J. T. Bruce.

FRIDAY, NOVEMBER 7th.

Bristol and District Radio Society. Social Evening at Comer's Restaurant, High Street.

TUESDAY, NOVEMBER 11th.

Radio Society of Great Britain. Transmitter and Relay Section. At 6.30 p.m. At the Institution of Electrical Engineers, Savoy Place, W.C.2. Captain P. P. Eckersley will give a talk on "2 LO's Control Room."
Radio Society of Highgate. At 8 p.m. At the Literary and Scientific Institute, South Grove. "What Valves to Use." By Major W. I. G. Page.
Leicestershire Radio and Scientific Society. At the Y.M.C.A. Lecture by Mr. Albert J. Schofield, L.D.S. (President).

READERS PROBLEMS

Readers desiring to consult the "Wireless World" Information Dept. should make use of the coupon to be found in the advertisement pages.

A MICROPHONE AMPLIFIER.

WIRELESS experimenters are very often asked to arrange apparatus to amplify speech so that it may be projected from a loud speaker for the purpose of announcements or addressing public meetings.

It is quite a simple matter to arrange the necessary apparatus, and a diagram of the circuit is given below. The microphone (M) and a local battery (B) are connected in series with the primary winding of the special microphone transformer T_1 . Microphone transformers are available from many of the principal manufacturers of wireless apparatus, and are constructed with a low resistance primary winding and a high step-up ratio. The intervalve transformer T_2 should be chosen to suit the characteristics of the valve V_1 . It would be convenient to use a D.E.5 type valve for V_1 and an L.S.5 for V_2 . With these valves a transformer with a ratio of 6:1, such as the Marconiphone "Ideal" transformer, could be used with advantage.

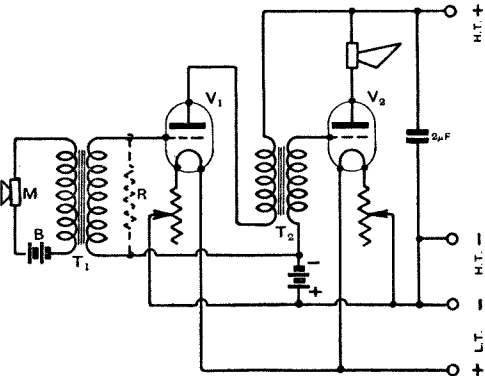

An amplifier for microphone currents.

If the loud speaker is connected directly in the plate circuit of the last valve, thicker gauge of wire should be used for the magnet windings. As the impedance of the L.S.5 valve is comparatively low, the loud speaker need not have a resistance above 1,000 ohms. Amplitude distortion may be caused if the microphone current is too high. In the event of distortion taking place the voltage of the battery may be reduced, or a resistance (R) of the order of 0.5 to 1 megohm may be connected across

the secondary winding. Incidentally, this resistance will tend to improve the quality of speech, apart from the reduction which it produces in the amplitude of the currents impressed on the grid of the first valve.

FINE ADJUSTMENT FOR REACTION.

ONE method of obtaining a fine control over the reaction coupling is to connect a vernier condenser across the reaction coil. As the value of this condenser is increased the current through the reaction coil is reduced, as the small capacity acts as a shunt to the H.F. currents. If the reaction condenser is provided with an extension handle this method is very satisfactory, provided that the natural wavelength of the reaction coil, in conjunction with the condenser, does not approach that of the signal being received. If possible the natural wavelength of the reaction circuit should be kept below that of the grid circuit of the valve. If the natural wavelength of the reaction circuit is above the wavelength of the signal received, there is always a possibility that during subsequent tuning adjustments the wavelength of the grid circuit will be raised until it equals that of the reaction circuit. When this occurs all control over the reaction is lost. Sometimes oscillation cannot be stopped, and under other conditions the set will not oscillate on one definite wavelength, and a "blind spot" occurs.

Unless one knows exactly the constants of the reaction circuit, it is better to dispense with the vernier condenser, and to employ a vernier adjustment on the coil holder itself.

Readers are referred to an article entitled "Efficient Reaction," by H. Stopher, in the issue of October 29th, 1924.

NOISE IN A NEUTRODYNE RECEIVER.

A READER who has constructed a neutrodyne receiver writes to say that a good deal of noise is experienced, and that it is his opinion that the noise would cease if a crystal detector were substituted for the valve detector.

At the present time receiver noises are very rarely due to faulty valves, and the disturbance is more likely to be due to poor insulation or a run-down H.T. battery. If an excess of soldering flux is used when wiring the panel the fumes are apt to cling to the surface of the ebonite panel and to destroy its insulating properties. Unless the detector valve happens to be the faulty valve in the receiver,

the substitution of a crystal detector would not in any way affect the amount of extraneous noise and in any case a crystal detector could not be employed in the neutrodyne receiver, as the variation of the resistance of the crystal contact would prevent a perfect balance being obtained.

SWITCHING A THREE-VALVE RECEIVER.

IN the circuit given below two low frequency amplifying valves are employed, the first transformer coupled to the detector valve and the second coupled by means of the resistance capacity method. In a receiver of this type it is essential to provide separate H.T. tappings for each valve, and three pole change-over switches are therefore necessary for switching off the L.F. valves. The circuit is suitable for general reception, and the coupled tuning circuit provides an adequate degree of selectivity.

wire in an aerial of this type would be less than usual, the result obtained would be better, owing to the lower capacity and effective resistance of the aerial. A small weight attached to the aerial wire a few feet from the lead-in prevents rain water from running over the lead-in insulator and reduces swaying.

A STABLE DUAL CIRCUIT.

REFERRING to the article under the above title, in the issue of January 3rd, 1924, a reader asks what value should be given to the fixed condenser connected in the anode circuit of the first valve.

The value of this condenser is not critical, and it may be given a value of approximately $0.0001 \mu\text{F}$. This condenser acts as a high frequency by-pass, and its capacity should therefore be kept small.

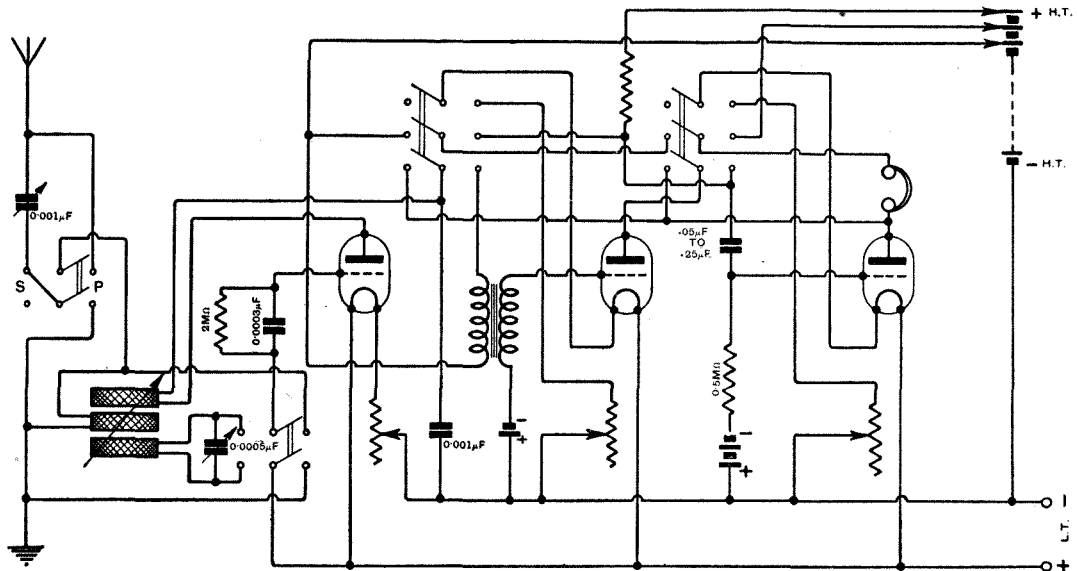

A three-valve receiver with transformer and resistance-capacity coupling for the L.F. valves.

ROOF AERIALS.

WHEN ground is not available for the erection of a mast at some distance from the house, it becomes necessary to erect an aerial on the roof of the house itself. In erecting this aerial it should be remembered that the effective height will be the height of the aerial wires above the roof of the house, and not above the ground level, and the poles supporting the horizontal portion of the aerial should therefore be raised as far above the roof as possible. In bringing the lead-in down the front of the house spreaders should be arranged to keep the wires as far as possible from the side of the house.

If it is impracticable to use poles on the roof greater than 10 or 15 feet in length, it would probably be better to dispense with the top portion of the aerial, and to use a single wire suspended from a light pole projecting at right angles from the side of the house. Although the length of

VARIABLE CONDENSER PLATES.

THE moving vanes of a variable condenser need not be placed symmetrically between the fixed vanes. The calibration of the condenser will vary, however, if the bearings of the moving vanes are not rigid. In other words, the calibration will vary if the moving vanes are moved longitudinally with respect to the fixed vanes.

RECEPTION ON 10 METRES.

SEVERAL readers have asked us to give designs for receivers to operate on wavelengths of the order of 10 or 15 metres. Special methods have to be employed for these wavelengths, and, in general, ordinary amateur aerials cannot be used. Readers interested in this subject are referred to the issue of this journal for June 30th, 1923.



"I never imagined that circuits could be made so easy, interesting and practical for the beginner!"

A typical remark from the experimenter who has hitherto found circuit diagrams to be puzzling affairs. This new edition of Mr. F. H. Haynes's popular book gives the fullest possible details for wiring-up no less than 117 circuits. Nothing has been left to chance. Every value has been inserted and full explanations accompany each diagram. Moreover, every circuit has been designed by a man who knows the difficulties encountered when constructing experimental apparatus. Circuits, diagrams and accompanying text are of an essentially practical nature. Containing the following special features, it is the most complete and easily understood circuit book available to-day:—

Copious notes on Crystal Receivers, single-valve sets, high frequency, low frequency and dual amplifiers, transmitting circuits. Several pages of most useful data have been added, including the method of pile windings, tables giving tuning range of commercial types of inductances, wavelengths produced by various tuning condensers, types of receiving valves and their characteristics, etc., etc.

A Huge demand is certain—obtain your copy at once.

THE AMATEUR'S BOOK *of* WIRELESS CIRCUITS

By F. H. Haynes

PRICE **3/6** NETT

Postage 6d.



NEW EDITION

now ready
contains
117 circuits!

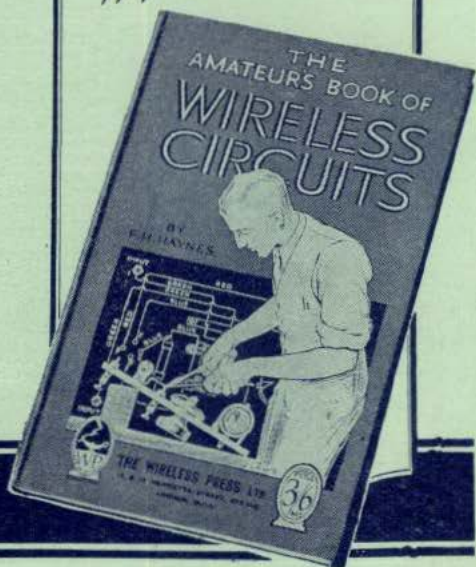

THE WIRELESS PRESS LTD.
12-13 HENRIETTA ST. LONDON WC2

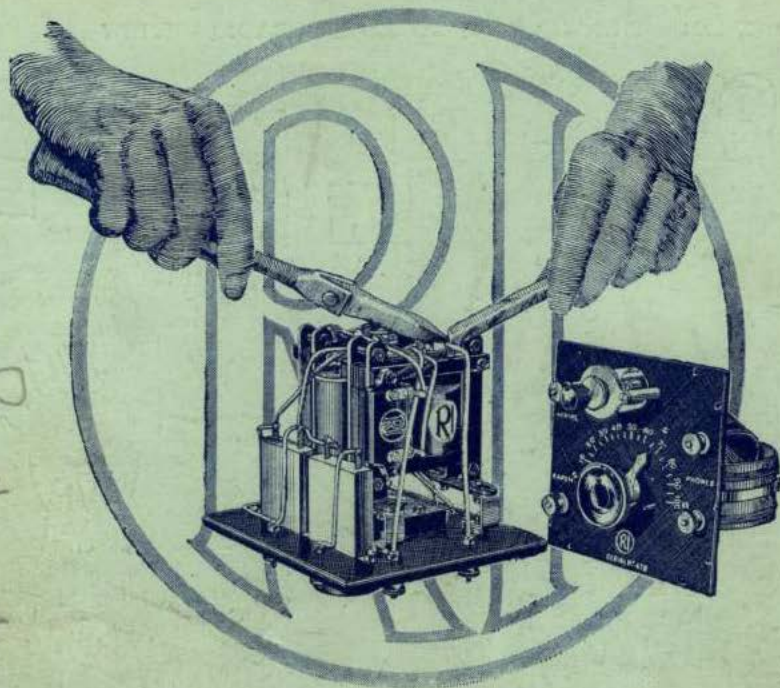

IN EVERY DETAIL

R.I. Components mark the peak of progress in Radio science. Years of experience lie behind them—successful years, in which inventive genius and the finest laboratory resources, were supported to an extreme by public appreciation.

Just try the combination:—Two of the New R.I. transformers coupled with the R.I. detector, and results will proclaim the finest amplifying unit possible.

What another enthusiast says—

Messrs. Radio Instruments, Ltd., London.

I should like to inform you that I am using two of your L.F. Transformers in a loud speaker public address system.

These transformers are giving every satisfaction and are standing up well with 150 volts on the plate using power valves.

The amplification is as good as a seven valve resistance coupled amplifier, and is not distorted.

I may say that within four days I burnt out five transformers of other makes. This will give you some idea of the test that your instruments are undergoing.

I shall be fitting two into my wireless set at a later date.

*Yours faithfully,
(Sgd.) Harry V. McCalla.*

Engineer Palace, Gateshead.

The New R.I. Transformer 25/-
Write for Catalogue free on application.

Telephone : Regent 6214-5-6

Telegrams : "Instradio London."

Radio Instruments Ltd.

12 Hyde Street, Oxford Street, W.1.



Printed by Sanders Phillips & Co., Ltd., Chrysell Road, London, S.W.9, for the Proprietors and Publishers, The Wireless Press, Ltd., 12-13 Henrietta Street, London, W.C.2; Sydney, N.S.W., 97, Clarence Street; Melbourne, 422-24, Little Collins Street; New York, 326 Broadway.



THE WIRELESS WORLD

AND
RADIO REVIEW



PRICE 4^D NET.

SELECTIVE
RECEIVING CIRCUITS

ONE-VALVE REFLEX
CABINET RECEIVER

DESIGN OF
TRANSMITTING
INDUCTANCES

EASILY BUILT
THREE-COIL HOLDER

No. 274 [No. 7
Vol. XV]

UNSOLVED PROBLEMS OF WIRELESS



Headphones



B.T.H. Headphones are supreme in all respects—in sensitiveness, tone, permanence, and comfort. Although fitting closely to the ears, and thus excluding extraneous sounds, very little pressure is exerted and they can be worn for hours without discomfort.

Price per pair (4000 ohms) £1 5s. 0d.

A Proof of Superiority.

Ask your dealer to tune out his demonstration set until you can only just hear. Then substitute B.T.H. Headphones and you will be amazed at the clearness with which you can hear every word and note of music.

We also make Crystal Sets, Valve-Crystal Sets, Valve Sets, Loud Speakers, Amplifiers, Valves (including B5-006 amps) and Tungal Battery Chargers.

Obtainable from all Electricians and Wireless Dealers.

The British Thomson-Houston Co., Ltd.
 Offices - - - Crown House, Aldwych, London, W.C.2

Branches at Belfast, Birmingham, Bristol, Cardiff, Dublin, Glasgow, Leeds, Liverpool, Middlesbrough, Manchester, Newcastle, Swansea, Sheffield.

2218

SELF CAPACITY?

To be efficient your Tuning Coils must have a minimum.

This is guaranteed if you use

**"Tangent"
Tuning Coils**



Unshrouded Efficiency! Rigid as a Motor Wheel!

The Reason—

Owing to the method of manufacture the impregnated cord not only passes between each layer to give the air spacing but also firmly braces up the whole coil—thus no swathing or shellac is required. The immediate result—LOW SELF CAPACITY.

Ask your dealer—Take no substitute.

Complete set of 4 Concert Coils—
 (W/L 250-1070) .. 16/- the set.

Complete set of 11 Concert Coils—
 (W/L 250-8750) .. £3-7-0 the set.

GENT & Co.
 Ltd. Est. 1872
 Faraday Works,
LEICESTER

Solder all connections, Where you can't—use "CLIX"!

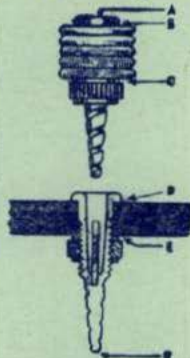

**CLIX Popularity—
The Secret !!**

You can't have efficiency in Radio *anywhere* unless you have efficient contact *everywhere*.

You can't use solder *everywhere*—but you can use CLIX.

By virtue of the tapered threaded design of its plugsocket CLIX ensures *perfect* contact, an obvious improvement on various forms of split-pin plugs, which, however accurately machined, can only permit of a "two-point" contact. Think it out!

CLIX may be wired at points A, B, C, D or E. F affords an ideal point for soldering when permanent connections are required.

Retail Prices.
 CLIX, with Locknut 3d.
 CLIX Insulators
 (6 colours) .. 1d. each
 CLIX Bushes
 (6 colours) .. 1d. pair



Obtainable from all Wireless Dealers or direct from the Patentees and Manufacturers:—

AUTOVEYORS LTD

Radio Engineers and Contractors,

54 VICTORIA STREET, LONDON, S.W.1

THE WIRELESS WORLD AND RADIO REVIEW

THE OFFICIAL ORGAN OF THE RADIO SOCIETY OF GREAT BRITAIN.

No. 274. (No. 7 Vol. XV.) NOVEMBER 12th, 1924. WEEKLY.

EDITOR:
HUGH S. POCOCK.

RESEARCH EDITOR:
PHILIP R. COURSEY, *B.Sc., F.Inst.P., A.M.I.E.E*

ASSISTANT EDITOR:
F. H. HAYNES.

QUESTIONS AND ANSWERS DEPARTMENT.
Under the Supervision of W. JAMES.

CONTENTS.

	PAGE
Radio Topics. By the Editor - - - - -	187
Selective Receiving Circuits. By N. W. McLachlan -	189
An Easily Made Three-Coil Holder. By G. H. P. Gibbs	194
Single Valve Reflex Cabinet Set. By R. H. Cook - -	195
Single-Point Detectors. By James Strachan - - -	200
Readers' Practical Ideas - - - - -	203
The Design of Transmitting Inductances. By N. V. Webber - - - - -	205
Patents and Abstracts - - - - -	210
The Measurement of Small Capacities - - - - -	212
Notes and News - - - - -	213
Unsolved Problems of Wireless. By R. H. Barfield -	215
Among the Societies - - - - -	219
Readers' Problems - - - - -	221

THE EDITOR will be glad to consider articles and illustrations dealing with subjects within the scope of the Journal. Illustrations should preferably be confined to photographs and rough drawings. The greatest care will be taken to return all illustrations and manuscripts not required for publication if these are accompanied by stamps to pay return postage. All manuscripts and illustrations are sent at the Author's risk and the Editor cannot accept responsibility for their safe custody or return. Contributions should be addressed to the Editor, "The Wireless World and Radio Review," 12 and 13 Henrietta Street, Strand, London, W.C.2.

SUBSCRIPTION RATES :

20s. per annum, post free. Single copies 4d. each or post free 5d. Registered at the G.P.O. for transmission by Magazine Post to Canada and Newfoundland.

As many of the circuits and apparatus described in these pages are covered by patents, readers are advised, before making use of them, to satisfy themselves that they would not be infringing patents.



EDITORIAL AND PUBLISHING OFFICES :

12 and 13 Henrietta Street,
Strand, London, W.C.2.
Telephone: Gerrard 2807-8.

ADVERTISEMENT MANAGERS :

Bertram Day and Co., Ltd.,
9 & 10 Charing Cross, S.W.1
Telephone: Gerrard 8063-5.

Tune the Table-Talker with the "Matched Tone" Headphones



The
Brandes
Family
Series.

YOUNG Bill is decidedly quiet. This most unusual phenomenon is duly commented upon. Mother says that it looks as though wireless has provided a remedy for which she has been looking for years. Previously the whole house was aware of

his presence by a piercing whistle or a cracked and tuneless rendering of an all too popular melody. A gentle trot from room to room characterised his movements and occasionally a shrill college yell. Now there are endless experiments which occupy his time. But if only he would cease to impress on us the technical advantages of Brandes Products. Technicalities don't interest us because we believe our own ears. The reception given by the *Table-talker* was vigorous yet pleasant and beautifully natural—we might be right in the Studio. **Ask your dealer for Brandes.**

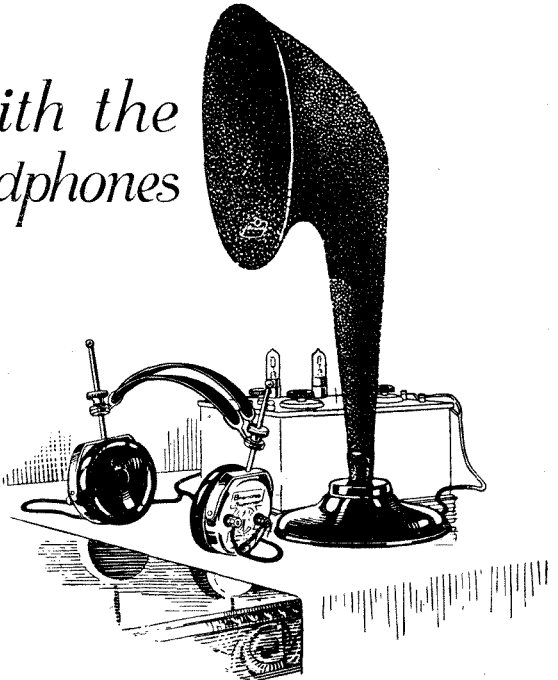

All Brandes products carry our official money-back guarantee, enabling you to return them within 10 days if dissatisfied. This practically constitutes a free trial.

The "Matched Tone" feature was embodied as the distinctive characteristic of Brandes' Headphones in 1908, and means that both your ears hear exactly the same sound at the same instant—and you learn a new beauty of tone. They are tested and re-tested for just this one vital point, and in addition their strength, long-wearing comfort and reliable efficiency make them undoubtedly **25/-** superior . . .

The *Table-Talker* is a Brandes quality product at a moderate price. The non-resonant, specially constructed horn is matched to the unit so that the air resistance produced will exactly balance the mechanical power of the diaphragm. This means beautiful sound-balance and remarkable tone qualities. It is twenty-one inches high, and has a self-adjusting diaphragm, and is finished a **42/-** shade of neutral brown . . .

British Manufacture (B.B.C. Stamped).

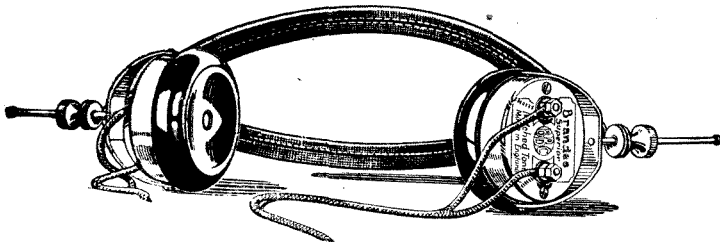

Brandes

Result of
16 Years
Experience

The name
to know in Radio

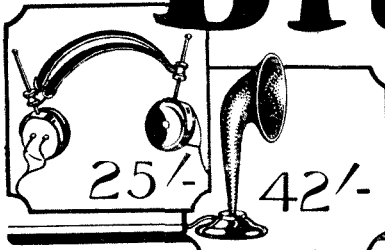

THE WIRELESS WORLD AND RADIO REVIEW



RADIO TOPICS.

THE TRANSATLANTIC BROADCAST TESTS.

IT will be remembered that last year *The Wireless World and Radio Review*, in conjunction with *Radio Broadcast* of America, organised a series of experimental tests of broadcasting between the United States and this country. The British Broadcasting Company kindly co-operated and conducted transmissions to America, whilst on the other side Mr. Lynch, editor of *Radio Broadcast*, had the support of the majority of the American broadcasting organisations in arranging for transmissions to England.

This year, as we have previously announced in *The Wireless World and Radio Review*, a further series of tests will be carried out from November 24th to November 30th inclusive, and although no detailed announcements have appeared recently in the columns of this Journal, the arrangements for the tests have been going forward steadily, and we are now in a position to give further particulars.

The British Broadcasting Company has again this year kindly undertaken to participate and the arrangements have been extended further by inviting broadcasting stations on the Continent to come in and join in the transmissions to America. As a consequence stations in almost every country in Europe will participate.

The interest which has been aroused in America and Canada over these transmissions is enormous, and so complete has been the response to the invitation made by *Radio Broadcast* that American broadcasting stations should co-operate that it has been possible to carry out arrangements whereby practically all American broadcast stations, and some others in addition, have under-

taken to keep silence during the hours when the European stations are transmitting.

Of course, it will be realised that the interest in America in these tests is likely to be greater than on our side for the reason that the ordinary hours of evening programmes of European broadcasting stations correspond to hours of daylight in America and the conditions are therefore so unfavourable to reception of the European stations that we understand it has not been possible for Americans to listen in at all to our programmes. By arranging for the European transmissions to take place in the early hours of the morning we have got over this disadvantage and the hour of silence when America will listen for Europe will be during or immediately following their usual broadcast programme hours.

In order to give Europe a special opportunity for listening to America, endeavour has been made to ensure as much quiet on this side as possible whilst the American and Canadian stations are conducting transmissions. These transmissions will be specially intended for European listeners and wherever possible increased power will be used by the transmitters. In addition to special musical programmes, various speeches will be made.

The American transmissions will take place from 3 a.m. to 4 a.m. G.M.T. each morning from November 24th to 30th inclusive. European transmissions will follow immediately from 4 a.m. to 5 a.m. and these will be by the stations of the British Broadcasting Company, including **5 XX** on the mornings of the 25th, 27th and 30th November, whilst Continental Stations will transmit as a unit from 4 to 5 a.m. G.M.T. on the

mornings of the 24th, 26th, 28th and 29th. All stations participating in the transmissions will give indications of their identity at frequent intervals in their transmissions, in order that the American listeners may be quite sure what stations they are receiving.

The four Parisian broadcasting stations will all participate in the tests, and among the other Continental stations also engaged will be those at Madrid, Brussels and Rome, and the German stations at Berlin (Vox Haus), Hamburg, and Koenigswusterhausen.

The organisation of the Canadian broadcasting stations in the international tests is in the hands of Mr. J. N. Cartier, who is the manager of the station **CKAC** owned by *La Presse*, Montreal. A view of the studio of this station appears on this page, and it will be seen to possess several novel features, and attention might be drawn to the novel method of controlling the extent of damping. The draping over the ceiling is removable, giving control of sound absorption and echo.

In America the tests provide unique opportunities for finding the extent of the range of receivers. Captain Eckersley, when he broadcast from **2LO** the other evening an account of his visit to America, told us that the American listener attaches more

importance to the selectivity and range-covering properties of his receiver than to its efficiency as a reproducer of good quality music and speech, so that the American will have a special interest in these tests. Captain Eckersley has taken a keen interest in these arrangements and on his visit to America recently he met Mr. Arthur Lynch, Editor of *Radio Broadcast*, and had the opportunity of discussing the details for the tests.

Since last year's tests a marked improvement has been made in the design of American receiving equipment. For instance, it was not until quite recently that the use of neutrodyne receivers came into general use, and the present extensive adoption of this type of set, with efficient amplification at high frequency, is likely to give rise to good reception of the European signals on a considerable scale. The supersonic heterodyne arrangement has also developed in the hands of the American public, and outfits of this class are in fairly general use.

The interest in America has not been confined to the United States alone, for Canada, Cuba and Porto Rico and other countries are also taking an equal interest in the arrangements.

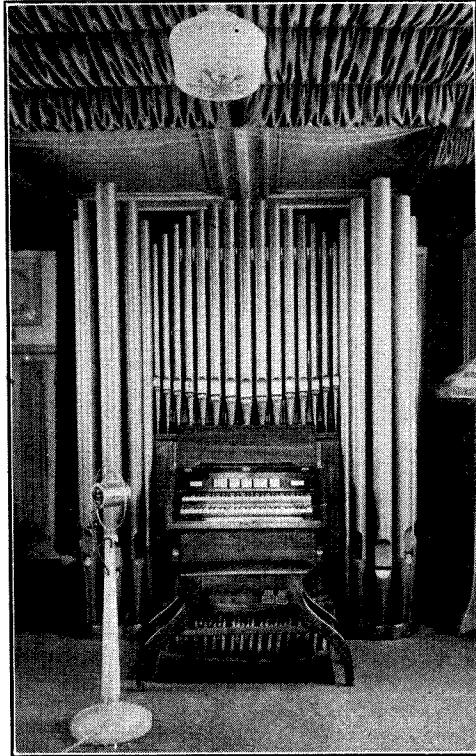

*The organ in the studio of the well-known Canadian Broadcasting Station **CKAC**, owned by "La Presse," Montreal. Note the curtains above, which can be drawn aside to lessen the damping effect. Operating on 425 metres, this station will take part in the International Broadcasting Tests during the last week of November.*

SELECTIVE RECEIVING CIRCUITS.

The conditions are reviewed in this article by which energy is set up and transferred in the tuning system of a receiver. The conclusions are of considerable importance in receiver design.

By N. W. McLACHLAN. D.Sc., M.I.E.E.

MODES OF ENERGY TRANSFER BETWEEN COMPONENTS.

EVERYONE is familiar with capacity effects in a receiver, the simplest of which is probably the so-called self capacities of the various coils. There are also the capacities of the different components to earth, thus enabling reception without a direct earth connection, and the capacities between adjacent coils. In treating the problem of coupled circuits mathematically, capacity effects are generally ignored—excepting, perhaps, the self capacities of the coils—and the transfer of energy from one circuit to another is regarded as being due to electromagnetic induction. We know, however, from practical experience, that this assumption is only approximately true even after great care has been taken in the design of a receiver, so that the capacity and other effects have been reduced to a minimum. A straightforward high frequency multi-unit circuit is illustrated in Fig. 1, and consists of an aerial A, coupled to the tuned circuits A₁, A₂, A₃. If the assemblage functioned according to the simple mathematical hypothesis, the energy collected by the aerial would be transferred—with, of course, the usual inter-circuital transmission losses—by electromagnetic coupling to A₁, thence to A₂ and A₃. But we know that there are other modes of energy transfer between the various components and from the incoming electric waves. These are summarised below :

- (1) Electromagnetic coupling between any two components. This, of course, can be reduced to a minimum by arranging the various coils with their axes in planes mutually at 90 degs. to each other. Since there are only three planes mutually at 90 degs., this arrangement will only work with three circuits.
- (2) Each coil acts as a frame aerial, and the incoming electric radiation from the distant transmitter yields currents in the circuits which are superposed on those induced from the aerial *via* the coupling coils. There is, of course, the exceptional case when a coil is oriented with its axis parallel or vertical with reference to the direction of propagation of the resultant electric field—assumed to be non-rotational—in the neighbourhood.
- (3) Condenser effect between any two circuits or between a circuit and earth.

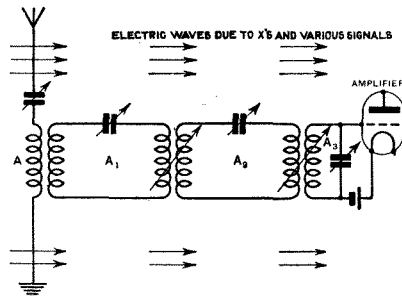

Fig. 1. The three stages of coupling produce an energy transference, accompanied by improved selectivity. The intermediate tuned circuits also act as collectors of energy and in consequence the property of extreme selectivity may be lost.

In order that the coupled circuits of Fig. 1 shall operate most effectively, it is imperative to avoid the three extra sources of energy transfer to the fullest extent. The reason why these additional modes of energy transfer to the receiving circuit are undesirable is as follows. The purpose of any tuned aerial circuit is to collect as much as possible of the desirable energy from the incoming radiation, and to reject as much as possible of the radiation due to extraneous causes, *e.g.*, atmospherics and jamming stations. Moreover, the tuned aerial circuit

is a selective device, and its dead loss or wasteful resistance should be as low as possible. Having partially purged the radiation "mixture" in the neighbourhood of the aerial by the aid of a selective circuit, we shall assume the strength of the current due to the desired signal to have a certain relationship to currents due to other sources. When a closed tuned circuit such as A_1 in Fig. 1 is loosely coupled to the aerial, the ratio of the signal current to currents in A_1 from other sources will be greater than that in the aerial A . If, however, circuit A_1 is not protected from the incoming radiation, currents of other frequencies will be induced in it in addition to those induced from the aerial. The ratio of these alien currents to the signal current will depend on the degree of selectivity of this circuit A_1 . Thus although part of the energy transferred from A to A_1 is filtered to reduce the relative intensity of atmospherics, etc., there is a certain amount of energy penetrating the circuit directly, which is not filtered by A . Thus the ratio of signal current to alien currents is reduced, due to direct energy supply to A_1 from the incoming waves. A similar argument applies to coils A_2 and A_3 . In the case of coil A_3 , matters are much worse. The filtering which occurs in the normal way, due to the inductive couplings AA_1 , A_1A_2 , A_2A_3 reduces the signal strength to a very small value. Thus the alien currents—especially those caused by comparatively high voltage atmospherics, or by a powerful near-by transmitter—arising from A_3 acting as a frame aerial or otherwise—may be large compared with the filtered signal current which reaches A_3 in the orthodox manner. Hence if the various tuned circuits are left unprotected from extraneous radiation, their efficacy as filtering arrangements is impaired.

CONDENSER ACTION BETWEEN COMPONENTS.

The next aspect of the subject is one which merits attention. In viewing the action of an aerial from a physical standpoint, the simplest way is to consider the earth to be

one plate of a condenser and the aerial wire the other. This condenser and the loading inductance constitutes an oscillatory circuit. When the current is oscillating in the aerial, the earthed end is substantially at a constant potential, but there is a difference in potential between earth and any point on the aerial. If an alternating difference in potential exists between two parts of the same or different electric circuits, there is a condenser action brought into play. That is to say, there is a capacity effect between the two portions of the circuit, which causes a current to flow. Consider now an aerial whose circuit is similar to that of A in Fig. 1, but whose lower end is not earthed. This will receive signals and a current will flow, but the intensity will be small compared with that when the lower end is earthed. The reason why an unearthed aerial constitutes an oscillatory circuit is simply that the loading coil and the aerial have a capacity to earth, *i.e.*, the coil represents one plate of a condenser and the earth the other. There is also the action of the assemblage as an isolated oscillator (see below). The strength of the received signals is most marked on short wavelengths. The effect is somewhat similar to that when a small shortening condenser is placed between the loading coil and earth, and may be designated "antenna" action. The

equivalent circuit is illustrated in Fig. 2. There is a supplementary action due to the loading coil acting as a frame aerial (mistuned.)

These latter actions are really particular cases of the general effect of electric waves on any suitably situated conductor. An electric wave is concomitant with a potential gradient in space. Since the gradient is of an oscillatory nature, currents are induced in any conductor situated in the electric field, so that a potential exists between two points on it. When the conductor is suitably dimensioned electrically (inductance and capacity), the response to the incoming waves is a maximum. For example, if a uniform straight wire of the proper length,

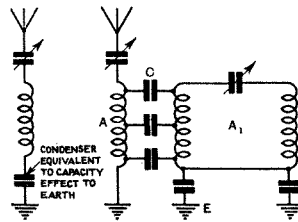

Fig. 2.

Fig. 2. The apparatus composing the tuned aerial circuit serves as a collector by virtue of its capacity to earth.

Fig. 3. The capacity C , presented between the circuits A and A_1 gives rise to energy transference owing to the potential differences existing between the two coils.

Fig. 3.

Fig. 3. The capacity C , presented between the circuits A and A_1 gives rise to energy transference owing to the potential differences existing between the two coils.

about half a wavelength, is well away from earth and suitably situated in the path of an electric wave, the frequency of the natural oscillation on the wire is equal to that of the electric wave. In this case, both ends of the wire are free, and the maximum current (antinode) occurs at the centre of length of the wire.

We have already indicated that an alternating difference in potential between two parts of an electric circuit involves condenser action. The next step is to apply this principle to the receiving circuit illustrated in Fig. 1. Suppose we devote our attention to the aerial tuning inductance first. During reception there is a difference of potential between its ends.

This is due to two main factors: (a) potential drop due to the current flowing in an inductive circuit; (b) potential drop due to loss incurred by current flowing in the coil. The loss is chiefly caused by the eddy currents induced in the wire due to the oscillatory current, and to the effect of the oscillatory

voltages on the insulation between the neighbouring turns. The latter source is dielectric loss. Now the potential difference gradually increases from one end of the coil to the other, so that every part of the coil is at a different potential from the lower end. Thus there is the well-known condenser action between adjacent turns of the coil, and this is cumulative throughout its length. Since the aerial tuning inductance does not behave solely as such, but has condensive attributes also, we are led to ask what effect the latter have upon reception. If the received wavelength is much longer than the natural wavelength of the coil, *i.e.*, the aerial capacity is much greater than that of the coil, the condenser effect due to self-capacity can be disregarded.* Put in another way, the natural frequency of the coil must be much higher than the frequency of the incoming signals. This means that the capacitive impedance of the

coil is much greater than its inductive impedance. As the frequency is increased the inductive impedance is so large that most of the current is bye-passed due to condenser action.

Taking now the coupling which exists between the coils A and A₁ of Fig. 1. The adjacent parts of these coils during reception will be at different potentials owing to the currents in the two circuits. Thus there will be condenser action and energy will be supplied from circuit A to circuit A₁ just as though the two were connected by a condenser. An approximately equivalent circuit is shown in Fig. 3. Owing to the capacity effect of coil A₁ to earth, there is a complete

circuit formed, *viz.*, ACA₁E. The condenser current which flows between A and A₁, A₁ and earth, traverses the windings of A and A₁. If C is the capacity of a condenser, V the difference of potential between its terminals and n the frequency, then the condenser current which flows is $I = 2\pi nCV$. Thus the current increases

with increase in (a) frequency; (b) capacity; (c) voltage or potential difference. From (a) we see that with given coils the condenser effect is most conspicuous on short waves. A good example of condenser effect is that between two adjacent aerials. The capacity coupling is large owing to the geometrical configuration of the structures allowing a copious inter-linkage of *electric* strain lines. In practice the only item likely to be fixed is the frequency. Thus to minimise condenser effect at a given frequency, it is essential to reduce the capacity and also the difference in alternating potential which exists between adjacent parts of the circuit as much as possible. So far as capacity between adjacent coils is involved, it is the best policy to avoid using the main portion of the coil for coupling purposes. Coupling can be obtained most conveniently by small auxiliary coils in series with the main coils. This is illustrated diagrammatically in Fig. 4, the auxiliary

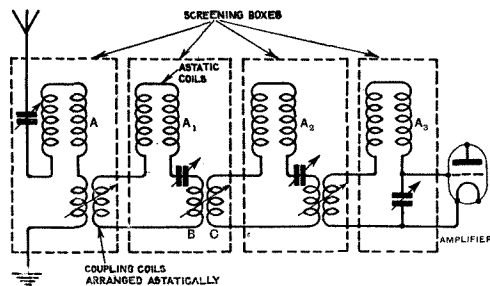

Fig. 4. To minimise capacity coupling, only a portion of the coils between which a low potential difference exists is shown coupled.

* A fly-wheel circuit is not considered here.

coils being B and C. Although we have illustrated the use of two small coupling coils in Fig. 4, quite satisfactory results can be obtained with only one coil, *e.g.*, B, this being coupled to the main coil of the next circuit, thus dispensing with coil C. The reduction of potential difference effects is best obtained when all the coupling coils are kept as near to earth potential as practicable. Thus in Fig. 4 the aerial coupling coil is situated next to earth. The complete aerial system as shown roughly in Fig. 1 has been rearranged in Fig. 4. The result of the rearrangement as exhibited in Fig. 4 is to reduce very appreciably (1) direct reception of electric space waves by any portion of the circuit except the aerial; (2) electromagnetic interaction between the units of the receiver, excepting that which exists in virtue of the inter-coupling coils; (3) condenser action between the units of the receiver.

It is of interest to compare the tuning properties of the circuits in Figs. 1 and 4. Suppose all the circuits of Fig. 1 are accurately tuned to the incoming signals; then let the condenser in circuit A_2 be varied. As we pass away from the tune point, the signals will fade fairly rapidly at first, but as we get farther from this point, there is little variation in the signal strength. Thus there is a "residue" which is due to energy penetrating the system in the unorthodox ways which have been quoted above. Let us turn now to an arrangement constituted on the lines of Fig. 4. Assuming all the circuits to be at their resonance or tuning points, again vary condenser in circuit A_2 . The signals will fade very rapidly at first, and will gradually die away to inaudibility as the condenser is moved farther away from the tuning point. This clearly shows the advantages and the absolute necessity for designing a receiving circuit to function in a proper manner.

In addition to the use of metal screening boxes to enhance selectivity, we ought to mention that the coils must be sufficiently far away from the faces, especially if the boxes are constructed of iron, so that the action now familiarly known as "spade tuning" is avoided.

In low decrement filter circuits it is of paramount importance that all the units should be accurately tuned to the incoming signal. A departure from this rule means

that when the signal arrives, it impulses the untuned unit and creates oscillations of two different frequencies; (1) the forced oscillation having the same frequency as the signal; (2) the free oscillation having the frequency of the mistuned circuit. The effect of these two oscillations obtained from the arrival of morse signals of suitable speed can be studied by the aid of reaction. When the decrement of the circuit is low enough, two beat notes are audible in the telephones, one corresponding to the *free* and the other to the *forced* oscillation. With strong atmospherics the influence of mistuning a low decrement circuit is to receive the atmospherics, but to exclude the signal. This is due to the fact that the strength of the atmospheric in the tuned circuit is almost the same for all tune points within a narrow zone on either side of the signal frequency, whereas for *optimum signal* strength accurate tuning is imperative.

ASTATIC COILS.

There is an auxiliary artifice worthy of mention, and which is often of great value whether screening boxes are available or not. The arrangement about to be outlined assists in the annulment of (1) electromagnetic effects between the components of a receiving circuit; (2) frame aerial effect due to incoming radiation acting directly on the coils.

In the early days of galvanometer construction, the late Lord Kelvin invented the arrangement known as an astatic couple. This consisted of two parallel bar magnets suspended one above the other with unlike poles adjacent, *i.e.*, the north pole of one was immediately above the south pole of the other, and *vice versa*. The arrangement was independent of the earth's magnetic field, and did not point north and south, as one of the magnets would have done if suspended by itself. In more general language, the system was free from the influence of uniform external magnetic fields. Now this principle of astaticism can be applied with success in the design of radio receivers, to protect the circuits from the influence of uniform oscillatory electromagnetic fields.

If two identical coils of wire arranged with their axes parallel and at right angles to the plane of the paper, are situated in a uniform alternating or pulsating electro-

magnetic field, the electromotive force induced in each will have the same value. The e.m.f. will be alternately positive and negative at the near ends of the coils. Imagine that it is positive; then the far ends will both be negative. Thus if the far ends of the coils are united, the potential difference so far as electromagnetic effects are involved, between the near ends will be zero (see Fig. 5). This is due to the fact that the voltages induced in the two coils are equal but opposite. Moreover, the arrangement is astatic in the *electromagnetic sense*, and is, therefore, free from the disturbing influence of a *uniform* alternating magnetic field. We may now pass on to consider the effect of a non-uniform pulsating field on the above arrangement. It is clear that if the field is stronger in one coil than it is in the other, the voltages induced in the two coils will no longer be equal and opposite. Thus the arrangement will cease to function astatically.

For example, suppose a coupling inductance coil from an adjacent valve oscillator is brought near the end of one of the pair of coils—let it be placed co-axial with it. The e.m.f. induced in this coil will be much greater than in the other. If, however, the coupling coil were arranged symmetrically with regard to the astatic pair, but not sufficiently near to introduce appreciable electrostatic coupling effects; the resultant e.m.f. induced in the pair would be zero. In practice, when coupling together two unscreened adjacent astatic units electromagnetically—in this case the

circuits would be completed by the usual tuning condensers—the coupling coils themselves, which form part of the circuit, must also be arranged astatically. Thus a separate coupling coil is used for each unit of an astatic pair, as indicated in Fig. 6.

When circuits are arranged in this manner, and also effectively screened from the electric and magnetic components of the incoming radiation by metal boxes, there is little fear of mutual electromagnetic interaction between them, apart from the orthodox amount introduced by the coupling coils. Also the effect of external magnetic fields is reduced to a considerable degree. The principle of astaticism can, of course, be applied to low frequency circuits with either air or iron-cored coils. In unscreened note filters, it is useful in avoiding reaction due to magnetic coupling.

In general, it is advisable to connect all screening boxes to a good earth. It should be borne in mind that—so far as signal strength is concerned—two distant points on a common earth connector may have an appreciable potential difference between them, due to the current in the wire, arising from its acting as a leak to earth and as a mistuned aerial, as explained above in the section on "Condenser Action." Also it is sound policy to connect the negative poles of both high and low tension batteries to earth. The employment of carefully designed screens is gradually growing as the radio art progresses, but they ought to be used more frequently than is usual at present.

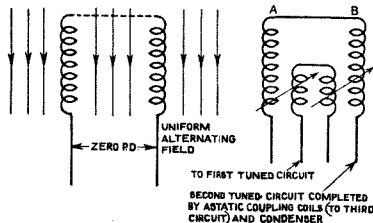

Fig. 5.

Fig. 6.

An astatically arranged tuning coil (Fig. 5), and an astatically arranged coupled circuit (Fig. 6).

WIRELESS WANTED FOR CHANNEL ISLES.

Strange as it may seem, there is no wireless installation in any of the Channel Islands, despite the dangerous nature of the surrounding coasts. Thus a distress message sent out from the Casquets or Corbieres can reach neither Guernsey nor Jersey except through England, whence it is transmitted by cable. Moreover, on Sunday the post offices are closed after 10 a.m., and telegrams are not delivered.

To remedy this serious state of affairs, the Jersey States passed a resolution last December

to the effect that a wireless installation be erected forthwith on the most suitable spot. This was referred to the State's Piers and Harbours Committee for execution, but up to the present nothing has been done.

In view of the ever-present dangers to navigation, such a situation is deplorable and the Piers and Harbours Committee would be well advised to proceed with the work at once, before the winter storms set in.

AN EASILY MADE THREE-COIL HOLDER

By G. H. P. GIBBS.

THIS coil holder was the result of an attempt to construct a simple and inexpensive coil holder which would permit of fine coupling adjustments. As may be seen from Fig. 1, the three-coil holder consists of a base carrying a fixed holder and two movable holders.

The base is of hard wood measuring 6 ins. by $2\frac{1}{2}$ ins. by $\frac{5}{8}$ in. In the centre of the base is mounted the fixed holder, consisting of an ebonite strip, $2\frac{1}{2}$ ins. by $\frac{1}{2}$ in. by $\frac{3}{8}$ in., which carries two valve sockets. These sockets are $\frac{3}{4}$ in. apart, and are each connected to a terminal by a wire run between them in a groove cut in the under side of the ebonite.

Examination of the figure will reveal the method of mounting the moving coil holders.

The base of the holders have a slot of width sufficient to clear a 4 B.A. screw. An easy way to make the slots is by drilling a number of holes, and then removing the surplus material by filing. Be sure not to make the slots too wide—they should just clear a 4 B.A. screw.

A 4 B.A. screw is mounted in each part of the base to operate as a pivot for the movable coils. It is necessary to employ a large washer between the head of the screws and the upper surface of the holders, and to place a spring washer between the

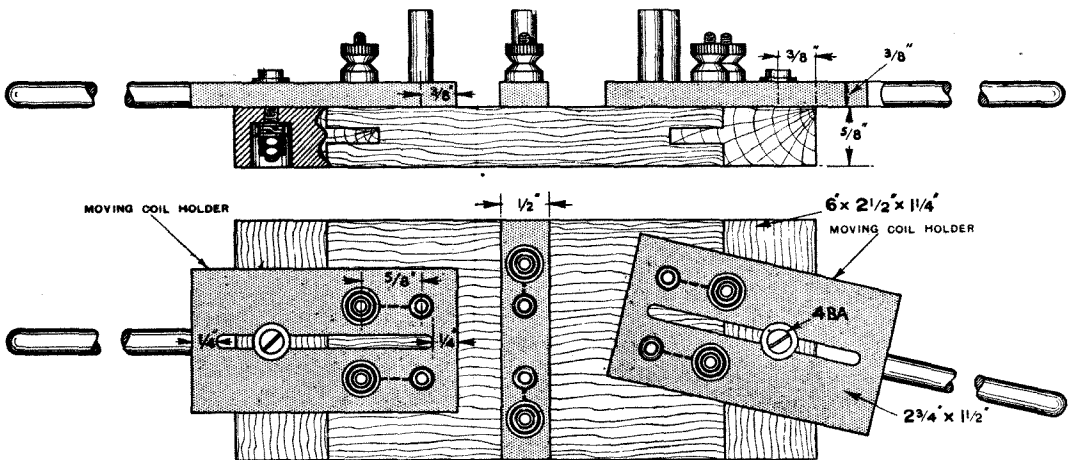

Details for constructing a simple three-coil holder. Adjustment of coupling is obtained by rotating as well as by increasing the distance between the coils.

Each moving coil holder comprises a piece of ebonite, $2\frac{3}{4}$ ins. by $1\frac{1}{2}$ ins. by $\frac{3}{8}$ in., which carries at one end the sockets for the coil and the terminals for the connecting wires. The sockets are $\frac{3}{4}$ in. apart and mounted $\frac{3}{8}$ in. from the end of the strip. It is necessary to drill and tap the ebonite strip to take the screwed ends of the sockets and terminals, and care must be taken when cutting the threads. Connection between the sockets and terminals is made by a length of wire run in a groove cut in the under side of the ebonite.

nuts and the base on the under side of the base. The figure shows the details quite clearly.

Handles for moving the coil holders may consist of lengths of strip wood or ebonite, screwed to the holders.

The spacing of the sockets of the holders given above are correct for most types of basket-coil holders. Those who use ordinary plug-in type coils will find it an easy matter to fix panel mounting type holders instead of the valve sockets.

SINGLE VALVE REFLEX CABINET SET.

By R. H. COOK.

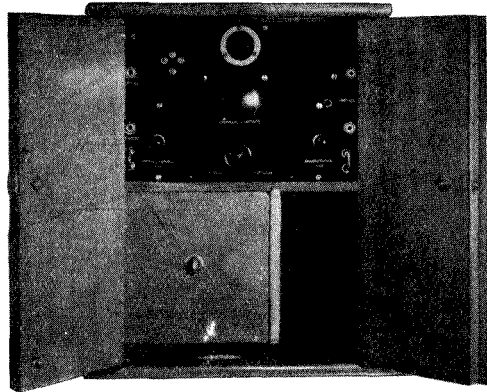

A front view of the receiver.

NOT only is the external design of the receiving set governed by the purpose for which it is required, but the circuit and the tuning system also must be carefully considered. The receiver to be described here has been designed for the use of the non-technical listener, for it so often falls to the lot of the wireless amateur to construct a set for the use of his wireless friends to whom the science of wireless makes little appeal.

This receiver is not a loud speaker outfit and is better described as a simple set, easy and inexpensive to build and requiring a minimum of filament current.

Reference to the circuit diagram, Fig. 1, will show the receiver to consist of an aerial tuning inductance which is not variable as

to the number of turns, but is tuned by means of the inductance change brought about when a copper cylinder slides over the winding. The tuned plate circuit of the valve which provides the necessary amplification at high frequency is tuned in a like manner, while in both aerial and anode circuits connectors are introduced for the insertion of loading coils, when it is desired to extend the wavelength range for the reception of the high power and continental broadcasting stations. A crystal detector is employed and the rectified signals fed back into the grid circuit, while the telephone receivers are connected in the high tension positive battery lead. This dual amplification circuit is probably the best-known and although it is not claimed to be in any way equal in results to separate valves performing the function of high and low frequency amplifiers, it is a system that produces good all-round results, giving a high degree of amplification of the local station, and at the same time is sensitive to distant transmissions.

The material required is as follows:—

One cabinet built to the dimensions shown in Fig. 7. To those who may find difficulty in completing a job of this sort it might be mentioned that there are many useful types of containing cabinets available, which can be used, and involve, of course, slight amendment of panel dimensions.

One ebonite panel, 9 ins. by 6 ins. by $\frac{1}{4}$ in.
Two ebonite tubes 4 ins. in length by 2 ins. in diameter.

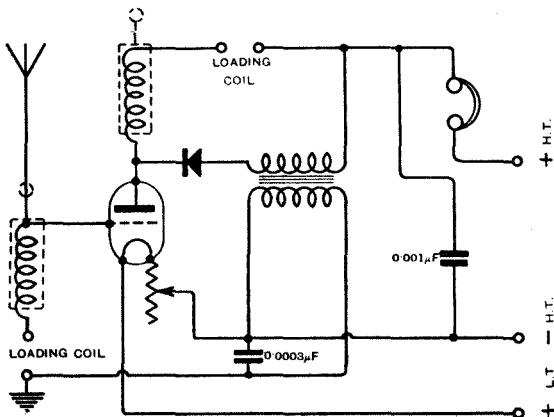

Fig. 1. A reflex circuit is employed and tuning is effected by the inductance change produced when a copper cylinder covers the windings of the tuning coils.

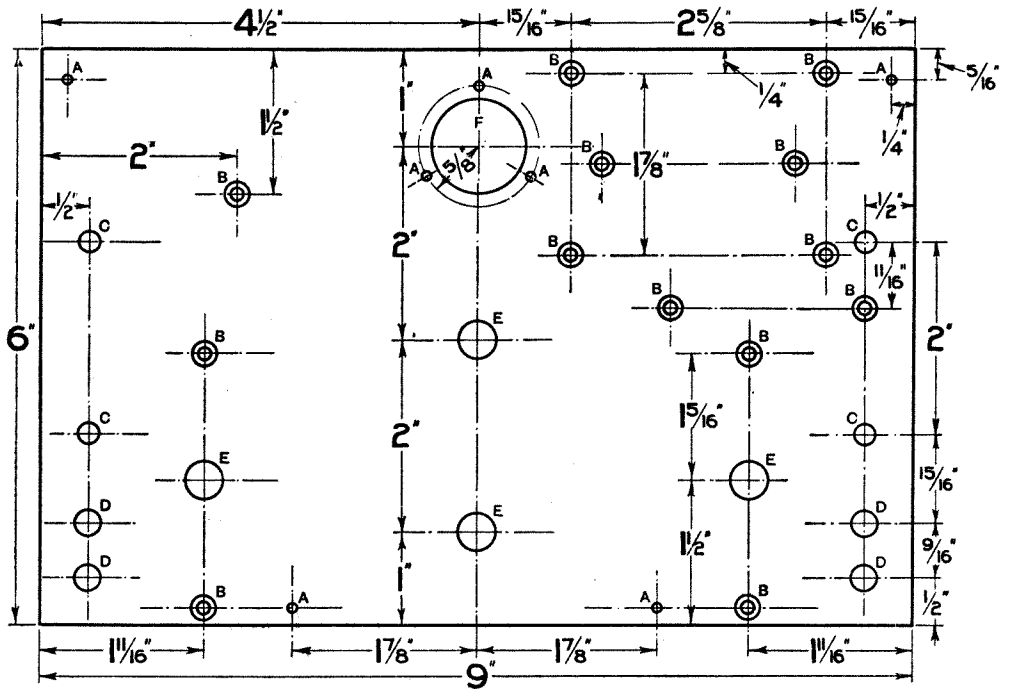

Fig. 2. Details for drilling the panel, viewed from the front. A, $3/32''$ for No. 3 round headed brass screws. B, $1/8''$ and countersunk on face. C, $7/32''$. D, $1/4''$. E, $3/8''$. F, $1''$.

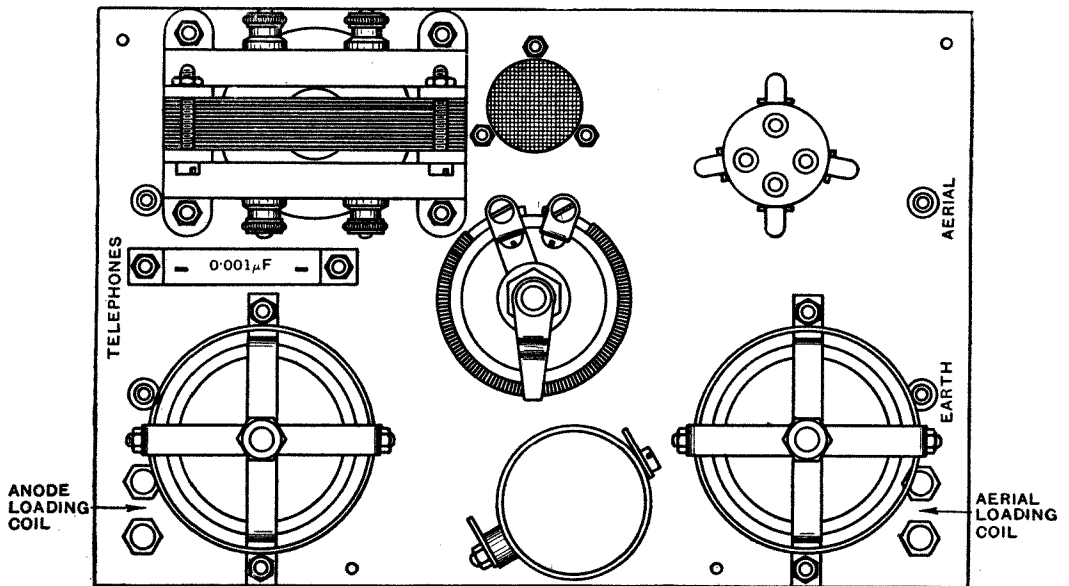

Fig. 3. Arrangement of the components on the back of the panel.

- Two copper tubes 3 ins. in length by $2\frac{1}{4}$ ins. inside diameter by about No. 20 S.W.G. in thickness.
- One filament resistance.
- One crystal detector of a type that will provide easy adjustment.
- One valve window.
- Six "Clix" sockets and 8 plugs.
- 4 Valve legs.
- 2 ft. of $7/32$ in. brass rod.
- 18 ins. of brass strip $5/16$ in. width by No. 16 S.W.G. in thickness.
- 2 Small ebonite knobs.
- 2 Sets of coil plugs and sockets.
- 2 Fixed condensers, 0.001 mfd.
- One intervalve transformer.
- 4 ozs. D.C.C. copper wire No. 34 S.W.G.
- 4 ozs. D.C.C. copper wire No. 30 S.W.G.

the ebonite tube also is another brass bracket which is drilled $15/64$ in. to give good clearance for the rod which slides through. The purpose for using rod of this size is that brass bushes are obtainable for fitting to the panel and through which the rod will slide. If the hole is not found to be exactly the size required, then a $5/64$ in. drill must be passed through. Care must be taken in setting up the rod, that the holes through which it passes are in alignment.

The necessary details for drilling the panel are shown in Fig. 2. The panel, as will be seen, is arranged to carry all of the components. The filament resistance is mounted in the centre and the valve window immediately above it. Although the valve is not immediately behind the window, which

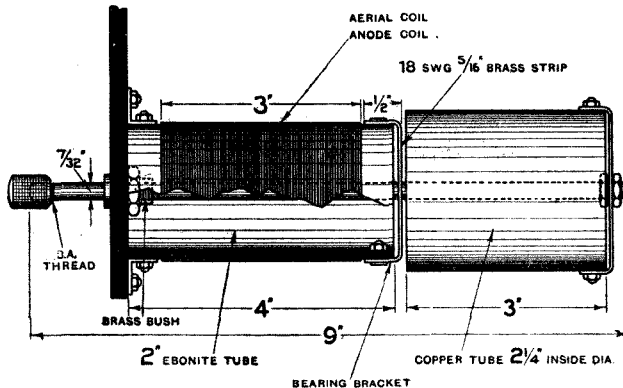

Fig. 4. Constructional details of tuning coil and cylinder.

Some No. 16 tinned copper wire for connecting up.
Screws, nuts, etc.

Referring to the components used in this circuit, the tuning coils are wound on ebonite tube 2 ins. in diameter by 4 ins. in length. The aerial coil is wound with No. 30 D.C.C. and the anode coil with No. 34 D.C.C. The windings cover 3 ins. of the tubes, and are set up according to the details given in Fig. 4, so that the copper tubes pass down over the windings. Suitable copper tube can be purchased at a metal warehouse, and the pieces cut to length, using a fine-toothed blade in the hacksaw. Brass bridging pieces are fitted across one end of each piece and attached to lengths of $7/32$ in. rod by means of a centre hole, the rod being threaded 1 B.A. Across the open end of

in this design was not found possible to arrange, the window will serve to indicate as to whether the filament is glowing as the illuminated interior of the box can be seen. To avoid the fitting of terminals in positions somewhat inaccessible, plugs and sockets are made use of for connecting up aerial, earth and telephones. Both the aerial, and tuned plate circuits can be loaded for reception on the longer wavelengths, and for this purpose "U" links with plugs and sockets are fitted to the front of the panel. The tuning rods which operate the copper cylinders are symmetrically arranged on either side of the filament resistance.

The set is simple to make up and to anyone acquainted with the process of squaring up and marking out ebonite, drilling and countersinking, the accompanying practical drawings give all necessary details. These

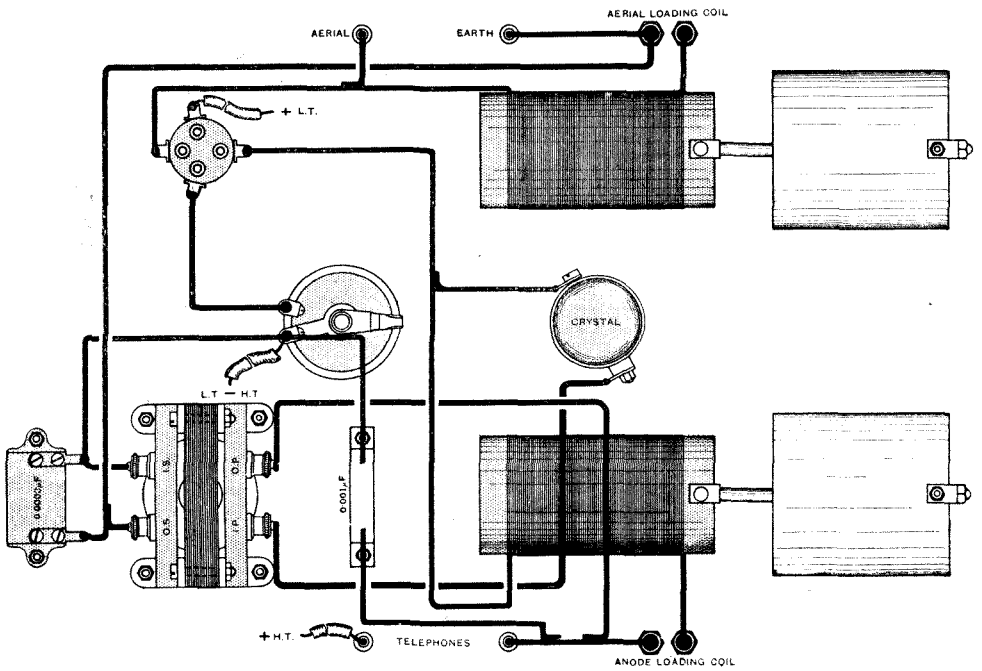
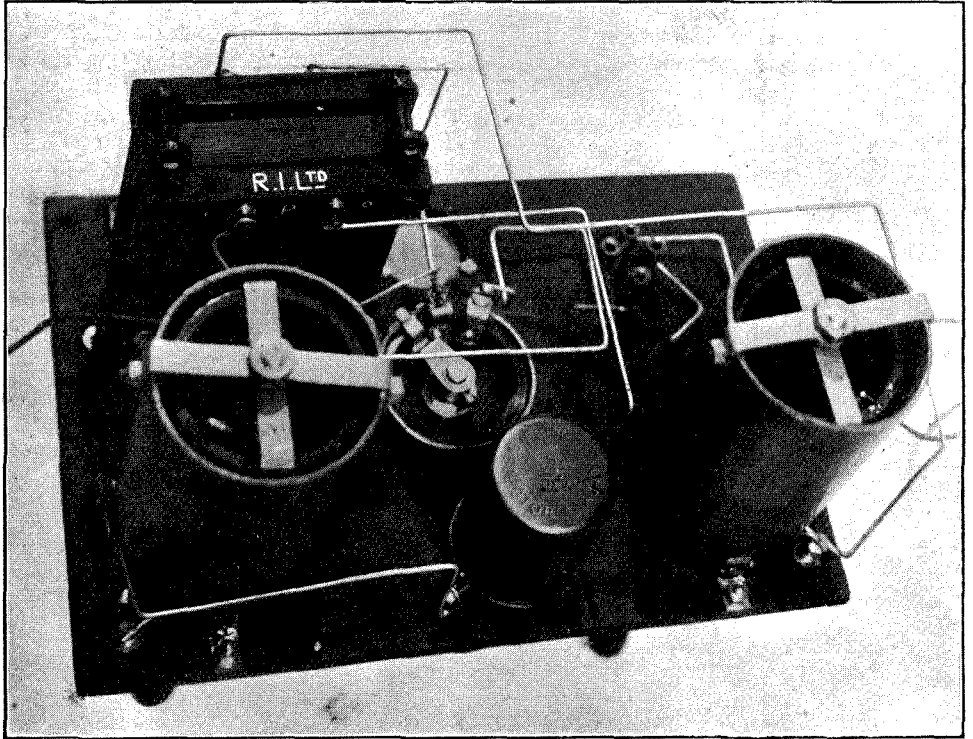

Figs. 5 and 6. View of underside of panel and practical wiring diagram.

can be worked to without further explanation.

The wiring is carried out with No. 16 tinned copper wire, and as the circuit is a simple one the number of wire leads will be comparatively few.

The panel, when completed, may with advantage be mounted in a cabinet, in which provision is made for the accommodation of the filament and H.T. batteries. A suggested form of cabinet is shown in Fig. 7.

When using a dull emitter valve of the 0.06 class, ample room will be found for including not only the high tension and filament batteries, but also one pair of telephone receivers.

A receiver tuned on the principle described here will not be found to possess great selectivity, which is probably an advantage when simplicity of operation is the aim. The operation of two tuning adjustments simultaneously makes tuning difficult if signals are only received at critical settings, which is the case when a highly selective tuning system is adopted. The comparative flatness of tuning given by this set renders tuning an easy process.

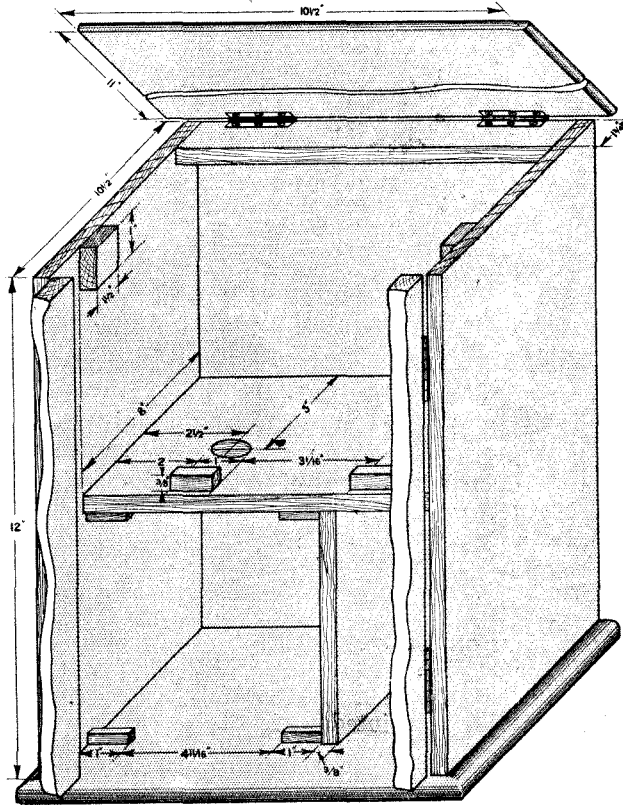

Fig. 7. A suggested cabinet design. Compartments for batteries and telephone receivers are provided.

FIRST STEPS IN WIRELESS

In spite of the large number of publications now available purporting to introduce the beginner to an elementary study of wireless, the little book under review* fulfils its purpose in a manner at once lucid and original. As a guide to the novice its brevity of treatment is a distinct advantage, for while nothing of fundamental importance is omitted, the reader is not confronted with pages of irrelevant and discursive detail.

The principles of wireless are approached in a way which robs them of their mysticism in the eyes of the beginner by means of some apt analogies in the phenomena of sound.

An explanation of electric current follows, after which practical advice is given on the erection of aerials and the preparation of a reliable earth system. The reader is then acquainted in turn with the principles of tuning, the telephone, crystal rectification, and finally valve detection and amplification. The concluding chapter treats of the operation of a typical three-valve broadcast receiver.

The great merit of Mr. Pocock's little book is the simplicity and directness of its explanations. The chapters on valve operation in particular are such as to be easily understandable to the veriest novice.

* "Your First Steps in Wireless." By Hugh S. Pocock, (The Wireless Press, Ltd., 12-13 Henrietta Street, London, W.C.2. 60 pages. 25 Illustrations. Price 9d. net. Postage 1d.)

SOME INTERESTING EXPERIMENTS WITH SINGLE POINT DETECTORS

The single-point film detectors described here are really improved forms of the so-called "film coherer" and are identical in their mode of operation with crystal detectors. In these detectors the manipulation of the metal point or "catwhisker" is a more delicate matter than in the case of the ordinary crystal detector. They are all easily fitted up and the experimenter may learn some useful lessons by trying them out in conjunction with a theoretical study of the subject on the lines indicated in former articles in this journal.

By JAMES STRACHAN, F.Inst.P.

THE majority of these experiments may be most conveniently conducted by means of a crystal detector in which the crystal cup is replaced by a small spring or screw clamp suitable for holding the various forms of the film supports.

OXIDE FILM ON BRASS.

The contact is made on the milled edge of an unlacquered brass terminal head (Fig. 1), using a pointed piece of No. 26 copper wire as "catwhisker." The milled edge is rotated and various contacts tried until the best results are obtained. The terminal used should not be quite new but should have the dull yellow tarnish. A correspondent advises that he has found the screwed periphery of a 2 B.A. brass rod quite good. The grooves in the milling or screw-cut present the requisite oxide film better than a smooth surface. Manipulation of the "catwhisker" is very delicate, but reception at best is quite equal to a good

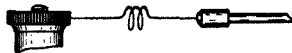

Fig. 1. A tarnished brass surface and a copper wire will function as a detector. The milled head of a terminal possesses many faces and detecting contact can more easily be found.

synthetic galena. Various pieces of brass should be tried until results are obtained. A good contact is easily disturbed by vibration. This detector is very sensitive to sudden increases in aerial current, which

produce repulsion and breaking of the contact. A poor contact is much improved by the use of an applied potential.

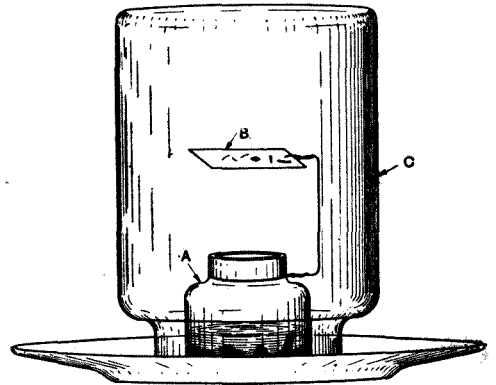

Fig. 2. Method of forming a sulphide film. Sulphuretted hydrogen is evolved from the iron sulphide and hydrochloric acid in A. The metal pieces to be treated are supported on the platform B.

OXIDE FILM ON COPPER.

The black oxide film on copper is most conveniently prepared by dipping a fragment of thick copper wire or of sheet copper in a strong solution of copper nitrate and heating the metal until a uniform black film is produced. The solution should be slightly acidified by adding a few drops of strong nitric acid. This preparation is not nearly so sensitive as the oxide film on brass, but works very well with an applied potential. When thick wire is used, a good contact may be established by allowing the catwhisker to cross at right angles, resting lightly upon it.

SULPHIDE FILMS ON VARIOUS METALS.

Sulphide films on various metals may conveniently be obtained by exposing the cleaned metals, such as lead, copper and silver, to a moist atmosphere, containing sulphuretted hydrogen gas, until the metal is thoroughly blackened. A simple method of doing this is shown in Fig. 2.

A one-ounce wide mouthed bottle A carries a support B of wire and celluloid on which the fragments of metal to be sulphidised are laid. A few fragments of black iron sulphide are placed in A and some spirits of salts (hydrochloric acid) added. The large glass jar C is then inverted over the apparatus, which may conveniently rest on a china plate. This operation should not be conducted in the drawing-room as the smell is unpleasant. Sulphide films prepared in this way require a delicate contact with the catwhisker and work best with an applied potential. Sulphide films may also be prepared by heating the metal in a glass test-tube to dull redness and dropping in a few grains of powdered sulphur while the heating is continued. In the case of lead the latter melts and a black film is formed on the surface. When cold a lead button is produced with the sulphide film on the flat surface. A hard glass test-tube should be used and a bunsen gas-flame. This method is quite useless with some metals, such as silver, but works well with lead and copper.

AMORPHOUS POWDER DETECTORS.

Sulphides and oxides may be prepared in the amorphous form most conveniently by precipitation, filtration and drying. Experimenters who are not familiar with such operations should purchase the pure substances from some chemical warehouse of repute, such as the British Drug House.

Various methods of using the powdered substances as detectors may be employed. The majority of my own experiments were carried out by spreading a film of the powder on the

flat surface of a brass binding screw-head on which had been soldered a disc of

platinum foil (Fig. 3). This was clamped in the crystal holder and the catwhisker applied vertically.

Another method of preparing the film is to mix the powder with a drop of distilled

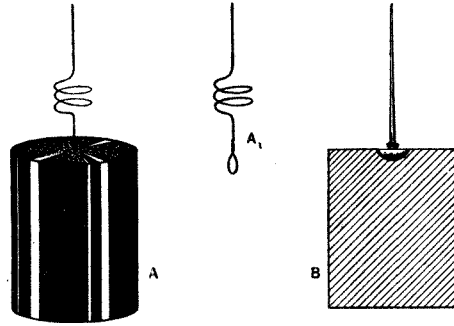

Fig. 4. A piece of arc carbon may be employed for making contact with powdered detecting substances.

water, spread it over the surface of the metal and dry by application of a gentle heat. Another method is to mix the powder into a paste with olive oil or liquid paraffin, and spread a film of the paste over the metal. Practically all substances which rectify in the crystalline state, also rectify in this condition of amorphous powder, but it is necessary to use an applied potential to obtain good results.

The most remarkable of these experiments lies in the fact that in many cases it is sufficient to use an applied potential for a few minutes only when the contact rectifies well after the local battery is switched out, so long as the contact is not disturbed. Each new contact requires sensitising in this way.

Fig. 4 shows two other very successful methods of using amorphous powders as rectifiers. In A the film is prepared by rubbing the powder over the end of a short piece of arc-lamp carbon with the forefinger and applying the catwhisker vertically. In many cases better results are obtained by using a cat-whisker with a blunt end or bent into a loop as A₁.

In B is shown (in section) another method of using the carbon rod film carrier. On the upper surface a shallow cavity is excavated, into which the powder is placed and in this case the catwhisker is an ordinary pin, the head of which is applied, varying the pressure, to the small pinch of powder in the cavity.



Fig. 3. The terminal head is covered with a piece of thin platinum foil for conducting experiments with amorphous powder detectors.

Yet another method lies in dusting the finely ground, dry, sieved powder, on to the surface of some dry mercury in a small wide-mouthed glass tube (Fig. 5).

Contact with the film-covered mercury is established by means of a piece of stout iron

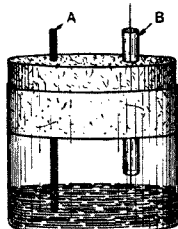

Fig. 5. An experimental detector in which the powdered detecting substance is floated on the surface of a small quantity of mercury.

wire A, while the catwhisker is applied through a short piece of glass tubing B, both of which are carried by the cork (soaked in paraffin wax), which closes the tube.*

CARBON FILM DETECTORS.

A piece of platinum foil coated with a carbon deposit by holding it in a tallow candle flame for a few seconds gives a film that rectifies quite well, using an applied potential.

A graphite film made by rubbing powdered graphite on the carbon rod (Fig. 4, A) is more efficient.

In Fig. 6 is shown a curious form of carbon film detector discovered accidentally.

A small spirit lamp A is burned until the business end of the wick is well charred. While still burning, a piece of stout copper wire is pressed into the charred wick for one contact and the catwhisker (a platinum wire) C applied vertically to the char. The two wires must not touch but they should both make contact with the carbon char. This works well with an applied potential.

THORIA FILM DETECTOR.

Thoria (oxide of thorium) is ground into a paste with distilled water and applied to a piece of platinum foil or stout platinum wire. When dry the platinum is held in the flame of a small spirit lamp or a very small Bunsen gas-flame. Contact is established with the

film by applying a thin platinum wire catwhisker when the platinum is red-hot (Fig. 6).
CRYSTAL FILM DETECTORS.

As the majority of amorphous rectifiers used in the film detectors described above require the application of an applied potential to obtain the best results, they are much more difficult to manipulate than crystal detectors, particularly as sudden variations in the potential across the contact, disturb the latter and frequently break it. It is interesting to note, therefore, that all good crystalline rectifiers may be ground up in an agate mortar to a finely crystalline powder which still rectifies quite as well as the large crystal. Such powders should be sieved through fine bolting-silk (200 meshes per lineal inch) and used in many of the above experiments without the use of an applied potential.

CONCLUSION.

It is not suggested that any of the detectors described above are efficient substitutes for the crystal detector. My purpose in describing them will be served if this article

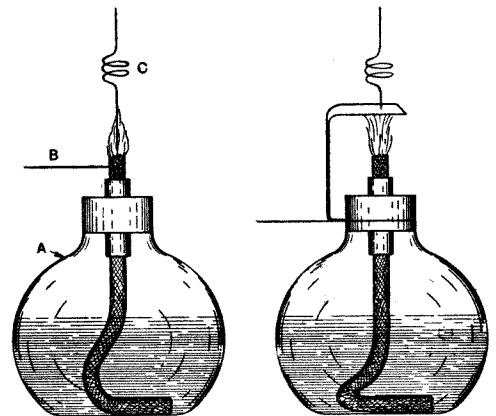
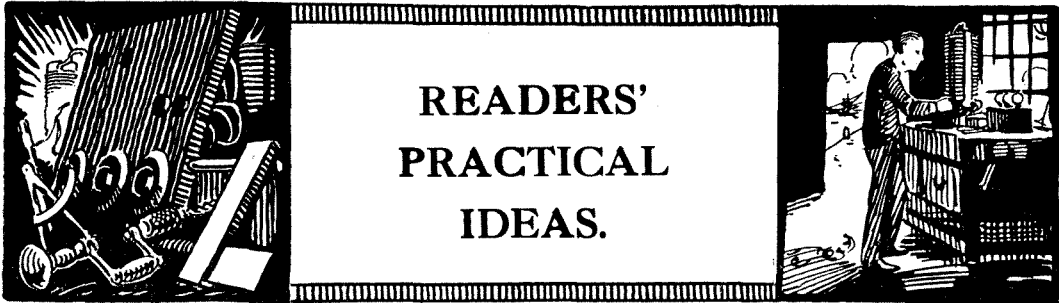

Fig. 6. The carbonising of the wick of a spirit lamp forms a detector using platinum wire contacts. The spirit lamp on the right carries a piece of platinum foil coated with thoria. This gives a detecting surface when red hot.

stimulates the amateur to carry out other experiments on similar lines. The real value of theories can only be grasped when theoretical studies are carried on in conjunction with practical work.

Such experiments not only help one to obtain a better grasp of the theory of rectification, but the manipulative skill required in getting them "to work" is most useful in other directions.

* Keep mercury away from wireless apparatus and avoid such things as mercury grid leaks and mercury vernier condensers as you would a corrosive acid. One drop of mercury will give off enough vapour to corrode all the aluminium in a wireless set.



This section is devoted to the publication of ideas submitted by readers and includes many devices which the experimenter will welcome.

Telephone Terminal Block.

WHEN telephones are employed in preference to a loud speaker a distribution point must be made to which all telephone cords may be attached. As the

to be operated a double pole switch may be added to the instrument for bringing it into operation.

G. H. W.

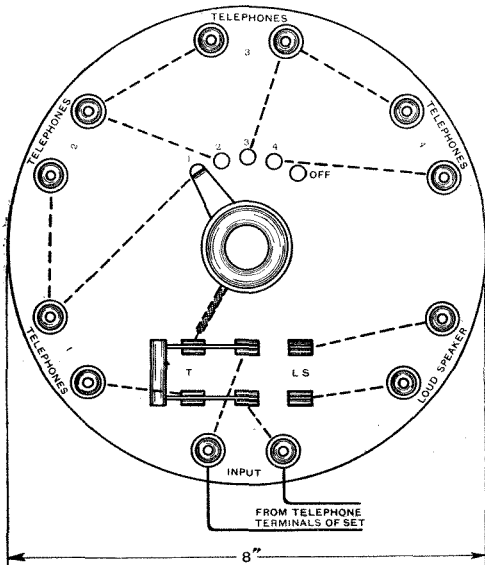

Telephone distributor board for varying the number of receivers in circuit.

Worm Drive Attachment.

THE simple device described here may easily be fitted to many types of coil holder, and in use gives just that difference between good and bad long distance reception, as the sensitiveness of a set as a rule depends upon the critical adjustment of the relative position of the inductances. A Meccano gear wheel and worm are used in its construction, together with two adjusting collars and set screws and one axle rod. The gear wheel is attached to the spindle of the moving coil holder, while the worm drive is attached to a brass spindle and is carried by a bracket made from strip metal. It is not

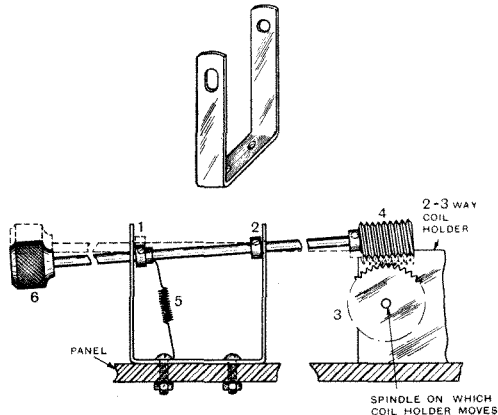

A simple method of obtaining fine coil adjustment. The spring holds the gears out of mesh for coarse tuning.

number of pairs of telephones in use is to be changed it is necessary to set up some form of switch for easily throwing out of circuit those receivers not in use. Such a switch, of simple construction, can be made up from a circular piece of wood or ebonite carrying four pairs of terminals for four sets of receivers, and a five-point switch for bringing them into operation. If the loud speaker is

intended that the worm drive action shall be used to propel the coil holder when making coarse adjustment, and for this reason a small spring holds the worm wheel out of contact with the pinion. A slot in the end of the supporting bracket allows of the worm wheel being brought into mesh and the necessary critical adjustment obtained.

J. G. S.

A Simple Coil Mounting.

THE accompanying drawings are self explanatory in giving a method for easily constructing a very useful form of coil holder. It will be noticed that small

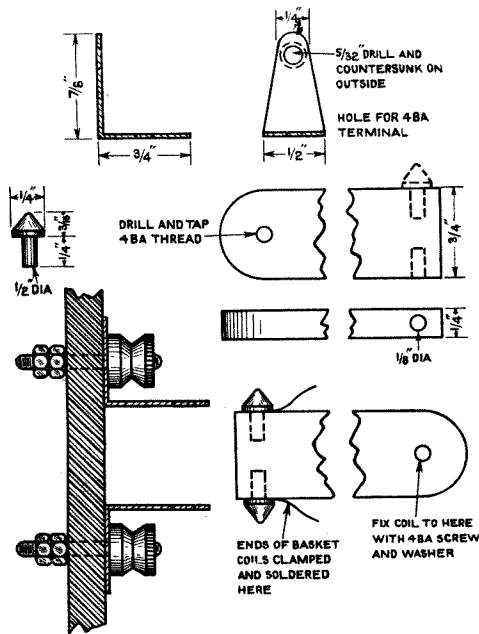

An easy method of constructing a useful form of coil holder.

brass pins are used to make contact between the arm which supports the coil and the two springs forming a bracket. Suitable dimensions are given.

H. H. P.

Winding with Fine Wires.

IN the construction of interval transformers and the re-winding of telephone receivers, insulated wire of exceedingly fine gauge and poor mechanical strength is used.

Extreme care is necessary in handling this wire, particularly as the insulated covering is usually stronger than the copper conductor it contains. As a result a bobbin may be

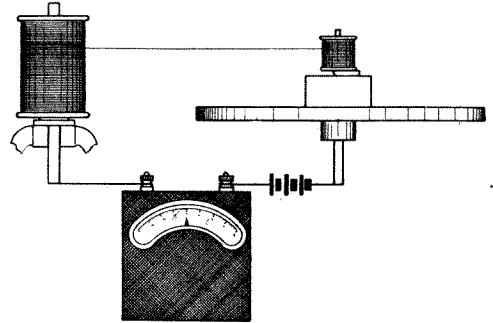

A galvanometer used to detect a break when winding fine wire.

wound in which the wire runs on continuously although an actual break may have occurred in the copper conductor. To guard against this, the reel from which the wire is drawn will be found to have the inside end brought out so that connection can be made to it, and by joining up the whole of the wire in circuit with a battery and sensitive galvanometer it is possible to detect a break immediately it occurs.

Small bobbins can be rotated by means of a clockwork motor such as that used for driving a gramophone. The coil to be wound must be mounted on a block of wood and arranged to run quite centrally to avoid any jerking action on the fine wire.

A. E. R.

Soldering Water Main Earths.

ONE of the most convenient methods of obtaining an earth connection is to employ the main cold water supply pipe. Owing to the heat conducting properties of the pipe it is an extremely difficult matter to solder a connecting wire to it when employing ordinary methods. The difficulty can be overcome by using a solder having a much lower melting point. A number of fusible alloys are suitable for the purpose, and one which has been used successfully for this purpose has the following composition in parts by weight: bismuth 3, tin 5, and lead 3. It is advisable to tin the copper wire and soldering bit in the usual manner with ordinary solder, and to bind the copper wire in position on the water pipe with thin tinned copper wire.

F. F.

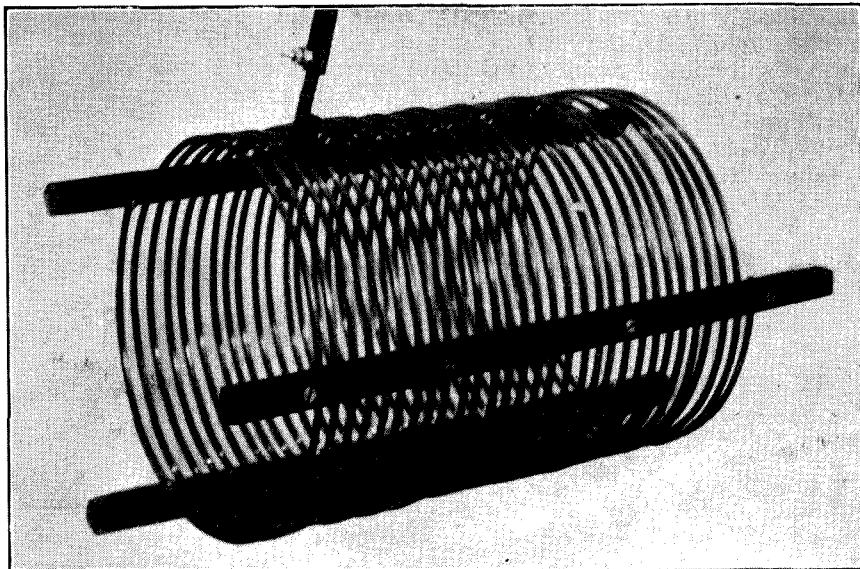

A useful form of air-spaced transmitting inductance.

THE DESIGN OF TRANSMITTING INDUCTANCES.

An article principally of interest to operators of transmitting apparatus. The design of inductances for use with valve transmitting apparatus has not previously formed the subject of an article, and it is felt that the information given here will be welcomed by many transmitters at the present time, when apparatus of extreme efficiency is being designed. Coils of the type shown possess minimum losses, and are capable of handling energies customarily employed in amateur stations and at the high radio frequency of the low wavelengths.

By N. V. WEBBER.

IN this article it is proposed to leave the calculation of the size of the actual inductance alone, and to ascertain these details the writer would recommend one of the many text-books published by the proprietors of this journal. Assuming that the dimensions are known, I will proceed to describe two types of inductances which are very popular amongst transmitters and which are very useful for short wave work. The pancake type is undoubtedly the easiest to construct, and this type will therefore be dealt with first. The internal diameter of this is 3 ins., and 12 turns are

employed spaced $\frac{1}{4}$ in. apart. First, in order that a host of calculations may be dispensed with, it is advisable to make a full-sized drawing of the proposed inductance. This need not be a very accurate affair, but should at the same time be sufficient to provide the necessary measurements.

Two lines should be set out at right angles on the drawing paper, and the arms numbered from one to four in rotation, either clockwise or anti-clockwise, it does not matter which, so long as all the inductances are made in the same way, and the winding is in the same "sense." A mark should be made on the

sketch on No. 1 arm at a point $1\frac{1}{2}$ ins. from the centre. In order that the winding will be worked outwards in spiral formation it becomes necessary to make the next point on No. 2 arm slightly out of register to that marked on No. 1, the exact measurement from the centre being $1\frac{9}{16}$ ins. It will thus

draw the remainder. A line is also needed joining points equidistant from the centre. Thus should be bisected and a line drawn at right angles. The line should be at least $\frac{1}{2}$ in. from the last turn, and the point where it cuts the arms of the cross will show their length.

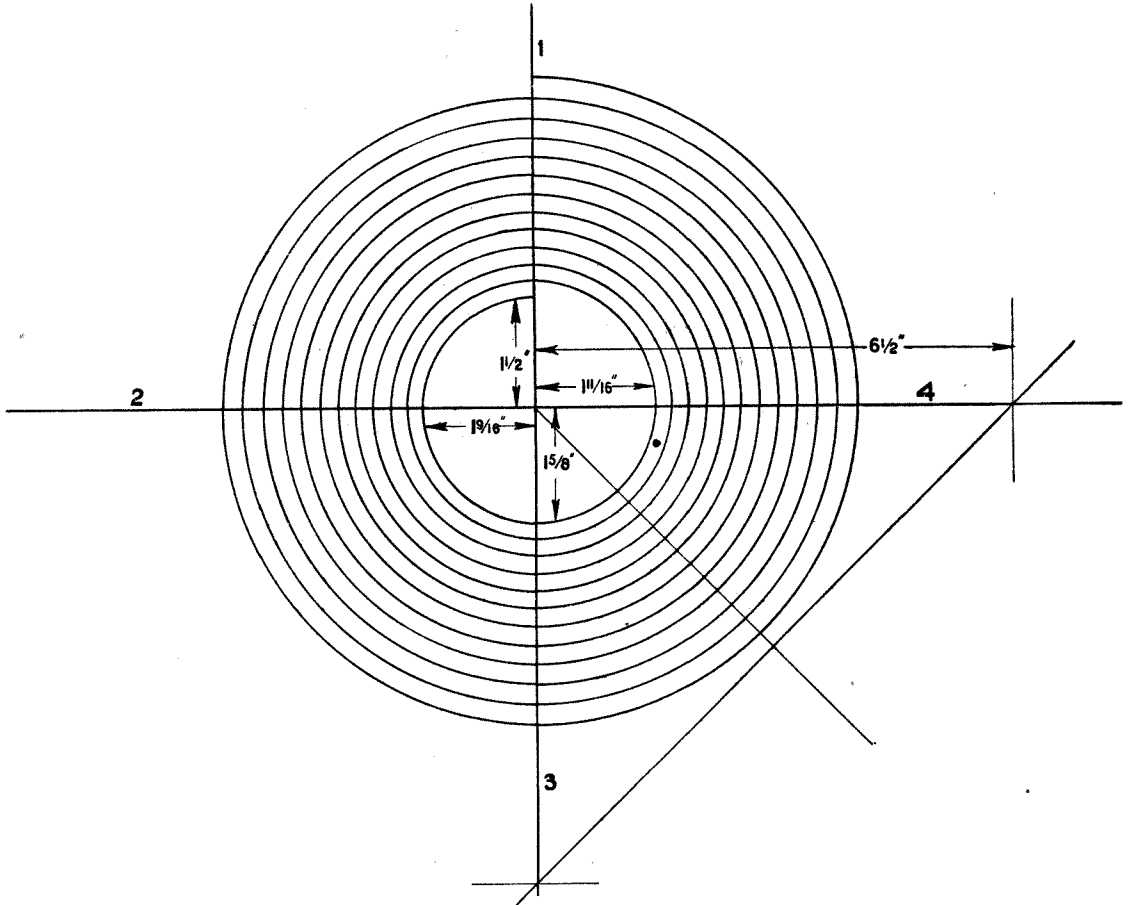

Fig. 1. A full-size drawing of the spiral should be prepared. The method of setting it out and the necessary dimensions is given here.

be appreciated that the marks on the arms 3 and 4 will be $1\frac{5}{8}$ ins. and $1\frac{11}{16}$ ins. respectively.

Having fixed the four points it is only necessary to mark outwards along the arms, points $\frac{1}{4}$ in. apart, until there are twelve to each side, when the position which the wire will occupy when it is wound on can be sketched. After a few turns have been completed, it will be found unnecessary to

The drawing completed, the ebonite strips may be cut, the width of which depends upon the width of the copper strip to be used. In the case of the inductance under description the strip is $\frac{5}{16}$ in. wide, and so if the ebonite pieces are cut $\frac{3}{4}$ in. wide by $\frac{1}{4}$ in. there will be ample support. The two strips in this case are cut 13 ins. long, and form the cross. Whilst the ebonite is being cut it would be well to make up two more strips

each $\frac{1}{4}$ in. square and 13 ins. long for use as clamps to keep the spiral in place. The next operation is to mark the ebonite for slotting. Centre the ebonite and mark off two points on either side of the centre, $1\frac{1}{2}$ ins. and $1\frac{5}{8}$ ins. respectively, which should be numbered 1 and 3. The other points can then be marked out as they appear on the drawing. With a set square lines should be scribed across the strip, and a line should be drawn on the ebonite which is the width of the copper ribbon from one of the edges. It is also necessary to draw in the centre of the ebonite arm a short line which is exactly half the width of the strip, *i.e.*, $\frac{3}{8}$ in., and then two lines $\frac{1}{8}$ in. from the centre. This performance should be repeated with the other piece of ebonite, which should be numbered 2, 4. (Fig. 2).

strips must fit into the slots easily, and should not have to be forced in at all, yet they must not be too loose or difficulty will be encountered when the wire is wound on. When the twelve slots have been cut take the strip out of the vice, and holding the unslotted end, give it a tap on the bench, and all the copper strips should fall out. If they do not do so they are too tight a fit, and the slots must be widened a little by running into them the back of an ordinary wood saw. All the slots having been cut, the strips should be rubbed over with emery to remove the scribed lines. The selection of the strip is an important point, for if it is of the correct type winding the coil is the easiest task of all.

The strip used in the construction of the coil under description is 20 S.W.G. $\frac{5}{16}$ in.

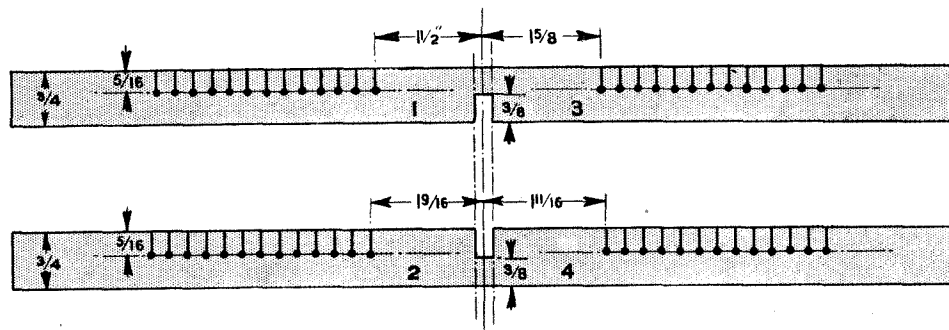

Fig. 2. The method of marking the ebonite strips for slotting.

The strips having been marked, the centre slots should be carefully cut with a fretsaw and the cross made in a similar manner to that in which an egg-box is constructed. If the joint is made to fit too tightly the ebonite will be bent and a flat inductance will not result. Before the various slots are cut in the strips, particular care should be taken to ensure that when the cross is assembled the slots will all be on the upper side. The slots are cut with a hacksaw, the ebonite being firmly gripped in a vice. A hacksaw blade should be chosen which is the same thickness as the copper strip, and as each cut is made a small length of the ribbon should be inserted.

The whole secret of a successful inductance lies in the fit of these slots. The copper

wide. It is essential that it should be soft copper for if it is hard drawn, difficulty will be experienced in bending it to the correct shape. The strip employed in this case was obtained from Messrs. Young's, of City Road, E.C. If only hard copper can be obtained it can be softened by heating it until it is at a dull red heat, and then cooling it in water, but this is rather a tedious operation. The amount of strip which is required should next be cut from the coil. This can be roughly determined by taking the length of the sixth turn on the drawing, and multiplying it by twelve, adding an extra foot to allow for accidents. This length of wire should be taken into the garden and the ends fastened so that the wire is stretched out, when it can be cleaned

with emery paper. Upon the completion of this operation the wire should be wound into a coil having a diameter of 1 ft. 6 ins.

The cross being fitted together with the numbers running consecutively, it is placed on the floor and kept in position by means of staples or long panel nails. Taking one end of the wire it should be placed in slot No. 1, and then bent into the shape of the curve and put into slot No. 2, then No. 3, then No. 4, and then to the second slot on No. 1. The first turn is then complete.

Continue winding until all the slots have been filled and cut off any surplus wire. The inductance is therefore finished with the exception of the top strips of ebonite which are to keep the wire in place. These strips are placed on top of the wire and screwed on. It will be necessary to cut one of the rods in half, for to construct this cross in a similar manner to that in which the larger one was made would involve a great amount of unnecessary trouble. Eight screws are used

to keep the longer strip in place, and four for the shorter pieces. These do not go right through the ebonite strip, but holes are drilled nearly through, and are then tapped with a 6 B.A. bottom tap. Where facilities exist for making suitable screws in fibre it is quite worth while substituting them for brass, in view of the losses which are liable to occur when metal parts are assembled in close proximity to the turns of the coil. The method of making clips for this type of inductance is described at the end of this article.

The solenoid inductance has not so many constructional details, but it is more difficult

to construct owing to the fact that it is not easy to wind the wire round absolutely evenly. The inductance to be described has a diameter of $5\frac{1}{2}$ ins. and consists of 30 turns spaced $\frac{1}{4}$ in. apart. A length of $\frac{3}{8}$ in. square ebonite rod is necessary, which in this instance is $10\frac{1}{4}$ ins. long, this allowing $1\frac{1}{2}$ ins. at each end. Three of these rods will be required. With a scriber one of the sides should be centred and a line marked $1\frac{1}{2}$ ins. from one end and a line every $\frac{1}{4}$ in., until there is a total of 30 points. These

points, which must be exactly in the centre of the rod, should be centre-punched and drilled, care being exercised that the drill is exactly the same size as the wire to be used. When one rod is drilled it can be used as a jig for the others. The sides of the rods will have to be drilled with a 6 B.A. clearance drill, for this rod is to be split down and these side holes used to clamp the two halves together. In drilling these holes care must be taken that they go between the holes which take

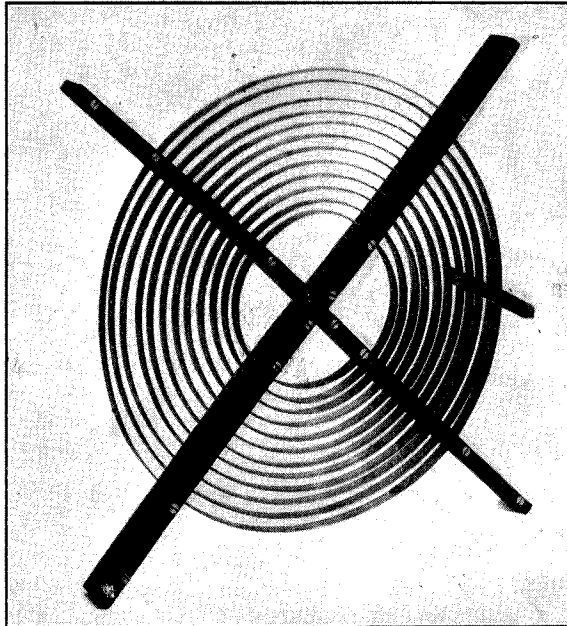

A pleasing and symmetrical appearance is preserved in the finished inductance.

the wire, otherwise there will be a danger of shorting the inductance.

Four screws are required for each rod, which are placed, one at the top, one between the 10th and 11th turns, one between the 20th and 21st holes, and the other at the bottom. When these holes have been drilled and countersunk, the rod is cut down through the 30 holes by means of a fretsaw. For this inductance 12 S.W.G. bare soft copper is used, the length required being ascertained by measuring the length for one turn and multiplying it by 30 and allowing an extra foot.

The wire is taken, straightened and

cleaned in exactly the same manner as the copper strip. Unless one is in possession of a lathe the wire should not be released. A former should be obtained slightly less in diameter than the finished coil is to be, to allow for expansion.

Two substantial pieces of wood should be nailed into each end of the former, to which one end of the wire is securely fastened, the other end of the wire remaining as it was for cleaning. It then becomes a fairly simple matter to wind on the wire, keeping the turns as close to each other as possible and winding without stopping, applying an even tension. Holding both ends of the wire securely, cut it off from its fastening and then release both ends simultaneously, when the wire will uncoil and expand to the required size. It is important that this procedure should be adopted, for should both ends not be released at once the end which is held last will be smaller in diameter than the other.

Taking one of the rods, fit in a screw and nut at one end and place the first dozen turns into the slots provided, when the second bolt can be placed in position and the two tightened sufficiently to hold the turns in place. Continue until the next ten turns are wound, and slip in the next screw. The final screw should be left until the other clamping rods are placed in position

when the three rods can be equally spaced round the inductance and all the screws fully tightened. Any wire over the 30 turns should now be cut off. The inductance will be found to be perfectly steady, and not inclined to wobble. To finish the component the ends of the screws inside the inductance should be cut off flush with a pair of wire cutters. Should a lathe be available it is, of course, advisable to use this for winding, but with care a hand-wound coil can be made very evenly, as will be seen from the photograph illustrating a hand-wound example.

Regarding the clips for these inductances, the pancake type are extremely easy to construct. From the copper strip a length of 3 ins. is cut and bent over 1 in. from the top. The part which is bent over should be pressed in a vice and the short end slightly splayed out with a pair of ordinary pincers. A short length of square rod is slotted and the lower end of the copper strip inserted and clamped in position by a bolt, care being exercised to ensure that the screw makes good contact with the strip. The clip for the solenoid is made in a similar manner except that, when the end is being bent over, a small drill or length of wire is inserted in order to make a slot for the wire. This must be small enough to fit tightly on to the wire of the inductance, otherwise it will sag downwards and short the turns.

PUSH-PULL AMPLIFICATION.

By GUSTAV LAMM (Swedish SMZY).

The writer has found an amplifier wired as indicated in the accompanying figure.

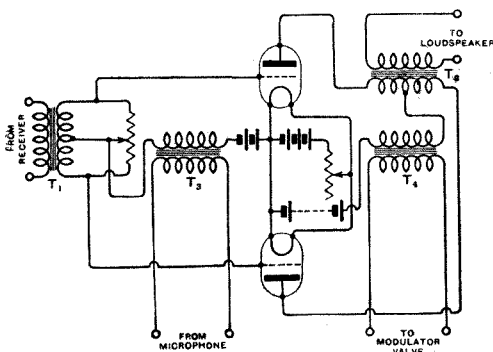

very useful. It will be observed that the "push-pull" system is employed. The transformer T_1 is connected to the receiver, and incoming signals are applied through this transformer to the grids of the two valves. In the output circuit is a transformer T_2 with a split primary winding and a secondary winding to suit the loud speaker.

When the instrument is to be used as a speech amplifier in conjunction with a valve transmitter a microphone is connected to the transformer T_3 , which applies the speech voltages to the grids of the two valves in parallel. In the output circuit is the transformer T_4 , which is connected to the modulator valve.

PATENTS AND ABSTRACTS



Crystal Detectors.

In ordinary crystal detectors of the type having an adjustable fine wire contact, provision is usually made for placing the end of the wire on any spot of the crystal, and the attention of designers has been devoted to producing a device which will admit of a delicate but firm adjustment.

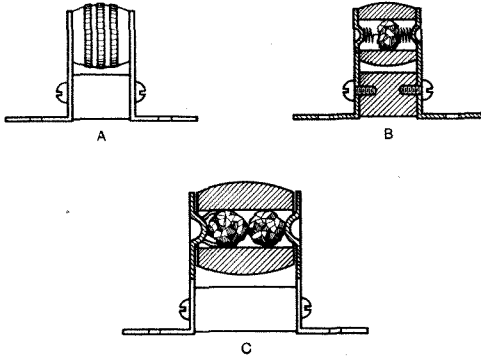

Fig. 1. Crystal detectors which may be adjusted by turning the barrel.

The detectors sketched in Fig. 1 were designed with a view to simplifying the setting of the detector (Patent No. 220,473) Fig. 1A is a side view of the detector, and Fig. 1B a section showing one arrangement of parts. A pair of flexible clips, pressed inwards at their upper ends, are mounted on an insulating base. Between the top portion of the clips is mounted a container of insulating material, which may be rotated, and inside this container is a crystal and two springs. The springs are fitted over the pressed-in portion of the clips. One serves to keep the crystal in position, and the other, which has a pointed end, serves as the wire contact. To adjust the detector, it is only necessary to rotate the container.

Another form of detector in which two crystals are employed is sketched in Fig. 1C.

A Single-Valve Receiver.

British Patent No. 221,951 discloses the circuit of Fig. 2, which has several novel features.

It will be observed that the aerial circuit is tuned by a coil L and tuning condenser C , and is coupled by one turn to a closed circuit A . The aerial coil L is not coupled to circuit A . Connected between the grid and the positive terminal of the plate battery is a tuned circuit B , comprising a coil L_1 and a tuning condenser C_1 . Coils L_1 and L_2 are mounted on the same former, but they are slightly separated. Circuit A is not tuned to the wavelength of the incoming signal. In the plate circuit of the valve is the usual reaction coil R , which is wound over the

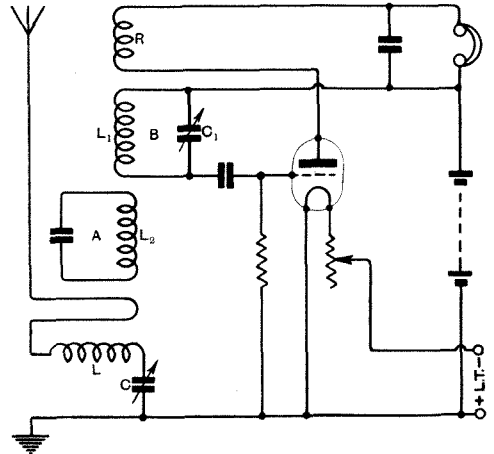

Fig. 2. Connections of a single valve receiver which it is claimed is very selective, and gives good amplification.

end of coil L_1 . Coils L_1 and L_2 are wound with thick wire, and the reaction coil with fine wire.

It is claimed that a receiver connected according to this diagram gives results

which are considerably in advance of the results obtained with ordinary circuits employing more than one valve.

of the interfering notes, but to pass the speech and music. Hence the original quality of the transmission is completely restored.

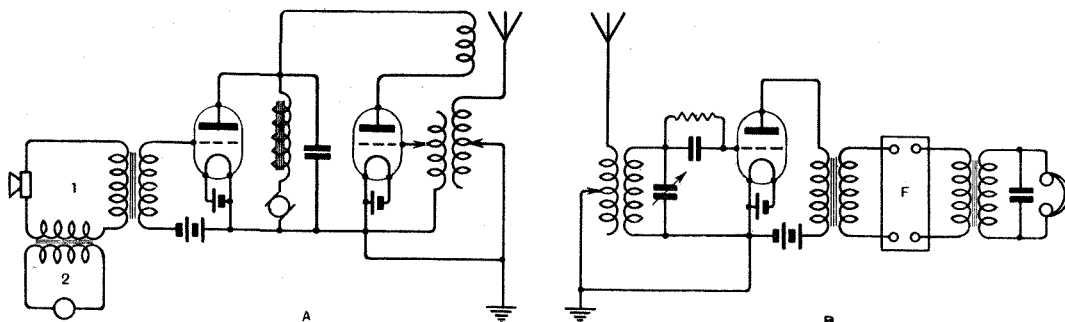

Fig. 3. Connections of a transmitter and receiver employed in one system of "restricted" wireless telephony.

Restricted Wireless Telephony.

In broadcasting systems as used at present, any person having a wireless receiver capable of receiving the wavelength on which the music and speech is transmitted may derive full benefit therefrom, regardless of whether such persons contribute towards the cost of operation of the broadcasting station. It is therefore desirable in some instances to limit the reception to authorised stations.

A specially arranged transmitting and receiving apparatus designed with this end in view (Patent No. 198,368) may be explained by referring to Fig. 3. Fig. 3A gives in outline the connections of the transmitter, and Fig. 3B of the receiver. The design is such that the oscillator of the transmitter is modulated by the speech or music which actuates the microphone, and by certain other tones, which may be very low tones, say 30 cycles per second, high tones above the normal range of speech or music, or by combinations of tones. In the figure, circuit 2 represents the source of the tones which are superimposed on the speech currents flowing in circuit 1. The grid of the control valve therefore receives voltages due to speech or music, and due to the interfering tone. At the receiver we have the ordinary tuning circuits, but if these alone were used, the speech heard would be unrecognisable, owing to the strong tones present with the speech. A filter, F, is therefore connected in the receiver. The purpose of the filter is to prevent the passage

A USEFUL POCKET FOLDER.

The Marconiphone Co., Ltd., have for issue a folder giving in brief operating instructions for the valves in general use.

This folder, one side of which is reproduced here, should prove an indispensable guide to all valve users.

THE MEASUREMENT OF SMALL CAPACITIES.

The usual bridge method is employed, and the variable standard capacity comprises two condensers connected in series.

IN wireless receivers there are certain very small capacities—for example the capacity between the electrodes of a three-electrode valve. These capacities may be of the order of a few micro-microfarads, or as small as 1 micro-microfarad or less, so that they cannot be measured by ordinary bridge methods; but they often play an important part in the operation of the set. Hence it is important that they may be determined accurately.

A bridge* found very convenient for this purpose is shown diagrammatically in the figure.

A difficulty which arises is the need of a variable standard of capacity which is capable of extremely fine adjustment, and which has a very open scale already calibrated. For such a standard two condensers connected in series may be employed, the capacity of one being large compared with that of the other.

If K is the capacity of the combination, then

$$K = \frac{cC}{c+C}$$

If now $\frac{c}{c+C}$ is arranged to be 0.1, then

if C is changed by 1 micro-microfarad, the capacity of the combination is changed by 100th of this amount. If C is an ordinary variable air condenser, calibrated to read micro-microfarads directly, then by putting a suitable small condenser in series with it, the scale of C may be made direct reading in hundredths or even thousandths of micro-microfarads for small changes of capacity of the combination.

The condenser to be tested (C_5) is connected by means of a pair of rigid leads in arm No. 1 of the bridge, in parallel with the standard condenser K_1 , made up of two condensers, c_1 and C_1 .

Arm No. 2 of the bridge is practically a duplicate of arm No. 1. Arms 3 and 4 consist

of non-inductive resistances, R_3, R_4 , each of 5,000 ohms, and in parallel with one of these is a small variable condenser, C_4 , which is for the phase angle adjustment. These resistances and condenser C_4 are all enclosed in metal screens, which are connected to the earthed point B of the bridge. The screens for the large condensers C_1 and C_2 are connected to the point A . The screens of c_1 and c_2 are connected to the points E and F respectively. These condensers must be placed as far away from the observer as possible, so that their capacities to earth are as little as possible affected by his movements.

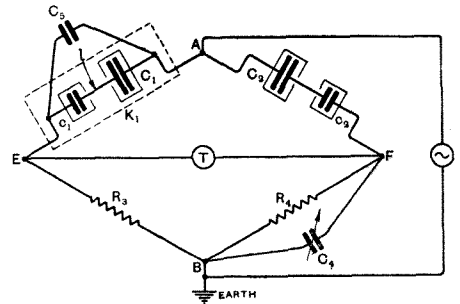

Connections of the capacity bridge.

The voltage applied to the points A and B is raised until the sensitivity is sufficient, the voltage which can be applied being only limited by what the condensers will stand. Several hundreds of volts may be used quite safely in nearly all cases. The bridge takes very little power, and thus a very small transformer is sufficient to step up the voltage to the required amount.

In practice the leads to the bridge may be connected to a coil of several henries inductance, and this coil coupled to the inductance coils of an oscillating valve set until the required voltage is obtained. The capacities c_1 and C_1 include the capacity between the lead l and the screen of the condensers. The leads should be of fine wire, and this lead capacity should be included when c_1 and C_1 are calibrated.

* Proceedings of the Physical Society of London: "A Method of Measuring Very Small Capacities."

NOTES & NEWS



The opening of the first regular wireless service between Sweden and America took place on October 31st, messages being exchanged between Varburg, near Gothenburg, and Long Island.

* * * *

On Friday, November 7th, the new premises of the Glasgow broadcasting station were opened. These are situated at 21 Blythswood Square and 4 Jane Street.

* * *

The Free Commune of the Island of Saint Louis, in the heart of Paris, is establishing a broadcasting station.

* * *

The new Dundee relay broadcasting station (2DE) transmits its first programme this evening (Wednesday).

* * *

BEAM WIRELESS IMPROVEMENTS.

An interesting announcement has been made by Senator Marconi, who has returned to London after an experimental voyage of three months. During this time he has been further developing his new "beam" system, with the result that the system will, he states, be effective for efficient telephone service over any distance by day as well as night.

NEW LOG RECORD.

The possibility that Australian amateur signals had been received in this country as early as October 6th by Mr. R. W. Galpin, 5 NF, was hinted at in our issue of October 29th.

We are now assured, however, by Mr. S. K. Lewer (G 6 LJ), who heard the transmission in question, that the nationality prefix was "U" not "A," which would at once identify the transmitter as American. Mr. Lewer adds that he has heard this station (U 2 ADJ) several times, and

that there can be no doubt as to its nationality. Mr. Lewer claims to have beaten the record log for one evening, claimed for Mr. W. A. S. Batement in our issue of October 29th. On the same night, i.e., October 12th, 6 LJ, using one valve, logged 93 American amateurs, included in all of the nine districts. Since the beginning of this year 730 different American and Canadian amateurs have been logged.

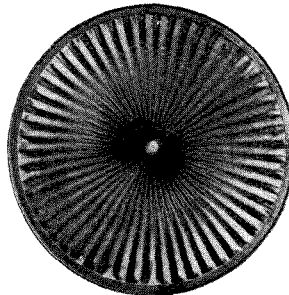

The loud speaker artistic. The Sterling "Primax" model in statuette form.

MODULATION SIGNS.

It is suggested by a French amateur that the following signs should be used in describing the quality of modulation in telephony transmission: M1—Speech indistinguishable; M 2—Speech broken up; M 3—Voice clear; M 4—Speech clipped; M 5—Speech very clipped.

FURTHER NEW ZEALAND SUCCESSES.

Good reception of New Zealand amateurs is reported by Mr. J. Allen Cash (2 GW), of Lymm, Cheshire. The loudest station is Z 4 AG, which, states our correspondent, can be easily read all over the room on the loud speaker, with a two-valve (0—v—1) receiver. A twelve-wire counterpoise is used, with an aerial 65 ft. high.

Another amateur to receive the New Zealand stations with almost daily regularity is Mr. A. Acland, in the Chatham neighbourhood, who uses a single-valve set.

A claim to have heard a New Zealand station as early as October 9th is forwarded by Mr. A. L. Carrad, of Wembley, who states that he heard Z 4 AK working with a French station at 6.45 a.m.

Mr. J. H. D. Ridley (5 NN), of South Norwood, first heard Z 4 AA, Z 4 AG, Z 4 AK on October 20th at 6.42 a.m. On the 26th Z 4 AA reported 5 NN's

signals as strong, but two-way communication was not effected owing to sunrise. 5 NN employs a Meissner transmitting circuit, his receiver being a Burndepth Ultra III, using detector and L.F. valves only. Mr. L. Heaton Armstrong, who has heard Z 4 AA, Z 4 AG, and Z 4 AK, reports that strongest signals are received from the first-named.

Working with Z 4 AA on October 30th, Mr. W. A. S. Batement (G 6 TM), was gratified to receive this message:— "You are the best station in G.B."

FRENCH PLEA FOR NEW RADIO REGULATIONS.

Wireless officers of the French Mercantile Marine are calling for an international radiotelegraphic conference on the use of wireless communication at sea, states our Paris correspondent. It is urged that the present regulations, formulated in 1914, have become obsolete owing to divergent national laws, and that complete revision is necessary.

METRONOME TUNING SIGNAL.

Instead of a tuning note, the Breslau broadcasting station uses a loud ticking metronome to enable listeners to tune in before the programme commences. It seems unlikely that this method can be as effective as the system used in this country.

CHINA'S NEW WIRELESS STATION.

The largest wireless station in China, and doubtless in the whole of the Far East, has just been installed at Shuang Chiao, near Peking. Its construction has been carried out by the Mitsui Bussan Kaisha under a contract made with the Chinese Government as far back as 1918. The delay is accounted for by material and racial difficulties. Material for the masts was hard to obtain locally, and the original design had to be altered several times to meet the constant desire of the authorities to give China the best possible installation for the money expended. It is said that the new station successfully violates some of the preconceived theories of radio engineers.

DENMARK CENTRALISING WIRELESS ORGANISATION.

To prevent unproductive competition, the Danish Government is now grouping under one organisation the three chief wireless stations of the country. These stations, all State-owned, are:—the Naval radio station, hitherto under the control of the Shipping Department; the Lyngby Station, operated by the Posts and Telegraphs Department; and the Military Station at Ryvang. An additional station to be included under the central organisation will be that now under construction by the Navy near Copenhagen.

Wireless is now making great progress in Denmark, and the development of broadcasting is opening up a new market for all kinds of apparatus and accessories.

EXTRAORDINARY SWEDISH TRANSMISSION.

An astonishing report of reception of a Swedish amateur transmission reaches us from Mr. F. H. Tyler (2 ASH), of Kirby Muxloe.

On October 12th, Mr. Tyler heard SMXX testing on 60 metres, calling "CQ de AGA (Göteborg)."

A report was at once sent to the Swedish station, with the information that his signals were heard at R 6 strength on detector and 1 L.F. The reply came that on the occasion referred to SMXX was working with an indoor aerial and the counterpoise lying on the floor! The power input was not stated, but the antenna current was given as only 0.3 ampere.

If any other reader heard this transmission his report would be interesting. The owner of SMXX is Nils Ericsson, c/o Aga Lux, Göteborg, Sweden.

FRENCH 8 SSU.

The French transmitter 8 SSU (Adjutant Bocquet), desires English amateurs to know that his new address is 42e Gnie, Bonn, R. Rhine, Rhenland. He has recently increased the power of his station to 50 watts, and is glad to answer all QSL cards.

HAVE YOU HEARD THE GONG?

When the Hamburg broadcasting station is about to commence its programme, a large brass gong is sounded. Two strokes on the gong announce an interval of two minutes, while another stroke signifies the beginning of a new piece.

We understand that an English news bulletin is broadcast nightly at 10.50 from the Hamburg station, which transmits on 387 metres.

AMERICAN AMATEURS AND SOLAR ECLIPSE.

An appeal to American amateurs to stand by during the solar eclipse of January 24th, 1925, appears in the November issue of the *Scientific American*. On that date the sun will be totally eclipsed over a large section of the U.S., extending from Cape Cod and Long Island to the northern boundary of Minnesota.

During the period of the eclipse a special effort is to be made to discover to what extent, if at all, wireless signals are influenced by the moon's shadow. American amateurs are asked to check the results obtained during the eclipse in California, last year, when the intensity of wireless signals increased, only to diminish in strength after the eclipse was over.

AMATEUR TRANSMITTING IN AUSTRIA.

Austria can now be added to the list of European countries which are just realising that the wireless amateur should be encouraged and not hindered. As a result of the new regulations, steps are being taken to form an Austrian Club for transmitting amateurs, and the organisers wish to have addresses of British amateurs willing to conduct tests with their members.

British transmitters with a knowledge of German or Esperanto who would like to be put into touch with Austrian fellow-amateurs, are requested to communicate with the Hon. Secretary, Internacia Radio-Asocio, 17 Chatsworth Road, London, E.5.

DO YOU HEAR ARGENTINE AMATEURS?

Amateurs who have received Argentine CB 8 or any other Argentine amateur transmitters are requested to communicate with Mr. Adrian B. Jones, Gothic Cottage, Malvern Wells, Worcestershire, who is a representative of the Radio Club of Argentina.

UNSOLVED PROBLEMS OF WIRELESS.*

By R. H. BARFIELD, M.Sc.

THE title of this article may be misleading, because I do not intend to discuss all the unsolved problems of wireless, but I am only going to deal with four, which are as follows :

- (1) Why is long distance wireless possible at all ?
- (2) Why are signals stronger by night than by day ?
- (3) Why do direction finding stations experience large errors by night, while the errors by day are practically negligible ?
- (4) Why does the phenomenon known as fading occur ?

These are the four problems which I wish to discuss.

Turning to the first problem I myself find it a very striking fact that although at present wireless communication is almost as common as line telegraphy, yet why it is possible at all must still be considered in the nature of a mystery. The reason for this can be shown by a diagram in a very simple manner (Fig. 1).

The question is whether a transmitter situated at London should be able to communicate by wireless with a receiver at New York. Theory informs us that in a homogeneous medium electromagnetic waves travel in a straight line. The straight line from London to New York (AB) passes through the opaque earth. The most favourable straight line for the waves to take would be the line AC, tangent to the earth at London, and these waves would pass 3,000 miles above New York. Therefore there are obvious reasons why wireless waves would not be expected to be able to travel from London to New York.

When in contradiction to this, the possibility of long-distance wireless communication was definitely established an explanation for the fact was at once sought. At

first three explanations were brought forward but they did not involve any new conceptions. They may be called the resistance explanation, the atmospheric explanation and the diffraction explanation. In the first case the argument was based on the well-known fact that the resistance of the earth causes the waves which are passing over the earth's surface to bend slightly forward. This bending can be shown to have an effect in causing the wireless waves to bend round the earth and so affords a possible explanation of the anomaly, but

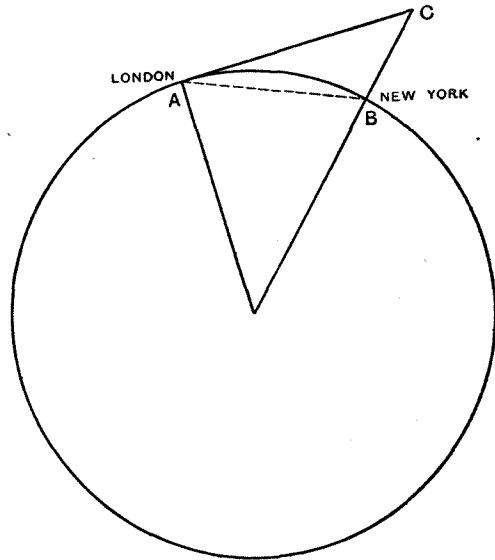

Fig. 1. A diagram which raises the question why a transmitter in London is heard in New York.

when the problem was worked out mathematically and calculations made, it was shown that although there was some effect it was an entirely negligible one, and failed entirely to account for the observed results.

The second explanation, having thus dismissed the first one, is the atmospheric explanation, and it is suggested that since the atmosphere surrounding the earth is not

* A lecture delivered before the Radio Society of Great Britain at an Ordinary General Meeting held on October 22nd, 1924, at the Institution of Electrical Engineers.

a homogeneous medium, the waves will not travel in a straight line. This lack of homogeneity is due, amongst other things, to the change in pressure which occurs with height. This change of pressure will produce a change in the dielectric constant so that the atmosphere will act as an optical lens and cause the waves to bend round the earth. But again, on attacking this problem in an analytical manner, it was possible to show that though the effect, did exist it could not by any means account for the strength of signals which are actually received over long distances.

The third explanation, which is the diffraction hypothesis, is much more difficult to dispose of. The argument here again is that we can only assume that the waves will travel in a straight line in a uniform medium. In the presence of an opaque body, electromagnetic waves are diffracted or bent.

The earth may be considered as an opaque body placed in the path of the wireless waves and therefore we must expect some diffraction and bending of the light due to the presence of the body of the earth. Again, it was only possible to settle the question by mathematics. The problem was recognised as a very interesting one as soon as it arose, at the time when Marconi succeeded in spanning the Atlantic by wireless in 1902. Many mathematicians of first rank attacked the problem, which appears to have been a very abstruse one indeed, for it took no less than 15 years for a general agreement to be arrived at between these authorities. We may now say, however, that they have arrived at a practically unanimous agreement, and the verdict is that diffraction is entirely unable to account for the passage of waves around the earth. We are enabled to arrive at the extent of the discrepancy from their calculations. As an interesting example the measured intensity of signals at a receiving station at Darien from a transmitter at Nauen in Germany was found to be more than two

million times as great as the theoretical value based on the diffraction theory. This is a very large discrepancy indeed, and thus we have a complete failure to account by known properties of the earth or of the surrounding atmosphere, for the phenomenon of long distance propagation and new hypotheses must be introduced to account for the effect.

Oliver Heaviside appears to have realised this very early, and to have dismissed the diffraction theory in his own mind without resort to mathematics. He suggested, as early as 1900, that there must be something in the upper atmosphere which accounts for the success of long distance wireless. He

suggested the existence of a surface, concentric with the earth, at a height of about 100 km., which would reflect the waves back to earth again, thus enabling them to bend round the earth.

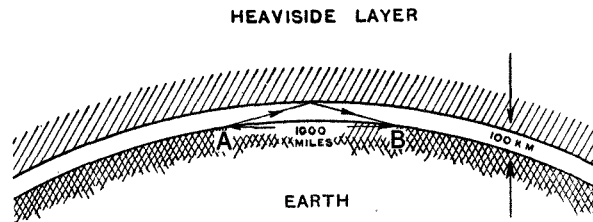

Fig. 2. Showing how the Heaviside Layer is supposed to act.

Fig. 2 provides a rough idea of how the Heaviside layer might be supposed to act. It will be seen that a wave travels from A to B, and it gets round the bend of the earth by being reflected from the upper layer. As to the nature of this layer it is supposed to consist of a highly ionised mass of attenuated atmosphere, this ionisation producing a degree of conductivity sufficient to give the layer its reflecting properties. The presence of such ions are strongly evidenced by other considerations of a meteorological nature. We are quite unable to account for the phenomenon of the Aurora without assuming the presence of an ionised upper atmosphere, and I also understand that the phenomenon of magnetic storms can be explained on the assumption of currents travelling in a conducting upper atmosphere. It is very difficult to criticise this theory of an upper layer, chiefly because it is at present only a nebulous speculation. It is interesting, however, to take the figures of Professor Watson, who calculated that assuming the layer had a height of 100 km., and had a conductivity about the

same as dry earth, it would very well account for all the observed facts. This, of course, was at the time he made the calculation in 1918. Whether it would do so in the light of recent events it is difficult to say.

I find it rather difficult to conceive why this upper layer should have the sharply defined lower surface which is necessary to account for some of the phenomena. It is, however, the only plausible theory existing at present which has not been destroyed by argument, and it is supported by the fact that the other problems I am going to deal with seem to require solutions on very much the same lines.

The second problem deals with the increase of signals at night. This phenomenon is very well established. It must be familiar to all those who have experimented in any wireless reception, but it does not occur at very close ranges. It is also very much more marked on short waves than on long waves, and I understand that on the longest waves it is scarcely noticeable at all. Since the tendency now is to use shorter and shorter waves, it is natural that the phenomenon should have become more and more prominent and in the last year or so the most striking examples have occurred. I refer to the successful establishment of communication across the Atlantic by amateurs. These results provide very striking examples of [the] increase of signals after darkness.

one. The most interesting thing about these problems is the entire failure to find causes in the earth which can account for it. If we examine the factors near the surface of the earth which might influence the propagation of waves—which might hinder them in the daytime and help them at night—we cannot find any single agency which could give rise to the effects which are observed. Changes of conductivity of the atmosphere, changes in the very slight trace of ionisation present even in the lower atmosphere, changes of pressure, changes of temperature and changes of resistance on the ground surface, all these can be shown to have entirely negligible effects. It is impossible to associate with such changes which may occur in these factors, the very large and persistent effects of signals increasing at night. The inevitable conclusion then is that we cannot find a cause at or near the surface of the earth, and if we cannot find it in the explored regions of the atmosphere, we can only conclude that it must lie in the unexplored regions. If we admit that in the upper atmosphere lies the solution of the problem, then the waves which experience this phenomenon must have travelled through the upper atmosphere on their way to the receiver. If they have travelled through the upper atmosphere they must have been reflected down from it or bent down in some way in order to arrive again at the receiver. It is easy to understand how they can get up to the higher strata of the atmosphere, but to imagine them getting down again we must suppose some sort of reflecting layer. We are thus led back to the second problem, to the existence, presumably, of the Heaviside layer in some form or other. Unfortunately, an upper reflecting layer is not sufficient in itself to account for the fact that signals increase at night. An extremely plausible hypothesis has been formulated by Dr. Eccles, in which it is clearly shown how the change between day and night is produced. The phenomenon of increased signals at night does seem to necessitate the existence of some reflecting surface in the upper atmosphere.

The third problem is that of night effect experienced in wireless direction finding. All those who have had experience with direction finding apparatus are well aware that whereas by day wireless direction finders obtain a very high degree of accuracy,

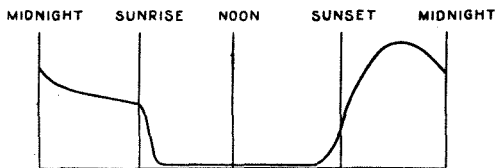

Fig. 3. A curve representing the measured intensity of short wave signals transmitted throughout 24 hours from Poldhu to America.

Fig. 3 shows how the signals increase as night comes on. It represents the measured intensities of the signals transmitted from the Marconi short wave station at Poldhu, and received in America. It is very striking to see how, during the daytime, the signals remain very weak, and how they increase at sunset and remain at a high value all night.

These examples I have given are taken from hundreds of others, and we must conclude that the phenomenon is a very fundamental

at night they are subject to large errors, and variable errors which occur at all sorts of irregular times and in a very irregular manner. The errors are known to amount in some cases to as much as 90 degrees, and may occur on any night. Fortunately for navigation, ships do not usually require to employ direction finding for a greater range than 100 miles, and within this range over sea the errors are practically never experienced. Like the phenomenon of increased signals, it is only experienced over comparatively long ranges.

In the course of this research conducted by Dr. Smith Rose under the direction of the Radio Research Board, curves were obtained showing the results of observations made on a direction finder at Bristol University over a period of 24 hours. The observations were made at several stations at a time, the transmitters being the German stations Nauen and Königswusterhausen, and three of the Marconi stations at Ongar in Essex. From these it was possible to see at a glance that during the day the errors are extremely small and are, in fact, practically negligible so far as direction finding purposes are concerned. Just before sunset, however, the errors commence, and they get greater and greater until a few hours after sunset, when they are very great indeed. Lasting all night until sunrise, they then disappear as mysteriously as they arose.

It was found from these investigations that direction finding errors were present on every wavelength investigated and very little difference could be detected between the various wavelengths. The fact that these curves have been selected from hundreds of others, is enough to show that this phenomenon is of a very fundamental nature.

Before discussing further this problem of the variation of wireless bearings at night I will turn to the fourth problem—that of the existence of fading. This phenomenon must also be very familiar to amateurs, and anyone who receives broadcasting stations over long ranges. It is a sudden dying away of signals, and again, only occurs at night over long ranges. Very little can be said about the nature of this phenomenon because it is so simple in its nature that there is not much to describe. It is a very striking thing, however, to hear signals suddenly fade right away and then burst

out again as strong as they were before, but beyond the fact that it does occur, little is known about the laws which govern it.

I think there are many points which seem to show that these last two problems are due to the same cause. Thus, for instance, if fading is present, variation in directional bearings is also very likely to be experienced. Again, the important thing in my mind with regard to the phenomena is that once more we look in vain for variations of some property at or near the surface of the earth or in the lower atmosphere which may account for them. Once more, therefore, we are led to the conclusion that since we cannot find the cause in the lower strata of the atmosphere, it must lie in the upper unexplored portion. The lower regions of the atmosphere, I suppose, are well known up to heights of some 10 or 15 miles, so that it is beyond these heights that we must look for the solution.

In conclusion, I have dealt with four problems and the chief thing I have wished to show is, that they are definitely established as forming a fundamental part of the phenomenon of the propagation of wireless waves. In order to do so I sought to show the most effective examples of each of them. It was accordingly rather a surprise to me that in the last few days the most striking illustration of the first two of the problems should have come to light. I refer to the successful establishment of communication between England and New Zealand.

I have arrived at the conclusion that we can only hope to find a solution for these problems, by looking to the upper atmosphere. Each in turn has led to this conclusion. As to the nature of this surface in the upper air, the existence of which seems now almost definitely established, I must submit my opinion that we are still very much in the dark. I think there is a tremendous need for more data of an experimental nature. Each of these phenomena which I have described should be examined in as quantitative a manner as possible, and on as large a scale as possible. Only by doing this can we get sufficient information on which to formulate satisfactory theories. Meanwhile, of course, it is possible that, apart from wireless, those physicists interested in the structure of the earth may find a more direct means of examining the content of the upper atmosphere.

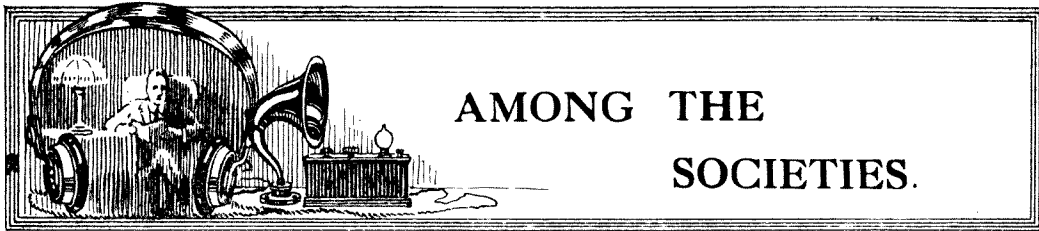

AMONG THE SOCIETIES.

How a knowledge of any of the other sciences can be very beneficial in the study of wireless was shown by Mr. A. E. Turville, lecturing before the Northampton Radio Society on Thursday, October 16th. The study of the laws of reflection of light served to explain in large measure the newly-introduced directional "beam" system of transmission, and the lecturer provided some interesting details of the experimental work proceeding at Poldhu.

* * * *

The reception of waves of the order of 5 to 10 metres was dealt with by Mr. Cole in an interesting lecture given before the Tottenham Wireless Society on October 15th. Mr. Cole's subject was "Short Waves," and in addition to his remarks on the ultra-short waves, the lecturer gave valuable information on 100-metre working, describing his own apparatus for this purpose and the results obtained.

The supersonic heterodyne also received attention and formed the subject of an informative discussion.

* * * *

At a recent meeting of the Kensington Radio Society, the President, Mr. J. H. Reeves, gave an enlightening discourse on "Fine Wire Coils." This was followed by a demonstration of the method of constructing formers and of winding coils.

* * * *

The subject of crystal reception, which has gained increased interest during the last few months, was dealt with in an interesting talk given by Mr. E. P. Bateman before the Southampton and District Radio Society on October 7th.

Mr. Bateman has been elected Hon. Secretary in place of Lt.-Col. M. D. Methven, O.B.E., resigned.

* * * *

At the second annual meeting of the Beckenham and District Radio Society, Mr. J. T. Butterfield resigned the position of Hon. Secretary, his successor being Mr. A. West.

The Society welcomes new members, and applications will be forwarded if addressed to the Editor of this journal.

* * * *

A monthly series of lectures on "Current Topics" has been instituted by the Borough of Tynemouth Radio and Scientific Society, the first lecture being given by Mr. Scott, who dealt first of all with wireless symbols.

He then spoke on high tensionless receivers, this being followed by a discussion on the "Beam" transmitter, which evoked considerable interest.

Radio Society of Great Britain.

T. AND R. NOTES.

A rather interesting discussion must arise out of the recent achievements of British amateurs as to which way signals travel round the world. It has been suggested that they proceed in the direction which is darkest, *i.e.*, via the American Continent. This does not explain why you can get a report from a U.S. amateur on the East Coast saying your signals are weak, when immediately afterwards you get in touch with a New Zealand amateur who states that your signals are too loud for the headphones. This was actually experienced by me several times. It has been suggested also that these signals travel *through* the earth. If the direction of our signals could be proved the results of these tests would be all the more valuable.



The reception of broadcast programmes is now permitted at stated times on board ship. Our photo shows the broadcast receiver on the s.s. "Perth."

Amateurs will probably be wondering what has become of **Z 4 AK**, I enquired myself of **4 AG** and was told that **4 AK** is very busy trying to get a 250-watt tube to oscillate. I heard him start up once, but he soon collapsed.

A new-comer into the field is **2 AC**, who, though weak, puts out a good signal.

I would again ask British amateurs to keep above 90 metres so as to leave the field below free for distant DX. I have received reports from A.R.R.L. headquarters, requesting us to keep above 90 metres at all costs, as the disturbance below is terrific.

The Americans are now getting busy and can be heard and worked most mornings up to 0800 G.M.T. They are all on the look out for us, and the 4th district is particularly assertive, represented especially by our old friends of last year, *viz.*, **4 IO** and **4 FQ**.

The 4th district and 5th in Canada are going all out this winter to work us, but this will have to be after 0530 (G.M.T.) owing to difference in time.

Arrangements have been made with New Zealand amateurs to transmit from 5 p.m. to 7 p.m. every Sunday, as they are particularly keen to find out whether it is possible to communicate this way round, and I shall endeavour to see if permission can be obtained from the Postmaster-General for our amateurs to use increased power permits at 7 p.m., should anyone hear a New Zealander calling.

We still want more reports, and the reports so far received are most disappointing considering the excellent DX which has been done this last month.

Don't be put off by the cold mornings; get up and start the old set going and be rewarded by joining in what will prove to be one of the most wonderful years that radio amateurs have ever experienced, or can possibly ever experience, unless we succeed in hearing our signals returning round the world!

Remember, the Argentine amateurs have yet to be worked, also the Mexican, and this should be possible very soon. So keep a watch and remember that there are prizes offered this year.

Members of the A.R.R.L. have offered their heartiest congratulations to the British amateurs for their splendid achievement, in establishing two-way communication with N.Z. amateurs.

GERALD MARCUSE

(Hon. Secretary, Transmitter and Relay Section, Radio Society of Great Britain).

NEW SWEDISH TRANSMITTERS.

We have received the following list of new call signs allocated to Swedish amateur transmitters. This list supplements those which have already appeared in our issues of September 24th and October 8th.

SMYE	Uno Sarnmark, Skeppsbrotaplatsen 1	Göteborg
SMYF	Nils Paul Renqvist, Villa Talltorp	Aby socken
SMYG	Nils Paul Renqvist, Drottninggatan 1	Norrköping

SMYH	Herbert Martensson, Rundelsgatan 27	Malmö
SMYI	Elof Jullander	Bofors
SMYJ	Gerhard Astrom	Bollnas
SMYK	Gustaf Berger, Bergdalen 3	Linköping
SMYL	Nils Petersson, Söderslotts-gatan 5	Trälleborg
SMYM	Erik B. and Gosta Nestius samt Nils Pichler	Trans Station
SMYN	Erik B. and Gösta Nestius samt Nils Pichler, Kvarteret Bullerbacken 8	Lidingön
SMYO	Erik B. and Gösta Nestius samt Nils Pichler, Kvarteret Stangslet	Appelviken
SMYP	Knut Hansson, Svartbacksgatan 28	Uppsala
SMYR	Bror Agren and Erik Sjöström, Söderslotts-gatan 10	Trälleborg
SMYS	Per Fritiof Gronlund	Leksand
SMYT	John Nordin	Finspong
SMYU	Bengt Welin, Adolf Fredriks Krykogata 9 B	Stockholm

WIRELESS IN CHILI.

In Chili public interest in broadcasting has grown to such an extent that although two years ago the country could boast of not more than half a dozen receiving sets, 6,000 receiving sets are now to be found in Santiago alone. A number of transmitting stations are already in existence and wireless dealers are reported to be doing exceptionally well.

FORTHCOMING EVENTS.

WEDNESDAY, NOVEMBER 12th.

Radio Society of Great Britain. Informal Meeting. At 6 p.m. At the Institution of Electrical Engineers. Talk and demonstration on "A Dynamical Model of an Oscillating Circuit." By Mr. R. C. Clinker.

Radio Research Society, Feckham. At 44 Talfourd Road. Lecture: "Rectifiers." Discussion and Demonstration on "Transformer v. Resistance and Choke L.F. Coupling."

Streatham Radio Society. At 35 Streatham High Road, S.W. Lecture: "Valves." By Mr. W. P. Wilson.

Bristol and District Radio Society. Wireless Lecture No. 3. By Mr. W. A. Andrews, B.Sc.

Edinburgh and District Radio Society. At 8 p.m. At 117 George Street. Lecture: "Western Relay Conversion." By Mr. W. Winkler.

THURSDAY, NOVEMBER 13th.

Bournemouth and District Radio and Electrical Society. At 7 p.m. At Canford Hall, St. Peters Road. Experimental Night. Lecture: "C.W. Reception and Heterodynes." By Mr. W. A. Peters, B.Sc.

Derby Wireless Club. Lecture by Mr. A. T. Lee.

Luton Wireless Society. At 8 p.m. At the Hitchin Road Boy's School. Experiments and Demonstration.

West London Wireless and Experimental Association. At the Belmont Road Schools. Lecture: "Constructional Details, Part II." By Mr. J. F. Bruce.

FRIDAY, NOVEMBER 14th.

Bristol and District Radio Society. Demonstration and Address by Sterling Telephone Co., Ltd.

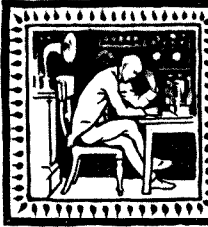

READERS PROBLEMS

Readers desiring to consult the "Wireless World" Information Dept. should make use of the coupon to be found in the advertisement pages.



A THREE-VALVE RECEIVER FOR TELEPHONY.

A READER has asked for a design for a three or four-valve receiver suitable for the reception of telephony, with the minimum amount of distortion. A copy of the circuit diagram is reproduced below.

It was decided to use a carborundum crystal for rectification, as a detector valve working in conjunction with a grid condenser and leak is frequently a source of distortion, particularly in the case of very strong signals. Of course, it would be possible to utilise the lower bend of the grid voltage—anode current characteristic of the valve for

a high amplification factor, will give very good results in this position. In order to ensure that no rectification shall take place in this valve, a grid battery of one or two cells should be connected, to prevent the flow of grid current. The aerial and grid coils could be coupled together, if necessary, to obtain reaction, but this measure should not be adopted unless absolutely necessary to obtain an adequate signal strength. If the receiver is situated near to the broadcasting station, and the volume of sound is unnecessarily large, it may be controlled by connecting a variable high resistance between the grid of the first valve and —L.T. This may

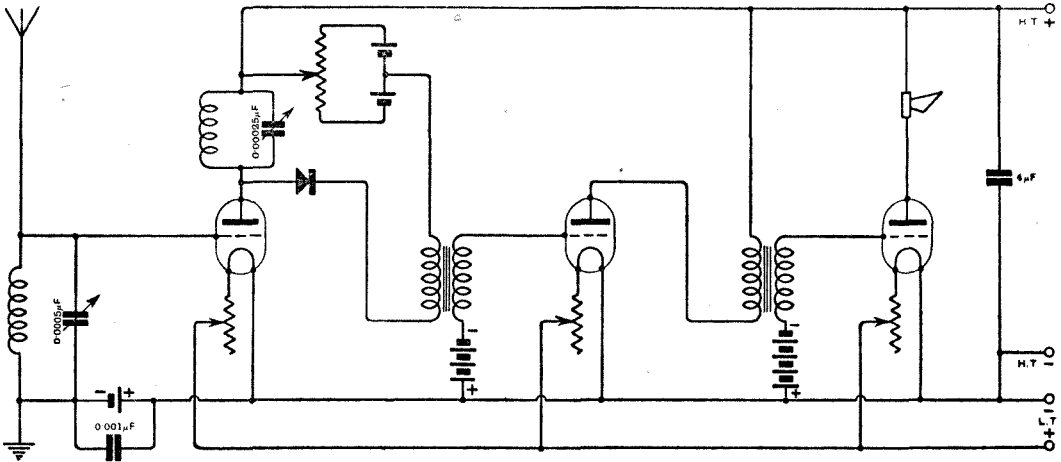

A three-valve receiver for telephony.

rectification, without the use of a grid condenser and leak, but in most cases the curvature is not sufficiently sharp to give good results unless several stages of H.F. amplification are used to increase the amplitude applied between the grid and filament of the detector valve. In the case of the crystal rectifier, on the other hand, a series of crystals may be tried until one having a suitable characteristic is found. The carborundum steel detector is very reliable, and will give service for a long period without adjustment. In order to obtain an increased amplitude of signals for application to the crystal, a single stage of H.F. amplification is employed. A D.E. 5.B valve, which has

decrease the selectivity of the aerial circuit and permit interference from other stations, since the anode circuit of the first valve is also highly damped by the resistance of the crystal detector. In this case the control resistance may be connected across the loud speaker or across one or other of the L.F. transformers. The latter method should not be used if the results obtained with the leak connected across the first valve are satisfactory, as the frequency characteristics of the transformers may be changed to a slight extent by connecting the resistance in parallel with one of the windings. For a similar reason it will be noticed that the usual by-pass condenser across the

primary winding of the first transformer has been omitted. If a condenser is found to be necessary, its value should be very carefully chosen.

With the introduction of special L.F. transformers, such as the Marconiphone "Ideal" transformer, the L.F. valves may be transformer coupled without introducing any appreciable distortion, while the degree of amplification per stage, and the smaller H.T. battery necessary, form distinct advantages over the resistance-capacity method of coupling. It is important to use valves having characteristics specified by the makers of the transformers, in order to obtain distortionless results. If the first L.F. valve is a D.E. 5 and the second an L.S. 5, the first interval transformer may have a ratio of 4:1 and the second a ratio of 6:1. An L.S. 5 type valve is recommended for the last stage, not by reason of the large volume of sound it is capable of delivering, but because a considerable portion of the straight part of the valve characteristic lies on the negative side of the zero grid bias line, and a fair degree of latitude is available before distortion can be caused by the curvature of the characteristic or by grid currents. An H.T. voltage of 120 volts may be applied to all three valves, and under these conditions a negative grid bias of 4.5 volts will be required for the D.E. 5 valve, and between 8 and 9 volts for the L.S. 5 valve.

telephones may be used; while in the third telephone jack, with both valves inserted, a loud speaker may be used. As the same H.T. voltage is applied to both L.F. valves, a common grid bias battery may be used.

RELATIVE SIZE OF AERIAL AND ANODE TUNING COILS.

THERE is no fixed relation between the sizes of coils used in the aerial and anode circuits of a receiver. The size of the anode coil can be fixed with a fair degree of accuracy, but the number of turns required in the aerial circuit will depend upon the dimensions of the aerial and the position of the aerial tuning condenser.

A reader has noticed a circuit in which the aerial coil is larger than the tuned anode coil, and asks if this is contrary to first principles.

It very rarely happens that the aerial coil is larger than the anode coil, and this relation can exist only when the effective capacity of the aerial circuit is less than the tuning capacity connected in parallel with the anode coil. When a series aerial tuning condenser is used, it is quite common to find that the same size of coil is required for both circuits. When the A.T.C. is connected in parallel, on the other hand, the aerial coil will be smaller than the anode coil. In the anode circuit, best results are obtained with a large coil and a small tuning capacity.

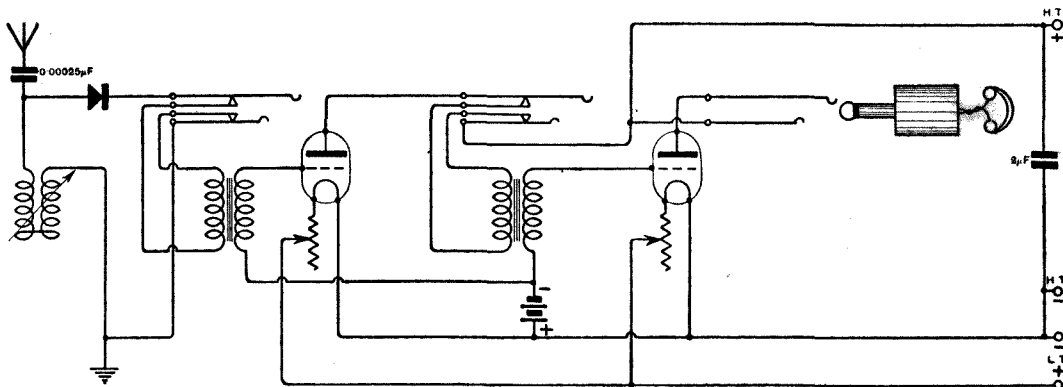

A crystal and two-valve receiver.

A CRYSTAL AND TWO-VALVE RECEIVER.

A DIAGRAM is given above of a wireless receiver suitable for use within a short distance of a broadcasting station. The aerial circuit is tuned by means of a variometer, and a fixed series condenser of $0.00025 \mu\text{F}$. A crystal rectifier is used, and is followed by two stages of L.F. amplification.

The simplest method of switching a receiver of this type is to employ telephone jacks. With the telephone plug inserted in the first jack, good results will be obtained with a single pair of telephones. With the telephones in the second jack, and the valve switched on, three or four pairs of

SOURCES OF DISTORTION.

MANY amateurs have found the difference in quality between resistance and transformer coupling so marked that they have decided definitely to abandon the latter method for the future. Before doing this they should make quite certain that the distortion is due to the coupling and not to the valves themselves. With transformer coupling the valves may have been overloaded owing to the high amplification per stage obtained with this method. On changing to resistance coupling, the variation of grid potential at each stage is reduced and amplitude distortion is minimised if not eliminated.

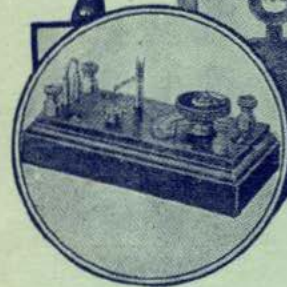
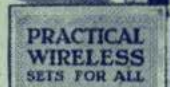
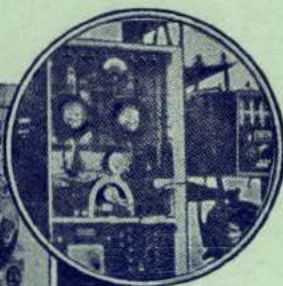

The ideal way to progressive wireless construction.

RADIO is essentially a progressive hobby. Half the attraction lies in the advancement from the chrysalis stage of the Crystal Receiver to a "Five-Valver" or even a full-blown transmitter. Yet your ultimate success depends upon the books which guide your steps along the path of wireless progress. You cannot do better than put your trust in *Wireless Press* publications. With their aid it is a simple matter for you to obtain a complete knowledge of the subject from A to Z.



The Wireless Press are the pioneers of authoritative wireless literature, catering for every possible need.

- "Crystal Receivers for Broadcast Reception." By PERCY W. HARRIS. Price 1/6. Postage 2d.
- "Construction of Amateur Valve Stations." By A. L. M. DOUGLAS. 1/6. Postage 2d.
- "Practical Wireless Sets for All-Home Construction Made Easy." By PERCY W. HARRIS. 1/6. Postage 2d.
- "The Wireless Press Enzi-Wiring Series":
 1. A Three-Valve Portable Receiver. By H. S. POCOCK.
 2. A Three-Valve Receiver (Cabinet). By F. H. HAYNES.
 3. A Two-Valve and Crystal Reflex Receiver. By W. JAMES. 2/- each. Postage 2d.
- "The Amateur's Book of Wireless Circuits." By F. H. HAYNES. 3/6. Postage 6d.
- "The Home Constructor's Wireless Guide." By W. JAMES. 3/6. Postage 3d.
- "Radio Experimenter's Handbook." Two Parts. 3/6 each. Postage 4d. each.
- "The Wireless Telephone: What It Is and How it Works." By P. R. COURSEY. 2/6. Postage 3d.
- "Wireless Telephony: A Simplified Explanation." By R. D. BANGAY. 2/6. Postage 3d.
- "The Elementary Principles of Wireless Telephony." By R. D. BANGAY. 7/6. Postage 6d.
- "Electrons, Electric Waves and Wireless Telephony." By J. A. FLEMING. 7/6. Postage 6d.
- "Wireless Valve Transmitters: The Construction of Small Power Apparatus." By W. JAMES. 9/- . Postage 9d.

THE WIRELESS PRESS, LIMITED,
12-13 Henrietta Street, Strand, London, W.C.2

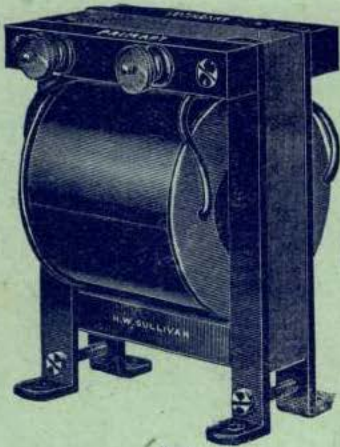

EFFICIENCY

QUOTATIONS FOR ANY
CLASS OF RADIO APPARATUS
ON APPLICATION

RELIABILITY

**CLEAR AND
UNDISTORTED
MAGNIFICATION**

IS ASSURED BY
THE USE OF

**SULLIVAN
INTER-VALVE
TRANSFORMERS**

PRICES—

20/- & 35/-

SPECIAL PRICES FOR QUANTITIES

H.W. SULLIVAN, LTD.

FORMERLY H.W. SULLIVAN, FOUNDED IN 1900.

Works and Showrooms: LIVERPOOL HOUSE, MIDDLESEX ST., LONDON, E.1. Phone: Avenue 4871
Offices: WINCHESTER HOUSE, LONDON, E.C.2. London Wall 3518

Telegrams: "Deedbeat", Stock, London.



Printed by Sanders Phillips & Co., Ltd., Chryssell Road, London, S.W.9, for the Proprietors and Publishers, The Wireless Press, Ltd., 12-13 Henrietta Street, London, W.C.2; Sydney, N.S.W., 97 Clarence Street; Melbourne, 422-24 Little Collins Street; New York 326 Broadway.



THE WIRELESS WORLD

AND
RADIO REVIEW



PRICE 4^D NET

LOUD SPEAKERS
WITH
PAPER DIAPHRAGMS

REFLEX
REINARTZ CIRCUITS

No. 275 [No. 5
Vol. XV]

INTERNATIONAL BROADCAST TESTS



NOTICE OF REMOVAL TO 15 GREAT SAFFRON HILL, LONDON, E.C.1

As the lease of our old premises recently expired, we decided to take the opportunity to move into more conveniently-planned premises, which will permit us to secure better facilities, both for our Repair Orders and also our regular Instrument work. For some time past we found great difficulty in handling satisfactorily an increased volume of business in our old position, but we hope we have solved this problem by the new Laboratory we have planned and completed. As soon as we have overcome the disorganisation due to moving our plant, we hope to place our Repair Orders upon pre-war delivery

basis, when about five or six days was the time limit for all Repair Orders, with the exception of our very accurate Model 5 Laboratory Standard Instruments.

It was not easy to find premises sufficiently large for our Laboratory and within reasonable distance of our old position; but we succeeded finally in securing these at 15 Great Saffron Hill, which is our new address.

We are confident that this change will enable us to give our clients a much improved service, and at the same time we have secured better working conditions for our employees.

In order to avoid unnecessary trouble and delay, we would suggest that you make a special note of the change of address.

WESTON ELECTRICAL INSTRUMENT CO., LTD.
15 Great Saffron Hill, London, E.C.1

Telephone: Holborn 2029.

Telegrams: "Pivoted, Smith, London."

THE WHITE CITY RADIO EXHIBITION NOVEMBER 15th to 29th

STAND
57

ABGAR
Radio Receivers
De-Luxe

A range of crystal, 2, 4 and 5 valve instruments, designed for the discriminating listener. The larger models will receive American broadcast on the loud speaker under favourable conditions, in addition to the European concerts. All prices include a complete and liberal equipment.

**ALL OUR RECEIVERS CARRY OUR
GUARANTEE AGAINST FAULTY
WORKMANSHIP.**

Traders and Factors should write for particulars of our agency and distributing propositions.



Regd. Trade Mark.

Mr. D. GLOVER,
23 Collings Park,
Plymouth,
and of Calcutta—writes:—

I have consistently received several American broadcast Concerts, particularly **WBZ**, Boston, Mass., and **KDKA** Pittsburgh, also **WJZ**. The two former stations were distinctly audible on the loud speaker using only three valves. Mr. Glover owns and uses a standard ABGAR receiver.

WRITE FOR CATALOGUE AND OTHER INFORMATION TO
ABGAR ELECTRICS, Dept. W,
39/40 ST. ANDREW STREET, PLYMOUTH, DEVON.
giving your dealer's name and address.

STAND
57

REDSPOT
Guaranteed
Radio Components

A complete range of high-class accessories for the home constructor who requires the best components at reasonable prices. The range includes—Coil holders, potentiometers, rheostats for D.E. and R type valves, including our dual rheostat; valve holders and switches of the no-capacity type, and laboratory and standard condensers.

**ALL REDSPOT COMPONENTS ARE
GUARANTEED AGAINST DEFECTS IN
WORKMANSHIP.**

Enquiries from
Overseas buyers
invited

THE WIRELESS WORLD AND RADIO REVIEW

THE OFFICIAL ORGAN OF THE RADIO SOCIETY OF GREAT BRITAIN.

No. 275. (No. 8 Vol. XV.) NOVEMBER 19th, 1924.

WEEKLY.

EDITOR:

HUGH S. POCOCK.

RESEARCH EDITOR

PHILIP R. COURSEY, *B.Sc., F.Inst., P., A.M.I.E.E.*

ASSISTANT EDITOR:

F. H. HAYNES.

QUESTIONS AND ANSWERS DEPARTMENT.
Under the Supervision of W. JAMES.

CONTENTS.

	PAGE
Radio Topics. By the Editor - - - - -	223
Loud Speakers with Paper Diaphragms. By G. W. Sutton	225
Sensitive Reflex Circuits. By J. G. W. Thompson -	229
New Appliances - - - - -	231
A Holder for Plug-In Coils. By H. M. Denison - -	233
Readers' Practical Ideas - - - - -	235
Combined Buzzer Wavemeter, Wave Trap and Crystal Receiver. By J. G. Macvie - - - - -	238
An Indirect Method of Determining the Grid Characteristic. By M. E. Janmoulle - - - - -	240
Patents and Abstracts - - - - -	242
The Super Heterodyne Receiver - - - - -	244
Two Reflex Reinartz Circuits. By H. C. Exell - -	247
Notes and News - - - - -	249
Among the Societies - - - - -	252
Unsolved Problems of Wireless (Discussion) - -	254
Readers' Problems - - - - -	257

THE EDITOR will be glad to consider articles and illustrations dealing with subjects within the scope of the Journal. Illustrations should preferably be confined to photographs and rough drawings. The greatest care will be taken to return all illustrations and manuscripts not required for publication if these are accompanied by stamps to pay return postage. All manuscripts and illustrations are sent at the Author's risk and the Editor cannot accept responsibility for their safe custody or return. Contributions should be addressed to the Editor, "The Wireless World and Radio Review," 12 and 13 Henrietta Street, Strand, London, W.C.2.

SUBSCRIPTION RATES :

20s. per annum, post free. Single copies 4d. each or post free 5d. Registered at the G.P.O. for transmission by Magazine Post to Canada and Newfoundland.

As many of the circuits and apparatus described in these pages are covered by patents, readers are advised, before making use of them, to satisfy themselves that they would not be infringing patents.



EDITORIAL AND PUBLISHING OFFICES:

12 and 13 Henrietta Street,
Strand, London, W.C.2.
Telephone: Gerrard 2807-8.

ADVERTISEMENT MANAGERS:

Bertram Day and Co., Ltd.,
9 & 10 Charing Cross, S.W.1
Telephone: Gerrard 8063-5.

Tune the Table-Talker with the "Matched Tone" Headphones



The
Brandes
Family
Series

BABY sits intently watching young Bill tuning up the receiver. He finds it mighty hard not to take up a roving commission among the shining accessories. He wonders devoutly to himself why Brother Bill should find it necessary to become involved in a mass of tangled wire and mutter whole-heartedly to himself. But he knows just what it will mean to him. In a little while the *Table-Talker* will speak easily and naturally of the many phantasies of his youthful imagination. Fascinated by the burnished discs and metal of the "Matched Tone" Headphones, he will be able to place them on his tender head with their gentle comfort, and listen to the sweet bell-like notes. Ask your dealer for Brandes.

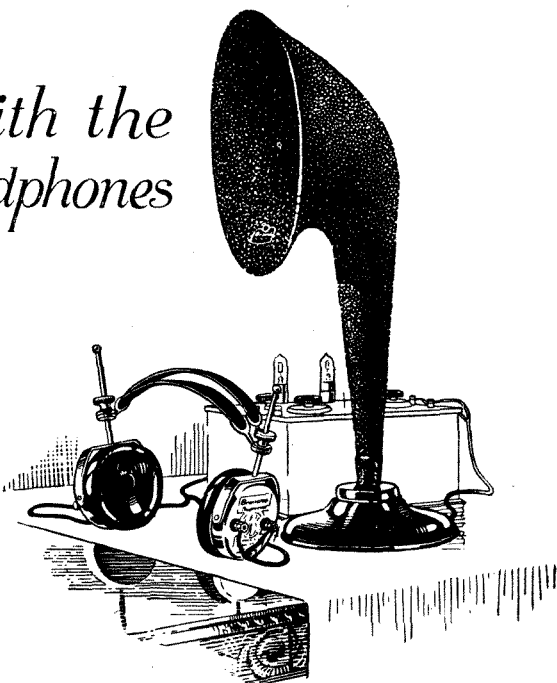

All Brandes products carry our official money-back guarantee, enabling you to return them within ten days if dissatisfied. This practically constitutes a free trial.

The "Matched Tone" feature means that both your ears hear exactly the same sound at the same instant—and you learn a new beauty of tone. They are tested and re-tested for just this one vital point, and in addition their strength, long-wearing comfort and reliable efficiency make them **25/-** undoubtedly superior.

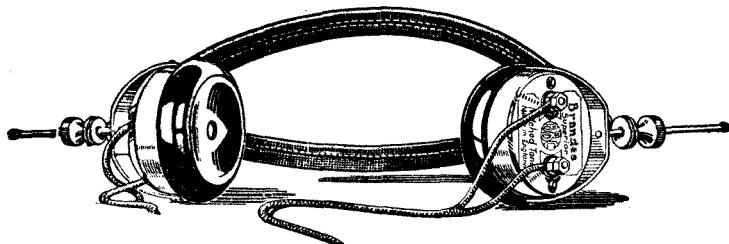

The *Table-Talker* is a Brandes quality product at a moderate price. The non-resonant, specially constructed horn is matched to the unit so that the air resistance produced will exactly balance the mechanical power of the diaphragm. This means beautiful sound-balance and remarkable tone qualities. It is twenty-one inches high, has a self-adjusting diaphragm and is finished a **42/-** shade of neutral brown.

British Manufacture (B.B.C. Stamped)

Brandes

Result of
16 Years
Experience

The name
to know in Radio

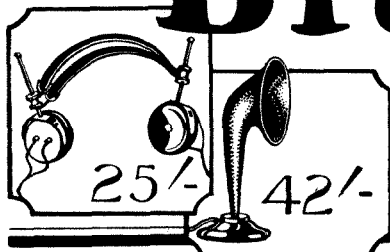

THE WIRELESS WORLD AND RADIO — REVIEW



RADIO TOPICS.

THE TRANSATLANTIC BROADCAST TESTS.

BEFORE another issue appears in print the Transatlantic Broadcast Tests will be under way. As we go to press the arrangements are practically complete and everything points to the probability of interesting results both as regards receiving American broadcasting in this country and the reception in America of the Continental as well as the British broadcasting transmissions.

It will have been observed from the programme outlined in our last issue that the tests, in addition to providing unusual facilities for British listeners to receive American broadcasting programmes, will also give a unique opportunity for the reception of the Continental broadcast stations when the B.B.C. stations will not be in operation and very little jamming is likely to be experienced.

We hope that there will be reasonable care taken by all those who listen-in so that whether receiving the Continental stations or the American broadcasting, there shall not be a storm of complaints afterwards of reception made impossible by oscillation.

The Continental stations will broadcast on their respective wavelengths from 4 a.m. to 5 a.m. G.M.T. on the mornings of the 24th, 26th, 28th and 29th November, whilst the American stations, including Canada and South America, will transmit to Europe from 3 a.m. to 4 a.m. G.M.T. each morning from November 24th to 30th inclusive. The British broadcasting stations, including **5 XX**, will transmit from 4 a.m. to 5 a.m. on the mornings of the 25th, 27th and 30th November.

When the first arrangements for the tests were being made, America asked that the

Continental and British stations should work on every day of that week as a unit; each station operating on its respective wavelength. The present programme, however, has been arranged in deference to two obstacles which stood in the way of all stations operating together. First of all, a good deal of heterodyne interference takes place between some of the Continental stations and the stations of the B.B.C., whilst secondly, it was found difficult to arrange for providing the necessary staff for each station every day of the week at such an unusual hour. We shall look forward to receiving from our readers, as early as possible, reports giving details of their reception of the stations transmitting on the other side of the Atlantic, since the utmost interest will be taken in America in the records of reception of the different stations.

Similarly we shall welcome reports of reception in England of the various Continental stations during the times that they broadcast.

WHERE THE AMATEUR IS JUSTIFIED.

IN these days, when so many things are being said of the amateur which are either untrue or at the least are calculated to mislead public opinion, it is well to take an opportunity from time to time to point out some of the advantages which accrue from the establishment of an amateur organisation such as exists in this country.

There are, of course, many interests which are opposed to amateur activities, and this fact must be faced. How far there is justification for antagonism towards the amateur is another matter and one which we are disposed to think that history will decide in favour of the amateur. In the

short record of broadcasting in this country opinions in some directions have already changed. We remember quite well that in the early days manufacturers of wireless apparatus believed that for wireless journals to advocate and facilitate the home construction of wireless sets was a policy extremely detrimental to their interests. Time has proved the fallacy of such a contention, for the home constructor has contributed very largely indeed to the prosperity of the industry and we doubt whether the wireless industry would have progressed to anything like its present proportions had not popular interest in what may be described as the "scientific hobby" side of the subject been cultivated. The fact, too, that the general public has been educated in wireless has made it almost impossible for unscrupulous dealers to traffic in "junk" apparatus. There is in this country absolutely no market for apparatus which falls short of reasonable expectations and if one cares to look for the reason it is that by education and by the increase in the numbers of comparatively skilled amateurs it is now impossible to impose upon the public. This circumstance

in itself has been the means of avoiding the public disgust in wireless and broadcasting generally which otherwise might well have come about.

Thus far we refer only to typical examples of how the amateur has contributed towards the success of broadcasting and of the industry. We find examples of his usefulness still more obvious if we turn our attention

to truly scientific fields. The amateur, as his very name implies, is not working for commercial interests, but for pure love of the science which he has selected as his hobby. Whatever successes he attains in the course of his amateur research work he is ready to announce them to the world for what they may be worth, either as definite advancements in the art or

as data of value to other research workers as having some bearing on unsolved problems. Those enterprises on the other hand which are conducted for commercial objects do not in their own interests and in the interests of their proprietors or shareholders divulge to the world the steps by which they develop. These evolutions towards commercial perfection are closely guarded secrets in such enterprises and if commercial perfection is delayed, perhaps for years, the research work done towards that goal must never be disclosed until perfection is attained. The amateur is quite prepared, for example, to admit that he is not the first to realise the possibilities of short waves if satisfactory evidence is produced by others to support their claims, but the fact will yet remain that the ama-

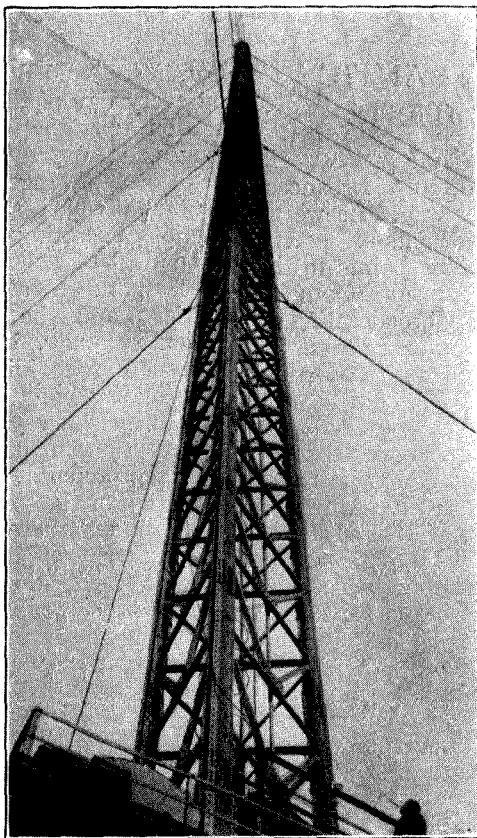

One of the eight giant masts for the aerial of the Rugby station which covers 800 acres. The masts are of triangular steel construction, each weighing 200 tons and are 820 feet high.

teur first gave his results to the scientific world and demonstrated in an indisputable manner the soundness of his conjectures.

The Services acknowledge the value of giving facilities for amateur work and development, and their opinion, we believe, should be enough to convince other parties who are inclined to show antagonism towards the amateur.

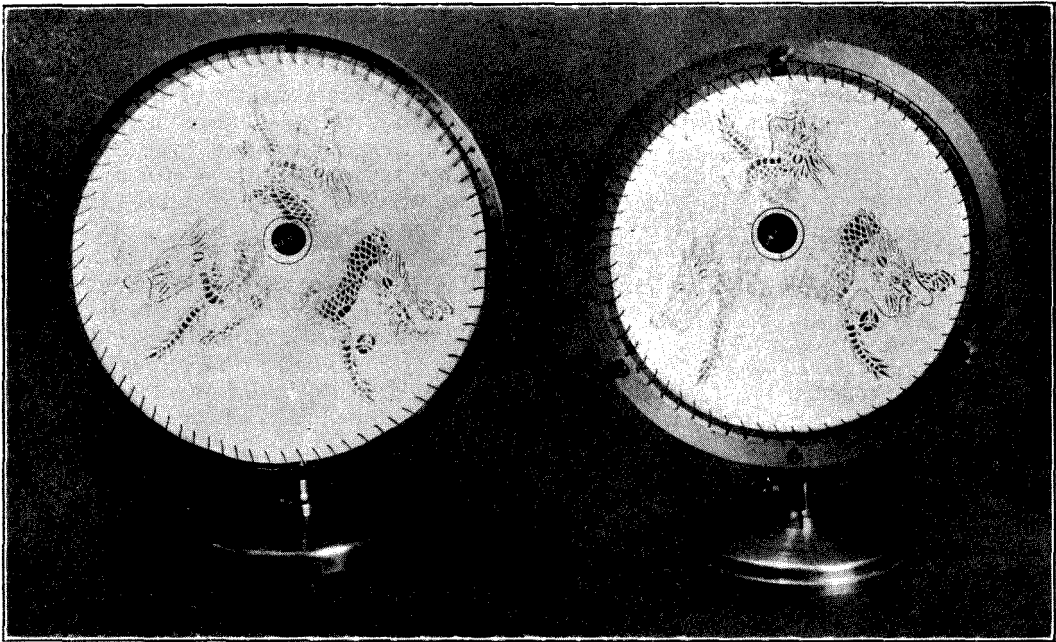

Fig. 1. Showing two of the loud speakers which are attractively finished.

A LOUD SPEAKER WITH A CONICAL PAPER DIAPHRAGM

The author describes the construction and performance of loud speakers having a conical paper diaphragm. Very good reproduction is obtained.

By G. W. SUTTON, B.Sc.

NOW that so many experimenters are turning their attention to the improvement of the quality of broadcast reception, the description of an easily constructed yet very satisfactory loud speaker may be of interest.

It is nearly two years since the idea of attaching a rigid paper cone to the reed of a telephone receiver (in place of the normal headphone diaphragm) was suggested to the writer. It at once appealed to him as a possible method of avoiding the resonance effects inseparable from the use of even a well-designed horn. Experiments with a pair of "A" type Brown headphones led to the adoption of instruments of

the type shown in the accompanying illustrations. When suspended from the ceiling of a small room these gave a pleasantly distributed volume of sound of what was then considered very satisfactory quality. The general dimensions of the cones may be gauged from the photographs, as neither the actual diameter nor the angle appear to be critical. The method of attaching the cones to the reeds used then, and in subsequent models, is to stamp out a small aluminium or copper cone, about $\frac{1}{2}$ in. in diameter, by means of two pieces of brass rod shaped as shown in Fig. 2. These cones are affixed to the paper by means of a few drops of thick shellac varnish, and to the reed by means of

the small screws from the original Brown diaphragms.

A transformer coupled amplifier built of reliable components and carefully adjusted as regards anode voltage, mean grid potential,

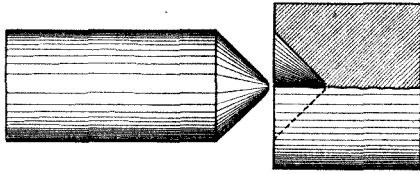

Fig. 2. Two pieces of brass rod suitably shaped are employed when stamping out the fixing cone.

etc., was employed at the time, and, although the quality of the reproduction was good at what may be described as "comfortable" volume, when further amplification was used for the benefit of visitors a certain unpleasant rattle appeared occasionally. It was thought that this was due to overloading these small

receivers. As is well known, there are several inherent sources of distortion in the moving-iron telephone. Amongst these, mechanical resonance and the "double-frequency" component of the wave of attraction of the reed are probably the most important. The latter in particular is a possible source of trouble when the permanent magnets are small and the amplitude of vibration large.

Subsequently, however, choke coupling was used in place of the transformers with noticeable improvement in quality, and finally, when a resistance amplifier was installed, it was found that very considerable volume could be obtained without any trace of the previous rattle. In fact, it is possible to so overload these little receivers that speech can be heard and understood all over an eight-roomed house without undue unpleasantness of tone. Such results are only possible, in the writer's opinion, when a

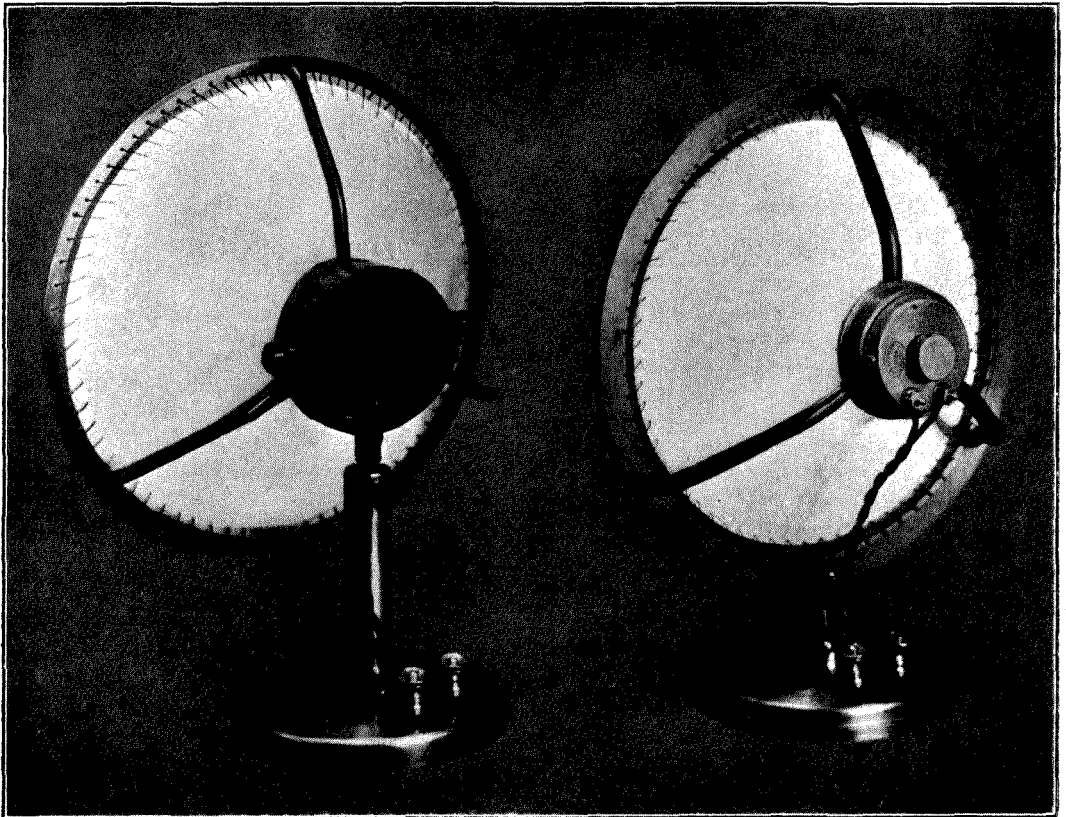

Fig. 3. Views of two of the author's loud speakers.

correctly adjusted resistance coupled amplifier is employed.

The writer uses a perikon crystal detector, followed by a resistance amplifier of two or

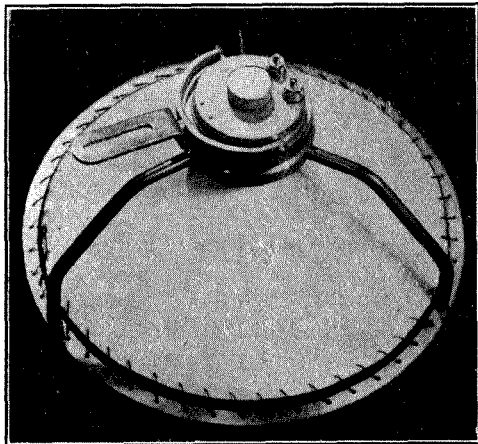

Fig. 4. A view of another loud speaker having a conical paper diaphragm.

three stages, depending upon the volume required. The anode resistances are made of No. 47 eureka wire, wound in 20,000 ohm sections, and arranged so that anything up to 80,000 ohms may be included in the anode circuits. The first two valves are D.E.R. type, and the third D.E.6. The mean grid potentials are adjusted to suit the H.T. voltages, and anode resistances used. On this set several standard loud speakers have been compared with those described above. The general impression received is that although horn type loud speakers are by no means as bad as there is a tendency to regard them, they all betray, in their reproduction, the fact that they are fitted with horns. The paper cone type, however, produces such natural results that the average person might readily mistake the reproduction for the original.

As regards volume, it is found that the standard type of instrument, of the larger sizes, is from twice to four times as efficient. This is not as important as it might appear to be, however, owing to the greater clarity of tone of the paper diaphragm type and the accommodating latitude of the human ear for different intensities.

The various constructional improvements which have been made to the original receivers are illustrated in the figures. Most

important of these is the method of supporting the paper cones at the rim. The object of doing so is to maintain a truly conical form and consequently a maximum of rigidity. The edge of the paper is reinforced by pasting around it on the back surface a narrow strip of white silk which has been cut on the cross. This allows a thread of black silk twist to be used to lace the cone to the surrounding brass ring without tearing the paper.

Various thicknesses of paper have been used without much apparent effect upon the quality of the reproduction. The most satisfactory, taking everything into consideration, is a good stiff drawing paper.

The details of construction of the types illustrated in Figs 1, 3 and 4 can be gathered from the line drawings in Fig. 5.

An attempt was made to ascertain if one of the instruments, which was fitted with a very light paper diaphragm, had any prominent resonant frequencies. In ordinary telephone receivers these may be readily detected by the rapid change of inductance

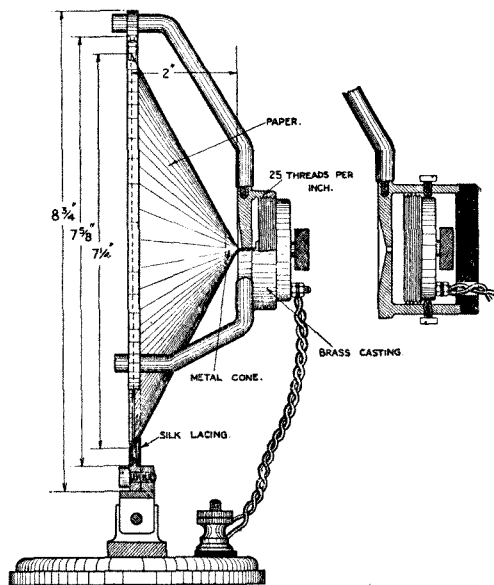

Fig. 5. Constructional details for a loud speaker having a conical paper diaphragm.

and effective resistance with frequency which takes place at these points. This is illustrated in Fig. 6, which shows the result

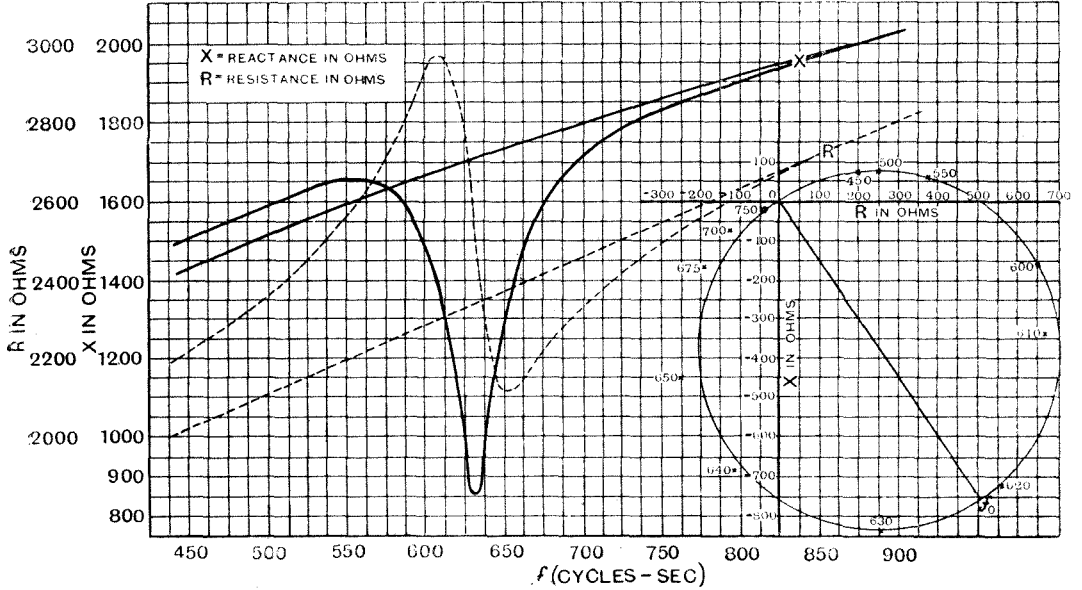
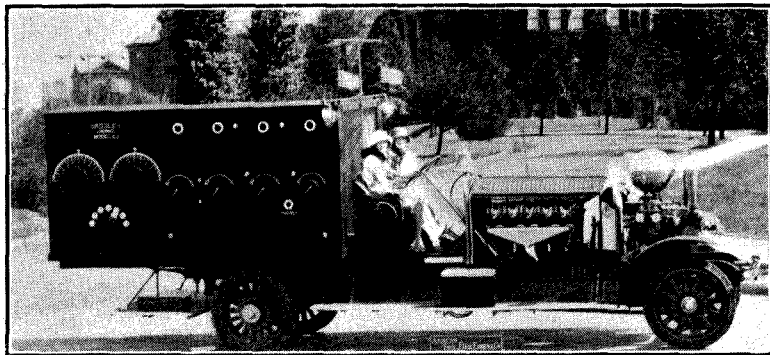

Fig. 6. The straight curves (two) show the variation of R and X with frequency when there is no mechanical resonance. The other curves show the effect on R and X of resonance in the mechanical system of a receiver.

of a test on a poor quality receiver. In the case of the paper cone loud speaker, however, no such change could be detected throughout a range of from 250 to 1,400 cycles per second. There may, of course, be one or more resonant points outside these values, or even a very heavily damped one within the range of the

test, as the readings were not taken with any great accuracy. These would not be likely to cause appreciable distortion. The effect of such a resonant point as is indicated in Fig. 6, on the other hand, occurring as it does in the middle of the audible range of frequency, is very pronounced.

ADVERTISING WIRELESS.



This picture illustrates an advertising idea of a prominent American wireless company. Although this huge model of a Crossley receiver is only externally complete it carries within receiving equipment and loud speakers so that broadcasting can be received at any time to entertain the crowds attracted by the novel appearance of the outfit.

A SENSITIVE REFLEX CIRCUIT.

The author discusses two well-known reflex circuits, and then describes a third circuit which he has developed.

By J. G. W. THOMPSON.

DURING the last year or so, the single valve and crystal reflex circuit has been very popular among experimenters.

The type of circuit usually favoured is that shown in Fig. 1. The valve here acts as both a high and low-frequency amplifier in the well-known manner, the low-frequency

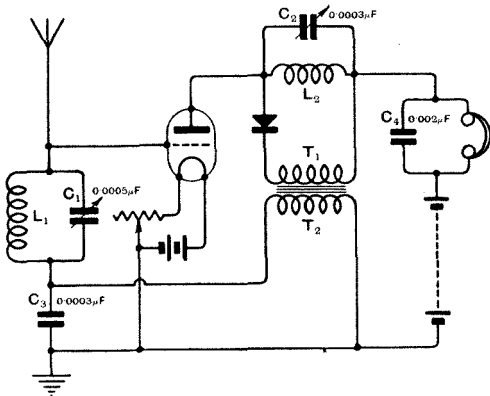

Fig. 1. A well-known one valve and crystal reflex receiver.

currents being fed back to the grid circuit by means of the L.F. intervalve transformer $T_1 T_2$. This type of circuit is too well known to need further description, and excellent results may be obtained from it. One of its greatest disadvantages, however, is the annoying "buzzing" so often produced when the set is brought to the oscillating point (by coupling L_1 and L_2), and which makes searching for weak signals a painful process.

A type of circuit which does not seem to have received the attention it deserves is that shown in Fig. 2, and is due to P. G. A. H. Voigt. The valve amplifies at H.F. and L.F. simultaneously, as before; coils L_2 and L_3 are the primary and secondary windings respectively of an H.F. transformer, the secondary being tightly coupled to the primary. The crystal rectifies the H.F.

currents induced from the primary, and the resulting L.F. impulses pass *directly* back to the grid circuit for re-amplification. The difference between these two reflex arrangements lies chiefly in the method of feeding back the L.F. impulses. The Voigt method eliminates the iron-core transformer, this being replaced by an H.F. transformer.

Reaction may be introduced by coupling L_1 to L_2 .

The circuit as shown is capable of giving very good results, the sensitivity to weak or moderate signals being about equal to a standard two-valve set—H.F. and detector.

The advantage of Fig. 2 over Fig. 1 is that the Fig. 2 circuit can oscillate quite quietly, with a very smooth reaction control, without the slightest low frequency "buzzing." In the writer's hands, it seems more sensitive to weak signals than the Fig. 1 circuit, and is still remarkably sensitive without any intentional reaction.

The purity of tone is exceptional, owing, no doubt, to the elimination of iron-cored transformers.

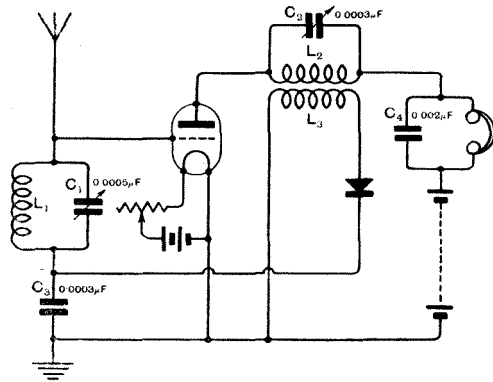

Fig. 2. A one valve and crystal reflex receiver described by P. G. A. H. Voigt.

For very loud signals (e.g., the local B.B.C. station) the volume falls somewhat short of that given by Fig. 1, for reasons which need not be discussed here.

To get the best results from Fig. 2, the following points should be noted.

1. Use the best components, particularly in the case of the crystal and detector mechanism.
2. Use a very fine and springy catwhisker ; No. 36 gauge silver wire is recommended.
3. Plug-in transformers are not recommended. Use two low-capacity basket

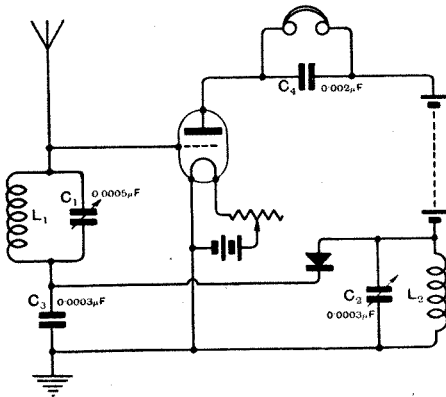

Fig. 3. This is a simpler circuit than that of Fig. 2, but the tuning changes when the telephones are handled.

coils spaced about $\frac{1}{8}$ in. apart. For B.B.C. waves, 70 turns on each will cover from 300-500 metres with a 0.0003 mfd. variable condenser across the primary coil. The connections of the secondary coil should be reversed to see which way gives best results. One connection is much better than the other.

4. The crystal connections should be as follows : For weak or moderate signals, crystal to transformer secondary, catwhisker to top of C_3 . For strong signals reverse above connections. A reversing switch is thus very convenient. The first way gives great sensitivity on weak signals and a very smooth reaction control, while the second way gives better results on strong signals, but if used on weak signals there is a pronounced "overlap" or "floppiness" in the reaction adjustment.
5. Various valves should be tried, as some "reflex" better than others. Dull emitters may very successfully be used.

Regarding results, the writer has clearly received all the main B.B.C. stations, several relay stations, and half-a-dozen or so of the continental stations on a small indoor aerial, but, of course, better results are given on a good outdoor one. (These results also apply to the circuit shown in Fig. 5.) As in most valve-crystal circuits, selectivity is not very high.

After about eight months' experimenting with various modifications of Fig. 2, the writer tried to simplify the circuit and eliminate the two coils L_2 L_3 , it being desired to substitute for them a single (tuned) plug-in coil. The first, and most obvious, method is shown in Fig. 3. This worked, but since the high tension battery and telephones are at a high frequency potential to earth, tuning is completely upset when the phones are handled.

The next attempt is shown in Fig. 4. Condenser C_5 is to insulate the crystal from the H.T. supply, and although this circuit worked, results were not satisfactory.

The final circuit is given in Fig. 5, and has proved very effective in practice.

Coil L_3 is a radio-frequency choke of about 250 turns, and of low self capacity. The H.F. potentials from the anode energise the tuned circuit L_2 C_2 via C_4 , which latter is to

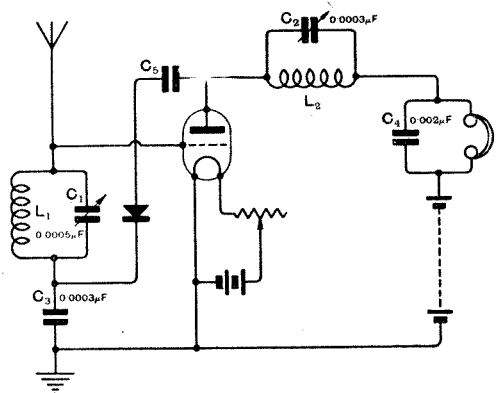

Fig. 4. This circuit is an improvement over that of Fig. 3.

prevent the H.T. passing through 'phones L_3 and L_2 . C_4 may have almost any capacity, 0.0003 μ F. being quite satisfactory. For longer waves than about 600 metres, it may be advisable to increase this somewhat, and of course L_3 will need to be larger—say up to 750 or 1,000 turns.

Reaction is obtained by coupling L_1 and L_2 in a two-coil holder.

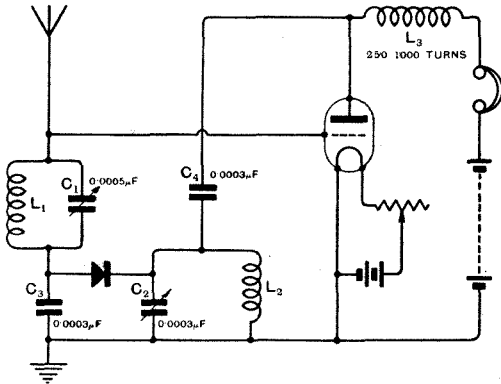

Fig. 5. A practical reflex receiver which can strongly be recommended.

A telephone condenser is now unnecessary, as the telephones are not in an H.F. circuit.

Results are equal to those given by Fig. 2, but the writer thinks the selectivity is slightly less.

The Fig. 5 circuit was suggested to the writer by the Reinartz circuit, and if C_4 is made variable, vernier reaction control may be obtained.

In concluding, the writer can strongly recommend the circuits of either Fig. 2 or Fig. 5, where sensitivity to weak signals, delightfully easy handling, and great purity of tone is required, but where the strongest possible signals from the local station are wanted, the circuit of Fig. 1 will give better results.

NEW APPLIANCES.

The Lissen Crystal Receiver.

IT has been the practice of manufacturers in the past to model their crystal receiving sets on one of three tuning principles. The tuning circuit has consisted either of a fixed inductance tuned with a series or parallel variable condenser, or a variometer tuner, and sometimes a coil tapped off at both ten and single turns. This latest product of the Lissen Company makes use of a coil of the plug-in type, suitable either for the wavelength ranges of the broadcasting and relay stations using say a 50-coil, while when it is desired to receive the transmissions from **5 XX** a 200-coil can be inserted.

Tuning is effected by altering the position of a pair of damping plates with regard to the turns of the inductance. It is well known that the inductance of a coil is reduced when a metal plate is brought against the winding and thus by carefully controlling the position of the tuning plates on this set, signals can be critically tuned in. The performance of this set is particularly good and signal strength is equal to that obtained by the best of any of the other tuning systems. It was thought perhaps with the tuning plates completely covering the coil that signal strength might perhaps be reduced, but tests were made using a

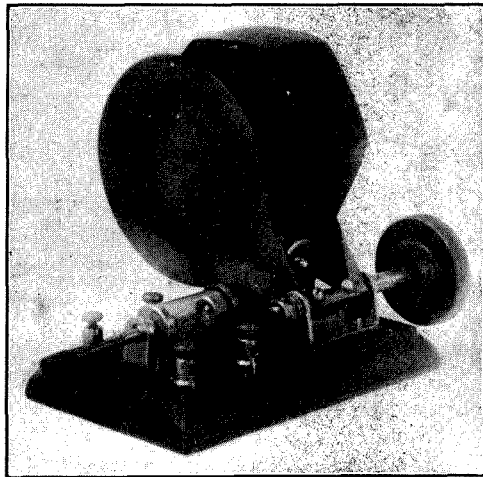

Lissen's new crystal set.

variable condenser in the aerial circuit so that a particular transmission could be brought in with various positions of the tuning plate and results showed that signal strength was equally good on all adjustments.

An interesting feature of this set is that the entire base is made of moulded material and all the necessary holes are made in the process of moulding. The wiring up is also

worthy of note inasmuch as stamped connectors of suitable shapes are dropped over the various terminals and screws as the components are assembled.

The outfit has a very good appearance and is a durable job, not likely to get out of order by constant use. The Lissen Company have every reason to be proud of their latest product.

Moulded Parts.

The variometer formers shown in the accompanying illustration afford good evidence of the progress which has been made in the production of intricate mouldings in insulated material. They are products of the Crystalite Manufacturing Co., Ltd., Tonbridge, Kent, and possess a good clean finish.

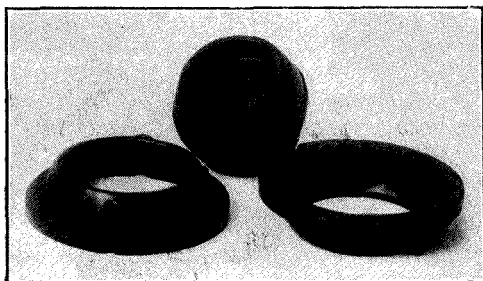

Moulded variometer formers.

"Aermast" Stay and Halyard Wire.

The needs of the amateur as regards aerial wire have been fully met by the manufacturer and there is a vast variety of types of wire all specially designed for aerial construction purposes. It is rather surprising that in the past little or no effort has been made to put out a special wire suitable for the construction of guy wires and halyards. The wire which one may purchase is usually too heavy or too difficult to handle.

A specimen of stranded wire specially made up for guying small masts has come to hand. It is strong and light and can be easily bent round insulators, masts and eyespikes. Made of stranded steel wire, it is heavily galvanised to protect it from the corrosive action of the weather and is of ample strength for ordinary amateur purposes, having a breaking strain of about half a ton. The complete stranded cable is equal in size to about No. 15 S.W.G., so it is quite inconspicuous and 100 feet of it

weighs only 14 ozs. The wire is of such temper that it is easy to handle and will not unwind when cut, provided that it is bent back sharply beforehand.

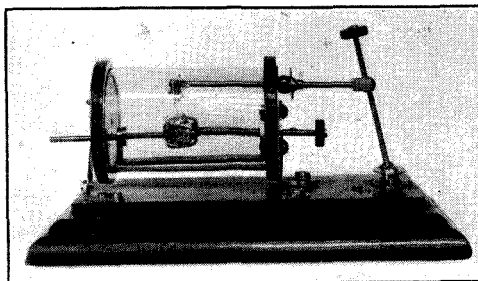

A useful crystal detector in which provision is made for using almost the entire surface of the crystal

A New Crystal Detector.

There are two requirements in crystal detector design. Firstly, the crystal must be so mounted that it can be moved to permit of the wire point making contact with any part of its surface and secondly, that the pressure between the crystal and wire point must be capable of critical adjustment.

The form of crystal detector construction shown in the accompanying photograph provides for the crystal being rotated and also propelled from side to side. An ingenious point in design is that the arm operating the wire can be swung about to search out good points on the crystal, whilst a vertical thread gives that very necessary fine adjustment of pressure. This interesting detector is a product of the Star Rotary Crystal Detector Co., of Manchester.

The Brandes Table-Talker.

The Brandes Company are well known as manufacturers of high grade telephone receivers, and it is with interest that we learn they are now devoting their attention to the production of a loud speaker. This is well designed from an acoustic standpoint and gives good clarity with reality.

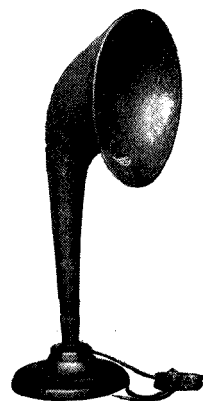

A HOLDER FOR PLUG-IN COILS.

H. M. DENISON.

The author describes a holder for plug-in coils which is inexpensive and easily constructed.

IT is surprising how few experimenters construct components (apart from tuning coils) which are employed in their receiver. One piece of apparatus in particular which is considered difficult to make is a holder for plug-in coils, yet it is quite an easy matter to construct an effective coil-holder.

The holder described here is of the two-coil type, and the moving holder is operated through a 3 to 1 reduction gear.

The materials required are:—Two ebonite coil plugs $\frac{1}{2}$ in. in thickness; piece of $\frac{1}{4}$ in. ebonite about 3 ins. by $3\frac{1}{2}$ ins.; 4 ins. of $\frac{1}{4}$ in. square brass rod; meccano cog-wheel $1\frac{1}{2}$ ins. dia. (57 teeth); meccano pinion $\frac{1}{2}$ in. dia. (19 teeth); ebonite knob tapped 2 B.A.; about 6 in. of $\frac{3}{16}$ in. round brass rod, and a few screws and washers.

The moving coil plug is first mounted on an axle, as in Fig. 1. A hole $\frac{5}{32}$ in. diameter is drilled right through the plug, $\frac{3}{8}$ in. from the bottom edge and tapped 2 B.A. Two pieces of $\frac{3}{16}$ in. round brass rod of lengths 1 in. and $1\frac{3}{8}$ in., are then cut, and each is screwed with a 2 B.A. thread

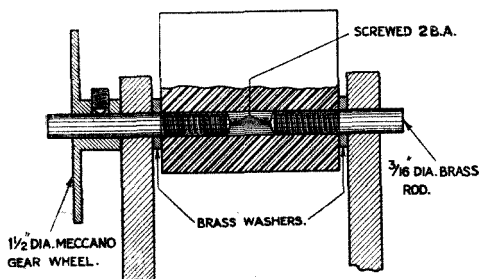

Fig. 1. A part sectional view showing the method of mounting the moving coil holder.

for $\frac{1}{2}$ in. of their length from one end. These are then screwed up tight, one into each end of the tapped hole through the ebonite plug, as in Fig. 1.

Two pieces of $\frac{1}{4}$ in. square brass rod each $1\frac{3}{8}$ ins. in length are then obtained.

Two holes, $\frac{3}{16}$ in. diameter are then drilled through each, one being $\frac{3}{8}$ in. from one end, as in Fig. 1, and one $\frac{3}{8}$ in. from the other end as in Fig. 2. One end of each piece of rod is then filed up flat and square, and a hole drilled for $\frac{1}{4}$ in. or so up the centre of each and tapped 4 B.A.

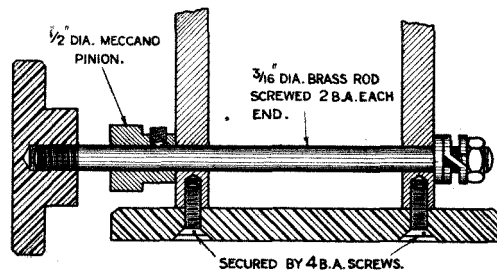

Fig. 2. Showing the method of attaching the pillars to the base, and the position of the pinion wheel and the knob.

The breadth of the ebonite plug, with a brass washer slipped over the brass axle on either side, is determined, and two holes of diameter sufficient to allow a 4 B.A. screw to slip through, are then drilled the above distance (plus $\frac{1}{4}$ in.) apart in the ebonite baseboard, about 1 in. from the edge, 3 ins. in length. Each arm of the axle is then passed through the top hole of each of the brass pillars, which are then secured to the baseboard by means of two 4 B.A. counter-sunk screws passing through the holes just drilled, as in Fig. 2. The coil plug should then swivel smoothly between the two brass pillars.

Another piece of $\frac{3}{16}$ in. diameter round brass rod about $3\frac{1}{2}$ ins. in length is then cut, and screwed for $\frac{3}{8}$ in. at each end with a 2 B.A. thread. This is then slipped through the two bottom holes in the brass pillars, as in Fig. 2. A brass washer and a spring washer are slipped over one end and a 2 B.A. nut screwed on as in Figs. 2 and 4. A meccano cog-wheel $1\frac{1}{2}$ ins. diameter (57 teeth) is then slipped over the longer

brass arm, and screwed tight with a set screw as "A," Fig. 4. It may be found necessary slightly to enlarge the centre hole. A meccano $\frac{1}{2}$ in. pinion (19 teeth) is also obtained, the centre hole slightly enlarged if necessary, and slipped on the rod as at "B" Fig. 4, and screwed up tight with a set-screw. An ordinary ebonite knob is then screwed on the rod on the same end as the pinion, the nut at the other end being adjusted to permit an even and smooth rotary action of the knob. The coil-holder will then appear as in Fig. 4. To ensure a good engagement between the gear wheels, it may be found necessary to put a washer between the wheel "A" and the brass pillar.

A plug for the fixed coil is then fitted to the base. A small block of ebonite is obtained (wood will do as well) of the same breadth and thickness as the coil plug, generally $\frac{1}{2}$ in. by $1\frac{3}{8}$ ins., and of height 1 in. Two holes $\frac{3}{16}$ in. diameter are drilled vertically upward through this, and $\frac{3}{4}$ in. apart.

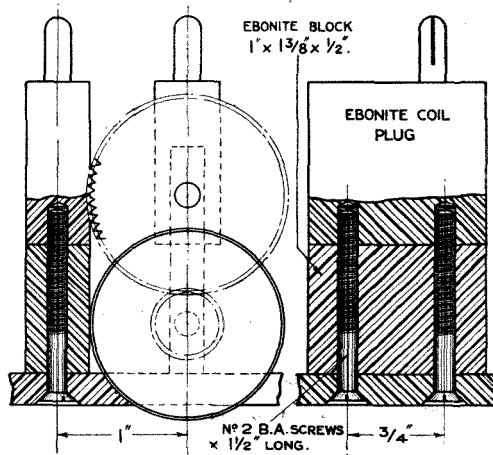

Fig. 3. The construction of the fixed holder.

Two holes are also drilled through the coil plug for $\frac{1}{2}$ in. approximately, being $\frac{3}{4}$ in. apart and $\frac{5}{32}$ in. diameter and tapped with a 2 B.A. thread. The ebonite base is drilled with two $\frac{3}{16}$ in. holes $\frac{3}{4}$ in. apart and 1 in. from the two holes securing the brass pillars, and countersunk on the underside. Two 2 B.A. brass screws $1\frac{1}{2}$ ins. in length are then passed up through the base

and through the ebonite block and screwed tightly into the coil plug so as to secure it firmly to the base as in Fig. 3. The coil-holder is then complete in assembly, and may be touched up, the edges of the base being bevelled off with a file.

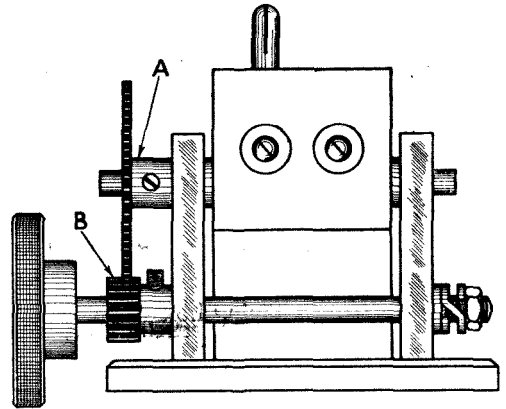

Fig. 4. A view of the movable holder.

If a three-way holder is required, it is quite an easy matter to fix another moving element similar to the first, and on the opposite side of the fixed plug.

This little device will be found easy to make, and an exceedingly smooth and fine adjustment can be obtained with just a little care in the fitting of the components.

KDKA.

FOURTH ANNIVERSARY OF FAMOUS AMERICAN BROADCASTING STATION

November 2nd was celebrated as the fourth anniversary of KDKA, the pioneer broadcasting station of the Westinghouse Electric and Manufacturing Co., at Pittsburg, Pa., U.S.A. The first programme transmitted by this famous station was devoted to broadcasting the voting results which resulted in the election of the late Mr. Warren Harding as President of the United States. The early transmissions under the call sign 8 XS were of an experimental nature, and were conducted from the home of Mr. Frank Conrad of Wilkensburg, Pa., and it was not until November 21st, 1920, that KDKA found its present home. Technical improvements were rapid, and indeed still are, for the engineers claim that the station has never been more than three months old!

Programme novelties have always been a feature of KDKA's transmissions, and this station is stated to have been the first to broadcast news, time signals, sporting events, church services and bedtime stories.

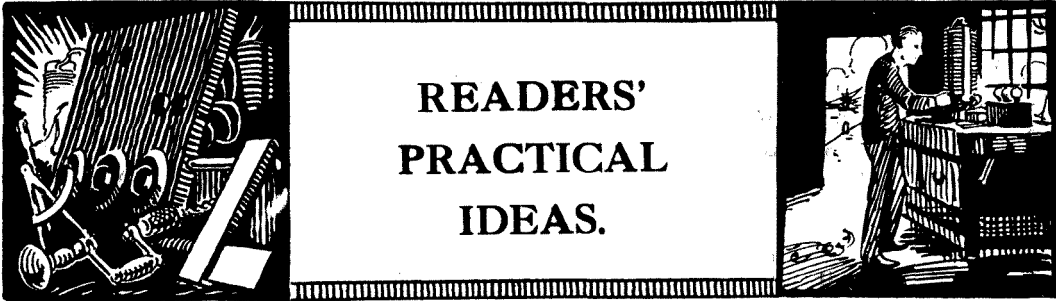

This section is devoted to the publication of ideas submitted by readers and includes many devices which the experimenter will welcome.

Protecting the H.T. Battery.

THE fitting of a resistance in the H.T. positive lead is rapidly becoming a standard practice. With a resistance of about 500 ohms so connected, the danger of damaging the battery by short circuiting

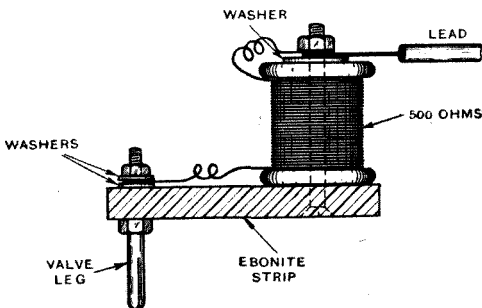

A spool of resistance wire connected in the H.T. battery lead to prevent short circuits.

is eliminated, whilst the burning out of valve filaments by accidental contact with the H.T. supply is entirely avoided. It is essential, however, when using a device of this sort to arrange for a 2 mfd. bridging condenser to be connected across the H.T. terminals of the receiving instrument. Such a protecting resistance is simple to make up* and a suitable design is shown here.

E. G. N.

Improving the Lead-in.

THE conventional form of leading-in insulator consisting of an ebonite tube with brass rod and nuts, suffers from the

* A suitable bobbin already wound can be obtained for a modest sum from Messrs. Woolworths, who have branches in various parts of this country.

serious defect that in wet weather its insulation may fall to a very low value owing to the short leakage path. To overcome this defect the insulator should be fitted with a "shed" which not only extends the distance over which leakage can occur but protects a portion of the insulator from moisture.

A simple design is shown in the accompanying diagram and can be cheaply made up from a piece of 1/2-in. ebonite tube about 18 ins. in length, a glass filter funnel 4 ins. in diameter, a small quantity of wax or pitch and a rubber tap-washer. To bend the tube to the shape shown it should be immersed in boiling water and the bend is made 6 ins. from one end at an angle of about 130 degs. The tube should then be inserted in the funnel and sealed in with melted pitch of a depth of about 1 in. The aerial

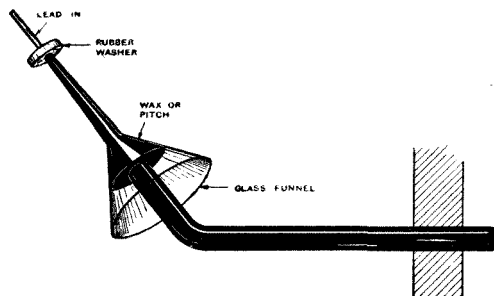

A glass funnel can be usefully employed for increasing the leakage path on the leading-in insulator.

lead-in is threaded through the stem of the funnel and the ebonite tube and to prevent moisture creeping in at the junction between

the aerial wire and the glass stem a tap-washer should be slipped over. If rubber cable of a suitable size is used for the lead-in this washer will not be needed as the insulation can be made to fit tightly. The insulator is mounted in the window frame by making it a good friction fit.

E. J. S.

Making an Aerial Mast.

THE drawing, which includes all the necessary dimensions for a 41-ft. mast, presents an arrangement possessing both good appearance and low cost. The necessary timber (which should of course be reasonably free from knots) and bolts can be purchased for about 10s. which is probably less than half the cost of a pole of the same length. When erected the mast looks quite well with stay wires secured to the points where the joints are made in the timbers. At least one coat of paint is essential and the buried portion should have two coats or perhaps better, a liberal treatment with tar or creosote.

E. M. T.

Shielding Variable Condensers from Dust.

A VARIABLE condenser can easily be rendered dust-proof and the time spent in making up a cover is probably little more than that required to thoroughly clean the vanes.

Procure some thin celluloid and cut a strip equal in width to the depth of the condenser and long enough to completely surround it with an overlap say of $\frac{1}{4}$ in. Temporarily clip the ends together with paper clips to form a cylinder. Now roughly cut two circular end pieces and allow plenty of overlap. Holes should be made in these pieces to clear spindle terminals, etc., and can be cut with a good sharp penknife. A small quantity of celluloid cement will be needed to hold the pieces together and can be made up by dissolving thin strips of celluloid in acetone. The celluloid will take some time to dissolve. The open side of the cylinder can now be cemented down and the end pieces fixed in position. The acetone will evaporate rapidly, leaving the celluloid white, but upon complete drying will again become transparent. If any difficulty is found in making a good job of the end pieces then it is advisable to securely attach small portions of the end pieces at a time,

using the cement sparingly, having made a good job of the cylinder first. When thoroughly dry the projecting edges of the end pieces can be removed with sharp scissors.

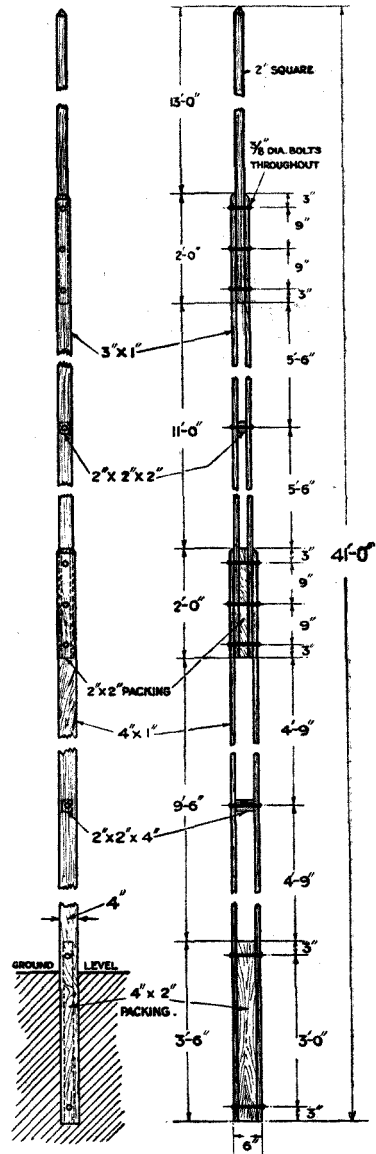

Constructional details of a timber-built mast.

Cement made with acetone shrinks on drying but possesses much more rapid drying properties than when amyl acetate is employed as a solvent. An acetone solution,

of celluloid makes a good insulating varnish and has many wireless uses.

J. B.

Another Suggested Variable Grid Leak.

SUITABLE constructional details are given though this idea is principally put forward as a suggested method of producing a substance capable of giving various

A Cylindrical Inductance Winder.

TO wind a cylindrical inductance, in the absence of a lathe, is not an easy task. Not possessing a lathe, a remedy was found in the use of an old type of cinematograph projector. Remove the whole of the upper portion of the mechanism with a hack-saw, merely leaving the base with the

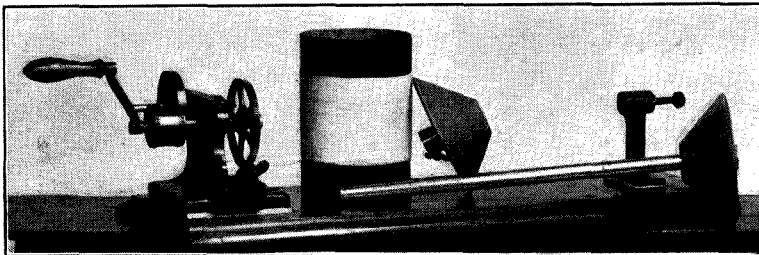

Coil winder constructed from cinematograph parts.

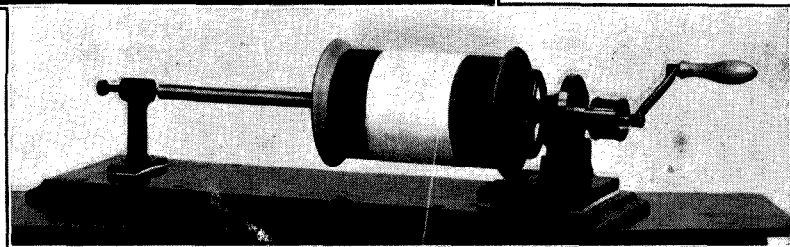

Formers of various sizes can be accommodated between the cones and single layer coils rapidly wound.

resistance values. The variable resistance element is mounted so that it can be compressed by means of a screw and spring and it consists of a small piece of sponge thoroughly impregnated with indian ink and allowed to dry. As pressure is applied the area of the sponge in contact increases, giving a drop in the resistance value. Such

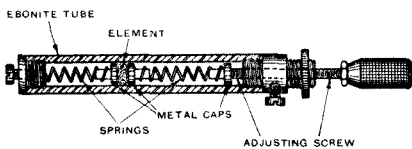

Constructional details of a reliable variable high resistance.

a resistance has been in use for some three months and has been found to be quite durable, giving reliable resistance values between one and ten megohms. Various ranges of resistance may be obtained by using larger or smaller resistance elements.

G. S.

crank and the flywheel, which is geared up relatively to the crank, in the ratio of 1 : 8. This flywheel provides a very nice steadying action whilst winding a coil. A mandrel was then constructed from a piece of $\frac{3}{4}$ in. steel tubing. One end fits on the boss of the large gear wheel, the other end being plugged and centred for the tail stock. This tube is fitted with two large 90° cones, one of which is fixed, and the other is adjustable longitudinally. Between these cones the tube is centred automatically, and with a very sure grip. The little machine will accommodate any tube from two to twelve inches long and from two to six inches in diameter, thus covering any possible requirement. The wire is fed to the machine from the reel, passing on its way through a friction grip composed of two pieces of cork. This friction is about three feet away from the machine. Keeping the wire tight, a coil can be wound very quickly, the adjacent coils being in contact and in perfect lay.

A. C. B.

A COMBINED BUZZER WAVEMETER, WAVE-TRAP AND CRYSTAL RECEIVER : 300 TO 700 METRES.

The buzzer wavemeter is one of the most useful instruments of an experimenter's equipment. Its use in the design and calibration of inductance coils and condensers often saves a considerable amount of time and calculation.

By J. G. MACVIE.

THE accompanying photographs and figures illustrate a compact and portable wavemeter, which was constructed from parts in the writer's possession. The fact that the finished instrument will also function as a popular form of wave-trap, and even as a simple crystal receiver will no doubt recommend it to those who desire an accurate though inexpensive piece of apparatus.

The containing box, which was originally used for storing film negatives (and may be purchased at any photographic dealers), is $4\frac{1}{2}$ ins. deep, $3\frac{1}{2}$ ins. wide, and $5\frac{3}{8}$ ins. long, internal measurements, while the lid is $\frac{3}{8}$ in. deep. The original yellow varnish was removed with sandpaper, the box stained and polished, and fitted with a leather carrying strap of good quality. All the components are mounted on an ebonite panel which fits flush with the top of the box, and

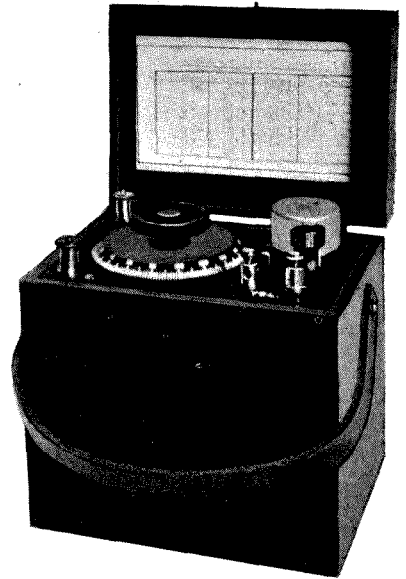

The complete instrument.

rests on narrow wooden strips glued to the inner side of the box. The actual lay-out of the panel will be clear from the photographs and Fig. 2.

The variable condenser is of 0.0005 microfarad capacity, and although one of the square law type would perhaps be preferable, a standard condenser of the ordinary type has proved satisfactory.

A honeycomb coil having 75 turns of No. 24 D.C.C. wire wound on a $1\frac{1}{2}$ in. former (with eleven spokes on each side) is employed as the tuning coil. The winding is given a coat of thin shellac, and clamped between two ebonite discs, which are held on an extension of the condenser, as indicated in Fig. 3. In order to leave room for the wiring of the switch, crystal detector, and telephone terminals, a narrow ebonite platform, supported on two short legs of No. 2 B.A. rod, is used to carry the buzzer and battery. The buzzer is of the high note type, and its windings are shunted by a non-inductive resistance. The shunt in this instrument consists of 12 ft. of No. 36 enamelled Eureka wire. The buzzer is excited from a 3-volt flash-lamp dry cell battery, which is held to the platform by means of a length of $\frac{1}{2}$ in. brass strip.

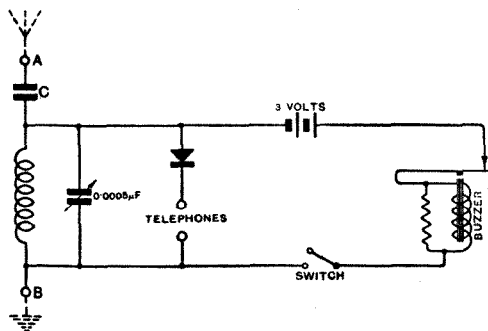

Fig. 1. The connections of the instrument.

The crystal detector to be employed should be one with small dimensions, in order that it may fit on the top of the panel, and will permit the lid of the instrument to be closed down. An unusual type of detector is employed in the instrument illustrated, but one of usual construction with a crystal and wire contact will give satisfactory results.

From the connections given in Fig. 1, it will be seen that the coil and condenser are connected in parallel. Across the tuned circuit is the crystal detector and telephone terminals, and also the buzzer, buzzer battery and switch. When the instrument is to be used to receive signals, a pair of high-resistance telephones (2,000-4,000 ohms) are connected to the telephone terminals, and the switch is put to the "off" position.

To use the instrument as a generator of oscillations the telephones should be removed, and the switch put to the "on" position. The buzzer then excites the tuned circuit which radiates oscillations of wavelength determined by the constants of the circuit and the setting of the variable condenser.

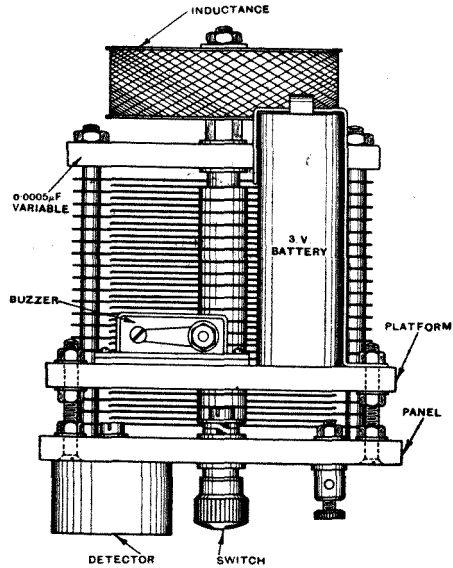

Fig. 3. An end view showing the method of fixing the battery, buzzer, tuning condenser and tuning coil.

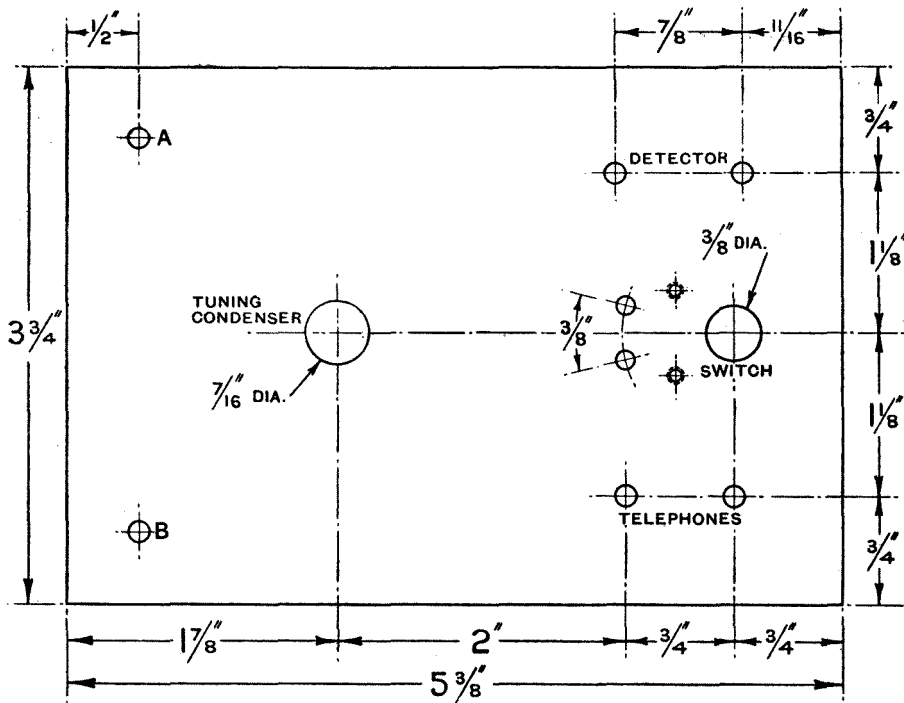

Fig. 2. Lay-out of the components on the ebonite panel.

When the instrument is to be used as a crystal receiver the aerial and earth should be connected to the terminals marked A and B respectively. It will be noticed that a fixed condenser C is connected between the aerial terminal and the tuned circuit. This fixed condenser may have a capacity of about 0.0001 microfarads. The setting of the tuning condenser for a given wavelength when the instrument is employed as a crystal receiver is only a little higher than when it is employed as a wavemeter.

Those who find that a simple tuned circuit performs satisfactorily as a wave-trap will be able to employ this instrument by connecting to the A and B terminals, removing the telephones from the telephone terminals and putting the switch in the "off" position.

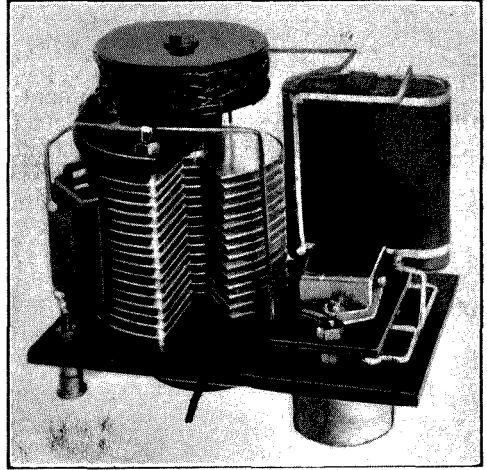

Fig. 4. A view of the instrument which shows the arrangement of the components.

AN INDIRECT METHOD OF DETERMINING THE GRID CHARACTERISTIC.

While the determination of the anode characteristic of a valve is a fairly simple matter to the possessor of a milliammeter, the determination of the grid characteristic involves the use of a microammeter, an instrument which few experimenters possess. An indirect method of determining the grid characteristic is therefore of interest.

By M. E. JANMOULLE, A.C.G.I., B.Sc.

THE circuit which is used is shown in Fig. 1 and does not differ materially from that usually employed for determining the anode characteristic, except for the provision of a grid leak and short-circuiting switch in the grid circuit.

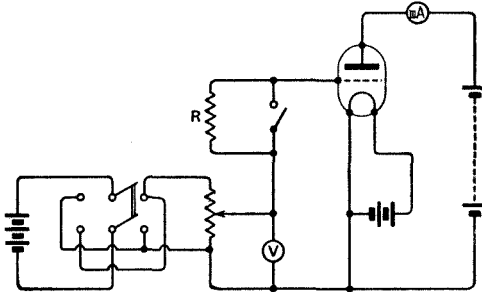

Fig. 1. The circuit arrangement for determining the grid characteristic.

The filament current and plate voltage need not be known, but both must be kept constant throughout the test.

Variable grid potentials may be applied to the grid either directly or through the grid leak by means of a potentiometer, reversing switch and grid battery, and may be read off on a low-reading voltmeter V.

The anode current may be measured by means of a milliammeter mA included in the anode circuit.

The value of the grid leak should be accurately known; it would perhaps be best to obtain one of reliable make, and to have it measured by the makers. Failing that, a Wheatstone bridge or a low-voltage insulation tester may be used to measure the resistance of the grid leak used.

The anode characteristic is first taken in the usual way, the grid leak being short-circuited. A series of grid potentials are

applied to the grid, and the corresponding values of the anode current noted. A curve is then plotted showing the relation between grid potential and plate current (curve 1, Fig. 2).

The grid leak is then inserted and the relation between the potential of the lower end of the grid leak and anode current found in a similar manner. The results are plotted on the same sheet (curve 2, Fig. 2).

It will be noted that the two curves differ considerably in shape. The grid characteristic may be derived from these curves in the following manner.

Consider two points A and B on curves 1 and 2 respectively such that the plate

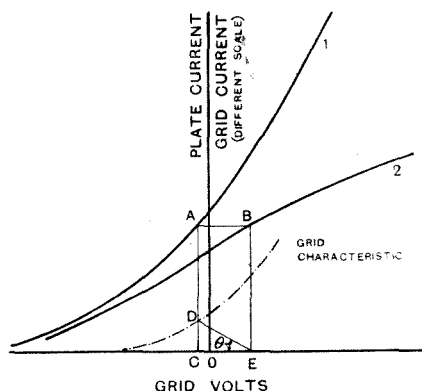

Fig. 2. Showing the method of obtaining points for the grid characteristic curve.

current is the same. The grid potential which corresponds to that current is obviously OC , hence the potential of the top or grid end of the grid leak corresponding to point B must also be OC . Since the potential of the lower end is OE , it follows that CE is

the drop of potential along the grid leak due to the grid current flowing in it. The latter may therefore be found by dividing CE expressed in volts by the resistance R of the grid leak.

This current may then be set off along CA at any convenient scale, and the grid characteristic is found by joining a series of points determined in this way.

A more convenient way of doing this is to set off a line ED from E such that

$$\tan \theta = \frac{I}{R},$$

due consideration being given to the scales of grid current and grid potential.

The point of intersection of ED with AC will give the required point on the grid characteristic. The complete characteristic is found as previously by joining a series of points.

The proof of the latter construction follows immediately from the geometry of triangle DCE :

$$\begin{aligned} DC &= CE \times \tan \theta \\ &= CE \times \frac{I}{R} \end{aligned}$$

but $CE =$ voltage drop along resistance

$$R = V, \text{ hence: } DC = \frac{V}{R} = \text{current in } R = \text{grid current.}$$

This method is naturally not so accurate as the direct method, but gives quite good results provided the grid leak is accurately known. Even when the grid leak cannot be measured at all, by giving it an arbitrary value, the *shape* of the grid characteristic can be determined, which in some cases is sufficient to find the best values of grid potential to suit the operating conditions of the valve.

THE FREE STATE AMATEUR.

Comment on the slow development of wireless in the Irish Free State was made by Mr. G. M. Harris, President of the Radio Association of Ireland, at a meeting in Dublin on October 7th. Although, he said, Irish wireless amateurs paid higher licence fees than were demanded in any other country, they were prohibited from experimental transmission and were left with no alternative but to listen in to what other people provided and paid for.

Mr. Bradley proposed that the Association should strongly condemn the attitude adopted by the Irish Post Office towards amateur wireless work in general, and Mr. Callaghan, seconding,

said that the time had come when licences should be granted for amateurs to participate in the Transatlantic tests. The original motion having been withdrawn the following resolution was finally passed:—

“That this Association disapproves most strongly of the lack of support and the absence of facility given by the Postmaster-General of Saorstát Eireann to the development of amateur wireless communication in the Free State. It considers it most unfair and unjust to impose the present fee for wireless reception, and strongly urges that a broadcasting scheme be at once undertaken and completed.”

PATENTS AND ABSTRACTS



A Regenerative Receiver.

Reaction effects are usually obtained by magnetic coupling between the anode and grid circuits, or by connecting a small variable condenser between the anode and grid of the valve. Unless the values of the components have been carefully chosen, there is usually difficulty in obtaining close adjustments. It is claimed (see Patent No. 222,595) that it is easier to make the desired adjustments by employing the circuit of Fig. 1.

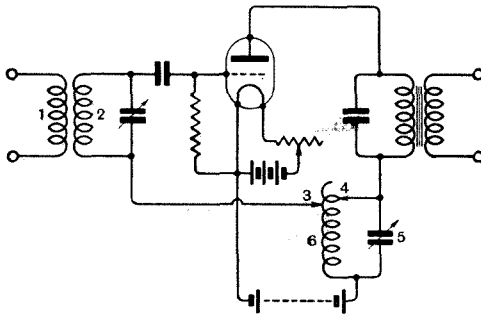

Fig. 1. Connections of a regenerative receiver having a tuned anode circuit. One end of the secondary circuit is connected to the anode circuit.

The ends of the coil 1 may be connected to the aerial and earth in the usual manner, and the secondary circuit, 2, comprises the coil and tuning condenser. The end of circuit 2 does not, however, connect direct with the filament, but is joined to a contact, 3, on coil 6, which is in the anode circuit. The anode circuit contains an intervalve transformer (or telephones), the tuned circuit 5-6, and the anode battery.

In order to obtain regeneration, it is desirable that the different tuned circuits be in resonance with the incoming signal, and for that purpose the tuned circuit 5-6 is tapped, the portion of coil 6 in circuit being determined by the position of contact 4.

The operation of the circuit is somewhat as follows: incoming signals are tuned by adjusting circuit 2, and setting up amplified voltages across circuit 5-6, joined to the anode of the valve. As circuit 2 is connected by contact 3 to coil 6, the amplified voltages in coil 6 affect the grid circuit, and are such as to assist the currents already flowing in the grid circuit. The degree of reaction may be varied by altering the position of contact 3 on the coil.

High Frequency Amplification.

In most receivers employing tuned intervalve high frequency couplings good results are obtained as regards selectivity and signal strength, but there is the disadvantage that it is difficult to tune in a signal whose wavelength is not accurately known. A further difficulty arises in connection with the provision of reaction to give effect both on the aerial and anode circuits.

With the object of removing these disadvantages, the arrangement of Fig. 2 has been devised and is described in Patent No. 222,562. It will be seen that three valves are employed. The first valve V_1 operates

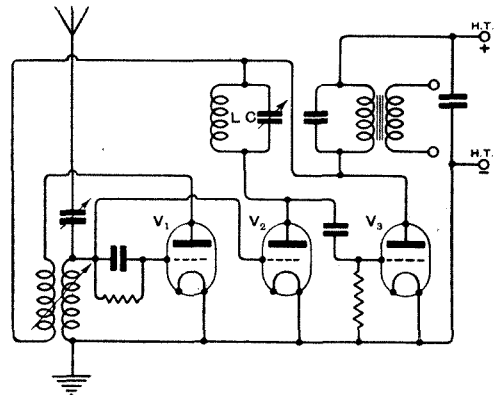

Fig. 2. A special method of connecting three valves to give ease of operation, and selectivity.

as a rectifier, and has a reaction coil connected in its anode circuit. The second valve, V_2 , is also connected to the aerial, and includes in its anode circuit a tuned circuit, L-C. There is also a third valve, V_3 , the grid of which is connected to the anode of the second valve through a condenser. The anode of the third valve is connected to the low potential end of the reaction coil, and to one end of the primary winding of an output or telephone transformer, or to telephones.

The method of using this circuit is as follows :—

If it is desired to receive a station whose wavelength is not accurately known, the filaments of the valves V_2 and V_3 are switched off, and the valve V_1 is used. When the station has been found, in order to introduce the tuned high frequency amplification, all that is necessary is to complete the filament circuits of (valve V_2 , with its associated detector valve V_3).

An important point is that no switching of any high frequency portion of the circuit is necessary. When these valves are turned on, it will be found that whatever the tuning of the anode circuit, the signal as received on the stand-by arrangement will not be lost, although it will be slightly weaker, owing to the extra loading of the grid of the valve V_2 . All that is then necessary is to tune the circuit L-C, until either the system oscillates or an increase of signal strength is noted.

The question as to whether the receiver will oscillate when L-C is brought into tune with the aerial circuit depends largely upon the ratio of C/L in the tuned anode circuit. If this ratio is large, the signal will be increased without oscillation commencing. If the ratio is small, immediately the two circuits come in tune, the receiver will for the moment oscillate. To stop this the coupling between the reaction coil and the aerial coil may be weakened slightly.

Simplified Tuning.

In the construction of a wireless receiver which is to be highly selective, it has been found advisable to provide at least three separate adjustments by which the operator can tune the receiving circuits to the desired wavelength. These three adjustments, for example, might comprise the following: (1) an adjustment to tune the aerial; (2)

to tune the secondary or grid circuit of a valve; and (3) to tune the anode circuit of this valve.

A receiving set with three such adjustments is difficult to operate, as it is obvious that one operator cannot make these three adjustments simultaneously. Accordingly, the Western Electric Company (Patent No. 221,868) have designed a receiver in which the knobs for making two or more adjustments are so associated with each other that the actuation of one knob will cause movement of the knobs controlling one or more of the other adjustments.

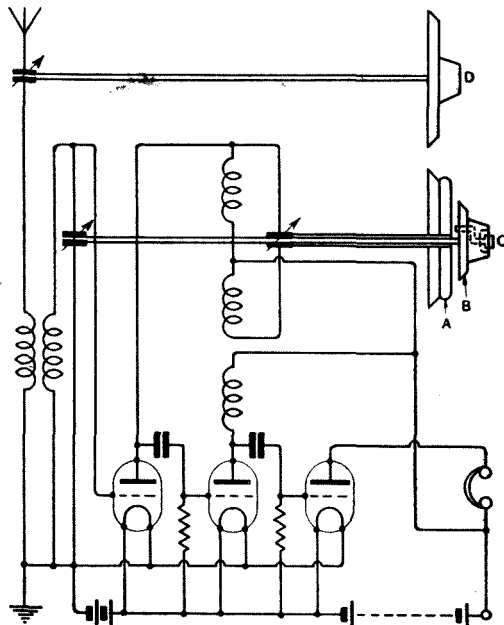

Fig. 3. A three-valve receiver having three tuned circuits arranged for easy operation.

This is effected by providing a small bolt, which may be moved to lock the knobs together. One arrangement is shown in Fig. 3, where the grid and anode circuits are tuned by variable condensers, the condensers being operated by knobs A and B.

When it is required to tune the set to any desired wavelength, bolt C is depressed, and the two knobs, D and A actuated until the signals to be received are heard in the receiver. To obtain a fine adjustment, the bolt C is withdrawn from knob A, and knobs A and B are then operated separately until the signal is heard with the greatest strength.

THE SUPER-HETERODYNE RECEIVER

AN ACCOUNT OF ITS ORIGIN, DEVELOPMENT AND SOME RECENT IMPROVEMENTS.*

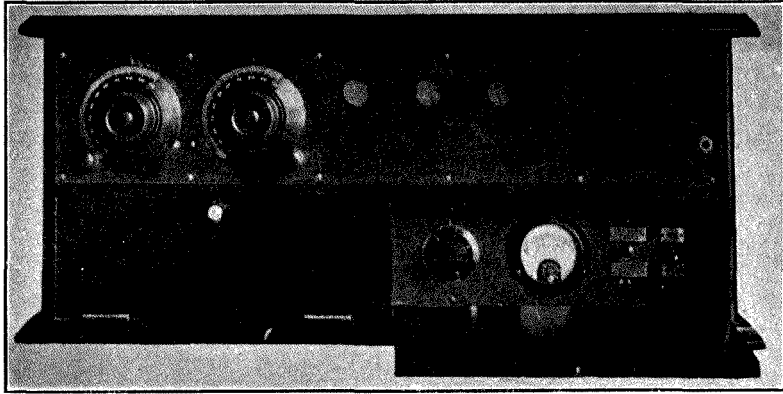

THE invention of the super-heterodyne dates back to the early part of 1918. After much experimental work an eight-valve set was constructed, consisting of a rectifier, a separate heterodyne oscillator, three intermediate frequency amplifiers, the second rectifier and two low frequency stages. The intermediate frequency stages were coupled by tuned aircore transformers adjusted for a frequency of about 100,000 cycles, with an

The arrangement of this circuit is given in Fig. 1. It gave satisfactory results, except that the inclusion of a regenerative control on the intermediate frequency amplifier made skilled handling necessary, as the adjustment of the frequency of the oscillator changed the plate current of the detector valve, and this in turn varied the resistance which that valve introduced into the amplifier and upset the regenerative adjustment.

For the purpose of determining the results

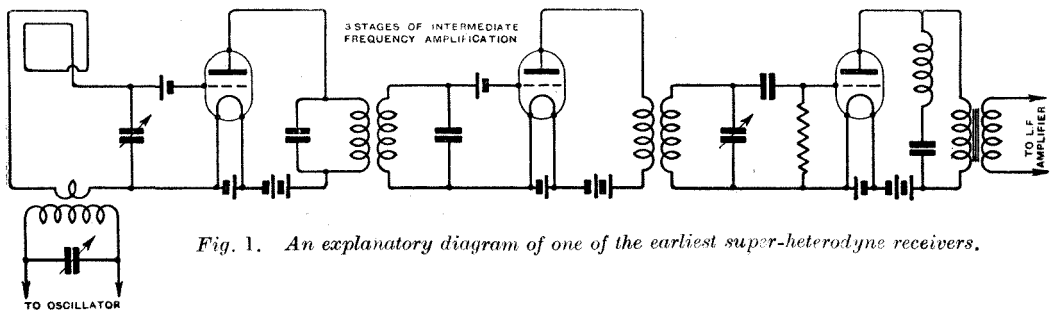

Fig. 1. An explanatory diagram of one of the earliest super-heterodyne receivers.

adjustment for controlling the regeneration. The amplification of voltage measured at the input of the second detector with the amplifier just below the oscillating point was equivalent to a radio-frequency amplification of 500.

* Described by Edwin H. Armstrong in a paper read before the Institute of Radio Engineers, New York, March 5th, 1924.

which can be obtained by pushing the method of super-heterodyne reception to the limit, a resistance-coupled intermediate frequency amplifier consisting of five valves having a high amplification factor was constructed.

The voltage amplification of the five stages was probably between 5,000 and 10,000 fold.

While greater amplification could have been obtained, the sensitivity of a set composed of a two-valve frequency converter, a five-valve intermediate frequency amplifier, a detector, and one stage of note magnification was such that on a 3-ft. loop, the sole criterion of reception was simply whether the signal was stronger than the atmospheric disturbances.

With the coming of broadcasting, and with the increase in the number of stations and the consequent interference, the super-heterodyne began to take on a new importance, an importance which was based not on its superior sensitivity nor on its selectivity, but on the great promise which the method offered in simplicity of operation. This solution lay in the construction of an intermediate frequency amplifier which would amplify a given frequency, and a band 5,000 cycles above and below it, and which would cut off sharply on either side of this

solely whether the signal strength was above the level of the atmospherics. The selectivity was such that stations which had never been heard before on account of interference from local stations were received without a trace of interference. While the performance of the set was much superior to any other receiver, the cost of production and maintenance was prohibitive.

It has been apparent ever since the question of the application of the super-heterodyne to broadcasting has been considered, that there were too many valves performing a single function which were quite capable of performing a double one. The most outstanding example is that of the separate heterodyne oscillator. Two tuned circuits were therefore connected to the oscillator, comprising a simple circuit tuned to the frequency of the incoming signal, and a regenerative circuit adjusted to oscillate at such a frequency that the second harmonic of this frequency, beating with the incoming frequency, produced the desired intermediate frequency. The circuit is shown in Fig. 2.

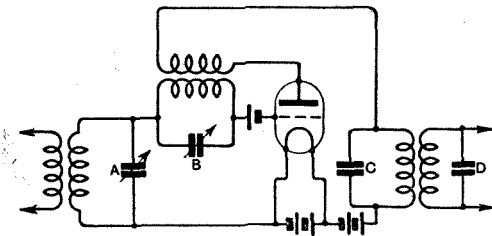

Fig. 2. One arrangement in which the valve performs a double function.

Referring to this diagram, circuit A is tuned to the incoming signal, circuit B is tuned to one-half the incoming frequency, plus or minus one-half the intermediate frequency, and circuits C and D are both tuned to the intermediate frequency. The operation of the system is similar to ordinary self-heterodyne action.

desired band. To determine just what could be accomplished on these lines, a set giving the maximum usable sensitivity and selectivity was constructed. A high frequency stage (untuned transformer), a rectifier, an oscillator, a three-stage iron core transformer-coupled intermediate frequency amplifier, designed to cover a band of 20,000 to 30,000 cycles, a second detector, and two stages of low frequency amplification were employed. The receiver is shown (without the low-frequency amplifier) in the accompanying illustrations.

By reason of the asymmetrical action of the valve, there are created in the circuits a

To prevent the intermediate frequency amplifier from oscillating each stage was shielded. The use of a high frequency stage before the first detector possesses the advantage that the reaction coil may be coupled with the detector valve circuit instead of the frame aerial circuit. The results obtained with this receiver were as follows. On a 3-ft. frame aerial, the factor determining the reception of the station was

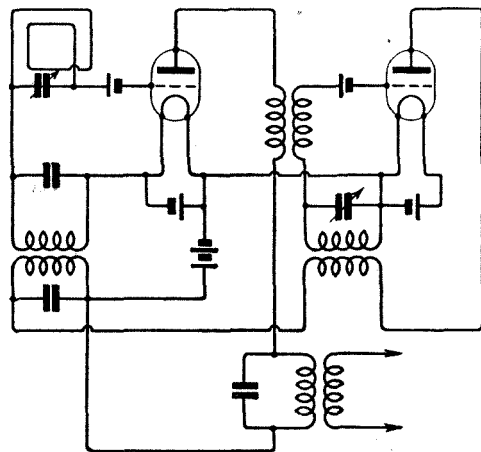
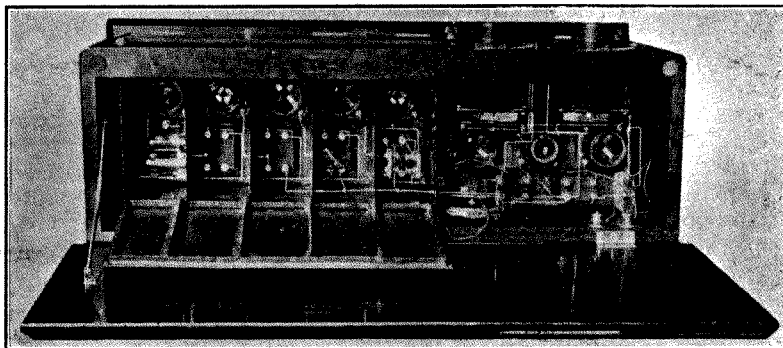

Fig. 3. The first valve amplifies the incoming signal and the intermediate frequency signal and the second valve is the second harmonic oscillator.

variety of harmonics. The second harmonic combines to produce beats with the incoming signals of the desired intermediate frequency. The valve rectifies them to produce the

to oscillations of various frequencies, and in addition prevents the reception of long wave signals by the intermediate frequency amplifier.



Rear view of an early type of super-heterodyne receiver.

desired intermediate frequency, and through circuits C and D the new frequency is supplied to the amplifier.

As circuits A and B are tuned to frequencies differing by approximately 100 per cent., a change in the tuning of one has no appreciable effect on the tuning of the other. This arrangement solved the oscillator problem, and in addition practically eliminated radiation.

The next step in the reduction of the number of valves was to make the radio-frequency amplifier perform the function of amplifying the intermediate frequency as well. The general arrangement of the circuit employed is shown in Fig. 3.

The signals received by the loop aerial are amplified at radio frequency by the first valve and applied to the grid of a second harmonic oscillator by means of an untuned radio-frequency transformer. The combined signalling and heterodyning currents are then rectified by the second valve, producing a current of the intermediate frequency, which is applied to the grid of the first valve, amplified therein, and passed to the second stage of the intermediate amplifier.

A more practical arrangement for the circuit is shown in Fig. 4, where the secondary winding of the first intermediate frequency transformer is connected to the grid of the first valve in parallel with the frame aerial. The parallel type of circuit eliminates a variety of reactions which would give rise

The arrangements just described were incorporated in a receiver which measured 18 ins. \times 10 ins. \times 10 ins., and was completely self-contained, the batteries, frame aerial and loud-speaker mechanism being enclosed in the box.

The possibilities of this type of receiver were recognised by the Westinghouse Electric and Manufacturing Company, the General Electric Company, and the Radio Corporation of America, who placed the invention in a commercial form. Many improvements and some new ideas of

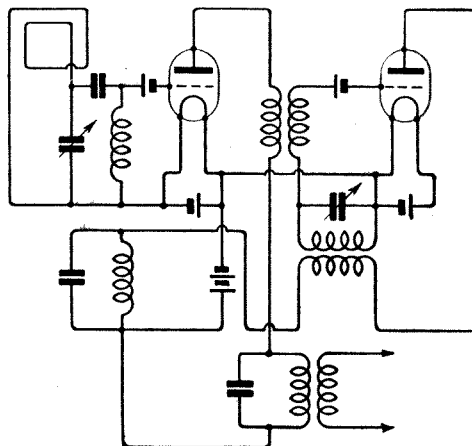

Fig. 4. A more practical circuit than that of Fig. 3.

designs have been introduced. In the final instrument an additional stage of low frequency amplification was added in order to ensure operation within steel buildings.

TWO REFLEX REINARTZ CIRCUITS.

Two circuits are described, one having a crystal detector and the other a valve detector.

By H. C. EXELL, B.Sc.

IN *The Wireless World and Radio Review* for May 13th, 1922, a full description of a simple Reinartz circuit was given, and in the issue for the following July 8th the addition of one stage of H.F. amplification was described.

TUNER.

The aerial coil (BD) is a continuation of the grid coil (AB). For tuning up to about 500 metres 50 turns of No. 20 D.C.C. wire are wound on a 3 in. diameter former, tapings being provided for by baring a short length of wire and twisting into a loop, to which the lead to the contact stud is subsequently soldered. Tapping points are arranged for after 10, 20 and 50 turns have been wound on, the final point being B (Fig. 1), and this is taken to a terminal on the panel on which the completed coil is mounted. The winding is continued past B for 10 more turns, tapings being taken from each turn. The reaction coil is then wound on the same former, starting immediately after the finish of the aerial coil. If the one-valve and crystal circuit is used (Fig. 1) the reaction coil is wound in the same direction as the aerial coil, but if the two valves are to be employed (Fig. 2) its direction is reversed, or else the connections of the reaction coil are made in the opposite way to that shown in the diagram.

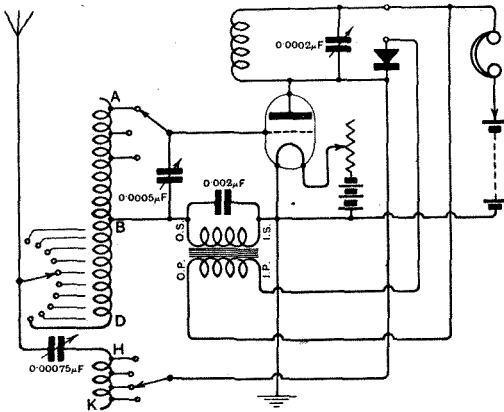

Fig. 1. A reflex Reinartz receiver employing a crystal detector.

It occurred to the author that L.F. amplification could be obtained by using a reflex or dual circuit, thus extending the use of this most selective method of tuning.

Two circuits were tried out, the first (Fig. 1) using crystal rectification and the second (Fig. 2) using a valve detector, both operating successfully. The latter circuit, using two valves, gave trouble at first owing to oscillations being set up which were just within audible frequency, and seemed very similar to the Armstrong oscillations in the super-regenerative circuit. These were apparently due to the winding of the L.F. transformer in the grid circuit of the first valve shunted by a condenser, and that in the plate circuit of the second valve, and were eliminated by careful design of the choke (C), Fig. 2.

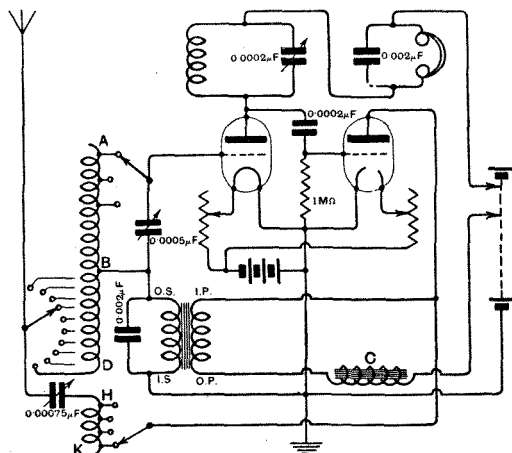

Fig. 2. In this reflex Reinartz receiver a valve detector is used.

Thirty turns of No. 20 D.C.C. wire are sufficient, and the coil is tapped at 10, 20 and 30 turns. A former for the whole tuner and reaction coil about $5\frac{1}{2}$ ins. long, will be necessary, and when wound may be mounted behind an ebonite panel 6 ins. by 6 ins., fitted with three switches and contact studs. One ten-point switch for the aerial coil, a three-point switch for the grid coil, and a four-point switch for the reaction coil.

ANODE COIL.

A decided advantage is gained by winding this with thick wire and employing a small tuning condenser. The maximum capacity should not exceed 0.0002 microfarads, and for tuning over the broadcast range the following coil will serve. Ninety turns of No. 20 D.C.C. wire are wound on a 3 ins. diameter former, and tapings are taken at 45, 60, 75 and 90 turns. The coil may be mounted on a panel with two terminals and a four-point selector switch to accommodate the tapings.

CONDENSERS.

As given in the diagrams, a $0.00075\mu\text{F}$ condenser is used for reaction, a $0.0005\mu\text{F}$ to tune the grid circuit, and a $0.0002\mu\text{F}$ for the anode circuit.

It would undoubtedly be better to use a smaller condenser across the grid circuit, and a correspondingly larger grid coil, but this would, of course, alter the reaction effects, and in all probability it would in that case be found better to alter also the size of the reaction coil and condenser. The former values were, however, used in the author's circuit and proved satisfactory, so were unaltered.

In the crystal detector circuit (Fig. 1) no condenser should be used across the primary

of the L.F. transformer or the 'phones, as the H.T. is supplied in shunt. If condensers are used the impedance will be insufficient to choke back the H.F. oscillations, and it will be difficult to make the circuit oscillate.

In the two-valve circuit, however, the telephones are in a circuit where H.F. oscillations may be by-passed by a $0.002\mu\text{F}$ condenser across them. In the latter circuit the $0.002\mu\text{F}$ condenser across the secondary of the L.F. transformer, *i.e.*, in the grid circuit of the first valve, may be reduced in size with advantage in many cases, and possibly a condenser as low as $0.0003\mu\text{F}$ may be found satisfactory.

CHOKE C.

This component is of high importance in this particular circuit on account of oscillations just within audible frequency which are liable to be set up. A telephone ear-piece and a L.F. transformer secondary were tried and found to be not very successful.

A suitable choke may be made by winding 3 ozs. of No. 40 gauge wire on a core of iron wires $\frac{3}{8}$ in. in diameter and about 6 ins. long, the winding occupying 2 ins. in the centre. When the winding is completed the ends are brought to terminals, and the iron core wires bent back round the winding as in a hedgehog transformer.

Hard valves are used with normal H.T. A perikon crystal detector will be found satisfactory, as it is sensitive and has the advantage of stability. Zincite-bornite is a good combination.

It will be found when using this circuit, that interference from local broadcasting can be eliminated, and the freedom from other extraneous noises, such as atmospherics, is remarkable.

ST. DUNSTAN'S NINTH ANNUAL REPORT.

The two outstanding impressions left by a perusal of the Ninth Annual Report of St. Dunstan's, are, firstly, the splendidly permanent effects of the work undertaken by the Organisation on behalf of the Empire's war-blinded men, and secondly, the efficiency and business-like character of the administration.

There is very clear evidence on reading this detailed Report of past achievement, present endeavour and future responsibilities, that St. Dunstan's work is far from finished yet. It will probably come as a shock to many of us who were

inclined to regard the work of St. Dunstan's as necessary only during the years of war, to learn that since the Armistice over six hundred men have been admitted to St. Dunstan's care and training.

The Council are to be congratulated upon showing a small balance on the right side. But it is pointed out that this position has only been rendered possible by the exercise of the most rigid economy and unremitting effort, no less than nine-tenths of the yearly income needed having to be raised by appeals to the public.

NOTES & NEWS



The Third Annual Chicago Radio Show, representing one hundred and eighty leading American manufacturers, besides English, French, Italian, German and Japanese, opened on November 18th.

Transmission of pictures by telegraph and wireless has been introduced as a branch of study at the Berlin Technical High School.

The Marconi Company announces a reduced tariff for wireless messages to Australia on and after December 1st.

The British Broadcasting Company celebrated its second birthday on Friday, November 14th.

BROADCASTING FROM BELGRADE.

The English Sports House at Belgrade advises us that the local broadcasting station transmits concerts every Tuesday, Thursday and Saturday from 5.45 to 6.45 p.m. (G.M.T.) on a wavelength of 1,650 metres.

SPANISH BROADCASTING PROGRESS.

The new Barcelona broadcasting station has been allotted the call sign **EAJL** and is at present testing on 325 metres with a power of 100 watts. The times of these transmissions are 6 to 7 p.m. and 9 to 11 p.m. Regular programmes will shortly commence with the broadcasting of operas from the Liceo Theatre in Barcelona.

NEW FRENCH BROADCASTING STATION.

French listeners remote from Paris have recently been bewailing the fact that, beyond the indifferent reception from the Parisian stations, they are unprovided for in the matter of broadcasting.

Those in the south-west parts of France will soon have their troubles removed, for a new broadcasting station is to be established at Agen, in the Department of Lot-et-Garonne, to operate on a wavelength of 300 metres. Official permission to erect the station is expected very shortly. The suggested power of 200 watts is somewhat low, but it is probable that this will be increased if public demand is forthcoming.

AUSTRALIAN SHORT WAVE SIGNALS HEARD.

What appears to be the first report of the reception of short wave amateur transmissions from

Australia has been sent to us by Mr. W. J. Randell (**G 6UD**) of 104 Talbot Street, Nottingham. At 7.45 a.m. on November 9th, states our correspondent, a faint C.W. station was heard calling **CQ de A 8GZ** on a wavelength between 75 and 80 metres. The station was heard a few minutes later, but was jammed by **U 1CMP**.

A further interesting report has reached us from Mr. F. Walker, of Walton-on-Thames, who at 6.35 on the evening of November 12th, heard the Australian short wave station **A 2ME**. Although the complete message was not heard, it was signed "Fisk," and addressed to **ICCN**. The signals reached a maximum intensity of about **R6** at 7 p.m., on a receiver consisting of a detector and one note magnifier. It is, however, probable that **A 2ME** was using much greater power than is customarily used by amateur transmitters. Of considerable importance is the fact that good reception was obtained at 7 in the evening, exactly a twelve hours' difference from the time when amateur communication with New Zealand has been most successful. From this it would appear that darkness over half the globe between the communicating stations is essential, though whether it be east or west does not matter.

The first Cheshire amateur to effect two-way communication with New Zealand is Mr. H. Williams (**2 JF**) of Wallasey, who successfully worked for a period of twenty minutes with **Z 4AG** on the morning of November 10th.

New Zealand **4 AA** was heard by Mr. E. Shackleton of Leeds at 6.58 a.m. (G.M.T.), on November 9th, working on 93 metres.

WIRELESS FOR LEPER COLONY.

The leper colony on the Island of Culion, in the Philippines is shortly to be linked to the outer world by wireless. A receiving set, presented by an electrical company, is being installed.

PROFESSOR BRANLY DECLINES BIRTHDAY CELEBRATIONS.

Those familiar with the temperament of Professor Edouard Branly were not surprised by the news that he had declined the proposal for the celebration of his 80th birthday with a banquet. The famous French radio pioneer intimated that he never dines out.

ZURICH ASKS FOR REPORTS.

A Swiss broadcasting station which is worth an attempt to hear is Zurich. It has already been picked up in London with detector and L.F. This station transmits nightly from 8.15 onwards on 650 metres, and employs a power of 500 watts. The announcements are made in German, and reports, which are welcomed, should be addressed to Radiogenossenschaft, Zurich, Switzerland.

M. LEON DELOY'S SUCCESS.

M. Léon Deloy, of Nice, reports that he has now successfully worked with a New Zealand amateur. On October 30th, at 6 a.m. after communicating with Mr. Carlos Braggio (DA8 ex CB8), M. Deloy made his first attempt to call New Zealand. He was immediately answered by two New Zealand stations, but owing to bad receiving conditions in France he did not hear their replies, which were passed on to him later by M. Menars (F8FJ), of Le Blancat.

On the following morning, however, successful two-way communication was established with Z4AK, who reported M. Deloy's signals as strong. The New Zealander's transmission was also good but signals faded, until at 7.4 a.m. they were indistinguishable.

M. Deloy points out that Nice is further away from New Zealand than the whole of Great Britain and the rest of France, the distance being actually

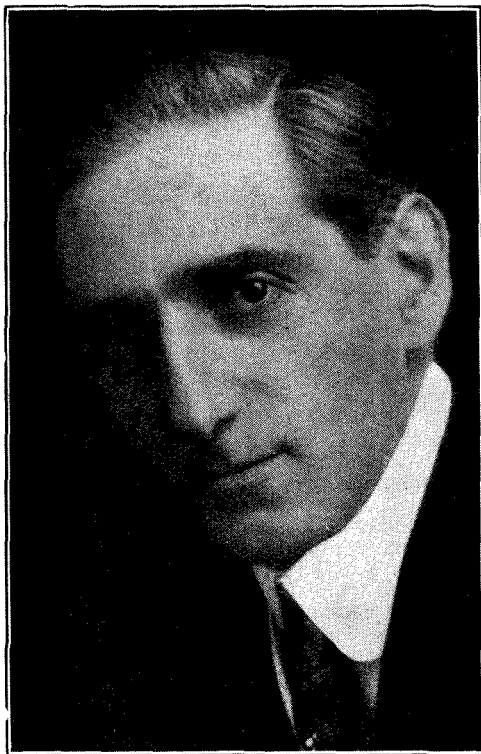

Mr. Godfrey C. Isaacs, who has resigned the Managing-Directorship of the Marconi Companies.

AN IMPORTANT RESIGNATION.

It was officially announced on November 13th that Mr. Godfrey Isaacs, for reasons of ill health, had been compelled to relinquish the Managing Directorship of Marconi's Wireless Telegraph Co., Ltd., and the Marconi International Marine Communication Co., Ltd., a position which he had held with distinction for fifteen years. The Companies will continue to have the benefit of his services in a consultative capacity. We feel sure that our readers will endorse our hope that Mr. Isaacs' recovery will be rapid and complete.

Mr. Isaacs is succeeded by the Rt. Hon. F. G. Kellaway, who joined the board of the Marconi Company in November, 1922. Mr. Kellaway will be remembered as the Postmaster-General who was responsible in 1922, for the institution of broadcasting, and for the drawing up of the agreement between the Post Office and the British Broadcasting Company.

EIFFEL TOWER SHORT WAVE TESTS.

Although the series of short wave tests from the Eiffel Tower have been temporarily suspended, the meteorological transmissions on 115 metres are being maintained at the following times (G.M.T.):

- 2.20 p.m. Le Verrier bulletin.
- 11.0 p.m. Maury bulletin.
- 4.0 a.m. Repetition of Le Verrier and Maury bulletins.



The Rt. Hon. F. A. Kellaway, who succeeds Mr. Isaacs, has had a wide experience in Government departments.



A novelty of the Lord Mayor's Show this year was the broadcasting of a description of the procession by onlookers. John Henry was one, and he is seen on the left in our photo, in a room overlooking Northumberland Avenue, down which the Lord Mayor passed.

11,220 nautical miles. M. Deloy's success is not surprising, for it will be remembered that he was the first European amateur to get in touch with America.

LONGITUDE BY WIRELESS.

A scheme to ascertain by wireless whether the world's longitudes are trustworthy, is being undertaken by General Gustav Ferrié, Chief of Radio Communications of the French Army.

Interviewed by our Paris correspondent, General Ferrié said that leading scientists have long suspected a certain error in the longitudes of the world, especially since the discovery of latitude variations caused by the erratic motion of the Poles. The great difficulty in checking longitudes has always been the small unavoidable variation in ship's chronometers. This trouble it is hoped to overcome by a chain of wireless stations. The original intention had been to operate with three stations, one on the American Pacific coast, one in China and one on the Mediterranean, but this number was found insufficient and plans are therefore delayed until an adequate number is available. This interesting research will probably commence in the winter of 1925.

RADIO AND RUM SMUGGLERS.

Wireless warfare is taking place in American waters owing to the action of the United States

Coastguard Service in equipping 475 vessels with radio apparatus to combat the "bootleg" rum fleet.

Many of these illicit craft are fitted with efficient wireless installations, by means of which they are able to communicate with smugglers on the coast. The aim of the U.S. authorities is to intercept these messages, with results that should make America drier still.

THE AERMONIC VALVE HOLDER.

We regret that in our description of the Aermoric Valve Holder on page 138 of our issue of October 29th, the name of the manufacturer was inadvertently omitted. This useful component is a product of Messrs. V. R. Pleasance, of 60 Fargate, Sheffield.

CKAC, MONTREAL.

An interesting photograph appeared in our last issue showing the organ in the studio of CKAC, the famous broadcasting station of "La Presse," at Montreal. This photograph was kindly supplied through the courtesy of the Internacional Ido-Radio-Klubo, to whom acknowledgment should have been made. This society is the international organisation of Ido-speaking amateurs.

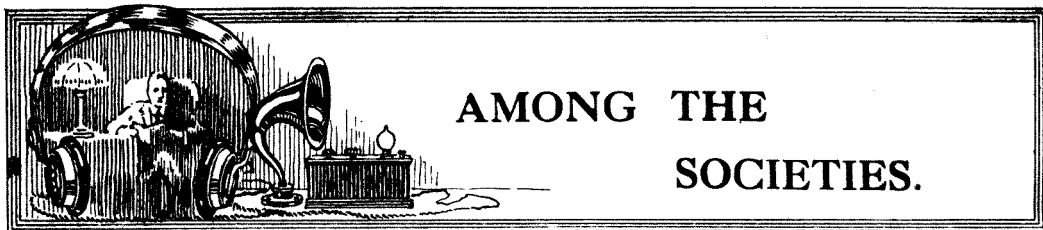

AMONG THE SOCIETIES.

Radio Society of Great Britain

An ordinary general meeting of the Society will be held at 6 p.m. (tea at 5.30), at the Institution of Electrical Engineers, Savoy Place, W.C.2, on Wednesday, November 26th, when Mr. L. B. Turner, M.A., will deliver a lecture entitled: "Wavemeters."

T. AND R. NOTES.

The transmissions of the Canadian amateurs are now rapidly growing in number, a welcome fact, for except C IAR, little activity has been apparent from them.

Our old friend 2 BG of Montreal, asked me to inform British transmitters that the Canadian second district are very anxious to test with us, and will work on 70-80 metres. I replied that we were all anxious to work the Canadian 4th and 5th districts, and gave him our wavelengths and times.

The American 4th district stations now come in very well on 70-80 metres, and a newcomer, 4 QF, puts out a very good signal. Doubtless our members are ambitious to work the New Zealanders, but they would be well advised not to lose sight of the fact that the period of audibility of their signals is getting later every day, owing to their fast approaching summer and longer days.

We have yet to work the 5th, 6th and 7th districts in America, for although one of our members claims to have worked a 6th district station, we must await confirmation of this.

A member also reports having worked U1 CMP on about one watt with an ordinary R valve. This seems indeed a record, and let us hope that confirmation follows! A report has also been received that 2 SH was received in Johannesburg in September. Also a cable has come to hand stating that Finnish 2 NM was received in Urdarband, India, on the 7th of November, at 2330 G.M.T. I have accordingly cabled that our members will transmit every Wednesday at 2330 G.M.T. Please note this. Wavelengths should be between 90 and 120 metres. 5 MO reports reception of Australian 2 AJ, 2 AL, and N.Z. 4 AA between 7 and 7.30 p.m., and members are requested to keep watch at these hours.

In conclusion, members who wish to carry out special tests should send me particulars, when I shall be happy to arrange for co-operative tests with other members.

G. MARCUSE.

(Hon. Secretary, T. and R. Section,

Radio Society of Great Britain).

November, 11th 1924.

* * * *

A series of elementary lectures on "Magnetism and Electricity" is being given before the Tottenham

Wireless Society by Mr. Usher. In the first lecture, given on October 29th, the properties of natural and artificial magnets were dealt with, together with magnetic fields, induced and electro-magnetism. Many interesting experiments were performed, illustrating the various points raised.

* * * *

Members of the Borough of Tynemouth Y.M.C.A. Radio and Scientific Society recently enjoyed an excellent paper on "A Universal Three-Valve Receiver," by Mr. G. J. S. Littlefield, L.D.S.

A minute description of the instrument was given, and the lecturer interestingly explained the theory of the set, from the moment the oscillations are received on the aerial until the audible signals were heard in the telephones.

* * * *

Wavelength, and mathematical data for calculating the length of wire necessary for correct tuning were the subjects of study at a recent meeting of the Brockley and District Radio Association, when this branch of research was interestingly dealt with in a paper by the President, Mr. B. Hughes, M.I.B.

After some instructive demonstrations of aerial oscillations, the lecturer explained the formula for calculating the inductance and capacity required for a given wavelength.

FORTHCOMING EVENTS.

WEDNESDAY, NOVEMBER 19th.

Edinburgh and District Radio Society. At 8 p.m. At 117 George Street. Fifth General Meeting of Series.

Tottenham Wireless Society. Practical Demonstration of Valves. Bristol and District Radio Society. Wireless Lecture No. 4. By Mr. W. A. Andrews, B.Sc.

Radio Research Society, Peckham. At 44 Talfourd Road. Lectures: "Gas and Petrol Engines," "Carrier Current Telephony," "Wired Wireless."

THURSDAY, NOVEMBER 20th.

Bournemouth and District Radio and Electrical Society. At 7 p.m. At Canford Hall, St. Peter's Road. Lecture: "Valve Manufacture" (Illustrated). By Mr. F. E. Goldup, of Mullard Radio Valve Co.

Luton Wireless Society. At 8 p.m. At Hitchin Road Boys' School. Demonstration of High Tensionless Circuits. By Mr. W. J. Banks, of the Bute Electrical Co.

West London Wireless and Experimental Association. At the Belmont Road School, Chiswick, W.4. Lecture: "Insulation Testing." By Mr. L. Shepherd.

FRIDAY, NOVEMBER 21st.

Bristol and District Radio Society. At Comers Restaurant, High Street. Social Evening from 7 p.m. onwards.

Sidcup and District Radio Association. At 8 p.m. At Sidcup Grammar School. Opening Meeting. Demonstration of Coil Winding.

TUESDAY, NOVEMBER 25th.

Leicestershire Radio and Scientific Society. At the Y.M.C.A. Lecture: "Simple Radio Measurements." By Mr. Cyril T. Atkinson, A.I.R.E.

Radio Society of Highgate. At 8 p.m. At the Literary and Scientific Institute. Lecture: "Coils for Short-wave Reception." By Mr. J. H. Reeves, M.A.

AMERICAN BROADCASTING STATIONS IN THE TESTS.

With the object of helping readers to identify the American stations participating in the Transatlantic broadcasting tests during the last week of November, we append a list of the more powerful stations in America. Besides these a number of the lesser stations will also take part.

- KDKA** Westinghouse Electric and Manufacturing Co., E. Pittsburg, Pa., 326 metres.
- KFKX** Westinghouse Electric and Manufacturing Co., Hastings, Nebraska, 285 metres.
- KGO** General Electric Co., Oakland, California, 312 metres.
- KUVQ** Kreetan Co., Johnstown, Drummond I. Mich., 450 metres.
- KYW** Westinghouse Station, Chicago, Ill., 536 metres.
- WBAP** Star Telegram, Fort Worth, Texas, 476 metres.
- WBZ** Westinghouse Electric and Manufacturing Co., Springfield, Mass., 337 metres.
- WEBH** Edgewater Beach Hotel, Chicago, Ill., 370 metres.
- WGN** Chicago Tribune, Chicago, Ill., 370 metres.
- WGY** General Electric Co., Schenectady, N.Y., 380 metres.
- WNYC** Dept. of Plant and Structures, New York., 526 metres.
- WSAI** U.S. Playing Card Co., Cincinnati, Ohio, 309 metres.
- WTAM** Willard Storage Battery Co., Cleveland, Ohio, 390 metres.

The powerful Canadian station, **CKAC**, owned by "La Presse," Montreal, will also participate, operating on 425 metres.

FOUR BROADCASTING BOOKS.*

The romance of the origin of broadcasting in Britain forms the preliminary theme of Mr. Reith's stimulating book. In the opinion of the author, broadcasting is only in its infancy, both as to its age and its possible influence on civilisation. Perhaps the most absorbing part of the book is that in which are discussed the educational, political, literary and religious possibilities of the new art. Will it have to develop its own news agency? This admirable volume supplies the reader with information and suggestions, and asks for his help, so that broadcasting may make the maximum and best contribution to life.

In the pages of "From My Window," many listeners will recognise the pleasantly intimate

*"Broadcast over Britain." By J. C. W. Reith, Managing Director of the B.B.C. (London: Hodder & Stoughton, Ltd., 231 pages. Price 6s. net.)

"From My Window." By "Philemon." With a foreword by J. C. W. Reith. (London: Hodder & Stoughton, Ltd., 255 pages. Price 3s. 6d. net)

"Hullo Boys," and "Hullo Girls." Two new Children's Annuals (London: Cecil Palmer, 49 Chandos Street, W.C.2. Published by courtesy of the B.B.C. Price 3s. net each.)

talks broadcast weekly from 2 LO by that intriguing personality "Philemon." Sane and helpful, without being sanctimonious, these talks cover a wide vista of human experience, revealing a breadth of vision not often encountered in the world to-day.

The uncles and aunts of the B.B.C. are to be congratulated on the appearance of their two new annuals, for boys and girls respectively, published by Mr. Cecil Palmer. The miracle of these books is their price, for it is difficult to understand how, for the modest sum of three shillings, it has been possible to produce such an artistic conglomeration of everything likely to delight a child. They can be warmly recommended as Christmas gifts.



Glasgow (September 20th to October 6th).

French: 8 BN, 8 CA, 8 DI, 8 EM, 8 EU, 8 GI, 8 NS, 8 OM, 8 PP, 8 PQ, 8 RR, 8 SG, 8 SR, 8 WL, 8 XR, 8 ZM, 8 ZZ, 8 JHL, 8 LMT. Finnish: FN 2 NC. Swedish: SMZP, SMZV. Dutch: LOOA, OBU, OQW, OXP. Danish: 7 RG, 7 EC, 7 ZM. Various: 3 CA, 3 XO, YA 40, 4 XZ, 4 RS, 1 CM, W 2, 4 ALS, IAR, IKW, IHT. (A. Ballantyne).

Copenhagen (May to October 15th).

British: 2 JF, 2 JU, 2 NM, 2 SR, 2 XG, 2 XY, 2 ZU, 5 BT, 5 FS, 5 LF, 5 LS, 5 MA, 5 NW, 5 OE, 5 RO, 5 SZ, 6 GM, 6 MP, 6 UD, 6 XG, 6 XX. French: 8 BN, 8 BRG, 8 DA, 8 DI, 8 EN, 8 EU, 8 PA, 8 RS, 8 WL, 8 WZ, 8 ZM, 8 ZN, 8 ZZ. Danish: 7 EC, 7 MZ, 7 QF, 7 ZM. German: 4 BK, 4 C2, 4 QS, 4 RS, 4 YZ. Finnish: FN 1 NA, FN 3 NB, FN 2 NM. Swedish: SMZN, SMZQ, SMZV, SMZY, SMZZ. Dutch: OBA, OBQ, OGA, OMS, OMN, ORW, OSS, OXA, OXP. Italian: 1 FP, 1 GT, 1 NA. Various: 3 NB, UFT 2, P I, 3 ZP. (Borge Jorgensen).

Sheffield (October 11th and 16th, on 80 to 150 metres).

French: 8 BRG, 8 CA, 8 CM, 8 DD, 8 DP, 8 GF, 8 GI, 8 GL, 8 JBL, 8 PA, 8 VV, 8 XH. Dutch: OBA, OIL, OKN, OMS, ORE. Swedish: SMZN, SMZV, FN 2 NM, FN 3 NB. German: 4 QS, 4 RS. Danish: 7 EC. Various: 3 DAX, B 7. (Leonard H. Crowther, 2 LH).

Weybridge (September 21st).

French: 8 DT, 8 RE. Dutch: OGC, OMLJ. Danish: 7 ZM. Unknown: IMO. (o-v-o.) (J. F. Perrin, 5 ZN).

Broadstone, Dorset (August 28th to September 14th).

French: 8 BG, 8 EN, 8 BS, 8 DP, 8 DS, 8 EP, 8 FC, 8 FH, 8 FW, 8 MN, 8 PP, 8 QN, 8 SR, 8 UU, 8 WZ. Dutch: OMS. Various: IMT, 3 AD, 3 XO, 24 XY, MM. (L-v-r.) (J. F. Metcalfe, 2 AHX).

Watford, Herts (during October. All below 150 metres).

French: 8 AL, 8 BRG, 8 BT, 8 BU, 8 CM, 8 CN, 8 CO, 8 DO, 8 EK, 8 EM, 8 EN, 8 GI, 8 GM, 8 JBL, 8 QG, 8 WK, 8 WZ, 8 ZM, 8 ZU, 8 ZZ. American: 1 AUR, 1 BE, 1 BGQ, 1 BQ, 1 BRB, 1 ER, 1 JW, 1 KC, 1 LD, 1 SE, 1 SW, 1 XW, 1 XAV, 2 AAY, 2 BGG, 2 BRB, 3 BDO, 3 BGC, 3 BQU, 3 BTU, 3 CBL, 3 CDG, 3 HL, 3 JW, 3 VW, 8 CYL, 8 NB, 8 XS. Miscellaneous: SMZF, YA 74, YA, PZ, OSE, 4 QS, 4 UU, EAR 3, NAB 2, 9 AD. (H. E. Nicholson, 6 VP).

Cambridge (October 11th to November 1st).

French: 8 AL, 8 BC, 8 EV, 8 EX, 8 FL, 8 FM, 8 FQ, 8 FS, 8 GH, 8 GL, 8 GM, 8 GN, 8 HSM, 8 JBL, 8 QG, 8 TO, 8 WAL, 8 ZUT. Dutch: OGA, OXX, OZA. Swedish: SMZQ, SMZN. Danish: 7 ZM. Finnish: 1 NA. Belgian: 4 ALS. American: 1 CAK, 1 CC, 1 CKP, 1 BGQ, 1 EN, 1 KC, 1 OW, 2 AGW, 2 ANM, 2 MC, 4 SA, 8 BAW, 8 XS. Canadian: 1 DM, 1 DQ. Unknown: AGA, AIN, B 7, GBGM, YA 77, 3 AF, 3 DAX. New Zealand: 2 AC, 4 AA, 4 AG. (o-v-r.) (G. W. Thomas, 2 AQB).

ANOTHER AUSTRALIAN HEARD.

As we go to press a report reaches us that Mr. F. Walker, of Walton-on-Thames, has heard the Australian amateur 3 BQ transmitting on 93 metres. 3 BQ was picked up at 6.50 a.m. on Friday, November 14th and continued to transmit until 7.5 a.m.

UNSOLVED PROBLEMS OF WIRELESS.

By R. H. BARFIELD, M.Sc.

(Continued from page 218 of previous issue).

DISCUSSION.

THE PRESIDENT, opening the discussion, said: I have to leave in a few minutes, and if you do not mind I will break the rule and open the discussion, and then ask Mr. Coursey to take the chair. The lecturer has laid a great deal on the shoulders of the upper atmosphere. It seems to have to bear the blame or the credit for everything that happens. It is credited with helping us to get round the globe, and it is debited with producing night variations in direction finding. The upper atmosphere is, as a fact, a very useful thing to us; as useful as the lower atmosphere. For instance, it is the upper atmosphere which prevents the meteors reaching earth. If it were not for the upper atmosphere we should have a great many more meteors landing on the earth's surface, or on human beings or houses, than we do, and the earth would be a dangerous place to live on. In the same way, the upper atmosphere keeps us from hearing, in wireless receivers, the atmospherics, as we call them, that would come from the sun and which would get through the upper atmosphere if it were not conducting. I think anyone with a little imagination can realise what might happen when they see pictures of these enormous prominences which are shot out of the sun. Prominences are being shot out daily, and the gases of which they are composed are highly incandescent and ionised, and they leave with enormous speeds far greater than matter is ever made to move on this earth. The friction and the ionisation must be enormous, and I think you will agree with me that the electrical discharges must be on the same enormous scale. Consequently, electric waves must be coming from the sun in the way of disturbances to wireless telegraphy, and probably would reach us in great force if the upper layers of the atmosphere were not conducting enough to prevent them penetrating them. I am only adding to the burdens of the upper atmosphere by suggesting these things. The other things which the author has suggested I imagine most of us agree with broadly. He spoke first of signals getting round the globe. Of course that would be impossible by aid of mere diffraction of the rays. You have to invoke the upper atmosphere, the ionised layer in the upper atmosphere, to enable us to understand that phenomenon at all. Then, to understand the next phenomenon, the difference between day and night, you have to invoke still another phenomenon, and I myself, in various publications, have suggested that the layers below the ionised layer—below the Heaviside layer, which, we assume, is permanently ionised—are ionised by the sun daily and de-ionised every night. Hence the waves, especially the short waves, find difficulty in travelling in the day. When these

layers become de-ionised at night, the Heaviside layer is exposed to the earth and the short waves especially can run about, so to speak, underneath the ceiling quite freely. The third problem was directional finding errors at night. Some people have suggested that the Heaviside layer is rather corrugated, or bent. I have forgotten who it was once suggested in this room that it was rather like playing billiards on a bumpy billiard table, the billiard table being upside down—the Heaviside layer—and the balls being the rays. That, however, is nothing like a sufficient explanation, and much more than that is wanted because, as a fact, the rays that are received seem to be polarised in different planes from the vertical plane in which the ordinary daylight signals are polarised, so that we want something that will twist or turn the plane of polarisation as well as reflect or refract, and that explanation has not been forthcoming yet, although, again, suggestions have been made that perhaps the motion of ions under the influence of the waves in the earth's magnetic field may cause some of the trouble. The question of fading, again, the author blames the upper atmosphere for, probably quite justly. It does seem that masses of atmosphere may become electrified or ionised. When you get a portion of atmosphere without any of these banks of ionised air—a portion thousands of miles long, of course—then you get good signals, and when you get ionisation taking place in the space between two stations you get fading. I leave you to discuss this, and I will now ask Mr. Coursey to take the chair.

Mr. G. G. Blake.

One theory has occurred to me which has not been mentioned. It is a very old one, and I do not put it forward in any way as a complete solution. In 1899, when Nikola Tesla introduced what he called "world-wave" telegraphy, he claimed to make the world an oscillator. In effect, the idea is this: that in true Hertzian wireless we have two oscillators insulated from the earth, while in the wireless we now use we have in nearly every instance an earth connection and one aerial or oscillator. The idea then would be that the aerial acts as a large condenser and is charged up and discharged to earth suddenly, and causes, shall we say, wired wireless on the earth, independent altogether of the Hertzian radiation that takes place, and possibly to a greater extent. I do not know whether there is any use for this old theory now. It would not, of course, account for fading in any way, or for the lightness and darkness effect and many of the things that require explaining. I believe that Tesla was led to this idea one day by

observing a passing thunderstorm.* He was in his wireless cabin listening-in when it came over, and he heard the storm getting nearer and nearer, then it passed away into the distance. He noted that as he listened the atmospherics at one moment sounded loudly, a period of time followed during which they faded almost entirely away, after which they again grew to a maximum. This process was repeated several times, and he concluded that the whole earth was oscillating electrically. As the storm travelled along the station alternately entered nodes and loops of the waves.

Captain M. A. Ainslie.

A point has occurred to me in connection with the phenomenon of fading. It does not seem to me necessary to postulate any serious irregularities in the Heaviside layer, certainly nothing that could be compared with "bumps" on the cushions of a billiard table. My idea is that possibly fading is mainly an interference effect. The waves from a transmitting station would normally, assuming the Heaviside layer to be spherical, follow the shortest possible path, like light. They will also follow other paths if there are any extensive deviations from the sphere in the lower surface of the Heaviside layer. I think, therefore, that it would be possible, without postulating any fundamental deformation of the Heaviside layer, that a slight deformation might set up, temporarily, a number of other possible paths for the waves, in which case there might very easily, and probably would, be well-marked phase differences between the waves arriving by the various paths. This might easily cause interference at the receiving station, which might, according to phase, increase or diminish the intensity of the resultant wave. This effect might go through all its variations in a short time, and it seems to me that fading might conceivably be set down to something of this description.

Mr. E. H. Robinson.

There is one interesting theory which I think it would be a pity to ignore, and I think it is quite a new one. A week or two ago Professor Howe, in *The Electrician*, suggested a theory with regard to transmission which is extremely ingenious and at the same time very simple. Suppose you have a station at a certain point on the earth, and that station is sending out in all directions. The waves spread out in zones very much like waves produced in water when you drop a stone in it, but the difference between the water analogy and Professor Howe's theory is this, that, if you drop a stone into a flat sheet of water, the waves go out and out and the intensity dies off continuously. Assuming, as has been pointed out to-night, that waves travelling round the earth are confined to a spherical shell between the surface of the earth and the effective level of the Heaviside layer, they will take the form of zones spreading out from the source and following the surface of the earth with decreasing intensity as they expand. The maximum size will be at the equator, where the intensity will be a minimum. After they have passed the equator they will contract naturally, until at the Antipodes they will concentrate to a point again. It is

perfectly reasonable to suppose that the intensity there will be a second maximum. Professor Howe pointed this out some weeks ago, and said that on this theory you would expect the maximum intensity of the signals again at a point diametrically opposite on the other side of the earth to the transmitting station. I thought it would be interesting to bring that out in view of the fact that communication has been established with the Antipodes during the last few days. I am told by amateurs who have been connected with the work that at such times as they have been in communication with New Zealand, reception conditions for American signals have not necessarily been good. In fact, Mr. Hogg tells me that he has heard these New Zealand stations when the American stations could not be heard, and it is a significant fact that two-way communication has been maintained with New Zealand at a time when I do not believe that two-way communication has been established with the Argentine, though I believe the attempt has been going on for a long while.

Mr. M. Child.

As a matter of historical interest, I would like to point out that the theory that one would expect to find the maximum strength of signals at the Antipodes of a station—I am referring to long distance stations—was put before me by Mr. Glew, who is a very well known radiologist and scientific worker, I think in the year 1901. It was just prior to the time when Mr. Marconi was expecting to get his stations finished to test across the Atlantic. Mr. Glew told me that he thought that if we looked for the signals at the Antipodes of the transmitting station, we should be more likely to get them there than by just going across the Atlantic. Thus you see that these theories which are sometimes given to us by many people are not new in any way. Of course, I do not wish to cast any aspersion upon what Professor Howe has proposed; perhaps it was absolutely original. A matter that has not been brought out this evening is the fact that these long distances have been covered with such small powers, and the distances so covered seem to be increasing as the wavelength goes down. It is this short wave question that we have not heard very much about to-night. I have heard of people receiving exceptionally strong signals with wavelengths as low as 40 or 50 metres, and it would therefore appear that there is some definite ratio of increased signalling strength at night with a given distance, as the wavelength goes down, the primary power being approximately the same. I suppose that when we have carried on this long distance communication for a sufficient length of time so as to enable us to collate some of these facts, we shall be able to determine a good deal more about the conditions necessary for satisfactory communication on exceedingly short wavelengths. Apart from that, we may be able to reproduce some artificial load. We may be able to introduce some artificial conditions under which we can test with waves of a few centimetres, and reproduce, as it were, if possible, our local conditions by means of laboratory tests on a scale which hitherto we have not been able to. Perhaps that is looking a little too far ahead, but it seems to me that when once we can make laboratory tests with extremely short wavelengths, which we can get much more

* He observed the thunderstorm in 1899 and patented his method of "world-wave" telegraphy in 1905.

under control, then we may be able to determine with a much greater degree of exactitude the actual conditions under which wireless waves are radiated and received over the whole surface of the globe.

Mr. F. L. Hogg.

It seems to me that recent work on short wave wireless telegraphy gives great support to the Heaviside layer theory, and also to the theory of Professor Howe. In that connection, however, it is interesting to note that we cannot communicate

good many occasions, particularly in certain localities. Possibly this also may be investigated, and it might be found that it is due to definite interference bands. The effect has not been noticed sufficiently long yet for any definite results to have been obtained. An interesting point, also, is that the stations which have been working in New Zealand are all, I believe, within 300 miles of the Antipodes of England, and there is certainly only one other really high power station in New Zealand, which is a good many miles further away.

THE NEW POSTMASTER-GENERAL.



Sir W. Mitchell-Thomson, Bart., the recently appointed P.M.G.

with California, for instance, and yet these signals reach the Antipodes. I have not seen Professor Howe's theory myself, but I imagine that this theory is based on the waves travelling on the surface of the earth. Surely that could be extended to short waves travelling along the Heaviside layer. There is a point concerning interference bands which might be investigated. There are 50 to 60 metre stations using a pure D.C. supply with a master oscillator transmitter, and having a perfectly fixed wavelength without any possibility of variation, such as those used by the Naval Research Department in the United States, whose notes sound as if they were using unrectified 25 cycle A.C. This hum does not appear always, but it does on a

But that has not been heard yet, although I should think it most unlikely that it has not been on the job on one of the five mornings on which communication has been established up to the present. Time only will show, but I should not be surprised to find that we shall only be able to communicate with stations within a comparatively small area in New Zealand. I have had a letter from the North of England in which they say they cannot locate New Zealand up there. May be we are in some anti-nodal zone in which signals can be received from New Zealand, but that again is a matter which time alone can show.

(The conclusion of the discussion will be included in our next issue).

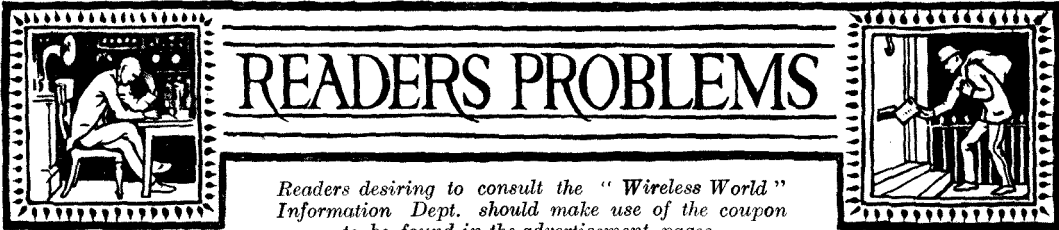

Readers desiring to consult the "Wireless World" Information Dept. should make use of the coupon to be found in the advertisement pages.

A THREE-VALVE FRAME AERIAL RECEIVER.

WITH careful adjustments, frame aerial receivers consisting of only two or three valves are capable of giving excellent results when used in conjunction with head telephones. It is not always necessary to use several stages of H.F. amplification with a frame aerial, and very good results have been obtained with a receiver of the type indicated in the figure below.

Three valves are used, the first operating as a high frequency amplifier, the second as a detector, and the third as a note magnifier. Tuned transformer coupling is employed between the H.F. and

D.C.C. on a former 3 ins. in diameter, the search coil may consist of 10 turns of No. 22 D.C.C. on a cylindrical former 2 ins. in diameter, mounted to rotate inside the reaction coil. A small basket coil having the same number of turns would do equally well for the search coil, and in this case the capacity between the two windings would be slightly reduced.

To reduce hand capacity effects in tuning, it may be an advantage to earth the negative side of the L.T. battery.

With a receiver of this type there should be no difficulty in receiving the transmissions from a main broadcasting station at distances up to 75 miles. Within a radius of five miles of the

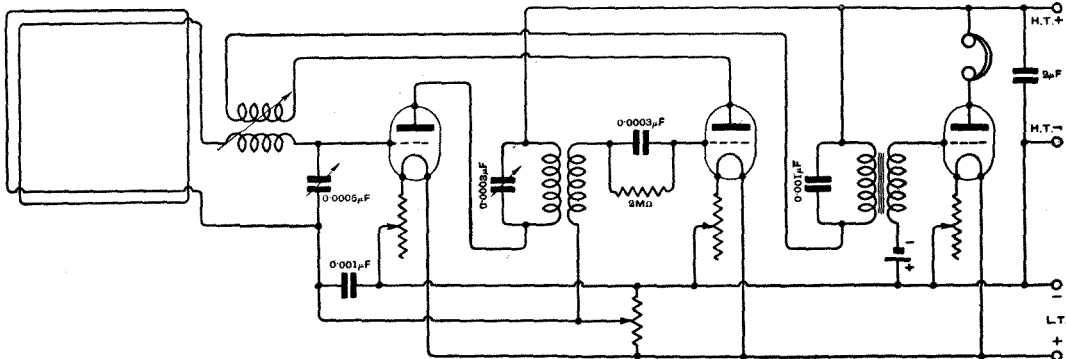

A three-valve frame aerial receiver.

detector valves, with potentiometer control for the grids of both these valves. A reaction coil connected in series with the primary winding of the low frequency transformer is coupled to a small search coil in the frame aerial circuit. It is important to notice the position of this search coil. Many beginners connect the variable condenser across the frame aerial, leaving the search coil out of the tuned circuit. The tuning condenser should be connected across the frame aerial and the search coil, which are connected in series.

For the band of wavelengths between 300 and 500 metres, the frame may consist of seven turns on a former 4 ft. square. For best results the reaction coil will have a greater number of turns than the search coil, and the search coil may therefore be made the moving coil in the coupler. If the reaction coil is wound with from 50 to 100 turns of No. 26

station it should be possible to work a small loud speaker.

FUSE WIRES.

A READER asks whether it would be possible to use commercial gauges of wire for fusing currents as low as 0.2 of an ampere.

The construction of fuses for currents of less than 1 amp. is a somewhat delicate matter. This will readily be understood when it is realised that No. 47 S.W.G. copper wire fuses with a current of 1 amp. For currents of less than 1 amp. it would be best to experiment with narrow strips of foil, and it will be found that tin or lead foil will give best results. Both these metals are very malleable, and can be rolled to thicknesses considerably less than .001 inch. The figures given below showing

the fusing current for round wires of various diameters may be found useful in obtaining an approximate idea of the cross section necessary for currents of less than 1 amp. A curve could be plotted from these figures, and the cross sections for currents below 1 amp. could be obtained by extending the curve.

Fusing current in amperes.	Diameter in inches.		
	Copper.	Tin.	Lead.
1	·0021	·0072	·0081
2	·0034	·0113	·0128
3	·0044	·0149	·0168

The thickness of wires for higher fusing currents may be obtained from the wire tables published by the London Electric Wire Co. & Smith's, Ltd., from which the above figures are taken.

conjunction with a frame aerial at a short distance from a broadcasting station. When difficulty is experienced in erecting an outdoor aerial, the problem can be solved in this way, provided that the distance from the station is not too great. We have ourselves had experience of satisfactory reception with an arrangement of this kind at a distance of five miles from 2 LO. The directional properties of the frame are very marked, and it is important to rotate the frame until the best position for reception is found. For the band of wavelengths between 300 and 500 metres, a frame consisting of eight turns on a former 4 feet square, tuned with a 0·0005 μ F condenser, will give satisfactory results. The crystal and telephones are connected across the frame aerial and condenser in the same way that they would be connected across the A.T.I. in an ordinary crystal receiver.

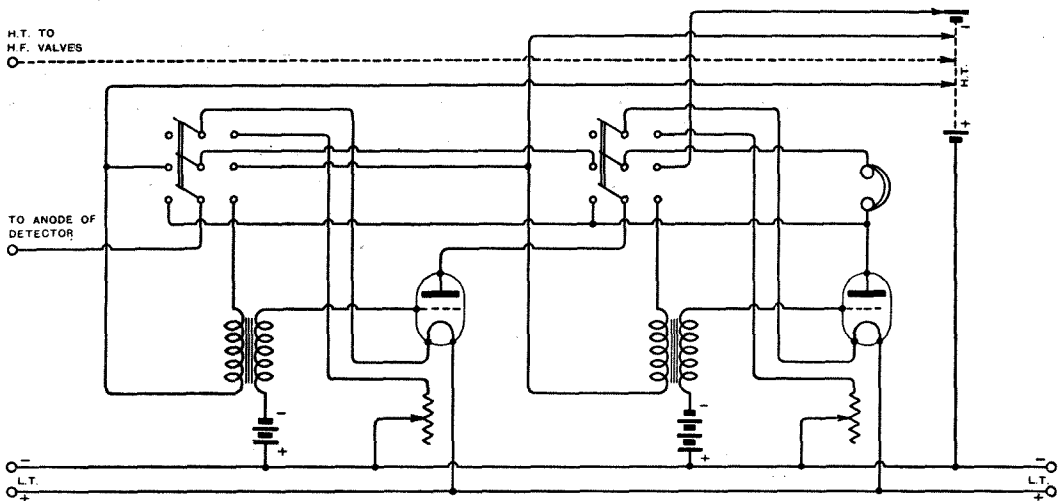

A two-valve amplifier.

A TWO VALVE AMPLIFIER.

THE connections of a two-valve amplifier suitable for addition to a valve receiver are given above.

It will be observed that the amplifier is connected to the receiver at four points. There are the plus and minus L.T. connections, and a single connection to the anode of the detector valve. If a reaction coil is used in the receiver, the connection of the detector valve will be made through this coil. The H.T. supply to the detector valve is taken from the amplifier H.T. battery, and if a separate H.T. tapping is necessary for any H.F. valves in the receiver, it will be convenient to provide a separate H.T. through the amplifier used.

Separate H.T. tappings are provided for each of the L.F. valves, and the three-pole change-over switches necessary under these circumstances have been included in the design.

CRYSTAL RECEIVERS WITH FRAME AERIALS.

IT is not generally realised that good results can be obtained when a crystal detector is used in

AERIAL INSULATION.

A CORRESPONDENT living in the country has written expressing disagreement with the paragraph on Aerial Insulation which appeared on page 57 of the issue of October 8th, 1924. He finds that cheap insulators are perfectly satisfactory, and does not consider that the expense of special types is justified in the case of receiving aerials.

We are quite willing to agree that this may be the case for aerials situated in districts where the air is comparatively pure, but in large towns it will be found that a thick gummy film makes its appearance on the insulators after they have been exposed for three or four weeks. If the leakage path over the insulators is short, this film will immediately give trouble, causing loss of signal strength, and, to a certain extent, selectivity. In town, however, the extra expense of insulators of large surface area is justified. The use of enamel covered wire for the aerial is an advantage, as the atmospheric deposit never actually comes in contact with the wire itself.



The ideal way to progressive wireless construction.

RADIO is essentially a progressive hobby. Half the attraction lies in the advancement from the chrysalis stage of the Crystal Receiver to a "Five-Valver" or even a full-blown transmitter. Yet your ultimate success depends upon the books which guide your steps along the path of wireless progress. You cannot do better than put your trust in *Wireless Press* publications. With their aid it is a simple matter for you to obtain a complete knowledge of the subject from A to Z.



The Wireless Press are the pioneers of authoritative wireless literature, catering for every possible need.

"Crystal Receivers for Broadcast Reception." By PERCY W. HARRIS. Price 1/6. Postage 2d.

"Construction of Amateur Valve Stations." By A. L. M. DOUGLAS. 1/6. Postage 2d.

"Practical Wireless Sets for All-Home Construction Made Easy." By PERCY W. HARRIS. 1/6. Postage 2d.

"The Wireless Press Ezi-Wiring Series":

1. A Three-Valve Portable Receiver. By H. S. POCKOCK.
2. A Three-Valve Receiver (Cabinet). By F. H. HAYNES.
3. A Two-Valve and Crystal Reflex Receiver. By W. JAMES. 2/- each. Postage 2d.

"The Amateur's Book of Wireless Circuits." By F. H. HAYNES. 3/6. Postage 6d.

"The Home Constructor's Wireless Guide." By W. JAMES. 3/6. Postage 3d.

"Radio Experimenter's Handbook." Two Parts. 3/6 each. Postage 4d. each.

"The Wireless Telephone: What It Is and How it Works." By P. R. COURSEY. 2/6. Postage 3d.

"Wireless Telephony: A Simplified Explanation." By R. D. BANGAY. 2/6. Postage 3d.

"The Elementary Principles of Wireless Telephony." By R. D. BANGAY. 7/6. Postage 6d.

"Electrons, Electric Waves and Wireless Telephony." By J. A. FLEMING. 7/6. Postage 6d.

"Wireless Valve Transmitters: The Construction of Small Power Apparatus" By W. JAMES. 9/- 3/4 Postage 9d.

THE WIRELESS PRESS, LIMITED.
12-13 Henrietta Street, Strand, London, W.C.2

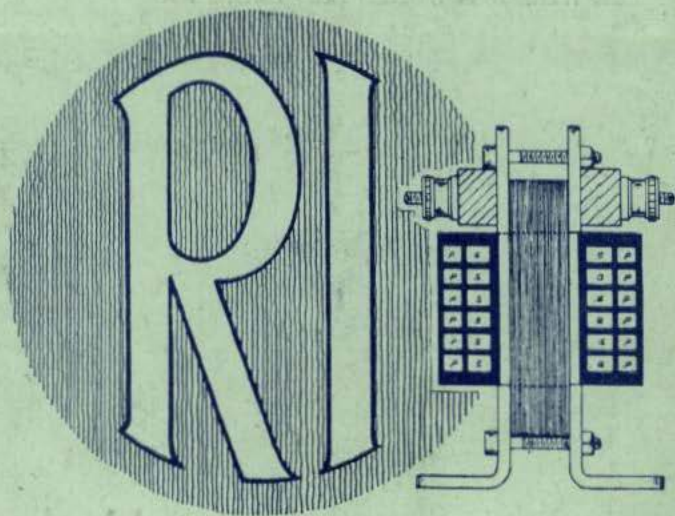

The construction that counts

True judgement and appreciation require to be based on more than outward appearance. Time after time the public are persuaded to buy the "just as good" article on the strength of similar outward appearances. The result is disappointment and distrust. Too late we rediscover the knowledge that it's the heart of things that counts.

Just look at the internal construction of the New R.I. Transformer. Note the careful symmetry of design and heavy insulation between coils. The primary and secondary are wound in twelve sections, the six sections of the primary being placed on the outside of the secondary sections, giving the lowest self-capacity (18 micro-microfarads) of any transformer in general use.

The further security of one year's guarantee is given with every new R.I. Transformer. Apart from these strong features of real worth the monogram R.I. carries more confidence for you of perfect workmanship in wireless components and sets than any other trade mark.

Price 25/-

*Ask your friends, and then write
for the New R.I. Catalogue.*

Telephone—Regent 6214-5-6.

Telegrams—"Instradio, London."

Radio Instruments Ltd.
12 Hyde Street, Oxford Street, W.C.1



Printed by Sanders Phillips & Co., Ltd., Chrissell Road, London, S.W.9, for the Proprietors and Publishers, The Wireless Press, Ltd., 12-13 Henrietta Street, London, W.C.2; Sydney, N.S.W., 97, Clarence Street; Melbourne, 422-24 Little Collins Street; New York, 326 Broadway.



THE WIRELESS WORLD

AND
RADIO REVIEW



PRICE 4^D NET.

BROADCAST
MICROPHONE
AND
AMPLIFIERS

DESCRIBED BY
Capt. ROUND

No. 276 [No. 9
Vol. XV]

250—2,000 METRE CRYSTAL RECEIVER

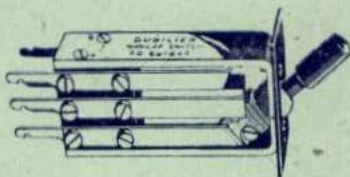

THE "MINICAP."

Every serious experimenter or constructor should number amongst his accessories at least one double-pole double-throw switch.

The uses for such a switch are numerous and varied.

With its aid can be compared the reproduction from different telephones, loud speakers, detectors, transformers, circuits or even complete sets, and, since the change-over is instantaneous, the comparison is far more effective than when numerous leads have to be changed.

Further uses are those of switching in and out steps of high or low frequency amplification, changing over from "series" to "parallel" adjustments, from "tune" to "stand-by," etc., etc.

In some of the instances mentioned, a small capacity between the various contacts of the switch is not harmful; in other cases, such as in H.F. circuits, it is imperative to eliminate self-capacity wherever possible.

The Dubilier MINICAP (minimum capacity) switch has been designed with the object of ensuring that no undue capacity effects occur in the switch itself.

It can be mounted on the panel of a set if it is to be fixed permanently in one position, or, for experimental work, it may be mounted on a separate panel of its own and provided with terminals. In this way it becomes one of the most useful pieces of apparatus on the experimenter's bench.

Price, with screws for panel mounting **8/-**

Ducon Works
Goldhawk Rd.
London,
W.12.

DUBILIER

CONDENSER CO. LTD

Telephone—
Riverside
1084.
Telegrams—
"Hivoltcon,
Phone,
London."

THE WIRELESS WORLD AND RADIO REVIEW

THE OFFICIAL ORGAN OF THE RADIO SOCIETY OF GREAT BRITAIN.

No. 276. (No. 9 Vol. XV.) NOVEMBER 26th, 1924. WEEKLY.

ASSISTANT EDITORS:
F. H. HAYNES,
W. JAMES.

EDITOR:
HUGH S. POCOCK.

RESEARCH EDITOR:
PHILIP R. COURSEY,
B.Sc., F.Inst.P., A.M.I.E.E.

CONTENTS.

	PAGE
Radio Topics. By The Editor - - - -	259
The Marconi-Sykes Magnetophone. By Captain H. J. Round - - - -	260
New Appliances - - - -	266
A Crystal Receiver. By R. H. Cook - - - -	267
The Experimenter's Note Book. By W. James - - - -	271
Measurement of Aerial Current. By N. W. McLachlan - - - -	273
Valve Tests. The M.O. D.E.7 Valve - - - -	275
The Speech Amplifier in Politics - - - -	277
Readers' Practical Ideas - - - -	279
The Thermoformer - - - -	281
Unsolved Problems of Wireless (Discussion Concluded) - - - -	283
Notes and News - - - -	286
Among the Societies - - - -	290
Readers' Problems - - - -	291

THE EDITOR will be glad to consider articles and illustrations dealing with subjects within the scope of the Journal. Illustrations should preferably be confined to photographs and rough drawings. The greatest care will be taken to return all illustrations and manuscripts not required for publication if these are accompanied by stamps to pay return postage. All manuscripts and illustrations are sent at the Author's risk and the Editor cannot accept responsibility for their safe custody or return. Contributions should be addressed to the Editor, "The Wireless World and Radio Review," 12 and 13 Henrietta Street, Strand, London, W.C.2.

SUBSCRIPTION RATES:

20s. per annum, post free. Single copies 4d. each or post free 5d. Registered at the G.P.O. for transmission by Magazine Post to Canada and Newfoundland.

As many of the circuits and apparatus described in these pages are covered by patents, readers are advised, before making use of them, to satisfy themselves that they would not be infringing patents.



EDITORIAL AND PUBLISHING OFFICES:

12 and 13 Henrietta Street,
Strand, London, W.C.2.
Telephone: Gerrard 2807-8.

ADVERTISEMENT MANAGERS:

Bertram Day and Co., Ltd.,
9 & 10 Charing Cross, S.W.1
Telephone: Gerrard 8063-5.

LISSENIUM

Use a RADIO SWITCH!

Many switches sold are undesirable for radio work—they have been designed from the purely electrical point of view, which is not good enough for radio, where the currents dealt in are so small.

LISSEN SWITCHES, on the contrary, have been designed *primarily* for radio, but they are useful also for other switching purposes. You just gently pull or push them, and you hear them make with a reassuring "click"—and you know they are free from capacity effect.

A LITTLE FAMILY OF SWITCHES—You just gently pull or push them all

LISSEN
2 - WAY
SWITCH
2/9

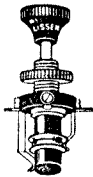

WHAT THE LISSEN 5 POINT SWITCH DOES

- (a) Switches off one stage of L.F. without touching the filament control—a separate switch for each stage.
- (b) Connects the telephones to the plate of whichever valve it is desired to use, and at the same time switches off the L.T. current from the unused valve.
- (c) Cuts out a stage of H.F. in the same way as it does L.F. (we do not recommend any switching in H.F. circuits where it can be avoided, but where it is desired to use a switch, this is the switch to use).
- (d) Will also disconnect both the H.T. and L.T. batteries, and short the aerial to earth so that the receiver can be left adjusted ready for switching instantly into commission next time. With diagram 4/-

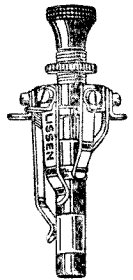

LISSEN
SERIES-
PARALLEL
SWITCH
3/9

LISSEN REVERSING SWITCH

Particularly useful when the LISSEN 5-point switch is used for cutting out one stage of H.F. When a H.F. stage is cut out, and reaction is being taken off the aerial circuit, it is necessary to reverse the reaction coil connections for each H.F. stage cut out, and this new LISSEN switch conveniently does it. Can also be used anywhere when it is necessary to reverse the connections of a battery, a coil, or a condenser, for instance. **VERY USEFUL FOR 4/-** COMPARATIVE TESTS. With diagram

Protects your dull emitters

This little device, called the LISSENSTAT RESISTOR, can be attached to any rheostat you may be using. Adds another 35-ohms resistance to it, which can be varied by means of the little finger switch shown, or entirely out of circuit by lifting the finger switch on to the centre contact. Is worth its price many times over Only 1/3

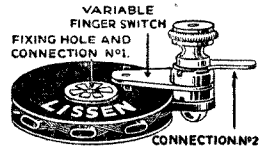

PARTS THAT PULL TOGETHER—when you know that every vital part in your receiver is pulling strongly with each other, you know that you have a receiver which is the best you can ever get.
BUILD WITH ALL LISSEN PARTS—there is one for every vital place

LISSEN LIMITED

Woodger Road, Goldhawk Road, Shepherd's Bush, London, W.12
New lines imminent—low wavelength, low loss coils for 100 metres and down

The WIRELESS WORLD — AND RADIO REVIEW



RADIO TOPICS.

THE PROBLEM OF PATENTS.

By The Editor.

THE granting of a patent by the Crown is, we believe, the only surviving example of the former privilege, which at one time was vested in the Crown, of granting monopolies of all kinds to individuals or Corporations either as a reward for services or as a means of raising revenue. Perhaps this is why an erroneous impression is still quite common that, when a patent is granted, it constitutes a sort of guarantee by the authority issuing the patent that no other claim in respect of the same invention already exists.

It would undoubtedly be ideal if every application for a patent could be so thoroughly investigated and such a complete search made that the risk of a prior claim being in existence in a patent previously issued to another party would be negligible. Several countries have, however, long since found that they could not undertake to set themselves such a task and consequently in such countries it very often happens that patents are granted without any search being made or any investigation into the novelty of the invention nor even a consideration as to whether the arrangement described in the specification will function at all.

In England it is customary for the Patent Office to conduct a search and take what reasonable precautions they can to prevent overlapping of patent claims but at the same time the Patent Office does not accept any responsibility if it is found that it has inadvertently issued patents covering the same invention to different applicants.

Every development of science is accompanied by a considerable influx of inventors' claims to the Patent Office and this is

especially the case where a popular application such as has been found in the use of wireless for broadcast purposes, is possible. In this connection it is of particular interest to observe the enormous increase which has taken place during the last two years in the number of patents taken out for inventions relating to wireless, particularly in regard to applications to broadcasting, yet if the actual utility of these patents were investigated it would probably be found that only a proportion of them are really of value. Considerable sums of money must have been expended since the introduction of broadcasting in obtaining patents or registering provisional applications for inventions which, in all probability, never did nor will have any intrinsic value.

We cannot help believing that quite a fair proportion of the inventions which can be placed in this category would never have been patented but for the ignorance of the applicant as to the novelty of what he believed to be his "invention," whilst many other applicants were probably under the impression that their claims to an invention would become indisputable the moment a patent could be obtained. The task of any Patent Office which attempts to make a search in the interest of would-be patentees must be an exceedingly difficult one in the case of wireless applications and whilst we deplore the fact that the Patent Office is not held responsible for duplicating patent grants for the same invention, we feel that they should receive every consideration in the very difficult task which they have to carry out, even under the present conditions of limited responsibility.

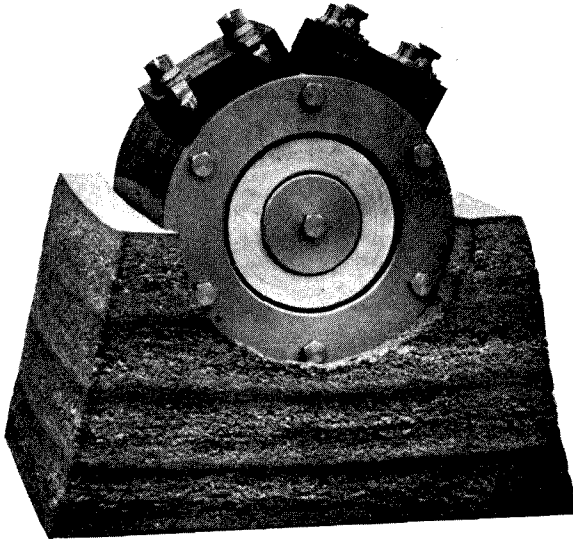

Fig. 1. The Magnetophone supported on its cushion of sponge rubber.

THE MARCONI-SYKES MAGNETOPHONE

A DESCRIPTION OF THE
EQUIPMENT WITH DETAILS
OF THE AMPLIFIERS.

This article, specially written for the *Wireless World and Radio Review* by Captain Round, gives for the first time a detailed description of the microphone and associated equipment which is used extensively not only for broadcasting stations but also for public speech amplifying, distributing and amplifying band music, etc.

By CAPT. H. J. ROUND, M.I.E.E.

THE advent of broadcast in England gave a stimulus to the production of high quality microphones and amplifiers for use in conjunction with them, and from the system, as a side issue, was evolved a high power loud speaker equipment to work either directly from these microphones and amplifiers or from gramophones or wireless.

The rights to manufacture, under the patent of Mr. A. S. Sykes, magnetophones of his type, was acquired, and after very considerable research a practical instrument was obtained which is in use in a great number of broadcast stations, and is also employed for public speech amplifying, amplifying of bands, or their transmission to other places, etc.

The magnetophone consists essentially of a cylindrical iron pot with a central core and a carefully arranged system of pole tips in between which is suspended an extremely light coil of aluminium wire supported on a backing of paper. This coil may be suspended in position in several ways.

One method which is not illustrated here is a trifoliate suspension of silk thread, the thread being supported on sponge rubber pieces fixed in slots on the pole pieces.

The method illustrated consists in cotton-wool pads fixed with rubber solution to

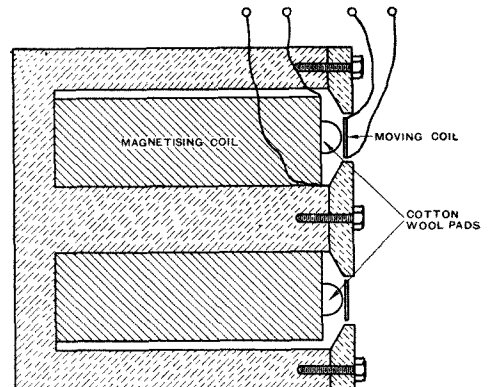

Fig. 2. A Section through the Magnetophone showing details of construction.

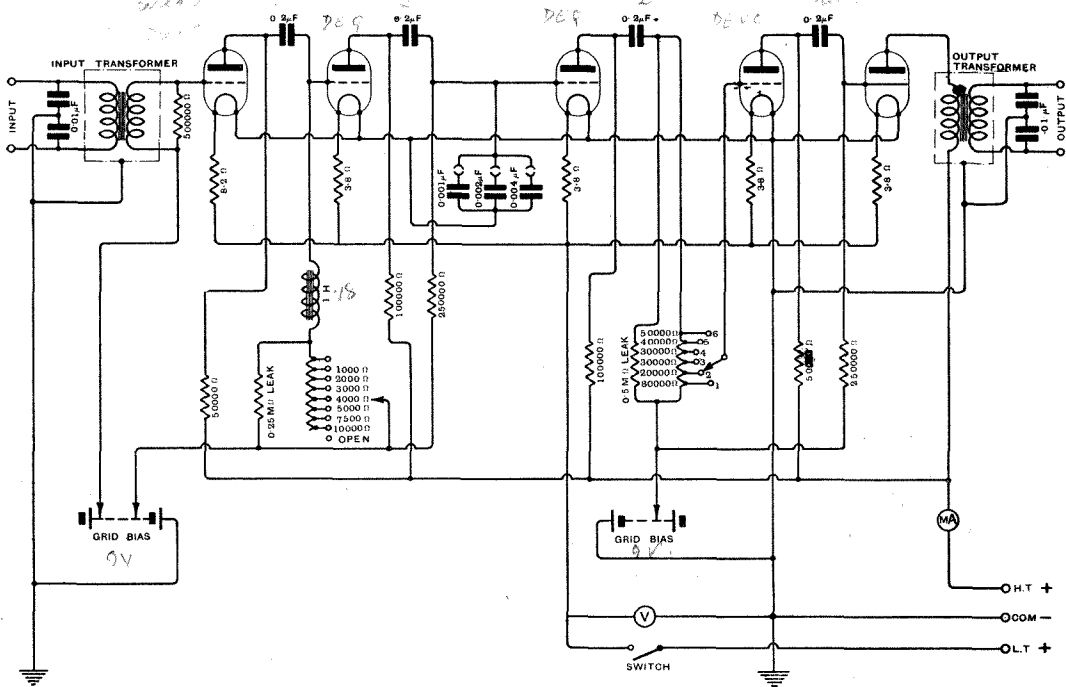

Fig. 3. Circuit diagram of the "A" amplifier.

the magnetising coil, whilst the moving coil is also fixed to these pads with rubber solution (Fig. 1).

Fig. 2 is a section through the whole instrument illustrating the arrangement of the magnetising coil. The coil normally takes 4 amperes at 8 volts and the flux density is

about 1,500 lines to the centimetre. The case of the magnetophone is damped by a special arrangement to prevent it from vibrating as a bell.

The coil, which usually has a resistance of about 40 ohms, can be connected to well shielded lines up to half a mile in

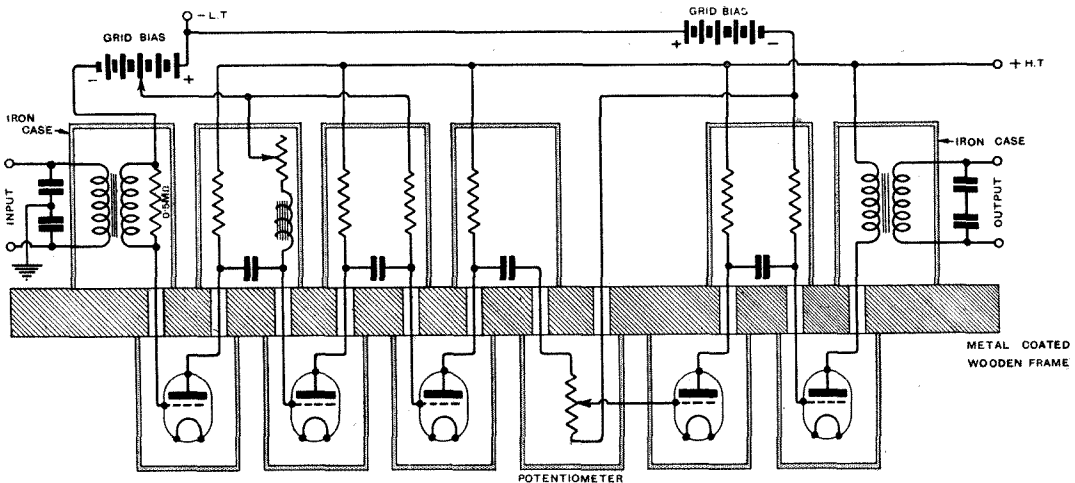

Fig. 4. Partial diagram of connections of the "A" amplifier illustrating the system of shielding.

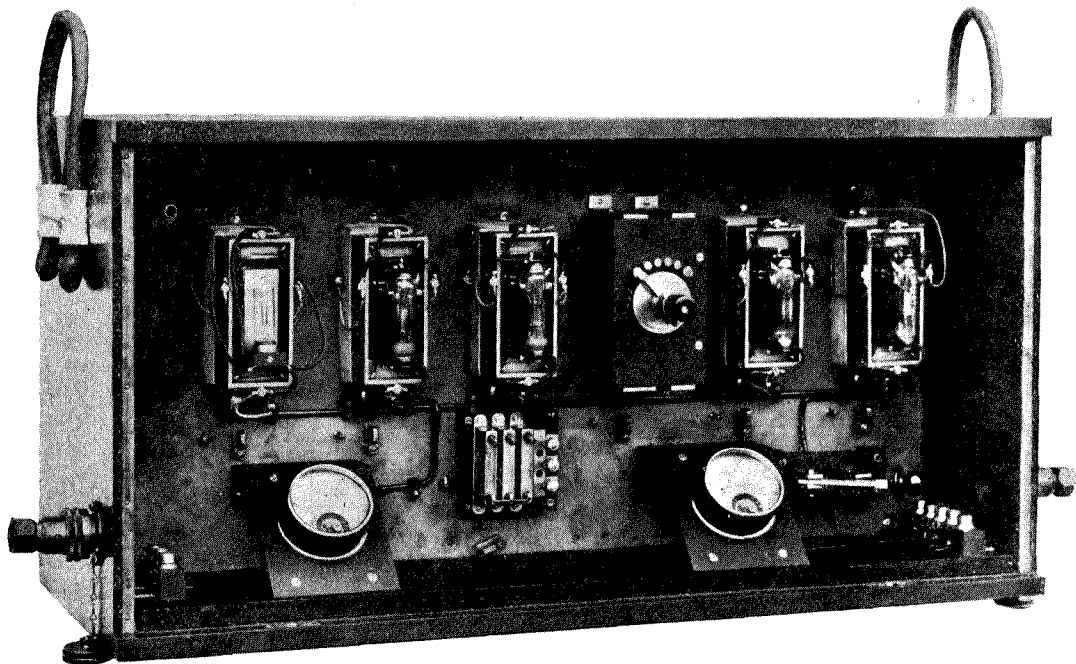

Fig. 5. A front view of the "A" amplifier with the covers removed.

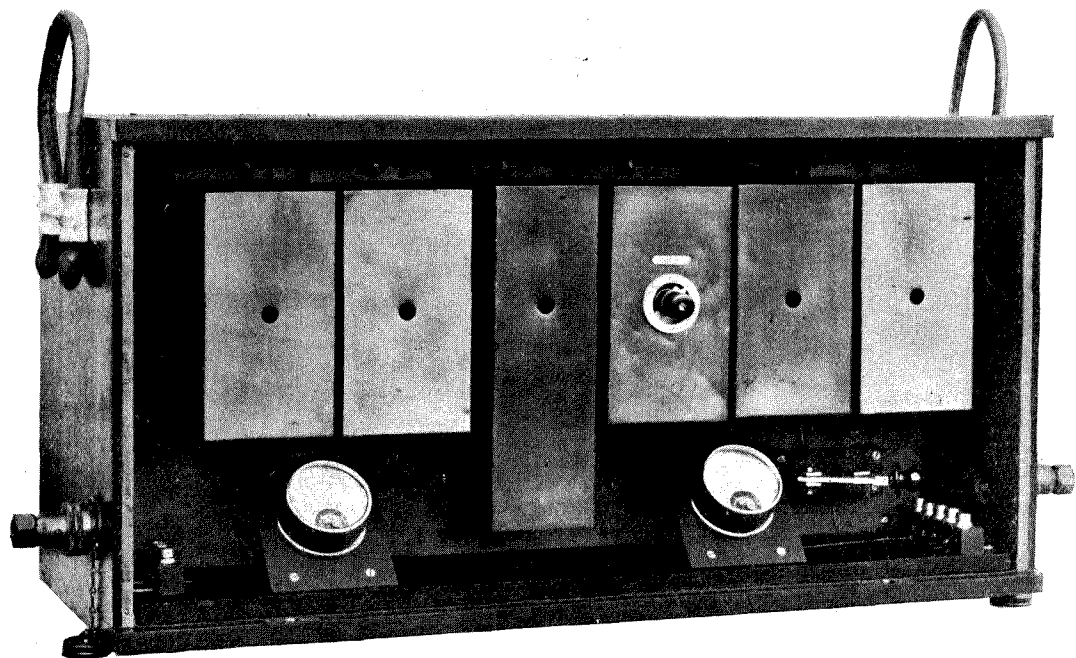

Fig. 6. The "A" amplifier (front) closed.

length and then to the "A" amplifier, but on account of induction it is preferable to keep the "A" amplifier within about 100 ft. of the magnetophone.

The magnetophone line is connected directly to a transformer of the "Ideal" type, and the resistance of the magnetophone coil is arranged so as to give the necessary damping to the resonant secondary of this transformer, just as the valve connected to the primary of an "Ideal" intervalve transformer gives the damping to the secondary (see Figs. 3 and 4).

The "A" amplifier consists of a five-resistance stage amplifier, which is seldom

inductance in its plate circuit, with a variable resistance in series up to 12,000 ohms (see Fig. 3). This gives a tone adjustment, in that decreasing this resistance steadily increases the ratio of high tone to low.

Across the second valve plate resistance is a variable condenser, variable in steps up to 0.007 mfd. This enables the high tones to be reduced in ratio to the low tones. These adjustments enable one to balance to some extent the sounds in different types of broadcast; for instance, in the studio little alterations from the normal straight magnification may be needed, but in a hall with a deep-toned resonance it may be

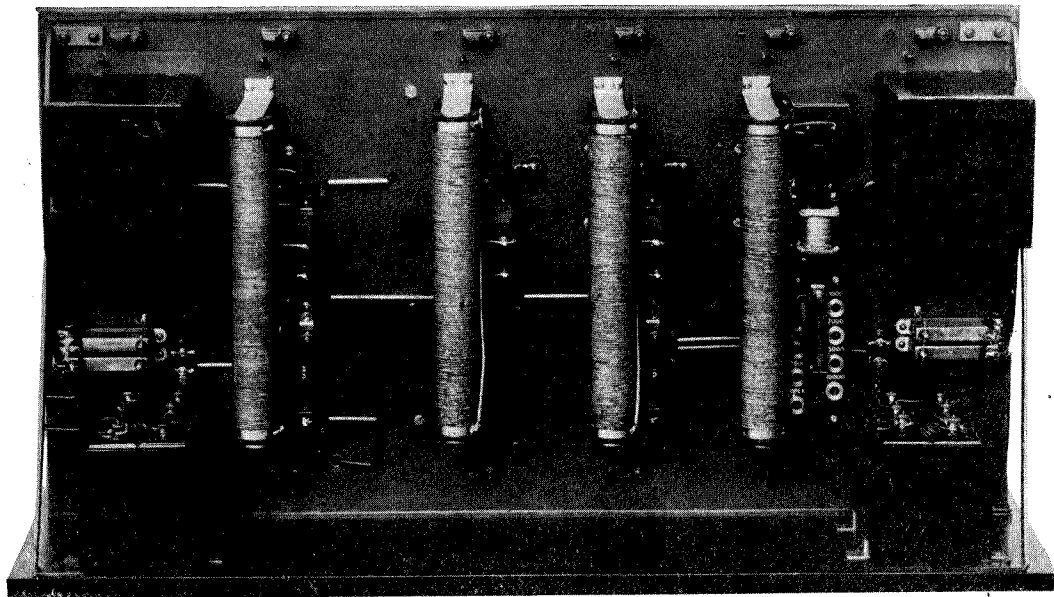

Fig. 7. A back view of the "A" amplifier with covers removed.

used all out, and a coarse potentiometer is arranged and set before any broadcast is put on so that no sounds likely to be produced can "blast" the amplifier. (The term "blast" is used to express the idea of carrying any part of the apparatus seriously beyond its linear limits.) The strength of signal at the end of the amplifier is ample to put over quite long telephone lines without induction trouble.

The amplifier has, of course, transformers for input and output, but the remainder is resistance coupled with two correcting arrangements. The first valve has a 1-henry

advantageous to sacrifice some of the lower tones. Or, again, a land line may have a strong tone lowering effect, and this may be counteracted to some extent. A shunt condenser is always advisable, serving to reduce to some extent very high frequencies which are musically useless and "blast" the transmitter seriously. Handbells are particular examples which should be very carefully shunted as the harmonics are very violent. Gramophone records can be considerably improved by heavily shunting with capacity.

The "A" amplifier terminates in a transformer the ratio of which is arranged

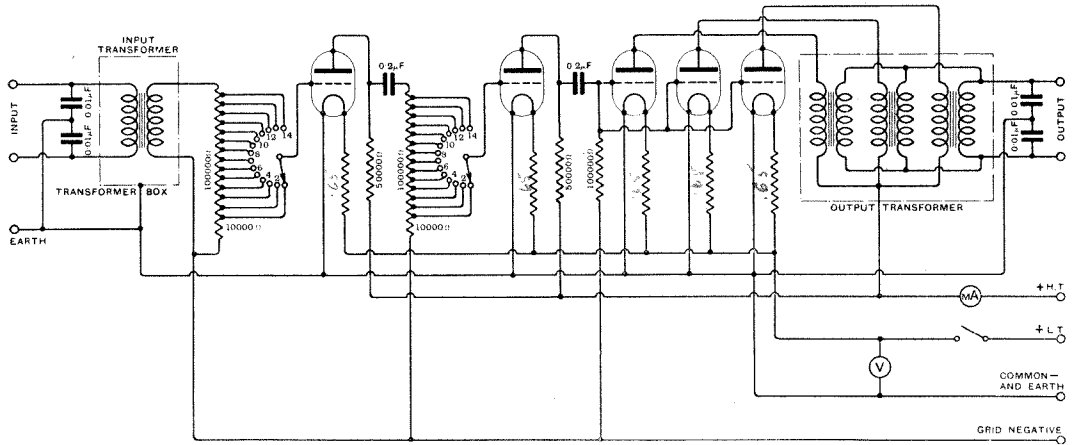

Fig. 8. Diagram of connections of the "B" amplifier.

to give the correct terminal connection for a 400-ohm line.

Fig. 3 is a full diagram of connections, and Fig. 4 is a partial diagram, showing the shielding system employed to prevent both reaction and induction.

Figs. 5, 6 and 7 are photographs of this instrument.

The "B" amplifier is chiefly a control amplifier. Two potentiometers arranged to work smoothly and to produce no electrical

noise, enable it to be altered in strength from less than the incoming signals to about sixty times their strength.

Three output valves in parallel are used to give a great margin so that under no circumstances can this amplifier blast until the transmitter is very much overloaded. All possible blast is thus removed to the transmitter.

The curious arrangement of transformers in parallel at the end is an accident of design

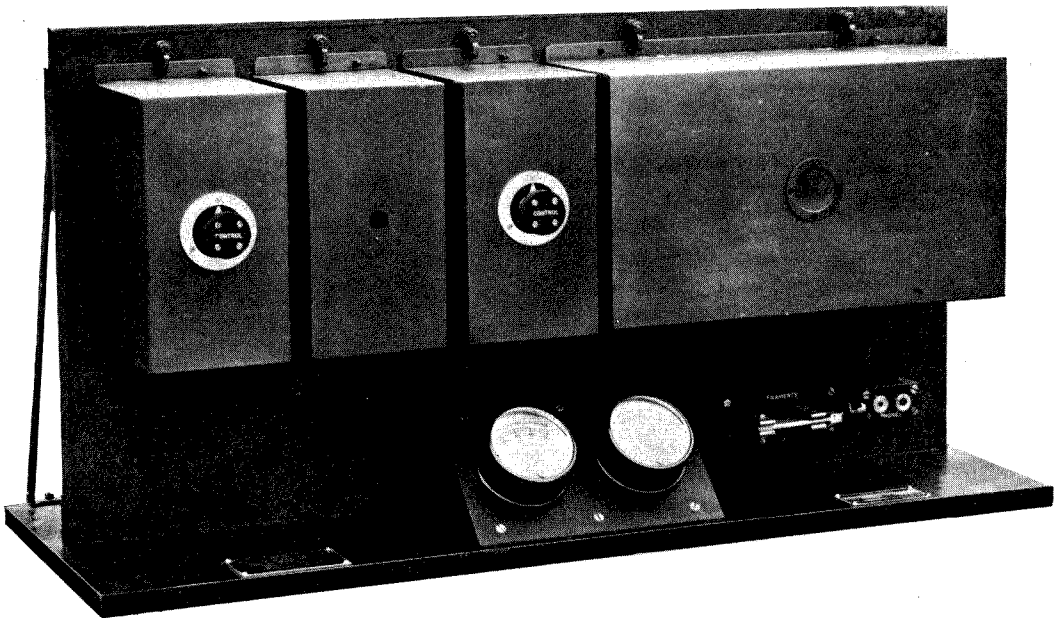

Fig. 9. The "B" amplifier (front view).

in that the properties of these transformers were thoroughly known so that it was considered preferable to use them rather than spend a lot of time investigating a bigger one.

Again, the output terminal conditions are arranged for a 400-ohm line.

The input transformer is also arranged for

lutely necessary, and when the "B" amplifier is used in connection with a power amplifier for the loud speakers this shunt is not used.

Similarly, the shunt on the input transformer of the "B" amplifier need not be used if the link to the "A" is a short one.

Fig. 8 is the ordinary diagram of connections of the "B" amplifier. Fig. 9 is the

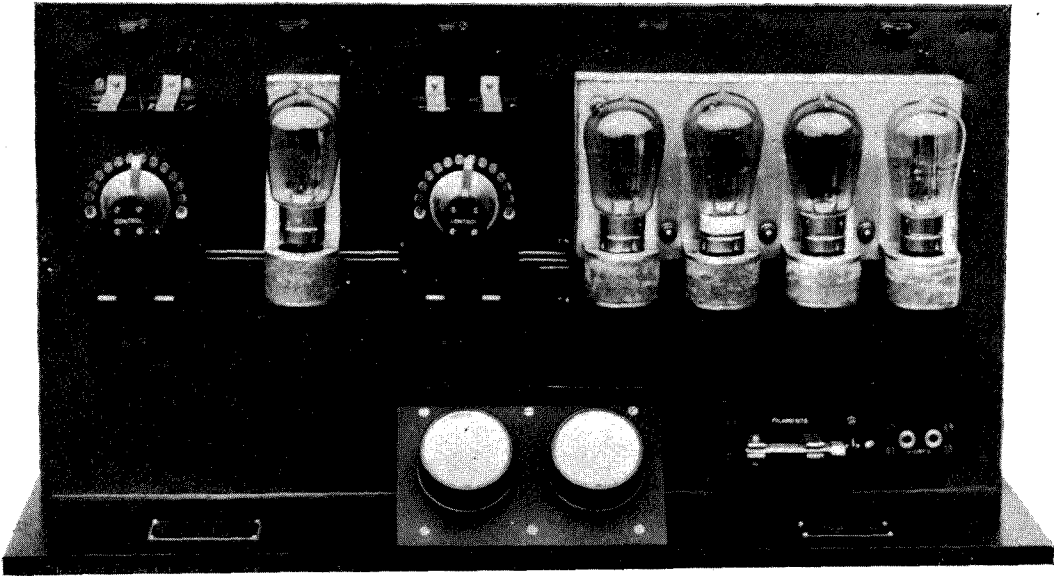

Fig. 10. The front of the "B" amplifier with covers removed

this condition. A transformer for the wireless set is arranged to connect with the line. With a long line it is advisable to shunt this transformer with the correct shunt but on a very short line the shunt is not abso-

front view (closed) of the "B." Fig. 10 is the same instrument with the covers removed.

Fig. 11 indicates how the magnetophone is coupled up to the broadcast transmitter through the complete system.

All the transformers used are of the "Ideal" type, investigated and developed by Mr. P. W. Willans, of the Marconi Company, and it is certainly a tribute to their aperiodicity over the whole frequency range that the London broadcast is transmitted through five of the transformers in cascade before reaching the high frequency transmitter.

I should, however, prefer to reduce this number if it were possible, but one has had to meet the engineering requirements.

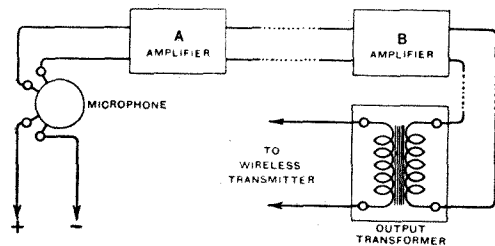
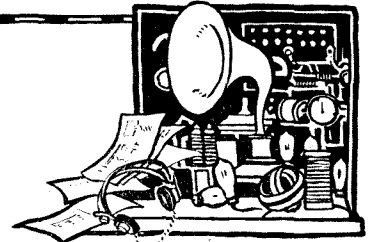

Fig. 11. A diagram showing the general arrangement of the magnetophone with its associated amplifiers connected to a broadcast transmitter.

NEW APPLIANCES.



Valve Marker.

The use of valve stems in place of the moulded type valve holder is becoming perhaps more generally adopted by amateurs, partly on account of low cost, and also with the object of reducing capacity

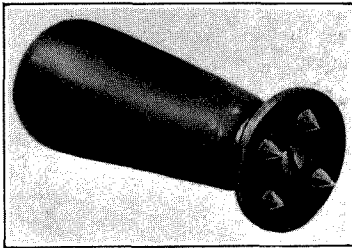

Valve pin marker, made in good hard steel with handle mounting.

between the valve connections. To accurately set out the positions for the valve stems a template is essential, and a convenient form is manufactured by Messrs. V. R. Pleasance, of Sheffield, in which a hard steel disc is carried by a wooden handle of convenient shape, and fitted with four pin points. Pressed on to the face of a panel, the correct setting out is at once obtained.

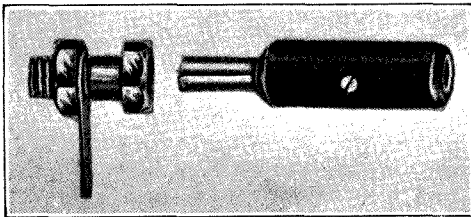

Messrs. Pleasance's plug and socket and connector. It is supplied with a tag for making a reliable soldered connection without over-heating the socket.

The Igranic Freshman Condenser.

A new type of fixed condenser has this week made its appearance on the market. The plates, after mounting, are clamped with a metal tube under considerable pressure, and thus securely held the condenser maintains its correct capacity value. The form of mounting, as will be seen from the photograph, provides tag connectors, so that this condenser can easily be set up on the instrument terminals without soldering.



A new type of fixed capacity condenser. It is clamped securely in a piece of metal tubing.

Plug and Socket Connector.

THERE has long been a need for a plug and socket connector for use in particular in receiver construction. Its special application is, of course, changing the number of turns in circuit of an inductance instead of employing a multi-stud switch, as the latter is difficult to set up. It is useful also in place of terminals and for making all the circuit changes usually brought about by the use of switches. The Aeronomic connector shown here possesses a good clean finish, and the plug makes a smooth fit in the socket, which is designed for panel mounting, and supplied with tag for making soldered connection.

A CRYSTAL RECEIVER

250-2000 METRES.

Probably the majority of people interested in the broadcast transmissions own a crystal receiver. If the receiver is of an old pattern very likely it will not tune to the long wavelength of the high-power station. If it is difficult to make the necessary alterations it would be better to build the instrument described below, which is easily constructed and very effective.

By R. H. COOK.

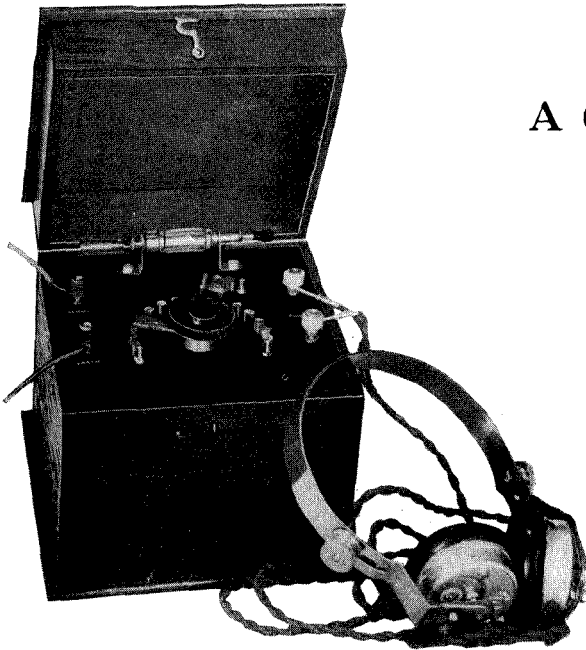

THIS crystal receiver, which is illustrated above, is easily constructed, and will tune over the broadcast band of wavelengths and to higher wavelengths, including that of the high power broadcast station. The ideal broadcast receiver has only one tuning control, but as the receiver is to be employed to receive long and short wavelengths, provision must be made for cutting out the long wave tuning coil of the receiver if the receiver is to be effective on the shorter wavelengths. It is usual to employ a coil suitably tapped for the short wavelengths, and to add a coil, such as a plug-in coil, to receive the long wavelength broadcast transmissions. In this receiver the short and long wave coils are contained in the set, and by a neat switching device the long wave coil is automatically removed from the circuit when receiving short wavelength broadcast.

switch B is in the "off" position. When the switch arm is moved to the first stud connected to coil E, switch B is automatically moved to the "on" position. The switches

The connections are given in Fig. 1, where A is the arm of the tuning switch which makes contact with the studs connected to the tapped short-wave coil D, or the long wave coil E. Switch B is a dead-end switch. While switch arm A is being moved over the contacts connected to coil D,

may be seen by referring to the illustration below. It will be seen that the dead-end switch has a forked projection which is operated by the arm of the tuning switch.

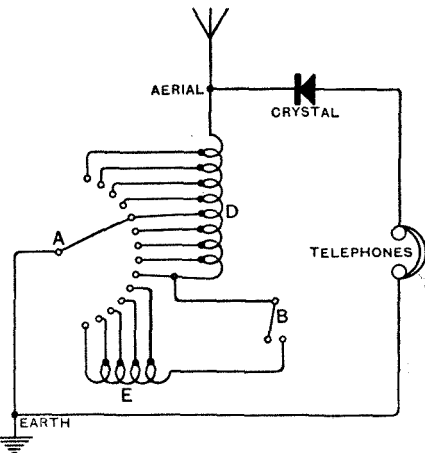

Fig. 1. Theoretical connections of the receiver.

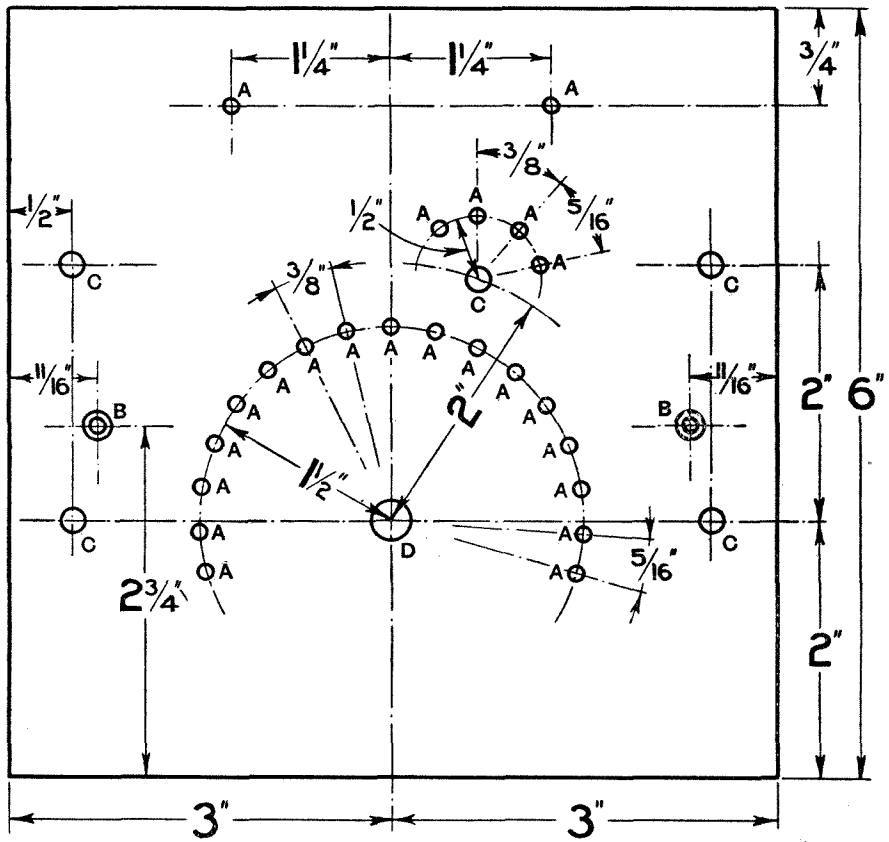

Fig. 2. Scale drawing of the ebonite panel. Drilling details: A, drill $\frac{1}{8}$ in. hole; B, drill $\frac{1}{8}$ in. hole and countersink on front; C, drill $\frac{3}{16}$ in. hole; D, drill $\frac{3}{8}$ in. hole.

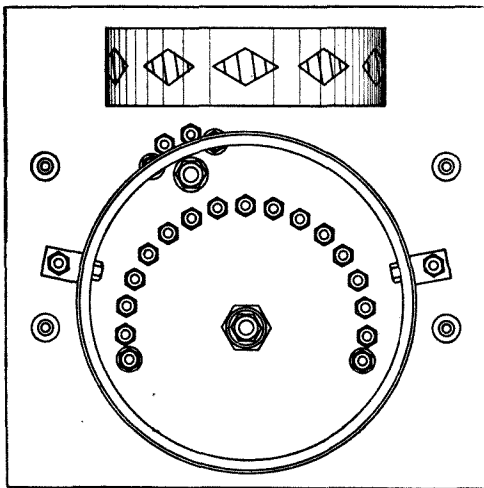

Fig. 3. Showing the underside of the instrument.

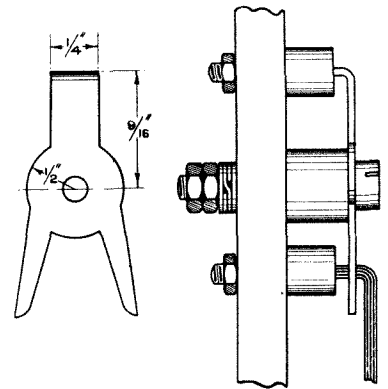

Fig. 4. Details of the "dead-end" switch.

The single layer tuning coil D, Fig. 1, consists of a tube of cardboard or ebonite 4 ins. in diameter and 3 ins. long, wound with 60 turns of No. 26 D.C.C. There are nine tappings taken from every fifth turn from one end. This leaves a group of 20 turns between the end of the coil and the first tapping. Thus, referring to Fig. 1, the group of 20 turns is between the aerial

winding the wire in the usual manner on a former 2 ins. in diameter to form a coil 1 in. wide. This coil has five taps about equally spaced.

THE PANEL.

A drawing of the top side of the panel is given in Fig. 2, and of the under side in Fig. 3. On the left-hand side of the panel

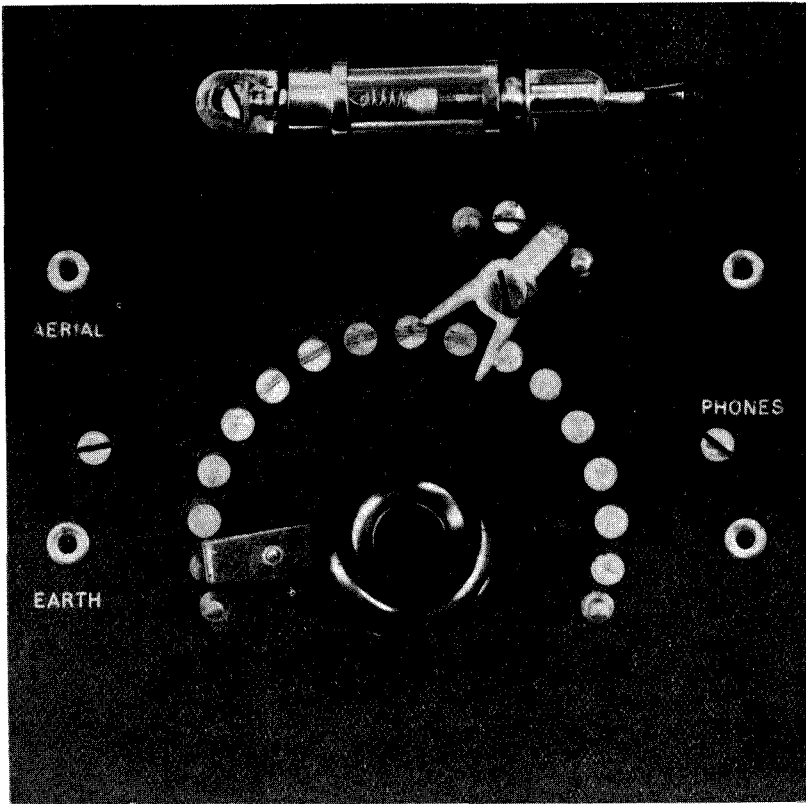

View of the panel of the set. The dead-end switch is below the crystal detector, and the forked projections are engaged by the arm of the tuning switch.

terminal and the first stud of the switch. As may be seen by referring to the figures, two brackets are employed to hold this coil to the panel. The wire should be twisted to form a loop at the tapping points, and the insulation removed so that the wires connecting the taps to the switch studs may be soldered.

A No. 200 coil may be employed as the long wave coil. This can be home made by

(Fig. 2) are two "clix" for the aerial and earth, and on the right-hand side two "clix" for the telephones. The crystal detector is mounted near the back edge of the panel, and the tapping switch in the centre. Details of the dead-end switch are given in Fig. 4. This switch has two studs, and the arm consists of a piece of No. 16 gauge brass cut to the shape shown in the figure. It will be noticed that the end which makes

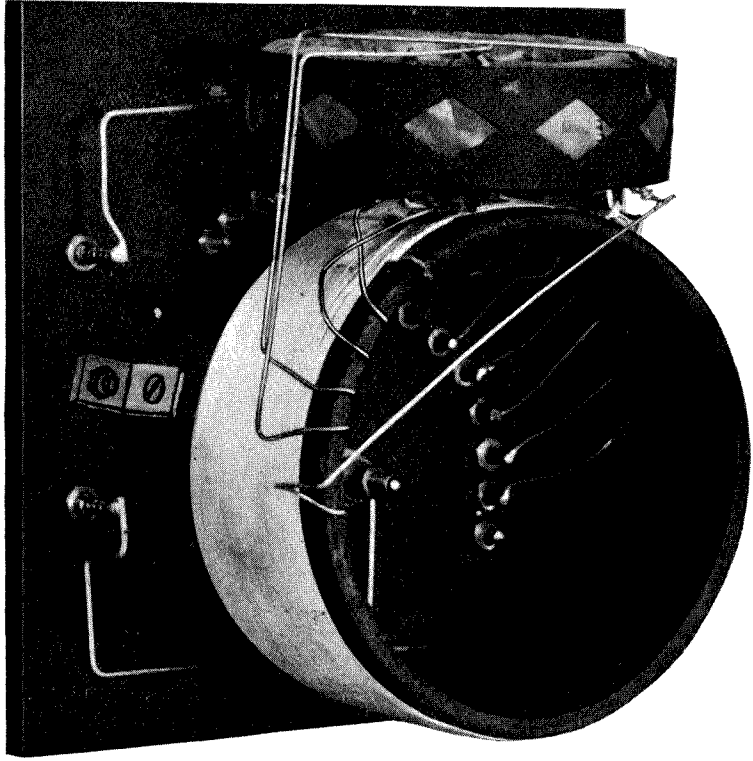

Showing the wiring of the coils to the switch, and the method of mounting the coils.

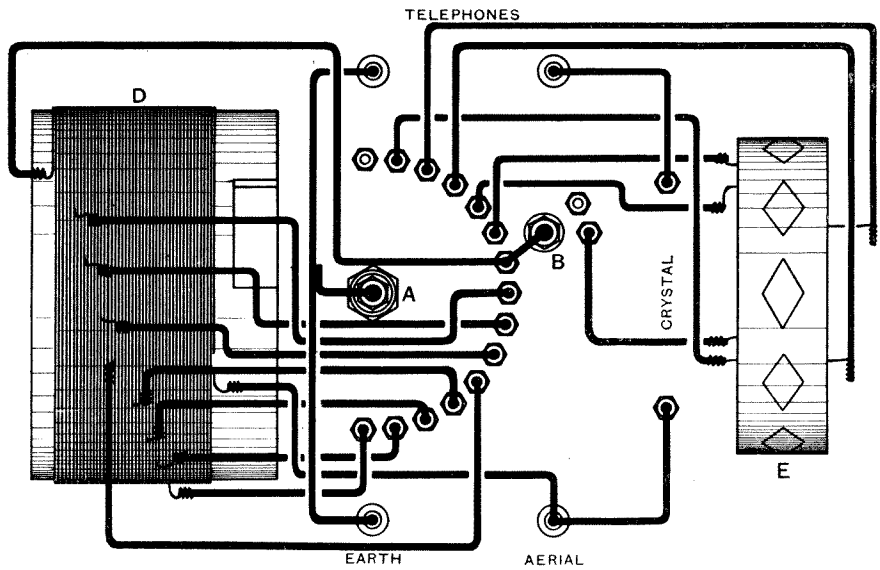

Fig. 5. Wiring diagram. The components are lettered to correspond with the lettering on the theoretical diagram of Fig. 1.

contact with the studs is slightly bent over.

The panel consists of a piece of ebonite 6 ins. by 6 ins. by $\frac{1}{4}$ in., and is drilled as shown in Fig. 2. The tapping switch employed has a radius of $1\frac{1}{2}$ ins. If a different size of switch is used care must be taken when marking out the position for the studs. When the holes for the studs are drilled, the studs can be mounted and firmly secured. It may be necessary to touch up the surface of the studs to make them of even height.

The long wave coil is held by securing the

ends of a fibre strap passed round the coil to the screws fixing the crystal detector.

WIRING.

The receiver should be wired with No. 18 or 16 tinned copper wire as indicated in the wiring diagram of Fig. 5. It will be noticed that the studs of the tapping switch are inside the bottom end of the cylindrical coil. The tapping wires should therefore be connected to the studs of the switch first, and then the tapping points on the coil.

THE EXPERIMENTER'S NOTE BOOK.

By W. JAMES.

Tuning with Condensers of the Semi-Circular Vane Type.

THE ordinary type of tuning condenser has two sets of semi-circular plates, one set being fixed and the other rotatable. As the movable plates are turned the area of overlap changes.

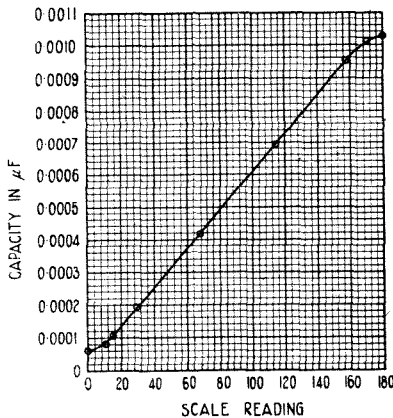

Fig. 1. The curve shows that, except for the extreme ends, there is a linear relation between the scale reading and the capacity of the condenser.

Now the area of overlap of the plates is approximately directly proportional to the setting of the scale of the condenser. That is, if the overlap when the condenser is set at 50 degs. is A sq. ins., when the condenser is set at 100 degs. the area is $2A$ sq. ins. Neglecting edge effects and stray capacities, the capacity of a parallel plate condenser is

directly proportional to the area of overlap and therefore to the setting of the condenser. For instance, if the capacity is 0.0005 microfarad when set at 50 degs., it is 0.001 microfarad when set at 100 degs. Thus there is in practice almost a linear relation between the capacity and scale reading over a large portion of the range of the condenser.

Fig. 1 shows the result of plotting the values of capacity against scale reading on squared paper, and connecting the points with a line. The line connecting the points is not perfectly straight, but bends a little at the lower and higher scale readings. This is due to the construction of the condenser.

The Tuning Range.

When a condenser of this type is connected across a tuning coil (Fig. 2), the wavelength of the circuit may be varied between the limits of $1884 \sqrt{LC_{min}}$ metres and $1884 \sqrt{LC_{max}}$ metres (where L is the inductance of the coil in microhenries, and C is the capacity of the condenser in microfarads), provided there is no other capacity in the circuit. Thus, if the condenser has a minimum capacity of 0.0001 microfarad,



Fig. 2. A circuit consisting of a coil and a condenser only, and Fig. 3, a circuit with a coil, tuning condenser and a fixed condenser.

and a maximum value of 0.001 microfarad, and the coil has an inductance of 253 microhenries, the wavelength range is approximately 300 to 950 metres.

In practice there is usually capacity in the circuit which is not localised in the tuning condenser. For instance, when the circuit of Fig. 2 is connected to an aerial, there is the capacity of the aerial in parallel with that of the condenser. If we assume the aerial to have a capacity of 0.0003 microfarads, we may for practical purposes represent the aerial circuit as consisting of a fixed condenser of this capacity in parallel with the tuned circuit, as in Fig. 3. The capacity range is now 0.0004 to 0.0013 microfarads, giving a wavelength range of approximately 600 to 1,080 metres.

Thus the wavelength range is considerably less when the circuit has a fixed condenser connected across it. When the tuning condenser alone was across the coil, the wavelength range was just over 3 to 1, but when a fixed capacity of 0.0003 microfarads is across the circuit the wavelength range is only a little less than 2 to 1.

It will therefore be seen that two circuits—for instance, an aerial circuit and a tuned anode circuit—will not tune over the same range of wavelengths or tune in the same wavelengths, even though both circuits have identical coils and tuning condensers when one circuit has a different fixed capacity to the other. The fixed capacity across the circuit may consist of the capacity of the coil and its mounting, the capacity between connecting wires, terminals, valve sockets and so on, or it may be the capacity of an aerial.

Tuning Curves with "Square Law" Condensers.

It is often said—sometimes by people who should know better—that if a tuning condenser of the "square-law" type is employed in a receiver, that it is only necessary to tune in two stations of known wavelength, plot the corresponding wavelengths and scale readings, draw a straight line between the points, and then read off the scale reading for other wavelengths.

This is not true, in fact this method is useless, as the curves of Fig. 4 show. A circuit was made up consisting of a No. 50 Igranic coil, an expensive "square-law" 0.0005 μF tuning condenser, and a valve detector. An accurate buzzer wavemeter

was loosely coupled to the circuit, and the wavelength corresponding to various settings of the condenser obtained. The results are plotted in Fig. 4, curve 1. It will be seen that the curve is a straight line between 180

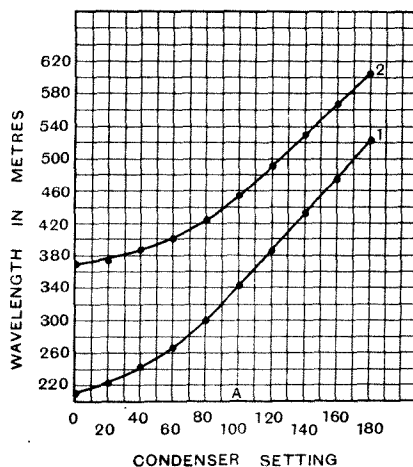

Fig. 4. Curves showing the relation between wavelength and the setting of a "square law" tuning condenser.

degrees and about 80 degrees. Between 80 degrees and zero the curve bends, and the wavelength is not directly proportional to the setting of the scale of the condenser.

Curve 2 shows the results obtained when a fixed condenser of 0.0002 μF * was connected across the circuit. The shape of this curve is different to the shape of curve 1, and the linear relation between wavelength and condenser setting only holds between 180 degrees and 100 degrees (A). The curve shows that a relatively large movement of the condenser is required to produce a small wavelength change at the lower end of the scale compared with the higher end of the scale.

The relation between wavelength and scale reading when "square-law" condensers are employed is therefore not linear, and further, the shape of the curve depends very largely on the amount of the fixed capacity in the circuit. Presumably the "square-law" condensers which may be purchased were designed to give the true "square-law" effect without considering the stray and other capacities of the circuits in which they are used.

These condensers will not give the "square-law" effect when connected in an aerial circuit, or in any circuit where there is appreciable stray capacity.

* Maker's rating.

MEASUREMENT OF AERIAL CURRENT

DESCRIPTION OF AN IMPORTANT METHOD.

In this article the author discusses the behaviour of iron in high frequency circuits, and explains the method of designing and constructing iron-cored current transformers.

By N. W. McLACHLAN, D.Sc., M.I.E.E.

Shunted Hot Wire Ammeters.

IN comparing the strength of the signals received from various transmitting stations, it is essential that the aerial current shall be measured accurately. For currents up to 5 amperes, unshunted hot wire ammeters are very serviceable although in some cases there are appreciable errors. When shunts are used for these instruments, there is an error which increases with decrease in wavelength (increase in frequency) due to unequal inductance of the paths between the terminals through shunt and hot wire. By equalising the inductances of the paths, provided the inherent and earth capacity effects are negligible, it is possible to use shunts to increase the range of the instrument.

Hot wire instruments which will read 100 amperes or more can be obtained, but these costly accessories are usually very large and may be subject to an error which increases with decrease in wavelength.

Iron in H.F. Circuits.

The purpose of the present article is to describe another method—not novel, but neglected—of measuring currents of radio frequency, which is in general more accurate than the usual method when the currents are large. In power systems where the frequency is 50 cycles, the customary procedure is to measure large currents by means of an iron-cored transformer. It is usually regarded as unorthodox to employ iron in or near the radio frequency circuits of a transmitting set. The use of iron in H.F. circuits at high flux density or in an inductance where there is no transformer action due to a secondary winding is certainly a heresy. If, however, the iron is used at low flux density in a transformer, it can be shown

that for given conditions the efficiency of the transformer, so far as the iron circuit is concerned, increases with decrease in wavelength.

Properties of Iron-Cored H.F. Transformers.

Suppose we have a closed iron circuit built up of insulated laminations, say rings of stalloy 0.25 mm. thick, uniformly wound with a single layer of insulated wire. Let us pass an alternating current through the winding and measure the voltages corresponding to various frequencies in a secondary coil wound over the primary.

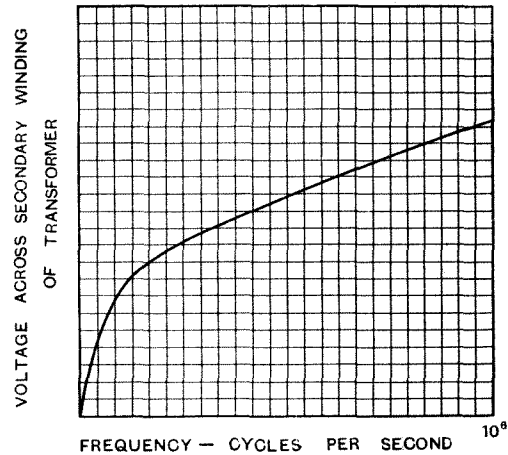

Fig. 1. Curve showing the relation of the voltage across the primary and secondary windings of the transformer to the frequency of the current. The current is held at a constant value.

When the current is kept constant the voltage across both primary and secondary windings will increase with frequency, as shown in Fig. 1. If, however, the primary current is regulated to give a constant

secondary voltage, the relationship between current and frequency is of the form depicted in Fig. 2, and the loss-frequency curve is similar in shape to that of Fig. 3.

Thus we find directly from experimental evidence that (1) when the secondary voltage

therefore be exercised in keeping the dielectric loss of the insulating material adequately low to secure high efficiency and in excessive heating.

The Accurate Measurement of H.F. Currents.

Some years ago, in conducting experiments with a Poulsen Arc, it was necessary to measure radio frequency currents from 1 to 10 amperes to an accuracy of 1 per cent.* No suitable hot wire ammeter was at hand, and so the method adopted was to use a Duddell thermoammeter reading to 100 milliamperes and an iron-cored current transformer with a ratio of 50/1 or 100/1, according to the value of the current to be measured.

This method can be extended to the measurement of much larger currents than 10 amperes. Transformers have been designed to measure currents exceeding 100 amperes with an error of less than 1 per cent. for a very wide range of wavelengths; say 100 to 20,000 metres.

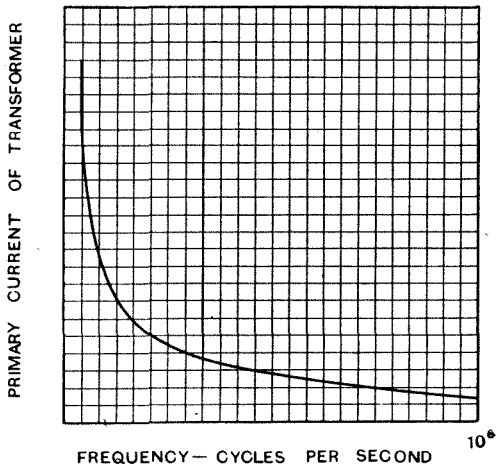

Fig. 2. If the primary current is regulated to give a constant secondary voltage the relationship between current and frequency is as shown by this curve.

is constant the current decreases with increase in frequency; (2) the iron loss decreases, and therefore the efficiency of the iron circuit increases with increase in frequency. In general, if the dielectric and copper losses can be kept sufficiently low, the overall efficiency of an iron-cored transformer increases with the frequency, *i.e.*, with decrease in wavelength.

Following the apathy of proper precedent in this country, the use of iron in radio engineering has been eschewed. But this has not been so in America and in Europe. For example, there are the Alexanderson, Latour and Goldschmidt high power radio-alternators, all of which use very thin iron laminations. Although alternators are defective from two main points of view, namely (1) only comparatively long waves can be used efficiently, (2) poor wavelength constancy compared with valve oscillators, their manufacture and use marks a definite epoch in the history of scientific achievement. Further uses of iron are to be found in frequency multipliers and in voltage transformers. In such cases the voltage per turn of winding is magnified manifold in virtue of the permeability of the iron, and care must

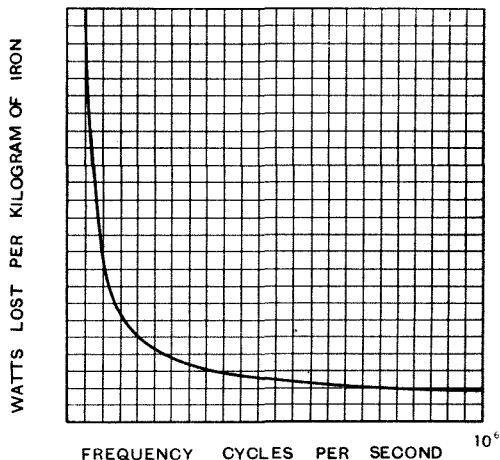

Fig. 3. A curve showing the relationship between the watts lost and frequency.

It is not usual to employ large currents at short wavelengths of 80 to 500 metres, so that the values on the short wavelengths would be less than 100 amperes. This may be more

* McLachlan, "Heating of Iron at H.F.," *Electrician*, September 17th, 1915. McLachlan, "Behaviour of Iron at H.F.," *Journal I.E.E.*, April, 1916. McLachlan, *Wireless World*, November and December, 1916.

readily appreciated when we consider the energy radiated from an aerial at say 100 metres. By suitable design the radiation resistance can be made large in comparison with the dead loss resistance—*e.g.*, a vertical wire with no earth connection, operating at its natural wavelength, the maximum current being at the centre.

Taking a radiation resistance of 60 ohms (the radiation resistance of any vertical wire at its own wavelength is 80 ohms approximately), and an aerial current of 10 amperes, the power radiated is 6 kilowatts, or about half that radiated from the long wave transoceanic aerials. With 150 amps, the radiated energy would be 1,350 k.W.

(To be continued.)

VALVE TESTS.

THE M.O. D.E.7 VALVE.

The M.O. D.E.7 valve is a four-electrode valve—having two grids. Although the average experimenter does not ordinarily employ valves of this class, they may be used with good results in a number of circuits. Valves of this type are employed in certain commercial receivers.

THE D.E.7 is a four-electrode valve manufactured by the M.O. Valve Co., Ltd., Hammersmith, W.6, and differs from the three-electrode type in that an auxiliary grid is fitted between the filament and the main grid. The standard four-pin base is, however, still used, so that existing bases may be employed, and the connection to the auxiliary grid,

(the one nearest the filament), is made by a screw terminal on the side of the valve cap.

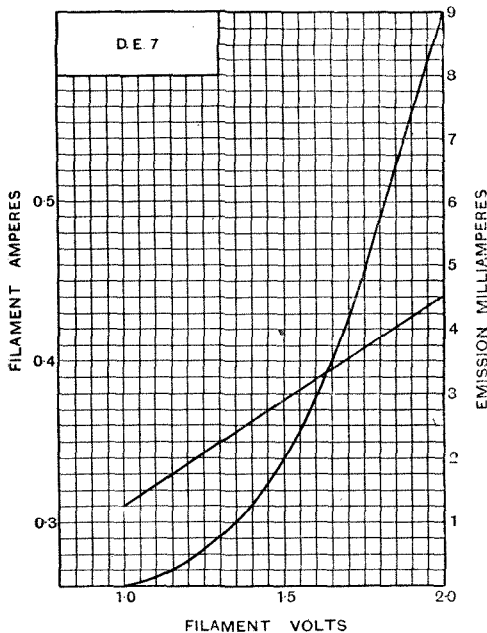

Fig. 1. Curves giving the relation of filament current and emission to filament voltage.

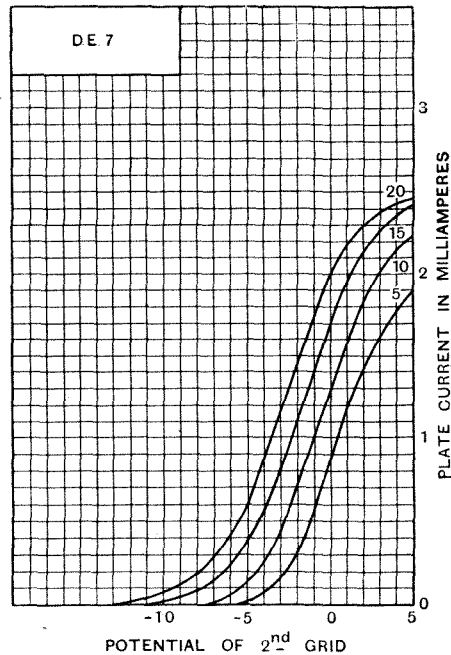

Fig. 2. Curves showing the relation of plate current to the potential of the second grid, the first grid having a fixed voltage of positive 15.

Our usual standard tests, as applied to three-electrode valves, are, generally speaking, not applicable to the four-electrode type, due mainly to the almost endless

variety of possible curves. Again, the circuit arrangements for use with these valves are so varied.

Should four-electrode valves really become popular amongst amateurs, we will devise a standard test for them, but in the meantime we give a few curves from which their general characteristics may be obtained.

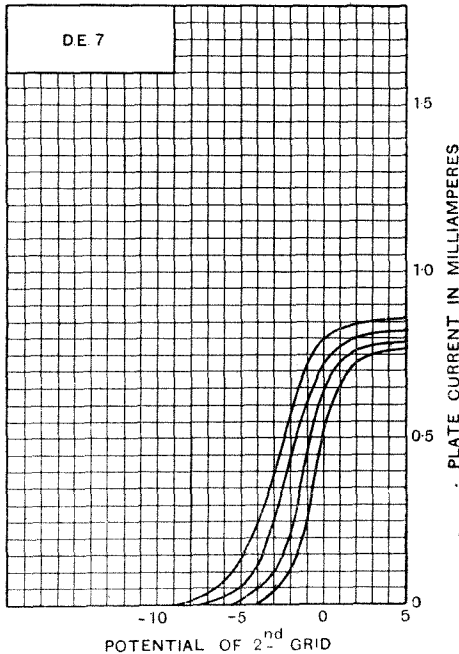

Fig. 3. The curves in this figure are drawn to a larger scale than those of Fig. 2. The first grid had a fixed potential of positive 6 volts.

The D.E.7 is rated as follows: Filament volts, 1.8; anode and inner grid volts, 6 to 15.

The filament characteristics of the valve under test are given in Fig. 1, from which it will be seen that at the normal rating the current is 0.415 ampere, giving a total emission of 5.7 milliamperes. Connected straight across a 2-volt accumulator, the emission rises to 9 milliamperes.

The curves of Figs. 2 and 3 show the performance of the valve when the second or outer grid is used as the controlling electrode, the first, or inner, grid being given a fixed positive voltage. These curves have the usual form, but it will be noted that the effect produced by increasing the voltage of the first grid is similar to that

produced by increasing the filament current of a three-electrode valve.

The same values of plate potentials have been used for both sets of curves, viz., 5, 10, 15 and 20, but the potential of the first grid in Fig. 2 was 15, whereas for Fig. 3 it was reduced to 6.

From the curves of Fig. 3, we find the magnification factor to be 5 and the internal impedance 22,000 ohms, whereas, for the same value of H.T. the curves of Fig. 2 show the impedance to have dropped to 12,500 ohms, the magnification factor at the same time falling to about 4.

The foregoing curves indicate that the valve is one that will work particularly well on low values of plate potential, but it must be borne in mind that the output from a four-electrode valve must of necessity be rather lower than that from a similar three-electrode tube, due to losses in the first grid.

A COMPACT THREE-VALVE RECEIVER.

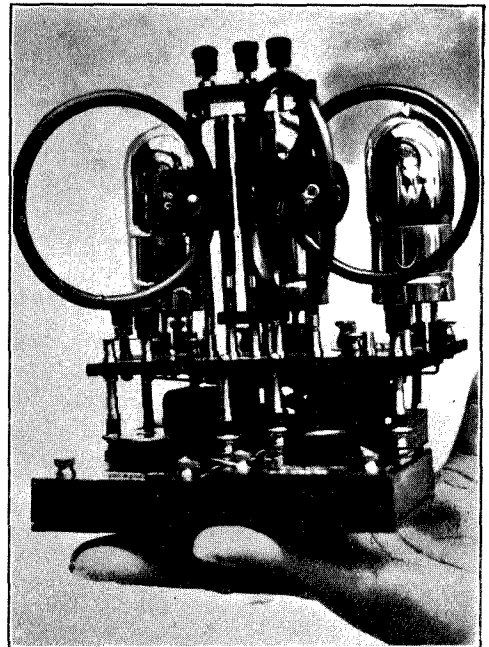

This set, which is of French design, is small enough to be held in the palm of the hand. Tuning is done by the two condenser dials on the base and the three coils.

THE SPEECH AMPLIFIER IN POLITICS.

CAPTAIN IAN FRASER'S SUCCESSFUL OUTFIT,

CAPTAIN Ian Fraser, whose political victory in the constituency of North St. Pancras was referred to recently in our columns, attributes his success in a large measure to his use of a

could be swung in all directions, so that all portions of the crowd could be reached at will.

The amplifier, hastily designed and constructed at the beginning of the campaign,

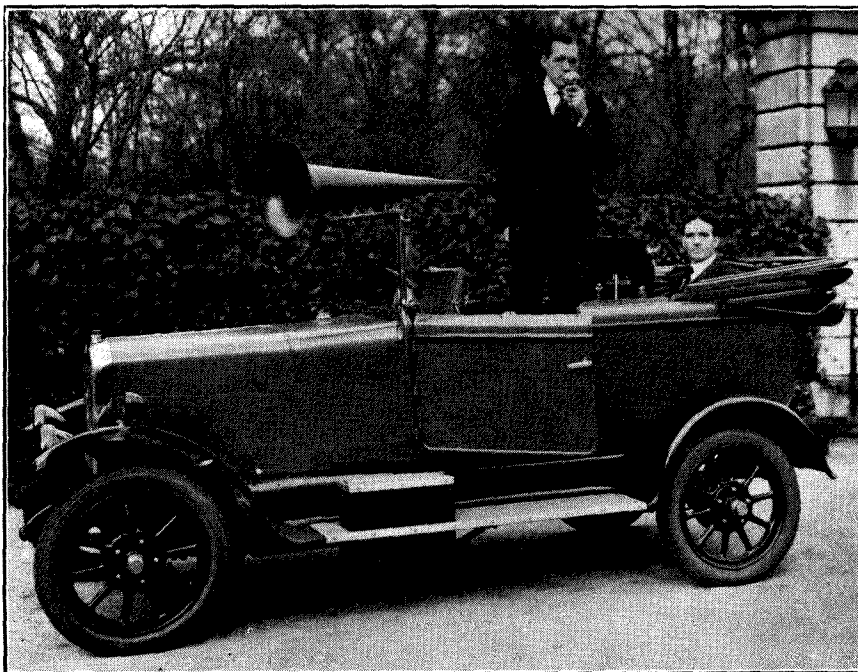

How the amplifier was used. Captain Ian Fraser is seen speaking into the microphone. On his left is Mr. A. E. Howlett, who constructed the instrument to Captain Fraser's design.

speech amplifier. By means of this instrument, designed by himself, he was enabled to address large crowds which would otherwise have been unapproachable.

The amplifier was constructed to Captain Fraser's design by Mr. A. E. Howlett. The loud speaker was fixed to the wind-screen of the car, as seen in the accompanying photograph, and consisted of a Standard Amplion model to which was fitted a pre-war Edison phonograph horn of very generous proportions. By means of a pivoting arrangement the loud speaker

made use of three valves. The microphone, of the ordinary Peel Connor solid back type, was connected in circuit with a few cells and the primary of a Marconiphone Ideal transformer having a 6 to 1 ratio. The output terminals of the transformer were loaded by shunting a resistance across the secondary terminals. This resistance was variable and had a range from 10,000 ohms to one megohm, and had the effect of considerably improving the quality, at the same time reducing the degree of amplification provided by the outfit.

The first valve was of the L.S. 5 type, which operates with a filament battery potential of $4\frac{1}{2}$ volts and passes a current of 0.8 amps, giving an emission of about 50 milliamperes. This class of valve was employed in consideration of the grid potential swing produced by the step-up transformer in the microphone circuit. The output of this valve was passed to a second valve of the same type through the usual resistance capacity inter-valve coupling, using an anode circuit

The whole set was mounted in a portable case with the components distributed on either side of a wooden partition which was covered with copper foil. This was connected to the common negative point and earthed to the chassis of the car. For filament lighting the 12-volt car accumulator was used tapped at 6 volts. A H.T. voltage of 200 was taken from an accumulator which was mounted in a suitable box in the rear of the car.

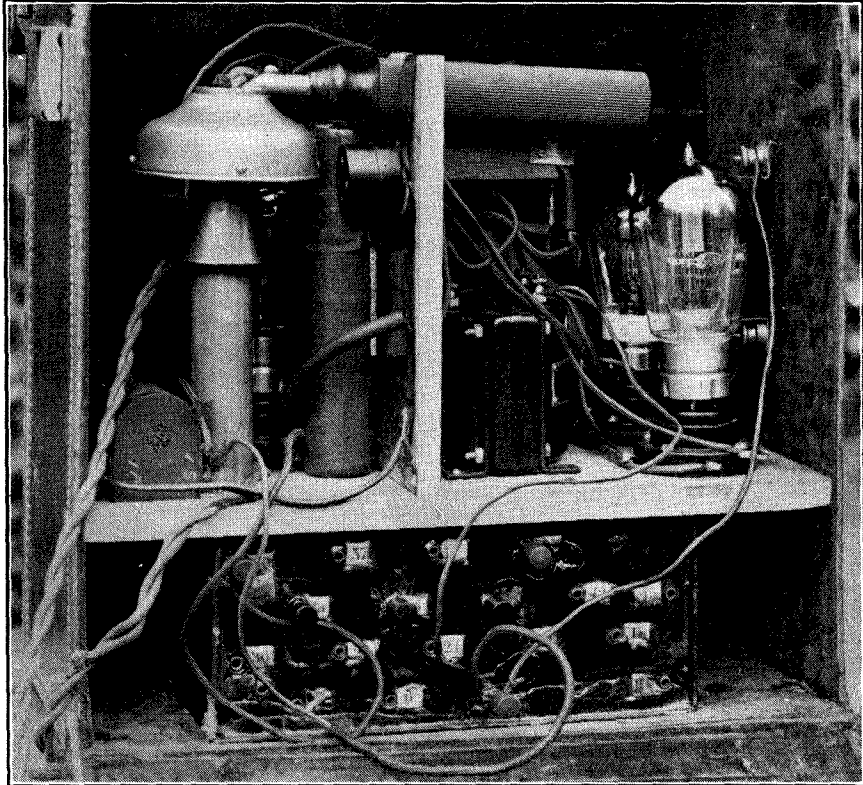

The amplifier was constructed for rough usage, and gave excellent results throughout the campaign. Many of the components can be identified. The battery in the lower compartment provides the requisite grid bias.

resistance of 100,000 ohms. This valve was coupled to a further amplifying circuit by means of a transformer, and a valve of a special type was here employed as its grid potential fluctuated over a wide range. The valve was an L.S. 5A and had a lower impedance than the L.S. 5 type, by reason of the use of a grid having somewhat wider spacing.

In practice, the outfit proved remarkably efficient, tremendous volume being obtained from the loud speaker.

On one occasion Captain Fraser addressed an open air meeting of about 700 strong with perfect ease and it was evident that his speech was heard by everyone present.

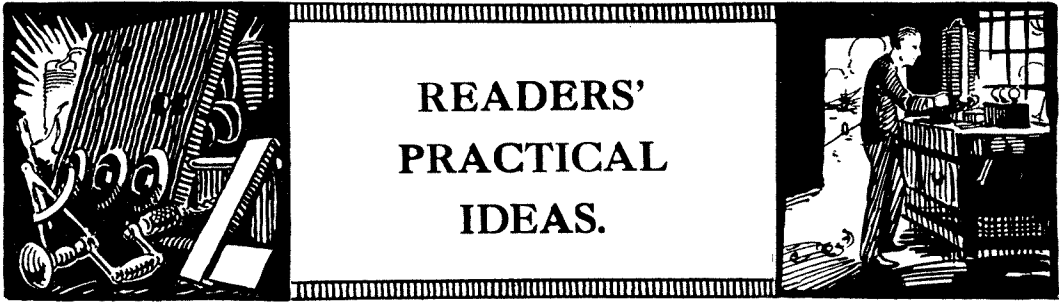

This section is devoted to the publication of ideas submitted by readers and includes many devices which the experimenter will welcome.

Checking Filament Voltage.

FILAMENT brightness is very little guide that the correct current is being passed by the filament and the only method of making sure that the filament is not being over-run is to connect a voltmeter across it. On a single-valve receiver the fitting of a voltmeter does of course add to the cost and complication, but with a multivalve set the fitting of a voltmeter and switch is recommended. The voltage applied across the filament of any of the valves can be accurately determined and by carefully avoiding excessive voltage values the life of the valves will be appreciably lengthened.

J. O. C.

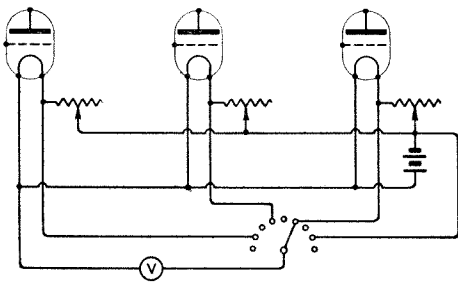

Method of applying a voltmeter across the filaments of a multi-valve set.

Low Capacity Valve Holder.

IT may not be known to many experimenters that a good valve holder possessing low capacity between its contacts can easily be made up from the tag type of terminal connector. The drawing is almost self explanatory and it will be seen that the end

of the tag is bent over at right angles and bolted to the face of the panel whilst the stem passes through a clearance hole. The holes

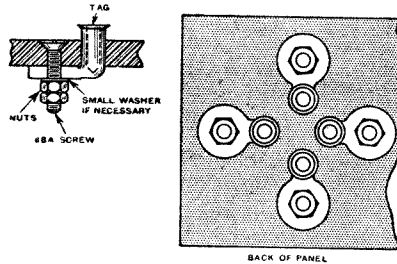

Valve sockets made from terminal tags.

for the sockets are best marked out with a valve template and drilled to hold the stem of the tag connector securely. By this means a good fit can be obtained with the pins of the valve.

D. O. B. G.

Economical Battery Charging.

ONE of the greatest difficulties met with by many wireless experimenters is that of the maintenance of the filament heating accumulator. When a continuous current supply is available the question of recharging is simple for it is only necessary to connect the battery to the circuit through a suitable resistance. This method, however, though simple is apt to prove somewhat expensive for nearly the whole of the current drawn from the mains is dissipated in heat in the resistance. A normal charging rate for a 60 ampere hour battery is 4 amperes. On a 200-volt circuit this is equivalent to

0.8 of a unit per hour or 8 units for a 10-hour charge. On a 240-volt circuit the energy consumed is proportionately higher, the cost of the charge working out at 9.6 units. At 5d. per unit the cost is respectively 3s. 4d. and 4s.

A better practice is to charge several small batteries in series and discharge them in parallel. A number of small cells may perhaps have a charging rate of 0.5 ampere and on a 240-volt circuit a 10-hour charge consumes 1.2 units, which costs 6d. on the same scale. After charging, the batteries may be connected up in two groups in series of six in parallel, giving a battery of 60 ampere hours.

A. J. B.

Mounting the Grid Leak.

ONE of the best methods for varying the value of the grid leak is by mounting it on the face of the panel and interchanging several resistances. In the accompanying diagram not only can this be done but by means of the clips 1, 2, and 3, the leak can

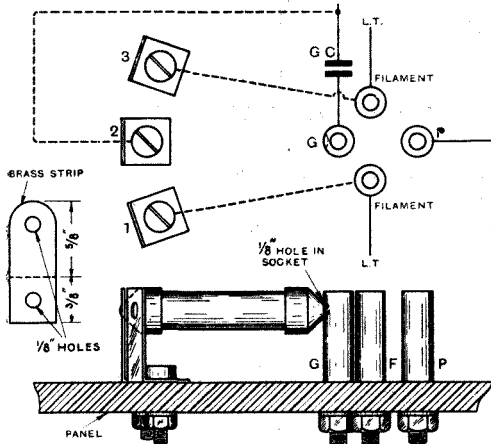

Simple method of changing grid potential.

be connected either across the grid condenser or to the low tension positive or negative leads. Thus the degree of self-oscillation in the receiver can be controlled by connecting the grid leak to the positive or the negative and the most suitable grid

potential can easily be obtained to give rectification depending upon the type of valve employed.

E. M.

Coil Holder Design.

CRITICAL coupling between inductances carried by a coil holder is best obtained by a rotating action as well as by

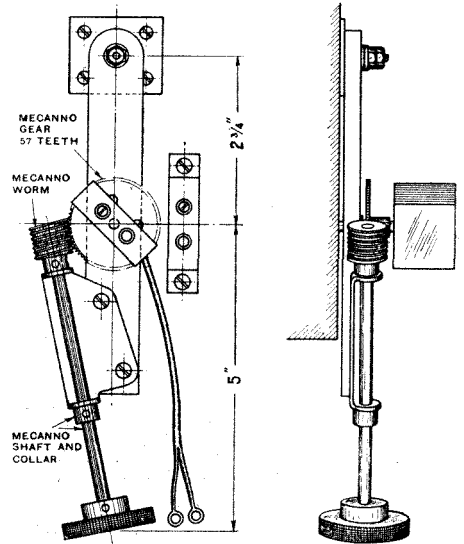

A rotatable coil holder mounting.

altering the distance between them. One coil is secured to the baseboard while the other is carried on an arm pivotted to provide the necessary swing. The second coil holder is mounted above the small pinion which is operated by means of a wormwheel.

G. K. C.

Basket Coil Winder.

MAKING use of a borrowed basket coil former wind with No. 18 tinned copper wire to a depth of about 3/8". While the turns are still on the former, smear with flux and well solder the turns together, taking care not to secure the spokes to the winding. On removing the soldered winding, it is only necessary to prepare a set of pins by cutting up some suitable wire.

U. W.

THE THERMOFORMER.

The problem of devising a method for deriving filament and plate current from alternating current supply has probably been solved in the instrument described here. It makes use of an entirely new principle inasmuch as current is produced by creating temperature changes at junctions of unlike metals. The old laboratory thermopile is probably well known to many readers; this new application is likely to centre interest in it as a method of producing the comparatively small currents required in wireless work.

A PERUSAL of the past volume of this journal will reveal that considerable space has been devoted to the development of rectifying equipment for use with alternating current mains, so that the alternating current supply can be used after rectification for filament heating and also for anode current in place

that rectifiers of the electrolytic type require careful maintenance to be of any practical utility.

Many types of vibrator rectifier have been developed and these serve their purpose excellently for the charging of both low tension and high tension accumulators, but of course, it is a great disadvantage to operate

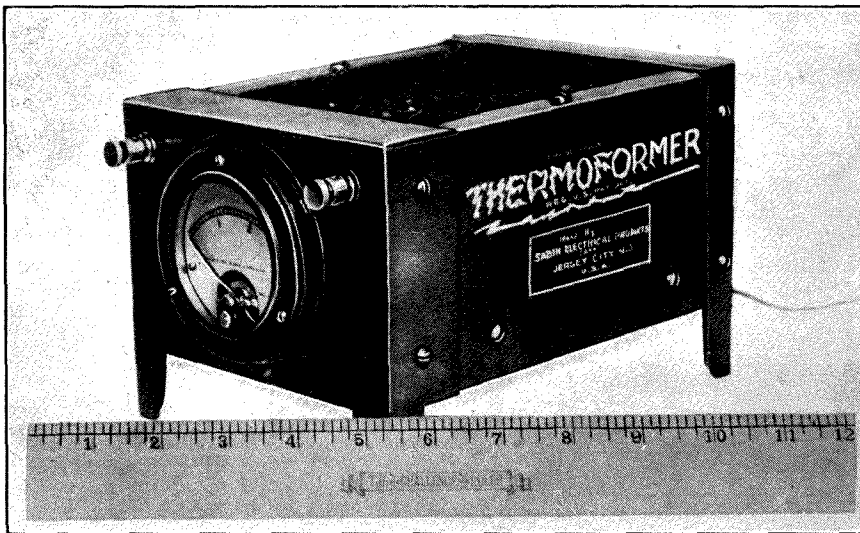

An instrument for generating filament and plate current by a thermo-electric process.

of the usual high tension battery. Although many amateurs are using rectifiers of the electrolytic type for both filament heating and H.T. supply it may be stated here that the use of wet cells for rectifying purposes is only a proposition in the hands of the expert experimenter and that considerable technical knowledge and skill is essential to manipulate this sort of equipment successfully. It is, of course, a very messy process requiring constant attention. It may be said in general

through a process of charging and discharging acid accumulators.

The device shown on this page marks a step towards meeting the needs of the amateur who only has available alternating current supply, whilst on the other hand it will operate equally well on direct current. It is of American origin and is marketed under the name of the "Thermoformer," and is the invention of Mr. R. A. Sabin of Somerville in co-operation with Mr. L. G.

Pacent who is known to many experimenters in this country as a designer of wireless apparatus.

It makes use of the current produced when junctions between unlike metals are subjected to change of temperature. The instrument consists of a large number of thermo junctions which are heated by the usual type of heating apparatus designed for operation from direct or alternating current supply. It is well known that the potential output from a thermocouple is very small and thus to heat the filament of the 0.06 type of valve which requires a potential of about 3 volts, a thermoformer consisting of 32 units is necessary, whilst the amount of current delivered may be sufficient to operate three or more valves in parallel depending upon the size of the apparatus. The instrument is, however, not only designed for filament heating, but supplies plate current and in addition, some models are fitted with terminals for the purpose of providing a grid biasing potential.

The accompanying circuit diagram shows the operation of the apparatus and by means of a number of multi-contact switches critical voltages for both filament heating and plate supply can be stepped off. A moving coil voltmeter is part of the equipment of the instrument, so that the output voltage can be accurately observed.

It might be thought at first that a device operating on this principle would occupy considerable space but one having an output suitable for operating six valve filaments

of the 0.06 type, as well as supplying the necessary H.T. potential, occupies less room than a standard form of six-volt storage battery.

One great advantage of using an instrument of this sort is that the output is quite free from ripple and no smoothing apparatus is needed, whilst in operation it is entirely

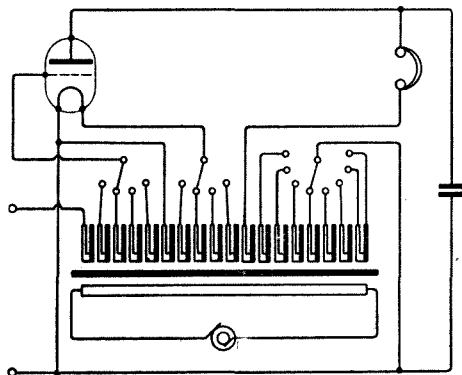

Circuit arrangement of the thermoformer in which provision is made for regulating the output voltage.

silent. There is little doubt that this type of apparatus for supplying both filament heating and plate current, will find considerable favour among wireless users who have alternating current supply mains available, whilst even in the case where direct current is fitted, the Thermoformer will still make an appeal owing to the convenience by which the necessary voltages can be obtained.

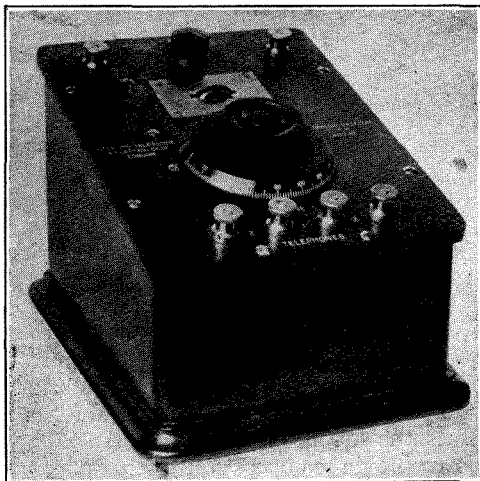

A NEW STERLING CRYSTAL SET.

As will be seen from the illustration, this crystal set follows in design other receivers of the Sterling Telephone Electric Company. The components are mounted upon a sloping ebonite panel fitted in a well-finished walnut case. It is a variometer tuned set making use of a new type of Sterling variometer, which is secured to the panel by one-hole fixing. The well-known Sterling automatic crystal detector is fitted. By means of a switch having contacts beneath the panel the necessary circuit changes are brought about for changing the wavelength from that of the short wave broadcast stations to 1,600 metres.

UNSOLVED PROBLEMS OF WIRELESS.

By R. H. BARFIELD, M.Sc.

(Concluded from page 256 of previous issue).

DISCUSSION (continued).

Dr. R. L. Smith-Rose.

I think that Mr. Barfield is to be congratulated on having chosen such an opportune moment for giving this lecture. The progress of the discussion so far has amply justified it, but the chief merit of the lecture is in drawing attention to the uncertainty which exists amongst all those who have examined the problem in some detail, as to the actual mode of propagation of wireless waves around the earth's surface. It has become almost a dogma until recently to speak of the Heaviside layer and blame it for everything we could not understand in connection with wireless communication, but it is only when one examines the theory in the light of quantitative data, which are happily now being increased by a tremendous amount, that one appreciates the limitations that are applicable to the theory in the light of our present knowledge. It is easy enough to talk in a general manner of a layer 100 km. above the earth which will reflect waves, and to say that these arrive out of phase, resulting in decreased signal strength or in phase and so accompanied by increased signal strength and so on, but now that we have quantitative results we find that the theory is lacking in some details. I believe that the mathematical theory, as far as it has gone, is quite adequate, but there is really a lot of experimental data required to explain the whole position, and to decide the direction in which to expand the theory to account for the established facts. Therefore, the chief difficulty at the present time seems to be in the experimental direction, and in obtaining the quantitative data on the various effects which are now generally understood to occur. Pending the obtaining of that adequate experimental data, I think we should treat with some caution the theory as it stands, and not rush hurriedly to immediate explanation of barely established facts.

Mr. Blake has referred to some old experiment of Tesla's, and there is an interesting side issue here. Tesla suggested some scheme, as Mr. Blake has mentioned, of oscillating the earth at its natural frequency. Now, it turns out from calculations made by Professor Fitzgerald that the natural frequency of the earth, taken as an ordinary bi-pole Hertzian oscillator, is about one-seventeenth second when in free space. If, on the other hand, it is surrounded by a conducting shell corresponding to the Heaviside layer at a height of about 100 km., that frequency will be reduced to one-tenth second, while if the layer was only 56 km. high, the natural period would be one-sixth second. Now Tesla filed his patents, and everything was calculated on the assumption that the earth was going to oscillate at one-sixth second, so that although he

did not, perhaps, make any use of the Heaviside layer, he apparently had some justification for assuming such a layer was in existence. I think the most acute problem mentioned by the lecturer to-night is the one relating to direction finding. It is comparatively easy to explain variations in signal intensity in long distance propagations, because there you are dealing with ordinary electromagnetic waves as we understand them, that is, the type of wave shown in diagrams which appear in the text books in which the electric field is vertical to the earth's surface, and the magnetic field is horizontal and at right angles to the direction of propagation. In daylight and under ordinary conditions that arrangement of the waves holds, and those of you who use frame coils know that in order to get the maximum strength of signal you put the plane of the frame pointing towards the transmission station so as to get the greatest possible linkage with the magnetic field. During the night time, however, the magnetic field or the horizontal component of the magnetic field is not at right angles to the plane of propagation, and in cases which are not at all unusual the induced E.M.F. in the frame is unaltered by rotation of the frame through 360 degrees. It is therefore evident that the magnetic field is equal in all directions, and the net result is that the magnetic field is no longer linear, but must be circularly polarised as a rotating component. To change the polarisation of the wave propagated at the receiver it is necessary to introduce a different type of wave from that which will explain the other three phenomena, *i.e.*, one in which the magnetic field has a component in the plane of propagation. There are various modifications of the Heaviside layer theory to explain the arrival of such a wave, but there are difficulties in visualising the way it arrives at all. In many cases a wave polarised in the manner I have described must be considerably stronger than the ordinary wave with which we are dealing, and which produces the other effects. It is interesting to note that a proposal has already been made to construct a model of the earth about one-thousandth full size, and have a sliding Heaviside layer which could be put in operation as required, everything being reduced in proportion. The suggestion is only a suggestion so far, and there are many obvious difficulties in putting it into practice. With regard to the means by which waves can arrive at the Antipodes or any point on the earth, I do not quite see that the theory recently put forward in any way alters what we knew before. If you admit that there is a conducting shell surrounding the earth, then these waves will always concentrate at a point at the Antipodes, whether they slide along

the earth or along the layer to get there, or whether it is accomplished by reflection. There will be a point where the waves will converge and produce a strength greater than at some places not so far round, but there will be many other points at which the field is considerably stronger than the field which is experienced, say, half way round the earth; and I do not think it is necessary to assume that there is only one point in New Zealand which can receive from a station in London on, say, a wavelength of 100 metres.

Captain M. A. Ainslie.

I had forgotten that the Antipodes are so near to the point with which communication has been established. Under the circumstances, any great circle drawn through London would very nearly pass through the point of reception, and if the point of reception is 300 miles from the Antipodes, the difference between the longest and shortest possible paths is only 600 miles. I should imagine that local conditions, such as distribution of land and water, or of light and darkness, might easily cause the most effective path for the waves not to be along the great circle at all; it might hardly touch any land at all, but might, for example, cross the Isthmus of Panama. Moreover if there are several receiving stations all within about 300 miles of the Antipodes, and only 20 or 30 miles apart, the great circles through them and London—even assuming the waves to follow the great circle—would be widely different. I had an idea that the Antipodes were a good deal further from New Zealand than 300 miles, so this point might be borne in mind.

Mr. F. L. Hogg.

Mr. Orbell, of New Zealand, has mentioned something of interest to me in regard to the Bordeaux station. He says that the long wave transmissions from Bordeaux are received extraordinarily well by all amateurs around the Dunedin district, where the stations which have been working on short wavelengths are located, but in the northern part of New Zealand, where the other stations are, Bordeaux is rarely heard under any circumstances whatever. This is rather what I suggested may actually be found to be the case.

With regard to the fourth New Zealand station, this has recently been received very weakly indeed on two of the best nights for communication with the others. Enquiries show that he has been working regularly. This station, so weak here, is one which has been heard in many parts of the U.S.A., and is, in fact, by far the loudest there, and is actually using more power than any other in New Zealand. This is what one would expect if the Antipodal idea is responsible for the results.

Mr. P. R. Coursey.

Before asking Mr. Barfield to reply, I would just like to say a word or two about the question of the Antipodes. I was a little surprised at the statement that it is only 300 miles away, because I had the impression that it was much farther, and, basing my belief on the great circle maps which have been prepared, I thought the Antipodes of London was considerably off the New Zealand coast altogether. That being so, there is a considerable difference between the two directions. If I remember rightly,

the nearest circle direction from London is in a north-easterly direction over Norway and Northern Russia, and then across part of Asia, and skirting Australia to New Zealand. That is my recollection of the great circle maps plotted with London as the centre. The tests which have been carried out by the French Government seem to show an increase of signal strength as the Antipodes is reached, and certainly indicate a very marked increase of signal strength of a local character in the proximity of the Antipodes. That, of course, applies solely to long wave transmission, and may not apply at all to the shorter waves we are now dealing with. That is obviously a matter which can only be found out by further investigation over a much longer period. Certainly it would seem very doubtful that the points from which signals can be received should be so localised as has been suggested. If such were the case it would very much reinforce one's belief in the theory of strengthening the signals at the Antipodes. It will, however, require very much further data before we can come to any further generalisation.

Mr. R. H. Barfield, replying to the discussion, said:—

Dr. Eccles referred to the important part which may be played by the upper atmosphere in screening us from the effect of powerful stray waves. I might also point out that it would have an equal effect in preventing our communicating by wireless with the other planets, since it would be an effective screen. I do not know how we shall penetrate this layer.

In reply to Mr. Blake I think the Tesla idea of surface waves being created by the transmitter is accounted for by the diffraction theory. I think it is all worked out in that theory so that the possibility of such waves along the surface of the earth accounting for propagation has really been dealt with in that problem.

With regard to Captain Ainslie, I certainly think interference is a possible solution of the fading problem, but I do think that the important thing at present is to obtain more experimental confirmation of these theories so that we can decide between the possible alternatives.

Mr. Robinson and Dr. Smith-Rose pointed out that on any theory, the Antipodes should certainly be the point where the waves concentrate. If there were no diffusion at the Antipodes we should get the same current in the receiving aerial that the transmitting aerial is sending out.

I think, in reply to Mr. Child, it would be very interesting indeed to go on decreasing wavelength until we find the optimum value obtainable. Every encouragement should be given to go to shorter and shorter wavelengths.

ANOTHER NEW ZEALANDER.

NZ IDQ, a New Zealand amateur hitherto unheard in this country, is reported to have been received by Mr. W. H. Bungard, of Wymondham, on the morning of November 13th. Audibility was about R 3 on a four-valve receiver (1-v-2), but no definite message was logged owing to atmospheric disturbance. Mr. Bungard believes that the New Zealander was calling G 2 NM.

THE TRANSATLANTIC TESTS.

THIS opportunity is taken of inviting our readers to forward to us as promptly as possible, reports on the reception of American and Canadian broadcast stations taking part in the Transatlantic tests.

The transmissions, as previously announced, will be made from America and Canada from 3 to 4 a.m. G.M.T. on the mornings of the 24th to 30th November inclusive. Special programmes are being transmitted from most of the high-power stations on the other side of the Atlantic, whilst speeches by eminent men, directed particularly to Europe, will be made. Mexico is, in addition, participating, and from the broadcasting station there a speech recording the voyage of Columbus is to be sent out particularly for the benefit of Spanish-speaking people of Europe.

All Europe is taking part in transmitting back to America from 4 to 5 a.m. on the same days, and as we have already mentioned, and in accordance with the programme published generally in the press, the British broadcasting stations will transmit from 4 to 5 a.m. on the mornings of the 25th, 27th and 30th, different stations taking part on different days. In addition to piano, gramophone and speeches organised for the other days of the transmission, a special organ recital from the Shepherd's Bush Pavilion, London, will be included, in addition to the speeches, on the morning of the 25th. It has been arranged that, as the British stations start to transmit, the hour from Big Ben will be broadcast at 4 a.m. and again when the stations close down at 5 a.m. Nearly all the broadcasting stations on the Continent are taking part and these will be transmitting on the mornings of the 24th, 26th, 28th and 29th November, from 4 to 5 a.m. These stations include: Radio Paris, l'Ecole Supérieure, Petit Parisien, Brussels, Madrid, Rome, Hamburg, on their usual wavelengths, Koenigs Wusterhausen (on 2,800 metres), Stockholm and Switzerland, whilst others are likely to take part although no definite information is available to publish.

It is hoped that all those who avail themselves of this exceptional opportunity for

listening-in to American broadcasting and to European stations will take whatever precautions are possible to avoid causing interference with other listeners through re-radiation, and will forward reports on reception, indicating the items received, to assist in verification.

CAPTAIN ECKERSLEY EXPLAINS.

Sooner or later it was likely that Captain Eckersley would be called upon to give some explanation for statements appearing in his recently published book,* which might be considered as belittling the value of the amateur.

Captain Eckersley took the opportunity of forestalling criticism when on the occasion of his address on Tuesday, November 18th, to the Transmitter and Relay Section of the Radio Society, he touched upon this matter before giving his address on "The Control Room at 2 LO."

Captain Eckersley said that it was unfortunate that a part of his book would perhaps not be altogether agreed with by those present at the meeting. He said he wished to emphasise that in all the articles he had written and in his book he had endeavoured to put before the amateur and the public his own point of view and that in the book he had said that he did not think that amateurs as amateurs had really contributed towards the science of radio telephony. He admitted that the statement required some explanation and he stated that a little further on in the book he expressed the opinion that the value of so many experimenters to the community, lay in the possibility that many of them might become good professionals. He stated that this summed up the whole point, because if a man who takes up wireless purely as a hobby is fortunate in striking upon a good invention, he immediately becomes a professional.

Captain Eckersley said he recognised the work of amateurs in the past in finding out various troubles and stated that he intended to recommend to the B.B.C. that more should be done to repay the debt owed to the amateur.

*Captain Eckersley Explains (Wireless Press, Ltd.)

NOTES & NEWS



Since the opening of the Nottingham Relay Station the number of broadcast licences issued in the district exceeds 18,200.

* * * *

The Soviet Government would appear to be short of land stations, judging from the announcement that the Russian ship "Ermak" (RBW) has been stationed at Leningrad to operate as a coast station.

* * * *

Signor Ermanno Fiammo, the inventor of a system of wireless control, has successfully demonstrated in the Gulf of Spezia that his apparatus is immune from jamming.

* * * *

The Borkum Riff Light-vessel will shortly commence a direction and distance-finding service by a simultaneous emission of fog radio signals and submarine bell signals.

* * * *

COPENHAGEN TESTING.

The Copenhagen broadcasting station is continuing its tests on 750 metres. Regular transmissions are also carried out on 471 metres on Sundays, Wednesdays and Thursdays.

2 OD's AUSTRALIAN SUCCESS.

Reference is made in the T. & R. Notes appearing on another page, to the feat of Mr. E. J. Simmonds (2 OD) in accomplishing two-way communication with an Australian amateur, A 3BQ. This was carried out on the evening of Thursday, November 13th, at 6.40 (G.M.T.); the Australian was heard transmitting a CQ call on 75 metres, with a rough A.C. note. 2 OD called him at 6.50, and received the reply "R. o.k. QRK, but QRN." Great difficulty was experienced in receiving 3 BQ owing to local heterodyne interference. After 2 OD had again transmitted times of suitable schedules, which were apparently received, 3 BQ's signals faded completely at 7.15.

Mr. Simmonds immediately cabled to Australia and received the following reply from Melbourne: "CONGRATULATIONS TIMES CORRECT—HOWDEN."

British amateurs will unite in congratulating G 2OD and A 3BQ on being the first amateurs to communicate between Britain and Australia.

Mr. Simmonds also worked on November 1st with Z 2AC, a New Zealand amateur, who had

not hitherto been communicated with from this country.

ACD, BOLOGNA.

Mr. Adriano Ducati, the well-known Italian amateur (ACD), who recently undertook a voyage to South America, transmitting on board ship with the call sign 1 HT, would be glad to receive reports from British amateurs who heard his signals. He is now back in Italy and will shortly resume operations with the original call sign ACD. His address is: 3 Via Garibaldi, Bologna, 29, Italy.

U.S. NAVAL RESEARCH SHORT WAVE SIGNALS.

Until further notice the U.S. Naval Research Laboratory (NKF) at Bellevue, Anacostia, D.C., is transmitting on 54 metres on Mondays, Wednesdays, and Fridays at the following times: 8 to 8.10 p.m., 9.0 to 9.10 p.m., 10.0 to 10.10 p.m., 11.0 to 11.10 p.m., Eastern Standard Time. (E.S.T. is five hours behind G.M.T.).

Dr. Taylor of the Naval Research Laboratory, emphasises the need of more short wave observers and will gladly welcome reports at the above address.

FRENCH BROADCASTING FEARS.

The control of broadcasting in the interests of national safety has recently been causing some anxiety to the French Government, and as a precautionary measure, the Sureté Générale has increased its staff. The reasons given are that with the million wireless receivers now in use, possibilities exist of the dissemination of harmful political information; and that Bourse and market quotations, particularly adverse, are liable to be propagated and used by unscrupulous foreigners to the detriment of the franc.

U.S. AND GERMAN PATENTS.

An echo of wireless in the war was provided by the action of the U.S. Navy Department on October 30th, in deciding to issue licences to sixty independent radio manufacturers under 129 German patents seized by the Alien Property Custodian at the outbreak of hostilities.

The majority of the patents were originally owned by the Telefunken Company, and included the well-known Wilhelm Schloemlich and Otto Van Bronk patent covering tuned radio frequency.

In 1919, under the *Trading with the Enemy Act*,

the Alien Property Custodian sold these patents to the Secretary of the U.S. Navy.

According to legal opinion, this latest step of the Navy Department will completely change the complexion of patent litigation in America.

MISUSE OF CALL SIGN.

A complaint of the illicit use of his call sign reaches us from Mr. Stanley Ward (**2 QS**), of Brixton, London, S.W. From reports received it would appear that the culprit is located in a district bounded by Manchester, York, Hull and Sheffield. Mr. Ward trusts that the publication of this fact will have the desired effect.

IMPORTANT TRANSMISSIONS FROM ARGENTINE.

Mr. J. C. Braggio, the well-known Argentine amateur, who is at present in England, has supplied us with some important information concerning transmissions now being carried out by his father, Mr. Carlos Braggio from **DA 8** (ex **CB 8**). These transmissions are sent out every morning from 4.30 to 5.30 G.M.T., and will continue until the end of the year. From 5.30 onwards, Mr. Braggio will listen for replies. He uses C.W. on a wavelength of 120 metres.

Amateurs who succeed in hearing these signals are requested kindly to report direct to Mr. Carlos Braggio, Alsina, 412, Buenos Aires, Argentine.

EVENING RECEPTION OF AUSTRALIA.

Consistent daily reception of New Zealand amateurs from November 10th onwards is reported by Mr. D. B. Knock (**6 XG**), who also claims to have received the Australian **A 2CM** on the morning of November 10th, using a detector and one note magnifier.

On the evening of November 13th, at 7 o'clock, he was also successful in receiving the Marconi "Beam" transmission from Australia, on 90 metres. Calling "**ICCM de Fisk**," the station

was easily readable, and appeared to be using full wave rectification.

A further report of the reception of Australian amateurs has reached us from Mr. J. Allan Cash (**2 GW**) of Lymm, Cheshire, who heard **A 3BQ** in the early hours of November 13th, and **A 2ME** on November 14th. The latter station was also heard by Mr. J. L. Heaton-Armstrong, of Wimbledon Park.

NEW ZEALANDERS HEARD IN BELGIUM.

Both **Z 2AC** and **Z 4AA** have been heard by a Belgian amateur. On the morning of October 22nd, the Brussels amateur **P 2**, tuned in these stations, the former on 75 metres, and the latter on 80 metres. Although the signal intensity in each case was only R3, both stations were easily readable. Our correspondent reports that on the same night he "logged" 112 U.S. amateurs between 60 and 80 metres.

JOHANNESBURG ACTIVE

High praise of the Johannesburg broadcasting station is expressed by Mr. L. C. Hughes, President of the Transvaal Radio Society, in some interesting notes he has forwarded to us concerning broadcasting activities in South Africa.

Johannesburg (**JB**), which commenced operations in July, has an aerial 75 feet above a seven-storied building, and in equipment is almost a replica of the Birmingham station. It transmits on 450 metres, and has some excellent distance records to its credit. For instance it has been heard on a single valve at Cape Town, 1,000 miles; Walvis Bay, 850 miles, and Durban, 400 miles; while with two valves it has been received at Bukama, 1,165 miles distant. Mr. Hughes advises British amateurs wishing to attempt reception of **JB** to listen nightly between 4.30 and 8.30 (G.M.T.).

MADAGASCAR WIRELESS SERVICE.

At present wireless communication between France and Madagascar, and France and French Western Africa, is one-sided. Messages are accepted

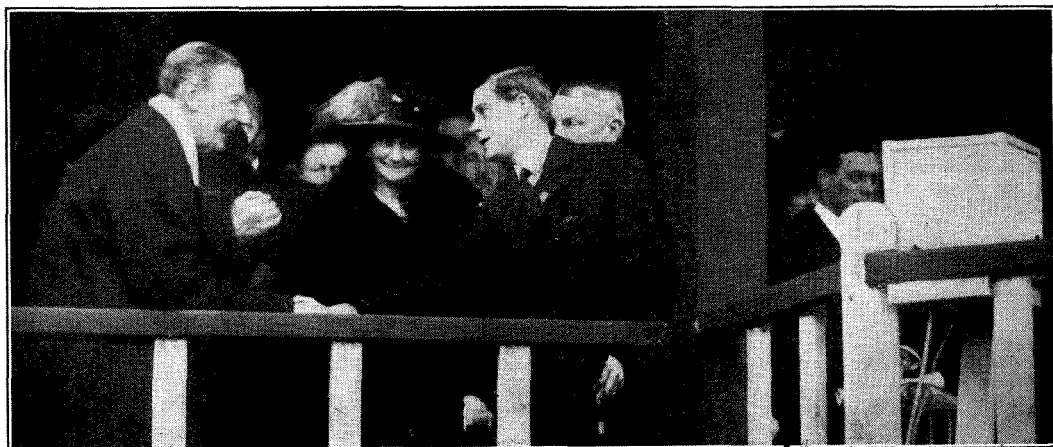

H.R.H. The Prince of Wales opened the reconstructed section of the Watling Street between Dartford and Rochester on Wednesday, November 19th, the proceedings being broadcast. The microphone can be seen on the right.

for transmission from France, but cannot be transmitted in the opposite direction. On November 27th the Minister of Colonies and the Under-Secretary of State for Posts and Telegraphs will formally inaugurate the service in both directions between Paris and Antananarivo, and Paris and Bamako.

RADIO EXHIBITION IN IPSWICH.

An exhibition which proved a great success, both from the point of view of the trader and of the amateur, was held at Ipswich on November 11th and 12th, under the auspices of the Ipswich and District Radio Society.

In addition to a good representation of the local wireless trade, amateur exhibits were well to the fore, exemplifying all types of receivers. These varied from the smallest of crystal sets to handsome cabinet receivers which reflected great credit on the abilities of their constructors. An important feature of the Exhibition was the demonstration of broadcast reception on loud speakers.

A COMPREHENSIVE WIRELESS CATALOGUE.

One of the fullest and most carefully-produced catalogues of wireless apparatus is that issued by Messrs. A. J. Dew & Co, of 33-34 Rathbone Place, Oxford Street, London, W.1. The book is of particular value as a means of reference to the wireless trader, for whom it has been specially prepared.

Radio Society of Great Britain.

An ordinary meeting of the Society will be held at the Institution of Electrical Engineers, Savoy Place, London, W.C.2, at 6 p.m., on Wednesday, November 26th, when L. B. Turner, M.A., M.I.E.E., will deliver a lecture entitled "Wavemeters."

* * * *

A meeting of the General Committee of Affiliated Societies will be held at the Institution of Electrical Engineers, Savoy Place, W.C.2, on Saturday, November 29th, at 3 p.m., at which various important questions affecting the amateur movement will receive attention.

* * * *

T. & R. NOTES.

I am very pleased to be able to supply with these notes a photo of Mr. Ralph Slade of Dunedin, New Zealand, best known by amateurs as **NZ 4 AG** (see next page). I have also been fortunate in receiving a visit from Miss Margaret Ford, also of Dunedin, and a great friend of Mr. Slade. It will doubtless interest a good many readers of the *Wireless World and Radio Review* to know that Mr. Slade is twenty years old, and is engaged in the Postal Telegraph services in Dunedin. I am also given to understand that it is almost entirely due to Mr. Slade's untiring efforts that amateur radio in New Zealand has arrived at its present most efficient stage, and that he is partly responsible for the building of **4 AK** and **4 AA**.

The most important radio amateur news of the week is **2 OD's** two-way communication with **A 3BQ** of Australia. Mr. Simmonds is the first

European amateur to link up with Australia, and deserves our heartiest congratulations. It is good to know that his painstaking efforts have been so suitably rewarded.

Some new distant stations have started up in the shape of Chilian amateur transmitters; one of these with the call sign **9 TC** gives his position as Los Andes Chili. His wavelength is about 86 metres and his note is DC. He was logged a week ago by Mr. Galpin (**5 NF**), whose reception seems to be very efficient and who seems to have been the first European to have received an Australian amateur, though I am not sure that his reception has been confirmed.

Mr. J. C. Braggio, who is at present in Birmingham, informs us that his father is transmitting every morning at 0430/0530 G.M.T. and listens for European amateurs from 0530; his wavelength is 120 metres.

I am extremely grateful to members of the T. & R. Section for their generous support in the way of reports, as in the last fortnight I have received the large total of **FOUR**.

I will conclude this week with that true old proverb:

"ACTIONS SPEAK LOUDER THAN WORDS."

GERALD MARCUSE,

Hon. Sec., Transmitter and Relay Section.

CHANGE OF ADDRESS.

Mr. T. W. Higgs (**5 KO**), late of Bristol, informs us that after November 21st his address will be "Park Side," 24 Leazes Terrace, Newcastle-on-Tyne. He hopes to resume transmissions very shortly.

FORTHCOMING EVENTS.

WEDNESDAY, NOVEMBER 26th.

Radio Society of Great Britain. Ordinary Meeting. At 6 p.m. At the Institution of Electrical Engineers, Savoy Place, W.C.2. Lecture: "Wavemeters." By Mr. L. B. Turner, M.A., M.I.E.E.

Royal Society of Arts. Ordinary Meeting. At 8 p.m. At John Street, Adelphi, London, W.C.2. Lecture with Practical Demonstration, "Talking Motion Pictures." By Mr. C. F. Elwell, B.A. (Mr. Alan A. Campbell Swinton, F.R.S., late Chairman of the Council will preside).

Radio Research Society, Peckham. At 44 Talfourd Road. Lectures: "Elimination of Interference," "Characteristic Curves."

Streatham Radio Society. At 35 Streatham High Road. Lecture: "Transmission," By Mr. L. E. Owen (**2 VS**).

Bristol and District Radio Society. At 8 p.m. Wireless Lecture No 5. By Mr. W. A. Andrews, B.Sc.

Edinburgh and District Radio Society. At 8 p.m. At 1.7 George Street. Lecture: "The Automatic Telephone." By Mr. J. Plucknett, A.M.I.E.E.

THURSDAY, NOVEMBER 27th.

Luton Wireless Society. At 8 p.m. At Hitchin Road Boys' School. Experiments and Demonstrations for Beginners.

Walthamstow Amateur Radio Society. Lecture by Mr. J. F. Stanley, B.Sc., A.C.G.I.

West London Wireless and Experimental Association. Question Night.

FRIDAY, NOVEMBER 28th.

Bristol and District Radio Society. Demonstration and Address by Metro-Vick Supplies, Ltd.



BROADCASTING.

REGULAR PROGRAMMES ARE BROADCAST FROM THE FOLLOWING EUROPEAN STATIONS :



GREAT BRITAIN.

CHELMSFORD 5 XX, 1,600 metres. Tests.
ABERDEEN 2 BD, 495 metres; **BIRMINGHAM 5 IT**, 475 metres; **BELFAST 2 BE**, 435 metres;
GLASGOW 5 SC, 420 metres; **NEWCASTLE 5 NO**, 400 metres; **BOURNEMOUTH 6 BM**, 385 metres
MANCHESTER 2 ZY, 375 metres; **LONDON 2 LO**, 365 metres; **CARDIFF 5 WA**, 351 metres;
RELAY STATIONS: LEEDS-BRADFORD 2 LS, 346 and 310 metres; **PLYMOUTH 5 PY**, 335 metres;
DUNDEE 2 DE, 331 metres; **EDINBURGH 2 EH**, 328 metres; **NOTTINGHAM 5 NG**, 322 metres; **HULL 6 KH**, 335 metres;
LIVERPOOL 6 LV, 315 metres; **SHEFFIELD 6 FL**, 301 metres. Tuesdays, Thursdays and Fridays, 1.0 p.m. to 2.0 p.m. (2 LO only). Regular daily programmes, 3.0 to 7.30 p.m., 8.0 to 11.30 p.m. Sundays, 3.0 to 5.0 p.m., 8.30 to 10.30 p.m.

FRANCE.

PARIS ("Radio Paris"), **SFR**, 1,780 metres. 12.30 p.m., Cotton Prices, News; 12.45 p.m., Concert; 1.30 p.m., Exchange Prices; 4.30 p.m., Financial Report; 5.0 p.m., Concert; 8.30 p.m., News and Concert.

PARIS (Ecole Supérieure des Poste et Telegraphes), 458 metres. 3.45 p.m. (Wednesday), Talk on History; 8.0 p.m. (Tuesday) English Lesson; 8.30 p.m., Concert; 9.0 p.m., Relayed Concert or Play.

PARIS (Station du Petit Parisien), 346 metres; 8.30 p.m., Tests.

BELGIUM.

BRUSSELS, BAV, 1,100 metres. At 2.0 p.m. and 6.50 p.m., Meteorological Forecast.

BRUSSELS ("Radio-Belgique"), 265 metres. Weekdays, 5.0 p.m. to 6.0 p.m., and 8.0 p.m. to 10.0 p.m.; Sunday, 5.0 p.m. to 6.0 p.m., and 8.30 p.m. to 10.0 p.m.

HOLLAND.

THE HAGUE, PGGG, 1,070 metres. 4.0 to 6.0 p.m. (Sunday), 9.40 to 11.40 p.m. (Monday and Thursday), Concerts.

THE HAGUE (Heussen Laboratory), **PCUU**, 1,050 metres. 10.40 to 11.40 a.m. (Sunday), Concert; 9.40 to 10.40 p.m., Concert; 8.45 to 9.0 p.m. (Thursday), Concert.

HILVERSUM, 1,050 metres. 9.10 to 11.10 (Sunday), Concert and News.

IJMUIDEN (Middelraad), **PCMM**, 1,050 metres. Saturday, 9.10 to 10.40 p.m., Concert.

AMSTERDAM, PA 5, 1,050 metres (Irregular), 8.40 to 10.10 p.m., Concert.

AMSTERDAM (Vas Diaz), **PCFF**, 2,000 metres, 9.0 a.m. and 5.0 p.m., Share Market Report, Exchange Rates and News.

DENMARK

LYNGBY, OXE, 2,400 metres. 8.30 to 9.45 p.m. (Weekdays), 8.0 to 9.0 (Sunday), Concert

SWEDEN.

STOCKHOLM (Telegrafverket), 440 metres Daily 12.45 to 1.0 p.m., Weather Report and Nauen Time Signal; Monday, Wednesday and Saturday, 8.0 to 9.0 p.m., Concert and News; Sunday, 11.0 a.m. to 12.30 p.m., Divine Service from St. James' Church.

STOCKHOLM (Radiobolaget), 470 metres. Tuesday and Thursday, 8.0 to 9.30 p.m., Concert and News.

BODEN, 2,800 metres. Tuesday and Friday, 6.30 to 7.30 p.m., Sunday, 5.30 to 6.30 p.m., Concert and News.

GERMANY.

BERLIN (Koenigswusterhausen), **LP**, 680 metres. Sunday, 10.50 to 11.50 a.m., Concert; 2,800 metres; Sunday, 11.50 a.m. to 12.50 p.m., Concert.

EBERSWALDE, 2,930 metres. Daily, 1.0 to 2.0 p.m., Address and Concert; 6.0 to 7.30 p.m., Address and Concert; Thursday and Saturday, 7.20 p.m., Concert.

BERLIN (Vox Haus), 430 metres. 11.0 a.m., Stock Exchange; 1.55 p.m., Time Signals; 5.40 to 7.0 p.m., Concert; 7.0 to 8.0 p.m. (Sunday), Concert.

BRESLAU, 415 metres.

HAMBURG, 387 metres.

SPAIN.

MADRID, PTT, 400 to 700 metres. 6.0 to 8.0 p.m., Tests.

MADRID (Radio Iberica), 392 metres. Daily (except Thursdays and Sundays), 7.0 to 9.0 p.m. Thursdays and Sundays, 10.0 to 12.0 p.m., Concerts.

MADRID, 1,800 metres. Irregular.

CARTAGENA, EBX, 1,200 metres, 12.0 to 12.30 p.m., 5.0 to 5.30 p.m., Lectures and Concerts.

PORTUGAL.

LISBON (Aero Lisboa), 370 to 400 metres. Wednesdays and Fridays, 9.30 to 12.0 p.m., Irregular Tests.

SWITZERLAND.

GENEVA, HB 1, 1,100 metres. Weekdays, 3.15 and 8.0 p.m., Concert or Lecture.

LAUSANNE, HB 2, 850 metres. Daily, 9.15 p.m., Concert and Address.

ZURICH, HBZ, 650 metres. 1.0 p.m., News and Weather Forecast; 8.15 p.m. to 10.15 p.m., Concert.

ITALY.

ROME, ICD, 3,200 metres. Weekdays, 12.0 a.m. 1,800 metres, 4.0 p.m. and 8.30 p.m., Tests, Gramophone Records.

ROME, 422 metres. Weekdays 7.30 to 9.30 p.m.,

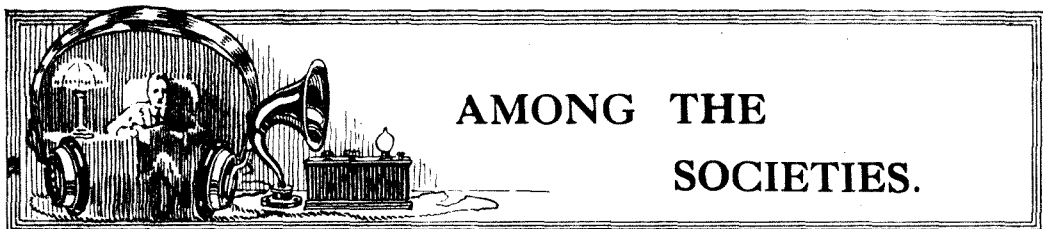

AMONG THE SOCIETIES.

A lecture of unusual interest, on the subject of "Wireless Component Parts," was given before the Ilford and District Radio Society by Mr. Welch on October 28th.

Practically every accessory used in wireless construction was dealt with, from the lead-in tube to the telephones and loud speakers, and the explanations were greatly assisted by suitable slides.

Similar lectures are to be given on the second and fourth Tuesday of each month.

* * * *

"How to Learn Morse" and "Faults in Dual Circuits" were the subjects of two instructive lectures delivered by Mr. Knight, A.M.I.R.E., at a meeting of the Beckenham and District Radio Society on October 23rd. Amateurs in the district desirous of learning Morse are invited to join the Society's Morse class.

* * * *

A lantern lecture on "High Frequency Devices" was given before the Brockley and District Radio Society by Mr. J. Goss (of the Igranic Electric Co), on Friday, October 31st. A simplified explanation was given of various methods of aerial tuning, making use of Igranic coils, and much interest was aroused by the description of the Igranic H.F. devices and the machines employed for winding them.

* * * *

The scientific work of Clerk Maxwell formed the subject of an illuminating lecture delivered by Prof. W. Wilson at a meeting of the Clapham Park Wireless and Scientific Society on Wednesday, October 22nd. The lecture served to show the influence of Maxwell's work on modern electrical theories and its bearing on wireless telegraphy and telephony.

On the following Wednesday an excellent account of the manufacture and properties of ebonite was given by Messrs. McWilliam and Shirley, of the British Ebonite Company.

Realising the value of developing the social side of club work, the Wimbledon Radio Society held a whist drive and dance on Saturday, November 15th, at the Welcome Hall, High Street, Wimbledon. A feature of the evening was the reception of the Savoy Bands dance music from 10 to 11.45 p.m.

Some interesting experiments with portable transmitting and receiving apparatus were carried out by a party of members on the journey to Banstead on Sunday, October 19th. The transmissions were successfully heard by 5 KS at Southfields.

* * * *

An instructive paper on the design and layout of panels was read by Mr. J. Bulman at a recent meeting of the Borough of Tynemouth Radio and Scientific Society. Much additional information was given after the paper had been read, questions being answered and illustrated on the black-board.



Mr. Ralph Slade (Z 4 AG) the New Zealand amateur whose signals were first heard in this country by G 2 OD.

READERS PROBLEMS

Readers desiring to consult the "Wireless World" Information Dept. should make use of the coupon to be found in the advertisement pages.

A SIMPLE FOUR-VALVE RECEIVER.

A DIAGRAM is given below of a four-valve receiver suitable for the reception of wireless telephony, either with telephones or a loud speaker. One stage of H.F. amplification and two stages of resistance capacity coupled L.F. amplification are used.

Separate H.T. tapings are provided for the H.F., detector, and low frequency valves, as the H.T. voltage for the latter valves will have to be increased on account of the method of coupling employed.

reduced, and the arrangement will suffer from one of the defects of transformer coupling. It would be much better to employ grid coupling condensers having values between 0.05 and 0.25 μF in conjunction with grid leaks of 0.5 megohms, even though this combination gave less signal strength. The use of resistance-capacity coupling is not justified unless the circuit is arranged to give an absolute minimum of distortion. If a slight amount of distortion is to be tolerated, then it would be better to employ transformer coupling, with a consequent reduction in H.T. voltage, and in the number of valves used.

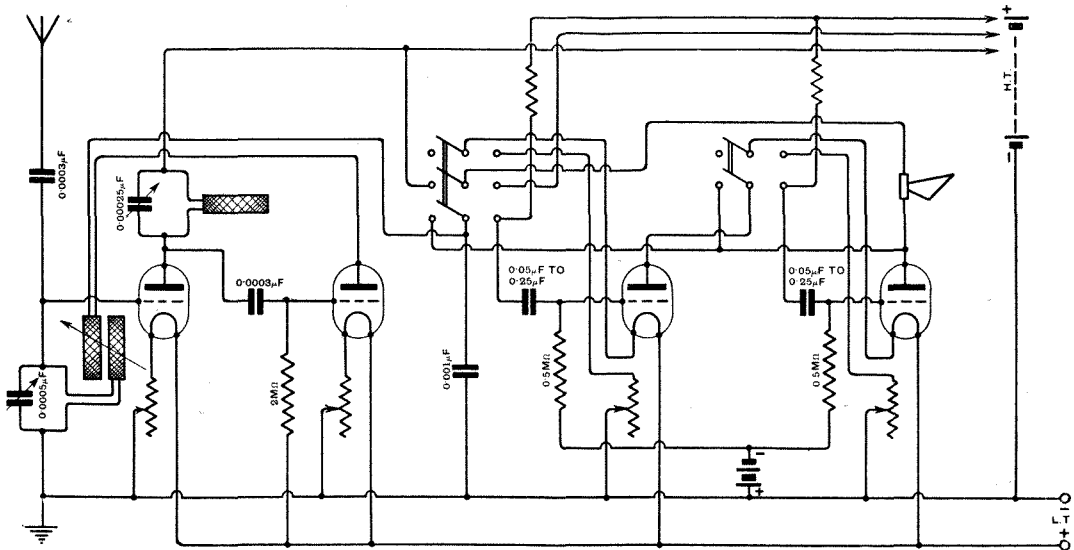

A four-valve receiver of simple and inexpensive construction.

COUPLING CONDENSERS FOR L.F. AMPLIFICATION.

A CORRESPONDENT writes to say that he obtains greater signal strength when using coupling condensers of 0.006 μF in conjunction with 2 megohm grid leaks, than with the values usually specified for these components. With small coupling condensers, however, the amplification of the lower frequencies will be considerably

CHOKE COILS FOR SMOOTHING CIRCUITS.

SEVERAL circuits have been described recently for the purpose of smoothing out the commutator hum when the H.T. current is derived from the D.C. mains. A reader has noticed that in nearly every instance Fullerphone choke coils have been specified, and asks if there is any particular feature in these coils which makes their use desirable in such circuits.

It is not essential to use this type of coil, and it is conceivable that under certain conditions a choke of this type would be too small. The size of choke will depend upon the magnitude of the ripple superimposed on the direct current, and this will depend, amongst other things, upon the type of machinery and the condition of the commutators at the generating station. The secondary windings of intervalve transformers in which the primary windings have been burnt out, make excellent choke coils, as also do the secondary windings of spark coils. The latter type of coil has the advantage that the layers are separated with waxed paper insulation, and are capable of withstanding the high voltages induced when the current is suddenly switched off.

winding should consist of a basket coil of 100 turns of the same gauge of wire, and should be mounted between the two sections of the secondary winding. The tuned condenser will be connected across the ends of the secondary winding, and the connection for the balancing condenser will be taken from the junction between the two halves of this winding. When the transformer is connected in the receiver the connections of the primary winding should be reversed to find the best method of connection.

A FRAME AERIAL RECEIVER FOR LONG WAVELENGTHS.

THE diagram given below shows the method of connecting a five-valve receiver for use in conjunction with a frame aerial. The receiver will

FIXED FILAMENT RESISTANCES.

IN making up a receiver with a minimum number of adjustments, a reader wishes to incorporate fixed filament resistances for the valves, and asks what values of resistances would be necessary for D.E. 3, D.E. 5, and D.E. 5B. valves respectively when a 6-volt accumulator is used. For a normal filament current, the D.E. 5 will require an external resistance of 54 ohms, the D.E. 5, 4 ohms, and the D.E. 5B., 2.25 ohms.

It will be observed that the difference of potential across the ends of these resistances, when the

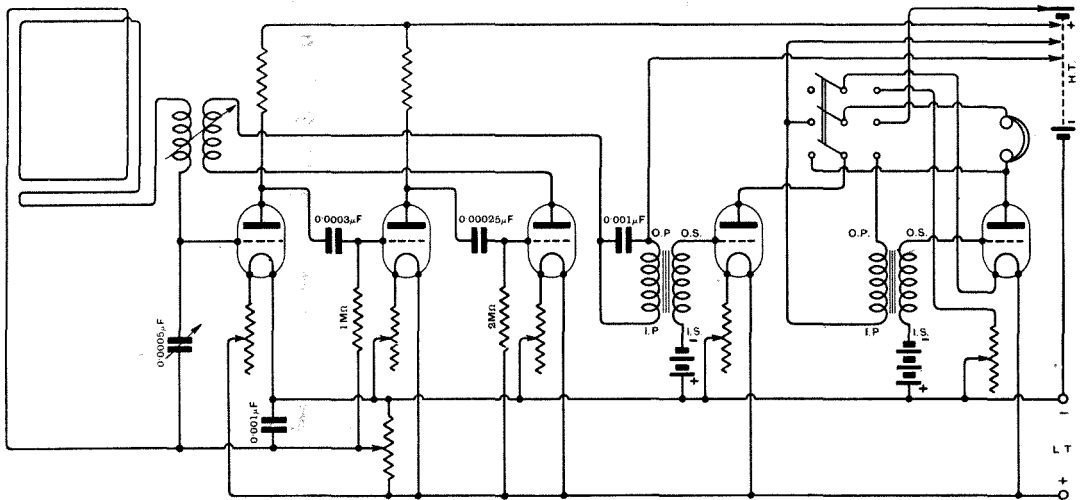

A frame aerial receiver for long wavelengths.

be suitable for wavelengths above 1,000 metres, and the use of resistance coupling for the H.F. valves will greatly simplify the tuning operations. A switch is provided to cut the last valve out of circuit when not required.

normal filament current is flowing through them, is equal to the amount by which the normal filament voltages differ from 6 volts. In other words, the external resistances may be regarded as reducing the voltage of the accumulator to the normal voltage required by each valve.

THE SUPER-SENSITIVE SET.

A HIGH frequency transformer suitable for the reception of the high power broadcasting station on 1,600 metres for use in the above-mentioned set may be constructed in the following manner.

Eureka resistance wire between No. 28 and No. 36 gauge may be used, the thicker wire being used for the D.E. 5 and D.E. 5B. valves, and the thin wire for the D.E. 3 valve.

The secondary winding should consist of two basket coils, each wound with 125 turns of No. 32 D.S.C. wire. The coils should be mounted together on the same axis, with the windings connected in series in the same magnetic sense. The primary

The following particulars may be of use in calculating the length of wire required:—

S.W.G.	Ohms. per yard.
28	3.90
30	5.57
32	7.35
34	10.13
36	14.04



EVERY EXPERIMENTER
SHOULD POSSESS A

Circuit Reference Book

A book which can be relied upon to contain all circuits of Amateur and Experimental interest.



THEORETICAL CIRCUITS

ARE CONVERTED INTO

PRACTICAL DESIGNS

IN

THE AMATEUR'S BOOK OF WIRELESS CIRCUITS

By F. H. Haynes.

New Edition. Obtain your copy at once.

PRICE **3/6** NETT

Postage 6d.

This new edition of Mr. F. H. Haynes's popular book gives the fullest possible details for wiring-up no less than 117 circuits. Nothing has been left to chance. Every value has been inserted and full explanations accompany each diagram. Moreover, every circuit has been designed by a man who knows the difficulties encountered when constructing experimental apparatus. Circuits, diagrams and accompanying text are of an essentially practical nature.



Contains the following special features. It is the most complete and easily understood circuit book available to-day:—

Copious notes on Crystal Receivers, single-valve sets, high frequency, low frequency and dual amplifiers, transmitting circuits. Several pages of most useful data have been added, including the method of pile windings, tables giving tuning range of commercial types of inductances, wavelengths produced by various tuning condensers, types of receiving valves and their characteristics, etc., etc.

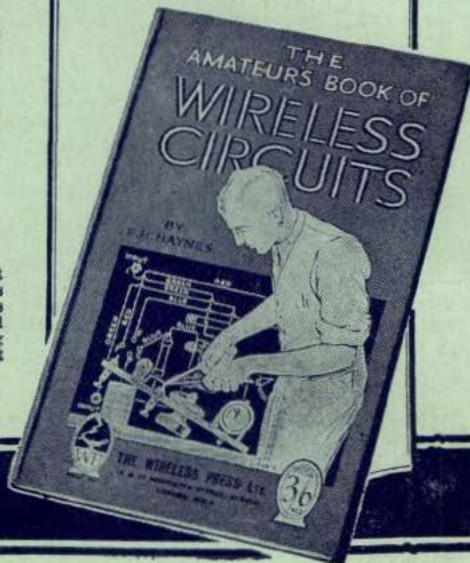

THE WIRELESS PRESS LTD.
12-13 HENRIETTA ST. LONDON WC2

Tune the Table-Talker with the "Matched Tone" Headphones



The Brandes Family Series.

GRANDPA is a tremendous favourite with the rest of the Brandes family. You have only to discover the shrewd kindness which evaporates from his still youthful personality to understand why. He has a philosophical outlook on life and a ripe experience. Here he is in the armchair, settling down for the evening with his equally mature and experienced friends. The polished bowl of his old briar peeps from behind the tobacco jar, waiting to be filled and give him solace, and there is the amber coloured liquid in a decanter nearby. Then we come to the Brandes Table-Talker with the "Matched Tone" Headphones. Soon he will be listening to their rich volume of sound pulsating and alive with vigorous cadence. A lively circle of acquaintances, all of whom have profited by experience.

Ask your Dealer for Brandes.



All Brandes products carry our official money-back guarantee, enabling you to return them within 10 days if dissatisfied. This practically constitutes a free trial.

The Table-Talker is a Brandes quality product at a moderate price. The non-resonant, specially constructed horn is matched to the unit so that the air resistance produced will exactly balance the mechanical power of the diaphragm. This means beautiful sound-balance and remarkable tone qualities. It is twenty-one inches high, has a self-adjusting diaphragm and is finished a shade of neutral brown. **42/-**

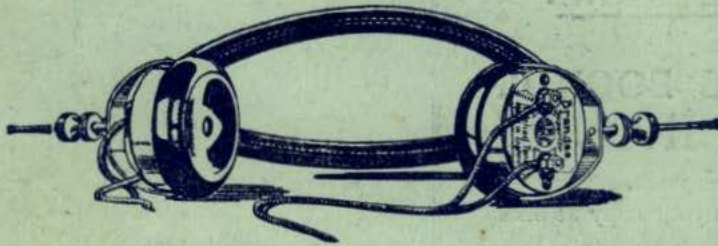

The "Matched Tone" feature means that both your ears hear exactly the same sound at the same instant—and you learn a new beauty of tone. They are tested and re-tested for just this one vital point, and in addition their strength, long-wearing comfort and reliable efficiency make them undoubtedly superior. **25/-**

British Manufactured (B.B.C. Stamped).

Brandes

Result of
16 Years
Experience

The name
to know in Radio

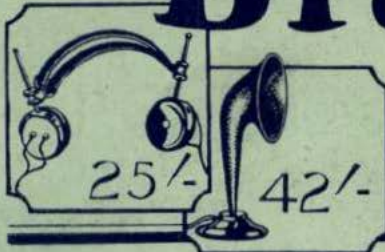

5X
W...
6 Aug 24
17 Sep 24