

Vol 9 # 49

# The WIRELESS WORLD



FORTNIGHTLY

4th FEBRUARY, 1922.

PRICE 6D. NET

## WIRELESS MADE EASY

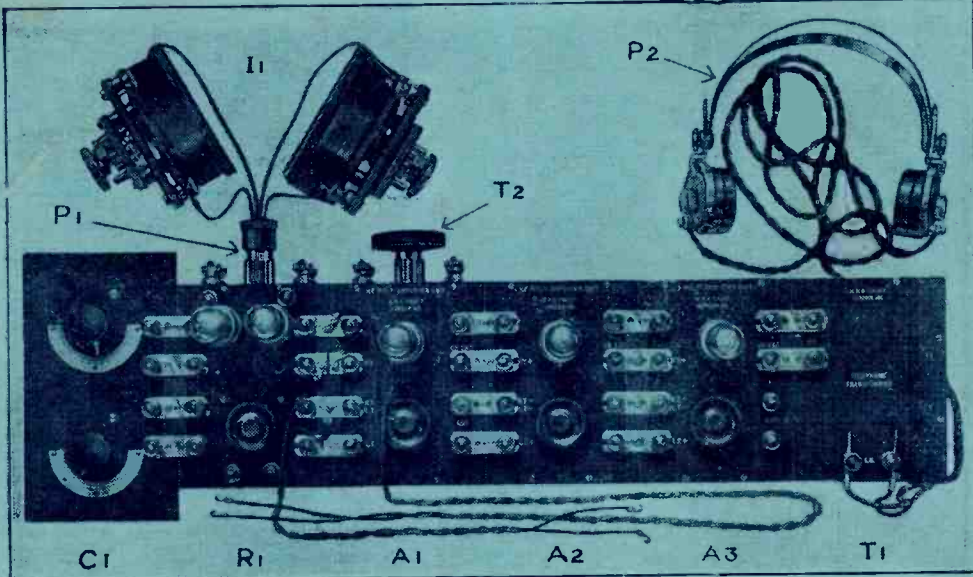

Please refer to page vi.

Office and Works  
Telephone:  
1916 Hammersmith

**W. R. H. TINGEY**  
Specialist in Wireless

Offices and Showrooms  
92, Queen Street,  
Hammersmith, W.6

## A SIMPLE GALVANOMETER

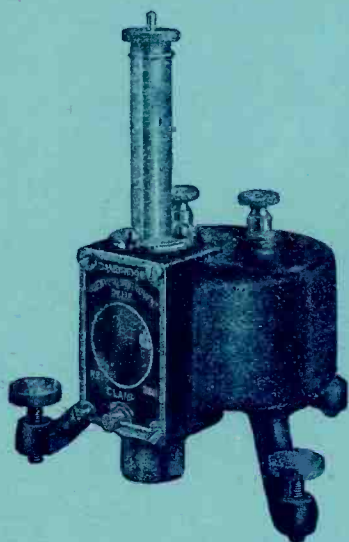

Further particulars on request.

A moving coil galvanometer of good sensitivity, suitable for general laboratory work and student's use. This galvanometer has been designed for quantity production, and on that account it is possible to offer it at a price which compares favourably with pre-war prices.

Approximate resistance of coil.	Deflection in m/m at 1 metre.	
	Per micro amp.	Per micro volt.
20 ohms	150	7.5
150 ..	320	2.13
400 ..	450	1.124

### THE CAMBRIDGE & PAUL INSTRUMENT CO., LTD.

Head Office and Showrooms—  
45, GROSVENOR PLACE, LONDON, S.W.1  
WORKS LONDON AND CAMBRIDGE

## OUR EXPERIENCE

in the Manufacture of High and Low Tension Condensers for all Types of Wireless Installations

## IS UNIQUE

IT IS AT YOUR SERVICE.

# DUBILIER

CONDENSER CO. LTD.

DUBILIER CONDENSER CO. (1921) LTD.

All American Enquiries to be addressed—

DUBILIER CONDENSER CO., Inc., 217 Centre Street, New York.

All enquiries other than American should be addressed to (Department W.)

DUCON WORKS, Goldhawk Rd.,  
Shepherds Bush, London, W.12

Telephone: - - HAMMERSMITH 1084.

Telegrams: HIVOLTCON, PHONE, LONDON.

Code: - MARCONI INTERNATIONAL.

FEBRUARY 4, 1922

Please mention the Wireless World

# GAMAGES

## SPECIALISTS IN WIRELESS

### WAVEMETERS

**Type C1, 180—4000 Metres, &  
Type A1, 3000—35000 Metres**

These instruments have been designed to meet the ever-increasing demand for high-class and reliable wavemeters, covering the whole range of wavelengths, at a reasonable price.

We offer our wavemeters to the public confident that we have produced the instruments required, and which, whilst being absolutely efficient, are brought within the scope of every serious experimenter. Long wave range wavemeters have been extremely costly apparatus until the advent of our instruments, which combine cheapness and high efficiency and all the latest improvements.

The A1 type will undoubtedly prove a great boon to amateurs as it will enable them to conduct experiments and measurements over a wavelength range which had not previously been explored owing to the prohibitive cost. Type C1 covers from 180 to 4000 metres, and as can be seen from the illustration, is fitted with a special high note buzzer enclosed in a removable brass cover, and on the right is a reliable top grade Crystal Detector. A double-pole switch enables either the buzzer or detector to be placed in circuit, or "off" position obtained.

A three-way switch is also provided to place different values of inductance in circuit, and is fitted with a most ingenious "dead end" device which secures the utmost efficiency. The variable condenser is of a very rigid type, designed to withstand distortion and variation of constants. The Condenser scale is of our usual high standard, clear and easily readable.



Type C1.

Type A1 Wavemeter covers from 3000 to 35000 metres, calibrated up to 26,000 metres, and is therefore valuable to the possessor of a lower reading instrument. It is similar in design and appearance to the illustration, with the exception of a Crystal detector which is not required over these wavelengths and the double-pole switch is replaced by a buzzer switch only.

**ALL INSTRUMENTS ARE CALIBRATED ACCURATELY AGAINST N.P.L. STANDARDS**

Polished mahogany case and cover, polished ebonite panel and highly lacquered brasswork put the finishing touches to these very handsome instruments.

Type A1, 3000—35000 metres,	-	PRICE	<b>12</b>	GNS. chart	with
Type C1, 180—4000 metres,	-	PRICE	<b>8</b>	GNS. chart	with
Carriage Paid.					

**GAMAGES · HOLBORN · LONDON · E.C.1**

FEBRUARY 4, 1922

iii

*Please mention the Wireless World*

# LESLIE McMICHAEL, M. Inst. Radio E.

**PROVIDENCE PLACE**

Telephone—  
HAMPSTEAD 1281

**KILBURN, N.W.6**

WEST END LANE (Bus Services 1, 8, 16, 28, 31  
all pass West End Lane.)

Nearest Tube Station: Kilburn Park (Bakerloo)

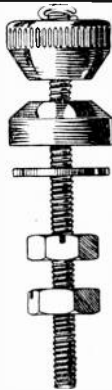

Terminals as above  
4 B.A. ... 2/- doz.  
2 B.A. ... 2/9 doz.  
Special terms for quantities.

## "R" Valves

Tested on signals 11/6

2 mfd. Condenser ... 1/6

.0005 Variable Condenser  
in mahogany box 14/-

Filament Resistance  
for panel mounting 5/6

Grid Leak & Condenser 5/-

Valve holder, Panel and  
Filament Resistance,  
four terminals, mounted  
in mahogany box 15/-

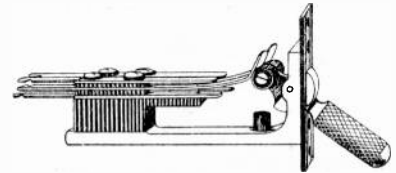

This switch is a double pole change over—a most useful piece of apparatus for panel mounting. One only, 3/6. Two, mounted in teak box with terminals, 7/- *Special terms to the trade.*

**All Wireless Accessories in Stock at Reasonable Prices.**

Full quotations and assistance given to those just embarking on Wireless reception. I give you **PROMPT** attention, **GOOD VALUE** and every **ASSISTANCE**.

Enclose 2d. Stamp for Catalogue just published.  
Orders UNDER £2 should include postage.

## FOR PERFECT TELEPHONY — USE A — SUPER VII RECEIVER

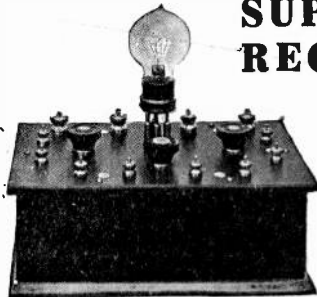

PRICE  
**£3 15 0**  
without valve

Single valve reception of telephony and music that cannot be bettered, will make your loose coupler or tuner work wonders on all wavelengths. Ask the man who owns one. He is satisfied. You could spend four or five times the price and not get better results.

WRITE FOR FULL PARTICULARS

*Agents—*

RUSSELL & SHAW, 38, St. James St., Bedford Row, W.C.1  
G. H. PARKER, 10, St. James Parade, Muswell Hill.  
E. T. CHAPMAN, A.M.I.R.E., Abbotsford, Serpentine Rd.,  
Poole, Dorset  
Sole Agent for Scotland: WILLIAM KERR DEWAR,  
206, Bath Street, Glasgow.

**GORDON CASTAGNOLI**  
MANUFACTURER OF WIRELESS APPARATUS  
15, Rayne Road, Braintree, Essex

## VARIABLE CONDENSERS (AIR DI-ELECTRIC)



The condenser illustrated above is of the highest mechanical accuracy, and electrical efficiency. The rotary aluminium vanes are carried by a square brass spindle, for which, top and bottom bearings are provided. Individual not cast spacers are used, which are gauged with a micrometer before assembly

Capacity in Mfd.	Price.
.001 ... ..	42/-
.0005 ... ..	36/-
.0003 ... ..	30/-

### OTHER ACCURATELY MADE ITEMS.

Laminated Switch Arms complete with bush, spring, washers, and nuts ... ..	3/-
Rotary Vane Vernier Condenser (assembled) ... ..	5/6
Valve-holders ... ..	1/6
Filament Rheostat for single valve ... ..	5/-
" .. .. three valves ... ..	6/6

*Actual Manufacturer*

**M. FOSTER, 15, Western St., Brighton**



BURNHAM & CO.

**WIRELESS BURNDDEPT APPARATUS**

MANCHESTER DEPÔT  
4, CORPORATION STREET
DEPTFORD, LONDON, S.E.8.
LONDON RETAIL DEPÔT  
19, HAND COURT, HIGH HOLBORN, W.C.

## THE BURNDDEPT ULTRA III RECEIVER

SUPPLIED TO AIR MINISTRY—INDIA OFFICE (FOR USE ON H.R.H. PRINCE OF WALES TOUR) — GREENWICH OBSERVATORY — and various COLONIAL, Etc., GOVERNMENTS

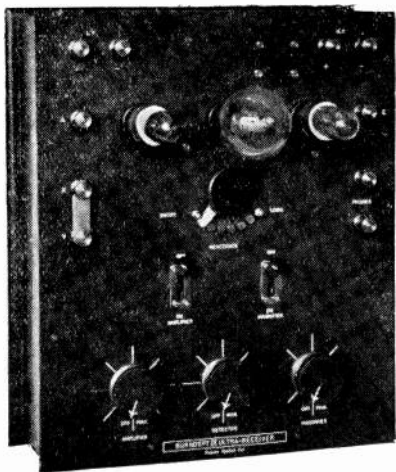

PRICE £25

made of the valve, so that signals can be thus received at almost the same strength as if 3 valves were used. By suitable arrangement of the rheostats selectivity of signals can be much improved.

- (3) The magnification of the third note or magnifying valve is obtained by intervalve transformer of finest manufacture—giving as much magnification as 2 valves used with resistance capacity coupling and economising filament current and valves.

### SOME POINTS OF SUPERIORITY OVER OTHER 3 & 4 Valve Receivers

- (1) The rectifying valve can be *used alone* or in conjunction with either the H.F. magnifier valve or L.F. amplifier valve, or both—This feature allows signals to be suitably magnified for comfortable reception according to original signal strength and economises valves and filament current.

- (2) Each valve is furnished with a *separate rheostat* thus allowing valve to be operated at its most sensitive point. As all valves have different properties, this feature enables the best use to be

**HIGH-CLASS MANUFACTURE AND FINISH (INSIDE AND OUTSIDE) WHICH CANNOT BE SURPASSED.**

For further particulars see our New  
Price List post free on application.

**BURNHAM & CO., DEPTFORD, LONDON, S.E.8**

# "WIRELESS MADE EASY."

By W. R. H. TINGEY.

THE pieces of wireless apparatus, known as "Wireless made Easy," are designed with a knowledge of what all amateurs require, and are worthy of note from a technical and a practical point of view by amateurs of all types; those that make their own apparatus, and those that buy their apparatus ready made; by the experimenter, and by the man who requires a drawing-room set.

Before starting any description, let me state quite clearly that I am not claiming anything new in the general idea of a wireless unit; there are many on the market. However, in both electrical and mechanical construction there certainly are novel points which I consider advantages, and have been developed by a careful study of what all amateurs want. I think that all must admit that the scheme is capable of a great development, and, like the well-known toy, "Mechanics made Easy," can be increased *ad lib*.

## MECHANICAL :

The general description is roughly as follows: The apparatus consists of standard units and clips or junctions; there being, at present, Condenser Units, Receiver Units, Inductance Units, H.F. Amplifier Units of all types, L.F. Amplifier Units, Transformer Units and Experimental Units.

With the exception of the Condenser Units, they are all of the same size. The clips vary slightly according to the types of amplifier that have to be connected together. The junctions are so strong that when a number of units are connected together, they form a complete instrument, the units butting together and forming one panel.

A Unit can be added or removed in a few seconds, and there is an entire absence of loose connecting leads. It is ideal for the drawing-room, and at the same time being perfect for the experimenter who requires to change the wiring of a valve without affecting the rest of his apparatus.

One great asset of this method is that those who have in mind to get a multi-valve receiver and who cannot afford it at once, can buy the receiving portion only, and add unit after unit to any desired degree of any desired type of amplification. The whole thing is simplicity itself, at the same time being exceptionally efficient, selective and silent in action.

## GENERAL ELECTRICAL DESCRIPTION :

In the receiver portion, both circuits are intended to be tuned, the first of the two valves, of course, being H.F. amplifier. The second valve performs whatever function is required of it, according to what unit is attached. If no unit is attached, then a switch throws in the grid leak, which causes the second valve to rectify. A second switch on the set throws the aerial condenser into series or parallel, in the aerial circuit. For loop reception, the loop is placed across the A. and E. terminals, and the switch in the series position.

There is a plug for the inductances, but they can also be connected on to two pairs of terminals, if preferred. As stated before, any type of amplification can be added, but the A<sub>4</sub> is particularly advised as being the best of the H.F. type; but for those that do not want to go to the expense and trouble of an extra inductance and condenser, the A<sub>2</sub> Choke Resistance type is extremely good. The A<sub>1</sub> is the ordinary interchangeable transformer type, and requires a condenser to get best results from it; but even then, only one of the two sides of the transformers is tuned. In order to get over this difficulty, the A<sub>4</sub> type has been designed, which employs one inductance only on the Auto-transformer principle, and so the tuning of the one automatically tunes both P and S, thus giving a decided improvement both to the strength and also to the selection of the signals.

The Inductance on this set can be of any type, and a valve socket is mounted in so as to enable the interchangeable type to be employed; also a switch throws on or out, a grid leak and condenser, so as to enable this valve to rectify if required. The crystal unit can be inserted after as many H.F. amplifications as required, and either the transformer unit or L.F. units as many as required, placed after it. The crystal is a better rectifier of weak signals than the valve, and is better for weak signals especially for use on loop work and telephony.

The A<sub>3</sub> Unit is the ordinary L.F. Transformer Amplifier and is used to magnify up existing signals. The Telephone transformer Unit is always advised, however many valves are employed, as otherwise the insulation of the telephones will break down, and their magnetisation is lost. A<sub>3b</sub> Unit is an ordinary L.F. Amplifier Unit, only employing two valves in parallel. This is especially advised as the last Unit in an amplifier where a large current is required, such as for lecture work or more especially for recording.

The X Unit is a blank Unit, containing all the terminals and points, but only the L.T. connected. It is intended either as an experimental Unit, or for amateurs who already have the parts and want to make it up into unit form.

The inductance unit up to the time of writing is not completed but it contains two sets of Honeycomb coils such that will cover the whole range with a .001 condenser.

## PRACTICAL TESTS :

As is well known, a large number of tuned H.F. Valves is very troublesome, as the tuning has to be extremely accurate, and all condensers tuned approximately at the same time.

This necessitates some mechanical means of connecting up all the condensers, and disconnecting them at will, to enable accurate tuning to be attained.

The following is a combination of 8 valves, which has been found very satisfactory. The instrument being so silent when no signals are present that telephones can be worn with comfort, but, as soon as the signals come the strength is so terrific that it would be dangerous to keep the telephones on the head, the signals being intense enough for the largest of lecture halls.

Firstly, the R I. two-valve unit, which employs two condensers; followed by an A<sub>4</sub>, a third tuned H.F. Amplifying Valve, employing one other condenser; this being followed by an A<sub>2</sub> H.F. Amplifier Unit, which is wired on the resistance amplifier system, only a choke is employed instead of a resistance, which has the effect of making the amplifier more constant and silent; and as the grid of this unit is connected to a small condenser, this valve also rectifies. These are all the H.F. Amplifying Units that are employed; and after this are added three L.F. Units, the last of the three being the A<sub>3b</sub> type, which employs two valves, wired in parallel in all respects, the sole object being to pass a greater current to work the loud speaker.

Here is a point, that to my mind, is such a great advantage. Although, at the moment, I am extremely satisfied with this combination and have seldom, if ever, heard an 8-valve instrument to equal it, both as regards silence when no signals are present, and strength of signals when they are, I am quite certain that in a few weeks' time I shall find a combination that is even better.

Had this set been made up as one complete Unit, the difficulty of changing it would have been great, but, as it is, it is a matter of a few seconds only, either to slip in an extra Unit, take out Units, add to the H.F., or add to the L.F., or anything that is required.

I think from this general outline, it will be seen that these units can be made up into a multi-wave set of any description known or yet to be designed, and is ideal for the experimentalist, as any one section is so easily removed and changed.

W. R. H. TINGEY,  
92, Queen Street, Hammersmith, W.6.

# FOR THE FIRST TIME

## Complete Sets of Parts to Construct C.W. Telephone TRANSMITTERS

Low-power Telephony is a most fascinating subject. The chief factor opposing its more universal adoption amongst experimenters has been the high cost of transmitting gear.

We have placed upon the market constructional parts which will enable the amateur to make highly efficient Telephone apparatus at a surprisingly low cost. The speech range of these instruments when completed is **40 miles**, with 10 watts input at 250 volts. C.W. range, 100 miles.

Complete sets of parts, of the finest material obtainable, to construct 10 watt Transmitters, wavelength 1000 metres

**Price . . . . . £10 : 0 : 0**

*All Component Parts supplied separately.*

*These include:— Tuner and reaction coils (wound with Litz cable), steel wall brackets, valve holders, choking coil, smoothing condensers, non-reactive resistance, variable condenser, modulation transformer, aerial ammeter, all nuts, bolts, screws; and wiring diagrams.*

### Several other lines that will interest you.

L.F. Transformers, new type (NOT ex-army) **18/-**. Variable condensers, ebonite insulation, '0005, **12/6**; '001, **£1**. Special capacity reaction condensers, **5/-**.

### FOR THE SERIOUS WORKER.

### Ask for details of our new REGENERATIVE RECEIVER

Super-sensitive; inductances and condensers self-contained; universal wave-length range. **WILL BE ILLUSTRATED SHORTLY.**

## SCOTTISH RADIO SUPPLIES

Works: 60, St. Vincent Crescent,  
GLASGOW, W. Tel.: Central 2878

2, Royal Crescent, GLASGOW, W.  
Tel.: Charing X 491

## VARIABLE H.T. BATTERIES



**D**ISTANT LOW POWER TELEPHONY can only be received by using correct H.T. Voltage the value of which varies with the type of valve and filament voltage.

THE W.A.S. VARIABLE H.T. BATTERIES will increase the efficiency of your set and give you undistorted speech and music.

These batteries being made from a special formula have a longer life than any that are on the market and are perfectly SILENT in working.

If a cell gives out it can be quickly "shorted" with only the loss of 3 Volts. In other makes the whole unit would have to be thrown away.

#### PRICES:—

15 Volt Unit, tapped every 3 volts **4/3** postage 9d.  
36 " " " " **7/6** " 9d.  
60 " " " " **13/6** " 1/-

AGENTS WANTED. **Sole Manufacturers—**

**W. A. SAXBY & CO., 3-5, Gayford Road,  
London, W.12 Telephone: Hammersmith 443.**

## DON'T READ THIS

if you are a millionaire.



Price 2/6 per doz. 4ba. large.  
2ba. single terminals, 9d. per doz. small.

<b>Brown's 'Phones</b>	
120 ohms, complete with cords	20/- (tested)
1500 ohms, " " "	22/6 "
<b>New Sullivan's 'Phones</b>	
8000 ohms, complete with cords	18/6 (tested)
120 ohms, " " "	7/6 "
<b>Second-hand ditto</b>	
120 ohms, complete with cords	3/3 "
<b>Complete Spark Transmitters</b> ....	25/-
<b>Contact Studs</b> , per doz. ....	6d.
<b>Dutch Concert Tuners</b> ....	7/-
<b>Marconi Variable Condensers</b>	
'01 M.F. (tested) ....	£2
<b>Valves, Receiving</b> (tested and guaranteed)	11/-
<b>Valve Holders</b> for above (R TYPE) ....	1/9

Postage extra on all the above prices.

**J. LIPOWSKY, 614, OLD FORD RD.  
BOW  
LONDON, E.3. 'Phone: East 3345**

## "R" TYPE VALVES

Price **1 1/6** Post Free

Mr. W. Corsham, Willesden Wireless Society, with three of our "R" Valves received signals in Transatlantic Tests and was awarded a prize. This proves they are not "duds" we offer you.

"ORA" VALVES (Mullard) - 15/-  
 2 Valve Amplifier L.F. - - 110/-  
 Single Valve Receiver Panel - 78/6  
 Tuner (Short-Wave) - - 47/6

Best on the Market for Dutch Concerts, &c.  
 Valveholders 1/9, 2/- Screw Legs 2/6  
 36 volt H.T. Batteries, Plugs - 8/-  
 Filament Resistances 3/9, 5/- & 12/6

All Lines cheaper to Callers, Registration 4d.  
 CARRIAGE AND PACKING FREE.

*Agents for*  
 GORDON CASTAGNOLI INSTRUMENTS.

**RUSSELL AND SHAW,**  
 38, Great James St., Bedford Row, W.C.1  
 From Holborn through Brownlow Street, or Hand Court

## The Wireless Equipment Company

The **TUNED ANODE RECEIVING SET** which we are now placing upon the market is the most efficient Receiver for the reception of music and speech.

The advantages of this circuit over the usual reaction circuit are too numerous to mention, the crystal rectification giving absolutely pure speech, and being entirely free from all valve noises.

The valve is employed as a **HIGH FREQUENCY** magnifier and, working in conjunction with the crystal, renders this set equal in efficiency to any reaction set where 3 H.F. valves are employed.

The **DUTCH CONCERTS** are received in the North of England, with exceptional clearness and strength without further magnification, on a set of this type.

Whilst manufacturing the complete set, we also place before the Amateur Experimenter our **TUNED ANODE PANEL**, which can be adapted to existing inductances.

**TUNED ANODE RECEIVING SET**  
 complete with Condensers, Crystal,  
 Inductances and Potentiometer. W/L.  
 500 to 3000 m. .... £8 17 6

**TUNED ANODE RECEIVING PANEL**  
 with Potentiometer and Crystal  
 £2 18. 0  
 All Valves Extra.

*Illustrated Price Lists sent on receipt of stamp.*

Works: WICKFORD, ESSEX.  
 Experimental Station: BRENTFORD.  
 Office: 22, PARK ROAD, COLLIER'S WOOD, S.W.19  
 Agents for Holland: "RATABOS," DEVENTER.



TRADE MARK

**The WHITECROSS**  
 COMPANY, LIMITED  
 :: WARRINGTON ::

Manufacturers of All Descriptions of  
**WIRE ROPES**  
**AND WIRES**

The most reliable and efficient  
 Batteries for Wireless Work are

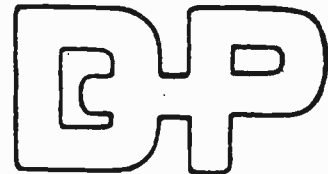

**STORAGE**  
**BATTERIES**

D.P. Batteries are made to fit almost any size of box. The output of our Works runs to hundreds of thousands of plates yearly.

*Write us for particulars*

**The D. P. BATTERY CO., Ltd.**  
 BAKEWELL — DERBYSHIRE  
 & 11 Victoria St., London, S.W.



**"A F A" Accumulators "A F A"**

Anode and Filament Batteries of all types stocked by all leading dealers in "Wireless Supplies."

They retain their charge for very long periods,      **"DUROS" Cells**      The only accumulator supplied in a charged state. Supersedes all primary cells

*Wholesale only from Sole Agents:*

**E. G. LIND & CO., 58a, BUCKINGHAM PALACE ROAD, WESTMINSTER S.W.1**

# THE WIRELESS WORLD

THE OFFICIAL ORGAN OF THE WIRELESS SOCIETY OF LONDON  
A MAGAZINE DEVOTED TO WIRELESS TELEGRAPHY AND TELEPHONY

## CONTENTS

Simple Measurements on Valves.    By Philip R. Coursey, B.Sc., F.Inst.P., A.M.I.E.E.	675
The Transatlantic Tests.    Description of Apparatus used by Prize Winners	677
Description of Apparatus.    By Paul, F. Godley	689
"Polaris" Apparatus	695
An Inductance Calculator	696

*Contents continued on next page.*

A NEW YEAR'S RESOLUTION:—

‘ To get out of the rut in 1922.’

**WHY ?**

Because otherwise you will very soon be one of the "Also Rans" a "Back Number" Etc., Etc.



CWG  
WIRELESS

**HOW ?**

Just drop a Post Card in the nearest letter-box and leave the rest to me. Don't wait until tomorrow or next week.

DO IT NOW

Micawber waited "for something to turn up,"—but that won't do in 1922, and besides Micawber was not interested in Wireless.

2/Lieut. E. REDPATH, 19, Niger St., BARROW-IN-FURNESS.

*(Late Instructor, C.I.P., W.T., R.A.F.)*

# RAPID WIRELESS TRAINING

DAY AND EVENING CLASSES: Correspondence Classes with Instrument work at School if desired. Postal Course on Valves. Classes for Amateurs and Experimenters.

INLAND TELEGRAPHY: Sounder, Wheatstone Punching, Type-sending, etc. For details send P.C

Phone: North 1036. ELECTRICAL TRAINING COLLEGE, Radio House, Manor Gdns., Holloway, London, N.

## CONTENTS *(Continued)*

Note on the Separate Heterodyne. By R. C. Clinker	696
Wireless Club Reports	697
A "Wireless" Slide Rule	704
Questions and Answers	705
Share Market Report	710

THE WIRELESS WORLD is published fortnightly on alternate Saturdays.

All correspondence relating to contributions should be addressed to THE EDITOR, THE WIRELESS WORLD, 12-13, Henrietta Street, London, W.C.2.

No responsibility can be taken for MSS. or photographs sent without stamps to defray cost of return postage.

Editorial and Publishing Offices, 12-13, Henrietta Street, Strand, London, W.C.2.

Telegraphic Address: "Radionic, Rand, London." Telephone No.: Gerrard 2807.

Advertisement Managers, Bertram Day & Co., Ltd., 9 & 10, Charing Cross, S.W.1.  
Telephone No.: Gerrard 8063 and 8064

### SUBSCRIPTION RATES.—

17s. per annum, post free. Single Copies 6d. or post free 8d.

*Registered at the G.P.O. for transmission by Magazine Post to Canada & Newfoundland.*

## **MEN** in the WIRELESS SERVICES DESIRING RAPID ADVANCEMENT

Train in spare time in the subjects of your choice, or to obtain some recognised Engineering Qualification such as

A.M.I.E.E., A.M.I. Mech. E., A.M.I.C.E., B. Sc. Eng<sup>t</sup>

During Twelve years hundreds of successes have been secured by "U.E.C." (Regent's Park, London, N.W.1) by the "U.E.C." system of

**Individualised Postal Training for Engineering Exams. & Professional Work**  
*(Officially approved and adopted by Leading Engineering Firms).*

State YOUR ambition, in confidence to—SECRETARY'S DEPARTMENT, (Desk W.),

**UNIVERSITY ENGINEERING COLLEGE, Westgate-on-Sea, KENT**  
and expert advice, with the New Prospectus, No. 8, will be sent you without obligation.





# HART ACCUMULATORS

SPECIAL SALE OF SMALL ACCUMULATORS  
AT LOW PRICES TO CLEAR STOCK

These Accumulators are suitable for all  
Electrical Circuits. British Made Throughout.  
Fully Guaranteed for 12 months. Easily Re-charged.  
First-class Design and Workmanship.

Type.	Voltage.	Capacity Amp. Hrs.		Approximate Overall Dimensions.	Type of Box.	Net Price (each).	
		"Intermittent" Rating.	"Continuous" Rating.			Singly.	For 2 or more
PL 3	2	2	1	$\frac{3}{8}$ " $\times$ $2\frac{5}{8}$ " $\times$ 3" high	Celluloid	<sup>s</sup> 3 <sup>d</sup> 6	<sup>s</sup> 3 <sup>d</sup> 0
AP 7	2	22	11	$1\frac{7}{8}$ " $\times$ $1\frac{7}{8}$ " $\times$ $6\frac{3}{4}$ " ..	Ebonite	6 0	5 9

TERMS : CASH WITH ORDER. CARRIAGE PAID. Subject to being unsold on receipt of order.

**HART ACCUMULATOR CO., LTD., STRATFORD, LONDON, E.15**

## ECONOMIC ELECTRIC LIMITED

Telephone :  
MUSEUM 1055.

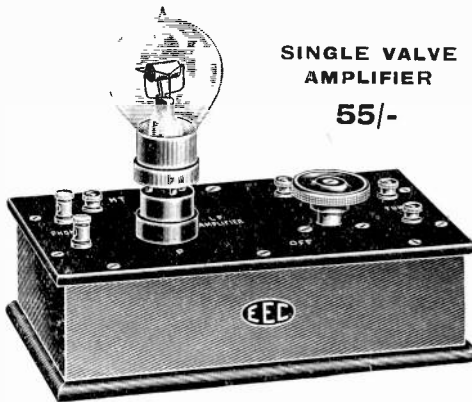

SINGLE VALVE  
AMPLIFIER

55/-



WRITE AT ONCE  
FOR OUR NEW 26  
PAGE WIRELESS  
CATALOGUE SENT  
POST FREE FOR 4d.

FEBRUARY 4, 1922

Do you possess one of these?  
IF NOT, WHY NOT?  
*The Best is Always the Best.*

### THE HETERODYNE RECEIVER

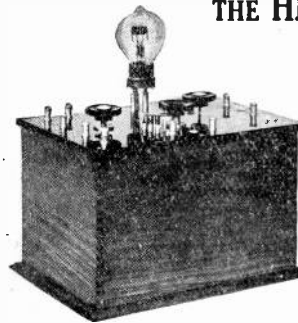

This is a complete Receiver and the very finest on the market. It embodies all the latest improvements. Fitted with Filament Resistance, Reactance, Aerial Tuning Inductance, tuning from 400 to 2,800 metres. No outside coils are necessary, this instrument being a complete Receiver in itself. It is specially designed to receive long-distance

telephony and music. The following are some of those heard every day with distinct clearness, and are easy to tune:— Paris Time Signals and Telephony. Le Bourget, Croydon, Lympne, Chelmsford. Aeroplanes crossing the Channel. The Dutch Concerts can be enjoyed in your armchair every Sunday afternoon.

PRICE £4 15 0 Complete with Valve.  
Send for my Illustrated List before buying elsewhere.

**T. H. ISTD, Wireless Engineer,**  
Terling, nr. Witham, Essex.

# THE WIRELESS WORLD

THE OFFICIAL ORGAN OF THE WIRELESS SOCIETY OF LONDON

VOL. IX. No. 49.

FEBRUARY 4TH, 1922

FORTNIGHTLY

## Simple Measurements on Valves

By PHILIP R. COURSEY, B.Sc., F.Inst.P., A.M.I.E.E.

A SHORT time ago two articles were published in these columns which emphasised the point that the proper design of certain portions of the wireless receiver need not necessarily prove as difficult as is sometimes imagined. Those articles dealt with simple methods of calculating the leading dimensions of inductances, and reduced the problem to simple arithmetic, coupled with references to tables of constants. The calculation of coils, however, is only one of many processes which may be simplified to meet the needs of the radio experimenter, and it is the purpose of this article to show that the measurement of certain fundamental constants of three-electrode valves may likewise be simplified, so as to require the use of nothing more than a few pieces of apparatus usually available in the experimenter's station.

Of these constants, one of the most fundamental and important is the voltage amplification factor of the valve. It is well known that the operation of a valve as an amplifier depends upon the much larger effect produced in the plate circuit by a small impulse applied to the grid.

The voltage amplification factor of a valve may be described somewhat as follows: The anode circuit of the valve comprises the H.T. battery in series with a certain impedance, which is made up of the resistance of the filament-anode path of the valve plus any external resistance, inductance or other impedance which may be joined in series with the valve. Under normal working conditions a certain current flows round this circuit from the high-tension battery, and if the grid potential is maintained at some suitable constant value and the voltage of the H.T. battery is altered by a small amount, there will result a small change in the anode current flowing round the circuit (provided, of course, that the valve is not operating in the saturated condition). If, however, the high-tension battery voltage had not been altered, but the voltage on the grid of the valve had been changed instead, it would be possible to bring about the same change in the anode current that we had previously by means of a much smaller voltage applied to the grid. The ratio of these two voltages, viz., the anode voltage required to

produce a given change in the anode current, and the grid voltage required to produce the same change in current, gives us a measure of the voltage amplification produced.

This effect may be visualised for the case of the ordinary types of "hard" valve, somewhat in the following manner. When the valve filament is heated, emission of electrons commences, whether or not any H.T. voltage is applied to the tube. These liberated electrons collect in the space round the filament and continue to accumulate there until either they are drawn off to the anode by the positive potential applied to that electrode, or if no H.T. voltage is connected, until the total electrical charge accumulated in this manner is sufficient to repel back again to the filament any more electrons that are emitted from it. This accumulation or cloud of electrons formed in the space surrounding the filament and between the filament and the anode is usually known as the "space charge." Since this space charge opposes the flow of current from the H.T. battery, its effect is analogous to a back E.M.F. in the anode circuit of the valve. As soon as a positive potential is applied to the anode from the H.T. battery some of this space charge is neutralised by the attraction of electrons to the positively charged electrode, thus reducing the repelling force of this charge on the electrons trying to come out of the filament, enabling more electrons to be emitted, and the flow of electrons to the anode (which constitutes the anode current) to be maintained. This partial annulment of the space charge is therefore equivalent to reducing the back E.M.F. due to this charge. If, now, a positive voltage is applied to the grid, some of the space charge electrons will be attracted to that electrode, thus again bringing about an effect equivalent to reducing the space charge back E.M.F., and therefore leaving more of the H.T. battery voltage available for maintaining the current flow to the anode.

If we represent the back E.M.F. effect of the space charge by the symbol  $e$ , the voltage of the H.T. battery by  $E$  and assume that the resistance of the whole anode circuit is  $R$ , including the internal resistance of the tube itself, then the anode current

$I_a$  flowing through the tube is evidently given by the expression :—

$$I_a = \frac{E - e}{R}$$

Hence, if by any means such as applying a positive voltage to the grid, we cause the back E.M.F.  $e$  to be reduced, the anode current  $I_a$  will obviously be increased. This, then, is the reason for the control of the valve anode current by the potentials applied to the grid.

Since the grid of the valve is nearer to the filament than is the anode in most normal valve constructions, a given voltage applied to the grid will have a greater effect upon the space charge electrons than will the same voltage applied to the anode; or, in other words, it requires a greater change in the voltage applied to the anode of a valve to produce a given change in the normal anode current than it does if the voltage changes are applied to the grid. The ratio of these two voltages is, as we have seen, the voltage amplification factor of the valve.

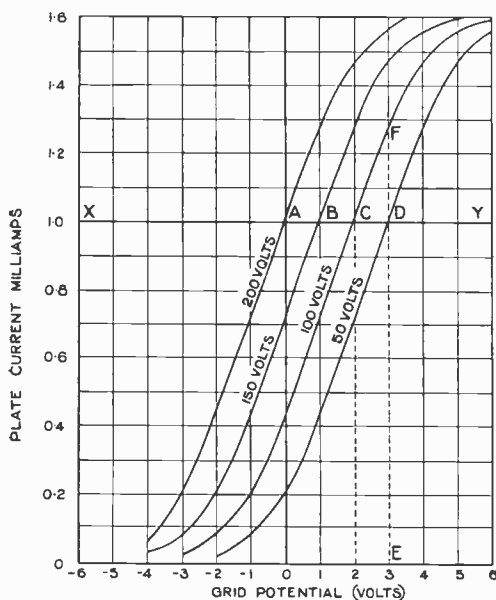

Fig. 1.

Evidently from the meaning of the term “voltage factor” as given above we can deduce its value from a series of characteristic curves of the valve under test, if these are available, or if we possess the means of readily drawing them out by taking readings of the valve anode current (at constant filament current) for various voltages applied to the grid. Such a series of curves taken on a particular type of small valve is shown in Fig. 1. On this diagram will be seen a line  $XY$  drawn in, corresponding to a constant anode current of 1 milliamp and intersecting the four characteristics shown. It will be noted that the points where this line  $XY$  intersects the characteristic curves

are separated by distances representing approximately 1 volt measured on the grid voltage scale, and that the successive anode voltages applied to obtain these curves differ by 50 volt steps. Thus consider the intersection point marked  $C$  in this diagram. We see at once that if the valve is adjusted to be on this point, and the grid voltage is then increased by 1 volt, *i.e.*, to the value represented by the point marked  $E$ , the anode current flowing through the valve will increase to the value represented by the ordinate  $EF$  of the curve that passes through our original point  $C$ . In order now to restore the anode current to its initial value represented by the height of the line  $XY$  (*i.e.*,  $ED$ , or 1 milliamp in our case), it is necessary to reduce the voltage applied to the anode of the valve to the value represented by the curve passing through the point  $D$ . This amount is evidently 50 volts from the values marked on the curves. Hence we see that in the case of this particular valve, an increase of the grid potential by 1 volt has caused the neutralisation of 50 volts of the space charge back E.M.F., so that the applied anode voltage has to be reduced by this amount in order that no extra current may flow through the valve. The voltage factor of this tube is therefore 50.

Similarly it may be seen from the curves that had the grid voltage been reduced by 1 volt it would have been necessary to increase the H.T. voltage by 50 volts in order to maintain the anode current at its original value.

To return now to the question of the measurement of this factor in a simple manner which does not involve plotting out several characteristic curves. Many methods of carrying out these measurements have been proposed from time to time, but several, while perhaps giving greater accuracy, possess the disadvantage of requiring rather more complicated apparatus than is necessary for obtaining approximately accurate results. A simple arrangement that can be fitted up with such components as are to be found in almost every experimenter's station is shown in Fig. 2. The resistance, marked  $P$ , which is of the potentiometer type with an adjustable contact, is connected across a source of alternating current, represented in the diagram by an alternator, and connections are taken from its ends to the grid and anode circuits of the valve in the manner

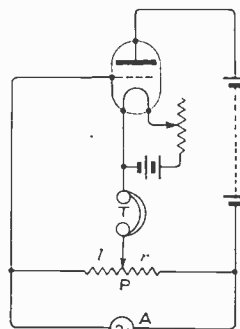

Fig. 2.



## SIMPLE MEASUREMENTS ON VALVES

indicated. The filament should, of course, be lit up from an accumulator battery in the usual way, but this battery is not shown in the diagram. A connection is taken from the negative terminal of the valve filament through the telephones T to the sliding contact on the potentiometer resistance.

The supply of audio-frequency alternating current, which is shown symbolically in the diagram as an alternator A, may be taken from a buzzer circuit, or, better, from a separate valve oscillating at an audible frequency. The latter arrangement gives a purer sound than the buzzer, and consequently a better balance in the telephones. To carry out a measurement the audio-frequency supply to the potentiometer should be switched on and also the filament circuit of the valve. The filament current should be adjusted to its normal value by the resistance shown in series with the filament battery in Fig. 2, or alternatively it should be adjusted to the particular value at which it is desired to make the measurement of the voltage factor of the valve. The H.T. battery should also be adjusted to the particular value at which it is desired to carry out the measurement. When this has been done it will usually be found that there is a loud sound in the telephones T (produced, of course, by the audio-frequency current from the source A). By adjusting the position of the slider of the potentiometer P, a place will be found at which this sound disappears almost completely. This is the balance position, and the distance of the slider from each end of the potentiometer should be noted carefully. Generally it is sufficiently accurate to assume that the resistances of the two parts of the potentiometer will be proportional to these lengths on each side of the slider, so that the voltage factor of the valve is then given by the ratio of the two lengths marked  $r$  and  $l$  in Fig. 2, *i.e.*, by the ratio  $r/l$ .

The reason for this result is evident when we consider that the effect of connecting the grid and anode circuits of the valve to the two terminals of the alternating current supply from A is to apply to those electrodes voltages which are of opposite sign at any given instant, and hence when silence has been secured in the telephone receivers, it means that the plate current does not

vary. This condition can only be obtained if, when we apply, say for example, a positive voltage to the grid at the instant considered, we at the same instant apply a negative voltage in the anode circuit of the right valve to reduce the effective H.T. battery voltage by an amount just sufficient to compensate for the positive voltage on the grid. The ratio of these two voltages is, by the definition given above, the voltage factor of the valve, and this, as we have seen, is given by the ratio  $r/l$ .

Greater accuracy in the measurements can be secured if the potentiometer resistance P is fitted with tapping points and switches for giving more definite resistance ratios, since when an ordinary potentiometer slider is used the actual point of contact on the resistance wire is not usually very well defined. The resistance of P should not be very large, and need only be about 10 to 20 ohms, although if the resistance does not exceed 100 to 250 ohms very little inaccuracy will be caused. The telephones T should also be of the low-resistance type. Alternatively a slide wire resistance can be employed for P, in order to obtain an accurate ratio.

The source A of the alternating current of audible frequency (say, 300 to 1,000 ~ or thereabouts) should be kept some little distance away from the remainder of the apparatus, particularly if an oscillating valve is used for this purpose. Some further details of a convenient way of building up an oscillating valve circuit for this purpose will be described in another article, since the one here described is by no means the only useful measurement which can be carried out by simple apparatus of this type.

The above-described measurement of the voltage factor can be carried out with varying adjustments of the filament, H.T., and steady grid voltage, and the results plotted out in the form of curves; but usually it is found that the value so found differs very slightly with changes in these adjustments, and changes by a few per cent. only over the whole range of working adjustments. At extreme values, however, a larger change may occur, but its magnitude will not even then be very great. The voltage factor is determined almost entirely by the physical structure of the valve, rather than by the circuits to which it is attached.

---

## The Transatlantic Tests

### APPARATUS USED

AS announced in our last issue we are printing this week a description of the receiving apparatus used by Mr. Godley during his experiments in this country. The apparatus described on page 689 was used by him both in his preliminary experiments at Wembley Park, and also during the actual period of the Tests at Ardrossan. Put as briefly as possible the set is a nine-valve Armstrong super-heterodyne amplifier, in which the first valve acts both as a

regenerative high-frequency amplifier (with variometer tuning in its plate circuit), and also as a detector. The earthing inductance of the Beverage antenna was coupled to the tuned grid circuit of this first valve, and the first heterodyne was also coupled to it. The next five valves in order constitute a five-stage resistance-capacity coupled amplifier for magnifying the long wave signals (wavelength = about 3,000 metres) which result from heterodyning the incoming signals by the

second valve. The plate circuit of the last valve in this series is tuned to this long wavelength, and is capacity-coupled to the second detector valve, while the last valve (the ninth) is a note-magnifier. The final heterodyning of the long wave signals could be effected either by electrostatic reaction autodyne on the long wave amplifier, or by an entirely separate heterodyne, the last method being the one most favoured.

We are also publishing in this issue (see below)

descriptions of the receiving apparatus used by the British Amateurs who achieved the best reception, as announced in our last issue. It is interesting to compare these instruments with the apparatus used by Mr. Godley, especially remembering that the former were used with ordinary aerials of the type and size licensed in this country.

We hope in future issues, as space permits, to describe and illustrate the other apparatus on which American signals were heard. P. R. C.

### The First-Prize Set: Description of Apparatus used by W. F. Burne.

IT has always appeared to me that the greatest thing in wireless is the covering of long distances with a minimum of power. Notwithstanding the fact that we have so many high-power transmitting stations, it seems to me yet possible to communicate over great ranges with greatly reduced power. The better way would doubtless be to concentrate on the receiver, making it very selective and at the same time extremely sensitive. Any station may blaze away with its hundreds of kilowatts; yet to my way of thinking this tendency is defeating the best interests of the science. Therefore, amateurs granted only a 10-watt permit have really a great field for research, though they may treat such a permit with disdain. Let us have real experimenting with these transmitters; let a man use his stuff in the interests of science, not for the purpose of amusing the "dabbler" with the latest gramophone "rags."

The experience gained in the recent Transatlantic Test has more than ever enforced this idea. At the time of writing it is too early to offer any hints as to the success of my efforts, yet the origin of some of the signals cannot for a moment be doubted. Very soon it should be possible for amateurs, here and in America, to put up world's records in short wave transatlantic signalling; both by Morse and speech. Experimenters should be urged to build apparatus for short-wave work, trying it out and improving it. It would seem that to listen for a station over 3,000 miles away transmitting on 200 metres, using a power of 1 kW, would be a fool's game. Friends of mine frankly confessed their doubt. "It would be hard enough using at least a dozen valves," they said.

My aerial is a twin wire inverted L type, supported by a mast on the house and one in the garden; the former being 56 feet high and the latter 45 feet high (Fig. 1). The wires are spaced 10 ft. 6 ins. apart on bamboo spreaders, the lead-in being taken down at the house end. It is held away from the house by insulated cord stays, and even though our Society\* is backward in the art of aerial erection, its members at least know how to get the best out of 140 feet slung skywards! The masts are stayed with wire stays, soundly insulated.

The aerial is within G.P.O. limits, being 45 feet long and having a down-lead of 50 feet. The connection to the earth is made to the water main, though at present earth plates are being laid under the aerial.

The set used in this great effort was mostly of home construction. Indeed, one cannot call it a set, that designation would be flattering. "It was," as one friend of mine remarked, "a glorified collection of junk!" The set—for we will name it so for brevity's sake—consisted of two, three-valve panels used on the high frequency side, all rheostats, sockets, handles, wood-work, etc., being made at home. The panels in front of the valves are used to "house" the high-frequency transformers and variable condensers. Two or three loose variables

were employed, also home-made. The transformer formers were turned from solid 1½ in. ebonite rod, and a groove ¼ in. deep turned in each former. In this the primary and secondary are wound. The first winding being of 30 turns of No. 38 D.S.C. copper wire. The second winding of 35 turns of the same wire, wound directly over the first winding.

\* The Manchester Wireless Society.

#### Stations Heard by Mr. W. F. Burne.

##### FIRST PRIZE WINNER.

- 2 FP J. K. Hewitt, 252, Neptune Avenue, Brooklyn, N. Y.
- 2 BML R. B. Bourne, P.O. Box 13, Riverhead, Long Island.
- 2 ZL J. O. Smith, 3, Corona Road, Valley Stream, Long Island.
- 1 BCG Special Station (see last issue of *Wireless World*, p. 647).
- 1 UN Joseph B. Dodge, 26, School Street, Manchester, Massachusetts.
- 1 XM Massachusetts School of Technology, Cambridge, Mass.
- 1 ZE I. Vermilya, 24, Allen Street, Marion, Mass.

The first three receptions included the correct code word as well as the calls, and the last contained one or two errors in the code word which, however, was easily understandable. 1 UN and 1 XM were in the "free for all" period."

## THE TRANSATLANTIC TESTS

These formers are mounted on a set of pins, not in the ordinary arrangement of unequally spaced pins, but at the four corners of a square. The two primary ends are then soldered to two *opposite* pins and likewise the secondary. Thus, simply by giving the transformers a  $\frac{1}{4}$  turn, the windings can be reversed and a greater range of wavelengths obtained. The loss in efficiency is very small even with a number of valves, as the windings are so nearly the same on a short wavelength. These transformers serve for waves of 180—325 metres with the variable condensers made for the occasion. Another set was wound with 40 and 45 turns which covers a range of 210—360 metres wavelength.

the leak and terminals. A commercial article was tried, but was found inferior to the experimental one, so it was thereupon scrapped. On referring to the diagram of connections, Fig. 3, it will be seen that potentiometer control was used on the amplifying valves, while the connection from the secondary of the last transformer is taken direct to the positive leg of the filament. This tends to stop reaction. The potentiometer, purchased from B. Hesketh & Co., is the key to the successful operation of the set, reaction being either controlled or stopped with this instrument. The valves used were ES4 and ES2 in the H.F. side, whilst an ES4 and French valve were used in the L.F. side.

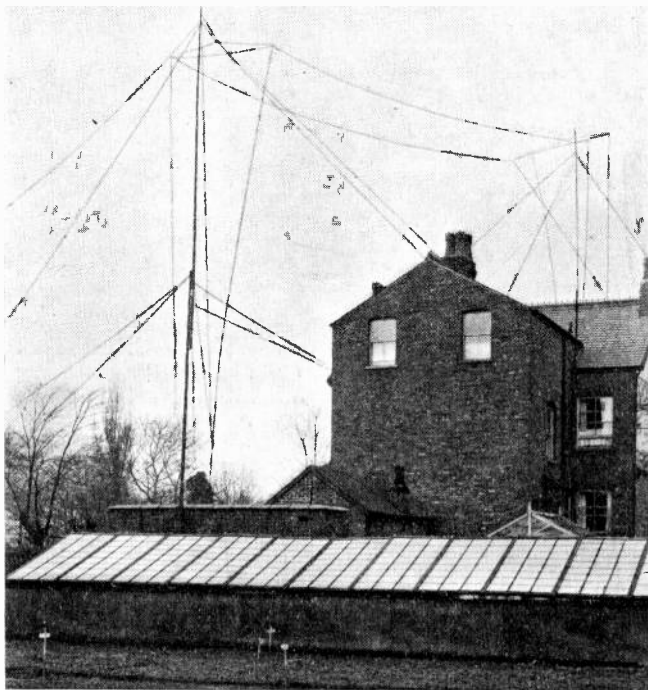

Fig. 1. *The Aerials.*

Other sets could be made for higher wavelengths if desired. All variable condensers, except those in the Mark III were made by myself, and are of the rotary vane type, air spacing being used. It would not be wise to offer any remarks on the general theory of high-frequency transformers as yet; little seems to be known about them in England and nothing in the States!

The leaky grid condenser was home-made. The condenser has two pairs of tinfoil plates, separated by very thin mica dielectric. The leak was made by drawing a scratch on a piece of ebonite and rubbing a pencil along the scratch. Small washers of tinfoil were cut out and placed under the terminals so as to ensure a good contact between

The tuner used during the greater part of the tests was a Mark III, purchased from Messrs. Halliwell & Good, of Manchester. As this instrument is calibrated it was used, and gave very good results.

Had the wavelength of the transmitting stations been within 20 metres of 200, a home-made affair would have been substituted after tuning the transformers. As it was, two coils of 15 and 26 turns were tried and worked quite as well as the Mark III.

On the first two nights—or rather mornings—four ES4 valves were used, making a total of five with the separate heterodyne, which was a Mullard "Ora." On the third night five valves were used

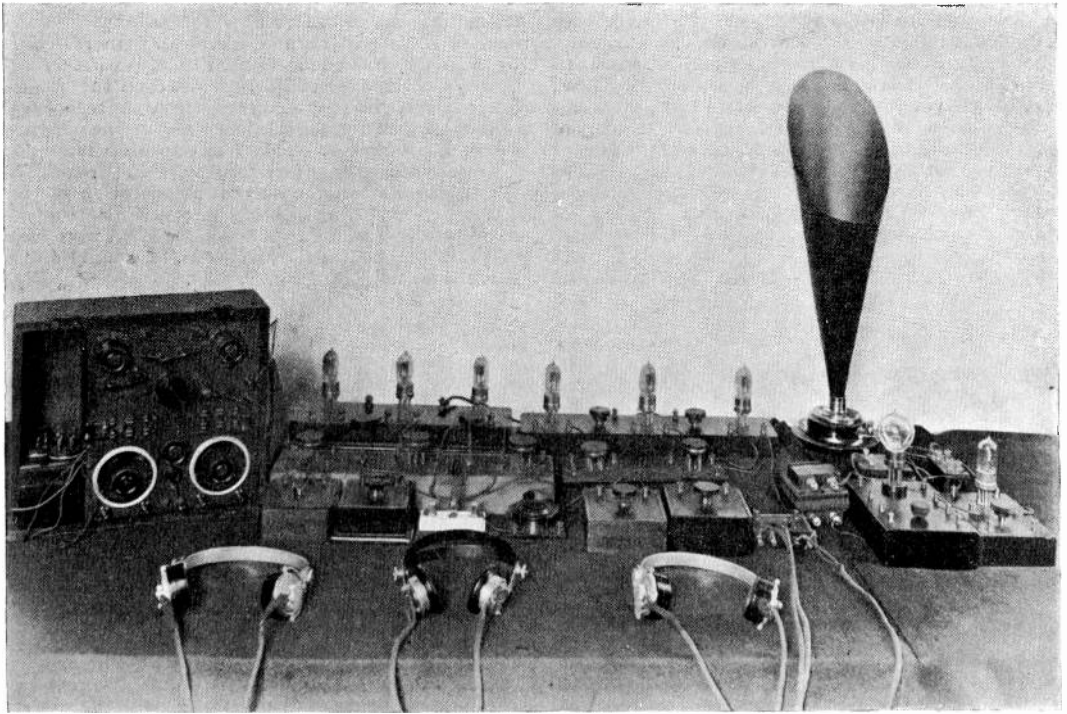

Fig. 2. The Apparatus used by Mr. Burne.

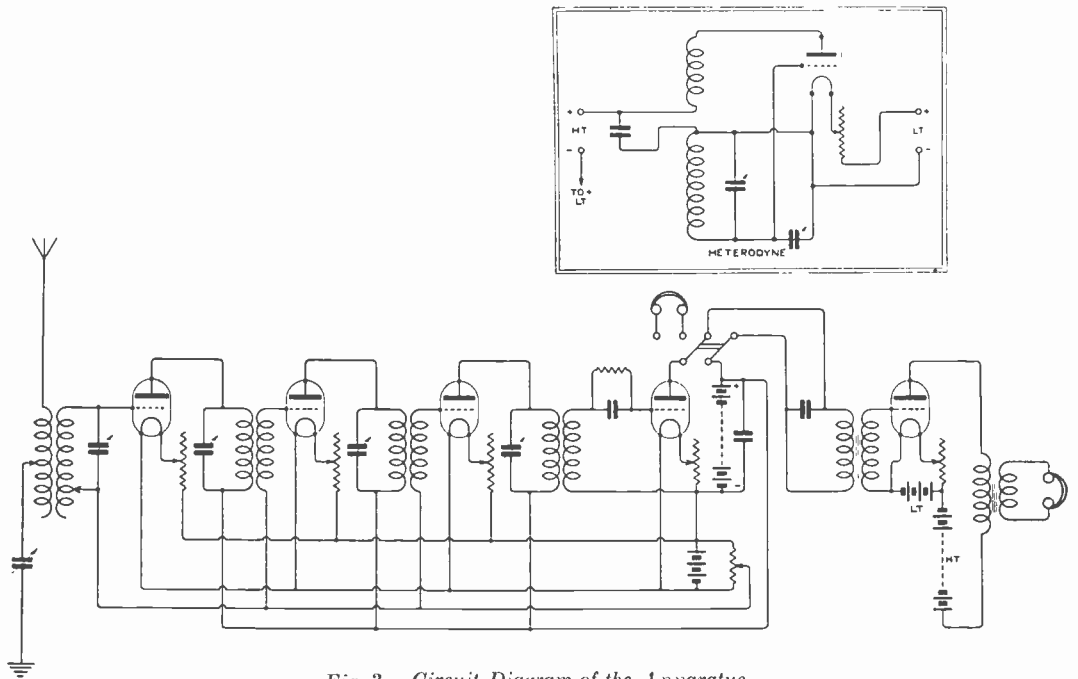

Fig. 3. Circuit Diagram of the Apparatus.

## THE TRANSATLANTIC TESTS

in the H.F. side and the heterodyne. On succeeding nights, six high-frequency valves were used, with the occasional addition of one or two low-frequency valves. The low-frequency side was run together at a moment's notice. A Sullivan L.F. transformer and L.F. transformers purchased from B. Hesketh being used alternately. The panels were of home construction. Brown's and Sullivan's 8,000 ohm telephones were used in the H.F. side and Sullivan's and a Concertone Magnephone in the L.F. side.

For the separate heterodyne (not shown in Fig. 2), a Tingey single valve panel was used. The coils, particulars of which were given in *The Wireless World*, were at first tried, but the instrument would not oscillate: accordingly, two lattice coils were wound with No. 22 D.C.C. copper wire on a 2 in. former, consisting of 25 turns each. It was thought better to wind the plate coil as nearly to the wavelength of the grid coil as possible. With this alteration the heterodyne worked splendidly. Extra high tension was taken from a 30-volt Halliwell & Good high tension unit. The high tension batteries used on the H.F. and L.F., were made up from "Volex" dry Batteries,

purchased from the Universal Electric Supply Co., Brown Street, Manchester.

Vernier condensers were used across the secondary terminals on the Mark III and for the heterodyne. It was not found necessary to couple the heterodyne to the grid circuit of the last valve, in fact it was placed at the other end of the room and the condensers only placed on the instrument table.

A considerable quantity of apparatus used has had to be left out of the photograph, Fig. 2, on account of room; this includes accumulators, high tension batteries, vernier condensers, heterodyne, various coils, transformers, variable condensers and switches. The main part of the apparatus is, however, shown.

In conclusion, I would like to add that I am greatly indebted to the members of the Manchester Wireless Society for their splendid assistance in this effort. Especially I would thank Mr. Milner, of this Society, for his very great help and loan of apparatus. May this be only a beginning to a long series of experiments between the American "Bugs" and ourselves, and may Manchester—even if it knows little of aeriols—be to the fore in these tests!

### The Second Prize Set: Description of Apparatus used by H. H. Whitfield.

FIG. 1 shows a general view of the apparatus, as used for the tests. My wireless den is very small and it is more or less impossible to get a photograph showing all the apparatus at once. On looking at it, one is apt to say, "What a horrible mess!" But the stuff, including the tablecloth, is laid out for use, and not for ornament.

The panel on the wall, left-hand side (Fig. 1), is my ordinary 4-valve receiving apparatus. Three of the valves are fixed along the top, and parts of them only, appear in the picture. The front of the panel is hinged and the connections, chokes, condensers, etc., at the back are easily accessible for alterations when necessary. I might mention here that I have never gone in for receiving sets of the "made-up" variety. My object has been to work out principles, and the panel as constructed is adaptable to many different circuits. The tuning apparatus is, as usual, laid on the table, separate and distinct, and connections between the two are made by means of the terminals along the bottom of the panel. The H.T. and filament batteries are on the floor, out of sight. The battery on the extreme right of the picture is the filament battery for the separate heterodyne.

The box on the table, extreme left, is an old Marconi telephone transformer, pressed into service on this occasion, as I used my own telephone

transformer as an inter-valve transformer for my fifth valve (standing on the table alongside). The fifth valve, it will be noticed, is a Cossor "H" transmitting valve, and it may be thought that amplification by means of a telephone transformer and a "B" valve on 60 volts would not be very efficient. It is not, but it was all I had, and although it didn't amplify much, it cleaned things up considerably.

The apparatus is all home-made with exception of condensers, valves, batteries and phones.

Like the majority of wireless strugglers, I am poor, and although one can make do with a lot in the way of

makeshifts, there are, of course, certain essentials which one must have. In this behalf I would like to mention my indebtedness to Messrs. Beresford Bros., of Bull Street, Birmingham, for the loan of two small variable condensers, also to Mr. T. Rogers, of Moseley, for the loan of a picked ES2 valve, which I used for the separate heterodyne. (The valve in the picture is a burnt-out "B," put there for the purpose of illustration only).

The small Mark III condenser in the centre of the table is the series aerial condenser and, being more or less at earth potential, did not require a long handle to operate it.

The variometer in the plate circuit of the second valve was fixed to the shelf over the top of the panel and does not appear in the picture.

#### Stations Heard by Mr. H. H. Whitfield. SECOND PRIZE WINNER.

- 1 AFV F. C. Estey, Salem, Mass.
- 1 BCG Special Station (see *Wireless World* last issue, page 647).
- 2 ZL J. O. Smith, 3, Corona Road, Valley Stream, Long Island, N. Y.

In the first and third case the special code signals were correctly received as well as the calls.

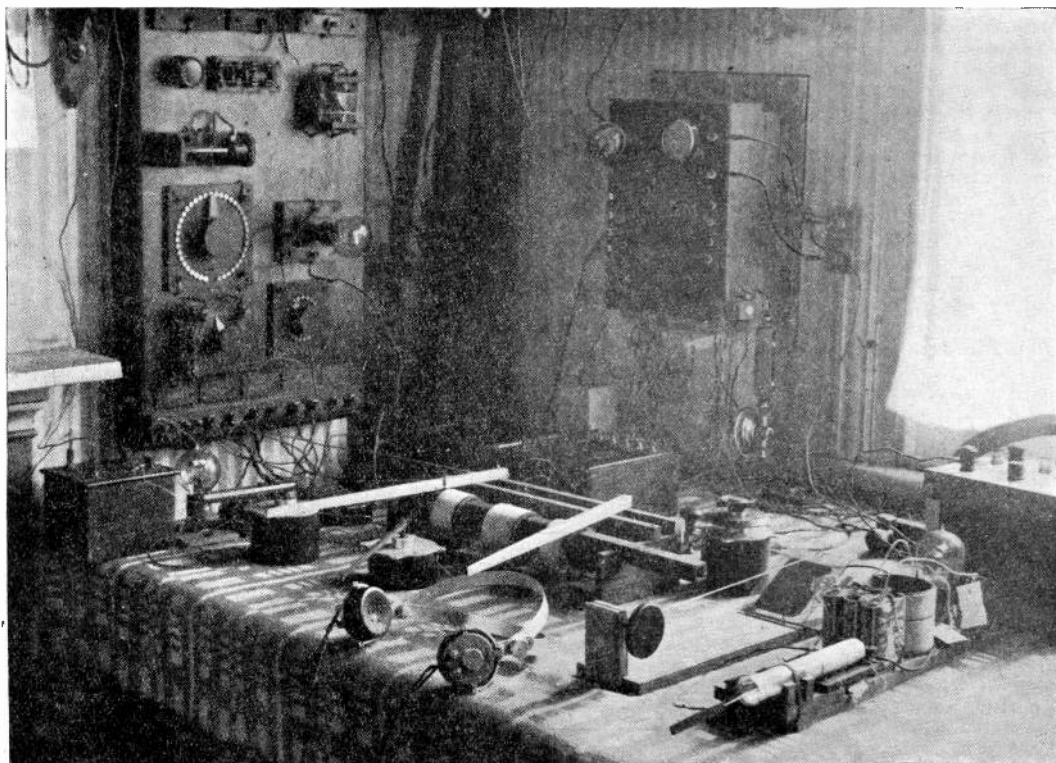

Fig. 1. General view of the Apparatus used by Mr. Whitfield.

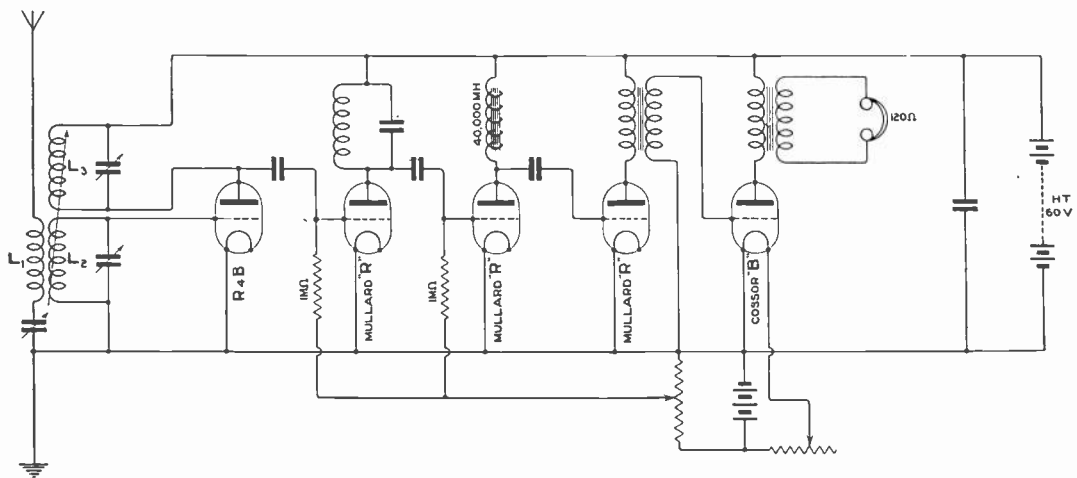

Fig. 2. Circuit Diagram of the Apparatus.



## THE TRANSATLANTIC TESTS

The tuning apparatus shown in plan, Fig. 3, consists of three coils wound on  $2\frac{1}{4}$  in. diameter ebonite tube. Their method of mounting is, I think, novel. They are simply hung on a piece of square ebonite tube, and the coupling between them is adjusted by means of the levers as shown, connected to the two outside coils (similar to the tool-feeding arrangement on a capstan lathe). This arrangement has the advantage of giving easy

with No. 32 silk-covered enamelled wire, the turns being spaced with white silk thread equal to about twice the diameter of the wire. The object of this spacing is too well known to need comment.

Referring to the diagram of connections, Fig. 2, it will be seen that the bottom end of the secondary coil is connected to filament negative instead of potentiometer, and self-oscillation of this valve is prevented by a reverse coupling of the anode and

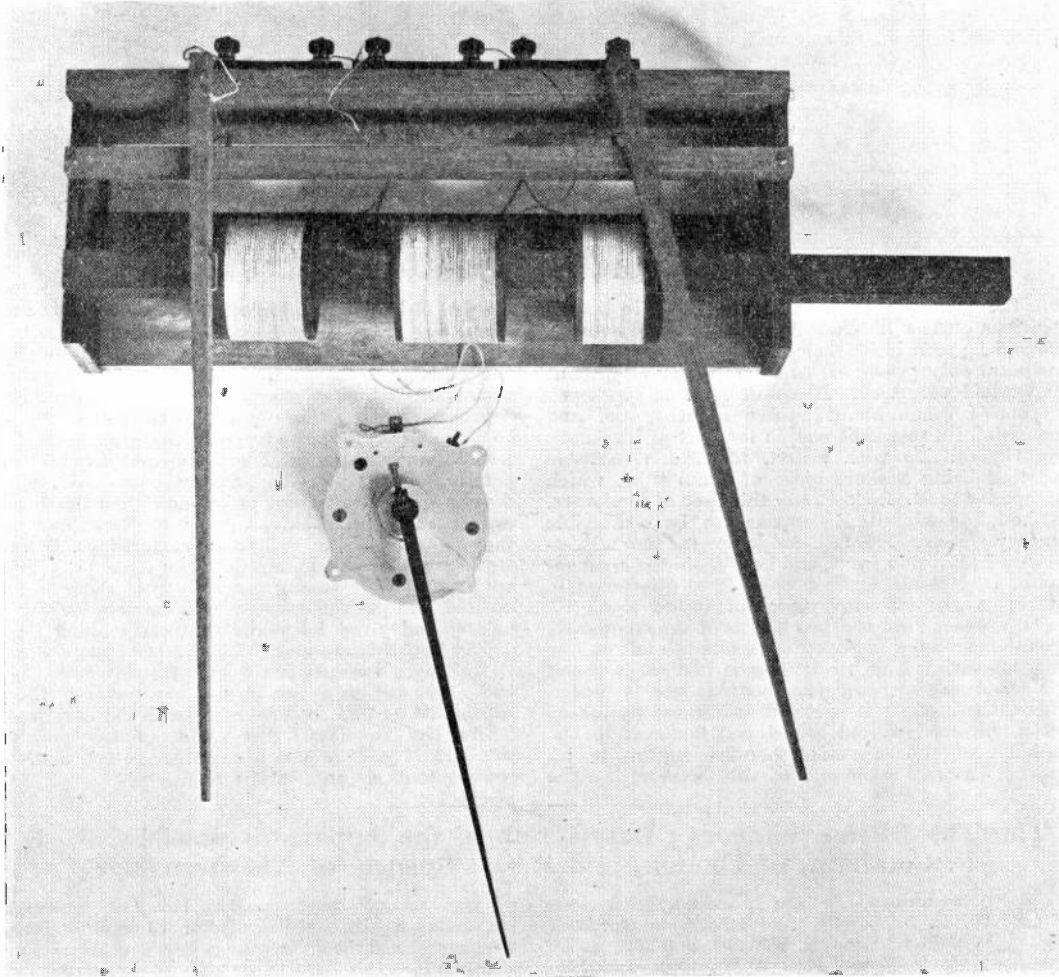

Fig. 3. *Tuning Apparatus.*

critical adjustment, and at the same time the long handles minimise capacity-to-earth effects, always very troublesome on short wavelengths.

The six terminals are at the back and therefore out of the way.

The coil on the right is the aerial coil of 27 turns. The middle one is the secondary and has 44 turns, and the one on the left of 34 turns is the anode coil of the first valve. The three coils are wound

secondary coils. I have used this method for the past eighteen months or so and find it a much better method of stopping self-oscillation, for, although grid-damping by positive volts will stop self-oscillation, it at the same time introduces undesirable noises into an otherwise quiet circuit, and therefore, should, I think, be avoided wherever possible.

The separate heterodyne (Fig. 4), although built

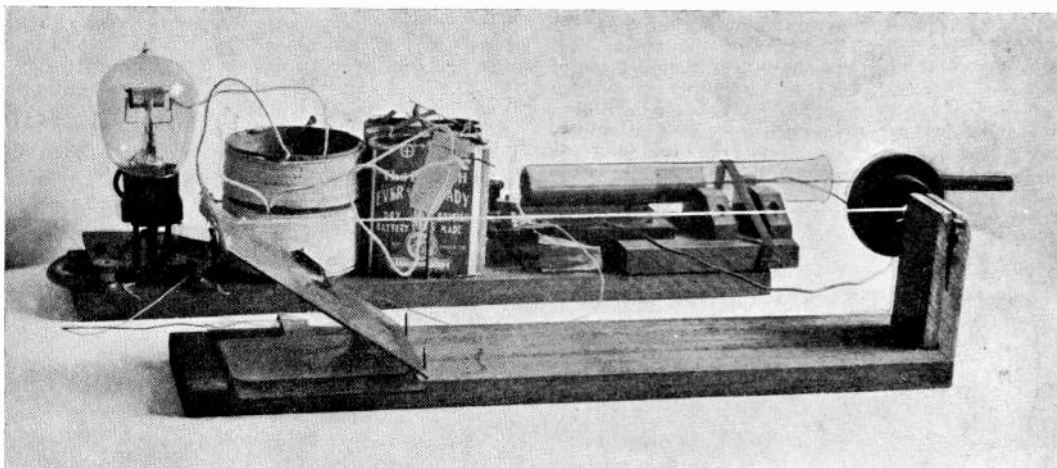

Fig. 4. *The Separate Heterodyne.*

on the principle of that as described in recent editions of *The Wireless World*, differs very much, as will be seen in its appearance. The time at my disposal only permitted of a temporary affair, but it worked very well. Its main variable condenser is one I made about twelve months ago, and consists of a test tube coated for part of its length on the outside with tinfoil, the inside movable portion being a short piece of brass tube, which happened to fit. Incidentally this type of condenser, although easily made, appears to be a horrible energy waster. The billi-condenser for fine adjustments is shown in front, and here again the arrangement is, I think, a novel one. Two quarter-plate negative glasses, with pieces of tinfoil stuck on with shellac, form the two halves of the condenser, connection being made by a flexible tab left on one side of each. The fixed plate is laid on its back on the baseboard and the movable one is hinged against two pins. It is raised or lowered by means of a silk cord wound round and fastened to the spindle of the operating handle, sprung in an upright at the other end of the baseboard. The

weight of the glass plate keeps the cord taut. Here, again, we have distant control, and the big air space separating the two capacities allows of very fine and easy adjustment for heterodyning signals of such short wavelength. The heterodyne being unscreened, I did not need to use any coupling coils between it and any particular part of the receiving apparatus, as I got sufficient strength of heterodyne without. An ES2 valve was used, with 8 volts on plate. I am of opinion that the billi-condenser to some extent acted as a radiator in the manner of the well-known Hertz oscillator. During use it was 18 inches away from the other apparatus. The tuning generally was exceedingly critical, and yet the set seemed to be very sensitive to any and every harmonic that came along.

The aerial is standard G.P.O., 140-feet, 2 wire, 40 feet high, due east and west. Lead-in from east end. 500 feet above sea-level. No screening. Clay subsoil. Wire 7/24, enamelled. Earth to water pipe.

The box-like affair, just visible on the wall at the back (Fig. 1) is part of my transmitter, and, of course, took no part in the test.

### The Third Prize Winners : Description of the Apparatus used by W. E. F. Corsham, of London, and R. D. Spence, of Aberdeenshire.

AS announced in our previous issue, Mr. W. E. F. Corsham, of Harlesden Gardens, Willesden, London, N.W.10, and Mr. R. D. Spence, of Craighead House, Huntly, Aberdeenshire, each heard signals from one station, with correct code words. Mr. Corsham used three valves and Mr. Spence used six, and for this reason the judges have decided that Mr. Corsham is deserving of the more valuable of the two third prizes that have been offered.

Mr. Corsham's aerial was 100 ft. single wire (7/20 enamelled) in the form of an inverted L. Two masts were used, one 20 ft. high, in the garden, and the other secured to the chimney pot in such a way that the height from the ground to the top

of this second mast was 46 ft. The receiving apparatus was situated in a room 15 or 20 ft. from the ground and the 25 feet down lead was taken from the highest point of the aerial. The arrangement was thus non-symmetrical, the free end of the aerial being practically no higher than the receiving instruments and the maximum height above the receiving instruments being 25 ft. A double earth connection was used, one consisting of a wire to the water tap and the other of a single wire running immediately beneath the aerial and earthed at the far end. Mr. Corsham informs us that the situation of his house is at the bottom of a hill with practically no screening.

It was intended to use two receivers, one a five-

## THE TRANSATLANTIC TESTS

valve low-frequency amplifier detector and the other a three-valve experimental receiver. The first caused trouble in the early part of the Tests and was therefore scrapped, attention being concentrated on the second circuit for the remainder of the Tests. A separate oscillator was, of course, used, similar in construction to the Marconi Independent Oscillator. Owing to the fact that it was Mr. Corsham's first attempt at using a separate oscillator on 200 metres, he had a certain amount of trouble with it and further, conditions did not permit of his listening in for the calibration waves. His calibrations were, therefore, made on harmonics from FFU, GFA and GKU. Time signals were checked from a Nauen harmonic.

The five-valve set, although silent in action most of the time, had an irritating habit of howling when least expected and was therefore discarded. The circuit of the three-valve set is shown in Fig. 6. According to Mr. Corsham, this set occasionally works better on short waves when the earth is disconnected.

We notice upon examination of Mr. Corsham's log that he reports "amateur interference heavy" about the time he received the signals from 1AFV (morning of December 12th). The signals from 1AFV are given by Mr. Corsham as of sufficient strength to be nicely readable and he thinks that if he had had more time to experiment with and adjust his apparatus, he would have received many more stations. The set is shown in the photograph, Fig. 5, and in the diagram of connections in

Fig. 6. It is of interest to note that Mr. Corsham is Chairman of the Willesden Wireless Society.

The other recipient of the third prize, Mr. R. D. Spence, of Huntly, Aberdeenshire, used the apparatus which is shown in the accompanying photographs and diagram (Figs. 7 to 10). The first photograph (Fig. 7) is a general view of the receiving gear. On the extreme left is seen the

high tension unit containing tapped-off resistance and two microfarad condensers. Next to it is the amplifier, then the Mark III tuner and on the right, a converted Marconi No. 16 receiver, used for long waves. On the right, in front, are the Townsend wavemeter and the heterodyne unit.

In the second photograph (Fig. 8) is a close-up view of the amplifier, removed from its case. Fig. 9

is a side-view of the amplifier, valves, interval transformers, grid leak, four or six-valves switch and reactance switch. The aerial consisted of a single wire "T" of 7/24 copper, average height 45 ft., length of horizontal wire 80 ft., with down-lead 20 ft. to instrument room situated 25 ft. from the ground. Earth connection was made to the water pipes and also to a wire running out under the aerial and buried about three inches in the ground. The Mark III tuner calls for no comment, being standard in its connections, with the detector switch kept on to the valve position so that the first valve amplifier is connected directly to the closed circuit of the tuner.

The amplifier is of Mr. Spence's own design and

**Station Heard by Mr. W.E.F. Corsham.  
(JOINT THIRD PRIZE WINNER)  
WITH THREE VALVE SET.**

**1 AFV F. C. Estey, Salem, Mass.  
With code group correctly received.**

**Station Received by Mr. R. D. Spence.  
(JOINT THIRD PRIZE WINNER)  
WITH SIX VALVE SET.**

**2 ZL J. O. Smith, 3, Corona Road,  
Valley Stream, Long Island, N.Y.  
With code group correctly received.**

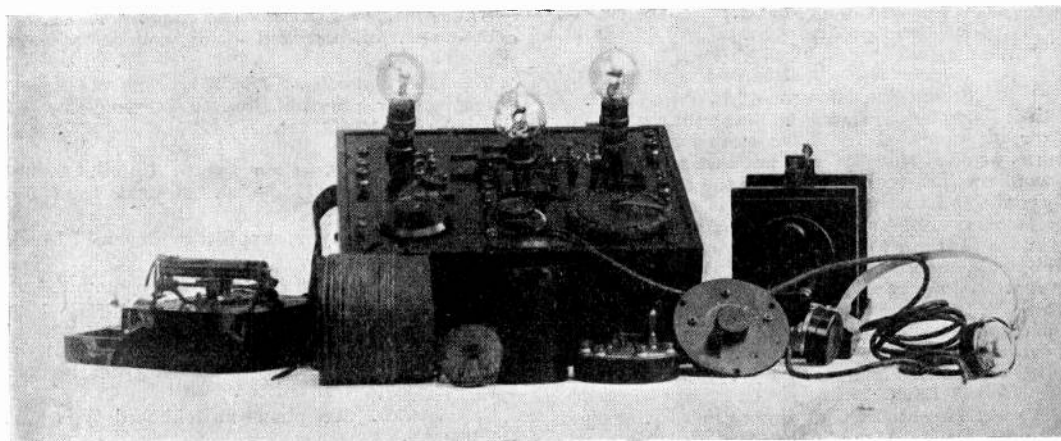

Fig. 5. Mr. Corsham's Apparatus.

constructed by his brother, Mr. H. R. Spence. Six R type valves are used, three as H.F. amplifiers, one as rectifier, and two as L.F. magnifiers. The details of the H.F. transformers are as follows:—

Dimensions of wooden bobbins:—  
 Mean diameter,  $\frac{7}{8}$  in.  
 Axial length,  $\frac{1}{2}$  in.

remaining points of the amplifier are dealt with below. The letters refer to the letters on the diagram (Fig. 10).

$T_1, T_2 = L.F. Transformers.$  These are Disposal Board goods and are the ordinary small Army pattern of transformer wound with 47 S.W.G. S.S.C. Ratio 4-1.

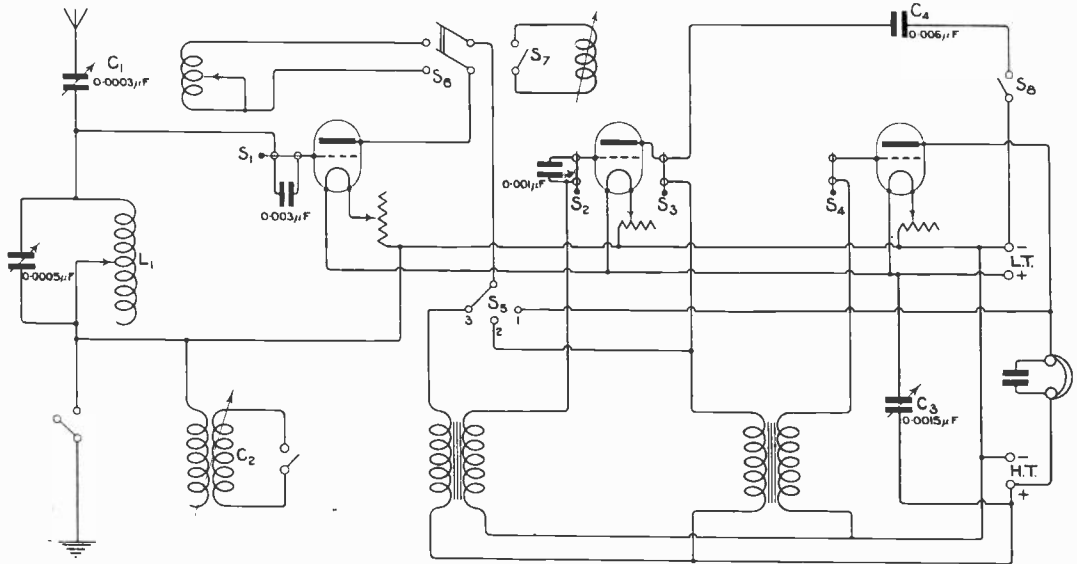

Fig. 6. Circuit Diagram of Mr. Corsham's Apparatus.

The switch in the aerial circuit is for the purpose of disconnecting the earth, as the set sometimes works better without the earth.  $C_2$  is a loose-coupled tuner. The switches  $S_1, S_2, S_3, S_4$ , consist of two terminals and a pin for shorting or breaking the circuits.  $S_5$  allows one, two or three valves to be used.  $S_6$  and  $S_7$  bring in either reaction or a coil for tuned plate circuit.  $S_1$  and  $S_2$ , although shorted in the diagram, were not so in the test. Apparently the loose-coupled tuner is used merely as a substitute for a fine tuning condenser, as slight alterations of the sliding coil give very fine tuning to the aerial. Condenser  $C_3$  gives even finer tuning.

Width of groove,  $\frac{3}{16}$  in.  
 Depth of groove,  $\frac{1}{8}$  in.

Windings:—

Primary (tuned), 45 turns 42 S.W.G. D.S.C.  
 Secondary, 50 turns 42 S.W.G. D.S.C.

The secondary is wound on first with the primary over it, separated from the secondary by a few turns of oiled silk cloth. The starting end of the secondary (*i.e.*, the inside end of the inner winding) is connected to the grid, which is thus kept free as far as possible from undesirable capacity effects, while at the same time the primary or tuned winding is outside and easily accessible, if it is desirable, to remove a turn or two to adjust the tuning of the three transformers to correspond. The tuning condensers for the primary windings of these transformers are closed circuit condensers from the earlier pattern of Mark III short wave tuners made by Mr. Robert Paul.

It will be noticed that there are two terminals connected by a strap in the plate circuit of the first valve. This enables inductive reaction or variometer reaction to be used if desired. The

$R_1, R_2, R_3 = Filament Rheostats.$  These are home-made, of platinoid wire wound on slate, with sliders.

$P = Grid Potentiometer.$  This is an old crystal potentiometer removed from a Marconi No. 16 "balanced crystal" set.

$r = Grid Leak.$  Mullard 1 megohm.

$C_3 = Grid Condenser.$  Mica and tinfoil, 0.0003 microfarad. Disposal Board. Bought from Mr. Tingey.

$Valves.$  "R" type, supplied by General Electric Co., Ltd.

$Valve Holders.$  Two sets of three mounted in ebonite, bought from Mr. L. McMichael.

$S_2 = Switch.$  This allows four or six valves to be used at will, as shown in diagram. It is of the "barrel" type and was removed from an old Disposal Board transmitter.

$S_1 = Switch.$  Telephone switchboard type (Mr. McMichael).

$Switches.$  These are small miniature tumblers,  $C_2 = Blocking Condenser.$  Mica and tinfoil,

## THE TRANSATLANTIC TESTS.

0.002 microfarad. This is the telephone condenser from a Marconi "Type 16" set.

$C_1$  = Reactance Condenser. This is home-made and has one moving and two fixed vanes of sheet

*H.T. Supply.* This is obtained from the lighting circuit which is supplied from 32 chloride cells, giving 64 volts. The mains are connected across a resistance of 100 ohms, tapped off to six

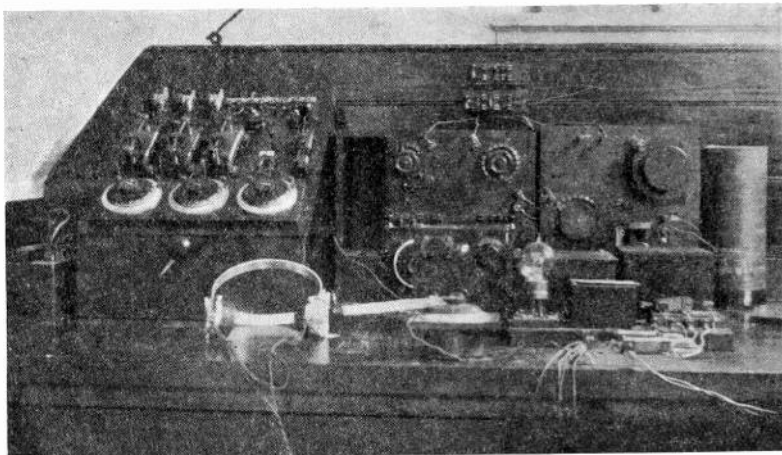

Fig. 7. General view of Receiving Gear.

zinc. Moving vane, quadrant shaped, 4 ins. radius.  
 $T_3$  = Valve-phone Transformer. Army pattern.  
 Disposals Board.

points. By connecting the H.T. terminals of the amplifier to two of these points, shunted by a two-microfarad Mansbridge condenser (O), I am

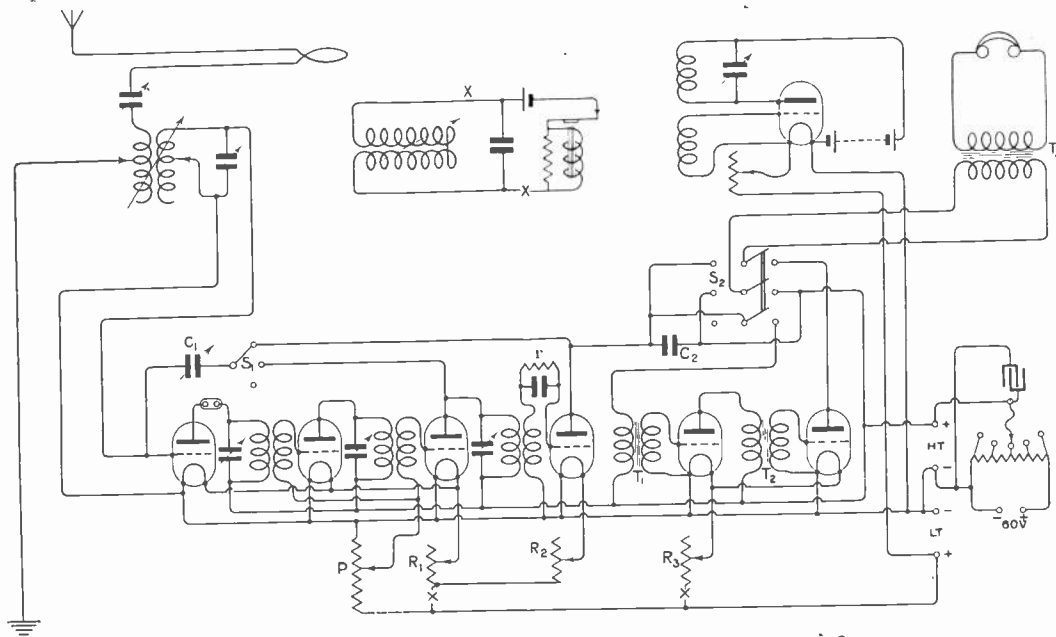

Fig. 10. Circuit Diagram of Mr. Spence's Apparatus.

*Phones.* Brown, 120 ohms. "A" type.

*L.T. Battery.* "Exide" type, six volts 50 amp.-hour, bought from Chloride Electrical Storage Co., Ltd.

able to get any desired portion of the total voltage.

*Heterodyne Unit.* The inductance and reaction coil are wound side by side on a cardboard tube (P),  $4\frac{1}{2}$  ins. in diameter and consists of 10 and 12

turns of 22 S.W.G. enamelled copper wire respectively. The condenser is a Mark III tuner, closed circuit condenser (R), as used in the amplifier. The range of wavelengths covered is about 170-390.

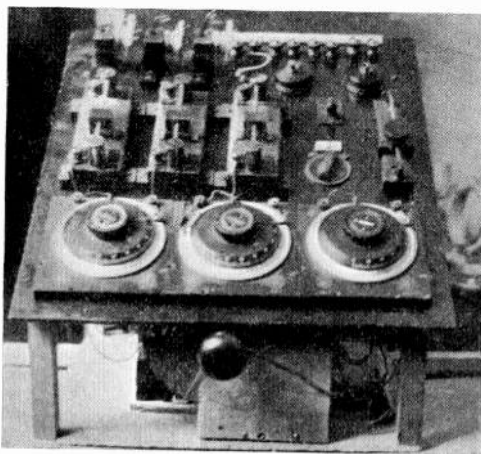

Fig. 8. A near view of the Amplifier.

A wooden "pot-handle" is fitted to the knob of this condenser to minimise the capacity effect of the operator's hand.

The H.T. for heterodyne valve consists of six "Ever-ready" cells (S).

X = Wavemeter. This is a Townsend wavemeter, 120-1,600 metres, specially calibrated from N.P.L. standard meter, and was given to me by Prof. Townsend.

*Remarks.* The chief difficulty encountered with a set of this type is in searching for a station if the wavelength is not exactly known. Owing to the tuning of the H.F. transformers, the tuning is very sharp indeed, and any alteration of wavelength means making five or six adjustments. I have tried gearing the condensers together, but have not found it satisfactory. If the wavelengths of the American stations had been known exactly, i.e., within 5 per cent., I am confident I should have heard more of them.

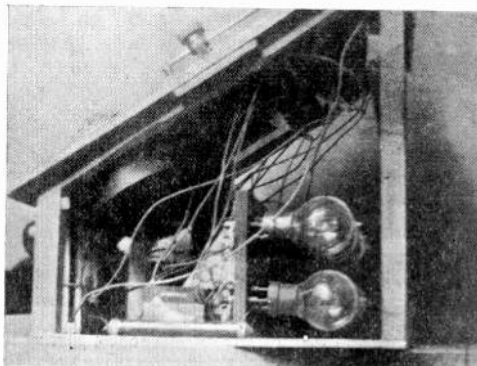

Fig. 9. Side view of the Amplifier.

My station is situated in the middle of a wood and is particularly badly screened towards the west by trees, which are higher than the aerial, and by sharply rising ground.

## 1 BCG.

### Some Notes on the Station.

THE distinction of having transmitted the first transatlantic signals from an amateur station, conforming in every way with the radio laws and regulations of the United States belongs to Mr. Minton Cronkhite, of Greenwich Connecticut, whose call "1BCG" was heard with considerable strength not only by Mr. Godley, but by British and Continental amateurs. His transmissions, however, were not strictly connected with the prize tests, as he transmitted over considerable periods during the whole time.

1BCG station, of which we shall publish further particulars in a later issue, was erected by Mr. Cronkhite in association with E. H. Armstrong (the well-known inventor), George Burghard, John Grinan, Walter Inman, and Ernest Amy. The set uses four Radiotrons\* UV 204, one as a master oscillator, and three as power amplifiers. The plate potential is 2,000 volts, supplied from a motor generator. The total input of the set was 989 watts, and 558 watts were delivered to

the aerial. The latter was of the T type, the horizontal part being 100 feet long. Both the flat top and the leads were eight-wire cages. The effective height of the aerial above the radial counterpoise was 75 feet. The counterpoise was 120 feet in diameter, supported on poles eight feet from the ground. There was no direct earth connection. The aerial resistance was 15.5 ohms, and all transmission took place on a wavelength of 200 metres.

The station was first heard on the morning of December 10th, by Mr. Paul Godley at Ardrossan. Godley immediately telegraphed to Mr. Cronkhite that his signals were "wonderful," and requested that he would transmit a complete message. This was done on the morning of the 12th, and receipt was duly cabled by Mr. Godley.

The best reception of 1BCG by an English amateur was undoubtedly that by Mr. Greenslade at the British School of Telegraphy. On one occasion Mr. Greenslade copied the signals from that station for nearly two hours, although he was not fortunate enough to receive the message referred to above, or any code signals.

\* Transmitting valves made by the Radio Corporation of America.



# Apparatus used in Transatlantic Reception.

By PAUL F. GODLEY.

A GREAT deal of interest will no doubt be displayed in the equipment used at Ardrossan. A brief description of the antenna follows. It consisted of a wire suspended on poles 12 ft. high, the wire being so arranged that it could be adjusted to a length equivalent to one wavelength for any wave between 190 and 325 metres. The wire is grounded on the far end through a non-inductive resistance of between 300 and 400 ohms and at the "home" station through an inductance which had a reactance of about 400 ohms for the frequency at which reception was being effected. No attempt will be made here to touch upon the theory of this antenna other than to say that its functions by virtue of those component parts of the electromagnetic wave which travel in a vertical direction rather than those which travel horizontally. Its use and proper adjustment enables the elimination of considerable atmospherics and interference due to its decidedly directional characteristics, and data gathered by engineers of the Radio Corporation of America, which Corporation uses

strength of signal received on a vertical antenna 65 ft. in height.

The receiver used was the well-known super heterodyne or autodyne receiver, wherein oscillations from a local oscillator are caused to produce beats with the incoming signal, the frequency of the beats being of the order of 50 to 100,000 cycles per second. Forming a part of the anode circuit of the detector valve is a circuit tuned to the beat frequency this circuit being coupled to the first valve of a multistage amplifier set to amplify frequencies of the order of 50,000 cycles. In the Ardrossan outfit amplification was effected at a frequency of about 100,000 cycles. In addition to the detector and oscillator valves 5 radio frequency amplifiers and one note magnifier was used. The various radio frequency valves being coupled with 100,000 ohm resistances of the "Lavite" type, while the radio frequency amplifier and the note magnifier were transformer coupled. In the detector valve advantage was also taken of regeneration at the initial frequency which enabled

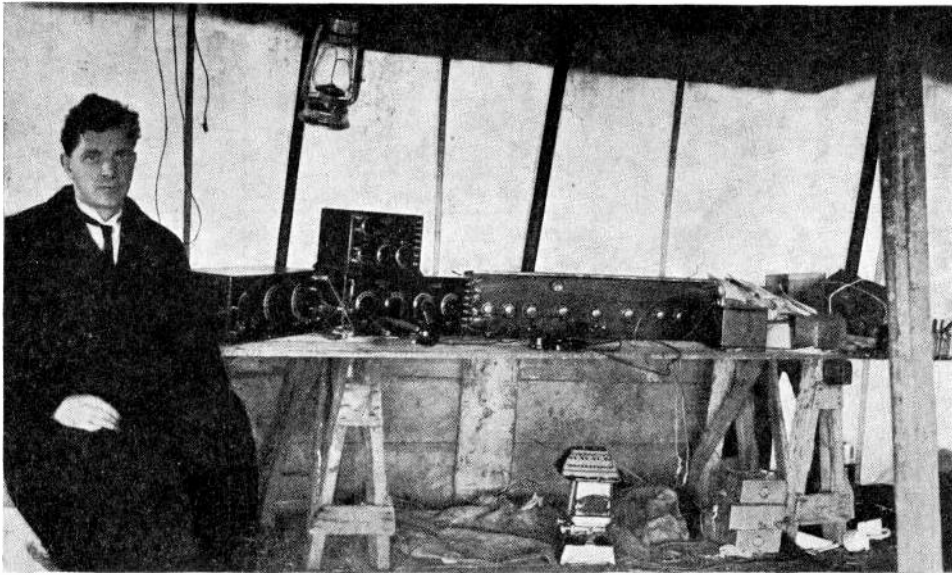

Fig. 1. The inside of the tent in which the signals were received showing the apparatus arranged on a bench. On the left is Inspector Pearson who assisted Mr. Godley.

this type of aerial in connection with all the transatlantic traffic, shows that potentials developed in the antenna are equivalent to those which would be developed in a vertical antenna whose height is equivalent to 1/10th of the length of the horizontal wire. In other words, assuming that it is desired to receive on 200 metres the length of wire to be out would be approximately 650 ft. and the strength of signals received in this length of wire at this wavelength would be equal to the

the building up of the signal to three or four times its initial value.

In the photograph, Fig. 1, the instrument on the extreme left is the closed circuit which is coupled to the Beverage wire and tuned to that frequency which it is desired to receive, the case also containing a variometer for regenerative action at this same frequency. The second case (lower) includes an auxiliary condenser for use on the initial frequency, coupling between the circuit of initial frequency and

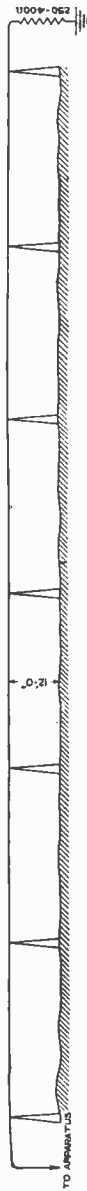

Fig. 2. The Beverage Antenna.

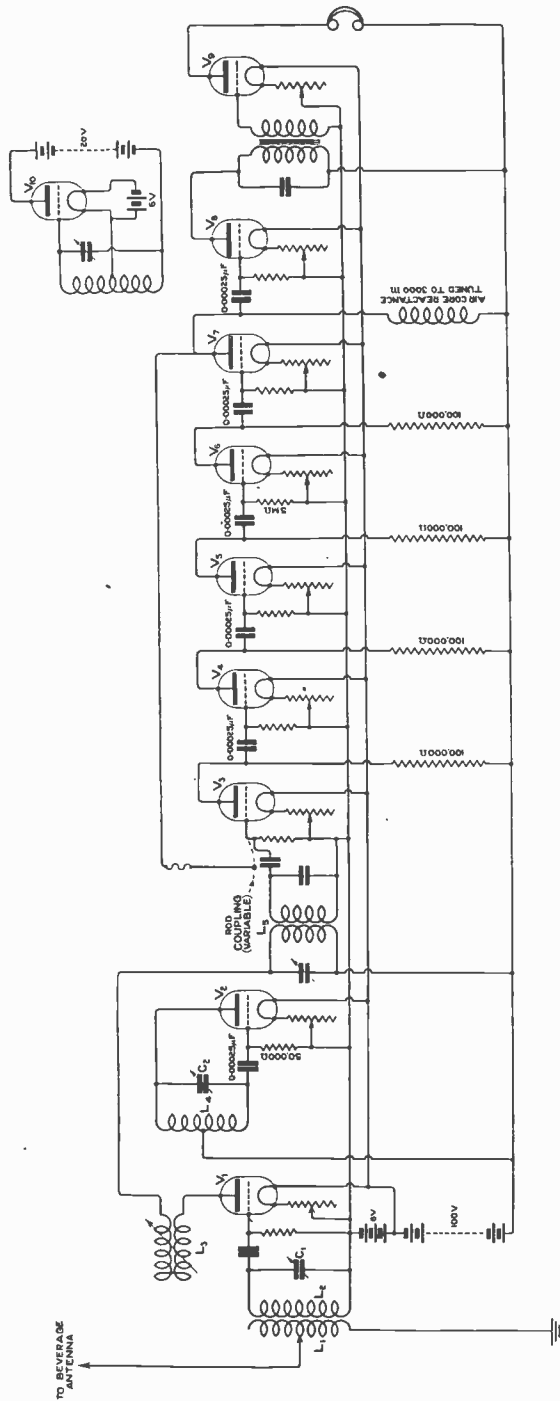

Fig. 3. Circuit diagram of the apparatus used.

$L_1$  = Inductance to give impedance of 400 ohms at the working wavelength;  $L_2, C_1$  secondary circuit with tuning range of 180 to 600 metres;  $V_1$  = first detector valve;  $V_2$  = short wave heterodyne valve (tuning range 180 to 600 metres);  $V_3$  to  $V_7$  = long wave amplifying valves (resistance-capacity coupled);  $V_8$  = long wave detector valve;  $V_9$  = note magnifying valve;  $V_{10}$  long wave separate heterodyne (range 2,000 to 6,000 metres).

## DESCRIPTION OF APPARATUS

the oscillator, condenser which controls the frequency of the oscillator, and a second condenser which controls the beat-note circuit in the anode circuit of the detector valve. The detector valve is inductively coupled to the amplifier and the cabinet last mentioned, also contains a transformer for this purpose whose secondary is tuned to a fixed frequency of about 75,000 cycles. The third cabinet holds in all nine valves, the first of which is the detector, the second oscillator, the third to eighth inclusive radio frequency amplifiers and the ninth note magnifier. The cases of all these units are lined throughout with copper sheet 2 ins. thick, and where necessary all external leads including those of the headphones (where necessary) are covered by a flexible copper sheathing. Com-

American equipment carrying the name "Paragon." To those British amateurs who may consider the construction of such an outfit as this, it might be well to caution them to use the greatest care in the selection of grid resistances, coupling resistances and grid condensers. Poor leaks, resistances or condensers oftentimes produce excessive loss and frequently give rise to troublesome noises. It will also be noted that the last radio frequency amplifier is coupled to the final detector by the use of an air coil reactance. This reactance is so chosen that its period is approximately that at which amplification is taking place. Its use tends toward the greatest possible quiescence and the elimination of many otherwise bothersome transients. Further attention is called to the fact

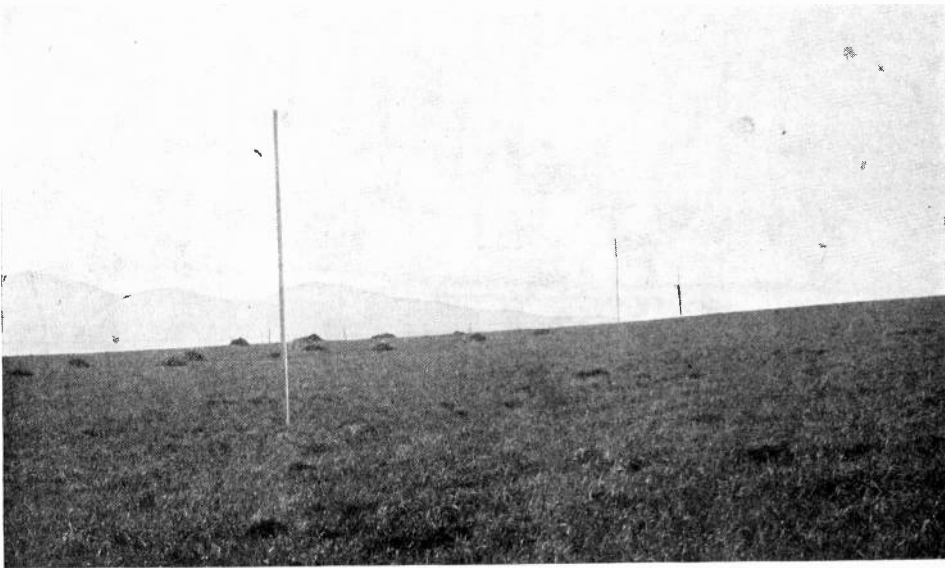

Fig. 4. Poles 12 feet high supporting the 850 feet of aerial wire.

mon battery is employed both for filament and anode of all valves, and a capacitive coupling (variable) is provided which enables one to take advantage of the regenerative action of the amplifier as a whole at the amplification frequency. For reception of C.W. the amplifier may either be caused to produce oscillations or an external oscillator may be set up in the vicinity of the apparatus and adjusted for a proper note. Such an oscillator produces energies far larger than necessary when it is set near the wavelength on which amplification is taking place. Therefore it is usually desirable to set the oscillator in such a way that its third harmonic falls at the frequency of amplification.

The unit which sits on top of the second cabinet mentioned is a combination detector and two-stage note magnifier also in a shielded copper-lined case. This unit is a companion for the left-hand unit and is a widely advertised combination of

that a condenser of approximately 500 micro microfarads is placed in shunt to the primary of the note magnification transformer. This to a large extent bypasses any radio frequency currents which might otherwise tend to get through to the note magnifier and ensures additional stability of the whole. Using this condenser it is usually unnecessary to shield the cords of the head telephones.

Obviously an amplifier of this type is considerably more flexible than one which amplifies radio frequencies directly. The writer has used this amplifier in his own station during the past two years on wavelengths ranging between 75 and 1,600 metres. It is equally sensitive on all of these and it is a far simpler matter to adapt such an arrangement to all the shorter wavelengths than it would be to adapt a strictly radio frequency amplifier to such a wide band. After reaching 1,600 metres it is possible to shift to amplifier direct and work on up to 20,000 metres. Without

doubt, however, for amateurs, some advantage would be gained by the placing of one or two stages of amplification (radio frequency) between the antenna and the first valve shown in the diagram. Additional complications encountered would in many cases be entirely compensated for. Inasmuch as quite complete descriptions of this type of apparatus have been published some time since in both British and American radio journals no attempt is being made at this time to go into any details. The tubes chosen for this work are those known as "Moorehead," and are very similar to

The note magnifier valve was used very little during the test. It was either out entirely or had the filament brilliancy reduced to a minimum. (Each valve was separately controlled by a 6-ohm circular rheostat). On one or two occasions the note magnifier was used to the fullest extent and signals resulted which forced one to remove the headphones.

During one of the watches at Ardrossan Inspector Pearson dozed off. The static was rolling in by the buckets full. After making several entries in his log Godley also fell asleep face down on the table

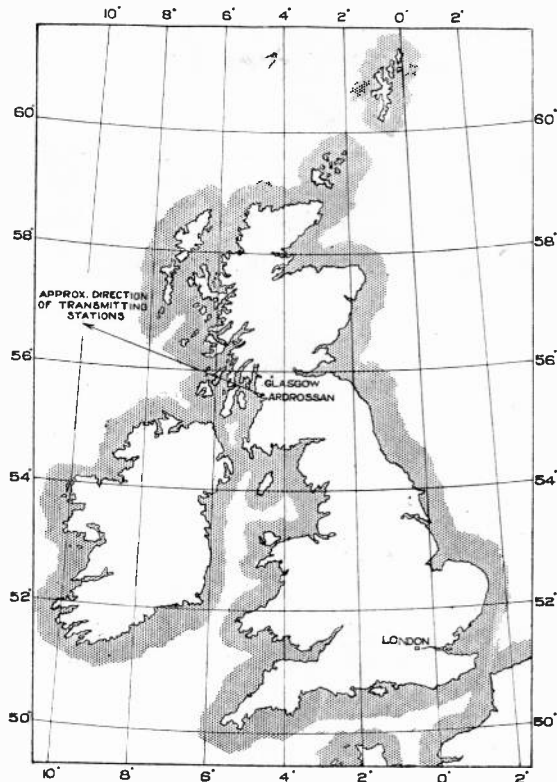

Fig. 5. Map showing the location of Ardrossan and average direction of American Transmitting Stations.

that valve which the British amateur knows as the "R" valve.

Baldwin's headphones were used throughout being extremely rugged in all respects and having a sensitivity at least equal to anything the writer has ever worn. H.T. batteries were of the "Burgess" type which are put up in 22½ volt units, each cell being carefully wrapped in paraffin paper sealed off from its neighbours and the whole cast *en bloc* in a resin wax. The performance of these batteries was excellent. During the whole test the batteries were on wet ground and a greater portion of the time were covered with a film of water. No difficulty of any sort developed from this direction.

but awakened shortly afterwards with wild thoughts of fire chasing around in his head. In coming to with a start Pearson was awakened and gazed at Godley with a ghastly expression.

Godley: "What's the matter. Did I startle you?"

Pearson (large eyes and ghastly expression on his face): "What's the matter with your face it's as black as ink."

The oil stove which was under the table had started to smoke. By virtue of cracks in the table everything had been fairly smoked up including Godley's face.

A great deal of trouble was experienced in keeping the pole line at the Ardrossan installation in shape.

## DESCRIPTION OF APPARATUS

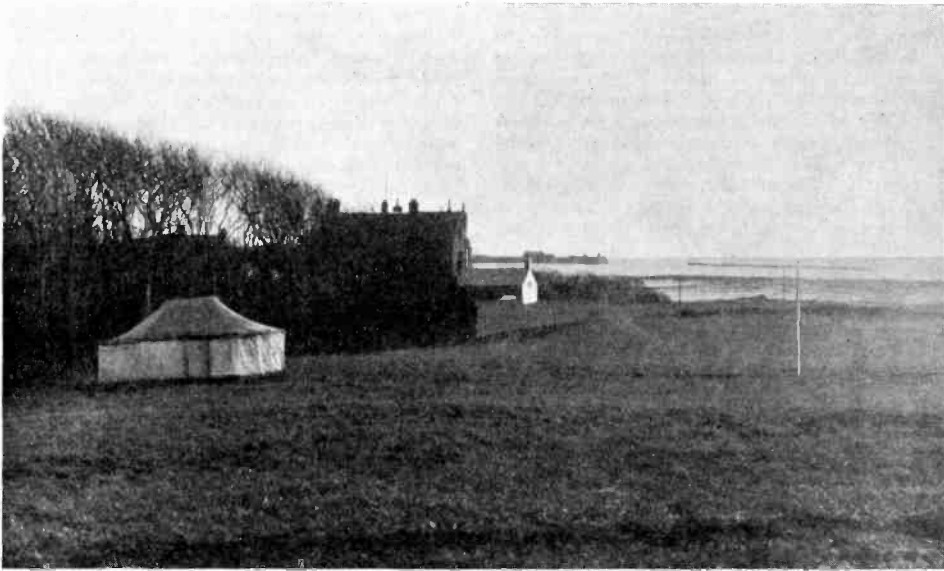

*Fig. 6. The Receiving Station tent and the first pole.*

The field in which the tests were made was used to pasture several horses all of which developed an appetite for the poles supporting the Beverage wire. These poles were gnawed freely and in several cases broken off short, as though the horses had tired leaning against the poles.

The seaweed which had been spread over the field in Ardrossan to act as a fertilizer made traveling up and down the line through the blackness of the rainy Scotch night a very difficult procedure. It was an easy matter to stray entirely away from the line, to fall down or to tangle oneself up un-



*Fig. 7. Another view of the tent. The first three poles can be seen.*

expectedly with the stay wires which were placed on some of the poles.

Several of the townspeople of Ardrossan visited the test station during the period and one gentleman who seemed to be proud of his ability to consume large quantities of Scotch liquor listened in during a period of 30 or 40 minutes to various H.P. stations picked up, having been told in each case "That's Berlin," "Here's New York," etc.

On account of the excellent signals of Friday, Saturday and Sunday nights violent efforts were made to get hold of a dictaphone in order that

windows and large crowds evidence considerable interest in the equipment.

Through error in coding the first station heard, IAAW, was broadcasted as being IAAV. A cable was received immediately to the effect that IAAV was a spark coil station and that the transmitter was not in operation. Immediately correction was sent by cable to the effect that IAAW was correct. A second reply came saying that IAAW had no transmitter. The location of this first station heard is still undetermined at the time this is written.

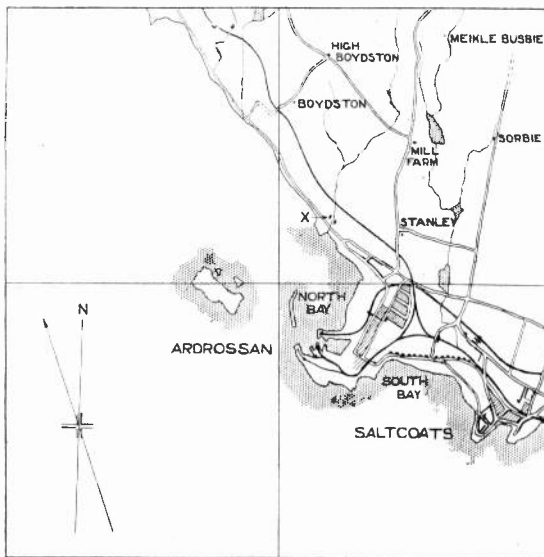

Fig. 8. Enlarged Map of Ardrossan.  
The approximate position of the station is shown at (X).

records might be taken of the Transatlantic Transmissions. A dictaphone arrived on the scene in due time but was never used. The dictaphone idea on the other hand may prove useful inasmuch as it is intended to take several dictaphone records of American signals on his return to the States, same to be forwarded to London for the information of members of the Wireless Societies of London.

Tremendous interest in the results of the American tests was created in engineering circles in America. Cables from various ones indicate that there may be some consideration on the part of various commercial firms to carry out a further test in order that more complete datum on short wave transmission may be available.

A cable from Greenwich, Connecticut, states that station IBCG had an input of 1 kW having a total of 600 watts in the antenna. The transmitter consists of a master oscillator and three amplifiers, the whole being supplied from a direct current source. This particular transmitter is now being displayed in one of New York City's large show-

## Waves and Wireless

PROFESSOR J. A. FLEMING'S LECTURES AT THE ROYAL INSTITUTION.

PROFESSOR FLEMING recently completed a series of six lectures on "Electric Waves and Wireless Telephony" primarily intended for a juvenile audience, at the Royal Institution. The lectures were throughout crowded with fascinating experiments calculated to raise enthusiasm for the subject in the hearts of even the youngest members of his audience. Professor Fleming commenced the series of lectures with an explanation of waves in other and more readily appreciated mediums such as air and water, before going on to the less tangible explanation of aether waves.

During the last of the series of lectures a demonstration of wireless telephony was given. Music, transmitted from Marconi House, being made to operate a Stentorphone.

In a later issue we hope to give a resumé of these lectures with an account of some of the experiments.



# "Polaris" Patent Action.

**I**N response to requests from our readers we are giving below the abridgements as published in the *Illustrated Official Journal (Patents)*, of patents numbers 13636 and 28413 of 1913, referred to in this action.

13,636. 1913. WIRELESS TELEGRAPHY AND TELEPHONY. MARCONI'S WIRELESS TELEGRAPH Co. and FRANKLIN, C. S., Marconi House, Strand, London. June 12th, 1913.

In a receiving-system in which an ionized gas relay magnifies the received oscillations, the outgoing circuit of the relay reacts on the incoming circuit, so as further to strengthen the current. By this means the damping of the receiving-system

so that the magnified oscillations in the circuit  $f, n, o$  tend to maintain the oscillations in the circuit  $c, l, m$ . Similar circuits can be arranged for tuning to the spark frequency or to the note obtained in a receiver when using the interference method of receiving continuous oscillations.

28,413. 1913. WIRELESS TELEGRAPHY. MARCONI'S WIRELESS TELEGRAPH Co., and ROUND, H. J., Marconi House, Strand, London. December 9th, 1913.

In a receiver for continuous waves having a vacuum tube containing a heated filament  $c$ , a grid  $b$ , and a third electrode  $d$ , an oscillation circuit

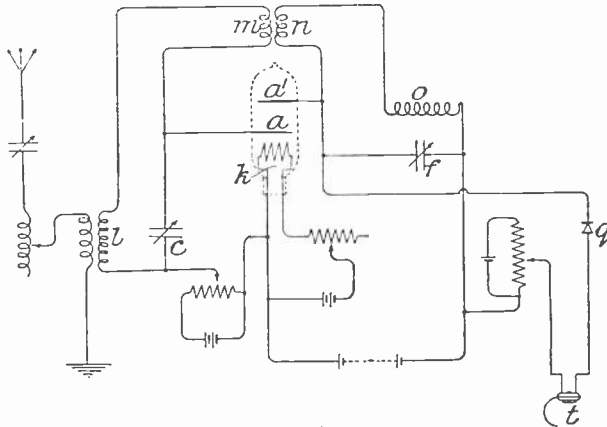

Reproduction of Figure from abridged specification of Patent No. 13,636 of 1913.

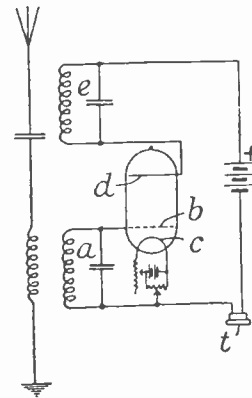

Reproduction of Figure from abridged specification of Patent No. 28,413 of 1913.

is reduced and the tuning of the system is made very sharp. In the system shown, the gas relay has a heated cathode  $k$  covered with an oxide, and a perforated anode  $a$  arranged between the cathode and the main anode  $a'$ . The electrodes  $a, k$  are connected across the oscillation condenser  $c$ , and the electrodes  $a', k$  across a condenser  $f$ , which is connected to a detector  $g$  and telephone  $t$ . The tuned circuits  $c, l, m$  and  $f, n, o$  are coupled

$e$  tuned to a frequency slightly different from that of the received waves is connected across the filament and the third electrode. The oscillations in the circuits  $a, e$  produce beats of audible frequency in the telephone  $t$ . The circuit  $e$  may be arranged to interact with the aerial circuit or with the circuit  $a$ . The grid  $b$  and electrode  $d$  may both be formed as cylinders completely surrounding the heated filament.

## An Inductance Calculator.

**T**HE importance of accurate methods for calculating the inductance of coils for radio circuits, or for designing such coils to have a given inductance, has often been emphasised in these columns. With a view to simplifying such calculations, an inductance calculator was designed some time ago by Mr. Norman Lea, and has recently been put on the market.\* This apparatus

is of slide rule form, but has two sliding scales instead of the one commonly found in ordinary types of calculating slide rules. Four scales in all are provided, marked respectively with (Length/Diameter): Diameter (cms.); Turns per centimetre; and Inductance (microhenries). The first and last of these scales are fixed on the outer parts of the calculator, and the other two are engraved on the two sliders.

\* Inductance Calculator for Air Core Solenoids, evolved from Nagaoka's Formula, by Norman Lea. [Messrs. B. Hesketh (Sole Licensee), High Street, Chalvey, Slough. Celluloid covered cardboard. Price 12/6, post free.]

To calculate the inductance of a coil of which the dimensions are given, it is first necessary to evolve the simple ratio of the (Length/Diameter) of the coil, and then to set an arrow mark on the upper slider against the value of this ratio on the top

scale of the calculator. An arrow on the second slider is then set against the Diameter of the coil as read off on the scale on the first-mentioned slider, and when this has been done the inductance of the coil can be read off on the bottom fixed scale against the value of the turns-per-centimetre-length of the winding as read on the scale on the second slider. Thus setting the position of the two sliders enables the inductance of the coil to be read off at a glance. Similarly, of course, if the inductance is given, suitable dimensions can be obtained by reversing the above processes.

A useful feature of the rule is the marking against certain values of the turns-per-centimetre scale on the second slider, of the gauges of wire which, when double-cotton-covered and wound with turns touching, will give those numbers of turns per centimetre. On the back of the rule corresponding data are given for single and double silk coverings.

On the back of the rule also an abac is given from which values of the product  $LC$  can be read off corresponding to any given wavelength.

The calculator is, of course, only available for single layer solenoids of such dimensions that the thickness of the windings is negligible compared with the diameter of the coil; but it may also be applied to single layer pancake coils by reading the radial depth of the winding as the length of the coil. It may be of interest to note that sample calculations carried out by the writer on this calculator, and also by the more cumbersome method, using logarithm tables, indicates that results accurate within 1 per cent. may easily be obtained from the calculator—which accuracy amply suffices for all ordinary experimental purposes.

PHILIP R. COURSEY.

## Note on the Separate Heterodyne.

By R. C. CLINKER.

**T**HE advantage of using a separate heterodyne in receiving long waves has frequently been pointed out. It enables the receiver to be tuned exactly to the incoming signal instead of being so much mistuned as is necessary when autodyne reception is used. The writer does not remember to have seen pointed out, however, the great amplification which can be obtained by—(1) using critical retroaction on the receiver, together with (2) exceedingly exact tuning. The adjustment is admittedly critical, but the result is somewhat surprising when one tries it for the first time. Call  $S$  the distant station,  $A$  the receiver and  $B$  the separate heterodyne. The procedure is as follows:—

Tune  $A$  as exactly as possible to  $S$  when non-oscillating. Couple  $B$  loosely to  $A$  and adjust  $B$ 's frequency until the beat note of  $S$  and  $B$  gives a convenient pitch. Now slowly increase the retroaction of  $A$  until oscillation just begins. Has the beat note of  $A$  and  $B$  the same pitch as that previously heard between  $S$  and  $B$ ? If not, adjust the tuning of  $A$  until the pitches of these two beat notes are identically the same. This is done by repeatedly (1) stopping  $A$ 's oscillation, (2) re-tuning, and (3) starting oscillation again, until no difference in pitch can be noticed. A best value of coupling between  $A$  and  $B$  will also be found. Now set the retroaction of  $A$  so that oscillation is just about to commence, when it will be found that the signals are greatly amplified. Also the tuning of  $A$  is now far more exact than could be obtained by setting at the "silent point" (which latter is a very blunt point for long wave stations).

The writer tried this method on the occasion of the opening of the Long Island Station of the Radio Corporation of America and found that with

one detector and 3 LF amplifiers the signals could be read anywhere in the house.

Annapolis signals may, by this dodge, be brought out loudly from other jamming stations. It would be interesting to hear if others have noted the effect. It requires exceedingly close adjustment to get the best result.

### D. P. Storage Batteries.

The D. P. Storage Battery Co., Ltd., have sent us a booklet entitled "Storage Battery Working," which they state they will be pleased to send to anyone who is in charge of batteries of their manufacture. The little booklet gives the fullest instructions in the care and maintenance of accumulators.

### "Quest."

It is understood that the call letters used by the *Quest* are GSZV. An enquiry for this information appeared in these columns recently.

### Lectures on Wireless Telegraphy.

At the East London College (University of London), Mile End Road, E. 1, a series of eight lectures are to be given on Tuesday evenings during February and March, at 6 p.m., by Professor W. H. Eccles, D.Sc., F.R.S., and by C. F. Elwell, M.I.E.E., Fellow I.R.E. Professor W. H. Eccles will deal with the subject "The Three-Electrode Valve as a Generator of Electrical Oscillations" in five lectures beginning on Tuesday, February 7th, and continuing on the four following Tuesdays, i.e., 14th, 21st, 28th and March 7th. Mr. C. F. Elwell will then give three lectures on the "Poulsen Arc Converter" on March 14th, 21st and 28th.

A syllabus will be sent on application to the College. The fee for the Course is two guineas. Students attending University Courses at Colleges and Institutions of the University, 10s. 6d.

# Wireless Club Reports

*NOTE.*—Under this heading the Editor will be pleased to give publication to reports of the meetings of Wireless Clubs and Societies. Such reports should be submitted without covering letter in the exact form in which they are to appear and as concise as possible, the Editor reserving the right to edit and curtail the reports if necessary. The Editor will be pleased to consider for publication papers of unusual or special interest read before Societies. An Asterisk denotes affiliation with the Wireless Society of London.

## The City and Guilds Wireless Society.\*

A meeting was held on October 20th, the President, Professor E. Mallett, being in the chair. Mr. H. W. Baker delivered the first part of his lecture on the "Elements of Wireless Telegraphy," commencing from first principles and leading up to the theory of spark transmission. The paper was well illustrated by apparatus and slides, the latter lent by the Marconi Scientific Instrument Company. A good discussion followed, after which the meeting adjourned.

At the meeting on November 3rd, Mr. Baker concluded his lecture with the theory of crystal reception: he showed us a further selection of interesting lantern slides, finally winding up with a demonstration of transmission and reception from one room to another.

On November 17th, Captain W. R. H. Tingey gave us a delightful demonstration of reception of telephony and telegraphy.

Telephony was sent from his station at Hammer-smith and was received with remarkable clearness. The demonstration was not only most interesting and clever, but very instructive, and many useful "tips" were learnt by the 70 persons present. Many questions were asked and knotty problems discussed and solved, after which a hearty vote of thanks ended the evening.

The Society has now erected an aerial of its own, and is busy collecting apparatus, which will be installed at the Imperial College Union.

Hon. Secretary, Mr. L. G. Bolton, City and Guilds Engineering College, South Kensington.

## Burton-on-Trent Wireless Club.\*

Mr. J. L. Berry, F.R.M.S., lectured on "Sidelights on Science" at a meeting of the Club held on December 30th, when Mr. L. G. A. Sims presided over a good attendance.

In describing various instruments of precision, Mr. Berry explained the principle of the micro balance, whereby Sir Wm. Ramsay was able to determine the atomic weights of the radio-active elements. He stated that it was necessary for such a balance to be extremely accurate, because of the very minute quantities of the elements available, and their prohibitive cost. Mr. Berry described Professor Boys' radio-micrometer an exceedingly delicate instrument capable of detecting the heat emitted by a candle flame at a distance of  $3\frac{3}{4}$  miles.

He then gave a very interesting explanation of the electro-Cardiograph, an instrument whose elementary principle lay in the discoveries of Galvani and Volta early in the 18th century.

Mr. Berry also gave a demonstration of how the Sphygmomanometer is used to measure the pressure of blood in the human artery, and how, by its aid, the actual work of the heart may be expressed mathematically. He conjectured that

in the near future it would be possible that electro-Cardiograms might be sent by wireless from distant places for the criticism of a specialist say, in London, and his diagnosis.

Mr. Berry then discoursed on ultra-violet rays, and in conclusion, stated that in the discussion of "Sidelights on Science" he felt sure it would be realised that how great and important was the application of science to everyday life.

An interesting discussion followed, and the meeting was brought to a close with the customary vote of thanks, proposed by Mr. F. V. A. Smith, and seconded by Mr. W. C. Smith.

Mr. F. V. A. Smith called attention to the fact that wireless telephony was now being transmitted nightly at 9 o'clock from Mr. Selby's station (2KC), at 1,000 metres, and he said that if any of the local experimenters were not receiving they should get into touch with Mr. Selby, with a view to discovering defects in their apparatus.

At the next meeting of the Club Mr. C. Randle will give an interesting lecture, the subject of which will be announced later.

## North Middlesex Wireless Club.\*

Hon. Secretary, Mr. E. M. Savage, "Nithsdale," Eversley Park Road, Winchmore Hill, N.21.

The Club held its 82nd meeting on Wednesday, January 11th, at the headquarters. After the minutes had been read, and certain announcements made by the Secretary, the Chairman called on Mr. Geo. Evans to give his lecture on "Workshop Practice."

Mr. Evans said that he thought a better title for his talk, which he refused to call a lecture, would be "Instrument Making on a Kitchen Table." Mr. Evans is a practical instrument maker, and as such is acquainted with modern methods of mass production, and throughout his talk he contrasted the methods used in factories with those which could be used by the amateur working at home. The most important point to bear in mind, said Mr. Evans, was thoroughness. Even if it was only a small article of quite a simple nature, make a sketch of it before starting work. He also told his audience not to think that a lot of elaborate tools were required in order to turn out good work. If the simple tools were used to the best advantage any amateur could turn out work of which he could be proud. For instance, in working ebony, a Morse drill was not necessary: an ordinary French nail could be made into an excellent drill, and the lecturer showed how to do this. He instanced that the old fashioned instrument makers turned out the most excellent work with the most simple tools: three-jaw chucks were unknown to them, they used box-wood chucks.

Mr. Evans showed how to mark out work with a pair of dividers, taking as an example a ten-point switch. After marking it out on the back, so as not to spoil the face of the ebonite base, he showed how to use a template to ensure accuracy in drilling. He then explained how to finish the surface, but as this was a long process, time would not allow of a complete demonstration. Throughout his talk, Mr. Evans gave a number of hints and tips such as the correct way to tear emery paper, how to put it round a file, how to fix the base to the table when working it, and many others.

It was clear that the members will look forward to Mr. Evans's next talk on "Kitchen Table Instrument Making," when they hope to learn some more. A vote of thanks proposed by the President was carried with enthusiasm.

#### **The Cardiff & South Wales Wireless Society.\***

Hon. Secretary, Mr. P. O. Sullivan, 16, Adams-down Square, Cardiff.

A General Meeting was held at headquarters, The Wireless College, St. Mary Street, Cardiff, on Thursday, November 24th, 1921. Captain W. Harwood Moon occupied the chair. The minutes of the last meeting were read and adopted. The Chairman then invited all present to adjourn to the Instrument Room, where an exhibition of apparatus was to be held. At this stage, the Secretary took the chair. Messrs. H. C. Linck, A. Lawrence, W. E. Groves, J. G. Proger, and Capt. W. Harwood Moon all contributed to a very interesting and instructive evening. A hearty vote of thanks having been accorded to the exhibitors, Mr. N. M. Drysdale treated the audience to a sensational and awe-inspiring demonstration of high-frequency phenomena, passing hundreds of thousands of volts through his person.

At the meeting on December 8th, 1921, the Chairman, Mr. N. M. Drysdale, called upon Mr. H. F. A. Sanderson, who, in a very able manner, dealt with the subject, "Description of a Home-made Receiver, using 1-4 valves." The lecturer commenced by describing the particular aerial used at his station, pointing out the advantages and disadvantages of various materials employed in the erection of an aerial—his experience having proved that enamelled wire is much more efficient than the ordinary bare wire used most frequently by amateurs. The lead-in and "earth" were next dealt with, after which the construction of the set was fully explained. With the aid of a diagram on the blackboard, Mr. Sanderson described the wiring of the set, and the function of the various switches employed, when only one or all the valves are used. At this stage many questions were asked, and very clearly answered. The lecturer then demonstrated the set under working conditions. A great deal of interference was caused by the working of an electrical sign next door to headquarters, the noise set up being almost deafening. Mr. N. M. Drysdale carried out many experiments in the hope of neutralising the inductive effect of the sign. At this stage the sign ceased operating and Mr. Sanderson was able to proceed with the demonstration. He picked up the Dutch Concert, and with the aid of a "Weston Loud Speaker," music and speech was clearly audible

to everyone present. A most hearty vote of thanks was unanimously accorded to Mr. Sanderson.

At the meeting held at headquarters on Thursday, December 22nd, 1921, Mr. N. M. Drysdale delivered a lecture entitled, "Elementary Principles of the Thermionic Valve." As certain features of the thermionic valve are also found in the old crystal rectifiers, the lecturer first dealt with early types of receiving apparatus. He showed how the famous Marconi Coherer set was evolved and then gradually developed the subject until the crystal set was clearly understood by all. Types of waves, properties of crystals, curves, all were ably explained.

The action of the valve was dealt with; how the heated filament gave off negative electrons and what the electron consisted of; the function of the grid, how it behaved when charged with an ether wave, and its effect on the plate circuit. The action of the grid condenser and leak followed and then a typical circuit was drawn on the blackboard and explained clearly. As the hour was by this time late, the lecturer had to cut short his discourse and the members showed their appreciation of Mr. Drysdale's capable method of treating the subject by expressing the hope that he would continue the subject when convenient. Before leaving we were privileged to listen on a De Forest amplifier set, which was remarkably silent in action and gave excellent signals.

Will all members and friends willing to assist by giving lectures, demonstrations, etc., please communicate with the Hon. Secretary.

#### **Croydon Wireless and Physical Society.\***

A meeting of the Croydon Wireless and Physical Society was held at the Central Polytechnic, Scarbrook Hill, Croydon, on Saturday, January 7th, 1922.

Mr. F. G. Reynolds was called upon to deliver his lecture on "Colour Experiments with Polarised Light." To illustrate his lecture, Mr. Reynolds showed a great number of slides of his own construction, the colour effects of which, when showed on the screen, were very attractive. At the conclusion, the Chairman moved a very hearty vote of thanks to Mr. Reynolds which was accorded by the audience. The vote of thanks and appreciation was carried unanimously.

Arrangements are being made for the Society to pay a visit to The Croydon Aerodrome Wireless Station. Particulars will be announced later.

The Hon. Treasurer will be glad to receive subscriptions for the year 1922.

Hon. Secretary, Mr. B. Clapp, Meadmoor, Brighton Road, Purley.

#### **Wireless and Experimental Association.\***

The meeting of the Association on Wednesday January 4th, was mainly occupied in the consideration of Messrs. Marconi's circular letter re "Polaris" apparatus.

A meeting was held at the Central Hall, Peckham, on Wednesday, January 11th, when the Society had the pleasure of hearing their member, Mr. A. E. Greenslade, relate how he received the American Amateur Wireless Signals across the Atlantic in the recent tests. He was spurred on to his ultimately successful exertions by an article which appeared in an American journal, after the failure of last year,

## WIRELESS CLUB REPORTS

and which stated with true American self-restraint and modesty the belief that it would not be till a "good American amateur" brought his gear over here that the signals would be received and backed his opinion by staking his "new spring hat." There is no record whether the aforesaid hat is a tin one, but at any rate it is forfeit to Mr. Greenslade. The good American amateur who came over for the purpose, Mr. Godley, got what he came for, but he went to bare and bonnie Scotland to get it and upon the sloping shores of Ardrossan, with a directive 850 feet of aerial pointing to the heart of America, he got his heart's desire, and went to bed every morning with the consciousness of having a good log. Mr. Greenslade, with our English standard 140 feet of aerial pointing N.N.W. S.S.E., got the signals, closed down his station, arrived home at 6 a.m., ready to begin his usual day's work at 9 a.m., and he kept it up for ten days, December 7th to 14th. Is it any wonder that one of the entries in his log reads, "close down for the night, feeling queer."

At 3 a.m. on December 11th, however, he had his reward. 1 BCG called up England with his more or less kilowatt and called GODLEY. The derided British apparatus had been equal to the occasion without the fortuitous aid of another 700 feet of aerial: and in London, where Mr. Greenslade picks up his living, he picked up the signals so many of us fain would have read. From 3 a.m. to 5 a.m. he continued to get the signals, fading away occasionally and more often being jammed out of existence by powerful commercial stations. Five closely-typed pages of his log testify to the receipt of the messages and the din through which he had to work. The next night also he got messages but the jamming became so bad that on this occasion he had to give up much earlier. For two hours our members listened spellbound to the racy discourse, making light of troubles in the joy of achievement, and if we didn't get the Americans ourselves, it was the next best thing that a Britisher did and that that Britisher was one of our own members.

A hearty vote of congratulation and thanks was moved by the Chairman and seconded by the Secretary and carried with acclamation, and Mr. Greenslade modestly and suitably replied.

Further correspondence with Messrs. Marconi referring to their recent "Polaris" circular was read, and seven new members were enrolled.

### Bradford Wireless Society.\*

Hon. Secretary, Mr. J. Bever, 85, Enum Lane, Bradford.

A meeting was held in the Club Room at 7-45 p.m. on January 13th, with Mr. W. C. Ramshaw in the chair. The minutes of the previous meeting were read and passed as correct, following which four new members were elected.

Mr. Ramshaw then vacated the chair, which was taken by Mr. A. Bever, who called upon Mr. Ramshaw to open the debate on "Low Frequency v. High Frequency Amplification." This debate was very keenly followed by those present. Mr. Ramshaw explained the advantages and disadvantages of the low-frequency method, and the high-frequency was championed by Mr. J. Bever,

in a very able manner. Mr. Liardet, who followed, took the middle course and championed the judicious use of both types of amplification, and most of those present took this view. At the conclusion of the debate, a hearty vote of thanks was passed to the various gentlemen concerned. The meeting was then declared open to general discussion.

### Dartford and District Wireless Society.\*

The members of the above Society held their usual meeting on Friday, January 13th, 1922, at Dartford Grammar School, Mr. J. R. Smith, A.M.I.E.E., Vice-President, in the chair.

The minutes of the previous meeting were read and confirmed and the Hon. Secretary read a letter received from the Marconi Co., appertaining to the use of the "Polaris" receiving sets.

After discussing various business items, the Vice-President called on Mr. W. L. McPherson, B.Sc., of the Woolwich Radio Society, to present his paper on "Continuous Wave Systems."

Mr. W. L. McPherson, B.Sc., had very kindly come over in response to a request by the Hon. Secretary to the Woolwich Radio Club, and we were very pleased to welcome a few members of that Society, including their Hon. Secretary, Mr. South.

The lecture dealt very exclusively with the various systems of transmitting C.W., each system being very lucidly explained. A few remarks were also given with regard to reception.

A hearty vote of thanks was proposed to Mr. McPherson, B.Sc., by the Vice-President, seconded by the Hon. Secretary, who remarked on the members' appreciation of the Woolwich Radio Society's paternal interest.

Hon. Secretary and Treasurer, Mr. E. C. Deavin, 84, Hawley Road, Wilmington, Dartford.

### The Leeds and District Amateur Wireless Society.\*

Hon. Secretary, Mr. D. E. Pettigrew, 37, Mextonborough Avenue, Chapletown Road, Leeds.

A General Meeting of the Society was held on January 13th, at 7 p.m., at the headquarters (Leeds University). Mr. J. O'Donohoe officiated at the buzzer class held for junior members until 8 p.m., when Mr. G. P. Kendall, B.Sc. (Vice-President), took the chair. The Chairman called upon Mr. A. M. Bage (Vice-President) to deliver his paper on "The Turner Trigger Relay and Recording Apparatus." The Society had looked forward to this lecture with pleasant anticipation and Mr. Bage had a large and eager audience. The lecturer briefly outlined the work that had been done with Turner valve relays, and then very thoroughly expounded on the theory of the action of the valve relay, putting forward some of his own ideas, which, as the discussion afterwards showed, were very feasible suggestions. Mr. Bage described the essential difference between polarised and unpolarised magnetic relays, and illustrated by means of very clear diagrams how the magnetic or P.O. relay controlled the oscillations in the Turner valve relay circuits. He explained the necessity of an "uprighting" magnetic relay, after the action of the P.O. relay had been described, and went on to describe the printer. Meanwhile specimen tape

records, printed with the apparatus described, were passed round amongst the audience, and were examined with great interest. Mr. Bage concluded his paper, after treating many practical points concerning the apparatus he had on view, and convinced the meeting that plenty of use can be made of old alarm clocks and snuff boxes by any amateur mechanically inclined. Mr. Bage's outfit was almost entirely home-made—to quote from the paper, “out of various junk.” The Chairman then declared the discussion on the lecture open. This was heartily joined into by many of the members present, and led up to some very interesting points in value theory. The discussion gradually approached an argument and eventually Mr. Bage proved to the meeting that theory was not everything. His apparatus worked, and worked very well!

A hearty vote of thanks was accorded to Mr. Bage, and the proceedings officially came to an end. However, the audience had been so worked-up that it took some time to persuade those present that there would not be “an all-night sitting.”

All particulars regarding the Society may be had from the Hon. Secretary. The annual subscription is five shillings, and meetings are held bi-monthly.

#### Manchester Wireless Society.\*

On Thursday, December 29th, Mr. J. McKernan (Chairman) delivered a lecture on “Selenium Cells, their Construction, Care and Application.”

The chair was taken by Mr. T. Maguire, Vice-Chairman of the Society, at 8 p.m. After expressing satisfaction at the attendance of the meeting, Mr. Maguire called upon the lecturer to proceed with his subject.

Mr. McKernan opened his discourse by announcing the fact that in many ways Selenium was closely allied to several crystals, mentioning Carborundum as a case in point. The reason for this was that, in the case of a crystal, a change of resistance was brought about by the passage of a high frequency current. In the case of Selenium, a similar function was performed by the means of light rays. The discovery of Selenium was made by a Swede in 1817, and was extracted from the residual mixture, or mud, at the bottom of the leaden mugs used in the manufacture of sulphuric acid. It has also been found in various ores, and in isolated cases pure Selenium has been discovered in the earth. There are three kinds, namely, amorphous, vitreous and metallic. The first kind is of a brick red colour and is soluble in sulphuric acid: the S.G. is 4.26, and at a temperature between 80 to 100 C. is an insulator. The vitreous kind is obtained by heating the amorphous Selenium to a temperature of 200 C. and then cooling off very quickly. By this process the S.G. is increased two points (4.28) and presents a bright shiny surface. The metallic formation is brought about by heating the vitreous substance to a temperature of 210 C. and then allowing it to cool off gradually to 150 degrees C. It has now changed from a red to a black colour, and possesses the same characteristics as metal, though of a very high resistance. The S.G. of this is now 7.7, and is the kind that is used in the making up of Selenium Cells. It is sold at the rate of 3s. 6d. per oz.

To make a cell the following procedure is recommended. Obtain a piece of mica about 2 inches by 1½ inches and wind it with two helices of bare copper wire 28 S.W.G. The coils should be spaced about 1/32nd apart. The Selenium, which is supplied in the form of a stick or pencil, should then be heated over a bunsen to a temperature of about 160 degrees C., at which point it is sufficiently pliable to admit of it being smeared over the helix. It should be spread out in as thin a layer as possible in view of the fact that light will only penetrate to a depth of 1/5,000th part of an inch, therefore, a thick layer is simply a waste of metal. When the interstices between the turns have been filled in, the temperature should be steadily increased to 217 degrees, during which time the Selenium changes from a dull greyish colour to a black. Upon reaching 217 degrees the temperature should be gradually reduced to 200 degrees at which point it should be kept for about two or three hours. After allowing the substance to cool off naturally, the cell should be tested for resistance, the optimum ratio being about 10 to 1 for this type of cell, that is, the “dark” resistance should be ten times that of the “light.” (A special type of Selenium Cell, the “Fritz,” has been known to possess a ratio of 337 to 1, which is an exceedingly high efficiency.) Using one end of each helix for connecting, the cell is now ready for use, and should not be allowed to remain uncovered in a strong light, and should be kept in a cool place. Regarding the uses to which Selenium can be applied, the chief are in connection with the following:—1. Photometry: 2. Control of light buoys: 3. Burglar alarms: 4. Registering the intensity of sun and starlight: 5. Amusement purposes, such as mechanical dolls, motor cars and other models, a very good specimen being that “Electric Dog,” used by the Americans. It is also possible that they may be used for generating current, inasmuch, that a Selenium Cell, connected in series with a galvanometer, without any local battery, has been known to cause a deflection on being subjected to strong rays of light, thus proving that electricity is generated by the change of resistance or temperature. Therein lies the secret of the so-called “Solar energy!” By exposing a large number of these cells to a strong light simultaneously, it may be possible to store the energy, thus released, into some kind of storage battery. This and other numerous experiments could be carried out with a view to finding the possibilities of this, as yet, little known or used, instrument. Another peculiarity is that, if a coloured screen is placed before the cell, it will not register any appreciable change unless a light of a similar colour to the screen is used, that is, in order to work a cell screened by a sheet of red glass, a red beam of light must be thrown upon it. Still another peculiarity lies in the fact that when using the cells in conjunction with a relay, the latter is practically unworkable, if bichromate cells are used, a little better if Leclanche cells are used, and optimum if ordinary cells are used. These and other phenomena require research, and it is up to the amateur to try a few experiments in order to further the interests of science.

## WIRELESS CLUB REPORTS

This concluded Mr. McKernan's lecture after which he invited questions, and quite a lively discussion followed, testifying to the interest which he had aroused among his audience.

In proposing a hearty vote of thanks Mr. Maguire hoped that some of the members would try a few experiments with Selenium so that they could give their experiences before the Society at some future date.

Mr. Evans seconded the proposal and admitted that he was tempted to drop wireless for a time and plunge into the mysteries of Selenium. Certainly he would attempt the construction of at least one cell on the lines drawn up by Mr. McKernan.

The members immediately showed their appreciation of the interesting lecture by generous applause, after which the meeting was closed.

A whist drive and dance was held in the Marble Hall, Albion Hotel, on Saturday, January 21st. Several of the items included dance music by Wireless Telephone. Hon. Secretary, Mr. Y. W. P. Evans, 7, Clitheroe Road, Longsight, Manchester.

### Liverpool Wireless Association.

The Annual Meeting of the above Society was held at the Royal Institution, Colquhoun Street, at 8 p.m., January 11th, 1922.

After the adoption of the accounts which showed the satisfactory balance of £18 the meeting proceeded to the election of officers for the ensuing year.

Professor Marchant was re-elected President, with Dr. Richardson as Vice-President. Mr. James K. Wilkie was elected Secretary in place of Mr. J. Coulton, whose resignation was accepted with great regret on the part of all the members.

Mr. Wainwright was re-elected Treasurer.

The meeting then adjourned for an hour on the invitation of the President of the Liverpool Engineering Society through Mr. Marchant to hear Commander Slee of the Marconi Company lecture on the Marconi Distress Calling Device which was accompanied by practical demonstrations such as working the alarm bell when two stations were working in close proximity to the calling station. This lecture and demonstration was much appreciated by the members.

After the adjournment the Wireless Association had a discussion as to the desirability of making the Society more popular and better known to the members in the district of whom there are a large number. It was decided therefore to appeal to all amateurs, whether members of the Society or not, to come and hold an open meeting at the Royal Institution on Wednesday, February 8th, at which it is the earnest hope of the Committee that every amateur in the district will endeavour to attend and if possible express his views so that the Society may be in a position to know what is required of it and be representative in every respect.

The following gentlemen were nominated and duly elected members of the Committee:—

Mr. N. B. B. Hyde, Mr. S. A. Keary, Mr. E. B. Grindwel, Mr. J. Coulton, Mr. W. Balmer, Mr. E. G. Bush, Mr. J. M. Lamb.

Mr. Hyde was elected Engineer and Technical Adviser.

We now wish to make the Society a real live thing in Liverpool, and cannot emphasise too strongly the need of every amateur showing his interest in this respect and turning up and giving us his support and his views on how to be successful.

If possible the Hon. Secretary would appreciate a note to say that you are attending and especially if you wish to speak so as to arrange a suitable order for all speakers.

All communications should be sent to the Hon. Secretary, Mr. James K. Wilkie, Avondale, Knowsley Road, Cressington Park, Liverpool.

### The Hartlepoons and District Wireless Society.

Hon. Secretary, Mr. R. L. Howey, 33, Grange Road, West Hartlepool.

The above Society has been gaining in interest and increasing in membership during the last few weeks. Captain Perry, one of the members, has kindly given the Society the use of a splendid room at 11, Church Street. We also have full permission to use Captain Perry's aerial.

There was a good attendance at the first meeting in the New Year, which was held on January 10th, Mr. Morris in the chair. After the minutes of the previous meeting had been read and confirmed, the Chairman called upon Mr. Alton to read his paper on "Accumulators." This proved to be a very interesting paper, and after several questions had been asked and answered, a hearty vote of thanks was passed to Mr. Alton.

The Society's library has been formed, and Mr. Wylam, the librarian, will be pleased if members can give or loan books on wireless or electricity in general.

The Society meets every Tuesday at 7.30 p.m., the first half-hour being devoted to the all-important buzzer practice.

The business meetings are held on the first Tuesday in the month.

The Secretary will be pleased to furnish full particulars to any gentlemen interested in the Society.

### Cambridge and District Wireless Society.\*

The New Year's session opened with a joint meeting of the Cambridge Photographic Club and the Cambridge Wireless Society, in the lecture room of the former Club, Ram Yard, Cambridge, on Tuesday evening, January 10th, when there was a very large attendance.

Mr. Winship, who presided, briefly introduced Mr. W. S. Farren, Chairman of the Wireless Society, and the latter proceeded to give an outline of the progress of wireless telegraphy. He explained the details of the apparatus in use previous to the war and showed the developments that had taken place during and since the war, one of the chief developments being the invention of the thermionic valve, which was largely due to the research work of Professor Sir J. J. Thomson (Master of Trinity College, Cambridge) and Professor J. A. Fleming. Mr. Farren then showed a series of lantern slides, illustrating various types of wireless installations, ranging from those of amateur members of the Cambridge Wireless Society, to the



very large commercial stations in various countries of the world. The members of the Wireless Society exhibited many pieces of apparatus for the purposes of the demonstration, and the uses of the various instruments were fully explained by the lecturer. A set had been previously arranged, comprising a three-valve H.F. amplifier, Brown relay and loud speaker, and signals from various continental stations were heard by everyone present. Arrangements had been made, through the kindness of Mr. Crampton, of the Wireless Society of London, with Mr. Burnham, also of that Society, to transmit telephony during the evening, gramophone selections being received quite distinctly on the head telephones. Mr. Crampton, who was present, connected up a Mark III amplifier and the telephony from Mr. Burnham was received on this set. Special mention is due to Mr. Farren for the great amount of work he did in regard to the assembling of the apparatus, and it was chiefly due to his efforts that a successful evening was enjoyed by so many. A hearty vote of thanks to Mr. Farren, Mr. Crampton, Mr. Burnham and members of the Wireless Society, was proposed by Mr. F. J. Strakley, F.C.S., and carried with acclamation.

The next meeting will be held in the Club Room, Ram Yard, when a lecture by Mr. T. W. Wormell, M.A., will be given, the subject being, "The Chemistry of Cells."

All communications should be addressed to the Hon. Secretary, Mr. J. J. Butterfield, 107, King Street, Cambridge.

#### The Kensington Wireless Society.

Hon. Secretary, Mr. W. J. Henderson, 2, Holly-wood Road, S.W.10.

The First Annual General Meeting was held at 2, Penywern Road, Earl's Court, on January 5th, at 8.30 p.m.

The balance sheet for 1921, showing a satisfactory amount in hand, was approved, and the election of officers for the ensuing year resulted as follows:—

President, Capt. H. de A. Donisthorpe; Chairman, Dr. A. Gordon Wilson; Hon. Secretary and Treasurer, Mr. W. J. Henderson; Committee, Messrs. M. Child, A. S. Hawthorne, J. Murchie and J. H. Reeves.

It was decided that meetings should in future be held on the first Thursday in the month, and that the annual subscription be reduced to 10s. 6d. for ordinary members and 3s. for student members.

An attractive programme is being arranged for this year, commencing with a lantern lecture by Capt. Donisthorpe, and including several "outings," whilst other interesting lectures and demonstrations have been promised.

New members will be welcomed, and all enquiries will be gladly answered by the Hon. Secretary.

#### Redhill and District Y.M.C.A. Wireless Society.

A meeting of the above Society was held on the 4th inst., when Mr. A. P. Fletcher gave an interesting lecture on the "Principles of Wireless Telegraphy," which was greatly appreciated by those present. After this he gave a description of a receiving set which he thought would be suitable for Club use. It was decided to apply at once for permission to

instal receiving apparatus at the Y.M.C.A. When this is granted, a set will be put into operation for the use of members. This will greatly add to the interest of the proceedings. Four new members were elected.

An interesting meeting took place at the Y.M.C.A. on Wednesday, 11th, when Mr. J. S. B. Clarke gave a lecture on "Elementary Electricity and Magnetism." The lecturer dealt with the subject by explaining the electron theory and with the aid of diagrams succeeded in making clear the various phenomena, after which questions were invited and answered. A Sub-Committee was appointed to deal with the erection of an aerial and receiving apparatus.

There are still a number of amateurs in this district who have not yet come forward. The advantages of so doing are obvious.

I should like to point out that any person of either sex, whether having previous knowledge of the subject or not, providing they are interested, are eligible for membership. Full particulars may be obtained from the Hon. Secretary, Mr. F. Howell, 111, Station Road, Redhill, Surrey.

#### The Lowestoft and District Wireless Society.

On November 1st, an interesting lecture was given by Mr. H. C. Trent, on "Valves," the lecturer illustrating his subject with numerous diagrams, etc., on the blackboard. A very instructive and interesting evening was concluded with a vote of thanks from the Chairman.

A good muster of members assembled on Saturday afternoon, November 19th, to erect a new mast and aerial and to carry out various work in connection with the club room.

On November 22nd, Mr. B. G. Searle, being in charge of experiments, a three-valve L.F. receiver was set up, with indoor aerial, in an adjoining building, and another in the club room, to demonstrate to what extent radiation affects another set in the vicinity; after various experiments had been carried out, a microphone was included in one set for transmission of speech, but the time being short, further experiments in this connection could not be carried out.

On December 6th, a lecture and demonstration on "Soldering and Joining Metals," was given by Mr. L. Burcham. The first part of the evening was taken up by a sale of surplus gear of members' installing new gear.

On December 20th, Mr. H. C. Trent gave another highly interesting evening on "The Valve as an Amplifier of Small Noises." A carbon pencil microphone being connected to A and E of a converted Mark III to a two-valve set, and watches of various makes being placed on the table close to the microphone, the ticking of the watches, in some cases inaudible, became loud enough for all present to hear through a loud speaker. The evening concluded with members listening to the Dutch Concert—PCGG.

Full particulars can be had of the Society to all interested from the Hon. Secretary, Mr. L. Burcham, "Gouzeacourt," Chestnut Avenue, Oulton Broad.

## WIRELESS CLUB REPORTS

### Loughborough College Wireless Society.

Further to the report of the above Society on page 550 of *The Wireless World* dated November 26th, 1921, it is desired to state that in the report "the College transmitters to work on 1,000 metres wavelength for communication purposes," etc., this should read: "the College transmitters to work on a wavelength of 1,000 metres for *experimental* communication purposes," etc.

This correction also applies in the case of the portable transmitters.

The College Wireless Society are using the apparatus for carrying out experiments on behalf and under the control of the College authorities as per the conditions of the permit.

### Sheffield and District Wireless Society.\*

Hon. Secretary, Mr. L. H. Crowther, A.M.I.E.E., 156, Meadow Head, Norton Woodseats, Sheffield.

On January 6th, our Annual Exhibition and Sale of Wireless Apparatus was held at the Department of Applied Science, George Square, Sheffield.

In addition to apparatus made and exhibited by members of the Society, our energetic Secretary, Mr. L. H. Crowther, arranged for a supply of apparatus and stores from Messrs. L. McMichael and H. W. Sullivan, London.

The good work of the members was so much appreciated that practically all of their exhibits were quickly sold at good prices.

The apparatus of Messrs. McMichael and Sullivan roused considerable interest and afforded members a valuable opportunity of examining the actual apparatus so extensively advertised in *The Wireless World*. This method of enabling provincial wireless experimenters an opportunity of seeing the best types of apparatus is highly appreciated. In this case a considerable number of purchases were made, and it is expected many more will follow.

On January 13th, the presidential address was given by Mr. E. H. Crapper, M.Eng., M.I.E.E., the subject being "Wireless Engineering" or "Radio Communication." He referred briefly to the electrical discoveries of Oersted, Faraday, Maxwell, Hertz and Marconi, showing that there was a rapid decrease in the time between each great achievement varying from 100 years to five years, and that this would probably still further decrease.

A brief survey was made of the development of Radio communication. The wonders of the thermionic valve, which can be used for transmitting, receiving, rectifying and amplifying wireless signals, made us hopeful that we were on the eve of still greater discoveries.

Lantern slides were used to show the lay out of the great American Radio Station at New York which within a compass of 10 square miles is to have 12 stations communicating direct with every continent in the world.

### Wimbledon and District Wireless Society.

A meeting of the above Society was held on January 14th, 1922, at the Wimbledon Technical Institute, under the Chairmanship of Mr. H. Nutton, A.M.I.E.E., when Mr. R. J. Hibberd, of Grayswood School, Haslemere, Surrey, read a paper entitled, "The Educational Value of Wireless." Mr. Hib-

berd, during the course of his paper, pointed out that the late war had shown the great necessity for the teaching of some form of science in public elementary schools. The most prominent branch of science was electricity, and it was essential that every boy and girl should have some knowledge of it when leaving school.

Electricity and magnetism in some attractive form should be included as one of the essential subjects in every school curriculum. But the knowledge should be imparted in some interesting and attractive style, other than the usual "dry as dust" text book style. This object can be obtained through the medium of wireless telegraphy and telephony. The theory and practice of wireless comprises the application of all the known principles of electricity and magnetism, and from actual experience in teaching the subject shows that it arouses great interest among the pupils. The reception of signals by Morse code and the picking up of signals from various stations throughout the world cultivates concentration of a high order.

The study of wireless when correlated with other school subjects such as physical and political geography, arithmetic, Mathematics, Manual Training and languages is of great value.

Its value as a science lesson is obvious, having in view the fact that present day wireless is effected by the use of the thermionic valve, the action of which is based upon the electron theory. There is no better field for research work than this branch of science in which great discoveries are imminent.

A number of members of the teaching fraternity of Surrey were present at the invitation of the Society, and in the discussion which followed the conclusion of the paper it was obvious that the guests of the Society did not accept the lecturer's views. A great deal of adverse criticism was an outstanding feature of the discussion.

Captain W. R. H. Tingey conducted the demonstration for the lecturer, and during the course of the evening music by wireless telephony was audible all over the hall.

A vote of thanks proposed by Mr. Garner and seconded by Mr. R. E. Miller was duly accorded, and the proceedings terminated.

Hon. Secretary, Mr. Wm. Geo. Marshall, 48, Warren Road, Merton, S.W.19.

### The Newbury and District Wireless Club.

Since its formation in October, the Club has made very good progress.

The membership has increased from 12 to 30 in three months, and shows every promise of growing still larger.

Now that the ground work has been overcome the members look forward to having interesting meetings. Several evenings have been booked up for the present quarter, on which papers are to be read and demonstrations will take place. The Club is fortunate in having erected a 60 ft. mast which supports a single wire aerial.

At a meeting on Thursday, January 12th, the President, Capt. F. White, gave a most interesting demonstration with a seven-valve R.A.F. amplifier, a Mark II C.W. set, and a German short-wave tuner. This was followed by a closer examination

of the sets, the points of interest being clearly explained by Captain White.

Hon. Secretary, Mr. E. B. Turner, 86, Northbrook Street, Newbury.

**Scarborough and District Wireless Club.**

In connection with the recently organised Scarborough and District Wireless Club a public meeting was held in Barclays' Bank Chambers on Friday evening, and was very well attended, an enthusiastic gathering being representative of Scarborough and the country districts round about. Commander Colclough was in the chair.

The aims and objects of the Club were thoroughly discussed and the rule which had been drawn up at a previous meeting were approved.

A club-room has been obtained and apparatus and furniture has been freely promised. Judging by the number of keen members present the success of the Club in the future is assured.

A party is to commence fixing the receiving

instrument, permission for which has already been obtained from the Postmaster-General.

Lectures, competitions, and exhibitions of wireless material were promised, and it has been arranged to hold buzzer practices.

A Club library is to be formed, and the subscription has been fixed at 10s. per annum.

Mr. H. Frain, School House, Snainton, is the Hon. Secretary, and Mr. Hugh Gardiner, Hon. Treasurer. Anyone interested in wireless is asked to communicate with the Secretary.

The Committee which has been appointed is as follows:—Messrs. W. Thompson, A. Cooper, F. Greathead, W. Rymer, G. Blaney, R. D. Caddy, and the Rev. C. M. Barker. The Vice-Presidents of the Club are Mr. M. Spiegelhalter (Malton), Councillor Crawford, Mr. A. H. Robinson (Ayton), Mr. F. C. Gardiner, and Mr. R. D. Caddy. Commander Colclough has been appointed acting Chairman.

## A "Wireless" Slide Rule.

By B. HODGSON, Ph.D., M.Sc. and S. BRYDON, D.Sc.

**D**URING work involving the very frequent solution of the equation

$$\lambda = K \sqrt{LC}$$

where  $\lambda$  = wavelength.

$L$  = self-inductance.

$C$  = capacity.

$K$  = a constant depending upon the units used.

it was found that the appliances in use led to frequent errors on the part of inexperienced workers, and a device was sought that would enable a quick solution to be obtained with a fair degree of accuracy. The slide rules already on the market involved often some mental arithmetic operation, in addition to the setting of the instrument, and plotted curves or tables of  $LC$  values were slow and cumbersome in application.

The slide rule to be described was found to give no trouble in use, and by including in its ranges practically all values of self-inductance and capacity in common use, mental arithmetical corrections are avoided.

divisions 0.00001 microfarad and 0.1 microfarad. The use of the red indexes will be described later.

The left-hand black index is used with the upper wavelength scale, *i.e.*, 6 to 600 metres, whilst the right-hand black index is used in conjunction with the lower scale, 600 to 60,000 metres.

This movement of the index from one end of the scale to the other in effect doubles the length of the wavelength scale without making the slide-rule unnecessarily large.

The red indexes are used when the unit of inductance is changed from microfarads to jars. (The jar is a unit used most in the Royal Navy, 900 jars being one microfarad.) The scale is graduated as if 1,000 jars were equal to one microfarad, and thus a second graduation is avoided. To yield the right wavelength, the red index is used and this index is displaced just the right amount to correct for this utilisation of the microfarad scale.

The method of using is extremely simple. The red or black arrow is set to the inductance in question and the wavelength, which coincides with the capacity in question, is read off directly on its appropriate scale.

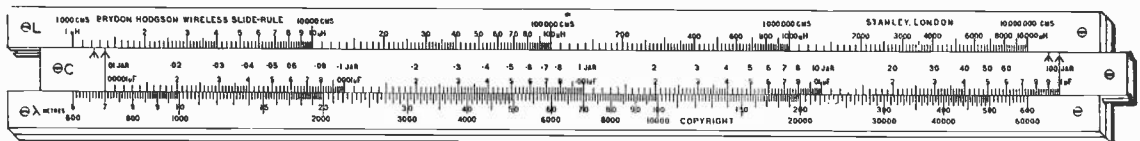

The self-inductance range is from 1 to 10,000 microhenries, the capacity range from 0.00001 to 0.1 microfarads, and the wavelength range from 6 to 60,000 metres—in two parts, *viz.*, 6 to 600 metres and 600 to 60,000 metres.

The slide rule is shown in Fig. 1, where it will be seen that there are four index arrows, two of which are red and two black, on the rule itself, the black indexes coinciding with the capacity

Although the inductance scale extends only between 1 and 10,000  $\mu H$ , it will be seen that the 100,000  $\mu H$  setting with right-hand index can be obtained by setting the left-hand index to 10  $\mu H$  and the rule then used as if it were thus extended; and a good range of wavelengths and capacities can still be read direct.

Other possibilities appear as the instrument is used.

# Questions and Answers

**NOTE.**—This section of the magazine is placed at the disposal of all readers who wish to receive advice and information on matters pertaining to both the technical and non-technical sides of wireless work. Readers should comply with the following rules.—(1) Each question should be numbered and written on a separate sheet on one side of the paper only. (2) Queries should be clear and concise. (3) Before sending in their questions readers are advised to search recent numbers to see whether the same queries have not been dealt with before. (4) **The Editor cannot undertake to reply to queries by post.** (5) All queries must be accompanied by the full name and address of the sender, which is for reference, not for publication. Queries will be answered under the initials and town of the correspondent, or, if so desired, under a "nom de plume." (6) **Readers desirous of knowing the conditions of service, etc., for wireless operators will save time by writing direct to the various firms employing operators.** (7) Four questions is the maximum which will be accepted at a time.

**G.R.H. (Elland)** asks (1) If having intervalve transformers near a valve will affect its working. (2) How to add a single valve H.F. amplifying unit to his set. (3) Suggestions for improving a set sketched. (4) If he should be able to get PCGG.

(1) An effect of this nature can be obtained but you are unlikely to get it unless your transformers are exceptionally leaky, and exceptionally near the valves.

(2) See diagram Fig. 1.

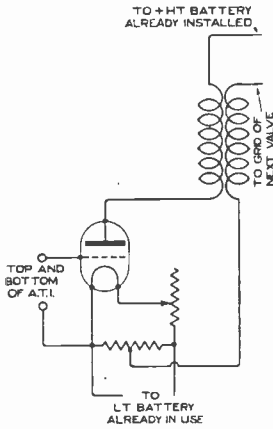

Fig. 1.

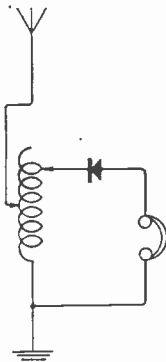

Fig. 2.

(3) We seem to remember giving this circuit about three months ago. It is quite all right as it stands.

(4) Probably not well without further H.F. amplification.

**A.M. (Cambridge)** asks whether a given circuit is correct, and if not, for the correct connections.

The circuit is correct as it stands if the lower slider is omitted. If two sliders are used, which is somewhat better, the connections should be as in Fig. 2.

**F.H.M. (Bexhill)** asks (1) For windings for certain coils for a telephone transmitter. (2) How to insert telephones to hear his own transmission.

(1) The suggested circuit is incorrect. Of the many possible alterations the best is to introduce the microphone by means of an iron cored transformer into the grid circuit, shunting the grid circuit winding of this transformer by a condenser. It is impossible to give the windings you ask for

without detailed knowledge of your aerial, transmitting condenser, etc.

(2) A possible way would be to insert the telephones with a crystal in series with them, in shunt across a few turns of the earth lead, but in general it is better to listen in by means of a separate circuit such as a wavemeter.

**"VALVES" (Wickford)** has a three-valve L.F. amplifier which works well, but howls if used without the third valve. He asks for help.

As you do not send a sketch, showing how you have the connections arranged, and how the third valve is cut out, we are afraid we cannot state the exact cause of the trouble. Try interchanging the connections of the intervalve transformers. Also try altering the pole of the L.T. battery to which the grid leads are taken.

**"BEGINNER" (Sevenoaks)** asks, re the school set described on page 389, (1) Whether a Mullard Ora valve could be used. (2) What resistance telephones should be used. (3) If it would receive PCGG.

(1) Yes.

(2) If no transformer is used, say 4,000 ohms, or if with a transformer, 120 ohms.

(3) Possible, but very unlikely, except with very skilful use and construction.

**ECKSLOOT (Nottingham)** asks (1) For a coupler for 180 to 200 metres. (2) For a diagram of a three-valve H.F. amplifier. (3) If No. 36 S.S.C. wire can be used for L.F. intervalve transformers.

(1) A.T.I. coil 2½ in. diameter wound with 6 in. of No. 22. Secondary, 2 in. diameter, wound with 5 in. of No. 22, with a 0.0002 microfarad condenser across it.

(2) Arrange the circuit as in Fig. 3.

(3) No. 36 will make rather bulky transformers. For an intervalve transformer, wind 10,000 turns

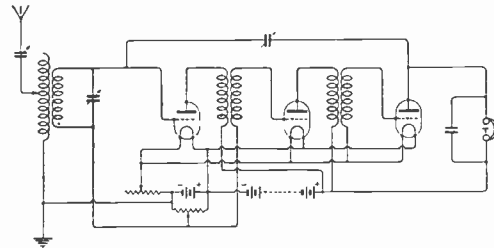

Fig. 3.

on the primary and secondary, and for a telephone transformer, 15,000 and 1,500 turns respectively.

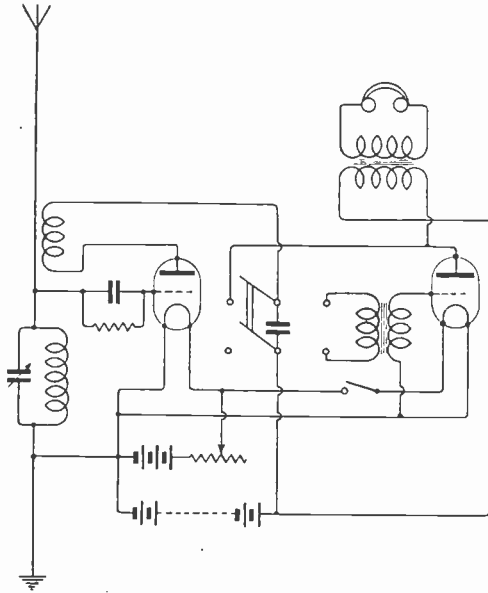

Fig. 4.

**C.J.W.P. (Harrow)** draws attention to an unnecessary connection in Fig. 4, page 526, of the November 12th issue of "The Wireless World," and asks (1) If this is incorrect. (2) If a grid potentiometer will improve the working of the first valve in this set. (3) What is the percentage magnification with the L.F. magnifier.

- (1) Correct diagram is given in Fig. 4, herewith.
- (2) Practically no improvement would be noticeable, as most valves are near a good magnifying

part of their characteristic when connected to the negative side of the filament.

(3) The actual magnification will depend on the magnification factor of the valve in use, which may be any value between 4 and 10.

**D.P.F. (Stalybridge)** sends a circuit as shown in Fig. 5, and asks for criticism.

This circuit should operate satisfactorily, and we are recommending it to another reader

**W.A. (Buxton).**—The diagram given by D.P.F. (Stalybridge), Fig. 5, is just what you require. A telephone transformer is not essential with a set of this type, but it is advisable to use one and also L.R. telephones, so as to avoid the risk of breaking down the insulation of the H.R. telephones.

**S.P.B.A. (Iceland)** wishes to light a seven-valve amplifier with low voltage A.C.

We do not think this has been tried in connection with these sets, and do not think it would be very satisfactory, owing to the L.F. hum which it would be difficult to eliminate.

**ENQUIRER (London)** asks (1) If it is possible to receive the Dutch concerts on a 4 ft. 6 in. frame with a single valve. (2) If 40 ft. of single wire—average height 25 ft.—will receive the same. (3) Are two or three wires better than a single wire aerial.

(1) Very doubtful: several valves will probably be needed.

(2) Yes, but two or three valves will be needed to obtain loud reception.

(3) Multi-wire aerials give stronger signals, but not proportionate to the number of wires.

**FOGGED (Hampstead)** has trouble with a two-valve set which will not oscillate.

The probable reason is that the impedance of the L.F. intervalve transformer winding is too great for H.F. currents. Connect a 0.002 microfarad fixed condenser across the anode winding of this transformer. A grid condenser and leak is unnecessary in the second valve circuit. The aerial and secondary circuits are not equally proportioned, and, as you realise, 0.003 condensers

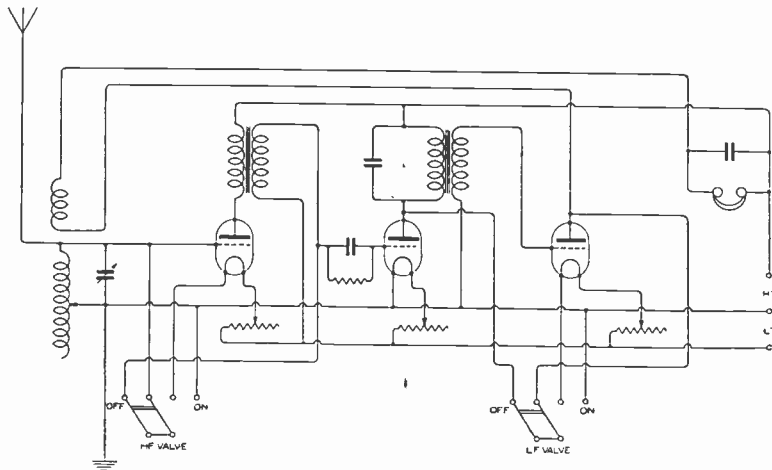

Fig. 5.

# YES

WE SUPPLY PARTS  
AND COMPLETE SETS

for the

## WIRELESS AMATEUR

Call or write for particulars to  
WIRELESS DEPT.

THE CHASE MOTORS CO., LTD.  
BARRAS BRIDGE  
NEWCASTLE-ON-TYNE

'Phone : 5089 Cent.

'Grams : Chase.

## REDUCTION IN PRICES. ACCUMULATORS

ENTIRELY NEW STOCK

Specially manufactured for us by "Peto & Radford"

Thoroughly well-  
made accumulators  
with wooden  
separators and non-  
corrosive terminals

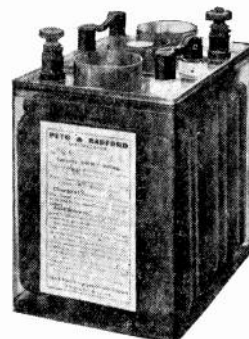

4 Volt, 44 Amp. ...	£1 4 6
4 " 66 " ...	1 12 0
6 " 44 " ...	1 16 0
6 " 66 " ...	2 9 0

### WATES BROS.

Retail Branch - 5, High Street, Bloomsbury, W.C.2  
Offices : 132, Charing Cross Rd., W.C.2 (Gerrard 576)

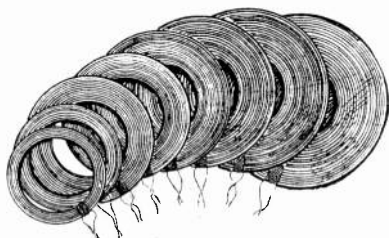

"OOJAH" Slab Inductances (set of 8) 300-30,000 metres 15/-  
Set of blueprint curves (8) and circuits for above ... 4/-  
"OOJAH" Basket Inductances (set of 7) 300-5,000 metres 9/6  
Pair of Basket Inductances specially wound for Dutch  
Concert ... 3/6

To avoid spurious imitations which are now being placed  
upon the market, look for the trade mark. All sets are  
wrapped in a transparent covering and bear the "OOJAH"  
seal. None are genuine without.

Applications are invited for Agencies in all parts of  
the United Kingdom (London excepted).

A. E. GREENSLADE, Jelf Road, S.W.2  
Telephone : Brixton 639.

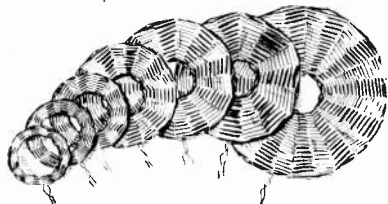

## Unit Coil Holders

Ebonite Insulation Throughout

F. Oxydised Brass Brackets, fixed.  
M. Oxydised Brass Brackets,  
movable, with extension arm and  
ebonite handle, guaranteeing freedom  
from capacity effects from  
hand of operator. Only 2 screws  
required to attach to any panel.

PRICE 6/6 each, movable, <sup>POST</sup>FREE  
" 5/- " fixed "

**Ashley Radio**  
69, Renshaw Street, Liverpool

## THE "BROWN" MICROPHONE AMPLIFIER

This Amplifier magnifies signals, or music, without distortion, and is of considerable interest to amateurs and scientific investigators. The Magnification is much greater than that obtained from two valves, and the current consumption is about 50 milliamps. In construction, this instrument is simple, and it is much more robust than other sensitive relays of this class. This instrument satisfies the urgent demand for a reliable, inexpensive amplifier, which the most inexperienced amateur can use, and which the most experienced requires. It is much cheaper, ultimately, than a multi-valve amplifier, and the operator is relieved from many of the varied causes of breakdown. It includes a transformer suitable for low resistance telephones or loud speakers. The price of the "Brown" Microphone Amplifier is £6 for low resistance (120 ohms) and £8 2s. 6d. for high resistance (2,000 ohms).

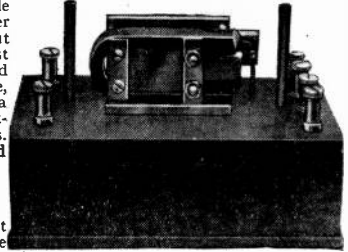

## THE "BROWN" LOUD SPEAKER

With an Amplifier signals or telephony may be so magnified as to cause discomfort to wearers of head-phones, yet not be loud enough to be audible at any appreciable distance from the head. Every wireless experimenter sometimes wishes to let his friends hear, which would involve the use of several pairs of telephones simultaneously with consequent loss of signal strength, as well as considerable expense. The "Brown" Loud Speaker was designed to meet this need efficiently and economically, and is used in 'all up-to date receiving stations. The sound is intensified by means of a horn.

The "Brown" Loud Speaker (80 ohms or 120 ohms) .. £5 10 0 Wound to special high resistance.. up to £5 15 0

## THE "BROWN" SUPER-SENSITIVE TELEPHONES FOR WIRELESS, ETC.

These Telephones are unquestionably the clearest and most sensitive made, and, consequently, increase the distance over which the wireless can be heard.

IN UNIVERSAL USE. As supplied to British, Allied and Foreign Governments.		£	s.	d.
The "Brown" "A" Type Radio Headphones—				
Low resistance .. .. .	per pair	2	18	0
High resistance .. .. .	per pair	3	6	0
The "Brown" "D" Type Headphones (Improved flat diaphragm type)—				
Low resistance .. .. .	per pair	2	8	0
High resistance .. .. .	per pair	2	12	0

The above telephone prices include Cords.

Sole Manufacturers: **S. G. BROWN, LTD.**

**SHOWROOMS** where the above Instruments may be inspected **19, MORTIMER STREET, W.1**

Works: Victoria Road, North Acton, London, W.3.

Telegrams: "Sadbrownix, London."

Telephone: Chiswick 1469.

Sole Agent for the Argentine: Horacio D. Guerrero, Las Heras 2480, Buenos Aires.

## W. T. COMPONENTS

Transformers: H.F. & L.F.  
H.F. Couplings: Reactance Capacity.  
H.F. Couplings: Resistance Capacity.  
Amplifiers: H.F., L.F. & Combination.  
Condensers, Anode Resistances, Leaks, etc.

**B. HESKETH,**  
Manufacturer of W.T. Apparatus,  
HIGH ST., CHALVEY, SLOUGH.

## EBONITE

I have now made arrangements to hold a small stock of Ebonite Rod, and to call upon the manufacturer for supplies of all other sizes. This is all freshly made and of the best quality. Original rods are 40" long, but I am ready to supply any quantity at prices as below. To minimise risk of damage in the post, lengths over 12" will only be sent if it is specially requested that the whole order be supplied in one length (max. 40").

EBONITE | Full Diam. over 1" 1 1/2" 2" 2 1/2" 3" 3 1/2" 4" 1"  
ROD | Price per FOOT 8d. 6d. 9d. 11d. 1/7 2/4 2/8 3/3

Cash with order. Postage extra on orders under 10/-.

**A. HINDERLICH, Central Hall, Southall.**  
Phone: Southall 121. Mdx.

## WIRELESS CONSTRUCTIONAL PARTS.

3-plate Vernier Condensers, Type B .. .. .	4/6
5-plate Vernier Condensers, Type B .. .. .	6/-
Novel Fil. Res. and Valve Holder with Grid Leak and Condenser entirely on Ebonite Panel .. .. .	10/6
High-frequency Transformer Bobbins, fitted pins .. .. .	3/-
Fil. Res. and Valve Holder on Ebonite .. .. .	6/6
High-frequency Coupling Unit; range, 600 to 30,000 metres, entirely on Ebonite, for easy Panel mounting	12/6
Tapped Slab Inductance in Ebonite, with Taps all ready for mounting; range, 800 to 8,000 metres .. .. .	8/6
Reactance Coil for above on Ebonite Swing Bar .. .. .	5/6
Fil. Res. on Ebonite Bobbin, with Knob and Switch Arm	3/3
Our New Booklet, "How to Make Receivers, Amplifiers, etc.", post free, 2d. Get our Big Bargain List also.	
Our Famous "Compactum Coils." Set of 7. Range 300 to 25,000 metres .. .. .	12/6
A smaller set of 4, range 300 to 6,000 metres .. .. .	5/6

## We Specialize in making them for the Amateur.

The "Falstead" Upright Panel Receiver, latest type, comprising Engraved Panel, large Variable Condenser, Fil. Res., Valve Holder, Grid Leak and Condenser, Phone Condensers, Plugs and Coils, Coil Stand, all drilling done. Full Set of Parts and Instructions .. 50/-

3-valve Amplifiers: 1 H.F., 1 Rect., 1 L.F. The Best Combination. Full Set of Parts, including H.F. Coupling, L.F. Transformer. 2 Fil. Res., 3 Valve Holders, Engraved Panel. Everything drilled, all Terminals, etc. .. .. . 70/-

The Multimetre Tuner, range 300 to 30,000 metres, for C.W. spark and telephony. Has a short wave section designed for telephony and long wave section with "Plug In" coils and stand. Made and tested .. 70 -

"Radio Constructa" Tuning Stand, for 2 coils .. 14 6

Plugs for above. Will fit slab or basket coils .. 2 9

Radio Constructa Interchangeable Parts Always in Stock.

**AMATEUR SUPPLIES ASSOCIATION, 134, Coteford St., Tooting, London, S.W.17**



## QUESTIONS AND ANSWERS

are wrong for such short wavelengths. The aerial tunes to 7,500 metres, and the secondary to 3,200 metres.

**N.M. (Chelsea)** asks (1) *if Ora valves are suitable for single valve circuits.* (2) *If a telephone transformer is necessary to use 2,000 ohm telephones in a school receiving set.*

(1) Yes, they should be perfectly suitable, probably giving best results with a grid condenser and leak.

(2) No.

**R.B. (Camberley)** refers to a diagram on page 462 of the October 29th issue, and asks (1) *The gauge and amount of wire for a variometer to tune to 15,000 metres.* (2) *The size of the formers.* (3) *If the coils could be wound duolaterally.* (4) *If the coils could all be adjusted simultaneously.*

(1) and (2) The set described was for 200 metres. For 15,000 metres the size of variometer required would render this method unpractical. Use a 50,000 ohm resistance in place of the variometer.

(4) The variometers would not be exactly similar, therefore they cannot all be mechanically adjusted at once. It is quite satisfactory to adjust one after the other.

**W.F.B. (Arnold)** asks (1) *The capacity of a 31-plate condenser with fixed vanes  $3\frac{1}{2}$  ins. diameter and  $\frac{1}{8}$  in. between fixed vanes.* (2) *A telephone condenser for 4,000 ohms telephones.* (3) *The inductance of two coils.*

(1) Approximately 0.0007 microfarads.

(2) 0.002 microfarads made of nine foils with  $4 \times 2$  cms overlap, and 0.005 inch mica.

(3) A—16,000 microhenries; B—27,000 microhenries.

**NOVICE (Bolton)** is making a crystal set, and asks (1) *For a diagram of connections.* (2) *The maximum and minimum wavelength.* (3) *The distance from which signals will be received.* (4) *How to improve the set at small cost.*

(1) See page 585 of the December 15th issue.

(2) 300 to 3,000 metres.

(3) and (4) There are very few stations apart from 600 metre ships which will be audible on a crystal set. You should hear Eiffel Tower, Poldhu and Nantes, with a good crystal. The only way to improve results will be to instal a single valve set, which will cost about £3.

**LOGARITHM (Sudbury)** asks (1) *The capacity of a certain condenser.* (2) *The inductance of a coil with spaced turns.* (3) *The wavelength given by (1) and (2).* (4) *The size of a loading coil to increase the range to 8,000 metres.*

(1) 0.0003 microfarads.

(2) Approximately 5,000 microhenries.

(3) With condenser and inductance in parallel on a P.M.G. aerial the maximum range will be 3,000 metres.

(4) A 6-inch diameter former wound with 14 ins. of No. 28 wire connected in series with the existing coil and with a condenser across both coils.

**G.W.O. (Earl's Court)** asks (1) *For criticism of a proposed receiving circuit.* (2) *Suggests pancake coils for an intervalve H.F. transformer.*

(1) A perikon rectifier is unnecessary, because the first L.F. valve shown with a condenser and leak will do the rectifying. The 0.0003 microfarad

intervalve condensers are suitable for low frequencies for which they should be of the order of 0.01 microfarad. The reaction coil should not couple into the H.F. circuits after three stages of L.F. magnification. We suggest you use three valves with anode condensers and resistances for H.F. magnification, and two valves with intervalve transformer for L.F. magnification with the reaction coil in the anode of the third H.F. amplifying valve. It will be found difficult to make a 50 to 1 ratio telephone transformer. 10 to 6 is about the biggest ratio to use.

(2) To cover 200 to 3,000 metres several transformers will be required. See Mr. Campbell Swinton's paper in the June 25th issue of *The Wireless World*.

**N.L.S. (Monmouth)** has a crystal set which gives no results.

(1) The circuit is correct, except that the crystal connection should be changed over so that the crystal is connected to the aerial side of the inductance. The transformer is probably defective.

(2) There would be a certain amount of screening but not sufficient to stop signals altogether. You should receive ships on 600 metres and, if the wavelength range of the aerial were increased from the present value of 2,000 metres to 3,000 metres by use of an extra loading coil, similar to the A.T.L., Eiffel Tower and Poldhu should be heard.

(3) We should certainly advise a valve set, and think the school receiving set quite suitable for your purpose.

**F.A.M. (Coventry)** assumes that H.F. magnification is not possible with valves because the constants of the circuit appear not to obey the "R less than

$\sqrt{\frac{4L}{C}}$  law" for oscillation.

The assumption is wrong because, although there are H.F. changes in the anode current, they are not oscillating currents. The phenomenon of resonance only occurs in the transformers which are connected in the anode circuit, and the H.F. changes in the anode current set up oscillating currents in the transformer windings, provided the natural frequency of the transformer windings is somewhere near the frequency of the changes in the anode current.

**C.M.H. (Canterbury)** asks (1) *The inductance of 24 in. of No. 24 wire on a 4 inch former.* (2) *The S.I.C. of ebonite.* (3) *The size of a reactance coil for a honeycomb coil of 15 layers of No. 28 which gives lowest wavelength of 400 metres.* (4) *If it is possible to receive the Dutch concerts on one valve at the North Foreland.*

(1) About 16,000 microhenries.

(2) Approximately 2.

(3) It is a mistake to put a large number of tappings on this type of coil with the object of getting a large wave range. It should be obtained by using several coils. For reaction with the whole honeycomb coil in the circuit a reaction coil nearly as large as the tuning coil will be required, but when working on the tappings this will be too large, and its natural wavelength will give a rejector effect.

(4) This is a good site, but signals will not be very loud with one valve.

**W.J.T. (Norbiton)** asks (1) Why he hears GBL on 33 wavelengths from 600 to 9,000 metres, and if he sends press at 1200 and 2000 hrs. (2) Who is YG who works with OHD. (3) For "Negatron" circuits. (4) The rating of Pulham, Lymgne and Croydon telephone sets.

(1) You are receiving him on harmonics of his wavelength and also harmonics of your own oscillations. We believe he does send Press at the times stated.

(2) Tours (France).

(3) A full description has already appeared in our publication the *Radio Review*, Vol. II, pages 598-602, November, 1921.

(4) Croydon is  $1\frac{1}{2}$  kW. Lymgne and Pulham are probably less.

**G.A.H. (Farnborough)** asks (1) Which of three ways of connecting the filament circuit will give best results. (2) If any benefit is obtained by earthing the negative I.T. and H.T. batteries. (3) If there is any advantage in using loose coupled transformers between the H.F. valve instead of the usual tight coupling. (4) If it is safe to use more than 4 volts on a 4-volt filament valve.

(1) Method A is correct.

(2) With a single circuit set it is necessary to earth the negative 6 v. to complete the grid circuit. With a coupled circuit it is not necessary.

(3) With loose coupling the set is much more selective, but for efficient working both circuits should be tuned to the wavelength being used.

(4) The valve may be slightly overrun but not more than 5 volts should be put on a 4-volt filament.

**R.A.F. (Cranwell)** asks (1) When a description of a crystal set was last given. (2) For condenser particulars on page 877 of the last volume. (3) Quantities of wire for coils of a long-wave set described in the last volume.

(1) No complete description has been given for some time now as crystal sets are not much used by modern amateurs, because, apart from ships, there are very few stations which will be received on a small aerial with a crystal set.

(2) Work to the particulars given on page 879.

(3) Excluding No. 2 unit about 6 ozs. of No. 26 and 3 ozs of No. 32 will be required. This set apparently does not work well below about 1,000 metres.

**J.N.C. (Muswell Hill)** asks for a diagram of M 9 panel.

We have no diagram of internal connections, but you can see for yourself by taking the bottom of the instrument off. For external connections connect the batteries and telephones to the terminals marked A and E terminals across the aerial tuning inductance. The reactance terminals should connect to the reaction coil, which couples to the A.T.I.

**TELEFUNKEN (Ealing)** asks for a diagram to add a resistance coupled valve to an existing single valve set.

See Fig. 6.

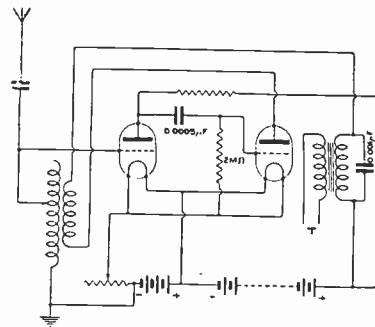

Fig. 6.

**S.S. (Paddington)** asks (1) Date of "Wireless World" in which a 0.0015 microfarad air condenser was described, and whether it is still in print.

Description given in August 21st, 1920, issue. Copies can be obtained from the Mail Order Department, The Wireless Press, 12-13, Henrietta Street, W.C.2.

**R.W.S. (Rugby)** asks (1) How to wind a variometer former he has purchased so that he can use it for a single valve L.W. set. (2) Difference in reaction coil windings for V24 and R valves. (3) If V24 valves are better than R valves. (4) What other alterations to make to use set with R valves.

(1) We cannot give windings unless the size of the former is given. In all probability the former will be too small.

(2) With a given reaction coil the R valve will probably oscillate slightly better than a V24.

(3) It is not quite so good as an R.

(4) None—unless you add a grid condenser and leak.

**L.A.F. (Birmingham)** asks (1) If a 2 microfarad condenser is too big for T.T. primary winding. (2) If it is necessary to have intervalve transformers with a two-valve L.F. set. (3) If advisable to have two condensers in aerial circuit. (4) If a single valve set will give him the Hague telephony.

(1) Yes, this is quite unsuitable: use 0.001 to 0.002 microfarad.

(2) There must be some method of coupling the valves together: use either 50,000 ohm resistances or L.F. transformers.

(3) No, your diagram is incorrect. The A.T.I. and the variable condenser should be joined together, and a lead from the junction of the two taken to the grid condenser and leak.

(4) A well designed set in the hands of an experienced man should make the Hague audible with one valve, but for good results in indifferent hands two or three valves are required.

**TYRO (Cheadle)** asks (1) Which is more effective, a long single wire or a shorter twin aerial. (2) The most effective proportion of down-lead to vertical height. (3) Should he receive Hague loudly at Stockport on a two-valve receiver. (4) If honeycomb coils give a marked increase in signal strength.

(1) The former will give better results with small aeriels.

1896 to 1921

The Experience  
of twenty-five  
years is embodied  
in present-day  
M A R C O N I  
A P P A R A T U S  
& E Q U I P M E N T

MARCONI'S WIRELESS TELEGRAPH CO., LTD.  
MARCONI HOUSE, STRAND, LONDON, W.C.2:  
Phone: CITY 8710. Cables: EXPANSE, LONDON.  
Telegrams: EXPANSE, ESTRAND, LONDON.



# A FEW ITEMS FROM OUR STOCK

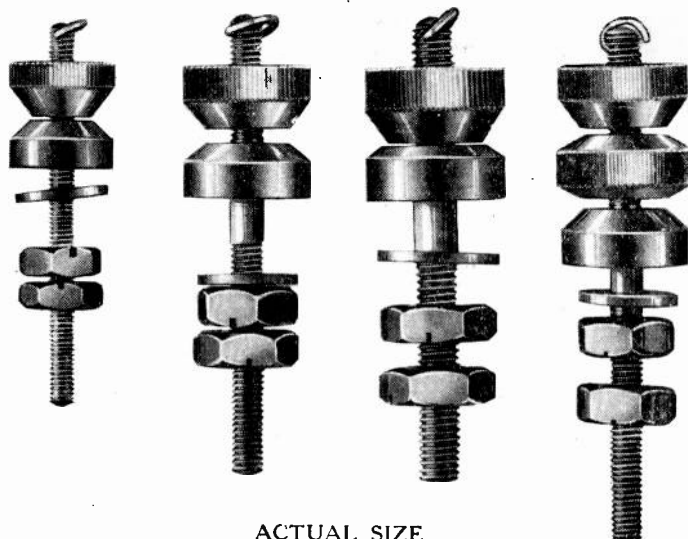

ACTUAL SIZE

BA<sub>4</sub>  
2/- doz.  
Post 6d.

BA<sub>2</sub>  
2/6 doz.  
Post 9d.

BA<sub>0</sub>  
2/6 doz.  
Post 1/-

BA<sub>2</sub>D  
2/6 doz.  
Post 1/-

- Grid Condensers and Leaks, any capacity and resistance ... 5/-
- Valves, best French make. Sent at our risk ... 12/6
- Five plate condensers for panel mounting 6/9
- Ivory Scales, engraved 0 to 180... 1/8
- Filament resistances for panel mounting. Superior make ... 5/6
- Double pole, double throw switches, with porcelain base 5/-
- Single pole, single throw ditto.... 2/9
- Insulating Sleeving, Dozen yards ... 3/9
- Microphone buttons, G.E.C. make ... 2/6

Valve panels, with grid Condenser and Leak, filament resistance, telephone condenser, &c., best make ... 35/-

Three Valve Receiver, one H.F., one rectifying, one L.F., with switching gear for efficient reception on all wavelengths 300 to 30,000 metres. Fuller description next issue W.W. ... 150/-

Duros cells. No first charge required. From stock. 2 volt 45 amp. unit ... 12/6

Balanced Condensers for panel mounting, engraved revolving scale, '001 27/6, '0005 25/6

Slab Inductances, wound with silk covered wire, 300 to 30,000 metres, per set ... 14/-

APPARATUS ADVERTISED MAY BE OBTAINED AT ANY OF OUR BRANCHES.  
AGENTS REQUIRED - - MUST GIVE TRADE REFERENCES.

Orders above 40/- Post Free.

POST ORDERS TO :-

## THE BRITISH WIRELESS SUPPLY Co.

6, BLENHEIM TERRACE, LEEDS.

Telephone: 26926

Also at:-

18, Eldon Square,  
NEWCASTLE-ON-TYNE.

TELEPHONE 380

33, High Street,  
SOUTHAMPTON.

TELEPHONE 403

11, Church Street,  
WEST HARTLEPOOL.

TELEPHONE 373

## QUESTIONS AND ANSWERS

(2) The small differences in ratio you give would give no noticeable difference in signal strength.

(3) Signals will not be loud, but should be well audible if the receiver is carefully adjusted.

(4) No.

**T.V.B. (Windsor)** suggests as a valve an ordinary lamp with a metal sheath round outside of glass and asks (1) *If any use as rectifier and magnifier.* (2) *Transmission range of a 1 in. coil set.*

(1) A similar arrangement with the sheath divided into two portions to act as grid and anode is patented in America, but we have no information as to its usefulness.

(2) Probably about 5 to 10 miles.

**I.S.C.O. (Windsor)** asks (1) *Time of Eiffel Tower telephony.* (2) *If the Hague still sends on Thursdays.* (3) *If he should receive both above on a two-valve set with additional note magnifier.* (4) *How add note magnifier to existing set.*

(1) For a few weeks there were programmes each day except Saturday and Sunday from 3 to 5 G.M.T., but at the present time only irregular experimental transmissions.

(2) Regular transmission Sunday only.

(3) Yes.

(4) Obtain a 1 to 1 ratio low frequency transformer with a 0.001 microfarad condenser across primary and connect the primary winding in place of existing telephones and the secondary to the grid and negative filament of the third valve. Same L.T. and H.T. batteries may be used.

**N.A.S. (Preston)** asks (1) *Which is better circuit for Hague—Page 68, April 30th issue, or Fig. 4, page 525, November 12th issue.* (2) *If formers slightly smaller than those given on page 68 may be used.* (3) *If small step down power transformer may be used as T.T.* (4) *If 0.0005 microfarad condenser is suitable for C<sub>1</sub>, page 68.*

(1) There is not much to choose between the two circuits, but we prefer the second one.

(2) Yes, for the page 68 circuit. For the page 525 circuit the A.T.I. must be 9 ins. of No. 22 and the reaction 6 ins. of No. 30 on 4 in. and 6 in. formers respectively.

(3) The only sure way is to try it. It may be necessary to wind on another telephone winding.

(4) Yes, this is a useful capacity whether used in series or parallel with A.T.I.

**A.B.C. (Westcliff)** has a three-valve L.F. amplifier which distorts speech. He wishes to make a four or six-valve set for 10,000 metres with lattice coils.

(1) L.F. amplifiers will distort speech if too many stages are used. The rushing sound is probably due to a bad joint in H.T. circuit.

(2) We have not sufficient data to hand to design lattice coils for given wave ranges. We suggest you try a three-valve set as shown in Fig. 3, page 640, January 7th issue. It is much better to make a short wave tuner for telephony and a separate one for long wave work.

**ENQUIRER (E8)** sends crystal diagram.

This is incorrect. See page 585, December 10th issue, for two crystal circuit diagrams. We cannot estimate range if you do not send particulars.

**H.N. (Newbury)** has a transformer amplifier as described in June 25th issue, and asks (1) *Why no signals are received unless reaction condenser is in use.* (2) *If telephony should be received at Newbury on a three-foot frame.* (3) *If capacity reaction is good enough for speech.* (4) *Formula for inductance of pile wound coils.*

(1) This may be due to a variety of reasons, the transformers may not be correctly wound, or there may be missing or wrong connections. Examine all circuits and see that they correspond to description.

(2) Yes, when the amplifier is working properly.

(3) It all depends upon the capacity. With both electro-magnetic and electro-static reaction it is necessary to have the constants of the circuit so proportioned that a gradual reaction is obtained. If there is too much reaction the circuit is oscillating vigorously at one position of the reaction and is not oscillating at all when reaction is weakened very slightly.

(4) The formulæ and curves in *The Wireless World*, October, 1919, pages 380-385, will give sufficiently accurate results for most purposes.

**S.A. (Old Oak)** asks (1) *How many plates for a 0.0005 microfarad condenser.* (2) *Particulars of slab coil for 15,000 metres with No. 28 wire.* (3) *Reaction for above coil.*

(1) If the area of plates is 10 sq. cm., and the spacing washers  $\frac{1}{8}$  in. between fixed and moving vanes 20 plates, 10 each side of condenser will be required.

(2) Slab coil is a vague term. Try a honeycomb coil 2 in. diameter, 2 in. wide, with 30 pegs each side and wind 30 layers. (See October 1920 issues.)

(3) Try a similar coil.

**MICROHENRY (Barnet)** asks (1) *Why previous queries were unanswered.* (2) *Refers to weather forecast article August 20th issue.* (3) *For latitude and longitude of eight stations in various parts of the world.* (4) *If reaction circuit shown is suitable.*

(1) Questions under this pseudonym have been answered recently.

(2) Article clearly states that there are five distributing wireless stations, the others are meteorological only.

(3) See "Wireless Year Book."

(4) Yes, a useful circuit. Couple anode inductance into grid inductance for reaction.

**H.C.S. (Putney)** asks (1) *How to stop a four-valve L.F. set howling.* (2) *Formers for short wave tuner 160 to 1,800 metres.* (3) *Same for 1,800-20,000 metres.* (4) *Wavelength of L.F. amplifier set.*

(1) With four low frequency magnetic valves and a switching arrangement which will give electro-static coupling between them it is impossible to stop howling. Try reversing the connections of all transformers in turn.

(2) No mention is made of spacing washers of A.T.C., so capacity is assumed to be 0.0005 microfarads. For short waves make 4 in. former 9 ins. long and wind full No. 22 with 3 in. reaction coil with 6 ins. of No. 30. If desired three or four tappings can be added for the shorter waves.

(3) For long waves up to 10,000 metres make a 6 in. diameter A.T.I. and wind with 14 ins. No. 28 and 5 in. reaction coil with 10 ins. of No. 30.

To increase to 20,000 use either parallel block condensers up to 0.003 microfarad or a honeycomb coil 2 in. diameter, 2 ins. wide, wound with 30 layers of No. 28.

(4) A L.F. amplifier is independent of wave-length.

**PERSEVERANCE (Blackpool)** asks (1) Capacity of condenser with 0.001 in. mica and two foils each one square inch area. (2) How to insulate a steel mast so that he may sink it into the ground. (3) How to polish ebonite. (4) Diagram of Armstrong circuit.

(1) Calculated capacities of condenser need not be taken to 10 decimal points Capacity = 0.0014 microfarad approx.

(2) This may be put straight into ground. The insulation of the aerial from the mast is obtained by using rope at the end of aerial.

(3) First rub the surface well with No. 1 Emery paper to smooth it. Then rub across the grain of first papering with No. 0 Blue Back Emery until all first scratches are taken out. Rub again with No. 0 Blue Back with a little oil until a polish is obtained. For bright polishing the surface must be finally buffed.

(4) There are several Armstrong circuits, but some general remarks with regard to the general arrangement of regenerative receivers were published on page 571 of *The Wireless World* for December 10th, 1921.

**L.WOW (Harpenden)** asks (1) For criticism of a certain make of receiver. (2) Its range for C.W. and telephony.

(1) We cannot criticise this set as we have no detailed information regarding it.

(2) Most Continental spark and C.W. stations should be received, and Königwusterhausen if your coils will tune up to the necessary wavelength (2,500 metres).

(3) No definite or regular telephonic transmissions or concerts are authorised under experimental licenses, and therefore no such list as you suggest is possible.

**BEGINNER (Wycombe)** refers to Fig. 5, April 30th issue, page 70, and asks (1) If variometer described page 6, April 2nd, would be suitable. (2) Would panel tuner inductance page 346, be suitable. (3) Capacity of condenser in grid of valve 2, page 70, and resistance of telephones. (4) Types of valves and transformers to use.

(1) The operation of a set of this type is not straightforward, and we do not recommend it to a beginner. The variometers suggested are not suitable for this set, and the best winding can only be determined experimentally. The variometer has two windings—one fixed and one rotating. They are joined in series, and the resultant inductance depends upon the relative positions of the two coils.

(2) We suggest you make the complete set.

(3) Probably about 0.001 microfarads. Telephones 120 ohms with transformer.

(4) Either V24 valves or R valves and any good make of transformer.

**MAGNA (Pontewan)** asks (1) If 120 ohm telephones are suitable for school receiving set. (2) Type of valve to use. (3) If a sliding glass

condenser would be suitable. (4) If variable resistances in filament and H.T. circuits would be an improvement.

(1) Yes, with telephone transformer.

(2) The design shows an R valve.

(3) A variable condenser may be made in this manner, but the tag should be made larger otherwise it will break off.

(4) A resistance in filament circuit might be useful, but is not needed in anode circuit.

**J.B.J. (South Molton)** asks (1) If possible to receive PCGG in Devon on three valves. (2) Best circuit arrangement.

(1) With three valves (if at least one is H.F.) and a good tuner it should be well audible.

(2) For tuner—make an A.T.I. 4 in. diameter, 9 in. long and wind it full of No. 22. Reaction coil 3 in. diameter wound with 6 ins. of No. 30. For amplifier diagram see Fig. 3, page 640, January 7th issue.

**W.T.E. (St. Helens)** is an old amateur interested who asks (1) For particulars of issues describing the construction with full electrical details of the various types of coil such as honeycomb, basket, etc. (2) Most suitable circuit for a beginner. (3) The effect of capacity in series and in parallel with the A.T.I.

(1) For an article describing the necessity for these coils, and their method of construction see *The Wireless World*, October 2nd, 1920 (page 473); October 16th (page 505); October 30th, 1920 (page 529); December 11th, 1920 (page 635).

(2) A single valve reaction circuit is most suitable for a beginner, see page 639, January 7th issue for a diagram.

(3) The aerial is a condenser and with a certain inductance is tuned to a certain wavelength. When a series condenser is inserted the wavelength is reduced because two condensers in series give a smaller resultant capacity. When a condenser is in parallel with the A.T.I. it is equivalent to two condensers in parallel and greatly increases the wavelength. A parallel condenser is very useful on small aerials, but is sometimes objectionable on large commercial aerials, because the aerial is tuned to three wavelengths—one with aerial capacity and inductance—another with the aerial capacity and the series capacity, and a third (the desired wave) with the aerial capacity and the added capacity in parallel across the inductance.

### SHARE MARKET REPORT.

Prices as we go to press, Jan 26th, are:—

Marconi Ordinary	.. ..	£1 14 0
„ Preference	.. ..	1 14 0
„ Inter. Marine	.. ..	1 2 0
„ Canadian	.. ..	5 9

Radio Corporation of America:—

Ordinary	.. .. .	15 0
Preference	.. .. .	13 0

# "ORA" Valves for Reception

Price 15/- each.

Anode 30 volts. Filament 3.6 to 4.0 volts.

THE Mullard "ORA" is a new departure in receiving valves. It combines efficiently the qualities of a rectifier and an amplifier. It is equally effective as 1st, 2nd, 3rd, 4th, etc. valve in a receiver, consequently only one kind of receiving valve is necessary to get loud signals. Still better signals can be obtained by operating the first "ORA" valves through a Mullard patent resistance and condenser.

Cut off the coupon and send for your requirements now and obtain extraordinary signal strengths with "ORA" valves. They amplify as they rectify as they receive.

If your usual Wireless Dealer cannot supply, forward the coupon and give his name.

Terms for quantities on application.

## Oscillate-Rectify-Amplify



None genuine without this Mark

# Mullard Radio Valve Co. Ltd

Claybrook Road,  
Hammersmith, W.6.

[Manchester Depot: 25 Market Street.  
Glasgow Depot: 206 Bath Street.

Contractors to

H.M. Admiralty. War Office

Royal Air Force & Post Office

Telephone: Hammersmith St. Telegrams: Radiovalve, Hammers London

Codes:  
ABC(5-Zd)

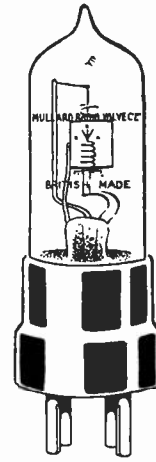

"ORA"  
MULLARD VALVES  
15/- Each



MULLARD PATENT  
RESISTANCE  
for Grid & Anode Circuits



MULLARD CONDENSERS



Mullard 4-pin Sockets

To the  
MULLARD  
RADIO VALVE  
CO., LTD.  
36, Claybrook Road,  
Hammersmith,  
London, W.6.

Please send me post free :

Quantity	Description and Price
	Mullard "ORA" valves ... each 15/-
	Mullard patent resistance combined with Mullard condenser ... 12/6
	Mullard Valve Sockets 4 pin type. Price 2/- each.

I enclose (cheque, money order, P.O.)  
for..... to cover the cost.

Name.....

Address.....

Name of usual Wireless Dealer.....

Address.....

CUT HERE



# AMPLIFIERS

1. **A. Mark IV.**—Consisting of 3 valves, 2 intervalve and 1 telephone Transformer, grid leak, grid condenser, HT, LT and telephone terminals, HT battery and condenser. Terminals are provided for shorting grid leak and condenser in the first valve thus making the whole instrument a complete 3 valve amplifier. By including grid leak and condenser in the circuit the instrument operates as a detector amplifier. The whole encased in heavy ebonite and mahogany. PRICE - £5 10s.
2. **C. Mark III.**—Consisting of 1 earth to valve, 2 intervalve and 1 valve-to-phones transformer. This type is used for amplification only and is easily adaptable to any existing set. A highly efficient instrument compactly and strongly made of the finest possible materials and all parts easily accessible. PRICE - £6 10s.

Watch Case Buzzers, in metal steel case ... ..	4/9 each.
Hot wire ammeters, 0.5 amps. ... ..	7/6 each.
Double pole double throw switches 25 amps. on porcelain base ... ..	5/3 each.
Single pole double throw switches 25 amps. on porcelain base ... ..	2/9 each.
Single pole single throw switches 25 amps. on porcelain base ... ..	2/- each.

POSTAGE EXTRA.

Wires :  
"EXONERATOR"  
LONDON

**ARNOLD, MACK & CO.**  
14 SUN STREET, FINSBURY SQUARE,  
LONDON, E.C.2

Phone :  
LONDON WALL  
7725

## " RADIO-CONSTRUCTA " Patents applied for

A series of highly-finished constructional parts made of ebonite throughout, by which the Wireless Experimenter and Amateur is enabled to easily build his own Apparatus, Receiving or Transmitting Sets, Experimental and Inventive Circuits. The parts are so designed that very little skill is required in assembling, and parts may be used any number of times, being assembled and dissembled at will. In addition to this each part is standardised and is interchangeable: The educational value of the invention is very great, and the amateur will learn more in devising his own type of apparatus in this manner, than by purchasing highly polished and expensive sets, which are boxed in, and have always an appearance of mystery

**" RADIO-CONSTRUCTA "** Makes Wireless Experiments easy and fascinating, and brings Wireless Telegraphy within the reach of all.

Realising the tremendous advance in Wireless, and especially Wireless Telephony, the Proprietors of " Radio-Constructa " have designed a number of complete sets of parts, by which anyone *without* previous knowledge of the principles of Wireless Telegraphy may build their own apparatus at the minimum of cost, with the maximum of interest and efficiency.

Below we give two illustrations of complete Wireless Receiving Sets, and the beginner will now be instructed to build these sets and others.

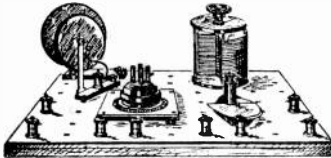

**SINGLE VALVE SET**

Comprising 13½ in. by 10½ in. Baseboard, drilled and the following articles for fixing into Baseboard, with long terminals and nuts for back wiring—Coil Stand and two plugs including two Basket Coils, 1,000 metres range, Combination Valve Holder, Filament Resistance and Condenser, Variable Condenser (.005), eight Terminals, Telephone Condenser, Wire and Insulating Sleeving.

£4 : 10 : 0 (Unassembled)

With Baseboard 6½ in. by 10½ in., 10/- less.

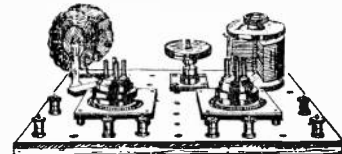

**TWO-VALVE SET**

Comprising the whole of the articles enumerated in Single Valve Set, substituting '001 Condenser, and adding additional Combination Valve Holder and Filament Resistance and Condenser, Mounted Valve Holder, Pin Transformer, H.F., 1,000 metres, and Vernier Condenser.

£6 : 10 : 0  
(Unassembled)

FOR FURTHER PARTICULARS APPLY TO :—

**RADIO-CONSTRUCTA (Dept. 2), 222 Great Dover Street, London, S.E.1**  
Telephone : HOP 3029. AGENCY APPOINTMENTS WILL BE CONSIDERED.

# NOTICE to purchasers of "Polaris" Wireless Receiving Instruments.

Marconi's Wireless Telegraph Company Limited GIVE NOTICE that an Order was made by Mr. Justice Eve on the 12th July last restraining Messrs. A. W. Gamage, Ltd. from infringing their Letters Patent No. 13636 of 1913 and 28413 of 1913. Messrs. Gamage were further ordered upon oath to destroy all "Polaris" receiving apparatus, and to pay the Marconi Company £150 as the agreed damages and also to pay the costs.

The Marconi Company are in a position to take proceedings against any purchaser of "Polaris" receiving apparatus for infringement of their patents.

The Marconi Company are prepared, however, to allow purchasers to continue to use the apparatus on payment forthwith of a sum equal to 10 per cent. of the purchase price of the apparatus in respect of its past and future use.

Purchasers desiring to obtain permission to continue to use such apparatus should therefore communicate with the Marconi Company immediately.

Marconi House,  
Strand, London, W.C.2.

### AERIAL INSULATORS

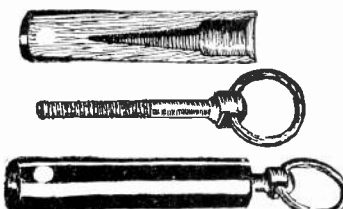

**LIGHT AERIAL INSULATORS**  
Ebonite  $2\frac{1}{2}$ " long with brass eye bolt Price 6d. each; 4/- dozen. Postage extra.

**H.T. BATTERY BOXES**  
Highly polished mahogany.

6 Plug Sockets and 2 Plug Leads. Size  $11" \times 7" \times 3"$ .  
Price 5/- each. Trade Terms on Application.

**LESLIE DIXON & CO.**  
9, COLONIAL AVENUE, MINORIES, E.1.

## WIRELESS TELEGRAPHY

Young men wishing to enter a remunerative and progressive profession should commence training as Wireless Officers. A new field is opened up for ambitious young men in the construction of Aircraft and Wireless Equipment. We give special facilities to those wishing to study in this branch.—Day and Evening classes.

THESE ARE THE ONLY SCHOOLS IN GREAT BRITAIN FITTED WITH COMPLETE STANDARD MARCONI, POUlsen AND SIEMEN'S QUENCHED SPARK SYSTEM INSTALLATIONS.

These Schools are now fitted with a standard Marconi Valve Transmitter and Amplifying Receiver.  
*Write now for Illustrated Prospectus.*

**North-Eastern Schools of Wireless Telegraphy**  
6, BLENHEIM TERRACE, LEEDS. 1, ELDON SQUARE, NEWCASTLE-ON-TYNE. Also THE SOUTHERN COUNTIES WIRELESS SCHOOL, 33, HIGH STREET, SOUTHAMPTON.

## URIAH BEATON'S BARGAINS.

Variometer's Tesla's, Ebonite Hinge or Book type ...	35/-
Transformers with 8 Terminals in case with Ebonite top ...	12/6
Dynamo's, 12 Volts, 14 Amps, ball bearings, Crompton Relays, Vibrating Strip and Spring ...	150/-
Relays, Polarised, Stroh's 1000 ohms ...	30/-
Relays, Polarised, Stroh's 1000 ohms ...	60/-
Headphones, 120 ohms, with cords, Sullivan's ...	3/9
Headphones, 2000 ohms with cords ...	6/6
Solder Tags or Eyes for instruments connecting, per packet of 1 gross mixed sizes ...	1/6
Packing and Postage Extra. Stamp for Reply.	
ESTABLISHED 25 YEARS.	
<b>45, CHALK FARM ROAD, N.W.1</b>	

## FOR SALE.

New 60-volt Battery Boxes, 5 Sockets with Plugs and Leads, Ebonite engraved, with Voltage Numbers	3/6
100 volt Polished Mahogany, 6 Sockets, with Leads and Plugs ...	5/-
Microphones in case, with Replaceable Insets with Control Button ...	2/6
Silk Wire Basket Coils, per set of four ...	2/6
Mark III 5-way Switches ...	5/-
Telephone Jacks, with 1 yard Telephone Flex and 2 Plugs ...	3/-
$1\frac{1}{2}$ " Milled Edge Knobs, for Switches, Condensers, etc., 3 for ...	1/-
New Mahogany Instrument Cases, with Brass Lock and Key, with Leather Carrying Straps, well made $11" \times 7" \times 3"$ ...	9/-
Spare Battery Plugs, with Beads, per pair ...	1/6
All Carriage Paid. Apparatus of all kinds in stock.	
<b>C. S. SWAN, 65, Windsor Road, Leyton, E.10</b>	



### 3 VALVE RECEIVING & AMPLIFYING STATION

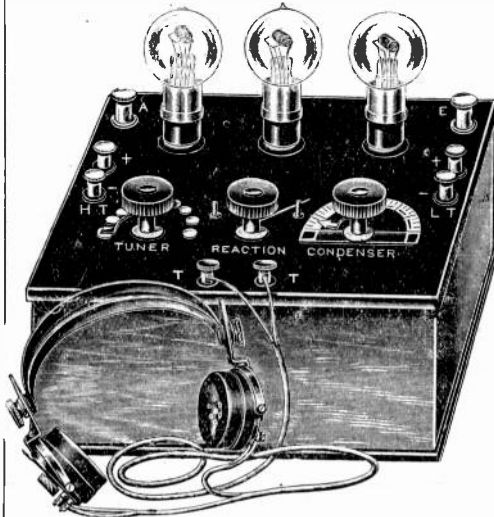

**EXCEPTIONAL results.** Comprises carefully wound inductance having wavelength 500 to 2,000 metres, small capacity tuning condenser, mica dielectric, enabling fine tuning, two low frequency transformers, grid condenser and leak and autodyne reaction. Specially designed for the reception of Dutch concerts from the Hague within a radius of 400 miles.

All that is necessary to complete this station, ready for use, is the addition of the usual double receivers, batteries and valves.  
**PRICE £10.** Extra per set of Valves £2.

**MULLARD "ORA" VALVES 16/- each.**

**ACCUMULATORS for High Tension work.**

60 volt Set ... 62/6 per set. 30 volt set ... 32/6 per set

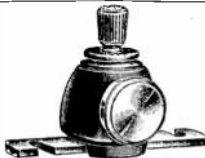

#### "EXCENTRO" CRYSTAL DETECTOR.

The most efficient and ingenious Detector made. As described in the "Wireless World" issue of Dec. 24th, 1921. Exceptionally good results obtainable. Price 16/-.

#### ALUMINIUM VANES FOR CONDENSERS.

Improved design Dia. 3½ ins.  
4/6 doz., post free.

**VANE HOLDER CENTRE ROD AND INDICATOR FOR CONDENSERS.** Length 4½" over all. 4/6.

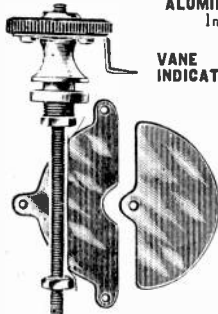

#### LAMINATED SWITCH ARMS

for making own sets. Complete with Insulated Knob, Brass Bush for Base Board and two clamping nuts



2/9  
Post Free.

## IT WILL PAY YOU TO GIVE US A TRIAL.

**MURDOCK'S VARIABLE CONDENSERS**, for external use, .0005 23 plate, 27/8; post, 9d. .001 43 plate, 32/8; post, 9d. Ditto, complete for panel mounting, .001 43 plate, 27/8; post, 9d. These condensers are a first-class, reliable, finished component, complete with terminals, pointer and scale. Can be used vertically or horizontally.

**FILAMENT RESISTANCE**, 1½" knob, mounted below 2½" by 2½" matt ebonite. Price, 5/6. Post, 4d.

**VERNIER CONDENSER**, with distant control lever. Price 6/6. Post, 6d.

**GRID LEAK** (2 meg.) and **CONDENSER**, 6/-; post, 6d. **GRID LEAK** (2 meg.) only, 3/-.

**ENGRAVED EBONITE DIALS**, 3½" diam., complete with 1½" ebonite knob. Price, 4/9. Post, 3d.

**1½" LAMINATED SWITCH ARM**, 1½" ebonite knob, spindle, spring, washers and locknuts. Complete with machined brass bush with screws and connecting lug. Price 3/3. Post, 6d.

**THE "POPULAR" H.T. BATTERY.** We recommend our superior Batteries in cardboard cases, as follows:—

18 volts. 36 volts. 54 volts. 72 volts.  
2/6. Post 9d. 4/9. Post 1/- 7/- Post 1/- 9/- Post 1/3

These batteries are meeting with universal approval owing to their high efficiency and low initial cost and maintenance.

**VALVE SOCKETS**, with screws and washers, 10d. set of 4; 2/3 per doz.; Post, 2d.

**VALVE LEGS**, for plugging into sockets, with 2 nuts, 10d. set of 4. 2/3 per doz.; Post, 2d.

**ANODE RESISTANCES**, 50,000, 60,000, 80,000 or 100,000 ohms. Price, 3/3. Post, 2d.

**SLAB INDUCTANCES**, 300 to 30,000 metres, with set of useful circuits. Price, 15/-; Post, 9d.

## SCIENTIFIC SUPPLY STORES,

8. NEWINGTON CAUSEWAY, LONDON, S.E.1

'Phone: Hop 4177.

## WIRELESS

All interested in Radio work are invited to inspect our stock which bears the most critical comparison with any other makes.

**AERIAL WIRES** per 150 ft. lengths. Phosphor bronze 7/25, 7/-; 7/22, 13/6; 7/20, 18/- Copper, 7/25, 6/-; 7/22, 11/6; 7/20, 15/- Longer or shorter lengths supplied.

**LEAD-IN INSULATORS**, brass rod fitted in ebonite, with soldering shoe for aerial wire one end and terminal the other. Suitable for running through walls or window sashes. 12" long, 3/3. Ditto, 9" long, 3/-.

**SPREADERS**, stout ash, 6" long, ¾" diam., 3/- each.

**SWITCHES**, on porcelain base, to carry 25 amps, S.P.D.T., 3/-; D.P.D.T., 6/-.

**SHELL INSULATORS**, the finest made, size A, 1/8 each; size B, 2/2 each.

**INSULATORS**, green porcelain, small size 1½" long by 1" diam., approx., recommended for lead-in guides and indoor aerials, 9d. each.

**AERIAL PULLEY BLOCKS**, galvanised iron, with hook complete, 2/6 each.

**ACCUMULATORS** for filament lighting. Best makes only supplied. 4-volt, 40 amp., 29/-; 4-volt, 60 amp., 35/-; 6-volt, 40 amp., 43/6; 6-volt, 60 amp., 53/3.

**NOTE.**—We have in stock a limited number of well-known American made Variable Condensers, air dielectric, in transparent case with ebonite top and bottom, fitted with graduated scale, pointer, knob, etc. To clear at exceptional prices.

Capacity .001 mfd., 30/-, .0005 mfd., 25/- Also pattern as above for fixing in panels, self supporting, complete with fixing screws, scale, knob, etc. Capacity .001 mfd., 25/-

Also a number of perfectly new Sullivan head 'phones, complete with cords. Resistance 120 ohms. All guaranteed in absolutely perfect condition. Per pair, 5/- Postage extra.

Cannot be repeated at the price.

Illustrated Catalogue, 7d., post free.

## RADIO SUPPLIES

Dept. 1

236, HIGH HOLBORN, LONDON, W.C.1

Telephone: Museum 6894.

# The London Telegraph Training College, Ltd.

Telephone  
WESTERN 2696.

Morse House, Earl's Court, S.W.

ESTABLISHED  
25 YEARS.

OFFICIALLY RECOGNISED BY THE WAR OFFICE AND POST OFFICE AUTHORITIES

## CABLE AND WIRELESS TELEGRAPHY.

**P**ARENTS desirous of placing their sons in either of the above Services and of affording them the best training facilities should apply for particulars of Courses and the methods of instruction which place this Institution in the first rank. Cable Telegraphy offers at the present time excellent prospects to youths from 15 years of age and upwards, and the College has exclusive facilities for obtaining posts for qualified students in the leading Cable Companies at commencing salaries of £150 to £300 per annum, with yearly increments of £12 to £25, and ultimate possibilities of obtaining positions as Supervisors, Assistant Superintendents, Managers, etc.

In the Wireless Telegraph Service the commencing remuneration at the present time is approximately £150 per annum, and Operators, when qualified by obtaining the Postmaster-General's Certificate of Proficiency, are nominated by the College for appointments.

*No Correspondence Classes or Branches*

**DAY AND EVENING CLASSES.**

*An Illustrated Prospectus containing all information will be forwarded on application to*

**THE SECRETARY (Dept. H), 262, Earl's Court Road, Earl's Court, London, S.W.5**

*Sole Proprietors of the "Scott" Training Disc which contains useful formulæ and other information for Wireless Telegraph Operators and is invaluable to Army Signalling Officers for range finding, etc.*

*Price, complete with instructions for use, 1/-. Postage 2d.*

## SLAB INDUCTANCES.

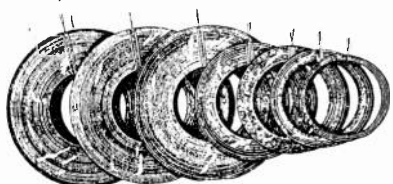

Per set of 8, range 300 to 30,000 metres, 15/-, postage 9d.

Per set of 7, range 300 to 25,000, 12/6, postage 9d.

These Inductances are useful as Aerial Tuning Inductances, Reaction Coils, Loose Couplers, Variometers, etc., and specially useful with "Radio Constructa" stand and holder, see page xviii.

**Basket Inductances.**—Specially wound for Dutch concert and general telephony, 3/8 per pair.

**Vernier Condensers** indispensable for fine tuning for telephony, 6/6, postage 6d.

**36-Volt H.T. Battery**, with Wander Plug. See illustration in previous number, 7/6, postage 9d.

**15-Volt Unit**, 3-terminal type, 3/6, postage 6d.

**Pin Type Transformer** to fit into R-Valve Socket in eight stages, from 6/- 300 metres, to 14/3 24,000 metres. Telephony range, 6/9 each. Postage 3d. in each case. The whole range of eight mounted on ebonite panel, with primary and secondary tapings, 52/6.

**Sullivan's 120 ohm Telephones**, double head gear (new), 27/6 complete with transformer, new.

**OUR NEW LIST** (over 100 illustrations), POST FREE, 4d.

**H. D. BUTLER & CO.,**

Showroom and Works: **61, Borough Road, Borough, S.E. 1**  
3 minutes from Borough Tube Station.

Office: **BANK BUILDINGS, 222, GT. DOVER ST., S.E. 1**  
Telephone: HOP 3029. Treg. "Ingenuity, Phone, London"

All our goods obtainable at the  
**Army & Navy Co-Operative Society, Ltd.,**  
105, Victoria Street, S.W.

## DIARY & NOTEBOOK FOR 1922 FOR WIRELESS OPERATORS & AMATEURS

Price **3/6** Net. :: Post **3/9** free.

In best leather cases, with two pockets, card and stamp divisions

**Complete with Special Sections to meet requirements of Operators and Amateurs**

When ordering please specify whether for Operator or Amateur

## 1922 REFILLS

FOR OPERATORS' & AMATEURS' DIARIES

Price 1/6 Net. Post 1/8 free.

**THE WIRELESS PRESS, LTD.,**  
12-13, Henrietta St., Strand, London, W.C.2

# The "CONCERTONE MAGNEPHONE"

THE MELLOW LOUD SPEAKER



42/-

or

\$10

\$10

or

42/-

This instrument is the result of much research, and is soundly constructed on acoustic principles.

**Don't Pass your 'Phones Round. Have a Loud Speaker**  
The Concertone Magnephone which was unconditionally offered in connection with the recent Transatlantic Tests was deservedly won by Mr. W. R. Burne, of Sale, Cheshire.

We are now supplying separate, to amateurs only, the "C.M." horn 2 ft. high, and solid brass plate 3½ in. dia. at 14/6 Postage 9d. extra.

Proprietors, Manufacturers and Sole Distributors:  
**The International Electrical Trading Combine,**  
London Agency: 100, Lancaster Road, London,  
See also Nov. 12th issue of this Journal. E.vi.

## "The Model Engineer"

A special paper for young Engineers, Apprentices, Students and Amateurs interested in Mechanics, Electricity and Model Making. It contains practical articles by experienced writers on Electrical and Mechanical subjects, Locomotives, Motor Cycling, Model Aeroplanes and Wireless Telegraphy.  
*Published every Thursday. 5d. post free.*

## "Junior Mechanics & Electricity"

The paper for beginners of all ages in Mechanics, Electricity and Model Making. All the articles are written in simple language so that everybody can read and understand them. It is well illustrated. There is also a Queries and Replies section, from which much valuable information can be obtained.  
*Published on 1st of each month. 4d. post free.*

### SOME USEFUL BOOKS.

Practical Lessons in Metal Turning .. 2/9	Small Accumulators .. 10jd.
Engineering Mathematics Simply Explained .. 2/3	Electric Bells & Alarms 10jd.
Practical Dynamo and Motor Construction 1/9	Electric Batteries .. 10jd.
Practical Induction Coil Construction .. 1/9	Small Dynamos and Motors .. 10jd.
Petrol Motors Simply Explained .. 1/9	Induction Coils for Amateurs .. 10jd.
Workshop Wrinkles and Recipes .. 1/9	Small Electric Motors 10jd.
	Alternating Currents 10jd.
	Windmills and Wind Motors .. 10jd.
	Wireless Telegraphy Simply Explained .. 10jd.

*Every Boy's Book of Electricity, 3d.*

*Every Boy's Book of Engines, 3d.*

Book List sent post free on receipt of card.

**PERCIVAL MARSHALL & CO.,**

66m, FARRINGTON ST., LONDON, E.C.

To all who mention the "Wireless World" and send 6d. for postage, we will send six back copies of the



free. This will prove to you that the PHILATELIC MAGAZINE is the best Stamp Collectors' Newspaper. All the news for 3d. a fortnight. Current issue from your newsagent 3d., or 4d. post free from:—

**HARRIS PUBLICATIONS LTD.,** Balham  
*Catalogue of Stamp Albums and Accessories free.*

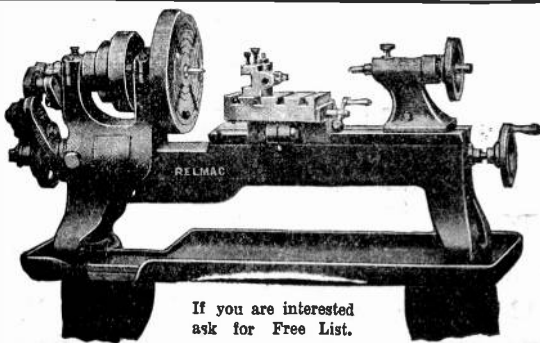

If you are interested ask for Free List.

## RELMAC & SUPER RELM LATHES FOR THE WIRELESS ENGINEER

4½" CENTRES, BACK GEAR, SCREWCUTTING, ETC.

Our aim is to ensure in these machines ACCURACY, RIGIDITY and RELIABILITY, and that is why THEY SELL. You cannot afford to buy any other Lathe, because in PRICE and SERVICE ours are CHEAPEST. PRICES FROM £14 8 0

COME AND SEE US.

**CHELTENHAM LATHE WORKS,**

PHONE: BRIXTON 2001.

86, ACRE LANE, BRIXTON, S.W.2

**Ever-Ready**  
British Made

**High Tension Batteries  
for Wireless Sets**

W.3. 60 volts.

21/-

W.11. 15 volts.

4/6

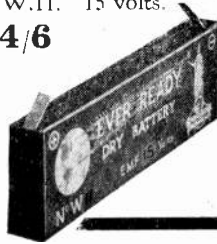
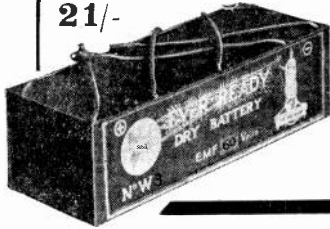

WE were the originators of all types of Wireless Batteries and manufactured and supplied them to the Admiralty, War Office, Air Ministry and Ministry of Munitions, etc., during the War. All sizes can be supplied and intermediate tappings for any required voltage can be arranged on receipt of specification. Our list of standard sizes and voltages will be sent on application to Dept. D.L.

Wholesale only from :

**The EVER-READY WORKS**  
HERCULES PLACE, HOLLOWAY, LONDON

**SEA, LAND  
and AIR**

THE AUSTRALIAN  
MONTHLY JOURNAL  
of Aviation, Radio-Tele-  
graphy & Radio-Telephony

Price  
**1/9**  
Post Free

Annual  
Subscription  
**21/-**

**THE WIRELESS PRESS LTD.**  
12-13, Henrietta St., Strand, W.C.2

"THE BOOK OF THE WEEK"

—John o'London's Weekly.

**FIFTY YEARS of  
ELECTRICITY**

The Memories of an Electrical Engineer  
by **J. A. FLEMING, M.A., D.Sc., F.R.S.**

371 Pages.

111 Plates.

PRICE

**30/-**

NETT.

(Postage 1/-.)

CONTENTS.

Introduction.

- Chap. I. Telegraphs and Telephones in the last Fifty Years.
- II. Dynamos, Alternators, Transformers and Motors.
- III. Electric Lamps and Electric Lighting.
- IV. Electric Heating, Cooking and Furnaces in Five Decades.
- V. Electric Supply Stations, Storage Batteries, Railways and the Transmission of Power.
- VI. Theory and Measurements.
- VII. Wireless Telegraphy and Telephony.

Conclusion.

**THE WIRELESS PRESS, LIMITED**  
Dept. W.W.,  
12/13, Henrietta St., London, W.C.2

**OUR EASY PAYMENT SYSTEM  
IS STILL OPEN TO ALL READERS**

FOR FULL PARTICULARS WRITE THE MANAGER, MAIL ORDER DEPT.,  
THE WIRELESS PRESS, LTD., 12-13, Henrietta Street, London, W.C.2

# THE WIRELESS WORLD EXCHANGE AND MART

## WIRES

### CLEARANCE OF STOCKS OF INSTRUMENT WIRES COTTON, SILK, ENAMELLED.

Bargain price list forwarded on receipt of stamp to  
**AMATEUR WIRE SUPPLY CO.,**  
Wire Manufacturers,  
35 Eastcombe Ave., Charlton, S.E.

H.F. "Concerttransformers" 1,000 metre, "Plugin," 8/6.  
.0003 Variable Condenser for tuning above, 15/- (Really fine results for telephony using these two.)  
Set of Seven "Compactum" Tuning Coils, 300-25,000 metres, 12/6.  
Complete Crystal Receiving Sets, 38/-, 42/-.  
Sets of parts to make amplifiers, 30/-, 40/-, 50/.

File Resistance on ebonite bobbins, 3/3.  
File Resistance and Valve Holder on ebonite, 6/6.  
Switch Arms, 1/6; Contacts, 1/6 doz.; Terminals, 2½d.

GET OUR LIST OF PARTS.  
AMATEUR SUPPLIES, 134, Coteford Street, Tooting, London.

### SILK, COTTON AND ENAMELLED WIRES AT VERY LOW PRICES.

B Mark I, 2-Valve Receivers	£ s. d.
3-Valve French Amplifiers	2 15 0
3-Valve Mark IV Amplifiers	3 5 0
Marconi 20-Watt Spark Coil Condenser	5 0 0
Morse Ke; and Spark Gap. In case	2 0 0
Ditto, Smaller Set, no Gap.	1 15 0
(All above in Mahogany Cases and Strap.)	
H.T. Battery Boxes. Fine Polished Mahogany, Filled 6 Plug Socket, 2 Plugs and Cords. Detachable Lid, size 11 ins. by 7 ins. by 3 ins., each.	0 7 6
Light Ebonite Aerial Insulators, Brass Shackles	0 0 6
Porcelain Pedestals, Ribbed Brass Stem, each	0 2 6
Earth Mats, Copper Mesh, Brass Bound, each	0 12 6
Ammeters and Voltmeters. Flush Switchboard.	0 10 6
6-Volt New P. & R. 40/80 amp. Accumulators	2 10 0
Marconi Alternators, ½ kW. and 2 kW.	10 0 0
A.T.I. 8-Way Lever Switches. Ebonite Base	0 7 6
½ H.P. 220 Volt A.C. Motors	10 5 0
Shunt Dynamos, 12 16 Volts 10 amps.	6 10 0
D.C. Motor Generator, Direct Coupled A.C. 220 Volt to 25 Volt 10 amps. for Battery Charging	33 0 0
50 volt Petrol Electric Sets, 1 to 2 kW.	42 0 0
SLATE PANELS, CABLE AND WIRE MOTORS AND DYNAMOS.	

**LESLIE DIXON & CO.,**  
9, Colonial Avenue, Minories, E.1.  
(Near Aldgate Station.)

**TARIFF.**—Lineage Advertisements are charged 2d. per word. Single letters and figures are counted as words and compound words as two words. Remittance must accompany all advertisements, which should be forwarded to Bertram Day & Co., Ltd., 9 & 10, Charing Cross, S.W.1

**TECHNICAL BOOKS.**—Second-hand and New Books on every conceivable subject Catalogue free. State wants. Books sent on approval. Books bought.—FOYLE, 121-125, Charing Cross Road, London.

**EDISON RECORDS.**—New Blue Amberols, list free.—ROBINSON, 333, Hainton Avenue, Grimsby.

**PORTABLE CABINET SET.** Two-Valve Receiver, One Valve Transmitter £7. Telephones, Brown's and Sullivan's, also Three-valve L.F. Amplifier, £4. Accumulators, separate Heterodyne, also Oliver No.9 Typewriter. Cash needed. No reasonable offer refused. Seen working.—125, Hurlingham Road, Fulham, S.W.

**WIRELESS SET.** 300-3 500. metres, Detector, Three-valve, L.F. Amplifier, Telephones, Loud Speaker, Batteries, etc., signals read 100 ft. away. Trial any night after 7. Excellent bargain.—GROOM, 110, Newington Green Road, N.1.

**AERIAL.** 100-foot, Insulators complete, as new, 10s.—SHELLEY, 96, West End Lane, West Hampstead, N.W.

**FIRM OF ELECTRICAL FACTORS** desire quotations for French Type Wireless Valves—SCAMMELL & ABBOTT, 100, Dale End, Birmingham.

**VALVE SET.** Good Instrument finish, £3.—PHILLIMORE, West Bank, Matlock, Bath.

**MARCONI M. 36 RETROACTIVE TUNER.** with Condenser, 160 to 2,800 metres, beautifully finished, cost £12 last September, accept £9.—KENNARD, Sotterley Rectory, Wangford.

8x, PRISM BINOCULARS, Exchange for L.F. Transformer or anything wireless.—CRISP LUCY, Wollaston, Wellingboro.

**FOR SALE,** as New, "Polaris" Receiver, complete set of Three Instruments, Mediawaver, Maxiwaver, Miniwaver, range 400 to 30,000 metres, including valve, for C.W. Spark Telephony. Accept £15 or nearest offer.—DONALDSON, "Glenbank," Sevenoaks.

**AIRCRAFT TUNER.** No. 35.—New Condition, £5, or exchange for Mark III Tuner.—DAVISON, 33, Algernon Road, Lewisham, S.E.13.

**PORTABLE HOLLOW SPAR MAST,** 20-ft., 11 lbs., 10s.—JOSCELYNE, Rushmere, Braintree.

**SIX-VALVE French Detector Amplifier,** Model Li, perfect condition, just overhauled, £8. Seen any time—65, Kings Road, Richmond, Surrey.

**WIRELESS AND ELECTRICAL LIST.** 55 huge pages full of useful information, post free.—THOMSONS, 5, Westboro, Scarborough.

**WANTED IMMEDIATELY.**—All types of dud army pattern L.F. Transformers. Good price offered.—Box L.F., BERTRAM DAY'S ADVERTISING OFFICES, 9-10, Charing Cross, S.W.1

**NEW VALVES FOR OLD!** Save your dud valves, they are valuable! Stamp for particulars and lists Write at once.—GENERAL RADIO, 24, Beaumont Avenue, Richmond, Surrey.

## 1922 PRICES

WITHOUT SACRIFICING QUALITY  
**Compare Them**

**Variable Condensers.** s. d.  
Max. .00005 mfd. for Panel Mounting, fitted with Knob and Pointer - - - 5 0

**Slab Inductances.**  
Per set of 7. Range, 300-17,000 - - - 10 6

**Interchangeable Transformers.**  
To fit valve holders—  
300 600 1,000 1100  
4/9 5/6 6/0 6/6  
4,000 6,000 12,000 -  
7/0 8/0 9/0

**Formers only.**  
Fitted with pins ready for winding (state wavelength) 3 6

**Formers—** For over 4,000 metres - - - 4 6

**Valve Holders.**  
In Moulded Ebonite plain legs - - - 1 8  
Solid Ebonite Turned, Legs fitted with 2 nuts and washers - - - 2 3  
Brass Sockets only, fitted with 2 nuts and washer, lacquered - - - per set 1 0  
1 Set Sockets on Ebonite - 1 6  
2 Set Sockets on Ebonite - 2 6  
3 Set Sockets on ¼" Ebonite 4 6  
4 Set Sockets on ¼" Ebonite 6 0  
5 Set Sockets on ¼" Ebonite 7 6

**Fixed Capacity Condensers.**  
Mounted between Ebonite Plates—  
.0002-.0003 - - - 2 0  
.001-.002-.003 - - - 2 9

**"Sphinx" Grid Leaks.**  
Cartridge pattern with brass clips - - - 2 6

**"Sphinx" Anode Resistance.**  
Always silent and constant 3 6

**PETO-COILS.** The only true Honeycomb Coil. At prices within everyone's reach.  
Wave-range when used in parallel with .001 M.F.D. Condenser.  
Price Unmounted.  
No. 1—200-600 - - - 3 0  
No. 2—350-1,050 - - - 4 3  
No. 3—600-2,000 - - - 4 6  
No. 4—1,200-4,000 - - - 6 6  
No. 5—2,400-8,000 - - - 10 6

**GET OUR CATALOGUE "W."**  
Mailed per return from

**PETO SCOTT** THE CONDENSER KING.  
17 Frome Rd., Wood Green, N.22  
Carriage extra on orders under £1.  
**TRADE INQUIRIES INVITED.**

# THE WIRELESS WORLD EXCHANGE AND MART

## More Bargains!

Single Valve Transmitter and Receiver Mk. 1 (two star) ex-Military ... .. 120/-  
 A. Mk. IV. Amplifiers ... .. 120/-  
 Two Valve 80 meter Receivers 45/-  
 Spark Coils in case with key 40/-  
 Wavemeters ... .. from 30/-  
 Variable Condensers '001 new 40/-  
 Mk. III. Tuner Cases ... .. 7/6  
 Ebonite, Mica, Copper Foil and all sundries

Send zd. Stamp or PARTICULARS & ADVICE to  
**RADIO EXPERIMENTAL CO.**  
 103, Gell Street, SHEFFIELD.

## STILL THE CHEAPEST FIRM FOR WIRES

All wire wound on bobbins free. Postage extra.

S.W.G.	S.C.C.	D.C.C.	Single Silk	D.Silk	Enmld.
10	1/9	1/10	4/-	5/4	1/7
12	1/10	1/11	4/-	5/4	1/8
14	1/11	2/-	4/-	5/4	1/9
16	2/-	2/1	4/2	5/6	1/10
18	2/1	2/2	4/4	5/6	1/11
20	2/2	2/3	4/8	6/2	2/6
22	2/6	2/11	5/-	6/8	2/8
24	3/-	3/6	5/6	7/4	2/8
26	3/7	4/1	6/8	8/2	3/2
28	4/4	4/7	7/2	9/-	3/6
30	5/-	5/6	8/-	10/-	3/10
32	6/-	7/3	9/2	13/-	4/2
34	7/-	8/3	11/6	14/-	4/4
36	8/8	10/2	14/-	15/6	4/8
38	11/3	13/2	16/-	19/-	5/3
40	15/-	18/-	18/6	22/6	6/6
42	17/3	21/-	31/6	34/-	9/-

At per lb.

**BOWER & CO.,**  
 Proprietors: Wimbleton Electrical Co., Ltd.  
 Manufacturing and Electrical Engineers.  
 15, KINGSTON ROAD, WIMBLETON, S.W.19

New "R" Type Valves ... 11/-  
 EDISWAN Transmitting Valves, to 50 watts (Type E. S. 4.) ... 22/6  
 Valve Amplifier Mark III ... 60/-  
 H.T. Units, 15 volt ... each 4/-  
 " " 36 " tapped every 3 volts ... each 7/6  
 Ebonite Sheet,  $\frac{3}{8}$ ",  $\frac{1}{2}$ " and  $\frac{1}{4}$ " thicknesses ... per lb. 3/-

Please include postage.

**MORGAN & TAYLOR,**  
 146, KING'S ROAD, CARDIFF.  
 Telephone 1239.

FOR SALE.—Tuning Inductance, complete; range 100-3,000 metres, almost new, price £3.—GILBERT TAIT, 137, Church Street, Chelsea.

WIRELESS CLUB SECRETARY, thoroughly conversant with all makes of wireless apparatus, desires progressive position where considerable clerical experience and organising ability would count.—Apply Box C, BERTRAM DAY'S ADVERTISING OFFICES, 9-10, Charing Cross S.W.1.

## LATHES.

The 1921 Velox 2 $\frac{1}{2}$ " centre Baby Super lathe is designed for Turning, Boring, Milling, and Gear-cutting. Price Complete £6 : 16 : 0. A. Plain lathe only. £2 : 16 : 0.

Further Particulars Stamp.

**VELOX TOOL CO.**  
 255, Westgate Road, Newcastle-on-Tyne.

**W. J. HENDERSON,**  
 2, Hollywood Road, South Kensington.  
 Aerial Stay Wre (aero cable), 15 cwt. breaking strain, sample on request, per 100 ft. 5 0  
 Strainers for above per dozen 7 6  
 Condensers, variable, Mk. III Type, 9 fixed vanes, 8 moving complete with scale and knob each 15 0  
 Leading-in Tubes, ebonite, with junction box length 8 $\frac{1}{2}$ " each 1 0  
 Valve holders each 1 6  
 Leyroy Tuners, 300-1,500 m., complete in carrying case, condenser alone worth the money each 40 0  
 Postage extra.

## GOODS BY WIRELESS

We cannot deliver goods by Wireless yet, but we can and do, make

— Prompt Deliveries: —

Give us a trial — Lists free.

**Electrical Supply Stores,**  
 5, Albert Terrace, King Cross, HALIFAX.

I Buy Wireless Gear of every description.

Send your particulars to:

**WILKINSON,**  
 Lonsdale Rd., Kilburn, N.W.6



Do you want a Better Job?

Ship Design.  
 Boiler Making.  
 Aeroplane Design.  
 Aero Engines.  
 Structural Engineering.  
 Civil Engineering.  
 Municipal Engineering.

Surveying and Levelling.  
 Reinforced Concrete.  
 Building Construction.  
 Sanitary Science.  
 Plumbing.  
 Heating and Ventilating.

Tell us which subject mentioned below interests you, we will then immediately post you on a very interesting FREE BOOK pointing out your chances of success and explaining how we can give you just that knowledge to qualify you for a BETTER JOB. We also help to place you in a good position with high wages. *WIFE TEACH BY POST* in your spare time and in your own home. The Directors of the Institute highly recommend each of these Postal Courses, not only to the OLDER MEN, but also to APPRENTICES, and to Parents of lads leaving school.

Wireless Telegraphy.  
 Electrical Engineering.  
 Electrical Installations.  
 Electrical Control Gear.  
 Alternating Current.  
 Lighting (Electric, Gas, etc.)  
 Telegraphy.  
 Telephony.  
 Power House Operation.  
 Mechanical Engineering.  
 Internal Combustion Engines.  
 Draughtsmanship.  
 Workshop Practice.

Machine Tools.  
 Electric Welding.  
 Mathematics.  
 Commercial Engineering.  
 Motor Engineering.  
 Elect. ic Motor Car Ignition.  
 Starting and Lighting Systems.  
 Boiler Inspecting.  
 Engineers' Quantities and Estimating.  
 Marine Engineering  
 Naval Architecture.

EXAMINATIONS:—We specialise in the following Exams.:—A.M.I.E.Mech.E.; A.M.I.E.E.; A.M.Inst.C.E.; A.M.I.A.E.; Board of Trade Marine 2nd Class, 1st Class, Extra 1st Class; City and Guilds Examinations in Telegraphy, Telephony, etc.  
 Write for this Book to-day. It may mean the turning point of your career. Do not forget to mention the subject which interests you.

**THE TECHNOLOGICAL INSTITUTE OF GREAT BRITAIN, LTD.**  
 32, Thanet House, 231 and 232, Strand, London, W.C. 2.





# MORE SELECTIONS FROM OUR LARGE STOCK OF ALL COMPONENT PARTS

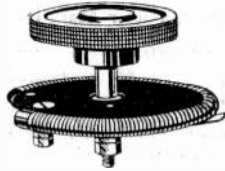

### FILAMENT RESISTANCES

Resistance wound on Erinoid Former, knob fitted with brass bush and pointer ... Price 5/6 each

### DIE CAST CONDENSERS

Fitted with counter balance weight and engraved revolving dial, exactly as illustrated.

'00035 ... .. 25/-  
'0011 ... .. 27/6

These are also specially designed for mounting on own panel.

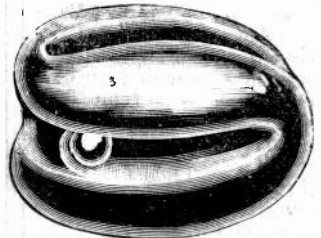
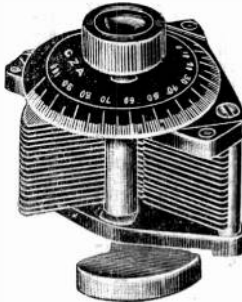

**EGG PATTERN INSULATORS**  
Suitable for stays or aerial. Light weight—Great strength. Price each 8d



### MICROPHONE BUTTONS

These are extremely sensitive, being made specially for detecting land operations, submarines, etc. Polished carbon diaphragm. Each 2/6 post free.

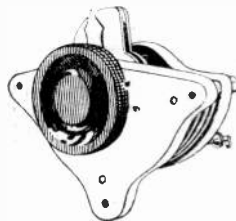

### A MOST USEFUL CONDENSER

For Fine Tuning  
Designed for panel mounting as illustrated. Price 6/9

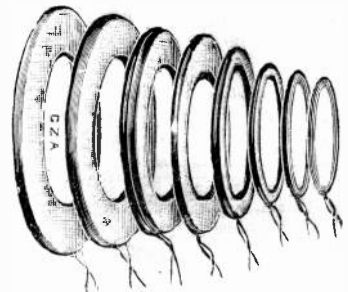

### SILK WOUND.

SLAB INDUCTANCES, per set of 8. Efficient for General purposes.  
λ 300—30,000 m. ... 15/-

We can now supply same mounted in ebonite cases, with pins and table holder for same. A Complete Tuner ... £3 10 0



**GRID LEAK** Mounted on Condenser Substantial : Reliable : Cheap

Leak between clips. Any value Complete ... .. 5/-  
Leaks only (with clips) ... .. 2/6  
Condensers ... .. 3/-



For Fine Adjustment.

**EBONITE KNOB**, fitted with brass bush and pointer, also 6" extended handle with knob as illustration 1/9



**VALVE LEGS**, with 2 nuts, lacquered. 3d. each

## WATCH

For our "DUPLIX" STATION TUNER

We invite enquiries for the manufacture of exclusive apparatus or parts, either Wireless or Scientific. Our works is fully equipped with modern machines, and only skilled workmen employed.



### IVORINE SCALES

Engraved 0—150  
Each 1/8

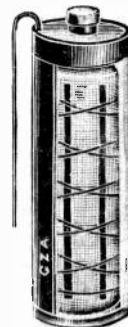

### THE NEW RECHARGEABLE H.T. UNIT

Exactly as illustrated. A Sac. element surrounded by a well-amalgamated zinc plate. Charge with ordinary Sal Ammoniac E.M.F. 1.5

Price 1/- each, 11/- doz.  
.. Larger 1/9 each  
19/- doz.

WORKS :  
**ELMORE STREET.**  
N. 1.

Phone: DALSTON 1405

## G. Z. AUCKLAND & SON

THESE GOODS CAN ALSO BE OBTAINED FROM :

**CORELLI & RELLY**, 48a, Grove Road, Eastbourne.

**WESTCOMBE WIRELESS SUPPLY**, 105, Eastcombe Avenue, Charlton, S.E.7.

OFFICES & SHOWROOMS :  
**395 ST. JOHN ST.,**  
**LONDON : E.C.**

## The OHMER INSULATION TESTING SET (COX'S PATENT)

This is the lightest, cheapest and best instrument of its kind on the market. It consists of an Ohmeter and Generator mounted in one case. The Ohmeter is of the Electrostatic type, giving extreme lightness. Absolutely unaffected by external fields. It reads directly in Megohms and is independent of the voltage or speed of the generator.

**NALDER BROS. & THOMPSON, LTD.,**  
97a, DALSTON LANE, LONDON, E.8.

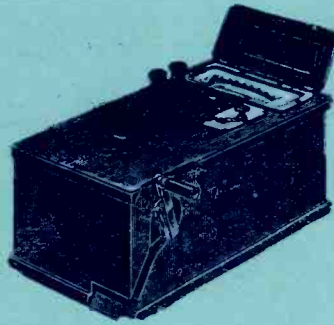

## ACCUMULATORS

SPECIAL OFFER—

ABSOLUTELY NEW — NOT EX-GOVVNT.

4 Volt.	40 amp.	...	...	18/6
4 "	60 "	...	...	21/6
4 "	80 "	...	...	24/6
4 "	100 "	...	...	29/6
6 "	40 "	...	...	24/6
6 "	60 "	...	...	32/6
6 "	80 "	...	...	35/6
6 "	100 "	...	...	44/6

ALL OTHER SIZES QUOTED FOR.

Large Stock DYNAMOS & ELECTRICAL ACCESSORIES

*Write for Lists. Good Discount to Trade.*

**F. YATES & SON,**

WHOLESALE ELECTRICIANS,

144 Church St., Kensington, London,

Phone—Park 4276.

W. 8

**SPECIAL PRICES**

## SUPER 3 VALVE AMPLIFIERS

Mounted throughout on Ebonite

EACH GUARANTEED  
to receive the Dutch Concert  
on a Standard G.P.O. Aerial  
within 100 miles of London

**Price £8 : 10 : 0**

*(excluding Valves)*

**L. JOHNSON**

HINDEHOUSE LANE, SHEFFIELD

Registered "NIPHAN" Trade Mark.

## WATER - TIGHT PLUGS AND CABLE COUPLINGS TO MEET HOME OFFICE REQUIREMENTS

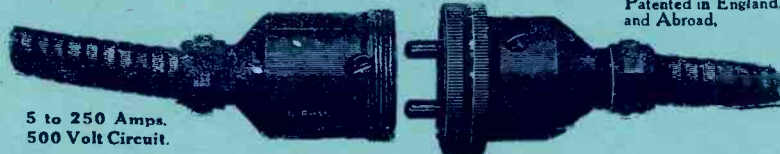

5 to 250 Amps.  
500 Volt Circuit.

COUPLING CONNECTING CABLES



3 WAY FEE.

As used by H.M. War Office, Electric Supply Companies  
Railway Companies, Marconi's Wireless Telegraph Co.

**SIMMONDS BROS., LTD.,**

4, 6 & 8, Newton Street, HOLBORN, W.C.

Phones: 2600 Gerrard

12061 Central.

Telegrams: "Niphon, London."

Patented in England  
and Abroad.

21  
50/100  
Widnes  
1889

**THE**  
**WIDNES**  
**FOUNDRY**

**COMPANY, LIMITED.**

**ESTABLISHED 1841**

---

---

**BUILDERS OF STEEL BRIDGES,  
PIERS, ROOFS, GIRDERS, & ALL  
KINDS OF CONSTRUCTIONAL  
STEEL AND IRON WORK.**

---

---

**ELECTRICAL TRANSMISSION MASTS**

---

---

**CHEMICAL PLANT MANUFACTURERS  
SEGMENT AND PIPE FOUNDERS  
CASTINGS OF EVERY DESCRIPTION**

**Contractors to the Admiralty, War Office,  
India Office, and Crown Colonies. The  
leading British, Foreign and Indian Railways**

---

---

*Works :*

**WIDNES, LANCS.**

*Telegrams :* "Foundry Widnes."

*Telephone :* No. 225 Widnes.

*London Agents :*

**GEORGE F. WEST & CO.,**

**IDDESLEIGH HOUSE,**

**CAXTON STREET, S.W.1**

*Telegrams :* "Westeelite, London."

*Telephone :* 4340 Victoria.



Engineering  
Library.

# The WIRELESS WORLD



FORTNIGHTLY]

18th FEBRUARY, 1922.

PRICE 6<sup>D</sup>. NET

## BURNHAM & CO WIRELESS BURNDDEPT APPARATUS

MANCHESTER DEPÔT  
4, CORPORATION STREET

DEPTFORD, LONDON, S.E. 8.

LONDON RETAIL DEPÔT.  
19, HAND COURT, HIGH HOLBORN, W.C.

LEEDS DEPÔT: 48, GT. GEORGE STREET.

### THE BURNDDEPT ULTRA IV RECEIVER



This is a newly designed receiver somewhat on the lines of the famous ULTRA III but with an additional note magnifier and an additional switch so that head phones can be immediately changed over to LOUD SPEAKER. Extra terminals are also arranged so that PRINTER—MICROPHONE RELAY or other auxiliary apparatus can be added without interfering with the telephones, which can be used at the same time if desired. The well-known ULTRA features are retained giving individual control of each valve by change-over switches and separate rheostats so that each valve can be worked at its best point. This set will give all the magnification required to work a Loud Speaker at sufficient strength for an ordinary room, also to work a printing circuit using the ordinary type sensitive relay.

PRICE—In sloping cabinet as illustrated :

**£35 0 0** (valves extra)

PRICE for complete set including Receiver, Tuner on Sloping Panels, four M.O.V. Valves and complete set Burndept Coils

**50 Gns. NET.**

Extras required to complete set : Tuning Panel including 2 condensers and coil holder on sloping panel, £7 10/-, SET BURNDDEPT PATENT COILS to cover all wavelengths, £5 17/6. Four Marconi Osram Valves, £5 9/6.

NOTICE—New Showroom at Leeds is now open. Please see address above.



# WESTON GALVANOMETER

Model 375 Galvanometer is a moving coil instrument with a uniformly divided scale 2.35 inches long. Its resistance is approximately 29 ohms and the current required for a millimeter (1 scale division) deflection is 20-25 micro-amperes.



**WESTON ELECTRICAL INSTRUMENT CO., LTD.**  
Audrey House, Ely Place, Holborn, E.C.

Telephone: HOLBORN 2029.

Telegrams and Cables: "PIVOTED, LONDON"

## FOR RADIO PANELS USE Condensite Celeron

This material is waterproof, immune to atmospheric and climatic conditions, will not warp, has high surface and volume resistivity, high dielectric strength, low specific gravity.

Read this table of standard tests

WAVE LENGTHS	APPROX. FREQUENCY	PHASE DIFFERENCE	DI-ELECTRIC CONSTANT
Metres.	Cycles per second.	Degrees	K
373	804,000	2.0	4.7
1,295	231,500	1.8	4.8
3,067	97,800	1.8	4.9

We supply this material in standard size sheets, Rods, tubes or any special component parts.

*Any further information will be sent you on enquiring from us.*

**THE DIAMOND FIBRE Co., Ltd.**  
High Road, South Tottenham, London, N.15

## ACCUMULATORS

SPECIAL OFFER—

ABSOLUTELY NEW — NOT EX-GOVMT.

4 Volt.	40 amp.	...	...	18/6
4 ..	60 ..	...	...	21/6
4 ..	80 ..	...	...	24/6
4 ..	100 ..	...	...	29/6
6 ..	40 ..	...	...	24/6
6 ..	60 ..	...	...	32/6
6 ..	80 ..	...	...	35/6
6 ..	100 ..	...	...	44/6

ALL OTHER SIZES QUOTED FOR.

Large Stock DYNAMOS & ELECTRICAL ACCESSORIES

*Write for Lists. Good Discount to Trade.*

**F. YATES & SON,**  
WHOLESALE ELECTRICIANS,

144 Church St., Kensington, London.  
Phone—Park 4276. W.8



9 No 50

# TELEPHONY TRANSMITTERS

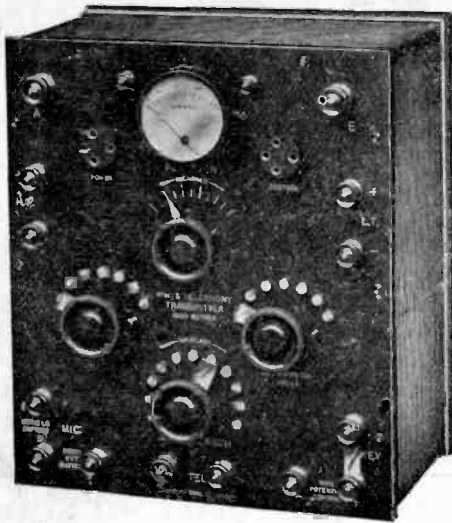

## TYPE "F."

Constructed on the choke control principle and adjustable for highest efficiency on any plate voltage from 100 to 2000 volts. Gives 1 ampere in aerial, 1000 metres, with 150 volts dry cell.

Price . . £16 0 0

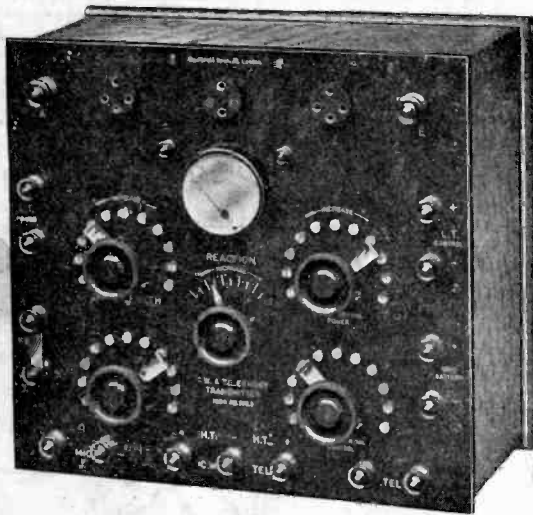

## TYPE "H."

The ideal transmitter for duplex telephony. The Microphone controls the supply of current from the generator to the oscillator, shutting off practically all generator current till speech takes place. (The microphone does not carry the H.T. Current). Consequently the normal aerial current is extremely small and rises to large values during speech. The modulation is excellent, the valves are quite cool, and the power consumption low.

PROV. PATENT NO. 33550.

Price . . £18 15 0

*Demonstrations given at our Works.*

**GAMBRELL BROS., LTD.** MERTON ROAD,  
SOUTHFIELDS,  
S.W.18



# ELECTRICAL AND Mechanical Engineers

*Contractors to the Admiralty, War Office & Air Force*

*Manufacturers of . . . .*  
**MARCONI'S WIRELESS DISC DISCHARGERS.**  
**ROTARY CONVERTERS.                      DYNAMOS.**  
**ELECTRIC MOTORS.                      TRANSFORMERS.**  
**BOOSTERS.                      BOX HIGH VACUUM PUMPS.**

COMPLETE ELECTRIC LIGHT INSTALLATIONS

For Country Houses and Yachts.  
Lighting Sets for Motor Cars and  
Aeroplanes.                      Estimates Free.

AN EFFICIENT STAFF FOR REPAIRS

*Inventors' ideas carefully and skilfully  
carried out from the preparation  
of detailed drawings to the completion  
of the finished article    ::    ::    ::*

## W. MACKIE & CO

ESTABLISHED 1882

THE PALACE ENGINEERING WORKS  
129, 131, 133, Lambeth Road, London, S.E.1

TELEPHONE 182 HOP



**TINGEY UNITS WIRELESS MADE EASY TINGEY UNITS**

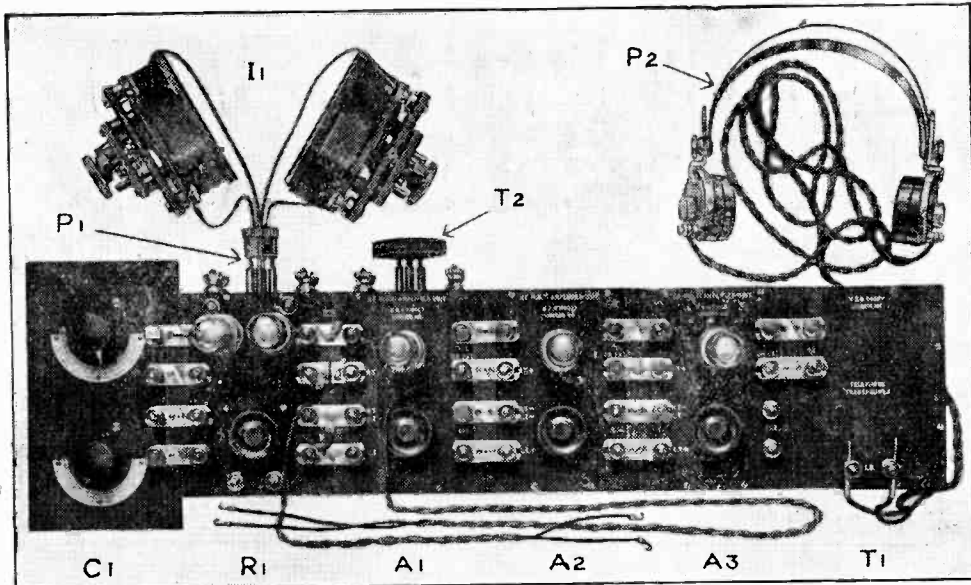

	£	s.	d.		£	s.	d.
C1. CONDENSERS. One pair mounted in case	4	0	0	I1. INDUCTANCES. C. Coil—5000-24000 metres. with approximate calibration	2	10	0
R1. RECEIVERS (without valves)	3	10	0	J1. JUNCTION BRACKETS	0	5	0
A1. MULTI H.F. AMPLIFIER TRANSFORMER UNIT, to be used with Interchangeable Transformers. Price, without Interchangeable Transformers	2	0	0	J2. " " with four leads	0	6	6
A2. MULTI H.F. AMPLIFIER UNIT, Choke and Resistance type	3	0	0	J3. " " with two leads	0	6	0
A3. MULTI L.F. AMPLIFIER UNIT	3	0	0	J4. " " "	0	3	0
A4. MULTI H.F. AMPLIFIER UNIT, without inductances or variable condenser	2	0	0	J5. " " "	0	5	0
A24. COMBINED UNIT, tuned or stand-by position	3	0	0	J6. " " with four leads	0	6	6
T1. MULTI TELEPHONE TRANSFORMER UNIT	1	15	0	J7. " " "	0	4	0
I1. INDUCTANCES. A. Coil—200-1600 metres, with approximate calibration	1	0	0	J8. " " with two leads	0	6	0
INDUCTANCES. B. Coil—1000-8500 metres, with approximate calibration	1	10	0	P2. BROWN'S PHONES (D Type), 60 ohms Per pair "ORA" MULLARD'S VALVES	2	8	6
				P1. INDUCTANCE PLUGS		0	15
				T2. INTERCHANGEABLE TRANSFORMERS			Application

**WIRELESS MADE EASY.**

Since my advertisement in the last issue, another Amplifier Unit has been designed. It is practically the last word in High-Frequency amplification. It is a combination of the A 2 and A4 previously mentioned.

Its action is roughly as follows:—Primarily this amplifier Unit is a tuned high-frequency Amplifier of the most efficient type. Any Inductance and Condenser can be attached thereby, making it flexible, and capable of being tuned to any wavelength.

As is well-known, an Amplifier containing many such Units is difficult to manage, but I have overcome the difficulty in these latest Units by a change-over Switch, the function of which is to turn this tuned frequency Unit into an untuned choke resistance type, and so, without any changing of the wiring whatsoever a number of these A24 Units can be employed; firstly, with all their switches in stand-by position, that is acting as resistance Amplifiers untuned. When the signal that is desired has been heard, the first of the A24 Units can be changed easily into a tuned high-frequency Unit by bringing the Switch over to the tuned side.

When the station has been tuned in and made correspondingly louder by this means, the second A24 Unit can be treated in exactly the same way. I think all experimenters will agree that this is an ideal method.

This is only the first of many developments that I am offering the Amateur with these Units. During all experimental tests I have found them to be ideal as it enables one to perform over double the number of experiments in a given time, owing to the extreme ease with which an individual Unit can be taken out, altered, and inserted again. These Units can be considered as a great step towards helping the Amateur to do useful experiments, and at the same time to keeping all his wiring neat.

I have also found these Units invaluable for Transmitting, both on the modulating side and on the H.F. side, and no doubt soon you will see Transmitting Units of exactly the same design and size, advertised by me.

The popularity of these Units has already been shown, and gives me great encouragement. Up to date I have sold all that have been made, even including my own Lecture set. We are now increasing our output of these Units so as to keep up with the demand.

An interesting feature in all my apparatus is that not only is magnetic reaction not employed, but great care has to be taken to avoid it. This set, like all others, oscillates with the greatest of ease without reaction, and special precaution has to be taken if oscillation is not required.

**Apply for Price List and Pamphlet on Tingey Units Post Free.**

Office and Works  
Telephone:  
1916 Hammersmith

**W. R. H. TINGEY**  
:: Specialist in Wireless ::

Offices and Showrooms  
92, Queen Street,  
Hammersmith, W.6



THE Edison Swan Electric Company Ltd are manufacturers of all the following electrical supplies:

ACCESSORIES  
ACCUMULATORS  
BELLS AND ACCESSORIES  
CIRCUIT BREAKERS  
DECORATIVE FIXTURES  
DRY CELLS  
ELECTRIC FIRES AND  
RADIATORS  
FANS AND VENTILATORS  
HEATING AND COOKING  
APPLIANCES  
SILK SHADES

INDUSTRIAL FITTINGS  
INERT CELLS  
INSTRUMENTS, INDICATORS  
INSTRUMENTS, METERS  
IRONCLAD SWITCHGEAR  
LECLANCHE CELLS  
"LITTLE GLUTTON"  
VACUUM CLEANER  
OIL SWITCHES  
TELEPHONES AND  
ACCESSORIES  
WIRES AND CABLES

AND

ROYAL  
"EDISWAN"

ELECTRIC LAMPS  
FOR EVERY PURPOSE

(Fully Licensed under Patent Nos.  
23499/09, 10918/13 and others.)

Let us know in which particular item you are interested and we will send you details.

THE EDISON SWAN ELECTRIC COMPANY LIMITED  
PONDER'S END - - - MIDDLESEX

LONDON SHOWROOMS:

123/125, Queen Victoria St., E.C.4. 71, Victoria St., S.W.1

**STILL ANOTHER SUCCESS**  
**WHY PAY MORE FOR THE VERY BEST**  
**THE HETERODYNE RECEIVER**  
**1, 2 and 4 VALVE**  
**SUPER AMPLIFIERS**

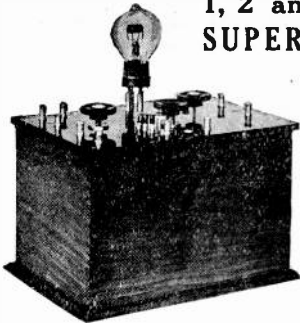

These instruments were the centre of attraction at the recent Birmingham Exhibition and pronounced by the public as being the best and most powerful in the building. They are specially designed to receive long-distance Telephony and music. The following are some of those heard every day with distinct clearness:—

Paris Time Signals and Telephony, Le Bourget, Croydon, Lympne, Chelmsford, Aeroplanes crossing the Channel. The Dutch Concerts can be enjoyed in your armchair every Sunday afternoon.

Amateurs should buy only the best.

PRICES—Single Valve Receiver	£4 15 0	with valves
Single Valve Amplifier	3 5 0	" "
Two Valve Amplifier	5 15 0	" "
Four Valve Amplifier	10 0 0	" "

Send for my Illustrated List before buying elsewhere.

**T. H. ISTD,** Wireless Engineer **Terling, Witham, Essex.**

**SLAB INDUCTANCES.**

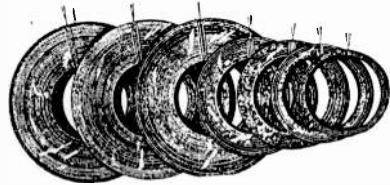

Per set of 8, range 300 to 30,000 metres, 15/-, postage 9d. Per set of 7, range 300 to 25,000, 12/6, postage 9d. Including a set of curves, one on each slab, and suitable circuits.

Each coil specially tested before dispatch, and delivered in sealed box.

These Inductances are useful as Aerial Tuning Inductances, Reaction Coils, Loose Couplers, Variometers, etc., and specially useful with stand and holder, see Radio Constructa advertisement on page xxi.

**A BATTERY OF MERIT.**

36-volt H.T. Battery with wander plug for varying voltage in steps of 3 volts. This Battery is made from a special formulae, giving exceptionally long life and silent working. Made specially to withstand climatic conditions. 7/6 each. Postage 9d. 15 volt—3 Terminal, 3/6.

**H. D. BUTLER & CO.,**

Showroom and Works: **61, Borough Road, Borough, S.E. 1**  
 3 minutes from Borough Tube Station.

Office: **BANK BUILDINGS, 222, G.T. DOVER ST., S.E. 1**

(Opposite Borough Tube Station)

Telephone: Hop 3029. Teleg. "Ingenuity, Phone, London."

All our goods obtainable at the  
**Army & Navy Co-Operative Society, Ltd.,**  
 105, Victoria Street, S.W.



TRADE MARK

**The WHITECROSS**  
**COMPANY, LIMITED**  
**:: WARRINGTON ::**

Manufacturers of All Descriptions of

**WIRE ROPES**  
**AND WIRES**

**At Low Prices**

SPLENDID

**TELEPHONY**  
**TRANSMITTERS**

900 to 1,200 metre wavelengths  
 Ebonite and Mica Insulation throughout

COMPLETE WIRING  
 DIAGRAM WITH EACH

**SINGLE SET £15**

(not including valves)

*Special quotations for quantities*

If not satisfied money refunded within 10 days

**L. JOHNSON**

**Hindehouse Lane, SHEFFIELD**

# "R" TYPE VALVES

Price 11/6 post free

Mr. W. Corsham used these Valves and got signals in the Transatlantic Tests.

**RUSSELL & SHAW, 38, Great James Street, Bedford Row, W.C. 1**

"ORA" VALVES (Mullard) - 15/-

Valveholders - - - 1/6, 1/9, 2/3

36 volt H.T. Batteries 8/- - 15 volt 4/-

Filament Resistances 3/9, 5/-, 12/6

All Lines cheaper to Callers, Registration 4d.

# THE WIRELESS WORLD

THE OFFICIAL ORGAN OF THE WIRELESS SOCIETY OF LONDON  
A MAGAZINE DEVOTED TO WIRELESS TELEGRAPHY AND TELEPHONY

## CONTENTS

New York Radio Central	711
Transatlantic Tests (Further Descriptions of Apparatus)	714
Model Engineer Exhibition	721
Receiving Circuits. By Crispin C. Redshaw, Assoc. I.R.E.	724
Wireless Society of London (Annual Reports and Balance Sheet)	728

*Contents continued on next page.*

## RADIO TELEPHONY & TELEGRAPHY

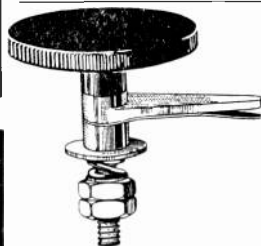

RS/91

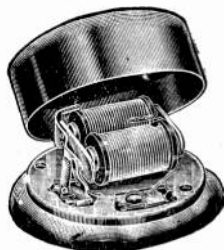

RS/52

**VALVE HOLDERS**, as illustrated, solid ebonite, 2/3. Ditto with large flange, 2/3 each.

**CONDENSERS**, fixed capacity, copper foil and mica, capacities guaranteed, .0001 to .0003 mfd., 4/2 each; .001 to .005 mfd., 5/- each; .01 to .05 mfd., 6/4 each.

**BUZZERS**, as illustrated, round or square type, 5/- each.

**KNIFE SWITCHES**, on porcelain base, carrying capacity 25 amps., 2/3 each.

**SHELL INSULATORS**, as illustrated, the finest made, size A, 1/8 each; size B, 2/2 each.

**SWITCH ARMS**, 1 1/4" radius, with phosphor bronze arm, complete with ebonite knob, spindle, bushing nuts, and spring washer. 4/-, 5/6 and 6/- each. All well made and thoroughly reliable for hard wear.

**FILAMENT RESISTANCE**, wound to 5 ohms. Superfine instrument of finest manufacture. Length, 5", height 2". Price, 18/-. Circular type for mounting in panels, complete with bushing, spring washer and washers, etc., 12/6 each.

### NOTE.

We have in stock a limited number of well-known American made Variable Condensers, air dielectric, in transparent case with ebonite top and bottom, fitted with graduated scale, pointer, knob, etc. To clear at exceptional prices. Capacity .001 mfd., 30/-; .0005 mfd., 25/-. Also pattern as above for fixing in panels, self-supporting, complete with fixing screws, scale, knob, etc. Capacity .001 mfd., 25/-.

Also a number of perfectly new Sullivan head 'phones, complete with cords. Resistance 120 ohms. All guaranteed in absolutely perfect condition. Per pair, 5/-. Postage extra. Cannot be repeated at the price.

Illustrated Catalogue, 7d., post free.



RS/114

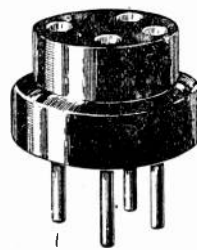

RS/58

**RADIO SUPPLIES** DEPT. 1, 236, HIGH HOLBORN, LONDON, W.C. 1

'Phone—Museum 6894.

**MEN IN THE WIRELESS SERVICES DESIRING RAPID ADVANCEMENT**

should train in spare time with the College which ensures this.

"U.E.C." (Regent's Park, London, N.W.1) has in Twelve Years secured hundreds of successes by Individualised Postal Training for Engineering Examinations and Professional Work.

State YOUR ambition, in confidence, to—SECRETARY'S DEPT. (Desk W.),

UNIVERSITY ENGINEERING COLLEGE, WESTGATE-ON-SEA, KENT,  
and expert advice with the New Prospectus, No. 8, will be sent you without obligation.

## CONTENTS (Continued)

Wireless Club Reports	730
Experimental Stations (Directory of Call Signs)	737
Correspondence	739
Questions and Answers	741
Share Market Report	746

THE WIRELESS WORLD is published fortnightly on alternate Saturdays.

All correspondence relating to contributions should be addressed to THE EDITOR, THE WIRELESS WORLD, 12-13, Henrietta Street, London, W.C.2.

No responsibility can be taken for MSS. or photographs sent without stamps to defray cost of return postage.

Editorial and Publishing Offices, 12-13, Henrietta Street, Strand, London, W.C.2.

Telegraphic Address: "Radionic, Rand, London." Telephone No.: Gerrard 2807.

Advertisement Managers, Bertram Day & Co., Ltd., 9 & 10, Charing Cross, S.W.1.  
Telephone No.: Gerrard 8063 and 8064

### SUBSCRIPTION RATES.—

17s. per annum, post free. Single Copies 6d. or post free 8d.

Registered at the G.P.O. for transmission by Magazine Post to Canada & Newfoundland.

## COUBRO & SCRUTTON, LTD.

Telegraphic Address:  
Coubro, Fen., London.

Head Office: 18, Billiter Street, London, E.C.3

Telephones:  
East 7, 716, 717

**MAKERS OF WIRELESS MASTS AND ACCESSORIES**

*ENGINEERS & SMITHS, FOUNDERS,  
MAST MAKERS AND RIGGERS*

Contractors to Admiralty, War Office, India Office, and Colonial Governments.

# SHORT-WAVE AUTODYNE RECEPTION

Wavelength Range, 150 to 750 metres

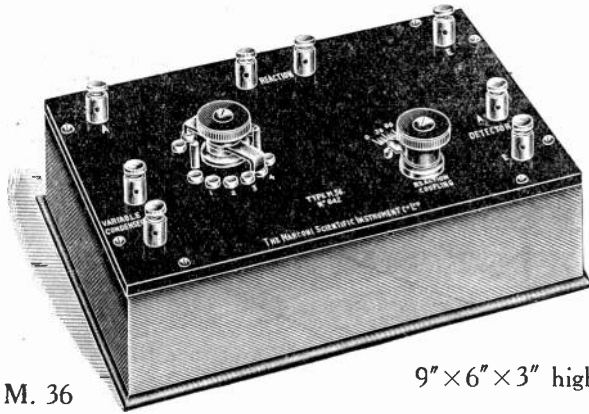

M. 36

9" x 6" x 3" high

Amateurs have realised the advantages offered by the emission of waves of short length, and a number of stations are employing them for the transmission of Telephony and Telegraphy.

The Type M. 36 Tuner represents an efficient solution of the problems involved in the reception of these waves. It is fitted with a magnetic reaction coupling and marks an entire departure from the type of apparatus designed with the belief that the insertion of a series capacity represents the sum total of possible achievement. It is not necessary to employ a grid condenser and leak in the associated rectifying circuit as these are embodied in the Tuner. An air condenser of not less than .00035 mfd. variable capacity should be attached to the terminals marked. Valves having little self-capacity, such as the "V 24" type, should be employed.

# RADIO-FREQUENCY AMPLIFICATION of WIRELESS TELEPHONY

Amateur interest in the rapid commercial development of Wireless Telephony has resulted in our receiving many inquiries for a multivalve radio-frequency Amplifier giving optimum amplification on the wavelengths employed in Telephonic communication. The Unit 12 five-valve Amplifying Detector is an instrument fulfilling this requirement. It possesses the additional advantage of highly efficient performance over the comprehensive waverange of 500 to 30,000 metres. This is rendered possible by the application of two distinct methods of intervalve coupling, each yielding maximum responsiveness over a definite band of wave-frequencies. The first three valves effect progressive amplification of oscillatory currents, the fourth functions as a rectifier, and the fifth magnifies the resultant note-frequency pulses. By manipulation of the selector clip, either two, three, four, or five valves may be used, but the sensitivity of the Amplifier is such that it is not as a rule necessary to utilise maximum amplification, particularly in the reception of speech and music. Fidelity of reproduction, absence of microphonic effects, and noiseless operation constitute other features which will be instinctively appreciated.

UNIT 12

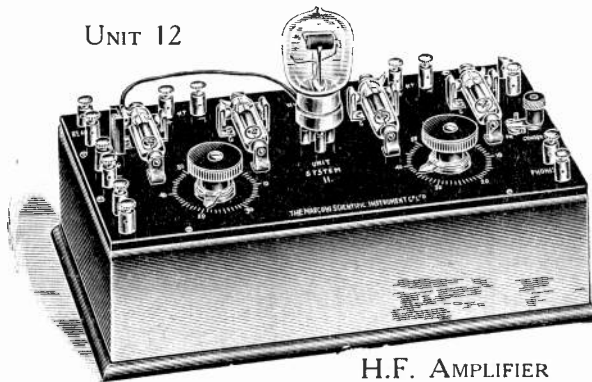

H.F. AMPLIFIER



**WRITE FOR PAMPHLET 12**



## THE MARCONI SCIENTIFIC INSTRUMENT CO., LTD.

Works : 21/25, St. Anne's Court, Dean Street, Soho. 'Phone : Gerrard 7745

Showrooms : 40, Dean Street, Oxford Street, W.1

## THE "BROWN" MICROPHONE AMPLIFIER

This Amplifier magnifies signals, or music, without distortion, and is of considerable interest to amateurs and scientific investigators. The Magnification is much greater than that obtained from two valves, and the current consumption is about 50 milliamps. In construction, this instrument is simple, and it is much more robust than other sensitive relays of this class. This instrument satisfies the urgent demand for a reliable, inexpensive amplifier, which the most inexperienced amateur can use, and which the most experienced requires. It is much cheaper, ultimately, than a multi-valve amplifier, and the operator is relieved from many of the varied causes of breakdown. It includes a transformer suitable for low resistance telephones or loud speakers. The price of the "Brown" Microphone Amplifier is £8 for low resistance (120 ohms) and £8 2s. 6d. for high resistance (2,000 ohms).

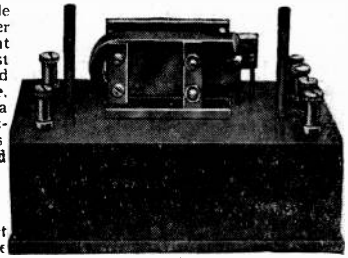

## THE "BROWN" LOUD SPEAKER

With an Amplifier signals or telephony may be so magnified as to cause discomfort to wearers of head-phones, yet not be loud enough to be audible at any appreciable distance from the head. Every wireless experimenter sometimes wishes to let his friends hear, which would involve the use of several pairs of telephones simultaneously with consequent loss of signal strength, as well as considerable expense. The "Brown" Loud Speaker was designed to meet this need efficiently and economically, and is used in all up-to-date receiving stations. The sound is intensified by means of a horn.

The "Brown" Loud Speaker (80 ohms or 120 ohms) .. £5 10 0      Wound to special high resistance.. up to £5 15 0

## THE "BROWN" SUPER-SENSITIVE TELEPHONES FOR WIRELESS, ETC.

These Telephones are unquestionably the clearest and most sensitive made, and, consequently, increase the distance over which the wireless can be heard.

IN UNIVERSAL USE.		As supplied to British, Allied and Foreign Governments.	
The "Brown" "A" Type Radio Headphones—			
Low resistance .. .. .	.. .. .	.. .. .	per pair 2 18 0
High resistance .. .. .	.. .. .	.. .. .	per pair 3 2s. and 3 6 0
The "Brown" "D" Type Headphones (Improved flat diaphragm type)—			
Low resistance .. .. .	.. .. .	.. .. .	per pair 2 8 0
High resistance .. .. .	.. .. .	.. .. .	per pair 2 12 0

The above telephone prices include Cords.

Sole Manufacturers: **S. G. BROWN, LTD.,**

**SHOWROOMS** where the above instruments may be inspected **19, MORTIMER STREET, W.1**

Works: **Victoria Road, North Acton, London, W.3.**

Telegrams: "Sadbrownix, London."      Telephone: Chiswick 1469.  
Sole Agent for the Argentine: Horacio D. Guerrero, Las Heras 2480, Buenos Aires.

**EBONITE AND  
VULCANITE**

TUBES—RODS—SHEETS

LARGE  
STOCKS

**BRITANNIA RUBBER AND  
KAMPTULICON CO., LTD.**  
7, NEWGATE ST., LONDON, E.C.1

Telephone:  
2168 Central

Telegrams:  
Britannia, London

ESTABLISHED 1809.

**NORTH BRITISH  
& MERCANTILE  
INSURANCE COMPANY  
LIMITED**

**FIRE LIFE**  
ACCIDENT ANNUITIES  
BURGLARY MARINE

FUNDS

**£25,746,000**

**INCOME - - £9,110,000**

Chief Offices:

LONDON: 61, Threadneedle Street, E.C. 2.

EDINBURGH: 64, Princes Street.

# THE WIRELESS WORLD

THE OFFICIAL ORGAN OF THE WIRELESS SOCIETY OF LONDON

VOL. IX. No. 50.

FEBRUARY 18TH, 1922

FORTNIGHTLY

## New York Radio Central

**T**HE high-power wireless station, which is being erected near Port Jefferson, Long Island, about 70 miles from New York, is designed for international wireless communications. The station was formally opened by President Harding, on November 5th, 1921, with a message of greeting to the world.

The station has been planned by the engineers of the Radio Corporation of America, in conjunction with the General Electric Company of America. The station is designed to supplement the existing communication facilities of the U.S.A., and to provide direct radio services with Great Britain,

for simultaneous radio communication over a number of different routes. Fig. 1 is a bird's-eye view of the station as originally planned.

In the pioneer days of high-power radiotelegraphy a station functioned alternately as a transmitter, a receiver and a telegraph office. This involved much loss of time and greatly reduced the traffic facilities, for a station had to stop sending while it received, and *vice versa*. It therefore became apparent that the ideal radio station should comprise three separate but closely connected units operated by remote control, these units comprising respectively the transmitter, the receiver, and the



Fig. 1. A Bird's-eye View of Radio Central.

France, Norway, Germany and other European countries as well as with South America.

The site of the station occupies an area of some 6,400 acres, and the station will eventually consist of a number of separate antenna systems, each provided with the necessary transmitting plant

central traffic office, the latter preferably in the heart of the business district in large cities.

In the case of the New York Radio Central, the first two of these units are located at Long Island and the third in New York City. The transmission plant is located at Rocky Point, some seven miles



east of Port Jefferson, on the northern shore of Long Island. The receiving station is at Riverhead, L.I., about 16 miles from the transmission plant, and has been so planned as to be able to receive simultaneously messages from as many countries as can be communicated with simultaneously by the transmitting station. The central traffic office at 64, Broad Street, New York City, is fitted with special remote control apparatus for operating the transmitters direct from that office. The

commenced in July, 1920, and the first test signals from the first part of the station were sent out in October, 1921. This is considered to be a record in the building of high-power equipment, considering the great amount of work that has been carried out on the station.

The aerial transmitting system was originally planned to comprise twelve arms for the various communication routes, these arms radiating out from the central power house like the spokes of a

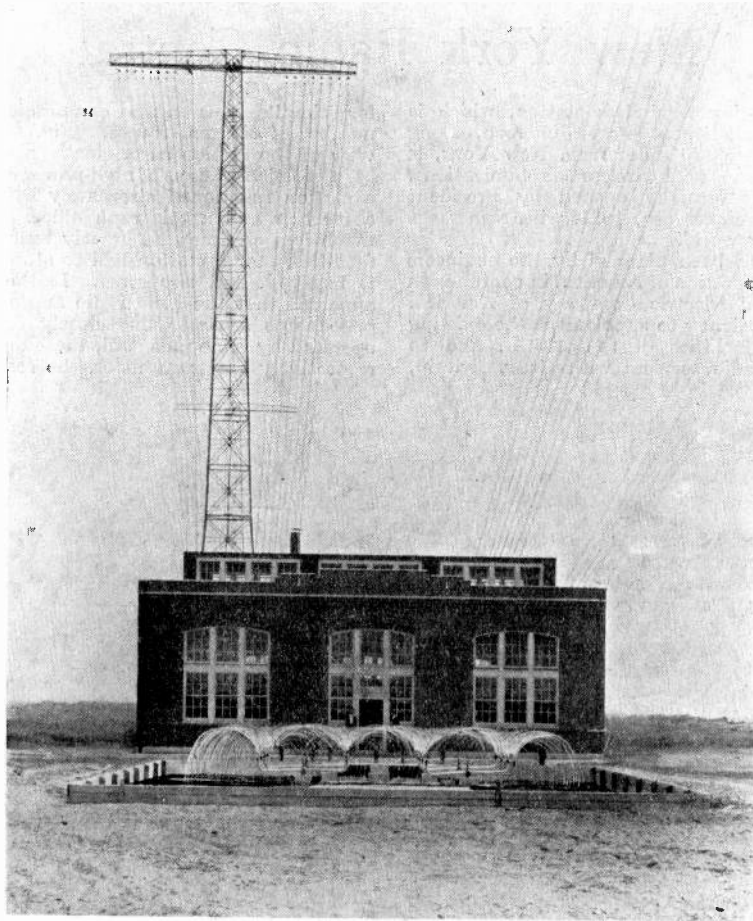

Fig. 2. View of the Power House showing the Cooling Pond in foreground.

incoming signals picked up at the Riverhead receiving station are also automatically transferred over the landlines to the central traffic office. The incoming signals can there either be transcribed by ear or automatically received on recording apparatus.

The construction of the Radio Central Station was

wheel. Up to the present two arms of the aerial system have been built, each arm having six towers 410 ft. in height. The distance between adjacent towers is 1,250 ft., giving a total of nearly three miles from end to end of the line of twelve towers already erected (Fig. 3). Each tower required nearly 150 tons of steel, the total amount used in

## NEW YORK RADIO CENTRAL

the twelve being 1,800 tons. The cross-arms from which the antenna wires are suspended on the top of each tower are each 150 ft. long. The steel work incidental to the construction of the towers and station buildings was erected by the American Bridge Company under the supervision

Each antenna is of the Alexanderson multiple-tuned type—*i.e.*, it is provided with several earth connections along its length, each connection including a tuning coil, these coils being set up in the open air.

The foundations for the twelve towers necessitated

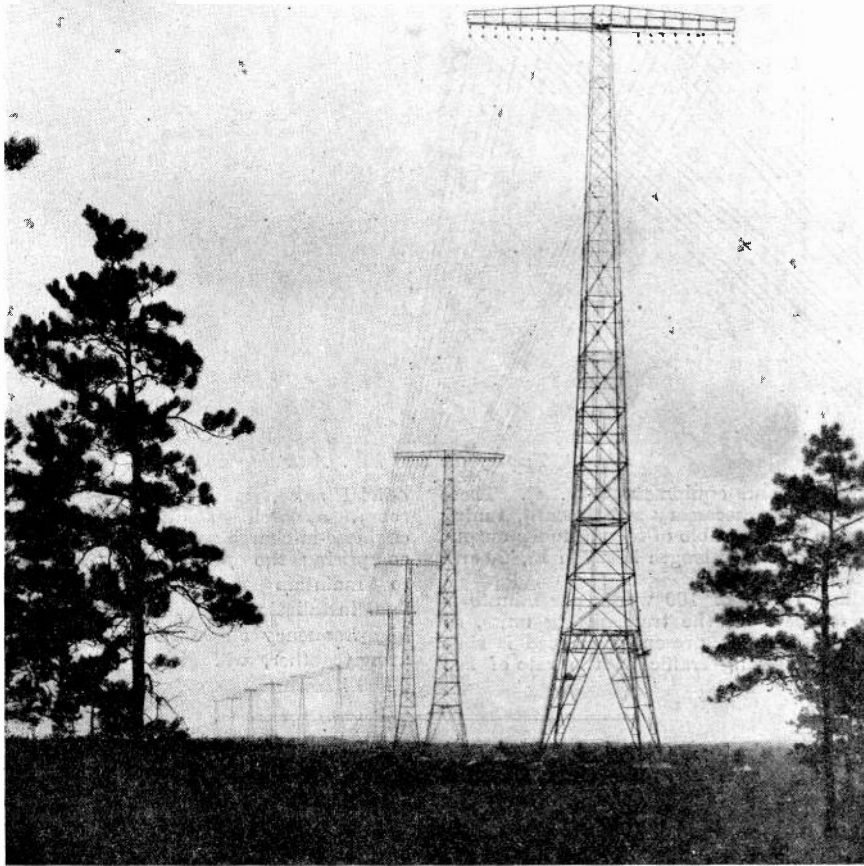

*Fig. 3. The first twelve Towers of the Aerial System.*

of the J. C. White Engineering Corporation of New York. The 23,000 volt transmission lines by which energy is supplied to the station run from Port Jefferson, a distance of seven miles, and were erected by the Long Island Lighting Company. The control lines between the transmitting and receiving stations and New York City were erected by the New York Telephone Company.

the use of 8,200 tons of concrete since the base of each tower leg is sunk 9 ft. below the ground level and has a base area of 360 square ft.

For the construction of each arm of the antenna 16 stranded silicon-bronze cables,  $\frac{3}{8}$  in. in diameter, are used, 50 miles of this cable having been employed in the two above-mentioned antenna arms. Four hundred and fifty miles of copper wire have already

been buried in the ground to form the earthing system. The erection of the remaining arms of the whole antenna system is now being proceeded with and will eventually comprise 72 towers.

The first power-house section is located in the centre of the tower line, shown in Fig. 3, and covers a space of 130 ft. by 60 ft. (Fig. 2). It accommodates two 200 kW. high-frequency alternators

The reports of the reception of the opening message and of the preliminary test signals have shown that the range of the station is practically world-wide since its signals have been heard in all parts of Europe, in Australia, in South America and in Japan.

The Community House for the staff is a low one-storeyed building containing 16 single rooms, an

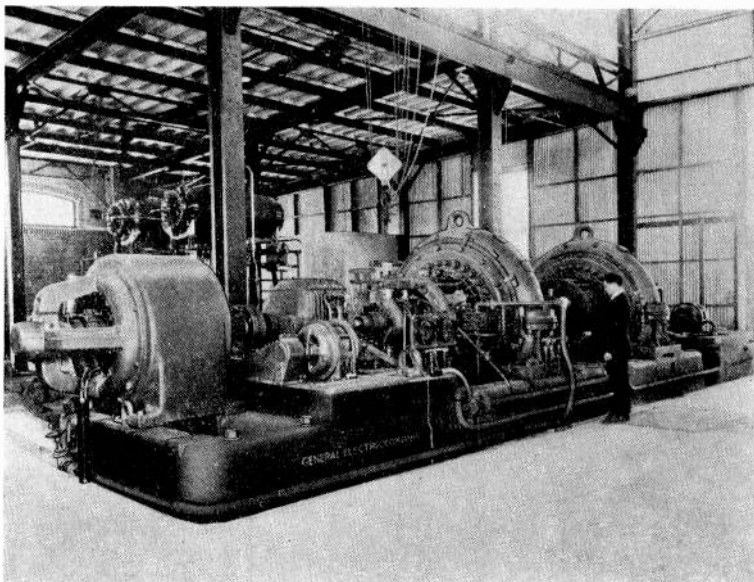

Fig. 4 Two of the 200 kW. Alternators.

with auxiliaries and equipment (Fig. 4). These machines, with the necessary switchboard, tuning coils, etc., are each capable of a continuous output of 200 kW. at any wavelength between 15,800 and 20,000 metres.

A signalling speed of 100 words per minute is attainable for each of the transmitting units, so that the equipment at present completed is thus capable of despatching traffic at the rate of 203 words per minute.

official suite, a large living-room and dining-room, as well as quarters for servants, the engineer-in-charge with a staff of 15 assistants, comprising the *personnel* at present necessary to maintain the station in operation. The final installation will include ten Alexanderson high-frequency alternators which, when all operating together, will give a total power output of 2,000 kilowatts.

## The Transatlantic Tests

### FURTHER DESCRIPTIONS OF APPARATUS USED FOR RECEPTION

**I**N our last issue we published descriptions of the apparatus used by those British amateurs who were most successful in the reception of the American signals during December. In the following pages we are printing accounts of the other sets on which the signals were heard. These will be found to contain several features of interest, and they also show that the reception of American amateur signals during the most favourable transmission periods has been effected with quite simple apparatus. In view of this there is not the slightest reason why many British radio experi-

menters should not listen in at any time for the signals from our American friends, since it should be remembered that all the American stations who were taking part in the special tests during December are working every night of the week handling amateur traffic amongst themselves, and passing relay messages across the continent. In addition to this telegraphic traffic between both spark and C.W. stations, there are regular telephone transmissions from a number of stations. Of these one in particular may be mentioned, viz., **WJZ** at Newark, N.J., which is operated by the Westinghouse

## THE TRANSATLANTIC TESTS

Electric Co. This station makes daily telephonic transmissions on a wavelength of 360 metres between 1.20 a.m. (0120) and 2.15 a.m. (0215) G.M.T. We shall be glad to hear from anyone in this country who hears the transmissions from this station, or those from any other American amateur station.

We have recently received reports from various parts of the country of the interception of telephonic transmissions on 200 metres from two stations using American call signs, and inquiries are on foot

to verify these transmissions, if possible. Should these signals really turn out to have an American origin, and to be sent under amateur license conditions, another milestone would have been reached in the road of progress with short-wave transmission. For the moment, however, we must wait for further reports, but in the meantime it is hoped that particulars of all interceptions of this nature will be forwarded to this office for investigation or verification.

P. R. C.

### Description of Apparatus used by A. E. Greenslade and E. McT. Reece.

Stations heard were 1 BCG (special station—see last issue of *The Wireless World*), and 1 RU (R. S. Miner, 68, Quaker Lane, Hartford, Conn.).

portion approximately 35ft. long, down leads 35ft. Height of aerial about 45ft. Aerial lies N.N.W. by S.S.E. with free end pointing to N.N.W.

The aerial is badly situated with regard to surrounding trees and buildings, etc. Lead roof nearby and corrugated iron roof immediately under

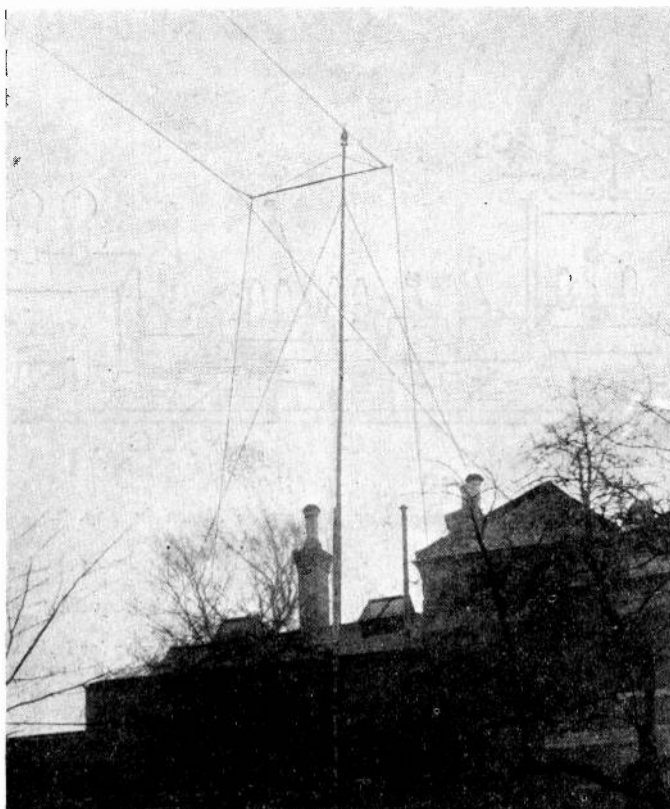

Fig. 1. Aerials used by A.E. Greenslade and E. McT. Reece at the British School of Telegraphy.

*Location.*—The British School of Telegraphy, 179, Clapham Road, S.W.9.

*Aerial.*—Inverted "L" type of 7/20 phosphor bronze. Marconi stop insulators. The horizontal

aerial. This with the direction of aerial gives a bad situation to an otherwise good aerial. (Fig. 1.)

Earth consists of a copper earth mat, buried 3 ft. deep, directly under aerial.

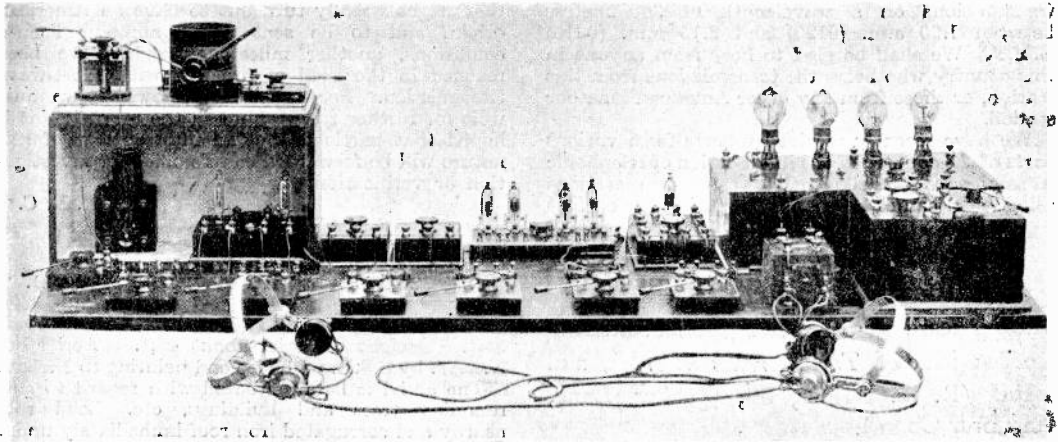

Fig. 2. First Apparatus used by A. E. Greenlade and E. McT. Reece.

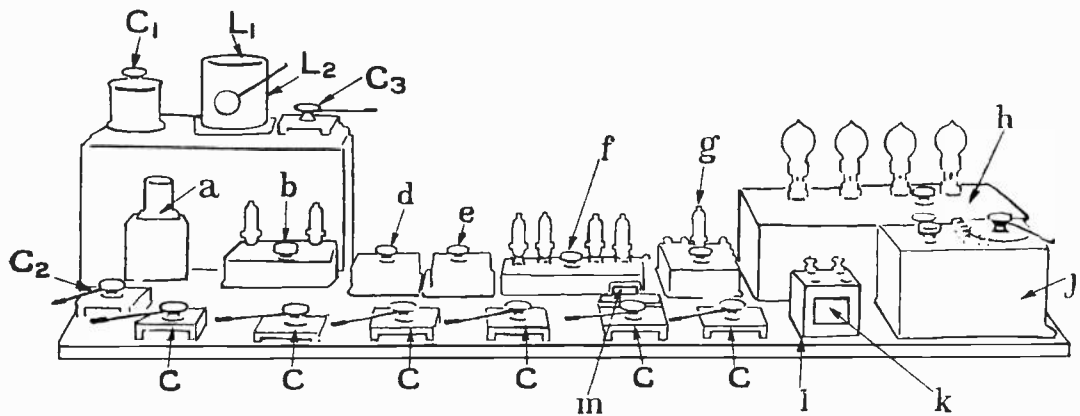

Fig. 3.—Outline sketch of Apparatus shown in Fig. 2.

- |   |  |
|---|--|
| $L_1$ = Primary of coupling coil in aerial circuit (Ball winding inside $L_2$ ).  | $h$ = Two high-frequency stages (subsequently discarded).                                |
| $L_2$ = Secondary coil.   | $d$ = Potentiometer for H.F. valves.   |
| $C_1$ = Aerial series tuned condenser.  | $e$ = Potentiometer for rectifying valve.  |
| $C_2$ = Vernier condenser in shunt to $C_1$ .   | $f$ = Four-valve-panel (H.F.).   |
| $C_3$ = Vernier condenser across secondary.   | $g$ = Rectifying valve panel.  |
| $C$ = Condensers across secondaries of high-frequency interval transformers.  | $h$ = Low frequency amplifier.   |
| $a$ = Buzzer, with capacity and inductance circuit adjusted to 200 metres wavelength, and used for tuning purposes. This was placed on roof during tests. | $j$ = Separate heterodyne.   |
|   | $k$ = Telephone condenser.   |
|   | $l$ = Telephone transformer.   |
|   | $m$ = Grid leak and condenser used occasionally when V.24 valve was used for rectifying. |

The H.F. interval transformers can be seen in the photographs immediately behind the Vernier condensers C.

The lettering in this sketch corresponds wherever possible with the lettering of the diagram in Fig. 5.

## THE TRANSATLANTIC TESTS

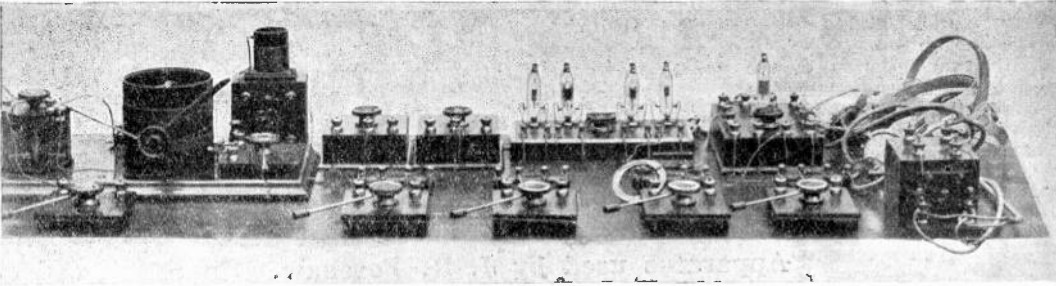

*Fig. 4. Simplified Apparatus used by A. E. Greenlade and E. McT. Reece.*

*Apparatus.*—The aerial circuit shown in the accompanying sketch (Fig. 5), consists of a primary winding  $L_1$  wound on a ball former and capable of rotation through 90 degrees for coupling variation. It is connected in series with a variable (air) condenser  $C_1$ , of maximum capacity of 0.0005 microfarad, this condenser being shunted by a vernier condenser,  $C_2$ , to obtain the necessary fine adjustment.

Six H.F. valves, transformer coupled, come next, the first of the series being connected to the secondary winding  $L_2$ .

Across the secondary a vernier condenser  $C_3$  is connected to obtain a range of wavelengths from approximately 180m to 230m.

Owing to only 24 hours' notice of tests taking place on wavelengths higher than 200 metres no time was available in which to construct a further

series of transformers to tune to waves up to 375 metres. This rendered listening after certain times mentioned in the schedules useless, especially the last few days of the tests when the experience gained in the manipulation of the apparatus would have been most valuable.

Marconi V24 valves were used for H.F. amplification ( $V_1$  to  $V_6$ ). Next came a "Q" valve ( $V_7$ ) for rectifying (occasionally a V24 with a grid condenser and leak was used).

A four-valve L.F. amplifier, which could be switched in if desired was also installed, but was seldom used on account of the noises from the A.C. lighting mains, etc.

"Clifton" accumulators were used for filament lighting.

S. G. Brown's telephones, type "A" 8,000 ohms, were used.

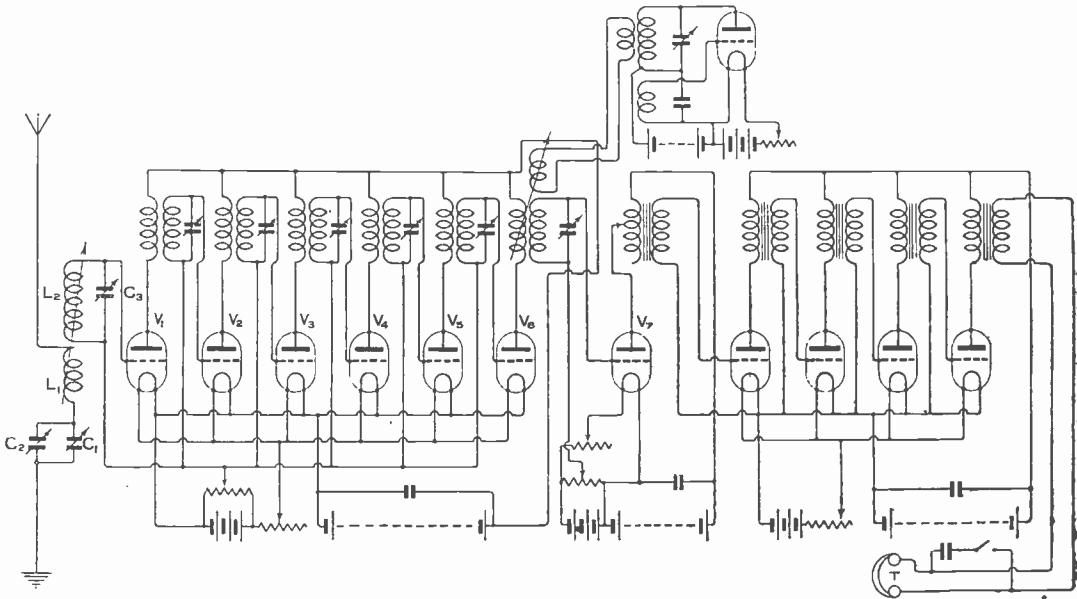

*Fig. 5.*

An illustration of the complete apparatus is given in Fig. 2, and an outline sketch in Fig. 3, with the parts labelled to enable them to be identified in the photographs.

With the exception of the valves, telephone receivers, and accumulator battery every piece of apparatus, used in the reception of the Transatlantic short-wave signal tests, was of my own design and manufacture—(Trade Mark "Oojah.")

Owing to the difficulty in management two steps of H.F. amplification were discarded after the first two evenings.

The actual short-wave signs from America were therefore received on 5 valves, viz., four H.F. and one rectifying, and this simplified apparatus is shown in Fig. 4.

A separate oscillator, built from the instructions issued in *The Wireless World* was used.

### Apparatus used by J. R. Forshaw.

Station heard 1 BCG.

*Location.*—Westville, St. Helens Road, Ormskirk, near Liverpool.

*Remarks.*—I did not enter my name to take part in the American amateur tests, the reason being that my set was not working well. I could only use two valves, the third inter-valve transformer (low frequency) having the primary burnt out. Two valves and a crystal (Perikon) were used when the signals were received, the circuit arrangement being shown in Fig. 6.

The strength of signals was, I should imagine, between six and eight—and they were sent at the rate of about 15 words per minute. They were continuous wave signals.

Signals failed gradually until they were inaudible, and then without moving anything they slowly came on again, faint to normal strength. I noticed that the signals failed as a steam train passed my house which is near the L. & Y. Railway Liverpool to Preston Line, and it is not the first time I have noticed such failing, which is probably caused by the cloud of steam and smoke emitted by the engine. The railway runs on the west side of my house, therefore it would be between me and the source of signals.

The general arrangement of the apparatus may

be seen from Fig. 7. It will be noticed that the centre valve socket is empty, as a crystal detector was used for the reason given above.

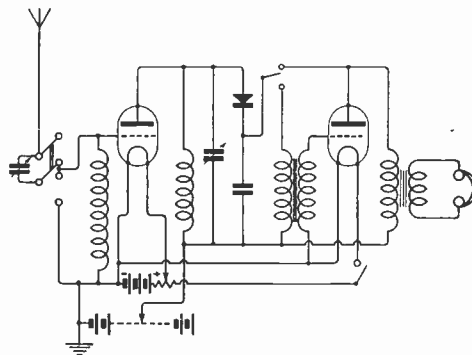

Fig. 6. Circuit diagram of arrangement used by J. R. Forshaw. Both the inductances shown had 30 turns: and the Aerial Tuning Condenser was used in series with the Aerial Circuit.

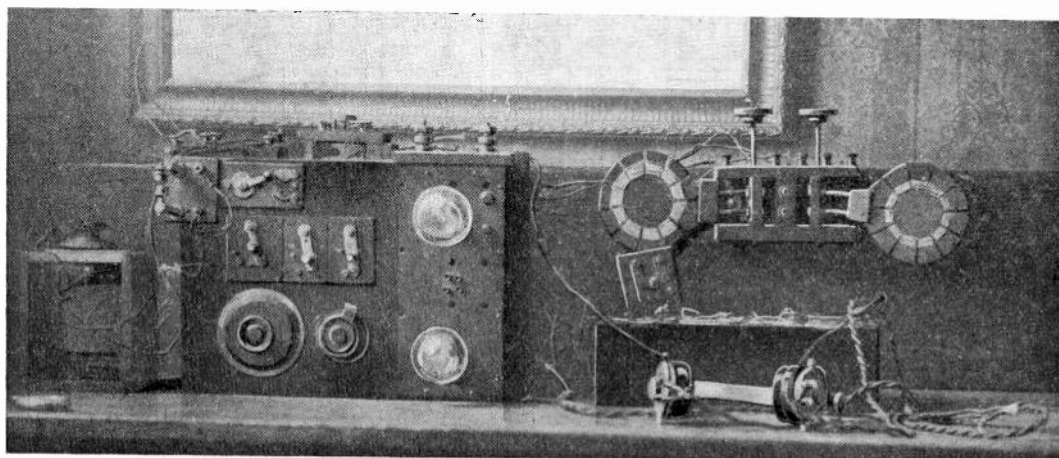

Fig. 7. Apparatus used by J. R. Forshaw.

# THE TRANSATLANTIC TESTS

## Apparatus used by T. Cutler.

Station heard 2 ZC.

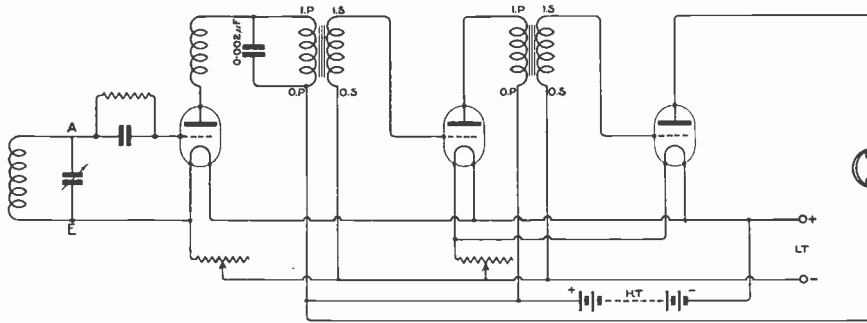

Fig. 8. Diagram of Apparatus used by T. Cutler.

*Location.*—24, Floating Bridge Road, Southampton.

*Station,* situated on edge of sea front.

*Aerial.*—140 ft. of wire. Directional to Atlantic. Height of poles = 60 ft. and 38 ft.

*Apparatus used.*—A three-valve set, consisting of one detecting and two low-frequency valves, arranged as in Fig. 8, made up from the following

components; the source from which each was purchased being indicated in brackets in each case :  
 1 German detecting valve (Disposals Board);  
 2 Note-magnifying valves (Disposals Board);  
 1 Naval condenser (Hadley, Sheffield);  
 1 Marconi variable condenser (Disposals Board);  
 2 Intervalve transformers (Southern Counties Wireless School, Southampton and Leeds) [1 to 5 ratio];  
 1



Fig. 9. Apparatus used by G. J. Eschauzier.



Cylindrical coil, wound with No. 22 gauge D.C.C. tapping every 5 turns (Disposals Board); 1 Ball reactance inside coil, wound with No. 36 D.S.C. (Disposals Board); 1 Townsend wavemeter (Disposals Board); 1 pair of Western Electric telephones, American make (Wall, Colbury, Hants); Accumulators and H.T. batteries (Smethwist, Southampton); Marconi double pole switches (Disposals Board); 0.002 microfarad condenser (own make); Grid leak and condenser (own make); filament resistance (Vivian, Southampton); Switch arm and contact studs (Disposals Board).

Signals were only listened for during three nights.

### Apparatus used by G. J. Eschauzier (Holland).

Station heard 1 BCG.

*Location.*—19, Parkweg, The Hague (Holland).

*Aerial.*—Three wires, 60 ft. long, 35 ft. above house which is 45 ft. high.

*Apparatus.*—A four-electrode Schottky valve was used as detector, with a two-stage amplifier using soft Phillips valves. The receiving sets that were used were:—

- (1) A two-circuit receiver with variometer coupling.
- (2) A special receiver type "Bivario" manufactured by the Nederlandsche Radio Industrie.

The general arrangement of the complete set may be seen from Fig. 9, while Fig. 10 gives a more detailed illustration of the "Bivario" receiver.

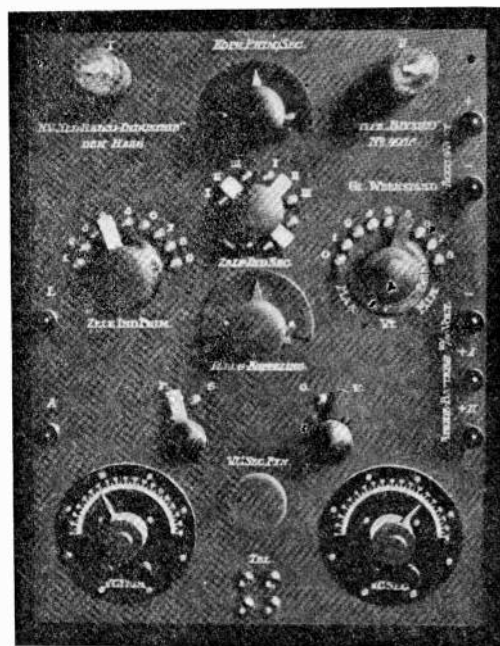

Fig. 10. The "Bivario" Receiver used by G. J. Eschauzier.

### A Useful Coil from Oddments.

A USEFUL multi-layer coil for shorter wavelengths can easily be constructed with discarded Litz wire from the formers of an old Mark III tuner. If at the same time the amateur has available the ebonite tube used for the inductance and reaction coil of a 65-metre Mark I rear set, the construction of the coil is further facilitated. Take this latter tube and saw it into two equal portions. Round the edges of either portion drill a set of holes equally spaced and of such a size that half a wooden match will just fit in each of them. Eight holes round each edge will be enough, the two rows being staggered in relation to one another. When the holes have been made, stick half-matches tightly into them and wind a single layer of Litz between the rows. Next zig-zag the wire for a complete turn, winding it in and out of the matches and wind on the next layer, as described by Mr. Coursey in *The Wireless World* for December 11th, 1920, p. 635. About half of the wire of one Mark III. former will make a coil of sufficient inductance to tune 600 metres, with about 15 to 20 divisions of a 0.0015 Mark III condenser in parallel. Plug mountings for these coils can be purchased from the dealers in wireless materials. After the complete coil has been wound on, withdraw the matches one by one and thread a piece of twine through the loops and the hole in which the matches have been placed. When the thread has been taken through all the holes and loops the ends should be secured by tying.

### French Experimental Licenses.

FROM the January issue of *La T.S.F. Moderne* we learn that the French Authorities have at last granted transmitting licenses to French Amateurs for Experimental transmissions. Up to the present, we have heard of only four licenses being issued, one of these being to the Managers of *La T.S.F. Moderne*, the wavelength authorised being 200 metres and the power 100 watts (in the aerial!); system, spark or C.W.

It appears then that although the French authorities have been slow in giving sanction to amateurs to transmit this has been compensated for by the very liberal terms of the licenses now granted. From the wording of the letter of authorisation there appear to be no restrictions imposed as to the nature of the transmissions or the number of stations with which communication may be conducted. The power (100 watts in the aerial) will strike envy into the hearts of British Amateurs, who with their restrictions of 10 watts input would consider an output of 5 watts in the aerial an achievement in efficiency.

In the near future then we may look forward to being able to listen-in to the transmissions of our amateur friends in France, and we are justified if we feel somewhat apprehensive that they may wrest from us the honour of the first short wave transatlantic transmissions from this side.

# The "Model Engineer" Exhibition.

**D**URING the first week in January a very interesting exhibition was held under the auspices of the *Model Engineer* at the Horticultural Hall. The popularity of this exhibition was prominently evident by the large crowds of students and others who attended it.

Amongst the many numerous exhibits there were a large number of exhibitors showing wireless

Howell's exhibit of a paddle steamer, which was equipped with a small transmitting apparatus, capable of communicating over one mile.

A brief description of the trade exhibits may be of interest.

MESSRS. G. Z. AUCLAND & SON'S exhibit was devoted almost entirely to component parts, and any amateur who was considering the construction of a radio receiving installation was naturally attracted to this stall. These component parts included cheap and well-manufactured variable condensers.

MESSRS. BOWER & CO. exhibited a large number of component parts, as well as certain three-electrode amplifiers of French manufacture.

MESSRS. BURNHAM & CO. were exhibiting their Ultra-Five receiving apparatus, and their honeycomb coils. An interesting instrument which they were showing was the telephonic transmitter which is used for the wireless telephone concerts sent from the Hague, and with most of us so familiar.

MESSRS. ECONOMIC ELECTRIC, LTD., amongst their numerous electrical exhibits, showed some interesting pieces of wireless apparatus, including an instrument wherein a thermionic valve is used in the limbs of the well-known Wheatstone Bridge.

MESSRS. A. W. GAMAGE, LTD., were exhibiting a large number of component parts, and in particular their multiple inductance units.

MESSRS. THE MARCONI SCIENTIFIC INSTRUMENT CO., LTD., had a unique exhibit of receiving units, including a complete set of their six units, of which the first unit is a condenser, the second a tuner, the third a high-frequency amplifier, the fourth a detector, the fifth a note magnifier, and the sixth



apparatus suitable for amateur use. For those who desired complete receiving equipments there was an ample selection to choose from, and for the more enterprising, who prefer to construct their own installations, there was an assortment of component parts, such as condensers, inductances, etc. The firms showing wireless apparatus were Messrs. G. Z. Auckland & Son, Bower & Co., Burnham & Co., Economic Electric, Ltd., A. W. Gamage, Ltd., Marconi Scientific Instrument Co., Ltd., Leslie McMichael, and F. O. Read & Co., Ltd.

Amongst the exhibits sent in by competitors for the *Model Engineer* model-making competition, it is surprising that there were but two models containing wireless apparatus—firstly, Mr. Ballhatchet's complete receiving outfit, of novel construction, and secondly, Mr.



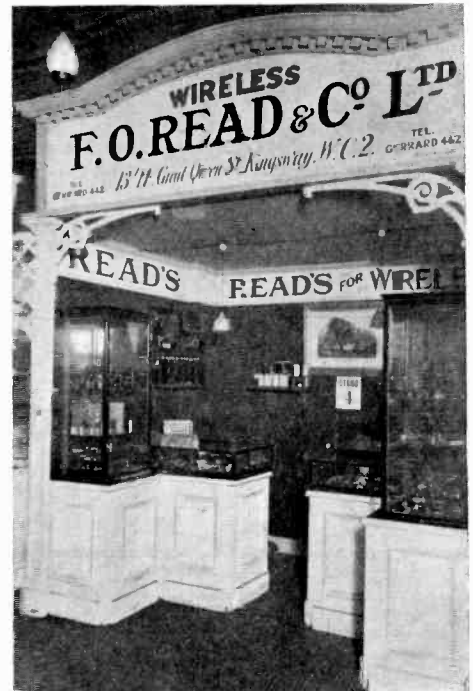
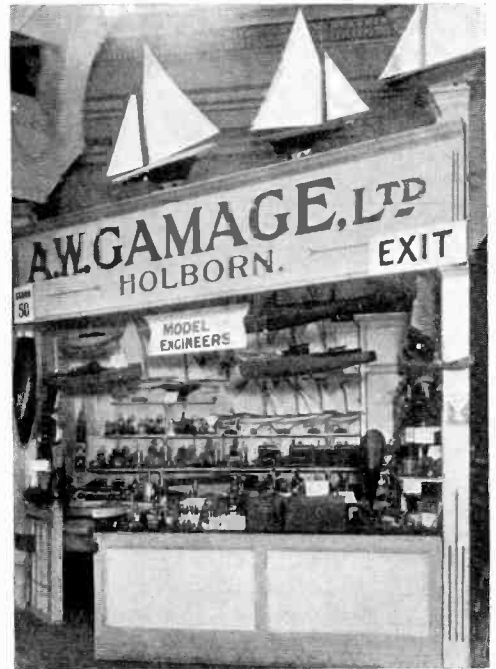

## THE "MODEL ENGINEER" EXHIBITION.

a telephone transformer. These instruments can all be bought separately, and when joined together, as they are designed to do, produce a highly efficient receiving unit. Besides this, there were various component parts, including thermionic valves and H.T. batteries.

MR. LESLIE McMICHAEL'S exhibit was devoted almost entirely to Disposal Board War Office apparatus, including Townshend wavemeters, short-wave tuners, condensers, and numerous component parts, such as valves and H.T. batteries.

MESSRS. F. O. READ & CO. showed a large number of complete instruments, including high-frequency and low-frequency amplifiers in various combinations, as well as a large selection of accessory apparatus.

It is to be hoped that, if the *Model Engineer* are considering further exhibitions, that they will take a larger hall, and so be able to accommodate the large crowds more comfortably than was the case at the Horticultural Hall. Altogether the organisers of the exhibition are to be congratulated on a most popular and attractive exhibition.



the photographs of the various stalls where wireless apparatus was on show which we publish herewith.

The exhibits of wireless interest formed, of course, only a small percentage of the engineering exhibits at the Horticultural Hall.

## DUTCH CONCERTS.

### FINAL SUBSCRIPTION LIST.

The following additional subscriptions to the Dutch Concerts Fund are hereby acknowledged:—

	£	s.	d.
Carried forward	54	7	0
Burton-on-Trent Wireless Club .. .. .	1	10	0
Derby Wireless Club .. .. .	1	1	0
Mr. G. F. M. Wynne .. .. .	1	1	0
„ W. T. Tucker .. .. .	1	1	0
„ V. Seaton .. .. .	1	1	0
„ J. P. Holden .. .. .	1	0	0
„ S. Blanchard .. .. .	10	6	
„ C. F. Crompton .. .. .	10	0	
„ F. C. Clark .. .. .	5	0	
	£62	6	6



We are indebted to the publishers of the *Model Engineer*, Messrs. Percival Marshall & Company for

At the suggestion of the Nederlandsche Radio Industrie (the organisers of the Concerts), we are now closing this subscription list and a cheque for the above amount will be forwarded to the Nederlandsche Radio Industrie. Their acknowledgment will be published in *The Wireless World*. We take this opportunity of expressing our appreciation of the efforts of the Dutch Concert organisers.

We also thank all those who have contributed to the Fund opened in this magazine.

# Receiving Circuits\*

By CRISPIN C. REDSHAW, Associate I.R.E.

THE object of this paper is to give a brief resumé of the various circuits employed for wireless reception purposes. I am often asked the question, "What is the best circuit to use for such and such a result?" or, "Why is one particular circuit better than some other par-

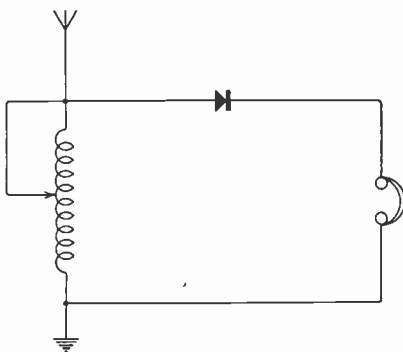

Fig. 1.

ticular circuit?" Well, practically any circuit you might care to draw—within reason—would work: that is to say you could, under suitable conditions, get signals with it. But would it work efficiently? To be more exact, would it work efficiently on the particular wavelength you most wish to receive, or for that particular purpose

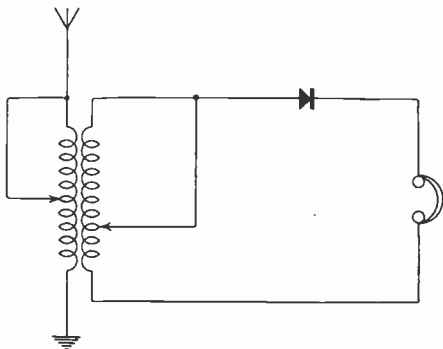

Fig. 2.

you most desire. Most people, when installing receiving gear, have some definite object in mind—perhaps it is the reception of very weak or distant signals—possibly they wish mostly to receive the famed Dutch concerts. Different circuits give different results for different purposes—looking at the problem from the efficiency point of view. Not everyone can afford to employ multi-stage amplifiers to get the desired results. For these people then, I have roughly classified a set of circuits, with values, where such values are likely to be useful.

\*A Paper read before the King's College Wireless Society.

Considering, firstly, the case of the raw amateur. He wants signals, is not too particular that there should be no interference between the various simultaneous signals he should get, and wants them as quickly and as easily and cheaply as he can get them. He erects an aerial. Before carrying on I should like to emphasize two points. Firstly, when he erects that aerial, let it be the best he can erect, keeping within the limits laid down by the P.M.G. Secondly, let him buy the most sensitive headgear he can obtain. With a good aerial and a good pair of telephones signals are a certainty. With a small aerial or indifferent telephones signals are much less certain unless supersensitive circuits are employed. By taking these points seriously to heart the raw amateur will save himself a great deal of disappointment. The simplest circuit I can give is shown in Fig. 1.

It suffers from many disadvantages, but is a good circuit with which to start off. Most people

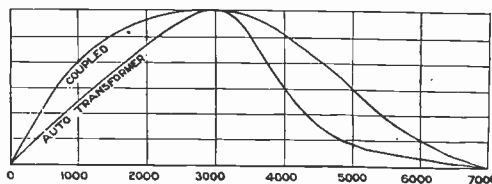

Fig. 3.

quickly transform it to the circuit given in Fig. 2. These two circuits have very similar characteristics. Circuit Fig. 2 gives less interference, or jamping, than does the circuit Fig. 1. Both are very suitable for all wavelengths above about 300 or 400 metres, and the efficiency on the longer waves is greater than on the shorter ones. Neither circuit, however, is capable of tuning to a longer wave than about

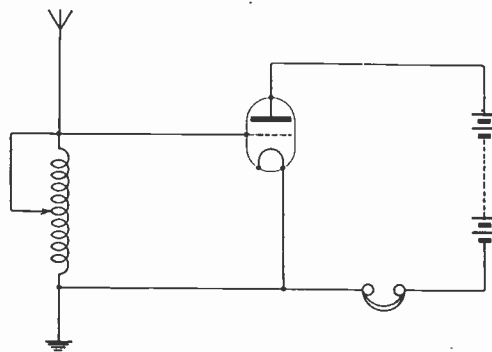

Fig. 4.

7,000 metres, and the efficiency at this wave is very low. Circuit Fig. 2 will give good results on short waves. Assuming an aerial of dimensions the maximum the P.M.G. allows, the efficiency curves

## RECEIVING CIRCUITS

of these two circuits are somewhat of the shape shown in Fig. 3.

The auto transformer curve corresponding, of course, to the circuit of Fig. 1, and the coupled

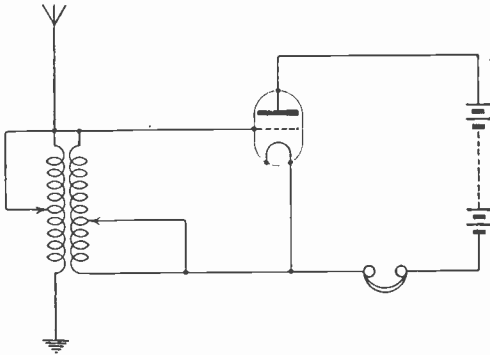

Fig. 5.

to that of Fig. 2. Points to notice in employing any crystal receiver circuit are these. The crystal detector is a voltage operated device; hence all capacities should be kept as low as possible. In bringing up a wavelength always add inductance in preference to adding capacity. Always add the inductance in such a way that the crystal receives the P.D. across the whole of it. In circuit Fig. 1 loading coils inserted in the aerial lead lower the efficiency. Neither of these circuits will respond to continuous waves, and usually it is not worth while adapting them for C.W., but if anyone has a small buzzer, a rotary commutator, or other interrupting device capable of making and breaking a circuit at an audible frequency (600 to 1,000 per

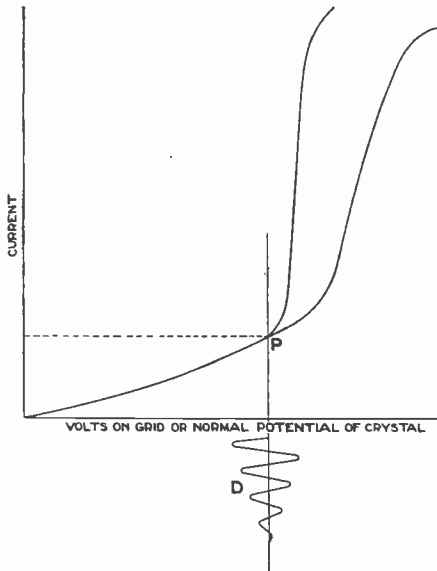

Fig. 6.

second is convenient) he may try inserting it in series with his telephones in such a way as to interrupt the telephone circuit; but let him be careful to screen it and silence it—telephones, and, in fact, the whole circuit is extremely sensitive to stray magnetic fields; also much noise would certainly drown out any but a very strong signal. The piece of apparatus used for this purpose is termed a "tikker."

So much for the "raw amateur." We will now consider the reception of spark signals with the valve.

The simplest form of circuit to use is given in Fig. 4. Again, this may be easily transformed into circuit Fig. 5. Precisely the same remarks as were passed about the circuits of Figs. 1 and 2 apply to 4 and 5, and neither 4 nor 5 is suitable for the reception of weak signals. This is due to the peculiar shape of the characteristic curve for a valve, at the point marked P in Fig. 6. crystal

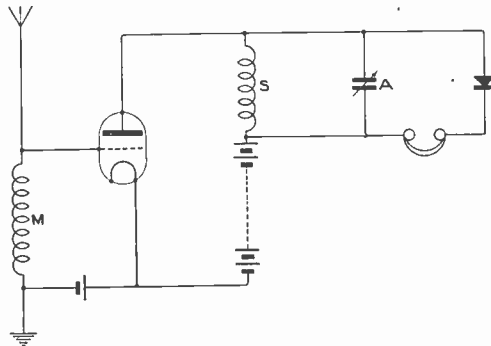

Fig. 7.

and valve characteristics are shown superimposed D is a damped wave varying grid potential about the point P. It will be seen that the average value of the anode circuit current is the same as if there were no signal varying the grid potential. At the same time, observing the crystal characteristic in the same manner, the average value of the current passing is considerably higher than the current passing when no signal is present. Hence, it is obvious that circuits 4 and 5 are unsuitable for the reception of weak signals.

However, a very efficient circuit for general purposes in damped wave reception can be made by combining crystal and valve as in Fig. 7. Here it will be seen that the valve will amplify the incoming signals, the grid being adjusted to such a potential as to cause variation by the signal about the point P'. Fig. 8. The anode current will now oscillate circuit S.A, and the crystal will rectify the amplified signal. This method of reception is extremely efficient, but another circuit may be given which is even more efficient.

Suppose we take a portion of the coil S, and couple it magnetically to the coil M, giving us the circuit of Fig. 9.

Now, the energy flowing in the anode circuit is obtained from the H.T. battery H, and is released by the varying potential of the grid, due to incoming

signals, its amplitude being proportional to the amplitude of such varying potential. Coil R, magnetically coupled to coil M, hands to M some of the amplified signal exactly in phase with the signal,

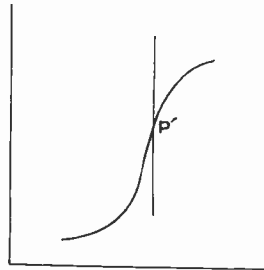

Fig. 8.

boosting up the grid potential, which, in turn, allows a greater anode current to flow. Hence the valve can be used most efficiently in a circuit of this description.

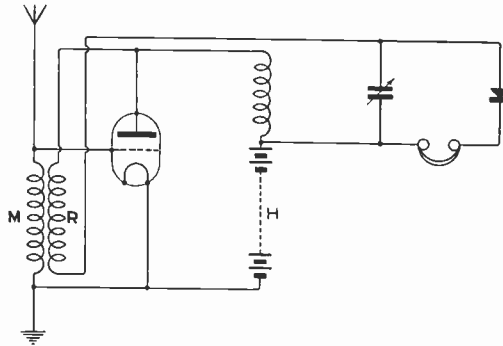

Fig. 9.

By coupling the two coils M and R sufficiently tightly together, the anode circuit can be made to "oscillate," that is, generate an oscillating current,

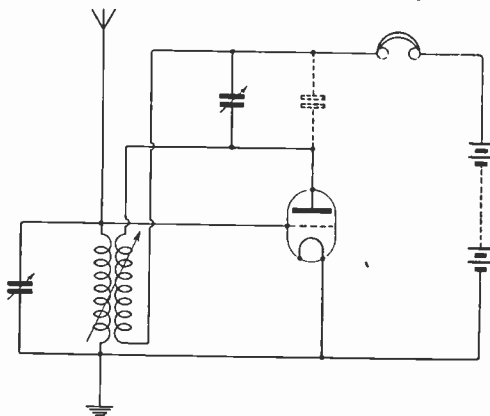

Fig. 10.

the energy being supplied by the H.T. battery. When oscillating, the circuit is in a condition to receive C.W. signals by the "beat" or "interference" method.

Fig. 10 is the circuit which I consider, after having tried nearly every known circuit having any degree of simplicity, to give the best all-round results. It readily oscillates on any wavelength between 400 and 20,000 metres, is simple to adjust and to keep in adjustment. It is equally good for damped or undamped waves, and really its only disadvantage lies in the fact that it will not readily

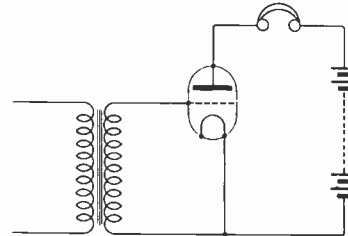

Fig. 11.

rectify on short waves—waves shorter than 600 metres. Using one "French" valve and this circuit, with the maximum P.M.G. serial in a good position, I have logged three different American stations.

For the man who wants loud—really loud—signals, the following is recommended. Firstly, get that last circuit I described working nicely. Then, in place of the telephones, fit the primary of an intervalve, low frequency transformer, and complete wiring as shown in Fig. 11. This attachment is termed a "note magnifier," as it increases the amplitude of the note-frequency vibrations. Several of these may be attached in series, so to speak, each with the primary of its intervalve transformer in the anode circuit of the previous valve. However, note magnifiers suffer from a disadvantage. They amplify the loud signals and other sounds in much greater proportion than they do the weak

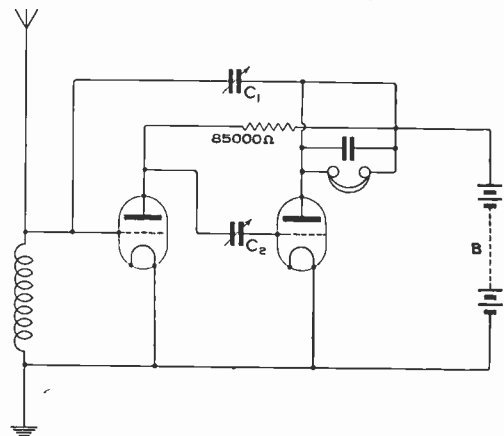

Fig. 12.

## RECEIVING CIRCUITS

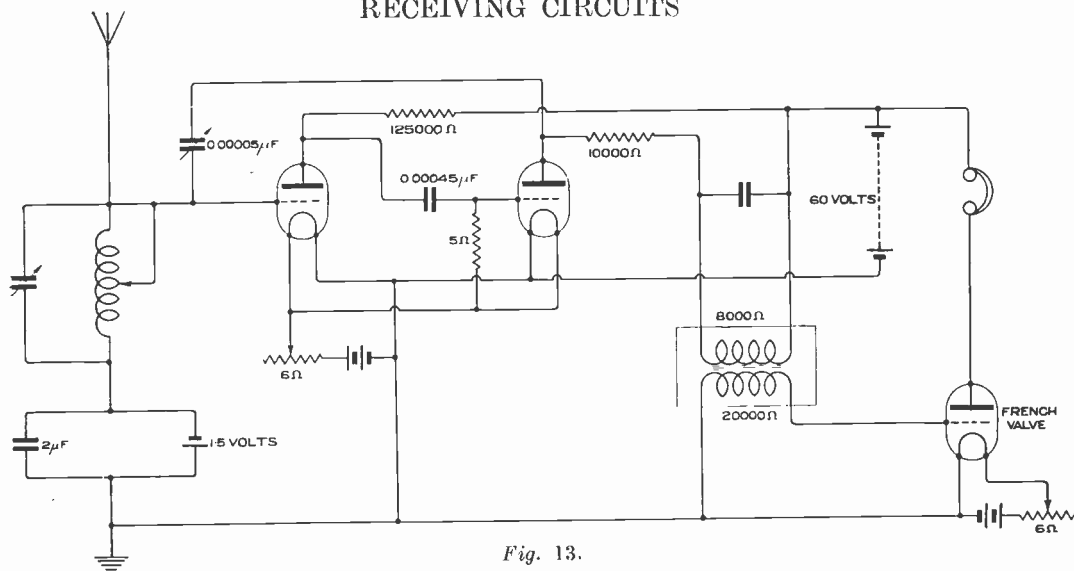

Fig. 13.

signals. Hence, something different is required for long range or weak signal work. For this purpose we use H.F. (high frequency) transformers when we wish to work over a short range of wavelength, but high frequency transformer coupling is not successful over a wide range of wavelengths, except where the complication of interchangeable transformers is introduced. For simplicity, therefore, it is best to use resistance-capacity coupling, as in Fig. 12. This two-valve circuit I have found most successful. I employ type E.S.4 valves. Values are as follows:— $C_1 = 0.0001$  microfarads, anode resistance = 85,000 ohms,  $C_2 = 0.0004$  microfarads (preferably variable) and B from 25—45 volts. Points to note in this circuit are: the resistance should be physically small, to have as little capacity to earth and to other instruments as possible. The same remarks apply to  $C_2$ .  $C_1$  is only necessary for short wave work. This circuit is particularly suitable for telephony reception as it is quite easy to get just off the oscillation point. It is a "quiet" circuit, and as such is suitable for the attachment of note magnifiers. With too tight a coupling it readily "howls," which is not conducive to the

long life of the valves, and gives very serious annoyance to your wireless neighbours.

My last circuit (Fig 13) is a development of Fig. 12, and I have found by experience that it gives somewhat better results. A critical adjustment can be obtained when the circuit just does not oscillate, but the arrival of a C.W. signal starts it off. On the other hand a spark signal will not start it oscillating unless the signal is very strong. Using this last circuit in conjunction with a three-valve note magnifier and a loud speaking telephone, the Dutch concerts are audible twenty yards distant. Using the two valves only these concerts are nicely audible, there being no distortion provided the set is kept just off the oscillation point.

I consider that magnetically coupled circuits in general are not suitable for speech reception on account of the distortion they produce when oscillating, or nearly so, and lack of definition of the oscillation point.

In conclusion I wish to tender my thanks to Mr. Mills, of Hastings Grammar School, for his kind co-operation in the investigations of the two last-named circuits.

## The Rating of Accumulators for Filament Heating.

USERS of the necessary 6-volt accumulators for heating the filament of their thermionic valves are sometimes puzzled by the discrepancy in the rating of well known sizes of cells sold by different dealers.

Before the advent of the thermionic valve, extensive use was made of portable accumulators for the coil ignition system on motor cycles. The intermittent discharge through a trembler contact gave an apparent duration of double the hours at which the accumulator could maintain a certain current.

This led to the ignition rating of portable cells which is entirely useless and misleading when

considering their use for wireless work where the discharge is continuous and for long periods.

To describe cells for wireless users as being of a stated "ampere" size is very misleading, to put it mildly.

The "ampere hour" is the only rating that should be used, and purchasers of accumulators should satisfy themselves on this point before purchasing.

To ascertain the exact capacity of a battery the discharge amperes should be maintained for 10 hours at a constant rate.

A battery stated to be 100 ampere hours should be capable of discharging at 10 amps. for 10 hours.

H. LESLIE DIXON, M.I.E.E.



# The Wireless Society of London

## ANNUAL REPORT OF THE COMMITTEE

FOR THE YEAR ENDING OCTOBER, 1921.

THE Committee have pleasure in recording a year of continued prosperity and progress which has kept pace with the increased activities of wireless telegraphists throughout the country.

The second Annual Conference was held at the Royal Society of Arts on March 1st, 1921, under the Presidency of Dr. J. Erskine Murray, most of the 33 Societies then affiliated being represented. It was resolved to apply to the Postmaster-General for permission for the Marconi Company to transmit a regular weekly programme including calibration waves, speech and music—a service which they were ready and willing to provide—and the negotiations have been diligently pursued during the last nine months, but at the close of the period to which this Report refers no definite result has been achieved.

Delegates and members of the London Society to the number of 40 afterwards dined together at Romano's Restaurant, and it is intended to establish the custom as an Annual Dinner on the occasion of the Conference and Presidential Address in future.

Fifty Provincial and Suburban Wireless Societies have now been affiliated.

The following Papers have been read during the year under review:—

November 18th, 1920. "Wireless Telegraphic Printing on the Creed Automatic System." By Mr. A. A. Campbell Swinton, F.R.S.

December 10th, 1920. "A Four-Electrode Thermionic Detector for Damped or Undamped Electric Oscillations of High or Low Frequency." By Professor J. A. Fleming, F.R.S.

December 21st, 1920. "Wireless Valve Circuits as applied to the Measurement of Physical Quantities." By Professor Whiddington.

January 27th, 1921. "The Wireless Stations of British Commercial Airways." By Lieut. Duncan Sinclair.

March 1st, 1921. "The Greatest Problem in Radio." By Dr. J. Erskine Murray.

April 5th, 1921. "Some Acoustical Effects in Wireless." By Dr. J. Robinson.

May 2nd, 1921. "Experimental Wireless Telephony." By Mr. Philip Coursey, B.Sc.

June 1st, 1921. "A Universal Amplifier, suitable for all Wavelengths." By Mr. A. A. Campbell Swinton, F.R.S.

June 27th, 1921. "The Design of High Frequency Resistance Amplifiers." Contributed

by Lieut. Edes, R.E., and read by Mr. Philip Coursey, who subsequently gave a demonstration of the Pieze-Electric Properties of Rochelle Salt Crystals.

September 30th, 1921. Discussion on "Some methods of Recording Wireless Signals." Opened by Mr. Philip Coursey, B.Sc.

October 26th, 1921. "Selectivity in Wireless Transmission." By Mr. Maurice Child.

All these Papers, with reports of the discussions arising from them, have appeared in the Official Organ of the Society, *The Wireless World*, and have been reprinted separately to form Volumes of our Proceedings. Our thanks are due to the Editor and Publisher for the excellent manner in which this work is carried out, and also for considerable clerical assistance given to our Hon. Secretary.

Most of the above meetings were held in the Lecture Hall of the Royal Society of Arts to whom our thanks are due. Arrangements have now been made for the regular meetings to be held in the Lecture Hall of the Institution of Electrical Engineers on the last Wednesday of each month.

A postal ballot of the members was taken to determine the most convenient hour, with the result that 6 o'clock was adopted by a majority of 25 (123 for 6 p.m., and 98 for 8 p.m.). Light refreshments are served at 5.30 p.m. prior to the meetings.

Two visits were arranged this year. The experimental station of the Radio-Communications, Ltd., at Slough, was visited on June 27th, and the Wireless Station of the Croydon Aerodrome, on November 5th by the kind permission of the Controller of Civil Aviation at the Air Ministry.

An illuminated Address was presented to Mr. A. A. Campbell Swinton, F.R.S., our first President, on the occasion of his resignation, and the Rules were altered so as to constitute him a Life Member of the Committee.

A meeting of members who transmit in London and district was called in July under the Chairmanship of Mr. Hope-Jones, to consider means for the amelioration of interference on 1,000 metre wavelength and their decision to limit transmission to 15 minutes at a time was confirmed and has since proved to be beneficial.

Major Basil Binyon, O.B.E. B.A., A.M.I.E.E., has been elected a Vice-President.

At the beginning of the period covered by this Report, the membership of the Society was 316, and is now 368.

## ANNUAL REPORT OF THE HON. TREASURER

FOR THE YEAR ENDING OCTOBER, 1921.

I am glad to report again that the Society's financial position shows steady improvement.

The Income has increased by roughly 45 per cent., whereas the expenditure is only about 34 per cent. in excess of the previous year.

It will be noticed that the heaviest item in expenditure is for printing the Proceedings, and

in this connection it is desirable that it should be clearly understood that the figures include for printing, blocks, and diagrams, special envelopes, and postage, etc., as well as for duplicating any notices in the same enclosure.

The expenditure for ordinary postage is also a serious, but unavoidable item, and shows the

## THE WIRELESS SOCIETY OF LONDON

extensive correspondence conducted between the Executive and the members of this and affiliated societies.

Ockleshaw, F.C.A., for the help given in preparing the Cash Statement, and for auditing the accounts.

(Signed) L. F. FOGARTY,  
Hon. Treasurer.

I desire to thank the Hon. Auditor, Mr. John

December, 1921.

### CASH STATEMENT FOR YEAR ENDING OCTOBER 1ST, 1921.

Dr.				Cr.
To Balance at October 1st, 1920	..	£118 17 0	By Reprints of Proceedings, Postage and Notices of Meetings	£138 13 0
„ Subscriptions	.. .. .	425 18 9	„ Printing Membership List and Book of Rules	36 13 0
			„ Printing and Stationery	31 6 4
			„ Hire of Lecture Hall	49 2 7
			„ Postages and Clerical Assistance	62 0 5
			„ Rent, Storage of Furniture and removal of same	13 4 0
			„ Sundry Expenses, Cheque Book, etc...	15 10
				£331 15 2
			Balance in Bank	212 10 1
			Petty Cash in Hand	10 6
				£544 15 9
				£544 15 9

## Transmission of Calibration Waves and Telephony for Amateurs.

At the Annual Conference of Wireless Societies convened by the Wireless Society of London, on Wednesday, January 25th, it was announced that the Postmaster-General had authorised the transmission of Calibration waves and Telephony for Amateurs for half an hour each week. The concession is the outcome of long continued negotiations on the part of the Wireless Society of London, culminating in the Petition which was presented to the Postmaster-General on December 28th last, the text of which appeared on pages 665 and 666 of

the January 21st, 1922, issue of *The Wireless World*.

At the request of the Wireless Society of London, the Marconi Company undertook to transmit these signals from Chelmsford. The following is the programme of the transmissions which will be made under the direction of the Marconi Scientific Instrument Company, Ltd., every Tuesday evening at 7 p.m., commencing on Tuesday, February 14th. The call sign 2MT will be used.

TIME G.M.T.	MESSAGE	TYPE OF TRANSMISSION	WAVELENGTH IN METRES	APPROX. POWER
1900 to 1905	CQ de 2MT 2MT 2MT (repeated). Here Marconi Scientific signals (repeated). Wavelength 1,000 metres. Aerial amperes . . . . . Series of V's Long Dash 2MT 2MT 2MT.	C.W. Telegraphy	1,000	1 kW
1910 to 1915	Message as above (With fresh data re Aerial amperes)	C.W. Telegraphy	1,000	$\frac{1}{2}$ kW
1920 to 1925	Message as above (With fresh data re Aerial amperes)	C.W. Telegraphy	1,000	$\frac{1}{4}$ kW
1935 to about 1955 15 minutes actual transmission of music, etc. 2 minutes interval between each section	Here the Marconi Scientific Instrument Company's Station at Chelmsford.	Telephony	700	$\frac{1}{4}$ kW

# Wireless Club Reports

*NOTE.—Under this heading the Editor will be pleased to give publication to reports of the meetings of Wireless Clubs and Societies. Such reports should be submitted without covering letter in the exact form in which they are to appear and as concise as possible, the Editor reserving the right to edit and curtail the reports if necessary. The Editor will be pleased to consider for publication papers of unusual or special interest read before Societies. An Asterisk denotes affiliation with the Wireless Society of London.*

## The Leeds and District Amateur Wireless Society.\*

Hon. Secretary, Mr. D. E. Pettigrew, 37, Mexborough Avenue, Chapeltown Road, Leeds.

A General Meeting was held on January 27th at the Leeds University. At 8.0 p.m. the President (Professor R. Whiddington, M.A., D.Sc.), called upon Mr. G. P. Kendall, B.Sc. (Vice-President), to take the chair. The President then delivered a Presidential address upon "The Application of Wireless Circuits to Minute Physical Measurements." The address was devoted to a description and demonstration of the principles underlying the ultra-micrometer, an instrument which the lecturer had invented and been working with for some time past. He stated that the engineer using a micrometer gauge did well if he (the engineer) succeeded in measuring with accuracy to a ten thousandth part of an inch, but by applying the ultra-micrometer it is possible to measure to less than a thousand millionth of an inch with extraordinary ease and accuracy. As yet the apparatus had only been used in the laboratory, but is capable of wider application, and in its present form it has been successfully used to record extremely minute variations of temperature and pressure. At the conclusion of the address the Chairman opened the discussion, during which some interesting points were raised. At the close of the discussion a hearty vote of thanks was accorded to the President. The meeting then broke up to inspect the apparatus on view, amongst the exhibits being the R.A.F. 7-valve amplifier used in conjunction with a novel design of frame aerial. Loud-speaking telephones, a three-valve L.F. magnifier, and a neat accumulator H.T. battery were also on view. Towards 9.30 the meeting terminated, and doubtless some of those present during the evening went straight home "to try it." Attendance only fair, this being undoubtedly due to adverse weather conditions.

On Saturday, January 28th, some members of the Society paid an informal visit to the first annual exhibition of the Bradford Wireless Society, held at the Technical College, Bradford. A very enjoyable time was spent examining the numerous exhibits which included practically everything from contact studs to seven-valve amplifiers, model liners, guns, and C.W. transmitters. Music and songs from 2QK were received at the exhibition and provided quite a variety turn. The visitors from Leeds came away very enthusiastic from the Exhibition, and were well rewarded for their travelling in Cup-Tie "Specials."

Particulars of the Leeds Society may be had from the Hon. Secretary. Meetings bi-monthly; annual subscription, 5s. The Hon. Secretary would like to know what has happened to the 400 odd men who trained for the Merchant Service during 1917/18 at Leeds.

## Bradford Wireless Society.\*

Hon. Secretary, Mr. J. Bever, 85, Emm Lane, Bradford.

The Society has now held its first Exhibition, and the work of the organisers has been well repaid.

By the courtesy of the Technical College authorities we were granted the use of the College Hall. The proceedings were opened at 7 p.m. on January 27th, by the Lord Mayor of Bradford (Mr. T. Blythe), a large number of people being present.

The exhibits were many and various, the principal trade exhibitors being Messrs. Burnham & Co., The Mullard Valve Co., Ltd., and the British Wireless Supply Co. All are to be complimented upon the excellence of their productions.

Demonstrations were given at intervals, signals being heard all over the hall by means of a "loud-speaker."

On Saturday, January 28th, the Exhibition was open from 2 p.m. to 10 p.m.

By the courtesy of General Ferrié, of the Eiffel Tower Radio Station, special programmes of telephony were sent on both days. It is believed that we are the first Society out of London to be accorded this privilege, and needless to say it was much appreciated.

From 3 p.m. to 4 p.m. on Saturday, Mr. Hartley Bolton, the Yorkshire tenor, sang selections of songs over the wireless telephone from our Secretary's house at Heaton.

At 7 p.m. we were privileged to hear Professor G. W. O. Howe, of the National Physical Laboratory, give his lecture on "Electromagnetic Waves and their Use in Wireless Telegraphy," which all present very much enjoyed.

The Committee wish to express their appreciation of the hearty manner in which all concerned co-operated with them to make the Exhibition a success, and it is their profound regret that Professor Richardson, the Principal of the Technical College, was prevented by illness from being present.

## Manchester Wireless Society.\*

A lecture on "The Electric Arc," was given on January 12th, before the Society, by Mr. J. C. A. Reid (Vice-President). The lecturer very ably explained the theory of the arc, and by means of diagrams illustrated the various types in use to-day, and also those which were used extensively during the war. The practical side of the subject was minutely described, being based on the search-lights used in coast defence stations. In connection with the latter, two types of mirrors were dealt with, the one giving a parallel beam of light and the other a fan-shaped beam. The control of these machines, by hand and automatically, also gave the lecturer plenty of interesting notes to work from.

Mr. Reid also touched upon the arc from a wireless

## WIRELESS CLUB REPORTS

point of view, but time did not allow him to enlarge upon this theory. In the discussion which followed the lecture, many interesting questions were answered by Mr. Reid. In conclusion, Mr. Evans proposed a hearty vote of thanks to the lecturer, being supported by Mr. Mansfield, the members responding with generous applause.

A whist drive and dance was held on January 21st, at the Albion Hotel, Piccadilly, and a special feature of the dance programme was the reception of waltz music by wireless telephone, from a local member's station. The result was so successful as to ensure the company dancing the full extent of the hall, and a repetition had to be asked for. During the interval for refreshments, gramophone selections were received to the satisfaction and pleasure of all present.

Mr. Y. W. P. Evans, 7, Clitheroe Road, Longsight, Manchester.

### The North London Wireless Association.\*

Hon. Secretary, Mr. J. W. S. Prior, c/o Superintendent, Peabody Buildings, Essex Road, N.1.

The Association's first Annual General Meeting was held at the Northern Polytechnic Institute, on Monday, January 24th, 1922.

The Report covered the first thirteen months' activities of this Association, which was formed in November, 1920, with a membership of nine. During the period of the Report 21 papers were read before the Association, two field days were held, and a visit paid to the Museum Telephone Exchange. A library has been formed, and a Technical Committee organised for the purpose of helping members in the construction of their own sets, etc. The membership has increased to a total of 52. The balance sheet showed a total of £36 10s. 7d. received, against which is an expenditure of £28 10s. 9d., leaving a balance of £7 19s. 10d. to be carried forward to the coming year. Both the balance sheet and report were duly read before the meeting and unanimously adopted. Officers and Committee for the coming year were then balloted for and elected as follows:—

*President*, Dr. F. C. Knight; *Vice-Presidents*, Major Basil Binyon, B.A., O.B.E., Mr. R. S. Clay, B.A., D.Sc.; *Chairman*, Mr. G. F. Auckland, M.I.R.E.; *Vice-Chairman*, Mr. H. Norman Wilson; *Committee*, Messrs. A. de Villiers, V. J. Hinkley, A. G. Hill, J. Nicol, B.A., B.Sc., G. D. Meyer, W. Power; *Hon. Treasurer*, Mr. F. S. Angel; *Hon. Secretary*, Mr. J. W. S. Prior.

Following which three new members were duly elected. At the conclusion of this business Mr. Walter J. Jonghin was called on to read his paper on "Suggestions for Experiment." This paper was most interesting, and gave several ideas for future experiment by the members. A discussion followed in which Messrs. Gartland, Angel, Saville, Meyer, Robinson and Hinkley took part. At the conclusion of Mr. Jonghin's reply a hearty vote of thanks was accorded him. This concluded a very successful meeting.

### Woolwich Radio Society.\*

Hon. Secretary, Mr. H. J. South, 42, Greenvale Road, Eltham, S.E.9.

The Annual General Meeting of the above Society was held at Woolwich Polytechnic, on Friday, January 27th, 1922, at 8 p.m. Mr. W. L.

McPherson, B.Sc., Vice-President, was in the chair, and called for the Secretary's report for 1921. This was read by the Assistant Secretary, Mr. A. C. Beeson (in the absence, through illness, of the Secretary), and approved. The financial statement for 1921 was next submitted by the Hon. Treasurer, Mr. G. Dowley, and approved. A balance left over from 1921 of £1 18s. 3d. being considered satisfactory.

Mr. McPherson then read his paper on the "Aims and Objects of the Woolwich Radio Society," beginning with the formation of the Society in 1919, largely owing to the energy and enthusiasm of Mr. W. T. James. He sketched its growth up to the present time. He dwelt upon the objects of the Society, which were threefold, viz., to establish and maintain an efficient wireless receiving station; to advise and help the more advanced experimenter by means of lectures, demonstrations, papers, and literature bearing on wireless telegraphy; and, most important, to encourage, instruct and initiate the beginner into the fascinating mysteries of wireless telegraphy. To further these objects he proposed the creation of one new office and three sub-committees:—

(1) A Chairman of the Society was badly needed—one who, beside presiding at the monthly meetings should direct the energies of all the members into the most profitable channels.

(2) An Apparatus Sub-Committee, whose duty it should be to look after the apparatus possessed by the Society, and who should be empowered to buy and make such apparatus as the Society considered desirable.

(3) An Advisory Sub-Committee, who should look after the interests of the beginner, and initiate and instruct such as to the best way to begin the study and practice of W.T.

(4) A Librarian who should gather, acquire, and lend out such wireless books and papers as could be got.

The Chairman then called on the existing officers to resign, and called for fresh nominations.

The following were duly elected for 1922:—

*President*, Col. Cousins, C.M.G., R.E.; *Vice-Presidents*: A. E. Hogg, Esq., M.A., F.C.S., A. Vinycomb, Esq., D.Sc., Capt. C. T. Hughes, W. McPherson, Esq., B.Sc., W. T. James, Esq. *Chairman*, W. L. McPherson, Esq., B.Sc. (*pro tem*); *Hon. Secretary*, Mr. H. J. South; *Assistant Hon. Secretary*, Mr. A. C. Beeson; *Hon. Treasurer*, Mr. C. Dowling; *General Committee*, Messrs. James Frazer, Wren, Berry and Bargery; *Apparatus Sub-Committee*, Messrs. McPherson, James, Bridge and Morley; *Advisory Sub-Committee*, Messrs. Beeson, Houghton and South; *Librarian*, Mr. R. A. Palmer.

At the close of the meeting Mr. A. C. Beeson proposed a hearty vote of thanks to the Chairman, Mr. McPherson, for his wise counsels, which was carried unanimously.

### The Wireless Society of Highgate.\*

Hon. Secretary, Mr. D. H. Eade, "Gatra," 13a, Sedgemere Avenue, East Finchley, N.2.

This Society is now growing very satisfactorily, and a most interesting series of lectures have been given in the past few weeks, as follows:—

30th December. Mr. W. H. Saville. Lecture and demonstration on the manufacture of basket, slab and honeycomb inductances.

January 6th. Mr. L. Grinstead. The second of his series of lectures on the thermionic valve, the subject being "Transmission."

January 13th. Mr. H. Andrewes. Demonstration of a three-valve receiver of his own construction, with several novel features.

January 20th. Mr. F. L. Hogg. The calculation of inductance and capacity.

On January 27th the first formal General Meeting of the Society was held, and the following officers were elected:—Chairman, Mr. H. Andrewes; Vice-Chairman, Mr. L. Grinstead; Hon. Secretary, Mr. D. H. Eade; Hon. Treasurer, Mr. L. R. Rowlands; Hon. Librarian, Mr. S. B. P. Barnes; Member of Committee, Mr. R. E. Clay; the officers of the Society being *ex-officio* members of the Committee.

Mr. P. R. Coursey, the President of the Society, occupied the chair at this meeting, and gave his Presidential Address, in which he dealt with first the proceedings at the recent Conference of Affiliated Wireless Societies, and, secondly, with the various lines of research open to amateur wireless workers. A Committee of four was appointed at this meeting to deal with the erection of the Society's aerial and the installation of the Society's receiving set.

On Tuesday, January 31st, a very successful public lecture and demonstration were given by Mr. Philip R. Coursey, B.Sc., F.Inst.P., A.M.I.E.E., at the Highgate Literary and Scientific Institution, the chair being occupied by the Mayor of Hornsey. Between 150 and 200 persons were present, and they received with much enthusiasm the interesting facts demonstrated to them by the lecturer. Mr. Coursey explained very simply the principles underlying the production of high-frequency oscillations and their conversion into electric waves, illustrating his remarks with the well-known mechanical analogy of the coupled pendulums and with many interesting lantern slides. He touched on the great strides made in this branch of science during recent years, accelerated no doubt by the events of the late war, and pointed out the enormous revolution which had taken place in the methods of transmission and reception of wireless signals due to the invention of the thermionic valve. Mention was made of the progress being made in wireless communication by many European countries and America, and several excellent photographs of high power stations were thrown on to the screen. The aerial was then connected to a demonstration set brought by Mr. Coursey, and were picked up from various stations and made clearly audible throughout the hall by means of a loud-speaker. At a pre-arranged time, music and speech were received from Mr. McMichael and Mr. Burnham, who kindly transmitted to Mr. Coursey for the purpose, and these were heard distinctly and with little distortion. At the conclusion of the lecture a hearty vote of thanks was accorded to Mr. Coursey, and also to the Mayor of Hornsey for his kindness in taking the chair.

The meetings of the Society are now being held each Friday evening at 8 p.m., at the Highgate

Literary and Scientific Institution, 11, South Grove, Highgate, N., and it is hoped very shortly that an arrangement will be come to whereby this will be the regular meeting-place of the Society.

The Hon. Secretary will be pleased to receive any applications for membership or to answer any questions regarding the Society.

#### The West London Wireless and Experimental Association.\*

On December 8th Mr. C. W. Hirst continued his elementary lectures for the benefit of the Junior Section, and Mr. W. T. Fair (Librarian), detailed the new library schemes which he had drawn up, and also read the proposed rules which were agreed to by the members present. At the meeting held on December 15th, notices from the Wireless Society of London were read, and Mr. C. W. Hirst was appointed as second delegate to attend their meetings on behalf of the Association, together with the Vice-President (Mr. F. E. Studt). It was decided to adjourn the meetings of the Association until after the Christmas holidays. At the meeting held on January 12th Mr. F. E. Studt gave a very interesting demonstration and lecture on the Townshend Wavemeter, its Construction and Various Applications. Questions were invited, and replies were ably demonstrated, much to the satisfaction of the querists.

The Association had a very pleasant and interesting evening at their rooms in the Central School, Belmont Road, Chiswick, on Thursday, the 19th inst., when a very fine demonstration in wireless telephony was given by Lieut. H. S. Walker, A.M.I.R.E., and Mr. J. A. Partridge, of the Wireless Equipment Co., Merton.

Members and their friends gathered to the number of fifty-four, and both the lecturer and the officers of the Association were more than pleased with such a fine attendance. The demonstration started at 7.45 p.m., when the President (Mr. Geo. Oxford) opened the meeting by introducing Lieut. Walker and his assistants to those present: also he had much pleasure in welcoming the President (Mr. A. R. Pike) and other officers and members of the Hounslow and District Wireless Society, who had so kindly come along to make the gathering a success.

Mr. Pike replied on behalf of the Hounslow Society, and said it gave him great pleasure to attend such a fine meeting, and he sincerely hoped that it would not be the last time the members of these two neighbourly wireless societies would meet together in their endeavours to fathom the depths of this particular branch of science. Mr. J. F. Bruce, of Bedford Park, also five juniors from the science class of the Central School, were welcomed by the officers and Committee. Lieut. Walker then explained the apparatus laid out on three large tables, apparatus which is specially designed for the use of the amateur. The piece of apparatus which was very fully explained and described, and illustrated with diagrams on the blackboard, was his Tuned Anode Receiver. The next piece of apparatus dealt with was his three-valve H.F. amplifier, and also his one-valve amplifier and his Ravia Telephone Transmitter.

## WIRELESS CLUB REPORTS,

Lieut. Walker had arranged for his transmitting station at Brentford to transmit at 8.30 p.m. music to the meeting. "Hullo! Hullo!! Hullo!!! Brentford calling," was heard. Then music followed, to the amazement of some of those present, who for the first time had heard the human voice transmitted by wireless. The music lasted about fifteen minutes, and was then terminated by the rendering of the National Anthem. The lecturer then demonstrated the transmission of telephony from another room, and this was heard in the same way. Various circuits were explained by diagrams and questions were then invited. The lecturer was at once bombarded with various technical queries and he very fully replied.

Mr. Horace H. Cotton, Hon. Secretary, then took the opportunity of thanking all gentlemen present for their attendance and support, which was most gratifying to both the officers of the Association and more so to Lieut. Walker. 9.30 brought the demonstration to a close, and the remaining half-hour was spent by those present critically examining all the apparatus on view.

The Hon. Secretary will be pleased to hear from any gentlemen desirous of joining the Association if they will communicate with him at his address, 19, Bushey Road, Harlington, Middlesex.

### Sheffield and District Wireless Society.\*

Hon. Secretary, Mr. L. H. Crowther, A.M.I.E.E., 156, Meadow Head, Norton Woodseats, Sheffield.

On the 9th December the Society held their second Annual Social gathering in Atkinson's Caf . A reception was held by the President (Mr. E. H. Crapper). A pleasant and enjoyable evening was spent in a whist drive of twelve tables, followed by a number of excellent songs by members and friends, after which a presentation of a Single Valve Receiving Set was made to Mr. H. E. Yerbury, the past President.

Mr. Crapper, in making the presentation, hoped that both Mr. and Mrs. Yerbury would find pleasure in the experimental work which the set would afford.

Mr. Yerbury, in replying, said any little assistance he had been able to give had afforded great pleasure and profit to himself. Much of his knowledge of wireless had been acquired by attending the Society's lectures, and he would prize the opportunity of being able to put to a practical use the present they had made to him.

The interesting and very enjoyable social was concluded with a dance to wireless music, arranged by Messrs. H. Lloyd and J. G. Jackson.

On the 16th December Mr. J. Patrick gave a paper on "Automatic Telephony," illustrated by lantern slides showing the essential pieces of apparatus required in a Small Exchange. A lengthy discussion followed, which showed that a deep interest is taken in the proposed introduction of an Automatic Exchange at Sheffield.

### Leicestershire Radio Society.\*

The Annual General Meeting of the Society was held on January 16th at Headquarters, the Vaughan College, the President (Mr. C. J. Atkinson) in the chair. The minutes of the last meeting were read

and confirmed. Last year's officers having retired, the result of the ballot was read, the new officers being: *President*, Mr. C. J. Atkinson (re-elected); *Vice-President*, Mr. H. Dysart (re-elected); *Committee*, Messrs. L. Pratt (re-elected), R. Crawley (re-elected) and W. Morton. The Secretary (Mr. J. Pallet) and Treasurer (Mr. P. Holyland) handed in their resignations. Mr. J. Rudkin was elected Treasurer and Mr. R. Crawley, Secretary *pro tem*.

The late Treasurer then gave his report for last year, which showed the Society to be in a much better position than the year before. A hearty vote of thanks was accorded for the work he had done for the Society.

The late Secretary then gave his report, stating that the membership had considerably increased, now numbering 42. The chief items of the year were the Exhibition, held on April 2nd, and the Social and Dance, held October 15th, both of which financially showed gratifying results.

The President addressed a letter to all members, hoping that the lectures for the new year would prove helpful to all and that all meetings, both general and informal, would be well attended, as some useful work was hoped to be done.

Members are reminded that subscriptions are now due. All interested in the Society should write to Mr. J. R. Crawley, Hon. Secretary, *pro tem*, 269, Mere Road, Leicester.

### North Middlesex Wireless Club.\*

Hon. Secretary, Mr. E. M. Savage, "Nithsdale," Eversley Park Road, Winchmore Hill, N.21.

The 83rd meeting was held at Shaftesbury Hall on the 25th January. The chair was taken by Mr. A. J. Dixon, and after the Secretary had read the minutes he reported on the Conference of the Affiliated Wireless Societies which had taken place that afternoon. He then called on Mr. W. A. Saville to give a talk on "The Construction of High-frequency Amplifiers."

Mr. Saville said that the use of high-frequency amplifiers was not sufficiently appreciated by most amateurs, and for telephony in particular the results were excellent, the freedom from distortion being a noted feature. He drew a typical circuit on the blackboard, and showed how to wire up the connections on a panel, which he passed round for inspection. He also described the making of the transformers in detail. Mr. Wordham described an alternative method of construction, which had the merit of cheapness, enabling several to be made up and comparative tests made. Other members contributed to the discussion and a lot of useful information was gleaned.

The Club proposes to hold its Annual Social Evening on the 22nd February. It will be remembered that the last one was a great success, and members are asked to make a note of the date. The Annual General Meeting will be held on March 22nd.

### Wireless and Experimental Association.\*

Hon. Secretary, Mr. George Sutton, A.M.I.E.E., 18, Melford Road, S.E.22.

The members of the Wireless and Experimental

Association, on January 18th, at the Central Hall, Peckham, listened to a well-prepared lecture by a member (Mr. W. G. Noakes) on "Electrical Measuring Instruments." There was not an instrument used in measurement that was left out of his list, and he had much of interest to tell us of most of them.

#### Willesden Wireless Society.\*

The Willesden Wireless Society met at its headquarters on Tuesday, 17th January, when Mr. W. E. F. Corsham (our Chairman) reported upon the Transatlantic Tests. He has been awarded Third Prize in the Competition, and we at Willesden are naturally very proud of the fact that to us has fallen the honour of being the only Middlesex Club to have a prizewinner in our ranks. We send our hearty congratulations to all other successful competitors. It is with great pleasure that we heard various details sent to Mr. Corsham by the other successful amateurs, and note that our man probably used the lowest number of amplification stages in the tests. Our Chairman stated that the jamming in London during the tests was terrible, and he has great sympathy for the other competitors. One night he received an apparently endless Transmission from a telephone station on the test wave, and what with the arc's, spark and amateur jamming, some very weird if not very pleasing noises were heard at most hours of the test, and in some cases even with a fairly readable signal reception would be impossible. A neighbouring pen of young cockerels for ever dispelled the illusion that "the cockerel's shrill clarion heralds the approach of dawn." It was one continuous dawn to those cockerels! The usual London cat serenade also took place regularly about 1 a.m. to 3 a.m. each morning. We send special greeting to the Wireless Experimental Association, with whom we share the London honours, and Mr. Godley's remarks on Wembley (about four miles distant from Willesden), make the Londoner's victory even sweeter.

Messrs. Blunden and Arnoll were our lecturers, and both gentlemen were in a very witty mood. They soon proved that they had a very sure knowledge of their subjects, and a very interesting meeting was the result. Mr. Blunden lectured on "Lathe Working," and Mr. Arnoll on "Voltsmeters and Ammeters." Towards the close of the meeting Mr. Wyatt (our pet figure man) rose "To say a few words," at 9.55 p.m. Mr. Wyatt was still saying "his few words" at 10.35, and, incidentally, looking for a new blackboard! Our Chairman diplomatically closed the meeting.

#### The Corinium Wireless Society.\*

The first year's work has been quite satisfactory. All being novices, except one or two, we have naturally had to begin at the beginning, and so the lectures have dealt with such subjects as Capacity, Inductance, Wavelength, and the Action of the Valve. Morse buzzer practice has been fairly well attended, but will have to be a still more prominent feature in the near future. The meetings are monthly (usually the second Tuesday), and while our present membership is only twelve, it is rare

for a member to miss an attendance. There is a real spirit of keenness, which augurs well for the future.

The election of officers for 1922 took place at the January meeting, with the result that the President (Mr. T. Frazer, M.A., F.C.S.) was re-elected, also the Hon. Secretary and the following three additional members of Committee—Messrs. Daffon, Miles and Stradling. The Hon. Secretary, who will be glad to hear of any new members, is the Rev. B. R. Keir Moilliet, The Old Vicarage, Cirencester.

#### Burton-on-Trent Wireless Club.\*

Hon. Secretary, Mr. A. J. Selby, 66, Edward Street, Burton-on-Trent.

A meeting of the Club was held on Friday, January 13th, with Mr. A. Chapman in the chair. The Secretary (Mr. A. J. Selby) had received a letter from the Wireless Society of London with respect to the petition to the Postmaster-General, signed by over 63 provincial wireless societies, representing over 3,300 amateur wireless telegraphists in Great Britain. In an informal discussion reference was made to the amount of wireless telephony and music which is being transmitted by amateurs every evening.

Mr. C. E. Randall gave an address on "Science and Human Progress." An entertaining discussion followed, and the customary vote of thanks terminated the proceedings.

#### The Wandsworth Wireless Society.\*

The above Society is still in existence and progressing in the right direction. The past year has been successful in all respects, and this year gives promise of being another successful one.

On January 7th the first meeting of this year, we had a social evening, comprising a general conversazione and concert. The concert was ably arranged by our Treasurer (Mr. J. Turner), who through illness was unavoidably absent. The evening—an all-too-short one—proved a great success, and was much appreciated by the visitors, several of whom belonged to neighbouring societies.

On January 20th we had the pleasure of a lecture by Mr. W. J. Fry on "Short Wave Transmission and Reception," the former showing how one can keep within the 10-watt limit and have efficiency also. Mr. Fry also exhibited a very neat short wave tuner, the construction of which was explained in detail.

We have promise of many interesting papers and demonstrations by members and friends of the Society. Our membership is now 50, and new members will be welcome any Friday evening at 7.30 p.m. at the Technical Institute, Wandsworth, High Street, S.W.18.

Hon. Secretary, Mr. F. V. Copperwheat, 9, Birdhurst Road, S.W.18.

#### Liverpool Wireless Association.

Hon. Secretary, Mr. James K. Wilkie, Junr., "Avondale," Knowsley Road, Cressington Park, Liverpool.

The Liverpool Wireless Association held a meeting

## WIRELESS CLUB REPORTS.

at the Royal Institution, Colquhoun Street, on Wednesday, the 25th January. It was decided to hold the open night on February the 9th, instead of the 8th, as previously announced, as on this date several special transmissions by telephony for the benefit of those who attend the meeting had been announced. The Hon. Secretary (Mr. James K. Wilkie) announced that he had received a letter from Mr. W. R. Burne, winner of the recent Tests, announcing that he was prepared to give a short lecture to the Society. This offer was received with loud applause.

The Committee authorised Mr. Hyde to take steps to get all the Society's apparatus into working order by the purchase of new parts. (Mr. Hyde is the engineer and technical adviser of the Society).

Mr. J. Coulton was elected Assistant Hon. Secretary.

due and payable on January 1st of each year. There are a considerable number of last year's subscriptions unpaid. At a Committee meeting, held on January 25th, 1922, it was resolved that all members whose arrears and current subscriptions are not paid by the last day of February in any year shall be deemed to have resigned from the Club, and shall be struck off the rolls.

*Election of Members.*—It was also resolved that Rule 3 shall be extended by a byelaw to the effect that all names of proposed members shall be placed before the Committee and posted upon the Club notice board, together with the names of proposer and seconder, for fourteen days. Any objections to be made in writing to the Secretary before the expiration of this period. Should no objections be raised, election will take place at the first following formal meeting. New members first subscriptions

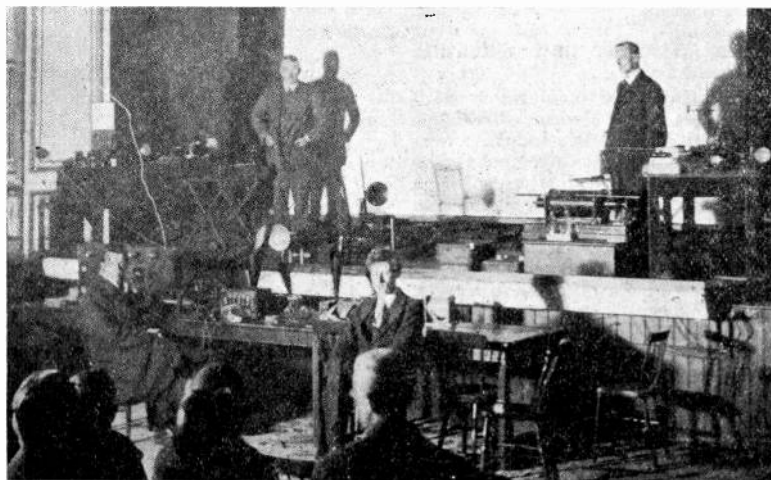

*Ipswich and District Wireless Society's Demonstration.*

### Derby Wireless Club.

Meetings will be held at "The Court," Alvaston, every Thursday evening at 7.30 p.m.

February 17th—Mr. E. V. R. Martin, "Single Valve Circuits."

February 23rd—Informal Meeting.

March 2nd—Mr. E. F. Clarke, "Alternating Currents."

March 9th—Informal Meeting.

March 16th—Mr. C. L. Drury, "Soldered Joints."

March 23rd—Informal Meeting.

March 30th—Informal Meeting.

April 6th—Mr. J. E. Allen, "Ignition."

April 13th—Informal Meeting.

April 20th—Mr. F. V. R. Martin, "Short Waves."

April 27th—Informal Meeting.

Will members willing to give papers please advise the Committee? Any dates given above for Informal Meetings may be chosen.

In common with other Wireless Clubs, the sum of £1 is. has been voted from the Club funds to the fund for the Hague Concerts.

*Important—Subscriptions.*—All subscriptions are

are due and payable on election.

*Library.*—This requires modernising. Good textbooks are costly, but with a little assistance from members a really good library, helpful to all members, can be formed. We have a keen Librarian, but to make the utmost use of him we must have the books. Several books and donations of 5s. and 10s. have already been promised. The Committee will be very pleased to receive donations, in cash or kind, for the Library.

Hon. Secretary, "The Limes," Chellaston, Derby.

### Ipswich and District Wireless Society.

Hon. Secretary, F. T. G. Townsend, 46, Grove Lane, Ipswich.

At a Committee meeting of the above, held on January 9th, it was resolved to accept Mr. Lewis's offer of an excellently appointed furnished room at 55, Fonnereau Road, for meeting purposes every Monday evening from 7 to 10 p.m. There are excellent prospects of the Club possessing the finest aerial in the town, **BYE** excepted.



On Tuesday, January 17th, a successful lecture, entitled "The Romance of Wireless," was given by Mr. Stanley Lewis, at the Waterside Works. The lecturer demonstrated with numerous experiments, including the use of a 14-inch spark coil (with 230-volt mains on the primary!). The lecturer also traced the history of our favourite science by means of lantern slides, and a most enjoyable evening was spent. In the accompanying photograph Colonel Ionides and Mr. Lewis are shown on the left and right respectively of the stage.

A Johnsen and Rahbek loud speaker is shown at front of stage, behind the Brown loud speaker.

The Club demonstrated with a three-valve amplifier, kindly loaned by Messrs. F. O. Read & Co., a Marconi 551 amplifier and the home-made set belonging to the Treasurer (Mr. Keeble). In spite of local disturbances, loud signals were received from POZ, OUI, etc., at the close of the meeting.

#### The North Essex Wireless and Scientific Society.

At an informal meeting, held on January 24th at Braintree, it was decided to form a Wireless Society for North Essex. Mr. Adshead, B.A., was elected President. Temporary arrangements were made with a view to holding a further meeting later, when all the amateurs in the district had been communicated with.

The birth of the Society was happily marked by the gift of a tuner and a single valve receiver by Mr. Castagnoli, and also by an offer made by Mr. Surman to charge all the Club's own batteries free. The Society, therefore, commences life with practically a complete single valve receiver.

The temporary headquarters are 15, Rayne Road, Braintree, Essex. Will those interested please communicate with the Secretary, care of the above address.

#### Lincoln and District Wireless and Scientific Society.

On December 14th a public demonstration and lecture was arranged by the Society in the Municipal Technical School. The idea was to arouse the interest of local scientific men, and in this respect the meeting was an entire success, being attended by well over 200 people.

The lecturer was Captain W. R. H. Tingey, and the Society could not have made a better choice, for from start to finish Captain Tingey held his audience enthralled. He outlined the development of wireless knowledge from the earliest time, and explained the methods for the propagation and reception of aether waves. His lecture was illustrated by experiments.

The practical reception of telegraphy and telephony was accomplished by means of a Tingey "Three-valve Set," amplified by a captured German four-valve note magnifier, and made audible to the whole assembly by a Brown loud speaker. There was no doubt about the loud speaker; it shrieked out the C.W. signals. A CQ message was read and written on the blackboard for the benefit of the audience. But the crowning interest of the evening was the reception

of telephony; Mr. Burbury transmitted, and the reproduction was splendid.

Later in the evening the Dutch Concert was picked up, and could be heard very distinctly by all, though the interference set up by a harmonic of Leafield and a spark station spoiled the effect.

The vote of thanks proposed to Captain Tingey was carried with enthusiasm.

In the near future an exhibition of instruments made or possessed by members is to be held. Demonstrations of the use of these will be made by the owners and all people known to be interested in the district will be invited. By this means it is hoped to still further swell the membership, which at present is 33.

Some few wireless amateurs in the district do not yet belong to the Society, but now that various instruments, such as four-valve note magnifier, loud speaker, wavemeter, etc., have been purchased and can be borrowed by members, it is hoped to rope these in.

#### Croydon Wireless and Physical Society.

At a meeting of the Croydon Wireless and Physical Society, held at the Central Polytechnic Croydon, on February 4th, 1922, Mr. A. H. Howe, of the Marconi Osram Valve Co., Ltd., gave a most interesting lecture on "The Construction of Thermionic Valves." The Lecture was illustrated by some very excellent lantern slides, depicting the construction of all types of valves from the smallest receiving valve used by amateurs to the largest transmitting valve used on transatlantic work. The lecturer also brought specimen valves of all types, also the component parts used in the construction, all of which proved of very great interest to the members present. The lecture was followed by a very keen discussion.

The Chairman announced that a visit to the Croydon Aerodrome W/T Station had been arranged to take place on Saturday, March 4th, 1922, details of which would be announced later. Members wishing to attend must notify the Secretary as soon as possible. The Meeting then terminated with a very hearty vote of thanks to Mr. Howe.

The Secretary, Mr. B. Clapp, Meadmoor, Brighton Road, Purley, will be pleased to receive applications for membership.

#### Middlesbrough Wireless Society.

The Middlesbrough Wireless Society would be extremely obliged if you would kindly insert a small notice to the effect that all wireless operators in port at Middlesbrough will be very welcome at any of the Society's meetings, which are held every Tuesday evening at 7.30, at the Society's meeting room in Borough Road East, Middlesbrough.

The Society is now progressing very well, and though it does not possess any complete apparatus, some very fine apparatus have already been demonstrated by some of the members at the meetings. At these demonstrations connection was made to a temporary aerial which is slung over a neighbouring high roof. It is hoped to supersede this aerial at an early date, and materials have already been requisitioned for the purpose.

# Experimental Stations.

## DIRECTORY OF CALL SIGNS.

The particulars regarding the following stations which have appeared in *The Wireless World* for August 20th, 1921, and subsequent issues, should now be deleted :—

AKX, 2 AB, 2 AL, 2 AM, 2 AZ, 2 FB, 2 FR, 2 FU, 2 HR, 2 IL, 2 IN, 2 JX, 2 JZ, 2 KF, 2 KG, 2 KM, 2 KN, 2 KO, 2 KR, 2 KV, 2 KW, 2 KY, 2 LA, 2 LB, 2 LF, 2 LP, 2 LY, 2 MB, 2 MD, 2 MF, 2 MI, 2 MZ, 2 NA, 2 NM, 2 NO, 2 OA, 2 OI, 2 ON

The following additions or corrections should be inserted :—

Call Letters.	Power in Watts.	Wave-lengths in Metres.	Hours of Working.	System.	Name and Address.
2 AB	—	200 700 1,000	2000-2200	Spark, C.W. and Telephony.	Capt. H. de A. Donisthorpe, London.
2 AL	—	180 1,000	2000-2200	C.W. and Telephony.	W. Halstead, Briar Royd, Briar Lane, Thornton-le-Fylde.
2 AZ	—	1,000	1500-1600 2000-2100	Spark, C.W. and Telephony.	W. Le Queux.
2 BM	—	—	2000-2200	C.W. and Telephony.	J. H. A. Whitehouse, 25, Ennerdale Road, New Brighton, Cheshire.
2 CH	10	1,000	Wednesday and Sunday, 1700-2100	C.W. and Telephony.	Science Society, The School, Oundle, Northants.
2 FB	—	—	1900-2100	Telephony.	W. Ison, Watford.
2 FR	Artificial aerial only.	180	Various.	Spark	S. Rudeforth, 54, Worthing Street, Hull.
2 FU	10	180 1,000	2030-2230	Spark C.W. and Telephony.	E. T. Manley, Jr., 27, Home Park Road, Wimbledon Park, S.W.19.
2 HK	—	—	—	—	A. A. Campbell Swinton, Chester Square, W.
2 HR	10	180	1700-1900	C.W. and Telephony.	F. O. Read & Co., Ltd., 13-14, Gt. Queen Street, Kingsway, W.C.2.
2 IL	10	1,000	—	Telephony	H. R. Goodall, Fernlea, Winchester Road, Bassett, Southampton.
2 IN	10	180 1,000	2000-2200	C.W. Spark and Telephony	J. E. Fish, "Thornleigh," Thornton-le-Fylde, nr. Blackpool.
2 JX	10	1,000	1900-2100 Weekdays, 1100-1200 Sundays.	C.W. and Telephony.	L. Vizard, 12, Seymour Gardens, Ilford.
2 JZ	10	1,000	2030-2230	C.W. and Telephony.	R. D. Spence, Craighead House, Huntly, Aberdeenshire.
2 KF	10	1,000	2100-2300 1600-1800 (Sunday).	C.W. and Telephony.	J. Partridge, Park Road, Merton, S.W.19.
2 KG	10	180 1,000	Various.	Spark, C.W. and Telephony, T.T., and Arc.	A. E. Hay, "Glendale," Abernant, Aberdare.
2 KM	Artificial aerial only.	180	Various.	Spark	C. Stainton, 44, Kimberley Street, Hull.
2 KN	Artificial aerial only.	—	—	C.W. and Telephony.	A. B. Day, Finchley.
2 KO	10	180 1,000	2000-2200 Weekdays, 1100-1300 Sundays.	C.W. and Telephony.	C. S. Baynton, 48, Russell Road, Moseley, Birmingham.
2 KQ	10	—	1830-1915 2100-2200	—	Wolverhampton (communications to Taylor, Relief Motor Co., Ltd., Cleveland Street, Wolverhampton)

2 KR	10	180 1,000	1600-1630 2030-2100 2200-2300	C.W. and Tele- phony.	E. Edmonds, 2, Yew Tree Road, Edgbaston, Birmingham.
2 KU	10	180 1,000	1830-2030	Spark, Tele- phony, C.W. and T.T.	A. J. Selby, 66, Edward Street, Burton-on-Trent.
2 KV	—	1,000	2000-2200	C.W. and Tele- phony.	W. J. Crampton, Weybridge.
2 KW	—	150, 180 1,000	1930-2130	C.W. and Tele- phony.	W. R. Burne, Springfield, Thorold Grove, Sale, Cheshire.
2 KY	10	180 1,000	2000-2200	C.W. and Tele- phony.	L. Pollard, 209, Cunliffe Road, Blackpool.
2 LA	—	180 1,000	1900-2000 2100-2200	C.W. and Tele- phony.	H. F. Yardley, 121, Victoria Road, Headingley, Leeds.
2 LB	—	180 1,000	1900-2000 2100-2200	C.W. and Tele- phony	H. F. Yardley, 6, Blenheim Terrace, Leeds.
2 LF	—	—	2100-2300	Spark and C.W.	P. Harris, Chilvester Lodge, Calne, Wilts.
2 LP	10	180 1,000	Thursdays and Saturdays. 1500-1600 2000-2100 Other days, 2000-2100 2200-2300	Spark, C.W. and Telephony.	A. W. Knight, 26, Stanbury Road, S.E.
2 LY	10	1,000	1230-1330 2230-2330	Telephony	H. H. Thompson, 59, Redlands Road, Road, Penarth, Glam.
2 MB	10	180 1,000	1930-2130	C.W. and Tele- phony.	E. H. Jaynes, 67, St. Paul's Road, Gloucester.
2 MD	10	180 1,000	2000-2200 Wednesday and Saturday.	Spark, C.W. and Telephony.	C. Chipperfield, Victoria Road, Oul- ton Broad, Lowestoft.
2 MF	—	1,000	Various.	C.W. and Tele- phony.	Marconi Scientific Instrument Co., Ltd., 21/25, St. Anne's Court, Dean Street, W.1.
2 MI	10	180 1,000	1030-1230	Spark, C.W. and Telephony.	L. McMichael, Stag Works, Kilburn, N.W.
2 MZ	—	—	2130-2230 Except Monday, Tuesday and Thursday.	—	J. Mayall, "Burfield," St. Paul's Road, Gloucester.
2 NA	10	1,000	1800-2000 2100-2400	C.W. and Tele- phony.	H. Frost, Longwood, Barr Common, Walsall.
2 NI	10	180 1,000	—	Artificial aerial	R. H. Lyne, Dartford and District Wireless Society. Hither Green.
2 NJ	—	—	—	—	G. Marcuse, Little Coombe, Coombe Dingle, near Bristol.
2 NM	—	180 1,000	2100-2300	C.W. and Tele- phony.	H. R. Adams, Crescent Cabinet Works, Walsall.
2 NO	10	200 1,000	1900-2000 Monday and Friday.	C.W., Tonic Train and Telephony.	Morton, Kingston.
2 NQ	—	—	—	—	H. C. Trent, Secondary School, Lowestoft.
2 OF	10	180 1,000	2000-2200	Spark, C.W. and Telephony.	H. S. Walker, Park Lodge, Brent- ford, Middlesex.
2 OM	—	1,000	—	C.W. and Tele- phony.	Major H. C. Parker, 56, Stern Hall Street, Walthamstow, E.17.
2 ON	10	180 1,000	1900-2100 Monday-Saturday 1100-1200 1900-2100 Sunday.	Spark, C.W. and Telephony.	
2 OY	10	180 1,000	Friday to Monday 2000-2200 Other days 1500-1700	C.W. and Tele- phony.	Capt. E. J. Hobbs, 4th Tank Battn., Wareham.

## EXPERIMENTAL STATIONS

2 PI	10	180 1,000	1900-2100	Spark, C.W. and Telephony.	Loughborouge College; Leicester- shire.
2 PJ	As above,	but portable set for 10 miles radius.			
2 PR	10	1,000	1730-1930	C.W. and Tele- phony.	A. E. Whitehead, "Hollingwood," King's Ride, Camberley, Surrey.
2 PS	10	180	1930-2130	C.W. and Tele- phony.	J. H. Gill, 18, Fourth Avenue, Sherwood Rise, Nottingham.
2 PU	10	180 1,000	Weekdays, 2100-2200 Saturday and Sunday, 1600-1700	Spark, C.W., and Telephony.	C. R. W. Chapman, "Nirvana," 44, Chaplin Road, Wembley.
2 QH	10	180 1,000	1830-1930 2130-2230	C.W., T.T. and Telephony.	A. Hewins, 42, St. Augustine Avenue, Grimsby.
2 QI	—	—	—	—	Balham.
2 QK	10	180 1,000	2000-2200	C.W. and Tele- phony.	J. Bever, 85, Emm Lane, Bradford.
2 QL	—	300 700	Various.	C.W. and Tele- phony.	R. J. Hibberd, Grayswood School, Haslemere, Surrey.
2 QN	10	180 1,000	Weekdays, 1930-2030 2130-2230 Sundays, 1000-1100 1930-2030	Spark, C.W. and Telephony.	A. Hobday, Flint House, Northdown Road, Margate.
2 QQ	—	—	—	—	Burnham & Co., Experimental Station, Wembley.
2 QS	10	180 1,000	2000-2200	Spark, C.W. and Telephony.	S. Ward, "Ravenswood," 339, Brix- ton Road, S.W.9.
2 QU	—	—	—	—	Blackheath.
2 QV	10 100	—	Evenings and all Saturday and Sunday.	Telephony	Altrincham Wireless Society, Breeze Crest, Plane Tree Road, Hale, Cheshire.
2 QY	—	Below 150 160	—	—	London, N.W.6.
2 RH	10	160	1030-2030 2130-2230	Spark	H. A. Pound, 101, High Street, Broadstairs.
2 SF	—	180 1,000	—	C.W., T.T. and Telephony.	C. Midworth, 4c, Vicarage Mansions, West Green, N.15.
2 SH	—	—	—	C.W., T.T. and Telephony.	F. L. Hogg, 37, Bishops Road, N.6.
2 SK	—	—	—	—	K. G. Styles, 52, Jerningham Road, S.E.14.
2 SL	—	—	—	—	A. G. Styles, "Kitscot," Maidstone, Kent.

## Correspondence

*To the Editor of THE WIRELESS WORLD.*

DEAR SIR,—With reference to Mr. Godley's remarks in this week's issue of *The Wireless World*, in regard to the choice by British amateurs of the wavelength of 1,000 metres in preference to that of 180 metres for transmission, as the possessor of a transmitting licence I should like to point out that in the first place most British amateurs transmit on telephony instead of the more obsolete spark method used by the majority of American amateurs, and transmitting spark on 180 metres, using an input of 1 kW. is an entirely different matter to getting a 10 watt valve transmitter to oscillate and work efficiently on that wavelength. Secondly, as regards the reception of these short wavelengths, it is extremely difficult to design a H.F. amplifier that will work efficiently on this

wave. Our American friends tell us that they can do it, and no doubt they can receive short wave spark and C.W., but as all their receivers depend upon regeneration for their great amplification it is quite a different story when it comes to the reception of telephony. I also notice in the American radio magazines that most of the telephony transmission is reported as being done on a wavelength of about 300 metres.

In conclusion, I should like to point out in defence of the British amateur, that whereas in America for an amateur to have a telephony transmitter appears to be the exception rather than the rule, in England practically every possessor of a transmitting licence uses telephony.

M. C. ELLISON.

*To the Editor of THE WIRELESS WORLD.*

SIR,—Numerous experiments with aerials, "freak" and otherwise, have been carried out on the other side of the Atlantic, but so far as I know, very little has been done by British amateurs in this direction.

I have experimented quite a lot in this way myself and have had some very interesting results. My latest effort consists of using the usual water-pipe earth with a gas-pipe "aerial" and with these connections, using the usual reactance circuit and two-step L.F. amplifiers, I can copy IDO, OUI, POZ, LY, LCM, NSS, WII, WSO and WQK, consistently. Static is greatly reduced, but signal strength is constant and does not appear to suffer a decrease, this in comparison with signals on 55' single wire, 32' high. On the latter aerial static is very bad most times and fading is noticeable occasionally. Series tuning condenser is necessary with gas-pipe "aerial," otherwise set won't oscillate and induction from electric mains and cars is heard.

Personally, I prefer long wave working, on a gas-pipe "aerial," in contrast to usual "din" obtained on ordinary antenna. It is also interesting to note that the human body is capable not only of passing signals, when interposed between and in connection with aerial lead to receiver, but of actually acting as an aerial!

I would like to see, through your columns, any observations other amateurs would care to make.

C. G. WILLIAMS.

Liverpool.

December 26th, 1921.

(NOTE: This result should not always be expected as it must depend upon fairly good insulation between the gas pipe and water pipe systems, such a condition does not always exist.—Ed.)

*To the Editor of THE WIRELESS WORLD.*

SIR,—Re enquiry made by Mr. Spence (2JZ), Aberdeenshire, in your issue of December 24th.

I am afraid I am the innocent cause of my name having wandered among the solitudes of Aberdeenshire. The circumstances are these:—

I have installed at this address a three-valve receiving set. Early in November last I visited Wolverhampton and had the privilege of inspecting a friend's fine installation there. His call is 2KQ. When I left for home we arranged that he should call me at 3 p.m. on November 6th, working on 1,000 metres.

On reaching home I discovered that my H.T. battery (owing to damp in my wireless cabin) had deteriorated and thus prevented my getting his call. Apparently he tried again later in the day on the offchance of my listening in.

I have since removed my set indoors, and it is now working well. I shall be glad to receive calls from Mr. Spence or anyone say from 7.30-8 p.m. on Thursdays, calling me by name and giving address of caller. I will send a postcard if they reach me.

May I add that I heartily agree with Mr. Adams' letter re transmission of music and speech by a British high-power station.

J. NOKES.

January 2nd, 1922.

*To the Editor of THE WIRELESS WORLD.*

SIR,—I was interested to read the letter from Mr. Pratt, in *The Wireless World* dated November 26th, stating that he had received the Dutch Concert on a frame aerial. It would be interesting to know if Mr. Pratt has an outdoor aerial with a lead-in that passes near his frame, and if this lead was earthed during his reception of the concert.

Personally, I can get Paris on a four-foot frame, using a crystal detector without amplification, when the outside aerial lead is left unearthed; but when it is earthed, signals become unreadable.

F. WALKER.

*To the Editor of THE WIRELESS WORLD.*

SIR,— . . . If I might be permitted the space, I should like to say a few words in connection with Mr. Brian H. Colquhoun's article, published in your issue of September 17th, on the construction and erection of masts. Mr. Colquhoun, no doubt, has a great deal more experience and knowledge of wireless matters than I, but I hardly think he is fair in his criticism of the wooden mast. He states at the end of his article that wooden masts must be made in sections not more than four to five feet, and that the maximum height is about 40 feet. My mast at free end of aerial (the home end is taken to a high chimney of the house) is just 50 feet 6 inches in height, and is made up of three sections. Admittedly it is heavier than a steel mast, but it has been made up of material which I happened to have at hand. Top section 18 ft. long, tapered from 1½ in. to 2 in. square. Second section 20 ft. 6 in. tapered 3 in. by 3 in. to 3 in. by 5 in. Bottom section 19 ft. long, 6 in. by 4 in. Overlap top section 3 ft. Bottom section 4 ft. Stayed at 45 ft. and 27 ft. with three single strand 12 S.W.G. galvanised wires, insulated top and bottom. The bottom section is bolted against the wall of an outbuilding. I had absolutely no trouble in erecting the mast, and only required the assistance of three friends for a few minutes to hold the top stays during the last part of the operation, this was principally due to there being a fairly strong wind at the time. I am no doubt advantageously situated in having a wall against which to bolt the bottom section, but I cannot agree with all the disadvantages which Mr. Colquhoun lays at the door of the wooden mast. Mine is in a most exposed position, and has stood some very heavy gales with no ill effects.

G. F. M. WYNNE.

November 1st, 1921.

*To the Editor of THE WIRELESS WORLD.*

SIR,—Would it be possible for you to obtain from "Experimenter," Glasgow,\* an account of his experiences to be printed in *The Wireless World*, and so be available for the vast numbers of enthusiasts who must surely have been keenly interested in his results, given in *The Wireless World* recently.

F. BARKER.

\* "Experimenter," Glasgow, is invited to supply this information.—Ed.

# Questions and Answers

**NOTE.**—This section of the magazine is placed at the disposal of all readers who wish to receive advice and information on matters pertaining to both the technical and non-technical sides of wireless work. Readers should comply with the following rules.—(1) Each question should be numbered and written on a separate sheet on one side of the paper only. (2) Queries should be clear and concise. (3) Before sending in their questions readers are advised to search recent numbers to see whether the same queries have not been dealt with before. (4) The Editor cannot undertake to reply to queries by post. (5) All queries must be accompanied by the full name and address of the sender, which is for reference, not for publication. Queries will be answered under the initials and town of the correspondent, or, if so desired, under a "nom de plume." (6) Readers desirous of knowing the conditions of service, etc., for wireless operators will save time by writing direct to the various firms employing operators. (7) Four questions is the maximum which will be accepted at a time.

**W.M.C. (Preston)** has calculated split pile windings for a tuner 2,000 to 20,000 metres, and asks our opinion.

The circuit design is quite useful, but there is no necessity for a fixed condenser in series with the secondary condenser. We should prefer a magnetic reaction. The inductance valve may be correct, but it is rather difficult to predict very accurately the actual values of coils with spaced windings such as described.

**W.H.B. (Castleford)** gives diagrams and description of a set, and asks (1) How to calculate the total inductance of three sections of winding in series. (2) Minimum wavelength on short waves. (3) Formula for calculation of lattice wound coils. (4) Whether to use separate heterodyne or reaction for telephony.

(1) This involves the mutual inductance between the sections. See Nottage's handbook, pages 29-36 for a treatment of this.

(2) Minimum wavelength of section circuit will be about 100 ms., but you will not get signals on this wavelength unless the windings of the H.F. transformers are suitable for this wavelength.

(3) Method described in *The Wireless World*, Oct. 1919, pp. 380-385.

(4) A reaction receiver is most suitable for telephony.

**D.M. (Liverpool).**—(1) The connections are correct, except that the coupling coil should be in series with the A.T.I., and not in parallel with it as shown.

(2) The circuit of Fig. 3, page 398, September 17th, should meet with your requirements.

**S.B.P.B. (Highgate)** asks (1) For a four valve set, three receiving and one separate heterodyning valve. (2) If loose coupler coils may be used for the heterodyne coils. (3) Whether to use R or B valves.

(1) Diagram given in Fig. 1.

(2) Yes, but a considerable saving in space is made if fine wire basket coils are used. You will notice a small coil in the earth lead coupling into the oscillator inductance.

(3) Use an R valve.

**W. H. J. (Hull)** asks for "a suitable H.F. and rectifying valve diagram."

We could assist you more if you had given us some more definite information as to your requirements. The circuit of Fig. 4, page 556, November 26th issue, is one of many answering to your description.

**J.H. (Birmingham)** asks (1) What material is used for spacing washers in a variable condenser. (2) If he can use No. 36 wire for a reaction coil. (3) What No. 32 D.W.S. wire is.

(1) Ebonite fibre, or other similar insulating material.

(2) Yes, in most cases.

(3) Wire of No. 32 gauge, wound with a double covering of silk.

**G.W.B. (Dunstable)** asks various questions with regard to the addition of a L.F. valve to the single valve long-range set, described in detail in the last volume.

We doubt whether this addition will enable you to hear the Dutch Concerts at such a distance without additional H.F. amplification. However

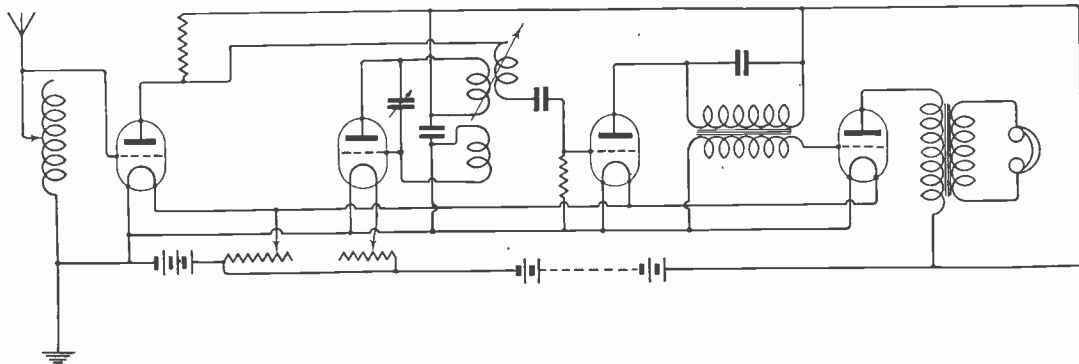

Fig. 1.

transformer windings may be 1 and 3 oz. of No. 44 wire on a core (of iron wires)  $\frac{1}{2}$ " in diameter and 3" long. Any hard valve may be used. Complete connections of the set should be as in Fig. 3, page 555, November 26th issue.

**S.L. (Burnley)** asks for advice in the elimination of interference from a small dynamo near his set.

If you have access to the machine, you will very likely improve things by carefully cleaning the commutator, bedding down the brushes and adjusting their position, if this is possible. Failing this, you can earth each pole of the dynamo through as large a condenser as you can obtain, say, 1 mfd. Or try screening your receiving circuits in iron boxes. If these attempts do not cure the trouble, you will have to try one of the anti-noise circuits of the type you refer to on page 307.

**H.F.M. (Bexley)** sends a circuit diagram, and asks (1) Whether it is suitable for addition of another valve. (2) If so, for a suitable diagram.

It would certainly be possible to add another valve to the circuit shown, but we do not recommend it, as the circuit is not a good one for receiving, as it is not flexible and gives serious re-radiation effects. We should recommend you to scrap it and to adopt one of the more normal types of two-valve circuit, as often given in these columns.

**T.B.H. (West Hartlepool)** wishes to build a frame aerial into a space  $10'' \times 11\frac{1}{2}'' \times 2''$  for use with a three-valve set. He asks (1) If this is possible. (2) Number of turns and spacing. (3) If multilayer. (4) For particulars of the B.T.H. frame aerial.

(1) This can be done if desired, but you would get better results with a larger frame.

(2) and (3) Wind as much No. 20, unspaced, as you can get on a single layer into the space available. Provide another similar former, similarly wound, as a reaction coil, and arrange for the coupling between these coils to be variable, e.g., by hinging the formers together.

(4) The B.T.H. Company use two formers of this type, hinged in this way; but the size is somewhat larger, about 16" square.

**W. (Leeds)** sends a diagram of a circuit (one valve and crystal), and asks (1) If correct. (2) If it would give PCGG on a P.M.G. aerial. (3) If more valves required for a circuit. (4) Sizes recommended for condensers.

(1) Circuit incorrect. Anode closed circuit, with shunted crystal and telephones, should be inserted between positive of H.T. battery and the plate of the valve. 0.001 mfd. condenser should be in shunt across the H.T. battery, not in series with it as shown.

(2) and (3) No; you will require about three valves. Try the circuit of Fig. 3, page 398, September 17th, and add another H.F. valve if necessary.

(4) A.T.C. about 0.002 mfd. Closed circuit condenser 0.0005 mfd.

**S.H.F. (Bilston)** asks for advice on an economical method of charging a six-volt accumulator from an A.C. supply.

If capital expense is immaterial, we should recommend the installation of one of the B.T.H. "Tungar" thermionic rectifiers. These are, however, somewhat expensive. You can obtain

results, with a certain loss of efficiency, by means of a rectifier of the Nodon type, for which see an article in the March 19th, 1921, issue.

**M.L. (Highgate)** asks various questions about the Turner aperiodic amplifier, described on page 840, of March 5th last.

This amplifier functions as described, but is somewhat critical in operation. If got into a sensitive state it is rather liable to give trouble from persistence of the signals. It gives high magnification, but is not economical in H.T. batteries. Common L.T. batteries may be used, but separate H.T. batteries are necessary. We have no information as to the best values of resistance for particular valves. Try the values suggested and modify, if necessary. The arrangement will work on all wavelengths, except probably those below about 600 metres.

**"GAMMA" (Huddersfield)** has a three-valve amplifier, and asks (1) If it is possible to re-arrange it for use with a separate filament resistance for each valve. (2) If so, how to do it.

Electrically this is, of course, possible; but we are unable to say without detailed knowledge of the set, which we do not possess, how much constructional difficulty the job will give. Separate filament control introduces extra complications and possibilities for development of faults. A simple temporary way of doing this for valves of the V type is by means of two plates of copper foil, insulated by mica, introduced between one terminal of the valve and the holder, wires to the rheostat being soldered to the plates.

**F.H.R.L. (Ilkley)** asks (1) In what number the construction of a simple wireless telephone set was described. (2) What resistance telephones are necessary for spark and also for telephony.

(1) No detailed constructional article on this subject has appeared, but you will get much practical help from a Wireless Society of London paper on Telephony, published in the May 28th issue.

(2) The best resistance for the telephones depends on the type of set, and not at all whether it is to be used for spark or telephony. See any text book.

**"OLD SUBSCRIBER" (Liverpool)** asks (1) For windings for a loose coupler for telephony. (2) For suggestions for improvement of his set.

(1) Wind primary full of No. 22 and secondary full of No. 26. You will want about  $\frac{1}{4}$ -lb. of No. 22 and rather less of the No. 26.

(2) If your set receives PCGG at such a distance with one stage of H.F. amplification, we should be inclined to leave well alone; but your sketch shows two stages of H.F. in use. You might add potentiometers to the grids, which should improve results; or you could try grid condenser rectification, in which case a potentiometer is unnecessary for the rectifying valve.

**G.W.T. (Manchester)** asks (1) For windings for lattice coils to tune to 4,000 and 25,000 metres with a 0.0003 mfd. condenser, the winding former being 1" long by 1" in diameter, with 15 pegs at each side. (2) Formula for the wavelength (? inductance) of such coils. (3) The weight of wire (No. 28) necessary.

(1) With such a small former you will require

# FLUID CELLS

for

## Wireless Receiving Sets

Although the demand for the Siemens dry battery for high-tension purposes is increasing, nevertheless, a large number of users of wireless apparatus prefer fluid cells of the Leclanché type for this purpose. To meet this demand the Company has introduced and is manufacturing small Leclanché cells of the fluid type.



Dimensions  
1 1/4" dia. x 3" high

These cells comprise a carbon element of the "sack" form and fitted with a brass terminal. The zinc is cylindrical with a wire connection.

These elements are contained in a circular glass jar provided with a cork cover to prevent evaporation. Two sizes of this cell are manufactured, measuring respectively 1 1/4" dia. x 2 3/4" high overall and 1 1/4" dia. x 4 1/4" high overall. In addition, the Company manufactures a larger cell of the same type measuring 1 1/2" square x 5 1/4" high overall, having a brass terminal on the carbon and a wire connection on the zinc. The top of this cell is completely sealed, an aperture with a stopper being provided for charging. These cells can be supplied singly or made up in batteries for either 50, 60 or 100 volts, the battery being contained in a black varnished deal box fitted with two outside terminals and a leather handle.

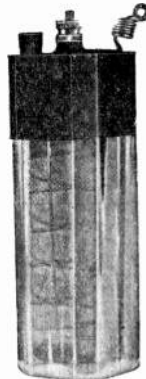

Dimensions  
1 1/2" square x  
5 1/4" high

Prices on application.

Manufactured by :

**SIEMENS BROTHERS**

& CO., LTD.

WOOLWICH, LONDON, S.E. 18

— Obtainable from all Dealers —

# REDUCTION IN PRICES. ACCUMULATORS

ENTIRELY NEW STOCK

Guaranteed First-class Manufacture.

Thoroughly well-made accumulators with wooden separators and non-corrosive terminals

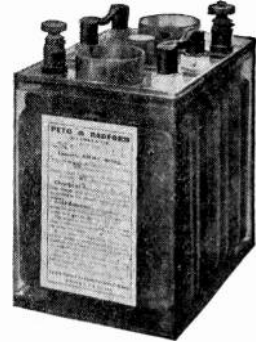

4 Volt, 44 Amp. ...	£1	4	6
4 " 66 " ...	1	12	0
6 " 44 " ...	1	16	0
6 " 66 " ...	2	9	0

## WATES BROS.

Retail Branch - 5, High Street, Bloomsbury, W.C.2

Offices : 132, Charing Cross Rd., W.C.2 (Gerrard 576)

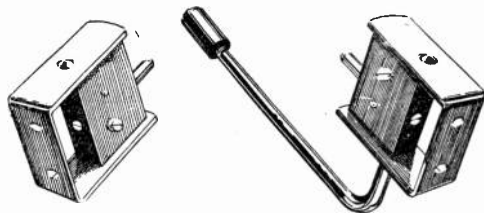

## Unit Coil Holders

Ebonite Insulation Throughout

F. Oxydised Brass Brackets, fixed.  
M. Oxydised Brass Brackets, movable, with extension arm and ebonite handle, guaranteeing freedom from capacity effects from hand of operator. Only 2 screws required to attach to any panel.

PRICE 6/6 each, movable, <sup>POST</sup>FREE  
" 5/- " fixed "

## Ashley Radio

69, Renshaw Street, Liverpool



PHOTOGRAPH OF "HART" STAND AT  
**BIRMINGHAM SECOND ANNUAL WIRELESS EXHIBITION**  
 18th TO 21st JANUARY, 1922.

WRITE FOR PRICE LISTS



PROMPT DELIVERIES FROM STOCK

Head Office : MARSHGATE LANE : STRATFORD : LONDON : E.15

**IT WILL PAY YOU  
 TO GIVE US A TRIAL.**

**MURDOCK'S VARIABLE CONDENSERS** for external use—  
 .005 23 plate, 25/-; post, 9d. .001 43 plate, 30/-; post,  
 9d. Ditto, complete for panel mounting, .001 43 plate,  
 27/6; post, 9d. These condensers are a first-class, reliable,  
 finished component, complete with terminals, pointer and  
 scale. Can be used vertically or horizontally.

**FILAMENT RESISTANCE**, 1½" knob, mounted below 2½" by  
 2½" matt ebonite. Price, 5/6. Post, 4d. Ditto for Panel  
 Mounting, 5/6. Post, 6d.

**VERNIER CONDENSER**, with distant control lever. Price  
 6/6. Post, 6d. Ditto, 5 plate for Panel Mounting,  
 6/9, post 6d., with 1½" knob and pointer.

**GRID LEAK** (2 meg.) and **CONDENSER**, 6/-; post 6d. **GRID  
 LEAK** (2 meg.) only 3/-.

**ENGRAVED EBONITE DIALS**, 3½" diam., complete with  
 1½" ebonite knob. Price, 4/9. Post, 3d.

1½" **LAMINATED SWITCH ARM**. Ebonite knob spindle,  
 push and locknuts, 2/3. Post, 4d.

**THE "POPULAR" H.T. BATTERY**. We recommend our  
 superior Batteries in cardboard cases, as follows:—  
 18 volts. 36 volts. 54 volts. 72 volts.  
 2/6. Post 9d. 4/9. Post 1/- 7/- Post 1/- 9/- Post 1/3

These batteries are meeting with universal approval owing  
 to their high efficiency and low initial cost and maintenance.

**ANODE RESISTANCES**, 50,000, 60,000, 80,000 or 100,000  
 ohms. Price, 3/3. Post, 2d.

**SLAB INDUCTANCES**, 300 to 30,000 metres, with set of  
 useful circuits. Price, 10/- Post, 9d.

**BASKET INDUCTANCES**, 300 to 4000 metres. Set of seven  
 7/- Post 6d.  
 Two wound for Dutch Concert 2/6. Post 6d.

We are Sole Agents for **OOJAH APPARATUS**  
 in S.E. London.

**SCIENTIFIC SUPPLY STORES,**  
 8, NEWINGTON CAUSEWAY, LONDON, S.E.1

'Phone: Hop 4177.

**W. T.  
 COMPONENTS**

Transformers: H.F. & L.F.  
 H.F. Couplings: Reactance Capacity.  
 H.F. Couplings: Resistance Capacity.  
 Amplifiers: H.F., L.F. & Combination.  
 Condensers, Anode Resistances, Leaks, etc.

**B. HESKETH,**  
 Manufacturer of W.T. Apparatus,  
 HIGH ST., CHALVEY, SLOUGH

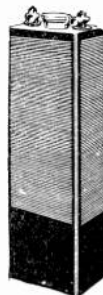

**EDISON  
 ALL-STEEL  
 Accumulators for  
 WIRELESS**

Edison Accumulators Ltd.  
 15, Upper George Street,  
 London - W.1

## QUESTIONS AND ANSWERS

about 40 layers of wire for the 4,000 metres and 200 layers for the 25,000, if you use such a small condenser.

(2) See curves given in *The Wireless World* for October, 1919, pp. 380-385.

(3) About 3 oz. for the small coil and 1-lb. for the big coil.

**C.G.G. (Lowestoft)** is making an "Amateur Mechanic" crystal set, and asks (1) How to adapt this set for the reception of PCGG and C.W. (2) If it is necessary to use an outside earthing switch.

(1) This was a good long wave crystal set with a range to 7,000 ms., but is not of much use for the purpose you suggest. For C.W., you should use a separate heterodyne with it, and for telephony you can either use a 2-stage note magnifier, or completely rearrange the set for H.F. amplification with reaction.

(2) No.

**M.J.D. (Brussels)** asks (1) Capacity of blocking condenser for 4,000 ohm telephones. (2) If condenser should be across loading coil and A.T.I. when used in parallel for long waves. (3) If a fixed condenser may be used in conjunction with a variable to increase the wavelength. (4) If a loose coupled tuner is as good as pancake coils for a crystal set.

(1) 0.0005 to 0.001 mfd.

(2) Yes, across both coils.

(3) Yes—connect them in parallel, and make the fixed condenser of about the same capacity as the variable.

(4) Yes.

**H.D. (Hornsey)** asks (1) For the capacity of a condenser. (2) If it is worth while to enamel his aerial wire. (3) If an R valve may be used instead of a V24 for the "long wave set."

(1) Approx. 0.004 mfd.

(2) It will do no harm, but we doubt whether you will get any advantage to compensate for your trouble and expense.

(3) Yes.

**E.A.F. (Stepney)** has a Marconi 31a receiver, and asks (1) If it will give good results on a small aerial. (2) Max. wavelength with a small A.T.I. (3) If it will receive telephony. (4) If we can supply details of the receiver if required.

(1) Signals will not be very strong.

(2) Max. wavelength of secondary circuit is 2,800 metres. To tune aerial to this an A.T.I., 12" x 5", wound with No. 24 will be required. Your A.T.I. will tune to about 2,000 metres.

(3) Yes, but not very strongly.

(4) Yes, we can supply any information required on this receiver.

**H.R.T. (London)** asks (1) Which is best at 1,000 metres, transformer or resistance coupling. (2) Best values of resistance and condenser to use. (3) Criticism of a set submitted. (4) Why signals are better with 120 ohm telephones and a 5/1 transformer than with 2,000 ohm telephones.

(1) Depends chiefly on skill of design and construction. Under best conditions for each there is little to choose between them at this wavelength.

(2) Best resistance depends on type of valve, and best capacity on the wavelength. Try about 50,000 ohms, 0.0005 mfd., and a leak of 2 to 5 megohms.

(3) O.K.

(4) The 2,000 ohm telephones are probably of poor construction or defective in one or both windings.

**K.L.R. (Cambridge)** asks (1) Wavelength range of a certain set. (2) If sharp tuning would be obtained without a variable condenser. (3) Criticism of the circuit. (4) If it would receive PCGG.

(1) Aerial circuit will tune to about 3,500 metres, and the secondary circuit to 8,000 metres.

(2) No.

(3) For satisfactory working make a reaction coil 4" x 6", wound with No. 30 wire, and insert it in the anode circuit, between the telephones and the anode of the valve.

(4) No—it will hardly be audible. Another valve should be added.

**C.G.I. (Leyton)** asks (1) How to convert a crystal set into a valve set. (2) What additional apparatus will be required.

(1) Connect as in Fig. 2, page 613, Dec. 24th issue.

(2) 1 valve, 1 filament resistance, 3 ohms 1 filament battery, 4 to 6 volts. 1 anode battery, 30 to 50 volts. The voltage of the batteries will depend on the type of valve chosen. It would be advantageous to increase the size of the A.T.I. somewhat.

**A.A.R. (Birmingham)** asks (1) For a criticism of a set. (2) Wavelength range. (3) If reaction should slide in and out of the A.T.I., or be hinged at one end.

(1) Good tuning will be difficult without a variable condenser in the aerial circuit. Also a grid condenser and leak will give better rectification. Connect a 0.001 condenser across the telephones and H.T. battery.

(2) Up to 3,500 metres.

(3) In your case it should slide in and out of the A.T.I., as you have barely sufficient winding on the reaction coil.

**D.G. (Glasgow)** asks (1) If No. 33 S.C.C. may be used for a long wave set reaction coil. (2) If No. 24 may be used for the No. 2 unit. (3) Particulars of a frame aerial. (4) Gauge of a sample of wire, and whether suitable for a potentiometer.

(1) Yes.

(2) Yes, if the same number of turns are used in each case.

(3) Frame aeriels are almost useless with less than three valves.

(4) No. 44 Eureka, resistance 84 ohms per yard, This is too fine for a rubbing contact potentiometer.

**J.R.B. (Scunthorpe)** asks (1) The gauges of samples of wire. (2) If the finer one is suitable for school receiving set coils.

(1) Bare wire No. 26, enamelled wire No. 36.

(2) This is too fine for the winding of an A.T.I. except in special circumstances. It may be used for a long wave reaction coil if desired.

**R.O.F.W. (Corsham)** asks (1) Name of station transmitting telephony on 2,600 metres. (2) Also one on 1,000 metres. (3) Wavelength of PCGG. (4) If possible to receive this near Bath on a single valve.

(1) Probably Eiffel Tower if the transmission is during the afternoon.

- (2) Probably some amateur station.  
 (3) 1,070 metres.  
 (4) Not impossible, but it would be an achievement.

"Handy" (Birmingham) asks (1) The maximum wavelength of a set described. (2) If a brass tube condenser described would improve it. (3) Where to connect it if useful. (4) Connections of various parts.

- (1) Approximately 2,000 metres.  
 (2) Yes.  
 (3) Connect across B and C.  
 (4) Connect A to B, D to K, E to B, F to G, and H to D.

"Crystal" (Dublin) cannot place his receiver directly under his aerial and asks whether unequal length lead in wires will matter.

No, but it will probably be better to join the wires together at the end of the horizontal portion, and use a single lead-in wire from this point.

F.E.W. (Wednesbury) has a crystal set and asks (1) Why he only gets a few weak signals. (2) Why lengths of cord are used hanging down from the ends of some twin aerials. (3) If 2,000 ohm telephones are suitable for a crystal set. (4) Average cost of a valve.

(1) Amateur crystal sets are becoming obsolete, owing to the increasing use of C.W. transmission, which is inaudible on such a set without special methods or a separate heterodyne set. This increasing use of C.W. probably explains the few stations you hear. You should, of course, get a fair number of ships on about 600 metres.

(2) These are simply used to prevent the aerial becoming twisted.

- (3) Yes.  
 (4) From 15/- to 25/-. See advertisement columns.

C.A.S.H. (Harlesden) wishes to know how to use 2,000 ohm telephones in conjunction with 8,000 ohm telephones.

Join the telephones in series. It is not worth while to make a transformer for the 2,000 ohm telephones.

S.J. (Carshalton) asks (1) For criticism of a diagram. (2) If lead in wire inside house is counted in the 100 ft. aerial allowed by the P.M.G. (3) If it is more efficient to have one large A.T.I. with tappings or separate coils. (4) If PCGG should be received on a valve and crystal set.

(1) Circuit is good, except that grid leak of No. 2 valve and the bottom end of the secondary circuit should be connected to negative filament instead of the positive. Also put A.T.C. in parallel with all the inductance in the circuit instead of with a part of it.

- (2) We think not.  
 (3) Immaterial, except in the case of very large wavelength ranges, when it is advisable not to use part of a very big coil for the shorter wavelengths covered.

(4) With the set reacting and carefully tuned, speech should be audible, but not very strong.

E.W.K. (Sutton) asks whether his circuit is a H.F. or a L.F. amplifier, and how to improve it.

The first valve will probably do a certain amount of rectifying, and the other valve act as L.F. amplifier. We do not like the reaction circuit

which is probably having a rejector effect, and the condenser C acts as a bypass for H.F. or as a capacity reaction. Intervalve condensers should require leaks unless they are themselves very leaky, which would be inefficient. Check the values of the anode resistances. The set should give no trouble if the components are O.K.

E.H.C. (Leeds) asks (1) If possible to use capacity reaction with a single valve. (2) If this is not advisable, for a two-valve circuit with capacity reaction.

(1) Capacity reaction is not in general of any use on a single valve circuit, although there are certain exceptional cases in which it does work.

(2) A two-valve circuit is given in the figure above, the reaction arrangements being exactly similar if transformer coupling is used.

S.S. (Wood Green) sends a two-valve diagram and asks (1) For anode condenser and resistance values. (2) If 50 and 250 ohms are suitable values for  $R_1$  and  $R_2$ , page 529, November 26th issue. (3) If connections shown are suitable for changing from 1 to 2 valves. (4) If circuit is correct for adding a valve to a single valve set.

(1) 0.0005 mfd. and 50,000 ohms, grid leak 3 megohms.

(2) Apparently suitable, but the best values can only be determined experimentally.

- (3) and (4) Yes.

G.T.S. (Newark) asks how to arrange a circuit so that he can put a note magnifying valve in or out of action by means of a switch.

The easiest way will be to have a telephone transformer for the note magnifier valve anode circuit and to wind a third telephone winding of about 2,000 ohms over the intervalve transformer. Telephones may then be changed from one telephone winding to the other by a two-pole, two-way, switch.

"SPARKY" (Baslow) asks (1) If the ends of his twin T aerial should be joined together. (2) How to connect a capacity reaction in a single valve circuit, and the quality of the results obtained. (3) Results to be expected on PCGG with a three-valve L.F. set.

- (1) Both ends should be left open.  
 (2) Results generally quite useless. If tried, connect between grid and anode in the usual way.  
 (3) Probably readable, but not strong. It would be much better to use some H.F. amplification.

D.P. (Middlesbrough) has a crystal set and asks how to improve results without the use of an amplifier.

Circuit is incorrect. See page 585, December 15th issue. We cannot give wavelength as no winding particulars are given. Sets of this type are only useful up to 3,000 metres, and there are not many stations except ships on 600 metres to receive. A single valve set would give the results you require. The aerial you mention, a 5-foot vertical wire 45 feet above the ground, is useless except with a multi-valve set.

"CRYSTALITE" (Newhaven) asks (1) For a loose coupler to tune an aerial to 3,000 metres. (2) If certain stations should be heard with a crystal set. (3) Simplest way of making a tuner for a crystal set. (4) The cost of a single valve set.



*Marconi*  
WIRELESS APPARATUS  
INSTALLED UNDER RENTAL  
& SERVICE AGREEMENT OR SOLD  
OUTRIGHT WITH SERVICE AS  
REQUIRED.

THE MARCONI INTERNATIONAL MARINE COMMUNICATION CO. LTD.  
MARCONI HOUSE, STRAND, LONDON, W.C.2.

# HIGH-CLASS UNIT APPARATUS

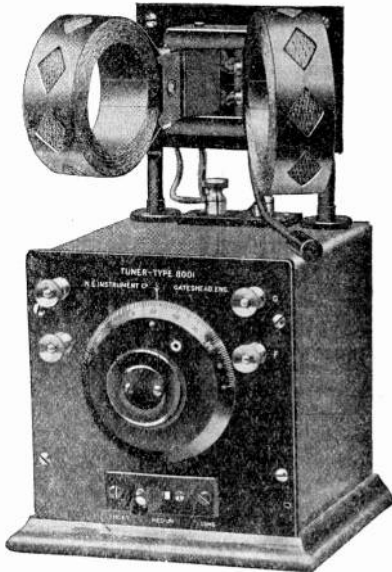

UNIT TUNER .. .. . £6 15 0  
 UNIT DETECTOR .. .. . 4 0 0  
 UNIT AMPLIFIER .. .. . 5 15 0

All same style and size.  
 This Amplifier gives result equal to any two-valve amplifier.

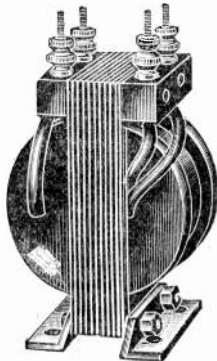

“BRITWIRE”  
 L.F.  
 TRANSFORMER  
 As good as the best  
 Ratio 1 to 5  
**22/6**

SEND FOR LIST  
 Post Free.

GOODS OVER 40/- CARRIAGE PAID.

## THE ‘BRITWIRE’ COIL

(AS ILLUSTRATED)

A Duolaterally Wound Coil at a price within everybody's reach. We are now manufacturing a Duolaterally Wound Coil (the most efficient type in the world) and can supply mounted or unmounted.

### PRICES UNMOUNTED.

Coil No.	Wave Range	Price.
1	130-250	2/-
2	183-450	2/3
3	250-700	3/-
4	400-1,200	4/-
5	500-1,600	4/6
6	600-2,500	4/6
7	1,000-3,000	4/8
8	1,200-4,500	5/-
9	1,500-5,500	6/6
10	2,000-6,500	7/6
11	3,000-7,500	8/-
12	4,000-12,000	9/-
13	5,000-14,000	9/6
14	6,000-18,000	10/-
15	10,000-22,000	12/6
16	15,000-30,000	15/-

Mounted 3/6 each extra.  
 Three Coil Holder on Mahogany base .. .. . 20/-  
 Better Type Geared .. .. . 32/6

### BALANCED CONDENSER

for panel mounting,  
 with revolving scale.

'001. ... 27/6  
 '005 ... 25/6

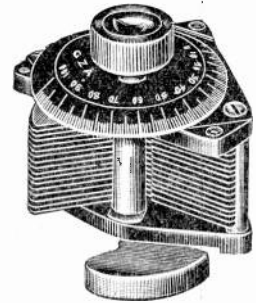

### EXTENSION HANDLE

for telephone tuning  
**1/9**



Sole Wholesale Distributing Agents for North of England, Scotland and Ireland for

**G. Z. AUCKLAND & SON**  
 LOCAL AGENTS WANTED

EXPERIMENTAL STATIONS—2 LA, 2 LB

TRANSMISSIONS—Sunday 1400-1500 G.M.T.; Tuesday 2100-2200 G.M.T.  
 on 1000 metres.

POST ORDERS TO:—

**THE BRITISH WIRELESS SUPPLY CO.,**

6, BLENHEIM TERRACE, LEEDS.

Telephone: 26926

Branches:—

18, Eldon Square,  
 NEWCASTLE-ON-TYNE.  
 TELEPHONE 360

11, Church Street,  
 WEST HARTLEPOOL.  
 TELEPHONE 373

33, High Street,  
 SOUTHAMPTON.  
 TELEPHONE 403

## QUESTIONS AND ANSWERS

(1) Primary 6" × 10", of No. 24, with a similar sized loading coil; secondary, 5" × 8", of No. 28, with about three tapings.

(2) You should hear most of the French stations. The German and Croydon telephony will be weak.

(3) Try the circuit first with the parts loose on a table. When you have got them to work well in this way you can afterwards box them up in the most convenient manner.

(4) About 15s. to 25s. for the valve, plus about £1 for a H.T. battery if of pocket lamp cells, and probably another £1 for an accumulator for lighting the filament.

"ANDRE" (Leeds) asks for a criticism of a set and for information as to the "best possible type of H.F. amplifier for 400-20,000 metres."

The circuit is a very useful one, but we do not like the tuned reaction circuit. Try the H.F. transformer with the tuned side in the grid instead of in the anode. The best type for your purpose is the resistance coupled type, owing to the large wavelength range to be covered.

"ANXIOUS" (Rotherham) asks questions relative to a crystal set.

The 12 × 6 former will tune a P.M.G. aerial up to 3,500 metres. Arrange the circuit as in the figure on page 585, December 10th issue. The French telephones will be quite suitable. You can use the condenser, crystal holder, potentiometer, and telephone condenser from the Mark III set.

H.C.F. (Moseley) asks (1) For a criticism of a single valve set. (2) The life of a "R" valve on intermittent use, and the correct filament current. (3) For a book describing C.W. transmitters.

(1) Quite a useful set. Omit the condenser across the reaction coil. Have a grid condenser and leak for efficient rectification. Connect a 0-001 mfd. condenser across the L.F. amplifier terminals.

(2) Filament current about 0.7 amps. Life up to 2,000 burning hours with care and careful avoidance of over-running.

(3) We do not know of any suitable book.

S.W.M. (Stratford) (1) asks for a criticism of a set. (2) Ditto of a tuner. (3) Wavelength range of the set with certain windings.

(1) Connect upper side of reaction condenser to the anodes of the valves instead of to the grids. Grid battery would be more useful on second valve than on the first. Circuit should work well if the H.F. transformers are suitable.

(2) and (3) Arrange the secondary to be fixed with the aerial coupling coil at one end, and the reaction coupling at the other. The set should tune to about 15,000 metres.

G.J.R. (Bolton) has a two-valve H.F. set and wishes to make a 4-foot frame aerial for use with it.

Wind about 40 turns of the sample wire, which is No. 20 gauge, slightly spacing the turns, and use a 0-001 mfd. condenser. It is very doubtful if you will hear PCGG.

STH. (London) asks (1) If the addition of a potentiometer to the second grid of a two-valve H.F. magnifier will be an improvement. (2) Why the set works well with the grid leak and condenser

shorted. (3) If the H.F. transformers he uses are copper or resistance wound.

(1) Probably some improvement, but not very much.

(2) Either your valves are very good rectifiers without the grid condensers, or the grid leak is of entirely wrong value. You should try various values until the best is determined.

(3) We cannot say. Enquire of the makers.

J.R.H. (Tunbridge Wells) has a crystal set and asks questions re the same.

(1) These are not telephone transformers, and therefore are of no use to you.

(2) This aerial is almost useless for a crystal set. It should be much higher and longer.

(3) A receiving license from the secretary of the G.P.O., London.

(4) Your circuit is incorrect, see page 585, December 10th, 1921.

"QUAERE" (Leicester) sends a diagram of an aerial, and asks for criticism and suggestions for improvement.

You will probably get little improvement from insulating the guys for reception; this is more important for transmission. Do not take the lead in from the far end. Drop it at right angles to the main span, near the house. In this case you might find a twin aerial preferable.

T.D. (Godstone) asks (1) how to calculate the inductance of basket coils. (2) How to calculate the inductance of and how to wind duolateral coils. (3) Correct proportions of reaction coils and aerial tuning inductances. (4) Best combination of crystals.

(1) Same as inductance of a solenoid wound with the same wire, of the same mean diameter, and of a length equal to the mean winding depth of the basket coil.

(2) See article in *The Wireless World*, October, 1919, for curves giving approximate results. For construction see the three issues of October, 1920, and also December 11th, 1920.

(3) Varies largely with circumstances. Best found experimentally, or from past experience under similar conditions.

(4) The most sensitive combinations suffer from lack of stability. You cannot do better than zincite-bornite or carborundum.

W.G.H. (Plaistow) sends particulars of a single valve set and asks for criticism and wavelength range.

A good circuit which should give good results on an aerial 100 feet long and 20 feet high. Maximum wavelength will be 2,600 metres with the condenser in series, and 6,500 metres with it in parallel. For a suitable reaction coil wind a 3" × 8" former with No. 30 wire. It is quite suitable for C.W., spark and telephony if the reaction coil is properly adjusted.

A.L. (Torquay) asks (1) If the single valve receiver described in the February and March issues of last year is suitable for speech, and PCGG and (2) if it will receive Paris time signals. (3) How to insert extra valves.

(1) No, this set is unsuitable for the purpose.

(2) Certainly, but a crystal set will do this.

(3) Set was designed for single valve work. If you require a multivalve set it will be much better

to build one up afresh, rather than to adapt this set to a purpose for which it was never intended. For a three-valve set see a forthcoming issue of *The Wireless World*.

**"FAWLEY" (Southampton)** asks for dimensions for a tuner with a maximum wavelength of about 1,200 metres.

A.T.I. 5" x 4", No. 22 wire. Series A.T.C. 0.002 mfd., closed circuit inductance 4" x 3", of No. 22 or 24 wire. Condenser 0.0005 mfd., reaction coil 3" x 2 1/2", of No. 28 or 30. All coils with tapings.

**G.B.Y.C. (Port Elisabeth)** asks (1) Correct voltage for a V24 valve. (2) Ditto for a Q valve. (3) If a Q requires a grid condenser for rectification. (4) If a V24 and a Q may be used with a common filament resistance.

(1) Anything between about 4 volts for a separate heterodyne oscillator to 60 for grid condenser rectification, or even 100 for special purposes with negative volts on the grid—24-40 should be about right for L.F. amplification.

(2) From about 30 for rectification without a grid condenser to 250 for condenser rectification or power transmission.

(3) No  
(4) A common resistance may be used, except for very critical work, where separate resistances are desirable owing to the different characteristics of the valves.

**H.E.C. (Kentish Town)** asks (1) For criticism of a set and for suggestions for its improvement. (2) If it will receive PCGG.

(1) Set is of very poor type. Initial rectification, followed by many stages of L.F. amplification is very inefficient, and generally results in a set which howls and does nothing much else. Your crystal rectifying arrangements and also your grid condenser circuit are incorrect. Redesign the set for two stages of H.F., followed by crystal rectification, and then one stage of L.F., each section being on the lines of many circuits given in these columns.

(2) Not as you suggest, but you should have no difficulty after redesigning on these lines.

**E.R.S. (Carlrow)** asks (1) For a detailed design for a four-valve set for PCGG. (2) How far a reaction coil should be inserted inside an A.T.I. (3) If 70 volts is O.K. for a Mullard R valve. (4) For a small book on foreign meteorological messages.

(1) Such a detailed design is outside the scope of these columns. Set should be of 2 H.F., 1 R., and 1 L.F. type, and should be transformer coupled for the H.F. valves.

(2) This depends on the windings and other factors. If windings are on the small side, complete insertion will be necessary, but if sufficient windings are provided, it may not be necessary to insert the reaction coil at all. Never couple tighter than actually necessary to provide the reaction required.

(3) Yes.  
(4) Not known.

**J.L. (Stratford)** asks for the formula for the construction of H.F. transformers for a given wavelength.

There is no suitable formula, as the optimum wavelength depends on a variety of almost in-calculable factors such as the self and mutual capacities of the windings. Windings are usually determined experimentally, with the aid of previous experience. In your case be guided by the dimensions and wavelength of the instrument you already possess.

**H.W.B. (St. Neots)** asks (1) If a circuit is correct. (2) If dimensions of the parts are correct. (3) Advantage of a blocking condenser. (4) If advantageous to increase size of condensers.

(1) Yes, if telephones are H.R.  
(2) and (4). O.K., except that a smaller blocking condenser might give better results.  
(3) It improves signals.

**L.W.H. (Mitcham)** asks (1) if certain multilayer coils could be used for reception. (2) If so, for winding particulars. (3) If the coils would give PCGG on a simple single valve set.

(1) Coils of this type are quite useless for reception, owing to excessive self capacity. Nearest approach for satisfactory nature is a honeycomb coil, which are best purchased, as they are troublesome to make without special apparatus. The type of coupler suggested is quite good. For PCGG use flat basket or solenoid coils.

**J.R.B. (Wantage)** asks (1) Whether a twin aerial, 70 feet long and 18-25 feet high will do for crystal work. (2) If a 1/2" spark coil will do for a telephone transformer. (3) If a loose coupler wound with steel wire will be of any use. (4) If an electrolytic detector is as sensitive and reliable as a crystal.

(1) Fairly well, but considerably more height is desirable.  
(2) No, windings are unsuitable.  
(3) No.  
(4) Quite as sensitive, but in general less reliable.

SHARE MARKET REPORT.

Prices as we go to press, Feb. 10th, are:—

Mareoni Ordinary	.. ..	£1 14 6
„ Preference	.. ..	1 13 9
„ Inter. Marine	.. ..	1 2 0
„ Canadian	.. ..	7 0

Radio Corporation of America:—

Ordinary	.. .. .	17 3
Preference	.. .. .	12 0

# 1<sup>ST</sup> & 2<sup>ND</sup>

## TRANSATLANTIC PRIZE WINNERS

### Used MULLARD Valves.

Cut off the coupon and send for your requirements now and obtain extraordinary signal strengths with "ORA" valves. They amplify as they rectify as they receive.

*If your usual Wireless Dealer cannot supply, forward the coupon and give his name.*

*Terms for quantities on application.*

## Oscillate-Rectify-Amplify



None genuine without this Mark

# Mullard Radio Valve Co. Ltd

Claybrook Road,  
Hammersmith, W.6.

Manchester Depot: 25 Market Street.  
Glasgow Depot: 206 Bath Street.

Contractors to  
H.M. Admiralty, War Office  
Royal Air Force & Post Office

Telephone: Hammersmith 312. Telegrams: Radio Valve, Hammersmith.

Codes:  
ABC(57Ed)

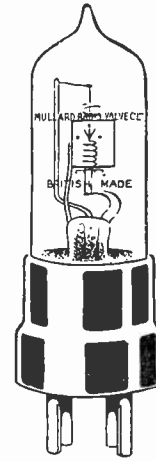

"ORA"  
MULLARD VALVES  
15/- Each



MULLARD PATENT  
RESISTANCE  
for Grid & Anode Circuits



MULLARD CONDENSERS



Mullard 4-pin Sockets

To the  
MULLARD  
RADIO VALVE  
CO., LTD.  
35, Claybrook Road  
Hammersmith,  
London, W.6.

*Please send me post free:*

Quantity	Description and Price
	Mullard "ORA" valves ... each 15/-
	Mullard patent resistance combined with Mullard condenser ... 12/6
	Mullard Valve Sockets 4 pin type. Price 2/- each.

I enclose (cheque, money order, P.O.)  
for..... to cover the cost.

Name.....

Address.....

Name of usual Wireless Dealer.....

Address.....

CUT HERE



HEAR THESE:—

## WIRELESS CONCERTS.

G.P.O.'s Half-Day a Week Concession to Amateurs

The G.P.O. have agreed that, starting early in February, permission will be given for the sending out by wireless telegraphy of speeches and music, for half an hour on one day in every week, for the benefit of amateur wireless enthusiasts.

The Marconi Company will undertake all necessary arrangements at their high-power station at Chelmsford.

—Reprinted from the "Evening News," Jan. 30th, 1922.

AND OTHER TELEPHONY:—

### THE TUNER

G5 Type

£2 15 0

Patents applied for.

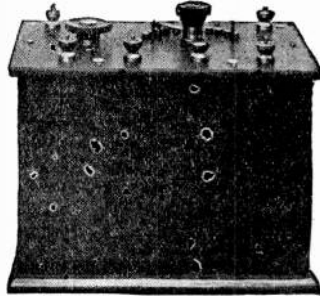

### THE RECEIVER

Super VII

PRICE

£3 15 0

without valve

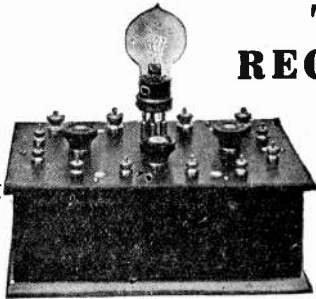

For unequalled results.

Amplifiers for 1, 2 and 3 Valves.  
H.F. and L.F. Cheapest and best. Write for particulars.

## GORDON CASTAGNOLI

MANUFACTURER OF WIRELESS APPARATUS

15, Rayne Road, Braintree, Essex

## URIAH BEATON'S BARGAINS.

Double Headphones with cords in order 2000 ohms 6/6

Double Headphones " " " 120 ohms

Sullivan's " " " " " 3/9

Relays P.O., small, for Panel mounting - 12/6

Morse Tape, small and large rolls - 6d. & 9d.

Morse Ink, Genuine, in stone bottles - 2/6

Single Telephone Jacks, double pole - 9d.

Plug and Cord for same - 1/-

All articles previously advertised still obtainable.

ESTABLISHED 25 YEARS.

45, CHALK FARM ROAD, N.W.1

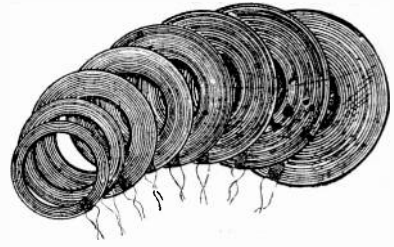

"OOJAH" Slab Inductances (set of 8) 300-30,000 metres 10/-  
Set of blueprint curves (8) and circuits for above ... 1/6  
"OOJAH" Basket Inductances (set of 7) 300-5,000 metres 7/-  
Pair of Basket Inductances specially wound for Dutch Concert ... 2/6

To avoid spurious imitations which are now being placed upon the market, look for the trade mark. All sets are wrapped in a transparent covering and bear the "OOJAH" seal. None are genuine without.

### RELAYS.

To those experimenting with automatic reception I am able to offer NEW Polarised P.O. Relays and travelling case at £2 2 0 Carriage free.

Second-hand ditto, but in almost new condition, less travelling case, at £1 10 0 Carriage free.

All relays are fitted with their original platinum contacts. Rewinding of your own, or above relays with 5,000 turns of No. 44 S.W.G. Silk covered wire, £1 extra.

### H.F. AMPLIFICATION.

Look for my advt. in the next issue of "The Wireless World," which will give particulars of a new type of H.F. transformer used in the successful reception of the recent Transatlantic signal tests.

A. E. GREENSLADE,

JELF ROAD, S.W.2 'Phone: Brixton 639.

## BA. TERMINAL of the DOUBLE type

4 EFFICIENCY like this



Actual Size

Price 2/6 per doz. 4ba. as illustrated.  
2ba. single terminals, 9d. per doz. small.

Brown's 'Phones	
120 ohms, complete with cords	20/- (tested)
1500 ohms, " " "	22/6 "
New Sullivan's 'Phones	
8000 ohms, complete with cords	18/6 (tested)
120 ohms, " " "	7/6 "
Second-hand ditto	
120 ohms, complete with cords	3/3 (tested)
Complete Spark Transmitters	25/-
Contact Studs, per doz.	8d.
Dutch Concert Tuners	7/-
Marconi Variable Condensers	
'01 M.F. (tested)	£2
Valves, Receiving (tested and guaranteed)	11/-
Valve Holders for above (R TYPE)	1/9
Transmitting Keys, (Silver Contacts)	3/-

Postage extra on all the above prices.

J. LIPOWSKY, 614, OLD FORD RD.  
Bow.  
LONDON, E.3. 'Phone: East 3345

# OUR EASY PAYMENT SYSTEM IS STILL OPEN TO ALL READERS

FOR FULL PARTICULARS WRITE THE MANAGER, MAIL ORDER DEPT.,  
THE WIRELESS PRESS, LTD., 12-13, Henrietta Street, London, W.C.2

To all who mention the "Wireless World" and send 6d. for postage, we will send six back copies of the



free. This will prove to you that the PHILATELIC MAGAZINE is the best Stamp Collectors' Newspaper. All the news for 3d. a fortnight. Current issue from your newsagent 3d., or 4d. post free from:—  
**HARRIS PUBLICATIONS LTD., Balham**  
*Catalogue of Stamp Albums and Accessories free.*

## LIST OF Regular Transmissions OF WIRELESS STATIONS

Giving Time, Call Sign, Wavelength, System, etc.

PRICE **6d.** POST FREE.

**The Wireless Press, Ltd., Dept. W.W.**  
12-13 Henrietta Street, London, W.C.2.

## THE WIRELESS AGE

THE AMERICAN MONTHLY JOURNAL OF  
WIRELESS TELEGRAPHY AND TELEPHONY

A "Go-a-head" Magazine for Operators and Amateurs.

Sole European Agents: **THE WIRELESS PRESS LTD., 12-13 Henrietta St., Strand, London, W.C.2**

**SHEET, ROD AND TUBE** stocked in quantities suitable for all Wireless work.  
**KNOB** (Moulded), various patterns stocked  
**CONDENSER SCALE BLANKS,**  
**CONDENSER COVERS,**  
ETC. ETC.

**EBONITE**  
(HARD RUBBER)

Enquiries Solicited.

**WHOLESALE ONLY.**

**AMERICAN HARD RUBBER CO.**

(BRITAIN) LIMITED

13a, FORE STREET, LONDON, E.C.2.

Telegrams: "Eboniseth, London." 'Phone: Central 12754

## A NEW BOOK FROM AMERICA.

### Prepared Radio Measurements

with  
SELF COMPUTING CHARTS.

By RALPH R. BATCHER, A.M.I.E.E.,

Price **10/6** Nett.

(Postage 5d.)

The Charts included in this book represent formulae that are apt to occur in ordinary computations.

**THEY ARE DESIGNED TO ELIMINATE  
ALL MATHEMATICAL WORK**

except in a few cases when it is necessary to evaluate simple ratios, AND REQUIRE NO SPECIAL EQUIPMENT.

The accuracy of these charts is above that with which the various factors that enter into the formulae can be measured with ordinary means.

**The Wireless Press, Ltd.,**

Dept. W.W.,

12-13, Henrietta Street, London, W.C.2

## P. ORMISTON & SONS

(P. H. ORMISTON) :: ESTABLISHED 1793  
79 Clerkenwell Rd., London, E.C. 1  
"Ormiston, London." :: :: 13259 Central

Silk and Cotton Covered H.C. Copper Wire, Resistance Wires, Fuse Wire, Binding Wires, Charcoal Iron Core Wire, Asbestos Covered Wire, Braided and Twisted Wires, Bare Copper Strand and Flexibles of any Construction, Wire Ropes and Cords (fine sizes) in Galvanized Steel, Phosphor Bronze, &c.

Established 1900.

**ARE YOU QUALIFIED?**  
**FOR THE JOB YOU SEEK?**  
*IF NOT—WHY NOT?*

**What Proof of Efficiency do You Carry?** Your word to an employer is not proof that you are efficient, but a College Qualifying Diploma or Certificate signed by the Professional Staff, is a proof of efficiency, and a valuable asset in seeking a remunerative position.

If you are preparing for any exam, ask our advice. We specialise in all exams connected with technical subjects. All particulars **FREE OF CHARGE.** Parents should seek our advice for their sons.

### CHALLENGE!

We are prepared to produce on demand 6,000 unsolicited testimonials from successful students or pay £100 to any charity you appoint. Having helped 6,000 to prosperity, surely we can help YOU. If you are interested in any of these subjects write, naming the subject, and we will send our **FREE BOOKLET.**

Please State Your Age.

**ADVICE FREE.**



### WE TEACH BY POST

the following subjects:

- Architectural Drawing
- Building Construction
- Clerk of Works Duties
- Aviation
- Boiler Engineering
- Boiler Making
- Chemistry
- Civil Engineering
- Concrete and Steel
- Draughtsmanship
- Electricity
- Engineering
- Foundry Work
- Internal Comb. Engines
- Marine Engineering
- Mathematics
- Matriculation
- Metallurgy
- Mining
- Mine Surveying
- Motor Engineering
- Naval Architecture
- Pattern Making
- Salesmanship
- Sanitation
- Shipbuilding
- Structural Engineering
- Surveying and Levelling
- Telegraphy & Telephony
- Wireless Telegraphy
- Special Course for Apprentices

HINGED LID

RECESS FOR PLUG LEADS

— Ex "W.D." —  
**H.T. BATTERY BOX**  
Fine polish mahog.  
6 plug sockets, 2 plugs  
**BRAND NEW**  
**7/6**  
**AERIAL INSULATORS**  
Ebonite - Brass eye  
4 L Doz.

### LESLIE DIXON & CO.

(Dept. W.), 9, Colonial Avenue, Minories, E. 1

Tel. Address— Telephone—  
"Gardlocket, Fen, London." 1650 Avenue (3 lines).

## GARDNER, LOCKET and HINTON, LTD.

LONDON, CARDIFF, NEWCASTLE-ON-TYNE, GLASGOW, ETC.

Quotations and Specifications given for all descriptions of Welsh and other Steam and Manufacturing Coals.

Apply to Head Office:  
**13, FENCHURCH AVENUE, E.C.3**

## STANDARD SUPPLIES

HIGH CONDUCTIVITY COPPER WIRES.

	In Stock.	At Short Notice.
Double Cotton } Single Cotton }	20-30 S.W.G.	32-40 S.W.G.
Double Silk } Single Silk }	20-47 S.W.G.	48-50 S.W.G.

Any quantity over ½ oz. supplied from those in stock.  
Prices and full particulars in issue of January 7th, 1922, or on application.

**EBONITE ROD.**  
From ½" to 1" diameter. Prices, etc., in last issue.

**TERMINALS** in great variety, to suit all requirements.

**A. HINDERLICH, Central Hall, Southall.**  
Phone: Southall 121. Mdx.

## RAPID WIRELESS TRAINING

DAY AND EVENING CLASSES: Correspondence Classes with Instrument work at School if desired. **Postal Course on Valves.** Classes for Amateurs and Experimenters.

**INLAND TELEGRAPHY:** Sounder, Wheatstone Punching, Type-sending, etc. For details send P.C

'Phone: North 1036. **ELECTRICAL TRAINING COLLEGE, Radio House, Manor Gdns., Holloway, London, N.**

# "RADIO-CONSTRUCTA" Patents applied for

A series of highly-finished constructional parts made of ebonite throughout, by which the Wireless Experimenter and Amateur is enabled to easily build his own Apparatus, Receiving or Transmitting Sets, Experimental and Inventive Circuits. The parts are so designed that very little skill is required in assembling, and parts may be used any number of times, being assembled and dissembled at will. In addition to this each part is standardised and is interchangeable. The educational value of the invention is very great, and the amateur will learn more in devising his own type of apparatus in this manner, than by purchasing highly polished and expensive sets, which are boxed in, and have always an appearance of mystery.

"RADIO-CONSTRUCTA" Makes Wireless Experiments easy and fascinating, and brings Wireless Telegraphy within the reach of all.

Realising the tremendous advance in Wireless, and especially Wireless Telephony, the Proprietors of "Radio-Constructa" have designed a number of complete sets of parts, by which anyone *without* previous knowledge of the principles of Wireless Telegraphy may build their own apparatus at the minimum of cost, with the maximum of interest and efficiency.

Below we give two illustrations of complete Wireless Receiving Sets, and the beginner will now be instructed to build these sets and others.

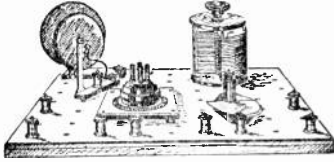

**SINGLE VALVE SET**

Comprising 13½in. by 10½in. Baseboard, drilled and the following articles for fixing into Baseboard, with long terminals and nuts for back wiring—Coil Stand and two plugs including two Basket Coils, 1,000 metres range, Combination Valve Holder, Filament Resistance and Condenser, Variable Condenser (.005), eight Terminals, Telephone Condenser, Wire and Insulating Sleeving.

£4 : 10 : 0 (Unassembled)

With Baseboard 6½in. by 10½in., 10/- less.

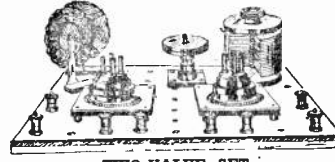

**TWO-VALVE SET**

Comprising the whole of the articles enumerated in Single Valve Set, substituting .001 Condenser, and adding additional Combination Valve Holder and Filament Resistance and Condenser, Mounted Valve Holder, Pin Transformer, H.F., 1,000 metres, and Vernier Condenser.

£6 : 10 : 0 (Unassembled)

FOR FURTHER PARTICULARS APPLY TO :—

**RADIO-CONSTRUCTA (Dept. 2), 222 Great Dover Street, London, S.E.1**  
AGENCY APPOINTMENTS WILL BE CONSIDERED.  
Telephone: HOP 3029.

## FOR SALE.

Silk Wire Basket Coils, per set of four .. .. .	2/6
Four Way Telephone Cords .. .. .	9d.
Sleeving, per yard .. .. .	4d.
Mark III Tuners, less buzzer and condensers .. .. .	30/-
60-Volt Battery Boxes, with plugs .. .. .	3/6
100-Volt, Polished Mahogany, with plugs, 11" x 4" x 3" (Slightly soiled) .. .. .	5/-
Ebonite Milled Edge Knobs, 1½", three for .. .. .	1/-
Mahogany Instrument Cases, with brass lock and key, with leather carrying strap (new) .. .. .	9/-
H.T. Battery Box Plugs, pair .. .. .	1/6

All Carriage Paid.

C. S. SWAN, 191, Bishopsgate,  
Near Liverpool Street Station, LONDON, E.C. 2.  
Telephone: London Wall 9623.

## MY

## ELECTRICAL WORKSHOP

A BOOK for the ELECTRICAL EXPERIMENTER  
By FRANK T. ADDYMAN,

**PRACTICAL & INTERESTING.**

249 pages. 169 diagrams, etc.

PRICE 7/- NET.  
(Postage 9d.)

**THE WIRELESS PRESS, LIMITED,**  
DEPT. W.W.  
12-13, HENRIETTA ST., STRAND, LONDON, W.C.2

## WIRELESS TRAINING COLLEGE LTD.

ST. MARY ST., CARDIFF, & NEPTUNE CHAMBERS, VICTORIA ST., BRISTOL.

The above Colleges are amongst the most successful in Great Britain for quickly qualifying Students for the Wireless Service. We have, since the outbreak of War, passed over 1,000 Students to Wireless Appointments. Two Systems are taught, the Marconi and Siemens Quench Spark System. We make a speciality in training ex-service men who have some knowledge of Wireless. Ex-service men can have a free test to ascertain the time it would take to qualify them if they will call at the College.

For Terms apply to—

**LIBUT-COMDR. J. R. SCHOFIELD, M.B.E., R.N.V.R. (C), Principal.**

P.S. Every student who qualified at our Colleges was placed in a permanent situation.

# WIRELESS BOOKS FOR THE LIBRARY

**CONTINUOUS WAVE WIRELESS Telegraphy.** Part I. By W. H. Eccles, D.Sc. Price 25/- net. Post free 25/9. 407 pages. 306 diagrams and illustrations.

**THERMIONIC TUBES IN RADIO Telegraphy and Telephony.** By John Scott-Taggart, A.M.A.I.E.E. Price 25/- net. Post free 25/9. 424 pages. 344 diagrams and illustrations.

**THE THERMIONIC VALVE and Its Development in Radio Telegraphy and Telephony.** By J. A. Fleming, M.A., D.Sc. Price 15/- net. Post free 15/9. 279 pages. 144 diagrams and illustrations.

**WIRELESS TELEGRAPHY and Telephony.—First Principles, Present Practice and Testing.** By H. M. Dowsett, M.I.E.E. Price 9/- net. Post free 9/9. 331 pages. 305 diagrams and illustrations.

**TELEPHONY WITHOUT WIRES**  
By Philip R. Coursey, B. Sc. (Eng.), A. M.I.E.E. Price 15/- net. Post free 15/9. 414 pages. 250 diagrams and illustrations.

**STANDARD TABLES AND EQUATIONS in Radio Telegraphy.** By Bertram Hoyle. Price 9/- net. Post free 9/6. 159 pages.

**THE WIRELESS TELEGRAPHER'S Pocket Book of Notes, Formulae and Calculations.** By J. A. Fleming, M.A., D.Sc. Price 9/- net. Post free 9/6. 352 pages. 39 diagrams and illustrations.

**VACUUM TUBES IN WIRELESS Communication.** By E. E. Bucher. Price 12/6 net. Post free 13/3. 178 pages. 130 diagrams and illustrations.

**RADIO TELEPHONY.** By A. N. Goldsmith, Ph.D. Price 15/- net. Post free 15/9. 256 pages. 226 illustrations.

**T.S.F. LA TÉLÉGRAPHIE SANS FIL. La Téléphonie Sans Fil.** By G. E. Petit and Leon Bouthillon. Price 12/6 net. 13/- post free, paper cover. 15/- net. 15/9 post free, cloth bound. 304 pages. 197 diagrams and illustrations.

**THE OSCILLATION VALVE. The Elementary Principles of its application to Wireless Telegraphy.** By R. D. Bangay. 6/- net. Post free 6/6. Crown 8vo. 215 pages. 110 diagrams and illustrations.

**YEAR BOOK OF WIRELESS TELEGRAPHY and Telephony, 1921.** 1,355 pages. 21/- net. Post free 22/-.

## The "W.P." MORSE PRACTICE KEY

A well-finished and reliable instrument made of  
brass mounted on a Bakelite Base

PRICE **7/6** POST FREE

**THE WIRELESS PRESS, LTD.,**

DEPT. W.W.

12-13, HENRIETTA STREET, STRAND, LONDON W.C.2.

# WIRELESS BOOKS FOR THE LIBRARY

**MAGNETISM AND ELECTRICITY FOR HOME STUDY.** By H. E. Penrose. Contains 50 complete lessons. Price 6/- net. Post free 6/6. 515 pages, 224 diagrams.

**THE ARMATURE MODEL FOR 1½ K.W. ROTARY CONVERTER.** Price 1/3 net. Post free 1/6. Shows every winding of the Converter Armature.

**DICTIONARY OF TECHNICAL TERMS USED IN WIRELESS TELEGRAPHY.** By H. Ward. Price 2/6 net. Post free 2/8. 253 pages containing over 1,500 definitions.

**SELECTED STUDIES IN ELEMENTARY PHYSICS: A Handbook for Wireless Students and Amateurs.** By E. Blake, A.M.I.E.E. Price 5/- net. Post free 5/6. 176 pages. Crown 8vo. Cloth. 43 diagrams and illustrations.

**WIRELESS TRANSMISSION OF PHOTOGRAPHS.** By Marcus J. Martin, Second Edition. Revised and Enlarged. Price 5/- net. Post free 5/6. 143 pages. Demy 8vo. Cloth. Diagrams and illustrations.

**CALCULATION AND MEASUREMENT OF INDUCTANCE AND CAPACITY.** By W. H. Nottage, B.Sc. Price 3/6 net. Post free 3/11. Demy 8vo. 144 pages. Over 50 illustrations and diagrams.

**PRACTICAL WIRELESS TELEGRAPHY.** By E. E. Bucher. 8vo. 352 pages. 340 illustrations. Price 12/6. Post free 13/3.

**THE ELEMENTARY PRINCIPLES OF WIRELESS TELEGRAPHY.** By R. D. Bangay. Crown 8vo. Published in two parts or bound in one volume. Price per part 4/- net. Post free 4/4. In one volume 7/6 net. Post free 8/3.

**MAINTENANCE OF WIRELESS TELEGRAPH APPARATUS.** By P. W. Harris. Price 2/6 net. Post free 2/10. 127 pages. 52 diagrams and illustrations.

**A SHORT COURSE IN ELEMENTARY MATHEMATICS AND THEIR APPLICATION TO WIRELESS TELEGRAPHY.** S. J. Willis. Price 5/-. Post free 5/6. Demy 8vo. 182 pages. 120 diagrams.

**ALTERNATING CURRENT WORK. An Outline for Students of Wireless Telegraphy.** By A. Shore, A.M.I.E.E. Price 3/6 net. Post free 3/10. Crown 8vo. Cloth. 163 pages. 86 diagrams and illustrations.

**THE OSCILLATION VALVE. The Elementary Principles of its application to Wireless Telegraphy.** By R. D. Bangay. 6/- net. Post free 6/6. Crown 8vo. 215 pages. 110 diagrams and illustrations.

**USEFUL NOTES ON WIRELESS TELEGRAPHY.** By H. E. Penrose. Crown 8vo. 1/4 each. Post free 1/6. Book 1. Direct Current. Book 2. Alternating Current. Book 3. High Frequency Current and Wave Production. Book 4. The 1½ K.W. Ship Set. Book 5. The Oscillation Valve.

**THE HANDBOOK OF TECHNICAL INSTRUCTION FOR WIRELESS TELEGRAPHISTS.** By J. C. Hawkhead and H. M. Dowsett, M.I.E.E. Price 7/6. Post free 8/3. Second edition. Revised and enlarged. Demy 8vo. 310 pages. 240 diagrams and illustrations.

**TEST QUESTIONS AND ANSWERS ON WIRELESS TELEGRAPHY.** Price of each Series of Questions or Answers 2/6 net. Postage 3d.

Invaluable for self-examination. Series 1. The Elementary Principles of Wireless Telegraphy. Part I.—Series 1a. Book of Model Answers. Series 2. Covering the Ground for the Postmaster-General's Examination. Series 2a. Book of Model Answers. Series 3. The Elementary Principles of Wireless Telegraphy. Part II.—Series 3a. Book of Model Answers.

Todas las publicaciones de la Wireless Press, Ltd., pueden obtenerse por intermedio del Señor Horacio D. Guerrero, Las Heras, 2480, Buenos Aires.

**THE WIRELESS PRESS, LTD.,**  
12-13, HENRIETTA STREET, STRAND, LONDON, W.C.2

# THE WIRELESS WORLD EXCHANGE AND MART

**TARIFF.** Advertisements are accepted for this Section at the rate of twopence per word, with a minimum charge of two shillings. The advertiser's name and address will be charged for, and single letters or single figures will be counted as words. Compound words will be counted as two words.

**DEPOSITS.** All advertisements must be prepaid in the form of Postal Orders, the remittance being forwarded to Messrs. Bertram Day & Co., Ltd., 9 & 10, Charing Cross, S.W.1.

Intending purchasers may deposit the purchase money of any article advertised or sold by advertisers with Messrs. Bertram Day & Co., Ltd., who will acknowledge its receipt to the vendor and the depositor, the full addresses of whom should be given. Subject to special agreement between the parties, it is understood that all goods are sent on approval, each party paying carriage one way in the event of the goods being returned. The deposit will be retained until due advice of the completion of the purchase has been given or until the articles have been returned and accepted. In order to cover postage, etc., a fee of 6d. in respect of sums of £1 and under and 1s. for sums in excess of £1, must be paid at the same time as the deposit. For persons not resident in the United Kingdom these fees are doubled. We cannot undertake to receive any deposit less than 2s. 6d.

Deposits must be sent by either Postal Order or by Registered Letter; cheques will not be accepted. If the deposit is sent by Money Order it should be made payable to the advertiser of the goods, and the fee mentioned above should be sent in stamps or Postal Orders as a separate amount.

## WE REPLY BY RETURN POST

Send your Wireless enquiries to us, and get **IMMEDIATE** attention Everything for the Amateur in stock.

LISTS FREE.

**Electrical Supply Stores,**  
5, Albert Terrace, King Cross,  
HALIFAX.

I Buy Wireless Gear of every description.

Send your particulars to :

**WILKINSON,**  
Lonsdale Rd., Kilburn, N.W.6

Make your own Cigarette & see what you save.

**ALWAYS USE A.G. CIGARETTE PAPER BEST & PUREST**

**TECHNICAL BOOKS.**—Second-hand and New Books on every conceivable subject. Catalogue free. State wants. Books sent on approval. Books bought.—**FOYLE, 121-125, Charing Cross Road, London.**

**TWO 24 h.p. Wireless Generators; One 50 ft. Portable Mast; Sextants, Drafting Instruments, etc.; ex-Admiralty surplus; half-price.—THE LONDON ELECTRIC FIRM, Croydon.**

**VALVE SET, complete; Brown's telephones, H.T. and Accumulators. Can be heard working; £8 10s.—W. H. S. VINCENT, 72, Penton Street, N.1.**

**WANTED.**—Any quantity of dud Transformers, any make; best price given.—**LIPOWSKY, 614, Old Ford Road, Bow, London, E.3.** See Terminal Advt.

**EXCHANGE.**—Sullivan Telephones and Transformer for Brown's H.R. Telephones.—**BARKER, 9, Shambles, York.**

**C. MARK III AMPLIFIER, excellent order, £4.—FIELD, 12, May Street, Upper Brook Street, Manchester.**

**EFFICIENT Receiving Set; Sullivan 103A Tuner with Long and Short Wave key switch; Sullivan 122 Transformer; large, well-made Valves Panel; solid French Variable; Gamage H.T. Box; reaction billi; assembled mahogany finished neat unit base; photos. Worth £40. Offers.—DENISON BROS., Wireless Engineers, Halifax.**

**AMATEUR'S Set and Sundries for Sale, £2 10s.—Particulars, SYKES, 18, Friars Road, Coventry.**

**C. MACDOUGALL, Scientific Instrument Maker, Devonshire Road, Hastings. Repairs of Every Description.**

**MARCONI Multi-valve Detector, Type 55, Tuner M39, Brown's Loud Speaker, wanted.—WILLIAMSON, 28, Percy Gardens, Tynemouth.**

**B.T.H. Portable Set, complete; perfect and almost new condition; bargain, £25. Polaris Set, complete, with amplifier; offers. 12-in. Spark Coil, elaborate instrument; suitable for transmission or rays; offers.—WOODS, Belmont, Upper Colwyn Bay.**

**FOR SALE.**—Complete Wireless and Transmitting Valve Set.—**ALLIOTT, 118, Chatsworth Road, Morecombe.**

**FOR SALE.**—Seven Uniform White Suits, perfect condition; also Two White Civilian Jackets, £3.—**DUBRUCQ, 77, Wood Vale, Forest Hill, S.E.**

**RESISTANCE AMPLIFIER, two-valve, 40s.; Note Magnifier, 30s.; Six-volt Accumulator, 15s.; High Tension Battery in Box, 10s.—Write, COOPER, 66, Oakley Street, S.W.**

**VARIABLE CONDENSERS, '00028, ebonite top, wooden cabinet, 10s. each.—HOLLAND, 44, Harrington Street, Derby.**

**ADVERTISER (26) seven years' practical wireless seeks situation. Instrument maker. P.M.G. certificate. Knowledge all systems, especially portable sets. Expert with petrol engines and cars. Box 2, C, BERTRAM DAY'S ADVERTISING OFFICES, 9-10, Charing Cross, S.W.1.**

**WANTED.**—Complete crystal set—Reply Box D. BERTRAM DAY'S ADVERTISING OFFICES, 9-10, Charing Cross, S.W.1

**BARGAINS.**—£14 Spark Transmitting Set for 6s. or near offer—Write Box 5, BERTRAM DAY'S ADVERTISING OFFICES, 9-10, Charing Cross, S.W.1

## PETO COMES TO TOWN

For the convenience of FOREIGN and PROVINCIAL CUSTOMERS who have expressed to us the desire to visit us if only we were in town, because they have seen and heard such good results of our instruments and components, we have secured the lease of a city office and showroom.

In addition to our stores and office at WOOD GREEN we shall be at home to all in our Showroom and office at

**7 FEATHERSTONE BUILDINGS, HIGH HOLBORN, W.C.1**

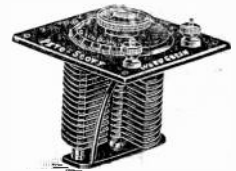

Complete SET OF PARTS ready to assemble. NO DRILLING REQUIRED. Supplied with engraved ebonite top.

'0015 27/- '001 '0005 21/- '003 14/- '002 11/- '0005 8/- '0005 5/-

Cabinets to suit, from 1/4. If required with bevelled indicating dial, 3/6 extra.

THERE ARE BIG BARGAINS IN OUR CATALOGUE

Ask for List "W" and enclose two stamps.

**INTERVALVE L.F. TRANSFORMERS.** Closed Iron Core for Panel Mounting. . . 17/6

Larger size, 1.5 times as efficient as ex-Army . . . 21/-

**LAMINATED SWITCH ARMS.** Heavy brass bush, lock nuts and spring washer (the only switch with the "Velvet Fitting") . . . 2/9

**CONTACT STUDS,** . . . per doz. 1/6

Nuts to fit above . . . per doz. 4d.

**VALVE LEGS, fitted with 2 nuts and washer, lacquered, per set of 4** . . . 1/-

**FILAMENT RHEOSTATS, Ebonite former and Pointer, Knurled Handle, Screens, etc., ready for panel mounting.** 4/ (This has a smooth action and does not produce thunder storms in the 'phones.)

**SPHINX GRID LEAKS, Tubular, with Brass Clips** . . . 2/6

**SPHINX ANODE RESISTANCES, 50,000, 60,000, 80,000, 100,000. Guaranteed twelve months** . . . 3/6

Try one of these as an amplifier and it will surprise you.

**PETO SCOTT THE CONDENSER KING.**

**17 Frome Rd., Wood Green, N.22**

2 minutes from the "Wellington."

And 7, Featherstone Buildings, Holborn, W.C.1

2 minutes from Holborn Tube Station.



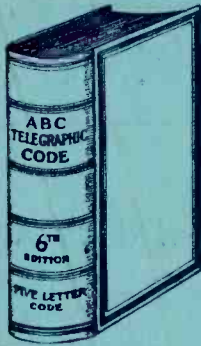

AN ENTIRELY NEW WORK.

## The ABC Telegraphic CODE 6th Edition

FIVE-LETTER CODE.

An up-to-date Work, containing Five-letter Artificial Code Words with at least a TWO-letter difference and a TERMINAL-INDEX of the words at the end of the Book.

Cost of Cabling brought to a Minimum :: Simple to Use.

PRICE £3 3s. 0d. net (U.K. and Colonies.)

Inland Parcel Post 1/6 per copy. Continental Book Post 2/- per copy.

Publishers:—

**EDEN FISHER & CO., LTD., 6, 7 & 8, Clements Lane, E.C.4**  
**And 95, 96 and 97 Fenchurch Street, London, E.C.3.**

## CARDIFF

### ELECTRICAL SUPPLIES

29A, BUTE TERRACE, CARDIFF

'Phone : : 5799.

WIRELESS APPARATUS AND ACCESSORIES of all DESCRIPTIONS

"R" Valves - - - -	11/-
Townsend Wavemeters - -	75/-
Grid Leaks and Condensers -	5/-
Condensers, '002, '0004, '0005	3/-
Grid Leaks and High Resistances (with clips) - - -	2/6
Variable Condensers, '0011 -	32/6
Variable Condensers, '0006 -	25/-

Etc., Etc.

Postage Extra.

**SHEET, ROD AND TUBE** stocked in qualities suitable for all Wireless work.  
**KNOBS** (Moulded), various patterns stocked.  
**CONDENSER SCALE BLANKS,**  
**CONDENSER COVERS,**  
 ETC., ETC.

**EBONITE**  
 (HARD RUBBER)

Enquiries Solicited.

**WHOLESALE ONLY.**

### AMERICAN HARD RUBBER CO.

(BRITAIN) LIMITED

13A, FORE STREET, LONDON, E.C.2.

Telegrams: "Eboniseth, London." 'Phone: Central 12754

Registered "NIPHAN" Trade Mark.

### WATER - TIGHT PLUGS AND CABLE COUPLINGS TO MEET HOME OFFICE REQUIREMENTS

As used by H.M. War Office, Electric Supply Companies Railway Companies, Marconi's Wireless Telegraph Co.  
**SIMMONDS BROS., LTD.,**  
 4, 6 & 8, Newton Street, HOLBORN, W.C.

Phones: 2600 Gerrard  
 12061 Central.  
 Telegrams: "Niphon, London."  
 Patented in England and Abroad.



5 to 250 Amperes.  
 500 Volt Circuit.

COUPLING CONNECTING CABLES

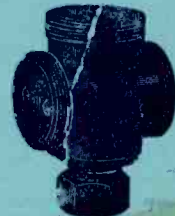

3-WAY TEE.

MARCH 18, 1922

Please mention the Wireless World

# SULLIVAN INSTRUMENTS

## HIGH AND LOW FREQUENCY INTERVALVE AND TELEPHONE TRANSFORMERS GREAT REDUCTION IN PRICE

These Transformers are guaranteed to be exactly similar as regards their electrical and magnetic constants and efficiency to Nos. 52, 53 and 54 illustrated and described in my old catalogue at Three, Four and Two guineas respectively.

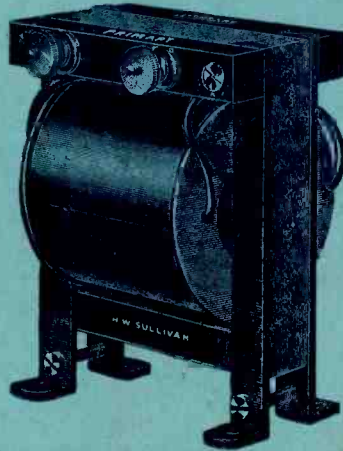

As pointed out in my previous advertisement, the present marked reduction is now made possible by the lower cost of fine wires, different method of mounting, and mass production, justified by the present demand.

Dimensions  $3\frac{3}{4}'' \times 2\frac{1}{2}'' \times 4\frac{1}{2}''$  high.

The Audio Frequency Transformer illustrated and the Telephone Transformer are built exactly on the lines of a power Transformer where saturation and other effects are taken into account. The core is built up of the finest stalloy iron laminæ and the coils of the Intervalve Transformer are wound with a large amount of the finest silk covered wire, the dimensions being so generous that the Transformer will not burn out with high anode voltages as is common with many of the smaller patterns now on the market. The Ratio is 5 to 1. They are quite silent and perfect for speech reproduction, as they are free from distortion.

The present reduced prices place them within the reach of all wireless experimenters.

<b>HIGH FREQUENCY INTERVALVE TRANSFORMER</b> ...	<small>PRICE</small> <b>27/-</b>
<b>AUDIO FREQUENCY INTERVALVE TRANSFORMER</b> ...	<b>34/-</b>
<b>TELEPHONE TRANSFORMER</b> ... .. .	<small>(As Illustrated)</small> <b>21/-</b>

Every experimenter should secure a copy of my new Catalogue W.3, containing the latest and most up-to-date improvements in wireless apparatus for both Transmission and Reception, also excellent diagrams of circuits for Telephony, now ready, price 1/- post free.

Book of twenty-one Valve diagrams 1/- post free.

<p style="text-align: center;"><i>Works.</i></p> <p><b>"LIVERPOOL HOUSE"</b> MIDDLESEX ST., LONDON, E.1 Phone: Avenue 4871</p>	<h2 style="margin: 0;">H.W. SULLIVAN</h2> <p style="font-size: small; margin: 0;">TELEGRAMS: "DEADBEAT, STOCK, LONDON."</p>	<p style="text-align: center;"><i>Offices.</i></p> <p><b>WINCHESTER HOUSE</b> LONDON, E.C.2., ENGLAND Phone: London Wall 3518</p>
--	---	---