

# ELECTRONICS WORLD

VOLUME 114, ISSUE 1867



JULY 2008 £4.60  
www.electronicsworld.co.uk

THE ESSENTIAL ELECTRONICS ENGINEERING MAGAZINE

## Situation-Based Information Systems Need Special Displays

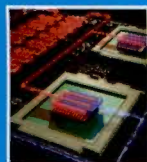
THE BEST WAY OF DEALING  
WITH PROJECT MANAGEMENT

MYK DORMER UNVEILS  
TECHNIQUES OF MAXIMISING  
BATTERY LIFE

THE BEST MCU FOR VEHICLE  
LIGHTING



WHAT DOES IT TAKE TO BE THE 21ST CENTURY CARRIER



**TECHNOLOGY**  
SERVERS  
GET OWN  
RADIATORS

**COMPANY PROFILE**  
MONICA  
HEALTHCARE  
HELPS MOTHERS-TO-BE



**CIRCUIT IDEAS**  
8085-BASED  
SINGLE-BOARD  
COMPUTER



ALSO IN THIS ISSUE: UKDL: WHY ARE REFLECTIVE COLOUR DISPLAYS SO BAD?



## Handheld Test Gear - Cool, Smart.



Atlas DCA - Model DCA55  
Semiconductor Analyser

Identifies type and pinout! Connect any way round.  
Measures gain, junction characteristics and more.



**New Low Price!**

Atlas ESR - Model ESR60  
ESR and Capacitance Meter  
Measures capacitance, ESR (in-circuit too!).  
Automatic controlled capacitor discharge feature!



Atlas LCR - Model LCR40  
Inductor, Capacitor, Resistor Analyser  
Automatic part identification, automatic frequency  
selection and auto ranging!



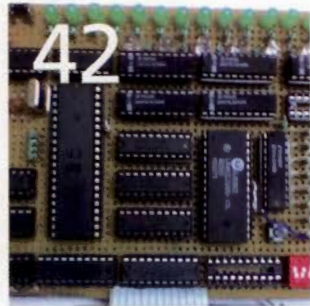
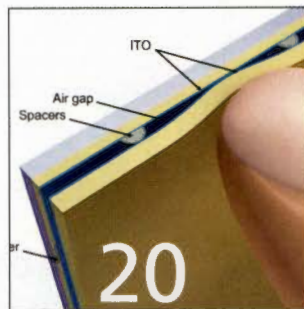
**New Low Price!**

Atlas SCR - Model SCR100  
Triac and Thyristor Analyser  
Connect any way round, auto lead identification.  
Auto gate test current from 100uA to 100mA.



**05 EDITOR'S COMMENT**

KEEP THE CHALLENGES COMING

**06 TECHNOLOGY****12 COMPANY PROFILE**BIRTH OF COMPANY HELPS MOTHERS-TO-BE  
by **Steve Rogerson****15 ROHS****Gary Nevison** answers readers' questions relating to the RoHS, WEEE and EuP directives, and REACH**16 INSIGHT**DESIGN'S ROLE IN COMPETITIVENESS  
by **Caroline Ward****18 THE TROUBLE WITH RF...**AVERAGE CURRENT ISN'T THE WHOLE STORY  
by **Myk Dormer****REGULARS****40 UKDL**WHY ARE REFLECTIVE COLOUR DISPLAYS SO BAD?  
by **Chris Williams****42 CIRCUIT IDEAS****45 TIPS 'N' TRICKS****50 PRODUCTS****FEATURES****20 CAN TOUCH THIS****Hal Philipp** discusses the evolving world of touch screen technology**23 SITUATION-BASED INFORMATION SYSTEMS****Mario Klein** and **Laurent den Hollander** explain how special displays make situation-based information systems in vehicles possible**26 INTELLIGENT VEHICLE LIGHT MANAGEMENT****Peter Aberl** and **Ralf Eckhardt** analyse the suitability of an MCU for controlling LED-type lighting in a vehicle**31 MIND MAPPING SOFTWARE – THE LOGICAL APPLICATION?****Scott Raskin** goes into detail as to why a graphical representation of projects can be of tremendous help and bring many benefits**34 IRIS JUDGE****Hasan Demirel**, **Mehmet Sarioglu**, **Yusuf A. Erdem** and **Gholamreza Anbarjafari** have developed a PCA-based iris recognition and verification system based on image processing**38 THE 21ST CENTURY CARRIER****Jonathan Bell** says that the route to becoming a 21st century carrier lies in an open standards approach





**QUASAR**  
electronics

The Electronic Specialists Since 1993

Quasar Electronics Limited  
PO Box 6935, Bishops Cleeve  
CM23 4WP, United Kingdom  
Tel: 0870 246 1826  
Fax: 0870 460 1045  
E-mail: sales@quasarelectronics.com  
Web: www.QuasarElectronics.com

Postage & Packing Options (Up to 0.5Kg gross weight): UK Standard 3-7 Day Delivery - £3.95; UK Mainland Next Day Delivery - £8.95; Europe (EU) - £8.95; Rest of World - £9.95 (up to 0.5Kg)  
!Order online for reduced price UK Postage!  
We accept all major credit/debit cards. Make cheques/PO's payable to Quasar Electronics. Prices include 17.5% VAT.  
Call now for our FREE CATALOGUE with details of over 300 kits, projects, modules and publications. Discounts for bulk quantities.



**08717**

Credit Card  
Sales

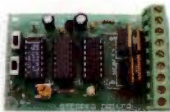
**177 168**

### Motor Drivers/Controllers

Here are just a few of our controller and driver modules for AC, DC, Unipolar/Bipolar stepper motors and servo motors. See website for full details.

#### PC / Standalone Unipolar Stepper Motor Driver

Drives any 5, 6 or 8-lead unipolar stepper motor rated up to 6 Amps max. Provides speed and direction control. Operates in stand-alone or PC-controlled mode. Up to six 3179 driver boards can be connected to a single parallel port. Supply: 9Vdc. PCB: 80x50mm. Kit Order Code: 3179KT - **£12.95**  
Assembled Order Code: AS3179 - **£19.95**



#### Bi-Polar Stepper Motor Driver

Drive any bi-polar stepper motor using externally supplied 5V levels for stepping and direction control. These usually come from software running on a computer. Supply: 8-30Vdc. PCB: 75x85mm. Kit Order Code: 3158KT - **£17.95**  
Assembled Order Code: AS3158 - **£27.95**



#### Bi-Directional DC Motor Controller (v2)

Controls the speed of most common DC motors (rated up to 32Vdc, 10A) in both the forward and reverse direction. The range of control is from fully OFF to fully ON in both directions. The direction and speed are controlled using a single potentiometer. Screw terminal block for connections. Kit Order Code: 3166v2KT - **£17.95**  
Assembled Order Code: AS3166v2 - **£27.95**



#### DC Motor Speed Controller (100V/7.5A)

Control the speed of almost any common DC motor rated up to 100V/7.5A. Pulse width modulation output for maximum motor torque at all speeds. Supply: 5-15Vdc. Box supplied. Dimensions (mm): 60Wx100Lx60H. Kit Order Code: 3067KT - **£13.95**  
Assembled Order Code: AS3067 - **£21.95**



### Controllers & Loggers

Here are just a few of the controller and data acquisition and control units we have. See website for full details. Suitable PSU for all units: Order Code PSU445 £8.95

#### 8-Ch Serial Isolated I/O Relay Module

Computer controlled 8-channel relay board. 5A mains rated relay outputs. 4 isolated digital inputs. Useful in a variety of control and sensing applications. Controlled via serial port for programming (using our new Windows interface, terminal emulator or batch files). Includes plastic case 130x100x30mm. Power Supply: 12Vdc/500mA. Kit Order Code: 3108KT - **£54.95**  
Assembled Order Code: AS3108 - **£64.95**



#### Computer Temperature Data Logger

4-channel temperature logger for serial port. °C or °F. Continuously logs up to 4 separate sensors located 200m+ from board. Wide range of free software applications for storing/using data. PCB just 45x45mm. Powered by PC. Includes one DS1820 sensor. Kit Order Code: 3145KT - **£17.95**  
Assembled Order Code: AS3145 - **£24.95**  
Additional DS1820 Sensors - **£3.95 each**



#### Rolling Code 4-Channel UHF Remote

State-of-the-Art. High security. 4 channels. Momentary or latching relay output. Range up to 40m. Up to 15 Tx's can be learnt by one Rx (kit includes one Tx but more available separately). 4 indicator LED's. Rx: PCB 77x85mm, 12Vdc/6mA (standby). Two and Ten channel versions also available. Kit Order Code: 3180KT - **£44.95**  
Assembled Order Code: AS3180 - **£54.95**



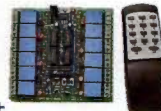
#### DTMF Telephone Relay Switcher

Call your phone number using a DTMF phone from anywhere in the world and remotely turn on/off any of the 4 relays as desired. User settable Security Password, Anti-Tamper, Rings to Answer, Auto Hang-up and Lockout. Includes plastic case. Not BT approved. 130x110x30mm. Power: 12Vdc. Kit Order Code: 3140KT - **£54.95**  
Assembled Order Code: AS3140 - **£69.95**



### Infrared RC Relay Board

Individually control 12 on-board relays with included infrared remote control unit. Toggle or momentary. 15m+ range. 112x122mm. Supply: 12Vdc/0.5A  
Kit Order Code: 3142KT - **£47.95**  
Assembled Order Code: AS3142 - **£59.95**



### PIC & ATMEL Programmers

We have a wide range of low cost PIC and ATMEL Programmers. Complete range and documentation available from our web site.

#### Programmer Accessories:

40-pin Wide ZIF socket (ZIF40W) **£14.95**  
18Vdc Power supply (PSU010) **£18.95**  
Leads: Parallel (LDC136) **£395** / Serial (LDC441) **£3.95** / USB (LDC644) **£2.95**

#### NEW! USB & Serial Port PIC Programmer

USB/Serial connection. Header cable for ICSP. Free Windows XP software. Wide range of supported PICs - see website for complete listing. ZIF Socket/USB lead not included. Supply: 16-18Vdc. Kit Order Code: 3149EKT - **£39.95**  
Assembled Order Code: AS3149E - **£49.95**



#### NEW! USB 'All-Flash' PIC Programmer

USB PIC programmer for all 'Flash' devices. No external power supply making it truly portable. Supplied with box and Windows Software. ZIF Socket and USB lead not included. Assembled Order Code: AS3128 - **£44.95**



#### "PICALL" PIC Programmer

"PICALL" will program virtually all 8 to 40 pin serial-mode AND parallel-mode (PIC16C5x family) programmed PIC micro controllers. Free fully functional software. Blank chip auto detect for super fast bulk programming. Parallel port connection. Supply: 16-18Vdc. Assembled Order Code: AS3117 - **£24.95**



#### ATMEL 89xxxx Programmer

Uses serial port and any standard terminal comms program. Program/ Read/ Verify Code Data, Write Fuse/Lock Bits, Erase and Blank Check. 4 LED's display the status. ZIF sockets not included. Supply: 16-18Vdc. Kit Order Code: 3123KT - **£24.95**  
Assembled Order Code: AS3123 - **£34.95**



Most items are available in kit form (KT suffix) or assembled and ready for use (AS prefix).



[www.QuasarElectronics.com](http://www.QuasarElectronics.com)

Secure Online Ordering Facilities • Full Product Listing, Descriptions & Photos • Kit Documentation & Software Downloads



# ELECTRONICS WORLD

**EDITOR:**
**Svetlana Josifovska**

Email: svetlana.josifovska@stjohnpatrick.com

**PRODUCTION EDITOR/DESIGNER:**
**Tim Wesson**
**DISPLAY SALES EXECUTIVE:**
**Matthew Dawe**

TEL: +44 (0) 20 7933 8999

Email: matthew.dawe@stjohnpatrick.com

**EDITORIAL DIRECTOR:**
**Melony Rocque**
**SALES DIRECTOR:**
**Chris Cooke**
**PUBLISHER:**
**John Owen**
**SUBSCRIPTIONS:**
**Dovetail Services**

800 Guillat Avenue,

Kent Science Park,

Sittingbourne,

Kent, ME9 8GU

TEL: +44 (0) 844 844 0230

Email: saintjohnpatrick@servicehelpline.co.uk

**SUBSCRIPTION RATES:**

1 year: £46 (UK); €120 (Europe);

\$145 (US &amp; worldwide)

**NEWSTRADE:**

Distributed by Seymour Distribution Ltd,

2 East Poultry Avenue, London, EC1A 9PT

+44 (0) 20 7429 4000

**PRINTER:**
**William Gibbons Ltd**

**St John Patrick Publishers**

## KEEP THE CHALLENGES COMING

**W**e'd have to congratulate firms like Eden Ventures and Salesforce.com who have recently jointly launched a £1m investment challenge for entrepreneurs and early stage companies to create new software solutions. Admittedly, it is a challenge specific to the Force.com platform, a Platform-as-a-Service (PaaS) software system, which is claimed to "enable" companies to develop and deliver any application on demand.

Nevertheless, it is a fairly generous award and in the process it will inspire a new generation of independent software vendors (ISVs) to develop and deliver new applications.

Equally, we have semiconductor giant Freescale which is offering \$61,000 (around £31k) for its 2008 technology forum "green" design challenge. Now, we'd also have to congratulate Freescale for creating the challenge but, let's face it, the award could have been higher. Doesn't developing a "green" technology warrant a "bigger" award?

The company says the challenge will encourage innovation in environmental design and is a "compelling" incentive to encourage designers to "go green". Freescale hopes that engineering community will find creative ways to use less energy, limit the environmental impact of existing products and create new products that help improve the world we live in.

Again, the company giving the award has an interest in offering this challenge, as participants will use its existing solutions to create these innovative, green, electronic designs.

Nevertheless, despite the questions raised over the sizes of the awards, these challenges are boosting innovation and will help a generation of engineers and engineering scientists to gain seed funds to create new solutions

## THESE CHALLENGES ARE BOOSTING INNOVATION AND WILL HELP A GENERATION OF ENGINEERS AND ENGINEERING SCIENTISTS TO GAIN SEED FUNDS TO CREATE NEW SOLUTIONS

and, hopefully, break into the commercial world.

It will also help re-build the already dented image of what engineering is about. The UK's Institution of Engineering Technology (IET) keeps going on about engineering having to dispel its image of hard hats and overalls if it is to attract more people into the profession. But maybe the IET should also get involved in raising some funds for similar and frequent challenges, starting with schools, where innovation, creativity and invention can be awarded from an early stage. It will be a good way of "putting money where the mouth is".

**Svetlana Josifovska**  
Editor



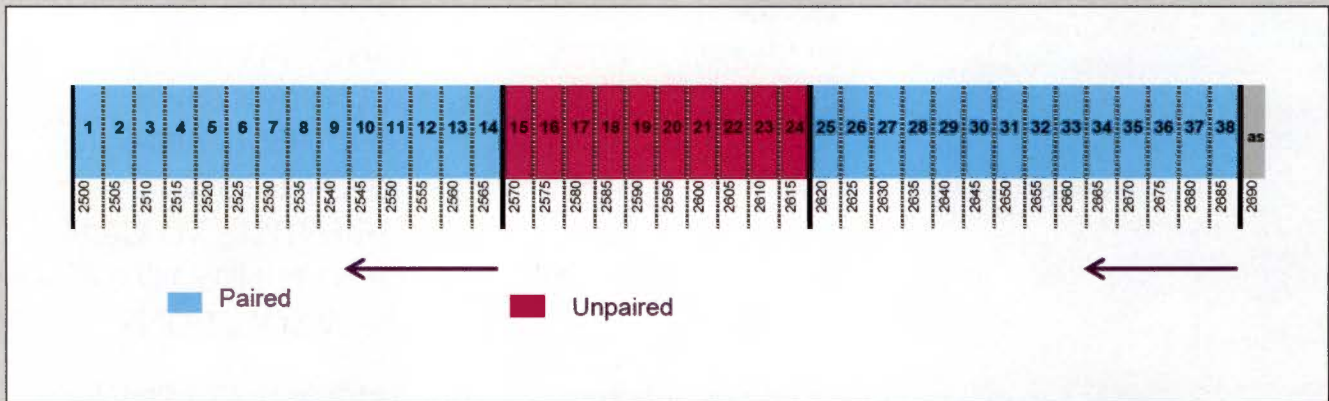
Check out Electronics World's new website by clicking on  
[www.electronicsworld.co.uk](http://www.electronicsworld.co.uk)

Electronics World is published monthly by **Saint John Patrick Publishers Ltd**, 6 Laurence Pountney Hill, London, EC4R 0BL.

Disclaimer: We work hard to ensure that the information presented in Electronics World is accurate. However, the publisher will not take responsibility for any injury or loss of earnings that may result from applying information presented in the magazine. It is your responsibility to familiarise yourself with the laws relating to dealing with your customers and suppliers, and with safety practices relating to working with electrical/electronic circuitry – particularly as regards electric shock, fire hazards and explosions.



# OFCOM CLEARS THE AIRWAVES FOR MOBILE WIMAX



2.6GHz band-plan with labelling of blocks #1 to #38 showing paired and unpaired spectrum as per the Comite Europeen des Postes et Telecommunications band plan. Arrows indicate how unpaired spectrum can increase over the minimum of 50MHz

The much-anticipated battle of the wireless broadband standards between 3G and WiMAX has officially begun in the UK, following confirmation by telecoms regulator Ofcom that a significant amount of radio spectrum will be made available for new services.

The communications watchdog has decided to go ahead with the auctioning of, what it calls, "the largest single release of spectrum suitable for mobile use to take place for a significant period of time". This includes 190MHz in the 2.6GHz band (between 2500-2690MHz) and a further 15MHz in the 2010MHz band (2010-2025MHz).

The move, which paves the way for the arrival of mobile WiMAX networks in the country, was fiercely opposed by the five mobile phone operators. However, following an extensive consultation that started in early 2005, Ofcom said awarding the spectrum as soon as possible was in the best interest of consumers.

"Our analysis suggests that there is a time-limited window of opportunity for new mobile providers to establish services using mobile WiMAX," said an Ofcom statement.

Mobile phone operators had lobbied for a delay in the award of the 2.6GHz band until uncertainties surrounding the liberalisation of 2G spectrum had been resolved. A delay would have given the cellular industry precious time to advance the development of LTE, their next-generation mobile technology that is expected to match or possibly outperform mobile WiMAX.

Ofcom's decision effectively opens the door for full competition between both technologies, leaving the market (and not regulation) to decide which one is best.

In line with current Ofcom policy, the regulator will make the new licences available on a technology-neutral and spectrum-trading basis. The award process is scheduled to start in July, with the initial bid rounds taking place in September.

Selection of the 2.6GHz band will also see the UK meet new European regulation. Indeed, Ofcom's announcement came only two days after the Radio Spectrum Committee of the European Commission agreed on the harmonised use of this particular band for terrestrial systems capable of providing electronic communications services.

Ofcom expects two main types of likely uses for the 2.6GHz band. In the first group, it identifies paired use for FDD (frequency division duplex) technologies which rely on paired blocks of frequencies separated by 120MHz. LTE and UMTS/HSPA are the two main FDD technologies relevant to 2.6GHz.

The other possibility is unpaired use for TDD (time division duplex) for technologies that rely on unpaired blocks, in which base stations and user equipment both transmit and receive at the same frequency but in different timeslots. Here is where prospective mobile WiMAX service providers will be looking to operate.



# Graphene Research Makes Further Advances



Researchers from the University of Manchester have built the world's smallest transistor, measuring just one atom thick and ten atoms wide.

The transistor was fabricated using graphene, the world's thinnest material. Discovered only four years ago, graphene, the first known one-atom-thick material, can be viewed as a plane of atoms pulled out from graphite. The research, led by Dr Kostya Novoselov and Professor Andre Geim from The School of Physics and Astronomy at The University of Manchester, proves that a single graphene crystal can be carved into nano-electronic circuits with individual transistors not much larger than a molecule.

The discovery could have revolutionary implications in the semiconductor industry given graphene's proven advantages over silicon to conduct electricity both faster and further.

Crucially, unlike transistors made out of silicon, the smaller the size of graphene transistors the better they perform. According to the researchers, graphene transistors

start showing advantages and good performance at sizes below 10nm, the miniaturisation limit at which current technology is predicted to fail because silicon then starts to oxidise, decompose and uncontrollably migrate along surfaces.

"Previously, researchers tried to use large molecules as individual transistors to create a new kind of electronic circuit," said Novoselov. "It was like a bit of chemistry added to computer engineering. Now, one can think of designer molecules acting as transistors connected into designer computer architecture on the basis of the same material [graphene], and use the same fabrication approach that is currently used by the semiconductor industry."

His colleague Geim admitted that it would be premature to promise graphene supercomputers just yet. But he said that the first significant step in that direction had now been taken. "In our work, we relied on chance when making such small transistors. Unfortunately, no existing technology allows the cutting of materials with true nanometre precision," he said. "But, this is exactly the same challenge that all post-silicon electronics has to face. At least we now have a material that can meet such a challenge."

Another major challenge that will need to be addressed before microchips can be built from graphene is the development of large enough wafers. While current standard silicon wafer size is 300mm (and projected to go up to 450mm at some point around 2015), the biggest graphene wafer anybody has been able to produce so far is only 0.10mm.

## IN BRIEF

- Electronics design network Silicon South West is looking for five new technology-based start-ups for this year's FASTtrack, a programme of tailored business support for companies based in the South West of England. The programme, now in its second year, has been backed with investment from the South West Regional Development Agency (SWRDA), which will be used to fund a package of professional support and strategic mentoring for the companies. The FASTtrack programme has been established to address the unique needs of technology start-ups. For more information go to [info@siliconsouthwest.co.uk](mailto:info@siliconsouthwest.co.uk).

- Venture capitalists Eden Ventures and Software-as-a-Service (SaaS) provider Salesforce.com have launched a £1m Force.com Investment Challenge for entrepreneurs and early stage companies building on the Force.com Platform. Force.com delivers Platform-as-a-Service, enabling companies to develop and deliver any application on demand. The challenge, the first of its kind in the UK, is designed to inspire a new generation of independent software vendors (ISVs) to develop and deliver SaaS applications on the Force.com Platform. The winner will be announced in November at Dreamforce 2008, Salesforce.com's user and developer conference.

- Semiconductor giant Freescale is offering \$61,000 plus incentives for the 2008 Freescale Technology Forum (FTF) green Design Challenge. The registration deadline for the 2008 Design Challenge Europe is June 6, 2008. The challenge aims at encouraging innovation in environmental design and offers compelling incentives to encourage designers to "go green". Freescale invites the engineering community to find creative ways to use less energy, limit the environmental impact of existing products and create new products that help improve the world we live in. Participants will create innovative, green electronic designs using a select group of solutions from the company's broad product portfolio, and will retain the intellectual property rights to their designs.



● Engineering needs to dispel its image of hard hats and overalls if it is to attract more people into the profession, says the IET. "Raising awareness that choosing in a career in engineering and technology is entering into a profession which presents well paid, creative and rewarding opportunities, is one of the biggest challenges facing the industry."

"Employers have a real responsibility to recognise that the employees of today are the ones who will fill the needs of the future. 75% of the people who will be our workforce in 2020 have already left education. There has to be an awareness of the gap in skills and a practical solution found to resolve this."

● The University of New South Wales (UNSW) has teamed up with software supplier Ansys to develop industry-ready work force. UNSW will use the Ansys academic products for teaching programs and research activities in various fields of engineering and science on all campuses across Australia.

"Deploying academic products from Ansys as an integral part of the curriculum allows our students to be trained on a cutting-edge commercial engineering simulation toolset, along with underlying numerical theory, making them ready for the simulation-driven product development environment of industry," said Professor Eddie Leonardi.

● Students at the Institute for System Level Integration (ISLI) are to receive 'CPD training credits' following their graduation to enable them to hone their existing skills whilst in the workplace. The Institute sits at the interface between the academic and commercial engineering worlds and this is another step towards achieving its mission to produce highly skilled design engineers and researchers to meet the needs of the rapidly changing global semiconductor industry. All MSc graduates will leave ISLI with 20 CPD Credits that can then be used in the two years post-graduation to supplement their original education and provide them with additional skills for the workplace.

## Holographs Technology Breakthrough

Researchers at the University of Arizona in Tucson, US, have developed a photorefractive polymer which will help create holographs in a lot shorter period of time than previously achieved.

Traditionally holographs have been created by mixing reflected laser light with a second laser beam to lay down a static image – a complicated, delicate process that has proven to be very lengthy and expensive.

With the new thin-film polymer type material, the manufacture of screens can take minutes, and they can be made very large by the way of tiling them.

Images are "written" to the screen in minutes and can just as easily be wiped off to be replaced by another image. The material has been shown to stay stable throughout hundreds of write and erase cycles.

The inputs to the screens can vary, but they all show promise for sharp 3D images.

The material and the process were first reported in Nature by Savas Tay and colleagues who carried out the research. The team is now working with Japanese firm Nitto Denko where the first 10cm by 10cm screen has already been demonstrated.

## "Racetrack" devices in a race with flash and HDDs over memory

IBM researchers are developing a technology they have dubbed "racetrack" memory to rival flash and hard disc drives (HDDs).

An IBM team at the Almaden lab in California has created a novel storage medium that harnesses the physical properties of the so-called domain walls that exist between magnetic regions in nanowires. The team has not only managed to successfully energise the fields, but control the pulse lengths and spin-polarise them to create the equivalent to '1s' and '0s'.

The team has also shown a viable method to fabricate the nanowires that would form the 'racetracks' on which the data is stored.



*The MP3 players of the future will hold 100 times more data.*

One of the main advantages of "racetrack" memory is the nanowires' small size and hence high densities, so for example a typical size MP3 player could potentially store as much as 100 times more data than it does today.

Another key advantage would be their low power and low heat generation, as they only draw minimal amount of current. Equally, they are expected to be more robust and as such

more durable than hard-drives, and less expensive than flash memories.

However, the IBM team concedes that it will be at least four years before the first prototype is put together and a further four before this type of memory systems are commercially available.



# ELECTRONICS WORLD

has now gone online  
[www.electronicsworld.co.uk](http://www.electronicsworld.co.uk)

You are clicks away from your own copy of  
the magazine – *faster than ever!*

Here, you can register for:

- key-word searches
- article searches
- customised newsletters
- buy any edition of the magazine – including the latest one, before it hits the newsstands
- buy CDs of past articles from different years
- chat on our exclusive forum with like-minded professionals
- comment on articles
- buy techy items
- get software code, references and additional material on certain articles run in the magazine
- win prizes

So, don't waste any time and go to  
**Electronics World's website now!**

[www.electronicsworld.co.uk](http://www.electronicsworld.co.uk)



# Engineers create high-performance transistors with disordered materials

In the first collaborative work with Hitachi Central Research Laboratory, Japan, researchers at the Advanced Technology Institute (ATI) of the University of Surrey have experimentally demonstrated that for transistors of disordered silicon films, superior switching performance (low leakage current and steep sub-threshold slope) can be achieved by making the conduction channel in the transistor very thin.

A higher ION/IOFF ratio, which exceeds 1011, can be achieved for devices with a 2nm-thick channel.

Another seminal work from the same research laboratory at Surrey is on the newly developed source-gated transistor (SGT) concept by Professor John Shannon. Compared to a field-effect transistor, the SGTs can operate with very short source-drain separations – even with a thick gate insulator layer – to achieve high speed, good stability and superior control of current uniformity, providing a significant advantage in terms of the fabrication process.

At present, high performance transistors are only available in crystalline materials, which are expensive and have to be

attached ex-situ onto larger area substrates. This adds to the expense and complexity of system design.

Equally, transistors on cheap and flexible substrates like glass and plastics are currently unable to deliver high performance and, therefore, do not lend themselves to seamless monolithic integration of increased electronic functions on many systems including displays and sensors. Now, the two advances will help marry electronics and large display substrates onto one platform.

Dr Xiaojun Guo, one of the lead researchers, said: "Engineering of the transistor structure itself rather than the channel material can lead to improved device performance. It will enable the design of high-performance large area circuits and systems based on low-cost reliable material processes."

Professor Ravi Silva, Director of the Advanced Technology Institute states: "This work will help extend the already well established CMOS fabrication technologies for use in large area applications such as displays and sensors, which are at the heart of consumer electronics."

## Watts Stand Still In Standby

Fujitsu Siemens Computers has developed the world's first computer monitor to operate in idle mode without consuming any electricity at all.

Unlike all existing models, which continue to draw small amounts of electricity when left in standby mode, a new switch in the monitor shuts down the device entirely when the computer signal is absent and turns it on again when the signal reappears, helping reduce both electricity bills and carbon footprints.

The relay, which is located in the monitor's power supply unit that is connected to the PC, automatically interrupts the entire electrical circuit of the monitor as soon as the video signal of the computer subsides. When the video signal returns, the low currents that begin to flow across the interface are sufficient to trigger the relay and restart the monitor.

Despite the minimal power consumption levels involved, leaving monitors in idle mode overnight can amount to tens of thousands of Euros in additional power costs per year for large companies with vast computer networks.

Chosen as 'Innovation of the Year' at the CeBIT 2008 trade show, the "zero-watt monitor", as the company calls it, will be commercialised for the price of a conventional monitor from this summer. It will initially be marketed to corporate customers as a new member of Fujitsu Siemens Computers's family of green IT products, which includes laptops, PCs and servers.

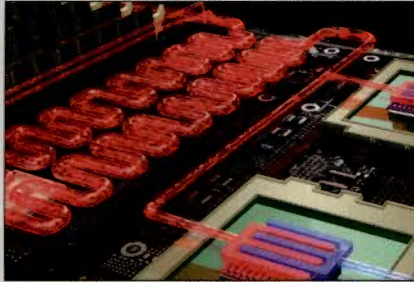


*A simple electrically-powered switch inside the monitor could signal the end of energy drain problems during standby operation*

The company was the first vendor to obtain the Blue Angel environmental label for some of its Esprimo Professional PCs. According to the firm, the Esprimo P Energy Saving Edition uses as little as 87kWh in its standard configuration, less than half of the average 183kWh needed by a four-year-old office desktop computer.



## Corporate servers to get 'the radiator treatment'



*IBM's Hydro Cluster system uses water to cool each of the 224 dual-core processors distributed across the 14 servers powering the supercomputer*

IBM has introduced a supercomputer that uses water running in close proximity to its microprocessors as the cooling mechanism.

A new version of the company's Power 575 supercomputer has been fitted with a network of water-chilled copper plates located on top of each processor's heat sink in an effort to remove heat from the electronics.

According to the IBM, water can be 4000-times more effective than air at dissipating heat in computer systems. As a consequence, typical energy consumption required to cool a corporate data centre can be reduced by 40%. Compared with standard, air-cooled Power 575 systems, the new configuration using water requires 80% fewer air conditioning units to achieve the same performance.

IBM has dubbed the technology 'Hydro Cluster' given the water-based system's ability to support clusters of hundreds of nodes in dense packaging configurations. The latest version of the Power 575 supercomputer features 14 servers, each of which packs 16 dual-core 4.7GHz Power 6 processors, yielding a total of 224 water-cooled dual-core processors.

Cold water is pumped in and distributed to each processor via an intricate piping network built throughout the rack. The resulting

hot water is subsequently pumped out. Some of the IBM scientists behind the technology suggest this hot water could one day be used to, for example, heat one or more nearby offices in a corporate setting.

Leak-proof couplings and connectors are used to avoid any risk of spoiling the electronics, while an active monitoring system makes sure water pressure and individual valve operation are kept under control.

With up to 256GB of RAM per server, total memory capacity of the supercomputer is approximately 3.5TB. "The Power 575, like all Power-based supercomputers, is designed for the most computationally-intensive problems in energy, engineering, aerospace and weather modelling," said Dave Jursik, the firm's vice president of supercomputing sales.

The machine, which can run AIX (UNIX) and Linux, is scheduled to be launched before the summer.

## ELECTRONICS WORLD

**IF YOU ARE INTERESTED IN STAYING AT THE CUTTING-EDGE OF ELECTRONIC DESIGN, ELECTRONICS WORLD IS THE MAGAZINE FOR YOU. SIGN UP AND BE INSPIRED EVERY MONTH.**

A subscription guarantees your magazine arrives every month promptly and without fail.

**SUBSCRIBE NOW! SUBSCRIBE NOW!**

Electronics World Subscription  
Dovetail Services  
800 Guillat Avenue,  
Kent Science Park,  
Sittingbourne,  
Kent, ME9 8GU  
Tel: +44 (0) 870 428 1426

Email: [saintjohnpatrick@servicehelpline.co.uk](mailto:saintjohnpatrick@servicehelpline.co.uk)



# BIRTH OF A COMPANY HELPS MOTHERS-TO-BE

**A RESEARCH PROJECT IN 1990 HAS BLOSSOMED INTO A START-UP COMPANY THAT COULD HELP LOWER THE NUMBER OF STILL BIRTHS ACROSS EUROPE. STEVE ROGERSON REPORTS**

**W**hat started as a research project at the University of Nottingham back in 1990 has blossomed into a start-up company that is already beginning to change the way doctors measure the health of foetuses in the womb.

The aim back then was to find a more comfortable way to monitor foetus heart beat than the current ultrasound method that involves sitting still in a chair or bed while the scans are done and can only realistically be done in a hospital or doctor's surgery. But since then, the work has become more relevant following various health scares concerning ultrasound including fears that they can cause brain damage and stunt growth.

What the Nottingham work was aiming for was to find a non-invasive method of monitoring foetal health and one that did not involve constant supervision. With ultrasound, a 2MHz signal is fired towards the womb and uses the Doppler shift to detect movement and then filters out everything but the heart beat. If the baby changes position during this process, the transducer also has to be moved, hence the constant supervision.

The alternative was to use the foetal ECG signal. The difficulty is that the signal is very small compared with the mother's ECG. An electrode placed on the skin near an adult woman's heart would pick up readings between 1000 and 5000 $\mu$ V compare with the foetal signal off between 1 and 10 $\mu$ V. Even if the electrode is placed near the abdomen, the mother's ECG signal will still be 100 $\mu$ V and thus can easily drown out the foetal signal.

## Early Research

In the early days of the research, the success in filtering out all but the foetal heart beat was poor but still good enough to make them believe the work was worth pursuing. Today, the spin-off company, known as Monica Healthcare (Monica is an acronym



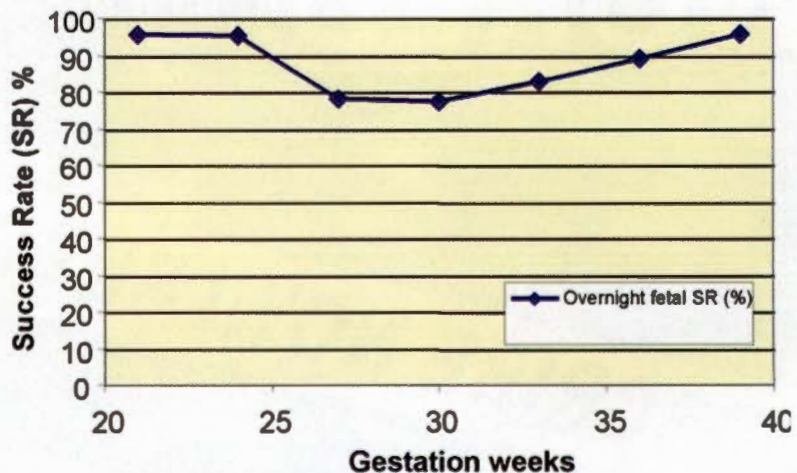
Monica Healthcare's foetal monitor

from "monitor" and "care") has a commercial device available that the mother can wear round her neck or on the pillow beside her and have a success rate of monitoring the foetal heart beat of more than 90%. Obviously, this rate varies with the activity of the mother and is at its best when the mother sleeps or is at rest.

"You can miss some beats because of mum's activity," said research director Barrie Hayes-Gill, one of the firm's founders. "When mum is down the gym, there is no chance, but when she is sitting and relaxing and definitely when she is asleep, the success rate is clinically acceptable."

The success rate also varies depending on the point within the pregnancy. Between 28 and 32 weeks, a protective layer forms over the baby. This is known as the vernix caseosa and weakens the electrical signal taking the success rate down to about 80%. But after that, the success rate picks up again as foetal movement causes the layer to break up.

The monitor also gets round the problem



The overnight success rate took a dip between 28 and 32 weeks when the foetus is enclosed in the vernix caseosa





The highest success rates happen when the mother is asleep

research assistant under the supervision of Hayes-Gill started work on the project and some five years later the work had achieved a success rate of 40%, nowhere near enough to be clinically acceptable, but good enough to attract the interest of the Action Medical Research charity, which put in three grants starting in 1996 totalling about £200,000. During this time, the university showed its belief in the work by investing about £2m.

In 1997, a top-class French engineer – Jean Francois Pieri – joined the project as part of his PhD work under the Erasmus scheme that lets European graduates travel round Europe to other universities.

He did an initial project with the team and then ended up taking a PhD on the work. This was funded through a Case (Collaborative Award in Science & Engineering) award from the UK Research Council. As the name suggests, this is

patent or publish the work. Once published, they wouldn't be able to patent it and if they did patent it, they would have to wait a year before their findings could be published.

"But without a patent, nobody would have taken us seriously, so that's what we did," said Hayes-Gill.

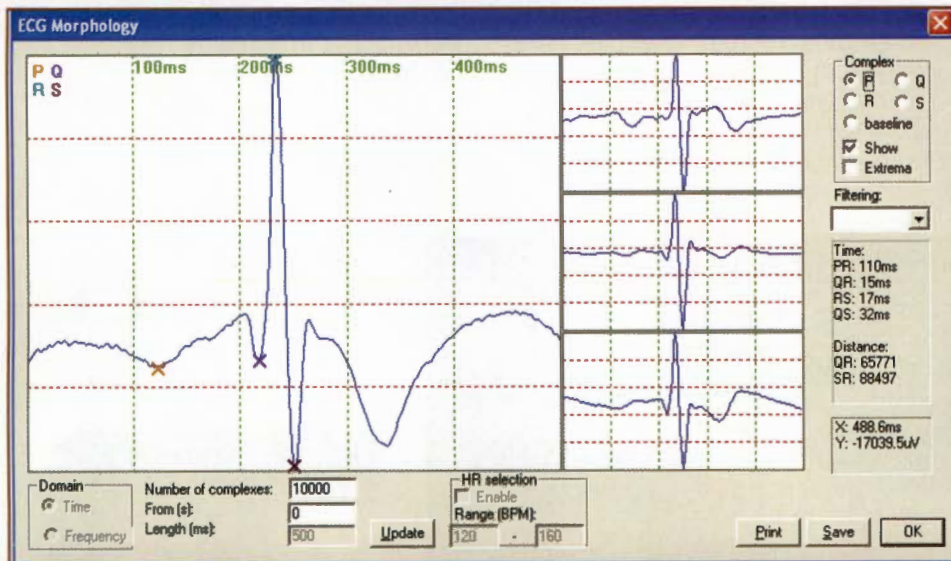
By 2001, the project was moving quickly, with more than 700 research records under their belts. To obtain these, they had to talk to the hospital's ethics committee, which had to give approval before they could work with expectant mothers. The device also had to be passed by the hospital's electrical safety unit. And each patient had to give her consent. This was always optional, said Hayes-Gill: "No mother was pressurised to do this."

The time was now right, believed the university, to explore the device's commercial potential. The favoured route was to find an existing company and then licence it to them. Money would then come into the university with the problems of manufacturing and selling transferred to someone else.

### Going for Grants

Despite initial interest from some big named companies, nobody would commit to a licence without full clinical trials, which could cost upwards of £250,000. Companies with investment in ultrasound technology were also nervous of the project because they saw it as a potential competitor to an established and lucrative business.

This was a set-back but work continued, helped in 2002 by a £16,000 grant from the Herobc Innovation Research Fund, another government body. The team also knew that to attract commercial interest, some work was going to have to follow a different route and so one of Hayes-Gill's old PhD colleague



Physiologists and maternal experts have access to long-term recordings of a range of foetal maternal data

of foetal movement as there are five electrodes placed on the stomach which form three channels that can pick up the heart beat as the foetus moves between channels. Also, unlike ultrasound, the technology is non-invasive; it just listens for signals that are already there.

### Rocky Road

Monica's monitor is now in production and sales have started to medical bodies across Europe, but to reach this point involved negotiating a rocky road that started in 1990 at the university's School of Electrical & Electronic Engineering. Three PhDs and one

collaborative award that included £20,000 from Oxford Medical and a further £60,000 of government money. Oxford Medical's managing director at the time was Terry Martin, a man well known to the university as he'd worked with them on other projects.

With this funding, the team fine-tuned the device and brought the success rate up to 70%, good but still well short of the 90%, they were going to need for it to be accepted by the medical world. It also had some reliability problems in those days.

In 1999, the team filed their first patent, not a cheap option at £3500 and caused a debate among them over whether to file the

**"THE SUCCESS IN FILTERING OUT ALL BUT THE FOETAL HEART BEAT WAS POOR BUT STILL GOOD ENOUGH TO MAKE THEM BELIEVE THE WORK WAS WORTH PURSUING"**





*The device continues monitoring the foetus even when the mother is walking around*

device was to be sold in Europe) and how they could manufacture the device in volume. His work was further funded by yet another government grant – a Medici Fellowship.

A £25,000 business prize in 2004 saw the team file a business plan after more attempts to licence the product failed, and so the decision to go alone was made. But now serious funding was needed and so they started talking with venture capitalist Lachesis. The initial £7500 allowed them to do the due diligence work on the patent, which was successful, and so they provided another £250,000. Another venture capitalist – Catapult – added £200,000 to the fund.

Monica Healthcare was thus formed in May 2005 and took offices in BioCity, a modern incubator building in the centre of Nottingham. The venture capital money allowed them to run the necessary clinical trials on 120 patients in the Netherlands between 2005 and 2007. Late in 2007, they got the much-needed CE mark. A company in nearby Derby called Tioga is manufacturing the product, which sells for £4500 and there are already a dozen distributors across Europe.

– Carl Barratt – was brought on board. He was given the task of exploring what would be needed to earn a CE mark (essential if the

## Perfect Patients

The initial target for the product are mothers classed as at risk, and these account for between five and ten percent of all pregnancies. They include women who have had a previous still birth, are diabetic or have a growth-retarded foetus. These three groups account for 50% of all still births in Europe.

The device lets the foetus of these women be monitored continually, not just when they come in for a check-up. The data it gathers can either be sent direct to the hospital (it has wireless capabilities using Bluetooth) or stored on an SD card. Its sensitive analogue front-end picks up the signal and is then processed with an Arm processor in real time.

With 500,000 potential mothers classed as high risk across Europe, the market for the device is large. And sales via distributors have already started, though still measured in tens rather than hundreds.

“It has been a long journey,” said Hayes-Gill, “but the work is now starting to pay off.” ■

## No Compromise Oscilloscope



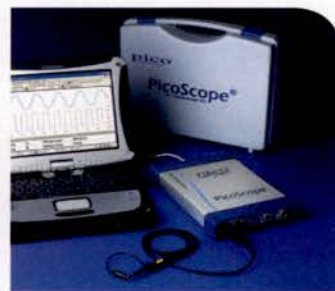
Other oscilloscopes in this price range force you to compromise on one of the key specifications: sampling rate, memory depth or bandwidth.

The PicoScope 5000 series is a no compromise PC oscilloscope at a price every engineer can afford.

[www.picotech.com/scope476](http://www.picotech.com/scope476)

01480 396395

**pico**<sup>®</sup>  
Technology



**1GS/s sampling rate**

**250MHz bandwidth**

**128M sample buffer memory**

**125MS/s 12 bit AWG built in**

**PicoScope 5203**  
32M buffer **£1195**

**PicoScope 5204**  
128M buffer **£1795**





Gary Nevison is chairman of the AFDEC RoHS team, and Customer Support Manager, Legislation and Environmental Affairs at Premier Farnell. As such he is our industry expert who will try and answer any questions that you might have relating to the issues of RoHS, WEEE and REACH. Your questions will be published together with Gary's answers in the following issues of Electronics World.

## BATTERIES DIRECTIVE – PART 1

### Batteries directive – Part 1

The European Union adopted the 'Batteries Directive' (91/157/EEC) back in March 1991. This introduced restrictions on the use of mercury in most batteries and encouraged collection and recycling. However, the objectives of this Directive have not been achieved as most portable batteries are still being sent to landfill. As a result, the EU has introduced – and adopted – a new Batteries Directive (2006/66/EC) that will come into force on 26 September 2008 and replace the existing Directive. National legislation is also due by this date.

### Producers' Obligations

Once the legislation comes into force, all battery producers will be obliged to register in each EU State where they place batteries on the market (with the possible exception of distance sellers in some States).

The approaches to compliance within each EU State are still under discussion but it is possible that portable batteries and industrial and automotive batteries might have different approaches. Collection rates for portable batteries are currently very low in most EU States, including the UK, whereas collection rates for many types of industrial and automotive lead-acid batteries are already very high. Therefore, two approaches are being considered for industrial and automotive batteries, whereas the most likely approach for primary batteries will be using producer compliance schemes.

### Portable Batteries

Portable batteries are used by consumers and by industry and are defined as sealed batteries that can be hand carried and are not for industrial or automotive use. They are sold as individual batteries and also in equipment. Primary batteries reach end-of-life (when discharged) before the equipment, and so many waste primary batteries will be available for recycling.

Rechargeable batteries are sold as individual batteries or in electrical equipment and so many will reach end-of-life when the equipments' life ends. As a result, the user will remove some and others would be removed by WEEE recycling schemes. Therefore, any system for collection of portable batteries will need to account for all of these routes. Options include:

- Take-back by retailers: This could be similar to existing distributor take-back schemes that are available for waste electrical equipment.
- Take-back by battery or equipment supplier: This approach is mainly appropriate for professional and industrial batteries, although larger manufacturers could collect batteries from consumers.

- Use of compliance schemes: Several compliance scheme options are being considered, ranging from one single national scheme to many competing schemes, with or without a coordinating body (e.g. a clearing house).

It is probable that a combination of approaches will be used in a similar way that the WEEE Directive is implemented. One option is for the authorities to set targets for collection of waste batteries, either for individual producers that have opted to collect batteries or for schemes that collect on behalf of members. Targets are likely to be based on current market share.

Batteries are already collected by WEEE compliance schemes when waste electrical equipment is disassembled. Most of these batteries will be portable and should be recycled. The collection targets for portable batteries are 25% by September 2012 rising to 45% by September 2016.

### Industrial and Automotive Batteries

Two options are being considered for batteries designed exclusively for industrial professional or automotive use, either to allow existing private arrangements to continue, or to set up producer compliance schemes. Compliance schemes may work with local authorities as is the case now with waste electrical equipment.

Although all producers must register, Member States may exclude 'small' scale producers (who sell only small numbers of batteries) from any obligation to finance collection and recycling of batteries. The directive does not define 'small' producers however.

The collection and recycling requirements will be enforced and, so, some form of evidence of compliance will be required from producers or the schemes that they join. The Directive specifies collection and recycling targets of 100%, which must be met by 26 September 2011. Disposal by landfill or incineration will be banned outright. ■

**The second part of this article, to be published in the next issue of Electronics World, will look at substance restrictions, labelling requirements and the potential impact of the batteries directive on equipment design.**

Please email your questions to:  
[svetlana.josifovska@stjohnpatrick.com](mailto:svetlana.josifovska@stjohnpatrick.com)  
 marking them as RoHS or WEEE.





## DESIGN'S ROLE IN COMPETITIVENESS

**CAROLINE WARD**, RESEARCHER AT DESIGNTALKS, DISCUSSES SOME OF THE MOST IMPORTANT ASPECTS OF CREATING A SUCCESSFUL, COMPETITIVE BUSINESS

**W**ithout question, design can be a powerful tool to improve competitiveness, able to address a range of manufacturing issues both up and downstream of the overall product development cycle. In addition, it can be used to achieve perhaps less tangible goals such as improvements to market positioning, service delivery and brand strategy.

Yet design cannot do these things in a vacuum. Instead, those manufacturers who make the most of design to improve competitiveness have found ways to integrate their design teams more effectively with other areas of the business, exploiting every ounce of market, product and process knowledge and applying it to address very specific business goals.

Distinct from other business goals such as profit and growth, competitiveness relates very specifically to a company's place within its own industry. Therefore, without a good understanding of a market, its suppliers and customers, or being armed with information about every aspect of the business and its performance, design's role in addressing competitiveness will inevitably be compromised – or non-existent. "It's very important to know your market and to know why your product is selling, no matter what the product is," says Aaron Moss, senior designer at Nokia. "Some consultancies may play up the stylistic side of design and they can focus on making things with innovation – very stylish, very fashionable – but they might not have the good business sense or the market knowledge to make those products successful."

Good market knowledge enables designers to pinpoint the real business needs behind a project (reduce tooling costs, increase margins, reach new customers etc), and to address them successfully, rather than just blindly bringing new products to market unnecessarily and at great expense. "I have great faith that design teams – most of them anyway – can produce a very good design solution to a given problem," says Colin Mathews from Team Consulting. "But one of the other key things is how well the problem is defined. We can come up with a good solution to the wrong problem, but if it's the wrong product, you're still lost. The research that goes into design is ultimately just as valuable to the output."

Within the traditional manufacturing landscape, given a little headroom, design can make a positive impact on almost every part of the product development process, increasing the overall competitiveness of manufacturers and their products by working

within the very real constraints of day-to-day business, to develop products and services that fit within them. This might mean understanding materials and technical specification, tooling, working with long-term supplier agreements, ironing out production-line problems or cost and procurement structures.

By using design to solve a problem at source, many decisions to address competitiveness are, when backed up with the right information, straightforward and logical. For example, companies like Olympus KeyMed use good design to ensure that their products require minimal assembly, since short assembly times enable UK manufacturers to compete directly with their Chinese counterparts. Rather than trying to solve assembly issues once the product has been designed, this upfront approach addresses the problem from the very beginning of the product lifecycle.

In other instances, design has been shown to help develop new markets, as in the case of this German furniture company: "We were asked to design furniture that would enable the company to communicate to a wider export market," says Tom Lloyd, Director of product and furniture consultancy PearsonLloyd. "Following the project, the company's export market grew from 10% to almost 60% of its turnover. The new products accounted for only a bit of that growth; the rest was sales of its original furniture. So the design process had actually helped them to develop a strategy for growth in their export markets which became more financially rewarding than the new products themselves."

Even companies with strong selling product portfolios can use design to reach new customers, by creating next-generation products that appeal to a broader user group, or different range of users. "If a product is doing really well, it might be tempting to leave well alone, but the addition of some new features may

**Distinct from other business goals such as profit and growth, competitiveness relates very specifically to a company's place within its own industry**



## One area of growing significance in manufacturing ignores the design of actual products altogether, looking instead to the services that surround them

attract more customers," says Martin Bennison of KeyMed. "We don't expect people to upgrade to the new model, rather to increase the customer base with people who haven't bought before." In this way, design enables companies to increase competitiveness by opening up markets within either existing or even new territories.

Sometimes, less tangible, more subtle links between design and improved competitiveness can be just as effective, such as in brand positioning. "We've designed several seats for a particular airline since 2001," explains Tom Lloyd. "One of which was a higher class seat which was actually very expensive to develop. The original idea was to create something that accurately communicated the company's brand values. It soon became clear that this investment was having a direct impact on the airline's success. The perceived value of the seats was such that the airline no longer had to discount any of its fares on its main competitive routes. This resulted in the company making an extra £50 million a year in revenue."

Of course, these kinds of design decisions are inherently riskier than say, reducing the weight of an airline seat to reduce fuel costs, but when considering competitiveness the risk can at least be reduced by sound business sense. "£120 million invested in a chair might be a huge amount for one company, but for a big airline the risk is lower and the brand equity they're getting from that seat – even if they're not directly making a profit – is making them a stronger company for the future," says Aaron Moss.

One area of growing significance in manufacturing ignores the design of actual products altogether, looking instead to the services that surround them. While there are some examples of companies that have already embraced the development of services to obvious competitive advantage (such as Apple's iTunes, or Ford cars, who only make a profit at all thanks for after sales servicing), there are still many industries where this area is being ignored and companies are losing out to more service-oriented competitors as a result. "Services are a huge area for growth where the design industry can make a massive difference," says Alan South, chief innovation officer at Solarcentury and former head of IDEO Europe. "On the whole, it is quite hard to buy a lousy mobile phone; they are all generally pretty good. But how easy is it to buy a really delightful phone service from Vodafone or Orange?"

There are practical ways where design is already used to help improve service delivery, such as creating products that are easy to maintain or with parts that are straightforward and quick to replace. But at a more strategic level, design can be used to actually create the entire customer experience, breaking down the barriers between product and end user that can make a

huge difference to sales and overall competitiveness.

"Our trade is a good example," says Dan Farrell, design manager at Pashley Cycles. "We often feel there is a huge disconnect between our products and our customers, as we cannot control the bike shop experience. Our bikes have a very strong appeal for a very specific type of customer and it would be great to be able to offer a consistent Pashley experience, in service delivery as well as in the bikes themselves. A well-designed service, such as personal delivery and ongoing maintenance would give us a better route to our customers, as well as greater definition and competitiveness in the market."

Global competition is a constant and very real battle for manufacturers, particularly within the UK, where it can be a struggle to keep costs low enough to stand a chance against pressure from China and emerging markets elsewhere. Within this landscape, it is more important than ever to make the most of resources – including design – that can have a significant bearing on the many factors that either restrict or enhance a company's ability to compete effectively.

By operating a more integrated approach to design and using its insights and research to develop longer-term business strategies, manufacturers can help shape the products, services and processes that can address market competitiveness both now and into the future. ■

You can find out more about this subject and related issues on DesignTalks's website: [www.design-talks.com/electronics](http://www.design-talks.com/electronics)

# RECEIVE 2 FREE ISSUES by subscribing today



Subscribe today  
to enjoy 2 issues free

Save 16% on our cover price - subscribe now

UK: 0870 428 1426

International: +44 1795 414608

Web: [www.electronicsworld.co.uk](http://www.electronicsworld.co.uk)



# AVERAGE CURRENT ISN'T THE WHOLE STORY

In a large number of wireless sensor application the provision of a long battery life is of the utmost importance. Often, the wireless device is in an inaccessible location, without any external power sources nearby and the manpower cost of frequent battery replacement cycles would soon dominate the installation cost of the network.

Techniques used to achieve long battery life are well understood. Careful design of ancillary circuits reduces unnecessary leakage currents, while the dominant current drain of the radio circuits and associated

THERE IS ANOTHER CONSIDERATION THAT IS CONVENIENTLY GLOSSED OVER IN MANY DISCUSSIONS OF LOW POWER NETWORK DESIGNS; THE PEAK CURRENT OUTPUT OF LONG SHELF LIFE LITHIUM BATTERIES IS VERY LIMITED

microcontrollers is minimised by greatly reducing the duty cycle (off time vs on time). If the power hungry transceiver only sends a burst of (say) 12mS every minute, then its average current will only be 0.0002 times its operating current drain.

In this way, an average supply current of below 10uA can be easily designed for, leading to a theoretical battery live from even a small lithium cell measured in years. To consider a real-world application example, among the better single chip Zigbee solutions we can find a transceiver with 27mA 'on' current (TX or RX) and 0.5uA in 'sleep'.

Assuming the sensor network data throughput is low (temperature monitoring in commercial buildings for instance could only require a few bytes per hour from each sensor), then the network can operate in the slowest "BLE" mode – beacon synchronised, with the longest (n=14) 251 second cycle.

The sensor nodes, which only need to support minimal "end device" functionality, once synchronised will only be active for two burst periods, to receive the beacon transmission and to send their own transmit burst. Active time is therefore roughly 32mS in every 251 second frame, or a duty cycle of 1/7800. This resolves to an average current consumption per node of 3.4uA, plus any leakage or sleep mode current. Even allowing 0.6uA for these will still result in an impressive 4uA current drain. So, would a 180mA/hr lithium coin cell last five years? Unfortunately, no.

There is another consideration that is conveniently glossed over in many discussions of low power network designs and that is that the maximum (peak) current output of long shelf life lithium batteries is very limited; this is especially the case with the inexpensive lithium manganese dioxide coin and button cells.

The popular CR2032 coin cell (abused in many miniature LED torches) is only rated for a 3mA continuous current drain. Even 1/2AA lithium thionyl cells can be problematical (some parts are limited to as little as 6mA, others can deliver 40mA).

Adding large storage capacitors to take up the short term load is only a partial solution, as the necessary 'farad' rating parts can easily exceed the cost of the battery they are protecting.

Reducing the duty cycle of the radio components can only be taken so far, before the increase in wireless link data rate necessary to reduce burst length will result in an increase in the receiver circuit current (and the necessary transmit power to achieve a useful range at the higher rate) that will exceed the ability of small batteries to cope with the instantaneous drain.

Depending on the application, and the power source available, it is sometimes worth considering a lower data-rate architecture. Simple FSK radios with data rates in the order of a few kbit/s can be used



by Myk Dormer

with receivers drawing 10mA or less (narrowband VHF receivers have been realised that have a supply current of only 1mA at 3V). At these data rates, link sensitivities of better than -115dBm are common, compared to a typical -100dBm for a professional Zigbee radio, so transmit power can also be reduced.

Let us imagine the same sensor system as previously considered, re-designed around low data rate (3kbit/s) VHF radios:

- The same 250 second beacon synchronisation cycle will be retained;
- The transmit burst length increases to 25mS (64 bits plus preamble);
- RX current is 10mA (Radiometrix NRX1-173);
- TX current is 9mA (Radiometrix TX1-173);

So average current is  $(0.025 \times 2)/251 \times (10+9\text{mA}) = 3.8\text{uA}$ . But the peak current is reduced to 10mA.

By adopting the older, simpler radio link the average current remains unchanged, but the peak current falls markedly. If this is considered against a 2.4GHz radio of equivalent range to a 1mW VHF link the difference is even more extreme. A claimed 200m range Bluetooth unit can require over 250mA and even the long range 'professional' (+20dBm output) Zigbee modules draw up to 100mA.

Myk Dormer is Senior RF Design Engineer at Radiometrix Ltd [www.radiometrix.com](http://www.radiometrix.com)



Check out our website, 1,000s of items in stock.



PM3082 - £195



HP 34401A - £500 to £550



HP33120A - £575 to £700



HP 8563A - £6,000

## DIGITISING/STORAGE OSCILLOSCOPES

|   |        |
|---|--------|
| HP 54616B Digitising 500MHz 2GS/S 2 Channel.....  | £1,100 |
| TEKTRONIX TDS520 Digitising 500MHz 500MS/S 2 Channel.....                                       | £800   |
| TEKTRONIX TDS360 Digitising 200MHz 1GS/S 2 Channel.....   | £650   |
| TEKTRONIX 2232 Dual Trace 100MHz 100MS/S.....   | £325   |
| HP 54600B Dual Trace 100MHz 20MS/S with RS232; 2HP Probes, Ops Manual, Pouch & Front Cover..... | £325   |
| TEKTRONIX TDS224 Digitising 100MHz 4 Channel 1GS/S.....   | £750   |

## SCOPEMETERS

|  |      |
|--|------|
| FLUKE 97 Dual Trace 50MHz 25 MS/S..... | £295 |
|--|------|

## OSCILLOSCOPES

|  |      |
|--|------|
| TEKTRONIX 2465B 4 Channel 400MHz Delay Cursors etc Incl. Tek Probes..... | £750 |
| PHILIPS PM3082 2+2 Channels 100MHz Delay TB etc Autosec.....             | £195 |
| TEKTRONIX 2445A 4 Channel 150MHz Delay Sweep Cursor etc.....             | £375 |
| GOULD OS300 Dual Trace 20MHz.....  | £75  |
| PHILIPS PM3217 Dual Trace 50MHz Delay Sweep.....                         | £125 |
| FARNELL DTV11-14 Dual Trace 12MHz.....                                   | £40  |
| TEKTRONIX P6139A 100MHz Probes - Unused.....                             | £140 |

## STEWART of READING

17A King Street, Mortimer, Near Reading RG7 3RS  
 Telephone: (0118) 933 1111  
 Fax: (0118) 933 2375  
 www.stewart-of-reading.co.uk  
 9am-5.00pm Monday to Friday



MARCONI 2024 - £1,250 to £1,500

## SPECTRUM ANALYSERS

|  |        |
|--|--------|
| HP 8563A 9KHZ-22GHZ Synthesised.....               | £6,000 |
| HP 8560A 50HZ-2.9GHZ Synthesised Various opts..... | £3,200 |
| HP 8590A 10KHZ-1.5GHZ.....                         | £1,400 |
| HP 3580A 5HZ-50KHZ.....                            | £295   |
| ADVANTEST TR4132 100KHZ-1000MHZ.....               | £750   |

## SIGNAL GENERATORS

|   |           |
|---|-----------|
| HP 83731A Synthesised 1-20GHZ.....  | £5,000    |
| Marconi 2032 Sig Gen. 10KHZ-5.4GHZ Opt 01/02/06 - Avionics.....             | £3,250    |
| HP 8648A Sig Gen 0.1-1000MHZ.....   | £750      |
| Gigatronix 7100 Synth 10MHz-20GHz (internal sweep/mod - 130 to +150BM)..... | £3,000    |
| Marconi 2024 9KHZ-2.4GHZ - HP/IB used/unused.....                           | £1,500    |
| Marconi 2022E Synthesised AM/FM 10KHZ-1.01GHZ.....                          | £500      |
| Marconi 2019A Synthesised AM/FM 80KHZ-1040MHZ.....                          | £1,250    |
| HP 33120A Function Gen. 100 microHZ-15MHz used/unused.....                  | £575-£700 |
| T.T.I TG210 Function Gen 0.002HZ-2MHz TTL etc.....                          | £70       |
| RAS APN02 Synth Function Gen 1HZ-260KHZ Bal/Unbal Output LCD.....           | £195      |
| Metric GX5000 Pulse Gen 50MHz Programmable.....                             | £150      |
| HP 3325A Synthesised Function Gen 21MHz.....                                | £295      |

|   |         |
|---|---------|
| HP 3312A Function Gen 0.1HZ-13MHz AM/FM Sweep/TH/Burst etc..... | £175    |
| HP 8112A Pulse Gen 50MHz.....                                   | £350    |
| HP 8116 Pulse/Function Gen 50MHz.....                           | £750    |
| Gould J3B Sine/Sq Osc. 10HZ-100KHZ Low Distortion.....          | £50-£75 |

## FREQUENCY COUNTER/TIMERS

|  |           |
|--|-----------|
| HP 5350B Counter 20 GHz.....   | £750      |
| Marconi 2440 Counter 20 GHz.....   | £500      |
| Racal 1998 Counter 10HZ-1.3GHz.....  | £225      |
| Racal 1991 Counter/Timer 160MHz 9 Digit.....                                 | £150      |
| HP 53131A Universal Counter 3GHz Opt. 001 oven unused/used.....              | £995/£750 |
| HP 53131A Universal Counter 225MHz Oven-In original boxes - unused/used..... | £700/£600 |

## DIGITAL MULTIMETERS

|  |           |
|--|-----------|
| HP/Agilent 34401A 6 1/2 Digit.....   | £500/£550 |
| Solartron 7150Plus 6 1/2 Digit True RMS IEEE with term measurement.....            | £75       |
| Fluke 77 series 2 3 1/2 Digit Handheld.....  | £45       |
| AVO 8 Mk5 In Ever Ready Case with Leads etc.....                                   | £75       |
| AVO 8 Mk5 with Leads etc.....  | £50       |
| Goodwill GVT427 Dual Ch AC Millivoltmeter 10mV in 12 ranges 10HZ-1MHz. Unused..... | £60       |

## MISCELLANEOUS

|  |        |
|--|--------|
| MARCONI 2955A Radio Communications Test Set.....                         | £1,000 |
| MARCONI 2955 Radio Communications Test Set.....                          | £625   |
| MARCONI 8960B RF Power Meter with head.....                              | £500   |
| MARCONI 893C AF Power Meter Sine Measurement Unused.....                 | £50    |
| HP 4192A Impedance Analyser with 16047A Text Fixture etc.....            | £3,500 |
| HP 8902A Measuring Receiver 150KHZ-1300MHZ.....                          | £4,500 |
| HP 85032A Calibration Kits.....  | £400   |
| SEAWARD Nova Pat Tester.....   | £195   |
| BIRD 43 Wattmeter - Many Elements Available.....                         | £75    |
| HUNTRON 1000 Tracker.....  | £75    |
| RACAL DANA 9343M LCR Oxtabridge Digital Auto Measurements of RCL QD..... | £95    |
| RACAL 8008 Automatic Modulation Meter 1.5MHz-2GHz.....                   | £90    |
| MEGGER PAT2 Tester.....  | £95    |

## POWER SUPPLIES

|  |      |
|--|------|
| FARNELL AP60/50 0-60V 0-50A 1KW Switch Mode.....   | £400 |
| FARNELL H60/250-60V 0-25A.....   | £400 |
| THURLBY PL320QMD 0-30V 0-2A Twice Digital.....   | £160 |
| H.P. 6626A Precision High Resolution 4 Outputs 0-7V 0-15mA or 0-50V 0-0.5A Twice 0-16V 0-0.2A or 0-50V 0-2A Twice..... | £500 |
| FARNELL XA35.2T 0-35V 0-2A Twice Digital.....  | £95  |
| FARNELL L330/10.30V 10A Variable No Meters.....  | £55  |
| FARNELL LT30-10-30 0-1A Twice.....   | £60  |
| FARNELL L30.2 0-30V 0-2A.....  | £50  |
| THURLBY PL330 0-32V 0-3A Digital (Kenwood badged).....   | £75  |
| THURLBY PL320 0-30V 0-2A Digital.....  | £65  |
| TAKASAGO GM035-2 0-35V 0-2A 2 Meters.....  | £35  |

## Used Equipment - GUARANTEED.

Most Manuals supplied  
 Please check availability before ordering or calling.  
 Prices plus carriage and VAT

# PCB-POOL®

SERVICING YOUR COMPLETE PROTOTYPE NEEDS

## 1 EUROCARD

- (160 x 100 mm)
- + Tooling
- + Photoplots
- + VAT

**€49**

Price example  
 Any size and contour possible!

## Optional:

- Soldermask
- Fast-turnaround
- Silkscreen
- 4-Layer Multilayer
- 6-Layer Multilayer

DOWNLOAD OUR  
 FREE LAYOUT SOFTWARE!



Freephone  
 0800-3898560

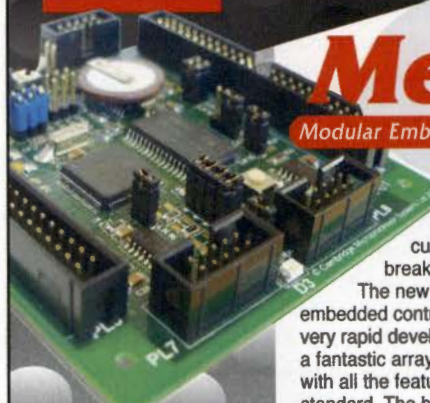
TEL: +353 (0)61 701170  
 FAX: +353 (0)61 701165  
 pcb\_pool@stetnet-ireland.com



Simply send your files  
 and order ONLINE:

**PCB-POOL.COM**

# HIGH PERFORMANCE LOW PRICE TAG



## Mesh8 Modular Embedded Systems H8

We've responded big-time to demand from our customer base with another breakthrough product.

The new Mesh8 board is the latest embedded controller that encourages very rapid development. We supply it with a fantastic array of development tools with all the features engineers expect as standard. The board has shed loads of I/O along with professional tools for fast development and easy expansion. It's got to be the best value for money in the market today. You'd call it a steal at the price, we call it Mesh8.

For more details go to:  
[www.aitch8.co.uk](http://www.aitch8.co.uk)

UK Distributors  
**CAMBRIDGE  
 MICROPROCESSOR  
 SYSTEMS LIMITED**

Unit 17 Zone 'D' Chelmsford Road Industrial Estate,  
 Great Dunmow, Essex UK CM6 1XG





**HAL PHILIPP**, FORMER CEO OF QUANTUM RESEARCH GROUP AND NOW CHIEF TECHNOLOGY OFFICER OF THE CAPACITIVE SENSE DIVISION AT ATMEL (AS ATMEL ACQUIRED QUANTUM THIS YEAR) DISCUSSES THE EVOLVING WORLD OF TOUCH SCREEN TECHNOLOGY

## CAN TOUCH THIS

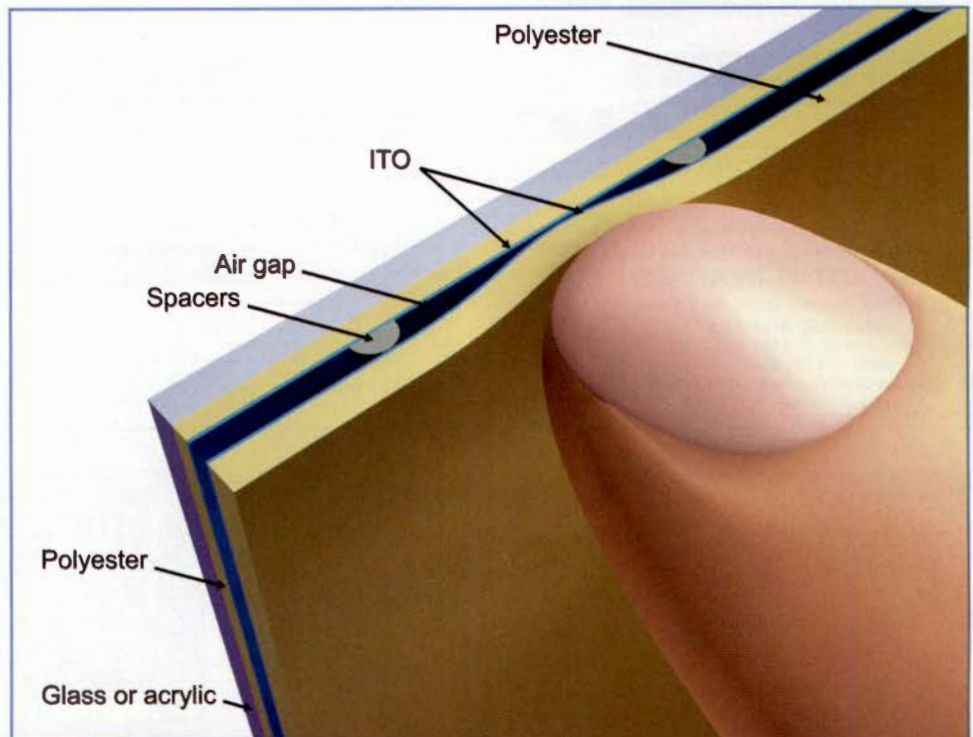
**W**e've probably all had the experience of repeatedly pressing a touch screen, applying ever more pressure, in the hope that our touch would register. Early resistive touch-screen technologies were deeply flawed, subject to a variety of wearout mechanisms and environmentally unstable. That has all changed.

Today, well-designed touch screens are a joy to use. The technology underpins creative, attractive and easy-to-use human interfaces. Such interfaces are easily modified and updated to accommodate new features or system functionality. Design changes in response to changing consumer demands are just a matter of software changes. Most importantly, the latest touch screens operate reliably and robustly, even in RF-polluted environments.

While the iPhone may be the most high profile mobile device to adopt a touch screen, some 60 other models of cellular phone will adopt the technology this year, with over 100 arriving in 2009. So pervasive will touch screens become on mobile phones that we expect to see around 500 million units with them by 2012. In the meantime, even low-end models will increase their use of touch buttons, sliders and wheels.

Mobile phones are just one application of course – PDAs, PCs, GPS systems and domestic appliances are just a few of the others where touch screen technology is making rapid inroads.

Five main types of touch screen technologies are found in electrical and electronic appliances: resistive, surface capacitive, projected capacitive, surface acoustic wave and infrared. Of these, the first three are suitable for mobile devices and consumer electronics. The others are too expensive or bulky to be useful in these applications. In all cases, the systems



*Figure 1: Resistive screens are cheap but suffer many design limitations*

consist of a sensing mechanism, interconnection to the electronic control circuit and the control circuit itself.

### Resistive Screens

Resistive screens (**Figure 1**) are perhaps not technically "touch" screens at all, because they require some degree of force to activate them, unlike true touch interfaces, some of which can even be activated by the proximity of a finger.

Resistive screens are designed using a sandwich of two layers of conductive indium tin oxide (ITO) printed onto a plastic (PET) film with an air gap in between. The gap is maintained by a series of tiny spacers. Contact is made when the two conductive layers are

pressed together with a finger or a stylus, and the location of the touch is detected by measuring a voltage ratio in the X- and then Y-axis.

There are four, five, six and eight-wire versions that feed data to a microcontroller for processing. The technology is cheap and has been widely adopted for high volume applications. However, universal acceptance has been limited by the inherent disadvantages of the technology. These include mechanical weakness, limited industrial design options, the need for a bezel in most applications, the thickness of the touch screen, poor optical performance and the need for user calibration.

Proximity detection – detecting a finger



approaching the screen – and multi-finger detection are not possible using this technology. Both of these options are now in demand by product designers.

### Surface Capacitive Screens

Surface capacitive screens (**Figure 2**) use a plain layer of ITO with a metallised border pattern. The electric field is approximately linearised across the ITO and when a finger touches the screen it bleeds charge from the panel. Sensing is done from the four corners and no sophisticated ITO pattern is needed.

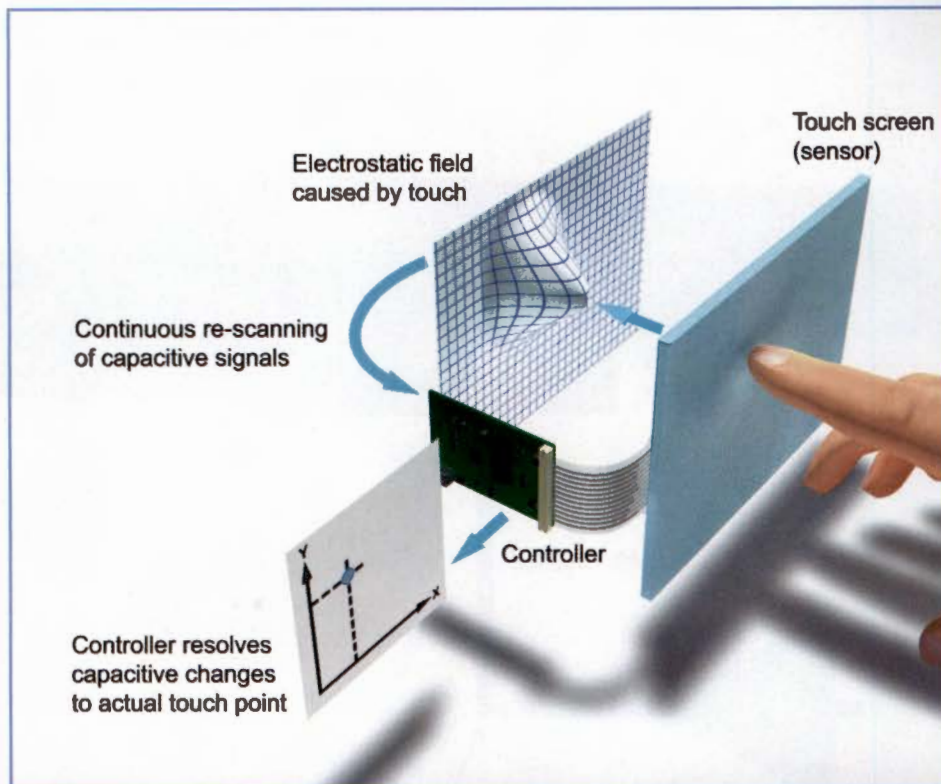
The most notable instance of this type of screen was devised by William Pepper, who filed for a patent on his pattern in 1978. This pattern formed the basis of capacitive products sold by Microtouch (now 3M).

Attempts to use surface capacitive technology behind a panel always meet up with the 'hand-shadow effect', a phenomenon that causes large sensing errors due to the capacitive coupling of the user's hand and wrist being near the panel, at quite random angles and distances. Because surface capacitive screens are homogeneous layers, they cannot suppress these erroneous signals, as they are convolved in three signal dimensions with the actual touch signal. Without structuring the ITO into rows and columns, attempts to use surface capacitive on the back of panels are certain to fail.

### Projected Capacitive Screens

Projected capacitive touch is the technology that is driving the uptake of touch screens in consumer electronics. It requires one or more carefully designed, etched ITO layers but offers a host of technical advantages over other approaches.

The ITO is etched to form multiple horizontal and vertical electrodes that are all driven by a capacitive sensing chip; the chip in turn can either offload the data to a host processor, or the chip can process the XY location of touch itself. Usually both the electrode sets are driven using single-ended sensing methods, i.e. there is nothing unique about the circuitry for a row versus a column; we refer to this as 'single ended' sensing. In some methods however, one axis is driven using a set of AC signals and the response through the



**Figure 2:** The plain ITO sensor electrode on a surface capacitive touch screen is prone to damage and cannot suppress false triggering due to hand-shadow effects

screen is detected back via the other axis electrodes. We refer to this as 'transverse' sensing because the electric fields propagate in a transverse manner from one electrode set (e.g. rows) to the other set (e.g. columns) via the dielectric of the overlying panel.

In either case, position is ascertained by measuring the distribution of the change in signals among the X and Y electrodes; mathematical algorithms are then used to determine XY co-ordinates of the touch event by processing these changed signal levels. Resolutions up to 1024 x 1024 through up to 5mm thick panels have been demonstrated in such touch screen implementations.

One notable problem with capacitive touch screens is that the LCD itself is very close to the ITO elements, if not in fact bonded together in an air-free stack-up. It invariably emits large amounts of electrical noise due to its constant scanning of pixels. This noise, which can range up to 20kHz, requires in almost all cases that there be a shield layer between the ITO sensing electrodes and the LCD module. This implies that it is usually necessary to have 3 ITO layers: two for

the XY sensing matrix and one to be used as a shield, which means added cost and reduced transparency.

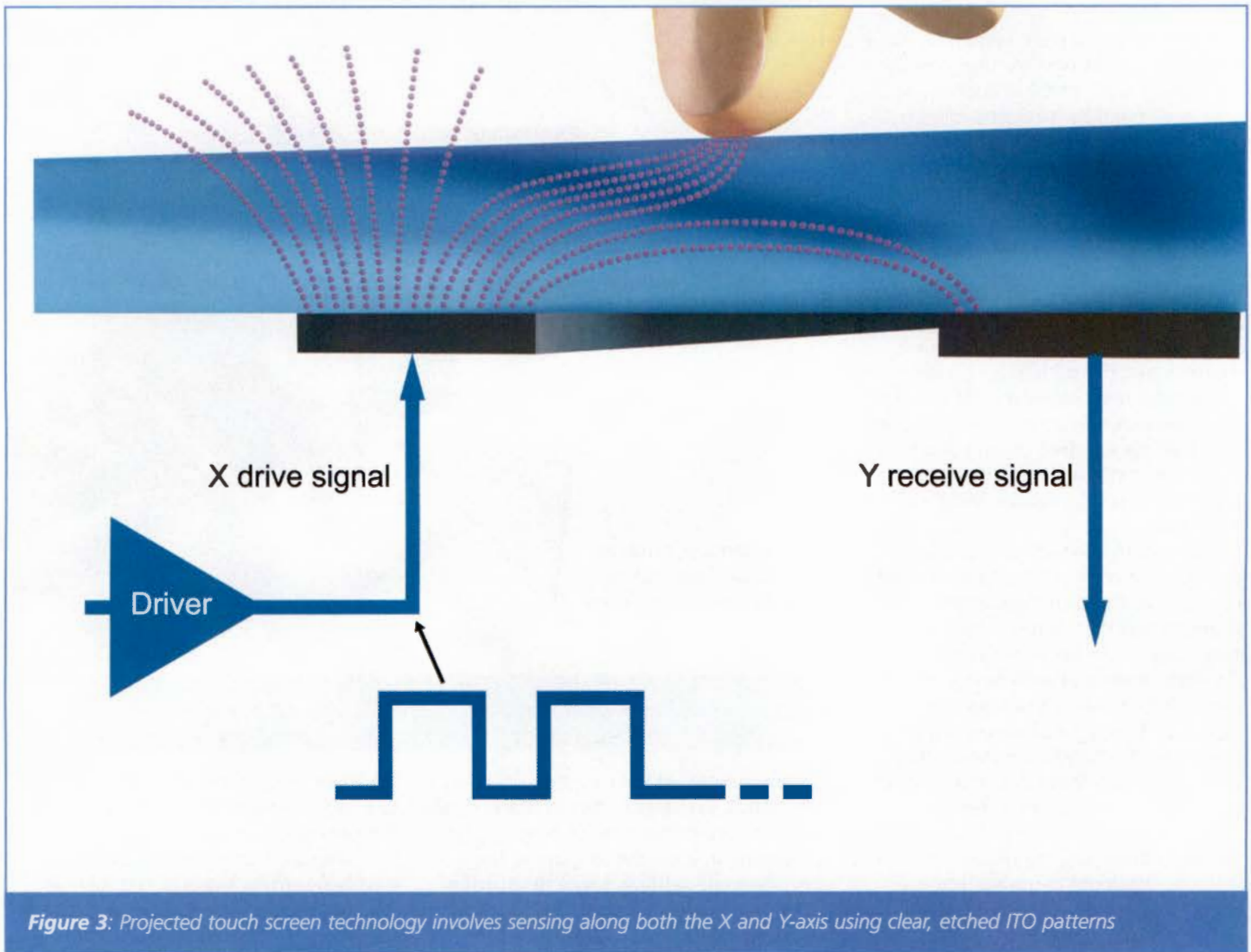
As a result, most suppliers employ at least two sensing layers of ITO, plus a shield layer to achieve noise-free operation; although it is notable that Quantum Research Group has now developed a unique, single layer projected XY matrix design that does not require a shield layer and which will become publicly available later in 2008. This design is already in production in three phones from a major mobile manufacturer.

Where a single layer of ITO can be used, costs are substantially lower, the layer stack-up thickness reduced, transparency improved and backlighting power requirements reduced. Importantly, manufacturability is also dramatically improved with single layer technology.

### Multi-Touch

Another hot topic is 'multi-touch', which is the ability to sense more than one detection at a time, made popular due to the incorporation of this feature in Apple's iPhone. Surface capacitive screens cannot





discern more than one touch at a time, because they use a homogenous sensing layer that blends all signals anywhere on the screen into one merely bigger signal; homogeneous layers destroy too much information to be able to report more than a single touch.

However, two-layer projected capacitive screens can discern two touches, although the single-ended variants cannot sufficiently differentiate between the two touches to be able to track them individually across a screen. A third sensing layer can resolve the remaining ambiguity, but at a significantly higher price. Two-layer projected capacitive screens using transverse sensing can, in theory, discern two or even more touches with perfect clarity, tracking each touch independently as it moves across a screen.

Projected capacitance screens, unlike resistive and surface capacitive screens, do

not require calibration by the user or often, not even in the factory because the structure of the electrodes largely defines the screen response and these are fixed. Homogenous screen technologies need substantial compensation, often repeatedly, because their surface resistances can become degraded and non-uniform over time.

**Right Basic Technology**

Creating an attractive, functionally reliable and rugged touch-screen based on projected capacitance technology involves selecting the right basic technology and a vendor who can deliver it. Some suppliers offer turnkey solutions consisting of a controller and a touch screen sensing element, often integrated together. Others will offer a chip solution and assist in the design and selection process of the ITO film.

The choice of supply chain involves many tradeoffs in this developing market that transcend the underlying technology. Key among these issues is the ability to multi-source the films, manufacturability and quality control and testing. Even the final process step, laminating the film into the end product, needs to be carefully through as this critical step is where many failures are introduced due to the stresses and in accuracies of the lamination process.

Projected capacitance touch-screens are here to stay. The technology solves many problems associated with the prior methods and is now available from at least two chip vendors. Selection of a suitable vendor will depend on the technical needs of the design, as well as cost and supply chain management issues, which are only now beginning to emerge as significant factors. ■



**MARIO KLEIN,**  
PRODUCT MARKETING  
AUTOMOTIVE LCD AND  
**LAURENT DEN  
HOLLANDER,** PRODUCT  
MARKETING FOR LSI AT  
SHARP  
MICROELECTRONICS  
EUROPE EXPLAIN HOW  
SPECIAL DISPLAYS MAKE  
SITUATION-BASED  
INFORMATION SYSTEMS  
IN VEHICLES POSSIBLE

Innovative TFT displays are important key components for situation-relevant driver information and in-car infotainment systems as they allow more flexibility and new functions in the design of modern vehicle interior and safety concepts.

Conventional instruments are unable to provide situation-based driver information e.g. speed, fuel level and hazard warnings. The information needs of front and rear passengers are normally different to those of the drivers'. TFT displays provide a solution for displaying information that is relevant to the actual driving situation. These liquid crystal screens offer a level of quality, flexibility and a range of design unmatched by virtually any other type of display.

TFTs are available in almost any size. Generally speaking, where TFT panels are used in vehicles they have to satisfy special requirements in terms of temperature resistance and mechanical load capacity through vibration. What is more, the latest trend in automotive displays is towards LED backlighting, which has better starting properties than conventional CCFL backlighting, particularly at low external temperatures and is more resistant to vibration and impacts.

But not every automotive LCD is suitable for every type of automotive application: the specific requirements vary depending on whether the TFTs are being used as an Instrument Cluster Display (ICD), Central Information Display (CID) or a Rear Seat Entertainment Display (RSE Display).

# SITUATION-BASED INFORMATION SYSTEMS



Displays also have to satisfy particular requirements when used in conjunction with Portable Navigation Devices (PNDs).

## High Contrast for Cluster Displays

Vehicle interior designers attach particular importance to consistency of appearance for fittings. Customers of prestige vehicles in particular do not accept any inconsistency in the background colour of displays and settings. TFT LCDs for the instruments cluster area must therefore have very high contrast values of well over 500:1. An improved colour filter and polarisers have enabled Sharp to increase the contrast of its high-contrast TFT LCDs for the dashboard area to up to 2500:1. In addition, Sharp uses a proprietary Automotive ASV technology for a special alignment of liquid crystal molecules to ensure that the high contrast values are not only visible from the main viewing angle, but also through a wide viewing angle of up to 176°. The black level optimised with

high contrast technology not only allows a seamless design-in of displays in the dashboard area, which are often matt black in colour, but also ensures clear representation of the full spectrum of colours, even in bright ambient light.

Instrument cluster LCDs (ICD) must also have extremely short reaction times as it is essential that the relevant driver information, in particular warning flashes, is displayed immediately. The displays offered by Sharp for cluster applications have optimised pixel switching times and are therefore among the fastest-reacting automotive TFTs currently available.

## System Driver LCDs

The limited amount space available in the fittings area presents a further challenge for developers of instrument cluster displays. In today's cars small cluster displays with 3.5-inch screens are wedged in between round analogue instruments. In the future, larger wide-screen displays with a screen size of



about 12 inch will occupy the whole fittings area and instruments with points will probably be phased out altogether. Owing to the limited space available the question remains: where do you put the control devices for the displays? Sharp's solution consists of System Driver LCDs. In this type of display the simple gate and source drivers attached directly to the LCD glass. But that's not all; these displays also feature integrated power supplies and timing generators, which allows relatively compact and economical construction. In addition, these displays require much fewer components and, in turn, costs are reduced.

## Infotainment for Passengers

Central Information Displays are playing an increasingly important role as central control units in modern vehicle designs. A screen embedded in the central console is already standard in many prestige vehicles, as a display and control unit for navigation and comfort systems (e.g. ventilation and airconditioning systems), mobile telephone and audio systems. This development will also be extended to medium-class vehicles at some point.

Unlike Information Cluster Displays, driver and front passenger CIDs not only have to look good, they also have to be easy to operate. This means that they need an extremely wide viewing angle.

Wide-screen formats are becoming increasingly prevalent in central information screens. They are best suited for providing intuitive menu prompts for controlling various electronic functions. Operating controls on the edges of the displays can be equipped with various functions displayed at the side of the screen, depending on the menu level. Alternatively, operating controls can also be provided by means of touch-screen functionality. In any case, there is still enough space in the middle of the screen of wide-screen displays to display information about the respective system, e.g. navigation, HiFi or mobile telephone.

## Individual Infotainment

Sharp is also taking another major step forward in the development of systems for displaying situation-relevant information. Drivers as well as front and rear passengers can use the newly developed triple directional viewing LCD to individually follow their own personal in-car infotainment programme, all at the same time and on the same screen.

### Technology innovation:

ASV (Advanced Super View) (transmissive wide viewing technology),  
High contrast: >2500:1  
Improvement of pixel design, color filter and polarizer



Conventional LCD  
(CR=500:1)



High Contrast LCD  
(CR>2500:1)

## High Contrast Technology for Instrument Clusters



A special film mounted as a parallax barrier with new geometry on standard automotive TFT LCDs directs the backlight in three different directions: left, right and forwards. The three images are displayed at the same time in alternating pixel columns and the parallax barrier selectively blocks pixels from view depending on the viewing angle. This means that the driver can use the display for the navigation system, while the front and rear passengers can watch television or surf the Internet at the same time, on the same screen. Despite the static strip mask, triple directional viewing LCDs can also be used as conventional displays with a wide viewing angle. To achieve this, it is only necessary to supply the same visual content for all viewing angles.

Further developments are being worked on at present in order to improve the visual separation of the display contents so that it will be possible to offer multiple viewing TFT LCDs that comply with strict European

safety regulations. These stipulate that the front passenger's entertainment programme must be hidden from the driver at all times, so that the latter does not become distracted.

## Navigation "To Go"

Unlike the CIDs embedded in the console, displays for portable navigation systems must meet the requirements for automotive displays and the conditions for portable consumer electronic devices, i.e. in addition to the robustness required for automotive use, rapidly changing light conditions are a particular challenge for PND legibility. This is because, unlike permanently installed navigation systems, the displays of portable navigation systems are not protected against bright ambient light.

Sharp is meeting this challenge with its transfective display technology, in which a small percentage of structures inside the displays – mainly passive elements such as





Individual in-car infotainment

strip conductors and transistors not used for imaging – are coated with reflective microstructures. This means that the display remains easily legible even in direct sunlight. In a dark environment, on the other hand, the backlight ensures the necessary brightness.

The second important aspect of PND displays is the touch-screen functionality. The screen is also an operating control in nearly all portable navigation systems. Sharp offers displays with screen diagonals from around 3.5 inches to some 4.3 inches to satisfy the special requirements of PNDs.

#### CCD Modules – the Digital Eyes

TFT liquid crystal displays are not just the basis of modern driver information and entertainment systems. Their flexibility in the situation-relevant display of information paves the way for innovative driver assistance and passive safety concepts. Warning messages can be flashed onto the screen in an easily visible way if barriers appear from the blind spot when the vehicle changes lanes or turns. The Information Cluster Display can also act as a monitor for a rear view camera during parking.

CCD cameras are an ideal solution for automotive requirements as “eyes” for viewing what is happening around the vehicle. Unlike conventional distance sensors, cameras give the

driver an exact picture of the respective situation via the LCD in order to be able to assess it more accurately and react accordingly. As compact modules with an edge length of only a few millimetres, CCD cameras can be easily integrated into side mirrors or the rear windscreen frame, for example.

There are modules with a viewing angle of up to 130° and a high light sensitivity of 1500mV for these types of applications. Such CCD modules also provide a clear view of the situation even in poor light conditions, such as in dark multi-storey car parks or on roads at night.

#### Interesting Applications

The TFT displays designed for automotive applications always function better as key components for innovative vehicle interior and safety concepts. They therefore also encourage the integration of other electronic components, such as camera modules as digital “eyes” of driver assistance systems or distance measurement sensors as contactless switches in the cockpit.

Technologies such as the triple directional viewing LCDs and high contrast LCDs are giving automotive manufacturers new opportunities for product differentiation and will further boost demand for navigation and entertainment systems. ■



## In your complex world ...

... only Keithley delivers an intuitive, integrated, one-box solution for DC I-V, pulse, and C-V characterization



MODEL 4200-SCS SEMICONDUCTOR PARAMETER ANALYZER WITH INTEGRATED C-V OPTION

- Integrate multiple test types easily into a single automated test sequence.
- Save time with our extensive C-V test library and built-in parameter extractions.
- Get your system up and running quickly and simply with turnkey application packages.
- Don't get stuck with obsolete hardware – get a system engineered to grow with you as your test requirements evolve.

Go to [www.keithley.com/one](http://www.keithley.com/one) and try a demo.

**KEITHLEY**

[www.keithley.com/contact](http://www.keithley.com/contact)  
info@keithley.de



# INTELLIGENT VEHICLE LIGHT MANAGEMENT

In new cars an intelligent interior and exterior light management is a differentiating argument for car OEMs. Moreover, conventional bulbs are increasingly replaced with light emitting diodes (LEDs), which provide an extended life time, less power consumption and a more flexible design of light elements.

Most of the lights require brightness control, which means that the brightness can be adapted depending on their assignment. Examples are the ambience light in a passenger compartment while driving at night or re-use of a back light as brake light or as flashing indicator. For an efficient brightness control the lights are supplied by pulse width modulated (PWM) signals. Variations of the battery voltage negatively impact the brightness. Continuous measurement of the battery voltage and updating the duty cycles of the PWM signals accordingly maintain a constant brightness. To avoid high current peaks due to simultaneous switching of PWM signals the signals have to be phase shifted.

**PETER ABERL WHO IS AN APPLICATIONS ENGINEER IN THE AUTOMOTIVE ELECTRONICS AREA AT TEXAS INSTRUMENTS AND RALF ECKHARDT, WHO IS TECHNICAL TEAM LEADER IN THE AREA OF ELECTRONIC BRAKING SYSTEMS AND COMFORT ELECTRONICS, EXPLAIN THE SUITABILITY OF AN MCU FOR CONTROLLING LED-TYPE LIGHTING IN A VEHICLE**

With the increasing number of light sources the probability of malfunction is also increasing and the localisation of such errors can become a time-consuming effort at a repair shop. Therefore, all active lights have to be continuously monitored regarding open or short circuit. A reliable diagnosis is only feasible during the active phase of the PWM signal.

## Choosing the Right MCU

An intelligent light management demands a powerful microcontroller (MCU) that is able to generate a multitude of phase shifted PWM signals with efficient brightness control and allowing a reliable and fast diagnosis of all light sources.

Modern intelligent light management applications have to control many loads like light emitting diodes (LED) or conventional bulbs interior or exterior of the car. LEDs are often organised in a matrix, for example for a backlight or a brake light of a car. Several LEDs can be serially connected in a channel and multiple channels need to be controlled by the ECU (electronic control unit).





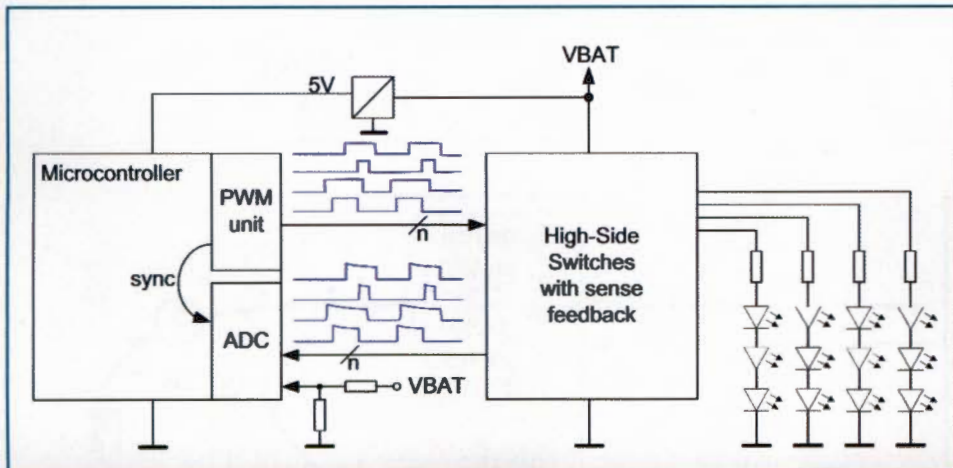


Figure 1: System block diagram – PWM controlled loads with diagnosis

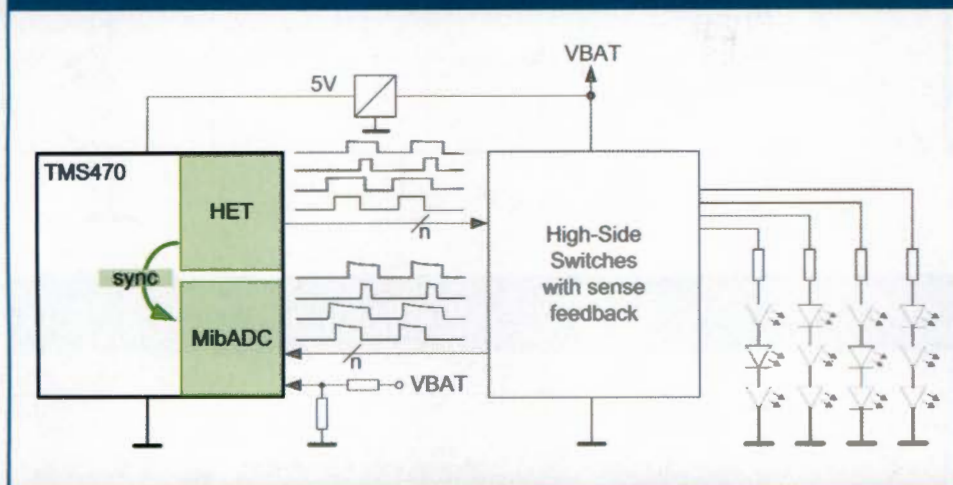


Figure 2: TMS470-based system model block diagram

Figure 1 shows the system block diagram of such an intelligent light management application, which in its basic function consists of two blocks, the microcontroller and the output drivers. The microcontroller incorporates a timer unit, generating PWM signals to drive the light elements and an ADC for diagnosis purpose. Depending on the complexity of the application, a flexible number of PWM signals are required to drive multiple channels. Each channel is controlled by a high side driver, and a current shunt provides a sense feedback of each channel current to the ADC.

The ADC measures a voltage that is proportional to the current of the load channel, which is required for diagnosis and monitors the supply voltage of the battery. In addition, a synchronisation possibility between timer and ADC is required, to measure the load current during the active

phase of the corresponding PWM channel to get a valid result. Without hardware synchronisation means between PWM unit and ADC, the CPU would need to perform the synchronisation task. This can become a very difficult and run-time consuming task in order to fulfill given real-time constraints of the dynamic sense signals.

PWM-based signals have the disadvantage of increased electro-magnetic emissions due to high current peaks when multiple loads are concurrently switched on or off. Therefore, the timer should provide phase shifted PWMs, to avoid current spikes and so to reduce EMI.

To ensure a constant brightness the variation of the battery voltage has to be compensated by closely monitoring the battery voltage. The duty cycle of the PWMs has to be adapted such that the channel current and hence the LED brightness remains constant.

### Phase Shifted PWMs

As discussed above, the brightness of bulbs and LEDs are controlled by pulse width modulated signals. The microcontroller has incorporated a timing module that can generate a number of PWM signals with no or low intervention of the host CPU. To control loads like bulbs and LEDs the PWM signals need to fulfill following requirements:

- The typical frequency to drive bulbs is 100Hz and to drive LEDs is 200Hz.
- The duty cycle of the PWM signals can vary from 0% (off) to 100% (maximum brightness), whereas the duty cycle during nominal operating conditions is in the range of 30% to 70%. This gives enough head room to compensate for varying operating conditions, like reduced battery voltage.

- The duty cycle resolution shall be in the range of 0.1% to 1% of the PWM period.

- The number of PWM signals can be high (e.g. 30 signals) and, hence, the load current gradient would be rather high if all PWM signals would switch on loads simultaneously. These current peaks could cause voltage spikes at the supply lines and, hence, would increase electro-magnetic radiations. Therefore, it is necessary to add individual phase shifts to the PWM signals. The individual phases of the PWM signals should be evenly distributed across a large portion of one PWM period.

Another important requirement is the way the duty cycle can be updated by the host software. Only a synchronous duty cycle update ensures flicker-free brightness control. An asynchronous duty cycle update could cause an unsteady PWM period during duty cycle transition.

Figure 2 shows a dedicated system block diagram based on the TMS470PLFx12 microcontroller. The TMS470PLFx12 is a family of 5V microcontrollers which are based on the 16-/32-bit ARM7TDMI CPU and are equipped with a comprehensive set of smart peripherals. The PWM unit is realised by the timing co-processor HET and the ADC task is performed by the MibADC.

The HET consists of a micro machine that operates a reduced instruction set that is optimised for timing tasks. It can manage up to 32 timing channels, whereas each timing channel can be freely programmed as PWM output, input capture or other timing function.

The HET executes its program once every loop period, whereas a loop period is a configurable but constant time span. The



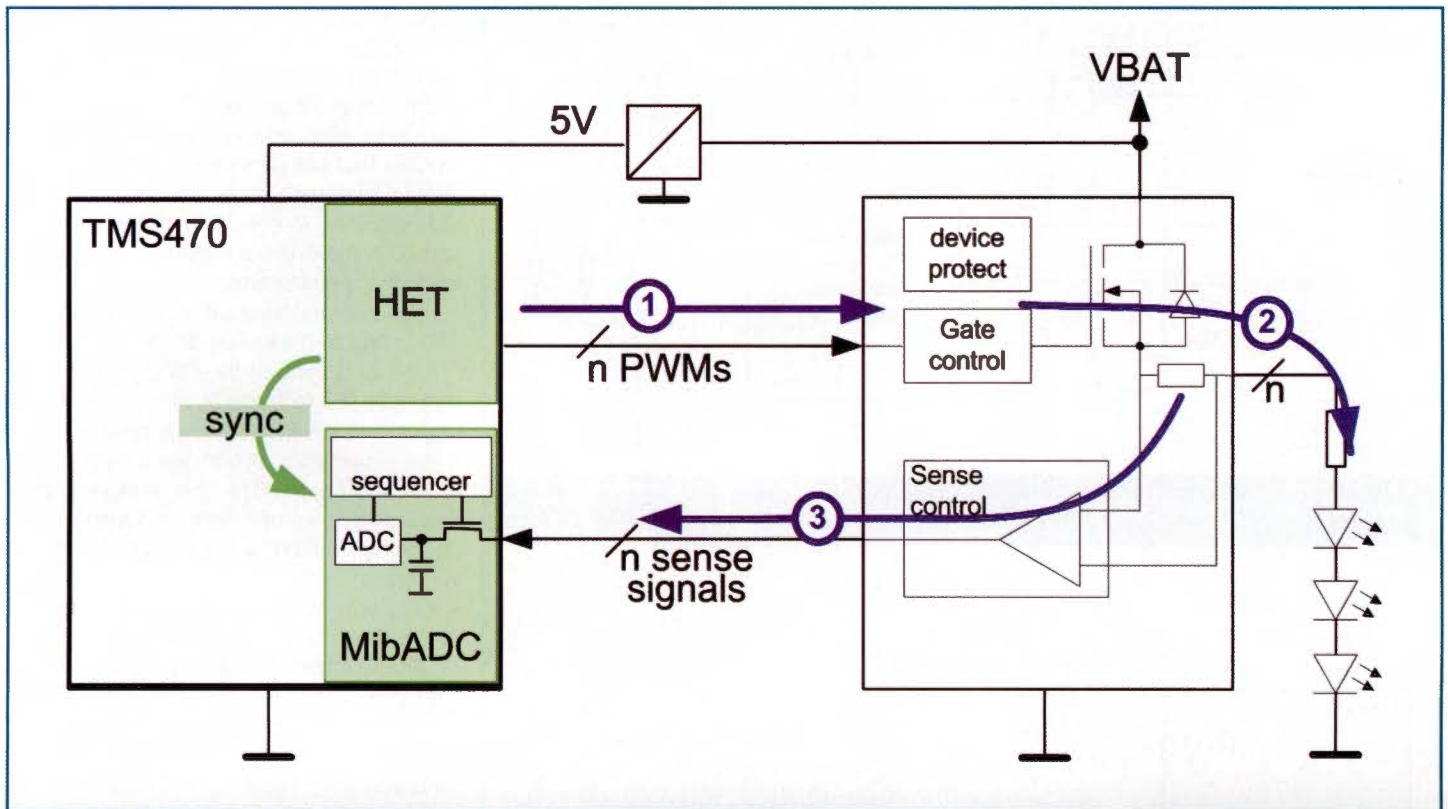


Figure 4: System timings to be considered for MibADC synchronisation signals

HET instructions are executed one after the other and conditional branches can cause a varying execution time. In order to de-couple the real-time behaviour of the PWM signals from the execution time and jitter of the corresponding instructions, the pin actions are delayed to the subsequent loop.

To increase the timing resolution beyond loop periods 5-bit hardware counters are implemented at the HET pins, which divide a loop period into 32 ( $= 2^5$ ) equidistant steps. The HET program selects at what step during the subsequent loop period the signal edge shall occur.

For the light control, accurate PWM signals with phase-shift are necessary. How this can be achieved with the HET is described below based on an example with two PWMs. The HET source code is shown in **Figure 3**.

A simple PWM signal can be implemented with one count (CNT) instruction and one equality-compare (ECMP) instruction. CNT counts to the maximum value, as defined by the parameter "max", and subsequently restarts at zero. ECMP compares the

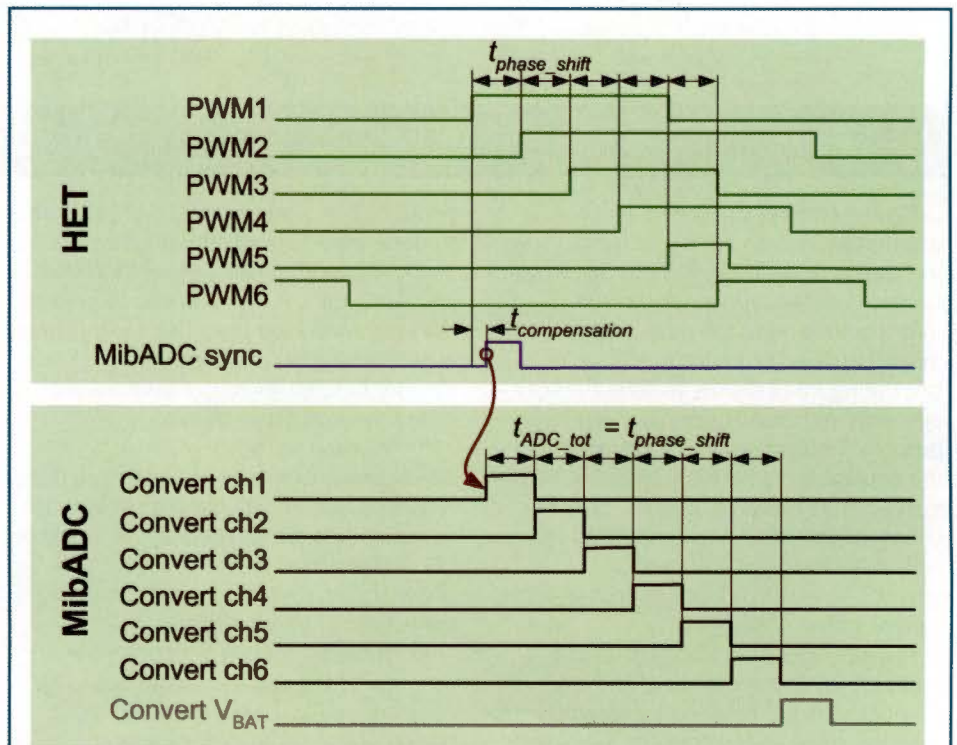


Figure 5: Matched PWM phase shift and total conversion time



actual count value of CNT with a reference value stored in the parameters "data" and "hr\_data". When the compare matches, then a pin action is enabled according to the parameters "pin" and "action". Every time when CNT restarts at zero an opposite pin action is enabled by ECMP. CNT defines the PWM period as a multiple of the HET loop period and ECMP defines the duty cycle, the timing channel number and the pulse polarity.

The duty cycle of each PWM signal could be changed by directly updating the parameters of the ECMP instruction. This would be an asynchronous update and could lead to an unsteady PWM period during transition from the actual to the new duty cycle. This temporary unsteady state could cause a recognisable flicker. The MOV32 instruction enables a synchronous duty cycle update. MOV32 copies its own data and hr\_data values to the data and hr\_data field at the remote address (see parameter "remote"), which is the corresponding ECMP instruction. MOV32 is only executed when the compare of ECMP matches, i.e. only once per PWM period right after the pin action has been enabled. This ensures steady and hence flicker free update of the duty cycle.

To achieve a static phase shift between the PWMs, a dedicated CNT instruction per PWM channel is required. These CNT instructions have identical maximum values (i.e. identical PWM periods), but have different starting values (i.e. the reset from maximum value to zero

happens at different points in time), which reflects the phase shift. The resolution of the phase shift is based on loop periods, such as in the above HET example, the phase shift between PWM1 and PWM2 is equal to two loop periods, whereas PWM1 is in advance of PWM2.

Let's come back to the initially stated requirements for PWM signals to control the lights of a car. Assuming a typical operating frequency of 40MHz and typical HET settings a duty cycle resolution of 100ns can be achieved. This reflects a relative duty cycle resolution of 0.002%, assuming a PWM frequency of 200Hz.

The phase shift and the PWM period can be configured with loop period accuracy, which is typically in the range of 2-5us. The HET is well suited to autonomously generate up to 32 phase-shifted PWM signals allowing a synchronous duty cycle update while meeting or even exceeding accuracy requirements.

#### Synchronous Diagnosis of the PWM-controlled Loads

As initially stated, the increasing number of light sources in a car results in a higher probability of malfunction and can become a difficult task at the repair shop to localise an error. In addition a failing bulb can be a safety problem if a head lamp or brake light burns through. Therefore, all light sources have to be continuously monitored regarding open or short circuit condition. In case of a safety critical light source a back-up light source (e.g. back light acts as break light) has to

be activated and the driver should be informed to replace the broken bulb.

As shown in the system model of **Figure 4**, the driver provides a sense feedback signal, which is a voltage signal that is direct proportional to the load current. For a reliable diagnosis of PWM-controlled loads, the sense signals have to be captured during the active phase of the PWM signals. This can become a challenging task for PWM signals with narrow active pulses. Therefore, hardware synchronisation (see *sync* signal in **Figure 4**) between the PWM unit and the ADC is required to avoid a high CPU load to meet stringent real-time constraints. The hardware synchronisation has to be flexible enough to account for system-dependent delays between PWM generation and conversion of the corresponding sense signal. In **Figure 4** all relevant delays are denoted and subsequently described.

The system-dependent delay parameters 1, 2 and 3 are shown in **Figure 4** and have following meaning:

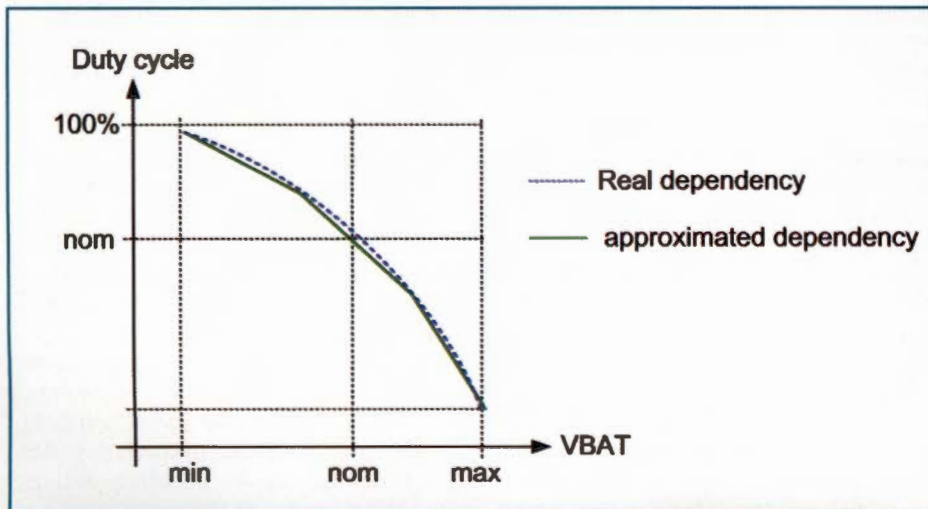
- Propagation delay of the HET signal to the power transistor gate control. This time depends on the input capacitance of the driver, but can be typically neglected.

- Switch on time of the power transistor. Depending on the load and the current flowing through the power transistor the switch on time can vary significantly. The driver datasheet reveals this parameter. A typical value is 100us.

- Settling time of the sense signal back to the analogue input. This time also depends on the actual driver device and therefore the datasheet should be consulted. A typical value is 50us.

In order to set up the trigger signal at the right time the parameters 2 and 3 have to be taken into account. In other words, *sync* needs to be delayed, say, by 150us to compensate the system delay and to start the AD conversion on time. When the sense signals are sampled and converted within the valid window, the host software reads the results and uses them as input into a diagnosis model. This software model considers dynamic effects like in-rush current or aging and detects failures by comparing the measured load current with the model-based target current.

As already depicted in **Figure 4** the TMS470 includes a multi-buffer ADC (MibADC), which is well suited in combination with the HET to support



**Figure 6:** Dependency of battery voltage and duty cycle for constant brightness



## TMS470 with MibADC

Microcontrollers of the TMS470 Body Control family from Texas Instruments offer intelligent peripherals, which are well suited to fulfill the requirements mentioned in this article. A 10-bit multi buffered Analogue Digital Converter (MibADC) as well as a software-programmable timing co-processor (HET, High End Timer) are available on derivatives of this microcontroller family. The MibADC offers up to 32 input channels and a configurable FIFO to store up to 128 conversion results. Started by a trigger signal, the MibADC sequentially converts all selected channels and these results are stored in the FIFO buffer. A group conversion gets started only once and runs then automatically without CPU interaction. The MibADC is internally connected to the HET which provides a trigger signal, synchronised with the PWM signals, driving the light elements. Further, the HET is able to generate up to 32 phase-shifted PWM channels to control the loads of the application.

synchronous diagnosis. The MibADC is built around a 10-bit conversion unit with a configurable sample-and-hold circuitry for 32 analogue input channels. A sequencer controls the order and the timing of conversions, whereas input channels can be organised in three conversion groups. Each group has a dedicated 12-bit sample time register, which allows to accurately adjust the sampling time in a wide range.

A group conversion may be triggered by software or by a hardware event, e.g. by the HET. The conversion results for each group are stored in individual FIFO buffers, whereas the FIFO sizes can be freely configured within the limits of the overall buffer size. Multiple conversion results can be intermediately stored before further processing by the host software. This can be useful if e.g. pre-filtering shall be performed before diagnosis.

The event inputs of the MibADC allow the synchronisation between the phase-shifted PWMs and the analogue-to-digital conversion of the sense signals. To achieve synchronous conversion of multiple sense signals with only one *sync* signal the PWM phase shift delay (see

$t_{phase\_shift}$  in **Figure 5**), and the sample and conversion timing (see  $t_{ADC\_tot}$  in **Figure 5**) need to be equal. With MibADC and HET this is no problem, because the sample time, as well as the phase shift delay, can be configured precisely and in a wide range.

**Figure 5** also shows that *sync* is another phase shifted PWM signal generated with a CNT and ECMP instruction. The phase shift between PWM1 and *sync* ( $t_{compensation}$ ) accounts for the system-dependent delays as previously described. The frequency of *sync* depends on how often load diagnostics shall be performed and is equal to or a multiple of the PWM period. For fast failure detection it is recommended to choose the PWM frequency for *sync*. In this case each PWM period one complete set of sense values are captured.

With the MibADC including HET synchronisation an accurate and reliable capturing of the sense signals can be implemented without involvement of the CPU. The host software can focus on the analysis of the captured results.

### Constant Brightness Control

To ensure a constant brightness of the light sources under varying operating conditions, the host software has to monitor the operating condition variations and has to take counter measures, i.e. adapt the duty cycles of the concerned PWM signals accordingly. The brightness control of LEDs is more critical than that of bulbs due to their faster and non-linear dependency on supply voltage fluctuations. Therefore hereafter only LEDs are discussed, whereas the same applies to bulbs as well.

The brightness of an ideal LED is linear proportional to its load current. The supply voltage across the LED is logarithmic to the supply current, which would result in an exponential dependency of brightness and supply voltage. A resistor in series to a LED string weakens the exponential relationship to a close-to-linear dependency. To account for the remaining non-linearity and to keep the computational effort low a sectorised linear approximation can be realised in software as shown in **Figure 6**.

Brightness control can be easily integrated into the TMS470-based system block diagram as shown in **Figure 2**. The supply voltage VBAT is connected through

a resistor divider to an additional analogue input of the MibADC. The conversion group with the PWM sense signals is expanded with the VBAT signal as indicated in **Figure 5**. This reveals one VBAT value per group of PWM sense values each PWM period, which can be used as input into the brightness control software model.

This model receives from the overall light control task a nominal duty cycle or nominal brightness respectively, which needs to be adjusted according to above constant brightness curve and the actual battery voltage. The adjusted duty cycle can be immediately forwarded to the HET program through the synchronous interface.

Similar to the previously described synchronous diagnosis, all time critical tasks for constant brightness control are performed autonomously by HET and MibADC. The host software receives all relevant information every PWM period and can focus on the brightness control algorithm. With this simple approach, a fast control loop can be realised that is able to efficiently compensate supply voltage variations of two and more PWM periods.

### Outlook

This article has shown how efficient and flexible certain MCUs with smart peripherals can be. They are able to generate phase-shifted PWMs to control vehicle lights and to synchronously capture the sense feedback for a reliable diagnosis.

The TMS470 HET, for example, can generate up to 32 phase shifted PWM signals with individual and synchronous duty cycle update for the light control and the trigger of the MibADC.

The MibADC with its flexible synchronisation possibilities is well suited to synchronise with the HET and to capture the sense signals exactly in the valid time window. The local FIFO buffer allows intermediate storage of several groups of sense values. The HET as well as the MibADC is performing tasks autonomously without CPU involvement. The CPU can focus on the less time critical and hence less run-time consuming tasks. It performs the update of the duty cycles depending on the actual battery voltage and the diagnosis of the active loads based on the MibADC group conversion results. ■



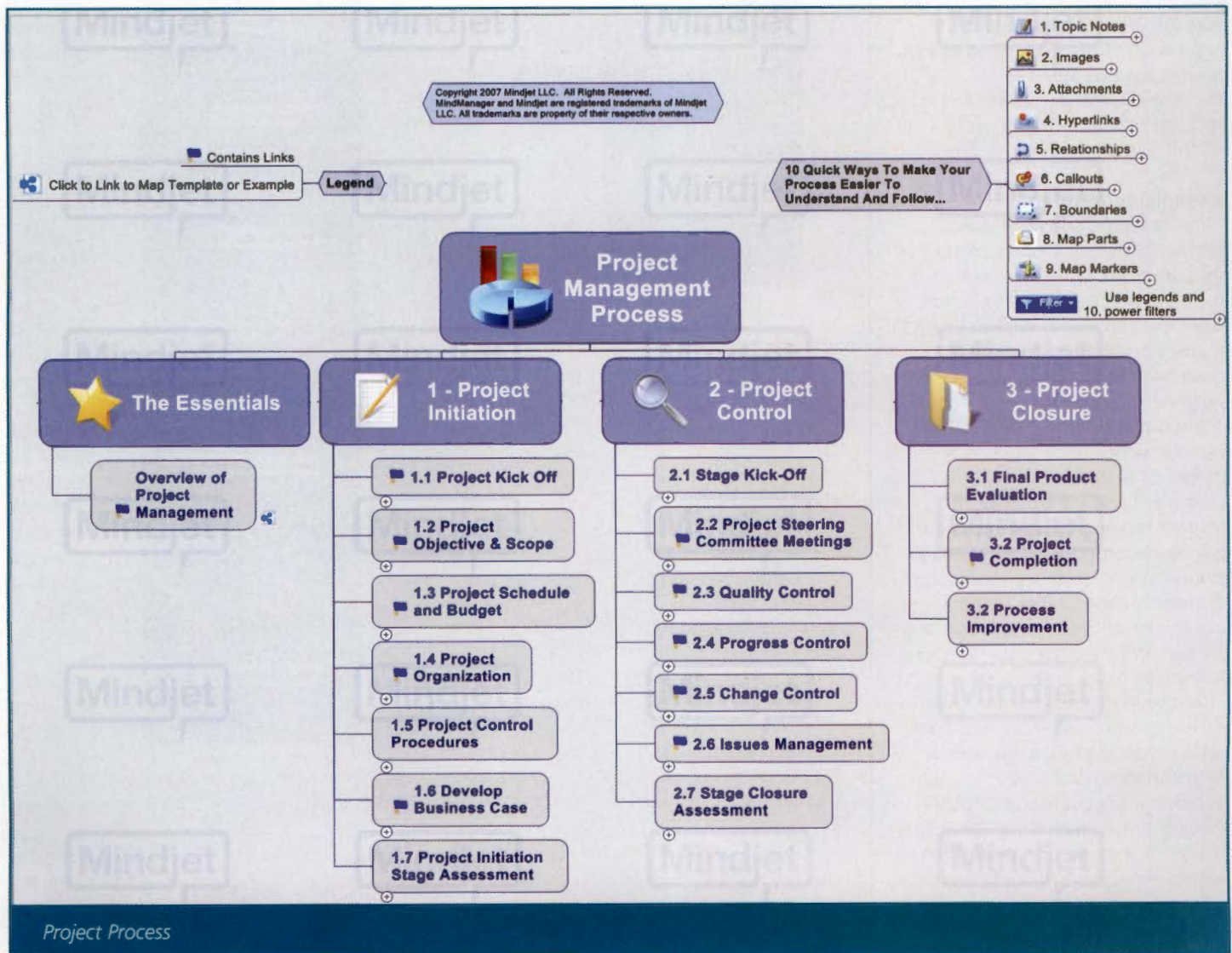
# MIND MAPPING SOFTWARE – THE LOGICAL APPLICATION?

**P**roject management is widely defined as a five phase process for making something happen: initiation, planning, execution, monitoring/control and completion. This definition would certainly fit comfortably with any research and development project, system development or upgrade implementation in electronics and it sounds easy enough. However, in every project there are constraints: cost, time and scope war with each other, so less time might mean more cost and reduced scope for the project.

Then, of course, there is the real fly in the ointment – people. Most projects involve people; people who have to be motivated, people who have to do things on time and within cost; people who have to be stakeholders for the project and so on. In large electronic product-related projects, and even some small ones, the people involved might not all be at the same location or even on the same continent, let alone working for the same organisation.

The project manager has to create a vision of the project, organise the

**SCOTT RASKIN, CEO OF MINDJET, GOES INTO DETAIL AS TO WHY A GRAPHICAL REPRESENTATION OF PROJECTS CAN BE OF TREMENDOUS HELP AND BRING MANY BENEFITS**





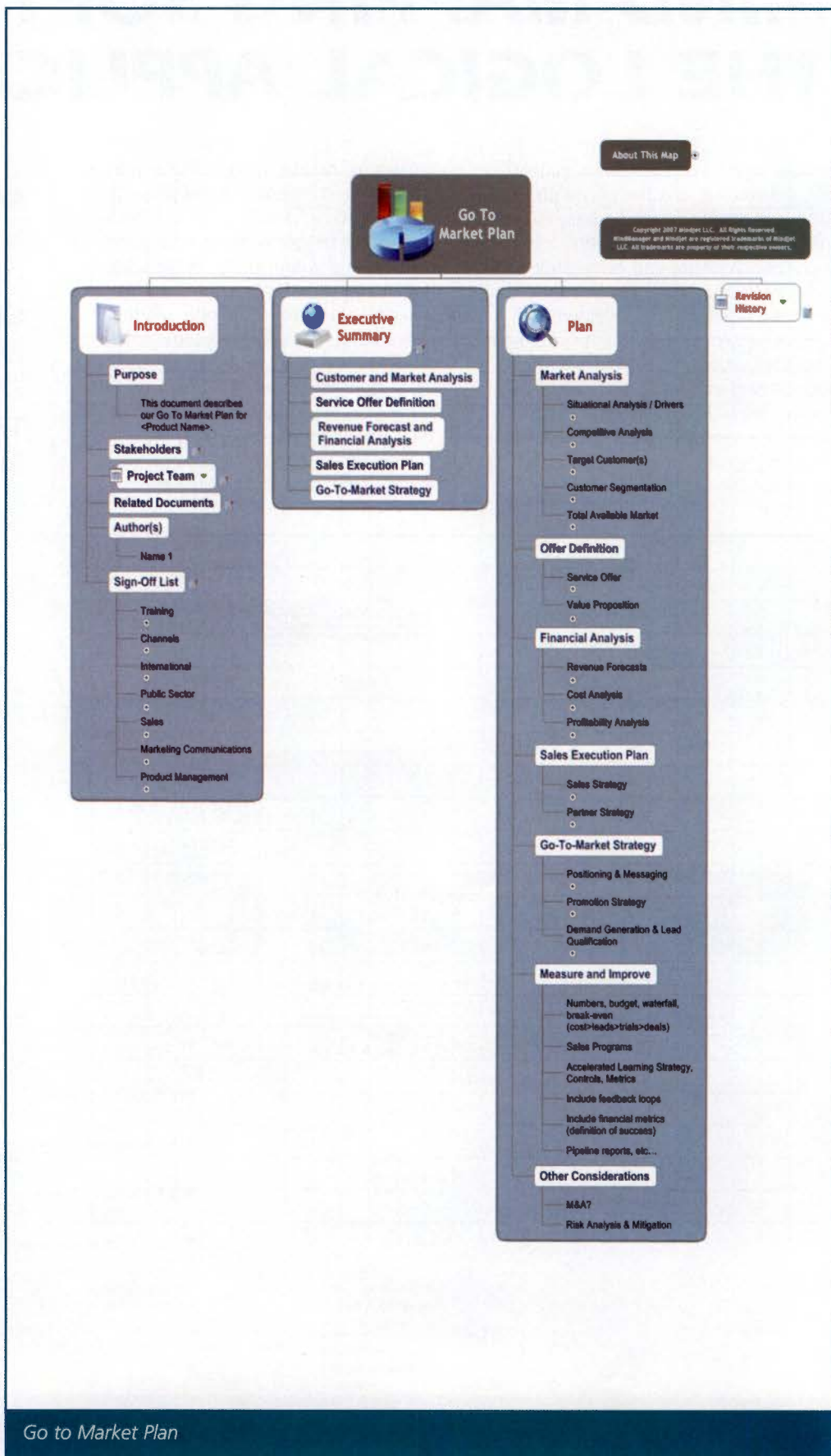
resources required (money, people, materials, space, energy, communications, etc) and then keep everything on track to a required quality through to completion. This generates a lot of activity and documentation in the form of minutes, reports, presentations and spreadsheets, all subject to regular update and change, so everyone involved not only has to have the information they need for their contribution but also be looking at the same issue of each document at any given time. We generally like to think we are at the top of our game and bring best-of-breed solutions to everything that we do, but wouldn't it be easier if we could add some memory to all the people involved, in the same way you can add memory to a PC to cope with the ever-growing pile of information we need to remember? The logical answer is to have software that organises all of this data.

## Organising Minds

Mind mapping software, best known in the electronics sector for its uses in project planning and business process planning, lends itself extraordinarily well to project management and could almost have been invented for the purpose.

Mind mapping, for those not familiar with the concept, is a graphical technique of taking notes and visualising thoughts using a radiant structure to place key words around a central image using colours, pictures, icons and drawings, because the human brain is much better at recognising shapes and patterns than words or numbers.

You work from a starting point of the central idea, object or goal, rather than starting a list with an often arbitrary first and subsequent sequence of actions. Placing the project objective in the centre of a page, or screen, then allows the team to radiate out 'spokes' or 'tentacles' to represent each area of activity that will be



Go to Market Plan



contributing to the successful completion of the project. Each of these can then further branch and divide as the area of activity is subdivided into individual tasks.

So, instead of the traditional timeline list or critical path representation of the project, there's a representational graphic of the project and its constituent parts. In the centre is the project goal and radiating from it are spokes representing finance, materials, sub-contractors, etc. Attached to each of these are branches to show how this element will be broken down into specific tasks. With the right software, you can then ensure that all communications with subcontractors is linked to that branch, budget performance spreadsheets are linked into the finance tentacle and so on.

The project manager, therefore, retains a clear overview of the project that can be 'mined' to extract timelines for linked tasks, indicate or allocate priorities, check what needs to happen before another aspect can be progressed, provide exception reporting on budget performance or see the impact of slippage in one area on other tasks.

Software, such as Mindjet MindManager, which already has a proven infrastructure used by more than a million users worldwide, gathers unstructured information and groups it under easy to access headings and sub-headings, so that all topic-related items are linked. It can even suggest links to aid creative thinking and planning. The added bonus is that any heading or statement can have a hyperlink to a document, therefore no searching for the most relevant or up-to-date file. The maps themselves can be exported to programmes such as Microsoft Office (Word, Excel etc), PowerPoint or Project.

The project manager, or an individual team member, can break down the big picture by selecting filters, for example to look at just one person's tasks and deadlines or to pick up on the next set of priorities.

The resulting project mind-map will give an overview of the project, enable exploration of options or make choices, help gather data and keep it accessible, encourage creation of new links and critical paths, increase the efficiency of all involved and present the whole picture in context – as well as the details – at the same time.

### Managing and Measuring

Successful project management is one of the greatest challenges for scientists, engineers and other managers in innovative and scientific companies. How can be built on the skills that will help organise and manage R&D projects and measure their performance?

The objective in project mapping is to improve performance at every stage of the project lifecycle, from communicating the big picture to tracking minutiae. Getting good and timely information on electronics projects that we are embarking on sometimes can be time-consuming and frustrating. Taking just this one aspect alone, conservative estimates by IDC (the global market intelligence company) suggest that an organisation with 1,000 employees wastes at least \$2.5m every year by failing to find existing information, searching for outdated information, or recreating information. Keeping all documentation related to a project linked to the project map ensures that project management does not exacerbate these problems.

Jeff Parshley, Principal at SRK Consulting, the global scientific and engineering consultancy, says that the main reason he added mind mapping software to his firm's desktop tool set is that it helps his engineers quickly gain and communicate to clients, a useful overview of complex topics. "A selected group of people can open a map at any time, get access to detailed information and, then, add their thoughts to the map at a time that's convenient to them. For a company like ours, whose success is tied directly to our ability to access intellectual capital located all around the world, the ability of these maps to significantly increase feedback provides a huge benefit, as opposed to circulating dossiers of minutes for people to read and respond".

With mind-mapping software, external presentation is expedited as well. SRK Consulting Parshley added: "To facilitate a strategic planning meeting among dozens of representatives of a large South African mining company, we ran into scepticism of the mapping at first, but within 20 minutes everyone was jumping in, telling us to add this thought to the map over here and move that branch over there. The meeting suddenly became very interactive!"

"Getting people to participate in these

larger meetings can be like pulling teeth. But the mapping interface really encourages interaction. Participants see their ideas added to the map in real time for all to see. Everyone understands immediately that their input is heard and valued," he said.

### Creativity and Cohesion

Keeping everything related to a project together and accessible, aids creativity and cohesion in the planning but, at its simplest, it can just save time. Air Products and Chemicals Inc uses mind-mapping software too, to get more innovative products to market – and fast.

"If there are eight to ten people sitting in a room and we can knock a half hour off the meeting, then we're really saving time. People can refer back to one map that has all the project ideas, action items and related documents. And the maps become agendas for subsequent meetings," explains Paul Wood, Project Manager on the Wichita Advanced Controls Initiative Project.

Project managers have tended to have large whiteboards or pin boards with charts breaking projects down. Sticky notes litter the chart and, if they are really unlucky, the floor. So project management was a messy business, with the presentation alone being a demotivating factor, as team members battle with confusing images and missing or outdated designs, pictures and files.

The mind thinks in terms of links, pictures, colours and patterns. It stands to reason that a map is much more effective than a list in organising your ideas and generating new ones. Project managers, whether planning an R&D project, a product launch, major new implementation or upgrade, through to a piece of market research or a cost-cutting exercise, can have a Project Map dashboard, which they can share and from which the project plan can evolve naturally in the same way that thought processes work – making links and leaps of creativity.

From the key objectives come task allocations, which lead to schedule and budget responsibilities and then to a clear understanding of what is required of each member of the team. Perhaps the real value of project mapping software is the ability to help us manage and present information, in a clear, concise and motivational way. ■



# IRIS JUDGE

**R**ecent developments in multimedia signal processing increased the use of biometric features for person identification and verification. Iris is one of the most accurate successful and reliable biometric features used for the identification and verification.

This article introduces a Principal Component Analysis (PCA) based identity verification system using the images of the iris biometric feature. The system includes a keypad based Personal Identification Number (PIN) entry hardware and PCA-based identity verification algorithm. After an entry of a PIN number the iris acquired from an infrared camera of that person is cross-checked to validate the identity. The performance of the proposed system reaches to 100% verification rate for two different iris databases used.

We've also introduced a graphical user interface (GUI) for easier application of the system.

Reliable automatic recognition of persons has long been an attractive goal. The key issue in pattern recognition problem is the relation between inter-class and intra-class variability: objects can be reliably classified only if the variability among different instances of a given class is less than the variability between different classes.

Biometric features of people have been used for identification for long time. A biometric system provides automatic recognition of an individual based on some unique characteristic owned by the individual. Biometric systems have been developed based on fingerprints, facial features, hand geometry and iris pattern. Iris recognition is a very reliable method for personal identity verification.

Biometric systems are mainly designed to capture the statistics of the sample images, such as faces, irises, fingerprint and hand veins. These sample images are transformed using some mathematical functions to build biometric features. The extracted features are used to transform any given image into a low dimensional space that better captures the characteristics of the input image for identification.

Due to uniqueness of some of the biometric features such as fingerprints and iris pattern, biometric systems play very important

**HASAN DEMIREL,  
MEHMET SARIOGLU,  
YUSUF A. ERDEM AND  
GHOLAMREZA  
ANBARJAFARI OF THE  
DEPARTMENT OF  
ELECTRICAL AND  
ELECTRONIC ENGINEERING  
AT THE EASTERN  
MEDITERRANEAN  
UNIVERSITY IN TURKEY  
HAVE DEVELOPED A PCA-  
BASED IRIS RECOGNITION  
AND VERIFICATION  
SYSTEM BASED ON  
IMAGE PROCESSING**

role in the security issues such entrances to the military bases, bank safes, airports, laboratories, etc. In order to produce a good biometric system, two issues of pattern recognition should be considered. Thus the probability of having same characteristics should be minimal for individuals, so that the feature of individual does not change over time. Furthermore, the system should easily capture images in order to provide efficient access.

PCA has been used for the classification and identification purposes. PCA-based eigenfaces method, which is a statistical face recognition system introduced by Turk and Pentland in the *Journal of cognitive Neuroscience* (1991, vol. 3, no. 1, pp72-86) has attracted a lot of attention from researchers. We have adopted PCA methodology to Iris Recognition. The system was tested on CASIA database of 145 subjects with four samples per subject and our own database of 15 students with 10 samples per student. Both in CASIA and our own iris databases the correct verification rate was 100%.

**Principle Component Analysis (PCA)**

PCA has been widely used for classification and recognition applications. PCA, also known as eigenspace analysis, is a standard statistical technique for finding directions of maximum variations in data. These directions, called the principle components, can be used to reconstruct all of the information within the set and can be tested to which level a test image couples with an image of the training set.

Principle components with smaller associated magnitudes can often be omitted, as they contribute less to the overall reconstruction of each data element. This allows sufficient representation of the original data set with a reduced set of principle components. For example, we may reduce the dimensionality of a given image by using only first twenty eigenvectors with the highest eigenvalues, while our whole eigenvectors are 250.

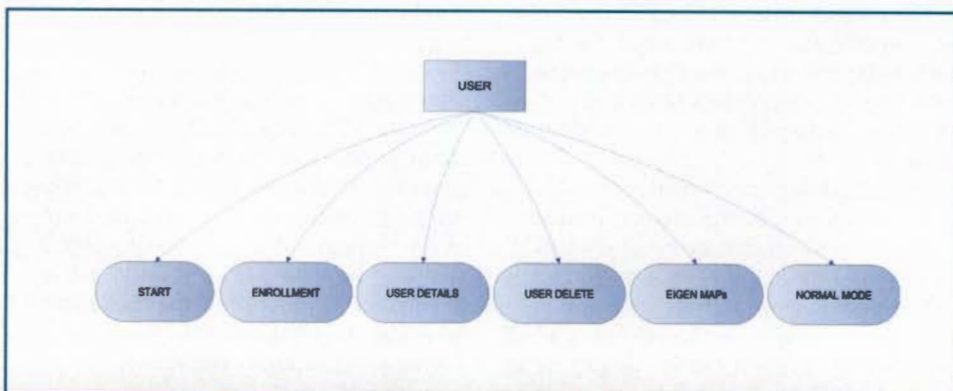


Figure 1: The main building blocks of the system software





Figure 2: Program interface and enrolment

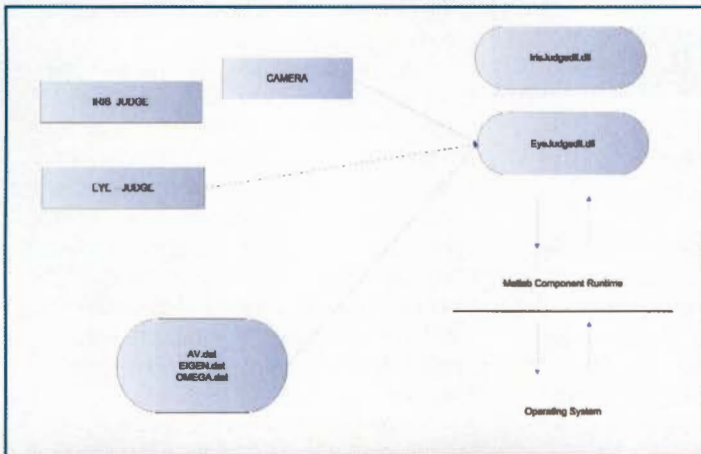


Figure 3: Operating procedure for software modules

In order to use PCA for image coding, the given image is converted to grey scale from the RGB colour space. A grey-scale image can be considered to be a two-dimensional matrix. This will speed up the matrix calculation as instead of a three dimensional RGB image only two dimensional matrices will be used. A given a gray scale image, that can be represented as a matrix of intensity values, can be converted into a column vector by concatenating each column of the image into a single vector one by one.

**Calculating Eigenvectors**

The principal components also referred as the eigenimages can be calculated as follows. Let  $\Gamma$  be an iris image from the collection of  $M$  images in the database. Average image  $\Psi$  is calculated as:

$$\Psi = \frac{1}{M} \sum_{i=1}^M \Gamma_i \tag{1}$$

After obtaining the average image, we required to build difference matrix. Each image  $\Gamma_i$  differ from the average image  $\Psi$  by the difference vector:

$$\Phi_i = \Gamma_i - \Psi \tag{2}$$

The covariance matrix of the dataset is defined by:

$$C = \frac{1}{M} \sum_{n=1}^M \Phi_n \Phi_n^T = \Lambda \Lambda^T \tag{3}$$

$$\Lambda = [\Phi_1 \Phi_2 \dots \Phi_M]$$

Since there are  $M$  images in the database, the covariance matrix  $C$  has only  $M-1$  meaningful eigenvectors. Those eigenvectors,  $u_l$ , can be obtained by multiplying eigenvectors  $v_l$ , of matrix  $L = \Lambda^T \Lambda$  (of size  $M \times M$ ) with difference vectors in matrix  $\Lambda$ .

$$u_l = \sum_{k=1}^M v_{lk} \Phi_k \tag{4}$$

Eigenvectors can be considered as basis images, which are also referred as the eigenimages. Among the eigenimages calculated, only first  $M'$  ( $M' \ll M$ ) eigenimages with highest eigenvalues are enough to represent any given image similar to the ones in the training data set.

After the calculation of the eigenimages, a given image can be projected onto the eigenspace as follows:

$$\omega_K = u^T_K (\Gamma - \Psi) \tag{5}$$

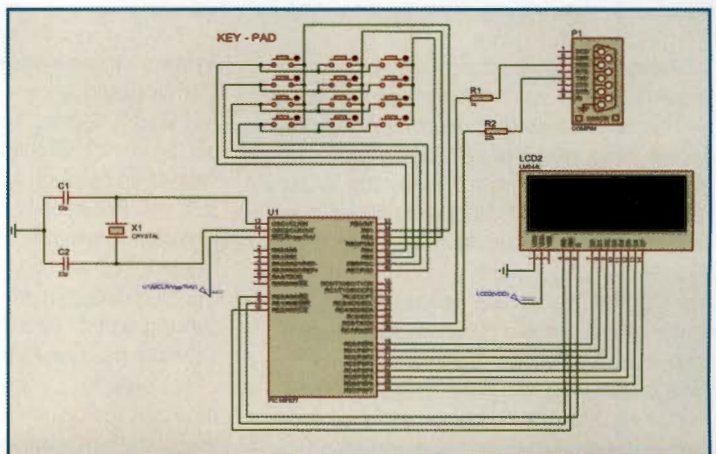


Figure 4: System hardware



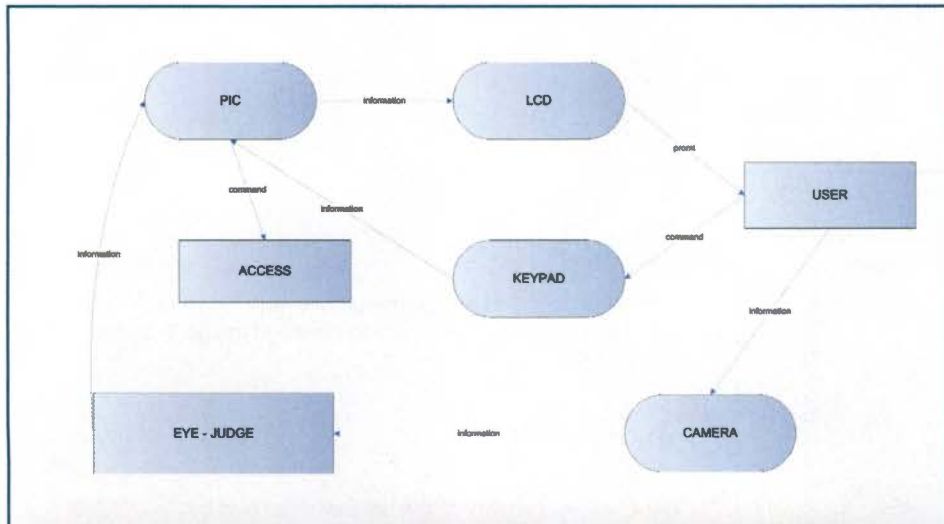


Figure 5: System hardware



Figure 6: Main operation procedure

Where,  $\Gamma$  is the given image  $\omega_k$  and is the  $k^{\text{th}}$  coordinate in the calculated eigenspace.

**Equation 5** describes point-by-point vector multiplications and summations, resulting in the scalar value. coefficients in each principal component directions are used to form the projection vector as follows:

$$\Omega = [\omega_1 \omega_2 \dots \omega_M] \quad (6)$$

Vector  $\Omega$  describes contribution of each eigenimages in representing the input image.

This vector is used to determine the class of the input image by calculating the minimum distance from a projection vector in the training set. The distance between two vectors reflects the similarity between them. Hence two vectors with the smallest distance refer to the most similar vectors. Euclidian distance is a suitable distance calculation between two vectors. Given a query iris image projected into the eigenspace by vector  $\Omega_q$ , the distance between  $\Omega_q$  and  $\Omega_k$  which is a projection vector representing another iris image in the training set that can be calculated by:

$$\Sigma_k = \|\Omega_q \text{ and } \Omega_k\|^2 = \sqrt{\sum_{i=1}^M (\omega_{qi} - \omega_{ki})^2} \quad (7)$$

In **Equation 7**  $\Omega_k$  describes  $k^{\text{th}}$  iris class, which is the average of the different representation vectors of that individual ( $k^{\text{th}}$  person) in the training set. An iris will be classified to be in the same class if the minimum is below a specified threshold; otherwise it will be classified as an "unknown".

### System Organisation

The proposed system is named as the Iris-Judge as it decides if an iris belongs to a person or not. The system software is developed by using MATLAB, VisualBasic.NET, SQL and PIC Basic Pro programming languages. A microcontroller (PIC) driven keypad, LCD and a USB camera constitutes the hardware part of the project. RS232 serial communication protocol was used to interface the system hardware and software.

The most important part of the proposed project is the system software, which includes the algorithms explained in the previous sections. The system software controls database and hardware to fulfil main

operating procedures. **Figure 1** shows the basic building blocks of the Iris-Judge software.

Visual Basic.NET gives an opportunity the programmer to design a user-friendly and efficient GUI. Furthermore, it uses SQL database effectively. The GUI for the Iris-Judge is shown in **Figure 2**.

### User Verification

The main program as it was mentioned was written in Visual Basic.NET. Many forms were used in the programming. Each form has been designed for different assignment and purposes.

The program also has three different skins for friendlier user interfaces such as Normal Mode. Firstly, the iris image has to be taken with the use of the infrared camera. Here, the input iris image can be used for either for recognition proposes or training the system to build database. The training procedure can be chosen by selecting the "Enrolment" option.

In the training process the system takes ten snapshots of the iris of each individual, where each iris image is added to the SQL database. The program automatically allocates a PIN number to each new user.

After creating a database, the new user can be verified for a possible validation, which requires running the verification form. When any user comes and enters his or her PIN number, the program checks whether the user is registered or not and if the user is re-registered, and it takes a snapshot of the iris through the camera. Finally, if the iris of the person is similar to the iris of the individual with the respective PIN number in the database, the person's identity will be verified.

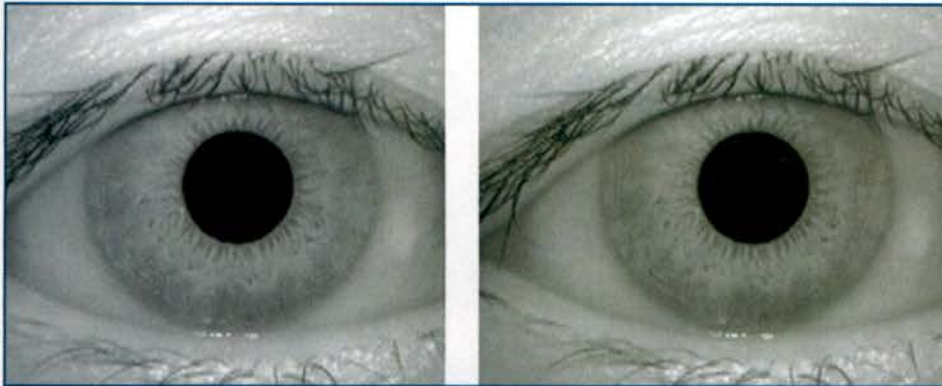
The program enables the system administrator to remove any registered user by using "User Delete" form. The administrator may reach the user details by pressing "User Details" button.

The administrator has the ability to configure the COM port which will be used for interface with other hardware, such as an entrance door for example. Furthermore, the administrator can configure how long the program can communicate with the external peripherals. For example, the administrator can set the duration of the time when a door is open.

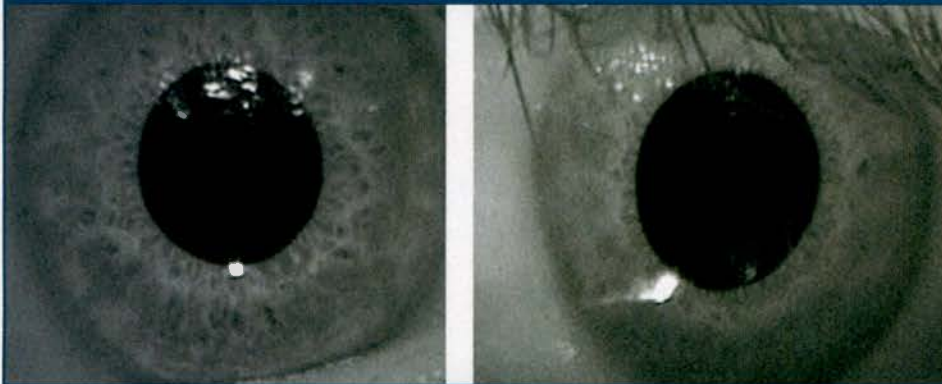
### The MATLAB Program Module

The PCA codes for the iris recognition and verification were written in MATLAB, which not only provides useful function routines,

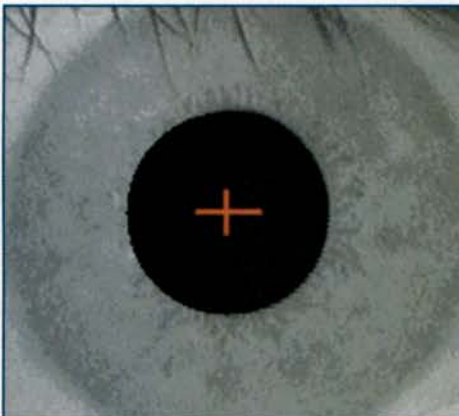




**Figure 7:** Eye samples from CASIA database



**Figure 8:** Eye samples from our database



**Figure 9:** Segmented iris image

but also a user friendly GUI. MATLAB files were used to create *dll* files to be used in the main programme. Combination of *dll* with other software component is shown in **Figure 3**.

In order to increase the verification rate, iris image segmentation is essential. This has been done by the use of MATLAB.

The system hardware contains a microcontroller driven keypad, LCD and RS232 serial interface port as shown in **Figure 4**. Additionally, a PC is used to

acquire an iris image through a USB camera. **Figure 5** clearly indicates how the system modules interact with each other.

### System Operation

**Figure 6** shows the operating procedure of the iris verification system for a possible gate access. Firstly, the iris images have to be taken with the camera to form the iris database. The eigenimages are calculated at the initial setup. After the initial setup the system can be used in normal operational mode as follows.

The procedure starts with entering PIN code by the user. The PIN code is sent to the main program via the PIC microcontroller through the RS232 serial port. The main program searches the entered PIN code through the database and checks if the PIN code is available. If the user was not a registered person, the program sends an error code to PIC and PIC prompts a "You are not a registered user" message on the LCD.

If the user has a registered PIN code, the program prompts user to come closer to the camera and press a snapshot button. Afterwards, the iris image will be segmented out from the input image to reduce the

amount of irrelevant objects, such as eyelashes from the input image.

Following that, with the help of the PCA the main program verifies the identity of the user and after grants access to that person. Getting the access command from the main program starts a new procedure for the PIC. It sends a control signal to the gate, which will open for the pre-defined period of time. If access is not granted by the main program, the sent-out command will action the PIC to inform the user that access has been denied.

The administrator may interrupt and control the gate by entering a security code which has higher priority than any user.

### Results and Discussions

We have collected some experimental and theoretical test results to measure the performance of the proposed system. Two different iris databases were used to measure the system performance. In the early development phase of the project we have used the CASIA

([www.sinobiometrics.com/IrisDatabase.htm](http://www.sinobiometrics.com/IrisDatabase.htm))

iris database. **Figure 7** shows two samples of iris images from CASIA and **Figure 8** shows two samples of iris images from our own database. CASIA database contains 145 subjects with four samples and our own database contains 15 subjects with 10 samples. Both in CASIA and our own iris databases the correct verification rate was 100%. Such a high rate is achieved by using iris image segmentation and PIN code. The same process in the absence of segmentation and PIN code achieved a recognition rate as low as 72%.

**Figure 9** shows an example of an isolated iris image after being segmented. The segmentation procedure helps to minimise most of unnecessary artefacts such, as eye lashes and eye lids.

### Conclusion

In this article an identity verification system called Iris-Judge, which can be used in security access control, has been presented. The system uses PCA-based eigenimages approach for the verification of an input iris image of a person entering his or her PIN code.

The proposed iris verification system was successfully tested on CASIA database of greyscale iris images. An automatic pre-processing procedure, including iris segmentation, has been introduced before the verification. The iris segmentation and the PIN code leads to 100% verification rate using PCA based approach. ■



# THE 21ST CENTURY CARRIER

**T**he 20<sup>th</sup> century was highly successful for the telecommunications industry, which went from telegram to telephone to mobile phone all in the space of 100 years. However, now in the 21<sup>st</sup> century the growth of the industry is slowing. The existing business model is under attack from other converging industries, such as Internet, entertainment and content businesses. In fact in recent years, telecommunications has been one of the worst performing sectors in stock markets around the world, and price-earnings ratios suggest there is little investor belief in the situation improving soon.

Some carriers are adopting a 'bit pipe' model, monetising something as simple as mobile phone ring-tones – for example, the Crazy Frog ring-tone alone reputedly earned more than \$2m for Jamster and a similar amount for the carriers who simply facilitated the download. At the same time, other telecom carriers are adopting a different perspective. They accept the inevitable emergence of a new value chain, but they have no intention of surrendering their lucrative position as a provider of communications services to settle for the role of a bit pipe utility. Instead, they are looking at how to reproduce the innovation and dramatic growth they have seen in Internet businesses and applications over the last decade. Indeed, SMS service has been the most recent run-away success in the telecoms market and it came about more as a result of user inventiveness than carrier innovation.

But which way should the 21<sup>st</sup> century operator turn? Can they be more than just a bit pipe?

## Trouble on the Horizon?

Carriers believe that they do have what it takes to succeed. However, the missing ingredient for them is agility in the new competitive landscape. They are hampered by networks that were conceived and built in an era that had a different view of the future of communications. It has left them with a legacy of disparate proprietary systems and vertically-oriented silos serving different access technologies.

**JONATHAN BELL, VP OF MARKETING AT OPENCLOUD, SAYS THAT THE ROUTE TO BECOMING A 21ST CENTURY CARRIER LIES IN AN OPEN STANDARDS APPROACH, WHICH WILL ENABLE OPERATORS TO MOVE AWAY FROM PROPRIETARY SERVICES AND VENDOR LOCK-IN, USING THIS 'OPENNESS' TO ACHIEVE BOTH INNOVATION AND COST LEADERSHIP**



*Real-time talk by text solution which runs on the OpenCloud server*

Carriers now recognise that the real threat to their business is no longer from competitors or new entrants, but from disruptive substitution. With comparatively minimal investment, Skype and similar

businesses have decimated telecoms revenue projections by delivering substitute call services at ultra-low costs, using disruptive communications technologies including broadband Wi-Fi and VoIP, which carriers no longer control.

There are learnings from comparable infrastructure-based industries, such as air travel, gas or electricity supply that different rules of competition will apply in the emerging telecoms value chain. Similar to the investment in aircraft or laying pipelines, the prohibitive costs of buying communications cables and building a core network mean carriers don't face losing their core transport business any time soon, although technologies like Wi-Fi and WiMAX mean that their monopoly is less secure. However, operators are not satisfied with being limited to bit pipe transport and access networks that form the commodity business. They recognise that the key to profit and growth lies in developing the value-add Next Generation Network services that generate new opportunities for revenue and customer loyalty.

## Cost Leadership

Despite the services layer of the Next Generation Network delivering the greatest potential for value creation and revenue growth, it is also the area of greatest competition. The carrier is just one of the players competing for a piece of this lucrative action. The factors that will give players a distinct competitive advantage in this arena are low costs, agility, brand marketing and product innovation.

All-IP networks promise savings in the transport network infrastructure but other measures are required to drive down service provision costs where competition will be toughest. The only alternative will be to surrender that market to more agile competitors who are not burdened with legacy infrastructure, entrenched organisational and technological silos and the associated cost-base.

Many carriers are used to competing by segmentation and differentiation. Continuing this course will bring them into head-on competition with Internet businesses in the services layer that they



want to dominate. Arguably, cost leadership will become a popular competitive strategy because it leverages carriers' strengths, notably scale economies (many carriers are global and tend to be sizeable organisations); experience of curve effects (many carriers have over 100 years' experience in the communications business); high volume business; and a large customer base.

But if carriers have such potential cost advantages, why are new entrants today able to undercut them with disruptive offerings?

|                            |                                  |                                |
|----------------------------|----------------------------------|--------------------------------|
| <i>Narrow market Scope</i> | <b>Segmentation</b>              |                                |
| <i>Broad Market Scope</i>  | <b>Differentiation</b>           | <b>Cost Leadership</b>         |
|                            | <i>Uniqueness<br/>Competency</i> | <i>Low Cost<br/>Competency</i> |

**Figure 1:** Cost leadership strategy

### Need for 'Openness'

The main obstacles to carriers achieving a cost leadership position in the market are the technical, commercial and contractual constraints of their current network infrastructure. Proprietary, vertically-oriented, monolithic network architectures are not enabling them to be flexible enough. Furthermore, these network architectures are both tremendously expensive to modify or enhance with new services and, also, expensive to operate, support and maintain across the various network silos. Finally, any modifications are slow to progress.

To achieve the required flexibility, carriers have spent a decade demanding open platforms from their suppliers. Against a series of open standards initiatives including Parlay and JAIN, founded by operators to drive this agenda, infrastructure vendors managed to rest on their proprietary technologies and associated high replacement costs to protect their domain. The carriers' own inertia and risk aversion also contributed to the status quo. In the past, carriers could afford to suffer the burden of being locked-in to a high-cost infrastructure because their competitors were in the same situation.

However, this is no longer the case. What is holding back innovation in telecoms today is not lack of foresight or creativity, but the prohibitive costs of developing new services or combining existing ones in new ways.

### New Lease of Life

Market analyst house Gartner recently stated that: "Adoption of a low-cost infrastructure for telecommunications will likely open opportunities for new services that are forbiddingly expensive today. The impact of the new services in a standards-based converged network will be broader and faster than it can be today."

What is needed is an open platform, and JAIN SLEE is the open Java standard for event-driven application servers that address this challenge. It is tailored to the large-scale execution of communications services across existing and Next Generation Networks, enabling JAIN SLEE-compliant application servers to provide the open, flexible service execution platform that is essential to achieve agility in service development and deployment, and to

also capitalise on cost leadership.

Parallel to the rise of the JAIN SLEE standard, a number of advances have combined to bring the proprietary infrastructure lock-in to an end. Commercial pressure, the introduction of disruptive technologies and the growing adoption of open standards are all generating exciting opportunities for application and service development by operators, as well as by third party developers.

**Commercial pressure** – Telecoms is seeing a new round of infrastructure investment after the lean years following the dotcom downturn. In looking to leverage existing investment and integrate new and legacy equipment, carriers are using the procurement of new equipment to apply pressure on suppliers for openness and access to proprietary protocol specifications.

**Disruptive technologies** – New open application servers now easily match proprietary intelligent network (IN) equipment in high-end transaction processing and carrier-grade reliability. This means that carriers benefit from continuous availability, telco-grade latencies and superior scalability, all on commodity hardware and operating systems.

**Open standards** – The mainstream adoption of JAIN SLEE has resulted in the compliant platforms becoming more readily available. By opening up the world of telecoms to millions of Java programmers worldwide, including carriers' own in house developers, JAIN SLEE-compliant platforms have created a vibrant and competitive market for off-the-shelf telecoms applications with the added benefit of service portability. With open portability across JAIN SLEE-compliant platforms, even a custom service developed specifically for a particular carrier can contribute to savings elsewhere by being re-deployed in other countries or networks that the carrier owns.

### Business Value

In contrast to the optimistic and exuberant investments in the past, carriers today expect a positive return on investment (ROI) within a period as short as 12 to 18 months. Given these criteria, investments in JAIN SLEE open platforms are easy to justify because costs of modifying and maintaining existing proprietary systems tend to be noticeably higher. However, the real value of the JAIN SLEE platform is experienced when innovative services are deployed.

The cost of developing and deploying services on an open platform is a fraction of that faced by carriers using proprietary alternatives, with the added bonus of a wider choice of suppliers. As the platform is already integrated with network switches and operational support systems (OSS), developers can focus solely on the development of the service logic, which drastically reduces in-house development from years to weeks. Carriers can experience even further cost benefits by licensing an off-the-shelf JAIN SLEE-compliant service from a third-party application vendor.

As a result, the successful 21<sup>st</sup> century Next Generation carrier will be a completely different beast to its 20<sup>th</sup> century predecessor. It will either be an efficient utility business providing transport, or it will leverage its cost leadership advantages to compete effectively as a provider of compelling communications services. Forward thinking service providers are already using open JAIN SLEE platforms across their infrastructure to achieve lower costs for deploying new and innovative services. The future of the industry lies in establishing a clear and sustainable competitive advantage. ■



# WHY ARE REFLECTIVE COLOUR DISPLAYS SO BAD?

By Chris Williams, UKDL

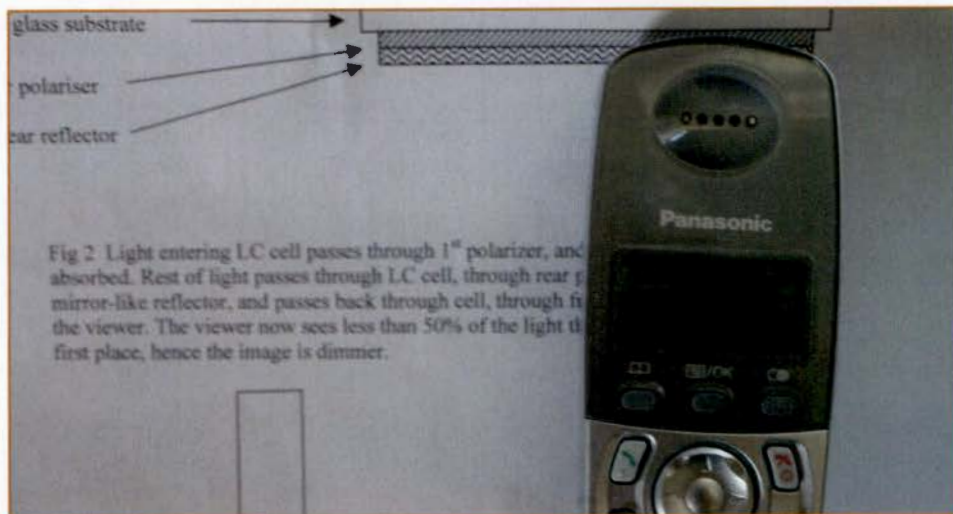
Don't doubt that you are just like me: whenever you look to buy a laptop computer/PDA/MP3 player/'smart' mobile phone, what you would really like is one that has an extended battery life.

The number of battery chargers in my life is excessive – at home, at work, in the car – all different types and output voltages to suit the kit that has to be charged. It is annoying, frustrating, expensive and horrendously wasteful in electrical power as literally tens of millions of chargers around the UK are left on with no device attached to be charged. Speculative assessments suggest that these unattached, unattended chargers are costing us the output equivalent to two or more power stations - not very "green"!

When we investigate the power budget of the various devices we own (laptops, phones, etc), it is inevitably the case that one of the largest users of the power within the unit is the display assembly. Why?

At this moment, the dominant display technology of choice is liquid crystal. No surprise here, perhaps, the global investments into the technology to date now exceed hundreds of billions of US dollars. Production volumes of simple LCD devices used in clocks

**THE HOLY GRAIL FOR ELECTRONIC DESIGNERS IS TO CREATE A REFLECTIVE DISPLAY THAT, IN DAYLIGHT, SIMPLY LOOKS AS GOOD AS WRITTEN TEXT AND GRAPHICS ON PAPER**



Comparison of reflective LCD display, paper and backlit LCD display.

and watches, calculators and simple mobile phones now exceeds 2.5 billion display cells per year. Production of the sophisticated Active Matrix LCD displays used in laptops, desktop monitors and advanced mobile phones now number in the hundreds of millions per year. Indeed, more than 85% of all the displays made on this planet today are liquid crystal, such is its dominance.

Of itself, the liquid crystal electro-optic switching effect is surprisingly efficient, being a voltage-driven effect consuming microamps per cm<sup>2</sup>, and not a current-driven effect. So, if the LCD switching element is efficient and low power, why is the display still the scourge of the power budget?

Because at the very heart of the matter lies the fact that the LCD doesn't look very good and, to compensate for a poor appearance, we use additional light sources to "make it look better". Proof? Look at your own mobile phone. Leave it until the backlight goes off and then look at the display. If you can read it at all, you will conclude that it is awful to look at without the backlight on.

The Holy Grail for electronic designers is to create a reflective display that, in daylight, simply looks as good as written text and graphics on paper. In other words, our display

engineers and scientists only need to make a display that looks as good as the basic form of written communication we have been using for the last few thousand years.

It would also be nice if, when the information is on the "electronic paper", it uses no power to retain that information, just the way that the printed word does. They haven't done it yet and it isn't going to happen for a while.

First – the problems. Most commercially available reflective displays – colour or black and white – use liquid crystal as the electro-optic effect. The most common types, or modes, of LCDs in consumer devices are twisted nematic and supertwisted nematic. There are several other LC modes – ferroelectric, cholesteric, smectic, pdlc, etc, but these tend to share two common problems: either they cannot easily be multiplexed, or the production process is too expensive compared to TN and STN for consumer devices.

The other technologies that are becoming available include electrophoretic (as made by E-Ink of the US), electrochromic (as made by NTERA of Ireland) and interferometric – a micro-electromechanical system (MEMS) made by Qualcomm. These technologies are



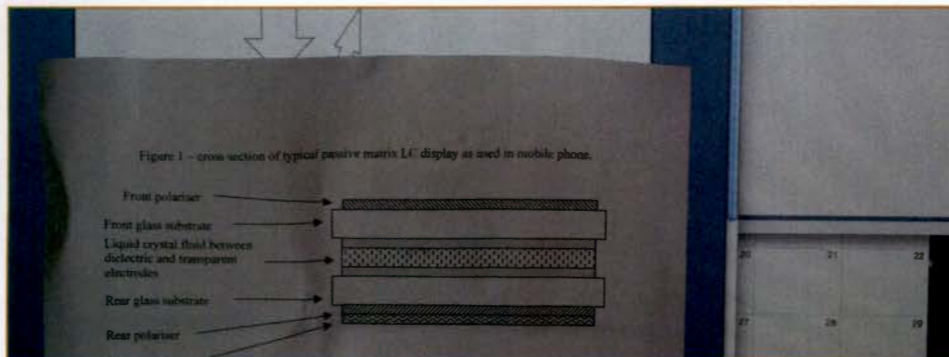


Figure 1 – cross-section of typical passive matrix LC display as used in mobile phone.

Light entering LC cell passes through first polariser and 50% of light is absorbed. Rest of light passes through LC cell, through rear polariser, reflects off a mirror-like reflector and passes the back-through cell, through a front polariser and on to the viewer. The viewer now sees less than 50% of the light that entered the cell in the first place, hence the image is dimmer

a move in the right direction, with much better visual performance in sunlight, but the commercial take-up is slow compared to the cosmic growth of LCD.

In twisted nematic and supertwisted nematic LCDs both types use front and rear polarisers, and the display image is achieved by the LC fluid switching to allow light to pass, or not pass, between the two sets of polarisers. The bottom line is that at least

50% of the light that is incident upon the displays is absorbed by the polarisers.

On top of that, at least 8% of the incident light will be lost due to surface reflections at the surfaces of the display glass, and if the display includes colour filters, then a further 67% of the incident light will be lost by absorption within the different colour polarisers.

That means that, at best, a monochrome

reflective LCD displays using polarisers will always be dimmer than a piece of paper that is placed under the same lighting conditions. This can work to one's advantage; the poor reflectivity of an LCD can result in a monochrome LCD being perfectly readable in very bright sunlight, when a piece of paper, say a newspaper, is too bright to read comfortably and in, most lighting conditions, a reflective monochrome LCD is just plain dull and boring.

When colour filters are added as well, the problem worsens and the reflective colour LCD looks pretty bad in most lighting conditions. There are no easy answers to this, but it doesn't stop companies from trying.

If we want to have better battery life and excellent displays in our products, we simply have to be prepared to pay more for them, so that manufacturers can justify using "better" display technology. Even that won't be enough though; we need to tell the manufacturers that today's products just aren't good enough.

*Chris Williams is Network Director at the UK Display & Lighting Knowledge Transfer Network (UKDL KTN)*

# Telnet

## Quality second-user test & measurement equipment

Tel: 02476 650 702 Fax: 02476 650 773

Web: [www.telnet.uk.com](http://www.telnet.uk.com) Email: [sales@telnet.uk.com](mailto:sales@telnet.uk.com)

All equipment is used – with 30 days guarantee and 90 days in some cases. Add carriage and VAT to all goods.  
1 Stoney Court, Hotchkiss Way, Binley Industrial Estate Coventry CV3 2RL ENGLAND



|  |         |   |       |
|--|---------|---|-------|
| Agilent (HP) 435A/B, 436A, 4637B, 438A Power Meters from         | £100    | Agilent (HP) 53310A Mod. Domain An (opt 1/31)                   | £2750 |
| Agilent (HP) 3561A Dynamic Signal Analyser                       | £2950   | Agilent (HP) 54600A / B 100 MHz Scopes from                     | £700  |
| Agilent (HP) 3562A Dual Ch. Dynamic Sig. Analyser                | £2750   | Agilent (HP) 8116A Function Gen. (50MHz)                        | £1500 |
| Agilent (HP) 3582A Spectrum Analyser Dual Channel                | £995    | Agilent (HP) 8349B (2- 20GHz) Amplifier                         | £1750 |
| Agilent (HP) 3585A and B Spec. An. (40MHz) from                  | £2500   | Agilent (HP) 8350B Mainframe sweeper (plug-ins avail)           | £250  |
| Agilent (HP) 35660A Dynamic Sig. An                              | £2950   | Agilent (HP) 85024A High Frequency Probe                        | £1000 |
| Agilent (HP) 4191A R/F Impedance analyzer (1 GHz)                | £2995   | Agilent (HP) 8594E Spec. An. (2.9GHz) opt 41,101,105,130)       | £3995 |
| Agilent (HP) 4192A L/F Impedance Analyser (13MHz)                | £3500   | Agilent (HP) 89410A Vector Sig. An. Dc to 10MHz                 | £7500 |
| Agilent (HP) 4193A Vector Impedance Meter                        | £2750   | Agilent (HP) 89440A Vector Signal Analyser 2MHz – 1.8GHz        | £7750 |
| Agilent (HP) 4194A Impedance Gain-Phase Analyser                 | £7000   | Agilent (HP) 33120A Function/Arbitrary Waveform Generator 15MHz | £850  |
| Agilent (HP) 4291B R/F Impedance Material Analyser               | £9750   | Agilent (HP) 53131A Frequency Counter                           | £750  |
| Agilent (HP) E4438C Vector Signal Generator(+various opts) cal'd | £17500  | Agilent (HP) 53181A Frequency Counter                           | £750  |
| Agilent (HP) 8508A (with 85031B) Vector Voltmeter                | £2650   | Agilent (HP) 4284A Precision LCR Meter                          | £5750 |
| Agilent (HP) 8970B Noise Figure Meter                            | £2250   | Agilent (HP) 6032A Power Supply (60V – 50A)                     | £2000 |
| Agilent (HP) E4420B Signal Generator 2 GHz                       | £2995   | Agilent (HP) 6671A Power Supply (8V – 200A)                     | £1350 |
| Agilent (HP) E4425B Signal Generator 3 GHz                       | £6650   | Agilent (HP) E4411A Spectrum Analyser (9kHz – 1.5GHz)           | £2995 |
| Agilent (HP) 8131A (opts 1 / 20) 500MHz High Speed Pulse Gen.    | £4550   | Agilent (HP) 8924C CDMA Mobile Station Test Set                 | £3000 |
| Agilent (HP) E4418B Power Meter                                  | £1275   | Agilent (HP) E8285C CDMA Mobile Station Test Set                | £3000 |
| Agilent (HP) 4396A Network / Spectrum Analyser 1.8GHz            | £7575   | Agilent (HP) 54520A 500MHz 2 Channel Oscilloscope               | £1000 |
| Agilent (HP) 3458A 8.5 Digit Multimeter (calibrated)             | £3850   | Agilent (HP) 54645D 100MHz Mixed Signal Oscilloscope            | £3000 |
| Agilent (HP) 54820A Infinium Oscilloscope 500MHz- 2Gs/s- 2Ch.    | £3450   | Agilent (HP) 8713B 300kHz – 3GHz Network Analyser               | £4500 |
| Agilent (HP) 4195A Network / Spectrum Analyser 500 MHz           | £5750   | Agilent (HP) 8592B 9kHz – 22GHz Spectrum Analyser               | £6250 |
| Agilent (HP) 8510B + 8515A Network An. + 'S' Parameter (26.5GHz) | £7750   | Amplifier Research 10W1000B Power Amplifier (1 GHz)             | £4700 |
| Agilent (HP) 8753A / 8753B / 8753C / with 85046A / 85047A        | various | Rohde & Schwarz XSRM Rubidium Frequency Standard                | £3750 |
| Voltech PM3000A AC Universal Power Analyser                      | £3000   | R&S SMG (0.1 – 1 GHz) Sig. Gen.                                 | £1750 |
| Agilent (HP) 4274A LCR Meter                                     | £1750   | Tektronix THS 720A 100MHz 2 Channel Hand-held Oscilloscope      | £1250 |
| Agilent (HP) 4275A LCR Meter                                     | £2750   | W&G PFJ 8 Error & Jitter Test Set                               | £4500 |
| Agilent (HP) 4276A LCR Meter                                     | £1400   | Wayne Kerr AP 6050A Power Supply (60V – 50A)                    | £1850 |
| Agilent (HP) 4278A Capacitance Meter (1KHz / 1MHz)               | £2500   | Wayne Kerr 3260A+3265A Precision Mag. An. with Bias Unit        | £5500 |
| Agilent (HP) 5342A Frequency Counter (18GHz)                     | £850    | Wayne Kerr 3245 Precision Ind. Analyser                         | £1750 |
| Agilent (HP) 5351B Frequency Counter (26.5GHz)                   | £2250   | Various other calibrators in stock. Call for stock / prices     |       |
| Agilent (HP) 5352B Frequency Counter (40GHz)                     | £3950   |   |       |



# 8085-BASED SINGLE BOARD MICROCOMPUTER

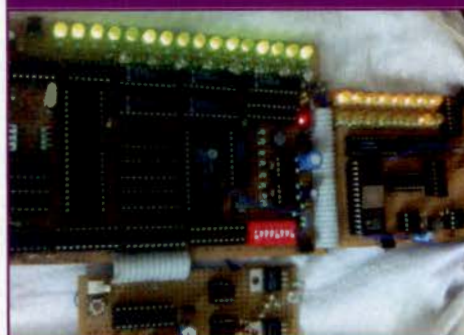
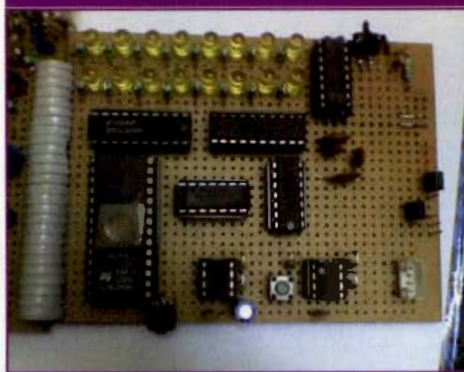
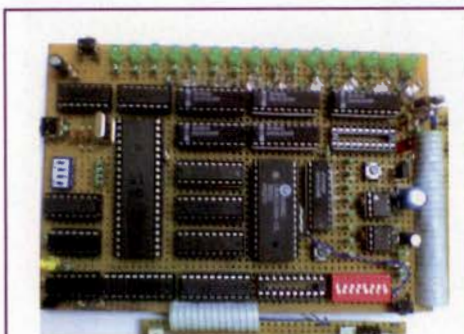
In this article, I present an 8085-based single board microcomputer, a dedicated hardware for robotics, automation and control, for wide-ranging applications and very useful to students. Its advantages include:

- The microcomputer contains dedicated hardware for program execution. It contains 256 pages of program memory, with each page containing 256 byte of program space. One of the 256 different programs can be selected using program page accessing switch and executed using a reset or trap button.
- The microcomputer contains separate hardware to select program pages, with a program page number [address] display LED.
- The RAM, as well as the EPROM, can be programmed on-board, not requiring separate programmers.
- The microcomputer is portable, as with an external battery power supply it can be used wherever needed.

## Applications

The microcomputer's applications include:

- In guided robots.
- In waveform generation, where the user can produce periodic signals, non-periodic signals, complex waveforms and so on.
- In small automation project. For example, in the execution of programs where a proximity switch needs to be activated (clearly, interfaced to the microcomputer).
- In stepper motor and DC motor speed control.
- High voltage switching circuits, when LED-Diac based opto-isolators are interfaced.
- By interfacing easy continuously operating type of A/D and D/A converters.
- The microcomputer can be used to measure small voltages, as well as send low voltages out.
- The microcomputer can be used to output direct temperature (degree C) when an A/D converter is interfaced. Equally, a hex output of the A/D converter is



*Different angles of the single-board computer*

converted into decimal readout. The lm35d is a convenient temperature to voltage transducer.

- The microcomputer can be used to measure the intensity of light when a photodiode or an LDR is interfaced to an A/D converter and the microcomputer. There are applications like switching when a threshold intensity of light is detected.

- Home electrical appliance automatic switching with the use of an external relay.
- Multiplexed display types of applications.
- The microcomputer can also used in applications such as infrared radiation measurements, ultrasonic transducer interfacing, liquid level measurement and others.

## The Switches

Swp1: Program page number(address) incrementer [EPROM]

Swp2: Program page address clear [EPROM]

Swd1: Program byte address incrementer [RAM or EPROM]

Swd2: Program byte address clear [RAM or EPROM]. 'Clear' means that the address goes to 0000

Reset: Program starts from address 0000

Trap: Program starts from address 24h

Swpe: If swpe is open-circuited this means that the system is in execution mode. If swpe is closed means system this means that it is in programing mode. During execution, lede1 glows.

Swr1: While the program is written into the RAM, swr1 is used. First, we need to select a memory location using swd1, and then we need to select the hex code the dip switch. Afterwords press swr1 to write the selected hex code.

Into memory location, press the switch until the lede2 goes off. As soon as lede goes into the on state, release the switch swr1.

Sp1/sp2: Sp1/sp2 is the switch used to select the program memory as being RAM or EPROM. If it is sp1, then the program memory is RAM; otherwise sp2 is the EPROM. One or the other selection has to be made at a time only, so it is convinient to use jumpers.

Sw pulse: The swpulse is the switch used to program the EPROM, so while triggering the swpulse switch the burst of square wave pulse is transmitted with a total time period of 1 ms, or a lower pulse width of 500 microseconds.



### Using the Microcomputer

#### \*Using the program memory as RAM

When using the program memory as RAM, the system power supply is switched on and the jumper settings are as follows:

A, b must be shorted

D, e must be shorted

First swpe must be closed to enter the system into the programming mode. The sp1 switch has to be closed to select program memory as RAM. Then swd2 is pressed to clear the address counter to 0000, so that all the address LEDs begin to glow.

Then the desired 8-bit code is selected using the dip switch. To write the code in the memory location, swr1 is pressed until lede2 goes to the 'off' state and the switch is released when lede2 goes into the 'on' state.

The address has to be incremented using swd1 and the desired code is selected using the dip switch. The swr1 is pressed so this step continues until all the code is written into the memory location.

After writing the codes, increment the address counter once then open circuit the swpe switch to enter the system into execution mode, followed by using reset or trap so that the program is executed. Reset executes the program from address 0000; whereas trap executes the program from address 24h.

The maximum program length written into RAM is 32kb, so only one program can be

executed using one interrupt.

#### \*Using program memory as EPROM

The hardware described here is a dedicated hardware just to execute a number of programs using only one interrupt. So, the maximum program length can be 256 bytes and as such 256 different programs can be executed by selecting the program page and then executing it.

Following the switching of the system power supply on, swp2 is pressed to clear the program page address counter and swp1 is used to select the program page. Swpe must be closed to enter the system into programming mode. Both sp1 and sp2 are open circuited (open-ended).

Swd2 is pressed to clear the address counter to 0000 so that all the address LEDs begin to glow. The jumper settings are as follows:

B, c must be shorted

H, i must be shorted.

Then the programming voltage is switched on and the desired 8-bit code is selected using the dip switch. Swpulse switch is pressed for 1 or 2 seconds then released. The swd1 is then pressed to increment the address, selecting the desired code using the dip switch. The code is written into the EPROM. Swpulse is pressed for 1 or 2 seconds then released.

The address has to be incremented using swd1 and the desired code is selected using

the dip switch. Swpulse is pressed so this step is repeated until all the code is written into the memory location.

After writing all the codes, increment the address once using swd1, followed by removing the programming voltage.

To execute the program present in the EPROM, the jumper settings have to be as follows:

A, b must be shorted

D, e must be shorted.

Only sp2 has to be closed. Open circuit the swpe switch to enter the system into execution mode, then using reset or trap the program is executed. Reset executes the program from address 0000, whereas trap executes the program from address 24h.

### Checking the Contents of the RAM

Jpc1 has to be closed circuit

Jpc3 has to be closed circuit

Jpc2 has to be open circuited.

By pressing swd1 we can increment the address and can analyse the data of the RAM being output to the LEDs.

While programming [RAM, EPROM]:

Jpc2 has to be closed circuited

Jpc3, as well as jpc1, have to be open-circuited.

### S. Vinay Kumar

The schematic of this design is on the next page.

## ORDER FORM – PLEASE HAND THIS TO YOUR NEWSAGENT

Please reserve one copy of Electronics World for me each month. I do/do not want the magazine delivering to my home address (delete as appropriate)

Name \_\_\_\_\_

Address \_\_\_\_\_

Post code \_\_\_\_\_

Telephone \_\_\_\_\_

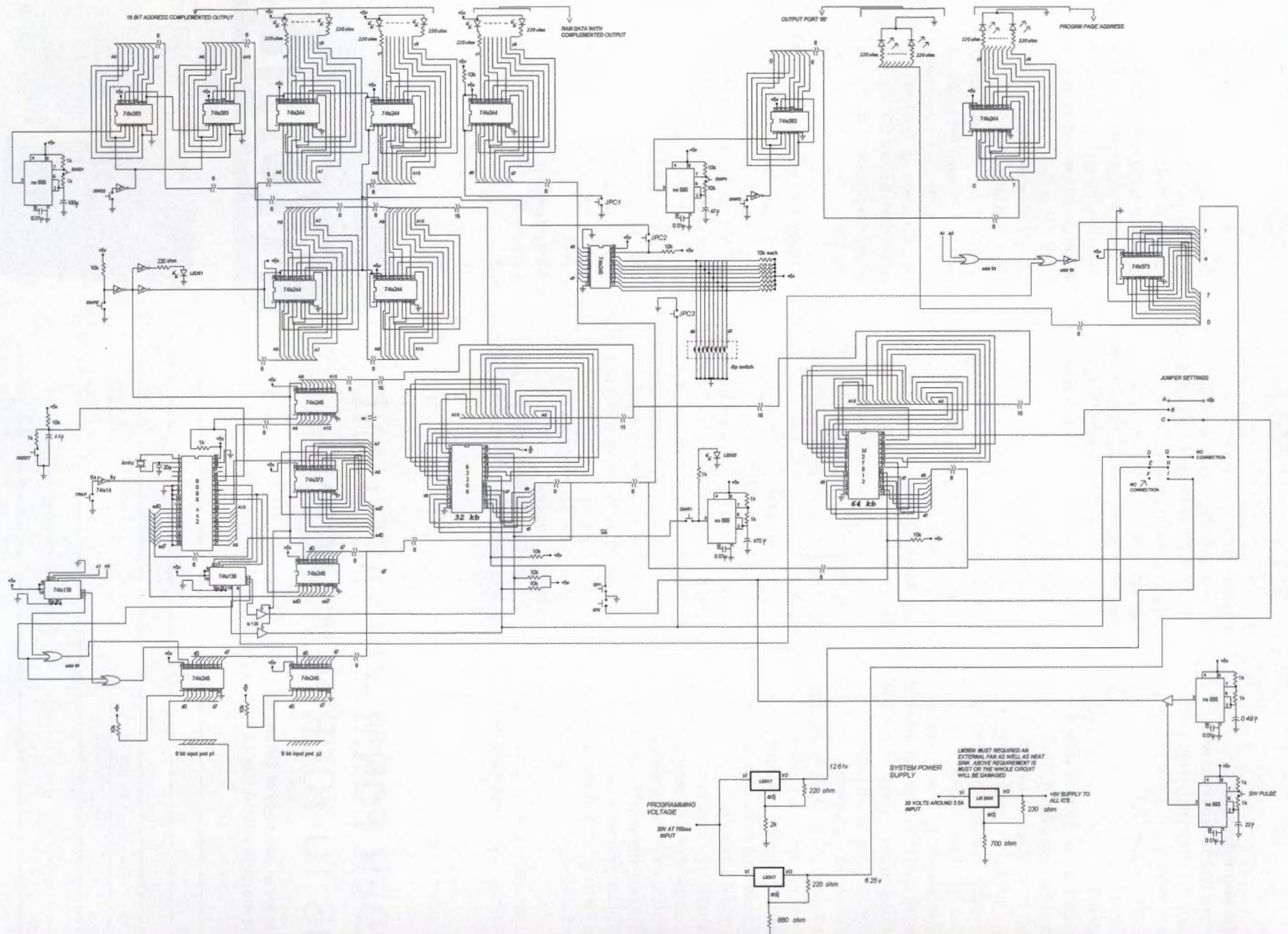
Date \_\_\_\_\_

Signature \_\_\_\_\_

# ELECTRONICS WORLD







Schematic of the single-board computer

LM309 MUST REQUIRE AN EXTERNAL PNP AS WELL AS HEAT SINK. ABOVE REQUIREMENT IS MET ON THE WHOLE CIRCUIT WILL BE DAMAGED

SYSTEM POWER SUPPLY

30 VOLTS AROUND 1.5A INPUT

12.6V

220 ohm

2k

20V AT 100ms INPUT

6.25V

220 ohm

800 ohm

10V SUPPLY TO ALL IC'S

230 ohm

700 ohm

SW PULSE

0.40p

0.01p

22p



PIC microcontrollers (MCUs) are used in a wide range of everyday products from washing machines, garage door openers and television remotes to industrial, automotive and medical products. While some designs such as Switch Mode Power Supplies (SMPS) are traditionally implemented using a purely analogue control

## TIP 1: AN ERROR DETECTION AND RESTART CONTROLLER

An error detection and restart controller can be created by combining **Tip 2** and **Tip 3**. The controller uses the PIC microcontroller (MCU) Analogue-to-Digital Converter (ADC) for making voltage and current measurements.

Input voltage, input current, output voltage, output current, temperature and more can all be measured using the A/D converter. The on-board comparators are used for monitoring faster signals, such as output current, ensuring that they do not exceed maximum allowable levels.

Many PIC MCUs have internal programmable comparator references, simplifying the circuit. Using a PIC MCU as a controller allows for a greater level of intelligence in system monitoring.

Rather than a single event causing a shutdown, a combination of events can cause a shutdown. A certain number of events in a certain time-frame or possibly a certain sequence of events could be responsible for a shutdown.

The PIC MCU has the ability to restart the supply based on the shutdown event. Some events (such as overcurrent) may call for immediate restart, while other events (such as overtemperature) may require a delay before restarting, perhaps monitoring other parameters and using those to determine when to restart.

It is also possible to build this type of error detection and restart controller into many of the tips listed within this guide.

## TIP 2: DATA-INDEXED SOFTWARE STATE MACHINE

A state machine can be used to simplify a task by breaking the task up into smaller segments. Based on a state variable, the task performed or the data used by the state machine can be changed. There are three basic types of state machines: data-indexed, execution-indexed and a hybrid of the two. This tip will focus on a data-indexed state machine.

The data-indexed state machine is ideal for monitoring multiple analogue inputs with the Analogue-to-Digital Converter (ADC). The state variable in these state machines determines which data is acted upon. In this case, the tasks of changing the ADC channel, storing the current result and starting a new conversion are always the same.

A very simple flow diagram for a data-indexed state machine is shown in **Figure 2**. As shown there, a constant array (CONSTANT[i]) can be created to store the values to be loaded into the ADC control register to change the ADC channel. Furthermore, a data array (ADCDATA[i]) can be used to store the results of the ADC conversion. Finally, the next conversion is started and the logic required to increment and bind the state variable is executed.

scheme, these designs can benefit from the configurability and intelligence that can only be realised by adding a microcontroller. **NOTE:** The tips 'n' tricks presented here assume a 3.3V supply. However, the techniques work equally well for other supply voltages with the appropriate modifications.

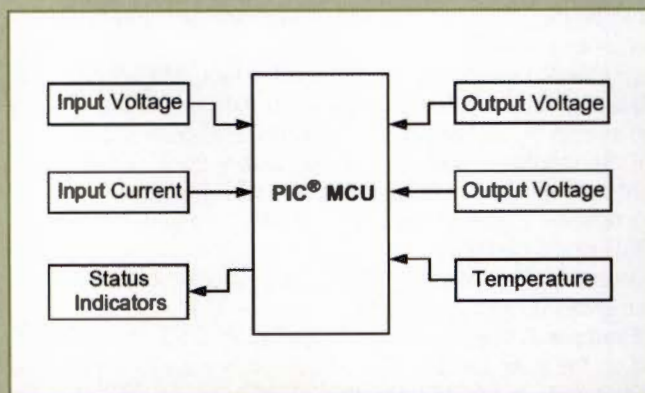


Figure 1: Block diagram PIC MCU

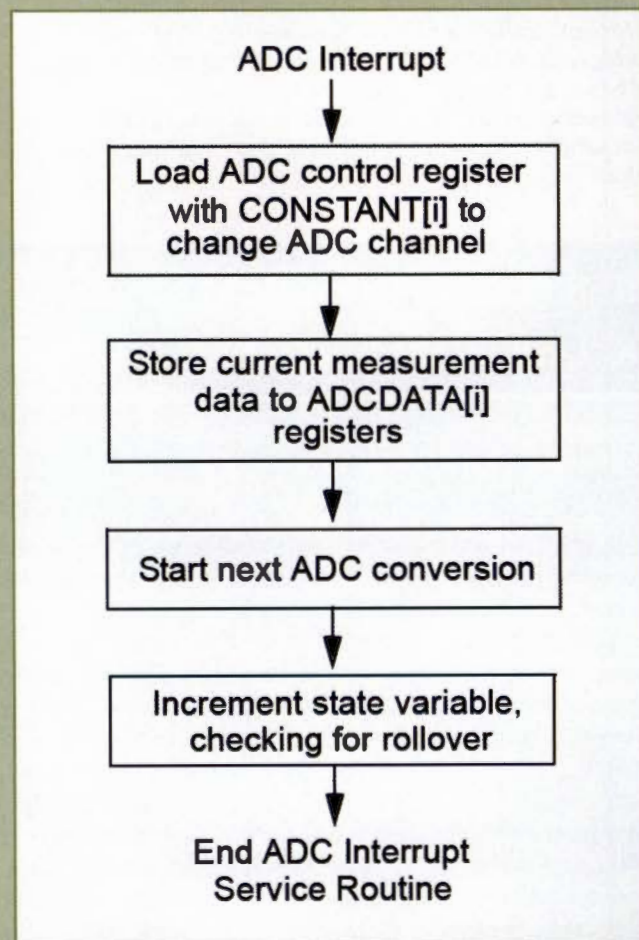


Figure 2: Data-indexed state machine flowchart



### TIP 3: EXECUTION-INDEXED SOFTWARE STATE MACHINE

Another common type of state machine is the execution-indexed state machine. This type of state machine uses a state variable in order to determine what is executed. In C, this can be thought of as the switch statement structure as shown in **Example 1**.

Each time the software runs through the loop, the action taken by the state machine changes with the value in the state variable. By allowing the state machine to control its own state variable, it adds memory, or history, because the current state will be based on previous states. The microcontroller is able to make current decisions based on previous inputs and data.

In assembly, an execution-indexed state machine can be implemented using a jump table.

In **Example 2**, the program will jump to a GOTO statement based on the state variable. The GOTO statement will send the program to the proper branch.

Caution must be taken to ensure that the variable will never be larger than intended. For example, six states (000 to 101) require a three bit state variable. Should the state variable be set to an undefined state (110 to 111), program behaviour would become unpredictable.

Means for safeguarding this problem include:

- Mask off any unused bits of the variable. In the above example, `ANDLW b'00000111'` will ensure that only the lower three bits of the number contain a value.
- Add extra cases to ensure that there will always be a known jump. For example, in this case, two extra states must be added and used as error or Reset states.

```
SWITCH (State)
{
  CASE 0: IF (in_key()==5) THEN state = 1;
          Break;
  CASE 1: IF (in_key()==8) THEN State = 2;
          Else State = 0;
          Break;
  CASE 2: IF (in_key()==3) THEN State = 3;
          Else State = 0;
          Break;
  CASE 3: IF (in_key()==2) THEN UNLOCK();
          Else State = 0;
          Break;
}
```

*Example 1: Example using switch statement*

```
MOVFW state      ;load state into w
ADDWF PCL,f      ;jump to state
                  ;number

GOTO state0      ;state 0
GOTO state1      ;state 1
GOTO state2      ;state 2
GOTO state3      ;state 3
GOTO state4      ;state 4
GOTO state5      ;state 5
```

*Example 2: Example using a jump table*

## Win a Microchip PICDEM FS-USB Demonstration and Evaluation Board plus an MPLAB ICD2!

Electronics World is offering its readers the chance to win a PICDEM FS-USB demonstration and evaluation board and an MPLAB ICD2.

The PICDEM FS-USB is a demonstration and evaluation board for the PIC18F4550 family of Flash microcontrollers with full speed USB 2.0 interface. The board contains a PIC18F4550 microcontroller in a 44-pin TQFP package, representing the superset of the entire family of devices offering the following features:

48MHz maximum operating speed (12 MIPS), 32Kbytes of Enhanced Flash memory, 2Kbytes of RAM (of which 1 Kbyte dual port), 256bytes of data EEPROM, Full Speed USB 2.0 interface (capable of 12Mbit/s data transfers), including FS-USB transceiver and voltage regulator.

The demonstration board provides the following functions:

20MHz crystal, serial port connector/interface (for demonstration of migration from legacy applications), connection to the MPLAB ICD 2 In Circuit Debugger, voltage regulation, with the ability to switch from external power supply to USB bus supply, expansion connector, compatible with the PICtail daughter boards standard, temperature sensor TC77 (connected to the SPI bus), potentiometer (connected to RA0 input) for A/D conversion demonstrations, 2 LEDs for status display, 2 input switches, reset button

The board comes pre-loaded with a USB bootloader that demonstrates the Enhanced Flash memory capabilities of the device. The PIC18F4550 can be re-programmed in circuit without an external programmer.

A CD-ROM is also included in the kit which contains full documentation about the board, application notes and software libraries for support of the HID, CDC and custom classes. Microchip is also giving away a MPLAB ICD2 to use with the PICDEM FS-USB Demo Board. For the chance to win these development kits, please log onto [www.microchip-comp.com/ew-fsusb08](http://www.microchip-comp.com/ew-fsusb08)





## TIP: FIXED OUTPUT BUS CONVERTER OPTIMISES SYSTEM EFFICIENCY SIZE AND COST

By Goran Perica, Linear Technology

Most telecom and industrial systems use a power architecture like that shown in **Figure 1**, where AC is converted to a system-wide 48VDC distribution bus, which is then converted at each application board to a 12V intermediate bus, which is again converted down to the core application voltages (1.8V, 2.5V, 3.3V, etc.) The advantage of this architecture is that each link in the modular power chain is in itself very simple, reducing application design time and time to market.

The first link in the chain is the standard, safety agency approved AC/DC converter (often called a silver box), which generates a 24VDC or 48VDC distribution bus. The 48V bus voltage is high enough to be a relatively efficient distribution voltage, but it is also safe, allowing engineers who don't have expertise in high voltage safety equipment or procedures to design board level power converters.

To further simplify board design, the 48V input is converted to a non-isolated 12V intermediate DC bus voltage on an application board. The 12V value is not required, nor is it always the best choice for an intermediate bus; it is just the most commonly used voltage. The 12V bus voltage is then converted to core voltages like 3.3V, 2.5V and 1.8V with simple non-isolated buck converters.

An intermediate bus converter can produce a constant output voltage or it can ratiometrically track the input (direct ratio converter). A constant output converter must monitor and regulate the output voltage, which can result in higher converter cost relative to a direct ratio converter.

A direct ratio converter provides no regulation; it simply generates an output voltage that is proportional to the input voltage. The direct ratio converter produces an output voltage range with the same ratio (usually 2:1) as the input voltage range. For example, if the input

voltage varies over 36-72V range the converter output may vary over 8-16V range.

If a direct ratio bus converter is used, the buck converters, which produce 1.8V, 2.5V, 3.3V etc, must be able to take the entire bus converter output range as input. Both, regulated or direct ratio converters, simplify the system design, but close attention should be paid to overall system performance when choosing the type of converter.

### System Efficiency Considerations

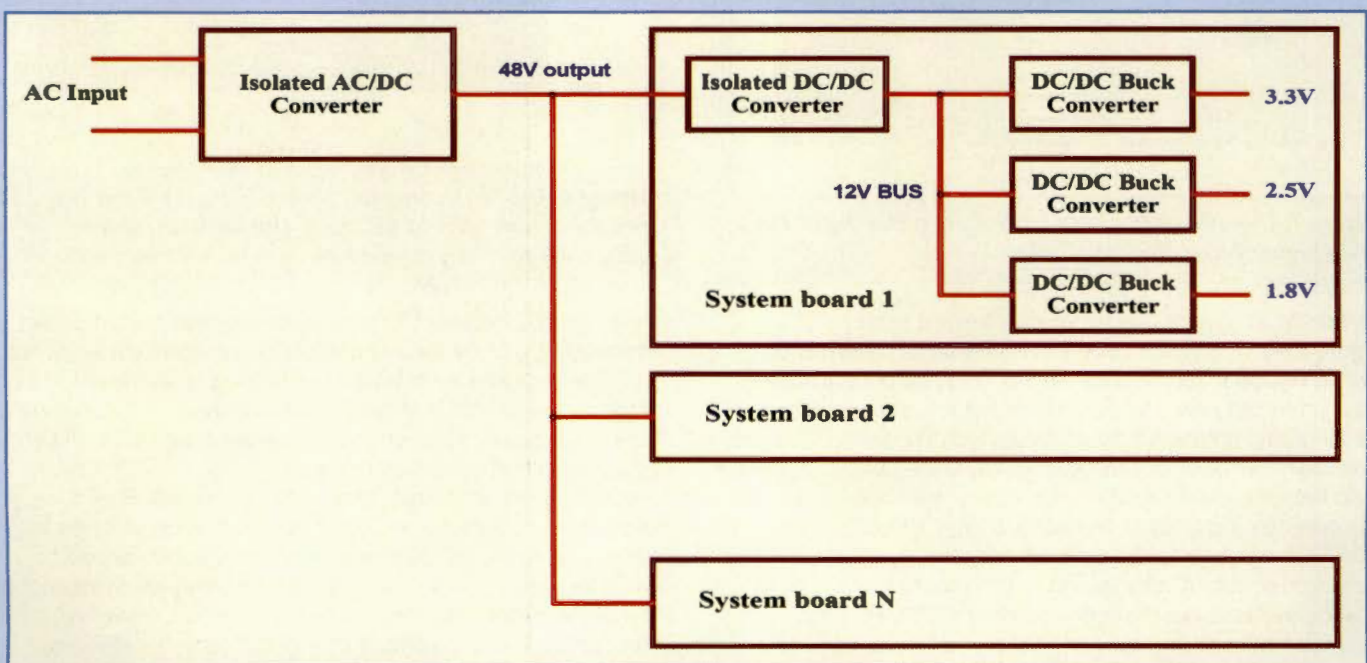
Modular simplicity and expandability are hallmarks of the power distribution architecture shown in Figure 1, but such ease-of-design comes at a cost. The main downside is that three power converters connected in series detracts the overall system efficiency as shown by:

$$\eta_{\text{SYSTEM}} = \eta_{\text{AC-DC}} + \eta_{\text{BUS}} + \eta_{\text{BUCK}}$$

Where  $\eta$  = Efficiency

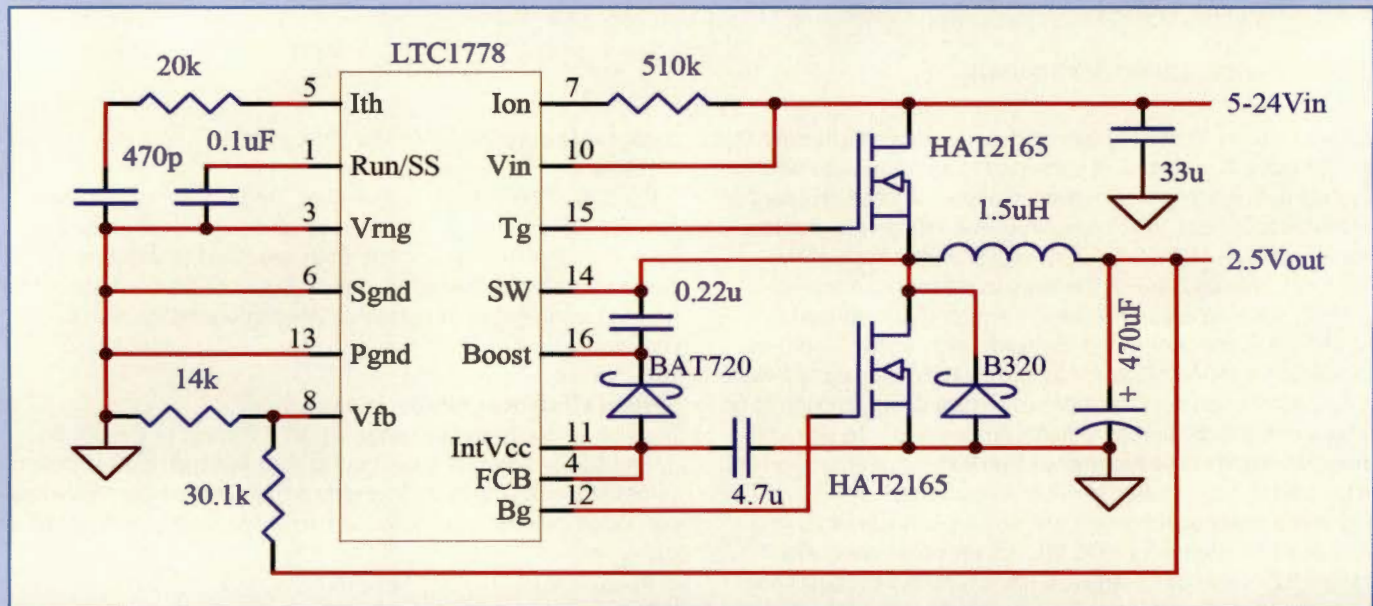
For example, if the efficiency of each block in Figure 1 is 90%, the overall system efficiency is 73%. If, however, the efficiency of each converter stage is improved by 1%, the overall efficiency jumps by 2.3% to 75.3%. It's not hard to see that in a large distributed system, with dozens, or hundreds of boards, a small improvement in efficiency at each conversion stage adds up to a significant power savings.

Overall system performance depends on the interaction of the bus converter and buck converters. For instance, if the bus converter produces a fixed output, the buck converter efficiency, size and cost can be optimised for the known bus voltage. Optimisation may not be as easy with a direct ratio bus converter because the buck

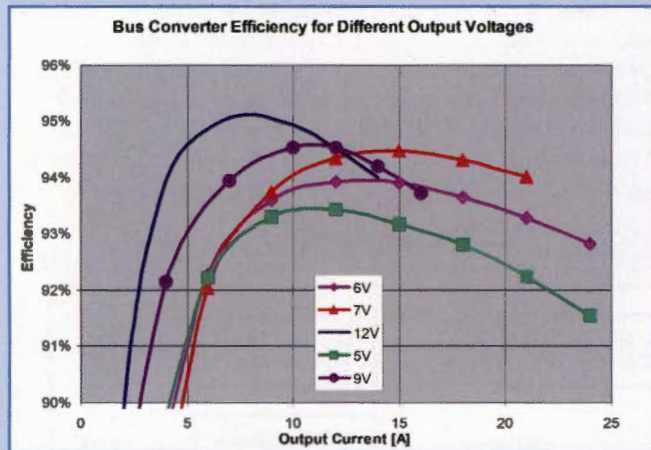


**Figure 1:** To keep power system design simple, AC power is converted to a 48VDC distribution voltage. Each system board converts 48V to an intermediate DC bus voltage, for example 12V, which is fed to non-isolated point-of-load buck converters

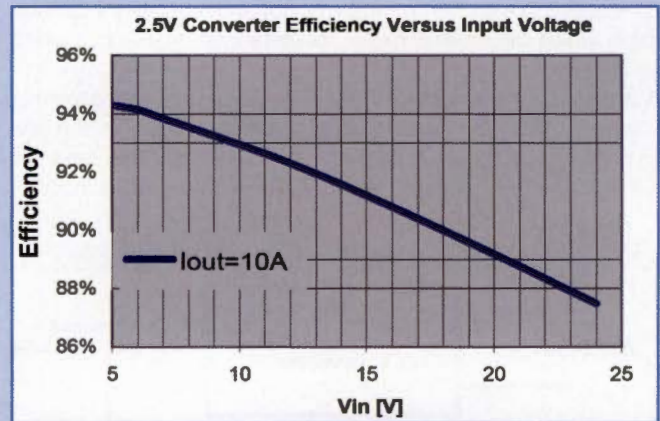




**Figure 2:** A typical synchronous buck converter is very simple and it can generate low voltage rails with efficiencies over 90%



**Figure 4:** The efficiency of bus converters generally goes up with higher bus voltages



**Figure 3:** The buck converter shown in Figure 2 has efficiency over 94% at 5V input. The buck converter efficiency generally goes down with higher input voltage

converters must operate over wider input voltage range.

**Figure 2** shows a typical buck converter, with its performance shown in **Figure 3**. This circuit is the model for the performance analysis presented here. The converter in Figure 2 operates over 5-24V input range and produces 2.5V at 10A output. The same circuit can be used to generate other core voltages anywhere from 0.8V to 0.9 •  $V_{IN}$ . To keep the analysis relatively simple, we will use four identical buck converters (Figure 2) all producing 2.5V at 10A output for a total of 100W. The analysis can be easily adjusted for any other combination of output voltages and loads. Also, to limit the scope of this article, we leave out the performance of AC/DC converter, which can be factored in at any time using the principles presented here.

### Choosing a Bus Voltage

What bus voltage is best? For most design engineers the answer is

simple, use 12V, because that is what was used on the last project. Unfortunately, that choice may result in lower system efficiency, hotter circuit operation and lower reliability. Choosing optimally-efficient bus voltage requires a little more work, including measuring the efficiency of the bus converter at various outputs and measuring the efficiency of the buck converters at various inputs.

Figure 3 shows an example of the latter data point. Buck IC manufacturers usually do not supply this information so it may be necessary to do the measurements in house. Efficiency should be plotted for the real world, worst-case load current, which may not be the maximum allowable output current of the buck converter.

The second step is to compile a set of bus converter efficiency curves for different output voltages, as shown in **Figure 4**. In this case, the 48V input is converted to 5V, 6V, 7V, 9V and 12V via fixed output DC/DC converters. The 12V output converter is shown in



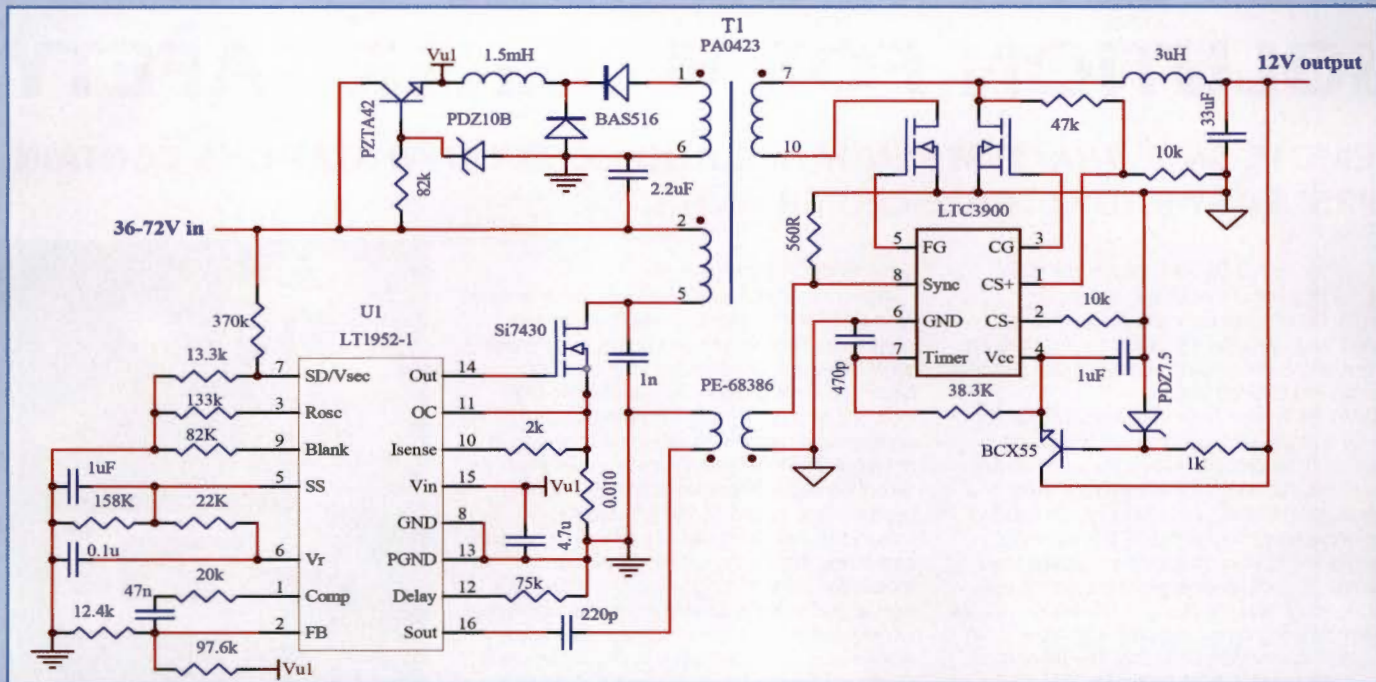


Figure 5: This simple 12V bus converter has peak efficiency of 95%, operates over full 36-72V telecom input and is easy to modify for different output voltages

Figure 5. The converters for the remaining output voltages are essentially the same circuit as that shown in Figure 5 except each is optimised with different transformers, output MOSFETs and inductors.

The third step is to calculate the system efficiency for each combination of bus converter and buck converter. For four buck converters shown in Figure 2, each producing 2.5V at 10A (or 25W of output power), the total load presented to each bus converter is:

$$P_{BUS} = P_{OUT} / \eta_{BUCK}$$

where  $P_{BUS}$  is the output power required from bus converter and  $P_{OUT}$  is the cumulative output power of all DC/DC buck converters. In this example  $P_{OUT}$  is  $4 \cdot 25W$  or 100W.

The last step is to calculate the required output current of each bus converter candidate:

$$I_{BUS} = P_{BUS} / V_{BUS}$$

For instance, a 5V bus converter must supply 21.2A to provide enough power to the load, considering the efficiency of the four bucks. Once this bus converter output current is calculated we can look up the bus converter efficiency at given output load and calculate total system efficiency:

$$\eta_{SYSTEM} = \eta_{BUS} \cdot \eta_{BUCK}$$

As mentioned earlier, to make the analysis simpler, the AC/DC converter efficiency is left out of these calculations and, besides, this efficiency is usually fixed by the choice of off-the-shelf silver box.

The calculated efficiency versus bus voltage is plotted in Figure 6. It may come as a surprise that the highest system efficiency occurs around 7V, since that is almost never used as a bus voltage. By using the above analysis it is easy to find out what configuration of converters will perform best at system level.

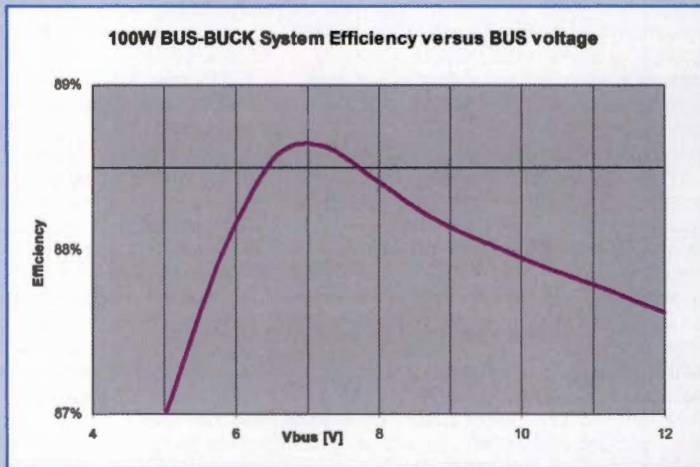


Figure 6: The overall system efficiency is highest for bus voltage of 7V. Different converters may result in a different optimal bus voltage and should be carefully evaluated to obtain highest system efficiency

### Whole System Consideration

By carefully considering the whole power system, efficiency can be maximised by selecting the optimal bus voltage for a particular application by using a few measurements and some simple calculations. In the end an optimised bus converter may be smaller, more flexible, require less cooling and be less expensive than an off-the-shelf 12V power module, thus meeting even most demanding application specifications.



# EASY-RADIO PROVIDES SOLUTION FOR WORKER SAFETY

**REMOTE SAFE TRACE-M PENDANTS AND CO BUDDY® STATIONS CONTAIN LPRS' EASY-RADIO TRANSCEIVER UNITS.**

**L**PRS, one of Europe's most successful integrators of industrial wireless communications solutions, has had its market leading modular wireless communications system easy-Radio designed into a unique personal location and tracking system.

Designed in New Zealand by Remote Safe Ltd, the Co Buddy®-range of products have been designed to automatically track the whereabouts of staff and monitor their safety. In the event of a worker going missing, becoming incapacitated or requiring emergency assistance, the system provides immediate notification ensuring a rapid response. In such an emergency the system will automatically relay the status of the worker to a 24 hour monitoring centre, typically within one minute of the incident occurring. The monitoring centre also has the ability to provide the location of the worker at any time.

The information received by the monitoring centre includes such details as the type of incident (duress, panic, or man down), the worker's name, their vehicle description, the current GPS position of vehicle and the worker's position in relation to a known fixed location (a Trace-M Waypoint or Locator).

The system was designed specifically to provide a "buddy" for lone workers, remote workers or multiple workers in high-risk industries (e.g. high voltage, oil and mining). This applies when they are working both above and below ground, and particularly where conventional communications are limited or unavailable. The manufacturers are receiving increasing interest from other sectors, to safeguard workers in health and other higher risk public services, local government, quarrying, warehousing etc.

Co Buddy® (Call out Buddy) Vehicle Systems are available as portable or fixed vehicle units and comprise a uniquely designed (Trace-M) individual 'Man Down' pendant and 'Control Unit', combined with a GPS unit and a Tait mobile radio. When a staff member is called out the Co Buddy® system is plugged into the vehicle (portable system) or switched on (fixed installation). This automatically sends an 'On Call' data message to the monitoring centre along with the GPS location of the vehicle. The worker then drives to their worksite. The monitoring centre tracks the vehicle remotely via GPS to ensure they arrive safely. On arrival at the job the pendant is removed from the Co Buddy® unit and attached to the worker. This automatically informs the monitoring centre that the person has "arrived on site" and gives the GPS location of the vehicle and any relevant fixed location that they are near (see Co Buddy®-Trace-M System). After completion of their work assignment, the worker returns the pendant to its holder, which sends an automatic "job complete" message to the monitoring centre. The worker then drives to the next location where the cycle is repeated or drives home (tracked via monitoring), where they sign off by pressing a single button on their Co Buddy®, which sends an "at home"

signal to the monitoring centre.

The Co Buddy® -Trace-M System (Trace Remote Alert Call Events - Monitor) was developed to support Co Buddy® Vehicle systems and is made up of a network of wireless devices (solar or battery powered), which are placed in strategic locations outside or inside a building, or underground complex, to provide a known fixed reference location. These devices can automatically detect Co Buddy® vehicle systems or Trace-M pendants (see below) and when used in conjunction with these devices, relay their location data to the monitoring centre. These are specifically designed to provide the location of a worker under duress where GPS is unavailable or where there is a requirement to actively track a worker around the complex (i.e. security or safety checks in high risk facilities). These devices all use the LPRS easy-Radio range of transmitter, receiver or transceiver modules.

To provide a robust and reliable method of data transfer to a monitoring centre, the Co Buddy® -Trace-M locators, waypoints and pendants have been designed to interface with the proven radio technology (conventional and trunking) of Tait Electronics. However Co Buddy®-Trace-M products are also capable of interfacing with other communications media such as cellular (GSM or GPRS) telecommunications, fibre optic and satellite.

The Co Buddy® -Trace-M pendant is the worker's lifeline and is the key component in the Co Buddy® Trace-M systems. The pendant is automatically armed when removed from its holder (either from a vehicle or in a building). It automatically communicates with the system of locators and stores location data as a worker moves around a complex. In the event the worker is injured or becomes incapacitated the worker can press the 'panic button' or the pendant will automatically send a "man down signal" which will be relayed to the monitoring centre. On activation the pendant also relays where the worker is in relation to the nearest locator (known fixed location) along with the nature of the emergency, (i.e. panic or man down) and the unique identifier code (user details), all within seconds of the event occurring. The pendant has a "crawl" function for when workers need to operate prone or in bent over positions and this deactivates the "man down" for a programmable length of time before it automatically resets itself. The pendant also has an "increasing chime alert" which prevents false activations of the man down feature.

All pendants can be detected by all Co Buddy® -Trace-M devices. For example: a lone worker travelling to a site (underground complex with a network of Locators on each floor) in a vehicle with a portable Co Buddy® Vehicle unit, will be monitored from his home to the site and then underground as he travels throughout the complex. Any activation of his pendant will relay who he is, the GPS location of his vehicle parked outside, the vehicle's registration, the known fixed



location of the locator he is nearest to (i.e. "11kva room, on level 3, North Eastern corner") and the nature of the emergency (panic signal or man down).

As part of their service commitments many organisations in high-risk industries have to provide after hours fault response. The person "on call" must be able to be contacted at any time of the day or night to respond to problems that occur in remote isolated locations with limited communication. These persons can often travel significant distances and attend to problems in highly dangerous environments (i.e. live electricity environment). Such workers are often by themselves with limited or no supervision and loose or minimal monitoring of their whereabouts and safety.

It has been a major concern for some time in a number of industries that there has not been a satisfactory means of monitoring the well being of such lone or remote workers or the ability to know when they are in need of assistance.

There is also a strong legislative requirement within an increasing number of countries to "take all practicable steps" to ensure the safety and well being of staff when working in an organisation. The sanctions for not doing so are also increasingly severe and can extend to very large fines for companies and even imprisonment for responsible company executives. The Co Buddy® system assists enterprises to comply with this requirement and avoid the risk of such sanctions.

Other benefits of the system include: knowing a worker's location at any time they are working, the automatic recording (via monitoring software) of the GPS co-ordinates as the worker moves about a complex, automatic recording of time, date and place as the worker perform his duties or passes specific key areas, among others.

For more information on how easy-Radio can facilitate your wireless system design, please visit [www.lprs.co.uk](http://www.lprs.co.uk) or call +44 (0)1993 709418.



## Triple-Output Stepdown Switching Regulator IC

The new A4490 from Allegro MicroSystems Europe is a triple-output stepdown switching regulator integrated circuit (IC) providing three high-current outputs that are adjustable from 0.8V to 5V with a maximum current of 2A.



Operating from an input voltage range of 4.5V to 34V, the A4490 uses multiphase switching to reduce electromagnetic interference and minimise stress on the input capacitors by interleaving the turn-on cycle of the regulators.

Features like soft start, power-on reset output and a small 4 x 4mm QFN package make this new device an ideal choice for many portable, office automation and consumer applications.

The A4490 uses 550kHz fixed frequency switching that allows the selection of small, inexpensive inductors and ceramic output capacitors. A charge pump is used to provide the supply to drive the power switches to ensure operation at very wide operating duty cycles and to avoid the need for power draining clamp circuits.

A power-on-reset circuit with programmable delay indicates when enabled regulators are in specification and a power-on reset flag indicates when the input voltage drops below specification. Internal diagnostics provide comprehensive protection against overloads, input undervoltages and overtemperature effects.

[www.allegromicro.com](http://www.allegromicro.com)

## High-Precision Power Analysers

Fluke has introduced compact, high-precision Fluke Norma Series Power Analysers with the latest power measurement technology to assist engineers with the development, testing and manufacture of motors and drives, inverters, lighting, power supplies, transformers and automotive components.



The series consists of the Fluke Norma 4000 Three-Phase Power Analyser and the Fluke Norma 5000 Six-Phase Power Analyser. Based on patented high-bandwidth architecture, the instruments deliver precision measurements of single or three-phase current and voltage, harmonics analysis (up to the 40th), Fast Fourier Transformation (FFT) analysis, as well as calculations of power and other derived values. They provide common mode rejection for any waveform, frequency, or phase shift.

Recorded data and waveforms can be viewed clearly in the large colour display and easily downloaded to a PC for analysis and report writing using the Fluke NormaView software supplied with the analyser.

The simple user interface ensures easy, intuitive operation, allowing users to specify the exact functionality required for their unique application. The Norma Power Analysers accurately display dynamic events on all phases at exactly the same point in time with simultaneous parallel acquisition of all phases.

[www.fluke.co.uk](http://www.fluke.co.uk)

## PC-Based Data-Acquisition System



The new Yokogawa SL1000 is a PC-based data-acquisition unit designed to provide high-speed data logging and fast data transfer in electro-mechanical and power measurement applications.

Featuring 100MS/s sampling on 16 channels and isolated inputs for high-voltage measurements, the SL1000 is also equipped as standard with intuitive, easy-to-use logging and control software for quick start and set-up.

The ability of the SL1000 to deliver independent, isolated-channel hardware at 100MS/s per channel rates, with no compromise in bit resolution, memory depth, or streaming performance, makes it

superior to high-speed digitisers that lack the isolation, attenuation or bit resolution necessary for power electronics testing. It also offers benefits over PC-based platforms with fast streaming throughput, which sacrifice noise immunity, signal conditioning and hardware integrity.

In addition to its high-speed acquisition, the SL1000 will transfer data to a PC or record to its internal hard drive at rates up to 1.6MS/s (3.2Mbyte/s). Data transfer is via USB 2.0 or 1000BASE-T Gigabit Ethernet. A stand-alone mode also allows data logging without a PC.

The high-speed acquisition rate is also available on a new 12-bit 1kV isolation module with 20MHz bandwidth.

[www.yokogawa.com](http://www.yokogawa.com)



## A New Encapsulation Process



A new way to encapsulate electric components and seal switches and wires has been developed by Power Adhesives of Basildon, UK.

Traditionally, the process involves the use of epoxy resins or

silicone-based products to prevent corrosion and moisture ingress. Silicones are slow to cure while epoxy systems need ovens to accelerate the process.

Power Adhesives has created a new process that reduces cost, increases process speed and involves no mixing or waste. The special polyamide hot melt potting compound TECBOND 7718 is applied using a conventional glue gun. It has a low viscosity, which allows the material to flow easily into small cavities. Once applied, the black potting compound prevents the encapsulated components being visible and ensures long-term stability of the device.

The product has a very fast-setting time of between five seconds and two minutes, depending on how much is required and the application temperature. This eliminates the need for drying racks, jigs, trays, etc.

The potting compound is supplied in the form of a 12mm diameter rigid stick, which is loaded into a conventional glue gun then dispensed in its molten form onto or into the component.

[www.poweradhesives.com](http://www.poweradhesives.com)

## Micro Card Edge Connector for 1.6mm PCB Applications



The new Harting Micro Card Edge connector is designed for surface mounting on 1.6mm-thick printed circuit boards (PCBs) in board-to-board mezzanine configurations, as well as in small pluggable daughterboard applications.

A key feature of the new connector is that it enables flexible but stable spacing between parallel boards to be achieved in configurations where small boards of different lengths are plugged between the connectors.

The Harting Micro Card Edge connector allows data transfer rates of up to 14Gbit/s and is available with 40 or 100 contacts in 0.8mm pitch.

An extremely smooth contact surface is achieved by the use of high-performance stamping tools, while a special surface finish ensures low insertion forces and high contact reliability.

The connector is also optimised for high-volume manufacturing with tape-and-reel packaging and pick-and-place machinery.

Harting connectors and network components are used in mechanical engineering and plant manufacturing, in automation systems, energy generation and distribution, and in electronic and telecommunication markets. Industrial connectors are also vital in construction machinery, rail vehicles and shipbuilding.

Harting offers Ethernet network components and cable systems for both indoor and outdoor networking applications involving power and data.

[www.harting.com](http://www.harting.com)

## Upgraded Automated Characterisation Suite Test System



Keithley Instruments has enhanced its Automated Characterisation Suite (ACS) software to include optional wafer level reliability (WLR) test tools for semiconductor reliability and lifetime prediction testing applications.

Version 4.0 builds on the ACS software's existing single and multi-site parallel test capabilities, adding a database capability, as well as software tools and optional licenses for the new Reliability Test Module (RTM) and ACS Data Analysis capabilities. Together, the new Reliability Test and Data Analysis tools allow ACS-based test systems to produce lifetime predictions as much as five times faster than traditional WLR test solutions. By accelerating WLR testing during the technology development, process integration and process monitoring phases of creating new integrated circuits, ACS systems can reduce time to market for new products

significantly.

ACS-based test systems have the hardware configuration flexibility necessary to address a wide range of semiconductor characterisation needs at the device, wafer, or cassette level. They can incorporate either Keithley's Series 2600 System SourceMeter instruments, the company's Model 4200-SCS Semiconductor Characterisation System, or both.

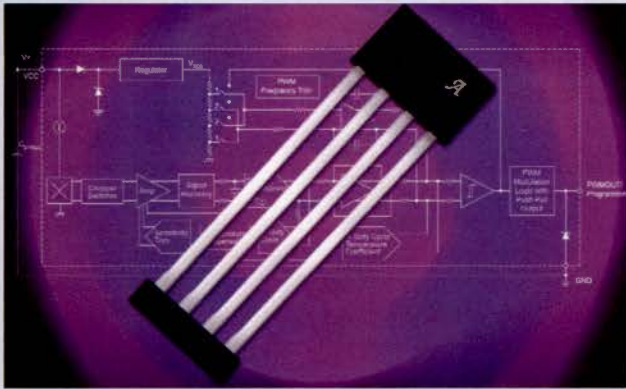
Wafer Level Reliability (WLR) testing is used to predict reliable lifetimes for semiconductor components such as transistors, capacitors and interconnects. These tests, performed on on-wafer test structures, can reveal critical reliability information during research and development. Similar tests are used to monitor the consistency of manufacturing processes once devices go into full production.

WLR testing is designed to accelerate failure mechanisms by stressing devices with elevated levels of voltage, current and/or heat.

[www.keithley.com](http://www.keithley.com)



## Precision Linear Hall Sensor



The new A1351 from Allegro MicroSystems Europe is a high-precision linear Hall-effect sensor IC with a 125Hz push/pull pulse-width-modulated (PWM) output that is proportional to an applied magnetic field.

The A1351 converts an analogue signal from its internal Hall sensor element to a digitally-encoded PWM output signal. The coupled noise immunity of the digitally encoded PWM output is far superior to the noise immunity of an analogue output signal, making the device ideally suited to current and position sensing applications in the automotive and industrial markets.

A BiCMOS monolithic circuit within the A1351 integrates a Hall element, precision temperature-compensating circuitry to reduce the intrinsic sensitivity and offset drift of the Hall element, a small-signal high-gain amplifier, proprietary dynamic offset cancellation circuits and PWM conversion circuitry.

The dynamic offset cancellation circuitry reduces the residual offset voltage of the Hall element, which is normally caused by device overmoulding, temperature dependencies and thermal stress. The high-frequency offset cancellation (chopping) clock allows for a greater sampling rate, which increases the accuracy of the output signal and results in faster signal processing capability.

[www.allegromicro.com](http://www.allegromicro.com)

## Low Phase Noise RF Reference Source



Fluke Precision Measurement has introduced the new Fluke 9640A-LPN (low phase noise) RF Reference Source, a higher-performance synthesiser designed to simplify RF calibration of the most demanding spectrum analysers, and improve calibration laboratory productivity for even more demanding workload coverage.

The phase noise specification of the Fluke 9640A-LPN is designed around maintaining adequate calibration margin capable of verifying the most demanding spectrum analysers, including the Agilent PSA series and Rohde & Schwarz FSU series, in a single instrument. Previous systems typically used two or more signal generators to cover close-in and far-out measurements, or simply did not have the necessary test accuracy ratio.

The Fluke 9640A-LPN Reference Source joins the Fluke 9640A in delivering level precision, dynamic range and 4GHz frequency capability in a single instrument. They can be used to calibrate a broad range of RF test equipment including spectrum analysers, modulation meters and analysers, RF power meters and sensors, measurement receivers, frequency counters and attenuators.

The Fluke 9640A-LPN and the Fluke 9640A are supported by a range of common RF workload procedures within the Fluke MET/CAL Plus Calibration Measurement Software.

[www.fluke.co.uk](http://www.fluke.co.uk)

## TTI Offers New Molex Mini-Fit Headers

TTI Inc, a passive and connector specialist, has boosted its product range with new Mini-Fit RTC headers from Molex. These devices provide an effective solution for mid-range power applications that require high-density and current carrying ability.

Designed with a high-temperature LCP housing that can withstand surface mount solder-reflow temperatures, the headers guarantee compatibility with lead-free RoHS reflow processes.

Sharing the same features of the Mini-Fit Jr devices, the new headers allow greater compatibility and reliability. More, Mini-Fit RTC's key design allows it to mate with standard Mini-Fit receptacle. Headers are available in circuit sizes 4 to 12, and 24 for full design flexibility.

[www.ttieurope.com](http://www.ttieurope.com)





## Downloadable-Data Automotive Instrumentation Website

Labcell, the specialist supplier of instruments for automotive and engine test applications, has updated its website and added numerous new PDF downloads.

This will be a great help to visitors who need easy access to detailed information.

Specifications and datasheets are available for Labcell's range of instruments including air-fuel ratio (AFR) analysers, air intake measurement instruments, blow-by monitors, exhaust gas recirculation (EGR) analysers and pressure calibration pumps. In addition, there is a useful selection chart for identifying the optimum AFR for particular applications.

To make access to the relevant documents as easy as possible, they are listed in the 'downloads' section and are available, as appropriate, directly from the web pages that describe individual instruments. As more information becomes available, further downloads will be added to the site.

In addition, Labcell has also added a 'News' section, where the company will post product innovations, customer case studies, and information about exhibitions and other events.

[www.labcell.com](http://www.labcell.com)



## 'Cook Book' for Cable Assembly Connector Kits

International franchised assembling distributor PEI-Genesis has brought out a new cable assembly 'cook book' that provides a step-by-step guide to designing, specifying and building cable assemblies.

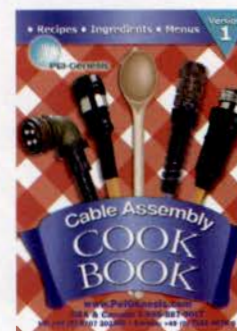
Starting with a number of standard cable design 'recipes', the cook-book uses a simple selection chart to help customers choose an appropriate design to match their requirements for criteria such as cable type, shielding and sealing. It then leads customers through the process of selecting, not just the right connector for the application, but also appropriate items from PEI's proprietary range of pre-tested and pre-matched backshells, shrink boots and other accessories, which offer a cost-effective solution for terminating the connector to the cable.

The complete kit of parts is supplied by PEI-Genesis in one bag with a single part number, thereby eliminating the need to order several different part numbers.

To make product selection as easy as possible, the 284-page cable assembly cook-book includes comprehensive data on 14 different ranges of connectors from leading manufacturers Amphenol and ITT Interconnect Solutions (ITT Cannon).

There is also an accessories section covering heat-shrink tubing, flexible conduit, potting compounds, cable ties and tools.

[www.peicookbook.com](http://www.peicookbook.com) or [www.peigenesis.com](http://www.peigenesis.com)



## New Med-eBase for Medical Equipment Test Records

Rigel Medical has introduced a powerful new software program dedicated to the efficient recording and management of electro-medical equipment safety testing records.

The new Med-eBase software has been developed for medical equipment companies and service firms to complement the recently introduced Rigel 288 advanced tester used to verify the status of electrical medical equipment in line with IEC 60601-1 and the new IEC62353 in-service safety testing standard.

The high performance database program is designed around Microsoft Windows user interface and allows the user to easily manage the transfer of data to and from the Rigel 288 tester using Bluetooth connectivity.

As well as all conventional equipment and test data, Med-eBase also has the facility to print out test certificates, store functional and performance test data and incorporate additional comments to

provide a comprehensive test database and asset management register for all medical equipment.

In this way, Med-eBase can be used to plan advance electrical maintenance schedules and re-test information can also be uploaded from the PC-based programme into the tester for fast preparation for re-test sequences.

Importantly, the new multi lingual program is SQL compatible and is therefore suitable for use by test engineers and medical facilities managers that utilise advanced database structures to hold medical equipment records.

Rigel Medical is part of the Seaward Group of test and measurement companies.

[www.rigelmedical.com](http://www.rigelmedical.com)





## CD of Semiconductor Device Test Applications



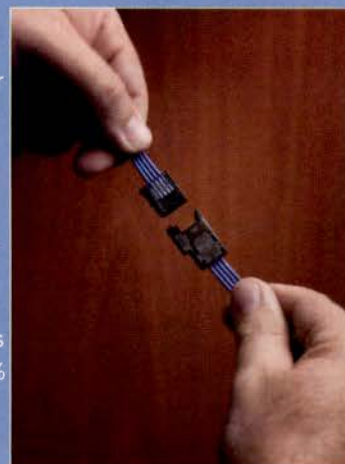
Keithley Instruments announced the availability of its 'Semiconductor Device Test Applications Guide'. In addition to the Applications Guide, this CD also includes a large variety of semiconductor test application information such as applications notes, white papers and presentations that enables users to reduce their cost of test while simplifying the most challenging applications.

The guide is divided into six main sections with topics including two-terminal device tests, bipolar transistor tests, FET tests, substrate bias and high power tests. The guide also features more than a dozen application notes on topics such as on-the-fly Vth measurements for bias temperature instability characterisation, increasing production throughput of multi-pin devices, optimising switched measurements, white papers on test sequencing instruments and the fundamentals of the LXI communication protocol, six presentations and an appendix of test scripts.

To request a free copy of the Semiconductor Device Test Applications Guide, visit [www.ggcomm.com/Keithley/May08PR\\_SemiAppsGuide.html](http://www.ggcomm.com/Keithley/May08PR_SemiAppsGuide.html) [www.keithley.com](http://www.keithley.com)

## New Mini-Clamp II Connectors

Technology company 3M has announced three new additions to the Mini-Clamp family of connector products: the Mini-Clamp II Wiremount Plug 371 Series, Boardmount Socket 372 Series and Wiremount Socket 373 Series. Target applications include factory automation and industrial controls.



The 3M IDC termination process enables time savings of up to 80% per connection, compared to manual crimping techniques. No specialist tools are required and terminations can be carried out using just a pair of pliers, helping to reduce the overall cost of wiring projects.

A key feature of the range is the use of 3M insulation displacement technology (IDC), which provides higher connection reliability, while at the same time eliminating cable stripping and tinning, as well as the need for repetitive screw-type wire terminations.

The 3M Mini-Clamp II connectors also have an integrated guiding and alignment feature built into the cover. Semi-transparent covers allow for visual inspection to check correct wire positioning prior to termination.

Polarising tabs help provide proper mating while latching features help provide a secure connection, even under severe conditions such as mechanical stress and vibration in industrial environments. [www.3M/UK/electronics](http://www.3M/UK/electronics)

## First Credit Card-Sized Computer-on-Module



Kontron unveiled the first extremely small (55mm x 84 mm) nanoETXexpress Computer-on-Module based on the low power Intel Atom processor. The nano form-factor is designed as an extension to the COM Express specification.

The credit card size, COM Express COM.0 Type 1 compatible Kontron nanoETXexpress-SP Computer-on-Module is the perfect fit for the next generation of ultra-mobile applications. With clock speeds between 1.1GHz and 1.6GHz, the Intel Atom processor offers excellent performance in a small and energy-efficient design (13 x 14mm).

The Intel Atom processor and single chip chipset (22 x 22mm), now called the Intel System Controller Hub US15W, have a TDP of < 5W. Compared with other

low power processors, the new chipset requires only one-seventh the size and uses only one-tenth of the energy. This makes the Kontron nanoETXexpress-SP Computer-on-Module ideal for ultra-mobile and embedded applications that require x86 processor performance, high-end graphics, PCI Express, USB 2.0 and Serial ATA combined with longer battery power. These applications can include handheld devices for medical or multi-media applications, small mobile data systems and a host of new applications that prior to now have not been possible due to size or power consumption constraints.

[www.kontron.com](http://www.kontron.com)



To reserve your website space phone Matthew Dawe 020 7933 8980  
or email [matthew.dawe@stjohnpatrick.com](mailto:matthew.dawe@stjohnpatrick.com)

## Beta Layout Ltd

[www.pcb-pool.com](http://www.pcb-pool.com)

The Best Value Online PCB Prototyping Service Available:  
Instant on line quotations & ordering (no pre registration).

We offer the following:

- No minimum quantity. • No tooling charges. • No drill Limitations. • 1 to 6 layers (prototype quantities) • 2 layers (small production batches) • Fr4, 1.6mm, 35 um, HASL (Pb free/Rohs/Weee) • Soldermask / Silkscreen (optional) • Leadtimes from 2-8 working days • Full DRC on all orders (we manually check every file !!!). • PCB-POOL®

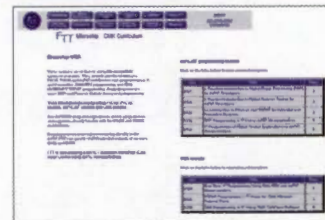


accepts direct outputs from 15 major layout softwares (see our website for details)  
Download our fully functional PCB LAYOUT software FREE of charge.  
Free Phone : 0800 3898560

## FTT

[www.ftt.co.uk/PICProTrng.html](http://www.ftt.co.uk/PICProTrng.html)

FTT (a Microchip Consultant Partner & Training Partner) has developed a range of courses – both distance learning and instructor led – covering Assembly and C Programming of PIC16, PIC18, PIC24 and dsPIC microcontrollers. For each processor family there are both C and Assembly programming courses at: • FOUNDATION LEVEL & • INTERMEDIATE LEVEL. For information about these courses, advanced courses and workshops such as: • Advanced C Embedded & Real Time Programming • TCP/IP & Ethernet • USB •



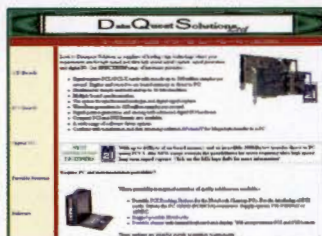
CAN • DSP • Motor Control • programming using Real Time Operating Systems such as uCOSII, CMX & Salvo and • other micro-controllers, please inquire.  
Tel: 020 8669 0769 Email: [pictng@ftt.co.uk](mailto:pictng@ftt.co.uk)

## DataQuest Solutions Ltd

[www.dqsolutions.co.uk](http://www.dqsolutions.co.uk)

As specialists in the supply of ultra high-speed instrumentation cards for the PC and industrial chassis, we provide an advanced product range with the following features:

- PCI, PCI-X, PCI-express & PXI formats.
- Signal capture (A/D) with sampling rates up to 500M samples/sec.
- Simultaneous sample and hold with up to 16 bits resolution.
- Waveform generation (D/A) to 125 million samples per second.



- Digital I/O and pattern generation for a wide range of logic levels.
- Storage of data to deep on-board RAM or PC memory.
- Fully portable systems for many types of card.

## Sky systems ltd

[www.sky-pcb.com](http://www.sky-pcb.com)

Sky Systems Ltd. was established with the vision and promise of providing manufacturing high quality, cost effective solution and one-stop service to meet the most demanding of our customers' requirements.

We offer the followings:

- 1-12 Layers • Fr-4 / Cem-3 • HAL (Lead Free), Flash Gold, Electroless Gold Plating, OSP, Immersion Silver, Immersion Tin • Gold Finger • Soldermask • Silkscreen • Routing / Punching / V-Cut • Online quotation • FREE PCB Prototype with quantity orders • Short



lead time • Fast worldwide delivery • Flexible quantity • CHINA Factory  
For more information or request a quote today from our web site.

## DB Technology

[www.dbtechnology.co.uk/](http://www.dbtechnology.co.uk/)

Anechoic chamber and open area test site.

- Compliance Tests
- Fixes included. FCC Listed.
- Flexible hourly booking available.
- Rapid, accurate pre-compliance tests.



## Telnet Ltd

[www.telnet.uk.com](http://www.telnet.uk.com)

Suppliers of quality second-user test and measurement equipment at prices you can afford. Manuals and accessories supplied. If you would like a quote, please call. We also purchase your surplus test equipment. Please call us for the best offers.



Mobile: 07860 400683  
Email: [dales@telnet.uk.com](mailto:dales@telnet.uk.com)

TELNET  
1 Stoney Court, Hotchkiss Way, Binley  
Industrial Estate, CV3 2RL  
Tel: 024 76650702 Fax: 024 76650773

## Designer Systems

<http://www.designersystems.co.uk>

Professional product development services.

- Marine (Security, Tracking, Monitoring & control)
  - Automotive (AV, Tracking, Gadget, Monitoring & control)
  - Industrial (Safety systems, Monitoring over Ethernet)
  - Telecoms (PSTN handsets, GSM/GPRS)
  - AudioVisual ((HD)DVD accessories & controllers)
- Tel: +44 (0)1872 223306



## Microchip Technologies

<http://www.microchip.com/>

Microchip Technology Inc. is a leading provider of microcontroller and analogue semiconductors, providing low-risk product development, lower total system cost and faster time to market for thousands of diverse customer applications worldwide. Microchip designs, manufactures, and markets a variety of high performance components for high volume, cost-effective embedded control solutions, including 8- and 16-bit PIC® microcontrollers; dsPIC® digital signal



controllers; development kits; serial EEPROMs, more than 350 mixed-signal analogue and interface products; KEELOQ secure data transmission products; and the PowerSmart® family of smart battery management products. Microchip's product solutions feature compact size, integrated functionality, and ease of development.



**ADVERTISING ENQUIRIES CONTACT MATTHEW ON: 020 7933 8980**

**ADVERTISING**

**EMC ADVERTISING GIFTS**  
1064 High Road, London, N20 0YY  
Huge range - All prices - Quick delivery

**PINNACLE GOLD Golf Balls**  
printed 1 colour  
24 packs of 15 @ £15.95 per pack

**TITLEIST PTS** printed 1 colour  
18 dozen balls @ £21.95 per dozen (12)

**GOLF SET**  
printed in 4 colours on markers  
50 sets @ £3.95 each.  
100 sets @ £3.25 each.

**EMC ADVERTISING GIFTS**  
Phone • email for catalogues  
tel: 0845 345 1064  
sales@emcadgifts.co.uk  
FULL CATALOGUE ONLINE  
www.emcadgifts.co.uk

**PCB DESIGN**

**SKY SYSTEMS LTD.**

**China Factory**

- \* 1 - 12 Layers
- \* High Quality
- \* Cost Competitive
- \* Flexible Qty
- \* World Wide Delivery

GS-9000  
UL  
ISO ROHS

Tel: (852) 2111 9428  
<http://www.sky-pcb.com>

**PRODUCT DEVELOPMENT**

**Creative Product Design**  
AV Accessories, Robotics & manufacturing

Automotive, AudioVisual, Telecoms, Marine, Industrial, Robotics

**Product Design and Manufacturing Services**

T. +44 (0) 1872 223306  
F. +44 (0) 845 8687573  
sales@designersystems.co.uk

**Designer Systems** consultant

**MICROCHIP**  
Consultant Program Member

for more information see our web site @ <http://www.designersystems.co.uk>

**ARTICLED WANTED**

**TOP PRICES PAID**

For all your valves,  
tubes, semi conductors  
and ICs.

**Langrex Supplies Limited**

1 Mayo Road, Croydon, Surrey CR0 2QP  
TEL: 020 8684 1166 FAX: 020 8684 3056

**BATTERIES/CHARGERS**

**ANSMANN energy**

**ANSMANN ENERGY (UK) LIMITED**  
Units 19/20, Maple Park, Essex Road,  
Hoddesdon, Herts, EN11 0EX, UK  
Tel: +44 (0) 870 609 2233  
Fax: +44 (0) 870 609 2234  
Email: info@ansmann.co.uk  
Web: www.ansmann.co.uk

**EMBEDDED SOFTWARE DEVELOPMENT**

**HARMONIC SOFTWARE SYSTEMS**

**EMBEDDED SOFTWARE DEVELOPMENT**

- ✓ REAL TIME SYSTEMS DESIGN, DEVELOPMENT & TESTING
- ✓ DIGITAL SIGNAL PROCESSING - TMS320, SHARC, DSP56K
- ✓ DEVICE DRIVERS, BSPs, LIBRARIES, FIRMWARE
- ✓ SAFETY CRITICAL TO SIL3, MISRA-C:2004, POSIX, VxWORKS
- ✓ VME, cPCI, PC104 OR CUSTOM HARDWARE

Tel: 01293 817635  
Web: [www.harmonicss.co.uk](http://www.harmonicss.co.uk)  
Email: sales@harmonicss.co.uk

Premium quality at a competitive price

**COMPONENTS WANTED**

Components wanted  
Excess/Surplus  
**www.mushroom.co.uk**  
**01234 363611**  
will collect anywhere in Europe  
Instant Cash Settlement

**DESIGN DEVELOPMENT & MANUFACTURE**

**Design Services**

- Switch Mode Power Supply Design
- Power Factor Correction Design
- Linear & Switching Amplifier design
- Protecting Intellectual Property
- Producing YOUR product
- Using OUR world class service
- Far East pricing & value
- Engineering & Testing Programme
- Global Logistics & Distribution

**class-d**

[www.class-d.com](http://www.class-d.com) or Telephone (01623 654 080)

**PCB DESIGN**

**DACS**

**Digital Audio and Computer Systems Ltd**  
High performance stereo pro-interface PCB £58.75

For information on these and other custom products:  
Website - [www.dacs-audio.com](http://www.dacs-audio.com), click "DACS Custom"  
Phone - 00 44 (0)191 438 2500

**PCB MANUFACTURE**

**PCBTrain**

No tooling charge  
5 or 10 DAY TURN AROUND

**Prototype PTH PCBs from just £30.00**

Prices published at [www.pcbtrain.com](http://www.pcbtrain.com)

The leading low-cost source for Prototype PCBs from 1-6 layers

+44 (0) 1635 40347  
f +44 (0) 1635 36143 e pcbtrain@newbury.tcom.co.uk

**FOR SALE**

**agar Circuits** *Super Fast Service*

**PCB DESIGN & MANUFACTURE**  
for both the Hobbyist and Professional

PCBs designed and produced from :

- Notes
- Schematics
- Specifications
- Descriptions
- Print - outs
- Gerbers

Available With or without component assembly

\* FREE \* PCB PROTOTYPE With Quantity Orders

Email: [adinfo@agarcircuits.com](mailto:adinfo@agarcircuits.com)  
Tel: 028 (90) 738 897



ADVERTISING ENQUIRIES CONTACT MATTHEW ON: 020 7933 8980

SERVICES

**PCB-POOL** 

- Prototypes at a fraction of the cost
- Tooling and setup included
- Industry standard quality
- Any contour

**FREE LAYOUT SOFTWARE!**

Follow up Services Runs •  
CAM/CAD Consulting •  
ONLINE Quotations •  
ISO-Approved •

FREE with first order (while stocks last) **Freephone 0800-3898560**

**WWW.PCB-POOL.COM**

Tel: +353 (0)61 701170  
Fax: +353 (0)61 701164  
sales@beta-layout.com

TRANSFORMER MANUFACTURE

**AUTOMATIC windings Ltd.**

**NEW**

Our new East European production plant for medium to high volume production is now fully operational.

We are pleased to offer an end to end solution for wire wound components Via a UK based company

D2, 4 Nimrod Way, East Dorset Trade Park, Wimborne Dorset. BH21 7SH.  
Tel: 01 202 87 21 01 Fax: 01 202 87 20 87  
E-Mail: sales@automatic-windings.co.uk  
Web: www.automatic-windings.co.uk






FOR SALE

**Agilent/HP3561A**

**Dynamic Signal Analyser**

**£1600.00 Inc. VAT**

**Excellent working Order**

**Good Cosmetic Condition**

**Operator & Service Manual**

**90 Day Warranty**

**Tel: +44(0)1454 315432**

**Email: sales@jelavender.fsnet.co.uk**



SURPLUS COMPONENTS FOR SALE

**new parts @ surplus prices**

**www.surplectronics.com**

REMOTE MANAGEMENT

**AWS Group Strengthens Management Team**



AWS Group, a UK specialist Electronic Manufacturing Services (EMS) provider, has announced additions to its senior management team, designed to support growth and improve the service the company delivers to its customer base. In the last few months, Mike Fairclough has joined as Group Sales Manager and Adrian Keane has been appointed Group Financial Director. Mike Berridge has also been given a board level position with responsibility to oversee Continuous Improvement and Strategic Development. AWS Group has grown under the direction of CEO, Paul Deehan, and now operates from

four sites in the UK and one in Slovakia. Currently the group turnover is around £40m. This enables the group to invest in the latest manufacturing technologies, yet still remain customer-focus. Deehan said: "We are investing in new businesses and in top line management. We plan further acquisitions of successful businesses that will strengthen our Group capabilities. We are also looking to open up facilities in the Far East and South America to support UK businesses wherever they choose to manufacture. To do this we need a strong management team." [www.awselectronicsgroup.com](http://www.awselectronicsgroup.com)



# The Proteus Design Suite

## Celebrating 20 Years of Innovation



- ↓ **1988** **Labcenter commences trading with PC-B for DOS**  
**1989.** First integrated autorouter added for PCB Design.
- ↓ **1990** **Schematic Capture added to PCB Layout package**  
**1991. World First** Schematic Capture for Windows™.  
**1992.** Topological route editing for easier PCB layout.  
**1993. Proteus** offers fully integrated circuit simulation.  
**1994.** Autorouter enhanced with Rip-Up and Retry algorithm.
- ↓ **1995** **Gridless, shape based power plane support**  
**1996.** True, mixed mode SPICE simulation introduced.  
**1997.** Interactive simulation - ideal for educational users.  
**1998.** PIC microcontroller simulation technology developed.  
**1999.** 8051 microcontroller simulation technology developed.
- ↓ **2000** **World First Interactive MCU co-simulation (VSM)**  
**2001.** High level language support added for MCU simulation.  
**2002.** ELECTRA adaptive shape based router interface added.  
**2003. World First** 32 bit MCU simulation support with ARM7.  
**2004.** Integration between **Proteus VSM** and MPLAB™.
- ↓ **2005** **Redesigned GUI across the Proteus Design Suite**  
**2006.** 3D visualisation engine integrated with ARES PCB Design.  
**2007. World First** USB schematic based USB Simulation.
- ↓ **2008** **Coming Soon:** Introduction of HDL support in simulation, ODB++ manufacturing output, improved core SPICE simulation algorithms, enhanced live DRC error checking and much more.

### LABCENTER ELECTRONICS LTD

A technology pioneer in the EDA Industry since 1988  
 Technical Support direct from the program authors  
 Flexible packages and pricing tailored to customer requirements.



**Labcenter**  **www.labcenter.com**  
**Electronics**

Labcenter Electronics Ltd. 53-55 Main Street, Grassington,  
 North Yorks. BD23 5AA. Registered in England 4692454  
 Tel: +44 (0)1756 753440, Email: info@labcenter.com



