

# ELECTRONICS WORLD

THE ESSENTIAL ELECTRONIC ENGINEERING MAGAZINE

VOLUME 112, ISSUE 1845



SEPTEMBER 2006 £4.60

**DIFFERENCE AMPLIFIERS**  
DESIGNING THEM IN  
**CURRENT GENERATION**  
USING OLD COINS



## PHASED ARRAY

THE TECHNOLOGY BEHIND THE DIGITAL SOUND PROJECTOR



**SPECIAL  
REPORT**  
AUTO-  
MOTIVE  
DESIGN

**PROFILE**  
PLAIN  
SAILING?



**TECHNOLOGY  
NEWS**  
BETTER SAFETY  
RADARS



ALSO IN THIS ISSUE: TIPS 'N' TRICKS • ROHS COMPLIANCE • CIRCUIT IDEAS

## featured products



£81.50

£61.00

### CAN-USB & CAN-232

affordable CAN Bus to USB and RS232 interface solutions

### Affordable CAN Bus Solutions

CANUSB is a very small dongle that plugs into any PC USB Port and gives an instant CAN connectivity. This means it can be treated by software as a standard COM Port (serial RS232 port) which eliminates the need for any extra drivers or by installing a direct driver DLL for faster communications and higher CAN bus loads. CAN232 is a very small dongle that plugs into any PC COM Port, or any other RS232 port in an embedded system and gives an instant CAN connectivity. This means it can be treated by software as a standard COM Port (serial RS232 port) which eliminates the need for any extra drivers. Sending and receiving can be done in standard ASCII format.

priced from £61.00 ( CAN-232 )

=== Bronze Prize Winner ===  
NASA Tech Briefs 2004  
Products of the Year



£125.00

### DS1M12 USB Scope / Logger

2 x 1MS/s Input Channels + waveform generator output. EasyScope & EasyLogger s/w included.

### USB Instruments - PC Oscilloscopes & Logic Analyzers

Our range of PC Instruments may be budget priced but have a wealth of features normally only found in more expensive instrumentation. Our DS1M12 and PS40M10 oscilloscopes have sophisticated digital triggering including delayed timebase and come with our EasyScope oscilloscope / spectrum analyzer / voltage and frequency display application software and our EasyLogger data logging software. We also provide Windows DLLs and code examples for 3rd party software interfacing to our scopes. Our ANT8 and ANT16 Logic Analyzers feature 8/16 capture channels of data at a blazing 500MS/S sample rate in a compact enclosure.

priced from £125.00 ( DS1M12 & ANT8 )



£36.00

### USB-2COM-M

2 Port Industrial USB RS232 Serial with wall mount bracket and DC auxiliary output

### 1 to 16 port USB to Serial Adapters

With over 16 different models available, we probably stock the widest range of USB Serial Adapters available anywhere. We offer converter cables, multi-port enclosure style models in metal and plastic, also rack mount units with integral PSU such as the USB-16COM-RM. Serial interfaces supported include RS232, RS422 and RS485. We also supply opto-isolated RS422 and RS485 versions for reliable long distance communications. All our USB Serial products are based on the premium chipsets and drivers from FTDI Chip for superior compatibility, performance and technical support across Windows, MAC-OS, CE and Linux platforms.

priced from £20.00 ( US232B/LC )



Low Profile Version  
also available

£65.00

£10.00

### UPCI-400HS

4 Port UPCI RS232 Serial Card with Spider Cable or COMBOX IO ( extra )

### UPCI Serial Cards

Discover our great value for money range of multi-port UPCI serial cards. Supporting from two to eight ports, the range includes RS232, RS422, RS485 and opto-isolated versions. Our 4 port and 8 port models can connect through external cables or the innovative wall mounting COMBOX.

priced from £21.00 ( UPCI - 200L )

## EasySync Ltd

373 Scotland Street  
Glasgow G5 8QB U.K.

Tel: +44 (141) 418-0181 Fax: +44 (141) 418-0110

Web : <http://www.easysync.co.uk>

E-Mail: [sales@easysync.co.uk](mailto:sales@easysync.co.uk)

\* Prices shown exclude carriage and VAT where applicable

# CONTENTS

## IN THIS ISSUE:



Technology – page 4



Company Profile – page 12



Products – page 56

- 03** ■ ■ ■ **Editor's Comment** | Another competitiveness speech
- 04** ■ ■ ■ **Technology**
- 08** ■ ■ ■ **Top Ten Tips** | On-line security
- 10** ■ ■ ■ **Insight** | The measurement industry rises to the challenge, by **Chris Martinez**
- 12** ■ ■ ■ **Company Profile** | Telecom Chameleon by **Juan Pablo Conti**
- 18** ■ ■ ■ **The Development of the Digital Sound Projector** |  
**Alex Bienek** explains the steps toward creating the perfect sound system
- 24** ■ ■ ■ **Difference Amplifiers are Different** | **Dietmar Schmid** presents the architecture of a difference amplifier and some of the challenges involved in designing it in
- 28** ■ ■ ■ **Designing Networks vs. Testing Networks** | **Thomas Heurung** and **Björn Westmann** explain that the best way to address performance and cost is at the design stage
- 34** ■ ■ ■ **Mechatronic Solutions for Automotive Local Networks** | **Herve Branquart** and **Bart De Cock** discuss mechatronic modules connected to the LIN infrastructure in automotive applications
- 38** ■ ■ ■ **Current Generation by Friction** | **Domenico Di Mario** presents the generating of current by the way of friction between two dissimilar metals
- 41** ■ ■ ■ **RoHS Forum** | **Gary Nevison** answers readers' questions relating to RoHS and WEEE issues
- 42** ■ ■ ■ **Carrier Ethernet Hastens IPTU** | **Paul Indoo** reveals the reasons behind the telecommunication industry's upheaval
- 44** ■ ■ ■ **Letters**
- 46** ■ ■ ■ **Book Review**
- 49** ■ ■ ■ **Circuit Ideas** | SMPS and brownout • VHF amplifier uses audio transistor
- 52** ■ ■ ■ **Tips 'n' Tricks** | 8-pin FLASH PICmicro microcontrollers
- 56** ■ ■ ■ **Products**

### Motor Drivers/Controllers

Here are just a few of our controller and driver modules for AC, DC, unipolar/bipolar stepper motors and servo motors. See website for full details.

#### NEW! PC / Standalone Unipolar Stepper Motor Driver

Drives any 5, 6 or 8-lead unipolar stepper motor rated up to 6 Amps max. Provides speed and direction control. Operates in stand-alone or PC-controlled mode. Up to six 3179 driver boards can be connected to a single parallel port. Supply: 9Vdc. PCB: 80x50mm. Kit Order Code: 3179KT - £11.95  
 Assembled Order Code: AS3179 - £19.95



#### NEW! Bi-Polar Stepper Motor Driver

Drive any bi-polar stepper motor using externally supplied 5V levels for stepping and direction control. These usually come from software running on a computer. Supply: 8-30Vdc. PCB: 75x85mm. Kit Order Code: 3158KT - £15.95  
 Assembled Order Code: AS3158 - £29.95



#### NEW! Bidirectional DC Motor Controller

Controls the speed of most common DC motors (rated up to 16Vdc/5A) in both the forward and reverse direction. The range of control is from fully OFF to fully ON in both directions. The direction and speed are controlled using a single potentiometer. Screw terminal block for connections. Kit Order Code: 3166KT - £16.95  
 Assembled Order Code: AS3166 - £25.95



#### DC Motor Speed Controller (100V/7.5A)

Control the speed of almost any common DC motor rated up to 100V/7.5A. Pulse width modulation output for maximum motor torque at all speeds. Supply: 5-15Vdc. Box supplied. Dimensions (mm): 60Wx100Lx60H. Kit Order Code: 3067KT - £13.95  
 Assembled Order Code: AS3067 - £20.95



### Controllers & Loggers

Here are just a few of the controller and data acquisition and control units we have. See website for full details. Suitable PSU for all units: Order Code PSU445 £8.95

#### Serial Isolated I/O Relay Module

Computer controlled 8-channel relay board. 5A mains rated relay outputs. 4 isolated digital inputs. Useful in a variety of control and sensing applications. Controlled via serial port for programming (using our new Windows interface, terminal emulator or batch files). Includes plastic case 130x100x30mm. Supply: 12Vdc/500mA. Kit Order Code: 3108KT - £54.95  
 Assembled Order Code: AS3108 - £64.95



#### Computer Temperature Data Logger

4-channel temperature logger for serial port. °C or °F. Continuously logs up to 4 separate sensors located 200m+ from board. Wide range of free software applications for storing/using data. PCB just 38x38mm. Powered by PC. Includes one DS1820 sensor and four header cables. Kit Order Code: 3145KT - £18.95  
 Assembled Order Code: AS3145 - £25.95  
 Additional DS1820 Sensors - £3.95 each



#### Rolling Code 4-Channel UHF Remote

State-of-the-Art. High security. 4 channels. Momentary or latching relay output. Range up to 40m. Up to 15 Tx's can be learnt by one Rx (kit includes one Tx but more available separately). 4 indicator LED's. Rx: PCB 77x85mm, 12Vdc/6mA (standby). Two and Ten channel versions also available. Kit Order Code: 3180KT - £44.95  
 Assembled Order Code: AS3180 - £51.95



#### NEW! DTMF Telephone Relay Switcher

Call your phone number using a DTMF phone from anywhere in the world and remotely turn on/off any of the 4 relays as desired. User settable Security Password, Anti-Tamper, Rings to Answer, Auto Hang-up and Lockout. Includes plastic case. Not BT approved. 130x110x30mm. Power: 12Vdc. Kit Order Code: 3140KT - £46.95  
 Assembled Order Code: AS3140 - £64.95



#### Infrared RC Relay Board

Individually control 12 on-board relays with included infrared remote control unit. Toggle or momentary. 15m+ range. 112x122mm. Supply: 12Vdc/0.5A  
 Kit Order Code: 3142KT - £47.95  
 Assembled Order Code: AS3142 - £66.95



### PIC & ATMEL Programmers

We have a wide range of low cost PIC and ATMEL Programmers. Complete range and documentation available from our web site.

#### Programmer Accessories:

40-pin Wide ZIF socket (ZIF40W) £15.00  
 18Vdc Power supply (PSU010) £19.95  
 Leads: Parallel (LDC136) £4.95 / Serial (LDC441) £4.95 / USB (LDC644) £2.95

#### NEW! USB & Serial Port PIC Programmer

USB/Serial connection. Header cable for ICSP. Free Windows XP software. Wide range of supported PICs - see website for complete listing. ZIF Socket/USB lead not included. Supply: 16-18Vdc. Kit Order Code: 3149EKT - £37.95  
 Assembled Order Code: AS3149E - £52.95



#### NEW! USB 'All-Flash' PIC Programmer

USB PIC programmer for all 'Flash' devices. No external power supply making it truly portable. Supplied with box and Windows Software. ZIF Socket and USB lead not included. Assembled Order Code: AS3128 - £44.95



#### "PICALL" PIC Programmer

"PICALL" will program virtually all 8 to 40 pin serial-mode AND parallel-mode (PIC16C5x family) programmed PIC micro controllers. Free fully functional software. Blank chip auto detect for super fast bulk programming. Parallel port connection. Supply: 16-18Vdc. Assembled Order Code: AS3117 - £24.95



#### ATMEL 89xxxx Programmer

Uses serial port and any standard terminal comms program. Program/ Read/ Verify Code Data, Write Fuse/Lock Bits, Erase and Blank Check. 4 LED's display the status. ZIF sockets not included. Supply: 16-18Vdc. Kit Order Code: 3123KT - £24.95  
 Assembled Order Code: AS3123 - £34.95



Most items are available in kit form (KT suffix) or assembled and ready for use (AS prefix).

**EDITOR:** Svetlana Josifovska  
**EMAIL:** svetlana.josifovska@nexusmedia.com  
**EDITORIAL EMAIL:** EWeditor@nexusmedia.com

**EDITORIAL ADMINISTRATION:** +44 (0) 1322 611274  
**EMAIL:** EWadmin@nexusmedia.com

**PRODUCTION EDITOR/DESIGNER:** Tania King  
**EMAIL:** tania.king@nexusmedia.com

**DISPLAY SALES EXECUTIVE:** Matthew Dawe  
**TEL:** +44 (0) 1322 611261  
**EMAIL:** matthew.dawe@nexusmedia.com

**PRODUCTION EXECUTIVE:** Dean Turner  
**TEL:** +44 (0) 1322 611206

**SUBSCRIPTIONS:** Customer Interface Ltd  
 800 Guillat Avenue, Sittingbourne,  
 Kent, ME9 8GU  
**TEL:** 0870 4287950  
**FAX:** 01458 271146

**SUBSCRIPTION RATES:**  
 1 year: £46 (UK); €120 (Europe);  
 \$145 (US & worldwide)

**PRINTER:** William Gibbons Ltd  
**ORIGINATION:**  
 Impress Repro A1 Parkway, Southgate Way,  
 Orton Southgate, Peterborough, PE2 6YN

**NEWSTRADE:**  
 Distributed by Seymour Distribution Ltd, 86  
 Newman St, London W1T 3EX

**PUBLISHING DIRECTOR:** Tony Greville

If you are experiencing problems getting copies through your newsagent, please call Debbie Jenner on +44 (0) 1322 611210

ISSN 0959-8332



## Another Competitiveness Speech

Competitiveness is never too far away from the mind of the UK government. Well, at least never too far from the lips of its PR posse. And so, we come to yet another area of interest to the UK government ministers, identified to deliver the UK the competitive edge it desperately needs – photonics. In July the government launched a £3.3m Knowledge Transfer Network – the 20th in its competitiveness arsenal – this time to focus on the identification of opportunities for British businesses in the field of photonics and commercialisation of home-grown IP, devices and services. At the launch, they said: “The UK has a world-class research in photonics.” They said, “The UK has the perfect skills for this sector” and “The UK has an active [photonics] community.”

Lord Sainsbury, the minister for science and technology stated that the photonics is the future technology of importance: “Photonics will be as important as microelectronics is now and steam engines were in the past.”

That comment is interesting in itself – for the government to have selected microelectronics as a point in case when illustrating success is particularly poignant. The UK has never been seen as successful in microelectronics: there aren’t any semiconductor makers here and there aren’t any particularly large indigenous electronics firms here either; just a few IP suppliers, of which the most successful is ARM. But one swallow does not make a summer and, if anything, the UK missed out big time in microelectronics. Year after year the country was severely criticised by the EU for not participating in large cross-country collaborative projects, such as MEDEA+ for example.

And here lies a potentially big danger zone for the fledgling photonics sector. Can the UK achieve this success in isolation? Nowadays, any serious research requires serious funding, serious skills and serious tools. If all we currently have is photonics SMEs of below 30 people each, our competitiveness will be a long time coming, because these companies will always miss at least one of these three parameters to make it big. Hence, cooperation is key, and not just cooperation with firms and academia within the UK but from abroad too – let’s join big EU photonics projects if there are any, or indeed why not instigate some. As the former CEO of German IC giant Siemens Semiconductor (later known as Infineon Technologies), Jurgen Knorr, once famously said about Philips: “We cooperate in the morning [through joint programmes] and compete in the evening”. Clearly, this indicates that cooperation, even with potential competitors, will not take that competitive edge away.

The other point I want to make about our competitiveness is that if photonics has been flagged up as the future growth area, why don’t we endeavour to create a large, buoyant manufacturing industry around it now? We will need companies that will manufacture in high volumes in the UK. This will mean mega-funding and the government is perfectly positioned to make this happen. But, will its talk of competitiveness show through actions, or remain just a lip service? It’s to be seen. According to the government officials, it will be five to 10 years before photonics opportunities are properly harvested. Let’s see what comes out of the ‘competitiveness speech’ then.

**Svetlana Josifovska**  
 Editor

Electronics World is published monthly by Nexus Media Communications, Media House, Azalea Drive, Swanley, Kent, BR8 8HU. Nexus Media Communications is a trading name of Nexus Holdings Limited. Registered in England. Registered Number 5346404. Registered Office: Hanover House, 14 Hanover Square, London W1S 1HP.

**Disclaimer:** We work hard to ensure that the information presented in **Electronics World** is accurate. However, **Electronics World’s** publisher – **Nexus Media Communications** – will not take responsibility for any injury or loss of earnings that may result from applying information presented in the magazine. It is your responsibility to familiarise yourself with the laws relating to dealing with your customers and suppliers, and with safety practices relating to working with electrical/electronic circuitry – particularly as regards electric shock, fire hazards and explosions.

## Radar units expected to take off in cars

Demand for next-generation, millimetre-wave radar in cars is likely to soar in the near future, based on a growing use of pedestrian detection, lane-change warning, collision warning, rear closing vehicle warning and side-impact warning applications, says academic from the University of Birmingham.

"Expect some 35,000 radars to be supplied per day to meet demand for these applications," said Dr Edward Hoare from the school of engineering at the University.

Radar is already been used by several vehicle makers, including Jaguar, Mercedes-Benz, BMW, Honda and Lexus, for adaptive cruise control, blind-spot monitoring, and front and rear parking assist. Lucas, Philips, GEC, Hughes, DASA, Vorad and others have all done work on mm-wave radar since the 1980s. "Some of them did fantastic radars, but they underestimated how difficult it is to create a mass product – high-tech and yet at \$10 a piece," said Hoare.

According to Cambridge Consultants's Dr Hugh Burchett, today's advances in signal processing, RF technologies and digitisation have allowed single-board designs, which lower costs significantly. "Single radar with sensors and software is very processor-intensive and it is quite a feat [to do]. But, we need to do everything in the bill-of-materials range of below \$100," said Burchett.

There are several operating bands for automotive radar – 76GHz narrow band, 24GHz narrow band and 24GHz ultra-wide band (UWB) – and such systems are already in production. The 76-81GHz UWB and 152GHz radars are currently being researched. Modulation techniques used with radar range from



Engineers at Cambridge Consultants have combined video with automotive radar and sensors to detect pedestrians. It only takes four sensors to enable thirteen programmable alarm zones to be formed to support safety and convenience features

FMCW, pulse and FSK with different type of antennas, including horn, parabolic reflector, patch fed lens and planar array. Angle measurements to date have been applied with 2-beam mono-pulse, mechanical scan, beam forming, quasi-optic and multiple-sensor triangulation.

Future vehicles will fuse data from mm-wave radars with vision, navigation, communications and vehicle dynamics to provide greater safety and convenience. Such developments lend this technology to other applications too, outside the automotive world, says Hoare. "The industry itself would like to see other application for these radars: surveillance, transport, ship docking, supermarket door openers and others – they want to see large markets".

## Hospitals get the Star Trek technology treatment

Pagers, phones, radios and even mobile phones used in hospitals have now been replaced by a wearable badge, thanks to a technology from the US firm Vocera Communications.

The system combines wireless LAN, voice over IP (VoIP) and speech recognition to deliver a simple communications means to medical personnel. In a scenario reminiscent of Star Trek, doctors can simply speak the name of the person into a badge, then the IVR system recognises the name and the PBX routes the call over WiFi to that person. They can also broadcast messages or locate a person, based on a triangulation method which locates the wearers of these communicating badges.

"By simply pressing a button on the badge and asking the system to call by name, title or function, staff will be instantly connected to colleagues they need anywhere in the hospital's wireless environment," said Paul Duffy, IT manager at the Royal Hospitals, the first chain of medical facilities to adopt Vocera's technology in the UK. "Nurses are especially excited about this solution because they will save time tracking down staff and resources and will be able to spend more time with patients.



Modern-day technology gets closer to the Final Frontier

# Speakers get an IP address in digital overhaul

The next generation of home electronics are going to have IP (Internet Protocol) addresses each so that they can communicate via the TCP/IP protocol. This will include all audio and video systems, surveillance and security systems, HVAC, in-door wireless networks and, to the greatest dismay of some, speakers.

"The [home] experience is going digital," said Herman Cardenas, founder and CEO of NetStreams, based in the US. "Today, all devices are stand-alone. It can be difficult to integrate them all and make them share content."

Some would argue that speakers cannot be digital, however, there's a growing trend to integrate the amplifier into the speaker itself, so that digital data can easily be 'pushed' around in the network. "IP speakers will give expensive speakers run for their money in terms of quality," said Cardenas. "IP will deliver audio exactly as it comes out of the source. It is a myth that IP is not good for [delivering] high-quality audio."

According to Cardenas, in the near future, speakers will become more intelligent. They will be able to adjust themselves automatically in any environment to deliver the best sound, even in instances when they get moved around, in a full room or an object or a person is blocking their output. Speakers will have built-in microphones for room acoustic equalisation; they will use meta data for real-time adaptive equalisation; they'll offer automatic frequency response correction and automatic "sweet spot" optimisation; they will even talk. "They will warn you of fire or smoke or accept commands to switch systems on or off in the house," said Cardenas.

Despite the speakers going completely high-tech, going digital will help connect and configure the rest of the electronic equipment in the home a lot easier than it has been until now.

"Proprietary networks are always difficult to install but, based on IP this will become so easy that school kids will be able to install and configure home electronics," added Cardenas. "All audio and video products will migrate from a centrally controlled architecture, where audio and video content in a home is distributed from a 'central box' as it is today, to one where the content is 100% digital and distributed, and managed across a home's CAT-5 network as computing products are today."



*Is the future in IP-interfaced multimedia systems?*

# Road to mobile TV is littered with problems

The TV broadcasting to mobile handsets promise is plagued with problems from the very outset, including multiple standards, lack of good performance low-cost receivers and allocation of spectrum in some countries, including the UK.

"The UK is having a bit of a nightmare with the [allocation of UHF] frequencies," said Yannick Levy, CEO of DiBCom, France-based supplier of mobile TV chipset.

Spectrum matters are being looked into by governmental bodies at present and are expected to be resolved by the year-end. "There are a lot of issues involving [the allocation of] spectrum, but by the end of the year at least, we'll hear more from the authorities of how this is going to be allocated," said Les Sabel, VP of technology at British DAB solutions supplier Radioscape.

However, even though the spectrum issues might be cleared up, there are plenty of technical challenges for the receiver itself that will need to be overcome. "In mobile phones there are several issues that don't exist [as problems] in set-top boxes, such as fading, sensitivity levels, the channel performance, FFT leakage, in-door coverage, the antenna issue and so on," said Levy.

On top of that, these receivers have to be of low enough cost to guarantee high volume take-up. But, despite so many problems, broadcasters across the world have started to roll out mobile TV services. DVB-H was launched in Italy and Finland in time for the World Cup; Germany did the same but with a different standard called T-DMB, which is also adopted in Canada. Japan has its own technology – ISDB-T, whilst the US has opted for MediaFlo, which modulation-wise is closest to DVB-H. In addition, DAB-IP is readied for an imminent roll-out in the UK, too.

Radioscape's Sabel said: "It's all about consumer demand. If they want mobile video we'll need to have it ready."



*Mobile TV proves a tough feat for a generation of suppliers*

1394 is being strongly challenged by USB in the PC and peripherals markets, says a report from market research firm In-Stat. However, digital televisions, cable set-top boxes and DVD recorders are all driving 1394 growth in the consumer electronics segment. In addition, the High-Definition Audio Video Networking Alliance (HANA) has endorsed 1394 as a transmission medium for high-definition content, a development that may spur adoption of 1394 in home video networks.

In the PC world, 1394 has had success in notebook PCs, but has struggled in corporate desktops, which account for a significant share of PCs sold annually.

\* \* \*

Halifax in the UK is set to become home to a European Centre for Automatic Identification and Data Capture (AIDC) technologies. Yorkshire Forward will invest over £5m in the centre, with additional funding from the Department of Trade and Industry, the European Regional Development fund and AIM UK.

AIDC technologies cover a range of products, including barcodes, biometrics, magnetic strips, Radio Frequency Identification (RFID) and smart cards. The market for RFID systems and services worldwide is growing at 30% a year, and is expected to reach almost \$12bn by 2008.

\* \* \*

Ofcom plans to release radio spectrum which could be used for a range of new broadband, wireless communications and broadcast services by both businesses and consumers. The body intends to auction licences for frequencies at 10GHz, 28GHz and 32GHz on a technology and application-neutral basis in the latter half of 2007.

Potential uses of these bands include broadcasting use for video links and wireless cameras; high-capacity, high-speed data connections for mobile and fixed broadband networks; and broadband access networks.

## HDMI 1.3 is the new standard for HD electronic devices

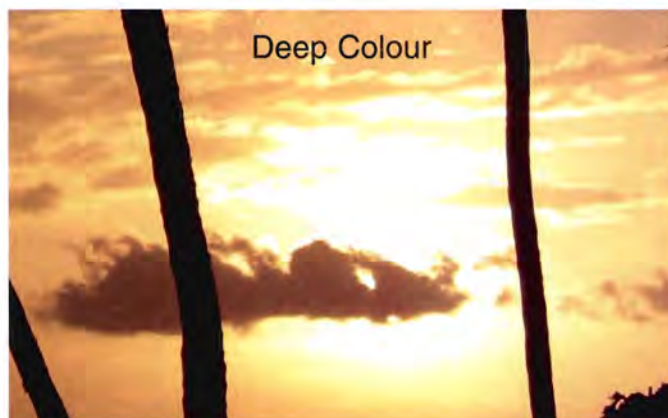
A major new version of the High Definition Multimedia Interface (HDMI) – version 1.3 – for connecting consumer electronic devices has just been launched by the seven HDMI founder companies: Hitachi, Matsushita, Philips, Silicon Image, Sony, Thomson and Toshiba.

HDMI 1.3 will enable the next generation of HDTV sets, PCs and DVD players to transmit and display content in billions of colours. The colour depth is now higher at 30-bit, 36-bit and 48-bit (RGB or YCbCr), up from the 24-bit depth in previous versions of HDMI. HDMI 1.3 covers xvYCC, which supports 1.8 times as many colours as existing HDTV signals, whilst eliminating on-screen colour banding. The bandwidth has also now doubled from 165MHz, or 4.95Gbit/s, to 340MHz, or 10.2Gbit/s. In addition, there's a mini connector

which will allow easier integration of the interface in portable devices, such as digital still cameras and camcorders.

HDMI has a bi-directional route, allowing certain intelligence to be built into it. "The interface will no longer be a constraining pipe that forces all content to fit within a limited set of colours, unlike all previous video interfaces," said Leslie Chard, president of the HDMI Licensing, the agent body responsible for licensing the HDMI specification.

The HDMI format has already been adopted by over 400 consumer electronics and PC makers. Market research firm In-Stat expects some 60 million devices featuring HDMI to ship this year alone. HDMI 1.3 has been selected by Sony for the PS3 game console, due to come out at Christmas.



Products implementing the new HDMI specification will continue to be backward-compatible with earlier HDMI products.

In the meantime, will HDMI's storming success spell out the demise of the DVI standard? "HDMI started on devices that are media-centric. If you don't have HDTV you don't need HDMI," said Chard. "But there's [still] room for DVI even though, at some point, you'll see DVI being replaced by UDI."

*HDMI 1.3 eliminates colour banding*



# Improved airport radar system will offer greater safety

A new radar technology in civil aviation, called Advanced Surface Movement Guidance and Control System (A-SMGCS), is gathering support from national bodies to be installed at airports and plane cockpits. It promises to increase airport operations efficiency, surveillance and safety.

There are several companies offering A-SMGCS systems, including Park Air Systems and Sensis Corporation. Sensis's system is based on solid-state X-Band radar with digital control. It uses multiple surveillance sources, such as primary and secondary surveillance radar, surface movement radar, multilateration transponders, Automatic Dependent Surveillance Broadcast (ADS-B) vehicle tracking and a multi-sensor data processor, to provide a comprehensive surveillance picture of the airport surface.

"We are taking advantage of additional technologies, such as using multilateration sensors. That way, we get automatic correlation between the target and its position. We now have a system that is more efficient for controllers," said Mark Runnels, an executive at Sensis Corporation. "Ordinary radar tells you where the targets are but not who they are. The A-SMGCS transponders 'interrogate' the plane and correlate its beacon to the flightpath, therefore, identifying it."

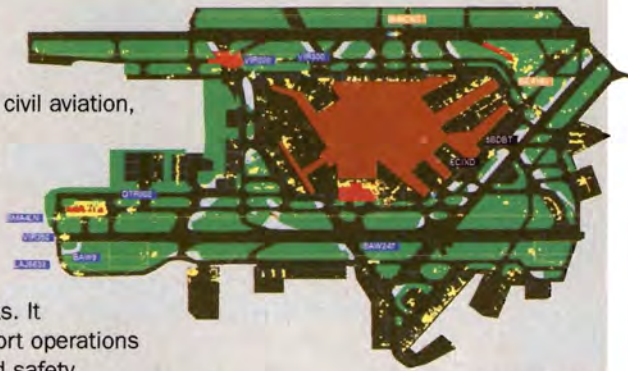
The A-SMGCS offers surveillance, conflict alert, guidance and routing to planes too. Guidance suggests to pilots what path to take at take-off and landing, whilst routing automates the taxiing routes. These two capabilities are yet to be implemented.

The system's update rate is 1s, and the accuracy is 7.5m. It detects "cooperative" and "non-cooperative" targets, and offers an emergency detection with a 99.9% probability rate.

"Heathrow Airport has 1400 operations per day – some 100 per hour; this is very busy. Normally, there are a lot of planes just waiting to move, burning fuel. We need to optimise these operations at an airport and end those plane queues. We are not doing everything we can do automate operations at airports, but with 1s-updates, 7.5m accuracy system we can do a lot," said Runnels. "The National Transportation Safety Board wants to see the warnings triggered by an A-SMGCS in the cockpit as well – to prevent collisions and near-misses."

The Eurocae industry body based in Paris is working on several aspects of a specification for radar use at airports. It is analysing A-SMGCS as part of the WG-41 'Improvement of Airport traffic safety and efficiency' project.

Surface movement radar tower at Heathrow Airport



Snapshot of an avionics radar display at Heathrow Airport



IBM and the Georgia Institute of Technology jointly demonstrated the first silicon-based chip capable of operating at frequencies above 500GHz. This is more than 250 times faster than the processors used in today's mobile phones, which typically operate at approximately 2GHz.

The chips were made from a prototype fourth-generation SiGe technology fabricated by IBM on a 200mm wafer. At room temperature, they operated at approximately 350GHz. Computer simulations suggest that this technology could ultimately support even higher (near-TeraHertz – 1,000 GHz) operational frequencies even at room temperature.

\* \* \*

NRE2 and Real-Time Innovations (RTI) have formed a strategic alliance to provide an enhanced software infrastructure for unmanned systems in military applications.

The two firms intend to integrate the RE2 Joint Architecture for Unmanned Systems (JAUS) Software Development Kit (SDK) and RTI Data Distribution Service to give vendors a comprehensive JAUS-compliant middleware solution for unmanned vehicles and robotic platforms.

\* \* \*

Your holiday abroad will never be the same again with Marmitek's latest FreeTV200 device, which allows access to free digital television (free-to-air DVB-T) on any PC or laptop, wherever you are.

The device consists of a USB tuner, a small digital antenna and CyberLink PowerCinema4 software that transforms any PC into an integrated multimedia player (see below). Most European countries broadcast Free-To-Air channels via DVB-T, which means that you can watch digital television without paying any subscription costs.

Its recommended retail price starts at under £55 in the UK.



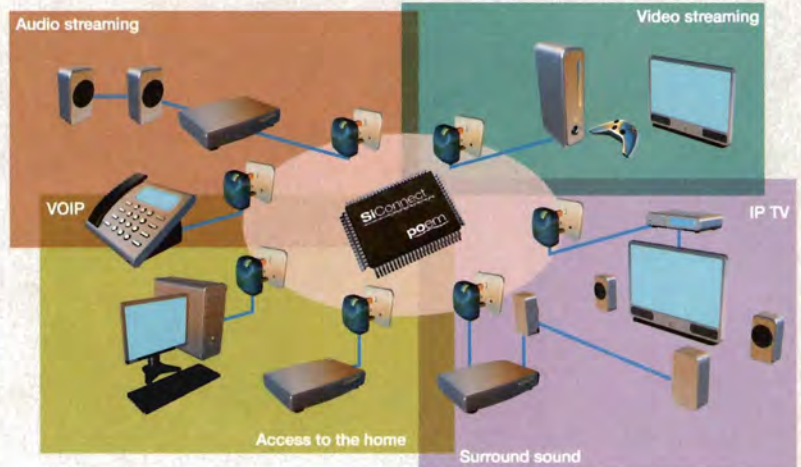
# SiConnect delivers low-cost powerline communication technology

It was founded only a year ago but now the UK start-up SiConnect is making significant inroads into the powerline communication technology with a new concept and \$5 transceiver chip.

So far, companies delivering powerline communications have been using spread-spectrum OFDM as the modulation scheme of choice. According to Trevor Sokell, the CEO of SiConnect, this is expensive whilst his company's POEM technology is better suited to deliver low latency and jitter, and better quality of service (QoS) required for this application – and at a lower price at that.

"We've chosen narrowband carriers and we are moving them along the spectrum," said Sokell. "[With our chip] You can move your carriers in the best 'blue sky' parts of the spectrum. This is fundamentally different to the way spread-spectrum

According to SiConnect, POEM technology will sit at the heart of the home powerline network



OFDM works. POEM is about efficient management of the available spectrum."

POEM uses a Synchronous Multiple Access/Contention Resolution (SMA/CR) scheme and an in-built QoS management structure that prioritises traffic at several different service levels. POEM's topology is a peer-to-peer mesh that can use all available power sockets in the home, with each node acting as a repeater and able to control latency and jitter. This also promises to make the home networks reliable for real time delivery of MPEG video and uncompressed audio, such as IPTV and surround sound home theatre systems.

## TOP 10 TIPS

## ON-LINE SECURITY

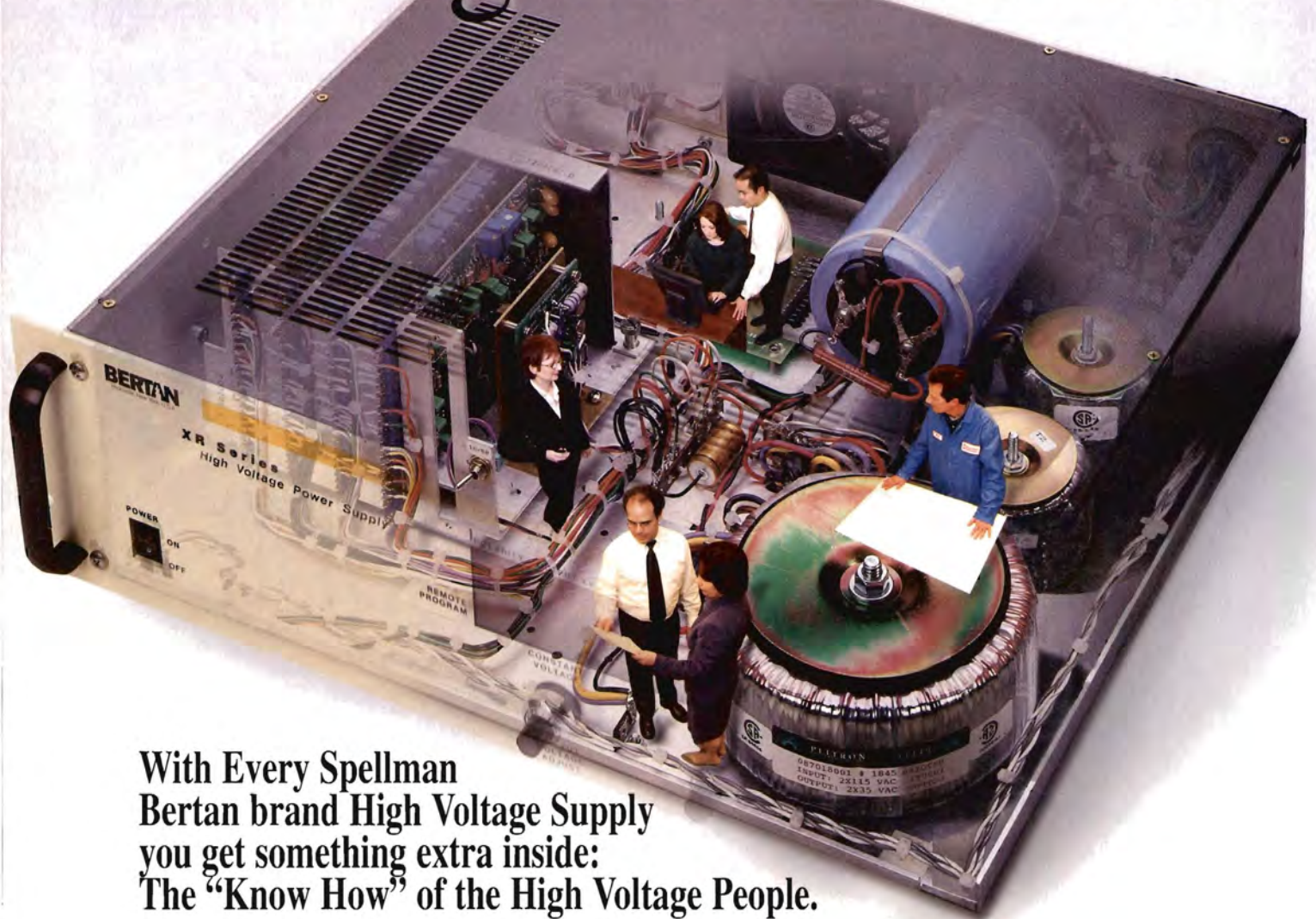
- 1 Never click on embedded or unsubscribe links in spam emails. Doing so will alert the spammer to an active email account and produce an even greater river of junk.
- 2 Make use of blocking or filtering products already provided, such as Windows firewalls.
- 3 Do not post your email address on bulletin boards or message groups.
- 4 Identify all the assets within the business, then prioritise the assets in terms of importance and level of protection required.
- 5 Devise and circulate an email policy for your company, which includes what content is prohibited, maximum size of attachments and how to respond to unsolicited mail.

- 6 Regularly review and renew passwords.
- 7 Make regular backups of critical data at least once a day.
- 8 Use virus protection software.
- 9 Do not keep computers online when not in use.
- 10 Check regularly for security patches and updates from your software providers.

This month's Top Ten Tips were supplied by What to Buy for Business magazine (sara.white@nexusmedia.com).

If you want to send us your top five or ten tips on any engineering and design subject, please write to the Editor at EEditor@nexusmedia.com.

# Thinking Inside the Box



With Every Spellman  
Bertan brand High Voltage Supply  
you get something extra inside:  
The "Know How" of the High Voltage People.

For more than 50 years, Spellman is the innovator of the High Voltage industry. With our recent acquisition of the respected Bertan High Voltage brand, we offer the world's most comprehensive line of generators, rack instruments, modules and Monoblock X-Ray Sources®.

► **Application Know How:**

Whether your field is X-Ray Analysis, Semiconductor Processing, Security Detection, Medical Imaging, Electron Microscopy, or Mass Spectrometry, we make a high voltage supply to meet your needs.

► **Engineering Know How:**

We have the largest engineering team in the business and one of the most innovative design libraries in our industry.

► **Manufacturing Know How:**

We maintain world-class ISO9001 production facilities in the US, Europe and in Mexico.

**Voltage:** 250V to 360kV

**Power:** 1W to 120kW

**Ripple:** depending on Application  
<.001% p-p

**Package:** Rack, Module, PCB,  
Benchtop, NIM, Custom

**Interface:** Analog, RS232, USB,  
Ethernet, IEEE

**The High Voltage People of Spellman:** responsive, professional and situated globally to support you. Put their know how to work for you today. For more on the inside story of Spellman's innovative high voltage solutions, call us or visit our website [www.spellmanhv.com](http://www.spellmanhv.com)

MONOBLOCK® is a registered trademark of Spellman High Voltage Electronics Corp.

475 Wireless Blvd.  
Hauppauge, NY 11788  
tel: +1-631-630-3000  
fax: +1-631-435-1620  
e-mail: [sales@spellmanhv.com](mailto:sales@spellmanhv.com)  
[www.spellmanhv.com](http://www.spellmanhv.com)

 **Spellman**  
High Voltage Electronics Corporation  
**BERTAN**

USA

EUROPE

JAPAN

MEXICO

CHINA



# Measurement rises to the challenge

**Chris Martinez**, worldwide design and manufacturing Marketing Director at Tektronix, says that whatever the design engineering community throws at the T&M industry, it successfully rises to the occasion

Present day developments are increasingly being driven by the demands of consumer electronics, with technologies such as HDTV, music and mobile entertainment, the ability to download music and movies, and the burgeoning games market, all creating their own unique demands. What is not always apparent to the general user is that all these developments rely on standards like Ethernet, USB and Firewire. Most people now take for granted the USB interface, and the same ease-of-use is now migrating to video and audio applications such as set-top boxes and DVDs.

Most of the new standards that make these interfaces possible are based on serial bus architectures, which offer increased performance in speed and throughput, while lowering the cost by needing fewer wires.

In addition to speed and complexity, another key element in the evolution of modern electronic products is power. One obvious area where power is becoming important is in battery operated and portable equipment, where the desire to prolong battery life has led to a host of new power management circuit designs and energy-saving display technologies. Equally important is the emergence of power quality as a major industry, with new standards being adopted in areas such as harmonics and electromagnetic compatibility.

The price of adopting standards – whether for interoperability, EMC or power quality – is that the debugging of designs and the resolution of problems require increasing sophistication from the test and measurement (T&M) sector. Ideally, any potential problems should be cured at the design and development stage to avoid costly issues of recalls and field maintenance.

The two key areas in which the T&M manufacturers are responding to these challenges are performance and flexibility. In terms of performance, measuring instruments always have to be one step ahead of the products they are testing: hence the emergence of 1GHz oscilloscopes for mainstream applications and 15GHz instruments for the top end of the market.

At the same time, an increasing variety of signal types have to be tested. In the past, test departments may have had separate, dedicated instruments for each application, but pressures on cost, space and set-up times make this a highly undesirable option these days. The modern test instrument needs to be versatile enough to take on all comers.

One emerging trend resulting from this need for flexibility is that modern instruments such as oscilloscopes are now providing application-specific

support to allow triggering, analysis and decoding for different technologies and standards. Examples are dedicated packages for analysing the latest serial buses such as HDMI, CAN/LIN and others, plus oscilloscope-based software for testing compliance with emerging standards in the power and telecommunications sectors.

An analogy can be drawn between the latest generation of test instruments and the PC. Indeed, it is no coincidence that many instruments are now being developed with embedded PCs and a Windows-based operating environment. The familiar user interface means that set-up and operation become fast and straightforward, while the use of a standard, open, software and communications environment enables engineers to produce documentation in word processing or spreadsheet formats, which can then be shared between different departments or even users in different countries.

The built-in intelligence provided by the embedded PC is complemented by new embedded functionality in the measurement hardware itself to help in the meaningful acquisition of data and its interpretation for the user. For example, modern instruments now incorporate specialist triggering and acquisition modes, which ensure that only the data or anomaly of interest is captured, without the need for the user to sift through huge amounts of data.

Similarly, the instrument has the intelligence to decode the physical layer data (the actual electronic signals on the board under test) to present data layer results relevant to the application.

Finally, just as it is for the consumer environment, so interoperability is a key factor in the design of modern T&M instruments. Engineers now expect features such as USB, Compact Flash and networking in the measurement laboratory. Not only does this help in the sharing, analysis and archiving of measurement

**“Modern instruments now incorporate specialist triggering and acquisition modes, which ensure that only the anomaly of interest is captured”**

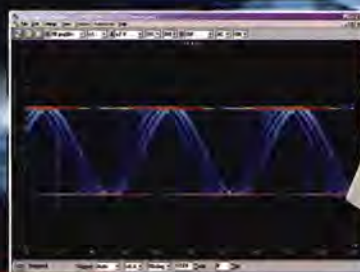
data, but it eases the task of using instruments together, so that an arbitrary waveform generator, for example, can work together with a digital oscilloscope to acquire and generate 'real world' signals and then modify them for use in a stimulus/response test scenario.

So, whatever the world of modern electronics comes up with, the measurement sector is proving itself more than capable of rising to the challenge.

## PicoScope 3000 Series PC Oscilloscopes

The PicoScope 3000 series oscilloscopes are the latest offerings from the market leader in PC oscilloscopes combining high bandwidths with large record memories. Using the latest advances in low power electronics, the oscilloscopes draw their power from the USB port of any modern PC, eliminating the need for mains power.

- **High performance: 10GS/s sampling rate & 200MHz bandwidth**
- **1MB buffer memory**
- **Advanced display & trigger modes**
- **Compact & portable**
- **Supplied with PicoScope (oscilloscope/spectrum analyser) & PicoLog (data acquisition) software.**



	2004	2009	2006
Bandwidth	20MHz	100MHz	200MHz
Sampling rate (effective)	8 GS/s	2GS/s	1125MS/s
Sampling rate (maximum)	999MS/s	100MS/s	20MS/s
Channels	2 (16-bit trigger)	2 (10-bit trigger/16-bit gen)	2 (16-bit trigger/16-bit gen)
DeepScope (memory)	5-mega (1000ns)	200ns to 50ns	1-mega (50ns)
Trigger accuracy	20ps	20ps	20ps
Clockout range	0 to 25MHz	0 to 50MHz	0 to 100MHz
Record length	256k	512k	1MB
Resolution (vertical)	8 bits	8 bits	8 bits
Power		0.5W to 2W	
PC (minimum) (operating system)		USB2 & USB1   Windows XP	

**Tel: 01480 396395**  
[www.picotech.com/scope354](http://www.picotech.com/scope354)

**pico**  
Technology Limited

Alcatel headquarters in Paris



# TELECOM CHAMELEON

**Juan Pablo Conti looks at how business has changed for the telecoms company Alcatel since its early days**

**B**eing a supplier of telecommunications equipment used to be a relatively simple, predictable business. Your customer base would typically be composed of a few well-known, state-owned national telephone carriers that were almost exclusively dedicated to routing voice services and didn't really know what the term 'competition' meant. From the beginning of the last century to practically the end of it, being a telecoms equipment vendor was easy.

The Internet bubble that burst in 2000 wasn't so much the main reason why things have changed so profoundly for companies like Alcatel. Instead, it was the Internet in itself – with its far-reaching networking implications – that was always going to complicate life for the Alcatels, the Ciscos, the Lucent's, the Siemenses and the Nortels of this world.

If life has become complicated and unpredictable for equipment vendors, spare a thought for those buying

the stuff. Running a major telecommunications network today and – more importantly – having to decide how to adapt it and upgrade it in order to meet user demands must be one of the most difficult jobs there is within the engineering profession.

The information revolution brought about by the Internet has meant that not only carrier but also corporate networks have exploded in size and complexity. Apart from the redundant overlapping of different network architectures to cater for different communication services, a multitude of wired and wireless access technologies, industry standards, routing equipment and electronics devices are being deployed to serve an increasing number of users that demand more flexibility, bandwidth, mobility and personalisation.

This represents a significant challenge for equipment manufacturers, with their product portfolios having to expand beyond their traditional fields of

expertise. "The complexity of the network operated by large incumbents means that the products and services they require could never be supplied by only one vendor," says Bettina Tratz-Ryan, research director of carrier network infrastructure with market analyst firm Gartner. "Even if you are a major vendor such as Alcatel, you need to be able to provide an ecosystem of application providers and software companies that can program services and collapse different networking layers and business partners' billing mechanisms into an end-to-end type of solution."

**Made In France**

Alcatel started life in 1898, when French engineer Pierre Azaria established the Compagnie Générale d'Electricité (CGE). Owned by the French government, the initial focus of the company was to take on the likes of Siemens and General Electrics. In 1925 CGE acquired the Compagnie Générale des Câbles de Lyon, effectively turning its attention for the first time to the nascent telecommunications industry.

The origin of the name 'Alcatel' can be traced back to 1966, when CGE absorbed another company: the Société Alsacienne de Constructions Atomiques, de Télécommunications et d'Electronique. The brand (Alcatel NV) was later selected to name one of CGE's most significant acquisitions, that of the European telecom activities of ITT in 1986. One year later CGE was privatised, renamed as Alcatel Alsthom in 1991 and, finally, it became just Alcatel in 1998.

Serge Tchuruk, who was appointed CEO just over a decade ago, is widely credited as having played a decisive role in the re-focusing of the company around telecommunications. Although he had announced his retirement by June this year, he was asked by the board to stay on for a few more months in order to oversee Alcatel's latest major acquisition – US-based rival vendor Lucent Technologies.

Announced in April, the deal was presented as a "merger of equals", but industry observers are viewing it mainly as an Alcatel initiative that was simply too good to be turned down by Lucent. A previous attempt to join both companies failed in 2001, largely because Lucent interpreted the move as an Alcatel acquisition. This time,

Alcatel finds itself in a much stronger financial position after having experienced a more solid recovery than Lucent from the 2000 telecoms downturn.

The proposed combined company – which won't be officially formed until between October 2006 and April 2007 – will be headquartered in Paris. Secrecy surrounds the name that it will adopt. All we know is that it won't be called either Alcatel or Lucent alone. Serge Tchuruk will become non-executive chairman, while Lucent's current chairman and CEO Patricia Russo will take the CEO position. Speaking at a press conference in Paris when the deal was announced, she said: "When you look at the strengths that Lucent has and the strengths that Alcatel has, as well as the compelling proposition around value creation, I have no doubts that, as we go forward, the combined

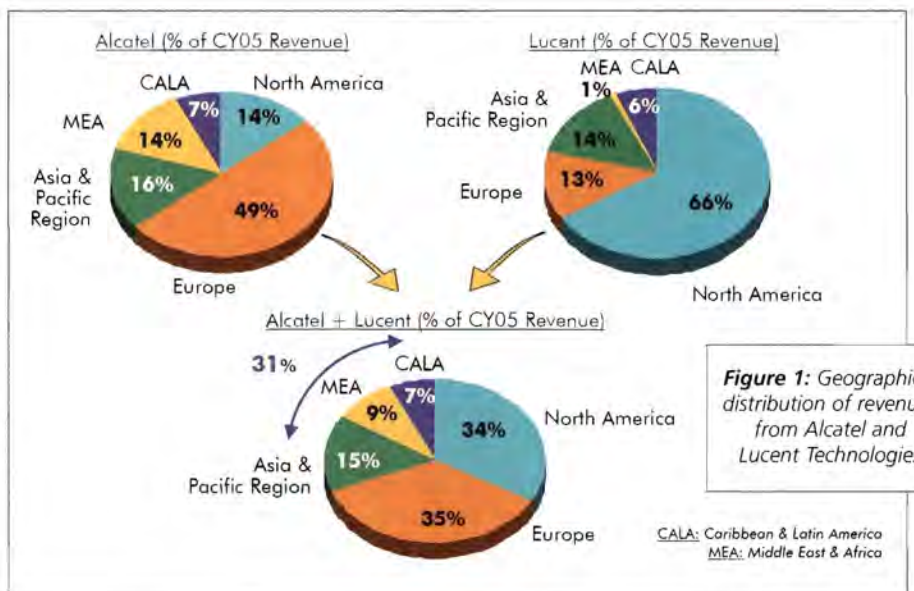
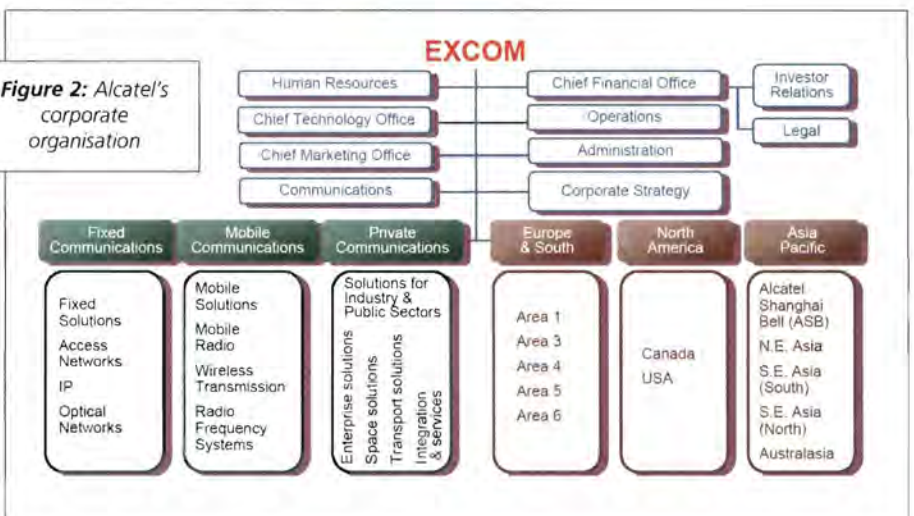


Figure 1: Geographical distribution of revenues from Alcatel and Lucent Technologies

Figure 2: Alcatel's corporate organisation





3G R&D centre in Stuttgart, Germany

Ryan. "They are somewhere in the Ethernet space, but have nowhere even close the market share that Alcatel has. About a year ago Lucent also re-focused its efforts – it continued to supply existing customers with solutions, but not putting a lot of R&D effort in the broad ATM, DSL and other types of access solutions. So, in that

companies will create value for shareholders in greater capabilities that either one would be able to create alone."

### A Good Deal?

Estimates based on adding 2005 annual figures from both companies show the new entity will have revenues of approximately €21bn, with one-third of them originating in North America, one-third in Europe and one-third in the rest of the world (see **Figure 1**). The combined workforce of 88,000 will be reduced by 10%, support functions will be consolidated and the supply chain optimised. These measures, Alcatel and Lucent expect, will help them achieve cost savings of €1.4bn in three years.

But how does the merger bode in terms of compatibility of carrier product lines? "It's very obvious that Lucent doesn't have a lot of access play," says Tratz-

respect, the merger makes sense, because here you combine a market presence and a name together, and that's a big plus for Lucent.

"Where it also makes sense is when you go onto mobile networking and next-generation switching to offer voice over IP (VoIP) and soft-switch-based topologies, especially to wireline operators. Alcatel has been experiencing a little bit of a delay in delivering next-generation wireline switching solutions, they had a couple of attempts to deliver a soft-switch but they had to cancel the product or make some modifications on it. Lucent wasn't a star either, but it has a stronger evolution path for the switching products and has gained significant market presence with its VoIP implementations. So Alcatel can benefit from this. And it can also benefit from Lucent's expertise in the mobile networking space, where Alcatel's portfolio has some holes that Lucent will be able to fill."

The French group is selling its satellite manufacturing business to Thales



### Structure

Alcatel as a group is organised into three main divisions: Fixed, Mobile and Private Communications (see **Figure 2**). The Fixed business has traditionally been the company's strongest performer, largely due to its leading position in two key markets – optical networks and broadband access.

According to data provided by Ovum-RHK, Alcatel has topped the global



*Fibre to the home, one of the access technologies addressed by Alcatel*



optical networking business during the past five years, currently enjoying a 16% market share. The company has a long history in the submarine cable industry, where it continues to provide a range of products and services. One example is Alcatel's recent involvement in the rollout of the Sea-Me-We 4 submarine cable network. Jointly built with co-contractor Fujitsu in 18 months, the network spans nearly 20,000km, links 14 countries between Singapore and France, and features 16 landing points.

Alcatel also has a strong presence in the terrestrial side of the optical business and is currently enjoying a surge in demand for both its 2G and 3G cellular backhauling products.

Broadband access is undoubtedly the market Alcatel is best at, with more than 86 million DSL lines shipped so far. Apart from supporting newer versions such as ADSL2+ and VDSL2, the vendor is currently involved in a marketing push for the rollout of triple-play services. At the start of 2005 it struck a collaboration agreement with Microsoft, designed to accelerate IPTV (Internet Protocol television) over broadband networks. Last May both companies were joined by HP, in what they hope will be an ideal cocktail of industry expertise in the fields of IPTV software (Microsoft), access networking (Alcatel) and, now, server solutions (HP).

In 2005, the Mobile Communications division contributed with €4bn of the €13.1bn in revenues registered by the group. Recently, it managed to secure its first major deal in HSDPA (high-speed downlink packet access, also called 3.5G) with a cellular operator. Orange is trialling the Alcatel solution in a couple of Paris neighbourhoods, before a full commercial service is extended to the rest of the operator's European markets.

The vendor claims all Orange will need to do is activate its "Evolium" HSDPA radio access technology as a simple software upgrade, as the 3G base stations already deployed by the operator are built to support the faster download throughputs.

### WiMax Ambitions

Another wireless market Alcatel is pinning its hopes on is WiMax, the long-range broadband access technology that is increasingly seen as in direct competition with HSDPA. However, the French vendor is being very selective in its strategy: "Alcatel is not pursuing the fixed wireless access part of the spec (standardised in the IEEE 802.16-2004) through its own production," says Tratz-Ryan. "Instead, it is concentrating directly on the mobility part of the spec (802.16e-2005). But, by the time this product set is certified by the WiMAX Forum, it will be at least a year or year-and-a-half out, so there will be no immediate impact from this technology. In the meantime, Alcatel

has a joint agreement in place with Alvarion to deliver broadband fixed wireless products when it is required. However, the company is not doing its own R&D or investing its own money in fixed wireless access because, from a spec and from a MAC-layer perspective, the standards are slightly different. So if you start from scratch, you are better off going directly into the mobile environment."

The third and final Alcatel business unit, Private Communications, is about to suffer some serious modifications. Of the four sub-market segments showed in Figure 2, three are soon to be transferred to defence electronics contractor Thales, a company into which Alcatel will increase its current ownership to 21.6% once the deal is approved. The most significant of these assets changing hands between the two French companies is undoubtedly Alcatel Alenia Space, one of the world's most recognised satellite manufacturers.

This will leave Private Communications with only one main market to focus on – Enterprise Communications. Steve Blood, research vice president at Gartner, says Alcatel's biggest challenge here is that "they haven't really made it outside of Europe; they have been slow to grow their business, and I think partly the reason for it is that, if you look at the enterprise sector, it has always been a very small piece of what Alcatel did."

If anything, the merger with Lucent is going to make of Enterprise even a smaller component of the Alcatel group, bringing it to about 5% of the total revenues.

"Alcatel really needs to crack the North American market," Blood insists. "I think the challenge is that it doesn't seem to want to make any further acquisitions to gain market share, while for example [rival vendor] Avaya went out and bought Tenovis to get a grip on the European market."

Looking ahead, Bettina Tratz-Ryan can also see key challenges for Alcatel in the carrier space: "I think the

Mobile TV testing equipment



The company is partnering with Microsoft and HP for IPTV



biggest challenge will be to transform itself from being simply a networking company into one that is also able to embrace the new service requirements that operators are going to demand. As we continue to open up the networks and get more and more into a standardised environment, the application and service layers will have to open up as well – and they already are.

“If you look at wireline/wireless convergence, the next-generation IMS (IP Multimedia Subsystem) topology is network-agnostic, so it really doesn't care what it's running on. Telecom equipment vendors will be increasingly required to provide, not only a networking solution, but also a service delivery architecture on top of that. That's one of the biggest challenges that not only Alcatel but any other incumbent telco vendor is currently facing. Yet, it becomes very urgent for Alcatel because, in its efforts to resolve its immediate integration issues with Lucent, it risks losing focus on this very critical challenge.”

Not what you would really call an “easy job” then, as it used to be only a few years ago for a company like Alcatel.

Optical terrestrial laboratory in Villarsceaux-Nozay, France



## ALCATEL IN BRIEF

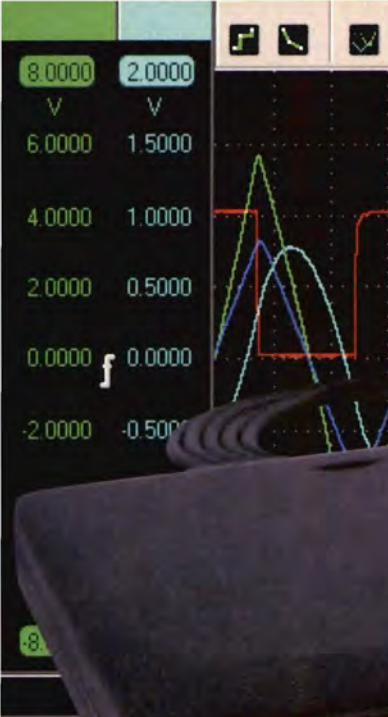
- Founded: 31 May 1898
- Headquarters: Paris, France
- Chairman and CEO: Serge Tchuruk
- President and COO: Mike Quigley
- Employees: 58,000 in over 130 countries
- Annual sales: € 13.1bn (2005)
- Net income: € 930m (2005)

## ALCATEL'S NUMBERS

- More than 450,000km of submarine cables deployed globally
- World record for a deep-water cable repair: 9400m, set in 2003, some 700km off Japan
- More than 86 million DSL lines shipped worldwide
- One of BT's selected suppliers for the 21CN all-IP communications infrastructure project
- 360 mobile operators among its customers
- More than 500,000 enterprise customers

HANDYSCOPE HS4

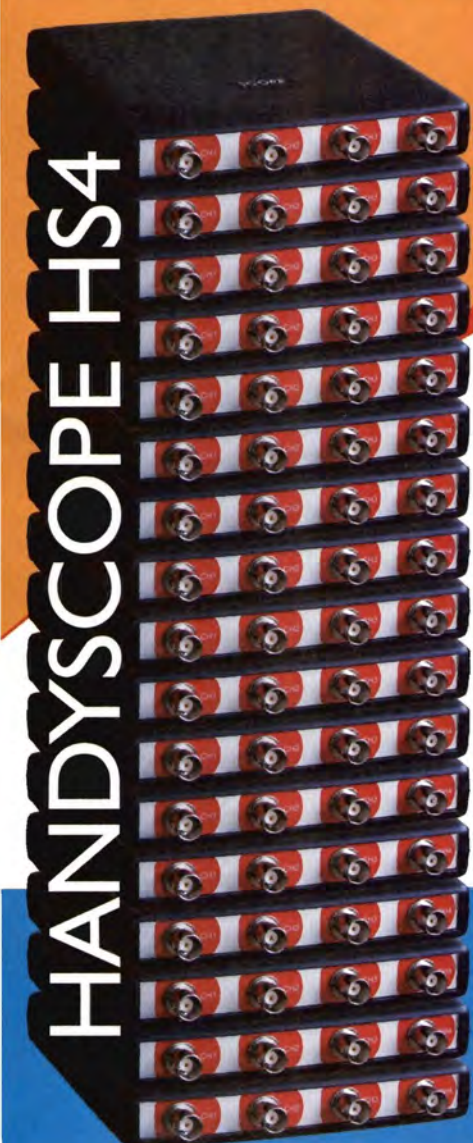
Four channels not enough



**512 CHANNELS IS THE LIMIT  
COMPLETE PACKAGE STARTING AT £ 440**

The Handyscope HS4 (50MHz 12/14/16 bit) is a powerful and versatile four channel measuring instrument with extension

WWW.TIEPIE.NL



HANDYSCOPE HS4

The Handyscope HS4 starts a new standard for multi channel measuring.

It offers perfect measure qualities and through the USB connection it is easy to connect to every PC. Because of the very versatile software it becomes simple to extend the instrument to 512 channels.

A four channel, 12-16 bit oscilloscope, spectrum analyzer, transient recorder and voltmeter created as a most compact instrument.

- Making virtual instruments (combine maximum of 128 instruments)
- Extension to maximum of 512 channels.
- USB 2.0 connection (USB 1.1 compatible)
- Sample speed up to 50 MHz per channel
- 12 to 16 bit resolution (6  $\mu$ Volt resolution)
- 25 MHz bandwidth
- Input sensitivity from 200 mVolt up to 80 Volt
- Large memory up to 131060 samples per channel
- Four integrated measuring devices
- Spectrum analyzer with a dynamic range of 95 dB
- Fast transient recorder up to 100 kHz
- Several trigger features
- Auto start/stop triggering
- Auto disk function up to 1000 files
- Auto setup for amplitude axis and time base
- Auto trigger level and hysteresis setting
- Cursor measurements with setup read-outs
- Multi window signal display
- Multi channel display

for more information, demo software, software, source code and DLL's visit our internet page: <http://www.tiepie.nl>



TiePie engineering (NL)  
Kopierslagersstraat 37  
8601 WL SNEEK  
The Netherlands  
Tel: +31 515 415 416  
Fax: +31 515 418 819

TiePie engineering (UK)  
28, Stephenson Road, St. Ives  
Cambridgeshire, PE17 3WJ, UK  
Tel: 01480 - 300695  
Fax: 01480 - 461654

# The DEVELOPMENT of the Digital Sound Projector

**Alex Bienek, Systems Architect at 1 Ltd in Cambridge, explains the steps toward creating the perfect sound system**



Figure 1: Yamaha's YSP-1000 Digital Sound Projector

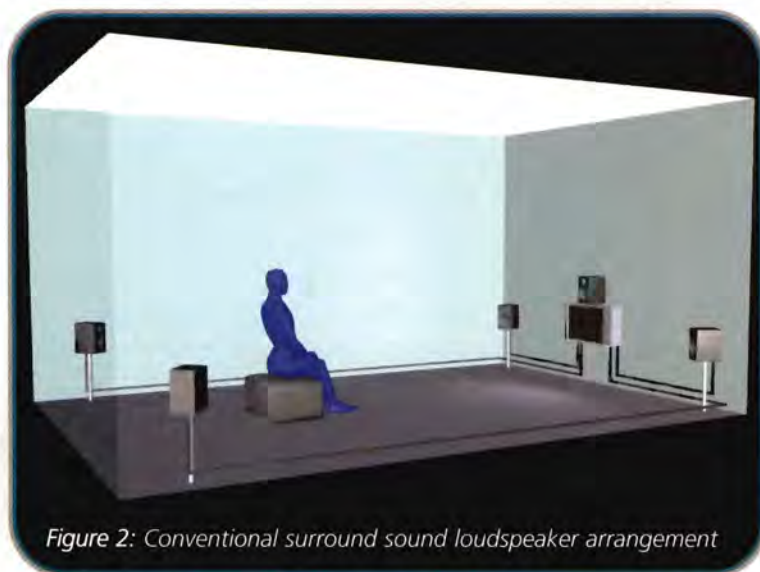


Figure 2: Conventional surround sound loudspeaker arrangement

Watching TV, for some people at least, has changed dramatically over the last five years. Large flat panel displays, digital broadcasting of hundreds of channels, good quality recording methods such as DVD and PVR, and multi-channel hi-fi surround sound have allowed viewers to create personal cinemas in their own living rooms. Indications are that the trend will expand to reach more and more of the viewing public. Global flat panel TV shipments are anticipated to reach 44 million units in 2006.

The majority of this home theatre equipment is a straightforward replacement for the existing systems. The flat panel display replaces the CRT, the DVD replaces the VCR and the DVB set-top box replaces the analogue tuner. But the surround sound system will be a new addition, requiring a decoder/amplifier unit, known as an 'AV receiver', five or six loudspeaker boxes and stands placed around the room and

all the cabling that goes with it. While previously the sound system was built into the TV and given little thought, now it can be the cause of a major headache trying to run wires around the room and find space for loudspeaker boxes.

1 Ltd from Cambridge, UK, licenses a technology that eliminates the difficulties associated with traditional surround sound systems. The firm developed Digital Sound Projector technology that allows surround sound to be created from a single loudspeaker unit placed above or below the display panel and, as such, does not require wires and loudspeakers to be installed around the room. This technology has been licensed to Yamaha, which now has several products on the market including the YSP-1000 shown in Figure 1.

## A Brief History of Surround Sound

The 1980s saw the introduction of multi-channel sound tracks for movies in the form of Dolby Pro Logic. This technique used phase-shifted versions of rear and centre channels added into the standard stereo left and right channels. The rear and centre channels were extracted from the stereo signal at playback time using a technique known as matrix decoding. In 1992, the first fully digital multi-channel movie soundtrack technology was introduced by Dolby. This is now known as Dolby Digital and is found on the majority of DVD releases. Dolby Digital carries five full range audio channels plus a low frequency special effects channel, all encoded into a single digital data stream.

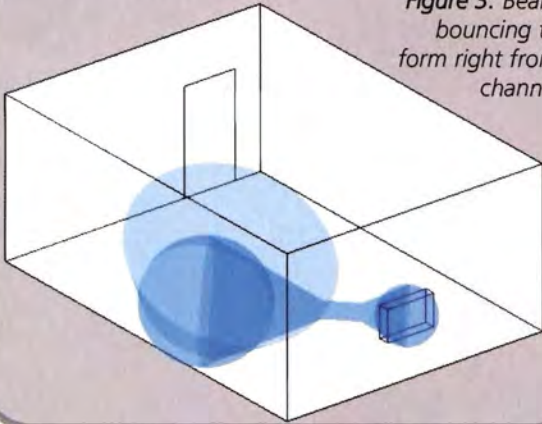
A second standard has also been defined by DTS (Digital Theatre Systems). Like Dolby Digital this can contain five or more full-range audio channels plus a low frequency special effects channel encoded into a single digital data stream. In order to reproduce the surround sound effect in your living room, it is necessary to place loudspeakers around the room, as shown in Figure 2.

For many people, the placing and wiring up of so many loudspeakers around their living room is impractical and, consequently, they cannot enjoy the surround sound experience of the movie.

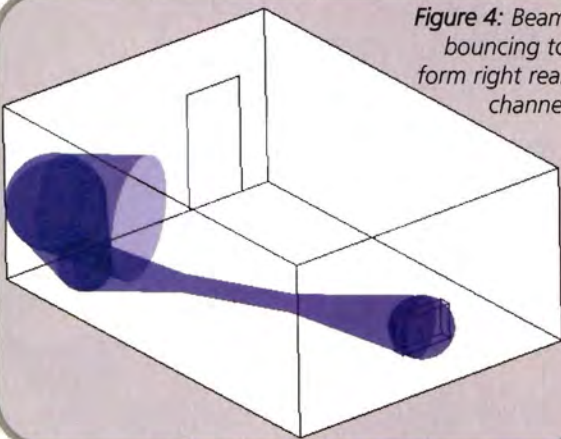
## The Digital Sound Projector

The Digital Sound Projector produces directed beams of sound. These beams bounce off ceilings and walls back to the listener so that the sound emanates from the bounce point rather than directly from the Digital Sound Projector. Figure 3 shows a beam bouncing off a wall and coming to the listener from his right-hand side. Effectively, the listener

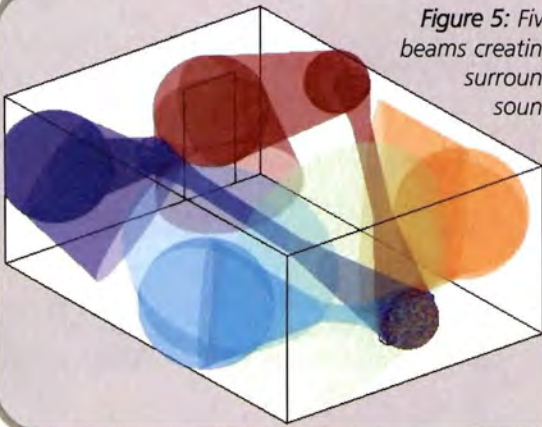
*Figure 3: Beam bouncing to form right front channel*



*Figure 4: Beam bouncing to form right rear channel*



*Figure 5: Five beams creating surround sound*



hears an 'image' of the Digital Sound Projector reflected in the wall, just as if the wall was a mirror.

Similarly, a beam can be sent behind the listener via two wall-bounces to generate a right rear sound source, as shown in **Figure 4**.

Following this process to its logical conclusion, we can recreate all five channels of a surround sound system from a single source, or the Digital Sound Projector (see **Figure 5**).

### The Technology

The underlying technology of the Digital Sound Projector is that of the phased array. The principles of phased arrays have been known for many years and used in radar, sonar and radio astronomy. More recently the technology has been finding its way into mobile phone

base stations, in order to increase capacity by directing the signal at the handset rather than radiating in all directions equally.

When it comes to audio applications, the most visible use has traditionally been in PA systems, such as those found in churches and airports. Here a column of loudspeakers are assembled such that there is a natural tendency for the complete array to have vertical directionality and, consequently, deliver the majority of the acoustic energy to the congregation rather than allowing it to reverberate around the colonnades. **Figure 6** shows one such application.

Static phase delays can be added to the loudspeakers in the column in order to direct the sound downwards.

*Figure 6: Static direction column array loudspeaker*

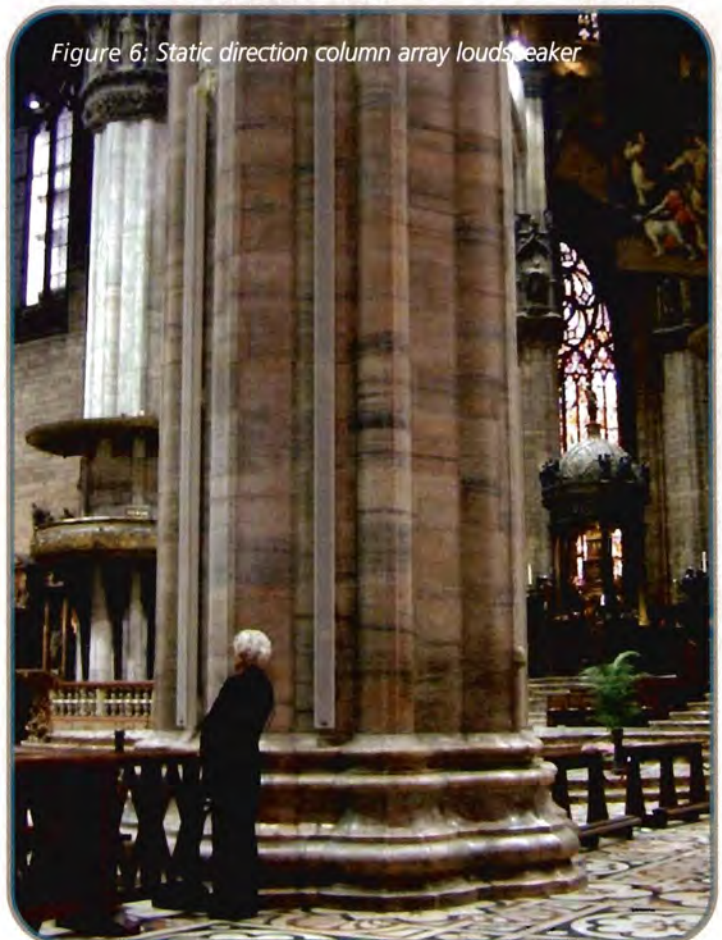


Figure 6: Static direction column array loudspeaker



Figure 7: Interference pattern generated by two point sources

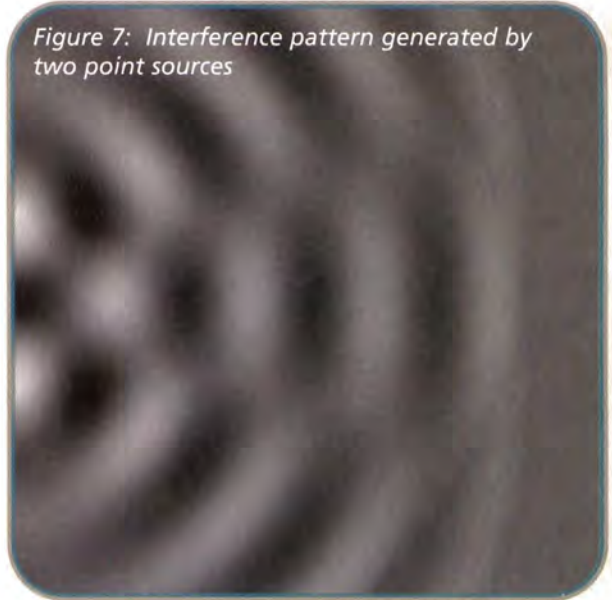
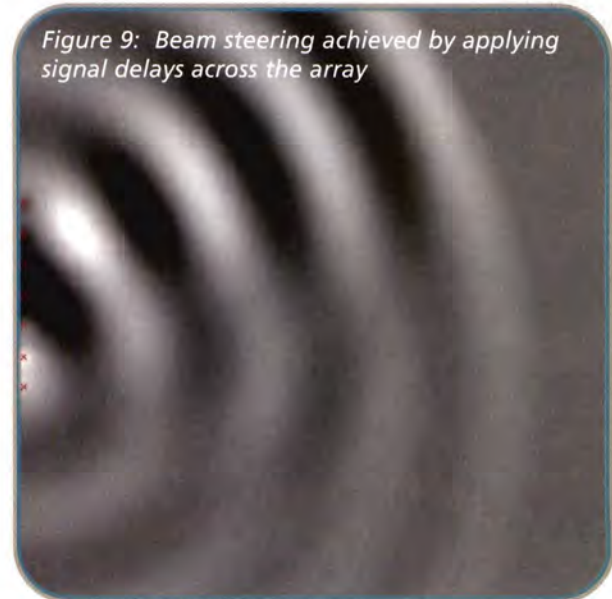


Figure 8: Natural beaming caused by an array of sound sources



Figure 9: Beam steering achieved by applying signal delays across the array



**What is a Phased Array?**

Sound is simply pressure waves in the air, somewhat analogous to electromagnetic waves such as light. And just as light waves can interfere constructively and destructively, as we all remember from those diffraction grating experiments in physics class, so can sound waves. **Figure 7** shows a point source.

The grey level represents the pressure level, white for high pressure and dark for low pressure, with a sinusoidal change in between for a single frequency tone. The diagram shows the sound waves emanating from a single point source equally in all directions. In practice, loudspeaker transducers are not point sources but have finite size and, therefore, do not radiate equally in all directions for all frequencies. Typically, transducers will start to radiate non-uniformly (that is, become directional) when the frequency they are producing has a wavelength less than twice the diameter of the transducer.

**Figure 8** shows how two ideal point sources interact forming the familiar interference pattern.

If the number of sources is increased significantly then

the result is a beam of acoustic energy straight ahead, with other directions being partially or mostly cancelled by the natural process of destructive interference. **Figure 9** shows this process.

In order to steer the beam left and right, we could either mechanically rotate the array of sources, or achieve the equivalent of mechanically rotating the array by applying a delay in the signals being fed to each of the transducers. The result of applying increasing delay to the transducers from top to bottom is shown in

**Figure 10.**

Using electronic delays to steer the beam, rather than mechanically rotating the array, has the advantage that by using the principle of superposition we can create multiple beams, each with a different direction.

A further enhancement is achievable by applying non-linear delay factors across the delay, resulting in the beam having a focal point, which may be a real focal point in front of the array, or a virtual focal point behind the array. The latter may be used to create a more dispersed beam, which is useful for the centre dialogue channel for example.

### Signal Processing Requirements

Development of Digital Sound Projector technology has meant overcoming some demanding signal processing requirements, which has only become possible quite recently. For some higher performance applications, a Digital Sound Projector may have hundreds of transducers. For example, an array of 256 transducers producing five audio channels on five beams with different steering angles requires the generation of  $256 \times 5 = 1280$  discrete audio channels. 1 Ltd has developed a custom ASIC, the TAC8256, capable of steering eight sound beams on an array of up to 256 transducers, resulting in 2048 audio channels. These channels are ultimately combined to form one unique channel for each of up to 256 transducers. There is an option to impose an individual window function across the array for each beam. Window functions can be used to lower unwanted lobe energy, but at the expense of maximum SPL and directivity.

A typical Digital Sound Projector architecture will consist of a surround sound decoding device to extract the five channels from the encoded digital audio data stream. This is then followed by a DSP to apply parametric equalisation, beam path length compensation, and to filter off those frequencies too low to be steered by the array into a separate channel. This low frequency channel (LFC) can be either sent to the array transducers, if they have the capability to handle the low frequencies, or to one or more larger transducers surrounding the array-proper. The crossover point to the LFC is set to a frequency where the human auditory system is less capable of discerning directional information, typically in the 250Hz to 500Hz region.

The five equalised channels are then fed to a beam forming processor (e.g. TAC8256), where the necessary delays and windowing are applied to steer and focus the beams. The output of the beam-forming processor will consist of an audio channel for each separate transducer. In most implementations several audio channels will be multiplexed onto each electrical pin.

The final stage is power amplification. A Digital Sound Projector will need a separate amplifier for each transducer in the array. For a large array this may be two hundred or more amplifiers. 1 Ltd has developed a 10-channel class-D amplifier (TAD108) to complement the TAC8256 beam forming processor. The TAD108 takes

a high speed, serial, data stream directly from the TAC8256 and delivers up to 2.5W rms per channel into 10 ohms.

The number of transducers and power output for each transducer will vary with each application, so the implementation will also vary. In some low cost applications the decoding, filtering and beam forming may all take place on one single chip, while in other higher performance systems separate ICs may be used. The trade-offs that have to be made here are typical of those in any product design.

### Other Applications

In addition to the capability of generating surround sound from a single loudspeaker source, a Digital Sound Projector can create effects not possible with conventional loudspeakers. One feature of particular interest to TV manufacturers is Beam2Me. Rather than bouncing the beams of sound off walls, they can instead be focused directly on the viewer. If the soundtracks of two programmes are down-mixed to mono and focused directly on to two viewers only a few feet apart, the viewers can listen to different programmes simultaneously with minimal interference. A typical application may be for sport and a sitcom to be viewed together (see Figure 11).

Digital Sound Projector arrays are being integrated into TV sets and personal computer screens, completely eliminating all wiring for sound, and restoring the TV to a 'simple to install' one-box device again.



Figure 11: Beam2Me can deliver two soundtracks to two viewers

Figure 12: Polar response for a typical 3.3-inch diameter loudspeaker at 2kHz

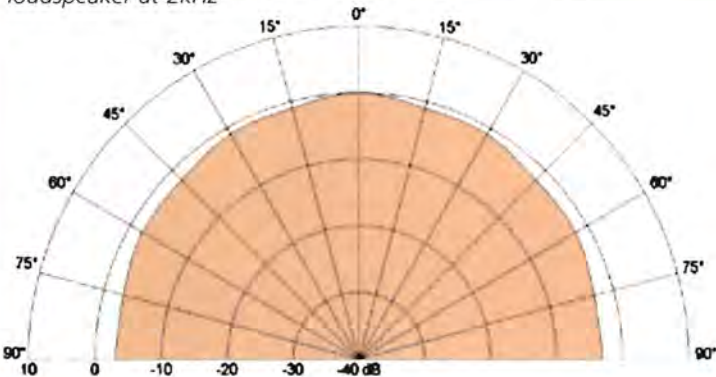


Figure 13: Polar response for a typical 3.3-inch diameter loudspeaker at 5kHz

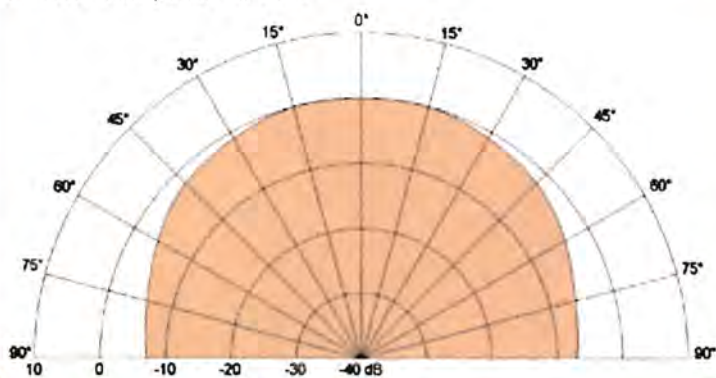
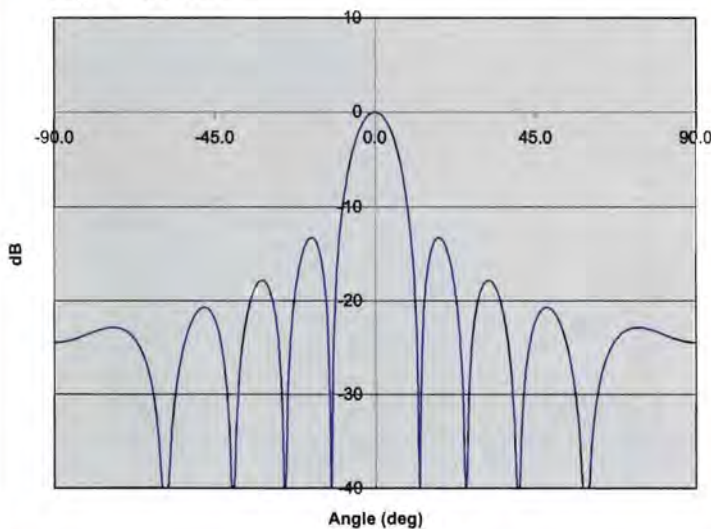


Figure 14: Polar response for a 50 transducer Digital Sound Projector at 2kHz



Other opportunities for Digital Sound Projector technology include more even sound distribution in PA applications such as churches, airports and concerts, novel audio effects in movie theatres and even noise cancellation.

### Fighting The Competition

Since the introduction of the first Digital Sound Projector products in 2003 there has been a noticeable increase in the claims of conventional loudspeaker manufacturers as to the directionality of their own products. This is particularly surprising as previous to this sea change a prominent marketing feature of many home theatre loudspeakers was their omnidirectionality. The prevailing wisdom at the time was that listeners should not hear the surround channels, particularly the rear channels, as emanating from a point source but rather as being diffused and all enveloping.

Following the introduction of Digital Sound Projector technology there are increasing numbers of loudspeaker manufacturers showing pictures of conventional loudspeakers with, what appear to be, beams of sound coming out of them. These beams then bounce off walls, or in some marketing material appear to curve around the listener, to create left, right and rear channels. In reality, conventional loudspeakers are no more or less directional than they have ever been, which is largely determined by their size. The polar response of a typical 3.3-inch diameter loudspeaker is shown for 2kHz and 5kHz in Figures 12 and 13.

The diagrams show that even at 5kHz the amplitude is only approximately 3dB down at 45 degrees off axis. Figures 14 and 15 show polar responses for a 50-transducer Digital Sound Projector of 780cm in length, also at 2kHz and 5kHz.

For the Digital Sound Projector, with the beam angled straight ahead, the amplitude is down more than 15dB 45 degrees off axis at 2kHz and more than 20dB at 5kHz. In simple terms, this means that the ratio of reflected sound to direct sound will be much greater for the Digital Sound Projector than for a conventional loudspeaker giving a far more convincing result of the sound emanating from the bounce point rather than from the loudspeaker itself. Promotional material showing conventional loudspeakers simply angled to bounce sound around the room should be viewed with some scepticism.

### Design Trade-Offs

The challenges facing Digital Sound Projector technology are familiar challenges faced by any new technology. To bring it to the mass market the costs have been brought down to a level where it can be incorporated into a flat panel TV for a modest additional cost. Designs have been created that reduce the number of transducers in the array. This, in turn, reduces the number of amplifiers required and the amount of processing required to form the beams. Designers, in their drive to bring low-cost Digital Sound Projector designs to market, will be careful to ensure



they do not compromise performance by building arrays that are either too small or too sparse to enable effective beam forming. If the array's overall length is too small then the lowest steerable frequency will be higher than desired.

For cost-effective manufacture, new techniques are being developed to assemble transducer arrays as a single low-cost component. Coupled with greater silicon integration Digital Sound Projectors with quite stunning capabilities can be produced cost-effectively. **Figure 16** shows a concept sketch for such a Digital Sound Projector.

### Conclusions

It is hoped that this article has given the reader an understanding of how 1 Ltd's Digital Sound Projector technology works and some idea of the possible applications for which it might be advantageous. Whilst the initial application has been to enable a convincing multi-channel home-cinema from a single cabinet, this is just the beginning for this new technology.

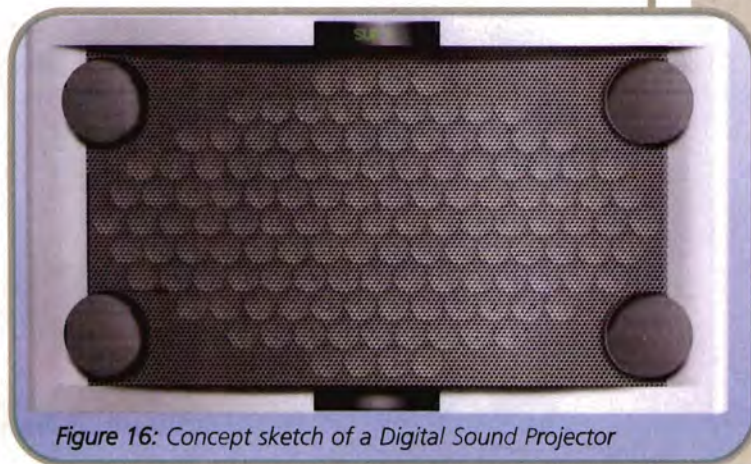
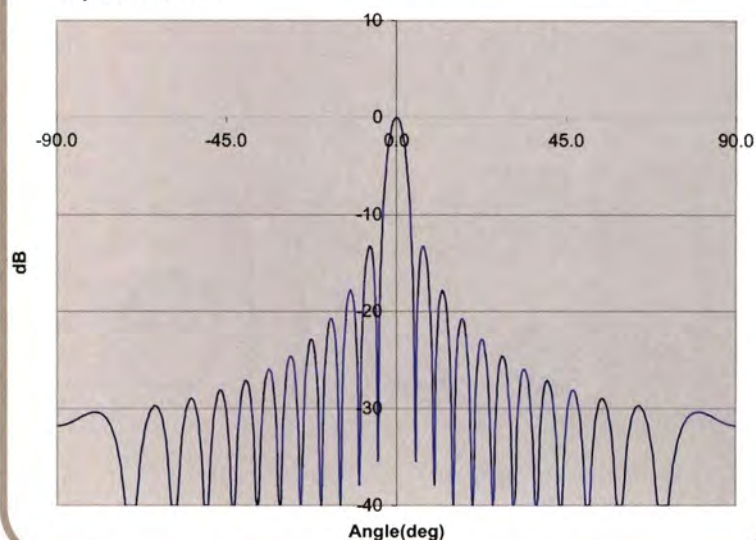


Figure 16: Concept sketch of a Digital Sound Projector



Figure 17: Helimorph actuator

Figure 15: Polar response for a 50 transducer Digital Sound Projector at 5kHz



### 1 Ltd – The Company

1 Ltd was founded in 1995 by Dr Tony Hooley, with the concept of developing a fully digital loudspeaker using arrays of small transducers to replace the traditional large paper cone transducers, which have dominated audio reproduction since the 1930s. These traditional transducers have very low efficiency (typically 1% or 2%) and relatively high distortion (1%), when compared to the amplifiers driving them. Alternative transducer technologies were investigated, including electrostatic, fluidic and piezo-electric. Ultimately, none turned out to be better suited than conventional moving coil technology but out of the research was born 1 Ltd's second technology stream, the Helimorph actuator. This is coiled coil of multi-layer piezo-electric material (PZT) which demonstrates (see **Figure 17**) a very high displacement for a small actuator and has found a major market for itself as the auto-focus motor in the next generation of mobile phone cameras.

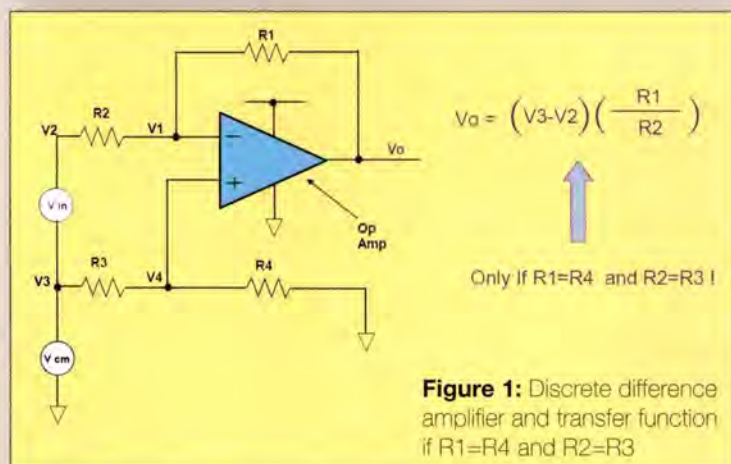
# Difference Amplifiers are different

Dietmar Schmid, Marketing Manager of Amplifier Products at National Semiconductor presents the architecture of a difference amplifier and some of the design-in challenges

For over four decades operational amplifiers have served in many applications. A rather special subcategory is the difference amplifier. Like classical op-amps, which are mainly categorised by high input impedance, low output impedance and high open-loop gain, the monolithic difference amplifier is a special circuit implementation, often using an input gain stage and a buffer, or low gain driving stage. This article will describe the basic structure of the difference amplifier and some of the challenges involved in designing and using it.

## Difference Amplifier Architecture

The difference amplifier is configured as a subtraction amplifier. In **Figure 1** a typical difference amplifier architecture is shown with four resistors



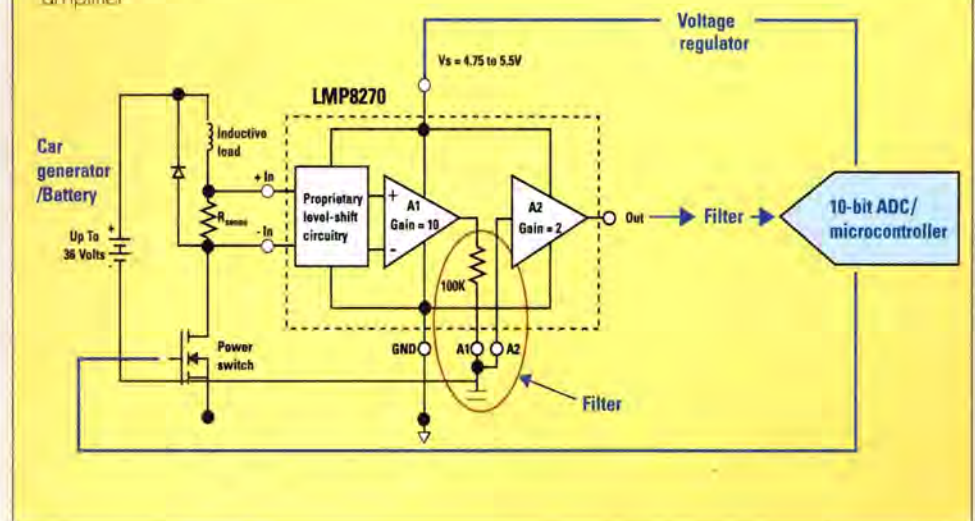
that form the subtraction circuit. Clearly, the resistor tolerances have a huge impact on the accuracy specifications. Those resistors (often having values of several hundred k $\Omega$ ), as with a standard op-amp, serve to maintain relatively high input impedances, while also enabling high input voltages.

As an example, the relation between resistor R3 and R4 indicates the divider ratio. For a 50V Common Mode Voltage Range (CMVR) on the inputs of the subtraction circuit and a 5V voltage input range of the amplifier, the ratio of 10 is also the shift factor for the  $V_{cm}$  and  $V_{in}$  signals toward the input of the op-amp ( $V_{cm}$  is the common mode voltage describing the potential that is present at both inputs referenced to V- or ground, whilst  $V_{in}$  or  $V_{diff}$  is the potential difference between the inputs).

Similarly, the resistor matching is a dominating factor for the accuracy as any common mode voltage would not be equally divided down, causing a lower CMRR (Common Mode Rejection Ratio). For a CMRR of 80dB resistor matching better than  $10E-4$  is required. As indicated, not only the common mode but also the difference voltage (the desired signal) is divided. For a 1mV  $V_{os}$  capability at the input pins and a divider ratio of 10, the op-amp needs to be better than 100 $\mu$ V at the offset. This clearly shows that the difference amplifier architecture needs precision design and test techniques.

An implementation using a classical op-amp would demand either a high voltage amplifier with a common mode range and common mode rejection values good enough to detect the small signal, or use a single supply amplifier with external resistors to implement the level shifting like in Figure 1. High

**Figure 2:** Typical application diagram for a difference amplifier



voltage precision resistors are available but are quite expensive. Board space and routing is an additional challenge, if you don't want to couple unwanted noise towards the output.

High voltage op-amps are expensive too (usually only available in bipolar technology), and challenging to design with similar accuracy specifications.

A modern semiconductor process is capable of economically implementing high ohm value resistors in thin film technology, providing unique accuracy advantages over discrete implementations, such as matching tolerances of 0.01% or better, and extremely low temperature drift of only a few parts per million (ppm).

CMOS or BiCMOS technologies do offer design flexibility, like trimming, and MOS transistors offer the best system cost advantages when excellent accuracy is needed. These monolithic difference amplifiers find use in special applications, where there is a need to detect signals outside the normal supply voltage range. They also save on board space, as there are solutions in S08 package with an area of around 30mm<sup>2</sup>.

### Suitable Applications

The 5V or even 3.3V supply rails are suitable for further analogue signal processing in the signal chain, as there should be no other signal compression towards the A/D converter input. The presence of high common mode signals or ground noise is the ideal terrain for modern difference amplifiers. Such conditions occur in motor control applications, sensing battery stack voltages, driving actuators and solenoids, sensing signals in high impedance current loops or bridge sensors with high excitation voltages.

A typical application is shown in **Figure 2**, where the load could be a motor coil or solenoid coil and the power switch is low Rds<sub>on</sub> Mosfet transistor. The used precision difference amplifier LMP8270 is feeding an A/D converter. The microcontroller would control the PWM frequency by measuring the average current and switching the FET accordingly. The difference amplifier is sensing the voltage across the shunt, usually a few milliohms or less, while suppressing the common mode voltage. The integrated level shifting circuit is, in principle, similar to the difference amplifier shown in Figure 1. The difference amplifier is working with a 5V supply,

whereas the common mode voltage and the difference voltage are independent of that and can reach 36V still keeping the LMP8270 fully functional. This maximum range is defined by the divider ratio. The survival maximum range is defined by the process parameters and ESD device voltage limitations. Clearly, the level shift resistors are very suitable for ESD protection, as they attenuate the potential going toward the transistor junctions and can limit current peaks. The drawback of these – and any other resistor – is the additional voltage noise created by them. In general, resistor noise can be expressed as noise power density per unit bandwidth in:

$$\frac{V}{\sqrt{Hz}}$$

by the equation  $eR^2 = 4 * k * T * B * R$ , where T is temperature in Kelvin, R is the resistor value in ohms, B is the bandwidth in Hz and k is the Boltzman's constant. Closer analysis of a motor control or solenoid (linear motor) control application shows that changing high voltages are present when the motor is switched on. In the automotive industry, controlling the fuel injection is a good example where those difference amplifiers are very useful. Similar applications include controlling solenoids in gear shifts, DC brushless motors for precise control of torque, or fuel pumps for precise and fault detectable operation.

In the industrial Market 3 phase, AC motor control can also benefit from precise voltage and current measurements. Assuming a current through a shunt is 10mΩ and a range of 3A down to 0.5A needs to be sensed, the resulting voltage across the shunt is between 30mV and 5mV. In general, a good compromise has to be found between high power dissipation in the shunt, the needed dynamic range and the accuracy of the signal processing. A precision amplifier, generally defined as an op-amp

with less than 1mV  $V_{OS}$ , is recommended here in order to accurately sense the 5mV signal, as the offset voltage is only part of the error contributors. With a signal presence on top of a common mode voltage of, for instance 12V, difference amplifiers like the LMP8270 or LMP8271 can provide all of the required analogue signal processing to feed an A/D converter.

The device family consists of a 2-stage difference amplifier with a 200k $\Omega$  common mode input impedance. The first stage provides the level shifting and a gain of 10. The first gain stage feeds through an integrated 100k resistor to an output. The second stage provides a gain of 2 and a push-pull output stage capable of driving an analogue-to-digital converter, either integrated in a micro-controller or a standalone SAR (Successive Approximation Register) converter, which usually provides a much better accuracy for the same number of bits. Between the two stages, a low pass filter can be implemented by adding a capacitor to ground. An anti-aliasing filter could be positioned after the second stage, offering the advantage to design for another corner frequency. This is useful when the averaging time constant needs to be adjusted without changing the sampling frequency.

### Error Sources

Care needs to be taken when calculating the error budget. The common mode rejection ratio of 80dB adds an error of 10 $\mu$ V per V of common mode change. In the example above, this would mean additional 120 $\mu$ V of common mode if the input is changing over that range. Obviously, the larger the voltage range the better CMRR is needed for a given error tolerance. As indicated, the difference amplifier moves the signal into a single supply 5V rail, which is useful to interface to an A/D converter without further compressing and, hence, eliminating a 12V power supply rail in the chain. Both devices guarantee a  $V_{OS}$  of 1mV. Over their entire temperature range delta of 165 $^{\circ}$ C, another 2.8mV needs to be assumed as worst case.

Smaller error contributors are the power supply rejection, the gain error and gain drift specifications. The power supply accuracy can typically be safely assumed with  $\pm$ 3% of a regulated supply voltage, yielding  $\pm$ 300mV in case of the 5V supply. Gain accuracy is typically 1% and the drift of the setting resistors over temperature is 25ppm/ $^{\circ}$ C. A typical application parameter set in a design using an LMP8270 could look like:

Vcm worst case:	12V
Vos:	1mV max at 2.5V Vcm
CMRR :	80dB
PSRR:	70dB
Gain error:	1%
Gain temp drift:	25ppm
Vdiff for a 10m $\Omega$ shunt and 0.5A to 3A current range:	5mV -30mV

The offset voltage can be defined as:

$$\begin{aligned} V_{OS} &= V_{OSinitial} + V_{OScommon\ mode} + V_{OSPSRR} \\ &= 1mV + \frac{9.5V}{10^{(80dB/20)}} + \frac{0.6V}{10^{(70dB/20)}} \\ &= 2.14mV \end{aligned}$$

The gain error is output voltage dependant. A small signal value for 100mV and 4.8V as a large signal value are useful to consider as the saturation voltages from the rails of the output stage are 20mV and 200mV in the worst case.

$$\begin{aligned} V_{gainerror\ small\ signal} &= 0.01 * \frac{V_{out}}{20} \\ &= 0.01 * \frac{20mV}{20} \\ &= 0.05mV \end{aligned}$$

and

$$\begin{aligned} V_{gain\ error\ large\ signal} &= 0.01 * \frac{V_{out}}{20} \\ &= 0.01 * \frac{4.8V}{20} \\ &= 2.4mV \end{aligned}$$

Considering an additional temperature error, the  $V_{OS}$  drift for 100 $^{\circ}$ C temperature range is given by:

$$\begin{aligned} V_{ostemp} &= \delta temp * vdrift \\ &= 100 * 15\mu V / ^{\circ}C \\ &= 1.5mV \end{aligned}$$

The gain error drift can be neglected here as the 25ppm/ $^{\circ}$ C, which is roughly a factor of 1000 smaller than the gain error, and only small input voltages are assumed.

This sums up as 3.69mV input referred error for small signals and 6.04mV for large signals. An additional error factor is the voltage noise. The LMP8270 family has 450nV/ $\sqrt{Hz}$  flat band noise at 1kHz. As the bandwidth needed in the control loop is usually only a few kHz, the noise error voltage can be neglected. In the above example, for a bandwidth of 10kHz the flat band noise contribution would approximately be:

$$\begin{aligned} V_{noise} &= 450 \frac{nV}{\sqrt{Hz}} * \sqrt{10000} \\ &= 45\mu V \end{aligned}$$

### Topology Considerations

Current measurement PWM (Pulse Width Modulation) is a commonly applied method when controlling a motor or a solenoid precisely. Different configurations of the switch, load and shunt can be implemented, such as high side or low side switching, indicating the position of the FET power switch. In some cases, not only that the on-current through the coil is measured but also the so-called off-current or freewheeling current needs to be measured to remove phase lags in the control loop for high speed, tight position and torque-controlled actuators and motors.

Additionally, during the freewheeling phase, the coil windings could be monitored through an average current comparison. This is often used in solenoid injection systems to control the amount of fuel going into a car engine's cylinder, for instance. These solenoids are highly stressed during their operation through high voltages and large pressures in the injection path, and are expected to flawlessly operate over a long time.

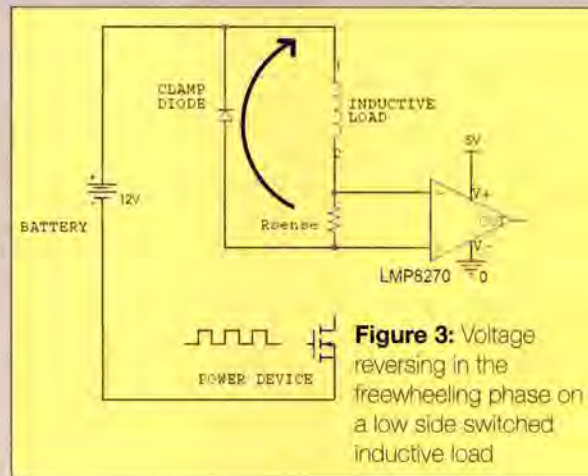
Having the option to detect solenoid winding shorts to ground or electrical malfunctions could be a huge benefit from a reliability and safety point of view.

Using a high side switch and a shunt referenced to GND, the common mode voltage is also close to ground level during the on phase of the FET. In the off condition, the clamping current is not going through the shunt. If the coil is connected to GND and the shunt is in the middle, then the amplifier inputs are pulled below GND, potentially by the reverse of the coil voltage in the freewheeling phase, and going through the full common mode voltage range towards the battery when in the on state.

A difference amplifier can easily survive and also operate several volts below its low supply rail. If more than one coil needs to be controlled by the same amplifier, all of them can share the same ground connection, which simplifies the wiring. A short to ground is also detectable when the clamping diode is connected between the high side Mosfet source and GND.

The low side switch (high side measurement) has the advantage that the gate drive process of the Mosfet is easier and the switch is less costly. The common mode voltage would, however, pull the inputs of the amplifier above the battery rail, a condition for which the difference amplifiers are well suited. **Figure 3** is showing how the voltage is reversing during the off state for a low side switched system.

Another important factor in PWM loops is the switching frequency. Usually a few kHz are used at maximum in solenoids and motors. However, the fact that the common mode rejection in difference amplifiers, as well as in op-amps, is frequency dependant – and is getting worse with higher frequencies – is often overlooked.



**Figure 3:** Voltage reversing in the freewheeling phase on a low side switched inductive load

AC common mode rejection specifications in the datasheets are only sometimes offered allowing a performance calculation with realistic specifications.

### Output Stages

Some difference amplifiers, such as the LMP8271, can be alternatively referenced to the middle of the power supply by connecting pin 7 to the V<sub>S</sub> pin. This allows for bi-directional measurements and detecting the polarity of the current. For a motor, the spinning direction could be derived by this feature.

When pin 7 is connected to another voltage, an asymmetrical reference value could be achieved at the output. A good example would be if the input signal is very small and close to ground; even with a gain of 20 the output will still be very close to the saturation voltage or in the low LSB area of the A/D converter. By applying a 200mV reference voltage to the offset pin, the output is shifted by half its value, in this case 100mV above ground and, therefore, comfortable in the A/D converter's input range, making it also more robust against ground noise. Almost no dynamic range would be lost in the preferred current range and direction.

### Solving Design Challenges

Monolithic difference amplifiers solve many design challenges when small signals need to be detected in the presence of large common mode voltage swings. They make use of the advantages in modern semiconductor processes, provide excellent precision specifications and save board space versus discrete implementations. Furthermore, they can offer the possibility of error budget testing of almost the complete analogue signal chain versus an individual summation of errors.

# Designing Networks vs. Testing Networks

THOMAS HEURUNG, EUROPEAN TRANSPORTATION SPECIALIST, AND BJÖRN WESTMANN, APPLICATION ENGINEER AT MENTOR GRAPHICS EXPLAIN THAT THE BEST WAY TO ADDRESS PERFORMANCE AND COST IS AT THE DESIGN STAGE

**M**ost in-vehicle networks today are validated predominantly by extensive testing. The design process is often limited to reusing and modifying legacy networks. Instead of focusing on getting an optimum of cost and performance during the design phase, a lot of effort is spent on validating the correct function of the in-vehicle networks through extensive testing.

However, changing the design paradigm to a structured engineering process can lead to better, cheaper and easier network designs, where more time is spent on the design and less on the validation of the network. With the right tools to support such a process, the network design itself becomes as predictable as the communication on the bus, and the

process of validating the network through lots of testing is replaced by the well defined task of verifying the correct implementation of the network.

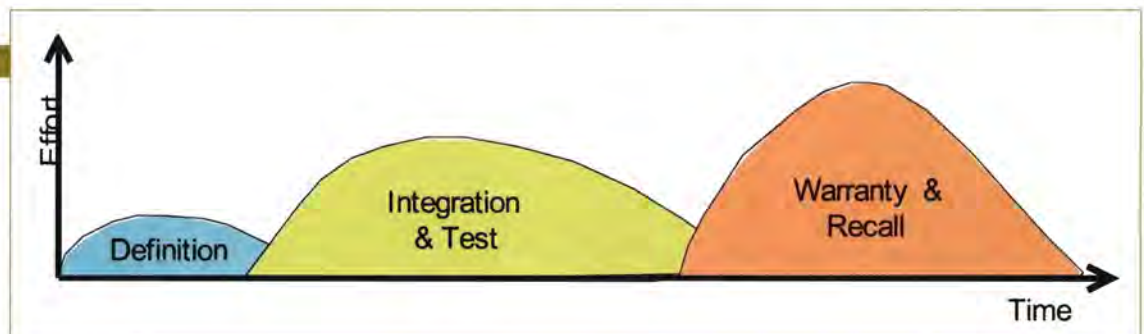
## Motivation

Traditionally, electrical systems engineering concepts have been applied to isolated electronic control units (ECUs), one by one. As long as the interaction with the rest of the vehicle was low, suppliers were able to conduct this engineering alone and without the need to consider the complete system. With the introduction of multiplexing, the interactions between ECUs and subsystems have increased, resulting in much more complex systems and design processes.

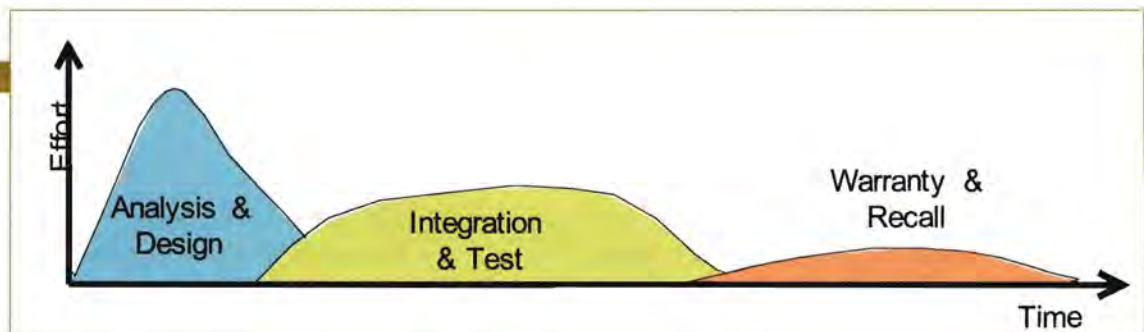
Design and verification of components is, in general, a well

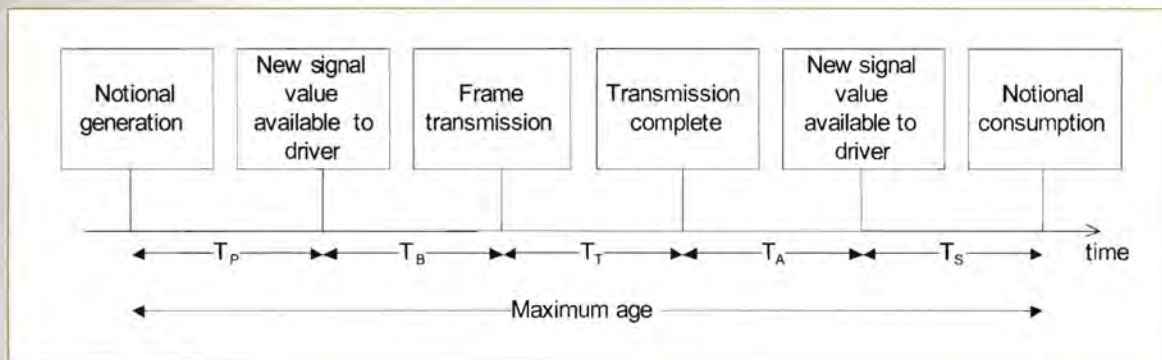
understood process and while it has its own challenges, it's the behaviour of the complete system that is creating problems today. In-vehicle network "design" today is a process where legacy systems are re-used, additional functions added and then validated through lots of testing performed on the real hardware. As a result, the integration of ECUs, i.e. the task of getting them to work together, is a challenging process because, very often, the specification at the complete vehicle level is incomplete, incorrect or nonexistent. **Figure 1** shows where and how much effort is typically spent in the different design phases. The "trial and error" character of the test and integration phase means that there is no certainty when and if the testing is completed, and many problems are not discovered until late in this phase process.

**Figure 1:**  
Correct-by-test

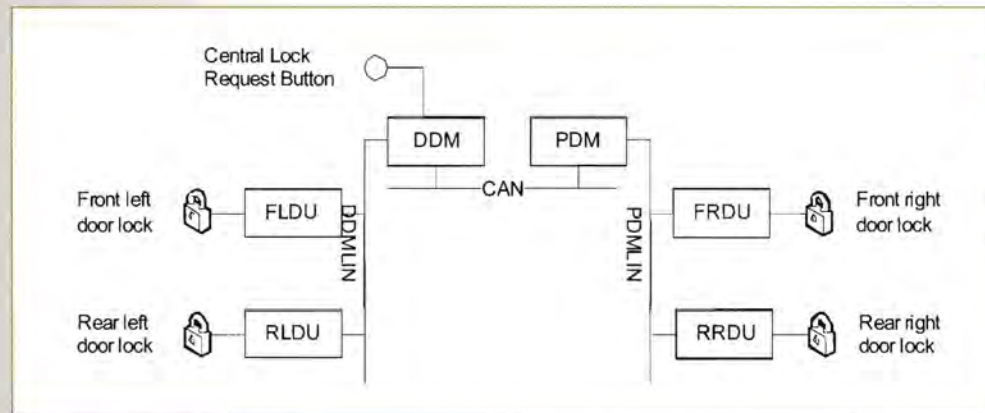


**Figure 2:**  
Correct-by-construction





**Figure 3:**  
Overall timing concept



**Figure 4:**  
Network for door locking

Typically, there's much more effort spent on integration and test than on definition of the specification, hence the effort of fixing implementation faults, or even design faults that slip through into production, is much higher.

This means that there is a great potential for savings, by introducing a "correct-by-construction" engineering concept into the design process of in-vehicle networks, where more effort is spent on the analysis and the design of the network in order to spend less time and money on the integration and test, and ideally none at all on warranty and recall (Figure 2).

The multiplex bus is one of the most important shared resources in a vehicle electrical system, with the electrical power being the other. By utilising this resource, interactions between vehicle functions happen. If one function increases its bandwidth consumption or timing behaviour it may affect all other functions. A good example to illustrate this is the commonly used CAN (Controller Area Network) bus, a system for automotive control purposes. Data on a CAN bus is transmitted in frames that are sent either periodically or sporadically. As the prioritisation works via CSMA/CA

(Carrier Sense Multiple Access/ Collision Avoidance), it is not clear when data is transmitted. The CAN bus is often perceived as unpredictable, non-deterministic and not well suited for real-time processes. Designing a complete in-vehicle network based on this bus concept without mathematical methods requires extensive analysis and testing of as many communication scenarios as possible. Each piece of data added to the communication concept increases the testing effort exponentially.

### Timing Requirements

In order to achieve deterministic network behaviour, it is essential to capture all timing requirements, enabling a complete understanding of all interactions between functions on the bus level and allowing automatic configuration of the complete network. This is a fundamental difference to traditional network design, where data is transmitted without understanding all of the timing requirements of the complete system and timing behaviour is analysed as a debugging procedure.

Figure 3 illustrates the overall timing requirements.  $T_P$  is the time between the occurrence of an event and availability of related

data for the software driver,  $T_B$  the time it takes to get the data into a frame on the bus,  $T_T$  the time to complete transmission,  $T_A$  the time when the data is available to the application software and  $T_S$  the time when the application is done processing the data. The sum of all individual timings must be less than or equal to the time at which the data becomes obsolete.

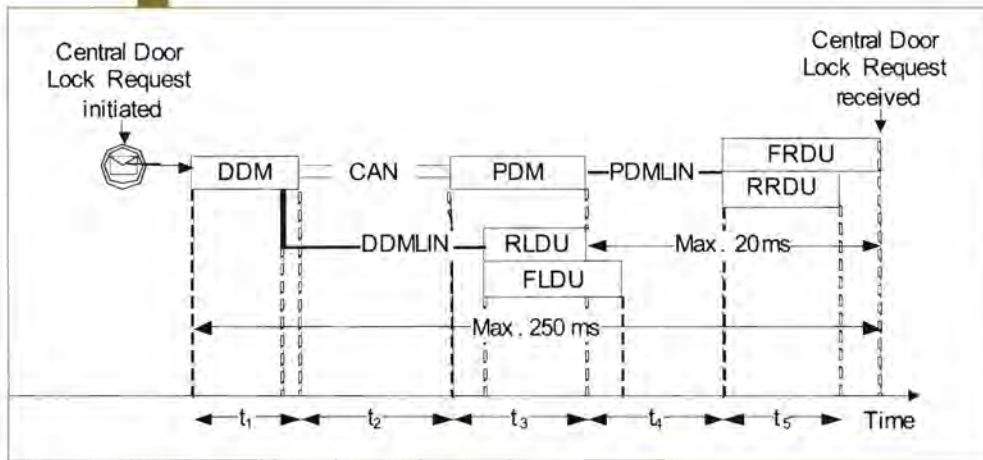
Timing requirements can be fairly complex and described in multiple, non-standardised ways. The example in Figure 4 shows a network to implement a central door-lock function. Its requirements could be described as follows:

1. When the Central Lock Request button is pressed, all doors must be locked/unlocked within 250ms.
2. All door locks must be locked within a time span of 20ms, so that no noticeable time delay between the four locks can be detected by a human ear.

The sequence of activities in the network is as follows:

- DDM (Driver Door Module) sends a signal called CentralLockRequest when triggered by the central lock request button.
- PDM (Passenger Door Module) reads CentralLockRequest and

**Figure 5:** Timing diagram for central door locking



**Figure 6:** Signal chain

<input checked="" type="checkbox"/>	<input checked="" type="checkbox"/>	Overall timing FLDU (Req1)	0.000	250.000
	<input checked="" type="checkbox"/>	CentralLockRequest		
	<input checked="" type="checkbox"/>	LockRequestFLDU	0.000	250.000
<input checked="" type="checkbox"/>	<input checked="" type="checkbox"/>	Overall timing RLDU (Req1)	0.000	250.000
	<input checked="" type="checkbox"/>	CentralLockRequest		
	<input checked="" type="checkbox"/>	LockRequestRLDU	0.000	250.000
<input checked="" type="checkbox"/>	<input checked="" type="checkbox"/>	Synchronised Timing FLDU RLDU (Req2)	0.000	20.000
	<input checked="" type="checkbox"/>	LockRequestFLDU		
	<input checked="" type="checkbox"/>	LockRequestRLDU	0.000	20.000
<input checked="" type="checkbox"/>	<input checked="" type="checkbox"/>	Synchronised Timing FLDU RRDU (Req2)	0.000	20.000
	<input checked="" type="checkbox"/>	LockRequestFLDU		
	<input checked="" type="checkbox"/>	LockRequestRRDU	0.000	20.000
<input checked="" type="checkbox"/>	<input checked="" type="checkbox"/>	Synchronised Timing FLDU FRDU (Req2)	0.000	20.000
	<input checked="" type="checkbox"/>	LockRequestFLDU		
	<input checked="" type="checkbox"/>	LockRequestFRDU	0.000	20.000

sends two signals called LockRequestFRDU and LockRequestRRDU on its LIN network.

■ DDM also sends signals called LockRequestFLDU and LockRequestRLDU on the DDM LIN network.

Figure 5 shows a graphical representation of the timing of the complete communication required to implement the function central door locking. After the door lock request was initiated, DDM requires the time  $t_1$  to process the input and send a message on the CAN bus. After  $t_2$ , the message is delivered to the PDM and it takes  $t_3$  to get the required message onto the PDMLIN bus. Delivery to

the front-right door unit (FRDU) and the rear-right door unit (RRDU) of the message takes  $t_4$  and the locking occurs after  $t_5$ . The total time for this must not exceed 250ms. Observing the network communication on the driver side (RLDU and FLDU) shows similar timing.

Requirement 2 means that the time difference between the first and the last units activating their locks must be less or equal to 20ms. In Figure 5 this is between RLDU and FRDU. Capturing these timing requirements is important for the design as well as the testing of in-vehicle networks. Figure 6 shows how the signal chain analyser of Volcano Tellus

captures all of these requirements for the purpose of testing the network implementation.

Once all the required data is captured, the network timing can be analysed, function data can be distributed in frames based on mathematical methods, and the worst case latency for each frame can be calculated. If all data can be transmitted in time within the given network parameters, a configuration file can be generated. This includes all the information for each networked ECU, such as Baud rates for the network hardware, setup data for the filtering hardware, identifier and size of all outgoing frames, timing behaviour and transmitting patterns, as well as placement of signal data within the frame. An implementation of this concept that supports this kind of structured network engineering process is the Volcano Network Architect.

### Increased Bus Utilisation And Reconfiguration Flexibility

There are a number of benefits gained by using this concept. Bus bandwidth can be better utilised as bus loads of 90% or more are possible without data loss. At the same time the communication overhead gets reduced. If, for example, a frame does not arrive within its deadline, it is due to a fault and is not something that can happen during normal operations. Therefore, there's no need for frame acknowledgement by the application and no time-outs with re-transmission occurs, which reduces the bus load significantly.

The traditional approach requires the message list to be fixed early in a vehicle project and then verified that it fulfils the requirements in an extensive validation effort, sometimes lasting for a year or more. During this time a strict engineering change order process is enforced to limit changes to the message list, because every application on all ECUs needs to use this list to identify and process



**Figure 7:** Known worst case vs. observed worst case of signal latencies

the relevant data. The complexity is further magnified by a segmented supply-chain, where multiple different companies supply ECUs to the network.

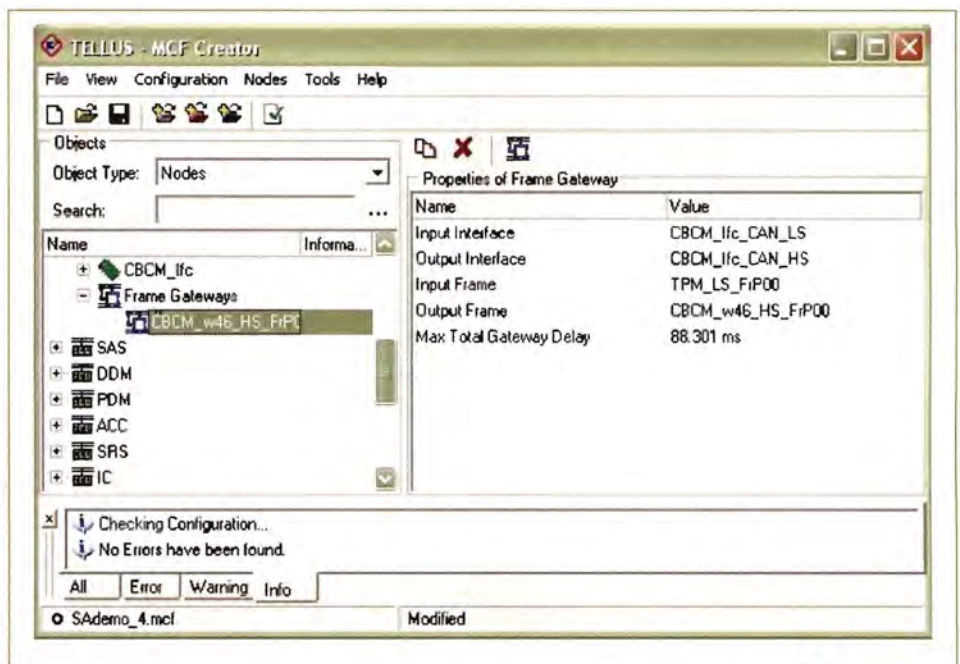
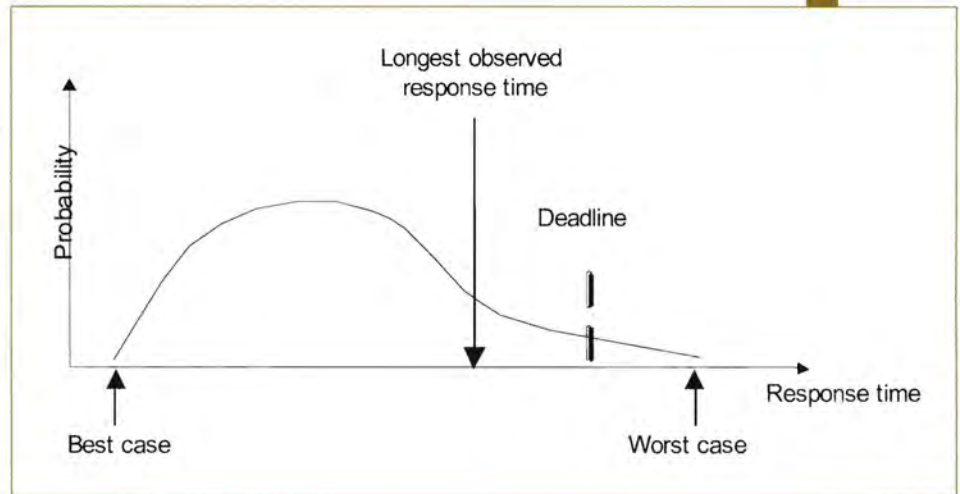
One way to tackle this complexity is to separate the network aspects from the application software by interfacing the application software through an API to dedicated network communication software packages. Combining it with the guaranteed message latencies of the communication layer from a deterministic network design, such as the Volcano concept, then there's no need for an early freeze of the message list, and changes to the message list can be made without affecting the application software at all.

**Impact On Testing**

A very important benefit of having deterministic network behaviour is that the verification effort increases linearly instead of exponentially and it is very clear what to test for. This means that the process of validating the network design through testing is replaced by verifying the correct implementation of a correct design by testing.

To illustrate this point **Figure 7** shows signal latencies that are usually distributed between a best case latency and a worst case latency. A traditional, non-deterministic network design process uses measurements to find out about worst case latency of frames, in order to determine the correct function of the network. However, measurements typically result in an observed "worst case", depending on the set of used test-cases. Because it is essential to have the signal delivered within the deadline, it's a typical approach to send all different signal combinations to cover as many situations as possible and, therefore, the measurement effort increases exponentially.

On the other hand, the previously described Volcano concept



**Figure 8:** Mapping messages

guarantees the correct function of the complete network when the implementation of the individual functions executes within the required timing parameters. The verification process is limited to measuring the timing of each individual signal and the testing effort increases only linearly with the number of signals.

**Analysing Gateways**

The analysis of gateways between different networks is another challenge in the network design and verification process. Because gateways are the

interfaces between different networks, it is a prerequisite for a reasonable gateway analysis to have unified description of all the attached networks. Very often different tools and processes are used to design or describe the different parts of the network and there is no common description. It is, therefore, very often necessary to gather all of the available data from the multiple configuration files and create one configuration description of the complete network connected to the gateway. While

processing configuration files for multiple networks in different formats (ldf, dbc, etc), gateways can automatically be identified by the fact that they appear in more than one network. The mentioned formats don't contain information about how data gets translated between the different networks, and the mapping needs to be done manually. A good format to store this kind of data is an XML format which can be used with different applications.

The example in **Figure 8** illustrates how a frame TPM\_LS\_FrP00 on a low-speed CAN interface of the Central Body Control Module is mapped to frame CBCM\_w46\_HS\_FrP00 on the high-speed CAN interface by using a so-called frame gateway. A frame gateway is an object that allows capturing of the mapping information as well as the information about the maximum gateway delay for this frame. Very often timing information is not captured in a standardised format, but in proprietary documents such as

Microsoft Excel tables. The advantage of using XML to describe the configuration of the complete network is that it is possible to automatically augment the XML data with additional, for example gateway timing, information. If the maximum gateway delay is not known, but a known good design exists, an alternative to this manual process is called signature analysis. Signature analysis is achieved by monitoring a known, good network to automatically determine a boundary for the delay time. Any time shorter than the measured latency is likely to be alright; any time longer than the measured latency could indicate a problem with the network.

If a deterministic design approach, such as Mentor's Volcano technology, is used, all of the above data is easily accessible and doesn't require any additional work at all. All maximum latency times are known and available in machine readable format. By using a suitable test tool, such as Volcano

Tellus, any violation of those requirements will be flagged automatically. In case all measured latencies are within the specification, the network will work correctly.

### Proven Concept

Capturing requirements and using a proven concept implemented in robust software is a very structured and effective approach, saving design time and increasing quality. Future technologies, such as AUTOSAR, rely even more on a reliable communication infrastructure that ensures data is delivered in time. And whilst AUTOSAR ultimately aims to reduce component cost, design and validation, complexity will increase. Suitable processes supported by advanced tools will be required to allow shifting the design paradigm from testing the correctness of network design to verifying the correct implementation of a correct concept.

## DESIGN HERE BUILD THERE EECO/XYE CHINA MANUFACTURING



EECO/XYE Contract manufacturing offers full service and support from design concept through finished product. Clients include top-tier OEM's worldwide in consumer electronics, auto aftermarket, telecommunications, security systems and many more. Enjoy cost-saving China production with local support.

Bring Your Next Project To EECO/XYE

Call +44 (0) 1954 781818 or

E-mail [xye@eecoswitch.co.uk](mailto:xye@eecoswitch.co.uk)

EECO/XYE

CAMBRIDGE, U.K.

See our capabilities at  
[WWW.XYETCHINA.COM](http://WWW.XYETCHINA.COM)

## PCB-POOL®

SERVICING YOUR COMPLETE PROTOTYPE NEEDS

### 1 EUROCARD

(160 x 100 mm)  
+ Tooling  
+ Photoplots  
- VAT

# €49

Price example  
Any size and contour possible!

### Optional:

- Soldermask
- Fast-turnaround
- Silkscreen
- 4-Layer Multilayer
- 6-Layer Multilayer

DOWNLOAD OUR  
FREE LAYOUT SOFTWARE!



Freephone   
0800-3898560

Over  
15,000  
Customers

LEAD FREE  
SOLDERABLE



Simply send your files  
and order ONLINE:

# PCB-POOL.COM

What would you give  
to get your hands on  
your own personal RF  
Spectrum Analyser ?



how does £795 sound?

The new PSA1301T from TTI totally re-defines the portable spectrum analyser.

By incorporating an advanced handheld computer, it offers a level of performance previously impossible for an instrument of this small size and low cost.

- ▶ 150kHz to 1.3GHz range; -93dBm typical noise floor.
- ▶ Half VGA TFT display; live & reference traces; unlimited waveform storage; dual markers with peak find & track.
- ▶ Truly handheld; 0.5 kg weight; four hours operation.
- ▶ Handheld computer is removable for independent use.

With so much to say about the PSA1301T, we can't cover much of it here. So there's a full Information Tour on our website. Or contact us directly to get a 8 page brochure sent to you.



Measurably better value

**Thurlby Thandar Instruments Limited**  
Glebe Road, Huntingdon, Cambs. PE29 7DR  
**Tel: 01480 412451**, Fax: 450409, e-mail: sales@tti-test.com  
**Web: www.tti-test.com/psa** or **www.tti.co.uk/psa**

**THURLBY THANDAR INSTRUMENTS**

# TELEVISION

A subscription guarantees your magazine arrives every month promptly and without fail.

If you are interested in television and consumer electronics, Television is the magazine for you. Sign up and every month you will find fault-finding guides for DVD, audio, satellite, TV, VCRs and test equipment reviews.

The magazine provides a forum for the industry's repair and installation engineers to trade ideas, solve problems and share information.

Yes I would like to subscribe to Television for:

- One year £41 in the UK, €95 in Europe and US\$145 Worldwide
- Two years £70 in the UK, €170 in Europe and US\$260 Worldwide, saving 10%
- Three years £95 in the UK, €220 in Europe and US\$345 Worldwide, saving 20%

Name \_\_\_\_\_

Job Title \_\_\_\_\_

Company \_\_\_\_\_

Address \_\_\_\_\_

\_\_\_\_\_

Postcode \_\_\_\_\_

Tel \_\_\_\_\_

Fax \_\_\_\_\_

Email \_\_\_\_\_

By providing us with your email, phone and fax you are giving us permission to contact you occasionally about your subscription or related products.

**PAYMENT CHOICE:**

- I enclose a cheque made payable to Nexus Media Communications Ltd
- Please invoice my company
- Please debit my card
- Visa     Mastercard     Amex     Switch     Delta

Card No

Issue No (Switch only)          Expiry date

Signature \_\_\_\_\_

Date \_\_\_\_\_

TO MAKE SURE WE KEEP OUR EDITORIAL RELEVANT TO YOU, PLEASE TICK ANY OF THE FOLLOWING THAT APPLY TO YOU. THANK YOU.

- |   |  |  |
|---|--|--|
| <p><b>1. Are you a:</b></p> <ul style="list-style-type: none"> <li><input type="checkbox"/> A Professional engineer</li> <li><input type="checkbox"/> B Serious hobbyist</li> </ul> | <p><b>2. Your profession:</b></p> <ul style="list-style-type: none"> <li><input type="checkbox"/> A Service/repair engineer</li> <li><input type="checkbox"/> B Design engineer</li> <li><input type="checkbox"/> C Installation engineer</li> <li><input type="checkbox"/> D Electrical wholesaler</li> <li><input type="checkbox"/> E Electrical distributor</li> <li><input type="checkbox"/> F Retailer</li> <li><input type="checkbox"/> G Education</li> </ul> | <p><b>3 Your company has:</b></p> <ul style="list-style-type: none"> <li><input type="checkbox"/> A 1-5 employees</li> <li><input type="checkbox"/> B More than 5</li> </ul> |
|---|--|--|

Your information will be handled in accordance with the UK Data Protection Act 1998. Your details may be released to other selected companies. Should you not wish to hear from other organisations, please tick here

All subscriptions run for their full term. No credit will be given for cancellations during this period.

Please complete payment and address details and return this order form to:  
**Debbie Jenner, Freepost SEA 11436, Television, Media House, Swanley, Kent BR8 8BR** (no stamp required UK only)

International Address: **Debbie Jenner, Television, Media House, Swanley, Kent BR8 8HU United Kingdom**

Ref: 625

# Mechatronic Solutions for

**Herve Branquart, Director of strategic marketing and Bart De Cock, Product Manager at AMI Semiconductor, based in Belgium, discuss mechatronic modules connected to the LIN infrastructure in automotive applications. Achieving an optimal mechatronic solution that meets performance and thermal design constraints requires judicious selection from several candidate technologies**



**E**ar manufacturers are committed to increasing the use of electronic controls within each new vehicle design. In the utilitarian and economy vehicle markets, advantages include cost savings due to easier and faster assembly compared to mechanical systems, as well as weight savings leading to greater fuel economy. In prestige cars, the emphasis is on offering advanced features and raising levels of comfort for occupants, to differentiate products and defend margins.

This trend has demanded a radical reshaping of the way vehicle wiring infrastructures, for example, are designed. Point-to-point wiring, as in a conventional wiring loom, quickly becomes prohibitively heavy and complex with increasing numbers of electrical subsystems.

Perhaps more importantly, the software development efforts associated with centralised control of large numbers of actuators adjusting the positions of

systems ranging from electric door mirrors to seat adjusters, to window lifters, become incredibly complex and time consuming, and challenge designers to create reliable software. In addition, complex signalling between a central controller and individual subsystems, such as PWM control of large numbers of electric motors, results in high electromagnetic emissions, creating difficult suppression techniques that are expensive to solve on a vehicle-wide basis.

### Intelligence In The Subsystems

Migrating intelligence towards the individual subsystems allows large reductions in vehicle wiring and signalling, and also offloads the central vehicle controller.

One solution has been to implement, for example, all the motor controllers required for door functions on a localised control board inside the door containing a processor hosting software for each function. This "direct drive" solution reduces the load on the vehicle's central

# Automotive Local Networks

body controller and also reduces the distances travelled by complex motor drive signals. However, as new vehicle designs require additional door-mounted features to be operated at the same time – for example, automatic anti-pinch sliding door and window-lift, high-end door locking functions and folding mirrors – software complexity increases rapidly. The tedious process to validate and qualify the software to operate a multitude of combinations of functions takes many engineering hours. Moreover, the development, fabrication and installation of different types of cable-trees, and the additional point-to-point wiring to each motor quickly adds further weight and cost. Electromagnetic radiation also begins to increase, resulting from the intensive signalling between the control board and the motors.

A more modular and easily scaleable solution is to integrate digital control into a monolithic or multi-chip motor driver solution. Adding, or subtracting, a motor becomes a more easily managed effort, by correspondingly adding or subtracting a motor driver chip or module. However, changes to the board layout may be required, and this solution does not reduce the complexity of the wiring between the control board and the motor array. Hence, a different solution is required if the cost and electromagnetic issues are also to be addressed.

Migrating yet more of the required intelligence toward the motor points enables the implementation of mechatronic modules comprising interfacing, control and driver functions as well as the motor itself, as a self-contained unit. This is indicated in **Figure 1**.

This reduces the control board implementation to contain only the processor and a bus interface, such as the three-wire LIN (Local Interconnect Network) bus. LIN has been widely adopted by automotive electronic integrators to reduce wiring complexity and signalling in vehicles. As an industry standard interconnection solution, LIN supports the integration of large numbers of mechatronic modules on-board vehicles, by implementing a standard LIN interface, as well as the control and driver functions within the module.

Adding an extra motor becomes a simple matter of connecting the motor as a complete mechatronic module

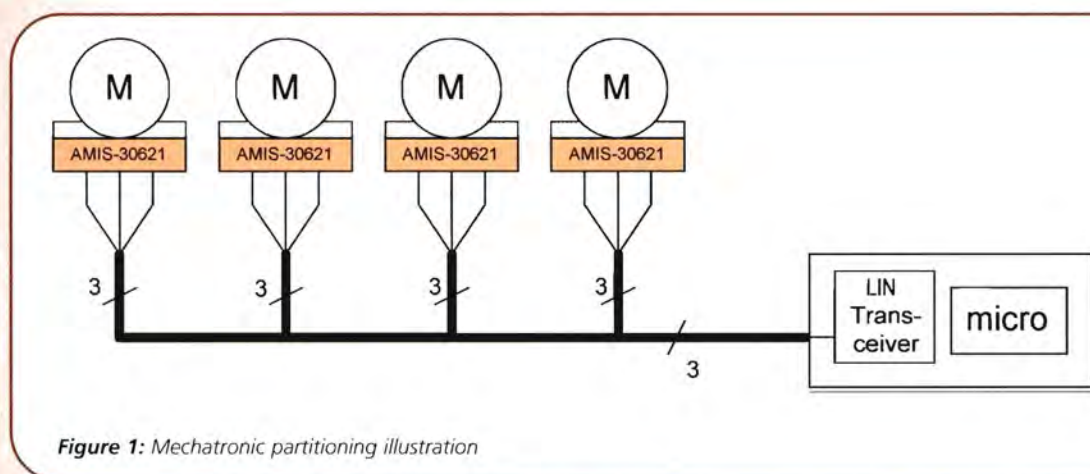
to the bus. This not only addresses the software complexity, EMI and scalability challenges, but also allows automotive component suppliers to deliver “shrink-wrapped” modules to their customers, the car makers. Hence, integration of electronic systems becomes more straightforward, leading to significant time-to-market benefits for new models as well as revisions to existing models. Subsystem vendors can also create new features and embed IP within the module, thereby achieving differentiation and also protecting their investment in product development.

## LIN Talk

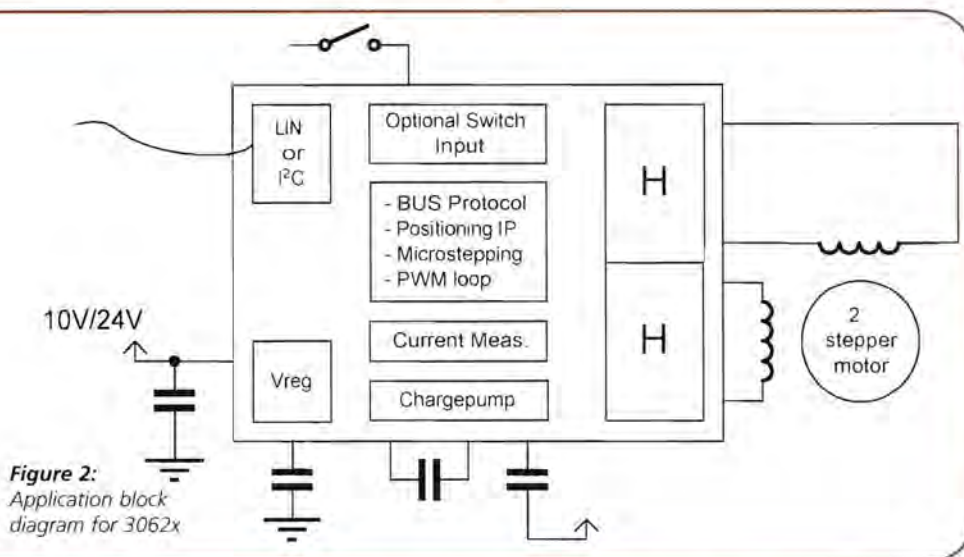
These benefits are especially applicable to LIN-based systems, as these are not subject to the intensive compliance analysis that applies to modules connected to the CAN network. The CAN network typically connects safety critical subsystems such as braking and airbag control, and therefore warrants much closer collaboration with the vehicle manufacturer.

Vehicle electronic modules that usually connect to the LIN network include door mounted drives for windows, mirrors and door locks, electronic seat adjustments, headlamp positioning systems, and motors and fans for climate control. Most of these applications require control of electric motors in one or several axes. To implement a mechatronic solution, therefore, system integrators not only require proven LIN interface IP but also configurable motor controls with integrated motor driver functions, CPU and memory subsystem integration, and power electronic technologies suitable for automotive voltage ratings.

**Figure 2** outlines the technology blocks implicit in an integrated bus interface and motor controller solution



**Figure 1:** Mechatronic partitioning illustration



**Figure 2:**  
Application block  
diagram for 3062x

suitable for a mechatronic stepper motor module. The LIN interface receives high level motor drive and position commands. The intelligent motor drive functions derive the necessary signals to move the motor from one position to another. A practical implementation may call for a state machine, micro-stepping current table and current controller, capable of being specified by the designer to meet exact system requirements. As well as the interface and control functions, other functional blocks such as the voltage regulator and charge pump required for stepper motor control, including the motor driver MOSFETs, must also be implemented. A smart power technology, for example, enables all of these blocks to be consolidated into a monolithic solution that can be readily integrated into the motor assembly.

### Implementing Sophistication

This approach also creates the opportunity to implement more sophisticated motor control features in hardware, such as current shaping. Designers would normally expect to implement their own current shaping if bringing up a stepper motor controller independently to support micro-stepping "forward", "slow decay", "fast decay" and "mixed decay" modes. Another design decision that has a critical impact on stepper motor operation is to determine the PWM frequency. If the frequency is set too high, then overheating can occur. On the other hand, if the frequency is too low, the drive will produce audible noise. Setting the ideal frequency depends upon operating conditions, including the supply voltage, typical current and operating temperature. These can be predicted quite accurately if the application is an automotive mechatronic module: assuming typical values, it is possible to calculate an optimal PWM frequency to be around 22kHz. Hence, it is feasible to fix the PWM frequency in hardware, thereby saving external components. Other features that may usefully be implemented in hardware, to maximise reliability and reduce component count, include on-chip flyback to eliminate the need for external diodes or Schottky devices, as well as on-chip current sensing. On-chip current sense allows the monolithic controller IC to respond independently to commands received via the LIN bus stipulating the desired motor current.

By implementing all the necessary stepper motor controls in hardware, the capacitors indicated in the diagram become the only external components required.

For electronic subsystem vendors, this streamlines hardware integration, reduces software design and allows developers to concentrate on application level design to add differentiating features cost-effectively. AMI Semiconductor (AMIS) has taken this approach to create a single-chip stepper motor controller for LIN-connected automotive mechatronic modules.

The AMI3062x is a monolithic IC built using a proprietary smart power concept, called Intelligent Interface Technology (I2T). I2T enables

integration of low, medium and high-voltage circuitry, high-precision analogue circuitry, non-volatile memory and some medium complexity digital circuitry in a single IC. In this device, the two H-bridge MOSFET drivers indicated in Figure 2 are implemented using 40V transistors with low RDS(ON), capable of satisfying motor current requirements up to 800mA.

Development tools supporting the smart power technology also allow engineers the flexibility to create custom motor control bus commands. These can be used to accelerate application development, as well as reducing signalling across the bus.

### Mechatronics Using Standard Products

Modules requiring higher motor drive requirements may require additional external MOSFETs, possibly using the I2T integrated MOSFETs as a pre-driver stage. Again, a module requiring more complex signalling may require a microprocessor. The use of a standard 8, 16 or 32-bit processor, combined with smart power or discrete solution based on standard digital components and power electronics stage is an alternative implementation.

On the other hand, a system on chip (SoC) solution gives maximum reliability, ease of assembly, low bill of materials and continuity of supply. A technology capable of supporting embedded microprocessors, as well as high precision analogue, complex digital circuitry and high-voltage functionality is required. As one example, Bipolar CMOS DMOS (BCDMOS) technology allows digital CMOS circuitry to implement microcontroller cores as well as on-chip memory, alongside isolated DMOS transistors implementing half-bridge or full-bridge high voltage motor drivers. Some figures of merit for a suitable BCDMOS technology include the maximum voltage rating for the DMOS transistors, as well as the size of available on-chip memories and the capabilities of the processor core. To address both 14V and future 42V automotive electrical standards for example, the DMOS transistors should be rated up to 80V.

As an example, AMIS's I3T BCDMOS technology implements digital CMOS circuitry in 0.35µm technology, capable of implementing a range of processor cores up to 32-bit complexity, such as the ARM7TDMI. There is also OTP memory, up to 64kByte of embedded flash for code memory and/or up to 1kB EEPROM for data. High-precision analogue circuits on-chip, including bandgap filters, ADCs and DACs, as

well as digital IP including LIN controllers, simplify development for Tier One suppliers.

**Multi-chip Module Solution**

Alternatively, building a multi-chip module, using a combination of smart power, digital and analogue technologies gives designers extra freedom to specify a more flexible processing subsystem with larger memory suitable for a complex, multi-axis solution. Moreover, the CPU subsystem components can be fabricated using a smaller design rule; the smaller die size leads to a reduced cost implementation, despite the extra processing bandwidth.

However, assembling a multi-chip solution as part of a mechatronic module is not a trivial undertaking. Tightly controlled System in Package (SiP) techniques are required, as part of a QS9000 certified assembly capability, in order to meet automotive quality and reliability standards. System integrators, therefore, must trade off the extra flexibility of the multi-chip approach against the risks to reliability and greater involvement in SiP development and assembly.

**Thermal Impact On Partitioning And Packaging**

The optimal configuration for a given mechatronic solution must also take into account the heat generated by the motor action, as well as the heat resulting from RDS(ON) and switching losses within the motor driver power MOSFETs.

A monolithic implementation, therefore, exposes the digital circuitry, including the MCU and memory, to a greater risk of exceeding the manufacturer's maximum recommended operating temperature. Qualifying the digital process for high temperature operation is one potential solution. On the other hand, using package technology innovations to remove the heat dissipated into the SoC substrate by the isolated DMOS transistors may also be effective in preventing over-temperatures from destroying the digital components. In practice, a combination of both techniques is likely to prove desirable.

**Clear Advantages To LIN Interfacing**

There are clear advantages to mechatronic solutions interfacing to automotive LIN infrastructures, both for subsystem developers seeking to deliver unique value proposition and for car makers wanting to enhance time-to-market, cost and sales appeal for new vehicle models. As a result, car buyers worldwide are set to benefit from greater reliability, more electronics on-board to make driving/use easier and more enjoyable, and enable a faster stream of new model enhancements.

To implement the electronic control functions of a mechatronic module, several technology solutions are available. The major issues to consider are the performance requirements, cost, flexibility, reliability and thermal performance. Above all, it is essential to choose a partner that has the necessary expertise in each of the applicable technologies, to implement the most suitable architecture to meet overall system requirements.

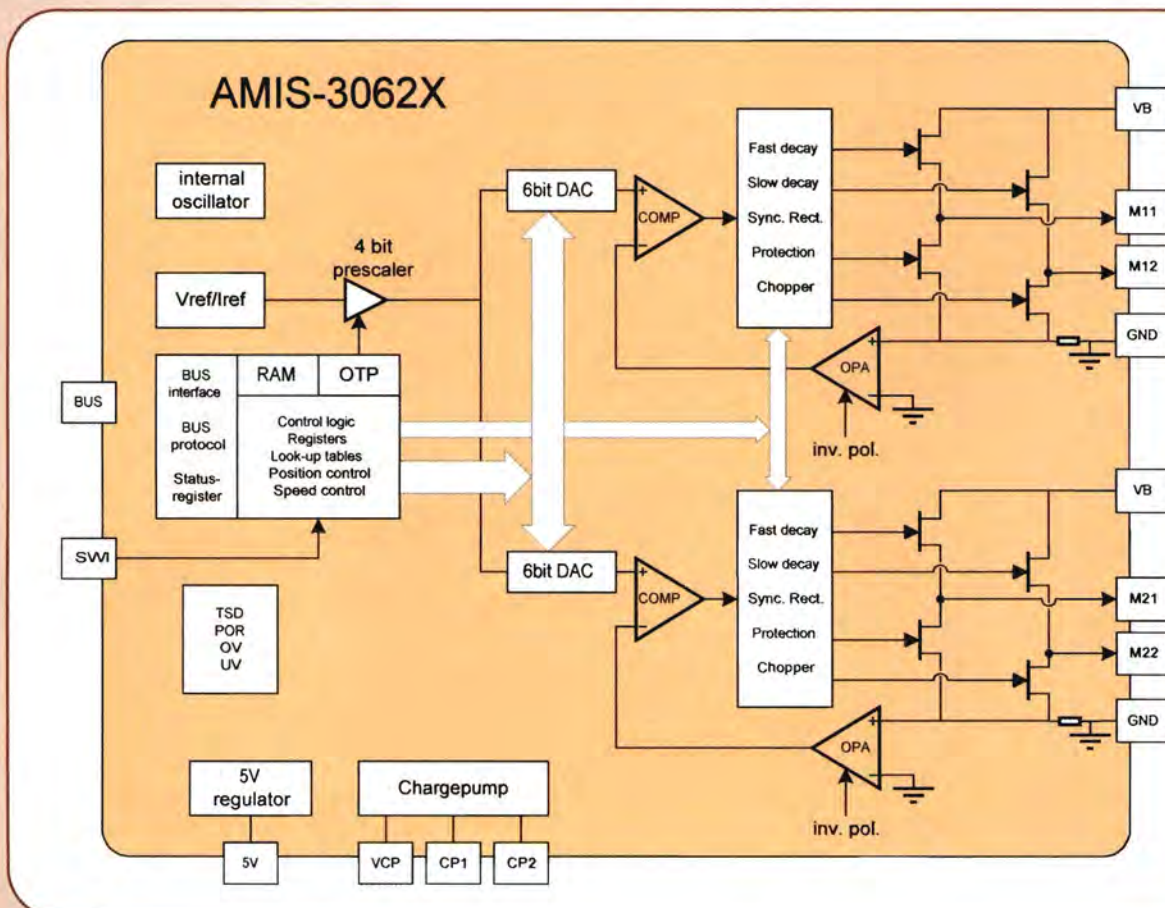


Figure 3: Block diagram of the AMIS3062x, which is fabricated in the proprietary Intelligent Interface Technology (I2T)

# Current Generation

**In this article, Domenico Di Mario presents the generating of current by the way of friction between two dissimilar metals**

**W**e are already familiar with electrostatic generators where friction between two different materials gives a very high voltage with a very small current. There is also another class of generators where high current is generated at a relatively small voltage. Faraday's homopolar generator is one of them but there is also a

current generator where electric energy is generated by means of friction between two dissimilar metals. Several configurations are possible including an AC generator.

## Electricity Generation

We know of many ways to generate electricity: photovoltaic, with thermo-

couplers and dynamos being just a few. They all transform one kind of energy into another: batteries transform chemical energy into electricity, alternators transform mechanical energy into electricity and so on. The little known current friction generator transforms mechanical energy into electricity by exploiting the difference of potential generated when two different metals run one against the other. To a certain extent it is similar to an electrostatic generator, properly called triboelectric generator but, unlike the latter, it generates a high current at a rather low voltage. There are no magnets, temperature differences or chemical reactions involved but only a controlled friction caused by mechanical action. The resulting generator is one of the easiest to build, although a careful choice of metals is fundamental in order to have a meaningful output.

## Simple Generator

Figure 1 shows the basic implementation of a friction generator. After a few preliminary tests it was found that nickel-copper coins were the ideal choice and, henceforth, adopted as reference discs. They are readily available and of the right size, and what is left to do is just some polishing of the rim with fine sandpaper. The metal to be tested was placed at the outer edge of the coin and the voltage measured while the disc was running. Several types of metals were tested with the aim to find the one giving the highest output. The result is reported in Table 1, together with the triboelectric series and the thermoelectric series. The tested metals do not seem to follow either of these series, although a modest contribution from a thermoelectric effect is to be expected as the metal under test is bound to become

Figure 1: A small nickel-copper alloy disc is rotated at 1500rpm. A bismuth contact is placed at the edge of the disc while another contact, made of the same metal as the disc, is placed at the centre. A voltage difference of 2-3mV was measured with a short-circuit current between 10 and 20mA. The disc is an old two-shilling British coin but other nickel based coins, including the two Euro coin will work fine

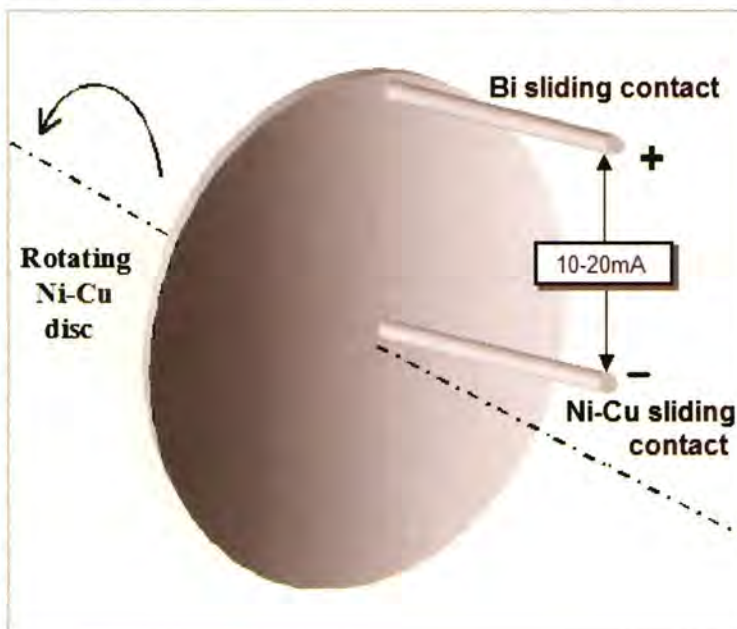
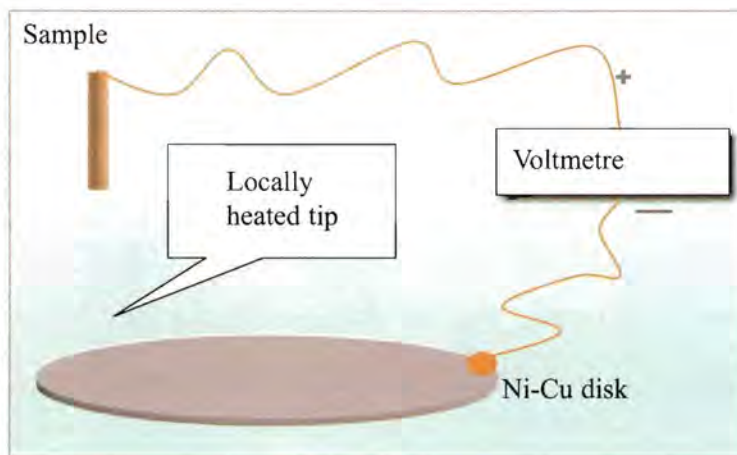


Figure 2: Any thermoelectric effect was measured with a brief application of heat at the tip of the sample and subsequent contact with the NiCu disc. All samples gave a positive reading, with the exception of bismuth that gave a negative reading





# by Friction

slightly warmer than the rotating disc.

The output terminals were loaded with a 2200 $\mu$ F capacitor in parallel with a 4.7k $\Omega$  resistor, and the current measurement was taken by connecting a digital meter directly to the output terminals; the reading is thus comprehensive of the contacts voltage drop and internal resistance of the instrument.

The voltage is positive and proportional to the relative speed of the disc, no matter which direction it is rotated in, but also to the pressure applied to the contact being tested. Actually, the higher the polishing of the sliding surfaces the higher the pressure required to get the same voltage. A rough surface needs a lower pressure but the internal resistance of the generator is increased.

Eventually it was found that bismuth gave the highest reading. Yet, only a small number of metals and alloys were tested and probably there is a combination of materials that would give a much better performance. For example, it was rather by accident that a chunk of conductive ferrite was available for testing, giving the highest negative reading; however, the sample had a resistance of a few k $\Omega$ , not quite a good conductor and definitely not good for a current generator.

## The Electrofriction Series

Voltage output was measured for many metals (Table 1). The output is purely indicative, as consistency could not be kept across all measurements, especially concerning the pressure and finish of the surface. They seem to follow their own rule, although more accurate measurements might give results closer to the triboelectric series (Table 2).

In order to see how local heating was influencing the output voltage, a

<b>Table 1 Electrofriction series, mV</b>							
$\approx + 2.4$	$\approx + 1.2$	$\approx + 0.7$	$\approx + 0.6$	$\approx + 0.5$	$\approx + 0.3$	Reference	$\approx - 5$
Bismuth	Iron	Chrome	18 kt Gold	Graphite	Silver	Nickel-Copper Alloy	Conductive Ferrite
	Cr-V Steel	Tungsten	Rhodium	Aluminium			
	Brass	Nickel	Carbon	Lead, Copper			
	Tantalum		Stain. Steel	Gold, Zinc			

<b>Table 2 Triboelectric series</b>						
+++++	++++	+++	++	+	Reference	
Lead	Aluminium	Iron	Copper Nickel	Silver	Brass Stain. Steel	Gold

<b>Table 3 Thermoelectric series</b>					
Bismuth	Copper	Chrome	Gold	Zinc	Iron
Nickel	Lead	Rhodium	Silver	Aluminium	Tungsten

test (Figure 2) was carried out. It was expected that a small positive voltage would develop due to heating generated by the friction between the metal under test and the NiCu disc. The experiment partly confirmed this, because a similar positive voltage was indeed produced, but only when the sample was heated at about 80-100°C above ambient temperature. The normal heating due to friction in our generator was measured at only a few degrees above ambient temperature.

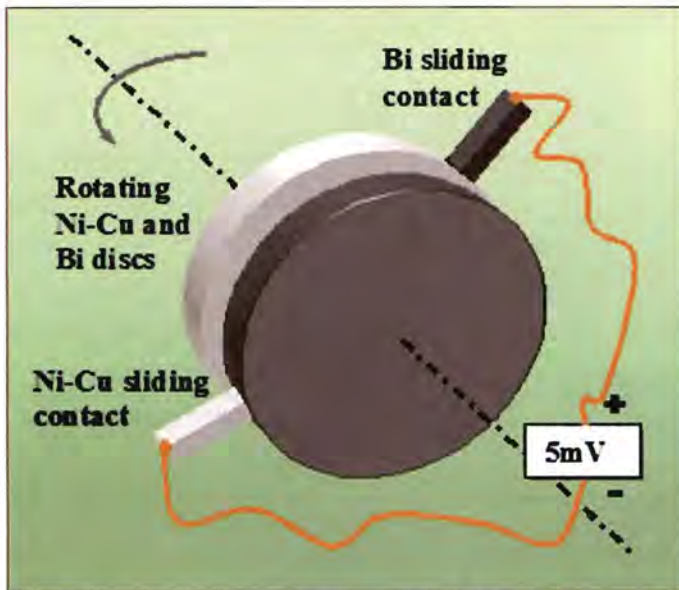
The conclusion is that most of the voltage comes from friction and not from the heating effect, besides, it was also found that the conductive ferrite gave a positive result when running the experiment of Figure 2, while in the friction generator it gives a negative voltage. Exactly the opposite happens with bismuth: in the experiment of Figure 2 it gives a negative voltage but it is positive in the friction generator. This is rather puzzling and it has not been investigated further.

It must be pointed out that the experiment of Figure 2 does not follow the thermoelectric series (Table 3). Here we have that the highest voltage is obtained by different metals heated at the same temperature, for example a bismuth-iron junction is most effective while a zinc-aluminium junction is not. In Figure 2 we have different metals heated at different temperature. In this experiment, even the same metal but at a different temperature gives a voltage output.

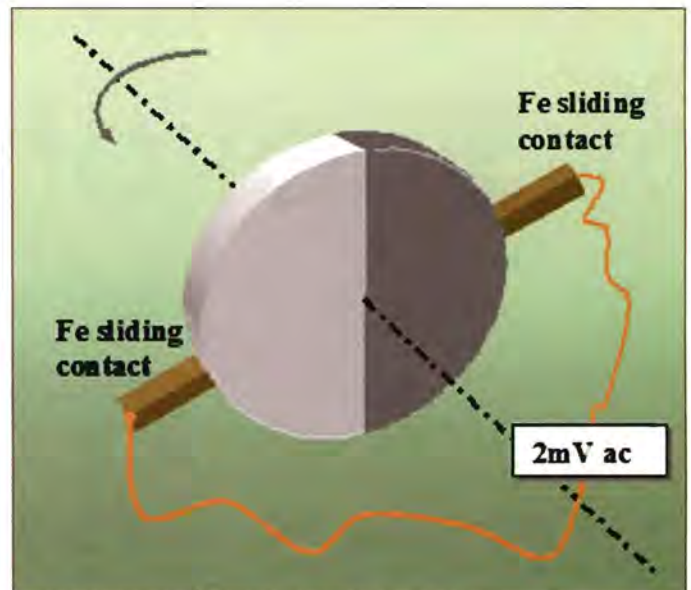
## Other Configurations

The voltage of these devices is usually fairly low and it is not feasible to wire more units in series, as they will add extra pairs of sliding contacts.

One solution to the above problem is to have two discs instead of one – with suitable choice of metals you can double the output. Figure 3 shows how a set of “complementary” metals, in this case bismuth and nickel-copper alloy, will give twice the voltage using one single pair of sliding contacts. The problem of these configurations – and all the



**Figure 3:** Twice the voltage is available if two discs are used instead of one only. The first disc is the usual nickel-copper disc with a bismuth contact, while the second is a bismuth disc with a nickel-copper contact. The discs are electrically interconnected and the position of the sliding contact can be anywhere on the edge of the disc



**Figure 4:** AC generation is possible by splitting the disc in two halves of different metals; in this case nickel-copper and bismuth. Both contacts must be of the same metal and from the middle of the electrofriction series: iron or brass work best and must be placed one opposite the other around the disc

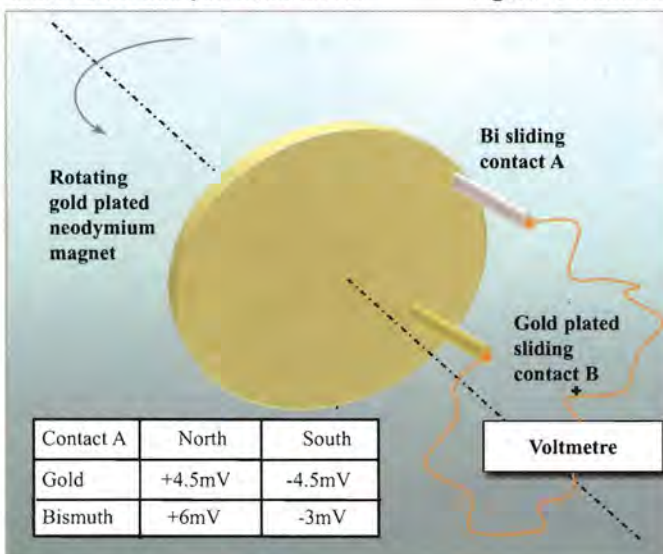
ones using bismuth – is that this metal is rather brittle and it is a pain to cut it as a round disc, it will just brake apart. The best solution is to cast it using a suitable form, but this is not always feasible and the only other alternative is to melt it on a flat metal surface and then cut it out using the hot tip of a soldering iron, or chipping it off a bit at the time. Bismuth has a low melting point, similar to lead, and you can do the casting operation in your kitchen, using all the proper precautions.

Another way to raise the low voltage is using a transformer but in order to do this you need an AC

source and **Figure 4** shows a solution: the disc is split in two halves while both contacts, of the same material, are placed at opposite places on the disc. The frequency of operation was 25Hz, and with a 1:100 transformer you get a more useful voltage. A soldering gun transformer was used in this test.

### Experimenting With Metals

Having experimented with Faraday homopolar generators in the past, I was interested to see the influence of the contact material on the performance of these generators. In **Figure 5** there is a classic



**Figure 5:** The type of material used for the sliding contacts can enhance or decrease the voltage output for certain configurations of the Faraday homopolar generator: differences of up to 30% were observed between a gold plated contact and a bismuth contact placed at the outer edge

configuration with a strong gold plated neodymium magnet. No appreciable difference could be detected when contact A was copper, aluminium or gold, but the difference was clearly detected when contact A was bismuth.

The voltage created by friction by the metal pair gold-bismuth adds algebraically to the voltage

generated by the homopolar effect. In the example of **Figure 5**, the voltage generated by friction is +1.5mV and will add in one case and subtract if you reverse the magnet rotation or polarity. Not every mechanical configuration will show this effect: when the contacts are symmetric there is no influence of the material used but it will be evident in case of asymmetric contacts as in **Figure 5**.

In all experiments we have seen that the material used is what makes the difference and there are metals or combination thereof that will work better than others. Constantan, for example, seemed a better alternative to nickel based coins, but only wires were available for experiments and could not be used as a reference disc. Highly conductive ceramic materials are also interesting and some surprise might come from mercury, easy to find but problematic to use in this application because it is a liquid.

It is felt that the best material is going to be some sort of hitherto unknown alloy or superconductive compound with the possibility to have friction without any physical contact, as investigated by some researchers. In the meantime, if you like to experiment with bismuth you may find it in some ammunition shops as it is used occasionally as an alternative to lead shots or, you can order it online from some suitable suppliers such as [www.scitoys.com](http://www.scitoys.com).

## Living with RoHS – the big questions

**Q:** What is the effect of low temperatures on lead-free solders? Most lead-free solders have at least a 99% tin content and pure tin is unstable below temperatures of 15°C, in time, when its molecular structure starts to change and turns into white powder. Given the near-pure tin composition, and the possibility that some equipment being in a freezing environment has consideration being given to long-term reliability in such situations?

Brian Daniels, UK

**A:** This issue is called 'tin pest' and has been a concern. However, research has been carried out and it should not be a problem at 'normal' ambient temperatures. The most common lead-free solder contains 95% tin – although some use SnCu with 99% Sn – and termination coatings may be pure tin, so have a greater risk of tin pest.

Tin pest occurs theoretically at 13°C but at this temperature only occurs with extremely pure tin and it takes a long time. Any impurities reduce the risk of this occurring but the risk (and rate) increases as the temperature decreases. Research shows that 99.99% is at risk at normal cold temperatures (-20°C) but this purity is never used in electronics. At 99.9%, which is used for termination coatings, tin pest could occur if components are stored at low temperatures and if this happens, they will not be solderable.

The time before it occurs depends on temperature. At 0°C it will be extremely slow and is very unlikely, but could become a problem at -10°C. Solders have other elements added and so are less at risk, but some research with Sn0.7%Cu solder showed that tin pest occurs after 1.5 years at -18°C. So, equipment routinely used at these temperatures should use SAC because it has more additives. I am not aware of research on SAC to determine at what conditions it suffers from tin pest but it probably needs a very low temperature and many years.

**Q:** Is the UK accountable for the country's uptake and compliancy to RoHS, in the same way that it is for WEEE?

**A:** In short, no. In the UK, each company that needs to be RoHS compliant is accountable to National Weights and Measures, the UK's enforcement body. National Weights and Measures won't be fined if they don't meet specific targets of compliancy, like the UK is being for WEEE. However, there is a good chance you will be by National Weights and Measures if you can't prove compliance and due diligence where necessary.

**Q:** I'm still confused about exemptions. Help!

**A:** There are two issues here, products that are exempt or excluded from the scope and exemptions which are for specific applications used in products. This is indeed a tricky area. And scarily it often isn't clear if a product is within the scope of RoHS or not. The situation for many types of industrial product will depend on how they are used. Equipment that is not dependent on electricity is also excluded such as gas boilers and petrol lawnmowers. Currently,

categories 8 and 9 are not within the scope of the RoHS legislation – but do fall within the WEEE Directive. However, a review is currently taking place for the European Commission by ERA Technology and it could well be that these are included, around 2010/2012.

Currently there are 28 approved exemption categories, with many more still to be reviewed. For a full list of exemptions see [www.ros.info](http://www.ros.info)

**Q:** I've been hearing noise about the EuP directive. What will this entail?

**A:** The EuP Directive is to bring about improvements in energy efficiency of energy-using products throughout their lifecycle. Its focus is on the design phase since it considered that this is the stage determining the resources used in a product. It became EU law in 2005 and is set to become national law by 2007 at the earliest. For more information visit Electronic Design World at [www.farnellone.co.uk](http://www.farnellone.co.uk)

**Q:** What's happened to WEEE?

**A:** WEEE hasn't really moved forward significantly in the last year. However, the final consultation is taking place in the summer of this year. B2B have advised that the legislation will come into force early next year, with producer registration expected around April 2007 and implementation likely in July 2007.

**Q:** We started our RoHS strategy about a year ago and know that our product isn't exempt, but we can't find a suitable compliant replacement component. What should we do?

**A:** Where there is no technical alternative for specific materials used in products, the RoHS legislation permits exemptions but these cannot be used until reviewed and accepted by the European Commission. This means that if there is genuinely no viable alternative for a material or design required for a particular application, manufacturers can request an exemption for this specific application (the product itself will not be exempt). All exemptions are temporary, however, and are reviewed by the European Commission every four years. If a substitute then exists, the exemption will be terminated. If a re-design is possible, the Commission will not accept a request for exemption, even if this option is expensive. If there is any doubt about a part, it is advisable to err on the side of caution and consult an expert, such as ERA Technology, or the European Commission itself.



Gary Nevison is chairman of the AFDEC RoHS team, board director at Electronics Yorkshire and head of product market strategy at Farnell InOne. As such he is our industry expert who will try and answer any questions that you might have relating to the issues of RoHS and WEEE. Your questions will be published together with Gary's answers in the following issues of Electronics World. Please email your questions to [EWeditor@nexusmedia.com](mailto:EWeditor@nexusmedia.com), marking them as RoHS or WEEE.

# Carrier Ethernet Hastens **IPTV**

**The telecommunications industry is undergoing upheaval – on one hand many subscribers now use a wireless phone as their primary phone, on the other, many have defected to the cable companies for their voice services – as a result, the number of households with landline phones is decreasing, reveals Paul Indoo of Nortel**

**T**raditional wireline services are now considered to be a commodity and are suffering from price erosion. Telephone service providers are responding to these pressures by bundling voice, Internet and entertainment like television, music and gaming together as a 'triple-play' service.

The belief is that by offering residential customers an innovative broadband service, the Average Revenue Per User (ARPU) will increase and customer churn decrease because users are no longer subscribed to a simple voice service. Virtually every service provider believes that this triple-play is vital to future success and, as a result, it has become the hot topic in telecommunications.

Central to the success of these triple-play deployments is Internet Protocol Television (IPTV). Market research firm Gartner Dataquest forecasts that the number of IPTV subscribers in Western Europe will grow to 16.7 million by 2010.

IPTV provides customers with the broadcast television, premium channels and Pay Per View (PPV) services that they would expect from their cable or satellite provider. In addition, service providers can create further value for their customers by combining the delivery of TV with IP data and telephony services. For example, customers can view and respond to email using the television as a monitor, display information about an incoming call on their TV screen and – if they want to take the call – automatically record the programme they are watching.

The IPTV service can also be personalised to suit, determining the multimedia content that they access and how they interact with other users while accessing this content. It is this flexibility that is the real differentiator helping service providers to respond to today's competitive threats.

## Infrastructure

Delivering all three services (voice, data and video) over a single connection requires a high bandwidth access network.

In general, 20Mbps per residential household is considered the minimum required to offer triple-play services, but the current broadband infrastructure supports only 1-2Mbps to each home. Metropolitan aggregation and core networks also need additional capacity, to cope with the explosion in bandwidth requirements.

To provide additional bandwidth capacity, service providers have turned their attention to Carrier Ethernet, a term that has emerged in the last 12 months to describe technologies that extend the performance and reach of Ethernet from the LAN (Local Area Network) into the WAN (Wide Area Network).

The main reason service providers are interested in this is cost. Ethernet is the dominant networking protocol in the LAN.

Almost every computer or networked device in the home or

office has an Ethernet port and, as a result of its ubiquity, Ethernet has experienced significant cost reductions. This means that Ethernet is a more cost-effective networking technology than traditional WAN protocols (e.g. ATM, Frame Relay). But it is not just the cost benefits that attract service providers; Ethernet is also very flexible because it allows bandwidth to be increased in increments of 1Mbps up to 10Gbps. These increments enable customers to match the size of their bandwidth subscription to their requirements, instead of settling for fixed bandwidth pipes such as 2Mbps and 34Mbps that resulted in oversubscription.

Carrier Ethernet allows enterprises to transparently integrate their LANs in different locations across a national or international network using native Ethernet, removing the requirement to translate Ethernet into an alternative Layer-2 protocol (e.g. ATM). Not only does this remove the additional element of cost and complexity from the network, but protocol translation can introduce jitter and delay to it, which can badly affect performance of real-time applications like IPTV and Voice over IP (VoIP). This means that Carrier Ethernet is better suited to supporting the roll-out of IPTV services.

Ethernet is widely used and it is well understood. That means that the network is easy to operate and manage, allowing service providers and customers to address their operational expenditure.

## Challenges

While service providers are convinced of the advantages of using Ethernet in the WAN, they are aware that the new network must achieve the same levels of performance as existing Frame Relay and ATM networks. In other words, Ethernet has to be carrier-grade. This means that Ethernet must match the scalability and reliability of existing networks; services must support hard Quality of Service (QoS); service providers must have access to the comprehensive service management tools and the network must support legacy services for existing customers. **Figure 1** summarises these carrier-grade Ethernet attributes as defined by the Metro Ethernet Forum.

Hard QoS is important, because with many different types of traffic such as voice, video and emails crossing the network, service providers must offer differentiated levels of service to match application requirements. This means that the network prioritises between different traffic streams, for example ensuring that the customer can watch a movie or football match uninterrupted by someone else in their street (or even in the same house) starting to download music from the Internet.

A number of QoS mechanisms already exist, for example IEEE 802.1p Class of Service (CoS) and IETF Differentiated Service (DiffServ), that prioritise frames so that applications

that are sensitive to jitter and delay are placed at the front of the queue.

However, these methods only provide applications with preferential treatment, if the network becomes too busy applications can still suffer from performance degradation as congestion occurs. Hard QoS goes a step further by ensuring that service level parameters agreed at the network entrance are adhered to across the network. This provides customers with the guaranteed performance they receive from their existing services but until now, hard QoS has been difficult to support on Ethernet networks.

**Ethernet Limitations**

To understand why this is the case, we need to take a closer look at how Ethernet works.

The primary function of an Ethernet switch is to forward data to its intended destination in the network – a simple enough task when the switch knows where a given address resides in the network. When a switch receives data destined for an unknown destination, its only option is to copy the data to all of its outgoing ports. This process is known as ‘flooding.’

Eventually, the intended destination is reached via one of the ports and a reply is returned. This reply is used by each switch to note which specific port corresponds to the destination – this is known as the ‘learning’ process.

As an approach this works fine in small networks, but as networks get bigger and more complex – in the WAN, for instance – the flooding and learning processes generate considerable network congestion and can create security concerns.

Furthermore, in order to provide customers with hard QoS, service providers require visibility and control over how traffic is routed across the network, so performance levels can be predicted and guaranteed. This is impossible when the network is controlling how individual Ethernet frames are routed across it.

Ethernet cost-points are still very attractive to carriers, so what’s needed is a way to deliver guaranteed, deterministic services over the Ethernet infrastructure on a wider scale, in order to deliver the multimedia services that enterprises demand.

**Backbone Transport**

Provider Backbone Transport (PBT) simplifies conventional Ethernet by using explicit configuration of switches instead of traditional flooding and learning techniques. The switch, in fact, still behaves largely as with traditional Ethernet: forwarding data to its intended destination. All that has changed is that the forwarding information is no longer learned by the switches, but provided directly by the management plane, resulting in a prescribed, predetermined path through the network and totally predictable network behaviour under all circumstances, as shown in Figure 2.

With additional control over the path that Ethernet frames take, the service provider can now predict the jitter and delay that a given data stream will experience across the network. Furthermore, because this path will not change and because it has been effectively ‘hardwired’ into the network, these

Figure 1: Carrier-grade Ethernet services

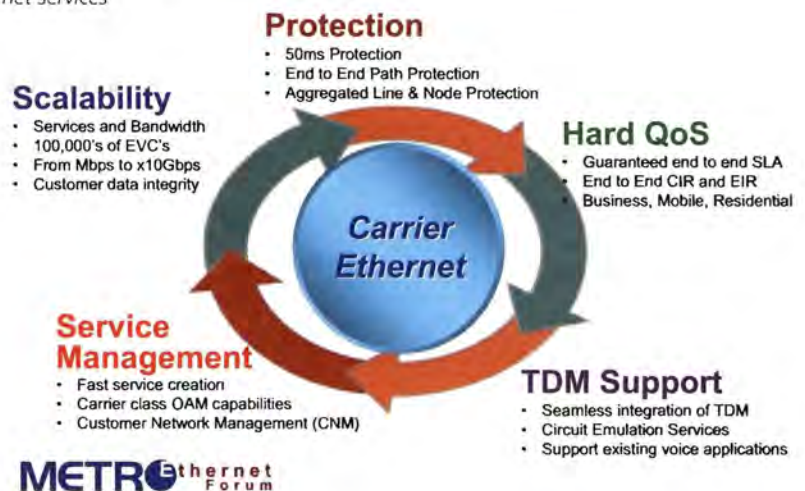
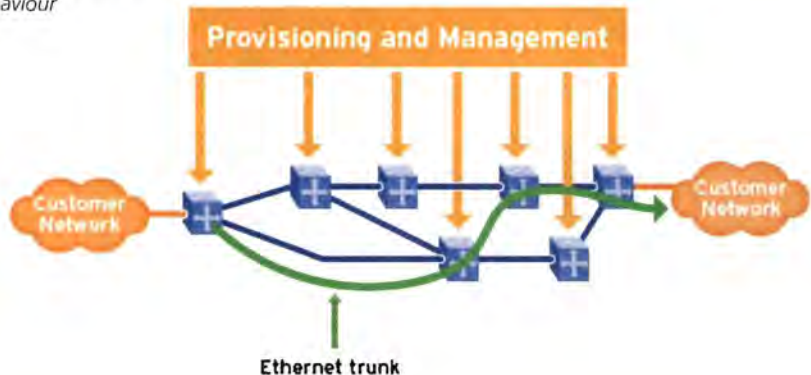


Figure 2: Network behaviour



performance levels can be guaranteed.

PBT also avoids the congestion problems caused by network flooding, which would otherwise be needed for the learning process. Protection routes can be provisioned across the network to provide backup in the event of failure, switching the traffic across in a mere 50ms – that is true carrier-grade reliability.

PBT also offers dedicated, point-to-point connections alongside traditional Ethernet, without complex and expensive network overlay technologies, so the service can be up and running quickly, with nominal outlay.

**Conclusion**

Service providers are increasingly turning to IPTV as a way to retain existing customers and grow new revenue streams. In order to deliver these bandwidth-intensive services, existing service provider infrastructures must be renewed.

Service providers have settled on Carrier Ethernet as the most cost-effective technology to support this increased bandwidth, but the mass deployment of IPTV over Carrier Ethernet requires hard QoS.

PBT addresses this issue by taking control over a data stream path away from the network and handing it to the service provider via their existing network management tools.

With the additional control and visibility of how Ethernet frames are routed across a network, service providers can offer guaranteed performance levels to their customers, and deliver hard QoS over Carrier Ethernet networks.



# Letters

## EMF problems, EW September 2005

Caroline Williams reviewed ('*New Scientist*' 4 Feb 06, page 8) recent findings on the effects of EM radiation (by mobile phones) on body tissues, which show that heat shock proteins, known to be implicated in a range of carcinomae. These are produced when nematodes are irradiated, although temperature increases were only about 0.1°C. To account for this, researchers propose that localised heating occurs in 'hotspots' due to resonance between centimetric EM waves and body parts of similar dimensions. Fundamental research on the nonlinear dynamics of temperature effects on DNA is being carried out by Libchaber (in Feigenbaum's team at Rockefeller University) who carried out the classic experiment on helium rolls which identified harmonics of Cvitanovic's constant 1.87, first reported (as a frequency-counter reading) by diMario in '*Electronics World*' ca 1995. Low frequencies, of the order of 1.87Hz, are important in brain processes involving cognition and memory, but nothing appears to have been reported so far in these respects: on-off cycles, switching rates and sub-carrier codings etc, although I heard suggestions about this many years ago.

Recent work by Marcus Pembrey, at the Institute of Child Health in London, shows that low-temperature effects carry over in several generations in

DNA, possibly, via a 'switch' (epigenetics), supporting Schroedinger's analysis, in his '*What is Life?*'; of long term stability of inherited characteristics and the stability of the quantum-mechanical, covalent bond.

Clair Wilson's article '*Glad to be gullible*', about using "electrical activity in the brain to access subconscious ancient memory", helps us to understand another strange phenomenon called synaesthesia, which may help research into the effects of brain damage by irradiation.

Details of the latest research into the interactions between mobile phone installations and biological cells are given at [www.mastsanity.org](http://www.mastsanity.org), including details of a blood test kit which can be purchased from a laboratory in Germany.

A G Callegari

## Looking for the right inverter

We are a designer, manufacturer and installer of electronic equipment for vehicles. We also prepare some facilities for transportation system.

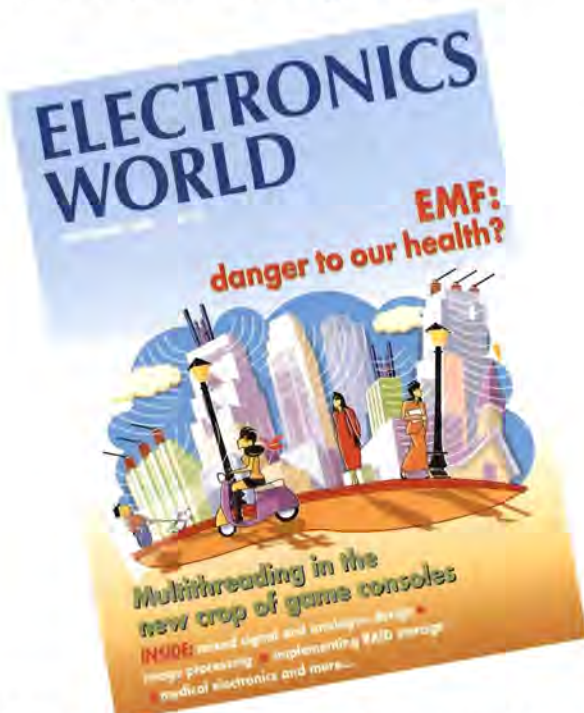
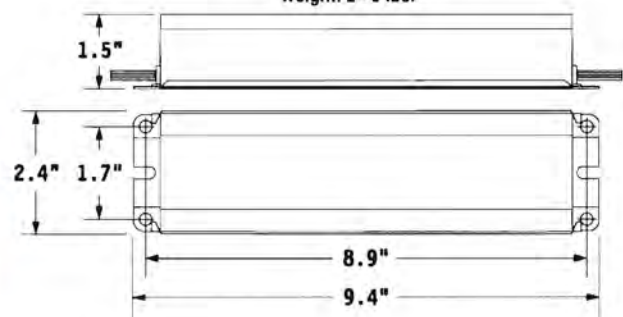
We are looking for an inverter, which is going to be used for fluorescent lamps in passenger train wagons. It should have the following features:

Input voltage:	24 VAC / 50 Hz
Output:	110/120 VAC
Output Freq. Range:	18KHz ~ 20KHz
Power Consumption:	50Watt

Further details of what we are looking for are:

### WIRING DIAGRAM

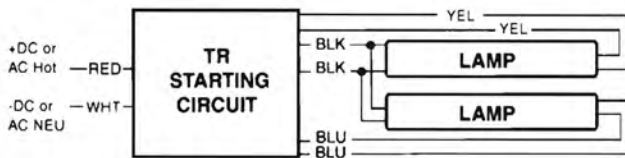
Weight: 2 - 3 lbs.



PLEASE SEND YOUR LETTERS TO:  
 ELECTRONICS WORLD  
 NEXUS MEDIA COMMUNICATIONS,  
 MEDIA HOUSE, AZALEA DRIVE,  
 SWANLEY, KENT BR8 8HU  
 EMAIL: EWLETTERS@NEXUSMEDIA.COM

ELECTRONICS WORLD RESERVES THE RIGHT TO  
 EDIT ALL CORRESPONDENCE

ELECTRICAL SPECIFICATIONS



Lamps Operated	(2) F15T8
Input Voltage	24 VAC
Input Current	1.4A
Operating Frequency	20kHz

Important: output frequency must be 20kHz.

I would be interested in hearing more from you (via the Electronics World editorial office) if you think you can meet our demand. Our order will be as high as 10,000 pieces of such a unit.

M. Mahsa

**'It's easier to carry on  
 using the same shows  
 every year'**

Not if they aren't performing...

# Hands On Power

27 & 28 September 2006

Be part of a new experience

www.handsonpower.com

from  
**£395<sub>+VAT</sub>**

The Dataman 40Pro, 48Pro and 448Pro are the next generation universal programmers built to meet the demands of field, development and production engineers.


- Extensive range of adapters available
- 30 day money back guarantee
- Same day dispatch
- Free software updates and technical support

**Programming Solutions**

[www.dataman.com](http://www.dataman.com)

**3 year warranty**

Dataman Programmers Ltd. Station Road  
 Maiden Newton, Dorset DT2 0AE UK  
 Tel (01300) 320719  
 Fax (01300) 321012



# Book Review

## **Bosch Automotive Handbook** **Wiley**

The cover notes of this book claim it to be a "Reference work for studies and everyday practice – all about automotive engineering in a pocket-book" and the contents list fully justifies this description.

This is not a book about cars, but one concerned with the science and engineering of the components and systems of both passenger cars and heavy commercial vehicles.

Almost every imaginable aspect of automotive engineering is covered, including some subjects which have come to prominence quite recently, such as the dynamics of lateral motion, the basis for Electronic Stability Programmes (ESP), and standardised On-board Diagnostic Systems (OBD). For the uninitiated, there is a ten page list of such abbreviations at the end of the book. An encouragingly comprehensive index, too often lacking in contemporary technical books, takes up a further thirty pages but there are some errors in the page numbering.

Initial impressions of the book will be very favourable, even exciting, because of the completeness of the contents list and the quantity and excellence of the line drawings.

The diagrams are presented in the distinctive Bosch house-style, familiar from the company's wide range of quality publications. While this is a constant reminder of the book's origins, the extensive and impressive list of contributors from

***There is now more electronic than mechanical engineering in a modern vehicle. For this reason, the book must be of great interest to any electronic engineer who wants to be conversant with a very significant branch of the discipline and required reading for any professional in either industry***

many engineering manufacturers and technical institutions refutes any suggestion of a narrow, company-bound view of automotive technology. Bosch equipment is only mentioned where it is entirely appropriate, due to its prominence in the field of application under discussion.

Almost without exception, the authors are German engineers and scientists, so it is not surprising that frequent reference is made to DIN standards and to German regulations and practice. The British publisher, Professional Engineering Publishing, (IMechE) has made no attempt to broaden these references to include British and international standards.

The first third of the book is a comprehensive compendium of the basic principles of physics and engineering, units, mathematics and engineering science, all applicable to any practical discipline. This part alone would be worthwhile as a reference source and could almost be used as a textbook of engineering science in its own right. It includes an outline description of the techniques of semiconductor device manufacture and a thirty page section on the working

principles of the wide range of sensors and their associated signal processing, which are becoming increasingly important in automotive control and management systems. The quality demands on these sensors will be easily understood given the vital role, which those designated "Reliability Class 1" in DIN 40050 play in safety-sensitive systems such as steering and braking. Interest in this section goes far beyond the automotive industry because reliability demands now match aerospace quality, while high-volume production offers unprecedented value for money.

Influences on vehicle behaviour, legislation, manufacturing technology, the composition of fuels, alternative energy sources, techniques of construction, development, testing and diagnostics and, even a short section on the technical aspects of motorsport, are all covered in addition to the considerable range of technologies popularly associated with the Bosch organisation.

The book effectively illustrates how modern vehicles are heavily dependent on electronics, often performing in extremely hostile environments with heavy demands on component and system integrity for long periods. Arguably, many of the subsystems are, in themselves, considerably more complex than a complete car of only twenty years ago. Just one example is the airbag system described in an outline of seven pages. This must be entirely dependable over a period of at least ten years, despite the impossibility of carrying out a comprehensive test, but respond and fully deploy an appropriate selection of airbags in 40ms after impact with complete discrimination between spurious and specified triggering effects.

Some applications of automotive electronics are merely useful or optional but there is simply no other practical means of meeting current legislation, for example on pollution limitation, or of matching customer expectations in safety, convenience and control. The reader will be easily persuaded that there is hardly any significant part of a modern vehicle that does not employ electronics. If there is, there are sections which describe the role of electronics in its design,

development and testing.

A case could be made that there is now more electronic than mechanical engineering in a modern vehicle. For these reasons, the book must be of great interest to any electronics engineer who wants to be conversant with a very significant branch of the discipline and required reading for any professional in either industry.

The publishers have chosen a pocket book format and the characteristic Bosch vinyl binding, originally intended for workshop manuals. Despite this, the book is unlikely to be used "on the bench". It is essentially a reference work more likely to be found in a design office or read as a study aid. There is no obvious reason for the small pages and a larger size would have allowed greater scope for the authors to explain their topics and more space to present some of the diagrams at a scale more appropriate to their complexity.

This book can justifiably be described as encyclopaedic, with the usual merits and limitations of the form. While the scope is vast, there are places where the depth is less than satisfactory. There is a general lack of references to further



reading, which often compensates for the limited space in books of this kind, but this is a topical book about a fast-developing subject and references could rapidly become outdated.

There have been 25 editions of the original, German, version of the book. The foreword tells us that the English edition has grown from 90 to over 1200 pages in just seven years but perhaps the expansion has been too rapid. The wording of some topics is so concise that significant prior knowledge would be necessary to make much sense of them. For example, we are informed that: "For cooling high-performance engines, or where space is limited, the best solution is a brazed flat tube and corrugated fin radiator with minimised aerodynamic resistance on the air intake side. The less expensive, mechanically assembled finned-tube system is generally employed for applications with less powerful engines or when more space is available". A specialist may understand the distinction, but without diagrams or further explanation, the general reader learns very little. Some interesting diagrams which are too involved to be understood without supporting text have only a very brief description or none at all.

In some cases, the writer seems to have been so restricted that he has felt it impossible to develop his subject adequately. Some sections appear to have been condensed from more extensive articles, not always successfully. The subject is summarised in an introductory paragraph but the body of the text can do little more than repeat the summary.

This, with possible "ghosting" by non-technical writers or questionable translation, may explain some inconsistencies and even contradictions, which one of the editors should have corrected. An example is the section on power operated steering and power assisted steering whose definitions seem, even after several readings, to be at variance with the descriptions which follow. Generally, it would be logical to explain how components work before the operating principles of units built from them, but here the order is sometimes reversed, interrupting the flow of the text and wasting space by the need for cross references.

In general, the translation is grammatically correct but would undoubtedly fail a linguistic equivalent of the Turing test. Other works from Bosch are a model in this respect; their Germanic origins are occasionally detectable but only enough to add a certain charm. Too often, the translator has been insufficiently conversant with the idiom of the subject, or even in some instances, general English, to choose the appropriate word or phrase, and too dependant on a dictionary. Not only does this become distracting but it wastes space denied to the original writers. Typically, (although this is not the only or worst example), the translator has repeatedly used the term "internal combustion engine" where "engine" would be sufficient throughout the section on starter motors. Fourteen lines on starter motor clutches are overwhelmed by three instances of the phrase.

The reader often has an uneasy feeling that a word has been translated by its general meaning rather than its specialised technical definition. This occurs in significant places where paradoxically the correctness of the grammar serves to deceive rather than inform. In several instances however, translation quality is so bad that the meaning of a sentence is completely lost. In an otherwise interesting and informative article on spark plugs there is the statement:

"Combustion can be characterised by smooth-running or uneven-running engine performance, either derived directly from engine speed fluctuations, or described indirectly by means of a static analysis of the mean induced pressure".

More disappointing still are occasional elementary linguistic mistakes, which add to the confusion. The reader will probably assume that "In addition, inadvertent or unintended operation of the parking brake while the vehicle is in motion MAY not cause a critical driving situation" means "While the vehicle is moving it MUST be impossible for the parking brake to be applied by mistake or because of a malfunction of the system as this might cause an accident", but in a technical work of some complexity it is safer to be sure.

Any book which reached its fourth English edition in 1999 and is now in its sixth must be considered a success. However, it is the privilege of the reviewer to advise the editor and the advice must be that authors should be allowed more scope to present their topics adequately, perhaps by considerably enlarging the page size.

This book is like a multi-purpose tool. It is packed with many attractive features, some of which might be difficult to find elsewhere. However, despite its compactness and reasonable price, it does not always live up to its promise and individual publications would often prove a better investment. The quality of the text is variable, reflecting the work of many contributors and possibly several editors and translators. However, on reading it, there is a growing feeling of disappointment, even frustration, that an opportunity has been lost. Compilation began with a highly commendable selection of the best professional sources, which were then denied their full potential by restrictive and, sometimes, technically ill-informed editing, and in places reduced to confusion by a translator who had not even the professionalism to ensure each sentence made sense in the 'target' language, let alone was faithful to the original technical content.

In these instances, the translation is unworthy of the contributors, the illustrations and the majority of Bosch publications. The editor of the English edition must bear much of the responsibility for releasing this flawed work onto the market.

It is to be hoped that the Bosch organisation will soon find a way to bring the next English edition up to the exacting standards of its founder and the great majority of its wide range of products and publications, while still offering a book which is reasonably priced.

**Peter M  
Munro**

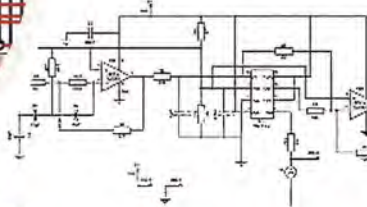


The World Beating PCB design software



Easy-PC version 10 sets another milestone

Winning accolades the world over, Easy-PC for Windows V10 is another major milestone in the evolution of this extremely popular software tool. Try a demonstration copy of Easy-PC and prepare to be amazed at the power, versatility and remarkable value for money.



Fully integrated Schematics & PCB layout in a single application complete with forward and back annotation. Design and rules checks at all stages ensure integrity at all times. Professional manufacturing outputs allow you to finish the design process with ease.

Version 10 features

- Intelligent Gerber Import option
  - Track/Shape 'Hug' Mode Routing
  - Text Callouts
  - Layer & Via Stack Previews
  - Blind & Buried Via Support
  - Teardrop Pads
  - Draw Spacing Clearances
  - Spiral Tracks & Shapes
- Plus many more exciting features.....

Stop press... Stop press... Stop press... Stop press...  
Easy-PC imports Eagle files as well as Tsien Boardmaker 2 files

call for a brochure, prices & CD on +44 (0)1684 773662  
or e-mail sales@numberone.com  
you can also download a demo from

[www.numberone.com](http://www.numberone.com)

Oak Lane, Bredon, Tewkesbury, Glos. GL20 7LR. United Kingdom



SeMitec CRDs - Constant Current Diodes



Semitec's range of current-regulating diodes (CRDs) delivers constant current output over a wide voltage range, from 1-100V. A single CRD can replace several components in a constant current network, allowing multiple input voltages and reducing the component count in space-critical applications.

With current values from 0.01mA upto 18mA, CRDs offers protection, stability and improved performance to circuits driving LEDs, generating waveforms and biasing amplifiers. They can also be used as an excellent voltage reference in conjunction with a standard zener diode.

CRDs are available in both DO-35 and mini-MELF packages. The glass encapsulation ensures long-term stability and operating use upto 150°C. By using them in series or parallel, both higher voltages and higher current ratings can be achieved.

Call us today for free samples to help us simplify your circuit design

ATC Semitec Ltd

Unit 14 Cosgrove Business Park  
Daisy Bank Lane, Anderton,  
NORTHWICH, Cheshire, CW9 6AA  
Tel: 0870 901 0777 Fax: 0870 901 0888  
E-mail: sales@atcsemitec.co.uk

Web: [www.atcsemitec.co.uk](http://www.atcsemitec.co.uk)



Leicester  
Amateur  
Radio  
Show

The 35th SHOW is coming soon!

Try your hand at DFing & WIN an ARDF Receiver !

Convention featuring Bob Heil, Software defined Radio,  
Enigma and Radio Astronomy

Over 100 STANDS of COMPUTERS, ELECTRONICS and RADIOS

DONINGTON PARK NW LEICESTERSHIRE

on Friday 8th & Saturday 9th SEPTEMBER

OPENING TIMES: Friday 9.30am to 5.30pm, Saturday 9.30am to 4.30pm

Featuring Flea Market, Bring and Buy, Local & National Clubs &  
Societies together with all your favourite radio magazines

ADMISSION PRICES

1 day ticket £3.50, concessions (OAPs & under 16) £3

2 DAY TICKET £6, concession £5

Under 12 free when accompanied by an adult

Further details from OUR INTERNET SITE at [www.lars.org.uk](http://www.lars.org.uk)  
or Geoff Dover, G4AFJ, tel: 01455 823344 fax: 01455 828273  
or E-mail: [Geoffg4afj@aol.com](mailto:Geoffg4afj@aol.com)

# SMPS and brownout

**S**witch mode power supply (SMPS) consists of power switching stage, switching regulator controller and an internal linear regulator, which supplies internal bias for controller and feeds bootstrapping circuitry for gate drive.

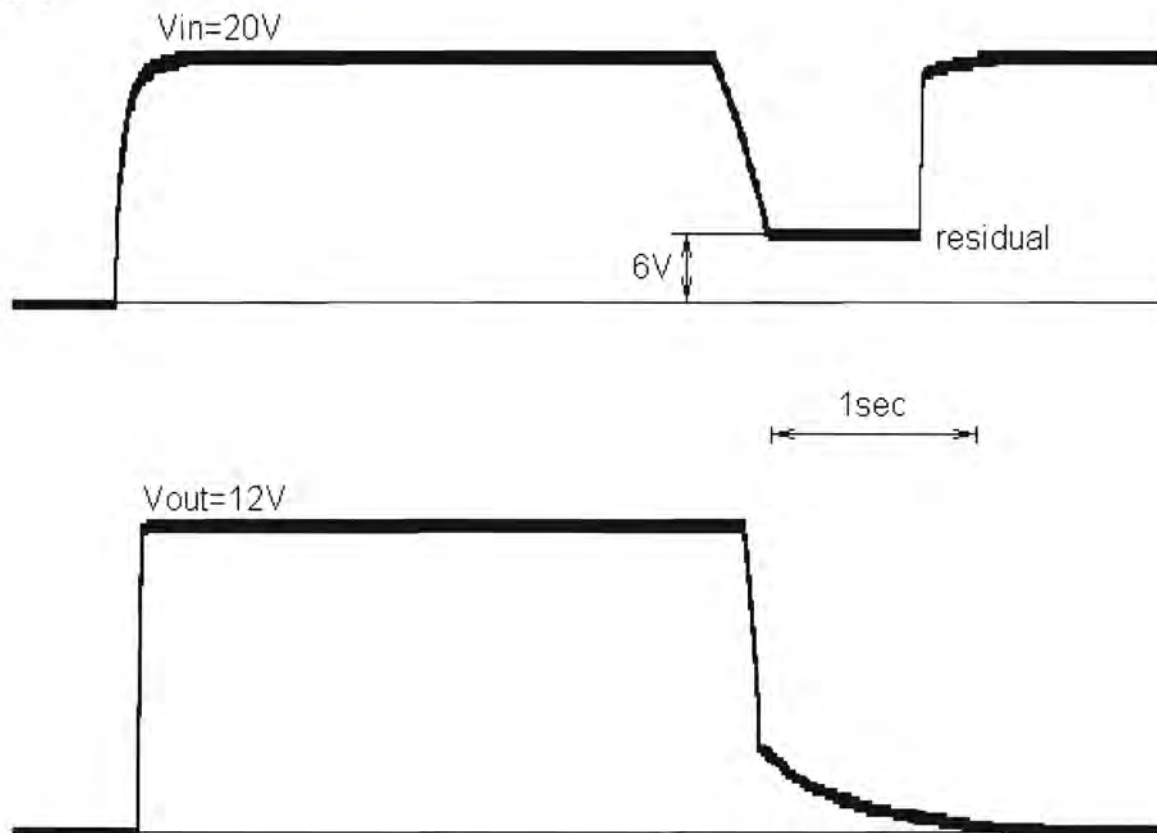
Let us consider the voltage on the input filter capacitor of the SMPS is fed from the ordinary rectifier and 60Hz transformer, when the power is switched on, off, and then on again. The typical waveforms are shown in Figure 1.

After the power disconnection, the filter capacitor

discharges through the load up to the moment when the SMPS internal circuitry cuts off. Then the filter capacitor residual charge remains for a long time.

It was found that the residual voltage is the function of the output voltage. For the LM2642/5642 regulators the residual voltage was around several volts at 5V output, but about 6V with 12V output. With 6V of residual input voltage the internal 5V linear regulator will work for a long time, supplying the internal SMPS control circuitry and preventing the whole supply being switched on when power is restored.

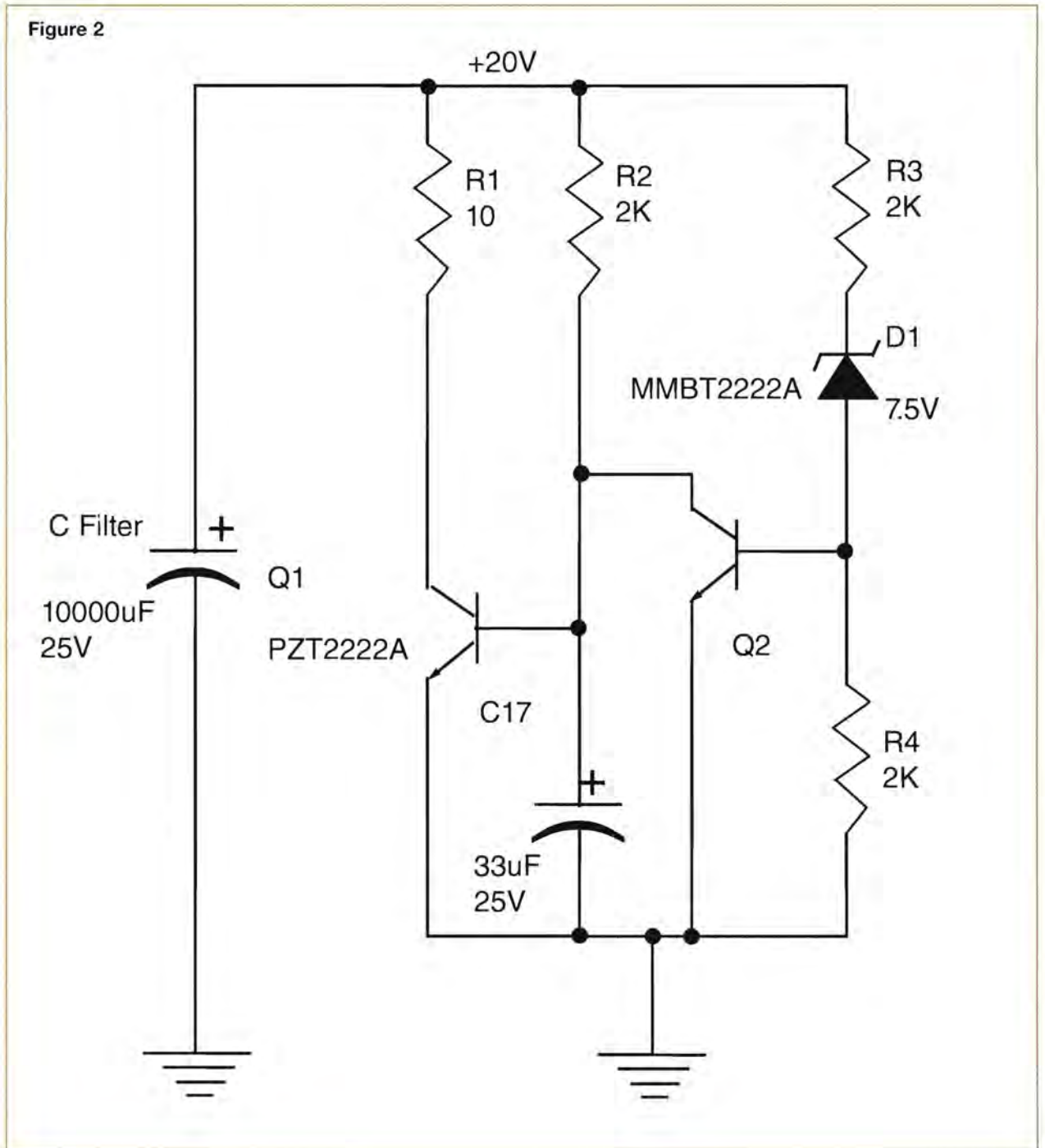
Figure 1



The simplest solution – the bleeder resistor across filter capacitor is a waste of energy. An alternative approach is shown in **Figure 2**. When the voltage across filter capacitor  $C_{\text{filter}}$  becomes lower than the Zener diode breakdown voltage, the capacitor discharges

quickly through R1 and Q1. The Zener diode breakdown voltage should be higher than the residual voltage on the filter capacitor.

*Dimitri Danyuk*  
USA



## VHF amplifier uses audio transistor

The BD 135/BD139 range of medium power TO126/SOT-32 plastic power transistors exhibit  $f_t$  of typically 250MHz.

This leads to the possibility of using these devices in RF amplifiers. An RF test circuit at 70MHz was built using LCC matching networks.

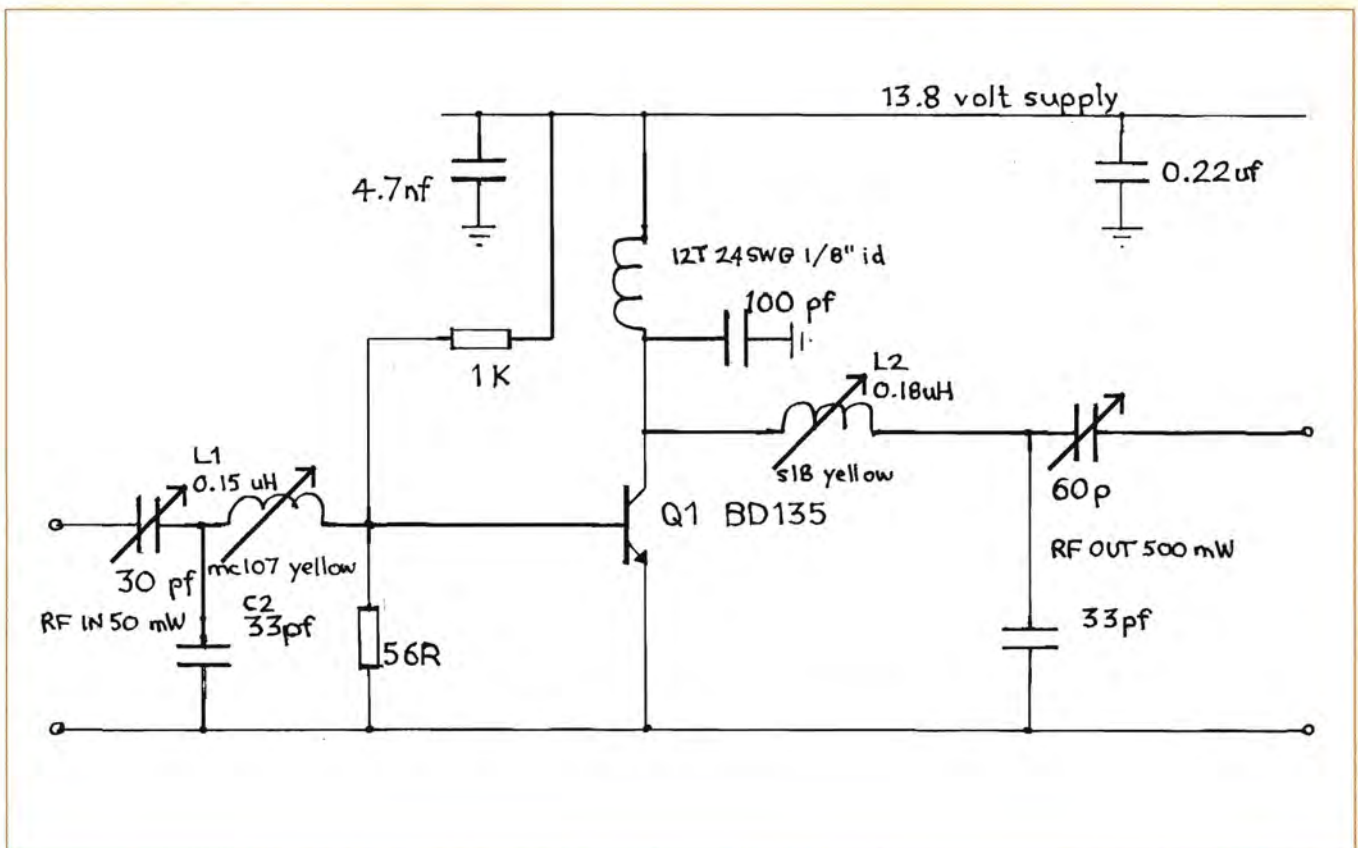
Typical results using various different manufacturers including ON Semiconductor, STMicroelectronics, TFK, Philips and Multi Components are >10dB power gain,  $I_c$  of 150mA at  $V_{ce}$  13.8V. The circuit bandwidth at -3dB

points was approx 4MHz.

It is most likely that higher gain will be achieved at frequencies below 70MHz. It is also possible that amplitude modulation of the device is possible, given the high  $V_{ceo}$  ratings of these devices.

For higher drive power levels, a DC feedback bias network that is also temperature tracked to the device will be needed.

Geoff Pike  
UK



Send new circuit ideas to:

The Editor, Nexus Media Communications,  
Media House, Azalea Drive, Swanley, Kent BR8 8HU

or email to:

[ewcircuit@nexusmedia.com](mailto:ewcircuit@nexusmedia.com)

# 8-pin FLASH PICmicro Microcontrollers

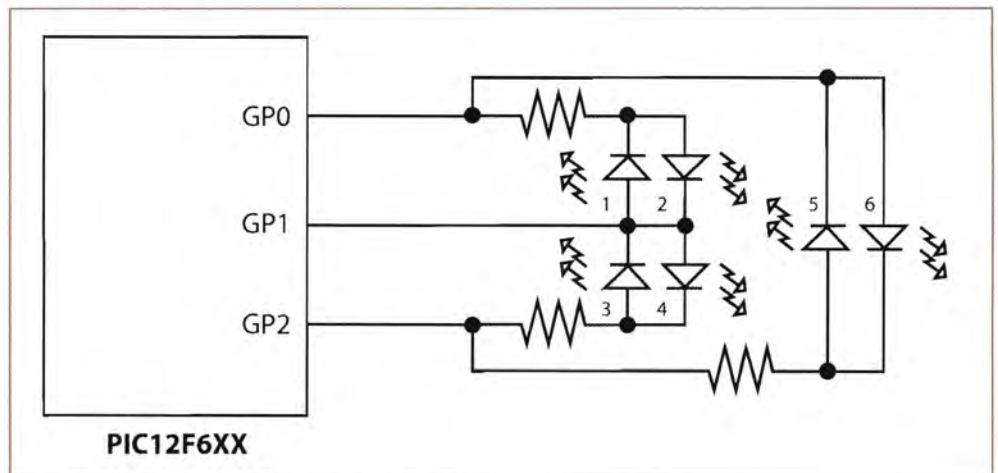
## TIP 1: INPUT/OUTPUT MULTIPLEXING

GPx	LEDs
0 1 2	1 2 3 4 5 6
0 0 0	0 0 0 0 0 0
0 0 1	1 0 0 0 0 0
0 1 0	0 1 0 0 0 0
0 1 1	0 0 1 0 0 0
0 Z 0	0 0 0 1 0 0
0 Z 1	0 0 0 0 1 0
1 Z 0	0 0 0 0 0 1
0 0 1	0 0 1 0 1 0
0 1 0	1 0 0 1 0 0
0 1 1	1 0 0 0 1 0
1 0 0	0 1 0 0 0 1
1 0 1	0 1 1 0 0 0
1 1 0	0 0 0 1 0 1
1 1 1	0 0 0 0 0 0

Individual diodes and some combination of diodes can be enabled by driving I/Os high and low or switching to inputs (Z). The number of diodes (D) that can be controlled depends on the number of I/Os (GP) used.

The equation is:  $D = GP \times (GP - 1)$ .

Example – Six LEDs on three I/O pins



## TIP 2: SCANNING MANY KEYS WITH ONE INPUT

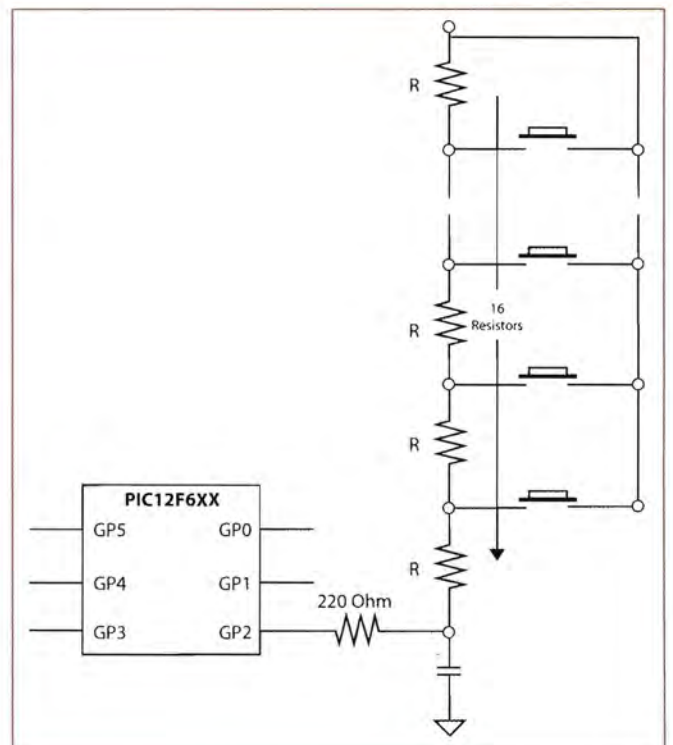
The time required to charge a capacitor depends on the resistance between VDD and the capacitor. When a button is pressed, VDD is supplied to a different point in the resistor ladder. The resistance between VDD and the capacitor is reduced, which reduces the charge time of the capacitor. A timer is used with a comparator or changing digital input to measure the capacitor charge-time. The charge time is used to determine which button is pressed.

Software sequence:

1. Configure GP2 to output a low voltage to discharge the capacitor through the I/O resistor.
2. Configure GP2 as one comparator input and CVREF as the other.
3. Use a timer to measure when the comparator trips. If the time measured is greater than the maximum allowed time, then repeat; otherwise determine which button is pressed.

When a key is pressed, the voltage divider network changes the RC ramp rate.

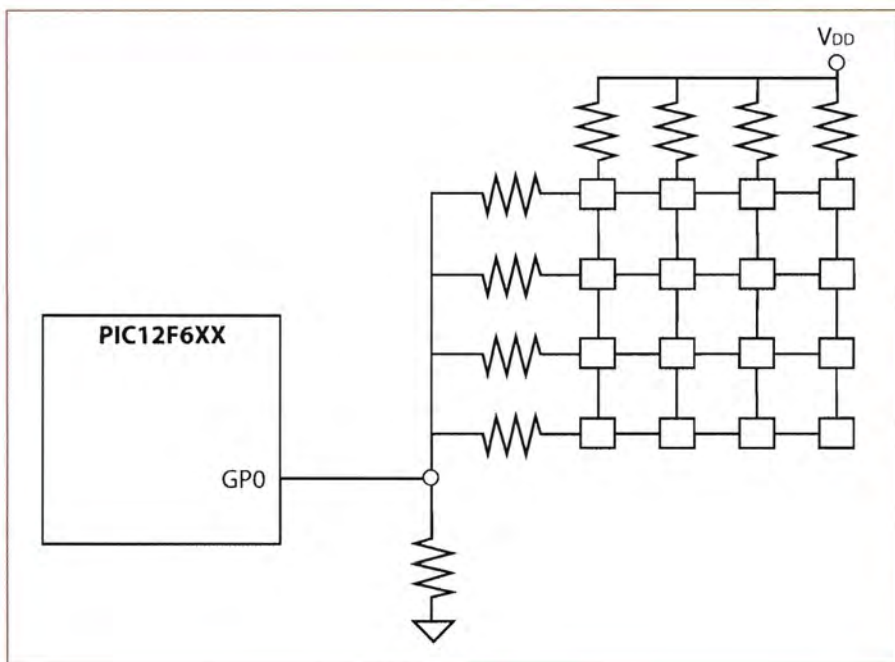
See Microchip application note AN512 'Implementing Ohmmeter/Temperature Sensor' for code ideas.



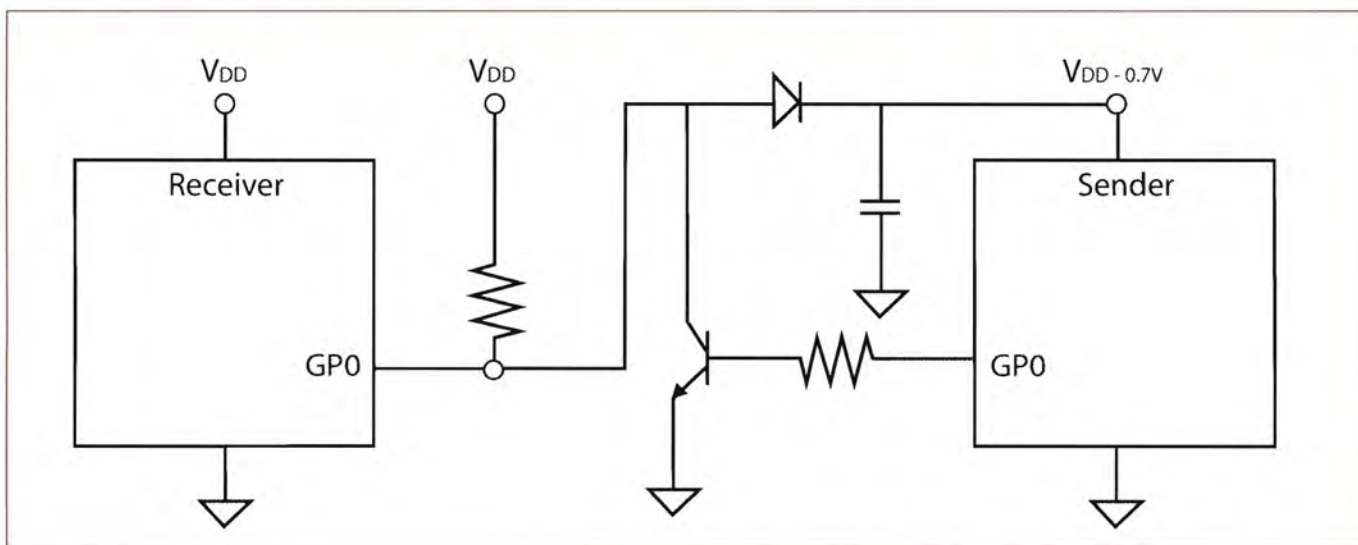
### TIP 3: 4X4 KEYBOARD WITH ONE INPUT

By carefully selecting the resistor values, each button generates a unique voltage. This voltage is measured by the A/D to determine which button is pressed.

Higher precision resistors should be used to maximise voltage uniqueness. The A/D will read near 0 when no buttons are pressed.



### TIP 4: ONE-PIN POWER/DATA



A single I/O can be used for both a single-direction communication and the power source for another microcontroller. The I/O line is held high by the pull-up resistor connected to VDD. The sender uses a pull-down transistor to pull the data line low or disables the transistor to allow the pull-up to raise it to send

data to the receiver. VDD is supplied to the sender through the data line. The capacitor stabilises the sender's VDD and a diode prevents the capacitor from discharging through the I/O line while it is low. Note that the VDD of the sender is a diode-drop lower than the receiver.



## TIP 5: DELAY TECHNIQUES

- Use GOTO "next instruction" instead of two NOPs.
- Use CALL Rtrn as quad, 1 instruction NOP (where "Rtrn" is the exit label from existing subroutine).

MCUs are commonly used to interface with the "outside world" by means of a data bus, LEDs, buttons, latches, etc.

Because the MCU runs at a fixed frequency, it will often need delay routines to meet setup/hold times of other devices, pause for a handshake or decrease the data rate for a shared bus.

Longer delays are well-suited for the DECFSZ and INCFSZ instructions where a variable is decremented or incremented until it reaches zero, when a conditional jump is executed. For shorter delays of a few cycles, here a few ideas to decrease code size.

For a two cycle delay, it is common to use two NOP instructions which uses two program memory locations. The same result can be achieved by using "goto \$+1". The "\$" represents the current program counter value in MPASM. When this instruction is encountered, the MCU will jump to

NOP NOP	;2 instructions, 2 cycles
GOTO \$+1	;1 instruction, 2 cycles
CALL Rtrn ... Rtrn RETURN	;1 instruction, 4 cycles

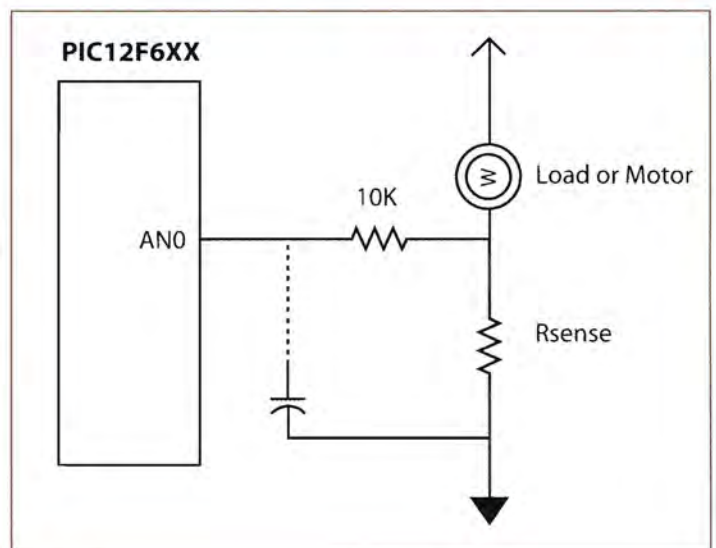
the next memory location. This is what it would have done if two NOPs were used but since the "goto" instruction uses two instruction cycles to execute, a two-cycle delay was created. This only used one location of program memory.

To create a four-cycle delay, add a label to an existing "RETURN" instruction in the code. In this example, the label "Rtrn" was added to the "RETURN" of subroutine that already existed somewhere in the code. When executing "CALL Rtrn", the MCU delays two instruction cycles to execute the "CALL" and two more to execute the "RETURN". Instead of using four "NOP" instructions to create a four-cycle delay, the same result was achieved by adding a single "CALL" instruction.

## TIP 6: USING PIC MCU A/D FOR SMART CURRENT LIMITER

- Detect current through low side sense resistor
- Optional peak filter capacitor
- Varying levels of overcurrent response can be realised in software

By adding a resistor (Rsense) in series with a motor, the A/D can be used to measure in-rush current, provide current limiting, over-current recovery or work as a smart circuit breaker. The 10K resistor limits the analogue channel current and does not violate the source impedance limit of the A/D.

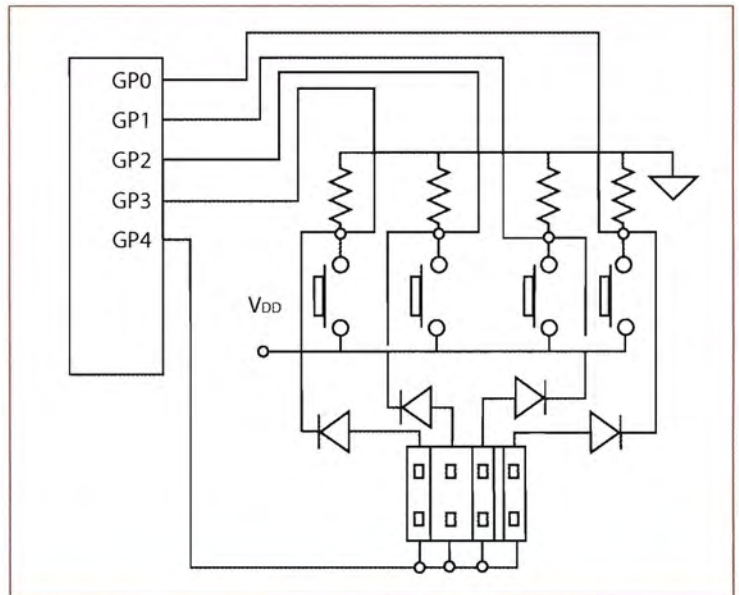




## TIP 7: DECODE KEYS AND ID SETTINGS

Buttons and jumpers can share I/Os by using another I/O to select which one is read. Both buttons and jumpers are tied to a shared pull-down resistor. Therefore, they will read as '0' unless a button is pressed or a jumper is connected. Each input (GP3/2/1/0) shares a jumper and a button. To read the jumper settings, set GP4 to output high and each connected jumper will read as '1' on its assigned I/O or '0' if it's not connected. With GP4 output low, a pressed button will be read as '1' on its assigned I/O and '0' otherwise.

- When GP4 = 1 and no keys are pressed, read ID setting
- When GP4 = 0, read the switch buttons



# WIN A Microchip MPLAB ICD 2

Electronics World is offering its readers the chance to win an all-in-one, low-cost In-Circuit Debugger/Programmer for Flash PICmicros

Microchip's MPLAB ICD 2 is an in-circuit debugger and programmer for their popular PICmicro microcontrollers. The PC based MPLAB ICD 2 supports Microchip's PIC16F and PIC18F Flash microcontrollers and dsPIC digital signal controllers. As new devices become available, users will be able to download new software code into the MPLAB ICD 2, at no cost, creating a highly adaptable tool that eliminates the expense of daughter board upgrades. The debugger supports real-time viewing of variables and registers. A single break point can be set and memory read/writes can also be accomplished. Additionally, the MPLAB ICD 2 can be used to program or reprogram the microcontroller on the product board. Other features include built-in over-voltage and short circuit monitors, support of 2 to 6 Volts operation, diagnostic LEDs, program memory space erasure with verification, and freeze-on-halt.



The MPLAB ICD 2 kit includes a demonstration board and samples of the PIC18F452 and PIC16F877 high-performance Flash micro-controllers. The demonstration board features a 2x16 LCD display, temperature sensor, EEPROM memory, LEDs, Piezo sounder, RS 232 interface. The kit also includes the MPLAB IDE (Interactive Development Environment) software.

For the chance to win a kit, log onto [www.microchip-comp.com/eworld-icd2](http://www.microchip-comp.com/eworld-icd2) and enter using the online entry form

## Low-Cost Marine AIS Solution

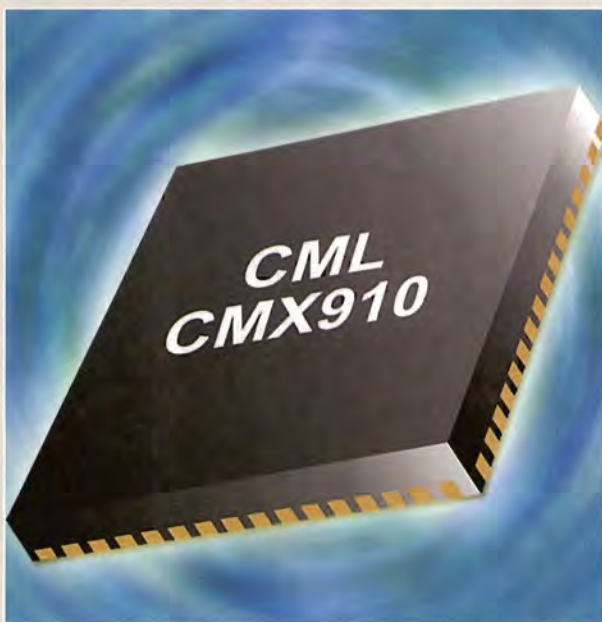
The new CMX910 from CML Microcircuits promises to give global designers of Marine Automatic Identification Systems (AIS) a helping hand in their quest to develop low-cost Class-A, Class-B and Rx only solutions, for both commercial and leisure maritime vessels of all sizes.

The CMX910 is a highly integrated baseband signalling processor IC, providing all of the required baseband processing, control and data formatting/unformatting. It is designed as an ultra-low-power IC (3.0V), so that many of the CMX910's on-chip functions can be power-saved when not actively required.

Half duplex in operation, the CMX910 comprises two I and Q Rx paths and one Tx path, configurable for AIS or FSK (DSC) operation. The device performs channel filtering and signal modulation/demodulation, along with associated AIS functions, such as training sequence detection, NRZI conversion and HDLC processing (flags, bit stuffing/de-stuffing, CRC generation/checking and slot-timing). A 1200bps FSK demodulator interface provides a third parallel decode path (required by the AIS class A market), using an external FSK modem.

The CMX910 meets International Maritime Authority IMO requirements (IMO-M1371) and IEC61933/IEC62287 standards, for inclusion in a Class-A or Class-B transponder. The CMX910 also supports the expanding Rx only leisure-craft market.

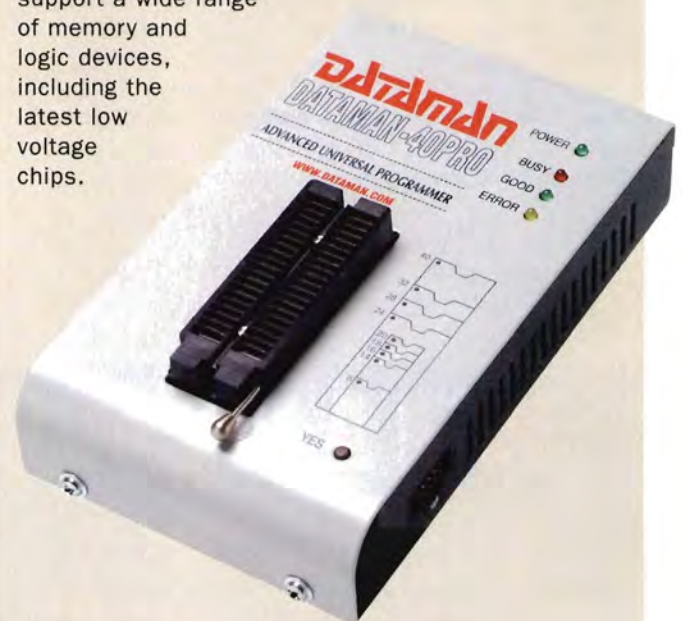
[www.cmlmicro.com](http://www.cmlmicro.com)



## New Generation Universal USB Programmings

Dataman has launched a new range of universal programmers built to support all types of device technologies. All of the new programmers have a USB2 interface, which will particularly suit the needs of those engineers who prefer to use a laptop for program development.

The Dataman-40Pro is a small, fast and portable programmer with a 40-pin socket, designed to support a wide range of memory and logic devices, including the latest low voltage chips.



The Dataman-48Pro is for engineers who want the best programming speeds and need to cover the widest possible range of memory and logic parts. It supports over 25,000 devices, from 5V down to 1.5V.

The Dataman-40Pro and Dataman-48Pro both have an In System Programming (ISP) connector with a JTAG interface, which programs chips whilst still inside the end target system. Large quantities of chips can be programmed more quickly by connecting multiple 48Pro programmers to the same PC. This setup will work either as a gang programmer or to program chips with different data simultaneously.

The new programmers are operated from an easy to use Windows interface. Software to cover new chips is released every 2-3 weeks and may be freely downloaded from Dataman's website.

These products also come with a 3-year warranty. [www.dataman.com](http://www.dataman.com)

## SD Memory Card Series Hits Global Market

Toshiba will launch new microSD Memory Cards and SDHC Memory Cards this summer and in September, to be available globally.

The different card versions meet diverse needs and continue to bring increasingly large capacities to increasingly small cards. The microSD Memory Card fully complies with the SD Memory Card standard and can be slipped into an adapter for use in products with slots for standard SD cards. Toshiba will meet growing demand for memory cards in this small format with 256MB, 512MB and 1GB capacity microSD Memory Cards.

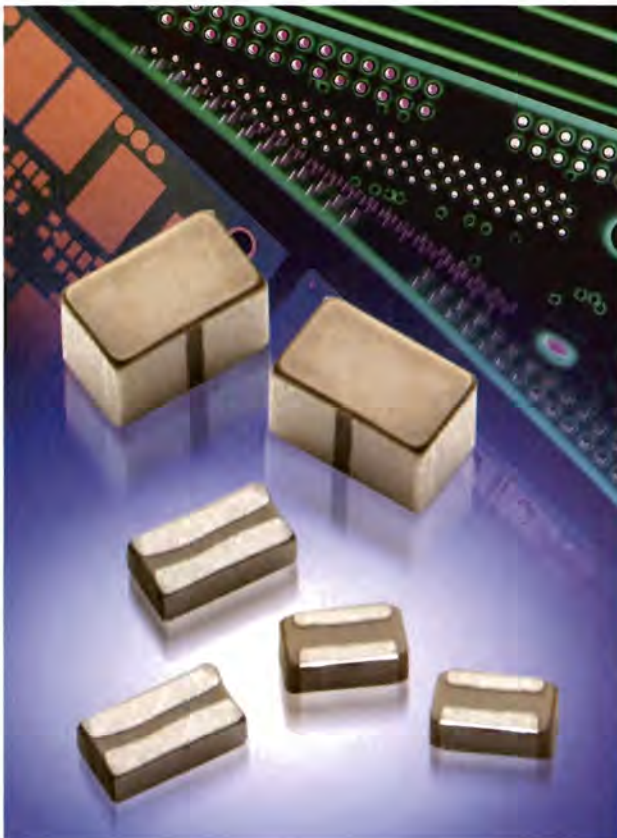
The SDHC Memory Card brings SD card to new level of performance in terms of capacity. SDHC meets the



new SD Memory Card Ver2.00 for cards with a capacity of over 2GB, and will boost memory capacity to 32GB in the near future. It also complies with Class 4 of SD Speed Class, a newly defined standard for data processing speed, and it supports a maximum write speed of 6MB per second. As a result, SDHC Memory Cards are optimised for high capacity and for applications such as digital video and continuous shooting mode for high-end digital still cameras.

[www.toshiba-components.com](http://www.toshiba-components.com)

## Land Grid Array (LGA) Capacitors



Land Grid Array (LGA) capacitors from AVX have achieved, thanks to patented design innovations, the equivalent high frequency performance of complex 8-terminal Inter-Digitated Capacitors (IDC) in a simple two terminal device. Using a new fine copper termination construction process and modified internal design, LGA decoupling capacitors reduce internal inductance by 50% compared with capacitors using more traditional reverse geometry or the multi-terminal IDC construction design. A two-terminal LGA capacitor using this process can achieve inductances down to 35pH. This feature is especially important in semiconductor package-level decoupling applications, where capacitors are placed on or very close to the processor die.

LGA capacitors reduce inductance by making the current loop of the mounted device as small as possible. This is achieved by using vertical electrodes which can be terminated very close to the centre of the finished device.

There are four package versions in the initial product release, LG12 (0204), LG22 (0306), LG32 (0508) and LGC2 (0805). The LC32 package offers typical inductances down to under 30pH. At 4V, the LG12 has capacitance values up to 0.10µF, and the LG22 up to 0.47µF. LGA capacitors come in thicknesses from 0.5mm to 1.5mm.

[www.avx.com](http://www.avx.com)

## Medically Approved External Power Supplies

Powersolve has announced five series of external power supplies designed specifically for use with medical equipment. They all meet UL, cUL2601-1 and EN60601-1 safety approvals and EMC standards to EN55011 or EN55022 "B" and FCC "B".

The PPT30M series of 30W plug-top supplies come with four interchangeable clip-on AC plugs for the UK, Europe, the US and Australia. Input is from 90 to 264AC and outputs are 5, 9, 12, 15, 18 and 24VDC.

The PSEM50 series of desk-top supplies provides up to 50W and its products are ideally suited for use in medical instrumentation systems. Any single output from 2VDC to 50VDC can be supplied and dual and triple output versions are also available.

The DPS50-M series provides up to 60W with single DC outputs of 5, 12, 15, 24 and 48V. Inlet is the standard 3-pin IEC320.

With power outputs up to 100W, the PSEM100 series includes single, double and triple output versions, ranging from 3.3 to 24VDC. They feature overvoltage and

overcurrent protection and an incorporated on-off switch.

The ED1048 3-stage 12V battery charger's input is the standard 90 to 264VAC, output power is a maximum of 60W and it comes with a standard IEC 320 inlet and can be supplied with an optional output connector.

[www.powersolve.co.uk](http://www.powersolve.co.uk)



## Antistatic Toggles For Logic-Level Applications



Arrow has introduced a new range of antistatic toggles designed specifically for logic-level applications by NKK Nikkai. The B series of process sealed, subminiature, antistatic, PC mount toggle switches incorporate NKK's award-winning sliding twin crossbar contact mechanism. This contact design provides unparalleled switching

reliability and smoother positive detent action. The B series features an antistatic superstructure, consisting of a carbon-impregnated bushing. When configured with a support bracket, it prevents static discharge to the contacts. Static electricity from the operator's touch travels from the actuator, through the bushing and bracket, to the PC board.

B series toggles are available in both single and double-pole models with a comprehensive offering of eleven circuits, momentary and maintained. The single-pole version is 6.8mm wide and the double-pole is 8.78mm. These measurements include a bushing 2.69mm long. The terminals are 2.54mm x 2.54mm spacing and conform to standard PC board grids.

B series toggles are 0.4VA maximum @ 28V AC/DC maximum. The mechanical life is 100,000 operations minimum for maintained circuits and 50,000 operations minimum for momentary circuits. The electrical life is rated at 50,000 operations minimum. The contact timing is nonshorting and the angle of throw is 26°.

[www.arrow.com](http://www.arrow.com)

# Website Directory

To reserve your website space phone Matthew Dawe 01322 611261  
or email [matthew.dawe@nexusmedia.com](mailto:matthew.dawe@nexusmedia.com)

## Action Circuits

[www.action-circuits.co.uk](http://www.action-circuits.co.uk)

Specialists in Chip Programming and SMD Reeling Services, Action Circuits (UK) Ltd offer subcontract services to the electronics industry second to none. We currently have trading partnerships with many Semiconductor manufacturers, distributors, CEM's and OEM's. Our component programming and tape & reeling service is available for high volume or sample quantities.

If you are looking for a service to tape and reel components or program your OTP or Flash programmable devices, then our highly experienced staff are committed to offering you a device programming service, laser marking and component taping service with a quick turnaround at a very competitive cost.



## Alban Electronics

[www.albanelectronics.co.uk](http://www.albanelectronics.co.uk)

Alban Electronics supports all PROMAX test equipment in the United Kingdom. Their TV aerial and satellite installation analysers have a reputation for quality with regard to technical performance, accuracy and reliability. Their Test and Calibration Centre based in St Albans ensures that product standards are maintained throughout their working life. The product range extends to educational training equipment, portable fibre optic spectrum analysers, DOCSIS analysers, data communications, WiFi and radio monitoring systems.



## Beta Layout Ltd

[www.pcb-pool.com](http://www.pcb-pool.com)

The Best Value Online PCB Prototyping Service Available:  
Instant on line quotations & ordering (no pre registration).

We offer the following:

- No minimum quantity. • No tooling charges. • No drill Limitations. • 1 to 6 layers (prototype quantities) • 2 layers (small production batches) • Fr4, 1.6mm, 35 um, HASL (Pb free/Rohs/Weee) • Soldermask / Silkscreen (optional) • Leadtimes from 2 - 8 working days • Full DRC on all orders (we manually check every file !!!) • PCB-POOL® accepts direct outputs from 15 major layout softwares (see our website for details)

Download our fully functional PCB LAYOUT software FREE of charge.  
**Free Phone : 0800 3898560**



## BVM

[www.bvm-store.com/](http://www.bvm-store.com/)

Suppliers of computer boards and systems for embedded application. Comprehensive ranges of standard boards and systems are described on the website together with a family of ultra slim panel PCs for Kiosk and information display systems.

In addition the company offer a customisation service for both CPU and I/O boards and complete assembled systems. Typical applications range for point of sale terminals to traffic management systems. Call **01489 780144** to discuss your system requirements or email [sales@bvmltd.co.uk](mailto:sales@bvmltd.co.uk)

**BVM Limited**

Hobb Lane, Hedge End, Southampton, SO30 0GH



## Class-d Design Limited

[www.class-d.com](http://www.class-d.com)

Established to give a cost effective solution to audio, lighting, general electronic design and manufacture for the leisure, commercial, industrial, domestic markets. Linear and Class-d design amplification including PFC power supplies. Full design through to manufacture and installation.

- Manufacturing equipment • Plastic injection moulding • Die-casting • Surface Mount production • Full volume manufacturing • Supplying sound systems • Energy saving • Lighting systems • LED lighting • Fluorescent Lighting ballasts



## Conford Electronics

[www.confordelec.co.uk](http://www.confordelec.co.uk)

Lightweight portable battery/mains audio units offering the highest technical performance. Microphone, Phantom Power and Headphone Amplifiers.

Balanced/unbalanced signal lines with extensive RFI protection. Specialists



## DB Technology

[www.dbtechnology.co.uk/](http://www.dbtechnology.co.uk/)

Anechoic chamber and open area test site.

- Compliance Tests
- Fixes included. FCC Listed.
- Flexible hourly booking available.
- Rapid, accurate pre-compliance tests.



## Designer Systems Co

[www.designersystems.co.uk](http://www.designersystems.co.uk)

Electronic product design company with over a decade of experience promoting it's own product range and designing and manufacturing innovative products for client companies/individuals.



Colour screen shot and text is just £350 + vat for 12 months

[www.electronicsworld.co.uk](http://www.electronicsworld.co.uk)

# Website Directory

To reserve your website space phone Matthew Dawe 01322 611261  
or email [matthew.dawe@nexusmedia.com](mailto:matthew.dawe@nexusmedia.com)

## Forest Electronics

[www.fored.co.uk](http://www.fored.co.uk)

Electronic product design company with over a decade of experience promoting its own product range and designing and manufacturing innovative products for client companies/individuals.



## Future Technology Devices International Ltd

[www.ftdichip.com](http://www.ftdichip.com)

<<http://www.ftdichip.com>> Future

Technology Devices International (FTDI) Ltd. are specialists in providing IC devices and modules which allow for interfacing legacy peripherals to Universal Serial Bus (USB). We offer the easiest route to USB migration by combining USB-Serial (USB-RS232) and USB-FIFO silicon solutions with our ready-to-go royalty free USB drivers

<<http://www.ftdichip.com/FTDrivers.htm>>. FTDI's "total" solutions offer reduced development and debug costs and a fast time to market.

Call us on 0141 4292777 or email [sales1@ftdichip.com](mailto:sales1@ftdichip.com)



## FTT

[www.ftt.co.uk/PICProTrng.html](http://www.ftt.co.uk/PICProTrng.html)

FTT (a Microchip Consultant Partner & Training Partner) has developed a range of courses – both distance learning and instructor led – covering Assembly and C Programming of PIC16, PIC18, PIC24 and dsPIC microcontrollers. For each processor family there are both C and Assembly programming courses at: •FOUNDATION LEVEL & •INTERMEDIATE LEVEL. For information about these courses, advanced courses and workshops such as: •Advanced C Embedded & Real Time Programming •TCP/IP & Ethernet •USB •CAN •DSP •Motor Control •programming using Real Time Operating Systems such as uCOSII, CMX & Salvo and •other microcontrollers, please inquire.

Tel: 020 8669 0769 Email: [pictrng@ftt.co.uk](mailto:pictrng@ftt.co.uk)



## Hammond Electronics



[www.hammondmfg.com](http://www.hammondmfg.com)

Hammond Electronics is one of the world's leading manufacturers of small plastic, die-cast and metal enclosures for use in the professional and hobbyist electronics, electrical and allied sectors. The well-known Eddystone range of die-cast aluminium enclosures is a Hammond brand. In the UK, product is available from the company itself or a number of major catalogue and specialised enclosure distributors. Visit [www.hammondmfg.com](http://www.hammondmfg.com) to see the full range of products and to download PDF and AutoCAD files of each unit; for specific technical information or to place an order, call 01256 812812.

## Harmonic Software Systems

[www.harmonicss.co.uk/harmonic.htm](http://www.harmonicss.co.uk/harmonic.htm)

Harmonic Software Systems develops embedded real-time systems and DSP solutions for industrial, commercial and military customers. We supply:

- Vx Works Board Support Packages and device drivers.
  - Software Development services.
  - Consultancy at excellent rates.
  - Safety critical systems up to SIL3.
  - Digital Signal Processing algorithms and kernel development.
- We are experienced in developing systems



utilising a wide range of technologies, including:

- MIL-STD-1553 • Firewire IEEE-1394
- Ethernet • CANBus • V RS232/422/485
- ARM, MIPS, PowerPC, x86 • TMS320, Sharp
- VME, cPCI, PC104 or custom hardware

Call us now on 01293 817635 to discuss your requirements.

## Kalestead Ltd

[www.kalestead.co.uk/cable.htm](http://www.kalestead.co.uk/cable.htm)

At Kalestead we do not simply supply coiled leads from stock or "off the shelf", the reason for this being that they are made to each customer's specific requirements. We can, however, offer a quick turnaround using cable available from stock which can be coiled to you own specification.

It is because of the specialised nature of our business that we are unable to provide a price list on our web site. Please do not hesitate to contact a member of our sales team who will discuss with you and supply you with an individual quotation.



## Microchip Technologies

<http://www.microchip.com/>

Microchip Technology Inc. is a leading provider of microcontroller and analogue semiconductors, providing low-risk product development, lower total system cost and faster time to market for thousands of diverse customer applications worldwide. Microchip designs, manufactures, and markets a variety of high performance components for high volume, cost-effective embedded control solutions, including 8- and 16-bit PIC® microcontrollers; dsPIC® digital signal controllers; development kits; serial EEPROMs, more than 350 mixed-signal analogue and interface products; KEELOQ secure data transmission products; and the PowerSmart® family of smart battery management products. Microchip's product solutions feature compact size, integrated functionality, and ease of development.



## MicroRobotics

[www.microrobotics.co.uk](http://www.microrobotics.co.uk)

Micro-Robotics is a Cambridge-based manufacturer of custom and off-the-shelf embedded control solutions and components. The company's VM-1 credit-card-sized control computer is ideal for a wide range of applications.

When used with the Micro-Robotics proprietary Venom-SC object-oriented programming language, the VM-1 controller can handle analogue and digital I/O, graphical user interfaces, communication protocols, data and text files and many other functions. This combination of powerful processor, easy to use application software and comprehensive I/O resources will make the VM-1 highly suitable for applications such as intelligent instruments, hand-held devices, industrial automation and process control systems, security systems and similar other applications.



Colour screen shot and text is just £350 + vat for 12 months

[www.electronicsworld.co.uk](http://www.electronicsworld.co.uk)

# Website Directory

To reserve your website space phone Matthew Dawe 01322 611261  
or email [matthew.dawe@nexusmedia.com](mailto:matthew.dawe@nexusmedia.com)

## Newbury Electronics

[www.pcbtrain.com](http://www.pcbtrain.com)

PCBT Train is a division of Newbury Electronics Ltd whose pcb manufacturing and assembling operations have been located in Newbury for almost 50 years.

Why pay more for a prototype pcb and small batch pcb production? Established for over 5 years, PCB Train is now the UK's leading supplier of prototype pcbs. The PCB Train concept has revolutionised the costs of pcb prototype and small batch pcb production.

The low cost is achieved by making different designs of pcb on "panels" on fixed production schedules yielding huge savings which we pass on to you. Buy from PCB Train and receive professionally UK manufactured (BS EN ISO 9001:2000 approved) prototype pcbs and small batch production runs of pcbs on time at prices a fraction of those typically quoted by our competitors.



## Nohau

[www.nohau.co.uk](http://www.nohau.co.uk)

Embedded Development Tools and OEM products. Nohau UK Ltd are specialists in embedded system development tools, software stacks and OEM products.

- Compilers, RTOS, TCP/IP
- Jtag & BDM debuggers, emulators
- Programmers
- USB Stacks
- USB Protocol Analysers and Factory Testers
- Bluetooth Analysers
- Bluetooth Serial Port Modules



- Automotive & Industrial Communications
- CAN interfaces
- CANopen bus stacks
- IC test probes and adapters
- BGA test sockets

## Peak Electronic Design

[www.peakelec.co.uk](http://www.peakelec.co.uk)

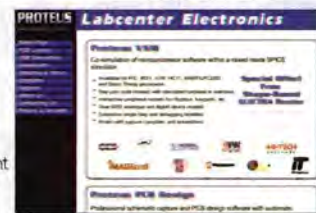
Smart handheld test equipment designed and made in the UK. Our instruments cover many requirements including automatic component identification (passives and semi's), network cabling analysis, datalogging and much more. Take a look at the Atlas DCA Semiconductor analyser for example, no other analyser can offer cool features (such as automatic part identification and automatic pinout identification) in such a smart, easy-to-use and cost effective instrument. Our new enhanced Atlas IT Network Cable Analyser has just got even smarter. The Atlas IT will identify network cable types even if they are faulty, it will then tell you the specific fault with your cable compared to a good cable of the same type.



## Proteus Design Suite

[www.labcenter.co.uk](http://www.labcenter.co.uk)

The Proteus Design Suite from Labcenter Electronics Ltd provides a unified development environment for the professional electronics engineer. From schematic capture, through simulation to PCB design Proteus delivers a cost-effective solution designed to streamline the development lifecycle and reduce the time to market. Proteus also includes the worlds first schematic based microcontrollersimulation technology, allowing you to test and debug your microcontrollerapplication alongside any analog and digital electronics connected to it. This enables parallel development, reduces costly prototyping revisions, simplifies testing and saves both time and money. With free support direct from the program authors, the Proteus Design Suite is the total solution, from concept to completion.



## Spellman High Voltage Electronics Corporation

[www.ftt.co.uk/PICProTrng.html](http://www.ftt.co.uk/PICProTrng.html)

Spellman High Voltage Electronics Corporation is the world's leading independent manufacturer of high voltage dc power supplies, X-ray generators, and Monoblock® X-Ray Sources. Established in 1947, Spellman is a trusted supplier to the medical, industrial and scientific communities, serving diverse applications such as: CT Scanning, Bone Densitometry, Non-Destructive Testing, Analytical X-Ray, Ion Implantation, E-Beam Lithography, Explosive Detection/Baggage Screening, Telecommunications, Mass Spectrometry, Electrophoresis, and numerous others. Spellman's ISO9001:2000 & 14001 certified, vertically-integrated, global facilities encompass over 250,000 sq. ft. of manufacturing space. Spellman's product line sets the industry standard for high voltage innovation



## Stewart Of Reading

[www.stewart-of-reading.co.uk](http://www.stewart-of-reading.co.uk)

Stewart of Reading is a small business with over 30 years experience in the surplus electronic test equipment market.

We are well known within the industry, have a good reputation and successfully distribute stock worldwide.

All equipment is fully tested and guaranteed before distribution.

**Stewart of Reading**

17A King Street, Mortimer, Nr. Reading, Berkshire. RG7 3RS United Kingdom

Tel: +44(0)118 933 1111

Fax: +44(0)118 933 2375



## Surplectronics

[www.surplectronics.com](http://www.surplectronics.com)

Surplectronics is a brand new electronics components e-Store with a difference. We specialise in popular electronic components from leading manufacturers at rock bottom prices that you won't find elsewhere.

New lines are arriving every day and many of our products are one-off specials that may not be repeated.

Our products are all new, unused and are fully guaranteed. Ordering is simple, with UK shipment free for orders over £50 and payment is completed credit card. Goods are shipped that day for prompt delivery.

**Surplectronics - serious about surplus. Tel: 0870 850 5258**



## Telnet Ltd

[www.telnet.uk.com](http://www.telnet.uk.com)

Suppliers of quality second-user test and measurement equipment at prices you can afford. Manuals and accessories supplied. If you would like a quote, please call. We also purchase your surplus test equipment. Please call us for the best offers.

**TELNET**

1 Stoney Court, Hotchkiss Way, Binley Industrial Estate, CV3 2RL

Tel: 024 76650702 Fax: 024 76650773

Mobile: 07860 400683

Email: [dales@telnet.uk.com](mailto:dales@telnet.uk.com)



Colour screen shot and text is just £350 + vat for 12 months

[www.electronicsworld.co.uk](http://www.electronicsworld.co.uk)

# Products & Services

ADVERTISING ENQUIRES CONTACT MATTHEW ON 01322 611 261

## ADVERTISING

**EMC ADVERTISING GIFTS**  
 Promotional Pens  
 Parker, Sheaffer  
 Cross - ONLINE  
[www.emcadgifts.co.uk](http://www.emcadgifts.co.uk)

**EMC ADVERTISING GIFTS**  
 Phone fax email for Catalogues  
 tel: **0845 345 1064**  
 fax: **0845 345 1065**  
 sales@emcadgifts.co.uk

**EMC ADVERTISING GIFTS**  
**Easy-to-buy**  
 Promotional Gifts  
 - ONLINE  
[www.emcadgifts.co.uk](http://www.emcadgifts.co.uk)



**face2face**

With a wealth of experience supplying promotional solutions to a variety of organizations, face2face can provide you with the best advice and products to keep your profile head and shoulders above your competition.

Have a look at our extensive online catalogue.

Website : [www.face2face.me.uk](http://www.face2face.me.uk)  
 Tel : 0208 684 0800 Fax : 0208 665 1220  
 Email : sales@face2face.me.uk

## ELECTRONICS DEVELOPMENT SERVICES

**Apex Design Solutions LTD**  
 Custom Electronics & Software Design Services



Embedded systems, Analogue, Digital, Data-loggers, Custom software, ...and more...

**...Rapid cost effective solutions!**

For more information or to request a quote contact us today or visit our website.

info@apex-ds.co.uk Tel/Fax: 0870 758 2688  
[www.apex-ds.co.uk](http://www.apex-ds.co.uk)


## ARTICLES WANTED

**TOP PRICES PAID**

For all your valves, tubes, semi conductors and ICs.

**Langrex Supplies Limited**  
 1 Mayo Road, Croydon, Surrey CR0 2QP  
 TEL: 020 8684 1166 FAX: 020 8684 3056

## BATTERIES & CHARGERS



**ANSMANN ENERGY (UK) LIMITED**  
 Units 19/20, Maple Park, Essex Road, Hoddesdon, Herts, EN11 DEX, UK  
 Tel: +44 (0) 870 609 2233  
 Fax: +44 (0) 870 609 2234  
 Email: info@ansmann.co.uk  
 Web: www.ansmann.co.uk

## EMBEDDED SOFTWARE DEVELOPMENT



**HARMONIC SOFTWARE SYSTEMS**

**EMBEDDED SOFTWARE DEVELOPMENT**

- ✓ REAL TIME SYSTEMS DESIGN, DEVELOPMENT & TESTING
- ✓ DIGITAL SIGNAL PROCESSING - TMS320, SHARC, DSP56K
- ✓ DEVICE DRIVERS, BSPs, LIBRARIES, FIRMWARE
- ✓ SAFETY CRITICAL TO SIL3, MISRA-C:2004, POSIX, VxWORKS
- ✓ VME, cPCI, PC104 OR CUSTOM HARDWARE

Tel: **01293 817635**  
 Web: [www.harmonicss.co.uk](http://www.harmonicss.co.uk)  
 Email: sales@harmonicss.co.uk

Premium quality at a competitive price

## COMPONENTS WANTED

**Components wanted**  
 Excess/Surplus  
[www.mushroom.co.uk](http://www.mushroom.co.uk)  
**01234 363611**  
 will collect anywhere in Europe  
 Instant Cash Settlement

## ENCLOSURE DESIGN



**CUBE CREATIVE PRODUCT DESIGN**



01702 292984  
 01702 292985  
 info@cubethree.co.uk  
[www.cubethree.co.uk](http://www.cubethree.co.uk)

## PCB MANUFACTURE



**Prototype PTH PCBs from just £30.00**

Prices published at [www.pcbtrain.com](http://www.pcbtrain.com)

The leading low-cost source for Prototype PCBs from 1-6 layers

+44 (0) 1635 40347  
 f +44 (0) 1635 36143 e pcbtrain@newbury.tcom.co.uk

## DESIGN DEVELOPMENT & MANUFACTURE

**Design Services**

- Switch Mode Power Supply Design
- Power Factor Correction Design
- Linear & Switching Amplifier design
- Protecting Intellectual Property
- Producing YOUR product
- Using OUR world class service
- Far East pricing & value
- Engineering & Testing Programme
- Global Logistics & Distribution



[www.class-d.com](http://www.class-d.com) or Telephone (01623 654 080)

## FOR SALE



**agar Circuits**

**PCB DESIGN & MANUFACTURE**  
 for both the Hobbyist and Professional

PCBs designed and produced from :

- Notes
- Schematics
- Specifications
- Descriptions
- Print - outs
- Gerbers

Available With or without component assembly

\* FREE \* PCB PROTOTYPE With Quantity Orders

Email: [adinfo@agarcircuits.com](mailto:adinfo@agarcircuits.com)  
 Tel: 028 (90) 738 897



# Products & Services

ADVERTISING ENQUIRES CONTACT MATTHEW ON 01322 611 261

## PCB MANUFACTURE

### RAK

Printed Circuit Boards

[www.rak.co.uk](http://www.rak.co.uk) - [data@rak.co.uk](mailto:data@rak.co.uk)

24 Hour Service

Quality Prototype and Small Quantity  
Printed Circuits Fast

Single Sided • Double Sided  
Multi Layer • PTFE • RoHS Compliant  
Silver & Gold • SMD Assembly

Unit 12, Shirehill Industrial Estate, Saffron Walden,  
Essex CB11 3AQ

Tel: 01799 526227 Fax: 01799 525107

## TAPE REELING & SERVICES

### action circuits

(UK) LIMITED

device programming & reeling specialists



### SMD TAPING & REELING SERVICES

Tel: 00 44 (0)1582 412323

Email: [sales@actioncircuits.com](mailto:sales@actioncircuits.com)

[www.actioncircuits.com](http://www.actioncircuits.com)

## POWER

### TOROIDAL TRANSFORMERS

- Product Range 10va - 6kva
- Short Lead Times
- Large or Short Production Runs
- Very Fast Prototype Service
- All products manufactured in UK

### TIGER TOROIDS LTD

Unit 5 Pulham Market Hall,  
Station Road, Pulham Market  
Diss, Norfolk, IP21 4XF

Tel: 01379 608 868

Fax: 01379 608 871

## POWER SUPPLIES

The World's Leading Independent  
Manufacturer of High Voltage DC  
Power Supplies, X-Ray Generators,  
& Monoblock X-Ray Sources.

Let Us Transform Your Ideas Into Reality.

Broomers Park, Unit #14  
Broomers Hill Lane Pullborough  
West Sussex, RH20 2RY, England  
Tel: +44(0) 1798 877000  
Fax: +44(0) 1798 872479  
Email: [Sales@SpellmanHV.co.uk](mailto:Sales@SpellmanHV.co.uk)

### Spellman

High Voltage Electronics Corporation



## PRODUCT DEVELOPMENT

### From Concept to Production

Turn-key product design, re-design (including RoHS) and manufacturing services to allow your business to stay competitive and meet your customers needs.

- Wide development coverage including telecommunications, broadcast, industrial, automotive, white goods and commercial.
- Industrial safety & control products.
- GSM/GPRS telemetry via SMS or data (TCP/IP) for M2M.
- GPS enabled systems for asset tracking, security or monitoring.
- Ethernet/WiFi telemetry.
- Broadcast audio & video routing and interfacing systems.
- Automotive audio visual, security and accessories.
- Robotics for education or the hobbyist.
- Professional DVD and network video player accessories.

email [sales@designersystems.co.uk](mailto:sales@designersystems.co.uk)

tel/fax +44 (0) 1872 223306

web [www.designersystems.co.uk](http://www.designersystems.co.uk)

Designer Systems



MICROCHIP  
Consultant Program Gold Award Member



## PCB MANUFACTURE

PCB MANUFACTURE  
VISIT **PCB-VALUE.CO.UK** FOR

- REAL-TIME QUOTES CALCULATOR
- LOW COST, EVEN FOR SMALL QUANTITIES
- A QUALITY SERVICE YOU CAN TRUST
- ON-LINE PURCHASING OPTION
- PCB LAYOUT DESIGN

CIRCUIT  
TECHNOLOGY  
LIMITED

UNIT 39, LANSDOWN IND. EST.  
CHELTENHAM, GLOS, GL51 8PL  
TEL: 01242 587700

## SERVICES

### POWER SUPPLY DESIGN

Switched Mode PSU  
Power Factor Correction  
*designed to your specification*  
Tel/Fax: 01243 842520  
e-mail: [eugen\\_kus@cix.co.uk](mailto:eugen_kus@cix.co.uk)

Lomond Electronic Services

## EXCESS STOCK

### SURPLUS WANTED

WE BUY: IC's, Memory, Relays, Caps, PSU's,  
Semiconductors, Populated Boards,  
Computers & Test Equipment

### ANYTHING CONSIDERED

For our wide range of Semiconductor +  
Passives List, please ring, fax or e-mail

### MAIL ELECTRONICS LTD

TEL: 0161-761 4520 / FAX: 0161-763 6863

EMAIL: [andrew@mailelectronics.com](mailto:andrew@mailelectronics.com)

Web: [www.mailelectronics.com](http://www.mailelectronics.com)

## DEVICE PROGRAMMING SERVICES

### action circuits

(UK) LIMITED

device programming & reeling specialists



### I.C. PROGRAMMING & LASER MARKING SERVICES

Tel: 00 44 (0)1582 412323

Email: [sales@actioncircuits.com](mailto:sales@actioncircuits.com)

[www.actioncircuits.com](http://www.actioncircuits.com)

# Products & Services

ADVERTISING ENQUIRES CONTACT MATTHEW ON 01322 611 261

## MICROCONTROLLERS

### KESTREL ELECTRONIC COMPONENTS LTD

178 Brighton Road, Purley, Surrey CR8 4HA  
Tel: 020-8668-7552 Fax: 020-8668 4190

[www.kestrel-electronics.co.uk](http://www.kestrel-electronics.co.uk)

**100+ PRICES** (many other items in stock)

PIC16F870-ISP	1.36	AT89S51-24PU	0.69
PIC16F873A-ISP	1.75	AT89S52-24PU	0.71
PIC16F874A-IP	2.11	ATMEGA128L-8AU	3.41
PIC16F876A-ISP	2.16	ATMEGA8515-16PU	1.15
PIC16F877A-IP	2.29	ATTINY26L-8PU	0.66
PIC12C508A-04P	0.38	ATMEGA8-16PU	0.81
PIC12F629-IP	0.42	ATMEGA16-16PU	1.51
PIC12C671-04P	0.89	PIC18F252-ISP	2.61
PIC12F675-IP	0.58	PIC18F452-IP	2.78
PIC16F676-IP	0.65	PIC18F1220-IP	1.48
PIC16C54C-04P	0.62	PIC18F1320-IP	1.69
PIC16C55A-04P	0.81	PIC18F2520-ISP	2.53
PIC16C57C-04P	0.85	PIC18F2525-ISP	2.82
PIC16F73-ISP	1.49	PIC18F2525-I/SO	2.78
PIC16F74-IP	1.77	PIC18F2620-I/SO	2.88
PIC16F77-IP	1.91	PIC18F4520-IP	2.78
PIC16F628A-IP	0.86	PIC18F4525-IP	3.29
PIC16F716-IP	0.77	PIC18F4620-IP	3.22
DS18820+	0.89	PIC18F6520-IPT	2.85
DS1307+	0.75	PIC18F6621-IPT	3.99
DS1302+	0.79	PIC18F4580-IP	3.21

We can also supply Maxim/Dallas, Analogue Devices  
NEC, OKI, IR, Phillips. Phone for full price list.

## TRANSFORMER MANUFACTURE

### AUTOMATIC windings Ltd.

Specialist in Ferrite coil Winding since 1976

Committed to delivering Quality Bespoke components, on time,  
by building on our success of supplying our customers with  
what they want, when they want it.



Nimrod Way, Ferndown Industrial Estate, Wimborne, Dorset BH21 7SH

Tel: 01 202 87 21 01 Fax: 01 202 87 20 87

E-Mail: [sales@automatic-windings.co.uk](mailto:sales@automatic-windings.co.uk)

Web: [www.automatic-windings.co.uk](http://www.automatic-windings.co.uk)

## SURPLUS COMPONENTS FOR SALE

new parts @ surplus prices  
[www.surplectronics.com](http://www.surplectronics.com)

This Magazine reaches over  
**10,000**  
potential customers

To advertise in this space call  
**Matthew**

**01322 611 261**

# WHAT BETTER CHOICE ?

FOR QUALITY, PERFORMANCE & AFTER SALES SERVICE

£1500



## THE 'TV EXPLORER'



**PRODIG 1+  
SATELLITE  
HUNTER**



**PRODIG 2  
AERIAL  
METER**



**MC 577  
SPECTRUM  
ANALYSER**



**PROLINK 4C  
Premium  
SPECTRUM  
ANALYSER**

- ★ TV TEST PATTERN GENERATORS
- ★ COFDM MODULATORS
- ★ CRT REJUVENATORS
- ★ ELECTRONIC TRAINING SYSTEMS
- ★ BENCH & FIELD DMM
- ★ ELECTRICAL TESTERS
- ★ WiFi ANALYSERS



[www.albanelectronics.co.uk](http://www.albanelectronics.co.uk)



**Alban**

**ALBAN ELECTRONICS LIMITED**

**THE PROMAX SERVICE CENTRE**

6 Caxton Centre, Porters Wood, St. Albans, Herts, AL3 6XT.

TEL : 01727 832266

FAX : 01727 810546

[www.albanelectronics.co.uk](http://www.albanelectronics.co.uk)

[info@albanelectronics.co.uk](mailto:info@albanelectronics.co.uk)

**SALES + SERVICE + CALIBRATION**

# B<sup>2</sup> SPICE Professional V5.2



**We've taken the heat out of the price not the performance**

- Virtual Instruments & unlimited simulation options.
- Real-world parts.
- See what's really going on with powerful new Dynamic Schematics.
- Fully animated graphs and charts.
- Real-time simulation means that parameters can now be altered as a simulation is running.
- Combine plots and digital signals from any graph, circuit, or simulation result
- New circuit wizard and graphing module.
- Over 30,000 models as standard.
- New 'easy view' and 'live circuit' functions PCB Export.
- No limit on circuit size.
- Free technical support.



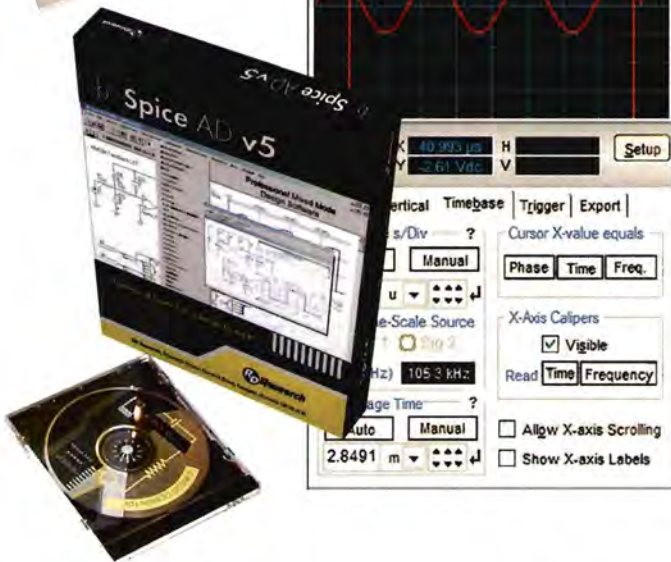
## What users say about B<sup>2</sup> Spice V5:

Since we started using B2 Spice V5, we consider it to be the most intuitive & powerful package we have found. Our Research and Development team consider it to be an essential element of their toolset. - **Naim Audio**

"I have used almost every Spice program in existence over the past 20 years, and I consider B2 Spice to be the most price-competitive on the market today." - **C Sayre, Senior Engineer Micro Linear Corp & author of Complete Wireless Design.**

I consider the program excellent value. Its performance and ease of use are equal to or better than anything else that I have tried, at a much lower cost. ... I have recommended that anyone here requiring SPICE look at your program. I believe that B2 Spice sets a new standard for price/performance."

**Terry Staton, Senior Engineer**



**Evaluate the full version completely free for 30 days**

*'We're confident the new B2 Spice will impress you. We offer an unconditional 30 day evaluation of the full boxed version, complete with printed user manual. If you don't like it, just return it.'*

**Outstanding value at only £229.00**

**Contact us now on 01603 872331**

**[www.spice-software.com](http://www.spice-software.com)**



All trademarks are acknowledged

