

ELECTRONICS WORLD

JULY 2005 £3.25



Design for
optimum noise
performance

Finding the
best ADC

TOP 10 TIPS:

Raising VC Funding



Rechargeable batteries with solder tags.

NIMH

AA 2000mah	£2.82
C4Ah	£4.70
D9Ah	£7.60
PP3 150mah	£4.95

NICAD

AA 650mah	£1.41
C 2.5A	£3.60
D 4Ah	£4.95

Instrument case with edge connector and screw terminals

Size 112mm x 52mm x 105mm tall.

This box consists of a cream base with a PCB slot, a cover plate to protect your circuit, a black lid with a 12 way edge connector and 12 screw terminals built in (8mm pitch) and 2 screws to hold the lid on. The cream bases have minor marks from dust and handling.

Price £2.00 + VAT (= £2.35) for a sample or £44.00 + VAT (= £51.70) for a box.



866 battery pack originally intended to be used with an orbitel mobile telephone it contains 10 1.6Ah sub C batteries (42x22dia the size usually used in cordless screwdrivers etc.) the pack is new and unused and can be broken open quite easily £6.46 + VAT = £8.77



Please add £1.66 + VAT = £1.95 postage and packing per order.

JPG ELECTRONICS

Shaws Row, Old Road, Chesterfield S40 2RB

Tel: 01246 211202 Fax: 01246 550959

www.jpgelectronics.com

Mastercard/Visa/Switch

Callers welcome 9.30am to 5.30pm Monday to Saturday

Contents

July 2005

Volume 111

Number 1831



Top: Book Review – p45

Middle: Planon's Docupen scanner – p41

Bottom: Part P compliant testers – p54

Front cover image supplied by National Semiconductor

Editor's Comment	3
Can we be 'ethical'?	
Technology	5
Insight	11
Nigel Gilhespy on smart and interactive fabrics	
Focus	12
Nick Flaherty reflects on the 40 years of Moore's Law	
Auto-light controller	14
David Ponting designs a DIY burglar deterrent	
Analogue to digital converters	23
Thomas Hargé: "Choosing ADCs does not have to be a daunting task"	
Signal conditioning for optimum noise performance	28
by Reza Moghimi	
VFA, CFA, bipolar or CMOS	32
Which high-speed amplifier is best for your low-noise application?	
Tried and Tested	38
Nick Merritt puts Kew Technik's Socket & See DIT400 through its paces	
Gadgets	41
Games	43
Wireless	45
Harmony – who needs it? By Mike Brookes	
Letters	46
Top Ten Tips	47
Circuit Ideas	48
• Simple Class D amplifier • Permanent-magnet and DC motor controller without feedback • UHF combiner/splitter with 4 inputs and 4 outputs • The 'tamed' gyrator • Tunable CFA-based, current-mode, all-pass filter • High-efficiency LED torch •	
Products	54



Quasar Electronics Limited
 PO Box 6935, Bishops Stortford
 CM23 4WP, United Kingdom
 Tel: 0870 246 1826
 Fax: 0870 460 1045
 E-mail: sales@quasarelectronics.com
 Web: www.QuasarElectronics.com

Postage & Packing Options (Up to 2Kg gross weight): UK Standard 3-7 Day Delivery - £3.95; UK Mainland Next Day Delivery - £8.95; Europe (EU) - £6.95; Rest of World - £9.95.

!Order online for reduced price UK Postage!

We accept all major credit/debit cards. Make cheques/PO's payable to Quasar Electronics. Prices include 17.5% VAT.

Call now for our FREE CATALOGUE with details of over 300 kits, projects, modules and publications. Discounts for bulk quantities.



QUASAR
 electronics

Get Plugged In!

0871

CREDIT CARD SALES

717 7168

Motor Drivers/Controllers

Here are just a few of our controller and driver modules for AC, DC, unipolar/bipolar stepper motors and servo motors. See website for full details.

NEW! Bidirectional DC Motor Controller

Controls the speed of most common DC motors (rated up to 32VDC/5A) in both the forward and reverse direction. The range of control is from fully OFF to fully ON in both directions. The direction and speed are controlled using a single potentiometer. Screw terminal block for connections.
 Kit Order Code: 3166KT - £14.95
 Assembled Order Code: AS3166 - £24.95

DC Motor Speed Controller (5A/100V)

Control the speed of almost any common DC motor rated up to 100V/5A. Pulse width modulation output for maximum motor torque at all speeds. Supply: 5-15VDC. Box supplied. Dimensions (mm): 60Wx100Lx60H.
 Kit Order Code: 3067KT - £11.95
 Assembled Order Code: AS3067 - £19.95

NEW! PC / Standalone Unipolar Stepper Motor Driver

Drives any 5, 6 or 8-lead unipolar stepper motor rated up to 6 Amps max. Provides speed and direction control. Operates in stand-alone or PC-controlled mode. Up to six 3179 driver boards can be connected to a single parallel port. Supply: 9V DC. PCB: 80x50mm.
 Kit Order Code: 3179KT - £9.95
 Assembled Order Code: AS3179 - £16.95
 Assembled Order Code: AS3113 - £24.95

NEW! Bi-Polar Stepper Motor Driver

Drive any bi-polar stepper motor using externally supplied 5V levels for stepping and direction control. These usually come from software running on a computer. Supply: 8-30V DC. PCB: 75x85mm.
 Kit Order Code: 3158KT - £12.95
 Assembled Order Code: AS3158 - £26.95

Most items are available in kit form (KT suffix) or assembled and ready for use (AS prefix).

Controllers & Loggers

Here are just a few of the controller and data acquisition and control units we have. See website for full details. Suitable PSU for all units: Order Code PSU445 £8.95

Rolling Code 4-Channel UHF Remote

State-of-the-Art. High security. 4 channels. Momentary or latching relay output. Range up to 40m. Up to 15 Tx's can be learnt by one Rx (kit includes one Tx but more available separately). 4 indicator LED's. Rx: PCB 77x85mm, 12VDC/6mA (standby). Two and Ten channel versions also available.
 Kit Order Code: 3180KT - £41.95
 Assembled Order Code: AS3180 - £49.95

Computer Temperature Data Logger

4-channel temperature logger for serial port. °C or °F. Continuously logs up to 4 separate sensors located 200m+ from board. Wide range of free software applications for storing/using data. PCB just 38x38mm. Powered by PC. Includes one DS1820 sensor and four header cables.
 Kit Order Code: 3145KT - £19.95
 Assembled Order Code: AS3145 - £26.95
 Additional DS1820 Sensors - £3.95 each

NEW! DTMF Telephone Relay Switcher

Call your phone number using a DTMF phone from anywhere in the world and remotely turn on/off any of the 4 relays as desired. User settable Security Password, Anti-Tamper, Rings to Answer, Auto Hang-up and Lockout. Includes plastic case. Not BT approved. 130x110x30mm. Power: 12VDC.
 Kit Order Code: 3140KT - £39.95
 Assembled Order Code: AS3140 - £49.95

Serial Isolated I/O Module

Computer controlled 8-channel relay board. 5A mains rated relay outputs. 4 isolated digital inputs. Useful in a variety of control and sensing applications. Controlled via serial port for programming (using our new Windows interface, terminal emulator or batch files). Includes plastic case 130x100x30mm. Power Supply: 12VDC/500mA.
 Kit Order Code: 3108KT - £54.95
 Assembled Order Code: AS3108 - £64.95

Infrared RC Relay Board

Individually control 12 on-board relays with included infrared remote control unit. Toggle or momentary. 15m+ range. 112x122mm. Supply: 12VDC/0.5A
 Kit Order Code: 3142KT - £41.95
 Assembled Order Code: AS3142 - £51.95



PIC & ATMEL Programmers

We have a wide range of low cost PIC and ATMEL Programmers. Complete range and documentation available from our web site.

Programmer Accessories:

40-pin Wide ZIF socket (ZIF40W) £15.00
 18V DC Power supply (PSU010) £19.95
 Leads: Parallel (LDC136) £4.95 / Serial (LDC441) £4.95 / USB (LDC644) £2.95

NEW! USB 'All-Flash' PIC Programmer

USB PIC programmer for all 'Flash' devices. No external power supply making it truly portable. Supplied with box and Windows Software. ZIF Socket and USB Plug A-B lead not incl.
 Kit Order Code: 3128KT - £34.95
 Assembled Order Code: AS3128 - £44.95

Enhanced "PICALL" ISP PIC Programmer

Will program virtually ALL 8 to 40 pin PICs plus a range of ATMEL AVR, SCENIX and EEPROM 24C devices. Also supports In-System Programming (ISP) for PIC and ATMEL AVRs. Free software. Blank chip auto detect for super fast bulk programming. Available in assembled format with ZIF socket only.
 Assembled Order Code: AS3144ZIF - £64.95

ATMEL 89xxx Programmer

Uses serial port and any standard terminal comms program. 4 LED's display the status. ZIF sockets not included. Supply: 16-18VDC.
 Kit Order Code: 3123KT - £29.95
 Assembled Order Code: AS3123 - £34.95

NEW! USB & Serial Port PIC Programmer

USB/Serial connection. Header cable for ICSP. Free Windows software. See website for PICs supported. ZIF Socket/USB Plug A-B lead extra. Supply: 18VDC.
 Kit Order Code: 3149CKT - £34.95
 Assembled Order Code: AS3149C - £49.95



www.quasarelectronics.com

Secure Online Ordering Facilities • Full Product Listing, Descriptions & Photos • Kit Documentation & Software Downloads

Can we be 'ethical'?

The Queen's Awards for Enterprise just keep growing. This year, some 15,000 applications have been made, of which 133 emerged as award winners. Awards are being made in several categories, including innovation, international trade, achievement in enterprise promotion and sustainable development.

During this year's hour-long presentation, one case study was presented by an executive from a company that won a Queen's Award in 2001. He explained that water reservoirs (whether drinking water, for industrial use or the power grid) suffer from fish straying into them. The conventional method is to 'scrape' the water for rubbish using nets, which includes any fish caught in them, and send that to landfills. Some one million fish per year get killed in this way.

The executive also explained that fish have a hearing, which ranges from 200Hz (for salmon, for example) to 3kHz (for catfish). Knowing this, his company created an underwater loudspeaker that doubles up as a vibration machine and very successfully chases fish away from water reservoirs.

Just as you utter "great idea", the executive spoils it by adding: "This is not done for altruistic reasons, but to prevent competitors from getting ahead and to protect our markets."

You've guessed it, his company's award was not for sustainable development (particularly, natural resource protection and environmental enhancement).

Why should we assume that industrial innovation and sustainable development cannot be 'merged'? Electronics, physics and most of the other sciences are such creative disciplines that anything could be achieved with them. So why not put that knowledge to not harm the environment? Why do we have to use electronics to advance in our markets and beat competition but in a non-ethical manner? Electronics and new advances in life sciences, such as biology and

nanobiotechnology should help protect what is precious – life and the environment – and not just act short-sightedly for the sole purposes of industrial advancement.

Some governments, like in the US for example, are introducing Acts that protect animals and the environment. Ideally, we should not wait on governments to drive initiatives as our own industry is full of bright minds that could fulfill the competitive needs of the market whilst protecting the environment.

The good news is that there are those who listen and try to make things better, however small those improvements might be. Some of them are large multinational corporations that have done us proud. One example is STMicroelectronics (ST), a big semiconductor maker with operations all over the world. A massive consumer of water for its front-end fabrication facilities, ST uses various techniques to preserve water – and even recycle it. It has also introduced lighting managing systems throughout its operations that will detect that a room is abandoned and switch off lights and other electrically driven systems.

Coming back to this year's Queen's Awards, there was a case study by Econnect Limited, a firm facilitating the grid integration of renewable energy. Chris Porter who made the presentation said that in addition to the firm's task, it also found a way of prevent eagles from landing on the power lines and getting killed.

If I am not mistaken, this is an altruistic streak and, yet, the company is still offering a market leading solution.

These cases make me rest a little easier and make me feel proud that I am part of an industry with consciousness.

Svetlana Josifovska
Editor

EDITOR: Svetlana Josifovska **E-mail:** s.josifovska@highburybiz.com **EDITORIAL E-mail:** EWeditor@highburybiz.com

EDITORIAL ADMINISTRATION: +44 (0) 1322 611274 **E-mail:** EWadmin@highburybiz.com

PRODUCTION EDITOR/DESIGNER: Jane Massey **E-mail:** J.Massey@highburybiz.com

SUBSCRIPTIONS: Customer Interface Ltd, Cary Court, Somerton, TA11 7BR **Telephone:** 0870 4287950, **Fax:** 01458 271146

SUBSCRIPTION RATES: 1 year: £38.95 (UK); €95 (Europe); \$125 US & worldwide

GROUP SALES: +44 (0) 1322 611254 • **PRODUCTION EXECUTIVE:** Dean Turner +44 (0) 1322 611206 **E-mail:** d.turner@highburybiz.com

PRINTER: William Gibbons Ltd • **ORIGINATION:** Impress Repro A1 Parkway, Southgate Way, Orton Southgate, Peterborough, PE2 6YN

NEWSTRADE: Distributed by Seymour Distribution Ltd, 86 Newman St, London W1T 3EX. • **PUBLISHING DIRECTOR:** Tony Greville

If you are experiencing problems getting copies through your newsagent, please call Debbie Jenner on +44 (0) 1322 611210

Electronics World is published monthly by Nexus Media Communications, Media House, Azalea Drive, Swanley, Kent, BR8 8HU Nexus Media Communications is a trading name of Highbury Business Communications Limited, a subsidiary of Nexus Holdings Limited. Registered in England. Registered Number 5346404. Registered Office: Hanover House, 14 Hanover Square, London W1S 1HP

ISSN 0959-8332

ABC

Disclaimer: We work hard to ensure that the information presented in **Electronics World** is accurate. However, **Electronics World's** publisher – **Nexus Media Communications** – will not take responsibility for any injury or loss of earnings that may result from applying information presented in the magazine. It is your responsibility to familiarise yourself with the laws relating to dealing with your customers and suppliers, and with safety practices relating to working with electrical/electronic circuitry – particularly as regards electric shock, fire hazards and explosions.

TELEVISION TEST PATTERN GENERATORS

The new **GV 998** is a digital pattern generator offering more advanced features at again a realistic price. Those features include :

- ◆ MPEG-2 format Transport Stream generation
- ◆ Video and audio included in the TS
- ◆ Video and audio inputs
- ◆ Generation of a variable frequency sound carrier for decoding verification
- ◆ Multistandard and multisystem analogue TV signal generation
- ◆ Possibility to edit different fields of the TS database to present the name of the service provider
- ◆ Remote control via a personal computer
- ◆ Moving video patterns to check MPEG-2 decoders



IDEAL FOR PLASMA DISPLAYS

IDEAL FOR WIDE SCREEN

PROMAX GV SERIES

- ◆ Choice of 12 instruments
- ◆ NICAM and Teletext
- ◆ 4:3 and 16:9 Formats
- ◆ Full field and VITS
- ◆ Computer Controlled
- ◆ Front panel memories
- ◆ Own Company Logo
- ◆ Computer Monitor testers
- ◆ Hand Held Models
- ◆ Multi Standard, PAL, NTSC, SECAM
- ◆ High Quality Construction
- ◆ Attractive Price Levels
- ◆ Full After Sales Service
- ◆ Available from Stock



FOR TELEVISION PATTERN GENERATORS, THERE'S NO WIDER CHOICE THAN WITH PROMAX

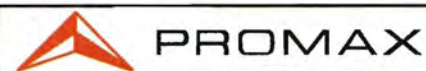

SELECTED ITEMS FROM THE PROMAX RANGE OF TEST EQUIPMENT

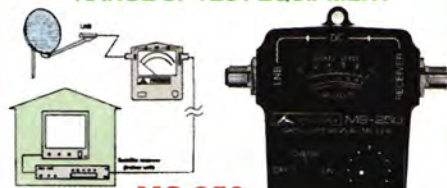

MS 250

Analogue and Digital Satellite Detector.



PRODIG 1+

Satellite Dish Installer's Meter Does more than just BSkyB



PRODIG 2

Analogue & Digital Aerial Meter Measures digital channel power and C/N



MC 577

Analogue & Digital, Satellite & Terrestrial Measures channel power and C/N



PROLINK 3 + 4 PREMIUM

Satellite & Terrestrial, Analogue & Digital, Spectrum Analyser with BER (optional on P3)



AA 930 AUDIO ANALYSER

TA 903B CRT REJUVENATOR



Alban

ALBAN ELECTRONICS LIMITED

THE PROMAX SERVICE CENTRE

6 Caxton Centre, Porters Wood, St. Albans, Hertfordshire, AL3 6XT.

TEL: 01727 832266 FAX: 01727 810546

WEB: www.albanelectronics.co.uk

EMAIL: info@albanelectronics.co.uk

SALES + SERVICE + CALIBRATION

Sensor identifies algae

A team of electronics and computer researchers at the University of Southampton has developed a sensor which, when dropped into water, can identify the types and quantities of algae present, providing valuable information for climate studies.

Algae flow through the device one at a time and at high speed. When the device shines light at the algae, they respond by emitting light at different wavelengths, allowing them to be characterised. The device also records data about the electrical properties of the algae. "There is very little known about the electrical properties of algae and it is those that tell us about the size of particles and the types of membranes," said Professor Hywel Morgan, leader of the research team.

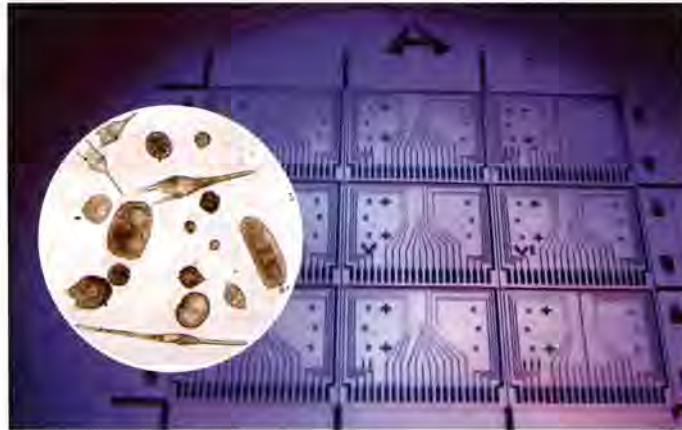

A wafer of impedance measurement chip
Inset: Mixed dinoflagellates algae [credit University of Southampton]

The sensor is a microfluidic chip made from glass with metalised regions, which are the impedance measuring electrodes. "We use S1818 to pattern metal (evaporated or sputtered) on a 4-inch wafer. The resist is used as a mask to either wet-etch or ion beam

mill the metal layers. Then we post-process this using either SU8 or Polyimide to make microfluidic channels," said Prof Morgan.

The chip is in an early stage of development, and certain processes and materials could be replaced to make it low

cost, which will widen its use. "Our aim is to make robust sensors that we can commercialise, so that eventually they will be licenced," added Prof Morgan.

Algae are now known to influence the climate in various ways. They use carbon dioxide and some lock up this gas in their calcified skeletons. Others produce compounds such as dimethyl sulphoniopropionate (DMSP) that can become climatically active. "We need to be able to differentiate the different algal types and enumerate them using equipment that is precise but cheap enough so that very many can be used. That is the real strength of this development," said Professor Peter Burkill from the Southampton Oceanography Centre.

Motor drives evolve with an Ethernet connection

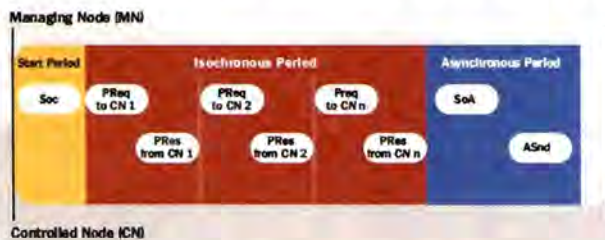

SoC - start of cyclic; SoA - start of asynchronous;
PReq poll request; PRes - poll response

Motor drives are set to take on much more of the networking control function in process control, as a real time version of Ethernet now sits directly on the drive. A new range of drives from Baldor uses the Ethernet PowerLink open standard as a real-time industrial Ethernet communication profile in IEC SC65C.

This standard is controlled by

the Ethernet PowerLink Standardisation Group (EPSG) and accepted by the International Electrotechnical Commission (IEC) as a publicly available specification (PAS). It uses the TCP/IP protocol with a multiplexed time slot scheduling system to provide the required timing down to accuracy of 1ms. This allows it to replace direct connections

and Fieldbus technologies, such as Profibus, and still have the cost advantages of Ethernet.

PowerLink also has an asynchronous capability, which allows other network traffic to be used, such as video for example, although the PowerLink network links back to a router that connects the subnet addresses to a standard Ethernet network. This protects the real-time network from intrusion, rather than having a wide-open Ethernet network.

This is the first commercial, mainstream drive maker to include PowerLink on its products and marks the start of a roll-out of PowerLink products from a range of vendors, says David Greensmith, prod-

uct manager for control products at Baldor UK in Bristol.

The new Baldor drive includes a communications sub-system that uses a Hynet processor with included MAC and PHY, as well as interfaces for CAN and USB buses. Each drive can also become a controller for a series of CANopen devices, controlled and accessed from the Ethernet network.

In addition, the drive includes an FPGA from Xilinx and a Texas Instruments DSP for motion control. The FPGA includes part of the PowerLink networking stack and is used to provide both the universal encoder interface, but also to implement different feedback schemes without having to change the design of the drive electronics.

Kodak has teamed up with printed displays firm Pelikon to study the behavioural characteristics of blue and green light emitting inorganic phosphors. Work will focus on stabilising and equalising the performance characteristics of blue and green light emitting inorganic phosphors, while at the same time extending their performance life. "Although inorganic phosphors are in wide commercial use, the emission mechanism and their performance characteristics are poorly understood," said Chris Fryer, Pelikon's CTO. The reliability of light emitting inorganic phosphors is notoriously difficult to predict. Not only do blue and green perform differently, but they age at different rates and manifest varying light intensities.

Ω

Innos and the University of Newcastle have delivered a 220% performance gain in strained Si-SiGe n-channel Mosfets. Introducing strained Si-SiGe in Mosfet devices can improve and extend the manufacturing lifetime of a CMOS technology node, due to higher electron and hole mobility. "While performance gains over Si controls are impressive, theoretical predictions for strained Si-SiGe Mosfets had not been achieved until now," said Dr Alec Reader from Innos. The team made significant performance gains in terms of on-state drain current and the maximum transconductance achieved, compared with Si controls. Device performance is found to peak using a virtual substrate composition of Si_{0.75}Ge_{0.25}.

Ω

University of Warwick's spin out AdvanceSis, its Department of Physics and the development agency Advantage West Midlands have invested £2m in acquiring a Low Pressure Chemical Vapour Deposition (CVD) reactor and a clean room suite for wafer processing. The new facilities will be used for growing high quality strain-tuning platforms, so-called 'Virtual Substrates' of silicon germanium and silicon germanium carbon. This group of advanced materials is believed to be one of the key 'booster' technologies needed to sustain the necessary performance of semiconductors. Virtual Substrates are seen to substantially reduce defects, such as threading dislocations, which can drastically affect yields in CMOS ICs.

Silicon tuner reduces power consumption in TV phones

Microtune has developed a silicon tuner for the DVB-H mobile TV standard that it says can overcome key problems with interference and power consumption.

The company developed its first silicon tuner in 1999 to replace the traditional 'tuner can' in digital cable TV systems and has used its integrated filter expertise for the new mobile TV tuner.

DVB-H (Handheld) is a variant of the DVB-T digital terrestrial TV standard that also uses COFDM scheme but adds a packet and time slot structure so that particular slots can be decoded without having to decode the whole multiplex. This, in turn, helps reduce power consumption by shutting down between the

time slots. The problem has been that traditional tuners need time to settle and this has meant that the power saving has not been as significant as the developers of the standard had hoped.

The new silicon tuner, developed at the Temic Telefunken division, acquired by Microtune last year and built in IBM's silicon germanium process, has a settling time of 25ms, which is enough to reduce the power consumption to as low as 20mW. This is sufficient to get five hours of TV viewing, as well as four days of standby and three hours of talktime out of a standard 717mAh battery on a mobile phone, says Jim Fontaine, Microtune's CEO.

The other area that is a key innovation is in the filtering, he

added. Microtune has developed an active filter in the tuner that can filter out the effect of the mobile phone's power amplifier in multiple bands and handle the different signal levels in the phone. This patented ClearTune filter will allow the phone to be used at the same time as watching TV or downloading data from the TV broadcast system.

The filter also works across all the bands proposed for DVB-H, from UHF in Europe to L-band in the US, where transmission mast operator Crown Castle is testing the technology with Nokia. Here in Europe, there are DVB-H trials in Oxford with Nokia and phone operator O2, as well as tests in Scandinavia and France.

Supercomputers land on European desks

Orion Multisystems has just confirmed that its 12- and 96-node desktop and desk-side cluster workstations – or personal supercomputers with a performance of up to 500GFlops – have arrived in Europe.

"This type of supercomputer was abandoned in the 80s and 90s by Sun Microsystems and Silicon Graphics, but we are bringing it back because there's a need for it. We are offering a cluster in a box for that huge gap in the middle between PCs with performances of 2GFlops and supercomputers of above 1TFlops," said Colin Hunter, Orion Multisystems's president and CEO.

"The reason this type of

computer died out in the 90s was that the performance advantage didn't exist then. Our system now is based on eight Orion Processor Array boards, each with 12 individual nodes, and each being a fully functional computer with its own x86 processor, chipset, memory, optional disk drive and networking capability," he added.

For its range of supercomputers, Orion has departed from the tried and tested Unix OS and selected Linux instead. To tackle massive data throughputs, it also has a dual 10GigE fibre card and a 12-port GigE switch. Even though prices start from \$54,000 for a single unit, Hunter believes this will not deter companies from

acquiring several of these supercomputers for all those departments that hate sharing resources. Orion already has some 50 accounts in the US and with its sales presence it has just launched in Europe and Japan, this number is expected to grow.

According to market analyst firm IDC, the global market for such supercomputers is worth some \$2.5bn today. Areas in which they are required range from formal verification, Verilog simulation, 3D rendering and finite element analysis in engineering disciplines to tomography and molecular dynamics in medicine and biology.

"In five to ten years' time you won't see non-clustered computers," said Hunter.

One in five of UK electronics manufacturers' company directors will be aged over 60 by the end of 2005, found research by Plimsoll Publishing. However, there is no evidence to suggest that age is a barrier to success in this industry. Of the 186 directors working beyond retirement, 43% are running companies rated as financially strong. For those considering a career here, the statistics show that the average salary is £73,626. Top earners can expect £140,000, which compares to a UK average of £162,000. The average time in office is just over five years, which compares to the UK average of eight years.

Ω

The British Antarctic Survey (BAS) is launching a recruitment drive to attract women from the engineering, construction and technology sectors to join its workforce on the frozen continent. As part of its annual recruitment campaign, BAS is actively encouraging women to join its teams working in Antarctica. "This is a tremendous chance for women with a sense of adventure to try something completely different. While the salaries are not as high as you can earn in the UK, there is an Antarctic allowance," said Jill Thomson from BAS. There are five research stations on and around the continent. The temperatures range from +5°C to -40°C.

Ω

Computer graphic boards firm Datapath, electronic components supplier Arcotronics, designer of gaming electronic control systems Heber, market research firm IMS Research, HF PCB maker Trackwise, bespoke marine electronic solutions supplier Yes Group and a developer of a personal radio for use by frontline troops Selenia Communications are this year's electronics sector winners of The Queen's Awards for Enterprise. In total, 88 awards were announced for achievements in international trade, 41 for innovation and eight for sustainable development. Winners ranged in size from SMEs to international firms employing 4,500. Over 45% of this year's winners employ less than 50 people.

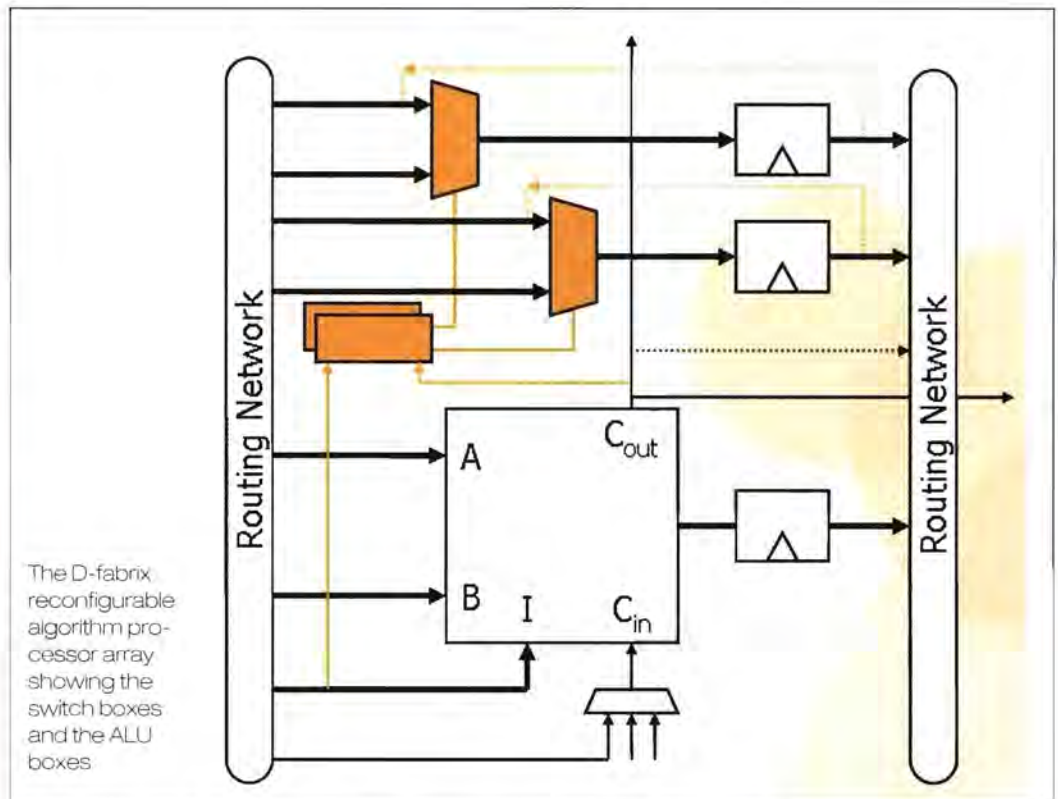

The D-fabrix reconfigurable algorithm processor array showing the switch boxes and the ALU boxes.

Elixent brings out a smaller processors-array for SoCs

UK configurable array processor firm Elixent has developed a new architecture that reduces the size of the array by 40% for the same performance.

The D-fabrix array of over a thousand 4-bit ALUs and associated interconnect switch blocks is aimed at algorithm processing in consumer and mobile applications as part of an SoC, with the chip being developed by Toshiba and Panasonic, among others.

Version 2 of the architecture tackles a key problem that arose from the real-world use of the first generation. There, over half the ALUs in the array were being used to handle multiplexing of data, rather than data processing, which was extremely inefficient. In version 1.2, Elixent added two multiplexers in the ALU to compensate, but still

a quarter of the ALUs were being used as muxes.

Now, with Version 2, the multiplexers have been separated out into the switch box and a level of local routing added. This has reduced the length of the wires, lowering the capacitance of the interconnect and so, reducing the power consumption or allowing a higher clock rate. The routing tools that take the RTL of the algorithm and map it to the array cannot use the ALUs as multiplexers, leaving the ALUs free for calculations.

At the same time, dedicated logic has been added to handle bit manipulation, taking approximately 20% of the load off the ALUs.

In benchmarks on existing designs, the changes benefited algorithms such as a Viterbi filter in a wireless LAN best, with a fourfold increase in

performance density, which means the same function can be handled in a quarter of the number of ALUs. A CABAC filter in H.264 video processing sees a threefold increase in the performance density, while a HARQ filter used in HSDPA 3 phones saw the least benefit with an increase of 1.3 times.

The point of the array is to have a single SoC that can handle a wide range of applications, so a typical array is 24x24 ALUs. The increased performance density means a smaller array could be used for the same performance, using a higher clock rate, or more functions could be handled in the same size array.

The Version 2 architecture is shipping to an SoC customer at the end of May, says Alan Marshall, chief technology officer and co-founder of Elixent.

IR makes redundant power systems more efficient with its new device

International Rectifier (IR) has launched a universal high-speed controller/N-channel power Mosfet driver for active ORing, a key requirement for many high-end systems requiring maximum up-time, such as in telecom and datacom system servers.

The IR500 is also suitable for reverse polarity protection and input as well as output ORing for redundant DC-DC and AC-DC power supplies. Its typical turn-off delay time is 130ns and a peak turn-off gate drive current 3A. Asymmetrical offset voltage of the internal high-speed comparator prevents potential oscillations when the current is very low.

ORing refers to combining outputs of two or more power sources together to create a redundant power source. In active ORing, ORing diodes (typically Schottky) are replaced with a Mosfet, which

works as a synchronous rectifier. In addition, there's a controller too. Although two diodes is a simple and easy to use configuration, the disadvantages are an unnecessary power dissipation, which requires a heat sink. This, in turn, increases cost and manufacturing complexity.

With Mosfet-based ORing, the power loss is only 0.37W (compared to 2.4W in the ORing diode circuit), the size of the configuration is 50% smaller and there are the clear advantages of protection features.

At present, the Mosfet is a separate component from the ORing IC, but IR plans to integrate all these functions onto a single chip sometime in the future.

Figure 1 (inset): Standard diode ORing circuit

Figure 2: IR's active ORing circuit

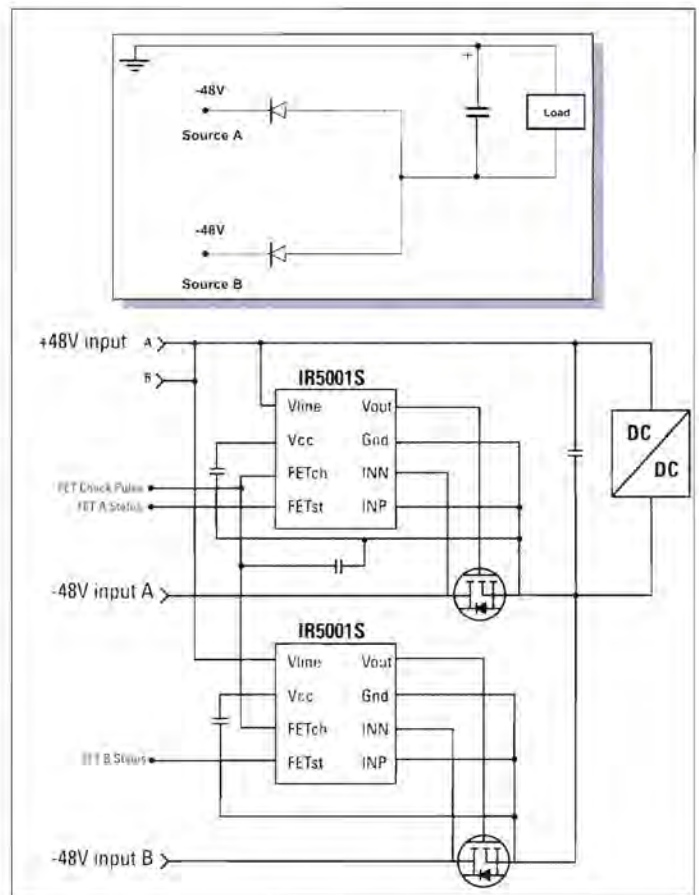

Fast and furious, from Tektronix

As Tektronix reaches the No 1 slot in the worldwide rankings of logic analyser suppliers (according to market analysts PrimeData), it launches two new products in the TLA7000 series and complementary, backward- and forward-compatible software.

"There are fewer and fewer engineers in a team and they are asked to do more work, so productivity needs to increase. We are announcing two mainframes and a new

version of software that will achieve better productivity. Our software will make it easy on them by removing any learning curves when moving from one logic analyser to another from the Tektronix range," said Dave Ireland, marketing manager in Tektronix's design and manufacturing division.

The new products are the portable mainframe - TLA 7012, the benchtop mainframe - TLA7016, and the v5.0 software, which Tektronix

customers can download from the web for free.

The company claims that by using the 2GHz Pentium M CPU in the portable mainframe, it has secured "the fastest analysis time in industry" and "the largest handling of throughput data" - a three times increase on Tektronix's previous generation, the TLA5000. Tektronix has incorporated GigE LAN interface for quick transfer of large data files, which can also be shared with remote

offices. Demonstrations show that the ease-of-use has been simplified to a single-click drag-and-drop for time-strapped engineers who want to gain quick measurements. The display has been enlarged from 12.4 inches in the TLA5000 to 15 inches in the TLA7000.

The TLA7012 can contain two modules, allowing up to 272 channels of logic analysis capability. The TLA7016 offers thousands of such channels.

Prices start from £8400.

NEW version B² Spice v5

PROFESSIONAL SOFTWARE AT AN UNBELIEVABLE PRICE

New powerful functions

- Virtual instruments – meters, scopes, transient recorder, function generator, power supplies and more
- Test mode, equivalent to the standard SPICE analyses and a separate continuous transient simulation mode that allows you to alter device and circuit parameters and examine the results immediately
- Layered sweeps, meaning you can step almost any device or circuit parameter on top of any test
- Monte Carlo analysis available for all tests including expanded Monte Carlo
- Easy part selection, including a customisable parts palette
- User-friendly interface with buttons and control tabs
- Live updating in simulation mode
- Circuit wizard makes it easy to generate standard circuits including attenuators, power supplies, filters, op-amp and tube-based circuits
- Over 25 thousand parts, unlimited circuit size
- Highly flexible 3D graphing
- NEW “realistic” models for caps, resistors, inductors
- Interactive parts including switches, fuses, LEDs, etc.
- Layered sweep tests (expanded)

B² SPICE is backed by comprehensive free technical support both local rate telephone and online, full user manuals and tutorials and a NO QUIBBLE, FREE 30 DAY EVALUATION OFFER

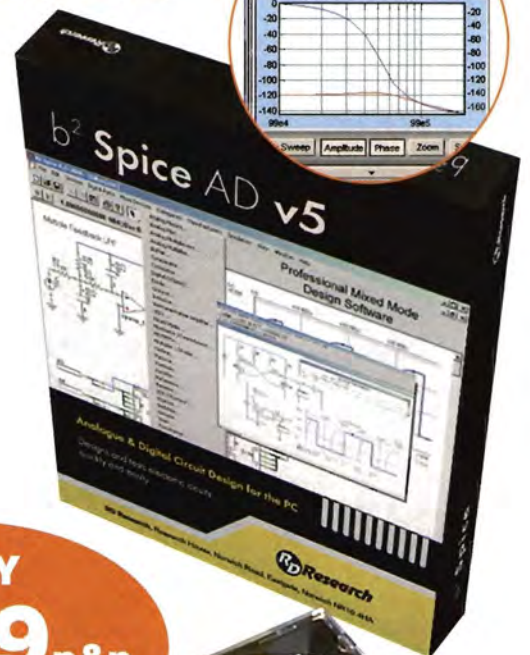

ONLY
£229 p&p
Ex VAT



CALL **0845 6017242**

www.spice-software.com

FREE 30 DAY TRIAL

FULL - OPERATIONAL SINGLE USER VERSION

Used worldwide by higher education, research and industrial professionals B² SPICE is a powerful and most importantly, ACCURATE software package for professional design engineers.



Very Interesting!

**The entire range of the 2005 Skytronic catalogue
available from Cricklewood Electronics**

This, Dutch Wholesaler's Catalogue, is now available to UK retail customers via Cricklewood Electronics and includes thousands of electronic items and components at bargain prices. The 432 Catalogue pages includes:
Plugs, Sockets, Cables, Switches, Speakers, Microphones, Components, Car Audio, Disco & PA & HiFi Equipment, CCTV Cameras & Recorders, Tools, Test Equipment, Inverters, Power Supplies, Electrical, Multimedia, Computer accessories, etc etc



Catalogue & Price List free to shop-callers. To have it posted - please send £2.00 towards postage costs. (UK only).

Cricklewood Electronics Ltd

40-42 Cricklewood Broadway, London NW2 3ET. Tel: 020 8452 452 0161, Fax 020 8208 1441
email: sales@cricklewoodelectronics.co.uk
Visit our website @ www.cricklewoodelectronics.com



Living in a material world

Nigel Gilhespy gives examples of application opportunities presenting themselves to designers and electronics engineers in the world of smart and interactive fabrics

Many manufacturers, designers and engineers believe that smart fabrics will redefine the way mobile electronics and wearable devices are designed and developed for the 21st century.

For too long the vision of wearable computing has been of plastic boxes, delicate flexi-circuits, PCBs and buttons sewn onto clothing. With no buttons, no wires and no mechanical parts to break down and wear out, the development of fabric interfaces is a simple reality.

By revolutionising product design processes and transforming the way users interact with electronic or electrically powered devices, smart fabrics create endless possibilities for designers and engineers – only really limited by their imagination.

Smart fabric contains fabric touch screen sensors that are only 0.6mm thick. The fabric is still washable, wearable and as flexible as any other fabric used in clothing manufacture, but also more durable, rugged and robust than flexi-circuits.

The fabric touch 'screen' measures changes in voltage across the fabric when it is touched. This change in voltage allows the sensor to pinpoint where it is being pressed and the force of that pressure. It does this by evaluating X, Y and Z axes measurements across and through the fabric sensor, using simple elec-

tronics and software. The sensor's output can be configured to recognise simple contact, movement and linear, scrolling and circular gestures for complete haptic interface development. It can even be configured to recognise something as complex as a tickle. It can be produced in sizes ranging from a square centimetre to a square meter.

The wearable technology market is certainly an exciting and expanding new product area. Fabric sensors can easily be incorporated into clothing to provide control for portable devices and technologies, such as MP3 players, sports/training devices and mobile communication units.

Being durable, washable and lightweight, fabric sensors can be seamlessly integrated into garments. In this way, it is possible to provide intuitive fabric controls that are truly part of the garment, since there are no hard components or wires, just soft, flexible controls. This means that clumsy push switch controls can be replaced with gesture controls so that you can swipe, scroll or stroke the fabric to control a multitude of devices.

Smart and interactive textiles will also play a major role in bridging the gap between people and the products that they interface with on a daily basis. Nowhere is the need for intuitive and innovative control interfaces greater than in the consumer electronics space. As the devices get smaller, the way in which we control them becomes more difficult. Fabric sensors are discrete, highly customisable and can perform multiple functions, all with one sensor. In such a competitive market sector, it is possible to offer innovative and fashionable control

solutions that make electronic devices more fun and easy to use.

Then there's the defence sector, where high technology already plays an undeniably crucial role. The 21st century soldier needs to be mobile and yet in control at all times. The controls they use for communication or navigation need to be simple, easy to find and easy to wear. When integrated in smart fabric as part of military uniforms, several computer systems and communications devices can be controlled, as well as the wearer's health signs monitored at all times.

Tiny light-weight sensors that can send and receive data, detect proximity and position, measure temperature and pres-

“Fabric sensors can easily be incorporated into clothing to provide control for portable devices and technologies”

sure, and provide other information that could serve medical, military and security sectors, can be incorporated into any item of clothing. With tracking devices and biophysical monitoring integrated into fabrics it will be possible to track emergency response personnel as well as tracking, locating and monitoring troop movements.

What is clear is that smart fabric technology has great potential. Market research firm VDC is expecting the technology to generate more than half a billion US dollars in revenues, by 2008, so smart textiles and fabric sensors are coming of age.

It is certainly an exciting time for this sector.

Nigel Gilhespy is Chief Technology Officer at Eleksen, based in the UK

Happy 40th Birthday Moore's Law!

This year, Moore's Law turns 40. Are there another 40 years in it?

By Nick Flaherty



Left: Gordon Moore back in the 60s

Below: Gordon Moore's original graph

Forty years ago, Gordon Moore sat down

with some data and a pad of graph paper and against two log axes plotted out three lines that have had a dramatic impact on the semiconductor business.

As one of the founders of Intel, he was looking at the period of 1965 to 1975 for a paper published on April 19th 1965 in Electronics Magazine, and never dreamed that 'Moore's law' would still be going forty years later. "These [1965] were the very early days of integrated circuits that typically had 30

components and, I could see in the lab, we had something with 60 components that would be launched in the next years," said Moore.

"So I looked back and saw that we had pretty much doubled the components every year, so I took this and extrapolated for the next ten years, to 60,000. That was a pretty wild extrapolation but it got the idea across. I hoped that making ICs would lead to cheaper components and electronics, but I didn't expect it to be so precise."

Initially, he saw the doubling every year, but that soon slowed to every two years. "At the end of 1975, I went back to look at what happened and why, and saw there were three components: more density, bigger chips and squeezing the waste space out of the chip. As we had squeezed all the spare space out by that stage, from 1975 it was doubling every couple of years rather than every year."

Then the 'law' has been appropriated for different uses. The original was the number of transistors, rather than anything else such as clock speed or performance on a device, will double every two years on average. "A lot of people have applied Moore's Law to anything that grows exponentially in the industry," he said. "The computing power increasing by a factor of two every 18 months probably came from Dave House when he worked at Intel so I think he deserves the credit for that."

One question he is always asked is how far Moore's Law will continue to operate. Even though the semiconductor industry starting- designs on processes with the smallest elements measuring 65nm – and a couple of them are even looking at 45nm designs at the moment – there is still plenty of room for development, he says.

"Something like this can't continue for ever," he acknowledges. "If you extrapolate too far you always end in disaster, and we are

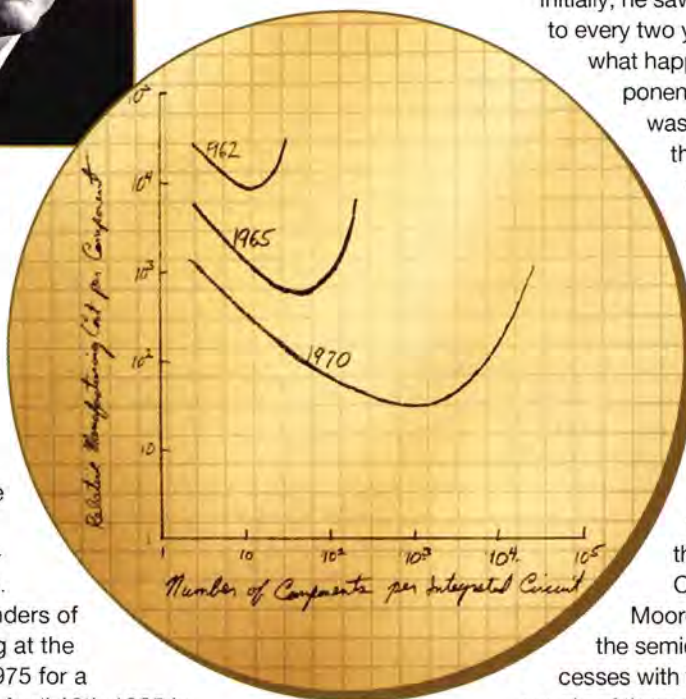

approaching the size of atoms, and that's a pretty clear limitation," he said. "But, I can see the next two to three generations of technology will be likely to proceed so we have ten to twenty years before we reach a fundamental limit."

That two or three generations is not, as might be expected, a mere six years left for the semiconductor industry. Instead, the time between process generations increases and each leap provides higher density, allowing Moore's Law to continue to hold true as the average density doubles every two years. "Even then, that's not the end of the progress, as engineers will have a budget of literally millions of transistors on a chip for their designs," said Moore.

What then becomes critically important is the power consumption of the devices. "Intel has been very concerned with power, particularly in mobile systems, but the desktops also need a lot of power," he said. "Our chief technology officer made an extrapolation that if we keep going the way we are, the energy density on a chip would be greater than the surface of the sun, so we clearly had to do something. That's the reason there's all the emphasis on dual and multiple cores." Intel has just launched its first processor for the desktop PC with dual cores, the 3.2GHz Pentium Processor Extreme Edition 840.

Pushing process technology to keep up with the law is also a

“Nanotechnology has many applications, but I'm sceptical it will replace ICs in the mainstream industry”

Gordon Moore

problem for semiconductor companies. Does this make the law a benefit or a curse? "The public benefits tremendously by the industry moving as fast as it does," said Moore. "For the industry participants it is rather daunting to

change as quickly as we do but, because the new technology makes cheaper electronics, it continues to be an advantage."

Moore is also doubtful that any other discipline, such as nanotechnology, will emerge to replace the semiconductor business. "The IC technology is the result of the cumulative investment in research and development of over \$100bn and something to replace it has to spring almost full blown. Now, nanotechnology has many applications, but I'm sceptical it will replace ICs in the mainstream industry. When you look at it, we are already operating well below 100nm, so standard silicon technology has become nanotechnology in that respect, but the idea of building up something atom by atom comes from a different direction."

"Rather than replace ICs, we are seeing something else happening as the technology of ICs is being used in other fields, such as gene chips and biochips. We have micromachined MEMS devices used in projection TVs and airbags, and increasingly there's microfluidics with chemistry labs-on-a-chip. This is not to say nanotechnology doesn't have phenomenal potential with impact in a lot of areas, but I don't think replacing ICs will be one of them," he added.

What about computer processing power? Is this ever going to approach that of the human brain? "I think computers are going in the wrong direction to do that. They were developed to solve problems in a particular way and all the attempts at artificial intelligence have fallen short. I believe that to really get human intelligence you have to go back and look at how the brain works and take a completely different approach."

But, says Moore, computers can advance some areas. "If you take a particular part of human intelligence and keep pushing computers you could probably do it. One that intrigues me is good language recognition for example, being able to distinguish between 'too' and 'two' by using the context. Once the computer recognises language, you can start to have an intelligent conversation with it and that will dramatically change the way they are used. I don't know whether it will be ten years of fifty years down the road, but it's possible."

As a measure of how much life there is in the industry, would Moore, as chairman emeritus of Intel, advise a young person today to go into computers? "If I were young today, I'd look at all the possibilities before I jumped into computers. Biotechnology is extremely interesting," he answered.

Forty years on, there are many more opportunities for the development of technology. But with Moore's Law still likely to be valid for another ten to twenty years, and seeing us building devices with feature sizes well under 45nm, there is still plenty to explore.

Transistor count

The transistor count doubled every two years in tune with Moore's Law

Microprocessor	Year of introduction	Transistors
4004	1971	2,300
8008	1972	2,500
8080	1974	4,500
8086	1978	29,000
Intel286	1982	134,000
Intel 386 processor	1985	275,000
Intel486 processor	1989	1,200,000
Intel Pentium processor	1993	3,100,000
Intel Pentium II processor	1997	7,500,000
Intel Pentium III processor	1999	9,500,000
Intel Pentium 4 processor	2000	42,000,000
Intel Itanium processor	2001	25,000,000
Intel Itanium 2 processor	2003	220,000,000
Intel Itanium 2 processor (9mb cache)	2004	592,000,000

Auto-light controller

By David Ponting



Table lamp ON, controlled by Unit, indicator LED RED.

Inset: Table lamp OFF, controlled by Unit, indicator LED GREEN.

The holiday season is with us again. It's a time to go away for rest and relaxation. So you do everything you can to secure your property, including leaving a light on. But, unfortunately, nothing is going to stop a determined burglar from breaking in. So here's a better thing to try as a deterrent – an auto-light controller.

This little invention will turn your selected lamp on and off in a manner which will appear to be random, although, in fact, the light will turn on for about 44 minutes, then off for the same period and so on. It will track how overcast or bright the evening is and not start these cycles until it is beginning to get dark and then around about midnight, it will switch off completely, not to switch on again until twilight the following evening. Its use can make apparent occupation look very authentic.

The controller is made from inexpensive components, uses a standard mains socket and matching wall box and is easy to construct. In addition to it being used to switch lamps on and off, it can also control other small mains loads, including fans. It is limited to a maximum supply current of 3A.

The circuit diagram

The circuit diagram is shown in **Figure 1** (see opposite). One of the problems that will need tackling when designing mains control equipment is the simple production of a small DC voltage from 230V AC mains. Consequently, the first section of this circuit is a solution for doing just that.

The direct approach might have been a large wattage resistor to reduce the mains voltage to a usable level. For example, before the advent of solid state switching, such a system was the only way that stage lighting could be controlled. However, the use of resistors in those circuits resulted in a great waste of power in the form of heat.

If only small currents are involved, a better voltage dropping component in AC circuits is the capacitor. For all practical purposes, when a capacitor is used in this way, the current and voltage are out of phase, and power loss in the form of heat is very small.

The voltage dropping component in Figure 1 is C1, a 220nF capacitor. Unfortunately, not any old 220nF capacitor will do. It must meet very tight safety parameters, including being specified for use on 250V AC and have a class X2 construction, which allows it to self-heal should mains spikes punch internal holes through the dielectric.

To calculate the effective impedance, Z , of a capacitor, a couple of formulae need to be considered.

First, the reactance X of a capacitor C used at a frequency f is given by:

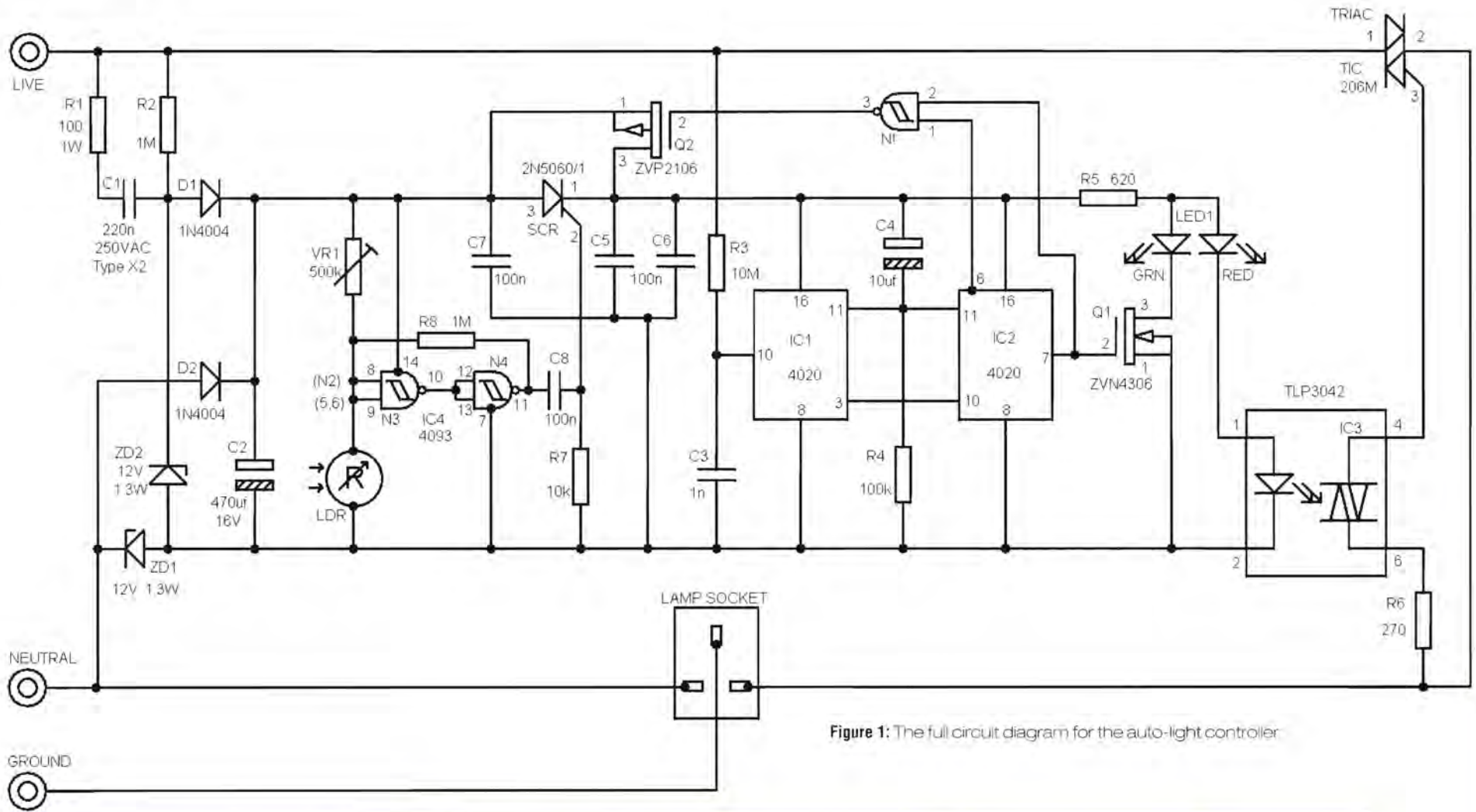

Figure 1: The full circuit diagram for the auto-light controller

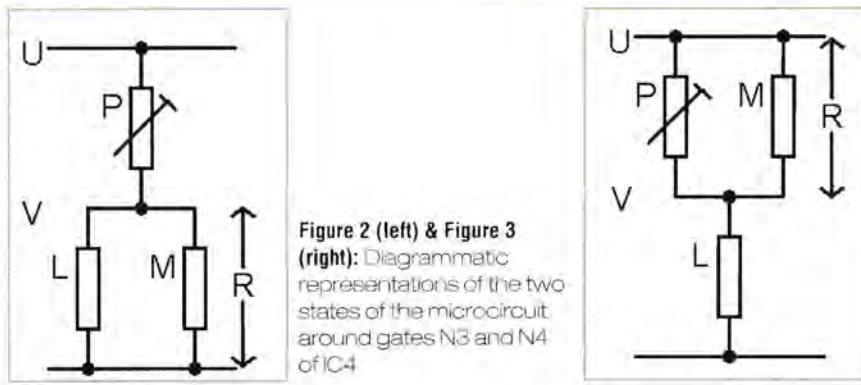

Figure 2 (left) & Figure 3 (right): Diagrammatic representations of the two states of the microcircuit around gates N3 and N4 of IC4

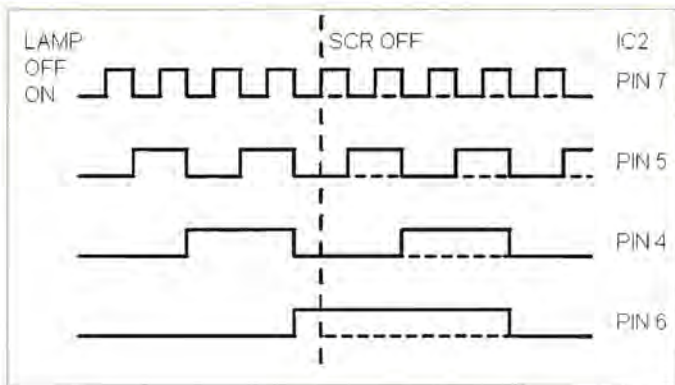

Figure 4 (left): Timing diagram, showing the division by 2, 4 and 8 of the input signals



Standard plug-box, fitted with mains cable and plug, and with three holes cut for the dual colour indicator LED, access of light to the LDR and access to set up the light level at switch-on



Edge view of completed PCB attached to the front face of the plug box

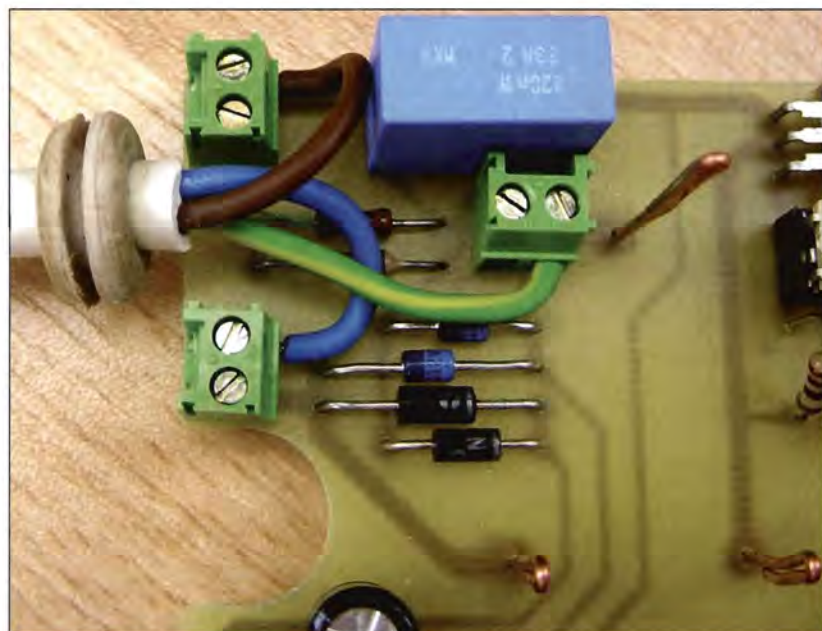

Connections of Live, Neutral and Earth onto the PCB, to provide the best strain relief

$$X = 1/(2\pi fC) \quad (1)$$

In this particular case, where C is 0.22mF, and assuming the mains frequency is 50Hz, **Equation 1** becomes:

$$X = 1/(2\pi \times 50 \times 0.22 \times 10^{-6}) = 14,467\Omega \quad (2)$$

If the total load resistance in the circuit is R, then the effective impedance is given by:

$$Z = \sqrt{R^2 + X^2} \quad (3)$$

But, as we are using this type of circuit to get just a few volts of DC from the mains, most of the voltage drop is across the capacitor. This means that in comparison with X, R is relatively small.

Consequently, to a reasonably good approximation:

$$Z \approx X \quad (4)$$

If the current flowing in the circuit is I and the mains voltage is V, applying Ohm's Law gives us:

$$I = V/Z \approx V/X \quad (5)$$

Substituting 14,467 Ω for X and putting V = 230V rms in **Equation 4** results in:

$$I = 230/14,467 = 15.9\text{mA (rms)} \quad (6)$$

which is enough current to operate this project.

Incidentally, it would always be possible to use a miniature transformer to produce the necessary low voltage but, if space is at a premium (and it is here since I intend to fit everything into a standard mains wall box), then a capacitor voltage-dropper is a better choice. Class X2 mains capacitors up to about 2.2mF are easily available and, for modest current demands, still continue to retain their size (and cost) advantage over a transformer. In fact, as a 2.2mF capacitor is ten times the one given as an example in the calculation above, using this larger component value in a similar application will result in a theoretical current supply of up to 159mA rms.

Current supply using a dropping capacitor is rather frequency sensitive and the value of 220nF for C1 is not suitable if this circuit is to be used on 60Hz, 115V AC mains. For these values and working backwards:

$$I = 0.0159\text{A} = 115/X$$

$$\text{Hence } X = 115/0.0159 = 7233\Omega$$

$$\text{Therefore from 1 above: } 1/(2\pi \times 60 \times C \times 10^{-6}) = 7233$$

Which gives us: C = 367nF

Consequently, the nearest higher standard capacitor value which will provide the necessary current

on 115V, 60Hz mains is 470nF, although you might get away with a 330nF component. Again, this must be of class X2 construction but can be designated at the lower working voltage of 115V AC.

So, C1 is the component that drops the mains voltage to a suitable level, while D1, D2, ZD1 and ZD2 form a bridge rectifier. A bridge used in triac circuits can create a particular problem (which is mentioned later) but, here, this form of bridge employing two standard diodes and two zeners serves a couple of useful purposes: as usual, it full-wave rectifies, but more importantly, it exploits the bi-directional nature of the zeners to stabilise the output DC voltage at 12V. The diodes D1 and D2 need to be 1N4006 types to have sufficient peak inverse voltage (PIV) for mains use but, even if the output is dead-short, we know that the maximum current flow is limited to 15.9mA. Consequently, the zener diodes ZD1 and ZD2 need be no more than a couple of hundred milliwatts so standard 1.3W devices will more than suffice.

R1 is an important component since it limits the current flow when the circuit is switched on. Initially, in-rush current is high so a 1W component should be used.

R2 is probably unnecessary but adds so little to the cost of this project that it remains included in the circuit for back-up safety. After switching off, a voltage-dropping capacitor used in the way described above could remain fully charged for months, if for some reason it was experiencing no load. During this period the 'live' pin of the mains input plug would be at a potential of around 400V. However, in this design, there is a discharge path through VR1 and the Light Dependent Resistor (LDR), while R2 provides an even more direct route should there be an open-circuit failure elsewhere.

C2 is the smoothing capacitor, which completes the production of a stable 12V DC at up to about 16mA.

Detecting twilight

The next part of the design detects twilight and provides supply switching for the remainder of the circuit.

IC4 is a type 4093 CMOS chip with four, two-input NAND gates, all of which switch with Schmitt trigger action. As the light falling on the LDR is reduced, its resistance increases and the voltage rises at pins 8 and 9 of IC4. At just over 8V, the gate switches and its output at pin 10 snaps from high to low. Hence, the output at pin 11 of the connected gate goes high. R8 increases the hysteresis of the switching action (see Box at the end of this article).

When IC4 pin 11 goes high, a pulse through C8 switches on the thyristor (silicon controlled rectifier), type 2N5060 or 2N5061. The advantage of using an SCR is that it behaves like a latching relay: once the

device is conducting, no further gate current is required and it will only switch off when the carrying current is reduced to near zero.

With the SCR switched on, power is applied to the remainder of the circuit. This reduces to little more than timers and a triac but, as mentioned earlier, there is one other problem that needs to be addressed. Switching mains with a solid state device usually requires that the triac has a direct connection with mains' neutral. However, with full-wave rectification, one of the diodes (in this case ZD1) will always prevent that. Consequently, this design employs a triac opto-isolator (IC3) as the gate trigger for the main device. Incidentally, the use of IC3 virtually eliminates mains switching noise since both switch-on and switch-off occur at mains zero-crossing points.

The timers used are standard 4020 CMOS ICs. Each chip consists of a series of divide-by-two stages, all of which output low when the reset pin 11 is high. In this design, C4 and R4 are common to both IC1 and IC2 and ensure that all outputs are low at SCR switch-on and no counting takes place until C4 is charged. The clock input of IC1 is pin 10. This is fed via R3 with an unswitched 50Hz signal from the mains 'live'. C3 ensures that no spikes on the mains degrade this clock signal. IC1 outputs at pin 3, a frequency equivalent to the input of 50Hz divided by 2¹⁴, providing a wavelength of about 5 minutes 28 seconds. This signal then becomes the input clock to pin 10 of IC2 where, taking the output from pin 7, the resultant frequency is the input divided by 2⁴, making available a total wavelength of about 1 hour and 28 minutes.

Initially, counting starts with all outputs low so, at SCR switch-on, Q1 is off. About 8.5V are dropped across R5 and a current of around 13.7mA lights both the Red section of the dual LED and the LED internal to the opto-isolator, IC3. This triggers into conduction the IC's internal triac, hence the external one and the lamp switches on.

After a period equivalent to half the wavelength, the output at IC2 pin 7 goes high, Q1 switches on the Green section of the LED, thus shorting out the other two and switching off both triacs and the lamp. Now 10V or so are dropped across R5, resulting in a current flow of about 16mA.

Following a further period of around 44 minutes, equivalent to the other half of the wavelength, IC2 pin 7 goes low again and the cycle repeats. It would continue to do so forever, were it not for gate N1 of IC4. The output of this gate at pin 3 will only be low when both of its inputs are high. The input at pin 2 will follow the output at IC2 pin 7 and as can be seen from **Figure 4**, the output at IC2 pin 5 will divide pin 7's frequency by 2, at pin 4 will divide it by 4 and at pin 6 by 8.

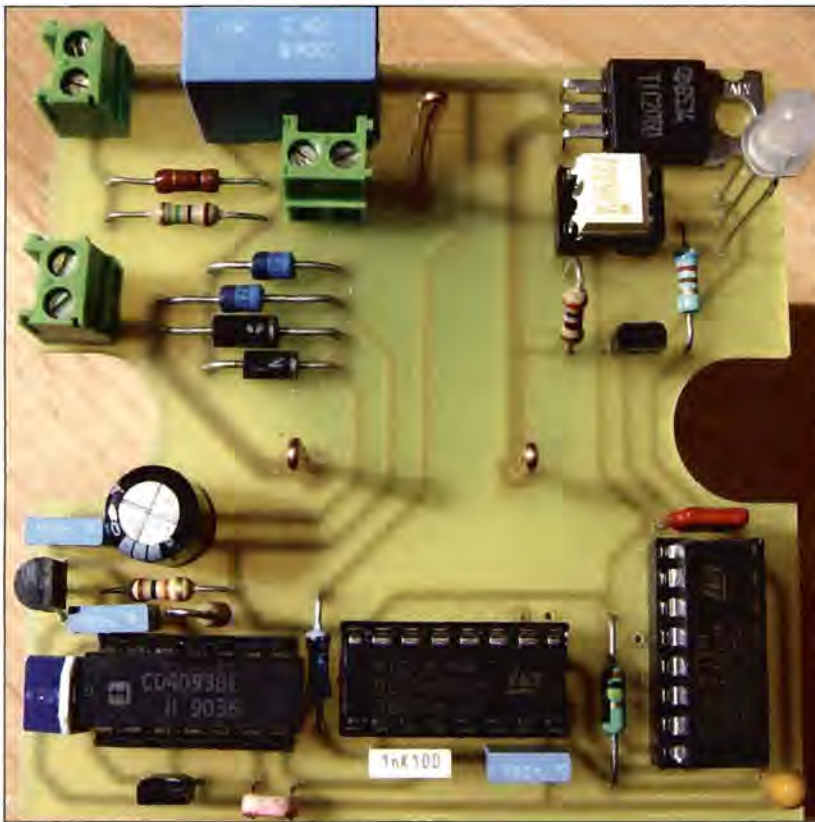

The fully populated PCB

Figure 5a: The single-sided printed circuit board, designed to fit into a standard mains plug-box

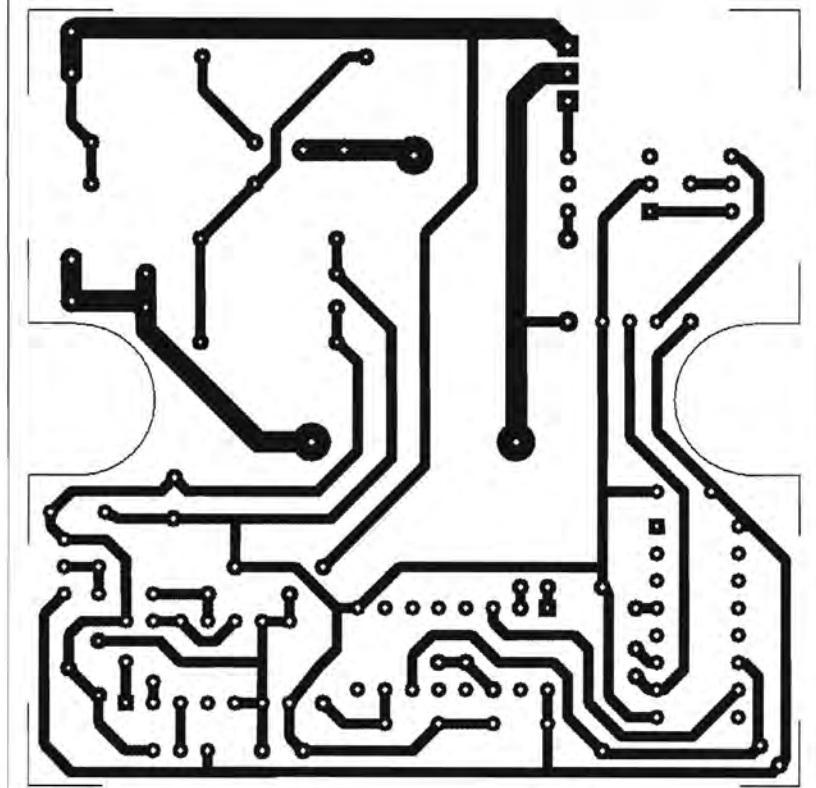

Consequently, after pin 6 has gone high and pin 7 goes high for the fifth time, both inputs to N1 will be high, the output at its pin 3 will go low and the PMOS FET, Q2, will switch on. This shorts the SCR and switches it off. About six hours will have gone by since the device first switched on. Now through the remainder of the night the system will stay in its off state. Daylight will take the LDR's resistance below its re-trigger point and the circuit will reset. The cycle will repeat with the onset of twilight that evening.

Building the circuit

Figure 5a is the single-sided PCB's copper traces, while **Figure 5b** illustrates the placement of components on a somewhat crowded board. There is room, however, for all the dual-in-line integrated circuits to be fitted into sockets. The ICs themselves and the FETs are of CMOS construction and should be handled as little as possible.

All the diodes and most of the resistors can be fitted lying across the face of the PCB, however some resistors will need to 'stand up'. The screw terminals for the connections of Live, Neutral and Earth should be orientated so that cable entry is as shown on the PCB layout. The triac has to be bent backwards so that its cooling tab lies on the face of the board. The three legs of the dual LED are of different lengths and the shortest will be only just long enough to allow the head of the LED to pass through the face of the socket on final assembly. Consequently, the LED should be soldered in to stand vertically, but to allow maximum height above the board. All capacitors on the PCB layout, which are not designated with a specific value, are 100nF.

Solder the 200k potentiometer in place and set it at its full clockwise position. The light dependent resistor is to be connected with its business surface facing outwards and perpendicular to the PCB. Consequently, its leads need to be bent through 90° before it is soldered in with an edge in contact with the board.

Once the PCB is completely populated, the socket and box need to be worked on. A single mains wall socket without a switch should be used. This, with the PCB attached, will fit into a standard 3cm-deep wall box. Depending on the type of mains socket bought and in order to get the necessary space to fit the 220nF capacitor, it may be necessary to remove an earth strap joining the Earth terminal with a brass ring in one of the fixing holes.

The faceplate of the socket needs a 5mm hole drilled at the appropriate point to allow the dual LED to poke through. One way to ensure that the hole is correctly positioned is to paste centrally onto the front surface of the socket a full size copy of the PCB and use that as a template.

The PCB is connected to the switch using heavy,

single strand mains copper wire, such as that found in standard mains cable. Prepare three pieces about 6cm long and double over about 1cm at one end of each. Put the three doubled ends into the Live, Neutral and Earth screw terminals on the switch and tighten each screw against the doubled section. Carefully feed the free ends of the copper wire through the matching holes on the PCB and ensure that the LED mates with the hole cut in the socket faceplate. Then, making certain that the PCB rests firmly against the back of the socket, solder the free ends to the board and trim the excess copper. Check that the assembly fits smoothly into the box. Mark the places on the box where holes must be cut for adjusting VR1 and to allow light to reach the LDR. Also mark where half-holes must be filed in both the box and the socket plate to allow the fitting of the mains supply access grommet, which should end up between the Live-In and Neutral-In screw terminals on the PCB.

Setting up and testing

This is a mains powered project and great care must be exercised while it is being set up and tested.

Separate the PCB from the socket by loosening the screws on the socket's terminals and prepare a three-core mains cable. This should start in a standard plug but fitted with a 3A fuse, pass through a grommet and end in prepared wires for connection to the correct screw terminals on the PCB.

With the exception of IC2, carefully fit all the integrated circuits into their DIL sockets and then re-assemble the mains socket and PCB.

For final use, two links have to be made on the solder side of the board but this configuration would require that six hours have to be spent on just checking the system. So for a quicker test, spare solder pads have been included on the PCB to fit links that will allow a shorter period.

Ensure that IC2 is not fitted at this time. Make a temporary link from IC2 pin 7 to IC1 pin 14; then a second one from IC1 pin 14 to IC4 pin 1. Finally, make a third link from IC1 pin 2 to IC4 pin 2.

Fit the socket assembly into its box and plug in a lamp. Make sure that any integral switch on the lamp is on. Attach the unit to the mains and switch on. If all of this is being done in bright light, nothing should happen. But if you can now put the plug unit into a drawer or otherwise make it dark, the device should go through its full program: the lamp should light with the LED glowing red, about 11 seconds later the lamp should extinguish and the LED go green, another 11 seconds and the lamp should light again and so on, until the lamp lights for the fifth time, then goes out, after which there are 11 seconds while the LED is green before it extinguishes.

This sequence can only be repeated by bringing

the unit into the light before placing it back in the dark. If this test is successful, the two permanent ones can replace the three temporary links. Join IC2 pin 7 to IC4 pin 2, and IC2 pin 6 to IC4 pin 1. Do not forget to separate the PCB and mains socket in order to plug IC2 in, before finally re-assembling everything.

With VR1 set at its maximum of 200k, the device will work with no further adjustment. However, you may want the unit to start its cycles with ambient light levels somewhat brighter than is possible with VR1 fully clockwise. It is more realistic for lights to be burning before it gets dark.

To adjust for the point of turn-on, wait until ambient light conditions have been achieved in the location where the unit is to be used and then very slowly adjust VR1 counter-clockwise until the light just comes on. Then, in future evenings, the unit will switch on at exactly the same level of illumination.

Wherever the device is situated, it should not receive direct illumination from the lamp that is being switched. It should, however, experience full daylight each day in order to re-trigger, ready for the twilight switch-on that evening. A good place to set up the unit might be on a window ledge between curtains and glass.

Building and adjusting this auto-light controller should allow you to leave with a little more safety confidence. You could work out a few minor modifications and incorporate them in a second unit that will switch the radio on all day and off at bedtime, too.

Figure 5b: The PCB with an overlay showing where the various components are fitted

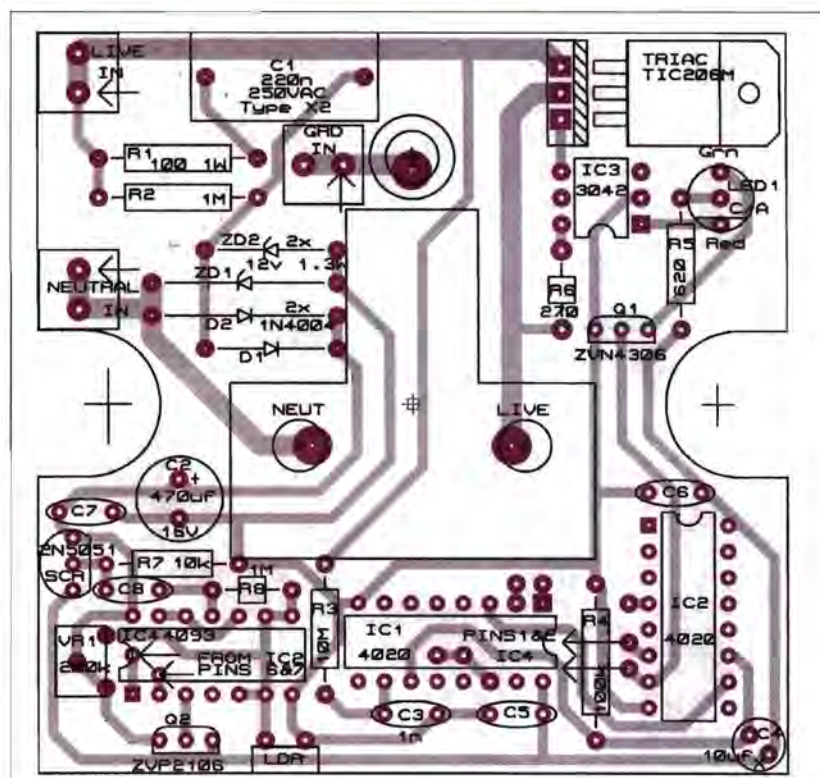

In a typical 4093 chip, the internal switching hysteresis of a gate with its inputs joined and used as an inverter is around 2V. As the input rises through about 8.2V, the output switches low. Conversely, when the input falls through about 6.2V, the output returns to a high level. Connecting a resistor across the input and output of a serially joined pair of these gates can greatly increase this hysteresis.

Figures 2 and 3 represent different states of the microcircuit around gates N3 and N4 of IC4. P is the resistance of VR1, L that of the LDR and M the bridging resistor R8, which, effectively, has one end connected either high or low, depending on the state of gate N4. U is the supply voltage and V that across the LDR. R represents the resistance of two paralleled resistors.

From Figure 2: $1/R = 1/L + 1/M$

From which: $R = LM/(L+M)$ (7)

Comparing voltage drops: $\frac{U}{P+R} = \frac{V}{R}$ (8)

Substituting for R from 7 into 8 and simplifying:
ULM = VPL + VPM + VLM (9)

From which: $L = \frac{VPM}{UM - VP - VM}$ (10)

Or: $V = \frac{ULM}{PL + PM + IM}$ (11)

From Figure 3: $1/R = 1/P + 1/M$

From which: $R = PM/(P+M)$ (12)

Comparing voltage drops: $\frac{U}{L+R} = \frac{V}{L}$ (13)

Substituting for R from 12 into 13 and simplifying:
ULP + ULM = VLP + VLM + VPM (14)

From which: $L = \frac{VPM}{(M+P)(U-V)}$ (15)

Or: $V = \frac{UL(P+M)}{LP+LM+PM}$ (16)

(a) With the resistance of L increasing and with the gate at the point of being triggered, substituting into **Equation 10** the values U=12, V=8.2, M=1MΩ and P=0.2MΩ (i.e. VR1 set at maximum) gives: L = 759kΩ

(b) Again with the resistance of L increasing but the gate having just triggered, substituting U=12, P=0.2MΩ, M=1MΩ and L now 0.759MΩ into Equation 16 gives: V = 9.84V

(c) Later when the resistance of L is decreasing and the gate is at the point of being re-triggered, substituting U=12, P=0.2MΩ, M=1MΩ and V=6.2 into **Equation 15** gives: L = 178kΩ

(d) Again with the resistance of L decreasing, but the gate having just re-triggered, the substitution of U=12, P=0.2MΩ, M=1MΩ and now L=0.178MΩ into **Equation 11** gives: V = 5.16V

These results show that the normal 2V hysteresis of a pair of serially joined 4093 gates when bridged by a 1MΩ resistor is increased from 2V to 4.68V (9.84-5.16). In addition, the resistance of the light dependent resistor has to reduce from 759kΩ to 178kΩ before the circuit is reset.

COMPONENTS

Resistors:

R1	100, 1W
R2	1M, 1/4W
R3	10M, 1/4W
R4	100k, 1/4W
R5	620, 1/4W
R6	270, 1/4W
R7	2k2, 1/4W
VR1	200k, miniature, vertical.
LDR	Miniature, 5MΩ dark resistance. (Rapid: Order Code 58-0127).

Capacitors:

C1	220nF, 250VAC, class X2
C2	470mF, 16V
C3	1nF
C4	10mF, tantalum
C5, 6, 7, 8	100nF

Diodes:

D1, 2	1N4006
ZD1, 2	12V, 1.3W Zener
LED1	Dual Red/Green, C/A

Semiconductors:

SCR	2N5060 or 2N5061
Triac	TIC206M
Q1	ZVN4306A MOSFET
Q2	ZVP2106A MOSFET
IC1, 2	4020, CMOS
IC3	TLP3042 (or MOC3042)
IC4	4093, CMOS
DIL sockets	1 @ 6 pin 1 @ 14 pin 2 @ 16 pin

Miscellaneous:

Screw terminals	3 (Rapid: Order Code 21-1655)
Mains socket, without switch	
Mains wall box, 3cm deep	
Mains plug, fitted with 3A fuse	
Cable etc.	

DESIGNERS NOTE: The LED is not an indication of whether the unit is powered or not. When the LED is red the socket is live, when it is green the unit is working through its timing period but the socket is currently off, when the LED is unlit, the unit may be powered but be outside its timing period or there may be no mains supply.

THERE IS INTERESTING NEWS



THE FIRST USB 2.0
100 MS/S, 12-16 bit
MEASURING INSTRUMENT
IN THE WORLD

PC CONTROLLED MEASURING INSTRUMENT
COMPLETE PACKAGE STARTING AT £ 435

OSCILLOSCOPE

FFT ANALYSER

VOLTMETER

RECORDER

The Handyscope 3 is a powerful and versatile two channel measuring instrument with an integrated function generator.

- USB 2.0 connection (USB 1.1 compatible)
- sample speed up to 100 MHz per channel
- 8 to 16 bit resolution (6 μ Volt resolution)
- 50 MHz bandwidth
- input sensitivity from 200 mV up to 80 Volt
- large memory up to 131060 samples per channel
- four integrated measuring devices
- spectrum analyser with a dynamic range of 95 dB
- fast transient recorder up to 10 kHz
- several trigger features
- auto start/stop triggering
- auto disk function up to 1000 files
- auto setup for amplitude axis and time base
- auto trigger level and hysteresis setting
- cursor measurements with 21 read-outs
- very extensive function generator (AWG) 0-2 MHz, 0-12 Volt

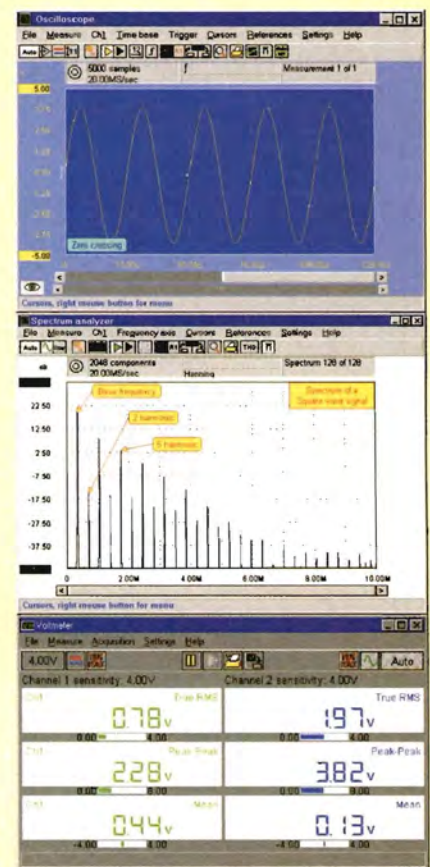

HANDYSCOPE HS3

WWW.TIEPIE.NL

for more information, demo software, software, source code and DLL's visit our internet page: <http://www.tiepie.nl>



TiePie engineering (NL)
Koperslagersstraat 37
8601 WL SNEEK
The Netherlands
Tel: +31 515 415 416
Fax: +31 515 418 819

TiePie engineering (UK)
28, Stephenson Road, St. Ives
Cambridgeshire, PE17 3WJ, UK
Tel: 01480-460028
Fax: 01480-460340

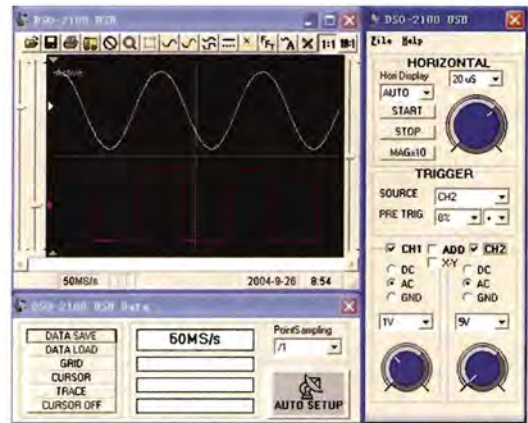

Take advantage of the low Dollar!

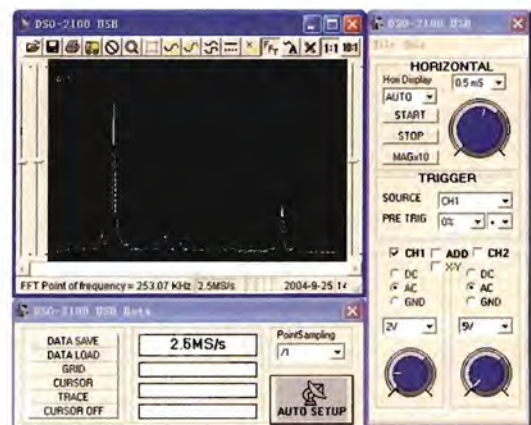
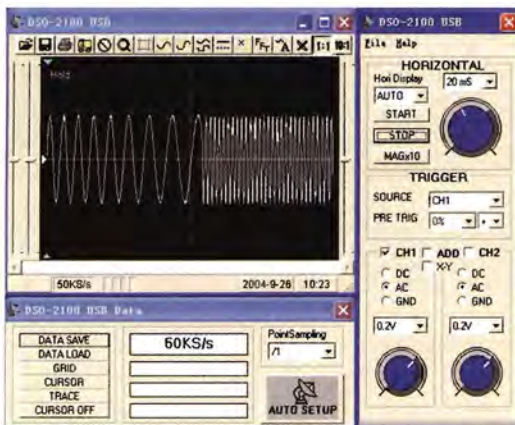

OSCILLOSCOPE

Memory Depth	32KB/Ch
Single Frequency	DC to 30MHz (DSO-2100 USB) DC to 5MHz (DSO-220 USB)
Max Sampling Rate	100MS/s (DSO-2100 USB) 20MS/s (DSO-220 USB)
Sample Rate Selection	Yes
Trace Display	Point/Line
Grid	On/Off
Vertical Mode	CH1, CH2, Dual, ADD

SPECTRUM ANALYZER

2-channel, Fast-Fourier Transform, Range: 0Hz-50MHz (DSO-2100USB), 0Hz-10MHz (DSO-220),
Cursor: Frequency, Data Point: 32K/chan

Unbeatable Price: DSO-2100 (30MHz): \$350.00, DSO-220 (5MHz): \$250.00

ORDER VIA: www.pc-instrumentmart.biz

Forced disintegration

Choosing standalone, integrated or, indeed, embedded ADCs does not have to be a daunting task, says **Thomas Hargé**, Application Engineer for National Semiconductor's Data Conversion Products in Europe

Over the past ten years, IC manufacturers have integrated ADCs into microcontrollers, DSPs and ASICs. This had many benefits: It decreased the overall system size and cost, it simplified the programming and it eased monitoring functions such as system voltage and temperature. It also demystified the ADC for hardware and software engineers, making it no more complicated than a UART or a timer. But microcontrollers and DSP manufacturers are now facing integration and performance issues with embedded ADCs. Noise, low voltage and silicon feature size are major issues in mixed signal blocks integration. While the general trend is to replace 8-bit core with low cost 32-bit CPU, the process size is shrinking, forcing the ADC to be disintegrated. Standalone ADCs have also improved; they are now tiny, flexible and provide high-end performance. The future will then bring split solutions again, with the double benefit of better CPUs and higher ADC performance and flexibility.

Integrated ADCs

Almost every microcontroller family has an ADC option. Among the different ADC architectures, only two are frequently implemented. The dual slope ADC is basically measuring the time needed for a capacitor to charge to the input voltage. This solution is inexpensive but has poor performance and low data rate. A better solution is the Successive Approximation Register (SAR) ADC. This architecture is based on a DAC where the output is compared to the input signal. During each clock cycle, the result of the comparison updates a register and improves the approximation. Such embedded ADCs feature a few hundred kilo-samples per second (ksps) and a resolution from eight to twelve bits. The strength of embedded ADCs is not the performance, but the ease of use. It is common to have an 8 to 16 channel input multiplexer where the General Purpose Input/Outputs (GPIOs) have an

analogue input alternate function. Each pin can be used to monitor a voltage/current or a temperature.

However flexible the embedded ADC is, most of the time it will lack the right performance to operate without compromise in the signal path. The main reason for this is the digital noise coupling between the CPU and the sample and hold stage of the ADC. This noise is generated by the digital switch that happens at each clock edge. When a CMOS gate is switching, it drives a significant amount of current which flows through the substrate to the ground. As every conductor is resistive, it creates a parasitic voltage peak between the substrate and the ground pin. Scaling this effect to the millions of gates that switch with different delays, result in a "noise" level of tens of millivolts. The track and hold stage is the most noise sensitive part of the ADC. As shown in **Figure 1**, it's simply a capacitor which is charged at the input voltage. For slow ADCs, a huge capacitor can be used to filter this noise. But for faster ADCs, this capacitor has to decrease and is, therefore, more sensitive to noise. The speed is then limited. As this noise is conducted by the substrate, it is inherent to any ADC which is embedded in a digital device. Comparing the Effective Number Of Bit (ENOB) (more details on this measure can be found at the end of this feature) will show that most of microcontrollers' 12-bit ADCs have a true resolution which is lower than 10 bits.

Disintegration is coming

In order to provide more performance and features at lower cost (following Moore's law), microcontroller manufacturers are now forced to use smaller processes and lower voltages. This is causing major problems for ADCs.

The first issue with smaller process is the dropping supply voltage with geometry. For a 350nm process, the oxide isolation is thick enough to accept 5V, but the maximum allowable supply is only 3.3V at 180nm and 1.8V at 90nm. Low voltages

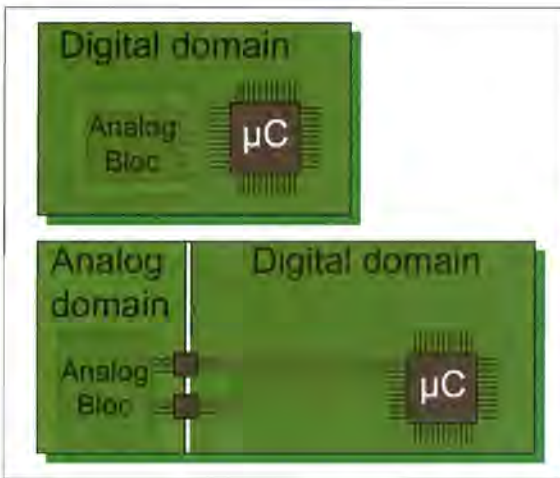

Figure 3a (top): With embedded ADCs, the analogue circuitry must be close to the MCU and is then surrounded by digital circuits

Figure 3b: Standalone ADCs can remove long analogue traces and then lower the noise sensibility

are very impractical for ADCs as the Least Significant Bit (LSB) is a small fraction of them. For 12-bit ADCs, the LSB is the full scale input voltage divided by 4095. Unfortunately, at 90nm, the RMS noise level remains the same or even goes up. When the RMS level of the noise is the same as the LSB step size, the resolution limit is reached. The only solution to overcome this problem is to add digital filtering, which requires power, silicon area and kills the acquisition speed.

A similar situation has already occurred with Operational Amplifier integration – another analogue function that was integrated in ASICs as an example. In this case, noise-versus-performance issues have forced disintegration for high performance amplifying functions.

A second big problem, which is structure size dependant, is the variation of geometries from die to die and transistor to transistor. The main parameter that is defined by the designer to give a function to a circuit is the size of each transistor. At 90nm, an individual transistor is too small to accurately predict the size ratio of two transistors. The only solution to overcome this problem is to use much bigger transistors, making this error negligible but the ADC block rather large. Besides the limited performance, MCU manufacturers are facing a cost problem in integrating ADCs. With smaller technology, the CPU size scales down while the wafer cost increases. But ADC block size remains nearly the same, which makes it comparatively much more expensive.

So, as digital process technologies continually evolve and transistor dimensions decrease, we will see a growing need of general purpose ADCs of real 8-14 bit resolution, with speeds up to 3MSPs. The death of integrated ADCs is not here yet but requirements for multiplexed input channels, single-ended and differential inputs, external and internal references etc, will also further increase the need for standalone general purpose converters.

Figure 1: Typical SAR analogue-to-digital converter input stage

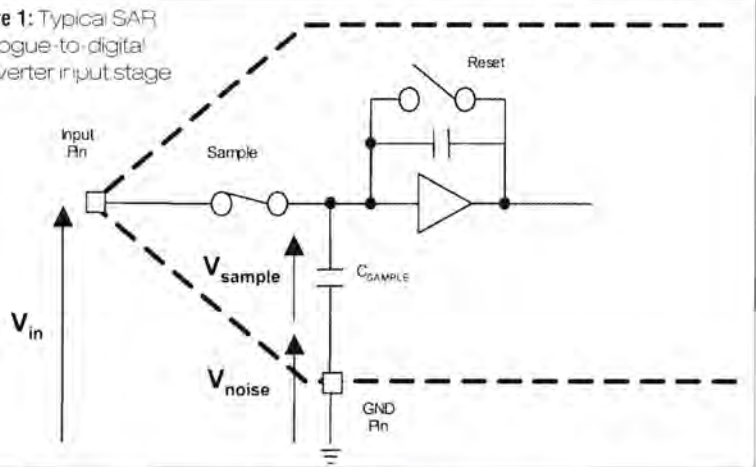

The SPI interface eases many tasks

Before ADCs were integrated onto the processing unit, they were in a huge 20-pin or higher lead count package. The digital communication was handled by an external memory like interface with parallel data output, few address lines, Chip Select, Write Enable and Data Ready lines. In total, between 12 and 20 GPIO pins of the receiving microcontroller were necessary, requiring as many traces on the PCB.

Later, these ADCs got integrated into the microcontroller. No digital lines were needed, but all the analogue lines had to be routed across the board to link the sensor to the microcontroller. Many GPIOs were still necessary, and the digital environment polluted the analogue lines.

Today, the look of general purpose ADCs has completely changed. They have a 3- to 4-wire SPI interface and come in package as small as SOT23-6 (6 leads, 3mm x 3mm). As shown in **Figures 3a and 3b**, it is now possible to make excellent PCB designs with a complete separation of the analogue and digital domain. The ADC should then be placed at the boundary between analogue and digital. Only the digital SPI signals are travelling on the PCB to link the MCU and other peripherals. Besides two decoupling capacitors, no external components, like voltage references, are required to operate the parts. This reduces board size and the overall system cost.

The last point to discuss with embedded ADCs is the programming. It is easy, because the output is a memory mapped register and, therefore, no CPU time is needed for data transfer. However, using a standalone ADC in conjunction with a hardware SPI block provides the same simplicity – the SPI feature is present in most modern microcontrollers.

Figure 4 shows a data transfer of the National Semiconductor's ADC128S101. The conversion is nothing more than a full duplex word exchange. The microcontroller writes the next multiplexer setting while the ADC is shifting out the conversion result.

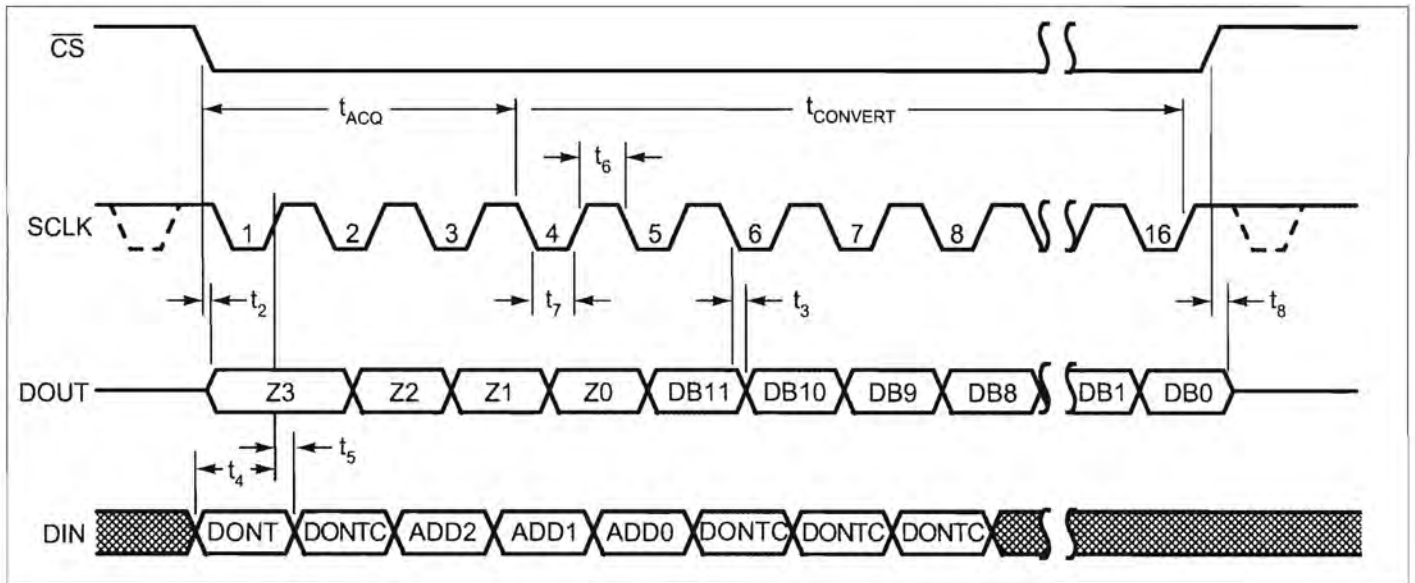

Figure 4: Serial interface timings

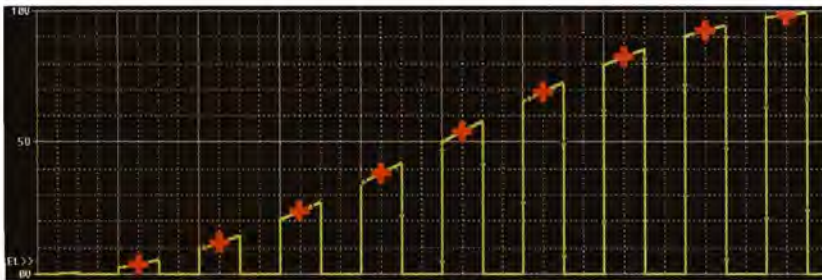

Figure 5a: Synchronous sampling allows the PWM notches to be removed

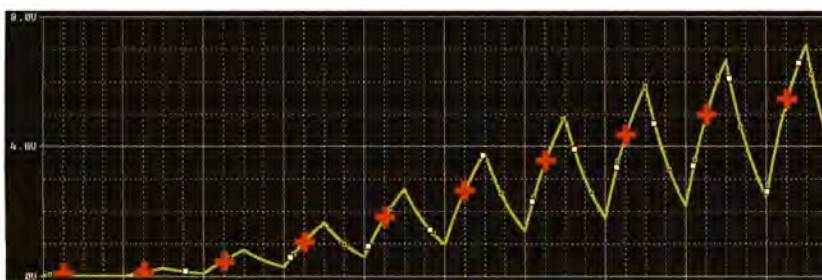

Figure 5b: With a 1MHz input bandwidth, the acquisition will be false

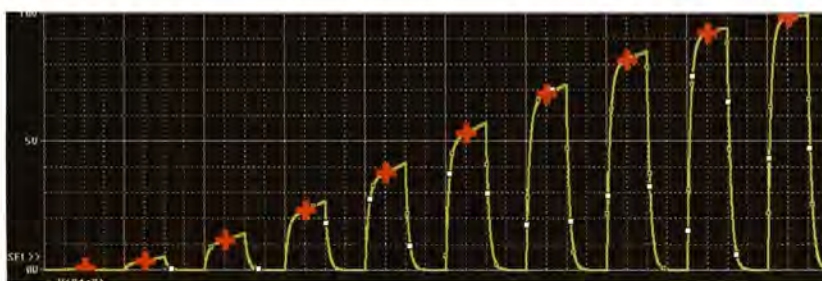

Figure 5c: 11MHz input bandwidth allows correct sampling

The CPU only needs to write the channel and to initiate the data transfer. An Interrupt can be generated when the result is completely received. Some advanced SPI blocks also provide a receive FIFO and Direct Memory Access (DMA) capability to make the acquisition automatic.

Easing the selection process

Choosing a standalone ADC can appear complicated. Each vendor's website or selection guide lists hundreds of them, and neither the speed nor the resolution is a fine enough filter to get the "right part". In addition, register addressing and pin-outs vary in many ways.

But using some general purpose ADCs is very simple: The designer first needs to choose the number of analogue inputs between 1, 2, 4 and 8 also defining the pin count of the package. At this point of the selection, the pinout is standard and fixed within the family (as with National Semiconductor's new family – see box on the right), and every resolution or speed upgrade can be done without changing the PCB.

The two next steps are to choose the resolution between 8, 10 and 12 bits and the sample rate which can be everywhere between 50ksps and 1Mps (Mega samples per seconds). In fact, some products specify static and dynamic performance over a broad range of sample frequencies rather than at a single test point.

A standardised part numbering scheme eases the selection of the device. For example, someone who is looking for an ADC with 12 bits resolution, 2 channels multiplexer, with a speed of 500ksps will choose the ADC122S051. The "S" refers to the serial SPI interface and the last digit to the supply scheme.

This family utilises the supply voltage as its reference. This saves a package pin and enables the devices to operate with a full-scale input range of 0V to VDD.

All these parts are manufactured on National's proprietary analogue optimised CMOS process. This provides excellent static and dynamic performance such as 11.7bits ENOB for the 12-bit device.

The wide input bandwidth for under-sampling

Another interesting feature that is not available in microcontroller's ADC is a wide input bandwidth. Usually, the input bandwidth is not a concern when choosing an ADC. The only requirement would be a minimum half the sampling frequency (according to Nyquist). It states that two samples per period are required in order to avoid false signal recognition called aliasing. When reversed, this condition states that no frequency higher than half the sampling rate should be fed to the ADC. So, surely, there is no point in having high input bandwidth? Not for every application!

It is possible, for example, to demodulate radio signals with sampling the input signal at lower frequency. This requires very high frequency bandwidth, beyond that of a general purpose ADC. However for speeds below 1MSPS, synchronous sampling can be used to remove PWM notches from a measured signal. **Figure 5a** shows as an example a simulated AC motor current, switched by a high

frequency PWM drive. The best way to acquire this signal is to trigger the acquisition on the rising edge of the PWM. The sample and hold will then happen shortly after this edge capturing the value during the "ON" time (red cross on Figure 5a). If the input bandwidth is not high enough, the sample and hold stage will filter the input signal and modify it as shown in **Figure 5b**. The acquisition will then be completely wrong. The only way to make a correct acquisition is to use an ADC with a high input bandwidth. **Figure 5c** shows that 11MHz bandwidth will provide sufficiently good results.

New general purpose ADC family

National Semiconductor is releasing this month (June) a complete family of 36 new SAR (Successive Approximation Register) ADCs. They are specially designed to easily replace embedded converters. Their small package and SPI (serial peripheral interface) makes the board layout simple and clear.

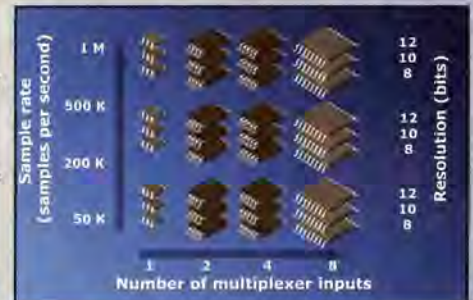

There are four different input multiplexer options (i.e. 1, 2, 4 or 8 channel). For each multiplexer option, 8, 10 or 12 bit resolutions are available, as well as any speed between 50kSPS and 1MSPS. The designer is then assured to find the correct part in this family. He will also have the benefit of outstanding performance such as low noise, low distortion and low power for each part.

ENOB indicates the ADC performance

The last step in any ADC selection process is to make sure that the performance parameters fulfill the application needs. Once again, the datasheets are not easy to compare and don't always give the same parameter values. So what to do in this jungle of THD, INL, DNL, SINAD, SFDR and ENOB? Is there a link between these values? Is there one which is easier to understand than others?

Let's have a look at the most commonly used ADC parameter that are SNR, THD, SINAD and ENOB:

- SNR is the Signal to Noise Ratio. The better the ADC is designed, the higher the SNR will be. However, there is a theoretical limit due to the quantisation noise, which is inherent to the digital conversion. For example, the SNR of a 12-bit ADC cannot be higher than 74dB ($6.02 \times 12 + 1.76$). Other noise is also created by the circuitry such as Sample and Hold, and timing generator, which tends to reduce the ADC performance.
- Total Harmonic Distortion (THD) is the result of the non-linearity of the ADC. This non-linearity will create some harmonics of the input signal on the output. This is not a desirable effect of the ADC and should be as low as possible.
- The effect of these two parameters are regrouped in the SINAD (Signal to Noise and Distortion) which is also a ratio expressed in dB. It can be calculated from SNR and THD

following the formula:

$$SINAD = 20 \text{ Log} \sqrt{10^{\frac{SNR}{10}} + 10^{\frac{THD}{10}}} \quad (1)$$

These parameters are not very digital designer friendly and decibels are still part of the analogue designer's territory. ENOB (Effective Number Of Bit) is more understandable because it is expressed in bits. Based on the SINAD of an ADC, it represents the resolution that a perfect ADC would have if it had the same SINAD. It can be calculated with the following formula:

$$ENOB = (SINAD - 1.76) / 6.02 \quad (2)$$

As shown by the **Equations 1 and 2**, the ENOB is based on both SNR and THD. It is, therefore, a good estimate for the performance of the ADC. This parameter is not shown on every datasheet. For example, a 12-bit ADC in a microcontroller often has an ENOB of 9.5 bits, which is not very attractive on the very first page.

- National Semiconductor's data conversion webpage has a useful and convenient calculator tool: <http://www.national.com/appinfo/adc/> on the bottom of the page, which can calculate the ENOB, SINAD and theoretical SNR of any ADC, knowing its THD and SNR.

2005 PRICE BUSTERS

In line with our policy of producing top quality products at amazing prices we have reduced the price of our best selling items by up to 50%

Don't delay - this is for a limited period only!



19" Horizontal 2U High

4	Sockets	13A/4/R	@	£22.65 ea. Nett
5	Sockets	13A/5/R	@	£24.99 ea. Nett
6	Sockets	13A/6/R	@	£27.57 ea. Nett
7	Sockets	13A/7/R	@	£30.96 ea. Nett

Vertical

4	Sockets	T13A/4	@	£20.25 ea. Nett
6	Sockets	T13A/6	@	£24.60 ea. Nett
8	Sockets	T13A/8	@	£31.47 ea. Nett
10	Sockets	T13A/10	@	£34.95 ea. Nett
12	Sockets	T13A/12	@	£39.62 ea. Nett

Vertical Left Hand with Switch

4	Sockets	4LH/MS	@	£20.25 ea. Nett
5	Sockets	5LH/MS	@	£23.37 ea. Nett
6	Sockets	6LH/MS	@	£24.60 ea. Nett
8	Sockets	8LH/MS	@	£31.47 ea. Nett
10	Sockets	10LH/MS	@	£34.95 ea. Nett
12	Sockets	12LH/MS	@	£39.62 ea. Nett

Vertical Right Hand with Switch

4	Sockets	4RH/MS	@	£20.25 ea. Nett
5	Sockets	5RH/MS	@	£23.37 ea. Nett
6	Sockets	6RH/MS	@	£24.60 ea. Nett
8	Sockets	8RH/MS	@	£31.47 ea. Nett
10	Sockets	10RH/MS	@	£34.95 ea. Nett
12	Sockets	12RH/MS	@	£39.62 ea. Nett

**WHEN IT COMES TO POWER
FOR RACKS IT MUST BE**



Olson Electronics Limited

490 Honeypot Lane, Stanmore,

Middlesex HA7 1JX

Fax: 020 8952 1232

e-mail: sales@olson.co.uk

http://www.olson.co.uk

**Send for your
new free catalogue**



**CALL OUR SALES HOTLINE
020 8905 7273**

This promotion cannot be used in association with any other discount or offer. Olson Electronics Ltd reserve the right to change the price without prior notice.

Signal conditioning for optimum noise performance

By Reza Moghimi, Applications Engineer, Precision Analog Products, Analog Devices

Do you need to measure a millivolt-level signal? If so, you'll want to design the lowest cost signal conditioning circuitry that achieves the required precision. What should you do first? The brute force approach may be to find an ADC with an LSB size that meets your requirements (**Figure 1**), but its price may be too high for your low-cost system.

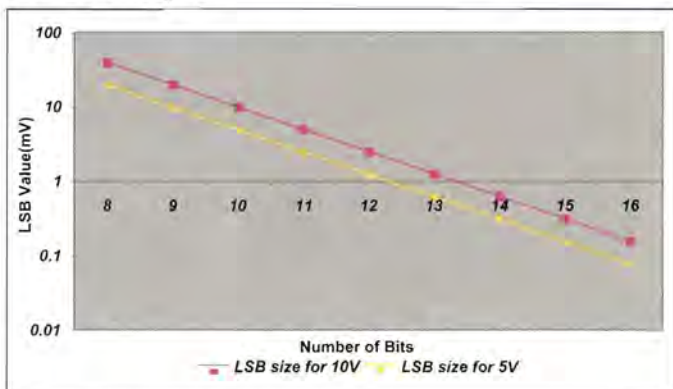

Figure 1: LSB size of 5V and 10V ADC

To measure a signal to your specified resolution, you can use a high-resolution converter alone, or you can amplify the signal before the measurement, which will allow you to use a lower cost, lower resolution ADC. The choice partly depends on whether component cost or parts count and ease of assembly is more important. Adding amplification before the ADC will lower the required resolution, but it will also reduce the full-scale input range. For example, using an amplifier with a gain of 8 ahead of an 8-bit ADC with a 5V full-scale range will increase the circuit resolution from 19.5mV to 2.44mV. At the same time, the full-scale input range of the circuit will be reduced to 625mV. In your

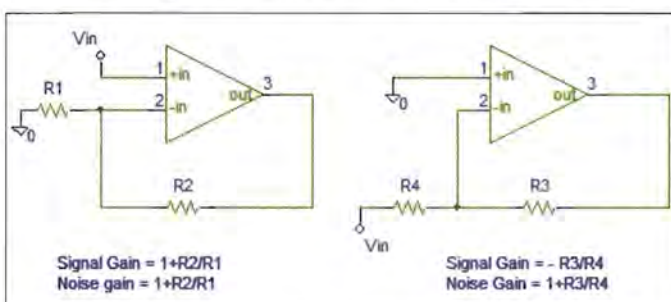

Figure 2: Non-inverting and inverting gain configuration

case, the signal range is small, so you decide to use an amplifier and a few common resistors to amplify the signal. This way you can meet your design cost target.

Amplifier modes

Amplifiers can be configured in inverting or non-inverting modes, as shown in **Figure 2**.

You select $R1 = 100$, $R2 = 100k$ to set your signal gain to $G = 1000$. You hook up an amplifier that you find in the lab and feed in your small signal. The output is noisy, however, and you can not measure small signals as accurately as you had expected. Where is the noise coming from? This paper explores the noise sources of the above circuits and will help in picking the best components. It will suggest ways to design for optimum noise performance.

The minimum usable signal is limited by both externally and internally generated spurious signals. External spurious sources include power supply ripple, 60Hz pick up and distortion due to EMI and RFI. These sources are deterministic and can be modelled as independent voltage and current sources that are appropriately located in the circuit. Internal spurious sources include random noise associated with the circuit components. These spurious signals are frequency dependent and can be represented as input referred voltage or current sources at the inputs of the op-amp. The signal looks clean when you probe the input of the signal conditioning circuit, but it's pretty noisy when you probe the output. A low noise amplifier would help, but the cost of the best performing amplifiers is too high.

Figure 3 shows the output noise versus noise density for amplifiers configured with gain of 1000.

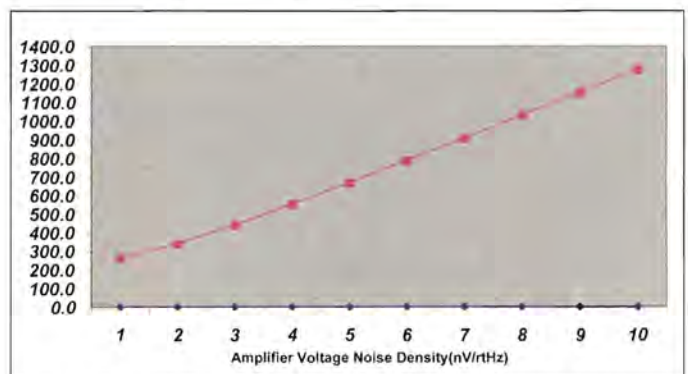

Figure 3: 10MHz amplifier configured for $R1=100$, $R2=100k$, $G=1000$. Amplifiers with higher noise specifications generate higher output noise

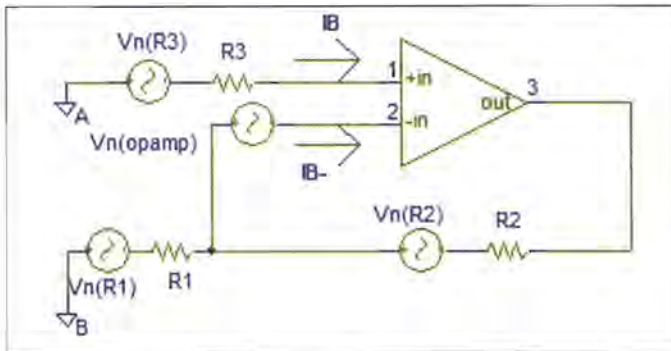

Figure 4: Signal condition shown with noise sources

Factors contributing to noise

What factors are contributing to the noise on the output? The physics of low noise has not changed over the last few years, but low noise design needs an in-depth understanding of noise sources. What noise specifications do you need from the amplifier?

To calculate the output noise in a closed-loop op-amp system, it is convenient to model the noisy amplifier as noiseless op-amp, with equivalent input referred mean square noise voltage and current sources connected to its input. If we redraw Figure 2 with noise sources, as shown in Figure 4 (R3 represents the source resistance at node A), we can find six separate noise sources: the Johnson noise of the three resistors, the op-amp voltage noise and the current noise. Each source has its own contribution to the noise at the amplifier output. Noise is generally specified RTI, or referred to the input, but it is often simpler to calculate the referred to output (RTO) noise, and to then divide it by the noise gain (not the signal gain) of the amplifier to obtain the RTI noise.

The output noise can be calculated as shown in Equation 1, where f_{closed_loop} is the closed loop frequency.

$$RTI_Noise = \sqrt{BW} \sqrt{V_n^2 + 4KTR3 + 4KTR1 \left[\frac{R2}{R1 + R2} \right]^2 + I_{n+}^2 R3^2 + I_{n-}^2 \left[\frac{R2 * R1}{R1 + R2} \right]^2 + 4KTR2 \left[\frac{R1}{R1 + R2} \right]^2}$$

$$RTO_Noise = \frac{1}{\beta} * RTI_Noise$$

$$BW = 1.57 f_{closed_loop}$$

Quantifying noise in an application

To optimise circuit noise, we must understand noise trade-offs, are realised that many things can produce noise and affect the output of a circuit. At room temperature a resistor has a Johnson noise of $\sqrt{4kTBR}$, where k is Boltzmann's constant (1.38×10^{-23} J/K), T is the absolute temperature, B is the bandwidth and R is the resistance. Note that this is an intrinsic property – it is impossible to obtain resistors that do not have Johnson noise. So, the 100Ω and 100kΩ resistors that we used before have 1.3nV and

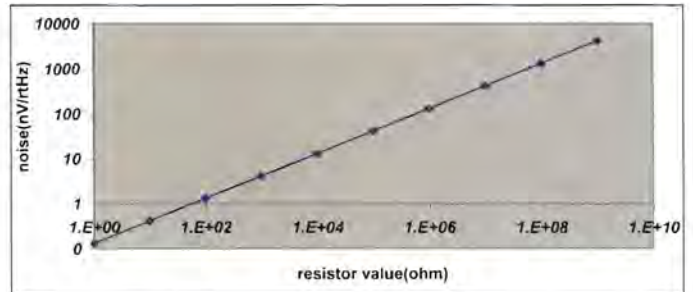

Figure 5: Noise of a resistor

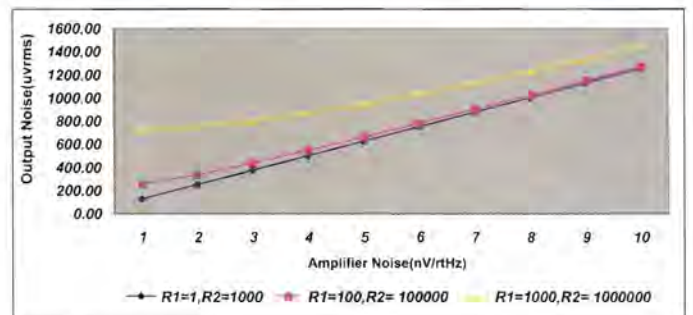

Figure 6: Picking large resistors for a given gain generates higher noise $G=1000$

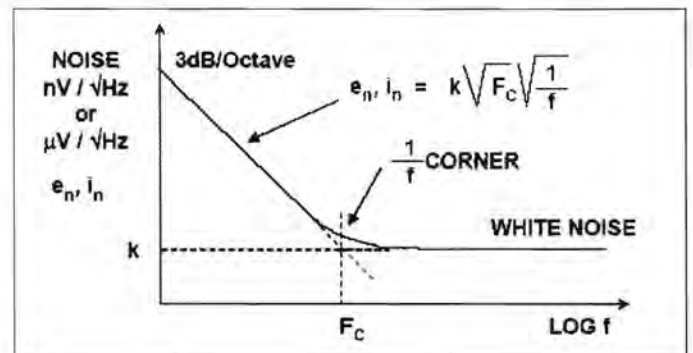

Figure 7: Voltage noise density of an amplifier

40nV of Johnson noise, respectively. Resistor noise for different resistor values is shown in Figure 5. It is thus critical to select the right set of resistors to add minimum noise to the circuit.

It is logical, therefore, that the optimum choice of a low noise op-amp depends on the impedances that are used around it. Figure 6 shows that as larger resistor values are used to set a gain of 1000, the output noise for a given amplifier also becomes the larger. So there is not any point in using a very low noise amplifier if you are using large resistors.

The amplifier has voltage and current noises, which were shown in Figure 4 as V_n , I_{n+} , and I_{n-} . The voltage noise appears differentially across the two inputs; the current noise sources appear in series with the inputs. Voltage noise density (Figure 7) is specified in $V/\sqrt{\text{Hz}}$ and current noise density is specified in $A/\sqrt{\text{Hz}}$. Amplifier noise depends on the input stage operating current, device process type and input circuit architecture. Voltage and current noise spectral density are generally specified in manufacturers' datasheets.

Current noise (I_{n+} , I_{n-}) is only important when it flows in impedance, thereby generating a noise voltage. Maintaining

low impedances at the input of an op-amp circuit thus minimises the effects of current noise. Consider, for example, an OP27 op-amp with low voltage noise (3nV/√Hz), but high current noise (1pA/√Hz). With zero source impedance, the voltage noise will dominate. With a medium source resistance, 3kΩ for example, the noise contribution from the current source (1pA/√Hz flowing in 3kΩ) will equal the voltage noise, but the Johnson noise (7nV/√Hz) is dominant. With a large source resistance, 300kΩ for example, the current noise portion increases to 300nV/√Hz, the voltage noise is unchanged and the Johnson noise (which is proportional to the resistance *square root*) increases tenfold. The current noise thus dominates. For comparison, the AD8655, the lowest noise CMOS op-amp, has 2.8nV/√Hz voltage noise and 40fA/√Hz current noise. The current noise will not become dominant until the circuit impedances get very large.

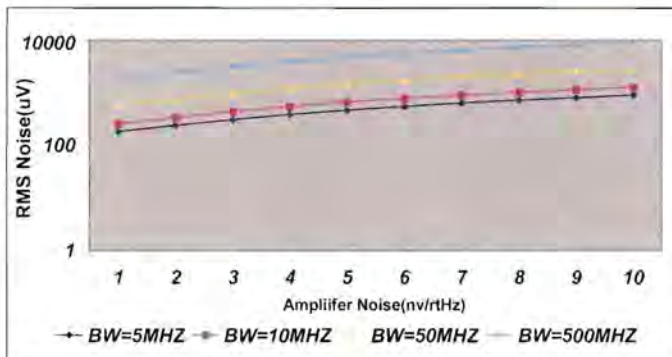

Figure 8: Output noise for different UGBW amplifiers, R1=100, R2=100k, G=100. Wider bandwidth amplifier with given noise spec generates larger noise

The noise is integrated over the amplifier's bandwidth, so it is smart to use an amplifier that has the lowest bandwidth required for the application. Amplifiers with 10MHz bandwidths and different noise specifications were used in Figure 2, but the results will be like those shown in **Figure 8**, if amplifiers with different bandwidths were chosen instead. It is clear that an amplifier must have very low noise when it is used in high frequency applications where a wide bandwidth is required.

Ensuring optimum noise performance

In addition to resistor values and the amplifier's voltage noise, current noise and unity gain bandwidth, circuit gain is another critical factor that must be considered. The resistor ratio R2/R1 appears in both signal and noise gain. Noise gets amplified by what is called the noise gain (1+R2/R1 for both inverting and non-inverting configuration).

For lowest noise, use the minimum required gain, as shown in **Figure 9**. It can be seen that the output noise is much larger when an amplifier with a unity gain bandwidth of 10MHz is configured for a gain of 1000 vs. a gain of 100.

So, to summarise, the factors that you need to consider, in order to get the optimum noise performance from your signal conditioning circuit, are:

- Use lower gains when possible.

- Use low value resistors when you can. In some applications such as low power designs, large resistors are common.
- Use amplifiers with the minimum required bandwidth. Do not select wide bandwidth amplifier if you do not need it.
- Use amplifiers with low voltage and current noise specifications.
- Use Equation 1 to calculate the RTO, RTI noise

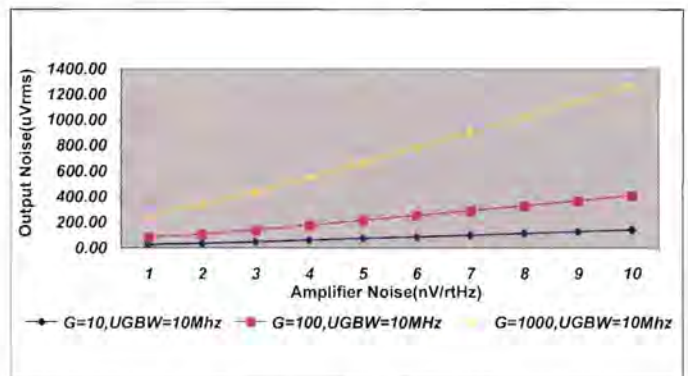

Figure 9: Noise for different amplifier gain, R1=100. Lower gain generates lower noise

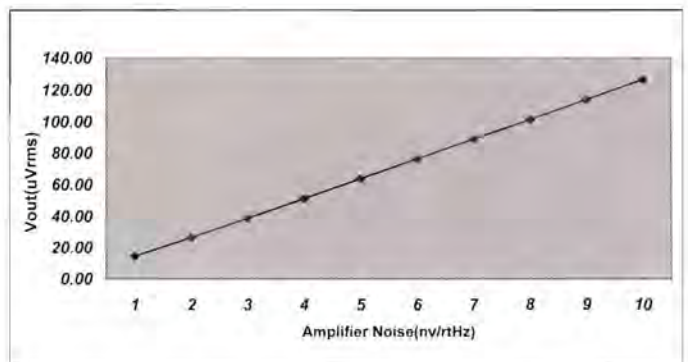

Figure 10: Optimised design for Vout vs noise. Following guidelines produces design for optimum noise performance

If you use the above guidelines, you will be able to optimise the circuit's noise performance, as shown in **Figure 10**. In this example, an amplifier with lower bandwidth (1MHz) is used, along with smaller resistors (R1 = 10Ω and R2 = 1000Ω) and a lower gain (100). As an example, for a given 5mV of signal to measure, the output signal will be 500mV. Picking an amplifier that has a 5nV/rtHz of noise will generate 63.7mV rms or approximately 370μV peak-peak of noise. This allows the usage of a 12-bit ADC.

This analysis assumes that the feedback network is purely resistive and that the noise gain versus frequency is flat. This applies to many applications, but if the feedback network contains reactive elements (usually capacitors), the noise gain is not constant over the bandwidth of interest and more complex techniques must be used to calculate the total noise.

One suggestion made earlier was to pick an amplifier with just enough bandwidth for the application. If you insist on using a wide bandwidth (perhaps you have one in stock), then you

want to create a low pass filter by placing a capacitor across the feedback resistor. The circuit shown in **Figure 11** represents a second-order system, where capacitor C1 represents the combined source capacitance, stray capacitance on the inverting input and input capacitance of the op-amp. C1 causes a breakpoint in the noise gain, so capacitor C2 must be added to obtain stability.

The addition of C1 and C2 cause the noise gain to be a function of frequency, peaking at higher frequencies (assuming C2 has been selected to make the second-order system critically damped). A flat noise gain can be achieved if one simply makes $R1C1 = R2C2$.

Optimising for noise performance at the lowest cost is a challenge that many system designers have struggled with and few have mastered. The above guidelines – when combined with good grounding, power supply bypassing and layout practices – will help you to optimise the performance of your signal conditioning circuit.

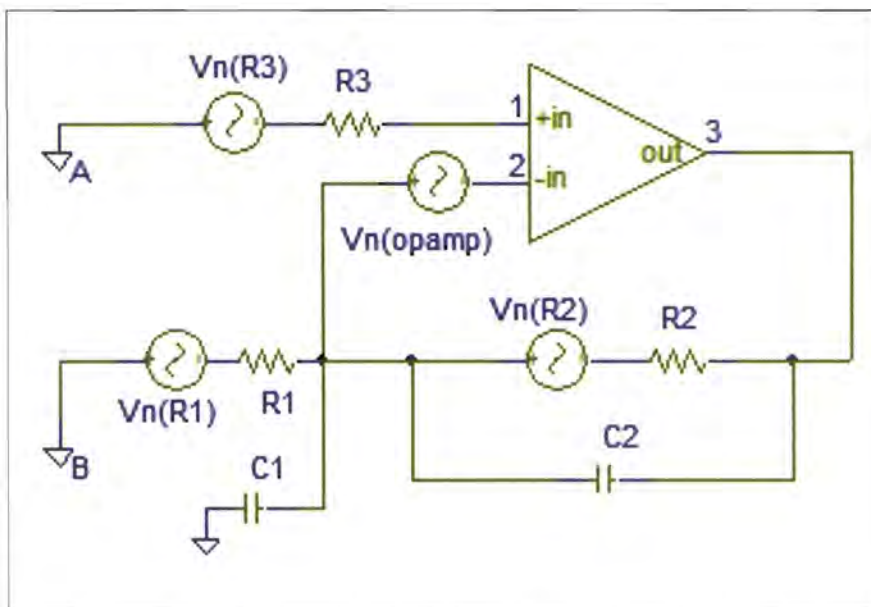
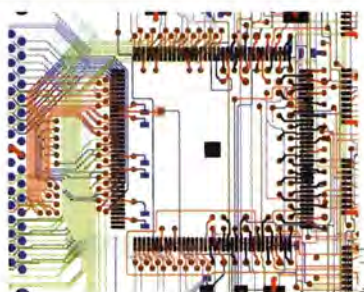

Figure 11: Op-amp noise model with reactive elements

№1 Number One Systems

Easy-PC for Windows

The world beating PCB design software



Easy-PC version 8 is released

Winning accolades the world over, Easy-PC for Windows V8 is a major milestone in the evolution of this extremely popular software tool. Try a demonstration copy of Easy-PC and prepare to be amazed at the power, versatility and remarkable value for money.

STILL FROM ONLY
£97
PLUS VAT

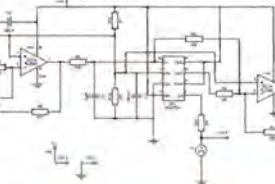

Fully integrated Schematics & PCB layout in a single application complete with forward and back annotation. Design and rules checks at all stages ensure integrity at all times. Professional manufacturing outputs allow you to finish the design process with ease.

New in Version 8

- Sketch Mode Routing
- ODB++ Format Export
- Import Bitmap
- Single-Sided AutoRoute
- Customisable Toolbars
- Auto Smooth & Mitring of tracks
- Wires & Jumpers
- Unified Quality Check
- Plus lots more.....

Stop press... Stop press... Stop press... Stop press... Stop press...
By customer demand now with Eagle import as well as Tsien Boardmaker 2 import.

call for a brochure, prices & CD on +44 (0) 1684 773662
or e-mail sales@numberone.com
you can also download a demo from

www.numberone.com



Number One Systems - Oak Lane - Bredon - Tewkesbury - Glos - United Kingdom - GL20 7LR UK

VFA, CFA, bipolar or CMOS

– which high-speed amplifier is best for your low-noise application?

**By Jeffrey Lies,
Tamara Papalias and Michael Wong,
Intersil Corporations**

Ten years ago, the bandwidth of a 'state of the art' high-speed amplifier was 200MHz. With advancements in fabrication processes, current high-speed amplifiers have broken the gigahertz barrier. Savvy engineers look for more than speed in making their amplifier selections. The most defining characteristic of a high-speed amplifier is its feedback topology, using voltage feedback or current feedback. The strengths and limitations of each topology reveal its optimal uses.

The basic circuit topologies of voltage-feedback amplifiers (VFAs) and current-feedback amplifiers (CFAs) are presented here. The differences in topology are correlated to noise and distortion performance. Details about these performance limitations accompany typical values. Since both topologies will be presented in their bipolar implementation, a CMOS example is also included for a complete introduction into high-speed amplifier options.

The VFA and CFA topologies

Voltage-feedback amplifiers are the most common operational amplifier topology. As most of us learned in college, there are

three stages: differential input stage, gain/level-shift stage and output stage. **Figure 1** presents a simplified schematic of the EL5157, a popular voltage-feedback amplifier.

The input stage is an NPN differential pair in parallel with a PNP pair. The second stage consists of a pull-up current source. Note that any difference (signal or error) in the currents of the signal-path transistors appears across the output impedance of the current source at the high impedance node. The output stage buffers the high impedance node to the output.

Current-feedback amplifiers have a very different input structure. In fact, the input stage has a unity gain buffer between its inverting and non-inverting inputs. This gives the CFA topology some distinct advantages that will be discussed later. Their popularity lagged voltage-feedback designs until the emergence of the fully complementary bipolar process. Fortunately, these processes are widely available today, so CFAs can exploit the fact that current switching is faster than voltage switching in bipolar circuits (all other things being equal).

A simplified schematic is shown **Figure 2**. The non-inverting input is high impedance and is buffered to the inverting input (see dashed box in Figure 2). The input impedance of the inverting input is very low and its signal reaches the high impedance node through current mirrors. The high impedance node, Z, is buffered to the output.

Another, higher-level look at the CFA structure highlights its advantages, so a simplified model is presented in **Figure 3**. Any voltage difference across the feedback resistor (R_F) creates an error current into the inverting input. Since the

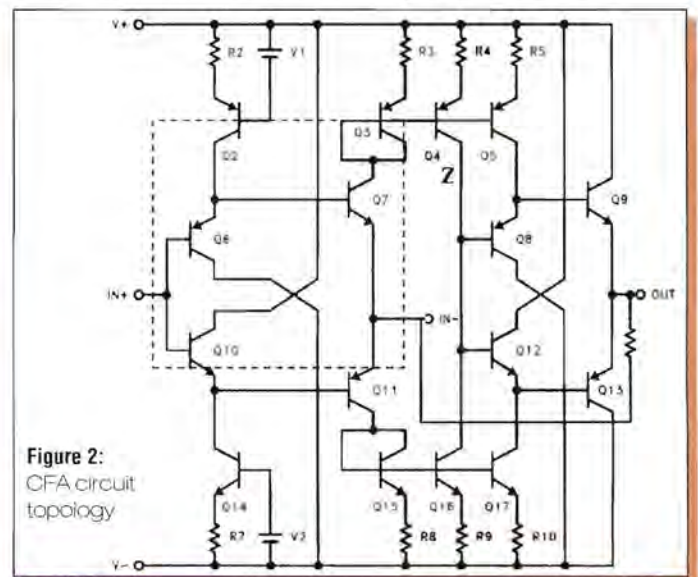
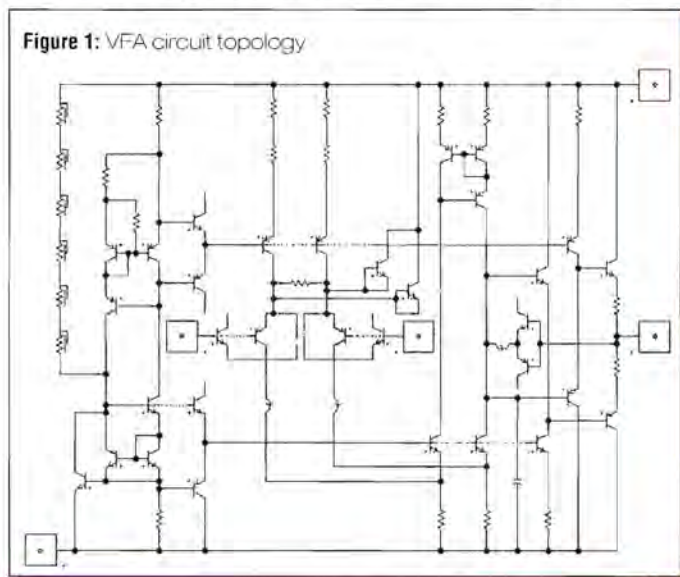

impedance at the inverting input is low, this feedback is a current. A CFA is also called a transimpedance amplifier because any change in the inverting input current results in a change of output voltage. It is noteworthy that the inverting input is capable of sourcing and sinking high transient currents, since it is not limited by a bias current. The current mirrors supply current on demand to the high impedance node from the power supply, giving CFAs high slew rates. A unity-gain buffer completes the circuit, driving the output to the voltage required to minimise the feedback error current.

The value of R_F determines the amount of current fed back to the inverting input. Therefore, when varying the gain of a CFA, it is suggested that the value of R_G be adjusted. Also, while VFAs exhibit a gain-bandwidth trade-off, CFA bandwidth is inversely proportional to the value of R_F .

Op-amp noise calculations

A classical noise model of an operational amplifier with feedback is presented in **Figure 4**. It shows all of the possible noise sources, including thermal noise (also called Johnson noise) voltages for the external feedback and gain resistors. While the resistor noise sources do not change versus frequency, the voltage and current noise sources in association with the op-amp have frequency characteristics. Therefore, plots of input voltage and current noise are given in op-amp datasheets.

The two main components of noise inside op-amps are flicker noise and white noise. Flicker noise, also called 1/f noise, because its contribution is inversely proportional to frequency, dominates at low frequencies (less than a few megahertz for CMOS and inside a few kilohertz for bipolar designs). White noise includes contributions of shot noise from bias currents and thermal noise from resistances in devices and other circuit structures. With its flat amplitude characteristic with respect to frequency, white noise dominates at medium and high frequencies. **Table 1** lists the types of noises and their mathematical equivalents.

By convention, noise quantities are input-referred. This means the value presented is the amount that would appear at the input

Table 1: Dominant types of noise in an operational amplifier

Type of Noise	Calculation
Thermal Noise (Johnson Noise)	$V_{nN} = \text{Sqrt}(4KTR\Delta f)$
Shot Noise	$I_{SN} = \text{Sqrt}(2qI_{DC}\Delta f)$
Flicker Noise (1/f Noise)	$I_{FN} = \text{Sqrt}(K_d I_{DC}^a f^{-b} \Delta f)$

where

K = Boltzmann's constant (1.38×10^{-23} J/K)

T = absolute temperature in Kelvin ($0^\circ\text{C} = 273$ Kelvin)

R = resistance of component/device

I_{DC} = DC current

q = charge on an electron (1.6×10^{-19} C)

Δf = system bandwidth

f = centre frequency of operation

K_d = device constant (varies by orders of magnitude – even on one wafer, MOS tends to be higher than BJT)

a = fabrication constant (ranges from 0.5-2)

b = constant (approximately = 1)

Table 2: Amount of noise per noise source

Noise Source	Noise (as a Voltage)	Noise Gain
Input Voltage Noise	V_n	$1 + R_F/R_G$
Inverting Input Current Noise	$I_n^- \cdot R_F$	1
Non-inverting Input Current Noise	$I_n^+ \cdot R_3$	$1 + R_F/R_G$
Johnson Noise of R_F	$\text{Sqrt}(4KT \cdot R_F)$	1
Johnson Noise of R_G	$\text{Sqrt}(4KT \cdot R_G)$	$-R_F/R_G$ (inverting)
Johnson Noise of R_{ninv}	$\text{Sqrt}(4KT \cdot R_{ninv})$	$1 + R_F/R_G$

to cause the resultant noise at the circuit output. For example, if a noise source exists at the output of an amplifier, it would be divided by the closed-loop gain to become input-referred. With all of the noise referred to the same node, the influence of various noise contributions can be compared and combined.

Figure 3: Simplified CFA model

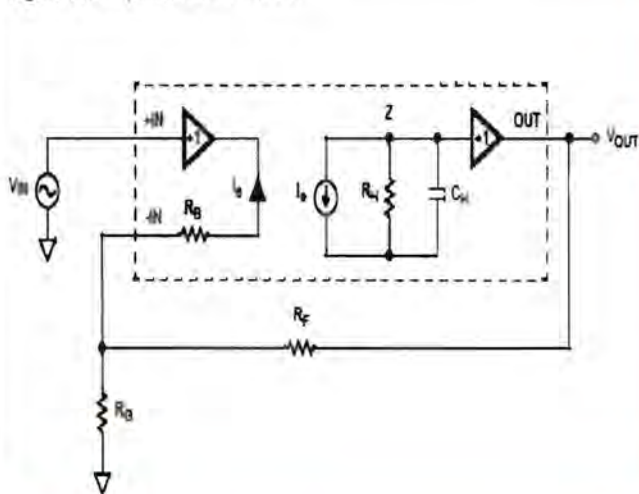
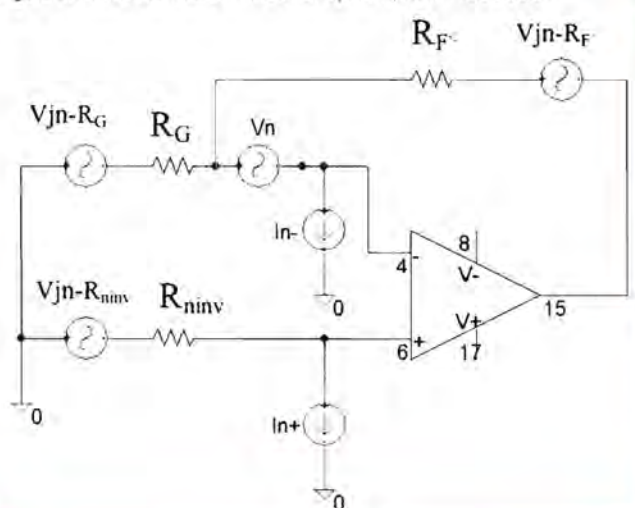
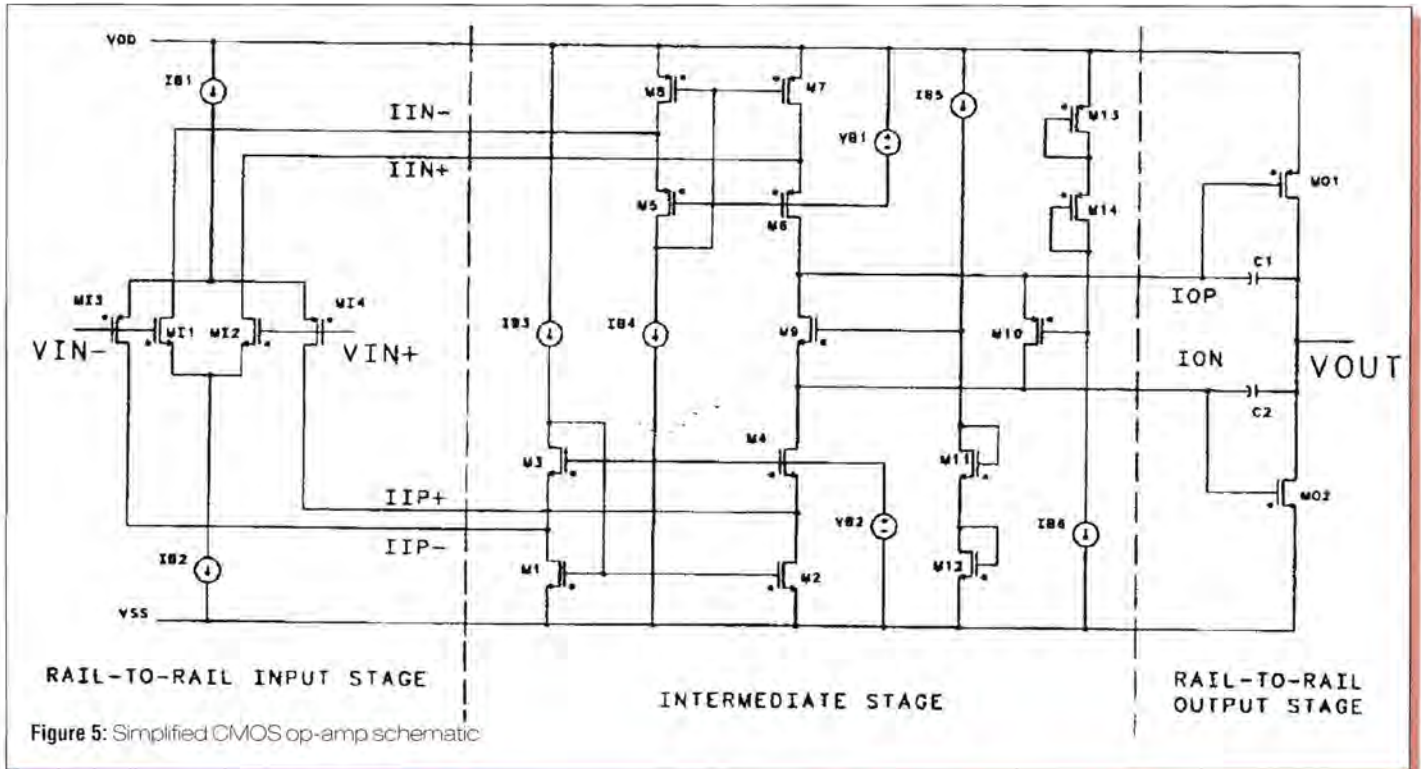

Figure 4: Classical noise model of op-amp with feedback





For the amplifier example in Figure 4, the noise sources can be calculated as shown in **Table 2**. To facilitate comparison, all noise sources have been presented in terms of voltage. The third column identifies the voltage gain experienced by each noise source.

Noise is a random quantity. The average voltage of a noise source is zero, just as the average voltage of a sine wave is zero. However, the average power is NOT zero. Therefore, when summing the contributions of different noise sources, we add the power of each noise contributor to get the total power. Power is proportional to voltage squared and inversely proportional to the impedance of that node:

$$P = I \cdot V = (V/R) \cdot V = V^2/R \quad (1)$$

With all of the noise sources referred to the same node, they will be across the same impedance. Therefore, we can calculate the total noise power at that point. If the related total voltage is desired, the answer lies in the reversal of **Equation 1**. These noise sources in Table 2 are uncorrelated and can be summed as described in the preceding paragraphs. Correlated noise sources are generated by a single or dependent source, relating the behavior of one source to another. Since correlated noise sources have related noise behavior,

Table 3: Typical values for noise quantities in VFA, CFA and CMOS topologies

	VFA	CFA	CMOS
V_n	0.86nV/√Hz	4nV/√Hz	20nV/√Hz
I_{n-}	1.4pA/√Hz	20pA/√Hz	2fA/√Hz
I_{n+}	1.4pA/√Hz	8pA/√Hz	2fA/√Hz

the source powers cannot be simply added.

VFA and CFA noise analysis

To understand the noise differences between voltage feedback and current-feedback amplifiers, one only needs to compare the architectural differences between their input stages (shown in Figure 1 and Figure 2.) The VFA input structure is a differential pair. Therefore, in bipolar technologies, the inputs are connected to bases of PNP and/or NPN transistor pairs. The currents through these nodes are small base currents and since the noise current is proportional to the amount of base current, a low input noise current results.

The current-feedback amplifier, on the other hand, has two inputs connecting to very different structures. The non-inverting op-amp input connects to the base of bipolar transistors, so the noise current is comparable to the inputs of VFAs. Conversely, the inverting op-amp input is the buffer's output, typically NPN and PNP emitters. Since emitter current is much larger than base current (by a factor of beta), the noise is proportionally higher as well. CFA inverting input noise currents typically run in the 20-30pA/√Hz range, compared to the VFA's 1-5pA/√Hz typical range.

This larger noise current is transformed into a voltage through the feedback resistor, R_F . Input-referred noise voltage is a more complicated parameter, being a function of not only the input transistors (primarily transistor base resistance and collector current), but also the type of load driven by the input stage. For our general case, it is sufficient to say that CFAs typically deliver an input noise voltage that is at least on a par with VFAs that haven't been optimised for low noise. **Table 3** shows typical noise currents and voltages for a voltage feed-

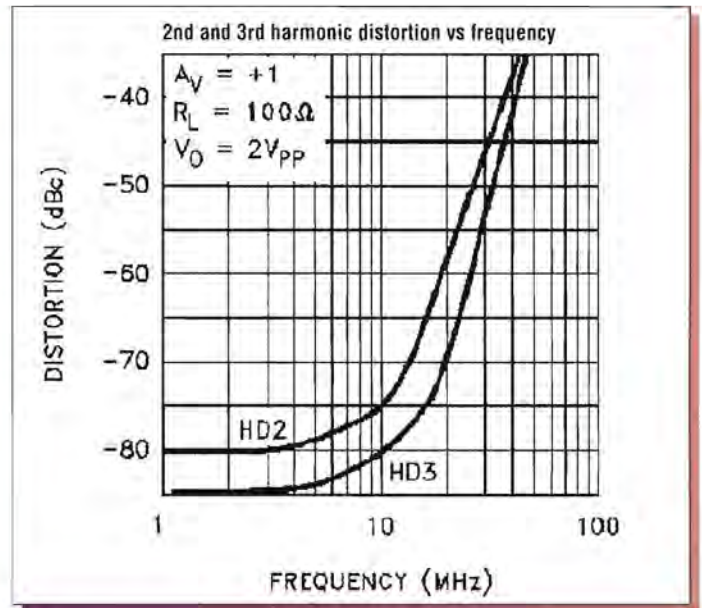
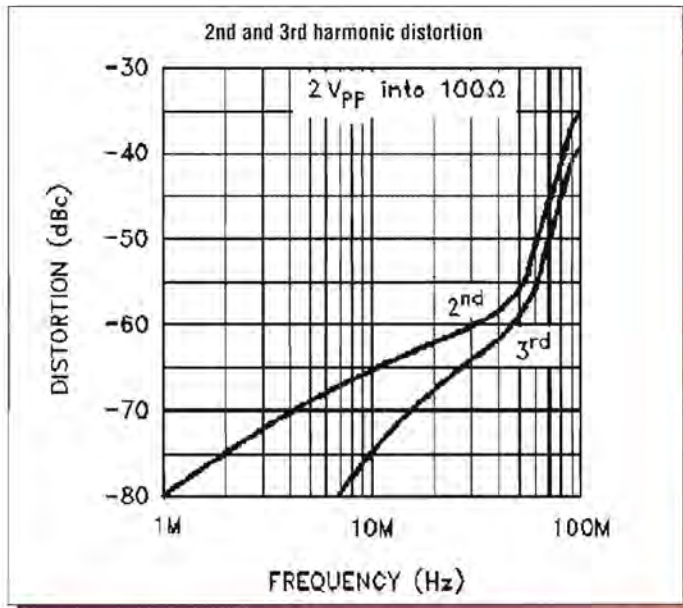

Figure 6: CFA and (right) VFA distortion comparison

back amplifier, a current-feedback amplifier and a CMOS amplifier (for comparison).

In a voltage-feedback amplifier, the circuit has been optimised for sensitivity to the voltage difference at the input. Therefore, the voltage noise contribution is the lowest of the three. The current noise at both inputs is low because the base current into each terminal is small.

For the current-feedback amplifier, the feedback node has emitter current flowing instead of a base current. This larger current will naturally have a larger current noise associated with it.

In the CMOS case, the input is purely capacitive. A simplified schematic is presented in Figure 5. The input is, again, a differential pair. Since both inputs connect to the gate of MOSFETs, which allows virtually zero current flow, only the voltage determines the output signal. This explains the CMOS amplifier's low level of input current noise. The input voltage noise, while higher in the CMOS case, is still within an order of magnitude of the other two examples. So if the voltage gain is low, as in transimpedance amplifiers, then the higher level of noise is inconsequential. A drawback to CMOS amplifiers is that the $1/f$ knee frequency is inversely proportional to the device channel lengths, so the more advanced the process the higher the frequency of the $1/f$ knee.

VFA and CFA distortion characteristics

At low frequencies, voltage-feedback amplifiers provide the lowest distortion. The differential-pair input stage acts much like an electronic see-saw. When provided with negative feedback, the op-amp attempts to level the see-saw. Distortion values from the datasheets of typical CFA and VFA amplifiers are provided in Figure 6. Of course, there are products on the market that do not follow these curves. Check the datasheet before choosing an amplifier for your application.

The current-feedback amplifier accepts a voltage at the non-inverting input and a current at the inverting input. The see-

saw effect is still there, but only after V_{in+} is translated into a current. This translation is imperfect, introducing errors, which appear in the 2nd harmonic distortion. At higher frequencies, the majority of loss comes from slew rate limitations. Since CFAs have higher slew rate than VFAs, they exhibit lower distortion characteristics at high frequencies. Also note that current feedback amplifiers give relatively constant distortion results for different gain settings.

Voltage-feedback example application: xDSL line driver and receiver

In xDSL systems, communication signals are transmitted through telephone lines that can reach lengths of 20,000 feet. The receiving signal can be as low as 30mV with a 4MHz bandwidth. A low noise amplifier is required to amplify the receive signal. The signal must also be filtered to remove the high frequency noise from the lower frequency transmit signal.

The closed-loop gain of the line receiver is at least 30V/V and the analogue-to-digital converter of the driver front end has 14-bit resolution. To fully utilise the full range of the 14-bit ADC, the signal-to-noise ratio of the input must be greater than 84.3dB. For example, a 20mV input signal would require a noise level under 1.2mV. The limit of the amplifier's input voltage noise is $0.9\text{nV}/\sqrt{\text{Hz}}$ with a 4MHz bandwidth. A voltage feedback amplifier is preferred – not only for its low input voltage noise, but also for the fact that VFAs are more flexible in active filter configurations.

Current-feedback example application: Driving an ADC

An application where CFAs excel is driving high speed, high resolution ADCs, especially for pulsed inputs. A distinct CFA advantage for this application is that the CFA's output rise time remains nearly constant, regardless of the output step size. The slewing current is equivalent to the inverting input

Figure 7: Transimpedance amplifier circuit.

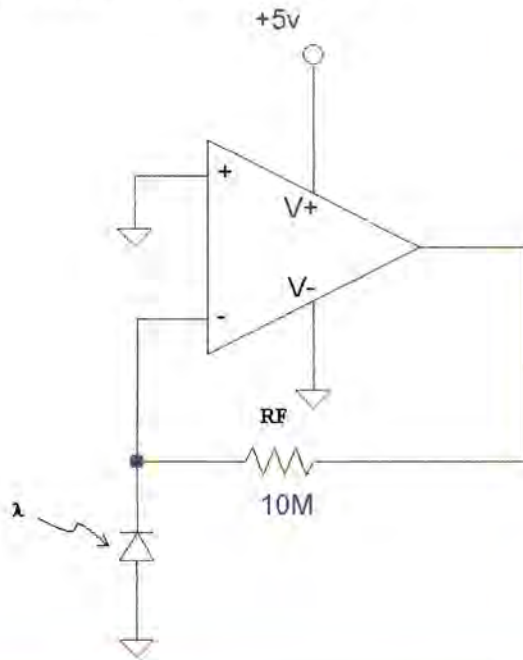

current during transients, which is a function of the voltage difference across R_F . Therefore the CFA's slew rate actually increases as the step size increases. Whereas a VFA may become slew-rate limited for voltage swings less than 1V, CFAs typically do not reach slew-rate limit for steps less than several volts.

In addition to the CFA's slew-rate advantage, its exceptional bandwidth (be careful, because excess BW still contributes to total noise), distortion, settling time and relatively low supply current, make it a prime contender for ADC drivers. For example, the EL5166 is an excellent choice for driving 14-bit ADCs, due to its 1.4GHz bandwidth, 6000V/ms slew rate and 70dB second harmonic distortion at 20MHz. With ADC drivers, the load presented by the CFA's feedback network is not usually a concern. This allows the designer to utilise low resistance feedback resistors to minimise noise contribution, while maximising its performance.

CMOS example application: Transimpedance amplifier/photodetector

Wide bandwidth and low input bias and noise currents make modern high-speed CMOS amplifiers ideal choices for photodiode transimpedance amplifiers. The key elements in a transimpedance design, as shown in **Figure 7**, are capacitance at the inverting input (including diode capacitance, input capacitance from the amplifier and parasitic capacitance), the transimpedance gain set by R_F , low input current noise to allow wide dynamic range and sufficient gain-bandwidth. With these three variables set, a feedback capacitor in parallel with R_F is often needed to control the frequency response and ensure stability.

If the amplifier is a rail-to-rail, single-supply device, the non-

Table 4: Summary of op-amp topologies, strengths and applications

Topology	Strengths	Example Use
VFA	Input Symmetry Low Input Voltage and Current Noise Low Distortion @ Low Frequency	Communications Systems
CFA	Slew Rate Bandwidth Low Distortion @ High Frequency	ADC Driver
CMOS	Dynamic Range Rail-to-Rail Operation Lowest Input Current Noise	Transimpedance Amplifier/Photodetector

inverting input can be connected to ground, allowing the output to reach true zero when the photodiode is not exposed to any light. This allows the circuit to avoid the delay the output would need to travel from the negative rail.

To achieve the best performance, components should be selected according to the following guidelines:

- For lowest overall system noise, select R_F to provide all the required gain in the transimpedance stage. Since the CMOS amp has virtually no current noise, a lower value of R_F (to lower the noise of the transimpedance stage), would necessitate including additional gain stages, ultimately producing poorer overall noise performance. The noise produced by R_F increases as the square root of resistance, whereas the signal value increases linearly, therefore, signal-to-noise ratio is improved when all of the required gain is placed in the transimpedance stage.
- Minimise capacitance at the inverting input. This capacitance causes the voltage noise of the op-amp to be amplified. A low-noise voltage source to reverse-bias a photodiode can significantly reduce its capacitance. Smaller photodiodes have lower capacitance. Use optics to concentrate light on a small photodiode.
- Limit the circuit bandwidth to only that required, since noise increases with increased bandwidth. Use a capacitor across the feedback resistor to limit bandwidth, even if not required for stability.
- Circuit board leakage can degrade the performance of an otherwise well-designed amplifier. Clean the circuit board carefully. A circuit board guard trace that encircles the summing junction (inverting input) and is driven at the same voltage can help control leakage.

Popular choices

Both current- and voltage-feedback amplifier topologies are popular choices for high-speed applications. An understanding of the differences in circuit topology along with basic noise and distortion characteristics are crucial for optimal product selection.

Table 4 summarises the discussion and examples presented.

SERIAL COMMUNICATIONS SPECIALISTS

Test and Measurement Solutions



featured products ▼



NETCOM-813
8 Port RS232/RS422/RS485 model
£350

NETCOM Ethernet- Serial Servers

NetCom are industrial strength, network based serial device servers for connecting RS232, RS422 and RS485 serial devices directly to a 10/100Mbps Ethernet network running TCP/IP. Netcom can control 1 or more serial devices located virtually anywhere (via Ethernet or Internet). NetCom can be configured over Driver Panels, WEB Browser, Serial Port, Telnet or SNMP and serves as a transparent serial channel without platform and distance limitation. Housed in a sturdy metal enclosure including DIN rail mount, one to eight port models are available. 19in rack-mount versions with internal switch mode PSU can also be supplied.

priced from £85 (NetCom 111)

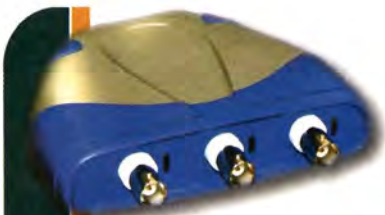

DS1M12 Oscilloscope / Datalogger
2 1MS/s Input Channels + waveform generator output
£125

USB Instruments - PC Oscilloscopes & Logic Analyzers

Our range of PC Instruments may be budget priced but have a wealth of features normally only found in more expensive instrumentation. Our DS1M12 and PS40M10 oscilloscopes have sophisticated digital triggering including delayed timebase and come with our EasyScope oscilloscope / spectrum analyzer / voltage and frequency display application software and our EasyLogger data logging software. We also provide Windows DLLs and code examples for 3rd party software interfacing to our scopes. Our ANT8 and ANT16 Logic Analyzers feature 8/16 capture channels of data at a blazing 500MS/S sample rate in a compact enclosure.

priced from £125 (DS1M12 & ANT8)



USB-16COM-RM
16 Port USB Serial Server Rack Mount with Internal PSU
£265

1 to 16 port USB to Serial Adapters

With over 16 different models available, we probably stock the widest range of USB Serial Adapters available anywhere. We offer converter cables, multi-port enclosure style models in metal and plastic, also rack mount units such as the USB-16COM-RM opposite. Serial interfaces supported include RS232, RS422 and RS485. We also supply opto-isolated RS422 and RS485 versions for reliable long distance communications. All our USB Serial products are based on the premium chipsets and drivers from UK company FTDI for superior compatibility, performance and technical support across Windows, MAC-OS and Linux platforms.

priced from £20 (US232B/LC laptop Companion)



PCI-800L
8 Port PCI RS232 Serial card
£150 (including cables)

PCI Serial Cards

Discover our great value for money range of multi-port PCI serial cards. Supporting from two to eight ports, the range includes RS232, RS422, RS485 and opto-isolated versions. Our 4 port and 8 port models can connect through external cables or the innovative wall mounting COMBOX.

EasySync Ltd

373 Scotland Street, Glasgow G5 8QB, United Kingdom
Tel : 0141 418 1081 / Fax : 0141 418 0110

Web : <http://www.easysync.co.uk>
E-Mail: saleseasysync.co.uk

* Prices shown exclude PP and VAT where applicable

Order of Merritt

NICK MERRITT

Nick Merritt of electrical contractor Merritt Brothers puts Kew Technik's Socket & See DIT 400 Digital Insulation and Continuity Tester through its paces. Nick takes up the story from here.

First we are going to test the continuity of the ring, which means you have a ring of sockets going out from the board. You have two twin-and-earths connected at the board, and you want to check that there is a continuous loop on the live, neutral and earth throughout.

This will also check that there are no spiders, or cross connected rings, or if the circuit is one big radial.

First you turn off the main isolator on the board, then you take the cover off. The probes go on the screw terminals on the live side of the main isolator to show that there is a voltage, followed by connecting them to the board side to show that the board is isolated.



Ring continuity

Now you want to test the continuity of the ring final circuit. It is best to switch off all the breakers and then unscrew the terminals of the breaker for the ring circuit that is being tested, as well as the earth terminals.

Some earlier installations may have the two earth conductors twisted together into one length of sleeving, but

nowadays it is more common to have each earth conductor in its own separate sleeve for good practice because you need to split the ring, which makes it easier for testing.

The board shown here has four 32A type 2 MCBs, one of which is for the cooker, with the other three supplying their own rings.

Then, there is a 15A MCB for the immersion boiler and, finally, five 5A MCBs for the lighting circuits.

The probes are attached with the aid of crocodile clips, firstly to each other to find the resistance of the test leads, in this case 0.09Ω . The Socket & See DIT 400 Digital Insulation and Continuity Tester used here allows this value to be automatically subtracted from the continuity reading by pressing a null button before connecting the crocodile clips to the leads.

The clips are first attached to the live conductors for testing live-to-live (R_l), then to the neutrals (R_n). The values should be about equal.

The clips I then attach to the earths (R_2), which should have a greater resistance, because on twin-and-earth circuits the lives have a cross section of 2.5mm^2 and the earths 1.5mm^2 .



Once you have tested the continuity of the lives, earths and neutrals, you then link out the opposite live and neutral and test. This should have a reading of around half the value of the live-to-live or neutral-to-neutral, but you have to allow for minor differences because of contact resistance.

Sockets



With the cables still linked out, you go to each point on the circuit, getting the same reading on each one, unless you hit a spur or branch, in which case it will be a higher reading, depending on its length.

Back at the board you link out the opposite lives and earths. Then test once again at each point as before, but between live and earth. The highest reading will be recorded on your test sheet as R1 and R2. This would also prove polarity at each point.

Lighting circuits

On a lighting circuit, which is not a ring, you would find the MCB and link out the live terminal with the earth conductor and, again, the highest resistance reading would be R1 + R2. Another way is to use a wandering lead from the earth terminal on the board and connect that to the live terminal on the light fitting, remembering to subtract the resistance of the lead by nulling it to find R2.

Insulation resistance

This entails testing between live and neutral, live and earth, and neutral and earth, by squirting a 500V potential from the tester to see if it jumps through the insulation down adjacent conductors.

You are looking for a reading above 0.5MΩ, but if the reading is lower than 2MΩ, which is low, you would want to investigate further to find out why.

Low readings could be down to cables being squashed together somewhere, or where something has nibbled at the insulation, or even where a screw or clip has cut into the insulation.



When testing a lighting circuit, you need first to make sure that all fluorescent fittings are disconnected, filament lamps are removed from their sockets and all switches are closed. Anything else that is vulnerable to voltage should also be disconnected.

The higher the reading, the better the separation is between live and earth. In the photo above, the live-to-earth shows 58.4MΩ. On the test sheet you have to enter live-to-neutral, live-to-earth and neutral-to-earth.

Polarity

The continuity tests will also show that each circuit has the correct polarity. When testing for R1 + R2 on a lighting circuit that uses Edison Screw lampholders, you can check the correct polarity on the

centre pin of the lamp holder.

The final test is Zs at each point on the circuit, with the highest reading recorded.

For similar content please go onto the *Electrical Times's* website:

www.electricaltimes.co.uk
Electrical Times is EW's sister publication.



PROS AND CONS

- ✓ Three Insulation voltage test pressure 250,500 and 1000 VDC
- ✓ One hand operation (very important up ladders!)
- ✓ Uses only 4 AA cells for power
- ✓ Very fast test result capture
- ✓ Clear display with instant audible good or bad indication
- ✓ Good quality test leads supplied as standard
- ✓ Good value for money
- ✗ Use of SFS (Super Fast System) not immediately obvious (although once familiar with results, it is super fast)
- ✗ Use of hands-free function not explained
- ✗ No carrying strap
- ✗ Front panel difficult to read in poor light conditions

SUGGESTED IMPROVEMENTS

- 👉 Some sort of short form single sheet instructions to allow instant use from new
- 👉 Tool to open 13A socket shutters to avoid having to unscrew sockets from wall to gain access for testing
- 👉 Batteries should be supplied from new



Radio Modules/Modems

www.radiotelemetry.co.uk

Radio Modules/Modems

- Range 100m to 20Km
- Data rates from 10Kbps to 1 Mbps
- RS232/485, MODBUS/TCP. Video
- Visit Us Today On...
www.radiotelemetry.co.uk
<http://www.radiotelemetry.co.uk>



Warwick Wireless Limited . The Manor . Aston Flamville . Leicestershire . LE10 3AQ

Tel : +44 (0) 1455 233616 . Fax : +44 (0) 1455 233 179 . Email : sales@radiotelemetry.co.uk

PLEASE ENSURE YOU TELEPHONE TO CHECK AVAILABILITY OF EQUIPMENT BEFORE ORDERING OR CALLING MISCELLANEOUS CLEARANCE STOCK

OSCILLOSCOPES	Dranetz 606 Line Distribution Analyser.....	£35	HP 37204 HPiB Extender.....	£10	Megger 1000V X2 Wind Up.....	£10
Tektronix 465B Dual Trace 100MHz Delay fitted into 19" rack frame.....	Wayne Kerr B601 Radio Frequency Bridge.....	£25	Hatfield 2115 Attenuator 75ohm 100dB.....	£10	Edgcombe 30A Clamp Meter Analogue.....	£10
HP 1740A Dual Trace 100MHz Delay (no lock).....	Feedback TFA607 Transfer Function Analyser.....	£25	Hatfield 2115R Attenuator 75ohm 100dB.....	£10	Linstead G1000 Generator 10MHz Sine/Sq/CMOS/TTL.....	£20
HP 1741A Dual Trace 100MHz Analogue Storage.....	Wavetek 52 Data Multimeter.....	£60	Hatfield 2118R Attenuator 75ohm 100dB.....	£10	Circulimate FG2 Function Generator 1Hz-2MHz.....	£30
HP 1744A Dual Trace 100MHz Analogue Storage.....	Gould S9200 RF Signal Generator.....	£20	Tektronix 1103 Tekprobe Power Supply.....	£10	Klippon UT2 Combi Check.....	£10
Philips PM3264 4 Ch. 100MHz.....	Chatillon Force Meter.....	£15	Level TG301 Function Generator 1MHz Sine/Sq/Tri.....	£30	AVO 1200R Clamp meter 0-500V 0-1200A Analogue.....	£10
Gould OS3000A Dual Trace 40 MHz.....	Alfred E105 Variable Attenuator 4-8GHz.....	£20	Solartron 7045 Digital Multimeter.....	£30	AVO TT189 Inst. Transistor Tester.....	£10
Trio CS1040 Dual Trace 40MHz.....	Cammetric 6 Decade Resistance Box.....	£15	HP 8404A Levelling Amplifier.....	£15	Thurby Thandar T102 Func. Generator 2MHz.....	£25
Golstar OS9200R Dual Trace 20MHz.....	Sullivan C8710 Precision 5 Decade Capacitor Box.....	£20	HP 3455A Digital Voltmeter.....	£50	Farnell ES01 Programmable Attenuator 500MHz.....	£15
Iwatsu SS5702 Dual Trace 20MHz.....	Marconi 60333 Waveguide.....	£20	Feedback FM610 Digital Frequency Meter.....	£25	Farnell ES01 Oscillator 1MHz.....	£15
Kikusui COS5020 Dual Trace 20MHz.....	Marconi 2169 Pulse Modulator.....	£20	Farnell TMS True RMS RF Millivoltmeter.....	£40	Tequipment CT71 Curve Tracer (Broken Knob).....	£20
POWER SUPPLIES	Marconi 2430A Frequency Meter 80MHz.....	£30	Thurby 1503 Digital Multimeter.....	£15	HP 5004A Signature Analyser.....	£20
Farnell L30BT 0-30V 0-1A Twice.....	Marconi 6950 RF Power Meter - No head.....	£35	Sullivan 6666 Milliohmmeter.....	£15		
Farnell L30AT 0-50V 0-500MA Twice.....	Marconi 6960 RF Power Meter - No head - Digital.....	£50	K&L Tunable Bank Reject Filter.....	£15		
Farnell L30 0-30V 0-2A Scruffy.....	HP X382A Variable Attenuator Waveguide.....	£20	Barr & Stroud EF4-01 Bank Pass Filter 1Hz-100KHz.....	£15		
Farnell L30-1 0-30V 0-1A Twice Scruffy.....	HP 5316A Counter.....	£50	Barr & Stroud EF4-02 LPHP Filter 1Hz-100KHz.....	£15		
Farnell L30-1 0-30V 0-1A Scruffy.....	HP 8750A Storage Normalizer.....	£60	Fluke 8810A Digital Multimeter.....	£30		
Farnell L308 0-30V 0-1A.....	HP 9079 Co-axial Sliding Load.....	£20	Fluke 8502A Digital Multimeter.....	£25		
Farnell L30AT 0-50V 0-500MA.....	Programma TM2 Timer.....	£20	Electronic Visual EV4040 TV Waveform Monitor.....	£20		
Farnell C1 0-50V 0-1A - 2 Meters.....	Racal 9009 Modulation Meter.....	£40	Tracer Northern TN1750.....	£30		
Farnell T0PS1 5V 1A +/- 15V 200MA.....	Texcan SAS0 102dB in 10B steps.....	£15	RS 555-279 UV Exposure Unit.....	£10		
Farnell L8500.2 0-30V 0-5A - 2 Meters.....	Bird 8341-200 Coaxial Attenuator 200B 40W 50ohm.....	£15	Varian VZL-6941F1 Travelling Wave Tube Amplifier.....	£60		
Countant LA200 2 0-3V 0-2A - 2 Meters.....	Bird 8341-200 Coaxial Attenuator 200B 40W 50ohm.....	£25	Moore Read SFC5000F AUXR Static Frequency Converter 120 Volts 400 Hz.....	£50		
Countant L01200 0-15V 0-2A - Twice.....	Wattmeter 6 & 30W 50ohm 30-50MHz.....	£40	Drager 21/31 Multi Gas Detector.....	£10		
Countant L01500 0-30V 0-1A Twice.....	Telonic TTF95-5-SEE Tunable Band Pass Filter.....	£20	Philips PM8237B Multipoint Data Recorder.....	£10		
Countant L015050 0-30V 0-500MA.....	Telonic 190-3EE Tunable Bank Reject Filter 125-250.....	£15	Endeuso 4417 Signal Conditioner X 2.....	£10		
Weir 761 0-30V 2A or 0-15V 4A.....	Telonic 195-3EE Tunable Bank Reject Filter 60-126.....	£15	PM1030 D14 Display with 1038-N10 Network Analyser.....	£30		
Weir 762 0-30V 2A or 0-15V 4A.....	Helper Inst CML1 Snadder.....	£30	Heads.....	£50		
Weir 431D 0-30V 1A - 5V 4A.....	Helper Inst S103 Snadder 3.....	£30	Megger M44MK2 Wind Up 1000V MOhm.....	£15		
Weir 400 0-0V 0.3A - 10V 1A.....	SXP110 Parallel to Serial Converter.....	£10	Melrohm 250V Pat Tester.....	£15		
Weir 460 0-60V 0.3A - 20V 1A.....	Micromaster LV.....	£40	Sullivan AC1012 4 Decade Resistance Box 0.05%.....	£10		
HP 6266B 0-40V 0-5A 2 Meters.....	Dataman S3 Programmer.....	£50	Brandsenbrun 020 Static Freq Converter 110/240V input 50/60Hz Output 115V 400Hz 20VA.....	£40		
HP 6256B 0-10V 0-20A 2 Meters.....	RS 424-103 Logic Pulser.....	£5	Narda 706 Attenuator.....	£10		
HP 6111A 0-20V 0-1A.....	Global S01 Shortcircuiter.....	£20	Analogic Associates X800 Audio Amplifier 800watt (400w per Channel no DC Protection).....	£60		
HP 6235A 6V 1A +/- 19V 200MA.....	Murhead A-6-B Resistance Box.....	£10	W&G PCG2 PCM Channel Generator.....	£30		
Kingshill 36V2C 0-36C 0-2A.....	Racal 9917A UHF Frequency Meter 10Hz-560MHz.....	£45	Sivers Lab 12400 - 10000 MHz.....	£10		
Marcon TF2158 0-30V 0-2A Twice.....	Racal 9915M UHF Frequency Meter 10Hz-560MHz.....	£40	Cropico V510 DC Standard 10V.....	£30		
Lambda 422FM 0-40V 0-1A Twice 4 Meters.....	Racal 9915M UHF Frequency Meter 10Hz-560MHz.....	£30	Dave 14050 Sound Level Meter.....	£15		
Lambda LK345A FM 0-60V 0-10A 2 Meters.....	Racal 9901 Universal Counter Timer DC-50MHz.....	£15	Cambridge 44228 Bulk Stress Monitor in Wooden Case.....	£30		
Syston Donner SH400-240-40V 0-2A - 2 Meters.....	Racal 9900 Universal Counter Timer 30MHz DC-30MHz.....	£15	Weirklife Model 6 Bulk Eraser.....	£10		
Sorenson SRL60-4 0-60V 0-4A.....	Wavetek 136 VCG/VCA Generator.....	£20	Caseila T8620 Heat Stress Monitor.....	£20		
Grenson BP04 +/- 5V 2.5A +/- 15V 0.5A.....	HP 435A Power Meter - No lead no head.....	£15	Negretti 0-55C Drum Recorder.....	£20		
RS 813-991 2 x 5v 2.5A or 2 x 12V 1.5A or 2 x 5V 1A.....	HP 8015A Pulse Generator.....	£30	Sageh 125 Series Drum Recorder.....	£20		
RS 208-197 Line Voltage Conditioner - Output 240V 0.65A.....	HP 4036 AC Voltmeter.....	£15	Sato Keiryoku NS307 Hydrothermograph Dual Channel -15c to +40c.....	£30		
Power Conversion PLC1000 Line Conditioner 1000VA.....	D-Log PR415 Phase Rotation Indicator.....	£10	OK Industries CECC00-015 Surface Resistivity/Resistance to Ground Meter - No Probe.....	£10		
Hartyn Automation PPS5200 System Power Supply.....	Rayovod D2000 Digital Indicator.....	£10				
Powerline LAB807-0-300V AC 0.75A.....						
Power Supply Model 12030 0-20V 0-30Amps - On Wheels.....						
Harmer Simmons 50/25/110 Input 240V 250 VA Output 240V 100VA.....						

SPECIAL OFFERS

Oscilloscopes	LECRYO 9400A Dual Trace 175MHz 5GS.....	£500
LECRYO 9400 Dual Trace 125MHz.....	£400	
TEKTRONIX 468 Dual Trace 100MHz Digital Storage.....	£300	
TEKTRONIX 475 Dual Trace 200MHz Delay Sweep.....	£250	
TEKTRONIX 465B Dual Trace 100MHz Delay Sweep.....	£250	
TEKTRONIX 465 Dual Trace 100MHz Delay Sweep.....	£175	
PHILLIPS PM3217 Dual Trace 50MHz Delay Sweep.....	£150	
THURBY PL2020MD 0-30V 0-2A Twice Digital PSU.....	£160	
H.P. 66312A 0-20V 0-2A Communications PSU.....	£200	
H.P. 6623A 3 Outputs PSU 0-7V 0-5A or 0-20V 0-2A 0-20V 0-2A or 0-50V 0-0.8A 0-7V 0-10A or 0-20V 0-4A.....	£425	
HP 6626A Precision High Resolution PSU 4 Outputs 0-7V 0-15MA or 0-50V 0-0.5A Twice 0-16V 0-0.2A or 0-50V 0-2A Twice.....	£500	
CIRRUS CRL254 Sound Level Meter with Calibrator 80-120dB LED.....	£35	
WAYNE KERR B424 Component Bridge.....	£50	
RACAL 9300 True RMS Voltmeter 5Hz-20MHz usable to 60MHz 10V 316V.....	£50	
RACAL 9300B True RMS Voltmeter 5Hz-20MHz usable to 60MHz 10V 316V.....	£75	
AVO DA116 Digital Avometer with Battery and Leads.....	£20	
FARNELL LF84 Sine/Sq Oscillator 10Hz-100KHz low distortion TTL Output Amplitude Meter.....	£75	
FARNELL 13B Sine/Sq Oscillator 10Hz-100KHz Low Distortion.....	£60	
HEME 1000 LCD Clamp Meter 0-1000A in Carrying Case.....	£35	
FLUKE 77 Multimeter 3 1/2 Digit handheld with Battery & Leads.....	£45	
KENWOOD VT1762 Channel Multivoltmeter.....	£25	
KENWOOD FL140 WOW & Flutter Meter.....	£50	
KENWOOD FL180A WOW & Flutter Meter.....	£75	
KENWOOD FL180A WOW & Flutter Meter Unused.....	£125	
MARCONI 6960B Power Meter with 6920 Head 10MHz - 20GHz.....	£450	
SOLARTRON 7150 DMM 6 1/2 digit True RMS IEEE.....	£75	
SOLARTRON 7150 Plus As 7150 + Temperature Measurement.....	£100	
IEEE Cables.....	£5	
HP 3312A Function Gen 0.1Hz-10MHz AM/FM Sweep/Sq/Tri/Burst etc.....	£200	
HP 3310A Function Gen 0.05Hz-5MHz Sine/Sq/Tri/Ramp/Pulse.....	£80	
RACAL 9008 Automatic Modulation Meter 1.5MHz-2GHz.....	£60	
ISOLATING Transformer Input 250V Output 500VA Unused.....	£30	
RACAL 1792 Receiver.....	£505	

STEWART OF READING

17A KING STREET, MORTIMER, NR. READING RG7 3RS
Telephone: 0118 9331111 Fax: 0118 9332375
www.stewart-of-reading.co.uk
Open 9am-5pm Monday to Friday (other times by arrangement)



USED EQUIPMENT - GUARANTEED. Manuals supplied.
This is a VERY SMALL SAMPLE OF STOCK. SAE or telephone for lists. Please check availability before ordering. CARRIAGE all units £16. VAT to be added to total of goods and carriage.

In a market where having the newest and best mobile phone is an imperative, Nokia steps out with the 6630. Among its features is a 1.3 Megapixel digital camera, capable of snapping images at a resolution of 1280 x 960. Where the Smartphone really breaks the mould is in its other features. It offers almost-broadband connection speeds, enabled by WCDMA and EDGE, and over an hour of high quality video. These capabilities make the Nokia 6630 a must have item this summer.

Around £329.99

www.nokia.com

or Virgin Mobile at

www.virginmobile.com/mobile



The DSM-320 wireless media player connects your network directly to your living room, allowing you to share, access and enjoy digital media (film, music or photos), without having to sit uncomfortably at the PC. Using D-Link proven technology, the unit allows streaming direct from the PC's hard drive to the media player, outputting through the TV. With a sleek grey design and great functionality, this is sure to be one of the better buys for the home.

£160 excluding VAT

www.dlink.co.uk



The Planon's Docupen is a small and yet a substantial gadget. It looks and feels like a pen, but its sole purpose is hidden beneath a stylish exterior. The world's lightest A4 scanner (Guinness Book of Records 2005) and the most portable around, it scans as you guide the pen over the page in under four seconds, storing up to 100 pages in two megabytes of internal flash memory.

With a USB port, fast and problem-free scanning is available at a very affordable cost. **£114.79**

www.planon.com



Smaller than the average cigarette packet, and lighter to boot, the Samsung Miniket is one device you'd most like to take with you to a desert island. Featuring a camera, camcorder, voice recorder and MP3 player, there's little it doesn't achieve in this small, yet stylish package. With almost one hour of recording time, all those budding James Bond types won't be seen anywhere without this essential piece of hardware.

£600. For Samsung brochure requests, e-mail

brochurerequests@samsung.com

2GHz full-performance RF Generator



£2,195

The new TGR2050 is a synthesised signal generator with a frequency range of 150kHz to 2000MHz.

Excellent frequency accuracy is matched with high stability, wide dynamic range, low phase noise and low leakage.

FM, phase and AM modulation modes are incorporated along with RS232 and GPIB (IEEE.488.2) interfaces.

The TGR2050 provides the most cost effective solution available for engineers needing a wide range high performance RF source.

- ▶ 150kHz to 2000MHz frequency range with 10Hz setability
- ▶ -127dBm to +7dBm amplitude range with 0.1dBm setability
- ▶ Better than 1ppm internal accuracy; external frequency lock
- ▶ FM, Phase and AM modulation, internal or external source
- ▶ Direct numeric entry or rotary control with user settable frequency and amplitude increments
- ▶ Non-volatile set-up memories for repetitive testing
- ▶ Full remote control via RS-232 and GPIB interfaces
- ▶ Unrivalled performance and features at this price level !

For applications with a narrower frequency requirement a 1GHz generator, the TGR1040, is available for around £1,200 .

For full details of both generators, please contact us directly, visit our website, or circle the reply number below.



Measurably better value

Thurlby Thandar Instruments Limited

Glebe Road, Huntingdon, Cambridgeshire PE29 7DR

Tel: 01480 412451, Fax: 450409, e-mail: sales@tti-test.com

Web: www.tti-test.com

THURLBY THANDAR INSTRUMENTS

Data Not Easily Accessible?

Radio Data Transfer From XL Systems..... Don't make a mountain out of it!

Your data
is here

remote process control,
telemetry & alarm monitoring ..
.. simple & straight forward
wireless solutions!

WWW.XLS.CO.UK
Tel 01883 622778
Sales@xls.co.uk

XL Systems Ltd

WEB SITE WWW.JOHNSRADIO-UK.COM WWW.JOHNRAIDIO.COM
JOHNRAIDIO ELECTRONICS TEST AND COMMUNICATION EQPT

LARGE QUANTITY SALE EX M.O.D.

MARCONI TF2019A Synthesized Signal Generators - 80Khz to 1040Mc/s
AM - FM - High Class with many functions - £285 each.

TEKTRONIX 2445 A OSCILLOSCOPE 150Mc/s Four Channel £300.

HP COMMUNICATION TEST SET 8922M - 10 - 1000Mc/s + GMS 83220E
Converter 1710 - 1900Mc/s - DCS - PCS - MS £500

HP COMMUNICATION TEST SET 8922M OPT 010(Dual) etc, £750.

ALL UNITS AND PRICED EX WORKS WITH INSTRUCTIONS - TESTED BASIC WORKING. CARR + PACKING IF REQUIRED EXTRA.

Phone for appointment or to request item lists, photos, site map.

All welcome, Private or Trade, sales, workshop repairs or calibration

PLEASE CONTACT PATRICIA AT WHITEHALL WORKS, 84 WHITEHALL ROAD EAST, BIRKENSHAW, BRADFORD, WEST YORKSHIRE, BD11 2ER.

Tel: 01274 684007 Fax: 01274 651160

WEB SITE WWW.JOHNSRADIO-UK.COM WWW.JOHNRAIDIO.COM

This Magazine reaches over
10,000
potential customers
To advertise in this space call
Ed on
01322 611260



SPLINTER CELL: CHAOS THEORY

GameCube, PS2, Xbox, PC

★★★★★

Sam Fisher's latest outing comes under the moniker of Chaos Theory, the third installment in the Splinter Cell series. Although the main premise of the game hasn't changed, it's the subtle differences that you'll notice. Immersing the player in the game is achieved more so than before by the removal of cut scenes, with every 'would be cut scene' happening real-time in-game, triggered by the events or routes you take through each level. Online co-operative modes are also a welcome addition to the series, bringing a return to form, for a game that continues to be the leader in the stealth action genre.

DOOM3

Xbox

★★★★★

Make no mistake, Doom 3 was one of last year's biggest releases on the PC. Developer Vicarious Visions, under the strict guidance of id Software, has taken on the mammoth task of converting the PC masterpiece into an epic for Xbox. The visuals are striking, the atmosphere mesmerising and the action almost unbelievable. That said, it does feel a little 'last year'. Certainly, it looks great and



plays wonderfully, but there's just nothing that defines it from the PC version – that is until you connect to Xbox Live. Featuring an exclusive co-operative game of a kind, not seen before in videogames, and even more players in deathmatch mode than the original PC release, the game really comes alive online. Squeezing every little drop of power out of the Xbox, this game will soak up every spare hour from your free time.

SPY VS SPY

GameCube, PS2, PC

★★★★☆

Almost twenty years after the first series of Spy vs Spy games on 8-bit systems, one of MAD Magazine's most successful franchises takes another stab at videogames. The original games were known for their graphical flair and multiplayer mayhem, and this latest

update doesn't fail in either of those departments. With its unique look, true to the original yet oddly impressive in its new 3D environment, fans of the magazine and the original games alike will be happy and, no doubt, planning their next move – be they black or white spy.



ESPN NBA 2K5

Xbox, PS2

★★★★★



Following on from 2004's successful ESPN basketball title, this year's iteration looks set to improve further on an already growing franchise. Featuring vastly improved graphics and AI, fans of the series will really notice the difference. The game's level of detail raises the bar in an increasingly crowded market, with the ESPN License allowing for new camera angles, greater stats levels, even more commentary than before, plus a polished

look that puts other sports games to shame.

The gameplay itself is fast and furious, with varying speed and difficulty settings, allowing new users to ease their way into the game, and more advanced users to jump in at the deep end. If its season mode you're after, multiplayer fun or even online matches, the ball is literally in your court. 2K5's multiple options mean you won't get bored of it, any time soon.



Software Defined Radio: Baseband Technologies for 3G Handsets and Basestations

Edited by Walter H.W. Tuttlebee

John Wiley & Sons



This book is part of the Wiley series on Software Radio. Taking the subject further, after earlier books in the series including Walter Tuttlebee's 'Software Defined Radio: Origins, Drivers and International Perspectives', 2002, and 'Software Defined Radio: Enabling Technologies', 2002, the book provides an analysis of SDR baseband processing requirements of 3G. The authors drill down to examine new technology that should allow SDR to come into its own.

According to the Software Defined Radio Forum, an SDR (or simply just Software Radio) is a radio that has software control over a variety of modulation/demodulation techniques, wideband or narrowband operation, communications security functions (such as hopping), and waveform requirements of current and evolving standards, over a broad frequency range.

Ideally, an SDR is a radio that:

- ❖ has hardware so generic that can be programmed to handle any modulation format, signal bandwidth and frequency desired;
- ❖ has functionality that can be altered at will by downloading new software;
- ❖ replaces traditional analogue sub-circuits with digital implementations;
- ❖ can perform adaptive signal processing and other operations to obtain clear communications within congested radio bands, to a degree not feasible with hardwired circuitry alone;
- ❖ can automatically recognise and handle various communications signal formats and protocols.

If you are not directly involved in mobile phone or communications radio design, you might think SDR is a nice concept whose time has not yet come. But SDR is arriving by stealth. The processing needs of 3G and beyond are increasing at a rate much higher than the development of silicon density, which follows Moore's Law. Power consumption is a big issue, especially with handsets. And with established design processes, time to market is too long. So it's time for rapid and significant innovation and the book outlines many directed at SDR.

Part I or Requirements, defines the book's scope and outlines what is driving the 3G industry into SDR. Following chapters are grouped into two parts: Part II, describing technologies aimed at handsets/terminals, and Part III, aimed at base stations. Each chapter was written by application engineers or marketing managers from chip manufacturers and fab-less design houses.

Part II comprises:

- Chapter 2:** Open Mobile Handset Architectures Based on the ZSP500 Embedded DSP Core, describing the ZSP500 silicon from LSI Logic;
- Chapter 3:** DSP For Handsets: The Blackfin Processor; describing the Analog Devices's (ADI's) Blackfin silicon;
- Chapter 4:** XPP – An Enabling Technology for SDR Handsets; describing the PACT XPP Technologies's XPP processing core available for license to manufacturers;
- Chapter 5:** Adaptive Computing as the Enabling Technology for SDR; describing QuickSilver Technology's Adaptive Computing Machine based on fractal architecture of linked computing nodes and its SilverC programming language.
- Chapter 6:** The Sandbridge Sandblaster Communications Processor; describing Sandbridge Technologies's Sandblaster silicon design and its compiler. This chapter includes compiled code benchmarks against other processors.

Part III comprises:

- Chapter 7:** Cost-Effective Software Radio for CDMA Systems, describing Texas Instruments's view of SDR issues, and an overview of the TCI platform incorporating the TCI100 DSP and TCI110 coprocessor;
- Chapter 8:** DSP for Basestations – The TigerSHARC, describing ADI's TigerSHARC general purpose DSP family claimed to have features that make suitable for basestation SDR.
- Chapter 9:** Altera System Architecture Solutions for SDR, describing Altera Corporation's views on the place for FPGAs in SDR, now and in the future and some information about how FPGAs can be enhanced for the job, e.g. with DSP elements along with the usual logic and

RAM. An overview of the FPGA design process and tools is included, as well as DSP function libraries for programming FPGAs. Basic information on Altera FPGA families is given.

Chapter 10: FPGAs: A Platform-Based Approach to Software Radios, describing a Xilinx view of how FPGAs programmed as signal processors can be used in SDR; an overview of DSP elements in Xilinx FPGAs, an overview of programming tools; the role of Hardware Description Language (HDL); and a quite informative discussion of actual signal processing implementations.

Chapter 11: Reconfigurable Parallel DSP – rDSP, describing Morpho Technologies's (a Californian design house that licenses silicon designs to chip manufacturers) view on how re-reconfigurable DSPs and system-on-a-chip can provide good solution for basestation SDR. This chapter is also a very informative and complete survey of the tasks and algorithms required for SDR processing.

Chapter 12: The picoArray: A Reconfigurable SDR Processor for Basestations, describes picoChip's massively parallel microprocessor arrays, which are integrated with DSP coprocessors, RAM, Multiply-Accumulate cells and other functions useful for SDR. The chapter gives a good summary of design issues of various approaches to SDR.

Part IV covers the Impact of Technological Change that relates market forces to the enabling technologies set out in the earlier chapters to identify trends.

While much of the book is of a marketing nature, with information that is downloadable from company websites, its value as a technical reference does go quite beyond that. It is of value in presenting what's happening, what will happen and how it will happen, in one volume. The book is intended for 3G product design engineers. It is also a 'must buy' if you manage 3G product design or you work for a telco involved in rollout of 3G and beyond.

Read it if you have any engineering interest in radio, as the technologies covered are certainly flexible enough for other applications known and not yet known.

Pam Creed



Harmony

— who needs it?

By Mike Brookes

For over four years the Short Range Device (SRD) industry has been engaged in writing a new harmonised standard for RFID (Radio Frequency Identification Devices) in the UHF band 865-868MHz. This standard has been eagerly awaited by brand name superstores worldwide as a catalyst for 'tagging' of product pallets and cases to speed up and control better the movement of consumer products.

The labyrinthine European process for driving the standard (EN 300 302) has involved the main drafting group ETSI TG34 in meetings up to three times a year, all over Europe. These meetings have been attended by in-depth navel inspections for compatibility, with other devices sharing the same band (WG SE24) and multiple deliberations about the effective use of radio spectrum (WG FM

and the Short Range Device Maintenance Group). This has also exposed the completed standard to public enquiry and resolution of all comments received, so that, by the beginning of 2005, ETSI was able to declare the standard 'approved'.

One may feel this would be the final hurdle before

al 'air interface' regulations and invokes national rules to enable the standard's introduction, with minimum delay.

In May this year, out of the 25 EU states just six – not including the UK – have done the deed. The remainder are still pondering it and, in some cases, not even thinking about it.

'common market' a competitive reality might produce a positive result.

No one doubts the commitment of individual representatives from both the industry and the Member State Radio Administrations in drawing up the new standards, but the outcome, in many cases, is poor. Meanwhile, our cousins in the US and Asia continue to pull ahead without the dead weight of European bureaucracy to restrain them.

In the following issue we will examine the status and intent of 'nearly' harmonised standards.

“ Given that the whole objective of harmonised standards is to achieve that great goal of a common market with no restrictions to the free movement of goods within it, the reality is laughable ”

the industry and clients could benefit from its publication – in all official European Union (EU) languages in the Official Journal (OJ), which stimulates each member-state to adopt the harmonised standard, allowing unhindered access to its market.

At least, that's the theory. In practice, each member state determines its individu-

Given that the whole objective of harmonised standards is to achieve that great goal of a common market with no restrictions to the free movement of goods within it, the reality is laughable. Industrial concerns that have spent millions on R&D and marketing, might expect that the vast sums spent by bureaucrats in making the

The LPPA (Low Power Radio Association) is a European trade body that represents manufacturers and users of short range devices (SRDs).

It is active in the production of SRD Radio standards and regulations.

Mike Brookes is LPPA's chairman.

Wireless Software Solutions

Firmware revision 2.1

Jan 05

Designed and manufactured in the UK by LPRS Limited, Witney, OX28 4BH
Tel: 01993 709418
Email: info@lprs.co.uk

If Bluetooth, 802.11, Zigbee, UWB etc don't suit your wireless application – "easy-Radio" will.

ER modules are embedded with all the wireless software you will need to achieve a short range wireless link over several hundred metres at speeds up to 19.2K over air.

New robust software ensures stability of user selected frequency, data rates and output power, configurable via Windows based software.

Go to our website to order an evaluation/programming kit and use our online calculator to see how time is saved and revenue returned faster with "easy-Radio" software solutions.



www.easy-radio.com/ew1



Thanks to you all

On behalf of Redeem, the mobile phone and printer cartridge recycling company, I would like to say a heartfelt thank you to everyone who has given their support to our recent Tsunami Recycling Appeal. Your readers have helped us raise over £5,000 for the Disasters Emergency Committee's (DEC's) Tsunami Earthquake Appeal. Those who helped the appeal were one of over 100 companies and more than 1,900 individuals.

We asked the public to send us their old mobile phones and empty printer cartridges to be recycled, in return we pledged to give money to the DEC. We are delighted with the response so far, with our total currently standing at £4,300 and as a company committed to charity work, we have contributed a further £700. This money will go to areas affected by the disaster via the DEC's member agencies, with the DEC ensuring it reaches those who need it most.

The DEC is appealing for outstanding donations to be banked, so if you requested a freepost bag to donate a mobile phone or cartridge, please endeavor to return it as soon as possible.

Although the Tsunami Recycling Appeal is coming to a close, there are other opportunities to help charities and the environment through recycling. Many of the UK's charities felt an impact on their funds when public attention was diverted to the tsunami disaster – so now's your chance to help. Our

partners include Marie Curie Cancer Care, Royal National Institute of the Blind, Children's Hospice Association Scotland, Roy Castle Lung Cancer Foundation, Northern Ireland Hospice Care and the Royal Society for the Protection of Birds. For further information visit recyclingappeal.com and choose a charity, or call 08712 50 50 50.

Thanks once again for your support.

Rob Morton

Corporate Responsibility Executive
Redeem Plc
UK

The myth of input impedance

Let's have a look at one common circuit, namely the standard 4-resistor, 1-OpAmp differential or difference amplifier. Very many manuals (like National Semiconductor's Linear Application Handbook, AN-20, AN-29 etc.) state that the input impedance at the inverting input is equal to the input resistor (R_1 , from source to inverting input node of OpAmp), without mentioning any exceptions. I argued about this a while ago and was told that the case was the standard one, where the inputs are equal but in opposite phase. This leads to the input impedance being equal to $2/3$ of input resistance, R_1 .

If both inputs are driven by the same signal (equal phase, equal amplitude, AC or DC), then the impedance is equal to the sum of the two resistors. Finally, if the non-inverting input is driven by 10 times the inverting input (opposite phase, 10 times amplitude), then the input impedance (again, at the inverting input only) is $1/6 \times R_1$. These calculations are easily verified by any Spice-related simulators.

Obviously, we must come to the conclusion that the impedance at the inverting input is not equal to R_1 , neither constant, but depends on magnitudes and phases of both input voltages and is, therefore, largely variable.

Here's also a question, what is the impedance, when both inputs are random or noise?

E-P Mänd

Helsinki
Finland



Impending barriers?

The Editor suggests in her comment 'Consumer Leads the Way' in the May issue (p3) that the future of computers and electronics will be led by the customer as opposed to the scientist inventing things just for the sake of inventing them. I agree, in our generation that is probably the way it has to be. But it poses another question – are we approaching the customer barrier? The latest PlayStation portable allows you to play games, watch movies and listen to music with IEE802.11 wireless interconnectivity. It is the size of a portable CD player. A long way above 'Pong' from 1975 – a plug-in TV video game, but what will such devices be like in 30 years' time? As a consumer, I cannot imagine wanting my portable video/music/games console to do anything more than this device actually does.

In five years' time we may have reached the limits of Von Neuman computers and be

developing Ivor Catt parallel processors. In ten years' time we may have reached the limits of silicon transistors – even with the help of Ivor Catt, whose kernel machines may make them work a while longer. Then, we will have the carbon nanotubes but, if this is consumer-led technology, what will the consumer do with nanotubes? We already have four dimensional computer games played as quickly as most operators can play them – a peculiar word invented by programmers to confuse mere mortals, four dimensional images are simply three dimensional images that change over time. Original 3D was static. Can anyone think of a fifth dimension to add to a computer game? We already watch video clips and listen to music on our mobile phones. Can anyone think of something else they want to do with one? What do we do when electronics and computers can do everything the consumer wants them to do? What then?

Malcolm Lisle

Gateshead
UK

Editor, Svetlana Josifovska, replies: *Malcolm Lisle's observations are correct, however, the comment in May reflects the state of play of the electronics industry today and in no way does it try to predict the future, whether in five, ten or 30 years' time. Companies that are developing technologies today are all telling the same story – the key driver of developments now is not a technology push or marketing pull but the end users themselves – the consumer is driving demand. As in any evolution, this key driver will change yet again.*

Technology – such as nanotubes, for example – will, no doubt, start pushing bound-

aries further when time comes, offering new opportunities we can hardly envisage at present. For now, let's allow the industry to enjoy this ride.

Final word on the Catt Anomaly

My article on the Catt Anomaly seems to have rekindled considerable interest in the topic. Readers who may have missed it can find it by following the "technical stuff" link at www.ianhickman.org.uk.

Ray Lee's letter in the April issue (p49) raises the question of finite switch closure. This is irrelevant to my argument, which is an Einstein-style "thought experiment". Ray's "net drift rate of zero" is precisely what I meant, neither more no less, when I said that the conduction band electrons could be considered as effectively at rest. The rest of his letter contains some very telling and interesting points, which will keep us all puzzling for quite a while.

The forces between electrons, and between those and their "parent" atoms, may be mediated by the exchange of "photons" or other "messenger" particles, as suggested to me by Erik Margan of the Experimental Particle Physics Department, Institute "Josef Stefan", 1000 Ljubljana, Slovenia.

Alternatively, as Len Cox suggests, further development of string theory may throw light on the subject, for those with sufficient mathematical ability to follow the arguments.

Ian Hickman
UK

Invisible breed

We live in a world that welcomes our products whilst oblivious to the fact that electronics exists as a profession. Electronics is an enabling technology, now essential to the realisation of many human aspira-

tions, whilst electronics professionals are an invisible breed.

Misapplication of electronics is as likely as effective application, with electronics professionals receiving much of the blame for problems and accepting responsibility for repairing the damage, when the "unexpected" happens. This is, largely, our fault, since we tend to enjoy the technology more than we do the human interactions. It is difficult for electronics professionals to keep up with electronic developments, whilst developing the status to deal with people issues, such as legislation, regulation, politics, markets, the media and popular prejudice, for example. Nevertheless, to improve the effectiveness and perceived value of electronics technology, it has to be done at all levels and in all sectors of electronics application, particularly, if we are to attract new blood to the profession.

Take one crucial example: the global thirst for the electricity required to power the things we make. We are told that the only viable alternative to fossil fuel is nuclear power and, yet, the prospects for housing and controlling sufficient nuclear power generation capacity to satisfy global demand are almost too terrifying to contemplate.

Or are they? We have known for a long time that the problems experienced by any system are, themselves, a function of that system and the manner in which it is used. Surely, there is a way to engineer nuclear power generation so that it doesn't present such a great threat to the environment and society? Safety measures are bound to be electronic-based, so who is better equipped to define them than the electronics professionals

who will design and make them? So, come on electronic engineers, get your thinking caps on.

One possibility I would contribute is to site small nuclear power stations deep down under every city situated in a geologically stable area. The small quantity of nuclear waste produced, would be kept on-site forever. This arrangement would reduce, to vanishing point, many of the potential problems associated with nuclear power generation and make any residuals more easily controllable.

On a more light-hearted tack, many thanks for continuing with the long tradition of EW/WW for informing, educating, stimulating and entertaining. I do like Circuit Ideas in particular. I try many of them out, often with remarkable results.

Bryce Kearey
Crowthorne
UK.

Breaking the taboo

Gamal Ali Labib's article "Data manipulation processor", Electronics World, May 2005, page 20, collides with a 40-year long taboo. Already in New Scientist in 1969, I was arguing for the content addressable memory (ivorcatt.org/icrns69mar.htm). I continued in Electronics World, June 2003, (ivorcatt.org/icrew2003jun_0001.htm).

It is possible that arguments such as Gamal's could break the logjam, but very unlikely. Society's commitment to having only one processor is very strong.

On a separate note, I was very interested to read Dr Thanh Tran's article on high-speed digital hardware in Electronics World, April 2005, p32.

Ivor Catt
St. Albans
UK



Raising VC funding

- ▶▶ Make sure your product and/or service solves a real commercial problem
- ▶▶ Ensure the size of the market you are addressing is greater than £500m
- ▶▶ Build a management team that will instill investor confidence
- ▶▶ Ensure that any Intellectual Property (IP) is completely defensible and innovative design work protected
- ▶▶ Develop a scalable business model designed to generate revenues of £10m plus per annum within three to five years
- ▶▶ Ensure there is a 'trophy' customer /reseller agreement in place, ideally demonstrating that your product/service is a strategic purchase
- ▶▶ Be aware fund-raising is a minimum six-month process before cash is in the bank
- ▶▶ Build a clear and simple business plan (no more than 30 pages long) covering all the essential points
- ▶▶ Develop a well thought-out Elevator Pitch and a concise Executive Summary
- ▶▶ Team up with an advisor who understands the technology market and has access to an appropriate funding network

Provided by Catalyst Venture Partners. For more information visit: www.catvp.com

If you'd like to send us your top five or ten tips on any subject you like, please write to the Editor at

EWadmin@highburybiz.com

Simple Class D amplifier

This amplifier is meant to be a replacement of a power-wasting amplifier IC in small audio equipment, where the audio needs most of the power for improving battery life. The component count is kept at minimum making the necessary RFI shielding easy. The design is optimised for simplicity, not for power and sound quality.

Constructed with SMD-components, this amplifier needs less than 7cm² and can fit in a metalised matchbox. With a good RFI-shielding, the amplifier can be used inside a portable radio, close to the internal antenna, without interference. Heatsinks are not needed.

Operation

A fast hex-inverter 74AC11004 is used as oscillator and PWM-modulator for driving a complementary Mosfet pair. The oscillator is of the fed-back Schmitt trigger type.

In each switching period, C7 is charged via R3 from the low- to the high- threshold or back, resulting in a oscillating-frequency determined by the input-hysteresis of the 1st gate, supply-voltage of output-stage and product R3·C7.

With the small 0.1V hysteresis of the 74AC11004 and values shown for R3, C7, the frequency is 1MHz at 6V.

While operating at 12V, the frequency will double and C7 should be 470pF to compensate this.

Other inverters as 74AC11004 may have a different threshold, so frequency should be re-adjusted with C7. The chosen 1MHz switching frequency is a compromise between idle power (12mA) and sound quality. Switching at 500kHz is possible too, resulting in half idle-power, a small output ripple and slightly

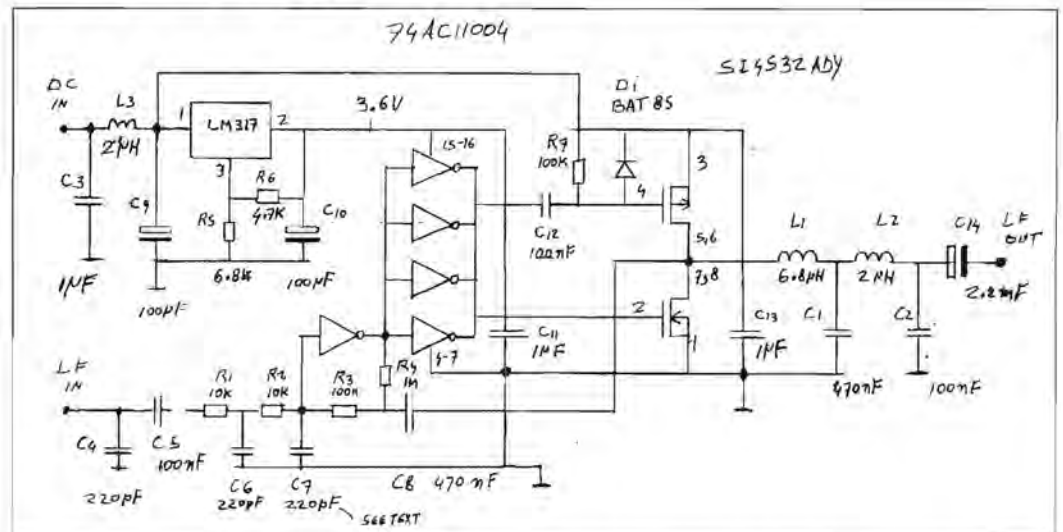

more distortion.

During modulation, the momentary frequency will drop by a factor of 0.35, while the minimum pulse-width will be halved at peak level. The symmetrical triangle signal at the input will turn in an sawtooth signal when modulating.

Output filter is optimised for 4Ω load, but is practically load-independent due to the high cut-off frequency (80kHz).

The components R4 and C8 are added for biasing the symmetry of the PWM-signal, independent of supply voltage. With a supply voltage equalling driver voltage (3-5V), these components can be ignored, resulting in DC feedback from output.

"Difficult" components and construction

The N-type and P-type Mosfets are in one SO8-package. For the SI4532ADY, nowadays there are many replacements. The only important specifications are: low threshold (<3V), low Rds-on (<0.1Ω) and small gate capacitance (< 500pF).

The first output-coil, L1, should be wound on a low permeability iron powder torroid.

Two piled T37-2 cores from Amidon are wound with 29 turns resulting in 6.8mH. These cores with a permeability of 10 are popular among radio amateurs for their high Q and saturation level at RF. The two other coils, L2 and L3, are not critical; you need 22 turns on a single T37-2, or 8 turns on a purple 4C65 ferrite torroid (Ferroxcube) of the same size (9mm).

Most capacitors are not critical. The effect of C5 (100nF) and C8 (470nF) on low frequency cut-off is cancelled if they have the same ratio as the voltage gain (5) determined by R1+R2 and R3. All ceramic capacitors are in a 0805 package. For low RF-emission, the caps C11 and C13 should be placed very short to the supply pins of the 74AC11004 and SI4532, respectively.

The input-line of 1st gate, between R2, R3 should be small to prevent ringing RFI from the output stage to this input, resulting in distortion by pollution of the triangle-wave signal at input.

For effective shielding the caps C2, C3 and C4 should be placed close together at the joint where the three cables leave the shielding. C14 is out-

side the shield.

The driver supply voltage, 3.6V, is derived from LM317. Any other low noise, low power voltage-regulator can be used. When using other Mosfets with a lower gate threshold, the 3.6V driver voltage can be reduced with R5.

The 1st gate draws most of the idle current, so power can be saved by reducing its supply voltage.

Results

At any supply-voltage between 5V and 12V, the amplifier has maximum output voltage of 2·0.4Vsupply, resulting in 0.7W RMS in 4Ω at 6VDC or 3W in 4Ω at 12VDC. The power efficiency is > 90%. The idle current is 12mA at 1MHz.

Voltage gain: 12 dB. Sound quality: <0.1 % THD at half level to 0.4% just below clip-level (at 1MHz).

As usual with Class-D amplifiers, the distortion is reduced proportionally at lower levels, in contrast with Class-AB.

Frequency response before C14 is almost flat (within 1dB) between 10Hz and 50kHz.

Paul Rebers
Enschede
Netherlands

Permanent-magnet DC motor controller without feedback

The simplest equivalent circuit of a DC motor is shown in **Figure 1**.

The relationship between the speed, torque and the internally generated voltage are governed by:

$$T = k\phi I_a \quad E = k\phi\omega$$

These can be solved in terms of the terminal voltage and speed to yield,

$$E(V, T) = E_o + \Delta V - \frac{R_a \omega_o}{E_o} \Delta T \quad (1)$$

$$\omega(V, T) = \omega_o \left(1 + \frac{\Delta V}{E_o} \right) - R_a \left(\frac{\omega_o}{E_o} \right)^2 \Delta T \quad (2)$$

Where E_o and ω_o are the nominal values (or the required operation point), ΔT is the change in load torque and ΔV is the change in terminal voltage.

Equation (1) can be represented by the equivalent circuit shown in **Figure 2**.

The control circuit

To get $\omega = \omega_o = \text{constant}$, from **Equation 2**

$$\omega_o = \omega_o \left(1 + \frac{\Delta V}{E_o} \right) - R_a \left(\frac{\omega_o}{E_o} \right)^2 \Delta T$$

Which yields:

$$\Delta V = R_a \left(\frac{\omega_o}{E_o} \right) \Delta T$$

This change in the terminal voltage is simply to compensate for the voltage drop across the armature windings resistance (this simplified model does not take into account the armature reaction effect).

In real time, to sample the voltage drop across the armature winding resistance " R_a " we have to insert an external resistance " R_s " in series with the motor circuit (Figure 3). This resistance will add extra voltage drop which must be added to the one caused by " R_a ". This is done via U1:C, mathematically, this means:

$$R_s \left(1 + \frac{R_1}{R_2} \right) I = (R_a + R_o) I$$

$$\left(\frac{R_1}{R_2} \right) = \frac{R_o}{R_s}$$

R_4 must be chosen in such a way that,

$$\left(R_s I_{\min} + |V_{os}|_{\max} \right) \left(1 + \frac{R_1}{R_2} \right) > V_{o\min}$$

where, I_{\min} is the minimum load current, $|V_{os}|_{\max}$ is the maximum offset voltage, and $V_{o\min}$ is used to set the minimum output voltage of the operational amplifier. The complete control circuit is shown in **Figure 3**.

TL431C is a shunt regulator which is used to set the desirable no-load internal voltage (E_o)

Figure 1

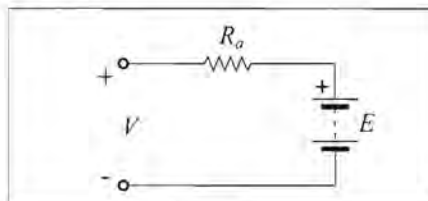
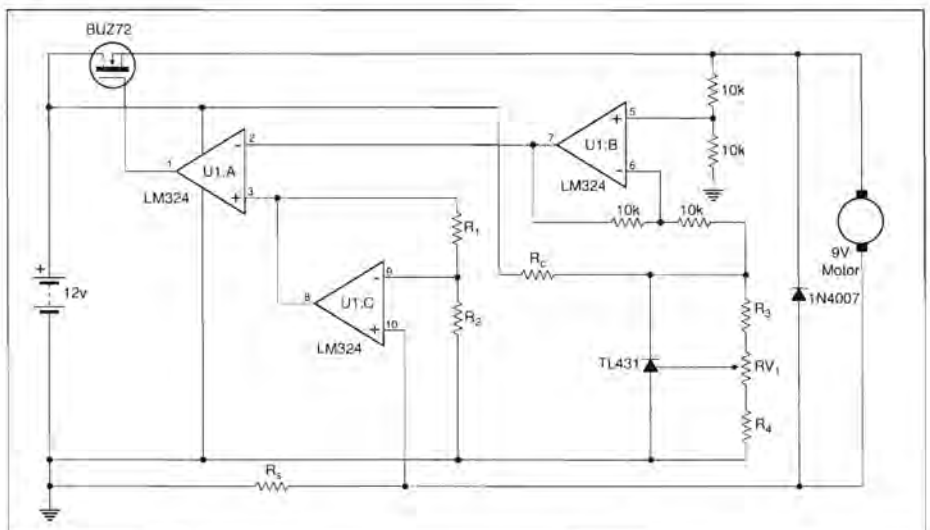

Figure 3



$$V_{o\min} = 2.5V \times \left(1 + \frac{R_1 + \alpha R_{v1}}{R_4 + (1-\alpha)R_{v1}} \right)$$

where α is the wiper setting of RV1. R_o will provide the bias current for the regulator, must be $>1\text{mA}$ at minimum V_{Batt} . U1:B will provide the required voltage difference between E_o and V_{terminal} . U1:A will compare the two signals and set the terminal voltage accordingly.

M Mohammed
Cardiff
UK

Figure 2

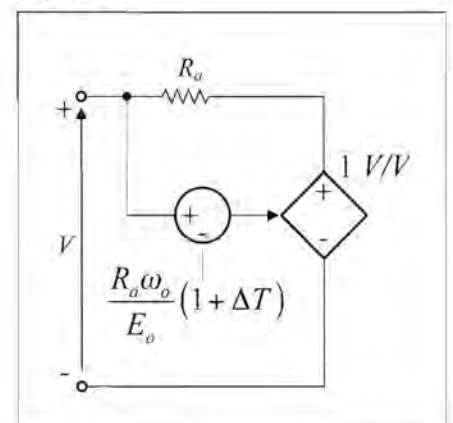

UHF combiner/splitter with 4 inputs and 4 outputs

It is easy to buy a "low-loss" splitter to take one UHF (or VHF) signal and produce two outputs, but seemingly impossible to find a low-loss passive unit to combine four signals and provide four outputs.

Figure 1 is a fairly well known two-transformer device for two inputs and two outputs, which, unfortunately, needs non-integer turns ratios for perfect impedance matching.

Figure 2 is my design for a properly matched 4-input 4-

output combiner/splitter, but still with only two transformers – has anyone else come across this simple solution? The sources and loads, and their connections, have been omitted for simplicity in this figure. Each output gets half of the voltage from each input, provided all inputs and outputs are terminated in the same resistance (typically 75Ω). The transformers have 1+1:1+1 turns; I used Maplin N03AC ferrite beads and enamelled wire.

The device dimensions should be kept small so as to be negligible compared with a wavelength at 850MHz (380mm). I made two square supporting rings, with an outward-facing coaxial socket in the middle of each section. One ring was fixed on top of the other but turned by 45 degrees (diamond on square), and the beads went in the middle. The device is broadband, so Input 1 could be used for a VHF (FM) aerial; Input 2

could be from a Telewest or NTL set-top (cable) decoder; Input 3 could be the UHF output from a VCR (also providing the aerial signal via the VCR); and Input 4 could come from a UHF modulator connected to the SCART output of a DVD player or Freeview DTV decoder. The outputs can then be cabled around the home to television and radio sets.

Bernard Gaydon
Chatham
Kent

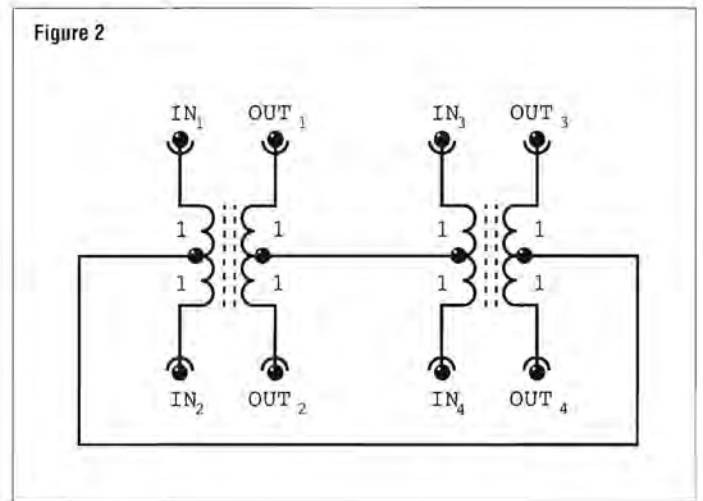
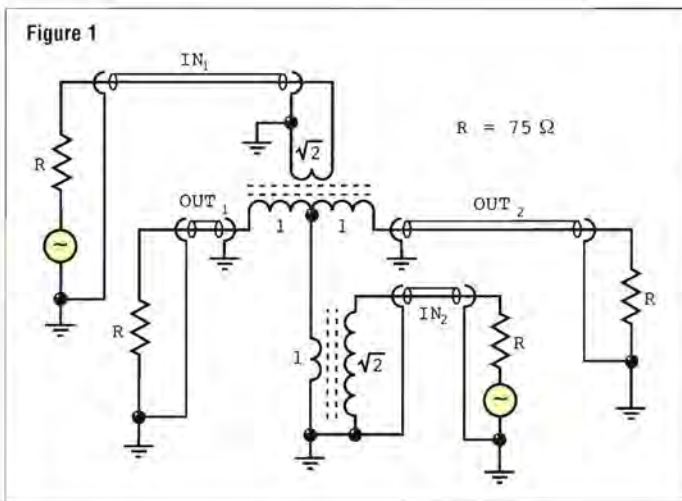

ELECTRONICS WORLD

NEWSAGENTS ORDER FORM

Please reserve/deliver a copy of **Electronics World** for me each month

Name and address

.....

Signed

Electronics World is published by Nexus Media Communications on the first Thursday each month. Photocopy this form, fill in your details and ask your newsagent to reserve a copy.

The 'tamed' gyrator

For those of us who still occasionally play with analogue electronics, the gyrator, or simulated inductor, is a valuable recipe for our cookbooks. It is most useful in low-frequency filters, where it offers both high inductance and high Q – and for no more than the cost of a dual op-amp and a few passive components. A conventional inductor would be bulky and expensive.

Unfortunately, the standard gyrator is very susceptible to high-frequency instability. In a typical application, a capacitor is placed in parallel with the gyrator to form a tuned circuit or resonator. If instability is present, it can appear as 'squegging' at the resonant frequency: its high-frequency origins are disguised by the natural selectivity of the circuit. This circuit idea explains why instability arises and shows how to avoid the problem.

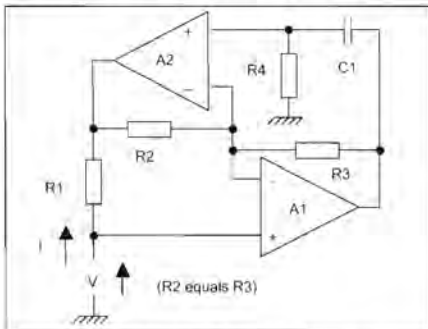

The gyrator circuit is shown above. Despite its eccentric 'noise-to-tail' appearance, the circuit is easy to analyse, at least for low frequencies. The reference provided at the end shows that, if a voltage V_0 is applied at time $t = 0$, the current flowing at time t is given by $I = (V_0 / C1 \cdot R4 \cdot R1) (t)$

This is just what one would expect for a 'real' inductor of value $C1 \cdot R4 \cdot R1$. Normally, all four resistor values are made the same, but it is only necessary for R2 to equal R3.

So far, so good; but how does one analyse the high-frequency behaviour and so avoid instability? At first glance, this appears to be difficult: the fortunes of the two op-amps seem hopelessly dependent on one another. However, a little ingenuity allows the circuit to be separated into two parts: an all-pass phase shifter and a unity-gain inverting amplifier:

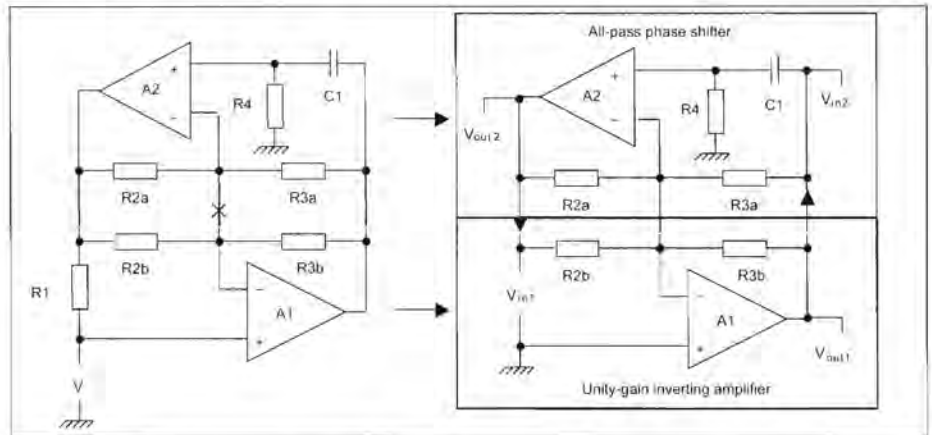

The first step is to divide the 'see-saw' feedback resistors into two, as shown in the left-hand diagram above. If R2a and R2b are each made twice the value of the original R2, likewise R3a and R3b, the operation of the circuit is unchanged. It is now possible to separate the inverting inputs of A1 and A2, again without affecting the operation in any way.

The right-hand diagram above shows that the two separated parts of the gyrator form a loop. If the loop is broken at a convenient point, the performance of each part – and hence the two parts in tandem – can be measured or calculated without difficulty. Note that the original input is shown as being grounded. This is a reasonable simplification to make, as the normally present resonating capacitor would offer low impedance at high frequencies. Once the input has been grounded, R1 is redundant.

Assuming that A1 and A2 are 'ideal' op-amps of infinite gain and no phase shift, the all-pass phase shifter provides a gain of +1 at high frequencies, whilst the inverter has a gain of -1. The complete loop has a gain of -1 and is, therefore, stable. If the 'real' op-amps are well behaved, the magnitude of the loop gain never exceeds unity, but falls away smoothly as the frequency increases. The circuit will remain stable, whatever the phase shift associated with the falling response.

Of course, op-amps are not always so obliging. Manufacturers, understandably, are tempted to maximise the gain-bandwidth product by keeping the internal

compensation to a minimum. The result is that the closed-loop gain of an op-amp stage can exhibit a high-frequency peak, sometimes amounting to several dB. If the gain of the complete gyrator loop is still greater than unity when the phase shift reaches 180° , the circuit will oscillate.

Fortunately, this analysis of the problem also suggests the cure. The loop response can be tamed by adding a small capacitor across R3b, see below with a value just sufficient to keep the loop gain below unity at all frequencies.

There is a penalty to pay in that the Q of the resonant circuit is reduced somewhat. Analysis shows that, if the resonant frequency is ω_0 and the time-constant of R3b and C is τ , the maximum available Q is $2\omega_0 / \tau$. However, at audio frequencies, this is unlikely to be an important effect.

Ranulph Poole

London

UK

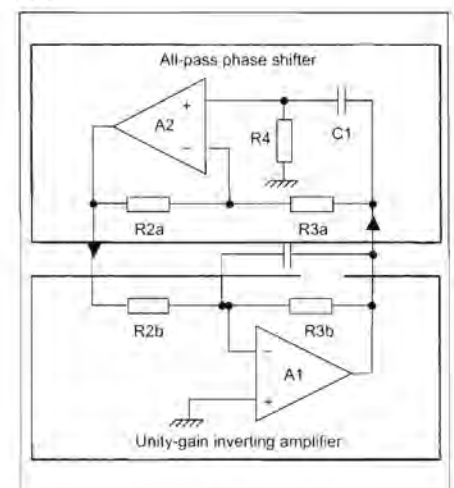

Tunable CFA-based, current-mode, all-pass filter

A current-feedback amplifier (CFA) based current-mode, all-pass filters, enjoying the facility of gain adjustment, independent of realisability condition, is presented here. The proposed circuit contains a single inverting current-feedback amplifier, a capacitor and three resistors. The circuit provides non-interacting tunability of phase and gain, without disturbing the realisability condition. The filter is highly stable against temperature variation, as the realisability condition is a function of the resistor ratios. In addition to all-pass filtering function, the circuit also supports simultaneously first order low-pass and high-pass filtering signals.

All-pass (AP) filters find applications in the construction of low sensitivity biquadratic filters, waveform correctors, multiphase oscillators and others. The function performed by the AP filter is to shift the phase of an input signal while keeping the amplitude constant. The change in phase can be effected by changing the frequency of the applied signals and/or by the passive component involved in the phase relation. CFA is a four terminal building block, which has the distinct features of high slew rate and constant bandwidth independent of closed loop gain, thus increasingly used in the construction of current-mode analogue signal processing circuits.

The development of current-mode continuous-time circuits has been attracting increasing attention in recent years, as these circuits offer potential advantages of wider bandwidth, greater linearity, larger dynamic range, simple circuitry and low power consumption vis-à-vis their voltage-mode counterparts and, accordingly, have received greater attention of circuit designers. Several AP filters operating in current-mode and voltage-mode using different active devices have already been disclosed. A detailed study of these circuits reveals that they are devoid of the important feature of providing gain adjustment of the output response. Therefore, there is an overriding need of developing low component count AP filter circuits, which can provide gain adjustment in a non-interacting fashion, in addition to phase variation.

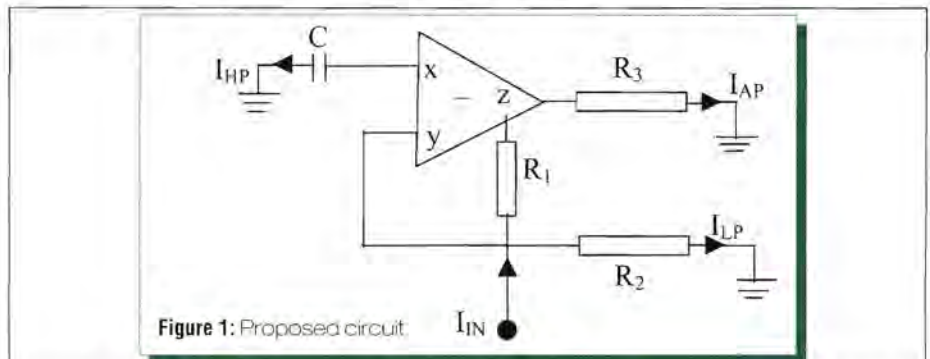

Figure 1: Proposed circuit.

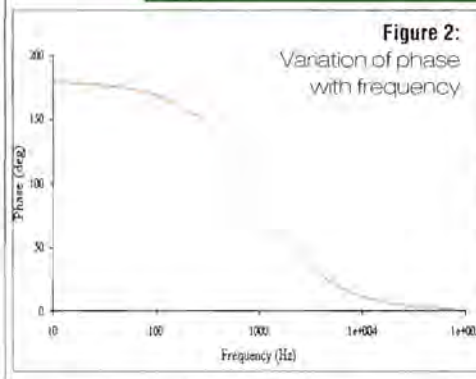

Figure 2: Variation of phase with frequency

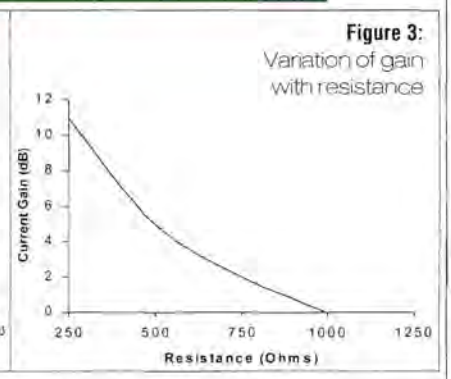

Figure 3: Variation of gain with resistance

Here, we are introducing a simple AP filter circuit operating in current-mode, which can provide adjustment of gain without disturbing the reliability condition. The circuit is canonical and uses one inverting CFA and four passive components, two of which are grounded. The realisability condition is simple, being function of resistor ratio, thereby making the configuration highly stable against temperature variations. It is worth to note that the circuit is capable of realising first-order low-pass and high-pass filtering function simultaneously, without inducing any change in the circuit topology, in addition to AP filtering function.

Circuit description

The inverting CFA is characterised by the following:

$$V_y = V_x, V_z = V_o, I_y = 0 \text{ and } I_x = -I_z.$$

A routine analysis of the proposed filter circuit diagrammed in Figure 1 yields the following:

> Current transfer functions

$$I_{HP} / I_{IN} = s / (s + 1/R_2C) \quad (1)$$

$$I_{LP} / I_{IN} = 1 / R_2C / (s + 1/R_2C) \quad (2)$$

$$I_{AP} / I_{IN} = R_1/R_3 [(1/R_1C - s) / (1/R_2C + s)] \quad (3)$$

From Equation 3, it is clear that the gain

adjustment can be achieved by R3 without disturbing reliability condition $R_1/R_2 = 1$.

The phase angle is given by
$$\phi = -2 \tan^{-1}(\omega RC) \quad (4)$$

An examination of Equation 4 reveals that change in phase angle can be achieved by adjusting C, besides frequency of the applied signal without upsetting of the realisability condition and gain of the circuit.

Simulation results

The proposed circuit was verified by PSPICE simulation program. The circuit was designed for a phase shift of 90° at a frequency of $f_0 = 1\text{kHz}$. The values of passive components chosen were $R_1 = R_2 = R_3 = 1\text{k}\Omega$ and $C = 159\text{nF}$. Figure 2 shows the variation of phase with frequency of the applied signal, while as Figure 3 depicts the variation of gain responses of AP with resistance R3.

Nisar Ahmed Shah, Mohammad Farooq Rather and Syed Zaffer Iqbal
 Department of Electronics and Instrumentation Technology
 University of Kashmir
 India

High-efficiency LED torch

This circuit makes a bright, compact and portable light source from a surplus 4.8V rechargeable mobile phone battery and little electronics. It is as efficient as many integrated SMD step-up converters and needs neither a choke nor a Mosfet. A voltage 'tripler' drives a string of three white 5mm LEDs in series.

Inverters Ua and Ub form a 2kHz oscillator with out-of-phase waveforms available at the in and out ends of gate b. Inverter pairs, Uc/Ud and Ue/Uf, square and buffer the signals to produce square wave trains on pins 8 and 12 to drive separate charge pumps. As the two wave-

forms are synchronous but out-of-phase, the positive and negative charge pulses are in phase and add, to maximise tripler voltage.

The circuit produces 9.5V across the three LEDs at 15mA and an excellent light from claimed 10Cd LEDs. Expect 10 hours of light from a battery. The current is 44mA at 4.8V input and electrical efficiency is nearly 70%. A freshly charged 4.8V battery has a voltage of about 5.3V and drives the LEDs more brightly still at 9.8V and 20mA. Battery current is then 58mA.

For NiMH batteries, as their self-discharge rate is higher than that of Nicads and they do not suffer from a memory

effect, a short charge/discharge regime is suggested. Frequent charging achieves a brighter light over the shorter discharge period and as the tripler is naturally current limited, you are unlikely to exceed the maximum suggested LED current substantially with even the freshest of batteries.

The light output is similar to that of a 6V LED torch based on a doubler. Lacking the extra cell, the tripler works rather harder and its efficiency is somewhat lower than the doubler's 80%, but battery life is satisfactory. Use of the newly available 20Cd LEDs subjectively doubles the brightness of these torches

and more than makes up for any efficiency shortfall in the tripler. As the circuit is symmetrical, it goes together neatly on 1x1.5" piece of strip-board mounted on the back of the battery. Fit the LEDs closely together and seal them at the rear to avoid backscatter. A reflector is unnecessary.

Performance suffers if the 74HC14 is substituted with a CD40106 or 74C14 and Schottky diodes, such as BAT 42 or 1N 5819, work better than regular 1N 4148s because of their lower forward voltage.

John Crichton
Orange
Australia

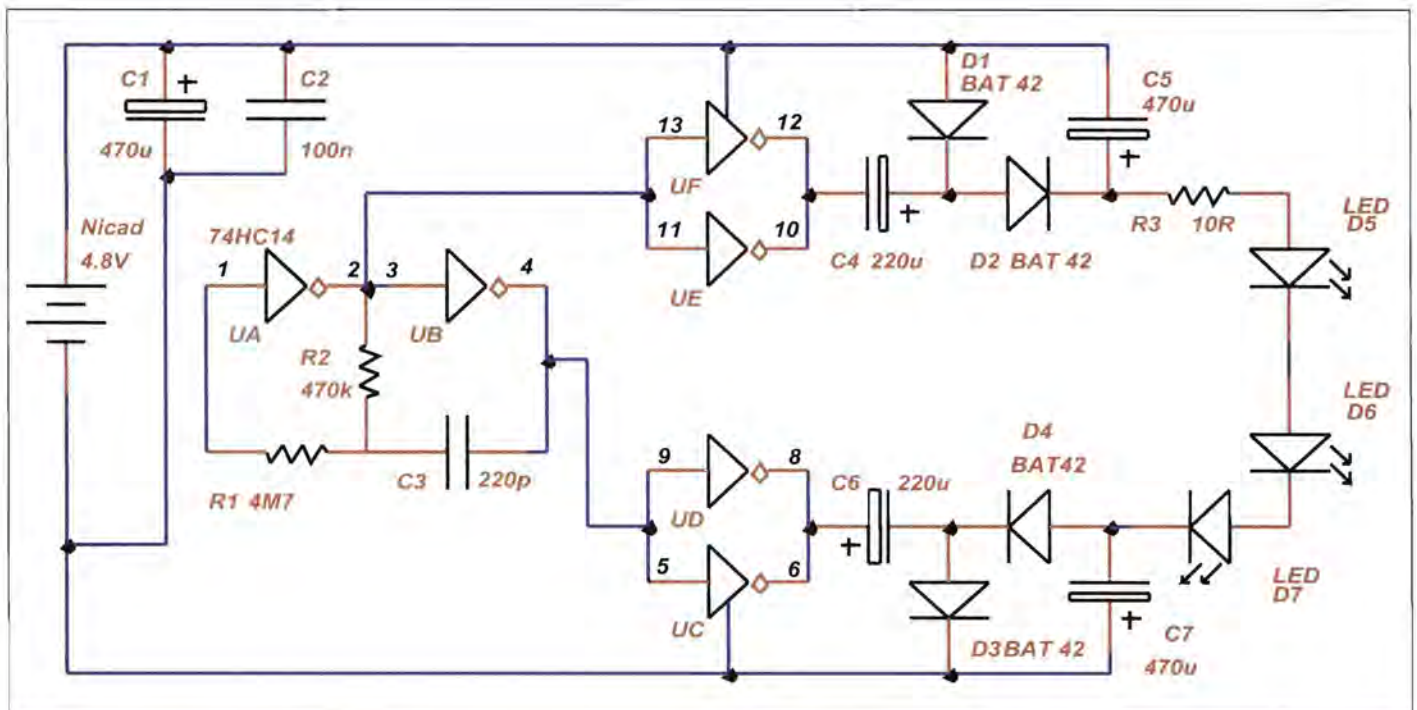

Send new circuit ideas to:

The Editor, Nexus Media Communications, Media House, Azalea Drive, Swanley, Kent BR8 8HU or email to:

ewcircuit@highburybiz.com

Part P compliant tester series

To help contractors meet the requirements of the new Part P regulations, Seaward Electronic has expanded its 800 series of test instruments.

The centerpiece of the range is the IR800 insulation and continuity tester, which complies with EN61557, EN1010 and all safety, environmental and EMC requirements. This battery-operated tester incorporates voltage measurements up to 1000AC or DC, a dual safety rating and robust design.

Part of the series is the DM800 digital multimeter, which provides accurate AC voltage measurement up to 750V and DC



voltages up to 1000V. DC current measurement is up to 6mA. The high specification DM800R measures AC and DC currents up to 10A.

The CM800 clamp multimeter features a 4000 count digital backlit display and it offers accurate AC current measurements up to 600A, AC and DC voltages up to 600V, and resistance measurements up to 400W. Seaward's 800 tester range also offers a current and voltage meter – the ET800, and a hand-held unit that confirms the functionality and accuracy of installation tester readings – the Checkbox 16.

www.seaward.co.uk

BGA socket converters



Slovakian firm Elnec has announced its first series of BGA converters. The converters are designed as optional accessories to the universal programmers BeeProg, JetProg and LabProg+. The converters use high quality ZIF sockets with operation life up to 500,000 actuations. ZIF socket accepts many variations of BGA packages that differ in ball diameter, ball width and package thickness.

The BGA converter consists of two boards. The top board carries the ZIF socket, which accepts a certain BGA package dimension chips (for example 8x8 ball array, 11 x 8mm body size). The bottom board provides a proper inter-connection from the top board to 48 pins, going into the ZIF socket of the programmer.

To offer the most effective solution of BGA converters, Elnec offers the top and bottom boards separately or as a complete unit. This means that the user doesn't need to buy more BGA converters to program chips in the same BGA package – just change the BGA-bottom boards.

www.elnec.com

Feature-rich low dropout regulator

Microchip has expanded its low dropout regulator (LDO) portfolio with the introduction of the MCP1726 device. It features a low minimum output voltage (down to 0.8V) and a high output current (up to 1A), making it ideal for a variety of high performance applications such as next-generation CPUs and logic cores.



The LDO is stable with a 1mF ceramic output capacitor, reducing cost and board space. The device also features a power good output with programmable delay option that allows engineers to program a system delay, providing additional flexibility for the design. Other features include a typical 140mA active supply current for optimum energy efficiency, a 150mV typical dropout voltage for the highest flexibility and fault tolerance; various shutdown and/or reset options; and a small 8-pin DFN package for space-constrained applications.

The MCP1726 LDO is available today for sampling and volume production in lead-free 8-pin DFN and SOIC packages.

www.microchip.com

Next-generation CAN transceiver

Next-generation controller area network (CAN) transceiver IC for high-speed, in-vehicle networking (IVN) is now available from AMI Semiconductor (AMIS). The new AMIS-42665 high-speed single-chip device combines operation to 1Mbaud with an extremely low current standby mode and a bus-initiated wake-up capability.

Suitable for both 12V and 24V automotive applications, the AMIS-42665 is fully compliant with both the ISO 11898-2 and ISO 11898-5 standards and is ideal for vehicle body and comfort control functions, ranging from electric windows to climate control. High tolerance to electromagnetic interference (EMI) and an electrostatic discharge (ESD) rating of $\pm 8kV$ HBM (human body model) eliminates the need for additional filtering and protection, while a low standby current helps designers to meet power targets when the vehicle is idle.

Remote wake-up can be initiated either locally or via the CAN bus, depending on specific application requirements.

Specifically, the device provides differential signalling capability to the CAN bus via the transmit and receive pins of the CAN controller. As package form-factor and pin-count are fully compatible with other transceiver ICs (including the Philips TJA1040), the AMIS-42665 can be used as a 'drop-in' replacement to deliver optimum performance in existing designs as well, to meet new application requirements.

In addition, the device offers a transmit data (TXD) dominant time-out function, thermal protection, short circuit protection and protection against transients commonly found in the automotive environment.

www.amis.com

ABB's 'jargon buster'

ABB, like many other companies and individuals, wants the industry to speak the same, clear language. As such, it has introduced the Safety Jargon Buster as a guide through a minefield of technical terms surrounding industrial process safety, including those relating to the IEC61508 and IEC61511 standards.

The Jargon Buster offers a glossary for those responsible for purchasing, handling or designing safety equipment

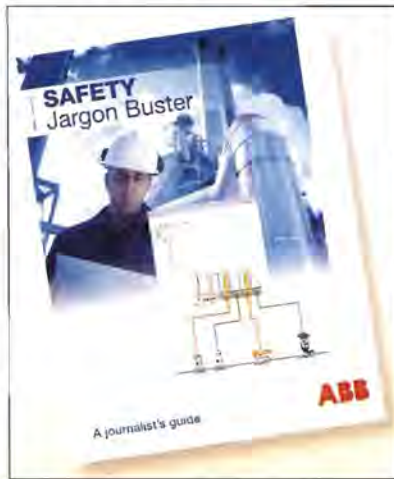

and systems for process applications.

Through hyperlinks, the user can quickly find any definition in the guide, while links within each article lead to further definitions on related topics.

The Jargon Buster is available as a PDF and is free of charge. You can request it by email using enquiries@abbiap.com (please add name, company and postcode). www.abb.com

Oscillator eases timing

US-based Fox Electronics introduced a new HCMOS crystal oscillator that eliminates the need to design an oscillator circuit using high ESR (equivalent series resistance) watch crystals for critical timing applications such as real time clocks and ICs. By replacing the high ESR crystal with the Fox465 SMD oscillator, the start-up reliability of the timing circuit is improved.

The new Fox oscillators operate at a frequency of 32.768kHz. Key feature of the devices is a low 5mA maximum input current, making it ideal for standby timing of ICs. It operates at any voltage from 1.5V to 6V. It measures 4 x 6.5 x 2mm.

The Fox465 family has an operating temperature range of -40°C to +85°C. Frequency stability is +30/-150 ppm and frequency tolerance at 25°C is +30/0 ppm.

The oscillator sells at \$1.94 for quantities of 10,000 units. Samples are available now. www.foxonline.com



New range of hand-held enclosures



Hammond Electronics has launched a new range of hand-held enclosures, the 1553 soft-side family. Featuring an ergonomic curved shape that fits comfortably into the hand, the cases are initially available in two sizes, 117 x 79mm and 147 x 89mm. The units are moulded in general purpose ABS and are ideal for housing hand-held instruments, remote controllers, flying lead machine controllers and many other applications.

Both sizes are available with or without battery door and compartment and have a removable plastic front panel. The battery compartments are complete with four clips for use with two AA batteries and a flying lead connector for a 9V PP3 size. The top cover is recessed to allow a membrane keypad to be flush mounted, PCB standoffs are moulded into the base; the larger unit is secured with four screws, the smaller with two.

www.hammondmfg.com

"Free Range" power supply

TMD Technologies Ltd (TMD) has developed a high-voltage power supply for radar, which achieves a noise level 100 times lower than that of previous designs. This provides the radar with significantly better range and accuracy of target identification. A key feature is that TMD's power supply does not need a synchronisation pulse from the radar, which enables the radar to run with a free range of pulse lengths and waveforms.

The power supply has a noise figure of better than -140dBc/Hz CW equivalent single sideband random noise and better than -80dBc spurious noise. This compares to a figure of -120dBc/Hz random noise, making TMD's achievement an improvement of over 20dB.

The company this year won the Queen's Award for Enterprise in the Innovation category.

"I am extremely proud of this Queen's Award for Innovation, following so closely after our first Queen's Award last year for International Trade. This marks another major milestone in the growth in our technology, which has resulted from many years of investment," said Peter Butcher, TMD's Chairman and Managing Director.

TMD designs and manufactures specialised transmitters for radar and electronic warfare applications, power supplies and microwave tubes. It also produces a range of commercial amplifiers for EMC testing, medical and scientific applications.

www.tmd.co.uk

Security sounders



Security sounders made by audio/visual signalling specialist Klaxon – Minn-XE – are sleek and compact, making them naturally unobtrusive for various applications. They have now been selected by contractor Altex for a residential environment, even though sounders of this type are more traditionally fitted on external walls.

“From a technical point of view, the Minn-XE was the ideal choice because the small size of the device lends itself to installation along building corridors,” said Alan Carvin, Altex’s Senior Partner.

“We were also impressed with the styling, which is very important where the unit is fitted in close visual proximity to the residents.”

Kristian Johnson, Klaxon’s Marketing Manager, says: “This is an exciting development as the Minn-XE has never before been used internally on a ‘per apartment’ basis where each apartment has its own dedicated strobe/sounder unit.” The Minn-XE is part of Klaxon’s Flashguard C-Series. It has a two-part assembly that is quick and easy to install. The cover offers an area for screen printing not found elsewhere on a similar size sounder.

www.klaxonsignals.com.

Upgraded Elite’s extended capabilities

Clare Instruments has upgraded its high performance Elite electrical safety testing system with the introduction of a number of additional technical features.

In response to customer demand for high-speed production line test throughputs and broader testing capabilities, the functional load test current of the new Elite has been raised to 16A, making it suitable for the safety testing of the vast majority of domestic electrical and electronic products.

The upgraded instrument also features expanded PC control software. Automatic control of up to 20 programmable test sequences can now be incorpo-

rated for maximum efficiency and high-speed testing on large volume production lines.

Another new feature to reduce test time and improve productivity is the ability to input product serial numbers held on bar codes by direct connection to the Elite via a bar code reader.

Hipot, insulation, earth bond, leakage and load test sequences are all user configurable to the exact specifications of the product under test and this feature has been further



extended to meet the needs of certain functional test routines.

With these adaptations and added features, different Elite instruments are available to meet national and international regulations for the production line safety testing of all electrotechnical manufacturing requirements.

www.clareinstruments.com

Extended temperature op-amps



Two new families of low-power, single-supply, extended-temperature, rail-to-rail input/output operational amplifiers (op-amps) make a debut from Microchip.

The MCP623X and MCP624X op-amps feature an extended industrial-temperature range of -40°C to +125°C. The devices offer voltage operation down to 1.8V. The MCP623X devices

have a current consumption of 20mA (typical) for a 300kHz bandwidth, while the MCP624X devices consume 50mA (typical) for a 650kHz bandwidth.

They are available in single, dual and quad packages. The single op-amps (MCP6231, MCP6241) are available in 5-pin SC-70 and SOT-23 packages. The dual op-amps (MCP6232, MCP6242), as well as the single devices, are available in 8-pin PDIP, SOIC and MSOP packages. The quad op-amps (MCP6234, MCP6244) are offered in 14-pin PDIP, SOIC and TSSOP packages. All six devices, in the various package options,

are available today for sampling and volume production.

To assist designers, Microchip provides the FilterLab Active Filter Software Design tool and SPICE Macro Models free of charge from its website. The FilterLab tool gives users full schematic diagrams of their filter circuit design with component values and displays the frequency response, which makes designing variable filters using Microchip’s op-amps easier. The SPICE Macro Models enable engineers to complete analogue simulation and modelling of their circuit design.

www.microchip.com

Phapsody 6.0 ready from I-Logix

Embedded systems and software provider I-Logix has just released Rhapsody 6.0, a UML 2.0 model-driven development (MDD) product. It uses a new graphical engineer to dramatically improve user workflow, extending its design capacity with advanced formatting, ergonomics and drawing capabilities, says the firm. A complete upgrade to the diagram editors allows capture of any type of diagrams relevant to the developer’s domain. In addition, there are other graphical features such as bitmap, rich text and hyperlinking, as well as enhanced formatting, presentation and printing functions development.

Rhapsody 6.0 also features The Rhapsody Gateway, an innovative requirements management component, designed to provide seamless bi-directional interface with third party requirements management tools including Requisite Pro, DOORS, Word and Excel.

Focusing on Mission Critical Certification, Rhapsody 6.0 provides the user greater control with a scalable and certifiable framework for C++. The framework is model-based, originating directly from the Rhapsody model, providing component structure and functionality.

www.ilogix.com

Highly integrated WiMAX SoC from Fujitsu

Fujitsu Microelectronics introduced a highly integrated WiMAX system-on-chip (SoC) - the MB87M3400 - for the low-cost development of WiMAX compliant broadband wireless access (BWA) equipment. The device is compliant with the IEEE802.16-2004 standard.

Being aimed at basestation and subscriber station implementation, the chip is claimed to bring cost-efficient, high-quality, fixed broadband connectivity to Metro Area Network users,

without the need for direct Line of Sight access to basestations from their remotely connected subscriber stations. The MB87M3400 is designed to enable deployment of BWA equipment for both basestations and subscriber stations in licensed or license-exempt bands below 11GHz.

It uses an OFDM 256 (Orthogonal Frequency Division Multiplexing) PHY that supports channels from 1.75MHz up to 20MHz, and can operate in TDD

or FDD modes, with support for all available channel bandwidths. A programmable frequency selection generates the sample clock for any desired bandwidth. When applying 64QAM modulation in a 20MHz channel and using all 192 sub-carriers, the SoC's data rate can go up to 75Mbps. Uplink sub-channelisation is also supported.

The WiMAX SoC incorporates a RISC engine that implements the 802.16 upper-

layer MAC, scheduler, drivers, protocol stacks and user application software. Also on board is a secondary RISC/DSP that functions as a co-processor, which executes lower-layer MAC functions, offloading processing from the upper-layer MAC and enhancing total performance. A multi-channel DMA controller handles high-speed transactions among agents on a high-performance bus.

<http://us.fujitsu.com/micro/WiMAX>

New handheld Primetest 300



Seaward Electronic's new PrimeTest 300 has been specifically designed to boost the test productivity of electrical contractors and service engineers by making portable appliance testing faster and easier.

The lightweight handheld tester incorporates all Class I and Class II required electrical safety tests in a compact and user-friendly design. Long life battery power eliminates the reliance on mains supply, reduces downtime between tests and makes the instrument totally practical and portable to use anywhere.

In addition, new Bluetooth technology enables the wire-

less connection of bar code scanners, label printers and other accessories - allowing totally cable-free testing, without the cumbersome and constant plugging and unplugging of leads and cords.

An intuitive and fast user interface supports straightforward operation and test control in either manual or automatic test modes. Operating features also include fast start-up and a large white backlit graphics display, which is supported by a full alphanumeric keypad, including programmable soft keys for customised test routines.

The PrimeTest 300's large internal memory facilitates the storage of test results for safety audit and traceability purposes. In addition, as well as test results, the tester can also record other details and descriptions of the equipment under test.

Wireless connection means that stored data can be transferred immediately and directly from the tester to PC-based record keeping systems at the touch of a button.

www.seaward.co.uk

Low-cost current transducer



current measurement of any type of waveforms (including AC, DC, mixed and complex). It has been designed to operate from a bipolar $\pm 15V$ DC power supply and will accommodate a round primary conductor of a diameter of up to 21.5mm.

In addition to its normal current output (150mA for 300A primary), an output indicating the transducer state is available.

The transducer is CE marked and it conforms to the EN 50178 and EN 50155 standards.

www.lem.com

LEM has introduced the ITB 300-S low-cost, high-accuracy current transducer, specified for nominal measurements of 300A rms. Its linearity is better than 0.001% and overall accuracy at ambient temperature is 0.05%. Thermal offset is only 1m A/K.

Featuring galvanic isolation, the ITB 300-S can be used for

TI - focused distributor for Bourns

TTI and Bourns have teamed up to provide customers with an extended range of circuit protection devices for high-value, critical telecom systems applications, as well as simple circuits. They can deliver a variety of cost-effective circuit protection component solutions that meet the demanding requirements of international regulatory standards.

"This joint initiative with offers us the opportunity to develop further our Circuit Protection

business in Europe. TTI will focus on this market to promote Bourns's extensive range of circuit protection products," said Bev McKnight, Bourns business development manager.

TTI has available large stocks of all Bourns's protection devices, including: TISP thyristor surge protectors, Multifuse resettable fuses, surface mount diodes, ChipGuard multi-layer varistor ESD protectors and gas discharge tubes, among others.

Efficient boost converter

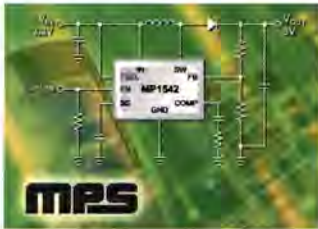

New from Monolithic Power Systems (MPS) is the MP1542, a current mode, step-up converter that uses a 2A, 0.18Ω internal switch to provide a highly efficient regulator with a fast response.

The MP1542 can operate at 700kHz or 1.3MHz, supporting easy filtering and low noise. An external compensation pin affords the user the flexibility to set loop dynamics, which allows the use of small, low-ESR ceramic output capacitors. A soft-start facility results in a low inrush current and can be programmed with an external capacitor. The MP1542 operates from an input voltage as low as 2.5V and can provide a 12V, 500mA output from a 5V supply

at greater than 90% efficiency.

Protection features of the MP1542 include under-voltage lockout, current limiting and thermal overload protection. The MP1542 is available in a low profile, 8-pin MSOP package and operates over an ambient temperature range of -40°C to +85°C.

The device is suitable for applications such as LCD displays, portable appliances and digital still and video cameras.

www.monolithicpower.com

TI cranks up DSP performance with a new generation of devices

Texas Instruments (TI) has launched a new DSP core – the C64x+, which offers higher performance, smaller code size and more on-chip memory but is still backward compatible with the previous generation of DSPs belonging to the C64x family.

The first in this series of devices is the TMS320C6455, implemented in 90nm CMOS process technology, which will be found particularly suitable in the areas of wireless, telecom and video infrastructure developments, as well as in imaging applications. The device incor-



porates serial RapidI/O with an interconnectivity of up to 25Gbit/s, GigE MAC, DDR2 external memory interface, 66MHz PCI bus interface and 2MB of L2 memory.

The C64+ DSP core on which this device is based, adds new specialised instruction that makes the control code up to 30% more compact and 20%

more cycle-efficient, compared to TI's previous core. The new instructions include complex and 32-bit wide multiplications and simultaneous add/subtracts, increasing FFT and DCT performance. The core can execute eight 16x16 multiply and accumulate instructions per cycle, twice as many as the C64x core.

The C6455 DSP will be offered in 1GHz, 850MHz and 720MHz versions, with prices ranging from around \$180 to \$260 per unit in 10k quantities.

www.ti.com

Digital IR thermometer with web browser

The new compact SOLOnet range from Land Instruments International gives flexibility in the way infrared thermometers are set up, configured and monitored.

Incorporating digital technology, SOLOnet offers an integral web browser and Ethernet capability so that thermometers can be set up remotely from a computer – laptop, desktop PC – without the need for specialist software, and can be connected and monitored on a company-wide network.

When set-up is completed, the PC can be disconnected, leaving the thermometer to operate independently as a stand-alone instrument.

SOLOnet can be interrogated remotely at any time and from any location via its web/Ethernet interface unit using Internet Explorer, Netscape or other standard web browser. Each thermometer is accessible by its unique IP address, providing an on-screen data collection and control centre, navigable using drop-down menus and other devices. There are four models in the range, operating at different wavelengths

www.landinst.com

Machine control goes wireless



ABB's new wireless proximity switch offers a reliable and cost-effective alternative to conventional proximity sensor systems for machine control applications. Utilising a new wireless protocol and power system developed by ABB, the wireless proximity switch eliminates the need for cabling in sensor applications, cutting the time and cost of installation by up to two-thirds, says ABB.

With this solution, data is relayed from the switch to the

machine control system using ABB's new WISA (Wireless Interface for Sensors and Actuators) protocol specifically designed for industrial applications. WISA links signals from sensors and actuators to an input module via radio antennas, which then communicate with the control system.

Through the switch's full duplex operation, radio signals can be simultaneously transmitted and received,

ensuring rapid flow of data to and from the switch.

The wireless proximity switch consists of two parts: the sensor head and the communication module. Power supply, signal transmission and human-machine communication are provided by a single type of communication module.

Currently, there are four different sensor heads available and cover distances ranging from 1.5mm to 15mm.

www.abb.com

To reserve your web site space phone Ed Robinson 01322 611260
e.robinson@highburybiz.com

CHYGWYN

www.chygywn.com



ChyGwyn Limited offers electronic design and embedded software development for remote monitoring, embedded appliances, set-top boxes and similar devices. We are experts in customisation of Linux and write device drivers for custom hardware.

COMPONENT TECHNOLOGY

www.component-technology.co.uk



- PIC microcontroller kits and modules for students and hobbyist.
- 18F45X, 16F87X Proto-Boards for ease and fast development of project ideas.
- Infrared Illuminators for CCTVs in low ambient light security areas.
- Analogue 8-channel high voltage isolator. Data logging.
- 5% discount code 'elwwdir2004' for Electronics World readers.
- Consultancy
- TIG control systems – REIS interface.
- Real-time X-ray Imaging.

CONFORD ELECTRONICS

www.confordelec.co.uk



Lightweight portable battery/mains audio units offering the highest technical performance. Microphone, Phantom Power and Headphone Amplifiers. Balanced/unbalanced signal lines with extensive RFI protection.

DB TECHNOLOGY

www.dbtechnology.co.uk/



Anechoic chamber and open area test site.

- Compliance Tests
- Fixes included. FCC Listed.
- Flexible hourly booking available.
- Rapid, accurate pre-compliance tests.

DESIGNER SYSTEMS CO

www.designersystems.co.uk



Electronic product design company with over a decade of experience promoting it's own product range and designing and manufacturing innovative products for client companies/individuals.

IPEVA

www.ipeva.com



IPEVA sell FPGA platforms and provide Design Services for Embedded Systems, OpenCores IP, Analogue, Digital, FPGA, ASIC, HDL Translations (e.g. Schematics/C/C++ to VHDL) and Migrations. Altium Nexar and Protel Bureaux. Tel 0870 080 2340

MCES LTD

Web: www.mces.co.uk



MCES are a specialist electronics company providing a high quality repair, rework and re-manufacturing service to electronic modules and sub assemblies, including handling both large and small volume production and rework for major manufacturers. Established in 1972 we have continued to make large investments in specialised test equipment, surface mount technology and tooling enabling us to diagnose repair and verify

a wide range of electronic modules to a very high standard. We also operate a fitting service for surface mount multi pin IC's and BGA's

REDRAT LTD

www.redrat.co.uk



Infrared remote control input and output for computers – USB and TCP/IP.

Applications areas include:

- Home automation
- PC based multimedia installations
- Consumer electronics test systems
- Broadcast monitoring
- Show and theatre control

TELONIC

www.telonic.co.uk



Telonic specialists in laboratory AC & DC Power Supplies, Electronic AC & DC Loads, Electrical Safety Testing and complete test systems. Plus RF Filters, Attenuators, Diesel Engine Smoke Measurement, Quartz Crystal Microbalances.

Tel +44 (0) 118 9786911

Lineage only will cost £150 + vat for a full year. Lineage with colour screen shot will cost £350 + vat for a full year

The Electronics World Book Service offers access to our team of specialist publishing experts. We can order any book or CD-ROM currently in print from *War And Peace* to the *Reference Data for Engineers*. All books are delivered free of charge within the UK unless otherwise stated. Order form opposite.

If you are ordering by credit card, need further information, or would like to use our search facilities, call **01737 812727 Fax 01737 813526**
 The order/helpline is open from 9am to 5pm, or leave your order on our out-of-hours answerline or email us at salesteam@boffinbooks.demon.co.uk
 When placing orders please quote
 ● Name ● Address (home & delivery) ● Daytime telephone number ● Debit/Credit card number
 ● Expiry date ● Details of order. Please note prices may change, but are correct at time of going to press.

TCP/IP EMBEDDED INTERNET APPLICATIONS

Edward Insam
 This text highlights an engineer's approach to Internet protocols and applications, reducing R&D time for engineers. The book aims to be the main design guide for the cutting edge of Internet-enabled electronic products and systems.
 Aug 2003 ▲ 384 pages ▲ Index ▲ Appendix
 PB ▲ Published in UK
 Code 0-7506-5735-9 **£32.50**

ELECTRONIC CLASSICS: COLLECTING, RESTORATION AND REPAIR

Andrew Emmerson
 This text encompasses all aspects of buying, collecting, restoring, repairing, sourcing parts, professional services, clubs and societies. The first part covers technical aspects of restoration and details where components can be found. The second part presents useful information for collectors.
 Aug 1998 ▲ 256 pages ▲ Index
 10 halftones ▲ 50 line illustrations ▲ PB
 Published in UK
 Code 0-7506-3788-9 **£21.99**

NEWNES GUIDE TO TELEVISION & VIDEO TECHNOLOGY

Eugene Trundle
 An exploration of television and video technology. It covers the fundamentals of digital television (satellite, cable and terrestrial) and digital video, as well as providing a grounding in analogue systems.
 3rd edition ▲ Feb 2001 ▲ 432 pages ▲ Index
 PB ▲ Published in UK
 Code 0-7506-4810-4 **£17.99**

NEWNES GUIDE TO DIGITAL TV

Richard Brice
 Covering all aspects of digital television, this text encompasses the electronics of the equipment, data compression, television production, servicing and the different transition methods - terrestrial, satellite and cable. The text has been updated with developments since the 2000 edition.
 2nd edition ▲ Oct 2002 ▲ 304 pages ▲ Index
 45 illustrations ▲ 15 photographs ▲ HB
 Published in UK
 Code 0-7506-5721-9 **£24.99**

RSGB RADIO & ELECTRONICS COOKBOOK

Radio Society of Great Britain
 Only a basic knowledge of electronics is assumed for this collection of electronics projects, and it is ideal for all electronics and DIY enthusiasts and experimenters. Designed by the RSGB, the UK radio amateurs federation, the projects are clearly explained step by step.
 Nov 2000 ▲ 336 pages ▲ PB ▲ Illustrations
 Published in UK
 Code 0-7506-5214-4 **£17.99**

REFERENCE DATA FOR ENGINEERS: RADIO, ELECTRONICS, COMPUTERS AND COMMUNICATIONS

Mac E Van Valkenburg; Edited by Wendy Middleton
 Written by professionals for professionals, this is a complete reference for engineers, covering a broad range of topics. As well as addressing radio technology data, it covers digital electronics, computers and communications.
 9th edition ▲ Aug 2001
 1568 pages & CD-Rom ▲ 1385 line illustrations
 HB ▲ Published in UK
 Code 0-7506-7291-9 **£90.00**

NEWNES GUIDE TO RADIO AND COMMUNICATIONS TECHNOLOGY

Ian Poole
 This is a guide to the technology and applications of modern radio and communications equipment. The author's approach provides a useful foundation for college students and technicians seeking an update on the latest technology.
 Jul 2003 ▲ 352 pages ▲ Index ▲ PB
 Published in UK
 Code 0-7506-5612-3 **£16.99**

INTRODUCTION TO DIGITAL SYSTEMS

John Crisp
 This self-study text introduces digital electronics from first principles, before going on to cover all the main areas of knowledge and expertise. It covers the practicalities of designing and building circuits, including fault-finding and the use of test equipment.
 Feb 2000 ▲ 302 pages ▲ Glossary ▲ Index
 PB ▲ Published in UK
 Code 0-7506-4583-0 **£18.99**

PRACTICAL ELECTRONIC FAULT FINDING AND TROUBLESHOOTING

Robin Pain (Design Engineer, Cotag International Ltd)
 A text using simple circuit examples to illustrate principles and concepts fundamental to the process of analog and digital fault finding. It aims to help the reader tackle any job, from fixing a TV to improving the sound of a hi-fi. A digital multimeter and oscilloscope are needed for these jobs.
 Apr 1996 ▲ 284 pages ▲ Index
 50 line illustrations ▲ PB ▲ Published in UK
 Code 0-7506-2461-2 **£21.99**

FUZZY LOGIC FOR EMBEDDED SYSTEMS APPLICATIONS

Dr Ahmad Ibrahim
 Written by a recognised expert in the field, this covers all the basic theory relevant to electronics design, with particular emphasis on embedded systems. It shows how the techniques can be applied to shorten design cycles and handle logic problems that are tough to solve using conventional linear techniques. All the latest advances in the field are discussed, and practical circuit design examples presented.
 Oct 2003 ▲ 312 pages ▲ PB
 Code 0-7506-7605-1 **£35.00**

DICTIONARY OF VIDEO AND TELEVISION TECHNOLOGY

Jack Tsatsoulis
 This work provides comprehensive and contemporary information on the essential concepts and terms in video and television, including coverage of test and measurement procedures. The CD accompanying the text includes an electronic version of the book.
 Sept 2002 ▲ 365 pages & CD-Rom
 Published in UK
 Code 1-878707-99-X **£29.99**

NEWNES DICTIONARY OF ELECTRONICS

S W Amos; R S Amos
 Aimed at engineers, technicians and students working in the field of electronics, this dictionary provides clear and concise definitions, including TV, radio and computing terms, with illustrations and circuit diagrams.
 4th edition ▲ Mar 2002 ▲ 394 pages
 100 illustrations ▲ PB ▲ Published in UK
 Code 0-7506-5642-5 **£12.99**

PRACTICAL ELECTRONICS HANDBOOK

Ian Sinclair
 A collection of all the key data, facts, practical guidance and circuit design basics needed by a spectrum of students, electronics enthusiasts, technicians and circuit designers. It provides explanations and practical guidance, and includes new sections on SHF techniques and intruder alarms.
 5th edition ▲ Feb 2000 ▲ 571 pages
 Illustrations ▲ PB ▲ Published in UK
 Code 0-7506-4585-7 **£16.99**

ANALOG INTERFACING TO EMBEDDED MICROPROCESSORS

Stuart Ball
 Provides hard-to-find information on interfacing analog devices and technologies to the purely digital world of embedded microprocessors. Gives the reader the insight and perspective of a real embedded systems design engineer, including tips that only a hands-on professional would know. Covers important considerations for both hardware and software systems when linking analog and digital devices.
 March 2001 ▲ 288 pages ▲ PB
 100 line illustrations
 Code 0-7506-7339-7 **£19.99**

HANDBOOK OF RF AND WIRELESS TECHNOLOGIES



Farid Dowla (Lawrence Livermore National Laboratory, University of California-Davis, USA)

Subjects covered include third-generation wireless, wireless sensor networks, RF power amplifiers, spread spectrum modulation, signal propagation and antennas. This is far more than just a tutorial or reference guide—it is a "guided tour" through the world of cutting-edge RF and wireless design, combining theory, applications and philosophies behind the RF/wireless design process.

November 2003 ▲ 720 pages ▲ HB
Code 0-7506-7695-7 **£59.99**

DIGITAL INTERFACE HANDBOOK



John Watkinson, Francis Rumsey

A detailed manual for those who need to get to grips with digital audio and video systems. It sheds light on the differences between audio interfaces and shows how to make devices "talk to each other" in the digital domain. Also includes detailed coverage of all the regularly used digital video interfaces. New information included in this third edition: dedicated audio interfaces, audio over computer network interfaces and revised material on practical audio interfacing and synchronisation.

3rd edition ▲ September 2003 ▲ 392 pages
231 line illustrations ▲ PB
Code 0-2405-1909-4 **£29.99**

TV FAULT-FINDING GUIDE



Edited by Peter Marlow

A distillation of the most-used fault reports from 11 years of *Television* magazine. Arranged by make and model, it features over 200 reports on over 300 models of television, including diagnosis and repair advice.

Mar 2000 ▲ 387 pages ▲ Illustrations
PB ▲ Published in UK
Code 0-7506-4633-0 **£20.99**

VALVE AMPLIFIERS



Morgan Jones

The author's straightforward approach, using as little maths as possible, should be of use to those with only a limited knowledge of the field as well as being the standard reference for experts in valve audio. Design principles and construction techniques are also provided.

3rd edition ▲ Aug 2003 ▲ 624 pages ▲ Index
PB ▲ Published in UK

Code 0-7506-5694-8 **£29.99**

VCR FAULT-FINDING GUIDE



Edited by Peter Marlow

A distillation of the most-used fault reports from 11 years of *Television* magazine. Arranged by make and model, it features over 2000 reports on over 200 models of VCR, including diagnosis and repair advice.

Mar 2000 ▲ 447 pages ▲ Illustrations ▲ PB
Published in UK
Code 0-7506-4634-9 **£20.99**

DESIGNING AUTONOMOUS MOBILE ROBOTS



John Holland

Covering topics such as advanced sensor fusion, control systems for a wide array of application sensors and instrumentation, and fuzzy logic applications, this volume is essential reading for engineers undertaking robotics projects as well as for undergraduate and graduate students studying robotic engineering, artificial intelligence and cognitive science. Its state-of-the-art treatment of core concepts in mobile robotics helps and challenges readers in exploring new avenues in an exciting field.

January 2004 ▲ PB & CD-Rom ▲ 352 pages
Code 0-7506-7683-3 **£35.00**

VIDEO AND CAMCORDER SERVICING AND TECHNOLOGY



Steve Beeching

A comprehensive guide to domestic VCR technology and repair techniques. This edition brings the information fully-up-to-date, with expanded coverage of camcorders, sections on DVD equipment and the latest VCR technology.

5th edition ▲ Apr 2001 ▲ 323 pages
Illustrations ▲ PB ▲ Published in UK
Code 0-7506-5039-7 **£20.99**

VIDEO DEMYSTIFIED



Keith Jack

This edition has been updated to include information on digital television, datacasting, interactive video, digital camcorders and VCRs, and video interfacing. Coverage is international, including European, Asian and North/South American video standards, methods and techniques.

3rd edition ▲ Jul 2001 ▲ 784 pages & CD-Rom
References ▲ Glossary ▲ Index ▲ PB
Published in UK
Code 1-878707-56-6 **£50.00**

ANALOG ELECTRONICS: CIRCUITS, SYSTEMS AND SIGNAL PROCESSING

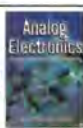

D Crocraff (formerly Open University); S Gergely (formerly University of Coventry)

Designed to complement the digital systems modules and develop the essential skills needed for RF circuit design, this book demystifies the art of analogue circuit design and analysis. The content meets the requirements of first and second year electronics engineering courses.

May 2002 ▲ 435 pages ▲ 150 line illustrations
PB ▲ Published in UK
Code 0-7506-5095-8 **£19.99**

AUDIO POWER AMPLIFIER DESIGN HANDBOOK



Douglas Self

This text on the design of audio amplifiers is based on Douglas Self's work in *Electronics World* magazine and a career at the cutting edge of audio design. This handbook aims to provide a practical guide to the state of the art, and includes detailed design and construction information.

3rd edition ▲ May 2002 ▲ 448 pages
62 line illustrations ▲ Index ▲ PB
Published in UK
Code 0-7506-5636-0 **£24.99**

AVR: AN INTRODUCTORY COURSE



John Morton (University of Cambridge)

AVRs have certain strengths compared to other microcontrollers but are less well-known or understood. The author wrote this guide to introduce AVRs to those who have little or no microcontroller background and to encourage them to start using these useful devices with easy projects to try.

Sep 2002 ▲ 256 pages ▲ 150 illustrations
Glossary ▲ Further reading ▲ Index ▲ PB
Published in UK
Code 0-7506-5635-2 **£16.99**

BEBOP TO THE BOOLEAN BOOGIE: AN UNCONVENTIONAL GUIDE TO ELECTRONICS



Clive Maxfield

The second edition of this comprehensive introduction to contemporary electronics now has added material. It is written for the engineer, hobbyist or student who needs a thorough electronics reference, as well as for non-technical people, and is accompanied by a CD-ROM.

2nd edition ▲ Jan 2003
500 pages & CD-Rom ▲ 184 illustrations
187 photographs ▲ Glossary ▲ PB
Published in UK
Code 0-7506-7543-8 **£27.50**

ELECTRONICS WORLD ORDER FORM

Please order or search the following:

Code	Description	Qty	Price

POSTAGE & PACKING **FREE** IN THE UK* TOTAL

Name Daytime Tel
Address
Postcode

I enclose a cheque/postal order value £ payable to 'Boffin Books Ltd'

Please debit my Access/Visa/Switch/Delta card Issue number (Switch only)

Card Number Expiry Date

Signed

*Postage charges outside the UK available upon request or email: salesteam@boffinbooks.demon.co.uk

Post to: Boffin Books Ltd, 24 Walton Street, Walton-on-the-Hill, Tadworth, Surrey KT20 7RT, UK



ELECTRONICS WORLD ON CD-ROM

2004, 2003, 2002, 2001, 2000, 1999

Electronics World magazine is enjoyed by some of the world's top circuit designers - but it's not just for professionals. Stimulating designers for almost a century, Electronics World covers analogue, RF and digital circuit technology and incorporates design information on everything from model train control to input/output via a 10baseT network... and it's now available all on CD-ROM.

- 12 issues on each CD-ROM
- full text and diagrams of all articles, circuit ideas, letters etc
- easy to browse
- fully searchable by keywords and index
- high-quality print in colour
- full software listings included
- easy to use

CDROMs are available for 1999, 2000, 2001, 2002, 2003 and 2004. Each disk contains 12 back issues of Electronics World in a searchable, browsable and printable format PLUS the library of software files. The CDROMs run on PCs with Windows '9x, Me, 2000 and XP. Requires IE4 or above and Adobe Acrobat Reader (supplied on the CD).

only £30 each including VAT and UK post, add £1 extra postage for Europe, £5 extra postage for Rest of the World, exclusively available from SoftCopy Limited, address below.

Limited special offer for readers of Electronics World and libraries - all six CDs for the price of five.

OFFICIAL ORDERS ACCEPTED

Order now at:

www.ewmag.co.uk



Please send the following CD-ROMs

- __ qty 1999
- __ qty 2000
- __ qty 2001
- __ qty 2002
- __ qty 2003
- __ qty 2004

Name _____
Address _____

Card Number _____ Expiry _____

SoftCopy Limited, 1 Vineries Close, Cheltenham GL53 0NU, UK
Tel: +44 (0) 1242 241455 Fax: +44 (0) 1242 241468 sales@softcopy.co.uk

by permission of Highbury Business, Electronics World magazine's publishers

Telnet

Quality second-user test & measurement equipment

Tel: 02476 650 702 Fax: 02476 650 773

Web: www.telnet.uk.com Email: sales@telnet.uk.com

All equipment is used - with 30 days guarantee and 90 days in some cases. Add carriage and VAT to all goods.
1 Stoney Court, Hotchkiss Way, Binley Industrial Estate Coventry CV3 2RL ENGLAND



Agilent (HP) 3314A Function Generator 20 MHz	£650	Agilent (HP) 53181A Frequency Counter	£750
Agilent (HP) 3325A and B function gen. from	£550	Agilent (HP) 4284A Precision LCR Meter	£5750
Agilent (HP) 435A/B, 436A, 4637B, 438A Power Meters from	£100	Agilent (HP) 6031A Power Supply (20V - 120A)	£1250
Agilent (HP) 3561A Dynamic Signal Analyser	£2950	Agilent (HP) 6032A Power Supply (60V - 50A)	£2000
Agilent (HP) 3562A Dual Ch. Dynamic Sig. Analyser	£3000	Agilent (HP) 6671A Power Supply (8V - 200A)	£1350
Agilent (HP) 3582A Spectrum Analyser Dual Channel	£1200	Agilent (HP) E4411A Spectrum Analyser (9kHz - 1.5GHz)	£3500
Agilent (HP) 3585A and B Spec. An. (40MHz) from	£2950	Agilent (HP) 8924C CDMA Mobile Station Test Set	£6000
Agilent (HP) 35660A Dynamic Sig. An	£2950	Agilent (HP) E8285C CDMA Mobile Station Test Set	£6000
Agilent (HP) 4191A R/F Impedance analyzer (1 GHz)	£2995	Agilent (HP) 54520A 500MHz 2 Channel Oscilloscope	£1000
Agilent (HP) 4192A L/F Impedance Analyser (13MHz)	£4000	Agilent (HP) 54645D 100MHz Mixed Signal Oscilloscope	£3000
Agilent (HP) 4193A Vector Impedance Meter	£2750	Agilent (HP) 8713B 300kHz - 3GHz Network Analyser	£4500
Agilent (HP) 4274A LCR Meter	£1750	Agilent (HP) 8566B 100Hz - 22GHz High Performance Spec. An.	£7000
Agilent (HP) 4275A LCR Meter	£2750	Agilent (HP) 8592B 9kHz - 22GHz Spectrum Analyser	£7500
Agilent (HP) 4276A LCR Meter	£1400	Amplifier Research 10W1000B Power Amplifier (1 GHz)	£4700
Agilent (HP) 4278A Capacitance Meter (1KHz / 1MHz)	£2950	Anritsu ML 2438A Power Meter	£1400
Agilent (HP) 5342A Frequency Counter (18GHz)	£850	Rohde & Schwarz SMY01 9kHz - 1040 MHz Signal Generator	£1750
Agilent (HP) 5351B Frequency Counter (26.5GHz)	£2750	Rohde & Schwarz CMD 57 Digital Radio Comms Test Set	£4250
Agilent (HP) 5352B Frequency Counter (40GHz)	£4950	Rohde & Schwarz XSRM Rubidium Frequency Standard	£3750
Agilent (HP) 53310A Mod. Domain An (opt 1/31)	£3450	Rohde & Schwarz CMD 80 Digital Radio Comms Test Set	£3500
Agilent (HP) 54600A / B 100 MHz Scopes from	£700	R&S SMIQ-03B Vector Sig. Gen. (3 GHz)	£7000
Agilent (HP) 54810A Infinium Scope 500MHz	£2995	R&S SMG (0.1 - 1 GHz) Sig. Gen.	£1750
Agilent (HP) 8116A Function Gen. (50MHz)	£1750	Tektronix THS 720A 100MHz 2 Channel Hand-held Oscilloscope	£1250
Agilent (HP) 8349B (2- 20GHz) Amplifier	£1950	W&G PFJ 8 Error & Jitter Test Set	£6500
Agilent (HP) 8350B Mainframe sweeper (plug-ins avail)	£750	IFR (Marconi) 2051 10kHz-2.7GHz) Sig. Gen.	£5000
Agilent (HP) 85024A High Frequency Probe	£1000	Wayne Kerr AP 6050A Power Supply (60V - 50A)	£1850
Agilent (HP) 8594E Spec. An. (2.9GHz) opt 41,101,105,130)	£3995	Wayne Kerr AP 400-5 Power Supply (400V - 5A)	£1300
Agilent (HP) 8596E Spec. An. (12.8 GHz) opt various	£8000	Wayne Kerr 3260A+3265A Precision Mag. An. with Bias Unit	£5500
Agilent (HP) 89410A Vector Sig. An. Dc to 10MHz	£7500	Wayne Kerr 3245 Precision Ind. Analyser	£1750
Agilent (HP) 89440A Vector Signal Analyser 2MHz - 1.8GHz	£8950	Wayne Kerr 6425 Precision Component Analyser	£2000
Agilent (HP) 33120A Function/Arbitrary Waveform Generator 15MHz	£850	Wavetek 9100 Universal Calibrator (Opts 100 / 250)	£9000
Agilent (HP) 53131A Frequency Counter	£750	Various other calibrators in stock. Call for stock / prices	

PicoScope 3000 Series PC Oscilloscopes

The PicoScope 3000 series oscilloscopes are the latest offerings from the market leader in PC oscilloscopes combining high bandwidths with large record memories. Using the latest advances in low power electronics, the oscilloscopes draw their power from the USB port of any modern PC, eliminating the need for mains power.

- High performance: 10GS/s sampling rate & 200MHz bandwidth
- 1MB buffer memory
- Advanced display & trigger modes
- Compact & portable
- Supplied with PicoScope (oscilloscope/spectrum analyser) & PicoLog (data acquisition) software.

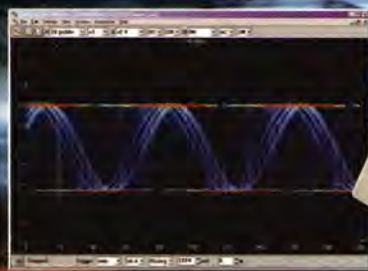

PicoScope	3204	3205	3208
Bandwidth	50MHz	100MHz	200MHz
Sampling rate (effective)	2.5GS/s	5GS/s	10GS/s
Sampling rate (single shot)	50MS/s	100MS/s	200MS/s
Channels	2 + Ext trigger	2 + Ext trigger/Sig gen	2 + Ext trigger/Sig gen
Dual/tri/tri-baseband	Single to 50MHz	2-tri to 50MHz	Tri to 50MHz
Timebase accuracy	50ppm	50ppm	50ppm
Spectrum ranges	0 to 25MHz	0 to 50MHz	0 to 100MHz
Record length	256k	512k	1MB
Resolution accuracy		8 bits / 3fs	
Ranges		10mV to 2V/div	
PC Connection/Power supply		USB 2.0 (USB 1.1 compatible)	

Tel: 01480 396395
www.picotech.com/scope270

pico
Technology Limited

Service Link

ARTICLES WANTED

TOP PRICES PAID

For all your valves,
tubes, semi conductors
and ICs.

Langrex Supplies Limited

1 Mayo Road, Croydon, Surrey CR0 2QP
TEL: 020 8684 1166 FAX: 020 8684 3056

FOR SALE

PRINTED CIRCUIT BOARDS

DESIGNED & MANUFACTURED

Prototype or production quantities

Fast turnaround available

PCBs designed from circuit diagrams

Almost all computer files accepted

PCB assembly - mechanical assembly

Full product design-manufacture-test-repair

Unit 5, East Bellast Enterprise Park

308 Albertbridge Rd, Belfast BT5 4GX

TEL 028 9073 8897 FAX 028 9073 1802

info@agarcircuits.com

SERVICES

ELECTRONIC DESIGN

Control, Instrumentation
& Prototype services

Tel/Fax: 01981-550528

e-mail: p.loughery @

wgrlectronics.co.uk

WGR'Lectronics

WANTED

BEST CASH PRICES PAID

FOR VALVES KT88,
PX4 AND MOST
AUDIO/OTHER
TYPES.

Tel: 01403 784961

Billington Export Ltd

Sussex RH14 9EZ

Fax 01403 783519

Email: sales@bel-tubes.co.uk

Visitors by appointment

SERVICES

PCB-POOL



• Prototypes at a fraction of the cost

• Tooling and setup included

• Industry standard quality

• Any contour

FREE

LAYOUT

SOFTWARE!

Follow up Services Runs •

CAM/CAD Consulting •

ONLINE Quotations •

ISO-Approved •

FREE



with first order
(while stocks last)

Freephone
0800-3898560

Tel: +353 (0)61 701170
Fax: +353 (0)61 701164
sales@beta-layout.com

WWW.PCB-POOL.COM

From Concept To Production



Electronic design and manufacturing services:

- Embedded monitoring & control
- PSTN telephones and test equipment
- Datacom interfacing, line driving etc.
- Printed Circuit Board design
- Industrial control and Safety systems
- Robotic products (wireless, GPS, control)
- LCD serial backer products
- Technical documentation, schematic layout & language translation
- Wireless telemetry systems
- Audio & Video processing and routing systems
- GSM telemetry via. SMS or data (TCP/IP)
- DVD player control products
- GPS positioning systems
- Small, medium & large scale manufacturing

Email: sales@designersystems.co.uk

Tel/Fax: +44 (0) 1872 223306



for more information see our web site @
<http://www.designersystems.co.uk>

POWER SUPPLY DESIGN

Switched Mode PSU

Power Factor Correction

designed to your specification

Tel/Fax: 01243 842520

e-mail: eugen_kus@cix.co.uk

Lomond Electronic Services

Service Link

For a
FREE
consultation on how best
to market your
products/services to a
professional audience
ring ED on
01322 611260

Service Link



PCBTrain

PTH PCBs with solder resist and legend from just £30.00 lot price.

Deliveries from

24_{Hrs}

Visit WWW.pcbtrain.com for full details.

- ▲ NEWBURY ELECTRONICS, the home of PCBTrain, the UK market leader for low-cost prototype PCBs
- ▲ Exclusive UK representatives for Circuit Mission Ltd (China) - manufacturers of low-cost high quality rigid PCBs
- ▲ Exclusive UK representatives for Sunflex Ltd (Taiwan & China) - manufacturers of flexible circuits



+44 (0) 1635 40347

NEWBURY ELECTRONICS LTD

Faraday Road Newbury Berkshire RG14 2AD UK

TEST EQUIPMENT SOLUTIONS

Quality Second User
Test Equipment
With 12 Months Warranty

The Industry's
Most Competitive
Test Equipment Rental Rates

Sample Stock List - If you don't see what you want, please CALL!

	Sale (GBP)	Rent (GBP)		Sale (GBP)	Rent (GBP)		Sale (GBP)	Rent (GBP)
AMPLIFIERS			OSCILLOSCOPES			SIGNAL & SPECTRUM ANALYSERS		
AT/HP 8349B 2-20GHz +15dB >50mW Amplifier	2700	82	AT/HP 541000 2 Channel 1GHz 40MS/s Digitising Scope	1375	83	Advantest R4131D 3.5GHz Spectrum Analyser	3450	138
AT/HP 8447E 1.3GHz Power Amplifier	1100	45	AT/HP 54501A 4 Channel 100MHz 20MS/s Digitising Scope	1275	53	AT/HP 3561A 100kHz Dual Channel Signal Analyser	2250	90
AT/HP 8449B 26.5GHz 26dB +7dBm Pre-amplifier	4500	180	AT/HP 54502A 2 Channel 400MHz 40MS/s Digitising Scope	1250	42	AT/HP 3562A 100kHz Dual Channel Dynamic Signal Analyser	2450	98
Amplifier Research 10W1000M7 1GHz 10W 40dB Amplifier	2950	118	AT/HP 54503A 4 Channel 500MHz 20MS/s Digitising Scope	1950	87	AT/HP 35660A 102.5kHz Dual Ch Dynamic Signal Analyser	3650	146
Amplifier Research 1W1000 1GHz 1W RF Amplifier	950	40	AT/HP 54600B 2 Channel 100MHz 20MS/s Digitising Scope	995	33	AT/HP 3585A 40MHz Spectrum Analyser	3500	106
SRS SRS10 Single Phase Lock In Amplifier	1750	70	AT/HP 54601A 4 Channel 100MHz 20MS/s Digitising Scope	1450	53	AT/HP 3588A 150MHz Spectrum Analyser	5450	233
SRS SRS30 Dual Phase Lock In Amplifier	1995	82	AT/HP 54602B 4 Channel 150MHz 20MS/s Digital Scope	1750	74	AT/HP 85024A 3GHz Active Probe	1350	45
COMPONENT ANALYSERS			AT/HP 54603B 2 Channel 60MHz 20MS/s Digitising Scope	850	30	Agilent/HP 85660A002 2.9GHz Spectrum Analyser	4500	180
AT/HP 4155B Semiconductor Parameter Analyser	21950	864	AT/HP 54616B 2 Channel 500MHz 2GS/s Digitising Scope	3650	146	Agilent/HP 8591A/010/021 1.8GHz Spectrum Analyser With TG	3950	119
AT/HP 4192A 13MHz Impedance Analyser	5100	258	AT/HP 54622D 2 + 16 Ch 100MHz 200MS/s Digital Scope	2750	115	AT/HP 8591E 1.8GHz Spectrum Analyser	3500	105
AT/HP 4193A 110MHz Impedance Analyser	5250	263				AT/HP 8594E/004/041/101/105 2.9GHz Spectrum Analyser	4950	149
AT/HP 4194A 40MHz Impedance Analyser	12950	518				AT/HP 8594E/041 2.9GHz Spectrum Analyser	4500	149
AT/HP 4263A 100kHz LCR Meter	2250	113				AT/HP 8595E/004/041/101/105 6.5GHz Spectrum Analyser	6750	204
AT/HP 4274A 100kHz LCR Meter	1995	101				AT/HP 8596E/041/053/140/151/160 12.8GHz Spec Analyser	9950	304
AT/HP 4278A 1kHz/1MHz Capacitance Meter	2695	136				AT/HP 8901B 1.3GHz Modulation Analyser	1750	70
AT/HP 4285A 30MHz Precision LCR Meter	8150	406				AT/HP 8903B/001/013/051 20Hz-100kHz Audio Analyser	1850	56
AT/HP 4286A 1MHz-1GHz LCR Meter	6975	350				Anritsu MS2601B 2.2GHz Spectrum Analyser	2950	130
AT/HP 4339A High Resistance Meter	3255	167				Anritsu MS2602A/01/02 100Hz-8.5GHz Spectrum Analyser	5950	242
DATACOMMS						Anritsu MS2651B 3GHz Spectrum Analyser	3950	120
Fluke DSP4000 Cat 5e/6 LAN Cable Tester	2950	144				Anritsu MS2661A/11 3GHz Spectrum Analyser	4950	200
Tek 1502C/03/04 High Resolution Metallic TDR	2950	155				Anritsu MS2711B/05 3GHz Handheld Spectrum Analyser	3450	104
Tek 1503C/03/04 Metallic TDR	2450	130				Anritsu MS2710B 10kHz-2GHz Spectrum Analyser	2150	65
Wavetek LT8600 Cat 5e/6 LAN Cable Tester	2250	144				Marconi 2392 9kHz-2.9GHz Spectrum Analyser	2750	83
ELECTRICAL NOISE						R&S FSP7 9kHz-7GHz Spectrum Analyser	14250	570
AT/HP 346A 18GHz APC-3.5(m) Noise Source	1100	41				Stanford Research SR760 Spectrum/FFT Analyser	2800	112
AT/HP 346B 18GHz APC-3.5(m) Noise Source	1100	41				SIGNAL GENERATORS		
AT/HP 8970A 1.5GHz Noise Figure Meter	1950	84				AT/HP 83711A/1E1 1-20GHz Synthesised CW Signal Gen	7950	239
AT/HP N8972A 10MHz-1.5GHz Noise Figure Analyser	9650	395				AT/HP 8642A/002 1GHz High Performance Synth Signal Gen	1650	52
AT/HP N8973A 3GHz Noise Meter	12250	368				AT/HP 8642B 2.1GHz Synthesised Signal Generator	4650	197
FREQUENCY COUNTERS						AT/HP 8648A/1E5/1E6 Synthesised Signal Generator	2750	112
AT/HP 5316A 100MHz Frequency Counter	595	36				AT/HP 8648B/1E5 2GHz Signal Generator	4250	128
AT/HP 5342A 18GHz Frequency Counter	895	59				AT/HP 8657A 1GHz Synthesised Signal Generator	1600	48
AT/HP 5350A 500MHz-20GHz Frequency Counter	1250	55				AT/HP 8657D/001 1GHz DQPSK Synthesised Signal Gen	1350	41
AT/HP 5350B 20GHz Frequency Counter	1790	75				AT/HP E4432A/1E5/UM3 3GHz Synthesised Signal Generator	6150	246
AT/HP 5351B 26.5GHz Frequency Counter	2150	87				AT/HP E4432B/1E5/UM4 3GHz Signal Generator	6950	209
AT/HP 5370A 100MHz Universal Time Interval Counter	1250	50				AT/HP E4433A/1E5/UM3 4GHz Signal Generator	7250	262
AT/HP 5370B 100MHz Universal Time Interval Counter	1350	54				Marconi 2026/01 10kHz-2.4GHz Multisource Generator	6250	247
AT/HP 5371A 500MHz Frequency/Time Interval Analyser	1650	66				Marconi 2030 1.35GHz Signal Generator	2950	118
AT/HP 5372A 500MHz Frequency/Time Interval Analyser	2875	119				Marconi 2031 2.7GHz Synthesised Signal Generator	3950	158
AT/HP 5385A 1GHz Frequency Counter	895	57				Marconi 2032 10kHz-5.4GHz Signal Generator	8450	254
Marconi 2440 20GHz Microwave Counter	1750	72				National VP-7201A 500kHz RC Oscillator	485	35
Racal 1991 160MHz Frequency Counter	450	28				R&S SME03/B11 5kHz-3GHz Signal Generator	5650	226
Racal 1992 1.3GHz Frequency Counter	950	30				R&S SME06 6GHz Signal Generator	9750	390
Racal 1992/55 1.3GHz Frequency Counter	1150	42				WIRELESS		
Racal 1998 1.3GHz Frequency Counter	695	35				Agilent/HP 8923B DECT Test Set	4250	174
FUNCTION GENERATORS						AT/HP 8920B/1A/7/13/14 1GHz Radio Comms Test Set	3950	119
AT/HP 3245A DC-1MHz Function Generator	2950	118				Anritsu ME4510B Digital Microwave System Analyser	4750	171
AT/HP 3312A 13MHz Function Generator	850	43				IIFR 2967/16/17/21 Radio Comms Test Set with GSM	5950	179
AT/HP 3324A 21MHz Function Generator	1150	46				Marconi 2935 GSM Test Set [Tri Band]	4950	179
AT/HP 3325A 21MHz Function Generator	950	42				Marconi 2945/05 Radio Comms Test Set	5950	180
AT/HP 3325B 21MHz Function Generator	1250	38				Marconi 2955B 1GHz Radio Comms Test Set	3500	126
AT/HP 3335A 81MHz Function Generator	1395	57				R&S CMU200/B12/B21/B41/B52/K21/K22/K23 RCTS	20950	629
AT/HP 3336B 21MHz Function Generator	1250	50				Racal 6103/001/002/014/420/430/04T Digital Mobile RTS	4250	128
AT/HP 8116A 50MHz Function Generator	1595	6				Racal 6104/001/002/003/006/014/04T Digital Mobile RTS	7250	217
AT/HP 8165A 50MHz Function Generator	1350	54				W&G 4106 GSM/DCS1800/PCN1900 Mobile Phone Tester	2250	70
AT/HP 8904A/001/002/003/004 600kHz Function Generator	2250	70				Wavetek 4107 Mobile Phone Test Set - Triband	2750	83
Philips PMS138 10MHz Function Generator	1250	50				Wavetek 4107S Mobile Phone Test Set - Triband	2750	83
Philips PMS139 20MHz Function Generator	1325	54				WaveTek 4202S Digital Mobile Radio Test Set - Triband	4200	126
Philips PMS193 50MHz Function Generator	1450	58						

Check out our latest
Product Guide !!
Call Us Now for Your Copy



The only company with the confidence to offer 12 month warranty as standard, with 24 month available!

FREE
Palm Zire shipped with every order over £5K

Prices shown are for guidance in £UK GBP, exclusive of VAT and Ex-Works. All items subject to prior sale. Rental prices are per week for a rental period of 4 weeks. Free carriage to UK mainland addresses on sale items. Rental or non UK deliveries will be charged at cost. This is just a selection of equipment we have available - if you don't see what you want, please call. All items are supplied fully tested and refurbished. All manuals and accessories required for normal operation included. Certificate of Conformance supplied as standard. Certificate of Calibration available at additional cost. Test Equipment Solutions Ltd Terms and Conditions apply. All E&OE.

01753 596000
Fax: 01753 59 6001
www.TestEquipmentHQ.com
email: info@TestEquipmentHQ.com