

OFFER! – DMM measures sound, light, moisture, heat...

ELECTRONICS WORLD



APRIL 2001 £2.80

**Phono preamp
for the CD era**

Sprint timer

**Digital camera
update**

**Designing
with DSP**

**Interfacing
with WAP**

**MOSFET valve
substitute**

Circuit ideas:

Controller for model racers

Switchable x-over filter

Bipolar stabiliser

Signal generator

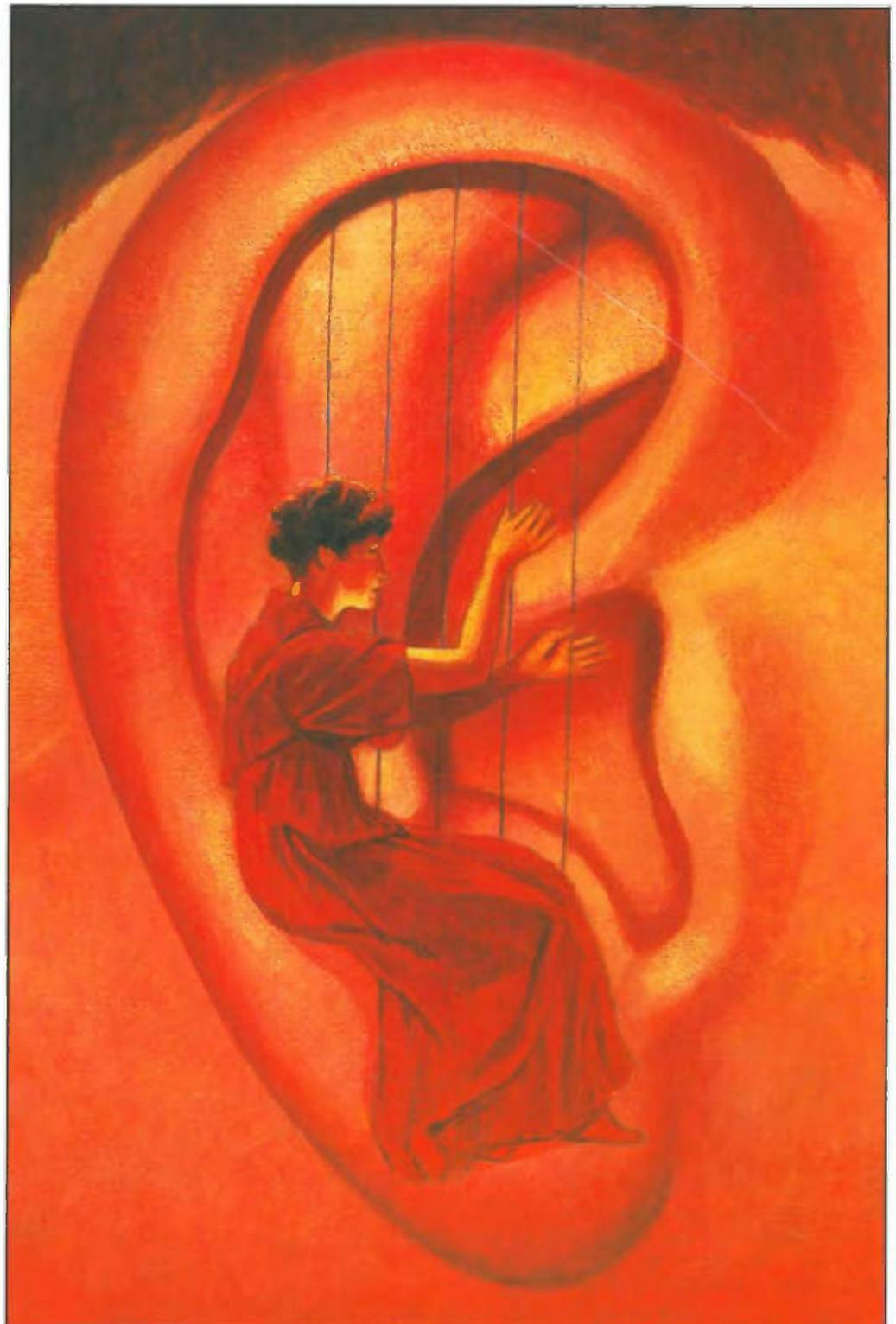

Telnet

Tel: 02476 650702

Quality second-user test & measurement equipment

NEW PHONE CODE FOR COVENTRY 02476

Hewlett Packard

8642A - high performance R/F synthesiser (0.1-1050MHz) £4750

3335A - synthesiser (200Hz-81MHz) £2400

Hewlett Packard

436A power meter and sensor (various) from £750

437B power meter and sensor (various) from £1100

Hewlett Packard

Wandel & Goltermann

SPECIAL OFFER

PCM-4 PCM Channel measurement set (various options available) from £5500

Marconi 6310 - programmable sweep generator (2 to 20GHz) - new £3250

Marconi 6311 Prog'ble sig. gen. (10MHz to 20GHz) £4000

Marconi 6313 Prog'ble sig. gen. (10MHz to 26.5GHz) £6250

Hewlett Packard

5370B - univrsal time interval counter £1500

Hewlett Packard 8662A synth. sig. gen. (10kHz to 1280MHz) £8250

Hewlett Packard 3324A synth. function/sweep gen. (21MHz) £2,500

OSCILLOSCOPES

Gould 400 20MHz - DSO - 2 channel £800

Gould 1421 20MHz - DSO - 2 channel £600

Gould 4068 150MHz 4 channel DSO £1500

Gould 4074 100MHz - 400 Ms/s - 4 channel £1350

Hewlett Packard 54201A - 300MHz Digitizing £995

Hewlett Packard 54600A - 100MHz - 2 channel £750

Hewlett Packard 54610A - 500MHz - 2 channel £1850

Hewlett Packard 54502A - 400MHz-400 Ms/s 2 channel £1800

Hitachi V152/V12/V22/V302B/V302F/V353F/V550B/V650F from £125

Hitachi V1 100A - 100MHz - 4 channel £900

Intron 2020 - 20MHz. Dual channel D.S.O. (new) £450

Iwatsu SS 5710/SS 5702 from £125

Kikusui COS 5100 - 100MHz - Dual channel £350

Lecroy 9354M 500MHz - 2 Gs/s - 4 channel £6000

Lecroy 9314L 300MHz - 4 channels £3000

Meguro MSQ 1270A - 20MHz - D.S.O. (new) £450

Philips PM3094 - 200MHz - 4 channel £1750

Philips 3295A - 400MHz - Dual channel £1600

Philips PM3392 - 200MHz - 200Ms/s - 4 channel £1995

Philips PM3070 - 100MHz - 2 channel - cursor readout £750

Tektronix 465 - 100MHz - Dual channel £350

Tektronix 464/466 - 100MHz - (with AN. storage) £350

Tektronix 475/475A - 200MHz/250MHz - from £450

Tektronix 468 - 100MHz - D.S.O. £650

Tektronix 2213/2215 - 60MHz - Dual channel £350

Tektronix 2220 - 60MHz - Dual channel D.S.O. £995

Tektronix 2235 - 100MHz - Dual channel £600

Tektronix 2221 - 60MHz - Dual channel D.S.O. £995

Tektronix 2245A - 100MHz - 4 channel £900

Tektronix 2440 - 300MHz/500 Ms/s D.S.O. £2450

Tektronix 2445A/2445B - 150MHz - 4 channel £1000

Tektronix 2445 - 150MHz - 4 channel + DMN £1200

Tektronix TAS 475 - 100MHz - 4 channel £995

Tektronix 7000 Series (100MHz to 500MHz) from £200

Tektronix 7104 - 1GHz Real Time - with 7A29 x2, 7B10 and 7B15 from £2500

Tektronix 2465/2465A/2465B - 300MHz/350MHz 4 channel from £1250

Tektronix 2430/2430A - Digital storage - 150MHz £4750

Tektronix 2467B - 400MHz - 4 channel high writing speed £750

Tektronix TDS 310 50MHz DSO - 2 channel £850

Tektronix TDS 320 100MHz 2 channel £1250

Tektronix TDS 340A 100MHz DSO - 2 channel £4950

Tektronix 544A 500MHz 4 channel

SPECTRUM ANALYSERS

Ando AC 8211 - 1.7GHz £1500

Avcom PSA-65A - 2 to 1000MHz £850

Anritsu MS 610B 10KHz - 2GHz - as new £3500

Advantest/TAKEDA RIKEN - 4132 - 100KHz - 1000MHz £1500

Hewlett Packard 8756A/8757A Scaler Network Analyser from £1000

Hewlett Packard 853A Mainframe + 8559A Spec. An. (0.01 to 21GHz) £2750

Hewlett Packard 182T Mainframe + 8559A Spec. An. (0.01 to 21GHz) £2250

Hewlett Packard 8568A (100Hz - 1500MHz) Spectrum Analyser £3500

Hewlett Packard 8568B - 100Hz - 1500MHz £5250

Hewlett Packard 8567A - 100Hz - 1500MHz £3995

Hewlett Packard 8752A - Network Analyser (1.3GHz) £5995

Hewlett Packard 8754A - Network Analyser 4MHz-1300MHz £1500

Hewlett Packard 8591E 9KHz-1.8GHz £4250

Hewlett Packard 3561A Dynamic signal analyser £3995

Hewlett Packard 35660A Dynamic signal analyser £3250

IFR A7550 - 10KHz-1GHz - Portable £1950

Meguro - MSA 4901 - 30MHz - Spec Analyser £700

Meguro - MSA 4912 - 1MHz - 1GHz Spec Analyser £995

Tektronix 2712 Spec. Analyser (9KHz - 1.8GHz) £3750

Wandel & Goltermann TSA-1 system analyser (100Hz-180MHz) £2750

Wiltron 6409 - 10-2000MHz R/F Analyser £1750

Radio Communications Test Sets

Marconi 2955 £2000

Marconi 2955B £4500

Anritsu MS555A2 £1200

Hewlett Packard 8922B (GSM) £6950

Schlumberger Stabilock 4031 £3500

Schlumberger Stabilock 4040 £1500

Racal 6111 (GSM) £1750

Racal 6115 (GSM) £3995

Rhode & Schwarz CMTA 94 (GSM) £4995

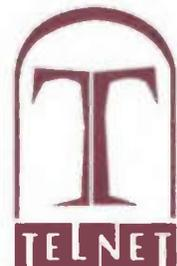

Fax 02476 650 773

MISCELLANEOUS

Eaton 2075-2A - Noise Gain Analyser at £2750

Fluke 5100A/5100B/5200A - Calibration Units (various available) from £1000

Fluke 2620 Data Buckets £500

Hewlett Packard 339A Distortion measuring set £1200

Hewlett Packard 435A + 435B Power meters from £100

Hewlett Packard 778D Dual-Directional Couplers £650

Hewlett Packard 3488A - Switch/Control unit £475

Hewlett Packard 3457A multi meter 6 1/2 digit £950

Hewlett Packard 3784A - Digital Transmission Analyser £4500

Hewlett Packard 3785A - Jitter Generator & Receiver £1250

Hewlett Packard 5385A - 1 GHz Frequency counter £650

Hewlett Packard 6033A - Autoranging System PSU (20v-30a) £750

Hewlett Packard 6622A - Dual O/P system p.s.u. £1250

Hewlett Packard 6624A - Quad Output Power Supply £2000

Hewlett Packard 6632A - System Power Supply (20v-5A) £800

Hewlett Packard 811A Pulse/Function Generator (1Hz-20MHz) £1250

Hewlett Packard 8112A - 50MHz Pulse Generator £2250

Hewlett Packard 8350B - Sweep Generator Mainframe £2000

Hewlett Packard 8656A Synthesised signal generator £850

Hewlett Packard 8656B Synthesised signal generator £1450

Hewlett Packard 8657A Synth. sig. gen. (0.1-1040MHz) £1750

Hewlett Packard 8660D - Synth'd Sig. Gen (10 KHz-2600MHz) £3250

Hewlett Packard 8901B - Modulation Analyser £2750

Hewlett Packard 8903A, B and E - Distortion Analyser from £1250

Hewlett Packard 16500A + B - Logic Analyser Mainframes from £1000

Hewlett Packard 16500C - Logic Analyser Mainframe £3250

Hewlett Packard 16501A/B & C - Logic Analyser System Expander Frame from £2000

Hewlett Packard 37900D - Signalling test set £3750

Hewlett Packard 5350B - 20Hz Frequency Counter £1950

Hewlett Packard 83220A DCS/PCS test sets £3000

Hewlett Packard 8657B - 100KHz-2060 MHz Sig Gen £3995

Hewlett Packard 8657D - XX DOPSK Sig Gen £4500

Hewlett Packard 8116A - 50MHz Pulse/Function generator £5250

Marconi 1066B - Demultiplexer & Frame Alignment Monitor (140MBIT to 64KBIT) £1750

NEW £999

Marconi 2305 - modulation meter £550

Marconi 2610 True RMS Voltmeter from £400

Marconi 6950/6960/6960B Power Meters & Sensors £1400

Philips 5515 - TN - Colour TV pattern generator £1500

Philips PM 5193 - 50MHz Function generator £1500

Leader 3216 Signal generator 100KHz - 140MHz - AM/FM/CW with built in FM stereo £795

modulator (as new) a snip at £500

Racal 1992 - 1.3GHz Frequency Counter £1250

Rohde & Schwarz NRV dual channel power meter & NAV Z2 Sensor £3250

Rohde & Schwarz SMG (B1/B2) sig. Gen. 1GHz £1995

Systron Donner 6030 - 26.5GHz Microwave Freq Counter £750

Tektronix ASG100 - Audio Signal Generator £950

Wavetek 178 Function generator (50 MHz) £1995

Wayne Kerr 3245 - Precision Inductance Analyser £2500

Wayne Kerr 6245 - Precision Component Analyser

All equipment is used - with 30 days guarantee and 90 days in some cases

Add carriage and VAT to all goods.

Telnet, 8 Cavans Way, Binley Industrial Estate, Coventry CV3 2SF.

CIRCLE NO. 101 ON REPLY CARD

Tel: 02476 650 702

Fax: 02476 650 773

243 COMMENT

Upwardly mobile?

244 NEWS

- Europe drives chip growth
- Passives built into PCBs
- 4Gbit synchronous DRAM
- Zinc-air cells give instant power
- Miniature robots
- Colour imaging for 3G phones
- Employers fail recruitment target
- 3D ICs solve interconnect problems
- Polymer LEDs beat conventional

250 DIGITAL CAMERA DEVELOPMENTS



Leslie Warwick takes a look at the current state-of-the-art in digital still-camera technology.

254 INTERFACING WITH WAP

Les Hughes explains how you can control equipment remotely from your WAP mobile phone – or any other WAP kit.

258 PHONO PREAMP FOR THE CD ERA

Norman Thagard's meticulously designed phono preamplifier features a high-level output compatible with most AV systems and receivers. And it has a noise figure of around 5nV/Hz.

268 DESIGNING WITH DSP

Patrick Gaydecki describes how to design and program real-time digital signal processing systems from the ground up.

274 INFRA-RED SPRINT TIMER

You might need a precise sprint timer, but **Simon Bateson's** micropower design provides interesting tips for anyone involved with battery operated infra-red transmitters and receivers.

279 NEW PRODUCTS

New product outlines, edited by **Richard Wilson**

291 LETTERS

Baird and bandwidth, Input-filter distortion, Engineering blues, EMC 'standards', Sky-scattered sunlight? Input-filter distortion, Linux? No thanks.

294 CIRCUIT IDEAS

- Switchable loudspeaker crossover
- Single-range 10Hz to 40kHz generator
- Simple wide-range VFO for RF
- Better model racing-car controller
- Bipolar voltage stabiliser
- Uses for CMOS switches
- Push-button thyristor operation
- Versatile flasher
- Courtesy light

300 CURRENT CONVEYORS II

Giuseppe Ferri et al explain how current conveyors can produce rail-to-rail output voltage swings even when running from a supply as low as 1.2V.

305 DESIGN COMPETITION

Win one of three prizes worth £900 in total.

307 RANDOM MEMORIES

Alf A. Particle looks at a down side of the Trans European Trunked Radio system.

308 VIEW HYSTERESIS CURVES

Fernando Garcia explains how you can display a transformer's hysteresis curve on your digital scope.

312 WEB DIRECTIONS

Useful web addresses for the electronics engineer.

316 A VALVE SUBSTITUTE

Unable to find a 6V6 audio power valve for his broken radio, **Dave Allen** made a MOSFET substitute which, he says, works better than the valve it replaced.



Illustration Hashim Akib



Measure humidity, light level, temperature, h_{FE} and even sound pressure – in addition to V, A and Ω – all on one meter. Turn to page 304 for more details.



Robots like this one, occupying just 4cm³, will be able to "work in a swarms like insects". More on page 246.



MOSFET alternative to a 6V6 valve – page 316.

May issue on sale 5 April

Next Generation Electronics CAD

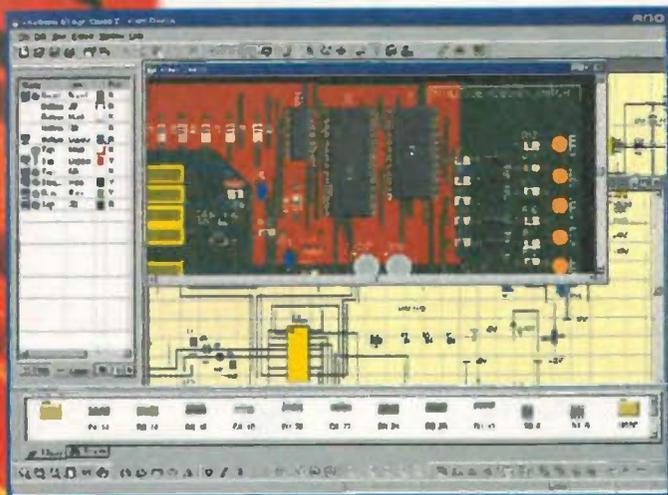

Introducing Electronic Design Studio 2, the new modular electronics design system that includes simulation, schematic, PCB, autorouting and CAD/CAM modules as standard.

Our state of the art integrated design environment brings powerful management to your projects and now features expanded libraries with 3D style PCB footprints, and the new Viper autorouter. EDS 2 Advance also includes rip up and retry routing, net styles, shape based realtime design rule checking (DRC), full copper pour support with unlimited automatic zones, split power planes with router support, cross probing, netlist navigation, DTP quality feature rich schematics and a wide range of Import/export options.

EDS 2 is fully compatible with the latest TINA Pro 5.5 with support for FAST TINA net import using the Project Wizard.

electronic design STUDIO 2



Quickroute Systems Ltd
Regent House, Heaton Lane,
Stockport SK4 1BS UK
Tel/Fax 0161 476 0202/0505
Email sales@dotqr.com
*Price excludes P&P and VAT.
(c) 2001 Quickroute Systems. E & O. E.

	Standard	Advance
Schematic, Simulation, PCB & CAD/CAM Modules	Yes	Yes
Viper Autorouter	Single Pass	Ripup/Retry
Multiple copper pour, thermal relief, power planes		Yes
Cross probing & Net Styles		Yes
Shape based Design Rule Check		Yes
Price*	£199	£349

www.dotqr.com

CIRCLE NO.104 ON REPLY CARD

PSA

www.psaparts.co.uk

If you maintain or repair computers, you have a powerful ally.

PSA is a leading stockist of spares for your industry, with over 36000 stock lines, serving customers in over 80 countries worldwide.

Telephone: +44 (0)20 8944 1538

Fax: +44 (0)20 8944 6694

PSA Parts Ltd

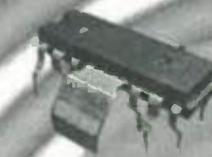

for repair of power supplies and computer monitors

Electronic Components



Canon / HP, Lexmark, OKI, Epson, Kyocera, Xerox

Laser Printer Spares



All major brands including Apple, Compaq, IBM, NEC, Texas, Toshiba etc.

Laptop Computer Batteries



All major brands including Apple, Compaq, IBM, NEC, Texas, Toshiba etc.

Laptop AC Adaptors

CIRCLE NO.105 ON REPLY CARD

Upwardly mobile?

EDITOR

Martin Eccles
020 8652 3614

CONSULTANTS

Ion Hickmon
Philip Dorrington
Frank Ogden

EDITORIAL ADMINISTRATION

Jockie Lowe
020 8652 3614

EDITORIAL E-MAILS

jockie.lowe@rbi.co.uk

GROUP SALES EXECUTIVE

Pot Bunce
020 8652 8339

ADVERTISEMENT E-MAILS

pot.bunce@rbi.co.uk

ADVERTISING PRODUCTION

020 8652 8339

PUBLISHER

Mick Elliott

EDITORIAL FAX

020 8652 8111

CLASSIFIED FAX

020 8652 8938

NEWSTRADE ENQUIRIES

020 7907 7777

ISSN 0959-8332

For a full listing of
RBI magazines:
<http://www.reedbusiness.com>

How we merry band of tax payers cheered last year when Gordon Brown raised £23bn from the third-generation (3G) mobile licence auction. Here was tax revenue that did not come directly out of our salary cheques or out of our pocket at the petrol pump.

However, it now seems that the mobile phone industry is facing the 3G crunch. On the one hand the mobile operators are desperate to get new high-speed data and wireless Internet services into the market as soon as possible. At the same time, however, they are being told by network infrastructure firms and handset developers that 3rd generation (3G) mobile technology will probably take longer than first anticipated to appear in commercial products.

If we go back a couple of years or so, the experts were predicting that 3G mobile handsets would appear by 2002. Whether the operators believed that date or not, they are now facing a very different prospect.

"3G handsets and services could be a long time coming," says Steven Baker, a mobile communications specialist at TTPCom.

The worst case situation being suggested is a launch for 3G services in 2004 or later. On the other hand at least one semiconductor supplier is confident of a launch a lot sooner. "Customers have orders," said Jean-Pierre Demange, director of Texas Instruments' wireless infrastructure business unit. "Our customers are currently in the design phase, with full product expected next year. But we also have orders this year for 3G deployment."

Despite this reassuring prediction at least one mobile operator has publicly questioned the logic of paying big money for a 3G licence. Concerns over the cost and availability of 3G mobile systems based on the UMTS standard are behind Bouygues' decision not to bid for a 3G licence in its key market of France.

Bouygues, which is the third largest mobile operator in France with 5.2 million customers, is the first operator to admit severe doubts over the availability of 3G handsets and network infrastructure and hence the timescale for the launch of 3G services.

It would seem that the reality of waiting until 2004 at the earliest to launch the mobile multimedia services promised by 3G systems is no longer attractive to Bouygues, and perhaps other operators also.

This is especially the case given that there is an alternative in the GSM upgrade technology, known as GPRS, which is much closer to commercial services. GPRS will be supporting mobile Internet services in the UK and Europe later this year.

"GPRS will be a standard fit on GSM handsets within 18 months," says TTPCom's Baker. That would support data rates of around 100kbit/s to your mobile phone.

That is easily enough to support reasonable quality

compressed video (50kbit/s) and significantly better than what is currently possible with GSM.

And when the next enhancement technology known as EDGE comes along in 2003, 200-300kbit/s data rates will be possible.

The late arrival of 3G technology and services is not a possibility being considered by everyone in the mobile phone industry. Semiconductor supplier, Texas Instruments is confidently depicting a rollout of the first 3G networks in Japan this year and in Europe in 2002.

"There is no delay in 3G deployment as we see it," said Jean-Marc Charpentier, business development manager at TI.

This comment will carry considerable weight in the market particularly as TI has confirmed orders for 3G UMTS wideband-CDMA basestation developments with six manufacturers including the world's biggest Ericsson, along with Nortel Networks and NEC.

The first volume 3G basestation orders will come from Japan, where operator DoCoMo will launch first commercial services in May. In Europe, Spain will roll-out 3G services this year with other operators, including BT in the UK, following next year, according to TI.

"We are seeing orders for 3G basestation deployment in the second half of 2001 for launches in Spring 2002," added TI's Demange.

The question remains however, is Bouygues is the only operator with concerns about the commercial attractiveness of the 3G mobile concept?

In the UK it is worth noting that five operators have already collectively paid £23bn for their 3G licences. Building networks will add a potential £10bn figure to that collective investment before first commercial services are possible.

It could be as long as four years before operators like Vodafone, Orange and BTCellnet see any income from their already substantial 3G investments.

Now either Bouygues is playing a very clever political game with the French authorities or it genuinely believes that 3G as currently proposed does not make commercial sense.

If it does not make sense for the French operator, there is a real possibility that it will not be that commercially favourable for the UK operators, who are already running up debts in order to finance their long-term commitment to launching 3G services.

It is perhaps too early to say yet, but within six months we will know for sure whether the French are crying wolf over 3G. If they are not, and there is some logic in what they say, then there may be some very serious fallout in the UK's mobile phone sector.

Let's hope that Brown's £23bn windfall really does turn out to be a price worth paying. ■

Richard Wilson

SUBSCRIPTION HOTLINE

Tel (0) 1444 475662
Fax (0) 1444 445447

SUBSCRIPTION QUERIES

rpb.subscriptions@rbi.co.uk
Tel (0) 1444 445566
Fax (0) 1444 445447

Electronics World is published monthly. By post, current issue £2.65, back issues, if available, £3.00. Orders, payments and general correspondence to **L333, Electronics World, Quadrant House, The Quadrant, Sutton, Surrey SM2 5AS. Tlx:892984 REED BP G.** Make cheques payable to Reed Business Information Ltd
Newstrade: Distributed by Markeforce (UK) Ltd, 247 Tottenham Court Road London W1P 0AU 0207 261 5108.
Subscriptions: Quadrant Subscription Services, Oakfield House Perryman Road, Haywards Heath, Sussex RH16 3DH. Phone 01444 445566. Please notify change of address.
Subscription, 1 year UK £36.00 2 years £58.00 3 years £72.00.
Europe/Eu 1 year £51.00 2 years £82.00 3 years £103.00
ROW 1 year £61.00 2 years £98.00 3 years £123

Overseas advertising agents: France and Belgium: Pierre Mussard, 18-20 Place de la Madeleine, Paris 75008. United States of America: Ray Barnes, Reed Business Publishing Ltd, 475 Park Avenue South, 2nd Fl New York, NY 10016 Tel: (212) 679 8888 Fax: (212) 679 9455

USA mailing agents: Mercury Airfreight International Ltd Inc, 10(b) Englehard Ave, Avenel NJ 07001. Periodicals Postage Paid at Rahway NJ Postmaster. Send address changes to above.

Printed by Polestar (Colchester) Ltd, **Filmsetting by** JJ Typographics Ltd, Unit 4 Baran Court, Chandlers Way, Southend-on-Sea, Essex SS2 5SE.

© Reed Business Information Ltd 1997 ISSN 0959 8332

Europe could overtake US in driving chip growth

Europe may become the future engine for world semiconductor market growth rather than the US, according to a report at IFS2001, the annual briefing on the chip industry from Future Horizons.

"One of the problems the US is struggling to come to terms with is its dependency on the PC and computer industries when the rest of the world has moved away from it," said the chairman of Future Horizons, Malcolm Penn. "The US has known no difference in the whole lifetime of the transistor, but computers are now becoming like calculators – they're just a tool."

Future Horizons reckons that Europe will become the main driver of high-tech markets because its skills are more converged than in the US. "Europe drives the mobile

phone industry and never gave up on consumer – while the US gave up on consumer products," added Penn.

"Japan may have the edge in consumer, and the US in computers, but Europe has all three. That makes Europe unique."

The recent downgrading of semiconductor market growth has been led by US analysts, whereas the vice-president for European operations at Dataquest, Joe D'Elia, reckons that there is not the same pessimism over her. "In my water I feel it's not going to be a bad year for semiconductors – nearer to 20 per cent growth than ten per cent," said D'Elia.

In broadband wireline, the US will fall behind the rest of the world this year with five to six million DSL subscribers compared to the rest of

the world's nine to 11 million subscribers, according to newsletter *DSLPrime*.

Leading world supplier of DSL equipment – Alcatel of France – recently announced 41 per cent growth in telecommunications equipment sales, whereas analysts expect Cisco Systems, US No 1 in communications equipment but currently suffering its worst ever quarter, to achieve between zero and two per cent growth.

Samsung develops 4Gbit/DDR SDRAM

Samsung is announcing the development of a prototype 4Gbit, double data rate, synchronous DRAM at this year's ISSCC.

Manufactured using a 0.10µm

process, the chip-scale packaged device measures in at a monstrous 645mm² – exactly one square inch.

Central to the operation of the circuit is a twisted open bitline architecture.

In a traditional DRAM architecture, such as a folded bitline, the wordline operation generates noise inside and between bitlines. Techniques to counter this are available, but they tend to overly increase chip area.

Twisted open bitline takes the sensing pair of bitlines (the bitline and its inverse) and swaps them over as they pass across the sense amps in the middle of line of memory cells.

In a conventional folded bitline scheme there is some 17mV of coupling noise, which is reduced to just 3mV in Samsung's twisted scheme.

In order to improve the sensing speed of the cells, a pre-sensing scheme uses a linear transconductance amplifier. This can knock a few nanoseconds off the 10ns charge sharing time before the sense amplifier is activated.

Integrated passives built into PCB

Integrated passive components (IPCs) for consumer devices may come out of University of Arkansas research. Scientist Rick Ulrich has been developing thin-film IPCs for military, aerospace and supercomputer applications at the University for nearly a decade. Apart from "some short-term issues" remaining, he sees lack of industry infrastructure as a primary problem for commercial IPC use. His are built into the surface of a circuit board as it is being made rather than older thick-film-on-ceramic construction.

Zinc-air cells give instant power

Zinc-air cells have hit the mainstream with Electric Fuel offering batteries for mobile phones and PDAs. Called Instant Power Battery (£9.99), the disposable 3.3Ah devices can power the phone directly or recharge the phone's own battery up to three times through the Instant Power Charger (£19.99), said the company.

www.electric-fuel.com

Part of the prototype 4Gbit synchronous dynamic RAM.

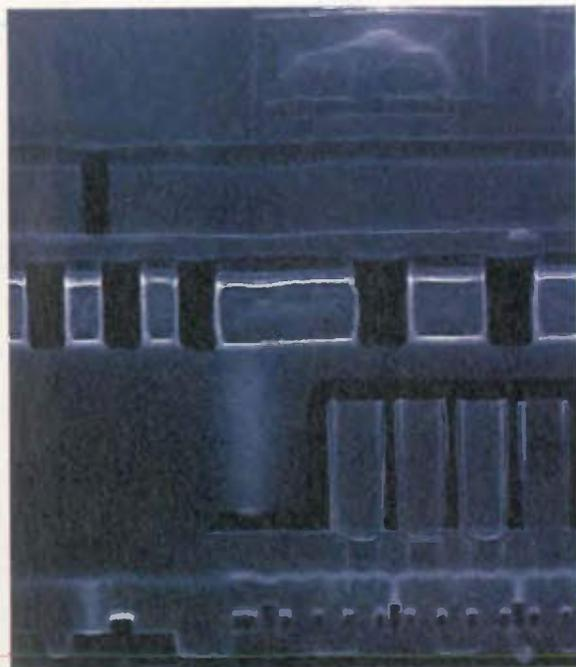

WWW.PCB-POOL.COM

Prototype PCBs
from your usual manufacturer for a
fraction of the cost

1 Eurocard^{ds / pfn}
+ TOOLING
+ PHOTOPLOTS
+ VAT
= **£49**

CIRCLE NO.106 ON REPLY CARD

FREE Layout Software
FREE Digital-Multimeter
on receipt of your first orders 100 order
FREE PHONE 0800 389 8560



pcb-pool@ukfast.com
http://www.pcb-pool.com



☎ +353 (0)61 701170
FAX 701164

Ramco

GENUINE GOVERNMENT SURPLUS

We currently have in stock a selection of MOD surplus electrical equipment. All items are untested and sold as seen. Please ring for more details.

Tektronics 466 Storage Oscilloscope	£99.00
Tektronics 2445a Oscilloscope 150mhz	£399.00
Phillips 3217 Oscilloscope 50mhz	£99.00
Could OS300 Oscilloscope 20mhz as new, boxed	£99.00
Could DS 4072 Oscilloscope 100mhz	£50.00
Racal 9009 Modulation Meter	£69.99
Thurlby DSA524 Digital Storage Adaptor	£50.00
Tektronics 2440 Digital Oscilloscope	£1200.00
TD2000 OTDR Fibre Optic Tester	£1500.00

From May 2001
we will be able to offer
tested equipment via our
refurbishment cell

TENDER SALE

MARCH 17-21st
You may find just what
you are looking for!
Check out our web
site for further details...

CHURCH LANE, CROFT, SKEGNESS, LINCS (JUST OFF THE A52)

01754 880880

FIND OUT MORE ABOUT US ON OUR WEBSITE

www.ramco.co.uk

EW 4/01

CIRCLE NO.107 ON REPLY CARD



Quality Alphanumeric backlit LCDs in 4x40, 2x40, 4x20, 2x20 and 2x16 formats

Supplied either bare or pre-fitted with one of our Eze-Use, Serial interface boards with options such as software buzzer control, backlight control, operator interface, start-up message, big character generation, and PC-AT Keypad /mouse interface - all at very competitive pricing.

We also stock Serial Interface Graphic modules and front panel bezels for all our LCDs. Please call (01977 683665) or check our web site (www.milinst.com) for full details and pricing.

Milford Instruments - your total LCD solution



Milford Instruments
Milford House, 120 High St
South Milford
LEEDS LS25 5AQ
Tel 01977 683665
Fax 01977 681465
www.milinst.com

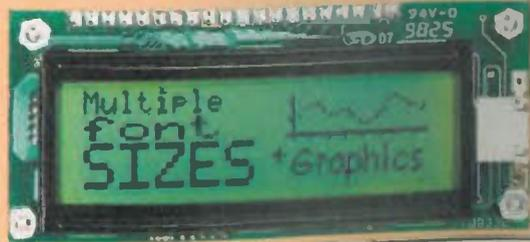

Miniature robots "work together in swarms"

Sandia Labs in the US has "possibly the smallest autonomous untethered robots ever created", according to co-developers Doug Adkins and Ed Heller.

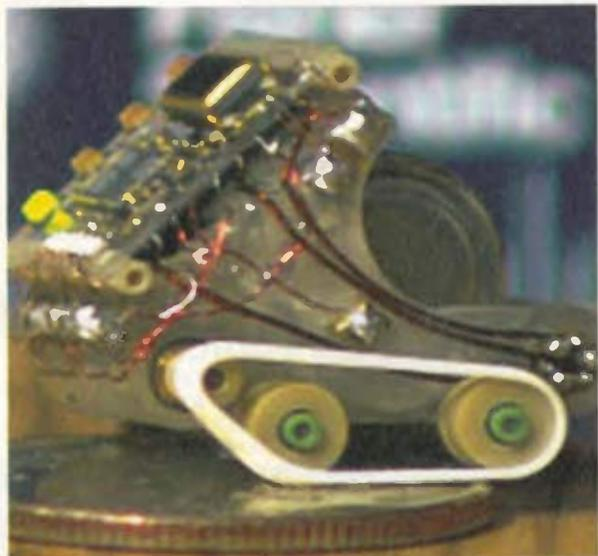

It occupies 4cm³ and weighs under 30g. Powered by three watch batteries, it rides on tracked wheels and has an 8kbyte ROM processor, temperature sensor and two drive motors.

"They will be able to work together in swarms, like insects. The miniature robots will be able to go into locations too small for their larger relatives," said Sandia.

The mini-robot has already manoeuvred its way through a field of coins at about half a metre per minute.

Unpackaged parts on a glass

substrate provide the electronics. "Previous small robots consisted of packaged electronic parts that were more bulky and took up valuable space. By eliminating the packaging and using electronic components in die form, we reduced the size of the robots electronics considerably," Heller said.

Over the next few years, Heller and Adkins expect to add either infrared or radio wireless two-way communication capability, as well as miniature video cameras, microphones and chemical sensors.

The Swiss Federal Institute of Technology built a 1cm³ robot to the designs of Professor Jean-Daniel Nicoud for the 1cm³ category at the International Microrobot Maze Contest in Nagoya Japan. "Realistically, 1cm³ is the smallest size that motors can be fitted into. If the

robot needs to carry its own batteries the size has to increase," said Nicoud.

Ex-watchmaker André Guignard built the microbot with multiple infra-red distance sensors and a PIC 16C54 microcontroller on board. Nicoud also designed a 16cm³ fully autonomous robot.

Colour imaging for 3G mobile phones

A colour imaging system suitable for 3G mobile phones has been demonstrated by STMicroelectronics at this year's ISSCC in San Francisco.

Engineers at the firm's Scottish image sensor division, formerly Vision, combined the 0.5µm sensor with a 0.18µm co-processor.

The module provides CIF 352 by 288 pixels resolution at 15 frames/s. Power consumption is claimed to be just 50mW.

ST's camera is interesting in that it uses different technologies for the image sensor and coprocessor. Keeping the coprocessor die size down and having two die seems to be cheaper than integrating everything in a single die.

Both devices are mounted on a ceramic substrate. A plastic lens is also mounted on a cavity in the substrate. The complete device

measures 10 by 10 by 7mm and works from a supply of down to 2.6V.

The CMOS image sensor is built using a two-poly, three-metal 0.5µm process.

The three transistor sensing element and conversion produces 10-bit, progressive scan Bayer pixel

data.

This data is fed to the 4.5MHz co-processor which produces a full colour image. Digital anti-aliasing filters are used to remove the stripe patterns and aliasing that affect Bayer patterned images.

Another potential problem for cameras is flicker from mains fluorescent lighting, at either 100 or

120Hz, depending on local standards. This can result in unsightly bands sweeping down the image.

To determine the lighting frequency, two column height 'super-pixels' detect lighting variations. This can be used to set the exposure controller to coincide with the lighting flicker.

Richard Ball

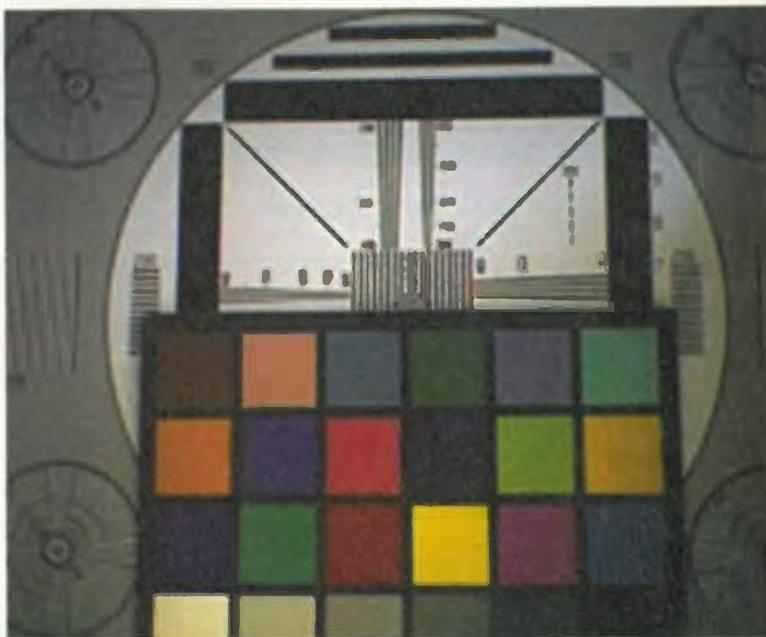

A test image captured by ST's mobile video module.

'Electronics and Computing Principles V7'

'95, '98, NT or 2000

Principles V7'

Studying electronics or computing or just want to keep up-to-date in a easy and enjoyable way, then this fully interactive software is for you.

visit eptsoft.com or telephone for full details of more than a thousand menu items.

Personal user £99.95 +VAT
Education £299.95 +VAT
(Includes unlimited multi-user site licence.)

Electronics:-

Atomic Structures, DC Current flow, Basic Electronics, Simple DC Circuits, Types of Switching, Variable Voltages, Ohm's Law, DC Voltage, DC Current, Series/Parallel Resistors, AC Measurements, AC Voltage and Current, AC Theory, RCL Series/Parallel Circuits, Capacitance, Capacitors, Inductance, Inductors, Impedance, Communication System, Signals, Attenuators, Passive/Active Filters, Tuned Circuits, Coupling and Selectivity, Oscillators, Circuit Theorems, Diode Theory, Diode Applications, Transistor Theory, Bipolar Transistor, Transistor Configurations, Transistor Circuits, Field Effect Transistors, Operational Amplifier Theory and Applications, Sum and Difference Amplifiers.

Electrical:-

DC and AC Power, SCR, Power Supplies, Voltage Regulators, Magnetism, Motors/Generators, Transformers, Three Phase Systems.

Digital Techniques:-

Logic Gates, Flip Flops, Combinational Logic, Counters, Counting, Shift Registers, Logic Interfacing, Timers, Boolean Algebra and DeMorgan's Theorems.

Microprocessors and PIC Microcontrollers:-

Basic Micro-Computer, Busses, A.L.U. Clock and Reset, Instructions and Control Memory Cells, ROM and RAM, Memory Addressing, Instructions, PIC Introduction, PIC16F84 Architecture, PIC16C71 A/D, Byte Bit, Literal and Control Instructions.

Measurement and Component Testing:-

Analogue multi-meter, Measurement, Component Testing.

Mathematics:-

Simple Numbers, Number Types, Roots, Triangle Ratio's, Triangle Angles, Area, Surface Area and Symmetry, Volume, Percentages, Ratio's, Fractions, Vectors, Circle Angles, Laws, Algebra Rules, Indices Powers, Simplifying, Equations, Graphing, Slope and Translation, Angles, Complex Numbers, Statistics, Lottery Number Prediction, Physical Science.

Computer Science:-

Hardware Devices, Data Structures, Data Files, Binary Numbers, Binary Arithmetic.

Toolbox:-

DC Calculations, AC Calculations, Numbers, Applications

Self-Assessment Questions:-

DC, AC, Power, Semi-Conductors, Op-Amps, Digital, Mathematics.

Components and Equipment Picture Dictionary:-

High quality digital camera images and explanatory text.

ELECTRONICS LAB (Optional add-on hardware).

eptsoft limited, Pump House, Lockram Lane, Witham, Essex. UK. CM8 2BJ.
Tel: +44 (0)1376 514008. Fax: +44 (0)870 0509660. Email: info@eptsoft.com.

Switch, Delta, Visa and MasterCard accepted.

No additional postage or airmail charges.

Engineering employers fail to meet recruitment target

A Government report on skills shortages says that a significant number of engineering employers are experiencing recruitment difficulties.

Skill shortages are especially apparent among professional engineers and the skilled trades, including electronics and IT skills.

The report is the first in a series from the Government dealing with the issue in various industries.

"While the electronics industry is predicted to grow by eight per cent each year for the next five years, more than half of electronics recruiters reported difficulties in meeting their targets," said Lifelong

Learning minister Malcolm Wicks. "We need to ensure training provision matches changes in skills needs and demand."

The assessments are aimed at getting detailed information about trends in skills supply and demand to planning bodies and careers services.

3D ICs solve multi-level interconnect problems

Researchers from MIT's Lincoln Laboratory have constructed two layer ICs – a technique that can overcome many of the problems associated with large area ICs and multi-level interconnect.

Stacking active devices vertically allows for shorter overall interconnect, reducing capacitance and hence propagation delays.

One test circuit fabricated by the lab is a CMOS active pixel sensor, with parallel analogue-to-digital conversion on the second layer.

The 64 x 64 active pixel matrix is constructed using 0.8µm CMOS on a 10µm epitaxial layer, chosen for its good visible and near-IR optical properties.

The a-to-d circuits were made using 0.8µm silicon on insulator.

After both sets of device were fabricated, the a-to-d wafer was inverted and bonded to the pixel matrix. The bulk silicon was etched from the a-to-d layer.

Two depths of vias were then etched to link the top side of the device (actually the buried oxide layer of the SOI wafer) to the metal layers of the two bonded wafers. Vias are 6µm square and

either 2.7 or 7.5µm deep. At 6µm square, the two vias have comparable resistance, around 0.85Ω.

The active pixel sensor circuit contains 4096 vias.

Also fabricated using the 3D technique were ring oscillators, in which each inverter in the ring was fabricated in an alternating layer.

At 5V, there is no difference in propagation delay between 3D and conventional ICs, under 1ns.

But at lower voltages, down to 1.5V, a difference emerges, with delay per stage of 10ns for the 3D layout and over 1µs for a planar layout.

The diagram shows the two wafers bonded, metal layers together. Vias connect from the top of the construct to metal one of the SOI wafer and metal two of the epi wafer.

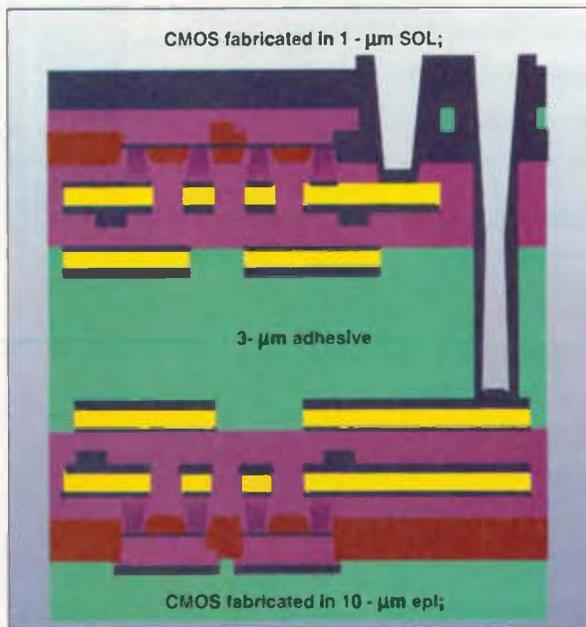

Polymer LEDs are "better than conventional"

Polymer LEDs may outstrip the efficiency of conventional types, claims research from the University of Utah

Physicists previously believed that no more than a quarter of the energy flowing into an LED could be emitted as light, with the rest radiating as heat, said university physics chairman Valy Vardeny, explaining that the electrons and holes have different spins which prevent all potentially useful recombinations being emissive.

Vardeny's measurement, however, shows that 41 to 63 per cent of the energy can be converted into light

using LEDs made from electrically conducting polymers and oligomers under the influence of microwaves.

Vardeny's team, at institutes in the USA and India, tested different light-emitting plastics in a magnetic field at super-cold temperatures. Lasers (instead of electricity) caused the materials to emit light.

Some of the materials emitted more light than they would have otherwise.

Vardeny's theory is that the microwaves randomise the spins of the incoming electrical charges so they combine more quickly, boosting the number of recombinations that emit light.

"We succeeded in fooling quantum mechanics," he said. "We did not break any laws of physics. We just fooled them."

The team is now seeking a method of doping plastics to remove the need for microwaves.

Alan Heeger, who won a Nobel prize for polymer semiconductor research, praised the Utah study as "nice work".

Steve Bush



Russian invention invades US.

Cybiko is a handheld device offering two-way walkie-talkie, text messaging and games with up to 99 other users in a short-range radio area. The device was developed in Moscow by Chinese-Armenian David Yang and sells at \$99.95 in the US, where it is becoming very popular. The device is expected to be on sale in the UK before next Christmas.

PIC Basic Pro

The Professionals Choice

Write your PIC programs In BASIC! - No STAMP REQUIRED!

PIC Basic - £59.95

Quicker and easier than 'C' or assembler, PIC BASIC is a true compiler providing faster execution and shorter programs than BASIC stamp interpreters, built in I2C routines and serial comms upto 115K Baud and full BASIC STAMP compatibility make writing for the Microchip PICmicro's easy! PIC BASIC compiles your basic language programs to Microchip Hex format for use with In-circuit emulators or for programming directly into the PIC CHIP. Supports PIC12C67x, PIC14Cxxx, PIC16C55x, 6xx, 8xx, 84, 92x and 16F87x. Full documentation with syntax examples are provided in the 168 page user manual. A technical support mailing list is provided for life time support.

PIC Basic Pro - £169.95 the professionals choice

The PIC BASIC Pro compiler instruction set is compatible with the Basic Stamp II providing additional functionality over PIC BASIC, feature like LCD, ADCin, I2CRead, I2CWrite customisable Serial In / Out. (Create a serial LCD display driver in minutes). Full de-bug facilities, compile with debug to produce assembly commented with your Basic commands PIC BASIC and PIC BASIC PRO compile tight efficient code without the use of a basic interpreter. Supplied with a 168Page manual, explaining each command and worked examples FREE PIC Macro compiler, FREE Programmers File Editor, FREE Windows Front End. PIC BASIC PRO Includes samples programs and code to support Smart card read&write.

Download the full 168 page PIC BASIC MANUAL and more
<http://www.picbasic.co.uk>
 Order Online via our secure server
<http://www.crownhill.co.uk>

- ◆ Low cost programmer for PIC12Cxxx, PIC12CExxx, PIC14Cxxx, PIC16C505, 55x, 6xx, 7xx, 84, 92x PIC 16CE62x and PIC16F87x
- ◆ ZIF adaptors are available for 8/18 In 40/28Pin DIL, 8, 18 and 28 SOIC, 44 Pin MQFP, 44 and 68 Pin PLCC
- ◆ Powered by 2x 9V batteries or AC adapter.
- ◆ Connects to PC parallel port
- ◆ Upgradable software is supplied for future PIC Micro's
- ◆ FREE 8051 style PIC Macro compiler



£35 When purchased with PIC BASIC

- Parallel port extension cable - £5.95
- 40Pin ZIF socket - £22.50
- 8/18Pin ZIF Socket - £22.50
- PIC8 Prototype board - £4.50
- PIC18 Prototype board - £5.50
- PIC64 Prototype board - £8.50

All prices are subject to VAT@17.5%

A comprehensive guide to using PIC BASIC

EXPERIMENTING with the PICBASIC PRO COMPILER



By Lee Johnson

A COLLECTION OF BUILDING BLOCKS AND WORKING APPLICATIONS USING MELABS SIMPLE TO USE YET POWERFUL COMPILER

A CROWNHILL PUBLICATION

INCLUDES COROM

- Section 1 Displays
- Section 2 Interfacing with Keypads
- Section 3 Serial EEPROMs
- Section 4 Analogue to Digital Converters
- Section 5 Digital to Analogue Converters
- Section 6 Remote Control
- Section 7 Temperature Measurement
- Section 8 Robotics
- Section 9 Audio Control
- Section 10 Programming Techniques
- Section 11 Powering Up the PIC

Free Download: Section 3 from www.picbasic.co.uk
Available NOW! £24.95 +P&P

SMARTCARD DEVELOPMENT SYSTEM

ChipDrive StarterKit + Windows Software
 Read and Write data on Smart Cards and Memory cards
 Microsoft PCSC compatible!
 Package Includes:
 Professional card Reader Writer (ChipDrive Micro),
 Assorted Smart Cards (3 pairs),
 Samples of source code in VB3,4,5+6, C and Delphi.
 Examples Apps to Read and Write to Smart Cards and GSM cards
 Documentation and detailed Windows DLL description.

£69.95

Visit our web site for Smart Cards, Programmers and Smart Card applications.
 The UK's largest stockist of Smart Card and Smart Card Technology
www.crownhill.co.uk/itm00047.htm

PIC Real-time Emulator' and Programmer

NEW LOW PRICE!

£119.95 PIC 16F877 In Circuit Programmer



- ☑ For PIC 16F87X (emulates most PIC 16C6X/7X devices)
- ☑ In-Circuit run time debugging
- ☑ Real Time code execution 32KHz to 20MHz real time operation
- ☑ High Speed Parallel port interface
- ☑ 2.5V to 6.0V operating range
- ☑ Built in device programmer
- ☑ Run, Step, Run to Cursor etc
- ☑ Conditional Animation Break
- ☑ Software animation trace captures 3 user defined variables in addition to opcode, W, Status, FSR registers and corresponding instructions.
- ☑ Source level and symbolic debugging
- ☑ Runs under PICICD IDE (win95/98 or NT) or MPLAB
- ☑ Supplied with ICD debug module, Proto board, 40Pin and 28Pin emulator headers, Cables IDE software and user guide

All prices are subject to VAT@17.5%

£356.00

LabProg 48LV

Low Cost - High Performance

Intelligent Universal Device Programmer

- Includes:
- Connection cable
 - Diagnostic POD
 - User Manual
 - PC Software Driver
 - 240VAC/12V adaptor

CE certified

- Plugs into parallel port of your PC
- Adaptors for TSOP, PSOP, QFP, SOIC, PLCC
- True No Adapter Programming upto 48 Pins
- Programs and Verifies 2.2, 7.3, 3.3 & 5V devices
- FREE software updates 3 Year Warranty

Universal Serial Eeprom programmer



£55.00

PreProm UNIVERSAL Eeprom Programmer
 Adaptors for TSOP, PSOP, QFP, SOIC, PLCC
 Adaptors for Microprocessors
 Adaptors for Eeprom
 Emulator adaptor

£135.00

All prices are subject to VAT@17.5%



The Embedded Control Solutions Company

- PIC 16F84 / 04p - £1.90
- PIC 16F84 / 04so - £2.00
- PIC 16F84 / 10p - £3.95
- PIC 16C622 / 04p - £2.50
- PIC 16F877 / 04p - £5.50
- PIC 16F877 / 20p - £6.00
- PIC 16F877 / 04p - £4.50
- PIC 16F874 / 04p - £4.50
- PIC 16F873 / 04p - £4.50
- PIC 12C508A - £0.63
- PIC 12C509A - £0.63
- 24LC16 - £0.95
- 24LC16 so - £0.95
- 24LC32 - £1.50
- 24LC64 - £1.50
- 24LC85 - £1.50

All prices are subject to VAT@17.5%

Crownhill Associates Limited



32 Broad Street Ely Cambridge Cb7 4PW

Tel: 01353 666709 Fax: 01353 666710



ORDER ON-LINE www.crownhill.co.uk

All prices are subject to a delivery charge + VAT@17.5%

CIRCLE NO. 110 ON REPLY CARD

LOWEST PRICES EVER

Call for other PIC and Memory prices PIC PROGRAMMERS and Universal Device Programmers

Leslie Warwick takes a look at the current state-of-the-art in digital still-camera technology.

DIGITAL CAMERA

As the digital still camera market continues to develop apace, some interesting technical developments have come to light. In addition, a few professional features have started working their way down to consumer level products.

One of the notable technical developments is the so-called 'megapixel' sensor – an image sensor with a million or more pixels. In 1998, the 1+ megapixel was in the news; 1999 it was the 2+ megapixel. Last year it was 3+ megapixel.

Of course the more pixels there are, the greater the resolution; but the ultimate image quality depends on more than just the quantity of pixels. This is one reason why professional cameras are more expensive.

'Megapixel' is also a slightly misleading term. Virtually all cameras have just the one sensor and require three filtered pixels to make the one full colour element. Additionally, the pixel figure quoted may well include optical black pixels. These are employed to sense

variations in black level caused by temperature-induced changes in dark (residual) current Fig. 1. This means that a 'megapixel' may not be much more than 300 000 pixels in terms of real resolution.

At the opposite extreme, Olympus has produced a medium-format camera with three 2048x2048 pixel sensors – a total of 12.6 million! At 48-bit full colour depth, this produces a file of about 25Mbyte per image.

The SHD-S1 prototype system consists of a camera body, lenses, computer board and software. There's also a large, pivoted LCD monitor for mounting atop the camera.

Liquid-crystal monitors on cameras have become notorious for draining batteries. In an attempt to combat the battery drain problem, Sanyo has launched the digiCAM 400, which has added solar power.

Virtually all consumer/business cameras have now followed professional practice. They use sensors produced specifically for still imaging, rather than borrowing them from video cameras, whose mass production has made them cheaper. This gives the latest cameras some advantages: square sensor pixels that match the square pixels of computer monitors, rather than rectangular video pixels; and progressive scanning instead of interlace.

Electronic shutter

It is also commonplace for consumer/business cameras to have an electronic shutter in the sensor, rather than a conventional electromechanical type. When the camera's shutter is set for fast speeds, the charge-carrying electrons are allowed to drain away from the pixels until the last, say, 1/500 second. They are then integrated for that pre-set time and read out.

An electronics shutter has no moving parts, so shutter times can be very brief indeed – up to 1/20 000 second at

Fig. 1. Arrangement of the optical black pixels around the imaging area of a CCD. These act as a reference to prevent black level varying with temperature.

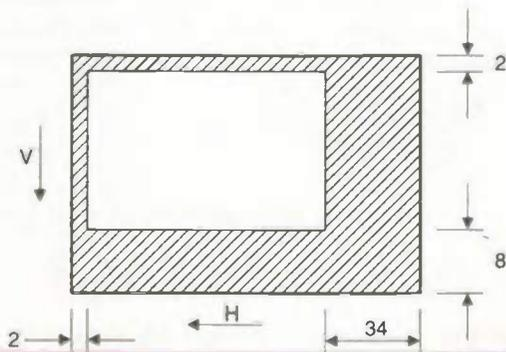



Minolta's Dimage EX1500 showing the interchangeable lens/CCD section – zoom and wide-angle. The EX Digital Bus allows a range of accessories to be added; the Digita operating environment lets you upgrade the firmware by flash card while the Digita script software provides the means of customising functions.

DEVELOPMENTS

present. In practice though, more modest speeds are the norm. For slow speeds the charge integration is continuous over the pre-set time.

Because most image sensors have a fairly low sensitivity, equivalent to ISO100-200 films, all consumer and most business cameras have a built-in flash. Cameras have also begun to appear with a flash-synchronisation socket.

Minolta's new Dimage EX1500 will have an adapter for external lighting later: this is made possible by its being the first upgradeable camera – which includes the possibility of replacing the 1.5 megapixel CCD. This is because the lens portion of the camera – including CCD – is detachable.

At present, the only alternative is a wide-angle lens unit to replace the zoom one. However, the EX Digital Bus offers a variety of expansion possibilities; as well as the facility to use a 1.5m lens extension cable – a feature first seen on an earlier Minolta model.

In addition, the Digital Operating Environment enables the camera's firmware to be updated from a flash card, to give new functions and additional performance.

CMOS sensors

Until now, all production cameras have used a CCD sensor, but Umax has launched a basic camera with a CMOS device. A unique colour filtering arrangement is used, involving red, green, blue and teal (greenish-blue), which is said to improve the tonal separation.

This is only one of a few cameras that has a professional 30-bit colour depth instead of the usual 24-bit. The 800 000 pixels of the CMOS can be increased to a processed resolution of 3 megapixels by interpolation.

Images are normally compressed for storage; generally

by the Joint Photographic Experts Group (JPEG) system. Most cameras offer two or more different compression ratios to provide a choice between image quality and quantity. Some are now following professional practice though by also providing a 'no compression' mode. The standard resolution is 640x480 pixels; but many of the latest cameras also provide much higher resolutions.

Until recently, most consumer/business cameras had an internal flash memory while professional models had removable memory – usually PCMCIA hard disk or flash card. Now, most of the former have bowed to user preference and have either a combination of both, or removable memory only – in this case small flash cards.

Sony's cameras though take a normal 3.5in floppy disk. The company has reintroduced the MAVICA name – MAGnetic Video CAMERA – originally used in 1981 for the world's first still-camera prototype. This was capable of recording fifty analogue video images on a 2in floppy disk, and inspired the short-lived Still Video format.

For those who need to store large numbers of images in the field, Olympus has developed the 'dimo'. This is an interface between the company's cameras and their portable 3.5in magneto-optical drive.

Companies like Peak Development and Premier Electronics have a range of PCMCIA adapters for flash cards, and internal and external card readers for computers not thus equipped.

Many cameras can directly download images to a computer through a parallel or serial interface – even those taking cards. Some of the latest models use the universal serial bus USB, formerly confined to professional cameras. This medium-speed bus allows connection and disconnection while the computer is running.

Cameras have also appeared with an infrared

Olympus pioneered the direct camera-to-printer interface for those who don't want to mess about with a computer. Note also the flash card slot.



'connection'. This conforms to the new IrTran-P (infrared transferred picture) protocol adopted by manufacturers of cameras for digital transfer via IrDA (Infrared Data Association) interface.

Many digital cameras can also output video. This has been almost exclusively NTSC until just recently. Now, models are becoming available that can be switched to, or are exclusively, PAL.

Camera-to-printer interface

Olympus has produced cameras capable of interfacing directly with the company's own printer. Other companies have followed suit, bringing out cameras that interface to their printers. But now, cameras are appearing with a

'multi-printer link' facility. This is useful, because the choice of printer can make a considerable difference to the print quality. Printers are also appearing with a flash card slot.

Fuji has taken the idea a step further, showing a prototype that combines the company's digital camera and instant print technologies. Called the Digital In-Printer camera, this system employs Fuji's new Instax Mini ISO 800 silver halide instant print film and a vacuum fluorescent print head. The prints are only 54x86mm (46x62mm image); but the images are filed on a flash card for other uses.

Fuji has also demonstrated the similarly small and light Digital Instax Mini Printer. This accepts flash cards, and has parallel and infrared interfaces.

It was Fuji, incidentally, that first developed a digital camera – the DS-1P prototype, shown in 1988. The company has recently launched the MX-2700 – the first camera to have a CCD aspect ratio of 3:2. A joint development with Matsushita, this CCD is designed to provide a standard size of colour print from the new 'digital minilabs' that produce prints from either computer files or films.

This camera is also one of the new 2+ megapixel types, with a resolution of 1800x1200. It can produce photographic quality prints up to 8x12in.

The CCD actually has 2.3 million pixels, not 2.16, but it is masked so as not to record the noisy pixels at the edges. Matsushita has introduced a model with a 16:9 mode – 1136x640 pixels – under its Panasonic brand.

Digital insert for standard cameras

Imagek has revived the idea of a digital insert that can replace film in a 35mm single lens reflex (SLR) camera. This allows images to be made electronically or chemically according to need.

There are two parts to the EFS-1 prototype – a pod for

Fuji's combination camera and printer using instant film. And the mini-printer using the same technology.



the main electronics, which fits into the camera's cassette chamber, and an extension piece. This extension lies in the film path to place the image sensor in the film gate, where it is held in place by a pressure plate, Fig. 2.

The image sensor is a 1.3 megapixel CMOS type. Because it is only about half the size of a 35mm frame, the focal length of lenses is effectively doubled. A resolution of 1280x1024 pixels is quoted, with 36-bit colour depth.

Sensitivity of the CMOS sensor is equivalent to 100ISO film, although it is planned to increase this figure for subsequent products. Exposures can be made at the rate of one every two seconds.

There's room for up to 24 images in the adaptor's on-board flash memory. Downloading in the field to a flash card is possible via the an 'e-box'. An 'e-port' provides both a protective housing for the device and PCMCIA/USB connection for downloading to a computer. Initial production will cater for the Canon EOS 1N and EOS A2/5, and for the Nikon F5, F3 and N90/F90.

Digital backs

There have been rumours that the major SLR camera manufacturers are developing digital back add-ons. All the up-market SLR system cameras already allow a data back to be substituted for the standard one so it would make sense from their point of view.

Retro-fittable backs would allow the interchange of information between the back and the camera body; and achieve the precision that could not be guaranteed with a device that simply replaced the film cassette. But, mainly, it would tie users to a particular SLR system.

In the medium and large format markets, the situation is the reverse. Here, virtually all the backs are made by independent companies and adapted to different makes of camera.

Whether the more up-market SLR backs will have a condenser optics system to compensate for the size difference between film frame and sensor remains to be seen. The only camera that does so at present is a professional model jointly developed – but sold separately – by Fuji and Nikon. This camera accepts Nikon's SLR lenses.

Figure 3 shows how the optical arrangement relays the image to the smaller CCD. This has the incidental advantage of concentrating the light, allowing a maximum ISO equivalent of 3200.

Some cameras can record a few seconds of digital audio with each image. This is not something that is catching on in the consumer market, but business and professional users are finding it helpful to record details of the subject or its exposure. There are also cameras that act as MP3 players.

Sanyo has created the 'video clip', enabling up to 5, 10, 20 or 60 seconds of images with sound to be recorded at 10 or 15 fps depending on the resolution and model of camera. Resolution options are 320x240 and 160x120 pixels, using Motion JPEG compression. There is also a higher quality fast sequential shot mode to record a burst of frames, but without sound.

Two of Sony's Mavica models record up to 60 seconds of MPEG-1 compressed images. A number of other cameras also offer some sort of burst recording facility. They have a buffer memory to hold the unprocessed images, because the processing times are still in the order of seconds.

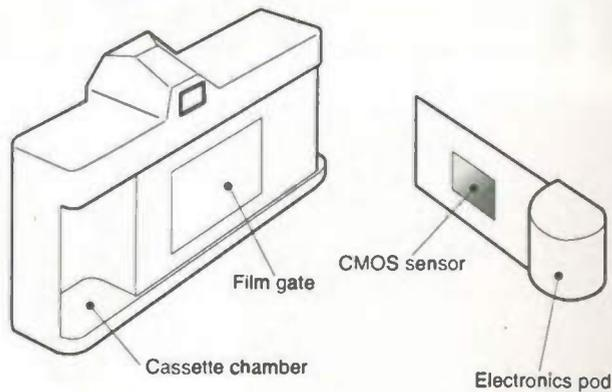

Fig. 2. The Imagek digital insert replaces the film in a single lens reflex camera. It is held in place by the pressure plate on the hinged back (not shown).

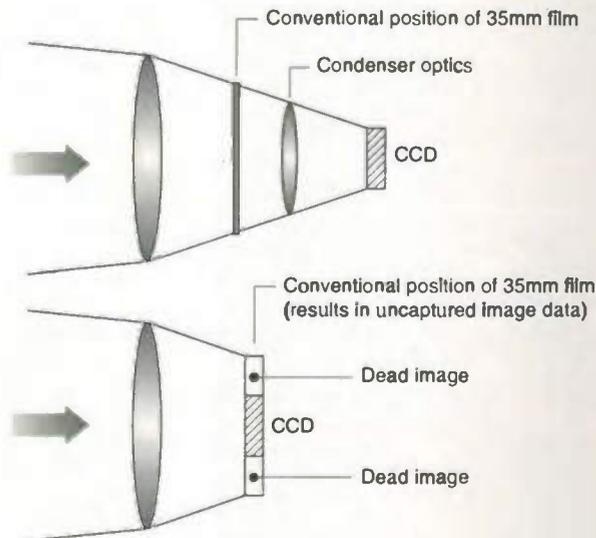

Fig. 3. Condenser optics relay the image to the CCD in the Fuji/Nikon camera, so that the lenses give the same image magnification as with a 35mm SLR.

Camcorders for stills

Both the Digital Video and new Digital8 camcorder formats have a 'photo shot' recording facility in their specifications. Camcorders have already begun to appear with flash memory for single image recording.

Camcorders with a single CCD do not have the resolution to compete with the megapixel CCDs of still cameras, despite a growing number that can be switched between interlace and progressive scan. But the results are quite adequate for computer uses – and their moving images are at present far superior to the attempts of still cameras.

And finally there is the Sharp Internet ViewCam. This is the first to use MPEG-4 compression to record digital video on a flash card – one hour on 32Mbyte. It could well take over from still cameras for some computer uses. ■

Interfacing with

WAP

Les Hughes explains how to start developing software that will allow you to control equipment remotely from your WAP mobile phone – or any other kit designed around the wireless applications protocol.

In my articles on Java¹⁻⁴ I looked at some of the more exciting developments in Internet technology and how they can be used in interfacing to real world devices.

Perhaps the most exciting 'development' of all is the convergence of telecoms and mobile computing. Small, personal computers (PDAs) are becoming cheaper, more powerful and more network aware, while mobile phones are starting to appear with the same operating system and features as some PDAs!

Although much progress has been made in the area, things are still quite primitive. Wireless application protocol, or WAP, devices are basic to say the least. Furthermore, with the advent of faster mobile networks later this year – GPRS, iMode, etc. – coupled with more powerful devices able to cope with richer content, WAP may prove to be a short lived 'standard'.

However, this is all academic. The use of a WAP device for Internet-based control is achievable today.

Behind the scenes

First I'll examine what happens behind the scenes of a typical WAP session.

In many ways, WAP Internet access is no different from 'normal' dial up. You simply make a data call to a service provider. Then, instead of starting Netscape or IE5, you use a WAP browser to request web pages.

Usually, this browser will be integrated into a mobile phone such as the Nokia 7110, but there's nothing to stop you using a Palmtop, such as a PalmOS or WinCE device, or even a PC WAP aware browser.

Although some WAP browsers – notably those running as applications on a PC – are sophisticated enough to

directly access wap sites, on the whole you will need to talk to a WAP gateway in order to receive pages. A gateway can be thought of as a proxy. It forwards your WAP requests as a standard HTTP 'get' or 'post' command to a web server – Apache or the like – and encodes any responses before sending them back to you.

Since this gateway merely acts as a go between, any web-server-side techniques can be employed in order to generate dynamic content; jsp, php, servlets, etc., depending on the web server and application.

While the gateway uses HTTP to talk to a normal web server, it doesn't expect to receive standard HTML pages. Instead, WAP has its own markup language, WML, which is short for wireless mark-up language.

WAP mark-up language – WML

WML is an extensible mark-up language implementation. The term extensible mark-up language is usually abbreviated to XML.

Newcomers from an HTML background may find WML's strict syntax something of an annoyance. HTML browsers often happily accept malformed markup – unclosed tags, incorrect nesting, etc. – doing their best to display the page. Extensible mark-up language on the other hand allows validating parsers to reject invalid markup. As a result, authors should always run their code through a validator before publishing.

Wireless mark-up language files are termed 'decks'. A deck comprises a number of 'cards'. Each card represents a screen of information.

Because WAP currently runs at 9600bit/s, this multiple-pages-per-file approach reduces the number of times that the browser has to connect back

to the server in order to move through a site. But any dynamically generated content based on user input will result in the browser reconnecting to the server anyhow. Also, the device imposes a limit on the amount of information in each deck.

WML supports basic formatting – paragraphs, bold, etc. – and simple monochrome images in the WAP bitmap format WBMP. User input is managed in a similar way to HTML through the use of forms, check boxes and the like, while basic scripting support is provided through WMLScript.

Software/hardware

In order to start experimenting with WAP you'll need to create a suitable development environment.

Figure 1 illustrates some of the various configurations. As the diagram shows there's a number of options depending on the hardware, software and Internet/private network connection available. Figure 2 should help you decide which pieces of infrastructure you'll need.

For those without a physical WAP enabled device, Nokia, Motorola and

others provide basic WAP tools. The Nokia SDK includes a WML editor/validator, basic WAP bitmap editor and two WAP phone emulators including the 7110. Since this device requires a gateway, the SDK includes a simple gateway that automatically starts when using the 7110 emulator. For simple WML development, an SDK is all you really need.

However, if you want to really go to town and establish a full-blown development environment for use with a physical WAP enabled device (7110, etc.), you will need a gateway, a web server to generate content and a dialup server and a modem in order to gain access to the system.

In terms of actual products, Apache is now the widest deployed web server – freely available for Windows & Linux. Windows RAS or Linux PPPD can be used to provide dialup access depending on your favourite operating system. Both of these products are bundled with the OS. A freely available open-source WAP gateway comes in the form of Kannel for Linux, although other free gateways are available for Linux and Windows.

What do I need to get started?

The combinations of real devices, emulators, browsers, protocols (WAP, HTTP) and language (HTML, WML) support makes a definitive answer to this question difficult.

For example, some newer devices have dual HTML/WML browsers than can talk HTTP directly to a webserver, removing the need for a gateway. Some PDA applications can go via a gateway or direct and use either a dialup connection or plug straight into a network.

Broadly speaking, the flow chart in Fig. 2 should help you decide what infrastructure you need. The simplest approach is to use an emulator on a PC talking directly to a webserver – Apache for example – on the same PC.

Of course, we are discussing WAP based control and therefore, at a minimum you will need a TINI and a PC plugged into a network and a WAP browser/emulator. See reference 4 for details of installing TINI.

Fig. 1. There are various ways of developing WAP applications. The one you choose will depend on what hardware, software and networking options are available to you.

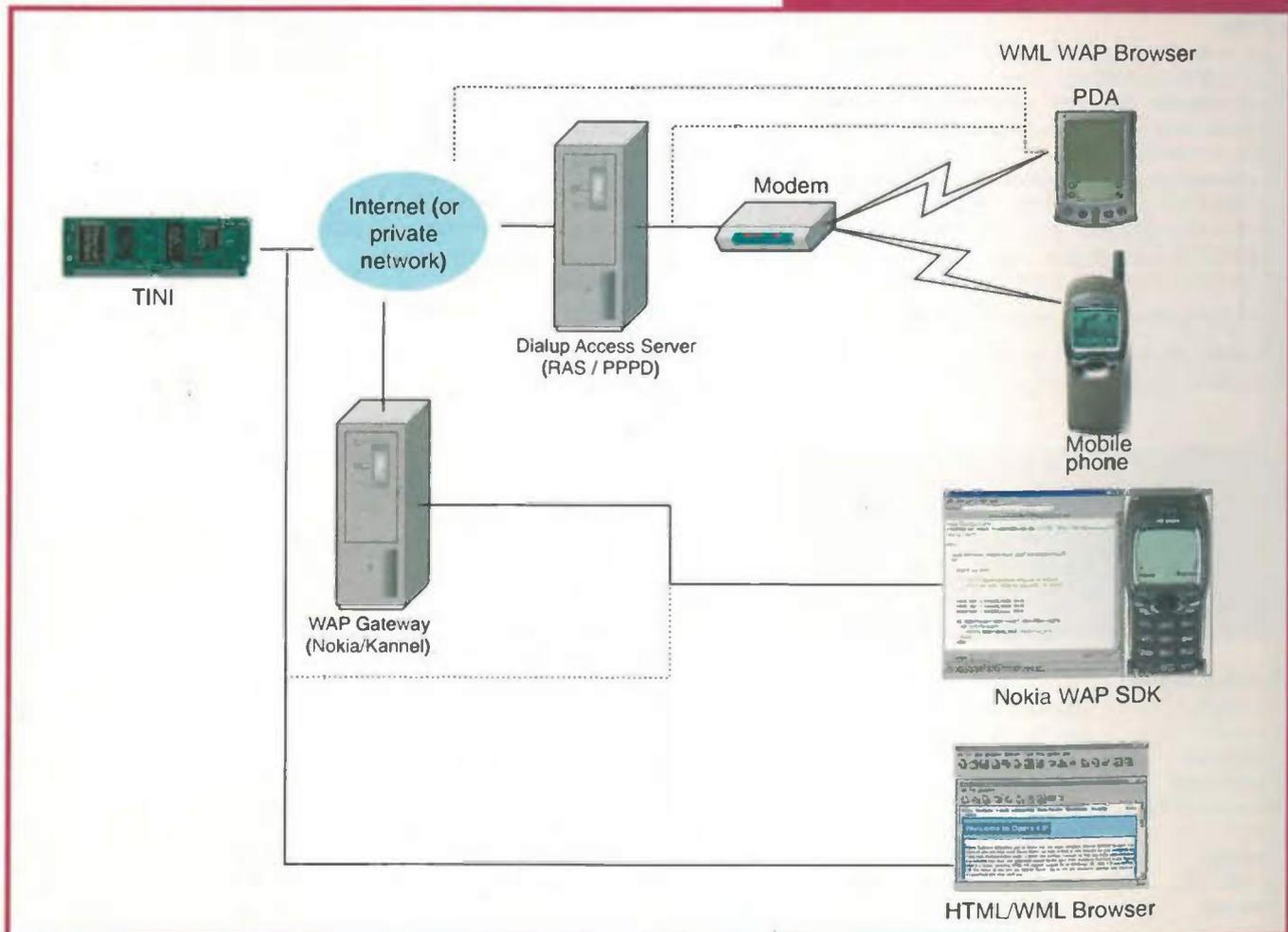

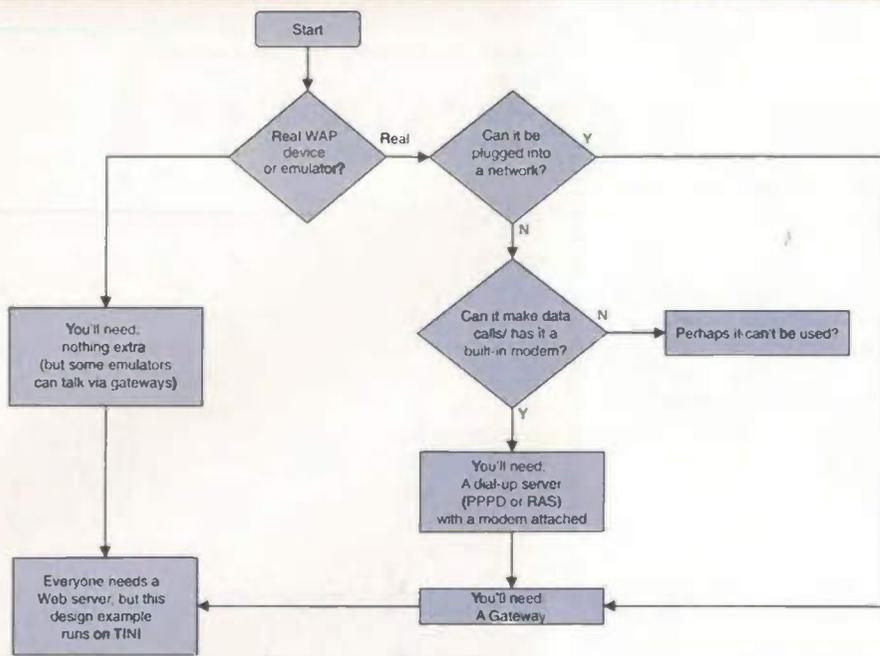

Fig. 2. There are various ways of implementing a WAP-based telemetry system.

It is quite a lengthy task to establish a professional quality development environment. But it is encouraging that all of the tools required are available for little or no cost and can all run on a single, reasonably powerful PC.

Remote control via WAP

Once you have your environment up and running, you are ready to start experimenting. While basic WAP is interesting enough to experiment with on its own, remote control of devices over WAP opens a whole new area.

Internet monitoring and control of devices can be easily achieved through the use of an embedded web server and some server side technology, such as Java Servlets. Indeed if you've been following my earlier articles, you may have already hooked up some devices to the net using an HTML interface.

All you need to do is to produce and process WML instead of HTML and suddenly you have a WAP-enabled system. You could even design a servlet that can detect whether it is talking to a WAP browser or HTML browser – or digital TV, etc. – and adjust the produced content accordingly. This is called multi-channel delivery in the business.

WAPFlash – a high-tech 'helloworld'
So, by using a number of components such as the embedded TINI controller⁴ and Java

servlets, you can now build a simple proof-of-concept application that will enable you to turn an LED on or off via WAP.

In such system, a WAP device or emulator might talk to TINI, possibly via a gateway, depending on your development environment. Whether or not the LED should be lit would be indicated through the use of WML 'postfields' – a form element in HTML speak. TINI will process this input and set an LED accordingly.

Code for this proof-of-concept application is contained within a simple Java servlet, List 1. This servlet has a doGet method that sets or resets an LED on the TINI board depending on the 'action' parameter sent by the WAP browser. This same servlet produces some WML that reflects the current state of the LED and provides the functionality to control the LED.

The servlet should be compiled into the TINI servlet engine and deployed with the instructions provided with the engine.

At this point you can either use the Nokia tools to talk directly to your TINI from a PC connected via a network or, if you've opted for using an actual WAP device, via dialup and a gateway on your network. Your WAPServlet should be listening out at:

```
http://123.456.789.000/servlet/WAPServlet
```

where 123.456.789.000 is the IP address of your TINI.

Further development

The simple proof-of-concept application shows how easy WAP control can be given the correct infrastructure. Actual control and monitoring of real world equipment could be achieved by connecting various single-wire devices to TINI's I-wire interface. Such a device is Dallas's DS240x parallel i/o interface. Alternatively you could use TINI's CAN and I²C buses.

As part of my full-time job, I have recently installed a demonstration system using these devices. It is a WAP-controlled soft-drink vending machine incorporating real-time fizzy-drink temperature telemetry! ■

References

1. Hughes, L. 'Exploring Java', *Electronics World*, Apr. 1999.
2. Hughes, L. 'Interfacing with Java', *Electronics World*, Sept. 1999.
3. Hughes, L. 'Ins and outs of Java', *Electronics World*, Nov. 1999.
4. Hughes, L. 'Tini Java', *Electronics World*, Jul. 2000.

What is TINI?

TINI is a tiny controller from Dallas Semiconductor designed for Internet connection. Although very low cost, this controller is a complete computer with Internet, network and serial i/o capabilities, giving it huge potential for remote i/o and telemetry applications.

All of the software required to develop applications for TINI is available free of charge from various Internet sites. Installing and configuring your environment in order to get TINI up and running consists of a number of tasks. Guillaume Fournier's excellent guide at

<http://www3.sympatico.ca/guillaume.fournier/>

describes in detail the process that you should follow in order to be able to boot your TINI.

For more information...

- www.opera.com Opera web browser has support for WML
- www.nokia.com Site for SDKs
- www.ericsson.com Site for SDKs
- www.motorola.com Site for SDKs
- www.ibutton.com/TINI TINI home page
- java.sun.com Java home page
- www.kannel.org Open source WAP gateway for Linux
- www.audicode.com A Windows WAP gateway
- www.apache.org The most widely deployed web server

List 1.

```

import java.io.*; //std jdk imports
import java.util.*;
import javax.comm.*; //std java extension imports
import javax.servlet.*;
import javax.servlet.http.*;
import com.dalsemi.system.BitPort; //Other imports
public class WAPServlet extends HttpServlet {
    BitPort cpuled;
    boolean state;
    HttpSession session;
    protected void updateLED() {
        if(state) cpuled.set(); else cpuled.clear();
    }
    protected void updateLED(boolean state) {
        this.state = state;
        updateLED();
    }
    public void init() throws ServletException {
        cpuled = new BitPort (BitPort.Port3Bit5);
        state = false;
        updateLED();
    }
    public void doGet(HttpServletRequest req, HttpServletResponse resp) throws ServletException,
    IOException {
        //set content type for wml
        resp.setContentType("text/vnd.wap.wml");
        //Turn LED on or off ?
        String action;
        if( (action = req.getParameter("action")) != null) {
            if(action.compareToIgnoreCase("on") == 0) updateLED(true);
            if(action.compareToIgnoreCase("off") == 0) updateLED(false);
        }
        PrintWriter out = resp.getWriter();

        writeWML(out);
        //Finish sending doc.
        out.flush();
        out.close();
    }
    //Helper method to generate some WML.
    private void writeWML(PrintWriter out) {
        //Output WML
        out.println("<?xml version='1.0'?>");
        out.println("<!DOCTYPE wml PUBLIC '-//WAPFORUM//DTD WML 1.1//EN'");
        out.println("<'http://www.wapforum.org/DTD/wml_1.1.xml'>");
        out.println("<wml>");
        out.println("    <card id='do_io'>");
        out.println("        <p align='center'>");
        out.println("            <b>TINI WAP Demo.</b>");
        out.println("            LED is currently ");
        //Send text representation of LED status
        if(state) {
            out.println("On.");
        } else {
            out.println("Off.");
        }
        out.println("        Select a function:");
        out.println("        <select name='onoff' value='on' title='LED On/Off:'>");
        out.println("            <option value='on'>Turn LED On</option>");
        out.println("            <option value='off'>Turn LED Off</option>");
        out.println("        </select>");
        out.println("        <do type='accept' label='Go!'>");
        out.println("            <go href='/servlet/WAPServlet' method='get'>");
        out.println("                <postfield name='action' value='${onoff}'/>");
        out.println("            </go>");
        out.println("        </do>");
        out.println("        </p>");
        out.println("    </card>");
        out.println("</wml>");
    }
    //Pass a POST request to the GET method
    public void doPost(HttpServletRequest req, HttpServletResponse resp) throws ServletException,
    IOException {
        doGet(req, resp);
    }
} //EOF

```

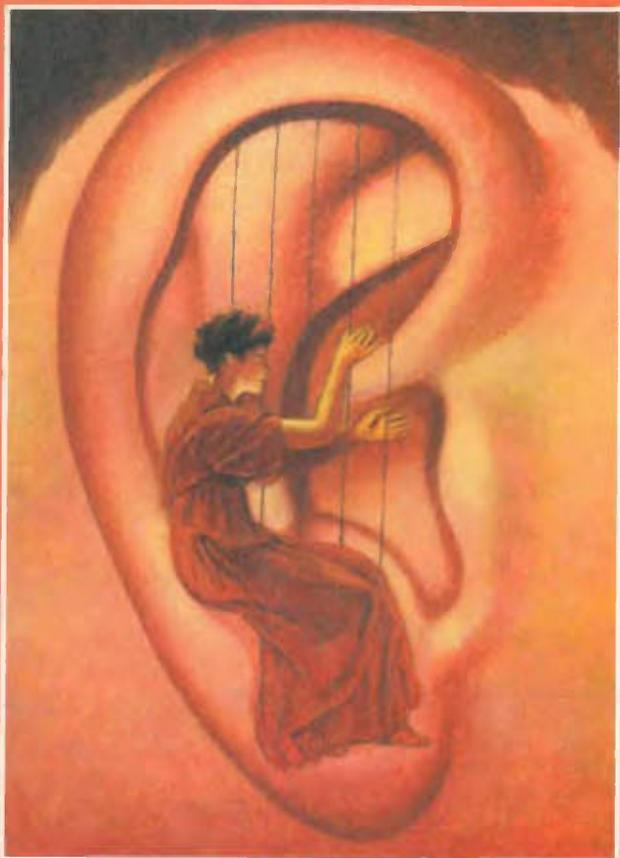

Norman Thagard's meticulously designed phono preamplifier solves several problems inherent in today's audio systems. Featuring a high-level output compatible with most AV systems and receivers, it has a noise figure of around $5\text{nV}/\sqrt{\text{Hz}}$ – hardly more than the Shure V15 cartridge that it was designed to amplify.

Phono preamp for the CD era

While I have designed and constructed several audio power amplifiers in the past 12 years, I have never, until recently, done much preamplifier work. I have considered attempting to design and construct a preamplifier for several years, but I find I am usually prompted to begin a project by need, rather than intent. That is true of the phonograph preamplifier I describe here.

The need arises

Unlike some audio purists, I have been very interested in surround sound since the early seventies. With the incorporation of my sound system into an audio/video system, I replaced my Krell preamplifier first by an Adcom and then by a Marantz A/V tuner/preamplifier.

Unfortunately, as with most modern units, neither the Adcom nor the Marantz had a phono input. Lately, the Krell has functioned solely as a pre-preamplifier, that is, as an interface between the phono cartridge and a high-level (Tape 1) input on the Adcom.

Having a bulky preamplifier in the system was undesirable though, because I had no more room for additional components in the equipment rack. I wanted to replace the Krell with a dedicated small phono preamp that I could locate behind the equipment rack.

It occurred to me that I was probably not the only one who might need a stand-alone phono preamplifier that would allow updating the system preamp without losing the phono option. So I finally developed the impetus to attempt the design of at least one component of a preamp – the phono stage.

The design I present here allows the phono cartridge to appear as a

high-level source that you can input into any of the standard, flat-response, high-level inputs on an audio or audio/video preamp or receiver. The few purists left will appreciate the irony of using the CD input, as I do with the Marantz.

The CD input circuitry in my 1985-vintage Krell PAM-5 manipulates the signal in some way – perhaps to compensate for the interchannel time difference in early CD players – so a tape or auxiliary input might be better in some cases.

I specifically designed this preamp for moving-magnet cartridges capable of at least a couple of millivolts output at 1kHz. With some minor changes, you could probably use it with a moving-coil cartridge

About the author

Five-time astronaut Norman Thagard was the first American to enter space aboard a Russian rocket for a 90-day mission to the space station Mir. With a total of 140 days in space, he became the most experienced US astronaut ever.

In addition to an MS degree in engineering science from Florida State University, he holds a doctorate in medicine from the University of Texas Southwestern Medical School.

Dr Thagard is currently Professor and Director of College Relations at the FAMU-FSU College of Engineering. An avid audiophile, he designs and builds audio amplifiers as a hobby.

Reprinted with permission from Audio Xpress.

TEST EQUIPMENT SOLUTIONS

Quality second user test equipment bought and sold

All purchases backed with full one-year warranty and technical support

AMPLIFIERS

Amplifier Research 1W1000 1GHz 1W Amplifier	1850
Kalmus AS0204-17R 2-4GHz 17 Watt Amplifier	4950
Kalmus AS0822-30R 0.8-2.2 GHz 30 Watt Amplifier	6950

CALIBRATORS

Fluke 5200A DMM Calibrator	1950
Fluke 5220A Transconductance Amplifier	2650

COMPONENT ANALYSERS

HP 4084B Switching Matrix Controller	4500
HP 4085A Switching Matrix	4500
HP 4085M Switching Matrix	5500

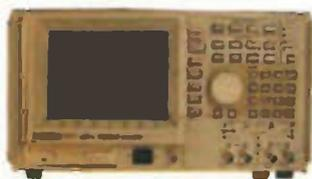

DATACOMMS

Fluke DSP-100 Cat 5 Cable Tester	1650
Fluke DSP-FOM Fibre Optic Meter For Fluke DSP Series	350
Fluke DSP-SR Smart Remote Injector for DSP-100	350
HP J2300C Internet Advisor	9500
Microtest PentaScanner CAT 5 Cable Tester	1650

ELECTRICAL NOISE

HP 8970B 1.6GHz Noise Meter	7950
-----------------------------	------

EMC

R & S EB 100 Miniport Receiver 20-1000MHz	3750
R & S EPZ 100 Mini Panoramic Display	1250
Wayne Kerr EASY ONE 1GHz EMC System	7500

FREQUENCY COUNTERS

HP 5385A 1GHz Frequency Counter With Battery Pack	650
Marconi CPM46 46GHz Counter Power Meter	5000
Philips PM6654C/526 1.5GHz/2ns Counter Timer	1250
Philips PM6666 1.3GHz Counter Timer	750

FUNCTION GENERATORS

HP 3325B 21MHz Function Generator	3750
Philips PM5193 50MHz Function Generator	1250

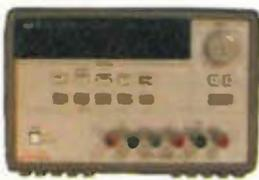

LOGIC ANALYSERS

HP 1650A 80 Channel Logic Analyser	1000
HP 1671A 102 Channel Logic Analyser	5750

MULTIMETERS

HP 3466A 4.5 Digit Digital Multimeter	350
---------------------------------------	-----

NETWORK ANALYSERS

Anritsu S331A / OS 3.3GHz Scalar Network Analyser	5500
HP 3577A 5Hz-200MHz Network Analyser	4500
HP 85046A 3GHz S Parameter Test Set (50 Ohm)	3950
HP 8720C 20GHz Vector Network Analyser	35000
HP 8753C 3GHz Vector Network Analyser	13950

OPTICAL FIBRE TEST

HP E6000A/E6003A Single Mode Mini OTR (1310/1550)	5950
---	------

OSCILLOSCOPES

HP 54111D 500MHz 2 Channel Digitising Scope	2950
HP 54121T 20GHz 4 Channel Digitising Scope	13500
HP 54602A 150MHz 20MS/S 4 Channel DSO	1250
HP 54603B 60MHz 2 Channel Digitising Scope	1150
Philips PM3295A/40 400MHz 2 Channel Analogue Scope	1500
Tek 2445A 200MHz 4 Channel Analogue Scope	1500
Tek 2465B 400MHz 4 Channel Analogue Scope	2500
Tek AMS03/A6302/TMS01 Current Probe Set	1750
Tek TA5465 100MHz 2 Channel Analogue Scope	695
Tek TDS350 200MHz 2 Channel Digitising Scope	1850
Tek TDS380 400MHz 2 Channel Digitising Scope	2500

POWER METERS

HP 436A/022 RF Power Meter With GPIB	750
HP 438A/002 Dual Channel RF Power Meter	1950
Various HP 848x Sensors (from)	300
Marconi 6960 / GPIB RF Power Meter	695
Various Marconi 69xx Sensors (from)	350



POWER SUPPLIES

HP 6282A/005/028 10V 10A DC Power Supply	150
HP 6284A 005/028 20V 3A DC Power Supply	150
HP 6632A 20V 5A Power Supply	1250
HP 6652A 20V 25A DC PSU	795
HP E3610A 15V 3A DC PSU	150
HP E3615A 20V 3A DC Power Supply	195
HP E3631A 25V 5A DC PSU	650
Hunting Hivolt Series 250 50kV, 5mA Power Supply	975
Various DC Power Supplies (from)	100

PROGRAMMERS

Elan 6000 Elite Eprom Programmer With Modules	250
Stag 1040 Universal Programmer With Modules	250

RF SWEEP GENERATORS

HP 8340B 26.5GHz Synthesized Sweep Generator	19500
HP 83620A 10MHz To 20GHz Synthesized Sweeper	23500

SIGNAL & SPECTRUM ANALYSERS

Advantest R3265 8GHz Spectrum Analyser	9700
Advantest R3361A 2.6GHz Spectrum Analyser inc T/Gen	7500
Advantest R4131B 3.5GHz Spectrum Analyser	3950
Advantest R4131D 3.5GHz Spectrum Analyser	4500
Advantest R9211A 100kHz Dual Channel FFT Analyser	3950
Anritsu MS2601B 2.2GHz Spectrum Analyser	5500
Anritsu MS2663A 9KHz-8GHz Spectrum Analyser	8950
Anritsu MS610B 2GHz Spectrum Analyser	2650
HP 3561A 100MHz Dynamic Signal Analyser	3250
HP 3562A Dual Chan 100kHz Dynamic Signal Analyser	4250
HP 35660A 102.5kHz Dynamic Signal Analyser	2950
HP 70000 2.9GHz Spectrum Analyser System	10000
HP 8560A 2.9GHz Spectrum Analyser	9950
HP 8562A 22GHz Spectrum Analyser	14500
HP 8591A 1.8GHz Spectrum Analyser	5950
HP 8593A 22GHz Spectrum Analyser	13500
HP 8901A 1.3GHz Modulation Analyser	1250
Lindos LA100 Audio Analyser (LA101 & LA102)	2750
Tek 492 /02 21GHz Spectrum Analyser	3950

SIGNAL GENERATORS

Advantest R4262Z 023 4.5GHz Signal Generator	12500
HP 8642A/01 1GHz High Performance Signal Generator	2500
HP 8656B /001 1GHz Synthesised Signal Generator	1150
HP 8657B 2GHz Signal Generator	5500
Marconi 2017 1GHz Low Noise Signal Generator	1000
Marconi 2019A 1GHz Signal Generator	1000
Marconi 2022 1GHz Signal Generator	650
Marconi 2031 2.7GHz Signal Generator	7250
R & S SMH 2 GHz Signal Generator	6950
R & S SMHU 4.3GHz Synthesised Signal Generator	13500

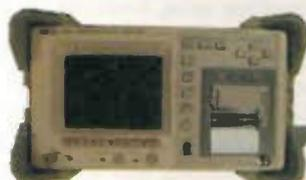

SWITCHES & MULTIPLEXERS

HP 3488A Switch / Control Unit	350
Various HP 444xx Switch Cards (from)	150

TELECOMS

Anritsu MD6420A Data Transmission Analyser	2500
Anritsu MD0623C 2MBPS CEPT Interface	1500
Anritsu MS371A PCM Frame Analyser	3500
GN Nettest LTE 3000	2250
HP 3788A/001 2MBPS Error Performance Analyser	1750
HP 4934A / J02 TMS Test Set	3500
Marconi 2840A Analyser	1950
Marconi Triton Signalling test set	2500
Sunrise Telecom SUNSET E10 Communication Analyser	4950
Trend Aurora Duet Primary Rate ISDN Tester	2250
Trend Aurora 30 Handheld Primary Rate ISDN Tester	1500
TTC FIREBERD 6000/7/8 Communication Analyser	5500
W & G PFA-35 2MBPS Communications Tester	4950
W & G DST-1 Handheld E&M Signalling Tester	1250
W & G PA-20 PCM Performance Analyser	2500
W & G PA-41 Frame / Signal Analyser	3950
W & G PCM23 Voice Frequency PCM Tester	2750
W & G PCM-4 PCM Channel Measuring Set (from)	9000



TV & VIDEO

Philips PM551ST TV Pattern Generator With Teletext	1850
--	------

WIRELESS

HP 83220A /022 PCS/DCS1800 Test Set	4500
HP 83220E PCS/DCS1800 MS Test Set	3500
HP 8920A 1GHz Radio Comms Test Set (various configs)	4500
HP 8922M GSM Test Set	8500
HP 8922S/006 GSM Test Set	7500
Marconi 2945A /001/003/023 Radio Comms Test Set	7500
Marconi 2955 Radio Comms Test Set	1950
Marconi 2955B/01 Radio Comms Test Set	3500
Racal 6103/001/002 GSM/DCS Test Set	7500
R & S CMT54 B1/B4/B5/B6/B9 Radio Comms Test Set	4500
R & S CMT56 B1/B4/B5/B6/B9 Radio Test Set	2250
R & S CMT84 B1/B5/B6/B9 Radio Comms Test Set	4500
R & S CMT84 B5/B6/B8 Radio Comms Test Set	4950
Schlumberger 4031 1GHz Radio Comms Test Set	3500
Schlumberger 4039 960MHz Radio Comms Test Set	1250
Stablock 4015 1GHz Radio Comms Test Set	4500

See our extensive online catalogue at www.TestEquipmentHQ.com Flexible commercial solutions available on all products.

Prices shown are in £UK and are exclusive of VAT. Free carriage to UK mainland addresses. This is just a selection of the equipment we have available - if you don't see what you want, please call. All items supplied fully tested and refurbished with one year warranty. All manuals and accessories required for normal operation included. Certificate of Conformance supplied as standard; Certificate of Calibration available at additional cost. Test Equipment Solutions Terms Apply. E&OE.

01753 59 6000
fax: 01753 59 6001

www.TestEquipmentHQ.com
email: info@TestEquipmentHQ.com

CIRCLE NO. 111 ON REPLY CARD



FREE

Free Palm m100 shipped with every order over £10K

whose output was 20dB less than this. I make no claims for this, however, because I did not examine this possibility.

Equalisation

The principles of preamplifier design do not differ greatly from those of amplifier design, the major differences being power and noise considerations. The exceptions are for preamps intended for tape heads and phono cartridges. The cartridge requires not only more amplification (because its output is significantly lower than, say, a CD player), but also equalisation.

Equalisation involves tailoring the frequency response of the preamplifier in a manner that exactly compensates for the frequency response of the signal at the input. The idea is that the overall frequency response will be 'flat' in the sense that the original spectrum of the sound is maintained in reproduction.

The frequency shaping that must take place in the phono preamp is that of the RIAA curve. This curve has been the basis of several previous articles. I have liberally footnoted this article with references that contain additional information for those of you wanting more details on this topic.

Equalisation is needed because neither the recording nor the cartridge response is flat. To avoid overly wide groove excursions on the record, the low-frequency components are compressed, while to improve signal-to-noise ratio, the high frequencies are emphasised.¹

On the reproduction side, a magnetic cartridge is a velocity-responding device. If groove amplitude were held constant, electrical output would be proportional to frequency. To compensate for these factors, response is boosted by a factor of about ten (19.3dB) at the low end and attenuated by roughly the same factor at the high end (19.6dB), where 1kHz is the reference (0dB) frequency.

Curve-shaping poles

Suffice it to say that there are two poles, one at 50Hz and the other at 2.122kHz, and a zero at 500Hz that shape the curve. There are many different ways to produce these poles and the zero, with different designers favouring different schemes.

The most economical method uses negative feedback around only one gain block, with the feedback network made frequency-dependent

by adding two capacitors and one resistor to the usual passive voltage-divider feedback network. You can easily accomplish single-ended designs with just two bipolar-junction transistors, or BJTs, per channel.

Since closed-loop gain is approximately equal to $1/\beta$, where β is the fraction of the output fed back to the input, it follows that a zero in β — i.e., a feedback zero — produces a closed-loop-gain pole, and a feedback pole produces a closed-loop-gain zero. Thus, there are two feedback zeroes and a feedback pole at the frequencies corresponding to the RIAA poles and zero, respectively.

Achieving great accuracy in RIAA curve tracking with this method is more problematical, because the components in the complex RC feedback network interact.² It is not a simple case of calculating the three break points as independent RC time constants.

Mathematically, there are cross-product terms in addition to the terms of interest. Then, too, if the amplifier is noninverting, the closed-loop-gain roll-off due to the feedback zero at 2.122kHz cannot be sustained, because this gain cannot drop below unity. In effect, an unintended zero is added to the response at some higher frequency.

While you can eliminate this latter defect with an inverting configuration, the ubiquitous 47kΩ moving-magnet loading resistor winds up in series with the cartridge's own DC resistance instead of in parallel with it.

The upshot of this is that the considerable noise generated by this resistor is input into the preamp rather than being largely shunted to ground through the source resistance of the cartridge, as it is in the noninverting configuration.

Design philosophy

You can find a discussion of the topics of the last paragraph, and the philosophy on which the design described in this article is based, in National Semiconductor Applications Note AN 346.³ This design largely obviates the problems that I've alluded to.

My preamplifier is based on this design, but using discrete components. It is a good challenge because the AN 346 design used two op-amps. Seeking op-amp performance with discrete components can involve a lot of parts, and implementing two such amplifiers in discrete form means yet another such group of parts. Near-op-amp parameters are, in fact, required because high input impedance, low

Fig. 1. Preamp schematic.
Power supply details will be discussed in a subsequent article.

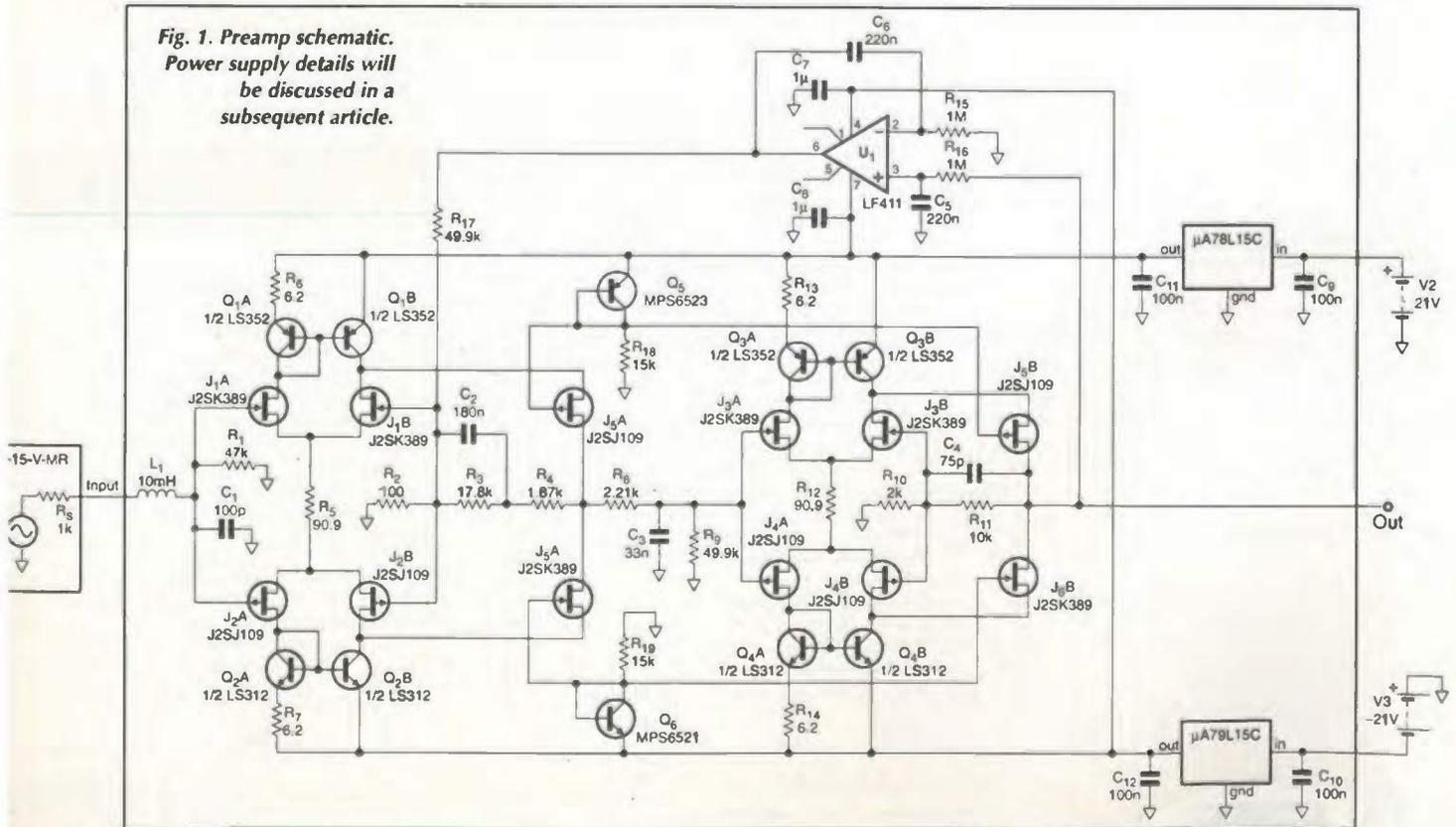

output impedance, and high open-loop gain are crucial to proper performance of the circuit.

As an engineering professor, I receive textbooks for evaluation from time to time. One of these described a one-stage op-amp,⁴ realised by using the folded-cascode topology. It could be argued that a cascode, folded or telescopic, is really two stages. However, from the standpoint of audio-frequency performance, a cascode has all the earmarks of a single, albeit compound, stage. It behaves like a 'super' common-emitter or common-source stage with higher bandwidth and lower distortion.

I have had a predilection for cascoded stages ever since reading an article on the subject by Nelson Pass.⁵ My very first amplifier design was a 100W Class-A (at 8Ω) DC monoblock that featured four telescopically cascoded stages, including the power output stage.⁶

In 1992 I designed and constructed a balanced-input amplifier. It featured a MOSFET-based differential-in, single-ended-out folded cascode very similar to the phono preamplifier described here. That design permitted a CMRR of over 60dB at 20kHz. Finally, the Thagard/Pass A75, the design of which was completely Nelson's, but which incorporated some topological features that I had suggested, offered the option of a folded cascode.⁷

Complementary symmetry

In the current application, using a folded cascode in complementary symmetry results in sufficiently high open-loop gain. This is because the drain of each common-gate device 'sees' the drain of its complementary partner as its load device. From the differential-amplifier input to the single-ended output, gain is given by $1/2g_m R_{load}$, where g_m is transconductance and R_{load} is the load resistance.

If R_{load} is the intrinsic resistance – call it R_o – looking into a JFET drain, then the gain is very high, because R_o often ranges from 100kΩ to 1MΩ. Of course, the caveat is that the input of the feedback network does not load the output node, and that is not a good assumption here.

Similarly, the following stage must not load the output node, either, and that is a reasonable assumption here. Apparently, the JFET transconductances are high enough to ensure that the open-loop gain is also sufficiently high.

I began with the intention of using the LM394 BJT 'superbeta' monolithic matched pair in the differential amp. Typically, JFETs have a transconductance that is an order of magnitude smaller than that of a BJT in a given application. Also, the source resistance of a moving-magnet phono cartridge is seldom more than about 1kΩ, so that a low-noise BJT such as the LM394 actually has an advantage from the standpoint of noise.⁸

The lower transconductance of most small-signal JFETs significantly adds to their noise voltage output.⁹ The JFETs used in this design have values of g_m closer to those seen in similar BJTs, so the LM394 noise advantage will be less. Another entry on the negative side is that the input-voltage offsets and drifts are higher in JFETs. The interelectrode capacitances are higher in JFETs, too, but the cascode largely obviates this negative aspect.

It was Erno Borbely's article describing the 2SK389/2SJ109 high-transconductance complementary monolithic pair JFETs that changed my mind.¹⁰ For one thing, I was aware of no p-n-p equivalent to the LM394. For another, input resistance of a bipolar transistor is much smaller than that of the JFET, although the LM394's high beta does result in a respectable resistance.

Thus, this design is mostly a JFET one. It is entirely JFET-based, if you accept the notion that the BJT active-load devices aren't really in the signal path. I believe that this is valid, since, ideally, no signal currents could pass through these devices.

Noise

I have never given much thought to noise in my power amplifier designs. Indeed, there was little reason to do so for a gain-of-twenty amplifier that requires an input of around 1V in order to produce full-power output. This is why one of my designs uses MOSFETs in the input differential amp. No one can make a good case for low-noise operation of the MOSFETs that would be used in a power amplifier.¹¹

Low-noise operation is a major consideration in designing a

preamplifier for moving-magnet cartridges. Gain at 1kHz is around 38dB, and the input signal might be about 5mV at best, depending on the cartridge.

The output will be boosted by another 20dB in the line-level preamplifier stage and a final 26dB by the power amplifier. This is a total amplification of almost 16 000. Signal or not, any noise at the input is amplified by this factor, which is why even my Krell has some audible noise in the phono position if your ear is close enough to the loudspeaker.

It should be obvious that the first stage in this chain is the most critical from the standpoint of noise. Paralleling devices reduces noise, so the complementary nature of the circuit helps, since the p- and n-channel devices are in parallel as far as the signal is concerned.¹² Unfortunately, a differential-amplifier stage has 3dB more voltage noise than a single-ended stage, and the two effects cancel.¹³

It may come as a surprise to know that the biggest contributor to noise in a well-designed phono preamp is the Johnson noise generated by the DC resistance of the cartridge itself. For the V15 Type V MR that I use, this resistance is 1kΩ, for a contribution of about 4nV/√Hz.

According to the PSpice model of the circuit of this article, total input noise – all noise is, by convention, referred to the input – is little more than 5nV/√Hz at most frequencies in the audio band.

If the model is correct, the preamp itself adds little to the total noise output. Although at the time of this writing I have made no noise measurements, listening indicates that noise is inaudible unless the ear is positioned immediately in front of the high-frequency drivers of the loudspeakers.

Radio-frequency interference

Figure 1 is the schematic of the preamplifier. Starting naturally at the input, a series inductor stands out prominently.

Inductors just are not encountered all that much in audio-frequency design. I had no intention at the outset to use this inductor. However, while doing listening tests during the breadboard stage, I heard not only the record that was playing, but a local radio station as well. I remembered a reference to this possibility¹⁴ and used the solution suggested in the reference – namely the addition of a 10mH RF choke.

A side effect of using the choke is a slight rise in high-frequency response that causes an RIAA tracking error of about 0.1dB at 20kHz. This rise is due to the interaction between the input capacitance and the inductor.

It is possible, of course, to lower the 2.122kHz pole to increase the 20kHz attenuation and thereby eliminate the induced error at 20kHz. I doubt that it is worth the effort though.

You can omit the choke if you wish. For compactness, I ordered a choke with a DC resistance of nearly 100Ω. This resistance is in series with the DC resistance of the phono cartridge and will add to the input noise.

There are coils available with much smaller resistances – like the M5942 from Digi-Key at 7.30Ω. This coil is significantly larger, though, and will be difficult to accommodate if you use the PC-board pattern of Fig. 2.

Designers need design only to the interface conditions specified by the cartridge manufacturer. As a result, I have not been motivated to research the subject. I have the impression from articles and from cartridge manufacturer-recommended capacitance values though, that the frequency response of a moving-magnet cartridge is, by design, extended by resonance. This resonance is due to the cartridge's intrinsic inductance and any capacitance in the preamplifier input circuit. If so, this is similar to the 'peaking' that is sometimes used in RF circuits to postpone high-frequency roll-off.¹⁵

The inductance of my cartridge is 425mH. If peaking is already intentionally used, adding approximately 2% to the cartridge's own inductance may well be less than the variation in intrinsic inductance from cartridge to cartridge. It would not then be reasonable to seek such accuracy in an area where other uncertainties exceed the likely gain.

Since the recommended load conditions for the V15 Type V MR are 47kΩ in parallel with 250pF, I added 100pF in the form of C_1 . That is because I use an SME 3009 Series II arm with 135pF of cable

capacitance, and the preamp has about 80pF of intrinsic input capacitance by measurement, or 40pF according to the PSpice version of the circuit.

Even though 100pF is a bit higher than the calculated optimum, I thought that this was probably a good all-around value. You are free to alter the value of C_1 for the particular cartridge at hand. Frequency response suffers, however, if there is too much deviation from the recommendation for the particular cartridge used.

Circuit topology

The input stage is a dual or complementary differential amplifier. I had hoped that the differential amp input would provide sufficient thermal stability to allow a true DC design. However, finding the zero temperature coefficient of the JFETs requires a knowledge of their pinch-off voltages.¹⁶

Since pinch-off voltage varies from transistor to transistor, it isn't practical to base this design on the zero temperature coefficient. Although I was able to unbalance the differential amp to achieve zero-output offset voltage, the drift was excessive.

In the end, I adopted the same DC servo used by many others before me.¹⁷ Even a venerable old $\mu A741$ op amp in the servo gave an acceptably low DC-output offset and drift. However, I accede to the almost universal use of the LF411 in specifying that part for this application. Certainly, the LF411 is a good choice, since it is sold as a low-offset, low-drift component.

On the breadboard, the LF411 required bypass capacitors near its power-supply pins, even though the supply rails were already bypassed at the point of entry onto the board. That is why there are two bypass capacitors on the supply rails, one at the output of each voltage regulator and another near pins 4 and 7 of the LF411.

You are welcome to experiment with eliminating the pin-4 and pin-7 capacitors. I included them on the prototype as a conservative measure. The $\mu A741$ did not require additional bypassing.

Be aware that the PSpice model showed considerable low-frequency distortion because of the servo. Increasing the integrator and low-pass-filter time constants corrected this problem in the model.

Since I saw no such distortion in the bread-boarded circuit, I left the components at the same $1M\Omega/220nF$ values that I have seen used in other designs. However, feel free to increase the time constant by increasing the value of C to 1.0 or even 220nF.

PSpice permits perfect device matching, so the simulated DC-coupled, servoless circuit had almost no DC-output offset or drift. This made it easy to determine that the apparent problem was with the servo.

JFET self-biasing

As with vacuum tubes, you can use self-biasing with JFETs. That is the function of resistors R_5 and R_{12} .

The target drain current was 3mA, meaning that 6mA should flow through those resistors. At 3mA, the JFET characteristic curves I

observed on a curve tracer suggested that $|V_{GS}| \approx 0.27V$ was required. With R_5 and R_{12} at 90.9Ω , about 0.55V source-to-source will be dropped.

Since the DC gate voltages are fixed at ground potential, the desired V_{GS} for both n- and p-channel devices is attained. Consequently, the desired drain currents are realised.

Characteristics of JFETs can vary. If you determine that the drain currents differ greatly from the design value, simply change the value of R_5 and/or R_{12} until $V_{RS}/R_5 \approx V_{R12}/R_{12} \approx 6mA$. Of course, increasing these resistor values decreases drain current.

The right-hand differential-amp devices J_{1B} , J_{2B} , J_{3B} , and J_{4B} are the common-source halves of a cascode. The more traditional cascode, originally constructed from vacuum tubes, is now sometimes called a telescopic cascode to distinguish it from the folded cascode.

A folded cascode 'folds' the cascode over toward the opposite voltage rail by using a device for the common-gate half of the compound stage that is complementary to the common-source device.

There were no complementary vacuum tubes, so it took the advent of the transistor before a folded cascode could be physically realised. It has the advantage of allowing the cascode output to be at 0V DC with proper biasing. It facilitates the construction of single-stage op-amps. Also, in discrete form, it is the basis for the current design.

Folded cascodes allow some flexibility in setting bias current in the common-gate device. This flexibility does not exist in the telescopic cascode, since the drain current is necessarily the same in both halves of the stage.

There are reasons for setting folded-cascode common-gate device bias at various levels depending on the design considerations.¹⁸ For simplicity and noise considerations, I elected to bias the common-gate devices at the same DC drain current as the common-source devices.

Each of the four dual bipolar transistors, Q_{1-4} , is configured as a kind of 'reverse' Widlar current mirror in order to establish the bias currents for the common-gate devices in the cascode. Again, it should not matter that BJTs are used in this capacity rather than JFETs, since the whole idea of a current mirror is to pass as little signal current as possible.

Some shun the use of active loads in preamplifier and amplifier designs – even for folded-cascode biasing. The reason, at least in some cases, seems to be a claimed adverse sonic effect. I am sceptical that any such effect exists, except as a perceptual alteration induced by knowledge of the material to which you are listening.

I prefer to use active loads because they ensure balanced differential-amp operation. Consequently, they potentially exhibit lower distortion than you could obtain with simple resistor loads.¹⁹

Collector current

In discrete design, it is easier to establish a given bias current with a bipolar-transistor-based Widlar mirror than with a scheme involving JFETs or MOSFETs.

In bipolar transistors, it is really base-emitter voltage that sets collector current. That is why the current ratio between the transistors in each half of each of the four mirrors is established by the difference in base-emitter voltages of those two transistors. This difference is $\Delta V_{be} = I_e \times R_e$, where I_e and R_e are the emitter current and emitter resistor, respectively, of the left-hand BJT of each mirror.

A 2:1 ratio is required if the common-gate JFET is to have the same DC drain current as the common-source JFET. That should be evident, since the symmetry of the two halves of each of the diff amps guarantees that their drain currents will be nearly equal at 3mA. Thus, if the collector current in the BJT on the right side of the four current mirrors is greater than that on the left side, the extra current must flow into the common-gate device.

If the right-side current is exactly 6mA, then 3mA will flow into the drain of the diff-amp JFET, while the remaining 3mA will flow into the source of the common-gate half of the cascode.

From the Ebers-Moll equation, it can be shown that $\Delta V_{be} = 0.0261n(I_1/I_2)$ is the difference required to establish the I_1/I_2 ratio. If a 2:1 ratio is desired, as is the case here, then $\Delta V_{be} \approx 18mV$ will do the trick.

Another good rule-of-thumb to commit to memory is that

Fig. 2: Preamp board parts placement, left, and PCB pattern, right.

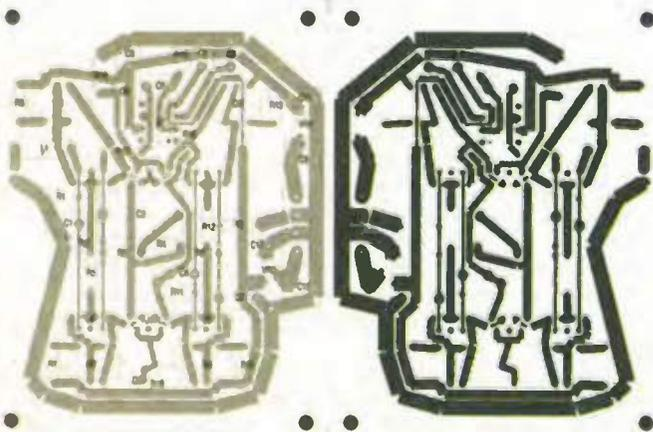

Visit our website
www.distel.co.uk

THE ORIGINAL SURPLUS WONDERLAND!

THIS MONTH'S SELECTION FROM OUR VAST EVER CHANGING STOCKS

Surplus always
wanted for cash!

THE AMAZING TELEBOX

Converts your colour monitor into a QUALITY COLOUR TV!



TV SOUND &
VIDEO TUNER
CABLE COMPATIBLE*

The TELEBOX is an attractive fully cased mains powered unit, containing all electronics ready to plug into a host of video monitors or AV equipment which are fitted with a composite video or SCART input. The composite video output will also plug directly into most video recorders, allowing reception of TV channels not normally receivable on most television receivers* (TELEBOX MB). Push button controls on the front panel allow reception of 8 fully tuneable 'off air' UHF colour television channels. TELEBOX MB covers virtually all television frequencies VHF and UHF including the HYPERBAND as used by most cable TV operators. Ideal for desktop computer video systems & PIP (picture in picture) setups. For complete compatibility - even for monitors without sound - an integral 4 watt audio amplifier and low level Hi Fi audio output are provided as standard. Brand new - fully guaranteed.

TELEBOX ST for composite video input type monitors £36.95
TELEBOX STL as ST but fitted with integral speaker £39.50
TELEBOX MB Multiband VHF/UHF/Cable/Hyperband tuner £69.95
For overseas PAL versions state 5.5 or 6 MHz sound specification.
*For cable / hyperband signal reception Telebox MB should be connected to a cable type service. Shipping on all Telebox's, code (B)

NEW State of the art PAL (UK spec) UHF TV tuner module with composite TV pp video & NICAM hi fi stereo sound outputs. Micro electronics all on one small PCB only 73 x 160 x 52 mm enable full tuning control via a simple 3 wire link to an IBM pc type computer. Supplied complete with simple working program and documentation. Requires +12V & +5V DC to operate. **BRAND NEW - Order as MY00. Only £49.95 code (B)**
See www.distel.co.uk/data_my00.htm for picture + full details

FLOPPY DISK DRIVES 2 1/2" - 8"

All units (unless stated) are **BRAND NEW** or removed from often brand new equipment and are fully tested, aligned and shipped to you with a full 90 day guarantee. Call or see our web site www.distel.co.uk for over 2000 unlisted drives for spares or repair.

3 1/2" Mitsubishi MF355C-L 1.4 Meg. Laptops only £25.95(B)
3 1/2" Mitsubishi MF355C-D 1.4 Meg. Non laptop £18.95(B)
5 1/4" Teac FD-55GFR 1.2 Meg (for IBM pc's) RFE £18.95(B)
5 1/4" Teac FD-55F-03-U 720K 40/80 (for BBC's etc) RFE £29.95(B)
5 1/4" BRAND NEW Mitsubishi MFS01B 360K £22.95(B)
Table top case with integral PSU for HH 5 1/4" Floppy / HD £29.95(B)
8" Shugart 800/801 8" SS refurbished & tested £210.00(E)
8" Shugart 810 8" SS HH Brand New £195.00(E)
8" Shugart 851 8" double sided refurbished & tested £260.00(E)
8" Mitsubishi M2894-63 double sided NEW £295.00(E)
8" Mitsubishi M2896-63-02U DS 5.14mm NEW £295.00(E)
Dual 8" cased drives with integral power supply 2 Mb £499.00(E)

HARD DISK DRIVES 2 1/2" - 14"

2 1/2" TOSHIBA MK1002MAV 1.1Gb laptop (12.5 mm H) New £79.95
2 1/2" TOSHIBA MK2101MAN 2.16 Gb laptop (19 mm H) New £89.50
2 1/2" TOSHIBA MK4309MAT 4.3Gb laptop (8.2 mm H) New £105.00
2 1/2" TOSHIBA MK6409MAV 5.1Gb laptop (12.7 mm H) New £190.00
2 1/2" to 3 1/2" conversion kit for PC's, complete with connectors £14.95
3 1/2" FUJIK FK-309-26 20mb MFPM I/F RFE £59.95
3 1/2" CONNER CP3024 20 mb IDE I/F (or equiv.) RFE £59.95
3 1/2" CONNER CP3044 40 mb IDE I/F (or equiv.) RFE £69.00
3 1/2" QUANTUM 40S Prodriv v 42mb SCSI I/F, New RFE £49.00
5 1/4" MINISCRIBE 3425 20mb MFPM I/F (or equiv.) RFE £49.95
5 1/4" SEAGATE ST-238R 30 mb RLL I/F Refurb £69.95
5 1/4" CDC 94205-51 40mb HH MFPM I/F RFE tested £69.95
5 1/4" HP 97548 850 Mb SCSI RFE tested £99.00
5 1/4" HP C3010 2 Gbyte SCSI differential RFE tested £195.00
8" NEC D2246 85 Mb SMD interface New £199.00
8" FUJITSU M2322C 160Mb SMD I/F RFE tested £195.00
8" FUJITSU M2322C 2 Gb SMD I/F RFE tested £345.00
Many other drives in stock - Shipping on all drives is code (C1)

TEST EQUIPMENT & SPECIAL INTEREST ITEMS

MTS. FA3445ETKL 14" Industrial spec SVGA monitors £245
FARNELL 0-60V DC @ 50 Amps, bench Power Supplies £995
FARNELL AP3080 0-30V DC @ 80 Amps, bench Supply £1850
1kW to 400 kW - 400 Hz 3 phase power sources - ex stock £POA
IBM 8230 Type 1, Token ring base unit driver £760
Wayne Kerr RA200 Audio frequency response analyser £2500
IBM 53F501 Token Ring ICS 20 port lobe modules £750
IBM MAU Token ring distribution panel B22B-23-5050N £95
AIM 501 Low distortion Oscillator 9Hz to 300kHz. IEEE £550
ALLGON 8360, 11805-1880 MHz hybrid power combiners £250
Trend DSA 274 Data Analyser with 7303(2M) 64 I/O £POA
Marconi 6310 Programmable 2 to 22 GHz sweep generator £6500
Marconi 2022C 10KHz-10GHz RF signal generator £1550
Marconi 2030 opti 3x 10KHz-1.3 GHz signal generator, New £4995
HP1650B Logic analyser £3750
HP3781A Pattern generator & HP3782A Error Detector £POA
HP6621A Dual Programmable GPIB PSU 0-7 V 160 watts £1800
HP6264 Rack mount variable 0-20V @ 20A metered PSU £675
HP54121A DC to 22 GHz four channel test set £POA
HP1830A opti 0-20 300 MHz pulse generator, GPIB etc £7900
HP A1, A0 8 pen HPGL high speed drum plotters - from £550
HP DRAFTERMASTER 1 8 pen high speed plotter £750
EG+G Brookdeal 95035C Precision lock in amp £1800
View Eng. Mod 1200 computerised inspection system £POA
Sony DXC-3000A High quality CCD colour TV camera £995
Keithley 590 CV capacitor / voltage analyser £POA
Recal ICR40 dual 40 channel voice recorder system £3750
Fliskera 45KVA 3 ph On Line UPS - New batteries £9500
Emerson AP130 2.5KVA industrial spec UPS £2100
Mann Tally M7645 High speed line printer £2200
Intel SBC 486/133SE Multibus 486 system, 8Mb Ram £945
Siemens K4400 64Kb to 140Mb demux analyser £2950

IC's - TRANSISTORS - DIODES

OBSOLETE - SHORT SUPPLY - BULK
10,000,000 Items EX STOCK

For MAJOR SAVINGS
CALL OR SEE OUR WEB SITE www.distel.co.uk

VIDEO MONITOR SPECIALS

One of the highest specification
monitors you will ever see !!
At this price - Don't miss it!

Mitsubishi FA3415ETKL 14" SVGA Multisync colour monitor with fine 0.28 dot pitch tube and resolution of 1024 x 768. A variety of inputs allows connection to a host of computers including IBM PC's in CGA, EGA, VGA & SVGA modes, BBC, COMMODORE (including Amiga 1200), ARCHIMEDES and APPLE. Many features: Etched acetate, text switching and LOW RADIATION MPR specification. Fully guaranteed, in EXCELLENT little

used condition. Order as MITS-SVGA
Tilt & Swivel Base £4.75 Only £119 (E)
VGA cable for IBM PC included.

External cables for other types of computers available - CALL

Ex demo 17" 0.28 SVGA Mitsubishi Diamond Pro monitors, Full multisync etc.
Full 90 day guarantee. Only £199.00 (E)

Just in - Microvitec 20" VGA (800 x 600 res.) colour monitors.
Good SH condition - from £299 - CALL for info

PHILIPS HCS35 (same style as CM8833) attractively styled 14" colour monitor with both RGB and standard composite 15.625 KHz video inputs via SCART socket and separate phono jacks. Integral audio power amp and speaker for all audio visual uses. Will connect direct to Amiga and Atari BBC computers. Ideal for all video monitoring / security applications with direct connection to most colour cameras. High quality with many features such as front concealed flap controls, VCR correction button etc. Good used condition - fully tested - guaranteed
Dimensions: W14" x H12 1/2" x 15 1/2" D. Only £99.00 (E)

PHILIPS HCS31 Ultra compact 9" colour video monitor with standard composite 15.625 KHz video input via SCART socket. Ideal for all monitoring / security applications. High quality, ex-equipment fully tested & guaranteed (possible minor screen bums). In attractive square black plastic case measuring W10" x H10" x 13 1/2" D. 240 V AC mains powered. Only £79.00 (D)

KME 10" 15M10009 high definition colour monitors with 0.28" dot pitch. Superb clarity and modern styling. Operates from any 15.625 khz sync RGB video source, with RGB analog and composite sync such as Atari, Commodore Amiga, Acorn Archimedes & BBC. Measures only 13 1/2" x 12" x 11". Good used condition. Only £125 (E)

20" 22" and 26" AV SPECIALS

Superbly made UK manufacture. PIL all solid state colour monitors, complete with composite video & optional sound input. Attractive teak style case. Perfect for Schools, Shops, Disco, Clubs, etc. In EXCELLENT little used condition with full 90 day guarantee.

20"....£135 22"....£155 26"....£185 (F)

We probably have the largest range of video monitors in Europe. All sizes and types from 4" to 42" call for info.

DC POWER SUPPLIES

Virtually every type of power supply you can imagine. Over 10,000 Power Supplies Ex Stock
Call or see our web site.

HP6030A 0-200V DC @ 17 Amps bench power supply £1950
Intel SBC 486/125C08 Enhanced Multibus (MSA) New £1150
Nikon HF-X11 (Ephiphot) exposure control unit £1450
PHILIPS PMS518 Pro. TV signal generator £1250
Motorola VME Bus Boards & Components List. SAE / CALL £POA
Triolo 0-18 vdc linear, metered 30 amp bench PSU. New £550
Fujitsu M3041R 600 LPM high speed band printer £1950
Fujitsu M3041D 600 LPM printer with network interface £1250
Perkin Elmer 299B Infrared spectrophotometer £500
Perkin Elmer 597 Infrared spectrophotometer £3500
VG Electronics 1035 TELETEX Decoding Margin Meter £3250
LightBand 60 output high spec 2u rack mount Video VDA's £495
Sekonic SD 150H 18 channel digital Hybrid card recorder £1995
B&K 2633 Microphone pre amp £300
Taylor Hobson Tallysurf amplifier / recorder £750
ADC SS200 Carbon dioxide gas detector / monitor £1450
BBC AM203 PPM Meter (Ernest Turner) + drive electronics £75
ANRITSU 9654A Optical DC-2.5Gb/s waveform monitor £5650
ANRITSU MS9001B1 0.6-1.7 uM optical spectrum analyser £POA
ANRITSU ML93A optical power meter £990
ANRITSU Fibre optic characteristic test set £POA
R&S FTDZ Dual sound unit £650
R&S SBUF-E1 Vision modulator £775
WILTRON 6630B 12.4 / 20GHz RF sweep generator £5750
TEK 2445 150 MHz 4 trace oscilloscope £1250
TEK 2465 300 MHz 300 MHz oscilloscope rack mount £1955
TEK TDS380 400MHz digital realtime + disk drive, FFT etc £2900
TEK TDS524A 500MHz digital realtime + colour display etc £5100
HP3855A Opti 907 20Hz to 40 MHz spectrum analyser £3950
PHILIPS PW1730 10 60KV XRAY generator & accessories £POA
CLAUDE LYONS 12A 240V single phase auto. volt. regs £325
CLAUDE LYONS 100A 240/415V 3 phase auto. volt. regs £2900

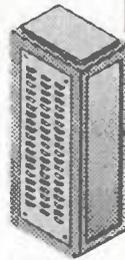

19" RACK CABINETS

Superb quality 6 foot 40U
Virtually New, Ultra Smart
Less than Half Price!

Top quality 19" rack cabinets made in UK by Optima Enclosures Ltd. Units feature designer, smoked acrylic lockable front door, full height lockable half louvered back door and louvered removable side panels. Fully adjustable internal fixing struts, ready punched for any configuration of equipment mounting, plus ready mounted integral 12 way 13 amp socket switched mains distribution strip make these racks some of the most versatile we require only two side panels to stand singly or in multiple bays.

OPT Rack 1 Complete with removable side panels. £345.00 (G)
OPT Rack 2 Rack. Less side panels £245.00 (G)

Over 1000 racks, shelves, accessories
19" 22" & 24" wide 3 to 46 U high.
Available from stock !!

32U - High Quality - All steel RakCab

Made by Eurocraft Enclosures Ltd to the highest possible spec, rack features all steel construction with removable side, front and back doors. Front and back doors are hinged for easy access and all are lockable with five secure 5 lever barrel locks. The front door is constructed of double walled steel with a 'designer style' smoked acrylic front panel to enable status indicators to be seen through the panel, yet remain unobtrusive. Internally the rack features fully slotted reinforced vertical fixing members to take the heaviest of 19" rack equipment. The two movable vertical fixing struts (extras available) are pre punched for standard 'cage nuts'. A mains distribution panel internally mounted to the bottom rear, provides 8 x IEC 3 pin Euro sockets and 1 x 13 amp 3 pin switched utility socket. Overall ventilation is provided by fully louvered back door and double skinned top section with top and side louvers. The top panel may be removed for fitting of integral fans to the sub plate etc. Other features include: fitted castors and floor levelers, pre-punched utility panel at lower rear for cable / connector access etc. Supplied in excellent, slightly used condition with keys. Colour Royal blue. External dimensions mm=1625H x 635D x 603 W. (64" H x 25" D x 23 3/4" W)

Sold at LESS than a third of makers price !!

A superb buy at only £245.00 (G)
42U version of the above only £345 - CALL

12V BATTERY SCOOP - 60% off !!

A special bulk purchase from a cancelled export order brings you the most amazing savings on these ultra high spec 12v DC 14 Ah rechargeable batteries. Made by Hawker Energy Ltd, type SBS15 featuring pure lead plates which offer a far superior shelf & guaranteed 15 year service life. Fully BT & B56290 approved. Supplied BRAND NEW and boxed. Dimensions 200 wide, 137 high, 77 deep. M6 bolt terminals. Fully guaranteed. Current makers price over £70 each.

Our Price £35 each (E) or 4 for £99 (E)

RELAYS - 200,000 FROM STOCK

Save £££'s by choosing your next relay from our Massive Stocks covering types such as Military, Octal, Cradle, Hermetically Sealed, Continental, Contactors, Time Delay, Reed, Mercury Watted, Solid State, Printed Circuit Mounting etc. CALL or see our web site www.distel.co.uk for more information. Many obsolete types from stock. Save £££'s

COLOUR CCD CAMERAS

Undoubtedly a miracle of modern technology & our special buying power! A quality product featuring a fully cased COLOUR CCD camera at a give away price! Unit features full autolight sensing for use in low light applications. A 10 mm fixed focus wide angle lens gives excellent focus and resolution from close up to long range. The composite video output will connect to any composite monitor or TV (via SCART socket) and most video recorders. Unit runs from 12V DC so ideal for security & portable applications where mains power not available.

Overall dimensions 66 mm wide x 117 deep x 43 high. Supplied BRAND NEW & fully guaranteed with user data, 100's of applications including Security, Home Video, Web TV, Web Cams etc, etc.

Web Ref - LK33 ONLY £99.00 or 2 for £180.00 (A)

SOFTWARE SPECIALS

NT4 WorkStation, complete with service pack 3 and licence - OEM packaged. ONLY £89.00 (B)
ENCARTA 95 - CDROM, Not the latest - but at this price! £7.95
DOS 5.0 on 3 1/2" disks with concise books c/w QBASIC £14.95
Windows for Workgroups 3.11 + Dos 6.22 on 3.5" disks £55.00
Wordperfect 6 for DOS supplied on 3 1/2" disks with manual £24.95
shipping charges for software is code B

DISTEL on the web !! - Over 16,000,000 Items from stock - www.distel.co.uk



ALL MAIL TO
Dept ww, 29/35 Osborne Rd
Thornton Heath
Surrey CR7 8PD
Open Mon - Fri 9.00 - 5:30

LONDON SHOP
Open Mon - Sat 9.00 - 5:30
215 Whitehorse Lane
South Norwood
On 68A Bus Route
N. Thornton Heath &
Selhurst Park SR Rail Stations

NEW DISTEL ©
Visit our web site
www.distel.co.uk
email = admin@distel.co.uk

ALL ENQUIRIES
0208 653 3333
FAX 0208 653 8888

All prices for UK Mainland. UK customers add 17.5% VAT to TOTAL order amount. Minimum order £10. Bona Fide account orders accepted from Government, Schools, Universities and Local Authorities - minimum account order £50. Cheques over £100 are subject to 10 working days clearance. Carriage charges (A)=£3.00, (AT)=£4.00, (B)=£5.50, (C)=£8.50, (D)=£15.00, (E)=£18.00, (F)=£20.00, (G)=CALL. Allow approx 6 days for shipping - faster CALL. All goods supplied to our Standard Conditions of Sale and unless stated guaranteed for 90 days. All guarantees on a return to base basis. All rights reserved to change prices / specifications without prior notice. Orders subject to stock. Discounts for volume. Top CASH price paid for surplus goods. All trademarks, tradenames etc. acknowledged. © Display Electronics 1999. E & O.E. 0799

CIRCLE NO. 112 ON REPLY CARD

$\Delta V_{be} \approx 60\text{mV}$ is good for a 10:1 ratio. I call these mirrors 'reverse' Widlar mirrors because the more usual configuration is to have the reference current higher than the programmed current.²⁰ Here, the left-hand BJT carries the smaller reference current, and the right-hand BJT serves as the current source by 'mirroring' a multiple of the reference current.

Since I_e and ΔV_{be} are known, Ohm's law dictates that $R_e = \Delta V_{be} / I_e = 0.018 / 0.003 = 6\Omega$. Current I_e is fixed at 3mA, so increasing R_e increases ΔV_{be} . In turn, this also increases the current ratio and therefore the current through the common-gate device.

Although 6Ω resistors do exist, they are less common than 5.6Ω or 6.2Ω components, and the latter is closer to the desired value. However, 6.2Ω resistors are not as common as 5.6Ω or 6.8Ω resistors. You may use any of these three values, since it isn't as critical as matching the value, whatever it is.

Unfortunately, I may have had the last of the available precision 6.2Ω metal-film resistors in my own parts bin. Currently available units have 5% tolerance.

It is, of course, acceptable to parallel two 12.4Ω resistors. These are available in 1% tolerance. I actually used 6.2Ω resistors in one channel and 6.8Ω in the other with no objective or subjective differences discerned between the two.

Gate-to-source voltage considerations

Common-gate JFETs will assume the gate-to-source voltage that corresponds to the drain current according to their square-law equation. For the complementary devices, this is the same $|V_{GS}| \approx 0.27\text{V}$ that was seen for the differential-amp JFETs, because the drain currents are the same.

The JFET self-biasing feature almost allows J_5 and J_6 to assume this gate-to-source voltage simply by tying their gates to the appropriate supply rail. Unfortunately, this places the right-hand current mirror bipolars very close to – if not into – saturation. The upshot is that this will work for some BJTs but not for others.

For instance, all of the 2N3811 and 2N2920 matched dual BJTs that I tried worked with this scheme, while none of the devices specified in the parts list did so. Since the 2N3811 is no longer available and the 2N2920 is hard to find and expensive, it was not

prudent to specify them as the components of choice. Besides, the data sheets on even these devices indicated that not every example could be counted on to work correctly in this application.

To ensure that Q_{1B} , Q_{2B} , Q_{3B} , and Q_{4B} would be in their active regions, I added diode-connected BJTs Q_5 and Q_6 , which, themselves, must be in their active regions. This is because $V_{cb} = 0$ for these two transistors, whereas saturation is the condition in which the collector-base junction is forward-biased. Thus, the magnitude of the collector-to-emitter voltage for the four current-mirror BJTs involved will be $|V_{GS}| + |V_{be}| \approx 1\text{V}$. This is more than adequate to ensure that they are not in saturation.

Substituting devices

Since the question will invariably arise about substitutions, I will mention in advance that, while low-noise matched dual BJTs are preferable, you can use matched low-noise discrete units. Manufacturers like NTE and RCA sell matched p-n-p and n-p-n complementary devices. Even unmatched devices may work, especially with the servo in place.

There is sufficient flexibility so that somewhere, somehow, you should be able to find appropriate substitutions. I noticed that Erno Borbely was offering them for sale. Being an electronic-engineering professor has its advantages, since I was able to persuade a wholesaler to sell to me both the n- and the p-channel devices in quantities of 100.

Unfortunately, it was necessary to take what was available, and the n-channel and p-channel devices that I used are from different I_{DSS} groups. I was able to find a sufficient number of complementary devices, nonetheless, through the use of a curve tracer.

If possible, choose all 'V' or all 'BL'. I do not recommend transistors from the 'GR' group because of the possibility that some units have values of I_{DSS} that are too low for this application.

You should certainly avoid getting one type from the 'GR' and the other from the 'V' group, since there is no I_{DSS} overlap between the two. In quantities of 100 each, the prices drop to less than \$1 per transistor. I am not at all sure that there are good substitution alternatives to these JFETs.

Preampifier parts – one channel only

Resistors – 0.25W, 1% metal film unless otherwise specified.

R ₁	47kΩ
R ₂	100Ω
R ₃	17.8kΩ
R ₄	1.87kΩ
R _{5,12}	90.9Ω
R _{6,7,13,14}	6.2Ω
R ₈	2.21kΩ
R _{9,17}	49.9kΩ
R ₁₀	2kΩ
R ₁₁	10kΩ
R _{15,16}	1MΩ
R _{18,19}	15kΩ

Capacitors – Panasonic P-series 50V polypropylene unless otherwise specified. Four 0.01μF disc ceramics are needed – two for phono-input bypass, two for AC line filter of power supply.

C ₁	100pF, 5%
C ₂	180nF, 2%
C ₃	33nF, 2%
C ₄	75pF, 5% silver mica

The following are Philips 63V, 5% metalised polyester film:

C ₅₋₆	220nF
C ₇₋₁₀	1μF
C _{11,12}	100nF

Inductors

L ₁	10mH RF choke
----------------	---------------

Semiconductors

J _{1, J_{3, J₆}}	Toshiba 2SK389 low-noise n-channel monolithic dual JFETs
J _{2, J_{4, J₅}}	Toshiba 2SJ109 low-noise p-channel monolithic dual JFETs
Q _{1, Q₃}	Linear Systems LS 352 low-noise pnp monolithic dual BJTs
Q _{2, Q₄}	Linear Systems LS 312 low-noise npn monolithic dual BJTs
Q ₅	Motorola MPS 6523 low-noise pnp BJT
Q ₆	Motorola MPS 6521 low-noise npn BJT

Integrated circuits

U ₁	LF 411 low-noise, low-drift op-amp
U ₂	mA78L15 +15V, 100mA voltage regulator
U ₃	mA79L15 -15V, 100mA voltage regulator

Power supply (subject of next article)

Resistors

R _{101,102}	220Ω, 2W, 2% metal
----------------------	--------------------

Capacitors

C _{101,102}	2 200μF, 50V aluminum electrolytic
C _{103,104}	4 700μF, 35V aluminum electrolytic

Transformer

T ₁	48V centre-tapped at 150mA (see text)
----------------	---------------------------------------

Fuse

F ₁	0.05A (see text of next article)
----------------	----------------------------------

Feedback-loop gain and frequency response

Notice that the output of the first-stage cascode is fed back to the input. No second or third stage is enclosed in the feedback loop. Also note that the feedback network is not frequency independent.

A 180nF capacitor, C_2 , is added. At low frequency, this capacitor is effectively an open circuit, and the gain is,

$$A_v = \frac{R_2 + R_3 + R_4}{R_2} = 1 + \frac{R_3 + R_4}{R_2} = 198 \text{ (46dB)}$$

As frequency increases, capacitive reactance X_{C2} will decrease until it equals R_3 . This defines the 50Hz breakpoint of the RIAA curve. This breakpoint is a zero in the feedback factor because the effect of decreasing capacitive reactance shunting R_3 is to increase the amount of feedback.

As frequency increases still further, it finally reaches a point where an additional decrease in the capacitive reactance causes very little change in the feedback factor.

When the feedback factor is within 3dB of its ultimate and maximum possible value, the second breakpoint is reached. This is a function of all three resistors and the capacitor, and occurs at 500Hz with the component values used.²¹ You will recognise this as the 500Hz zero of the RIAA curve. It is, of course, realised as a pole in the feedback factor, since it represents the point at which the rising feedback caused by the feedback zero at 50Hz is cancelled.

In the absence of other higher poles and/or zeroes, the closed-loop response above 500Hz would be flat. This approach, then, avoids the unintended high-frequency zero of the noninverting single-stage RIAA amplifier that was mentioned at the outset.

An important design consideration is the absolute value of resistor R_2 . After it is set, the values of R_3 , R_4 , and C_2 are set based on the desired closed-loop gain, the pole and zero frequencies, and the value of R_2 . Like R_1 , R_2 can be a major contributor to circuit noise. Therefore, from a noise reduction perspective, it should be as small as possible.

Unfortunately, you are faced with yet another trade-off, since, ideally, the input resistance of the feedback network would be infinite. However, the lower the value of R_2 , the lower this input resistance will be, since R_3 and R_4 must be scaled accordingly.

Power amplifiers have no problem driving low-impedance feedback networks, but many, if not most, preamps would.

Open-loop gain

If the feedback network loads the output, open-loop gain can also suffer. Low open-loop gain α or low-feedback fraction β can lead to deviations from the predicted value for closed-loop gain if, as a result, the closed-loop gain formula $A_{\beta} = \alpha / (1 + \beta\alpha) \approx 1/\beta$ becomes a poor approximation. For the no-feedback case, $\beta = 0$, so that $A_{\beta} = \alpha$.

Open-loop gain is usually quite variable, even among apparently identical amplifiers. As frequency decreases in the first stage, closed-loop gain rises, reflecting the decreasing β necessary if the rising low-frequency response dictated by the RIAA curve is to be realised.

Feedback, which is the difference between the open- and closed-loop gains, is being squeezed. This, combined with the relatively low open-loop gain, means the assumption that $\beta\alpha \gg 1$ – which is implicit in the approximate closed-loop-gain equation – must fail.

Precise RIAA tracking at low frequency is predicated upon $A_{\beta} = \beta^{-1}(f)$. Since there was almost no error, even at 20Hz, the open-loop gain must still be adequate despite the potential problems just discussed. There is no reason why you could not use the component values given in AN 346, and doing so ameliorates the potential problem discussed in this paragraph. Since performances of two units were identical and precise, I decided to use the 100 Ω value for R_2 , and I proceeded from there.

While I don't intend to repeat the application note, I do want to present the formulas for the component values. This will allow you to customise the design.

In AN 346, the technique is to set R_2 based on the aforementioned trade-offs. Next choose a 1kHz first-stage gain in the range $10 \leq A_{\beta} \leq 30$ (20-30dB), and then, based on these two factors, calculate component values starting with $R_3 = 8.058R_2 \times A_{\beta}$. From there, C_2 is $0.00318/R_3$,

and R_4 is $R_3/9 - R_2$.

The formula derivations, found on the last page of reference 21, follow directly from the transfer function. There is almost always more flexibility in choosing resistor values than capacitor values, so the closest commercial 1% capacitor value may differ enough that it is necessary to recalculate R_3 according to $R_3 = 0.00318/C_2$.

The application note then calls for a recalculation of R_2 . I doubt that this is necessary, however, because R_2 does not affect the 50Hz RIAA breakpoint at all. And it only affects the 500Hz zero slightly. It does have a major effect on the 1kHz gain, but this is not standardised, which is the reason why a range is specified in the first place.

Passive equalisation

There is, of course, another pole you must establish to conform completely to the RIAA curve. It is provided passively by the low-pass filter formed by R_8C_3 . Actually, the precise calculation of this pole frequency requires the Thévenin-equivalent resistance seen by C_3 .

Capacitor C_3 sees $R_8 \parallel R_9$ rather than simply R_8 . For this reason, the technique used in AN 346 is first to choose a 1% capacitor value in the range of 10-50nF, then to compute an $R_p = 75\mu s / C_3 = 2.273k\Omega$.

The 75 μs in the equation is simply the RC time constant corresponding to a pole at 2.122kHz. Since R_8 and R_9 are in parallel, choose a slightly larger 1% resistor value for R_8 . I chose 2.37k Ω .

Finally, compute R_9 so that $R_8 \parallel R_9 = R_p$. This can be done using $R_9 = 1 / (1/R_p - 1/R_8) = 55.536k\Omega$. The nearest 1% value is 54.9k Ω .

Resistor R_9 was required in AN 346 because the output of the first-stage op-amp was capacitively coupled to the input of the second-stage amplifier, which was an LM833 bipolar op amp. Without R_9 , there is no input bias current path for the LM833.

There is no such requirement in this design because the first stage is directly coupled to the second stage. Nonetheless, I decided to leave R_9 in to make the preamplifier more versatile.

At this point, I would keep the current topology, but make the second stage a gain-of-ten (20dB) stage and reduce the 1kHz reference gain of the first stage accordingly. This, of course, would require recalculating the feedback-network component values. Lowering first-stage closed-loop gain is another way of easing any problem of low open-loop gain in that stage.

Omitting R_9 seemed to make the frequency response – and consequently RIAA tracking – more sensitive to component-value variations. If you decide to eliminate R_9 altogether, PSpice shows that $R_8 = 2.15k\Omega$ gives the proper attenuation at high frequency.

PSpice also shows that R_3 should be simultaneously reduced to 16.9k Ω ; otherwise the boost at low frequency is excessive. Since it is cheaper and easier to use a number of 1% resistors than 1% capacitors, I suggest that you vary R_3 if low-frequency response needs trimming.

Eliminating R_9 also ameliorates the low-frequency, open-loop gain degradation by increasing the impedance magnitude that the first-stage output must drive. If you need lower output impedance for either the first or the second stage, you could easily add a follower/buffer. Of course, the whole idea was to keep it simple, and that would be a step in the wrong direction.

Early PSpice versions of the circuit used followers at the output of both stages. I eliminated these when PSpice indicated – and breadboarding confirmed – that the buffers were not essential.

Note that R_9 is 2.21k Ω . This is less than the calculated value of 2.37k Ω . The difference comes about because the output resistance of the first stage is not 0 Ω , as it very nearly is for the op amp-based design of AN 346. Output resistance of the first stage must be folded into the R_9 value, or the pole frequency will be lower than anticipated.

Despite the shortcoming of my discrete one-stage op-amp in the area of output impedance, I was able to achieve almost perfect high-frequency tracking of the RIAA curve, with the response dead on at most frequencies. The maximum errors measured were 0.1dB more attenuation at 20Hz and 0.1dB less attenuation at 20kHz than would be ideal. I have already alluded to the reason for the error seen at 20kHz.

The best feature is the reproducibility of the tracking. Both channels that I constructed tracked identically. Their gains at the 1kHz reference frequency were the same as the standard 1% capacitors and 1% metal-film resistors used at the breadboard stage. In one channel, I had no

CHART AUDIO LEVELS

In-vision colour display or hard copy printout

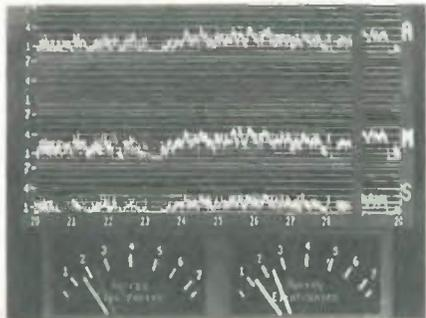

PPM10 in-vision PPM and Chart Recorder generates a display emulating the well known coaxial TWIN movements for monitoring stereo audio levels and mono compatibility. Also: **STEREO TWIN METER BOX** comprising a PPM9 board, featuring inherent stability with the law under microprocessor control. A free standing mains powered box frequently used for the final stereo monitoring when working to broadcast standards. Manufactured under licence from the BBC.



★ Advanced Active Aerial 4kHz-30MHz ★ Stabilizer frequency shift units for howl reduction ★ 5Hz Fixed Shift Circuit Board ★ Stereo Variable Emphasis Limiter ★ PPM9, PPM5 hybrid and PPM8 IEC/DIN - 50/+6dB drives and movements ★ Broadcast Monitor Receiver 150kHz-30MHz ★

SURREY ELECTRONICS LTD

The Forge, Lucks Green, Cranleigh GU6 7BG
Telephone: 01483 275997 Fax: 01483 276477

FRUSTRATED!

Looking for ICs TRANSISTORS?

A phone call to us could get a result. We offer an extensive range and with a World-wide database at our fingertips, we are able to source even more. We specialise in devices with the following prefix (to name but a few).



2N 2SA 2SB 2SC 2SD 2P 2SJ 2SK 3N 3SK 4N 6N 17 40 AD
ADC AN AM AY BA BC BD BDT BDV BDW BDX BF
BFR BFS BFT BFW BFX BFY BLY BLX BS BR BRX BRY BS
BSS BSV BSW BSX BT BTA BTB BRW BU BUK BUT BUV
BUW BUX BUY BUZ CA CD DX CXA DAC DG DM DS
DTA DTC GL GM HA HCF HD HEF ICL ICM IRF J KA
KIA L LA LB LC LD LF LM M M5M MA MAB MAX MB
MC MDA J MJE MJF MM MN MPS MP5A MP5H MP5U
MRF NJM NE OM OP PA PAL PIC PN RC S SAA SAB
SAD SAJ SAS SDA SG SI SL SN SO STA STK STR STRD
STRM STRS SVI T TA TAA TAG TBA TC TCA TDA TDB
TEA TIC TIP TIPL TEA TL TLC TMP TMS TPU U UA
UAA UC UDN ULN UM UPA UPC UPD VN X XR Z ZN
ZTX + many others

We can also offer equivalents (at customers' risk).

We also stock a full range of other electronic components.

Mail, phone, Fax, Credit Card orders & callers welcome.



Cricklewood Electronics Ltd

40-42 Cricklewood Broadway, London NW2 3ET
Tel: 020 8452 0161 Fax: 020 8208 1441

CIRCLE NO.113 ON REPLY CARD

New Version 2001 out now!

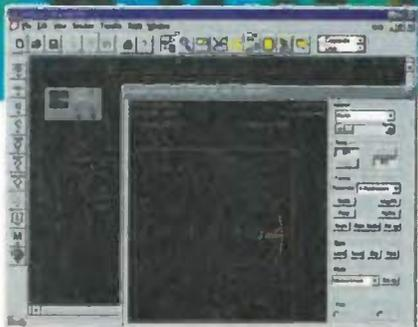

“multiSIM could very well herald the next step forward in PCB design methodology, because it can co-simulate both HDL and SPICE components... at a very affordable price”

Rita Glover, EDA industry analyst, President, EDA Today

SIMPLY THE BEST

Schematic Capture, Simulation & Programmable Logic

multiSIM - the professional design solution from Electronics Workbench.

Schematic capture, SPICE/VHDL/Verilog co-simulation of analogue and digital parts, built-in analyses and virtual instruments, and a huge library of parts in a single, affordable package.

Call **01462 480055** today for your FREE product guide or visit www.adeptscience.co.uk



Adept Scientific plc, Amor Way, Letchworth, Herts SG6 1ZA
Tel: 01462 480055 • Fax: 01462 480213
Email: ewb@adeptscience.co.uk
WebStore: www.adeptstore.co.uk



Electronics
WORKBENCH

multiSIM

Copyright © 2001 Adept Scientific plc. All rights reserved. All trademarks recognized.

CIRCLE NO.114 ON REPLY CARD

1%, 33nF capacitor, so I hand-selected a 10% unit whose measured value was within the 1% tolerance band.

Digi-Key is a convenient source of 2%-tolerance, 50V polypropylene capacitors. I ultimately used Digi-Key components in the prototype, and it is those capacitors for which the PC-board pattern is sized.

Again, claims are made for sonic effects due to capacitor dielectric material, but I am sceptical of the existence of such effects. Even so, polypropylene capacitors are objectively superior to most others, and they were the only precision capacitors available from this source.

Both channels of the prototype still track the RIAA curve with 0.1dB accuracy, but they do differ from one another by as much as 0.2dB, probably because of the relaxed tolerance on the capacitors. Since there is a price break for quantity purchases, you could order them in lots of ten, using a capacitor meter to find units that fall within 1% of the design value if slight tracking deviation were a concern.

Second stage

It is possible to realise the entire 38dB of gain in the input stage, although distortion would be greater. To do so, it would almost certainly be necessary to increase the output-node impedance magnitude by increasing R_2 and scaling the other equalisation-network values accordingly. In that case, or if you incorporated this phono section into a control preamplifier with a volume control of 50k Ω as previously discussed, the pot could then replace R_9 , and you could omit the second stage.

The increased distortion would probably be acceptable, but I did not like the idea of an unbuffered R_6C_3 filter output driving an unknown downstream device. So, I faithfully followed the scheme of AN 346 with a second folded-cascode single-stage op amp realised in discrete form. In fact, the second stage is identical to the first except for the feedback network.

All the equalisation is taken care of in the first stage and the interstage low-pass filter. However, an additional flat gain of 10 to 20dB is needed to bring the 1kHz gain to a level where the output is in line with that from a tuner or CD player. The gain used here differs slightly from that of the AN 346, which is a result of trimming the second-stage gain by ear.

With an LP as the source, I simultaneously fed the same cartridge channel into the phono input of a Dynaco PAT 5 preamp and my preamp. The output of my preamp was fed into the tuner input on the same PAT 5. I varied the gain of the second stage until the two signal paths produced the same speaker volume. I can say with certainty that the output level from this phono preamp is in line with at least one commercial preamp.

There is no output level adjustment, but this should not be a problem. Overall gain is within the range normally chosen for interfacing a moving-magnet phono cartridge with a preamplifier line stage. You can increase the value of R_{11} if you desire more gain, and vice versa.

Output impedance

The magnitude of the output impedance at the drains of J_{5B}/J_{6B} is around 60 Ω . This reflects the high open-loop impedance at this node. It cannot be lowered below this value despite the large amount of negative feedback to be found in a gain-of-6 configuration. Thus, if the preamp must deliver a lot of current, output voltage will fall rapidly. Still, this is not excessive output impedance for most circuits that would accept this output.

An advantage of the folded-cascode op-amp is that load capacitance does not contribute to instability; rather, it enhances stability by lowering the dominant pole frequency.²² I added capacitor C_4 for stability of the second stage, since a high-frequency oscillation existed under no-load output conditions. I did so even though the oscillation, as expected, disappeared with the output connected to a preamplifier.

It is poor practice to offer a design that has even a remote chance of oscillating. As was discussed elsewhere,²³ an excellent method of compensation, if it works, is to roll off the closed-loop response with a feedback zero such as that produced by the addition of C_4 .

As it turns out in this simple design, pole spacing permits successful use of such a scheme. PSpice did not predict this oscillation, which

Evaluation from a friend of the author

I got your preamp hooked up this evening into the Tape-2 input. It sounds great – very quiet and no hum at listening levels.

The gain is definitely less than my PS Audio phono stage: I'm running the volume control at the 11:00 position, whereas it's normally at 8:00 for phono listening.

I tried to match listening levels between your phono stage and my normal phono setup for a fair A/B comparison. Using Paul Simon's Graceland album, I noticed a wider and more three-dimensional sound stage, which seemed to be placed a bit lower. I don't recall any significant differences in musical detail, and it was definitely a clear, transparent sound.

Mitch

illustrates that the CAD tools are useful – but they also have their limitations.

I am convinced that running the output into one additional gain-of-ten cascode stage that's otherwise identical to the second stage of this preamp will yield a perfectly acceptable signal that could directly drive a power amplifier. In other words, the additional stage would serve as the line-amplifier stage, and the control preamplifier could be omitted if this were a phono-only system. For this, a 50k Ω dual-potentiometer should be inserted between the second stage of this circuit and the new line-amp stage to serve as a volume control.

You could build a complete control preamp around this topology if you so desired. ■

References

1. Manny Horowitz, 'How to Build Solid-State Audio Circuits,' Tab Books/No. 606, 1972, p. 250.
2. Reg Williamson, 'Understanding the RIAA Curve,' *The Audio Amateur*, 2/90, p. 20.
3. Kerry Lacanette, 'Linear Applications Handbook', National Semiconductor Corporation, 1994, pp. 822-30.
4. David Johns and Ken Martin, 'Analog Integrated Circuit Design', John Wiley & Sons, Inc., 1997, pp. 266-73.
5. Nelson Pass, 'Cascode Amp Design,' *Audio Magazine*, March 1978, pp. 52-59.
6. Norman E. Thagard, 'Build a Mono, 100-Watt Class-A Amp, Parts 1, 2, and 3,' *Audio Magazine*, January, February, and March, 1995.
7. Norman Thagard and Nelson Pass, 'Build the A75 Power Amplifier, Parts 1 and 2,' *TAA*, 4/92 and 1/93.
8. Paul Horowitz and Winfield Hill, 'The Art of Electronics', Cambridge University Press, 1989, pp. 441-42.
9. Sergio Franco, 'Design with Operational Amplifiers and Analog Integrated Circuits', Second Edition, McGraw-Hill, 1998, pp. 327-8.
10. Erno Borbely, 'JFETS: The New Frontier,' *AE* 5/99, p. 30.
11. Horowitz and Hill, *op. cit.*, p. 444.
12. Erno Borbely, 'A Moving Coil Preamp,' *TAA* 4/86, p. 12.
13. Horowitz and Hill, *op. cit.*, pp. 445-47.
14. *ibid.*, p. 1006.
15. *ibid.*, p. 869.
16. Erno Borbely, *op. cit.*, pp. 27, 30.
17. Brian Clark, 'DC Servo Loop Design for Audio Amplifiers,' *TAA* 3/82, pp. 14-23.
18. Johns and Martin, *op. cit.*, pp. 269-70.
19. Douglas Self, 'Distortion in Audio Power Amps, Part 1,' *AE* 2/99, pp. 19-20.
20. Horowitz and Hill, *op. cit.*, pp. 90-91.
21. Lacanette, *op. cit.*, p. 830.
22. Johns and Martin, *op. cit.*, p. 268.
23. Norman E. Thagard, 'A Case Study in Audio Amplifier Design, Part 1,' *AE* 5/99, pp. 16-18.

Next month, Norman gives full design details of a power supply for the preamplifier, complete with a discussion on grounding.

Designing with DSP

Patrick Gaydecki* describes how to design and program real-time digital signal processing systems from the ground up. This first article gives an overview of DSP using Motorola's DSP56002 as an example.

Digital signal processing, or DSP, is widely considered to be one of the fastest growing application areas in the field of digital computing technology. The range is enormous, with application areas including mobile communications, audio-signal enhancement, biomedical signal analysis, image analysis, signal compression, encryption and satellite telemetry.

DSP generally falls into one of two categories. It can be performed off-line, using conventional computers or workstations, or it can be performed in real time.

Off-line DSP is applied in circumstances when it is not necessary to synchronise the input and output signals. It is often used for image enhancement, post-recording audio-signal manipulation and data analysis in general.

In many situations though, off-line DSP is not an option. Signals involved in live performances, telephony and radio communications for example must be processed in real-time. In these circumstances, conventional PCs may simply be too slow to manage the processing involved.

Where speed is crucial, special microprocessors called digital signal processors are used. These devices have architectures that are optimised to perform at great speed the essentially simple arithmetic that lies at the heart of all DSP algorithms – multiplication, addition and shifting.

In this set of articles on DSP, I will be looking in detail at the Motorola DSP56002, which is a fast, industry

standard digital signal processor. Starting with its architecture, I will describe its features, and how you can design and program entire DSP environments based on the device. In addition, I will also be discussing how the device can communicate with a PC so that information and program code can be transferred.

Why DSP?

Signal filtering is a widely used application of DSP, since filters constructed in this way offer many advantages over traditional analogue methods. Most importantly, they are inherently flexible. Changing the characteristics of the filter merely involves changing the program code or filter coefficients; with an analogue filter, physical reconstruction is required.

Filters implemented in DSP are immune to the effects of ageing and environmental conditions, since the filtering process depends on numerical calculations – not the mechanical characteristics of the components. This makes them particularly suited for very low frequency signals.

For the same reason, the performance of digital filters can be specified with extreme precision, in contrast to analogue filters where a 5% figure is considered excellent.

There are some disadvantages associated with this kind of digital solution though. One of the most significant is the investment in terms of the time and intellectual effort needed to develop them.

You have to learn the functions and instruction set of a particular device, construct the system, and write the algorithms. This cycle can take many months. Contrast

Dr Patrick Gaydecki is a Senior Lecturer with the Department of Instrumentation and Analytical Science at UMIST in Manchester.

this with designing and fabricating a second-order analogue filter based on two resistors, two capacitors and one op-amp – a process that might take fifteen minutes.

Typically for digital filtering, the analogue waveform is first digitised by an analogue to digital converter, and the binary values are transmitted to a DSP device that performs a real time convolution operation in software using either a finite impulse response (FIR) or infinite impulse response (IIR) algorithm.

Processed data are then sent to a digital to analogue converter that produces a filtered analogue signal. In order to meet the requirements of the sampling theorem with respect to the incoming waveform, and to eliminate quantisation noise in the processed signal, an anti-aliasing filter is included before the a-to-d converter. Similarly, a reconstruction filter is included after the d-to-a converter.

How fast does it need to go?

So how fast does a real-time DSP device need to be?

Well, it depends on the application, but a very common one is audio-signal processing. For example, say an audio-signal is sampled at 48kHz (DAT standard) and is processed by an FIR filter with 512 coefficients. This means that the processor must be capable of performing 512 multiplications, additions and shifts within one

sample period. In this case, that amounts to 24.6 million such operations *a second!* This is often termed MIPS, ie millions of instructions per second.

Conventional microprocessors are often not optimised for this kind of work; although they may have access to a large address space, they do not distinguish between memory that holds program code (instructions), and memory that holds data. This is known as *von Neumann architecture*.

In contrast, DSP devices have access to a much smaller address space since it is assumed that programs that are going to operate in real time will by definition be fairly small. To maximise speed, they have physically separate memories and associated buses for holding instructions and data. This is known as *Harvard Architecture*.

Finally, they also incorporate hardware multiply-accumulate circuits that enable multiplications, additions and combined multiplication-summations to be performed in a single machine cycle. Hence a filter program implemented on a DSP device costing perhaps £10 will outpace one implemented on a PC by a factor of ten, since PCs have so much processing overhead.

Motorola's DSP56002

The DSP56002 is a general purpose digital signal processor capable of operating at speeds up to 33 MIPS.

Fig. 1. Internal architecture of Motorola's DSP56002. Super Harvard architecture is implemented through the use of separate code, x-data and y-data memories, together with their respective buses.

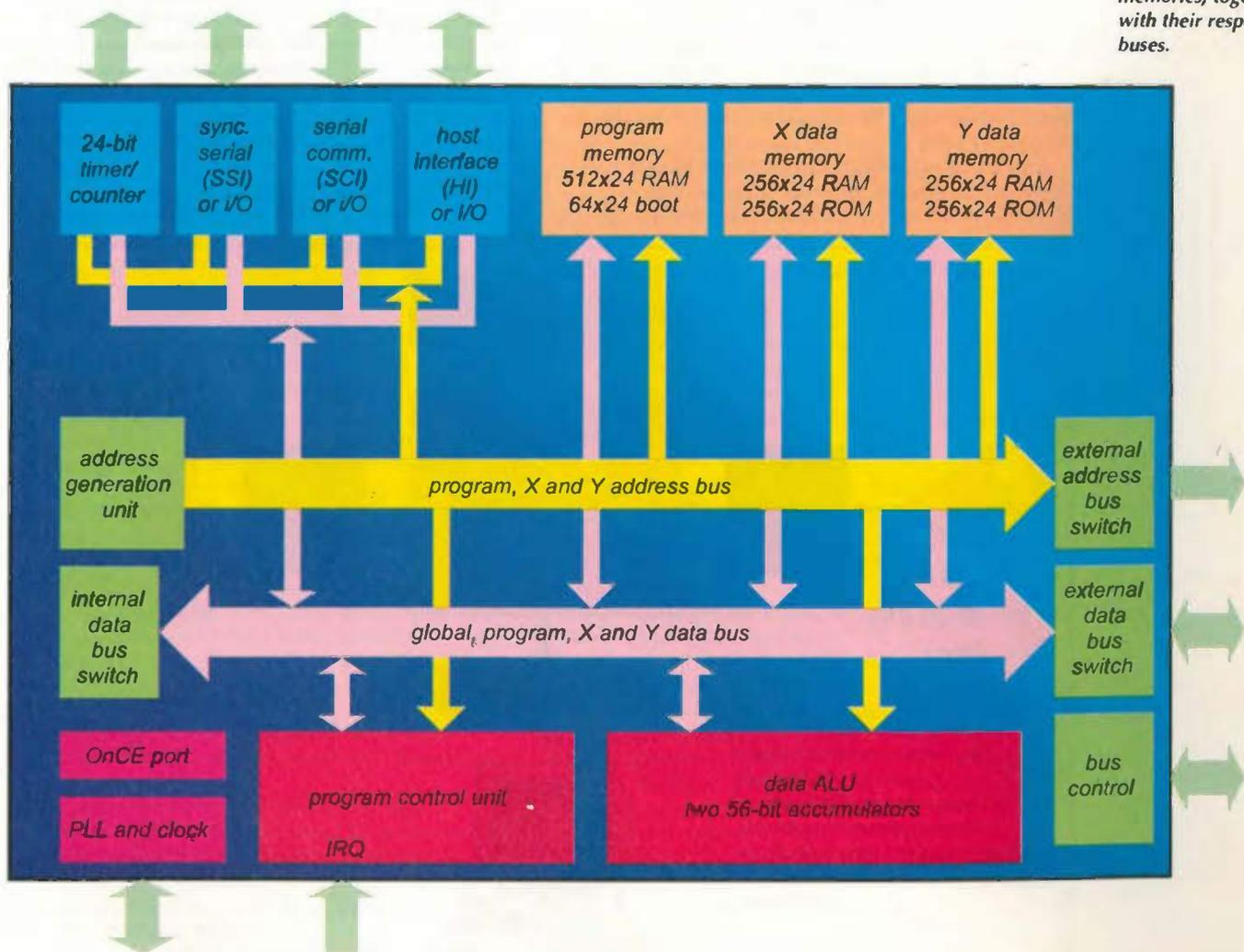

It comprises a 24-bit DSP core, program and data memories, various peripherals, and support circuitry.

An on-chip program RAM, two independent data RAMs, and two data ROMs containing sine, A-law, and μ -law tables feed the processor's core. Included on the chip are a timer/counter, a serial communication interface (SCI), a synchronous serial interface (SSI), and a parallel host interface (HI).

The device is *register-based*, in that addressing and loading the contents of control registers with specific bit-patterns configures the internal hardware; these determine the operational modes of the various sub-systems, Fig. 1.

Memory use

There are three memory areas within the DSP56002. These are the program (code or instruction) memory, x-data memory, and y-data memory.

Program memory is sub-divided into 512 words of user programmable RAM, and 64 words of bootstrap ROM. Each word is three bytes (24 bits) wide.

This may not seem like much memory, but remember that the device is *hardware oriented*. What this means is that operations that traditionally require many instructions to code can be implemented here using a single instruction, since the details are implemented in hardware.

For example, a complete FFT routine using the DSP56002 requires only 40 words, i.e. 120 bytes. In contrast, an FFT routine written on a conventional PC would require several thousand bytes. Many complex DSP routines can thus be held in the device's internal program memory, with no requirement for external memory circuits.

A bootstrap ROM holds a special program that is automatically invoked when the device is reset. Depending on how it is configured, it ultimately calls or

loads a user program that may reside in the device or it may reside externally.

One of the features that makes the DSP56002 so efficient is the sub-classification of the data memory into x and y areas. Each area can hold 256 words of user data. This is an extension of the Harvard Architecture philosophy and a feature not found on most other DSP devices.

The reason this has been done is because many signal-processing algorithms use two distinct signal vectors. For example, FIR filters require memory to hold the incoming signal, and memory to hold the filter coefficients; FFT routines require memory to hold the real and imaginary Fourier components, and so on.

Each of the three memory areas has its own data and address bus, and all of these connect to the outside world via bus multiplexers.

Communications

Apart from the memory buses, the DSP56002 has three main methods of communicating with external devices such as other processors, interfaces, a-to-d or d-to-a converters, etc.

The synchronous serial interface is mainly used for high-speed serial data transfer involving other processors and a-to-d or d-to-a converters. Since the data rate is synchronised to a separate clock signal, very high transfer rates are possible – typically 8M bit/s.

The serial communications interface is mainly used for boot loading and asynchronous data transfer, and may be interfaced to such devices as modems, etc. The host interface is a very high-speed parallel interface for direct connection to host computers or external boot memory. It can transfer data at a maximum rate of 12.5Mbyte/s.

The data arithmetic unit

At the heart of the DSP56002 lies a data arithmetic and

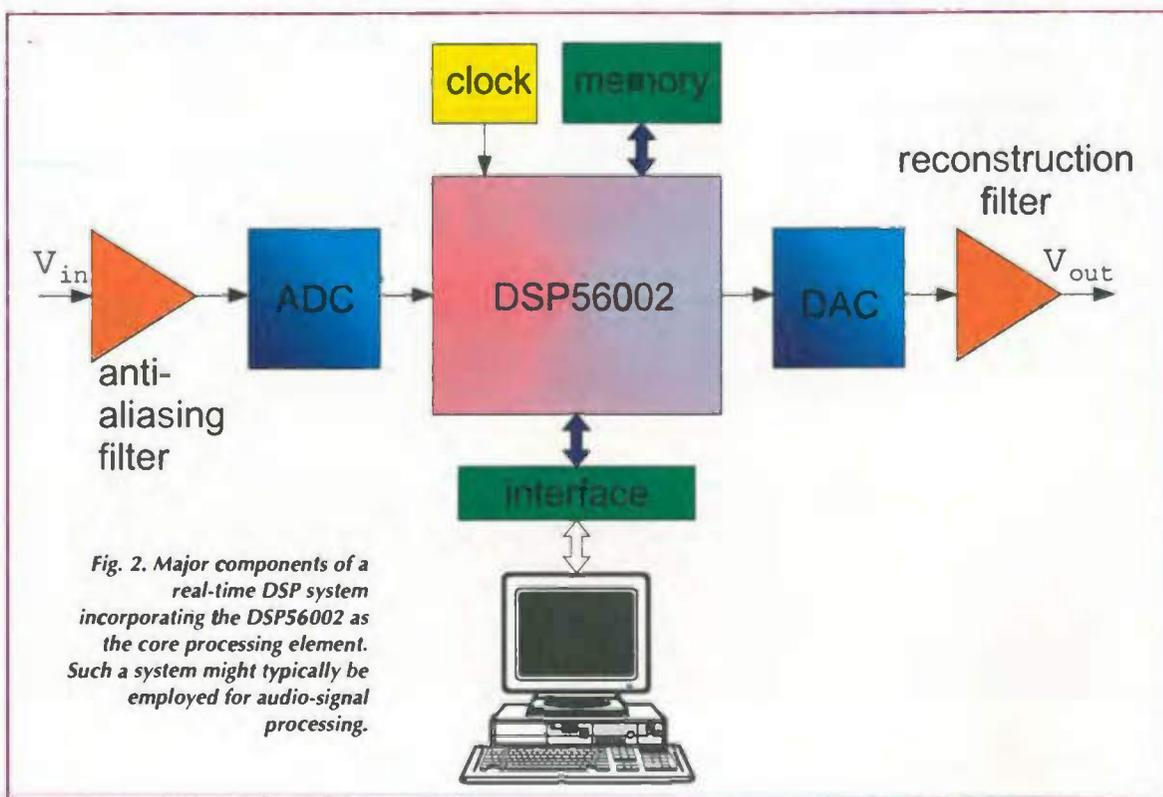

Fig. 2. Major components of a real-time DSP system incorporating the DSP56002 as the core processing element. Such a system might typically be employed for audio-signal processing.

logic unit, or ALU, which is responsible for carrying out the mathematical and logical processing of data held in the x and y data memories.

Technically, the device is a 24-bit fixed-point processor, representing numbers using two's complement fractional arithmetic, ie it processes using values between ± 1 . This level of precision – 1 part in 16777216 – is equivalent to 144dB of dynamic range. This is slightly unusual for fixed-point processors.

In brief, the ALU comprises four 24-bit input registers. To ensure overflow does not occur during intermediate stages of calculation, the two accumulator registers are 56-bits in length. In other words, they provide 336dB of internal dynamic range.

The processor also includes a number of other ALU registers – 48 in total. These control the way that data are addressed, and determine the operational status of the DSP core.

Processor ports

The 56002 includes three ports, A, B and C for communicating with external devices such as memory, other processors and interfaces.

Port A is the memory expansion port. It is used when external memory is connected to the processor. It comprises the 24-bit data bus, the 16-bit address bus and a control bus that enable conventional memory access.

Port B is a dual-purpose I/O port that can be configured either as 15 general-purpose I/O pins or as an 8-bit bi-directional host-interface, as described above.

Port C is a triple-function I/O port. It can act as a general-purpose I/O interface, as an SCI port or as an SSI port (see above). Since port C comprises nine pins, SCI and SSI modes can be made available together.

What are pipelining and parallelism?

The speed of digital signal processors in general, and the DSP56002 in particular, is enhanced by instruction pipelining and parallelism. Both are consequences of the architecture of the internal systems. Here, the program controller implements a three-stage pipeline that is essentially transparent to the programmer.

Instruction pipelining allows overlapping of instruction execution so that the fetch-decode-execute operations, which traditionally are performed sequentially, are here performed concurrently. Specifically, while one instruction is executed, the next instruction is being decoded and the one following that is being fetched from program memory. This clearly enhances the speed of the processing considerably.

Furthermore, the ALU, the address-generation unit and communication peripherals operate in parallel with one another. This enables the processor to perform, in a single instruction cycle (which is two clock cycles), an instruction pre-fetch, a 24-bit x 24-bit multiplication, a 56-bit addition, two data moves and two address pointer updates.

Since the communication peripherals also act in parallel, they may transmit and receive data concurrently with the above operations.

Incidentally, this also means that the power of a processor cannot be determined by the clock speed alone. In fact, the maximum clock rate of the DSP56002 is 66MHz – low in comparison to modern PCs – yet it is extremely fast because it performs so many operations in parallel and uses dedicated hardware.

What's next?

In the second article in this set of four, Patrick will be looking at the hardware issues in more detail; in particular, he will discuss how to clock the device, how to interface it to a PC, and how to connect an a-to-d converter, a d-to-a converter and some external memory.

Peripheral control registers

In addition to the ALU registers discussed above, the DSP56002 has 38 separate registers that control the behaviour of the various peripheral systems. By loading these registers with different control words, it is possible to modify the operation of a peripheral or change its function entirely.

For example, port C has nine pins, which by default are configured for general purpose I/O. By modifying specific control registers associated with this port, it is possible to change the function of the upper six pins to act as the SSI.

Further, the SSI has another set of registers that determine exactly which communication protocol will be used for data transmission and reception.

The processor's modes of operation

After reset, the DSP56002 can be configured into one of four operating modes, depending on whether it is to be used as a single chip system or with external memory. These modes are as follows:

Mode 0: Single-chip mode. All internal memories are enabled, and a hardware reset causes the DSP to jump to internal program memory at 0000_{16} and resume execution.

Mode 1: Special bootstrap mode. This is a special, and frequently used single-chip mode. Following a hardware reset, the DSP downloads a program either from external boot memory, from the serial communications interface or from the host interface – sent for example, by a PC. It stores the code in its *internal* memory, and starts executing the code from address 0000_{16} . It then switches to mode 0.

Mode 2: Normal expanded mode. This mode is in fact identical to mode 0, except that the reset vector points to location $E000_{16}$ (57344 decimal), ie this must be external memory.

Mode 3: Development mode. Similar to mode 2, but all internal memories are disabled.

Mode 1, the special bootstrap mode, is a very useful feature. Effectively, it means that source code can be developed and assembled (or compiled) using PC software commonly available from a number of suppliers including Motorola. It can then be downloaded directly to the device via the serial interface, without the need for any third party hardware. Thus a complete, flexible real-time DSP system with full functionality can be designed with minimum effort; it might typically appear as shown in Fig. 2. ■

BOOKS TO BUY

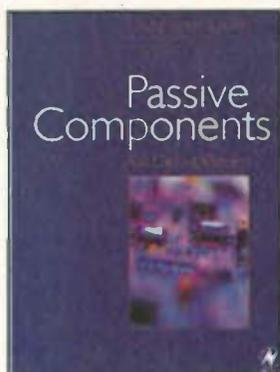

PASSIVE COMPONENTS FOR CIRCUIT DESIGN

Passive Components for Circuit Design is a unique introduction to this key area of analog electronics designed for technician engineers and anyone involved in circuit design. The coverage encompasses all component types capable of power amplification: resistors, capacitors, transformers, solenoids, motors and transducers. The behaviour of the components is explored along with the different types available and the principles of circuit design. Tolerances, stability, variation with temperature, reliability and manufacturing standards are all covered. Reading this book will improve your skills in component selection and analog circuit design. These are essential skills not only for the analog designer, but for all circuit designers, professional or amateur.

Contents: Preface; Fundamentals; Fixed resistors; Variable resistors, potentiometers and diodes; Capacitors; Inductors and inductive components; Inductive devices; Transducing components; SMT; Hardware; Index

Readership: Technician engineers, circuit designers, advanced hobbyists
Pages: 304pp
Price: UK £22.00
Europe £24.00
ROW £26.00

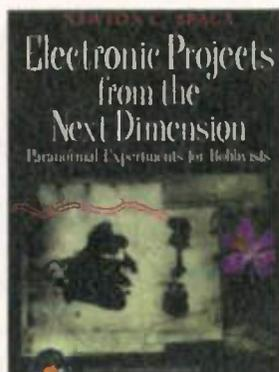

ELECTRONIC PROJECTS FROM THE NEXT DIMENSION

For years paranormal scientists have explored the detection and documentation of spirits, auras, ESP, hypnosis, and many more phenomena through electronics. Electronic Projects from the Next Dimension provides useful information on building practical circuits and projects, and applying the knowledge to unique experiments in the paranormal field. The author writes about dozens of inexpensive projects to help electronics hobbyists search for and document their own answers about instrumental transcommunication (ITC), the electronic voice phenomenon (EVP), and paranormal experiments involving ESP, auras, and Kirlian photography.

Although paranormal studies are considered esoteric, Electronic Projects from the Next Dimension teaches the technical skills needed to make devices that can be used in many different kinds of experiments. Each section indicates how the circuit can be used in paranormal experiments with suggestions about procedures and how to analyze the results.

Contents: White noise generators for use in instrumental transcommunication (ITC) and electronic voice phenomenon (EVP) experiments; Practical circuits for image experimentation, such as a

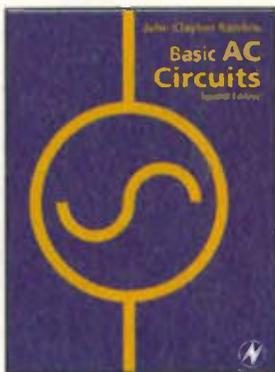

BASIC AC CIRCUITS

This is the step-by-step approach for beginners. This self-paced individualized learning tool covers concepts, terms, and the mathematics required to understand AC circuit problems. It has been designed to improve analysis techniques for prediction and control development.

Readership: Beginners meeting AC circuits for the first time; students; technicians
Pages: 921pp
Price: UK £27.00
Europe £29.00
ROW £31.00

wireless sparking image generator, horizontal bar generator, brontophic sound, magnetic field generator, high-voltage generators (Kirlian Machine's I & II); Paranormal skills experiments with temperature change, polygraph, electro-shock, random number generation, UFO detection, and ghost-finding.

Readership: Hobbyists, Electronics Enthusiasts
Pages: 256pp
Price: UK £22.00
Europe £24.00
ROW £26.00

Post your completed order form to:
 Jackie Lowe, Room L514, Quadrant House,
 The Quadrant, Sutton, Surrey, SM2 5AS

Fax your order form to 020 8652 8111

How to order

Book Title _____

I enclose a cheque/bank draft for £ _____
 (payable to Reed Business Information)

Please charge my credit/charge card

Mastercard American Express Visa Diners Club

Credit Card No: _____

Expiry Date: _____

Signature of Cardholder _____

Cardholder's statement address: (please use capitals)

Name _____

Address _____

Post Code _____

Tel: _____

TiePieScope HS801 PORTABLE MOST



ARBITRARY WAVEFORM GENERATOR-
STORAGE OSCILLOSCOPE-
SPECTRUM ANALYZER-
MULTIMETER-
TRANSIENT RECORDER-

Reliability

- The HS801: the first 100 Mega samples per second measuring instrument that consists of a MOST (Multimeter, Oscilloscope, Spectrum analyzer and Transient recorder) and an AWG (arbitrary waveform generator). This new MOST portable and compact measuring instrument can solve almost every measurement problem. With the integrated AWG you can generate every signal you want.
- The versatile software has a user-defined toolbar with which over 50 instrument settings quick and easy can be accessed. An intelligent auto setup allows the inexperienced user to perform measurements immediately. Through the use of a setting file, the user has the possibility to save an instrument setup and recall it at a later moment. The setup time of the instrument is hereby reduced to a minimum.
- When a quick indication of the input signal is required, a simple click on the auto setup button will immediately give a good overview of the signal. The auto setup function ensures a proper setup of the time base, the trigger levels and the input sensitivities.
- The sophisticated cursor read outs have 21 possible read outs. Besides the usual read outs, like voltage and time, also quantities like rise time and frequency are displayed.
- Measured signals and instrument settings can be saved on disk. This enables the creation of a library of measured signals. Text balloons can be added to a signal, for special comments. The (colour) print outs can be supplied with three common text lines (e.g. company info) on three lines with measurement specific information.
- The HS801 has an 8 bit resolution and a maximum sampling speed of 100 MHz. The input range is 0.1 volt full scale to 80 volt full scale. The record length is 32K/64K samples. The AWG has a 10 bit resolution and a sample speed of 25 MHz. The HS801 is connected to the parallel printer port of a computer.
- The minimum system requirement is a PC with a 486 processor and 8 Mbyte RAM available. The software runs in Windows 3.xx / 95 / 98 or Windows NT and DOS 3.3 or higher.
- TiePie engineering (UK), 28 Stephenson Road, Industrial Estate, St. Ives, Cambridgeshire, PE17 4WJ, UK
Tel: 01480-460028; Fax: 01480-460340
- TiePie engineering (NL), Koperslagersstraat 37, 8601 WL SNEEK The Netherlands
Tel: +31 515 415 416; Fax +31 515 418 819

Web: <http://www.tiepie.nl>



Infra-red sprint timer

You might not have a need for a precise sprint timer, but Simon Bateson's micropower design should provide some interesting tips for anyone involved with infra-red transmitters/receivers that need to be able to run from batteries.

This system was designed in response to a request from an athletics and sports-science department that wanted to profile the velocity of runners during sprint events.

Basically, the timer comprises a series of beam-break detectors distributed along a track, Fig. 1. Each connects to a master unit to indicate a series of time intervals.

While the specific application is unlikely to be common, a number of design ideas emerged during development that should have wider appeal. Most of these are to do with low-power design.

Infra-red beam detectors

Infra-red transmitter-receiver systems are widely used in TV remote controls. They are now found in a high-speed bi-directional form in interfaces such as the IRDA link for PCs and peripherals.

Typically, an infra-red emitting diode, or IRED, is modulated with data directly, or through modulation of a high-frequency subcarrier, often 38kHz.

High-frequency modulation can largely overcome the extreme levels of background IR due to sunlight and domestic heating sources. However, the first stage preamplifier and photodiode load need careful design to prevent DC or LF saturation occurring. Some infra-red control receivers fail to respond to their transmitters in bright light: this is due to first-stage overload.

The need to pick up low levels of

modulated IR in the presence of high levels of interference has led to the availability of application-specific ICs, such as the TBA2800, and complete IR photodiode/amplifier modules, notably those made by Sharp and HP.

However most receivers are integrated into fixed or mains-powered devices, so the battery saving measures all seem to have been concentrated at the transmitter end. There are no micropower receiver chips; all consume at least one – and sometimes several – milliamps.

Power consumption issues were addressed in a previous short article in the October 1994 issue of *EW&WW*. The circuit described there forms part of this system.

Reflection or transmission?

One early design question was whether to use a combined transmitter/receiver combined with a remote reflector, or two separate modules. The material cost of an additional box and battery, minus the reflector, was not great.

Separate boxes were eventually favoured because they are easier to set up. Aiming is straightforward, as shown later.

Having separate modules doubles the useful range, and it must be admitted, shielding between a circuit delivering 2A current pulses, and a circuit detecting microvolt signals, is always easier when they are several metres apart.

Finally, this had to be a high-

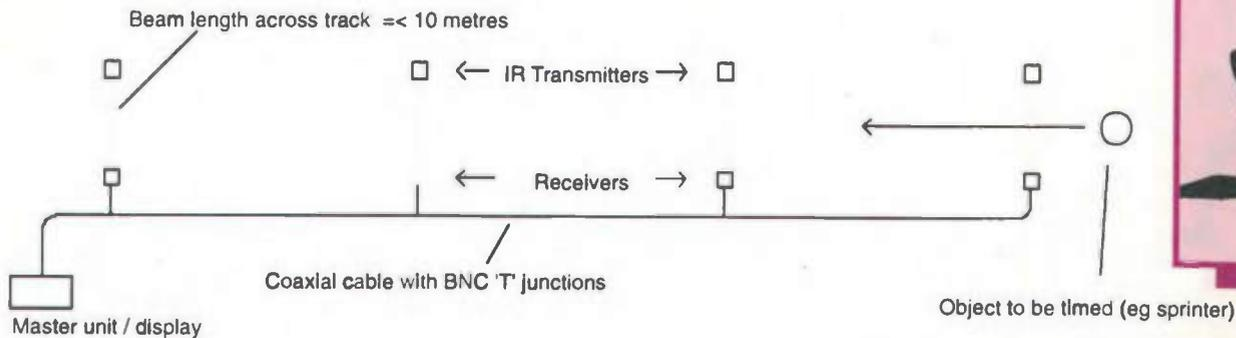

Fig. 1. Arrangement of detectors for timing athletic running events.

reliability system. In an evaluation prototype using combined transmitter and receiver, some white clothes acted as reflectors and would not always trigger the detector. A transmission beam is always unequivocally broken.

Having said that, there is no reason why the system should not operate in a reflective mode for other applications.

Transmitter circuit

As shown in Fig. 2, the transmitter is a conventional design using a TLC 555 low-power timer as the pulse source.

To maximise the efficiency of the system, the pulse duty cycle must be minimal. Against this was the fact that the pulse repetition frequency had to be high – more than 1kHz to satisfy the 1ms timing resolution of the system.

If the duty cycle was too low, the pulses would be very short and the receiver would need a very wide frequency response. This would increase noise and current consumption.

Eventually, the pulses were set at 3.6µs at a pulse repetition frequency of 1.3kHz. At an IR emitter peak current of 2A, mean battery drain was about 5mA. This ensured a full day's operation with a nickel-cadmium

PP3-sized battery.

A simple battery voltage indicator was included for testing purposes. When the unit is switched off, the battery can be charged with an ordinary NiCd trickle charger through an external socket. The diode renders the connector short-circuit proof.

Although supply line disturbances and pulse shape in a stand-alone transmitter are not terribly important, I originally developed the transmitter in the same case as the receiver, with the intention of sharing supplies with sensitive circuitry. I therefore spent a while on the choice of driver transistor, local reservoir capacitor and board layout to maximise the available current for the IREDS, while minimising power line disturbances.

Of those I tried, all the commonly available 'low ESR' capacitors specified for switch-mode power supplies gave good current delivery. On the other hand, most general-purpose electrolytics caused various degrees of ringing on the supply rails.

Despite its small size, the ZTX 750 transistor can drive high currents, and seems ideally suited for this application. It is important to minimise the area of the capacitor/transistor/IREDS high current loop on the PCB. Use thick tracks and keep them close together.

Since the average current is low, the circuit can be effectively decoupled with 10Ω resistors in both the supply and ground lines if a common supply is to be used.

Infra-red receiver circuit

Photodiodes are often required to detect relatively low-powered pulses in the presence of intense continuous sunlight or 100Hz illumination.

Commonly, the diode is used in reverse leakage mode – i.e., as a current source into the inverting input of an op-amp, or directly into a resistive load. However, in the presence of sunlight or incandescent lighting, these circuits saturate.

It is possible to use an inductor or transistor gyrator circuit but there are still two problems. Firstly, although the gyrator exhibits high AC impedance, there is no actual power gain from the transistor. Secondly, the considerable photocurrent induced in sunlight – several milliamps – must come from the power supply, and will drain batteries.

In Figure 3, the photodiode operates in photovoltaic mode. Transistor Q₁ saturates at a very low current and the collector sits around 0.3V. Its base is AC grounded. As a result, to signals with a fast rise time such as those generated by remote

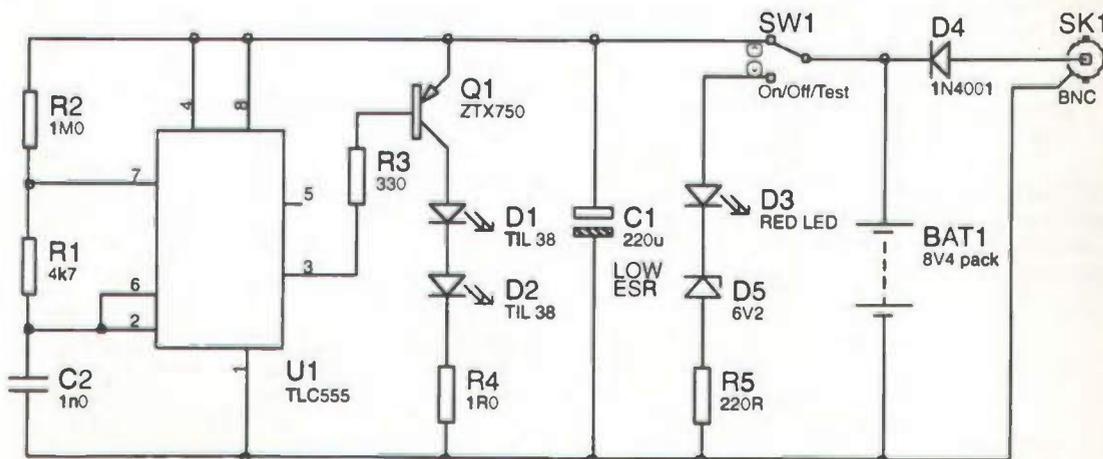

Fig. 2. Low-power infra-red pulse transmitter. With pulses at 3.6µs and a 1.3kHz PRF, battery drain was about 5mA, ensuring a full day's operation from a nickel-cadmium PP3.

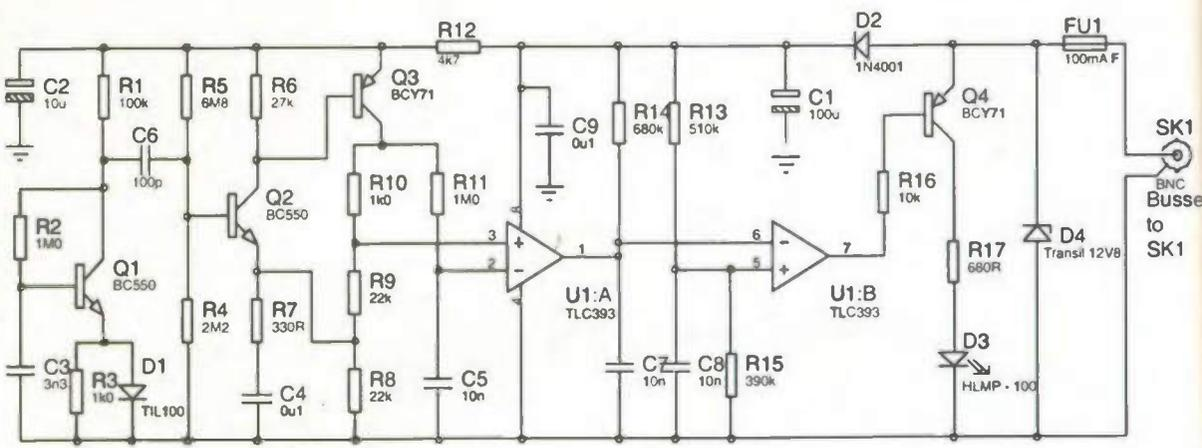

Fig. 3. IR pulse receiver/beam break detector. In the presence of IR pulses, the circuit consumes about 60µA; when tripped, it consumes about 10mA to light the LED.

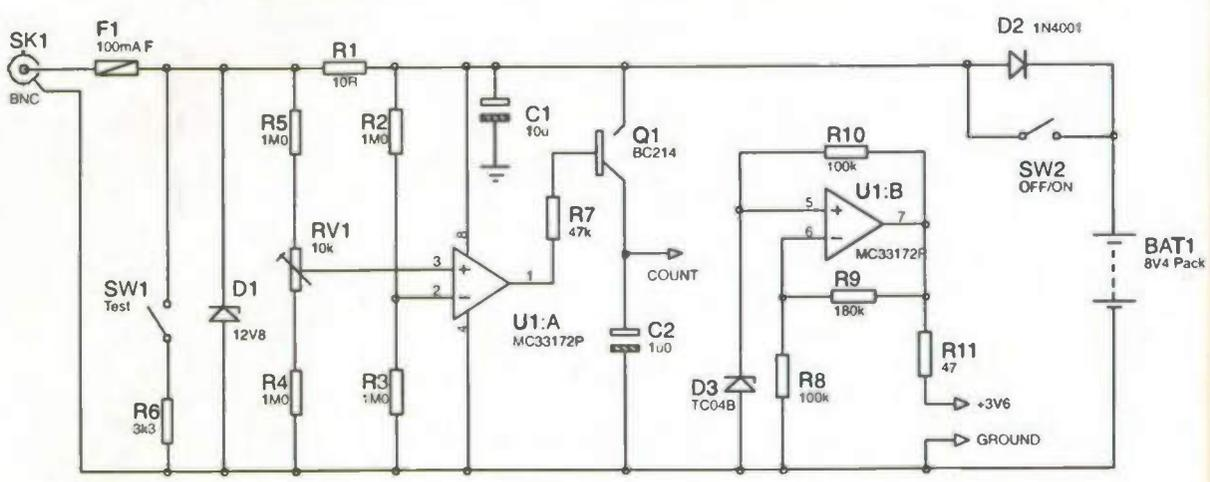

Fig. 4. Master unit analogue section. This section provides power to all receivers in the system.

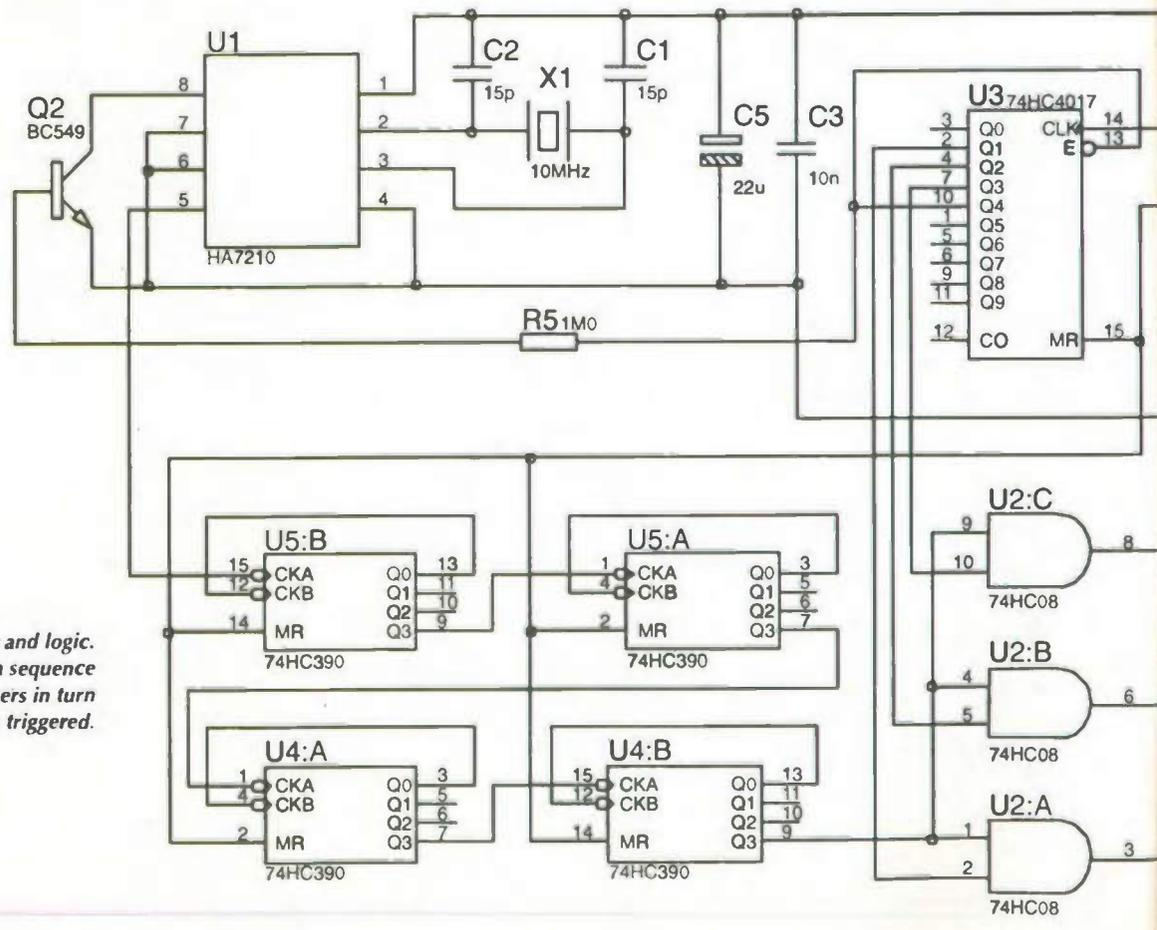

Fig. 5. Master unit counters and logic. Here, the 4017 forms a sequence generator to gate the timers in turn when tripped.



control transmitters, Q_1 emitter appears as a low impedance and the photodiode current is diverted into it.

Thus, Q_1 acts as a common-base amplifier and the collector current cuts off rapidly. Even at low collector currents, the response is fast because of the lack of Miller and storage effects. At low frequencies and in constant light, all the photodiode current passes through the $1k\Omega$ resistor rather than through the supply so there is no battery drain.

The following amplifier is a series-feedback pair operated at a low current. It has a good gain-bandwidth product considering its power consumption, but it can suffer from overload. Consequently, it can be slow to switch-off when heavily overdriven, for instance, when the IR transmitter is brought in contact with the photodiode.

To overcome the overload problem, the output is fed to a comparator through a bias/threshold network. Network R_{11} and C_5 provide an automatic bias that tracks LF shifts and saturation in the preamp, while R_8 , R_9 and R_{10} set the comparator threshold. This measure was found to preserve pulse width very well. In data or alarm applications, direct PCM signals can be passed to

decoder chips without error.

The TLC393 is a dual micropower comparator with open-drain output stages. Resistor R_{14} charges C_7 from the supply, but every time an IR pulse is received, C_7 is discharged through the comparator. Rather like in a 'watchdog' circuit, a loss of signal will trigger the second comparator, switching on the indicator LED.

Note the diode and rather large reservoir capacitor in the supply; these ensure that the circuit is undisturbed by the relatively large LED current.

In the presence of IR pulses, the circuit consumes about $60\mu A$; when tripped, it consumes about $10mA$ to light the LED. This change in current is the signal to the master unit that the beam is broken, so a single coaxial cable carries both power and signal – a simple current loop system.

The receivers are easy to set up; the transmitter is pointed roughly at the receiver. Next the receiver aimed either side of the transmitter until the LED comes on, then fixed mid-way between these two cut-off points.

Master unit – analogue circuitry

Figure 4 shows the analogue side of the master unit. This was built on a

board along with a rechargeable PP3 sized battery.

Connections to the outside world are as multi-purpose as possible. Power is supplied to all the receiver units, which are simply chained together like an Ethernet, using BNC adapters and leads. There are no 50Ω terminators, of course!

Current drain is monitored by R_1 . Potentiometer RV_1 is trimmed so that the op-amp, connected as a comparator, switches when the current draw exceeds about $7mA$.

Obviously, since the drain of a single receiver is only $60\mu A$, many receivers can be chained together if necessary.

The arrangement of Q_1 , C_2 of Fig. 4 and the LED/ R_6 load in Fig. 5 act as a battery condition indicator and signal indicator. It also acts as a short time constant to prevent potential multiple triggering – not that this ever actually occurred.

A regulated power supply is provided by the second op-amp. The op-amp is arranged in a self-biasing configuration discussed in Horowitz & Hill's book 'The Art of Electronics'. This gives a very stable low-voltage supply to the digital side of the system at a minimal power drain, which is not possible at the required voltage with three-terminal regulators.

When the unit is switched off, the battery can be charged through the external terminals via D_3 . The test button simply draws about $9mA$ when pressed to verify master unit function and battery condition.

When designing circuitry to be used – literally – in the field, protection against interference, wrong connections, etc., must be considered. Here, the master unit and all the receivers are protected against anything short of lightning strike or EMP by D_1 and a fuse. This diode is a 'Transil' or high-speed transient suppressor. It will pass $28A$, clamping at $21V$, within $10\mu s$.

Master unit – counters

For this application, three successive periods were measured, requiring three counters and four IR beams.

I considered using a microprocessor, but turned the idea down on the grounds of development time, current consumption and the need for three displays.

The displays were miniature 6-digit LCD counter modules (RS type 343-442) that consume just $10\mu A$. They are fed from a $1kHz$ signal to count milliseconds.

A Harris device specifically designed as a low-power oscillator

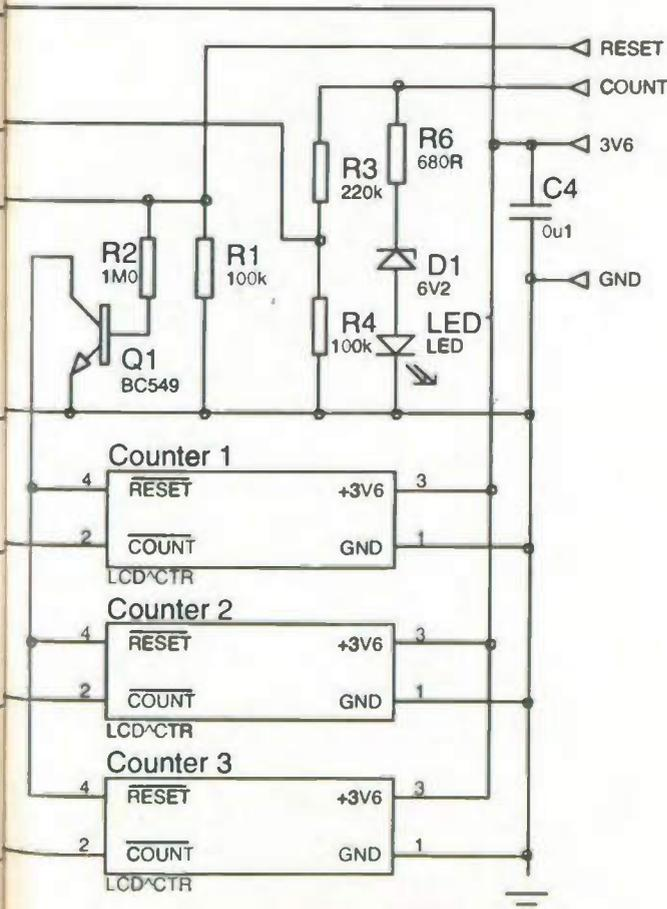

provides the clock signal. This clock is divided down to 1kHz using 74HC counters. It all works quite happily at 3.6V.

Note that the crystal loading capacitors connect to V_{dd} rather than ground, as the oscillator inside the HA7210 is referenced to V_{dd} . With the high-impedance circuitry used in low-power oscillators, it is essential to minimise track lengths, keep well away from surrounding digital signals and *not* to use an earth plane close to the crystal connections.

Remaining circuitry, Fig. 5, is fairly self-explanatory. The 4017 forms a sequencer to gate the timers in turn when triggered.

When running, the clock oscillator takes less than 200 μ A. Even so, I found it well worthwhile to use the disable function to stop the oscillator, reducing its consumption to 5 μ A at the end of the timer sequence – i.e. when 4017 output Q_4 goes high. It is re-enabled when the reset/arm button is pressed ready for the next set of measurements.

Implementation notes

However quiet the circuit, a lens always improves the signal to noise

ratio of an optical receiver.

In my prototypes, simple plastic lenses of focal length 80mm (Maplin FA95D) were glued and clamped in place. The photodiodes were supported against M3 pillars on the PCBs about 70mm from the lens to make aiming less critical.

The master unit was built in a polycarbonate IP67 box with transparent lid; a thin panel inside, with appropriate cutouts and labels, hid the circuit boards. With suitable LED fittings, toggle covers and BNC connectors all nine boxes are immersion-proof.

Applications

My design goals were to make an easy to use system that would last as long as possible on batteries, while having good beam sensitivity without interference and achieving a one-millisecond time resolution.

Early investigations included a 418MHz transmitter and encoder for a completely wireless system, gating the transmitter on as required. Although there was a start-up and transmission delay, there was no problem with measuring intervals since all the

delays were the same.

Eventually this approach was abandoned for two reasons. Firstly, the transmitters were sometimes at their range limits. As a result, the decoder occasionally failed to pick up the very first signal. This doesn't matter in an alarm signal transmitter, but we could not afford any time ambiguity in this particular application.

Secondly, trailing cables down one side of a track is no hardship. If marked at 25m and 50m intervals, they eliminate the need for a tape measure. Additionally, a 680 Ω resistor, LED and microswitch are the only components required to trip the counters manually or from starting blocks.

In other applications, such as security, a break beam can often be more useful than passive detectors. If the beam power and pulse repetition frequency is greatly reduced and a radio transmitter included, a stand-alone alarm could be made with a static power consumption of a few tens of microamps. This will easily run at 3V from rechargeable batteries and a small solar cell.

Restoring Baird's image (D F McLean)

Return to Jackie Lowe, Room L514, Quadrant House,
The Quadrant, Sutton, Surrey, SM2 5AS

Please supply the following title:

Restoring Baird's image

Total _____

Name _____

Address _____

Postcode _____

Telephone _____

Method of payment (please circle)

Mastercard/Visa/Cheque/PO

**Cheques should be made payable to
Reed Business Information**

Credit card no _____

Card expiry date _____

Signed _____

In the late 1920s, John Logie Baird – considered to be the inventor of television – was experimenting with 'phonovision' in which he attempted to record television signals onto gramophone discs. His efforts were mostly unsuccessful and this technology largely forgotten, until the 1980s when Don Mclean came across the discs and set about restoring them with modern computer-based techniques. The recovery of these images gives us a fascinating glimpse of what the earliest television was like (before official TV services started). As well as helping to explain a poorly understood period of television history, this unique book sheds new light on the activities of John Logie Baird and the definition and invention of television itself.

**316pp., 234 x 156 mm, hardback,
Price: UK £32.00 Europe £34.00 ROW £36.00**

"... the most authoritative book on Baird's work yet published." Andy Emmerson for the British Journal of the History of Science.

"... a fascinating book. Once you start, you won't want to put it down." Peter Yanczer for Amazon.com

"... represents essential reading for everybody with an interest in those days." Ray Herbert for the NBTVA

"Buy, read and enjoy." Jeffrey Borjnsky, for the BVWS Journal.

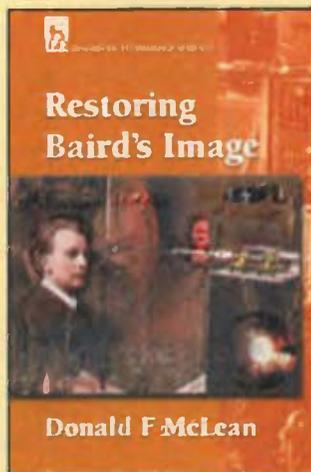

NEW PRODUCTS

Please quote *Electronics World* when seeking further information

170MHz oscillators with low jitter

Vectron has introduced voltage controlled crystal oscillators at frequencies from 1.024 to 170MHz. The J-type VCXOs are CMOS or PECL compatible with an input of +3.3 or +5.0V DC. The units have a typical jitter performance of less than 0.5ps rms (12kHz to 20MHz) at the output frequency for the CMOS version and less than 1ps rms for the PECL option. They come in six-pin J-lead ceramic packages and are hermetically sealed with a grounded conductive lid. Applications include clock smoothing and frequency



translation in Sonet, SDH, ATM, DSLAM and other telecoms applications.

Vectron
Tel: 0238 076 6288
www.vectron.com

Connectivity protocol goes to version 4.0

Pentek has announced Swiftnet version 4.0, which includes a streaming API to transfer bidirectional data streams between the host and target. Also included is support for the LabVIEW graphical programming development environment for data acquisition, analysis and presentation. Labview lets an engineer develop an application with Swiftnet using graphical blocks. Client and server support is available for Red Hat Linux for communications between the host and the DSP. The TCP/IP protocol manages the connection between Pentek's software development tools running on workstations and its VME bus DSP products based on Texas Instruments TMS320C30140 and 60 DSPs and Analog Devices' Sharc. It contains plug-in support

for TI's Code Composer Studio debugging software under TI's ExpressDSP initiative, letting the software communicate with an unlimited number of DSP targets in multiple locations.

Vectron
Tel: 0238 076 6288
www.vectron.com

DSL line driver comes in small footprint

Elantec has introduced a line driver for ADSL and HDSL2 applications. The EL1503CL comes in a 4 by 5mm leadless plastic package and is for DSLAM and DLC central office use. Height is less than 1mm, making it suitable for analogue front-end hybrid modules. The package makes use of a bottom-side thermal pad that attaches to the PCB



during surface mount soldering. The die transfers heat directly through this thermal pad to the PCB achieving a mounted junction-to-ambient thermal coefficient less than 40°C/W. Supply current is 12.5mA per amplifier and output swing $\pm 10.3V$. Output current capability is 450mA, letting it be used in DMT and Cap ADSL designs. It can run from supplies of ± 5 to $\pm 12V$ and has control features to improve power dissipation.

Elantec
Tel: 0118 977 6161
www.vectron.com

GU CompactPCI board targets telecoms apps

SBS Technologies has introduced a 6U CompactPCI CPU board for high-availability telecoms or data communications applications that need master-slave operation. The CE7 platform supports 400 to 566MHz Celerons, 500 to 850MHz Pentium IIIs, the Intel 82440BX chipset and up to 1Gbyte of memory with 100MHz SDRAM in one slot. Optional features

High-speed digital recorder for graphics, video and audio

Crellon Microsystems has introduced the DGx digital image recorder, which uses Firewire (IEEE1394) bandwidth to capture, compress, store and replay video signals. This includes computer, radar and other digital image data. The system, developed by RGB Spectrum, provides up to four input channels with PAL or NTSC options. Images from two selected channels can be output to separate monitors, or one monitor can display up to four quarter-size representations of the recorded images. It supports outputs of 25frame/s at 640 x 480 pixel resolution or 6frame/s at 1280 x 1024. Two audio input channels are available for digitised audio recorded with the video data, enabling stereo audio playback. The system supports event marking using SMPTE time coding. This is done manually from the front panel control or via serial commands over an RS232 interface. Event marking supports the random access feature, where the operator can start playback from any point in the recording. Compression complies with the DV Blue Book standard, and lets up to three hours of digital video data be recorded.

Crellon Microsystems
Tel: 0118 977 6161
www.crellon.co.uk

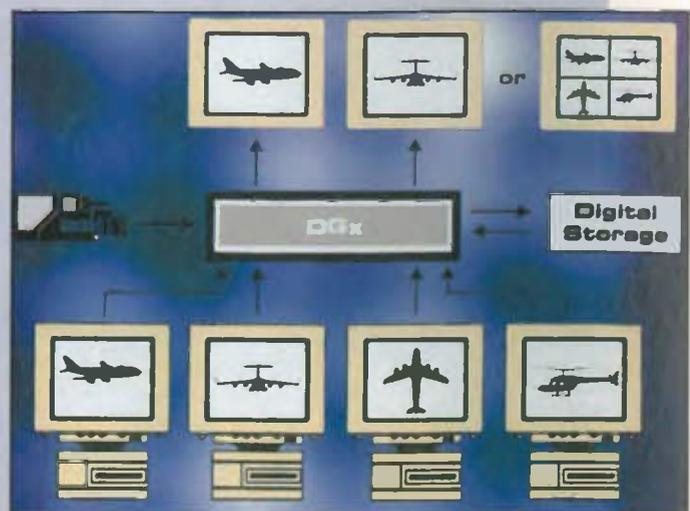

Please quote *Electronics World* when seeking further information

include a C&T69030 VGA and LCD controller with 4Mbyte SDRAM and a maximum resolution of 1600 x 1200, up to four 10/100BaseT Ethernet ports, front or rear panel I/O, up to 350Mbyte flash drive and a baseboard management controller supporting the IPMI architecture. It is also available with an optional extended temperature range from -40 to +70°C.

SBS Technologies
Tel: 00 49 821 5034-0
www.sbs.com

Octal Mac-phy chip handles 4.8Gbit/s

LSI Logic has available a Fast Ethernet octal Mac-phy combination chip. The L88800 integrates eight physical layer devices (phys) and eight media access controllers (Macs) on a chip. The device is for networking applications including Ethernet switches, backbones, network convergence and network

processors. Integrating the phys reduces pin count and eliminates the associated simultaneous switching outputs because the high-speed interface is internal, boosting performance and reducing EMI. The flexible bus interface is programmable for 64, 32 or 16-bit bidirectional or split bus. It can simultaneously transmit and receive from two ports. Working at full capacity, the chip can handle up to 4.8Gbit/s data from all eight ports at the same time, letting up to 24 full-duplex ports be configured on the one bus.

LSI Logic
Tel: 01344 413209
www.lsilogic.com

DC/DC converter controllers

The XC9301 and 9302 step-up and down DC/DC converter controller ICs have been introduced by Torex for battery-powered handheld equipment, such as mobile phones, PDAs, palmtop computers and portable audio equipment. Input voltage is 2 to 10V and output is selectable in 0.1V steps from 2.4 to 6V. Switching frequency is set at 180kHz (±15 per cent) and output is more than 250mA. They step up and down without using a linear voltage regulator. Efficiency is typically 81 per cent at 5V and 78 per cent at 3.3V. Soft-start time is internally set to 10ms to protect against inrush currents when power is switched on and against voltage overshoot. During standby operation, current can be

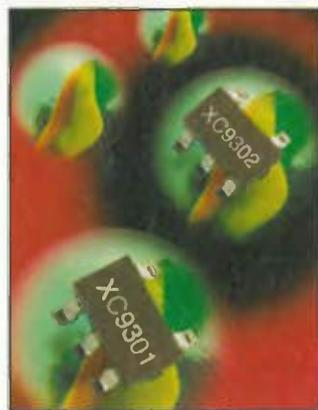

reduced to 0.5µA. They come in SOT25 packages and operate from -40 to +85°C. The 9302 switches from PWM control during large output currents to PFM for light load operation.
Torex Semiconductor
Tel: 01509 211992
www.torex.co.jp

Dual polar UMTS antenna has 16dBi gain

European Antennas has launched a dual polar UMTS basestation antenna that provides 16dBi gain on both polarisations (±45°). It can be used for most traditional macro sites as well as high density micro cells. Measuring 910mm high, 135mm wide and 72mm deep, the antenna can be installed alongside existing GSM antennas without significant effects on wind-loading, claims the company. Downwards facing 716 connectors allow for access and installation. The antenna elements are housed in an



aluminium chassis filled with dielectric to stop the build-up of moisture near the PCB.
European Antennas
Tel: 01638 731888

IR transceiver complies with IrDA version 1.3

Agilent Technologies has announced an infra-red transceiver that complies with IrDA version 1.3. The HSDL-3210 is 2.5mm high and is for PDAs, pagers and mobile phones. It is a 9.6kbit/s to 1.152Mbit/s transceiver that can

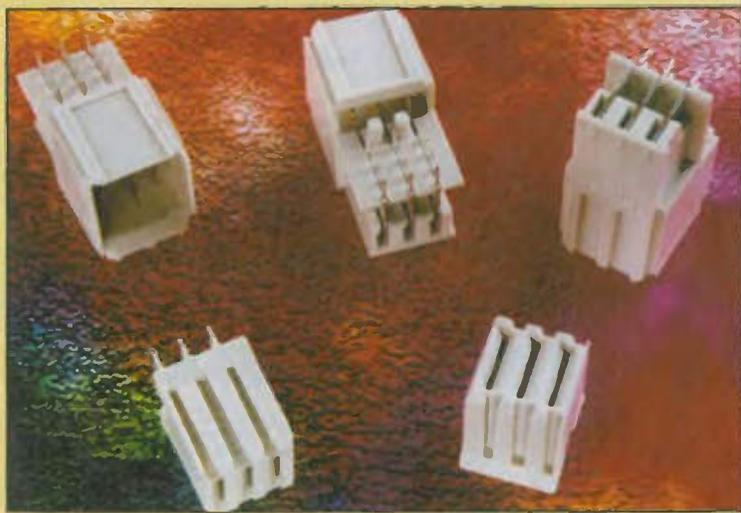

Power connectors handle 7A

Erni has introduced the Ermet EPM power connector modules. Available from Radiatron, they mate with UPM universal power modules and transfer power from the backplane to the daughtercard. Male connectors are available in three pin heights to enable sequential pin mating. All modules have press fit contact terminals, using flat rock tooling procedures. This is combined with a closed entry female receptacle on the backplane and a right angle male header on the daughter card. The male and female connectors operate from -55 to +125°C, with the power shared across four press fit terminals to increase heat dissipation. Current capability is up to 7A and the connectors meet IEC950 finger probe safety requirements, carry UL94V0 flammability rating and meet IEC1076-4-101.

Radiatron
Tel: 01784 439393
www.lsilogic.com

Please quote *Electronics World* when seeking further information

operate with logic levels down to 1.8V and from power sources down to 2.7V. Footprint is 8.0 by 3.0mm and it is IEC60825-1 class one eye safe. Typically, it draws 10nA in shutdown mode and 200µA in standby mode.

Agilent Technologies

Tel: 07004 666666

www.agilent.com

Coaxial connector for 3G mobile telecoms

A coaxial multiple connector has been developed by Harting for 3G mobile telecoms applications. The Mini Coax+ has adjusted levels of impedance

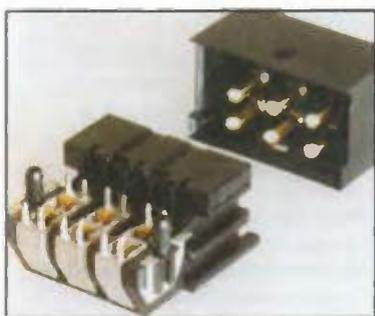

for all inner sections of the connector and allows signal transmission between the daughtercard and the backplane at frequencies up to 4GHz. Solderable surface mount technology is used on the inner conductors.

Harting

Tel: 00 49 5772 470

www.harting.com

Digital power meter tests motor efficiency

The PZ4000 digital power meter from Yokogawa comes with a plug-in module to test the efficiency of electric motors. The two-channel unit has inputs for measuring torque and speed, either from an analogue signal

Rectifier is efficient to 86 per cent

International Rectifier has introduced the IR1176 application-specific synchronous rectification IC (SRIC) for isolated DC-to-DC converters with voltage output down to 1.5V, powering telecoms and broadband network servers. Used with the firm's DC-to-DC converter-specific Hexfets, the IC provides 1.5 and 1.8V converters at 40A, with in-circuit efficiencies of 85% and 86% respectively for 1.5V output circuits with 48V input. It controls gate drive circuits to reduce losses in secondary-side, isolated DC-to-DC converter synchronous rectification Mosfets. It uses a

modified PLL to lock the switching frequency of the secondary-side synchronous rectification Mosfets to the primary-side switching action. This lets the Mosfets be pre-fired with programmable control of turn-on transition lead time, as well as the dead time and overlap between gate drive signals. Pre-firing the Mosfets eliminates parasitic diode conduction and all output current is conducted through the active Mosfet channels.

International Rectifier

Tel: 0208 645 8001

www.agilent.com



input or from pulses from suitable transducers. By measuring the electrical power consumption and relating it to the torque and speed, the instrument makes it possible to calculate and analyse the overall efficiency of the motor. Values can be measured and displayed cycle by cycle. The instrument is suitable for inverter-driven motors for domestic appliances such as washing machines, refrigerators and air-

conditioners as well as in electric vehicles. The instrument is a digital wattmeter with frequency capability up to 2MHz. It has a menu-driven TFT screen that will display instantaneous values, integrated values and voltage, current and power waveforms. Sampling is up to 5Gsample/s, voltage rating up to 1kV and DC input up to 20A. Higher values are possible with external current sensors. Accuracy is 0.2 per cent.

Yokogawa Martron

Tel: 01494 459200

www.martron.co.uk

Text-to-speech supports Linux

Force Computers has announced it will support Linux on its DECtalk text-to-speech speech synthesis technology for StrongARM and Intel processor-based wireless devices, including PDAs, laptop computers, wireless phones and car navigation systems. Uses include roaming Internet, e-mail

reading and hands-free, eyes-free text-to-speech applications. DECtalk supports English, American, Latin American Spanish, Castillian Spanish and German. The firm plans to add speech synthesis for other European and Asian languages.

Force Computers

Tel: 01296 310400

www.forcecomputers.com

Analyser measures WDM to 1620nm

Anritsu has introduced the MS9710C optical spectrum analyser with option 15 to let measurements be made on wavelength division multiplex systems at wavelengths up to 1620nm. WDM systems can have 48 channels with 100GHz (0.8nm) spacing with future systems having 200 channels with 50GHz (0.4nm) spacing, carrying more than 1Tbit/s over a 76nm spectrum with 10Gbit/s modulation. These will require wavelength amplification into L-band at up to 1620nm. The



Please quote *Electronics World* when seeking further information



analyser has an accuracy of $\pm 20\text{pm}$ from 1520 to 1620nm. Level flatness is $\pm 0.1\text{dB}$ and resolution accuracy is better than ± 3 per cent over the same range. Wavelength resolution is 50pm while level linearity and polarisation dependency are both $\pm 0.05\text{dB}$ measured at 1550 and 1600nm. RBW accuracy directly affects signal-to-noise ratio measurement accuracy and is ± 2.2 per cent.

Anritsu
Tel: 01582 433200
www.anritsu.co.uk



SM trimmers are auto-adjustable

Easby Electronics is stocking the SMD3165 taped surface-mount trimmer from Meggitt. The single-turn potentiometer has a power rating of 0.15W at 70°C. It incorporates a stable

cermet element and in-line terminations. Supplied on tape and reel, its footprint is 4.5 by 4mm and height 2.2mm. The range goes from 100 Ω to 1M Ω and operating temperature from -25 to +85°C.

Easby Electronics
Tel: 01748 850555
www.easby.co.uk

Chip-in-glass displays have seven outputs

Itron has introduced a chip-in-glass display comprising a 96-bit VF drive IC with a synchronous serial interface. There are seven output pins. Single and dual line 5 x 7 dot formats are available that are 16, 20 and 40 characters long. Graphic displays include 128x18, 128x32, 128x64, 192x16, 256x32 and 256x64 dot formats. Over 30 CIG displays are available. Operating temperature is -40 to +85°C.

Itron
Tel: 0845 6039052
www.itron

DC-to-DC converters Isolate to 4.2kV DC

Acal has 3W DC-to-DC converters providing galvanic isolation to 4.2kV DC. Made by Ibek Electronic, the units in the IPX3 family have I/O clearance and creepage distances of at least 2mm to meet EN6950 and UL1950 safety standards.

Internal filtering and the EMC design let them meet EN55022 level B without external components. They are surface-mounting. Standard units have input ranges of 9 to 36 or 18 to 75V DC and are for battery-powered applications. Output voltage options are 5, 12, 15, ± 5 , ± 12 and $\pm 15\text{V DC}$. They come in two ambient temperature ranges: -25 to +71°C and -40 to +85°C.

Acal Power Solutions
Tel: 01252 858585
www.aclelec.co.uk

PCB connectors use IDC technology

Weidmuller has introduced the BLIDCB 3.5 bus connector and BLIDC 3.5 socket block for standard PCB connections in industrial applications. The connectors use IDC technology. There is no need to strip wires for connection to either solid or flexible conductors and no need for special tools. Both types allow access for standard test probes of 1mm diameter. The bus connector allows multiple connections, in several orientations, without interruption to the bus if the plug is disconnected. It is available in two to eight poles and is stackable.

Weidmuller
Tel: 01625 434343
www.weidmuller.co.uk

The Distributor with 20,000 hard-to-find lines EX STOCK!!!

Semiconductors

We have one of the largest ranges of discrete parts in the UK, both new and obsolete types and, if we do not have it in stock, we can usually source it for you.

Call or fax for our latest Semiconductor stock list.

Computer products

We carry in stock everything to make a Personal Computer. CPUs - Memory - Motherboards - Cards - Scanners - Modems - Sound Cards - Speakers - All types of Drives - Cases - PSUs - Monitors etc

Components & equipment

Call or fax for our latest Semiconductor stock list.

Capacitors - Resistors - Connectors - Potentiometers - Cables - Batteries - Speakers - Amplifiers - Lamps - Microphones - Fans - Power supplies - Transformers - Buzzers - Sirens - Fuses and Holders - LEDs - LCDs - Relays - PA Systems - Tools - Test Equipment - etc

See our web site. Non-trade customers, send £9.80 to the sales office for a complete suite of catalogues.



Semiconductor Supplies International Ltd

Dawson House, 128 - 130 Carshalton Road,
Sutton, Surrey, England, UK. SM1 4TW
020-8643 1126 (Sales and Technical Queries)
Fax: 020-8643 3937 (For International use +4420)
e-mail: sales@ssi-uk.com Web: ssi-uk.com



Baseband processor and MAC IC

Intersil has announced a wireless single-chip baseband processor and media access controller for developing Internet information appliances that will give users wire-free access to data, video and voice-over-IP. It supports wireless Ethernet speeds for use in IEEE802.11 based systems and sits at the heart of the four-chip Prism 2.5 WLAN product.

Intersil
Tel: 01344 350250
www.intersil.com

Professional PCB Layout for Windows at Computer Store Prices!

Easy-PC For Windows 4.0

now reads Ultiboard designs/libraries*

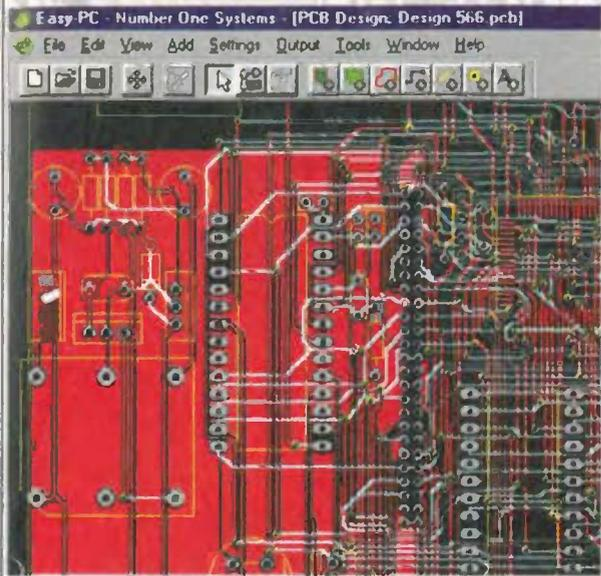

Suddenly, a professional level PCB layout product is available at a realistic price. Just check the specification and see what excellent value you get with Easy-PC For Windows. Then test before you buy with a demo version - you will be simply amazed with Easy-PC For Windows.

- True Windows 32 bit product
- Integrated Schematics and Layout as standard
- Windows drag & drop throughout
- Multiple documents open within display
- Technology files for fast start-up
- Tiled display - Cascade, Vertical, Horizontal
- Multi-level Undo/Redo
- Integrated standard Autoplace
- Optional shape based AutoRouter
- Full Copper Pour
- Split powerplanes
- Unlimited signal/powerplane layers
- Unlimited non-electrical/doc layers
- Keep out/keep in areas for routing
- R/H mouse menu support
- Pan across design to cursor position
- Cross probing between Schematics and PCB
- Full forward & backward annotation Schematics /PCB
- Modeless driven operation, no menu selection required

Over 7,000 users must be right!

Consistently, one of Europe's most popular PCB Layout products for Windows 95/98/NT/2000, Easy-PC has won praise from users for the wealth of features within each new release. Many of these new features are normally only found in the world's most expensive PCB Layout software packages.

Now try Easy-PC For Windows for yourself!

Number One Systems

Call +44 1684 773662 or Fax +44 1684 773664

E-mail info@numberone.com

call us for a demonstration copy or download from www.numberone.com

Number One Systems, Oak Lane, Bredon, Tewkesbury, Glos, GL20 7LR. UK

*Ultiboard is a trademark of Ultimate Technology

CIRCLE NO.116 ON REPLY CARD

MARCONI 2019A



AM/FM synthesised signal generator 80kHz-1040kHz

NOW ONLY £400

- H.P. 3312A Fun Gen 0.1Hz-13MHz.....£300
- AM/FM Sweep/Tri/Gate/Burst etc. H.P. 3310A Fun Gen 0.005Hz-5MHz.....£125
- Sine/Sq/Tri/Ramp/Pulse FARNELL LFM4 Sine/Sq Oscillator 10Hz-1MHz.....£125
- Low distortion TTL Output, Amplitude Meter H.P. 545A Logic Probe with 546A Logic Pulsar.....£90 and 547A Current Tracer
- FLUKE 77 Multimeter 3 1/2 digit Handheld.....£60
- FLUKE 77 Series 11.....£70
- HEME 1000 LCD Clamp Meter 0-1000A In Carrying Case.....£60

RACAL 9008

AUTOMATIC MODULATION METER AM/FM 1.5MHz-2GHz



ONLY £95

- H.P. 8494A Attenuator DC-4GHz 0-11dB N/SMA.....£250
- H.P. 8492A Attenuator DC-18GHz 0-6dB APC7.....£95

MANY OTHER ATTENUATORS, LOADS, COUPLERS etc AVAILABLE

DATRON 1061 HIGH QUALITY 5 1/2 DIGIT BENCH MULTIMETER True RMS/4 wire Res/Current Converter/IEEE £150

- MARCONI TF2015 AM/FM sig gen, 10-520MHz.....£175
- RACAL 9008 Auto Mod Meter, 1.5MHz-2GHz.....£200
- LEVELL TG2000MP RC Oscillator, 1Hz-1MHz.....£50
- Sine/Sq Meter, battery operated (batts not supplied)
- FARNELL LF1 Sine Sq. Oscillator, 10Hz-1MHz.....£75
- RACAL/AM 9343M LCR Databridge, Digital Auto.....£200

STEWART OF READING

110 WYKHAM ROAD, READING, BERKS RG6 1PL

Telephone: (0118) 9268041 Fax: (0118) 9351696

Callers welcome 9am-5.30pm Monday to Friday (other times by arrangement)



STILL AVAILABLE - PREVIOUSLY ADVERTISED WITH PHOTOS

- MARCONI 893C AF Power Meter, Sinad Measurement Unused.....£100
- Used.....£60
- MARCONI 893B - No Sinad.....£30
- MARCONI 2610 True RMS Voltmeter Autoranging 5Hz-25MHz.....£195
- GOULD J3B Sine/Sq Osc 10Hz-100kHz Low distortion £75-£125
- AVO 8Mk6 in Ever Ready Case, with leads etc.....£90
- Others Avos from £50
- GOODWILL GFC8010G Freq. Counter 1Hz-120MHz Unused.....£75
- GOODWILL GVT427 Dual Ch AC Millivoltmeter.....£100-£125
- 10mV-300V in 12 Ranges Freq 10Hz-1MHz
- SOLARTRON 7150 DMM 6 1/2 digit True RMS - IEEE £95-£150
- SOLARTRON 7150 Plus.....£200
- RACAL TRUE RMS VOLTMETERS
- 9300 5Hz-20MHz usable to 60MHz, 10V-316V.....£95
- 9300B Version.....£150
- 9301/9302 RF Version to 1.5GHz from £200-£300
- HIGH QUALITY RACAL COUNTERS
- 9904 Universal Timer Counter, 50MHz.....£50
- 9916 Counter, 10Hz-520MHz.....£75
- 9918 Counter, 10Hz-560MHz, 9-digit.....£50
- FARNELL AMN255 Automatic Mod Meter 1.5MHz-2GHz Unused.....£400

CLASSIC AVOMETER DA 116 DIGITAL 3.5 DIGIT COMPLETE WITH BATTERIES AND LEADS



ONLY £30

SOLARTRON 7045 BENCH MULTIMETER

4 1/2 digit BRIGHT LED WITH LEADS ONLY £30

IT'S SO CHEAP YOU SHOULD HAVE IT AS A SPARE

- HUNTRON TRACKER Model 1000.....£125
- H.P. 5315A Universal Counter, 1GHz, 2-ch.....£80
- FLUKE 8050A DMM 4 1/2 digit 2A True RMS.....£75
- FLUKE 8010A DMM 3 1/2 digit 10A.....£50

TIME 1051 Low Ohm Res Box 0.01ohm to 1M Ohm in 0.01ohm steps. Unused £100

SCOPE FOR IMPROVEMENT

GOULD OS 300 OSCILLOSCOPE

DUAL TRACE 20MHz TESTED WITH MANUAL

FOR THE FIRST TIME EVER ONLY IT'S SO CHEAP YOU SHOULD REPLACE THAT OLD SCOPE £95

- MARCONI 2022E Synthesised AM/FM Sig Gen.....£525-£750
- 100Hz-1.01GHz LCD Display etc
- H.P. 8657A Synthesised 2-18GHz Sig Gen.....£4000
- H.P. 8657A Synthesised 100kHz-1040MHz Sig Gen.....£2000
- H.P. 8658B Synthesised 100kHz-990MHz Sig Gen.....£1350
- H.P. 8658A Synthesised 100kHz-990MHz Sig Gen.....£995
- H.P. 8640A AM/FM 500kHz-102.4MHz Sig Gen.....£800
- H.P. 8640A AM/FM 500kHz-512MHz Sig Gen.....£250
- PHILIPS PM5328 100Hz-180MHz with 200MHz Sig Gen Freq Counter IEEE.....£550
- RACAL 9081 Synth AM/FM Sig Gen 5-520MHz.....£280
- H.P. 3325A Synth Function Gen 21MHz.....£600
- MARCONI 6500 Amplitude Analyser.....£1500
- H.P. 4275A LCR Meter 10Hz-10MHz.....£2750
- H.P. 8903A Distortion Analyser.....£1000
- WAYNE KERR 3245 Inductance Analyser.....£2000
- H.P. 8112A Pulse Generator 50MHz.....£1250
- DATRON AutoCal Multimeter 5 1/2-7 1/2 digit 1065/1061A/1071 from £300-£500
- MARCONI 2400 Frequency Counter 20GHz.....£1000
- H.P. 5350B Frequency Counter 20GHz.....£2000
- H.P. 5342A 10Hz-18GHz Frequency Counter.....£800
- B&K Accelerometer type 4008.....£300
- H.P. 11592D Dual Directional Coupler 2MHz-18GHz.....£1600
- H.P. 11591D Dual Directional Coupler 2MHz-18GHz.....£1250
- TEKTRONIX P6103B Probe 100MHz Readout, Unused.....£90
- TEKTRONIX P6106A Probe 250MHz Readout, Unused.....£95
- FARNELL AMN200 Auto Mod Meter, 10Hz-2.4GHz Unused £950
- MARCONI 2305 Mod meter, 500kHz-2GHz.....£750

RHODE & SCHWARZ APN 62 SYNTHESISED 1Hz-260kHz SIGNAL GENERATOR, BALANCED/UN-BALANCED OUTPUT, LCD DISPLAY

£425

H.P. 60128 DC PSU 0-60V, 0-50A 1000W.....£1000

FARNELL AP6050 1kW Autoranging.....£1000

FARNELL H6050 0-60V, 0-50A.....£750

FARNELL H6025 0-60V, 0-25A.....£400

Power Supply HPS3010 0-30V, 0-10A.....£140

FARNELL L30-2 0-30V, 0-2A.....£80

FARNELL L30-1 0-30V, 0-1A.....£60

Many other Power Supplies available

Isolating Transformer 240V In/Out 500VA.....£40

PORTABLE APPLIANCE TESTER

MEGGER PAT2 Only £180

USED EQUIPMENT - GUARANTEED. Manuals supplied

This is VERY SMALL SAMPLE OF STOCK. SAE or telephone for lists. Please check availability before ordering. CARRIAGE all units £16. VAT to be added to total of goods and carriage.

SPECTRUM ANALYSERS

- ADVANTEST R3261A 9kHz-2.6GHz Synthesised.....£4000
- EATON/AILTECH 757 0.001-22GHz.....£2500
- TEKTRONIX 492 50kHz-18GHz.....£3500
- H.P. 8558B with Main frame 100kHz-1500MHz.....£1250
- H.P. 853A (Dig Frame) with 8559A 100kHz-21GHz.....£2750
- H.P. 3580A Audio Analyser 5Hz-50kHz As new.....£1000
- MARCONI 2382 100Hz-400MHz High Resolution.....£2000
- B & K 2033R Signal Analyser.....£1500
- H.P. 182 with 8557 10kHz-350MHz.....£500
- MARCONI 2370 30Hz-110MHz.....from £500
- HP141 Systems 8553 1kHz-110MHz from.....£500
- 8554 500kHz-1250MHz from £750, 8555 10MHz-18GHz.....from £1000

UNUSED OSCILLOSCOPES

- TEKTRONIX TD5640A 4 Ch 500MHz 2G/S.....£4000
- TEKTRONIX TD5380 Dual Trace 400MHz 2G/S.....£2000
- TEKTRONIX TD5350 Dual Trace 200MHz 1G/S.....£1250
- TEKTRONIX TAS485 4 Ch 200MHz etc.....£900
- H.P. 54600B Dual Trace 100MHz 20MS.....£900

OSCILLOSCOPES

- PHILIPS PM3092 2+2 Ch 200MHz, Delay etc.....£800
- As new.....£950
- PHILIPS PM3082 2+2 Ch 100MHz, Delay etc.....£700
- As new.....£800
- TEK TAS465 Dual Trace 100MHz, Delay.....£1200
- TEK 2465B 4 Ch 400MHz, Delay Curs.....£1850
- TEK 2465 4 Ch 300MHz, Delay Curs.....£900
- TEK 2445/A/B 4 Ch 150MHz, Delay etc.....£500-£900
- TEK 468 Dig Storage, Dual 100MHz, Delay £450
- TEK 466 Analogue Storage, Dual 100MHz.....£250
- TEK 485 Dual Trace 350MHz, Delay.....£600
- TEK 475 Dual Trace 200 MHz, Delay.....£400
- TEK 465B Dual Trace 100MHz, Delay.....£325
- PHILIPS PM3217 Dual Trace 50MHz, Delay.....£250-£300
- GOULD OS1100 Dual Trace 30MHz, Delay.....£200

JUST IN

- HAMEG HM303 4 Dual Trace 30MHz Component Tester.....£325
- HAMEG HM303 Dual Trace 30MHz Component Tester.....£300
- HAMEG HM203 7 Dual Trace 20MHz Component Tester.....£250
- FARNELL DTV20 Dual Trace 20MHz Component Tester.....£180

MANY OTHER OSCILLOSCOPES AVAILABLE

CIRCLE NO.117 ON REPLY CARD

Please quote *Electronics World* when seeking further information

RF power Mosfets rate 300W at 50V

STMicroelectronics has introduced gold-metallised n-channel RF power Mosfets with ratings from 5W at 28V to 300W at 50V. The SD29xx models are for NMR and plasma discharge applications where severe load mismatch can occur. They are also suitable for HF, VHF and UHF applications in FM radio, TV, and DAB. Internal packaging uses a non-pedestal design to reduce thermal resistance and raise MTBF.

STMicroelectronics
Tel: 01628 890800
www.st.com

Analogue output board uses ± 10V converters

Keithley Instruments has announced the KPCI-3130 universal analogue output source board. It uses D-to-A converters operating over a ±10V range. The board can be wired in a two or a four-wire



Plug-board provides 16 isolated reed relay outputs

Amplicon has introduced its PCI263, 16-channel reed relay output board for PCI bus. The device is a plug in board providing 16 isolated relay contact outputs, and can be used with any PC supporting PCI bus version 2.1. The board is backward compatible with the PC263 for ISA bus, and makes use of the PCI-ISA interface chip – the PLX9052 – to reduce cost. The board features independently controlled single pole, single throw, dry reed relays, each of these associated with standard

LED in order to show its output status, and with every pair isolated. The relays are capable of switching 200V DC at 15W in 0.5ms (max). Also included is device drive software compatible with Windows NT, 95, 98 and 2000, as well as Agilent VEE, Delphi and Visual Basic example software. It operates in the temperature range 0°C to 60°C.

Amplicon
Tel: 01273 570220
www.amplicon.co.uk

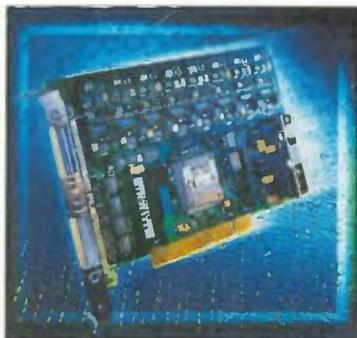

mode and provides local and remote sensing to eliminate lead line losses and improve load regulation. Each channel can source or sink up to 20mA for 4 to 20mA current loop applications without the need for an external excitation source.

Keithley Instruments
Tel: 0118 957 5666
www.keithley.com

133MHz AMD core drives PC module

The DIMM-PC/520-I PC module from Diamond Point is based on the compact Jumptec DIMM-PC module, measuring 68 by 40mm. It is driven by a 133MHz AMD AM5x86 CPU core integrating 16kbyte of write-back level one cache and

a floating point unit. The module delivers the functionality of an Elan SC520 board with CPU, system BIOS, 8, 16, 32 or 64Mbyte SDRAM, keyboard controller, real-time clock and 8, 16, 32 or 64Mbyte IDE compatible flash hard disk memory. The pin-out matches that of the ISA bus connector, making the two form factors electrically compatible.

Additional peripheral functions include com one and two serial ports with TTL signals and a floppy and IDE hard disk interface.

Diamond Point
Tel: 01634 722390
www.dpia.com

Sensor offers new angle for navigation

Murata has introduced an angular velocity sensor, the ENV-O5F-03 Gyrostar, for positional control of a moving object. This lets the piezoelectric ceramics be used for excitation and detection. Supply voltage is 5V DC ±0.5V and current consumption 15mA. Maximum angular velocity is ±60°/s with an operating temperature of -30 to +80°C. Dimensions are



11.5mm deep by 19.6mm wide by 23.2mm high. Weight is 20g. It can be mounted on PCB in a single DIN-sized box.

Murata
Tel: 01252 811666
www.murata.co.uk

Embedded board has dual Ethernet chips

Wordsworth has introduced the Magic-765 Socket-370 based embedded board, which includes the SMI710 LCD and CRT VGA controller, two Intel 82559 10/100Mbit/s Ethernet chips and audio and communications capability. Applications include point of sale, retail, multimedia, kiosk and Internet based systems. It is

based on the Intel 440BX chipset with up to 100MHz front side bus and supports Celeron and Pentium III processors in a Socket 370 base and up to 256Mbyte SDRAM via a 144-pin Soddimm socket. The board also has a solid-state disk-on-chip socket, PCI slot for add-s and ESS Solo-1E audio chip on board. The video controller supports dual-view function for CRT and LCD display. Super I/O is provided via three RS232 slots and one RS232, 422 or 485 selectable port with auto-direction functionality. There is also a parallel port and an IrDA interface.

Wordsworth
Tel: 01732 861000
www.wordsworth.co.uk

PIII or Celeron PC card is half the length

Advanced Modular Computers has released a Pentium III or Celeron half length PC card, the PCI-810E, that supports applications requiring pure PCI card expansion. Dimensions are 185 by 122mm and it can process speeds up to 800MHz. Front side bus speed is 66 to

Now
Supports the
MC68HC11
and
PIC16F877

PROTEUS VSM

Virtual System Modelling

Build It In Cyberspace

www.labcenter.co.uk

CIRCLE NO. 118 ON REPLY CARD

Develop and test complete micro-controller designs without building a physical prototype. PROTEUS VSM simulates the CPU and any additional electronics used in your designs. And it does so in real time. *

- CPU models for PIC and 8051 and series micro-controllers available now. 68HC11 coming soon. More CPU models under development. See website for latest info.
- Interactive device models include LCD displays, RS232 terminal, universal keypad plus a range of switches, buttons, pots, LEDs, 7 segment displays and much more.
- Extensive debugging facilities including register and memory contents, breakpoints and single step modes.
- Source level debugging supported for selected development tools.
- Integrated 'make' utility - compile and simulate with one keystroke.
- Over 4000 standard SPICE models included. Fully compatible with manufacturers' SPICE models.
- DLL interfaces provided for application specific models.
- Based on SPICE3F5 mixed mode circuit simulator.
- CPU and interactive device models are sold separately - build up your VSM system in affordable stages.
- ARES Lite PCB Layout also available.

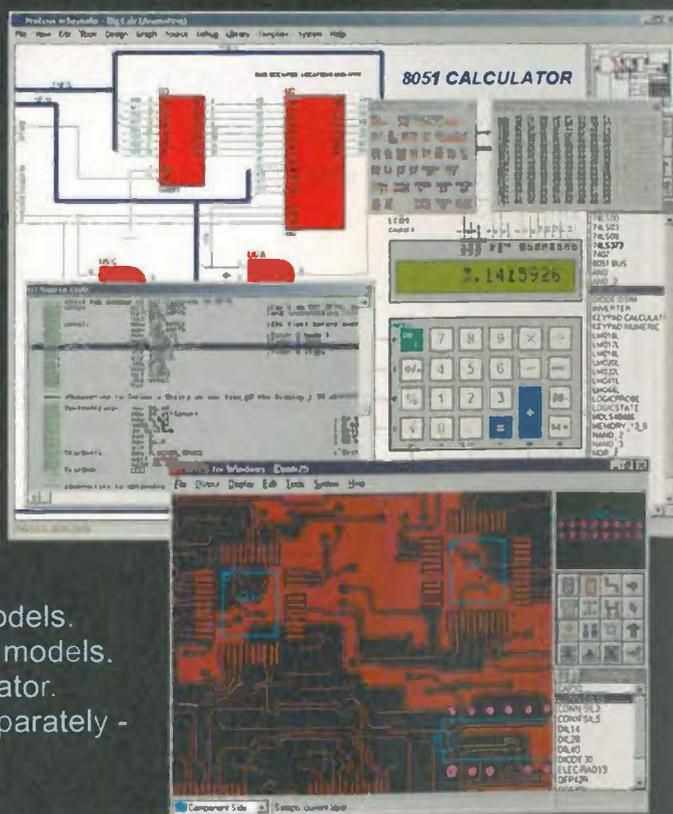

labcenter
Electronics

*E.g. PROTEUS VSM can simulate an 8051 clocked at 12MHz on a 300MHz Pentium II.

Write, phone or fax for your free demo CD - or email Info@labcenter.co.uk.
Tel: 01756 753440. Fax: 01756 752857. 53-55 Main St, Grassington. BD23 5AA.

NEW PRODUCTS

Please quote *Electronics World* when seeking further information

100MHz. Onboard attributes include a 10/100BaseT Intel 82559 fast Ethernet controller with wake-on-LAN and optional alert-on-LAN. It also has an AGP2x LCD and CRT VGA controller and secondary IDE connector for disk-on-module flash disk expansion.

AMC
Tel: 01753 580660
www.amcuk.com

19in enclosures for cable management

Olson Electronics has introduced standard 19in wall mounted and floor standing enclosures for cable management in commercial and industrial IT-based, voice and data communications installations. The Vero Imrak rack-mounting steel cases and cabinets are purpose-designed to provide a centralised, secure, controlled

environment for electronic equipment, cables and accessories. Using an all-steel construction with a lockable glass front panel, wall mounted cases are supplied in kit form in a choice of 7, 12 and 17U heights. For assembly and installation by one person, the cases have a load rating of 40kg.

Olson Electronics
Tel: 020 8905 7273
www.olson.co.uk

PCI radar scan off the shelf

Primagraphics has introduced a commercial-off-the-shelf 2k by 2k PCI radar scan converter for large screens in air traffic control and vessel traffic systems. The Advantage 2k PCI card works with the Raptor PCI 2k by 2k graphics controller from Tech-Source to provide



primary radar video direct onto a 2048 x 2048 display. The Advantage converter accepts rho-theta format data from up to three independent radars via the PCI bus and converts each to raster format. The card can also accept decompressed data, transferred via a LAN or other link, letting each operator generate a view at any scale or off-centre distance. It uses reverse scan conversion

technology implemented on Motorola's Coldfire 90MHz MCF5307 processor. Features include up to 3Mpixel/s conversion rate, variable persistence, multiple radar windows, image rotation in 0.18° steps, 360° rho-theta stores and a 4Mbyte onboard frame store.

Primagraphics
Tel: 01763 852222
www.primagraphics.co.uk

BOOK TO BUY

Servicing Audio and Hi-Fi Equipment

Return to Jackie Lowe, Room L514, Quadrant House,
The Quadrant, Sutton, Surrey, SM2 5AS

Please supply the following title:

Servicing Audio and Hi-fi Equipment

Total _____

Name _____

Address _____

Postcode _____

Telephone _____

Method of payment (please circle)

Mastercard/Visa/Cheque/PO

**Cheques should be made payable to
Reed Business Information**

Credit card no _____

Card expiry date _____

Signed _____

'Its readers will benefit from its wealth of easily assimilated information, and repairs hitherto thought impossible will speedily become routine. And the first may well cover its purchase price. Congratulations on a comprehensive, well-written and lucid work' *Electronics Informer*.

'Interesting, entertaining and useful for both practitioners and teachers. All round a satisfying book which deserves to be considered as a tool rather than an ornament collecting dust on the shelf.' *Skillset Newsletter*

Service engineers and technicians have come to regard this book as essential to their work. As a bench-side companion and guide it has no equal. Its purpose is to ease and speed up the processes of fault diagnosis, repair and testing of all classes of home audio equipment: receivers, amplifiers, recorders and playback machines. The mechanics and electronics of domestic audio are examined by Nick Beer in a down-to-earth and practical way, concentrating on what goes wrong, how to track down problems, and how to solve them.

A symptom index and comprehensive manufacturer and supplier guide allow quick access to specific advice and suggestions.

The third edition is bang up to date with the latest technology - DVD, CD Recordable, PC audio systems. There is also new material on PA equipment.

UK Price: £32.00 Europe £34.00 ROW £64.50

****Price includes delivery and packing****

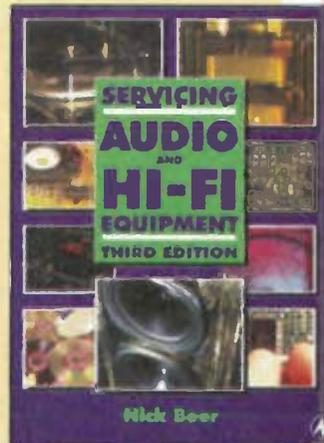

* Essential bench companion for all service engineers.

* New technology such as DVD and expanded material on MiniDisk will ensure another successful launch to this new edition

The science lab in a PC

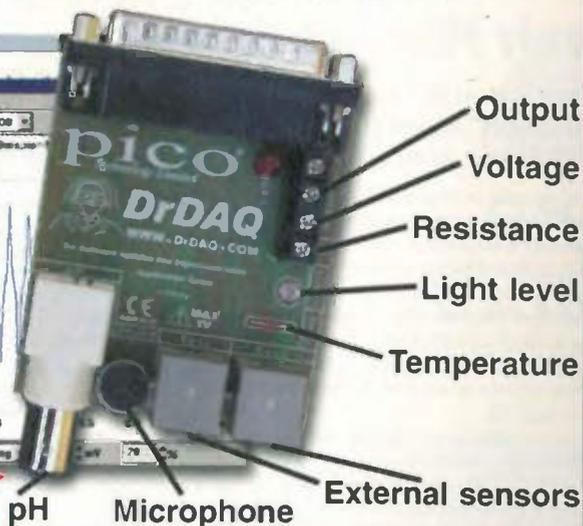
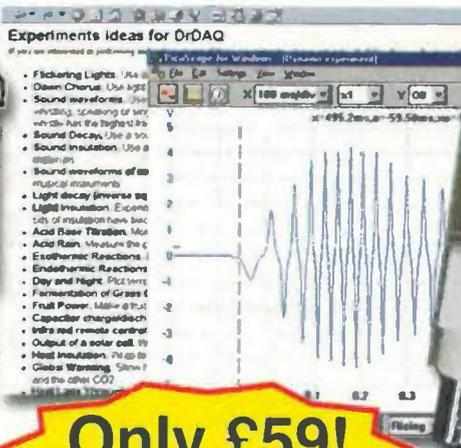

Only £59!
+VAT

The DrDAQ is a low cost data logger from Pico Technology. It is supplied ready to use with all cables, software and example science experiments.

DrDAQ represents a breakthrough in data logging. Simply plug DrDAQ into any Windows PC, run the supplied software and you are ready to collect and display data. DrDAQ draws its power from the parallel port, so no batteries or power supplies are required.

- ✓ Very low cost
- ✓ Built in sensors for light, sound (level and waveforms) and temperature
- ✓ Use DrDAQ to capture fast signals (eg sound waveforms)
- ✓ Outputs for control experiments
- ✓ Supplied with both PicoScope (oscilloscope) and PicoLog (data logging) software

Tel: 01480 396395, Fax: 01480 396296, E-mail: post@picotech.com, Web: www.drdaq.com

CIRCLE NO.119 ON REPLY CARD

pico
Technology Limited

envirowise
Practical Environmental Advice for Business

You can

save

up to £1000

per employee each year
through waste
minimisation

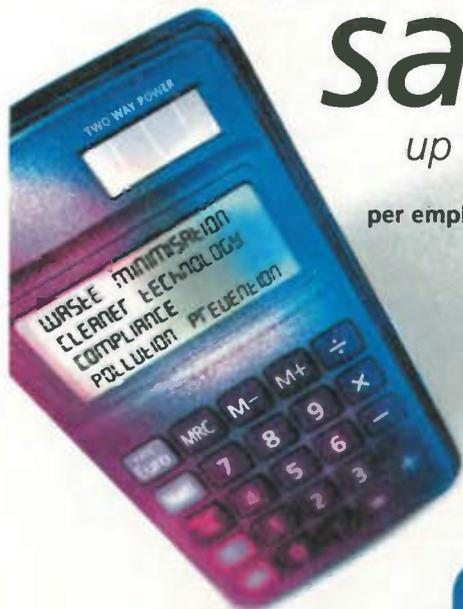

Free Independent Confidential Advice

HELPLINE | SITE VISITS | BEST PRACTICE GUIDES
WORKSHOPS | CLUBS | CASE STUDIES

Internet: www.envirowise.gov.uk

**Environment
& Energy
Helpline**
0800 585794

CIRCLE NO.120 ON REPLY CARD

Customised design services from Intec Associates Limited

INTEC look for interdisciplinary collaborations with experts who work in other fields. We supply creative and cost-effective solutions.

Key expertise

- PC interfacing applications
- Implementation of PIC micro-controllers and PC-104
- Implementation of radio linkers
- Implementation of sensors
- Analogue and digital circuit design
- PC software development using VB, VC, Java, Turbo Pascal and Delphi

Applied areas

- Standalone data logger using PIC micro-controller
- Standalone devices using PIC micro-controller
- Data logging/control system using PCs or PC-104
- Remote data logging/control via radio link
- Remote data logging/control via telephone line

Intec instant solutions

- PC-based data loggers controllers
- Standalone data loggers
- Sound loggers
- Remote control and telemetry applications

www.intec-group.co.uk

11 Sandpiper Drive, Stockport, Cheshire, SK3 8UL, UK

Tel: +44 (0)161 477 5855 Fax: +44 (0)161 477 5755

E-mail: mail@intec-group.co.uk

CIRCLE NO.121 ON REPLY CARD

Valve Radio and Audio Repair Handbook

* A practical manual for collectors, owners, dealers and service engineers * Essential information for all radio and audio enthusiasts * Valve technology is a hot topic

This book is not only an essential read for every professional working with antique radio and gramophone equipment, but also dealers, collectors and valve technology enthusiasts the world over. The emphasis is firmly on the practicalities of repairing and restoring, so technical content is kept to a minimum, and always explained in a way that can be followed by readers with no background in electronics. Those who have a good grounding in electronics, but wish to learn more about the practical aspects, will benefit from the emphasis given to hands-on repair work, covering mechanical as well as electrical aspects of servicing. Repair techniques are also illustrated throughout.

This book is an expanded and updated version of Chas Miller's classic Practical Handbook of Valve Radio Repair. Full coverage of valve amplifiers will add to its appeal to all audio enthusiasts who appreciate the sound quality of valve equipment.

Contents: INCLUDES: Electricity and magnetism; Voltage, current, resistance and Ohm's Law; Real life resistors; Condensers; Tuning; Valves; Principles of transmission and reception; Practical receiver design; Mains valves and power supplies; Special features of superhets; Battery and mains battery portable receivers; Automobile receivers; Frequency modulation; Tools for servicing radio receivers; Safety precautions; Fault finding; Repairing power supply stages; Finding faults on output stages; Faults on detector/AVC/AF amplifier stages; Finding faults on IF amplifiers; Faults on frequency-changer circuits; Repairing American 'midget' receivers; Repairing faults on automobile radios; Repairing battery operated receivers; Repairing FM and AM/FM receivers; Public address and high fidelity amplifiers.



UK Price: £22.50 Europe £25.00 ROW £27.00

** Price includes delivery and packing **

Return to Jackie Lowe, Room L333, Quadrant House, The Quadrant, Sutton, Surrey, SM2 5AS

Please supply the following title:

Valve Radio and Audio Repair Handbook

Total _____

Name _____

Address _____

Postcode _____

Telephone _____

Method of payment (please circle)

Mastercard/Visa/Cheque/PO

Cheques should be made payable to
Reed Business Information

Credit card no _____

Card expiry date _____

Signed _____

NEW PRODUCTS

Please quote *Electronics World* when seeking further information

LCD mounting range gets extension

Martel Instruments has added chip-on-board, chip-on-glass, chip-on-film and tape automated bonding LCD mounting technologies to its custom modules. They are made in an ISO90001 accredited environment. Applications range from low-volume specialised units for BAe flight simulators to 100,000 plus quantities for cable TV.

Martel Instruments
Tel: 01207 290266
www.martelinsruments.com

Modules feed 350mA on standard LAN cabling

Pulse has launched 10/100BaseTX LAN magnetic modules to eliminate the AC power requirements for IP telephones and other Ethernet devices. Capable of feeding up to 350mA on standard LAN cabling, the H2005A and H2006A dual-port modules allow for enough power to drive different applications over LAN cabling. These include IP phones, remote sensors, building thermostats and wireless LAN access points.

Pulse
Tel: 01483 401700
www.pulseeng.com

Low-pass filter meets digital testing needs

The Audio Precision S2-AES17LP filter from Thurlby Thandar Instruments meets the requirements for digital audio testing laid down by the Audio Engineering Society. The standard specifies, in section 4.2.1, the use of a standard low-

pass filter that has a sharp roll-off above the audio upper band (20kHz). It meets this with a stopband attenuation of 60dB or better above 24kHz. The filter must be inserted early in the measurement path to remove the out-of-band noise before the measurement notch filter and its subsequent gain. This will ensure that the noise part of the THD+N parameter contains only the in-band noise and distortion. Without the filter, the automatic gain ranging that normally follows the THD+N notch filter can behave incorrectly and the resulting measurement will be in error.
Thurlby Thandar
Tel: 01480 412451
www.ttinst.co.uk

Connector is no push over

The JAE SH3 push-push connector is for use with multimedia cards in portable data storage applications, such as PDAs, voice recorders, digital imaging equipment and electronic books. It has a push once to insert, push again to release operation. It meets Multimedia Card Association (MMCA) electrical and physical specifications. The surface mount connector provides seven contacts configured to allow hot insertion as pins three and four contact to card pads first, as required by the MMCA specification. Contact resistance is 100mΩ and rated current 100mA. Durability is typically one million. ■
JAE Europe
Tel: 01276 404000
www.jae.com



Self on Audio

Douglas Self

The cream of 20 years of Electronics World articles (focusing on recent material)

A unique collection of design insights and projects - essential for all audio designers, amateur and professional alike.

Scientific electronics based on empirical data

Douglas Self has been writing for Electronics World and Wireless World over the past 20 years, offering cutting-edge insights into scientific methods of electronics design.

This book is a collection of the essential Electronics World articles, covering twenty years of amplifier technology but with a very strong bias towards more recent material. The articles include self-build projects as well as design ideas and guidance for the professional audio designer. The result is a unique collection of design insights and projects - essential for all audio designers, whether amateur or professional.

Contents: Introduction; PRE-AMPLIFIERS: An advanced preamplifier MRPI; High-performance preamp MRP4; Precision preamp MRP10; Moving-coil head amp; Preamp '96 I; Preamp '96 II; "Overload Matters" (RIAA overload); Balanced line inputs and outputs, part 1; Balanced line inputs and outputs, part 2; POWER AMPLIFIERS: FETs less linear than BJTs; Distortion in power amplifiers 1-8; Distortion residuals; Trimodal part 1, 2; Load-invariant power amp INVAR.DOC; Common-emitter amps; Two-stage amplifiers; SPEAKERS: Excess speaker currents; Class distinction (amp classification); Relay control; Power partition diagrams; Audio power analysis.

**ELECTRONICS
WORLD**



**Self
on
Audio**
DOUGLAS SELF

Douglas Self has dedicated himself to demystifying amplifier design and establishing empirical design techniques based on electronic design principles and experimental data. His rigorous and thoroughly practical approach has established him as a leading authority on amplifier design.

Readership: Audio electronics enthusiasts;
Professional amplifier designers;
Power amp users
Paperback
Pages: 416pp

UK Price: £26.50 Europe £27.50 ROW £28.50

**Return to Jackie Lowe, Room L514, Quadrant House,
The Quadrant, Sutton, Surrey, SM2 5AS**

Please supply the following title:

SELF AUDIO

Total _____

Name _____

Address _____

Postcode _____

Telephone _____

Method of payment (*please circle*)

Mastercard/Visa/Cheque/PO

**Cheques should be made payable to
Reed Business Information**

Credit card no _____

Card expiry date _____

Signed _____

Letters to the editor

Letters to "Electronics World" Quadrant House, The Quadrant, Sutton, Surrey, SM2 5AS
e-mail jackie.lowe@rbi.co.uk using subject heading 'Letters'.

Baird and bandwidth

Regarding the news item, 'Baird TV might catch on yet', on page 86 of the February 2001 issue, I think the figure of 12.5kbit/s you quoted is a little optimistic.

I use an external five-bit a-to-d converter to digitise narrow-band TV pictures that typically have an audio bandwidth of 12kHz. The digitised signal is then recorded to a PC's hard disk drive through the parallel port.

The NBTV format is 32 lines at 12.5fps and I have chosen a slightly higher sample rate of 64 pixels per line. The net result is that a nine-second movie clip creates a 224kbyte file. So the data rate is a shade under 25kbyte/s, or 125kbit/s with 5-bit sampling.

Even allowing for a reduced sample rate of 48 per line, the serial data rate is still around 100kbit/s. In practice, if this were to be broadcast as a serial stream I suspect that some overhead would have to be built in for sync. error checking and correction.

My original reason for using a PC as an NBTV display device was to remove the annoying 12.5Hz flicker. But one major benefit that the PC confers is the ability to

interpolate pixels and smooth the otherwise very blocky appearance to the digitised signal.

Other advantages are to allow picture manipulation and simple editing/titling, although with only 32 lines to play with the font I produced is rather basic!

I am currently working on frame sequential RGB colour and have so far been able to demonstrate replay of an electronic test signal.

Readers who are interested may care to view a GIF animation of one of my earlier recordings. In transferring to the GIF format the file has increased to around 300kbyte. The recording was made at the NBTV convention in 1998 and was produced from a directly scanned vidicon camera with 2:1 interlace. Careful inspection of the image will reveal interlace movement break-up and photoconductive lag.

The site is at www.nbtv.vvenet.co.uk Click on 'HOT NEWS' at the top, then 'Interesting Links' near the end. 'Karen' is the recorded GIF to view near the end.

Graham Lewis
Billericay
Essex

Input-filter distortion

I read Graham Maynard's letter concerning the use of a 10k Ω plus 220pF filter in the January 2001 edition with interest. Indeed, the graph he presented is identical to a number of graphs I have plotted and I concur with his assessment that an input filter is not to be recommended.

In my analysis, a similar response was produced for any band-width limited amplifier, including Self's recommended topology¹, but to different extents according to the time-constant.

In Self's amplifier the use of 100 Ω resistor in series with the emitters of the input transistors and a 100pF 'Miller' capacitor the amplifier unity gain bandwidth is – nominally – 15MHz and the time constant 10ns.

Compared with the input filter time constant of 2.2ms, Self's amplifier will cause far less phase delay, despite achieving nearer 10MHz in practice. As Mr Maynard says though, this occurs at all signal levels – not just at extremes.

However, a word of caution is that the input filter, while not ideal in itself, may appear worse in tests if there are additional time constants limiting the frequency response of an amplifier. These include the response of the amplifier itself.

Most hi-fi amplifiers have a bandwidth of 100kHz or more, while older, and moderate designs may have lower bandwidths. Mr Maynard recommends a CD as a reference, but this has a 44kHz sampling rate, and presumably a 20kHz filter somewhere in the chain. These could have a more serious impact than the 10k Ω and 220pF filter, which has a 72kHz 'bandwidth'.

The proposed input filter together with a signal source bandwidth could combine to give a bandwidth as low as 15kHz or less, which would undoubtedly be audibly inferior to anyone with reasonably good hearing.

Mr Maynard's test of switching the network is perhaps the practical case as I implied, but a true test would have to 'unswitch' a similar response elsewhere, which would be difficult to accomplish in practice. I say this because the input filter itself ought not to be a problem, but may be when combined with other time constants.

In my analysis, I further suggested that the phase delay is superficially like crossover distortion, occurring on any change in the signal. Music, almost never made up from continuous sinewaves, is likely to be

Engineering blues

I have to take issue with a point made in Malcolm Lisle's despairing letter in the March issue. He gives no reasons to support his blank statement that immigration is not the real problem with the shortage of skilled engineers. Selective importation of skilled personnel is the real problem both for Britain and the immigrants' home countries.

As long as we have access to an unlimited supply of cheap, skilled engineers from third-world countries, no British firm will ever bother to train people like Malcolm Lisle. Does he not see that?

And is he so wrapped up his own unfortunate situation that he does not realise the negative effects that this policy has on the economies of the said third-world countries?

It is my experience over many years that British firms always take the cheapest, easiest, laziest route in acquiring the skilled people it needs. Astoundingly, the present Government has just made that very much easier for

them: a case of galloping short-termism at its worst. The Labour Party should be thoroughly ashamed of itself – and I speak as a lifelong socialist.

The root of the malaise lies in engineers themselves whom I have found in the main to be self-effacing and a bit unworldly. Apart from the occasional moan about low pay, lack of status and, as in Malcolm Lisle's case, poor employment prospects, you don't hear from them. They really should be in uproar, lobbying their MPs in an organised way like other pressure groups.

I rue the day I chose to go into engineering instead of finance, business of the law. I just look at what happened recently at Jupiter Asset Management, where 50 Jupiter employees shared £505 million, and at the City firm of Morgan Stanley where another 50 London employees got a Christmas bonus of £1 million each. This bonus alone is more than some ordinary people earn in a lifetime.

Simon Wright
Via e-mail

seriously impacted by this form of transient distortion. One is tempted to ask whether the differences perceived in older transistor amplifiers were due simply, in part, to bandwidth limitations.

This discussion leads to the question that if bandwidths of 72kHz as given by the 10k Ω and 220pF network lead to audible degradation – if the single time constant is the problem – then what bandwidth should an amplifier have to avoid such transient degradation, in other words, that is not acoustically perceptible?

Experiments on phase delay perception are not common but Lohstroh and Otala² reported on experiments indicating that 10° phase was detectable. Assuming a worst case frequency of 20kHz, the amplifier bandwidth should be 100kHz so as not to exceed this phase delay. This can be achieved in designs that Self advocates, as well as in the design that Lohstroh and Otala developed.

Another good performing amplifier was Bailey's 1968 design in *Wireless World*, which also has a high bandwidth. Perhaps then, with the main distortion components taken care of, a high bandwidth is the key to an amplifiers audible performance.

Are any of you aware of other experiments or data to show that 100kHz is the minimum standard an amplifier is required to achieve – or not?

Self's amplifier has a slew-rate limit of about 150kHz. It meets this comfortably, although my original recommendation to limit the input to 72kHz corresponded to an input stage non-linearity of about 10%. I recommended this to answer Self's concerns expressed in Letters in the July 2000 issue.

Clearly, a signal limited in bandwidth at source to less than, say 100kHz, will not overdrive the amplifier, but the phase delay occurs at all levels.

Incidentally, I would like to address some issues concerning Mr Maynard's letter in the August 2000 edition. When I referred to 100pF capacitance between the collector and base, I meant of course the external capacitance used to stabilise the amplifier. Regarding the "hard switching": the point in my letter (May 2000) was not addressed by Mr Maynard (Letters, August 2000).

A transistor *can* fully switch without saturating, and in the topology advocated by Self such switching occurs in extreme overdrive, when the current is limited by the emitter tail. Under these conditions the amplifier is slew-rate limited, dependent on the Miller capacitor, not the speed of the transistor. However, such overdrive is unlikely to occur in signals except perhaps directly from a live recording where percussion is used.

J. N. Ellis
via e-mail

References

1. Self, D, Amplifier, *EW*, Feb. 1994.
2. Lohstroh and Otala, *IEEE Jnl*, AU-21, Dec. 1973.

Could Mr Maynard please elaborate a little on his claims to filter induced linear distortion? I fail to see the point (fuss) he tries to make.

Response plots are shown that appear to simply depict a time delay, which is due to the transient response of the system when excited by an abrupt sine wave $U(t)\sin(\omega t)$, $U(t)$ being the (Heaviside) step function. All this is simply the effect of band limiting the amplifier, which raises that old chestnut: what is necessary bandwidth for hi-fi – 15, 20, 50, 100kHz?

What then is so special about the 10k Ω /220pF low-pass (~72kHz, -3dB) input filter when the complete signal chain from mike to speakers has many transfer functions in the shape of filters, equalisers and crossovers? Each of these elements has its own transient signature, which can produce in-band colorations.

Such distortion as described by Mr Maynard would show up on a simple square-wave test, as an hf loss (leading edge rounding, i.e. integration), whose elimination need be nothing more than a routine exercise in good design.

Taking this to an extreme would result in an amplifier a bandwidth overkill, having more in common with a video amplifier. Other things being equal, the bandwidth imposed by this filter is 72kHz. This is nearly four times the highest frequency normally considered the human limit. It is far greater if 10-15kHz is used for a human adult, and it is certainly far greater than that of most commercial music sources, barring SACD's at 50/100kHz.

What current speaker systems can go this high again, barring those few oddballs employing hyper-tweeters? A lot has been said and written about the audibility (or non) of linear distortions such as non-linear phase response. But as yet, I have yet to see an authoritative paper settling the matter apart from claims based on individual experiences.

Sheer extended frequency response *per se*, simply to avert 'audible' phase aberrations, is a moot point. Issues such as loudspeaker transducer polar patterns, which control the ratio of direct to reverberant sound ratios, as John Watkinson's articles explain, may go even further in creating that better sound stage illusion. But the very nature of a reverberant sound field created by additive – and incoherent – multipath propagation of sound waves does make you wonder about the true place for the linear phase concept when applied to loudspeakers in rooms full of frequency-dependent damping and dispersive items.

In the process of writing this letter, I read Mr Maynard's excellent article on linear phase sub-bass in the February issue, which I feel goes some way towards this end at the lower end of the spectrum.

Cyril Bateman takes the issue from the component (R,C) imperfections angle, which is clearly not of the essence in this instance, but nevertheless he has touched on a very

significant topic, which is not so widely documented.

Resistor linearity is something most of us take for granted at the common signal levels encountered in audio circuits, including valve ones. It would be interesting to quantify the order of magnitude of the effect they can introduce in typical circuits.

Reasons for the so-called 'resistor sound', carbon composition versus metal film or metal oxide are worthy of investigation. The reported 'subjectives' are not just characterised by their inherent noise performance.

Capacitor nonlinearity is, on the other hand, more heard about, especially among the hi-fi fraternity, where ridiculous amounts are regularly paid for 'audiophile' grades such as the film and foil types.

Mr Bateman's offer to undertake a study of passive component distortion is therefore difficult not to accept. I hope *EW* thinks so too.

George Evans
Lymington
Hants

EMC 'standards'

In the March Letters page, Alan Melia complains about *Electronics World* publishing a circuit idea for spreading the EMI generated by a switched-mode supply over a wider bandwidth, in order to make it pass EMC requirements.

While I totally agree with Alan on the sentiment expressed – namely that this technique actually generates more electromagnetic 'pollution' and is therefore a technically unworthy solution – this is not a sustainable position to maintain.

The problem is to do with standards and test methods. Current standards require the use of average and quasi-peak detectors for emissions measurements. The receivers and spectrum analysers designed for this purpose are expensive and nobody is keen to throw them away.

Also, the standards have been around for some time, albeit with minor tweaks here and there. In order to ban spread-spectrum devices, you would need to change both the standards and the test equipment; the cost implications are horrendous.

The FCC ruled on this point a few years ago and allowed spread-spectrum devices – probably because there was no cheap and easy method of prohibiting them.

We are therefore stuck with spread spectrum devices for the next few years at least. If and when the standards are changed to prohibit such devices, then manufacturers of ordinary equipment will be up in arms at the extra expense of testing. Manufacturers of the new test equipment required will of course get loads of extra business.

Of course the biggest offenders on emissions are PCs, but there are no requirements for home built machines. If a company builds a non-compliant computer it

can be prosecuted, but an individual can buy the same parts, make the same machine, and not have a problem.

All this self-certification on CE marking has turned into a fiasco. If you know what a proper CE mark looks like according to the regulations, you will see that at least 30% (guesstimate) of the CE marks on domestic appliances are not correct to the regulations. If they can't even get the symbol correct, how much credibility can you give to their self-certification?

Leslie Green CEng MIEE
Senior Principal Engineer
Gould Nicolet Technologies

Sky-scattered sunlight?

Regarding Gary Yates' Letter in the March issue, in 1931, the Commission International de l'Eclairage, or CIE, chose three standard illuminants to be used for colorimetry.

Illuminant A was that from a black-body radiator at 2856K – a gas-filled tungsten lamp for instance. Illuminant B was supposed to represent direct sunlight, and it seems to have fallen into disuse. Illuminant C was intended to represent "overcast skylight", but it was defined in terms of shining Illuminant A through two 10mm glass cells containing bluish copper sulphate based chemical solutions.

Illuminant C was used when NTSC Colour Television came to be specified in the USA in the early 1950s, but as the European systems were being drawn up in 1964, the CIE introduced an Illuminant D with the subscript 65. This represents a phase of daylight with a colour temperature correlated to 6504K.

I don't think it was ever measured as representing the light at any particular place. After all, Wales (OK, occasionally) sees the same sunlight that Australians do, and the lower average sun angle onto white clouds would only affect the long term average colour temperature.

Higher colour temperature (more bluish or 'colder') lighting gives the initial impression of being brighter. So colour televisions are now being sold in showrooms with the white set up to 9500K or beyond. Once the viewers get their purchases home under tungsten lights, they have been known to complain to Broadcasters that their pictures look too "cold"!

The new television display systems have forced many designers to go again over all these colorimetry issues of the 1950s and 1960s. Along with digital calibration, this has done a great service to the consumer in that you can now set up many of the previously forbidden colorimetry parameters from the remote control.

There's also the bonus of an even chance of getting it all back to where you started from.

John Emmett
Via e-mail

Linux? No thanks...

I would like to put a view from the developer's side on the leader article on PC operating systems in the August 2000 issue.

We have noted for a while that there has been a trend towards 'Microsoft bashing', but so far as I can see, the introduction of a second – totally incompatible – platform into the CAD software market would do no-one any good at all in the long run.

To support Linux, we would have to re-write large parts of our product. Vendors who have built their products on MFC (Microsoft Foundation Classes) would have an ever bigger job than us.

None of this effort would add a single functional feature to the products. Not only this, but every time we added a new feature, the user interface would have to be implemented twice. And the whole lot would have to be tested twice. Given that we have only a certain number of developers, the rate at which we could add genuinely useful features to the software would fall, and/or the prices would have to go up.

The introduction of Linux would not create a larger market, as it would simply divide the existing one between the two platforms. Any gain to a CAD company in supporting Linux would be short lived; in the long term the whole industry would suffer because of the huge increase in cost associated with coding for and supporting two platforms.

From a user's point of view, many people would find that half the software they wanted to use was only available for Windows, and the other half for Linux, as in more specialist applications than PCB CAD, the costs of supporting both platforms would be even harder to justify.

Yet another issue is whether Linux would remain as stable as is claimed if it became a mass market product. Our experience with technical support for our Windows products is that most of the system related problems that users suffer are not to do with Microsoft's code. They are to do with third party drivers for graphics cards and printers which have not been written and/or tested properly. In fact, we often suggest the installation of a Microsoft authored driver as a work around! I can see no reason at all why this situation would improve with Linux. Were there to be multiple flavours of Linux in use it could easily become much, much worse.

The political arguments about Microsoft's power are a wholly different matter, and I can see good reasons for breaking it up. But in my opinion, a world in which there were two or more incompatible desktop operating systems in widespread use would have far more problems than anything we currently have to deal with.

John Jameson
Managing Director
Labcenter Electronics

Regarding Gary Yates letter in the March issue, the particular "Standard Daylight Illuminant D" light source is explained in a book; 'Lamps and Lighting' by S T Henderson and M Marsden (1972) on p. 60, ISBN 0713132671. This book was first published in 1966.

The CIE recommended a daylight distribution at 6500K as a standard (D65) and the spectral power distributions for this, as well as CIE Standard Illuminants A, B and C, are shown on the same page.

All these and others were based on hundreds of natural skylight measurements by Henderson and Hodgkiss; Condit and Grum and by Budde. In the book, it was admitted that making light sources that closely imitate these spectral distributions was then (1972) impossible.

Incidentally; the author's name quoted referred to Dr Gerald Norman Patchett.

T J Wynn
Newport
South Wales

In response to Gary Yates's query about illuminant D in the March issue of *Electronics World*, I had to refer to various textbooks that I have not opened for years.

My edition of Patchett – 1968 – says on page 16, "The white used in television is known as illuminant C which is a rather blue white corresponding to sky-scattered daylight". It may be that Gary is using a later edition.

In another reference, IEE monograph series 3 Pal 'Colour Television' by Boris Townsend, published in 1970, I found the following which I hopes answers his questions.

"Illuminant C is a bluish white corresponding to an overcast north sky in midsummer at Greenwich, and has a correlated colour temperature of 6770K. A more recently defined daylight-colour standard, D6500 is coming into use, but for television purposes the difference is academic."

Incidentally the PAL system was devised in Germany by Dr W Bruch and his 'Selected papers II' was required reading when Colour television started in the UK. It led to the mnemonic for the colours of standard colour bars namely "When Your Colours Go Muddy Read Bruch's Book" for white, yellow, cyan, green, magenta, red, blue, black.

Tony Meacock
Norwich

CIRCUIT IDEAS

Fact: most circuit ideas sent to *Electronics World* get published

The best circuit ideas are ones that save time or money, or stimulate the thought process. This includes the odd solution looking for a problem – provided it has a degree of ingenuity.

Your submissions are judged mainly on their originality and usefulness. Interesting modifications to existing circuits are strong contenders too – provided that you clearly acknowledge the circuit you have modified. Never send us anything that you believe has been published before though.

Don't forget to say why you think your idea is worthy.

Clear hand-written notes on paper are a minimum requirement: disks with separate drawing and text files in a popular form are best – but please label the disk clearly.

Switchable constant-power or linear-phase loudspeaker crossover

This 2-way or 3-way-crossover offers the possibility of listening to the same speaker system with either constant-voltage and linear phase or with constant-power response.

Each loudspeaker is driven by its own power amplifier. A state-variable filter is used because high-pass, low-pass and band-pass outputs are simultaneously available and, since the denominators in their transfer function are identical, no additional adjustment is necessary.

In the first position, with switch S_{1A} open, the crossover acts as a constant-power filter. Only two drivers are active, the woofer and the tweeter.

The crossover frequency was chosen such that the two speakers work well within their operational limits. Total

output power, which is the sum of the high-pass and low-pass power, is frequency independent.

$$P_{tot} = P_{HP} + P_{LP}$$

$$= \frac{U_{HP}^2}{R} + \frac{U_{LP}^2}{R} = \frac{U_{in}^2}{R} = \text{constant}$$

In the second position, with switch S_{1A} closed, the crossover acts as a linear-phase filter. All drivers, including the mid-range, are now active. The sum of the three output voltages is frequency independent,

$$U_{HP} + U_{BP} + U_{LP} = |U_{in}| = \text{constant}$$

This concept, well known as filler-driver-loudspeaker, assumes that the three driver units have a linear behaviour, a constant phase shift and similar group delays. These can be achieved with all-pass filters inside the power amplifiers and a staggered positioning on the front panel.

Experience shows that the constant-voltage-crossover is superior to the constant-power-crossover if the listener is within the direct radiation field, i.e. inside the hall-radius. Outside the hall-radius, in the diffuse field, the constant-power-crossover is superior. This makes the switchable crossover an interesting alternative for loudspeaker boxes used in studio and home applications.

*Dr Gerd Schmidt
Frankfurt
Germany
D73*

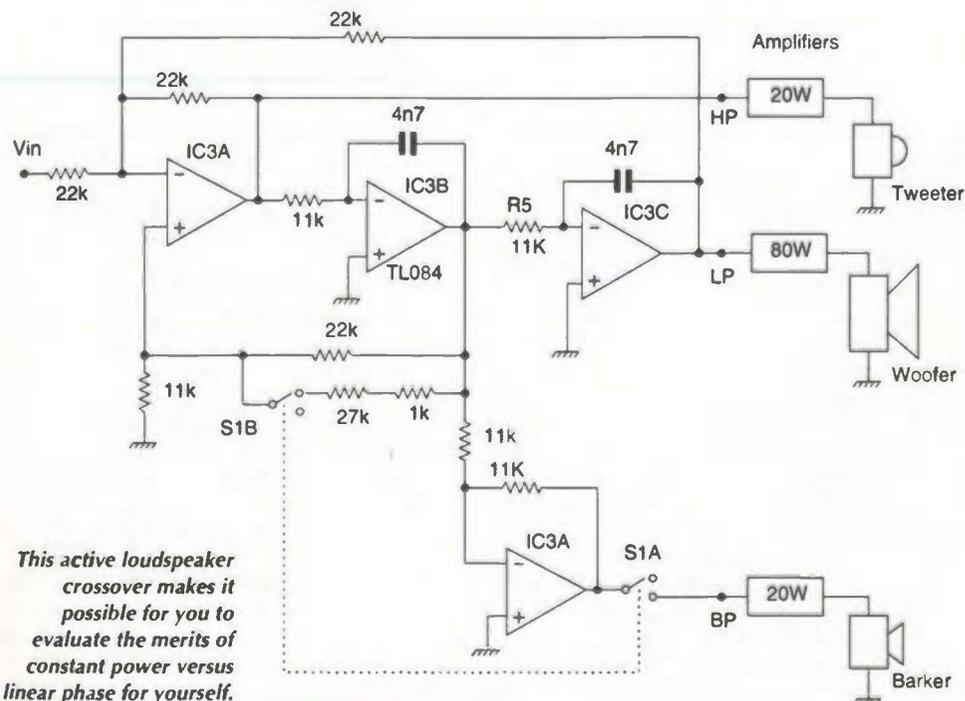

This active loudspeaker crossover makes it possible for you to evaluate the merits of constant power versus linear phase for yourself.

Single-range 10Hz to 40kHz audio generator

This generator is a bridged-tee application. A bridged-tee is a frequency dependent attenuator, so the bridge has to be applied in the negative feedback loop. The positive feedback loop is amplitude dependent by means of LP_1 , a low-consumption lamp.

Compared to the Wien oscillator, where the lamp is in the negative feedback path, in this circuit the lamp is the top element of the attenuator, so more voltage is applied to it. In order to provide the desired attenuation, the capacitors of the bridged-tee are not equal; this is not a printing error.

Two light-dependent resistors, LDR, provide optical tuning of the frequency, thus eliminating any potentiometer noise. Fine-resolution tuning is provided by regulating the micro-lamp LP_2 with a ten-turn potentiometer.

Note that while the op-amp is

not sensitive to ambient temperature, the lamp LP_1 is. As a result, the 500Ω wire-wound potentiometer should be mounted on the front panel. As can be expected in an audio equipment application, the self-inductance of the wire-wound potentiometer is not a problem.

An op-amp with COSMOS output is essential as these devices have symmetrical output limiting. Thus a distortion of 0.1% possible when the amplitude is adjusted to 95% of the maximum available output. A built-in output indicator as shown is a good idea.

Frequency is given by,

$$f = \frac{1}{2\pi R \sqrt{C_1 C_2}}$$

Wim de Ruyter
Oudkarspel
Netherlands
E64

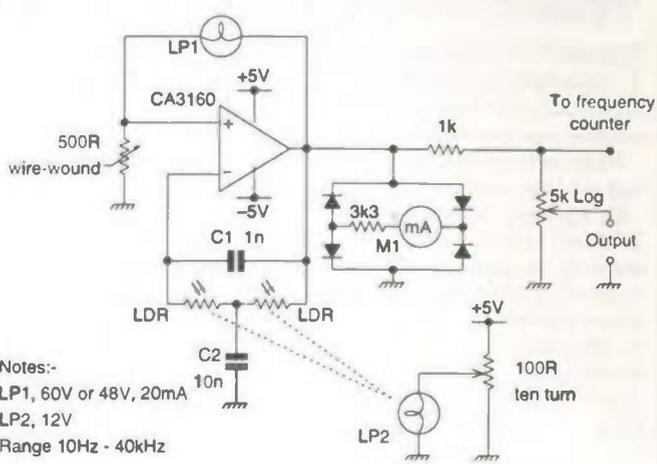

Notes:-
 LP_1 , 60V or 48V, 20mA
 LP_2 , 12V
 Range 10Hz - 40kHz

Audio generator for 10Hz to 40kHz in one range. Relying on brightness of a lamp for frequency control, this generator doesn't suffer from the noise associated with mechanical potentiometers.

Ten year index: new update

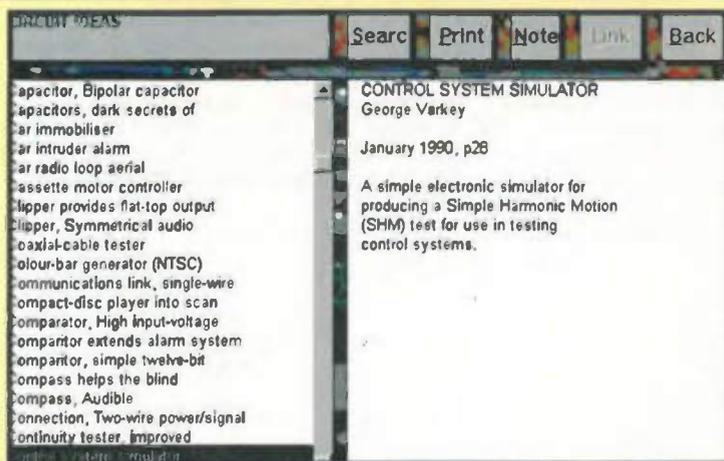

Hard copies and floppy-disk databases both available

Whether as a PC data base or as hard copy, SoftCopy can supply a complete index of *Electronics World* articles going back over the past nine years.

The computerised index of *Electronics World* magazine covers the nine years from 1988 to 1996, volumes 94 to 102 inclusive and is available now. It contains almost 2000 references to articles, circuit ideas and applications - including a synopsis for each.

The EW index data base is easy to use and very fast. It runs on any IBM or compatible PC with 512K ram and a hard disk.

The disk-based index price is still only £20 inclusive. Please specify whether you need 5.25in, 3.5in DD or 3.5in HD format.

Existing users can obtain an upgrade for £15 by quoting their serial number with their order.

Ordering details

The EW index data base price of £20 includes UK postage and VAT. Add an extra £1 for overseas EC orders or £5 for non-EC overseas orders

Postal charges on hard copy indexes and on photocopies are 50p UK, £1 for the rest of the EC or £2 worldwide.

For enquires about photocopies etc please send an sae to SoftCopy Ltd. **Send your orders to SoftCopy Ltd, 1 Vineries Close, Cheltenham GL53 0NU.**

Cheques payable to SoftCopy Ltd, please allow 28 days for delivery.

www.softcopy.co.uk

Photo copies of *Electronics World* articles from back issues are available at a flat rate of £3.50 per article, £1 per circuit idea, excluding postage.

Hard copy *Electronics World* index
 Indexes on paper for volumes 100, 101, and 102 are available at £2 each, excluding postage.

Wide-range VFO for RF uses only one IC

This RF VFO has a wide range around of 2.5 to 25MHz with values shown. It is built around a standard 74HC123 monostable and it needs just two fixed resistors – a 500k Ω variable one, and the chip itself.

Since there are two such circuits in the package, the other half could be used in the same way for another such oscillator.

By replacing the variable with a fixed resistor of around 39k Ω and connecting a crystal where the timing capacitor is normally connected, it can be used as a crystal oscillator in the range 10-20MHz. Such an oscillator could be the basis for a mixer-type BFO.

A. Ziemacki
Rotherham
South Yorkshire
D76

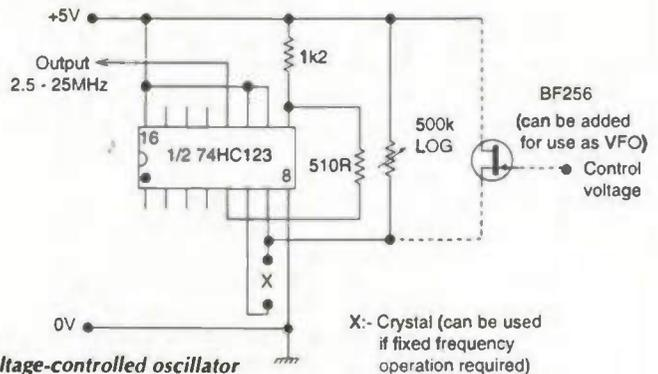

Exceedingly simple voltage-controlled oscillator for use between 2.5 and 25MHz.

Better model racing-car controller

A common problem with commercial model racing-cars that run in a slotted track is that the rheostat controllers are so abysmal. Starting a motor with a variable series resistor does not give a smooth take-off, and the car tends to over-rev once initial friction is overcome.

What you need is a true variable voltage supply – but even this can have difficulties with dirt on the brushes, oxide on the track, etc. A better method is to apply full-voltage pulses but of variable width: this way, power can be smoothly varied – and any contact-resistance is duly overcome.

In the circuit shown, a 555 timer produces pulses at a rate of 6.5kHz maximum, with a fixed off-time of about 150 μ s. The on time is less than 5 μ s in the quiescent state, but this rises to 45 μ s for starting and approximately 2ms flat-out. Thus the duty-cycle increases from 3% through 23% to about 93%, in a steady and repeatable manner.

Existing Scalextric Micro hand-held rheostats have a resistance of about 60 Ω variable down to less than an ohm for maximum speed.

However, there is an off-position when they become open-circuit. By using the current-source built around Tr_1 and D_5 it is possible to achieve the desired range of pulse-width control without modifying the rheostat.

The idea is that R_7 plus C_5 gives the desired 150 μ s off-time, but Tr_1 and the diode D_5 allow as much – or as little – charging current as necessary into C_5 during the on-time. Thus, when the controller P_1 is open-circuit, R_4 , R_5 and R_6 cause a collector current of 11mA to flow, and the on-time is minimal.

On the other hand, when P_1 is squeezed to near its minimum resistance, the base of Tr_1 is pulled up towards the +16V rail. Therefore the collector current is only 25pA or so, yielding the maximum on-time.

When P_1 is just engaged – i.e. at 60 Ω – the collector current is roughly 1.2mA, which gives around 45 μ s. Output from the timer conveniently drives the enhancement-mode MOSFET Tr_2 , with a gate resistor R_8 to slow the edges of the output waveform. A catching diode, D_6 , allow for

inductive effects in the track and motor.

There is some electromagnetic emission, but this falls off rapidly with distance, and the interference on LW/MW is comparable to that from 'electronic' transformers for 12V tungsten-halogen spot-lights.

Since two cars and hence two controllers are normally required, it is better to have separate circuits for each, i.e. with their own wiring from the transformer-rectifier and their own dedicated reservoir capacitors. But the jack-sockets for the rheostats tend to be on a common busbar. A compromise is to take the positive rail at Z_1 for both, and increase C_1 and C_2 to 1000 μ F.

Resistors R_1 and R_2 may need adjusting to suit the supply. The quiescent 6.5kHz causes a faint audible note from the car's motor; the frequency could be raised by reducing C_5 to say 3.3nF if desired – though losses may start to be significant.

C J D Catto
Cambridge
UK
D74

Here's an improved speed controller for all you Scalextric fans. It produces PWM, giving smoother control via the existing potentiometer.

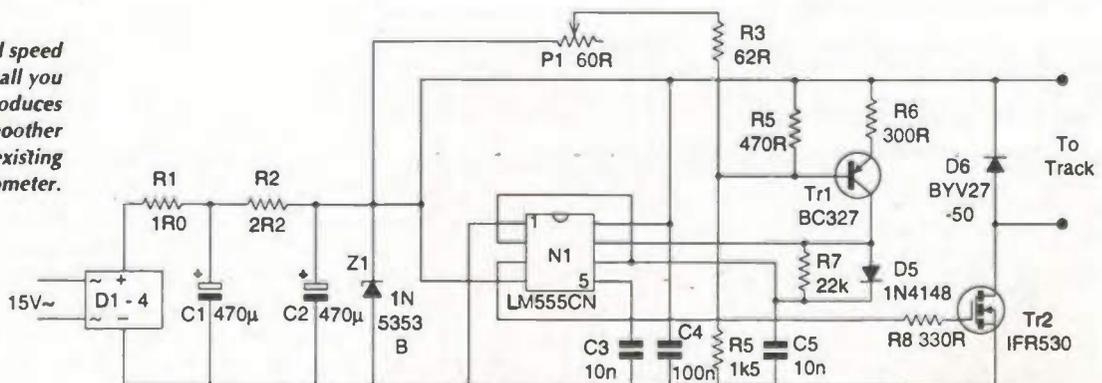

Bipolar voltage stabiliser

To stabilise a voltage of either polarity, low current symmetrical zener diodes are usually used, Fig. 1. A bipolar voltage stabiliser, Fig. 2, has a high loading capacity and good stability of the output voltage.

Symmetrical zener diode D_3 is still used but voltage across the zener now feeds the bases of high-powered transistors Tr_1 and Tr_2 . Diodes D_1 and D_2 supply an n-p-n or p-n-p transistor, according to the polarity of the applied voltage.

Loading characteristic of this bipolar voltage stabiliser is shown in Fig. 3.

Michael Shustov
Tomsk
Russia
E55

Symmetrical zener diodes can be used to stabilise an supply voltage regardless of its polarity, as in Fig. 1. Figures 2 and 3 show that adding buffer transistors makes significant difference to the performance of such a stabiliser.

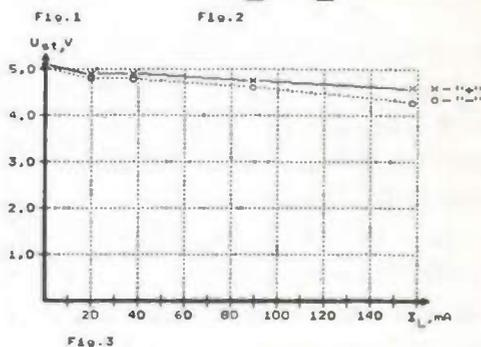
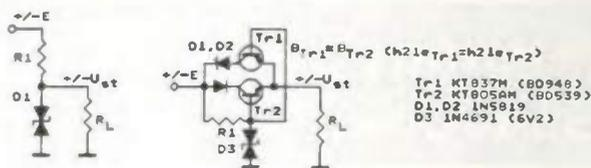

Uses for CMOS switches

CMOS switches can be used as intermediate elements in various switching devices for control applications.

Figure 1 shows a CMOS switch circuit using a CD4066. In the initial state, a low level voltage is present at the switch control input, pin 13. The switch channel is open so no current flows through the load.

Capacitor C charges through the closed contact of the button S_{B1} up to the device supply voltage. Pressing button S_{B1} momentarily, connects capacitor C_1 to the control electrode (pin 13) of the IC, switching the channel on.

Resistor R_3 keeps the control electrode voltage high, keeping the switch in its on state. If the button S_{B1} is kept pressed longer, capacitor C_1 discharges through resistor R_1 , R_3 and the load resistance R_L . Voltage on the control electrode falls and the switch turns off.

The switching processes is shown in Fig. 2. The circuit of Fig. 1 can also be used to produce pulses of a predetermined length.

Figure 3 shows a double-pole, two-way CMOS-switch. Here, control of the CMOS toggle switch can be carried out either by switch S_{A1} or by CMOS, as shown, or by a

transistor switch as in Figs 4 & 5. Control signals from the outputs of the transistor switches connect to Fig. 3 at the points marked 'x'.

A push-button CMOS switch is shown in Fig. 6. Whether the device is switched on or off depends on how long the push-button is depressed.

A switch based on similar principle, but using normally opened control button, is shown in Fig. 7.

Michael A Shustov
Tomsk
Russia

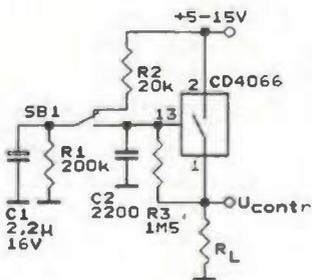

Fig. 1

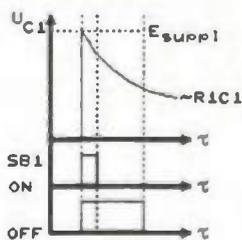

Fig. 2

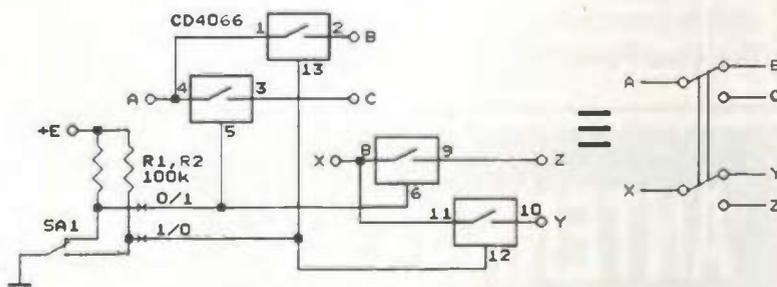

Fig. 3

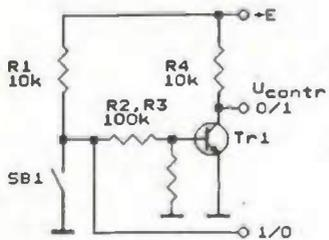

Fig. 4

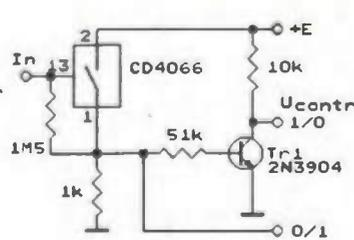

Fig. 5

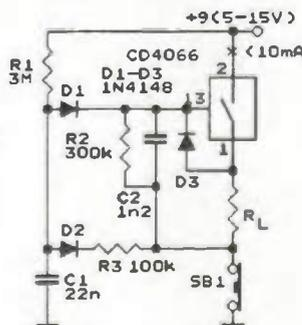

Fig. 6

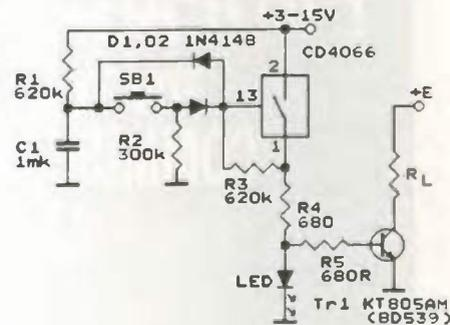

Fig. 7

Figure 1 is a pushbutton-controlled CMOS switch. Its state depends on how long the button is pressed. Figure 2 is Fig. 1's timing diagram while Fig. 3 is a double-pole changeover switch whose control inputs can be produced using Figs 4 & 5. Further normally-closed and normally-open push-button operated switches are shown in Figs 6 & 7 respectively.

Antennas and propagation for wireless communication systems

This will be a vital source of information on the basic concepts and specific applications of antennas and propagation to wireless systems, covering terrestrial and satellite radio systems in both mobile and fixed contexts. Antennas and propagation are the key factors influencing the robustness and quality of the wireless communication channel and this book includes:

- Illustrations of the significance and effect of the wireless propagation channel
- Overview of the fundamental electromagnetic principles underlying propagation and antennas
- Basic concepts of antennas and their application to specific wireless systems
- Propagation measurement, modelling and prediction for fixed links, macrocells, microcells, picocells and megacells

- Narrowband and wideband channel modelling and the effect of the channel on communication system performance
- Methods that overcome and transform channel impairments to enhance performance using diversity, adaptive antennas and equalisers

It will be essential reading for wireless communication engineers as well as for students at postgraduate or senior undergraduate levels.

Distinctive features of this book are:

- Examples of real world practical system problems of communication system design and operation
- Extensive worked examples
- End of chapter questions
- Topical and relevant information for and about the wireless communication industry

Post your completed order form to:-

Jackie Lowe, Room L514, Quadrant House,
The Quadrant, Sutton, Surrey, SM2 5AS

Fax your completed order form to
020 8652 8111

UK Price: £42.50 Europe £45.00 ROW £47.50
Price includes delivery

ANTENNAS AND PROPAGATION FOR WIRELESS COMMUNICATION SYSTEMS

SIMON R. SAUNDERS

How to pay

Antennas and propagation for wireless communication systems

I enclose a cheque/bank draft for £ _____
(payable to Reed Business Information)

Please charge my credit/charge card

Mastercard American Express Visa Diners Club

Credit Card No: _____

Expiry Date: _____

Signature of Cardholder _____

Cardholder's statement address: (please use capitals)

Name _____

Address _____

Post Code _____ Tel: _____

Push-button thyristor operation

Thyristors are often used to switch loads, like filaments, relays and motors, on and off. Two buttons are normally used to switch the thyristor off and on. Push-button thyristor control circuits like this one are less well known.

Referring to Fig. 1, in the initial state, the normally-closed push-button contacts bypass the thyristor control circuit. The thyristor resistance is maximum; current does not flow through the load. Operation of Fig. 1 is explained in Figs 2 & 3.

To switch the thyristor on, button S_{B1} is pressed. In this case the load is connected to the power supply through the normally-open contact of S_{B1} , but the capacitor C_1 charges through the resistor R_1 from the power supply.

The product of R_1 and C_1 , Fig. 2, defines the speed of capacitor charge. After the button is released, capacitor C discharges into the thyristor control electrode.

If the capacitor voltage is equal or more than the thyristor switch-on voltage, the thyristor latches on. Load switch-off is by a momentary pressure on the button S_{B1} .

As the button contacts shunt the thyristor's anode and cathode, the thyristor switches off. On release, the thyristor does not fire, as capacitor C has not had time to charge.

In Fig. 4, series connected diodes D_1, D_2 limit the maximum charge voltage of the capacitor.

Michael Shustov
Tomsk
Russia
E59

Whether the thyristor in Fig. 1 is on or off depends on how long the push button is depressed for. Timing details are shown in Figs 2 & 3 while Fig. 4 shows a variant of the circuit with gate-drive limiting diodes.

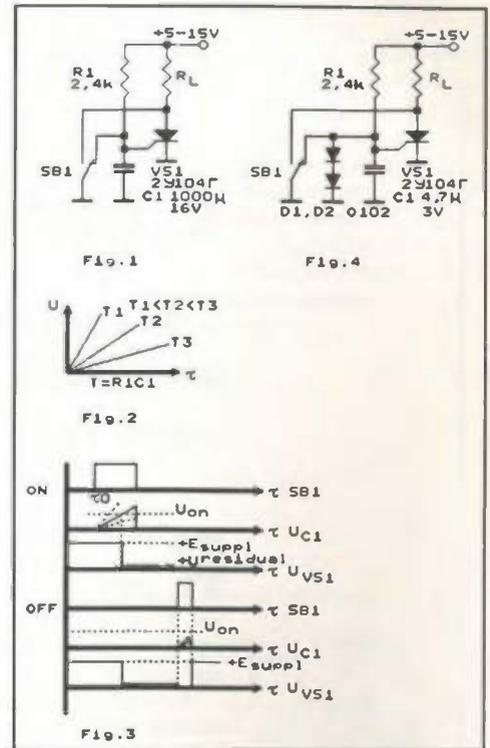

Versatile flasher circuit

When creating a circuit for a blinking indicator light, one could use a 555 timer. But in an attempt to create something different, I found circuit shown here better.

Output current of a 555 is limited to 200mA. By changing the output transistor of this circuit to handle the extra current, it is possible to use the circuit to generate a greater output current.

The oscillator starts when power is applied to it. It generates a squarewave voltage across the load connected to the output. Timing is set to 1Hz by C_1 and R_5 .

When power is applied to it, C_1 starts charging through R_5 and the load. When the capacitor reaches the level set by R_1 and R_2 , Transistor Tr_1 starts conducting. As Tr_1 conducts it drives Tr_2 , which creates a short-circuit.

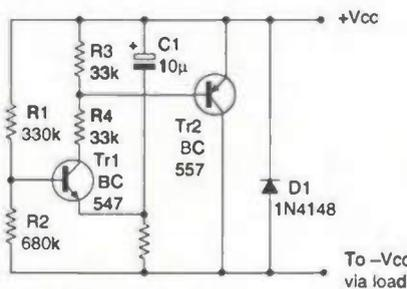

Simple flasher for insertion in the positive or negative side of a load.

Now, C_1 discharges through R_5 and Tr_2 until it can no longer sustain the base current of Tr_2 . Transistor Tr_2 also drives the load when C_1 is discharging. With a BC547, the circuit can drive up to 200mA.

For inductive loads D_1 must be included for protection. As the circuit doesn't contain any short-circuit protection, it is necessary to use a power supply containing short-circuit protection. The power-supply level doesn't influence the frequency, but with the transistors used, the level should be limited to 45V DC.

It is possible to connect the circuit to the load in two ways. In the first the load is connected to the $-V_{CC}$, while in the second configuration the load is connected to the $+V_{CC}$ terminal of the supply. These configurations do not affect the performance of the circuit.

B Van den Abeele
Evergem
Belgium
D75

Courtesy light

This circuit is intended to let the user turn off a lamp by means of a switch placed far from bed, allowing the person enough time to lie down before the lamp really switches off.

A 10V dc supply is derived from 220V ac mains by means of 330nF capacitor, two 1N4007 diodes and the 10V Zener diode. The CMOS 555 timer is wired as a monostable, providing a 15 seconds on-time set by 1.5M Ω resistor and 10 μ F capacitor.

When the on/off switch is closed, the 555 output, on pin 3, is permanently on, driving the triac which in turn feeds the lamp. Opening the switch operates the monostable and, after 15 seconds, pin 3 of

the 555 goes low, switching off the lamp.

The circuit is wired permanently to the mains supply but current drain is negligible. Due to transformerless design there is no heat generation.

Delay time can be varied changing 1.5M Ω resistor and/or 10 μ F capacitor values. Supplied from a car's 12V battery, the unit can extend the courtesy light

operation on closing the car's door. Alternatively, if the switch is a push button, the mains version can be used as a "minuterie," to temporarily light a front porch or corridor.

Flavio Dellepiane
Genoa
Italy
E50

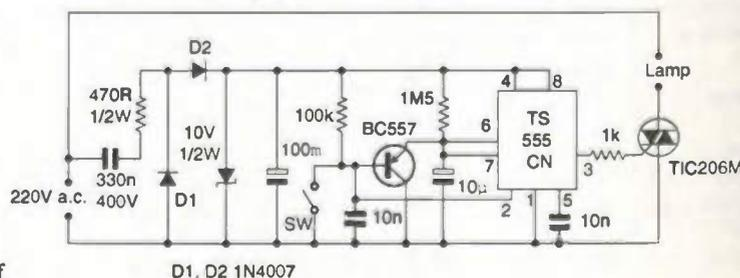

Suitable for mains or 12V battery operation, this light switch delays switching off for 15 seconds. With mains operation, power is derived via a capacitor so losses are low.

Current conveyors II

Giuseppe Ferri *et al* describe how current conveyors can be made to produce rail-to-rail output voltage swings even when running from a supply as low as 1.2V.

Recently, designers have been putting much effort into reducing the supply voltage and power consumption of digital, analogue and mixed-signal ICs and systems¹⁻⁴.

The trend towards lower operating voltages is mainly due to the following:

- In IC design, increasing the number of components in a given chip area also increases power

dissipation, making power consumption an important issue.

- Tighter chip geometries lead to lower break-down voltages, limiting the supply voltage.
- Increasing use of battery-operated portable electronics and wireless systems – including cellular phones, portable PCs and wireless terminals. Such devices demand low power consumption, as well as small size and low weight.
- Increasing use of low power solutions in other application areas

such as filters, audio signal processing, EMI and EMC compliant systems, and non-invasive sensors, integrated into silicon.

- The cultural scientific interest in exploring the technological and physical limits of integrated devices.

Current conveyors lend themselves to low voltage operation. In this second article we will be discussing some low voltage current-conveyor implementations and presenting their simplified schematics.

Giuseppe Ferri, Università di L'Aquila, L'Aquila, Italy.
 Pierpaolo De Laurentiis, Università di L'Aquila, L'Aquila, Italy.
 Giovanni Stochino, Ericsson Lab Italy SpA, Rome, Italy.

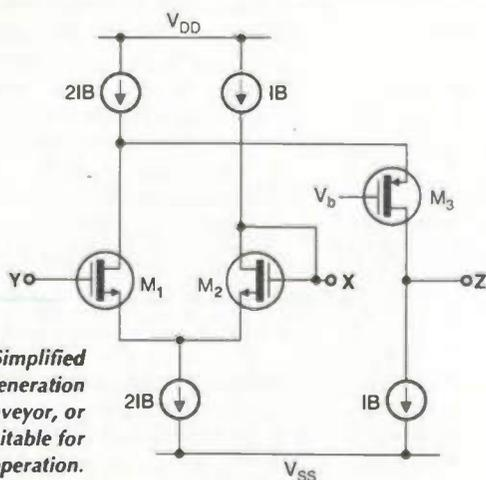

Fig. 1. Simplified second-generation current-conveyor, or CCII-, suitable for low-voltage operation.

Fig. 2. Improved current-conveyor topology. This is a positive conveyor so its abbreviation is CCII+. Voltage Vb is bias and transistor M9 is a voltage buffer.

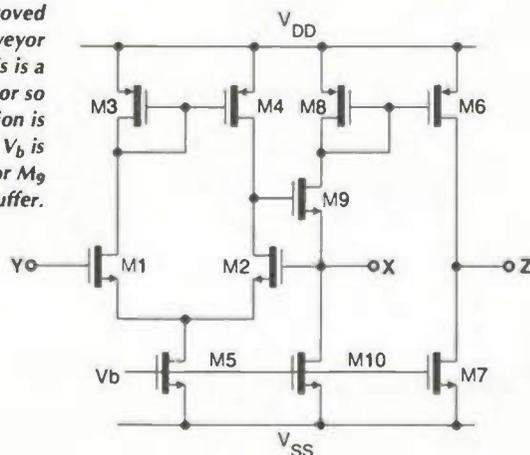

Table 1. Main performance features of the current conveyor shown in Fig. 1 powered by a 1.2V supply.

Parameter	Value
α	0.94
β	0.98
R_X	12k Ω
R_Z	1.1M Ω
C_Y	15fF
Bandwidth	8MHz

Table 2. Main performance of the CCII- of Fig. 3, determined using a 1.5V supply.

Parameter	Value
α	0.975
β	0.958
R_X	20k Ω
R_Z	132M Ω
C_Z	20fF
C_Y	910fF
Bandwidth	30MHz

Table 3. Electrical characteristics of the CCII shown in Fig. 4.

Parameter	Value
V_{DD}	1.5V
I_{B1}	0.1nA
I_{B2}	1 μ A
$M_1 M_2 M_5$	150/1(μ m)
$M_3 M_4$	100/1(μ m)
$M_6 M_9 M_{10} M_{14}$	1/1(μ m)
$M_7 M_{10} M_{12} M_{13}$	10/1(μ m)
$M_8 M_{11}$	1000/1(μ m)

Table 4. Main performance of the CCII, determined at 1.2V supply.

Parameter	Value
α	0.975
β	0.958
R_X	440M Ω
R_Z	500M Ω
C_Z	20fF
C_Y	19fF
Bandwidth	63MHz

Figure 1 shows a simplified second-generation current-conveyor, or CCII. Its main characteristics are given in Table 1, where α is the voltage gain (V_x/V_y) and β is the current gain (I_z/I_x).

An improved topology is shown in Fig. 2. Here, a positive second-generation current conveyor (CCII+) is shown. Voltage V_b controls the biasing current, while transistor M_9 performs the voltage buffering operation. From Fig. 2's topology it is possible to obtain a CCII- by simply adding a current mirror, as in Fig. 3. Its main characteristics are listed in Table 2.

Figure 4 shows a modified CCII-current conveyor that has been adopted for IC design. This circuit exhibits a current gain of $k=A \times B$ and will run from a 1.5V supply. Its electrical characteristics are shown in Table 3 and its performance figures in Table 4.

Introducing transistor M_6 in Fig. 4 allows the minimum operating supply voltage to be reduced to 1.2V. But the dynamic range for the conveyor is consequently reduced to about 70%, as shown in Fig. 5.

In this graph, the voltage at node X results if a sweep of the Y-node voltage from 0 to 1.2V is performed with typical biasing currents (I_{B1}) of 600nA.

Figure 6 shows a modification of the previous current conveyor. Transistor M_6 of Fig. 4 has been replaced by a pMOS transistor, MP_3 , so that the circuit will operate better at lower supply voltages.

In this case the circuit works with a full dynamic range, but only if the output stage is considered. Table 5 outlines Fig. 6's performance.

Wide dynamic range conveyor
In Fig. 7, you will find the simplified schematic of a complete wide dynamic range CCII.

A low-voltage rail-to-rail op-amp performs the voltage-following action between Y and X with good accuracy. Output current at the high impedance

Table 5. Main performance of the current conveyor in Fig. 6 running from a 1.2V supply.

Parameter	Value
α	0.97
β	0.98
R_x	35k Ω
R_z	100M Ω
C_z	20fF
C_y	150fF
Bandwidth	63MHz

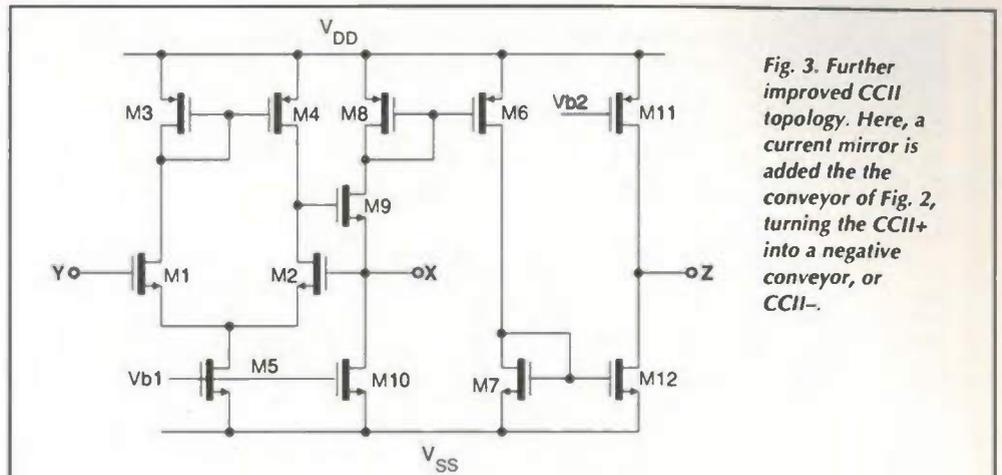

Fig. 3. Further improved CCII topology. Here, a current mirror is added to the conveyor of Fig. 2, turning the CCII+ into a negative conveyor, or CCII-.

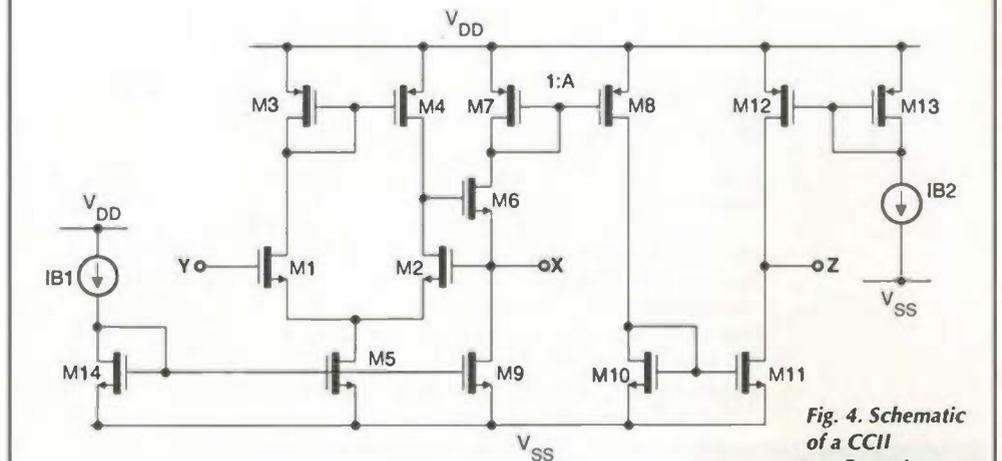

Fig. 4. Schematic of a CCII configuration adopted for IC designs. This topology will run from a 1.5V supply.

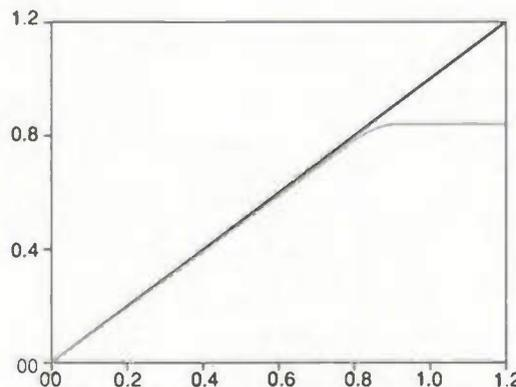

Fig. 5. Dynamic range of the CCII of Fig. 4.

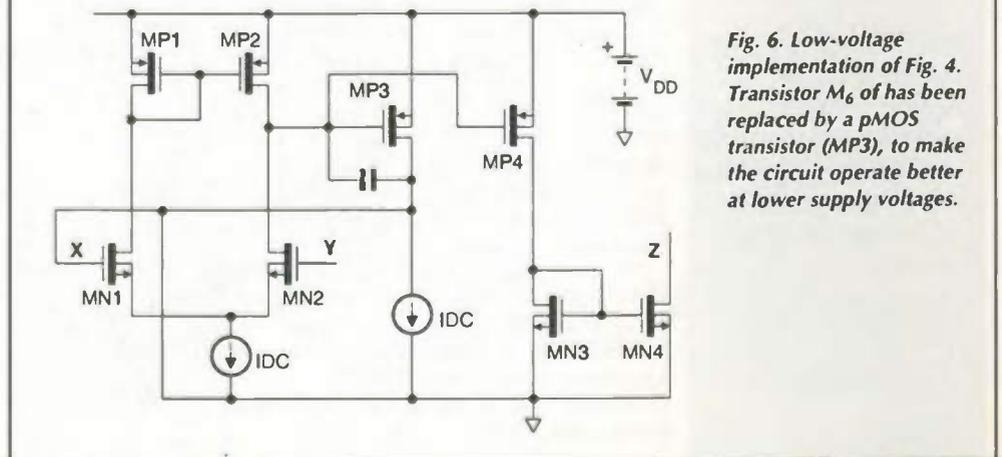

Fig. 6. Low-voltage implementation of Fig. 4. Transistor M_6 has been replaced by a pMOS transistor (MP_3), to make the circuit operate better at lower supply voltages.

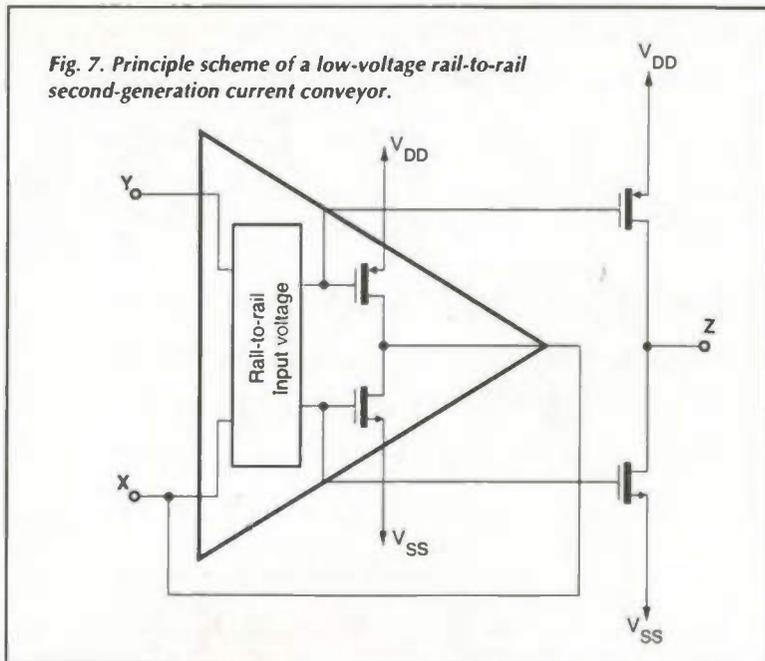

Fig. 7. Principle scheme of a low-voltage rail-to-rail second-generation current conveyor.

node is produced by a copy of the output stage of the op-amp. The op-amp has complete rail-to-rail dynamic range. This is ensured by a traditional constant- g_m input stage working in weak-inversion (one-to-one current-mirror switch). This stage is followed by a typical low-voltage AB biased output stage.

Impedance on input node X is kept sufficiently low by the feedback of the op-amp, which has an open-loop gain of around 80dB.

Unfortunately, this impedance reduction takes place as long as the feedback is effective. As it is only effective at low frequencies this technique does not lend itself to high

frequency designs.

It is also worth mentioning that this circuit architecture⁵ requires a supply voltage higher than $2(V_{gs} + V_{ds(sat)})$. ■

References

1. Ferri, G., DeLaurentiis, P., Stochino, G., D'Amico, A., 'Low-voltage design', *Electronics World*, Sept. to Dec. 1999 issues.
2. Hogervorst, R., Huijsing, J.H., 'Design of low-voltage low-power operational amplifier cells', Kluwer Academic, 1996.
3. Gonzales, R., Gordon, B.M., Horowitz, M.A., 'Supply and threshold voltage scaling for low power CMOS', *IEEE Journal of Solid-State Circuits*, Vol.32 No 8, Aug.1997, pp. 1210-1216.
4. Serdijn, W.A., Van der Woerd, A.C., van Roermund, A.H.M., Davidse, J., 'Design principles for low-voltage low-power analog integrated circuits', *Analog Integrated Circuits and Signal Proc.*, Vol.8 No1 July 1995, pp.115-122.
5. De Laurentiis, P., Ferri, G., Palumbo, G., Pennisi, S., 'A low pass 1Hz 2V-supply current conveyor based filter' - ECS 99 Conference, Bratislava, 1999.



TV Fault Finding Guide

Peter Marlow
 Contents: Introduction;
 A-Z of manufacturers
 and models
 Readership:
 Professional service
 engineers, some
 college courses.

Pages: 400pp

Price: £22.50

Unique expert authorship and trusted Television magazine identity Real repair and troubleshooting info - not just cribs from manufacturers' data sheets. Ease of reference - this book is an essential repair tool, not just another volume for the shelf, Television magazine's TV Fault Finding column is a unique forum for practical servicing tips, with the UK's leading service engineers and servicing writers contributing their observations and recommendations month by month. But try finding those faults reports for the Amstrad CTV2200 that's on your bench. Even with an index you will be chasing through a pile of magazines... until now. Peter Marlow's TV Fault Finding Guide is a distillation of the most used fault reports from 11 years of Television magazine. Arranged by make and model the information is extremely easy to access, and the book is a convenient size for the bench or to carry with you. This will undoubtedly become one of the service engineer's most useful tools. Unlike other fault guides, this one is based on top quality information from leading authorities, and genuine repair case studies. This is real-life servicing information, not just a compilation of manufacturers' manuals.

Over 2,000 reports covering over 300 models Instant on-the-spot diagnosis and repair advice Television magazine's leading writers' wit and wisdom available for the first time in book form. **To Jackie Lowe, Room L514, Quadrant House, The Quadrant, Sutton, Surrey, SM2 5AS**

How to pay

(TV Fault Finding Guide) paperback

I enclose a cheque/bank draft for £ _____
 (payable to Reed Business Information)

Please charge my credit/charge card

Mastercard American Express Visa Diners Club

Credit Card No: _____ Expiry Date: _____

Signature of Cardholder _____

Cardholder's statement address: (please use capitals)

Name _____

Address _____

Post Code _____ Tel: _____

LANGREX SUPPLIES LTD
 DISTRIBUTORS OF ELECTRONIC VALVES
 TUBES AND SEMICONDUCTORS AND I.C.S.
1 MAYO ROAD • CROYDON • SURREY CR0 2QP
 24 HOUR EXPRESS MAIL ORDER SERVICE ON STOCK ITEMS
 email: langrex@aol.com

PHONE
 020 8684
 1166

FAX
 020 8684
 3056

AZ31	£ 8.00	KT66 Special	20.00	5Z4GT	3.00	6U8A	1.50
CL33	15.00	KT88 Special	20.00	6AQ5	2.00	6V6G	10.00
E88CC	8.50	N78	8.00	6AR5	6.00	6V6GT	6.00
E180F	3.50	OA2	3.00	6AS7G	7.50	6X4	3.00
E810F	20.00	OB2	3.00	6AU5GT	4.00	6X5GT	3.00
EABC80	4.00	OC3	3.00	6AU6	2.00	12AT7	3.00
EB91	1.50	OD3	3.00	6AW8A	4.00	12AU7	3.50
EBF80	1.50	PCF80	2.00	6B4G	22.00	12AX7	3.50
EBF89	1.50	PCL82	2.00	6BA6	1.50	12AX7A	7.50
EBL31	25.00	PCL85/805	2.50	6BE6	1.50	12AX7WA	6.00
ECC33	12.00	PCL86	2.50	6BH6	2.00	12BA6	2.00
ECC35	12.00	PD500	8.00	6BQ7A	2.00	12BE6	2.00
ECC81	3.00	PL36	3.00	6BR7	4.00	12BH7	10.00
ECC82	5.00	PL81	2.00	6BR8	4.00	12B7YA	7.00
ECC83	3.00	PL504	3.00	6BW6	4.00	12DW7	15.00
ECC85	5.00	PL508	3.00	6BW7	3.00	12E1	10.00
ECC88	6.00	PL509/519	10.00	6BX7GT	7.50	13E1	85.00
ECC808	15.00	PL802	4.00	6BZ6	3.00	572B	27.50
ECF80	1.50	PY500A	3.00	6C4	2.00	805	45.00
ECH35	3.50	PY800/801	1.50	6CB8A	3.00	807	7.50
ECH42	3.50	QQV02-6	12.00	6DC6G	5.00	811A	10.00
ECH81	3.00	QQV03-10	8.00	6CL5	3.00	812A	55.00
ECL82	5.00	QQV03-20A	10.00	6CG7	7.50	813	27.50
ECL86	5.00	QQV06-40A	12.00	6CH6	3.00	833A	85.00
ECLL800	25.00	U19	8.00	6CW4	6.00	866A	20.00
EF37A	3.50	UABC80	1.60	6DO5	17.50	872A	30.00
EF39	2.75	UCH42	5.50	6DO6B	10.00	931A	25.00
EF40	4.00	UCL82	2.00	6F6G	8.00	2050A	12.50
EF86	5.00	UCL83	2.00	6F07	7.50	5687WB	8.00
EF91	2.00	UF89	4.00	6GK6	4.00	5751	6.00
EF183/4	2.00	UL41	12.00	6J5G	6.00	5763	8.00
EL33	15.00	UL84	3.00	6J5M	4.00	5814A	5.00
EL34	5.00	UY41	4.00	6J7	3.00	5842	12.00
EL34G	5.00	UY85	2.00	6JB6A	27.50	6072A	8.00
EL36	5.00	VR105/30	3.00	6JEC	27.50	6080	6.00
EL41	3.50	VR150/30	3.00	6J58C	27.50	6146B	15.00
EL84	3.00	Z759	10.00	6K6GT	4.00	6201	8.50
EL95	2.00	Z803U	15.00	6L6G	15.00	6336A	35.00
EL360	15.00	2D21	3.50	6L6GC	17.50	6550A	25.00
EL509/519	7.50	3B28	12.00	6L6WGB	10.00	6883B	15.00
EM34	25.00	4CX250B	45.00	6O7	3.00	7025	7.50
EM81/47	5.00	5R4G	7.50	6SA7	3.00	7027A	26.00
EN91	7.50	5U4G	10.00	6SC7	3.00	7360	26.00
EZ80/EZ81	5.00	5U4GB	10.00	6SG7	3.00	7581A	15.00
G232	8.50	5V4G	5.00	6S7	3.00	7586	15.00
GZ33/37	15.00	5Y3GT	2.50	6SK7	3.00	7587	20.00
KT61	15.00	5Z3	5.00	6SL7GT	5.00		
		5Z4G	6.00	6SN7GT	7.50		

OPEN TO CALLERS MON-FRI 9AM-4PM. CLOSED SATURDAY
 This is a selection from our stock of over 6,000 types. Please enquire for types not listed.
 Obsolete items are our speciality. Valves are new mainly original British or American brands.
 Terms CWO/min order £10 for credit cards.
 P&P 1-3 valves £2.00. 4-5 valves £3.00
 Add 17.5% VAT to total including P&P



CIRCLE NO. 123 ON REPLY CARD

**WATCH SLIDES ON TV
 MAKE VIDEOS OF
 YOUR SLIDES
 DIGITISE YOUR
 SLIDES**



(using a video capture card)

"Liesegang diatr" automatic slide viewer with built in high quality colour TV camera. It has a composite video output to a phono plug (SCART & BNC adaptors are available). They are in very good condition with few signs of use. For further details see www.diatv.co.uk
 £91.91+ vat = £108.00

Board cameras all with 512x582 pixels 8.5mm 1/3 inch sensor and composite video out. All need to be housed in your own enclosure and have fragile exposed surface mount parts. They all require a power supply of between 10 and 12v DC 150mA.

47MIR size 60x36x27mm with 6 Infra red LEDs (gives the same illumination as a small torch but is not visible to the human eye).....£37.00 + vat = £43.48
 30MP size 32x32x14mm spy camera with a fixed focus pin hole lens for hiding behind a very small hole.....£35.00 + vat = £41.13

40MC size 39x38x27mm camera for 'C' mount lens these give a much sharper image than with the smaller lenses£32.00 + vat = £37.60

Economy C mount lenses all fixed focus & fixed iris

VSL1220F 12mm F1.6 12x15 degrees viewing angle.....£15.97 + vat = £18.76

VSL4022F 4mm F1.22 63x47 degrees viewing angle.....£17.65 + vat = £20.74

VSL6022F 6mm F1.22 42x32 degrees viewing angle.....£19.05 + vat = £22.38

VSL8020F 8mm F1.22 32x24 degrees viewing angle.....£19.90 + vat = £23.38

Better quality C mount lenses

VSL1614F 16mm F1.6 30x24 degrees viewing angle.....£26.43 + vat = £31.06

VWL813M 8mm F1.3 with iris 56x42 degrees viewing angle.....£77.45 + vat = £91.00

1206 surface mount resistors E12 values 10 ohm to 1M ohm 100 of 1 value £1.00 + vat 1000 of 1 value £5.00 + vat

866 battery pack originally intended to be used with an orbitel mobile telephone it contains 10 1.6Ah sub C batteries (42x22dia the size usually used in cordless screwdrivers etc.) the pack is new and unused and can be broken open quite easily.....£7.46+vat = £8.77



Please add 1.66 + vat = £1.95 postage & packing per order

JPG ELECTRONICS

276-278 Chatsworth Road, Chesterfield, S40 2BH.
 Tel 01246 211202 Fax 01246 550959 Mastercard/Visa/Switch
 Callers welcome 9:30 a.m. to 5:30 p.m. Monday to Saturday

CIRCLE NO.124 ON REPLY CARD

RANGER

The Complete Integrated
 Schematic PCB Layout
 Package

Too good
 for words

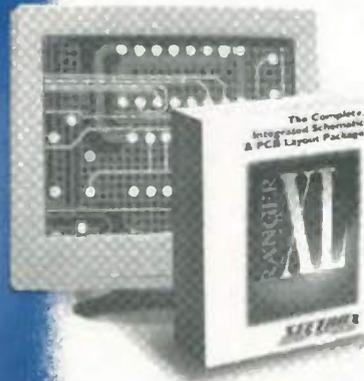

**The New Ranger
 XL Series**

Ranger 2 for Windows £170
NEW Ranger 2XL £500
NEW Ranger XL from £950
FREE Website Download Demo

FEETRIX
 Advanced Systems & Technology for PCB Manufacturers

Old Buriton Lime Works, Buriton, Petersfield, Hants. UK GU31 5SJ
 Tel: (44) 01730 260062 Fax: (44) 01730 267273

CIRCLE NO.125 ON REPLY CARD

5-in-1 digital multi-tester

Reader offer price £49.99 – fully inclusive

Complete with batteries, holster, test leads and temperature probe

Now you can record measurements together with readings of environmental conditions – temperature, humidity, light level and even sound pressure – using just one meter, the DT21. This 3.5-digit multi-tester even checks transistors.

Sound level readings in decibels are taken via the meter's inbuilt microphone. The **light** function relies on a very stable long-life diode – also built in – and is fully cosine corrected for the angular incidence of light. Relative **humidity** sensing – with direct reading in percentage – is taken using an inbuilt sensor, as is ambient temperature in °C. A probe is also supplied for making localised **temperature** readings. Alternatively, you can use any K-type thermocouple.

The digital multimeter performs AC/DC voltage, DC current, resistance measurement and audible continuity, diode, transistor h_{FE} test.

Features

- 11 functions: measures sound level, light, humidity, temperature, DC voltage, AC voltage, DC current, resistance, transistor, diode and continuity test.
- 3½ large LCD with indications for lux, °C, %RH and dB.
- Sound level: from 35dB to 100dB with C weighting, 0.1dB resolution.
- Light: levels ranging from 0.1lux to 20000lux.
- Humidity: from 25%RH to 95%RH with 0.1%RH resolution and fast time response.
- Temperature: -20 to 200°C and -20 to 1200°C ranges
- Transistor h_{FE} , 0-1000 with 10µA base current
- Diode test current 1.4mA
- Separate jack for 10A current measurement
- 1MΩ input impedance
- 220V DC or RMS AC maximum overload for 200mV DC range, 600V RMΣ AC on other DC ranges

Voltage and current and resistance

DC volts

Range	Resolution	Accuracy
200.0mV	0.1mV	
20.00V	10mV	±0.5% of rdg, ±2dig.
600V	1V	±1% of rdg, ±2dig.

AC volts

200.0V	100mV	±1.2% of rdg, ±10dig.
600V	1V	±1.2% of rdg, ±10dig.

DC current

200.0µA	0.1µA	±1% of rdg, ±2dig.
200.0mA	100µA	±1.2% of rdg, ±2dig.
10A	10mA	±2% of rdg, ±5dig.

Resistance

200.0Ω	0.1Ω	±0.8% of rdg, ±4dig.
2.000kΩ	1Ω	
200.0kΩ	100Ω	±0.8% of rdg, ±2dig.
2.000MΩ	1kΩ	±1% of rdg, ±2dig.



For a PDF file of the meter's manual, e-mail eworld.orders@rbi.co.uk with the subject heading 'Meter manual'.

Use this coupon to order your DT21 multimeter

Please send me DT21(s) at the special offer price of £49.99 each. Note that the price includes VAT and recorded UK delivery. Please add £5 for overseas orders.

Name

Company (if any)

Address

Phone number/fax

Total amount

£.....

Make cheques payable to Reed Business Information Group. Or, please debit my credit card.

Card type (Switch/Master/Visa etc.)

Card No

Expiry date

Issue no

Please mail this coupon to *Electronics World*, together with payment. Alternatively fax credit card details with order on 020 8652 8111. You can also telephone your order on 020 8652 3614. Address orders and all correspondence relating to this order to DT21 Offer, Electronics World, Quadrant House, The Quadrant, Sutton, Surrey SM2 5AS.

Design competition

Devise a useful and/or ingenious application for the ZXF36L01 versatile high-Q bandpass filter with integral mixer and you could win a £500 voucher to spend with Farnell. There's two runner up prizes of £100 vouchers too.

Rules

- Electronics World reserves the right to publish submitted entries. All designs published will be attributed to their designers. A minimum payment of £50 will be made for each design published.
- Submission of an entry does not remove your right to exploit your design, but it does give Zetex the right to use the entry as an application note, or as the basis thereof, effectively making the design public domain.
- Winners will be chosen jointly by technical experts from Zetex, Farnell and the editor of Electronics World. The judges' choice will be final and no correspondence will be entered into regarding the choice of winner.
- No employee of Reed Business Information, Zetex and Farnell, or any of their associated companies, may enter this competition, nor may members of their families.
- No entry will win more than one prize, but multiple entries may be submitted.
- Prizes are as stated here and not negotiable.
- Entries arriving after the closing date will be void.
- No purchase is necessary to enter this competition.
- Winners will be notified by post, and the results may be publicised.
- For a list of winning entries, send an SAE to the editorial offices.
- Submitting an entry for the competition implies acceptance of these rules.

Launched this year, the ZXF36L01 is a versatile high-Q bandpass filter requiring a minimum of external components. In addition to the variable-Q analogue filter there is also a mixer block, making the device suitable for a wide range of applications.

All you have to do to enter the competition is send a design idea incorporating the ZXF36L01 to the address below. Entries will be judged on ingenuity, originality and usefulness. All entries are subject to the rules set out below.

A designer's kit is available from Farnell and you can find full data on the device on Zetex's web site <http://www.zetex.com/pdf/ics/zxf36101.pdf>.

It is not necessary for you to prove your design, and buying the kit is not a condition of entry into the competition. The design you submit has to work in practice but you will not be penalised for not having built a prototype.

If you do submit a design that meets the competition criteria and you have bought the kit, then you will receive a Farnell voucher for £15, courtesy of Zetex.

Send your entry to Filter Design, Electronics World, Quadrant House, The Quadrant, Sutton, Surrey SM2 5AS. Note that it is not necessary to send your prototype! Simply send the circuit diagram and a clear, concise description of the circuit. It will help if you describe why you think that your circuit should be among the winners. You can also e-mail your entry to jackie.love@rbi.co.uk, but unless the e-mail has a subject heading that reads 'Filter Design' it will not be eligible. Please attach diagrams and text separately and include a daytime phone number with your entry if possible. The closing date for the competition is 30 April.

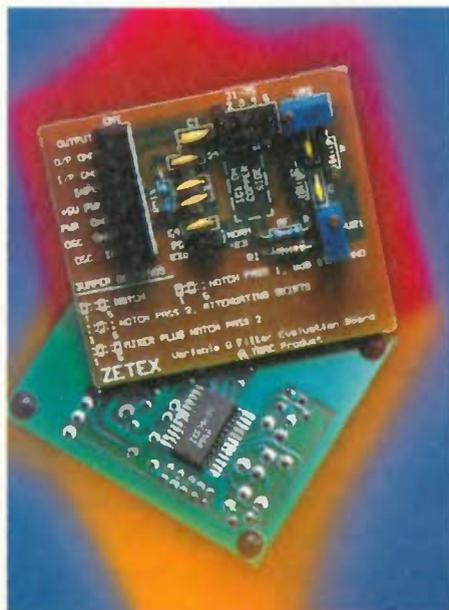
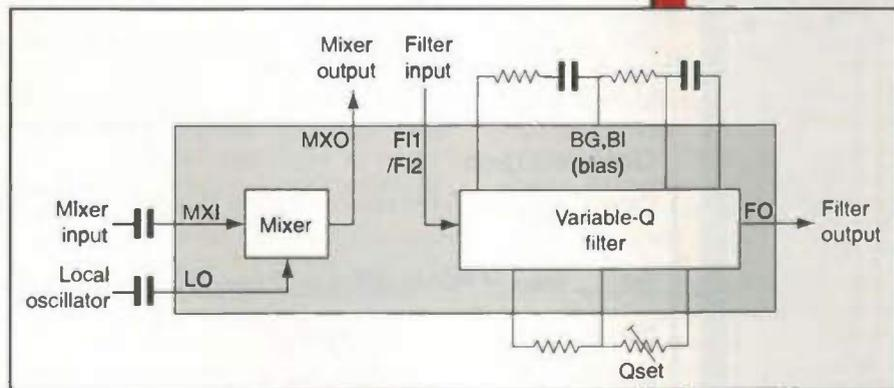

You don't need to buy this new development board for the ZXF36L01 in order to enter the competition, but if you do, and your entry meets the competition requirements, you will receive a Farnell voucher for £15 to help cover its cost.

**Win a £500
voucher
redeemable
at Farnell.**

For more information...

Visit <http://www.farnell.co> for details of the ZXF36L01 development kit or <http://www.zetex.com/pdf/ics/zxf36101.pdf> for more data on the filter chip.

This *Electronics World* competition is sponsored by UK semiconductor manufacturer Zetex and distributor Farnell Electronics Components.

Personal voice communications without a licence over a two mile radius for £75, exclusive.

Reader offer

A pair of two-way PMR radios for just £75*

RS 446 personal mobile radio...

To celebrate its launch, new test and instrumentation company Tecstar is offering *Electronics World* readers two RS446 personal mobile radios for just £75 excluding VAT and carriage.

Capable of transmitting and receiving voice over a distance of up to two miles, depending on terrain, the PMR 446 needs no licence. It offers eight channels, scanning – and with CTCSS up to 304 channel combinations.

A backlit liquid-crystal display shows volume level, channel number, sub-channel number, battery level and transmit/receive or channel busy. A unique call feature enables the user to alert the person they wish to contact.

Transmission distance is up to 2 miles. The radio has an accessory socket for an external headphone, earpiece or vox-microphone/headphone combination. A keypad lock and battery save feature are also standard.

The unit measures only 120 by 50 by 20mm and weighs less than 150 grams – including batteries. It is supplied complete with instructions and belt/mounting clip.

Compact, lightweight and low cost, the RS446 wireless personal-communications hand set has a wide range of applications. These include fetes, events and rallies. Builders on building sites could benefit from these radios, as could exhibitors at exhibitions and staff at warehouses, winter activities, sports events, maintenance departments, schools and care homes. Of course you can also use the RS446 just to keep contact with someone locally. The uses are almost limitless.

Send a cheque or postal orders to Tecstar Electronics Limited, 1 Nuffield Road, St Ives, Huntingdon Cambridgeshire PE27 3LX.

Tel 01480 399499, fax 01480 399503, e mail sales@tecstar.co.uk

Order coupon

Please send me RS446 personal mobile radios, for which I enclose:

For ___ pairs of RS446 radios at £75 per pair _____

Plus VAT at 17.5%, or £13.13 per pair _____

Plus £6 UK postage per order, or £14 overseas _____

Total _____

Fill in your name and address and post this coupon together with a cheque for the total amount above payable to Tecstar to the address below.

Name _____

Address _____

Post code _____

Signature _____

Send cheques, postal orders etc to Tecstar Electronics Limited, 1 Nuffield Road, St Ives, Huntingdon Cambridgeshire PE27 3LX.
Tel 01480 399499, fax 01480 399503, e mail sales@tecstar.co.uk

*excludes carriage and VAT



RS446 key features...

- Up to 2 mile coverage radius
- Scans main and subchannels
- Eight channels, each with 38 sub channels
- Backlit display for night time use
- Unique call function
- Headphone and mic sockets allow discrete use
- Battery status indicator
- Auto battery save feature
- Keypad lock-out

What is CTCSS

CTCSS – or 'continuous-tone controlled squelch system' – allows sub channels of the main channels to be used. There are 38 sub channels to each main channel. Using subchannels decreases the likelihood that someone else will be using the same frequency.

Random memories

by Alf A. Particle

In the world of low-power radio, there's justifiable concern at the moment about new frequency allocations likely to cause interference to existing systems.

A particular case for concern is the UK allocation for licence-free low-power devices, which is under threat from TETRA. Many existing licence-free low-power devices use up to 250 μ W effective radiated power at 418MHz. Although no new applications should use this band, numerous 418MHz modules are still in use. Supposedly they will all be phased out – some time.

TETRA – the Trans European Trunked Radio system – is currently being rolled out. It is being used by emergency services and some private users such as fleet vehicles. Portables operate in the range 410-415MHz at up to 1W effective radiated power and base stations in the range 420-425MHz with currently a 6W effective radiated power limit.

I connected a Band III aerial to my spectrum analyser, and sure enough, there were some signals at around 425MHz, at a whopping -78dBm. Presumably these were TETRA base stations.

Now, though, portables will have 410-420MHz, and the base stations 420-430MHz, with a 25W effective radiated power limit. Current users of 418MHz should migrate to the wider pan-European allocation of 433MHz, but the regulations for this band itself are up in the air at the moment. Furthermore, this is a shared band and some users are experiencing interference from radio amateurs.

In the mean time, there is concern that existing 418MHz users may experience interference from TETRA. Well designed units – FM superhet receivers with SAW filter front ends – should be OK, except perhaps in the immediate vicinity of a TETRA transmission. But cheap low-tech super-regenerative receivers – 'hedgehogs' – are likely to be in trouble.

Any of you wanting more information on this topic should visit the web site of the Low Power Radio Association at www.lpra.org, or e-mail the Association at info@lpra.org.

The super-regenerative receiver relies on periodically self-quenching oscilla-

tions, due to positive feedback, to obtain great sensitivity with but a very few components, at the expense of very poor selectivity.

So apart from being vulnerable to adjacent band transmissions, the 'receiver' also makes a low power transmitter in its own right – or own wrong, some would say. Its output, viewed on a spectrum analyser, shows a pack of spectral lines spaced at the quench frequency, and looking rather like the raised spines of a hedgehog, hence the nick name.

Any oscillator may 'squegg', that is to say, it may operate in distinct bursts at a supersonic frequency, like a super-regenerative, if the time constant of the bias circuitry is too long. While this phenomenon is used to good effect in the super-regenerative receiver, squegging is usually an undesired result of poor circuit design. Apart from some types of radar transponders – known as squitterers – the only other 'useful' application of squegging which I have come across was really rather nefarious.

Just before the Second World War, as the economy started to pick up and wages rose, many a family bought a mains set, and consigned the battery wireless set built by dad a few years earlier, to the loft.

The new set was frequently dad's pride and joy. It had a short wave band where you could actually receive Australian stations, with a long antenna, luck and a late night.

By the early 1950s, when as a young lad I started radio repairs as a way of increasing my pocket money, many of these sets were a sad case of tired valves. The owner would complain to a radio dealer that, while it was still OK on MW and LW, it was getting very few stations now, on short wave.

The less scrupulous type of radio dealer, while charging for a proper repair, would actually just raise the grid leak of the triode oscillator section of the frequency changer from 10k Ω to 330k Ω .

The triode hexode frequency changer operated just the same as before on MW and LW, but squegged at around 100kHz on short wave. With a whole bunch of spectral lines for the local oscillator –

instead of just the one – the set was now bursting with stations on SW again.

True, the same stations appeared over and over again along the dial, but the dealer would explain that with the Russian jamming, broadcasters had to use lots of different frequencies to get through to Iron Curtain listeners.

Write only memory

Like many of you, I suspect, I still get mail shots from companies that I contacted once years ago for information that did not in fact result in even one sale. I even get them from firms I never contacted in the first place – the result of the practice of organisations selling circulation lists to others.

The resultant destruction of forests for papermaking is a disgrace. Firms really should incorporate an 'expire this record on...' date marker in each address field of their data bases. But few firms seem to run such a system.

Of course, I really should write to each of these businesses, requesting them to delete my name from their mailing list, but inertia usually prevails, I must confess. Not that such action can be guaranteed to have the desired result. I have known cases where such a request has been simply ignored. Perhaps so few people take this step that there is no mechanism within the organisation for actioning it.

A particularly glaring example concerns the apparently ever-growing number of 'freebie' electronics magazines – the sort called 'controlled circulation' journals. These carry no cover price, being supported entirely by advertising revenue. Many consist entirely of advertisements, though some make a not-very-convincing show of including some editorial content.

In theory, I shouldn't be receiving these unsolicited free magazines. Most of them indicate that this or that independent bureau monitors their circulation list. This is supposed to assure potential advertisers that their advert really will reach so-many-thousand qualified professional readers.

I wonder how many advertisers know that any such assurance is as bogus as it is fake. ■

View hysteresis curves

Fernando Garcia explains how you can display a transformer's hysteresis curve on your digital scope.

A hysteresis curve is a useful graphical display of a transformer's magnetic characteristics. It allows you to view several parameters at a glance, and to determine the presence of manufacturing defects like air gaps, missing laminations, relative quality of the magnetic steel properties, etc.

Unfortunately the equipment needed for displaying a hysteresis curve is expensive. As a result, such equipment is usually only found in specialised laboratories.

If don't need to view a calibrated hysteresis curve though, but rather a relative curve shape, the very simple circuit described here will suffice. You will need a dual channel oscilloscope, but apart from that, only a handful of passive components¹.

The relative shape is helpful in comparing unknown units against a known good unit. This is particularly useful, for instance, when evaluating the steel lamination from different vendors.

Fortunately, with the newer digital oscilloscopes that incorporate mathematical functions, even that simple circuit is no longer required. The curve may be fully obtained by processing the waveforms with the scope's internal functions.

The basis for the operation lies in the relationships,

$$B = K_1 \times \int E dt$$

where, K_1 is a lumped constant for the frequency, number of turns and core area, and E is the applied

primary voltage and,

$$H = K_2 \times I$$

where K_2 is a constant for the turns, mean magnetic length and I is the magnetising current.

Both K_1 and K_2 are assumed constant if you are only comparing a known-good reference device against an identical device whose magnetic properties we are concerned about.

Lastly, the curve's characteristic shape is given by the change of permeability with the rate of change for the flux density and magnetising force. Thus,

$$\Delta\mu = \frac{\Delta B}{\Delta H}$$

Fig. 1. If you have a digital oscilloscope, all you need to display a transformer's hysteresis is an isolated variable transformer and a few passive components.

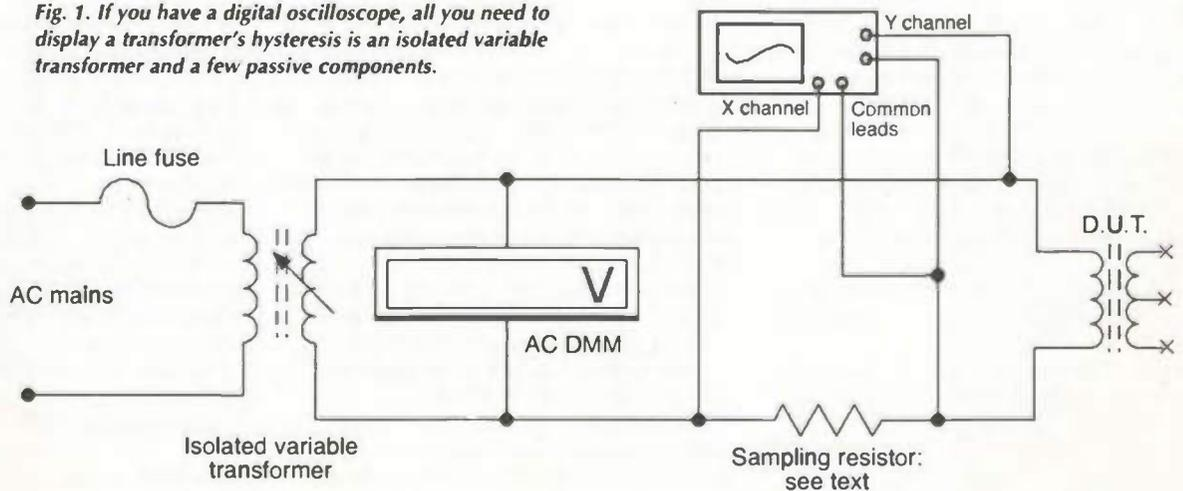

The trick is to apply the voltage developed through a sampling resistor by the magnetising current to the scope's horizontal X channel. The sampling resistor should be calculated such that at the device-under-test's rated magnetising current, about 100 to 200mV pk-pk are dropped across the resistor. Likewise, the applied primary voltage is fed to the scope's vertical Y channel, Fig. 1.

The procedure

With the scope still in the volt-time format, adjust the variable transformer's output to match the device under test's maximum rated primary voltage, as read on the digital multimeter.

At this stage, adjust the scope's time base to obtain at least a full waveform cycle. Adjust the vertical gain controls such that the maximum waveform amplitude fits within the graticule. Now find the scope's mathematical functions and apply integration to channel Y. You should have now a display similar to what is shown in Fig. 2a). Now remove the Y trace leaving only the integration and horizontal traces.

The last step is to change the scope format to X-Y mode. You should now have a waveform like the one in Fig. 2b). The position controls may require fine adjustment to centre the hysteresis plot to the centre of the graticule. If the curve appears mirror-image, apply the invert function to the X channel.

Remove the known-good device and replace it with a suspect device. You'll be amazed at the amount of information that may be obtained with a simple inspection of the curve.

A few words of caution. Always use an isolated variable transformer. Always fuse your circuit. Before plugging or unplugging the device under test, set the variable transformer all the way to zero volts and ramp up the voltage slowly. Finally, ensure that all secondary windings are open and suitably insulated. ■

Reference

1. Garcia, F., 'View a Transformer's Hysteresis Curve with an Ultra-Simple Circuit.' *Electronic Design*, December 1999, pp. 116-117.

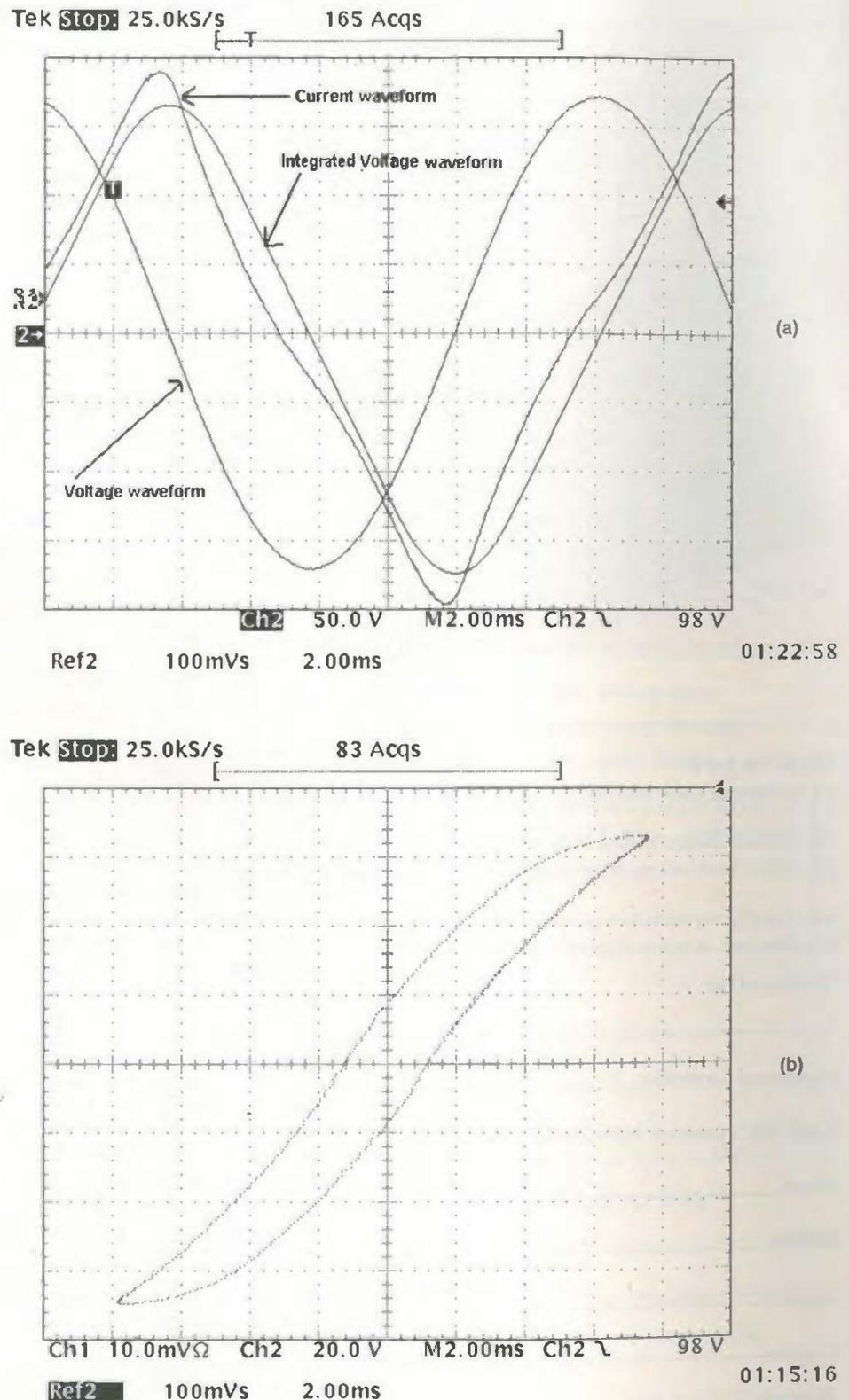

Fig. 2. In a) is an example of the type of display you should see after applying integration to the Y channel. Waveform 2b) should result after the last step of switching the scope to X-Y mode.

How to pay

(VCR Fault Finding Guide) paperback

I enclose a cheque/bank draft for £ _____
(payable to Reed Business Information)

Please charge my credit/charge card

Mastercard American Express Visa Diners Club

Credit Card No: _____ Expiry Date: _____

Signature of Cardholder _____

Cardholder's statement address: (please use capitals)

Name _____

Address _____

Post Code _____ Tel: _____

Television magazine's VCR Clinic column is a unique forum for practical servicing tips, with the UK's leading service engineers and servicing writers contributing their observations and recommendations month by month. But try finding those faults reports for the Amstrad XYZ123 that's on your bench. Even with an index you will be chasing through a pile of magazines... until now. Peter Marlow's VCR Fault Finding Guide is a distillation of the most used fault reports from 11 years of Television magazine. Arranged by make and model the information is extremely easy to access, and the book is a convenient size for the bench or to carry with you. This will undoubtedly become one of the service engineer's most useful tools. Unlike other fault guides, this one is based on top quality information from leading authorities, and genuine repair case studies. This is real-life servicing information, not just a compilation of manufacturers' manuals.

Approximately 2,000 reports on 193 models from 35 different manufacturers Instant on-the-spot diagnosis and repair advice Television magazine's leading writers' wit and wisdom available for the first time in book form



VCR Fault Finding Guide

Peter Marlow

This book is an essential repair tool, not just another volume for the shelf

Pages: 464pp

Price: £22.50

How to pay

(TV Fault Finding Guide) paperback

I enclose a cheque/bank draft for £ _____
(payable to Reed Business Information)

Please charge my credit/charge card

Mastercard American Express Visa Diners Club

Credit Card No: _____ Expiry Date: _____

Signature of Cardholder _____

Cardholder's statement address: (please use capitals)

Name _____

Address _____

Post Code _____ Tel: _____

Unique expert authorship and trusted Television magazine identity Real repair and troubleshooting info – not just cribs from manufacturers' data sheets. Ease of reference – this book is an essential repair tool, not just another volume for the shelf, Television magazine's TV Fault Finding column is a unique forum for practical servicing tips, with the UK's leading service engineers and servicing writers contributing their observations and recommendations month by month. But try finding those faults reports for the Amstrad CTV2200 that's on your bench. Even with an index you will be chasing through a pile of magazines... until now. Peter Marlow's TV Fault Finding Guide is a distillation of the most used fault reports from 11 years of Television magazine. Arranged by make and model the information is extremely easy to access, and the book is a convenient size for the bench or to carry with you. This will undoubtedly become one of the service engineer's most useful tools. Unlike other fault guides, this one is based on top quality information from leading authorities, and genuine repair case studies. This is real-life servicing information, not just a compilation of manufacturers' manuals.

Over 2,000 reports covering over 300 models Instant on-the-spot diagnosis and repair advice Television magazine's leading writers' wit and wisdom available for the first time in book form.



TV Fault Finding Guide

Peter Marlow

Contents! Introduction; A-Z of manufacturers and models Readership: Professional service engineers, some college courses.

Pages: 400pp

Price: £22.50

Post to Jackie Lowe, Room L514, Quadrant House, The Quadrant, Sutton, Surrey, SM2 5AS

BOOK TO BUY

The definitive biography of the century's godfather of invention—from the pre-eminent Edison scholar "Israel's meticulous research and refusal to shy away from the dodgier aspects of Edison's personality offers a fresh glimpse into the life of the inventor."—

New Scientist

"Remarkable."— *Nature*

"An authoritative look into Edison's working methods, here leavened by enough personal detail to give the achievements shape."—*Publishers Weekly*

"Israel's book should go a long way toward taking Edison out of the shadows and placing him in the proper light."—*Atlanta Journal-Constitution*

"Exhaustively researched, with strong emphasis on Edison's methods and achievements."—*Kirkus Reviews*

The conventional story of Thomas Edison reads more like myth than history: With only three months of formal education, a hardworking young man overcomes the odds and becomes one of the greatest inventors in history.

But the portrait that emerges from Edison: *A Life of Invention* reveals a man of genius and astonishing foresight whose career was actually a product of his fast-changing era. In this peerless biography, Paul Israel exposes for the first time the man behind the inventions, expertly situating his subject within a thoroughly realized portrait of a burgeoning country on the brink of massive change. Informed by Israel's unprecedented access to workshop diaries, notebooks, letters, and more than five million pages of archives, this definitive biography brings fresh insights to a singularly influential and triumphant career in science.

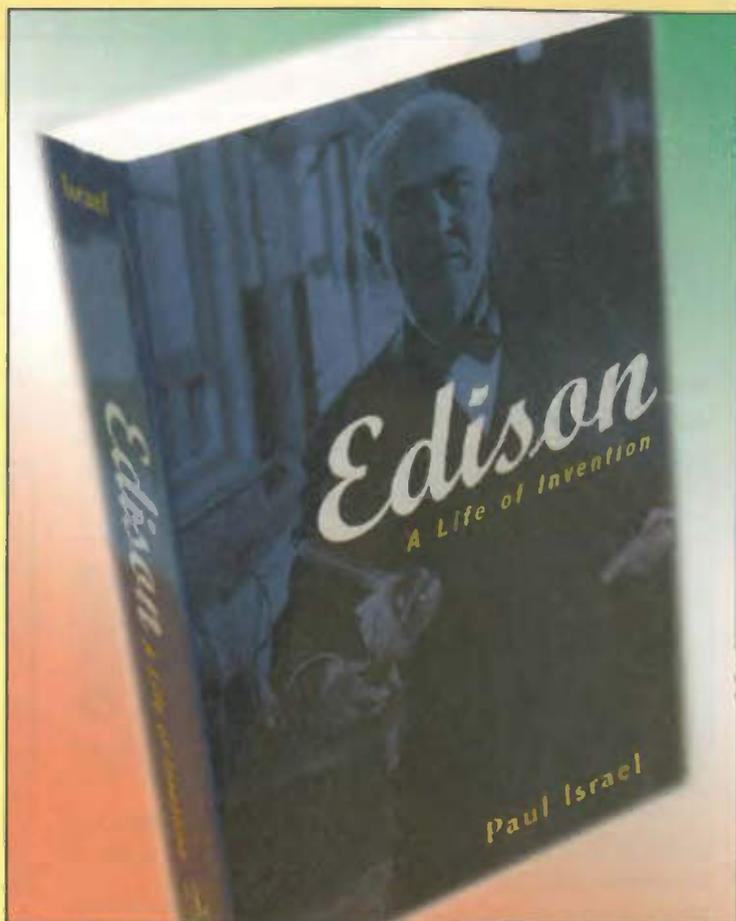

Post your completed order form to:-
Jackie Lowe, Room L514, Quadrant House,
The Quadrant, Sutton, Surrey, SM2 5AS

Fax your completed order form to 020 8652 8111
UK Price: £15.00 Europe £17.00 ROW £19.00
Price includes delivery

How to pay

(Edison) paperback

I enclose a cheque/bank draft for £ _____
(payable to Reed Business Information)

Please charge my credit/charge card

Mastercard American Express Visa Diners Club

Credit Card No: _____

Expiry Date: _____

Signature of Cardholder _____

Cardholder's statement address: (please use capitals)

Name _____

Address _____

Post Code _____ Tel: _____

WEB DIRECTIONS

ACQUIVISION

<http://www.acquivision.com>

AcquiVision solutions, including XY-Plotting, Oscilloscopes (with FFT), Data Logging and Custom Software, have been getting the most from computers since 1994. Download software. Telephone (01903)830502.

AQUILA VISION

<http://www.aquila-vision.co.uk>

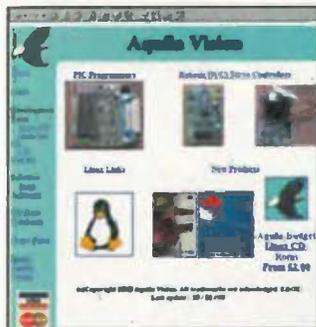

Aquila Vision specialises in supplying and supporting Embedded Microprocessor Development products from PICs to DSPs. We also stock robotics boards, Linux and general interest CD-ROM's.

ALCATEL COMPONENTS

<http://www.components@alcatel.de>

ASHWELL ELECTRONICS

<http://www.ashwell-hq.com>

Ashwell provide technical support for Apex Microtechnology op-amps and DC/DC'S; Aeroflex; EMP filtered connectors; M S Kennedy; Mintech obsolescence; NSC Mil/Aero; Teledyne Relays and isocom mil/optocouplers.

ARCOM

<http://www.arcomcontrols.com/ev/>



A leading international supplier of communication and control technology to industry, Arcom provides leading edge solutions through a comprehensive range of market leading products.

BROADCASTING COMMUNICATIONS SYSTEMS

www.broadercasting.co.uk

WINRADIO now brings you a complete choice in personnel computer controlled

radio scanning and reception solutions ● Broadcast ● Media ● Monitoring ● Professional Amateur Radio communications

BEDFORD OPTO TECHNOLOGY LTD

<http://www.bot.co.uk>

Optoelectronic products UK design development manufacture standard and custom, LED bargraphs, circuit board indicators, stand offs, transmissive/reflective switches, baseefa optocouplers tubular and surface mount, pannel mount LED assemblies.

CONCEPT ELECTRONICS

<http://www.conceptkey.co.uk>

Concept Keyboards are specialists in the design and manufacture of customer specified membrane panels and keyboards, and electronic design. Concept's membrane manufacture is supported by a full electronic production facility to provide a complete turnkey keyboard and electronics service, fully accredited to ISO9001.

CONTROL SOLUTIONS

www.controlsolutions.co.uk

Data acquisition and control for beginners, hobbyists, and professionals. Perform mathematical and logical operations on data in real time. Email: info@controlsolutions.co.uk

COOKE INTERNATIONAL

<http://www.cooke-int.com>
e-mail: info@cooke-int.com



Stockists of Quality Used Electronic Test Instruments and Operating & Service Manuals.

CROWNHILL ASSOCIATES LTD

<http://www.crownhill.co.uk>

Crownhill supply low cost development tools for use with Micro-Controllers and Smart Cards. Products include Smart Card development tools, Smart cards, Micro Development tools and Bespoke Design Services.



DANIEL MCBREARTY

<http://www.danmcb.demon.co.uk/eng.html>

Experienced engineer based in London, specialist in audio and control systems. Available for design, project engineering or general consultancy. Background of high-quality work.

DESIGNER SYSTEMS CO.

<http://www.designersystems.co.uk>



Electronic product design company with over a decade of experience promoting it's own product range and designing and manufacturing innovative products for client companies/individuals.

ECM SELECTION

<http://www.ecmsel.co.uk>

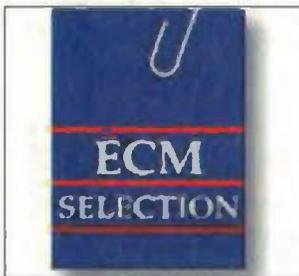

For the pick of the UK's Top High-Tech Software and Hardware career opportunities - from fresh Grad/PhD to Senior Engineer/Manager - £22,000 - £70,000

EDWIN PCB DESIGN SOFTWARE

<http://www.swifteurotech.co.uk>

Swift Eurotech supply the best-selling EDWin CAD/CAE system for PCB design, including schematics, simulation and PCB design. Discounts up to 60% for non-commercial users.

ELECTRONICS AND COMPUTING PRINCIPLES

<http://www.eptsoft.com>

Studying electronics or computing or just want to keep up-to-date in an easy and enjoyable way, then this fully interactive software is for you.

EQUINOX TECHNOLOGIES UK LTD

<http://www.equinox-tech.com>



Equinox Technologies UK Ltd., specialise in development tools for the embedded microcontroller market.

FELLER UK

<http://www.feller-at.com>

Feller (UK) Ltd. manufacture Fully approved cordsets (Moulded mains plugs and connectors) and Power Supply Cables for all Industrial Countries to National and International Standards

FLASH DESIGNS LTD

<http://www.flash.co.uk>

Flash supply low cost AVR ISP programmers (£39), MINI-ICE starter kits (from £69), MINI-ICE emulators (from £199), ICE Adapters & 'C' compilers for any ATME1 AVR, MCS51, Dallas, Hitachi H8 microcontroller. Download FLASH NEWS now, Watch out for Special Offers'. ARE YOU developing code in a Flash?

GOOT PRODUCTS

<http://www.kieagoot.co.uk>



Kiea Trading Company is the sole agent of Goot products. We specialise in supplying the soldering and desoldering product range manufactured by Goot Japan for the UK market. Goot uses advanced production technology to manufacture high quality soldering Iron products for Industrial, professional and general purpose use.

HSPS LTD

<http://dSPACE.dial.pipex.com/hsp/>

FILTER DESIGNER - Advanced analog and digital filter design software for the PC. - Standard and Professional versions. - Free download of Evaluation version.

To reserve your web site space contact Pat Bunce

Tel: 020 8652 8339 Fax: 020 8652 3981

HTB ELEKTRONIK

<http://www.htb-elektronik.com>

We are selling second-hand test & measurement equipment and accessories for over 10 years, from all leading manufacturers.

LEVY/LATHAM GLOBAL

<http://www.levylatham.com>

U.S. Military Surplus meters, plug-ins, test sets, oscilloscopes, power supplies, signal generators, spectrum analyzers and radio components from Tektronix, Hewlett Packard, Sony, Phillips and more!

LOW POWER RADIO SOLUTIONS

<http://www.lprs.co.uk>

LPRS markets low power radio transmitters, receivers and transceiver modules manufactured by ourselves, Radiometrix, Circuit Designs, RDT and Micrel. Applications for telemetry, video and remote control.

MATTHEY MICROFILTERS

<http://www.microfilters.net>



30 years experience in the design and manufacture of high quality passive filters and delay lines. Used in Broadcast, Telecommunications, Medical, Multimedia, and Computer Industries.

MATRIX MULTIMEDIA LTD

www.matrixmultimedia.co.uk



Matrix Multimedia publishes a number of highly interactive CD ROMs for learning electronics including: Complete electronics course, Analogue filter design, and PICmicro(R) microcontroller programming (C and assembly).

NEWNES - BOOKS FOR THE ELECTRONICS WORLD

<http://www.newnespress.com>

Over 300 books and information packages



for those working with electronics and engineering technology. Visit our site for a free catalogue and downloads.

NORCALL

<http://www.norcall.co.uk>

Suppliers and repairers of MOBILE RADIO equipment
SALES
HIRE
REPAIR
Huge stocks of used radios and spares
Pye Philips Simoco Icom Kenwood
Standard Clearstone Maxon Yaesu Key
Midland.
WE CAN PROGRAM ANYTHING
24hr Service

OMEGA RESEARCH LTD

<http://www.omega-research.co.uk>

"SMD prototyping adapters. Unique, flexible, low cost adapters to allow bench working with SM devices. Range suits most devices down to 0.5mm pitch."

PCA:PHILIP COLLINS & ASSOCIATES PTY. LTD

<http://www.pca.cc>

PCA manufactures Radphone 2000DX remote control systems for shortwave broadcasters and government agencies wanting worldwide control of communications receivers and transceivers from any tone phone.

POLY-FLEX CIRCUITS LTD

<http://www.polyflex.com>

Design, manufacture and population of printed polyester flexible circuits, including Flip Chip on Flex providing practical, low cost, reliable solutions for today's small lightweight products.

QUASAR ELECTRONICS

www.quasarelectronics.com



Over 250 electronic kits, projects and ready built units for hobby, educational & industrial applications.
TEL: 01279 306504, FAX: 07092 203496
or EMAIL: ewsales@quasarelectronics.com

QUILLER ELECTRONICS

<http://www.quiller.com>

100+ pages of detailed technical information on Schrack Relays, MEC Switches, Hirose Connections.

RADIOMETRIX

<http://www.radiometrix.co.uk>

Radiometrix specialises in the design and manufacture of VHF & UHF, RF data modules. We offer a broad range of PCB mounted miniature transmit, receive and transceiver modules for OEM use.

RADIO-TECH LIMITED

<http://www.radio-tech.co.uk>

Radio modules, modems, telemetry, audio transmitters, pagers, antenna, remote controls and much more. All UK designed and manufactured.

RALFE ELECTRONICS



professional test & measurement
www.ralfe-electronics.co.uk

RD RESEARCH

<http://www.looking.co.uk/spice>

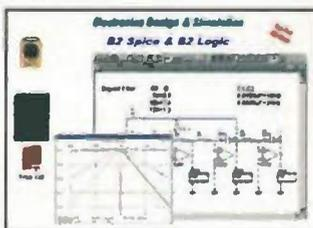

Analogue and digital SPICE modelling software. Full details available on this site. Available on a 30 day evaluation basis.

RS COMPONENTS LTD

<http://rswww.com>



The award winning on-line service from RS
- 110,000+ products available
- Technical data library
- Stock availability check
- Integrated on-line purchasing
- Order by 8pm - with you tomorrow.

SOFTCOPY

<http://www.softcopy.co.uk>

As a PC data base or hard copy, SoftCopy can supply a complete index of Electronics World articles over the past ten years. Photo copies of articles from back issues are also available.



SESCOM, INC.

<http://www.sescom.com>

SESCOM, INC. is a 30-year manufacturer of audio "problem solvers" and transformers. We also offer easily-fabricated aluminum enclosures for small production runs and prototypes.

STAFFORDSHIRE WIRELESS COMPANY

<http://www.staffs-wireless.com>

Wireless, communication, test equipment, bought and sold for very competitive prices visit our web site or telephone John on 01889 569928 or 0973 296461.

SUPRA AUDIO CABLES

<http://www.jenving.se>

Jenving Technology AB is the manufacturer of Supra Audio Cables. OEM productions are also accepted.

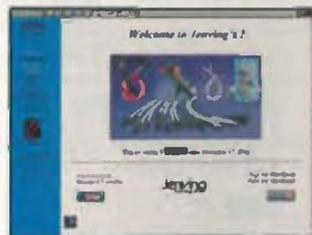

TEMWELL CORPORATION

<http://www.temwell.com.tw>

Manufacturer & Exporter of Helical BPF Filter, 30 Watts BPF Power Filter and Handset/Base Station Duplexers

TEST EQUIPMENT SOLUTIONS

<http://www.TestEquipmentHQ.com>

Quality second user test equipment with full warranty and support. All types of equipment from all leading manufacturers including general purpose, communications and industrial test.



Save 15% Pico ADC42

Virtual oscilloscope

£98
inclusive of VAT
and postage*

*UK only. Overseas readers please fax or e-mail for a quote including delivery charges.

Featuring 12-bit resolution and 1M Ω input impedance, the ADC42 samples at up to 15kS/s and includes software for spectrum analysis, oscilloscope functions and frequency display. Plugging into a PC's LPT port, the unit provides large, colourful displays and all the usual timebases and trigger options – all in a case slightly larger than a matchbox.

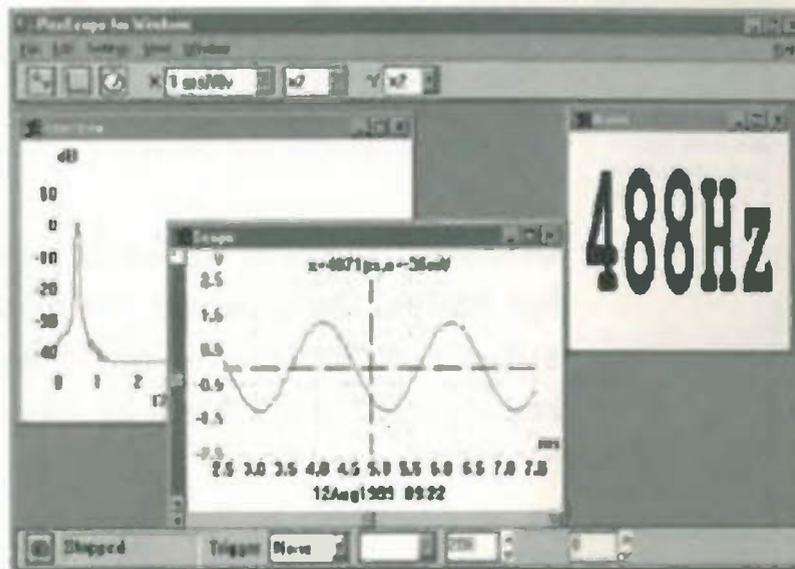

ADC42 single channel oscilloscope

- Low cost and easy to use
- No power supply required
- Ultra compact design
- Oscilloscope and data logging software included
- Write-to-disk on trigger function standard

The ADC42 is a single-channel pc based virtual instrument. Simply plug the unit into the parallel port of your pc and run the software. Designed for analysing low-frequency signals, it provide all the functionality of a conventional scope at a fraction of the price.

The ADC42 has 12-bit resolution making it suitable for applications where detection of small signal changes is needed.

Specifications

Scope timebases	500 μ s/div to 50s/div
Spectrum analysis	100Hz to 10kHz
Max sampling	15ksample/s
Voltage range	\pm 5V
Resolution	12 bit
Channels	1 BNC
I/P impedance	1M Ω , dc coupled
Accuracy	1%
PC connection	D25 to PC parallel port
Power supply	Not required

Use this coupon to order your ADC42

Please send me ADC-42(s) at the special offer price of £98 fully inclusive of VAT and recorded UK delivery, normal selling price £111.63 excluding postage.

Name _____

Address _____

Phone number/fax _____

Total amount £.....

I enclose a cheque _____

Please charge to my credit/debit card.

Card type (Master/Visa/Switch etc)

Card No _____

Expiry date ____ / ____

Please mail this coupon to *Electronics World*, together with payment. Alternatively fax credit card details with order on 0181 652 8111. Address orders and all correspondence relating to this order to Pico Offer, Electronics World, Quadrant House, The Quadrant, Sutton, Surrey SM2 5AS. email jackie.lowe@rbi.co.uk
Make cheques payable to Reed Business Information Group.

A valve substitute

Unable to find a replacement 6V6 audio power valve for his radio, Dave Allen set about making a MOSFET substitute which, he says, works better than the valve it replaced. Here's how he did it...

After giving me many years of good service, my faithful Murphy wireless recently fell silent. This was due to a failed 6V6 audio output valve.

The valve's demise was caused by the coupling capacitor feeding its input grid on pin 5 going short circuit. This resulted in a positive voltage being applied to the valve's grid, which in turn caused excessive current between the anode and cathode.

Apart from the dead valve and capacitor, the rest of the radio was in good order. Replacing the 0.1µF/400V cou-

pling capacitor was easy but finding a replacement valve was not. In view of this, I devised a direct plug-in replacement for the valve based on an IRF1830G high-voltage MOSFET – of which I had plenty.

In addition to the FET, all that was needed were a few peripheral components and the valve base from the dud valve.

Can this technique be applied to other valves?

It should be possible to build similar plug-in modules to valves other than the 6V6, like the 6P1 or KT61. This assumes that you can find information on the pin connections for the valve you want to replace, and that you have a suitable spare base to hand.

Such plug-in modules can directly replace a variety of octal-based output valves that are wired in a parallel heater chain without further modification to the original equipment.

Although I have not tried it yet, it should be possible to use similar MOSFET modules to replace output valves that are directly-heated – i. e. those with no separate cathode. Examples of these are the PX4 and PX25. Have you seen the price of these valves?

If a MOSFET valve substitute is to be used with a receiver that has a series connected AC/DC heater chain, fed via a mains dropping resistor, an additional resistor will have to be wired across the redundant heater pins on the valve holder. This ensures continuity of the

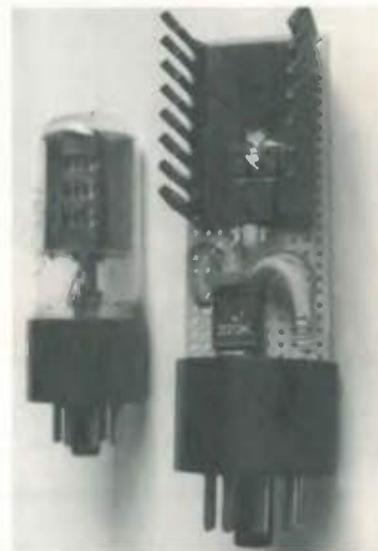

Substituting valves that are part of a series-connected heater chain

Removing a valve with a series-connected heater from a circuit disables all other valves in the same heater circuit. If you want to replace a valve with a series-connected heater using a MOSFET substitute, the missing heater will need to be substituted too using a resistor that simulates the heater.

A 20P3 valve is used here to illustrate how to determine the compensation resistor needed for the heater chain. This valve requires a heater voltage of 20V at a current of 200mA. Since $R=E/I$, the heater replacement resistor is 100Ω.

The power rating of the resistor is $E \times I$, hence 20×0.2 , which is 4W. For this example, a resistor with a 5% tolerance rated at 100Ω and capable of handling 7W would be a good choice.

As this resistor is replacing a valve's heating element, it will get hot, so it is advisable to place it where it will have sufficient ventilation and electrical insulation from the metal chassis.

Table 1. Pin connections for the 6V6 tetrode.

Pin	Description
1	No connection. This pin may be connected to the suppressor grid, g_3 , on certain pentode valves and can be ignored.
2	Heater
3	Anode
4	Screen grid (g_2)
5	Input grid (g_1)
6	No connection
7	Heater
8	Cathode

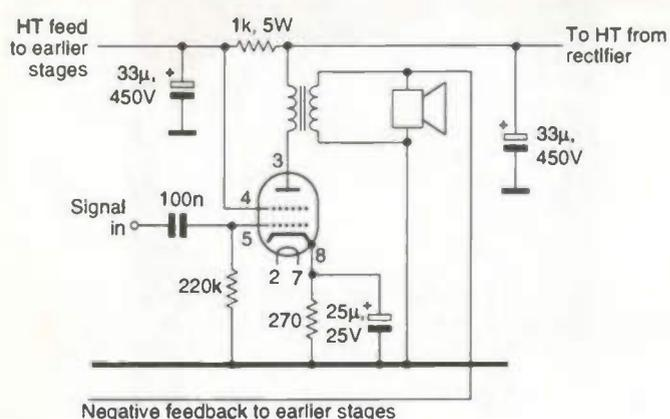

Fig. 1. Original valve audio power output stage.

heater circuit, as the replacement module does not have a heater.

Simply shorting the heater pins of the redundant valve may overload the other valve heaters and/or the dropper. There's more on this in the panel covering valves in series heater chains on the previous page.

Details for the 6V6

Connections for the 6V6 valve are shown in Table 1. Figure 1 shows a typical single-ended Class-A output stage using a 6V6 tetrode, or similar valve, incorporating cathode bias.

In Fig. 2 is the output stage – minus valve – and the relevant connections shown for use with the plug-in module. Figure 3 shows the circuit for the plug-in replacement module.

The circuit

The circuit is based on an IRF1830G MOSFET, wired as a triode. In this application, no screen grid connections to the valve base/holder are involved.

For the MOSFET to operate as an amplifier it has to be biased into conduction. This is achieved by applying a small positive bias to its gate.

Bias voltage for the FET is derived from a potential divider, fed from the HT rail. It consists of R_2 , VR_1 and R_1 . Resistor R_1 also serves as a current limit for the MOSFET and as a convenient test point for voltage monitoring when setting up the plug-in module.

Zener diode D_1 keeps the gate voltage stable, enabling the module to be used in a variety of receivers with differing HT voltages. Decoupling capacitor C_1 , connected across VR_1 , helps prevent any noise from the power supply entering the sensitive gate input of the MOSFET.

Capacitor C_2 provides input coupling for the module and is fed from an earlier audio stage in the receiver.

Implementing the valve substitute

A good starting point is the preparation of the valve base. Wearing safety goggles and gloves to protect you against cuts from broken glass is a good idea when reclaiming the valve base.

The best way to break the glass envelope is to place the dud valve in a thick plastic bag and tap the glass with a small hammer. Then carefully remove the shattered remains from the base.

Remnants of wire in the valve base pins can now be unsoldered.

A piece of 0.1in matrix stripboard with 11 strips by 32 holes is required for mounting the MOSFET, heat sink, and the few passive components.

After completion of the component board, three short flying leads can be connected to the board and taken to the relevant pins on the valve base and soldered. The board can then be held in place using epoxy resin adhesive.

Setting up

With the plug-in module completed, rotate the wiper of VR_1 so it is at the anode end of D_1 . This will ensure there is no positive bias voltage on the gate of the FET when you first switch on your receiver.

Now insert the plug-in module into its socket and connect a meter switched to its 20V DC range across R_1 . Switch on your receiver and let it warm up for about ten minutes.

Slowly rotate VR_1 until the MOSFET springs to life. This will happen quite suddenly. Finally adjust VR_1 for a drop of 2V across R_1 . This corresponds to a current of 20mA flowing through the output stage, which works well with my particular receiver.

Power dissipation considerations

As the MOSFET in this case is biased in class-A, it is constantly dissipating

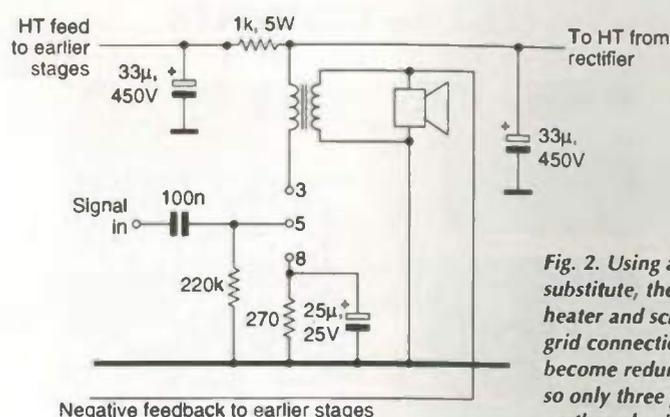

Fig. 2. Using a 6V6 substitute, the heater and screen grid connections become redundant, so only three pins on the valve base are used.

Main components

Resistors

R_1	100 Ω , 0.6W
R_2	1M, 0.6W
VR_1	220k, horizontal mounting preset

Capacitors

$C_{1,2}$	100n, 63V metallised polyester film, 5mm spacing
-----------	--

Semiconductors

IRF1830G MOSFET (Farnell). This version of the MOSFET has an insulated tab so the heat sink will not be at HT potential.

Diode

D_1 is an 18V/400mW zener diode

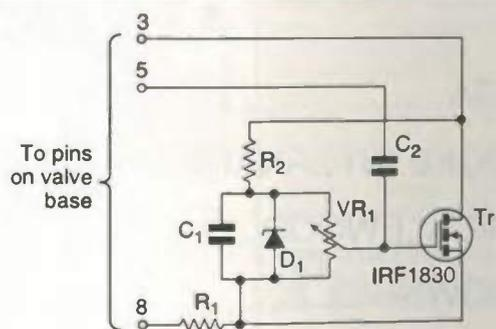

Fig. 3. MOSFET substitute for the 6V6 valve. Only three pins are needed on the valve base, to replace the valve's anode, cathode and grid.

power – or heat if you like – so a good heat sink will be required. The sink needs to be at least 9.9°C/W.

In my particular case, the voltage across the MOSFET was measured at 277V at a current of 20mA so the power being dissipated was 277×0.02, which is 5.54W.

In use

My original plug-in module has been in use for about two years now with no problems. As a bonus, the audio is much improved – especially at the high frequency end. ■



**SUPPLIER OF QUALITY USED
TEST INSTRUMENTS**

OPERATING & SERVICE MANUALS



NEW
Address and
Contact Numbers
1st March 2001

**Cooke
International
Second User
ELECTRONIC
TEST AND
MEASURING
INSTRUMENTS**

Unit 9,
Ford Lane
Business Park,
Ford, Arundel,
West Sussex
BN18 0UZ, UK

Tel:
(+44) 0 1243 555590
Fax:
(+44) 0 1243 551455
E-Mail:
info@cooke-int.com
Web:
http://www.cooke-int.com

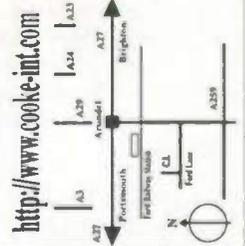

CIRCLE NO.127 ON REPLY CARD

ADVERTISERS' INDEX

BETA.....	245	LANGREX.....	303
COOKE INTERNATIONAL.....	318	MILFORD INST.....	245
CRICKLEWOOD.....	266	PICO.....	287
CROWNHILL.....	249	PSA PARTS.....	242
DATAMAN.....	OBC	QUICKROUTE.....	242
DISPLAY ELECTRONICS.....	263	RAMCO.....	245
ENVIROWISE.....	287	SEETRAX.....	303
EPTSOFT.....	247	SIGHTMAGIC.....	283
ICE TECHNOLOGY.....	IBC	SURREY ELECTRONICS.....	266
INTEC ASSOCIATES.....	287	TELNET.....	IFC
JOHNS RADIO.....	290	TEST EQUIP SOLUTIONS.....	259
JPG ELECTRONICS.....	303	TIE PIE.....	273
LABCENTER ELECTRONICS.....	285	WEB PAGES.....	312, 313, 314

As an advertiser you can be certain that your sales message is going to be read by decision-making electronics professionals with the power to purchase your products.

The pre-paid rate for semi-display setting is £17 per single column centimetre (maximum 4cm). Box number £22 extra. All prices plus 17½% VAT. All cheques, postal orders etc to be made payable to Reed Business Information. Advertisements together with remittance should be sent to Electronics World Classified, 12th Floor, Quadrant House, The Quadrant, Sutton, Surrey SM2 5AS. Fax: 0208 652 3981. Tel: 0208 652 8339

Service Link

ARTICLES WANTED

Rack Enclosures

New and Used most sizes 16U to 50U side and rear panels mains distribution 19" Panel mounts optima eurocraft. Prices from £45 +vat

M&B Radio

86 Bishopsgate Street Leeds LS1 4BB Tel. 0113 2702114 Fax. 0113 2426881

TOP PRICES PAID

For all your valves, tubes, semi conductors and ICs.

Langrex Supplies Limited

1 Mayo Road, Croydon, Surrey CR0 2OP TEL: 020 8684 1166 FAX: 020 8684 3056

SERVICES

PRINTED CIRCUIT BOARDS

DESIGNED & MANUFACTURED

- Prototype or production quantities
- Fast turnaround available
- PCBs designed from circuit diagrams
- Almost all computer files accepted
- PCB assembly - mechanical assembly
- Full product design-manufacture-test-repair

agar TEL 028 9073 8897
Circuits FAX 028 9073 1802
agar@argonet.co.uk
Unit 5, East Belfast Enterprise Park
308 Albertbridge Rd, Belfast BT5 4GX

LINEAGE

ROTEK 6000 AC/DC Multi meter calibrator together with 50 amp adaptor and manual. Also time DC voltage calibrator 20035. Tel: 0116 244 2211 days. 0116 288 4184 evenings.

P&P ELECTRONICS, Prototype Electronic System Designs by degree qualified staff. Tel: 01924 402931.

SERVICES

From **Concept** **98 HOUR SERVICE**
To **Production**

Electronic design and engineering services for the new millennium.

- Embedded control
- Telecommunication products
- Datacommunication products
- SM PSU and battery management
- Wireless transmission systems
- Audio and Video processing
- DVD control systems
- Internet site and graphics authoring
- PCB design
- Schematic layout and re-drawing
- Technical documentation & translation

Tel/Fax: +44 (0) 1872 223306
Email: sales@designersystems.co.uk



See our web site @ <http://www.designersystems.co.uk>

BEST CASH PRICES PAID

For valves KT88, EL37, DA100, PX25 and complete collections. Please ask for our wanted list.

WIDE RANGE OF VALVES & OBSOLETE CRT STOCKED

E-mail: sales@BEL-Tubes.co.uk

Tel: 01403 784961 Fax: 01403 783519
Billington Export Ltd., Sussex RH14 9EZ
Visitors by appointment please

FOR SALE

RF DESIGN SERVICES

All aspects of RF hardware development considered from concept to production.

WATERBEACH ELECTRONICS

www.rlaver.dial.pipex.com
TEL: 01223 862550
FAX: 01223 440853

POWER SUPPLY DESIGN

Switched Mode PSU
Power Factor Correction
designed to your specification

Tel/Fax: 01243 842520
e-mail: eugen_kus@cix.co.uk
Lomond Electronic Services

ELECTRONIC UPDATE

Hioki's New 8807/8808 Memory Recorder

These compact, light recorders have 2 or 4 analogue channels with isolated inputs, PC card slot, fax/modem communication function, versatile trigger functions and 3-way power. They are ideal for a variety of applications requiring long memory lengths and high transient speed capability.

Telonic Instruments Ltd
Tel: 0118 978 6911
Fax: 0118 979 2388

CIRCLE NO.129 ON REPLY CARD

The National Instruments Measurement and Automation Catalogue 2001 is the leading resource for engineers and scientists seeking the most effective customer-defined measurement and automation solutions. The catalogue details the complete line of NI products with comprehensive tutorials, product specifications and selection advice - all designed to help engineers and scientists develop integrated networked measurement and automation applications.

Tel: 01635 523545
Fax: 01635 524395
E-mail: info.uk@ni.com
Web: www.ni.com/uk

CIRCLE NO.128 ON REPLY CARD

Please Mention
Electronics World When Replying
to advertisements

APPOINTMENTS



Liscombe Park, Soulbury, Buckinghamshire LU7 0JL
Tel: 01296 689030 Fax: 01296 689031
post@vrl.co.uk

Satellite Comms - Hardware or Software

Essex £25-40k + bens
We're looking for both Software and Hardware Design Engineers to join this manufacturer of high-tech sub-systems for the international satellite telecommunications market. It's a privately owned company with a rock solid track record of continuous growth, so long term prospects are excellent. Software Engineers will need a Degree (maybe an HND) and at least two years of embedded C/Assembler - ideally on 8051, ARM or PowerPC processors. Any knowledge of DSP, Linux or LabView would be a plus. Hardware Engineers will require a broad set of skills - ideally including one or more of: FPGAs, Verilog, embedded processors, PLLs, Analogue IF Tx/Rx, Modulation Techniques, OrCad, Foundation, SystemView. The company offers an excellent 'package' along with smart purpose built offices in rural Essex, no traffic jams but your own transport is essential.
SPIROVAOS (spiro@vrl.co.uk) Ref SV/EWD171

Motor Racing Systems

Cambridge All levels £22-45k + bens
The real McCoy! This company is the undisputed leader in the supply of electronic systems to the world motor racing industries. Clients include most of the current Formula 1 teams, Le Mans teams, Rally Teams - even Top Fuel Dragsters and their list of clients should never be a dull moment here! Another big expansion means they are looking for both Software and Hardware Design Engineers at all levels from bright Graduates up to Senior Engineer. Software vacancies are for either embedded C or C++/Visual C++/MFC and the hardware jobs involve digital/embedded processors, FPGAs, EPLDs, and analogue sensor design. Superb offices just outside Cambridge and plenty of ongoing training await you - so don't miss it!
GEOFF COCKLE (geoff@vrl.co.uk) Ref GC/EWD172

DSP - UMTS Mobile Comms

Berks (and Japan!) £28-45k + bens + reloc
This is the European telecomms research centre for an international electronics group where they are working at the forefront of the 3rd Generation UMTS mobile comms system. All their R&D teams are expanding, but in particular they are keen to strengthen their DSP group with both Algorithm Developers and Software Implementation Engineers. Algorithm Developers will be working on advanced signal processing theory using MATLAB and COSSAP for modelling and simulation purposes. Implementation Engineers will be involved in the design, specification and coding of software in C and occasionally assembler. Selected individuals will get the opportunity for 6 or 12 month secondments to the group's headquarters in Japan - although it's not compulsory!
KAREN HAINES (karen@vrl.co.uk) Ref KHEWD173

Senior Analogue/Electro-Optics Designer

Cambridge to £45k + bens + shares
We are looking for a Senior Analogue Electronics Design Engineer to develop the high-speed driver/receiver stages of a revolutionary optical communications system. This will include driving solid state lasers, detectors and modulators at speeds of up to 1Gb/s. Candidates should have a good first degree (a PhD would be even better!) and ideally have experience including mixed signal ASIC design in addition to large-signal analogue design. The company is a newly formed spin-out from a highly regarded parent organisation so the salary package includes superb 'founder-member' share options in addition to an excellent base salary and benefits package.
KAREN HAINES (karen@vrl.co.uk) Ref KHEWD174

New Cambridge Start-Up!

Digital Designers - DSP Software Engineers £25-50k++ + pension,
Embedded Software Engineers - Protocol Software Engineers shares, relocation
RF Designers - ATE Engineers £4figure 'Golden Hello'
All the excitement, clean sheet design projects and new facilities (not to mention share options!) of a pre-IPO start-up, but with the financial stability and benefits package of the Euro Top 500 company backing them. The company is developing revolutionary comms infrastructure equipment that will combine voice and data over wireless IP networks. This is basically nano-scale cellular base stations but they're far, far cleverer than that! Anyway, they currently have 16 employees but need to more than double this as soon as possible, so they are looking for bright, enthusiastic Engineers covering all of the above disciplines. Phone us or better still email us a CV as we think these are some of the most exciting jobs around!
SPIROVAOS (spiro@vrl.co.uk) Ref SV/EWD176

It's bigger, it's better, it's brand-new - www.vrl.co.uk

Sennheiser UK, the world's leading manufacturer of professional audio equipment is looking to recruit an accomplished

ELECTRONICS SERVICE ENGINEER

Candidates must have experience in professional radio microphone and generic electronics service and repair to component level.

Responsibilities will include:

- Service and repair of the entire range of products distributed by Sennheiser
- Provide technical expertise to assist customers
- Client liaison

Minimum qualifications:

- 2-3 years experience in the audio or RF industries
- Experience in the testing and repair of RF and audio systems
- Good communication and interpersonal skills
- Computer literate

Remuneration subject to aptitude and experience.

Contact: Dave Hawker 01494 551552

dhawker@sennheiser.co.uk

Confidential fax: 01494 551521

DEVELOPMENT ENGINEERS

Radio Communication Systems Herts/Essex

A leader in the field of radio fire alarm systems, the company seeks engineers to fulfil expansion plans to penetrate world markets. To maintain our position at the cutting edge of technology we need:-

Senior Hardware Engineer to £40k + Benefits

A graduate with at least three years experience in micro processor based systems and analogue technologies, ideally at RF, you would be expected to manage a development project from initial conception through to production and be capable of overseeing all aspects of engineering and quality.

Design Engineer to £25k + Benefits

A graduate familiar with hardware design, embedded micro processor techniques and programming in both assembler and 'C' is required to complement our development team.

Working from our new premises in a friendly environment, prospects are excellent for the right candidates in this expanding company. Relocation expenses, employee share ownership and other benefits are included.

To apply, please send your CV to the Managing Director, or telephone 01279 635668 for an application form.

Electro House, Edinburgh Way
Harlow, Essex CM20 2TP
www.electrodetectors.co.uk

Electro-Detectors

ElectronicsWEEKLY

BE THE FIRST TO KNOW

What's the worst thing about engineering? Spending months designing a circuit, only to find someone is selling a complete chip for the job.

If you want to be the first to know about the latest developments in the electronics industry, and tell other engineers about them, then consider joining *Electronics Weekly*.

The UK's leading trade newspaper for electronics engineers is looking for a technical reporter to join its team of writers.

You'll be covering technology developments in fields ranging from semiconductors to mobile phone standards. You'll report on industry issues that affect engineers, whether it be new product launches or pay and conditions.

Applicants should have a relevant degree or similar qualification and, ideally, some experience working in the electronics industry.

A background in journalism is not required and training in news reporting, feature writing and interviewing is available.

Send your CV to: Richard Wilson, Editor, *Electronics Weekly*, Quadrant House, The Quadrant, Sutton, Surrey SM2 5AS. E-mail: richard.wilson@rbi.co.uk



For development or production...



A range of truly portable, Universal and EPROM/Flash programmers for every need

- Support for all types of devices including 8 and 16-bit memory, up to 128Mbit, PLDs, CPLDs, and over 300 microcontrollers
- Uses the parallel port of any PC or laptop
- Program and verify low voltage devices down to 1.8V
- Low cost package adapters available for PLCC, PSOP, TSOP, QFP, SDIP, SOIC and BGA
- No additional modules or adapters required for any DIP device
- Compatible with DOS, Windows 95/98, Windows NT
- Powerful and comprehensive software interface is easy to use
- Uses PSU/Recharger supplied, or batteries for real portability
- Includes Chiptester for TTL/CMOS, DRAM and SRAM devices
- Optional EPROM/RAM emulators also available

Model	Supports	Price
EPMaster IV-B	48 pin support for EPROM, EEPROM, Flash & Serial PROM	£295
Speedmaster IV-B	As EPMaster IV-B, plus EPROMs, PALs, CoMs, CPLDs and 8742/1 micro-controllers	£495
MkMaster IV-B	As Speedmaster IV-B, plus over 100 micro-controllers including 87C-BUS 1/196, PICs, AVR8s, 80Cxxxx, 516, AM 705711, SA8C709, TMS10770, 786, COP etc... FULL UNIVERSAL	£695
IV-B1 Portable	40 pin version of MkMaster IV-B + LCD & keypad	£995

...the best programmers are here...

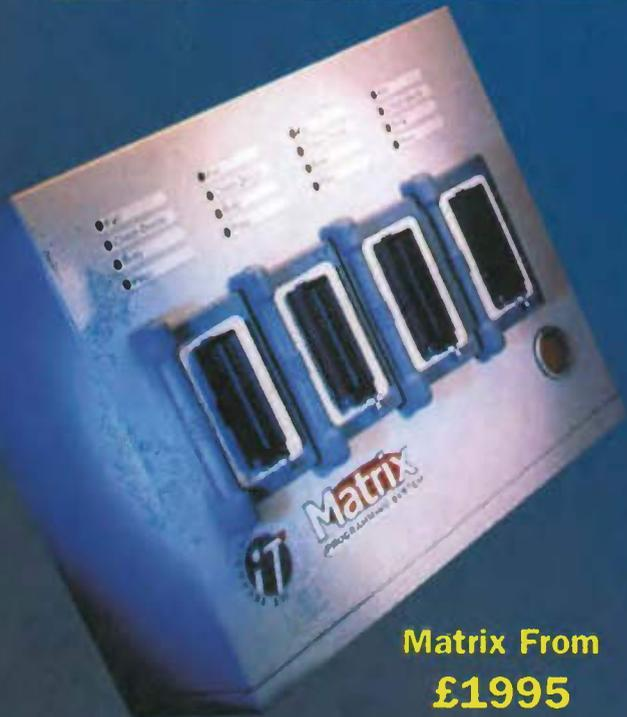

**Matrix From
£1995**

The new Matrix Programming System offers the most complete, flexible gang programmer you will ever need for production applications at an extremely competitive price from £1,995

- Two levels of device support: Memory only, or Universal support for memory devices up to 128Mbit, PLDs, CPLDs and over 300 Microcontrollers
- 4 or 8 independent programming sites per box
- Daisy-chaining allows up to 48 centrally controlled sites
- Very high throughput (program/verify time in seconds): 28F400 = 4/2.5, 28F160B3 = 18/12, 28F640J5 = 155/60
- Low cost passive socket modules give support for DIP, PLCC, PSOP, TSOP, QFP etc.
- Modules are not device specific giving major savings in cost of ownership
- True low voltage support down to 1.8V, plus marginal verification
- Intelligent auto-sensing of sockets eliminates need to continually access keyboard
- Powerful and comprehensive software, with easy-to-use interface
- Manufacturer approved algorithms for accurate programming and maximum yield
- Full on-board diagnostics
- Compatible with Windows 95/98 and Windows NT
- Universal input power supply - 90-260V, 50/60Hz

All ICE Technology programmers come with lifetime FREE software updates and technical support, 12 month warranty and 30-day money-back guarantee. For complete Device Support lists, FREE software updates, Demo software and full product information, just visit our website at www.icetech.com

...and here, www.icetech.com

ICE Technology Ltd, Penistone Court, Sheffield Road, Penistone, Sheffield, S36 6HP, UK
tel: +44 (0)1226 767404 • fax: +44 (0)1226 370434 • email: sales@icetech.com

ICE Technology Inc, ICE Technology Inc., 430 Peninsula Ave, Suite 4, San Mateo, CA 94401, USA
tel: (toll free US/Canada) 1 (888) ICE 2305 / 423 2305 (outside US/Canada): 1 (650) 375 0427
fax: 1 (650) 375 8666 email: iceusa@icetech.com

**ORDER NOW VIA OUR CREDIT CARD HOTLINE: +44 (0) 1226 767404
ALL PRODUCTS IN STOCK**

Find your local distributor at www.icetech.com or call your local office

1 Custom software and enhanced priority device support is also available for all programmer platforms. All prices are exclusive of carriage and VAT. All trademarks are recognised as belonging to their respective owners.

CIRCLE NO. 112 ON REPLY CARD



[TRUTH
OR
ILLUSION?]

the world's most powerful portable programmers

CE



£495
PLUS VAT

Dataman S4

[Analysis]

- Programs 8 and 16-bit EPROMs, EEPROMs, PEROMs, 5 and 12V FLASH, Boot-Block FLASH, PICs, 8751 Microcontrollers and more.
- EPROM emulation as standard!
- Rechargeable battery power for total portability.
- All-in price includes emulation leads, AC charger, PC software, spare library ROM, user-friendly manual.
- Supplied fully charged and ready to use.

S4 GAL Module

[Analysis]

- Programs wide range of 20 and 24 pin logic devices from the major GAL vendors.
- Supports JEDEC files from all popular compilers.

Dataman-48LV

[Analysis]

- Plugs straight into your parallel port of PC or laptop.
- Programs and verifies at 2, 2.7, 3, 3.3 and 5 V
- True no-adaptor programming right up to 48-pin DIL devices.
- Free universal 44-pin PLCC adaptor.
- Built-in world standard PSU – for go-anywhere programming.
- Package adaptors for TSOP, PSOP, QFP, SOIC and PLCC.
- Optional EPROM emulator.

Support

[Analysis]

- 3 year parts and labour guarantee.
- Windows/DOS software included.
- Free software updates via BBS/Internet.
- Free technical support for life.
- Next day delivery – always in stock.
- Dedicated UK supplier, established 1978.

Truth — Claim Verified

[Recommended Action]

Secure for own use without delay. Order via credit card hotline – phone today, use tomorrow. Alternatively, request more detailed information on these and other market-leading programming solutions.

CIRCLE NO. 103 ON REPLY CARD

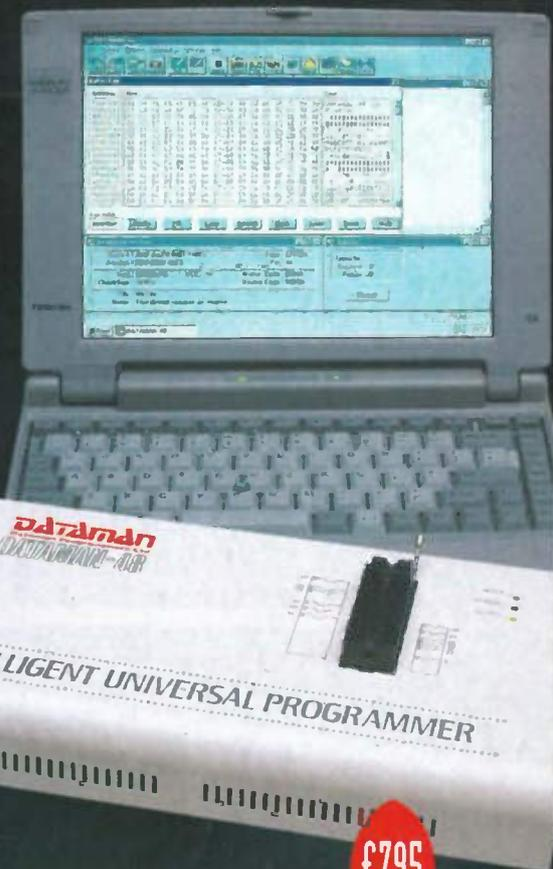

NEW MODEL

£795
PLUS VAT

3
YEAR

GUARANTEE

DATAMAN

Dataman Programmers Ltd, Station Road,
Maiden Newton, Dorchester, Dorset, DT2 0AE, UK
Telephone +44/0 1300 320719 Fax +44/0 1300 321012
BBS +44/0 1300 321095 (24hr) Modem V.34/V.FCN.32bis
Home page: <http://www.dataman.com>
FTP: <ftp://dataman.com> Email: sales@dataman.com

hotline
01300 320719



Orders received by 4pm will normally be despatched same day.
Order today, get it tomorrow!

Money-back 30-day Trial

Try the Dataman S4 or Dataman-48LV without obligation for 30 days. If you do not agree that these truly are the most powerful portable programmers you can buy, simply return your Dataman product within 30 days for a full refund.